

"345KV VOLTAGE"

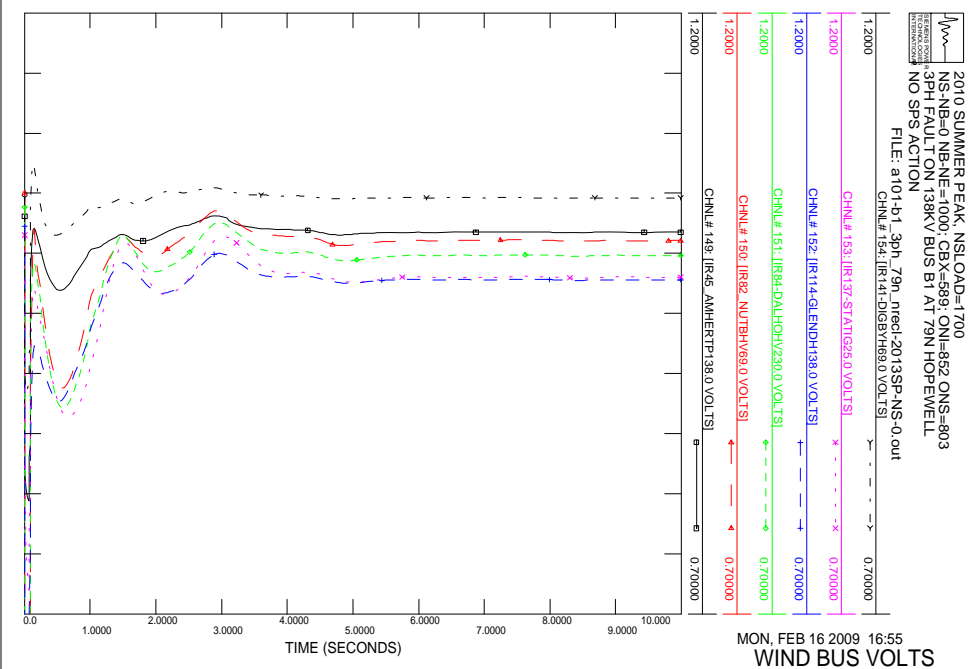

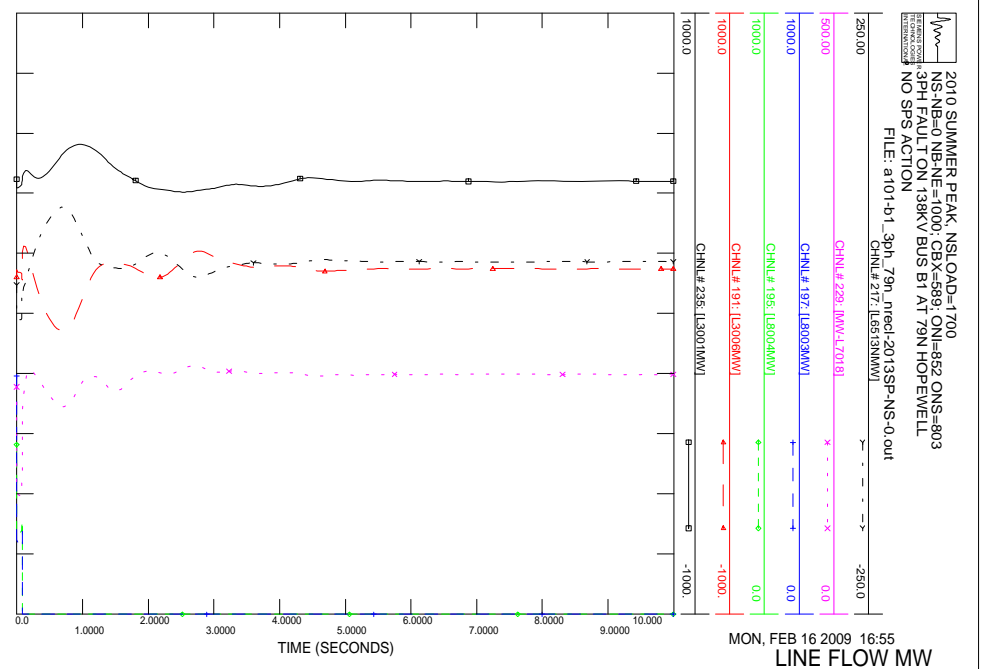

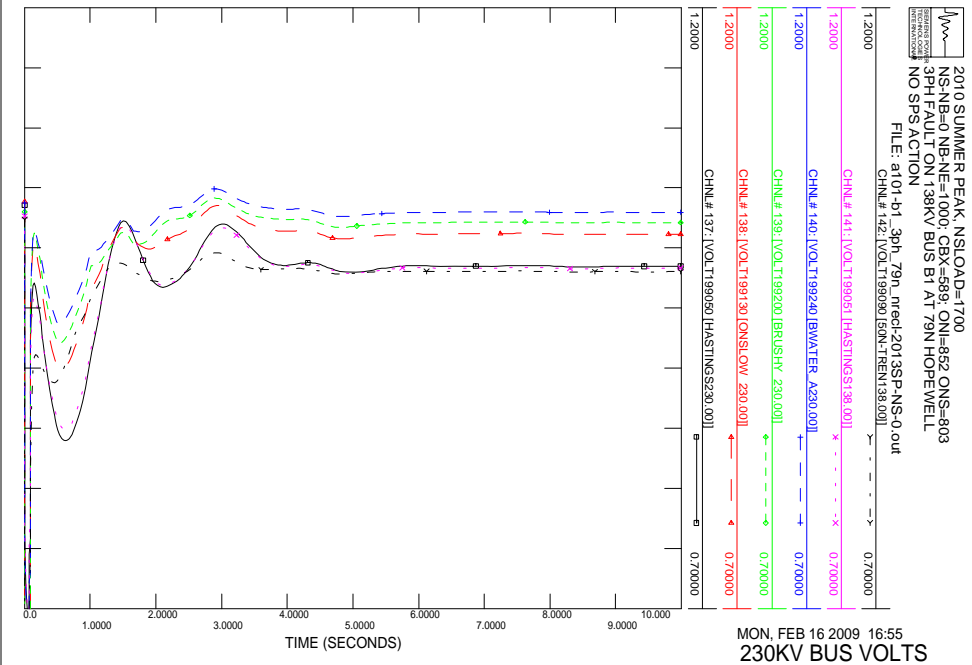

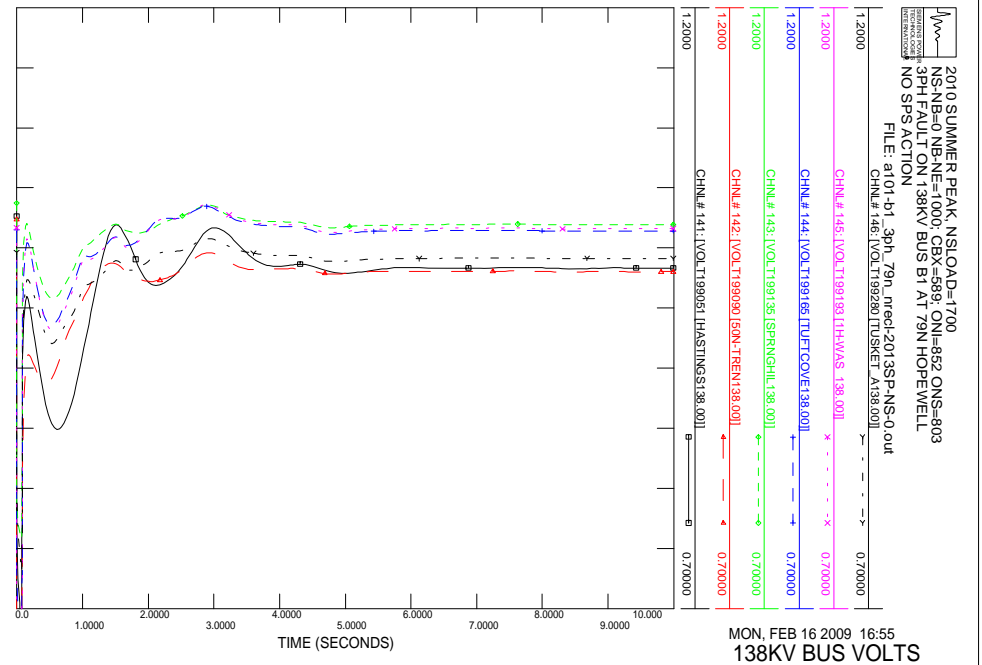
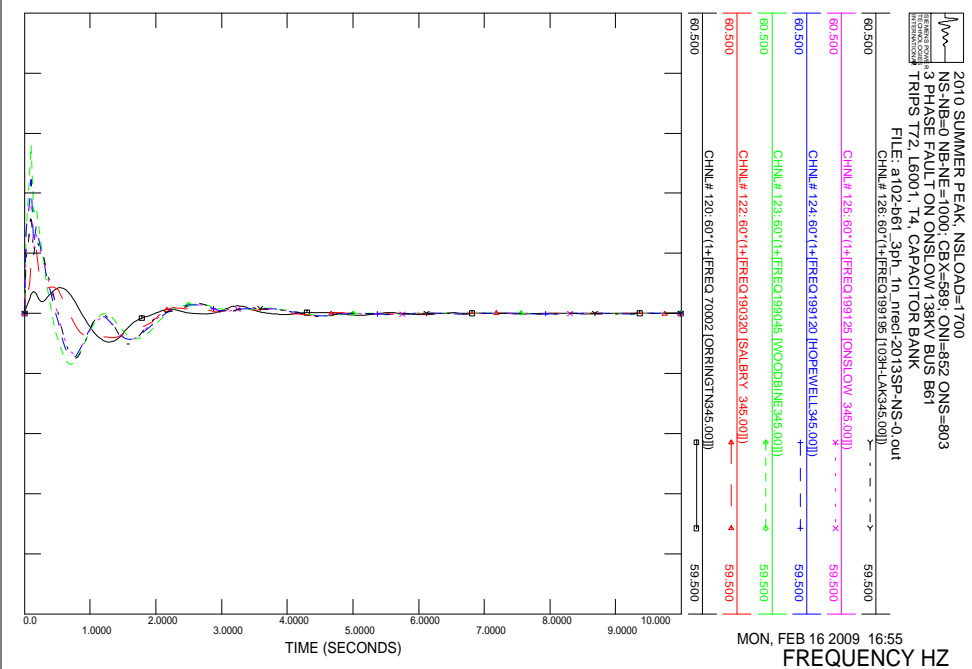
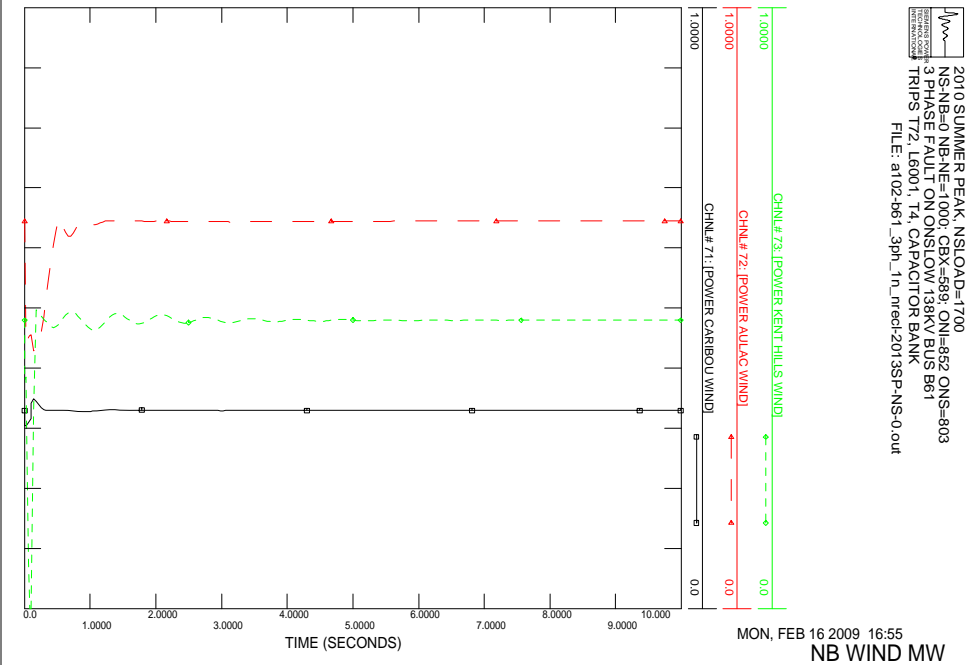
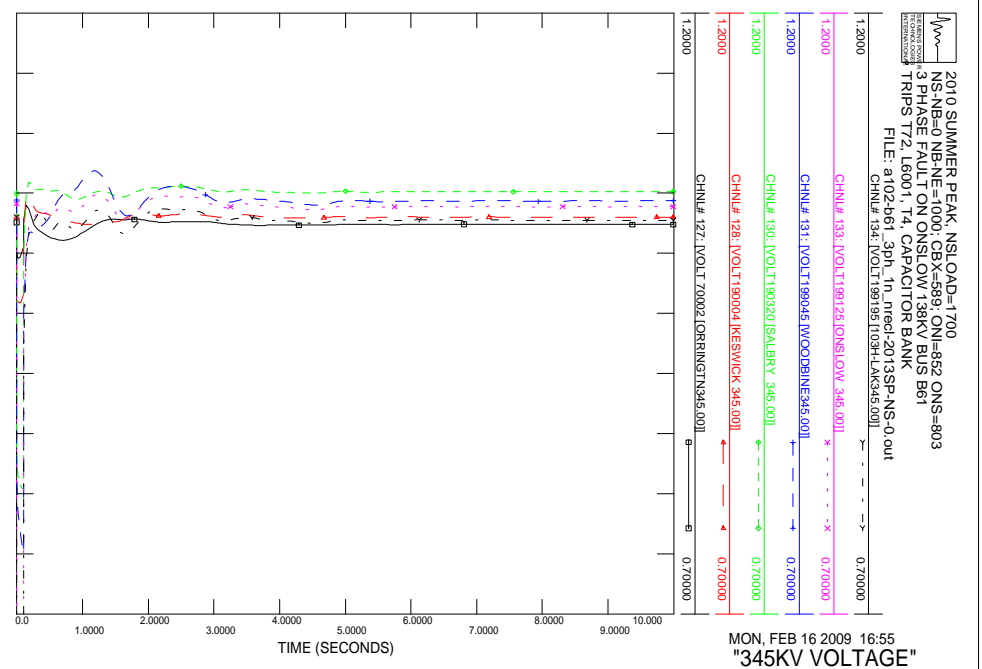
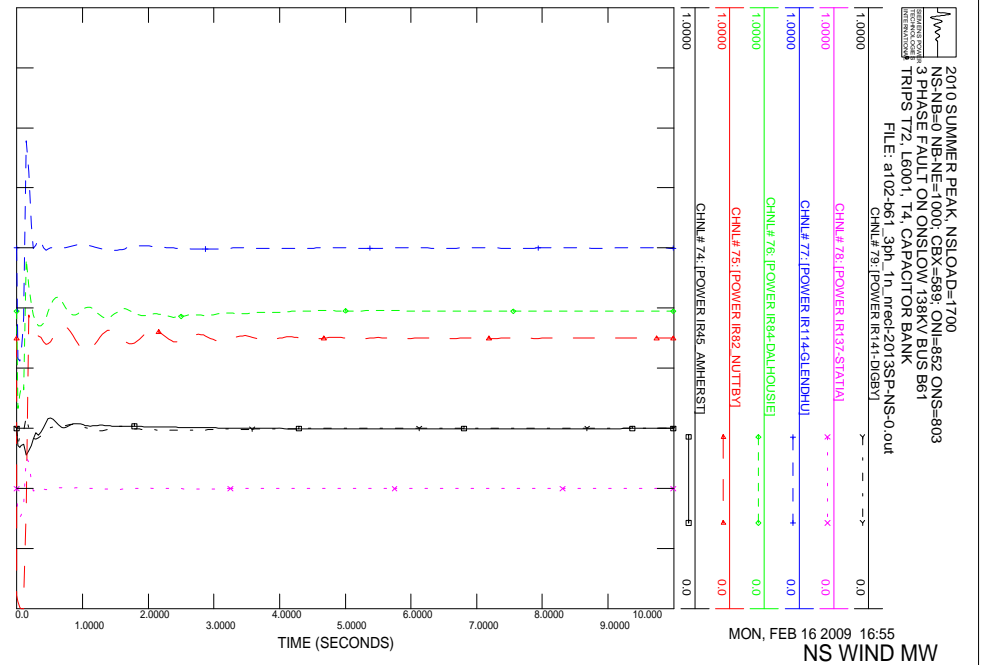
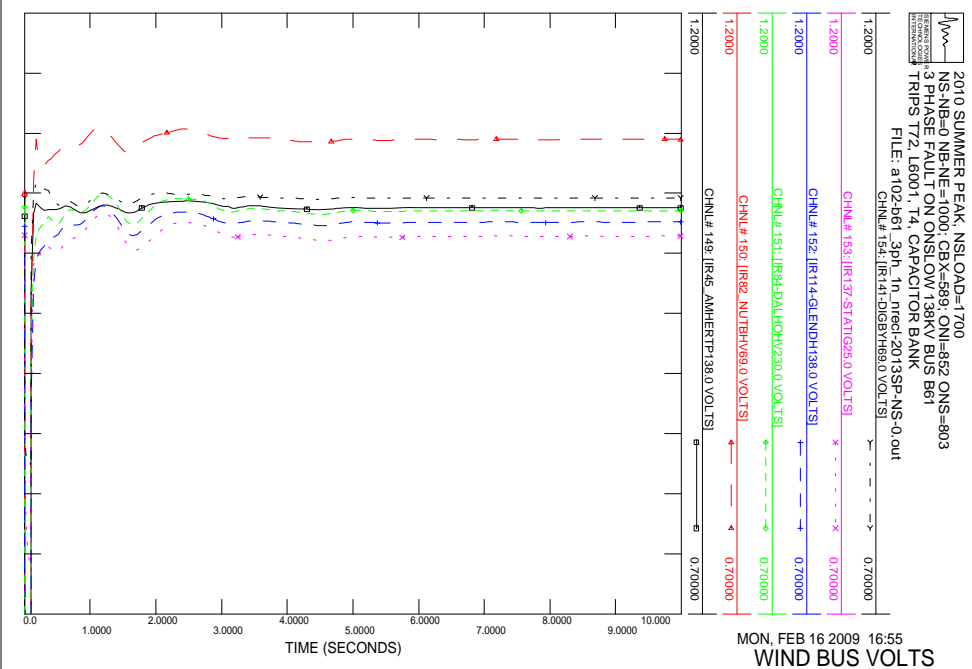
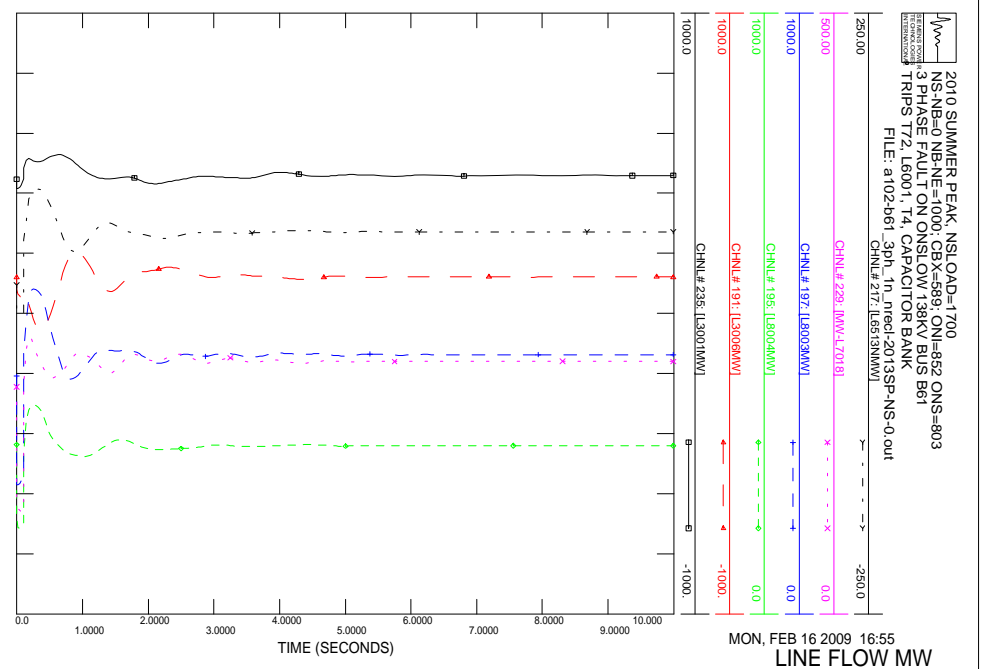
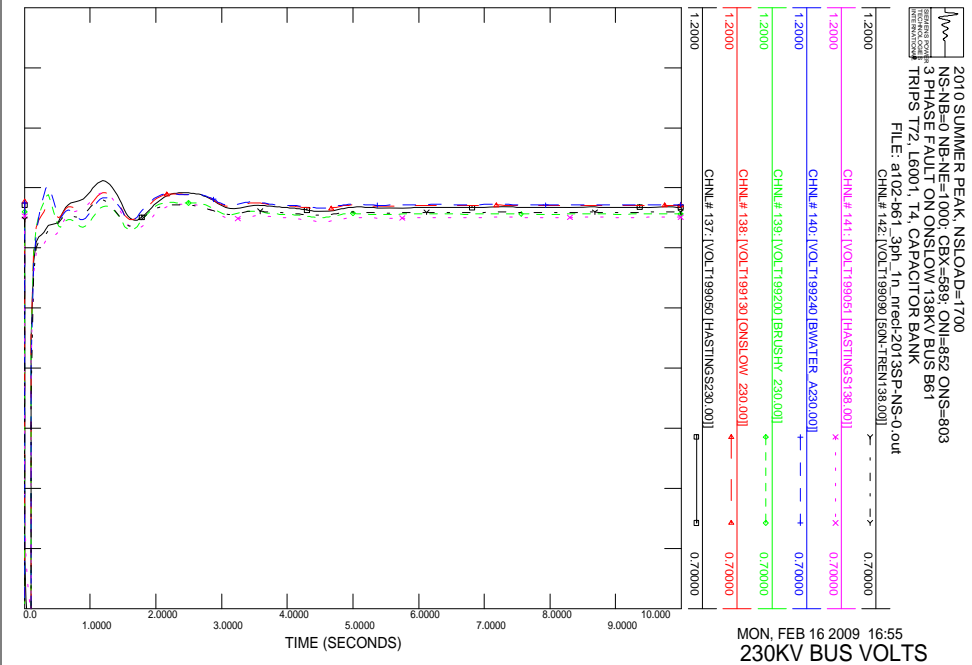
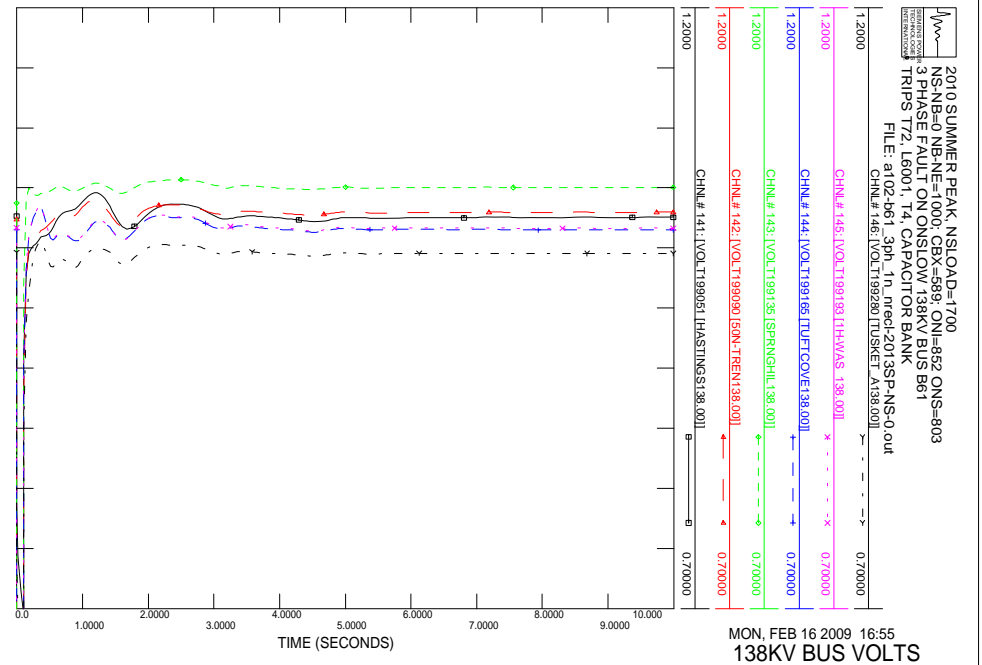
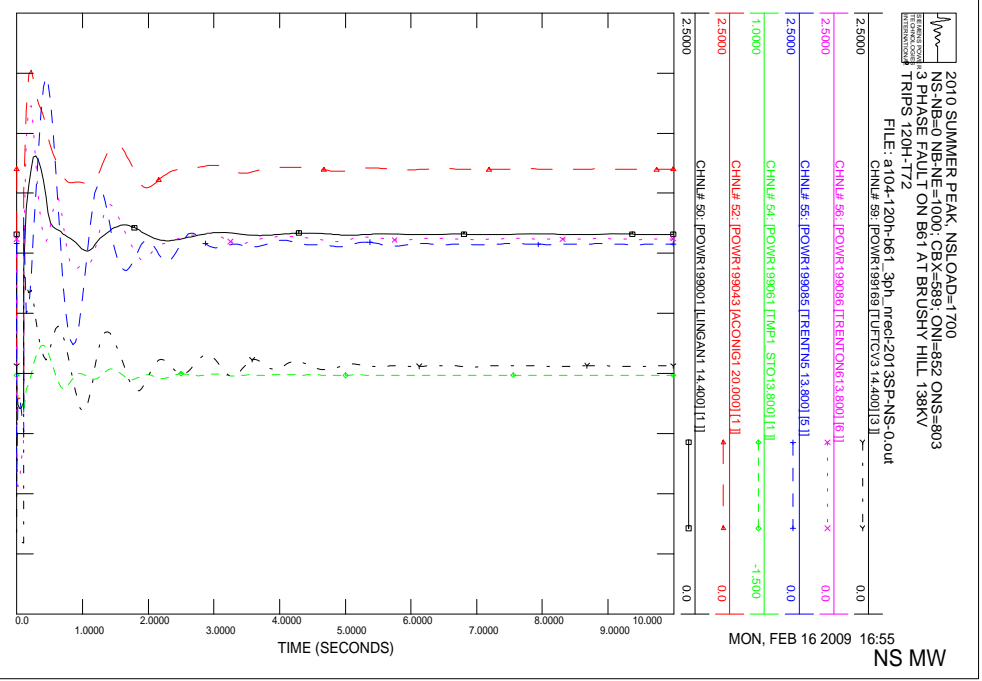
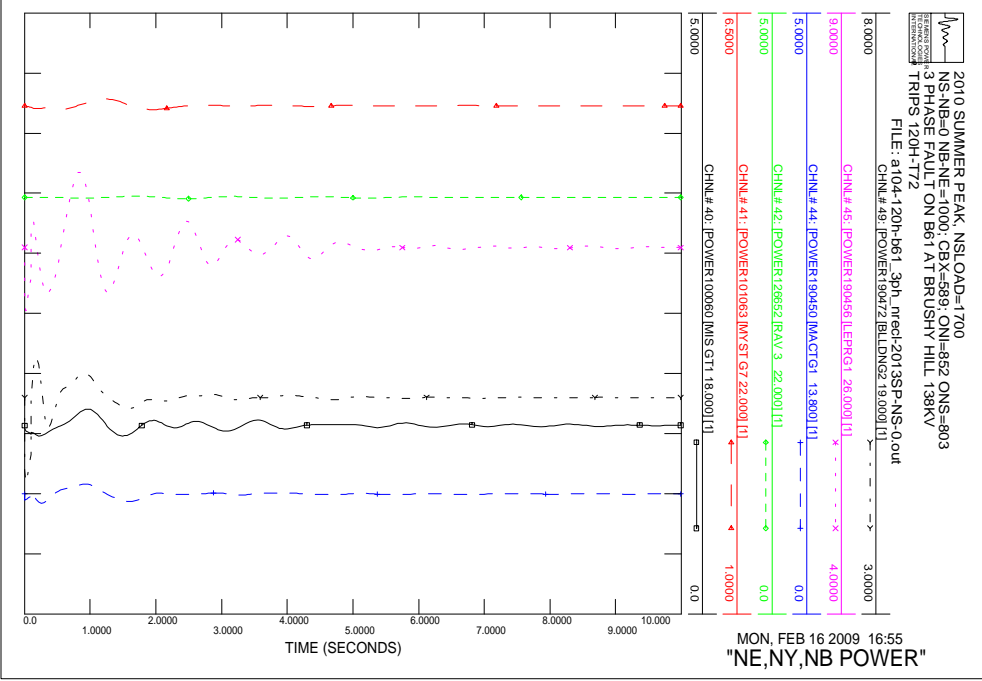
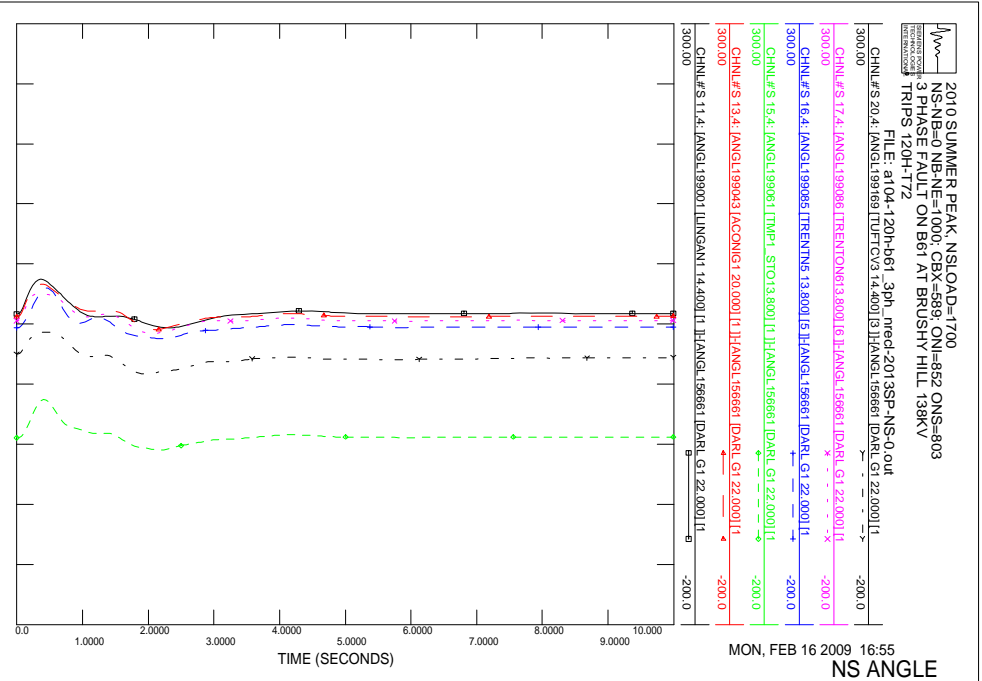
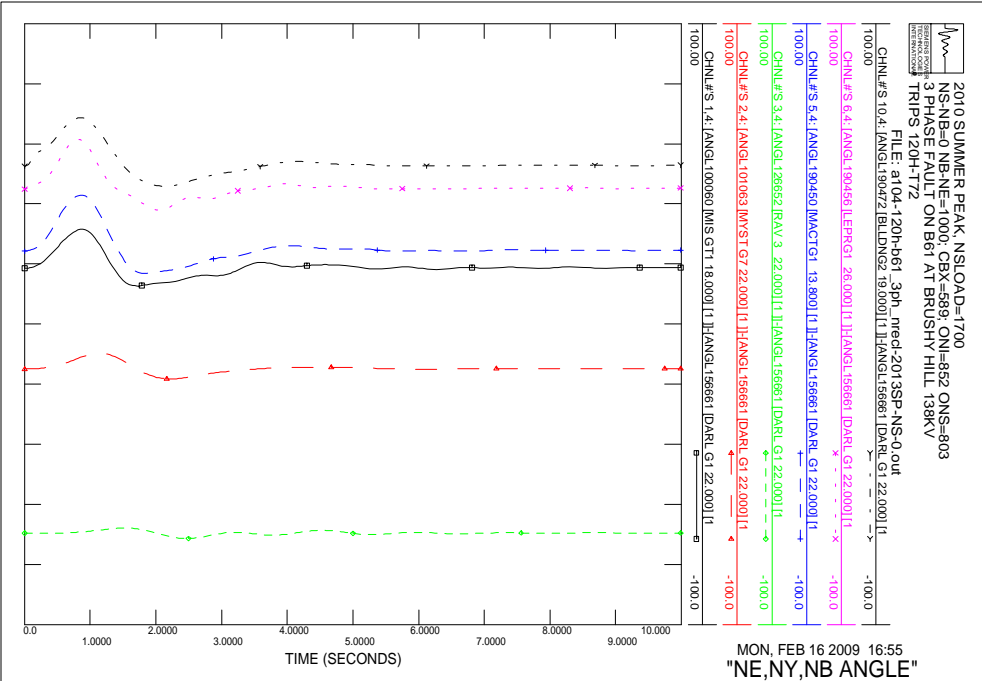

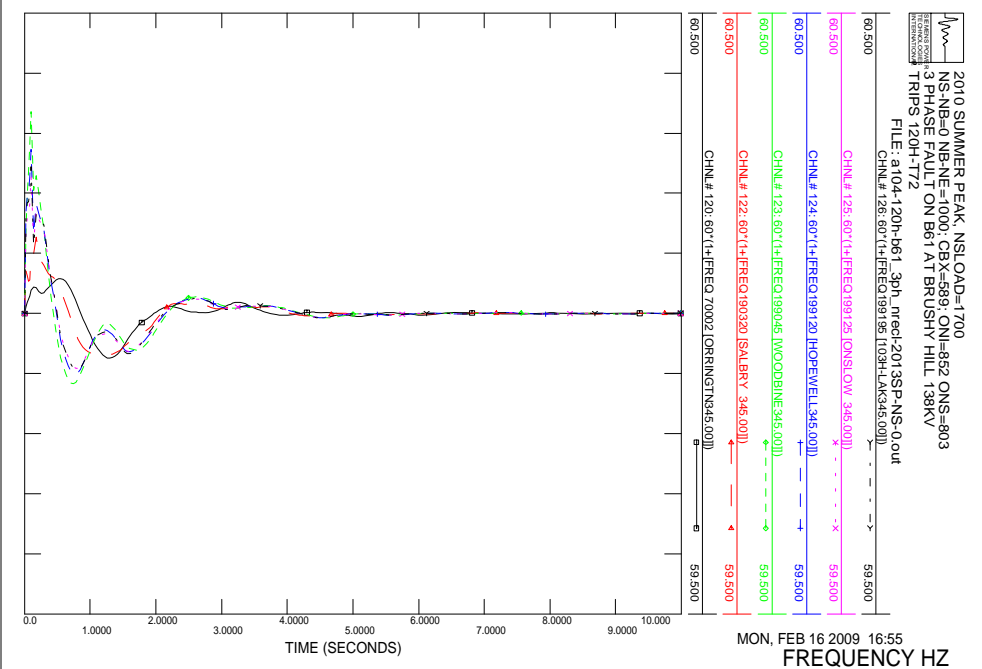
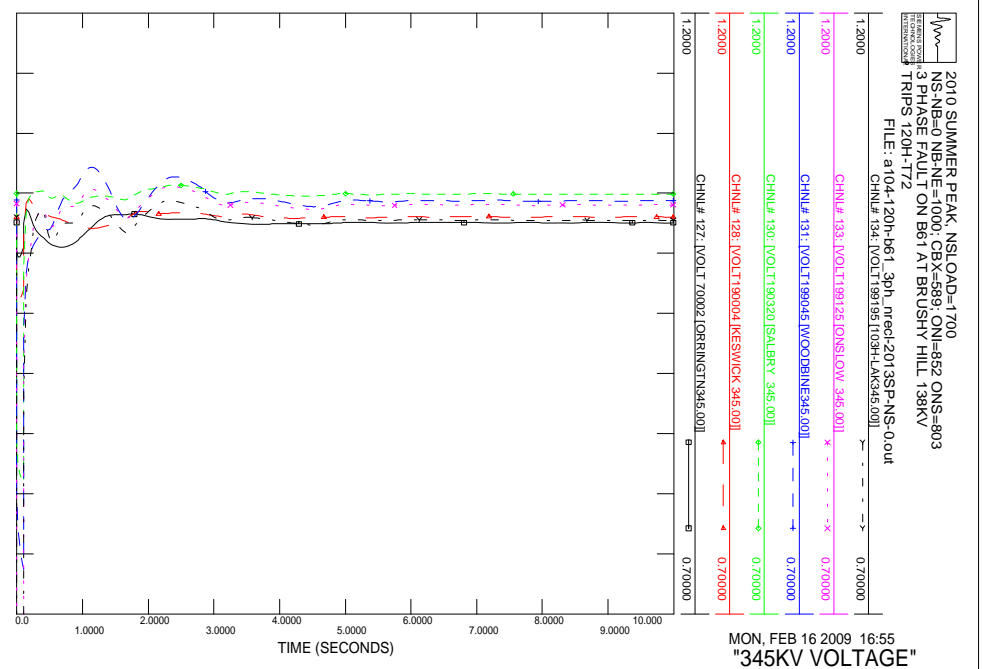
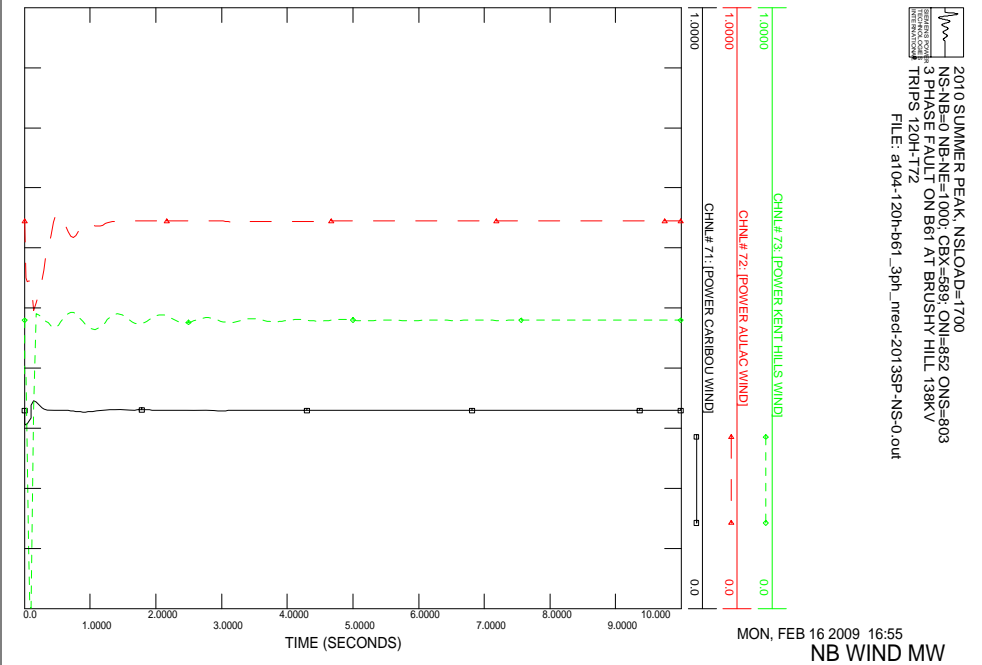
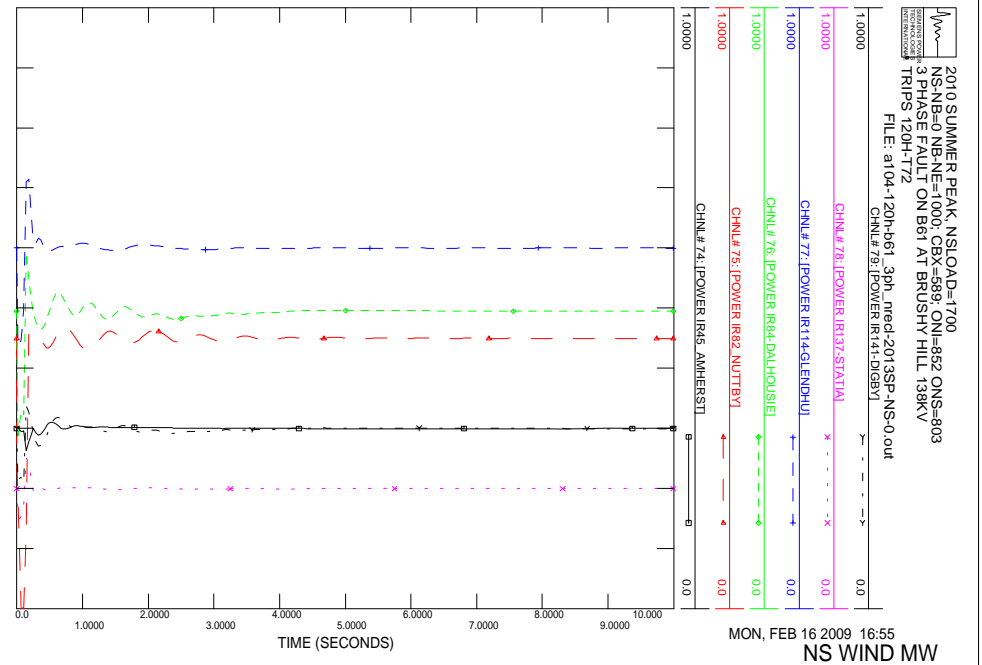

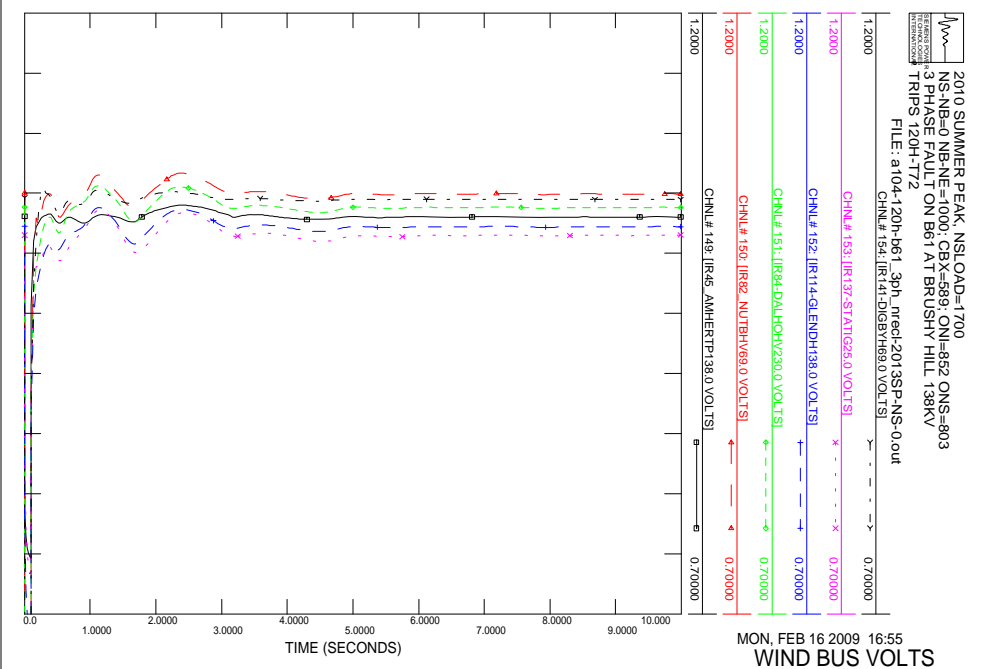
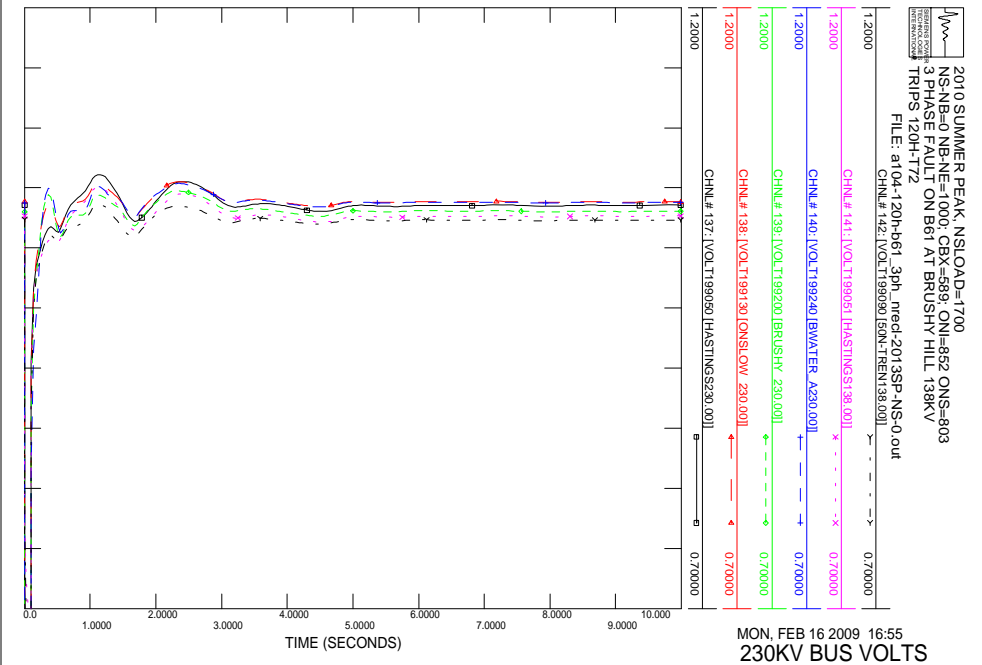
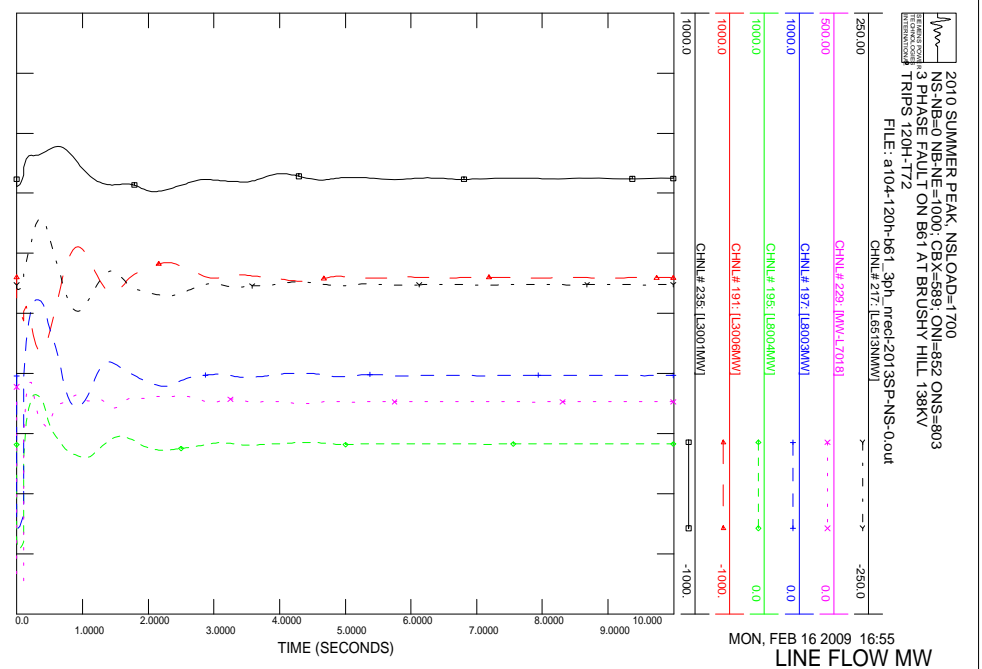
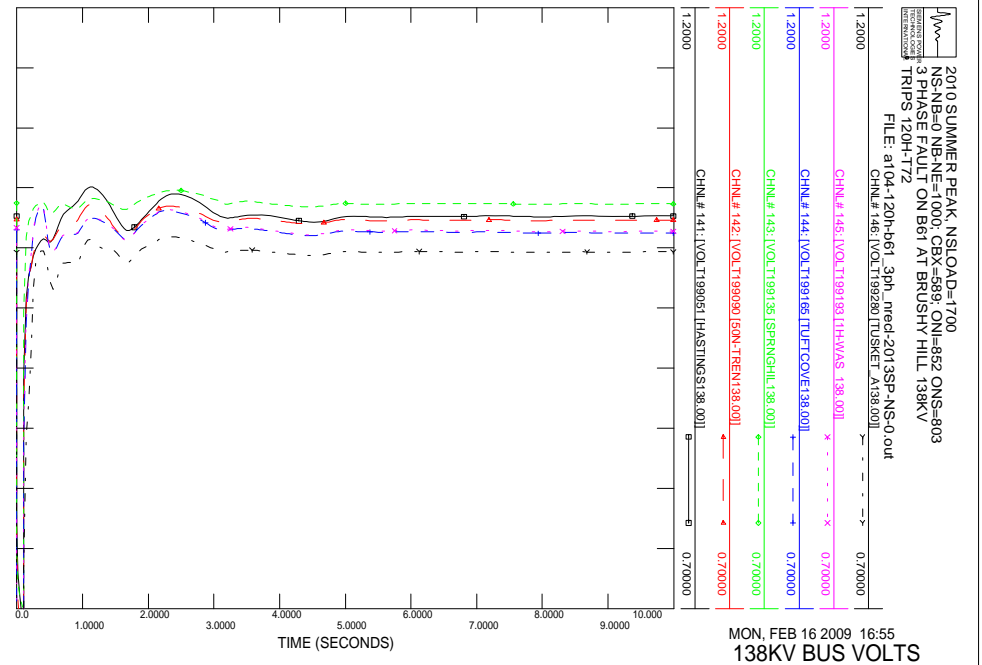

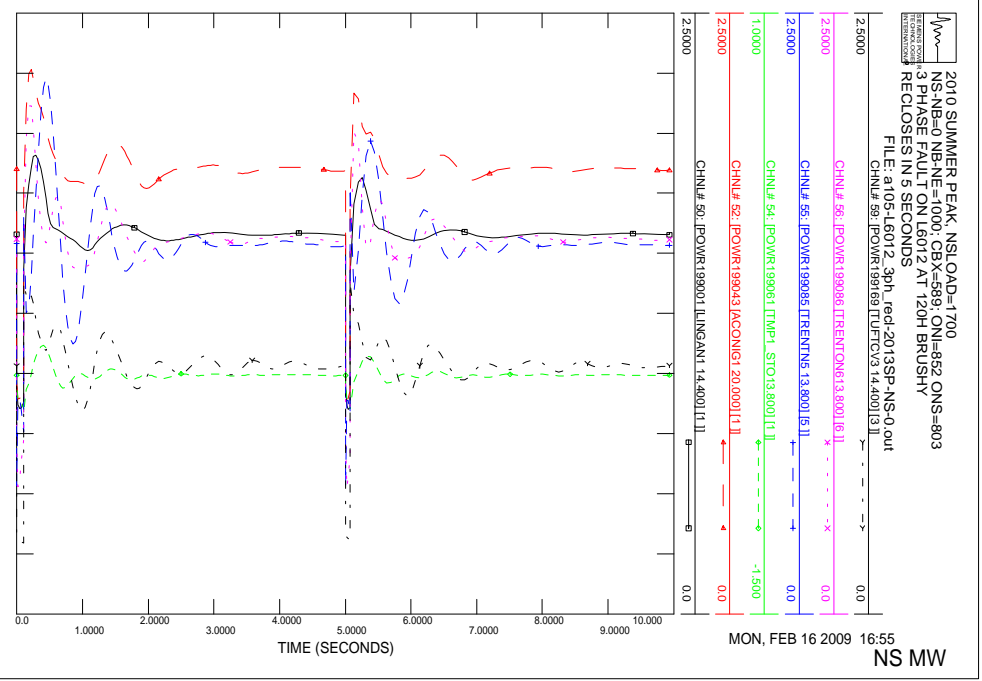
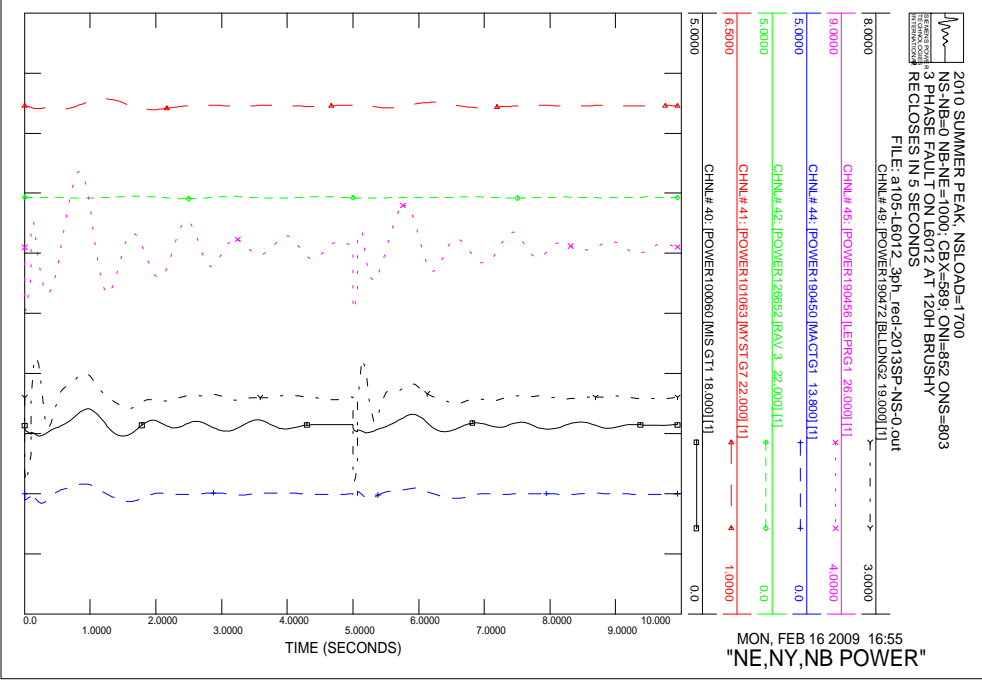
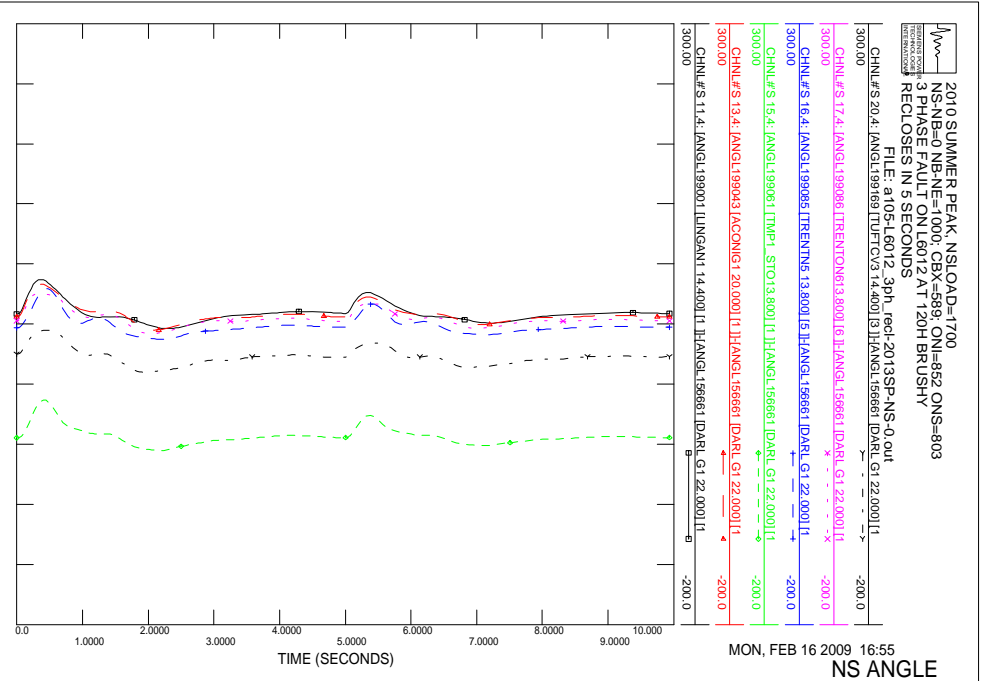
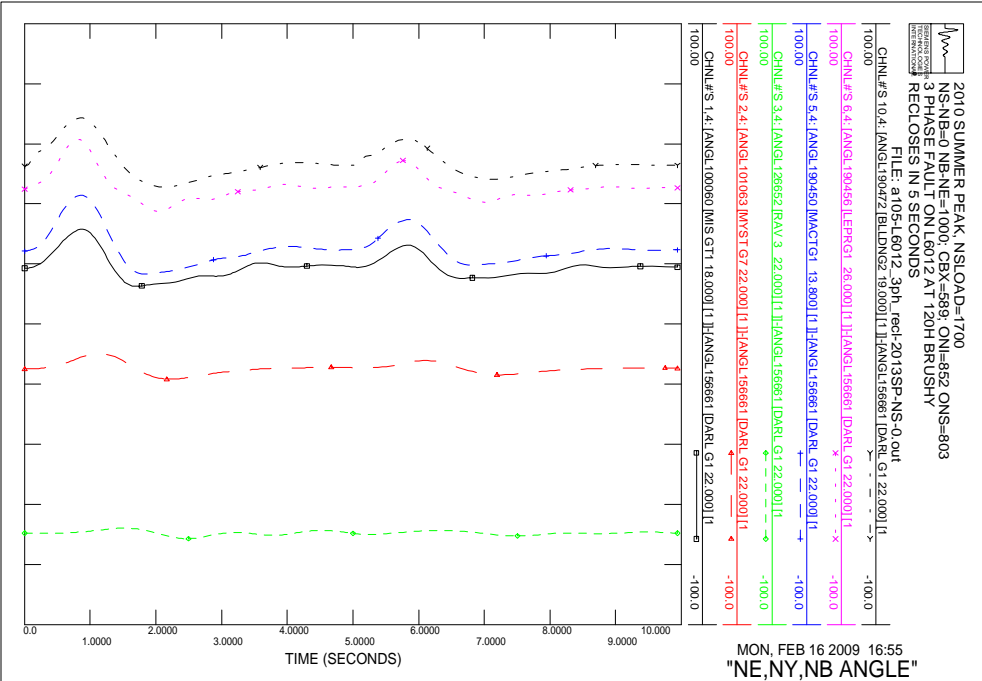

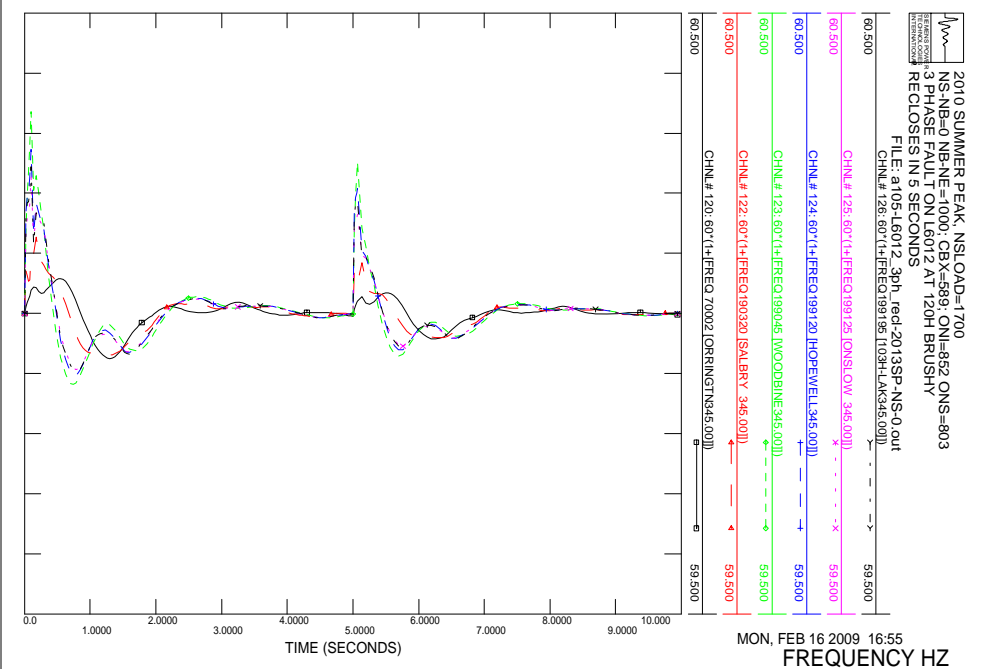
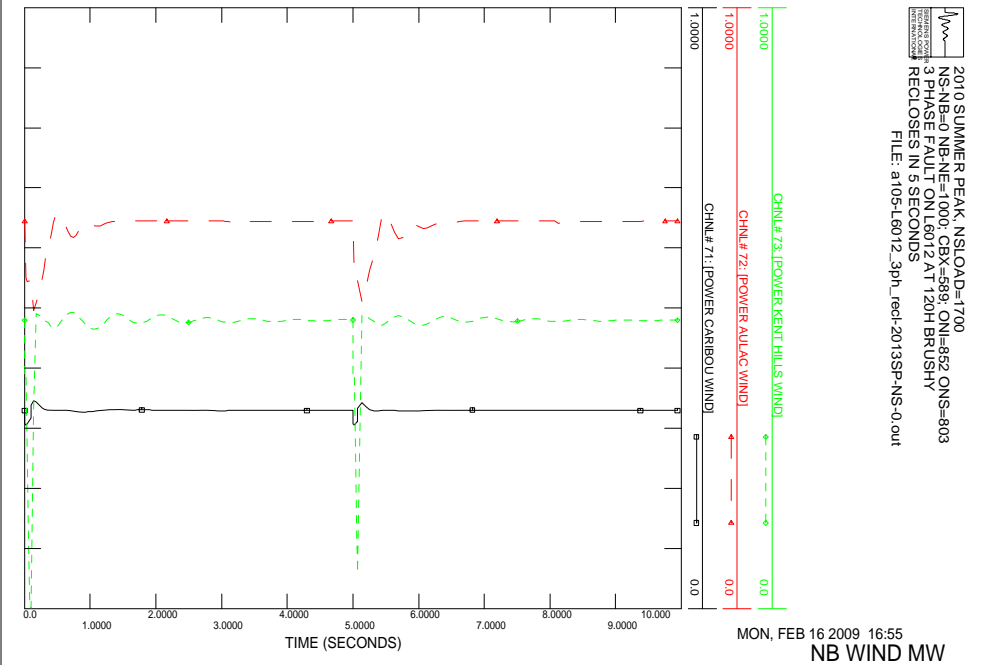
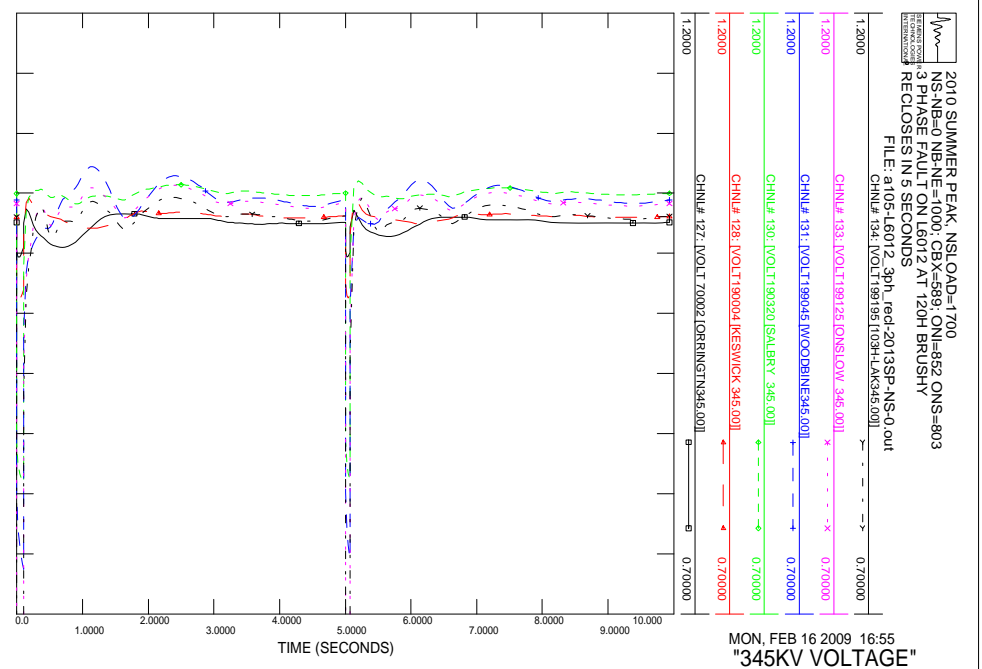
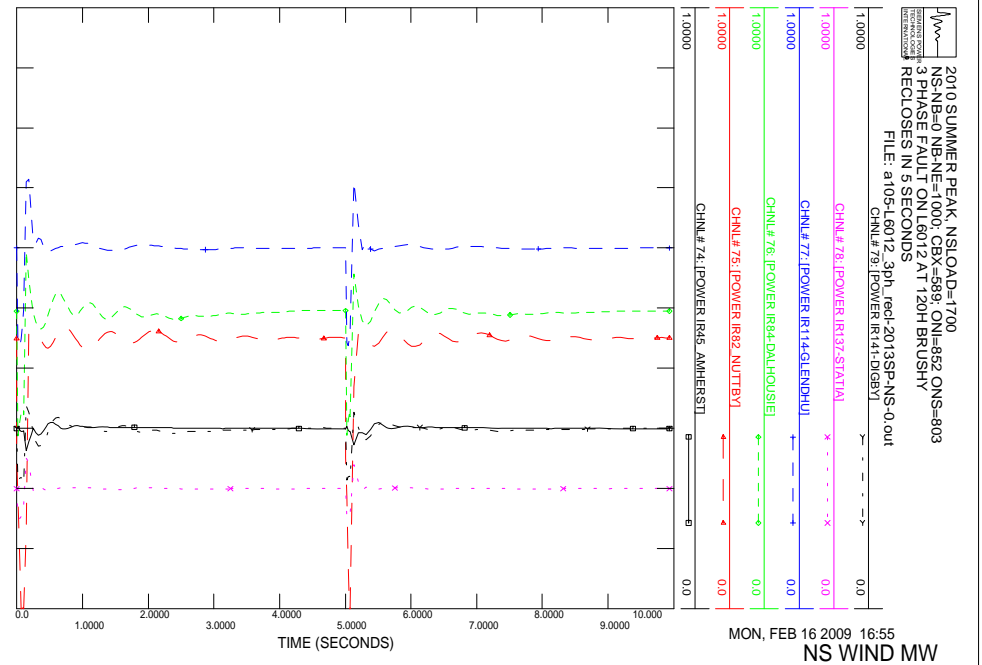

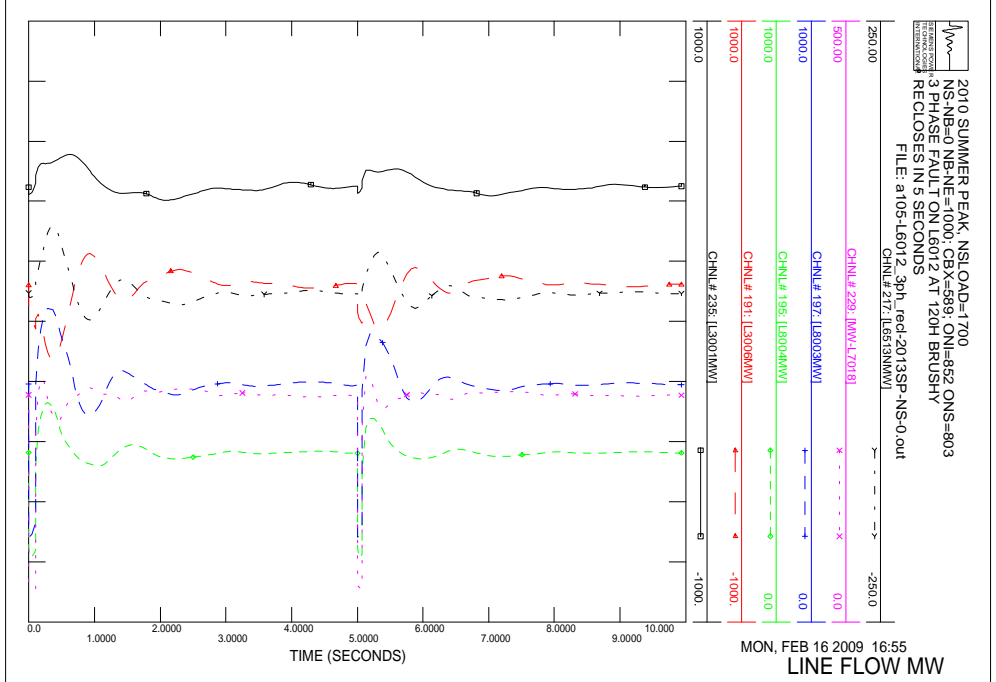
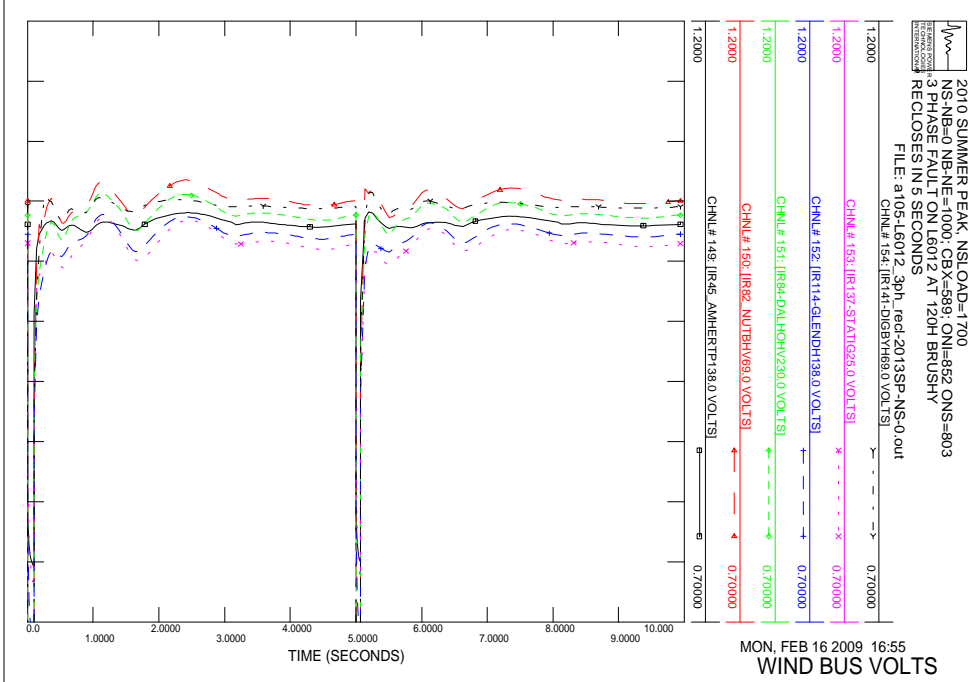
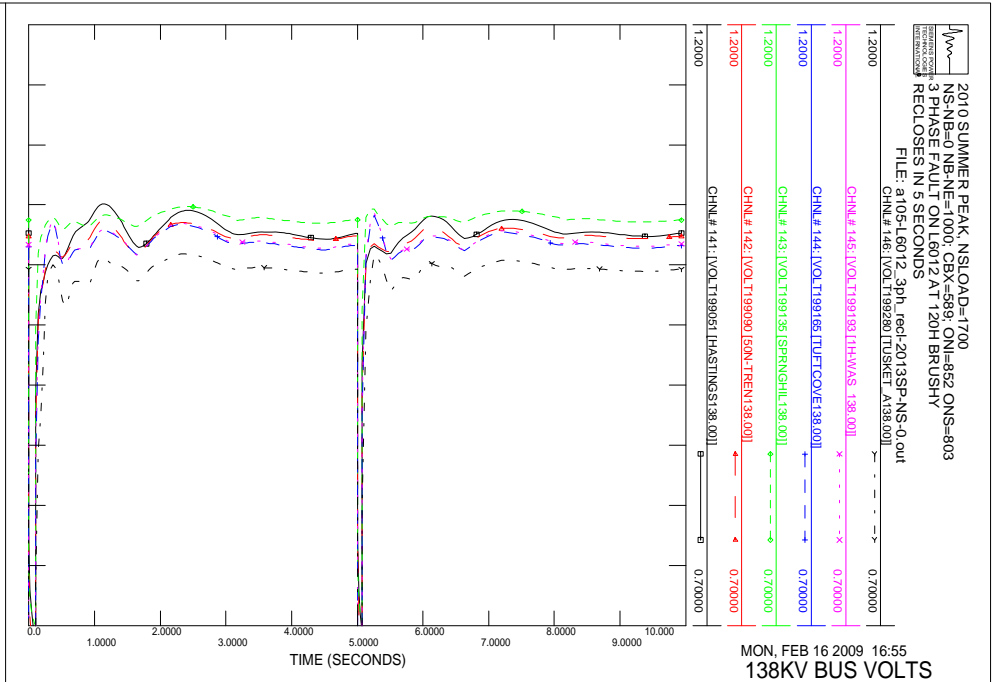
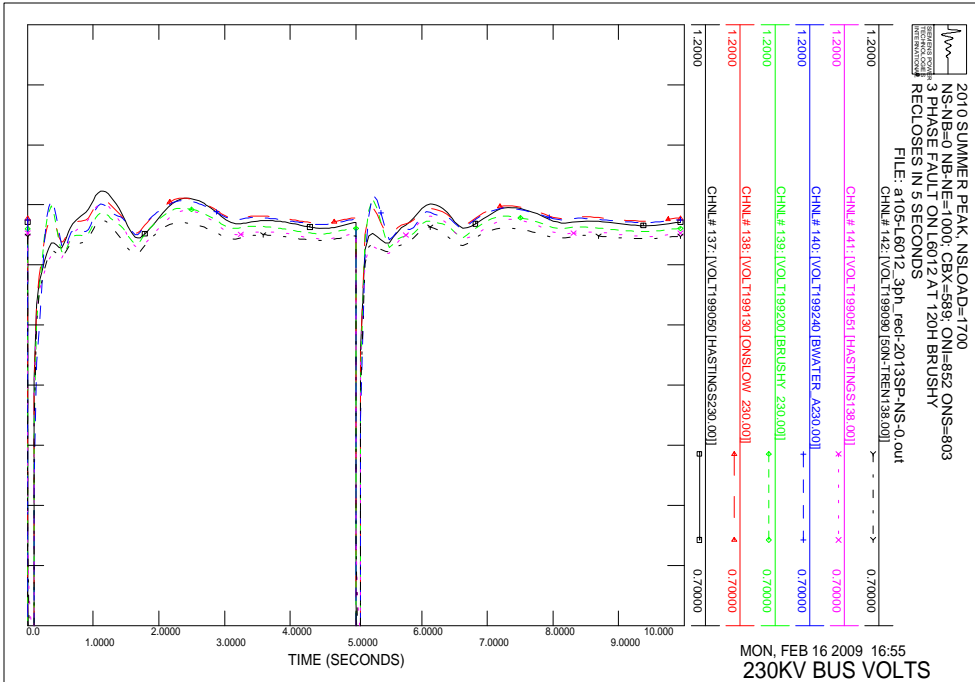

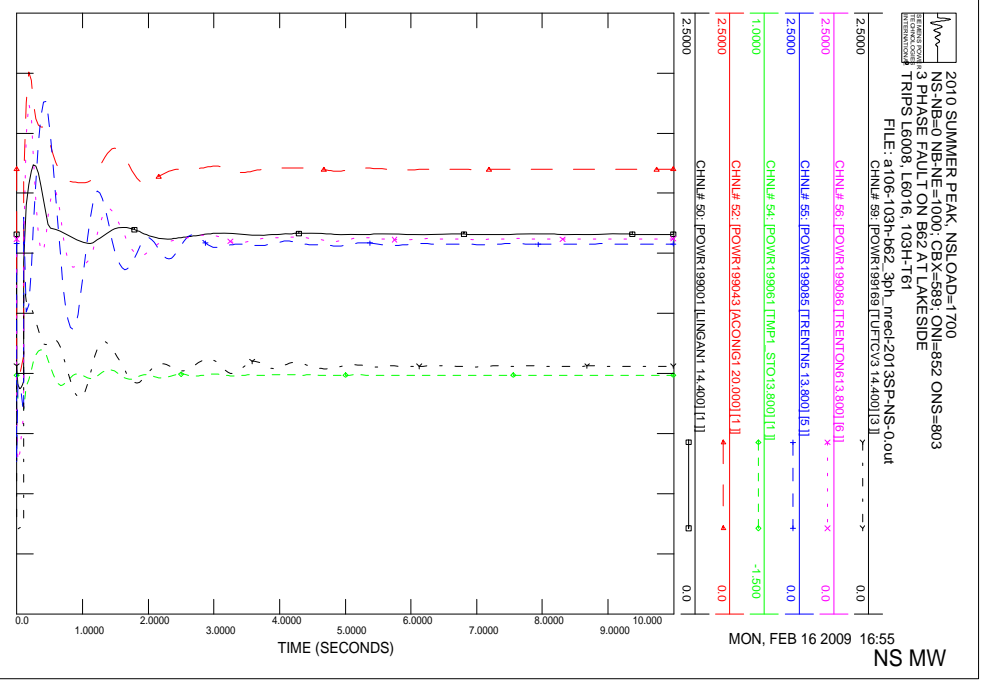
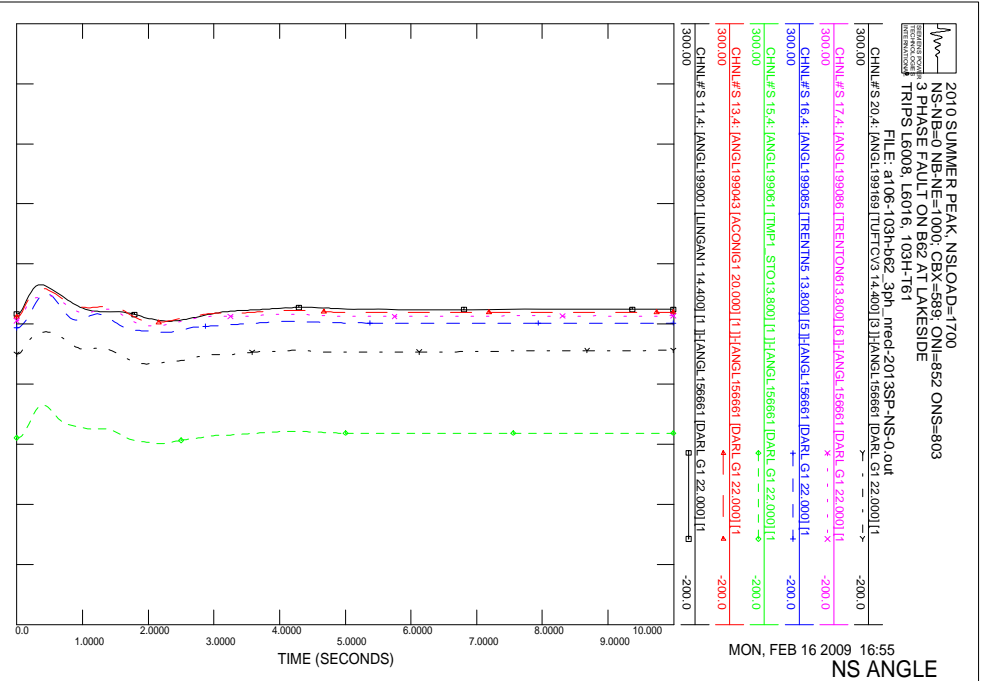
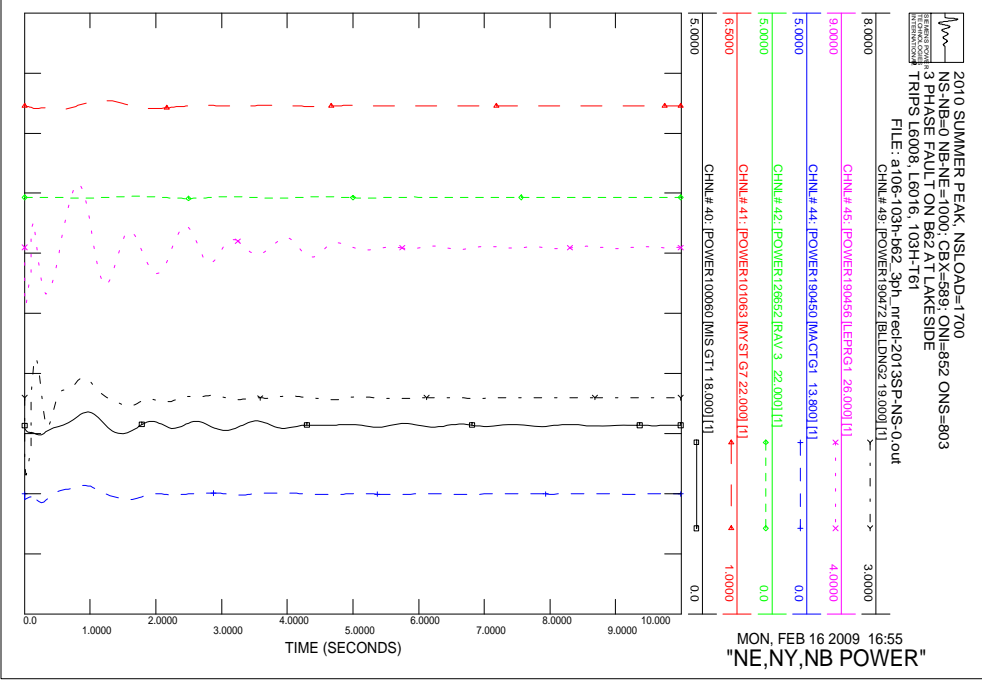
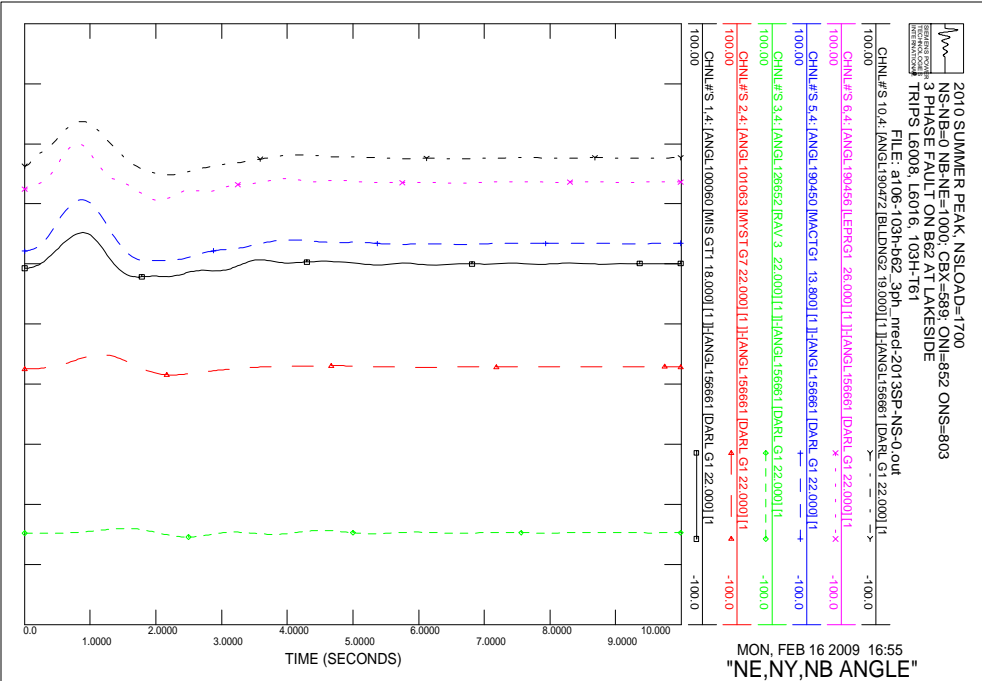

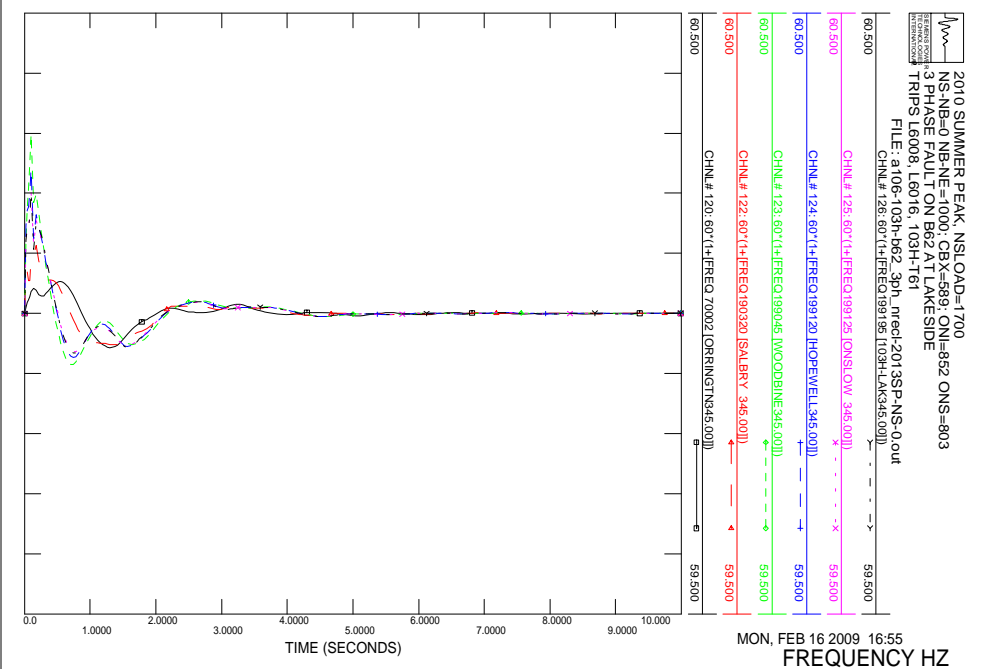
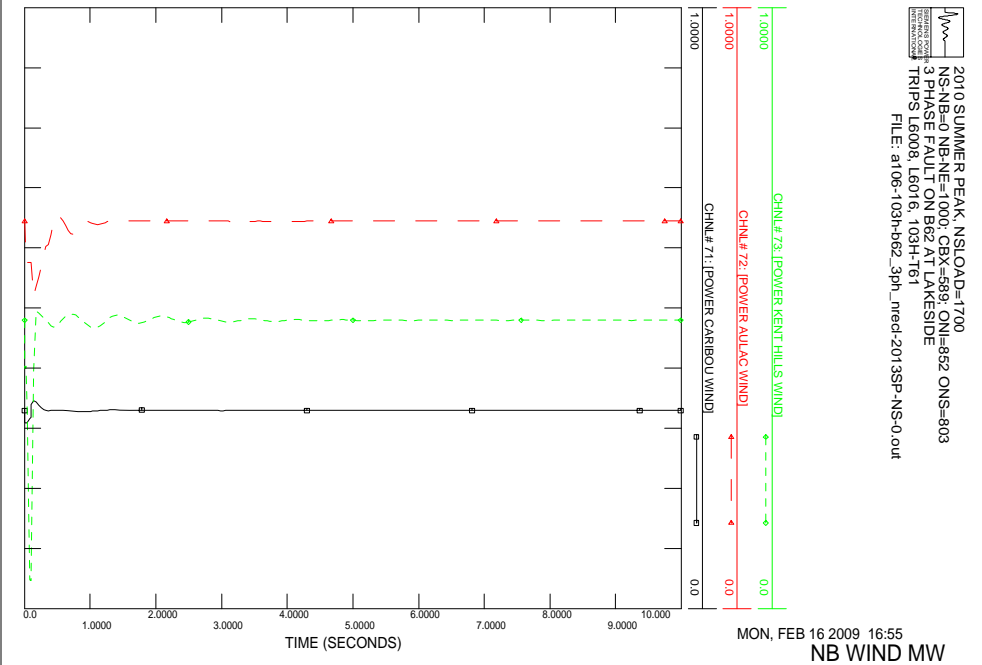
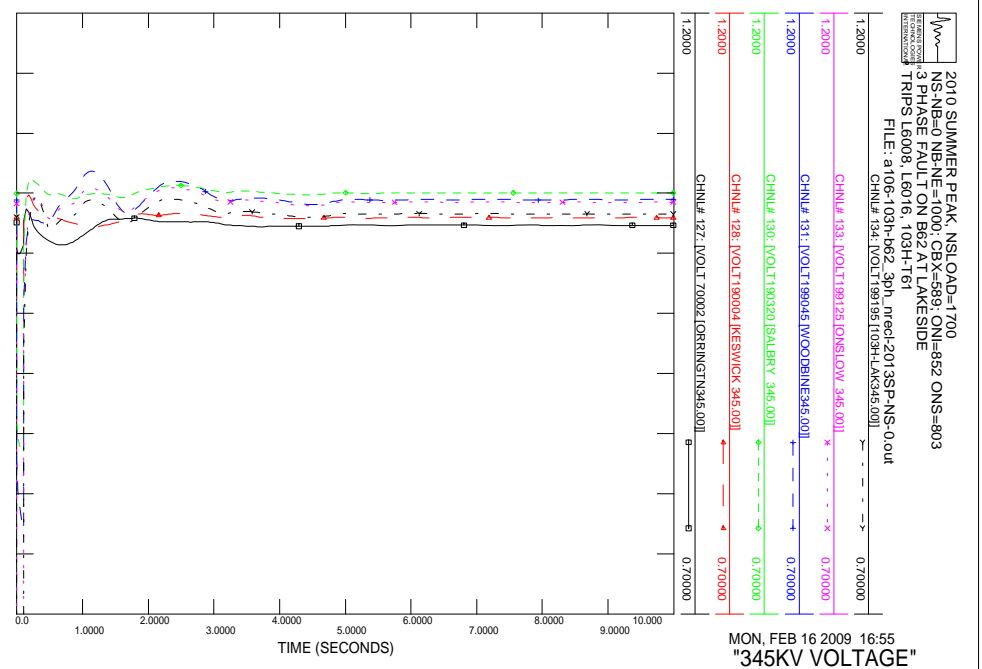
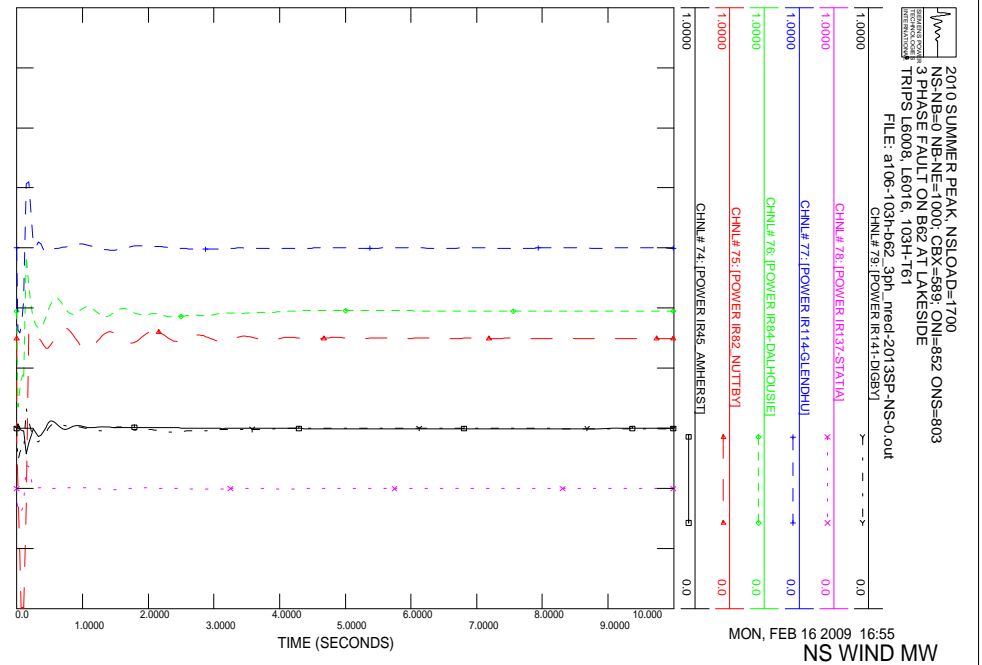

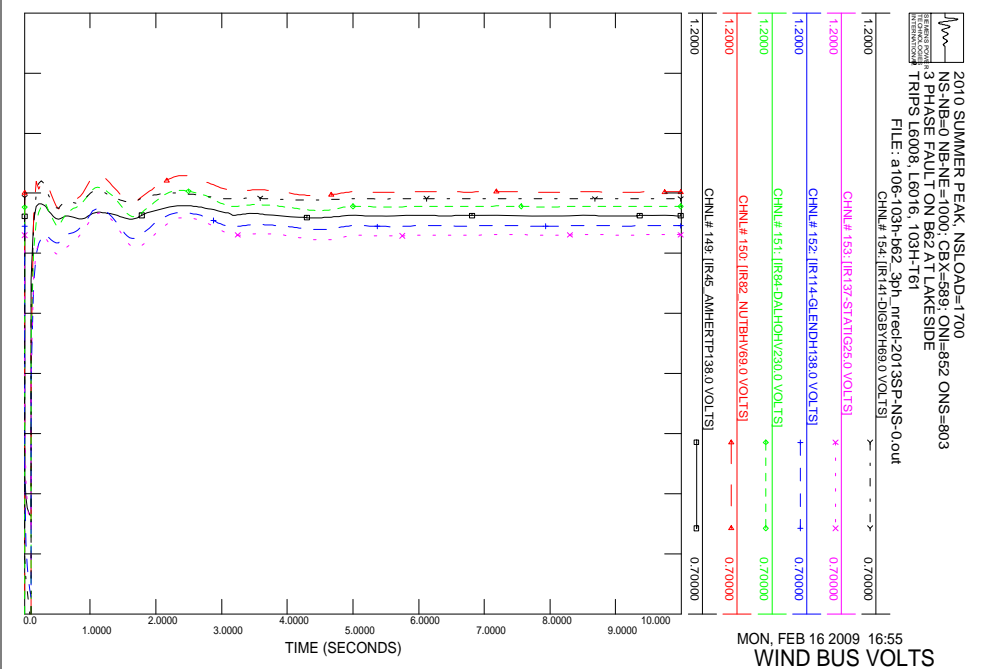
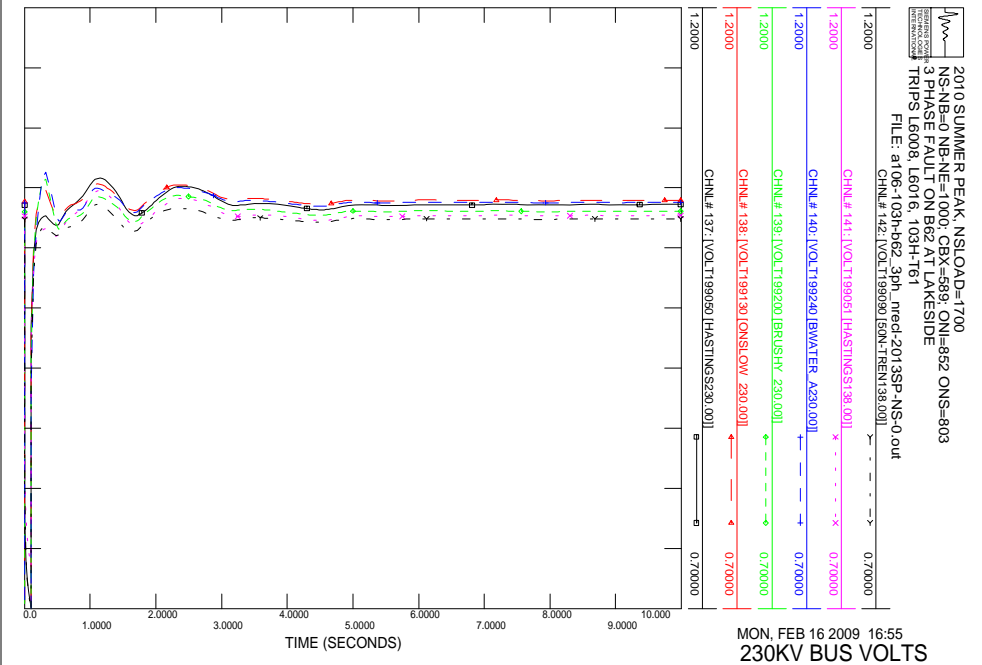
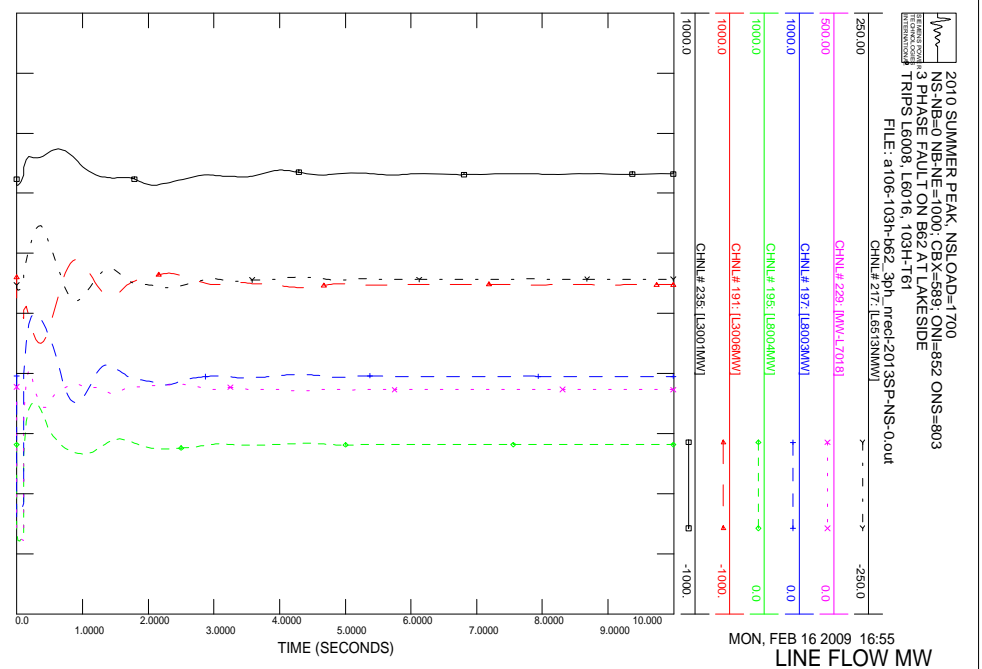
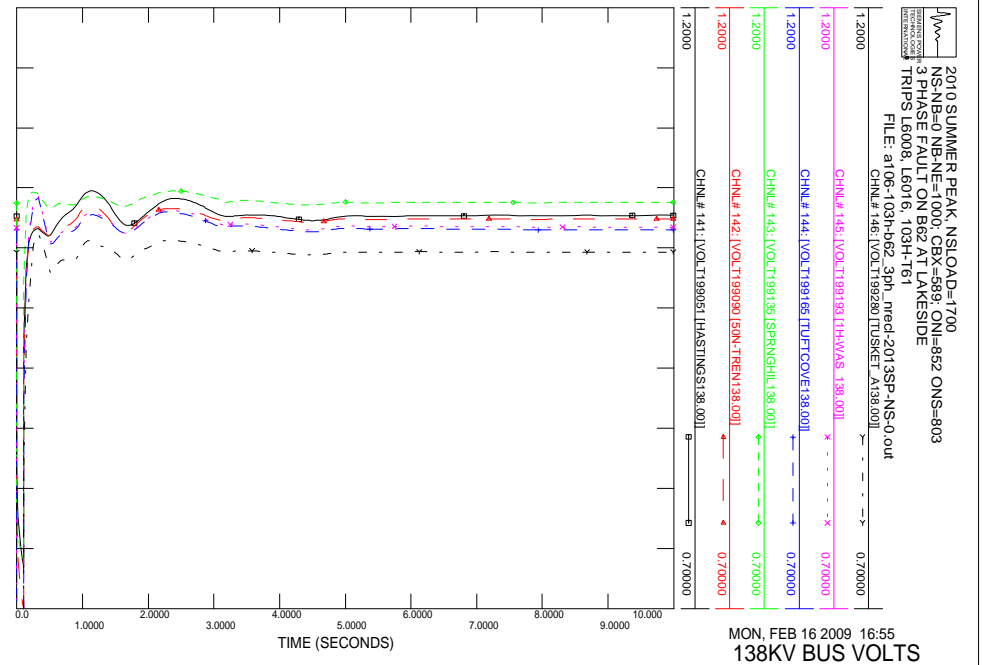

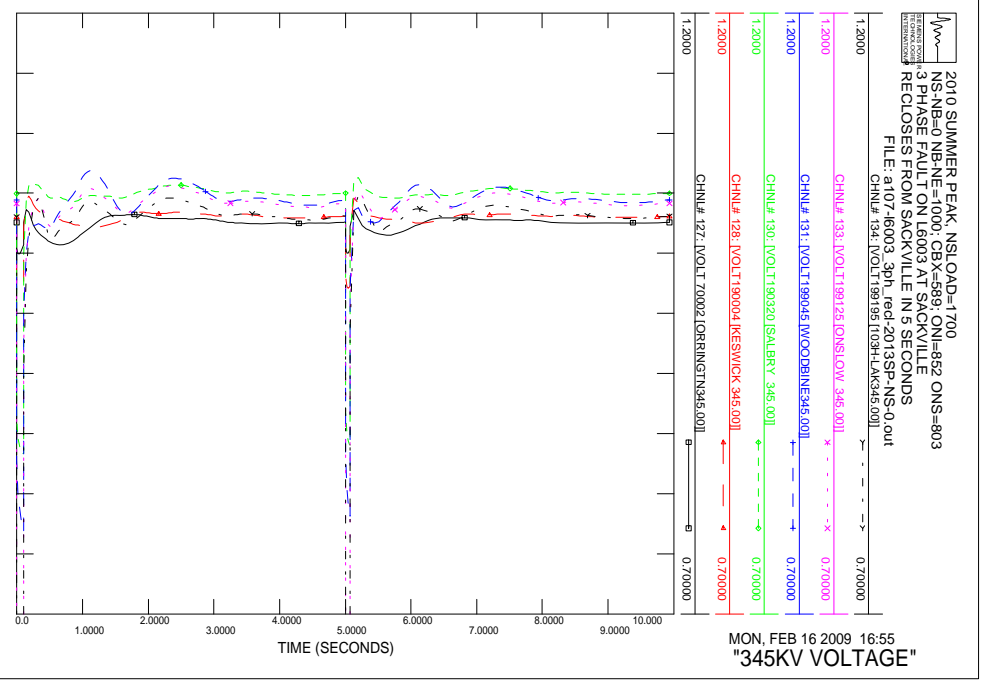
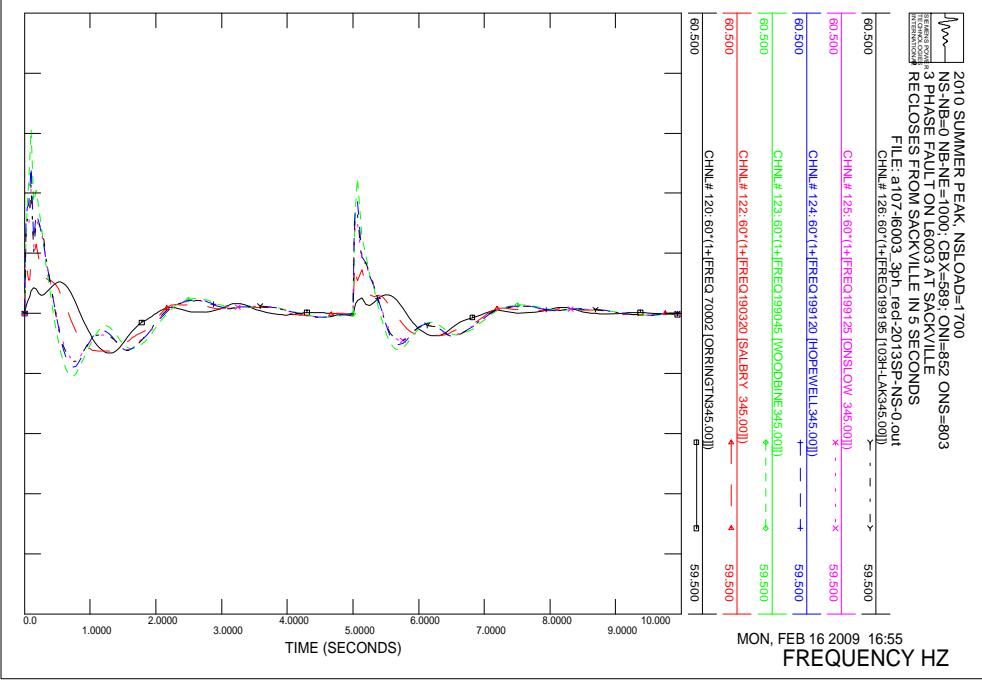
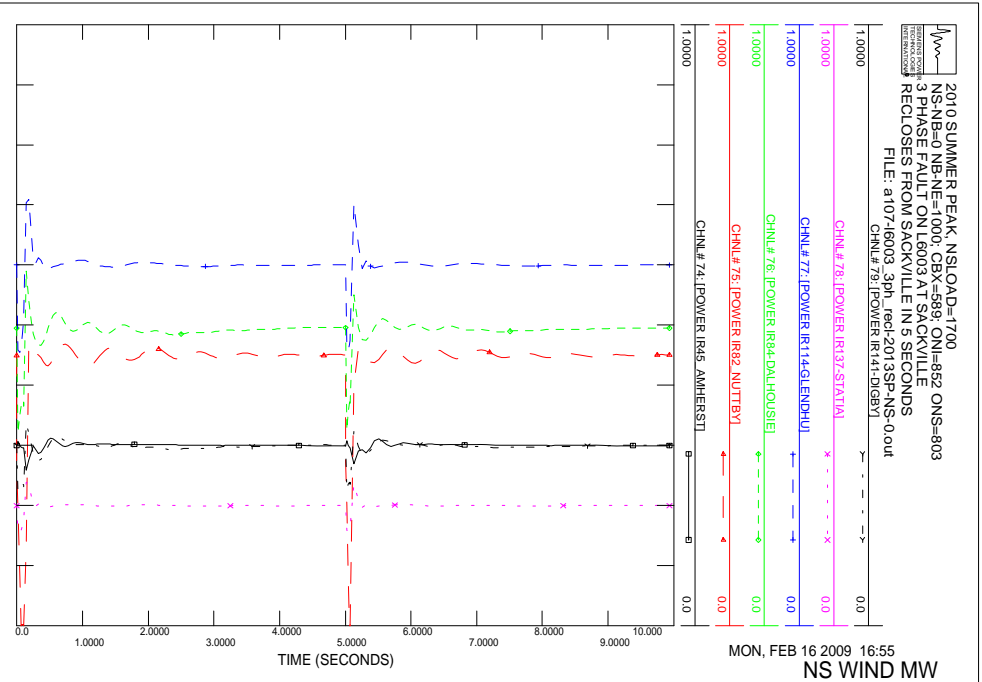
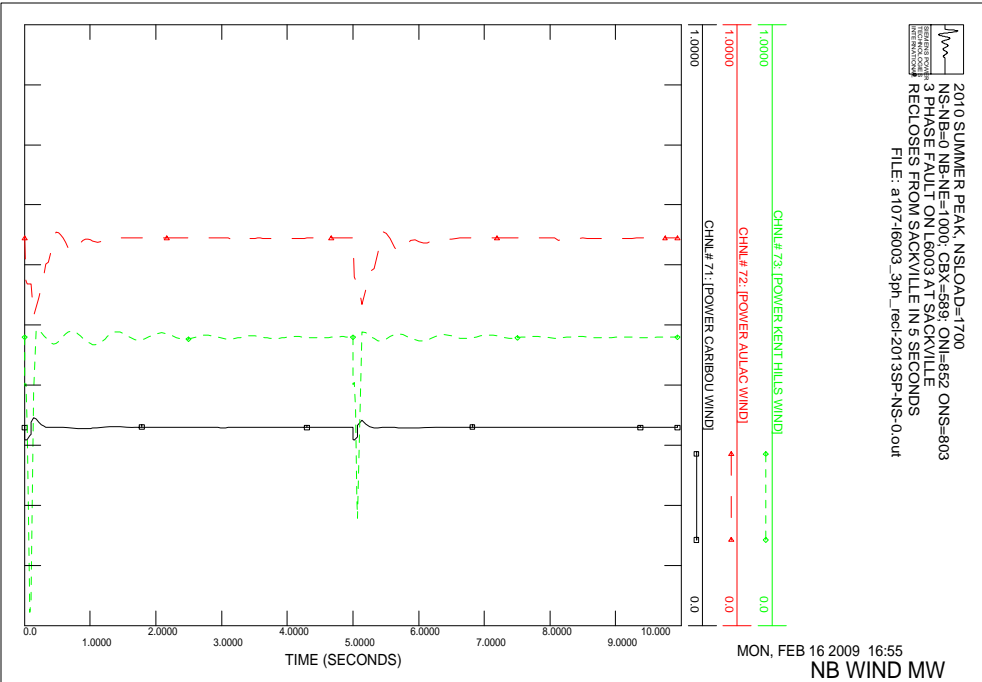

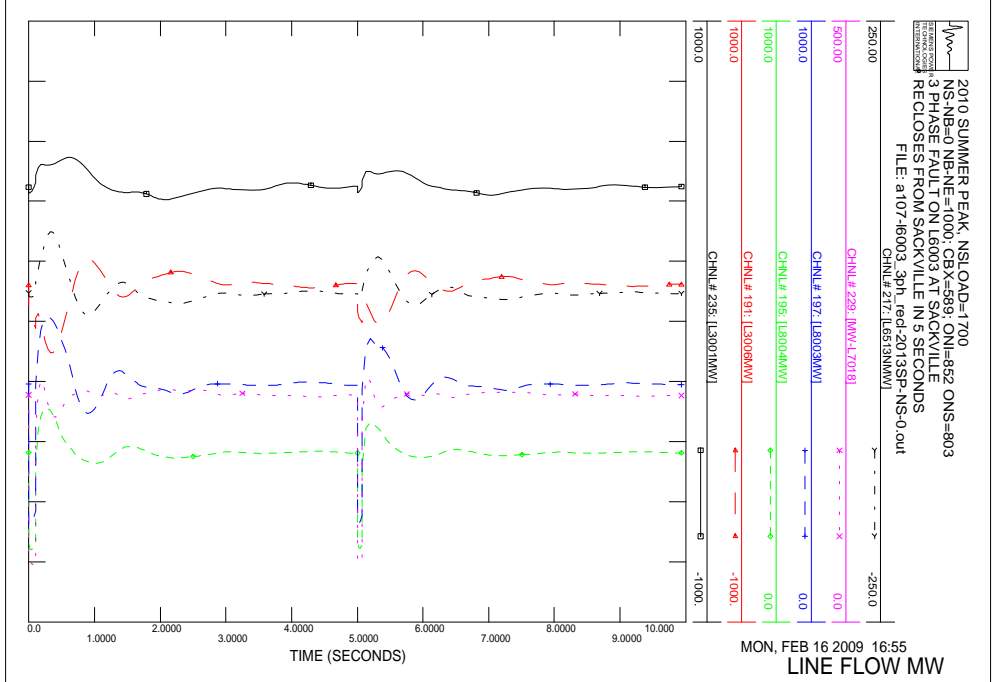
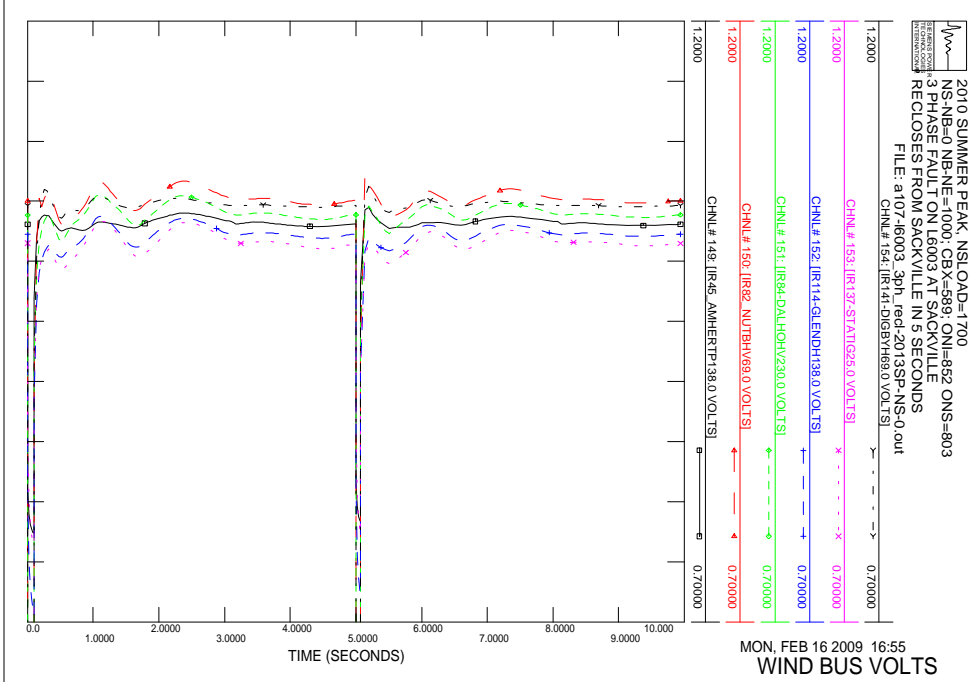
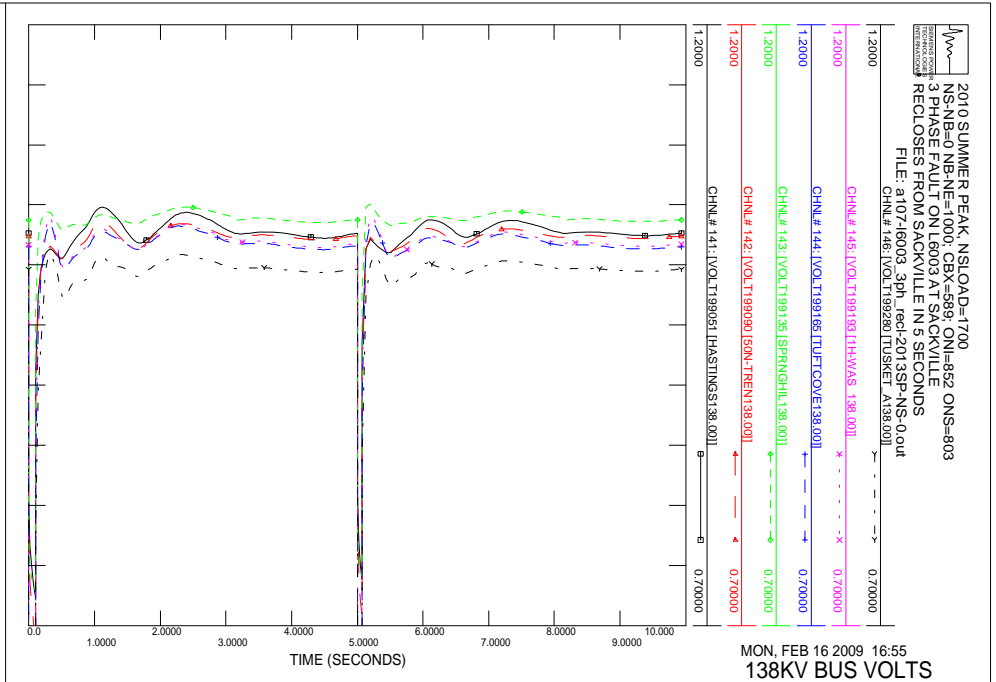
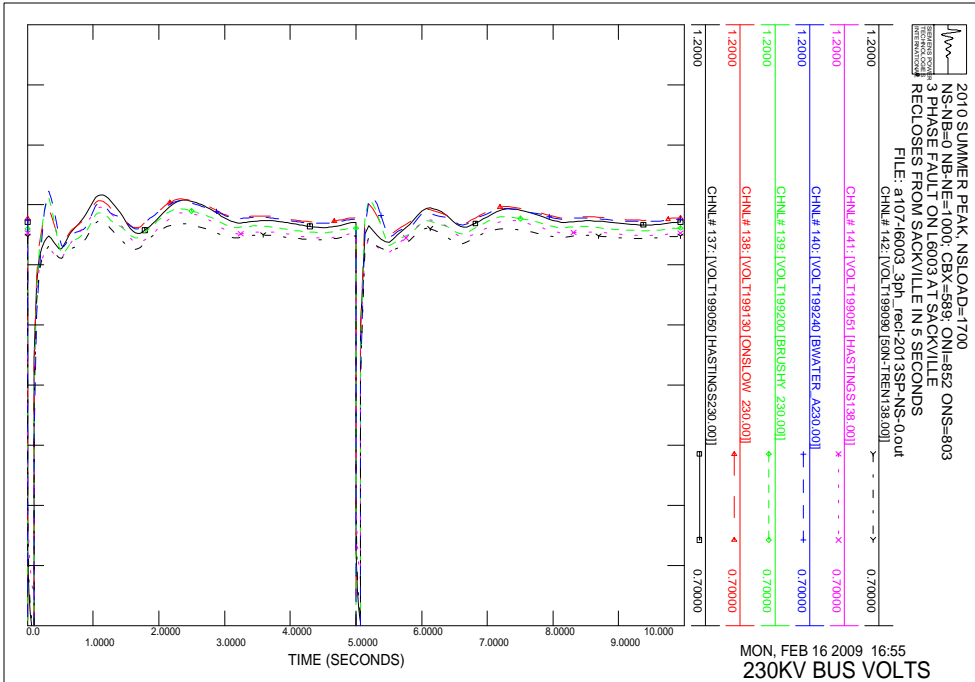

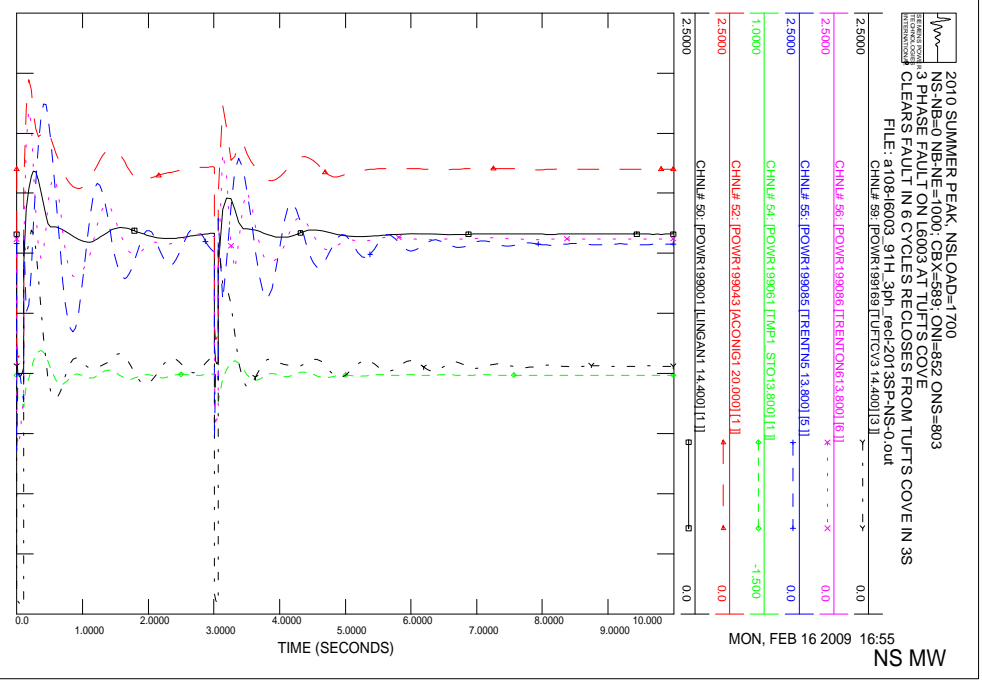
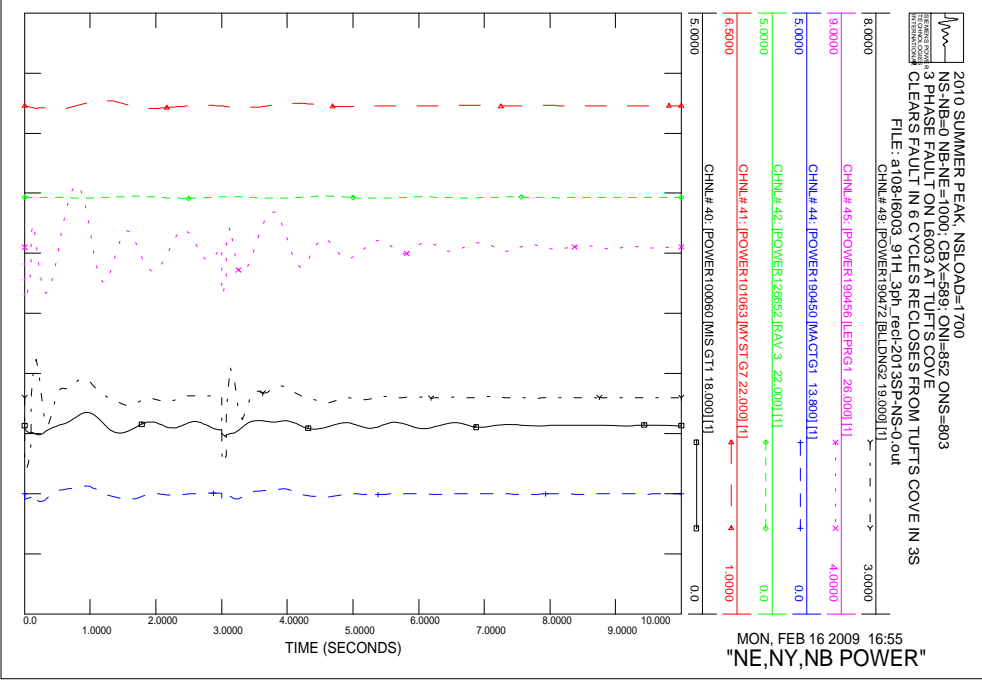
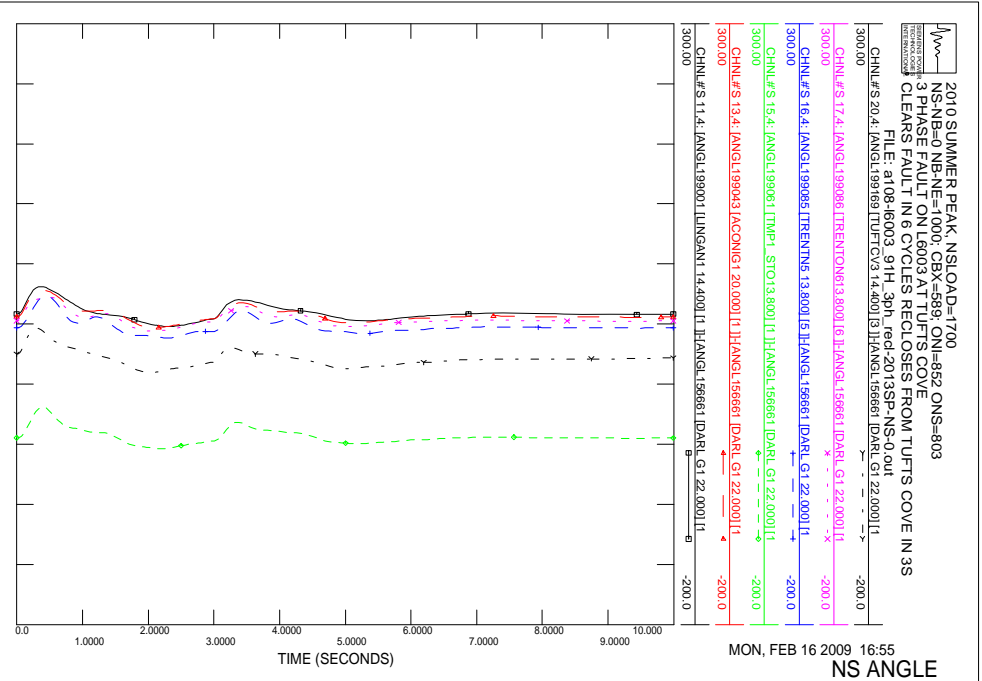
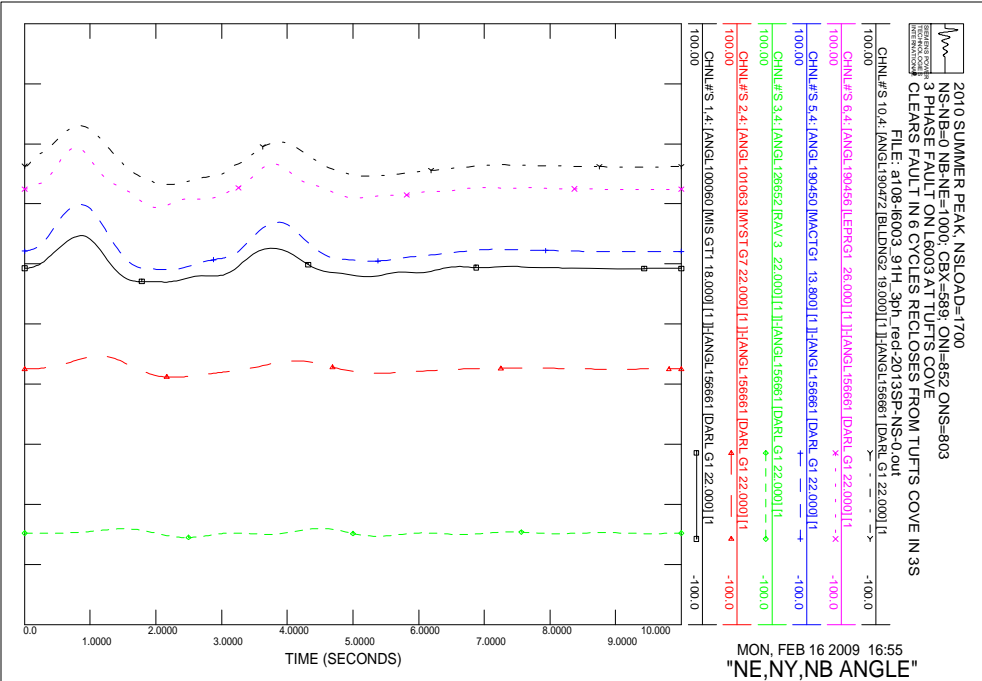

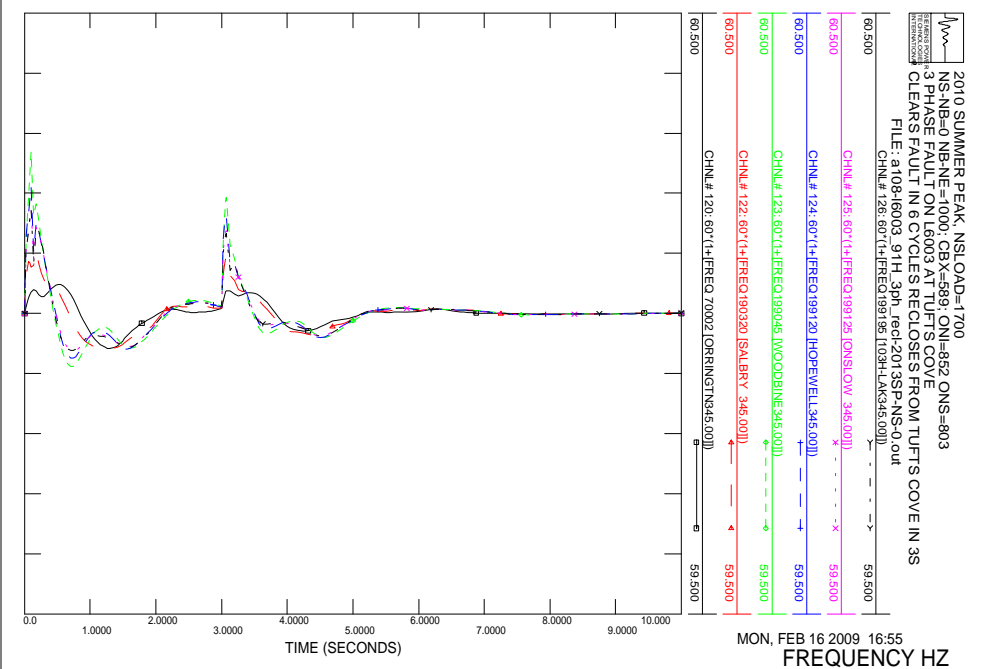
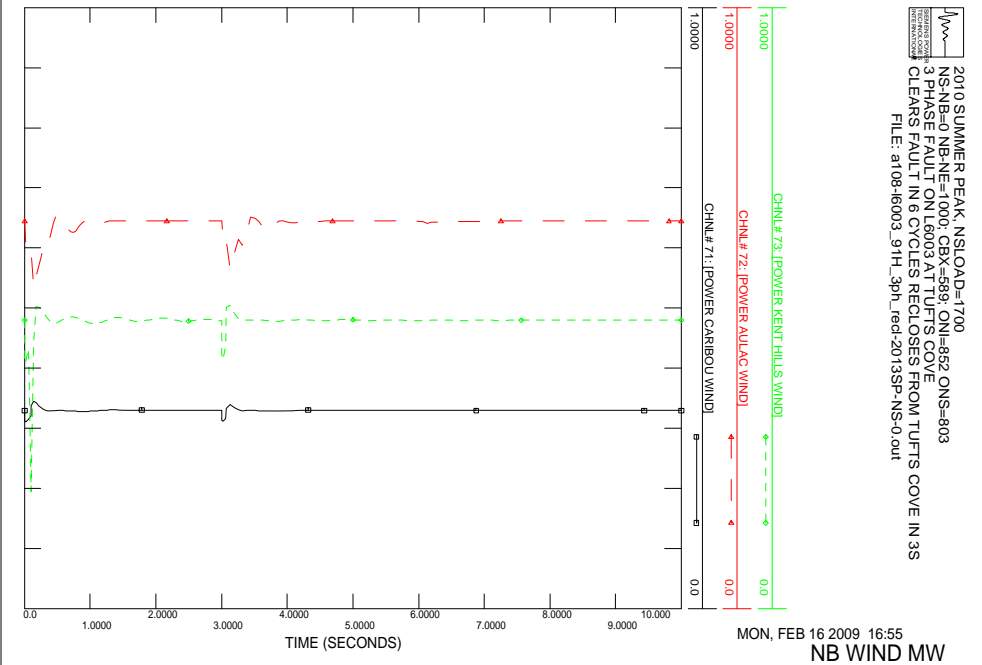
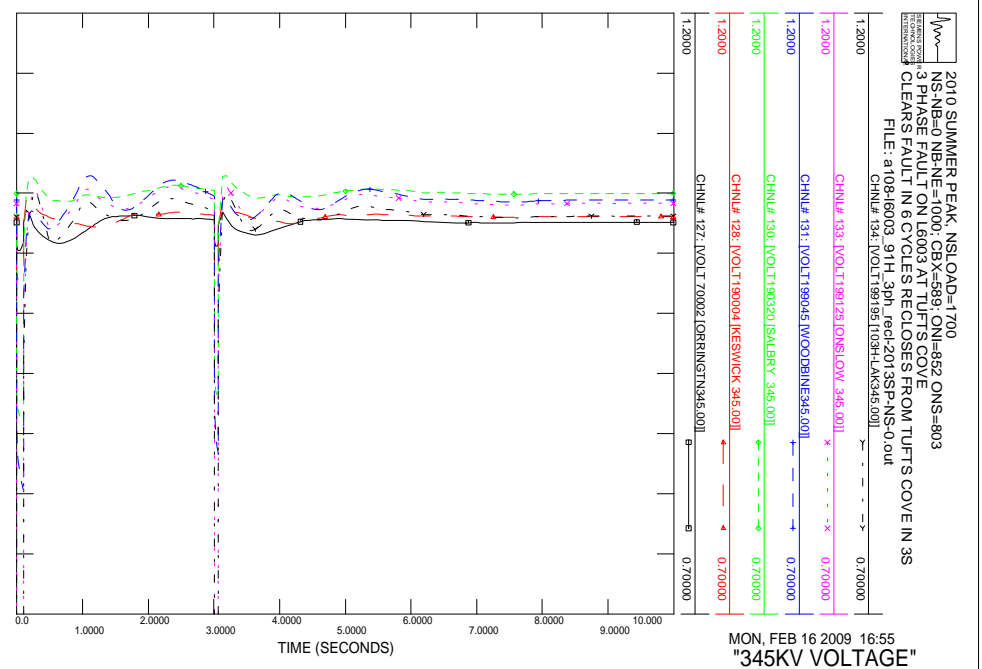
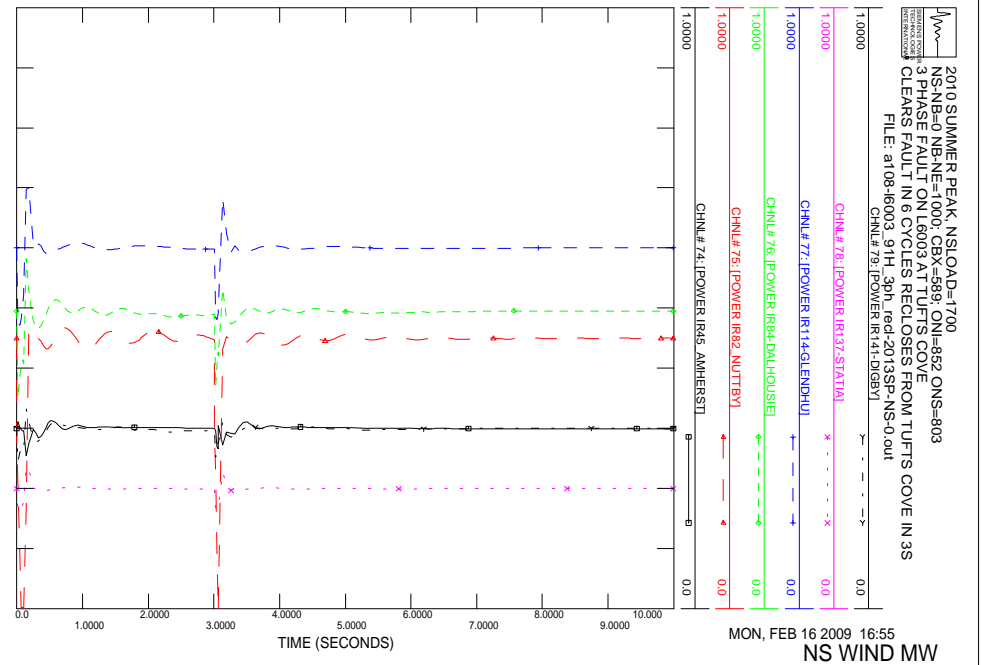

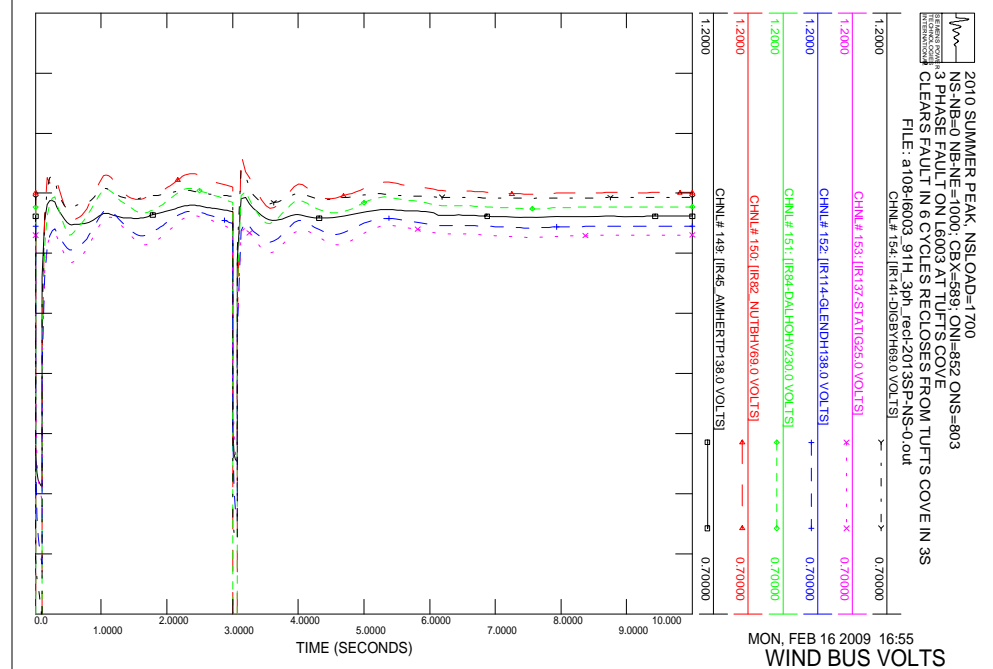
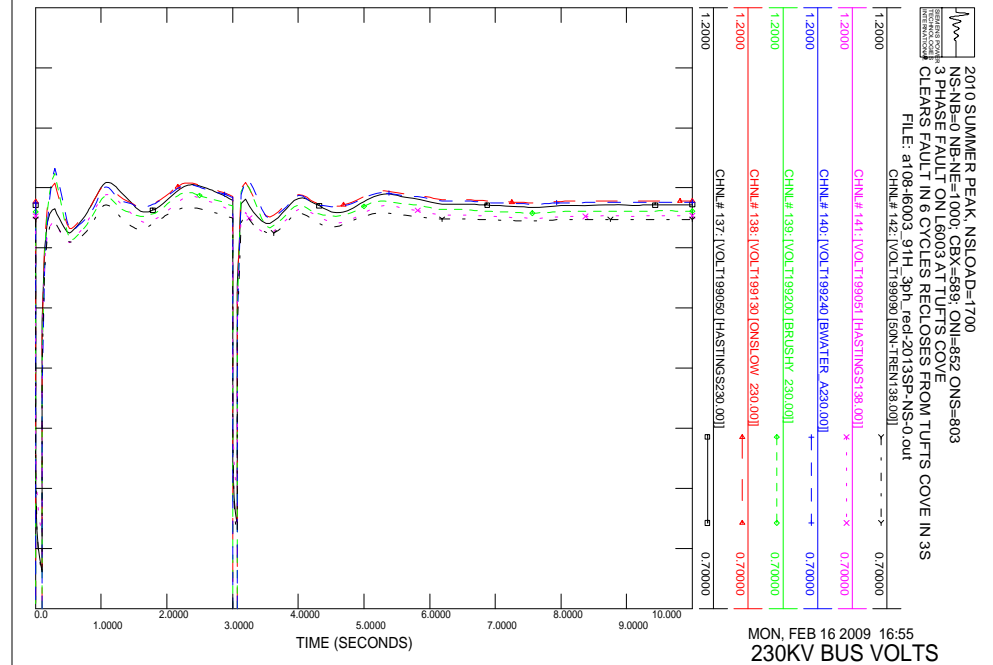
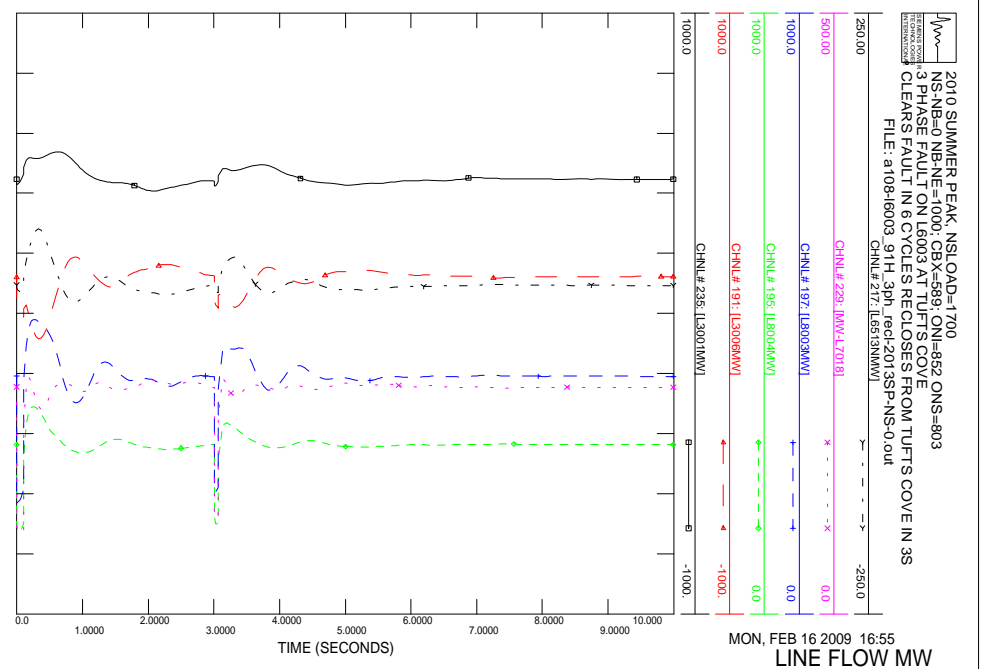
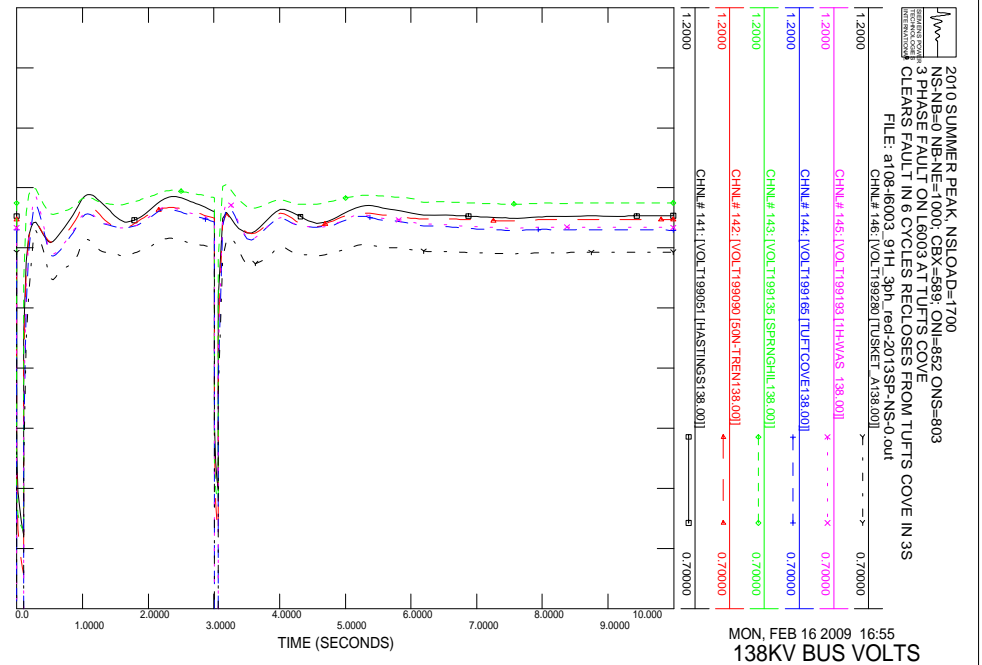

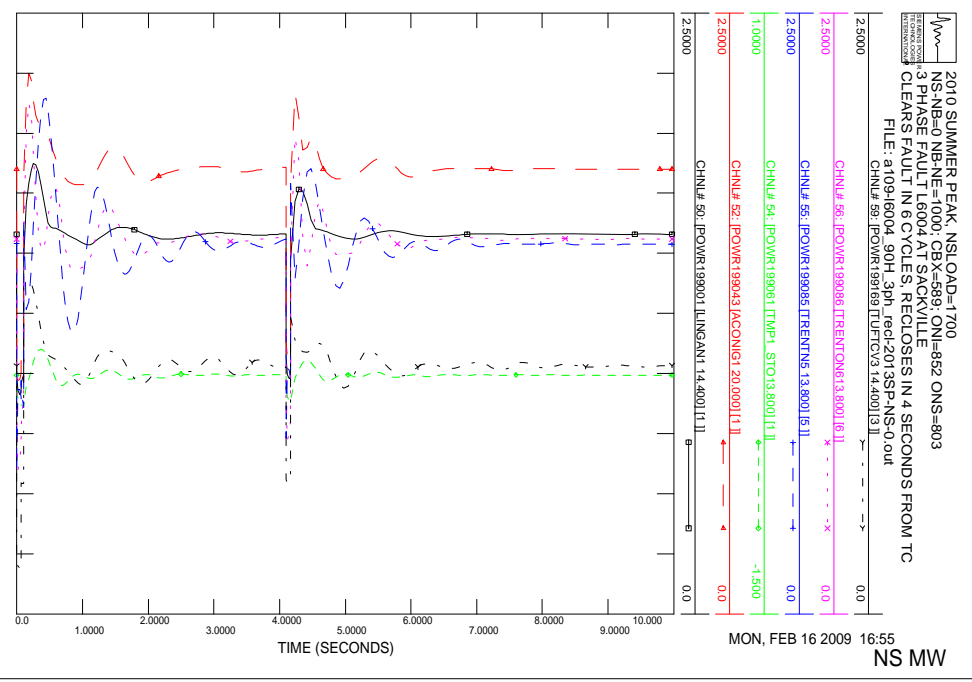
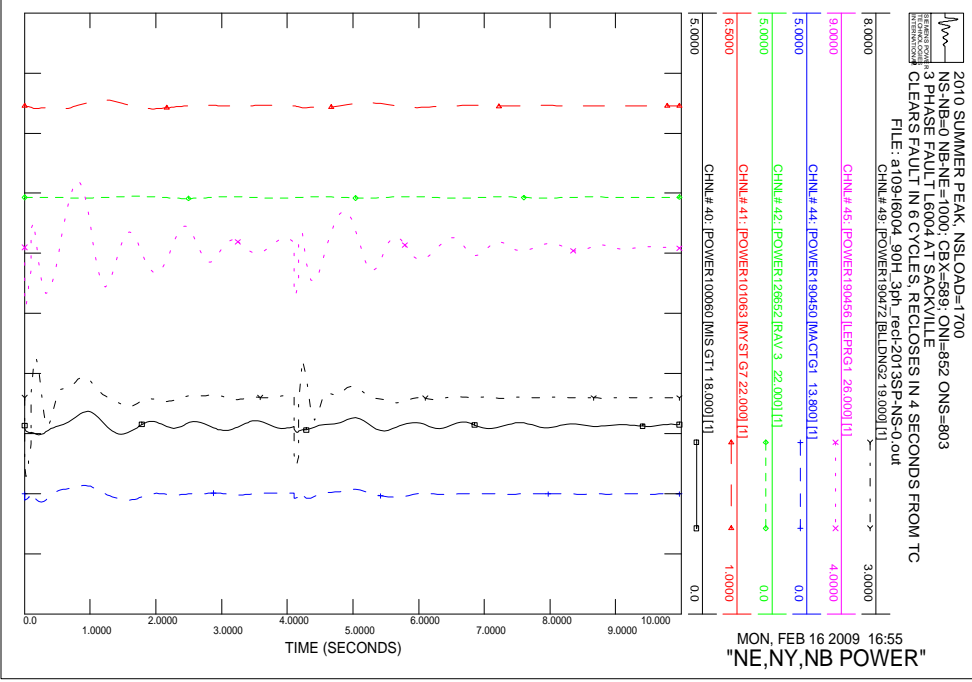
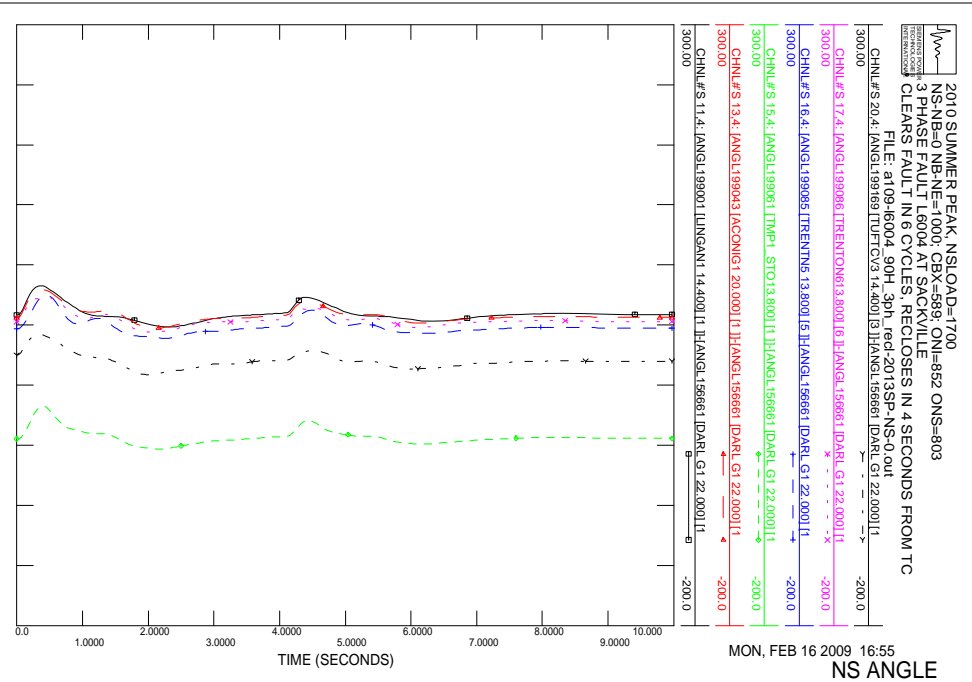
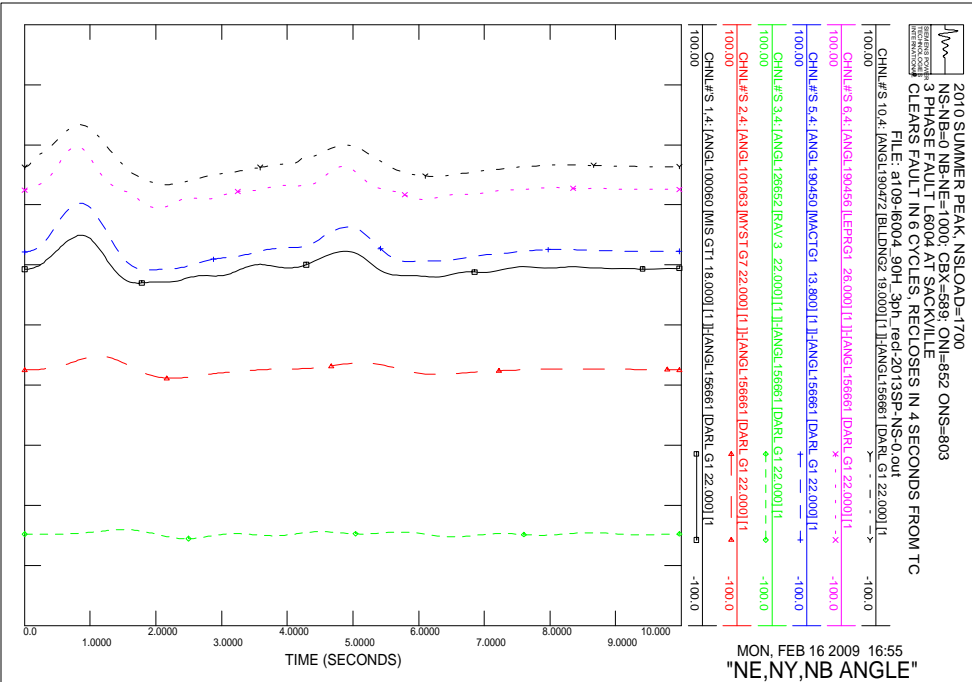

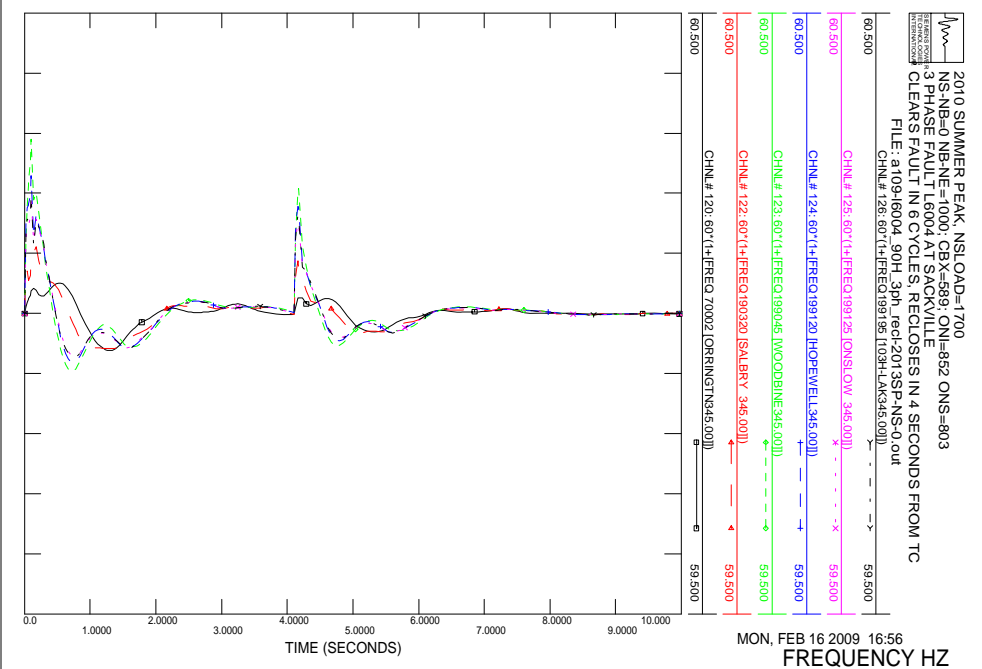
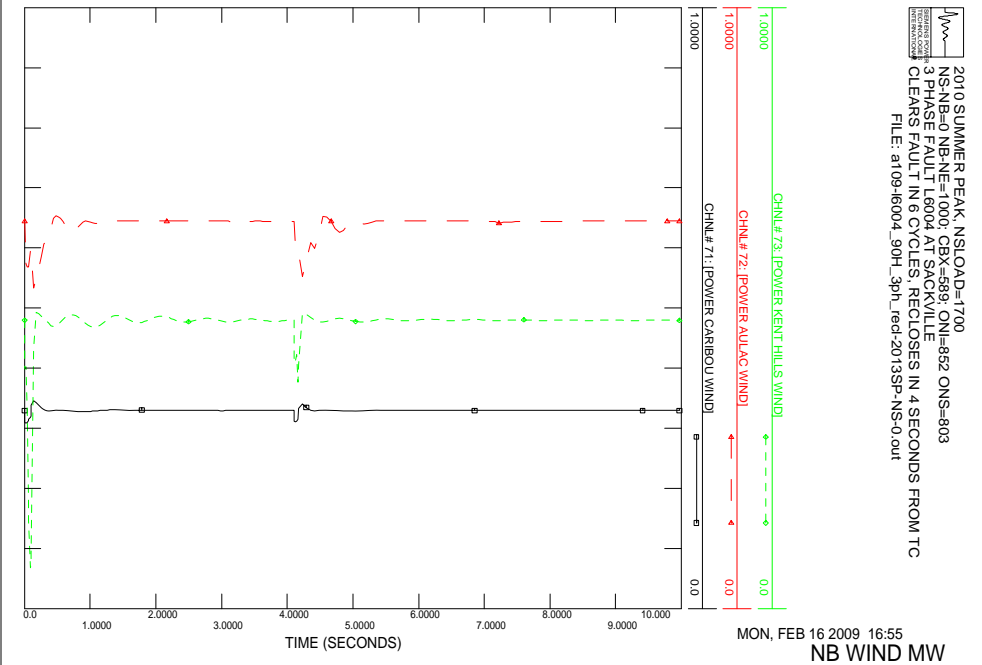
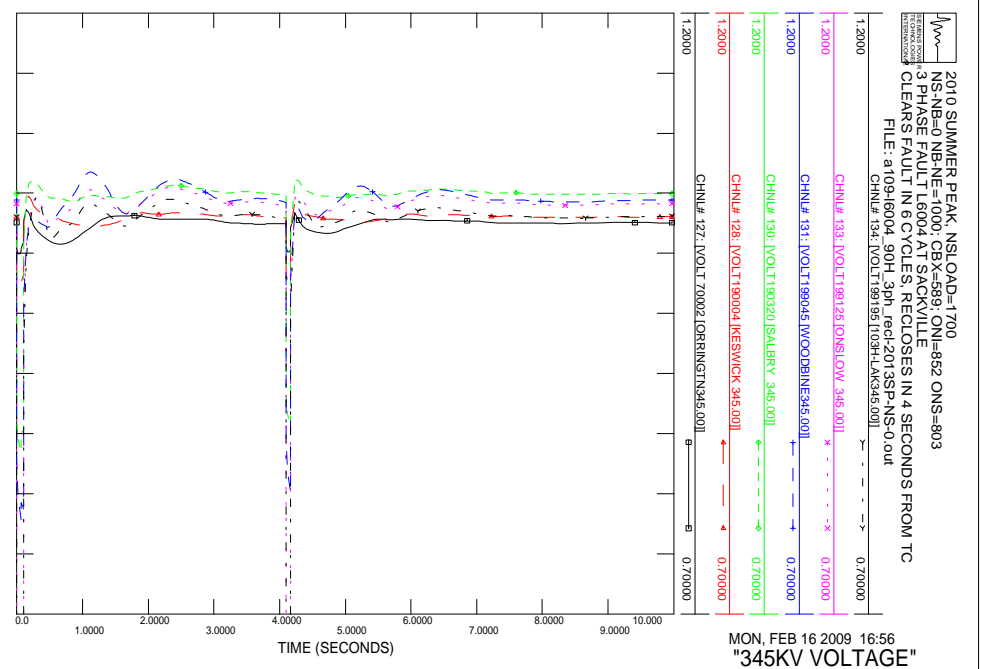
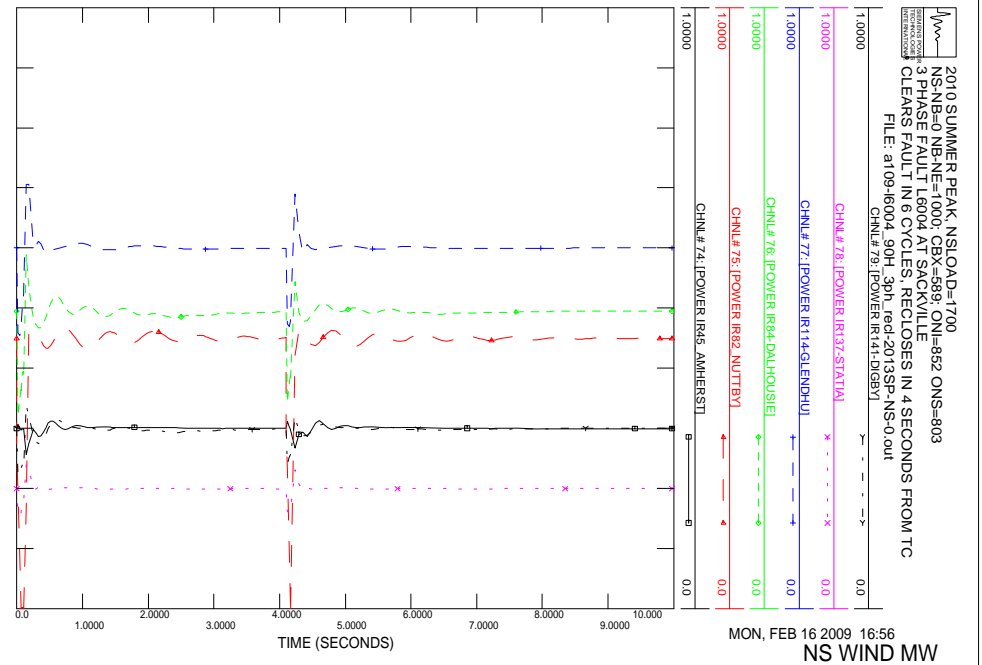

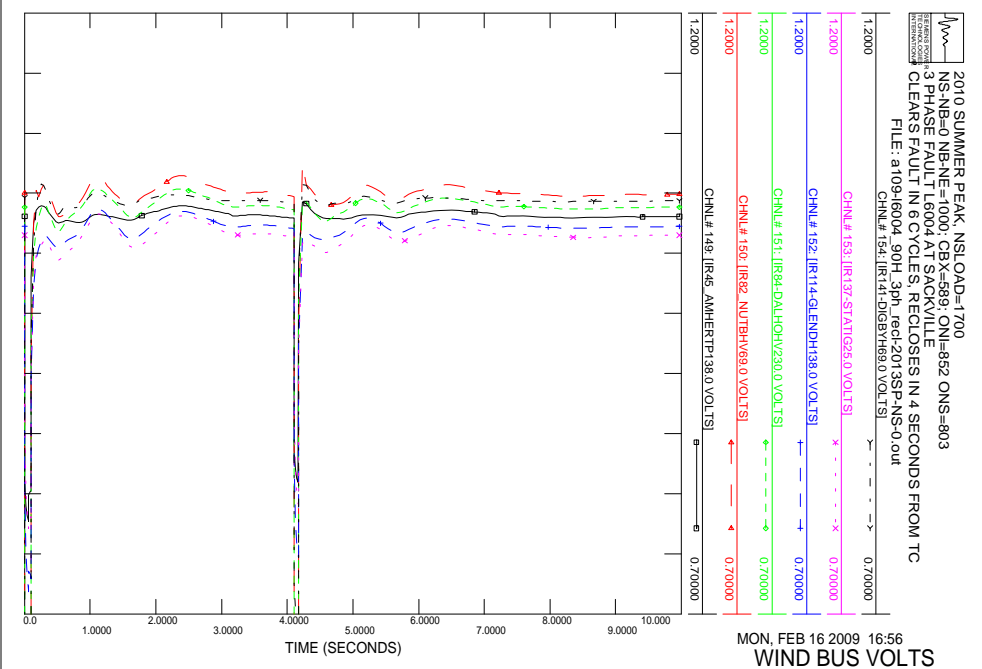
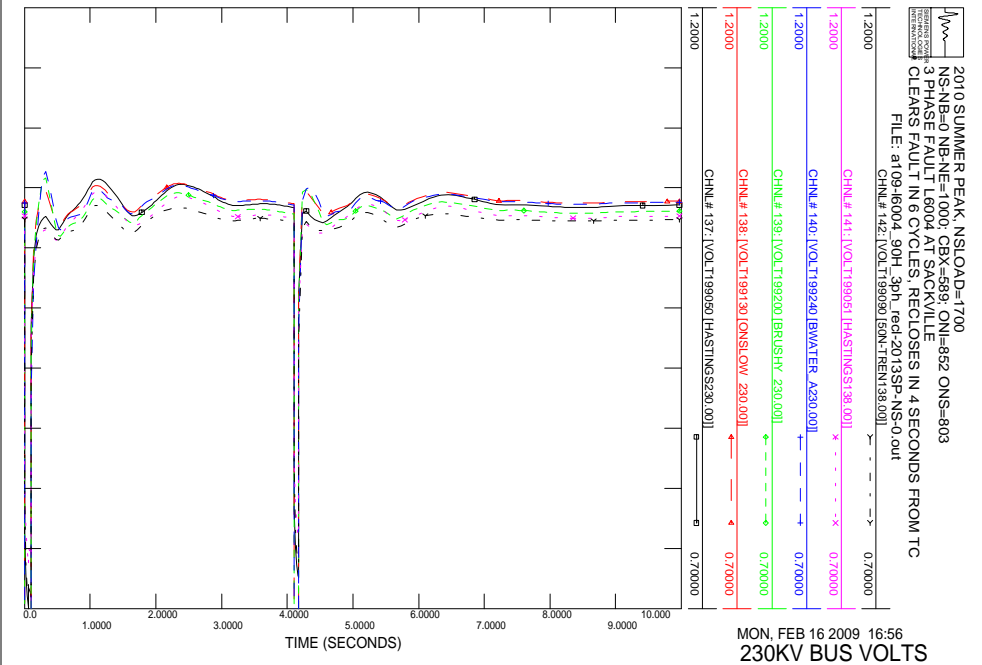
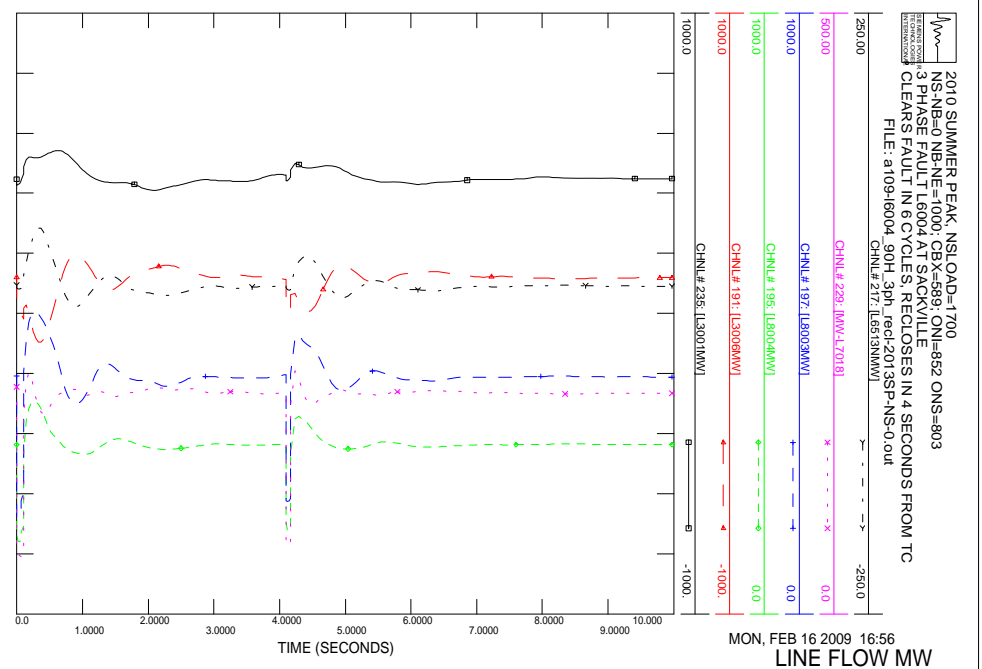
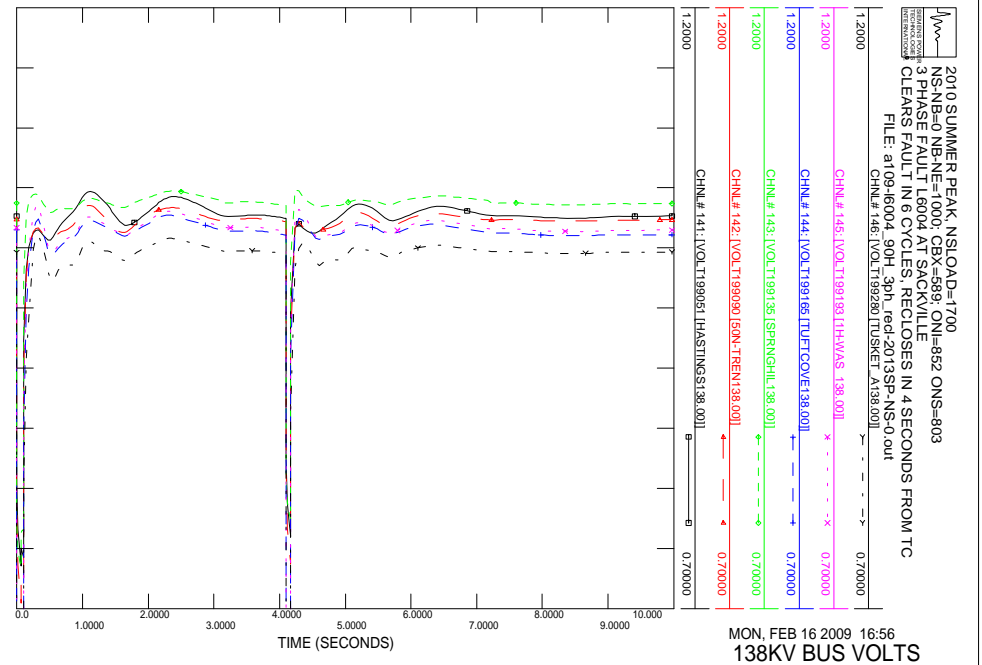

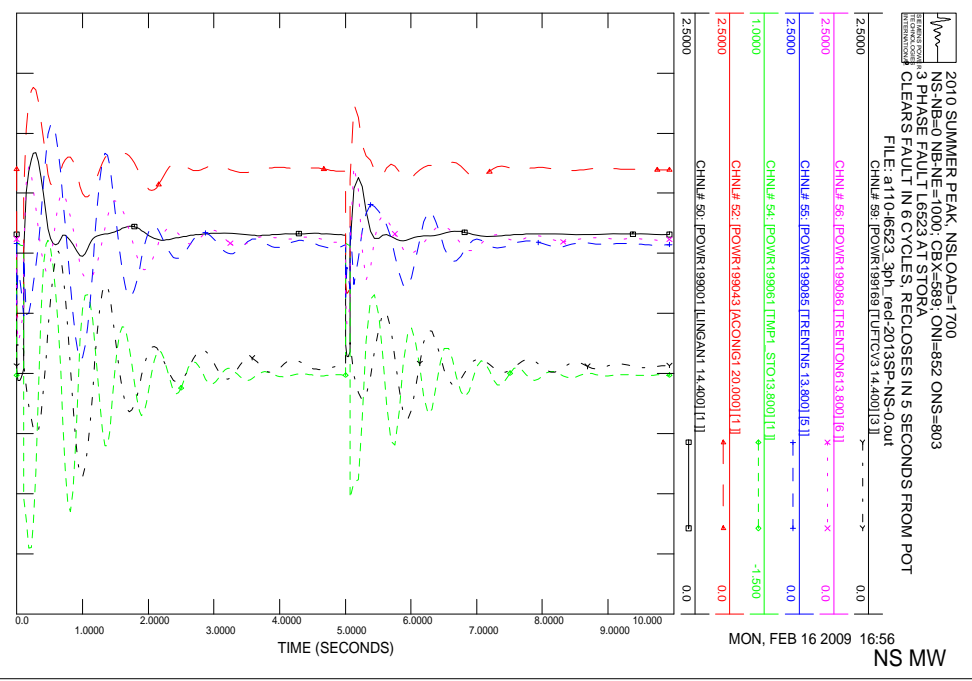
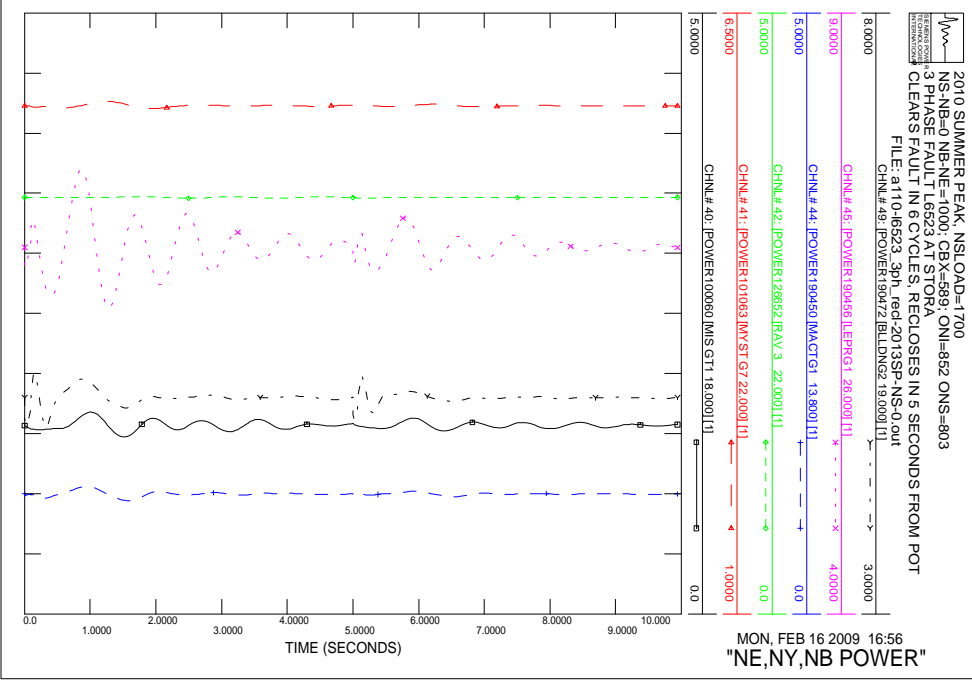
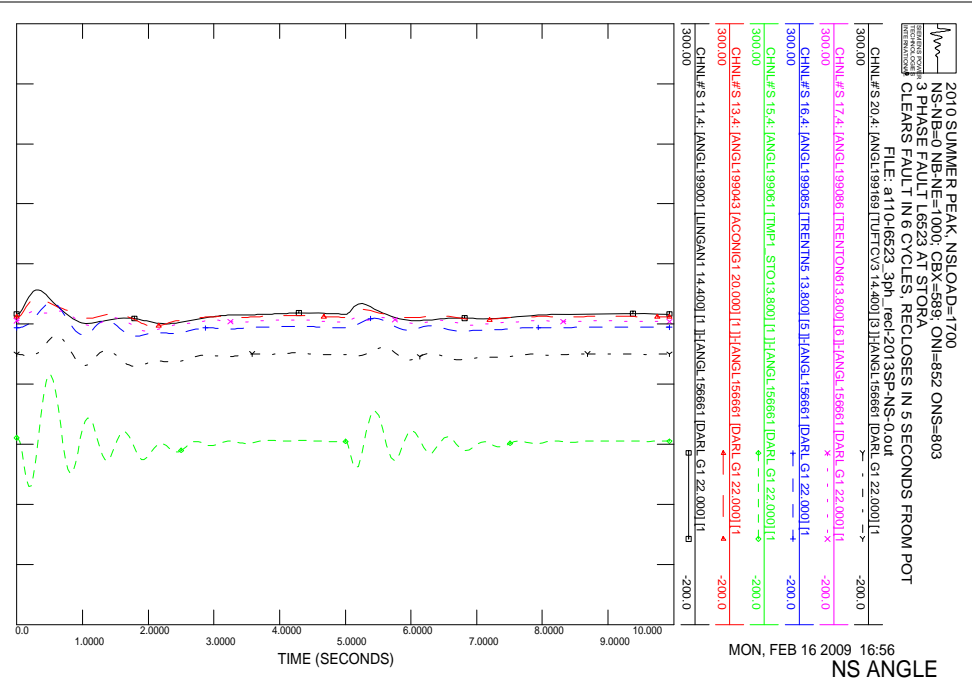
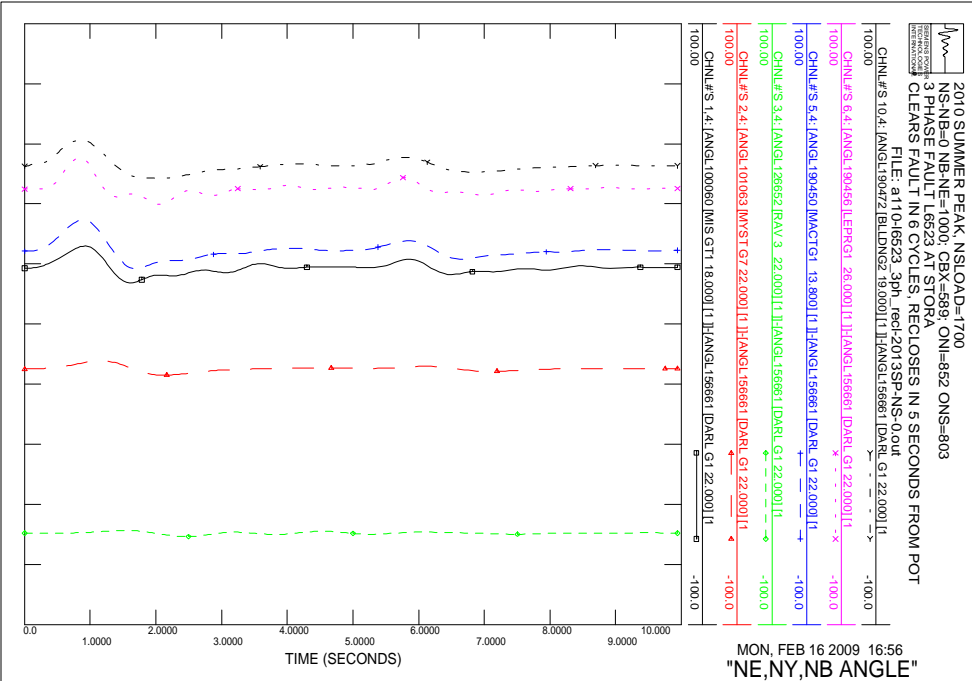

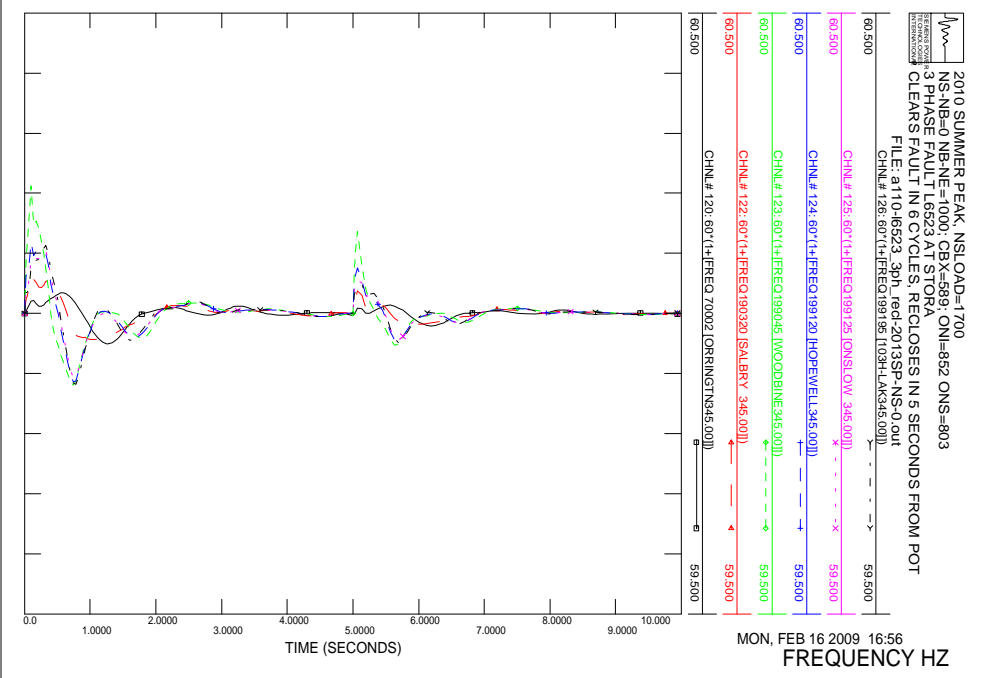
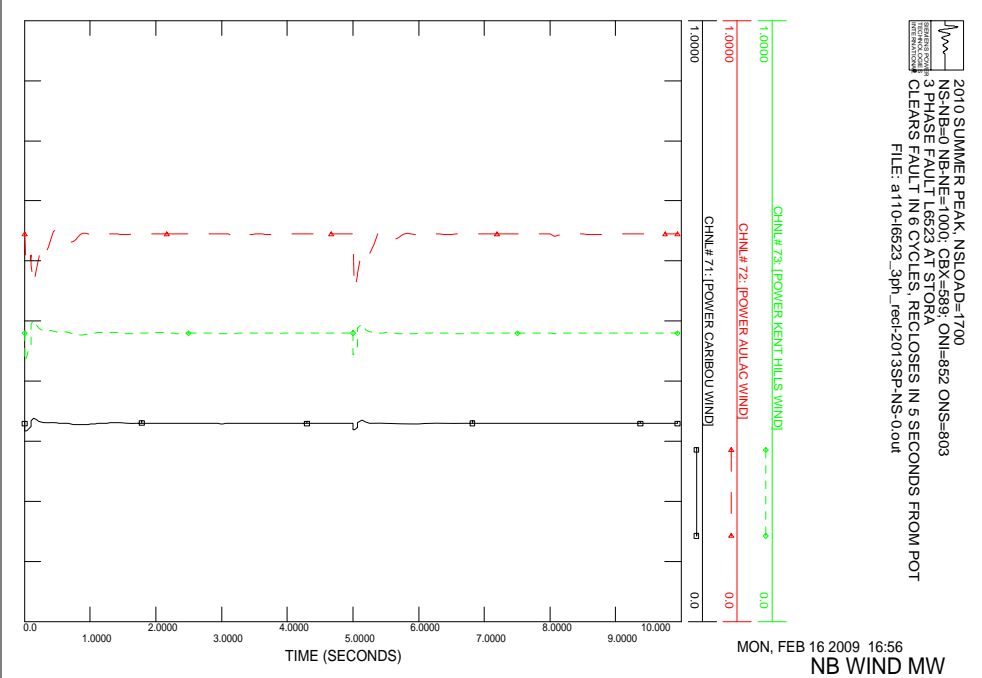
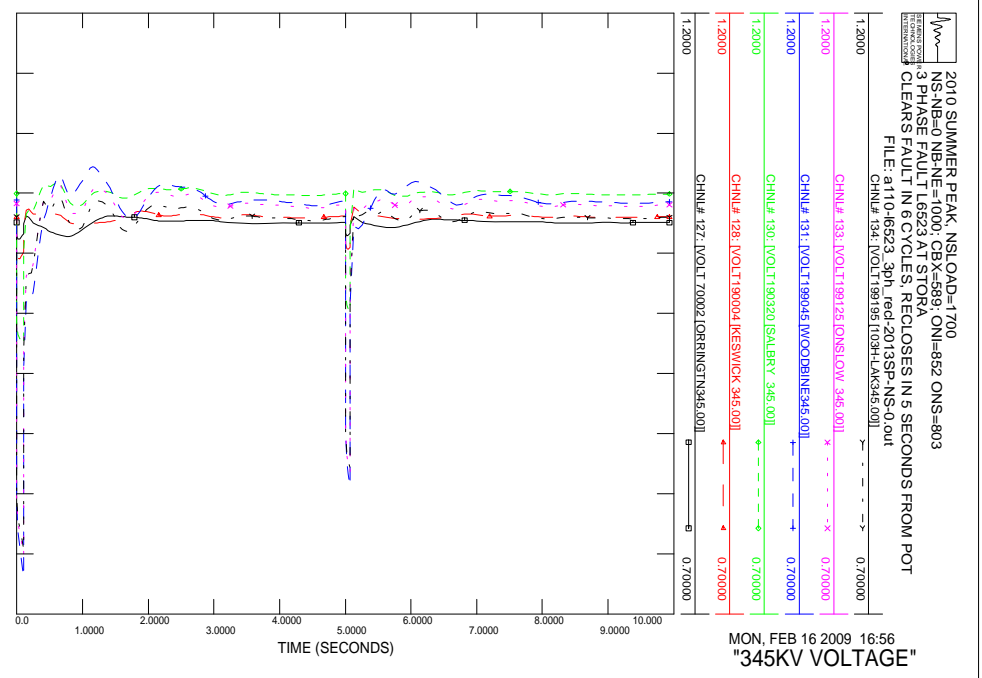
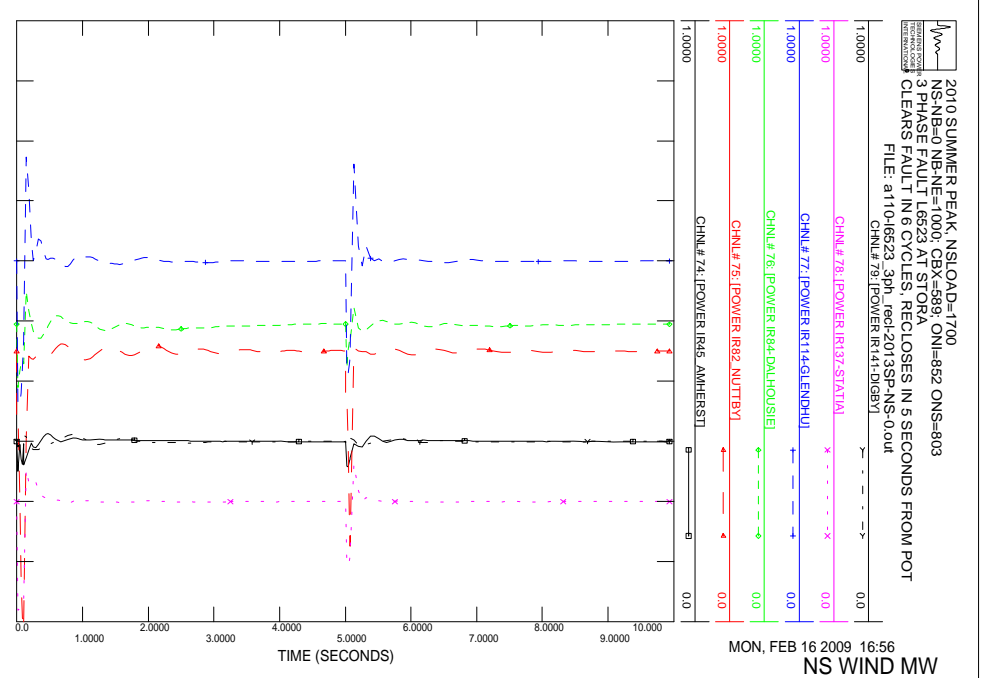

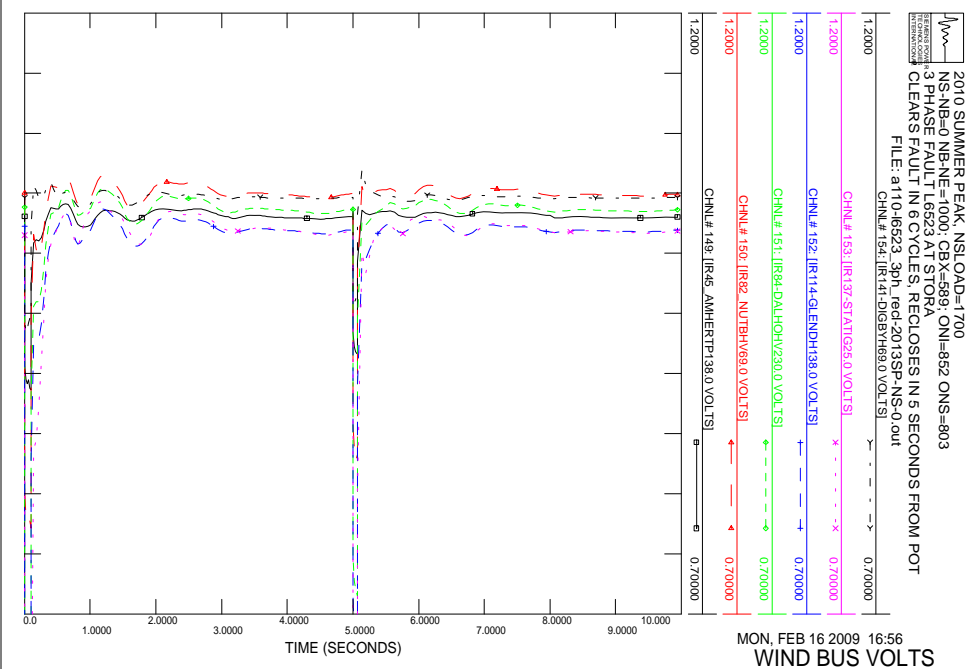
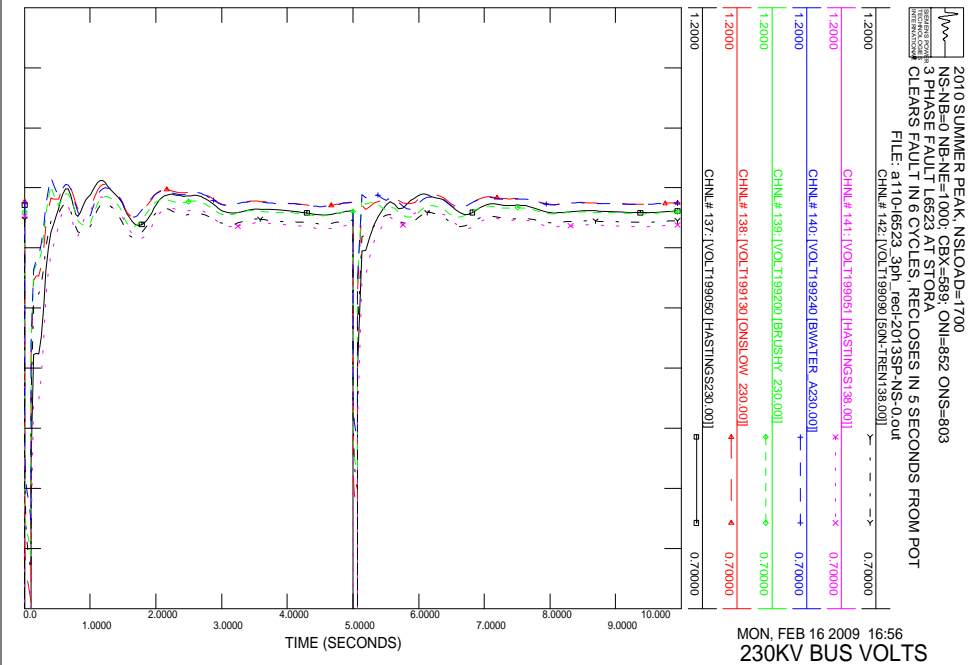
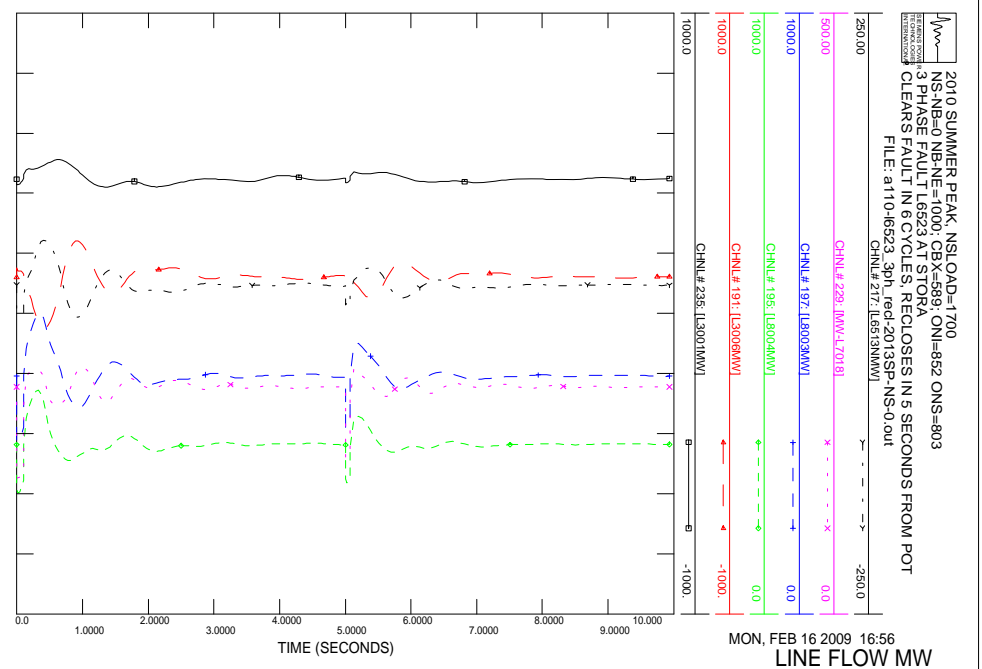
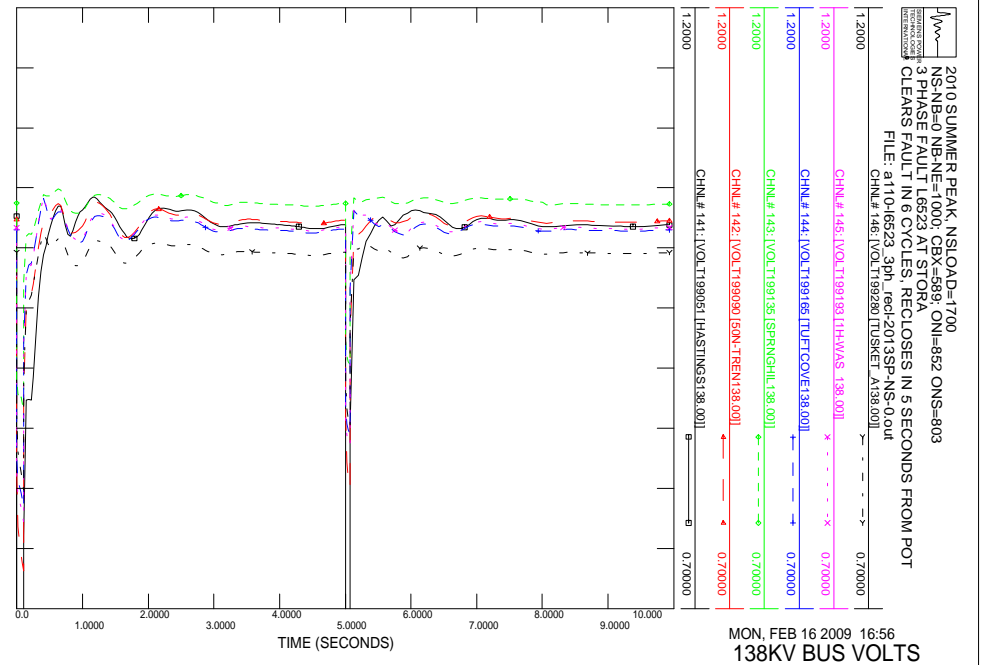

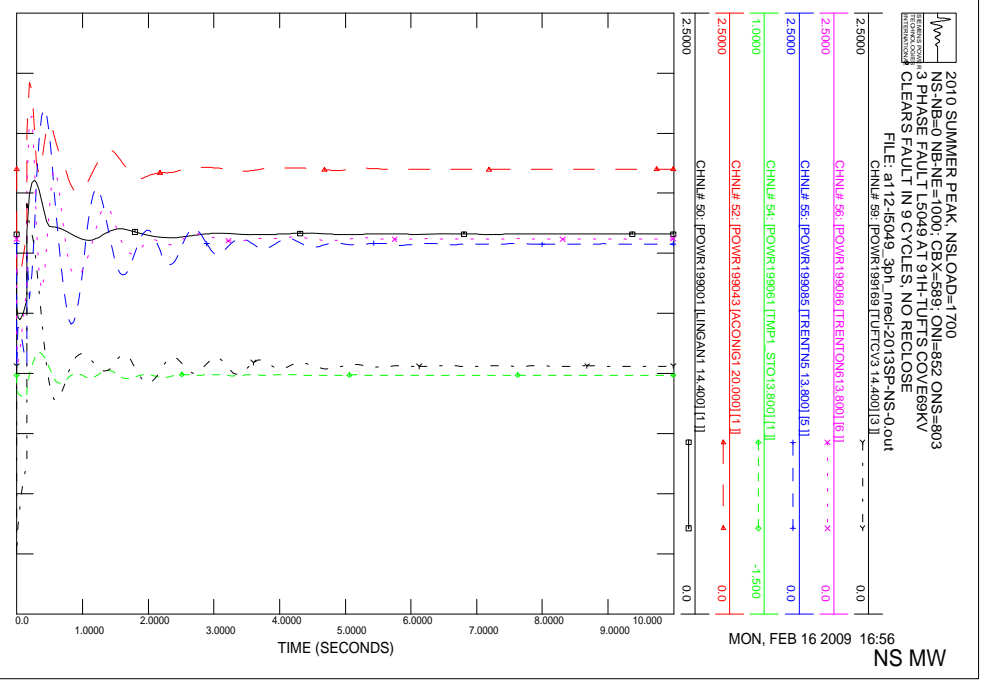
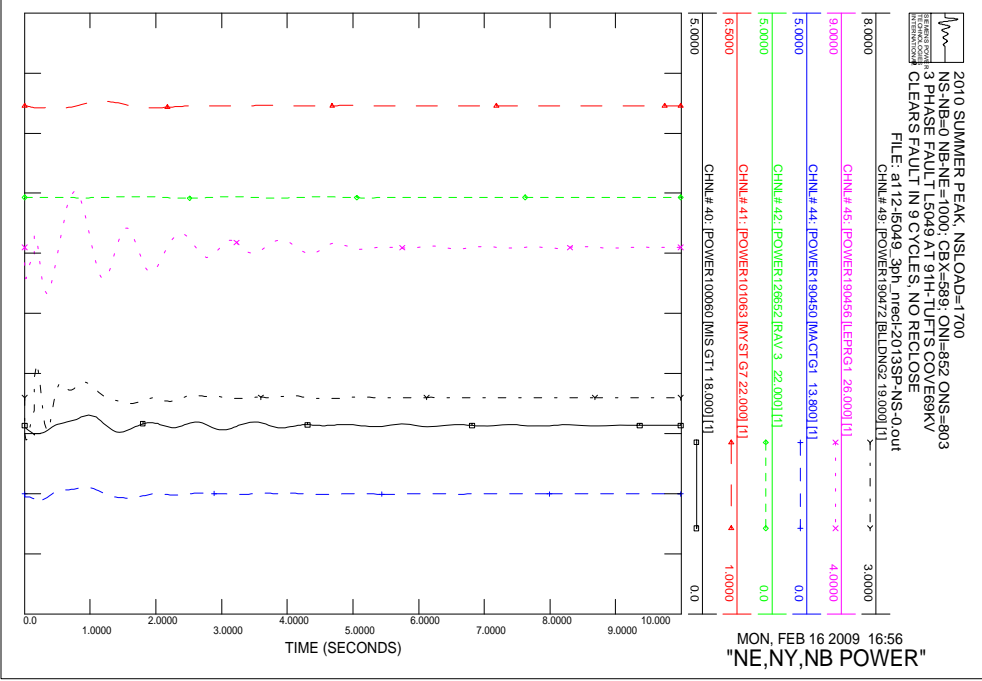
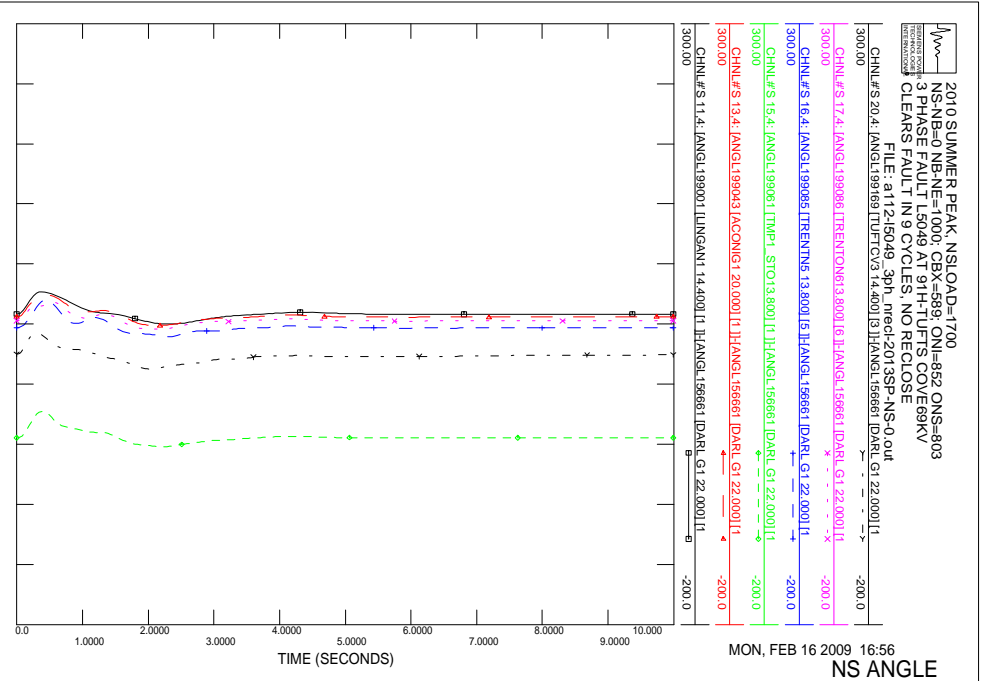
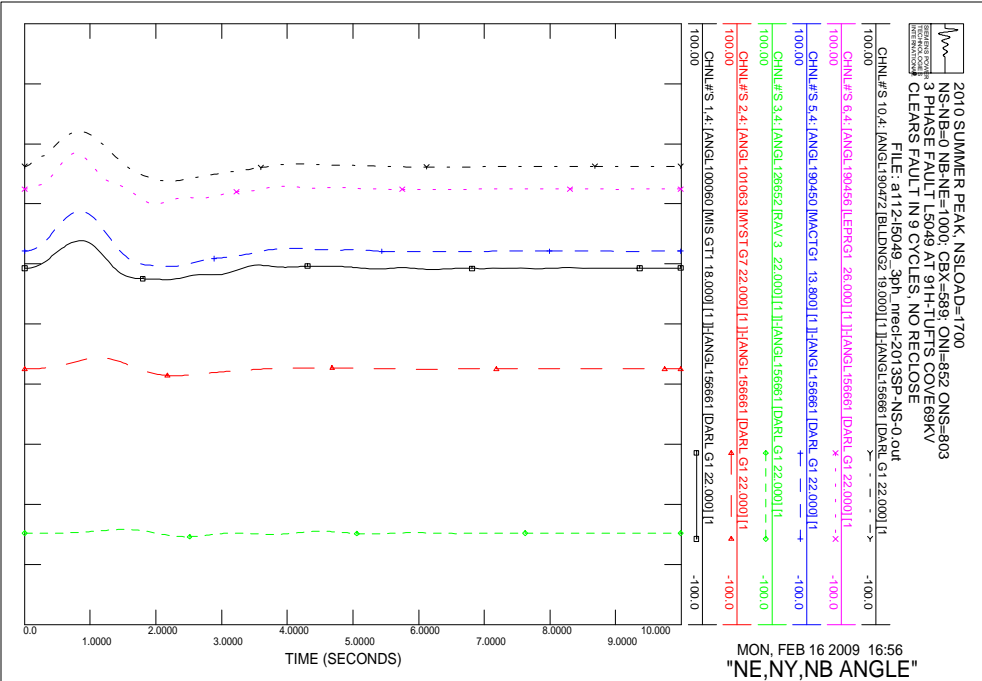

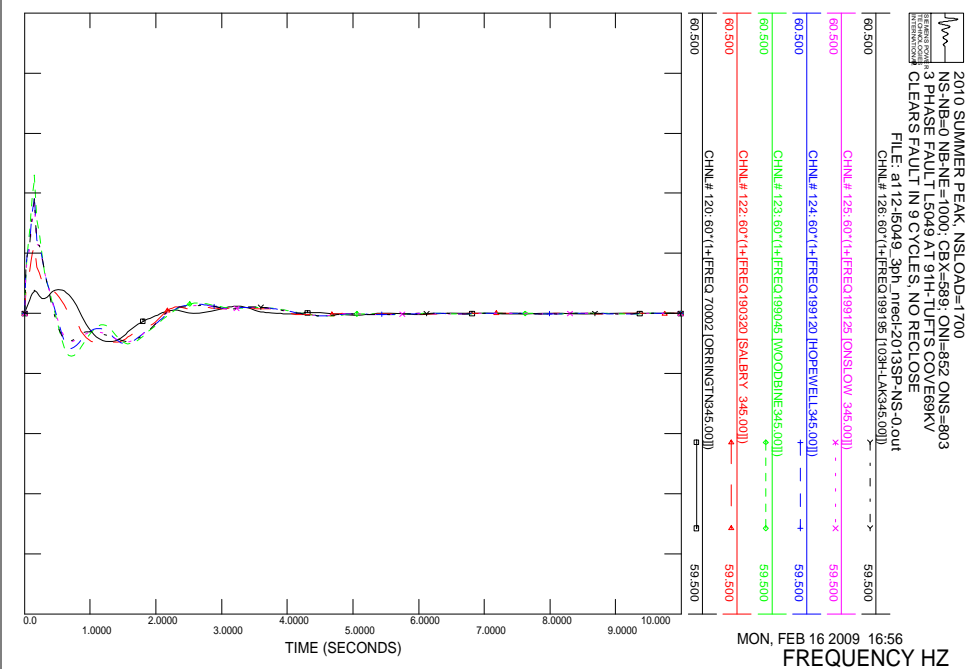
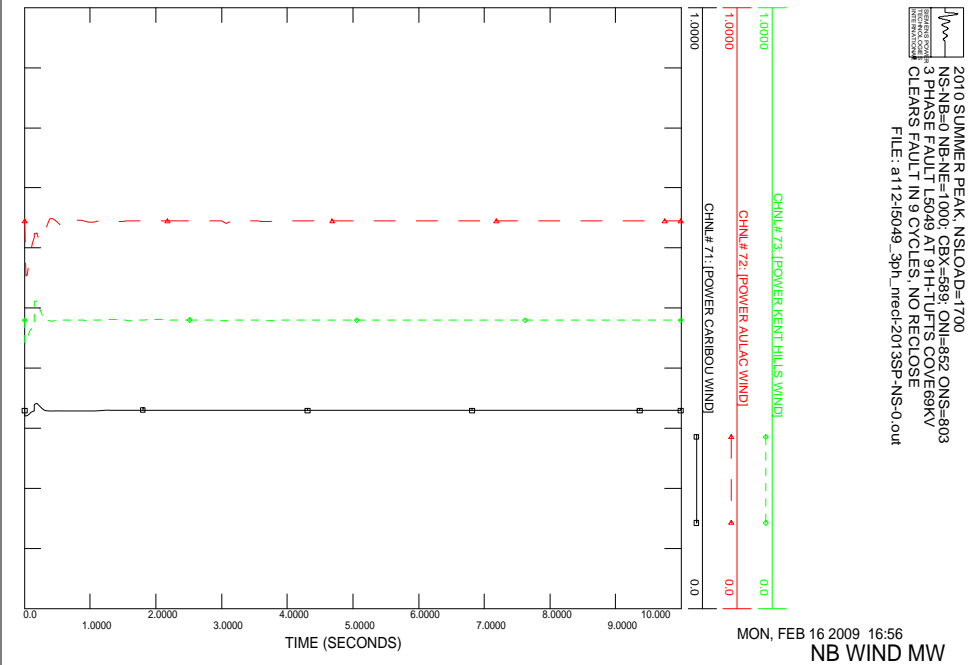
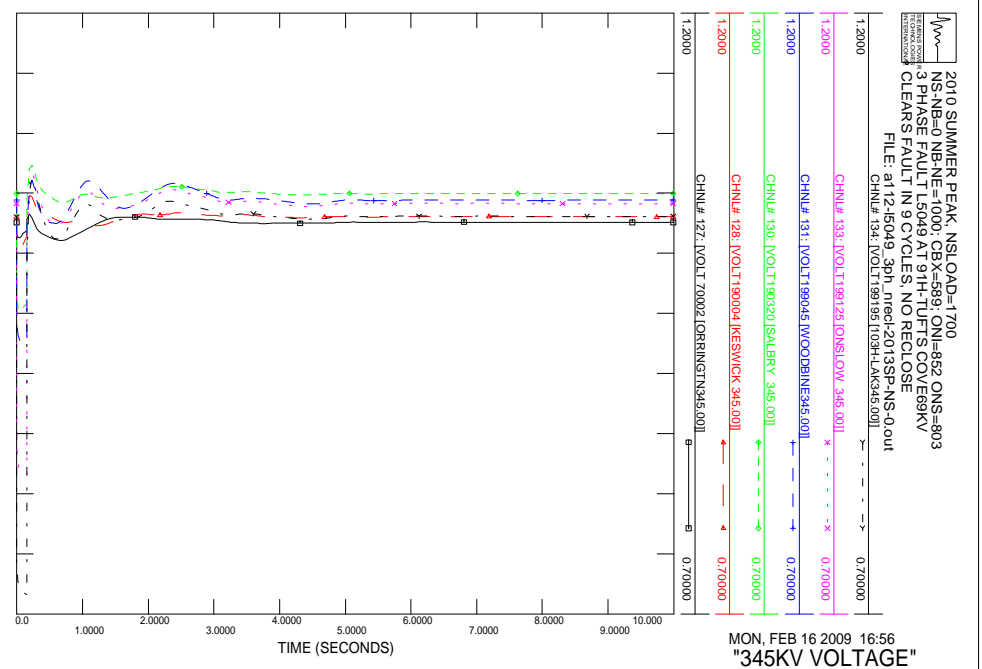
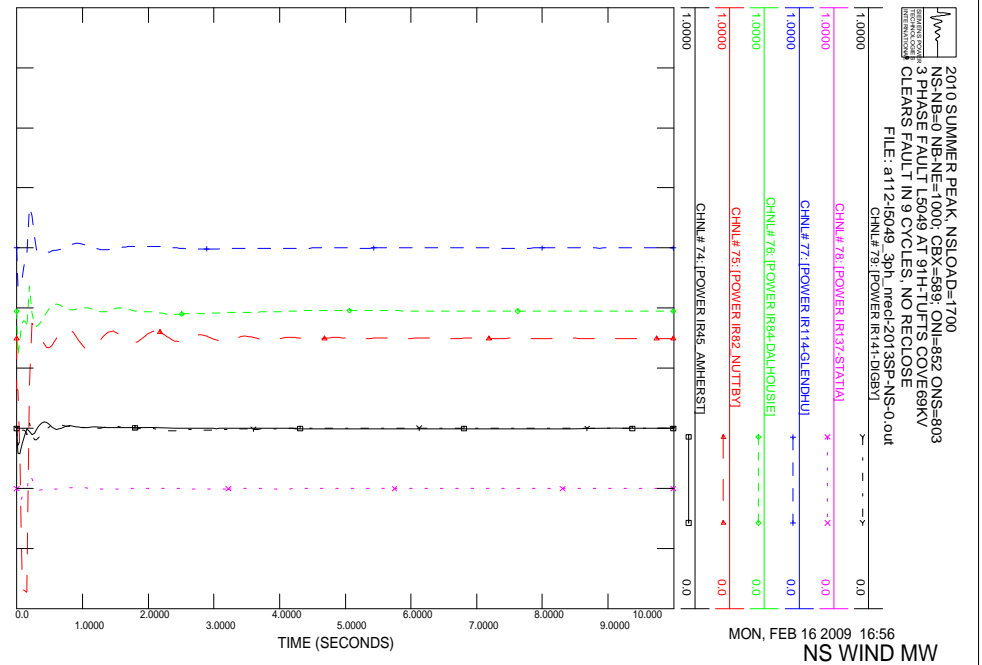

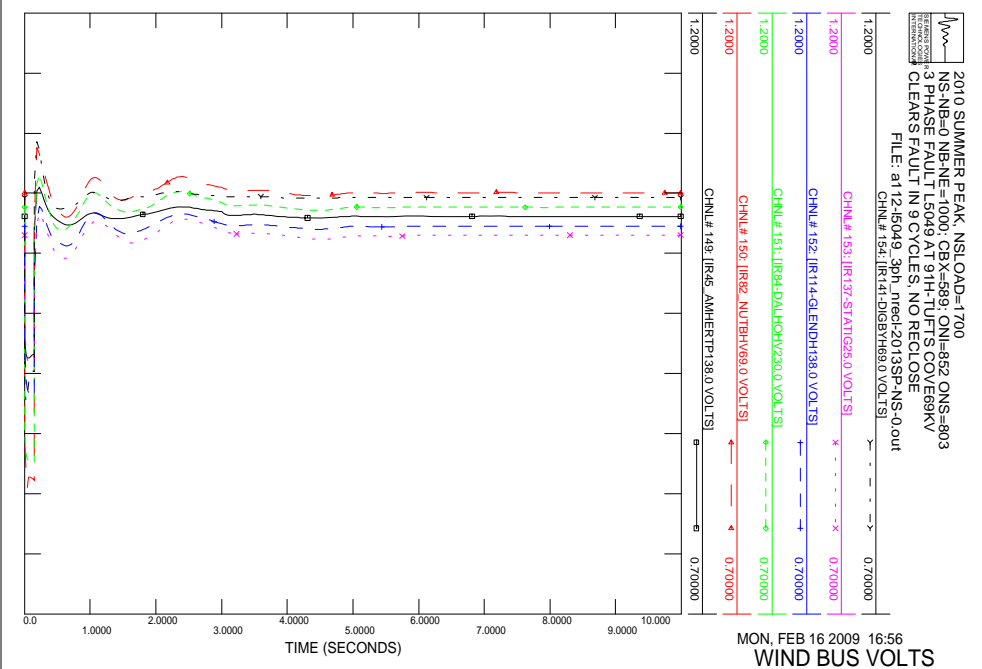
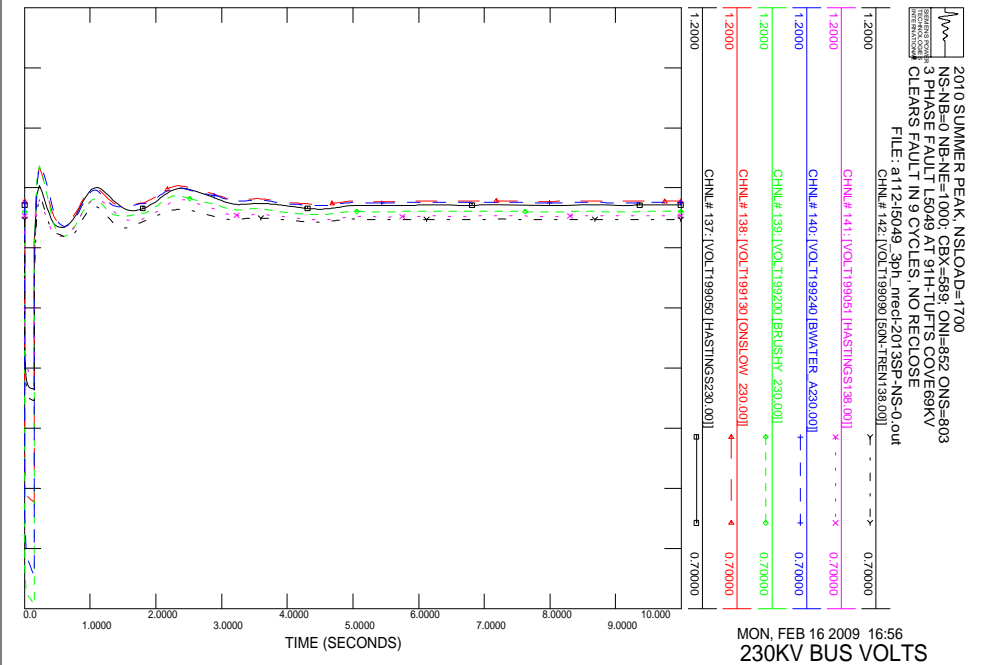
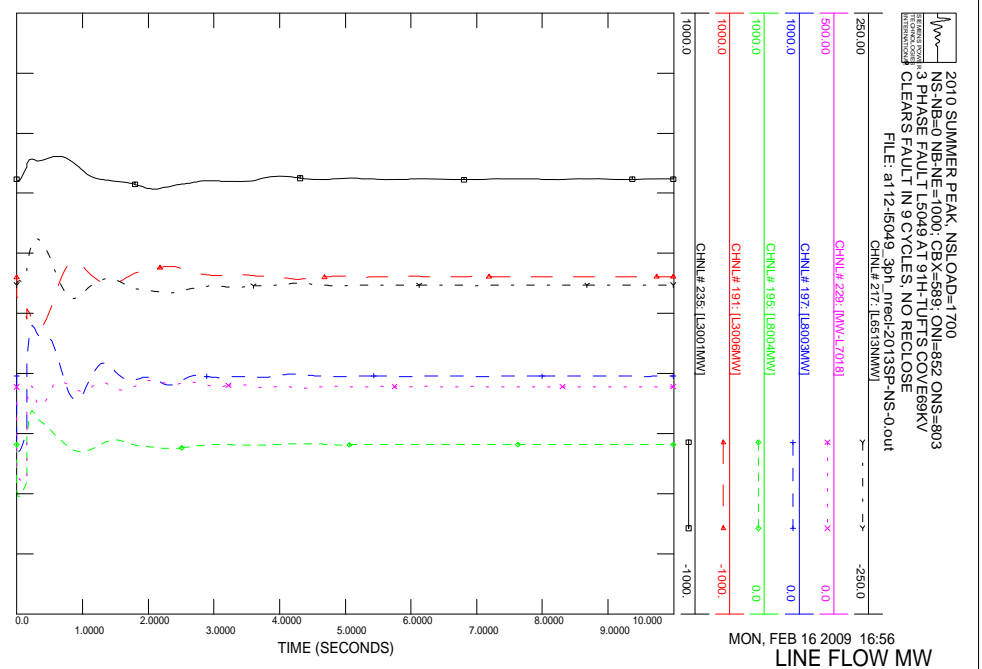
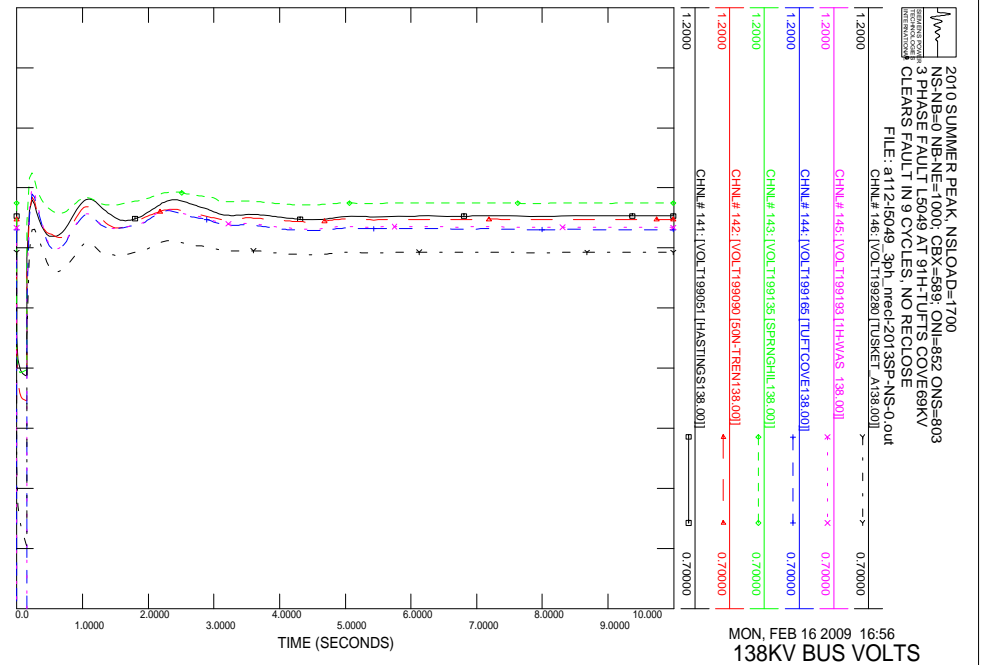

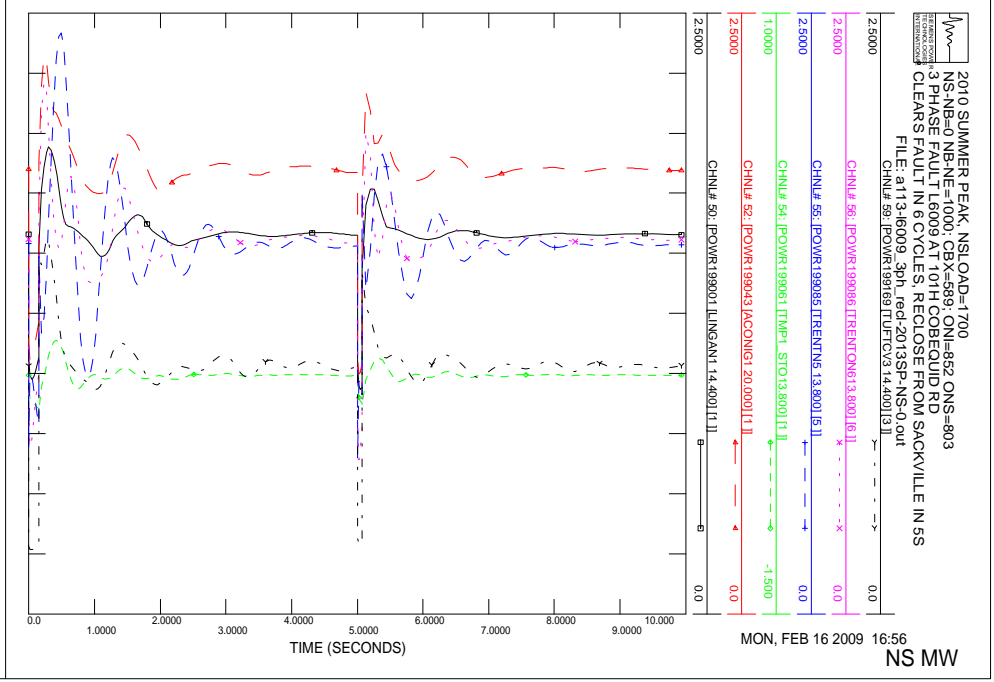
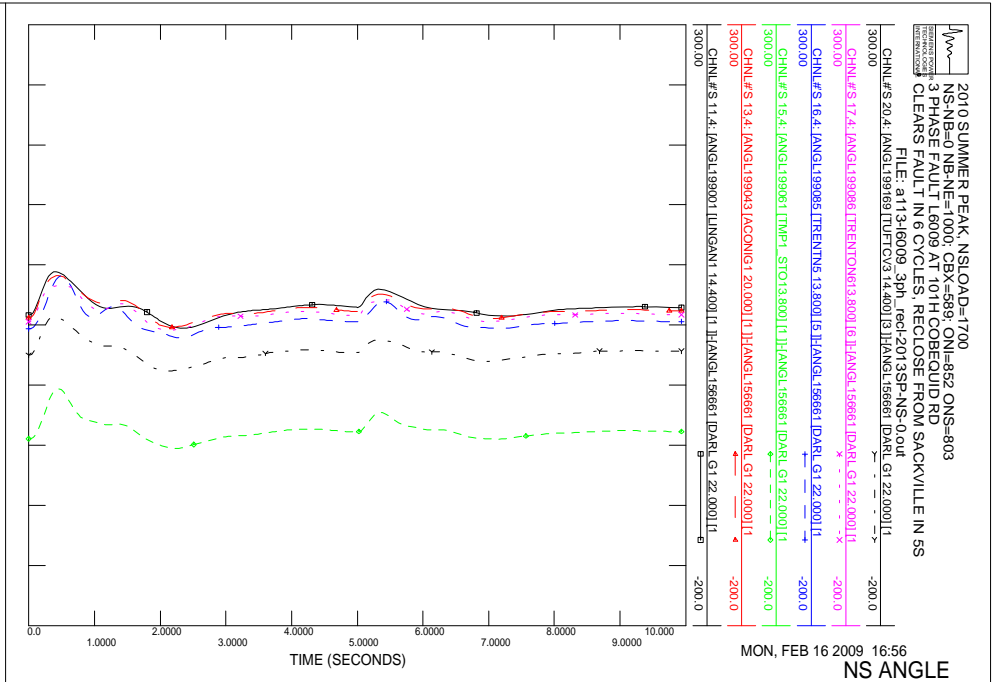
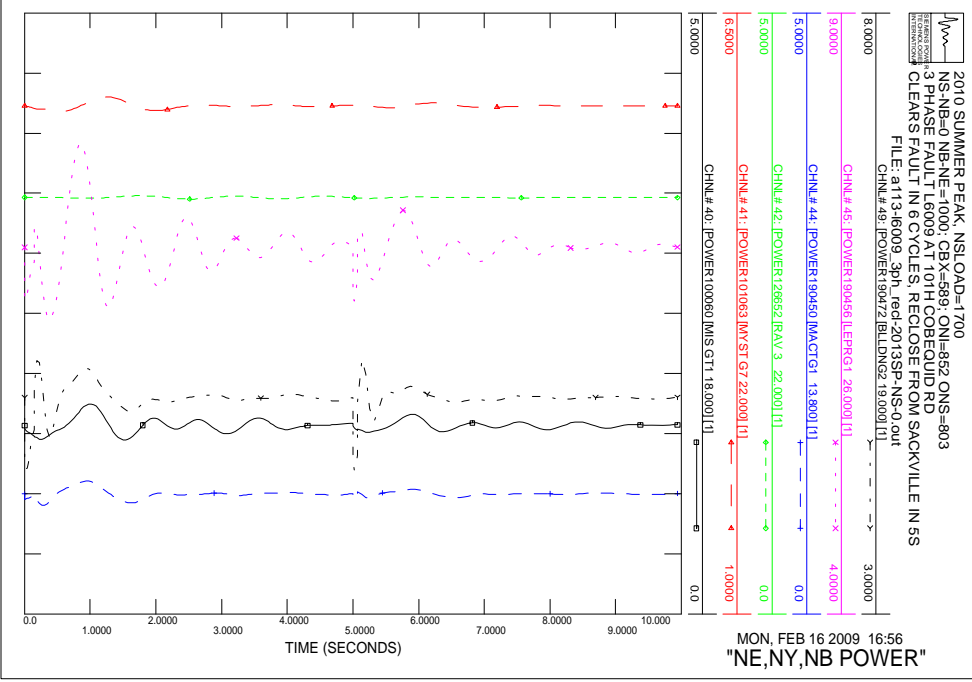
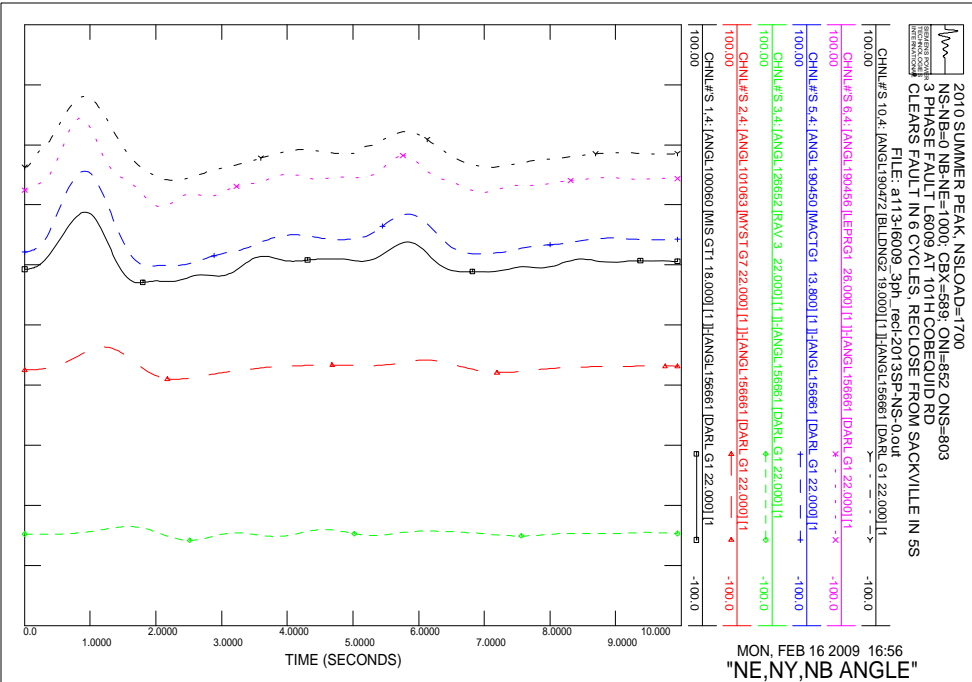

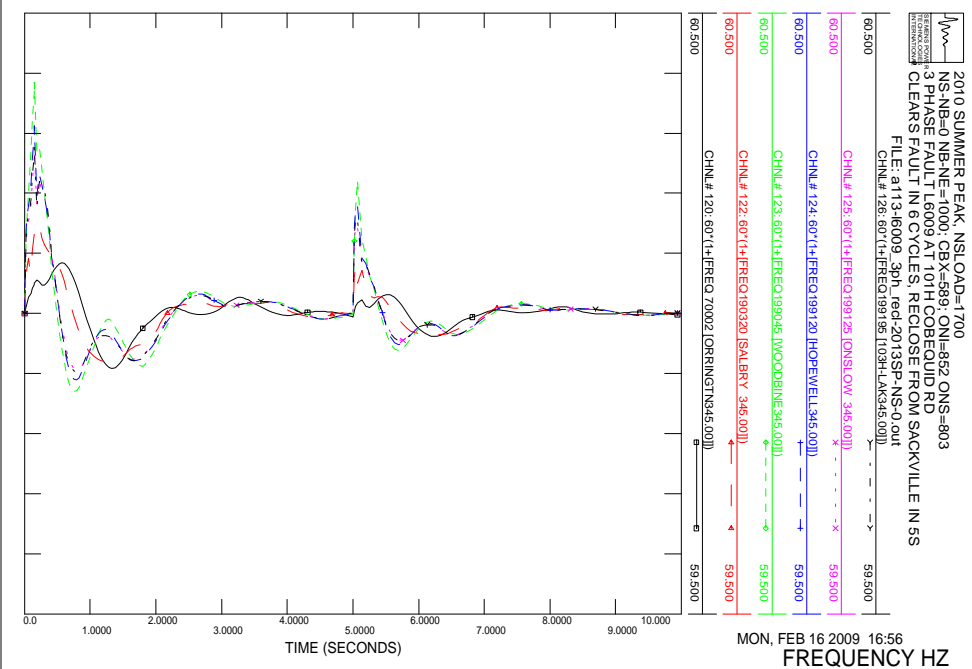
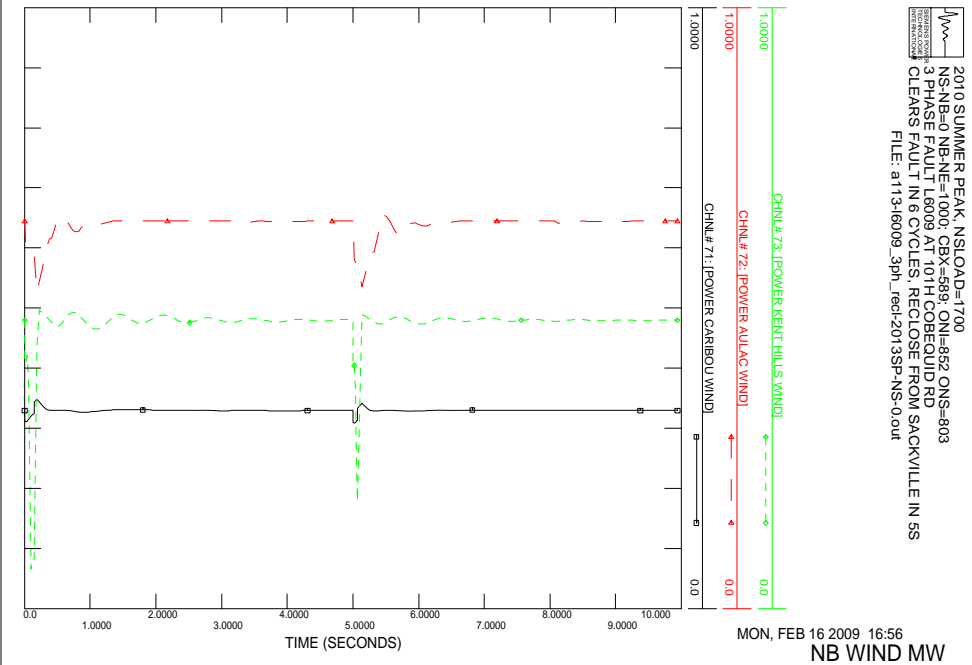
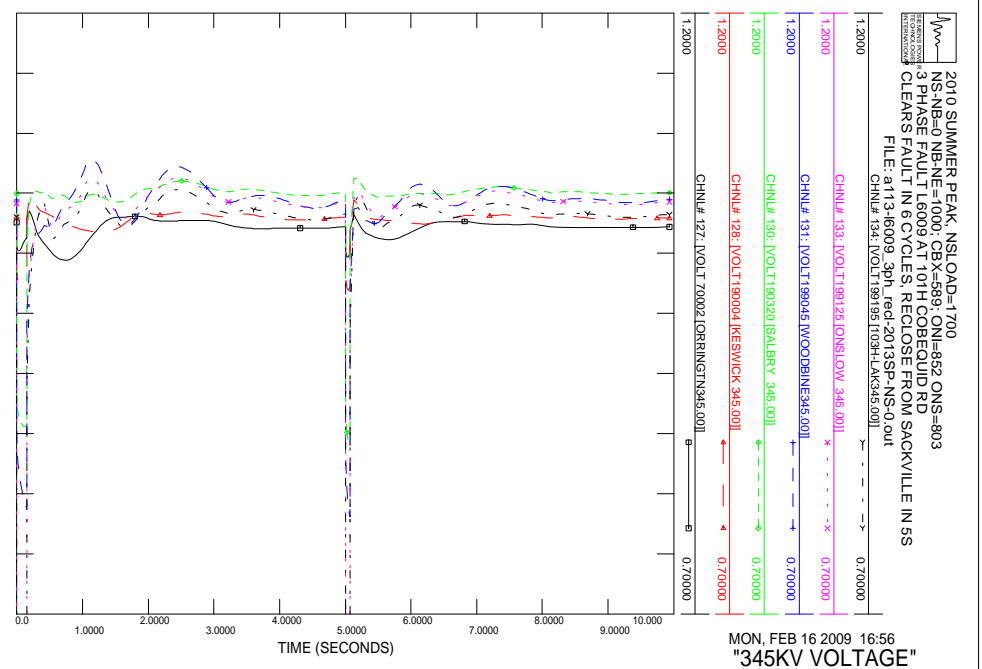
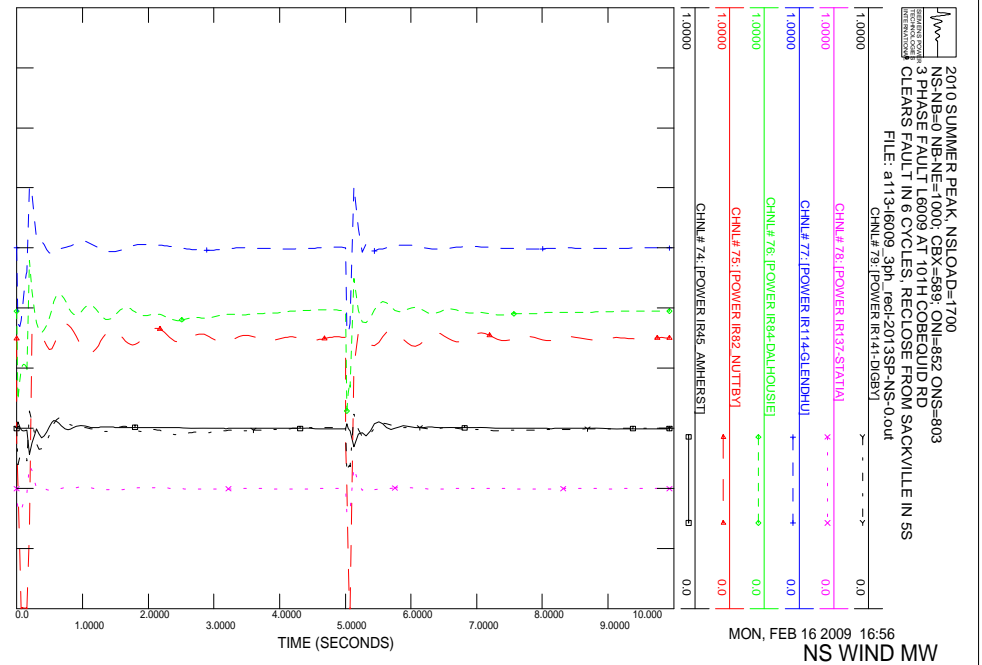

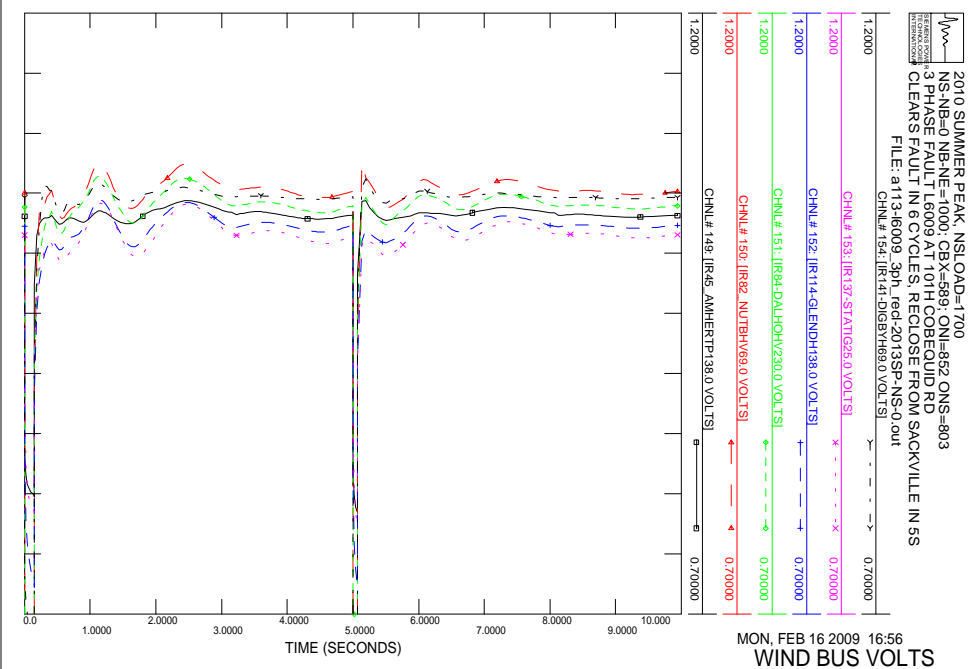
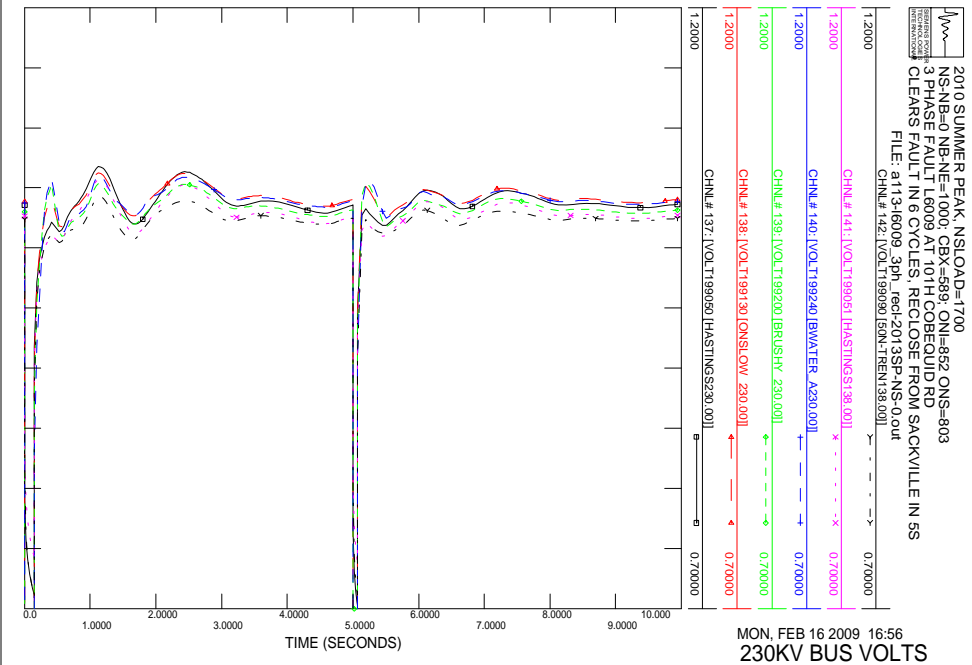
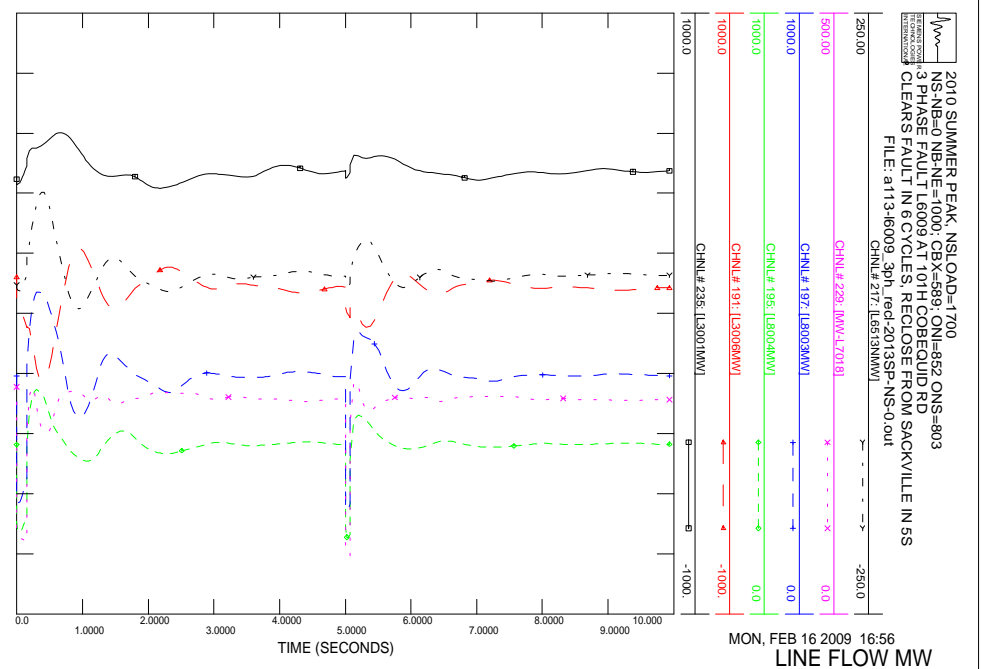
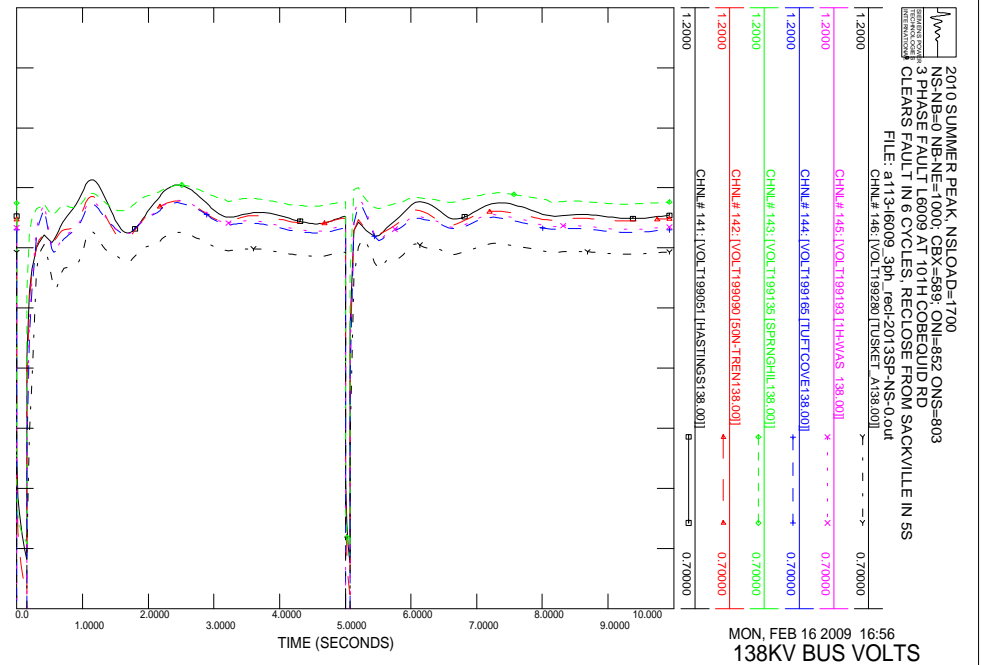

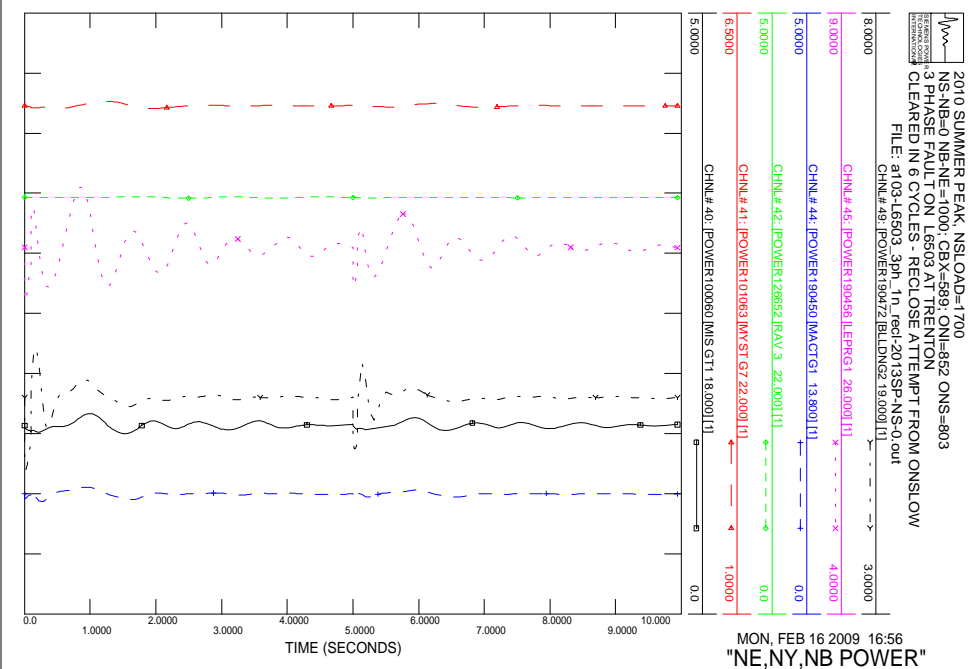
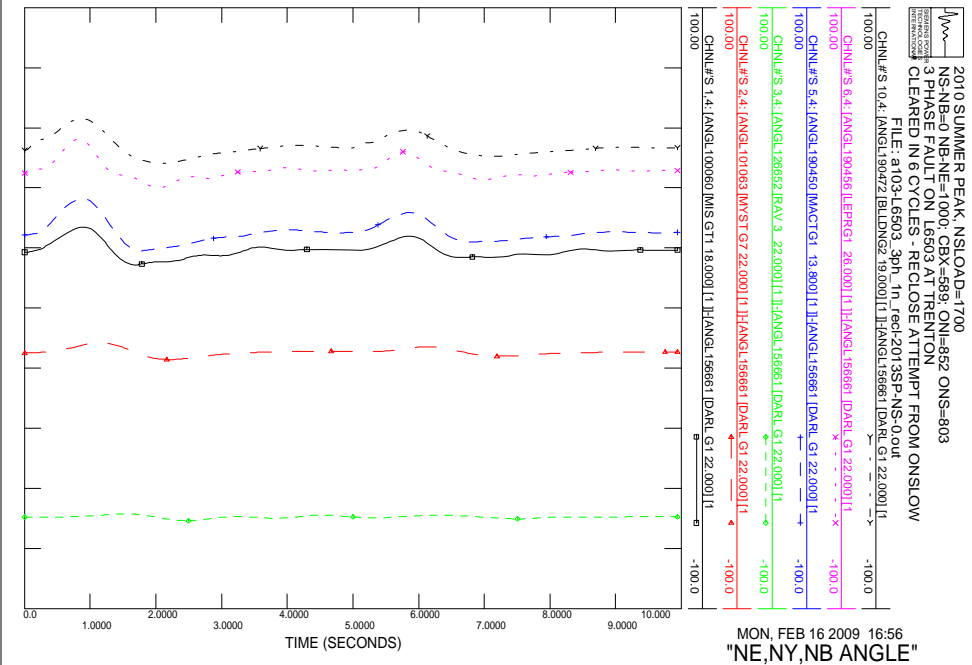
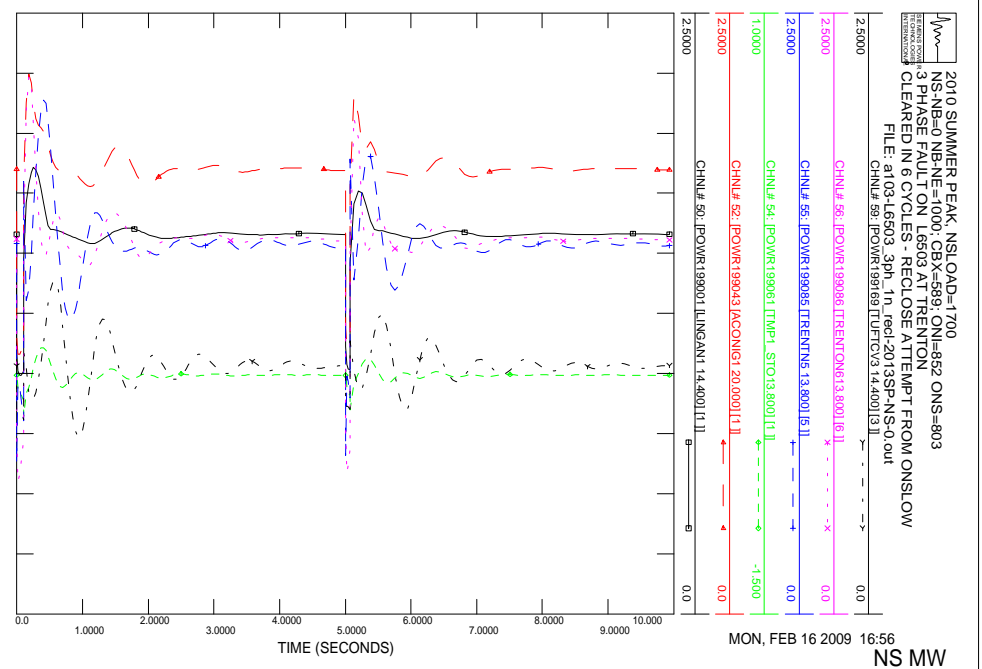
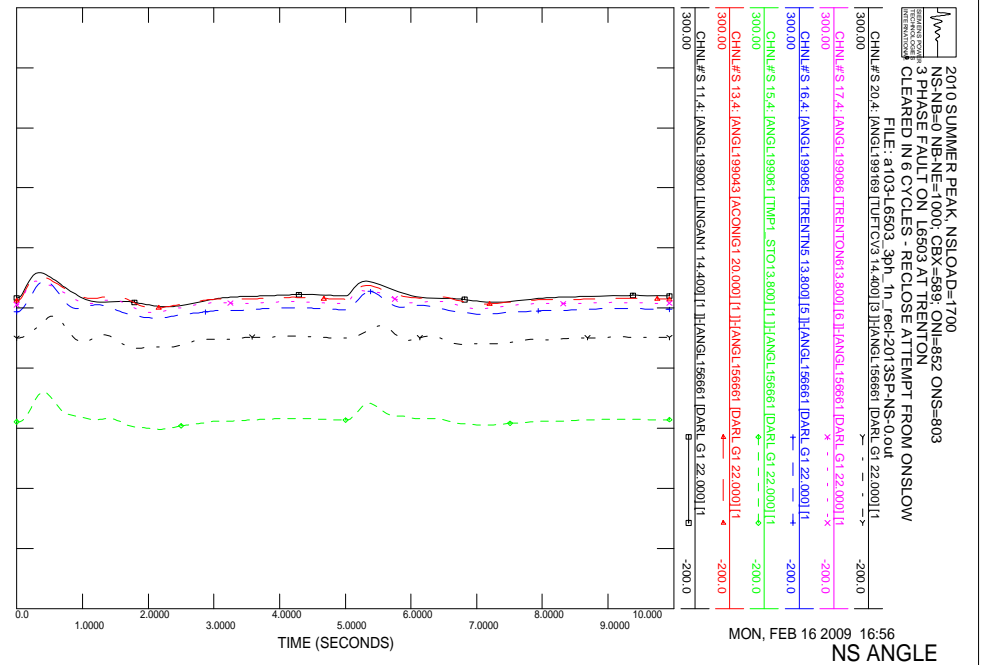

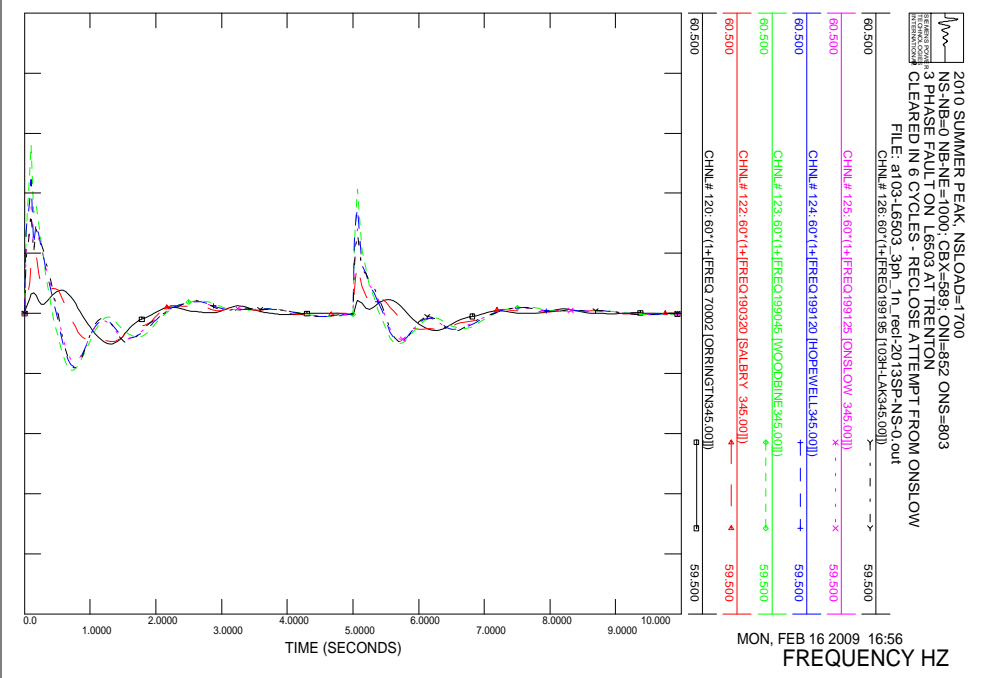
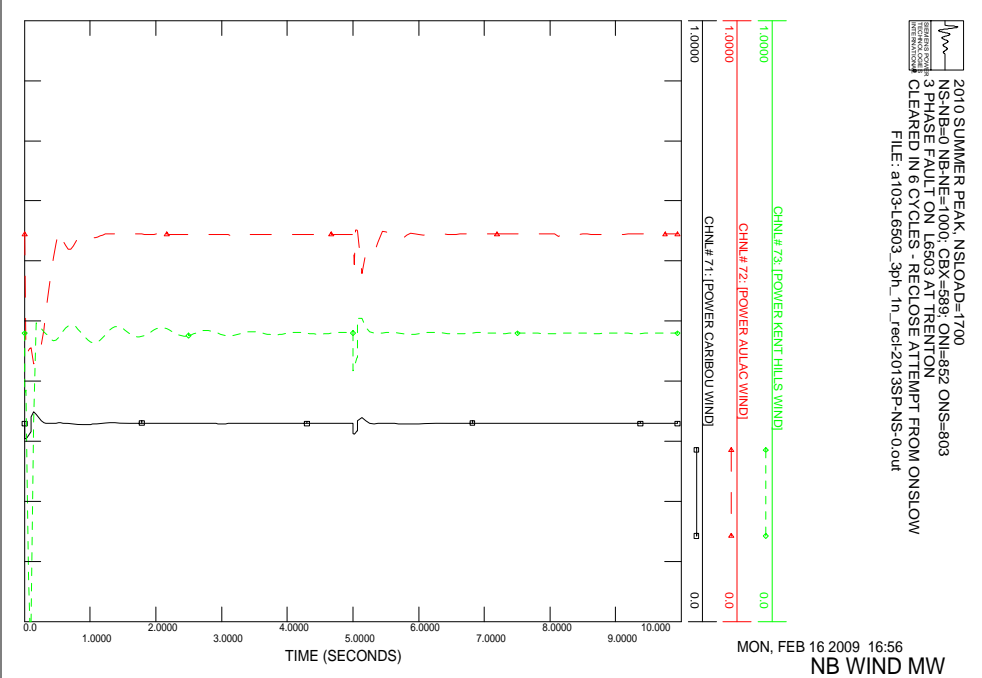
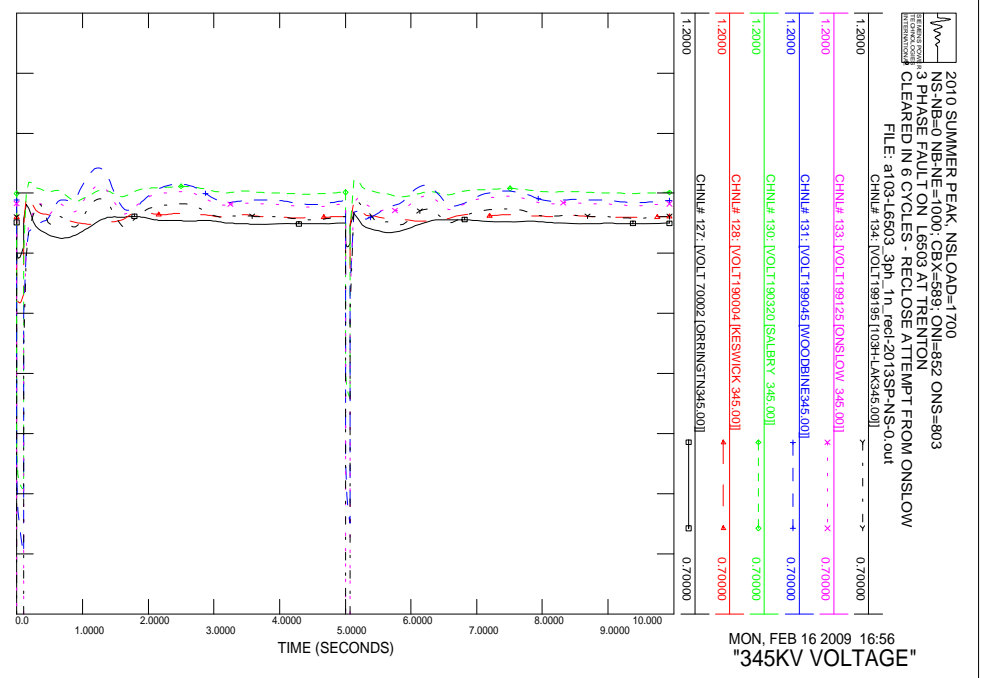
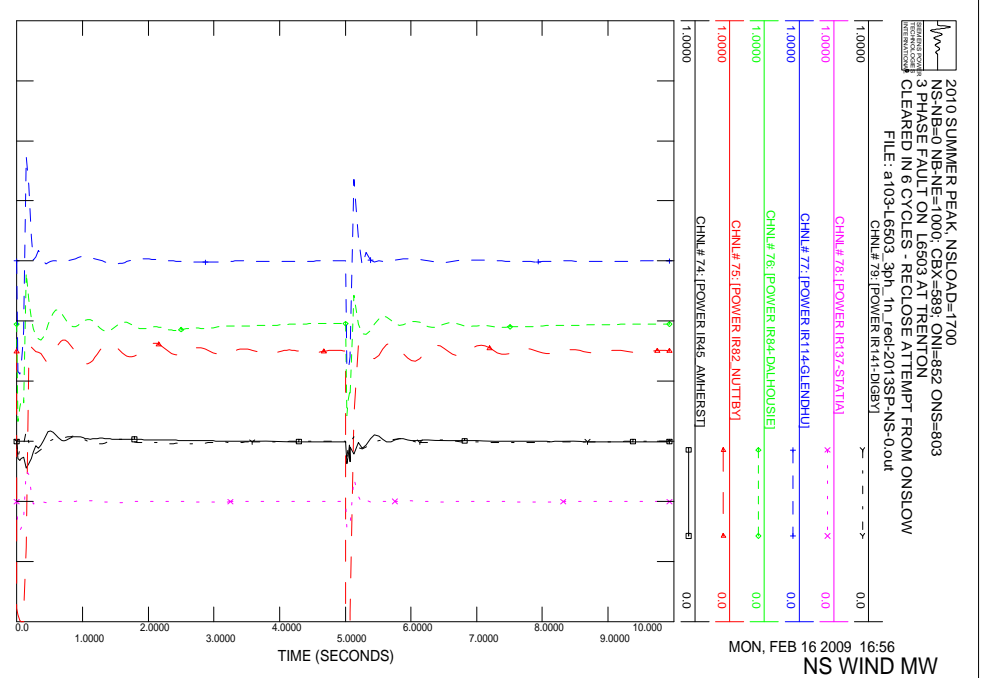

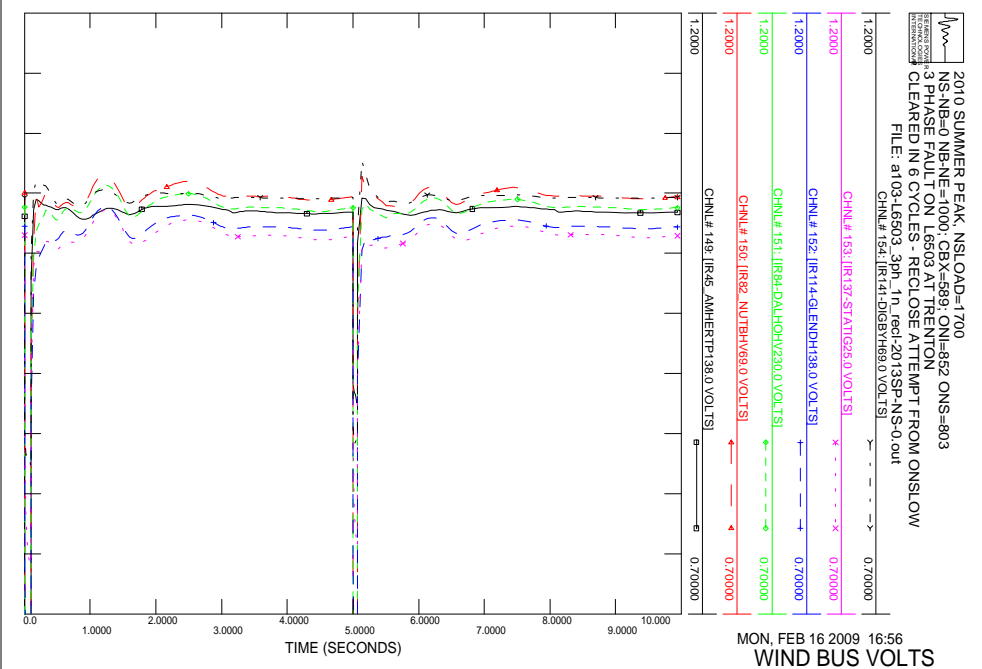
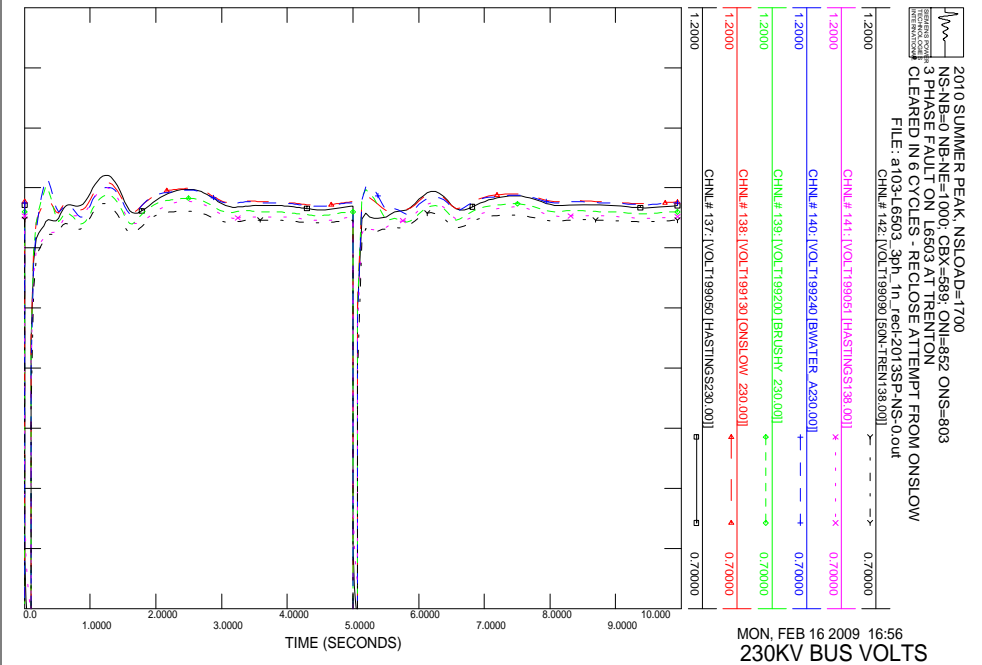
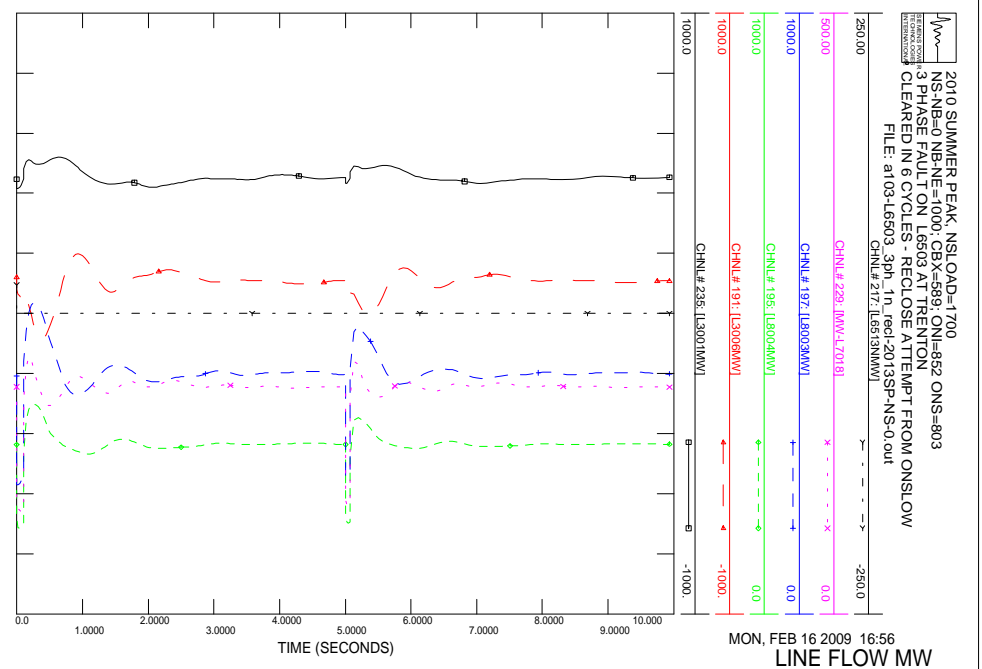
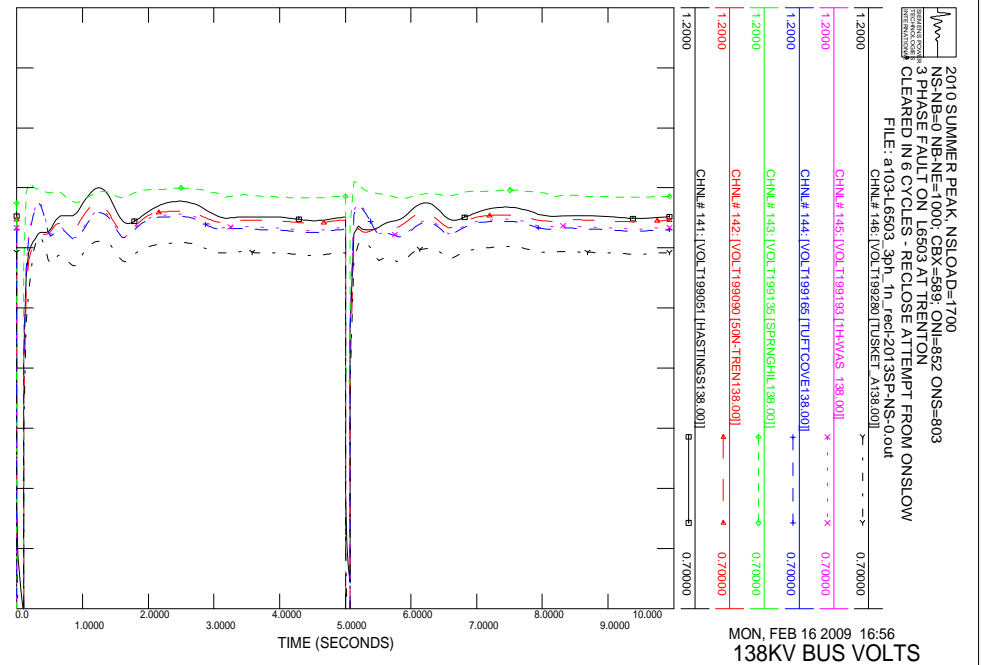

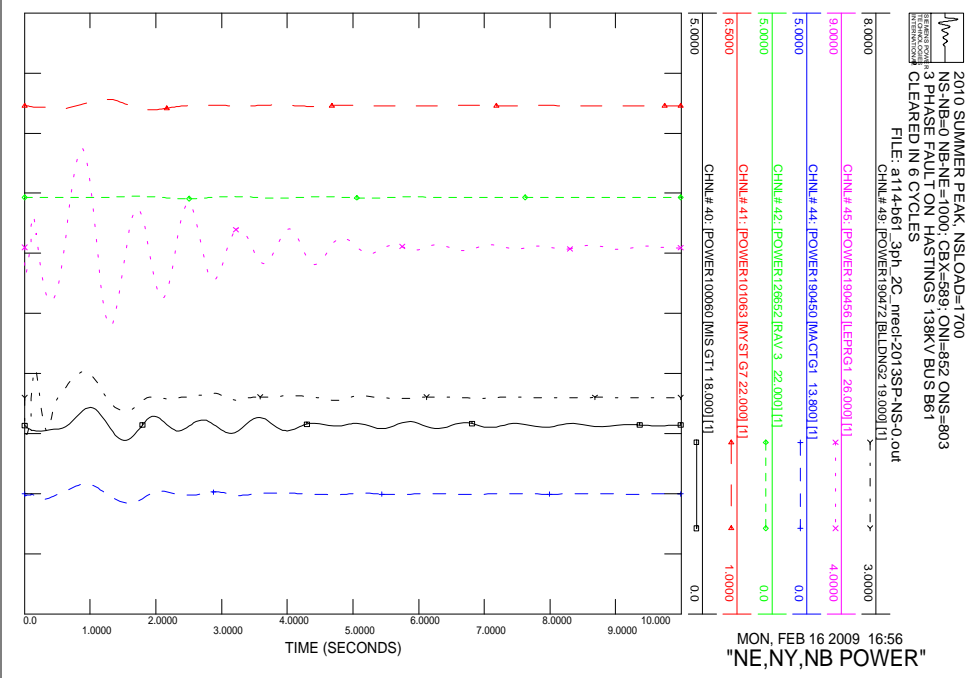
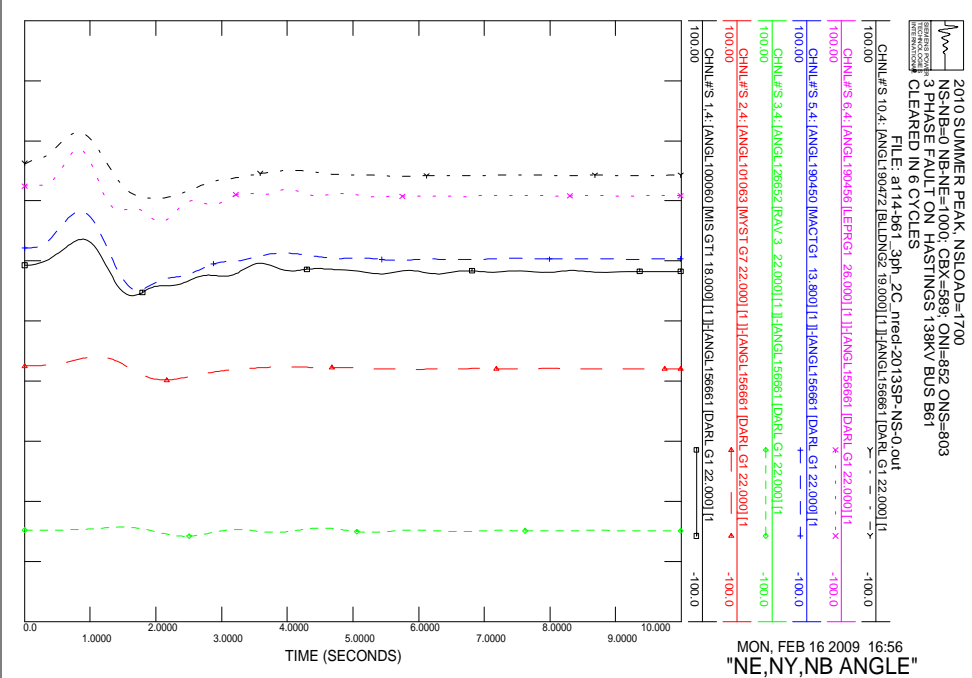
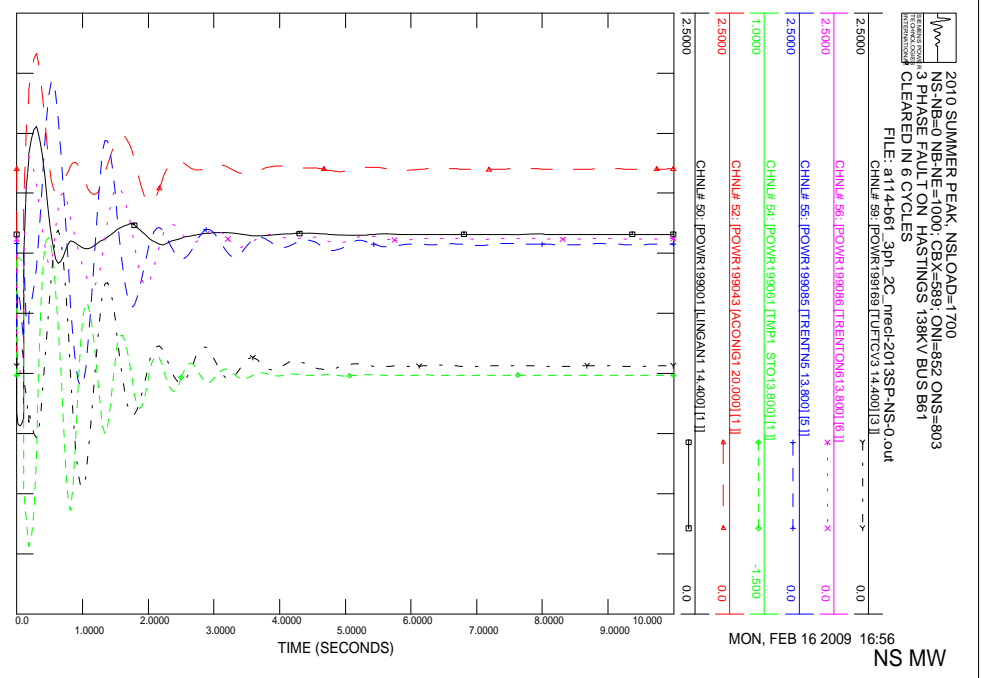
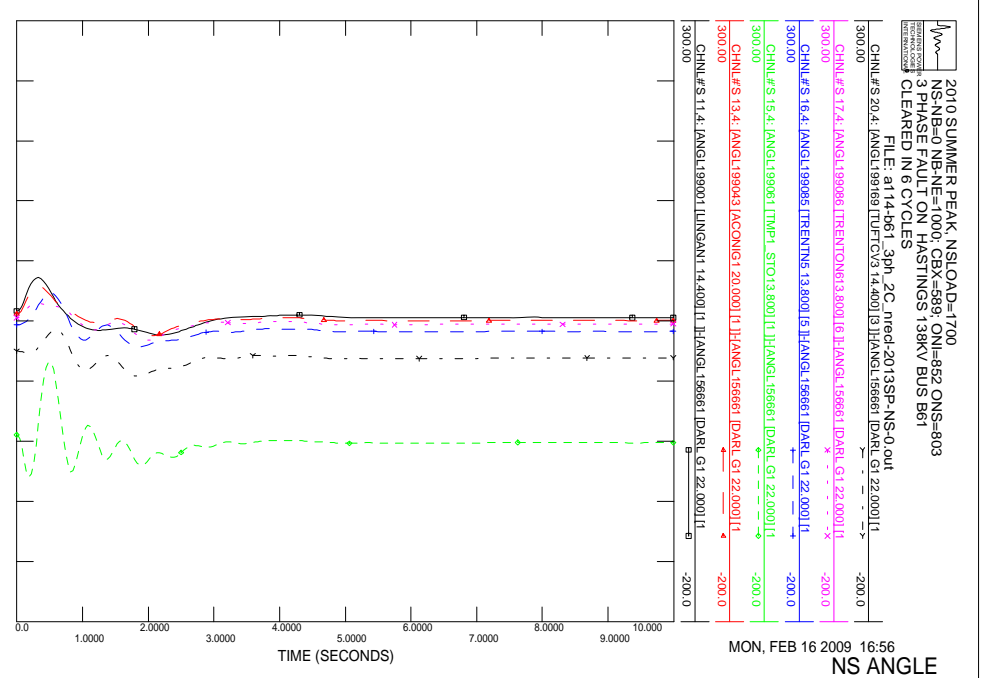

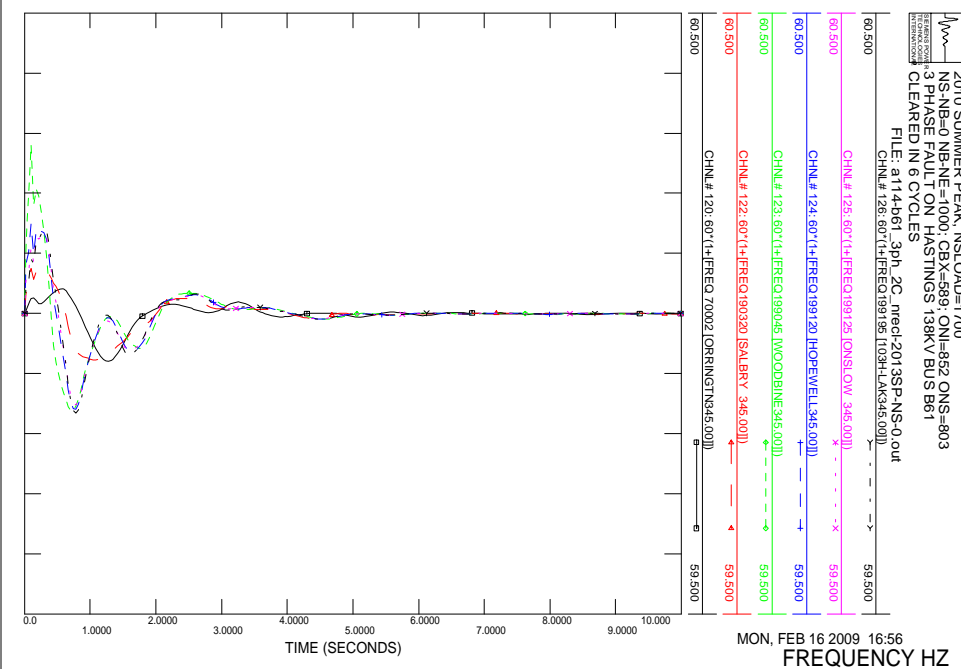
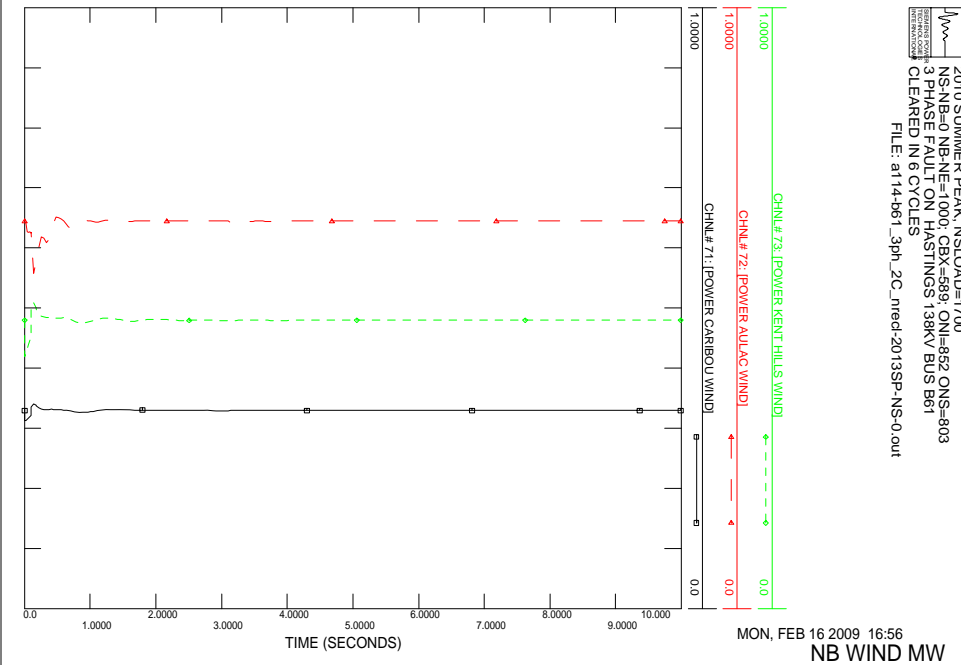
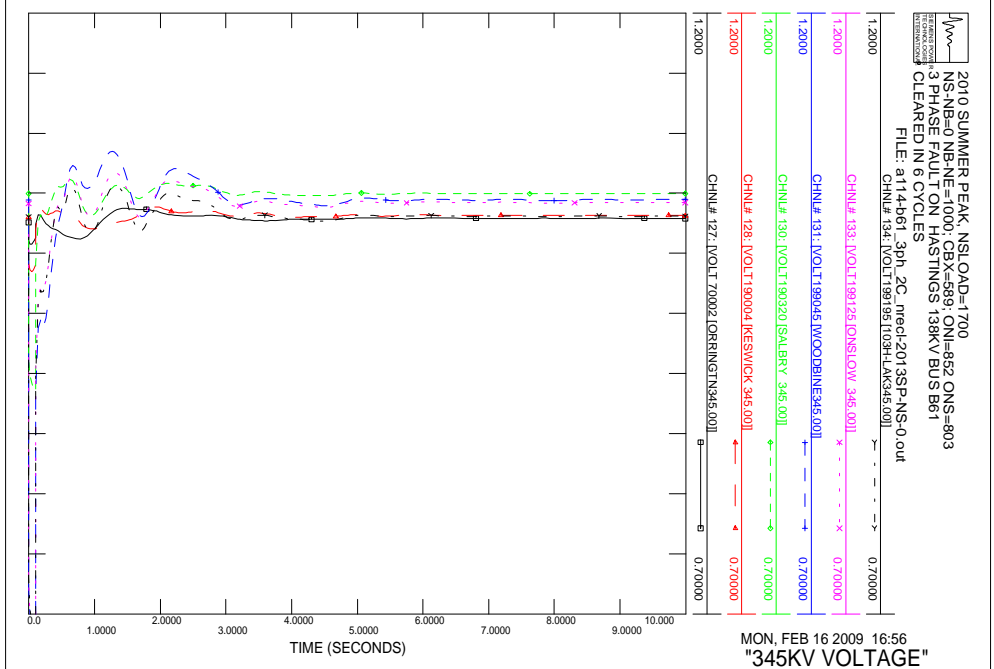
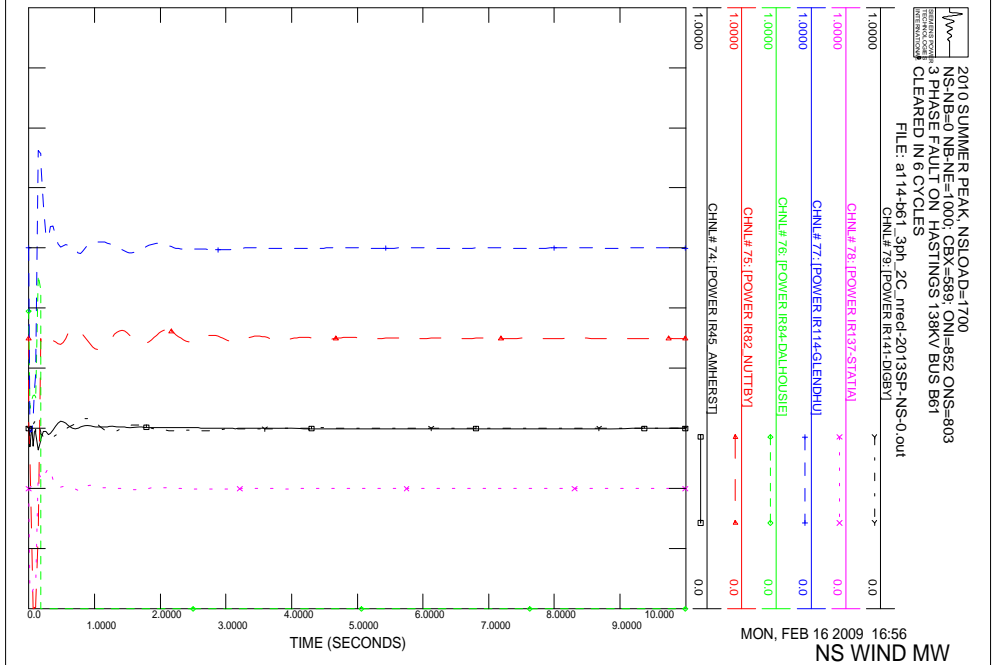

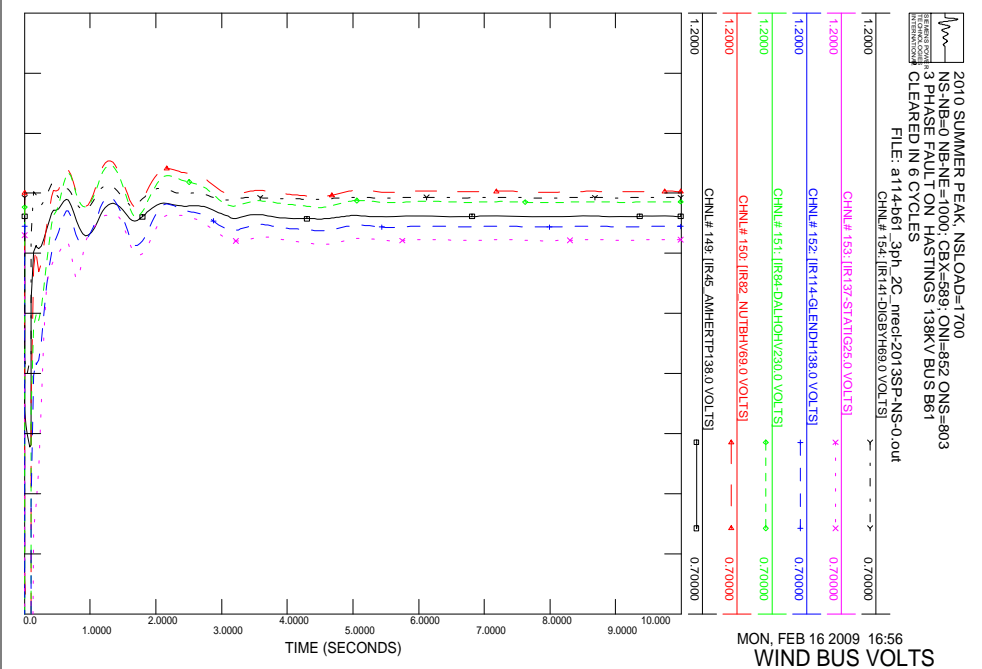
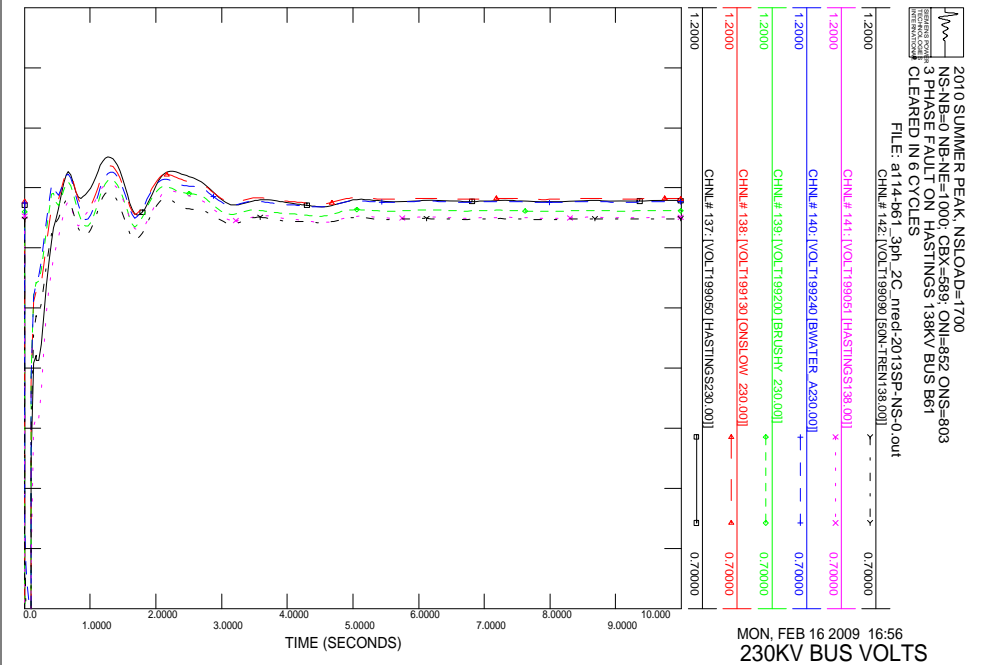
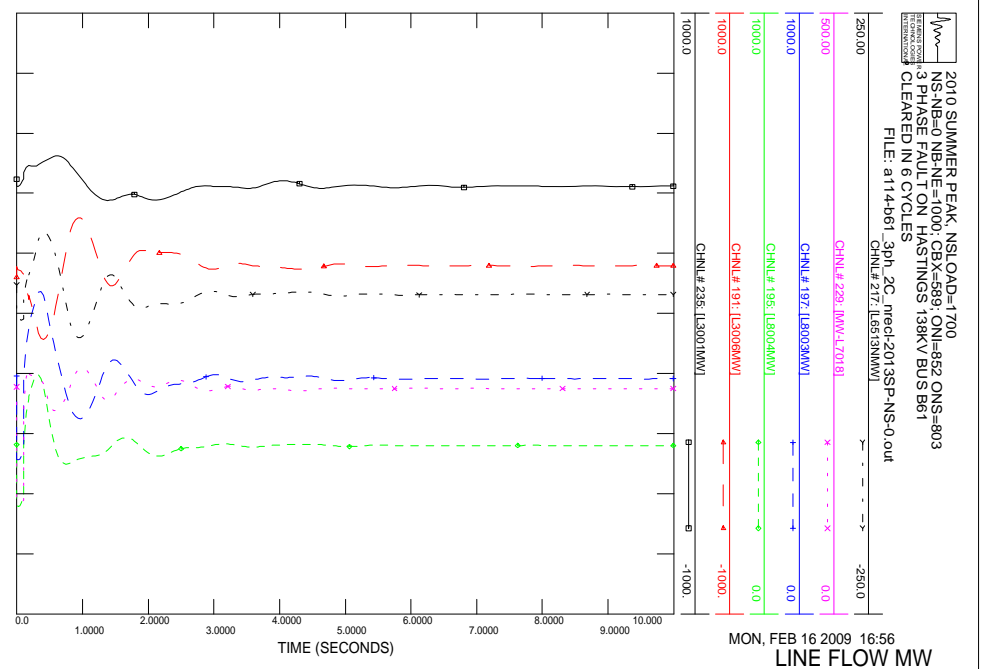
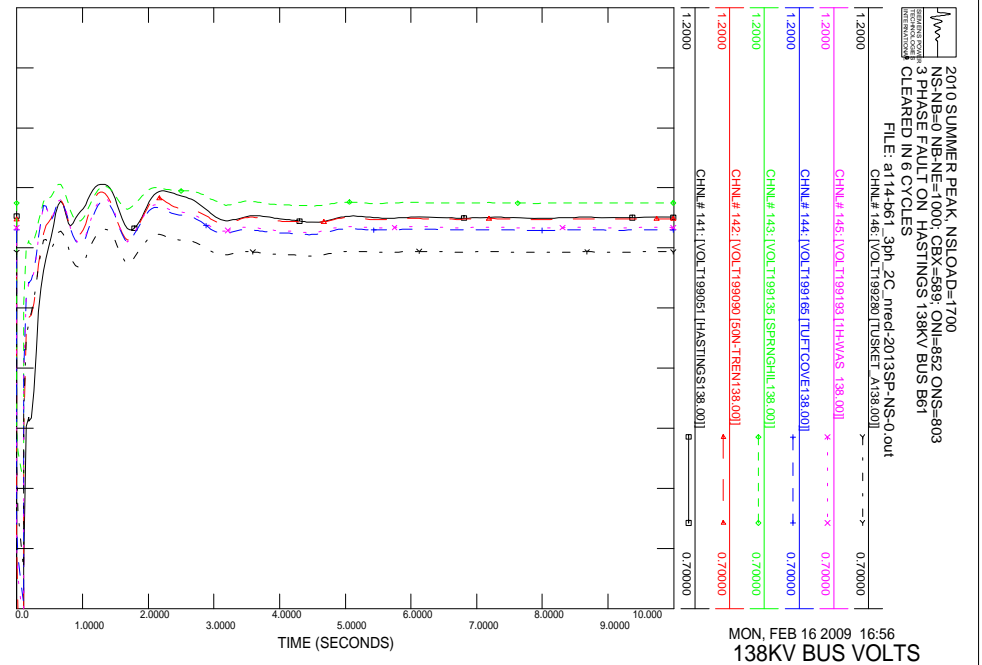

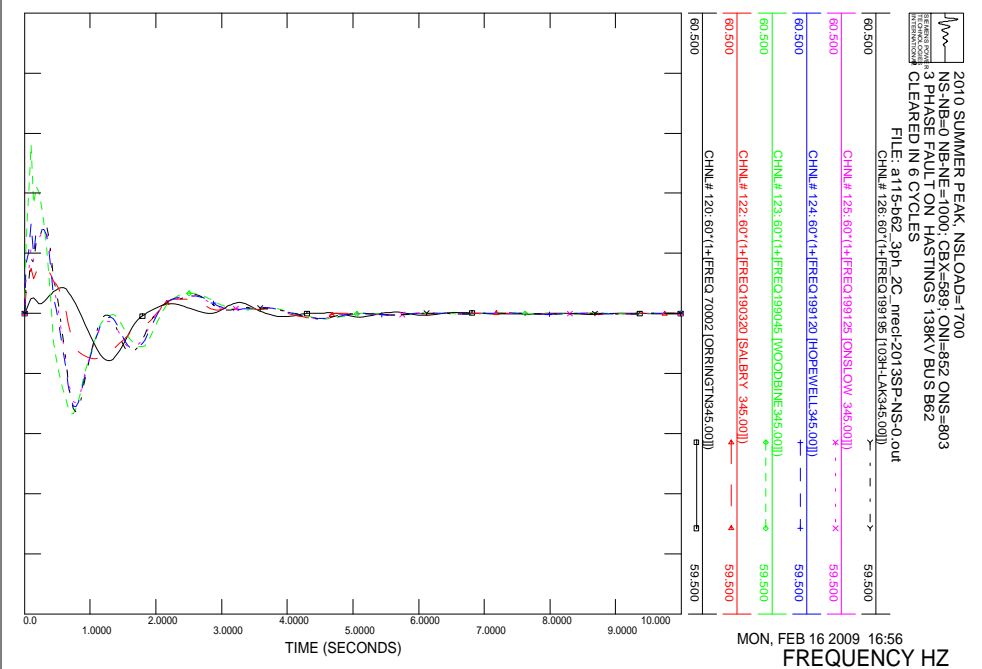
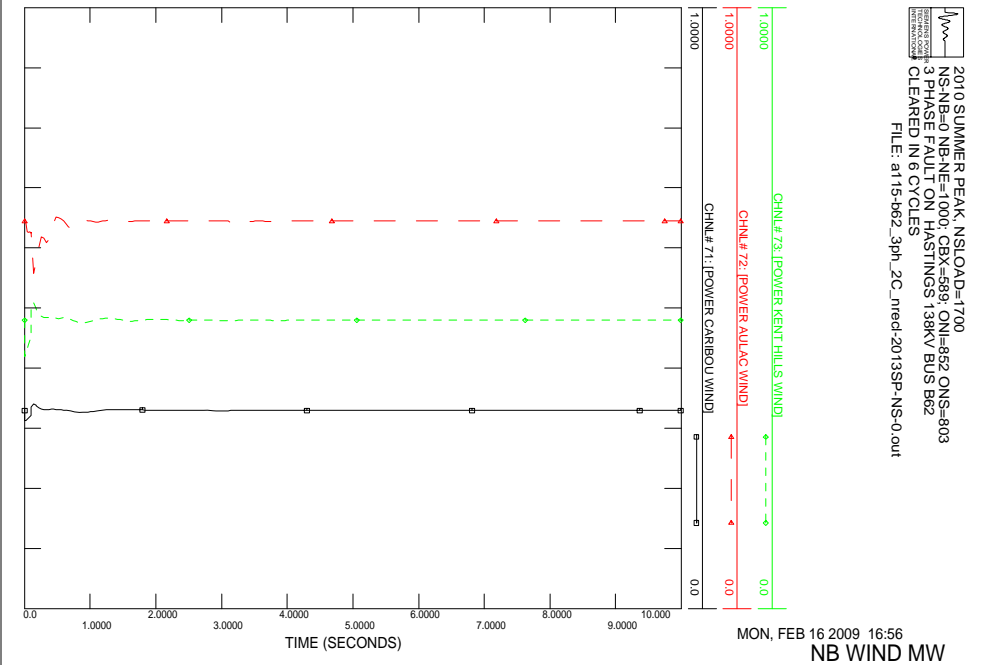
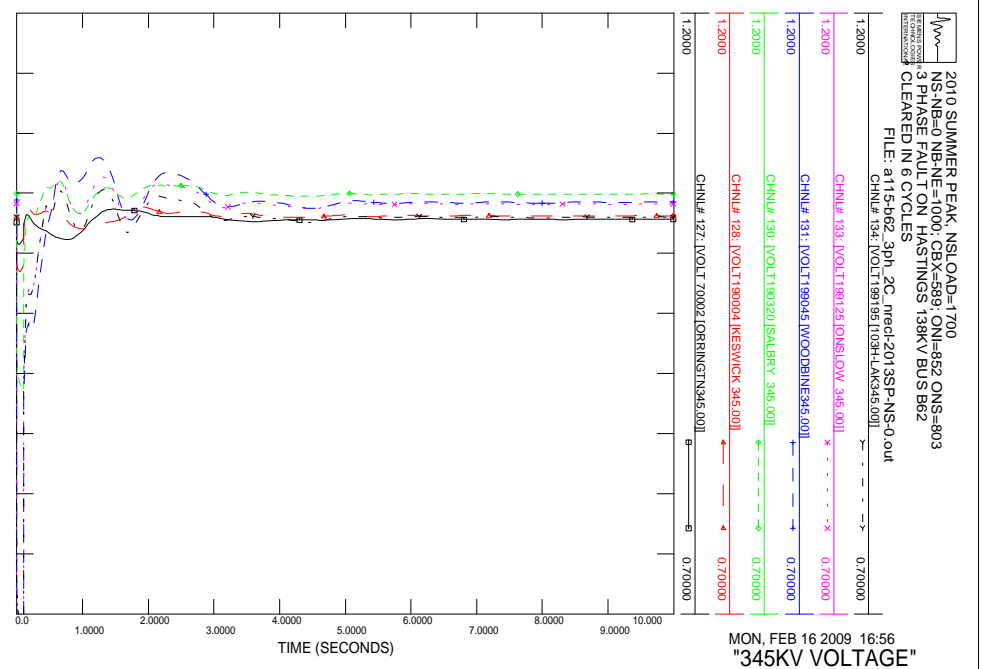
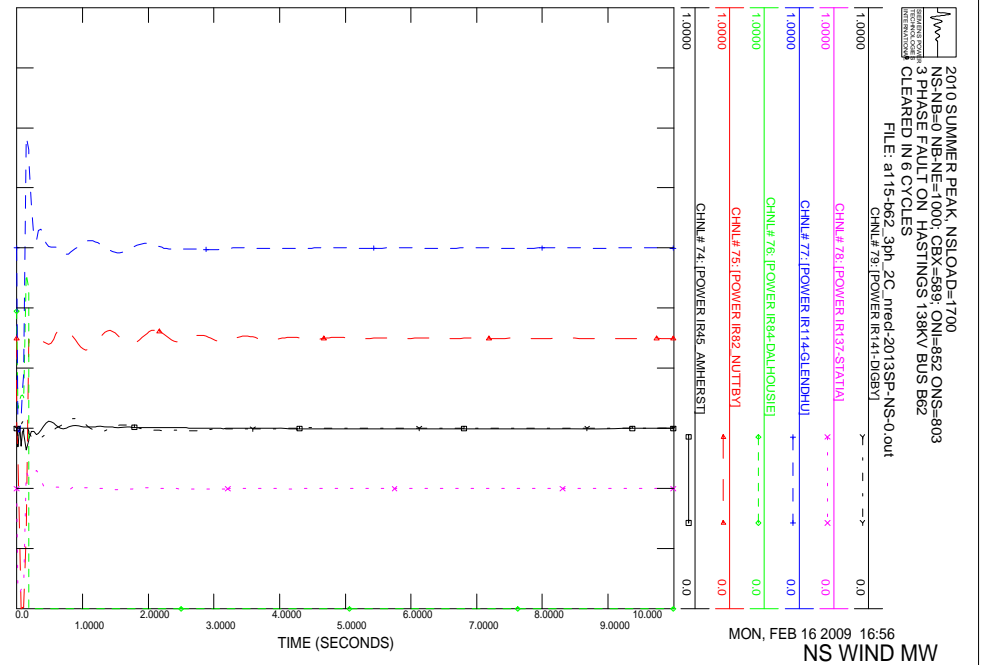

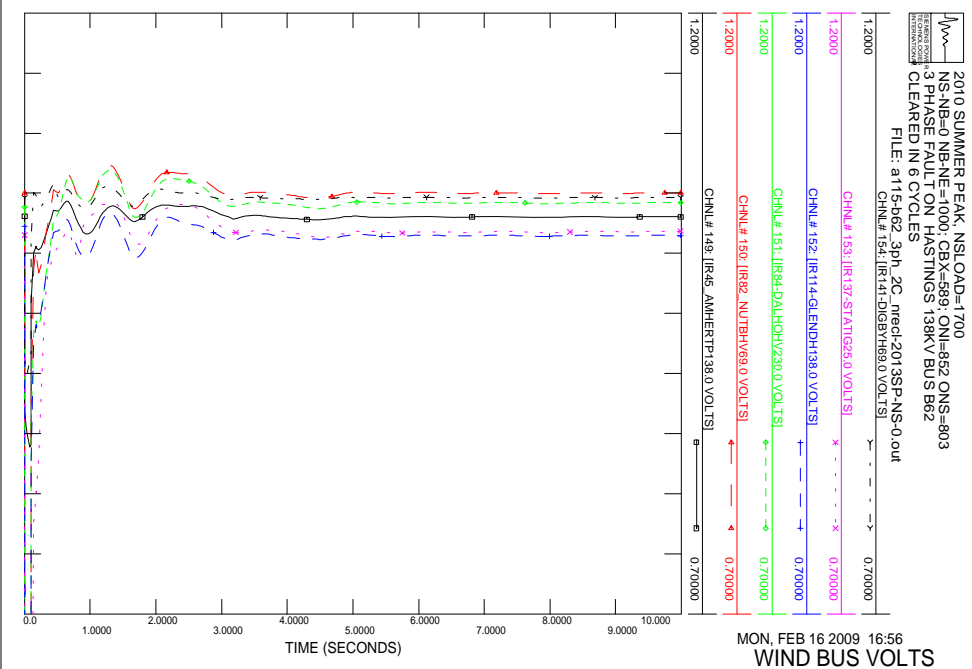
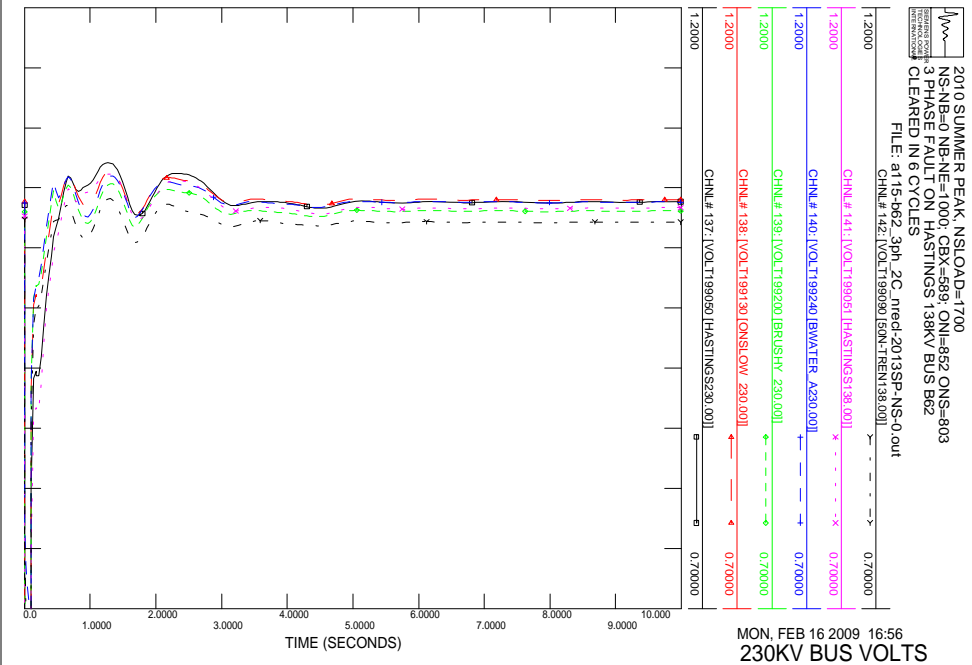
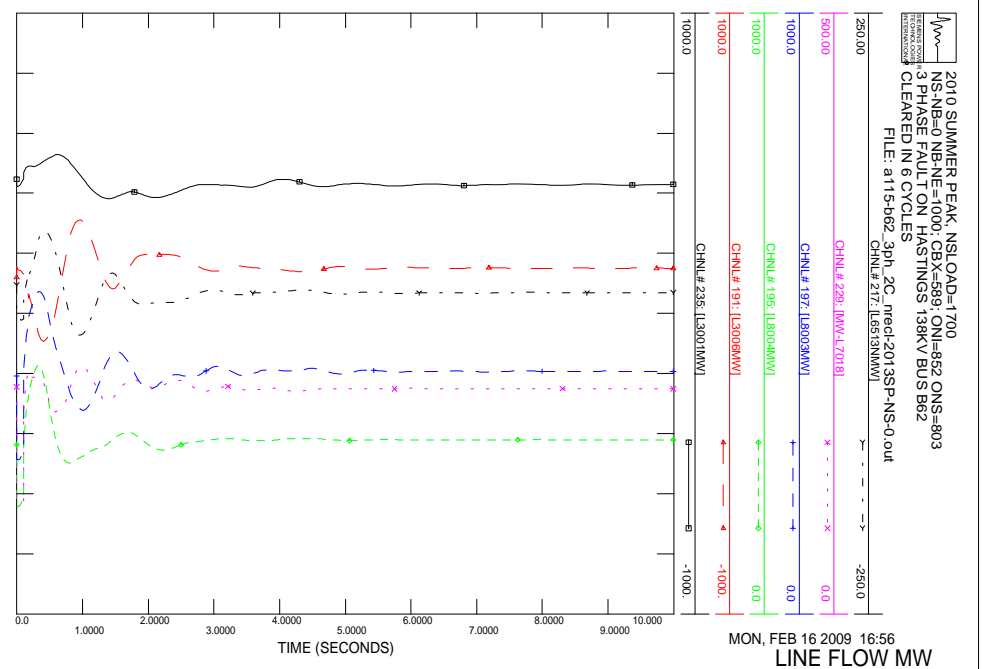
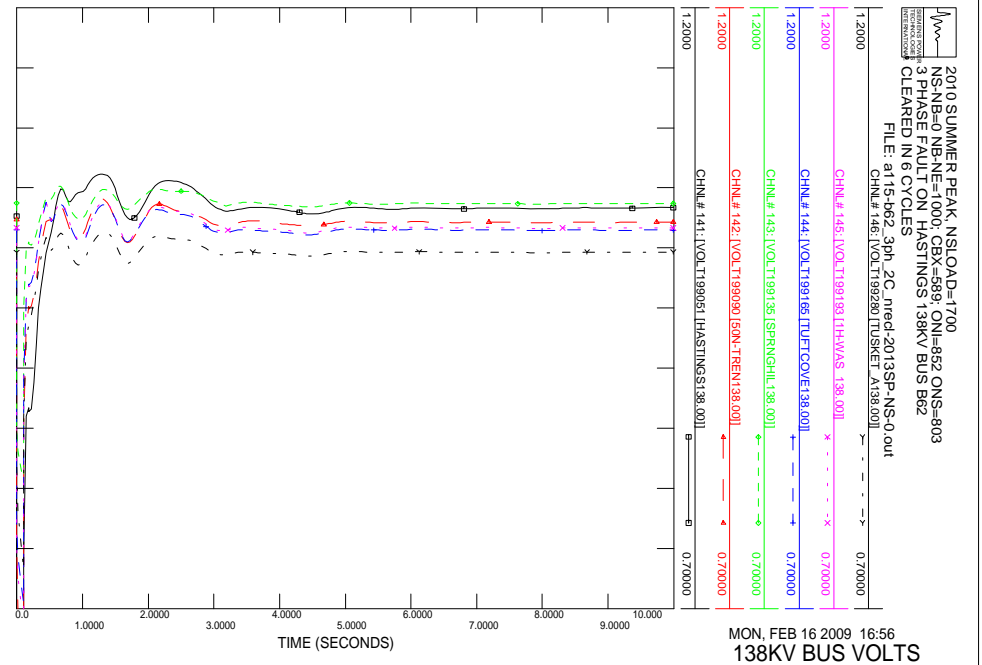

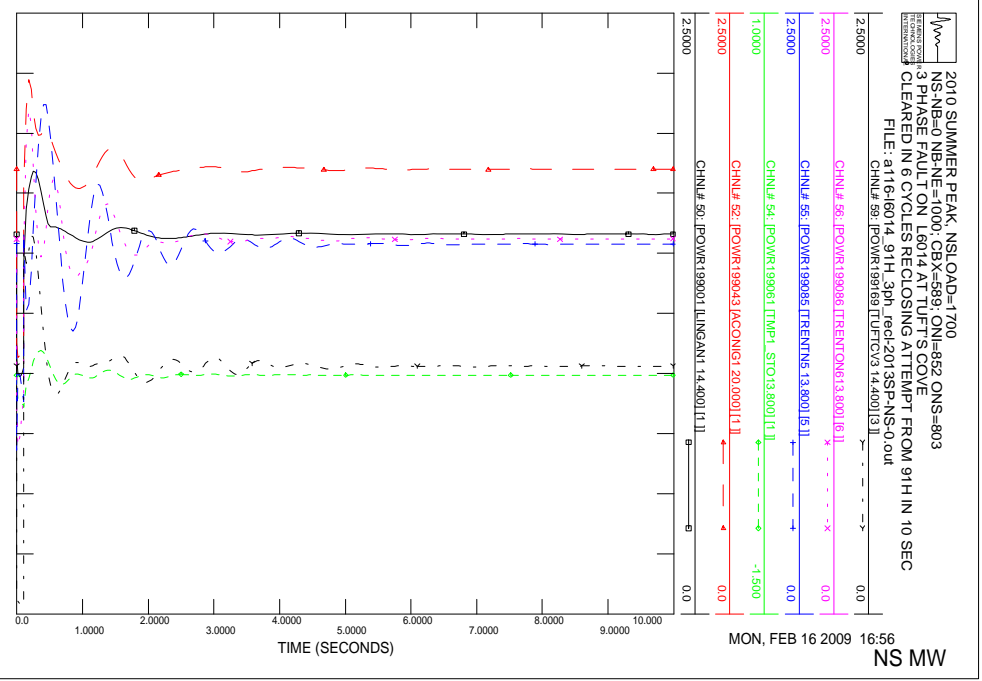
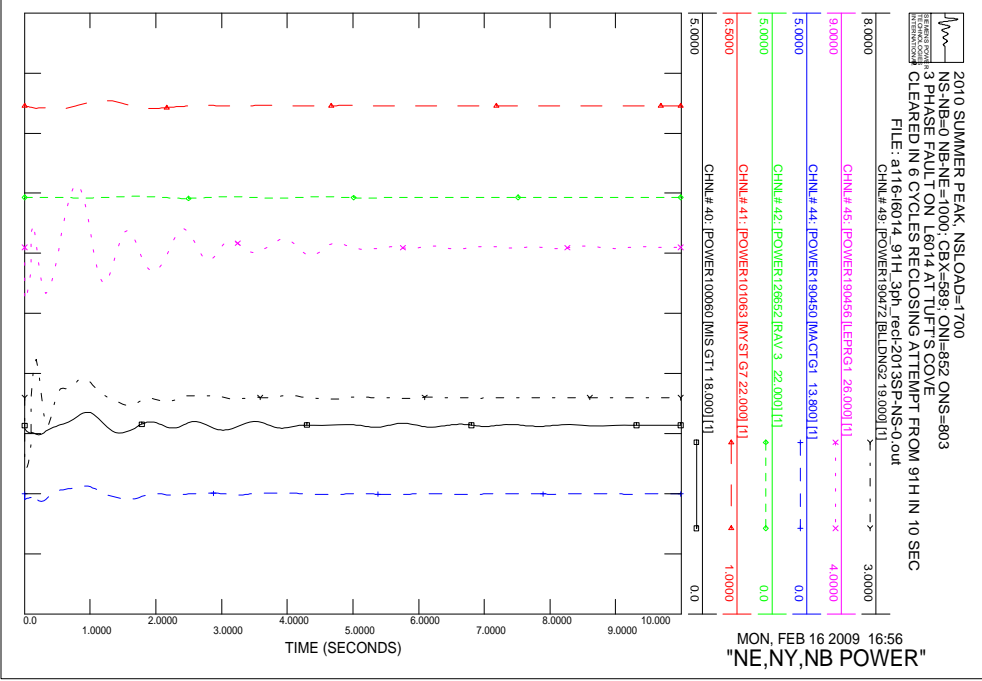
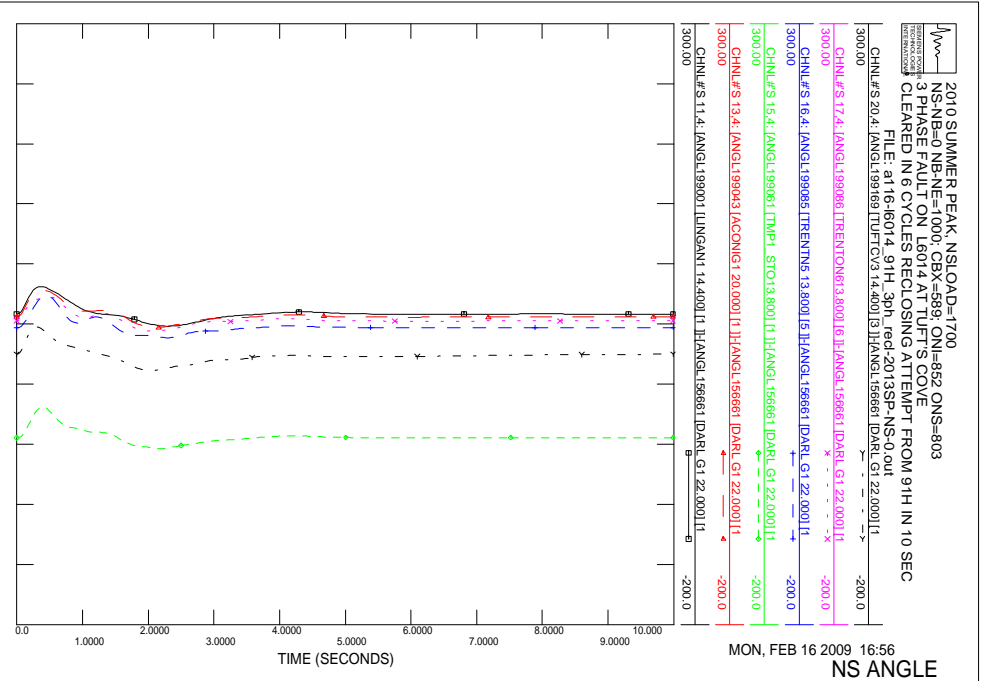
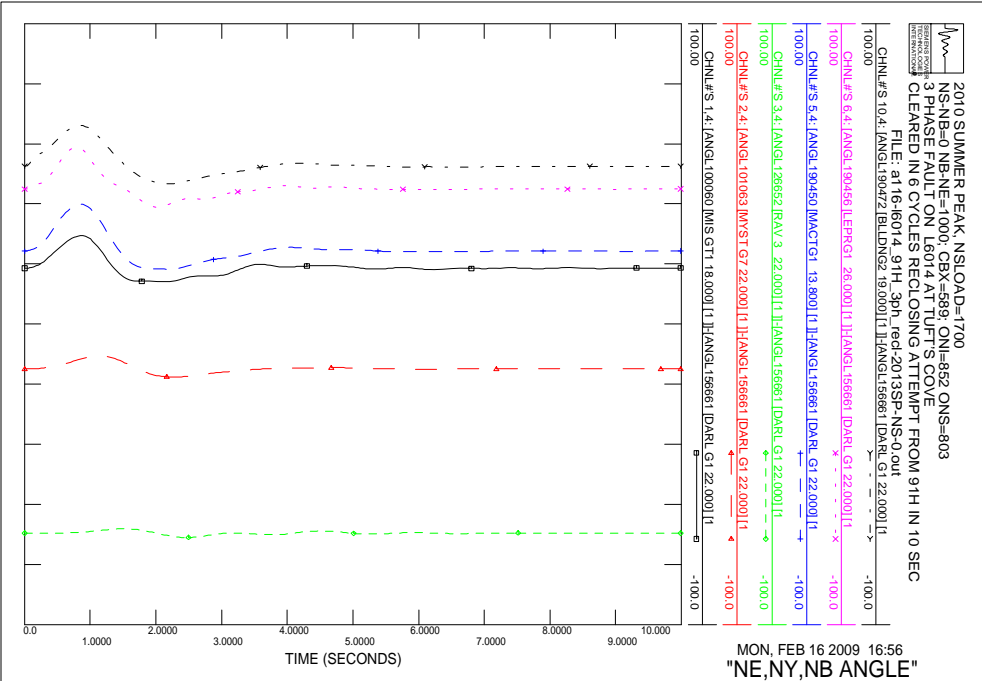

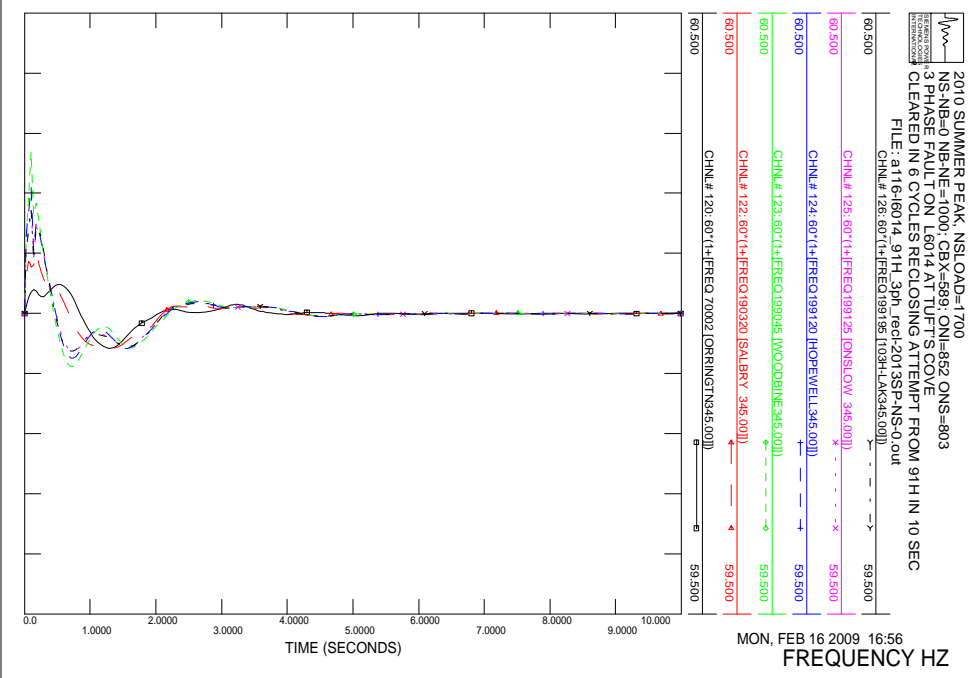
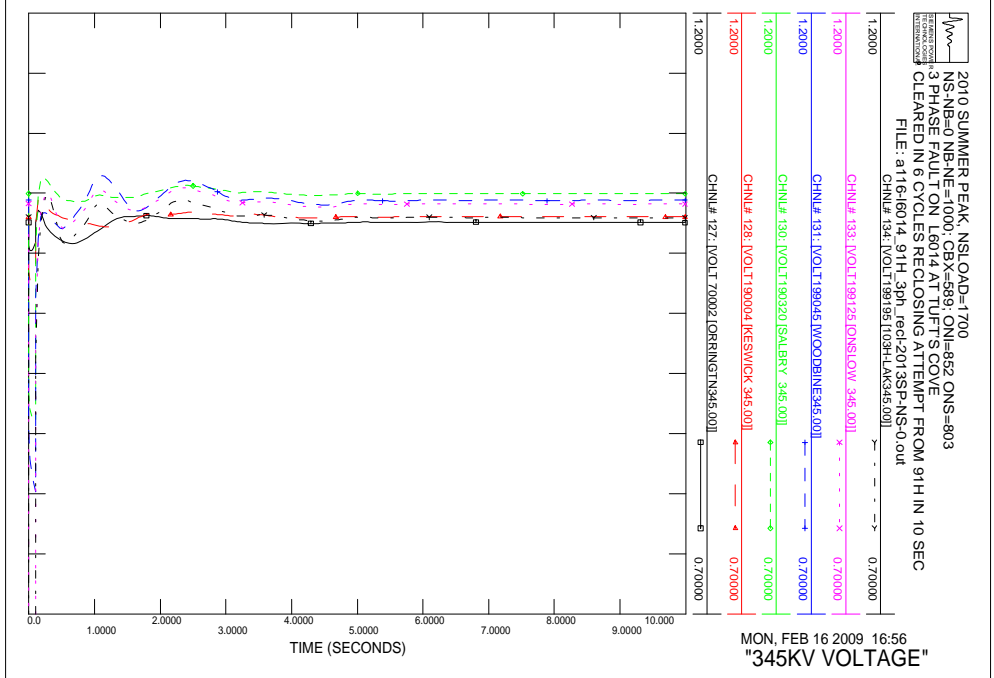
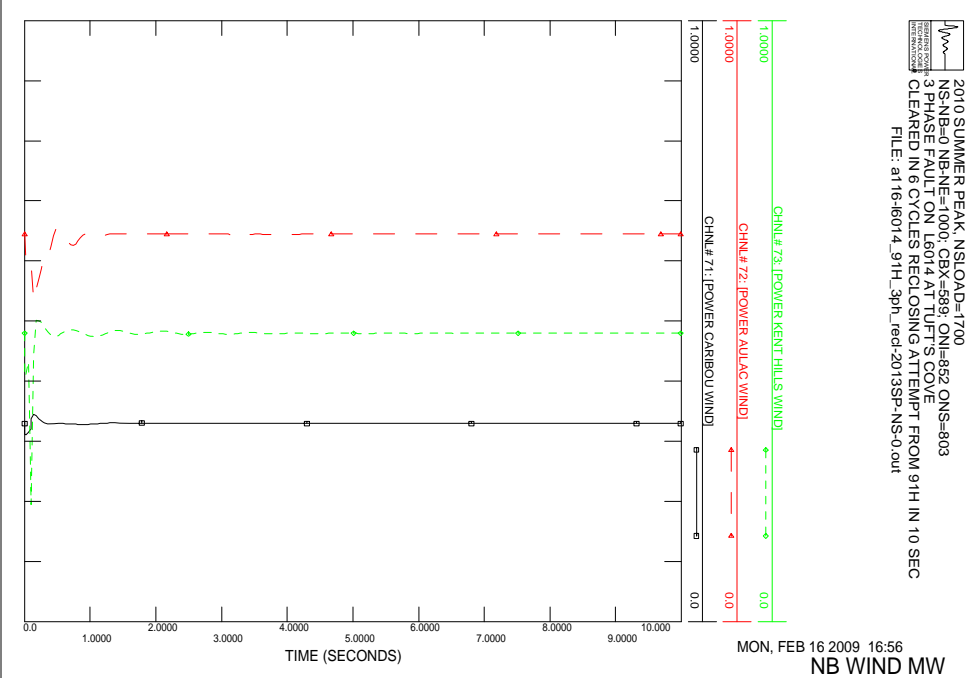
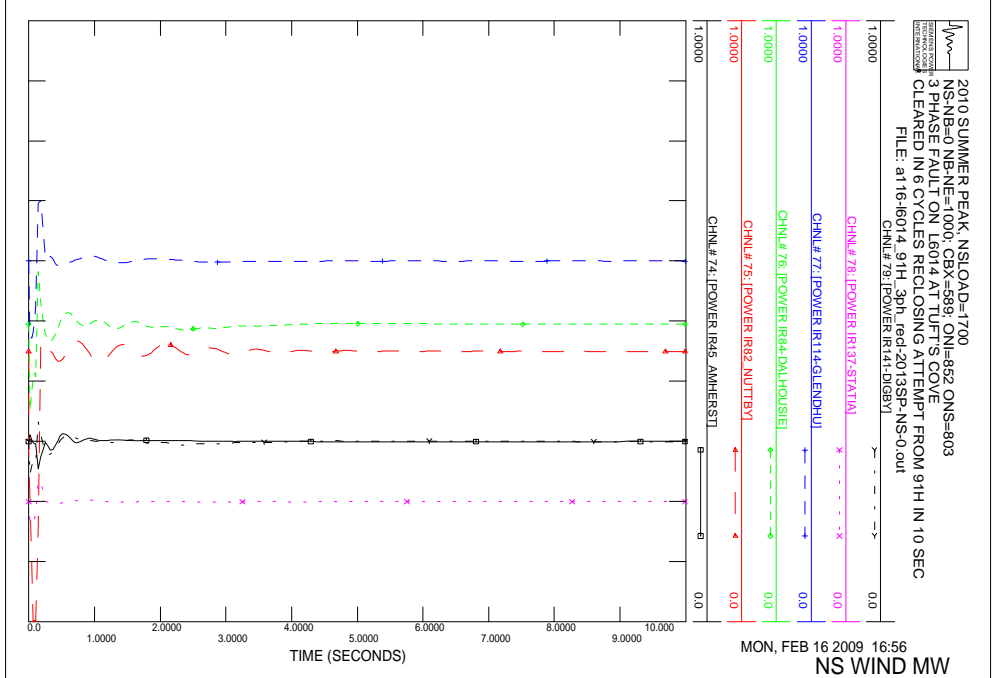

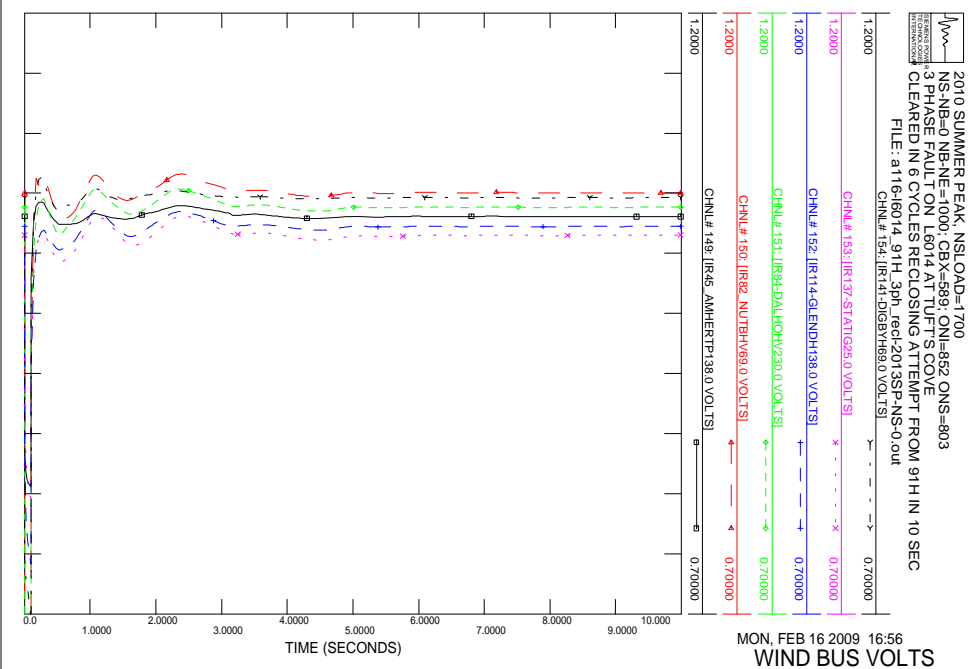
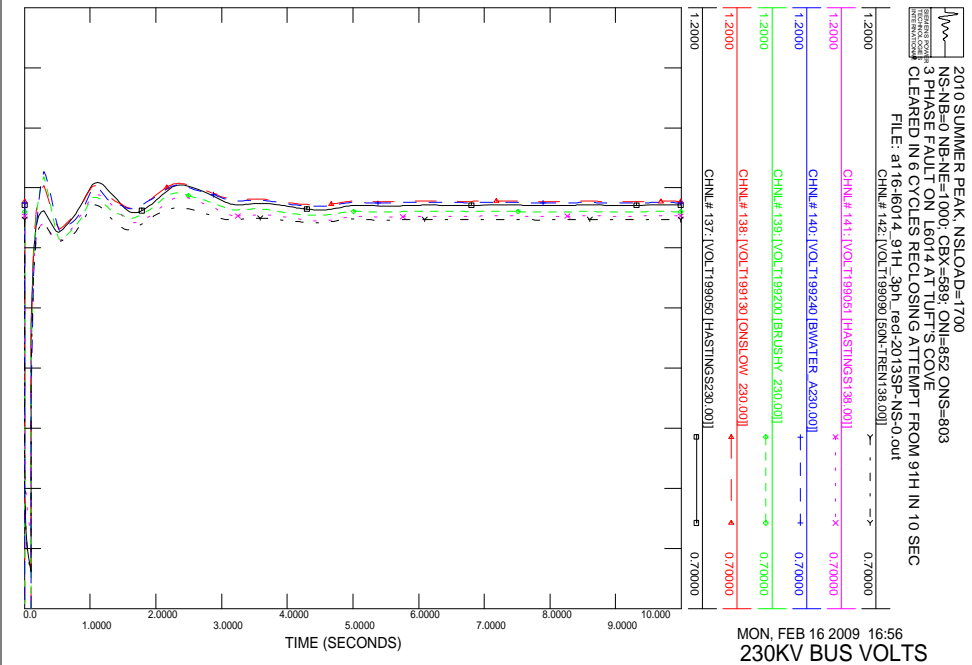
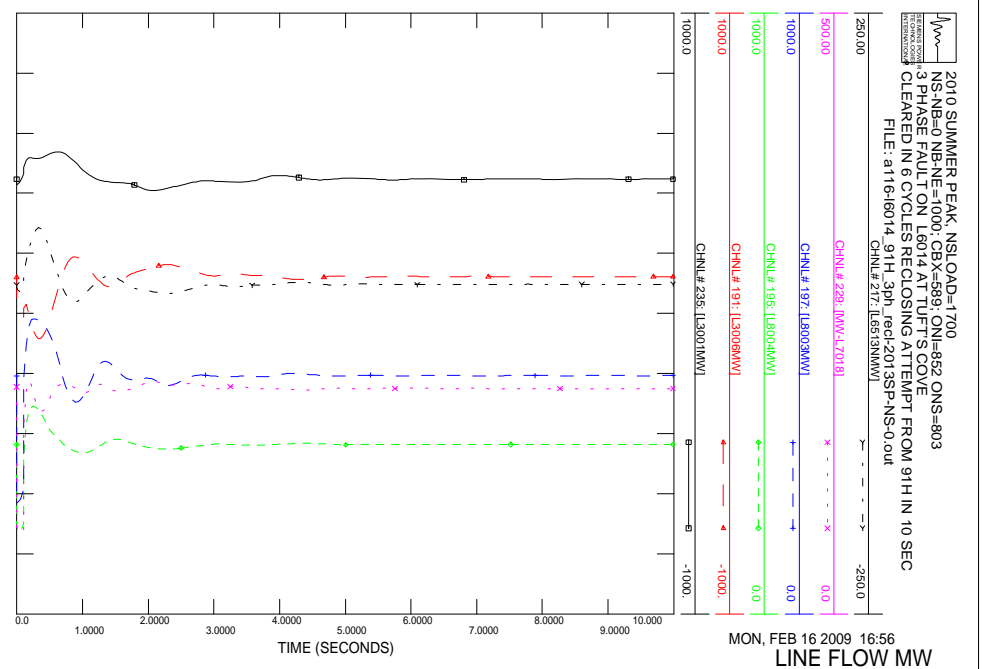
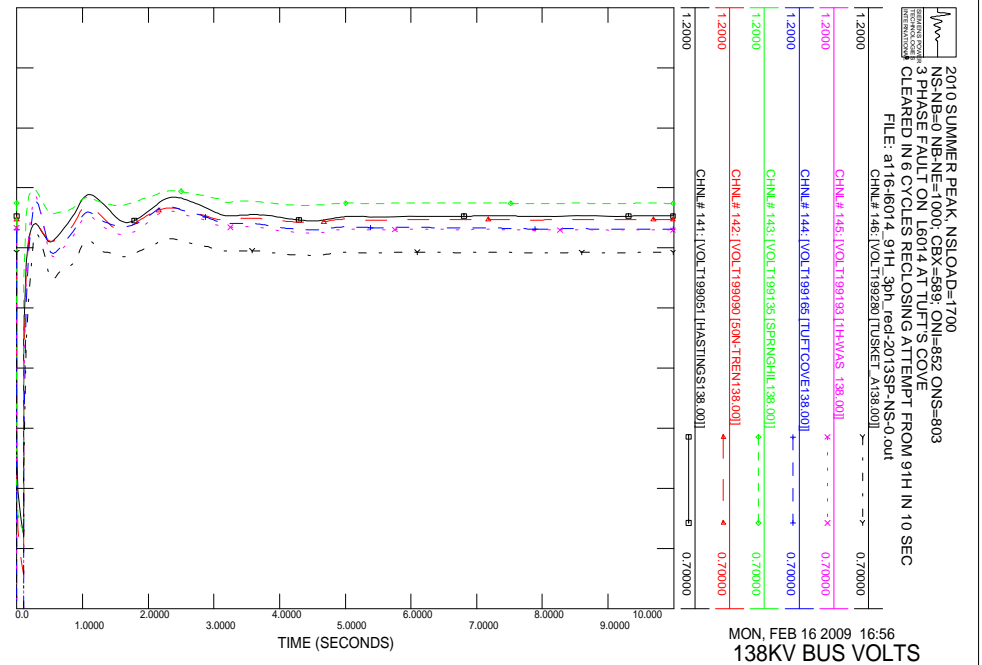

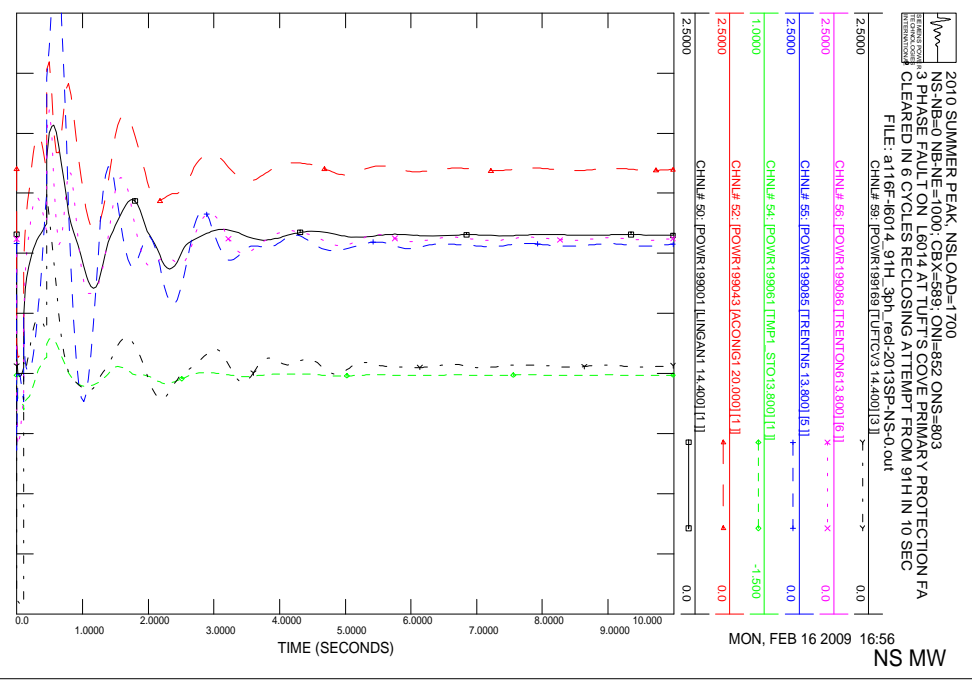
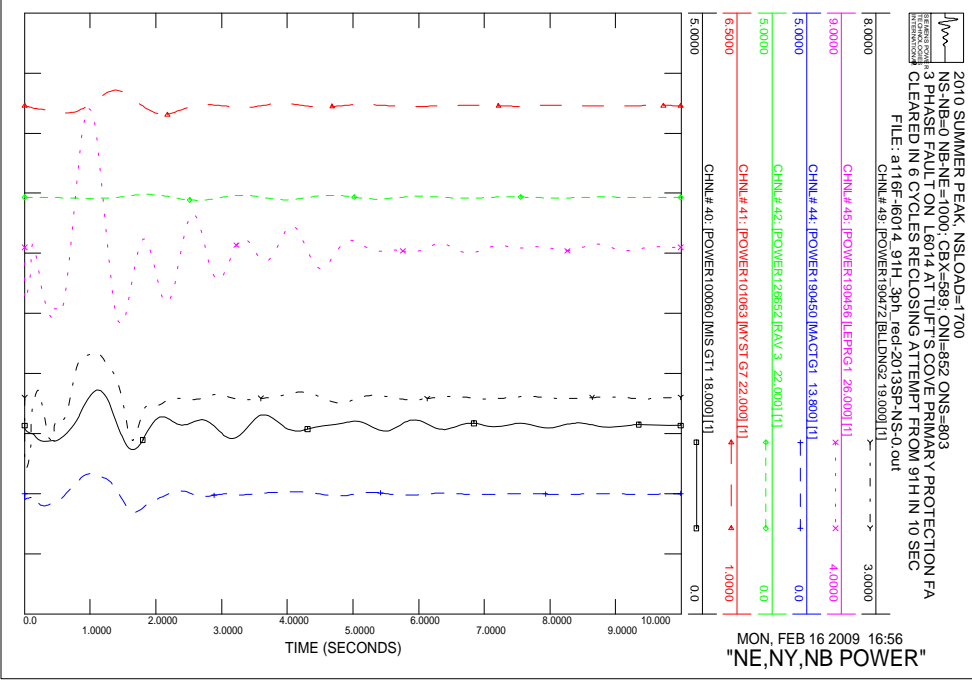
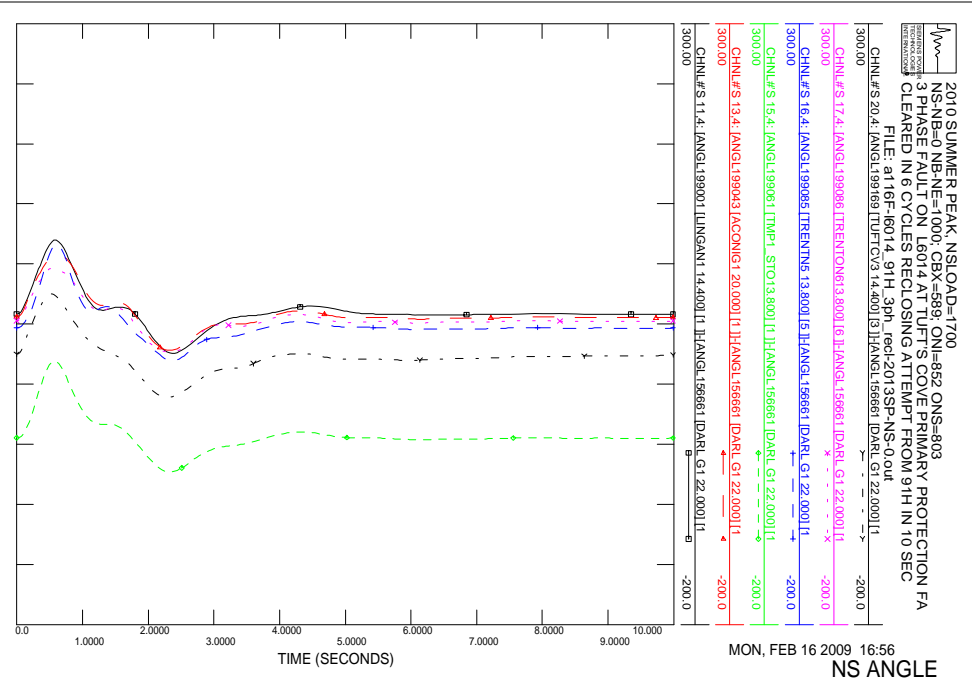
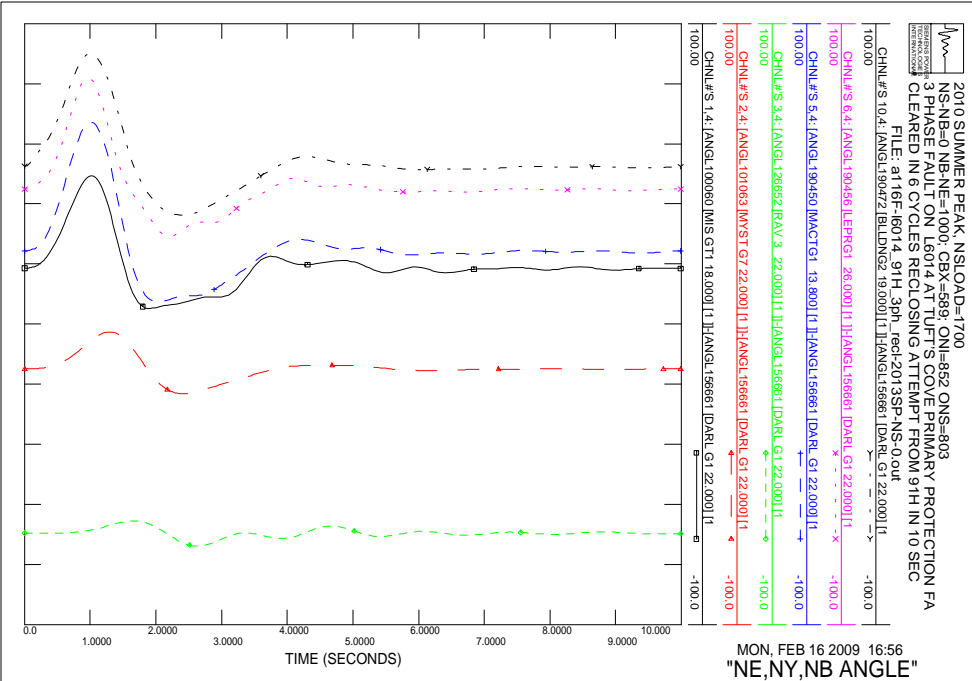

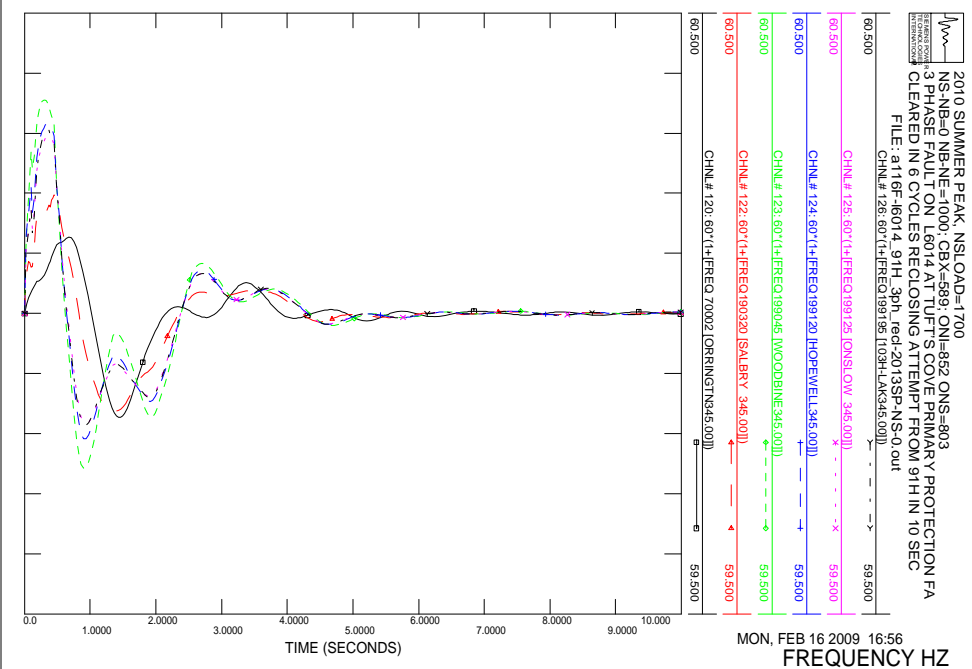
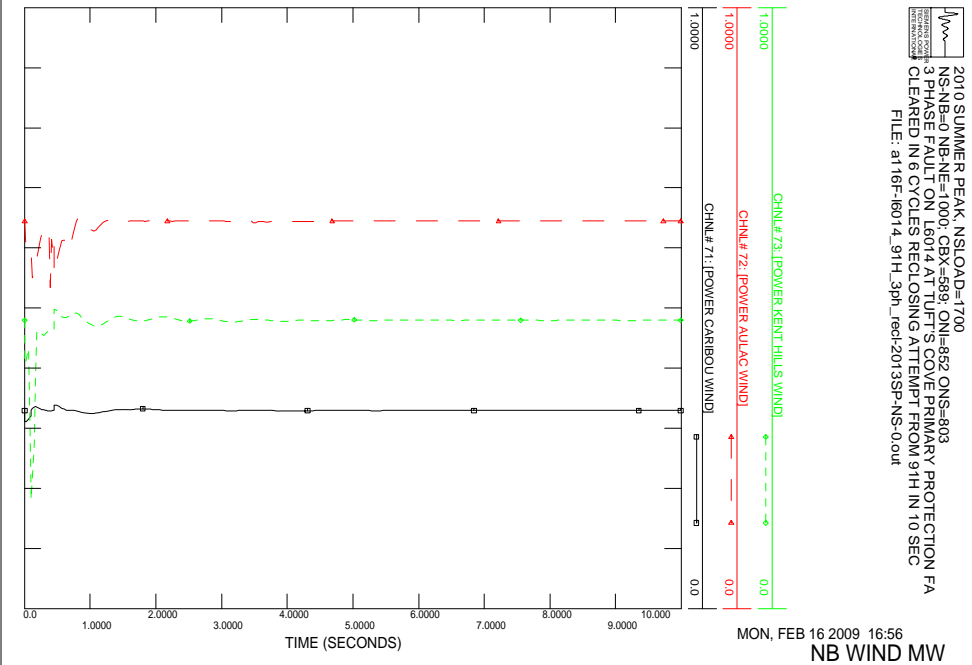
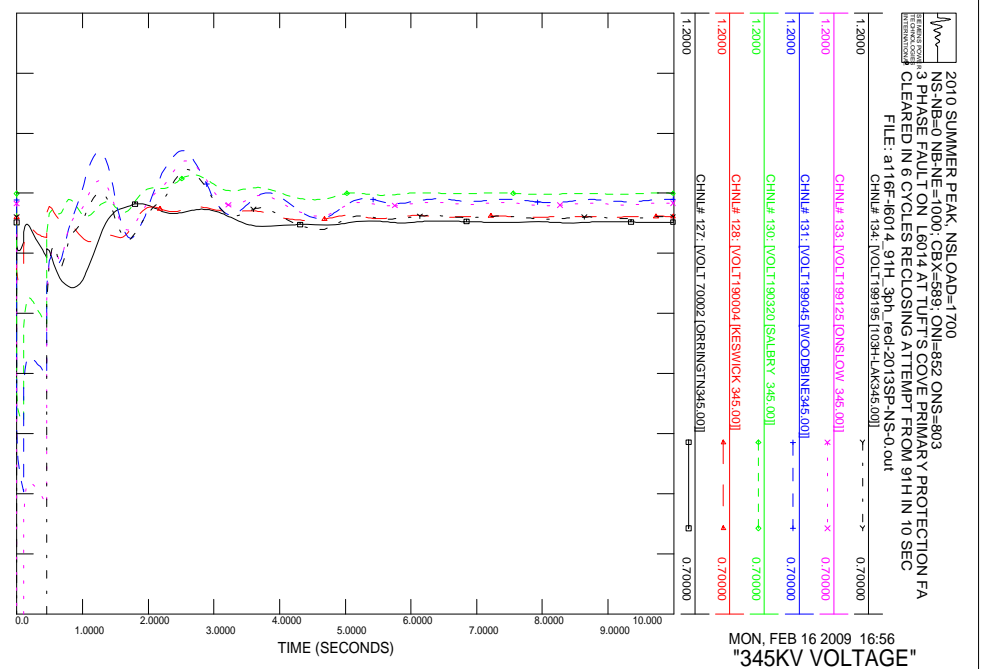
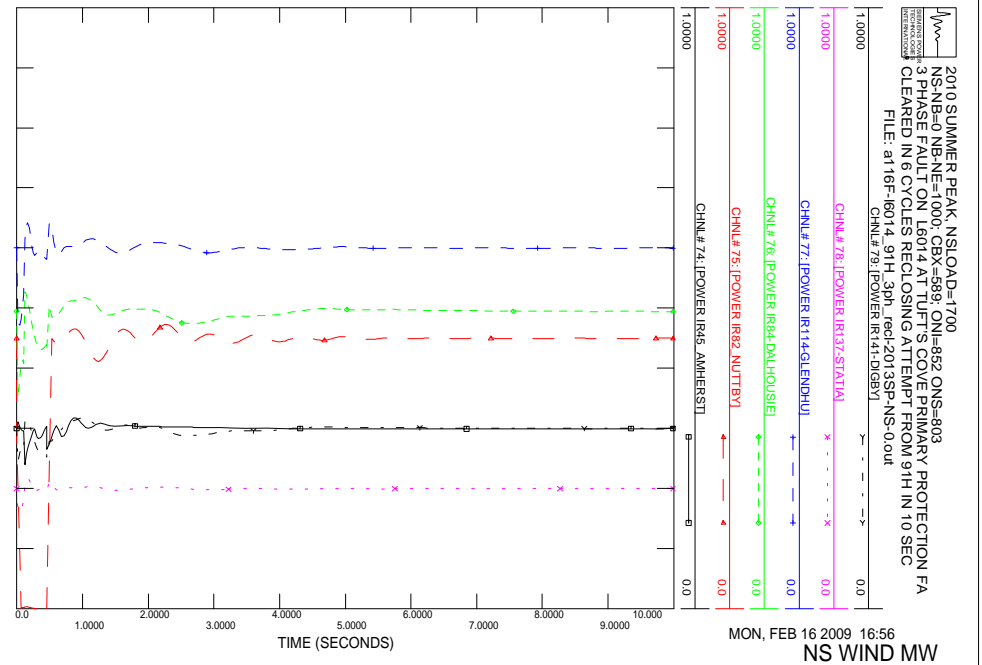

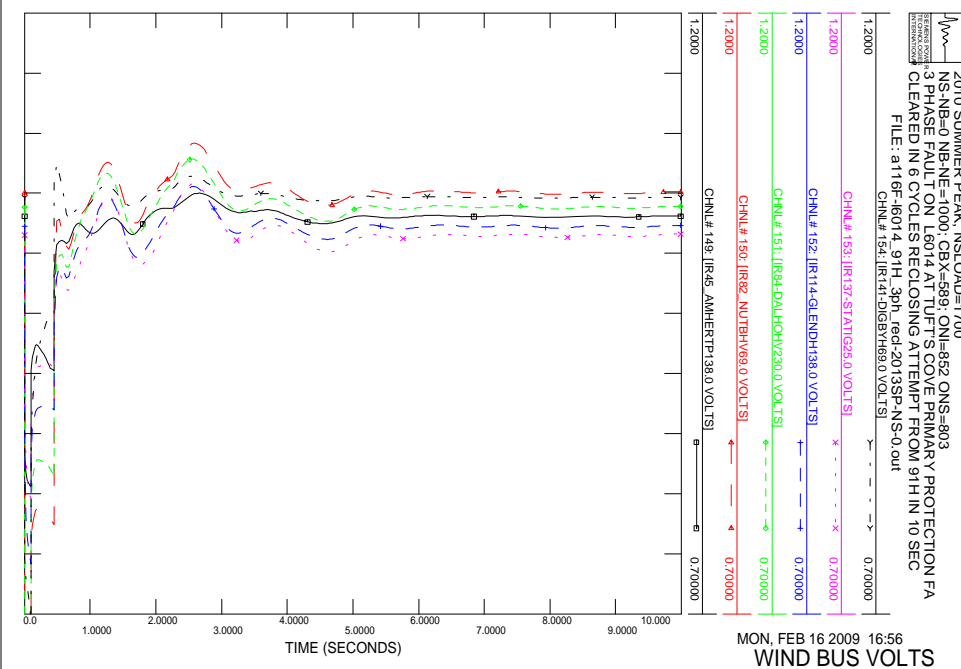
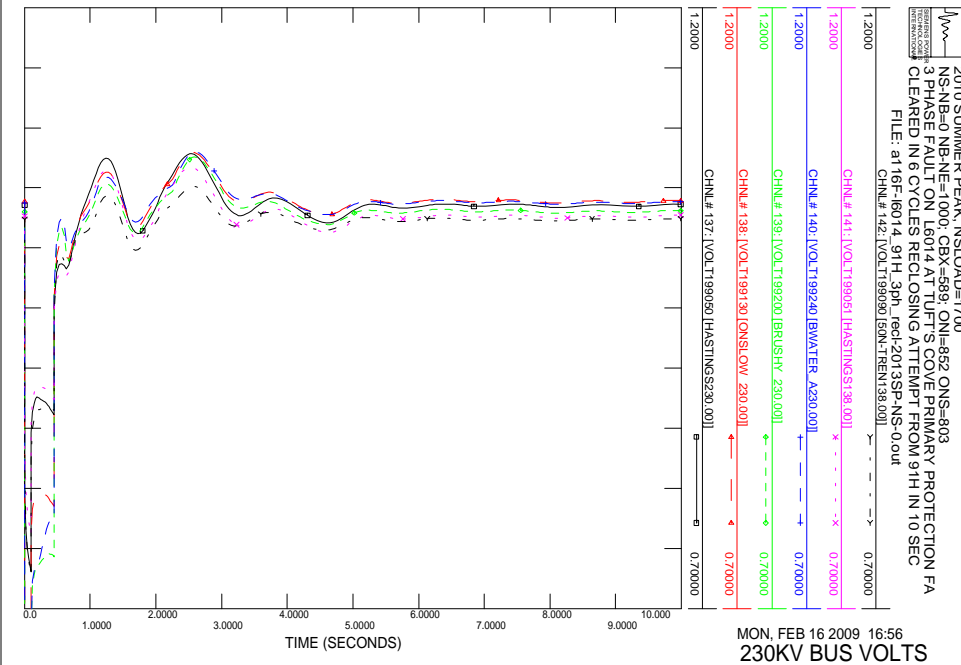
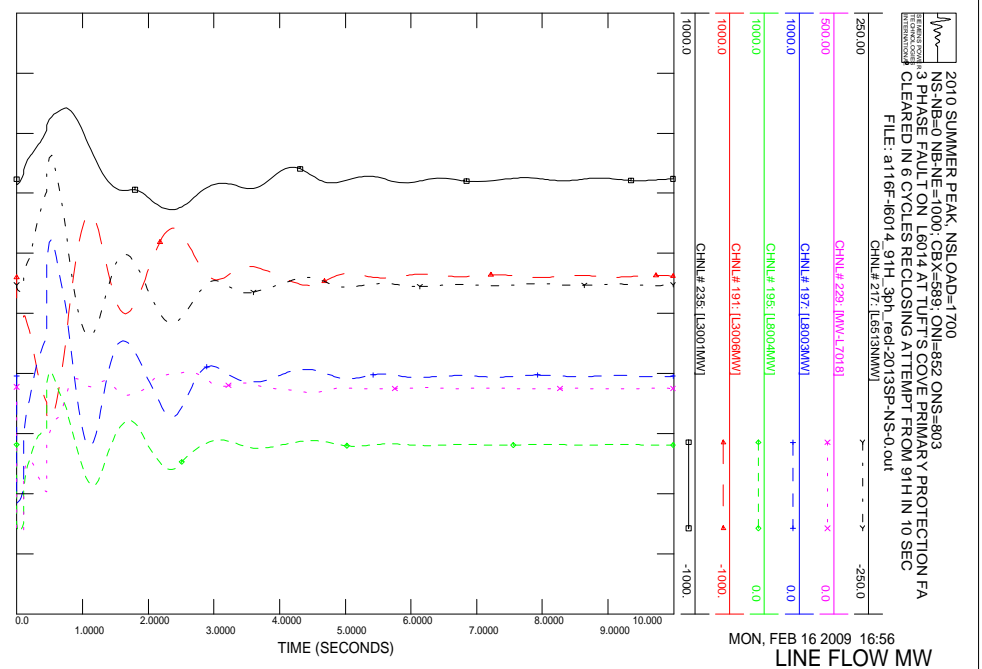
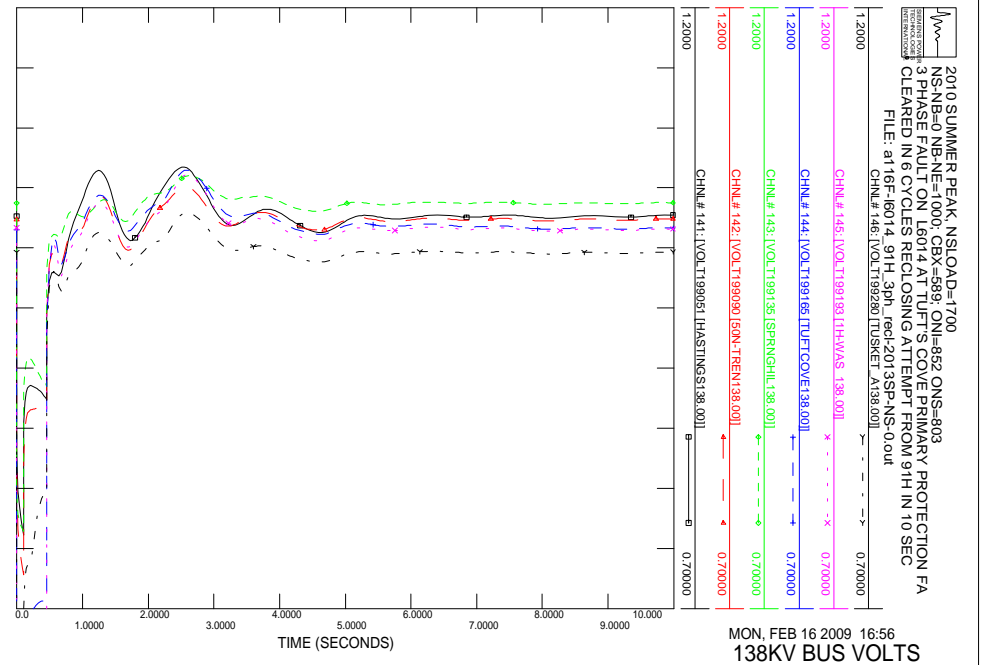

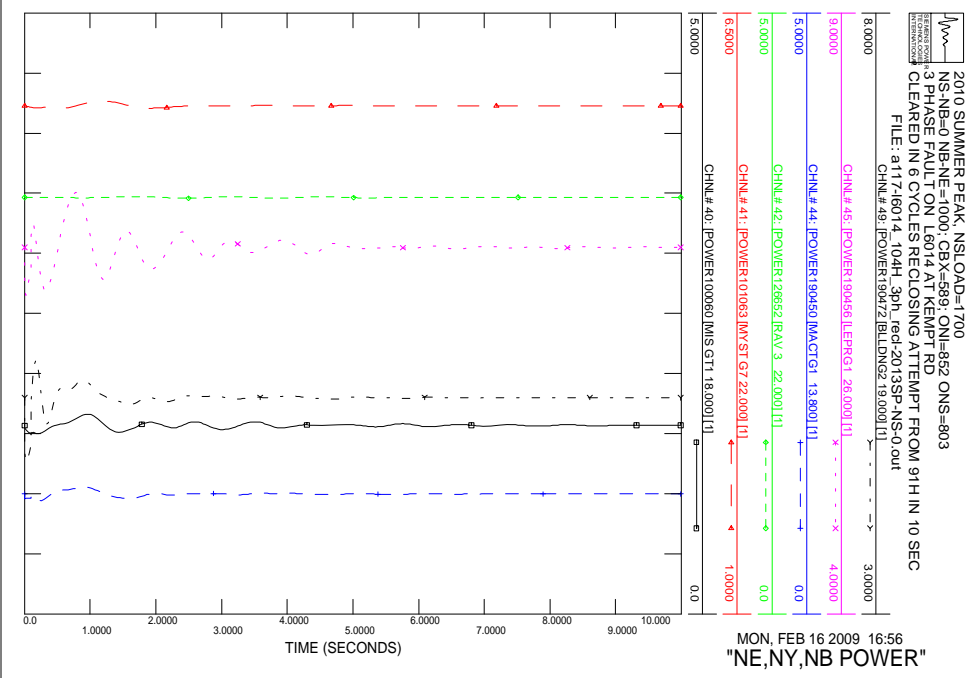
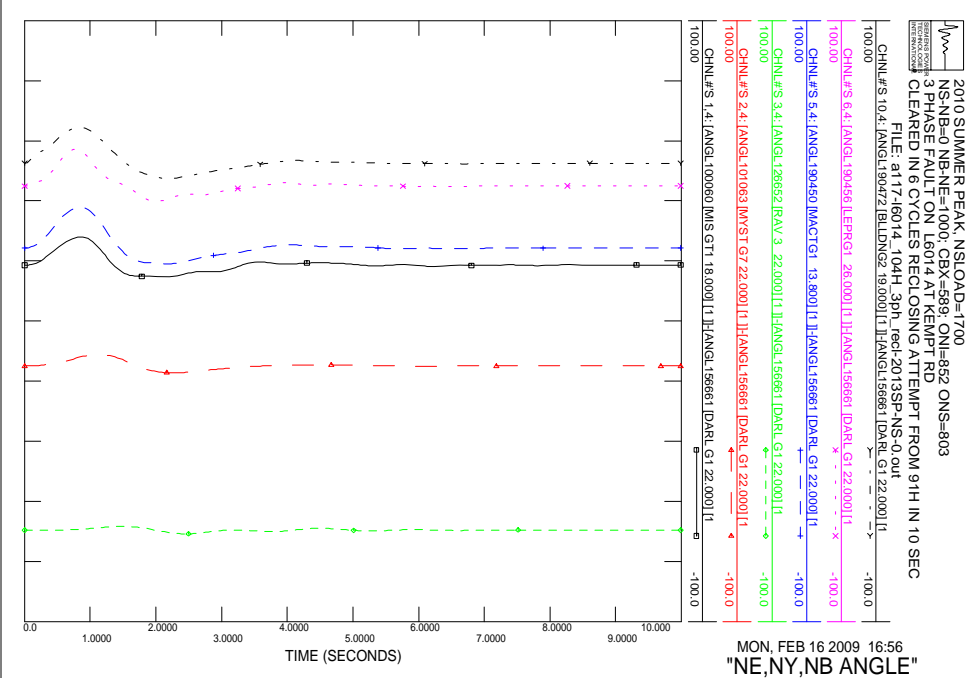
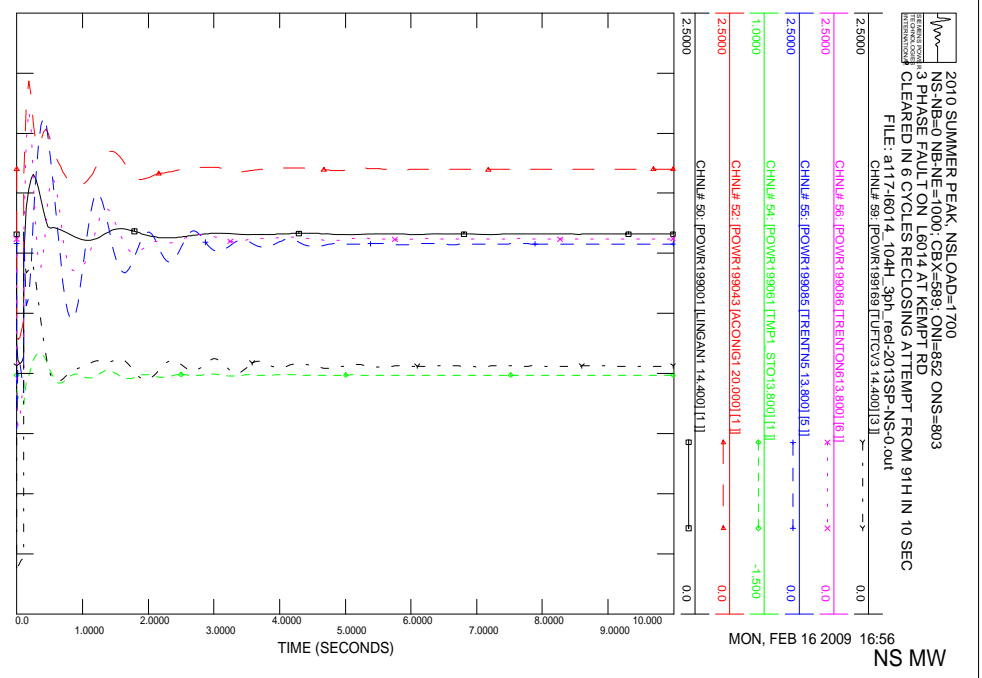
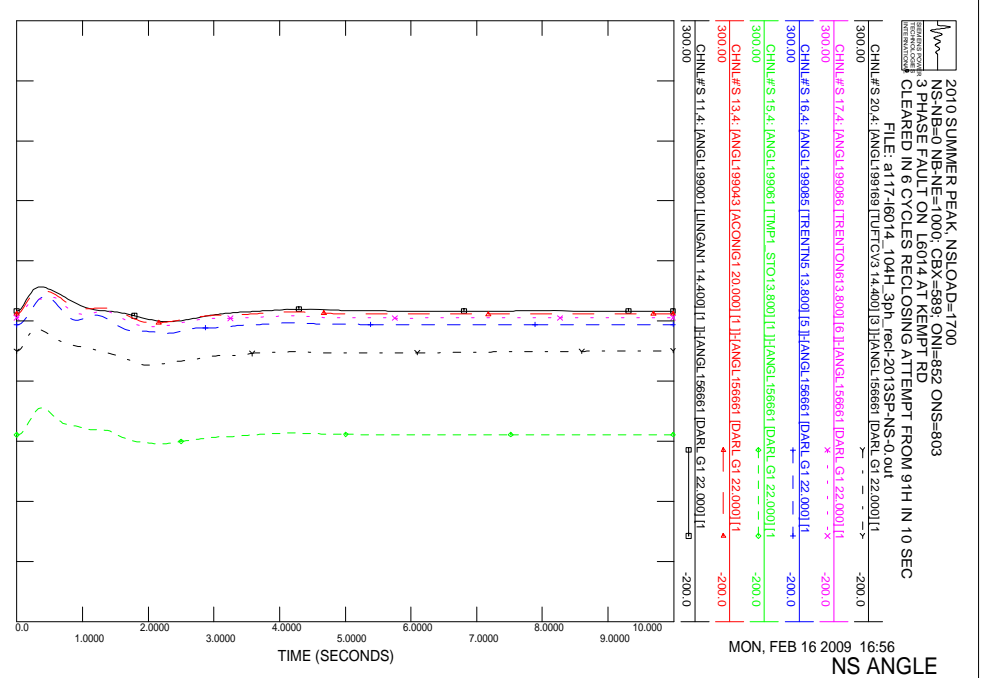

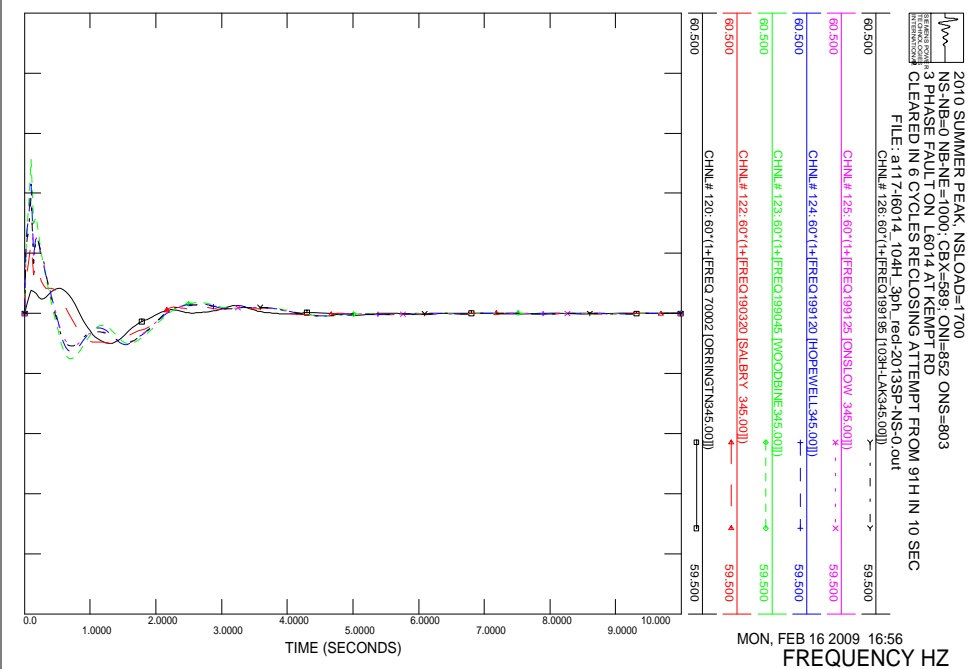
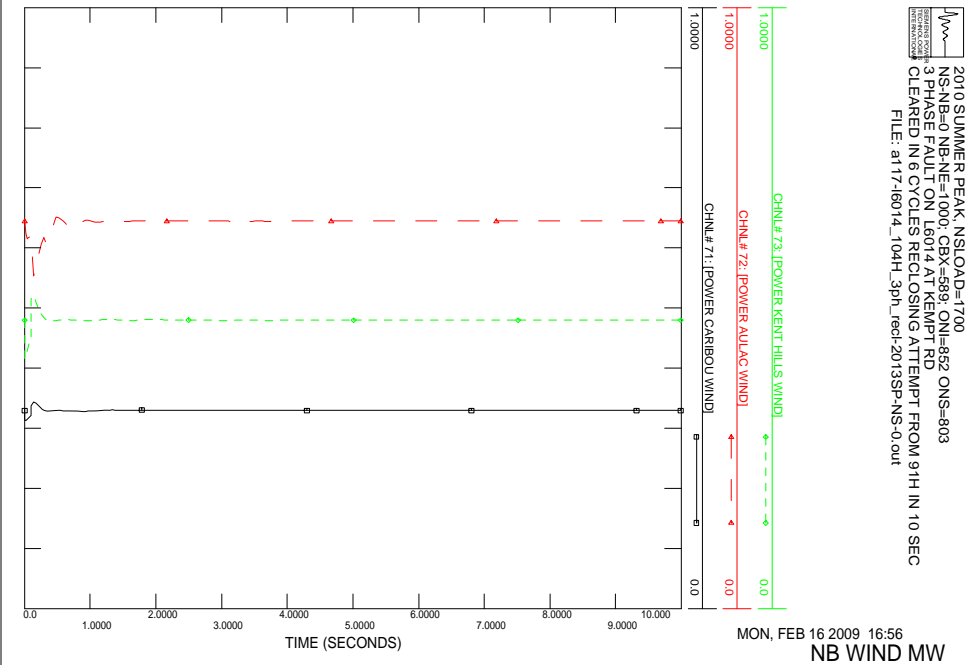
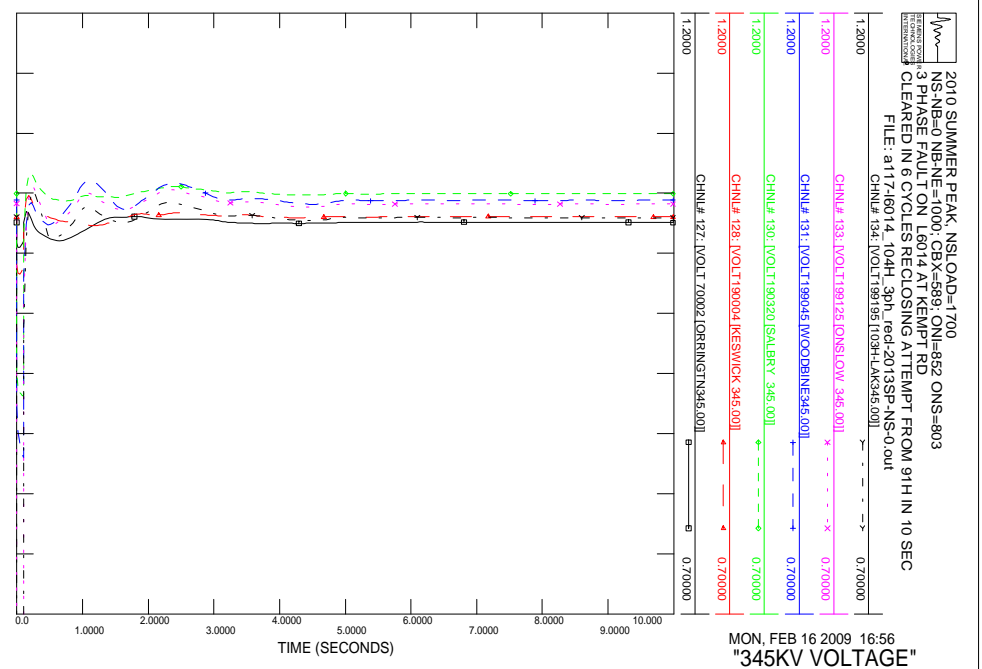
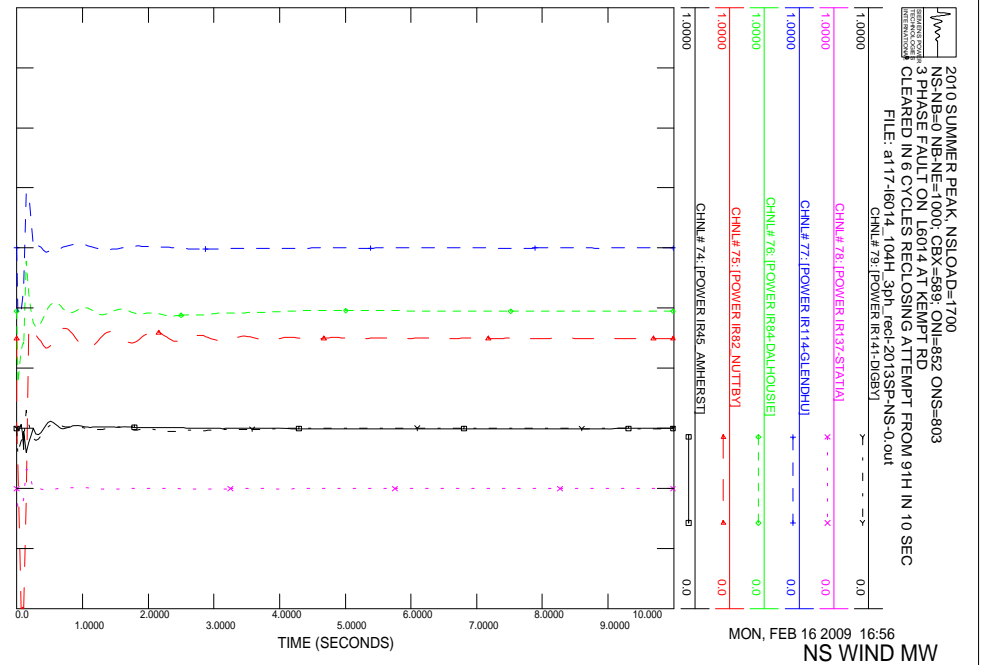

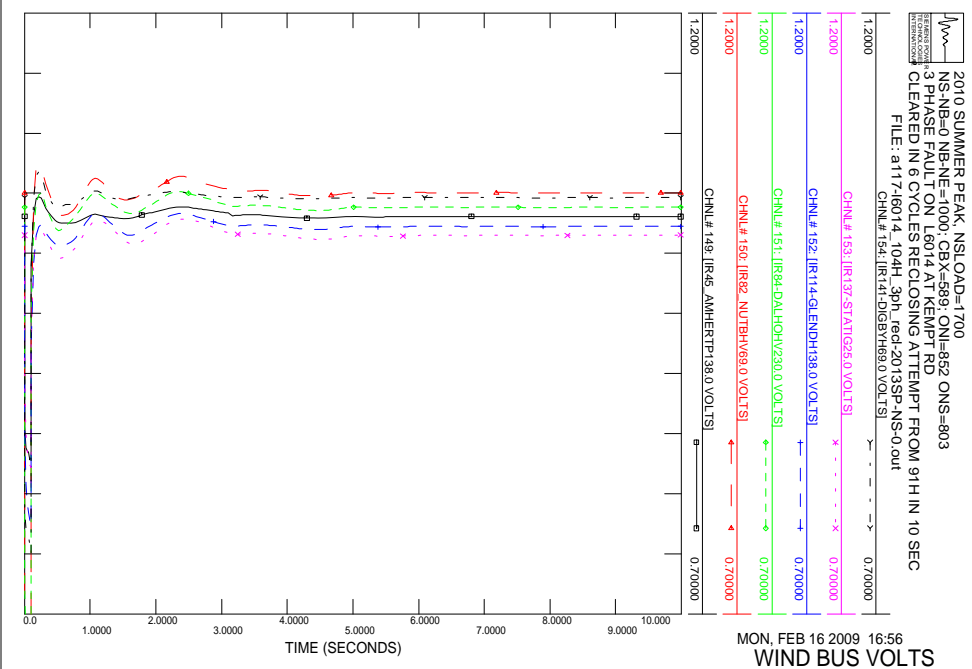
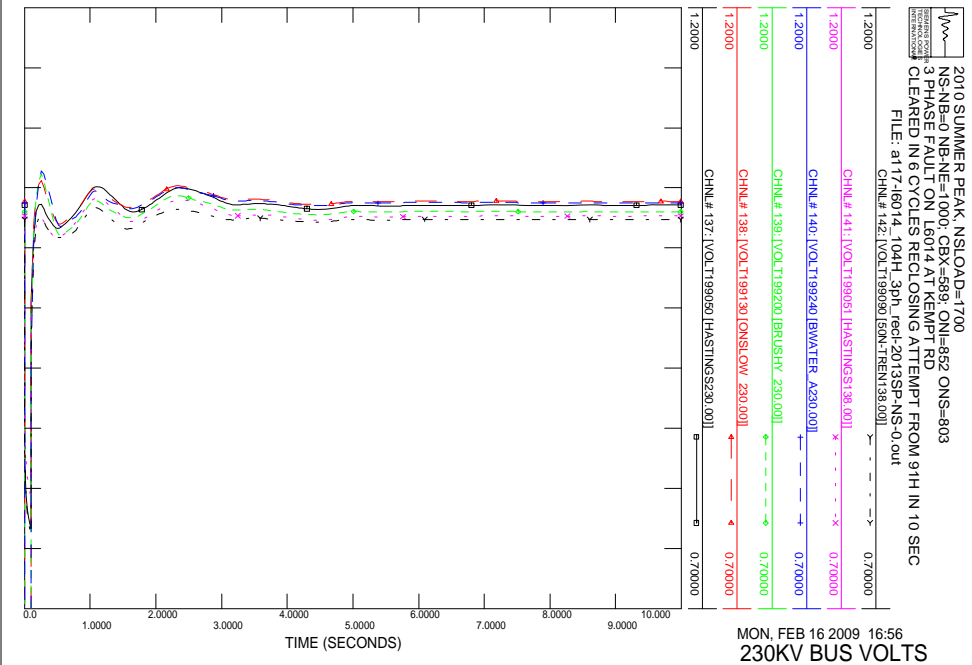
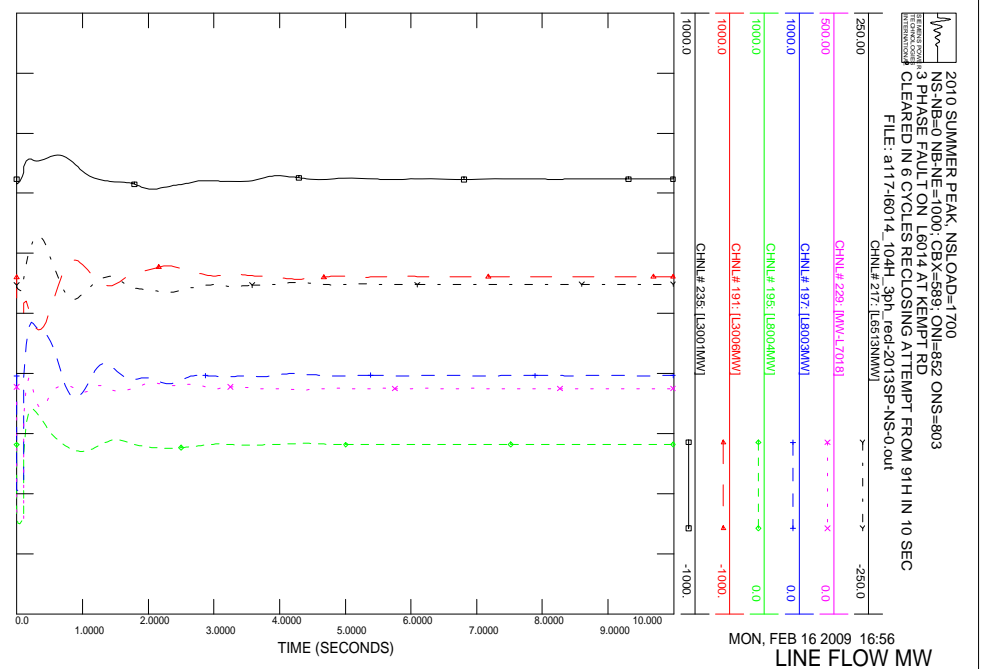
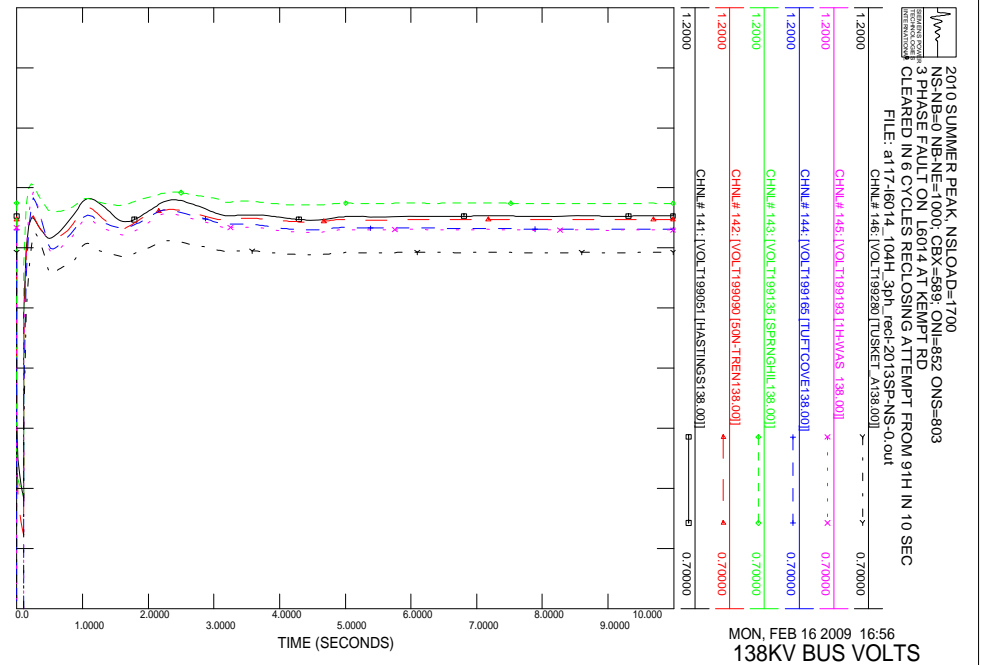

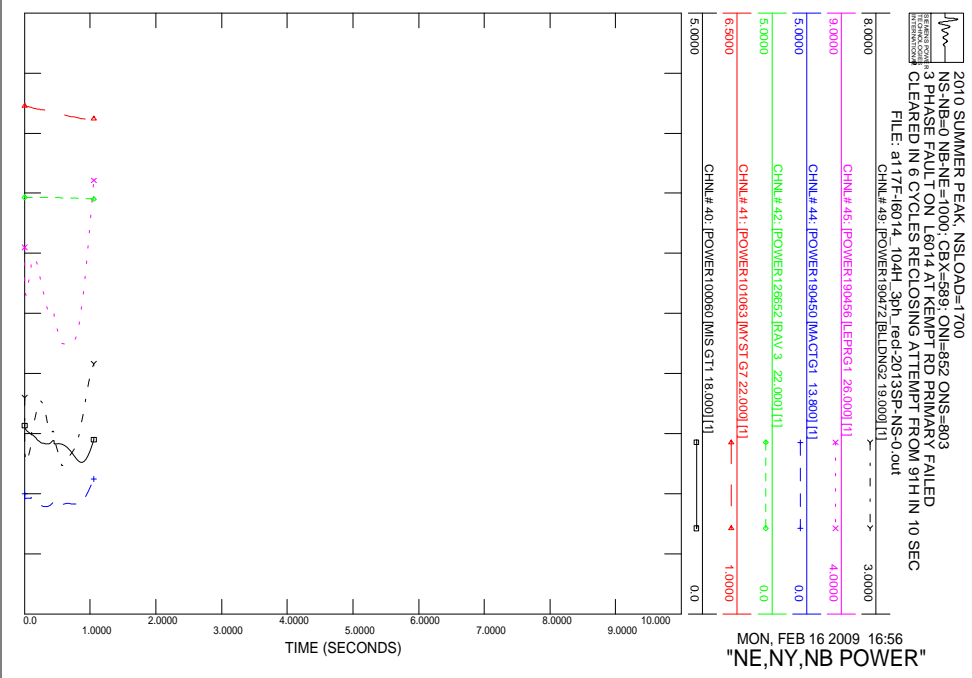
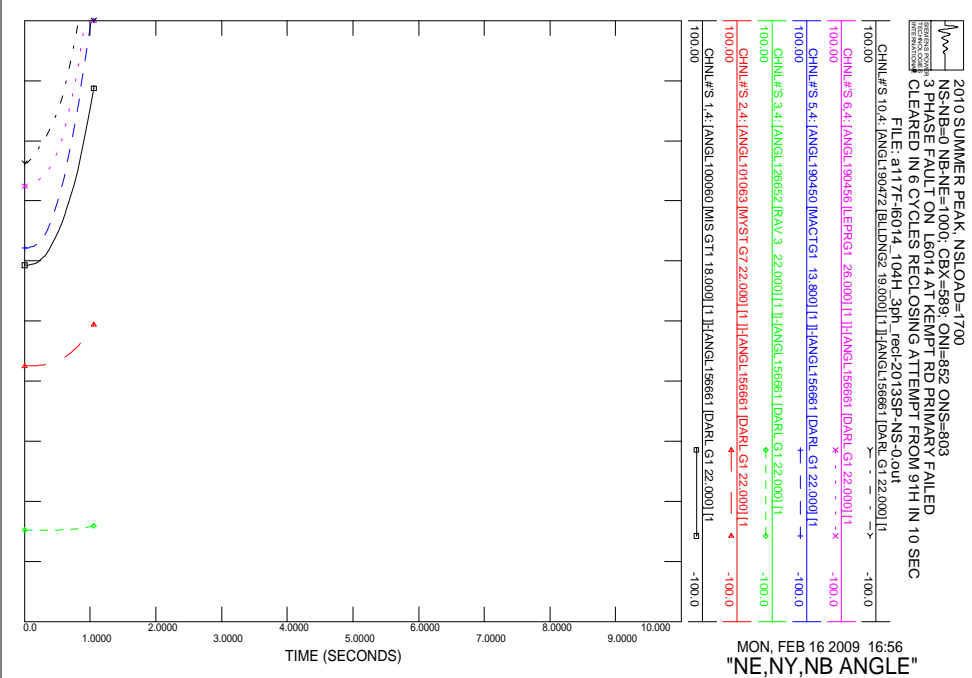
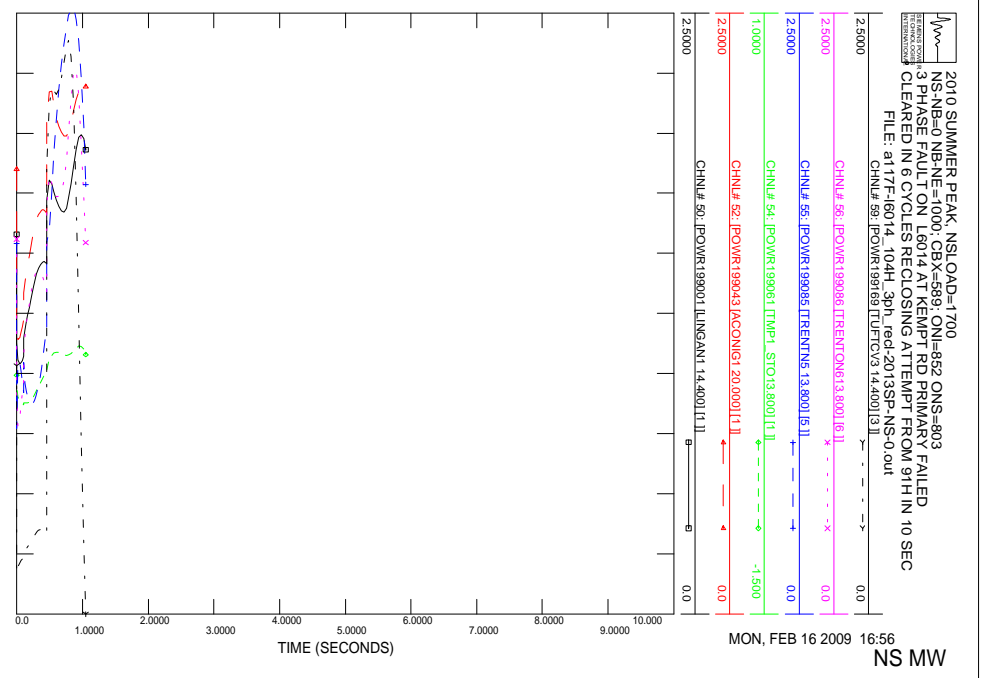
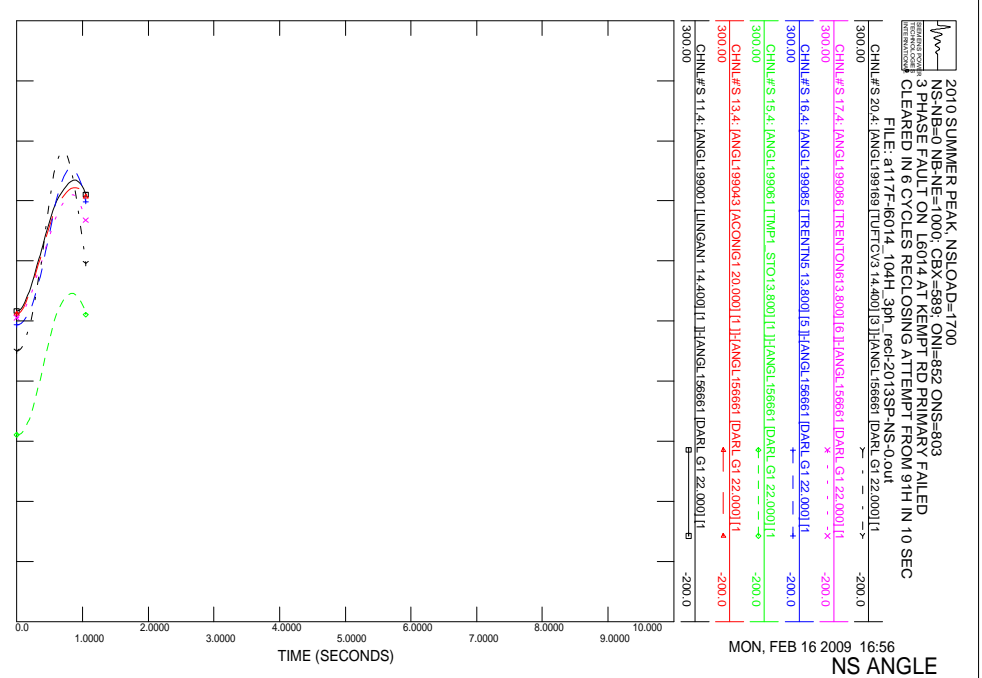

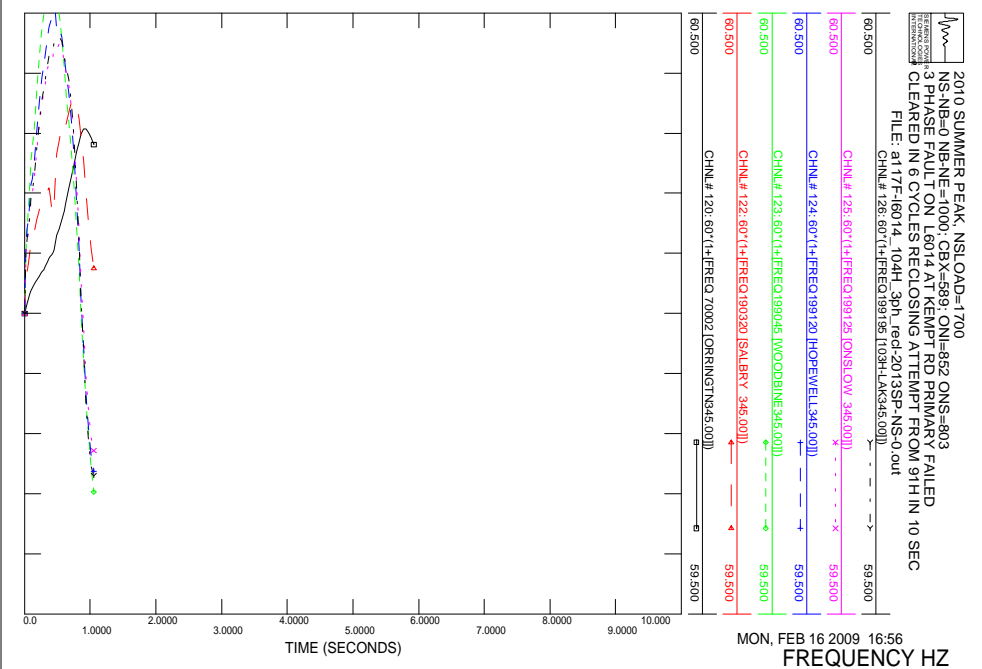
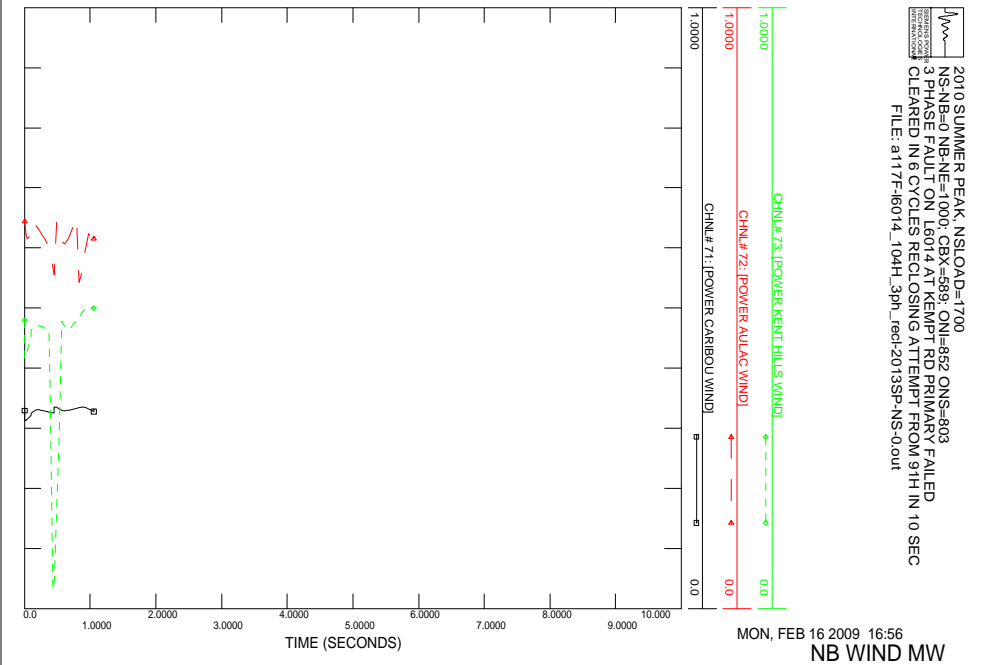
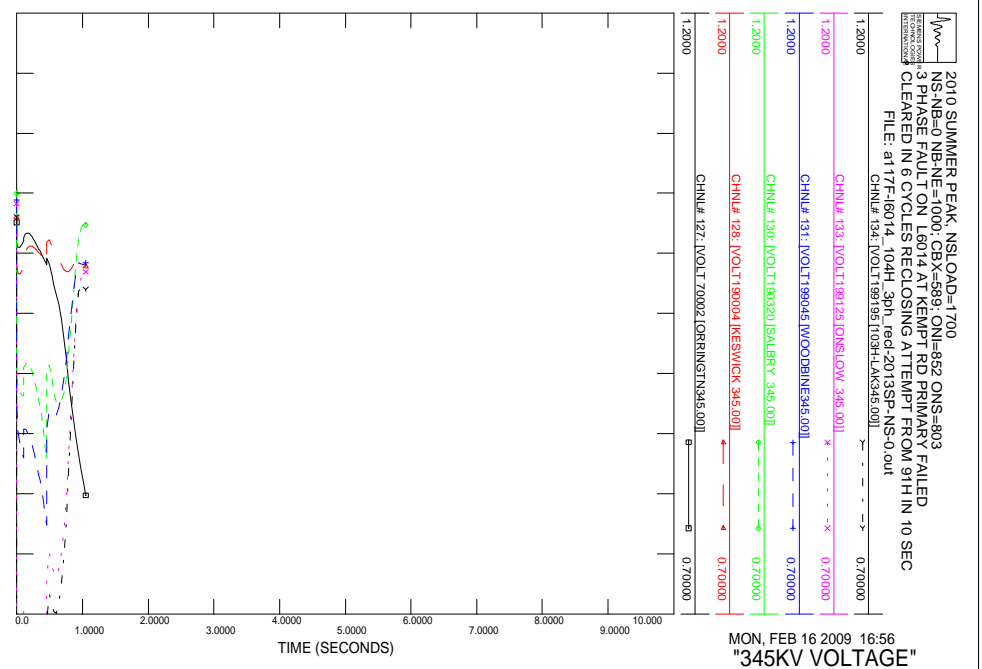
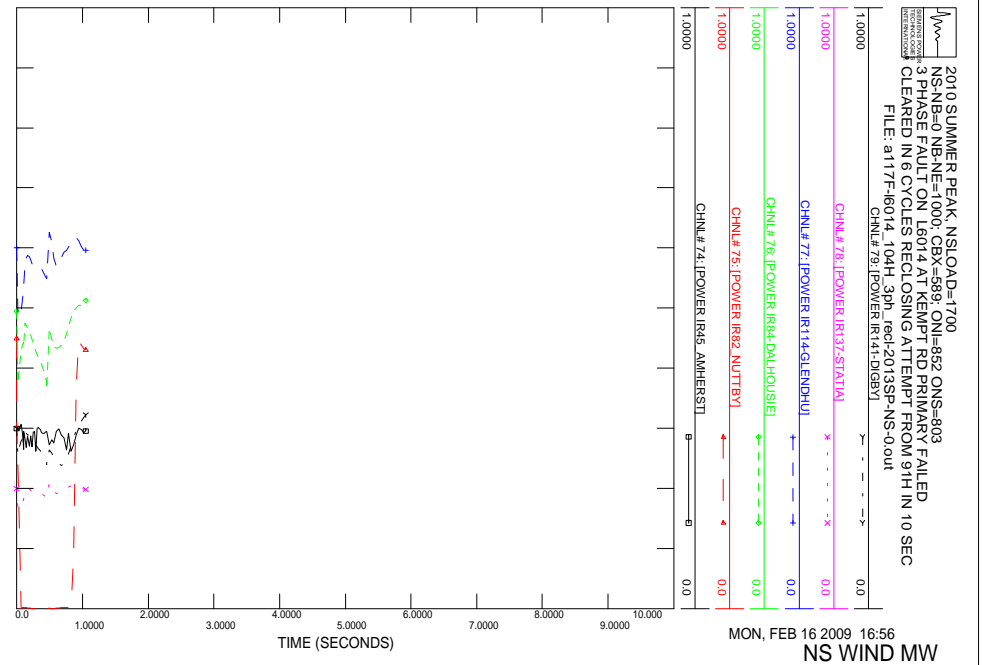

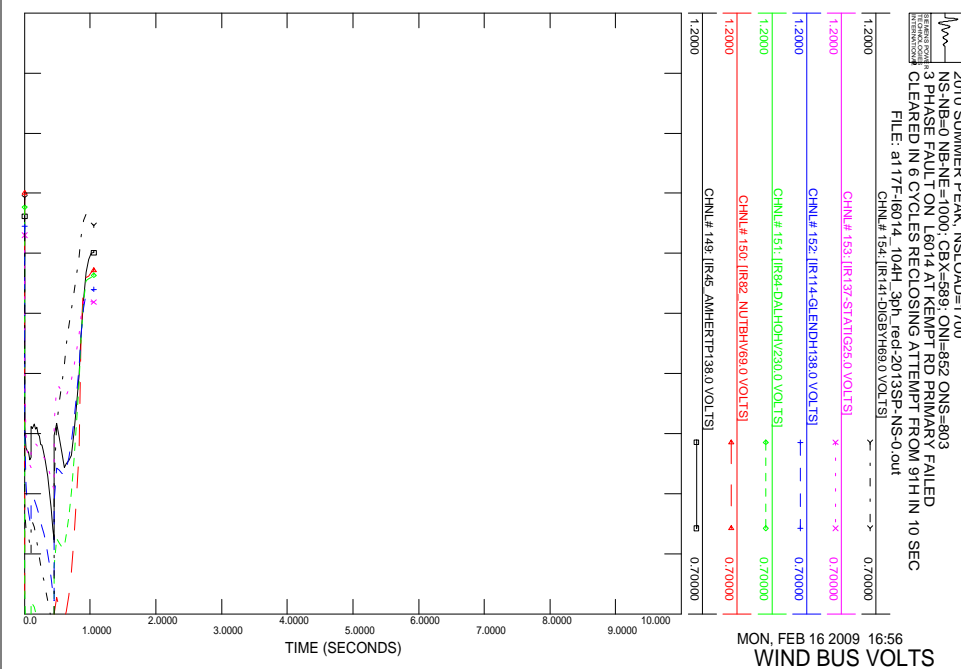
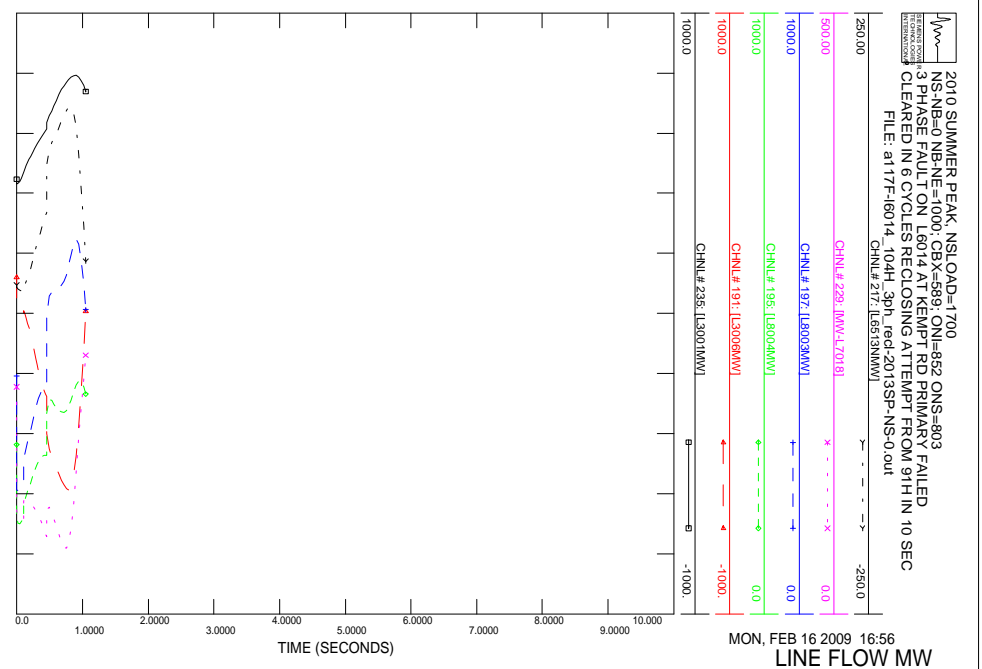
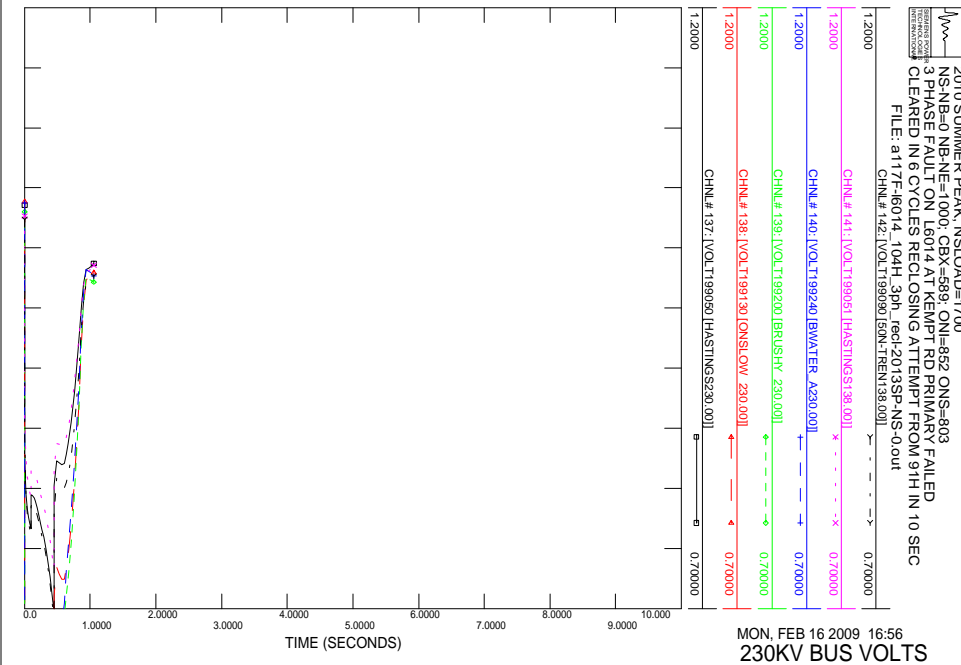
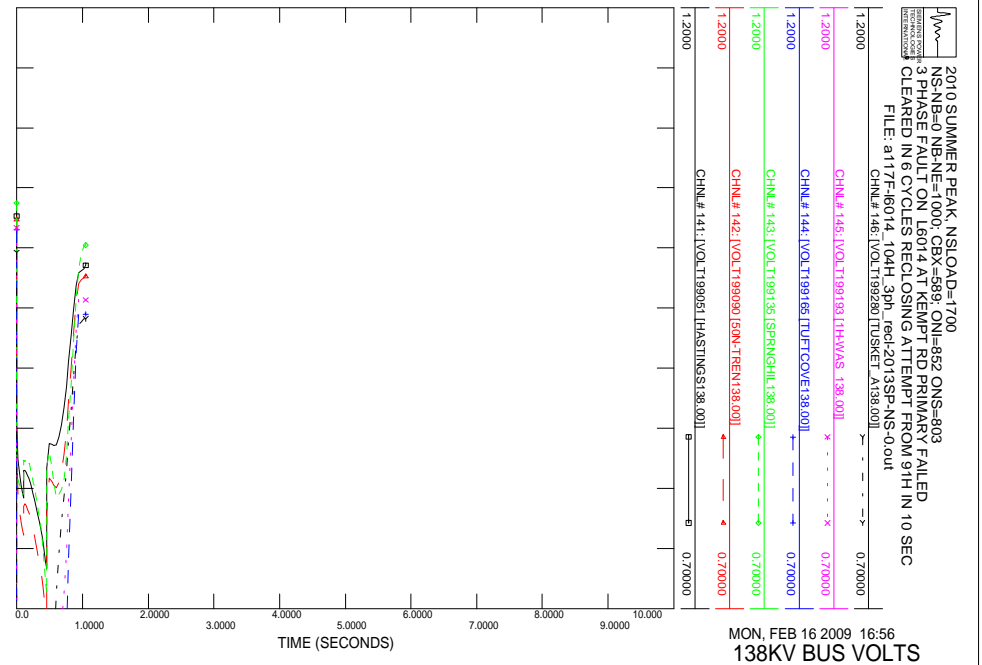

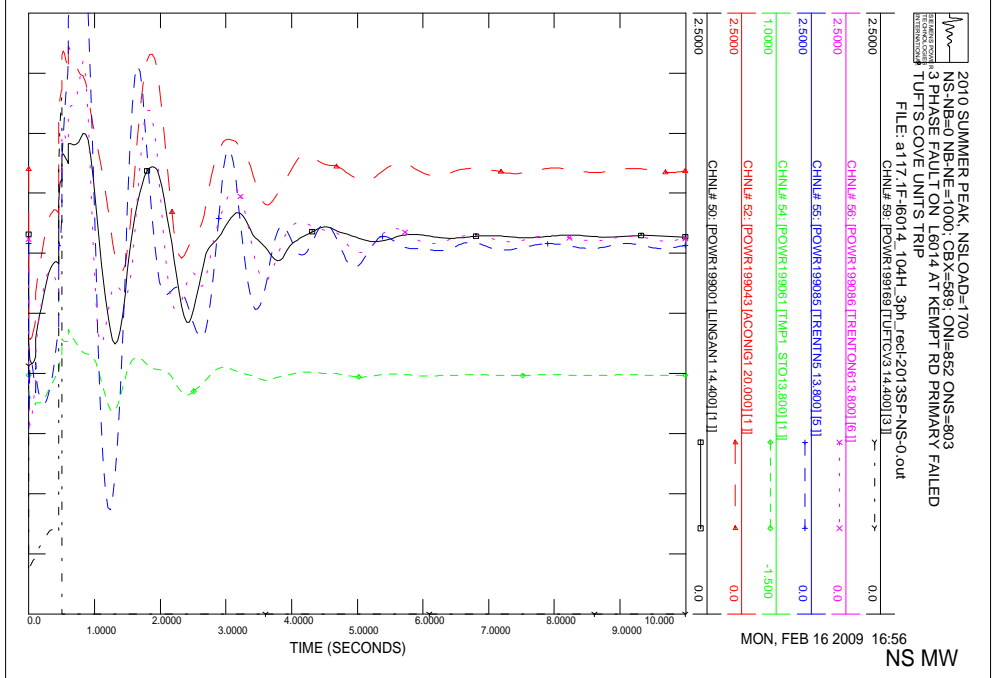
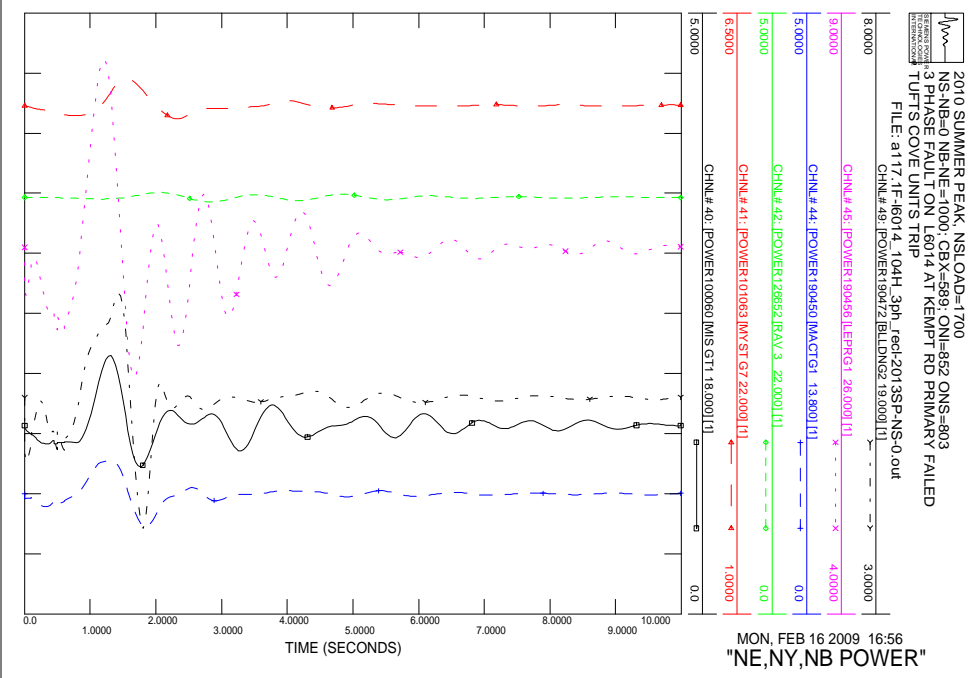
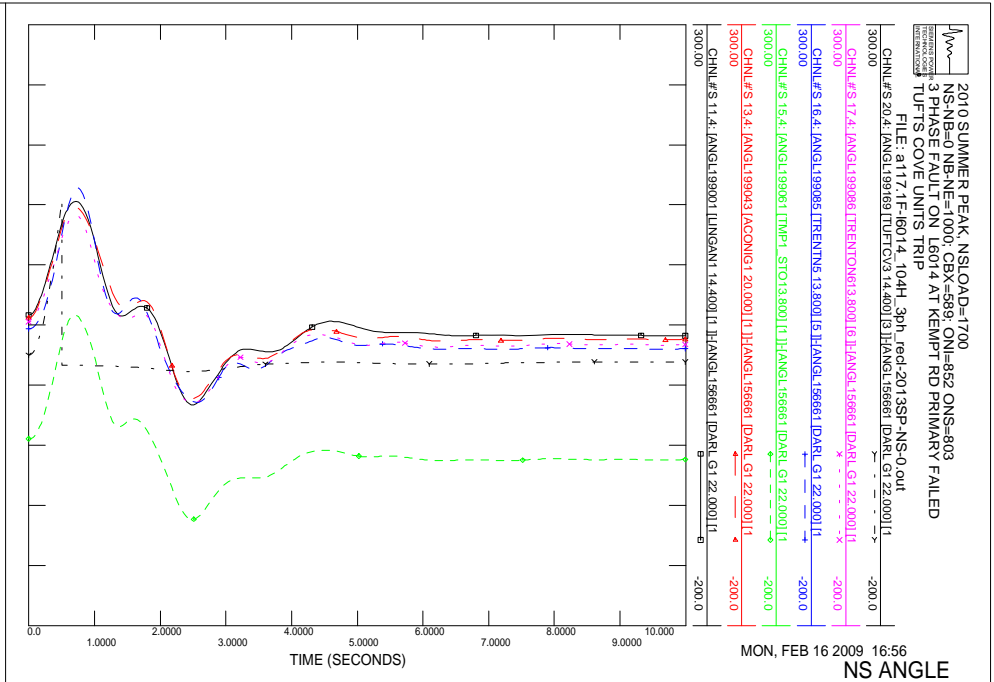
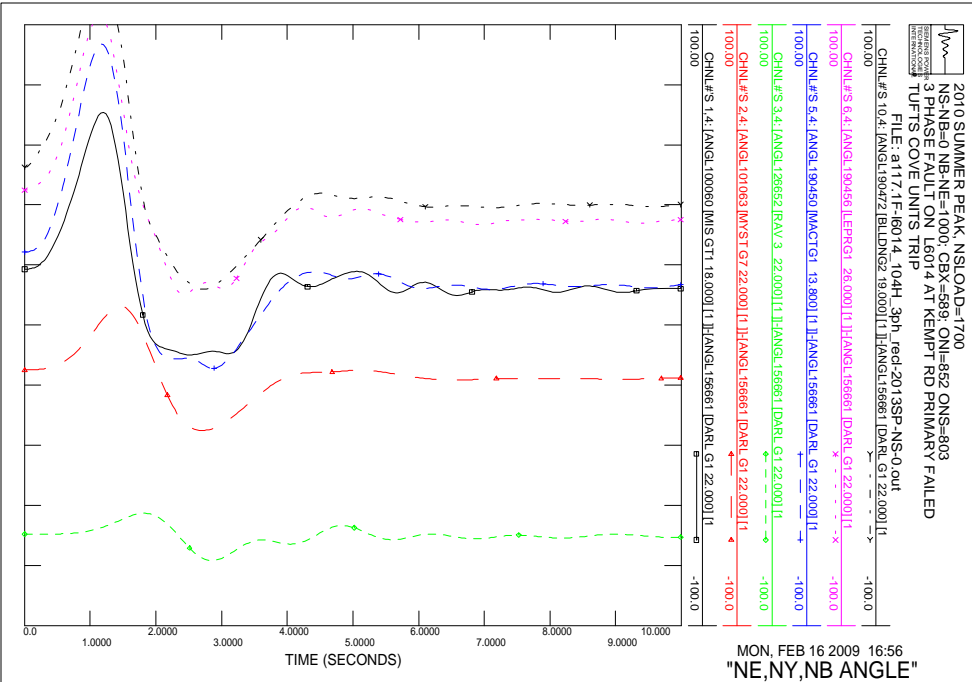

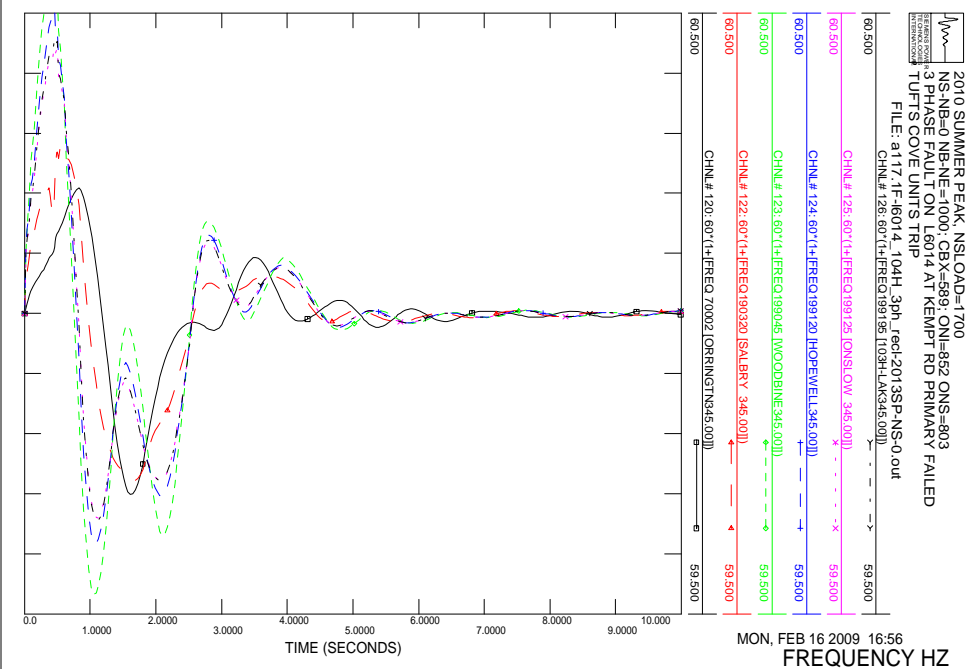
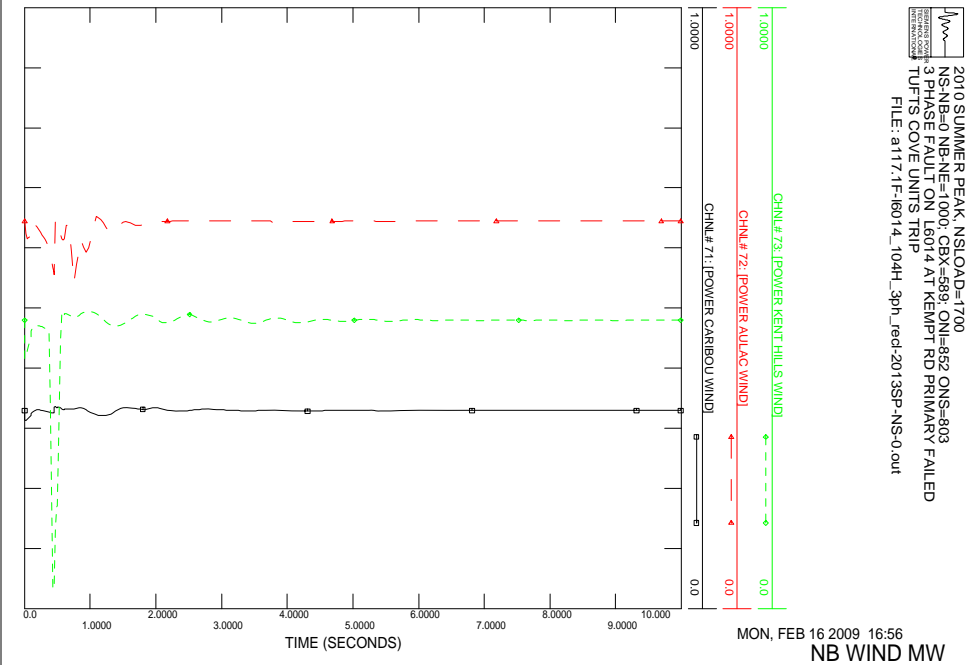
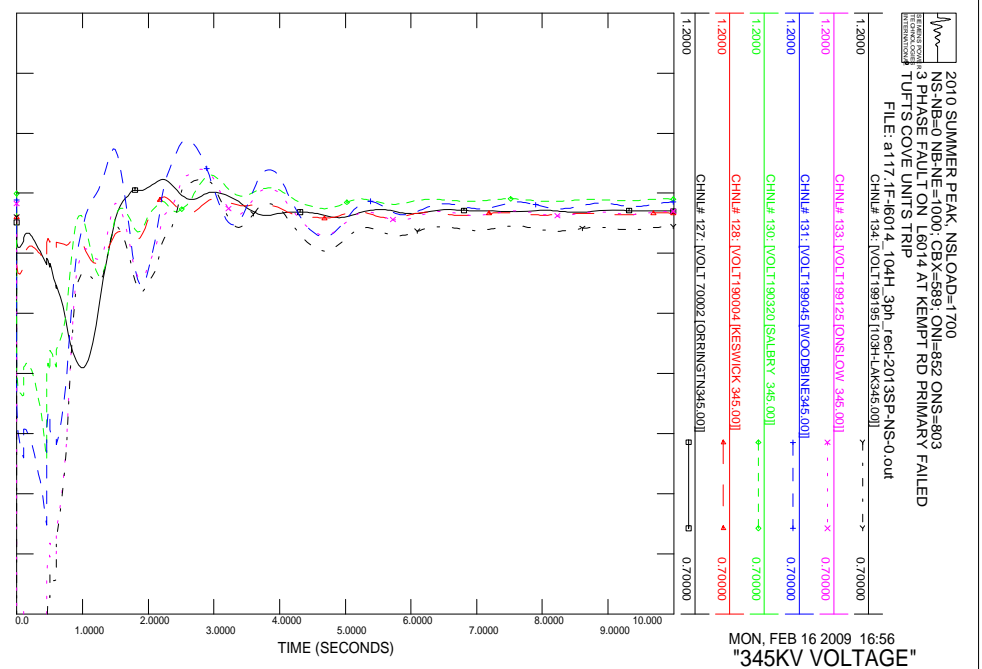
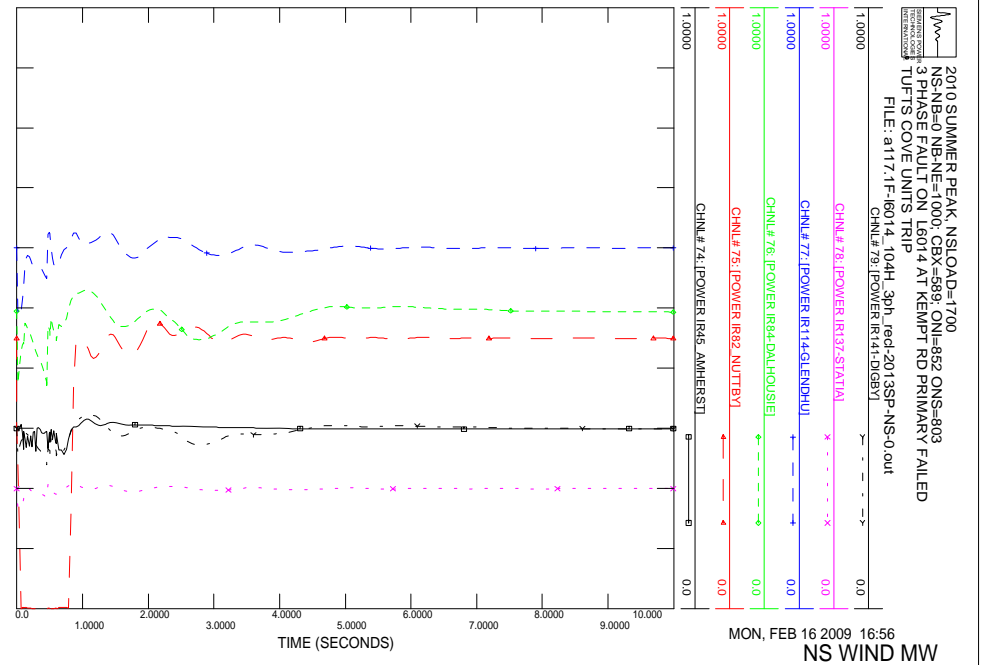

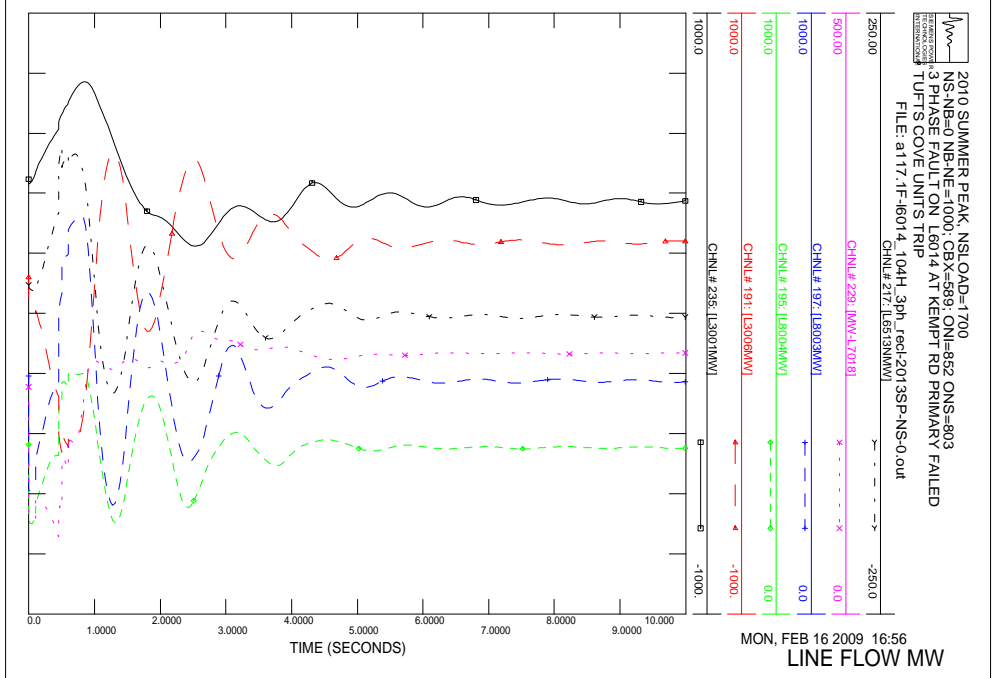
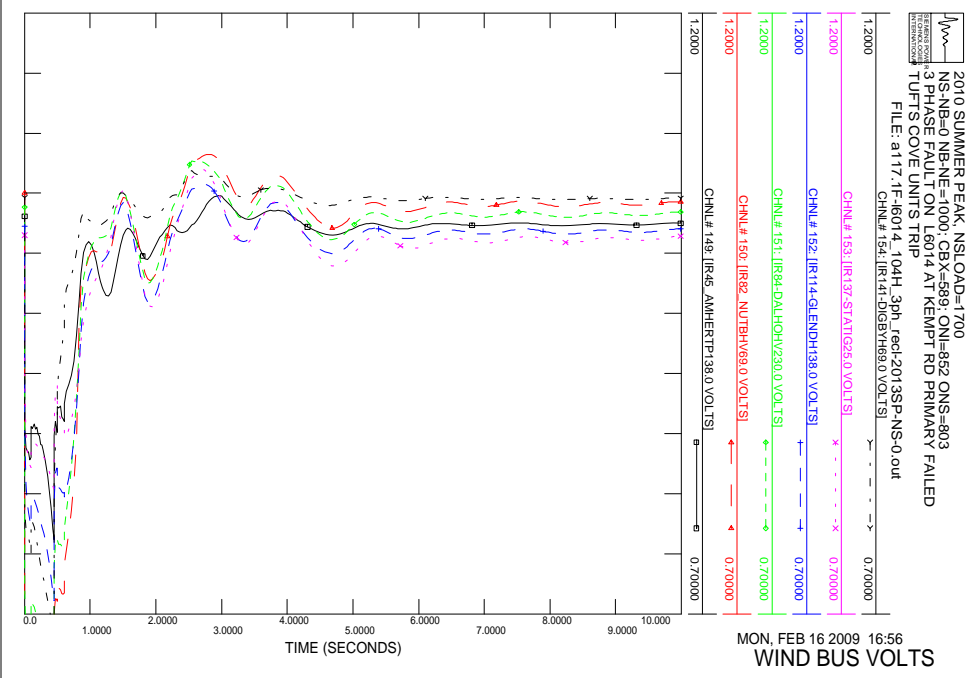
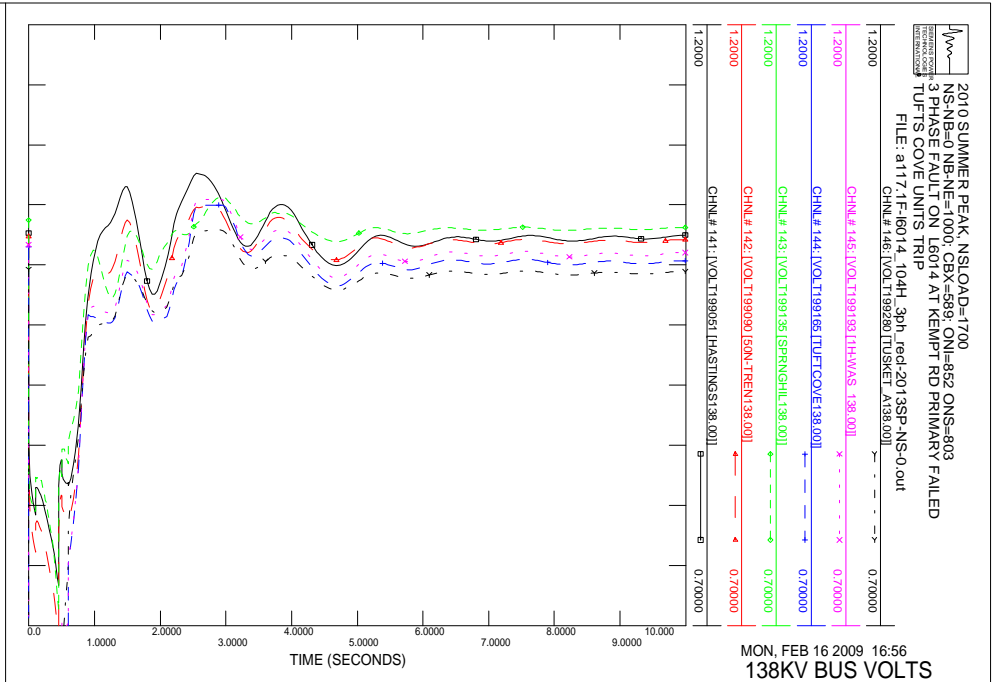
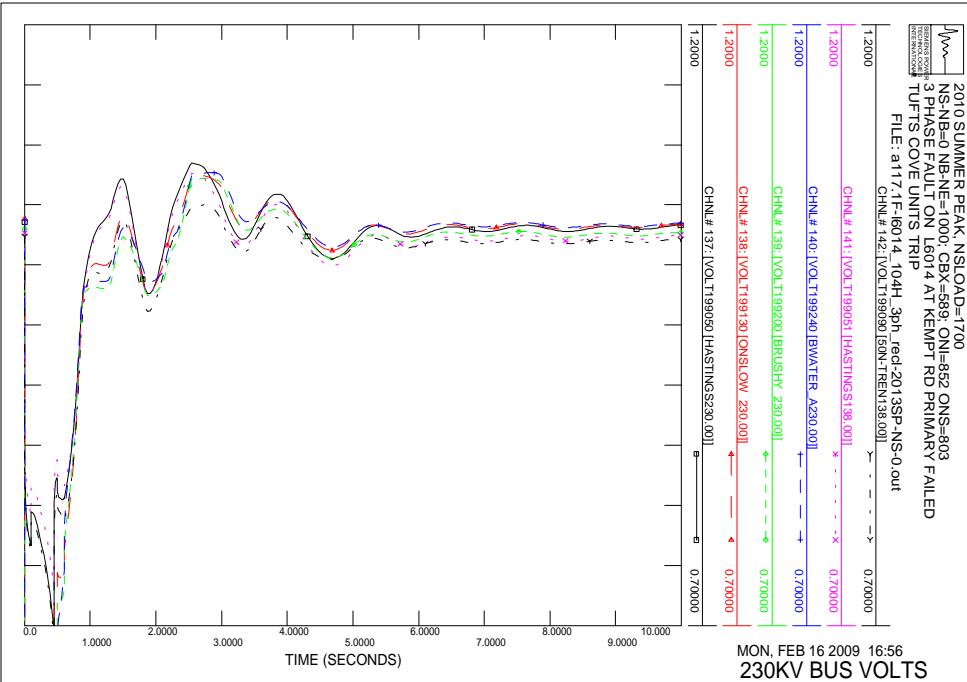

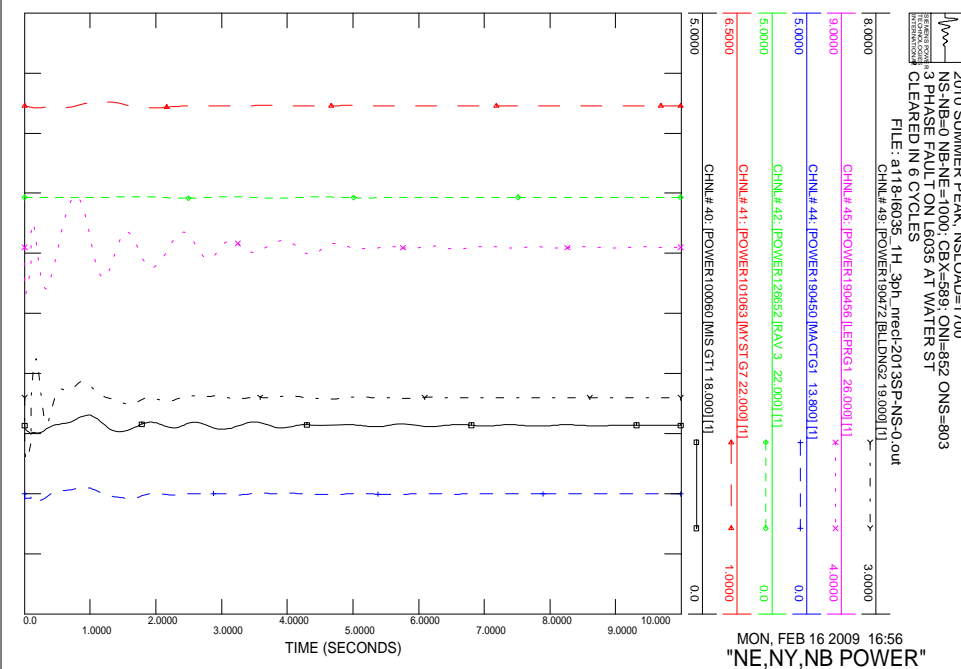
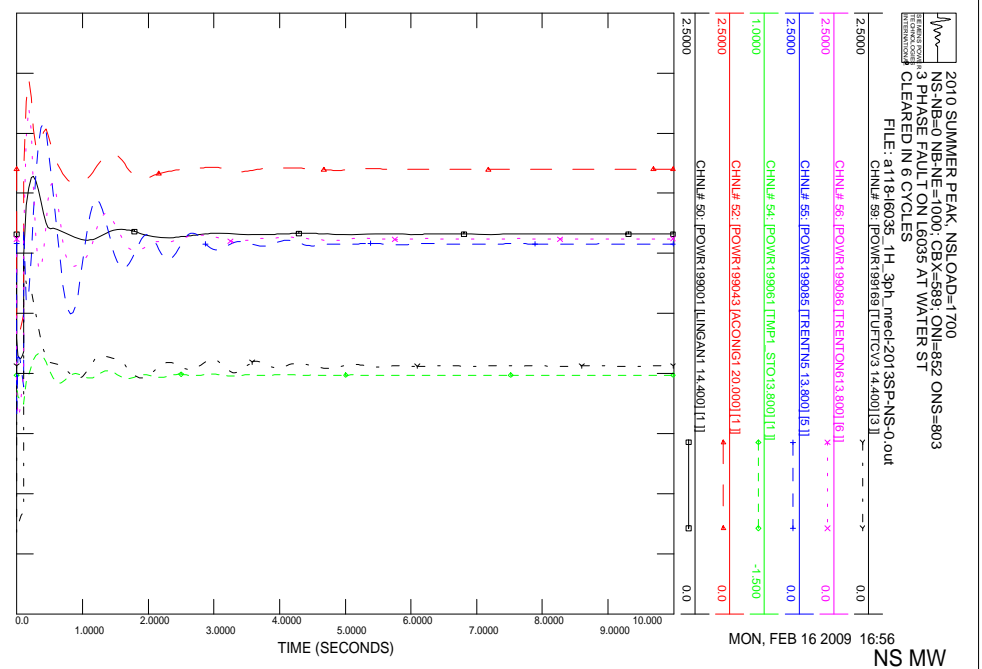
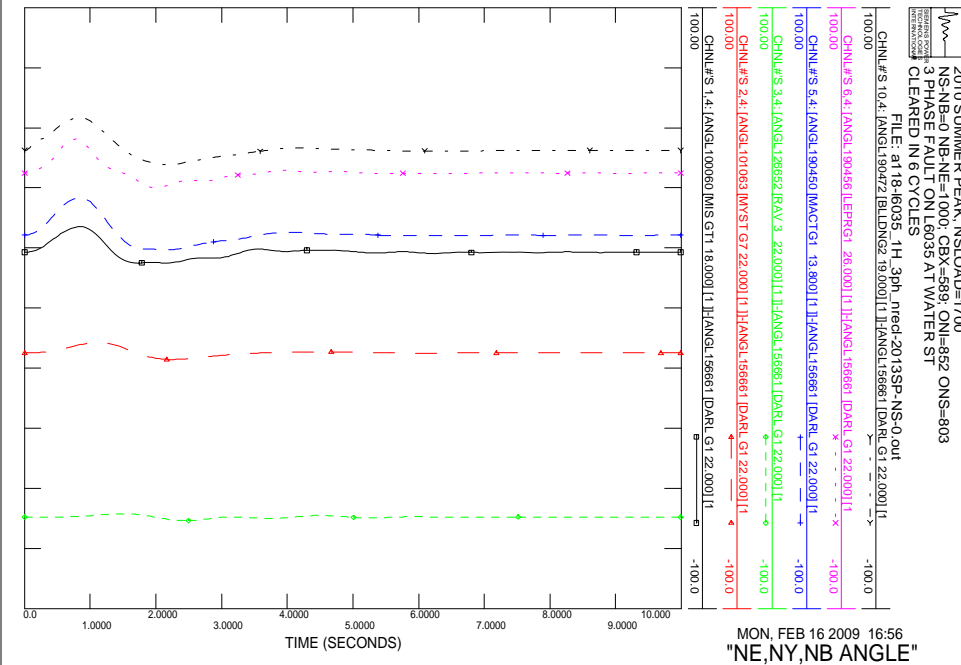
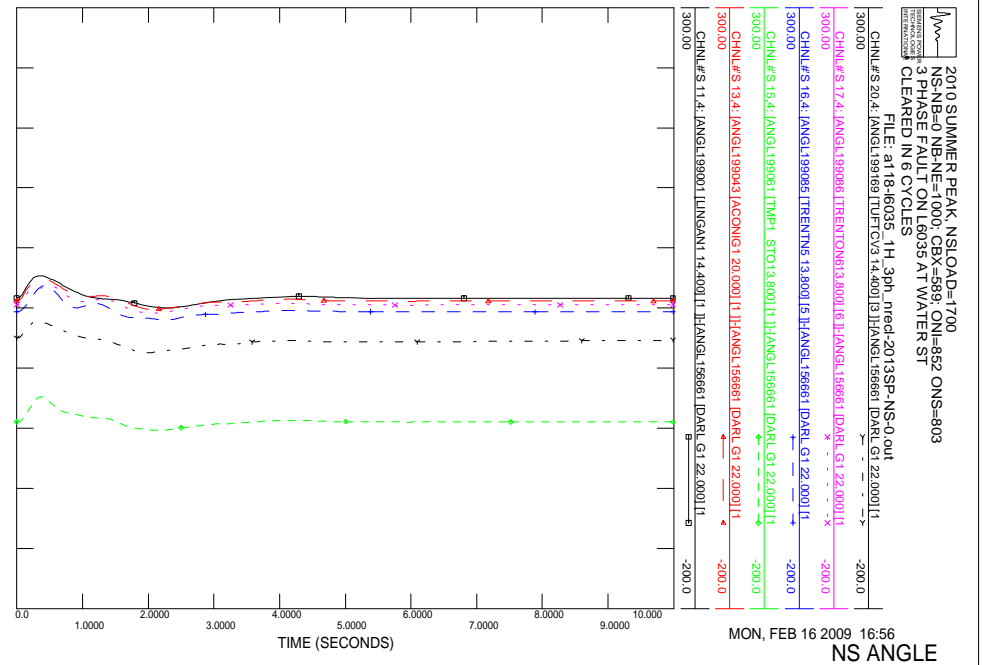

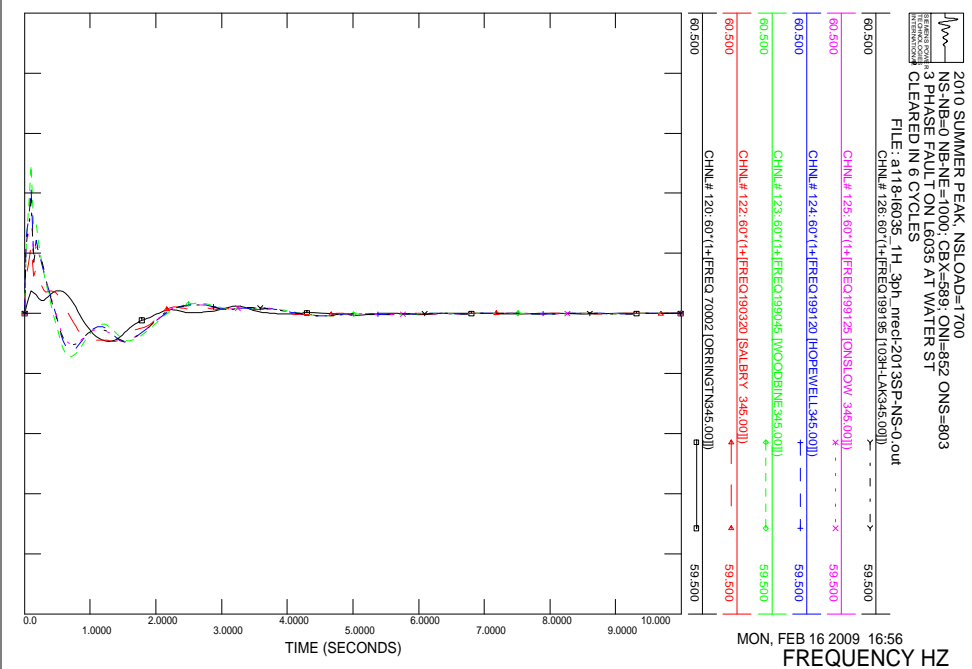
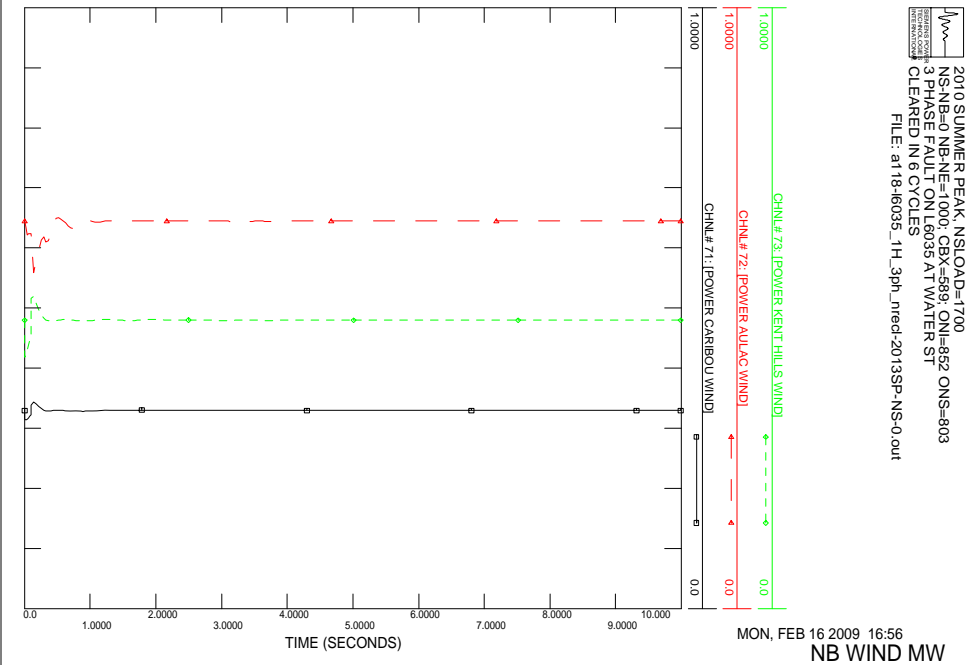
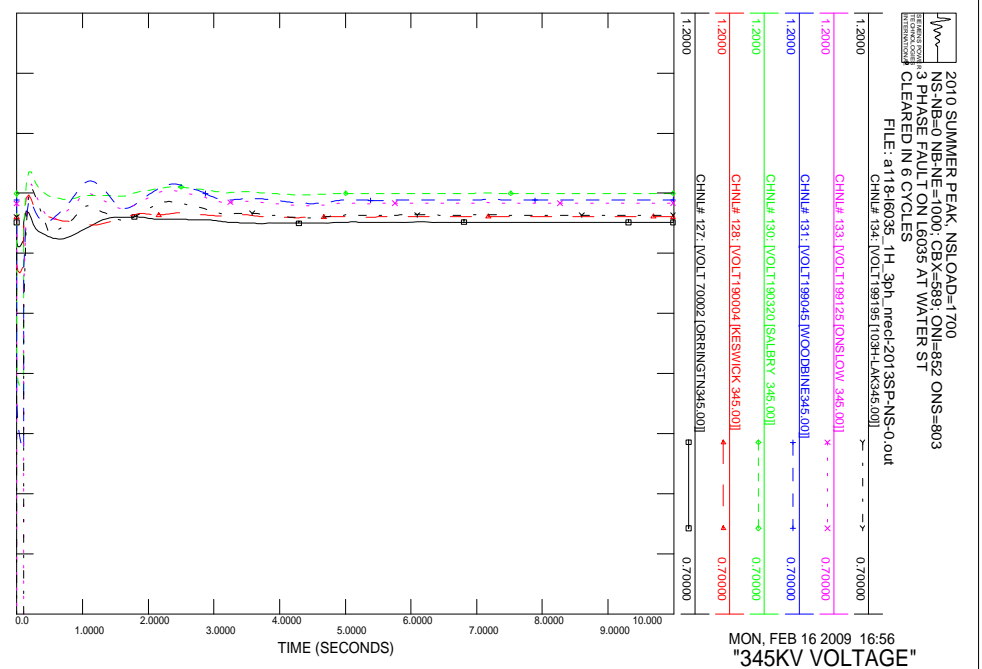
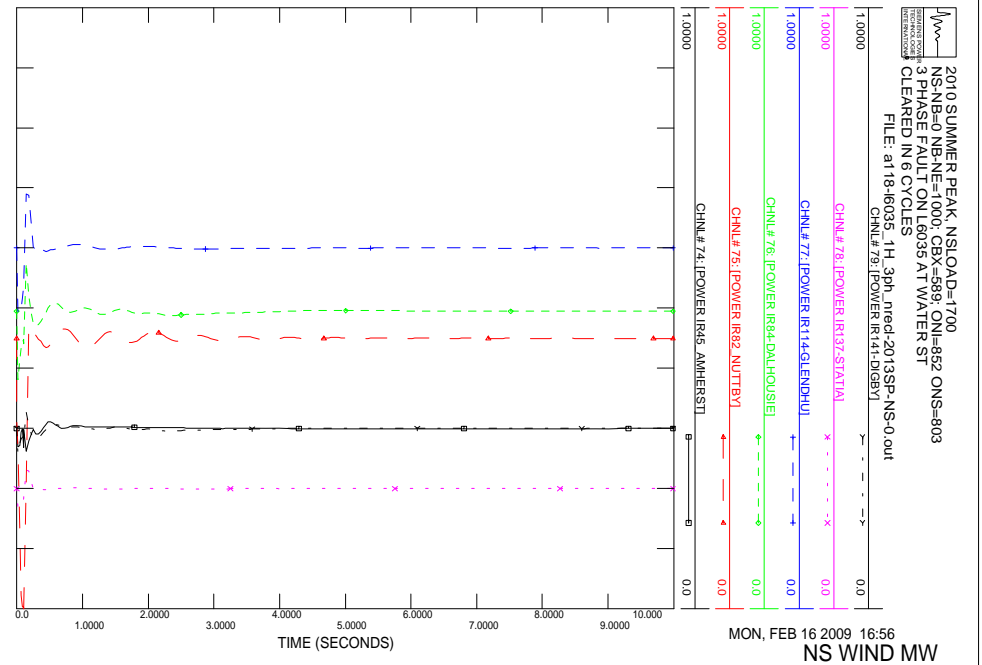

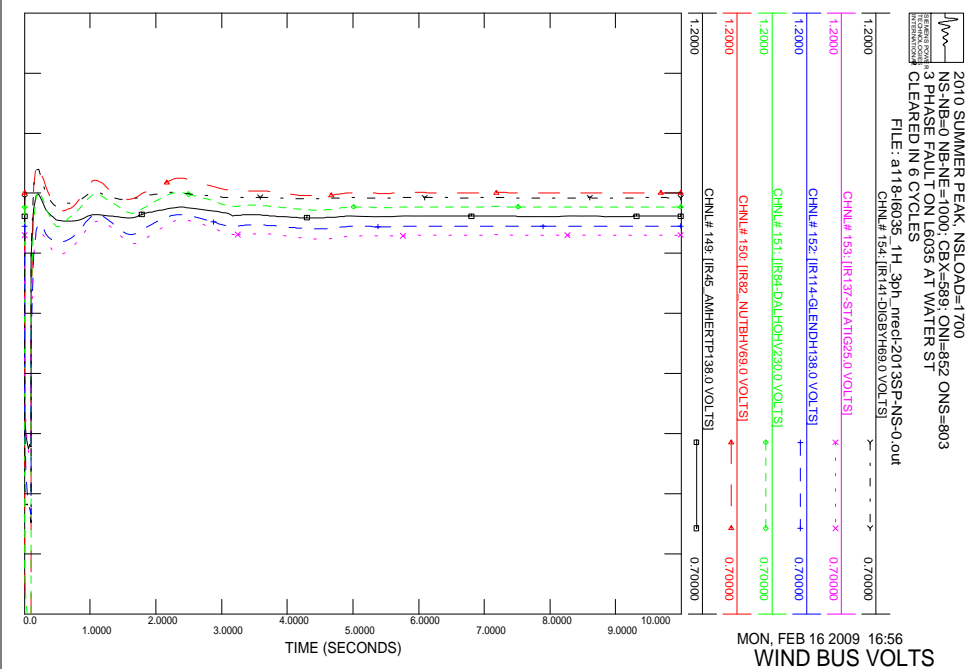
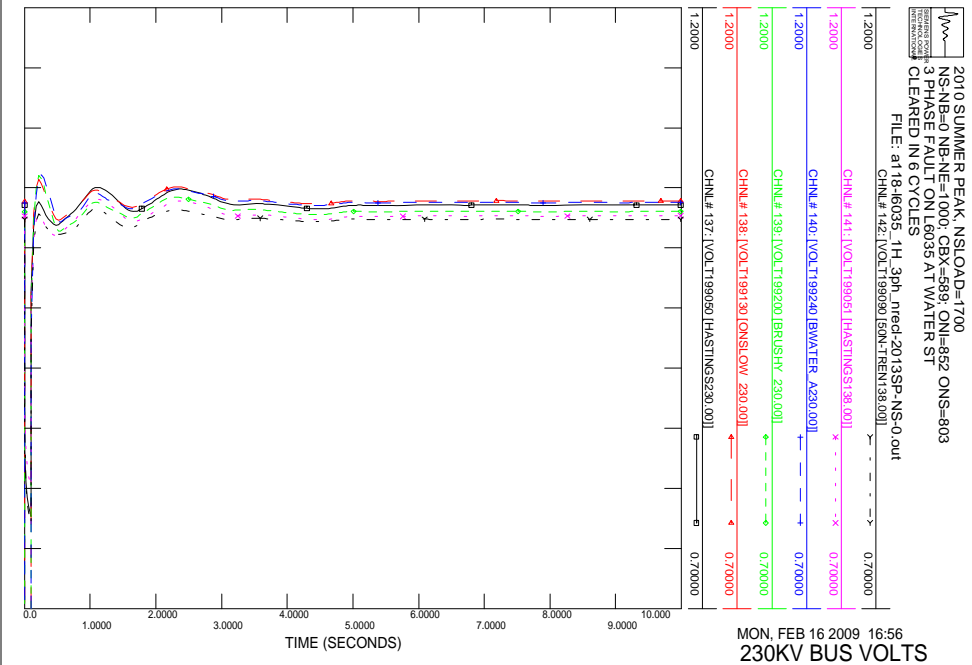
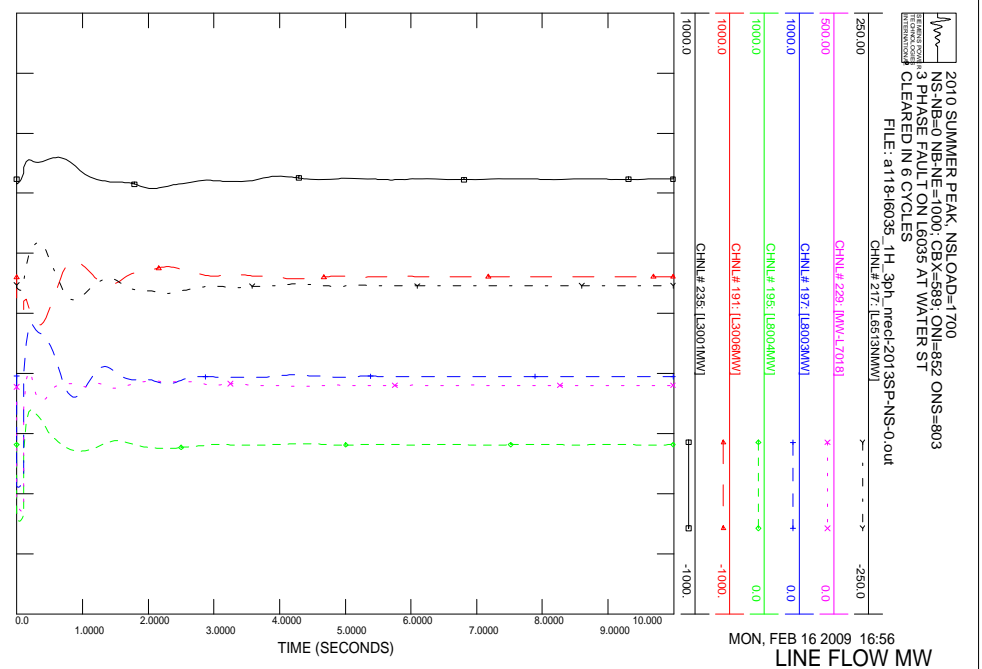
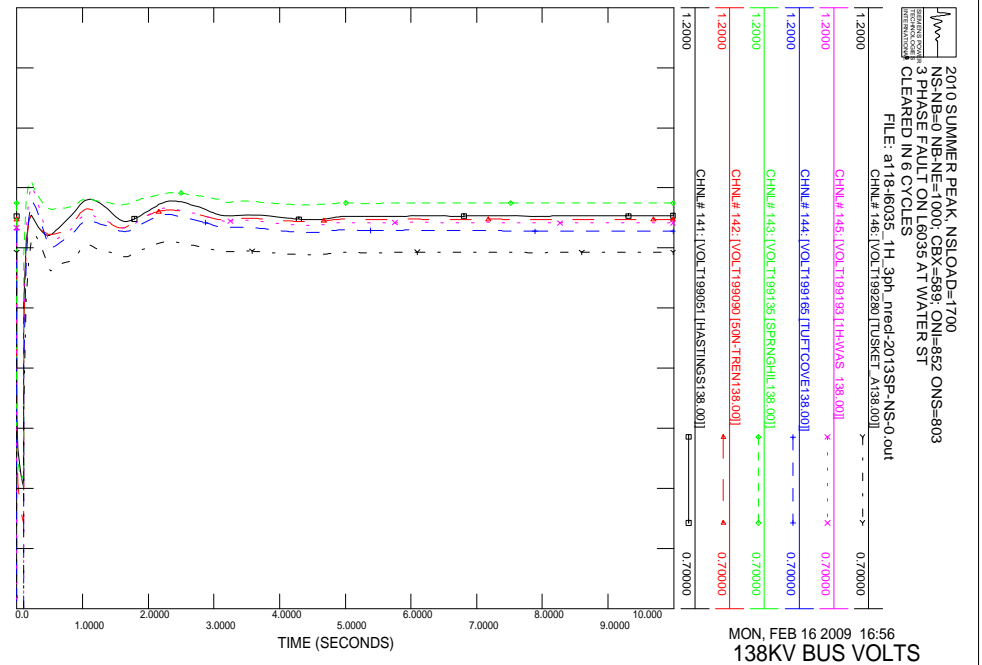

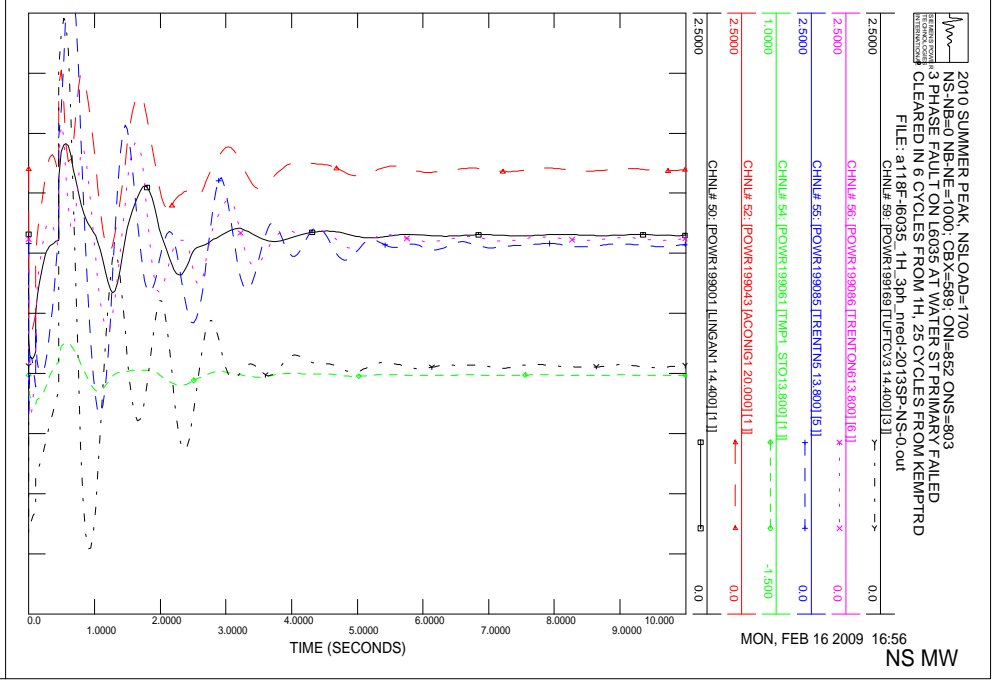
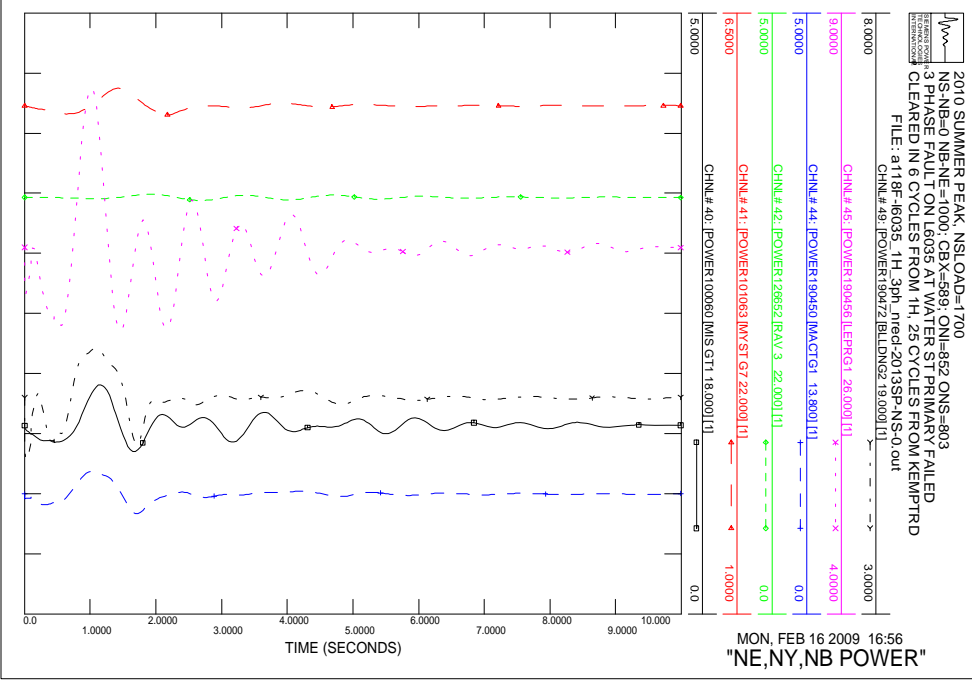
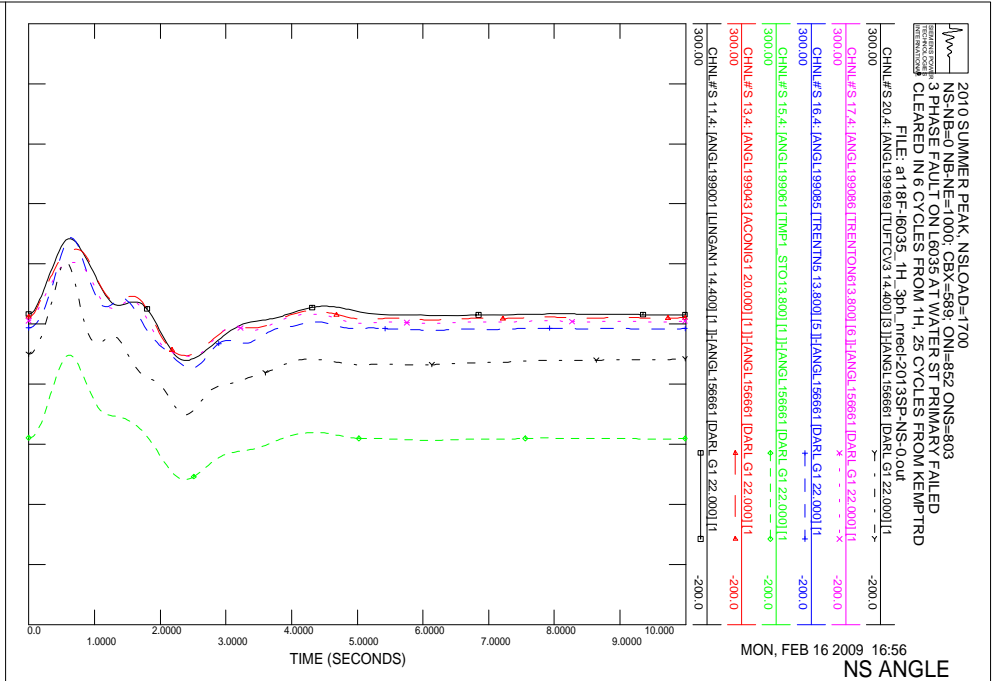
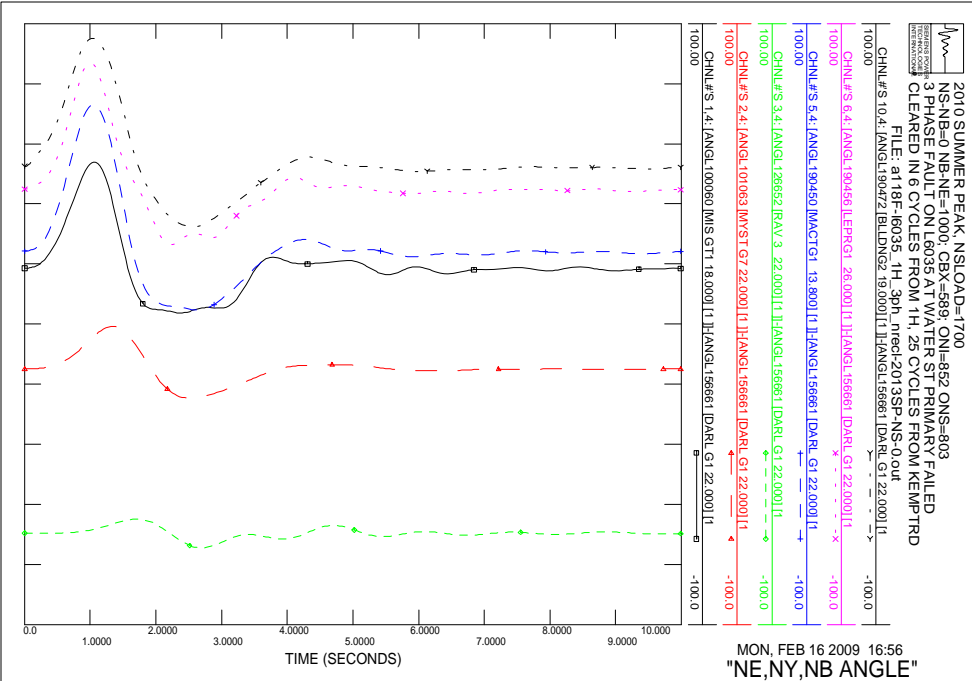

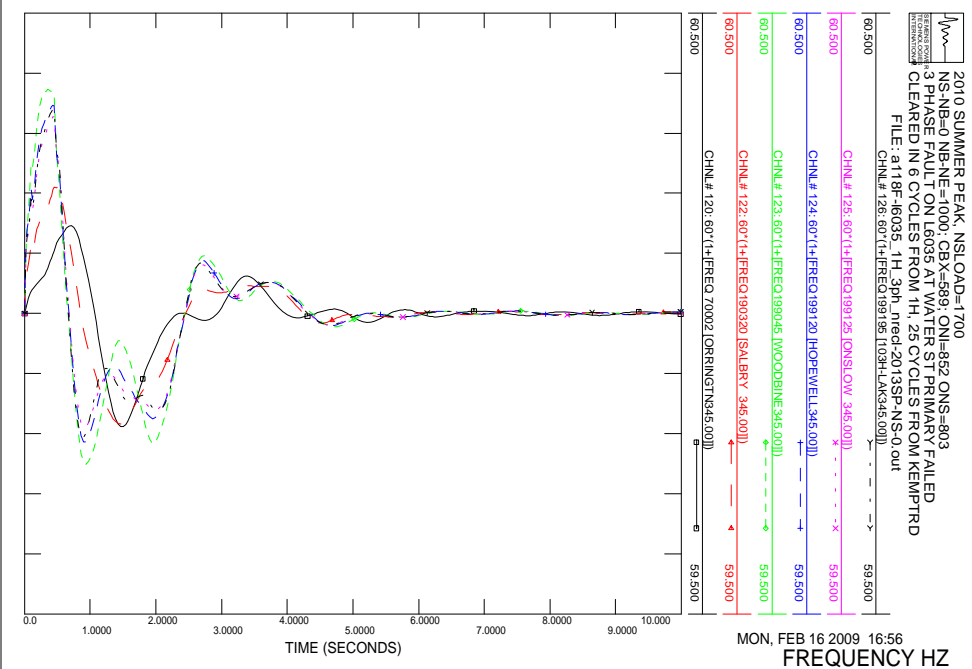
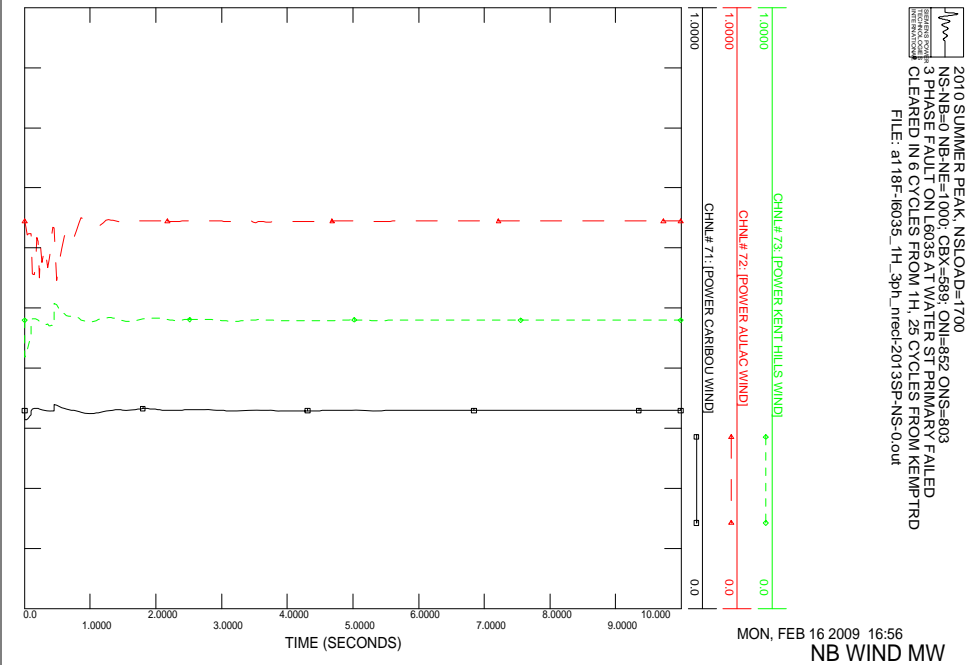
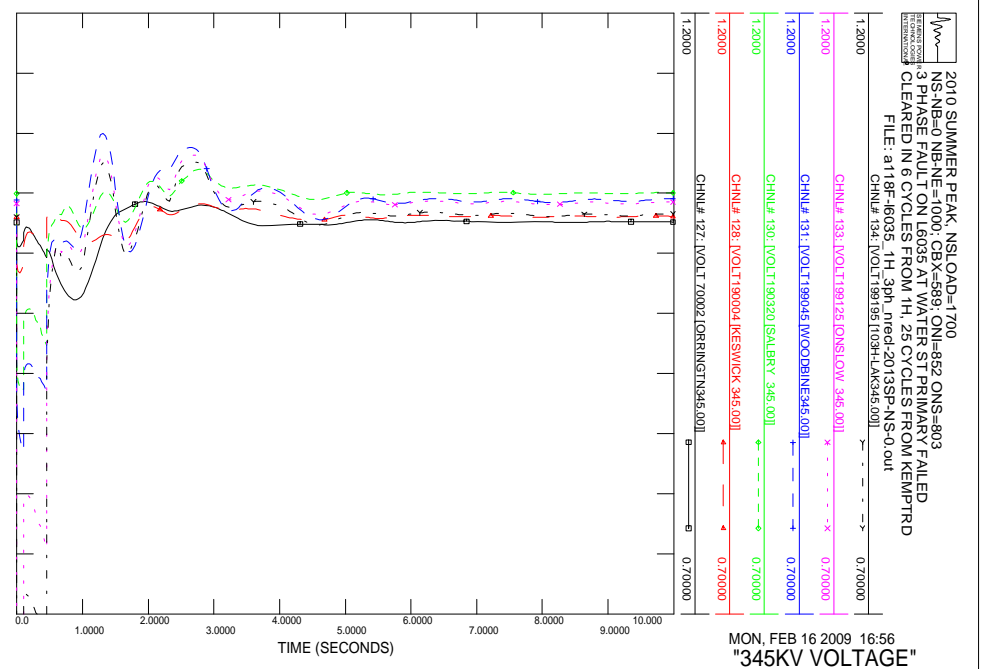
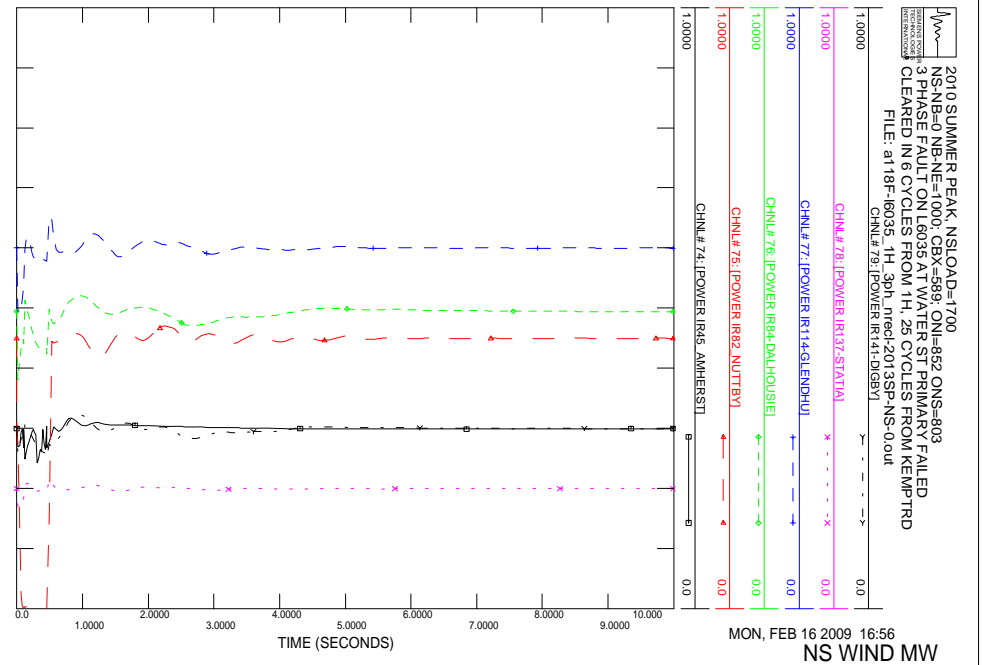

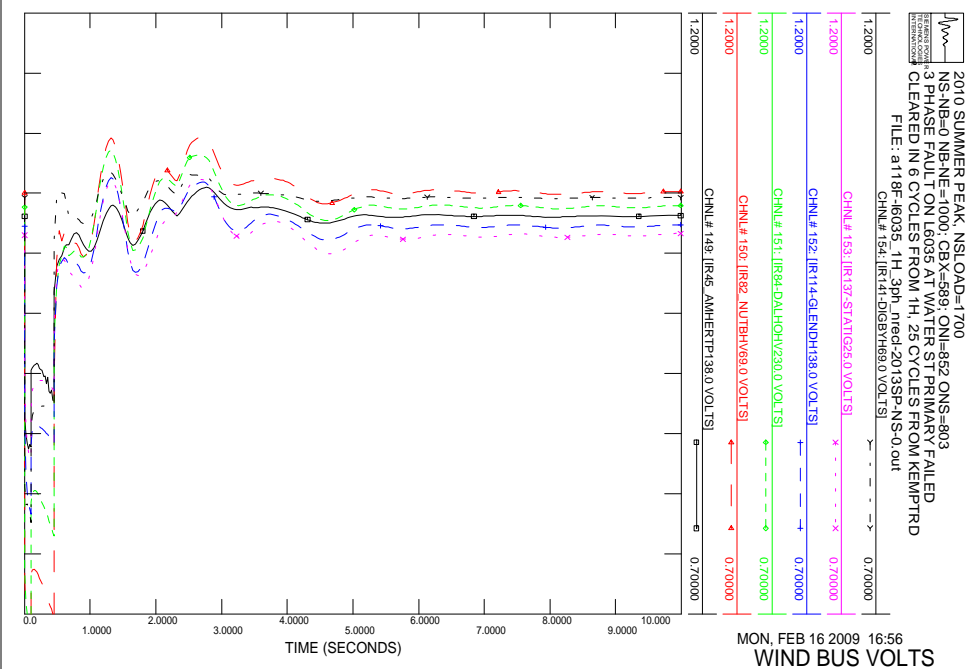
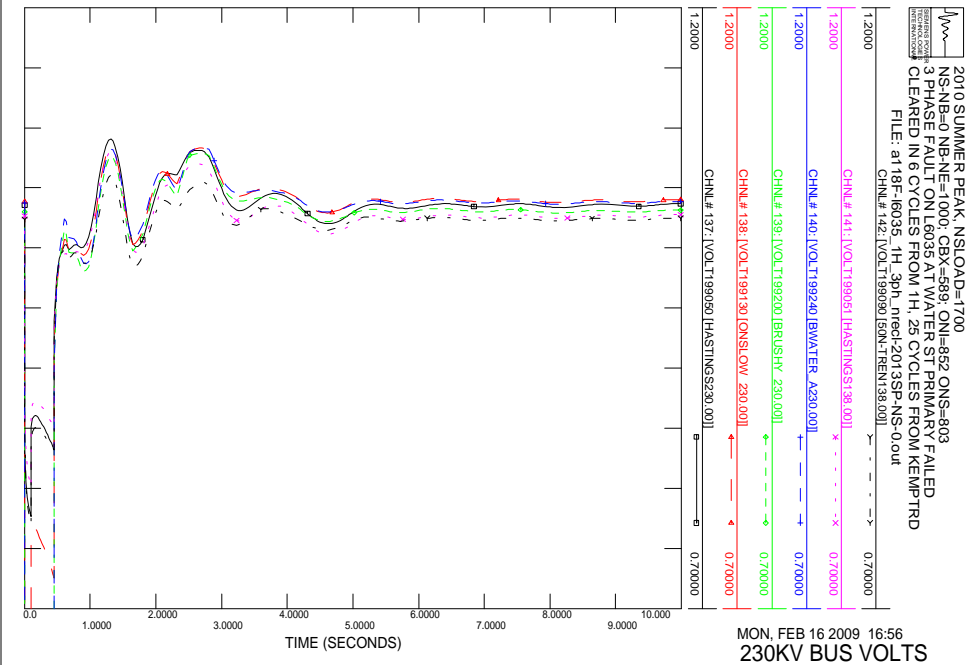
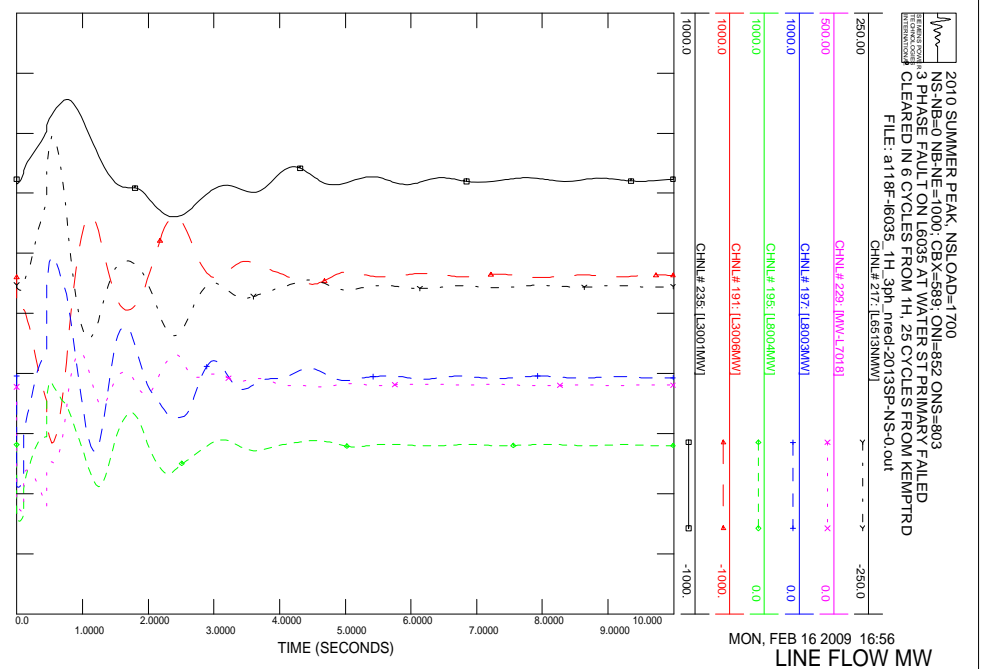
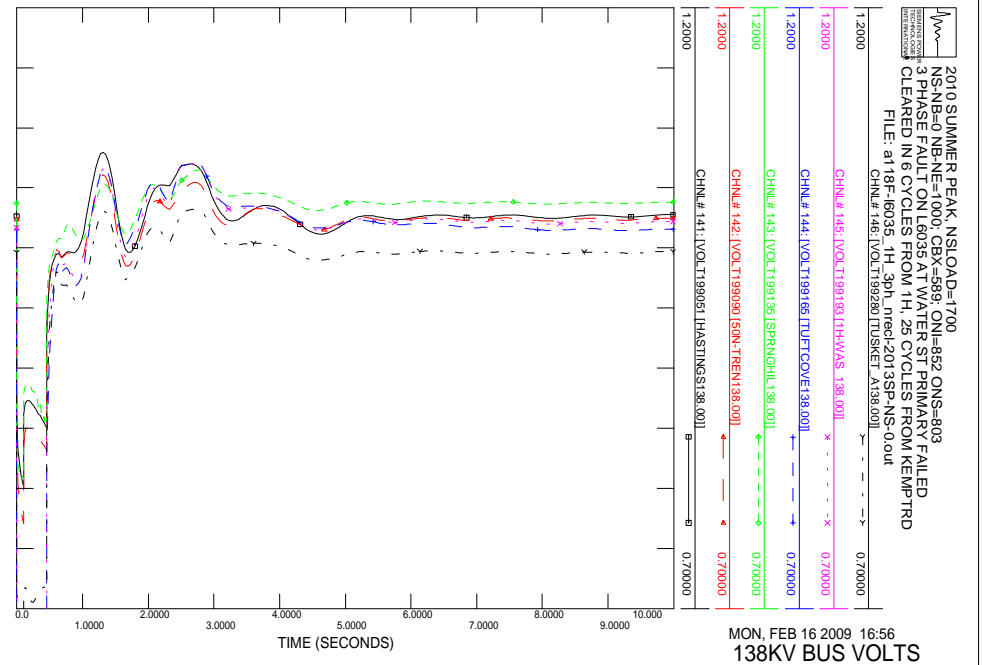

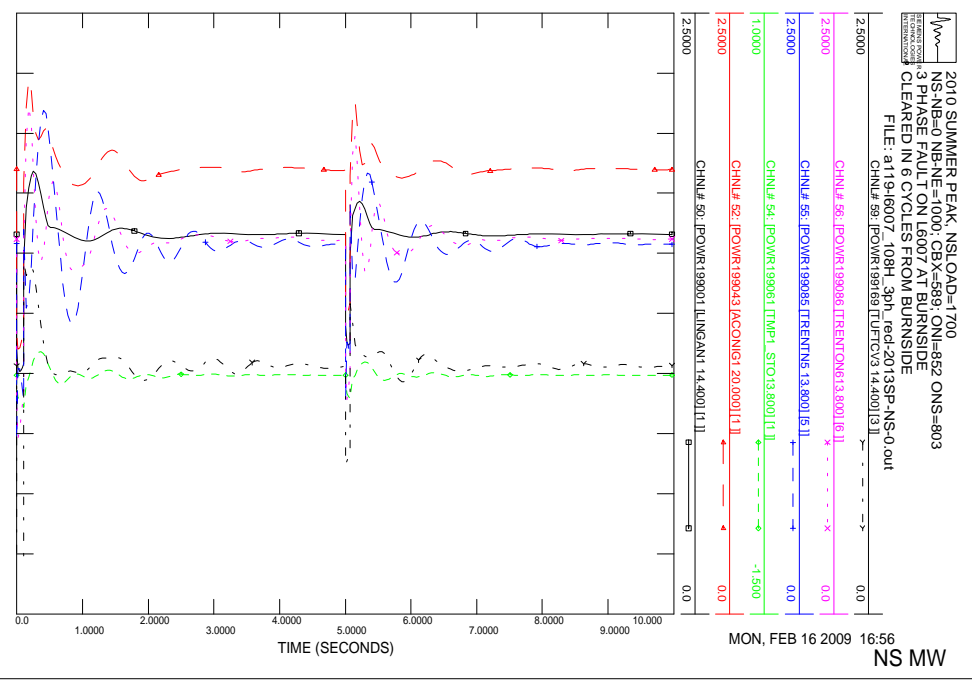
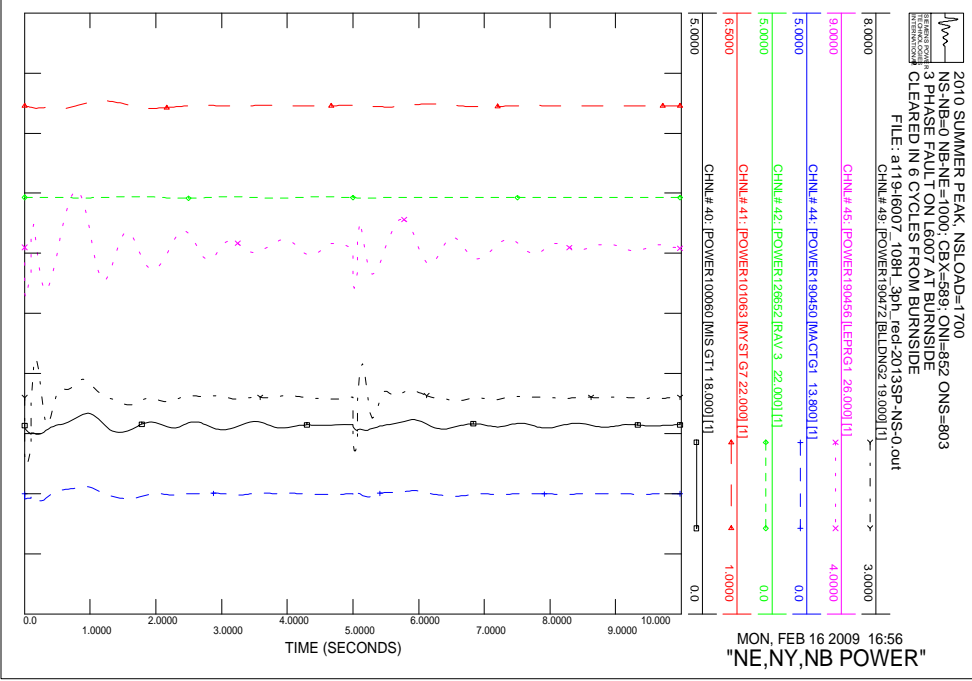
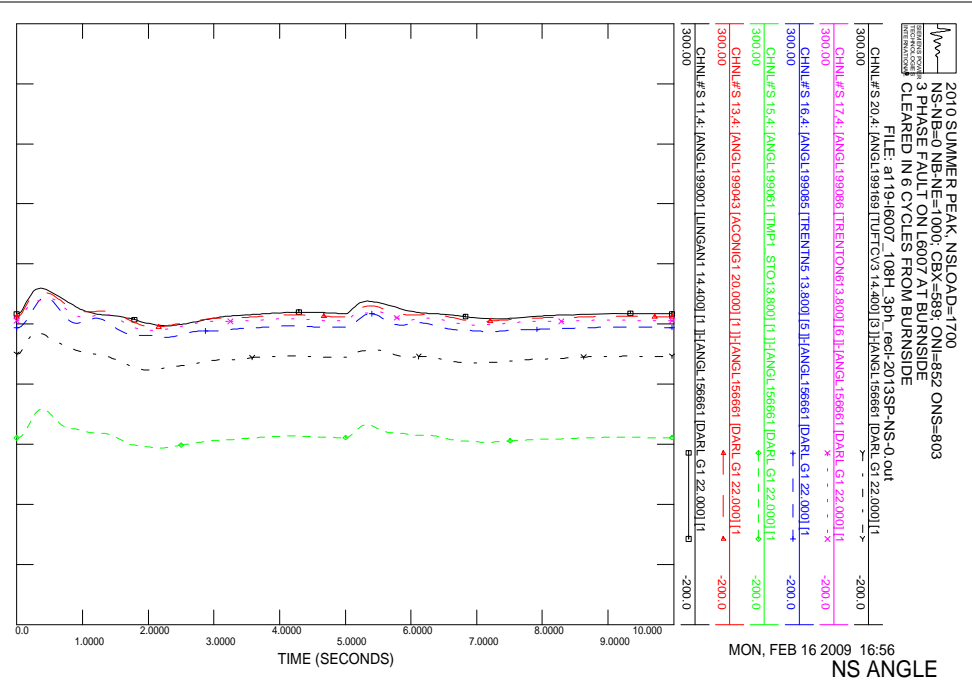
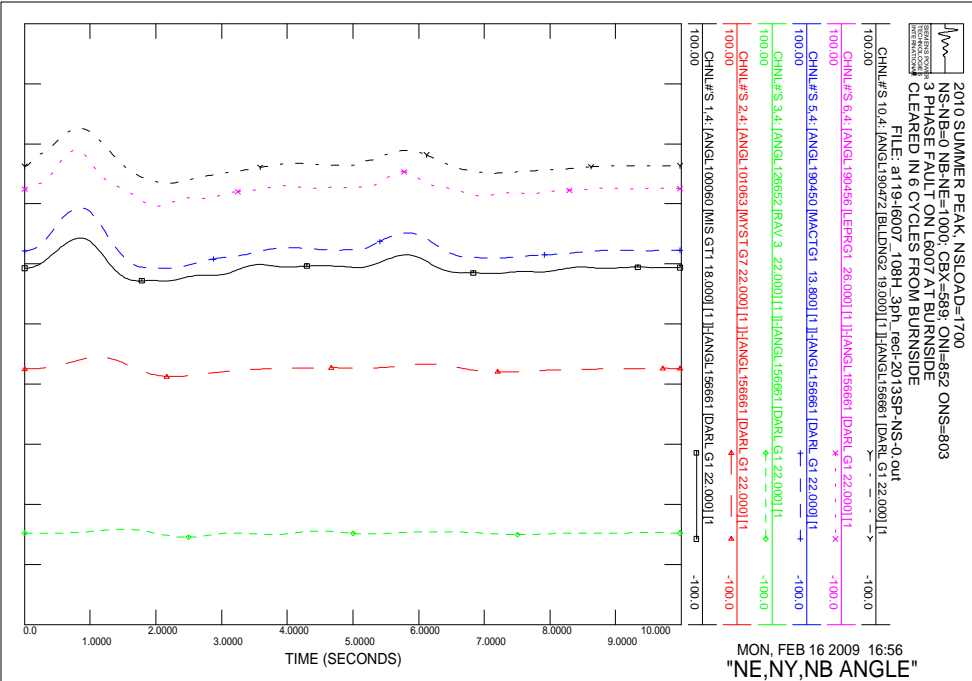

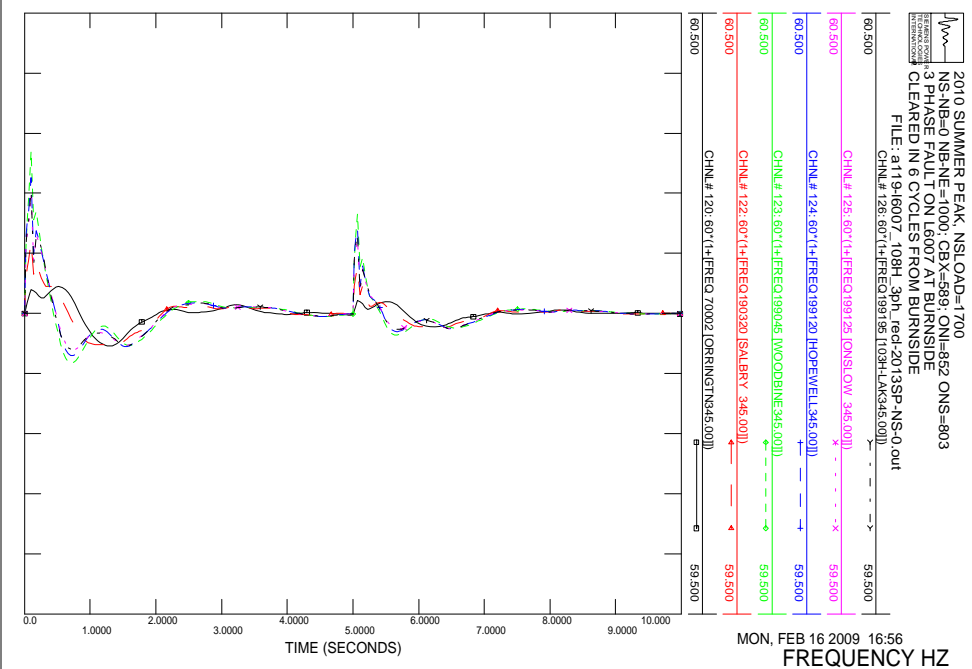
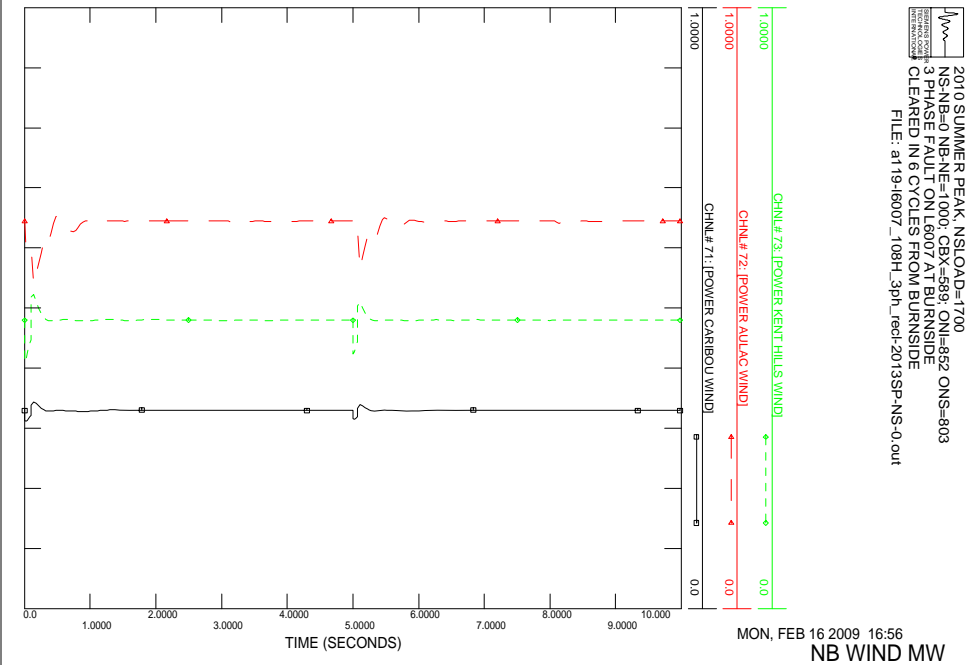
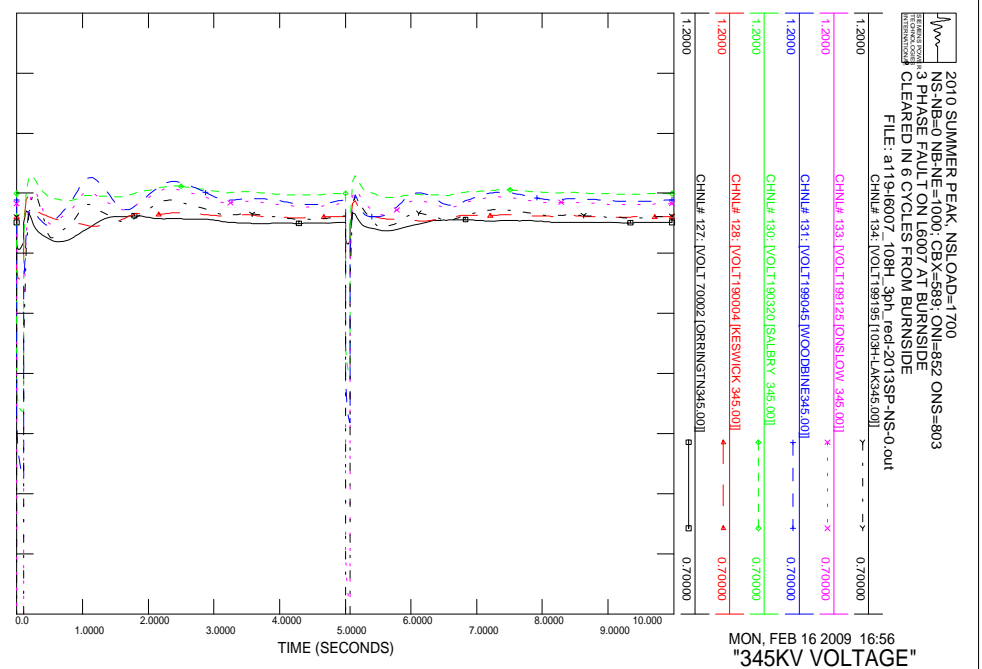
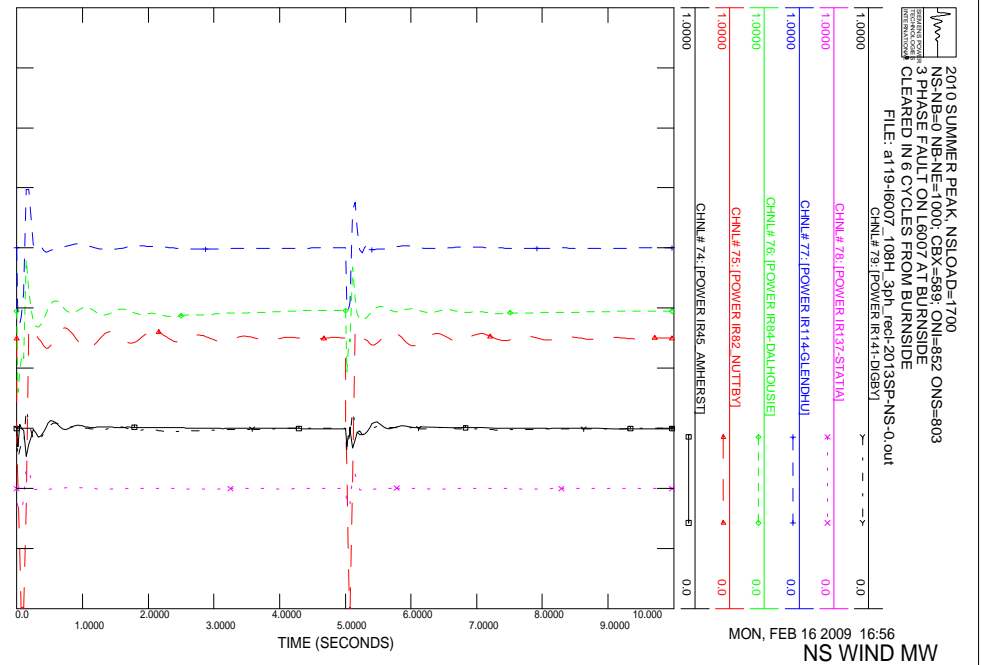

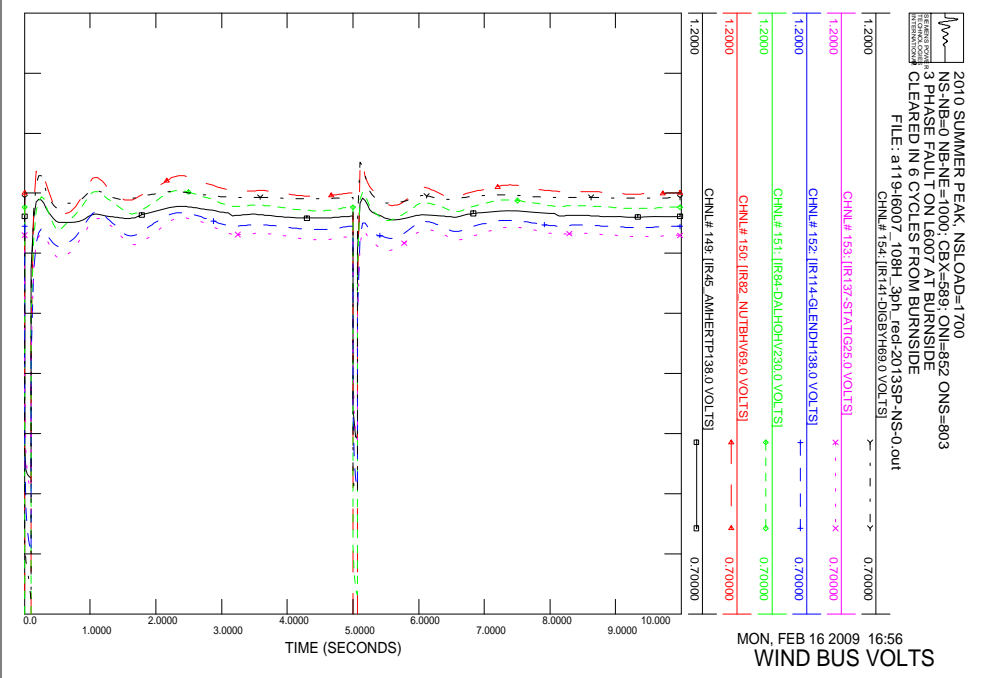
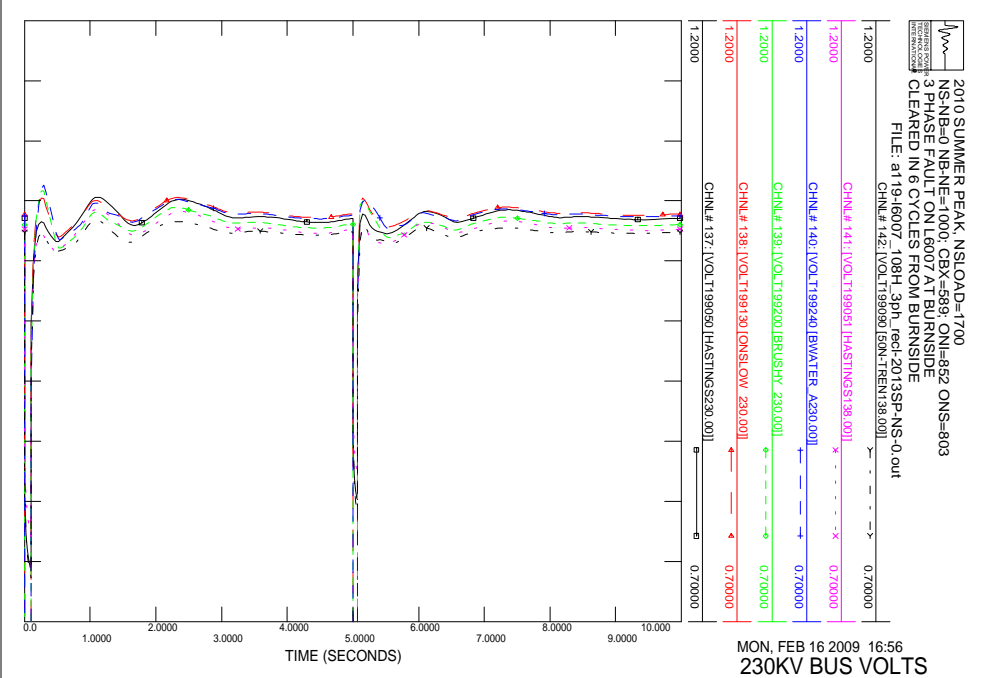
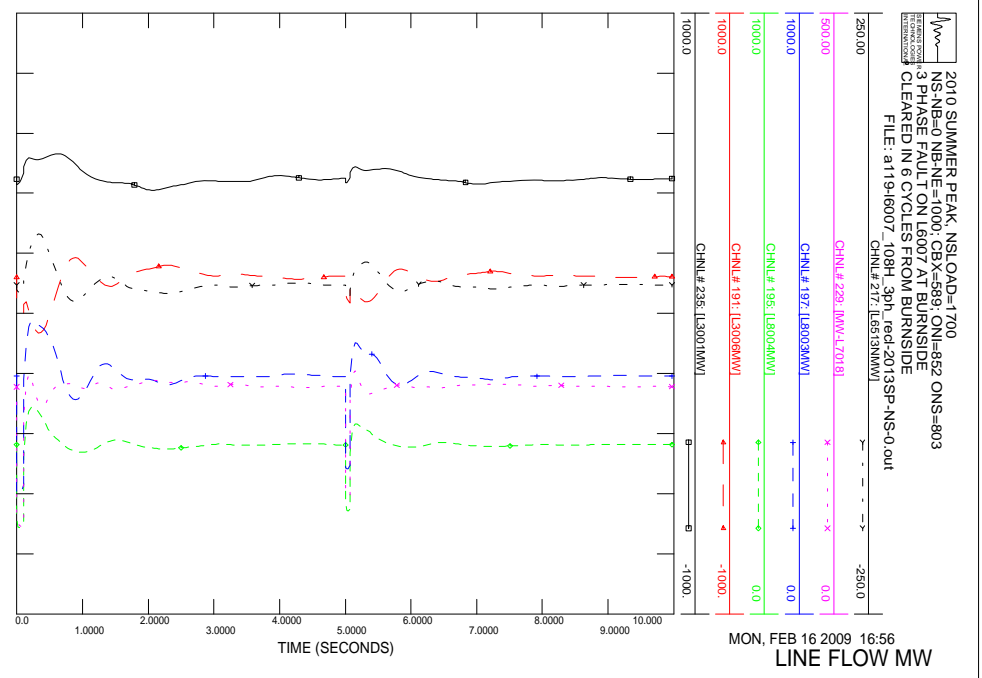
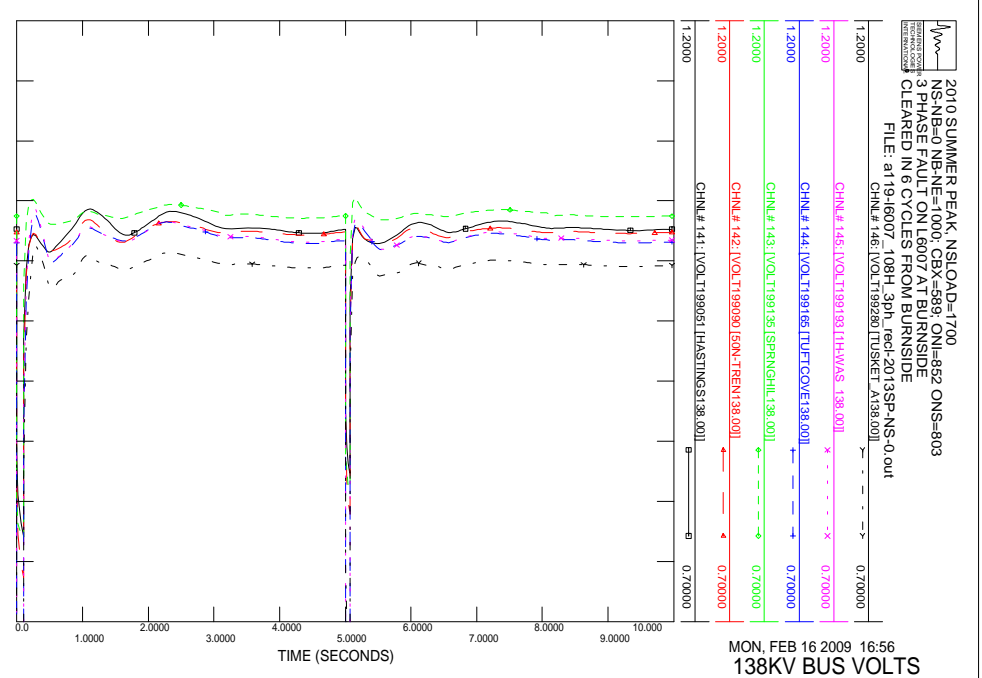

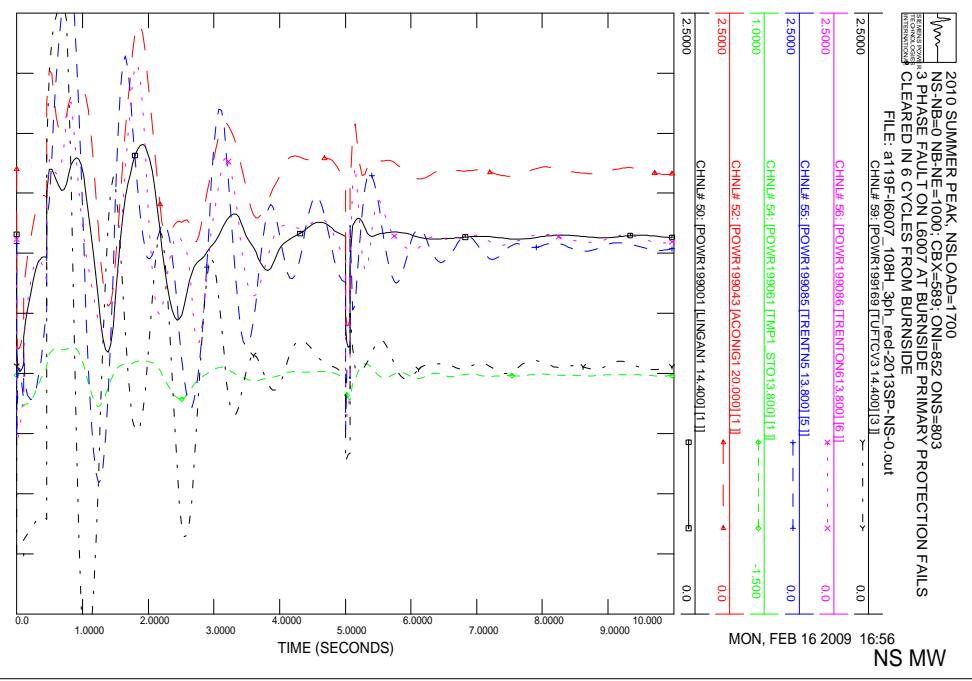
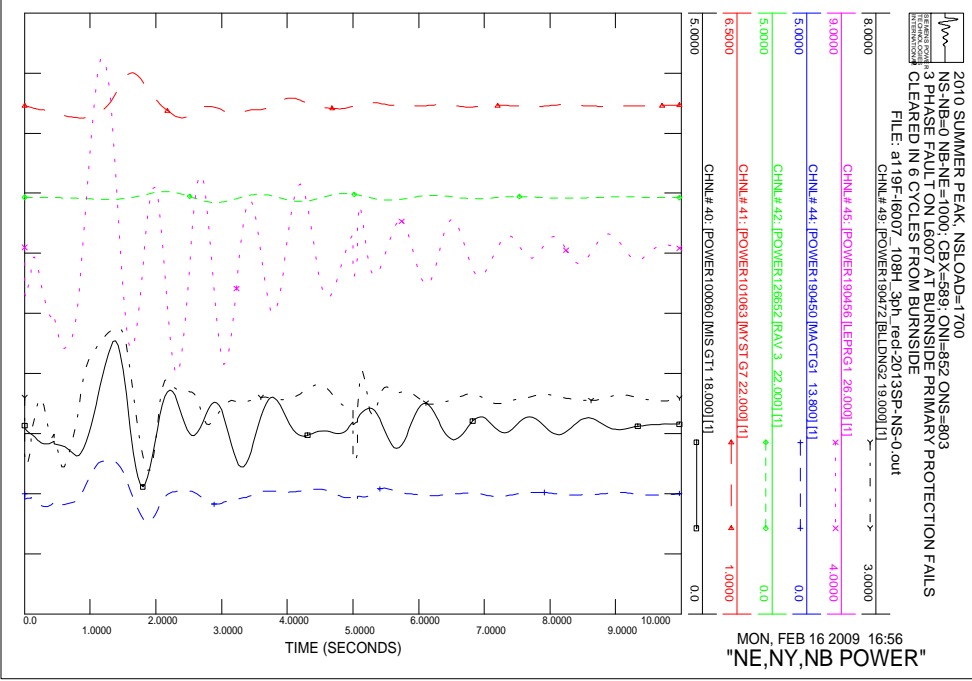
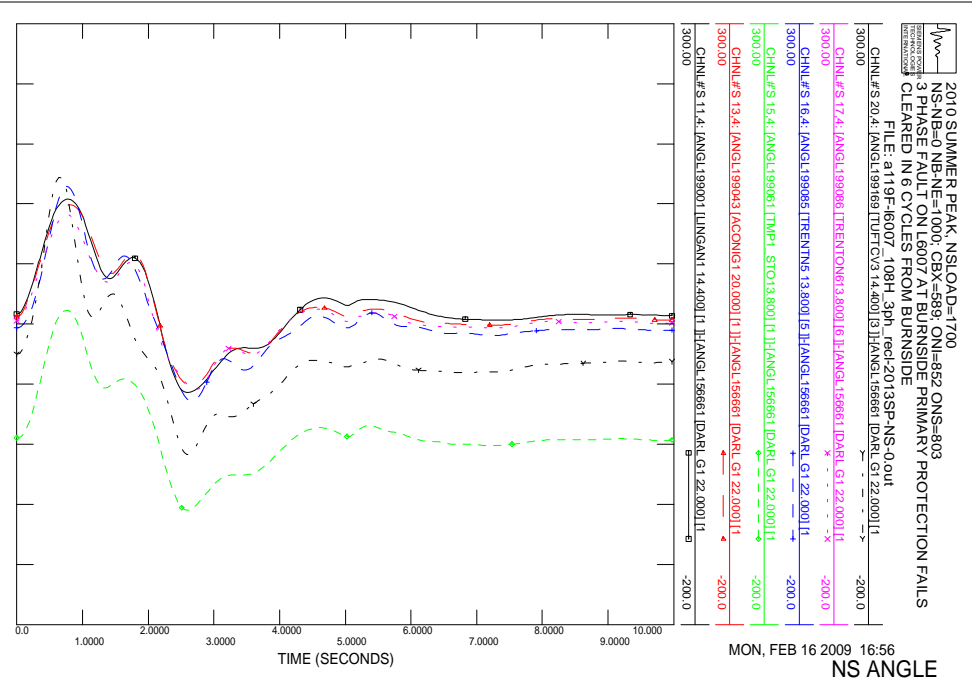
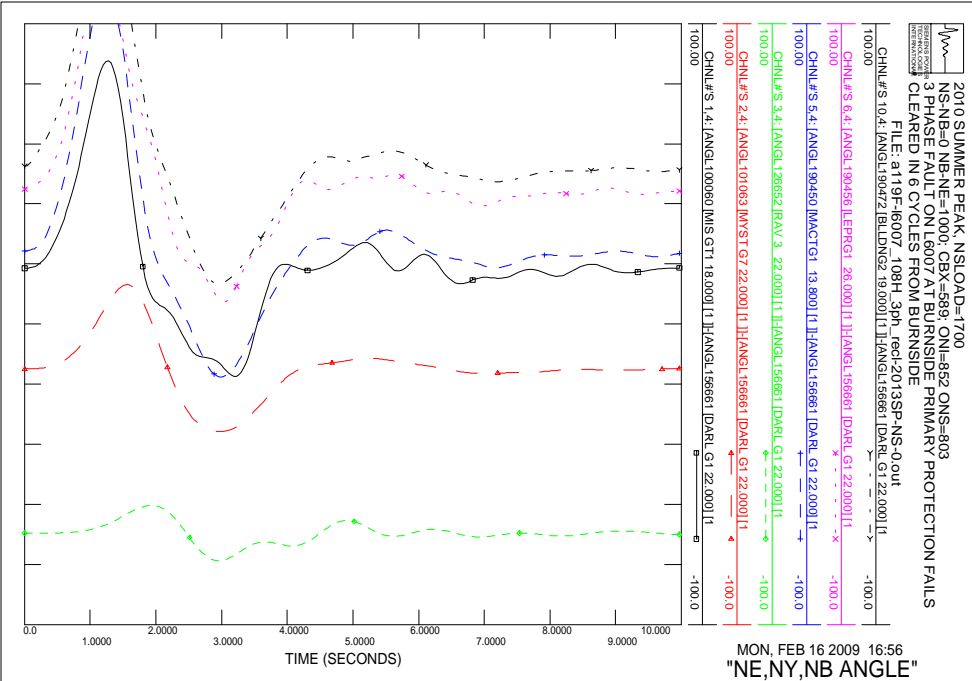

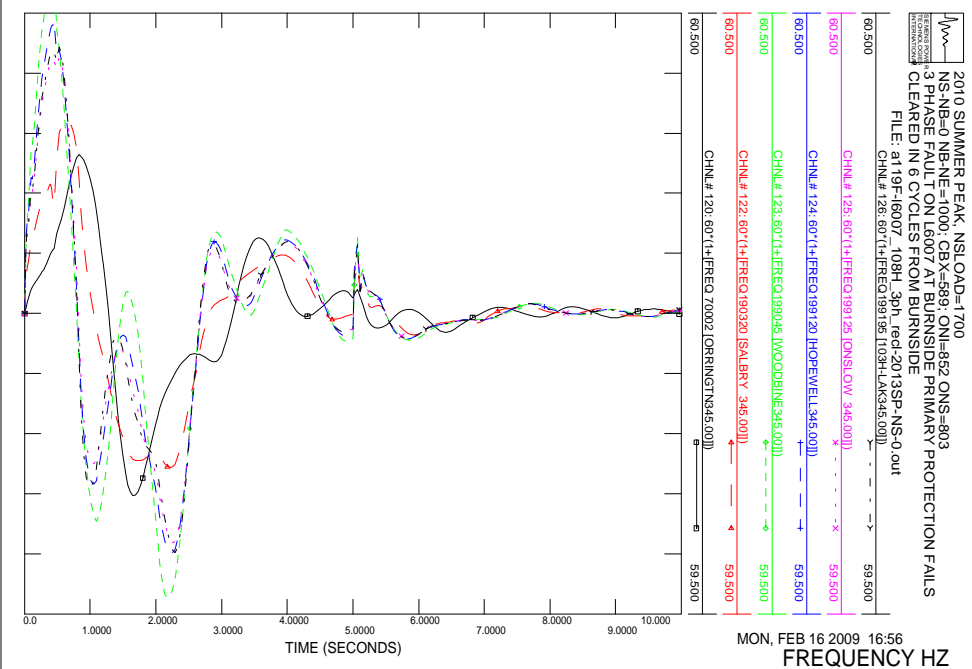
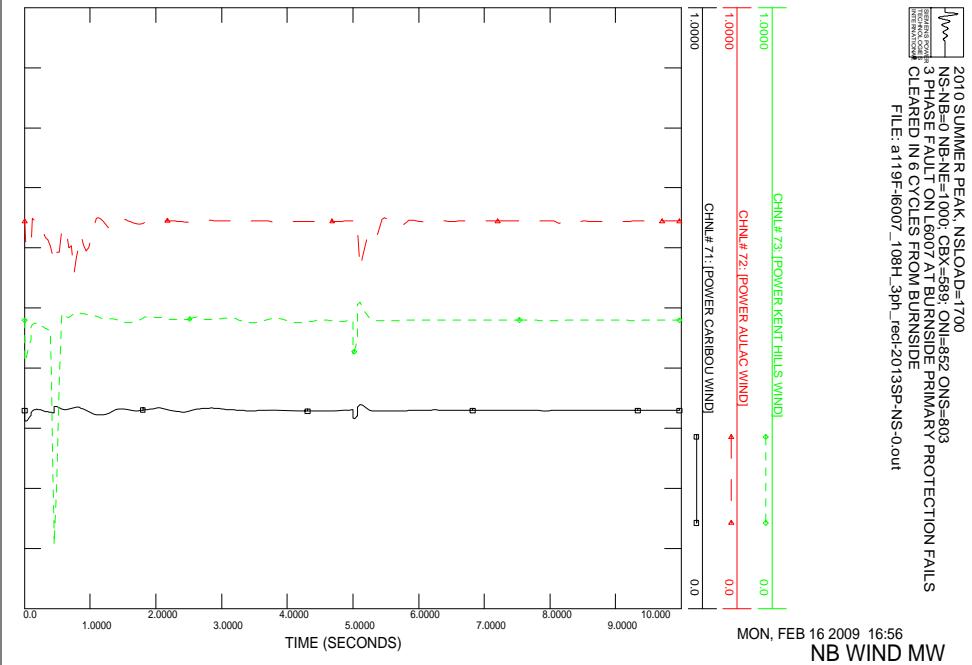
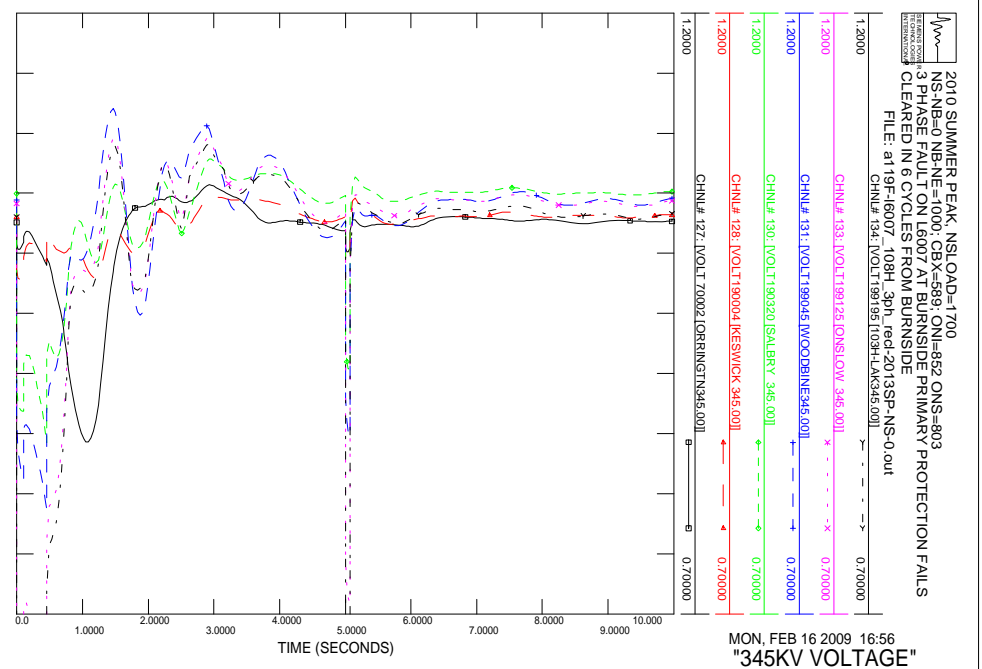
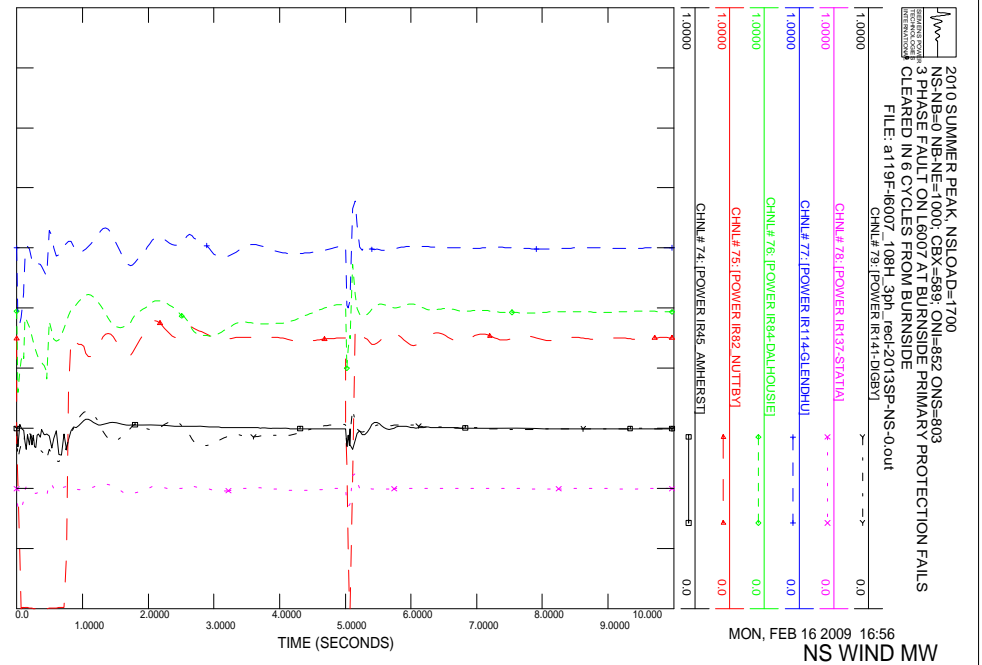

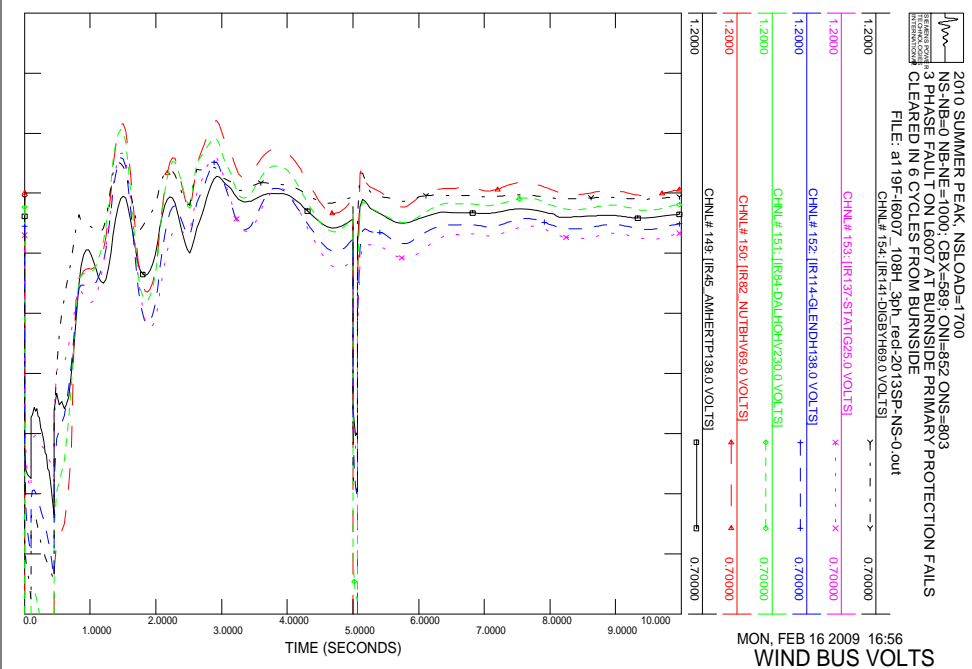
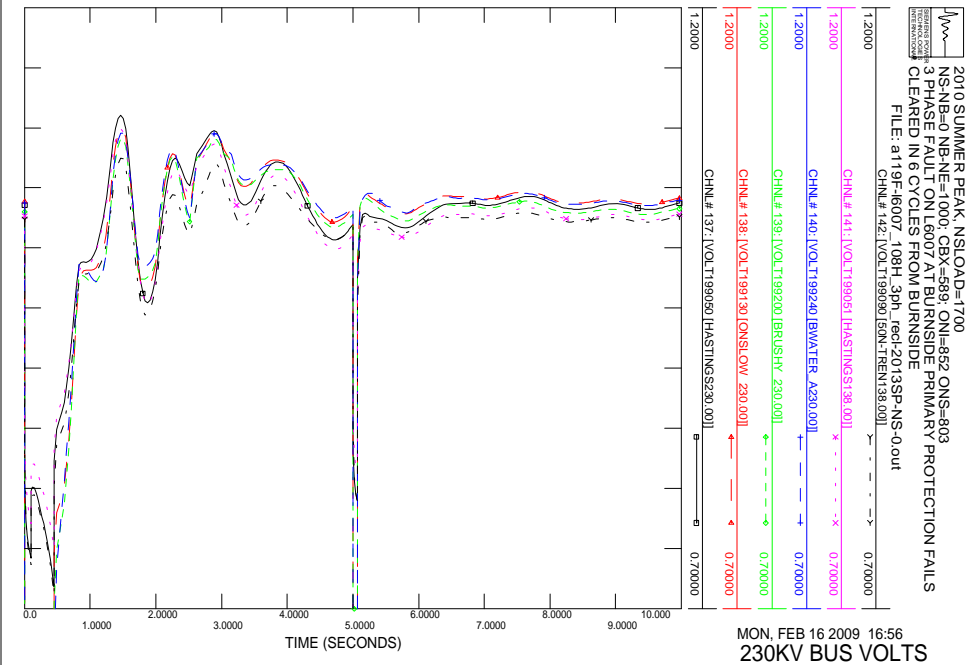
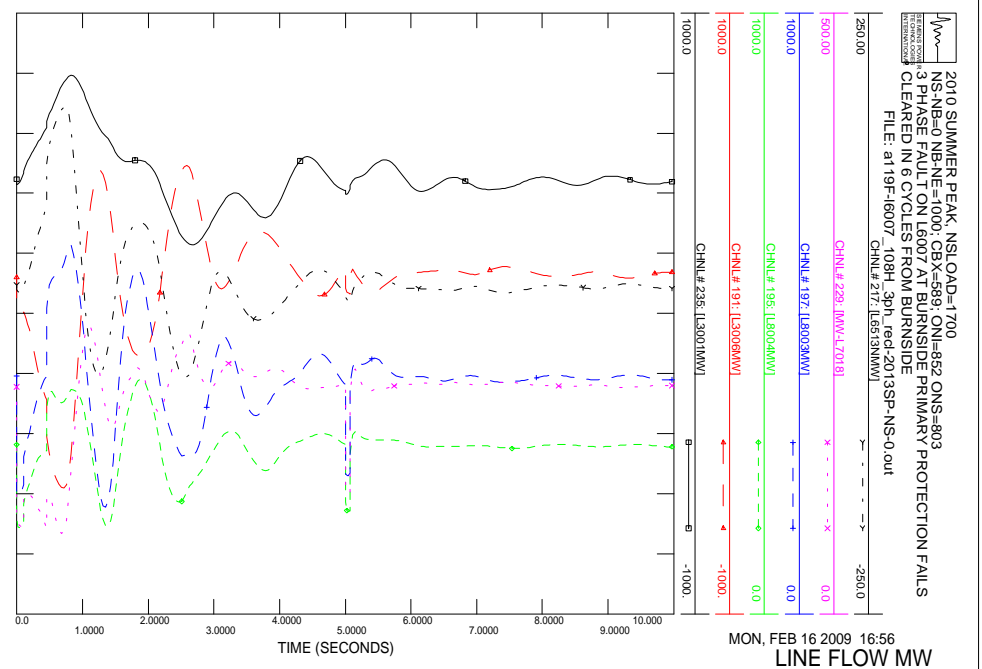
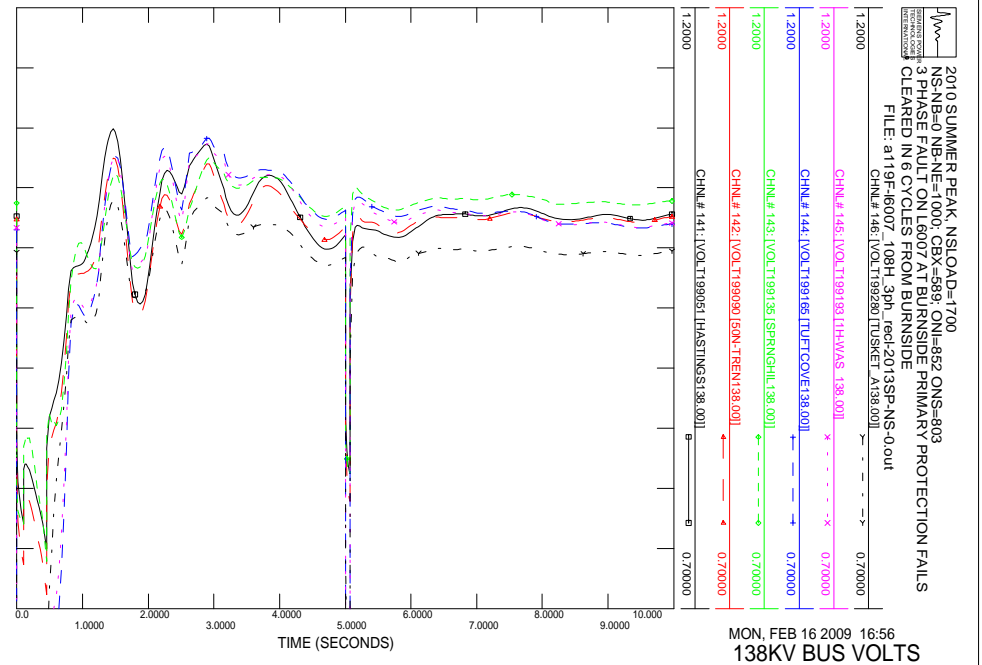

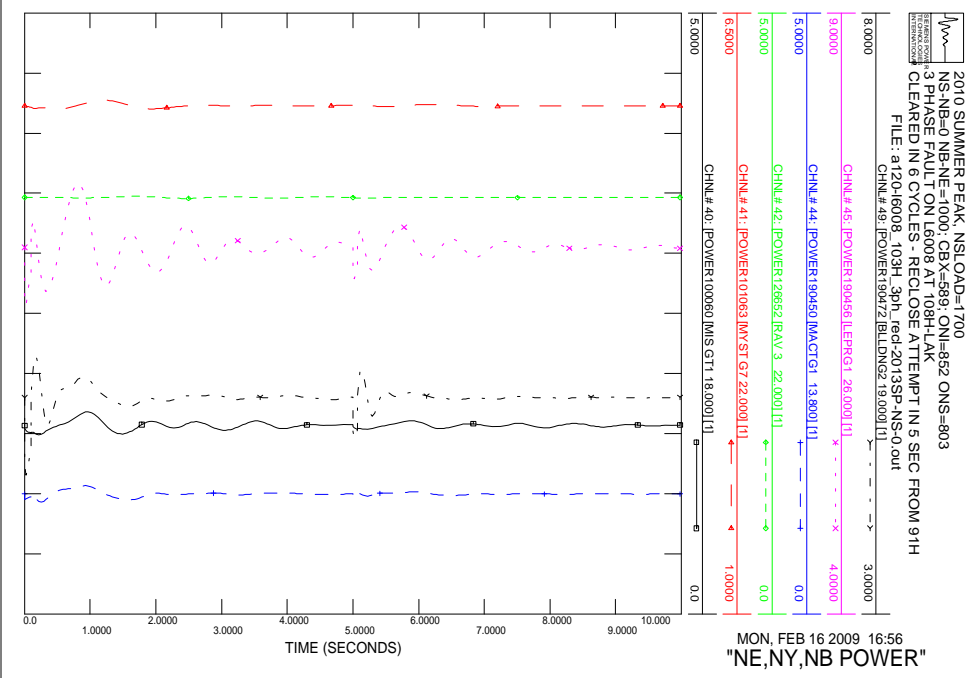
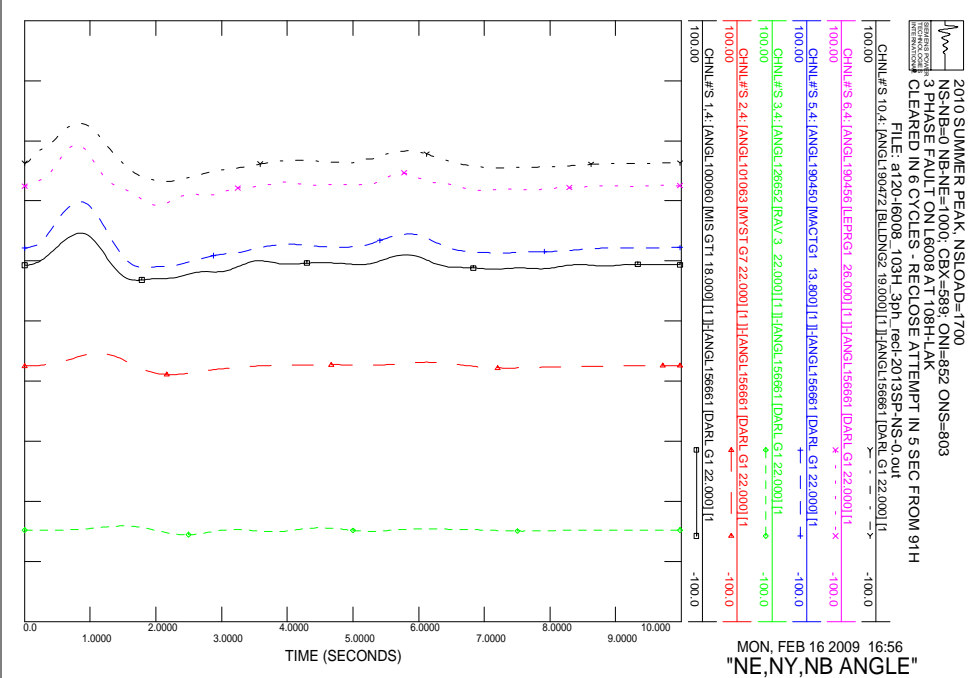
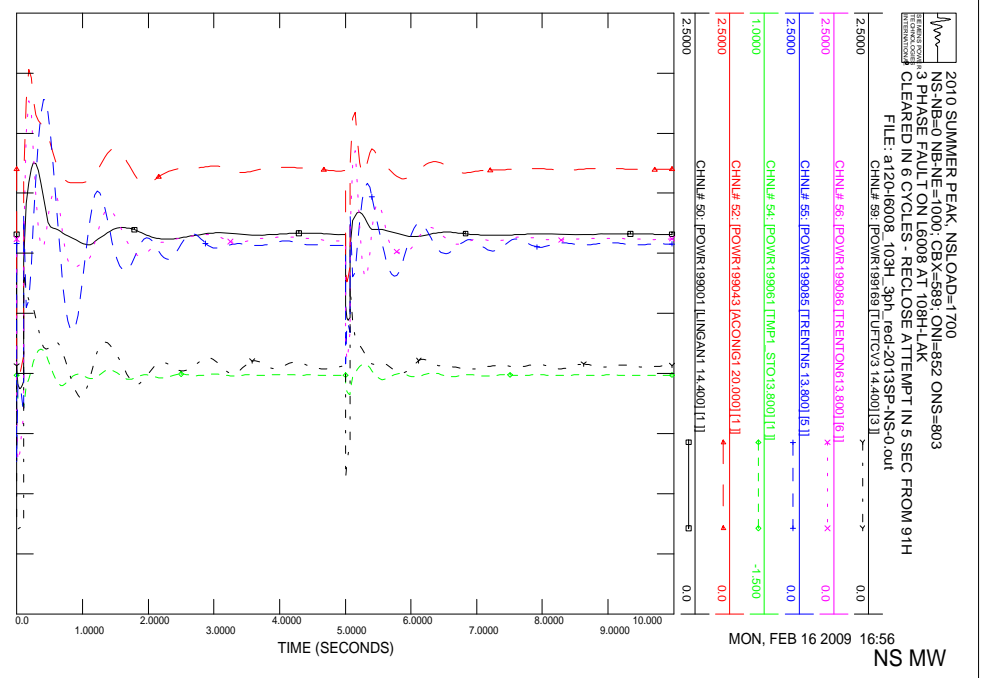
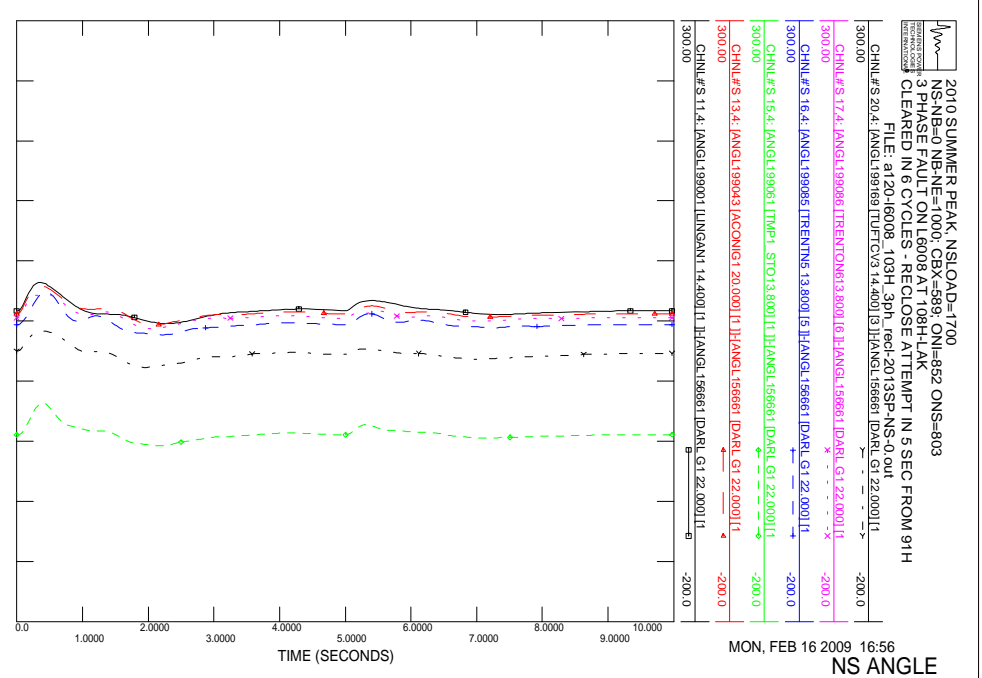

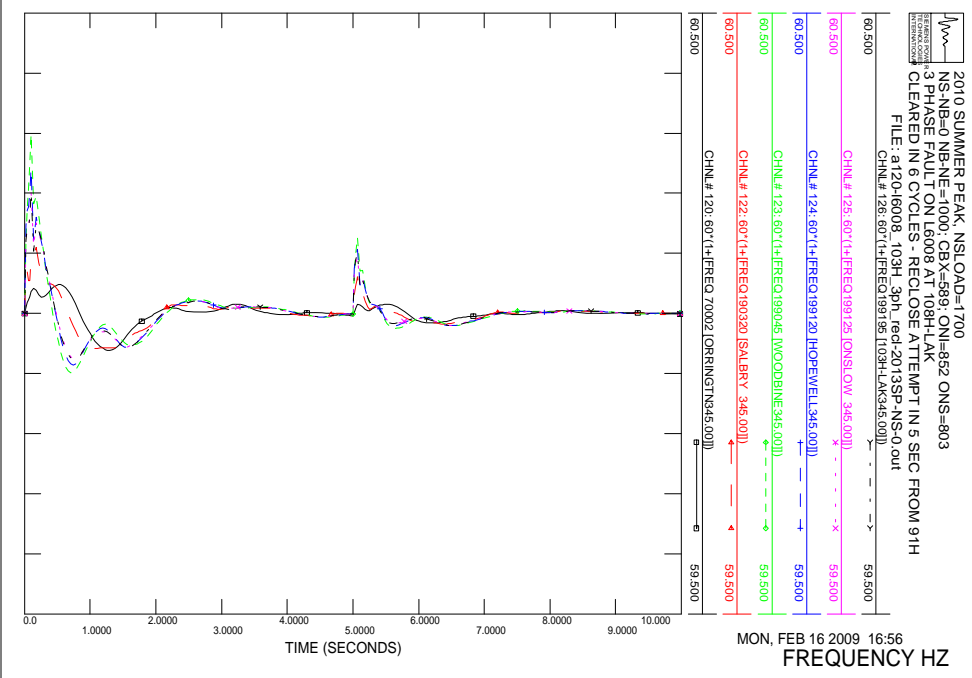
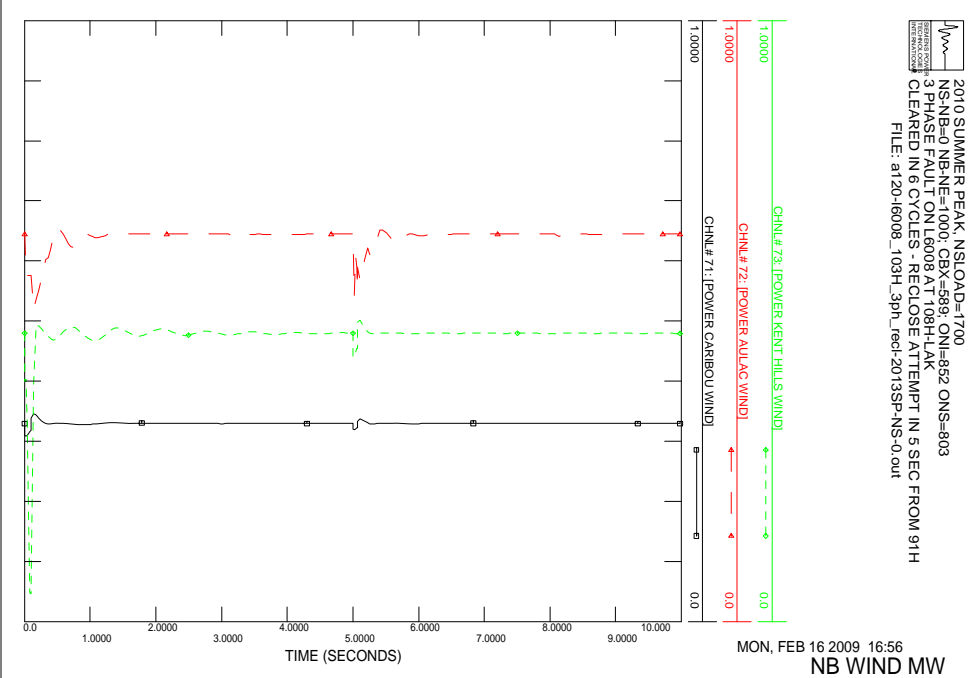
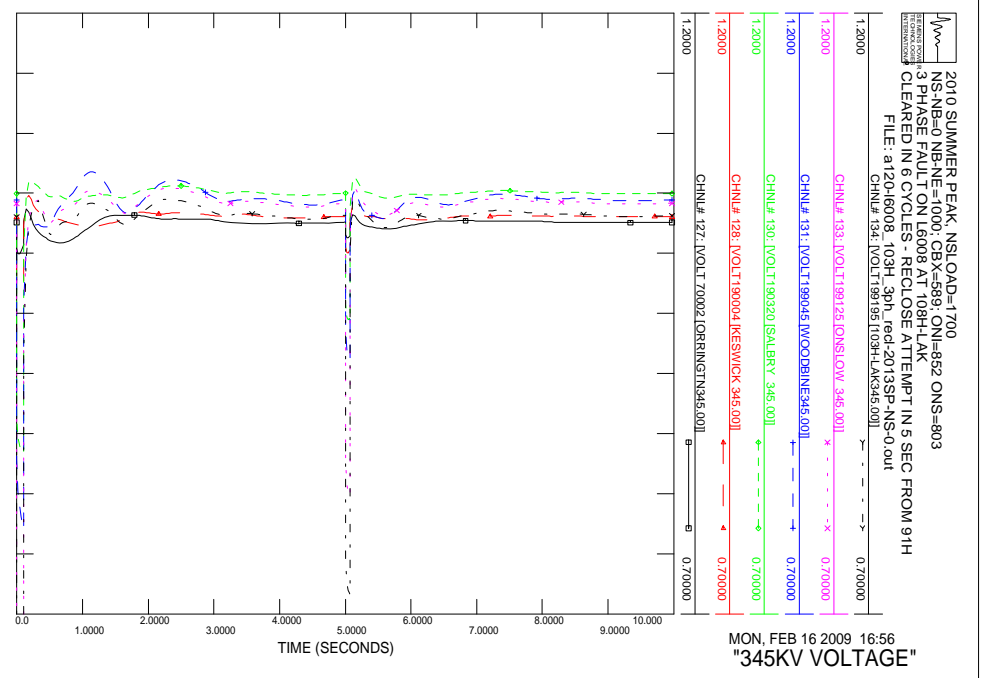
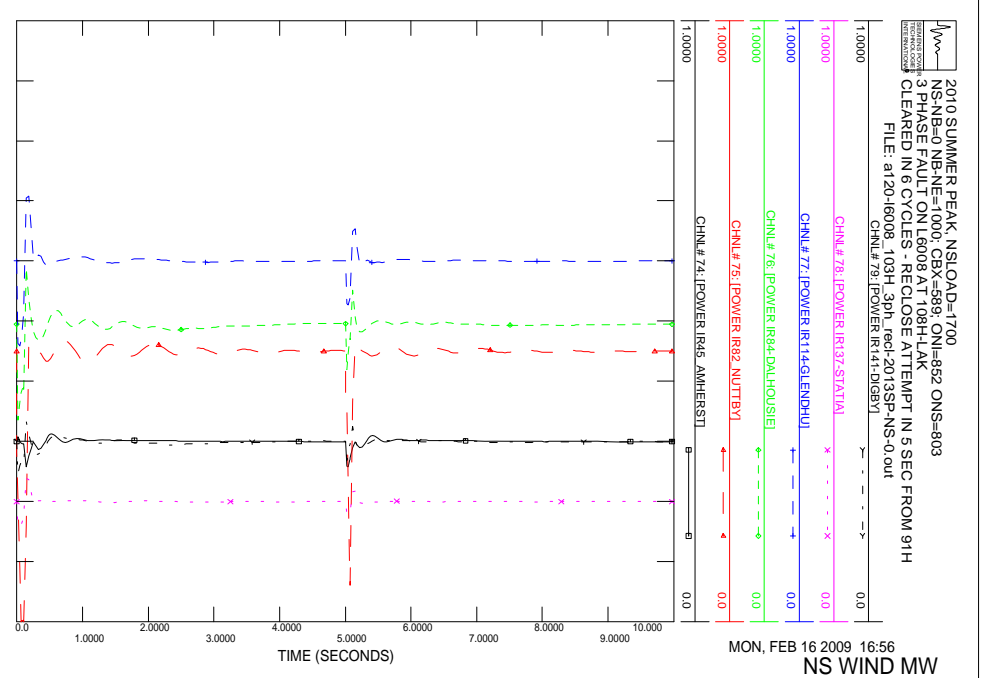

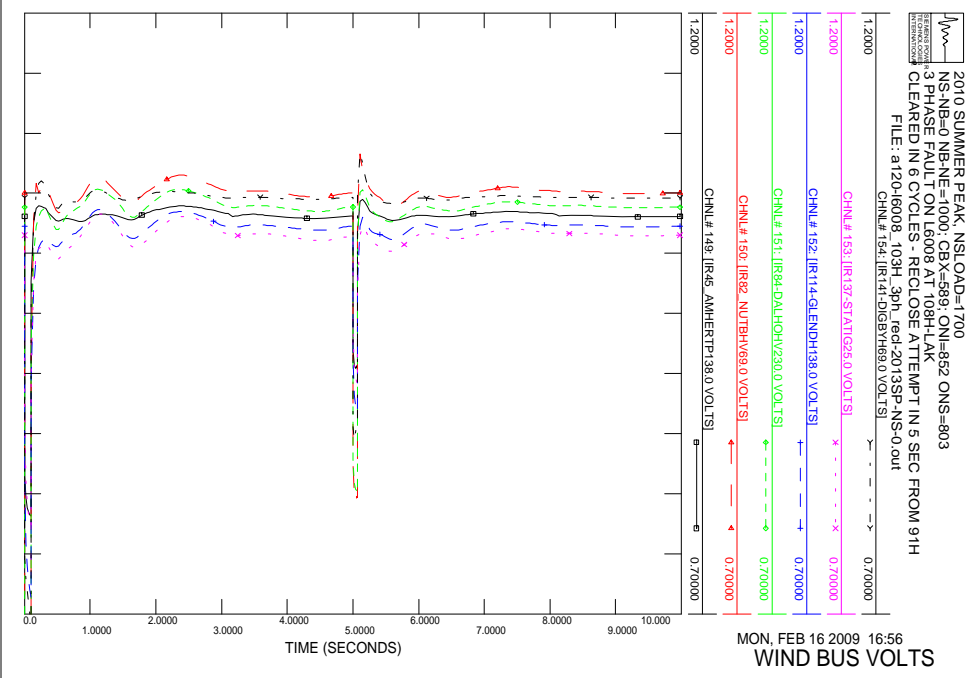
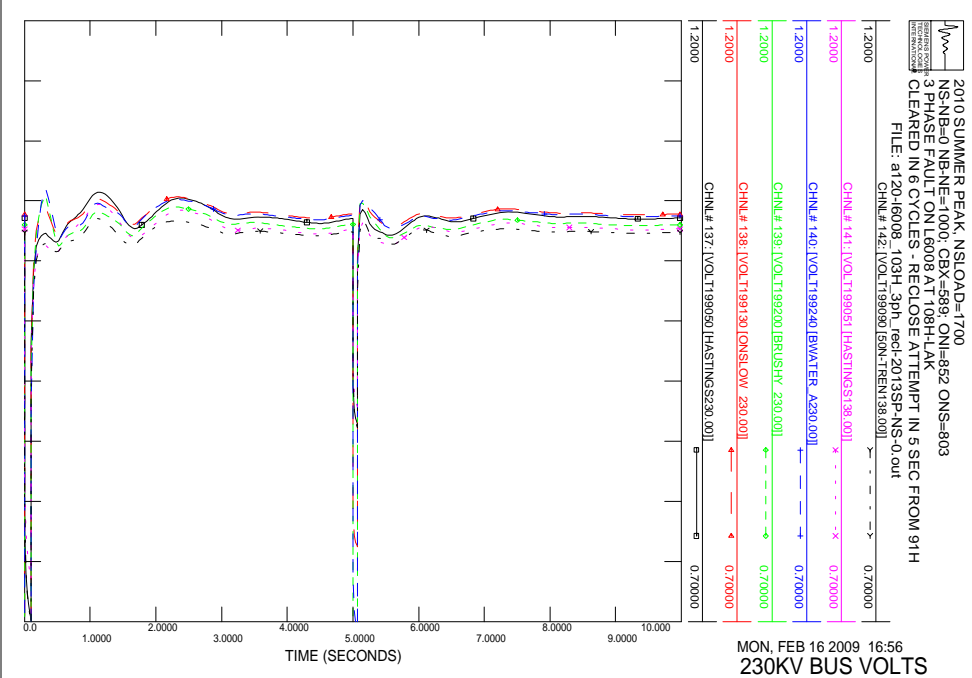
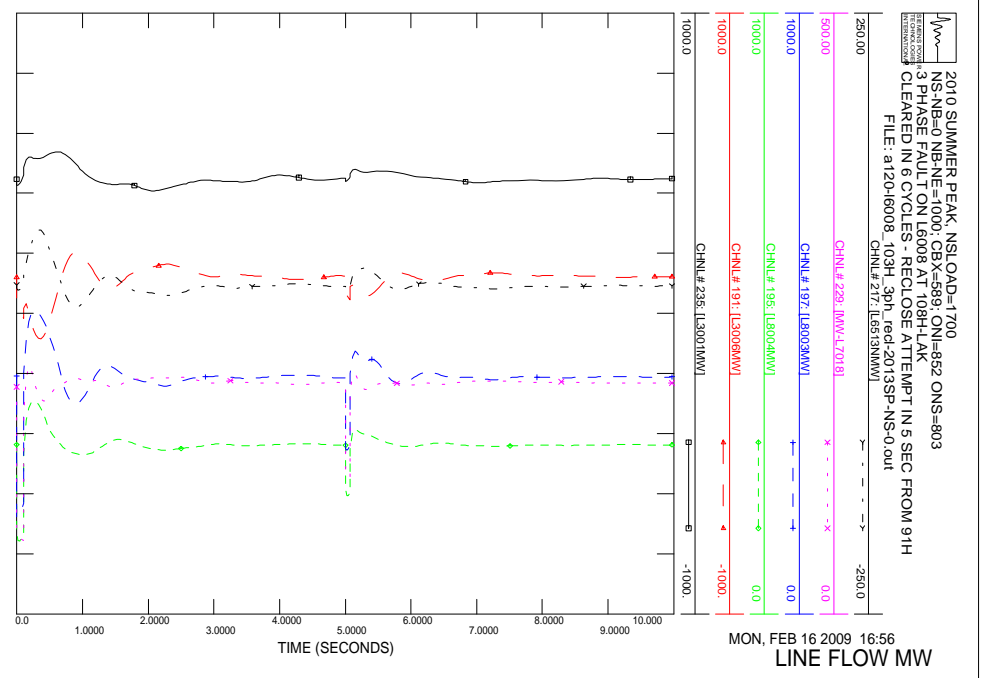
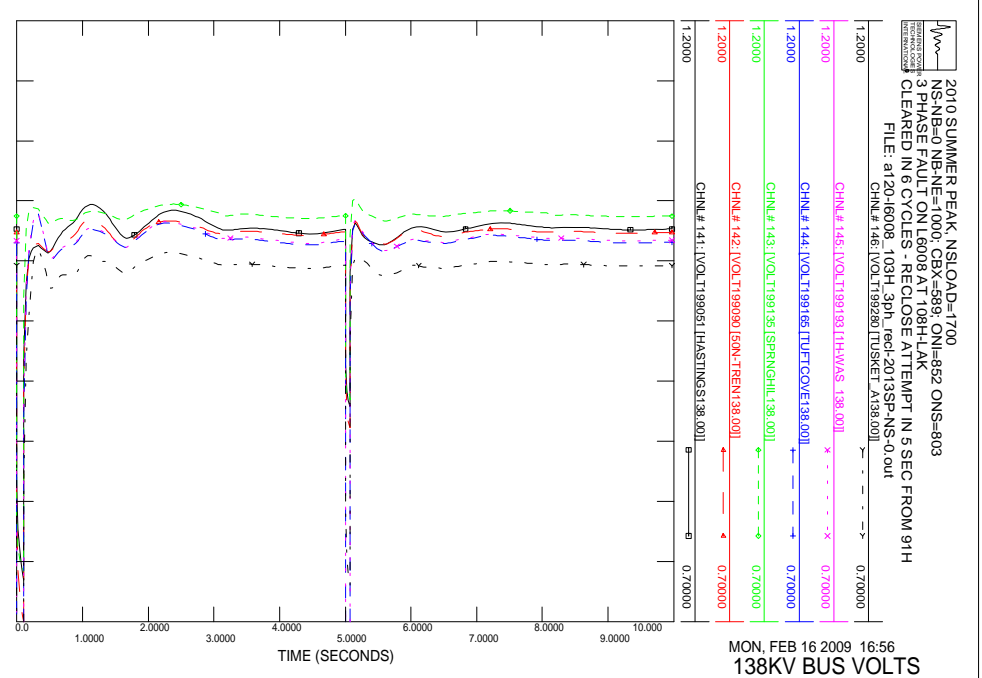

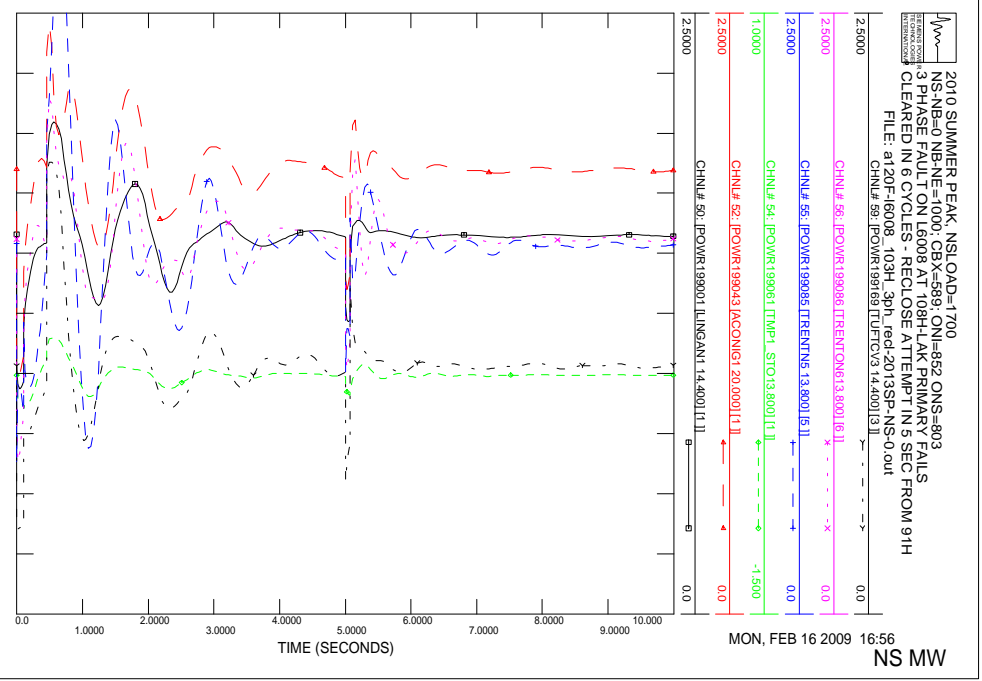
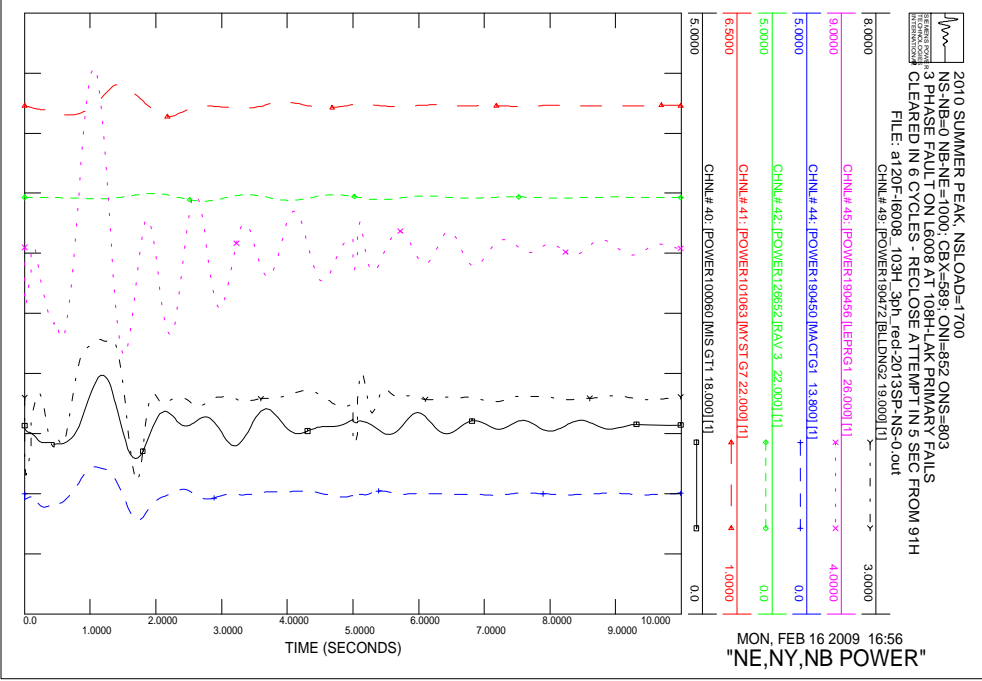
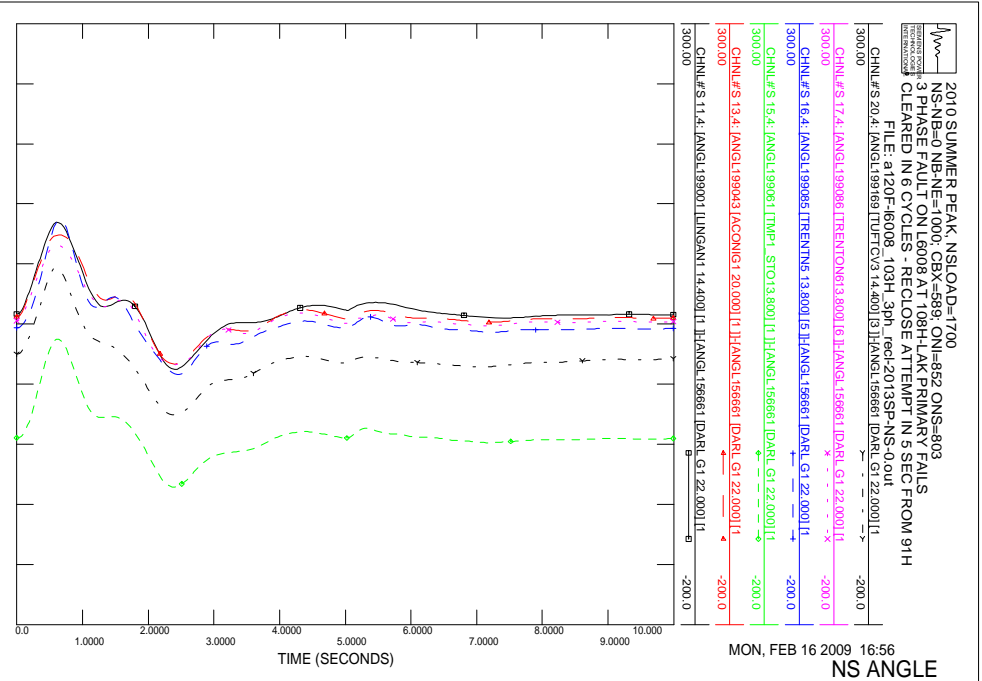
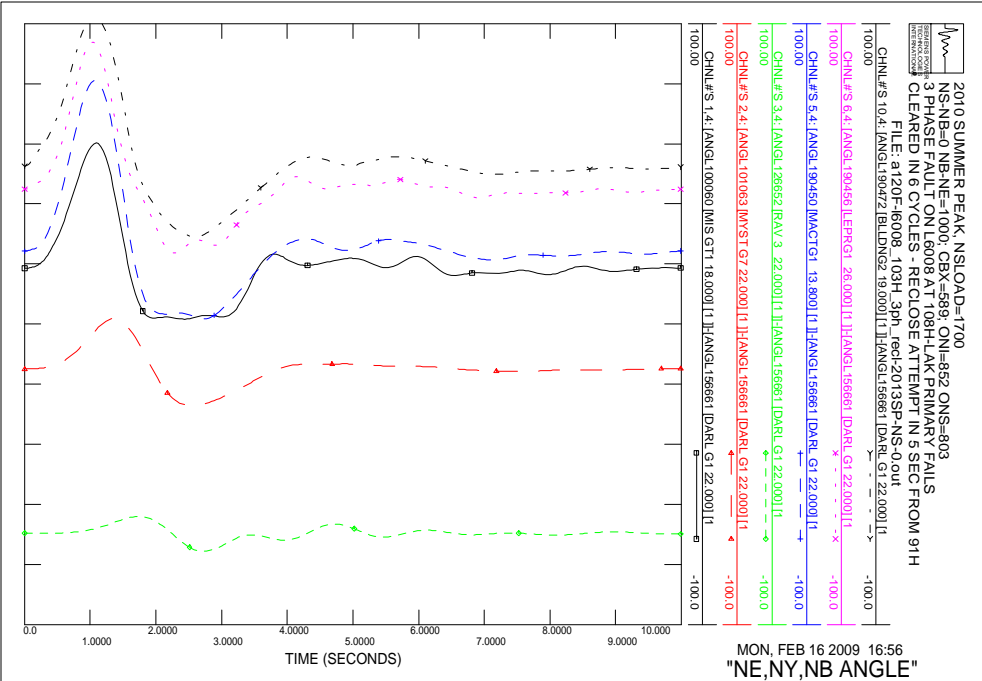

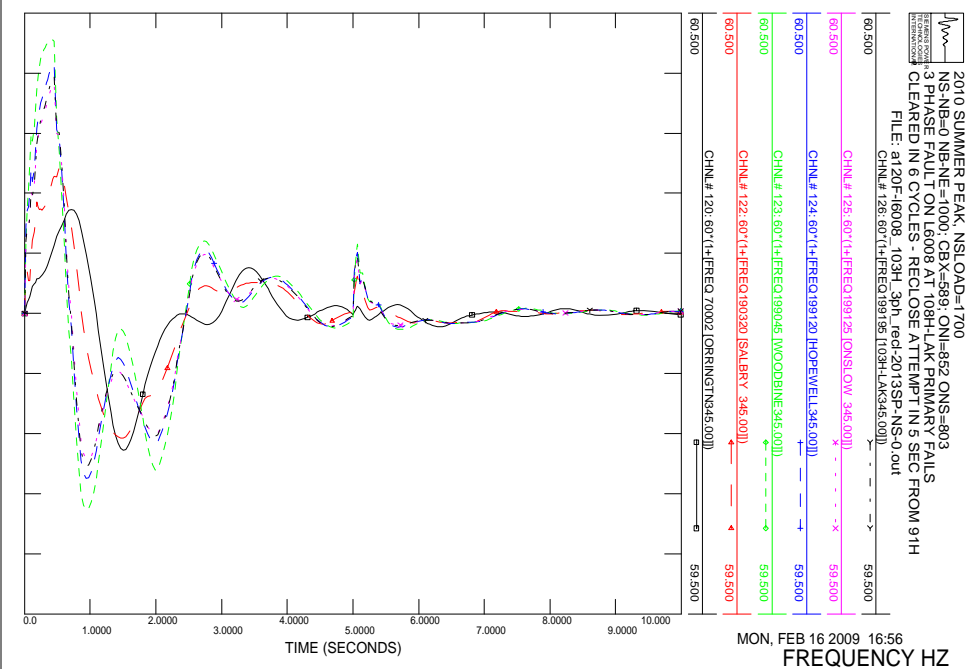
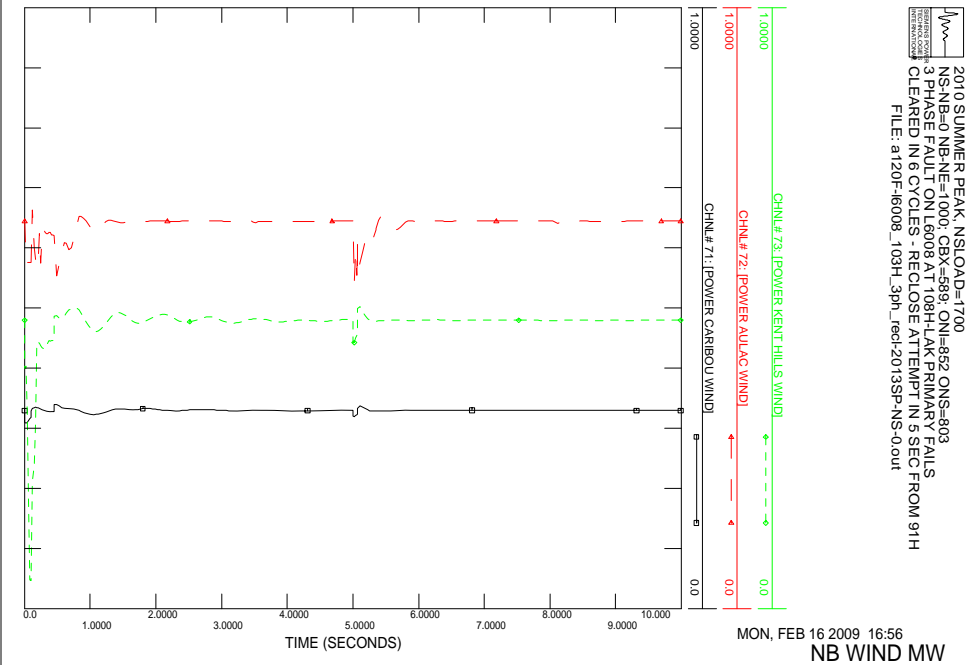
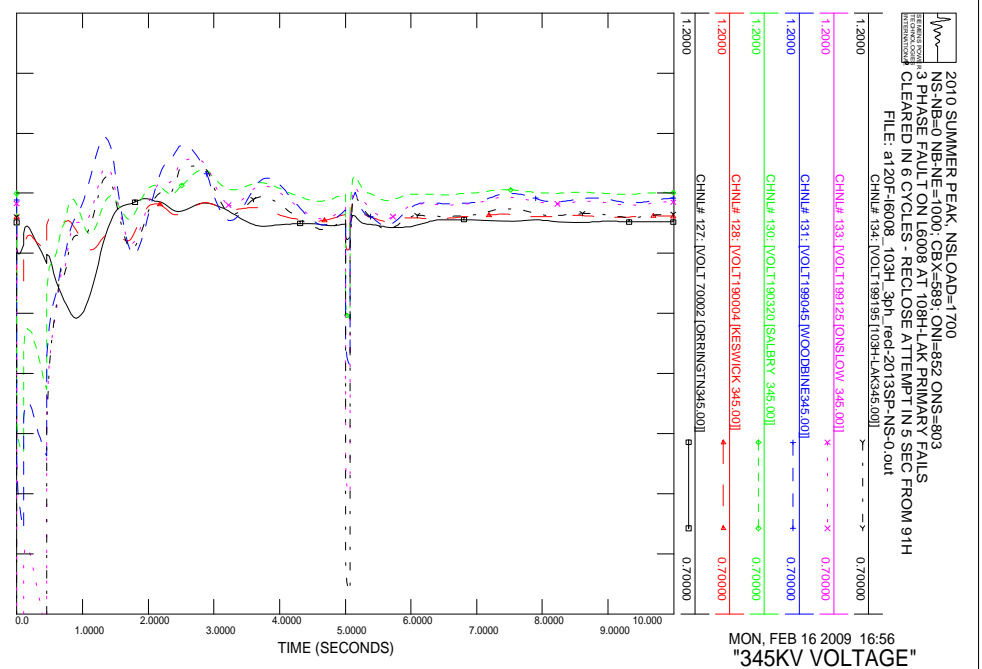
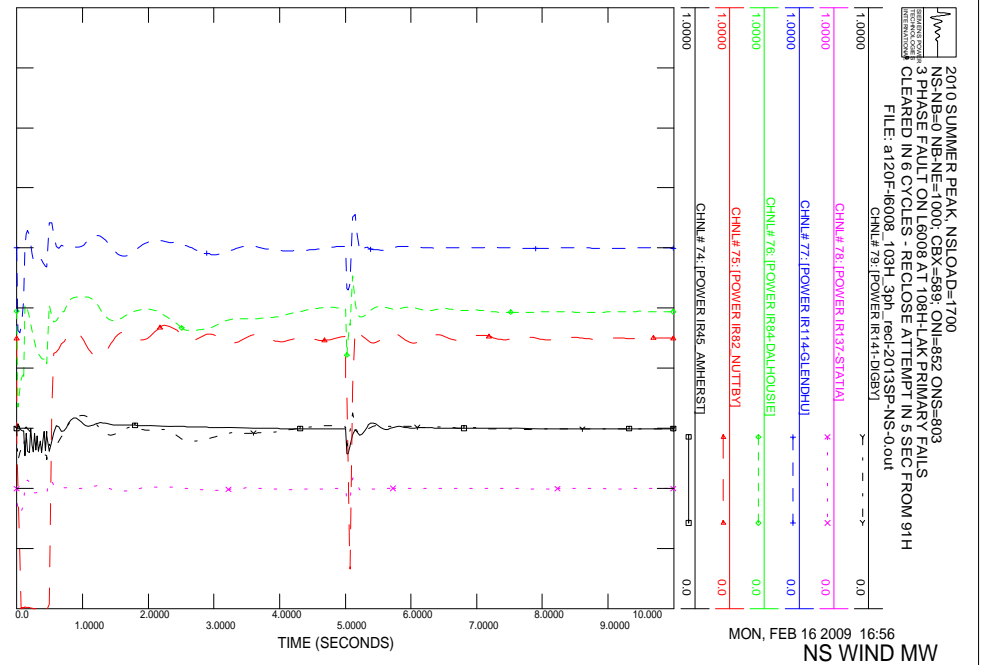

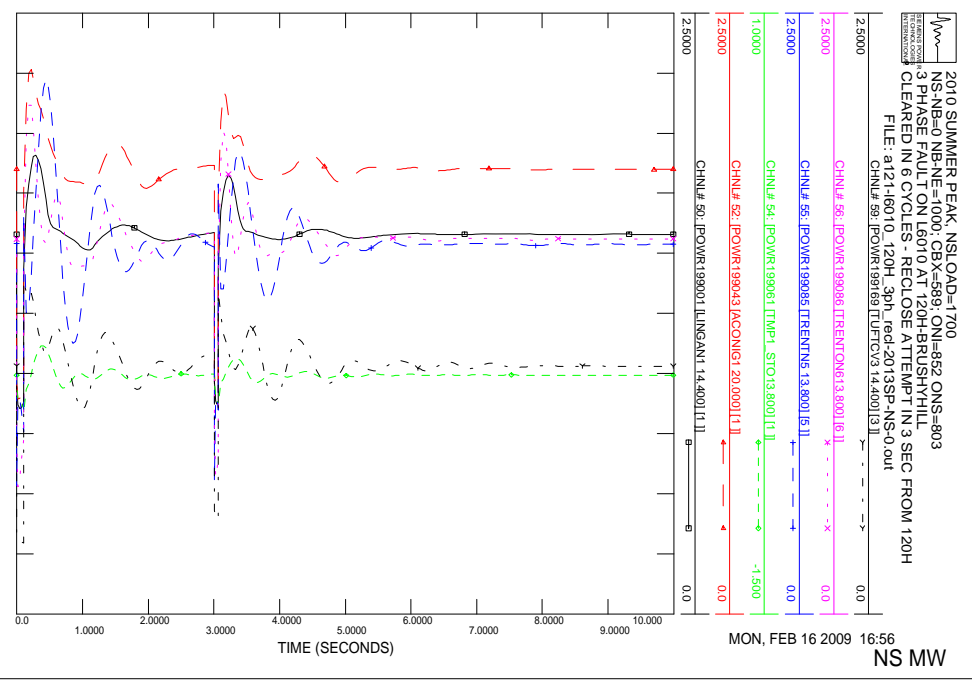
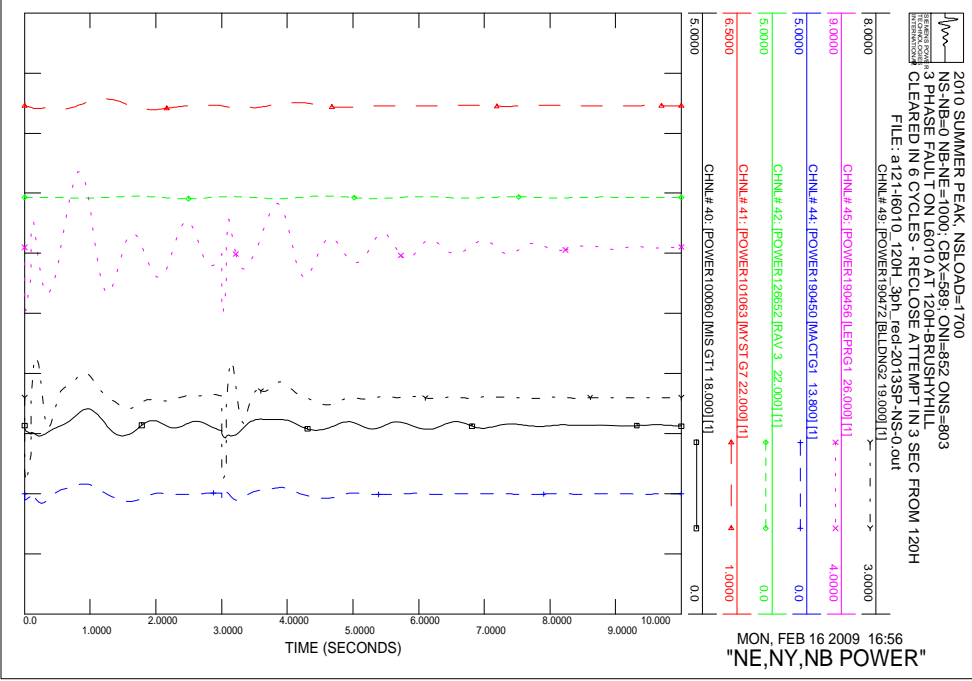
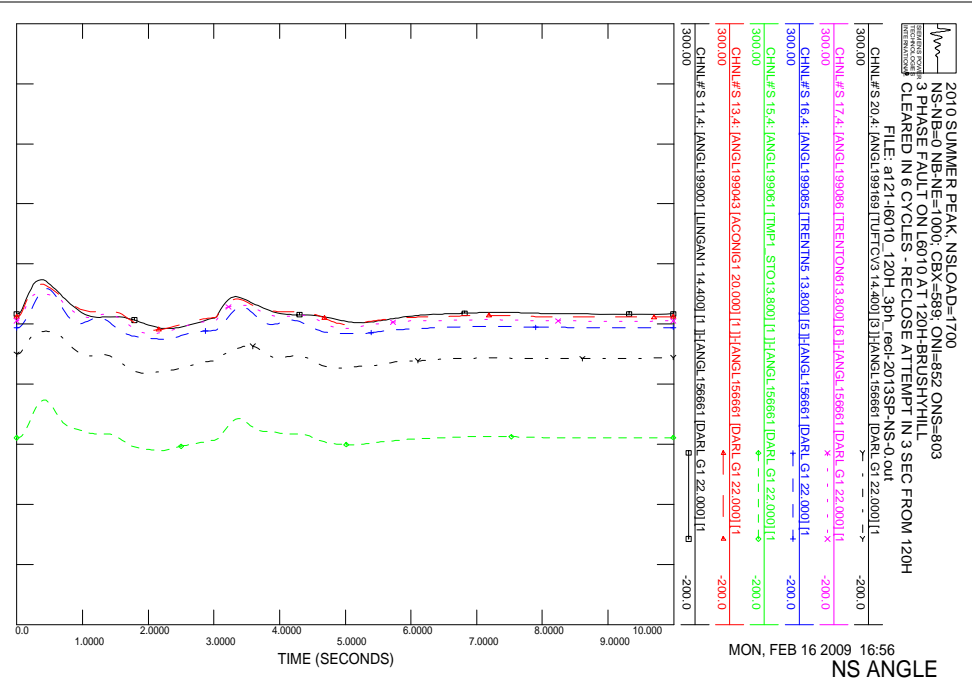
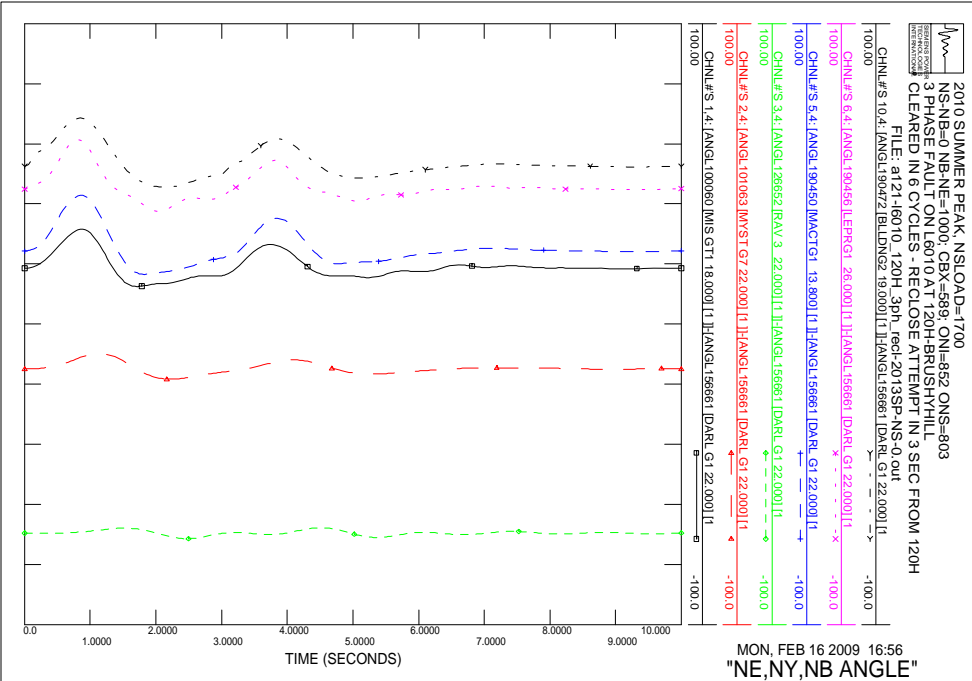

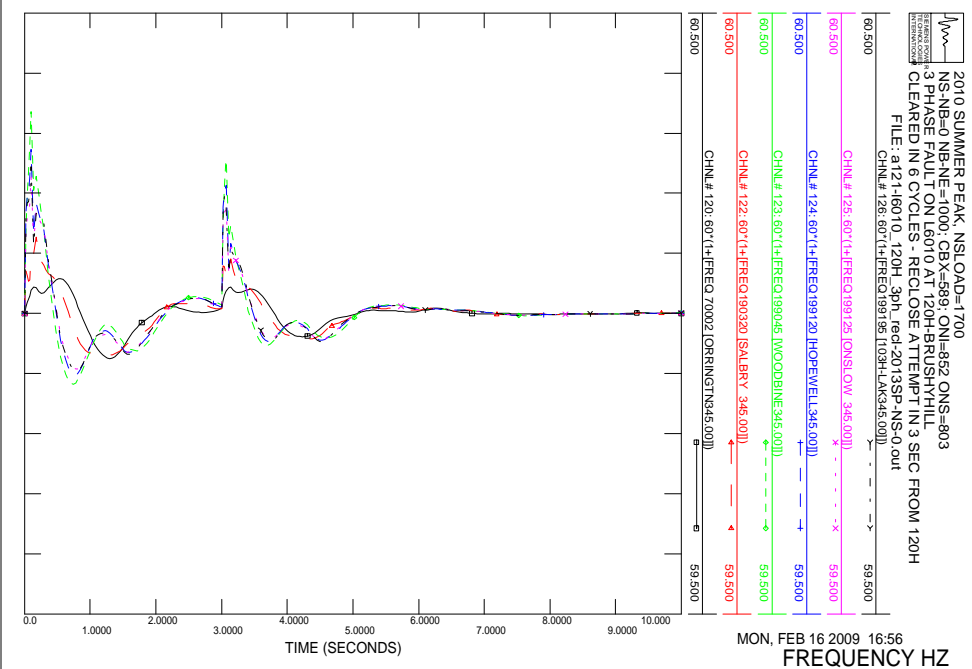
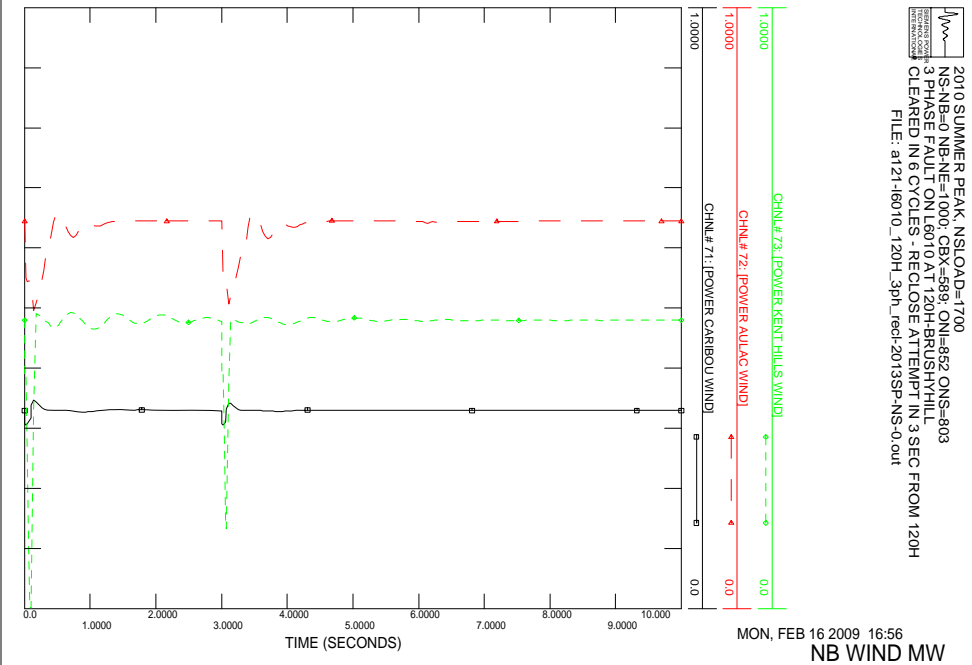
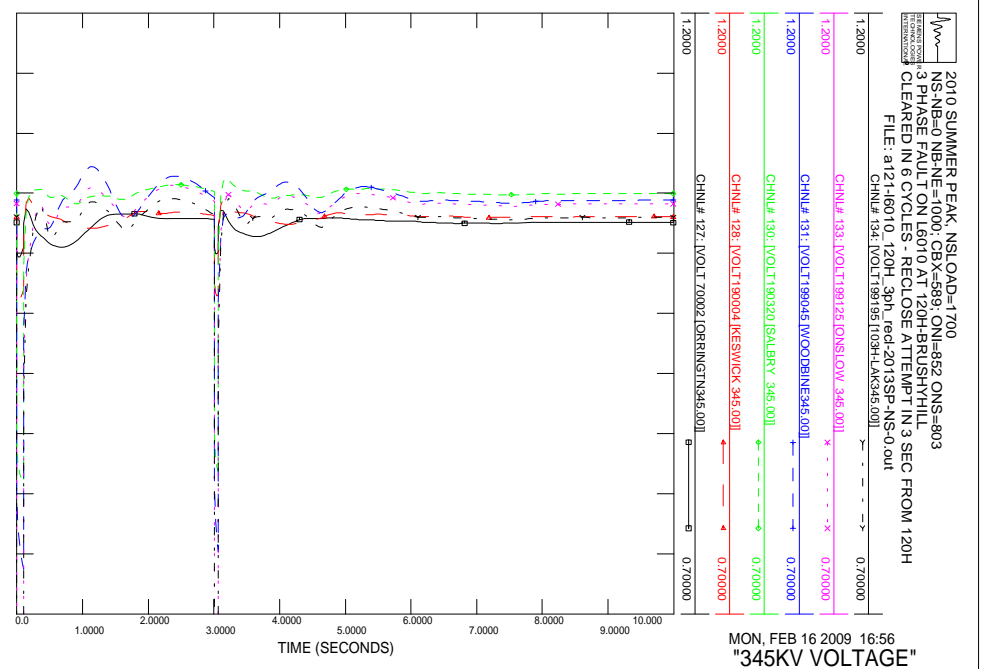
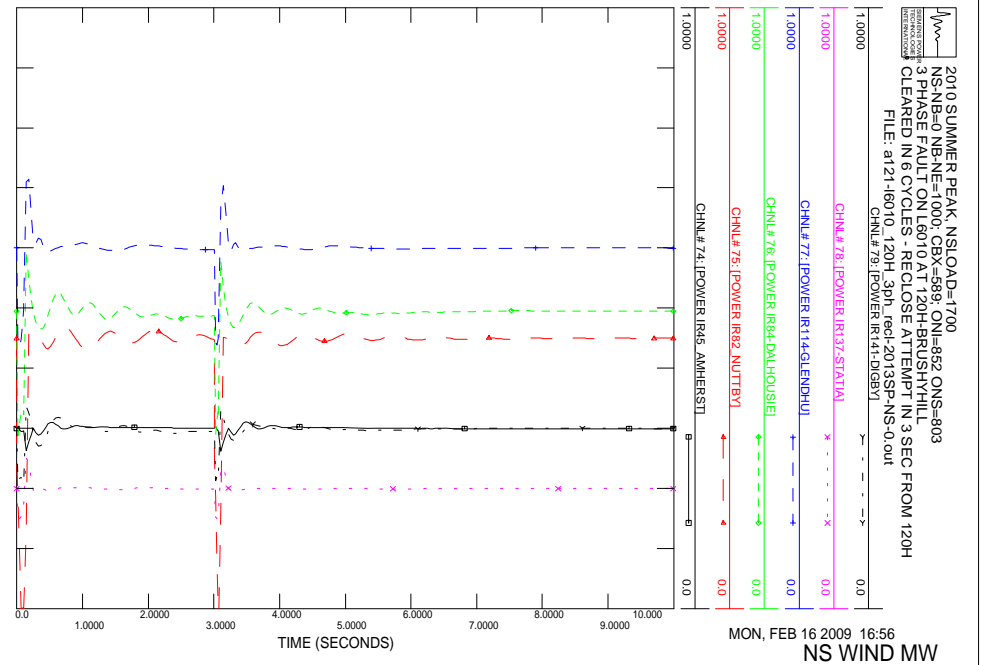

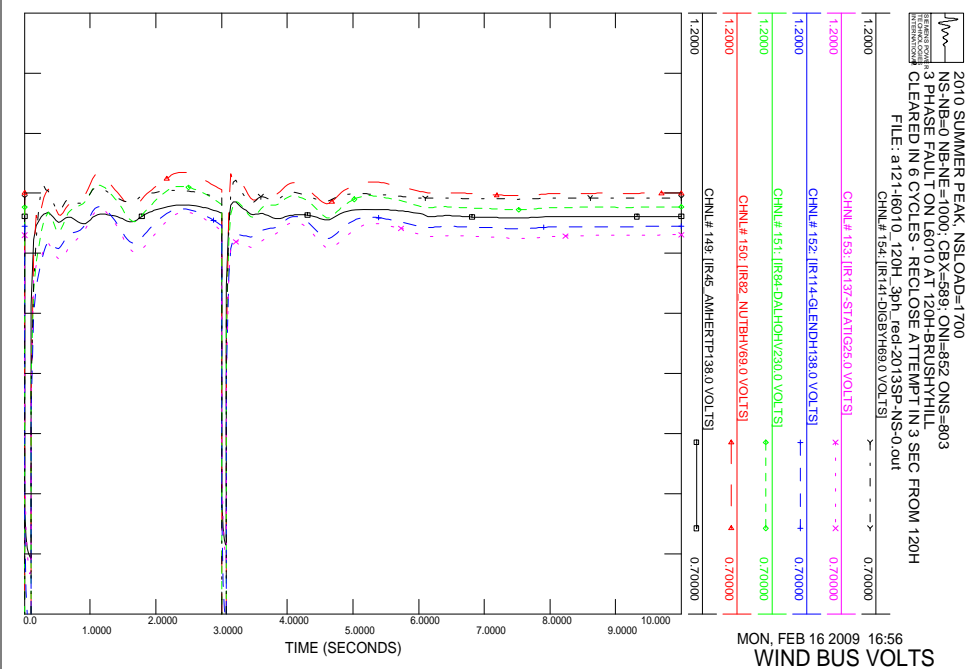
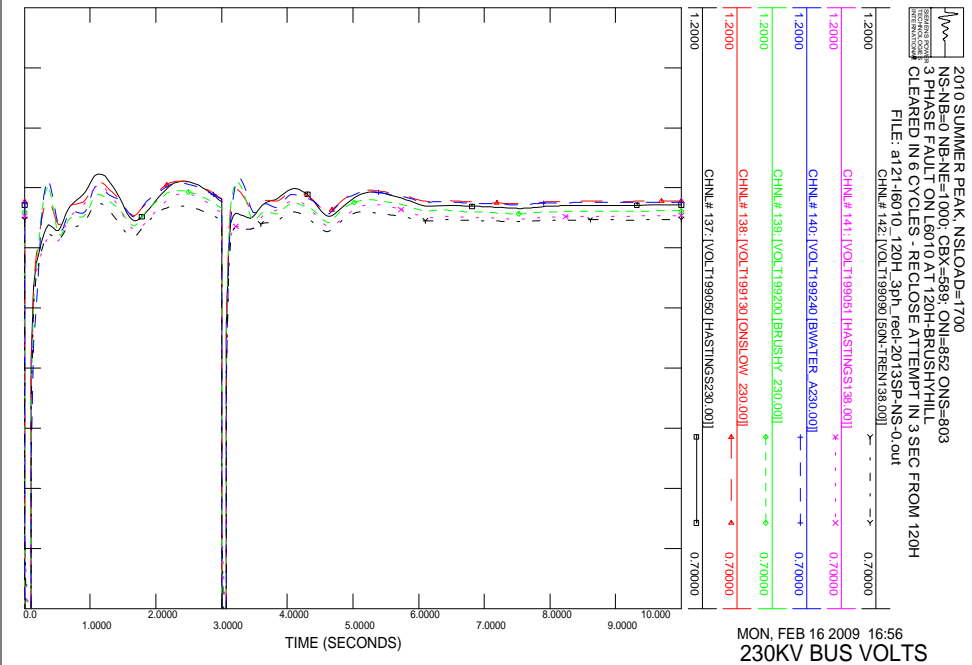
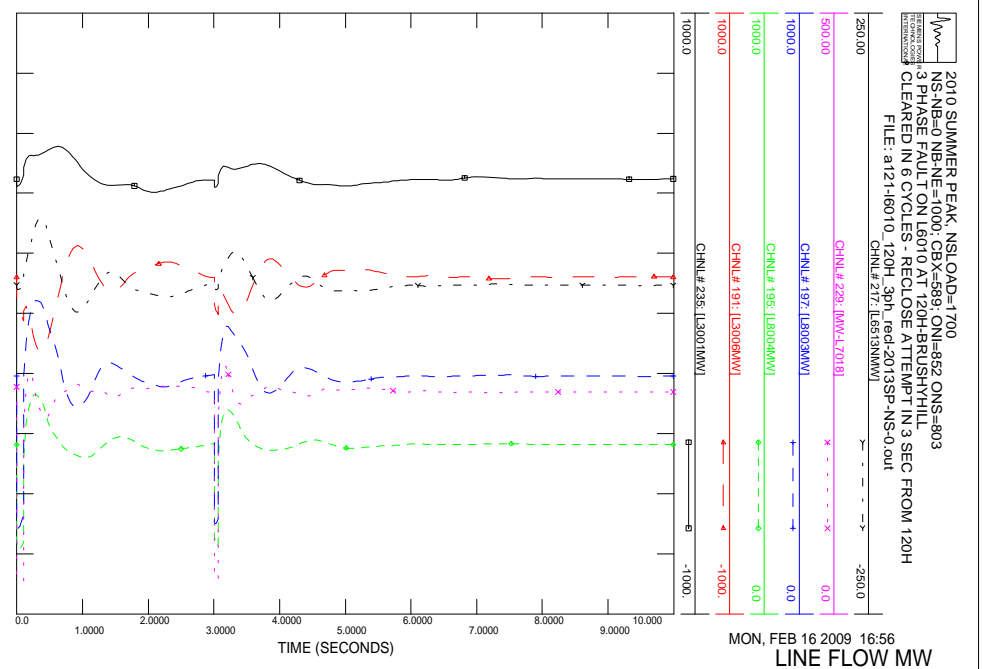
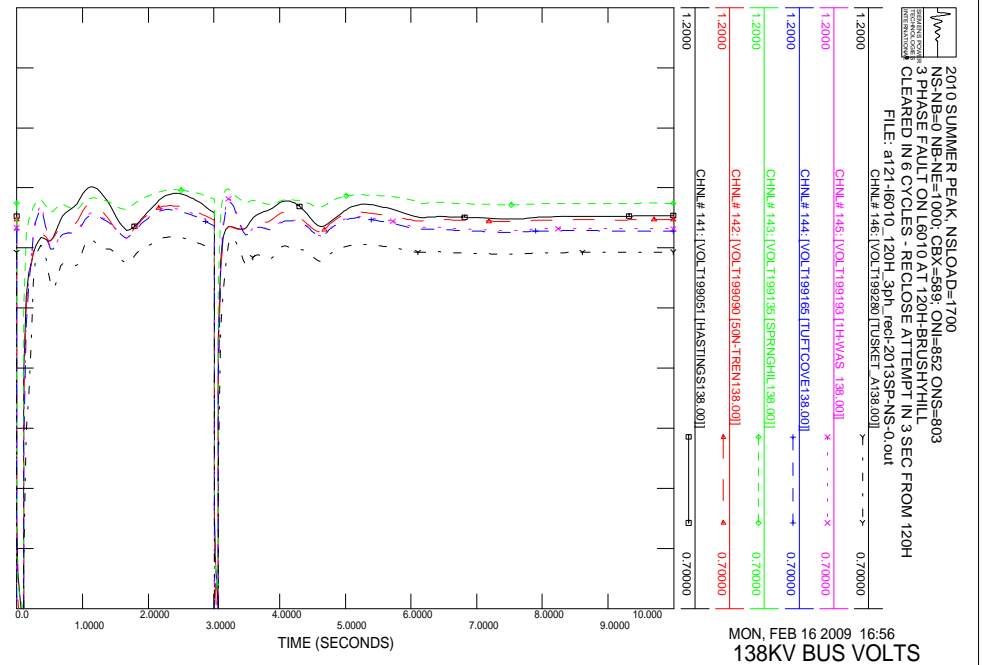

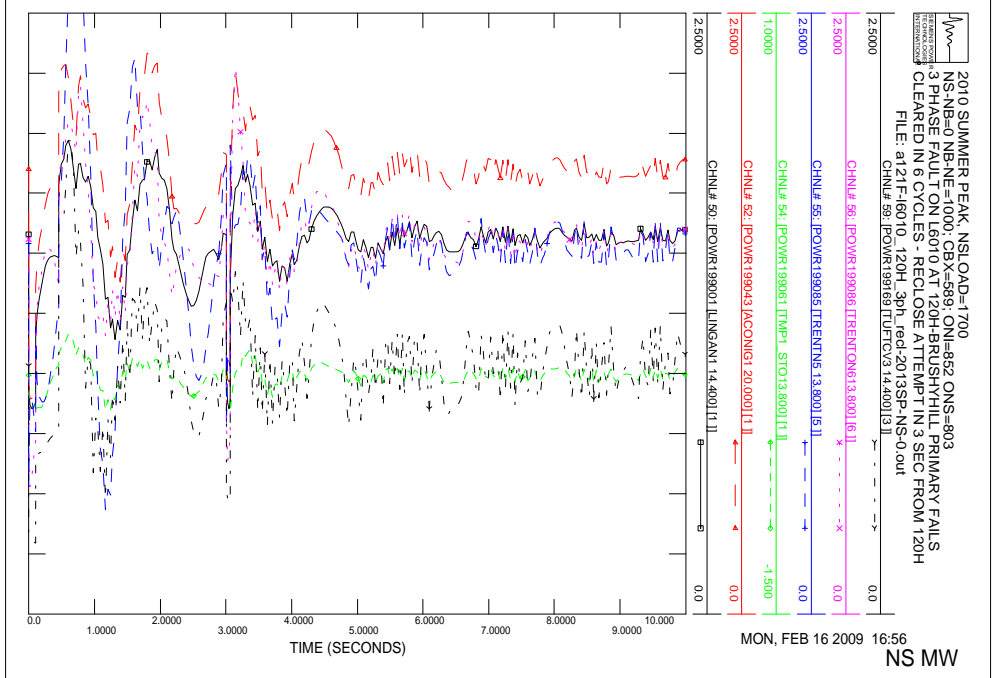
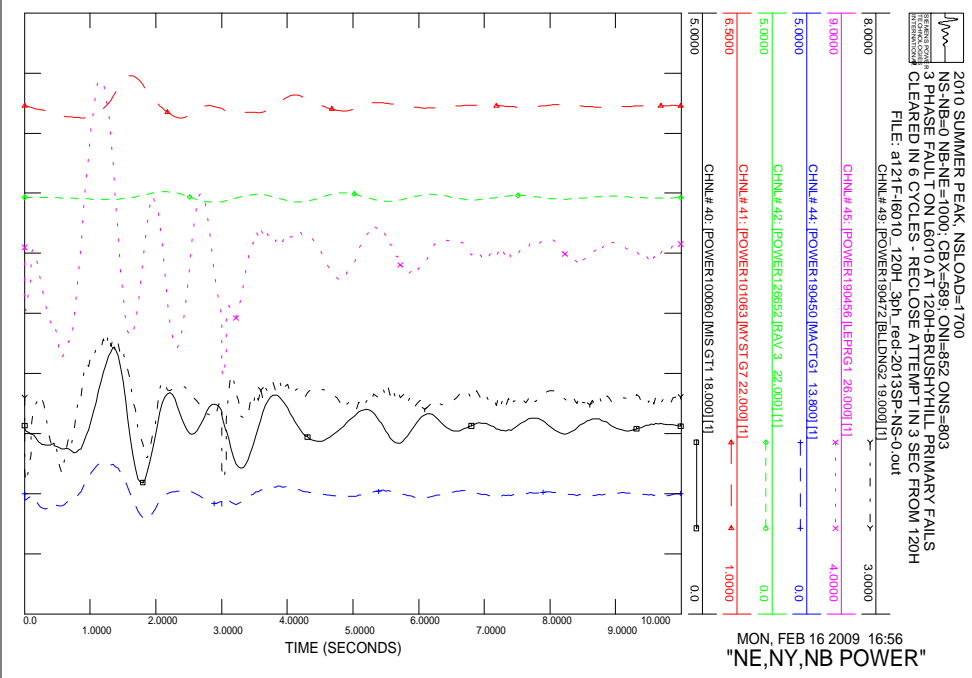
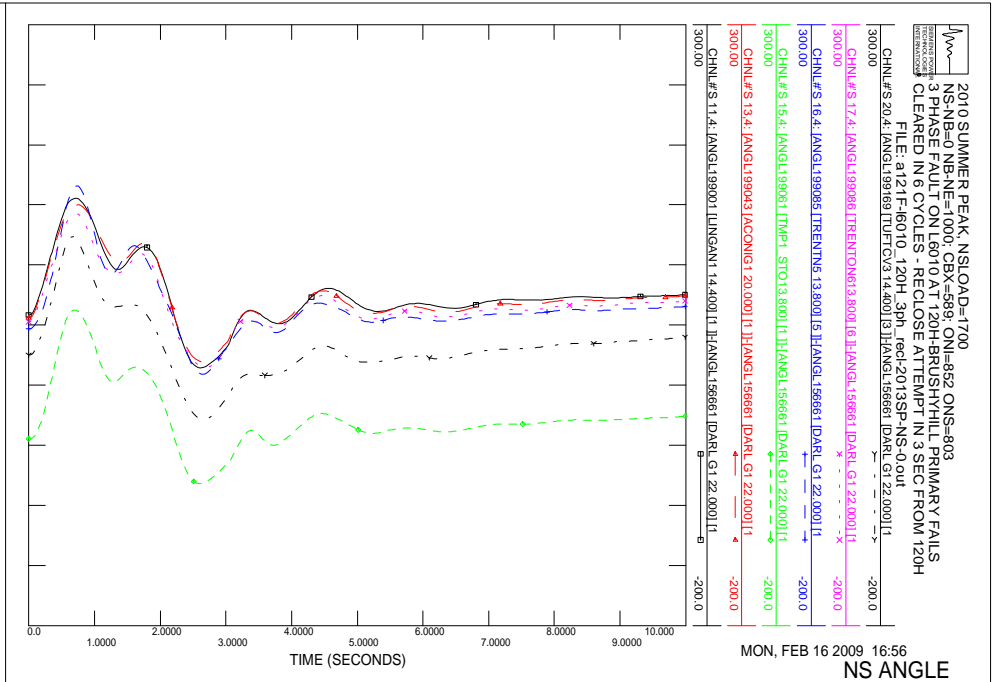
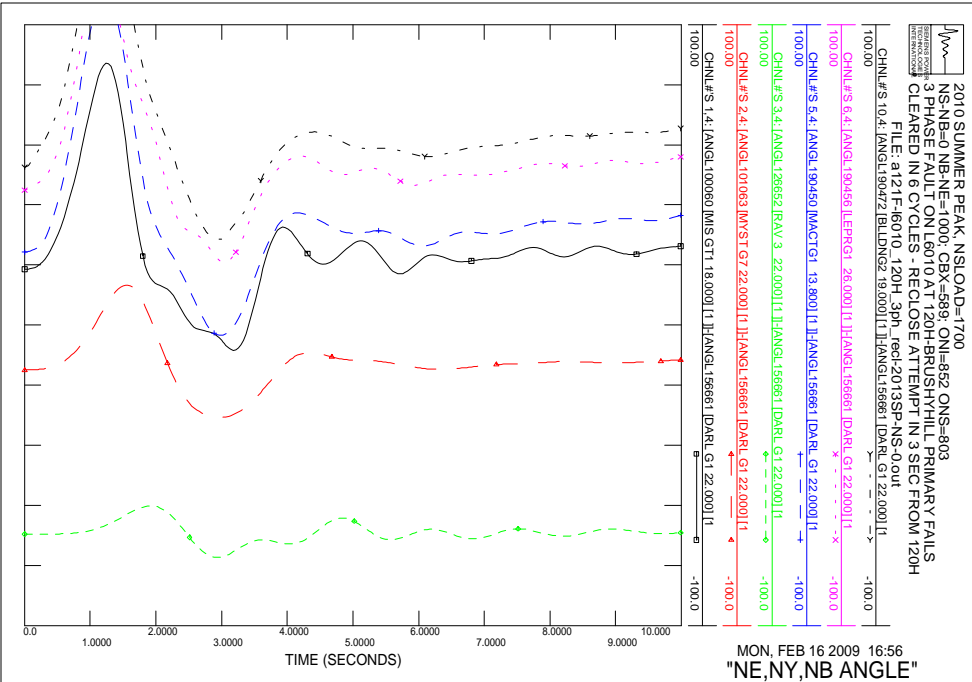

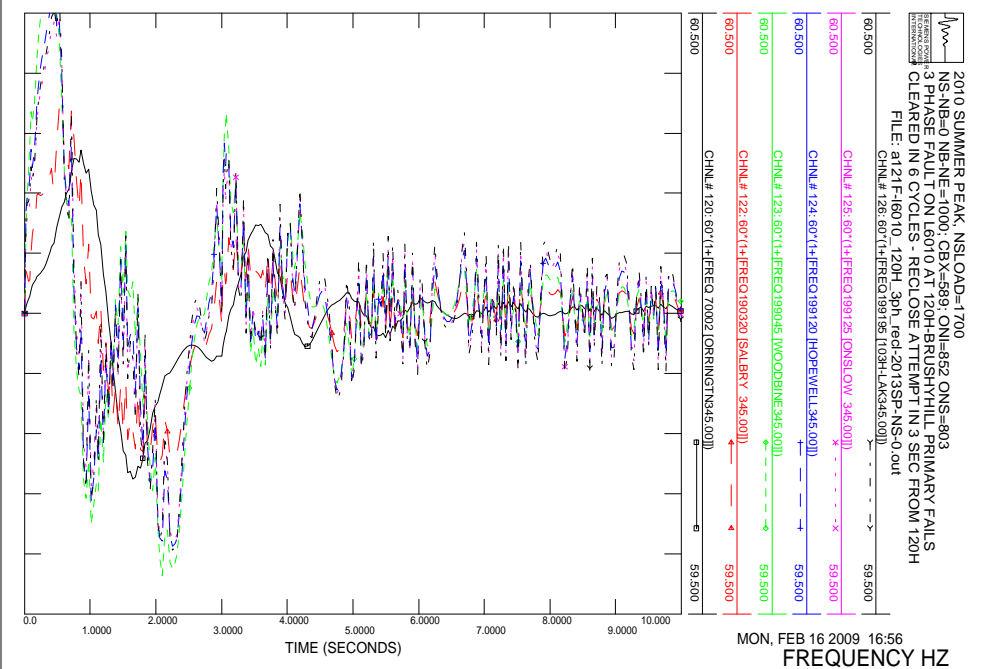
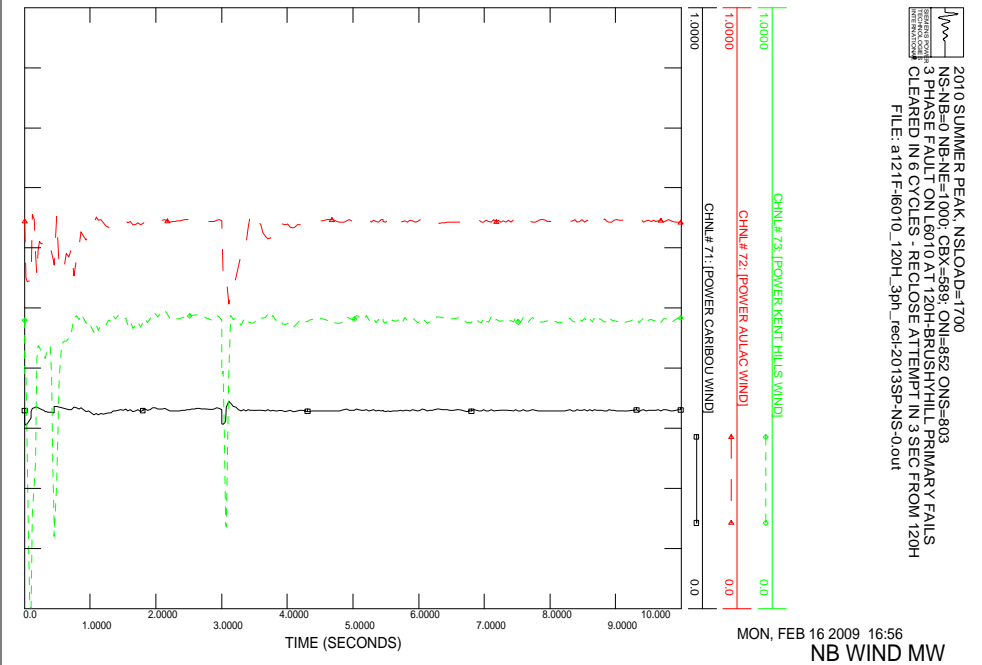
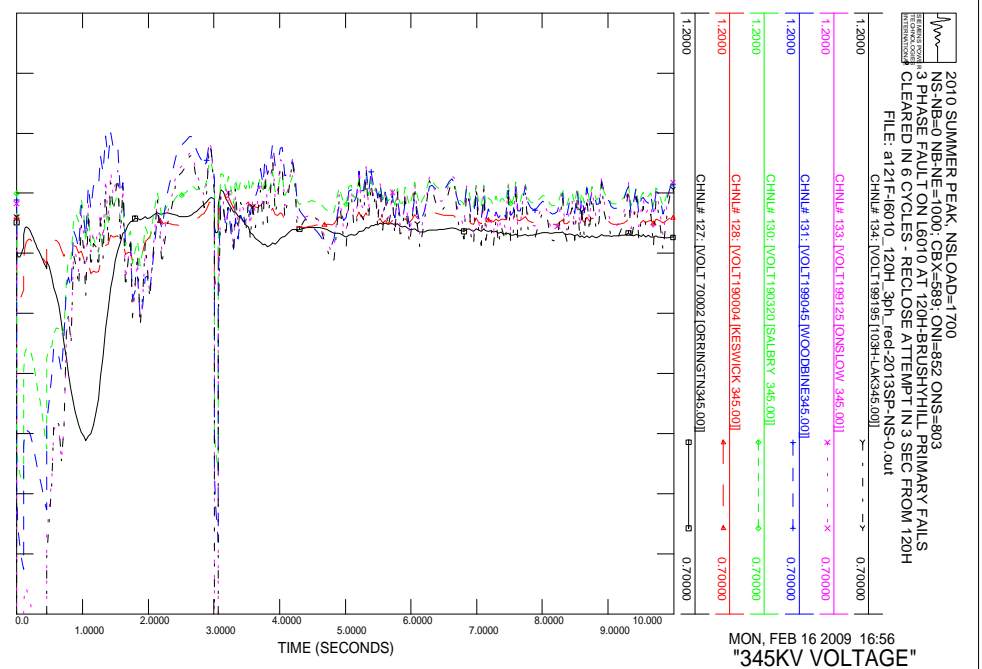
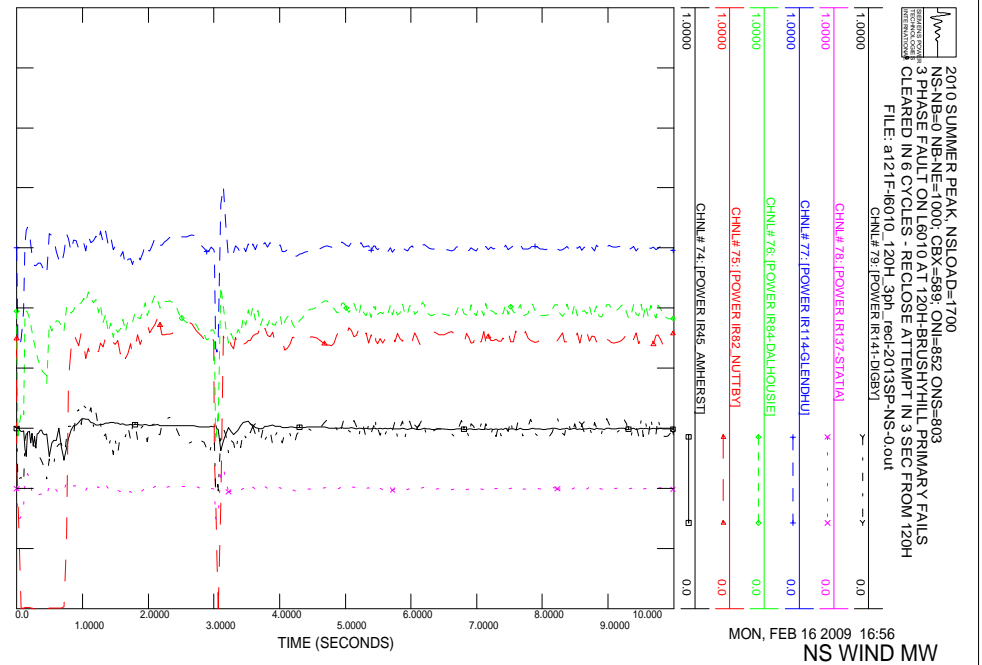

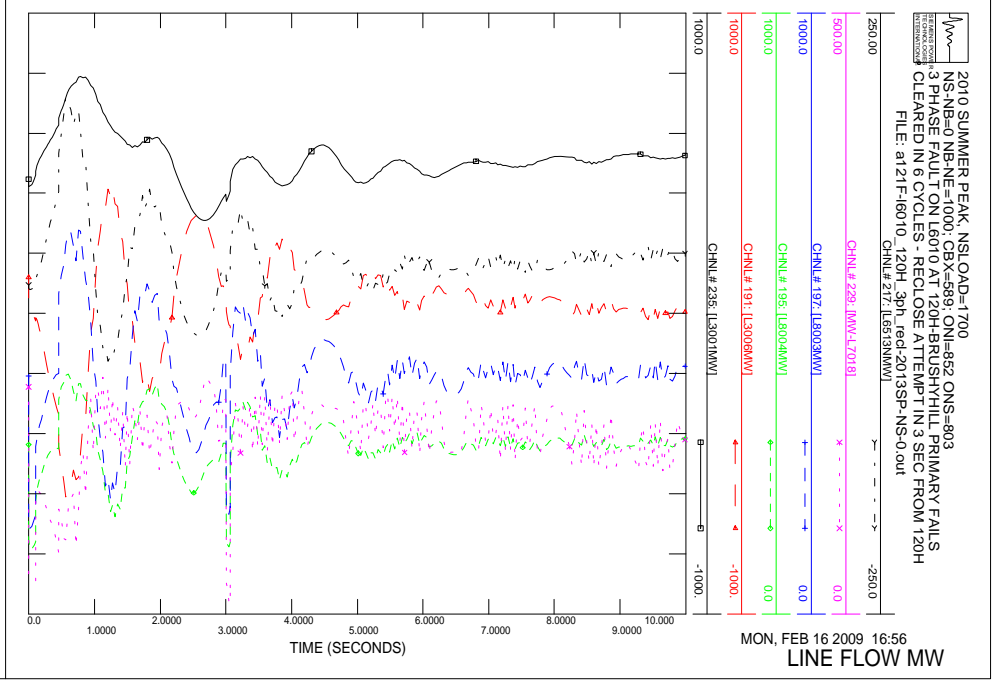
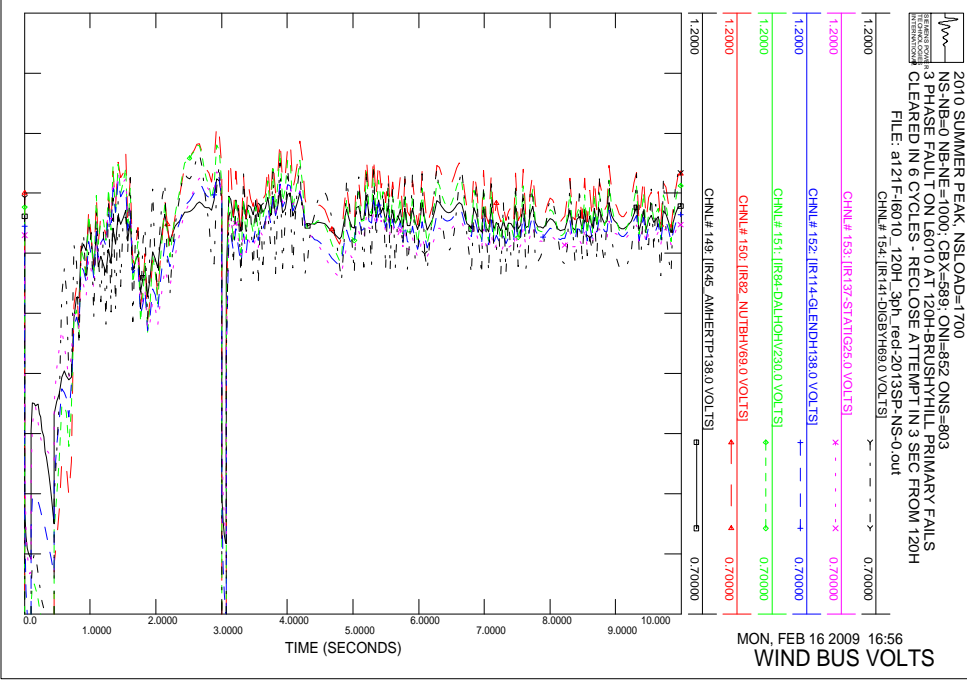
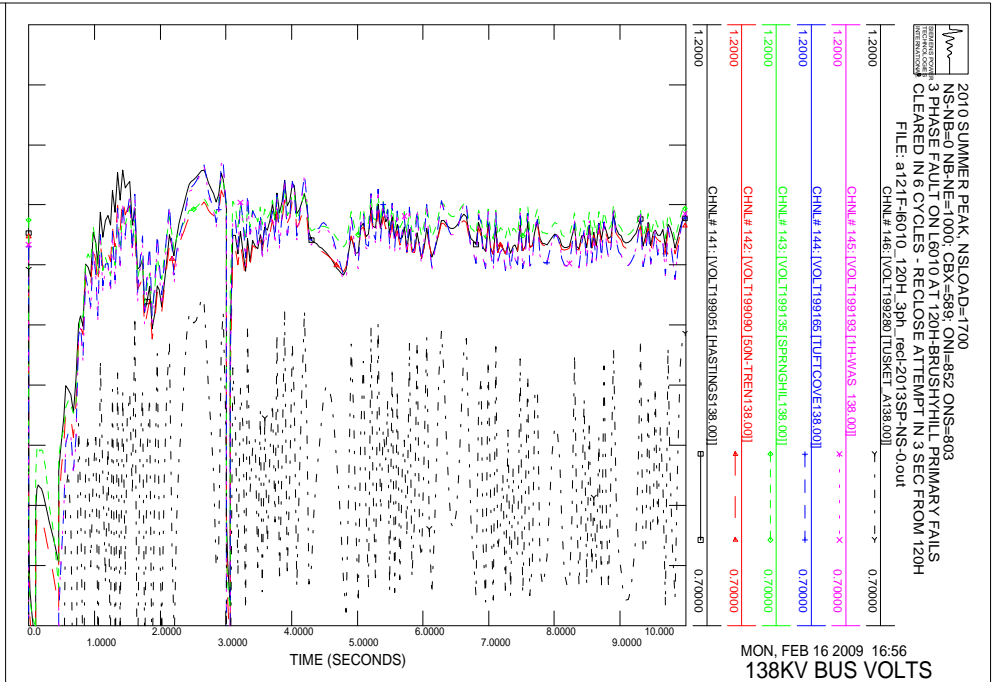
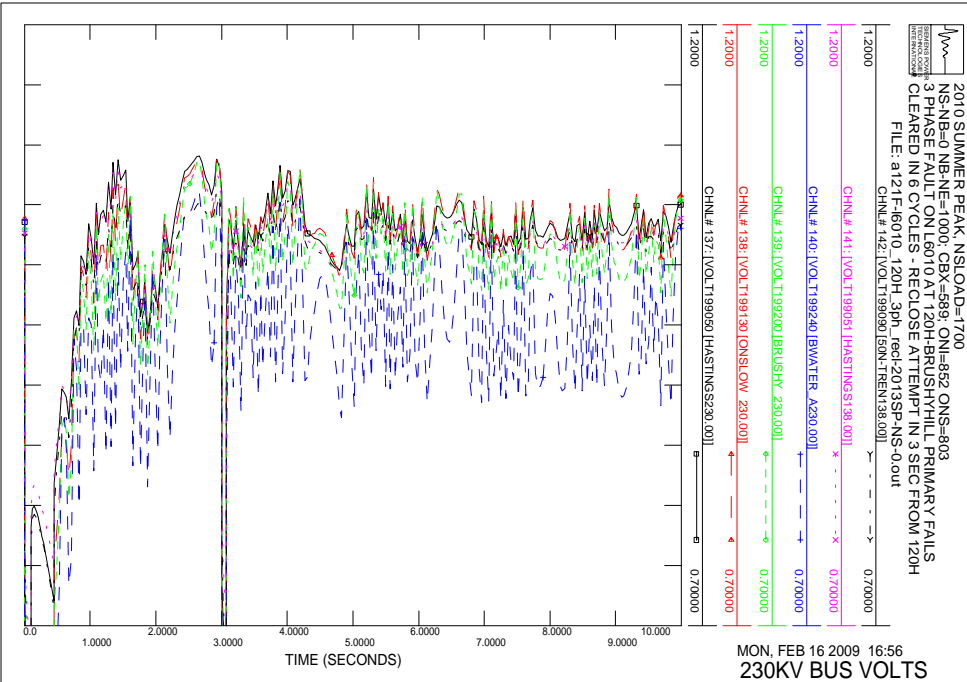

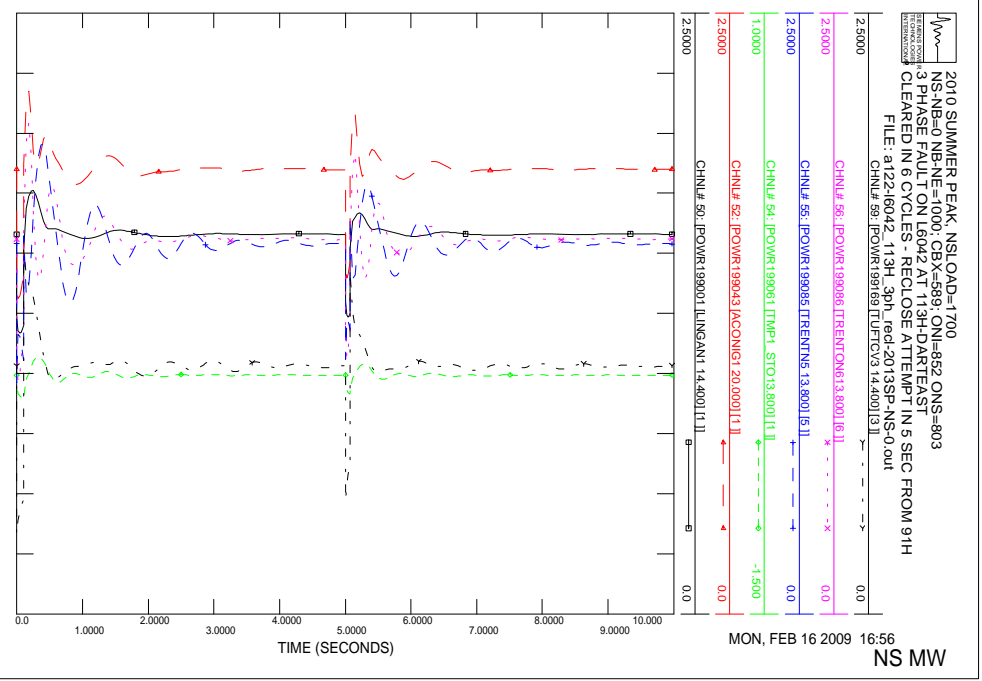
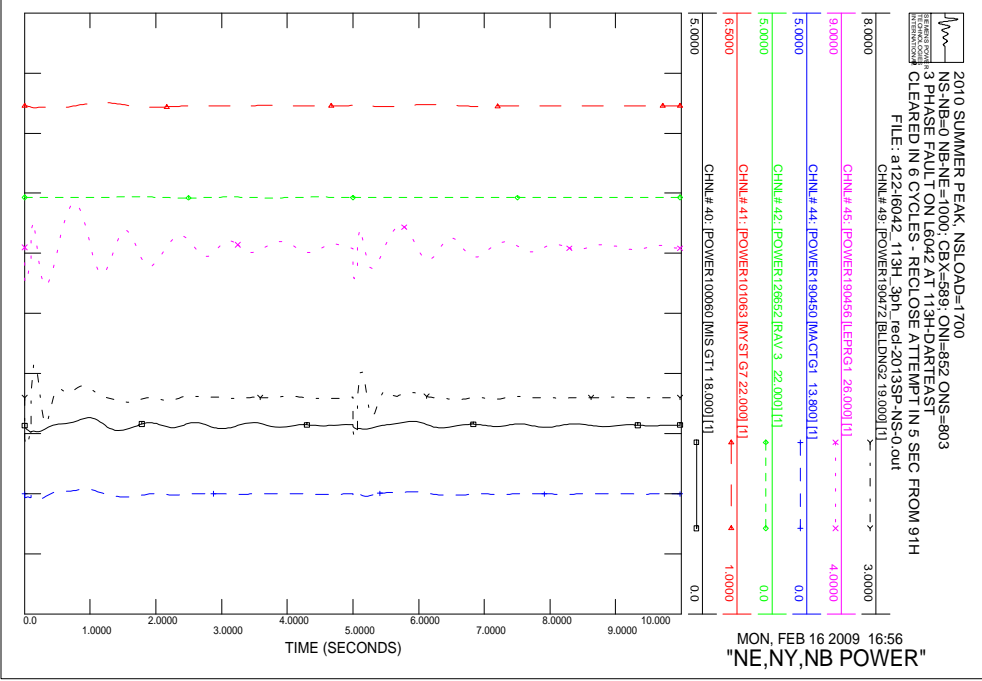
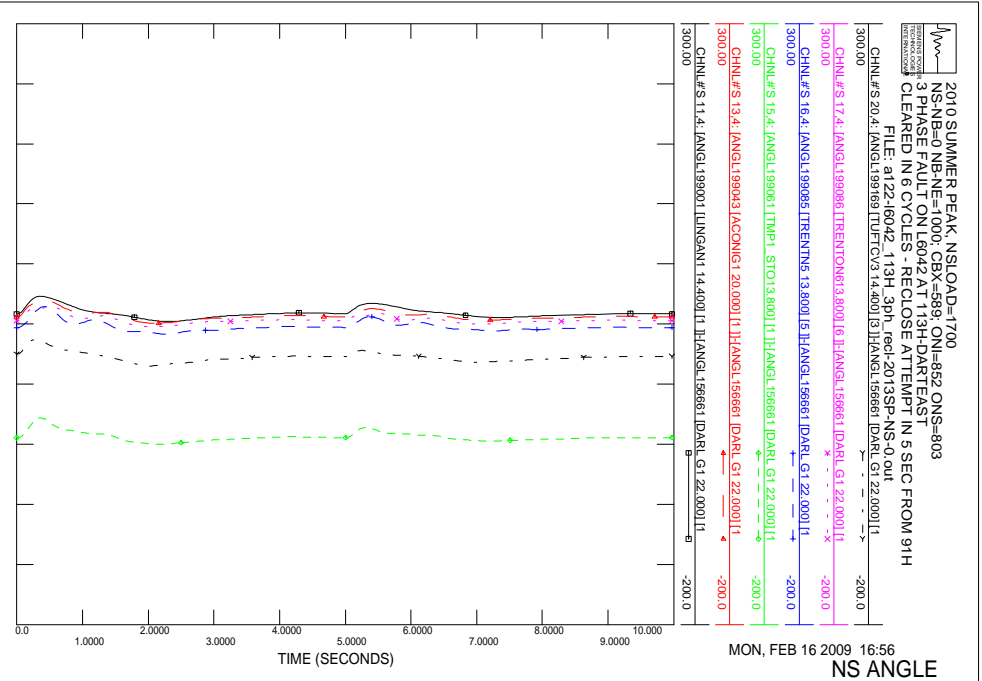
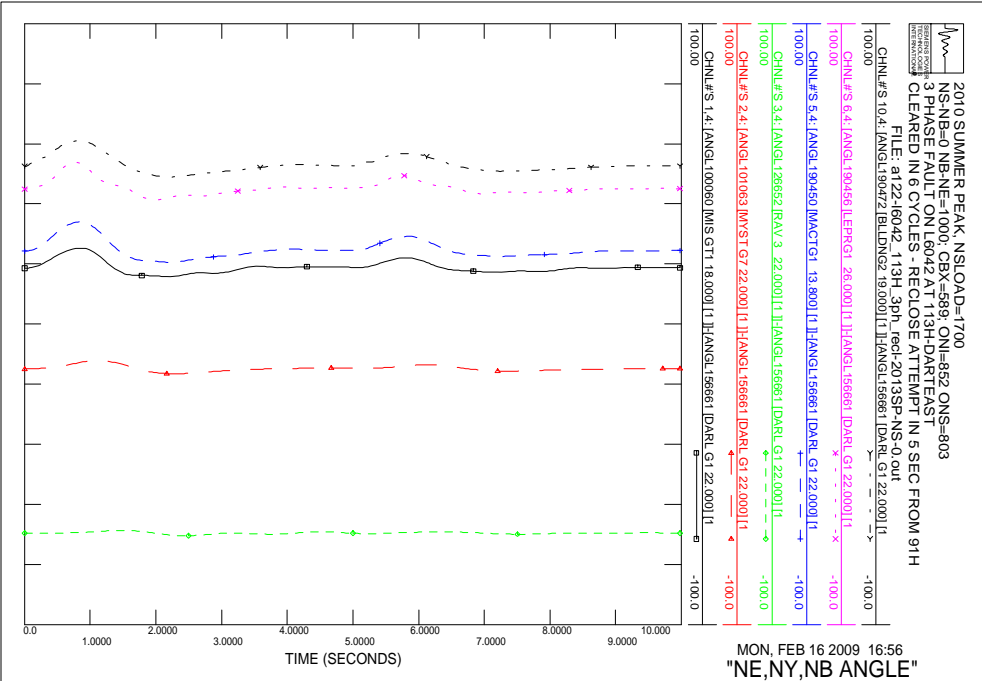

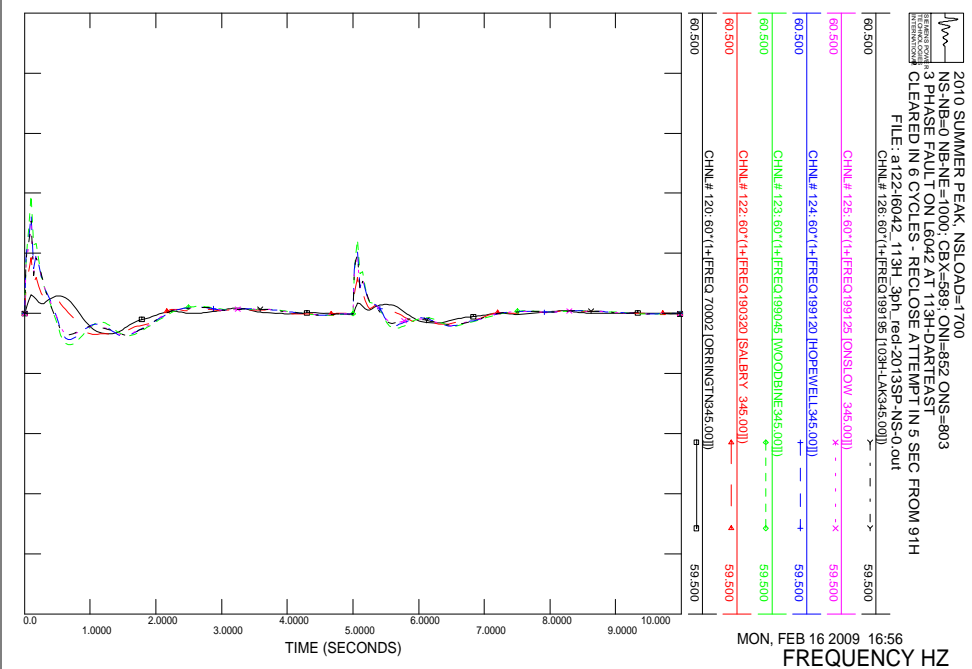
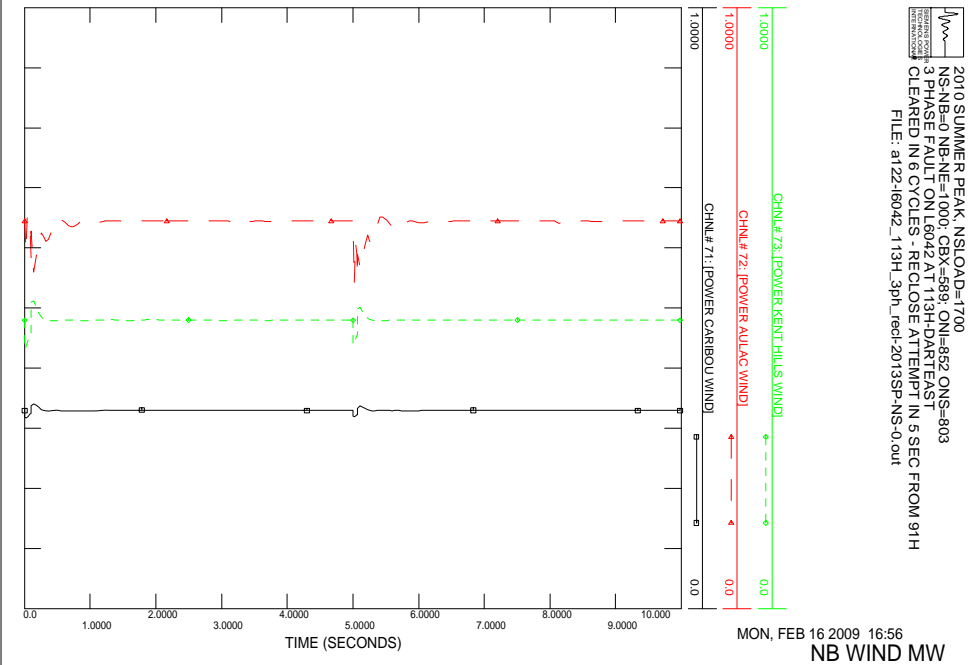
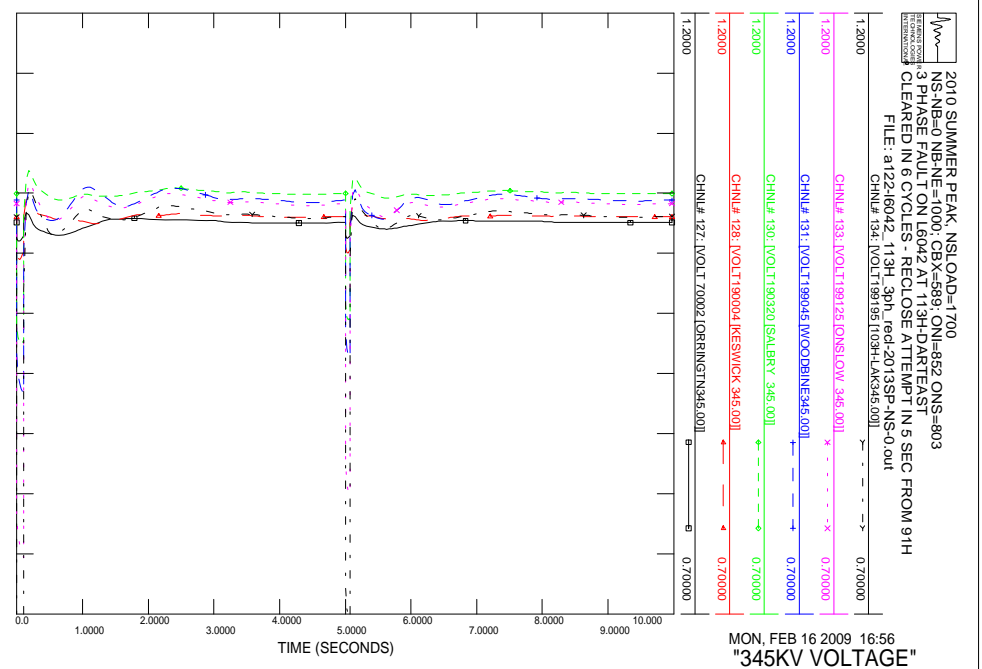
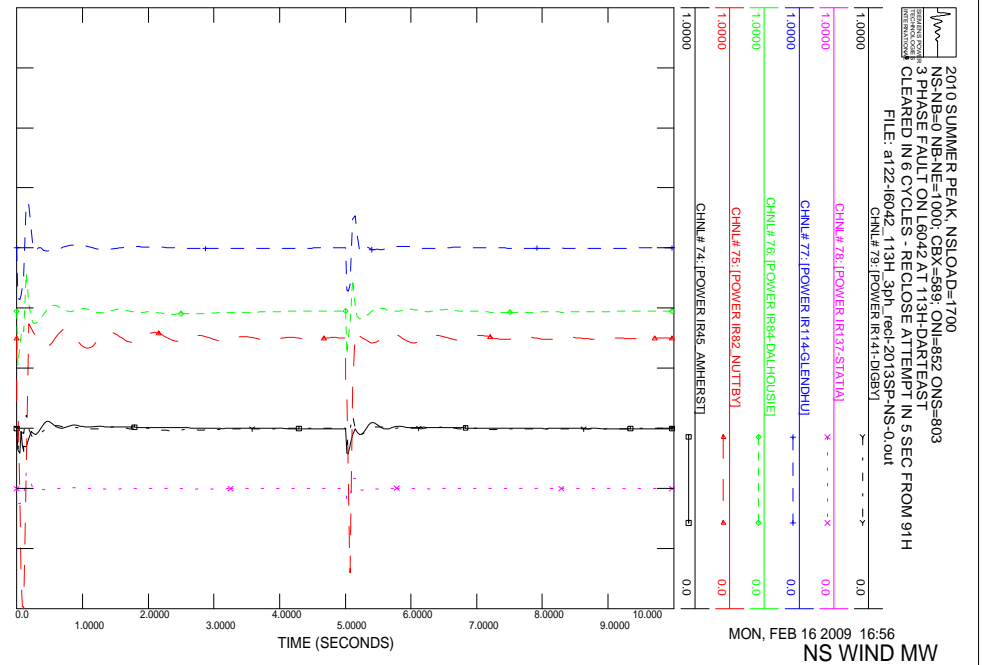

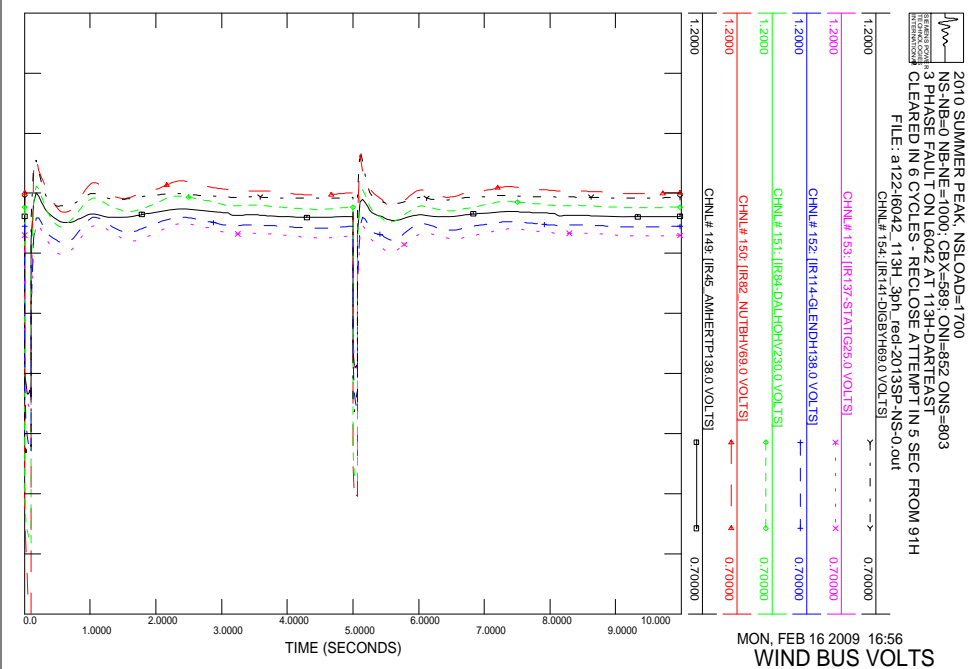
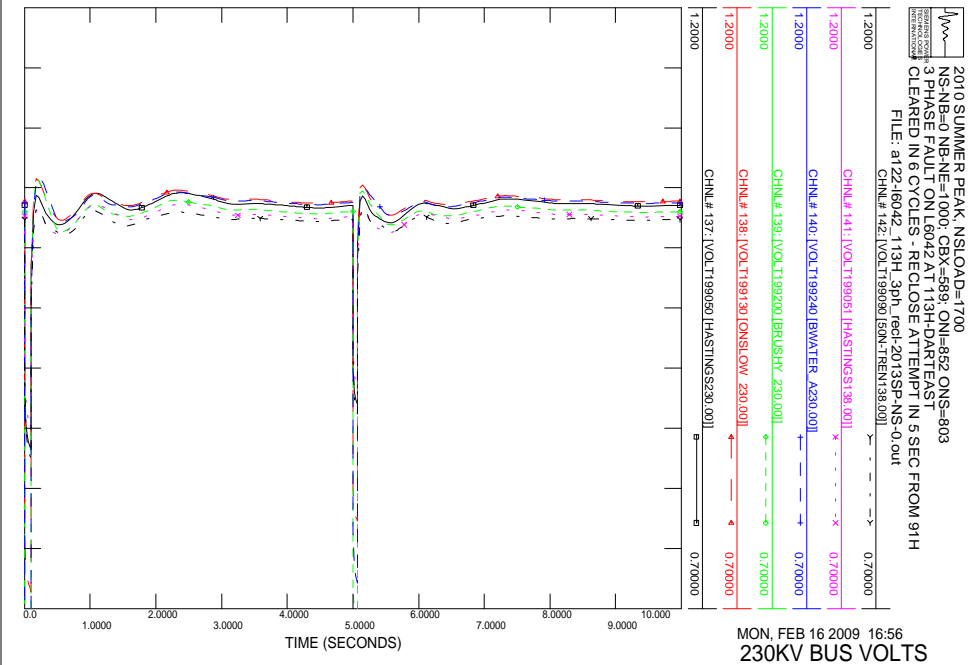
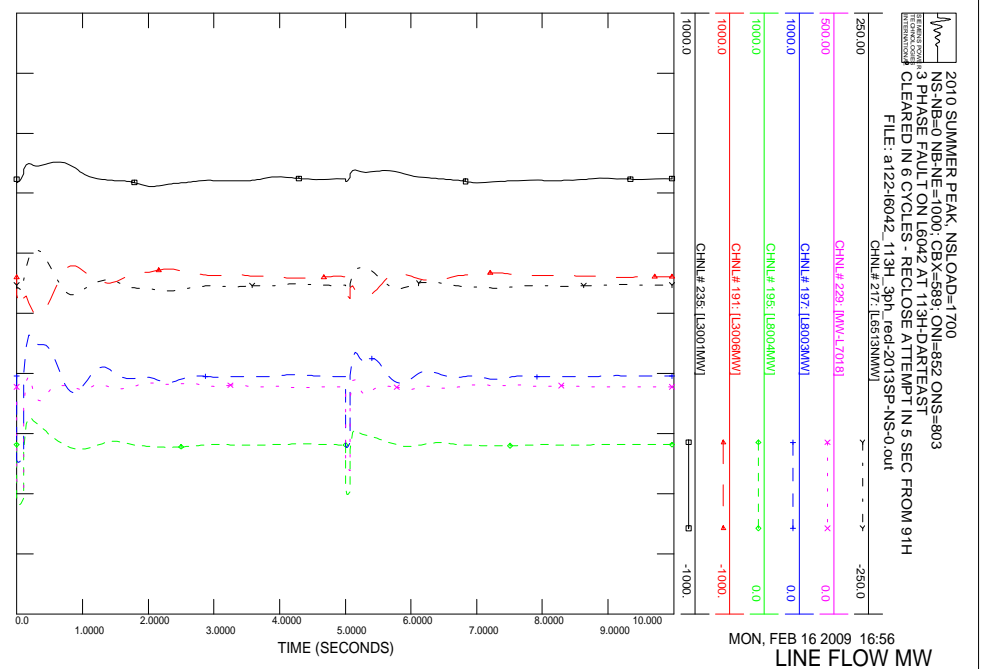
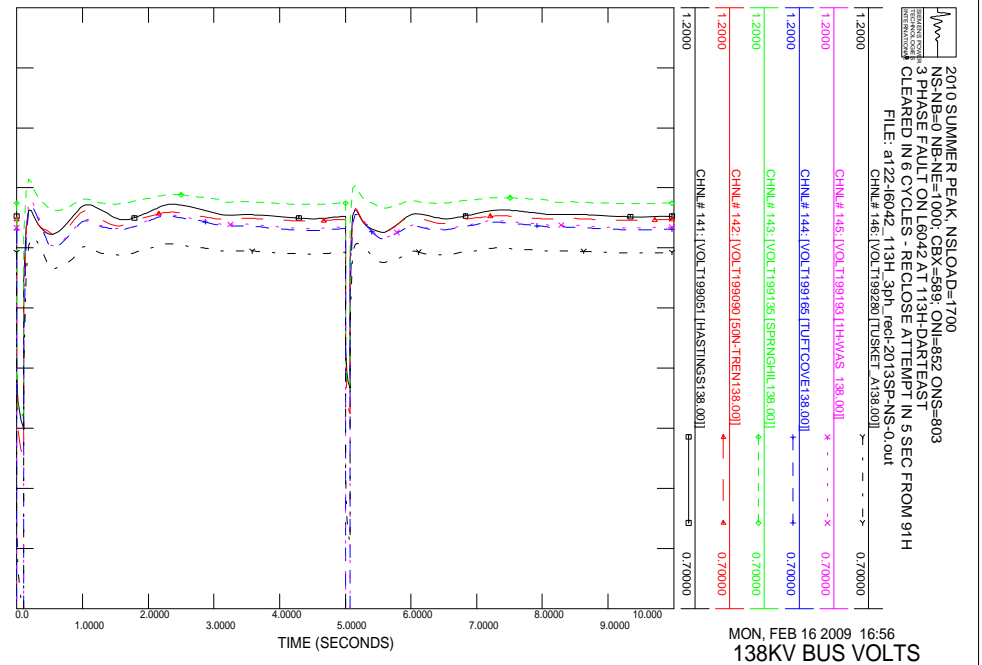

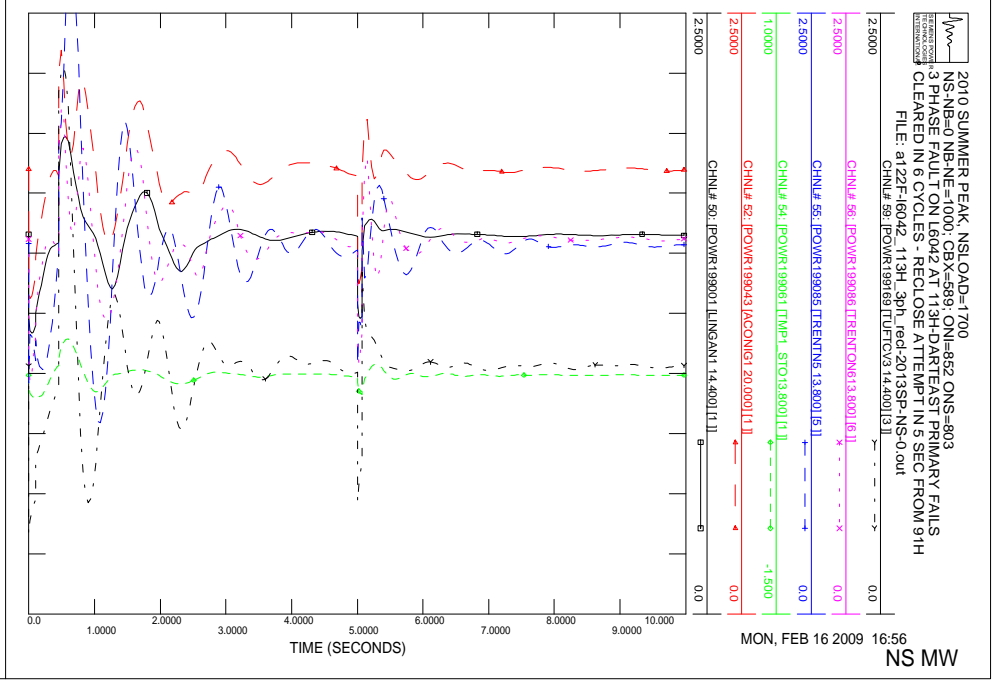
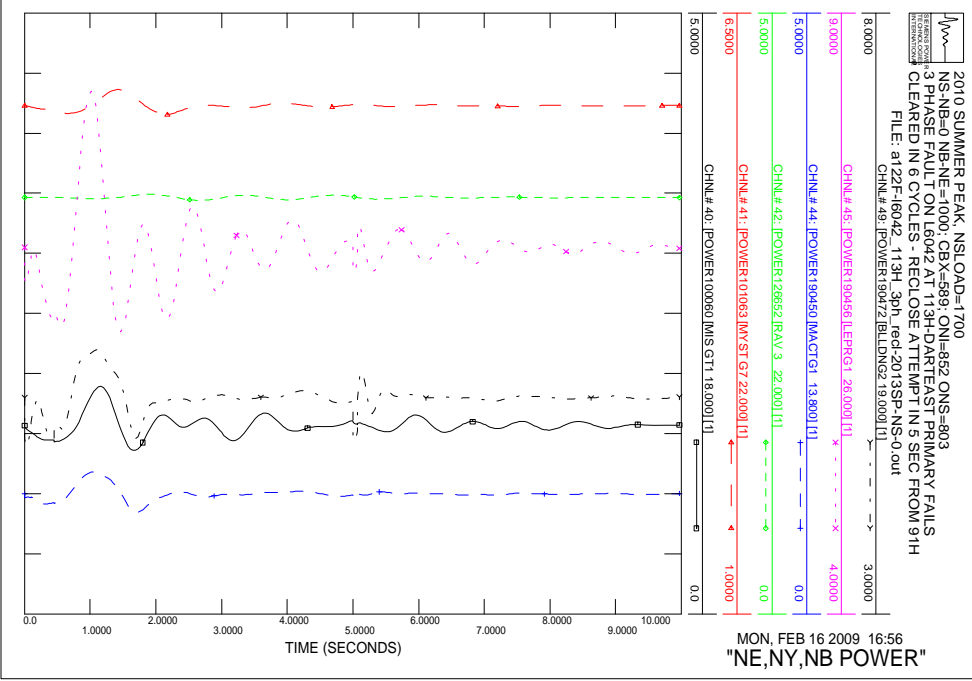
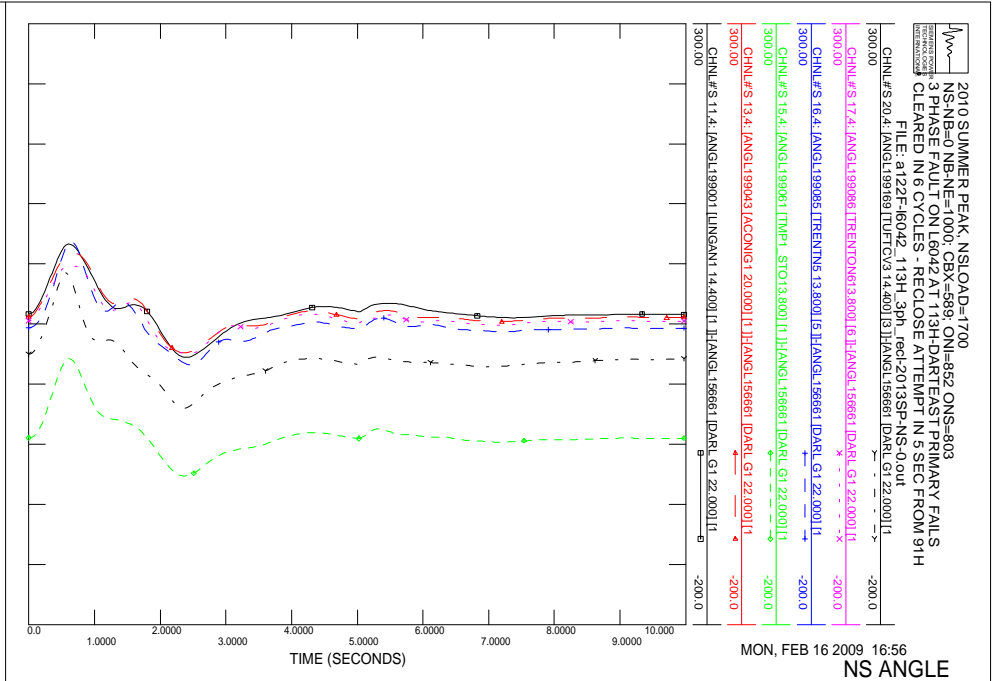
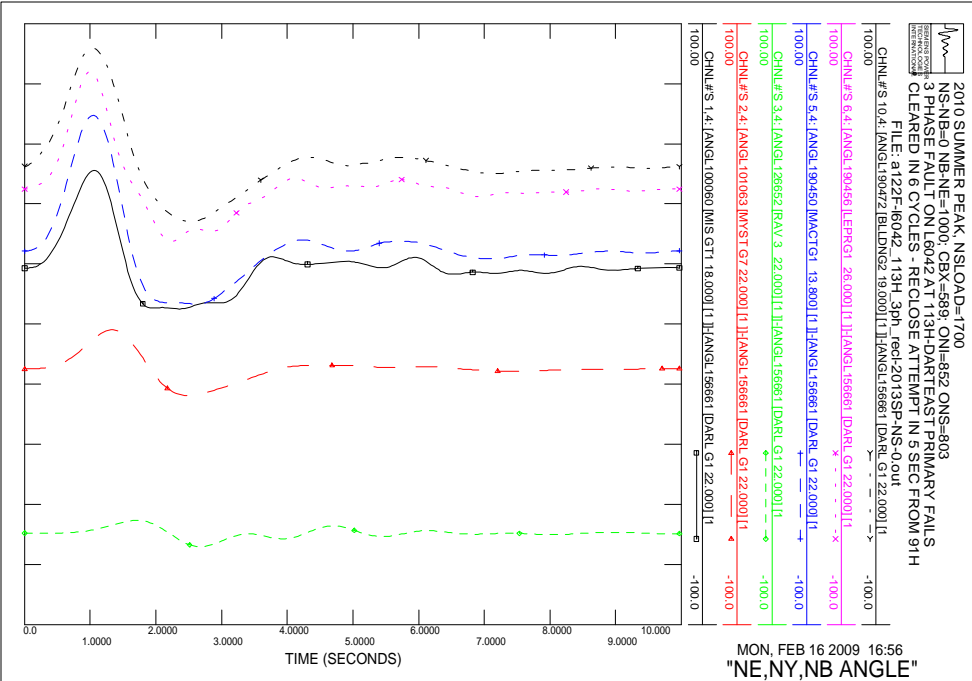

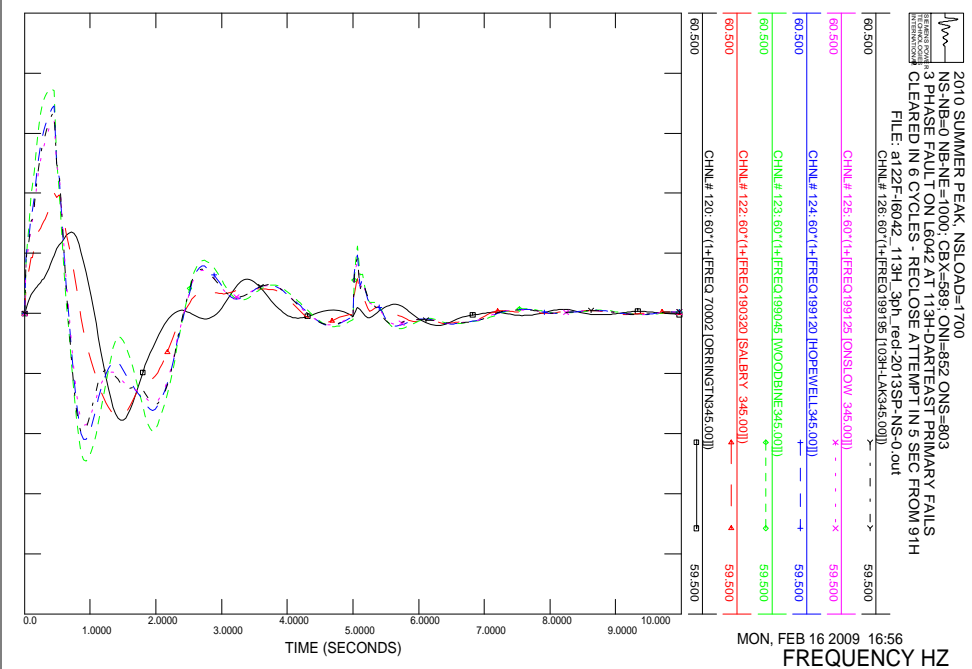
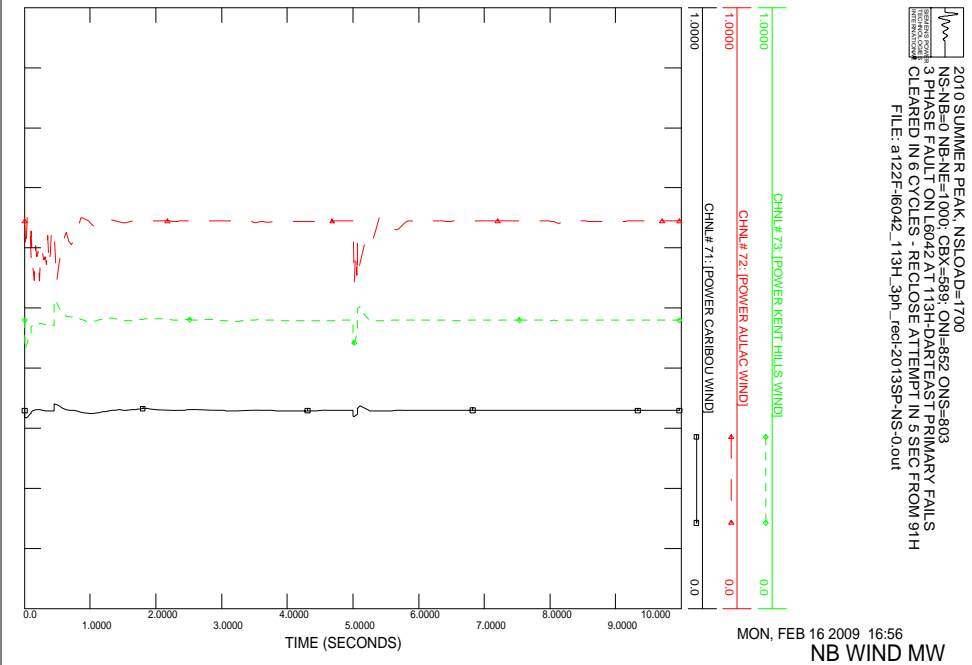
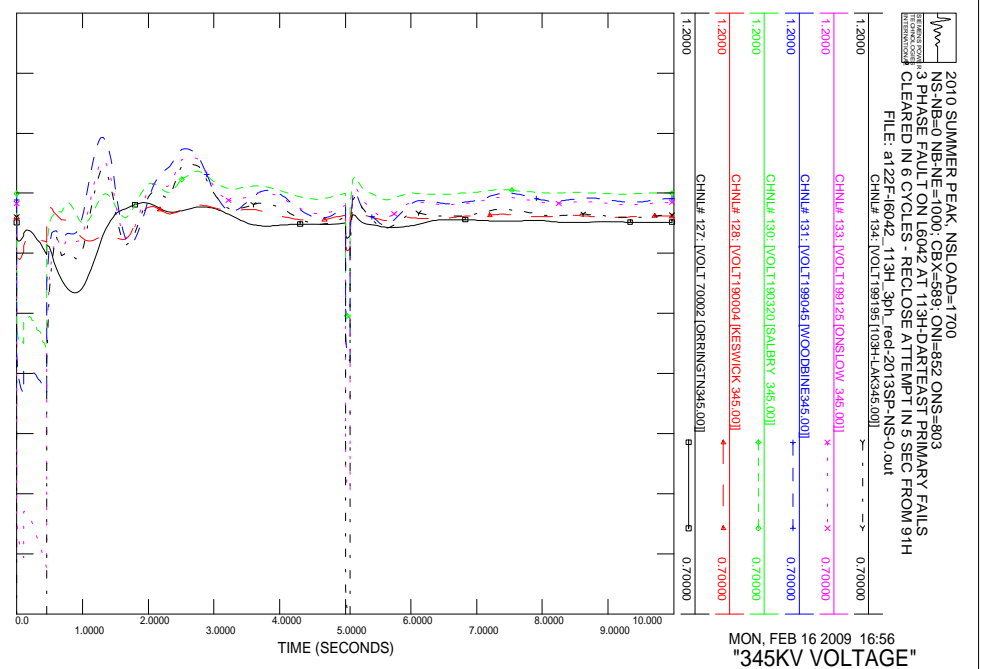
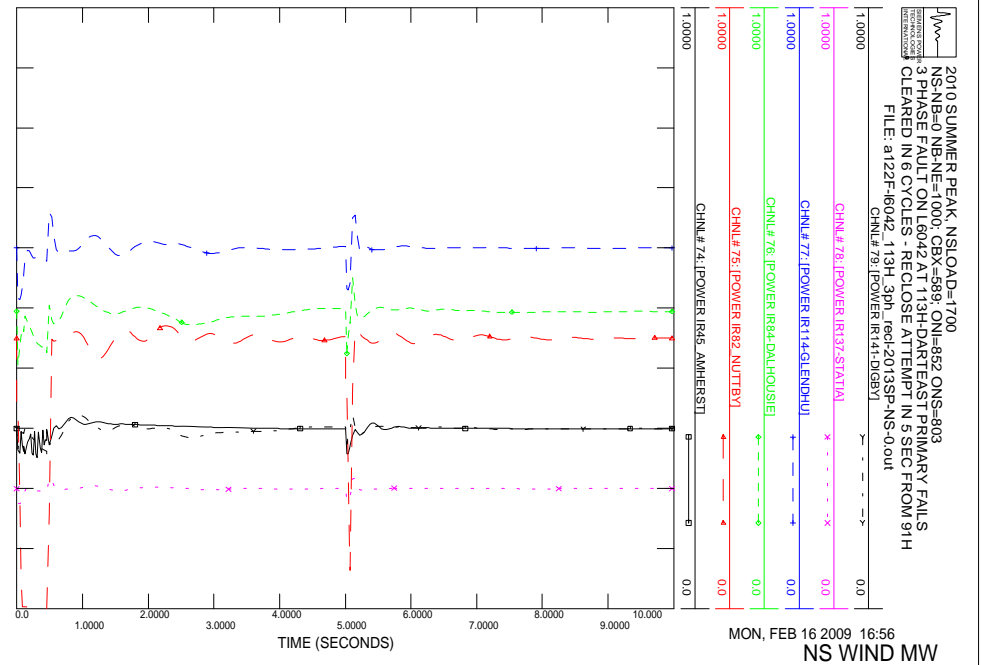

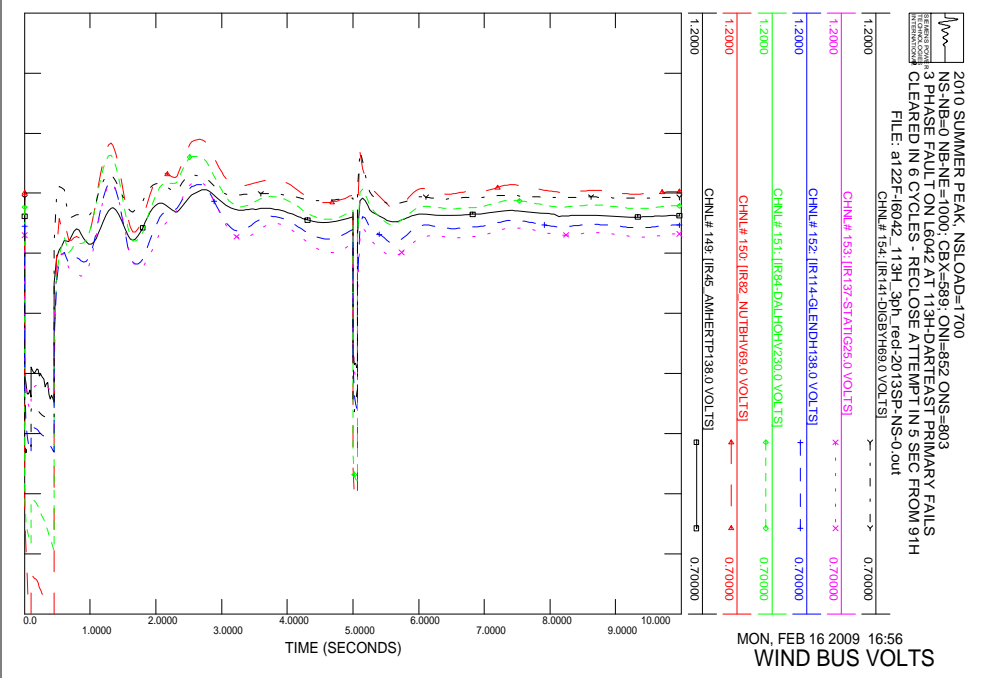
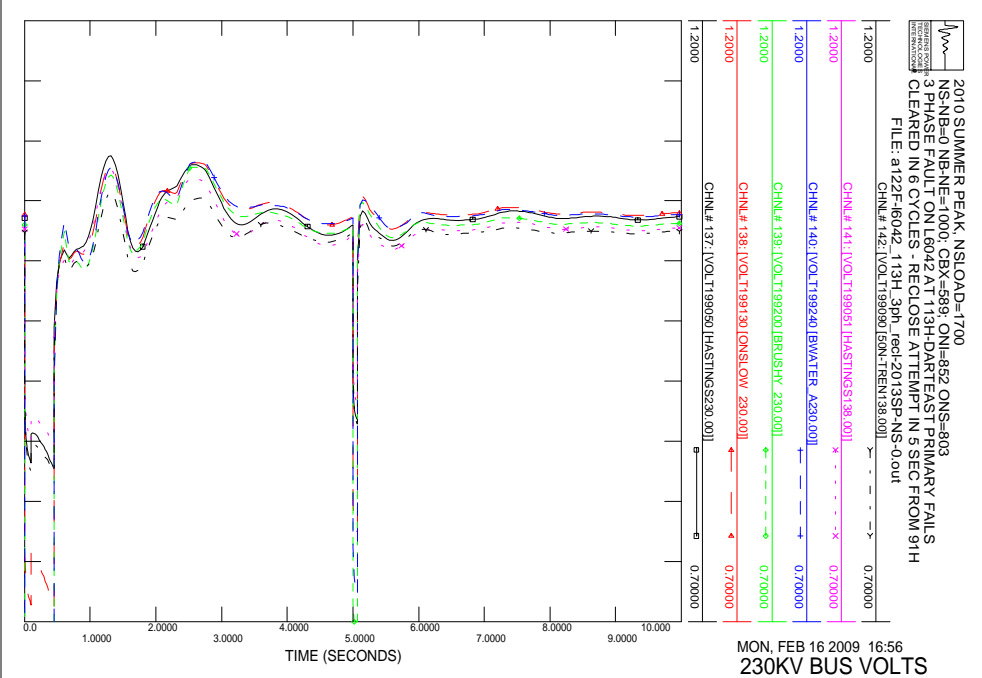
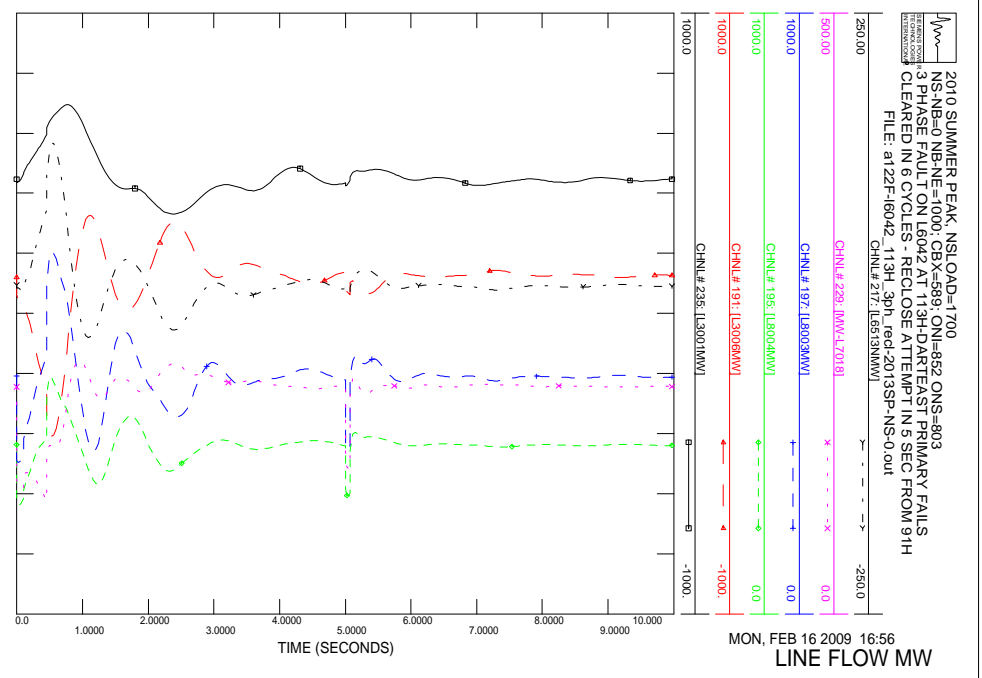
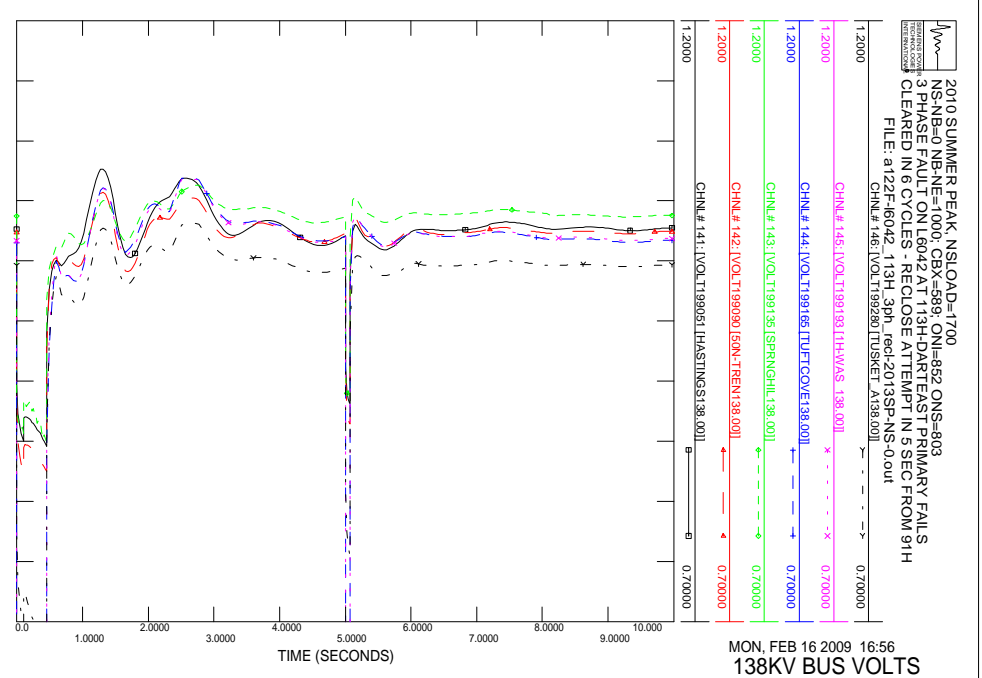

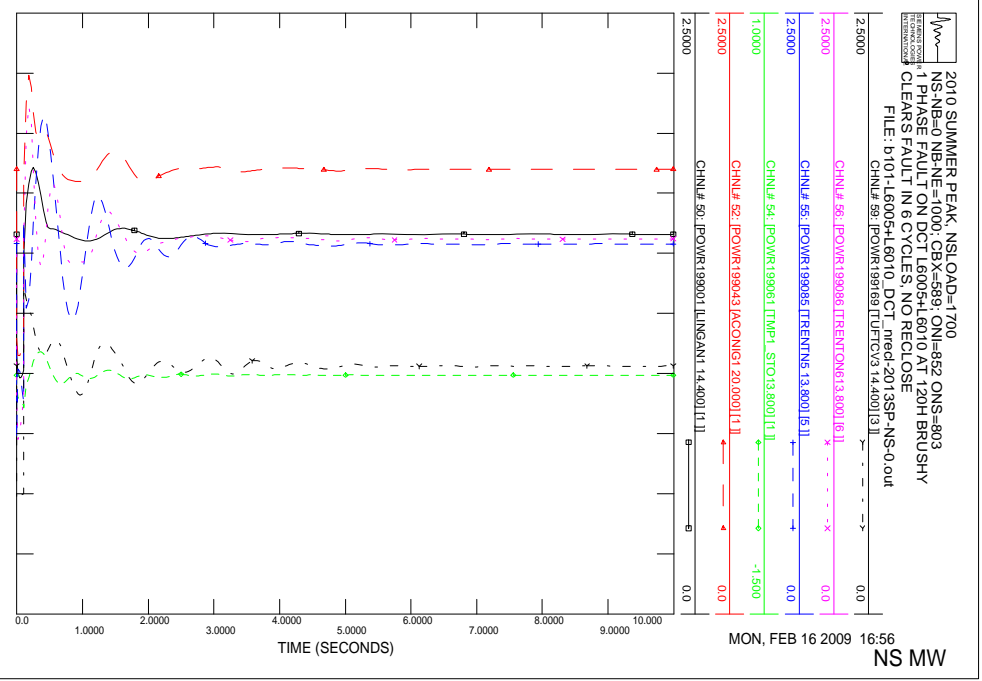
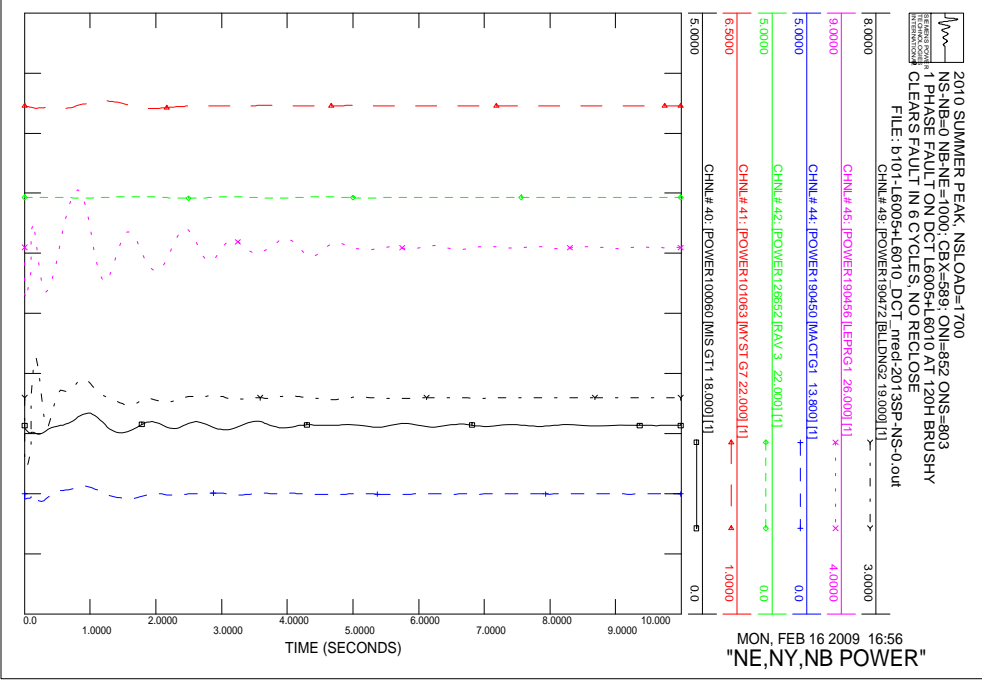
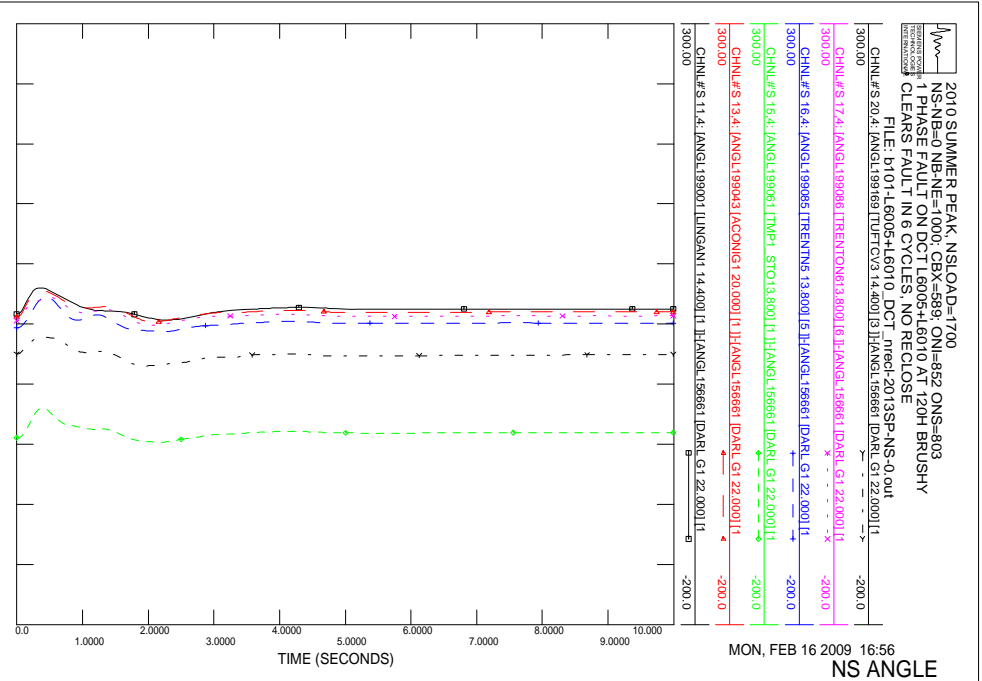
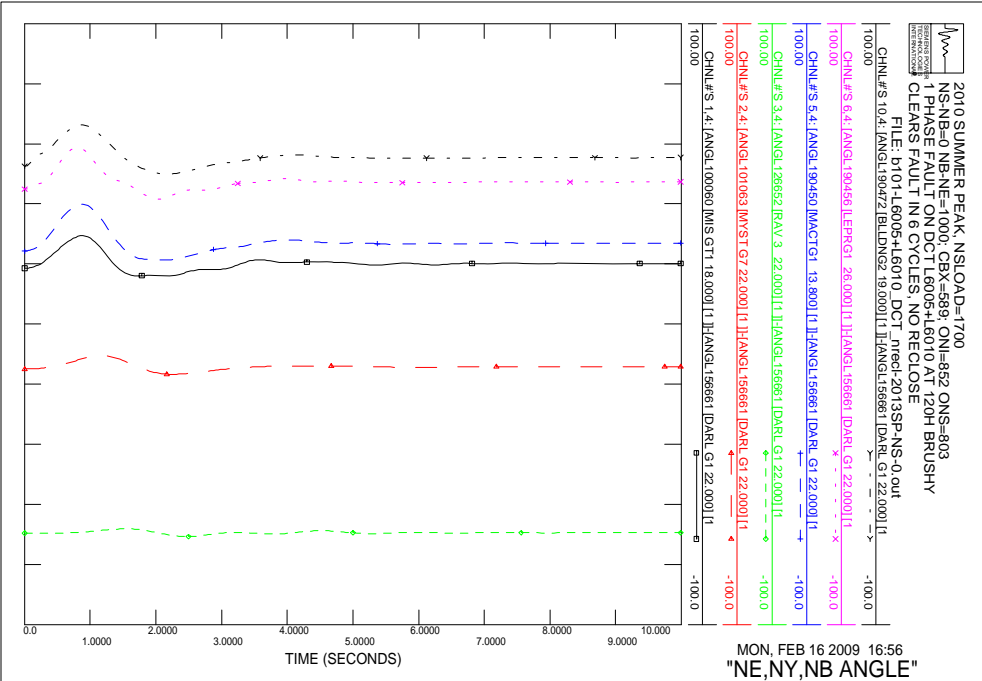

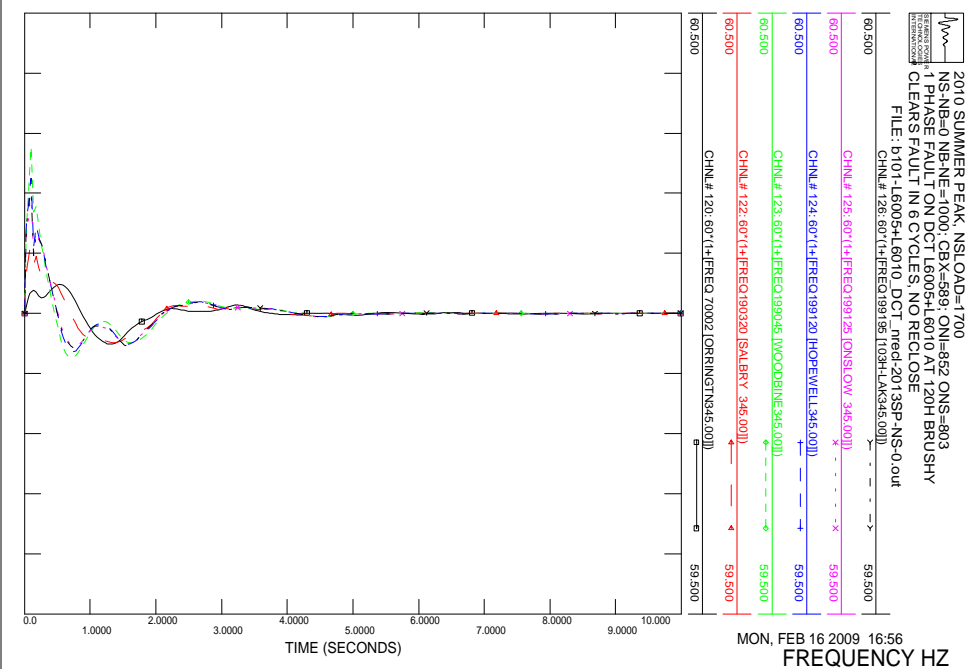
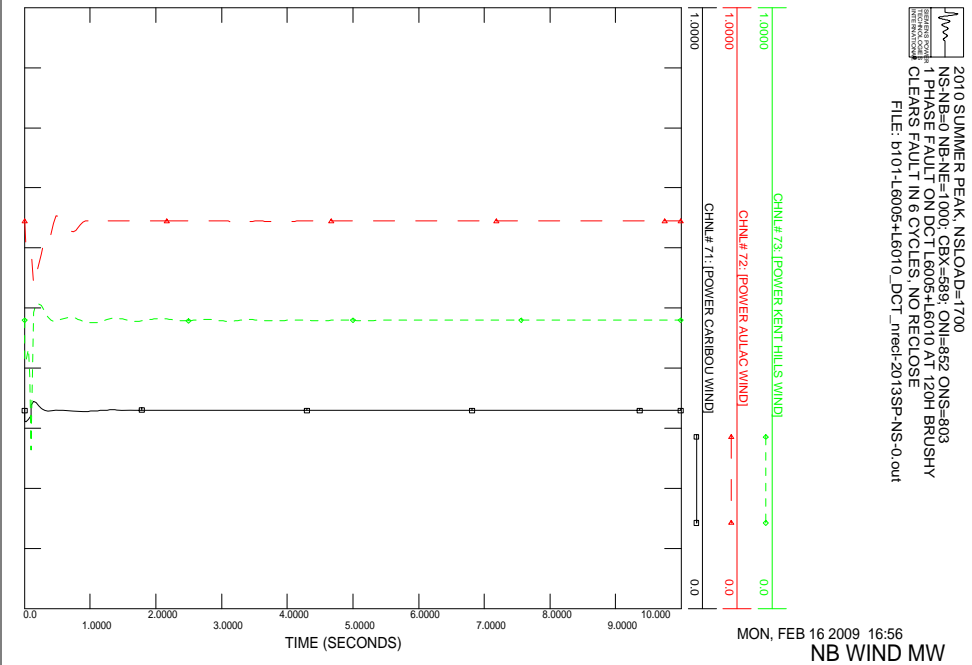
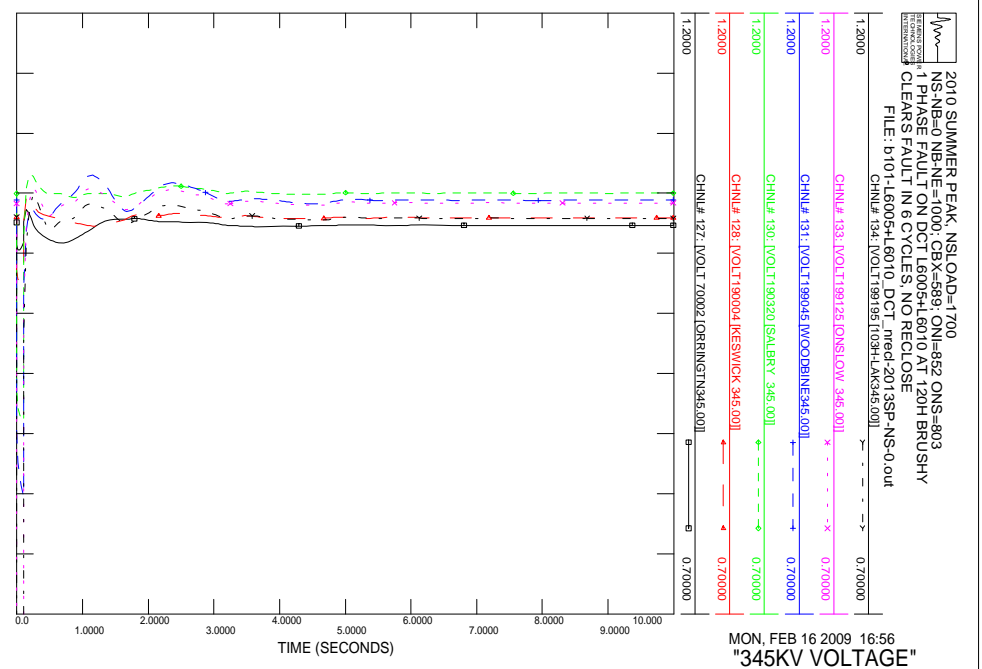
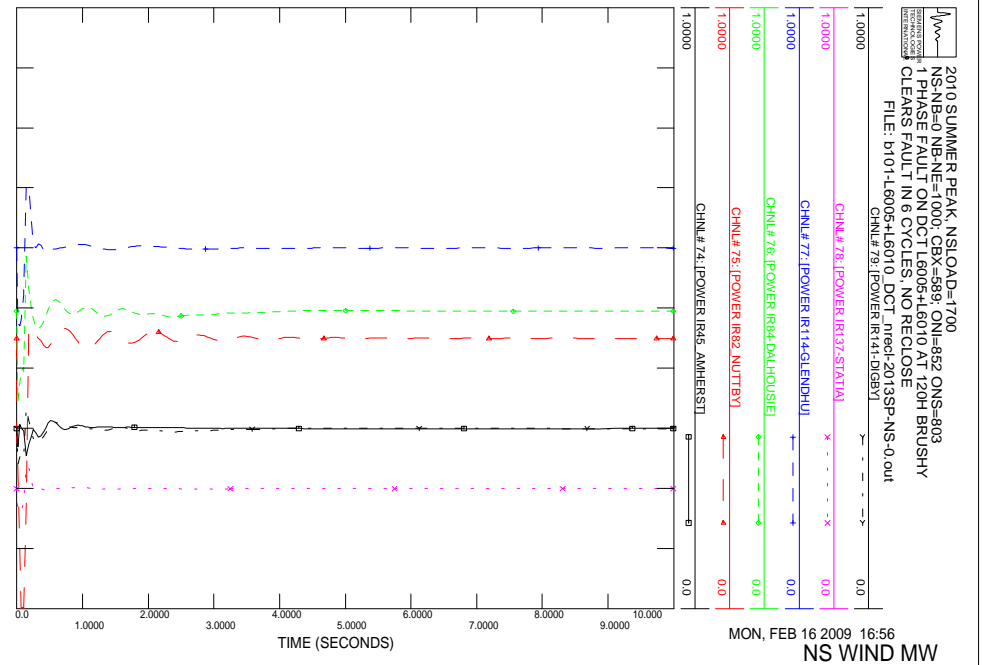

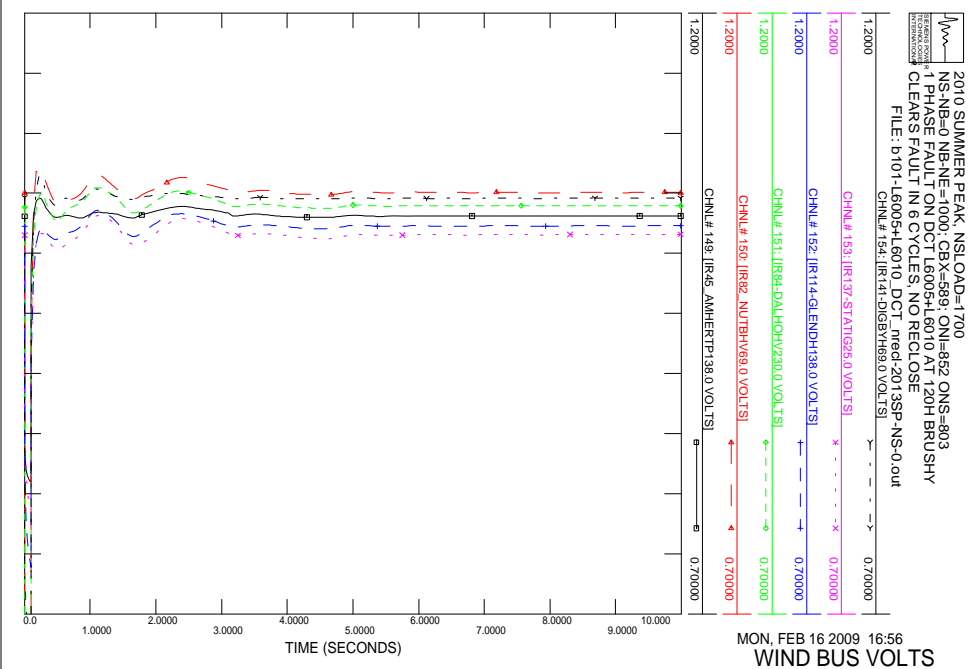
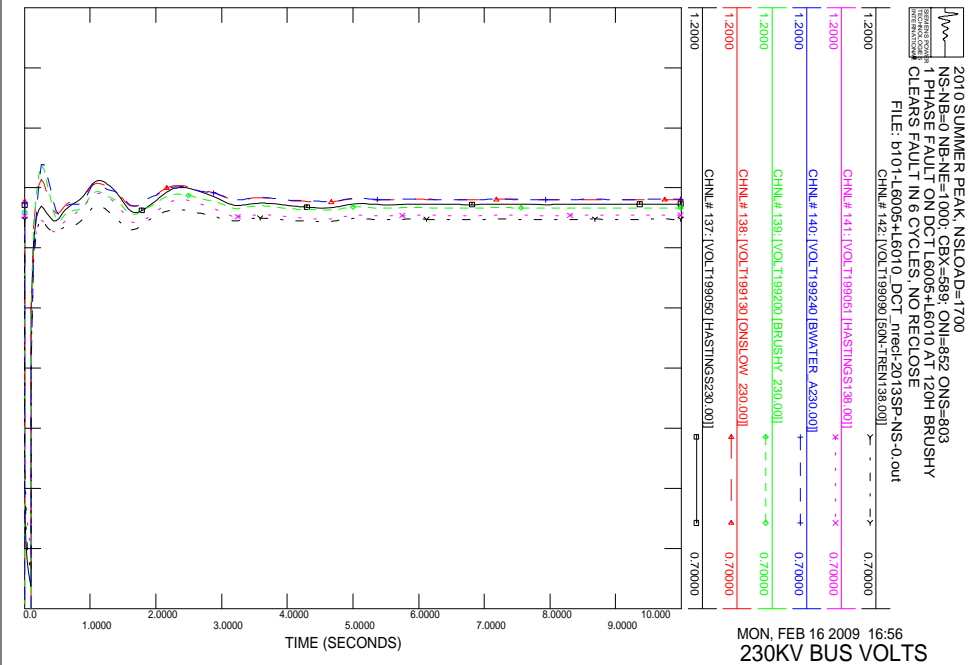
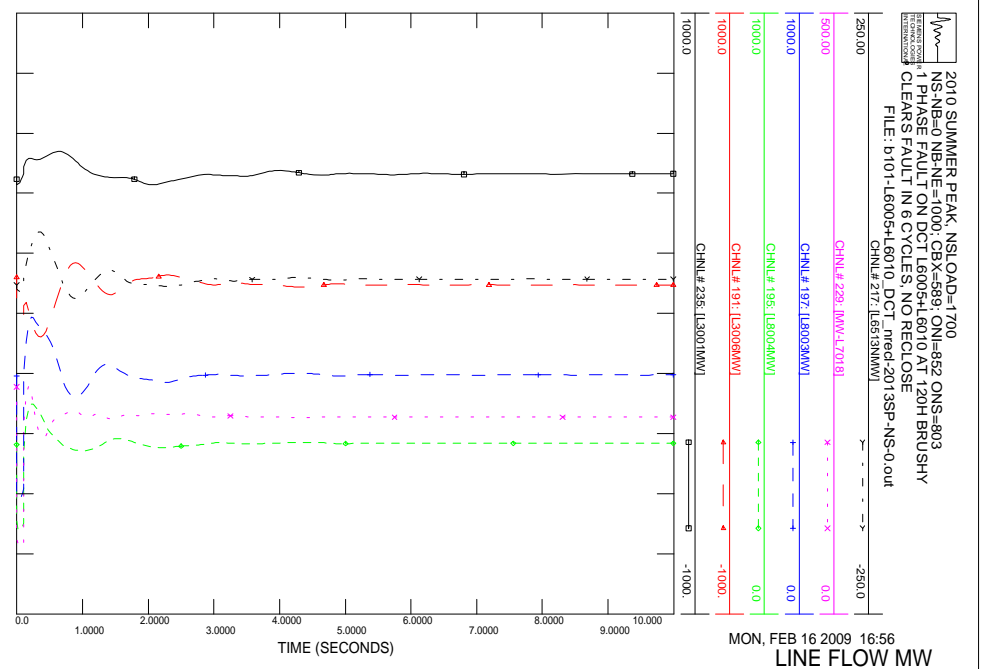
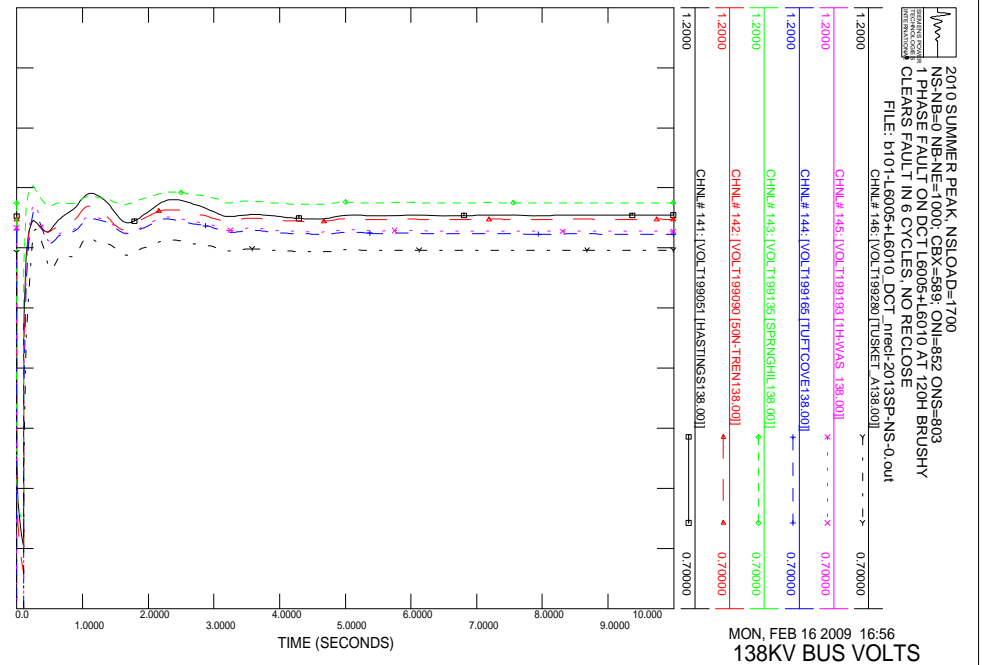

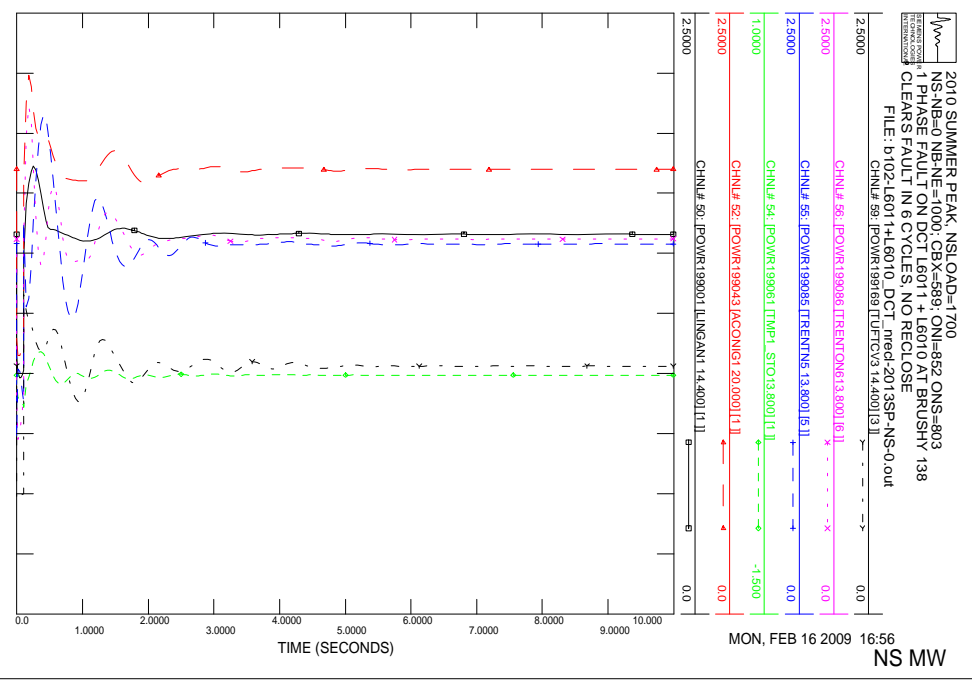
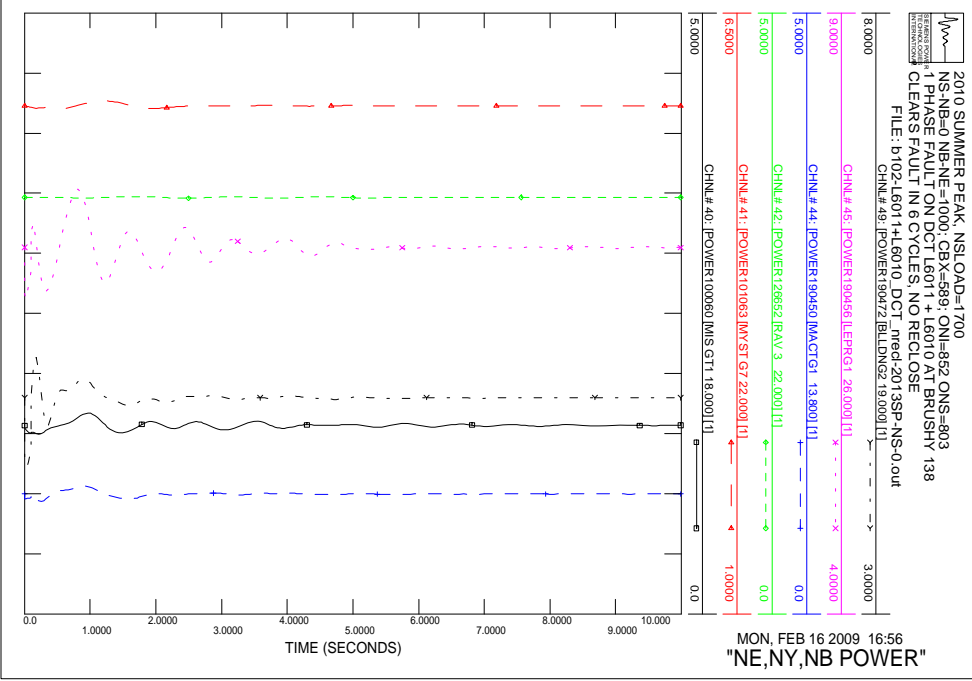
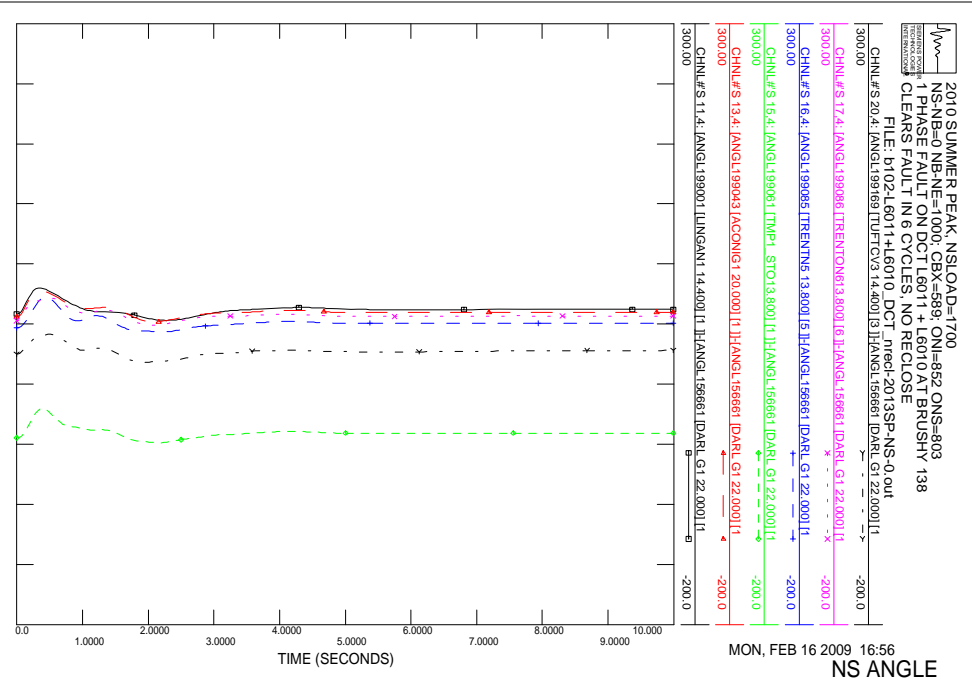
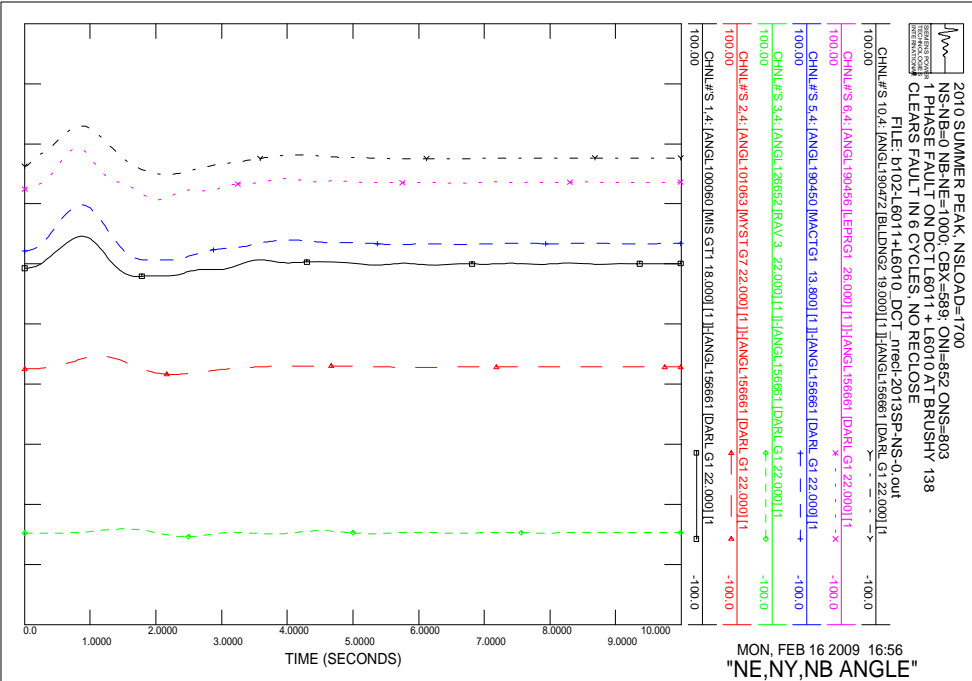

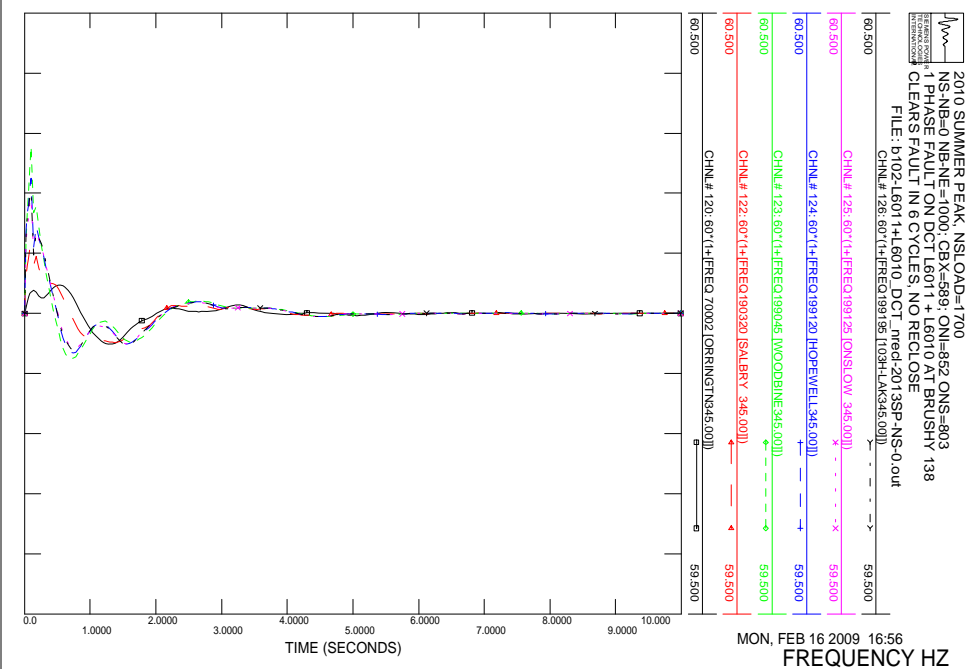
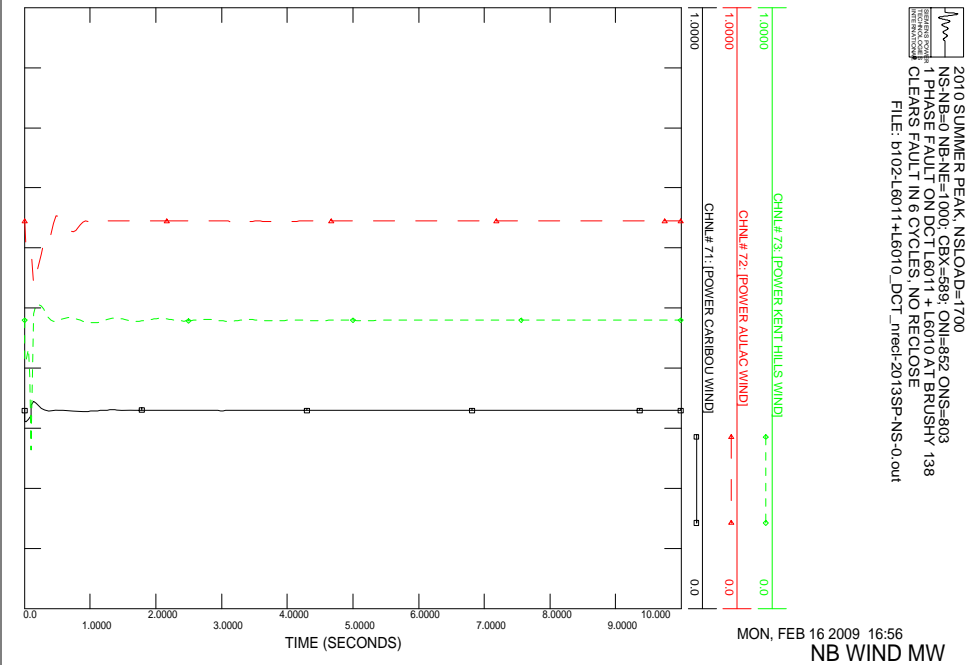
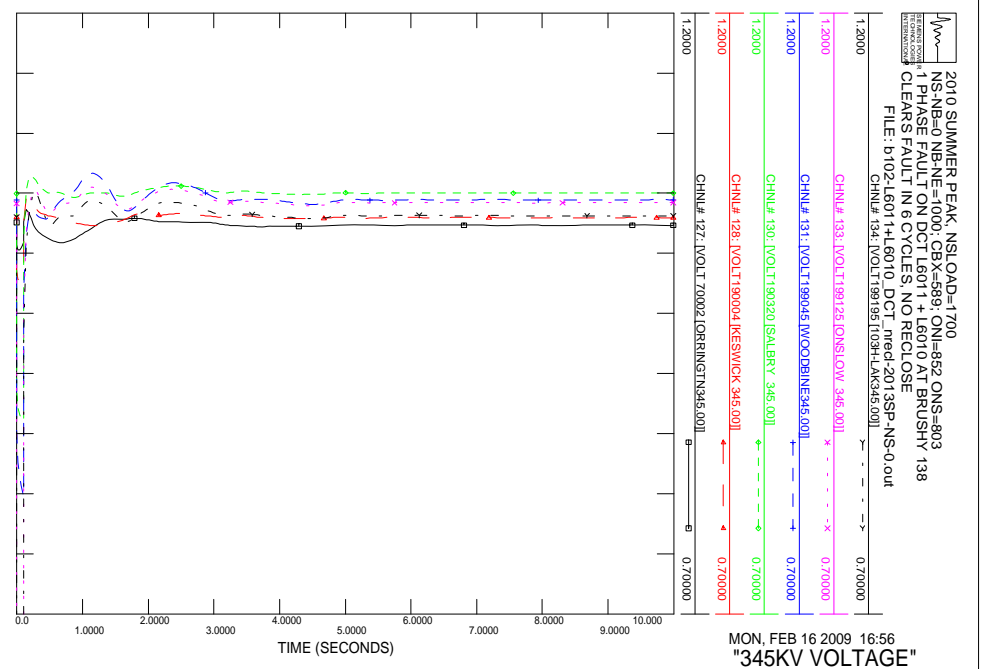
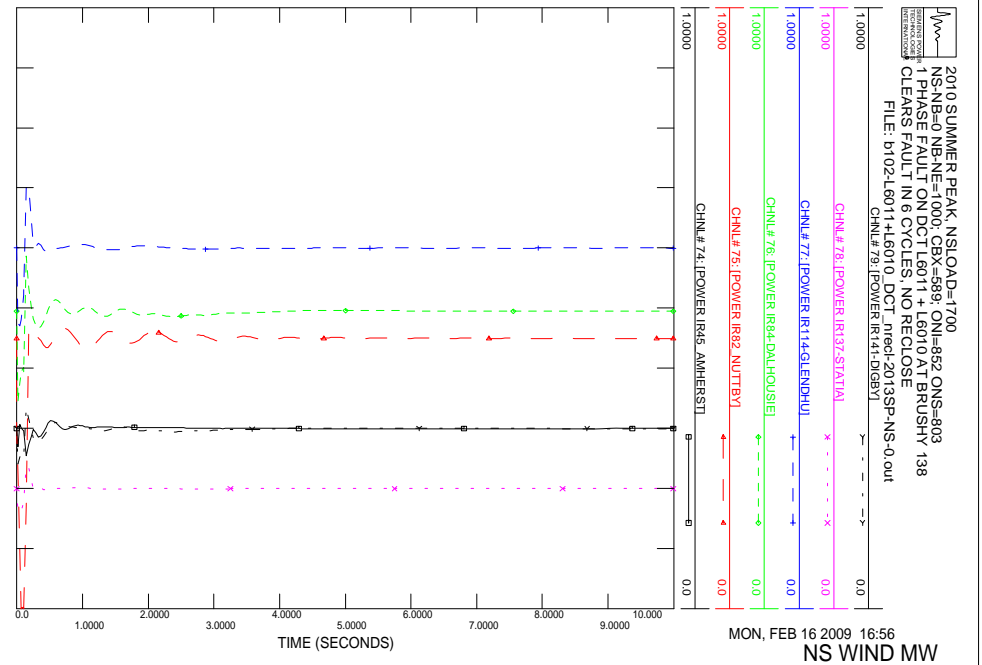

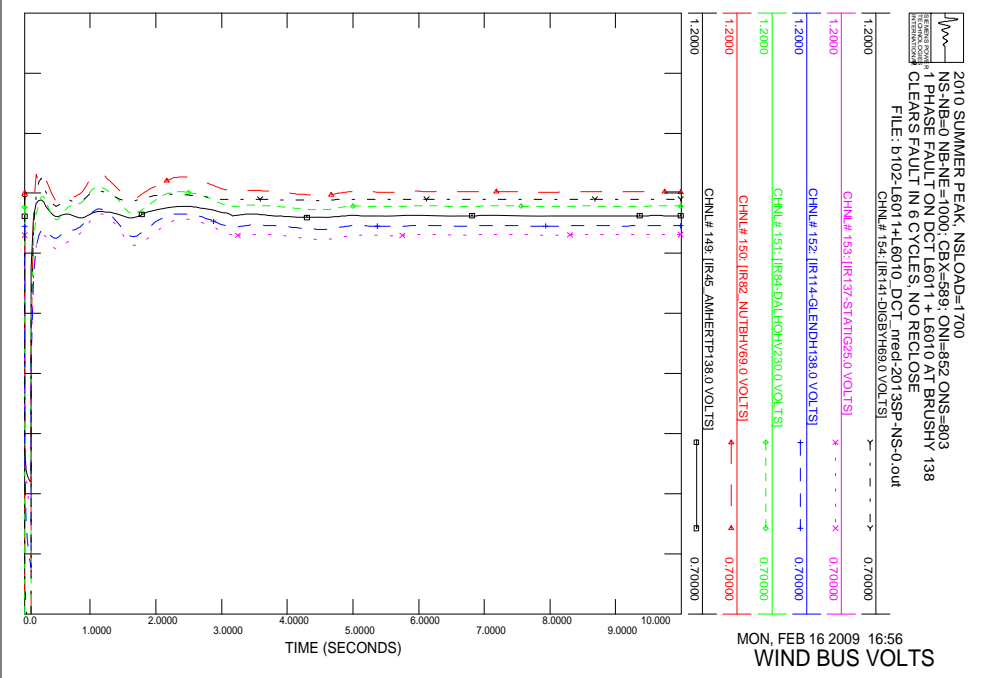
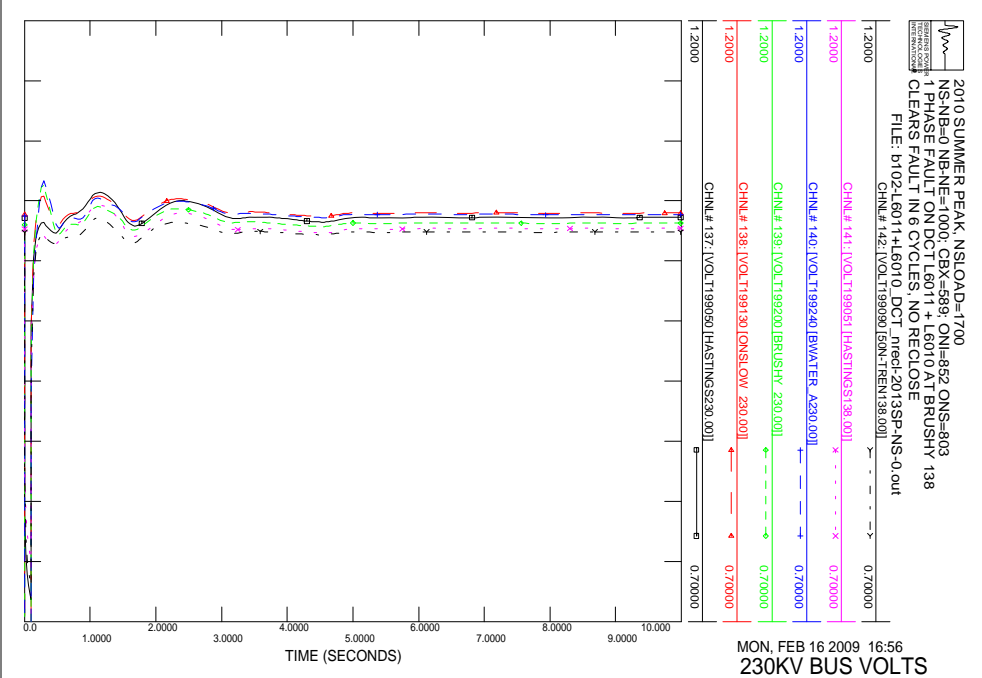
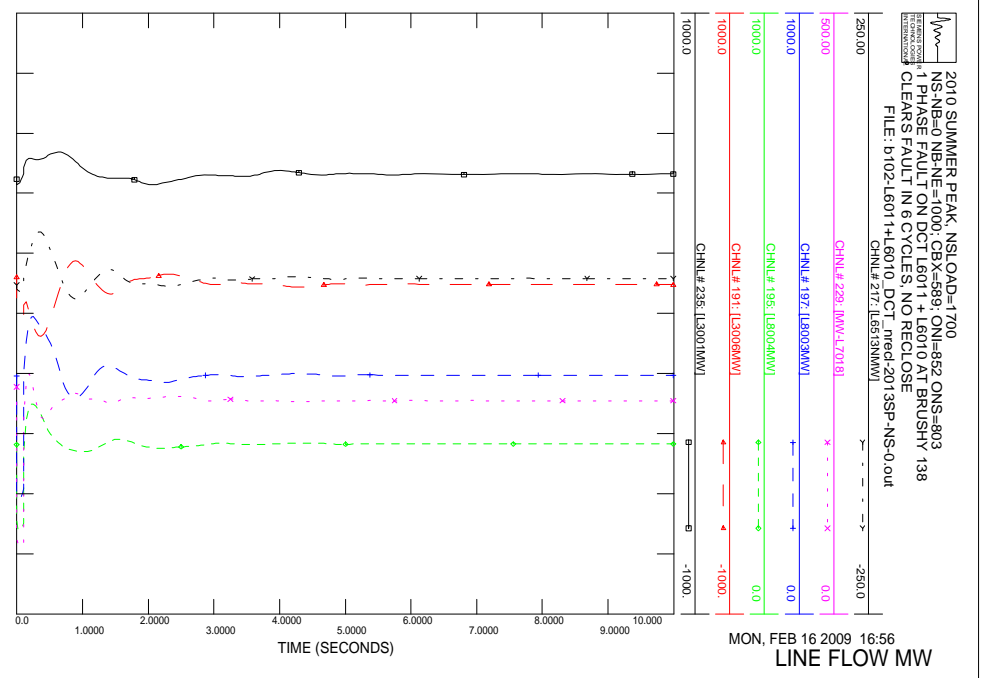
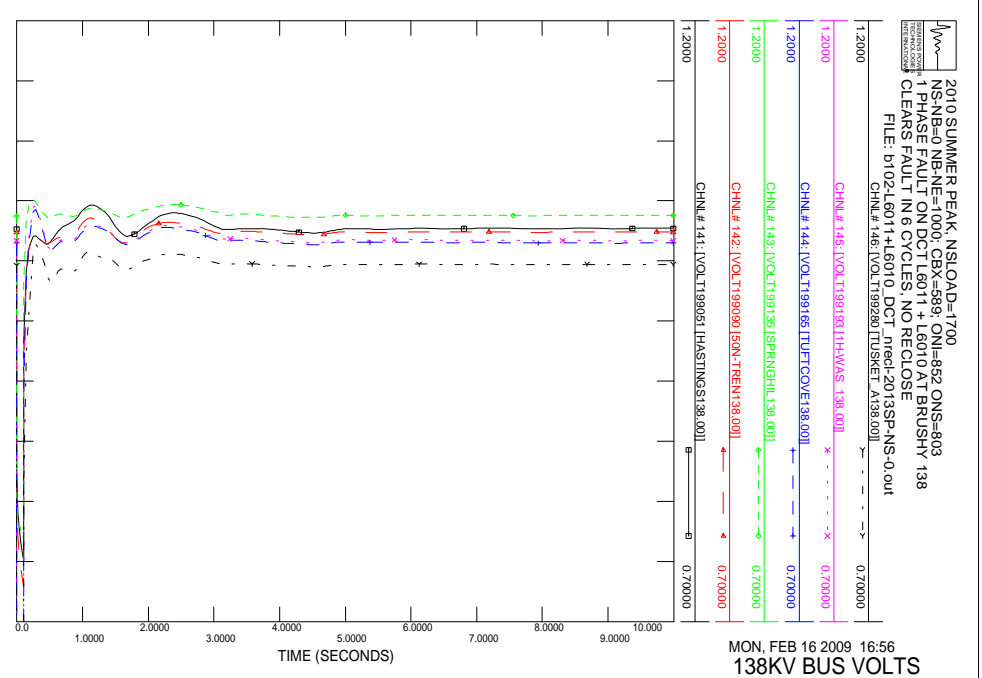

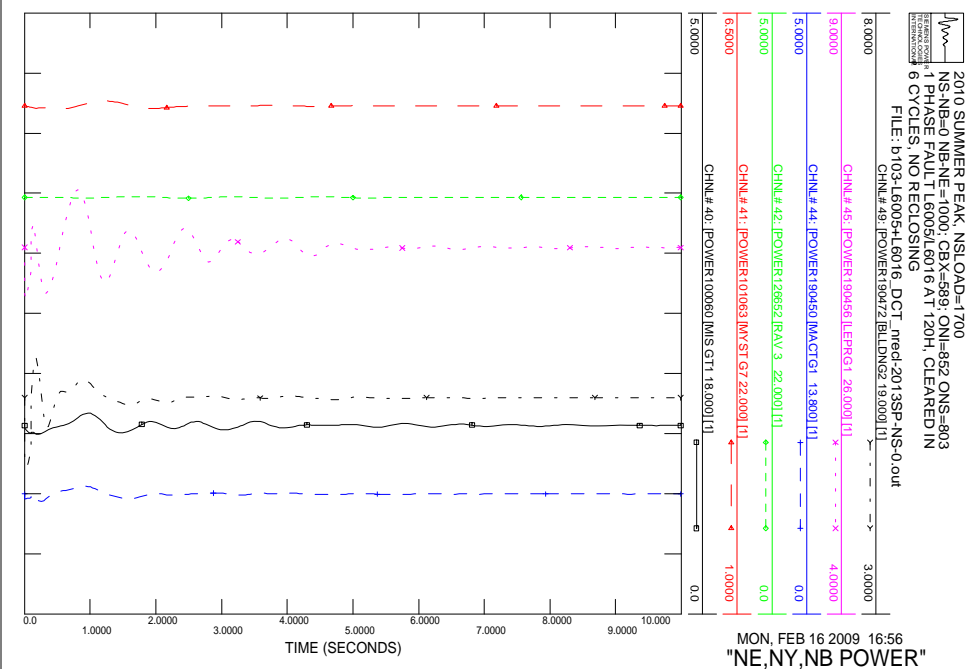
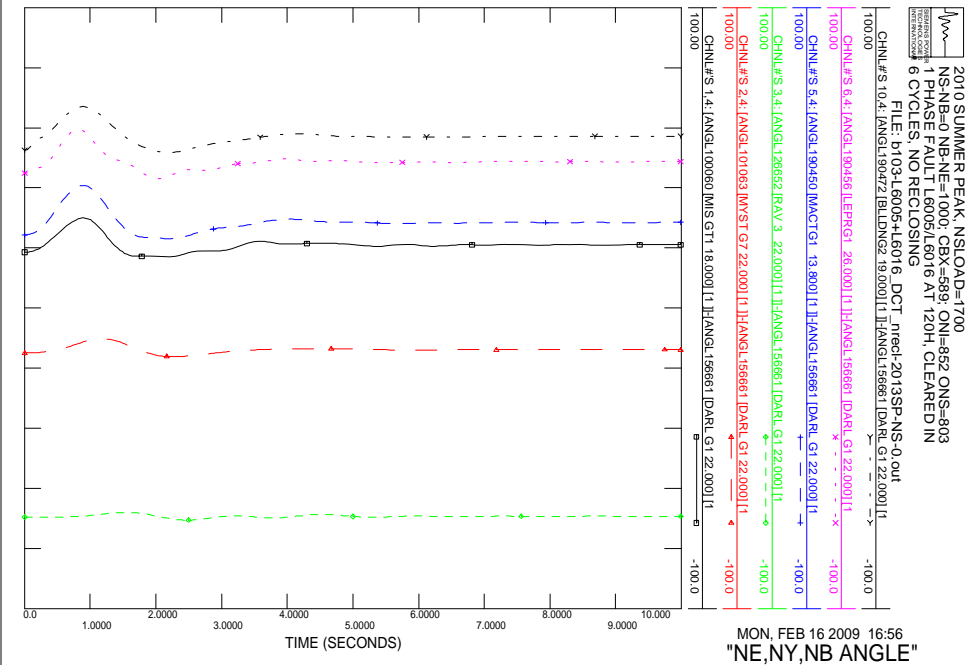
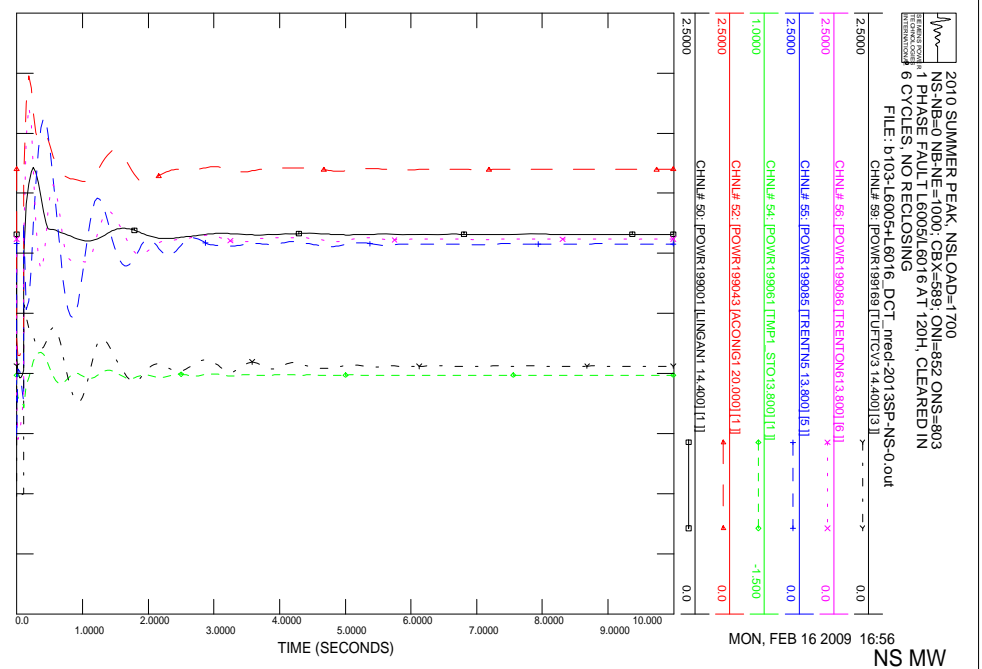
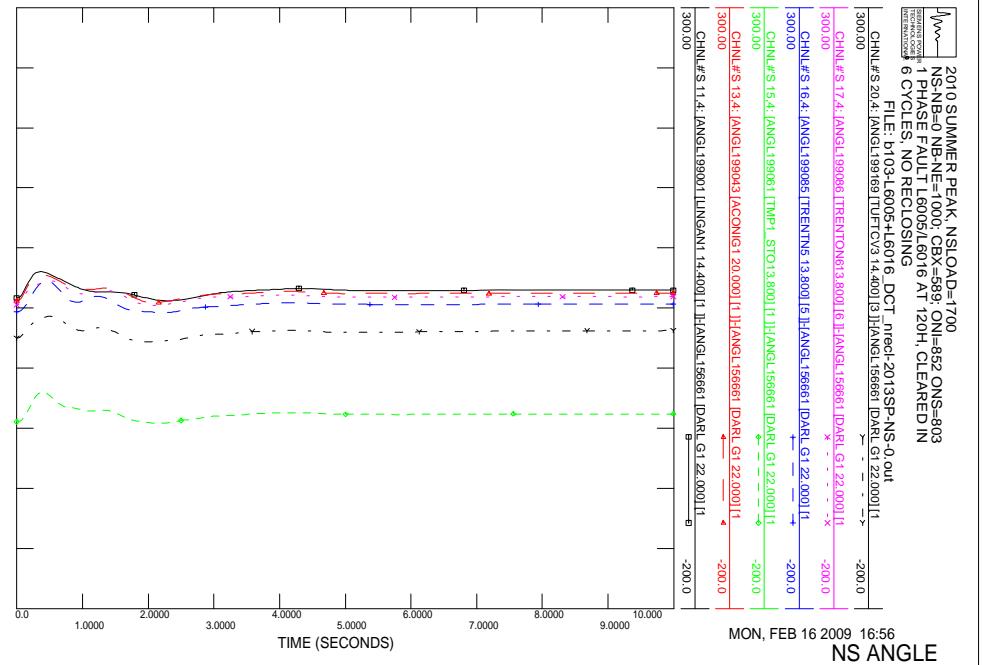

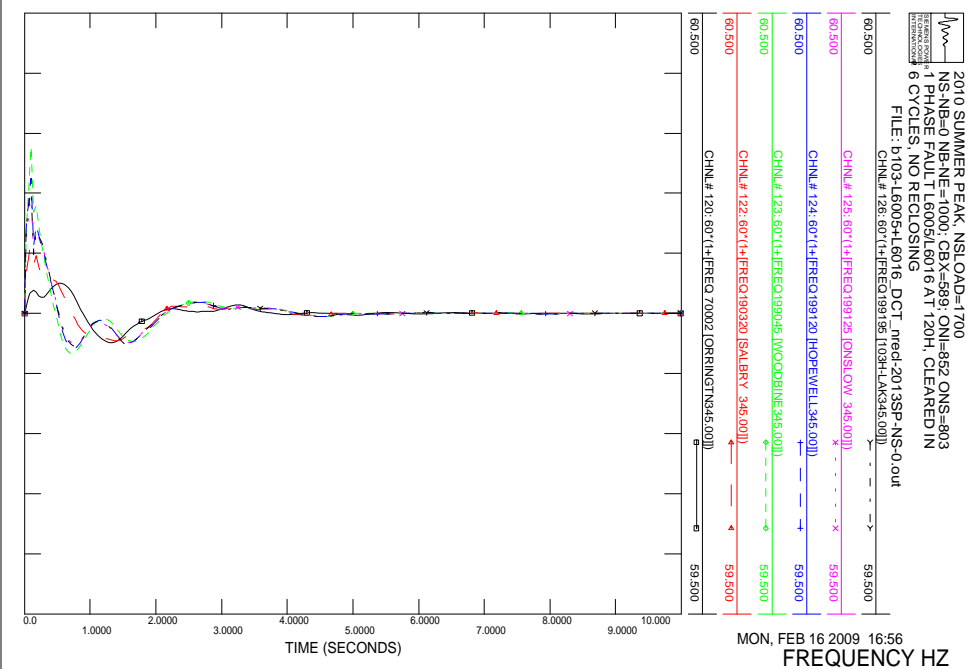
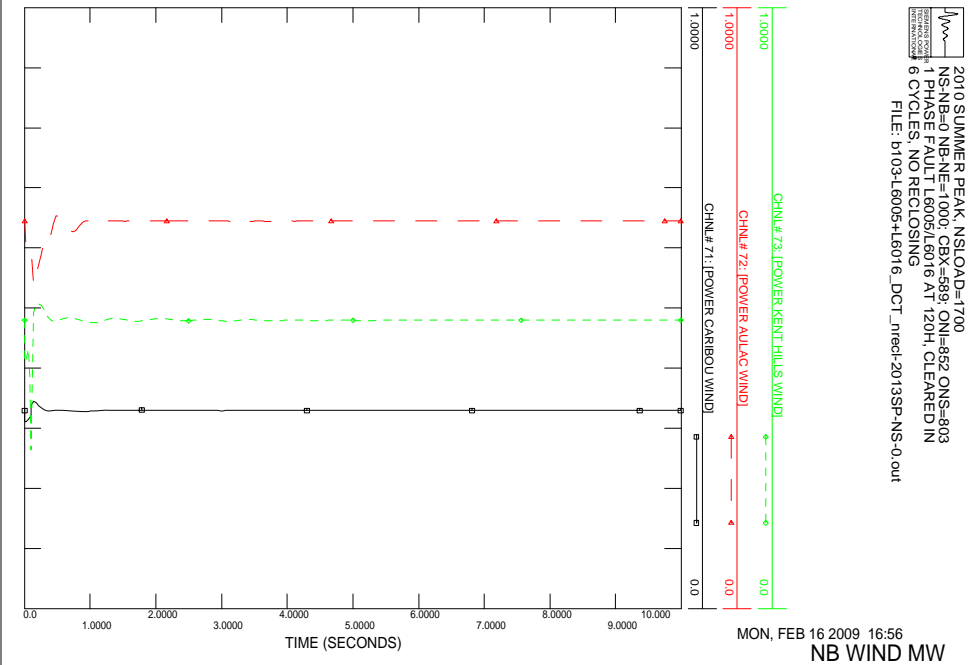
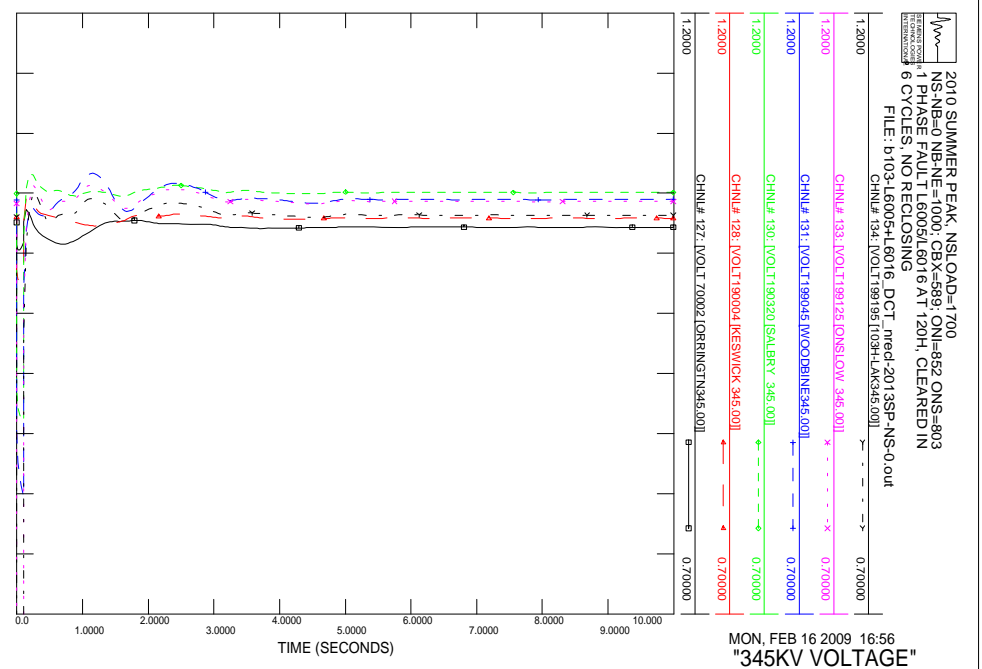
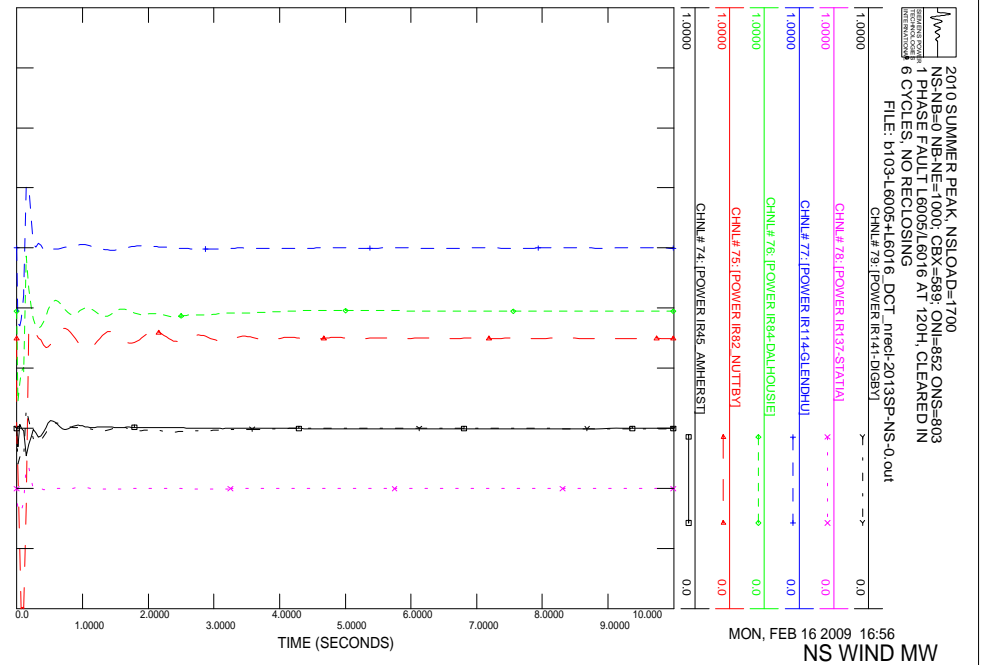

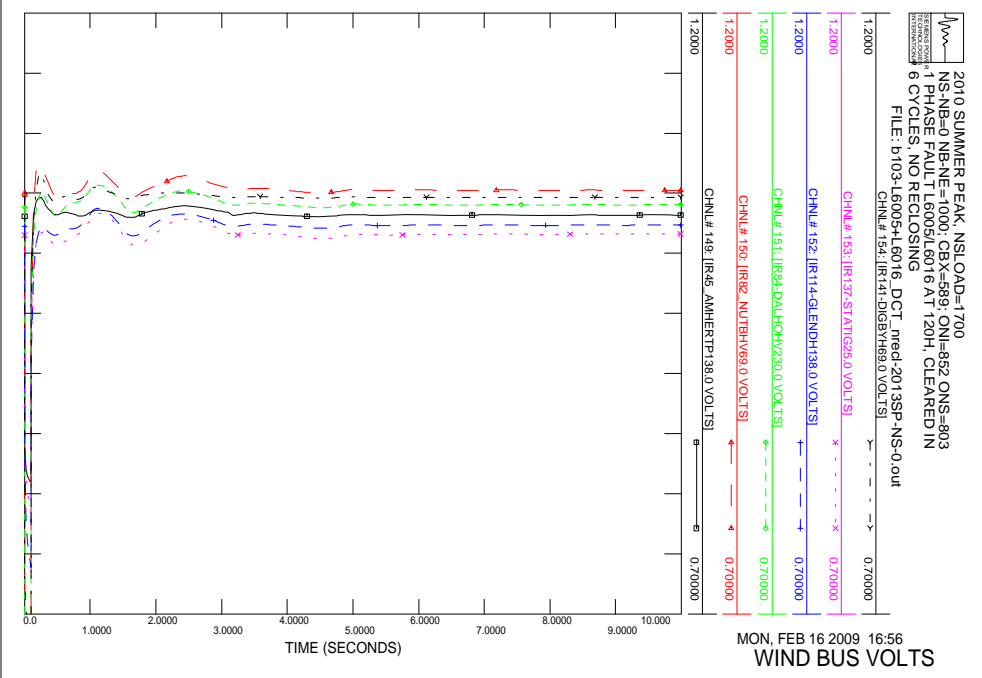
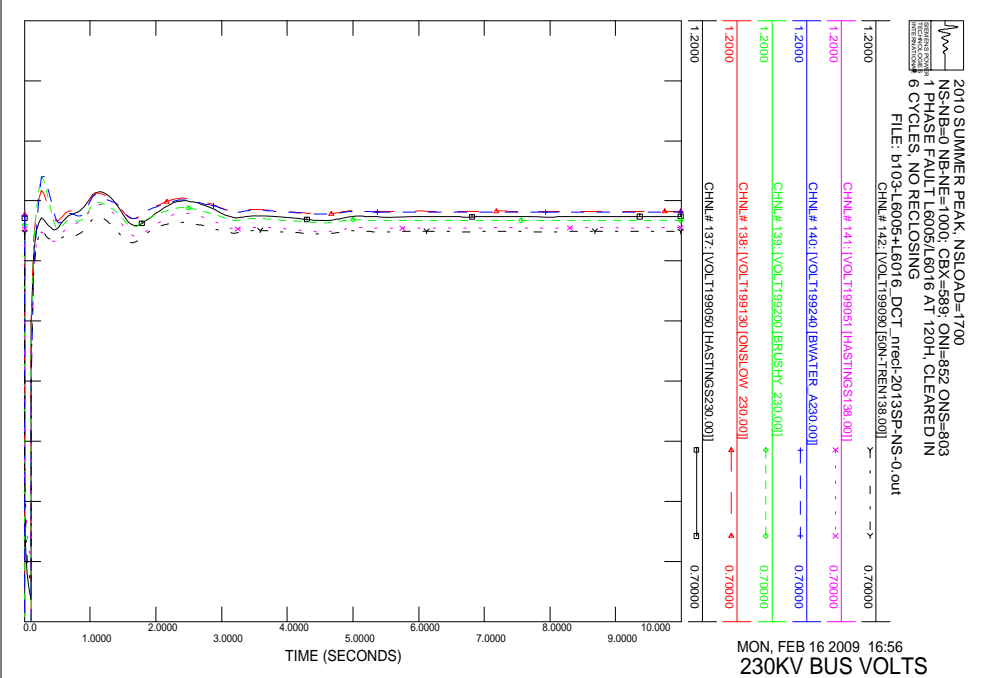
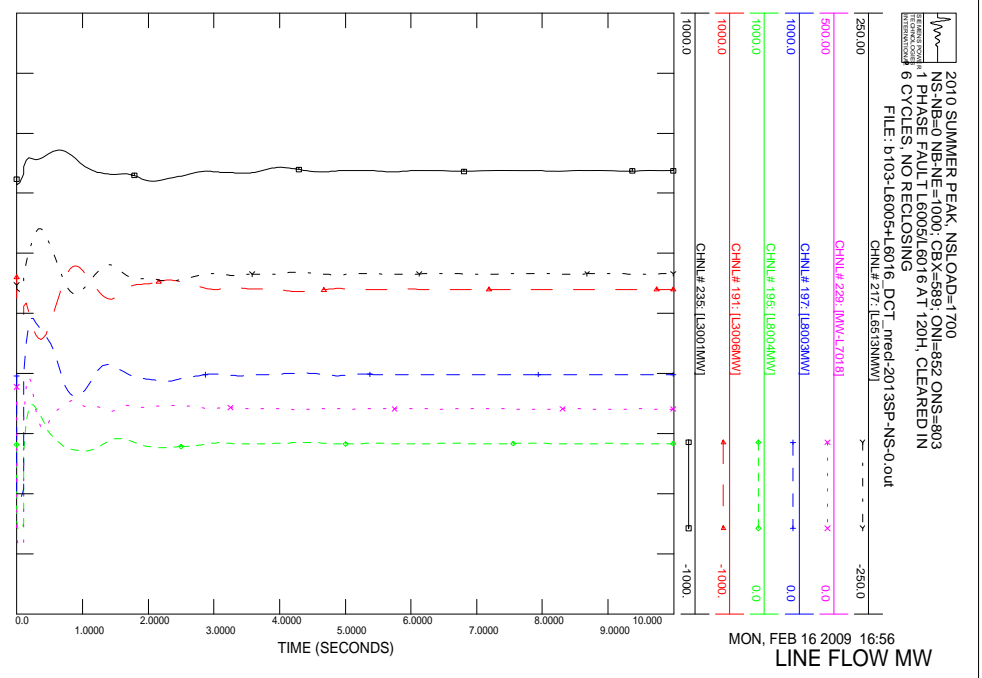
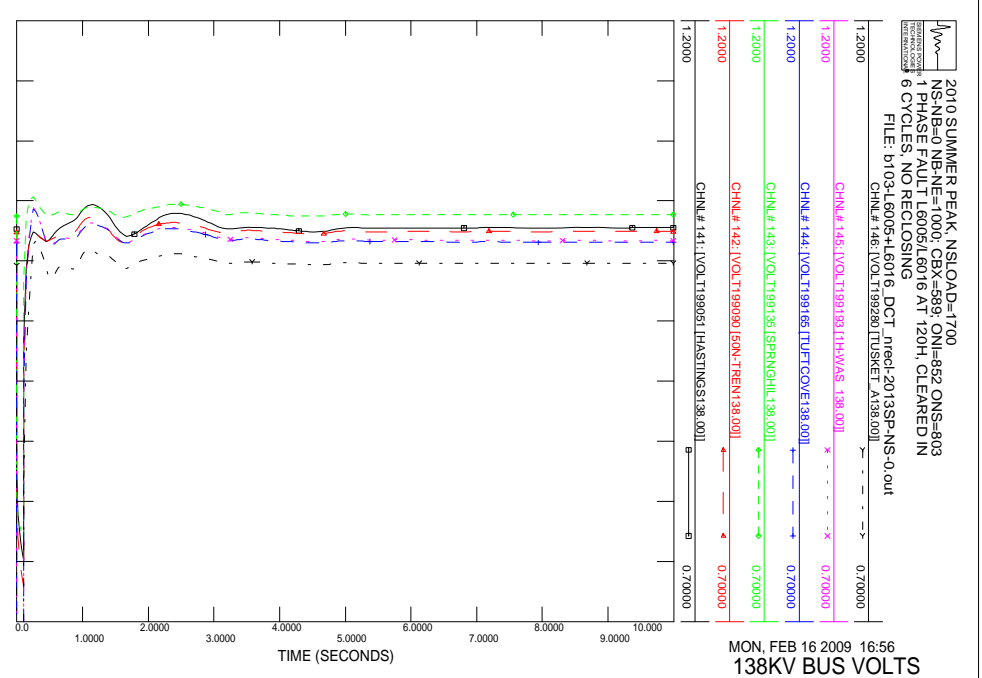

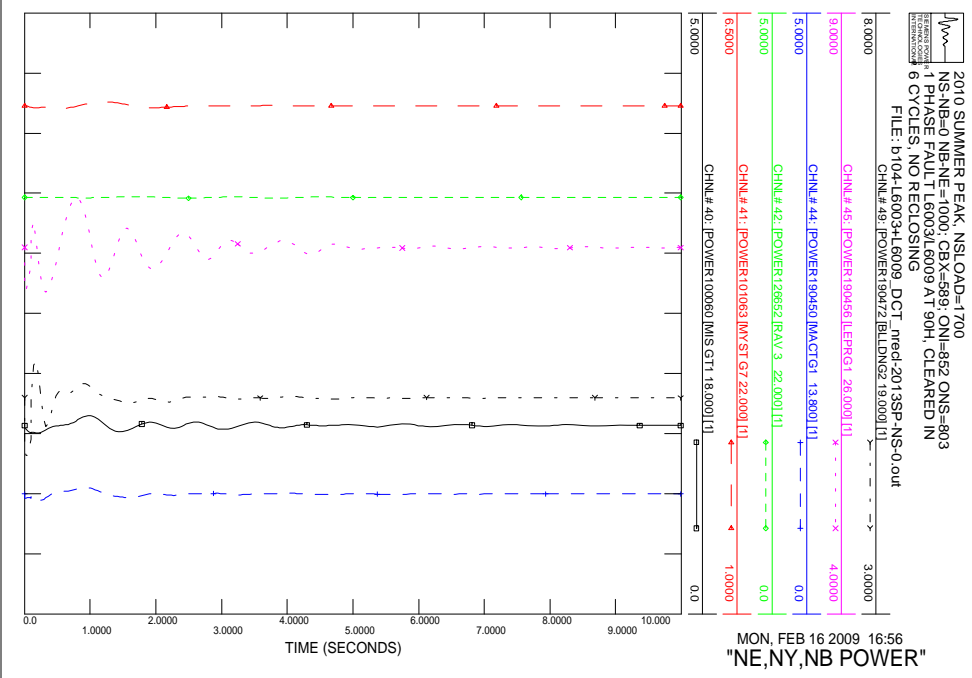
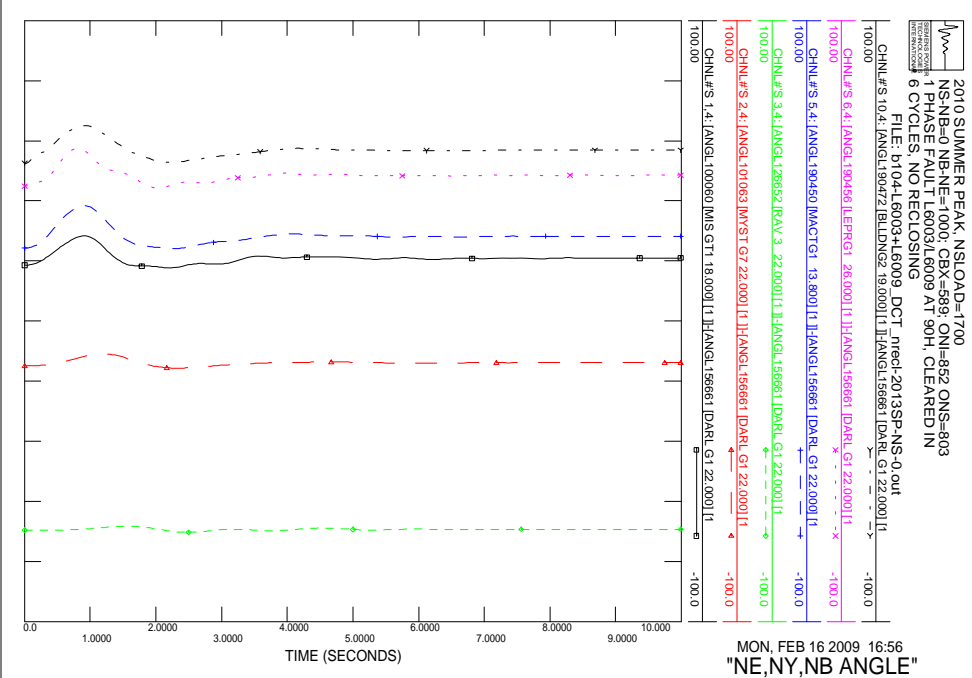
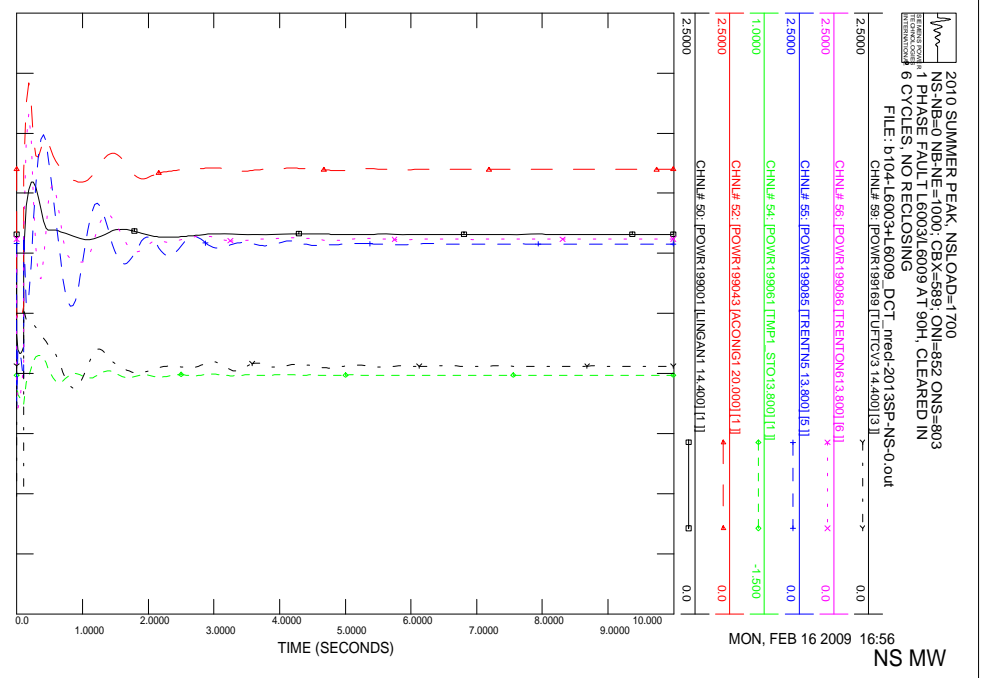
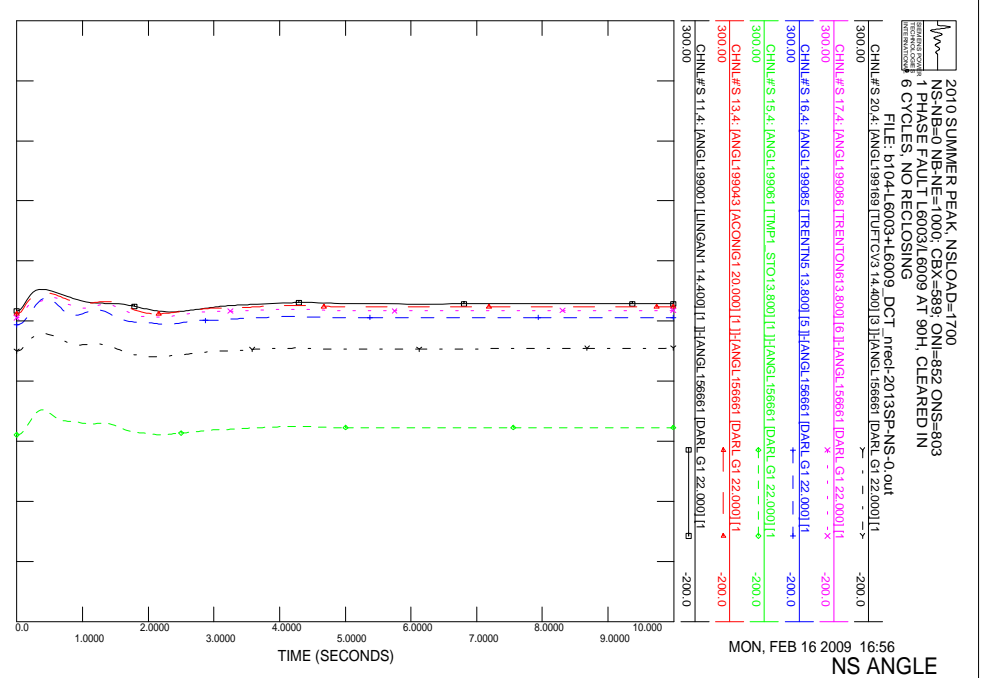

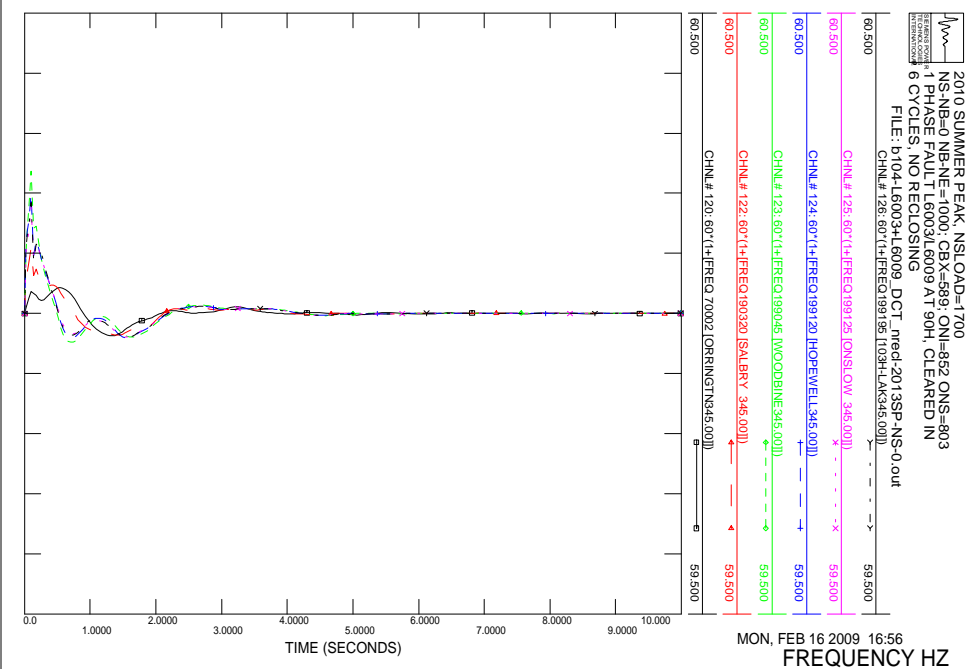
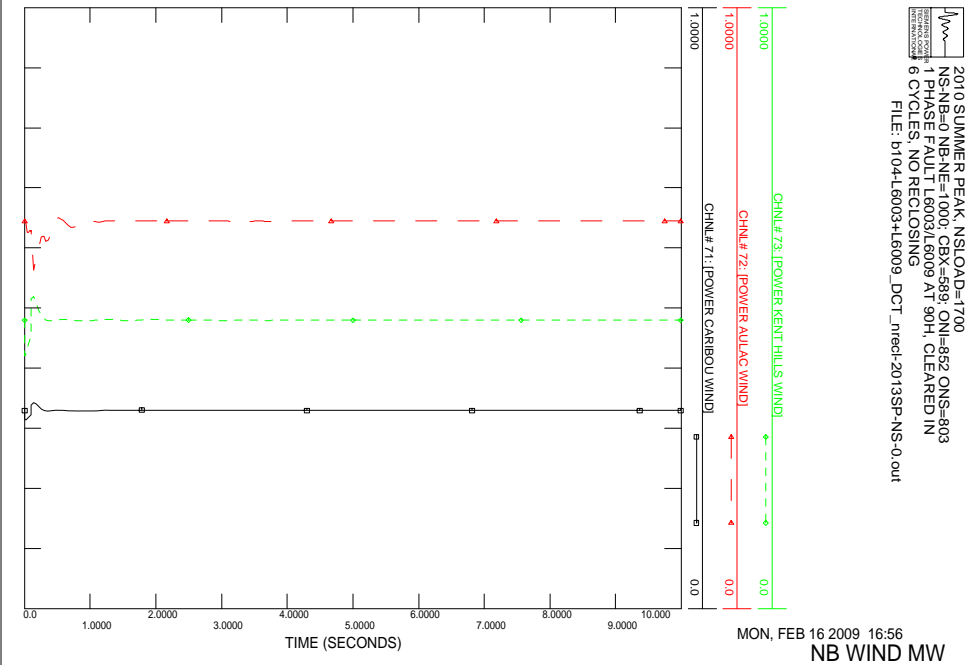
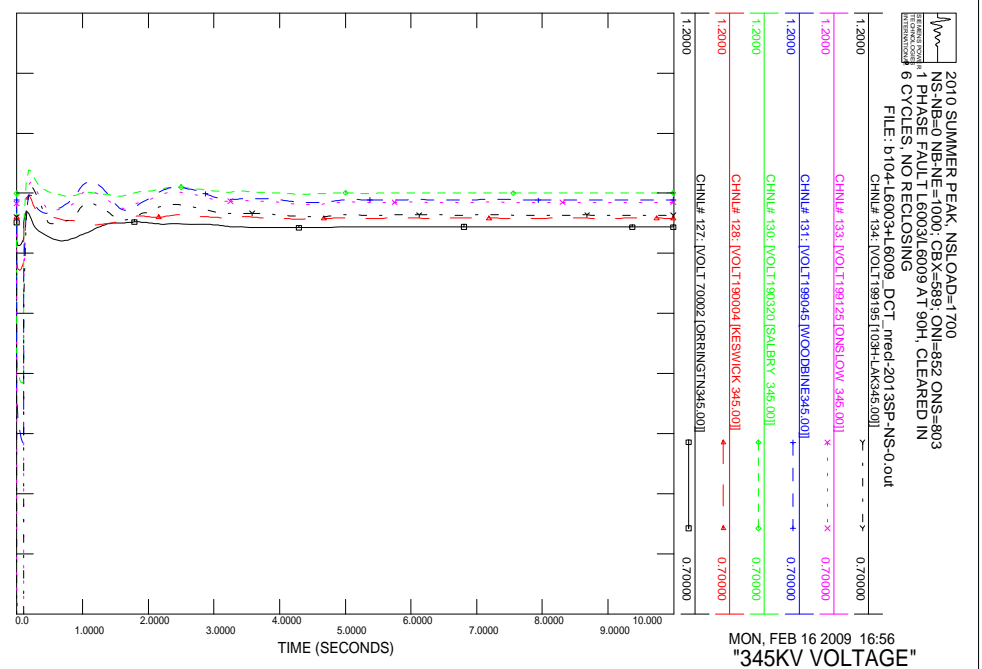
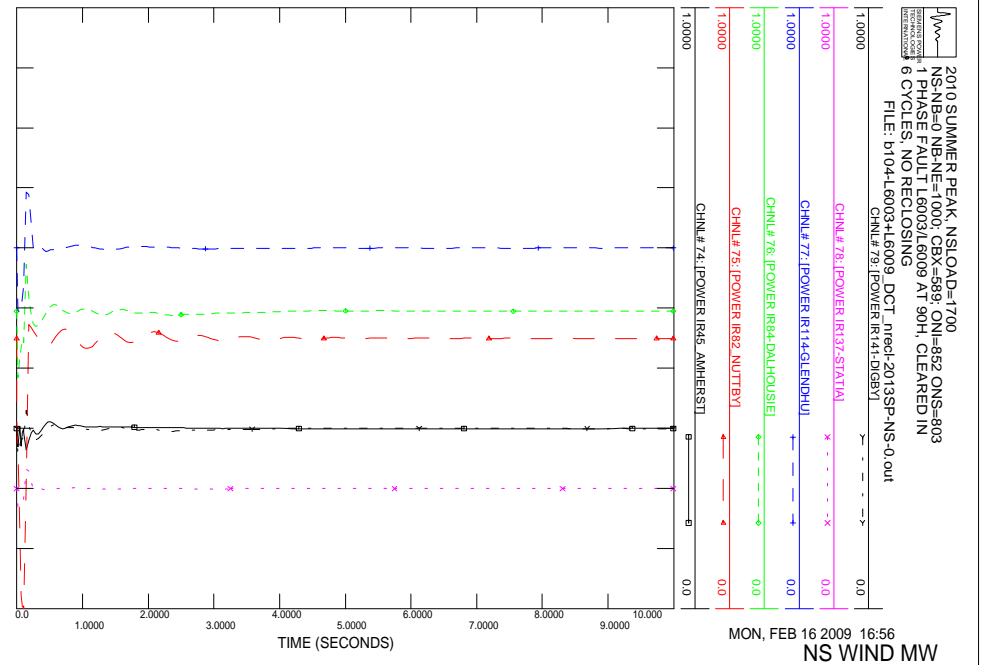

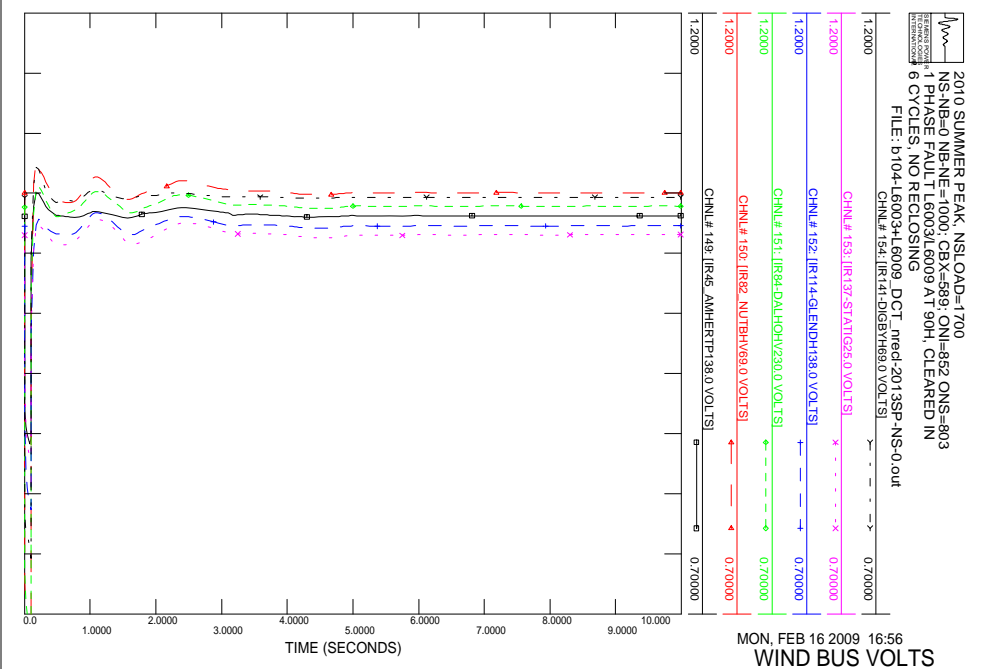
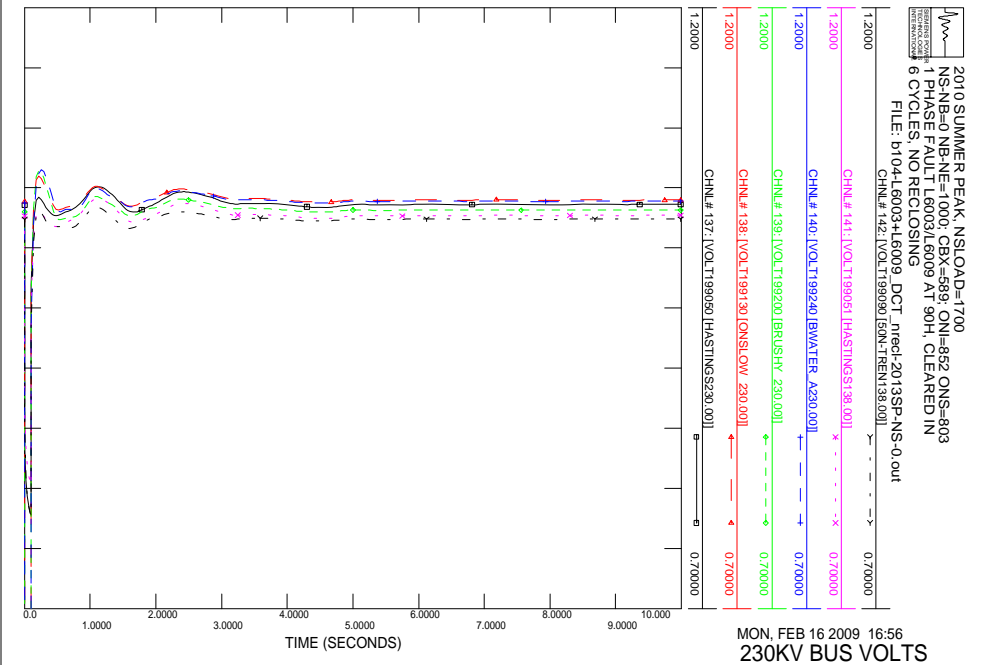
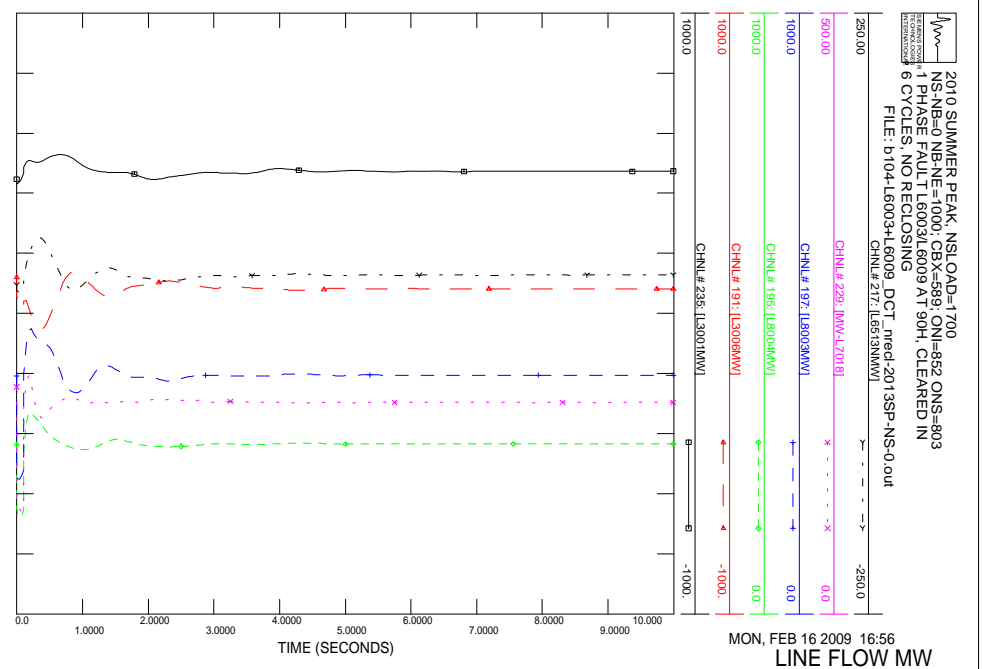
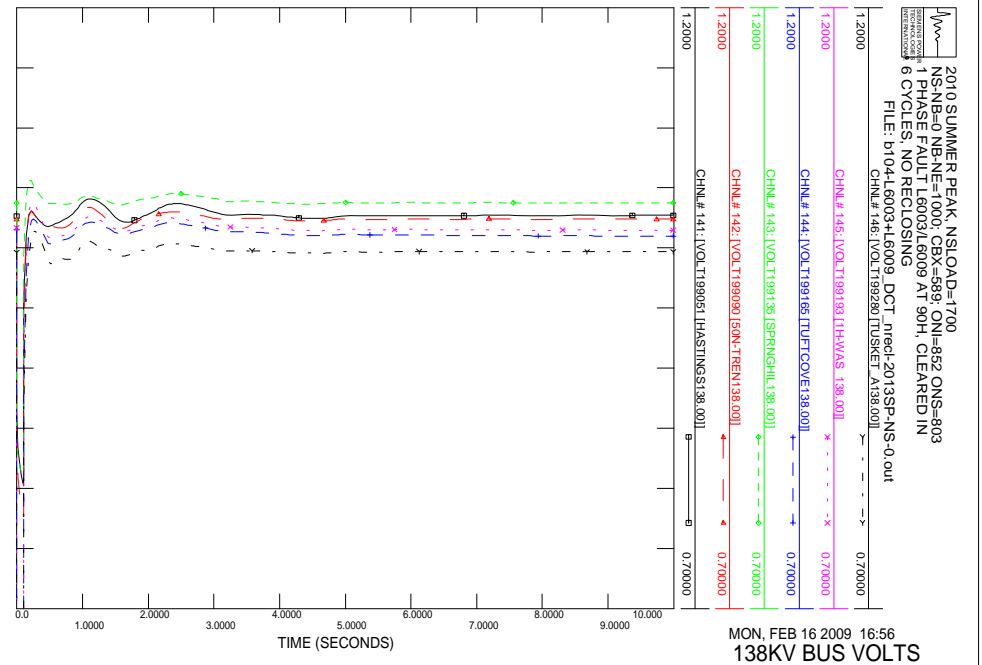

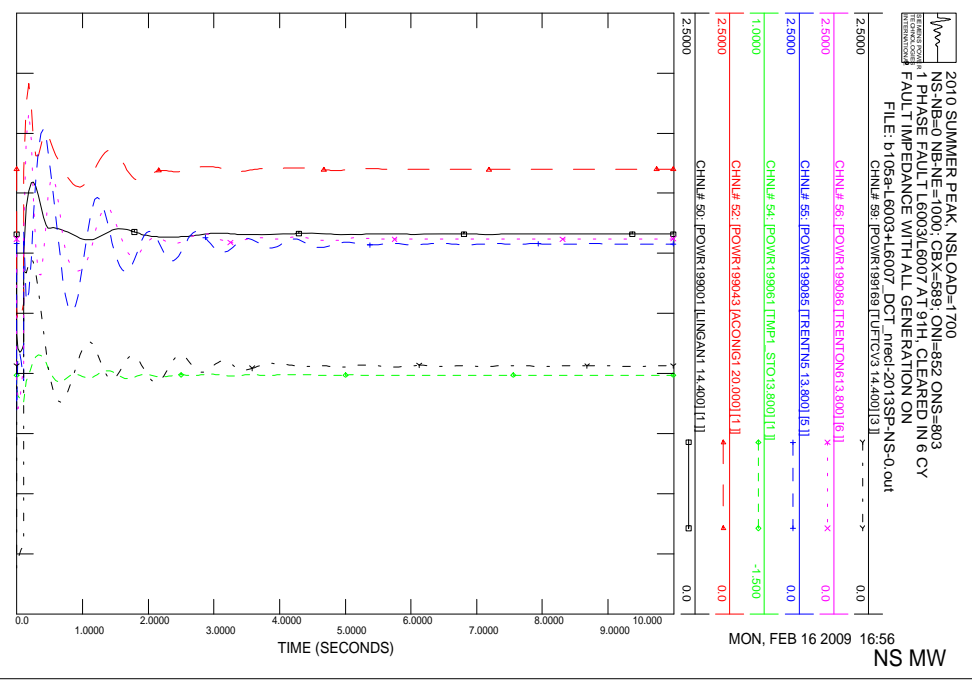
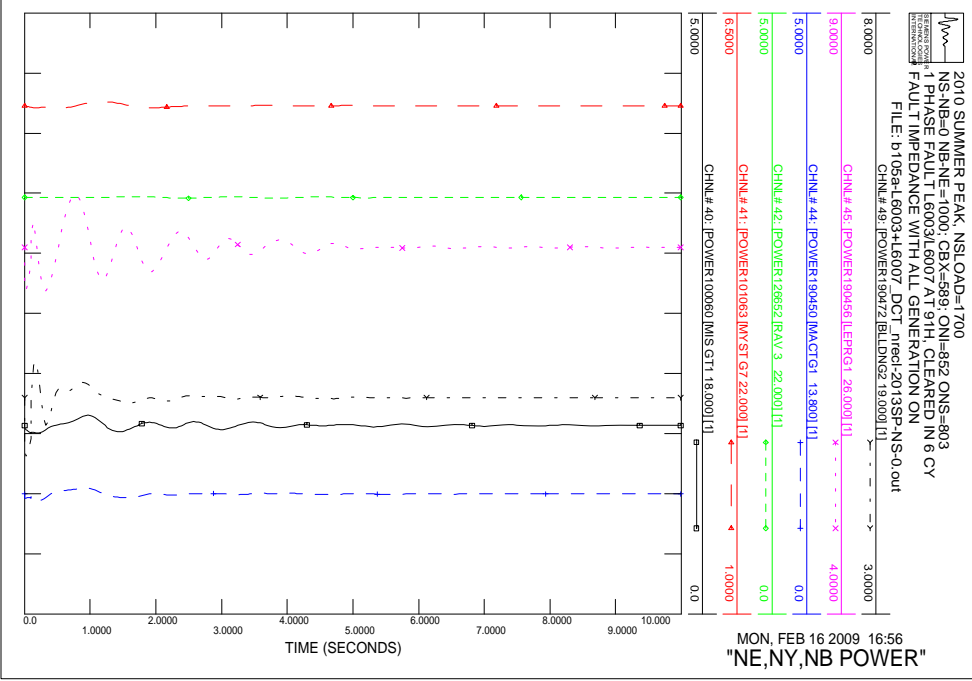
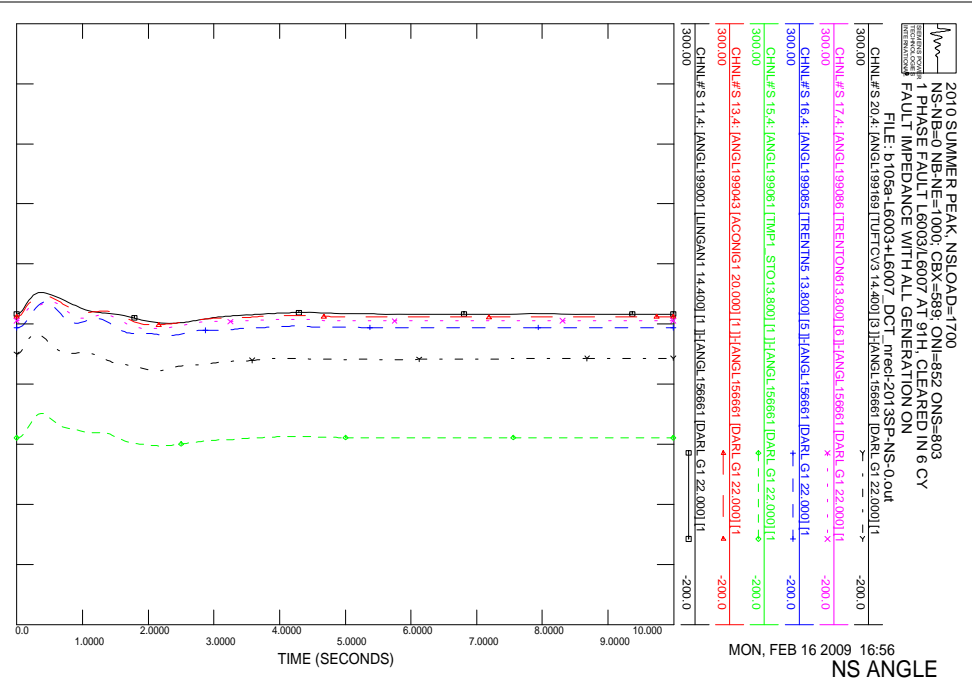
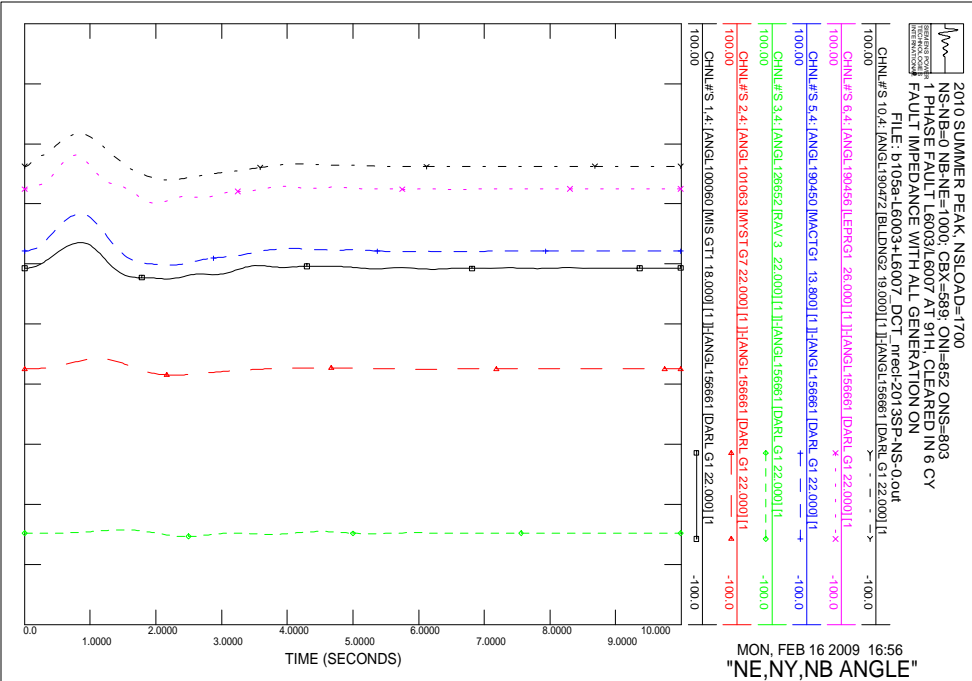

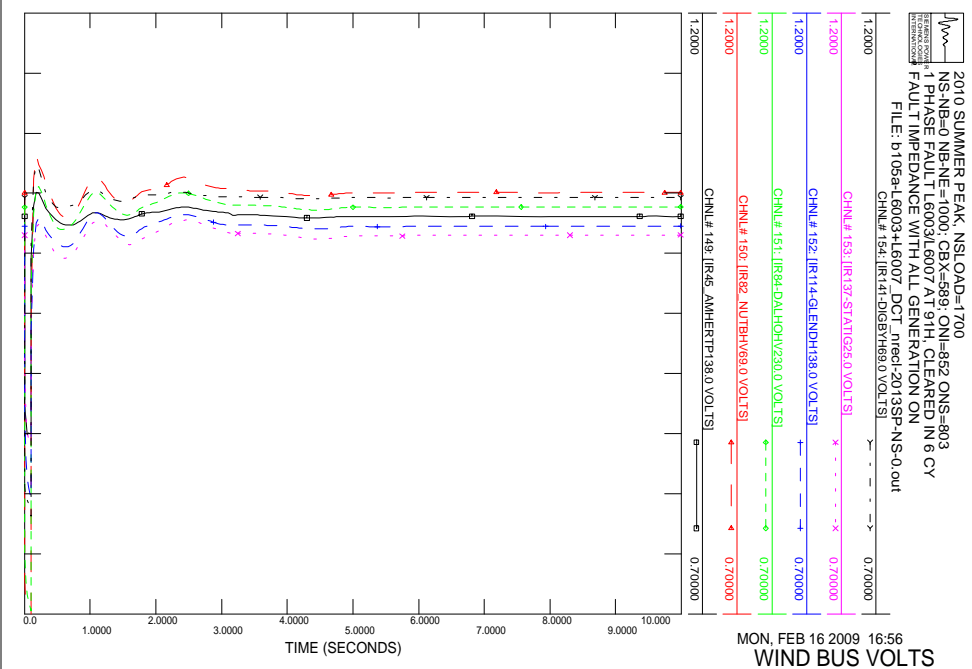
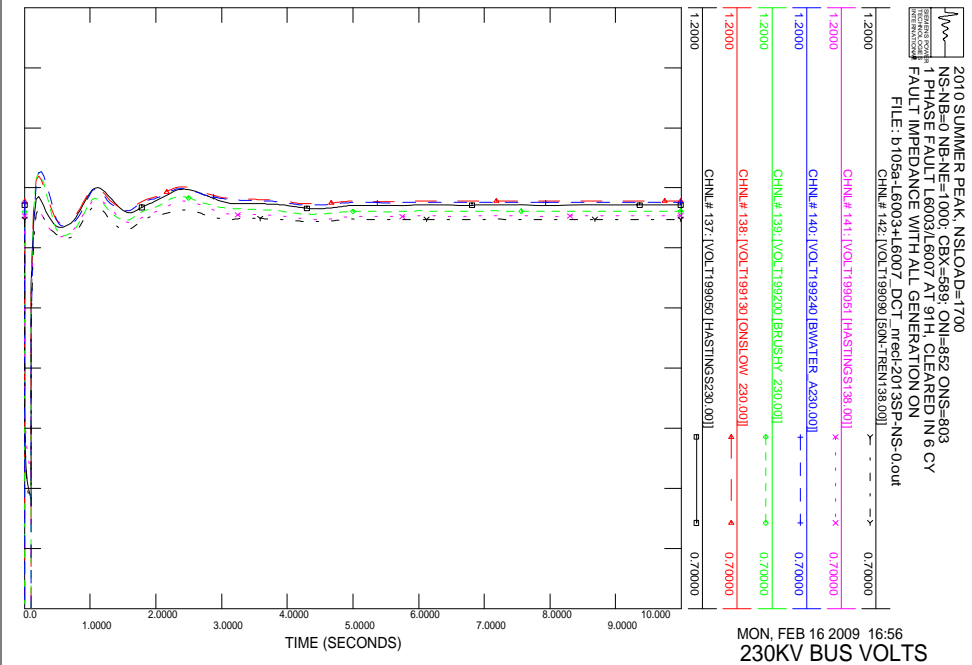
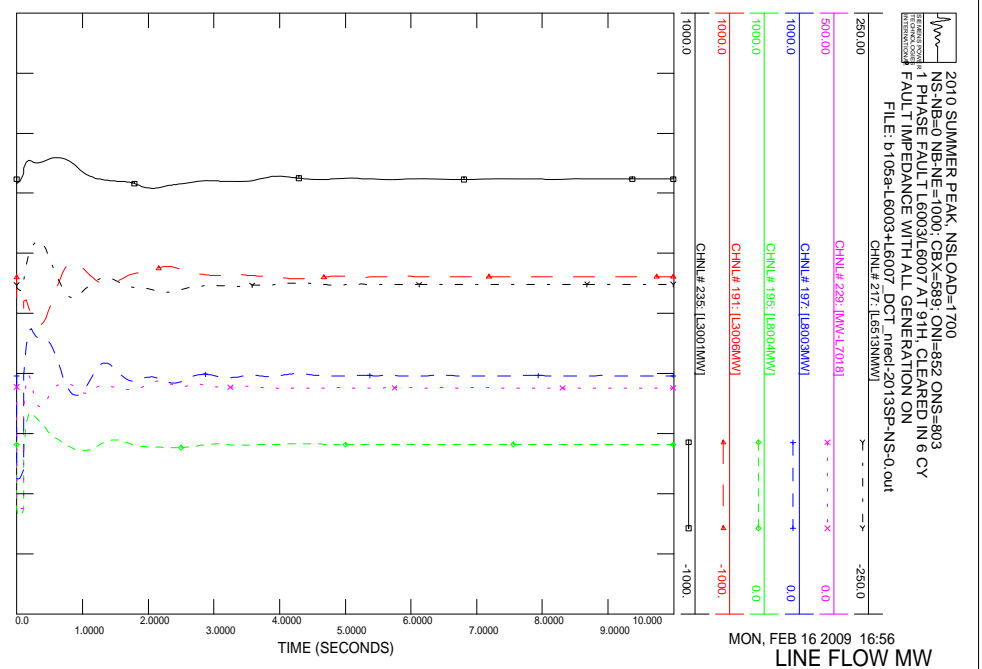
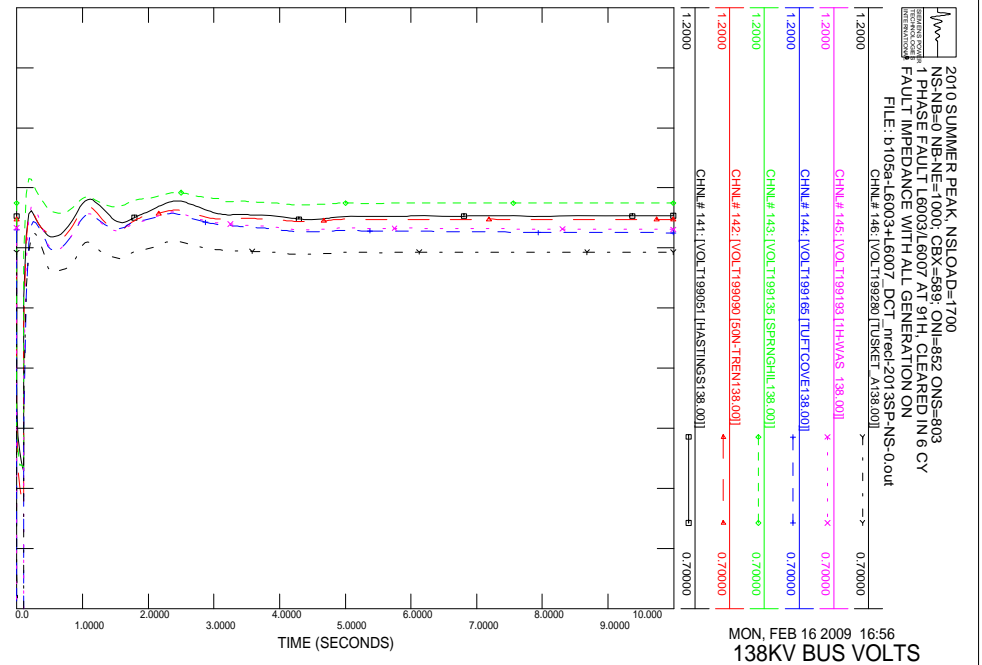

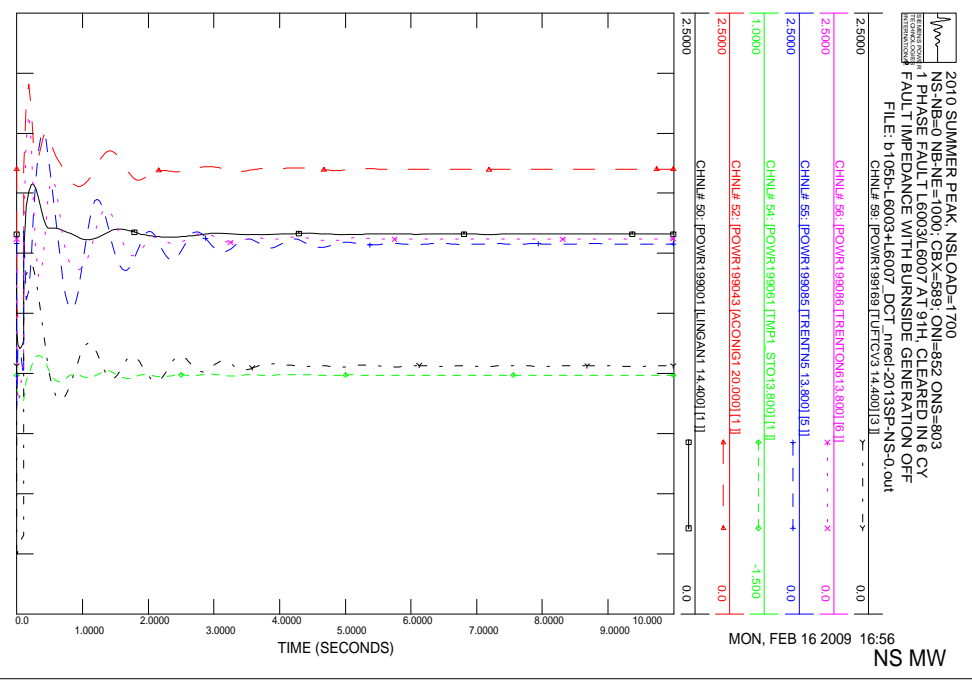
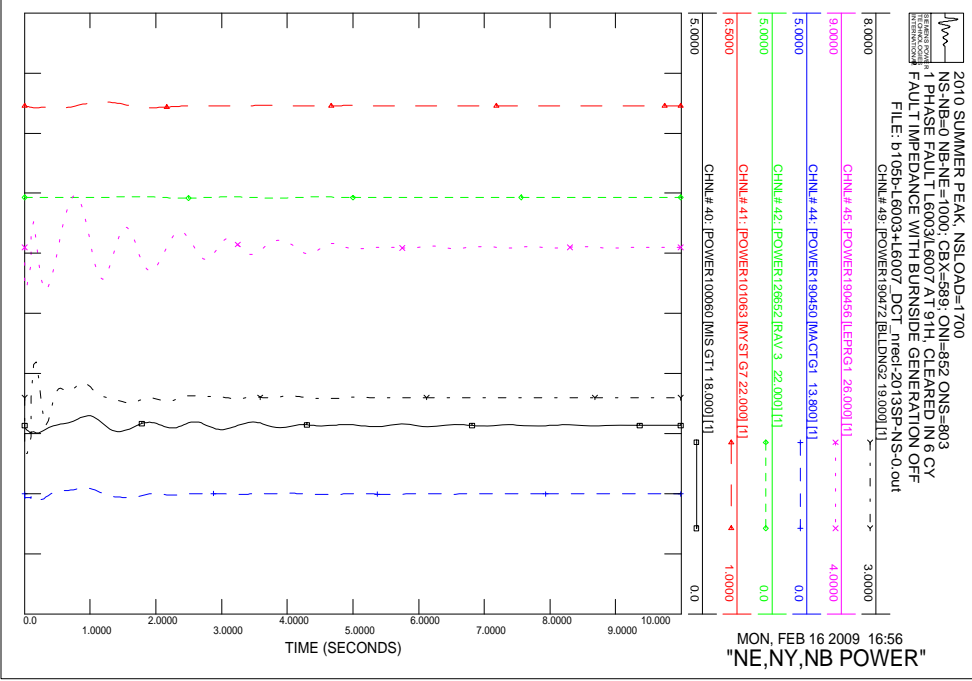
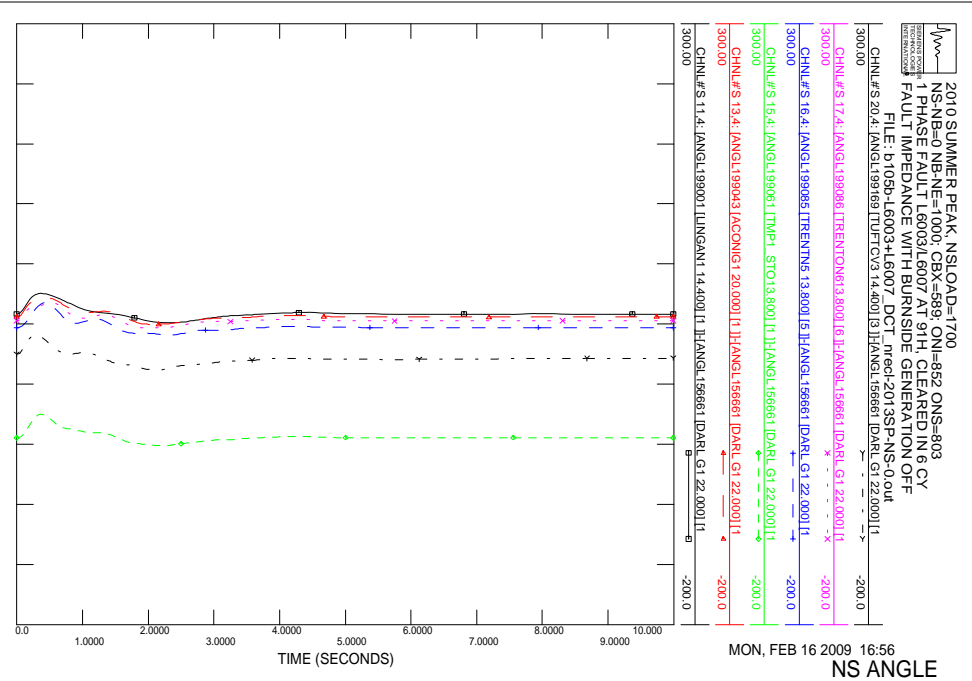
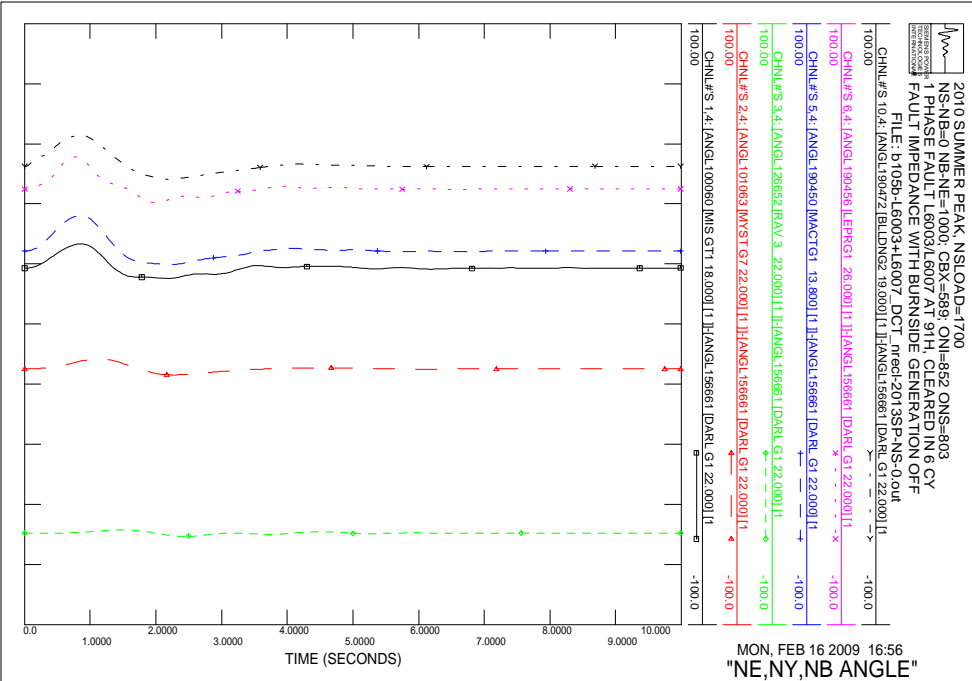

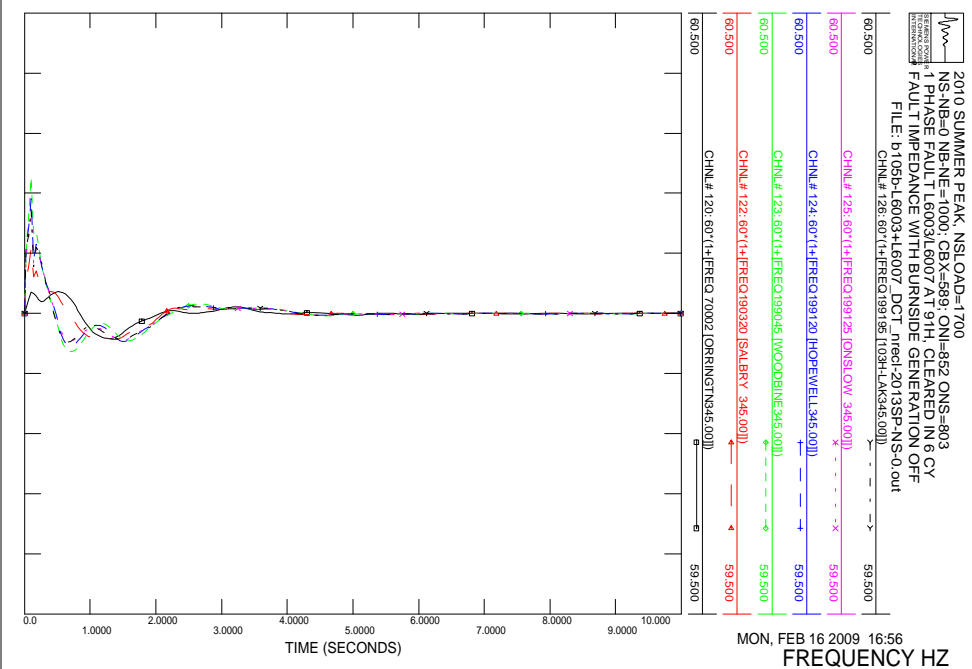
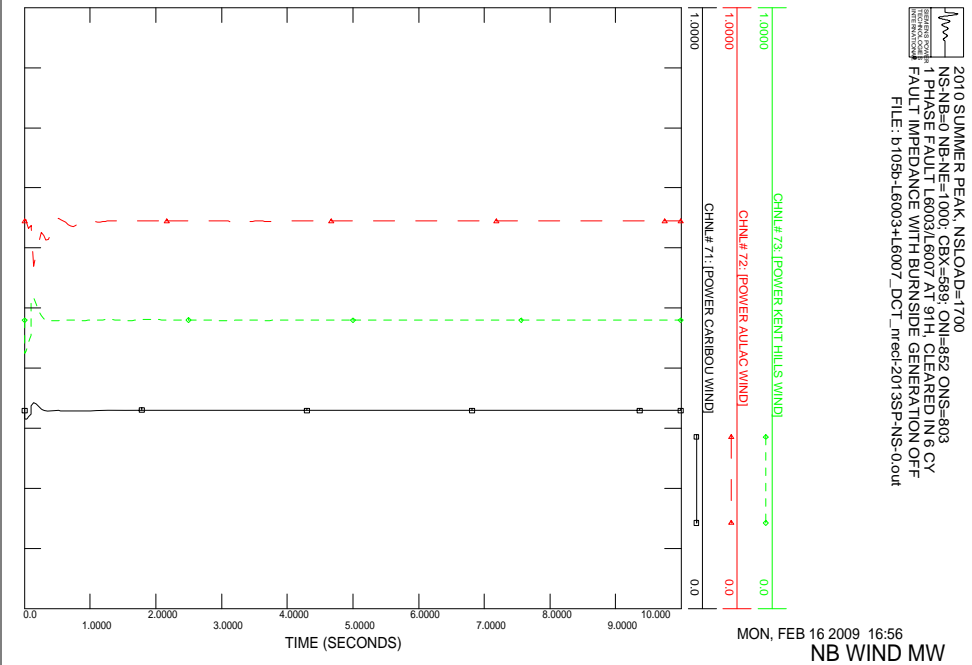
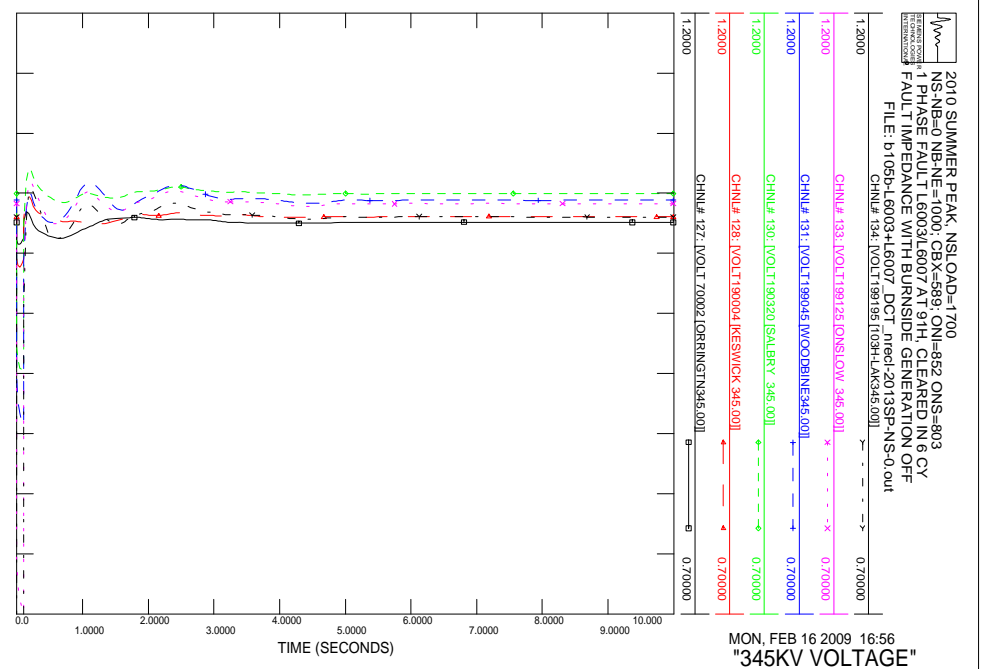
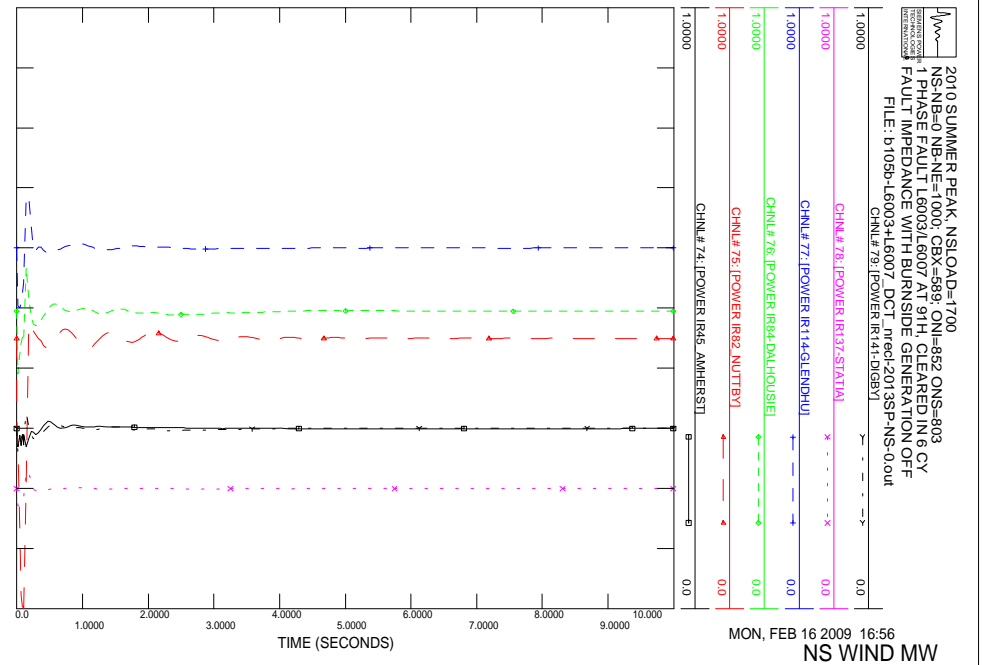

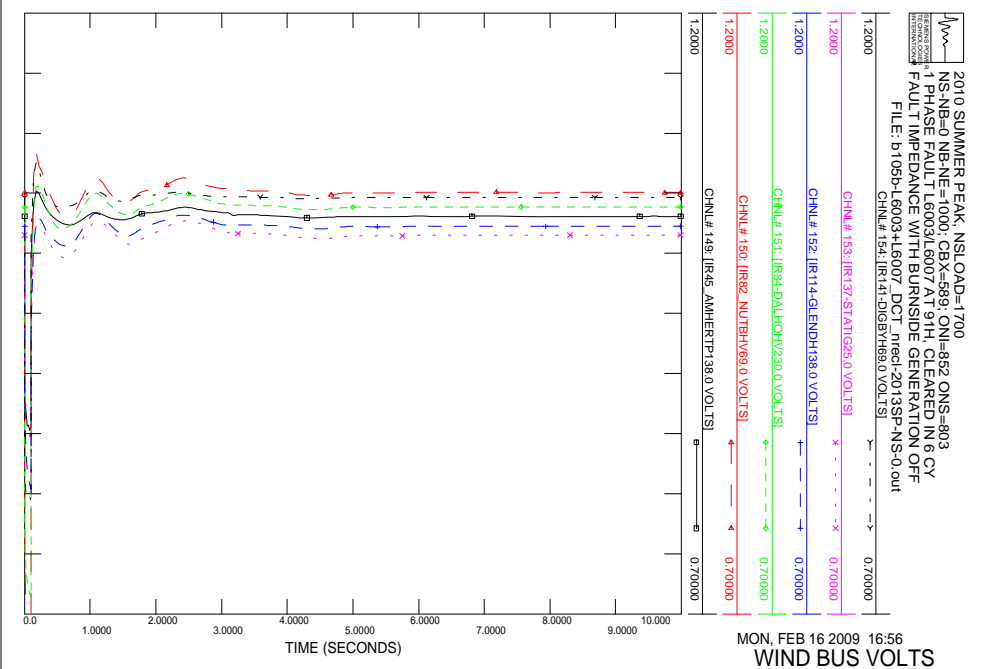
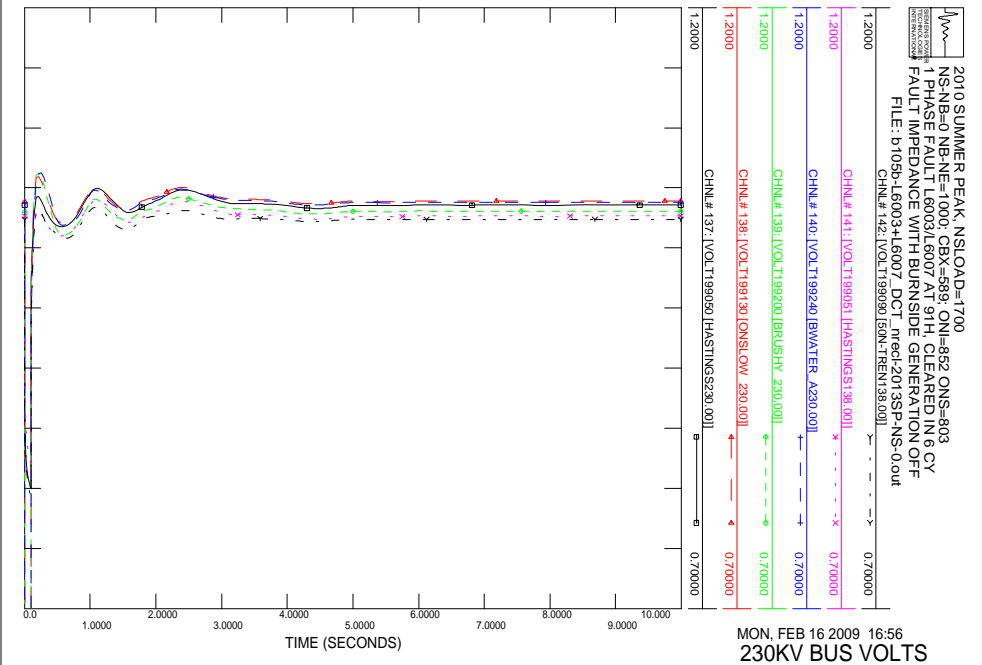
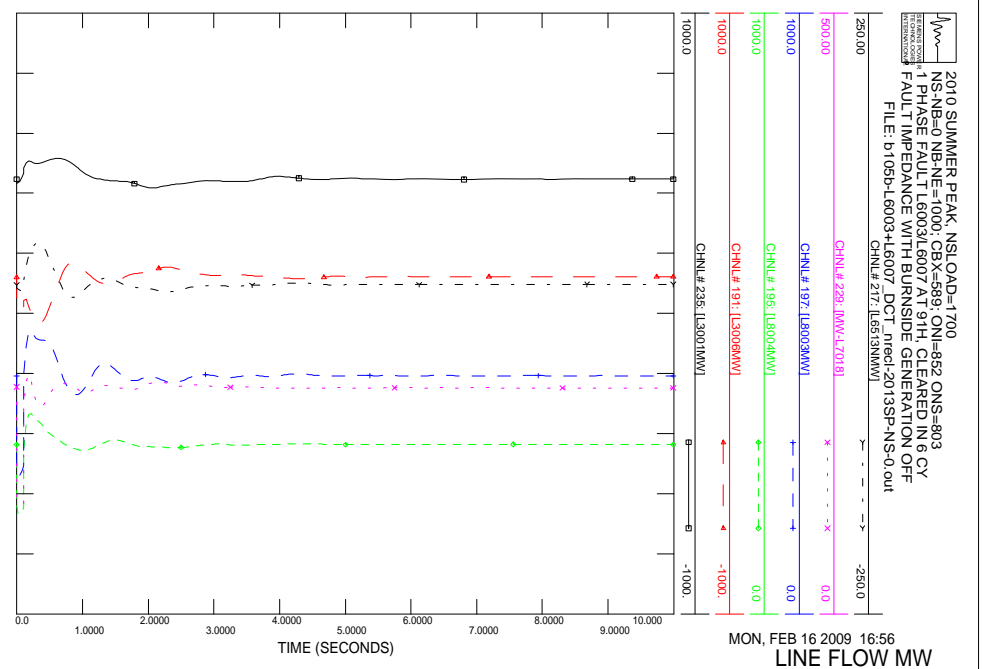
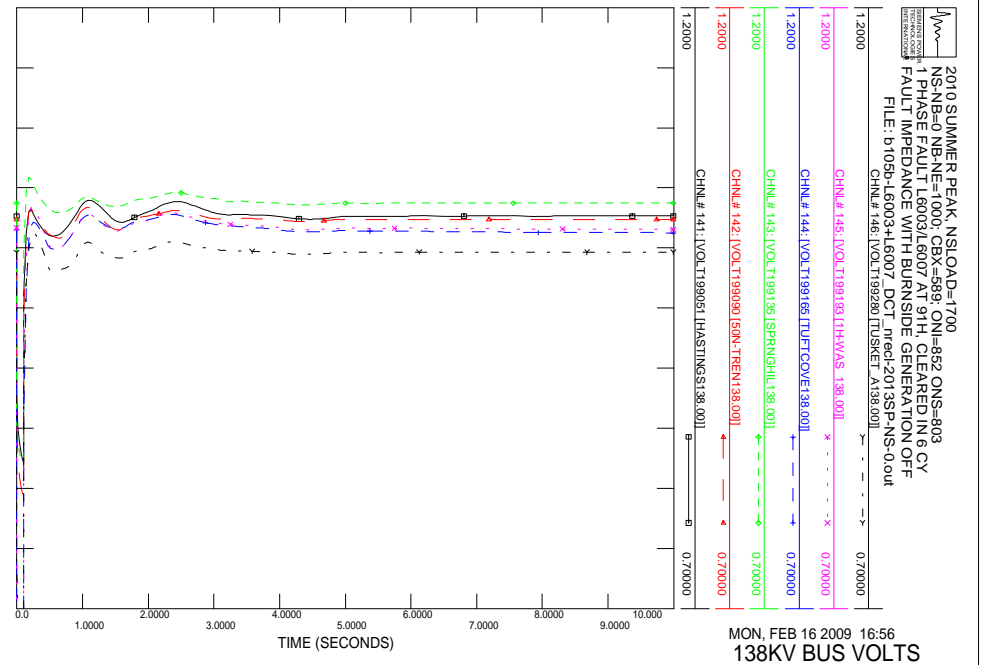

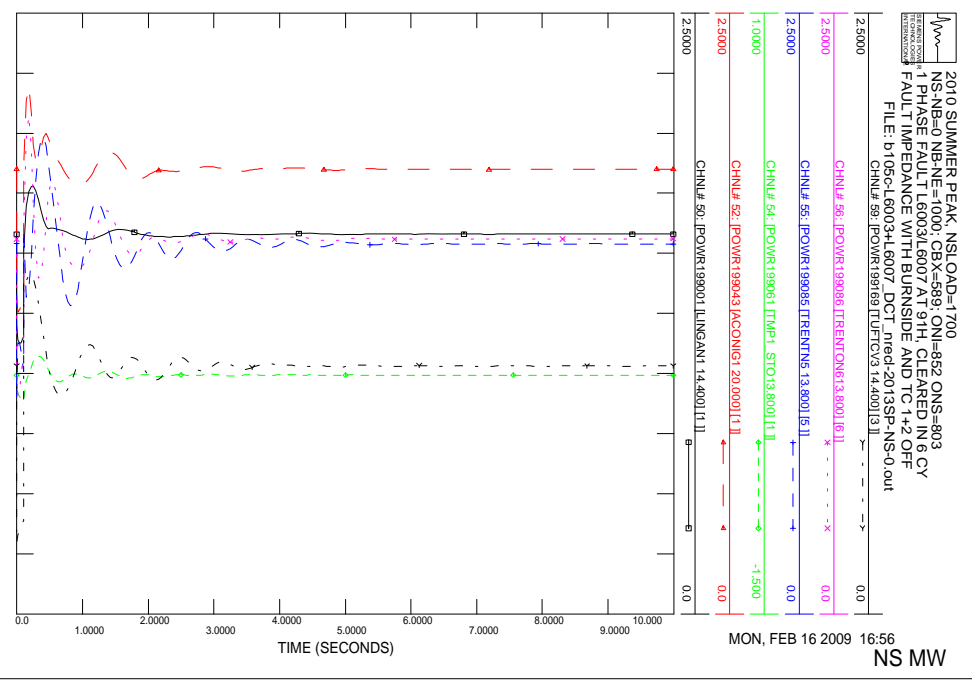
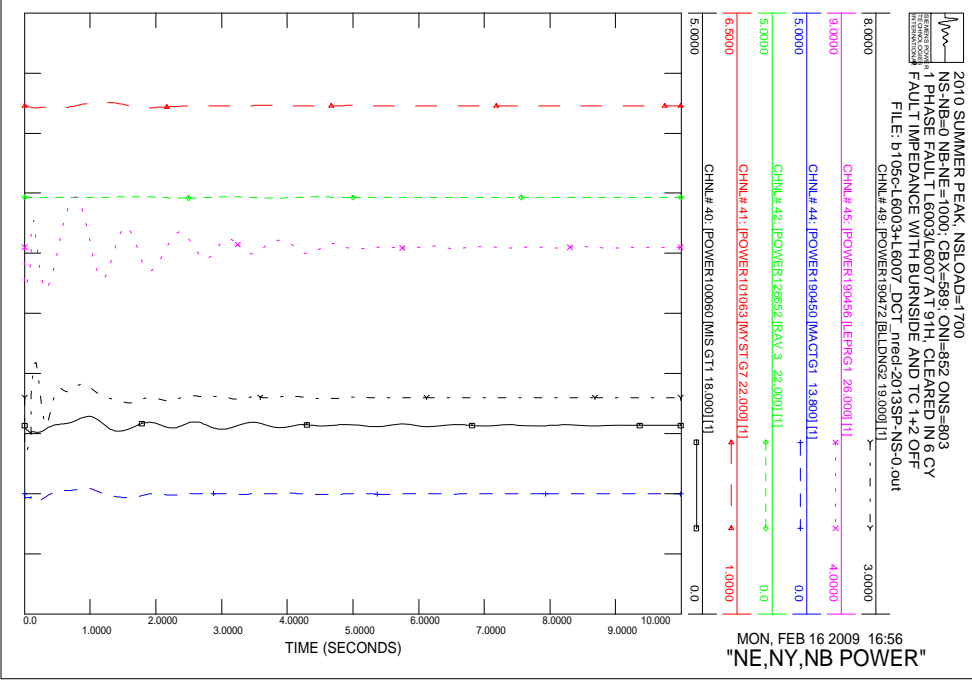
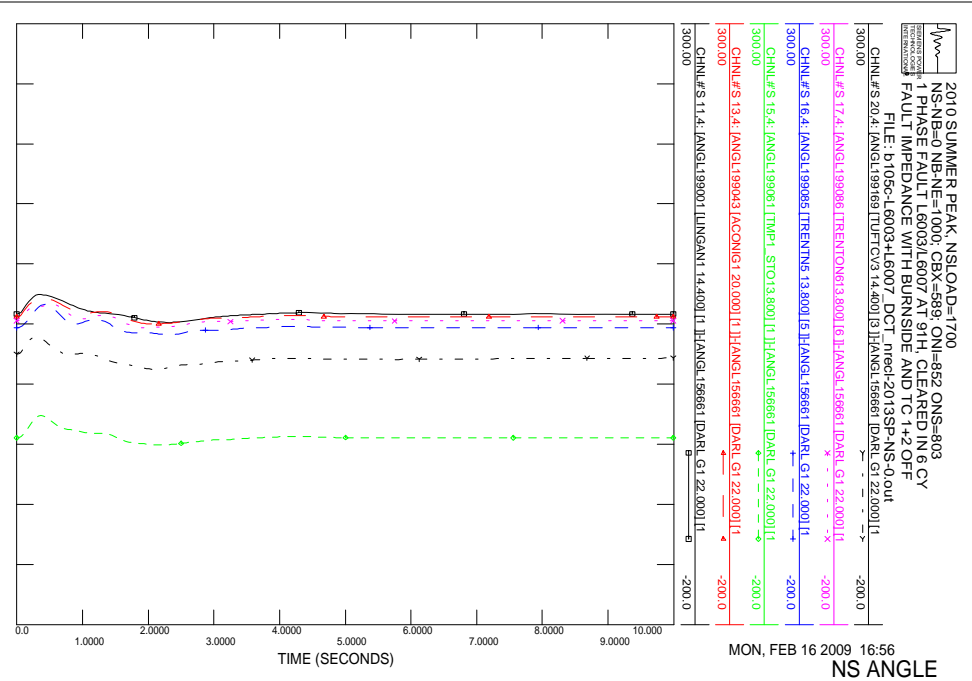
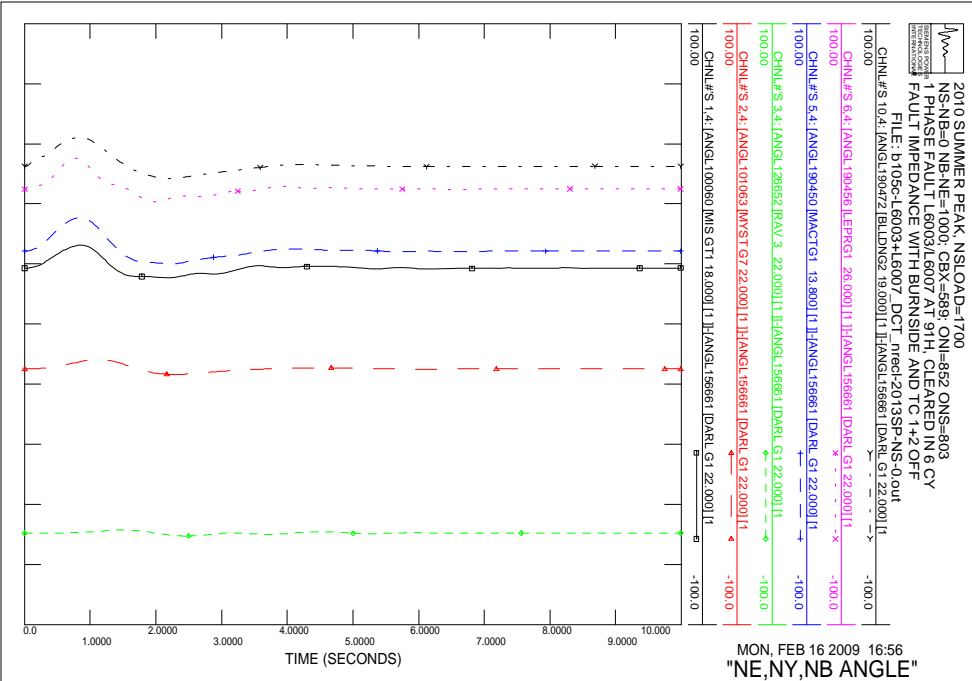

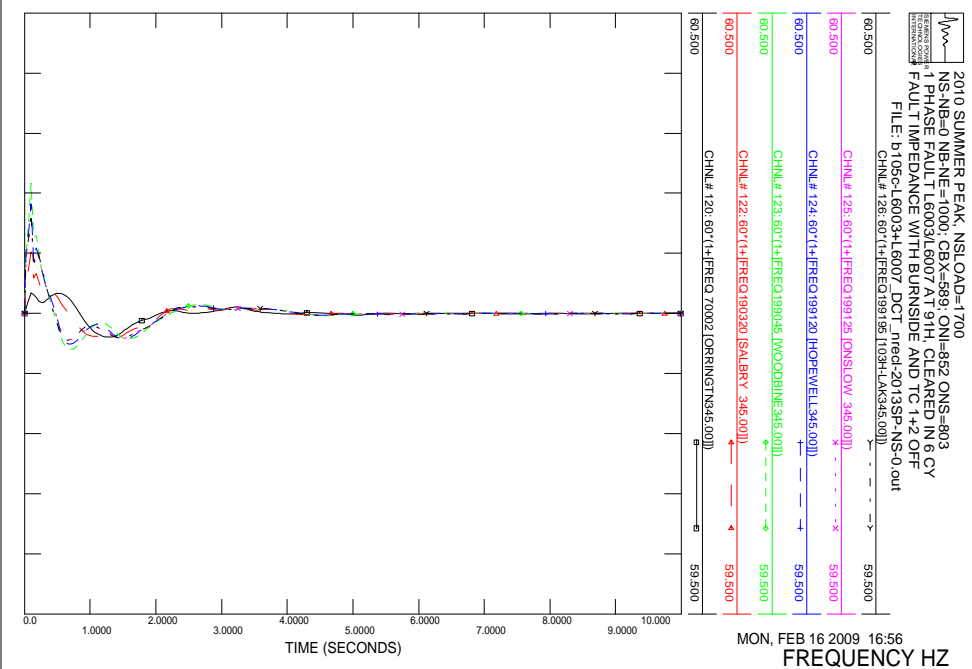
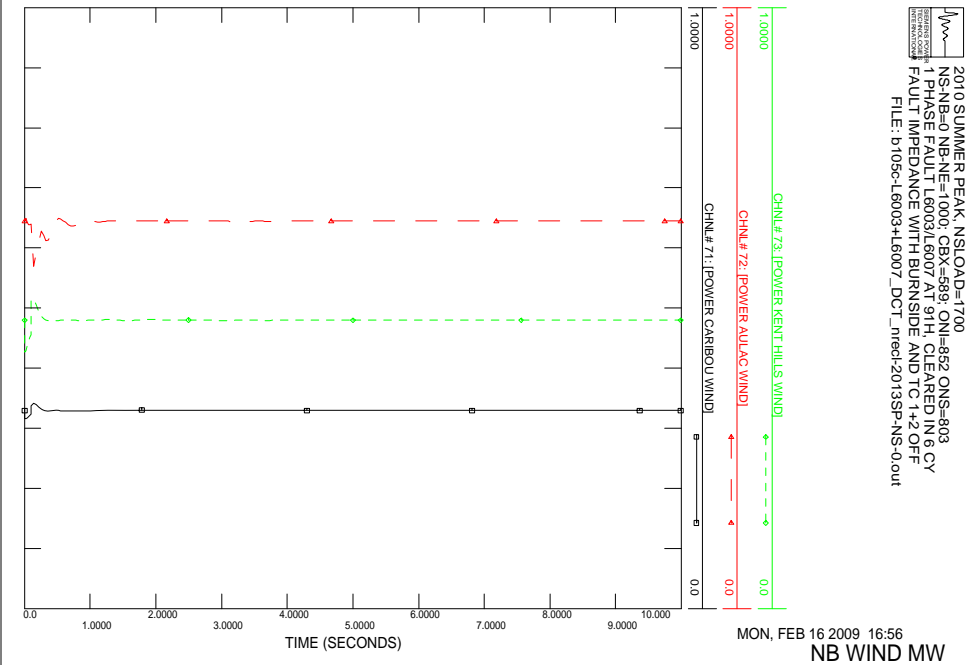
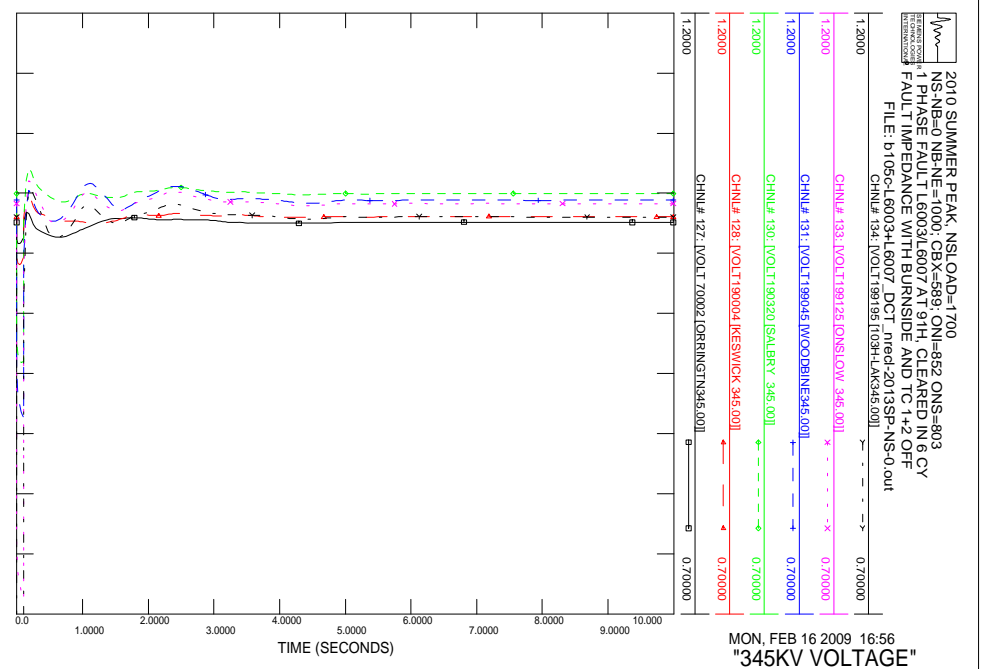
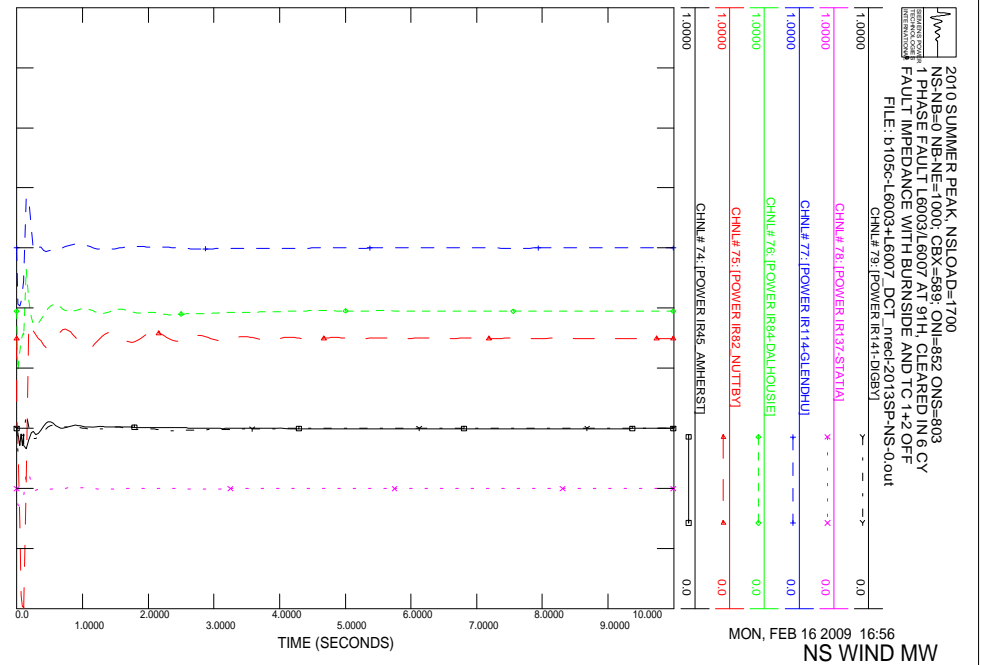

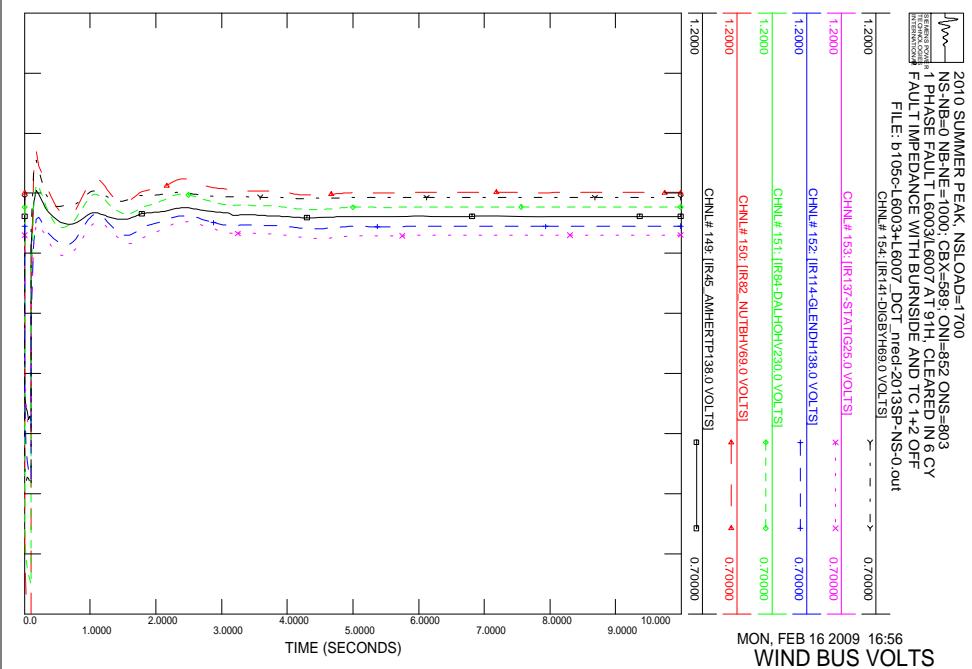
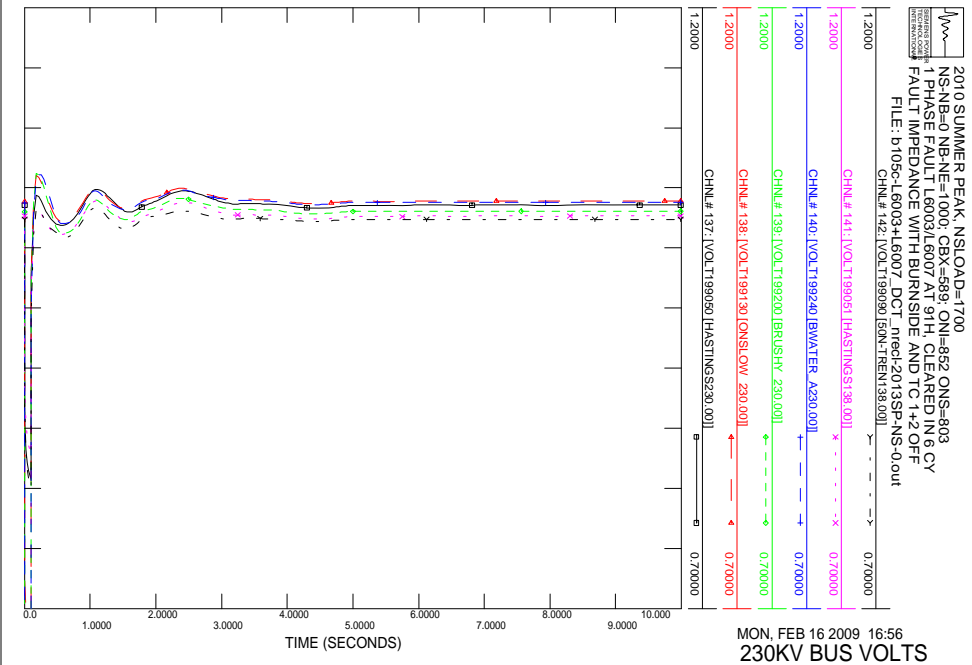
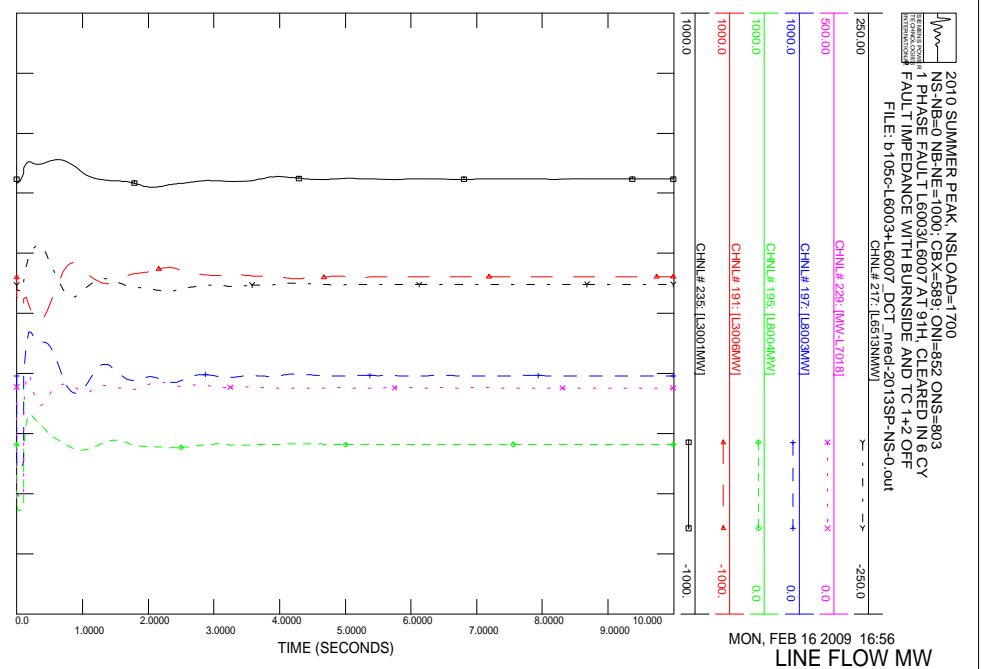
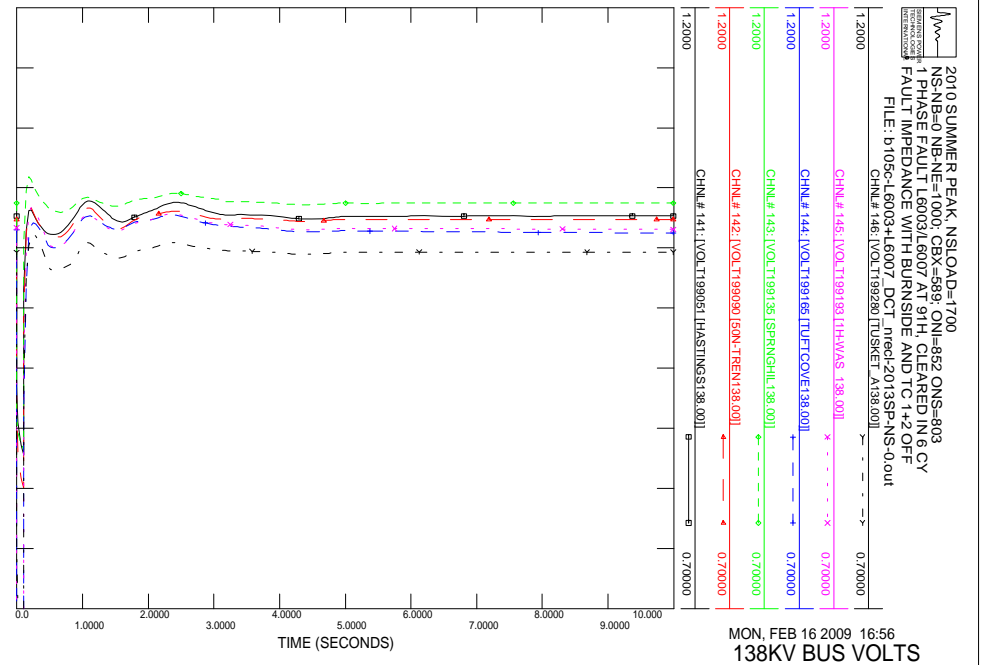

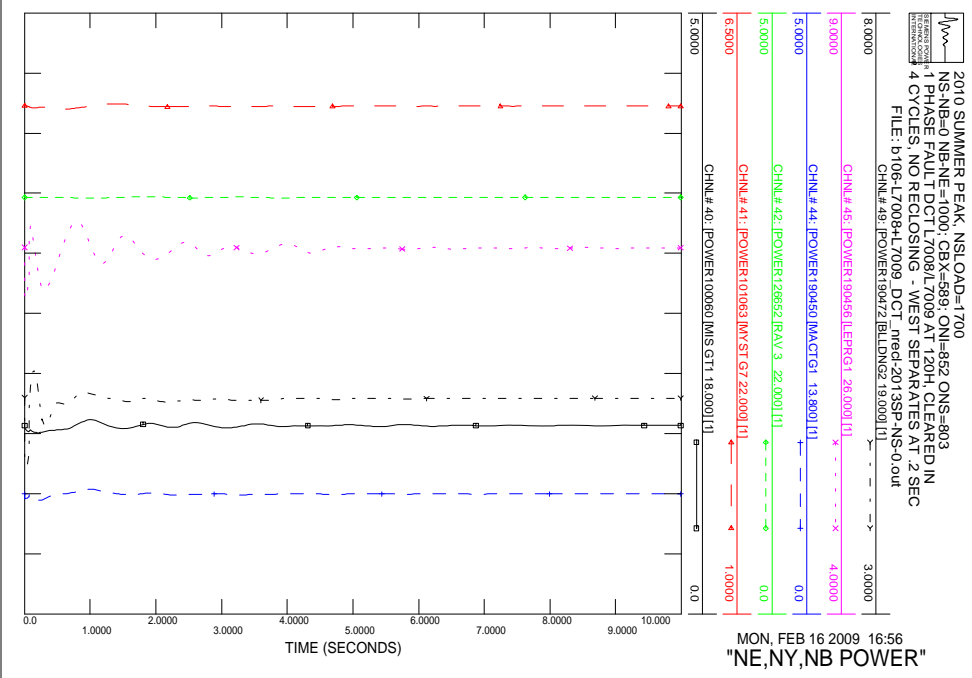
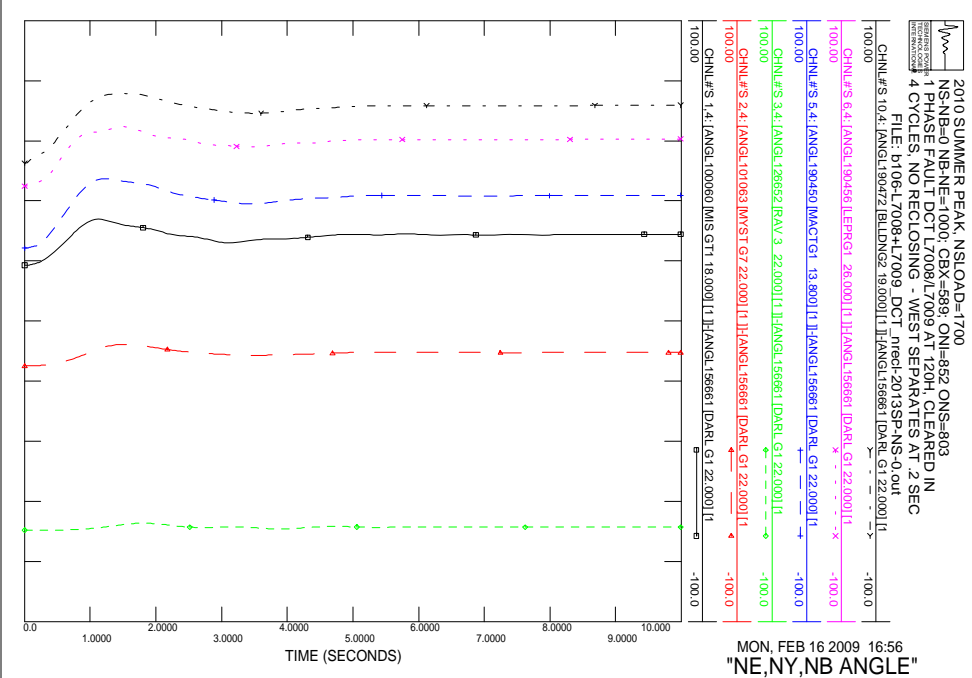
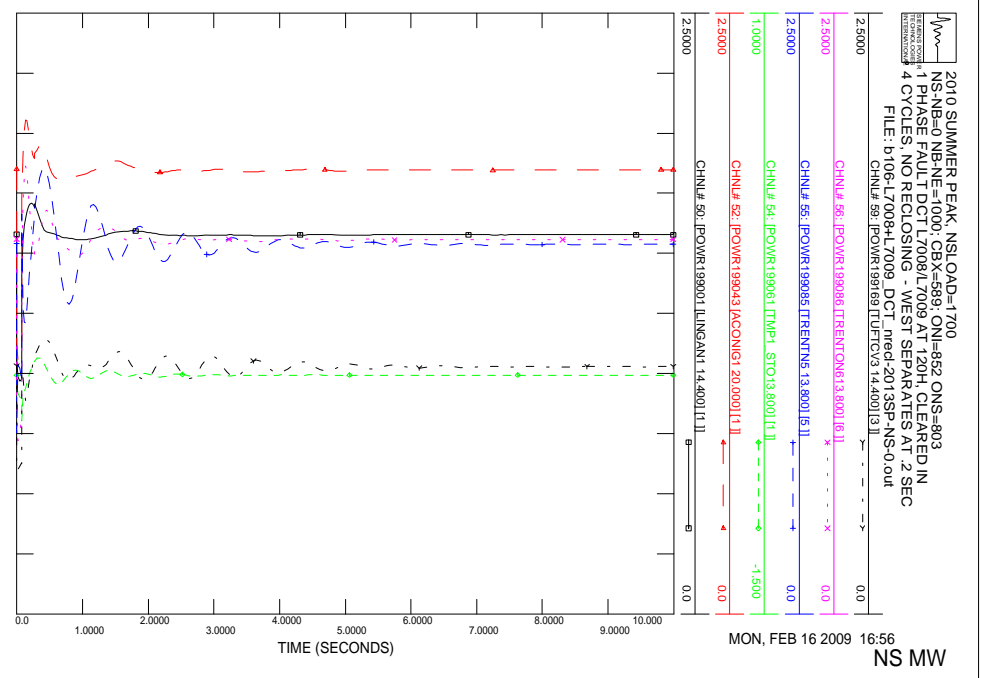
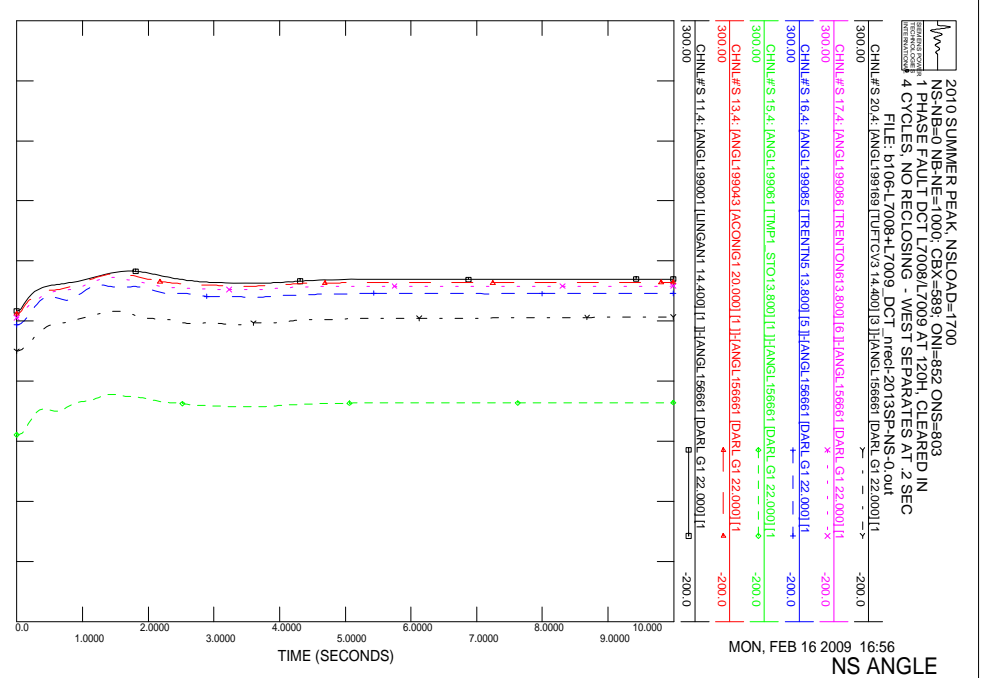

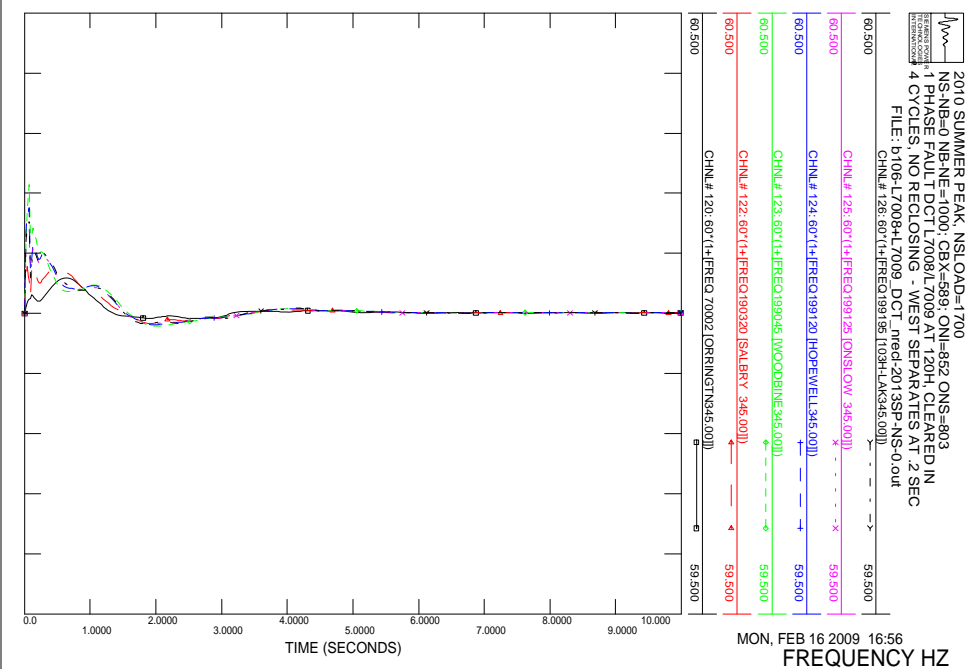
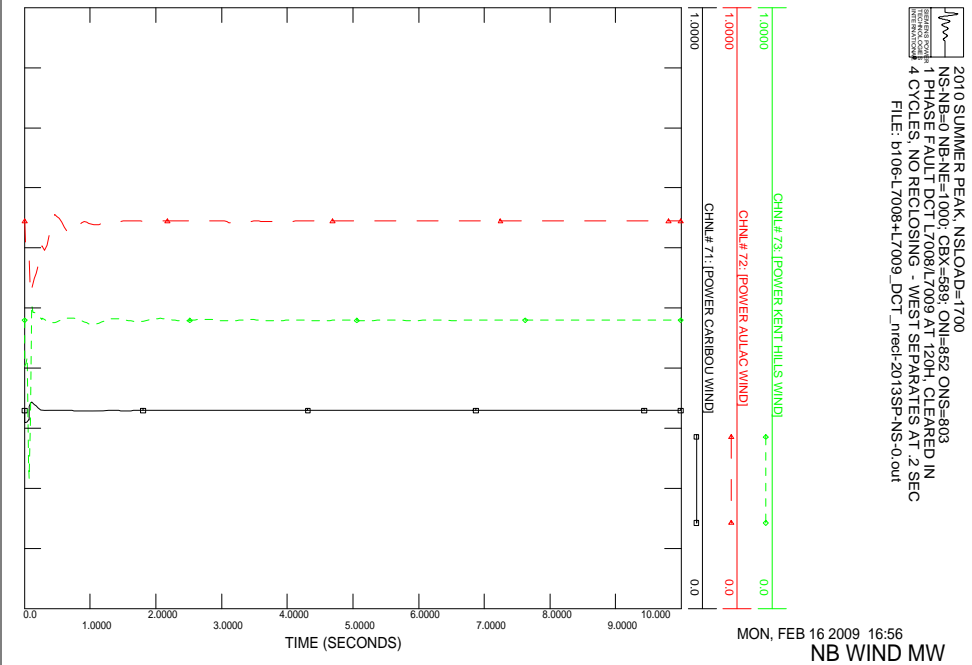
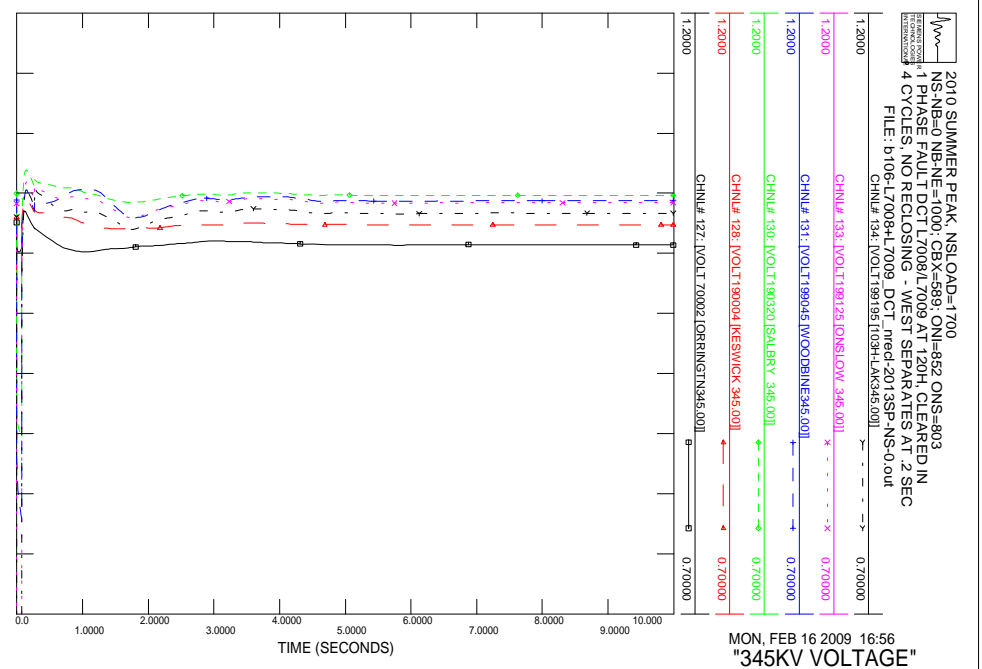
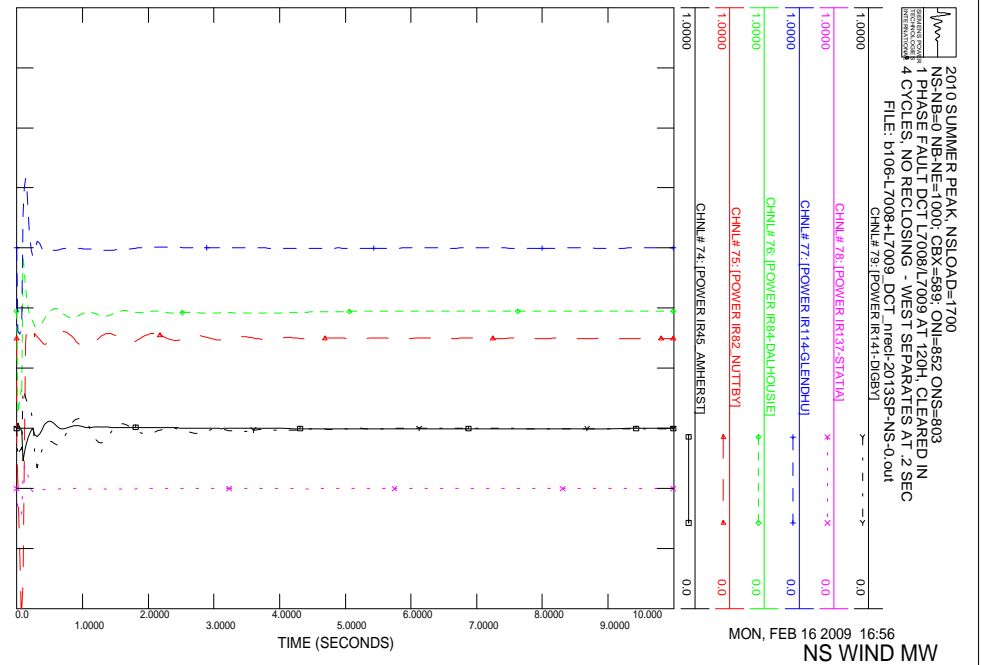

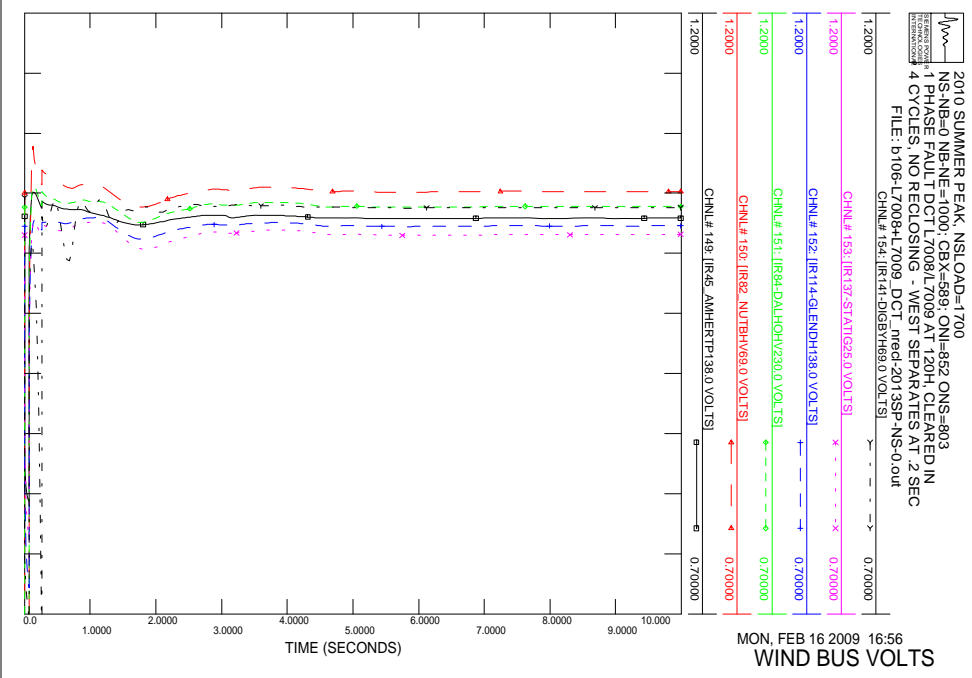
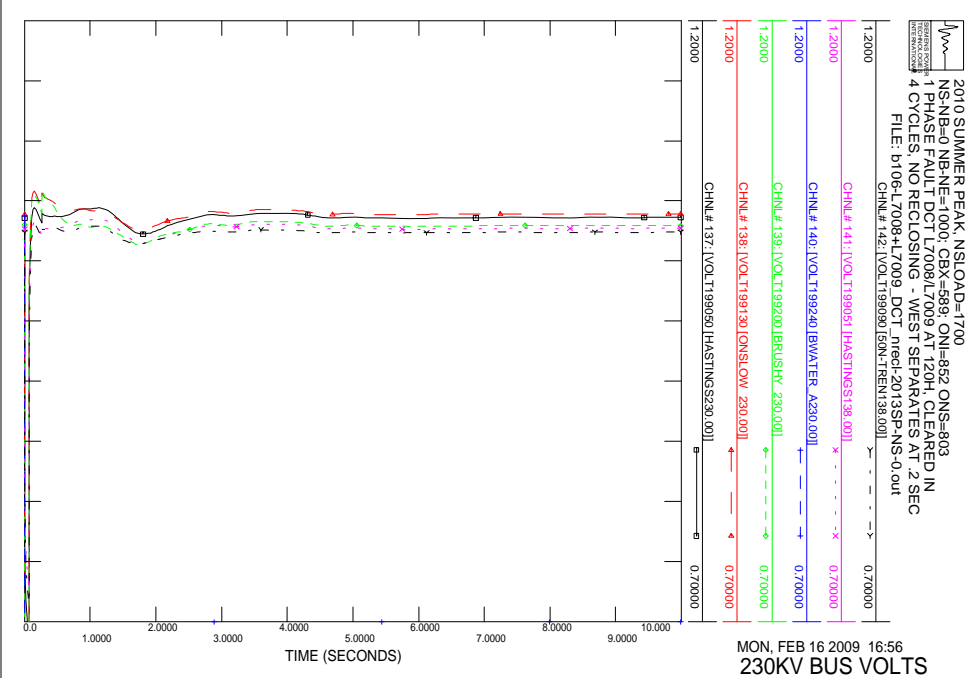
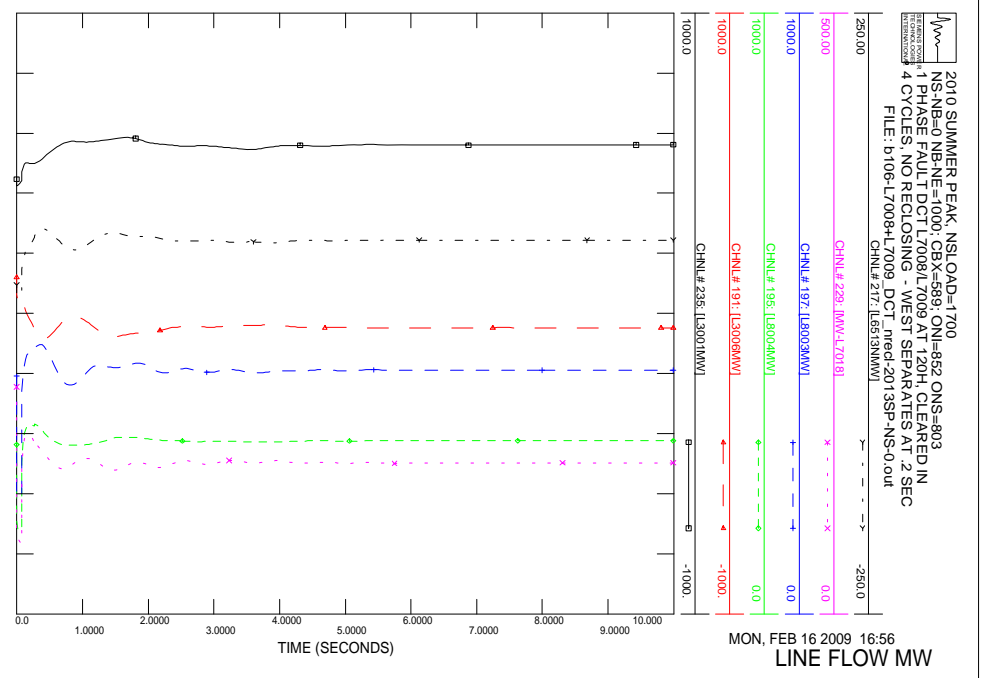
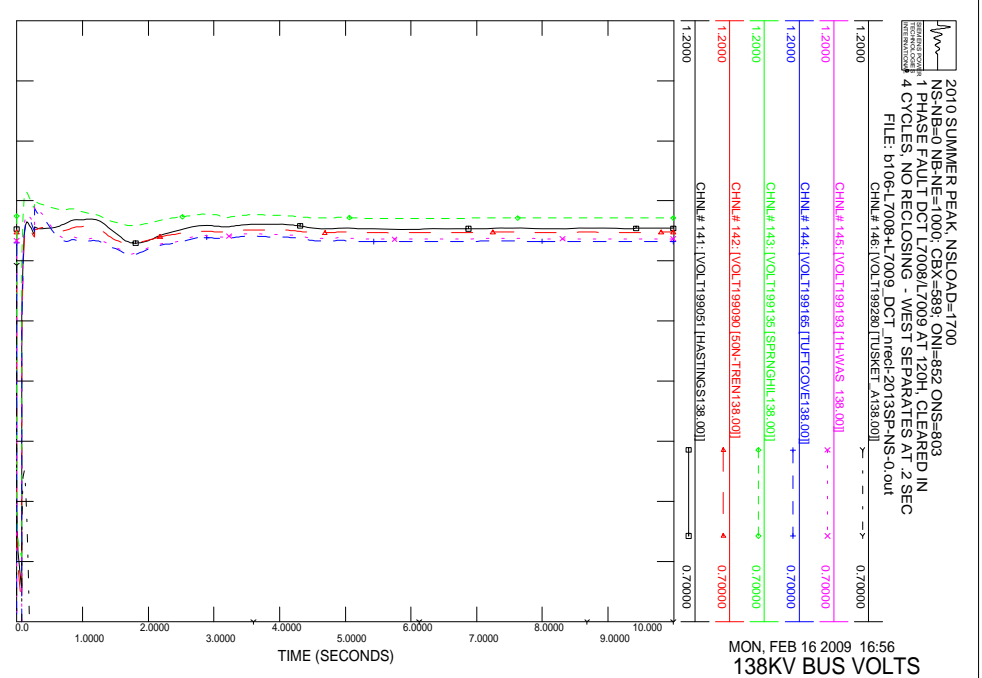

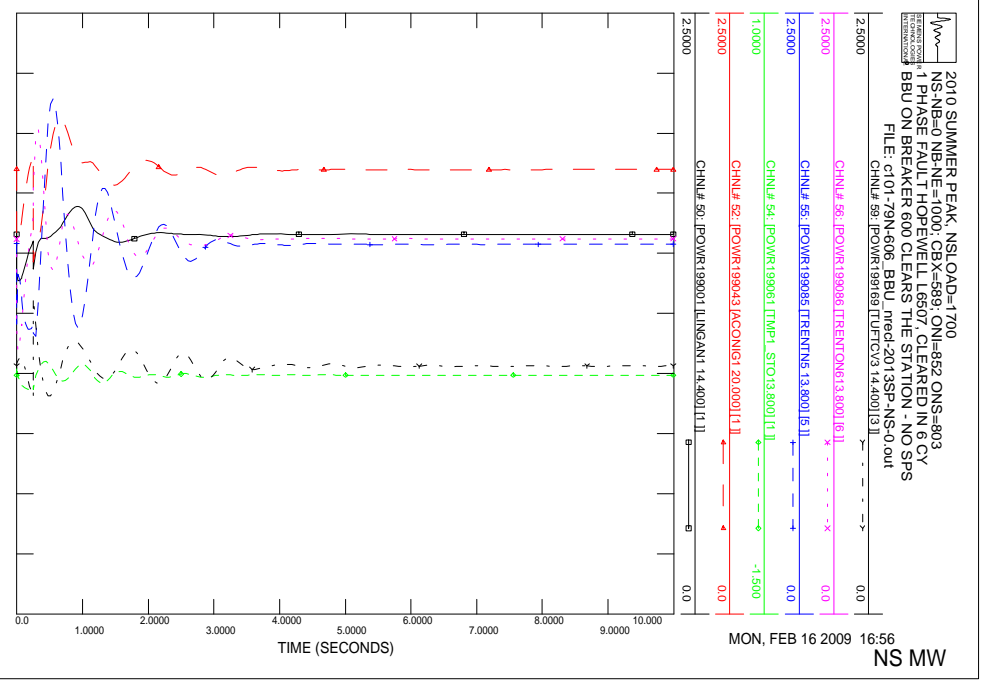
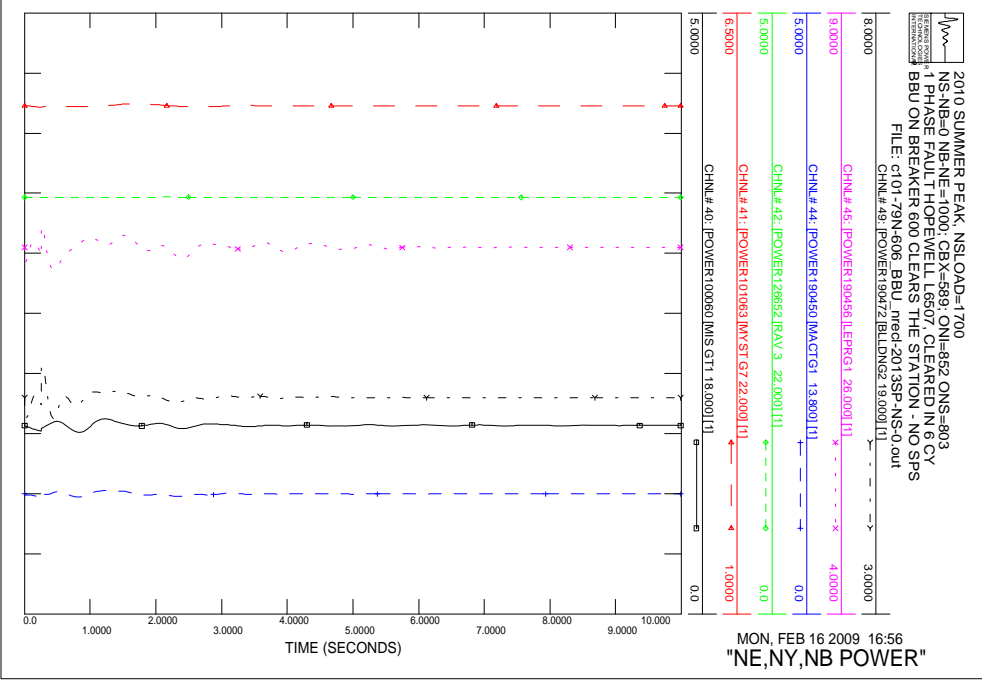
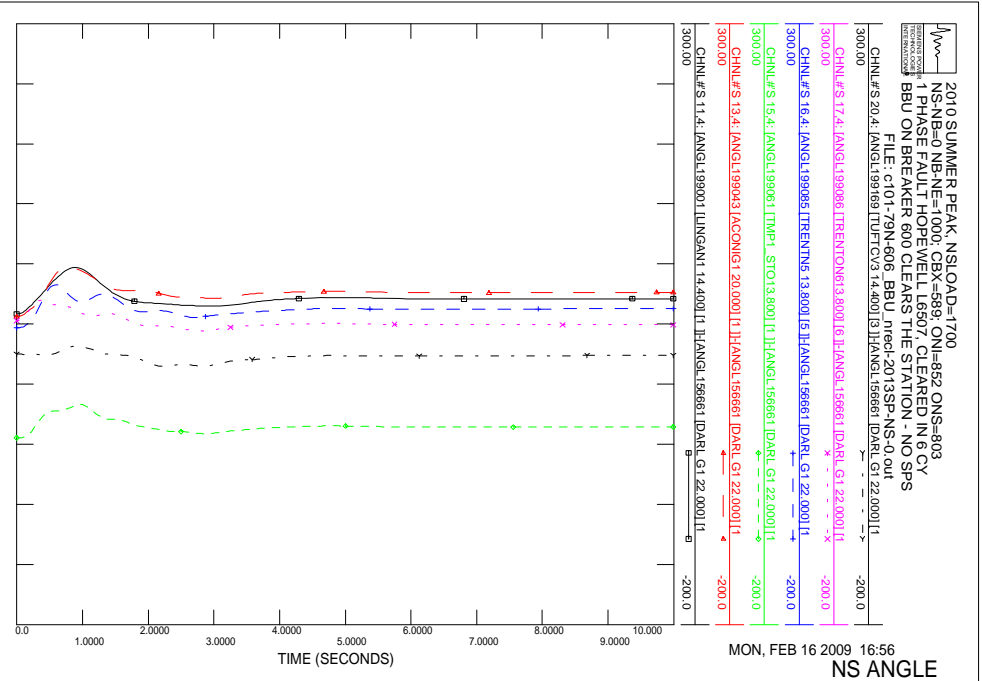
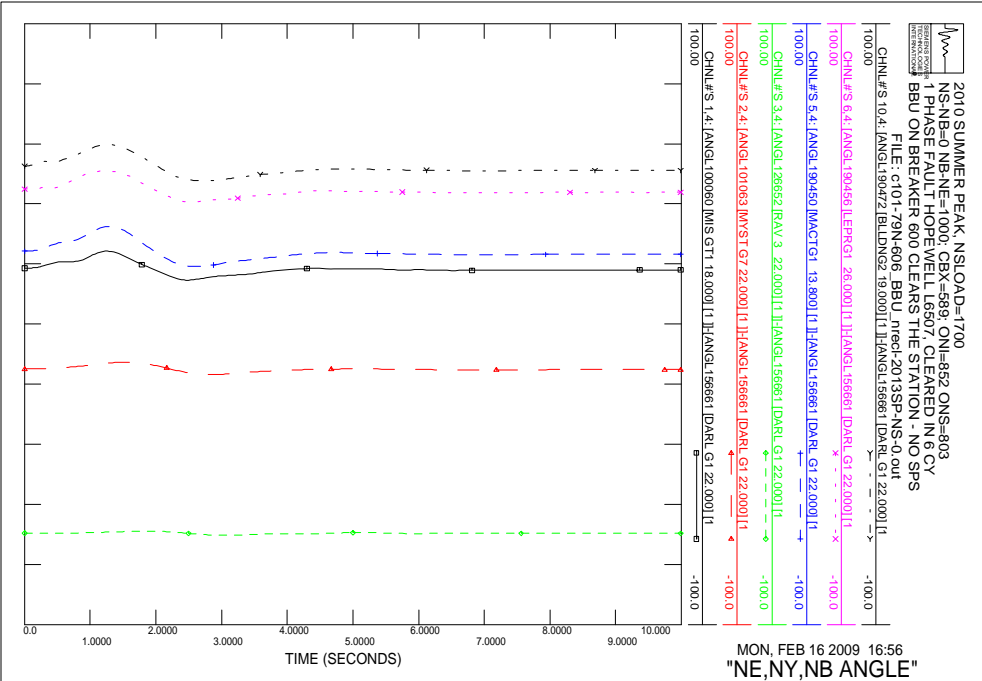

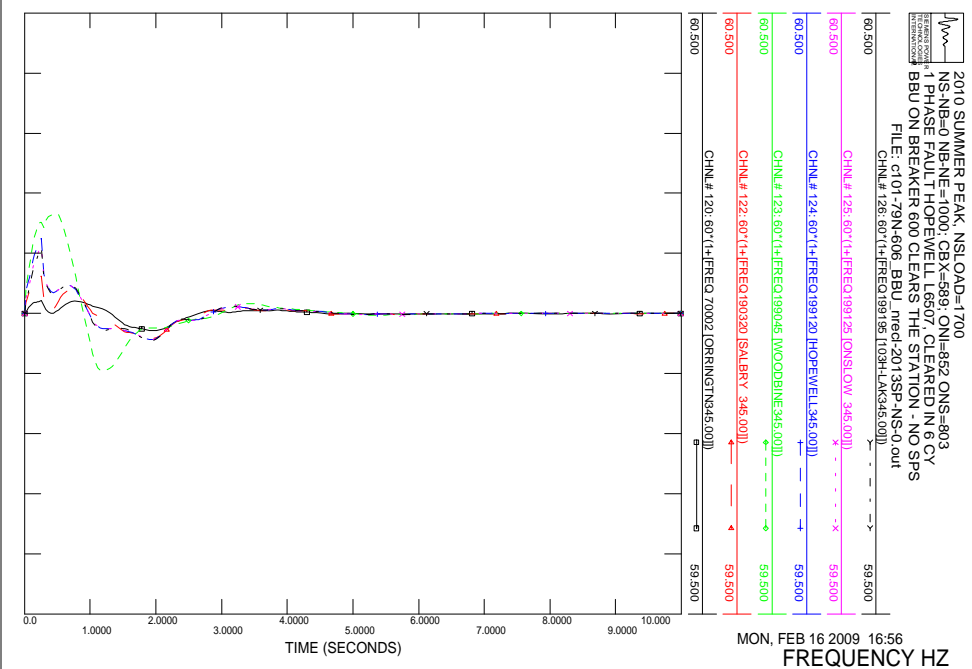
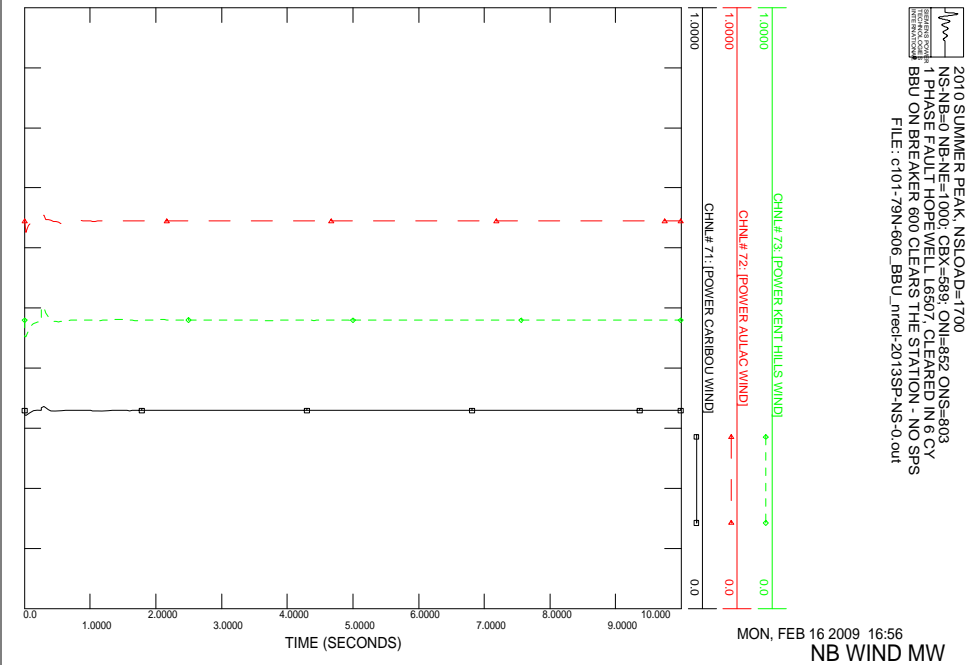
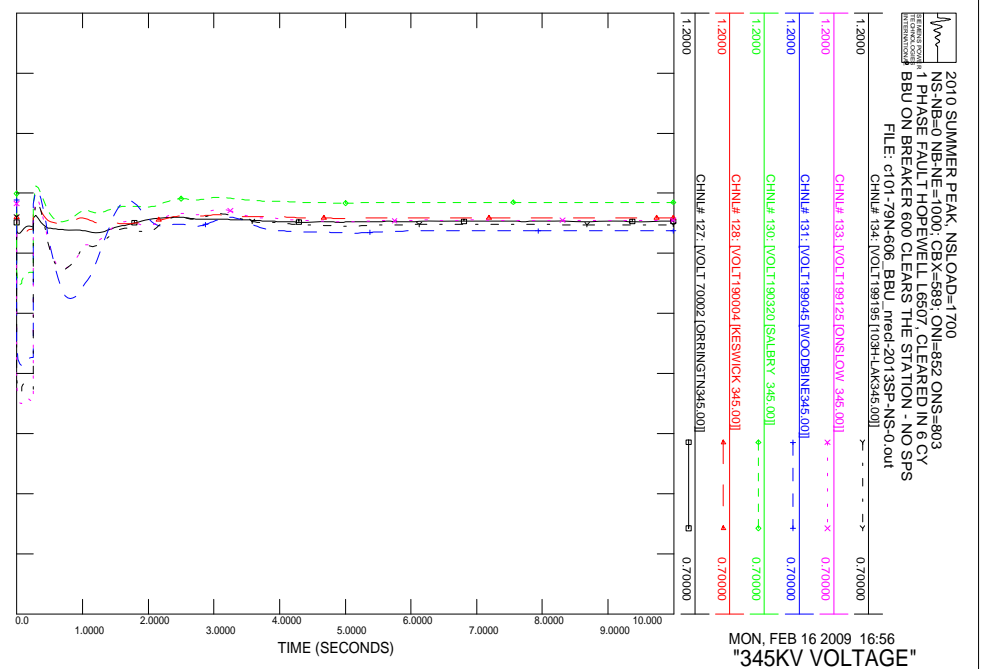
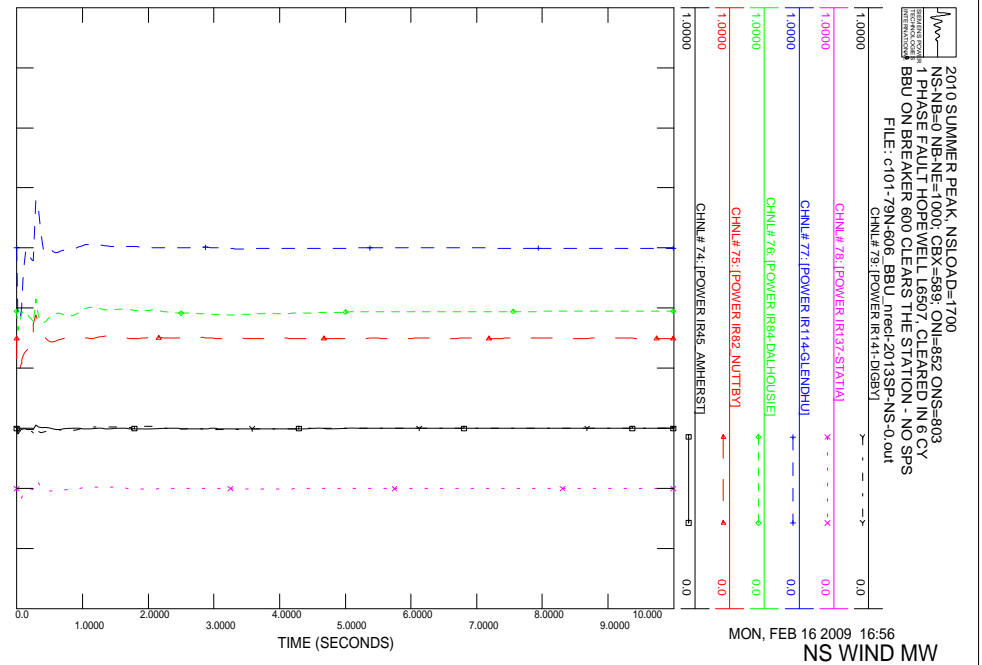

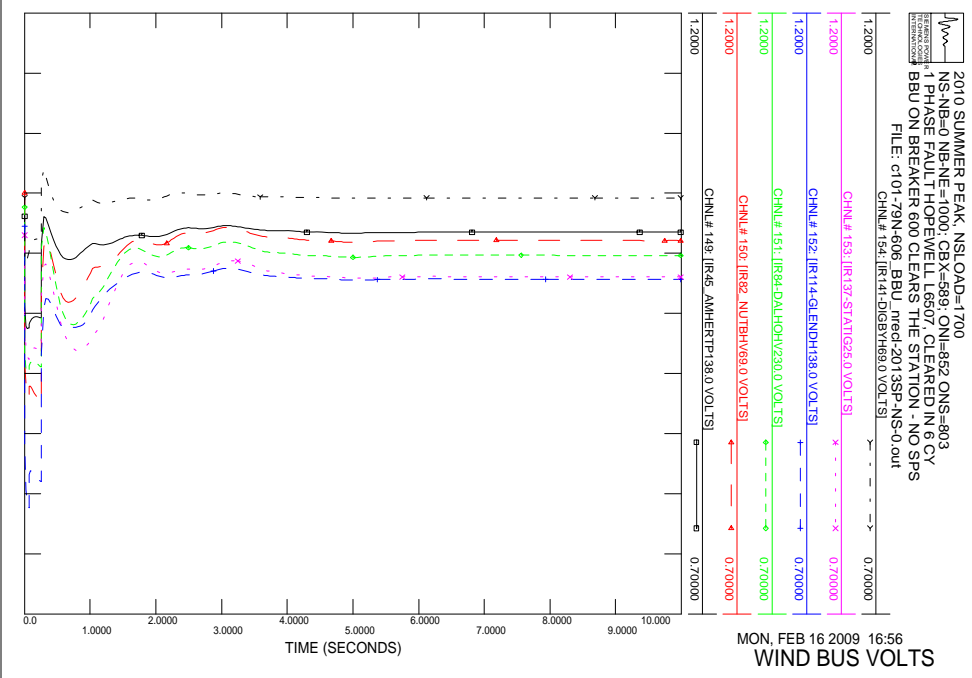
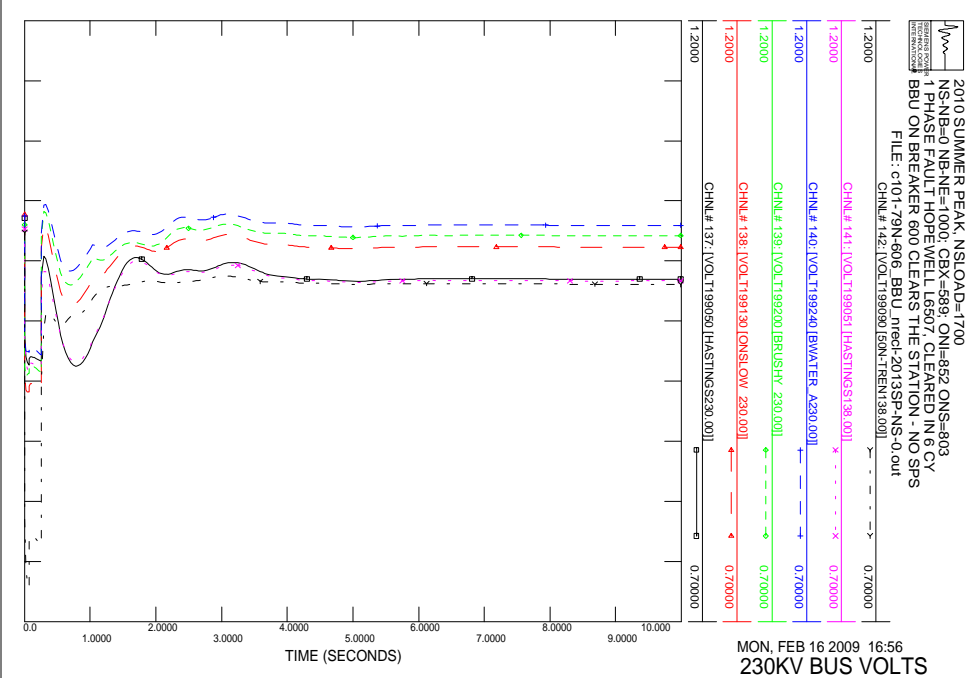
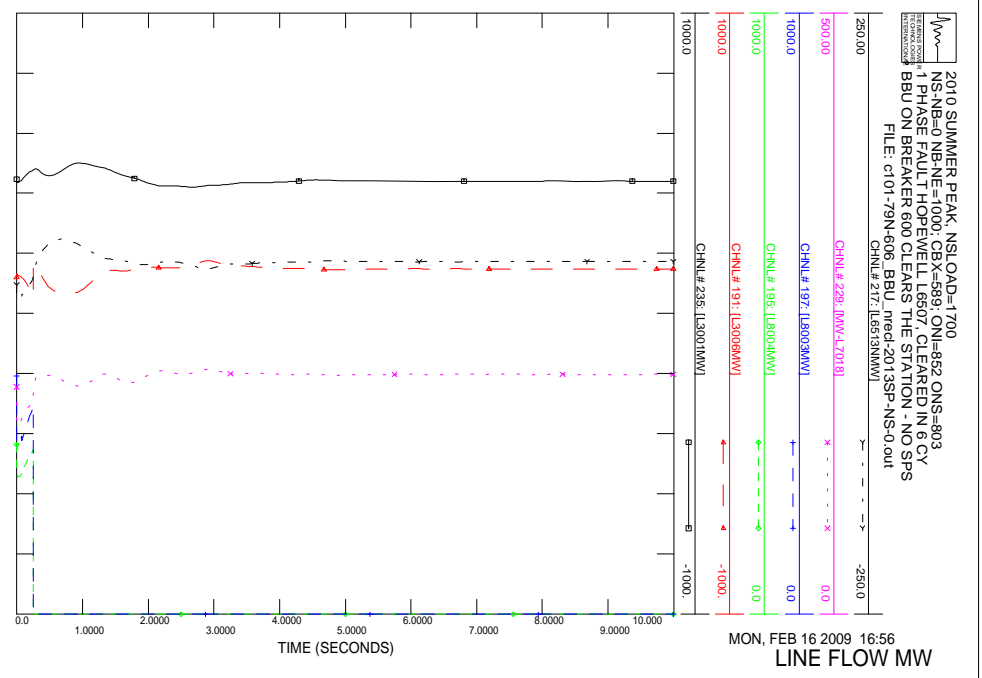
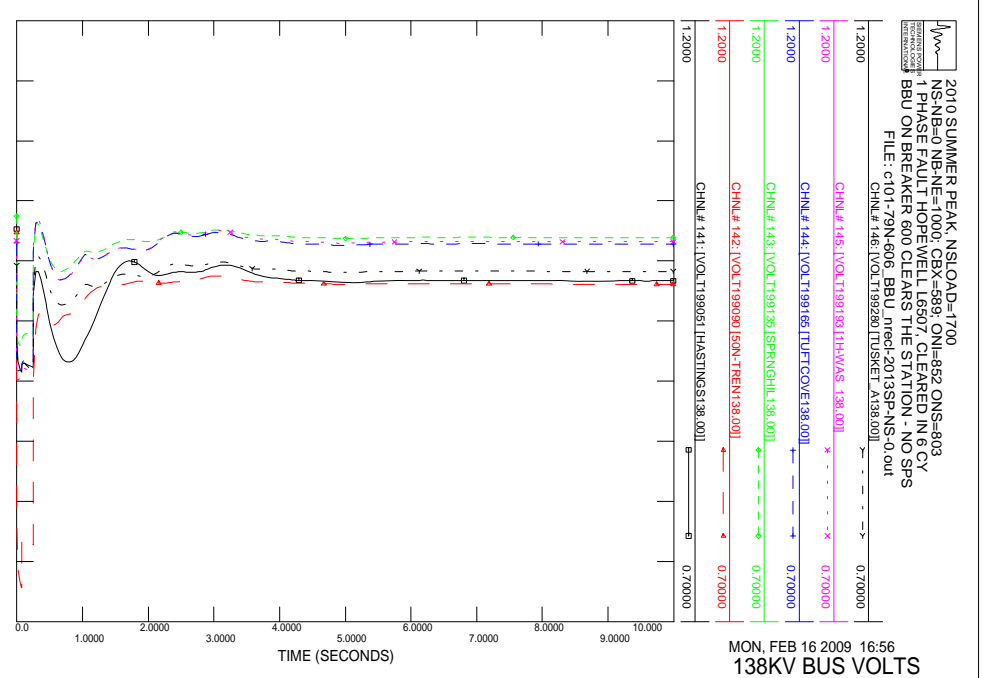

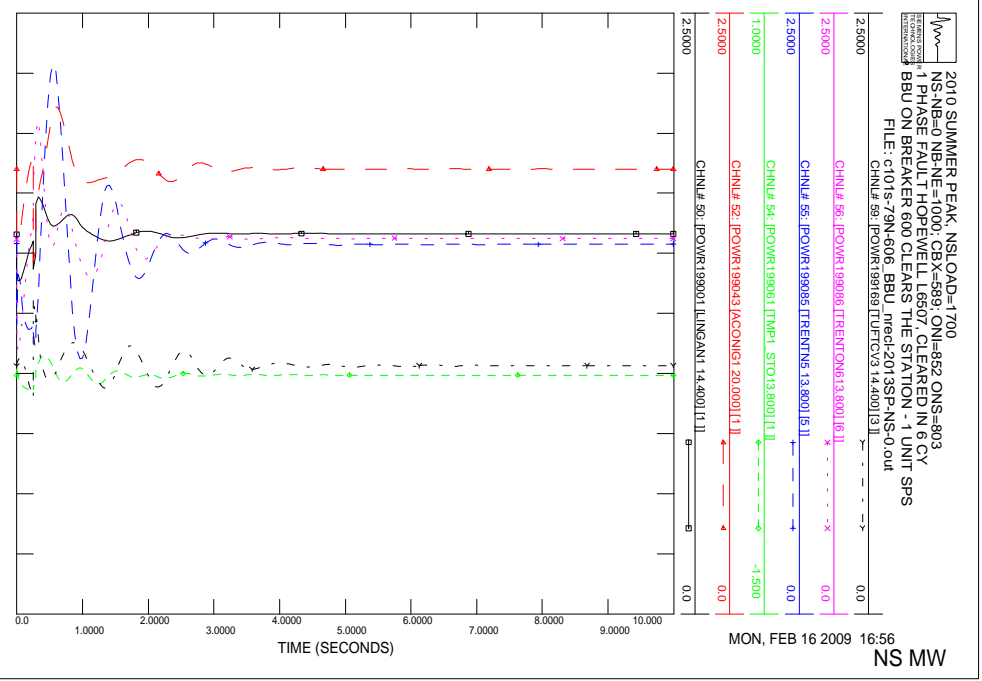
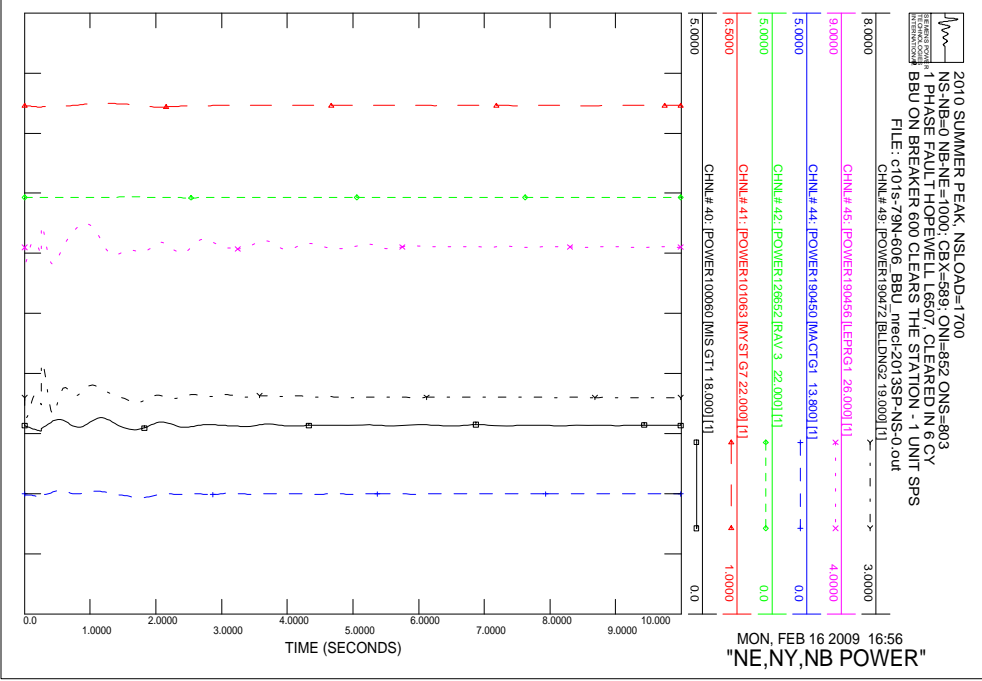
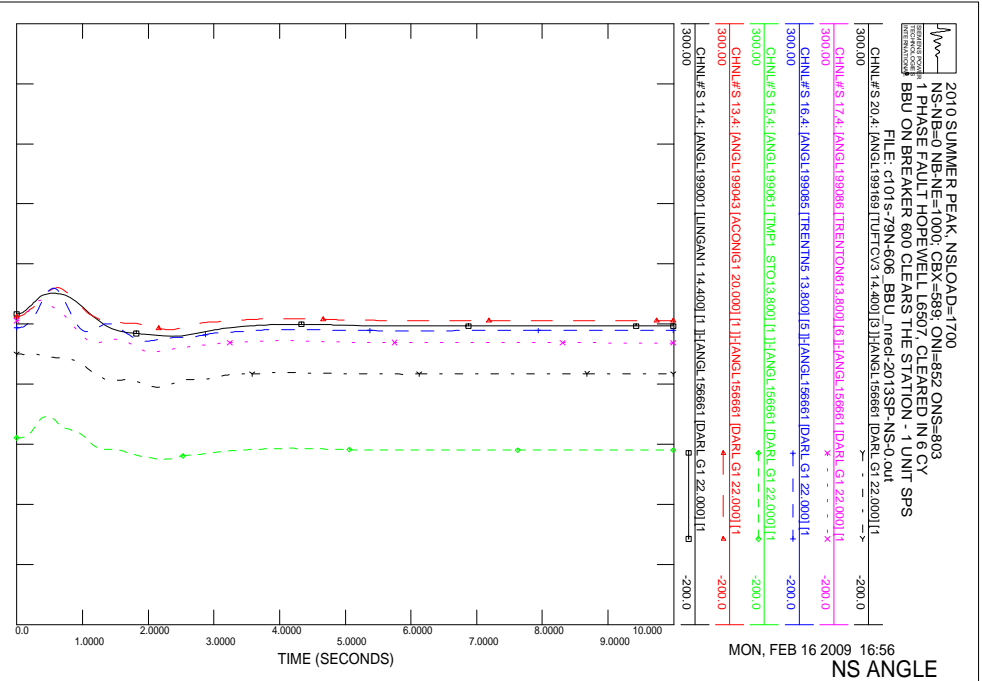
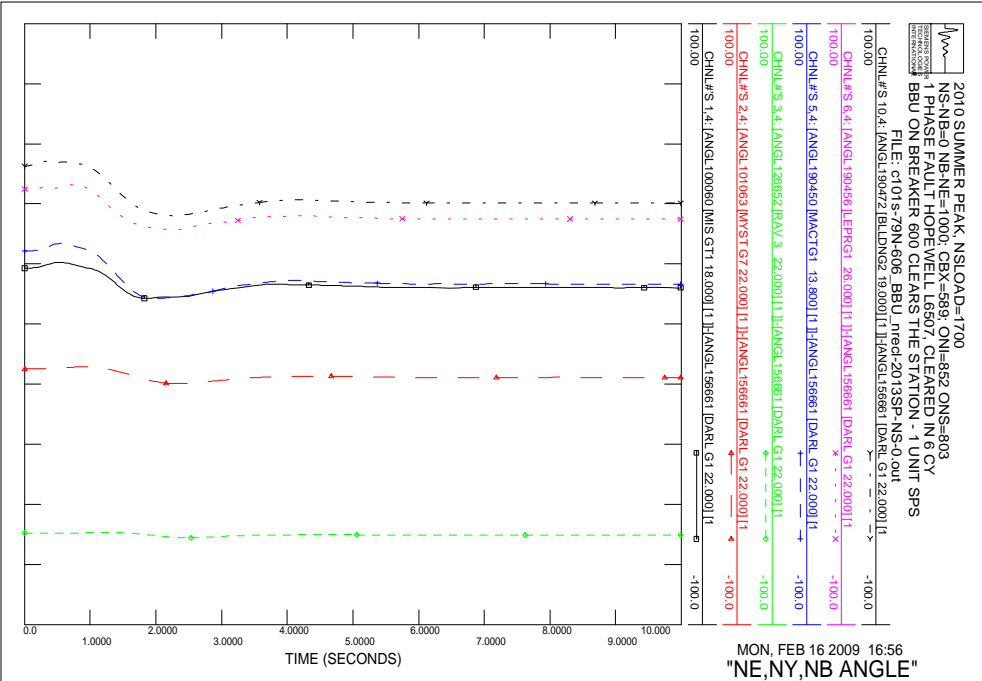

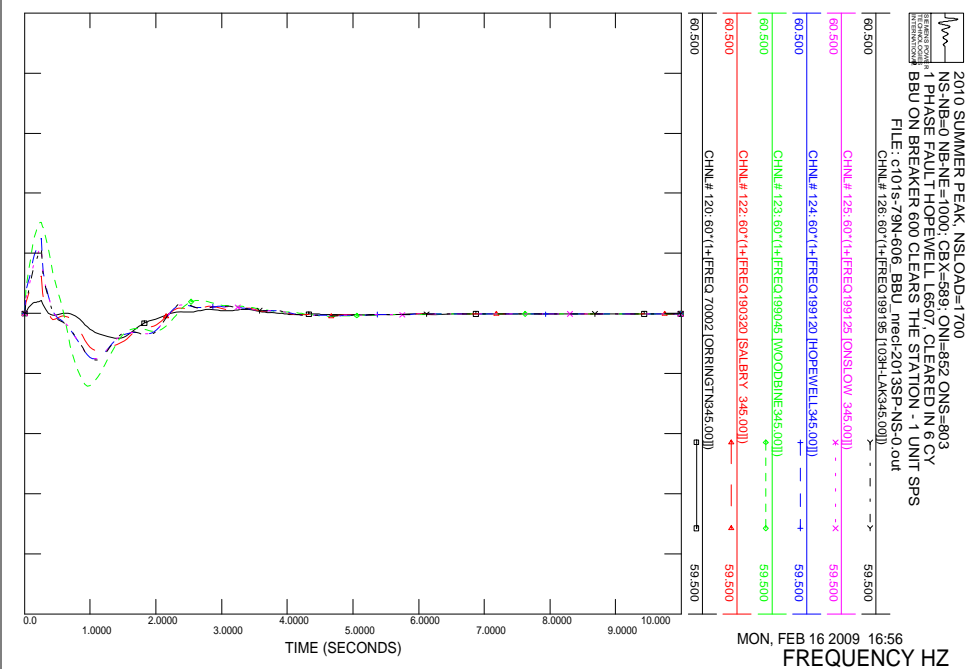
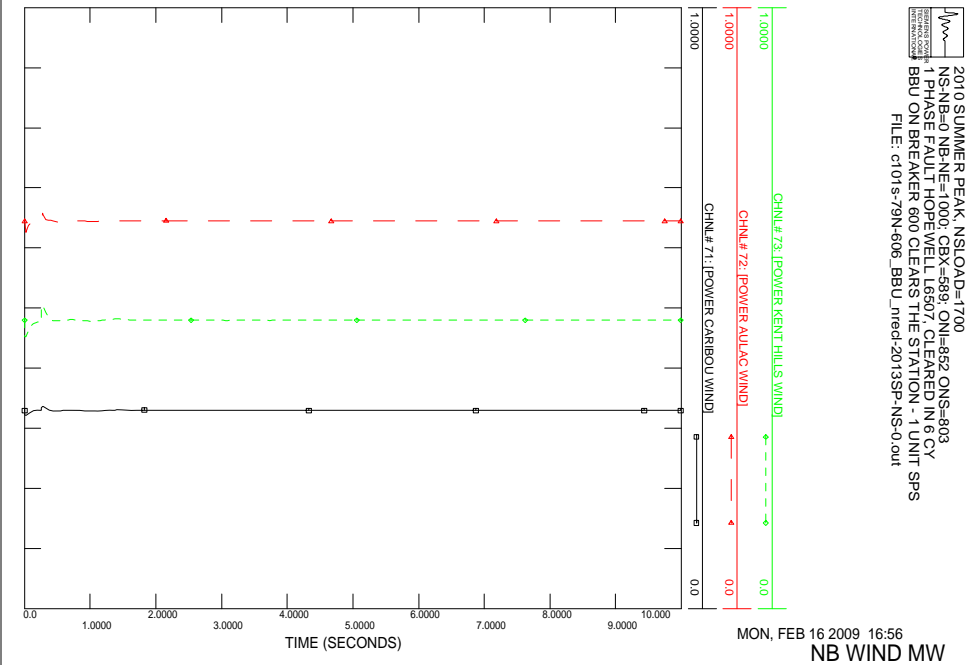
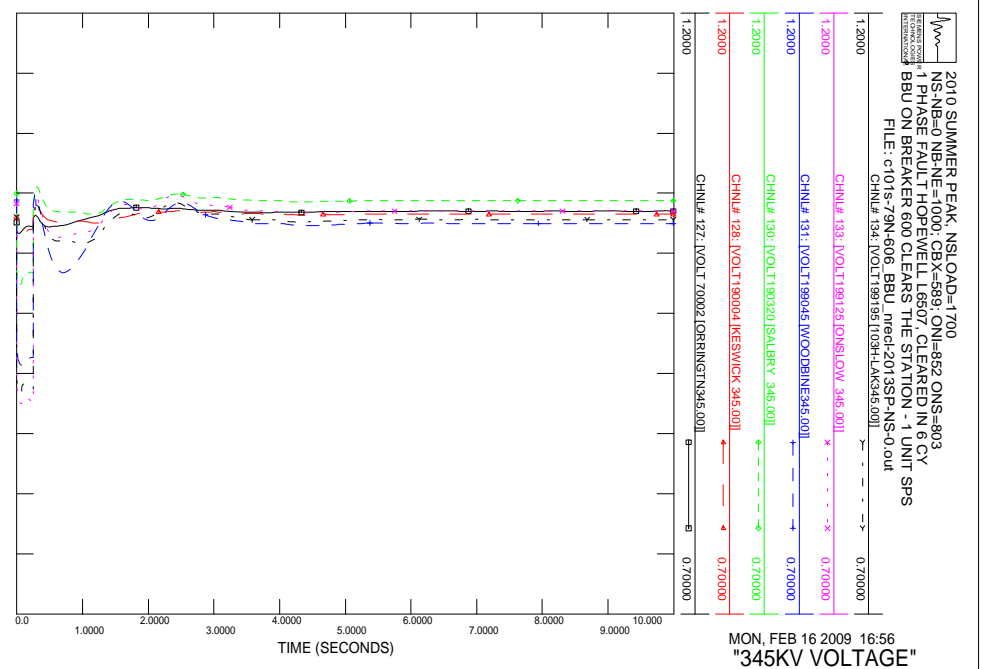
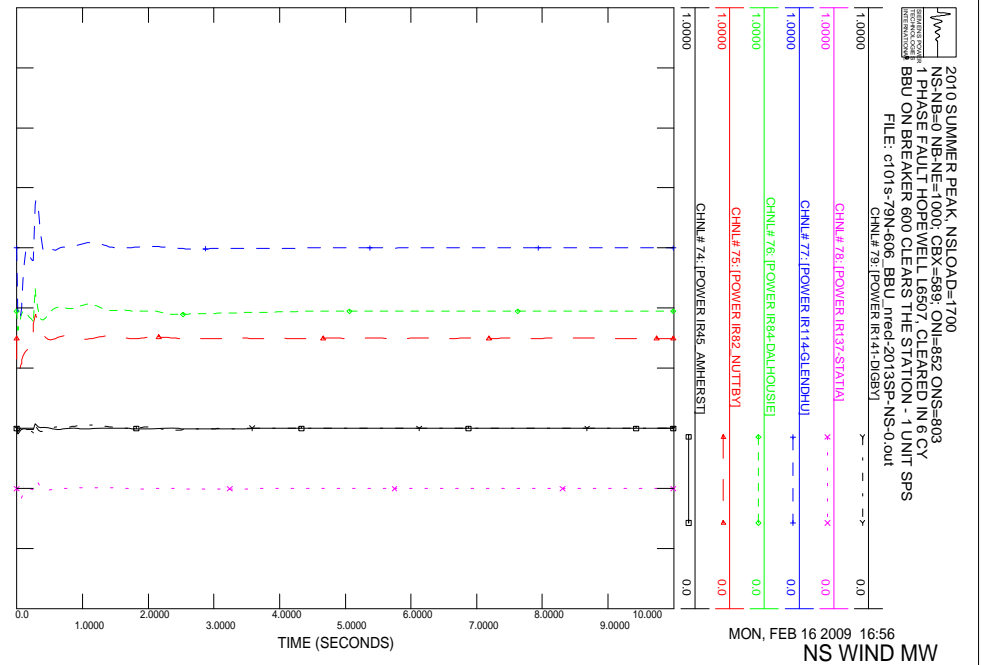

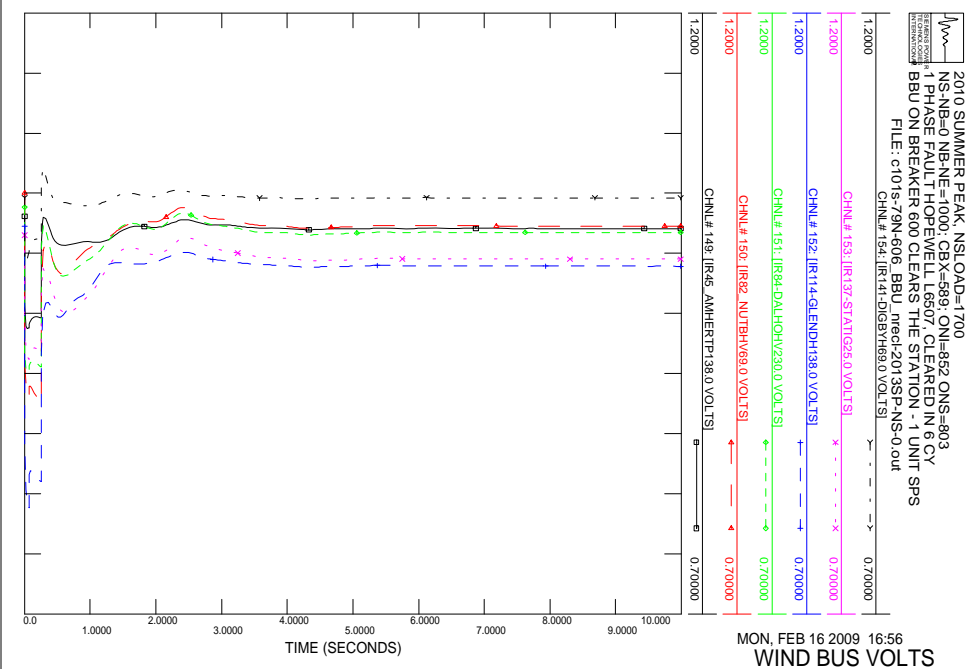
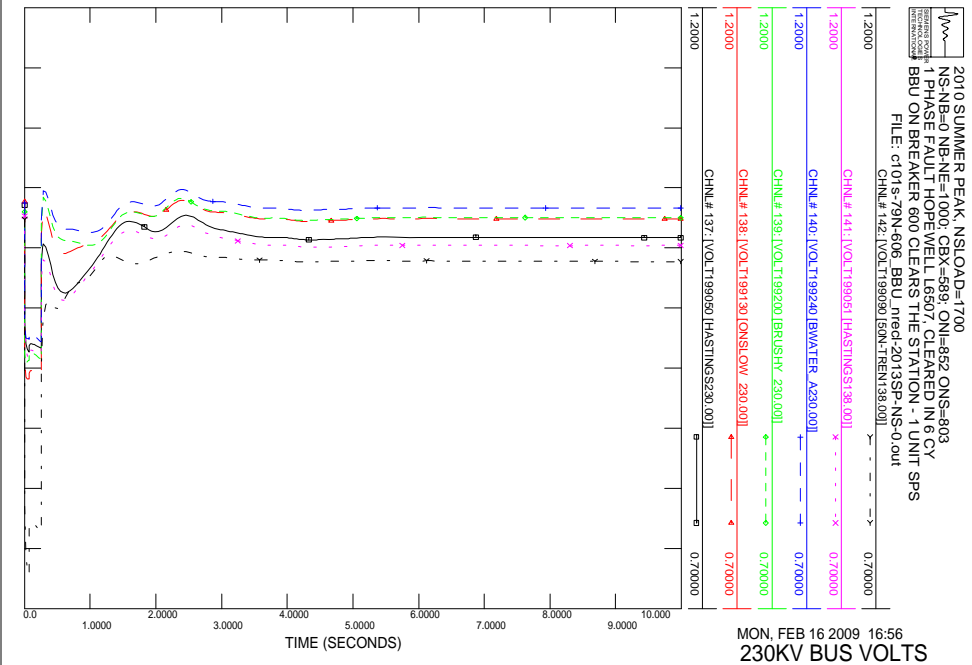
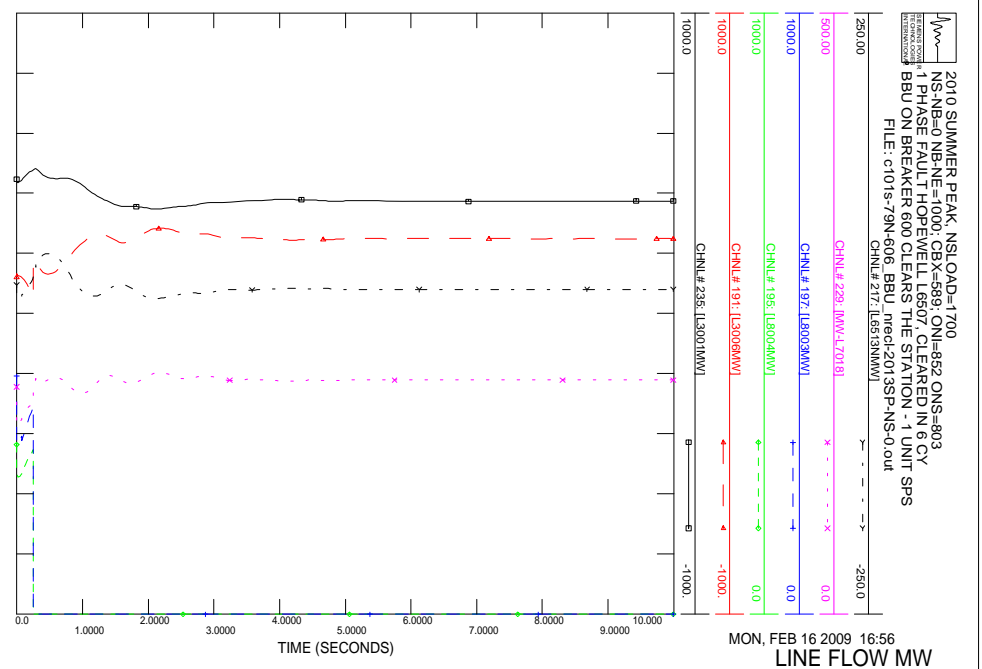
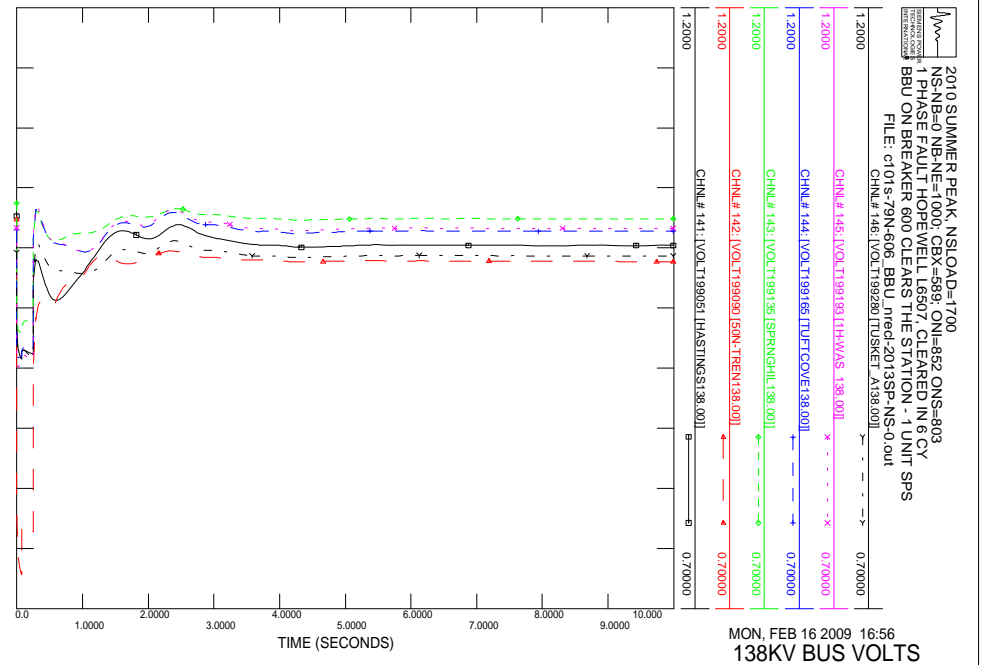

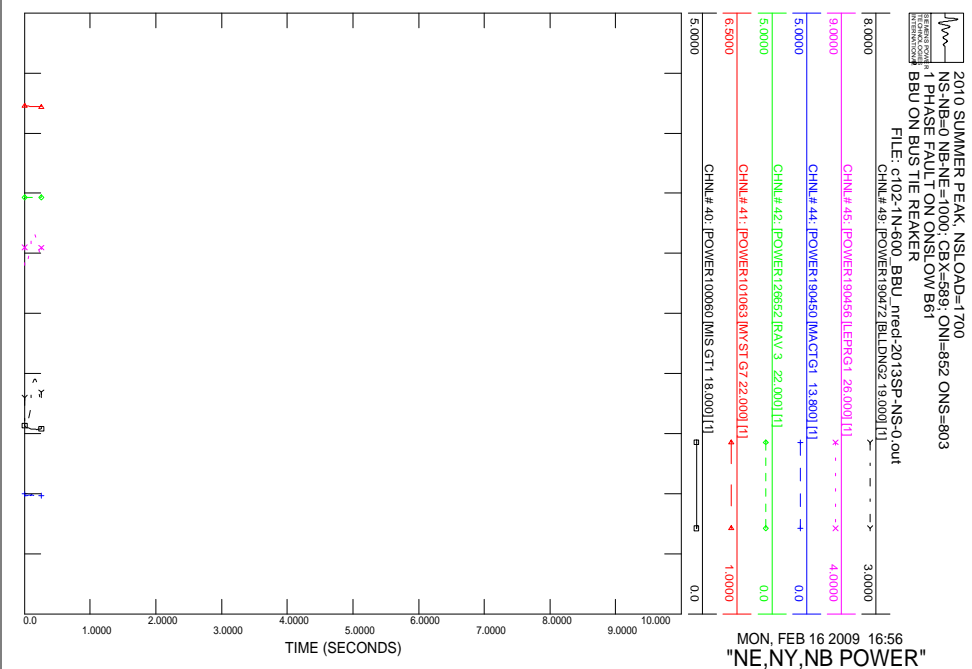
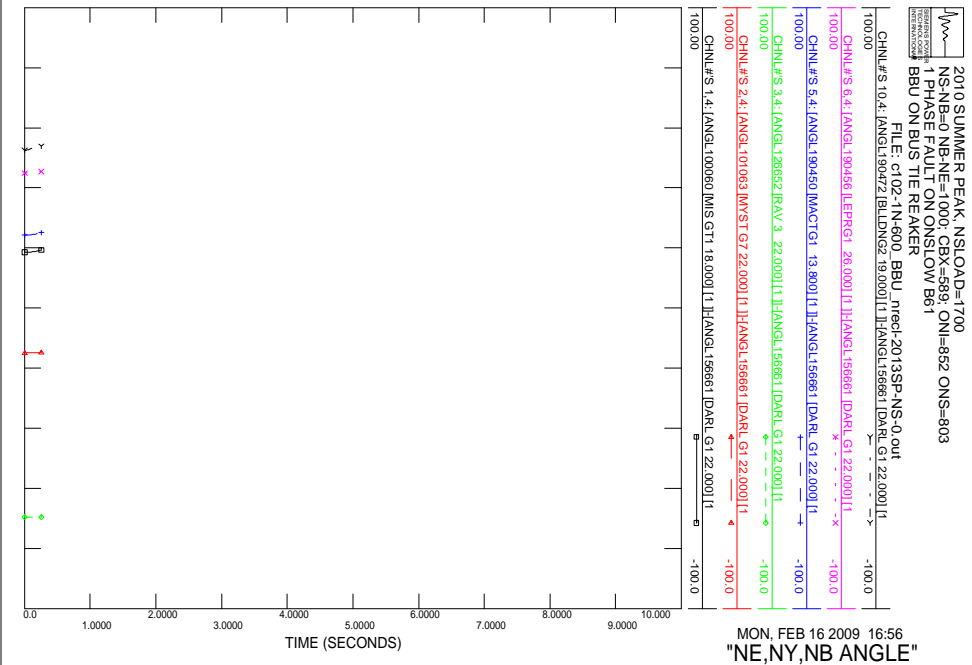
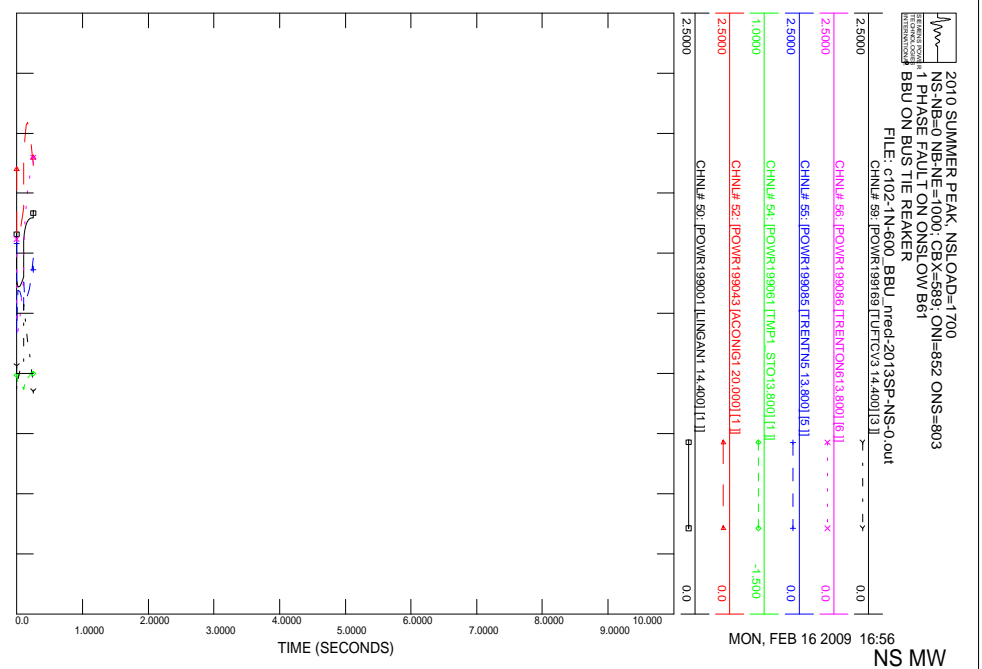
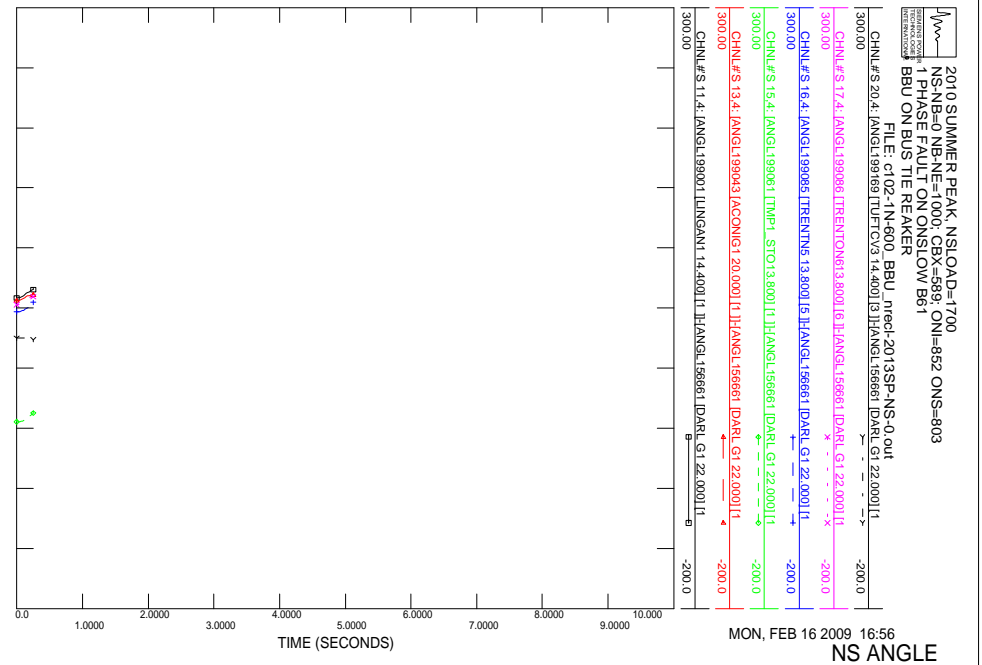

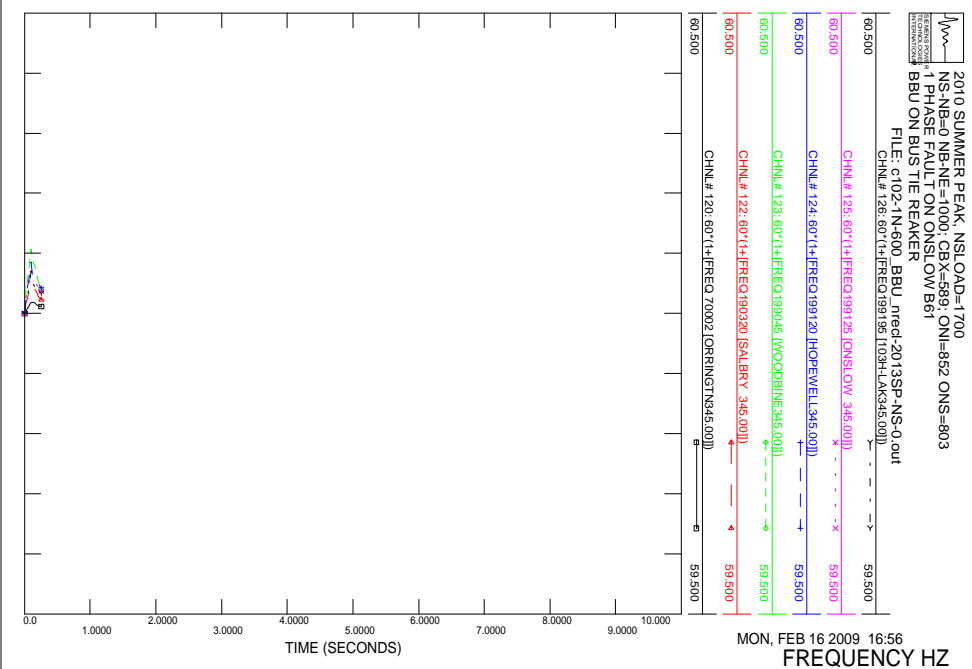
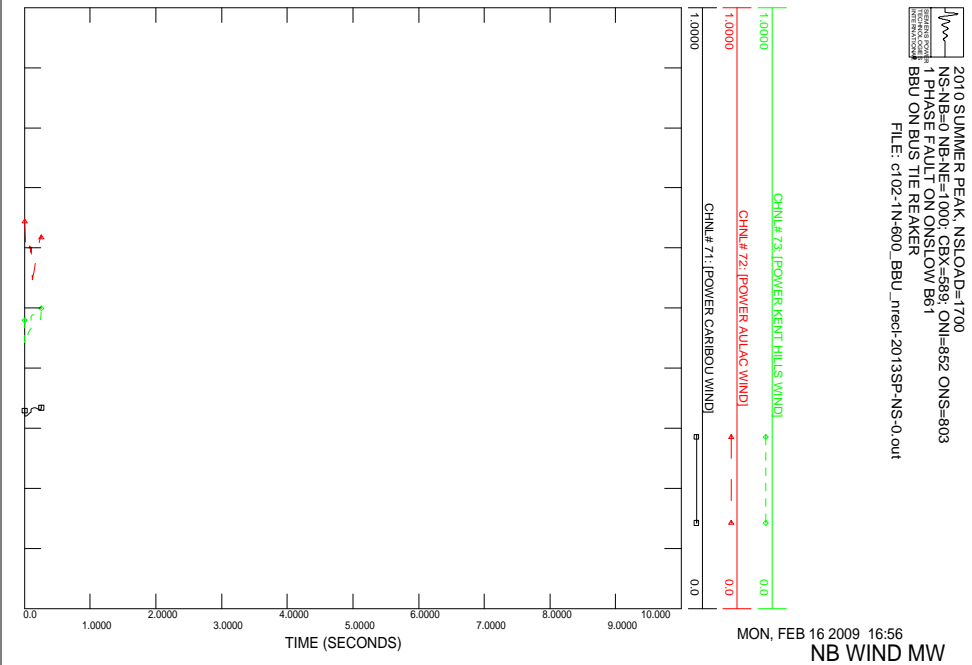
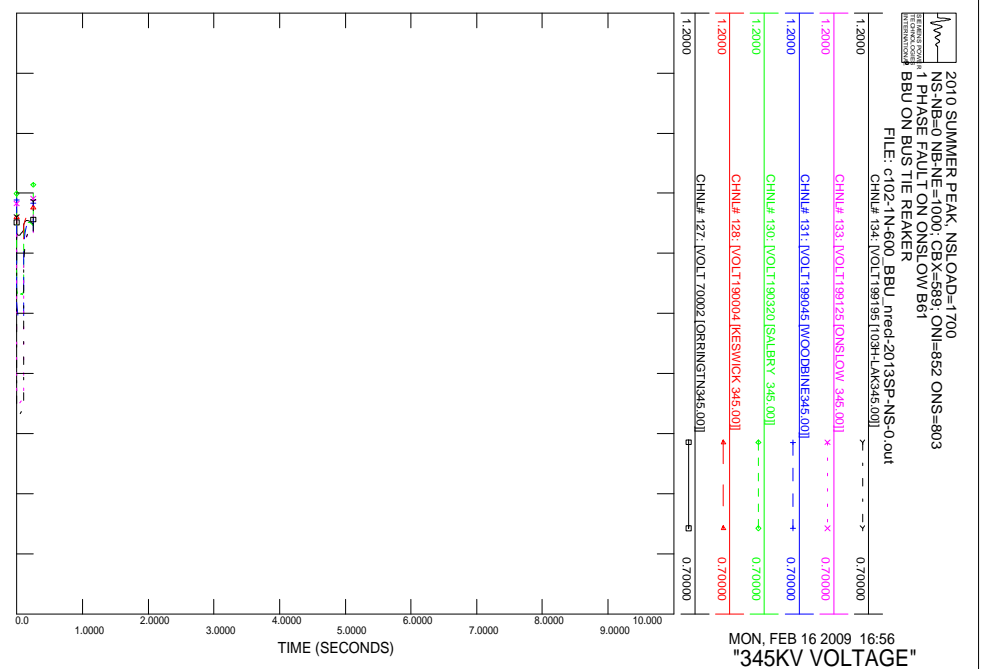
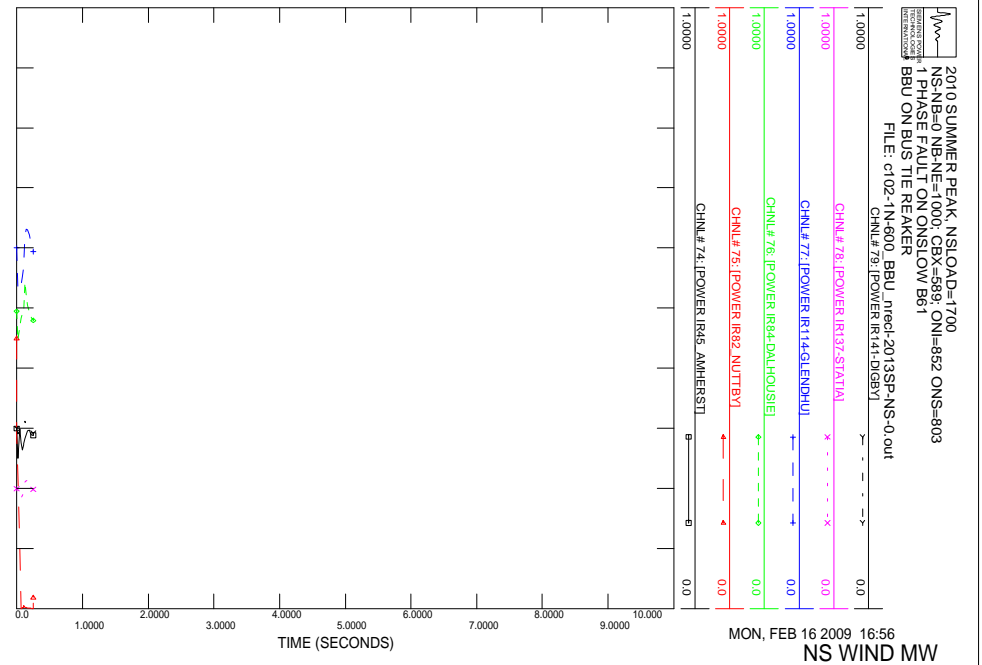

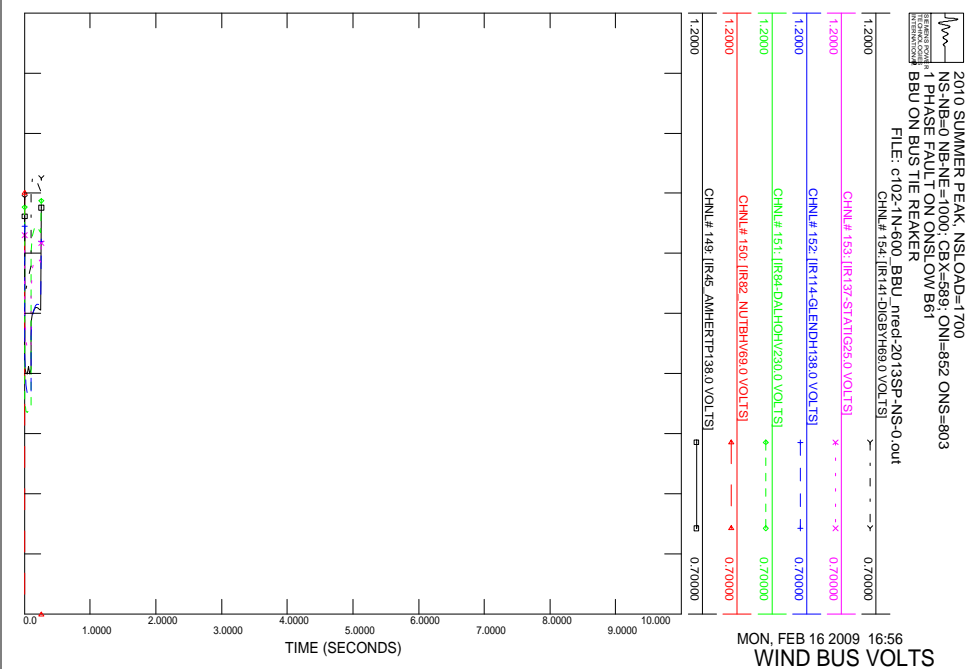
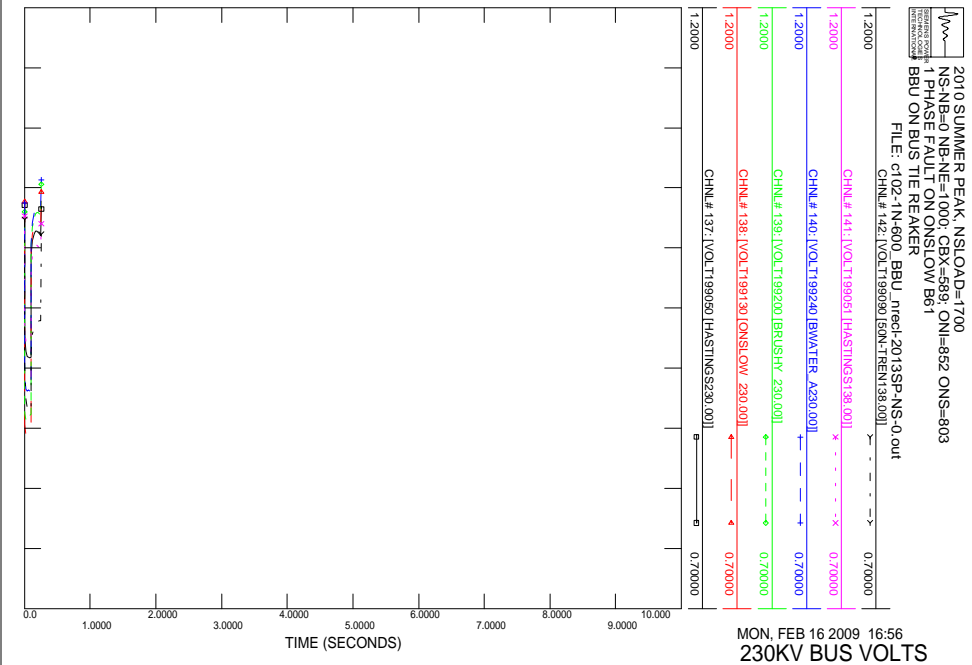
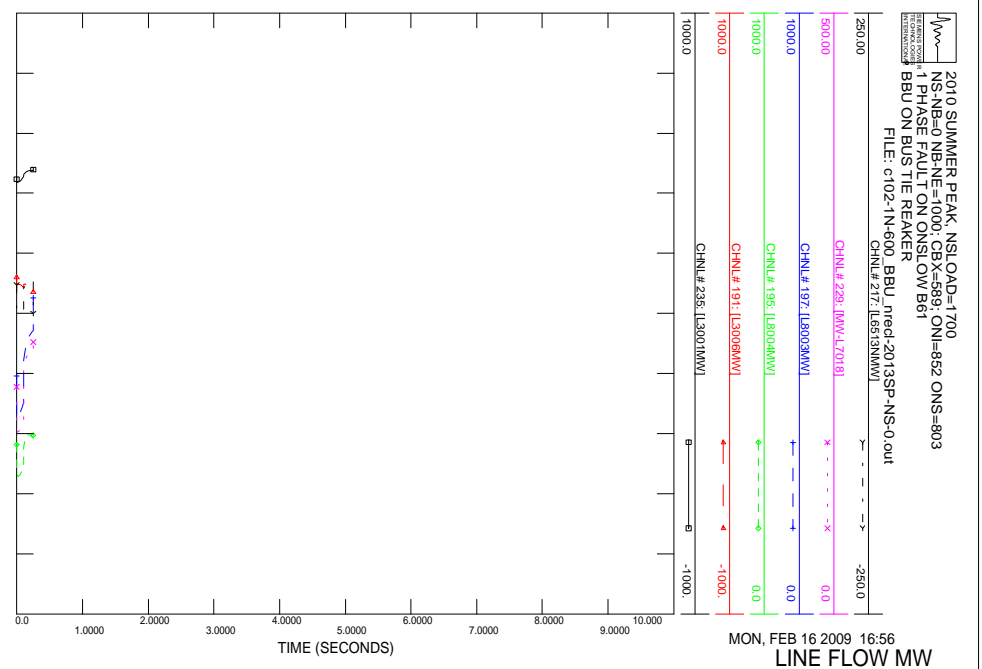
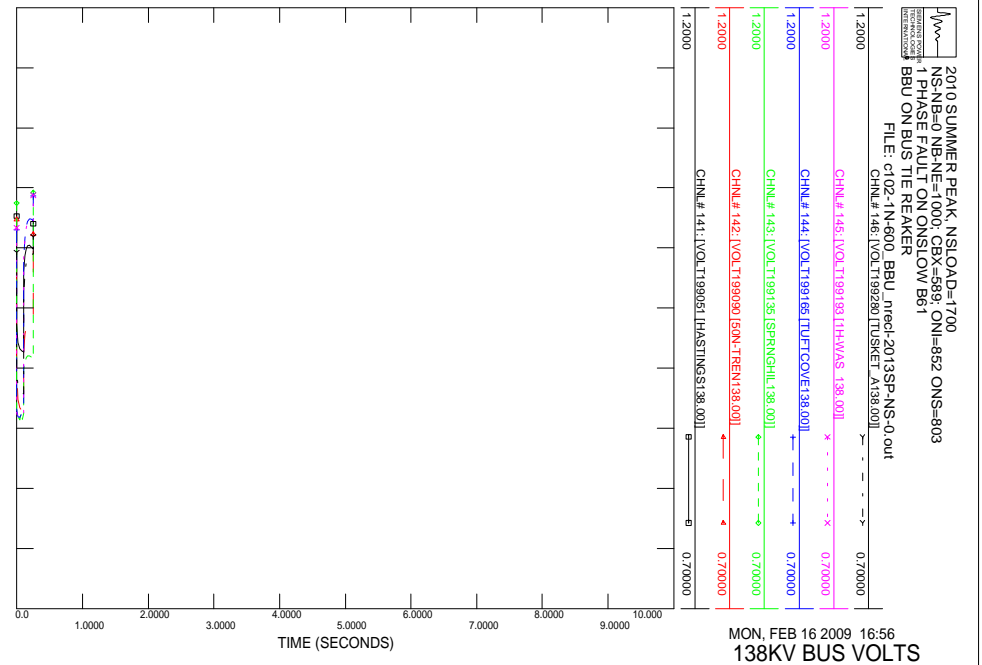

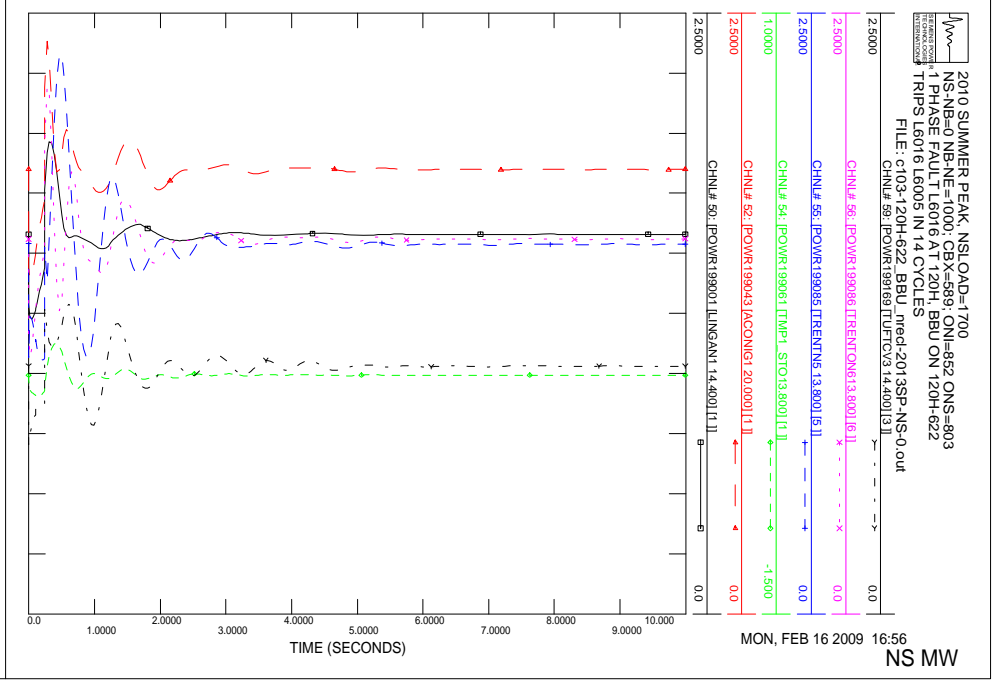
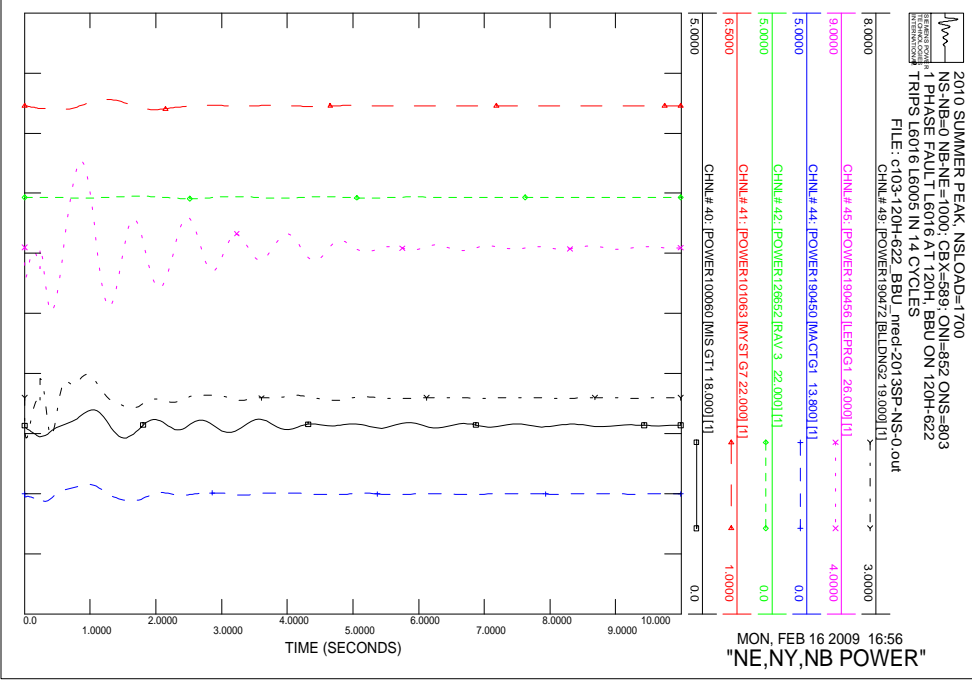
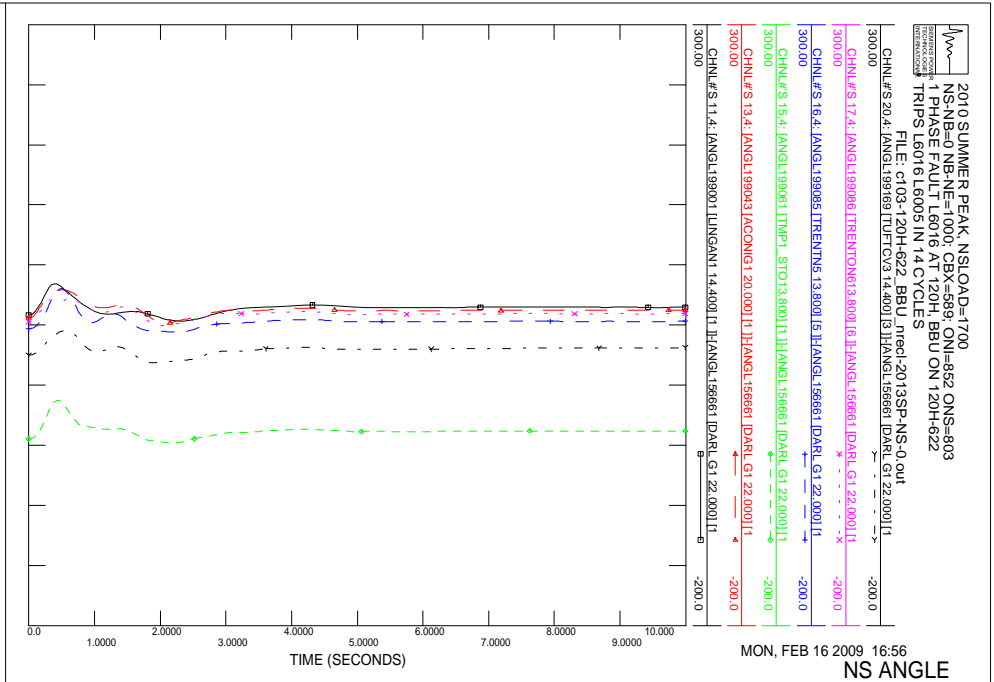
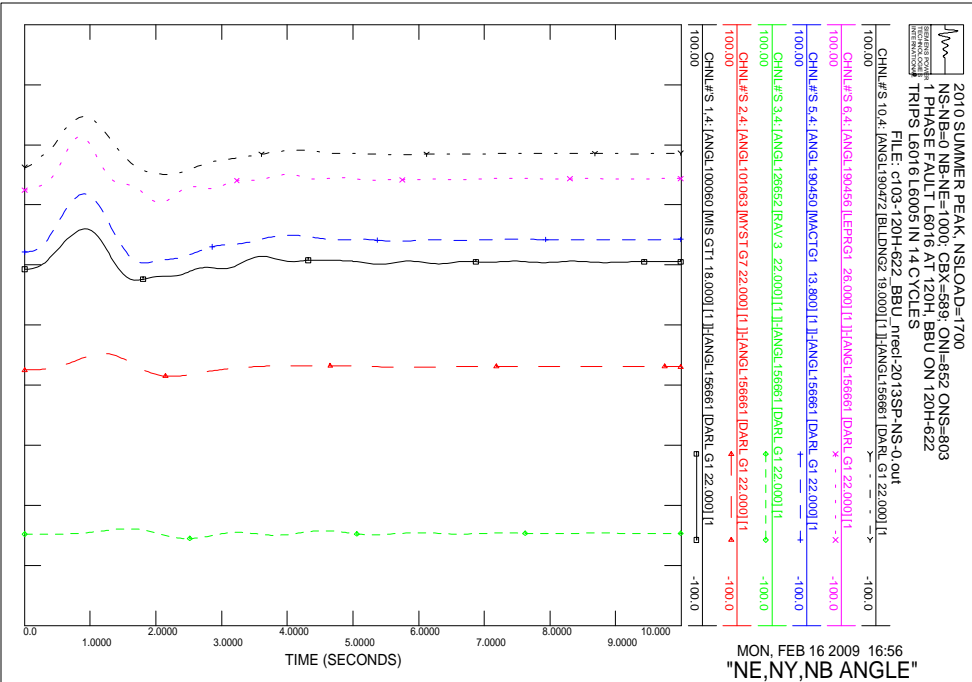

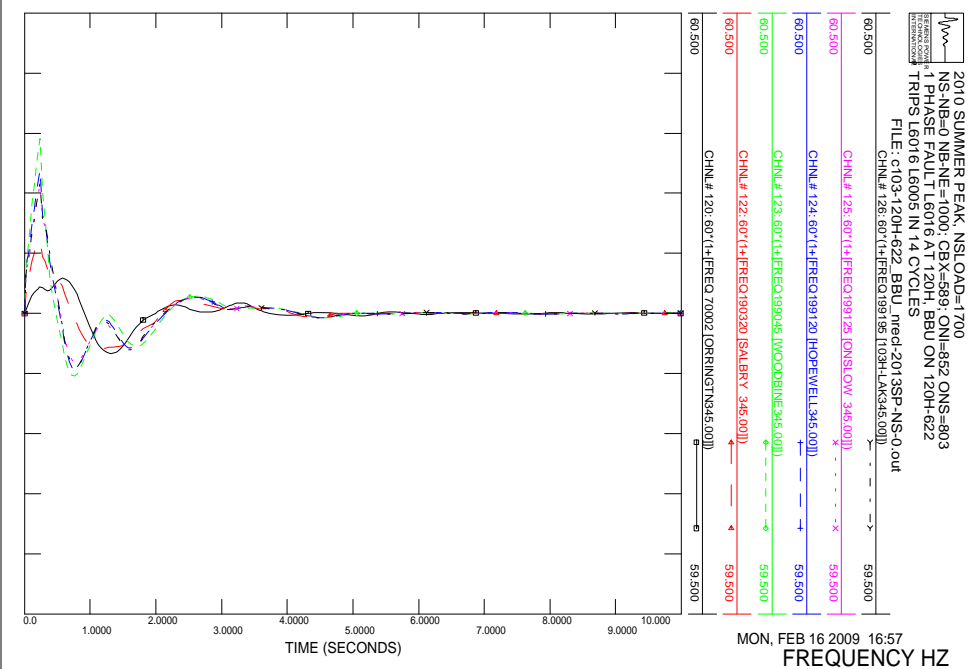
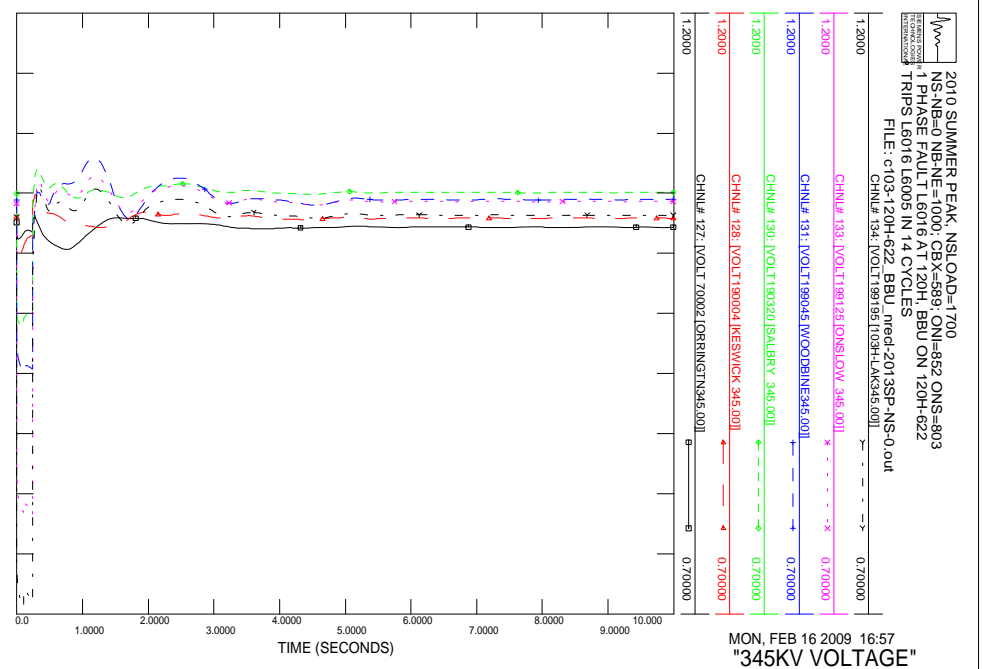
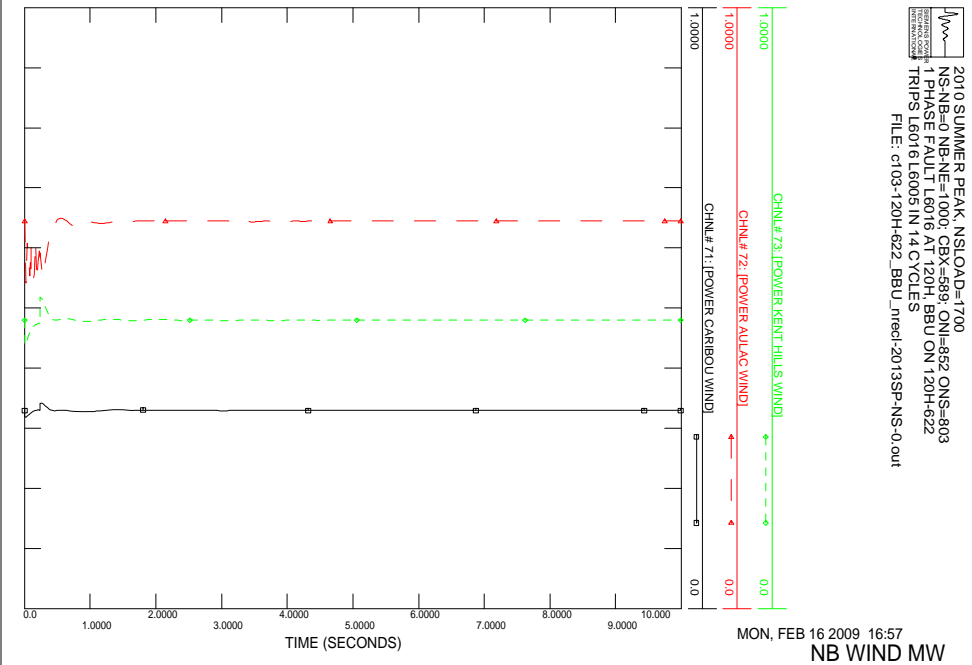
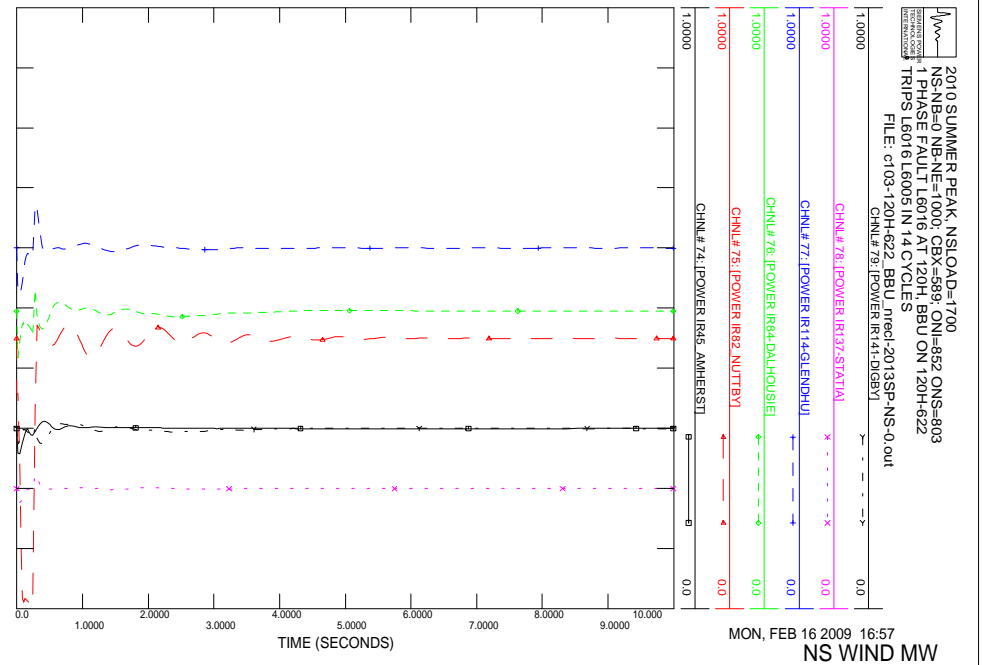

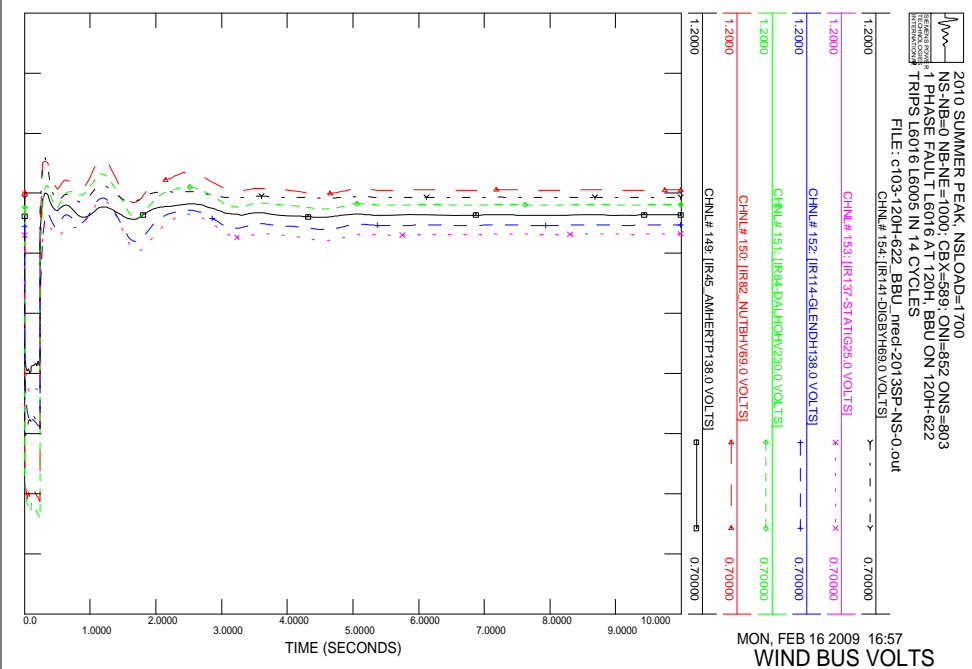
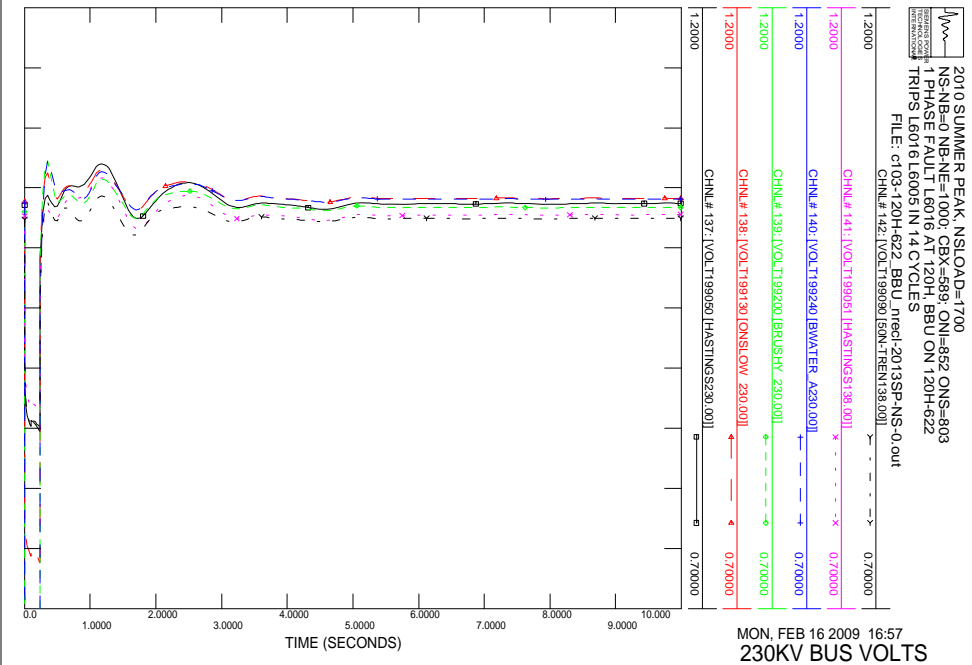
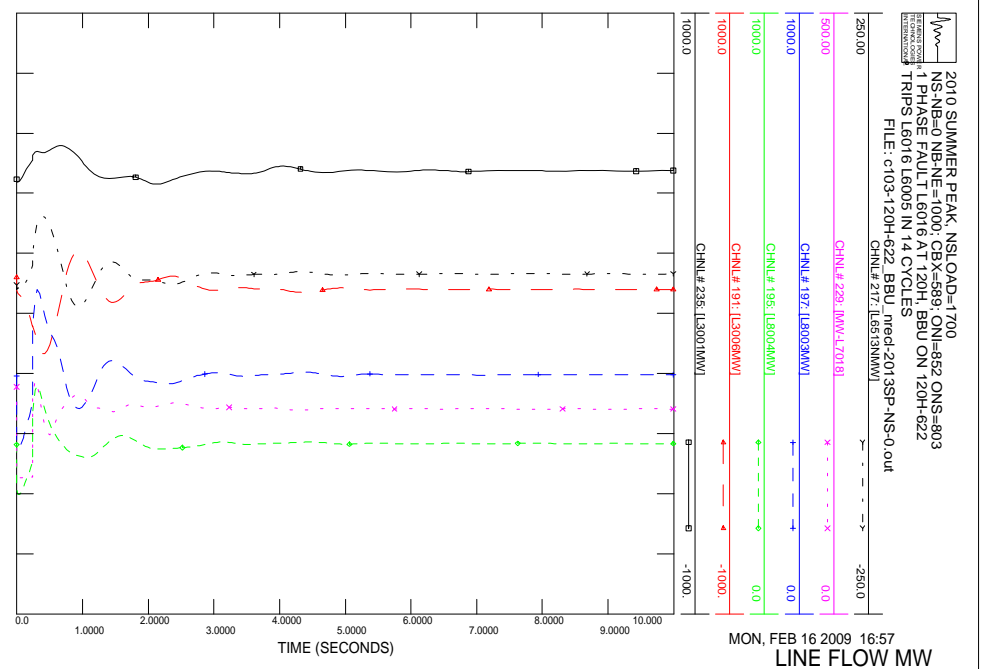
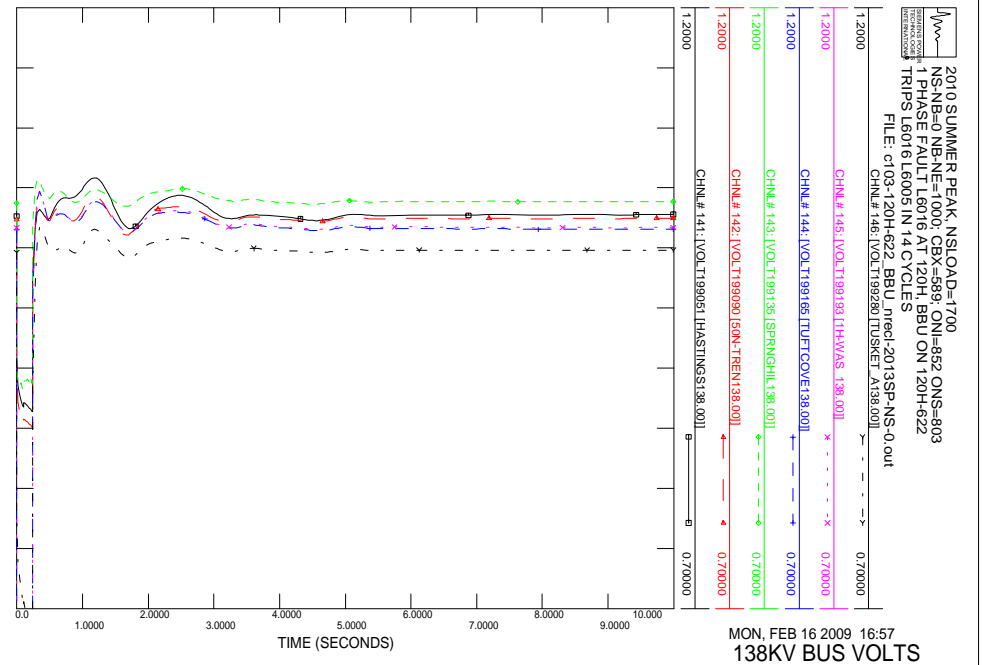

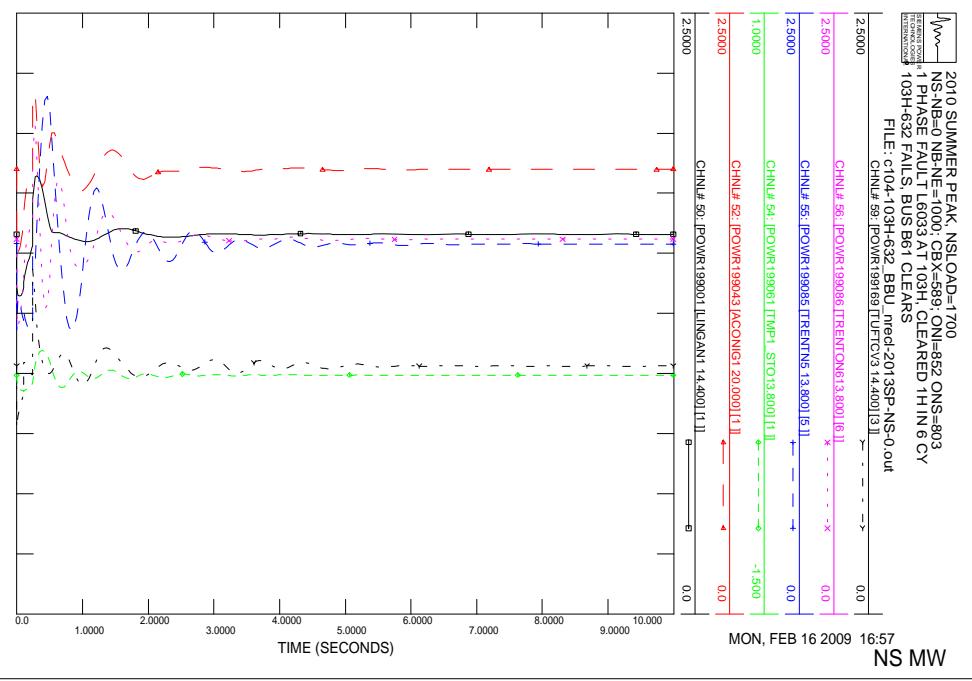
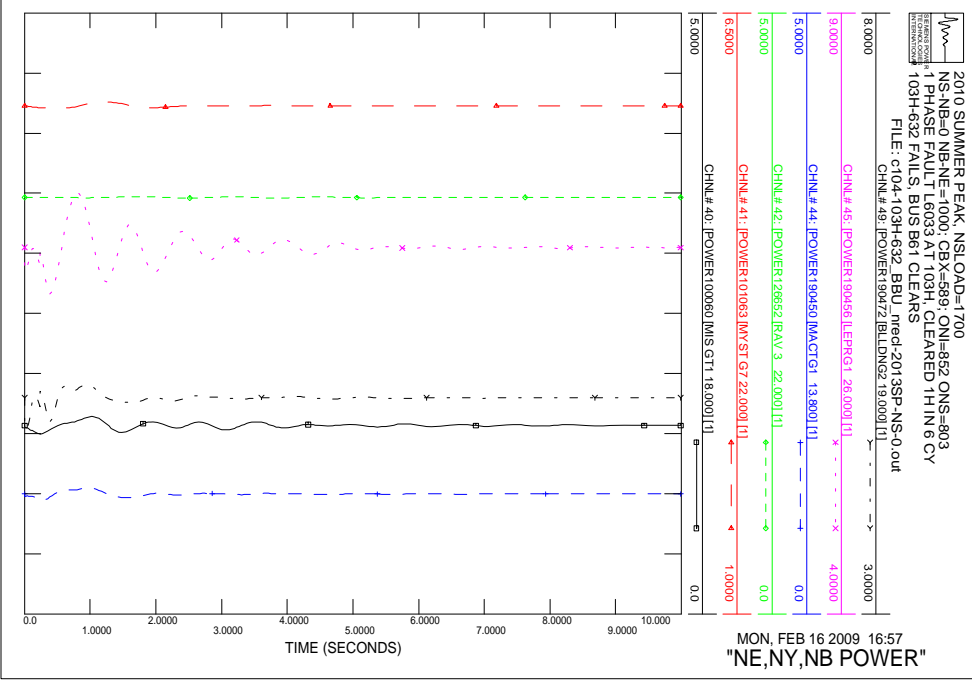
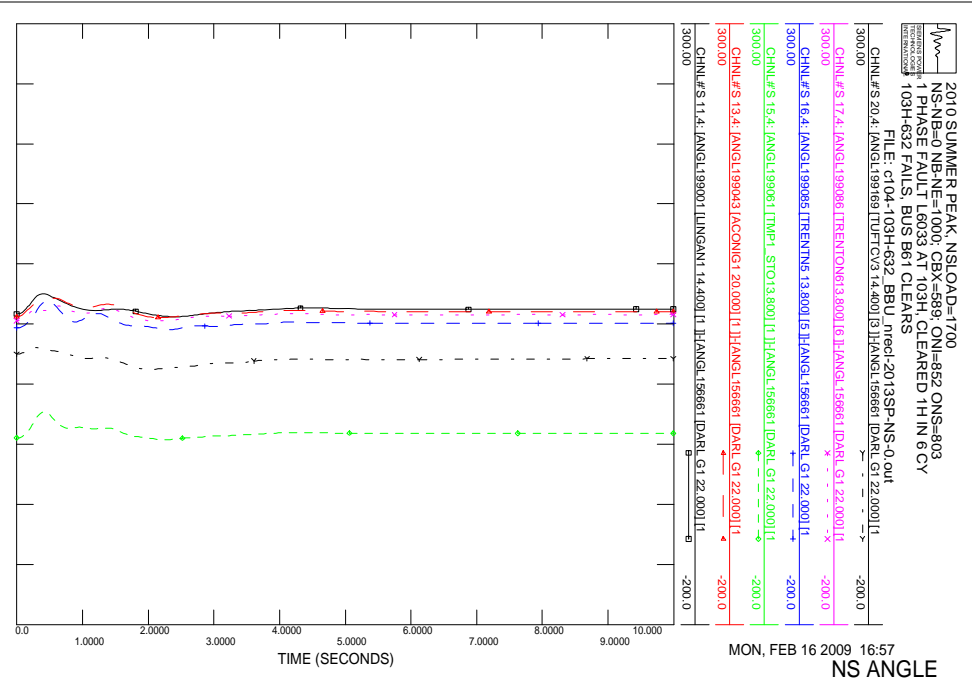
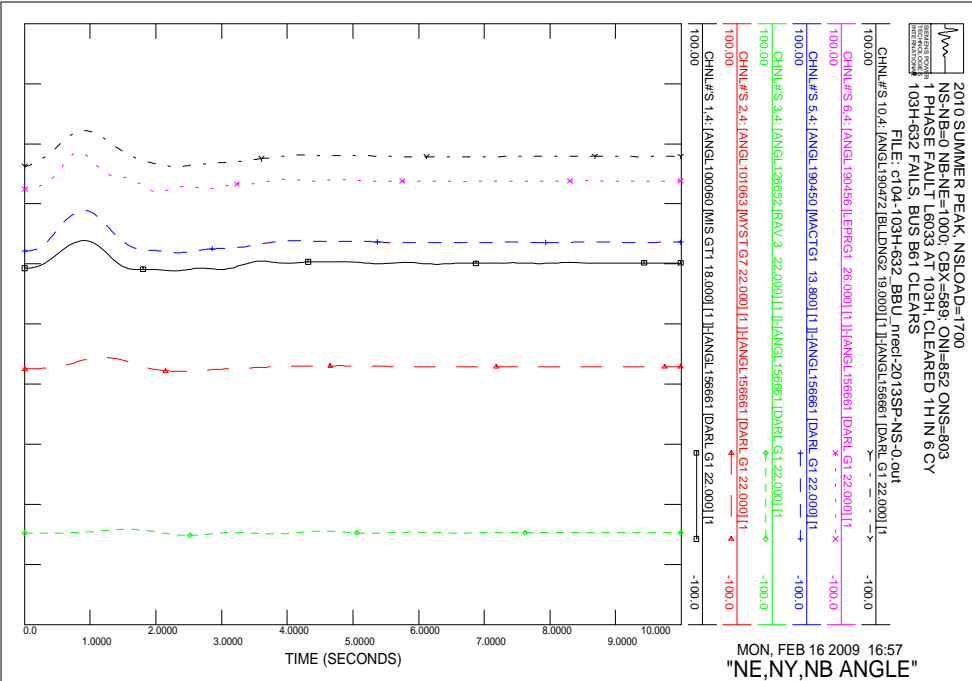

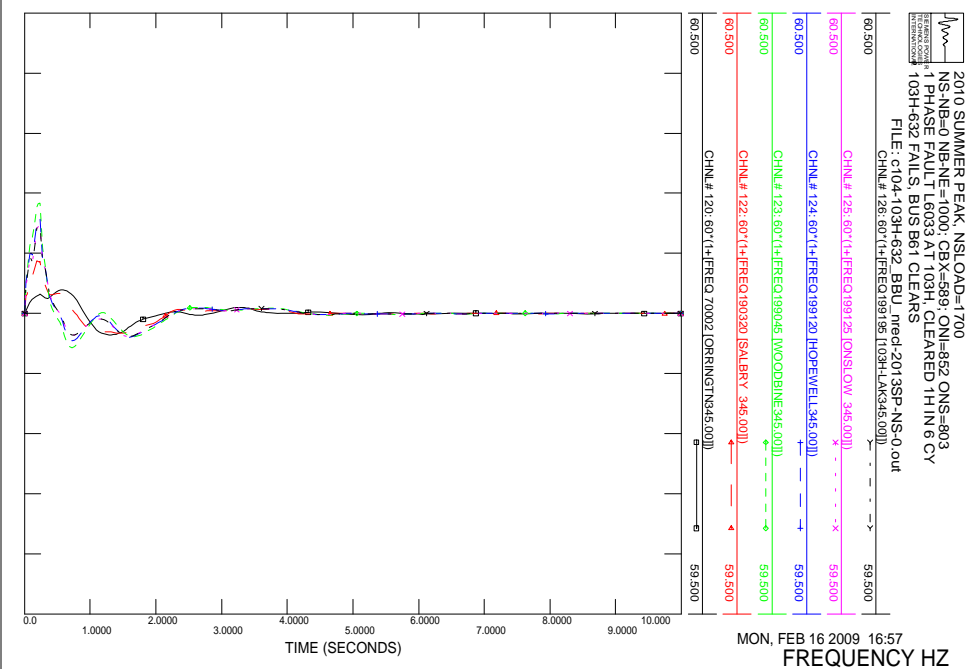
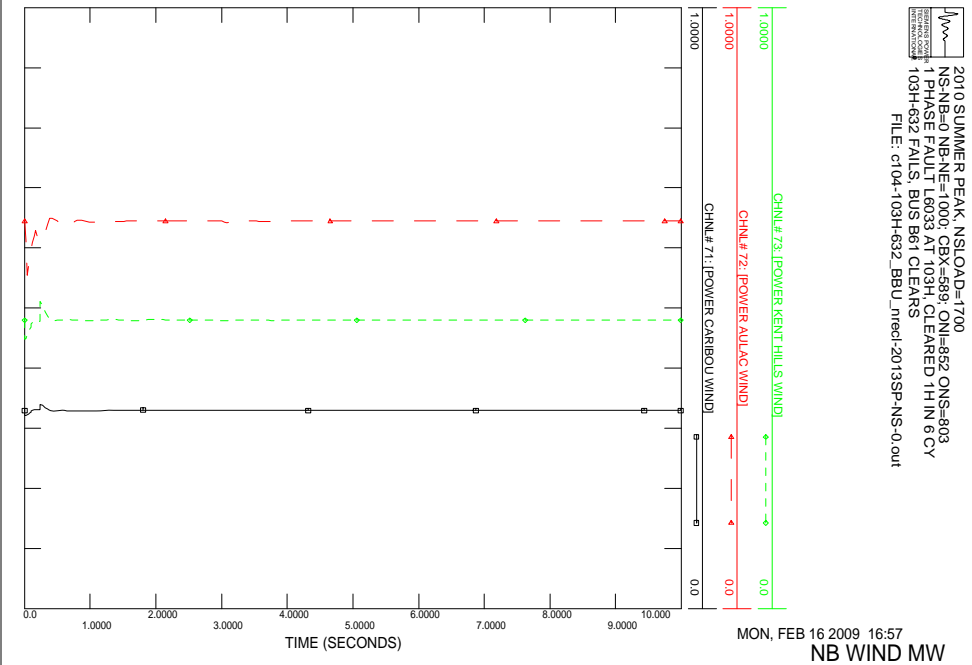
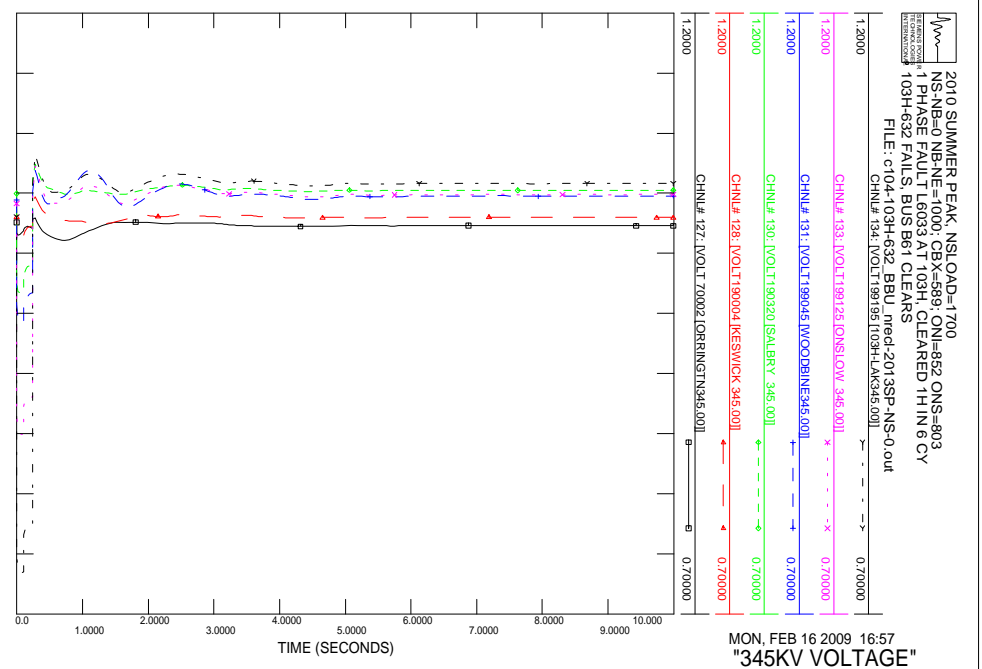
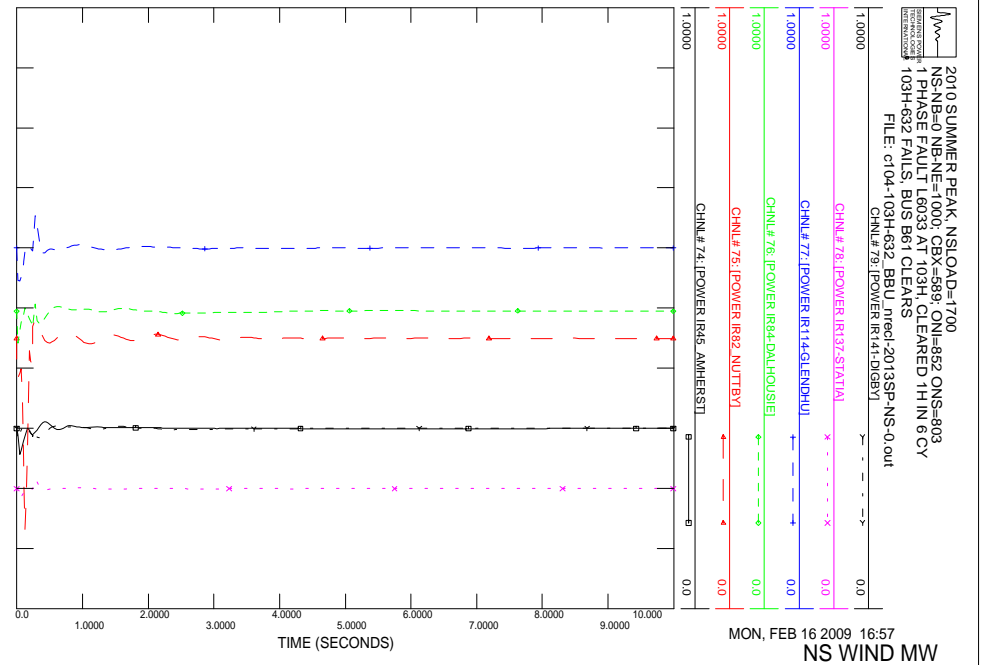

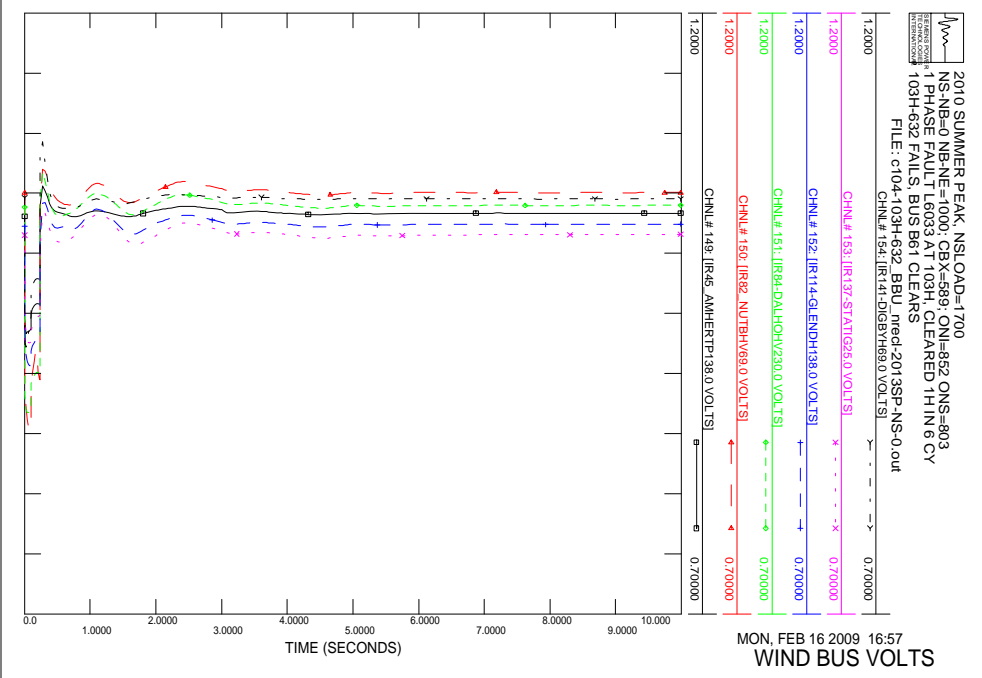
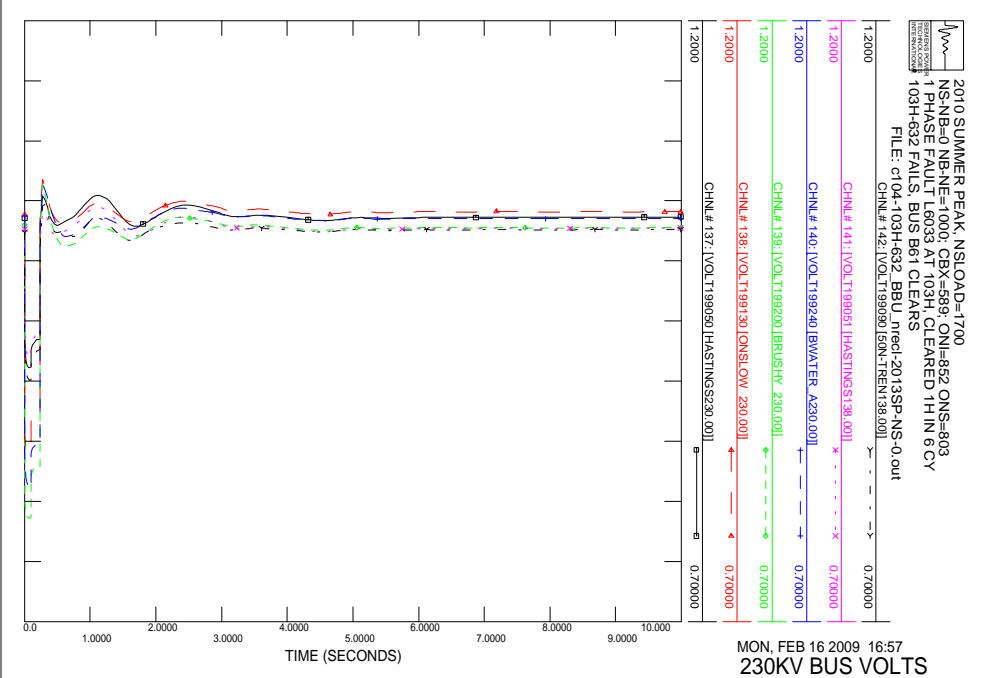
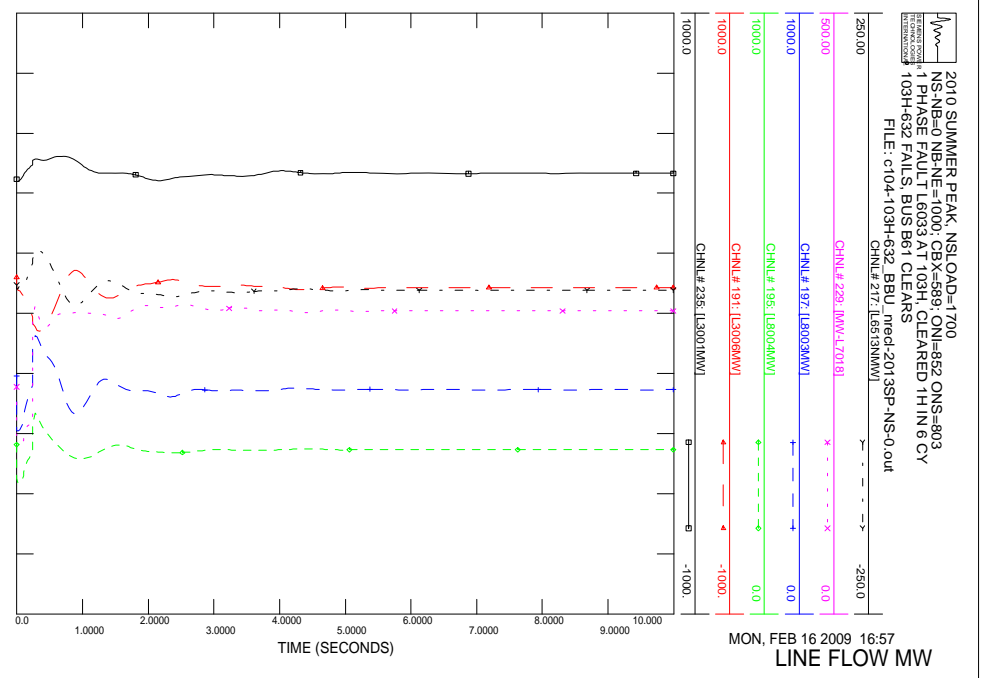
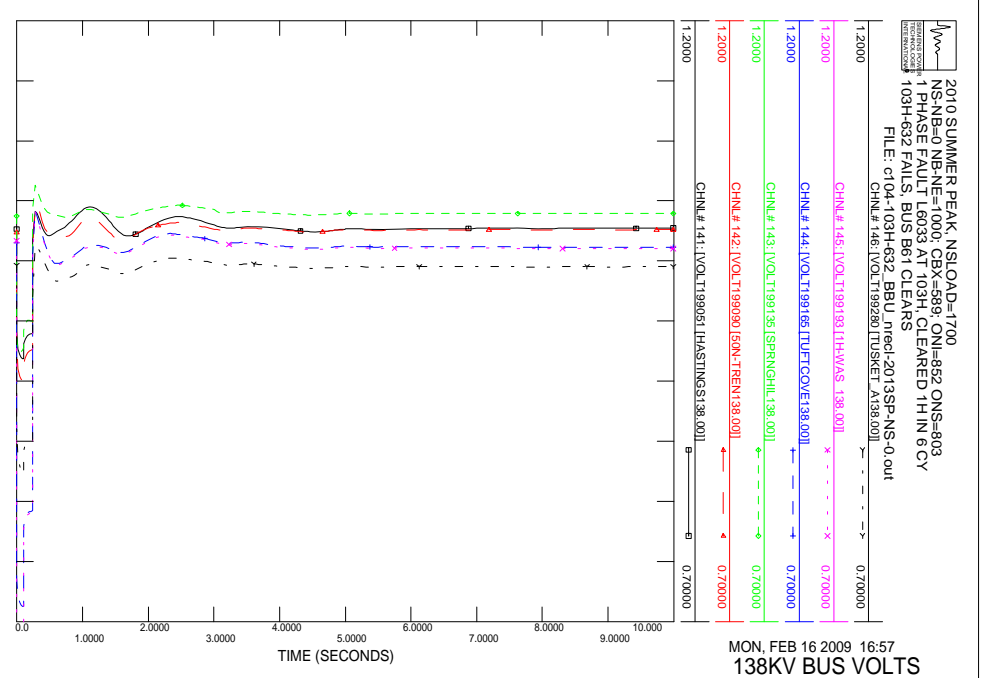

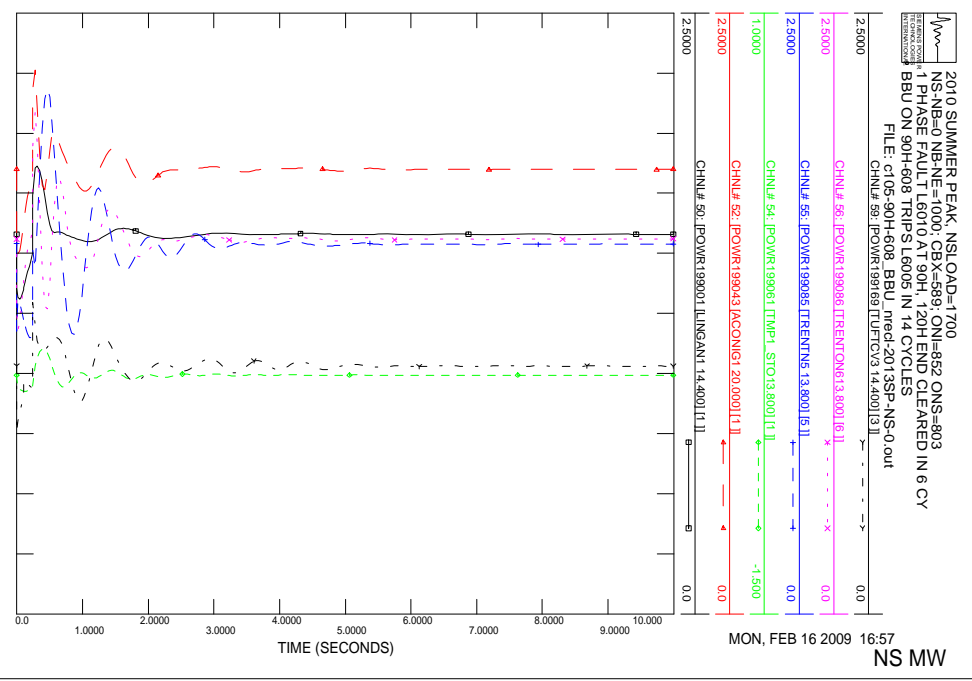
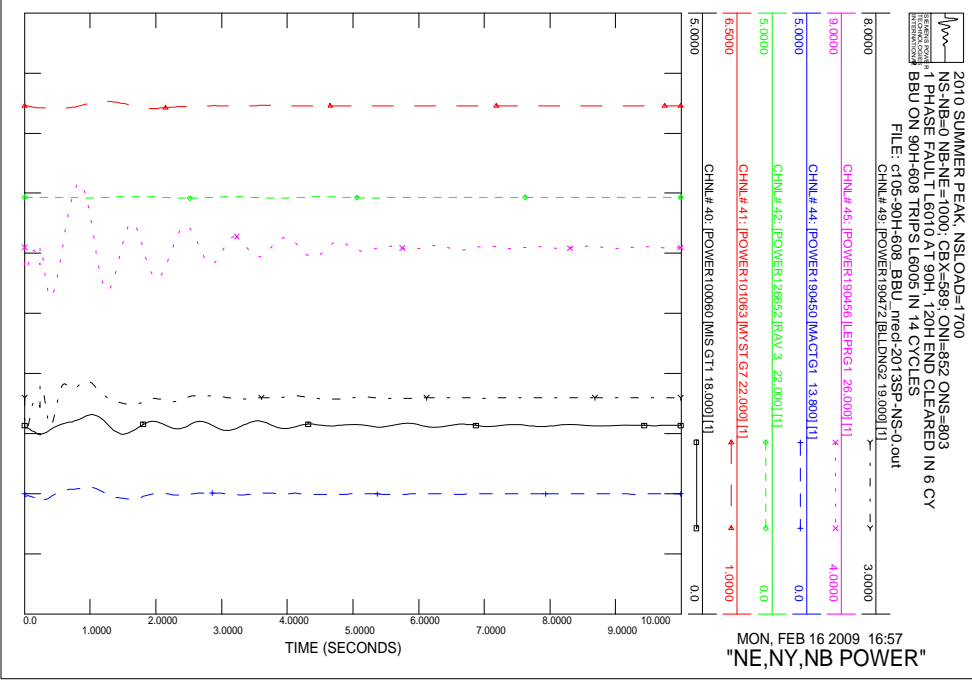
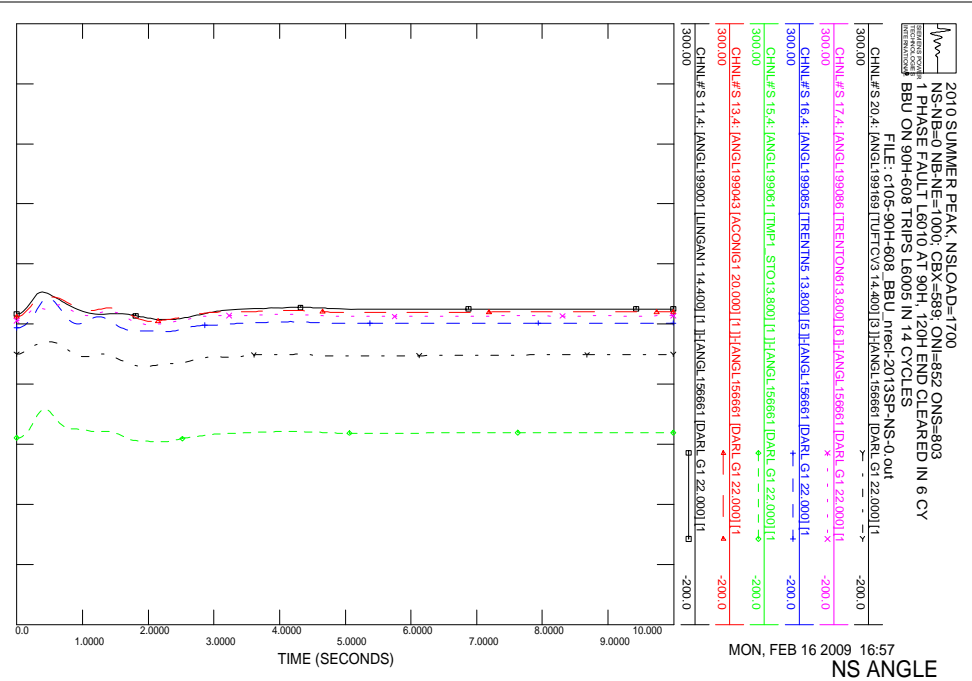
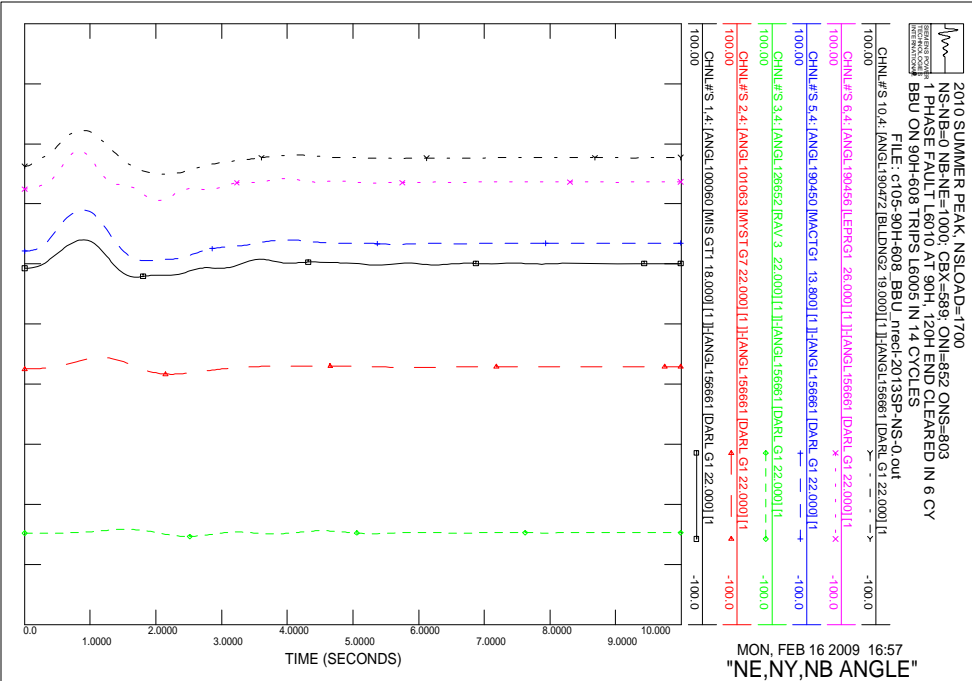

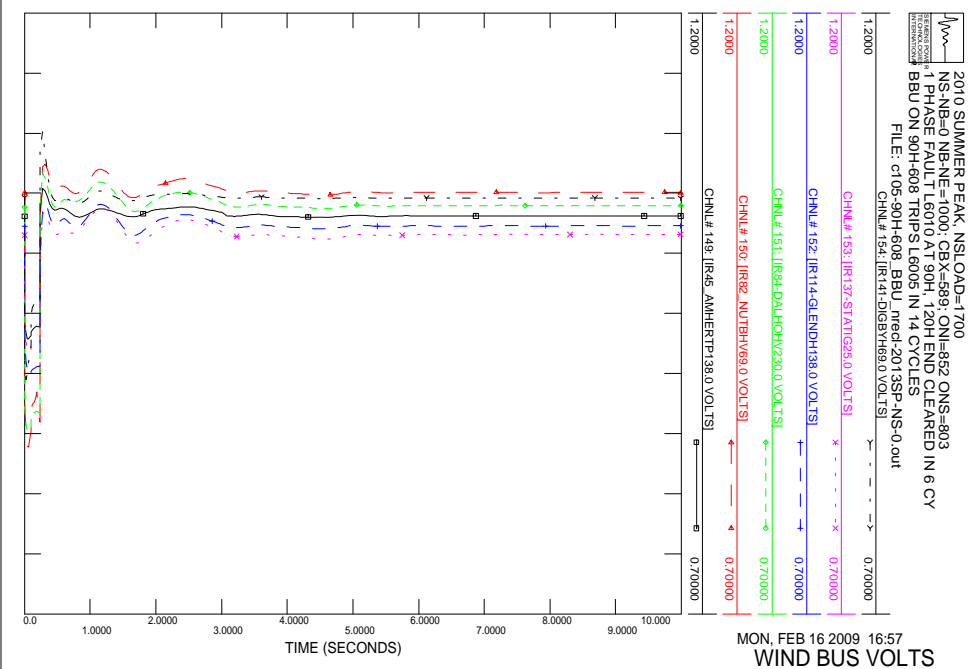
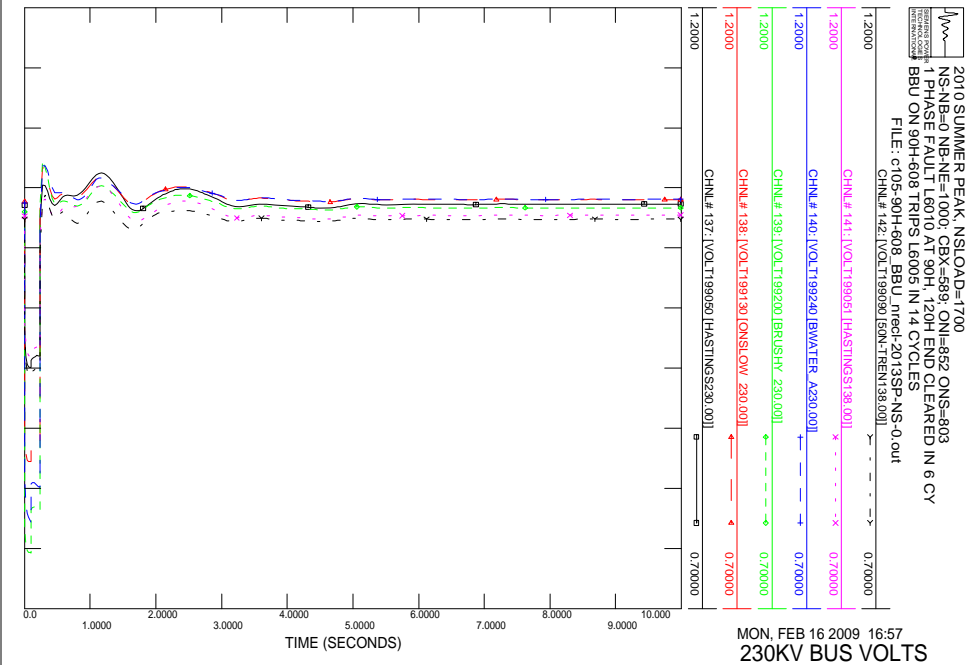
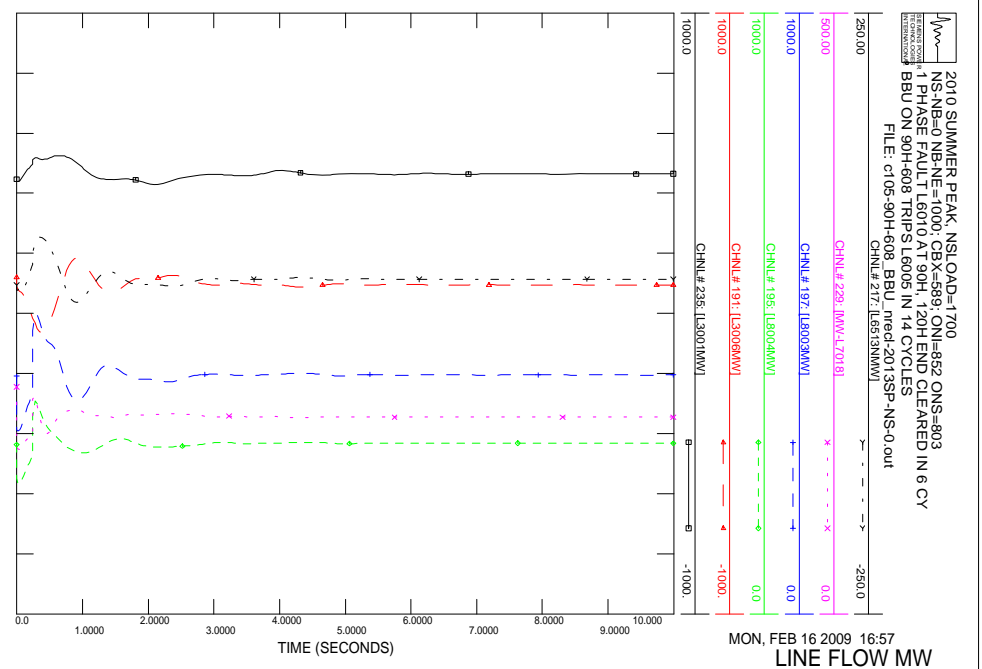
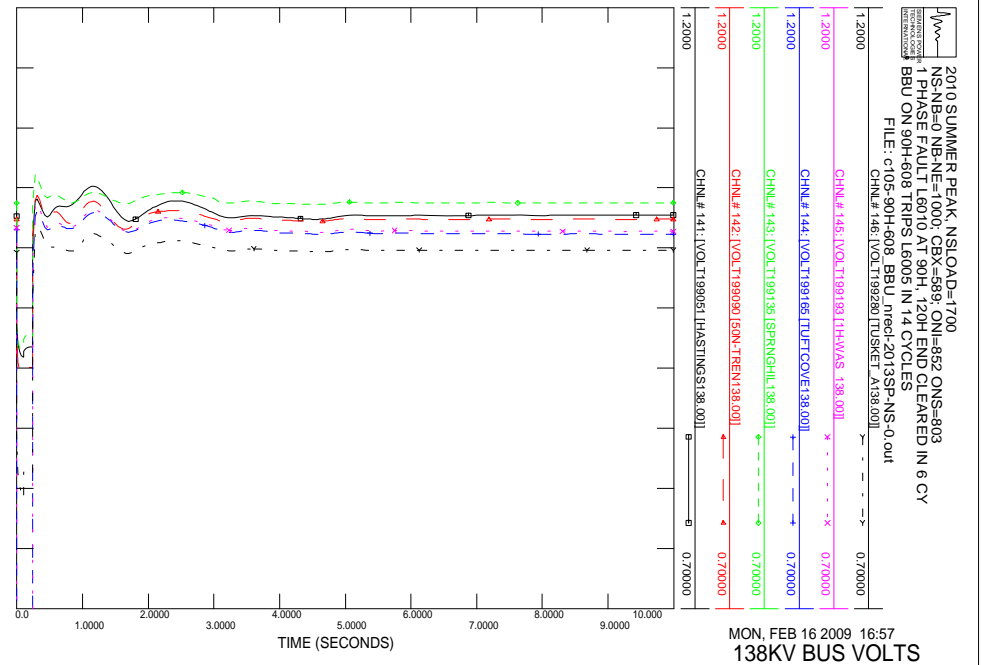

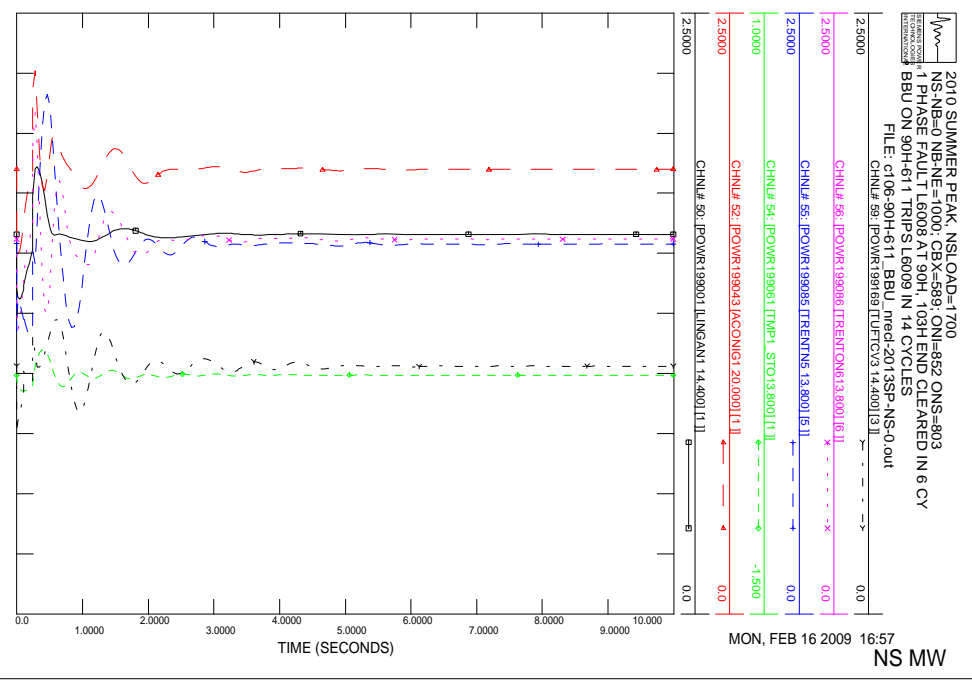
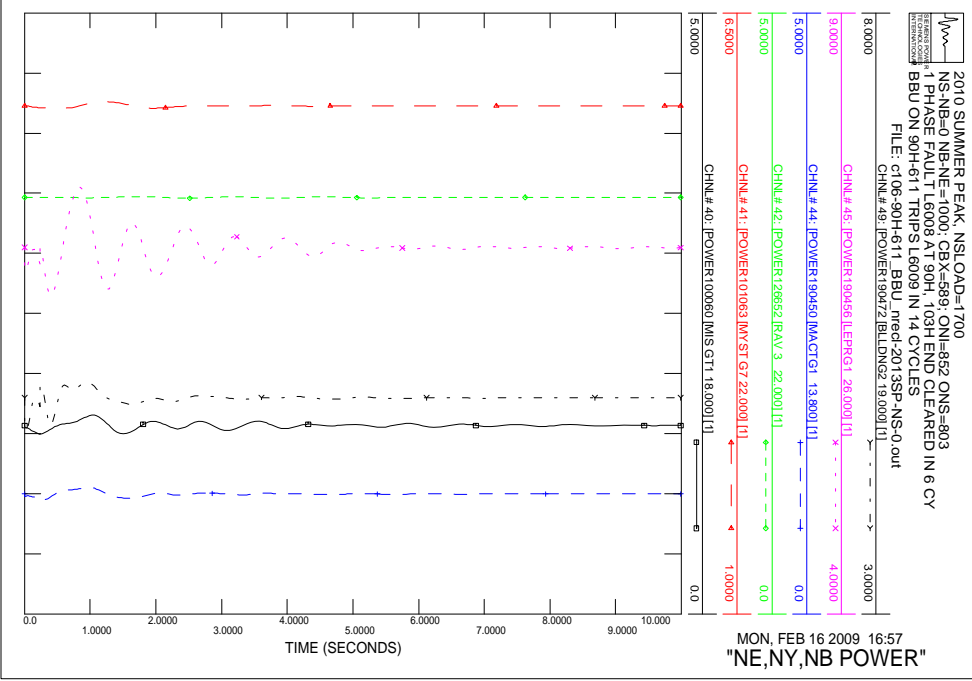
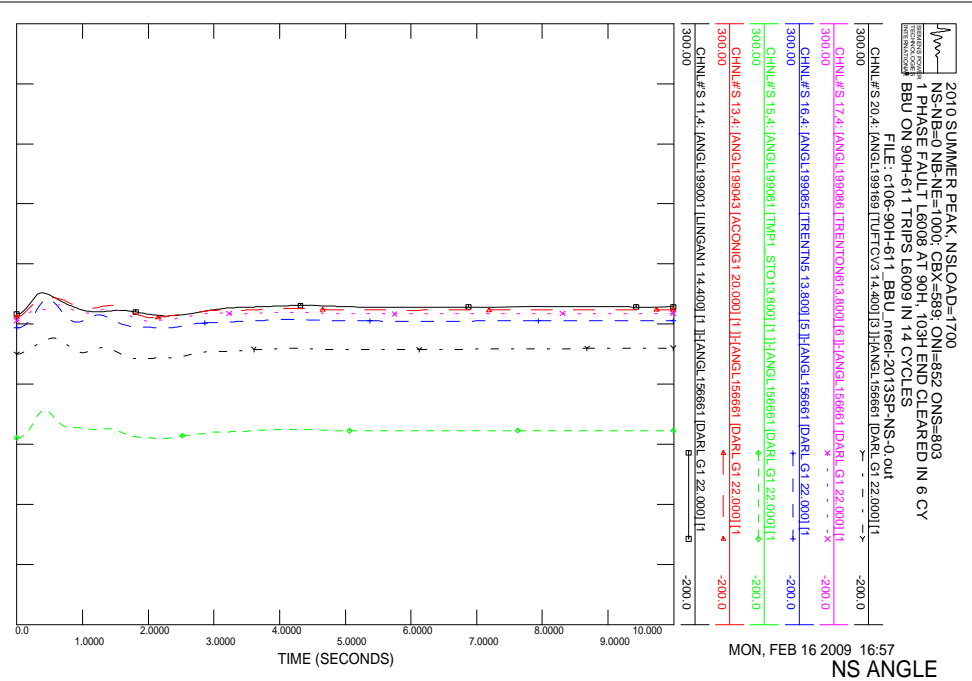
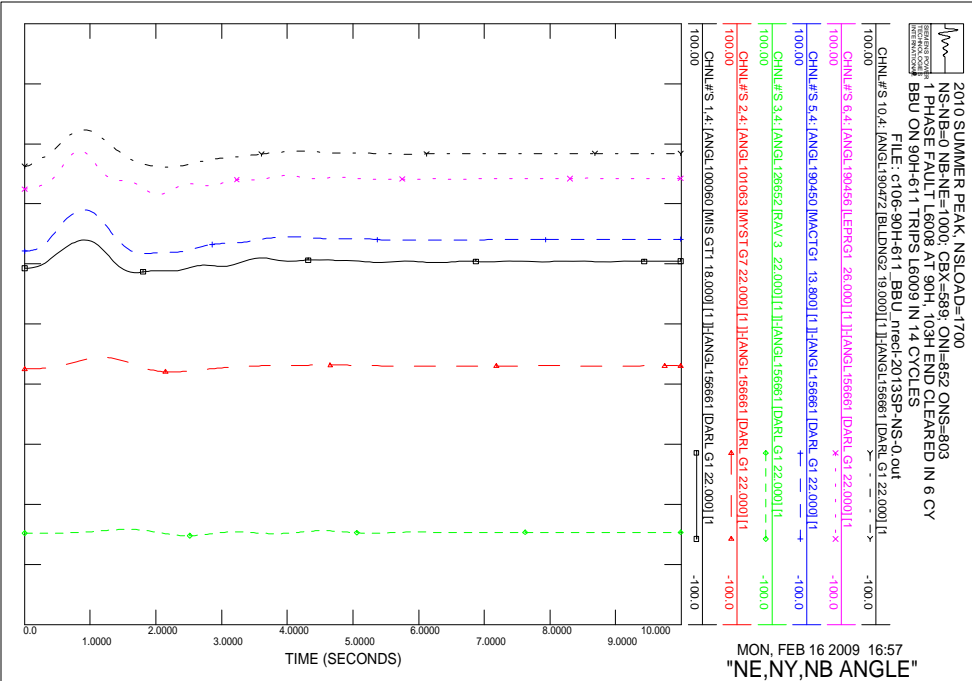

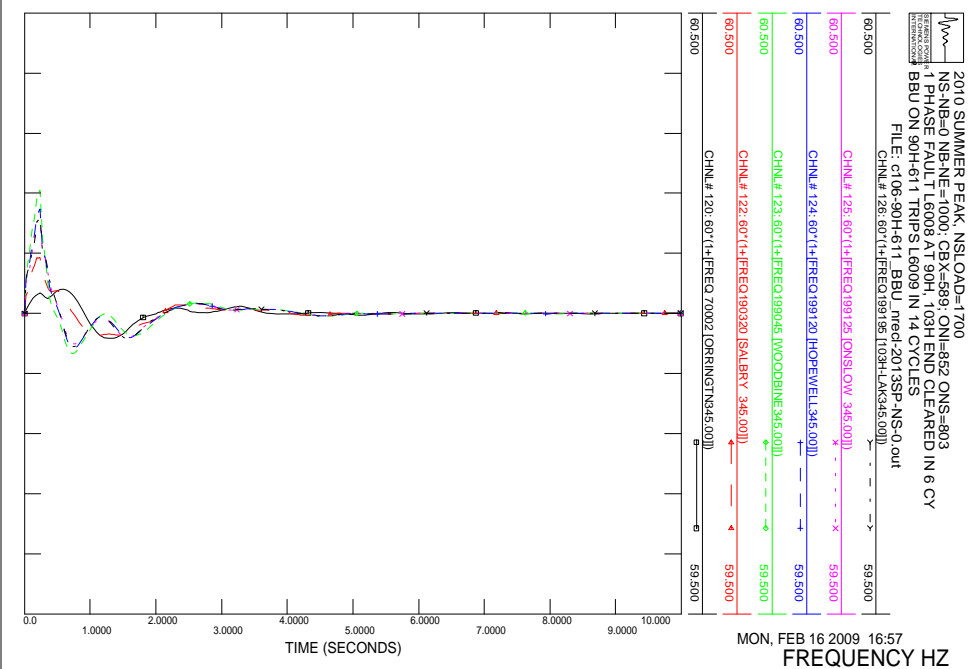
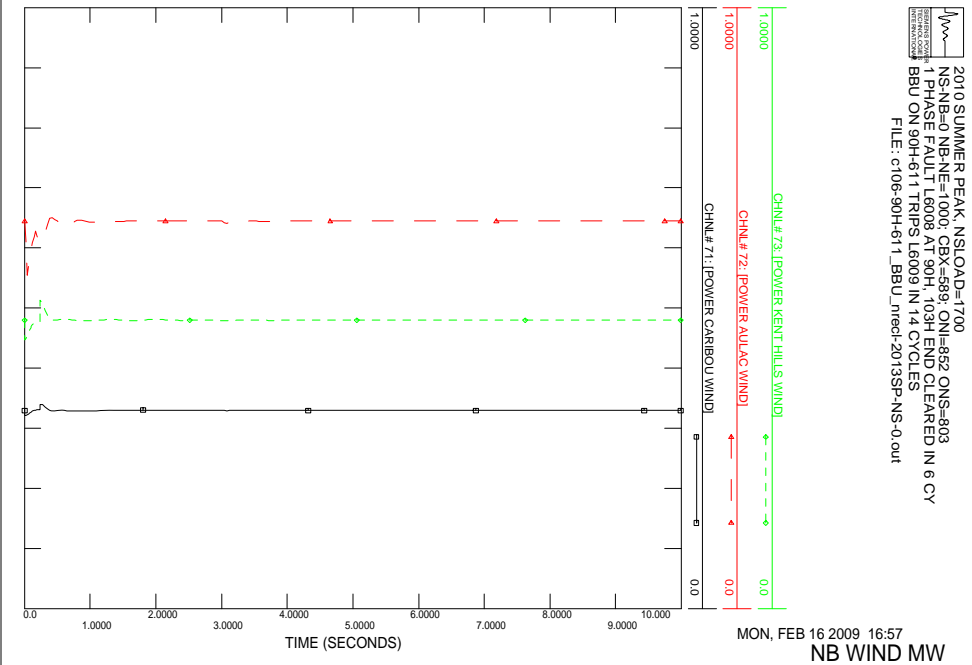
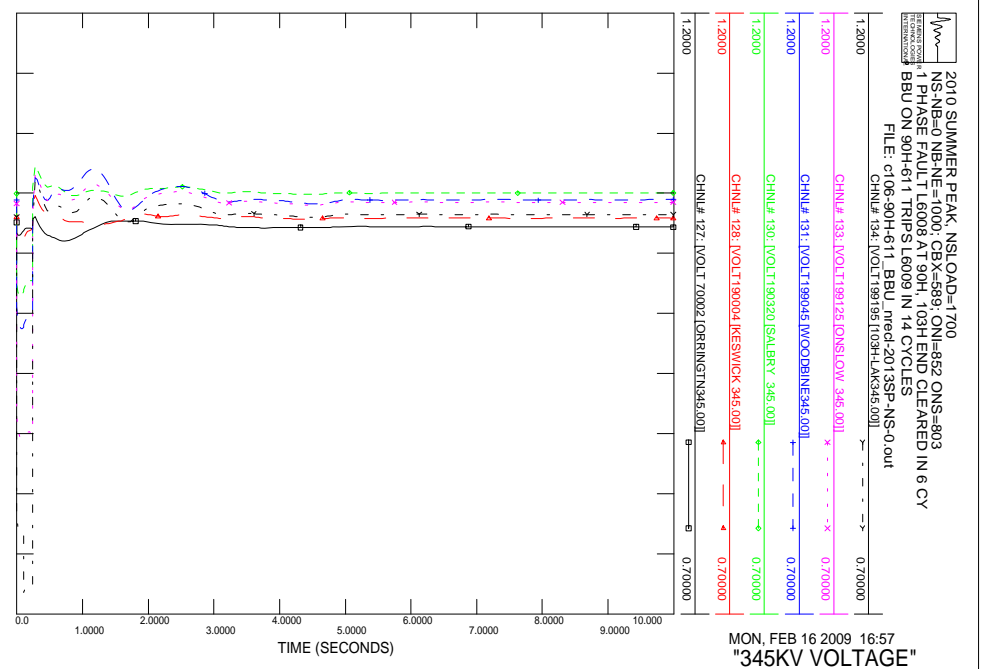
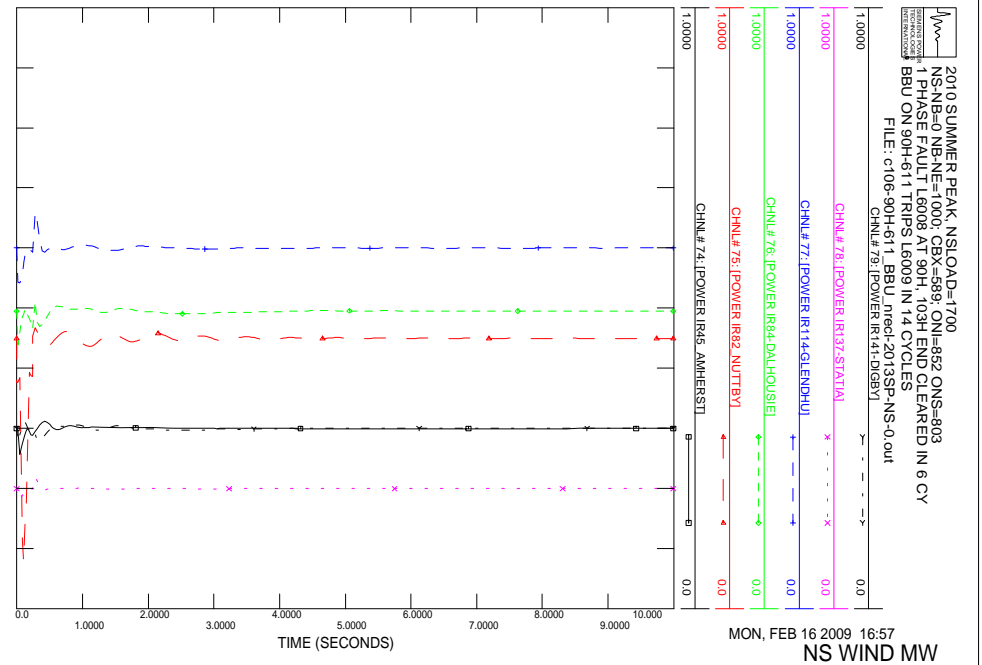

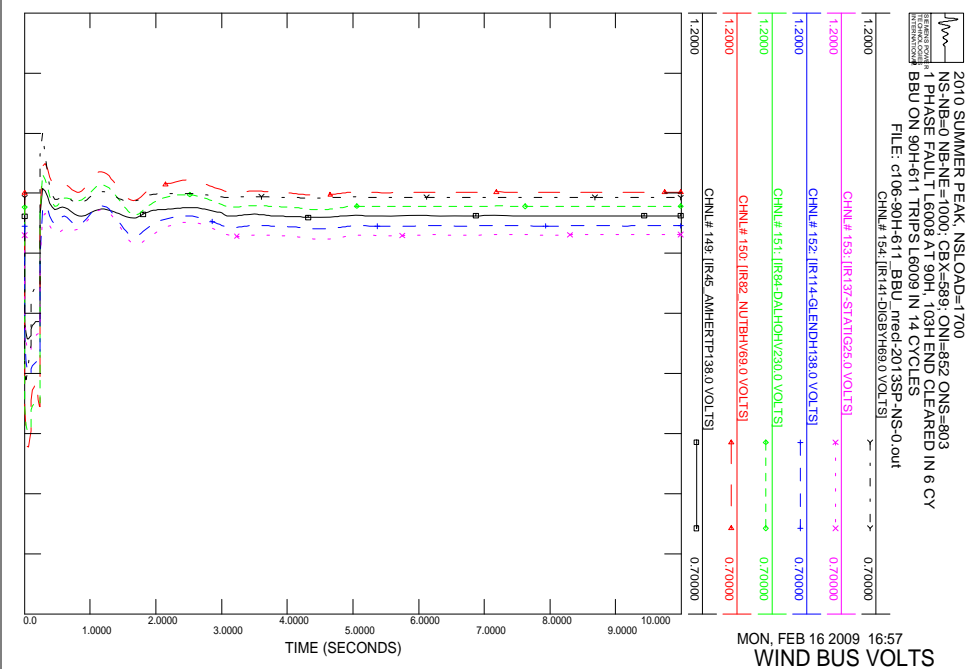
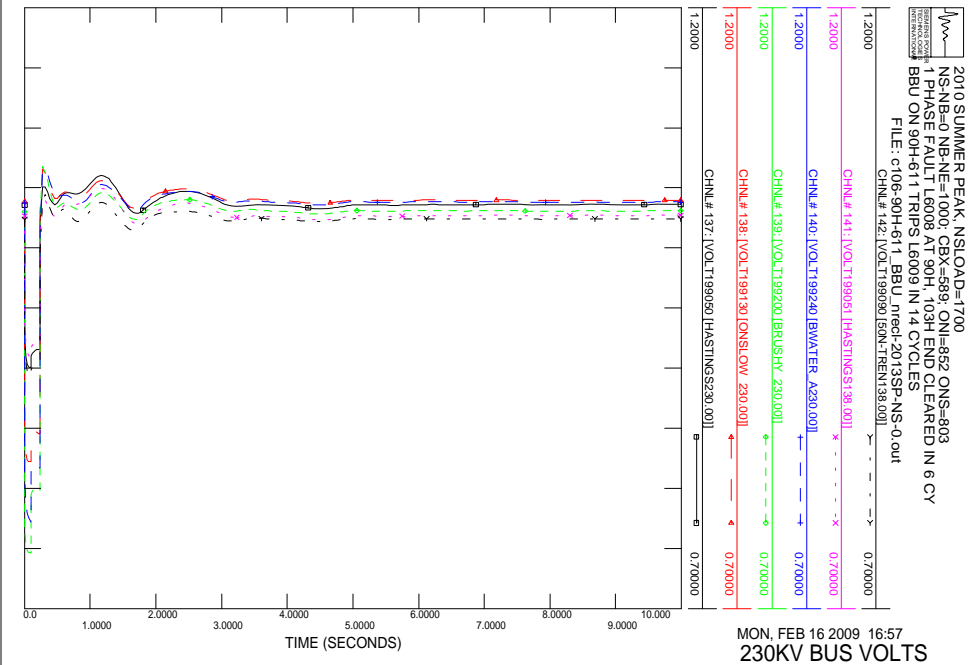
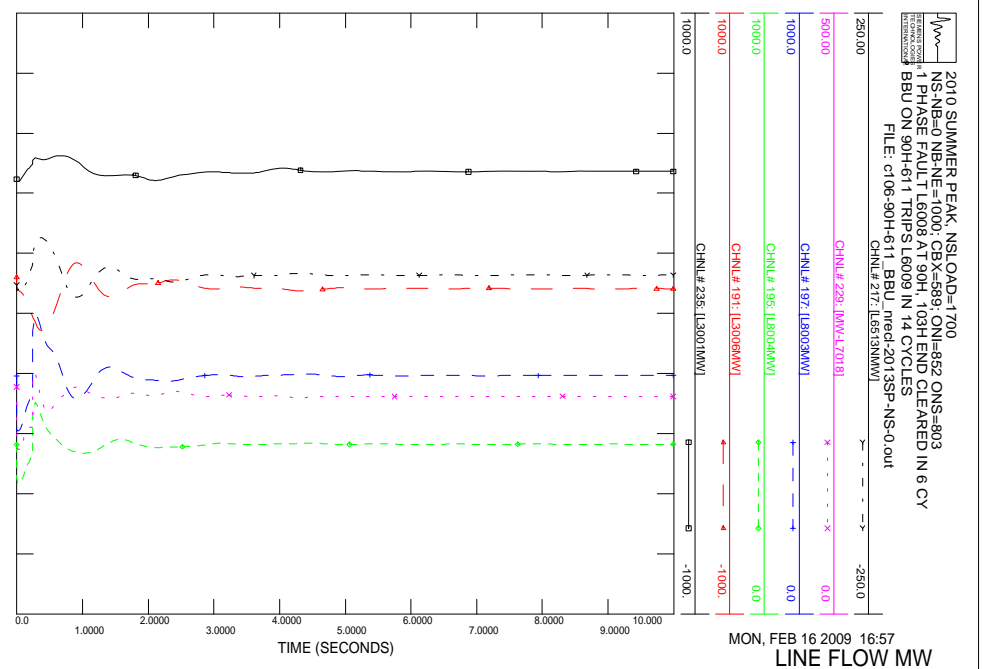
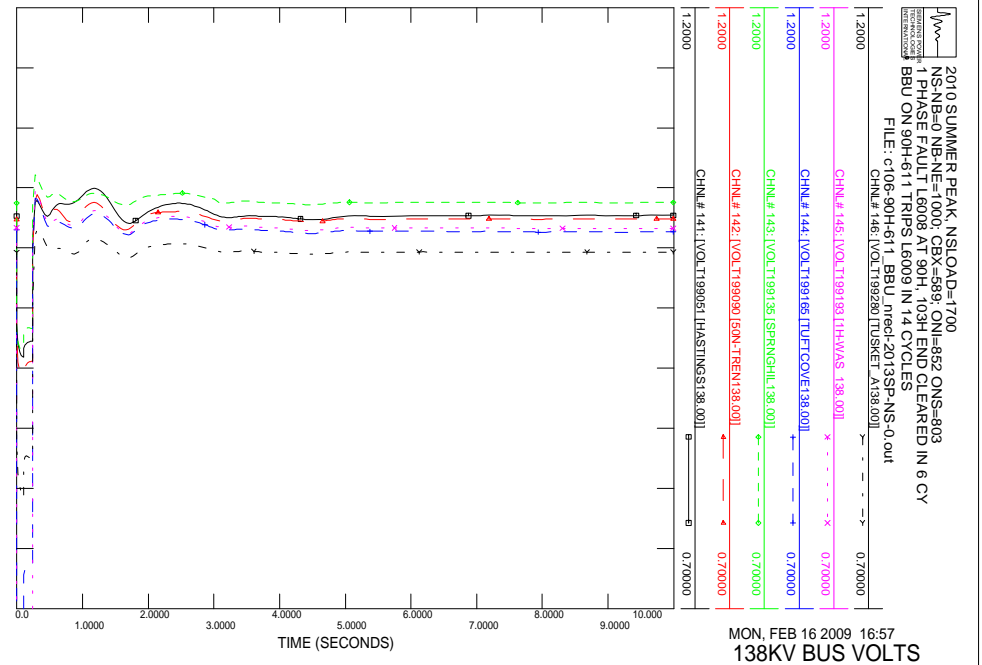

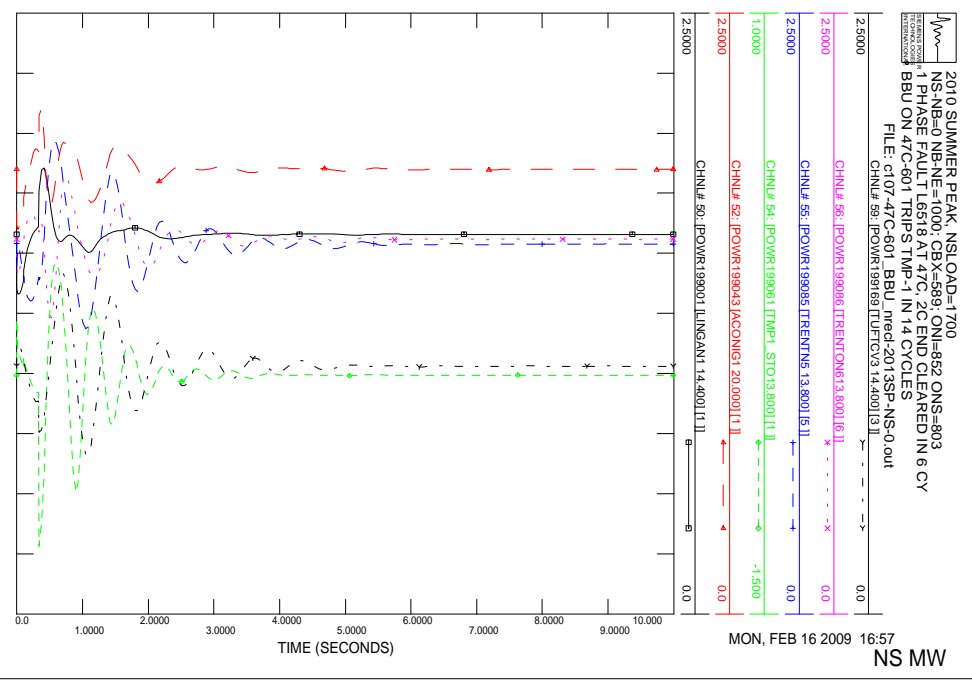
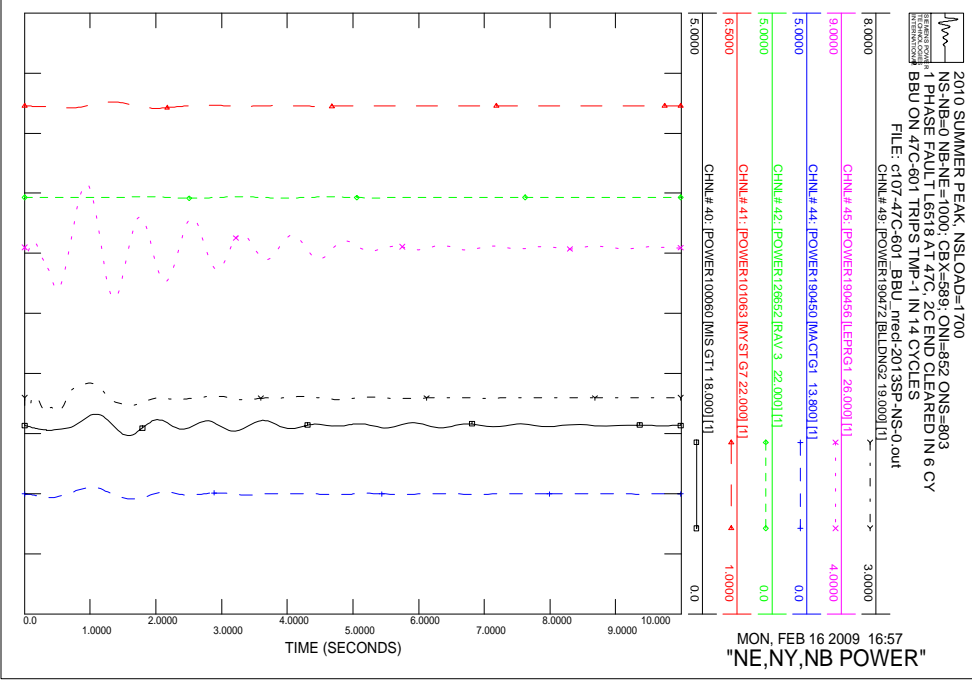
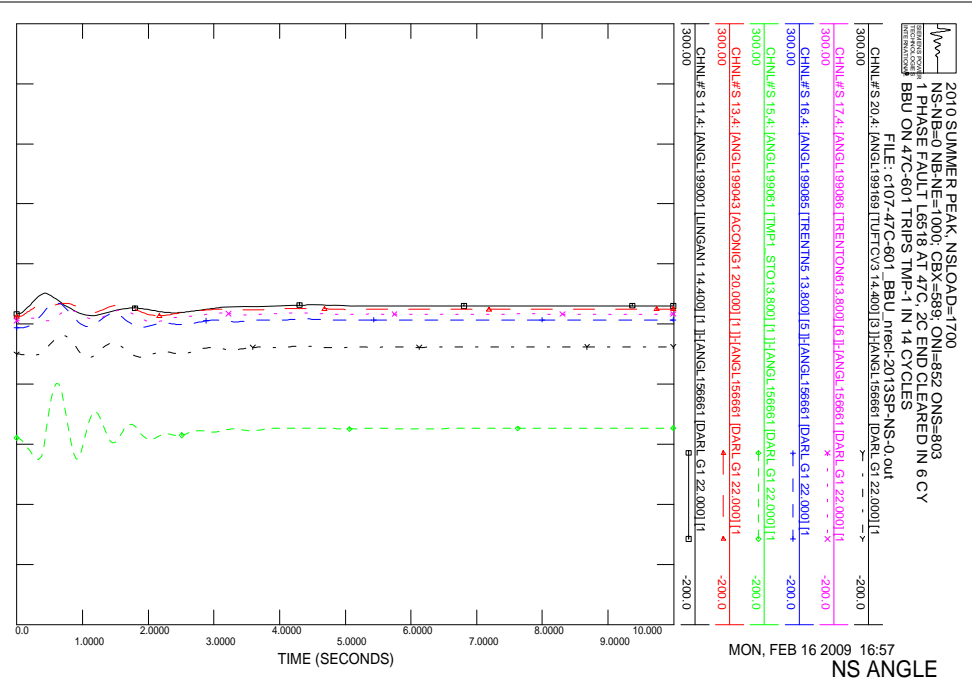
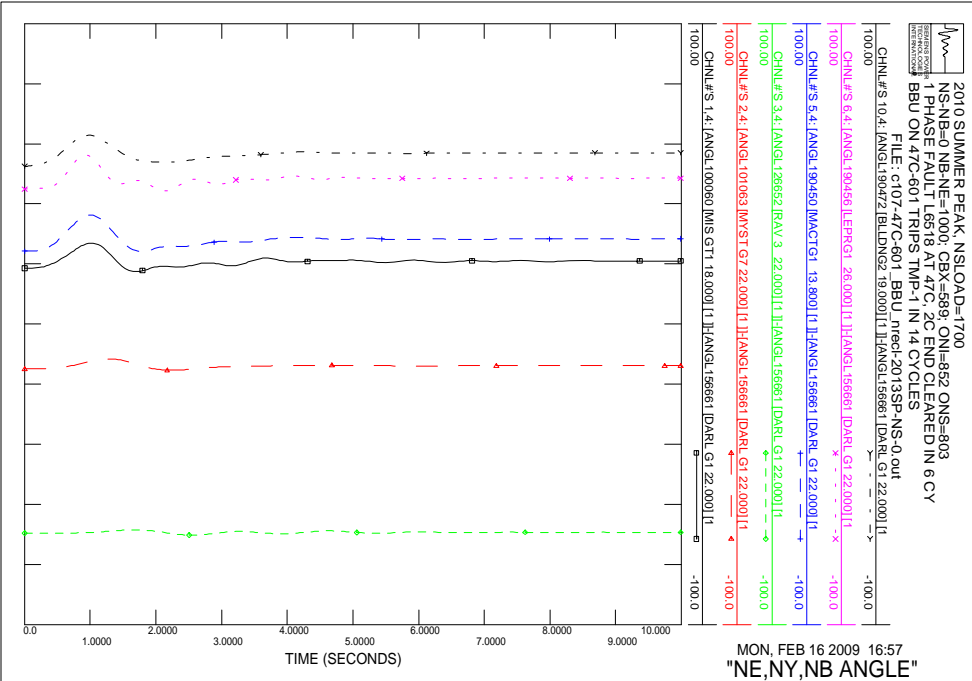

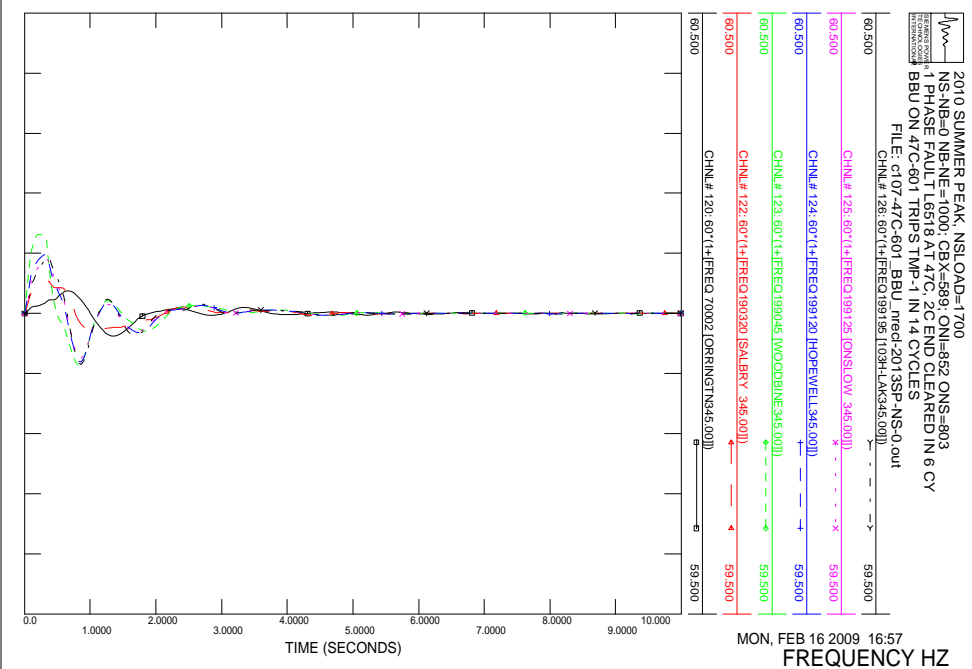
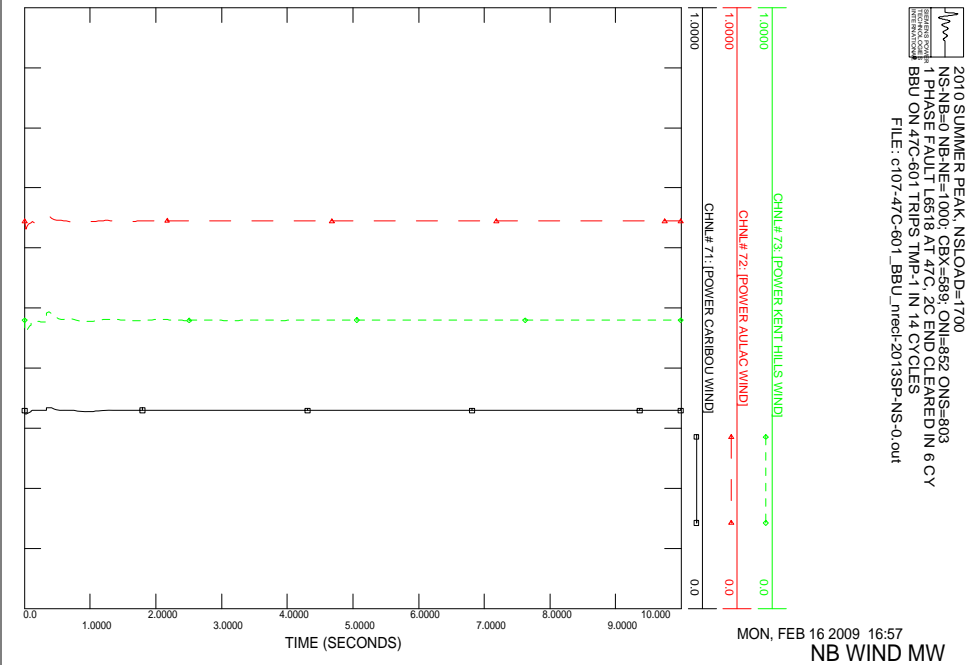
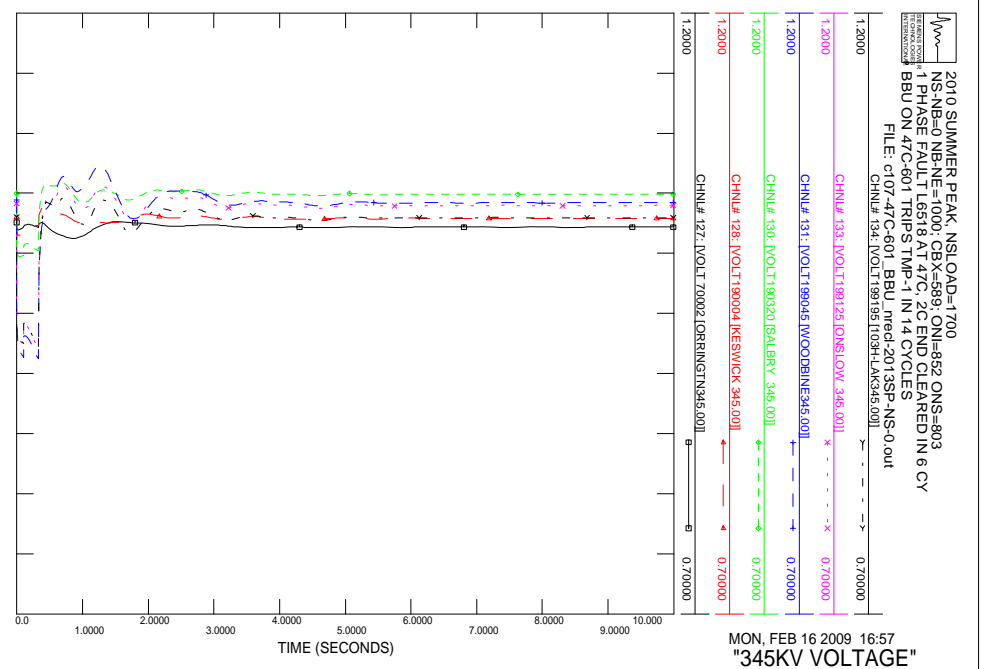
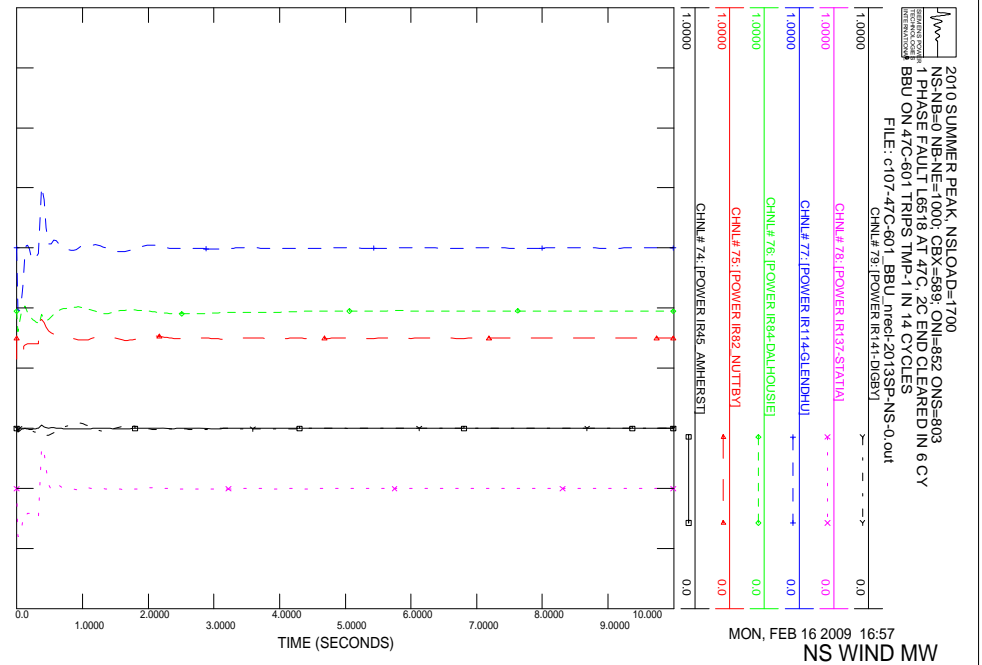

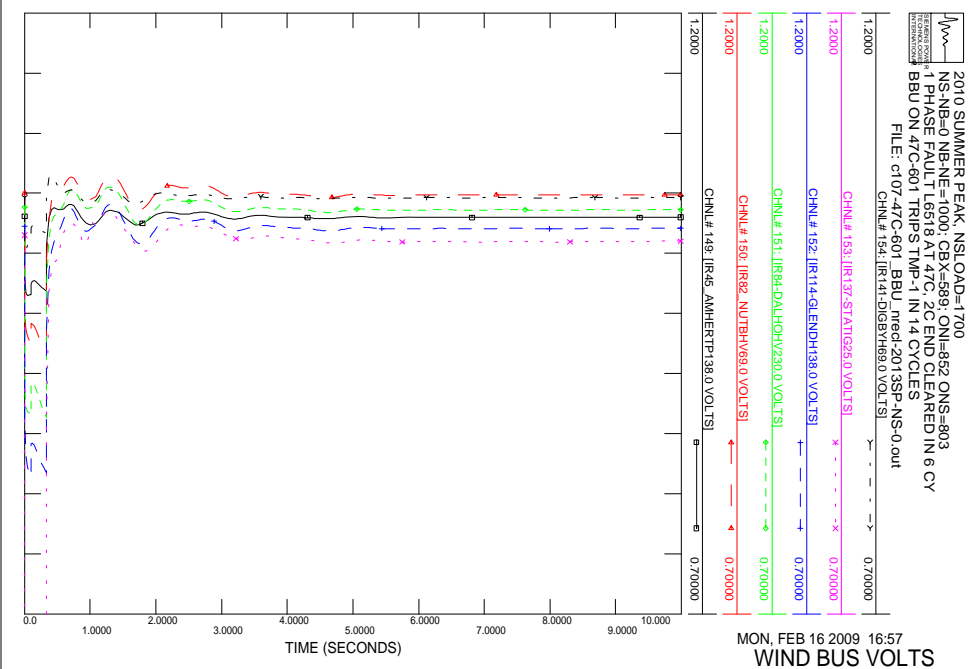
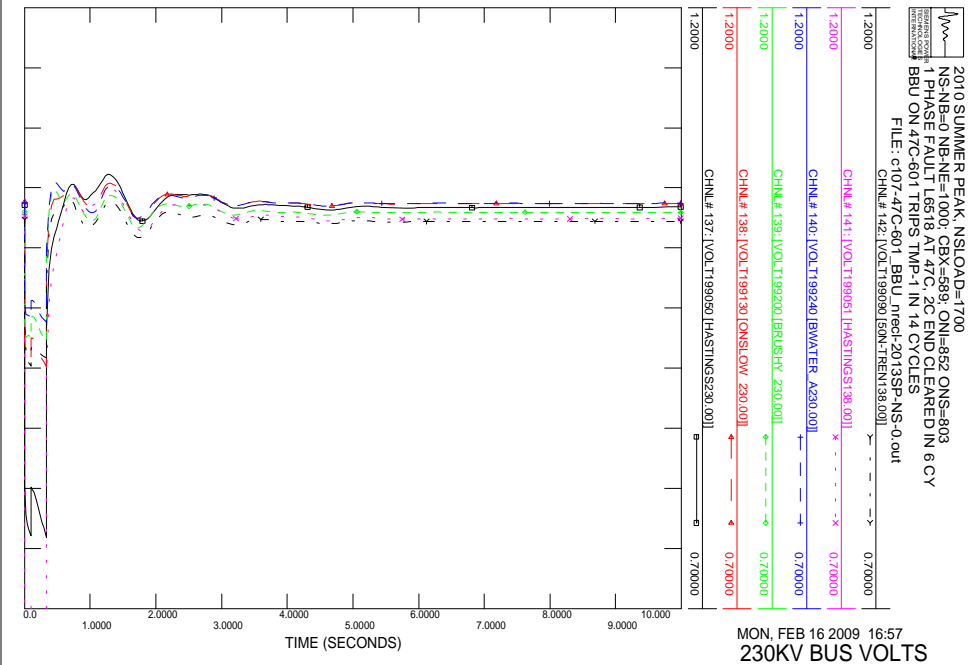
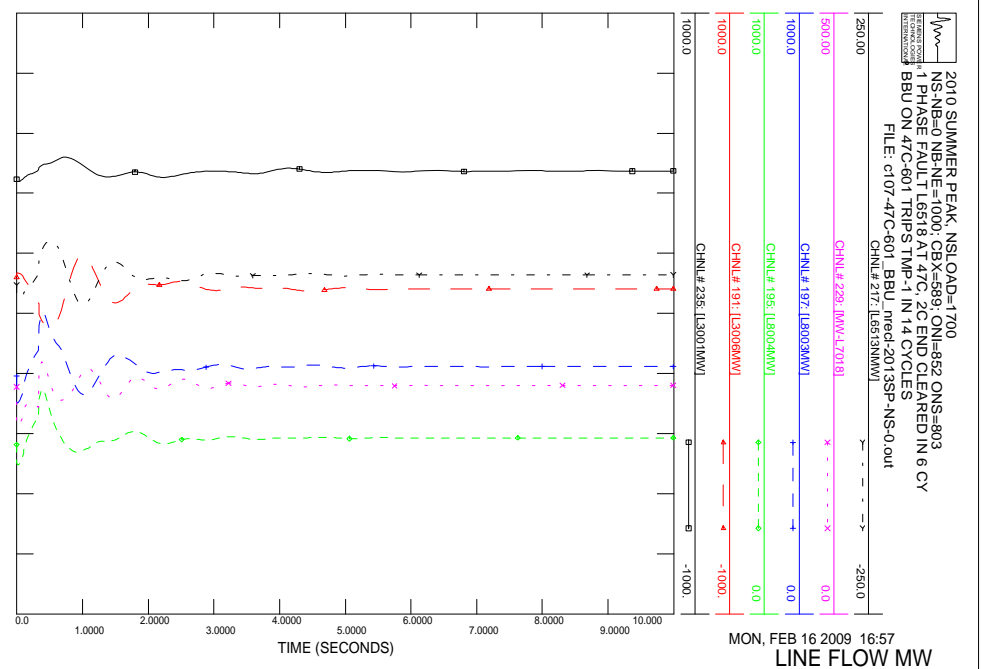
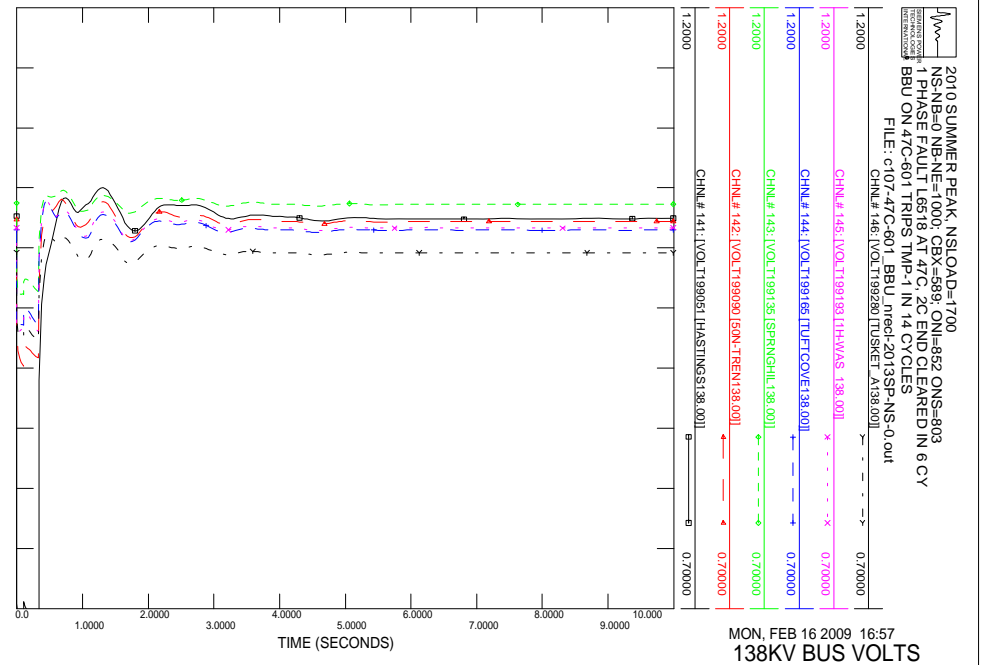

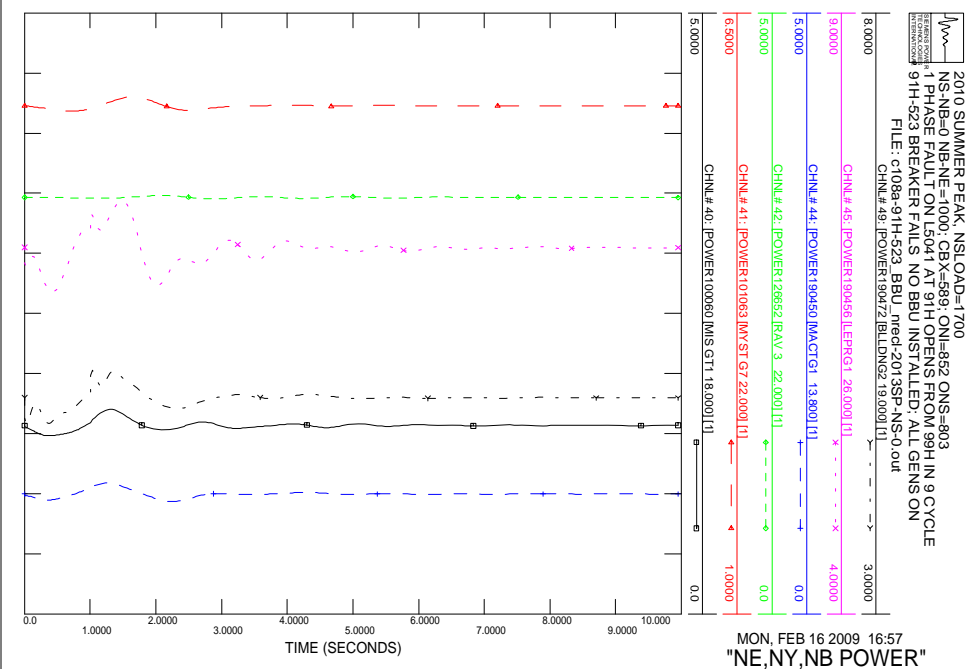
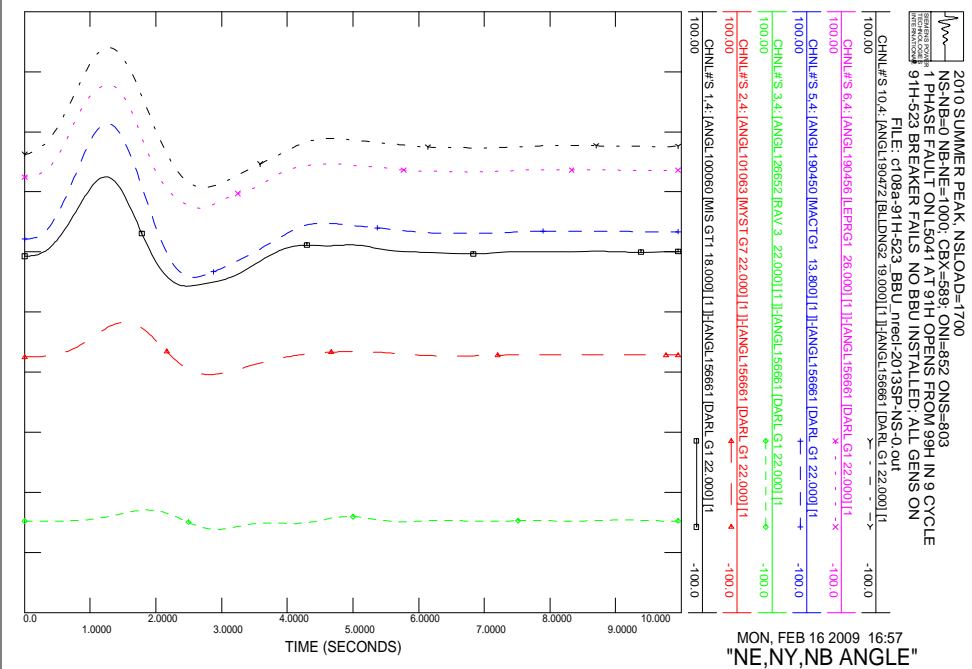
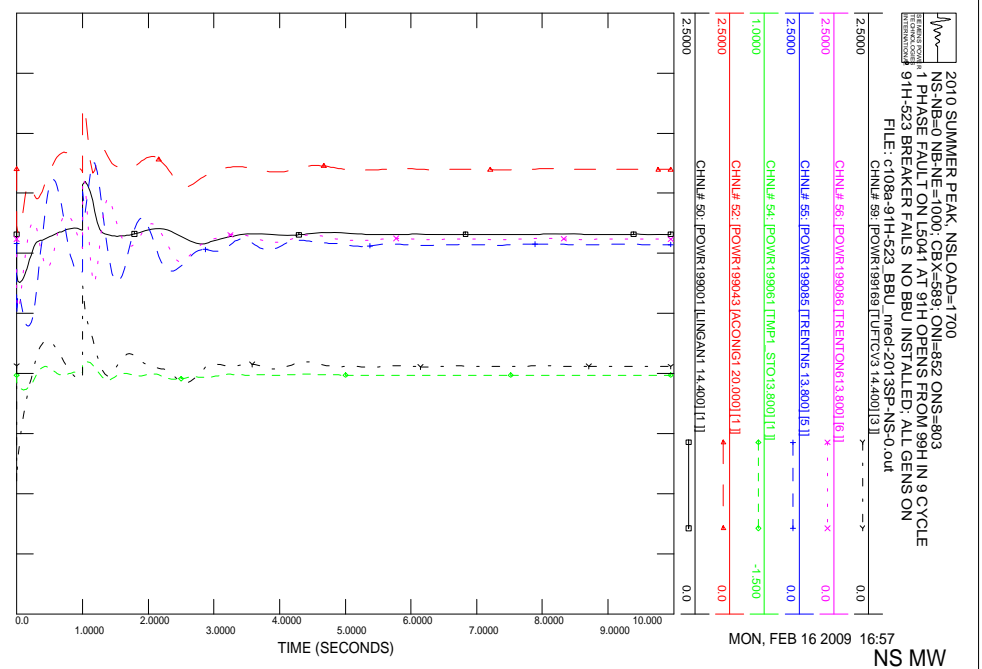
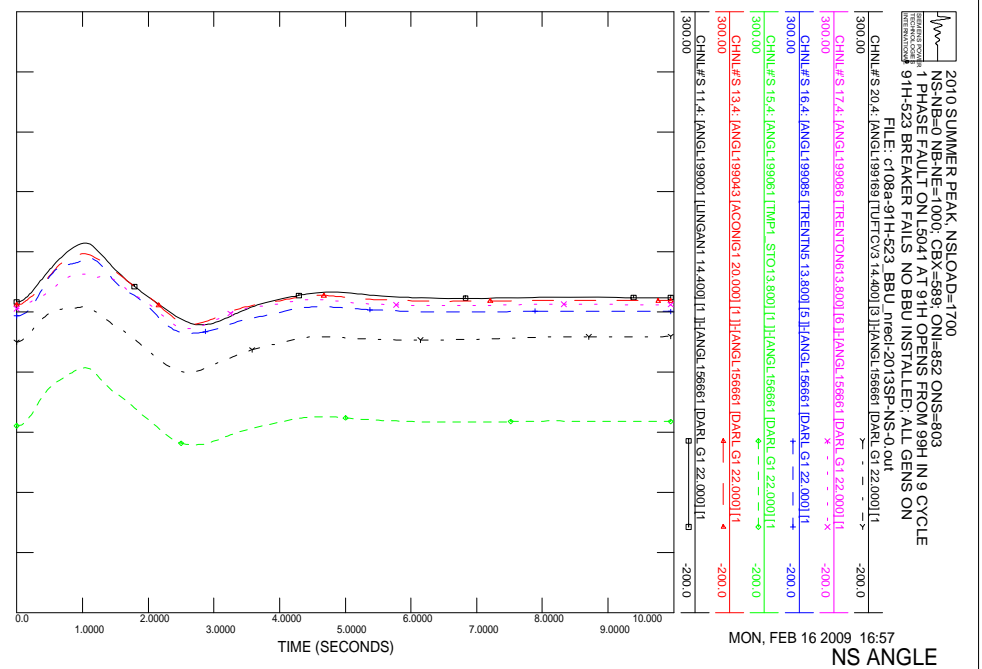

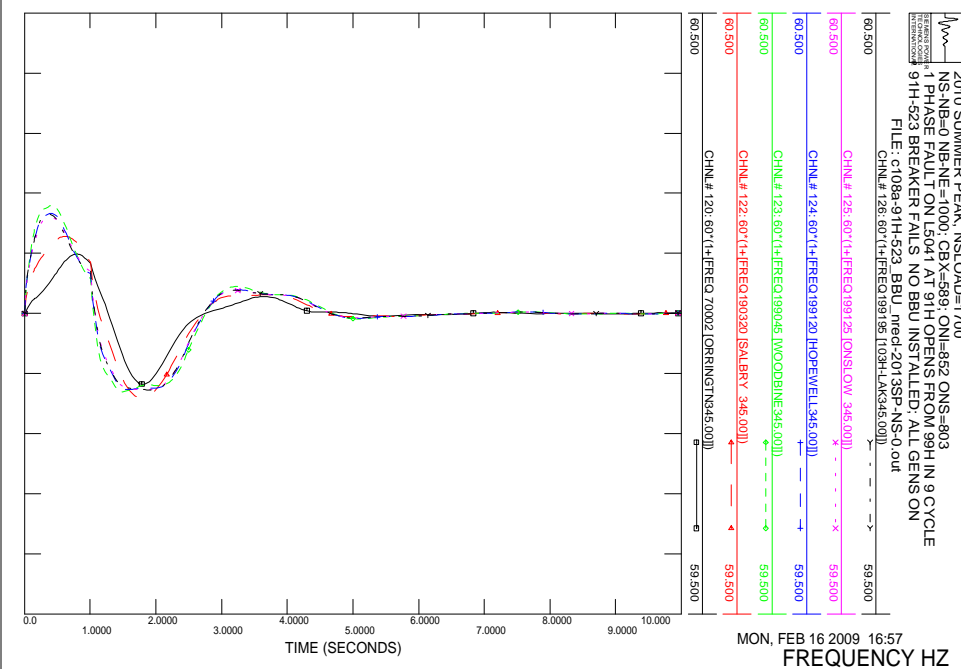
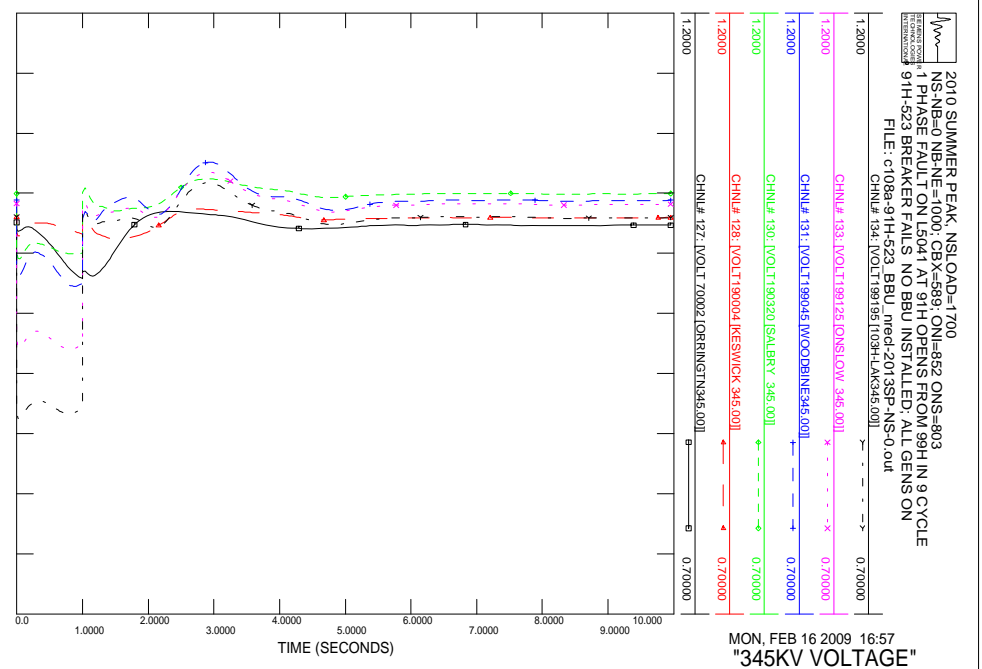
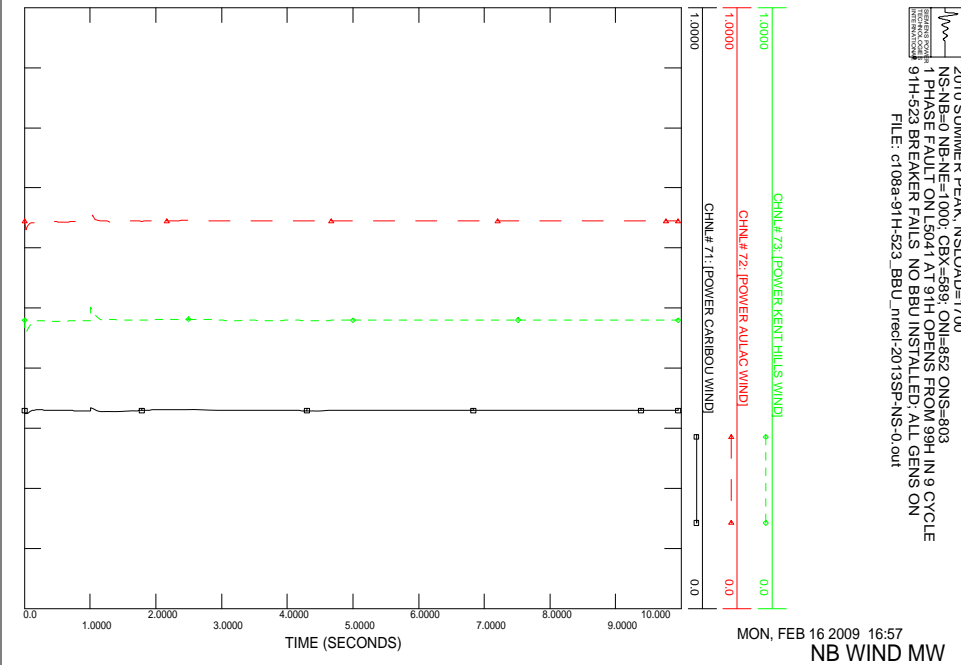
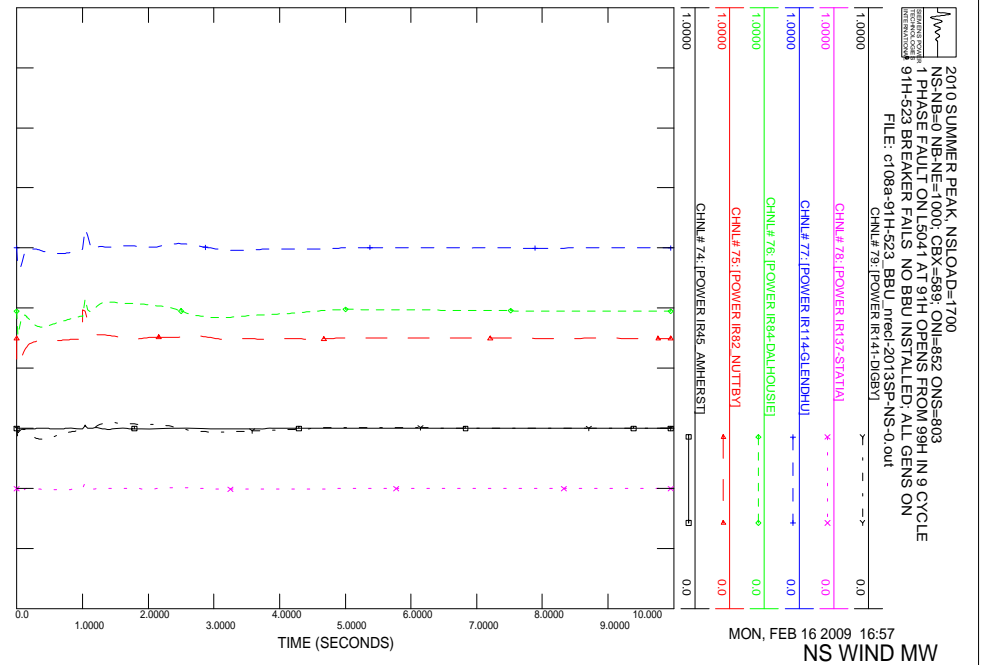

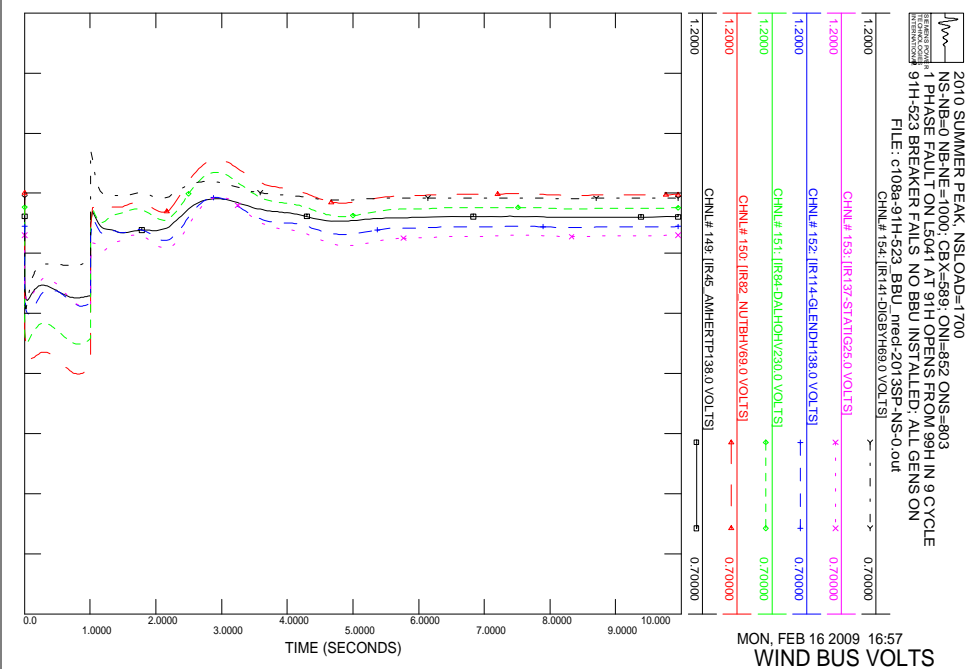
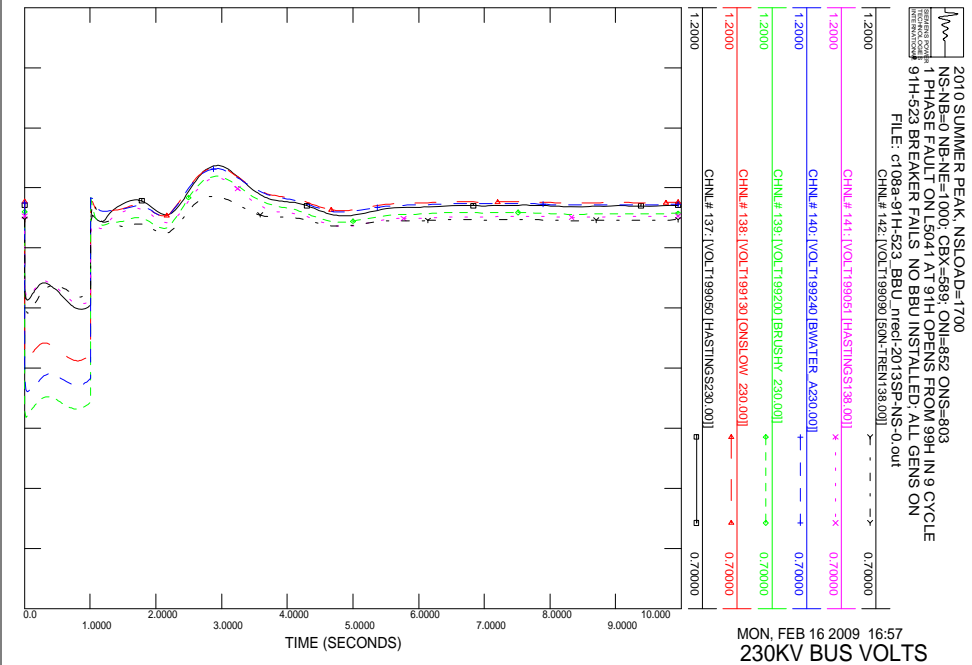
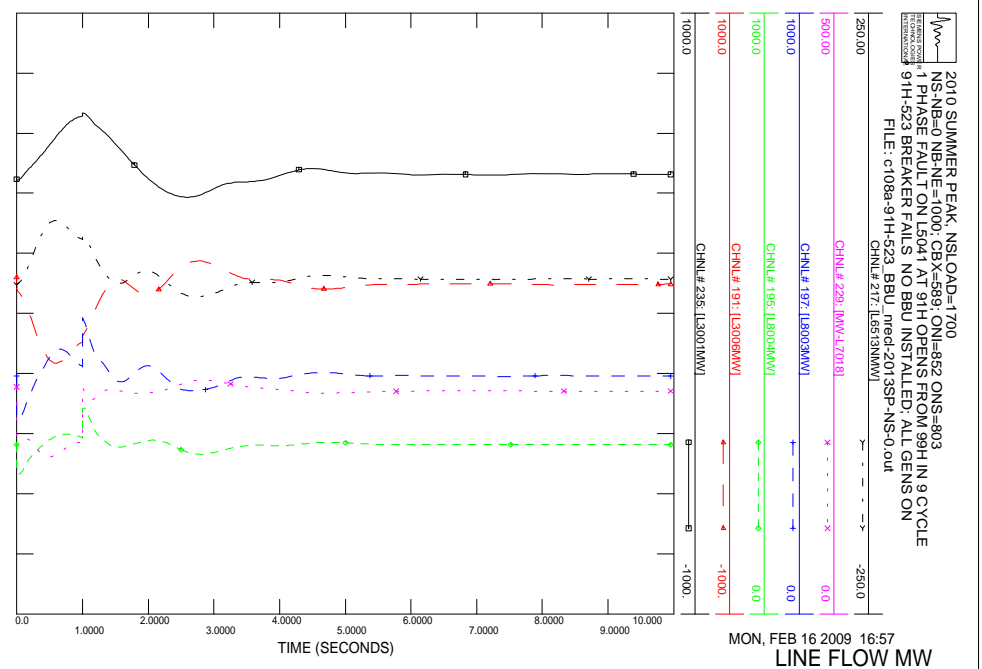
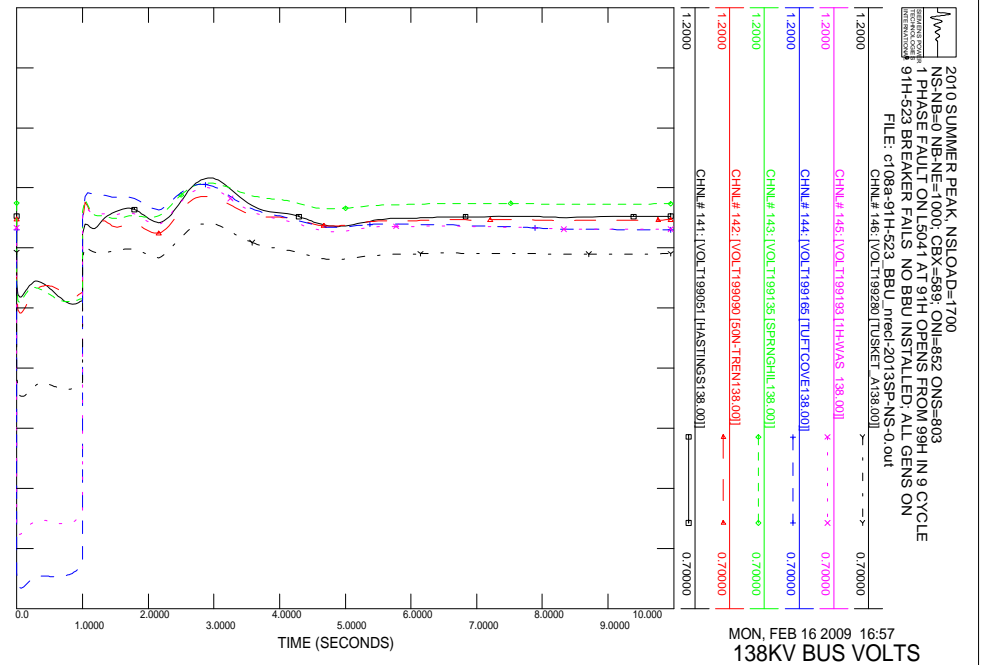

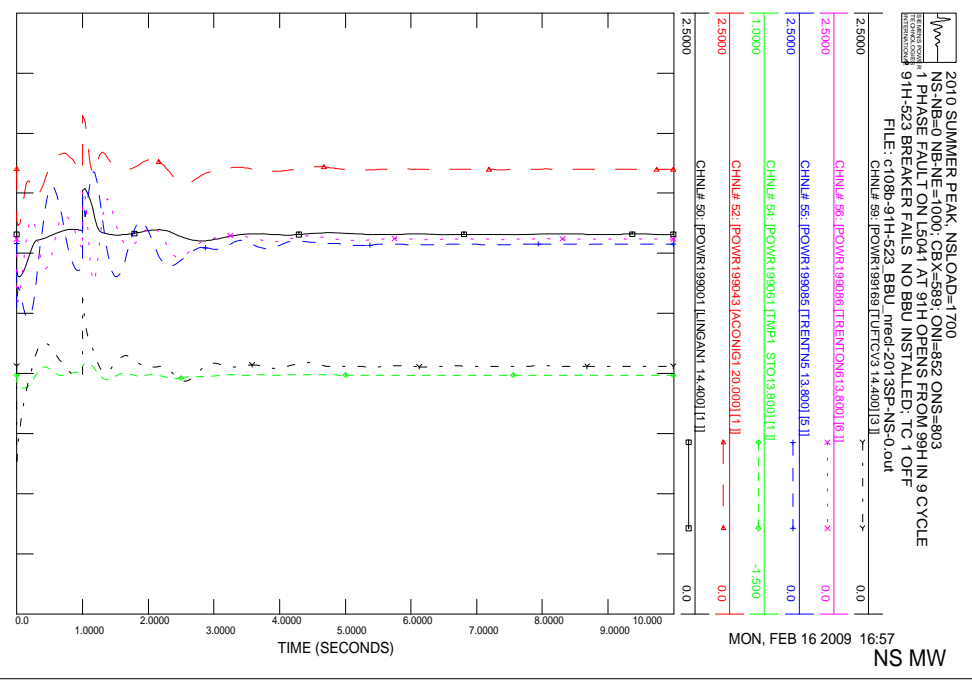
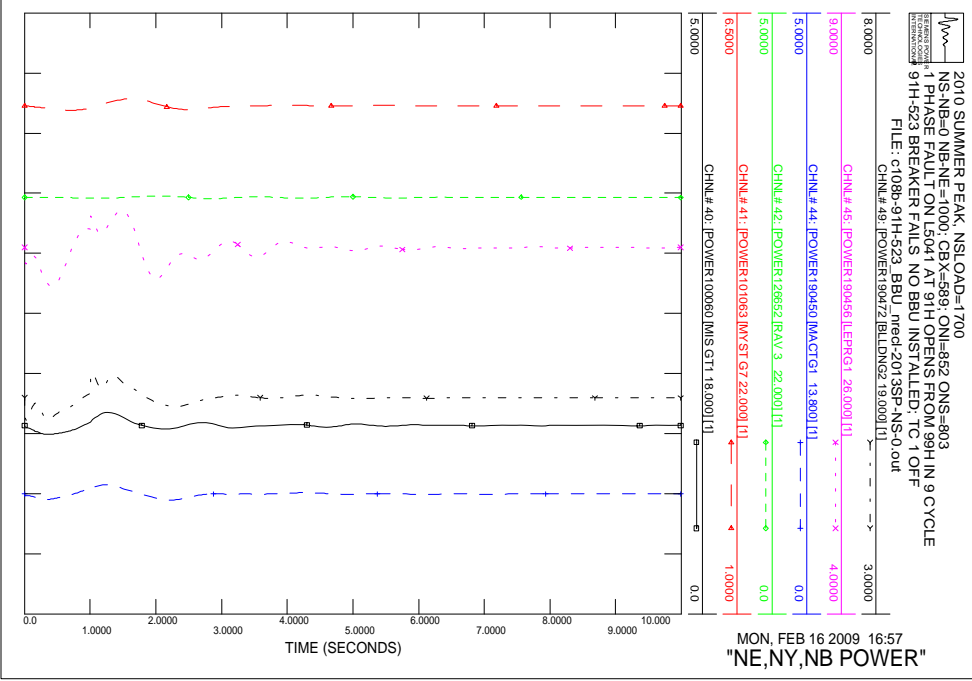
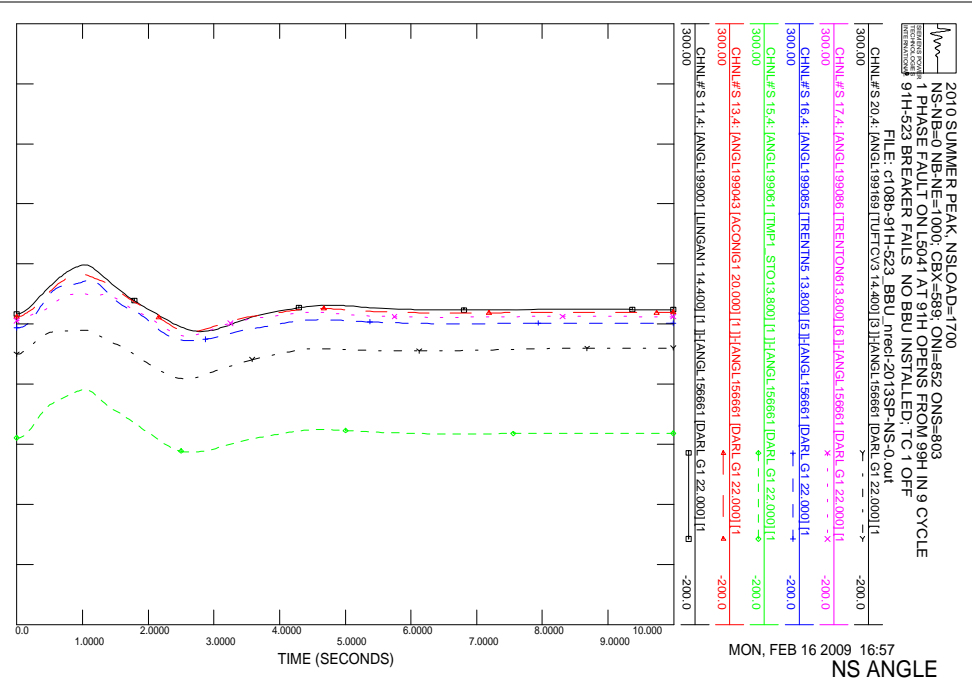
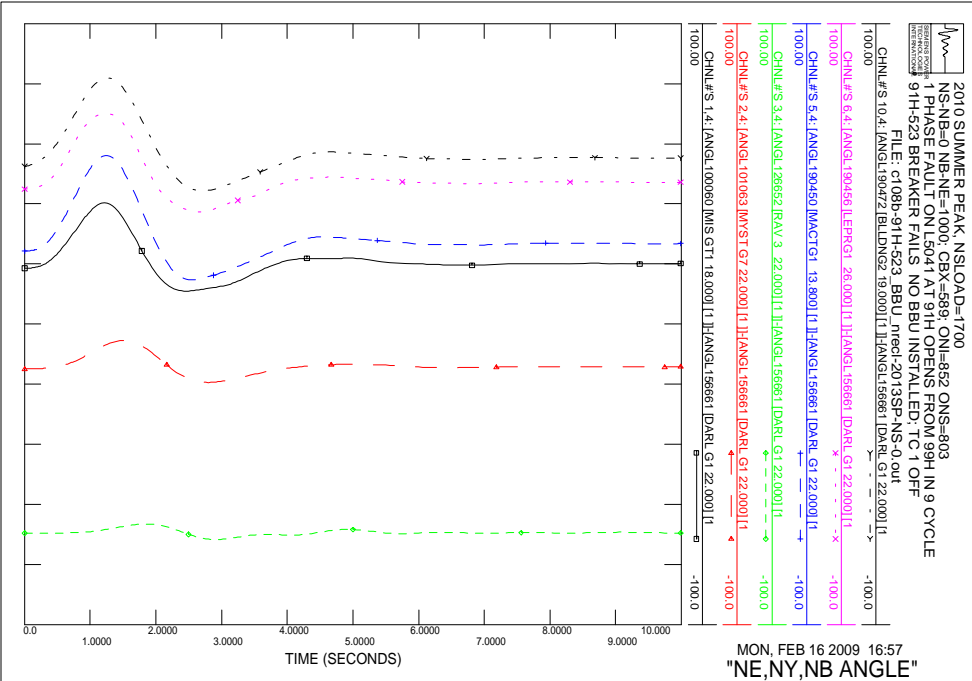

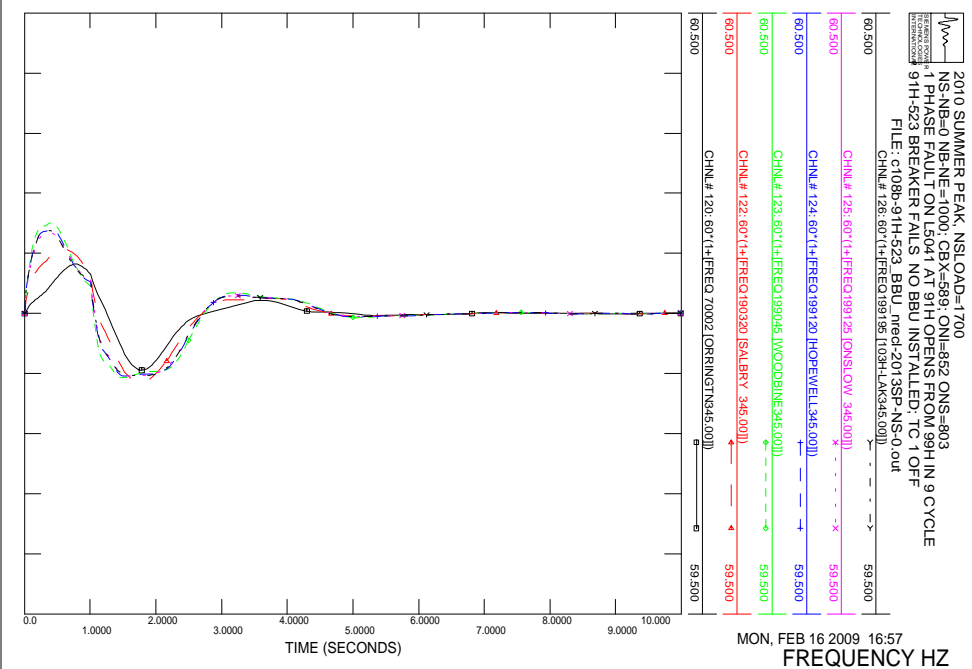
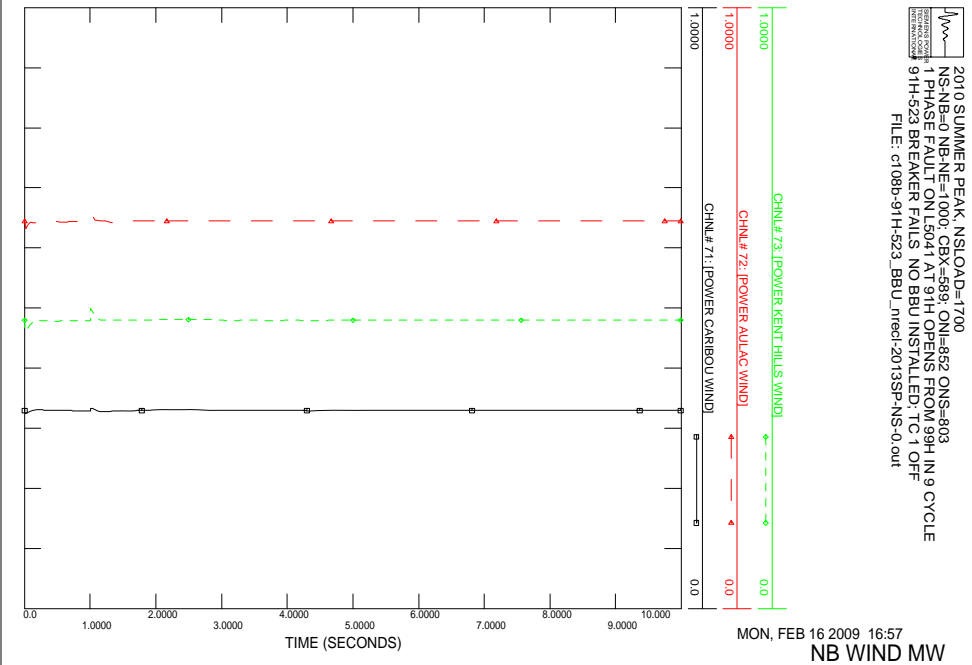
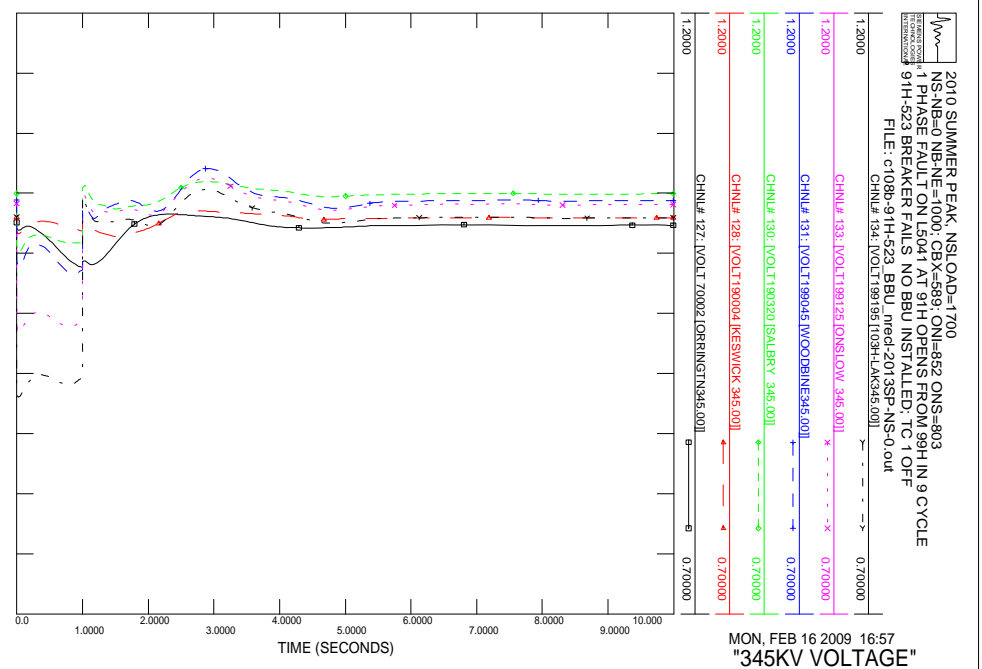
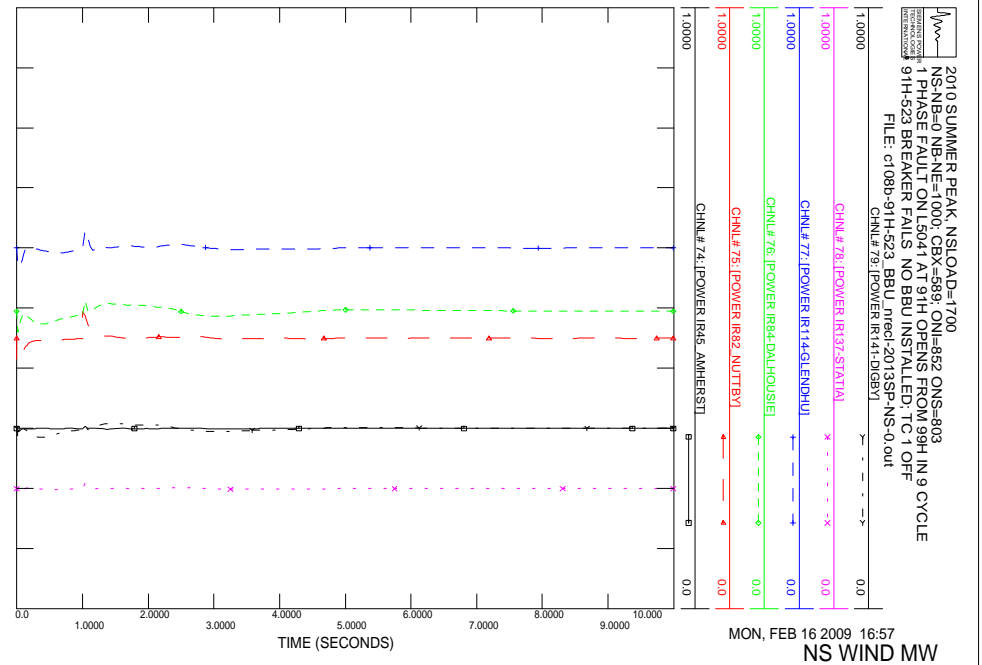

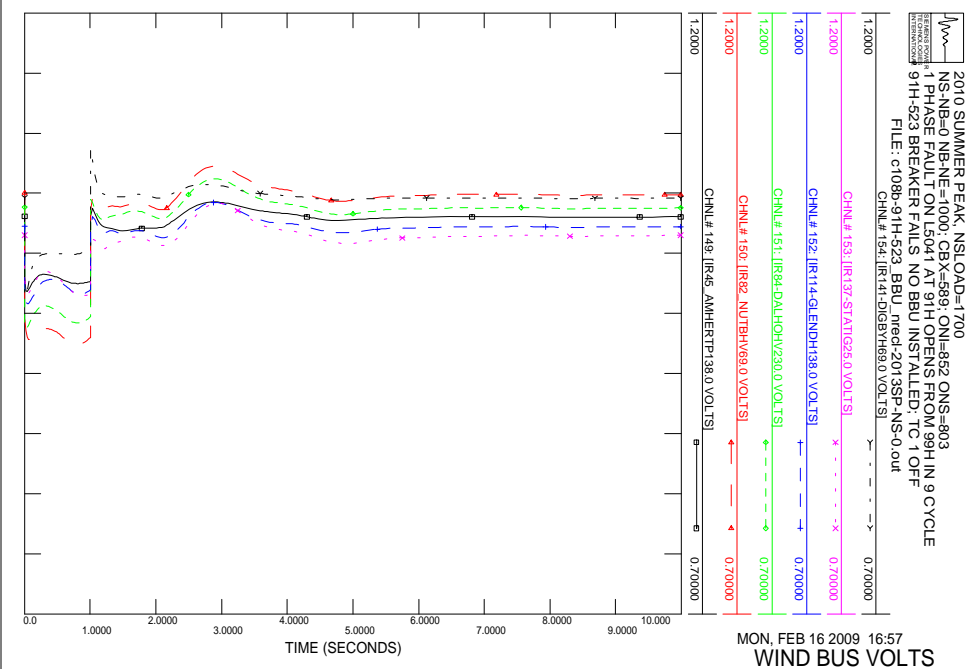
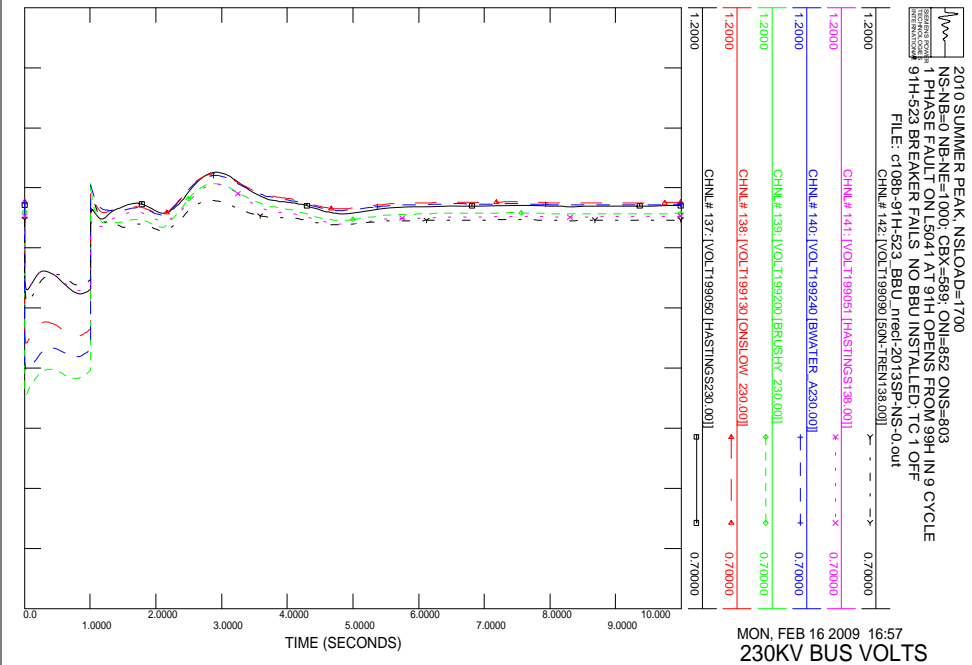
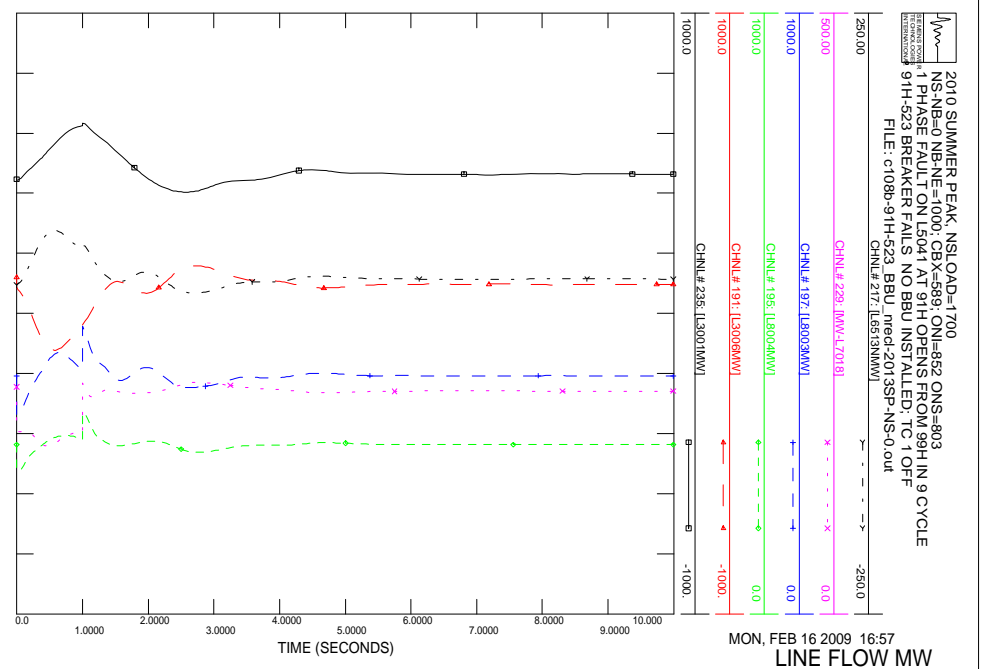
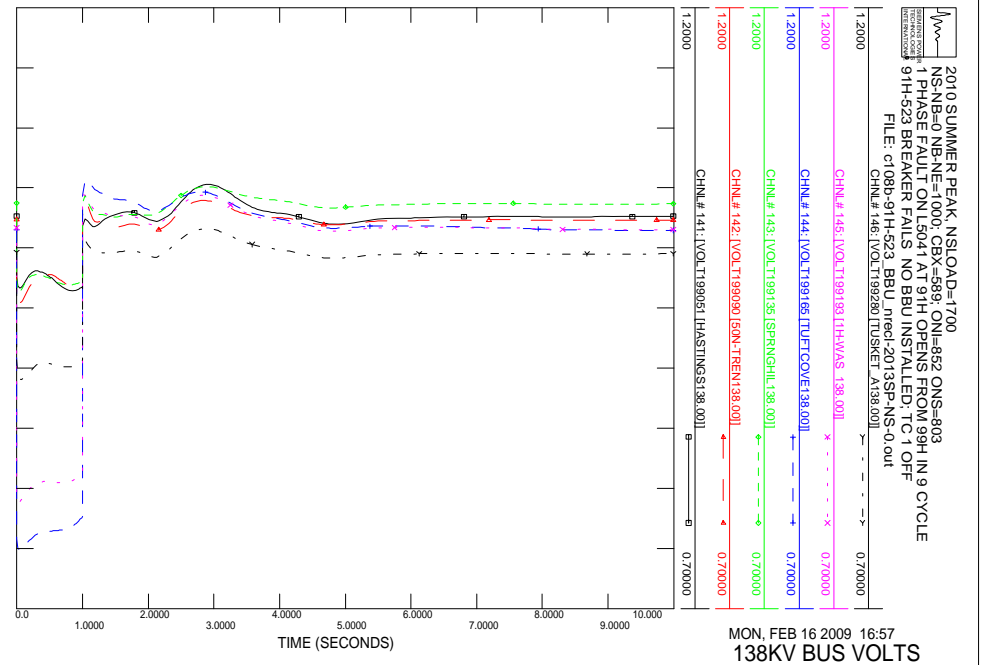

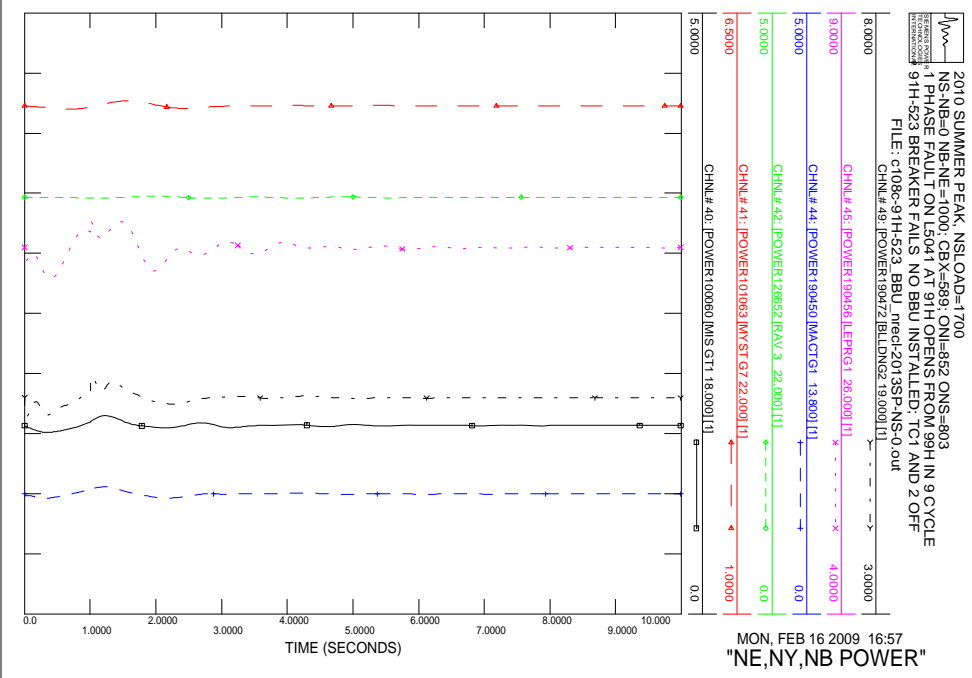
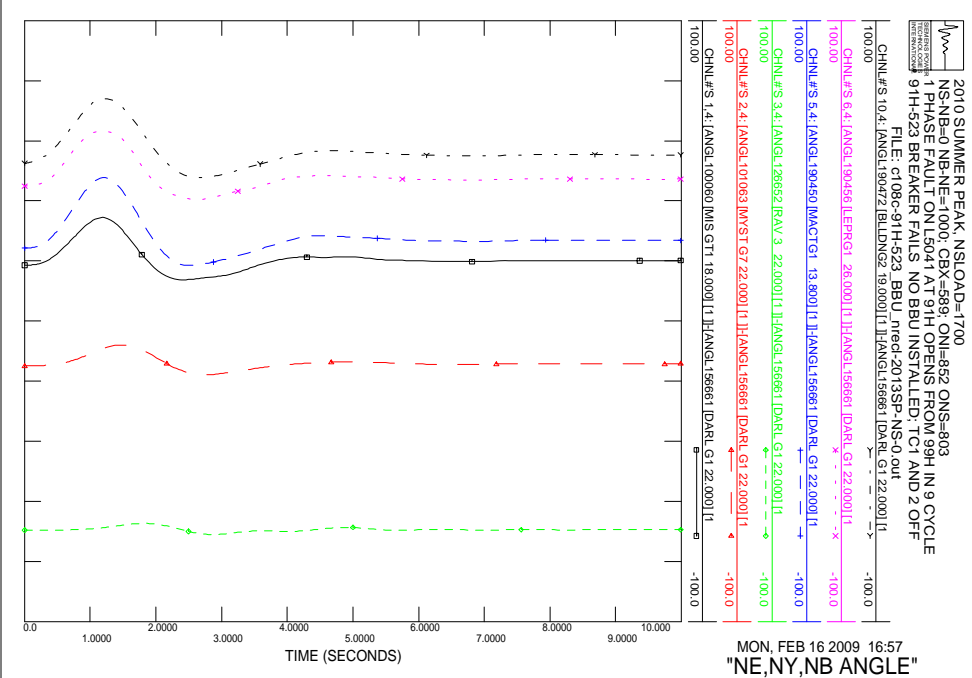
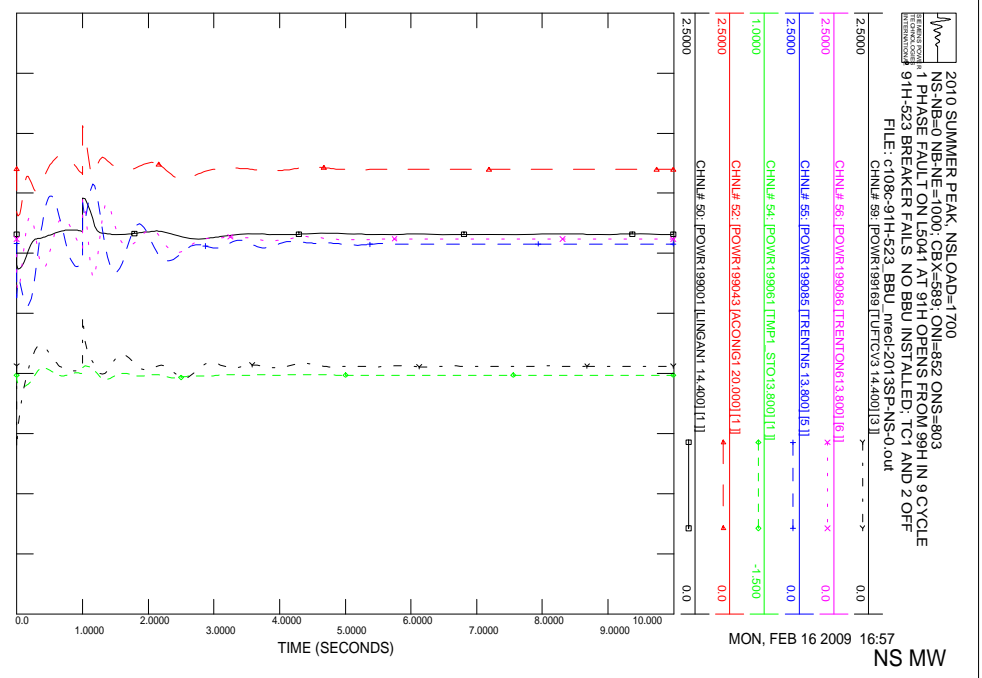
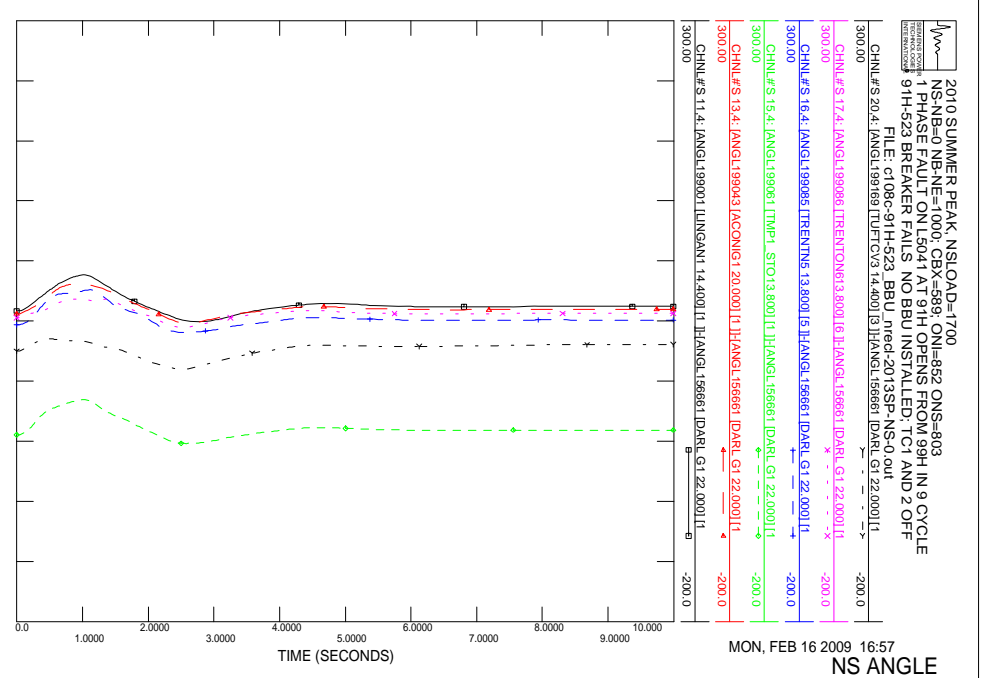

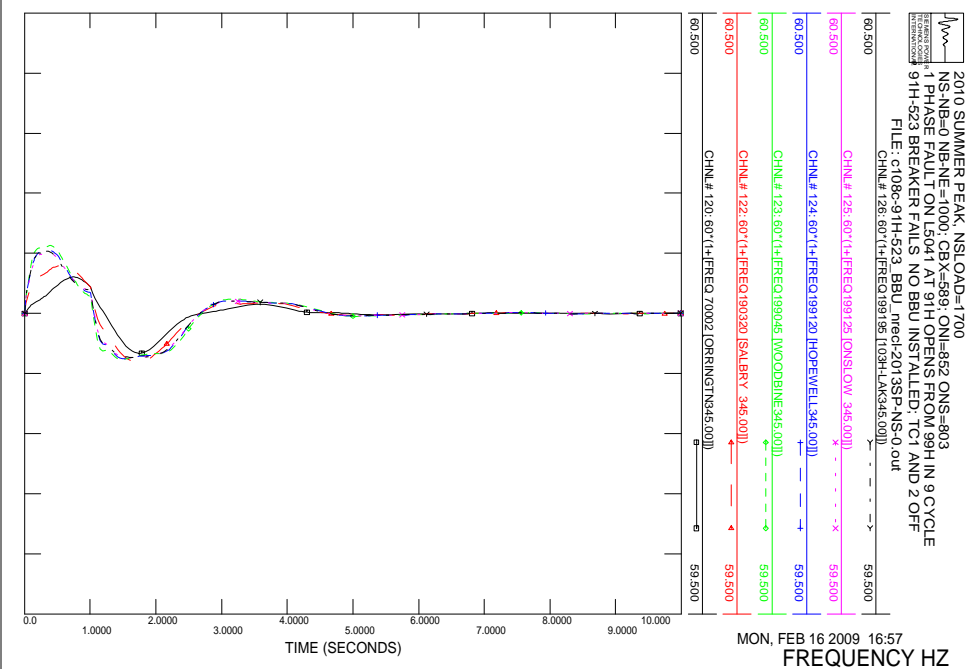
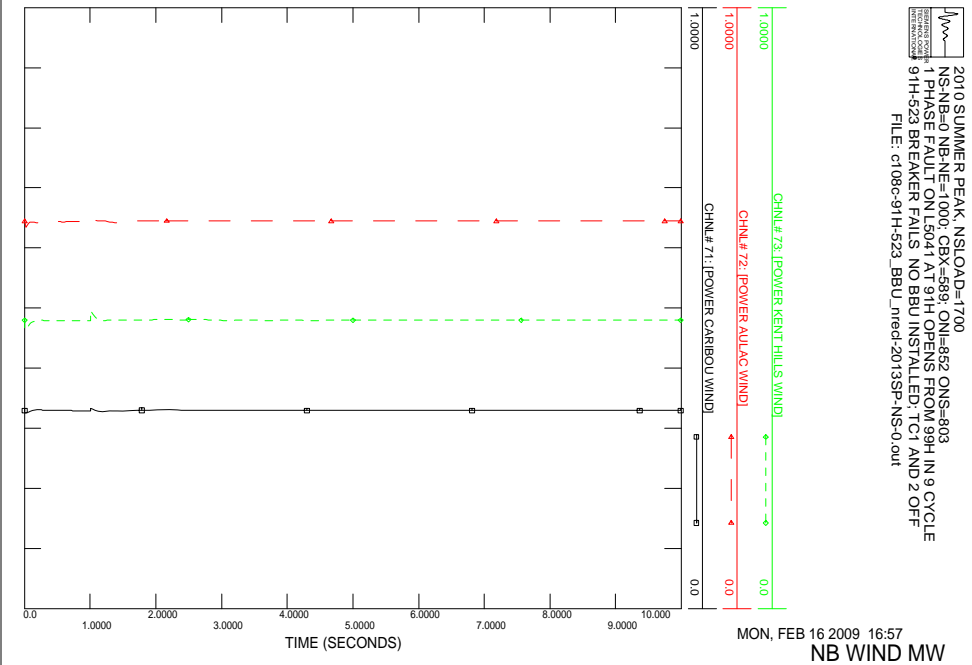
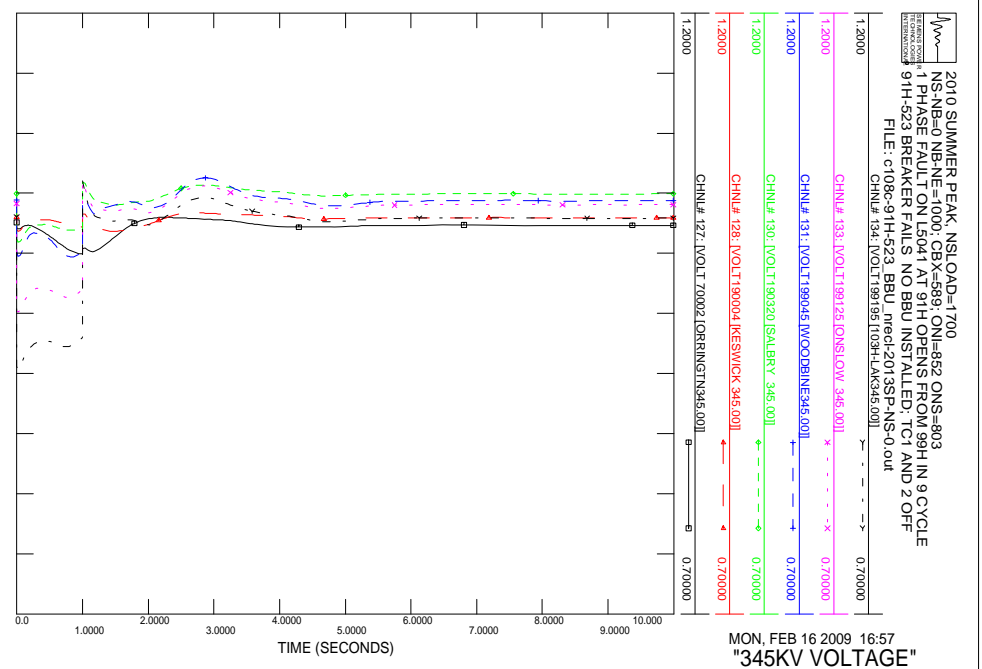
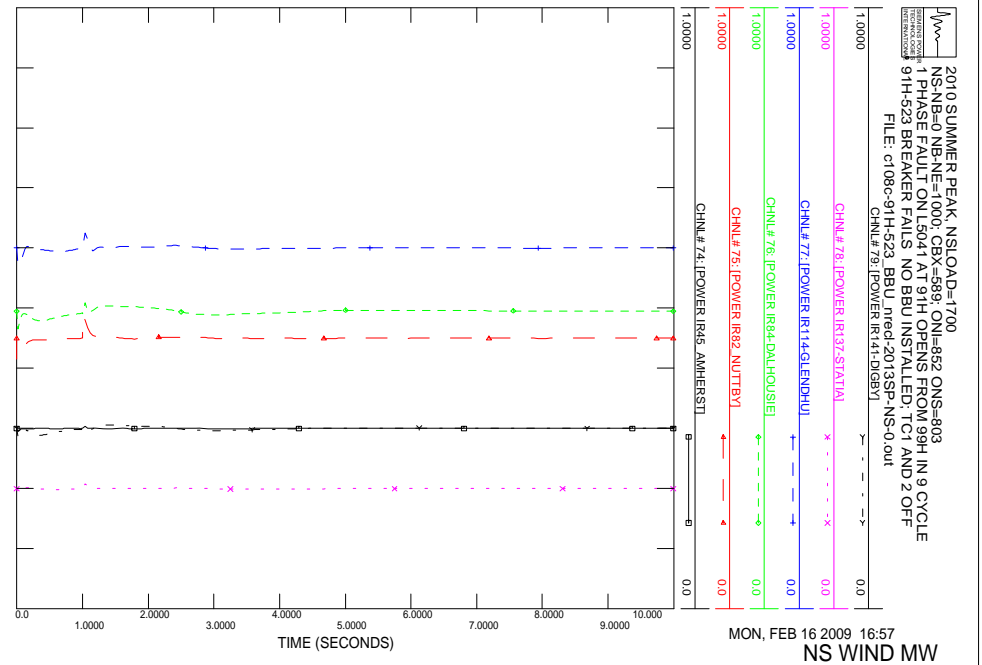

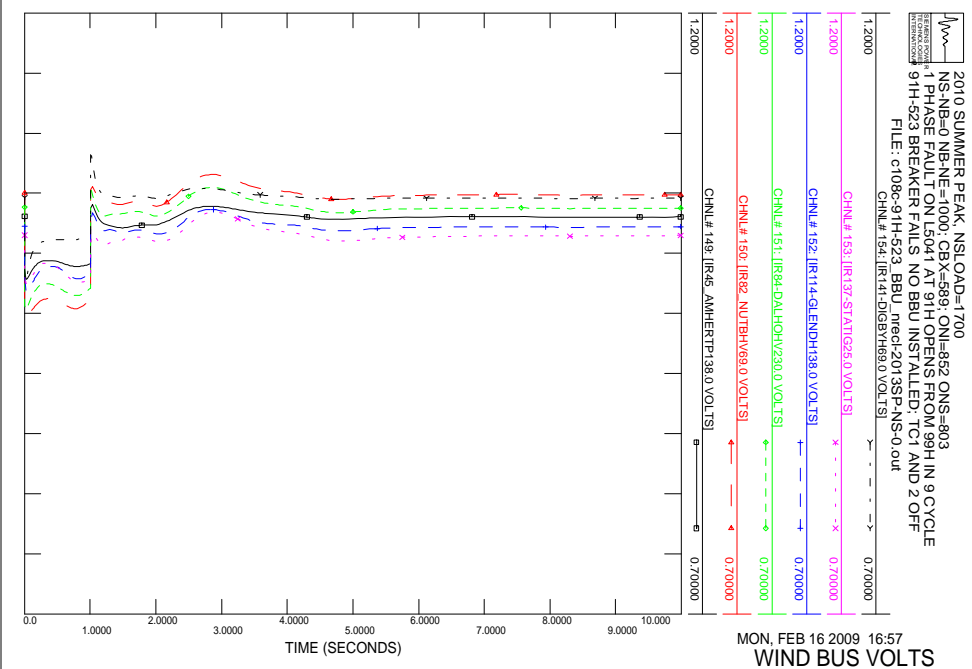
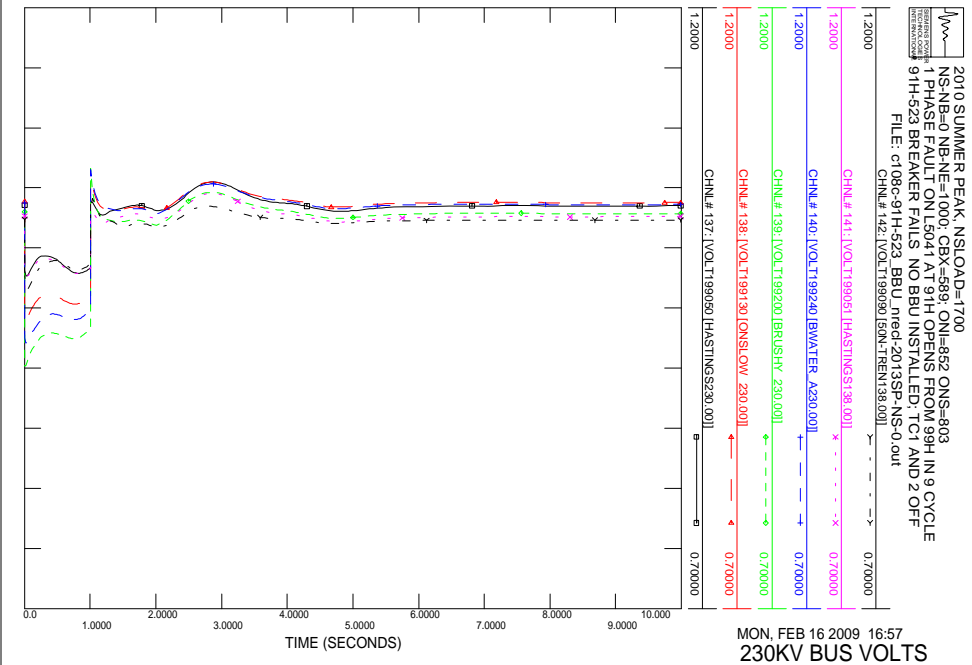
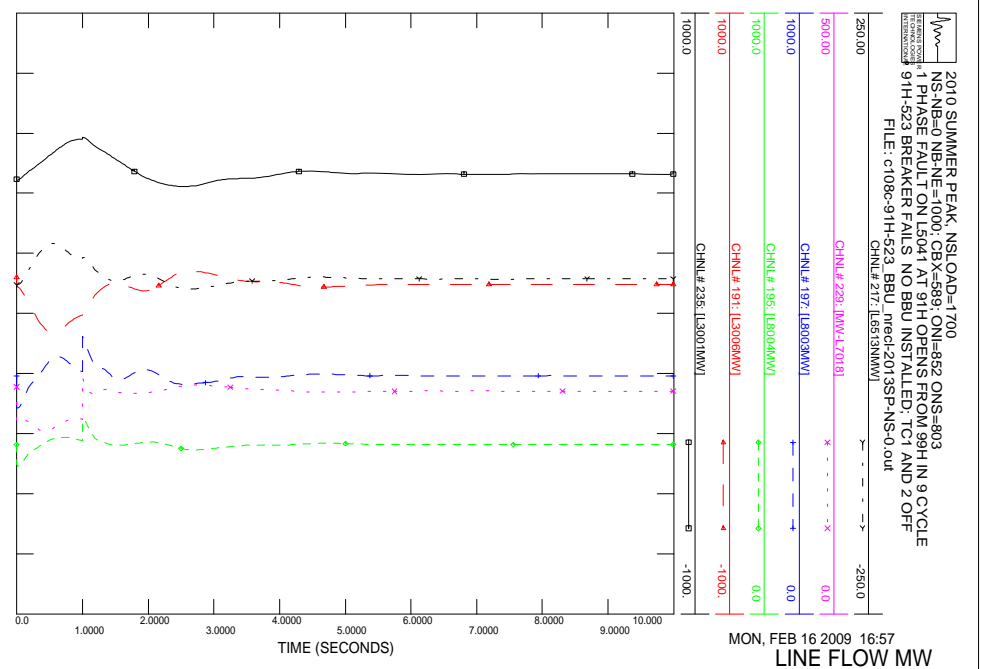
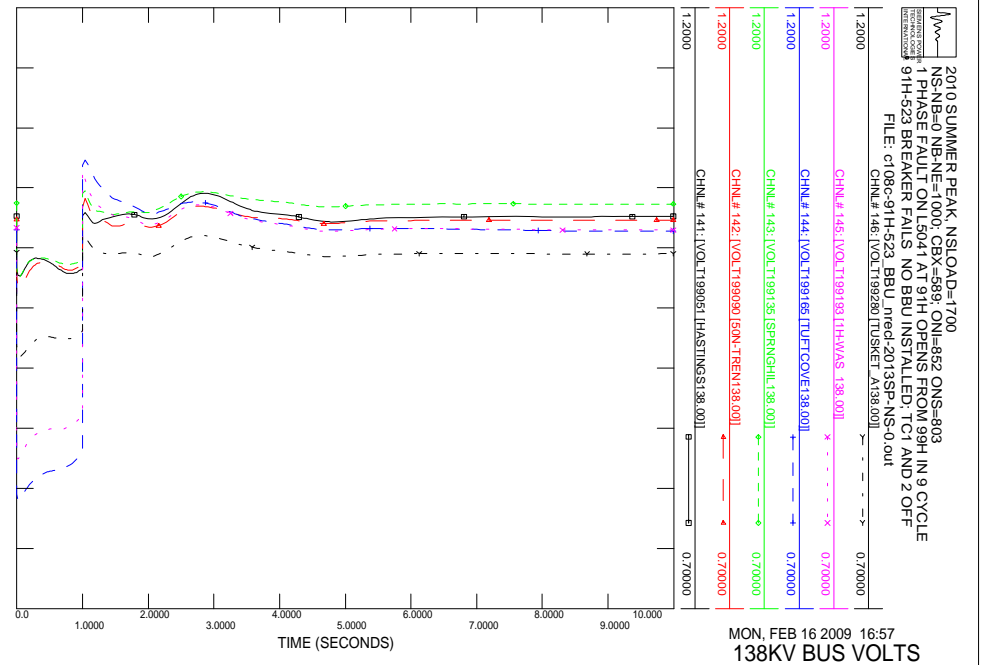

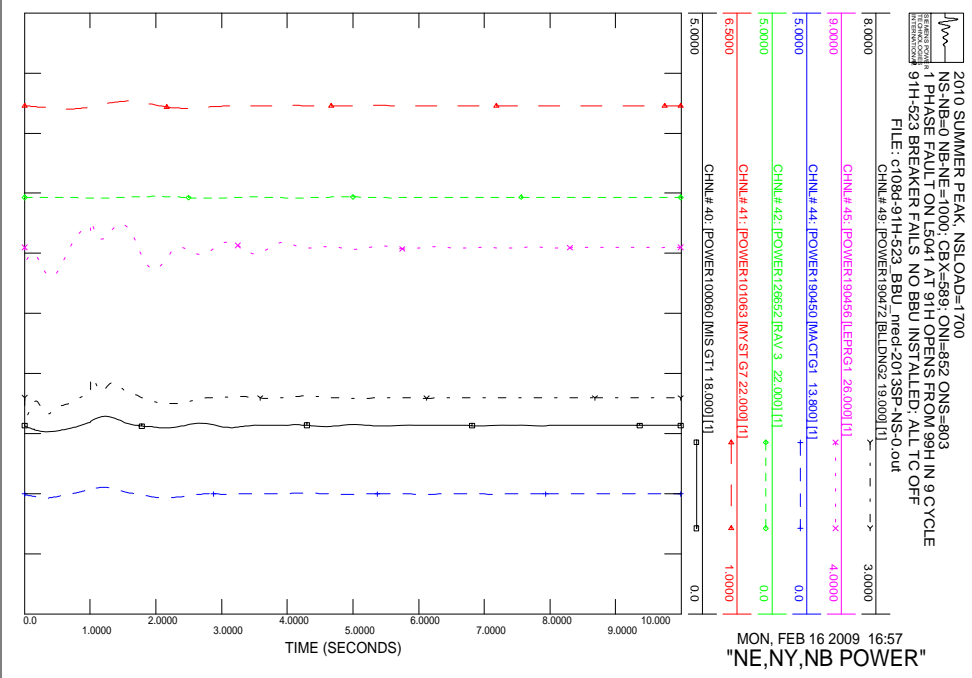
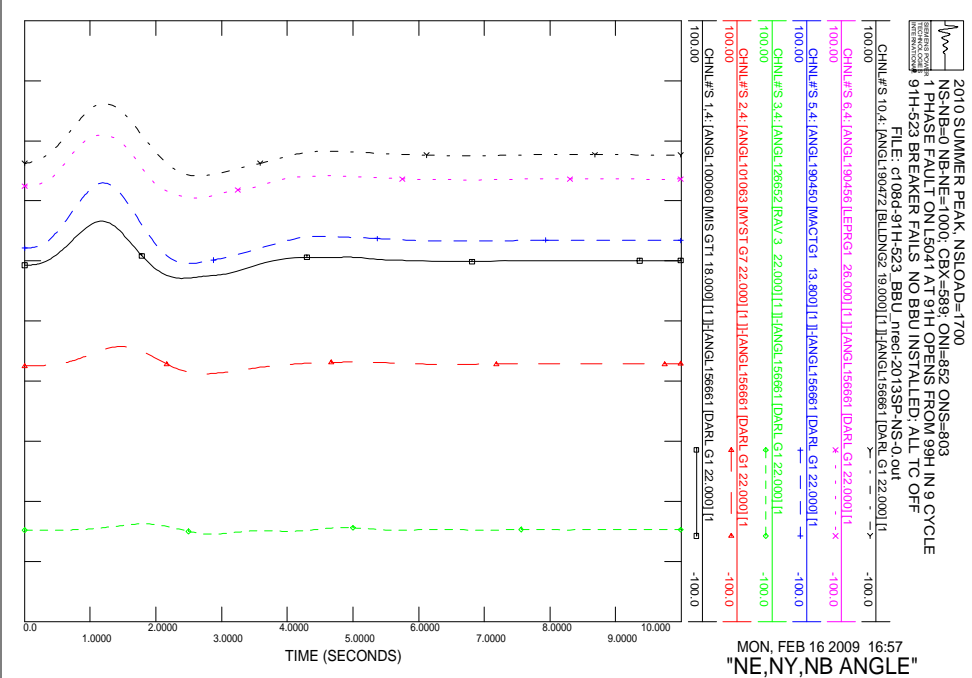
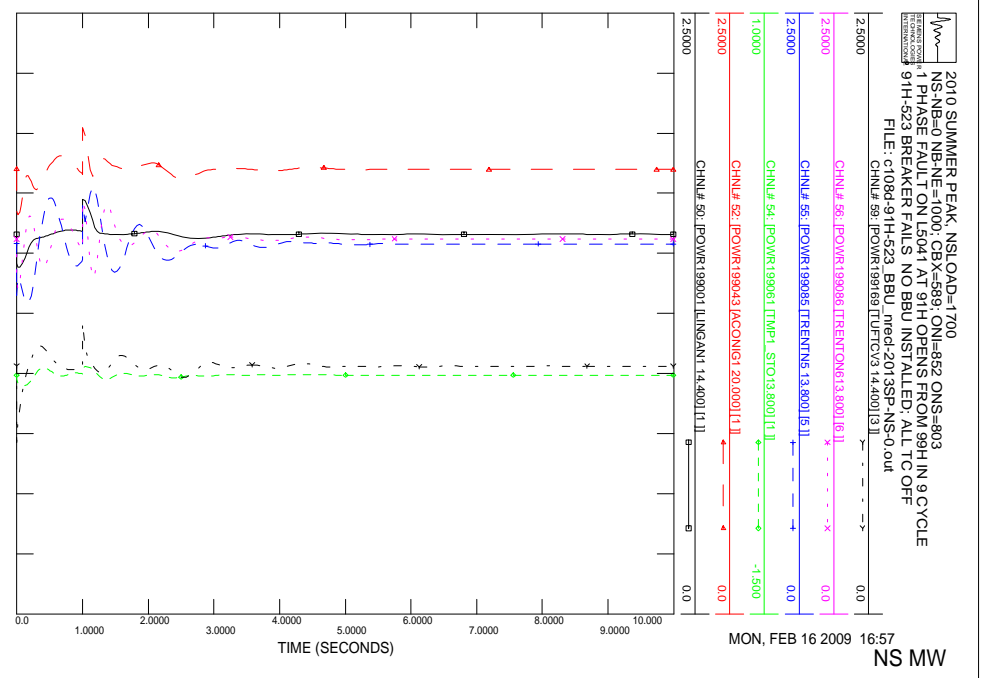
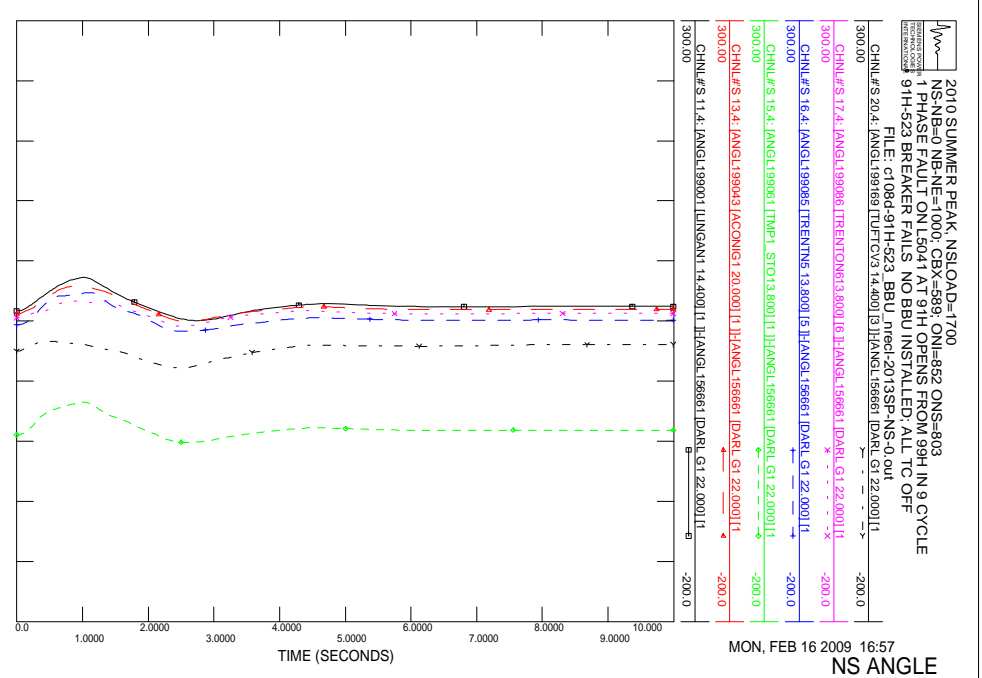

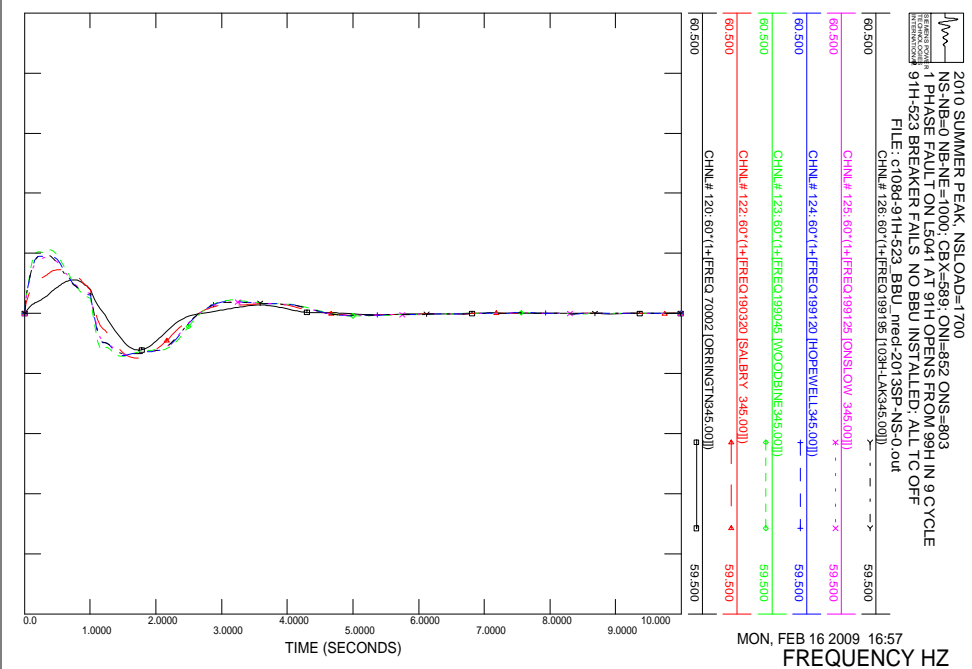
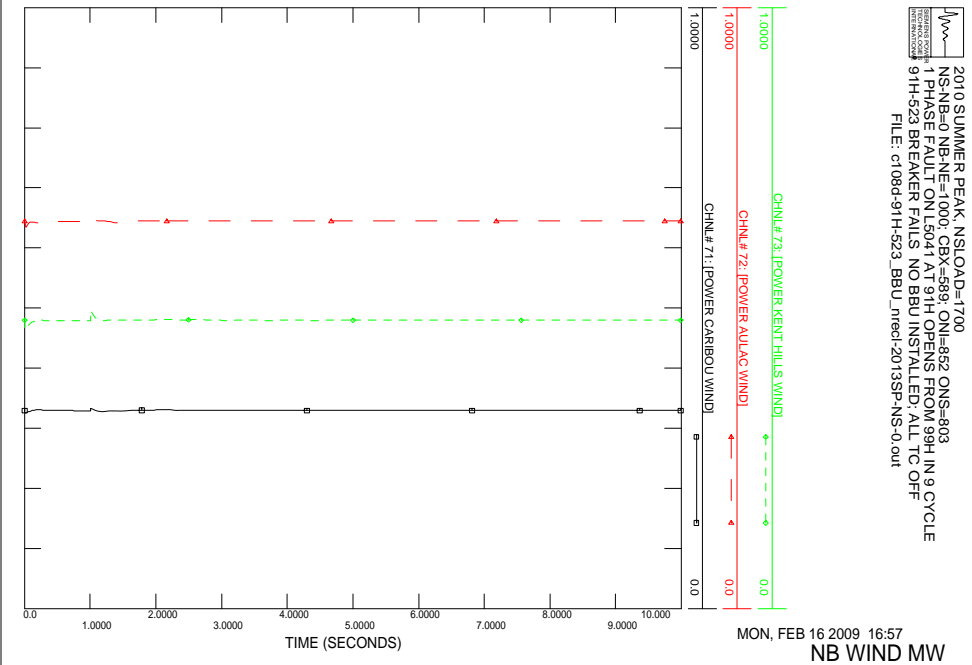
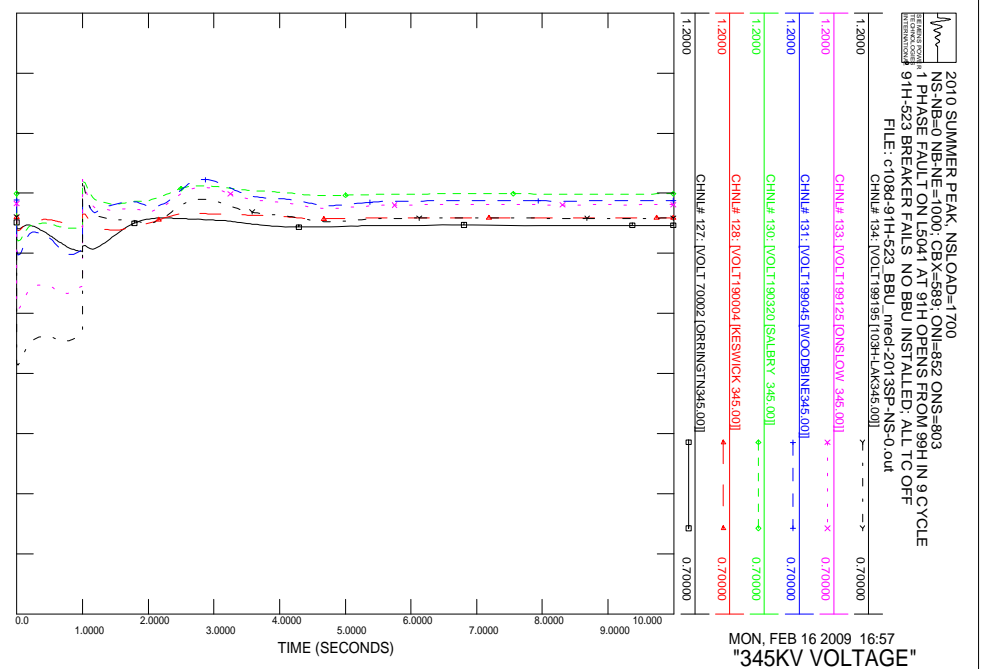
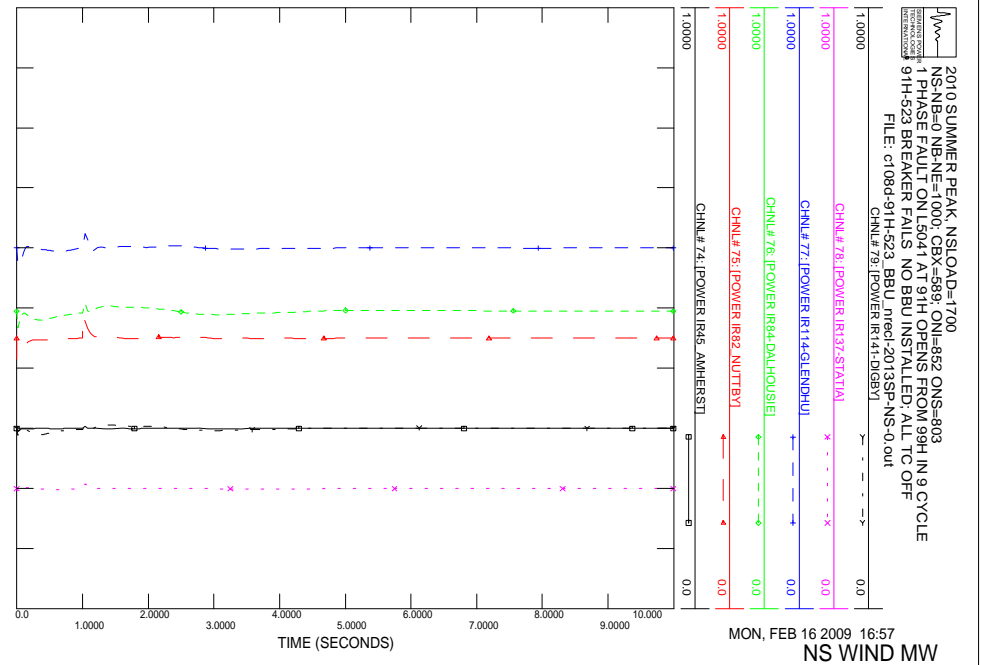

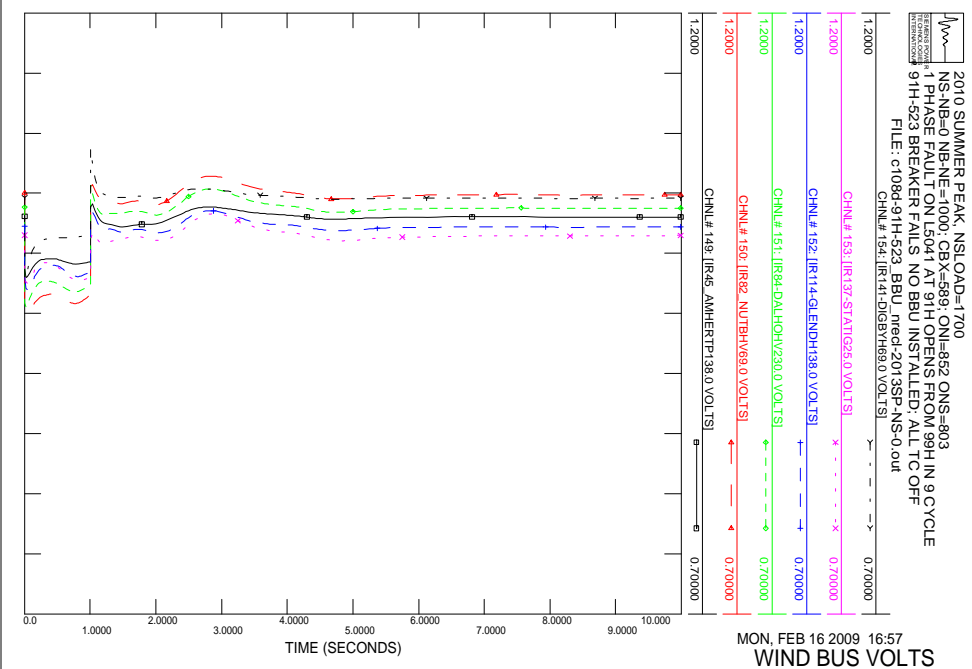
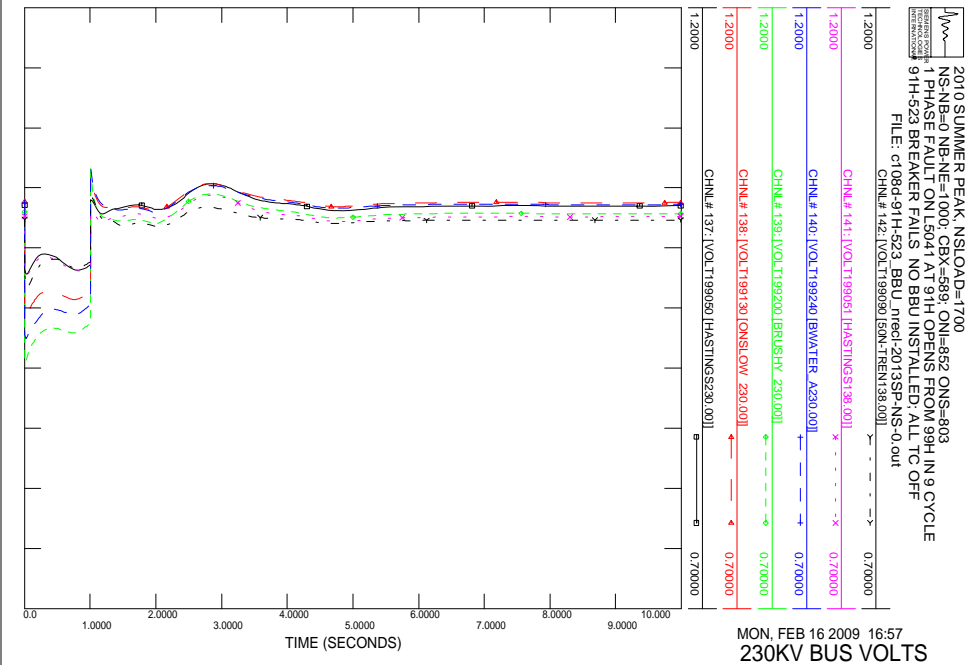
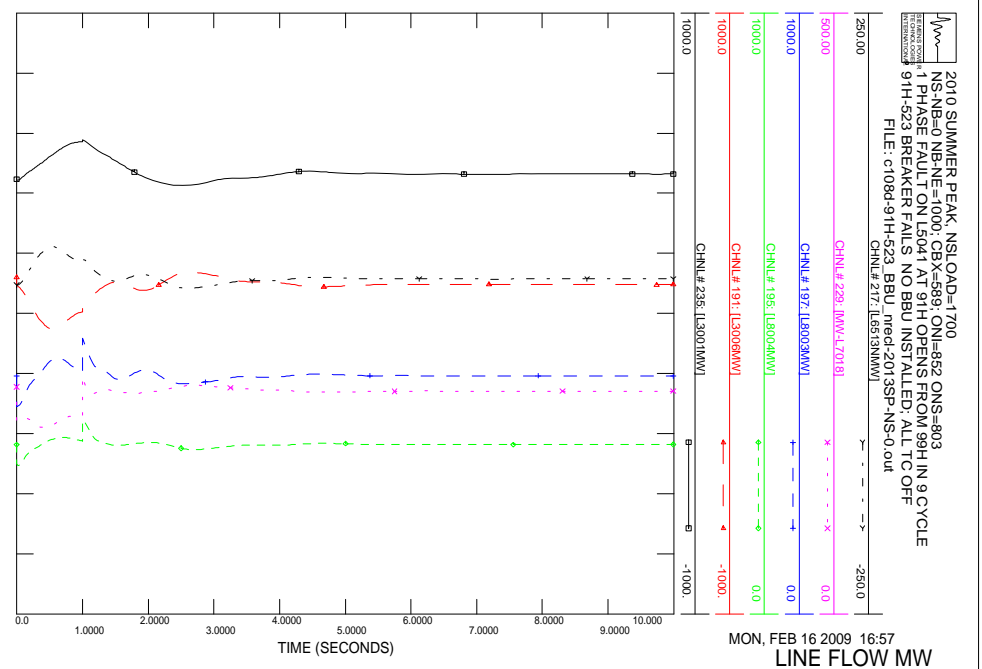
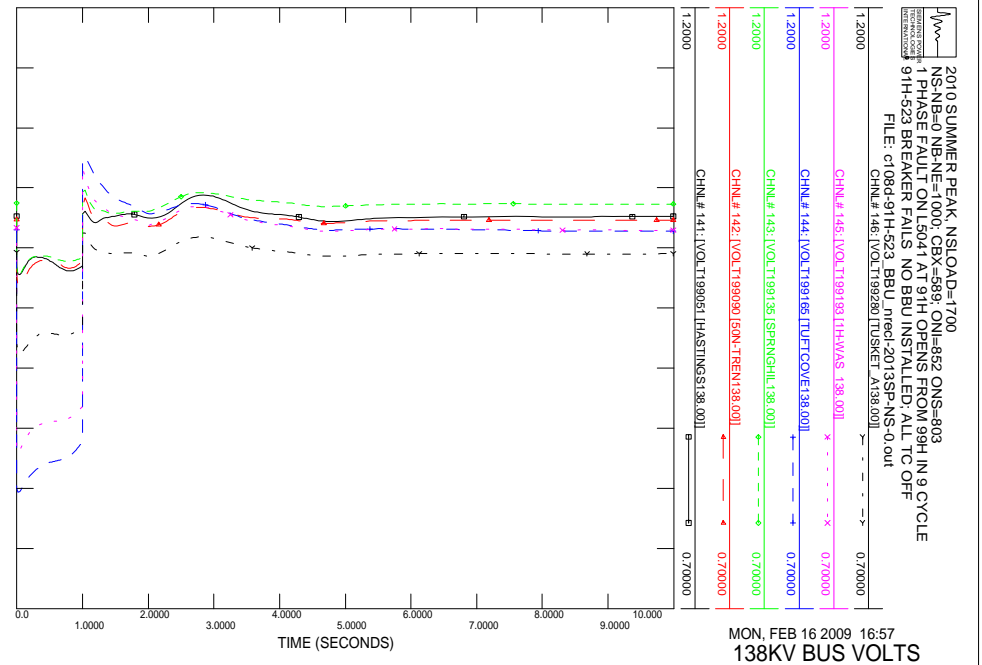

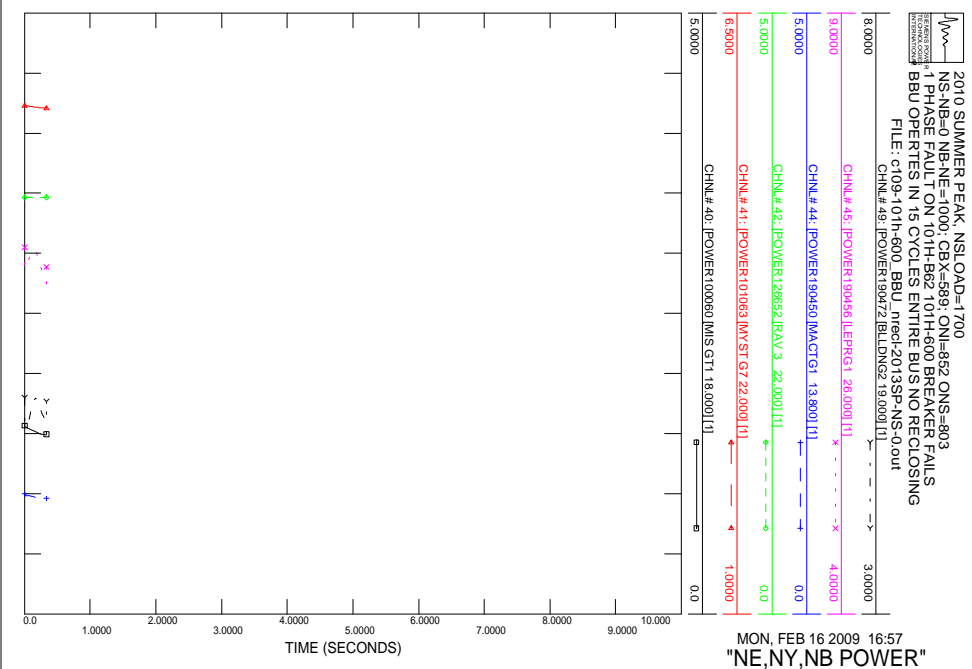
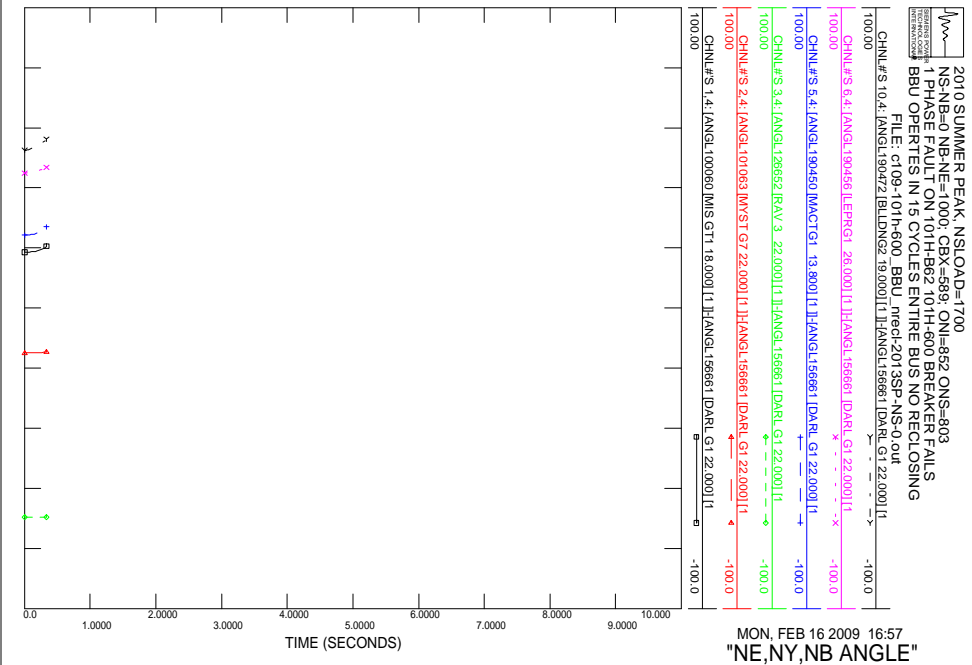
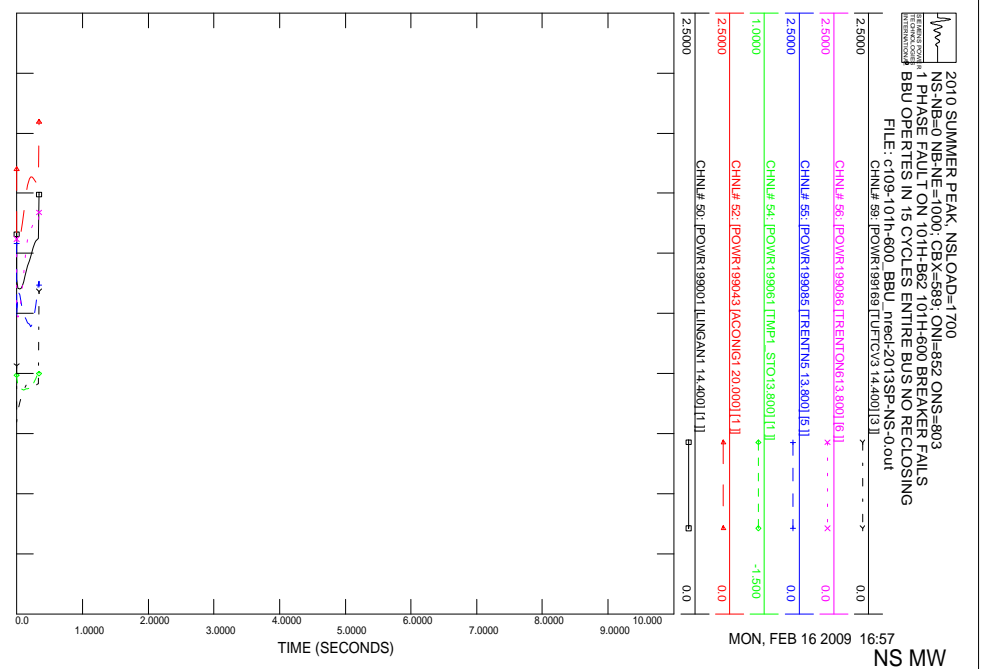
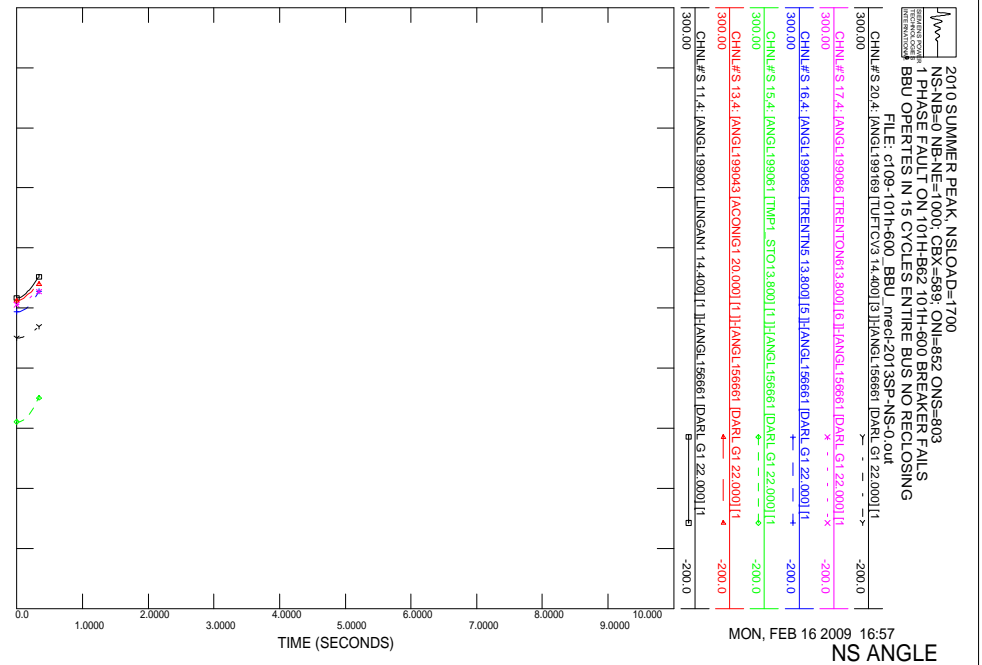

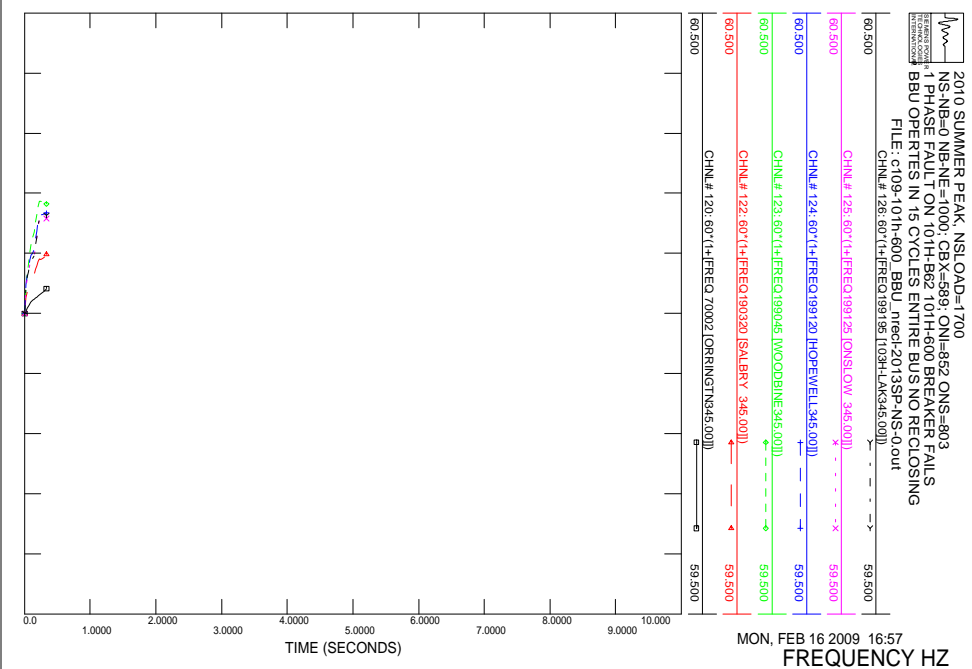
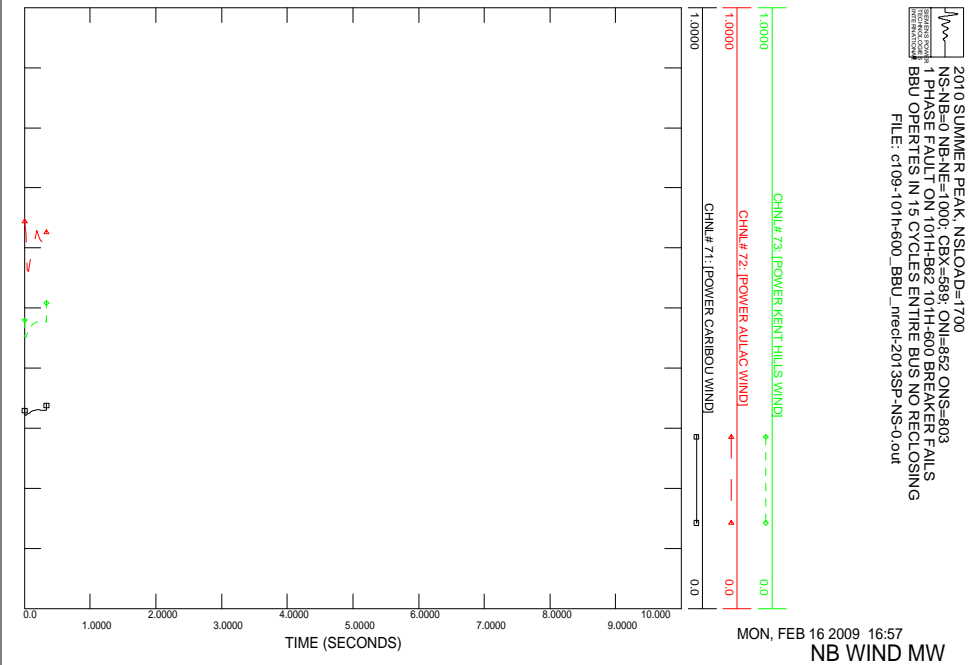
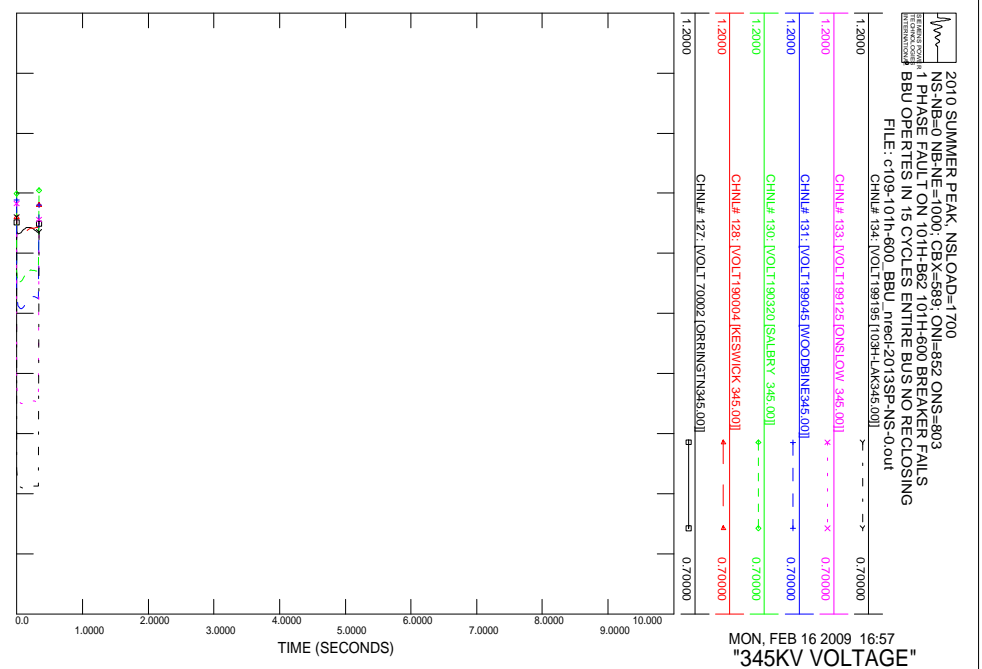
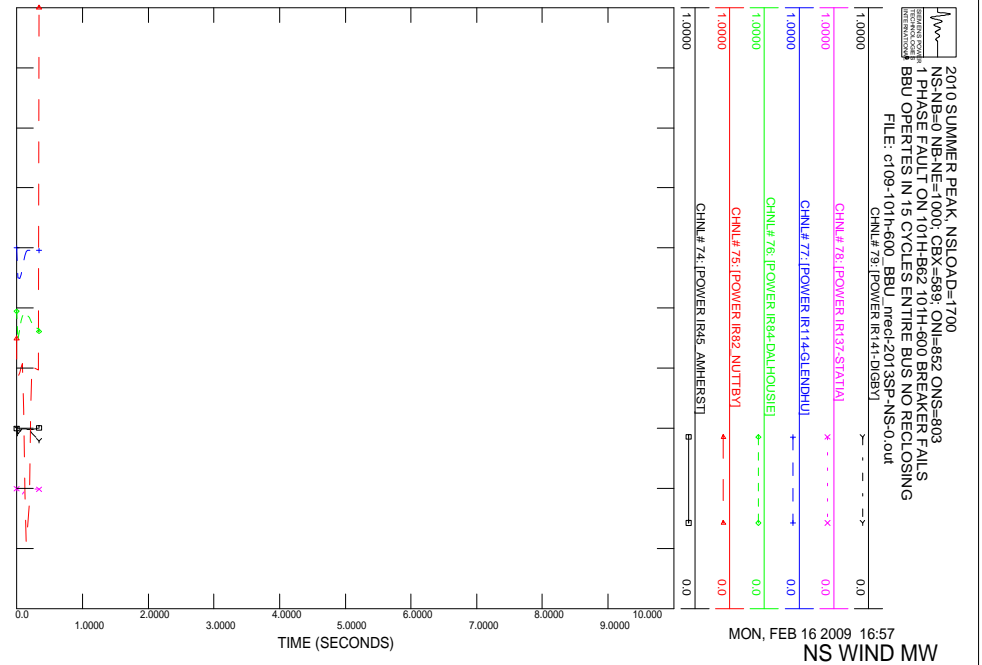

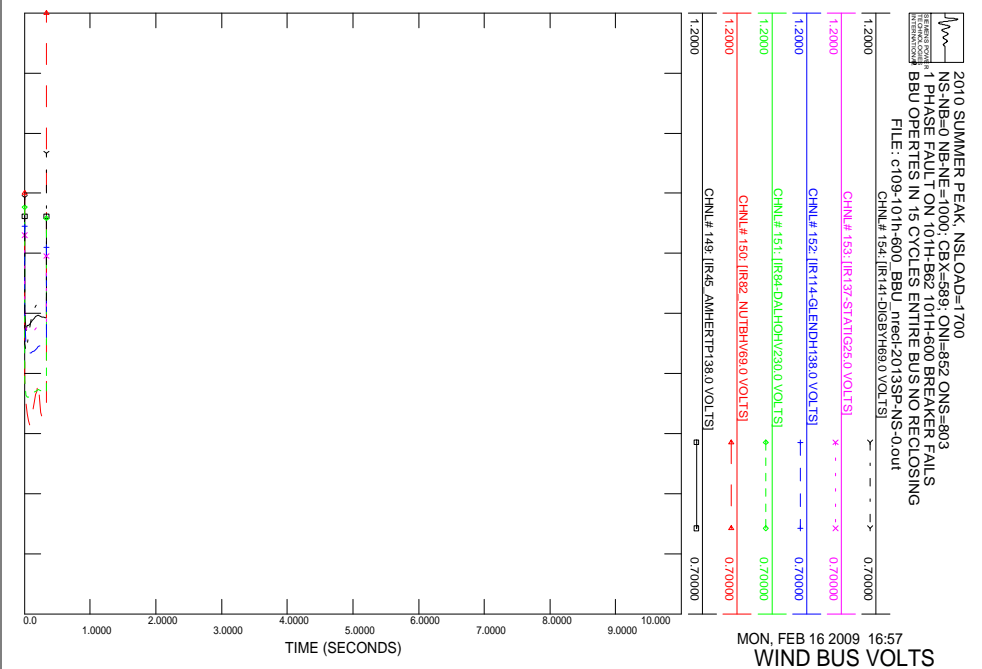
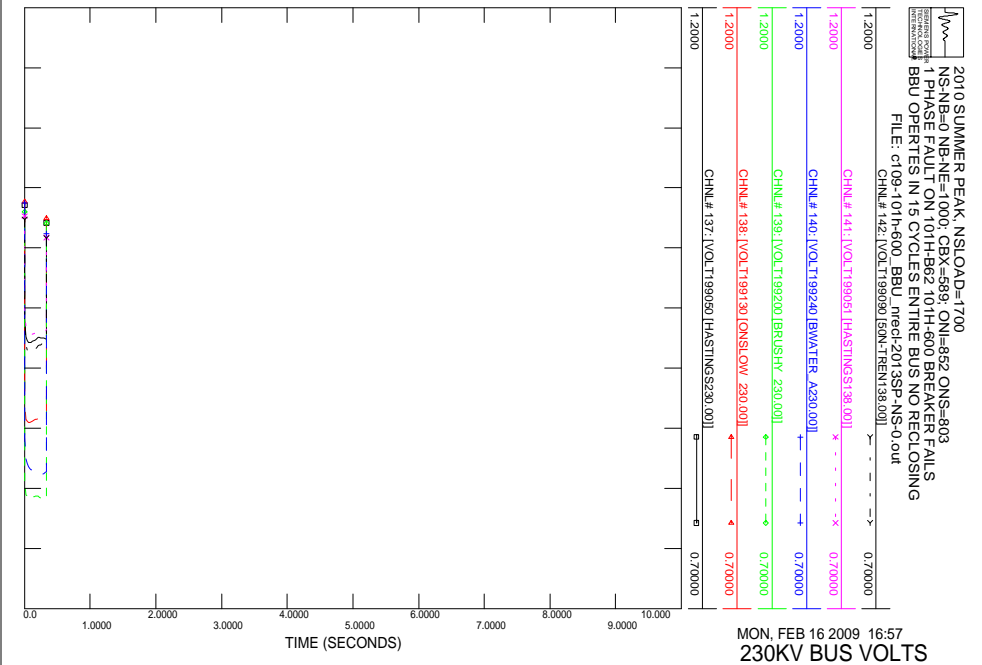
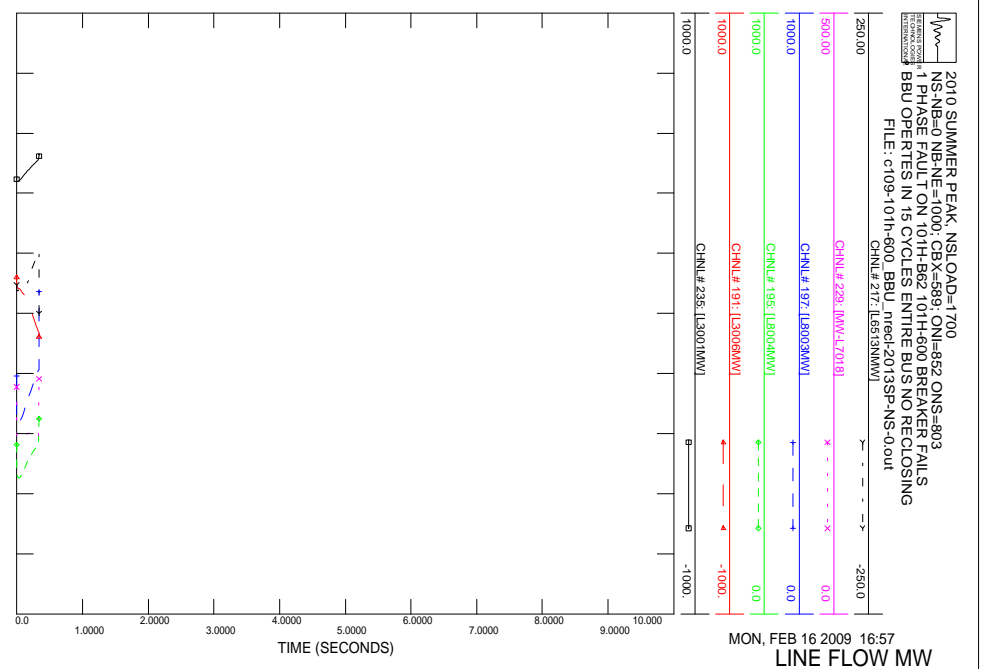
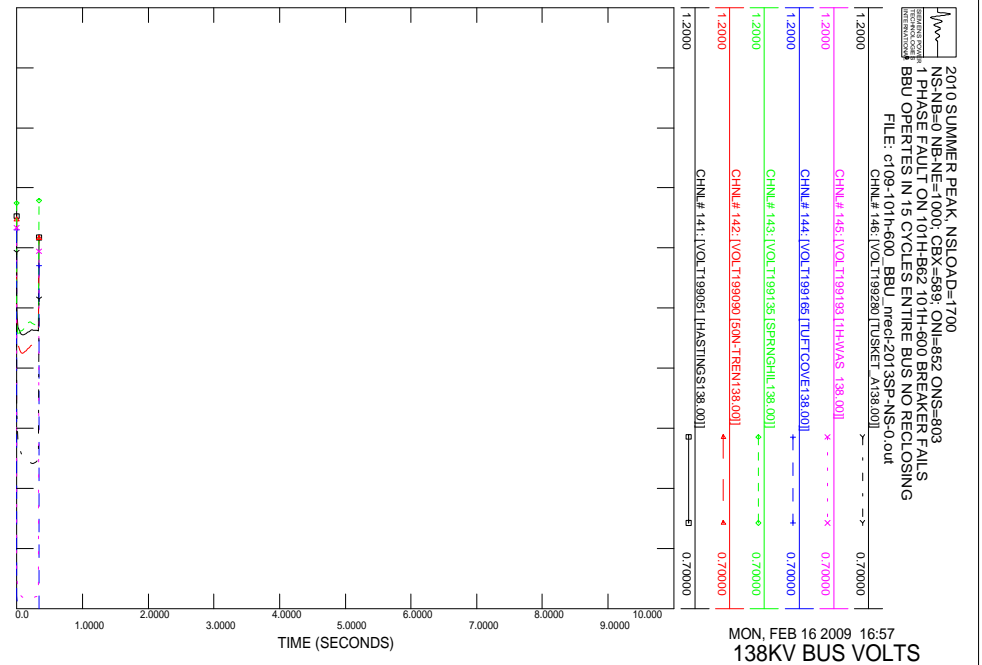

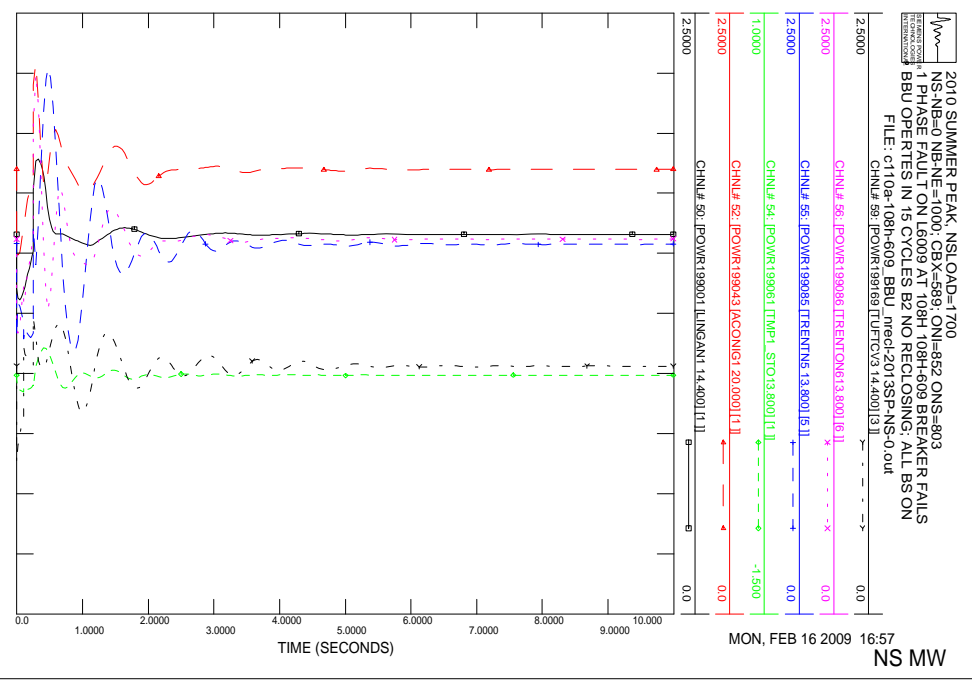
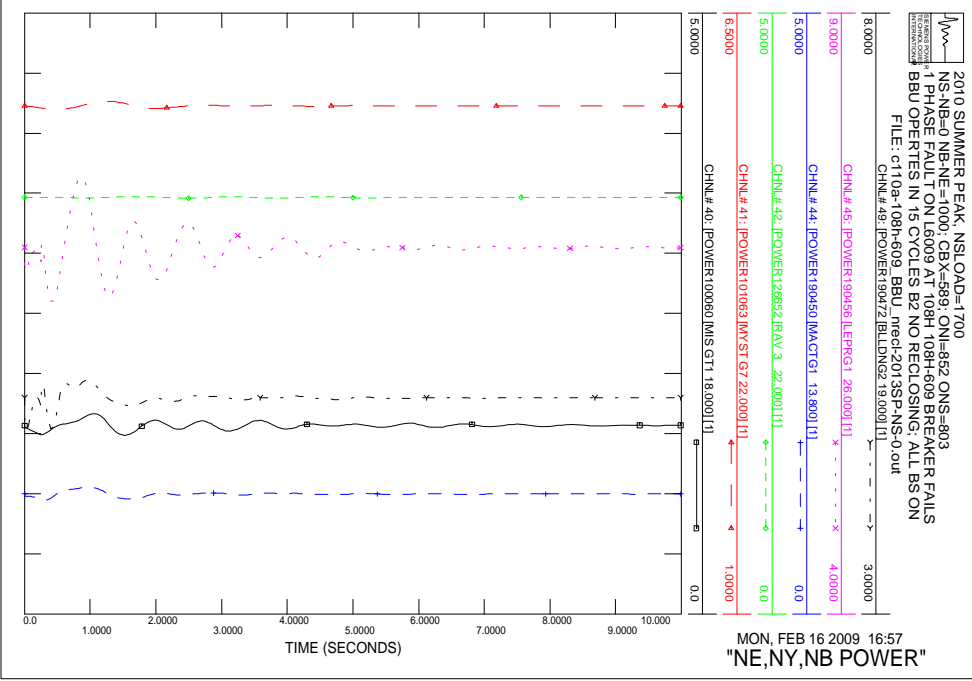
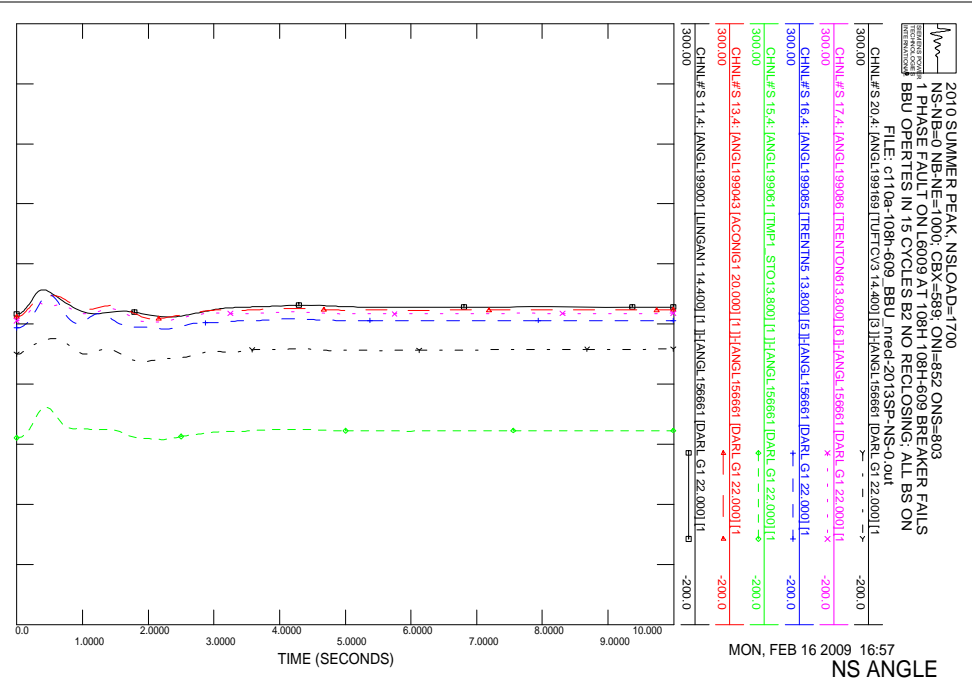
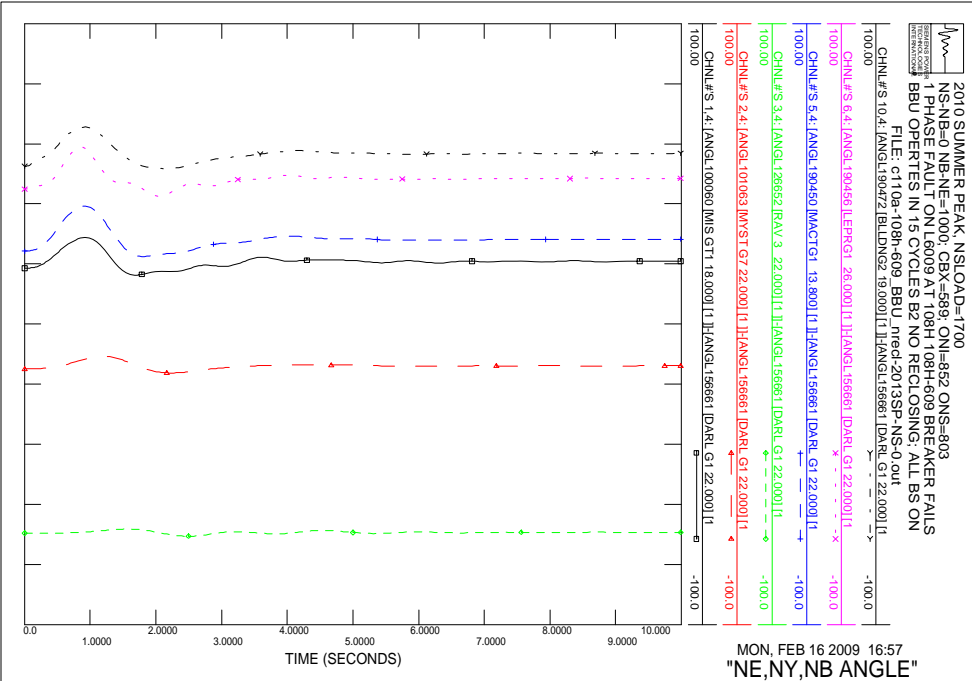

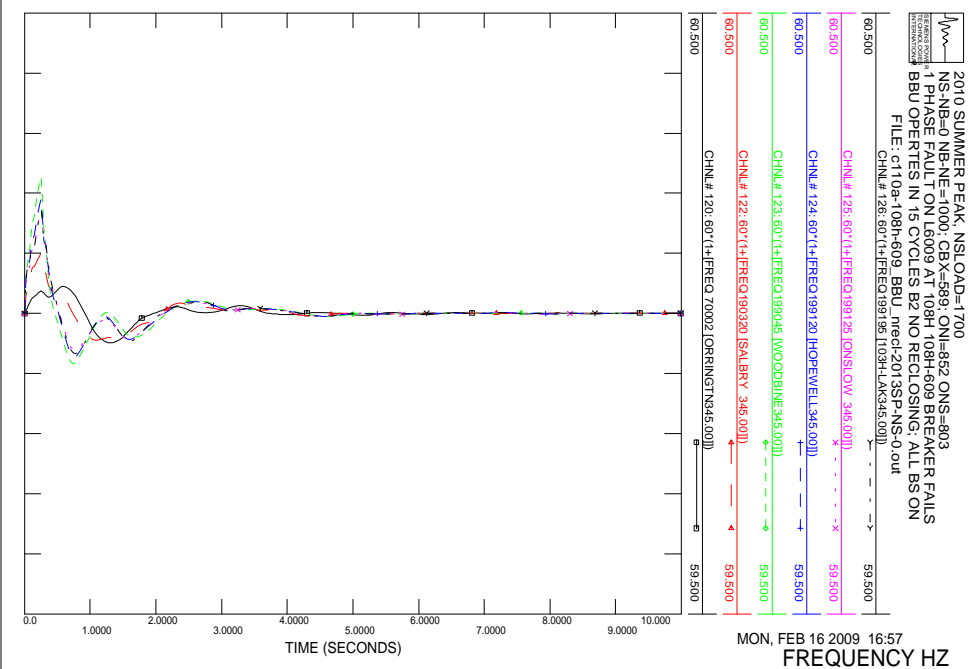
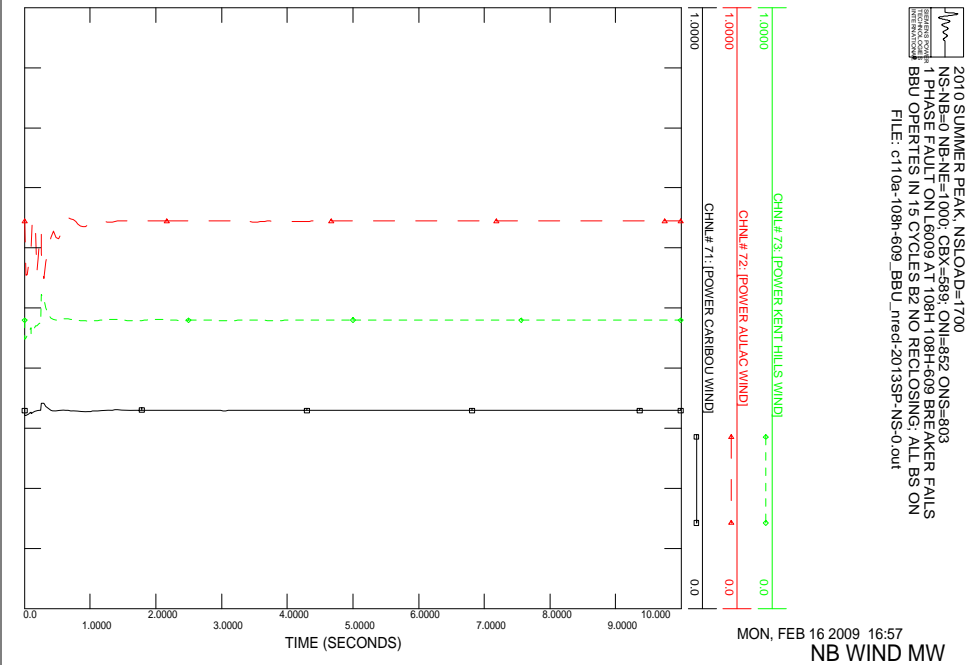
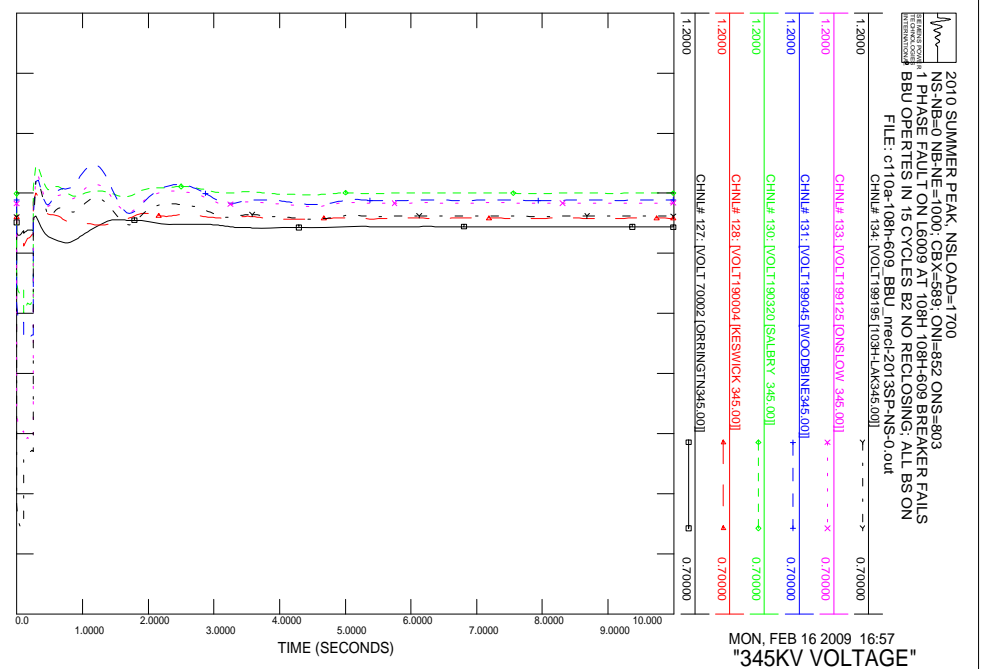
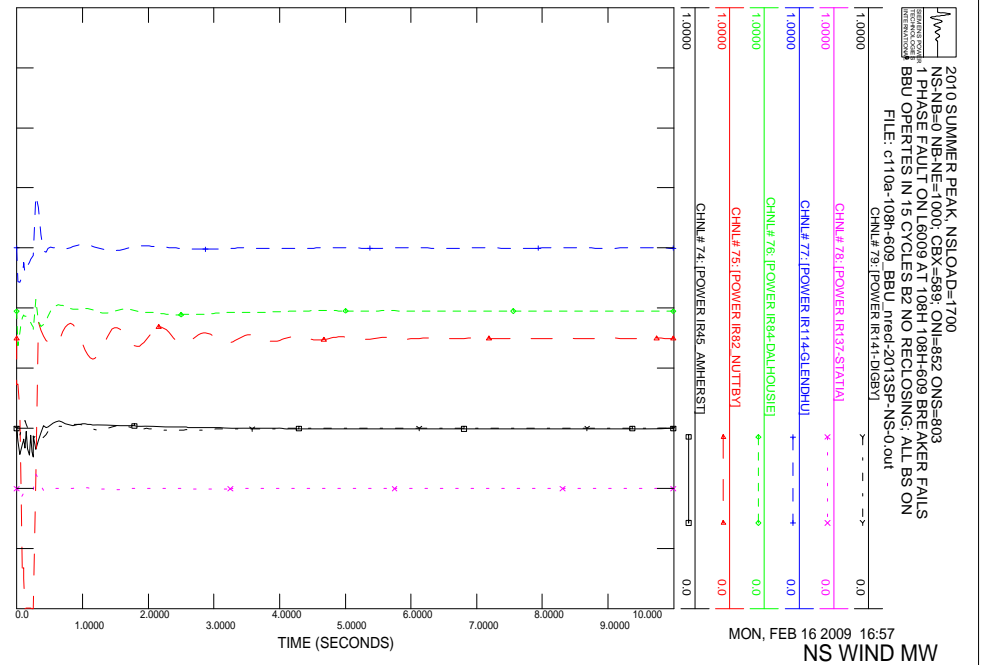

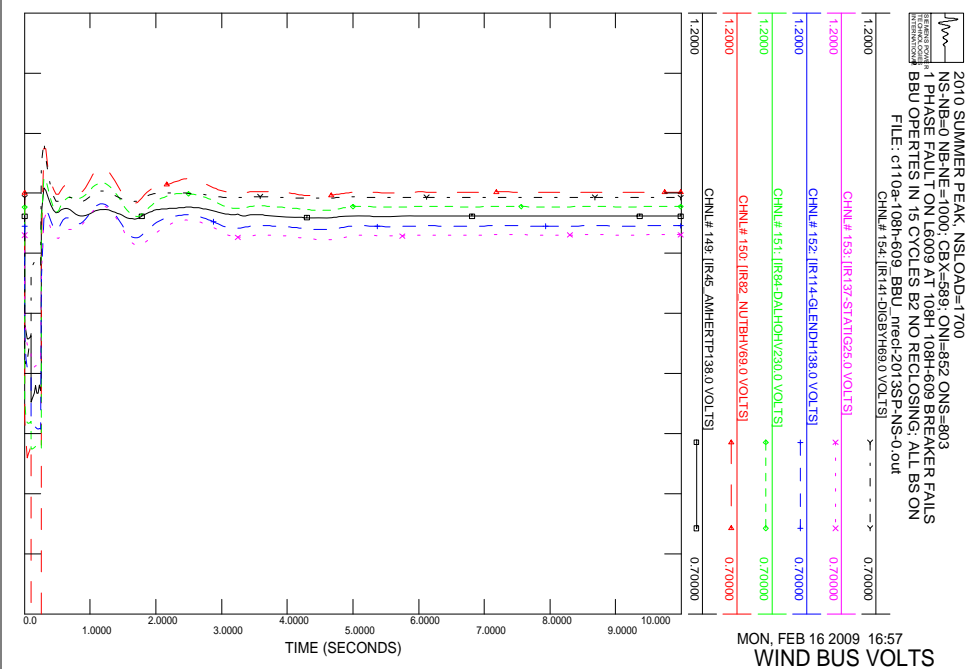
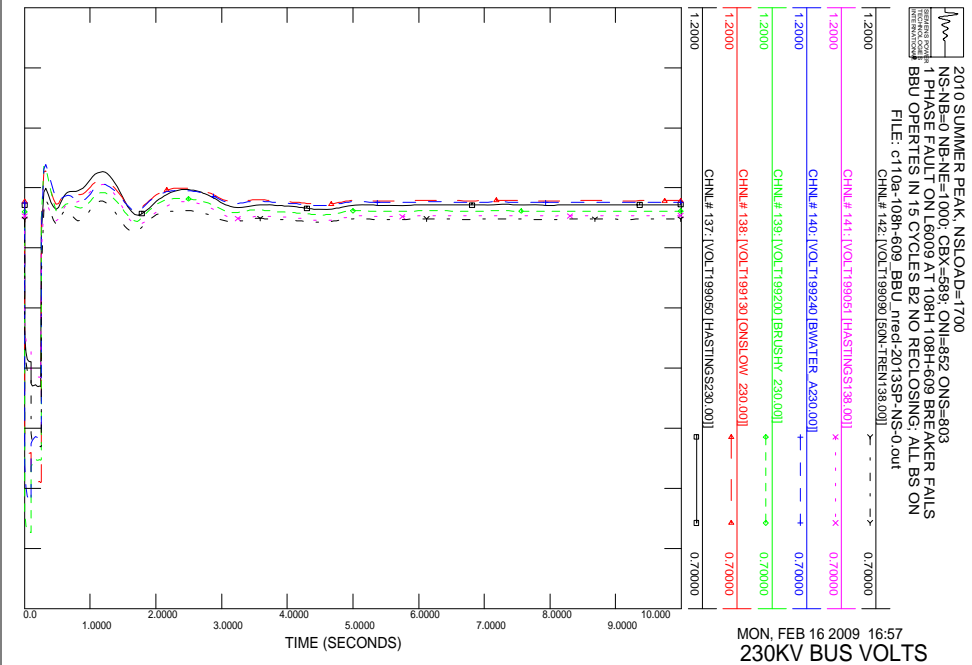
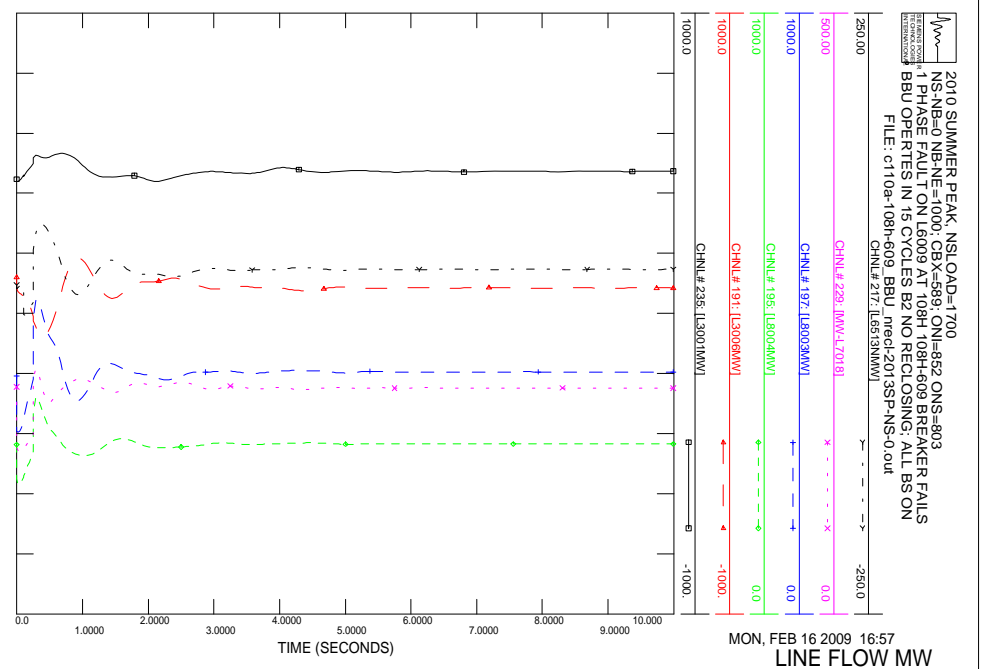
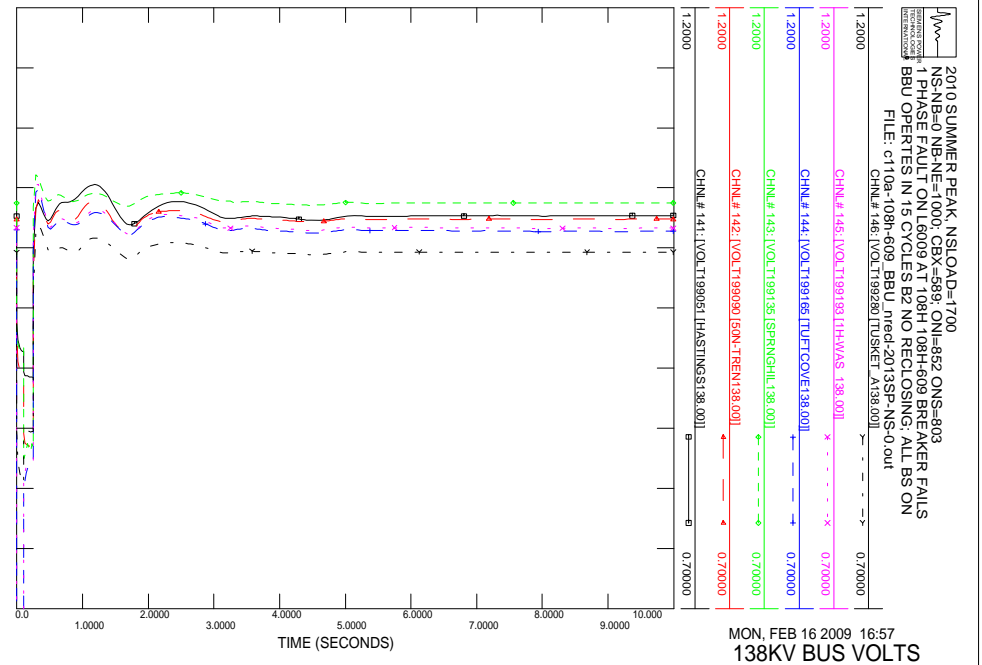

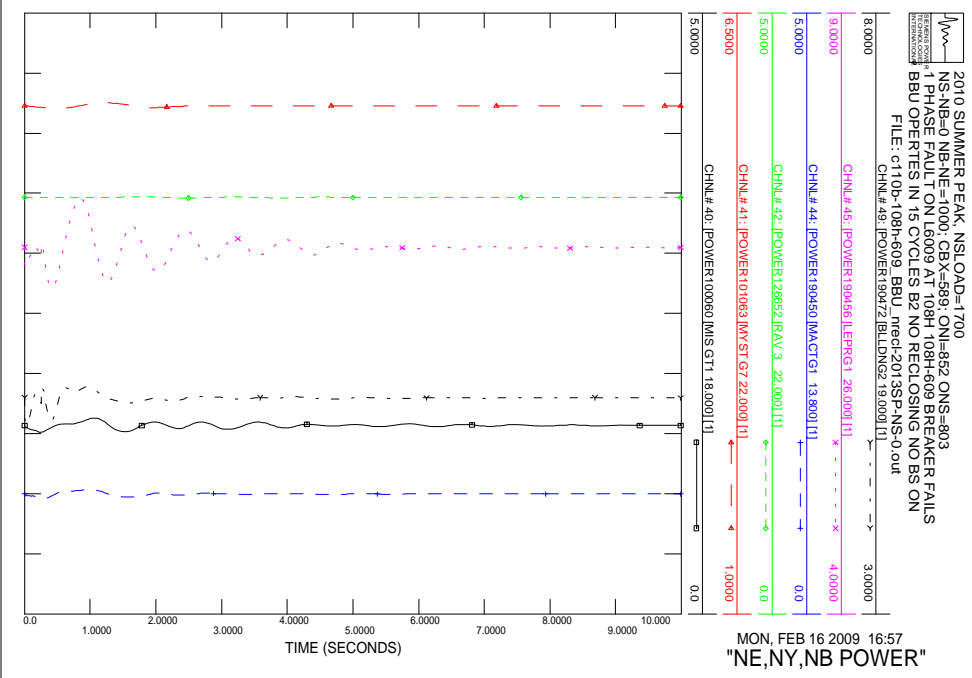
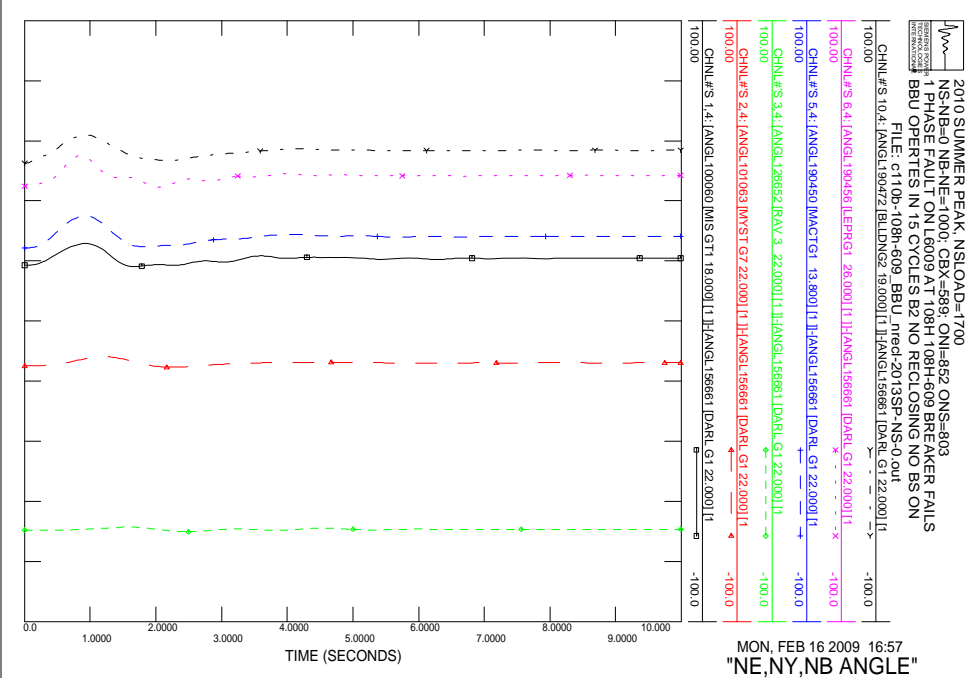
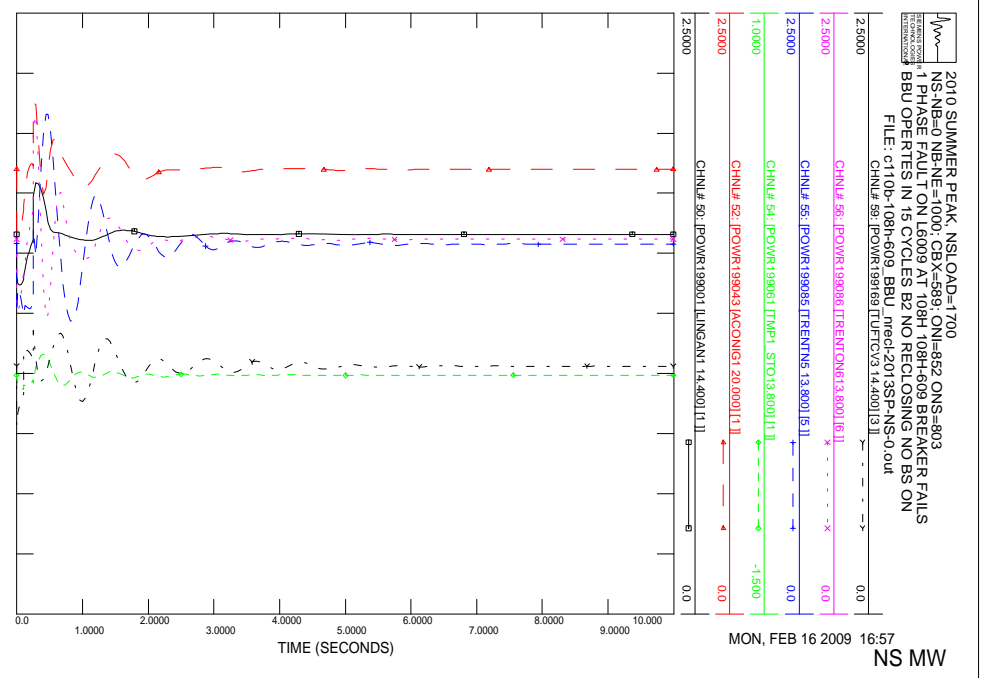
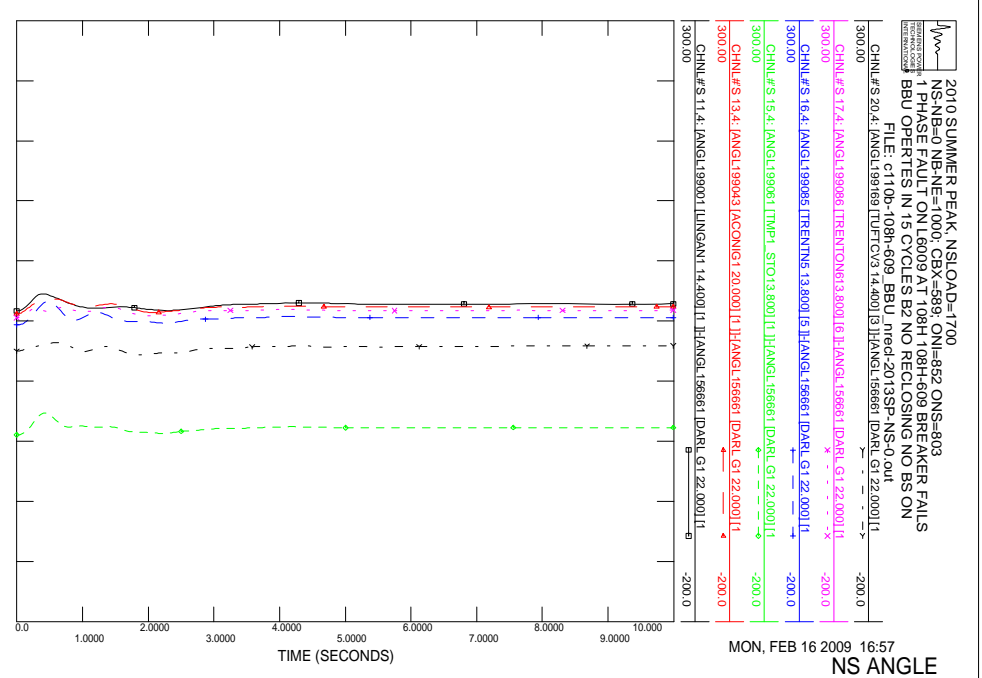

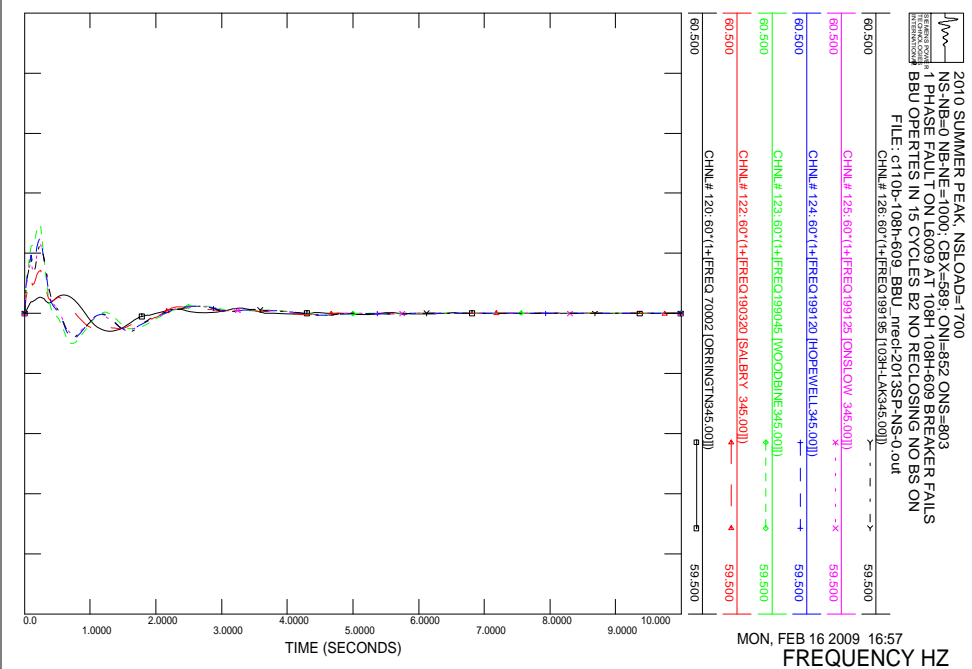
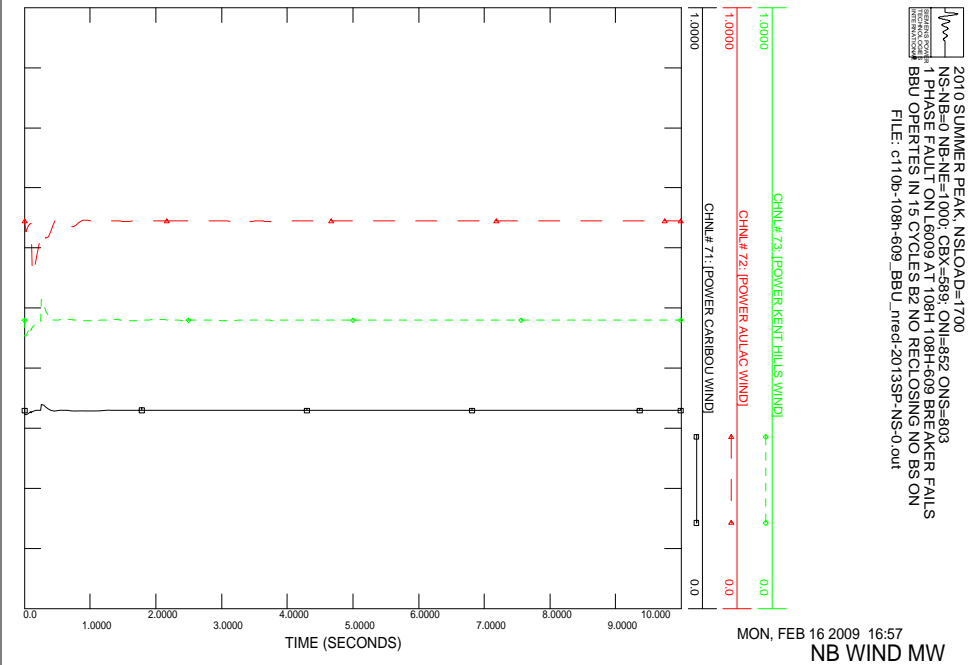
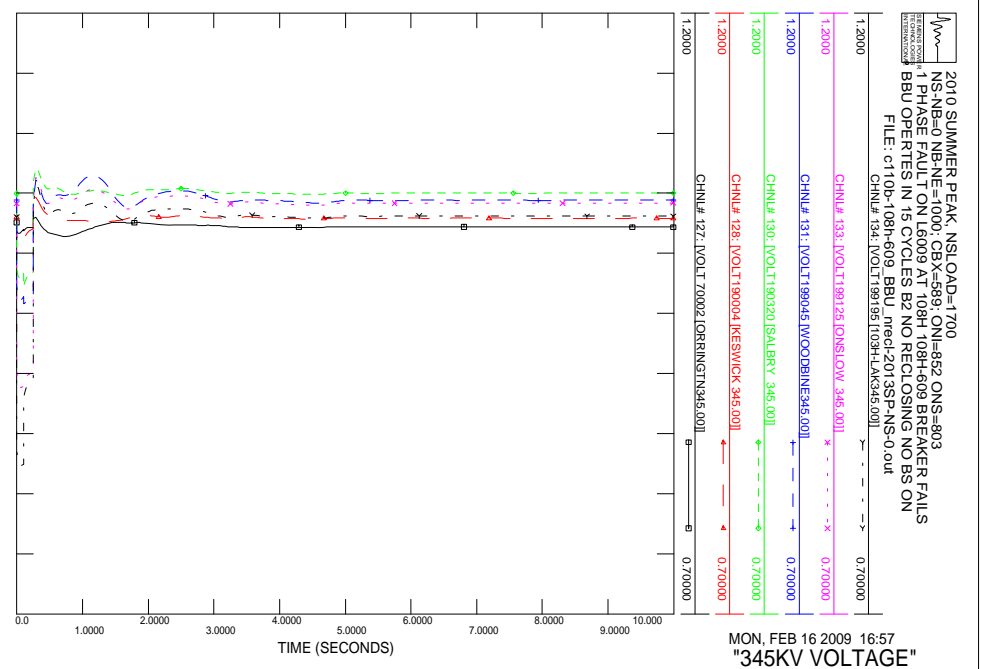
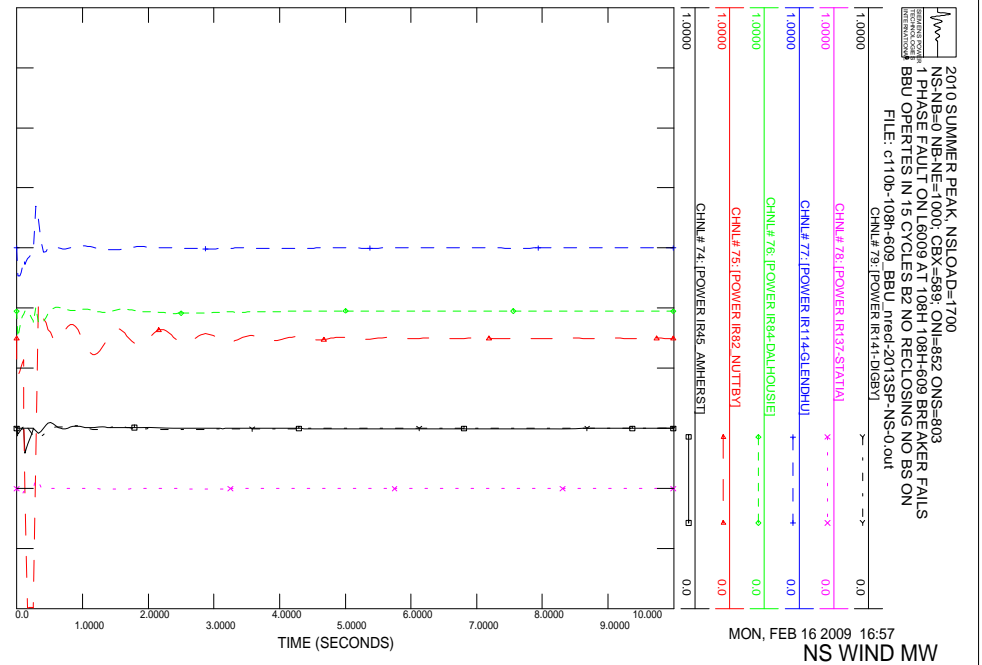

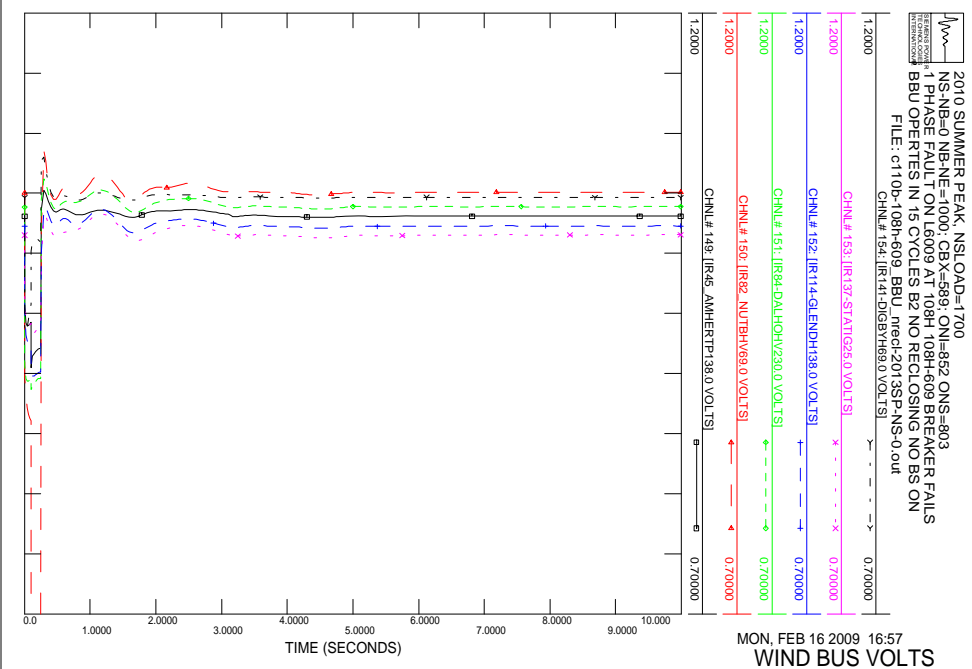
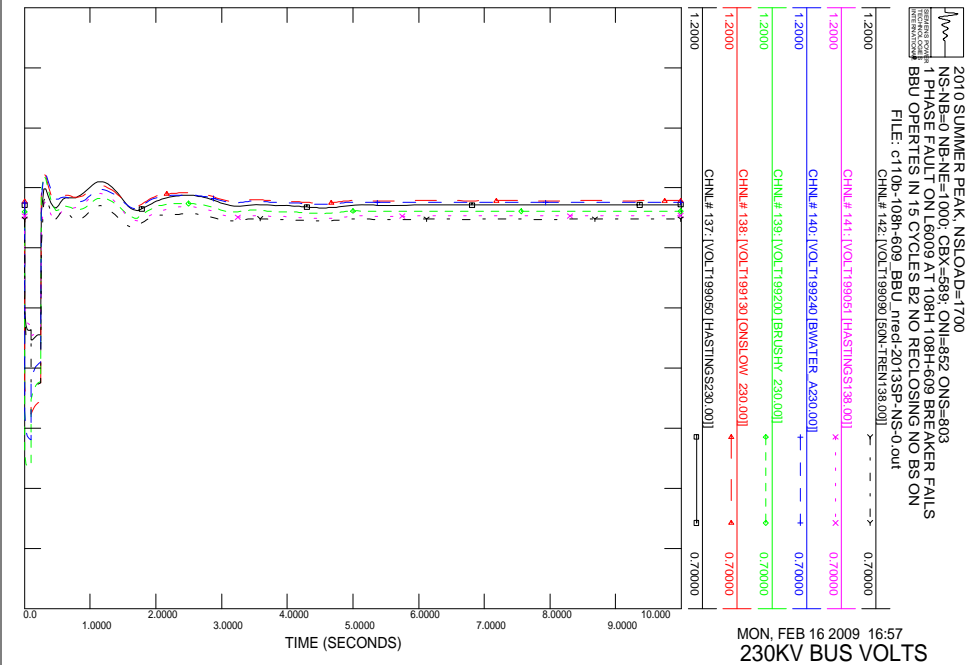
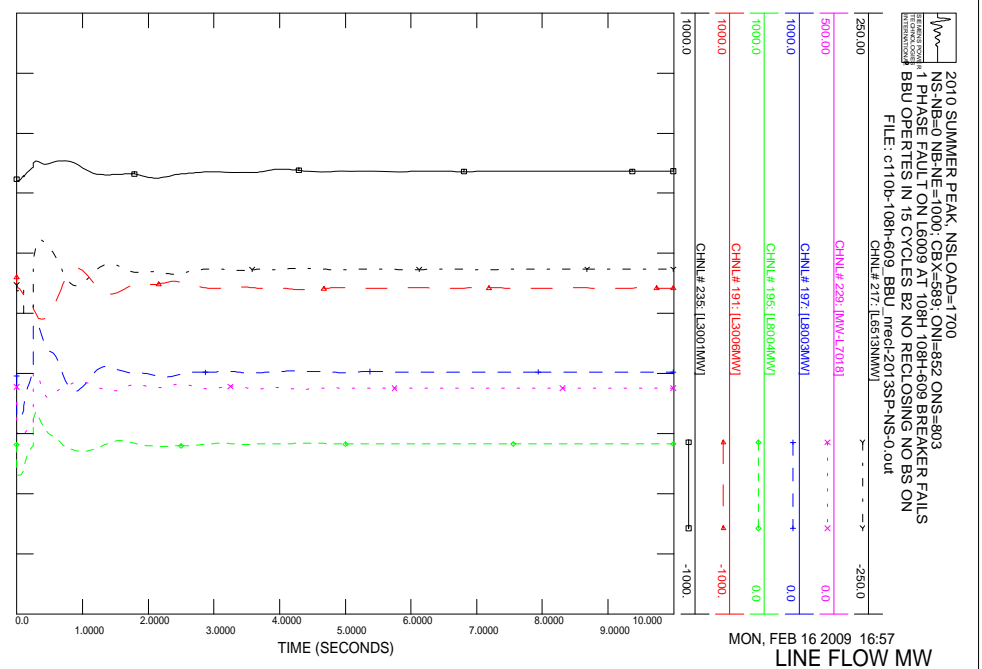
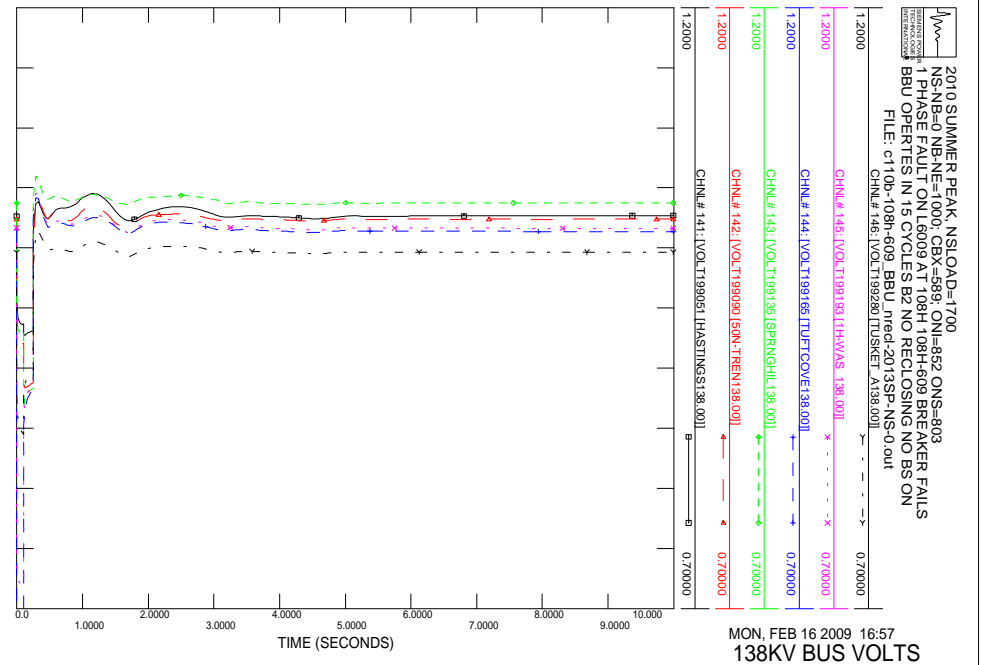

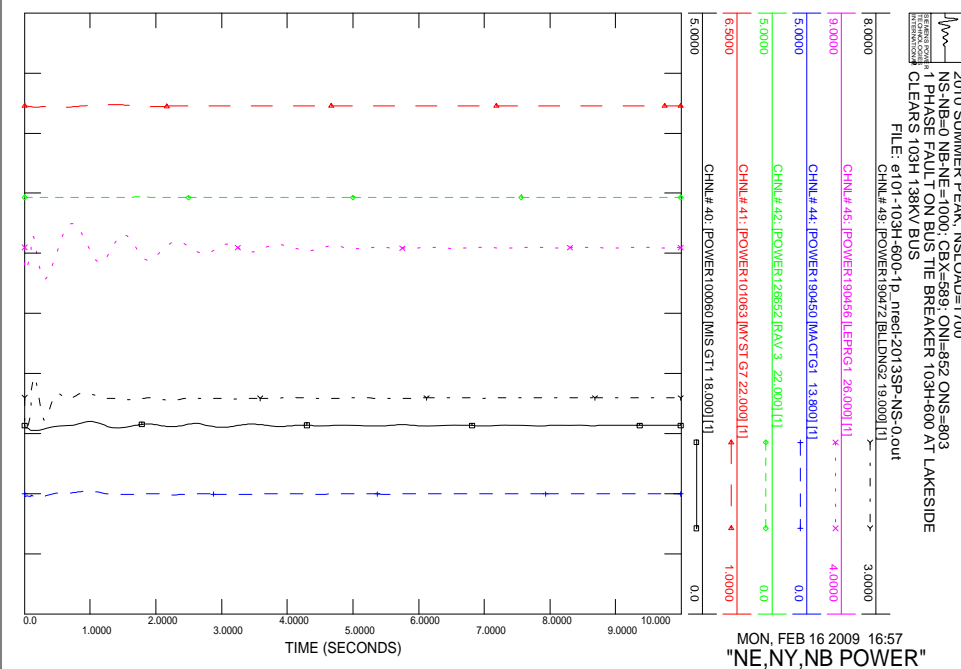
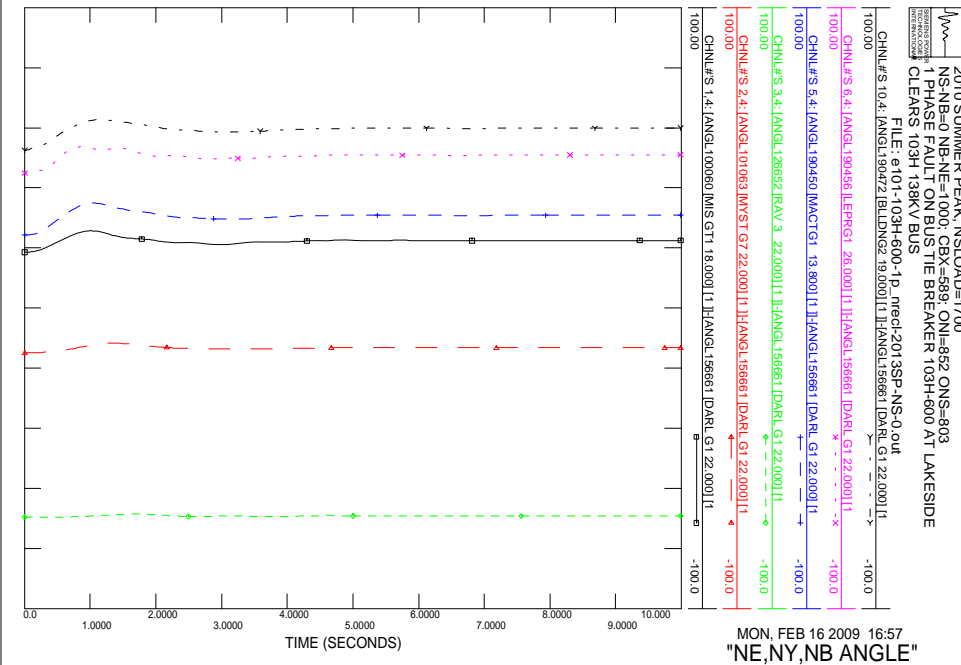
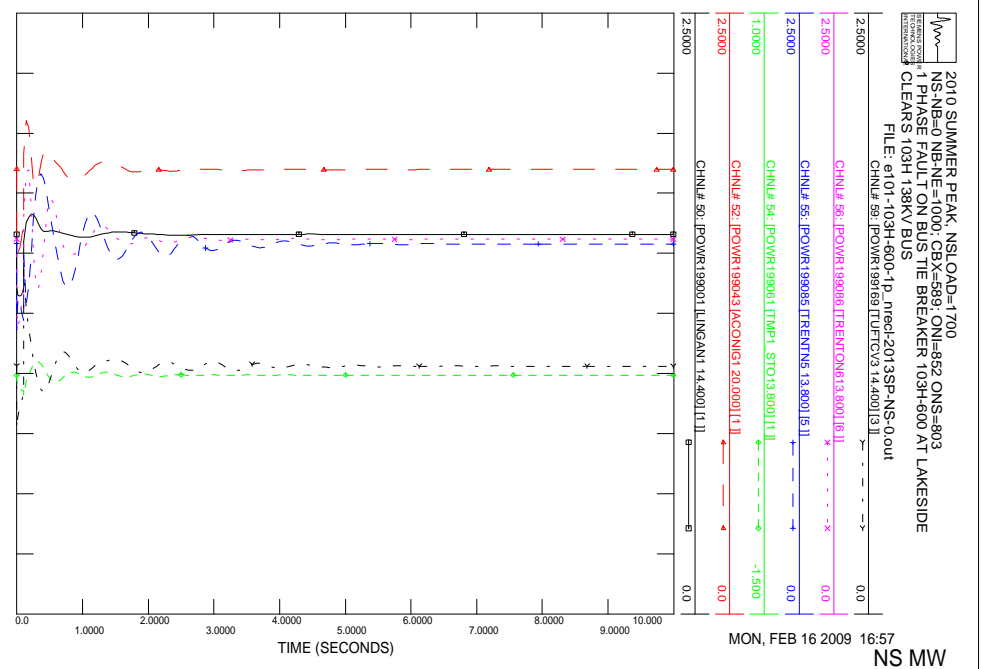
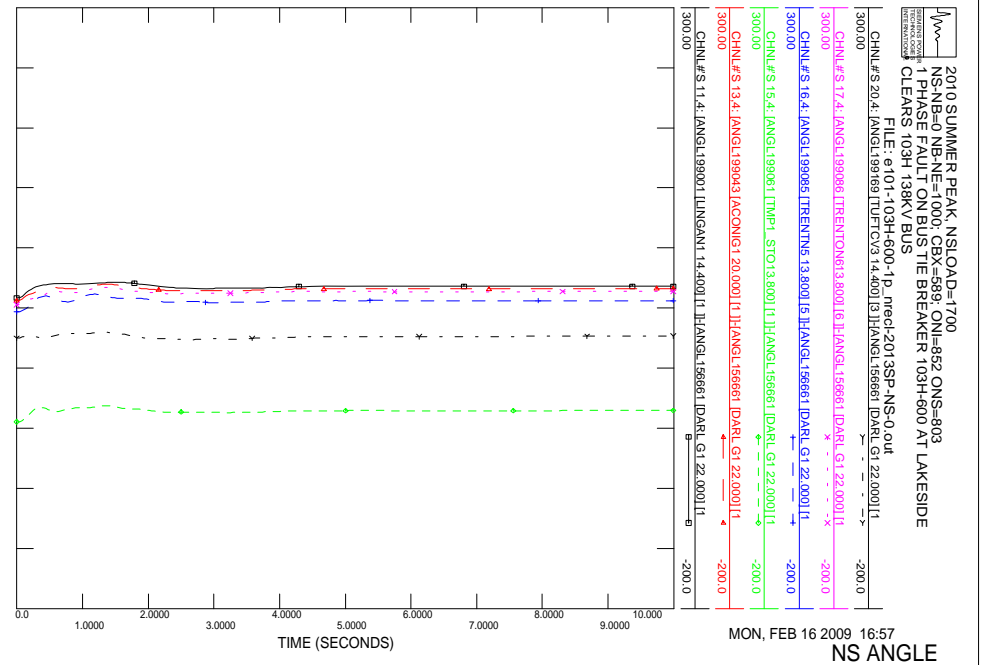

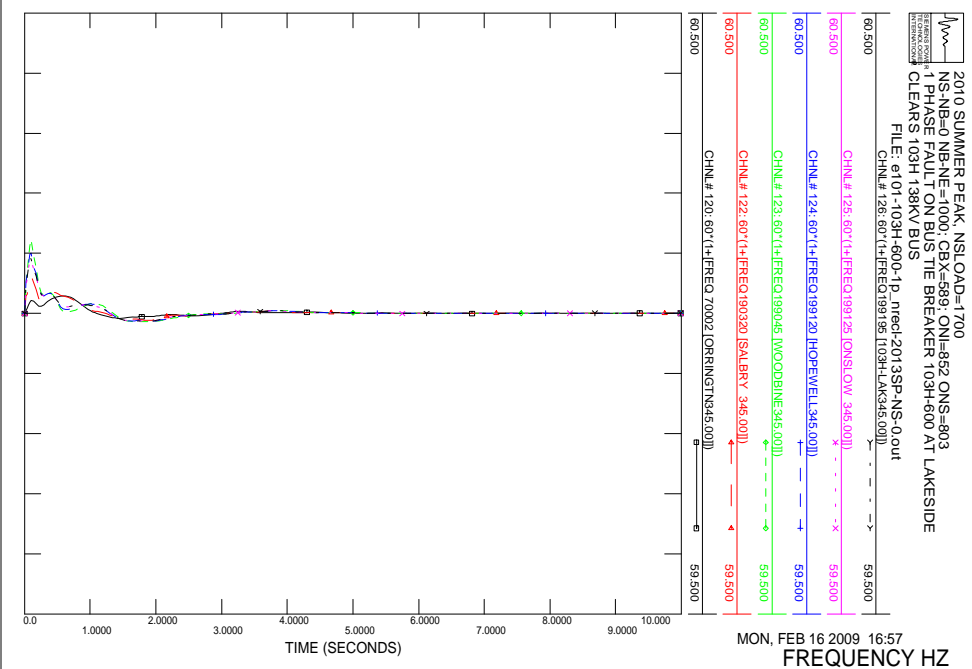
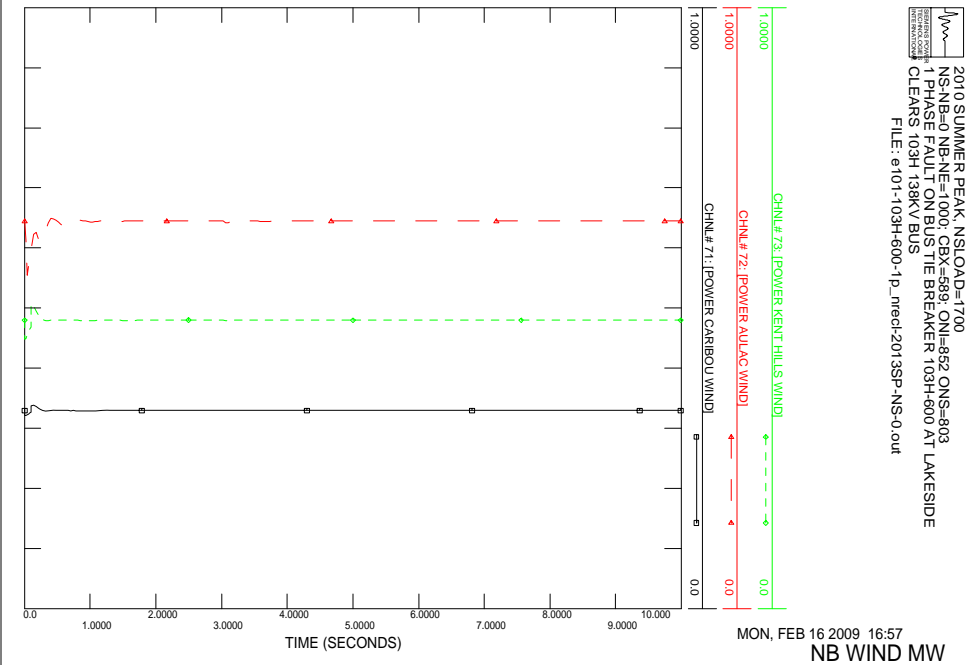
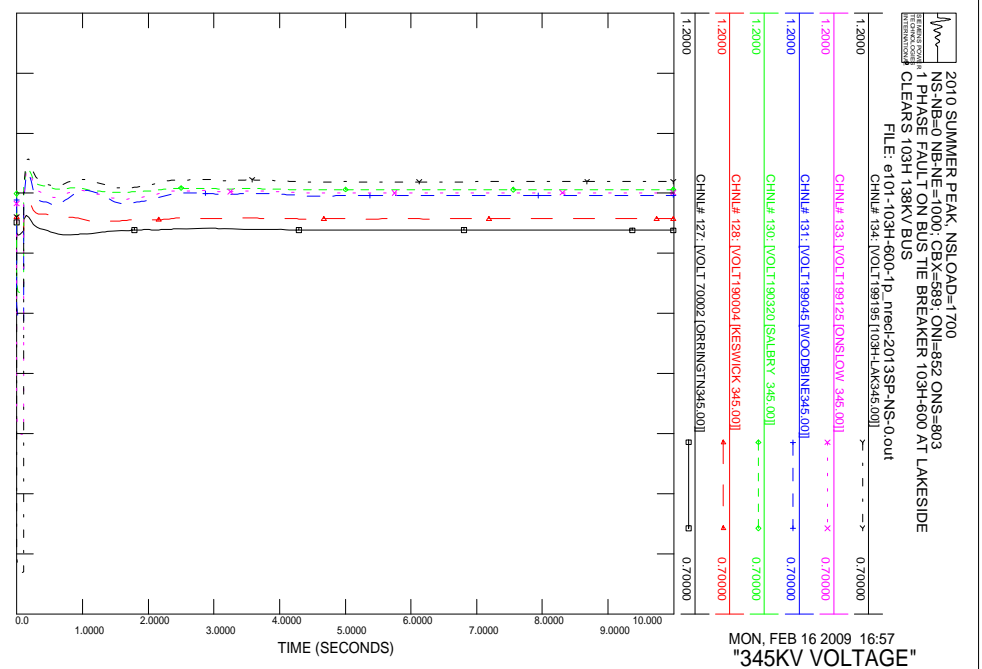
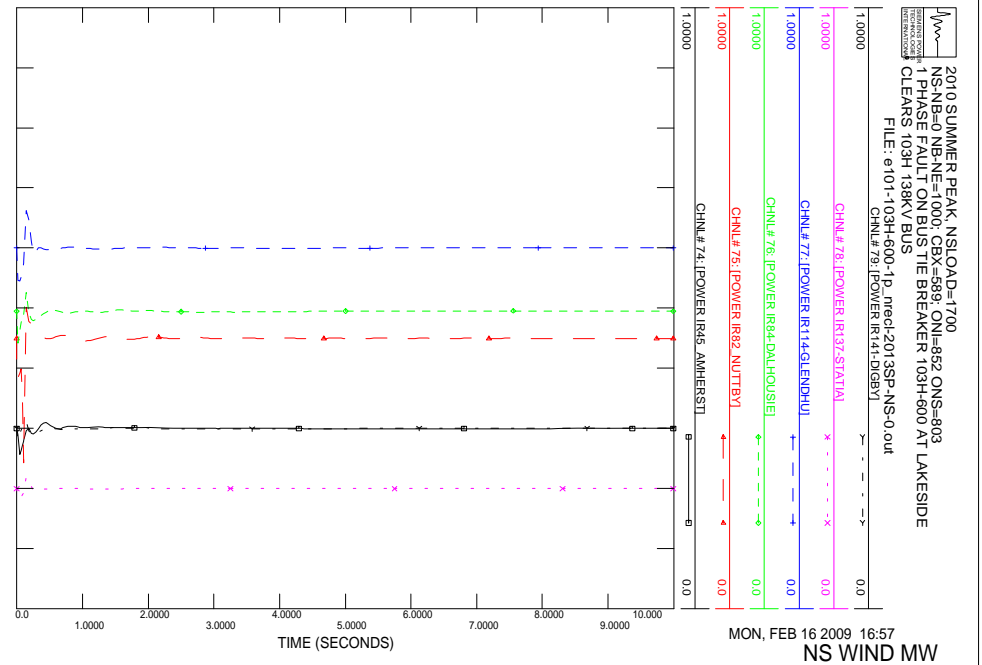

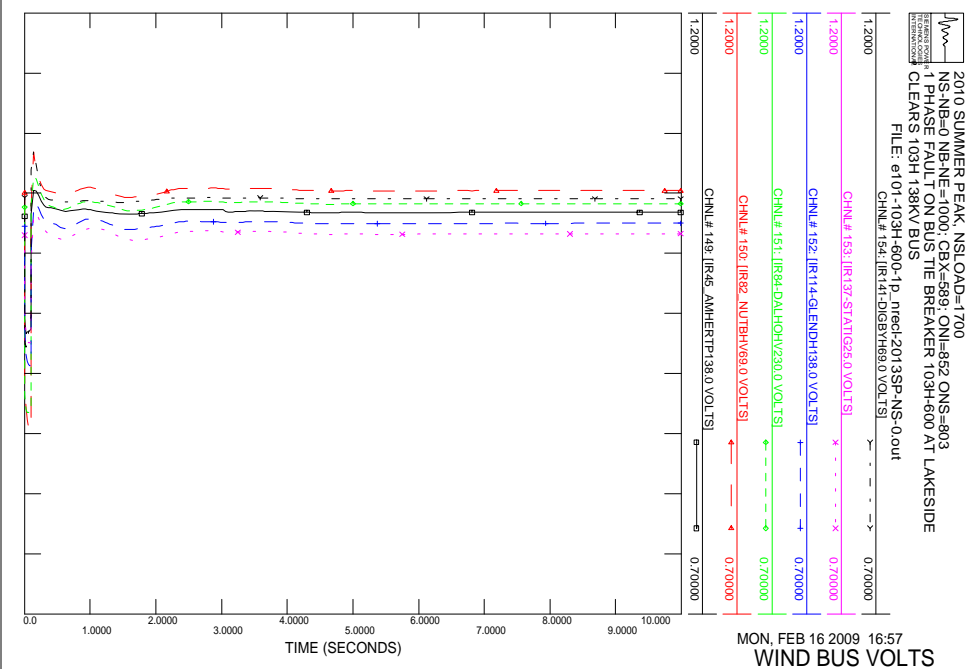
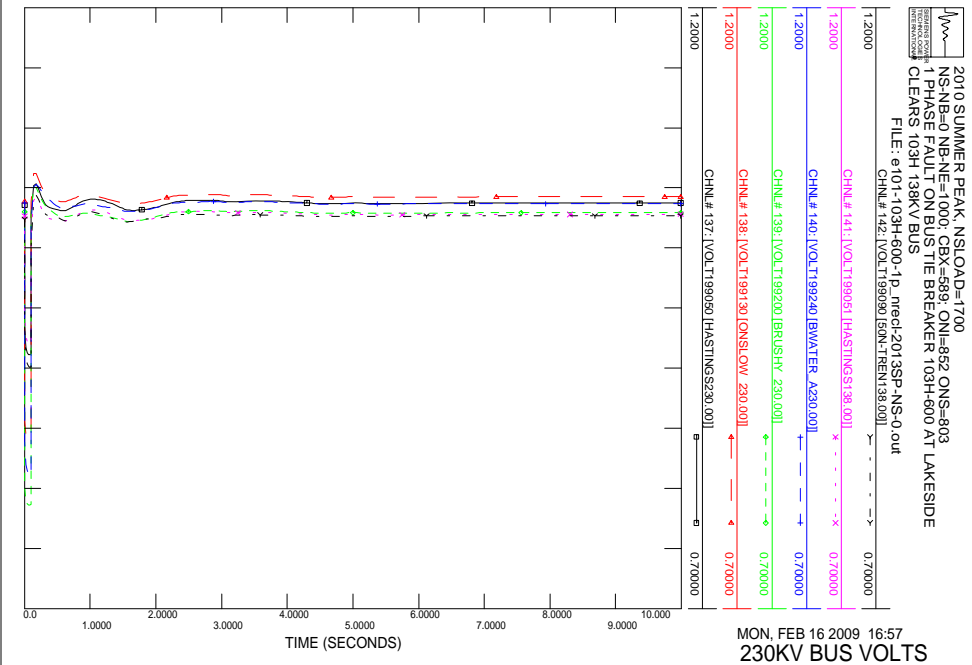
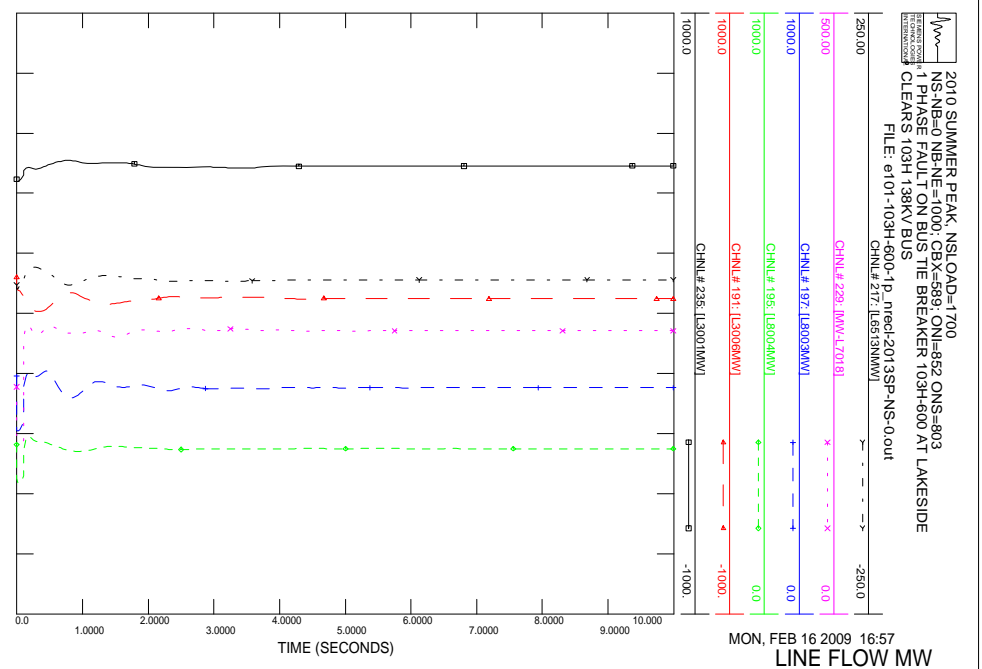
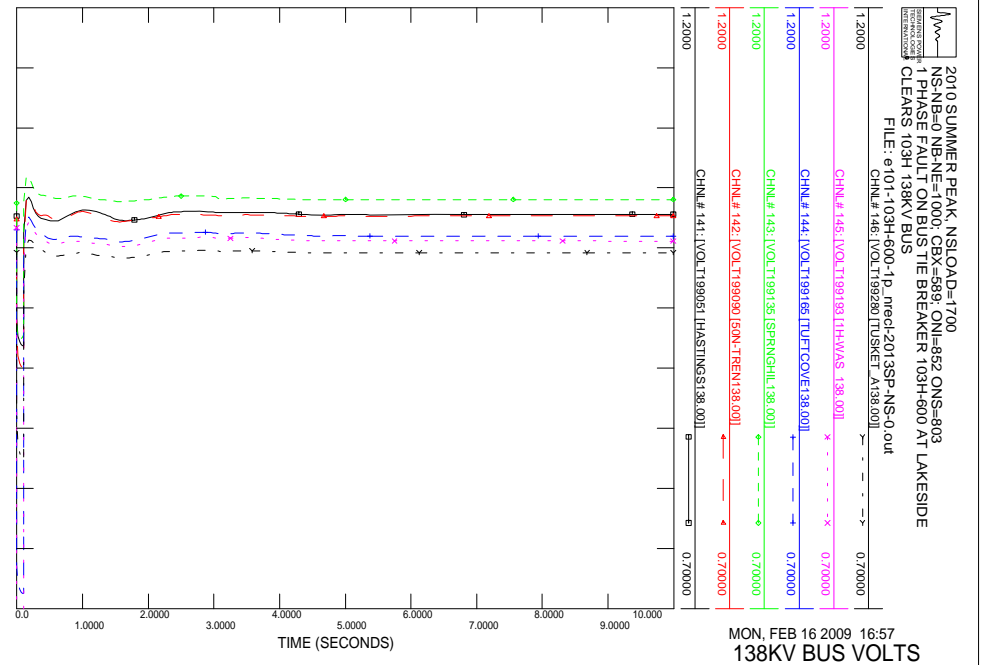

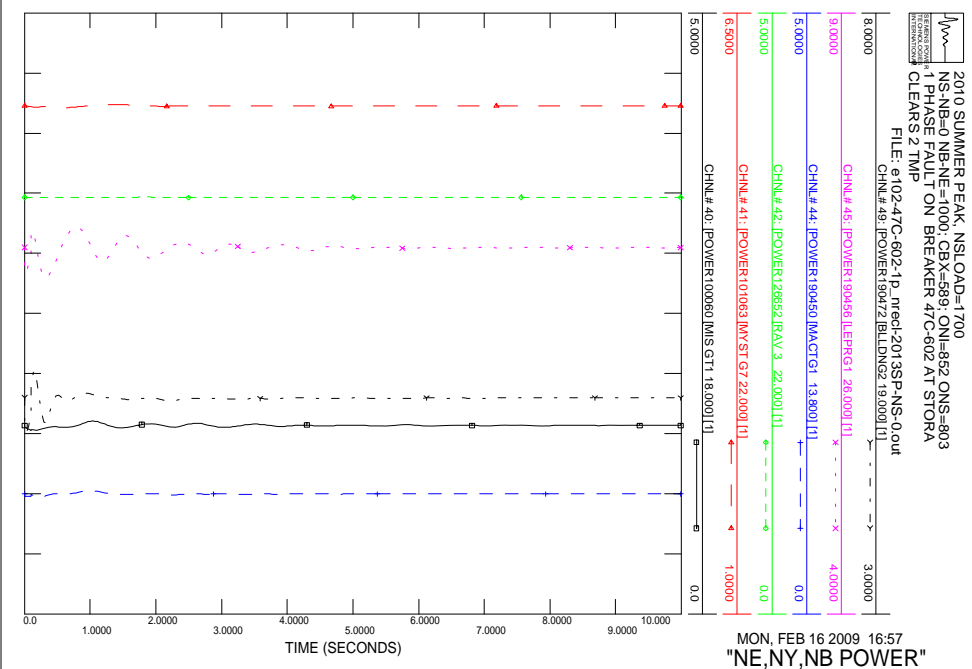
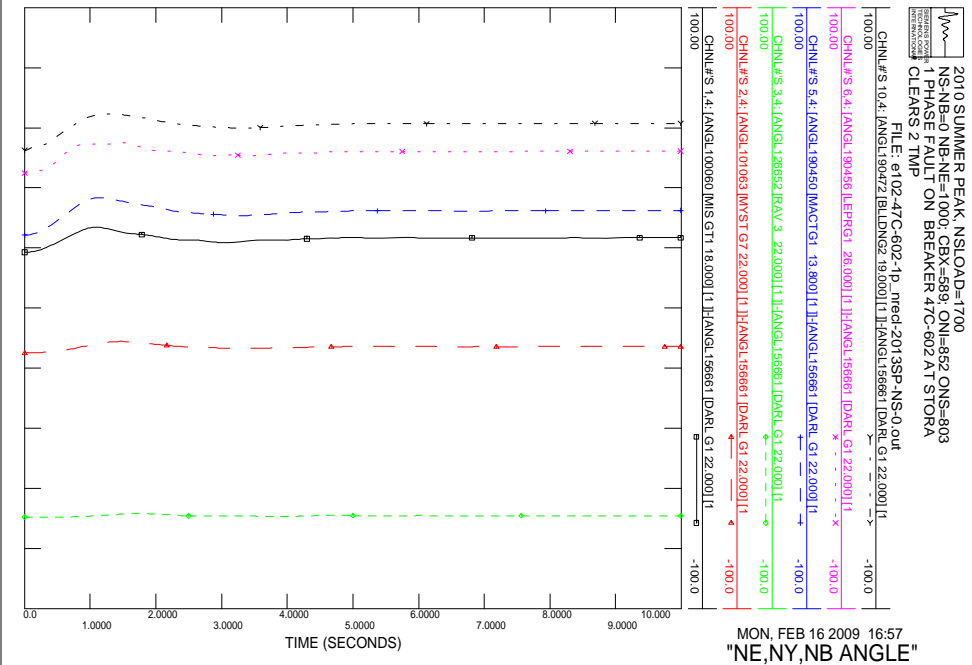
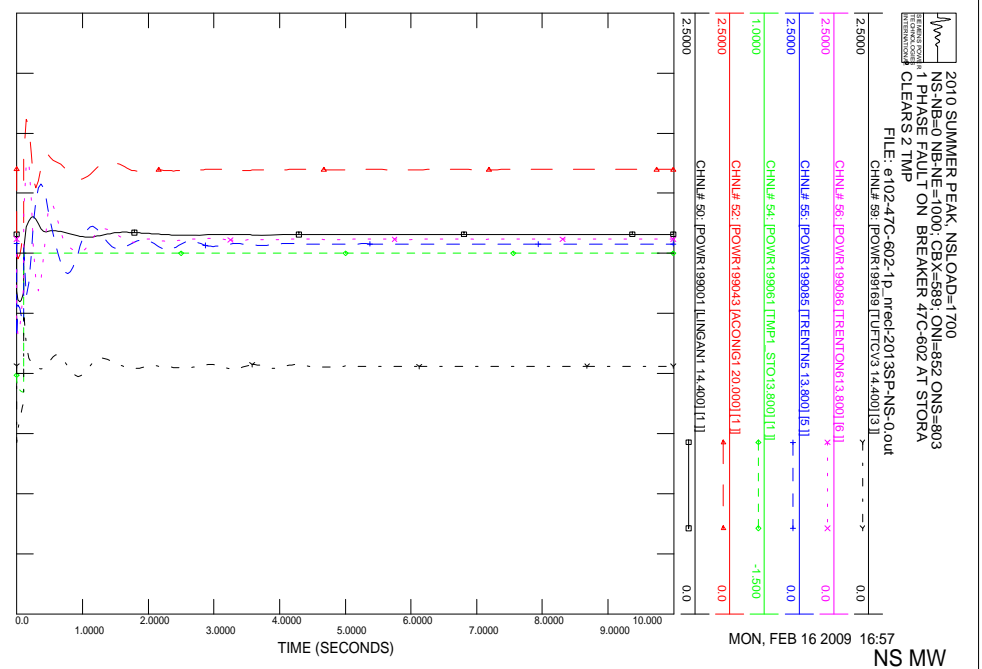
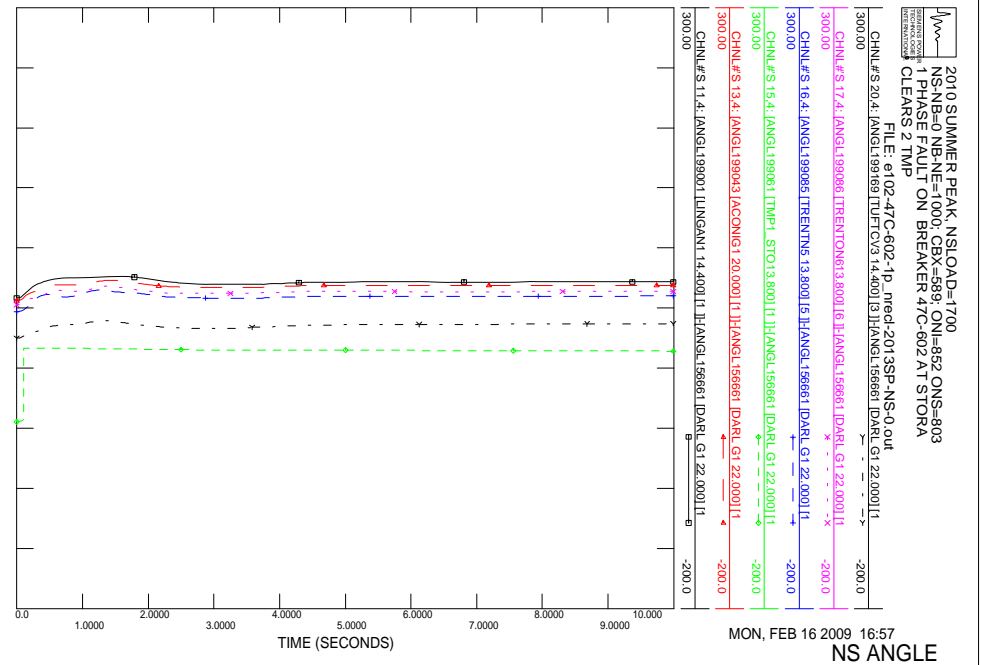

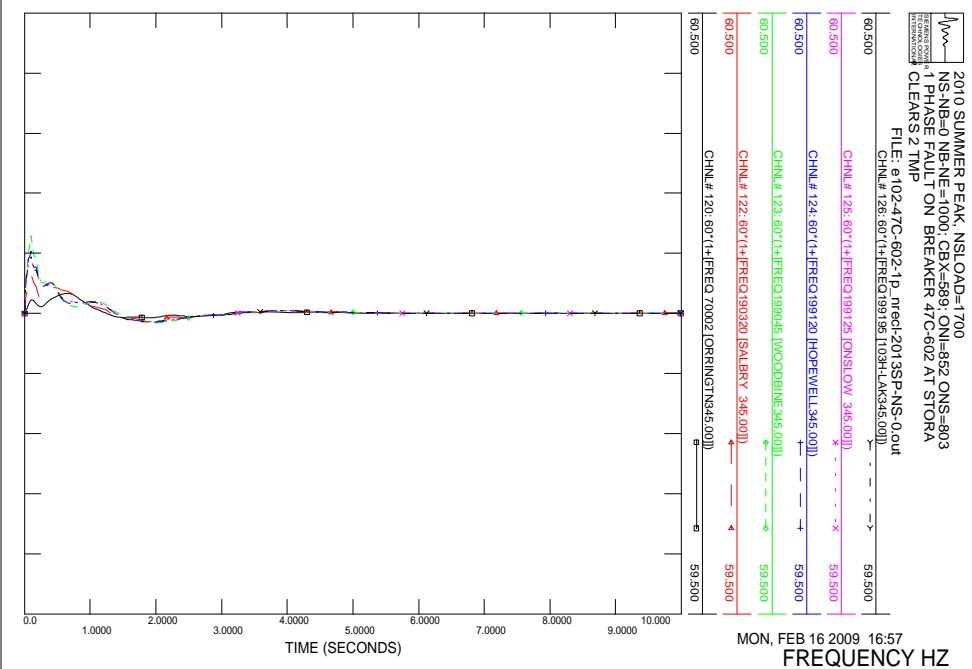
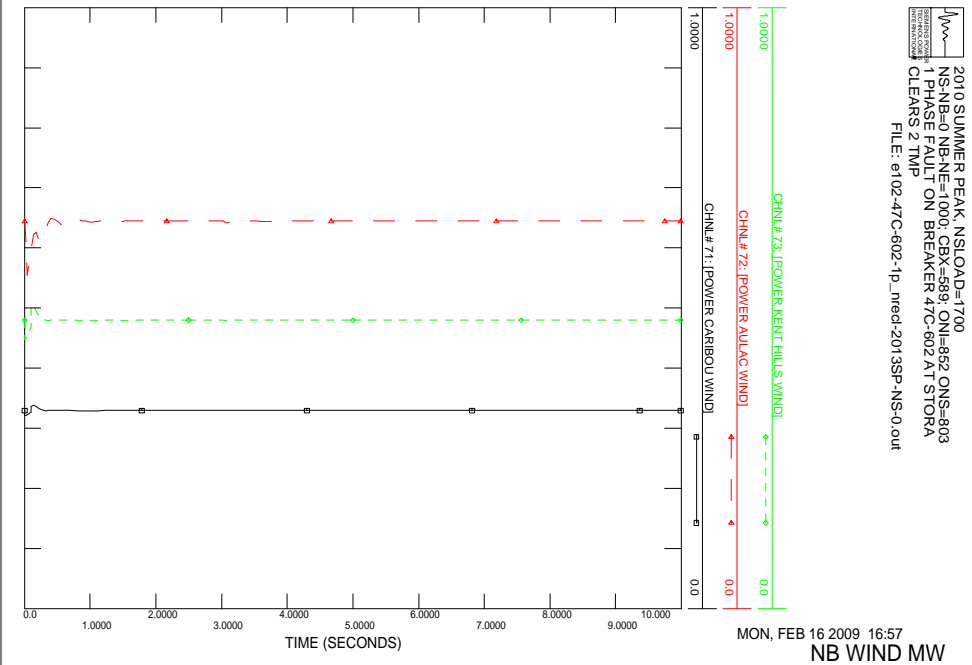
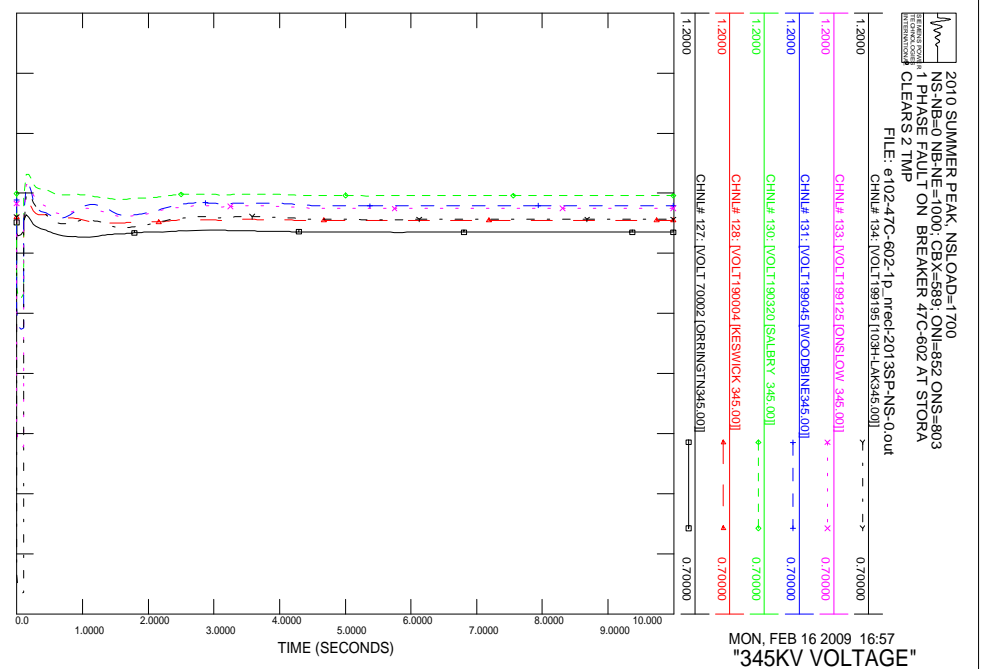
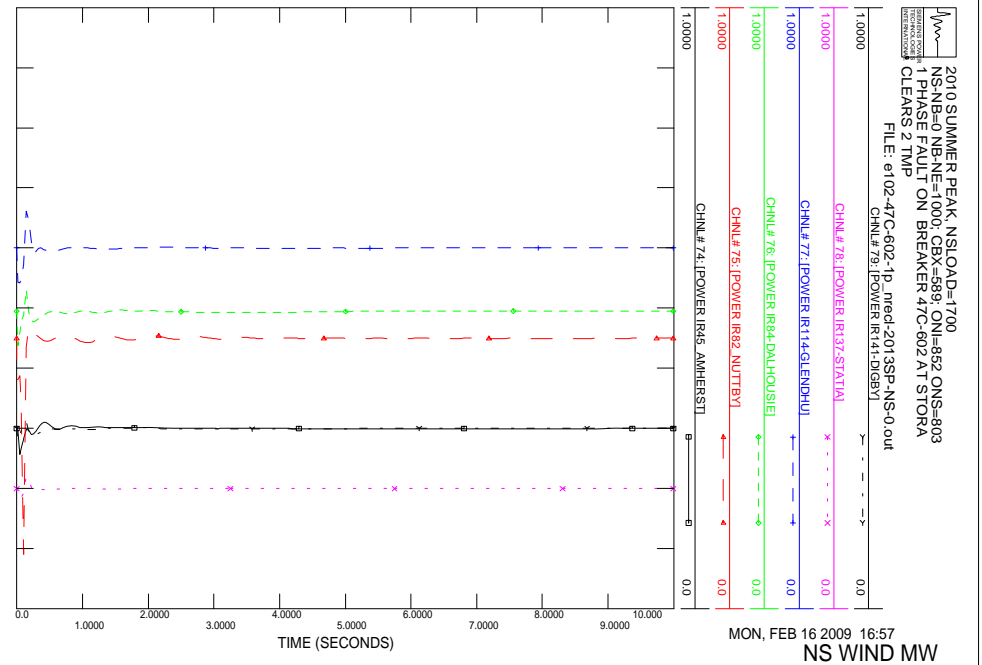

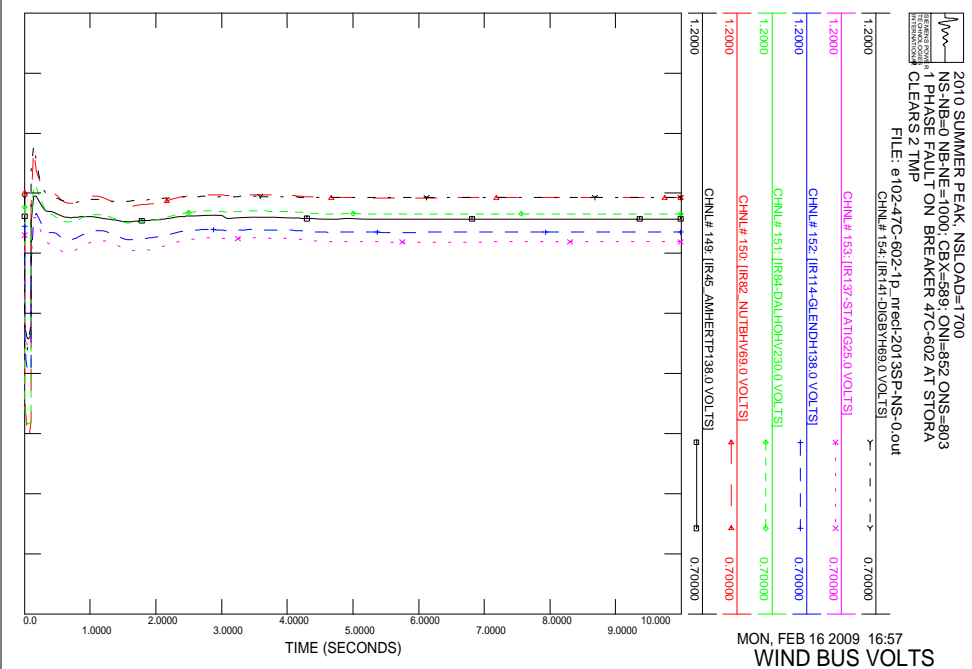
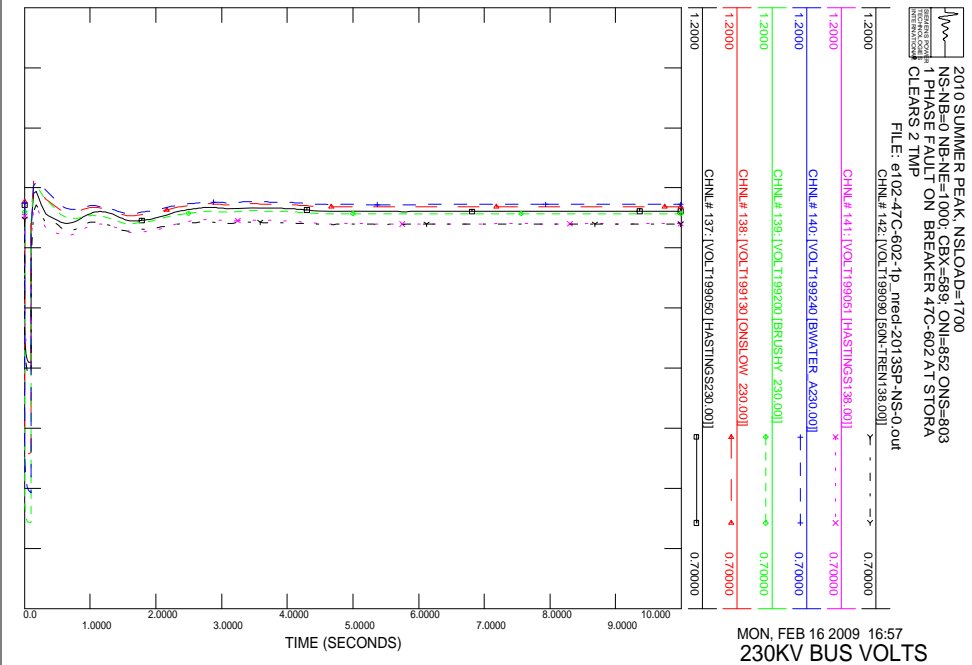
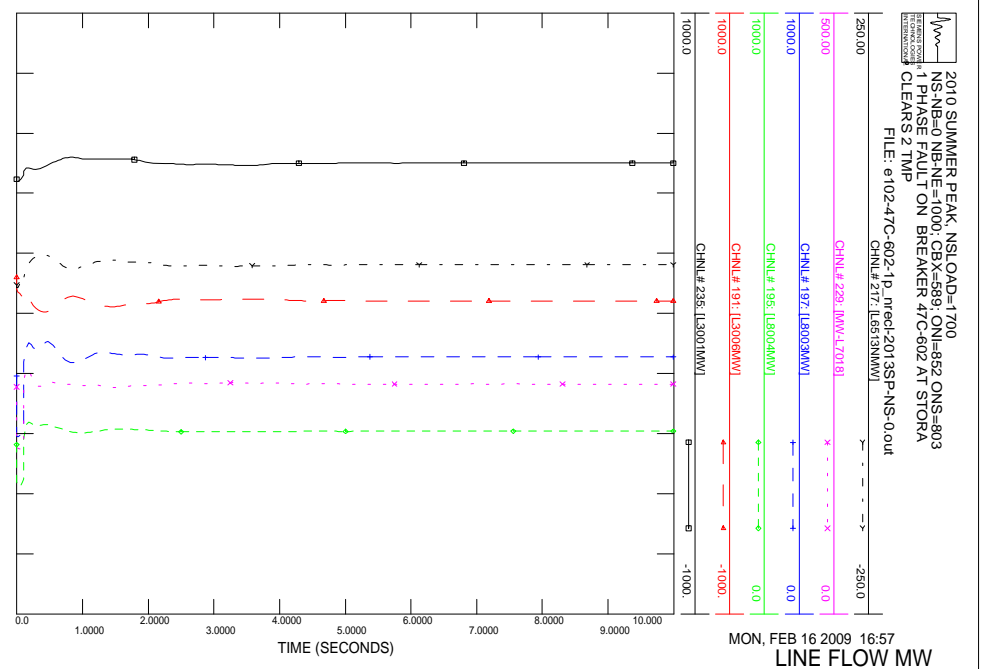
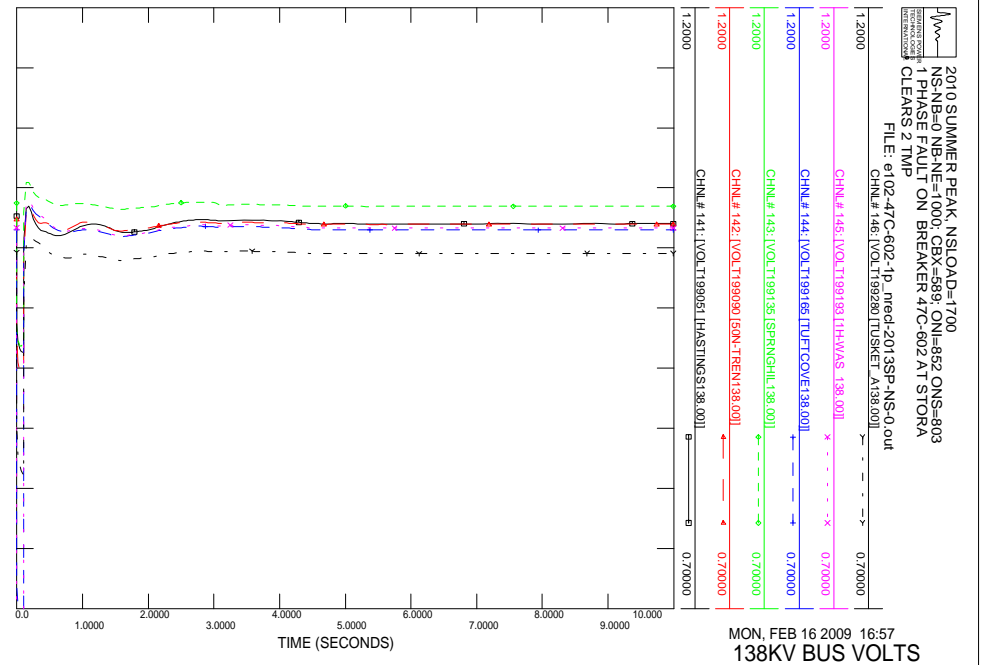

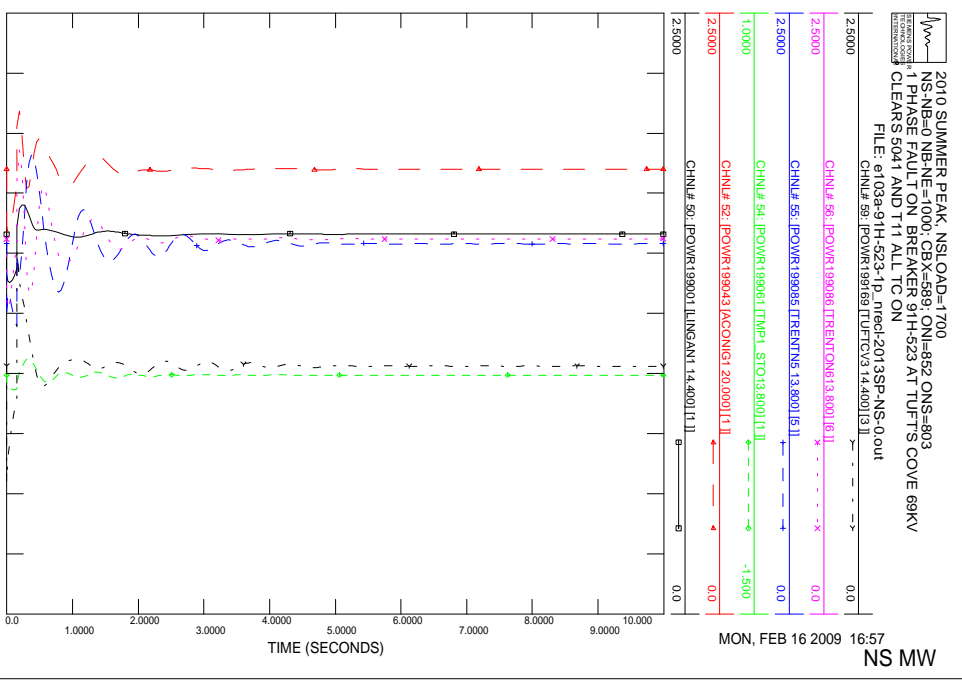
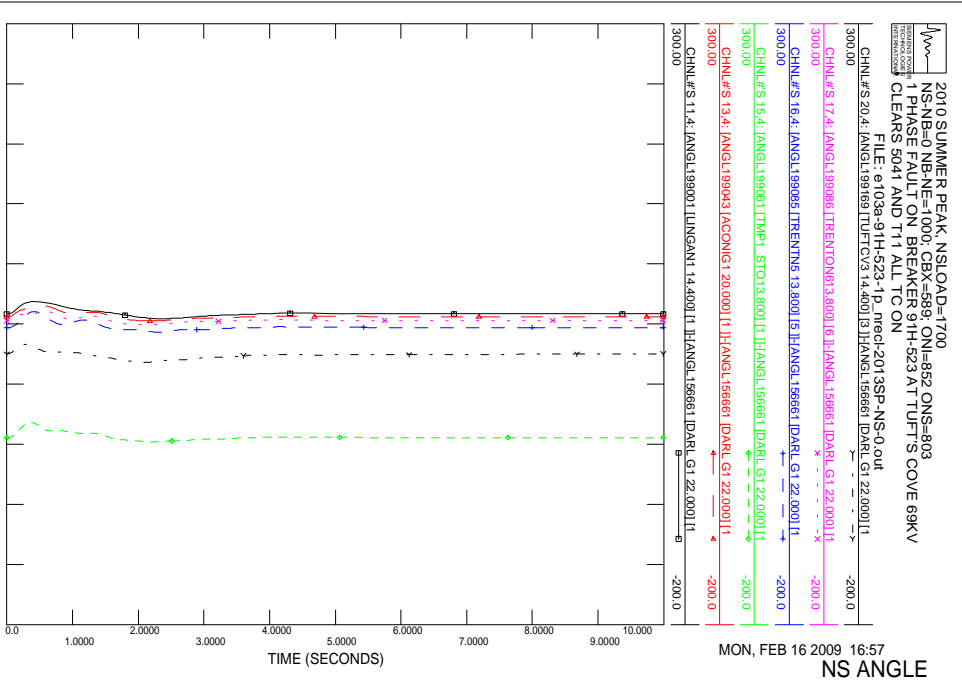
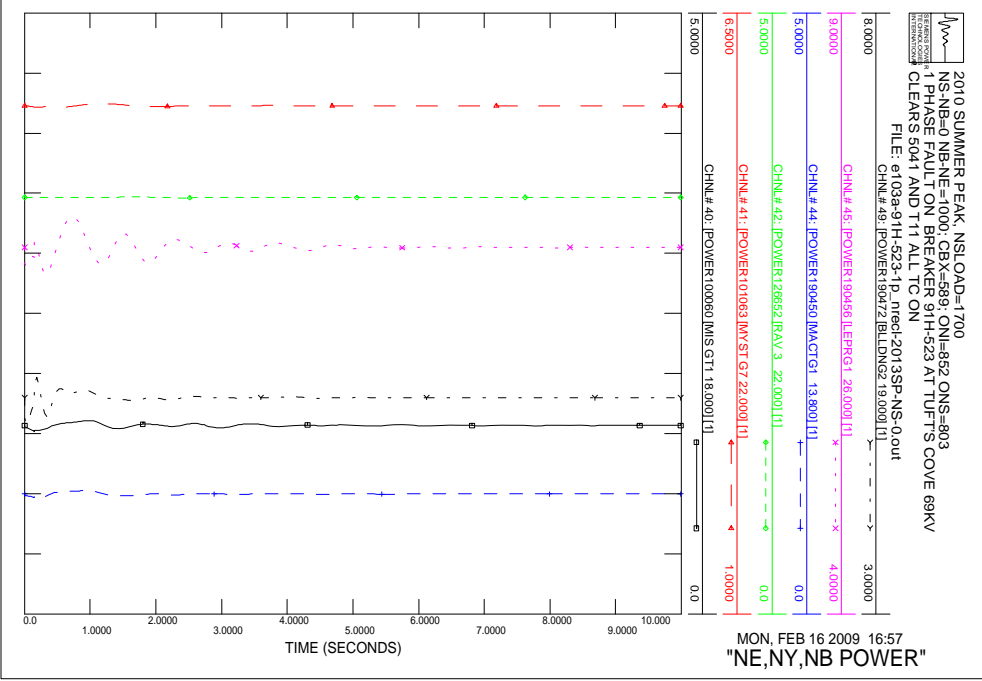
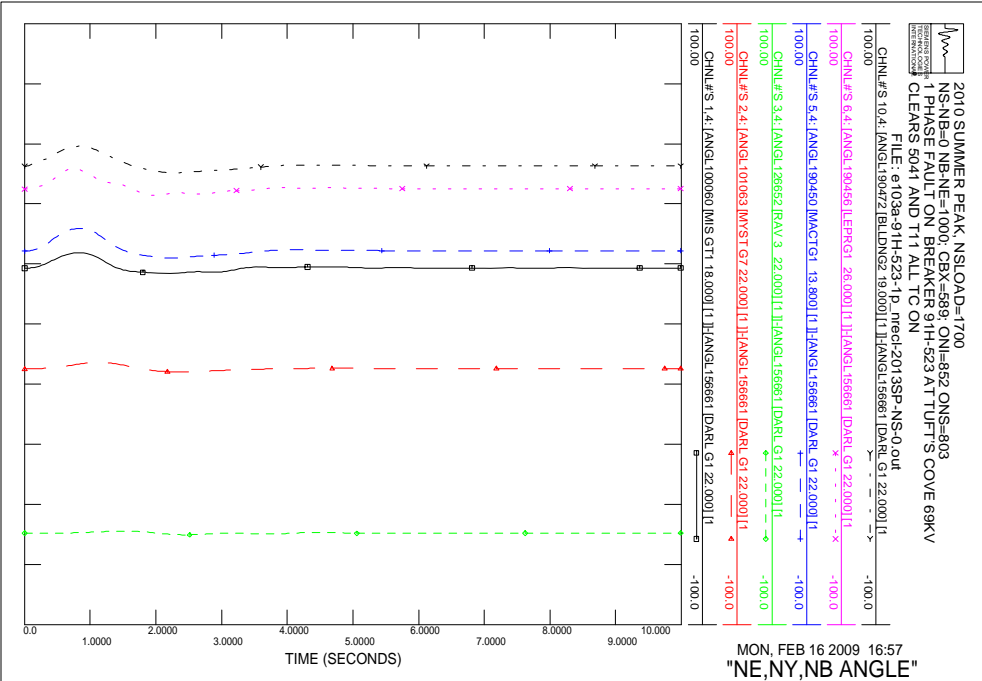

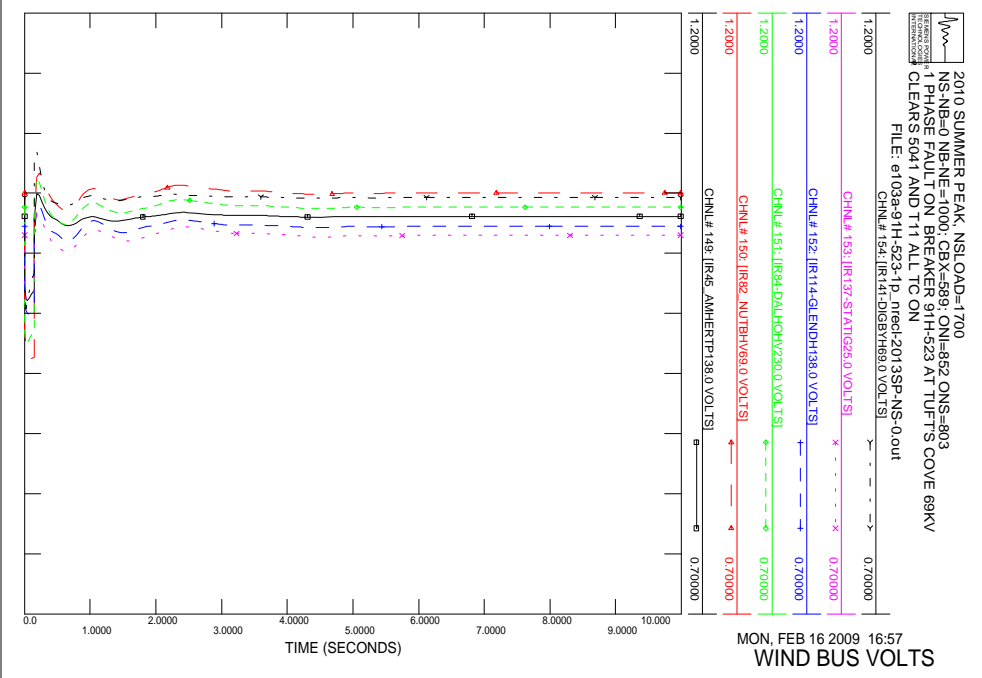
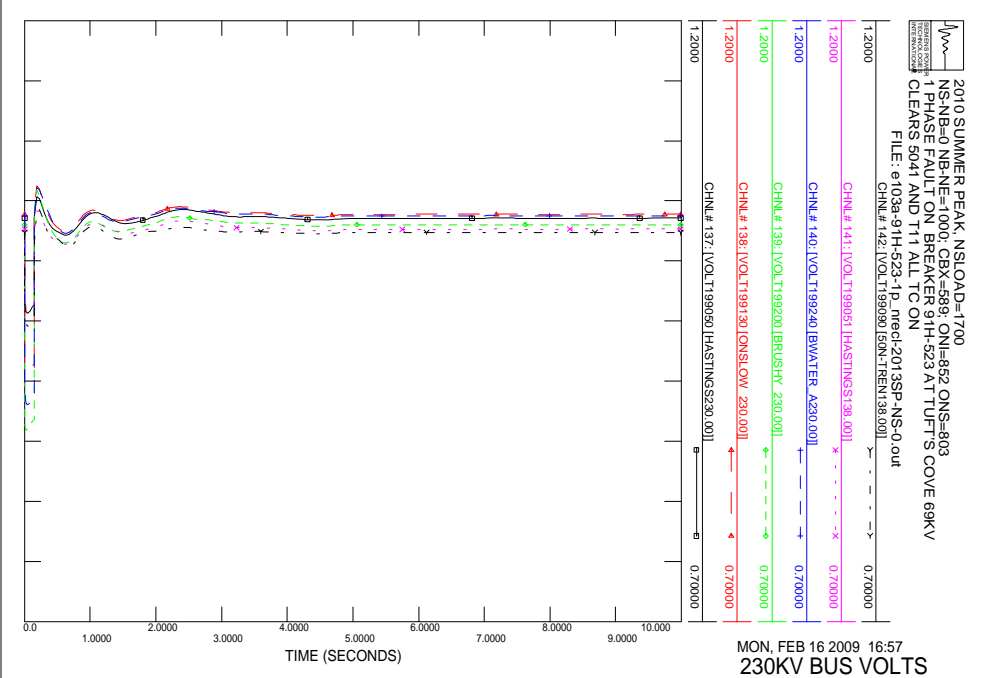
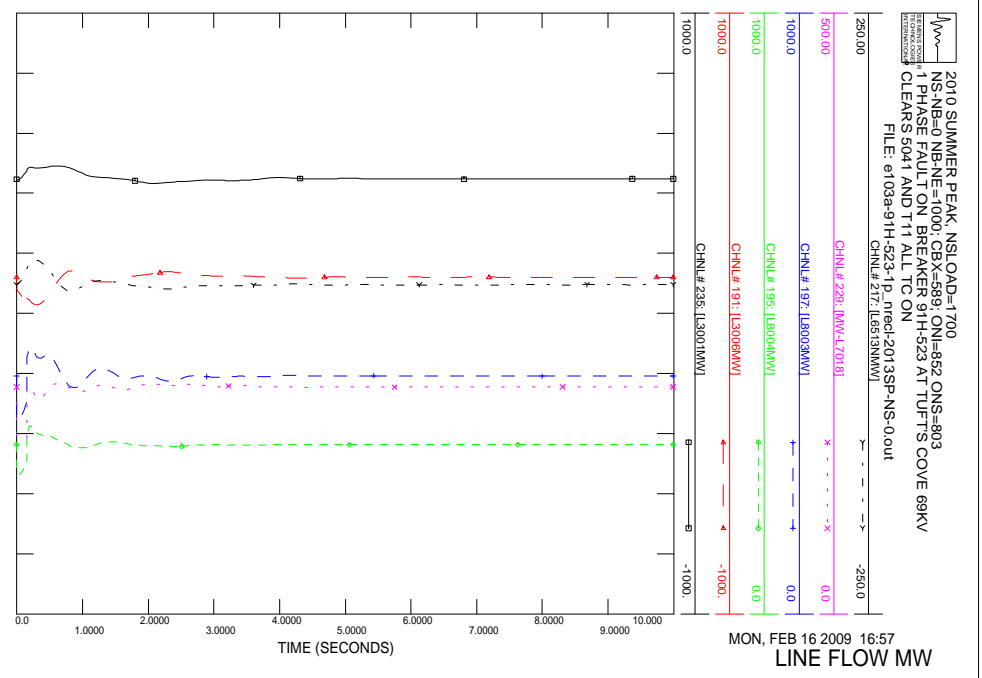
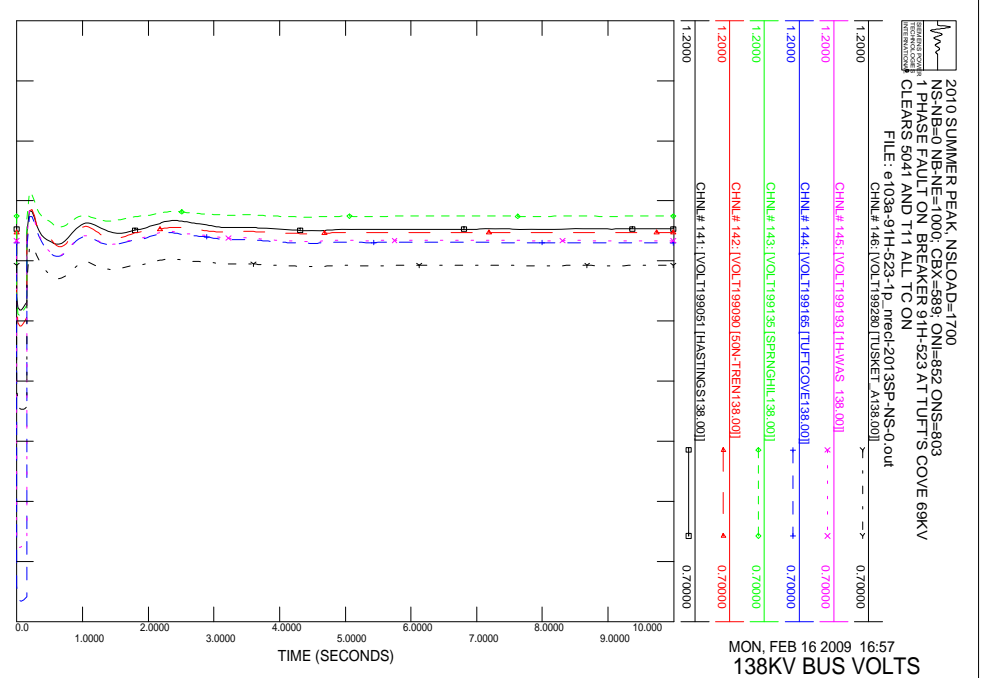

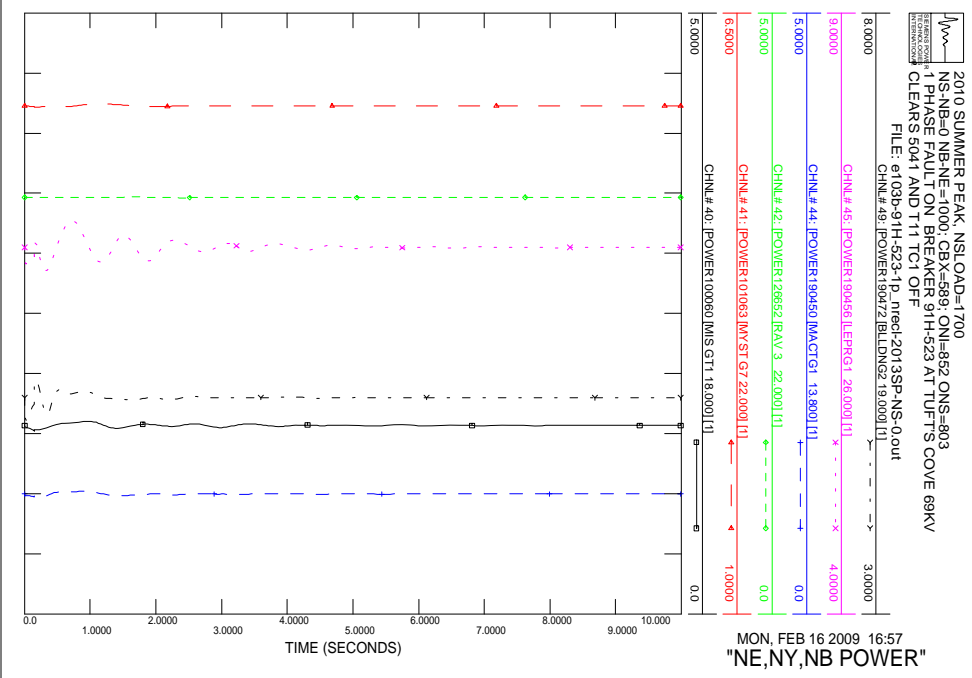
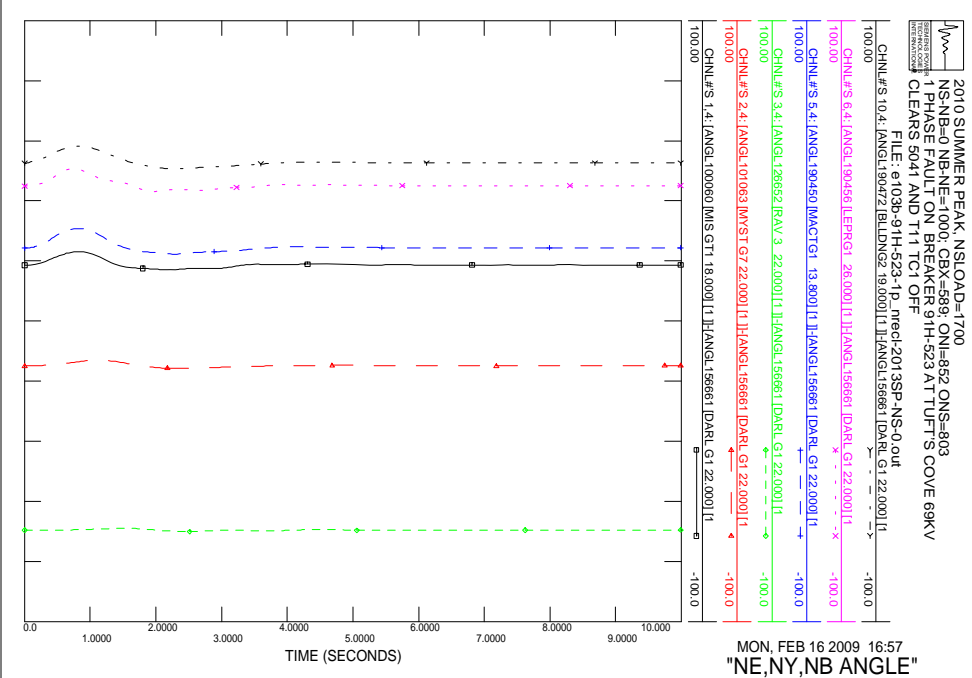
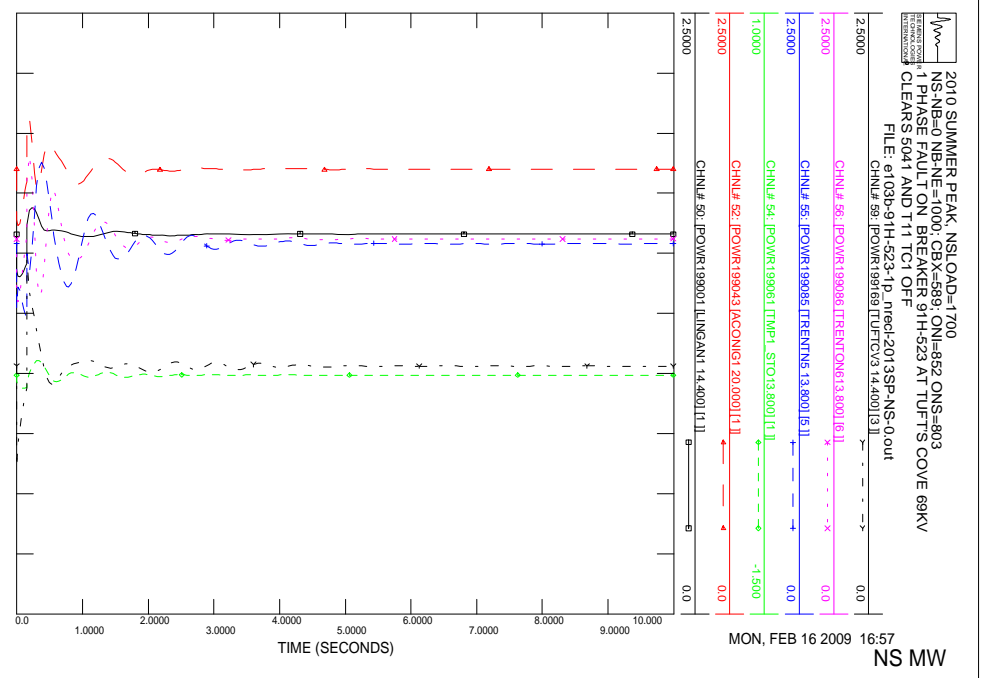
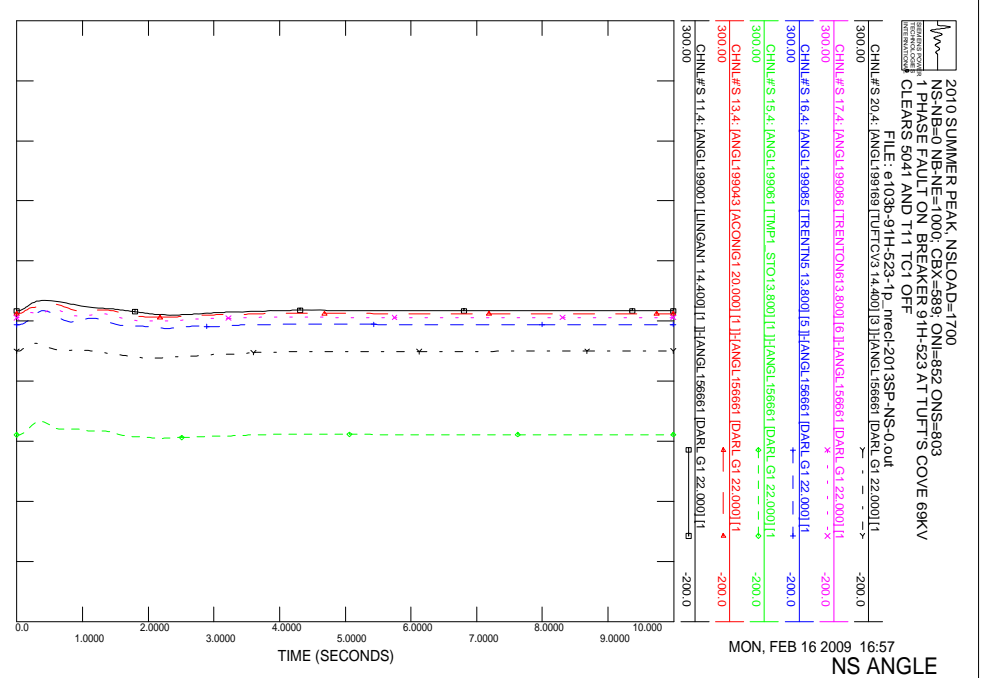

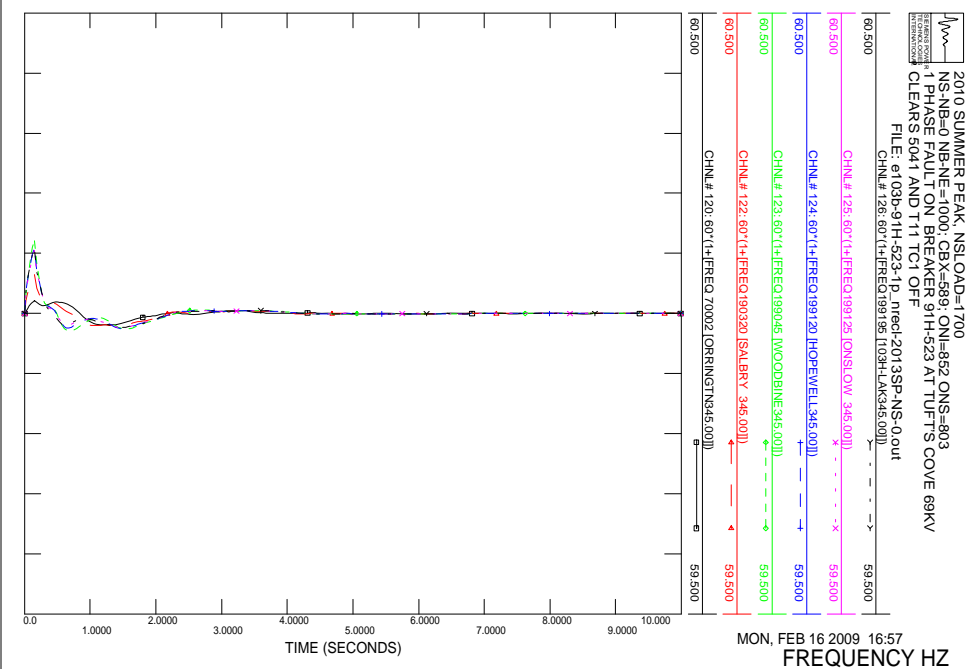
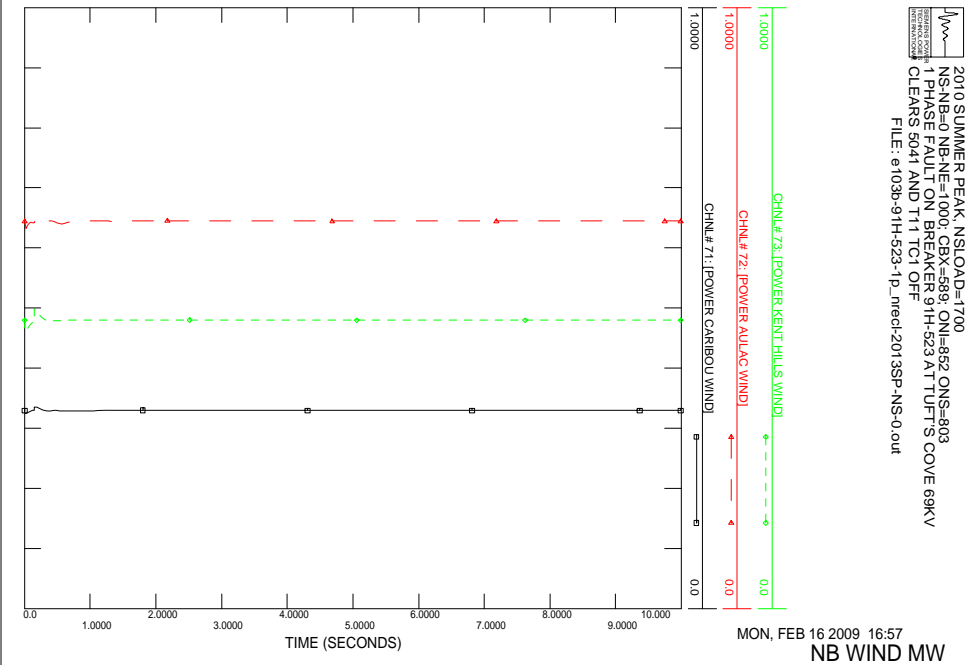
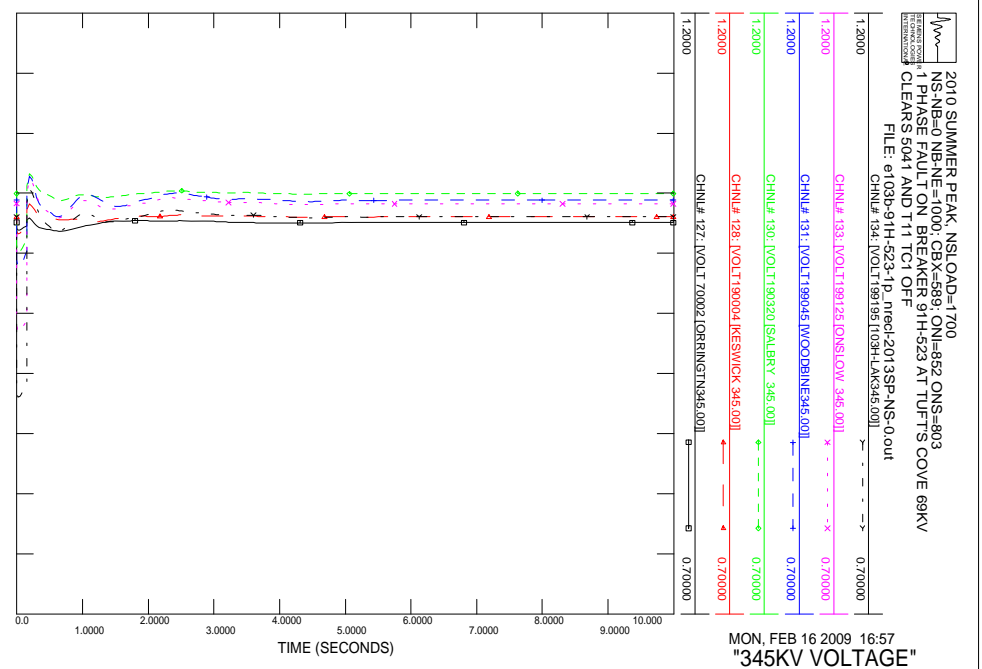
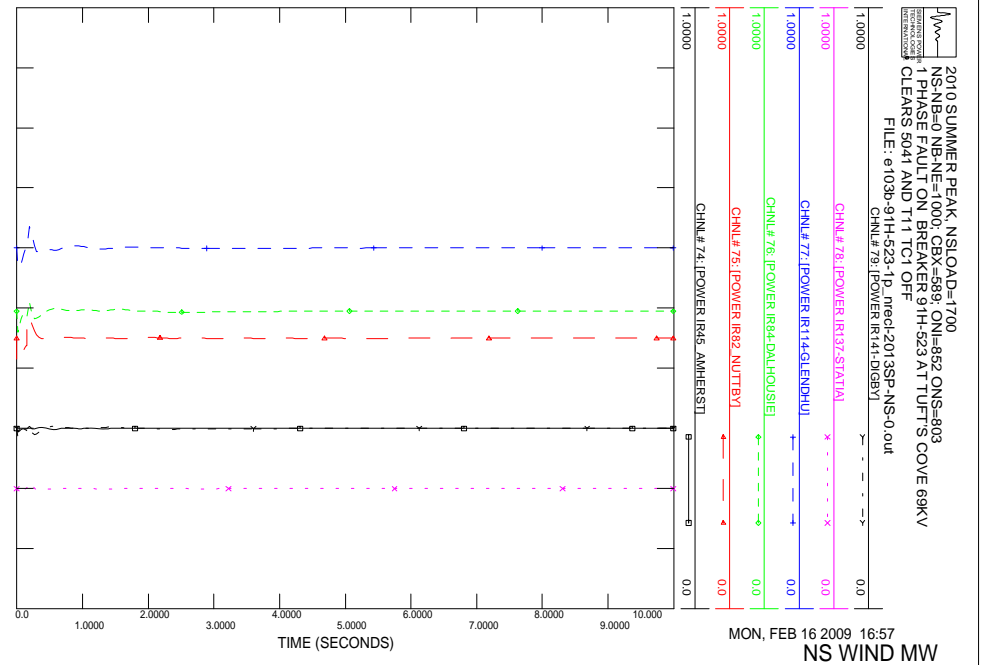

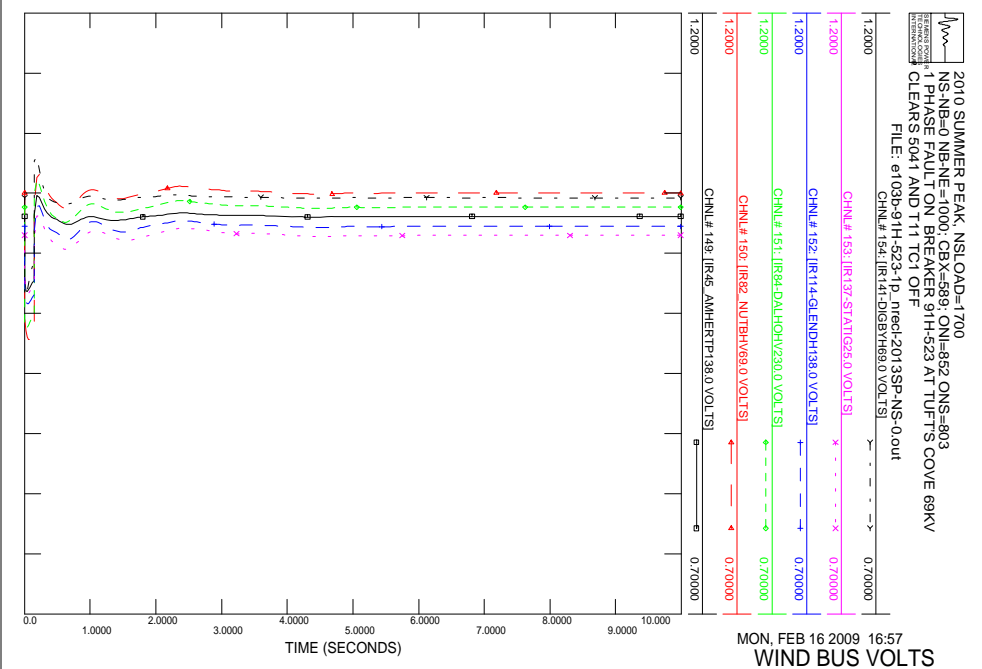
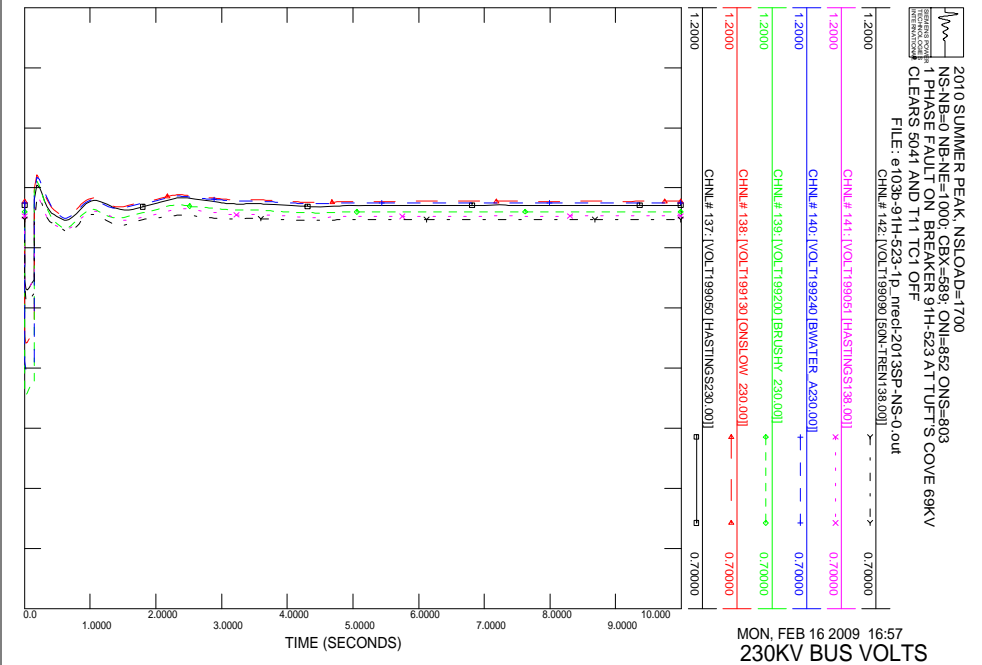
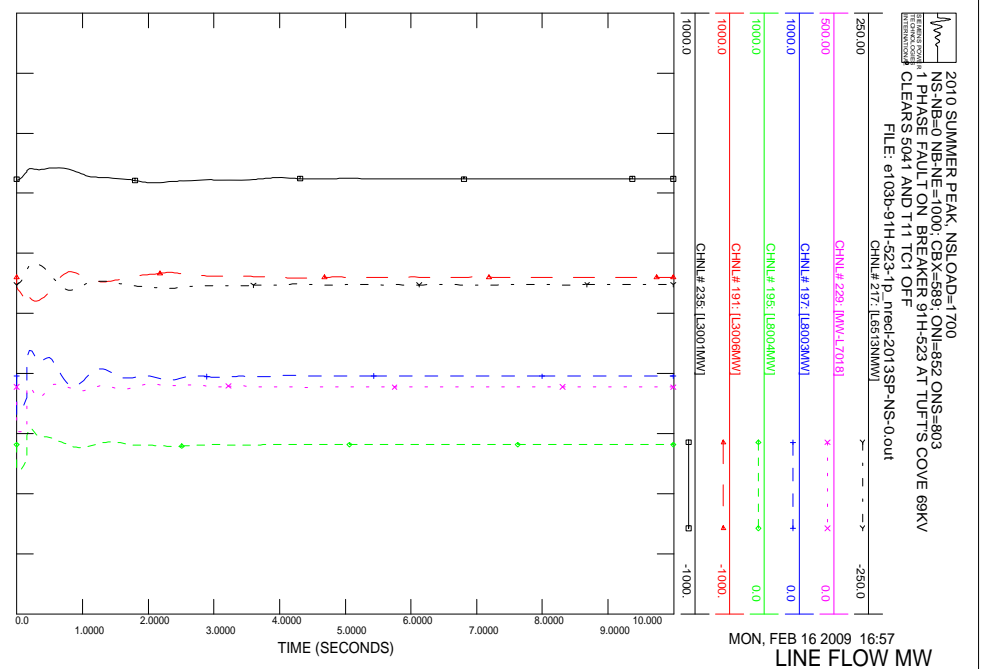
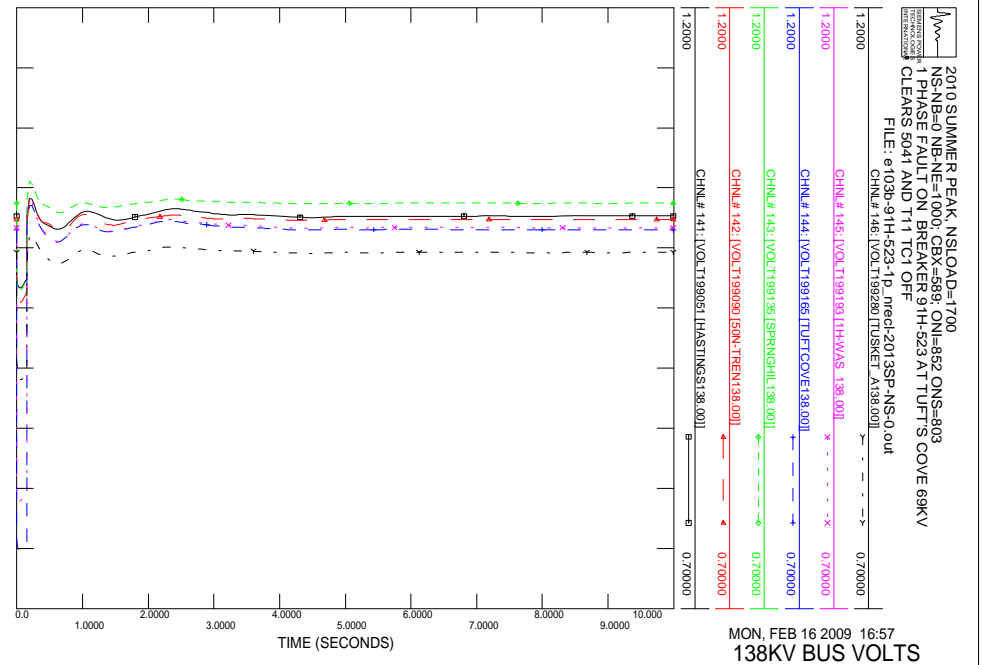

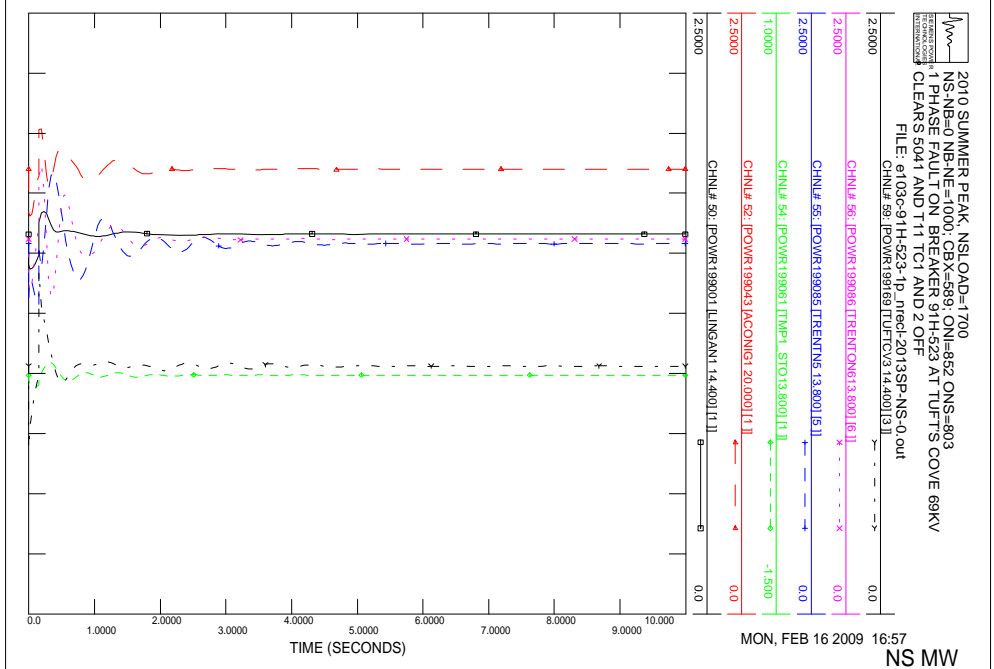
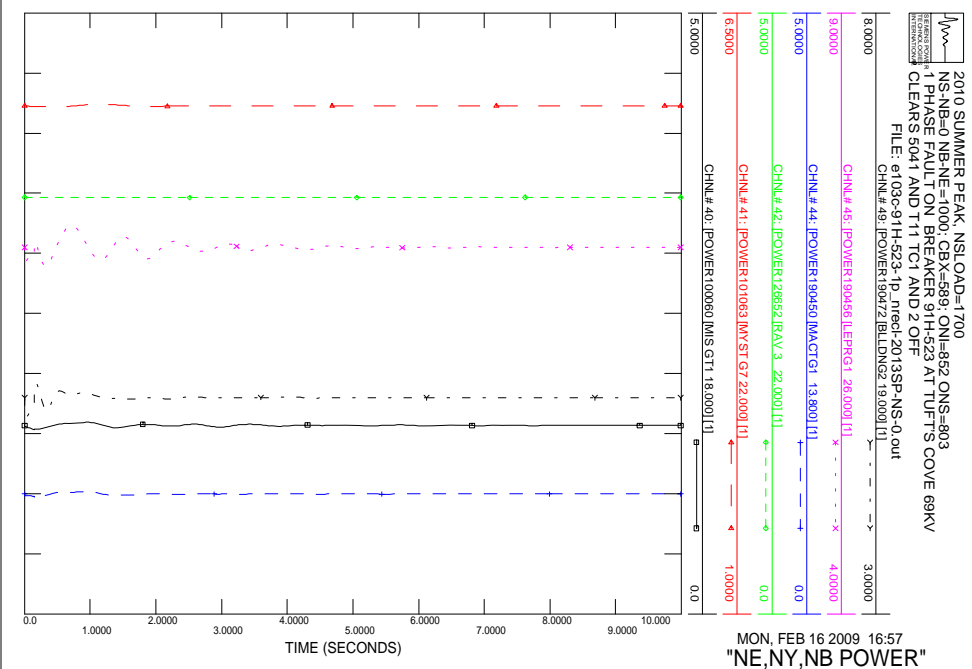
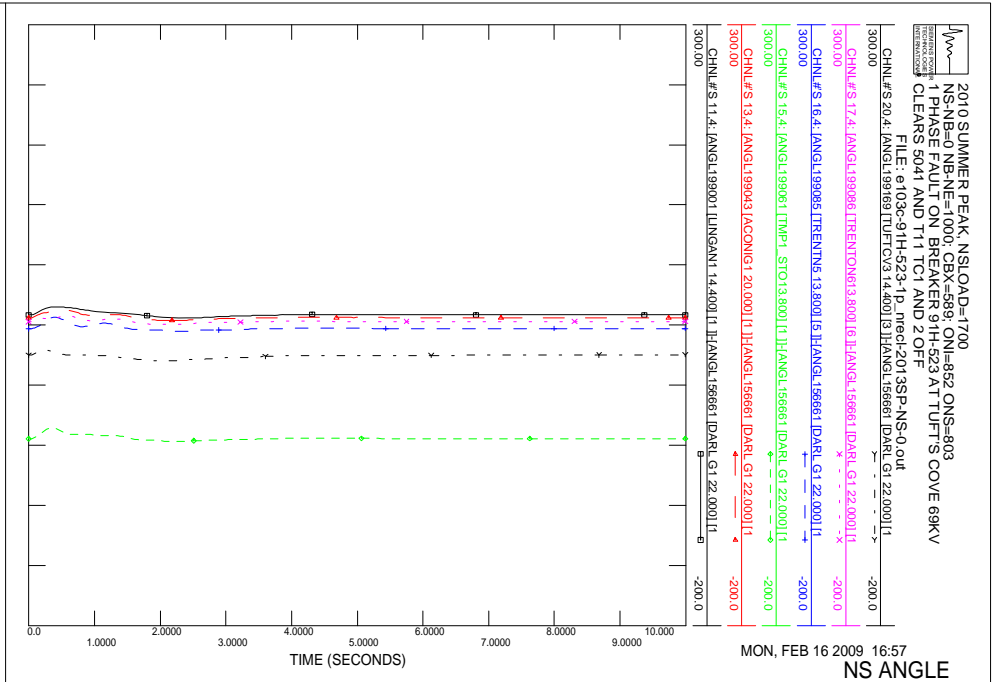
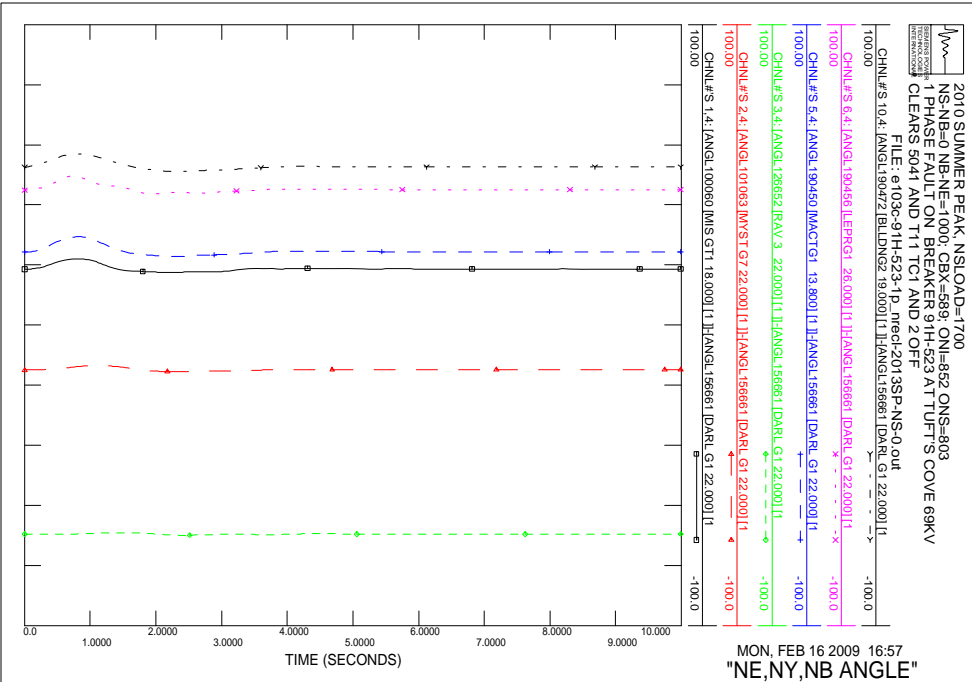

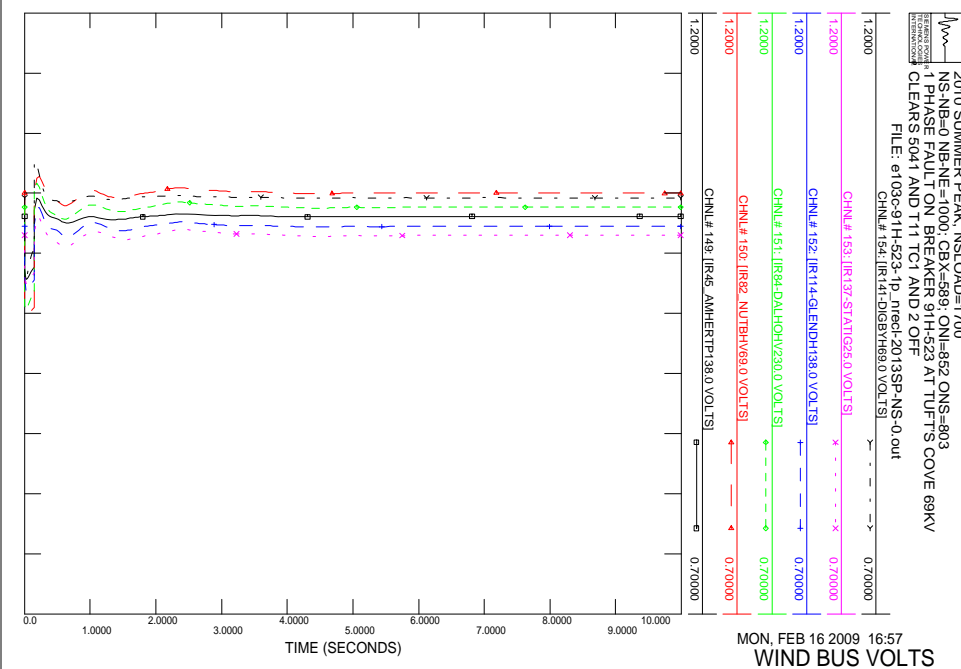
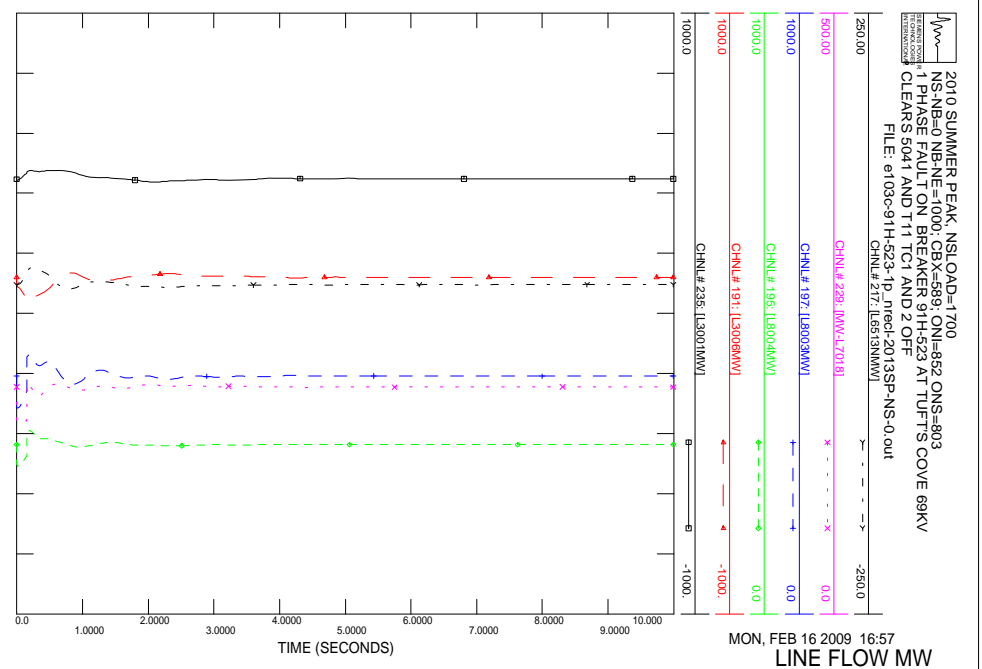
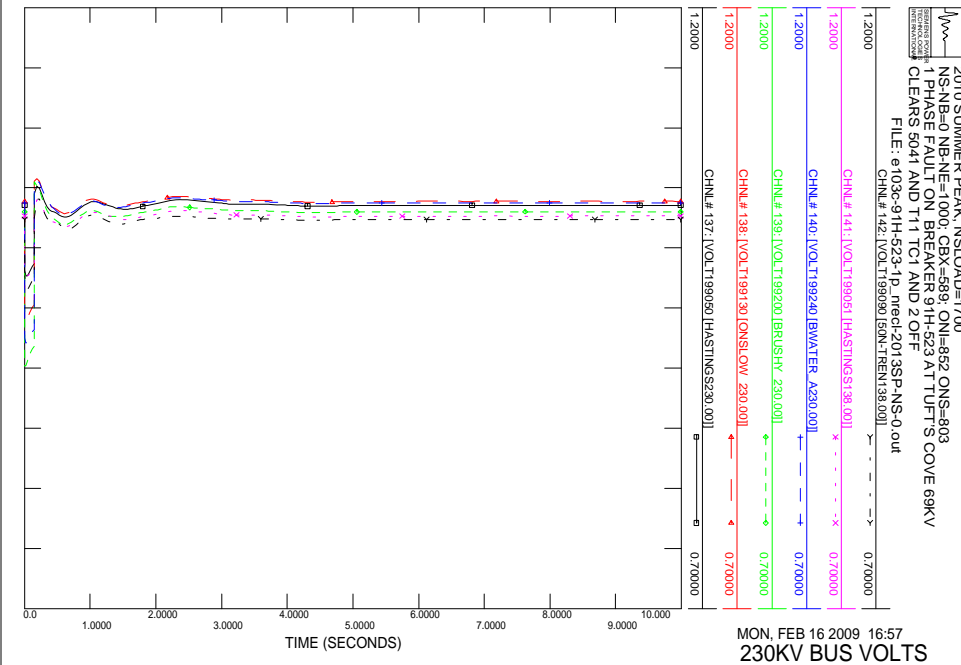
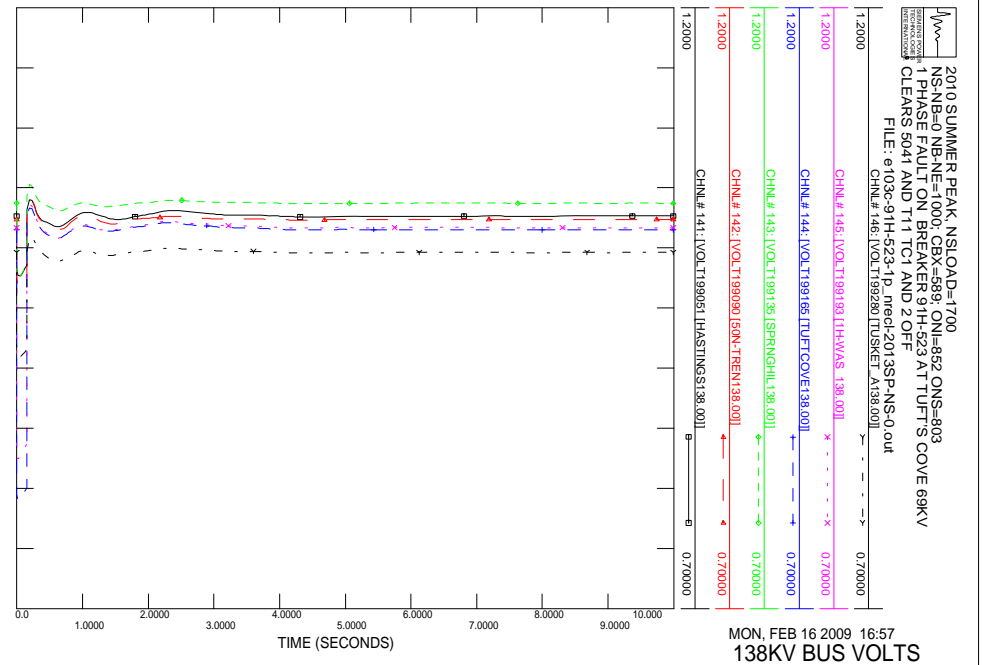

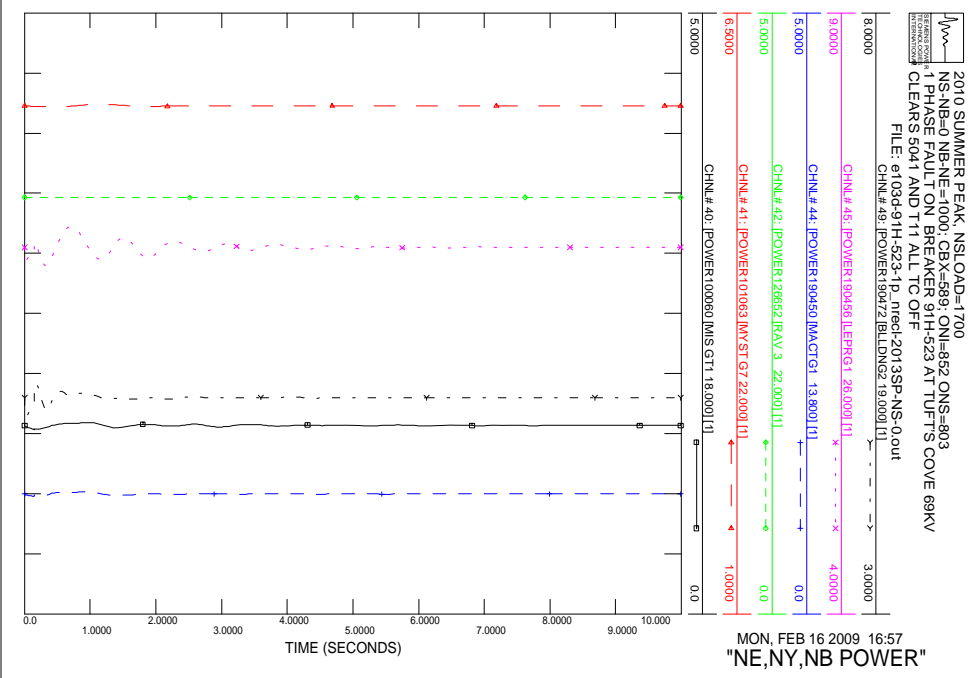
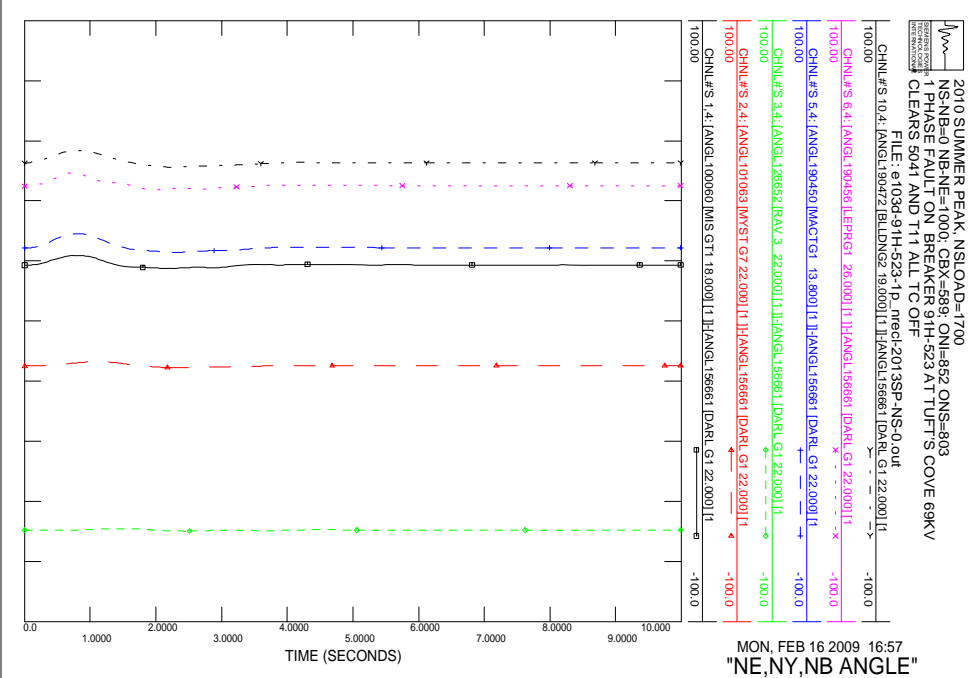
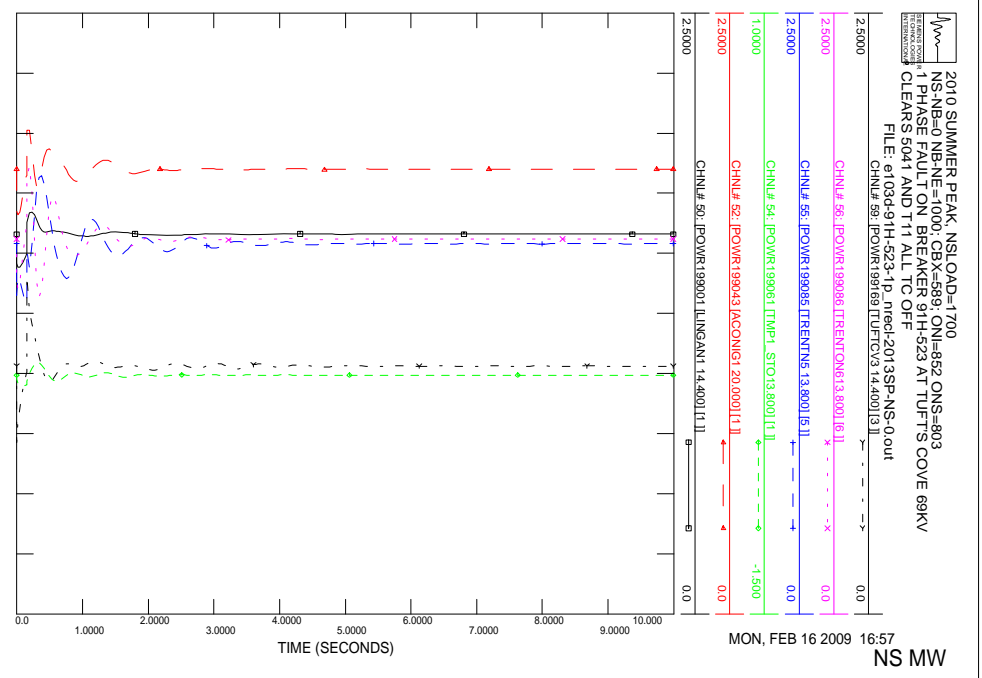
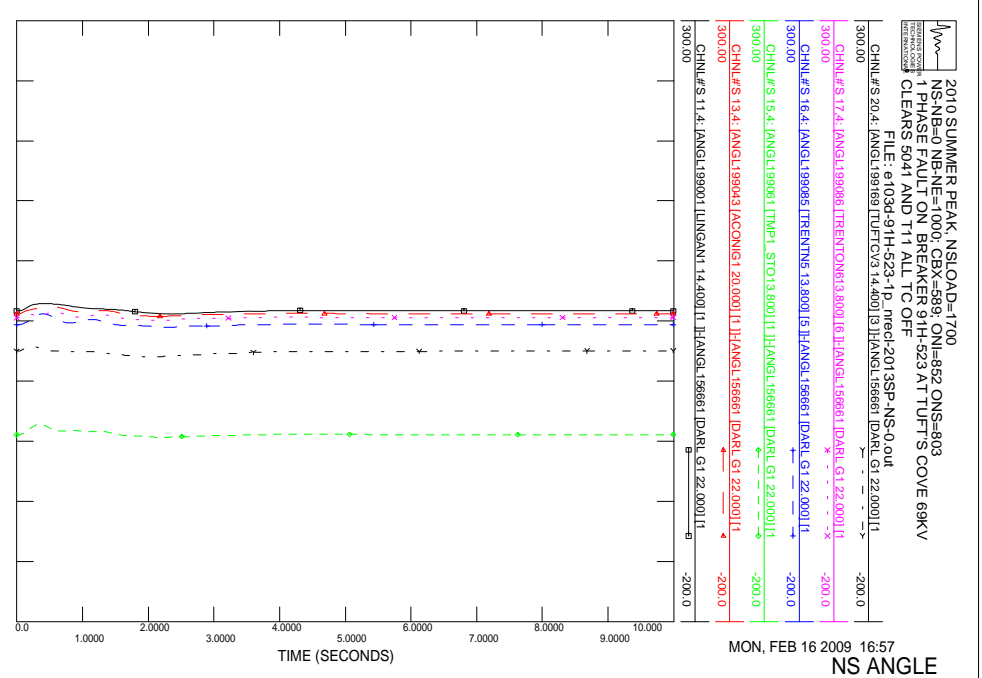

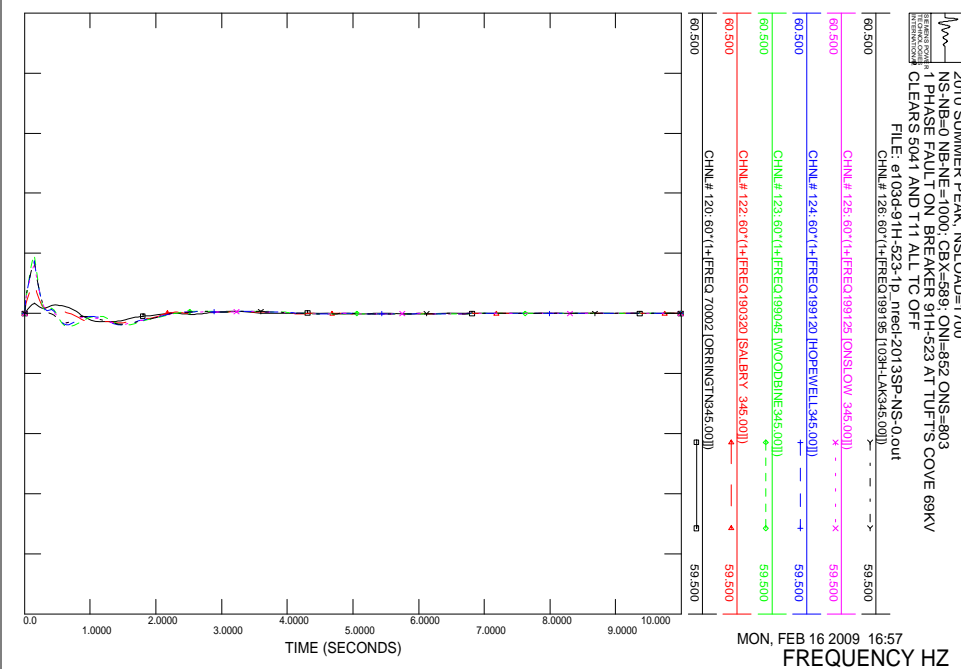
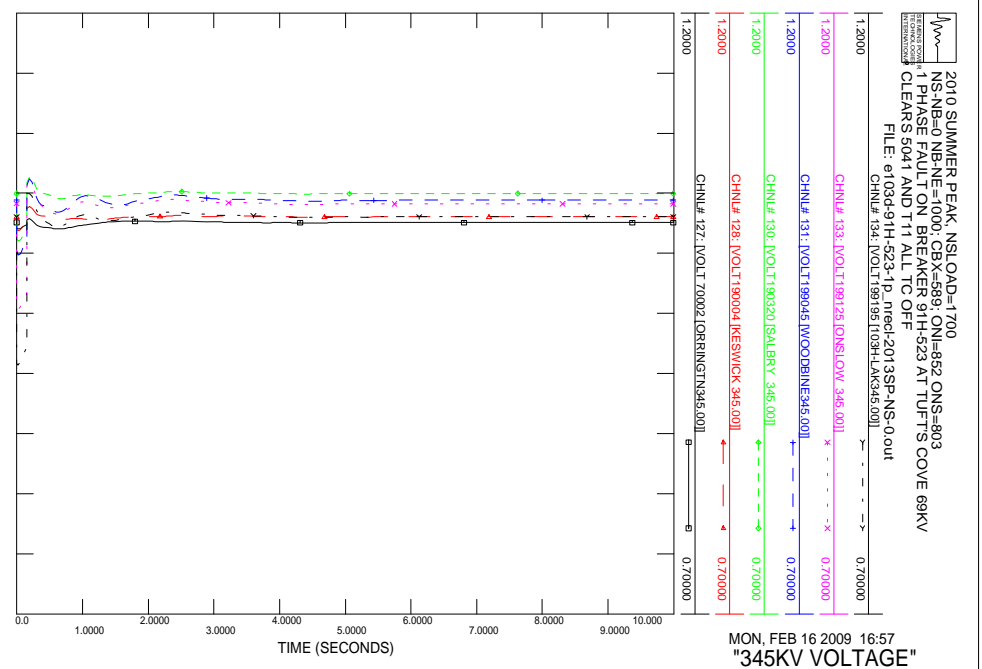
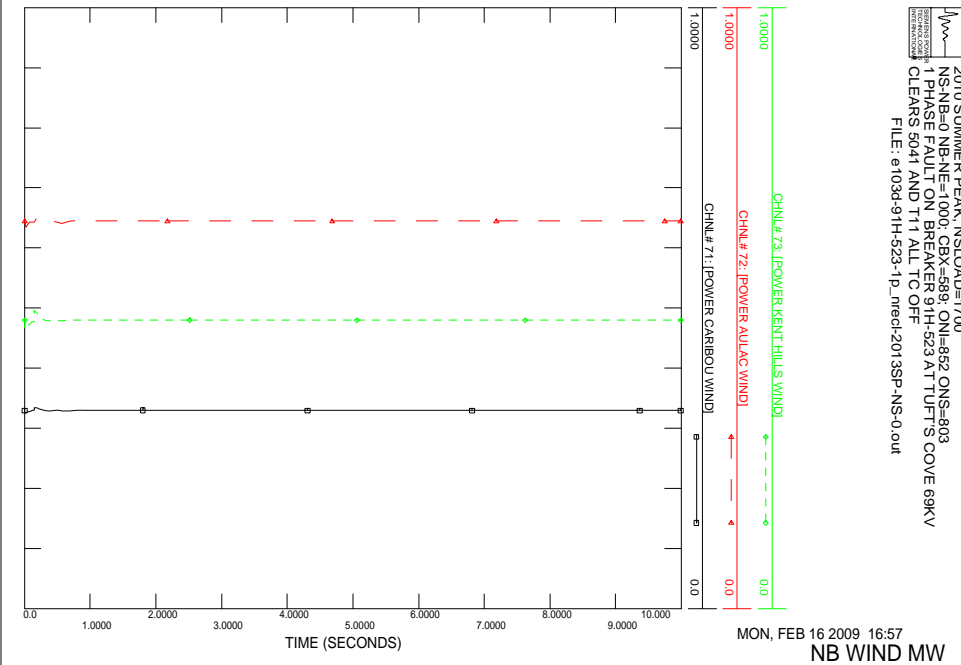
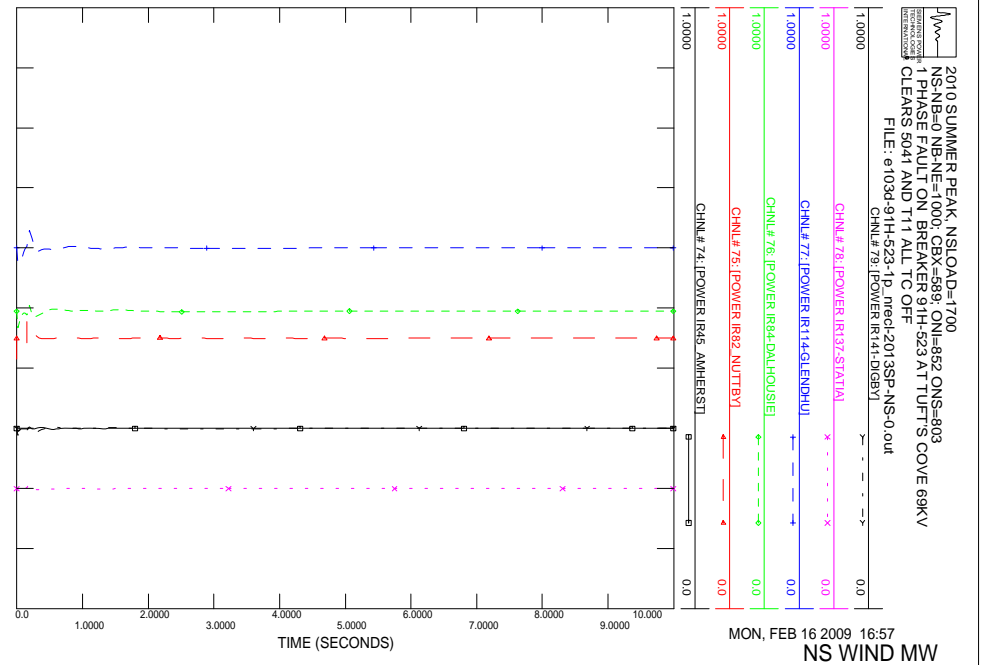

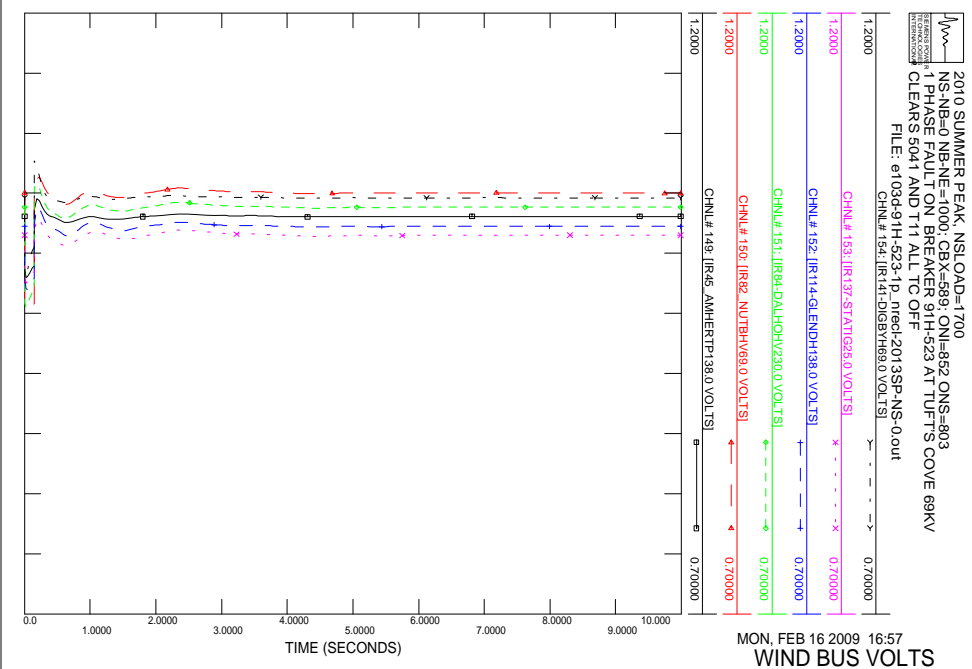
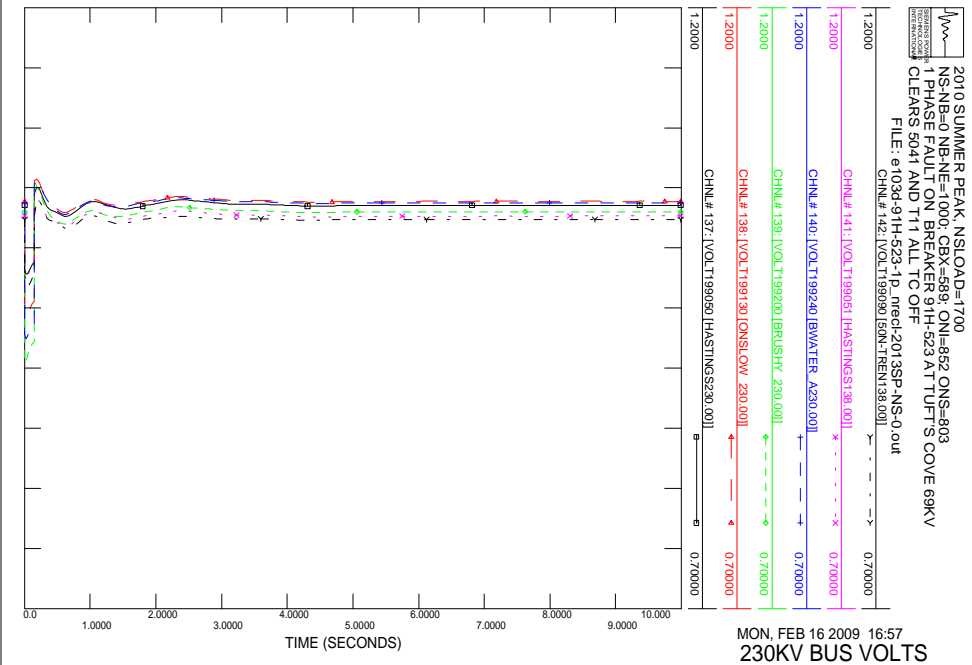
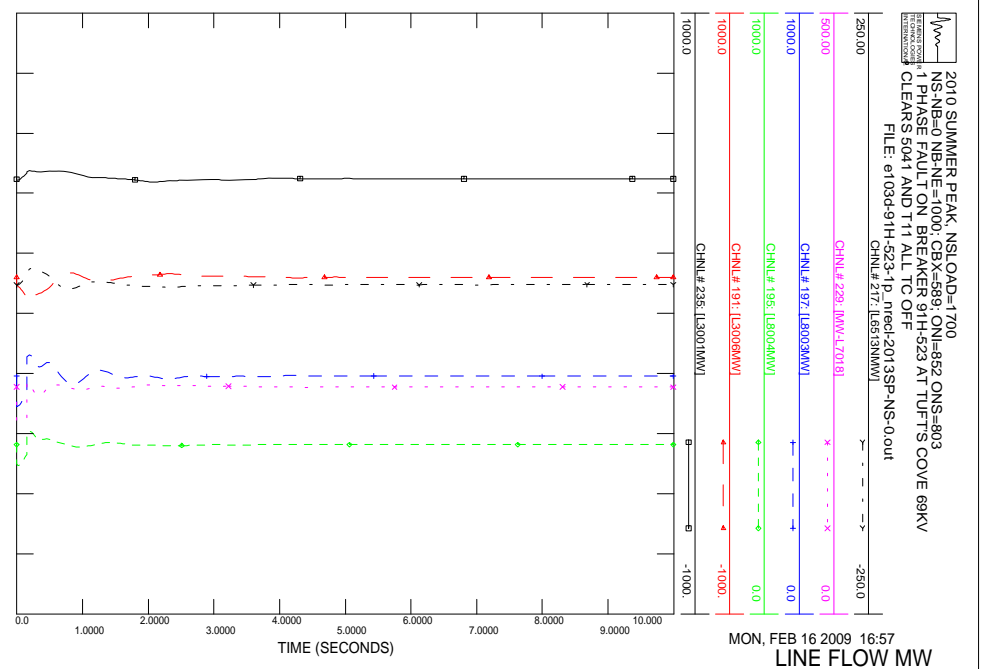
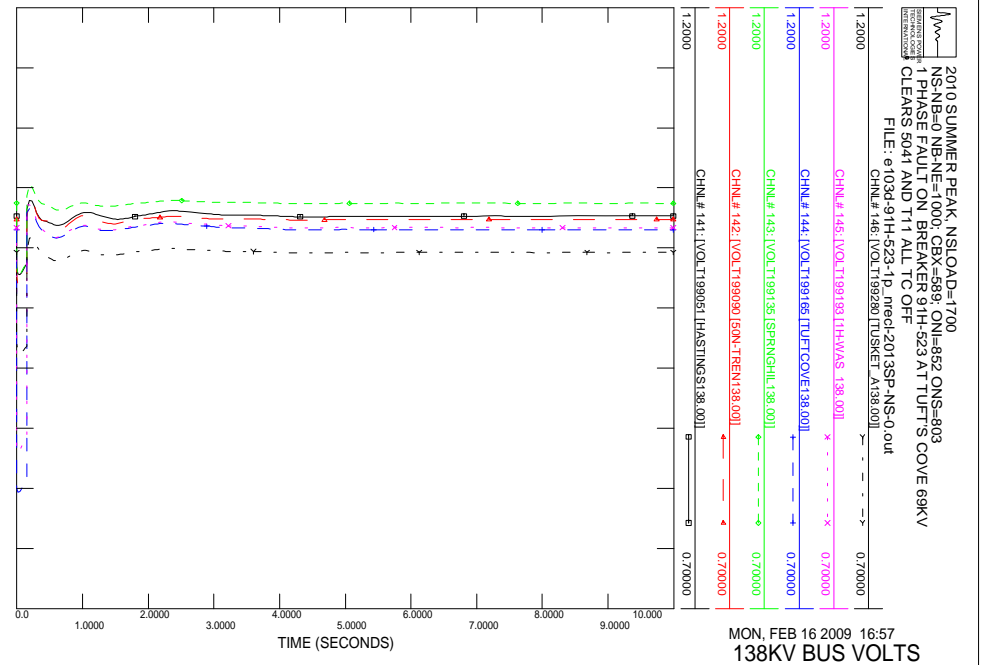

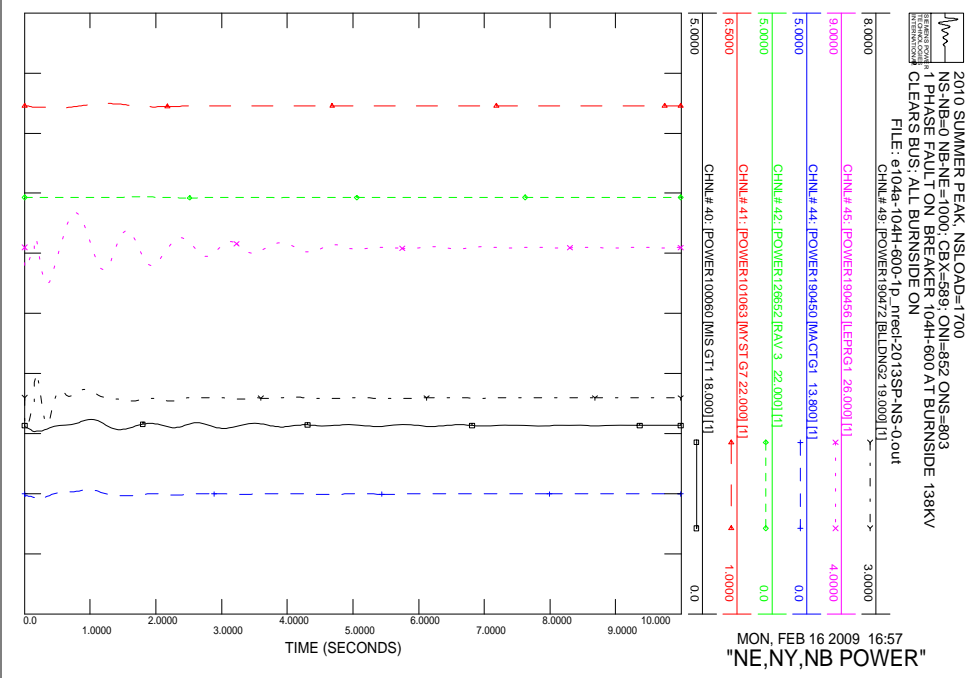
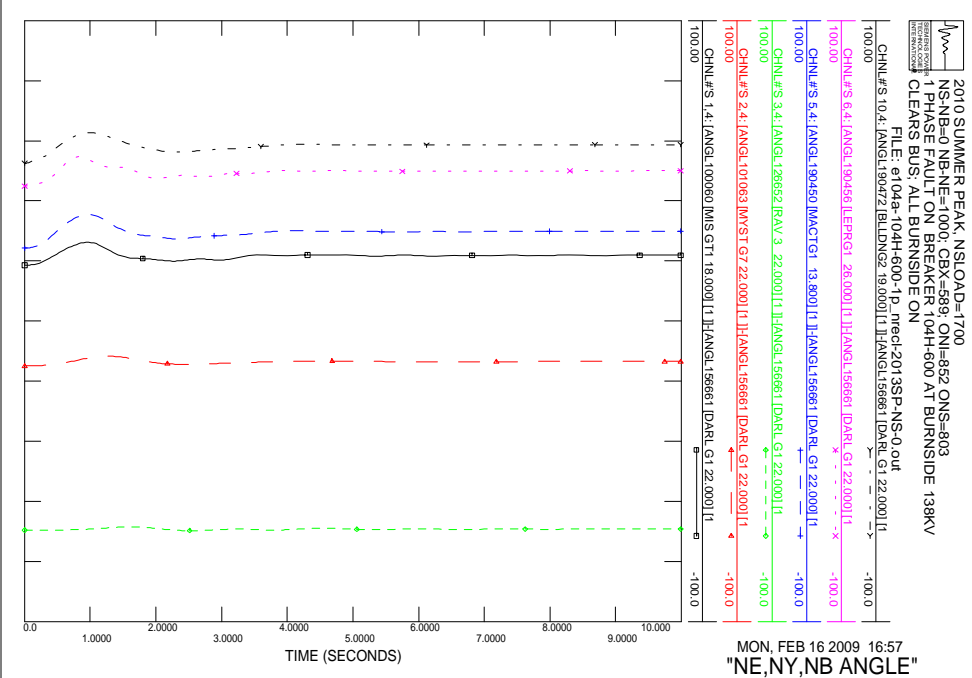
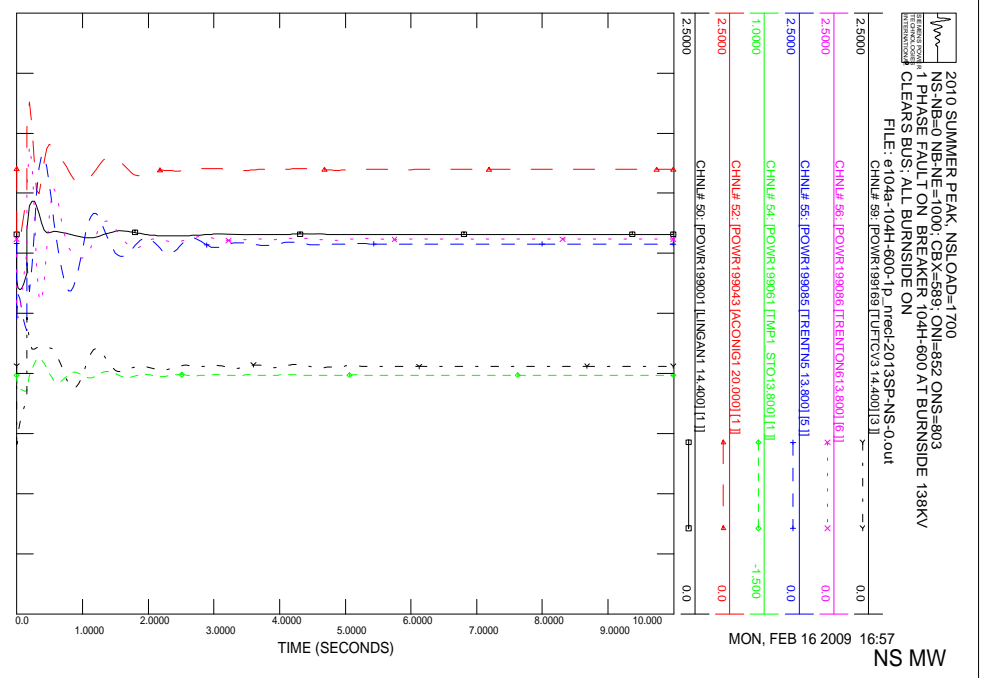
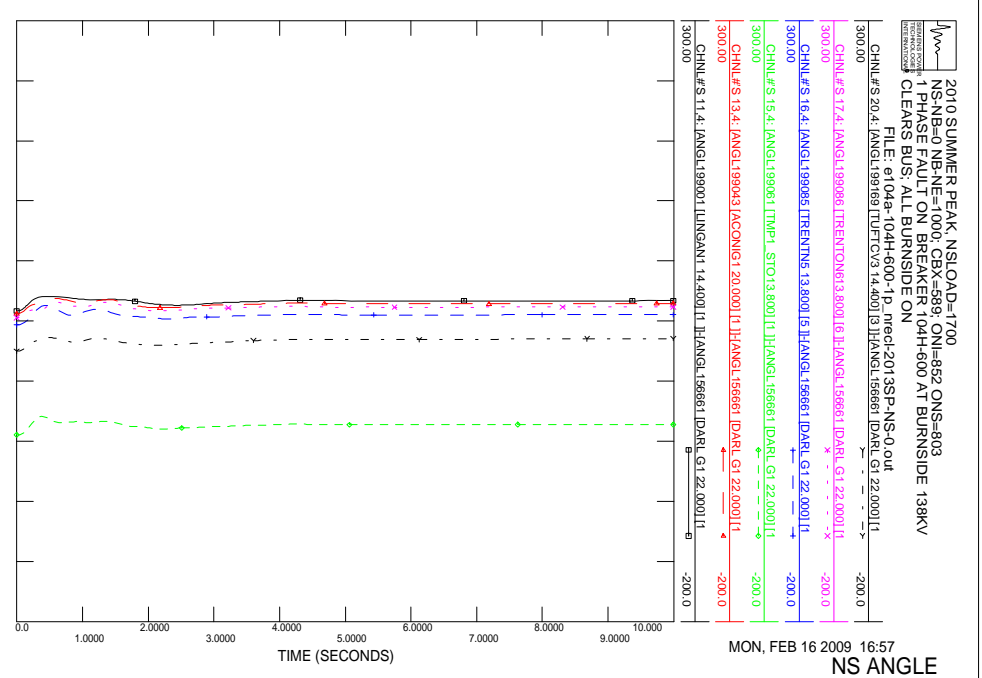

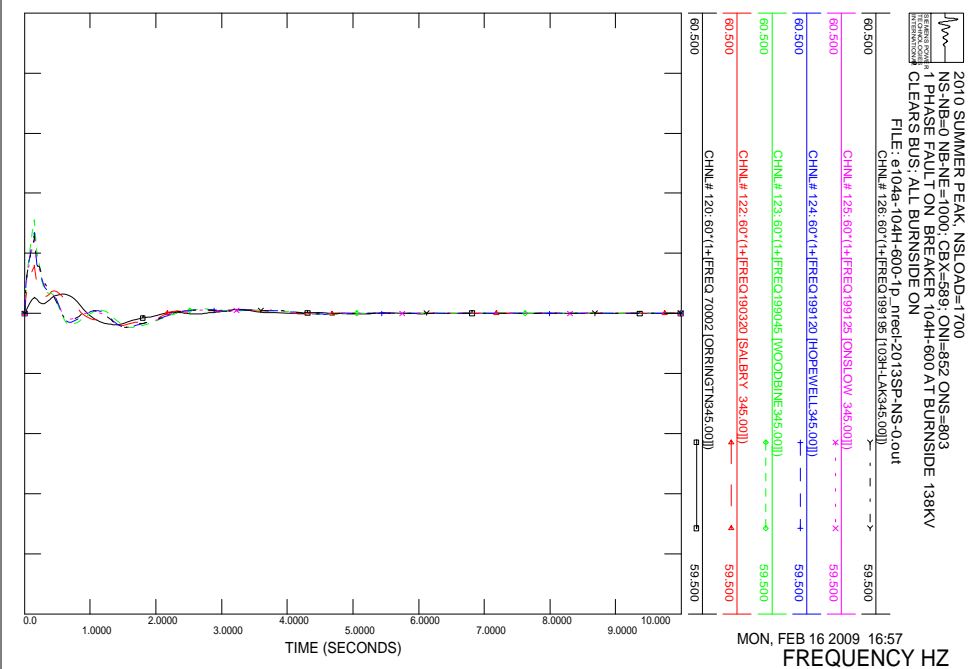
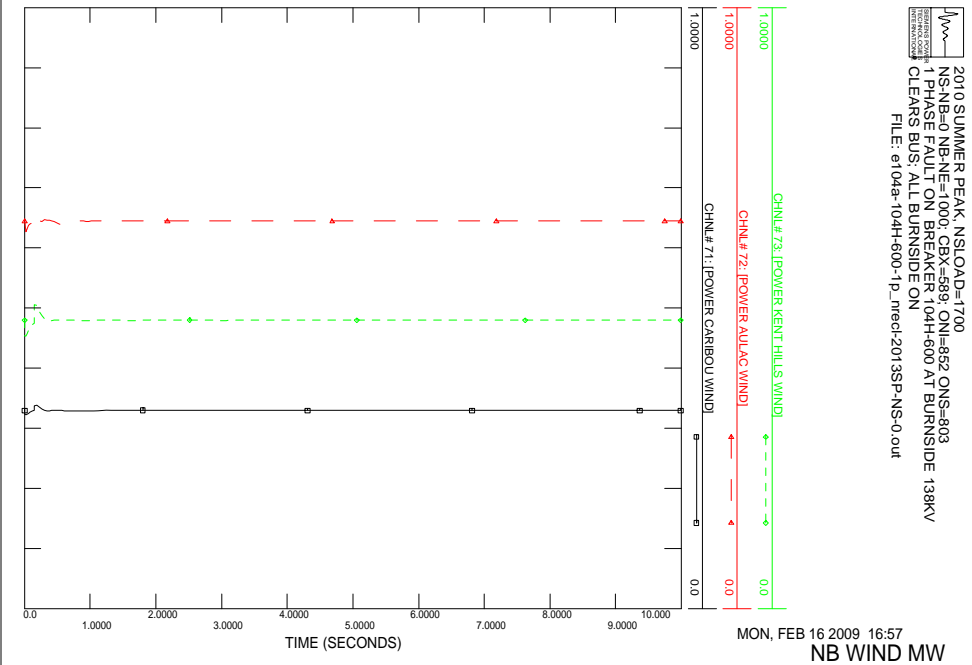
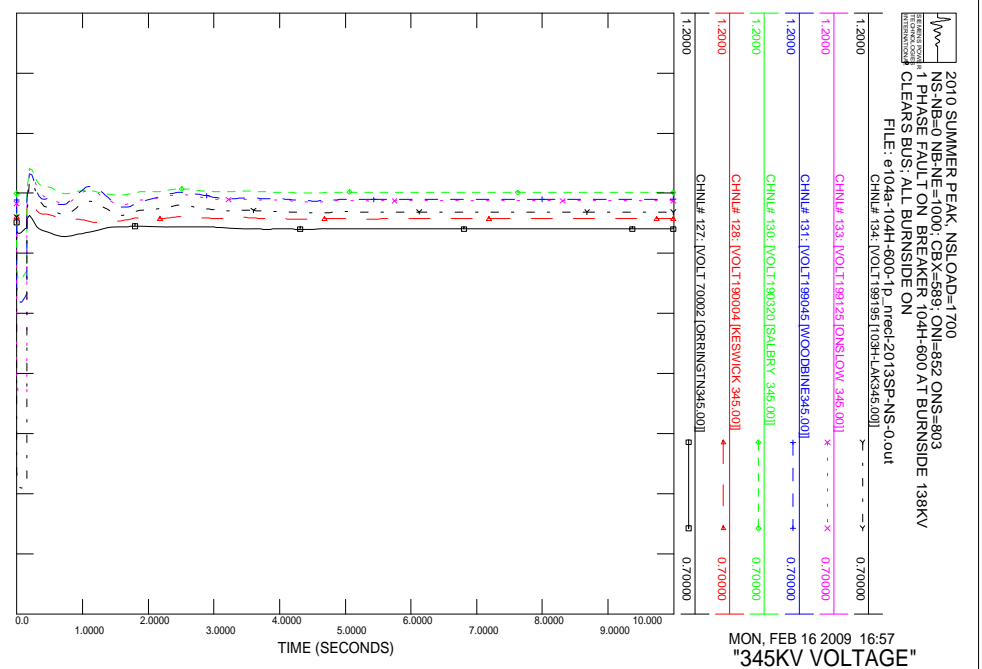
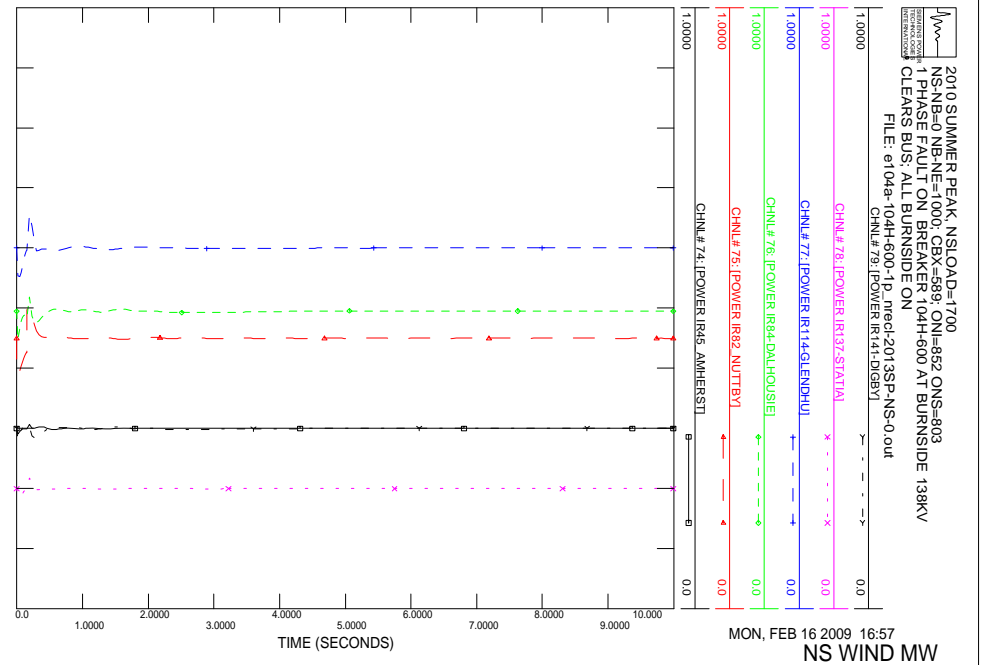

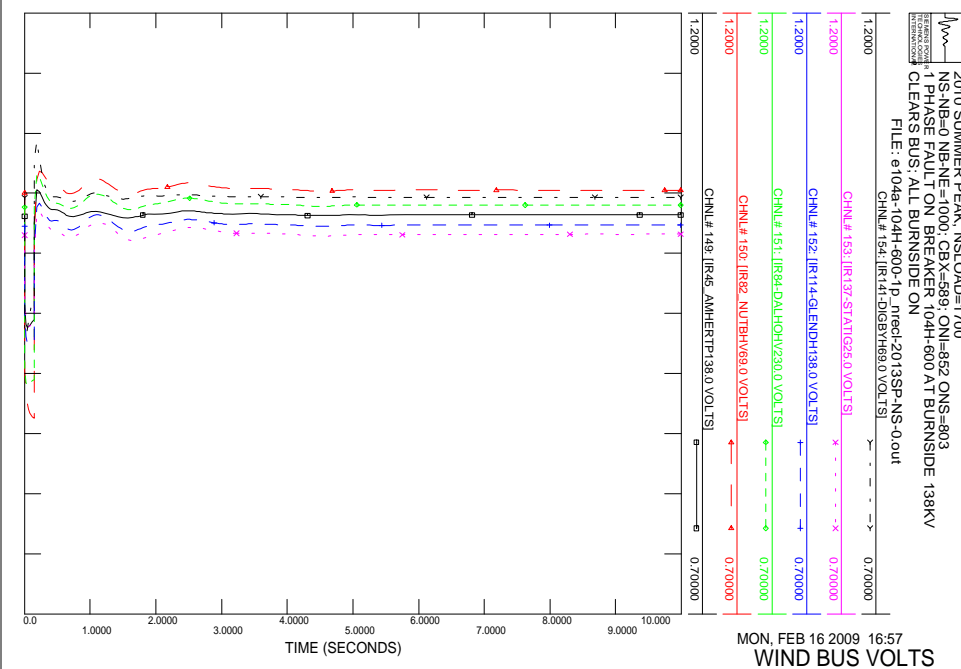
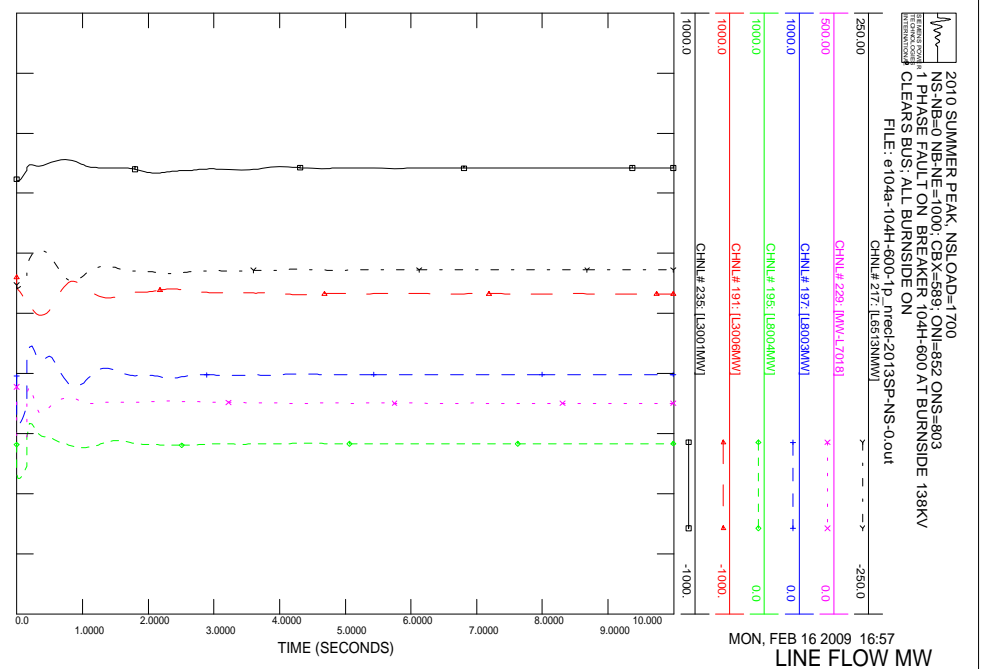
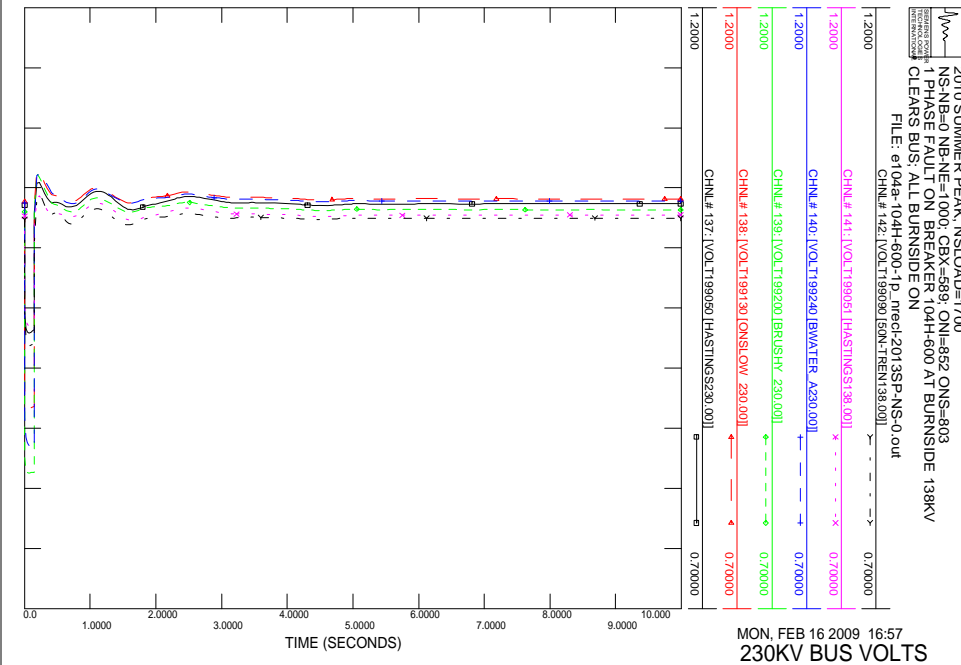
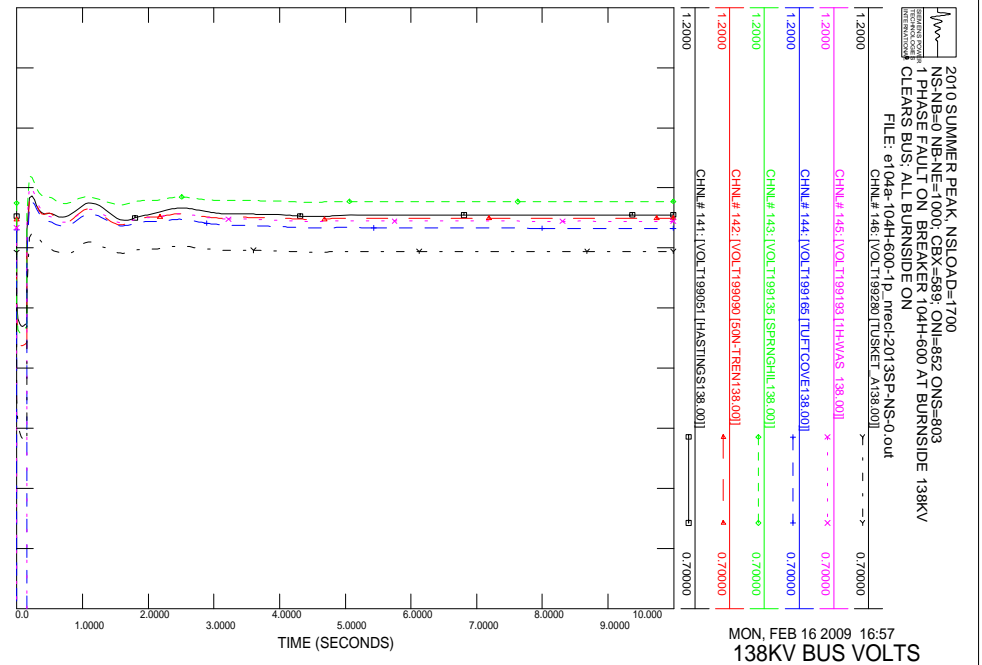

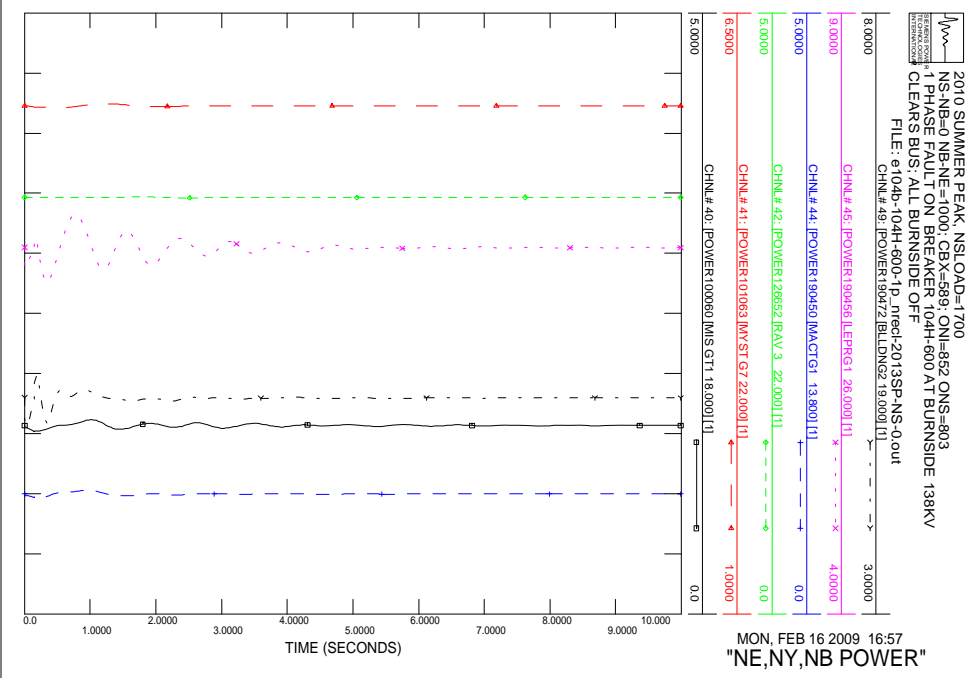
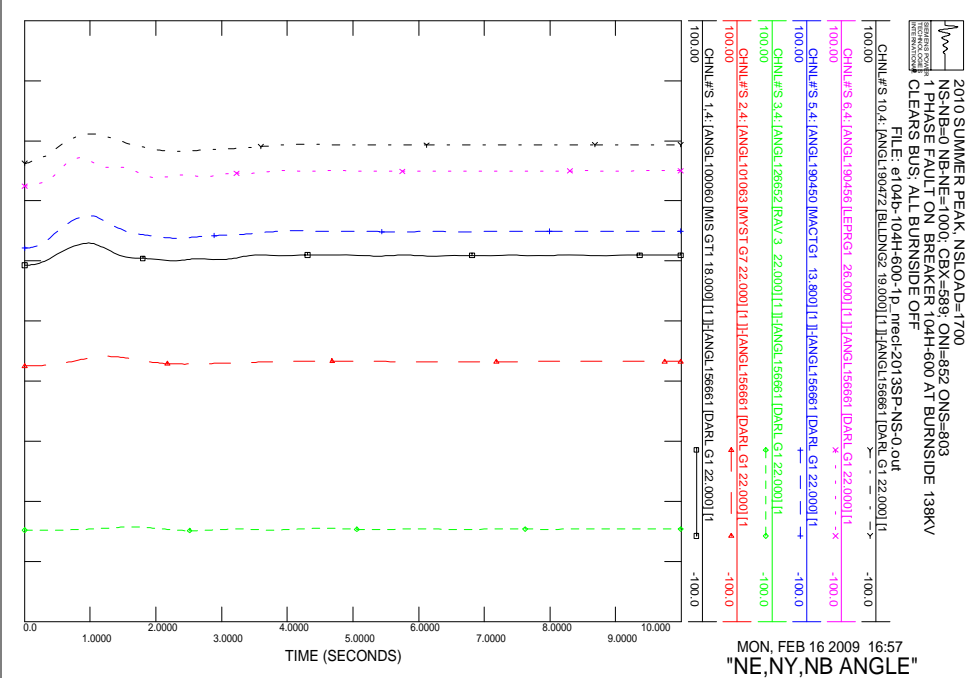
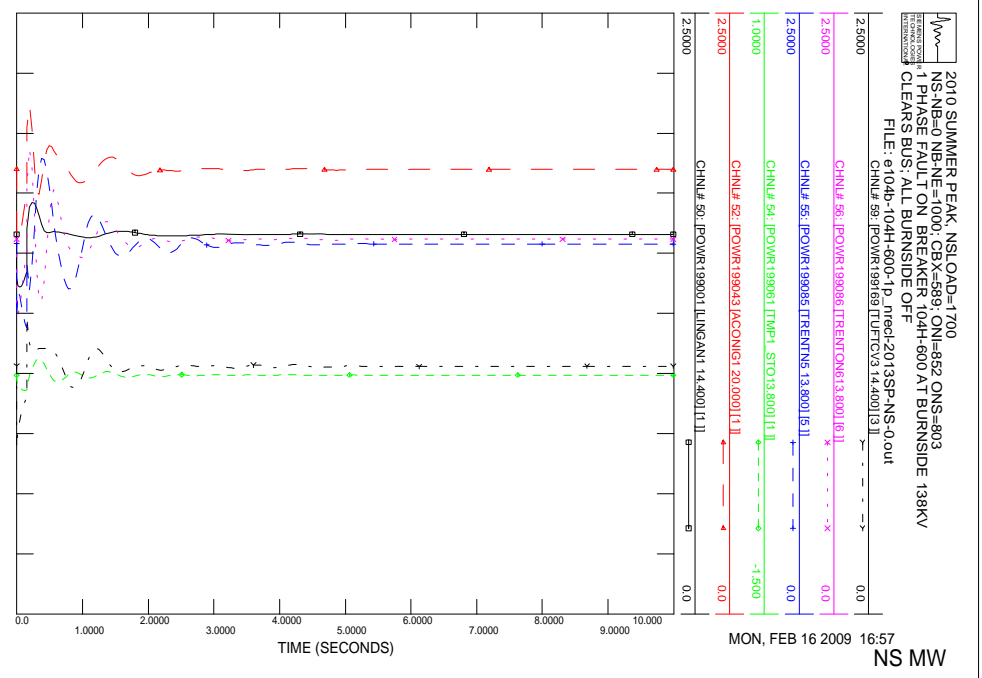
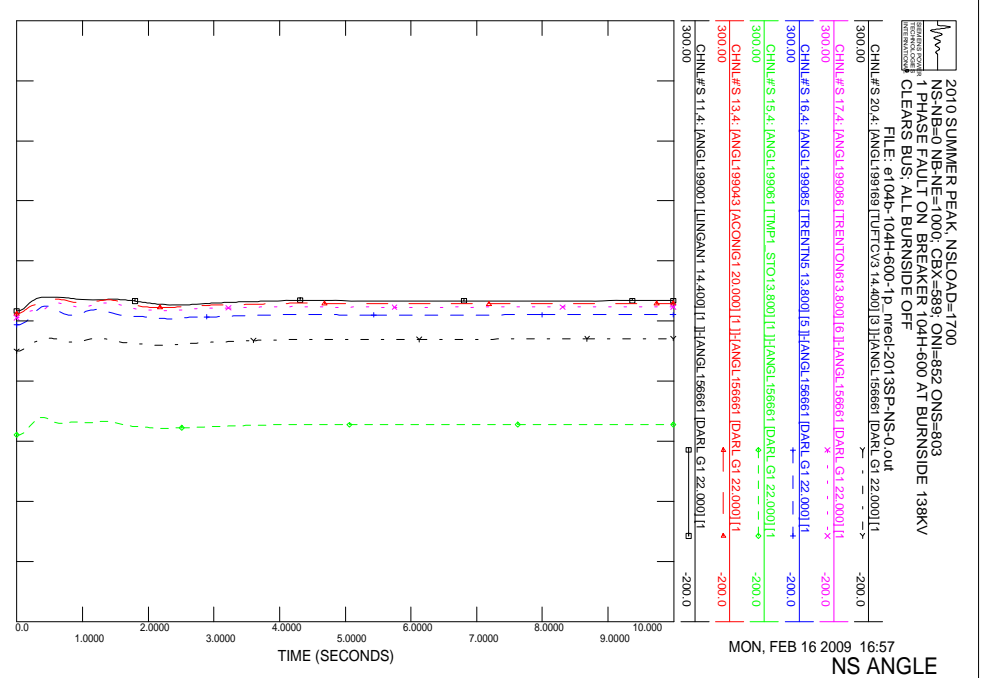

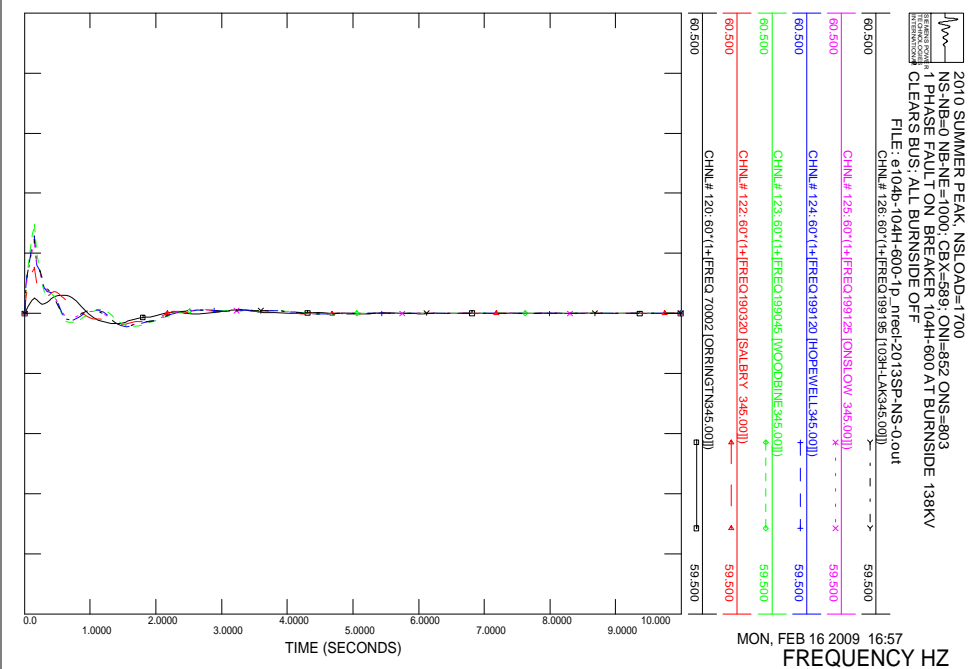
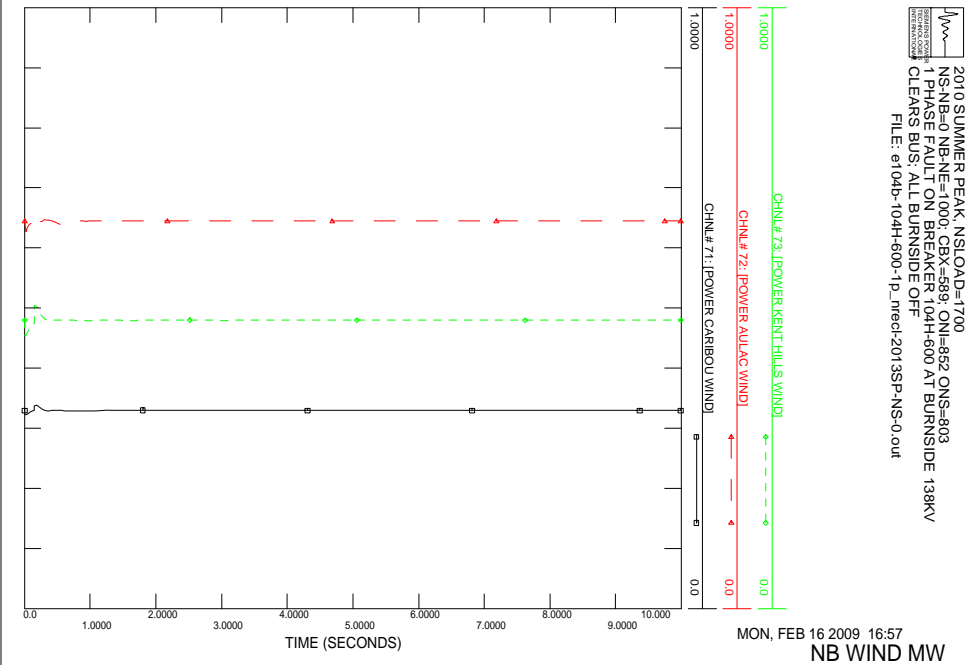
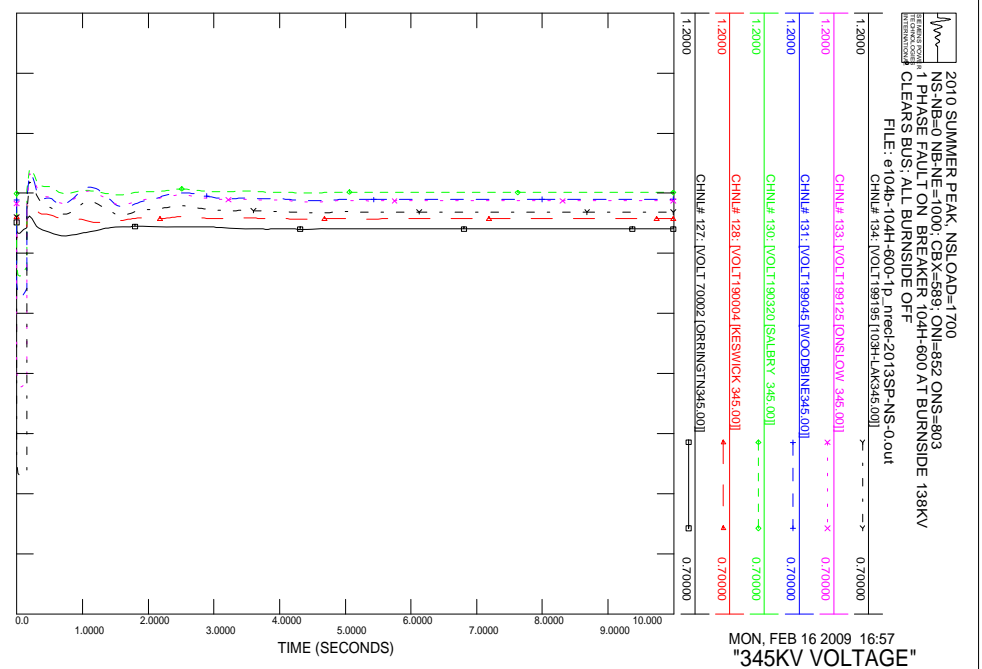
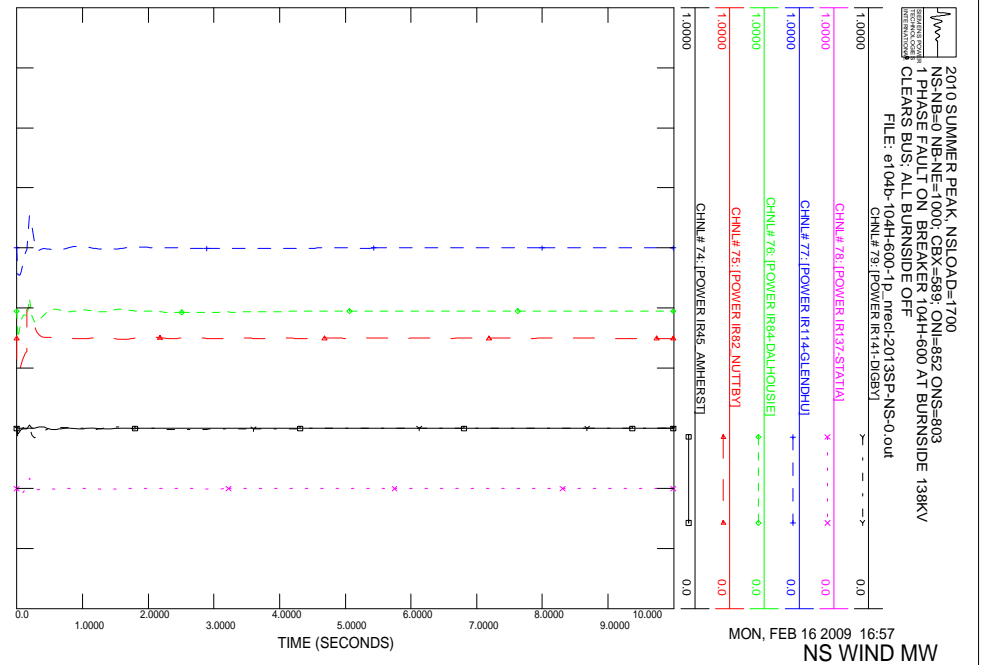

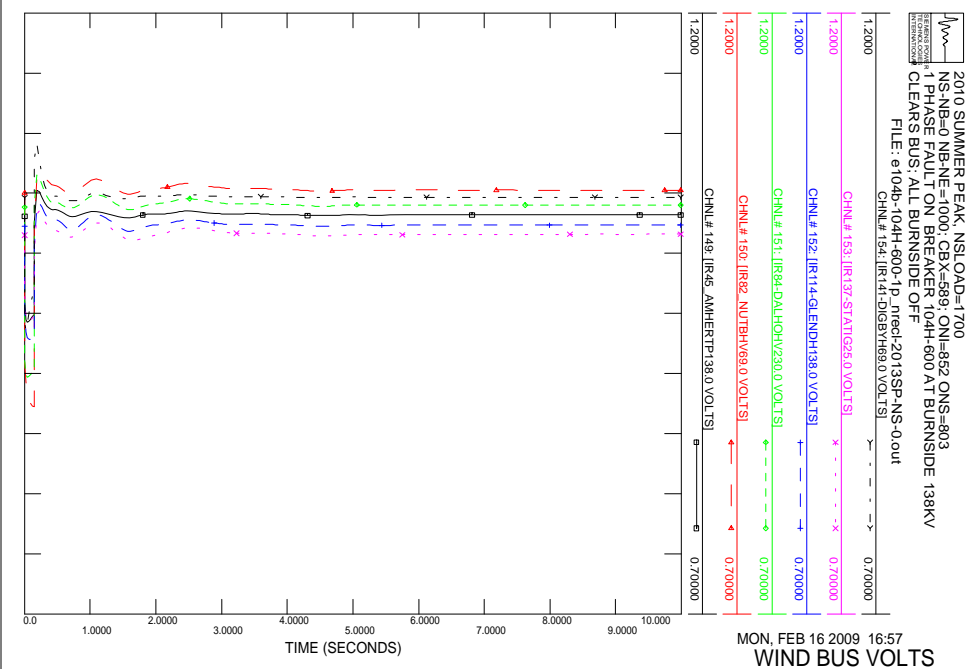
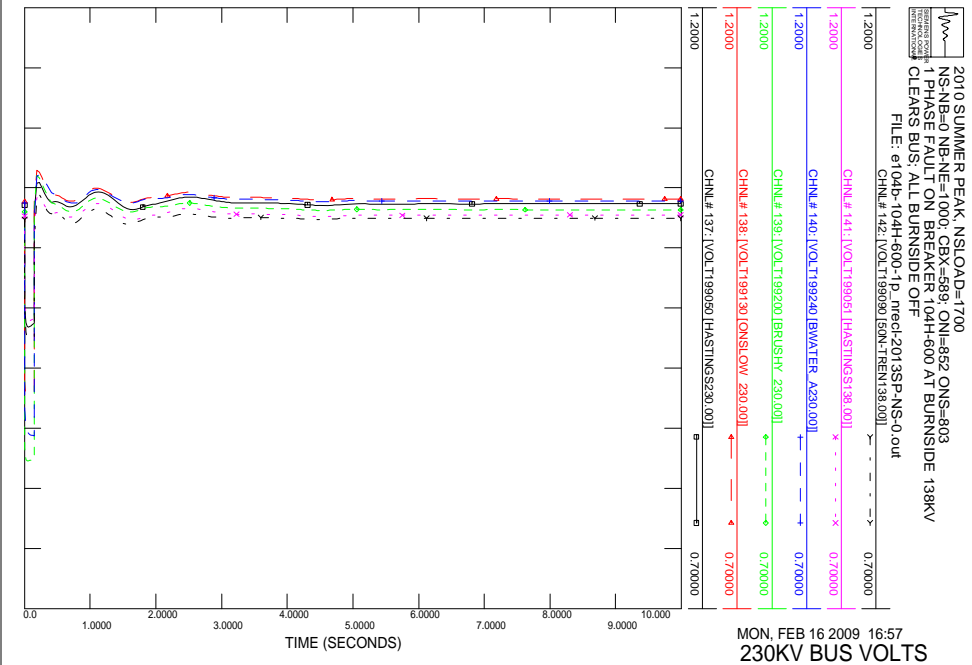
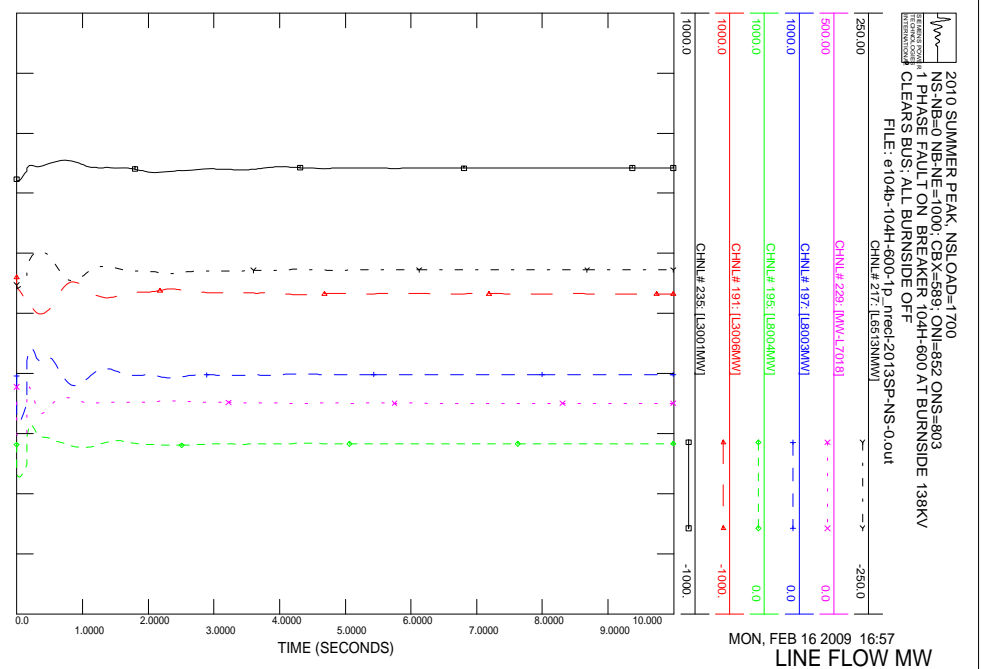
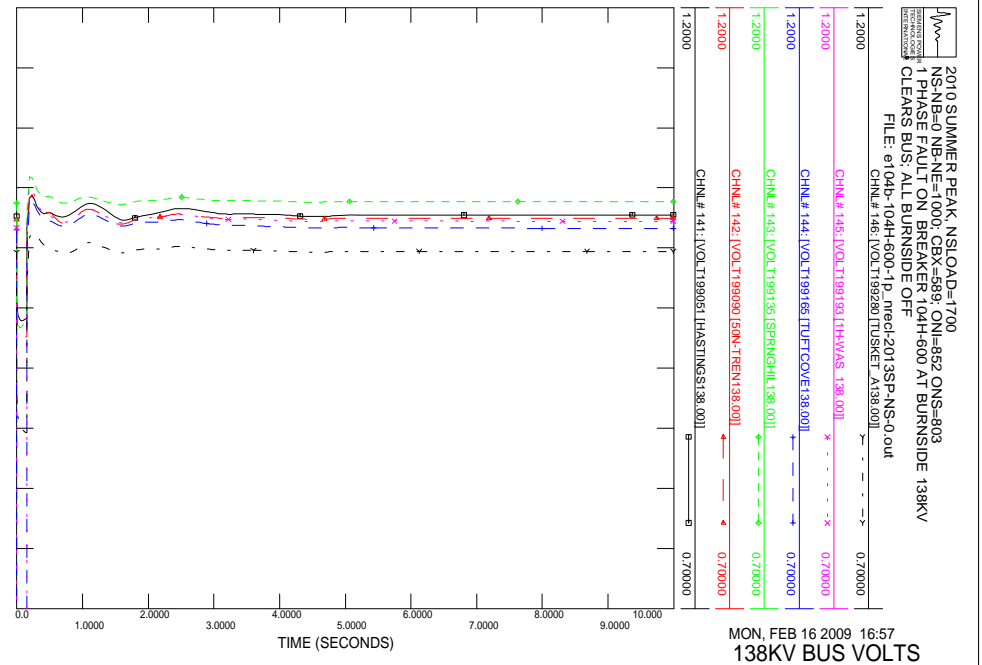

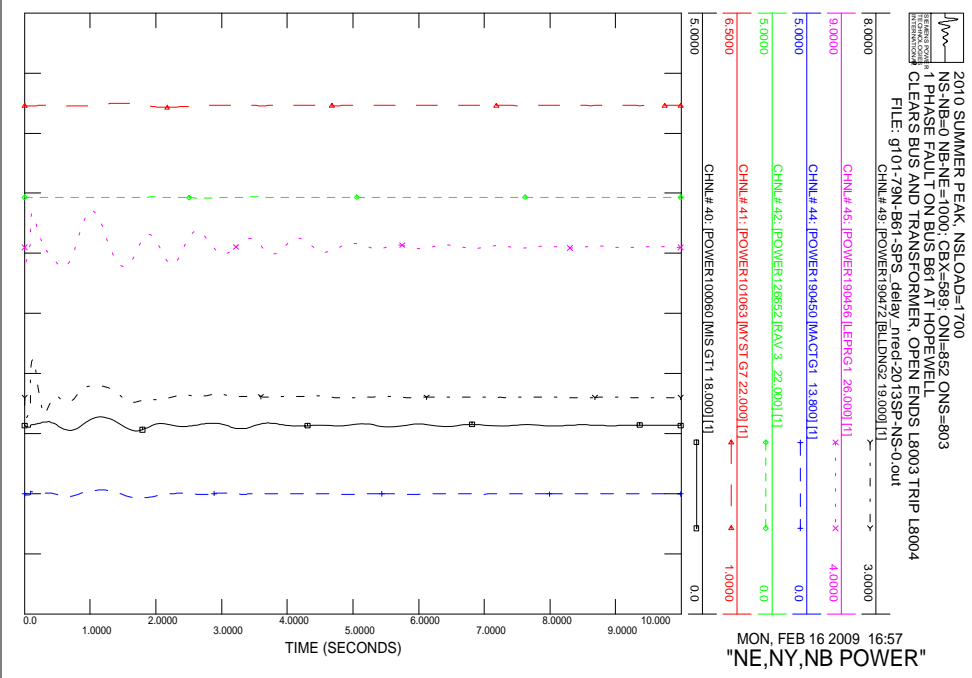
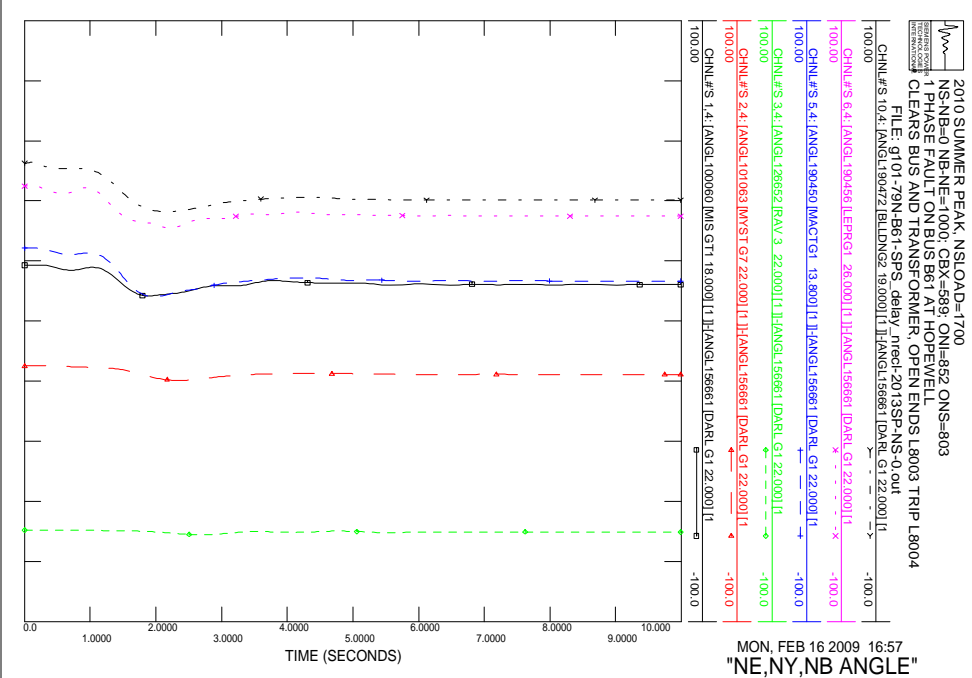
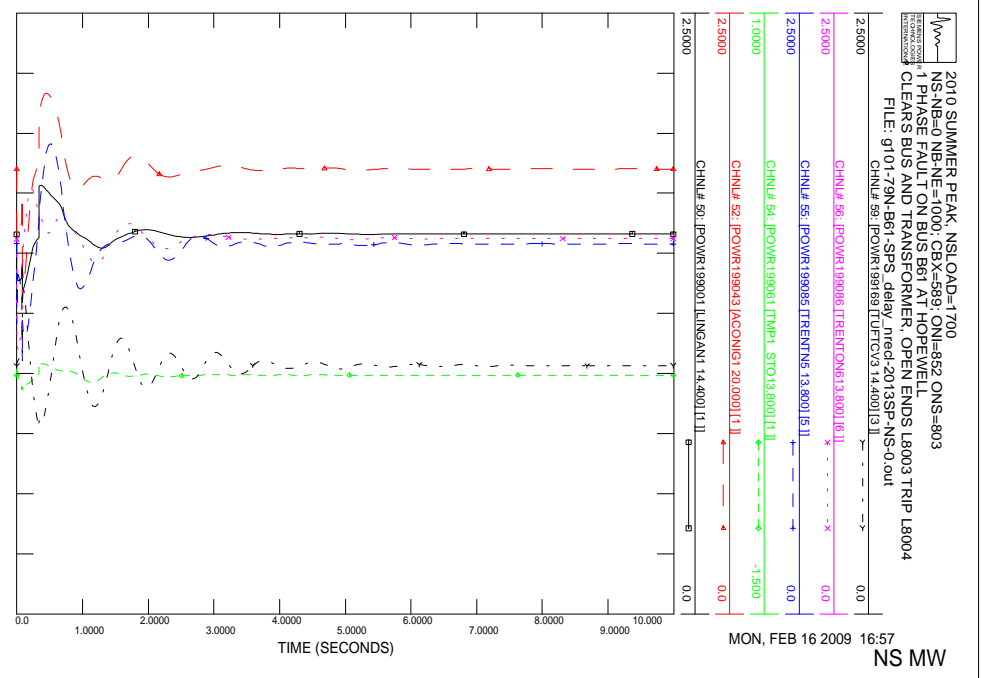
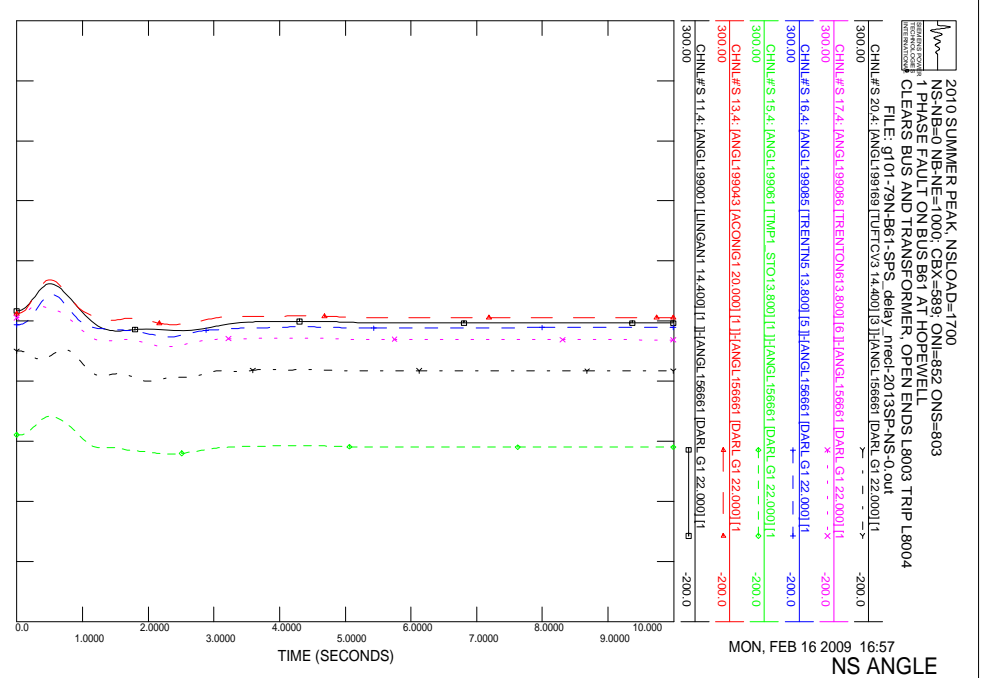

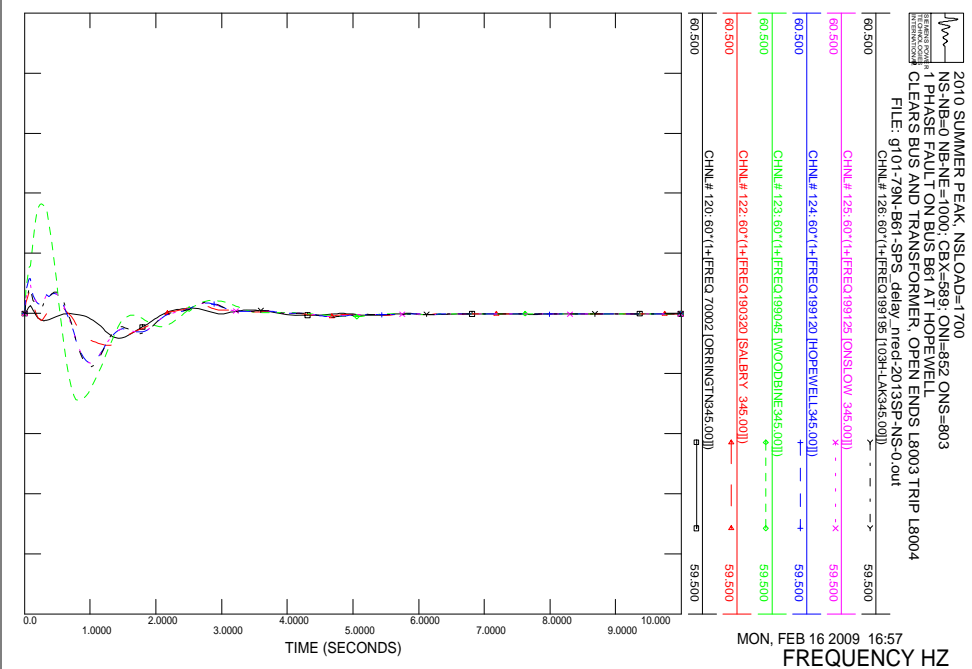
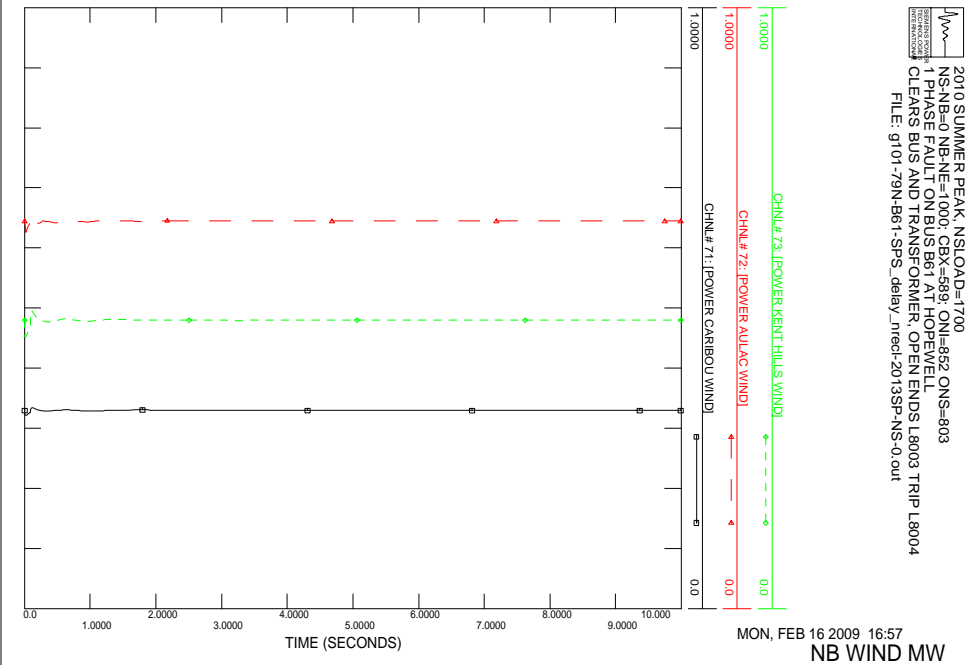
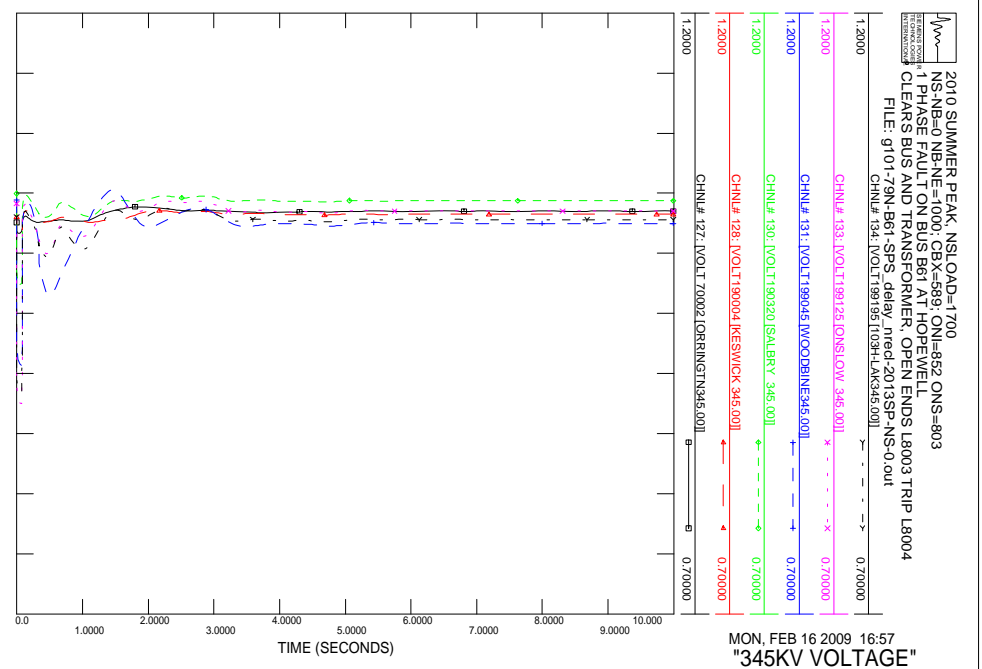
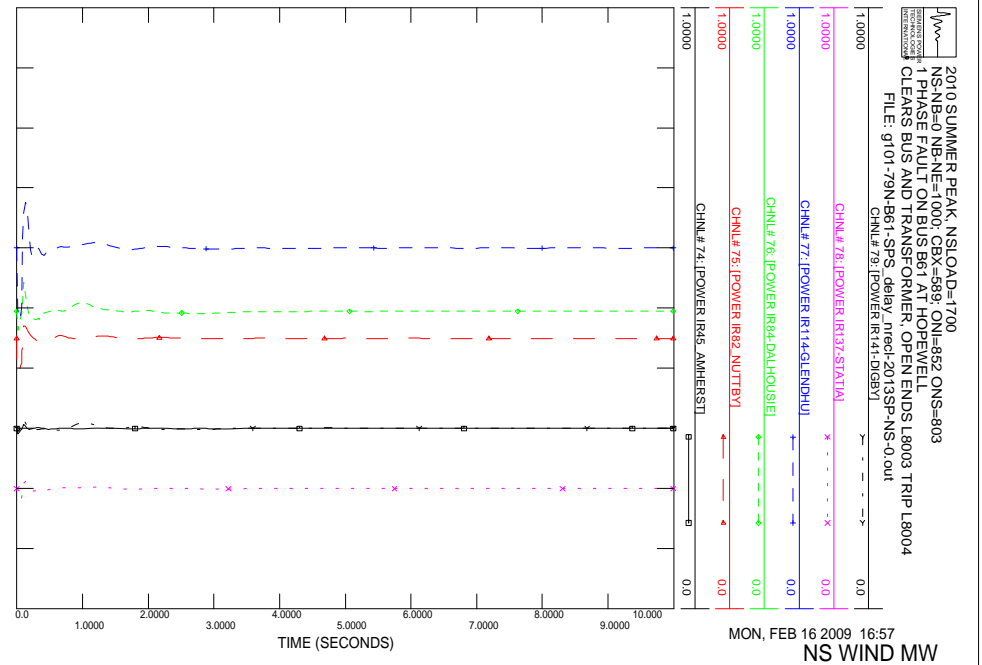

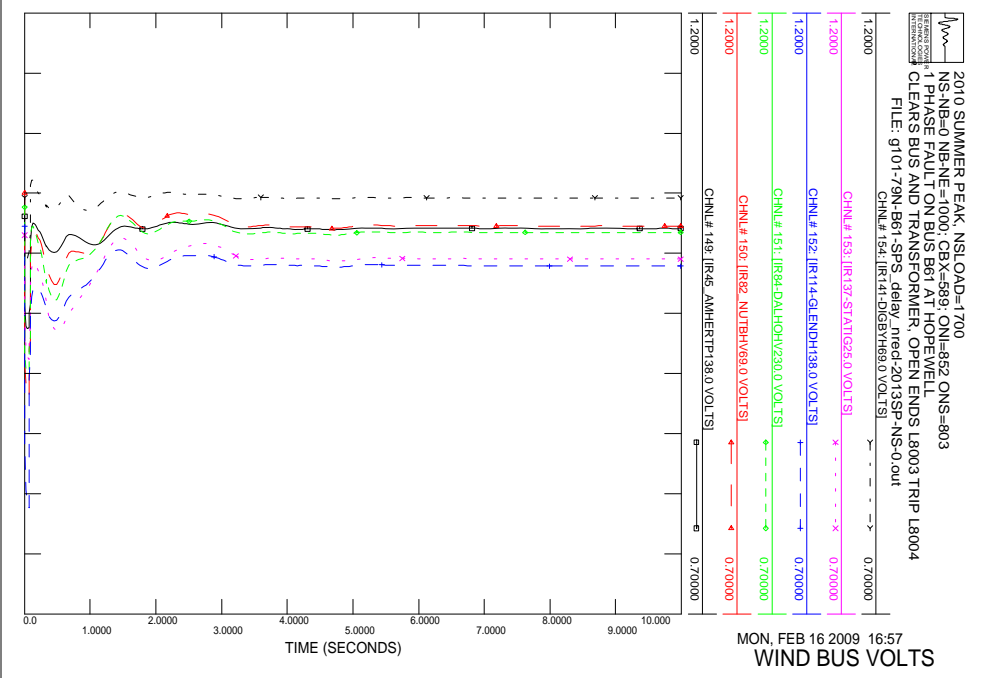
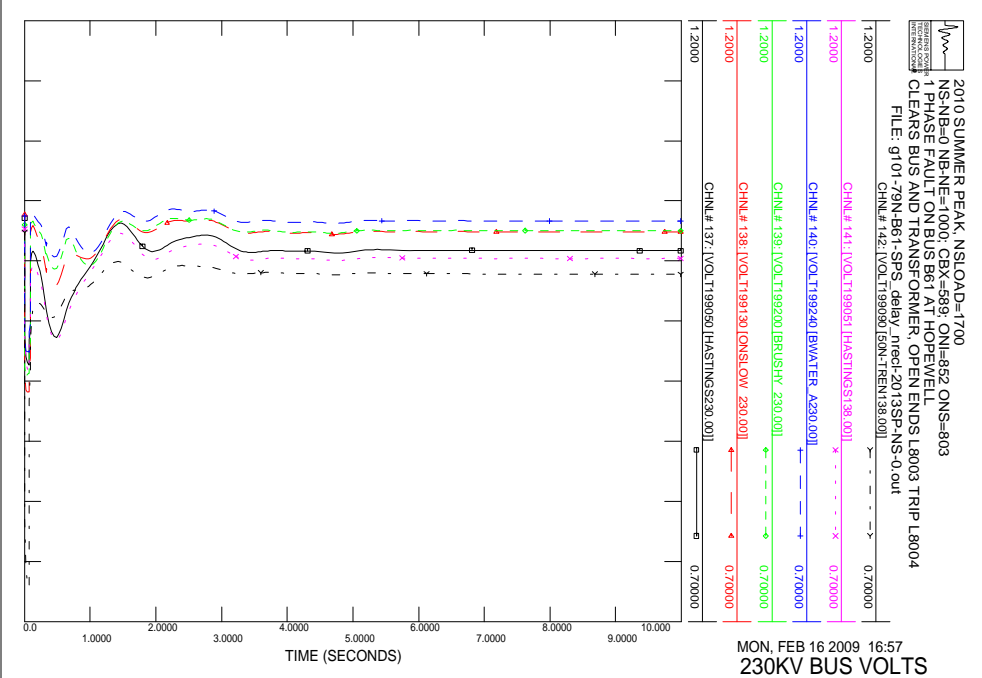
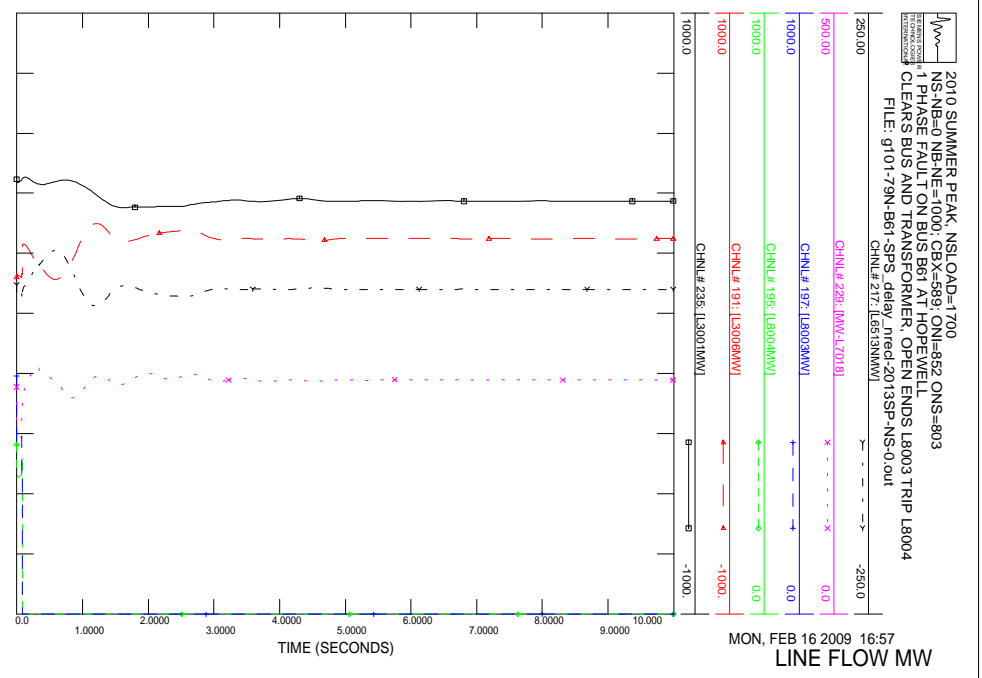
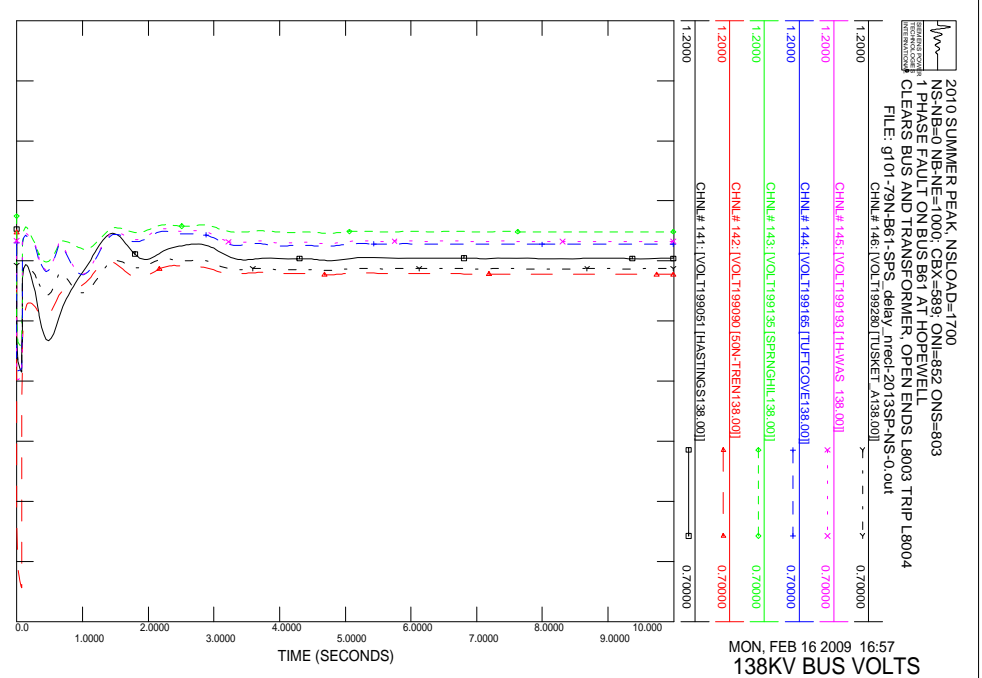

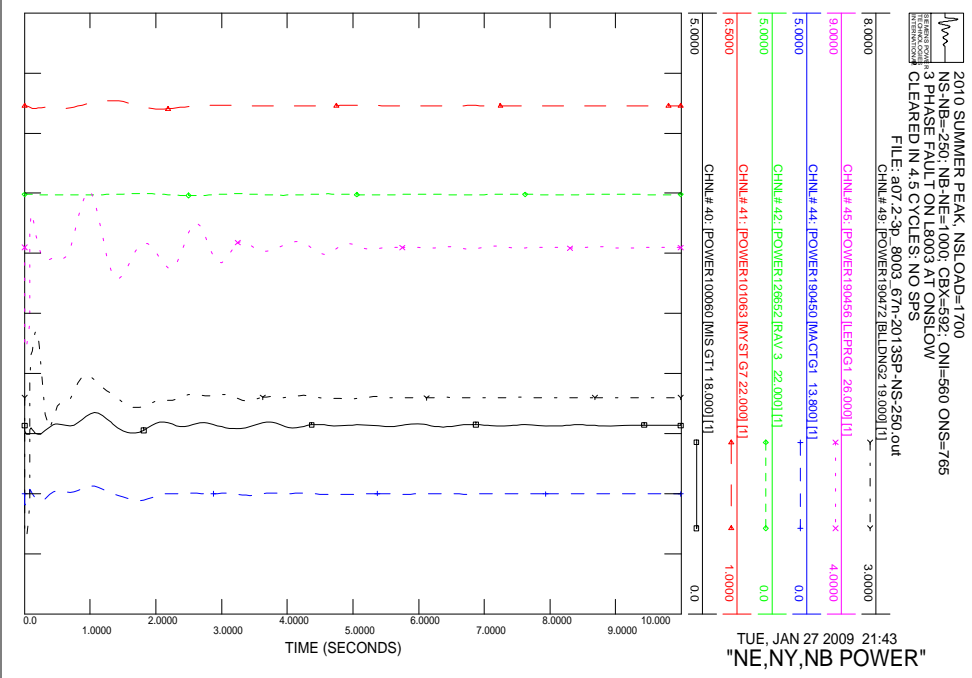
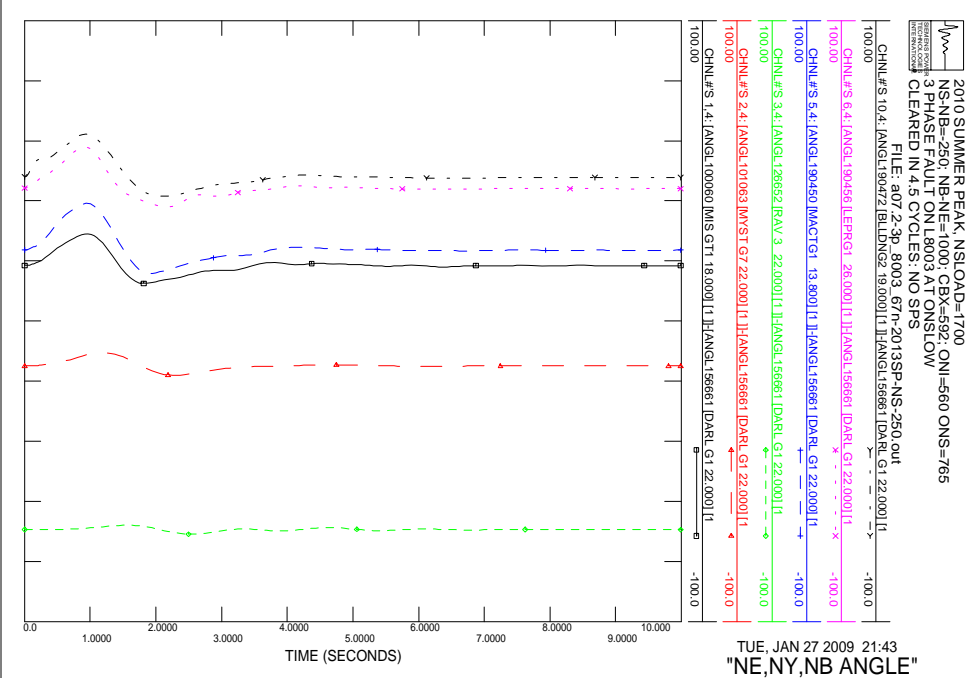
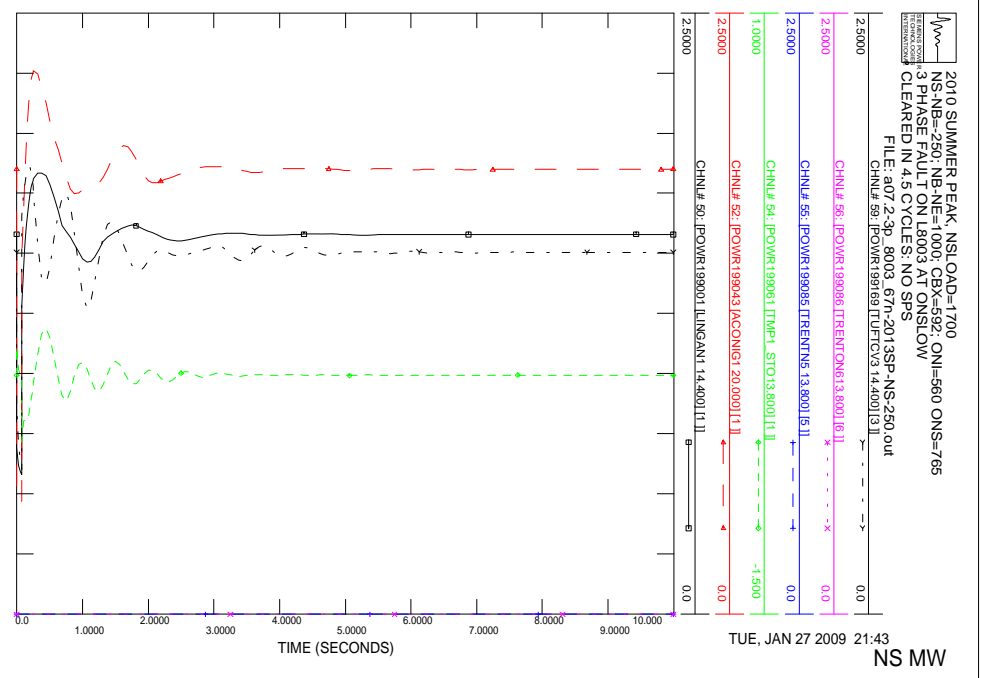
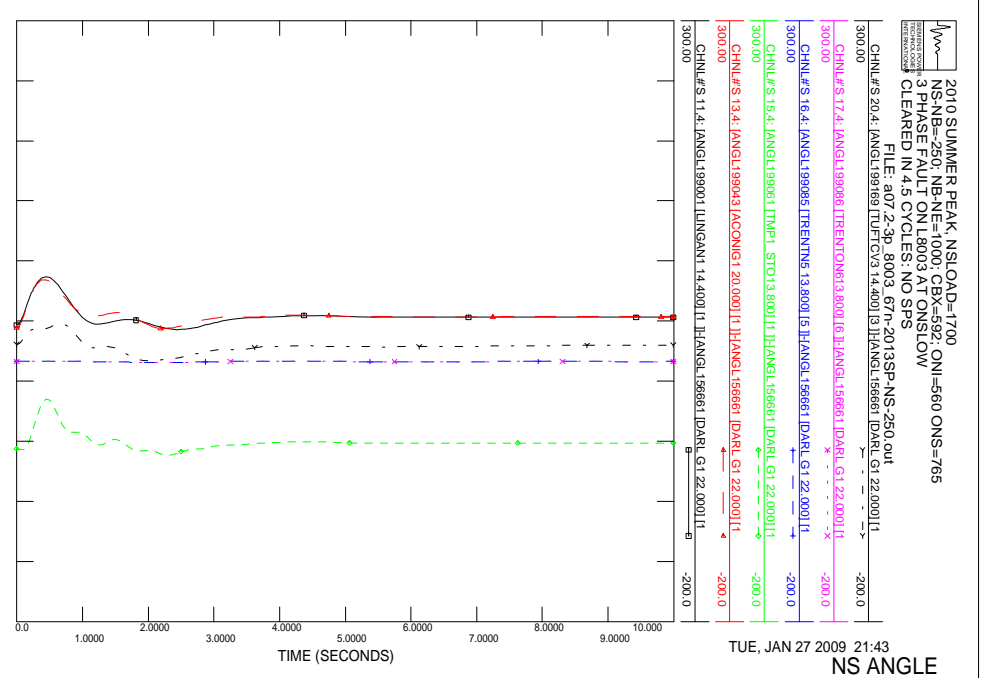

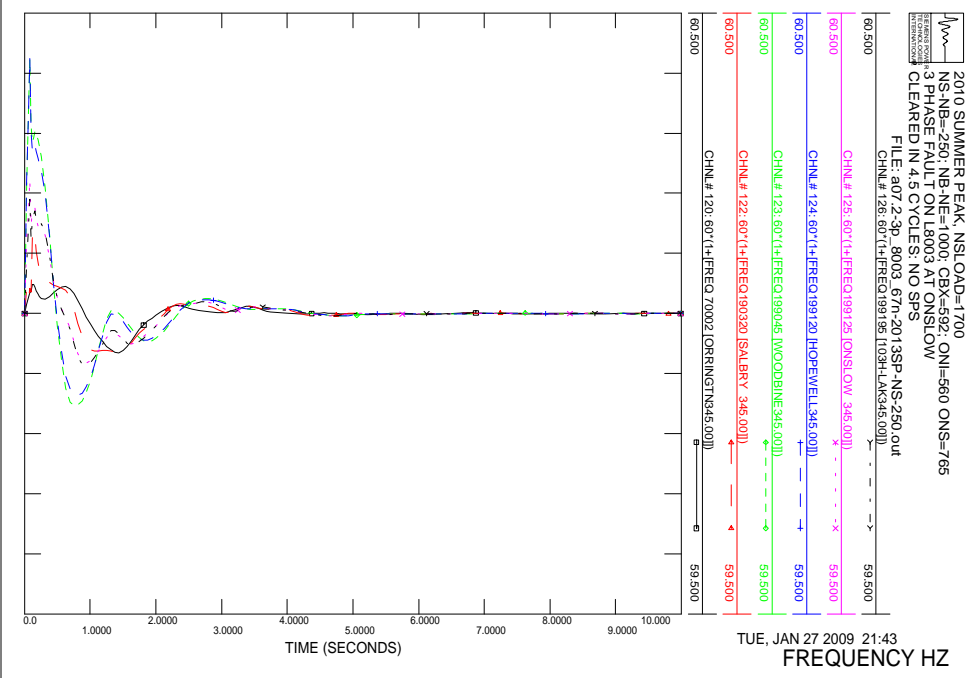
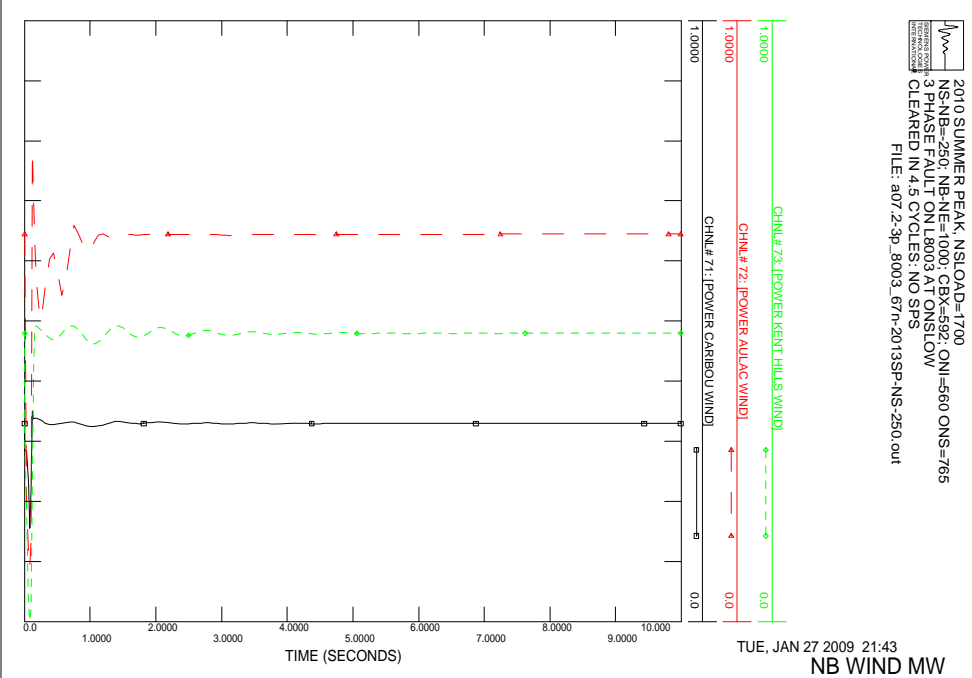
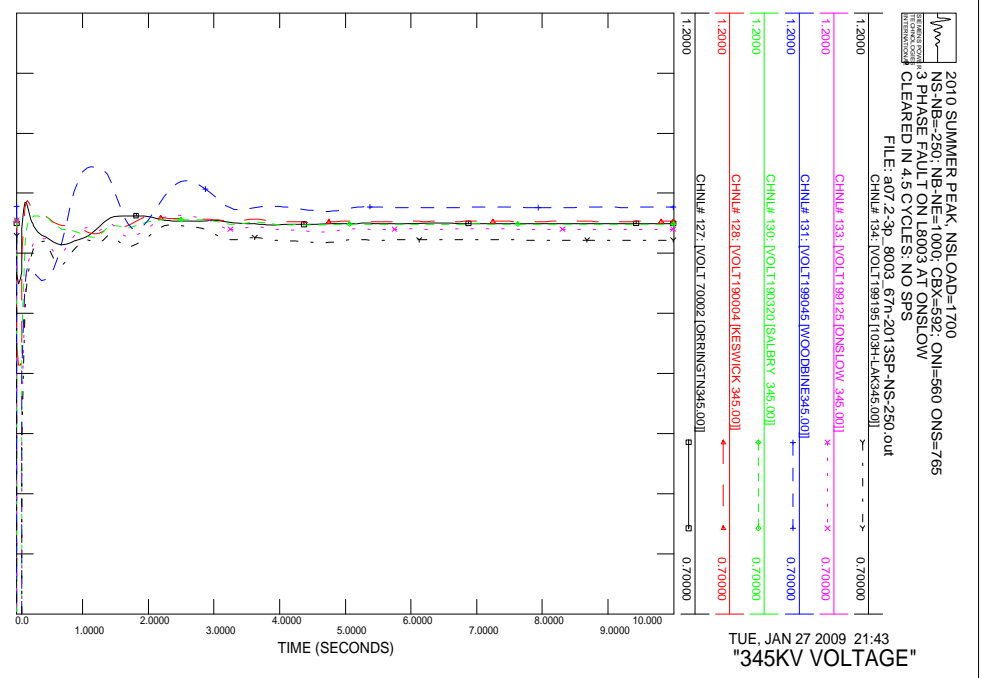
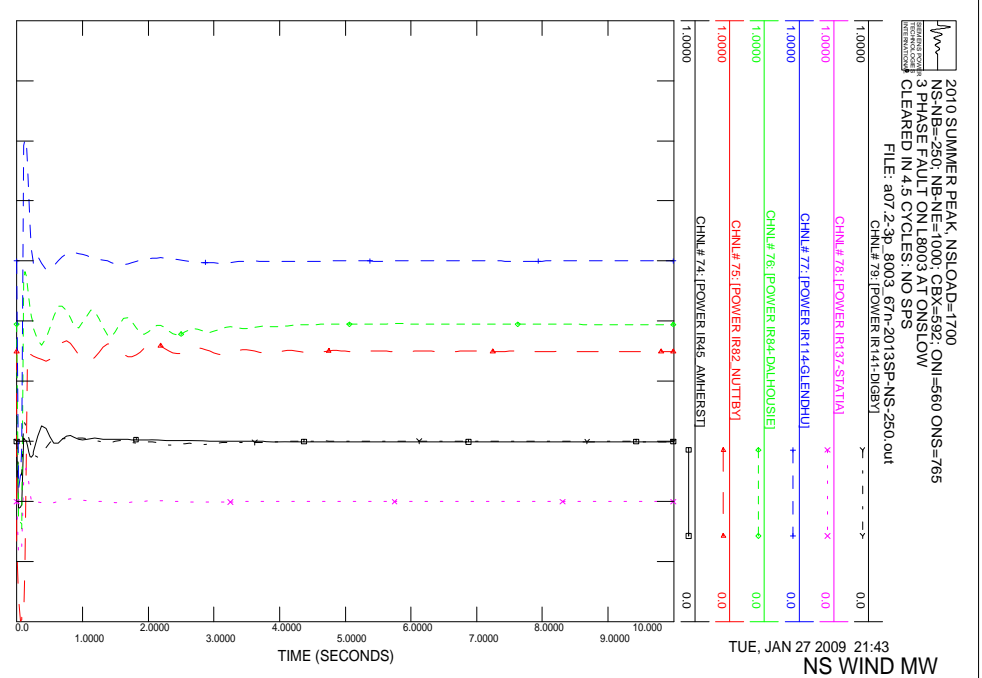

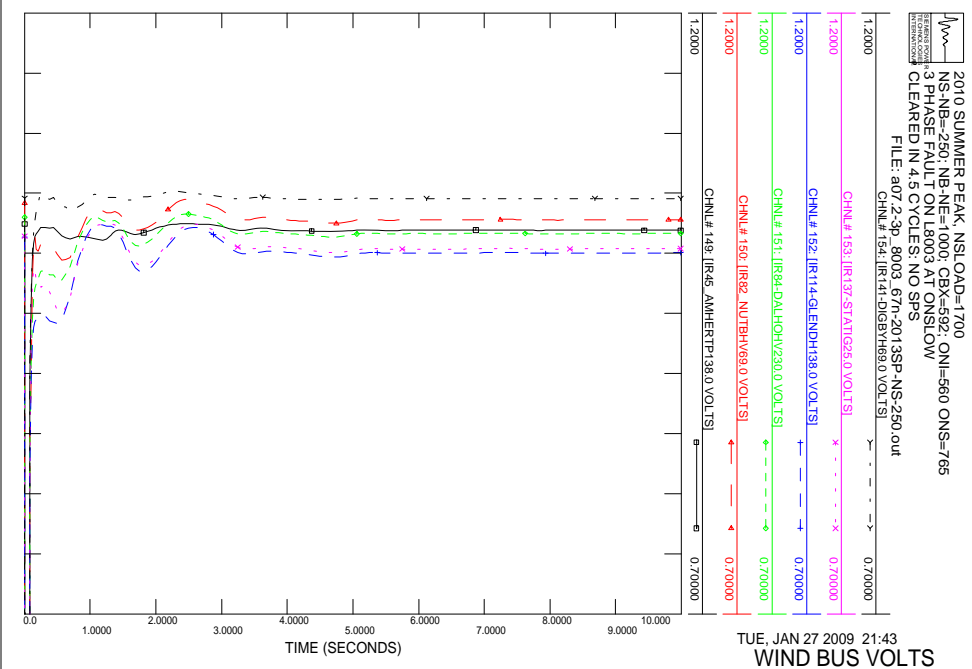
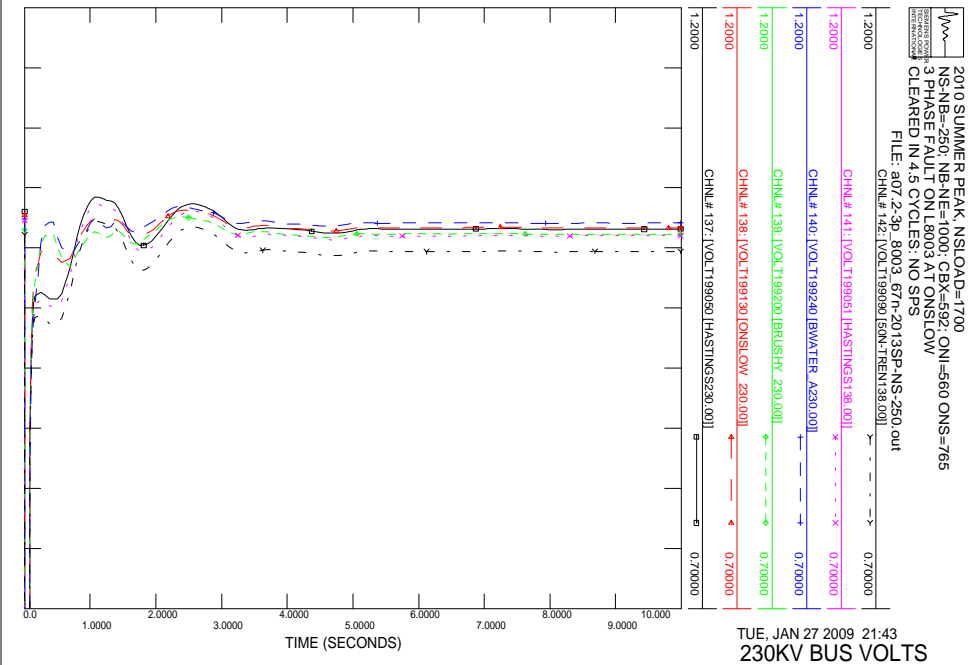
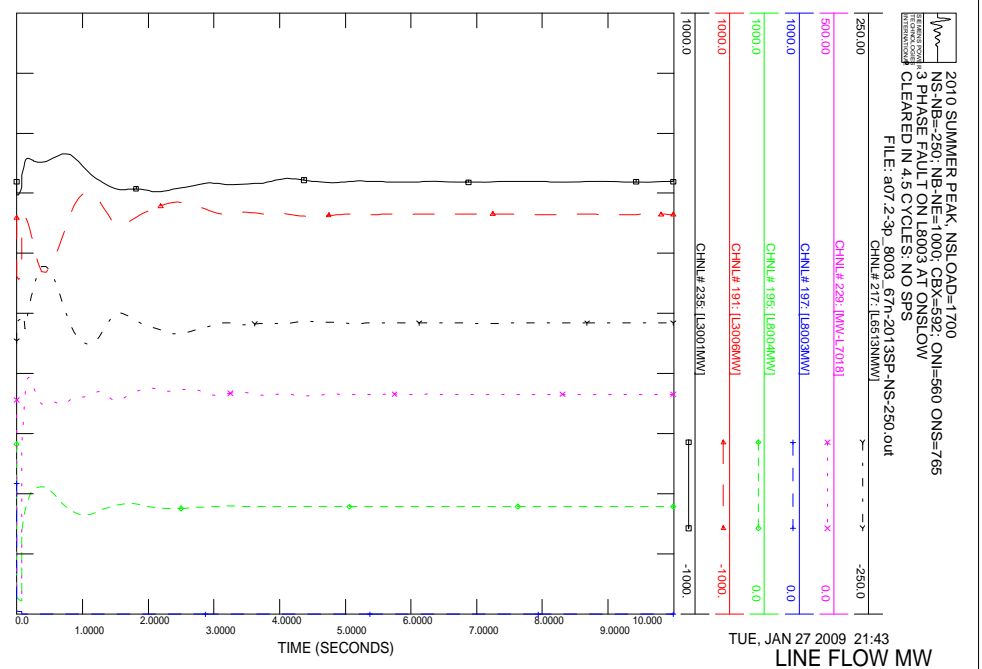
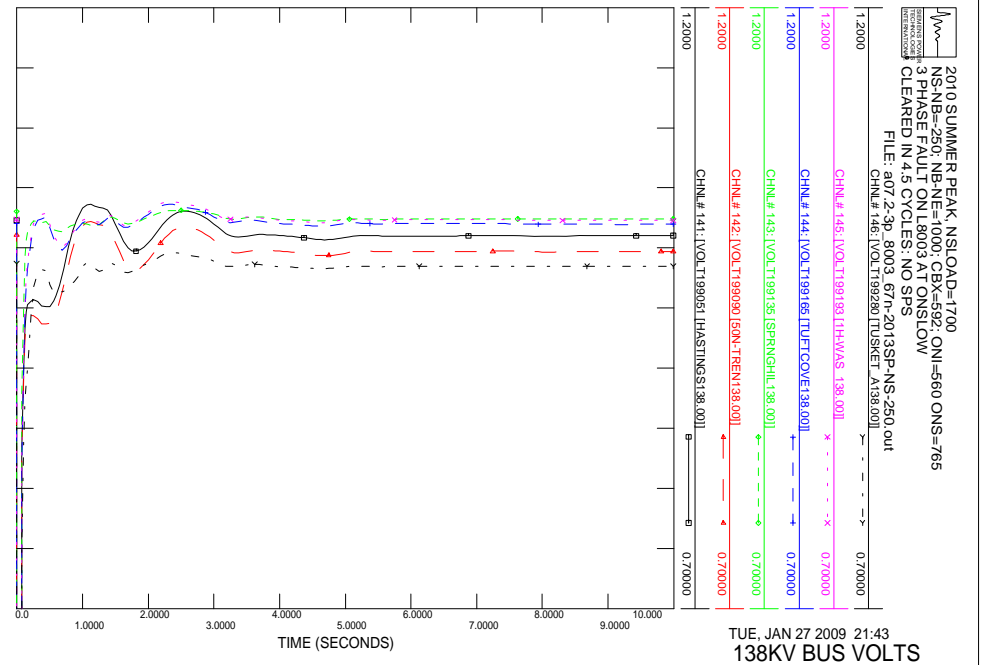

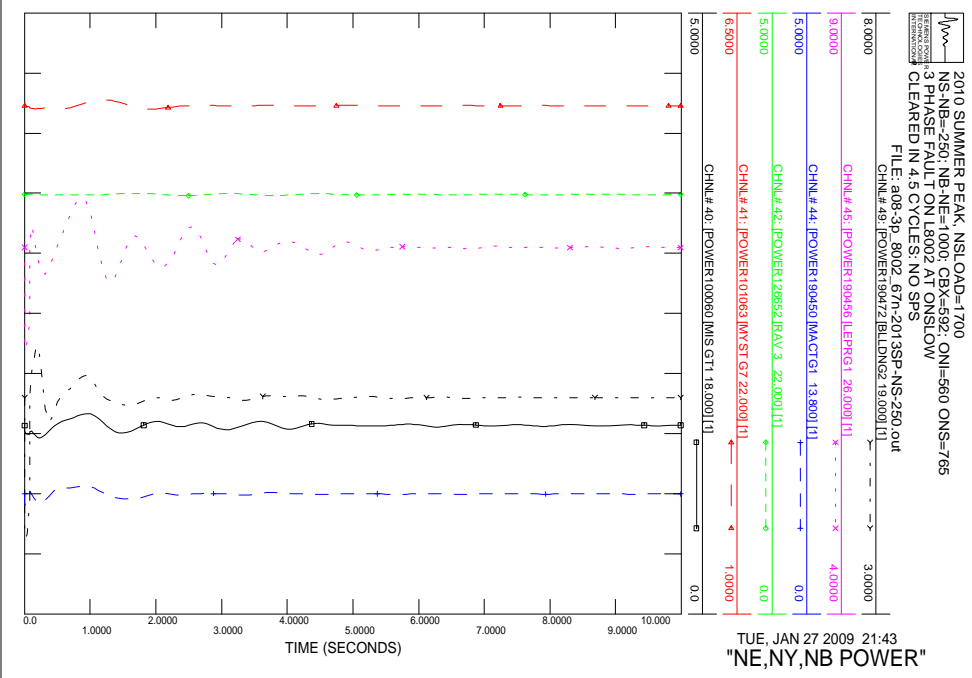
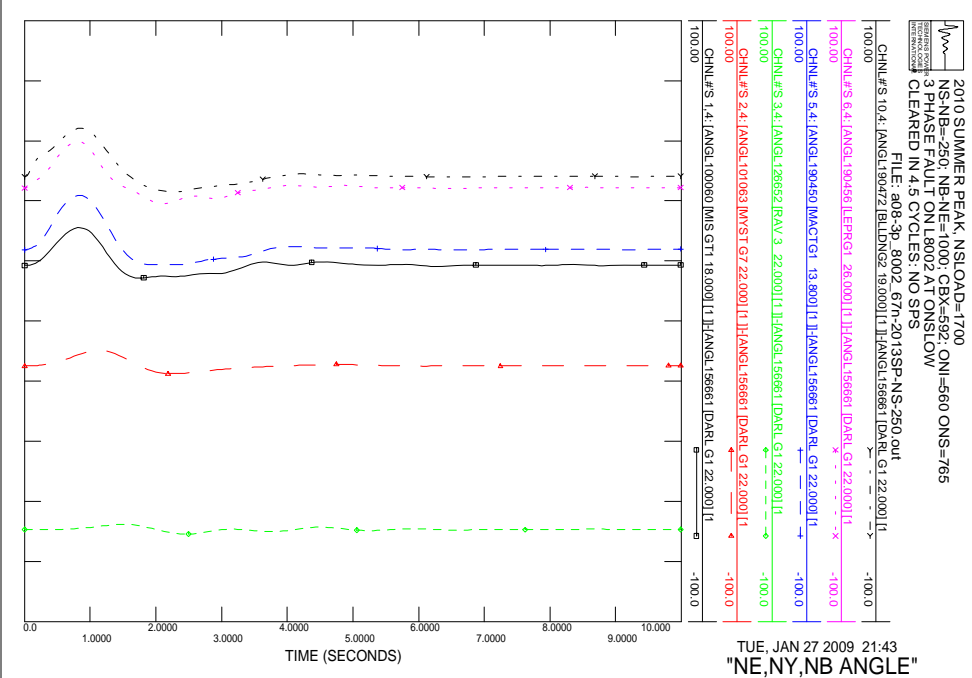
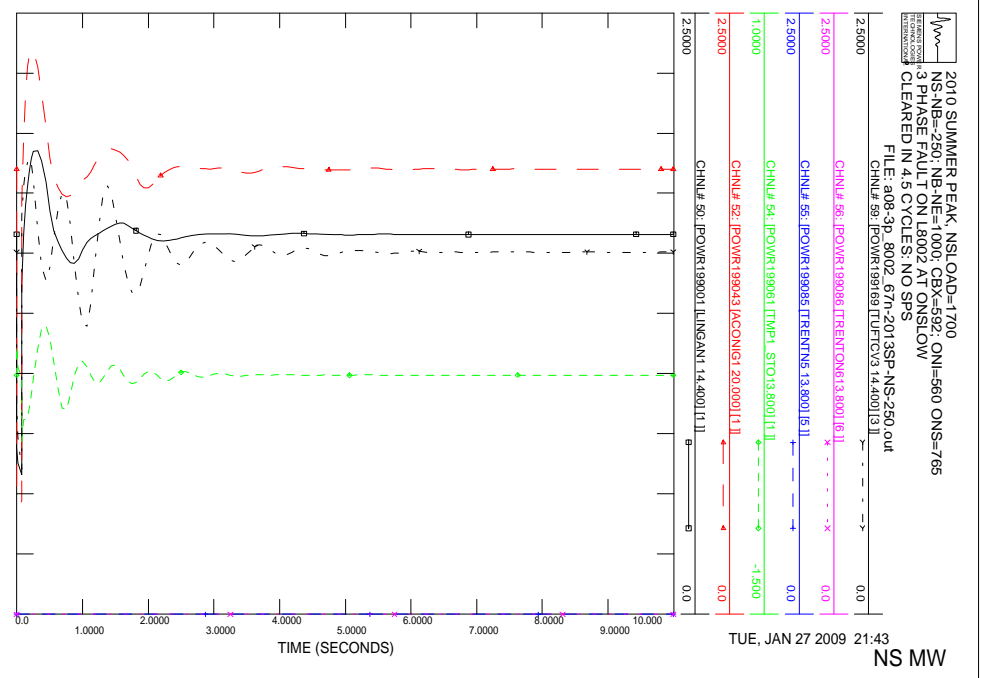
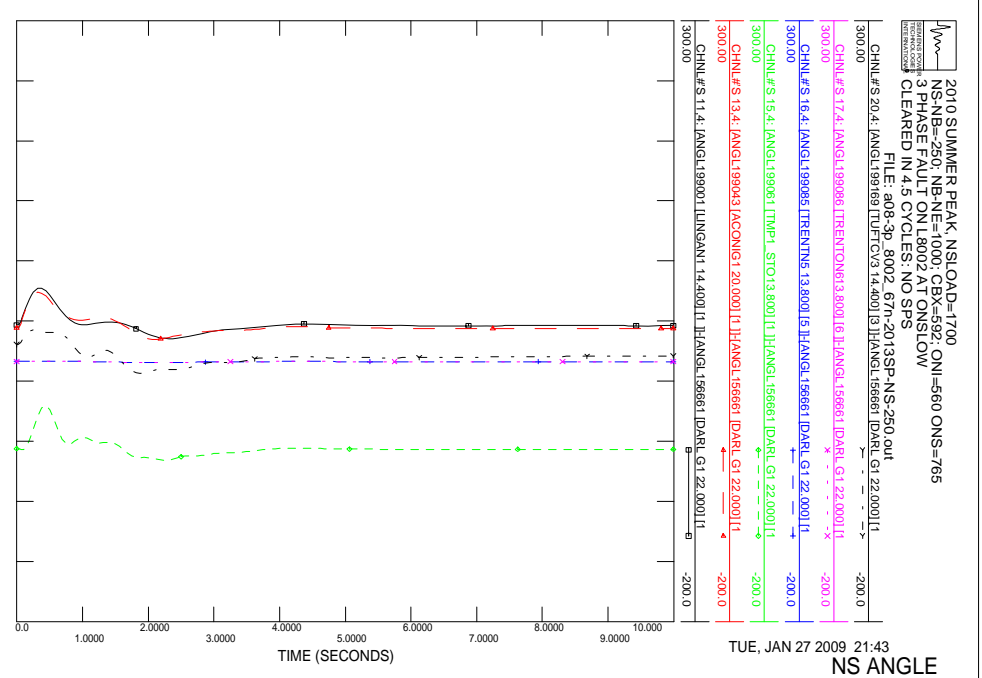

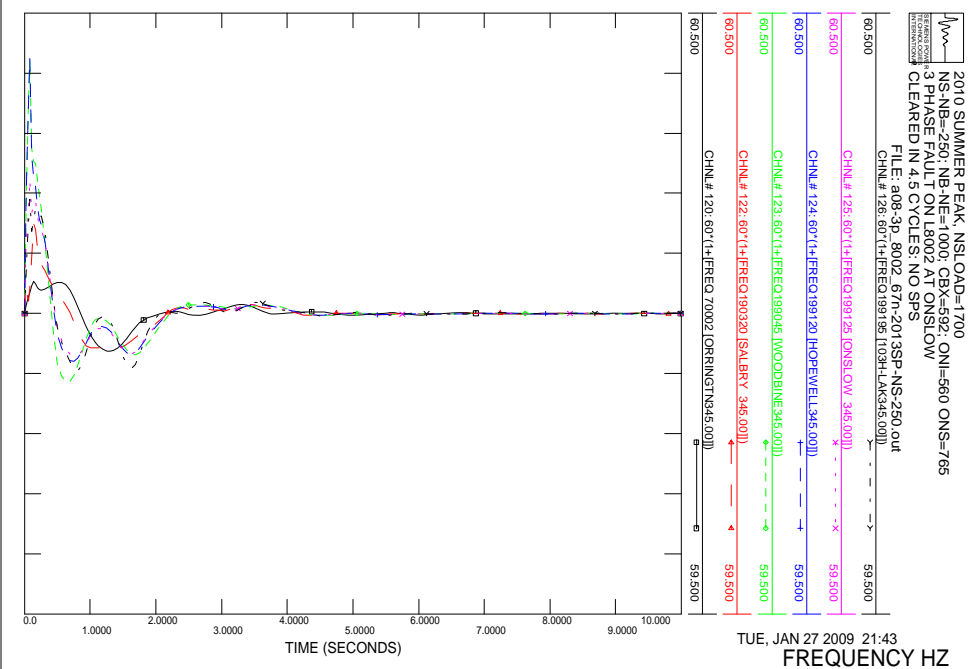
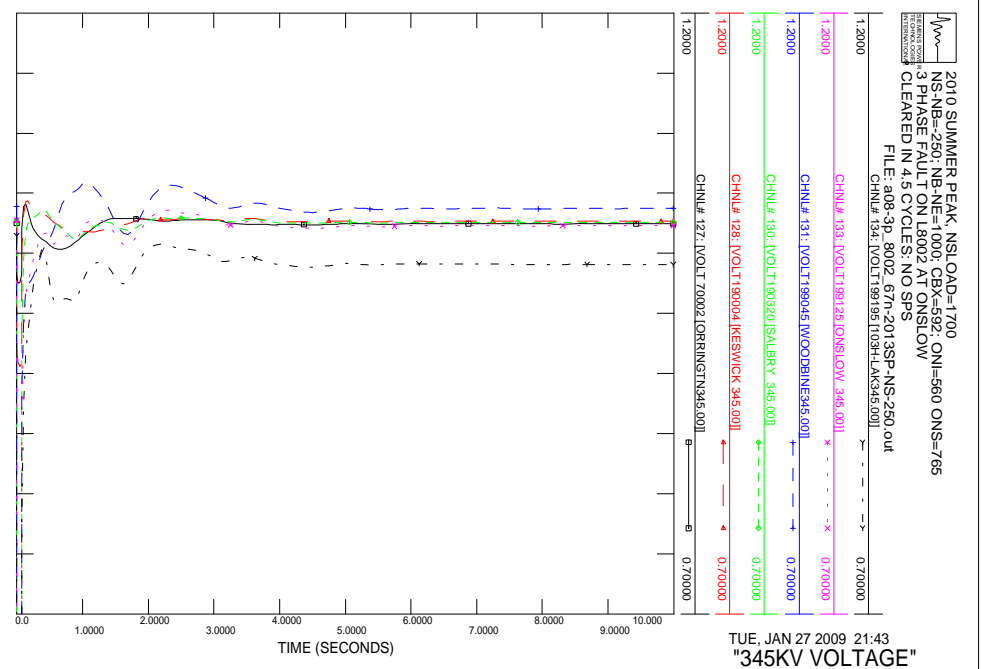
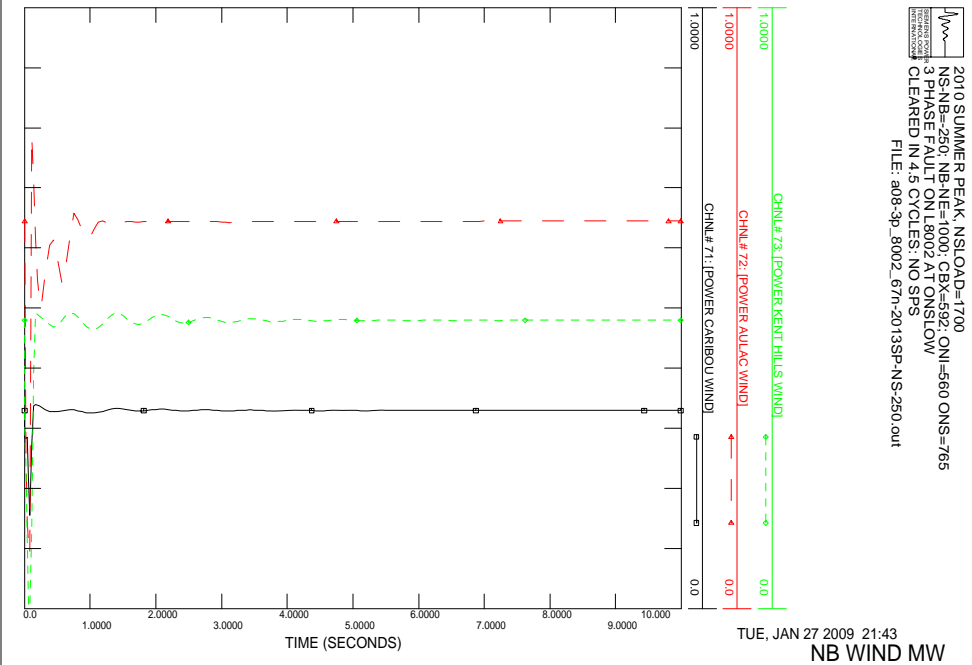
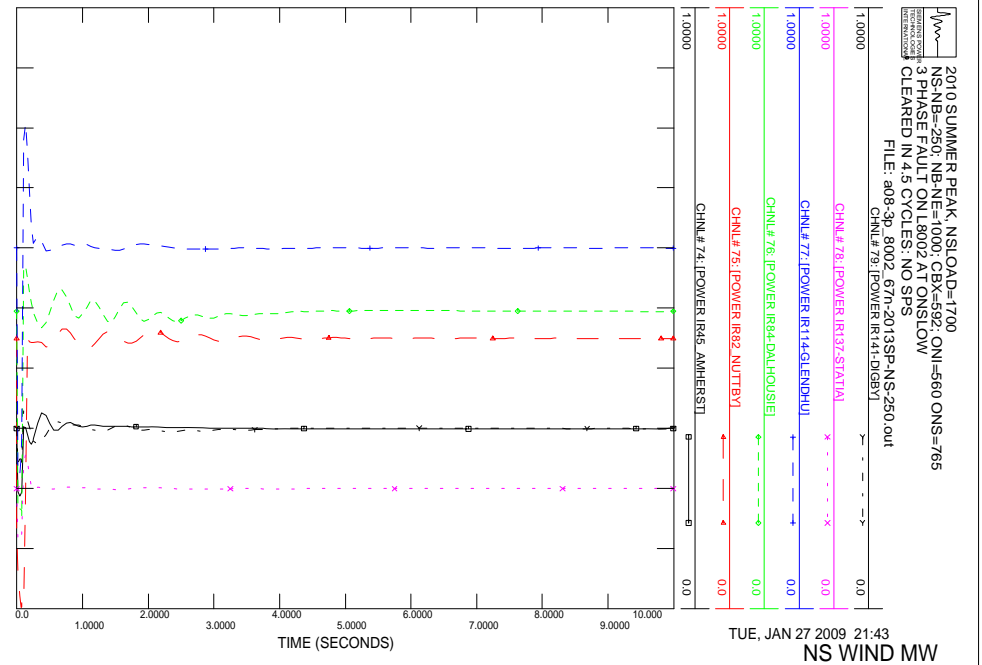

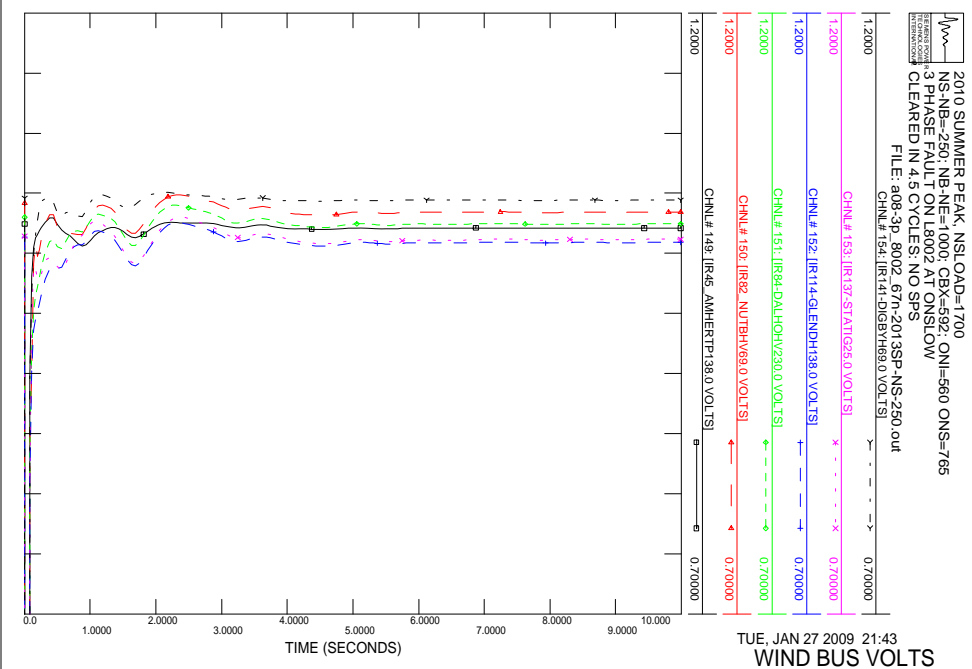
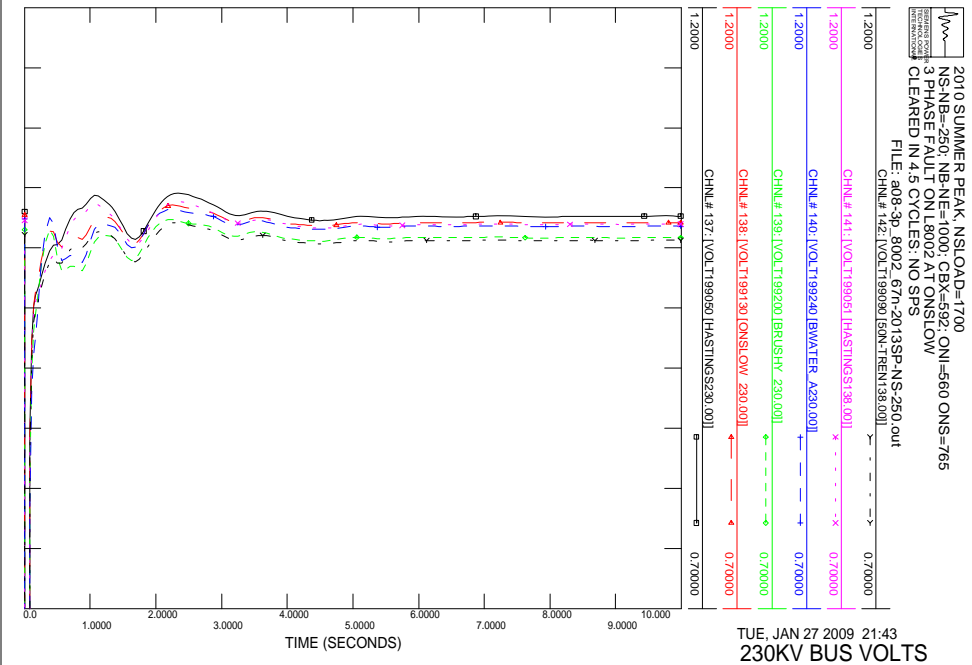
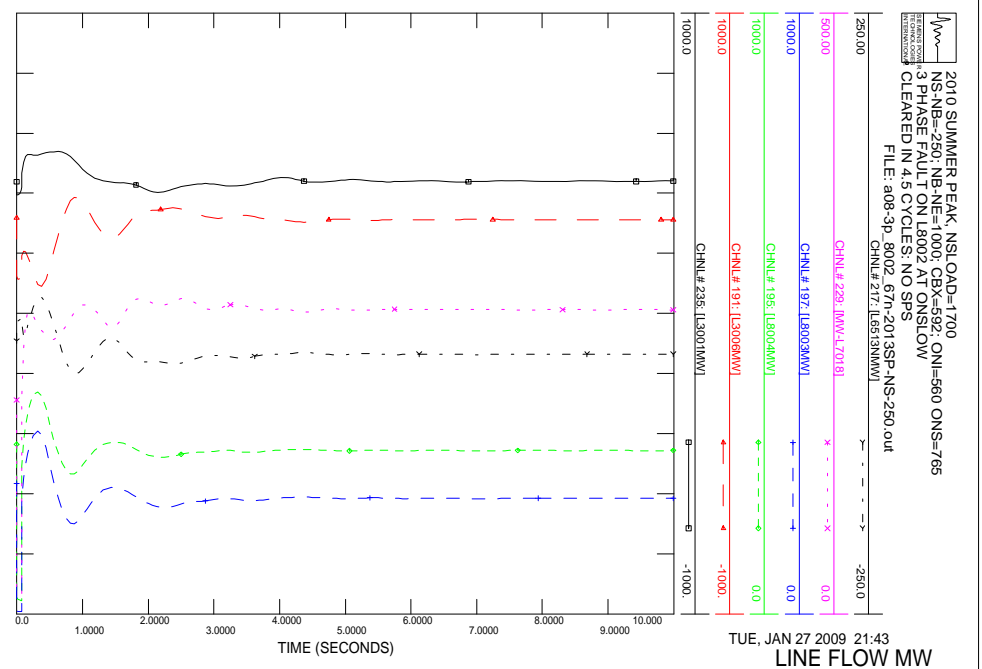
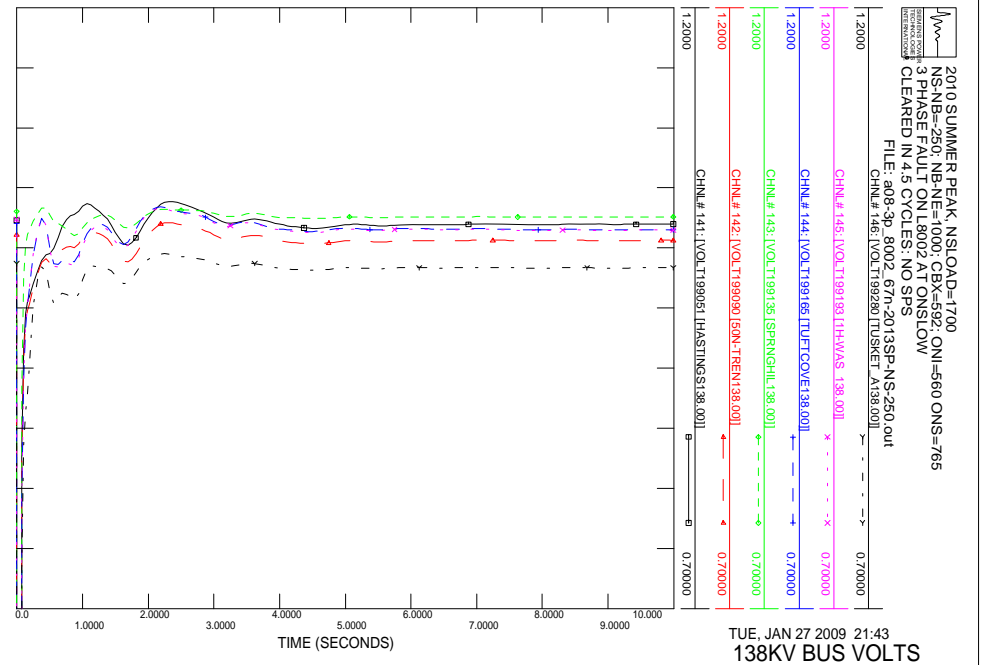

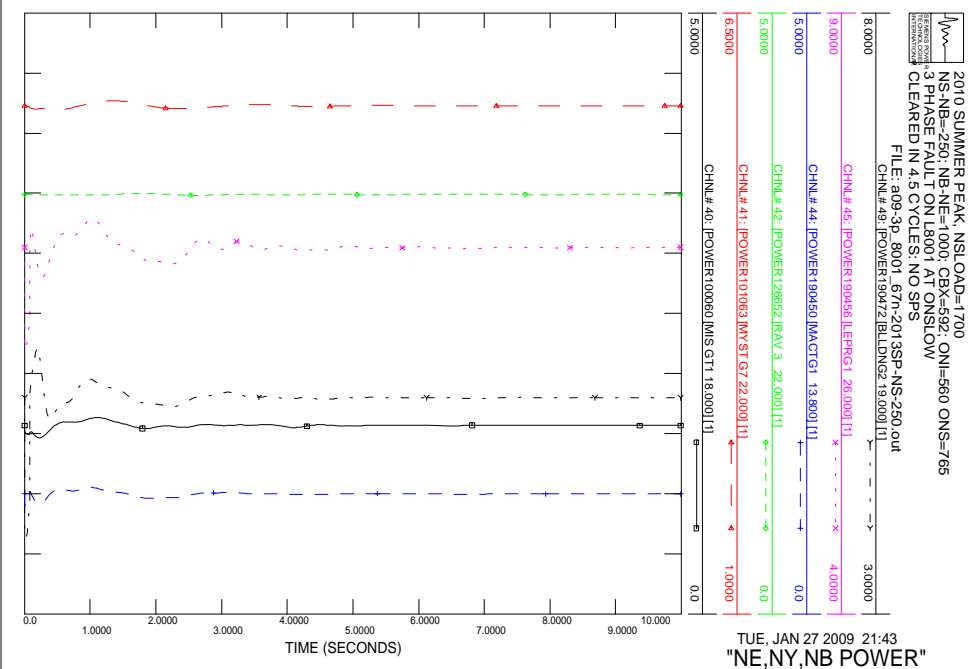
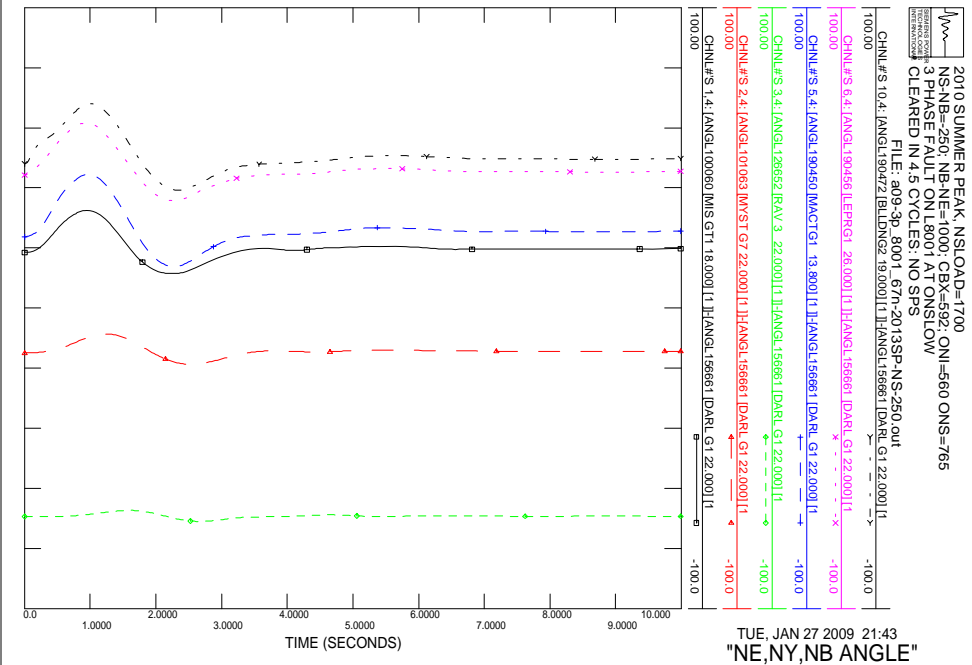
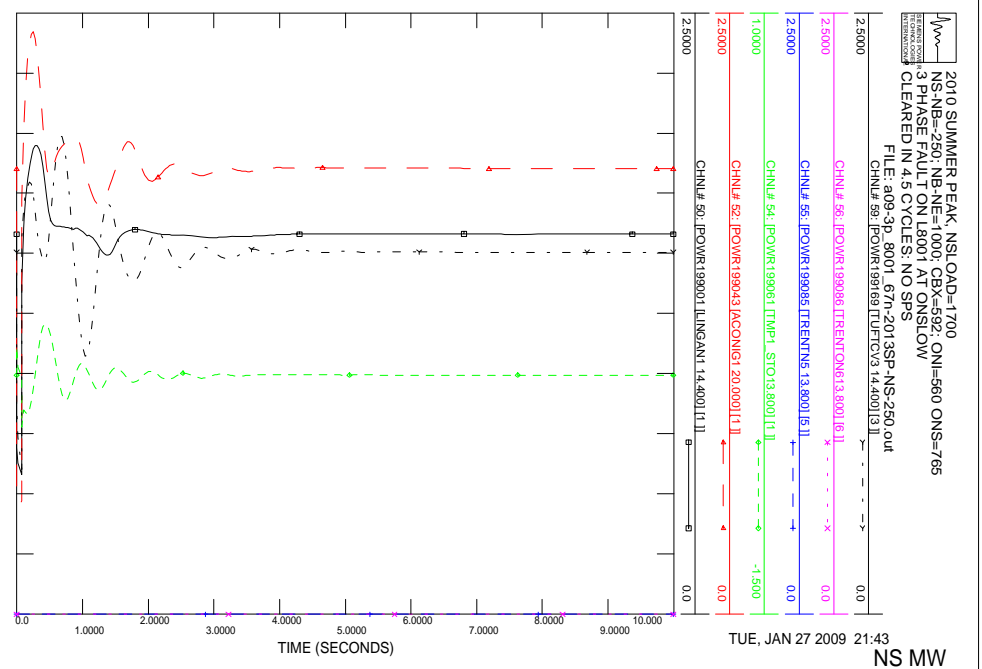
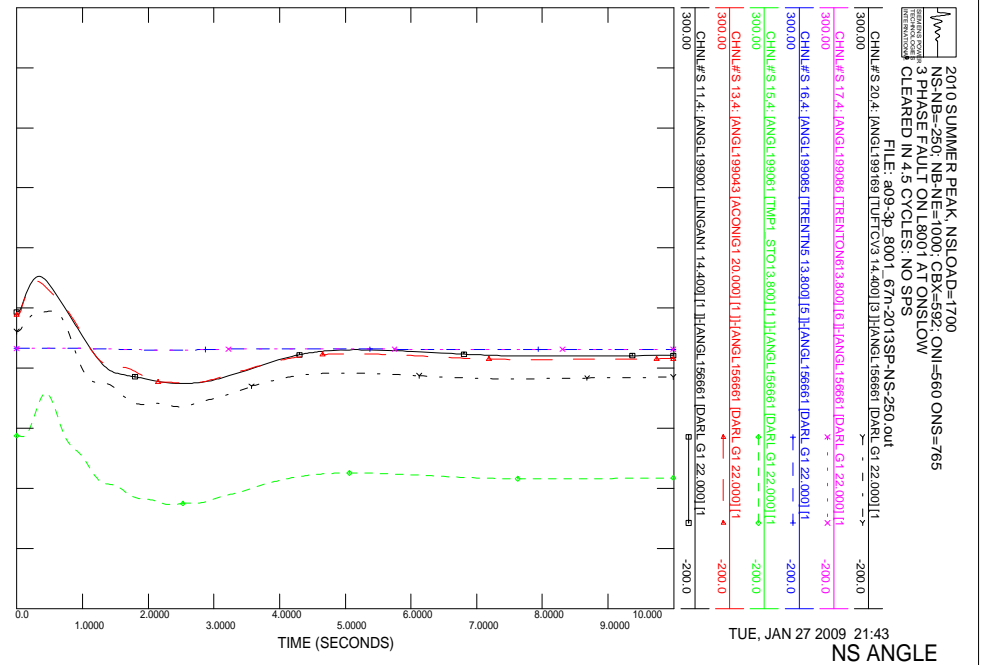

TUE, JAN 27 2009 21:43 "NS ANGLE"

TUE, JAN 27 2009 21:43 "NE,NY,NB ANGLE"

TUE, JAN 27 2009 21:43 "NS MW"

TUE, JAN 27 2009 21:43 "NE,NY,NB POWER"

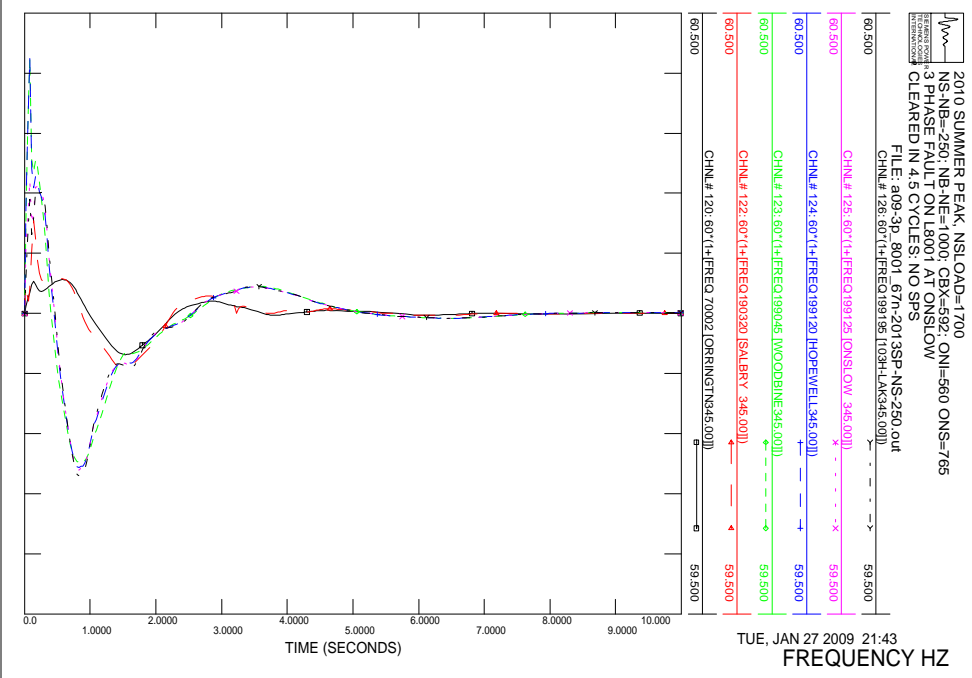
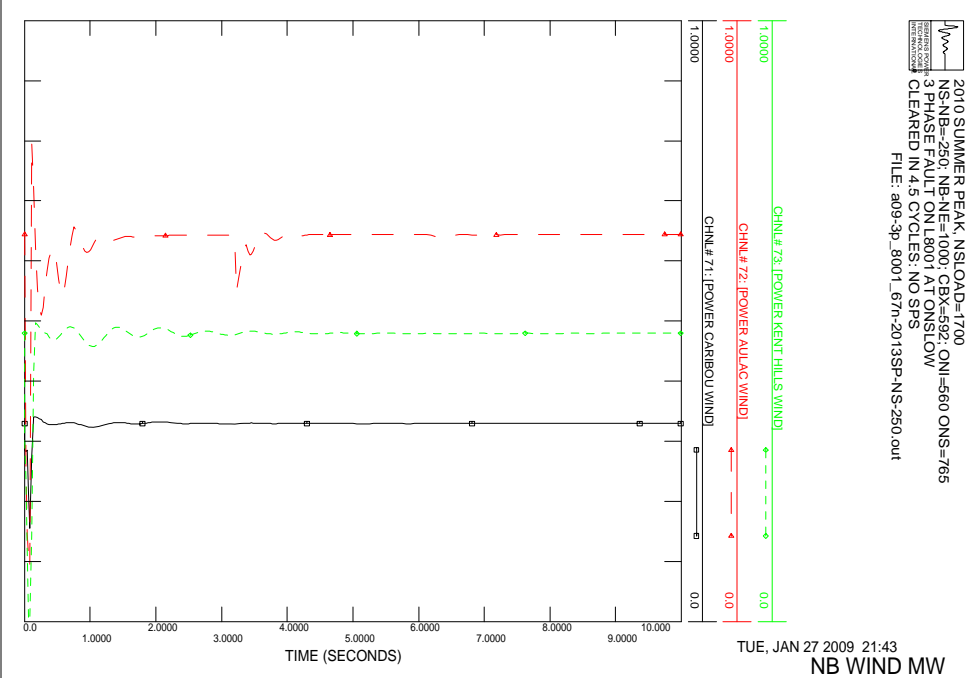
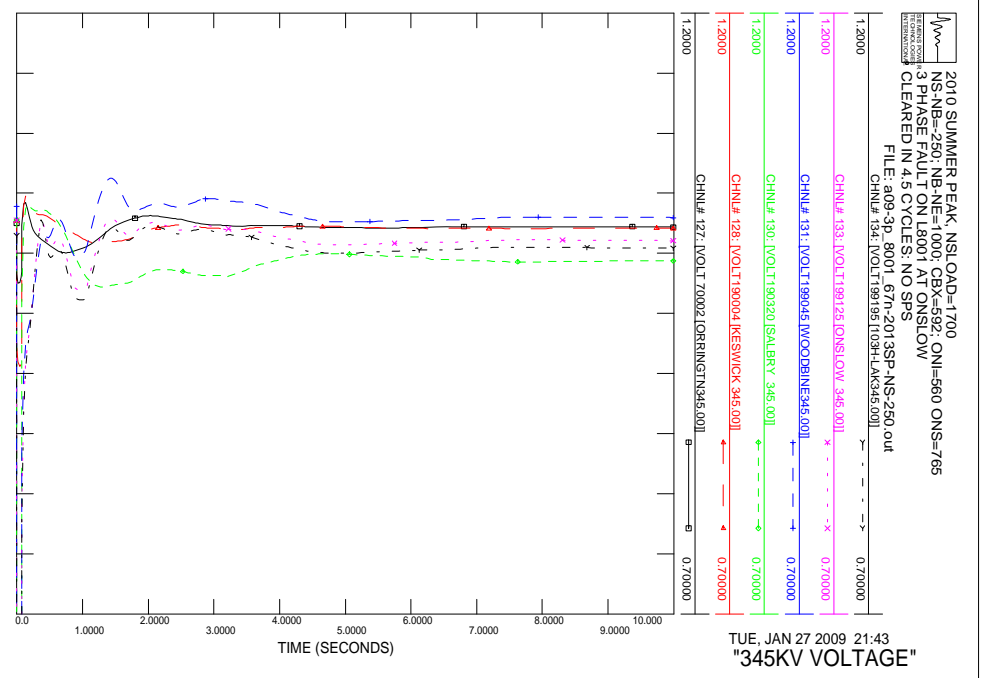
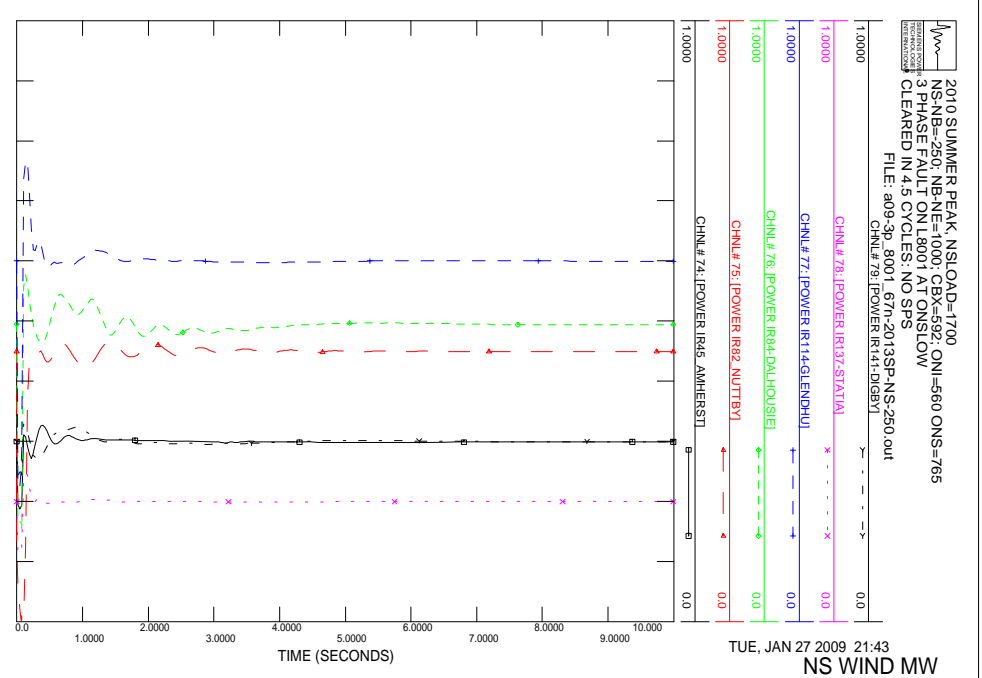

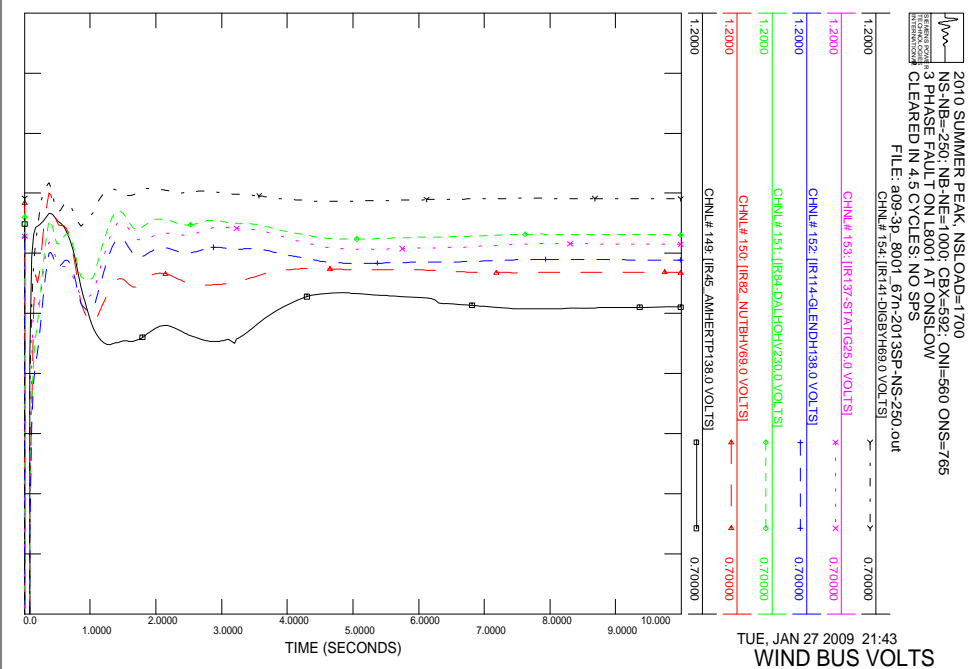
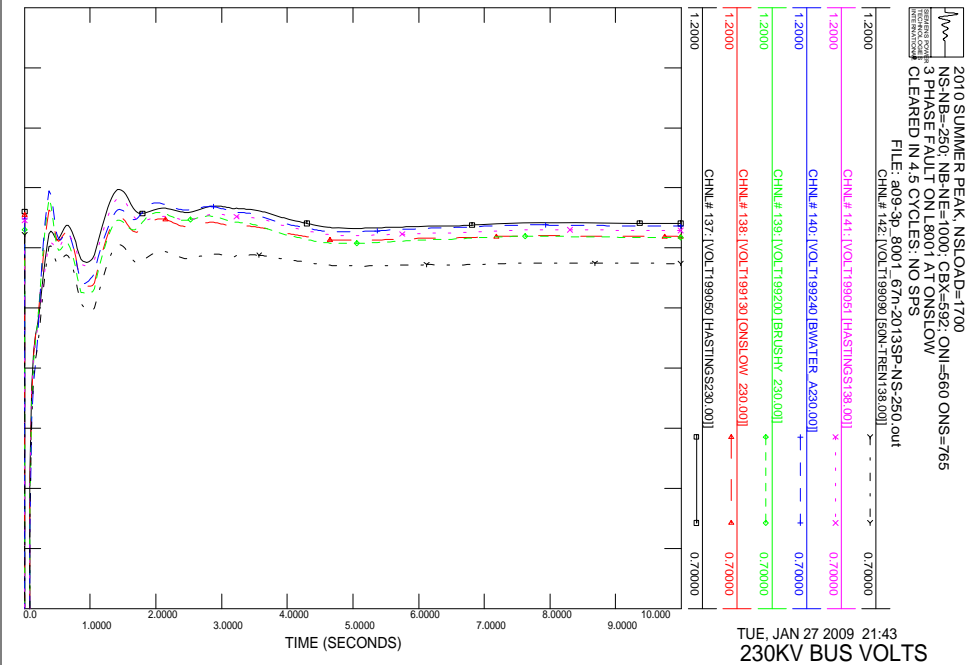
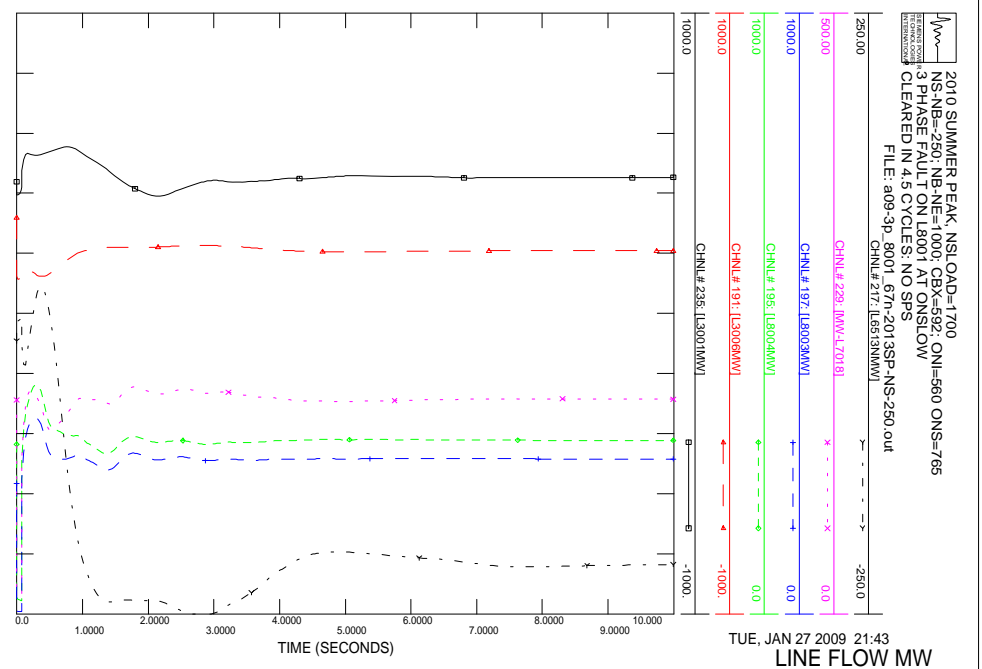
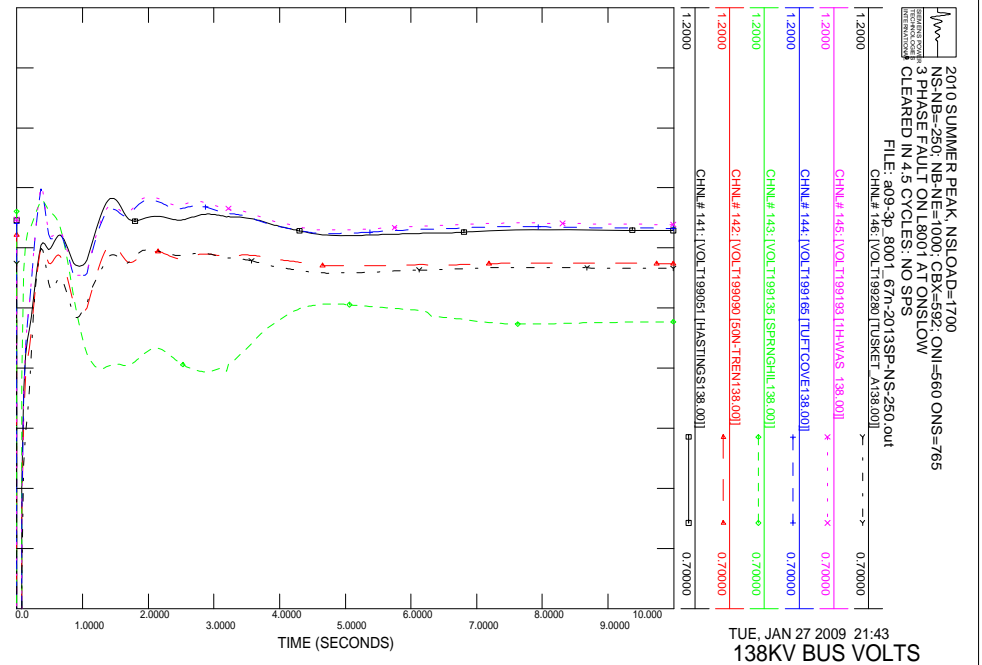

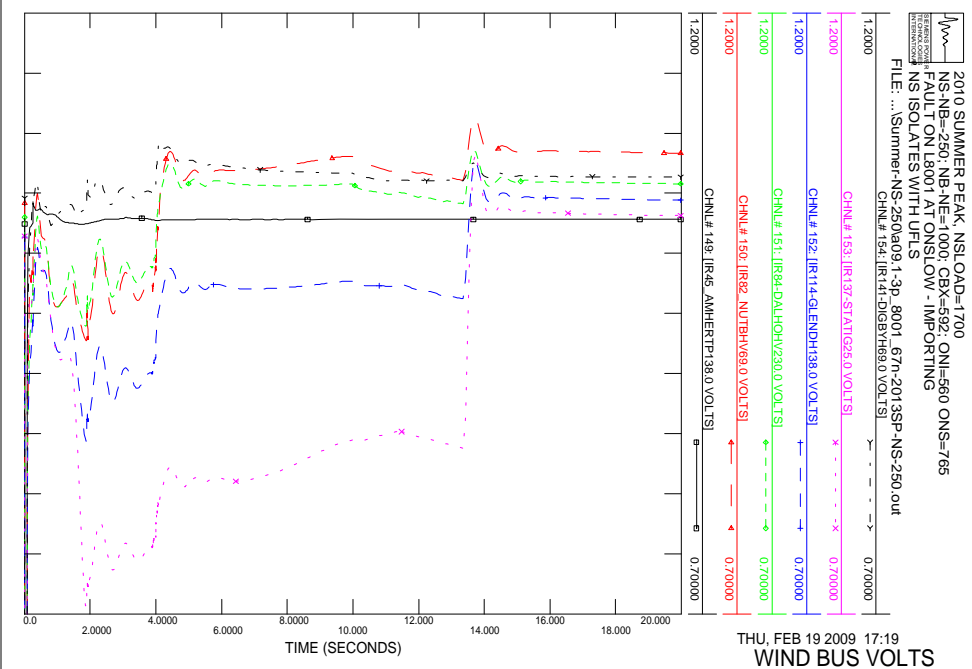
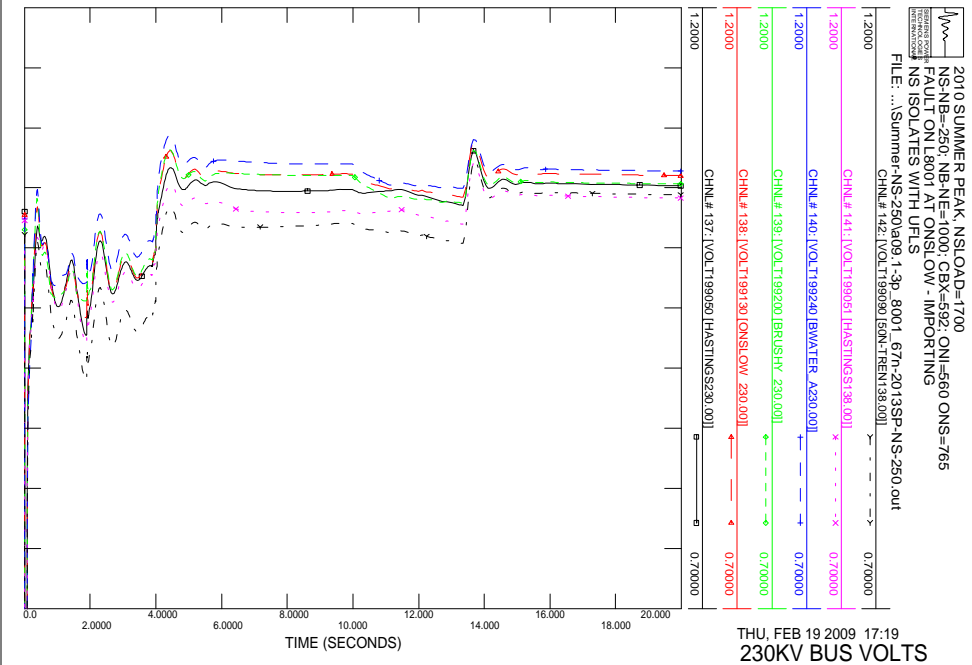
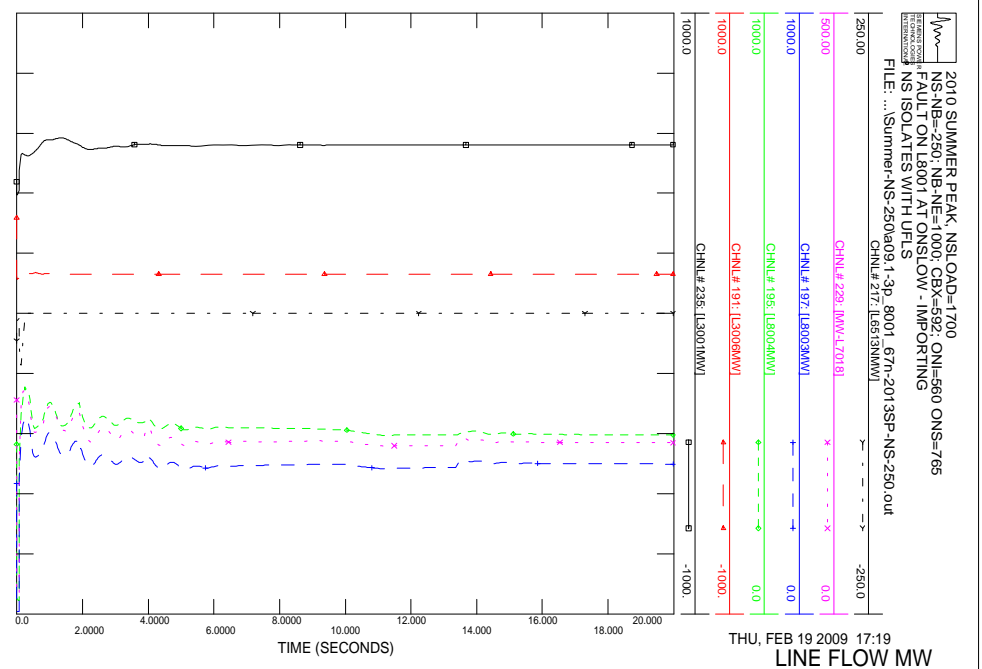
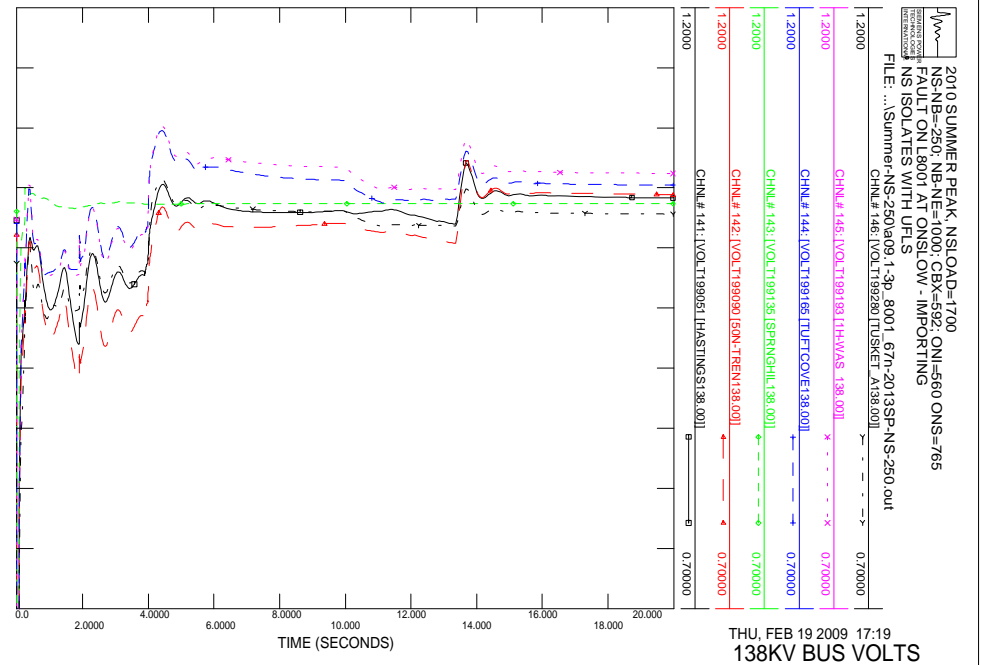

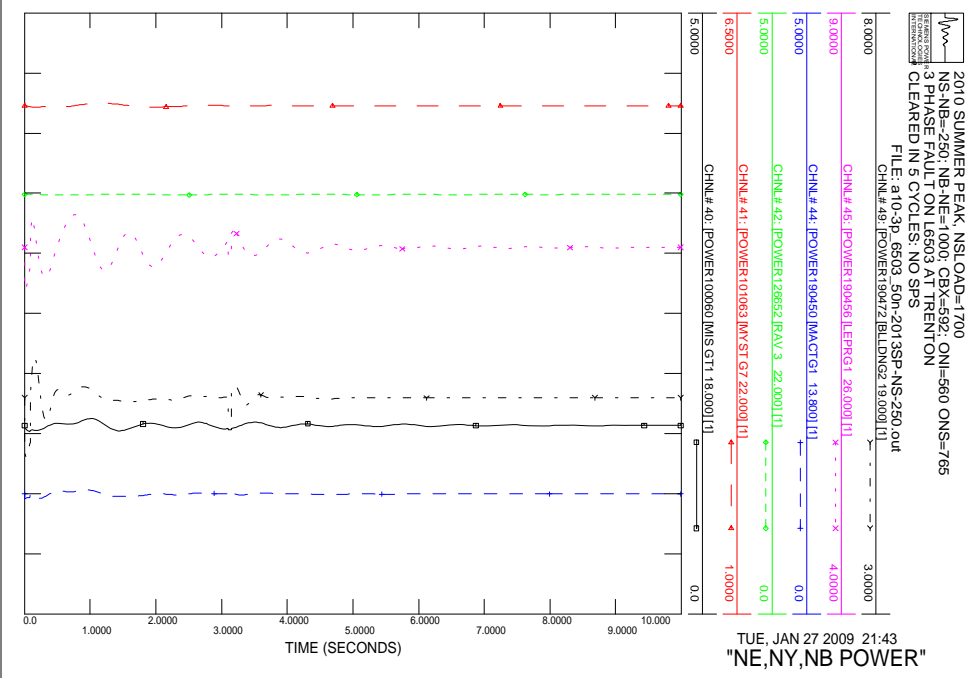
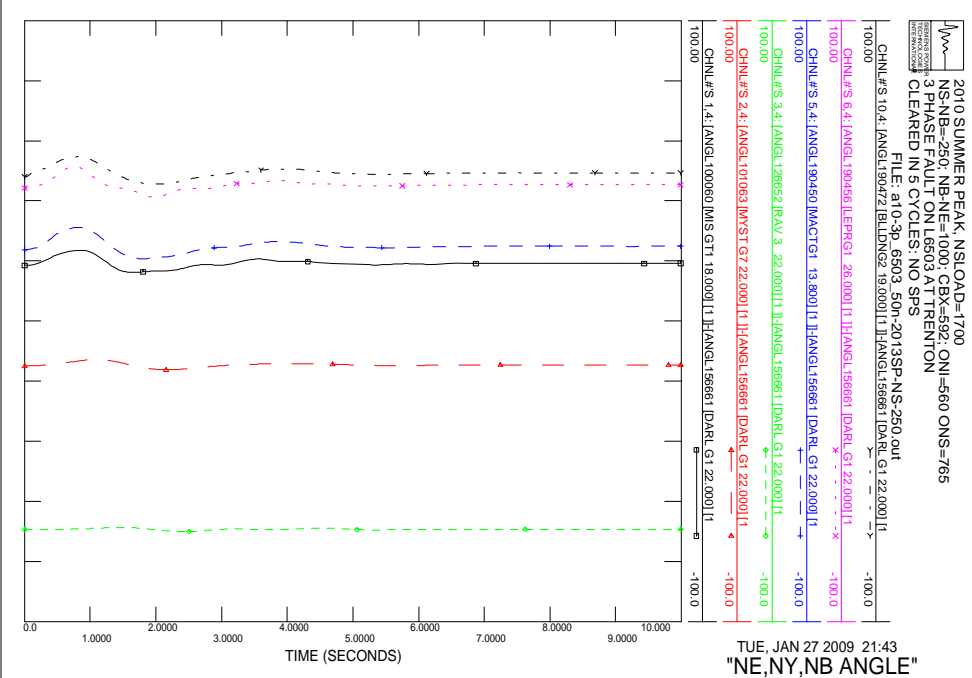
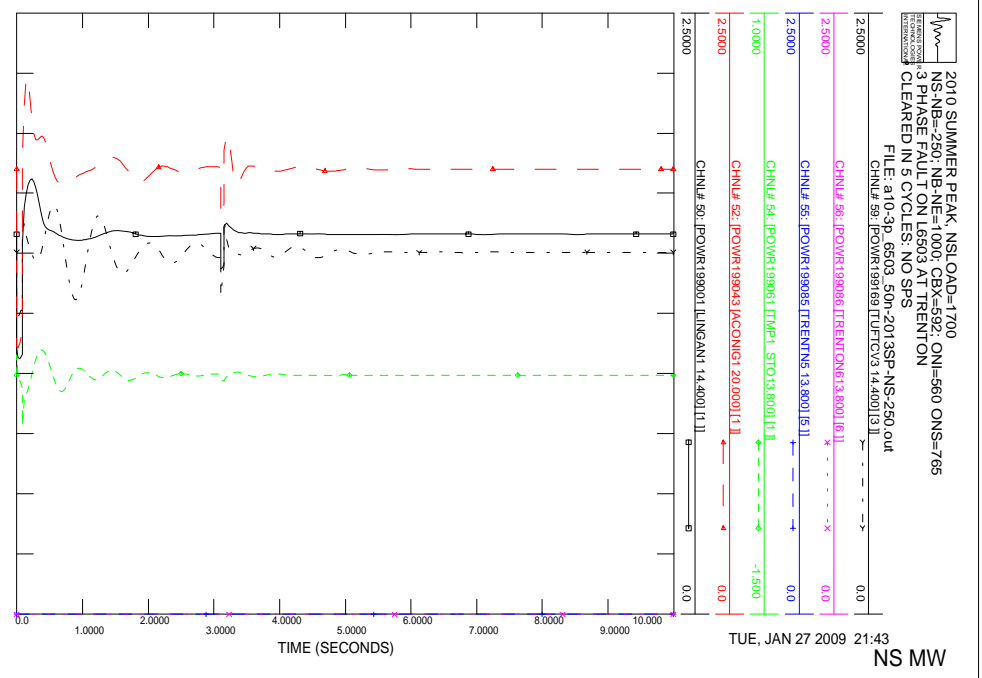
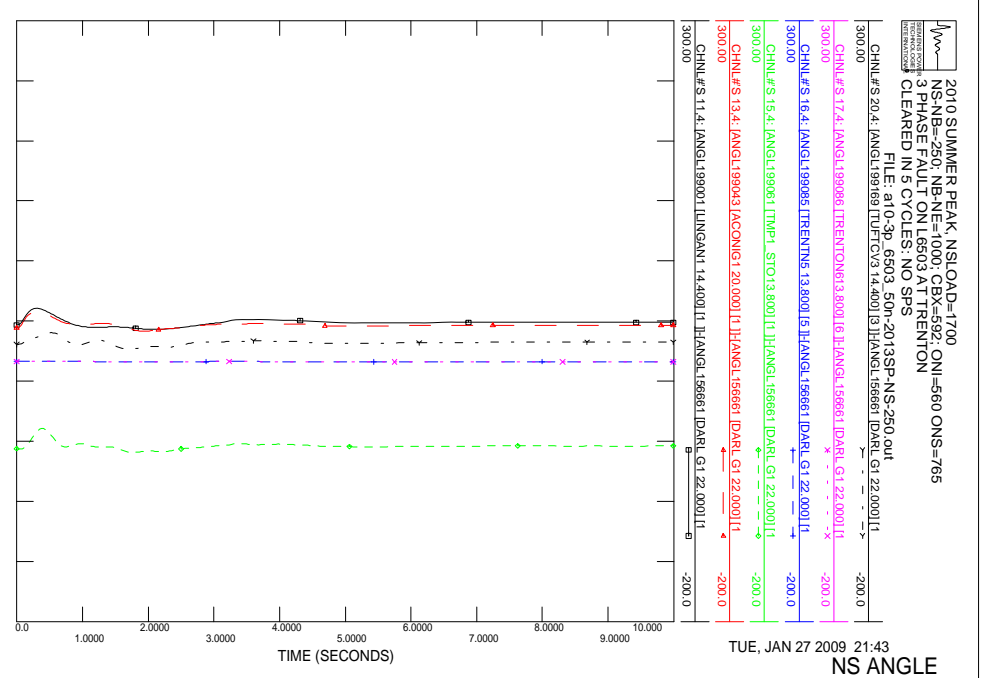

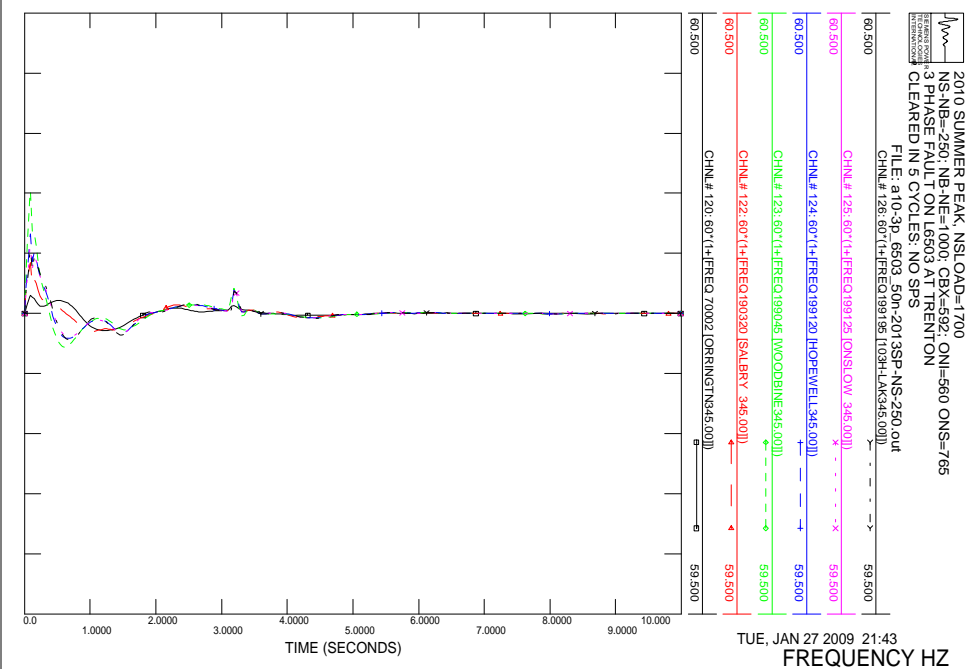
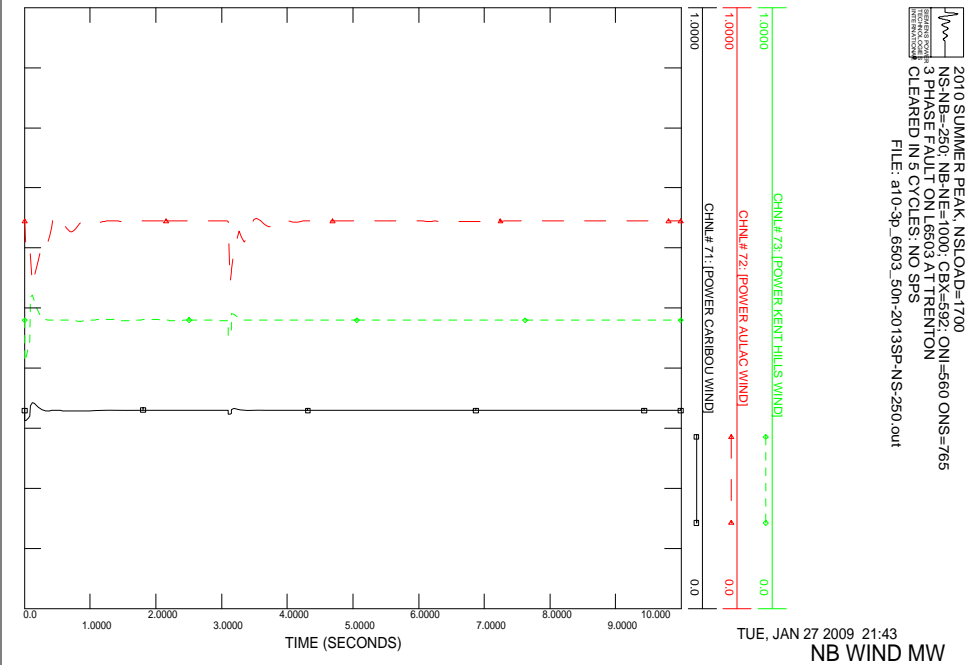
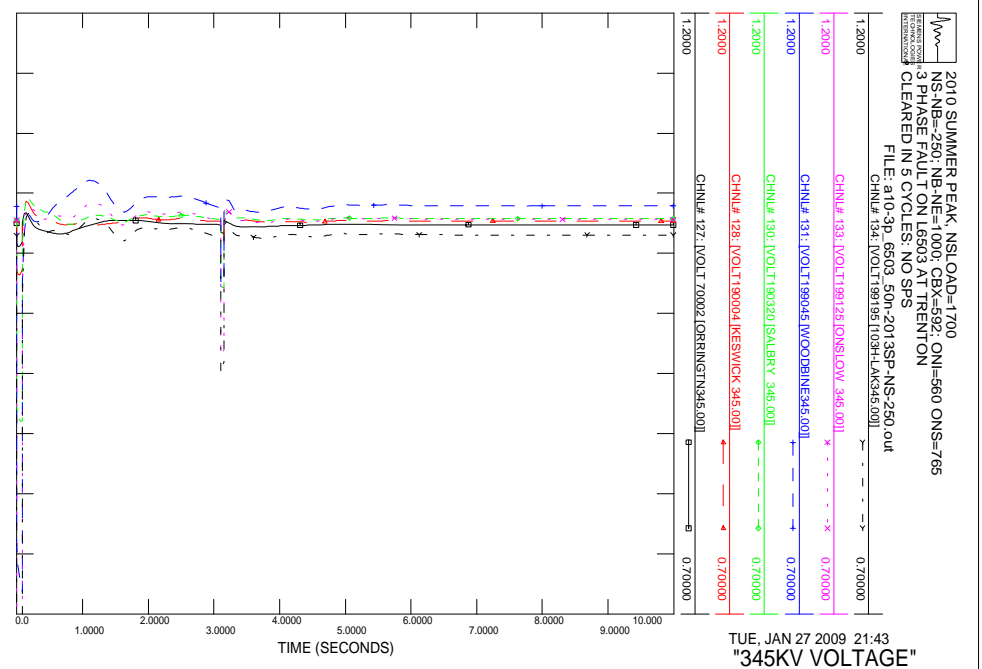
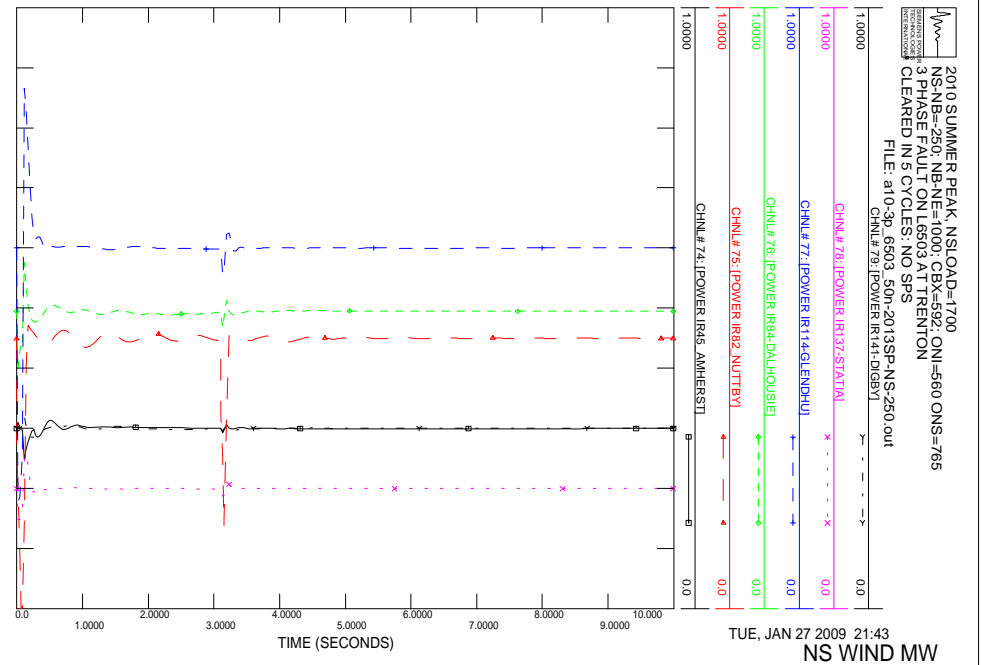

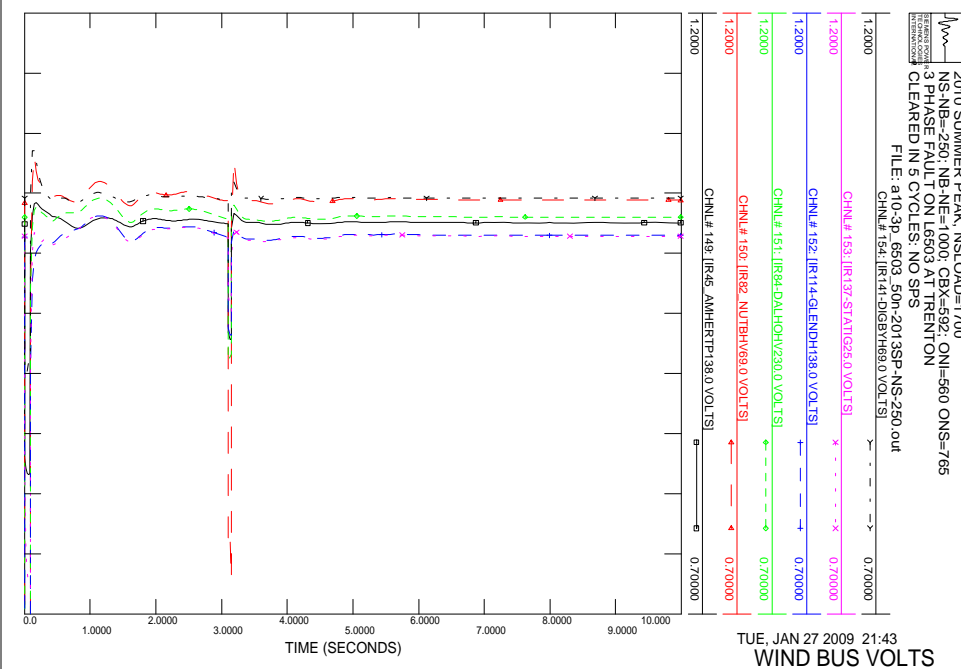
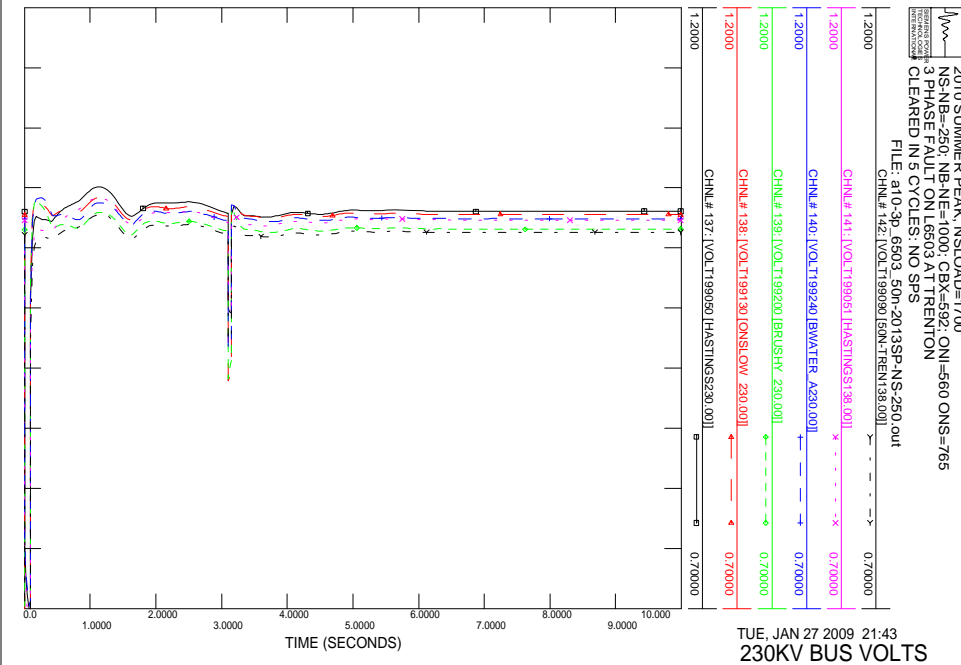
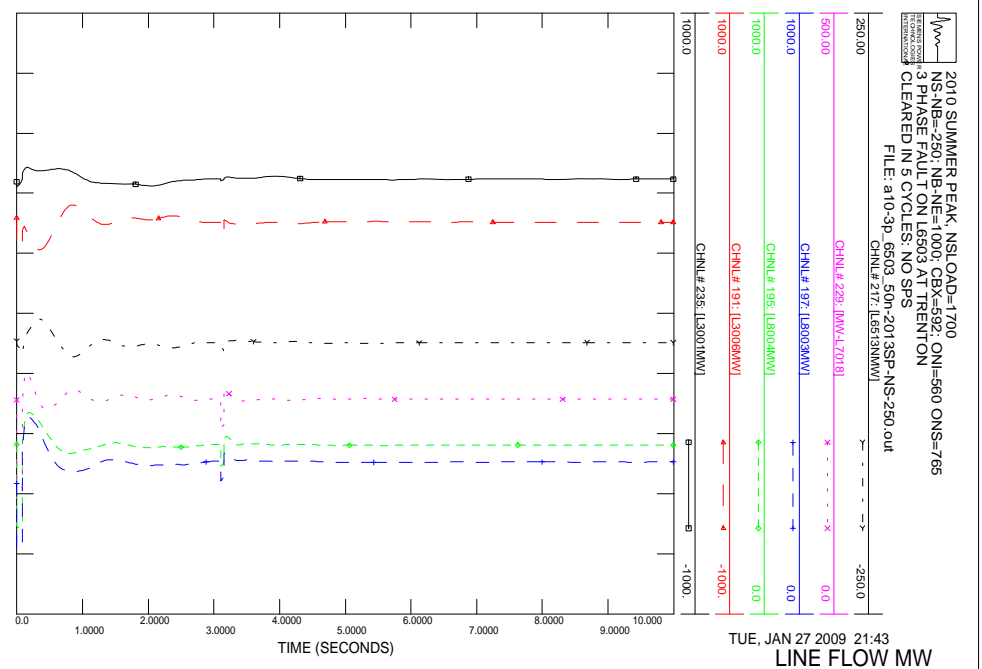
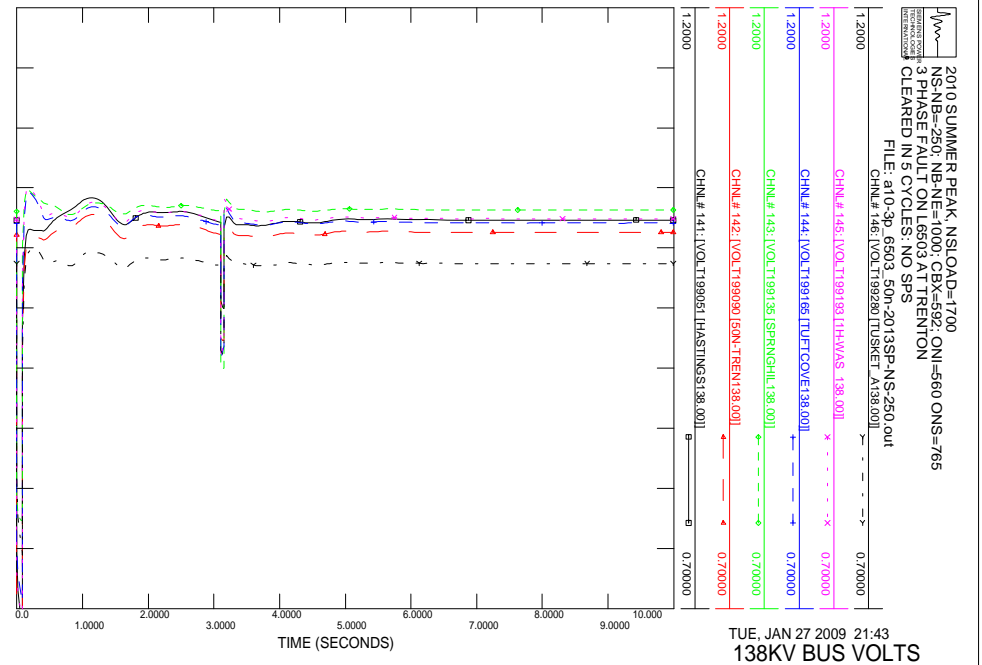

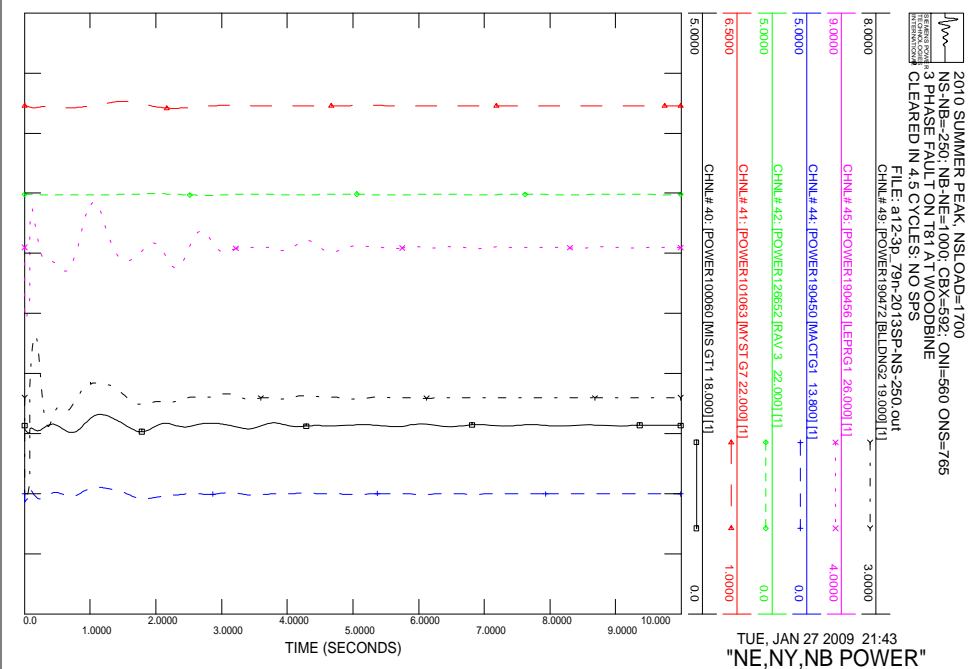
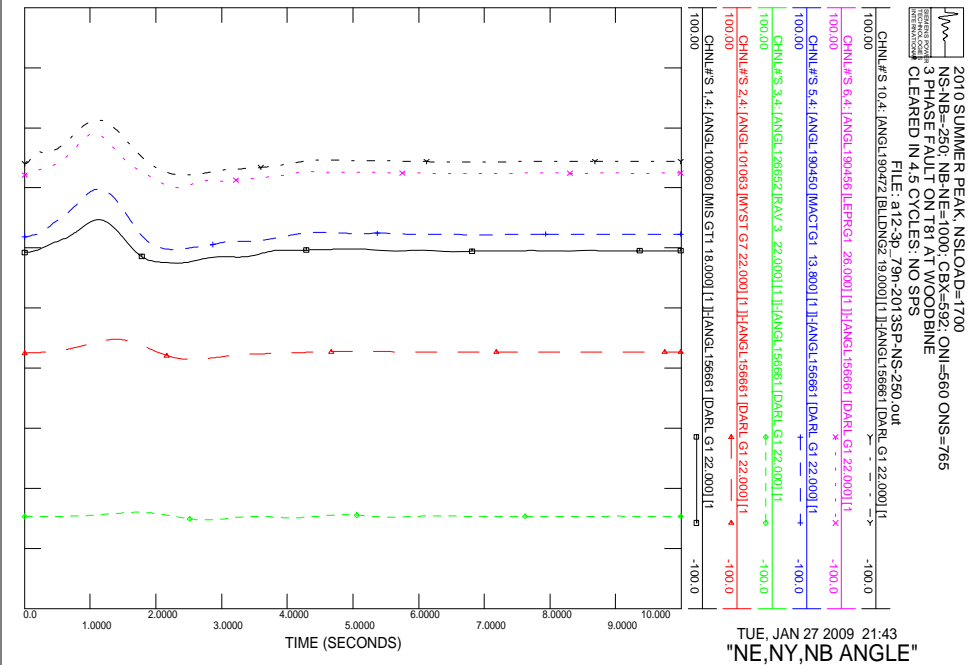
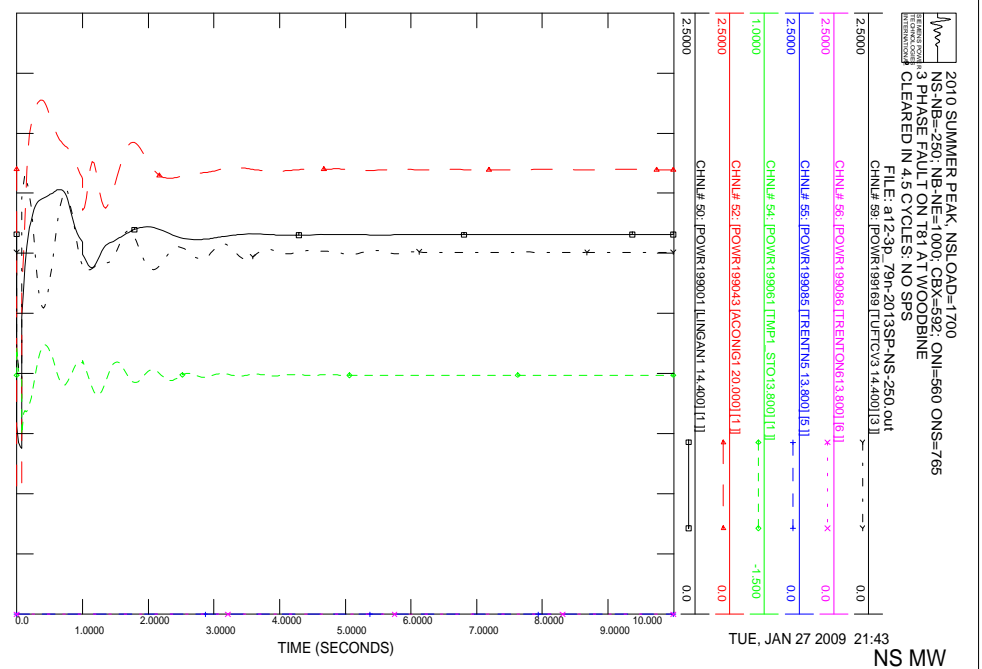
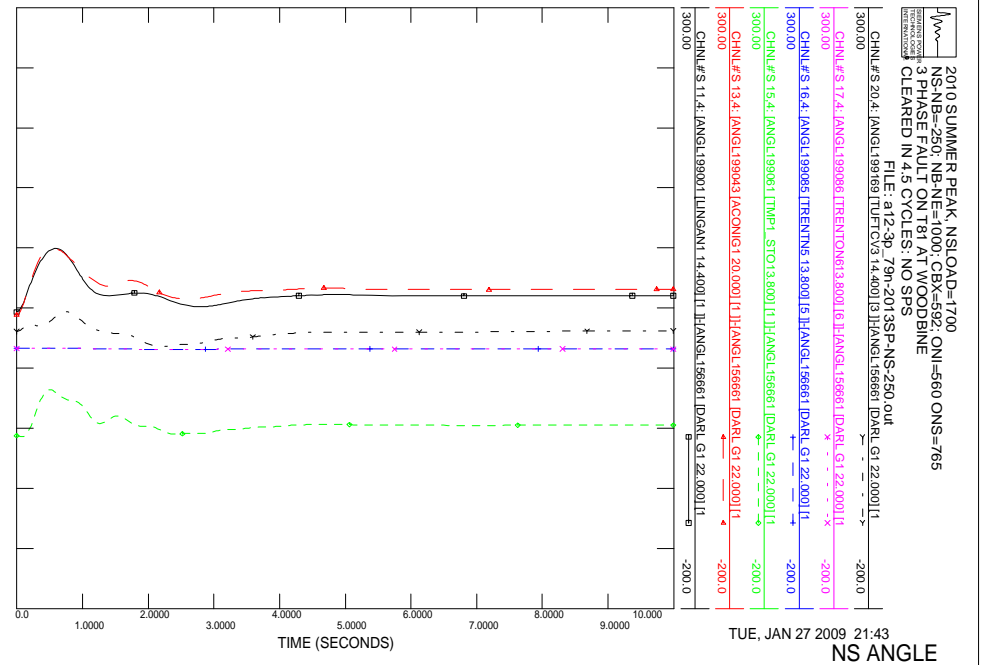

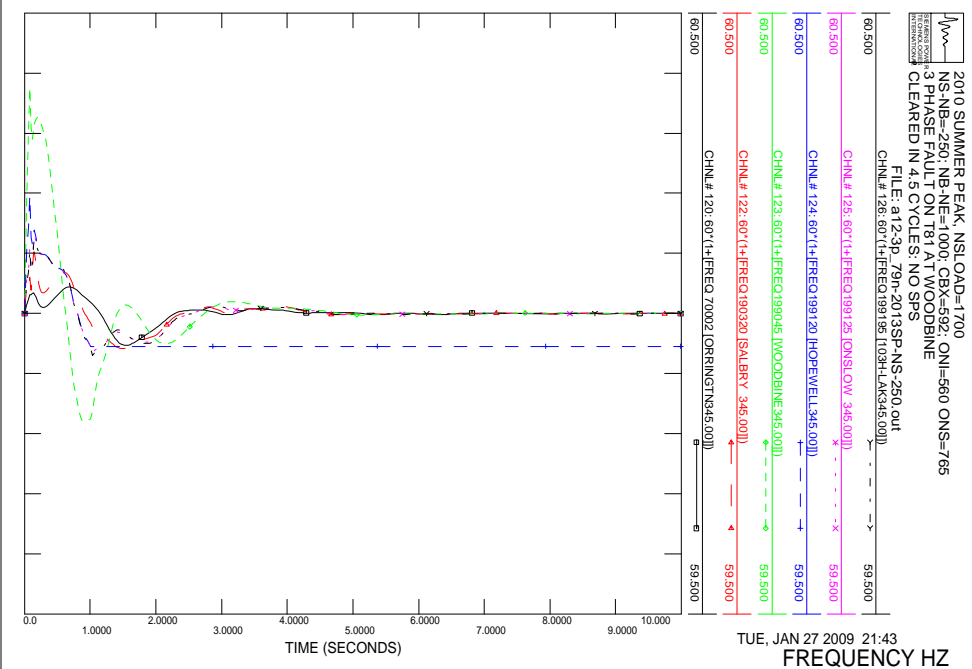
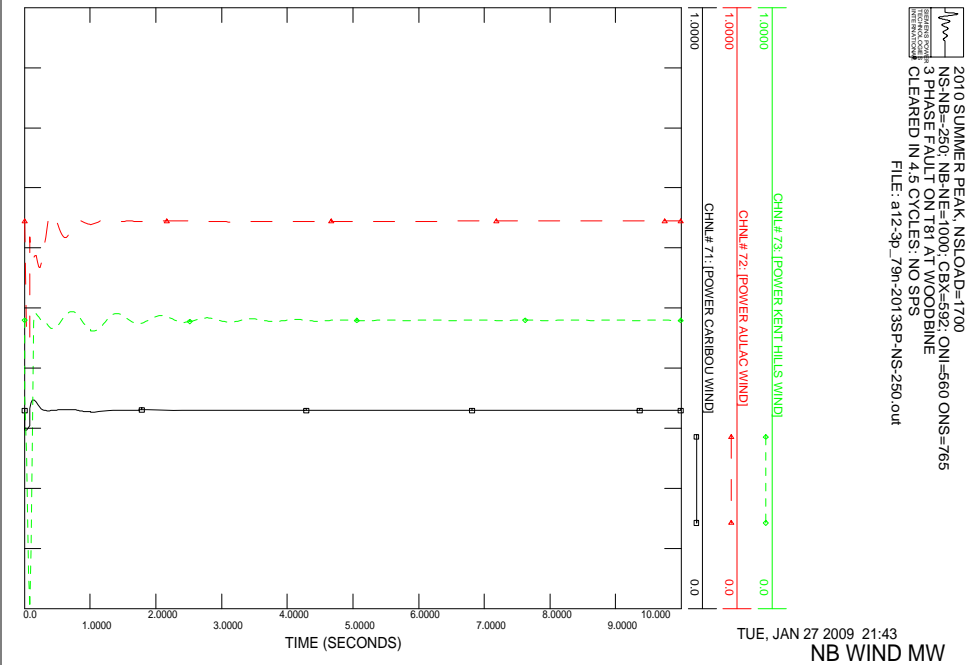
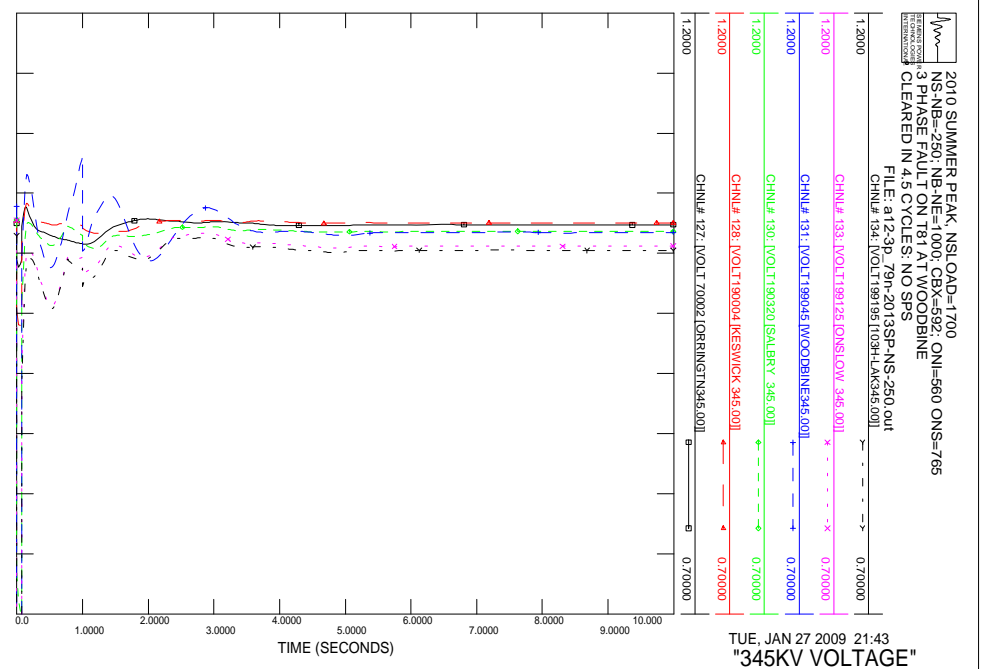
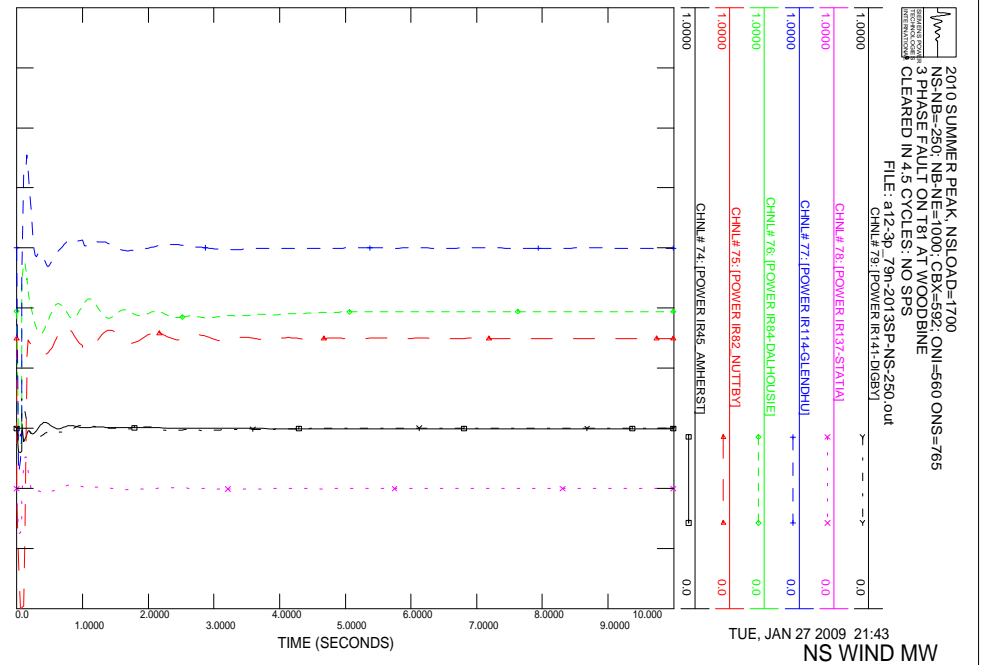

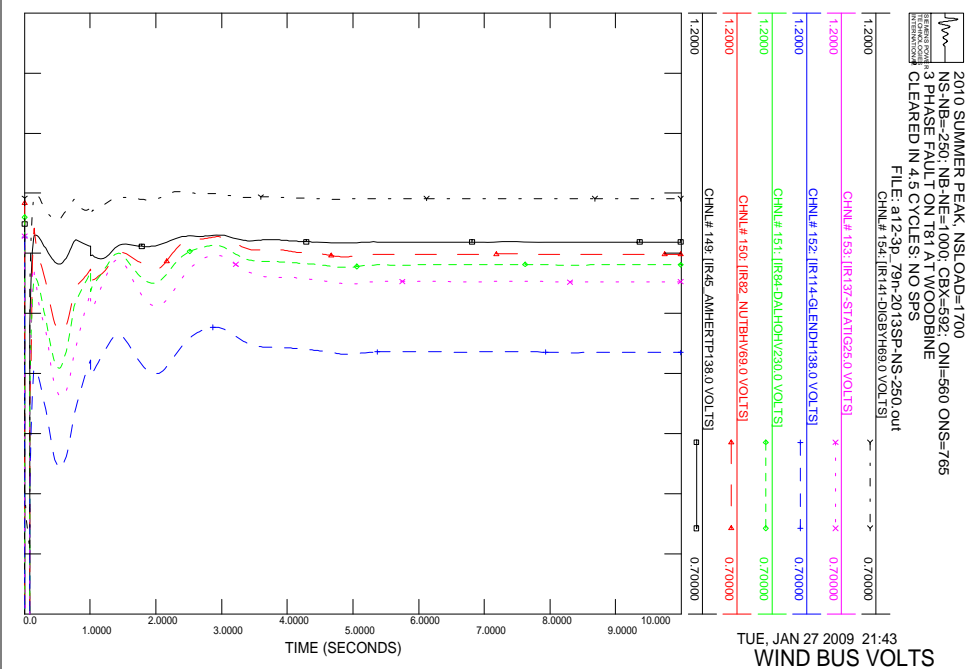
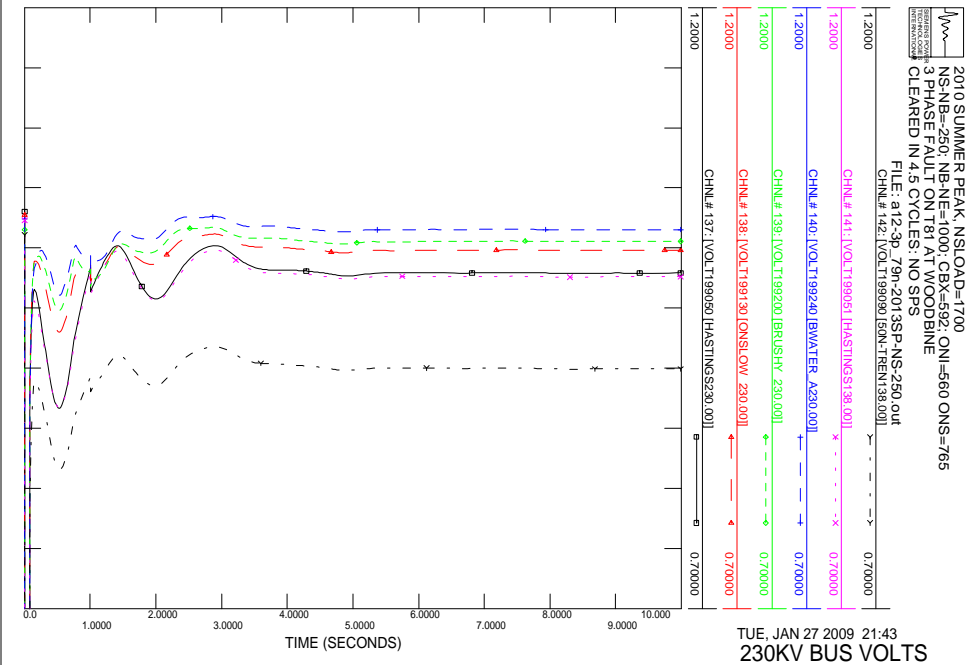
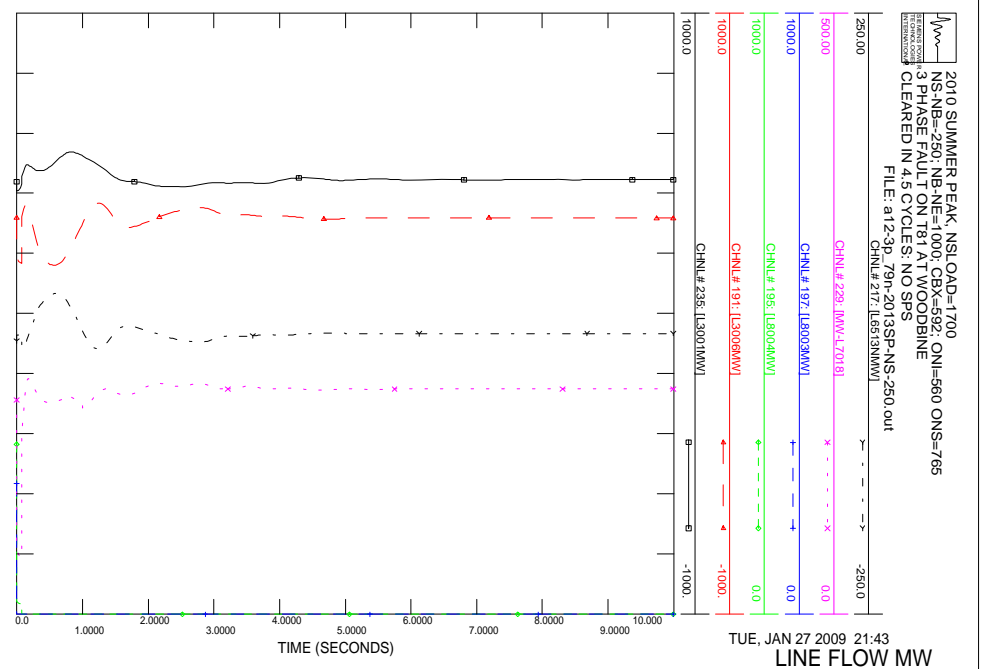
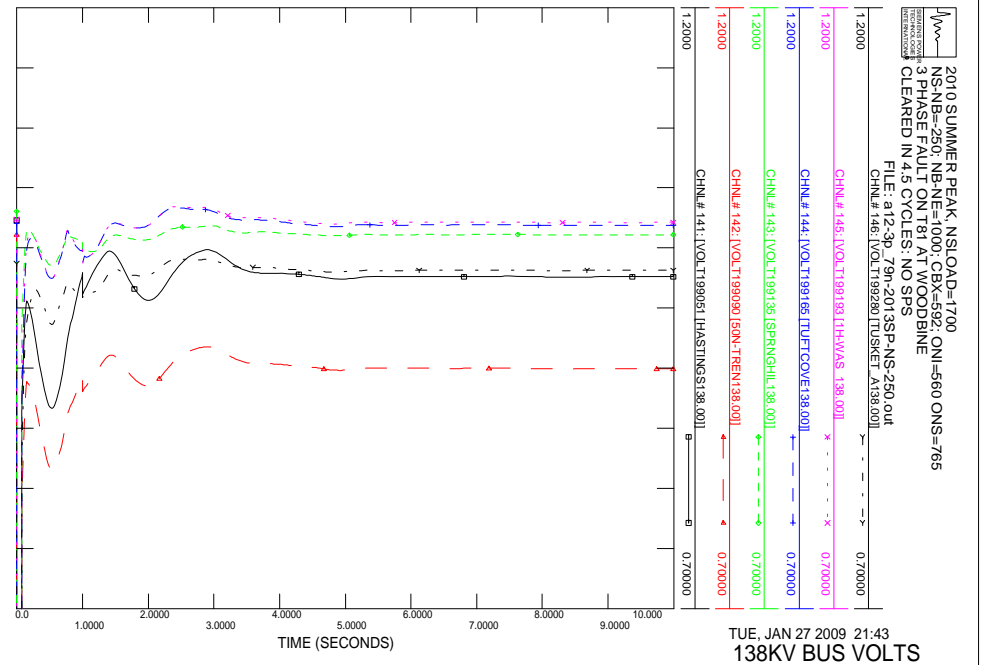

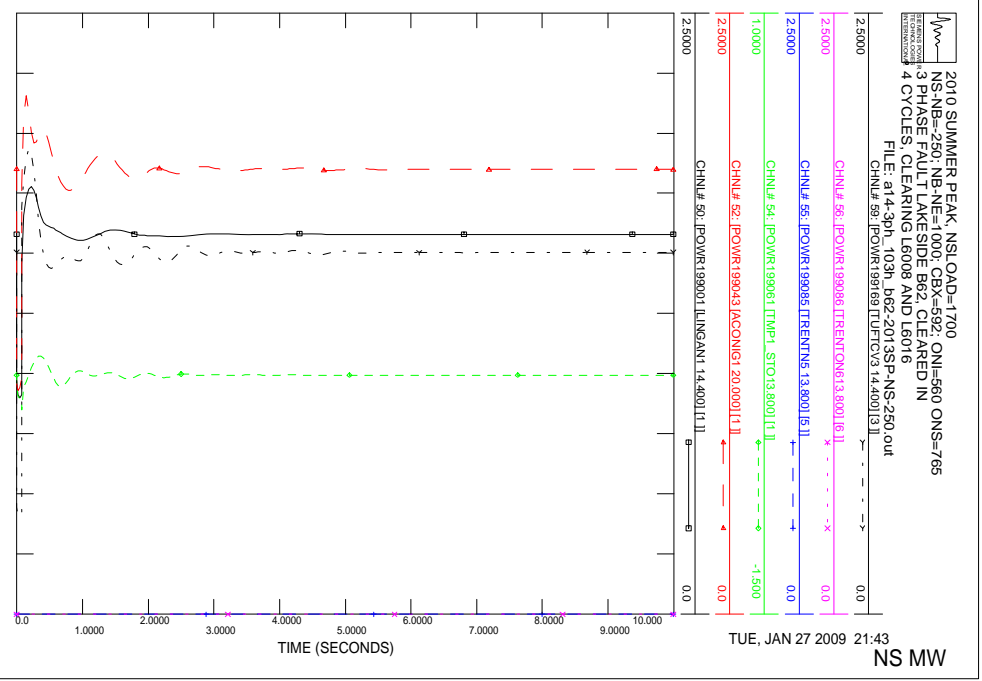
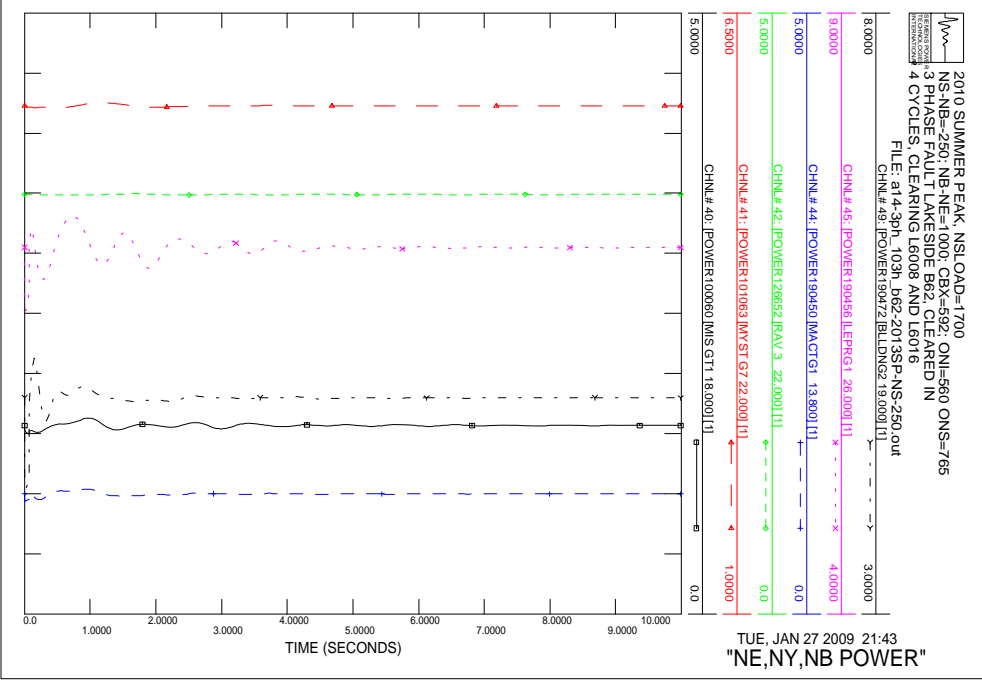
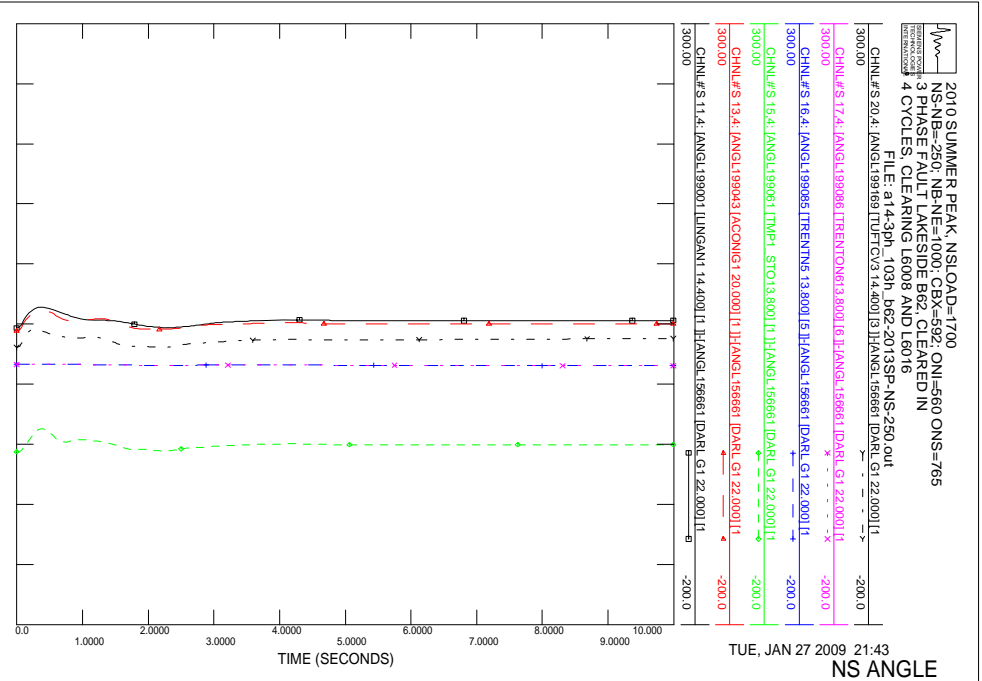
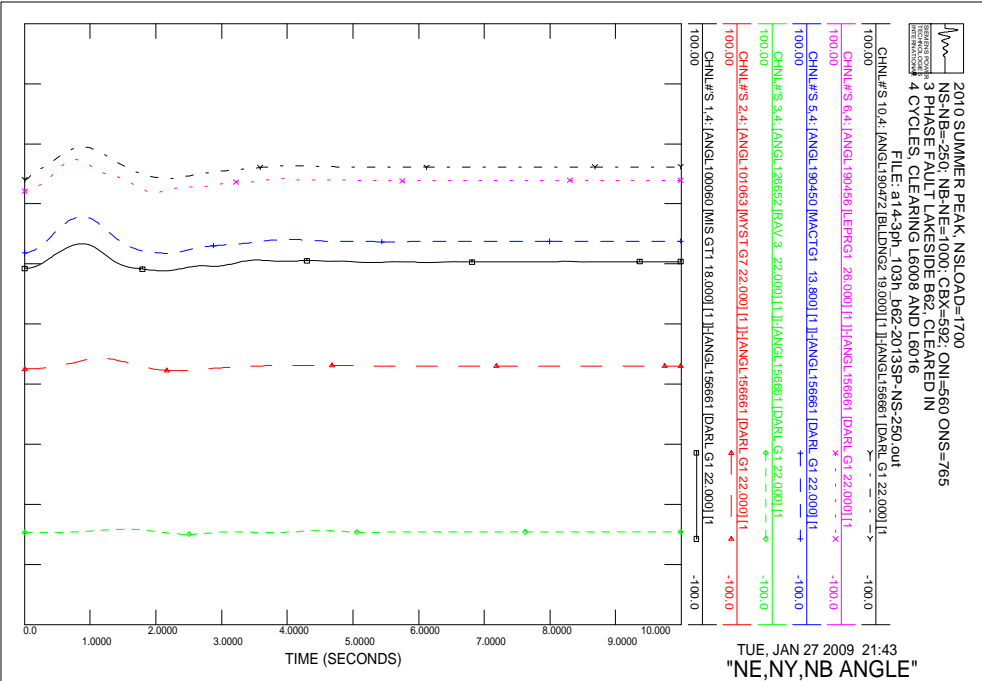

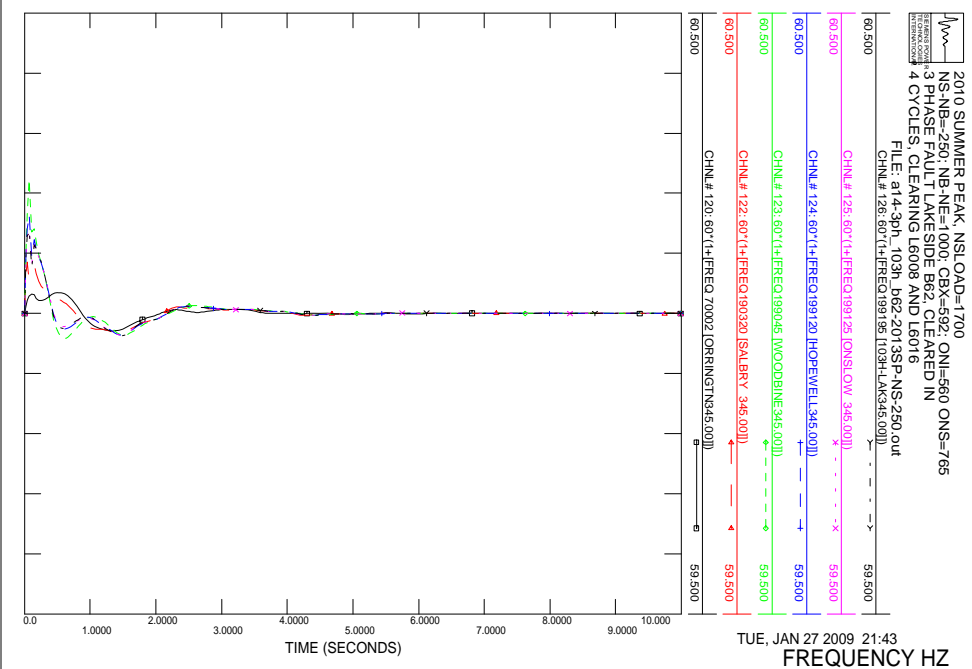
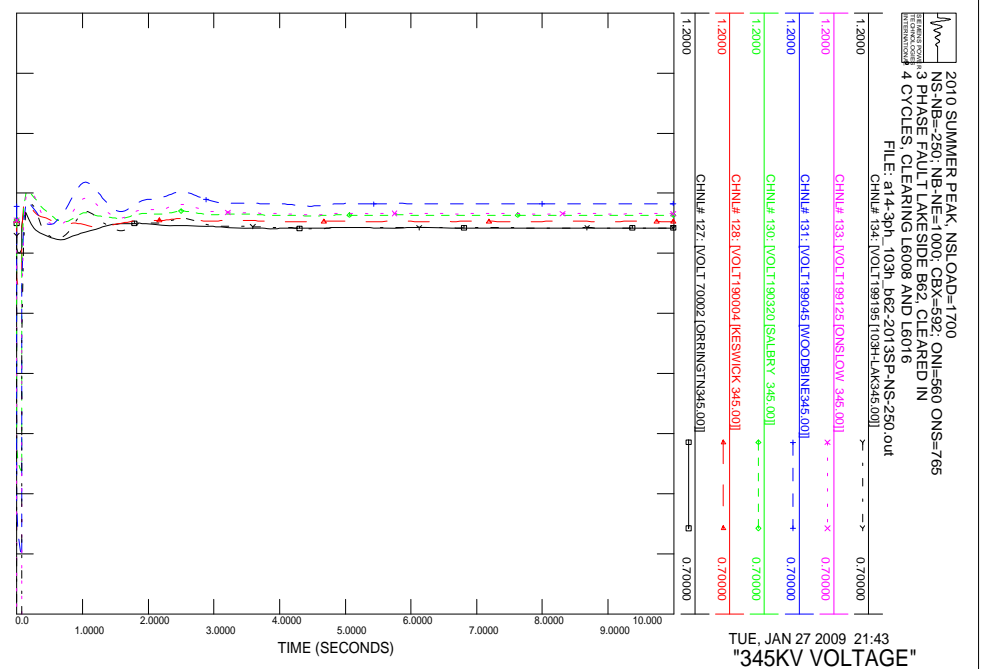
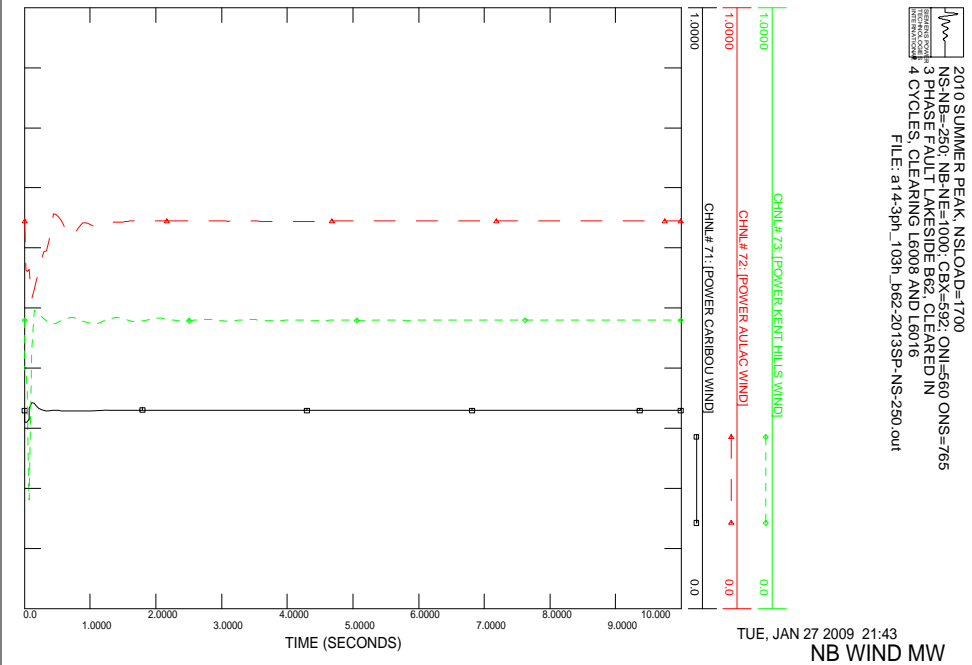
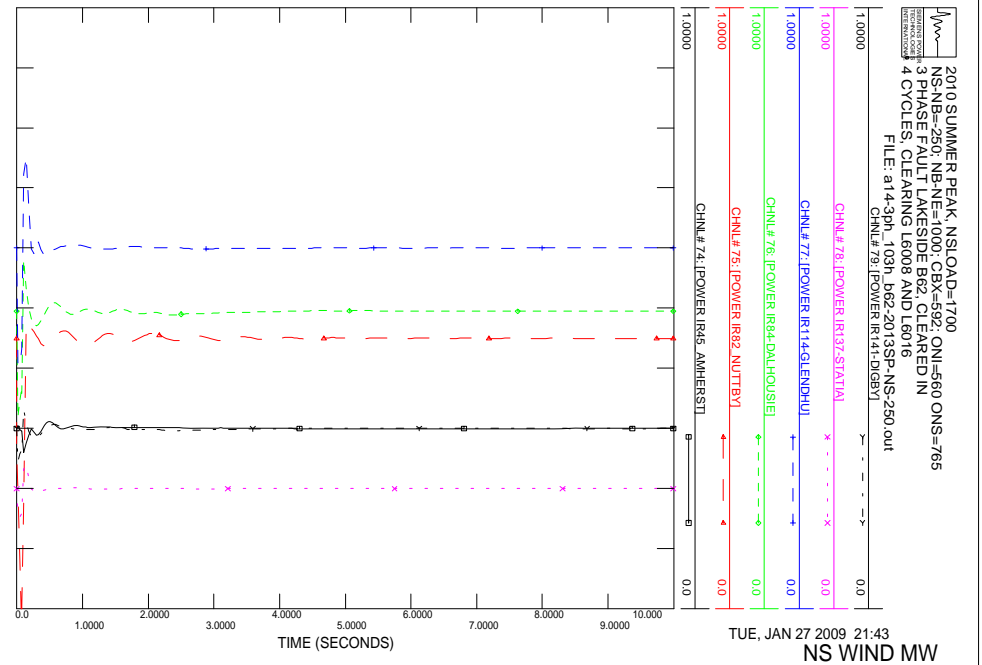

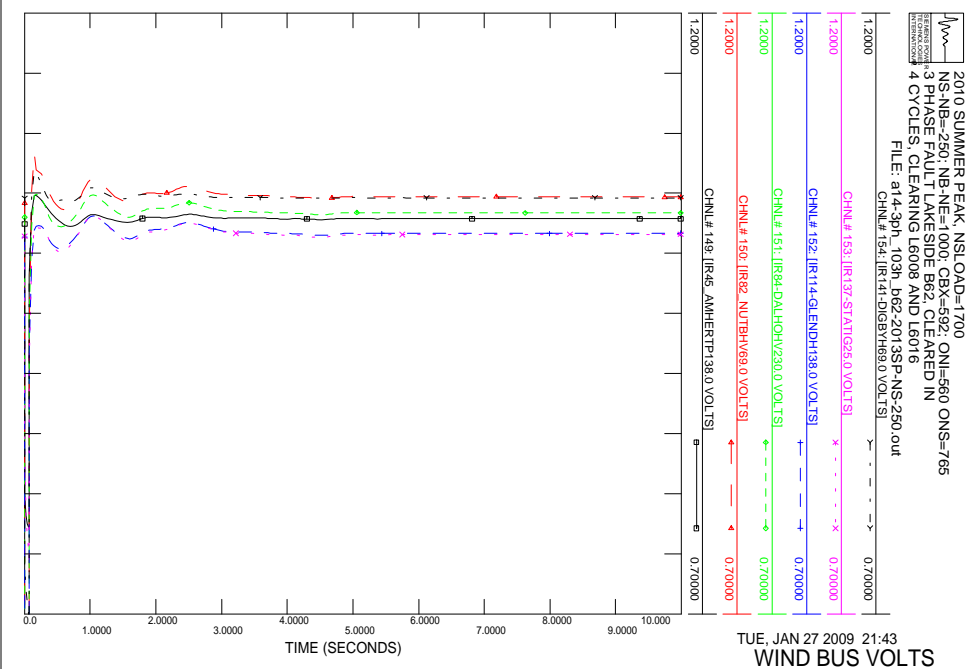
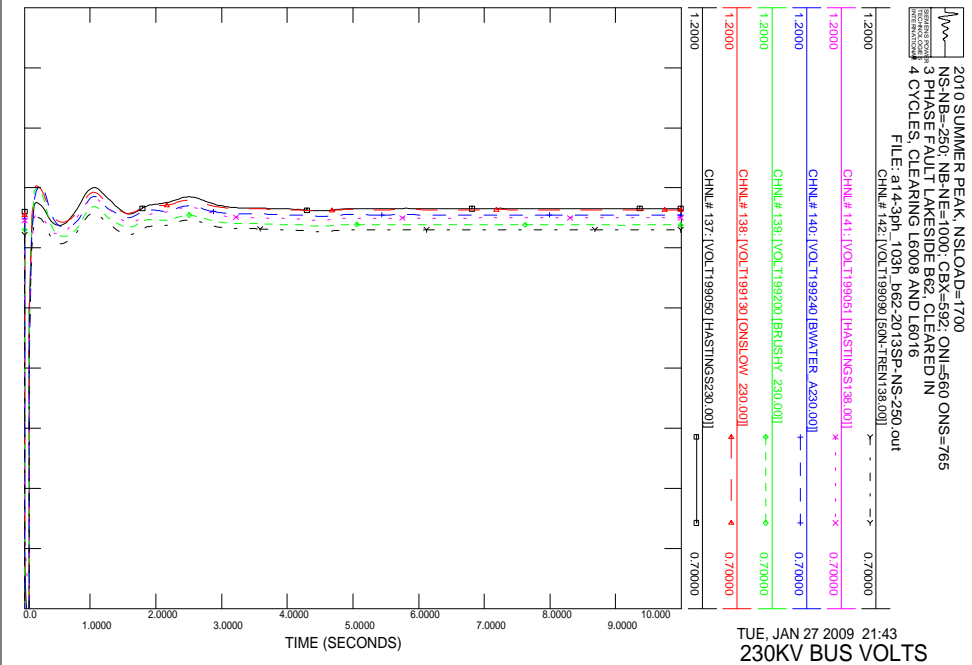
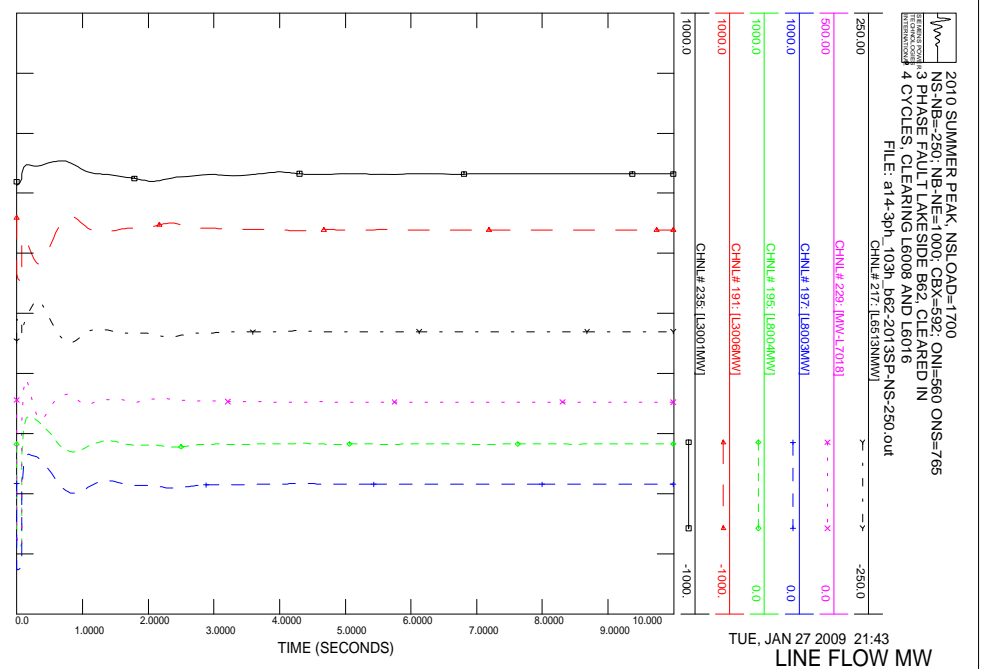
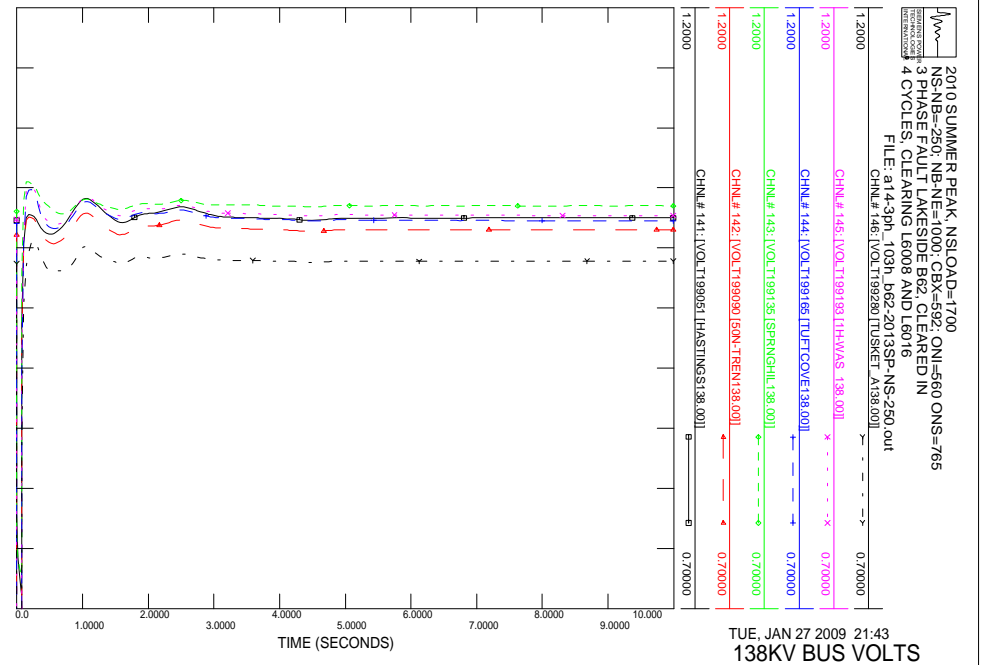

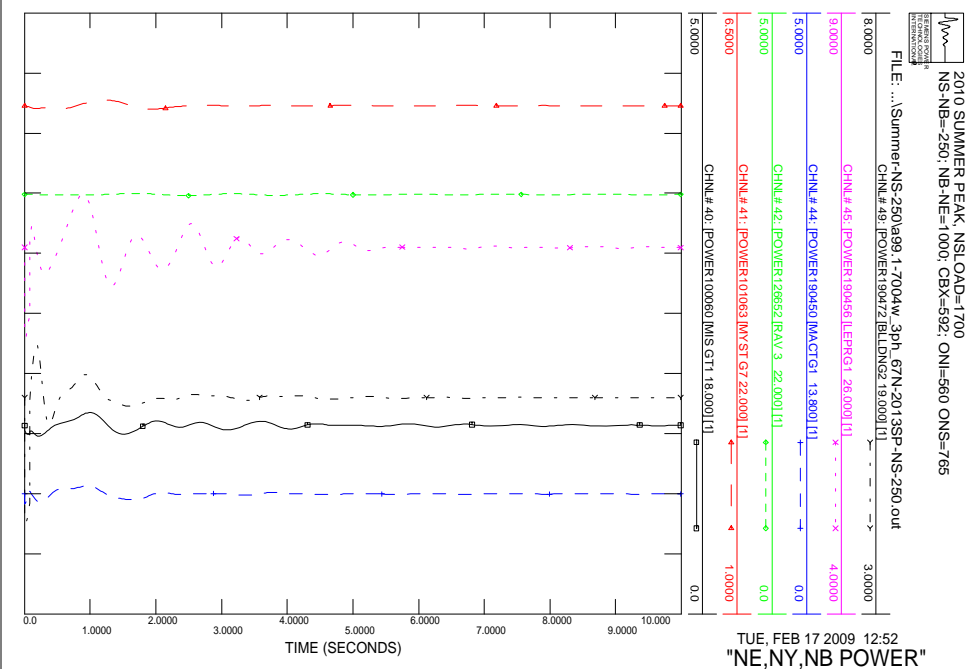
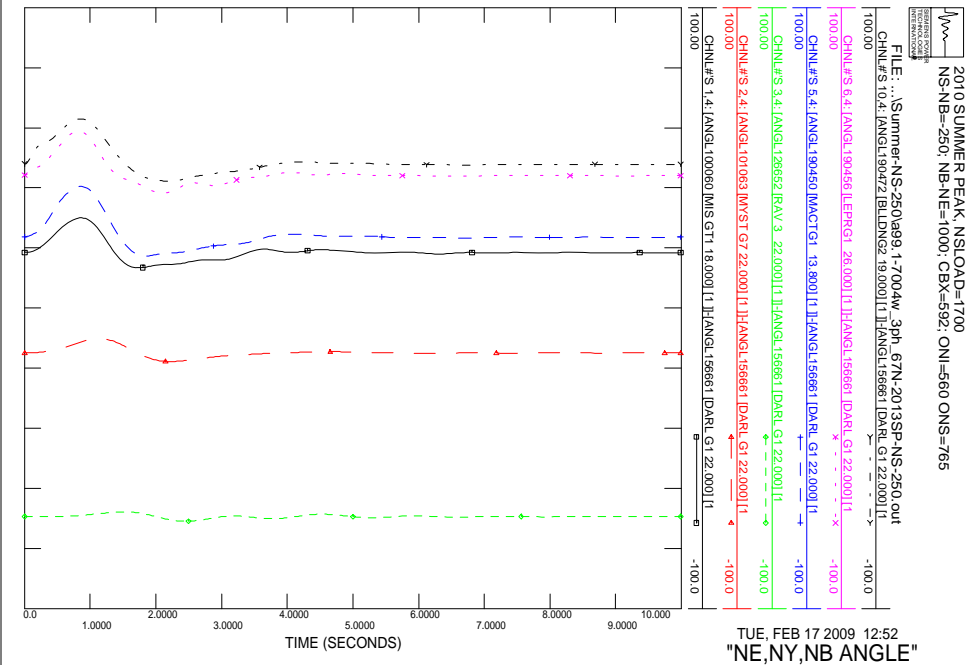
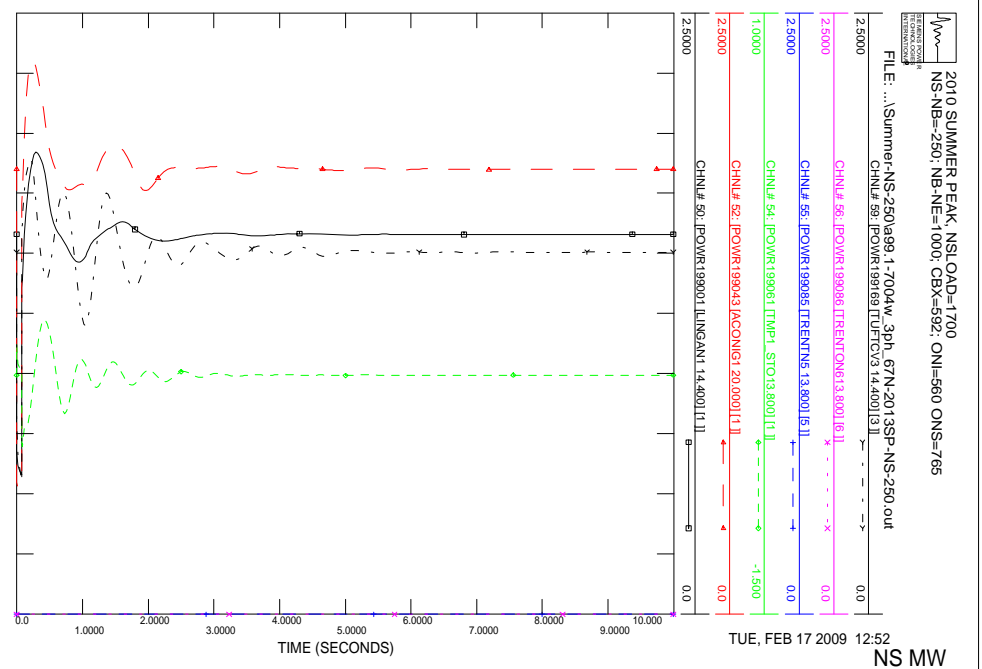
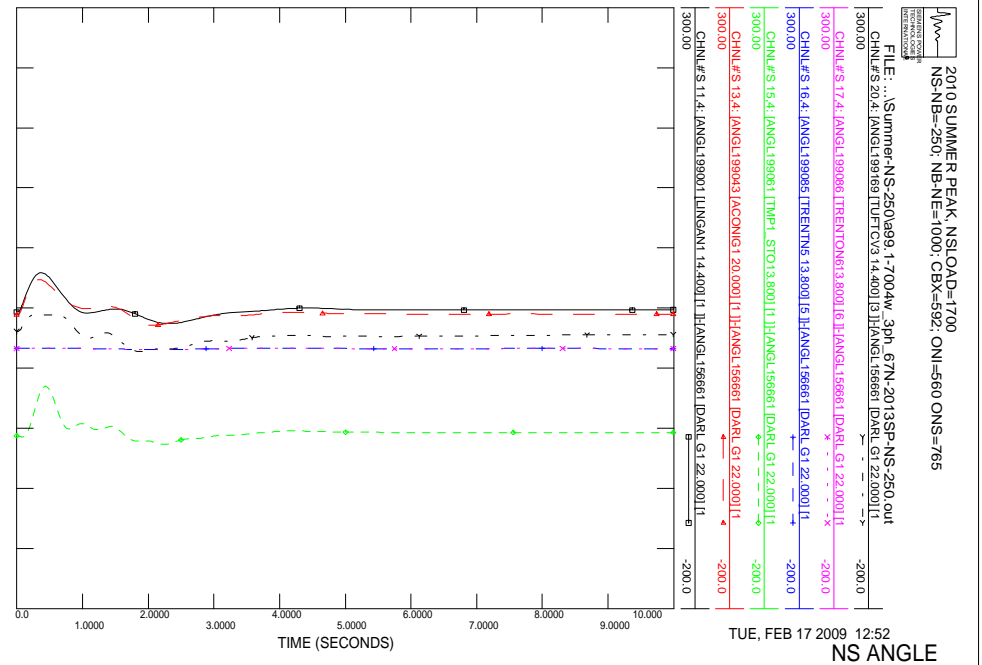

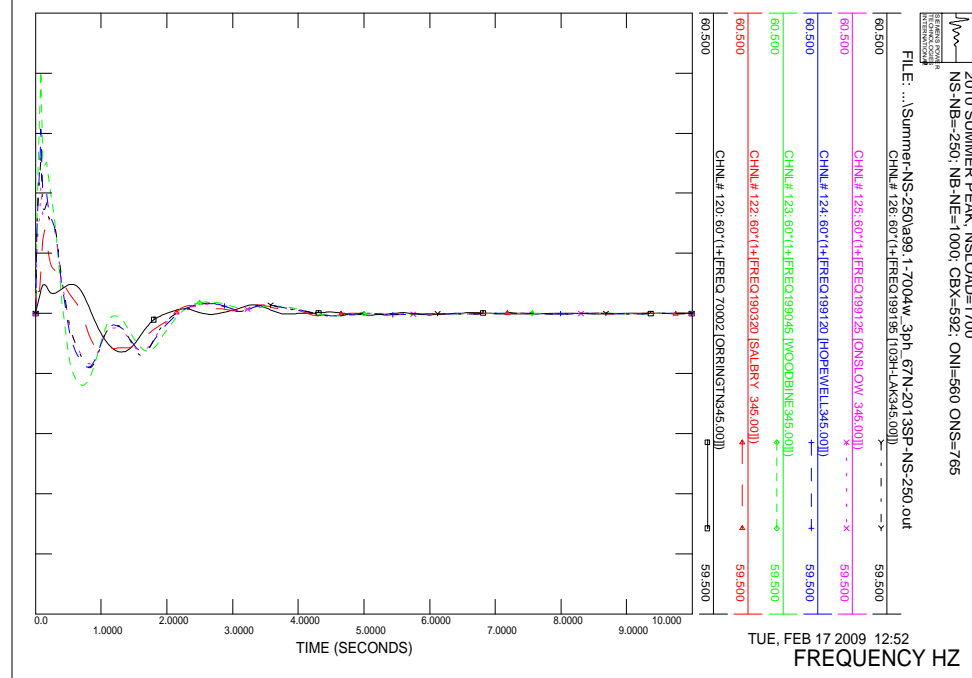
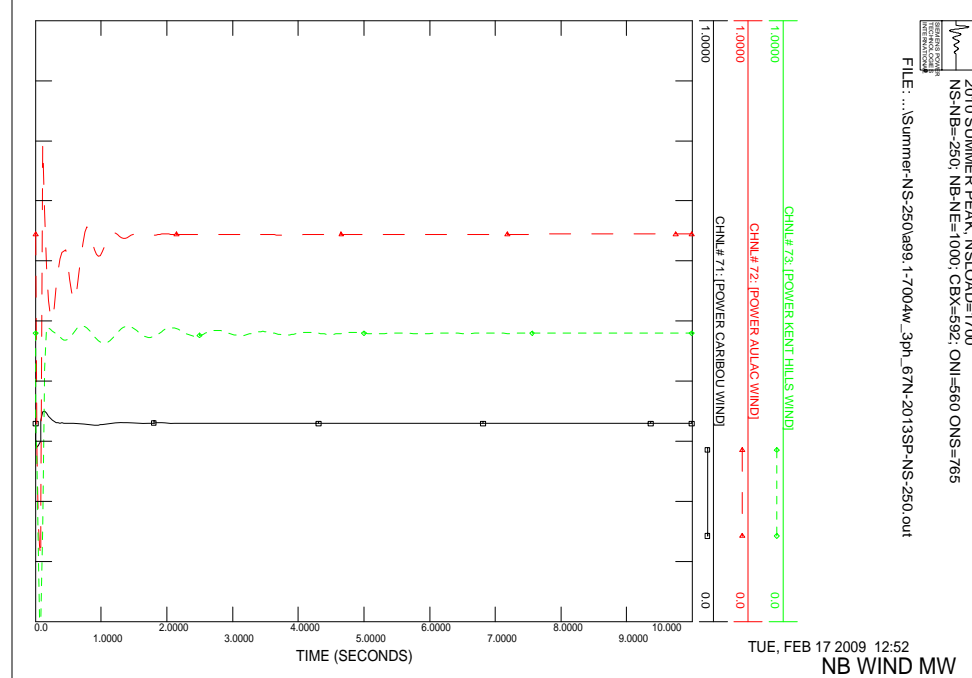
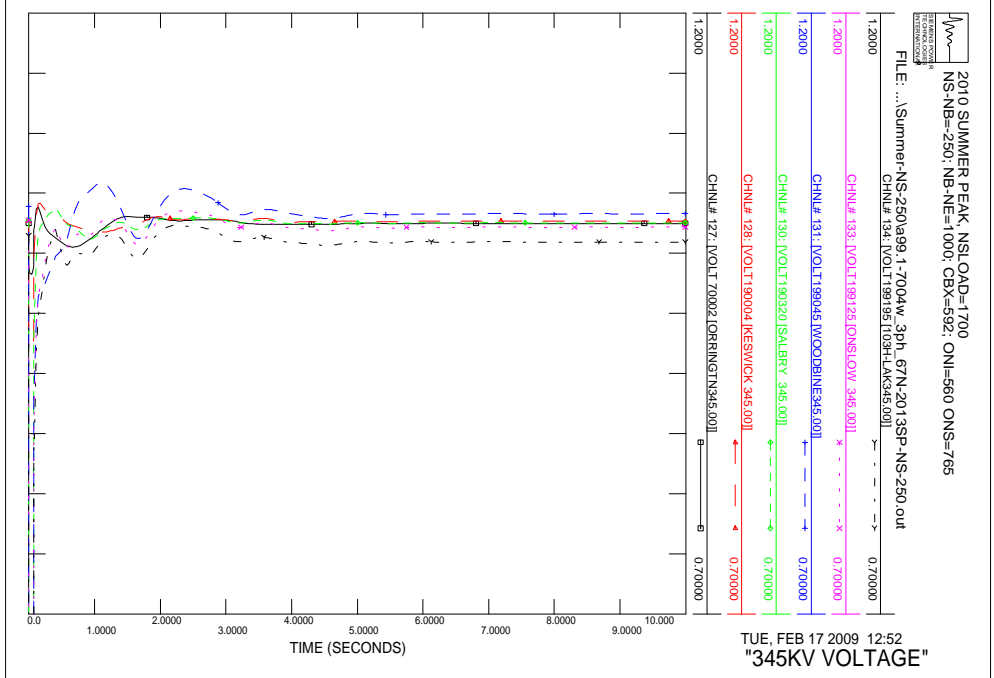
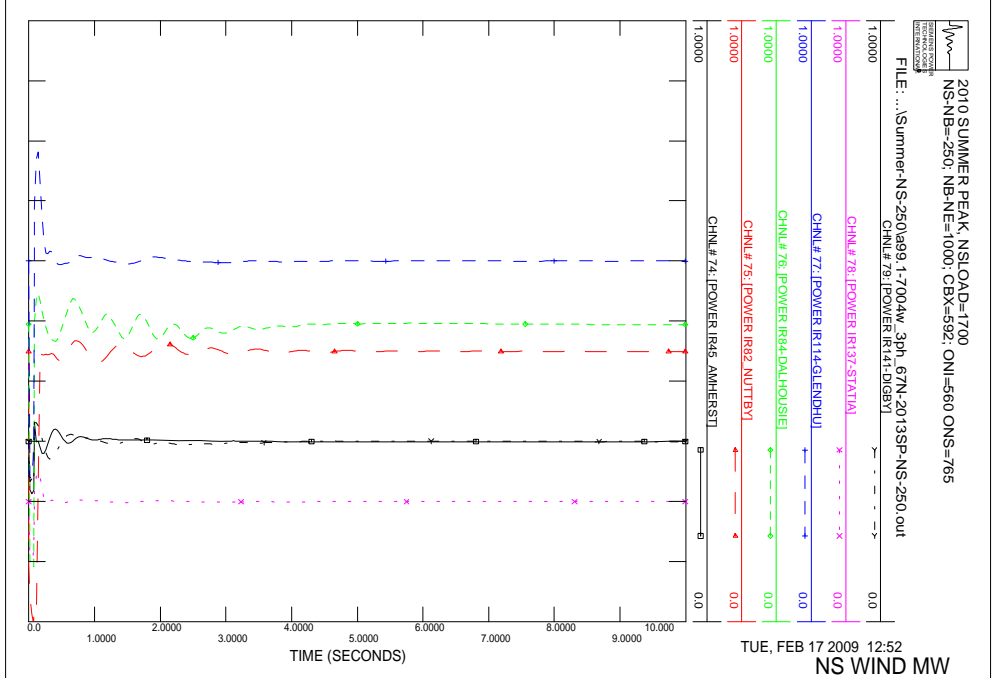

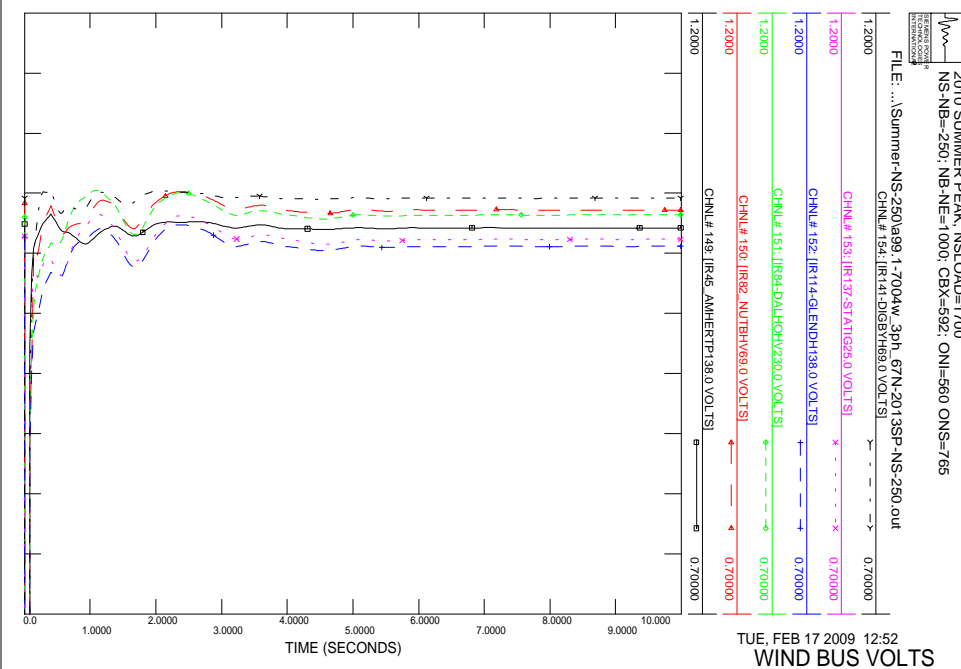
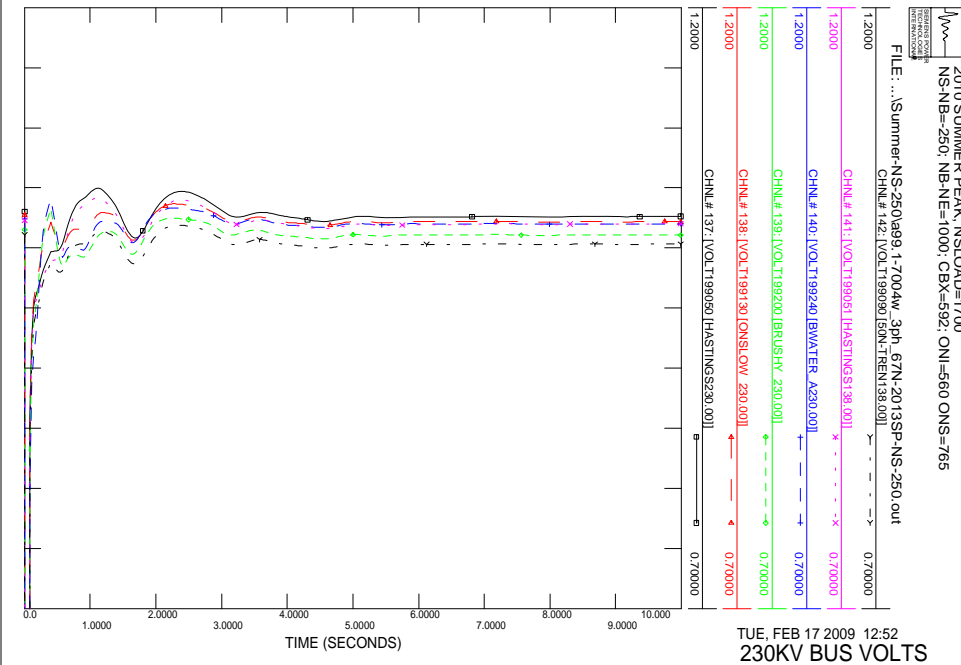
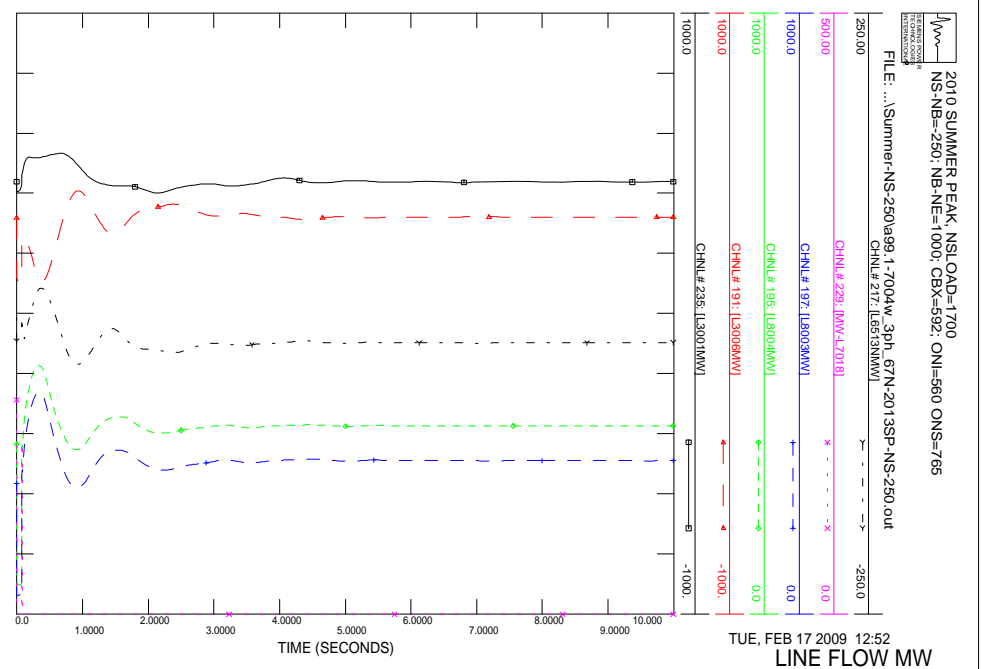
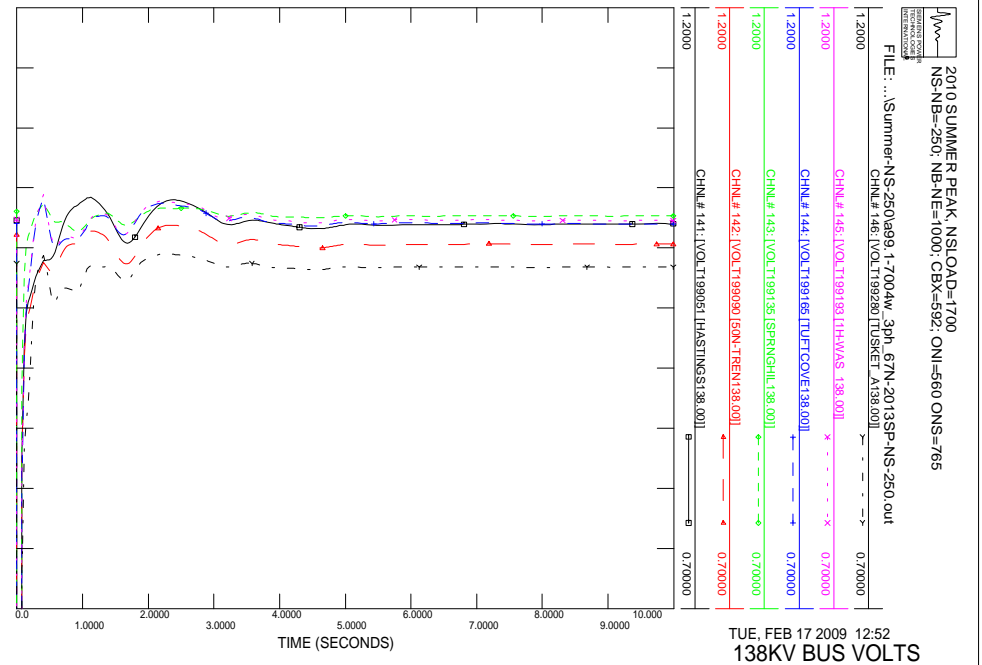

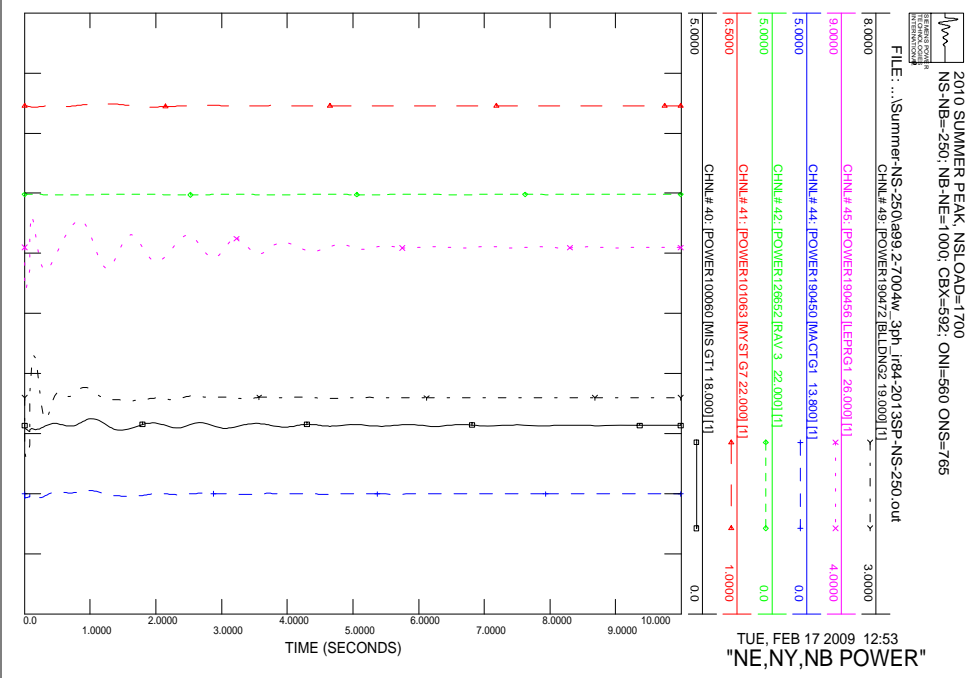
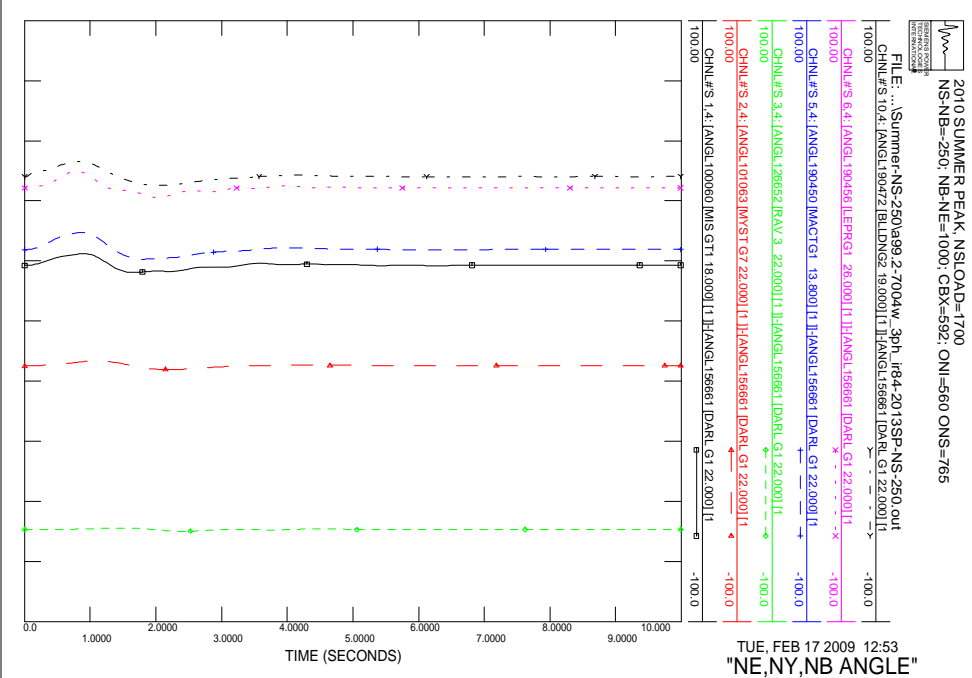
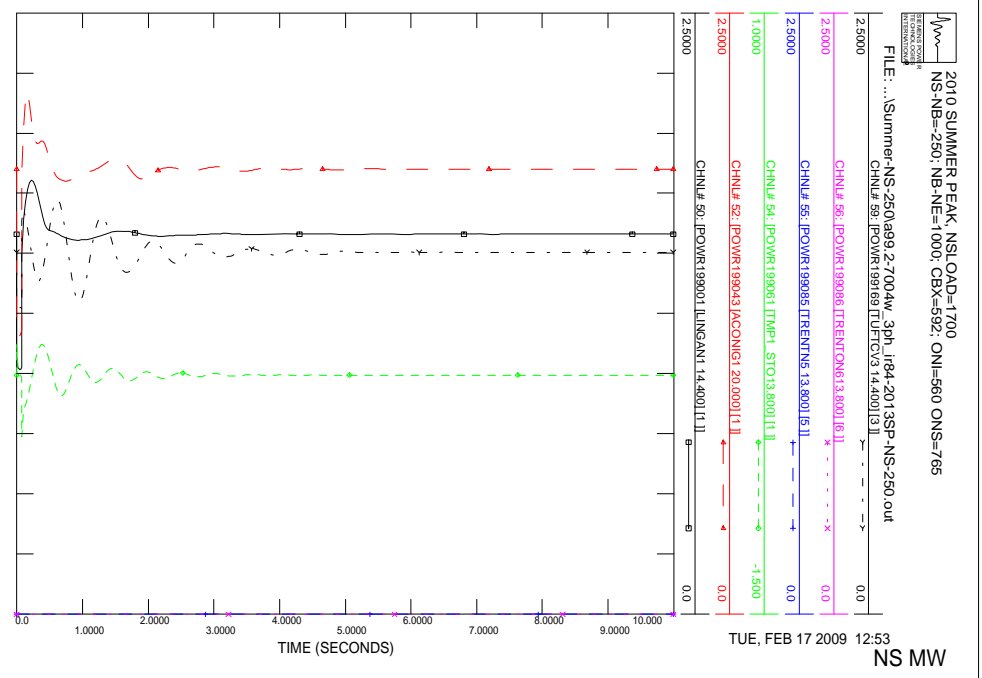
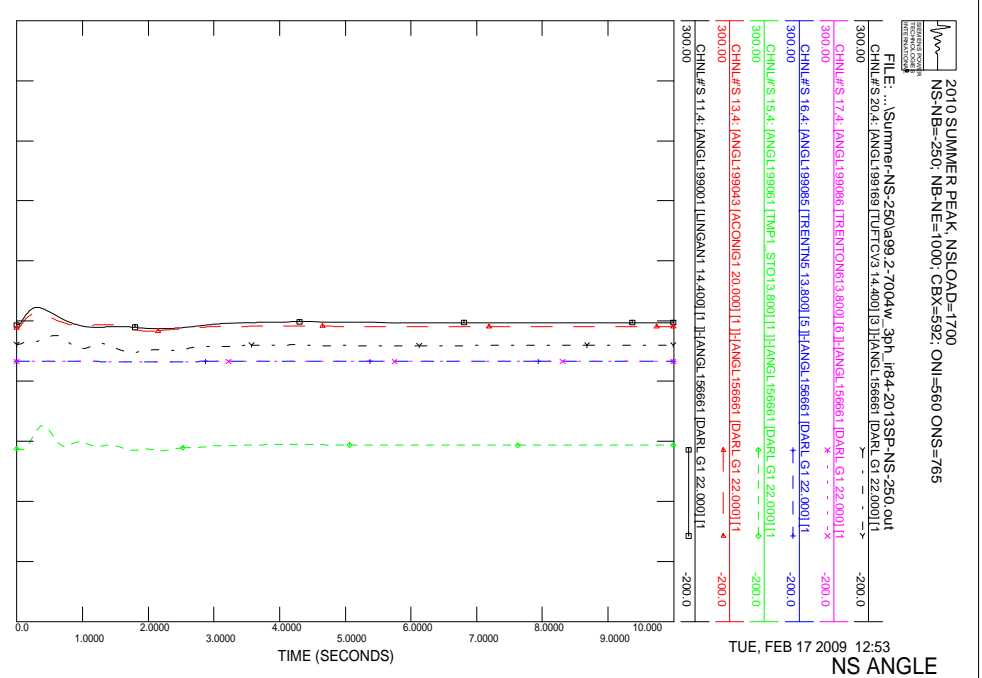

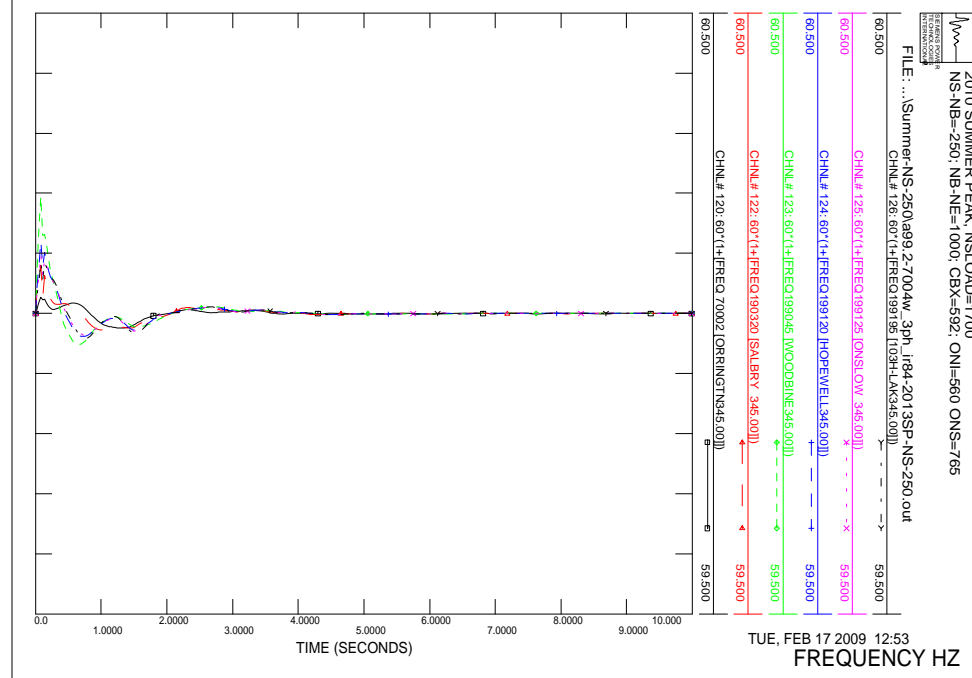
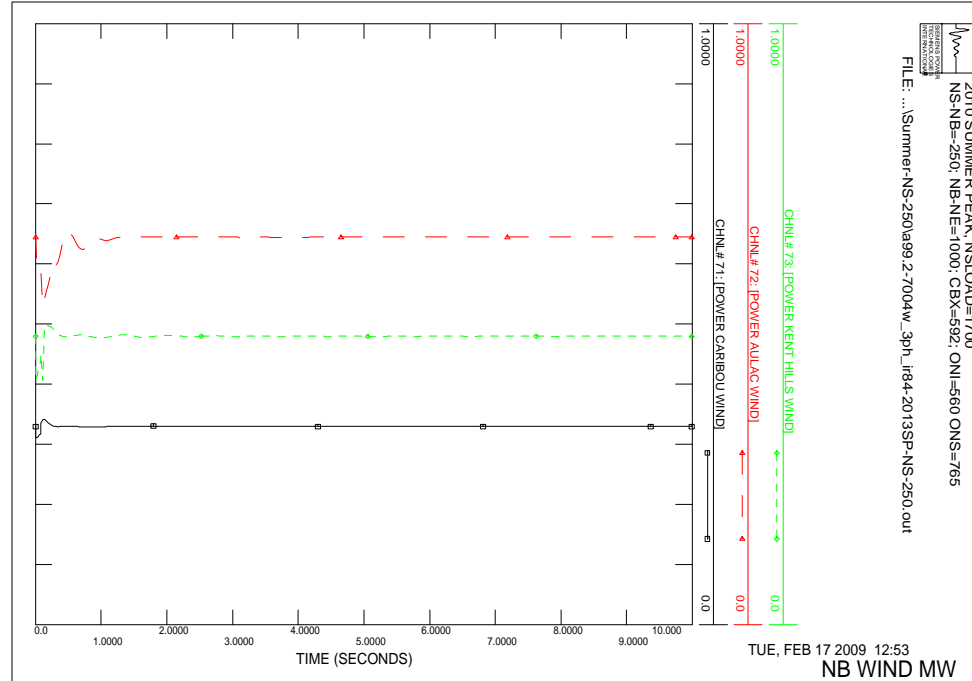
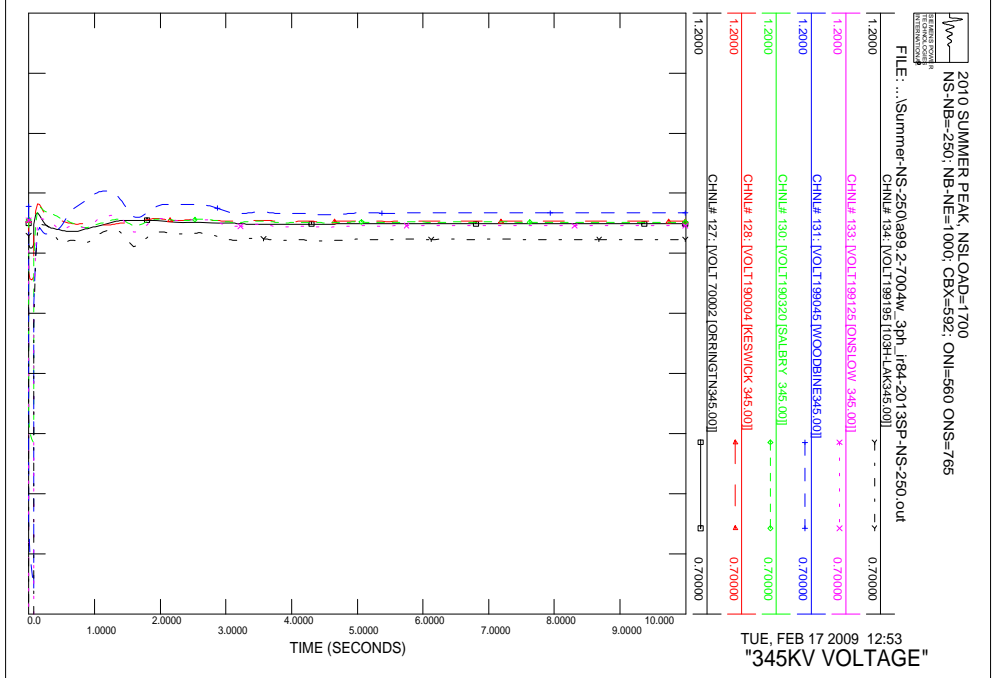
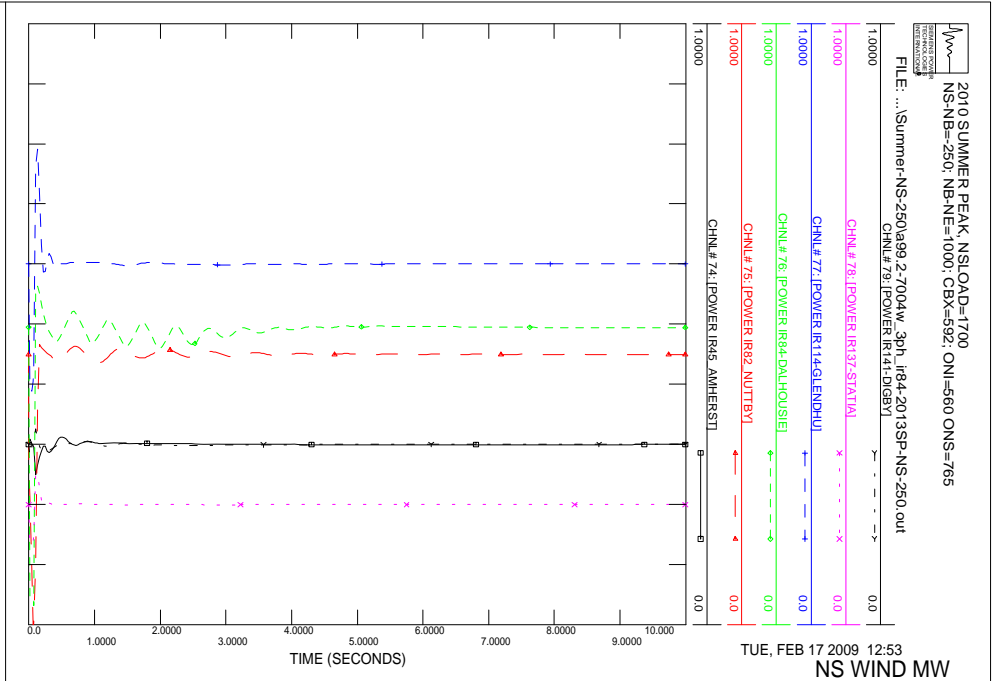

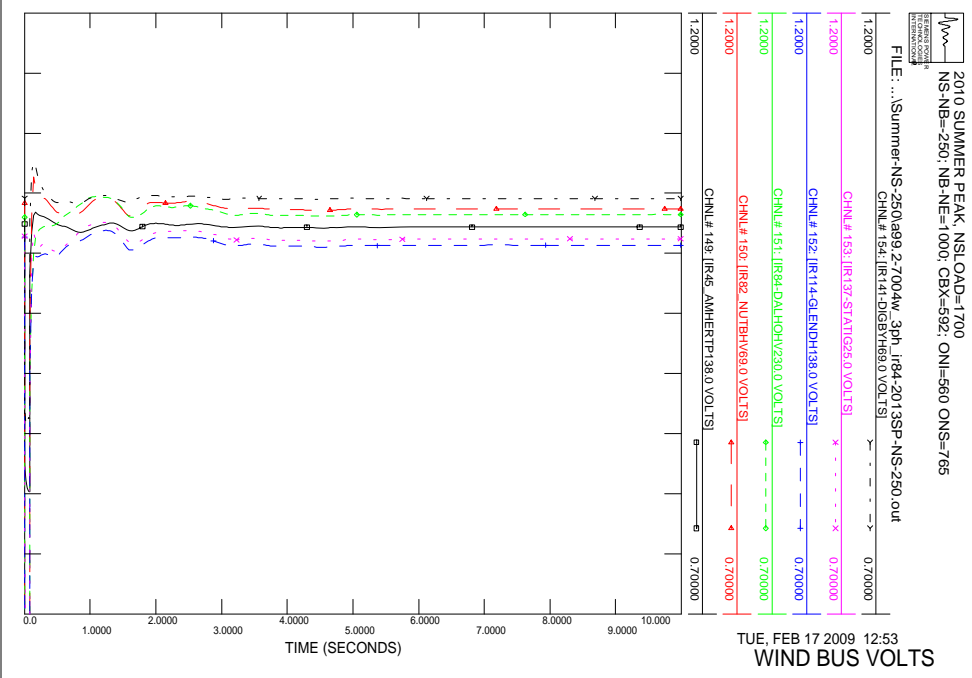
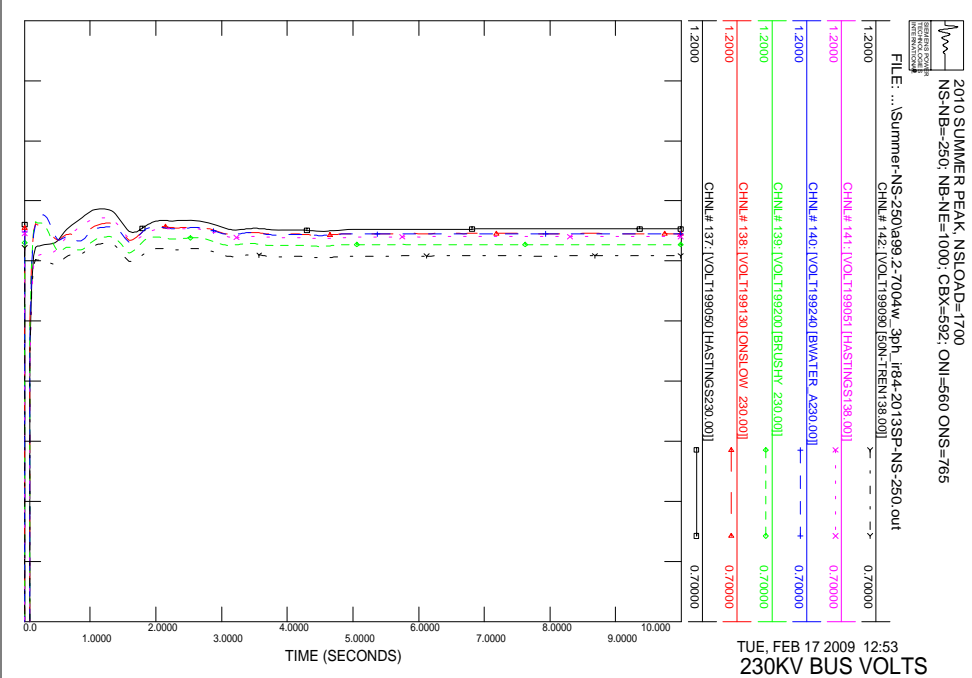
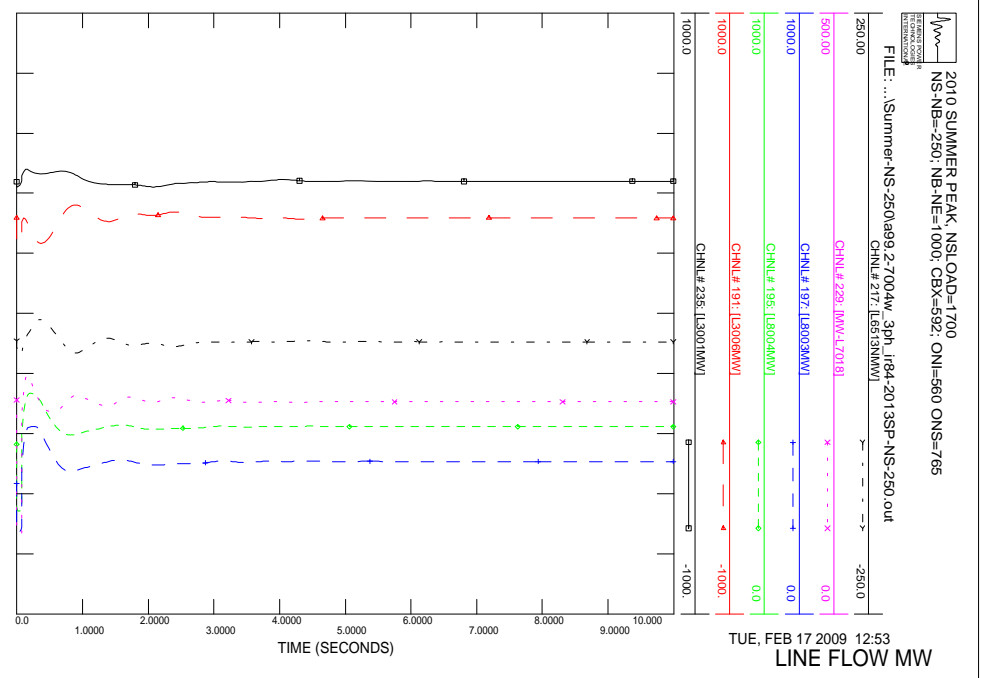
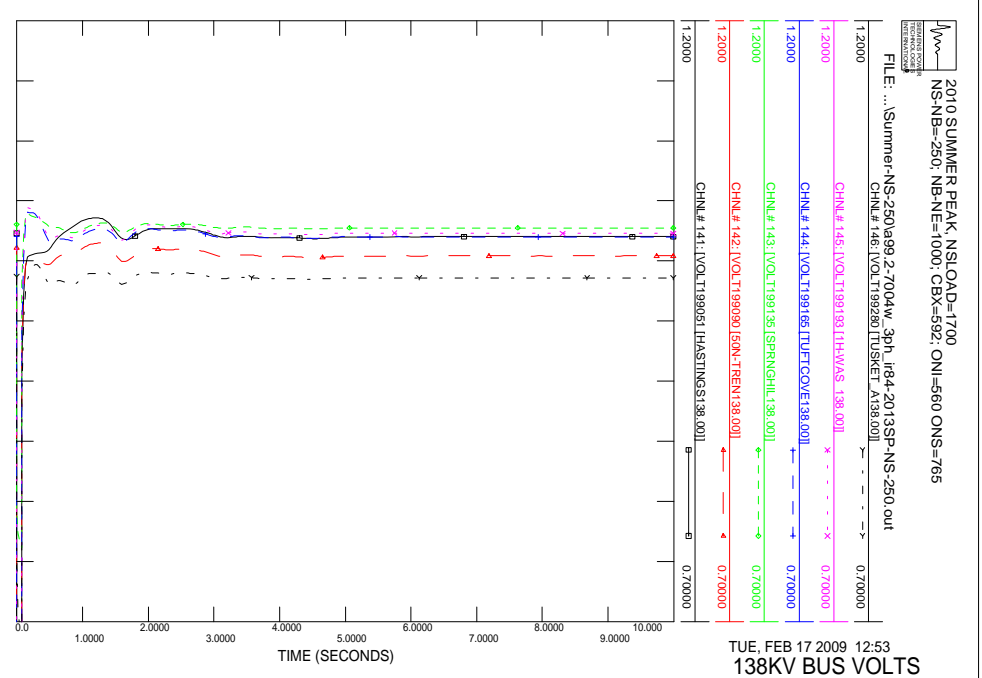

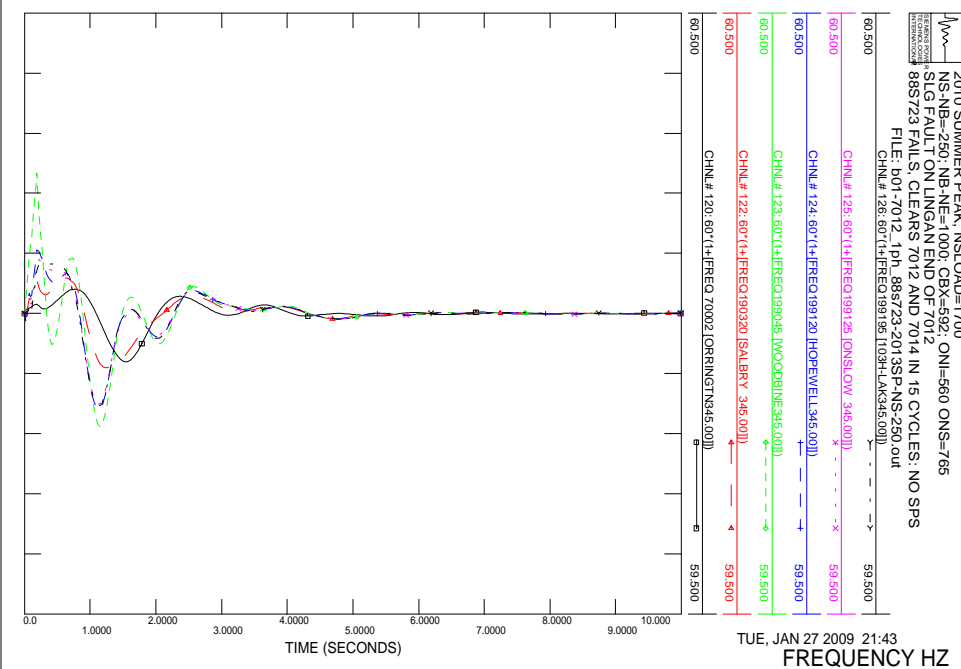
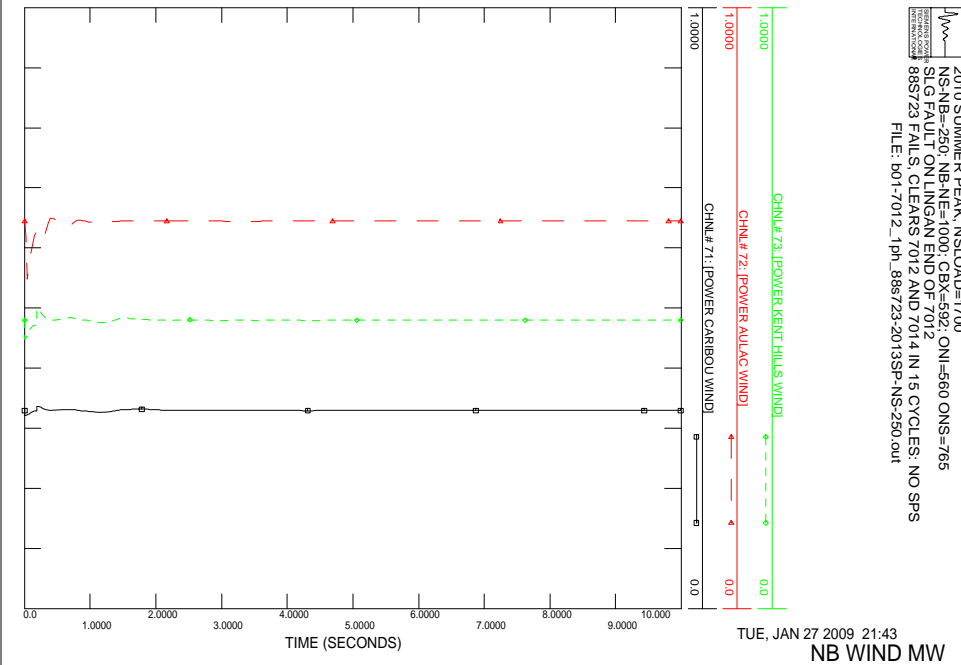
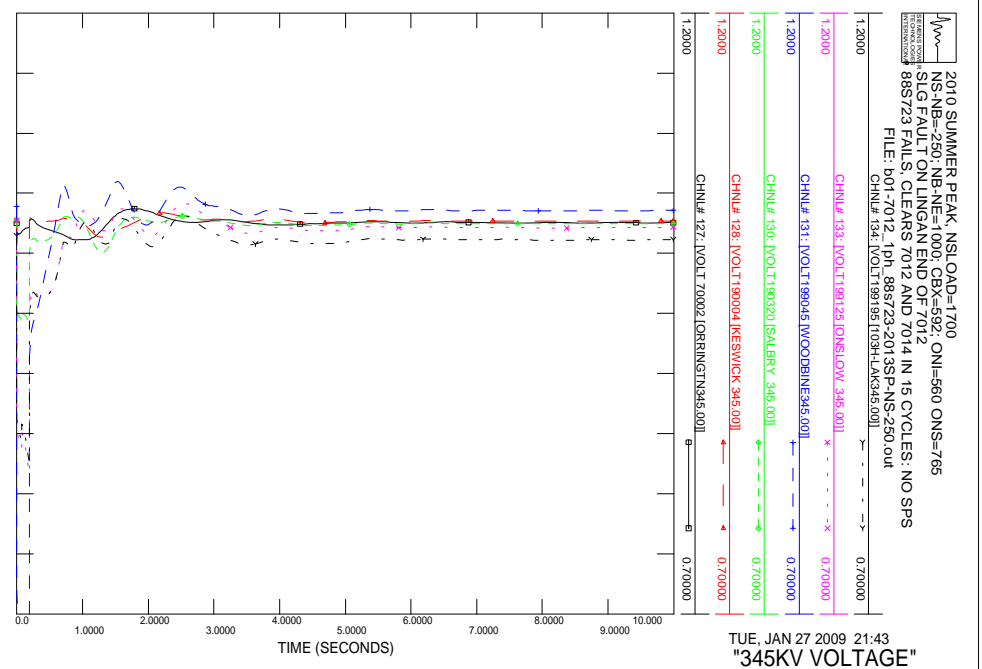
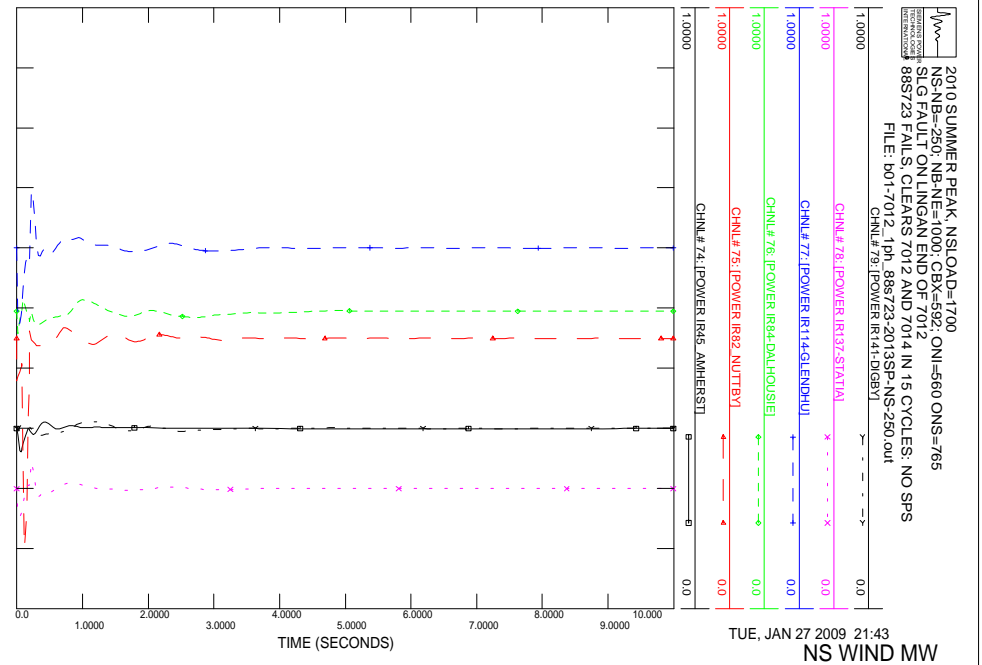

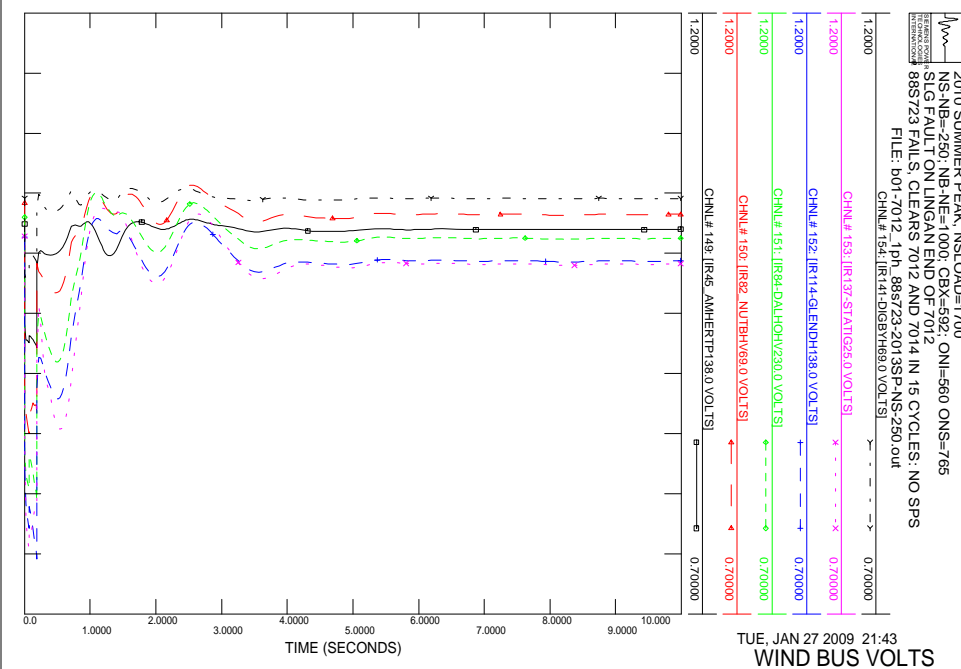
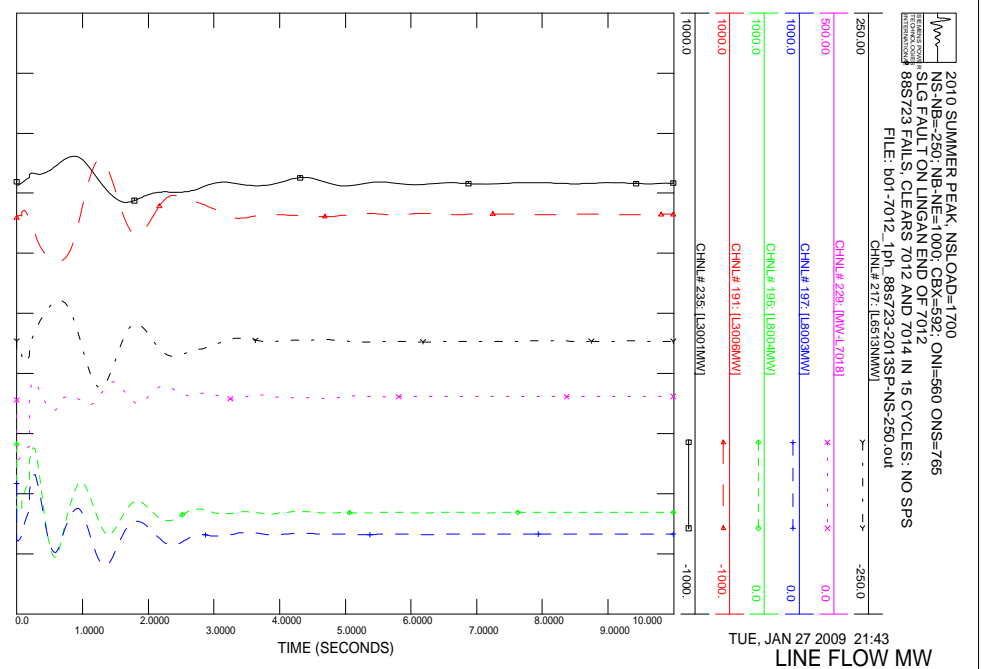
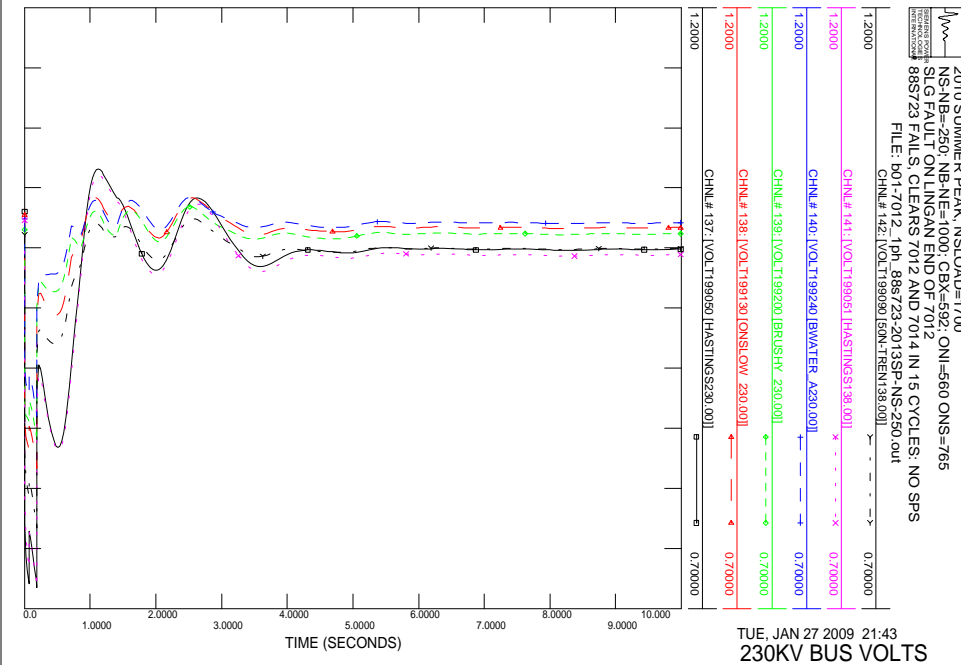
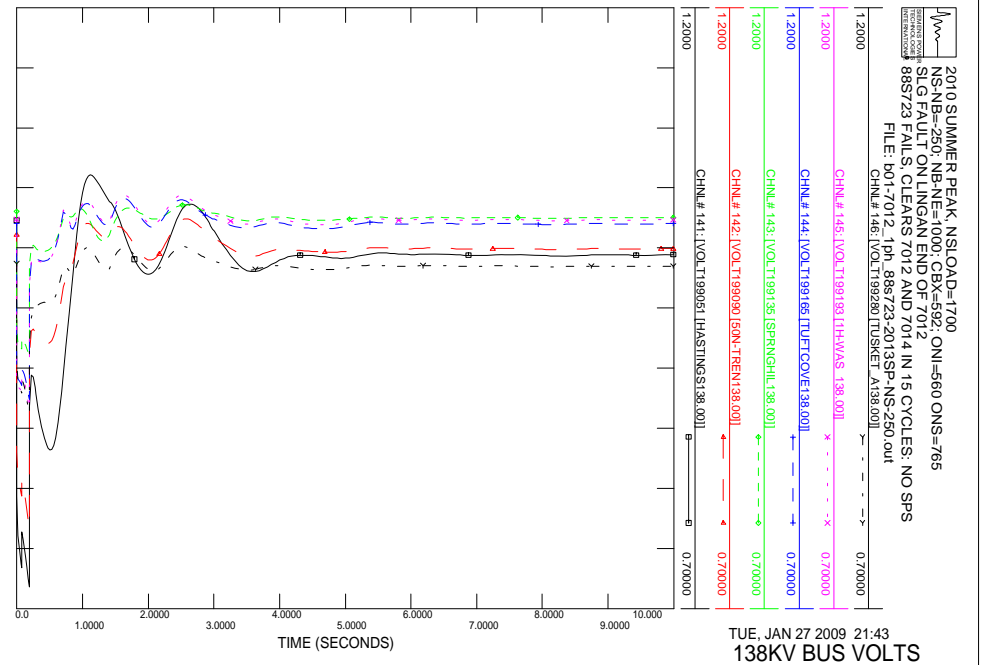

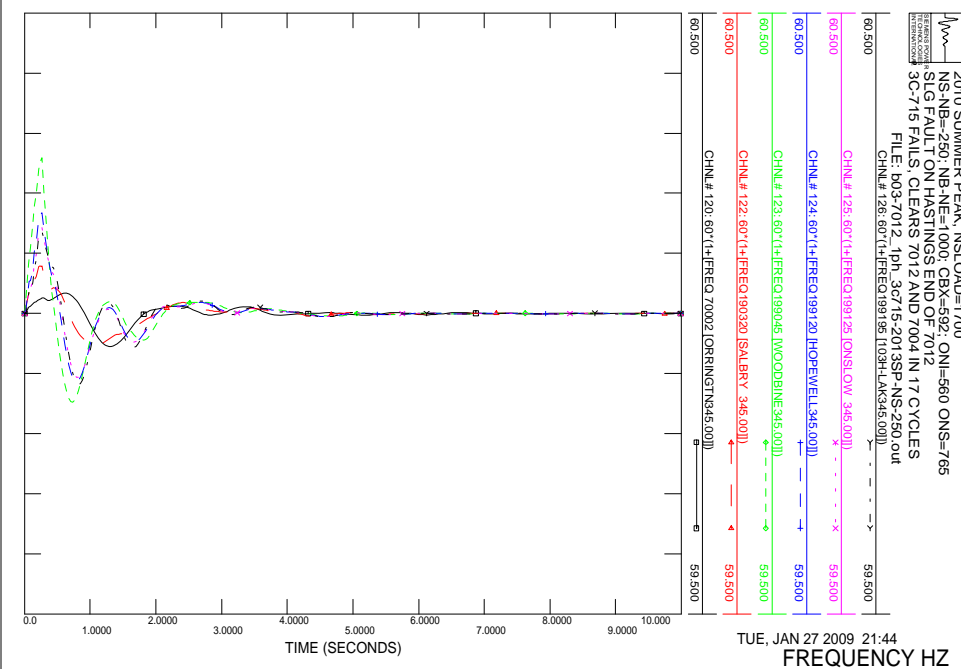
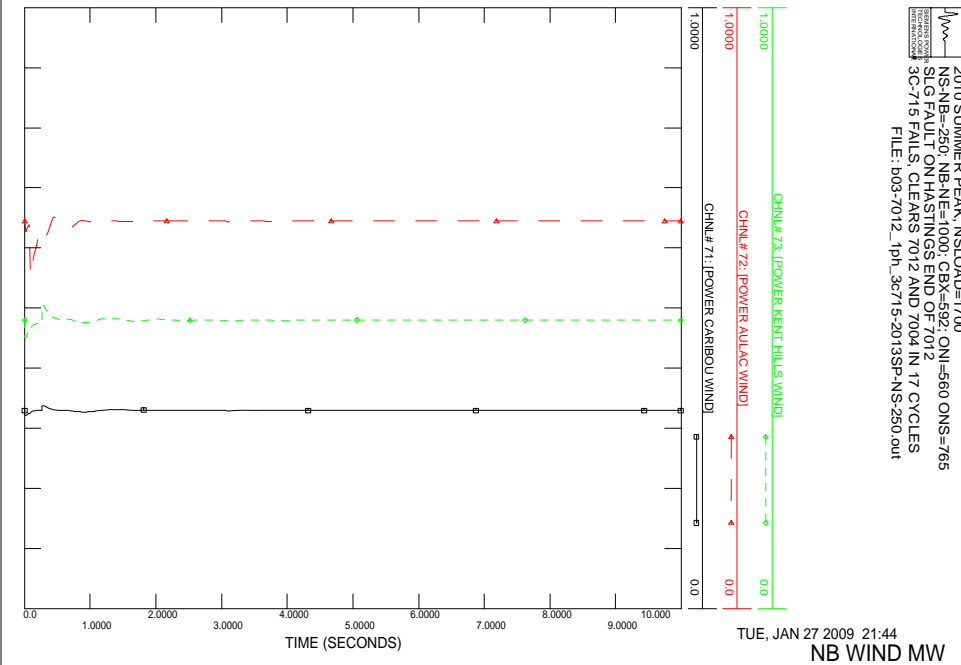
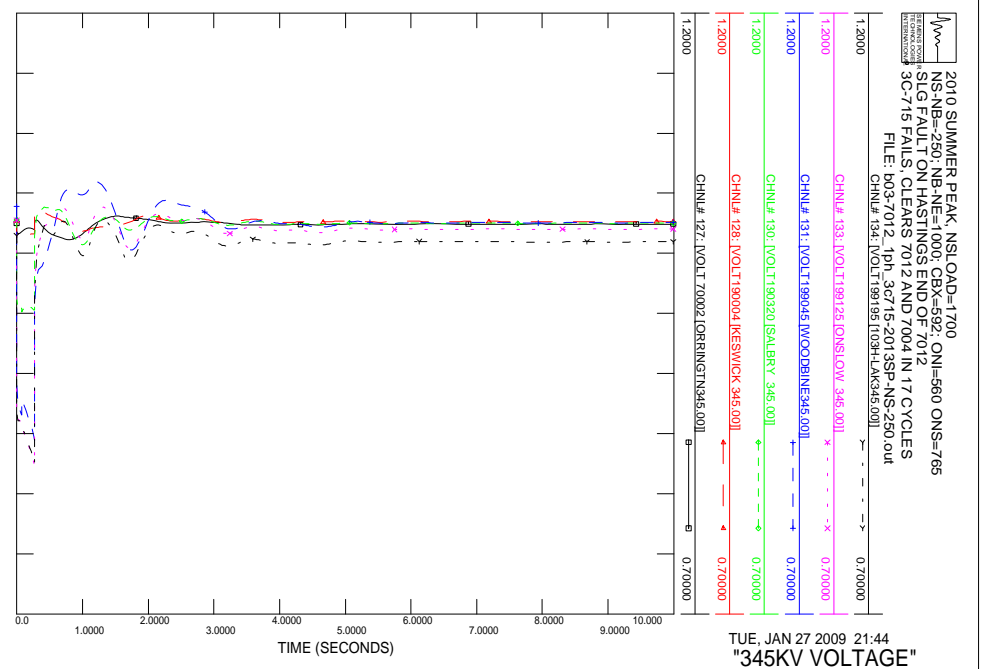
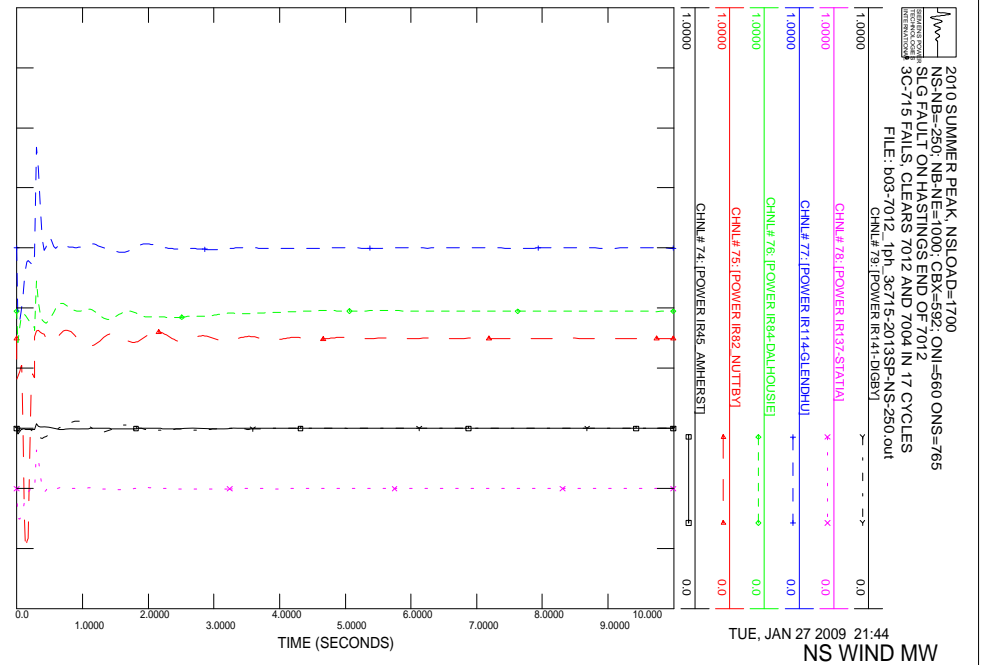

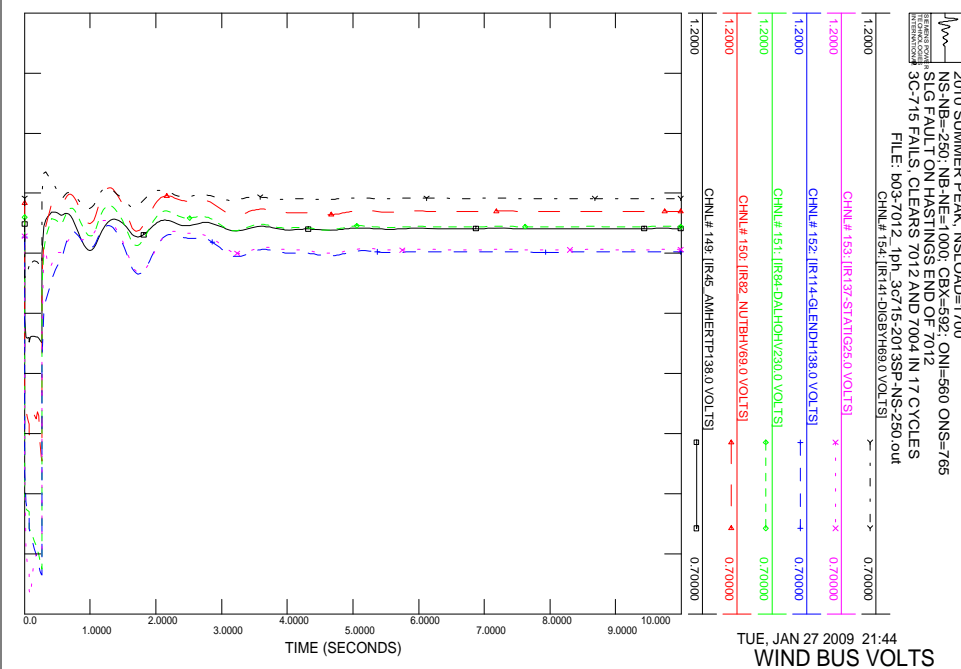
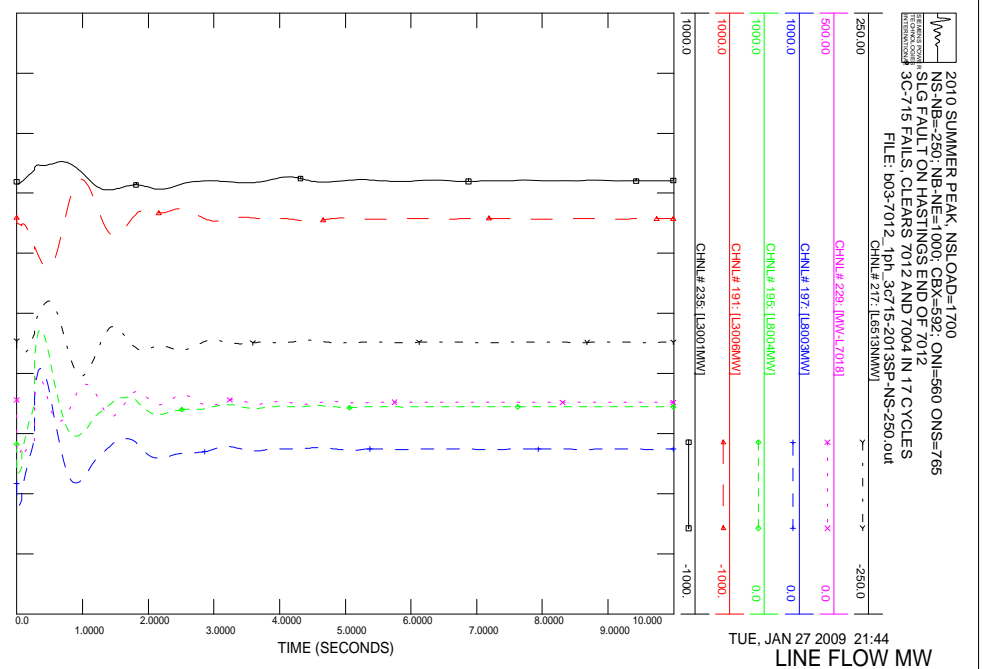
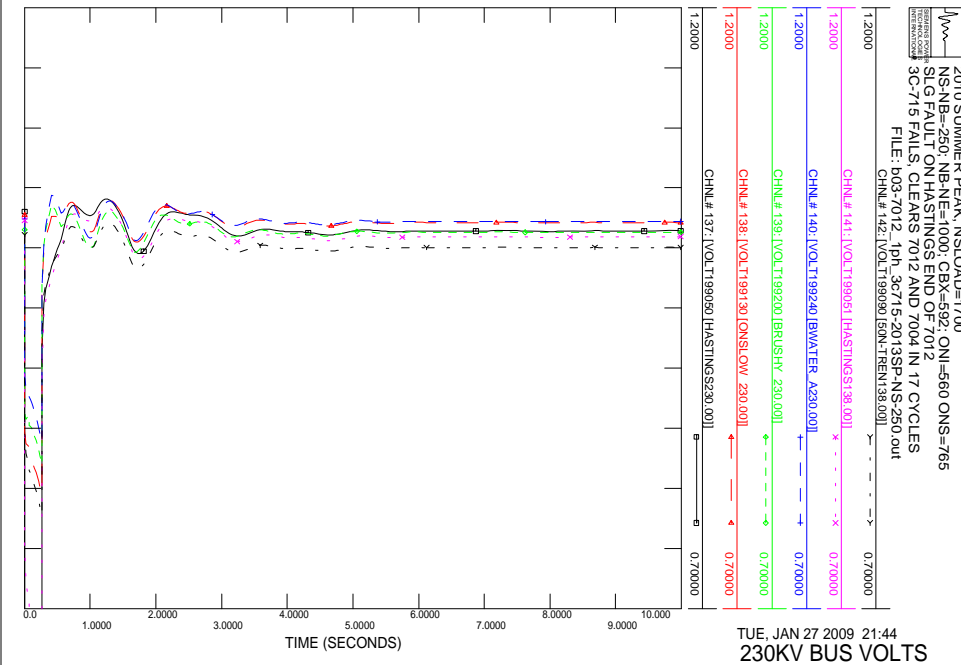
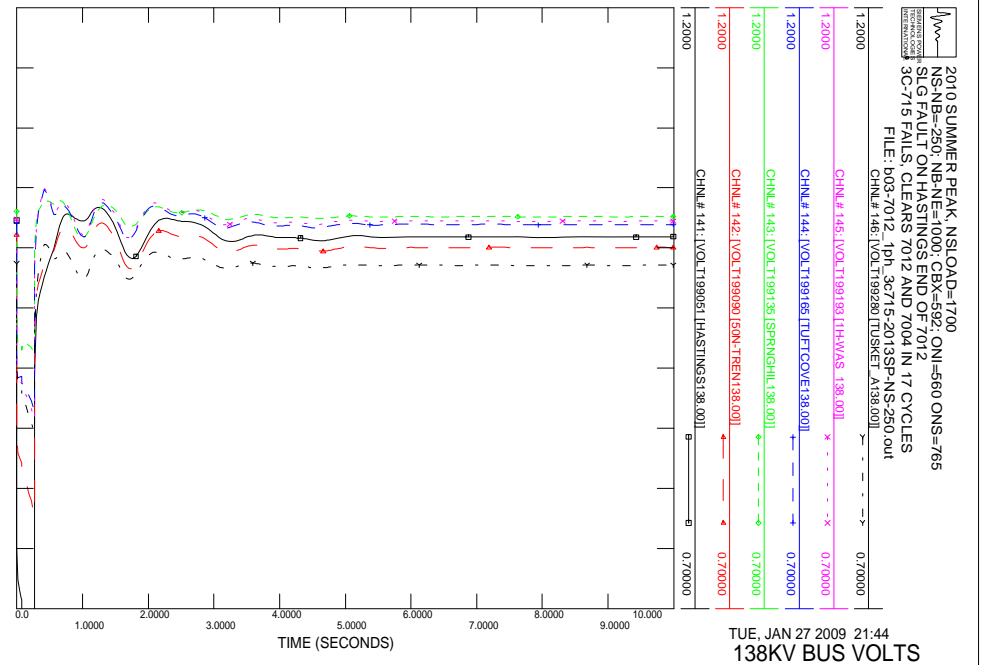

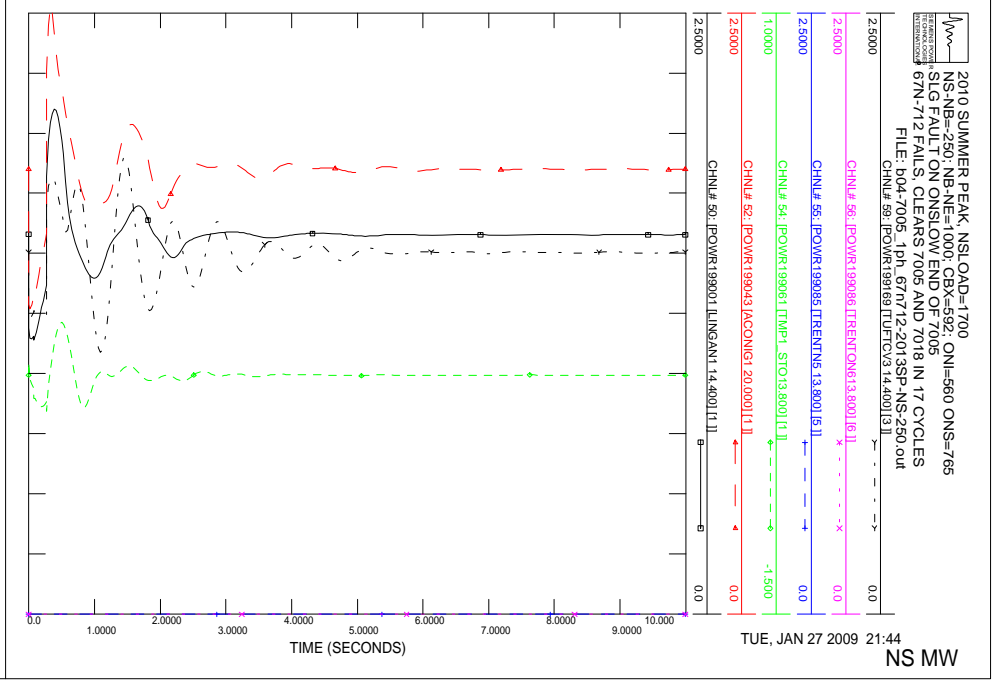
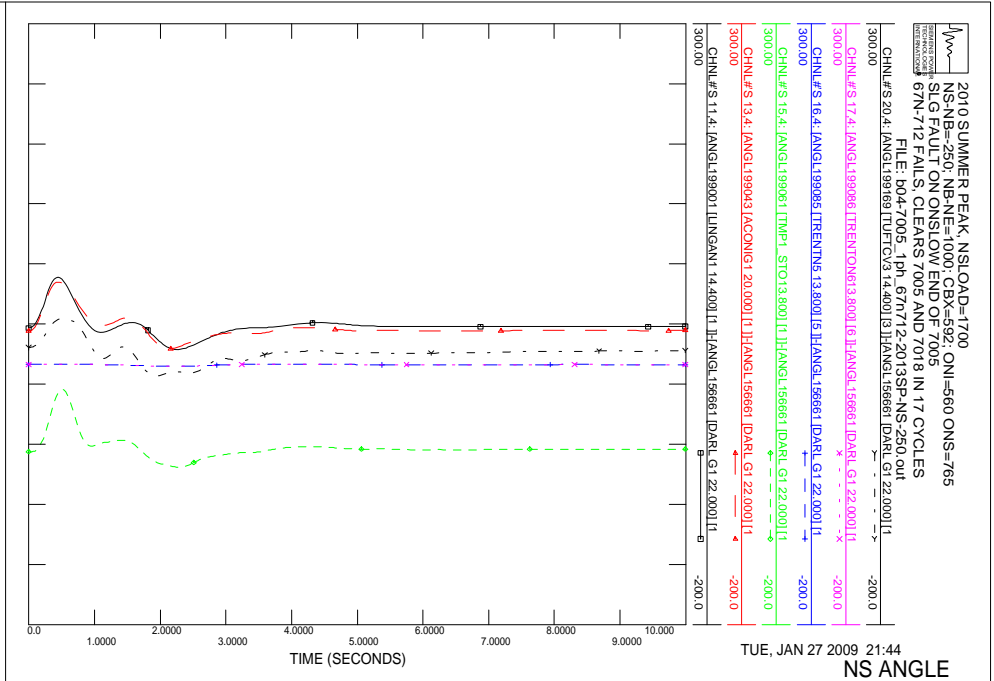
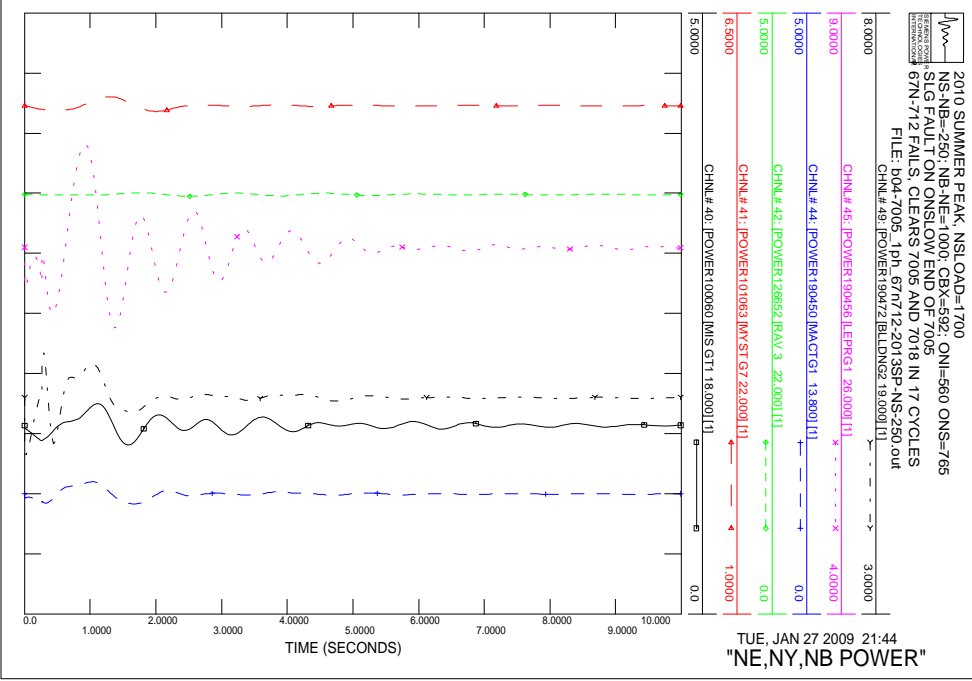
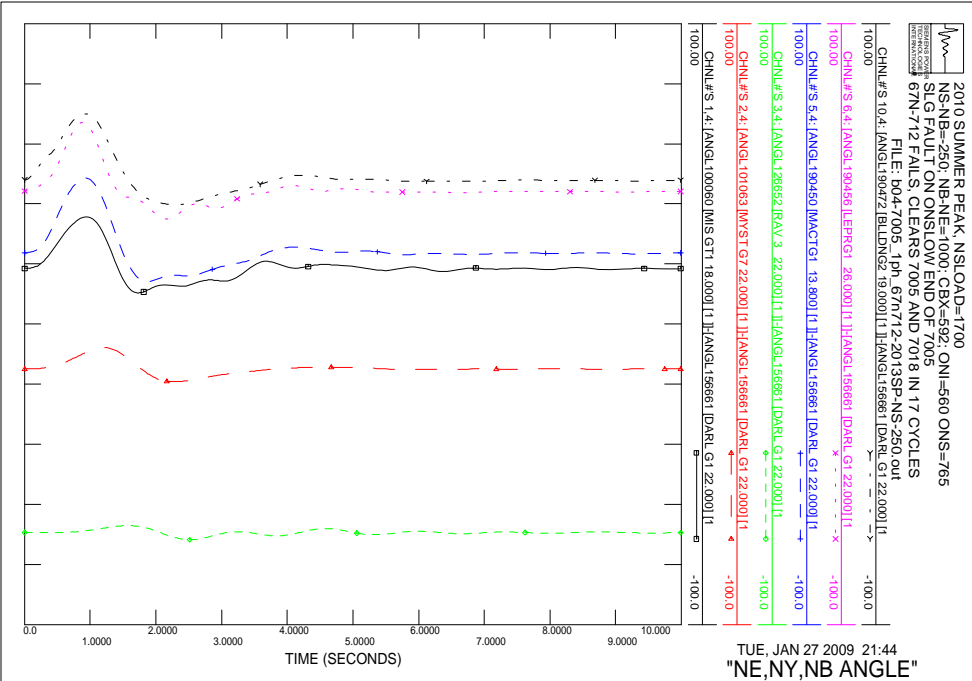

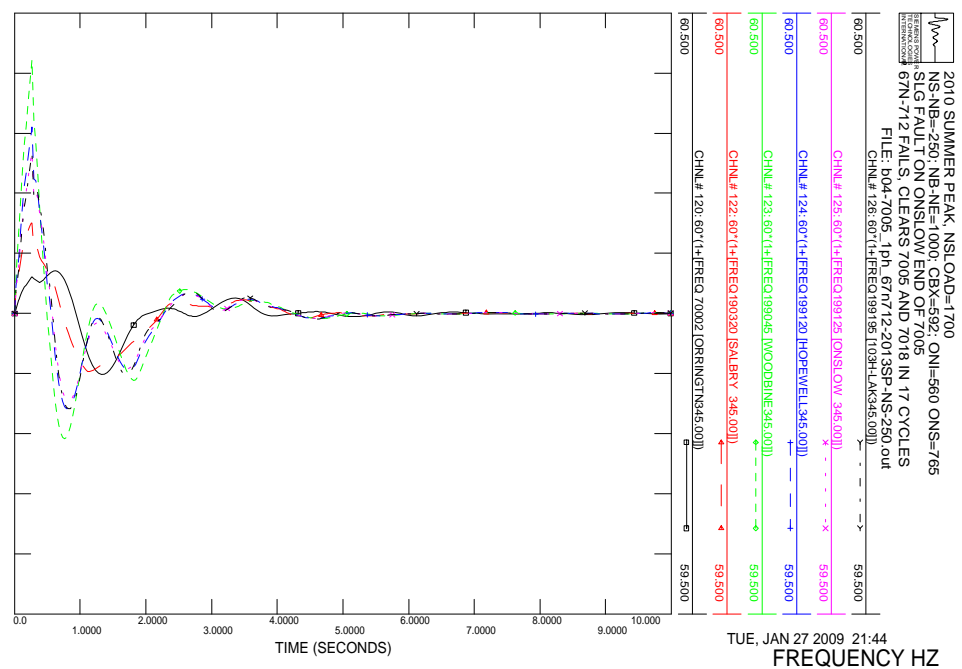
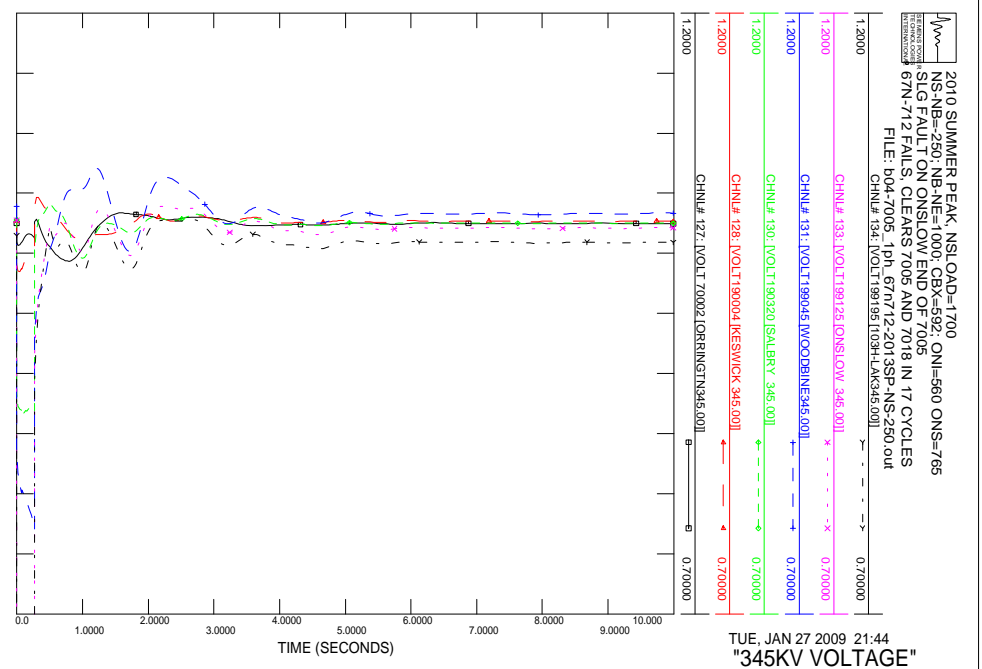
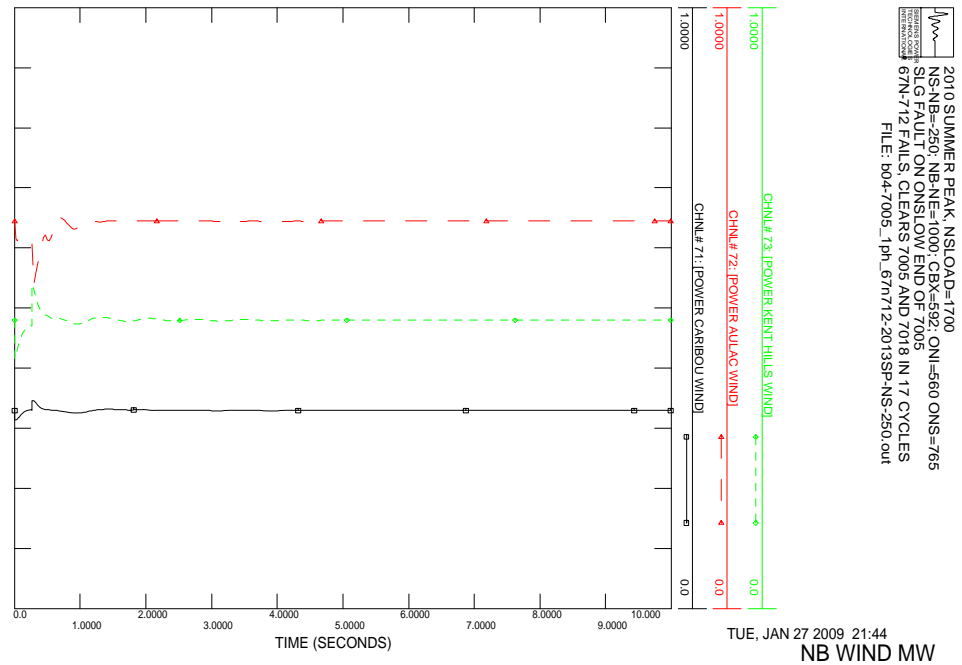
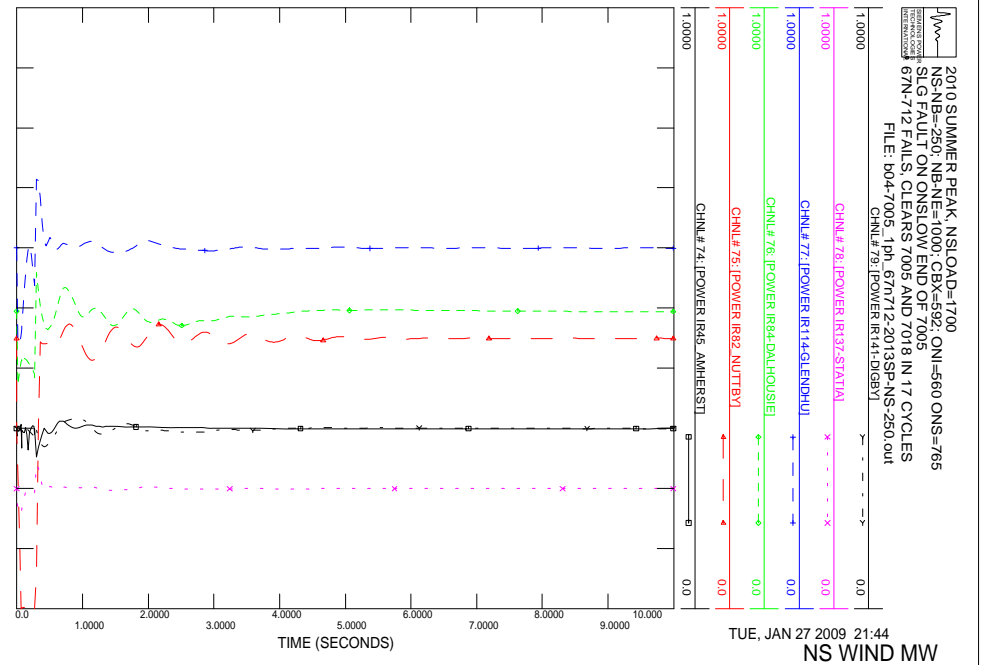

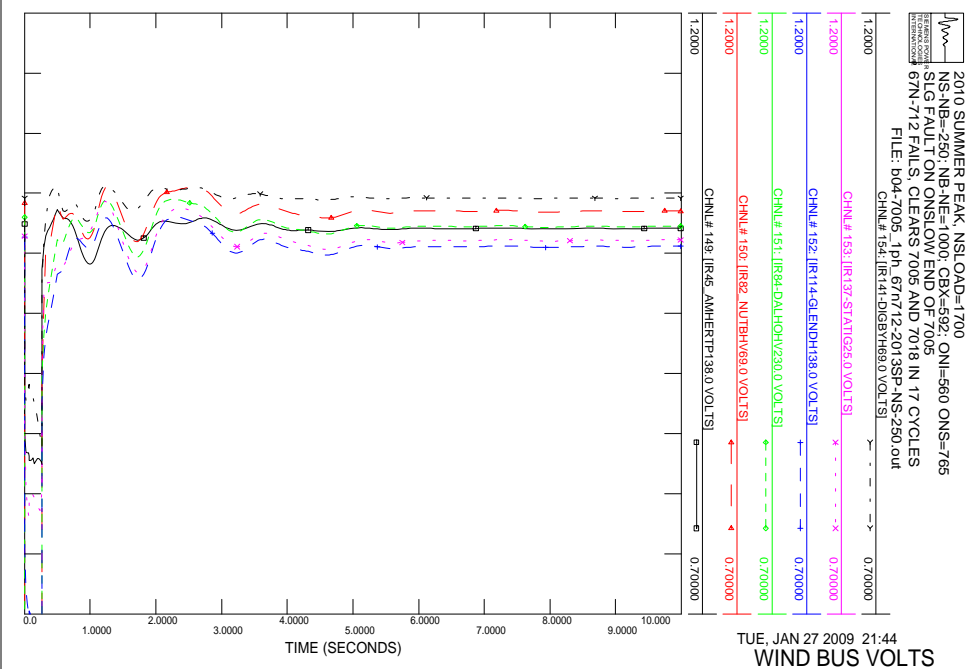
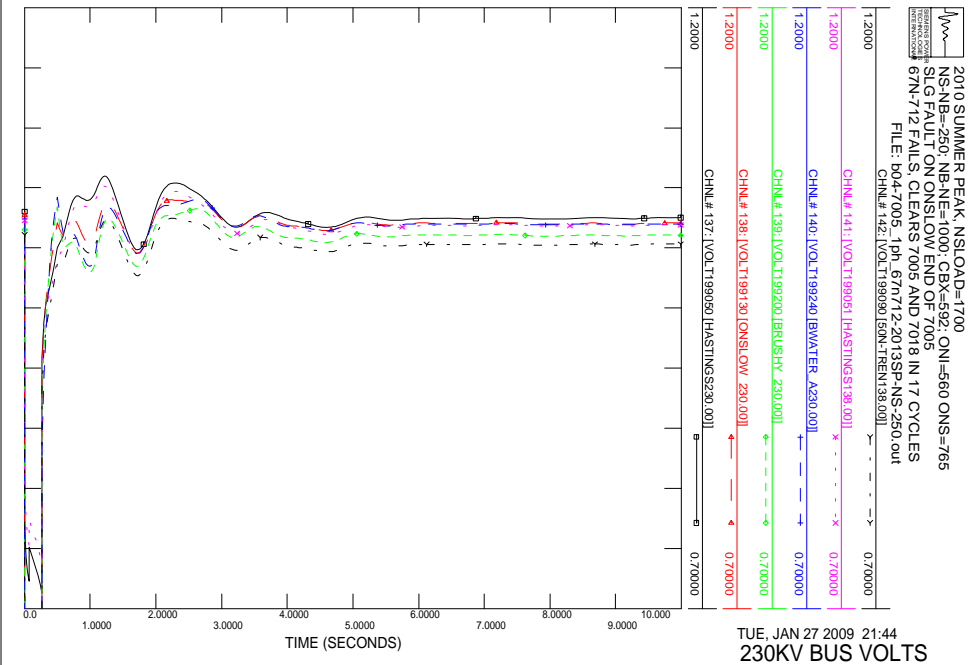
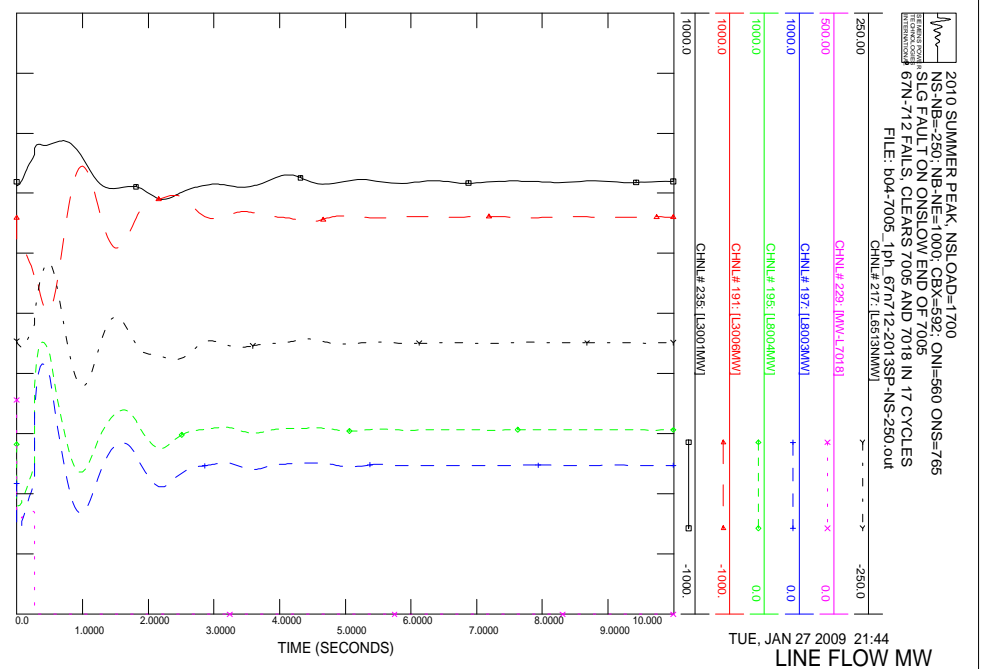
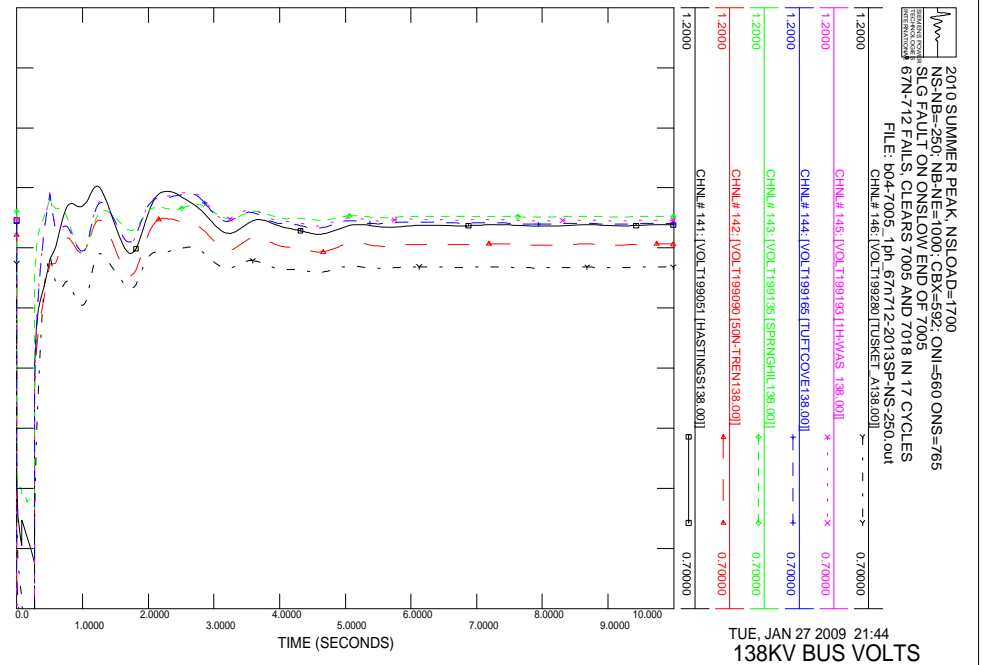

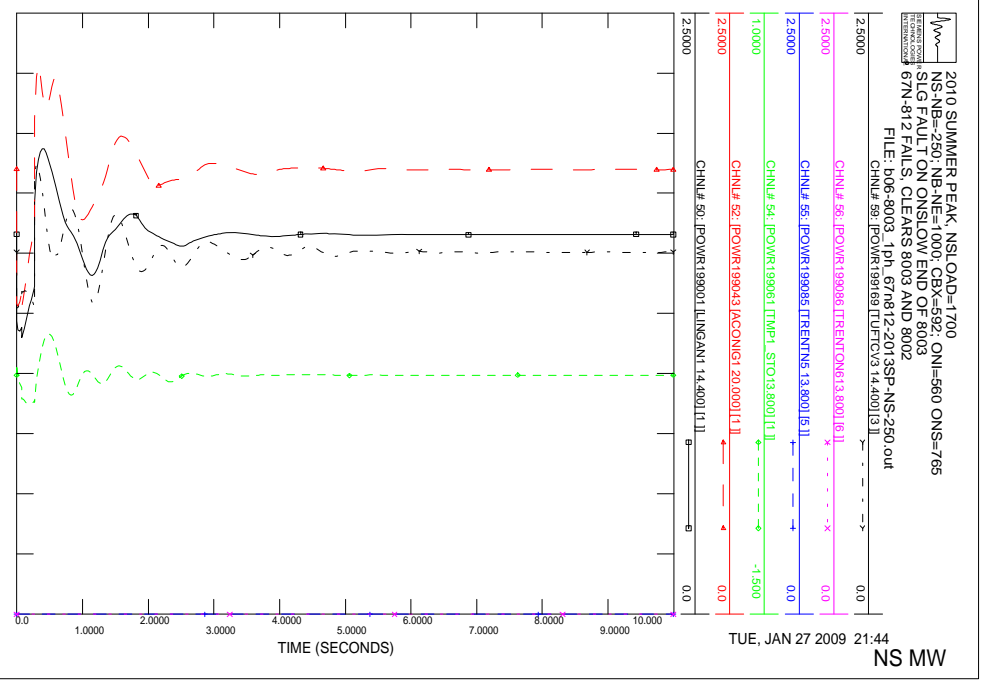
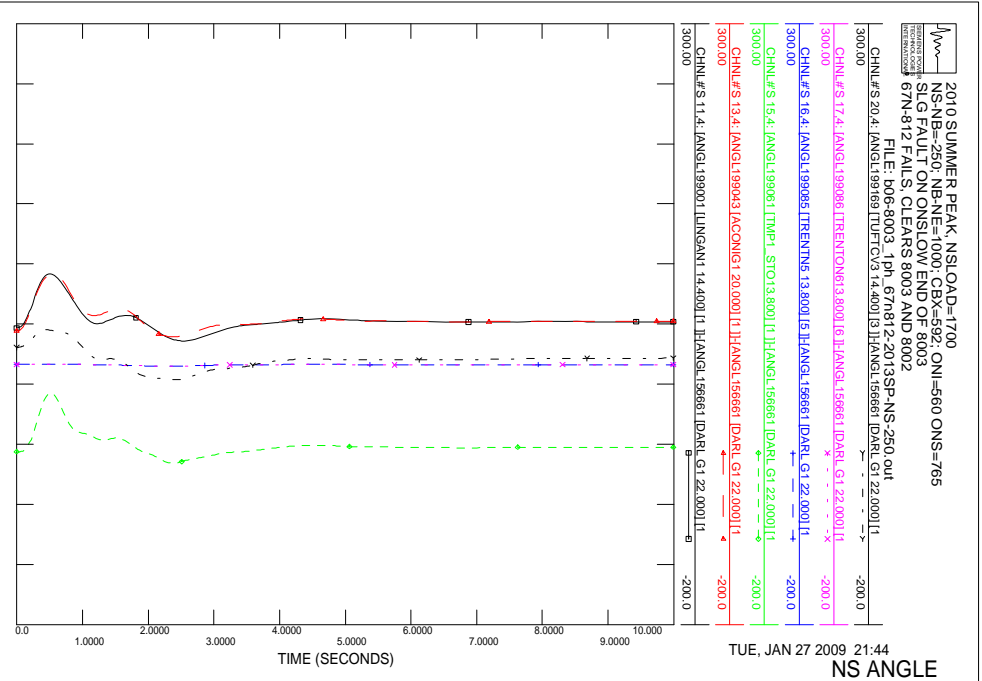
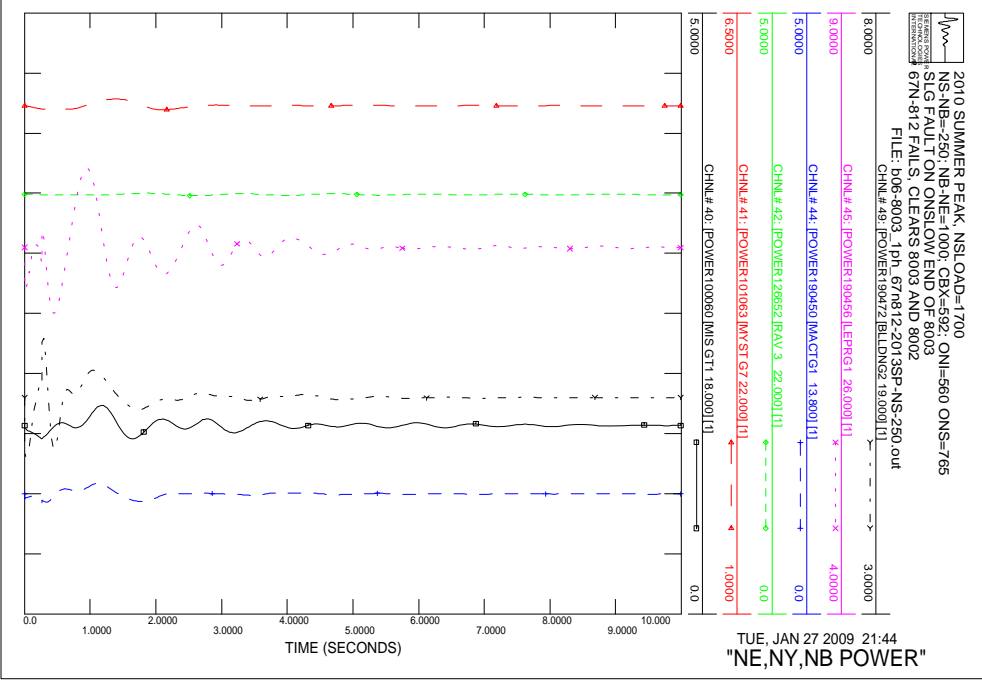
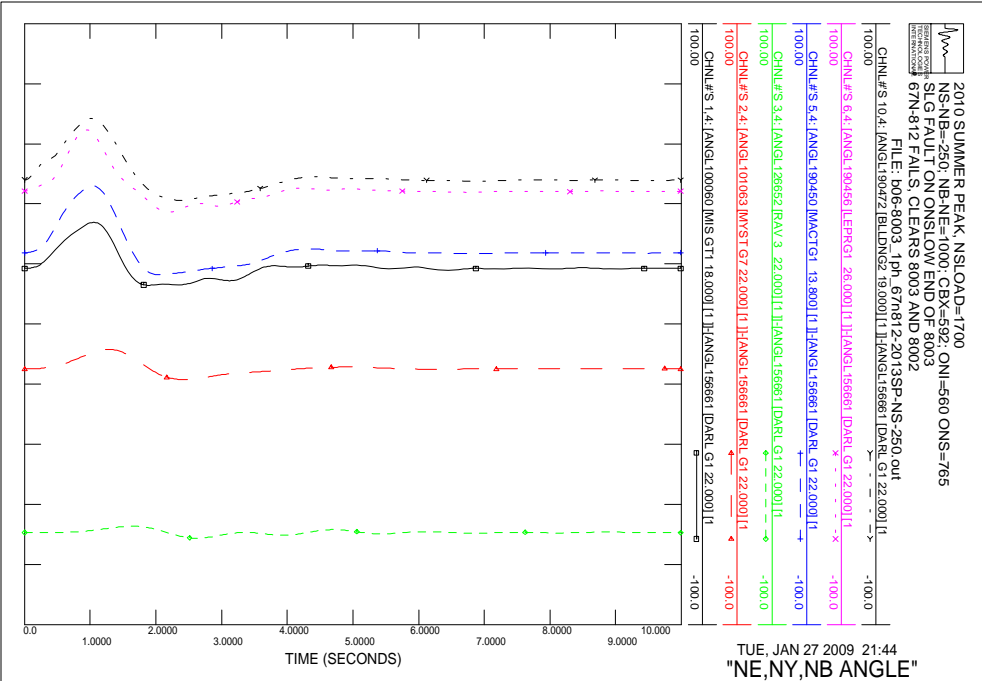

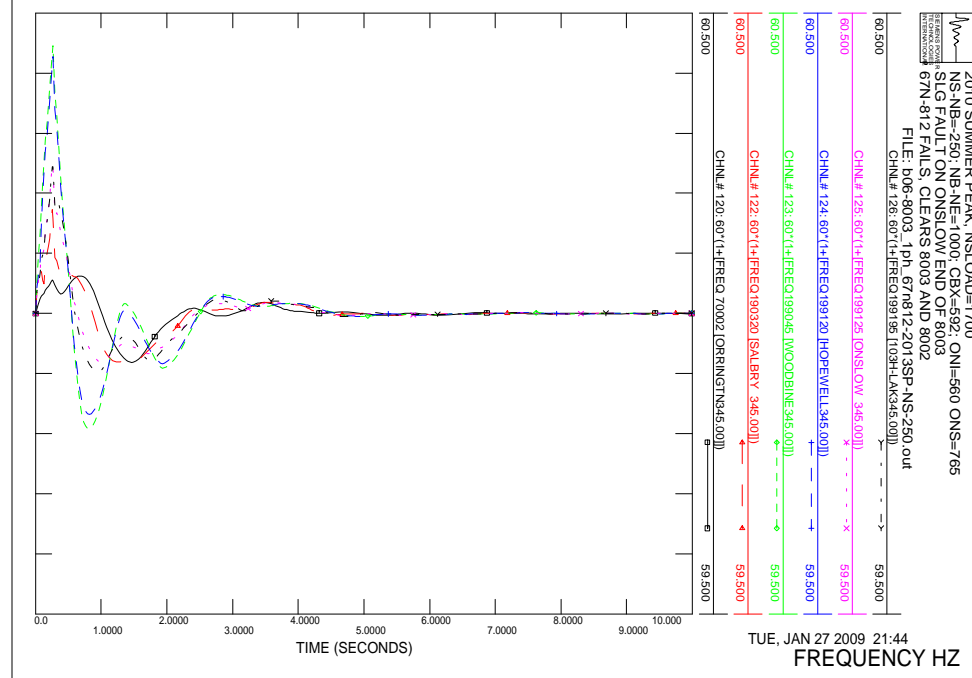
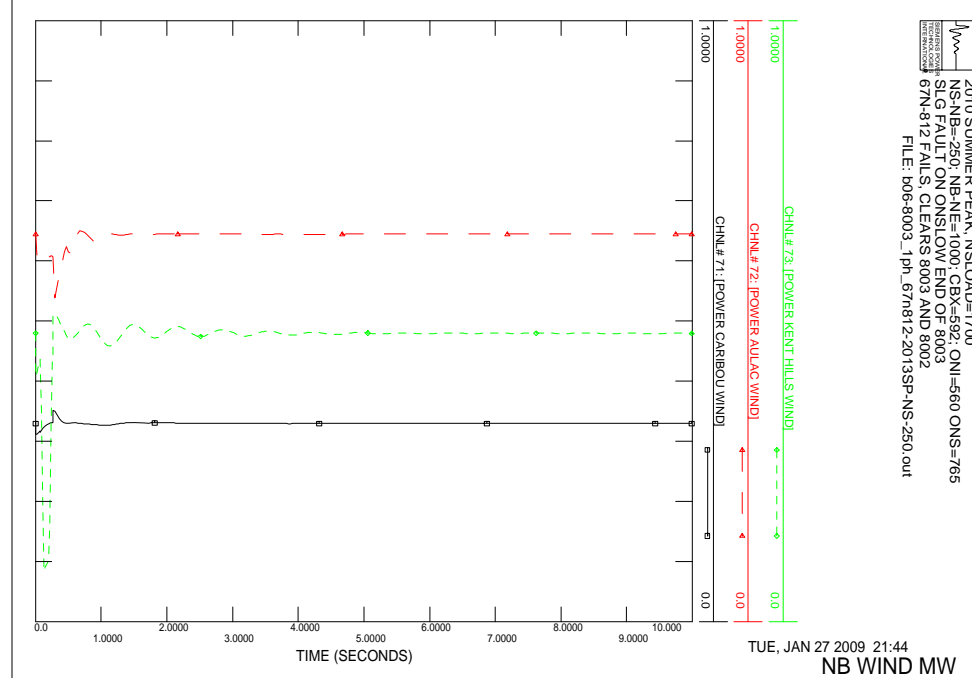
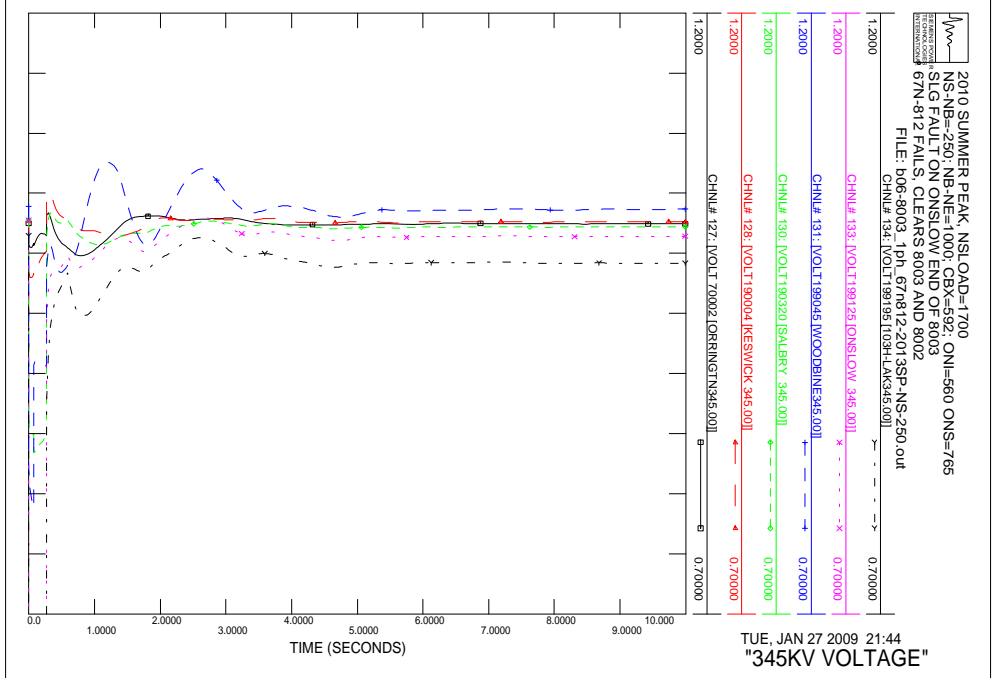
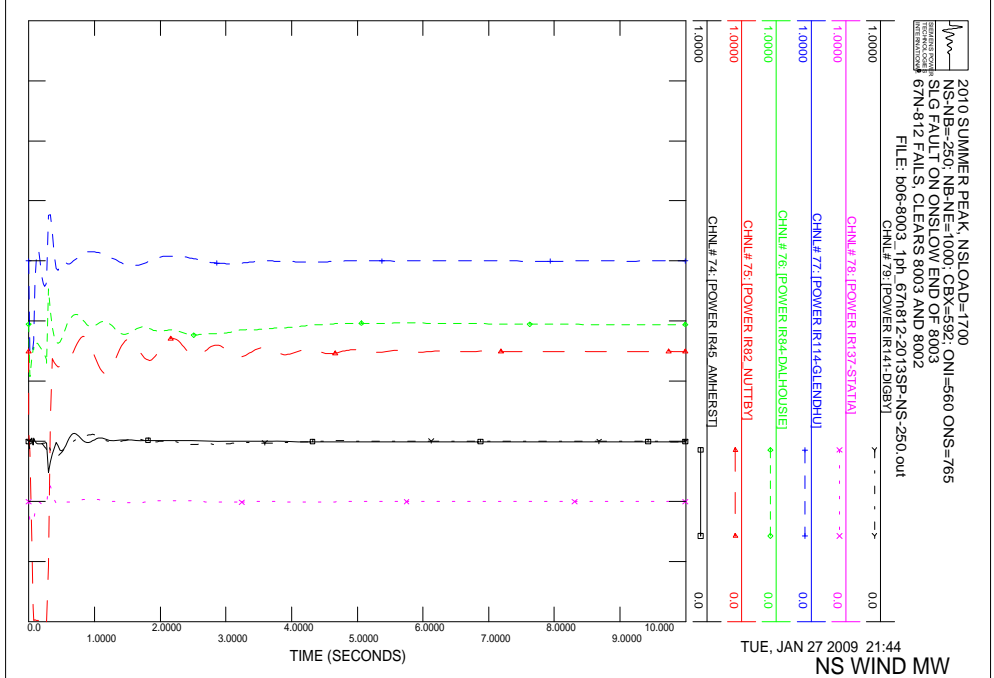

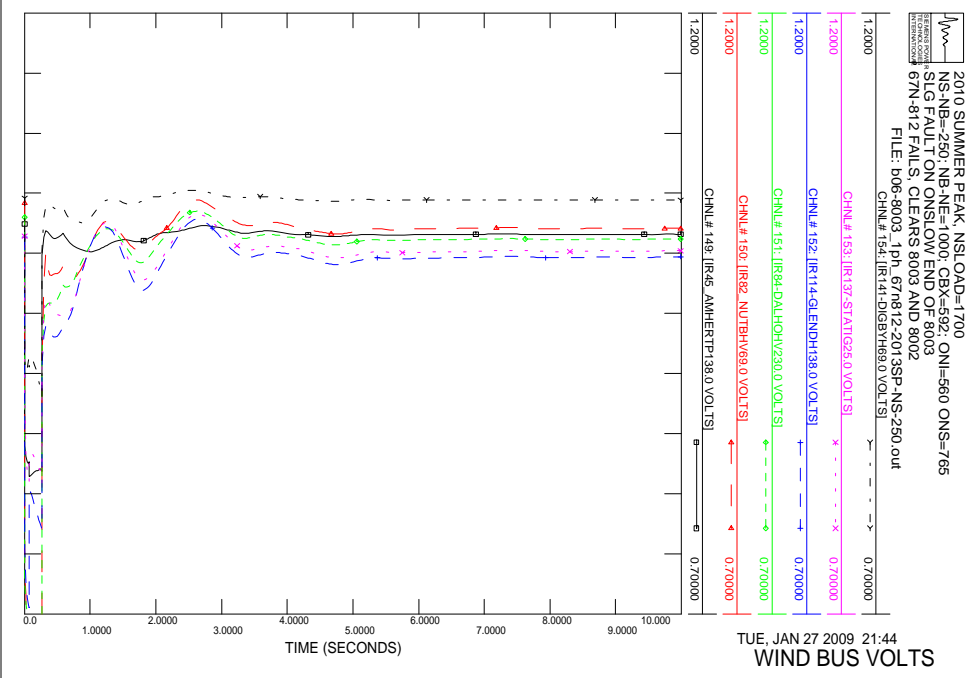
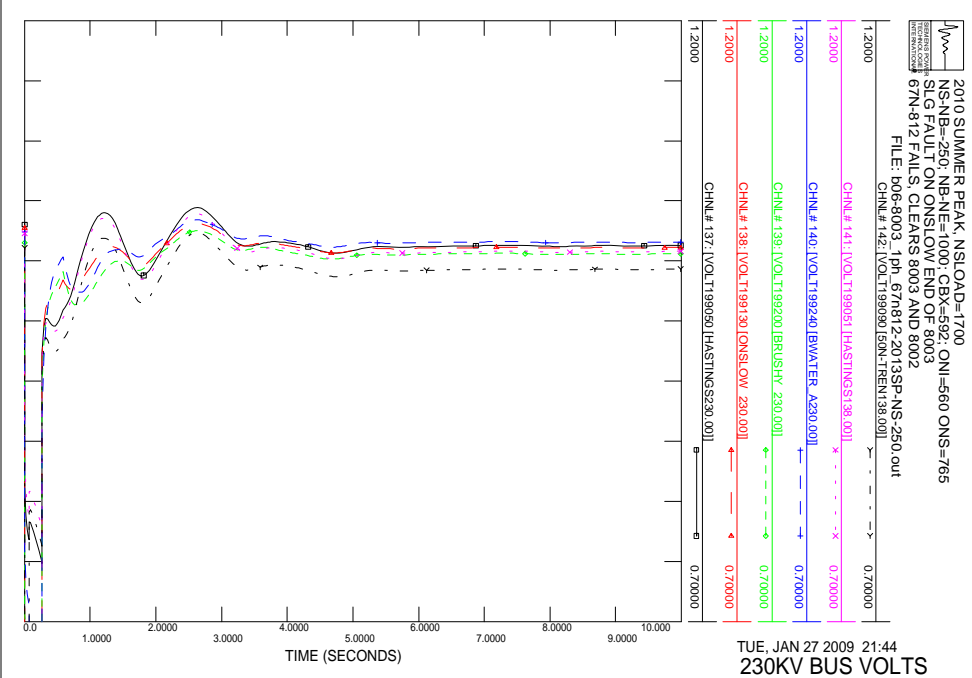
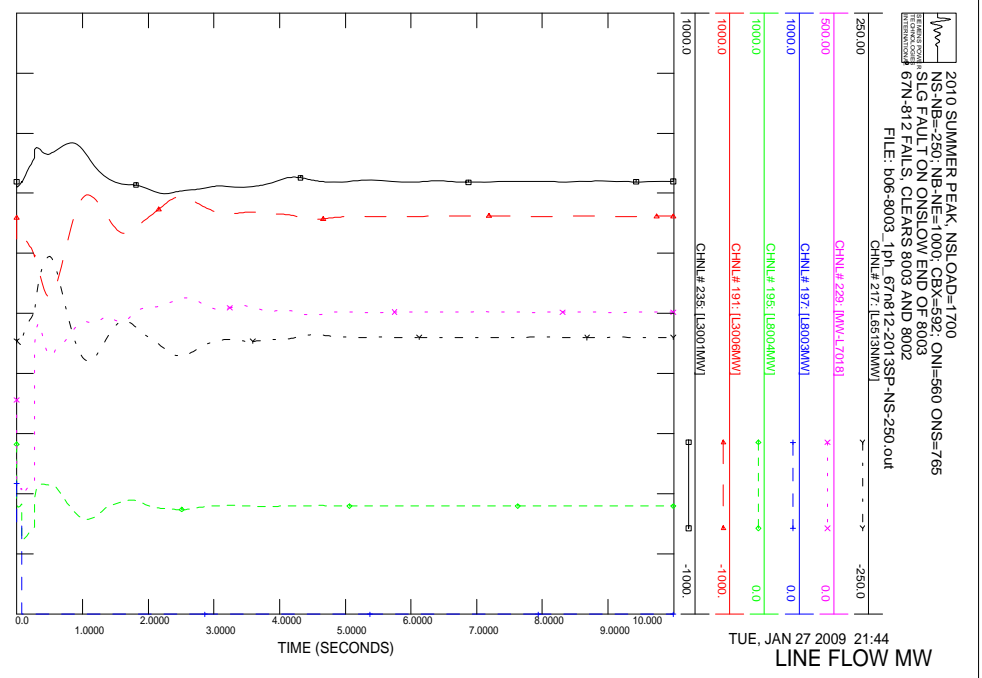
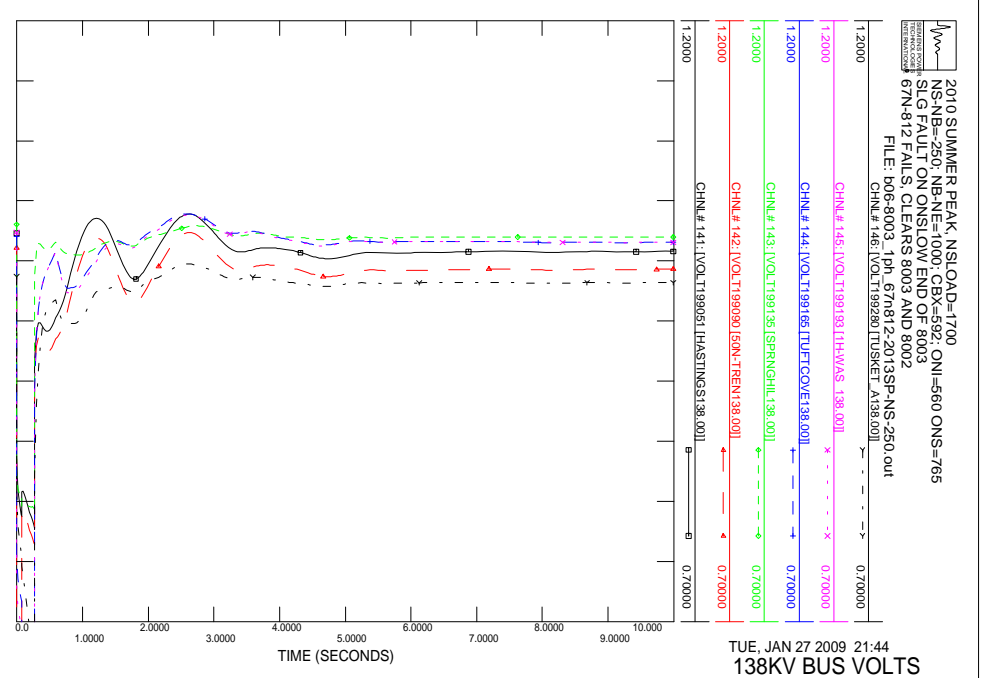

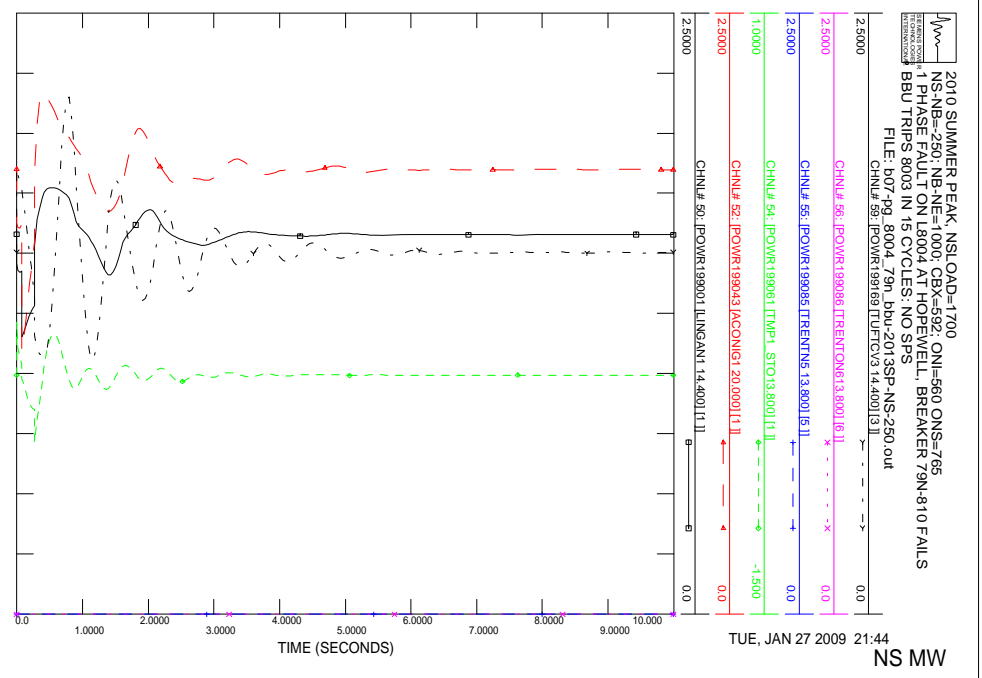
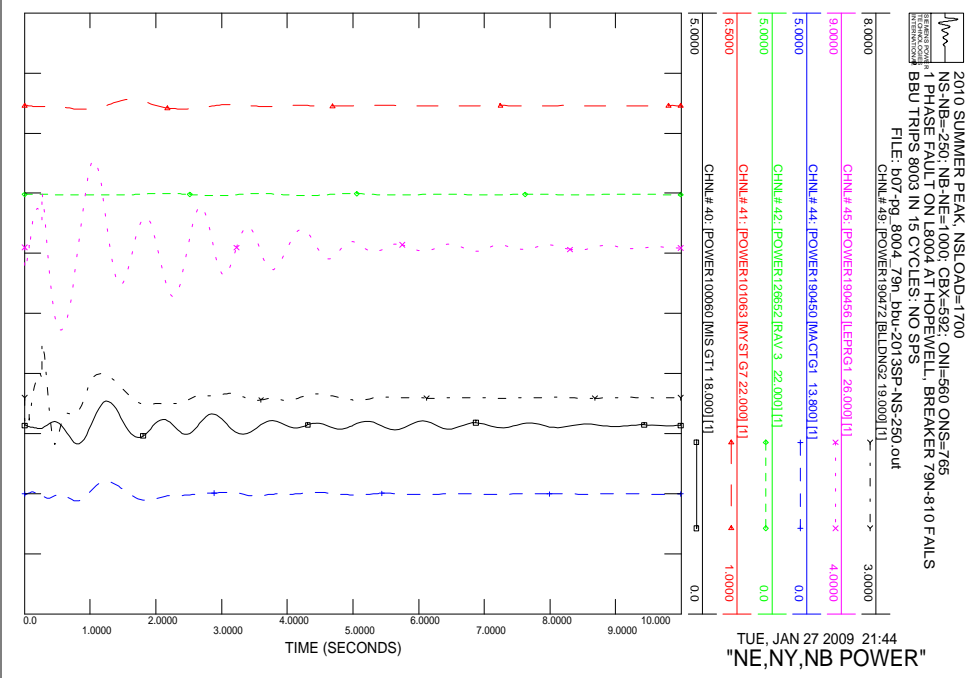
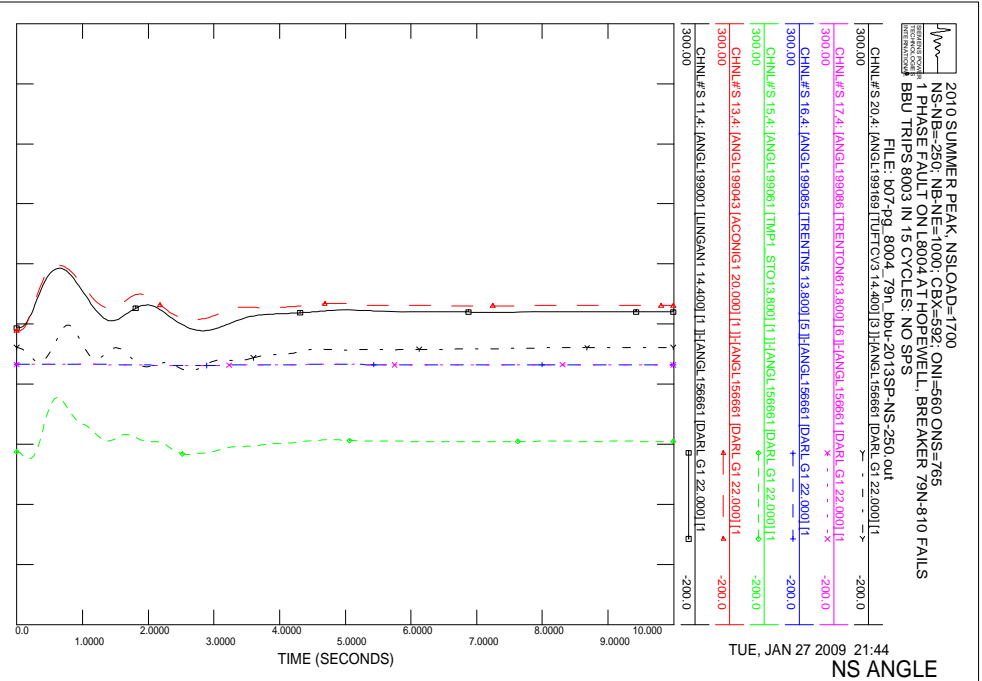
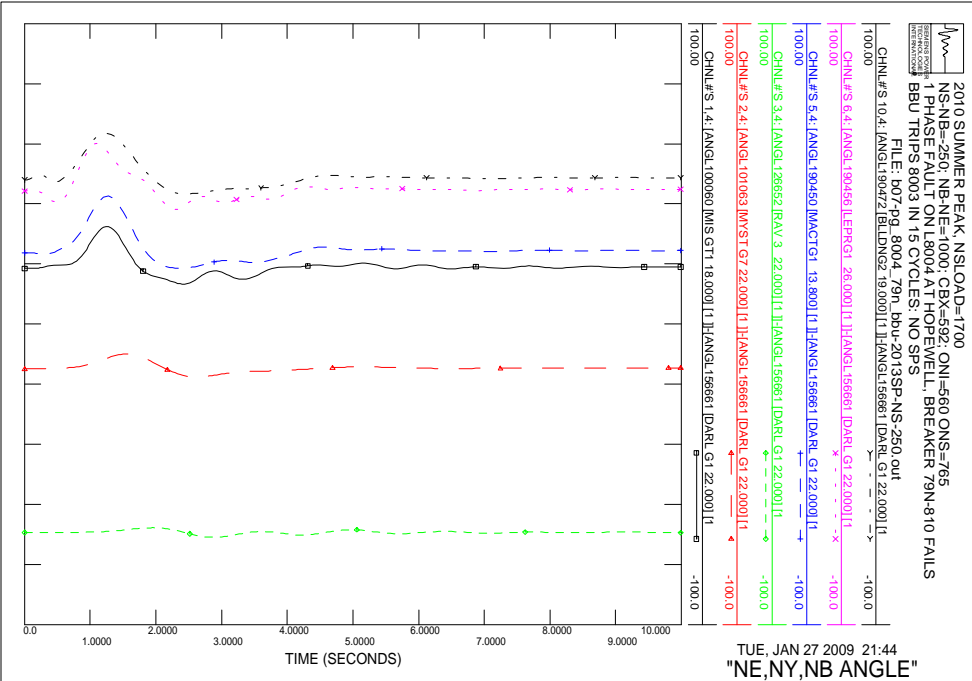

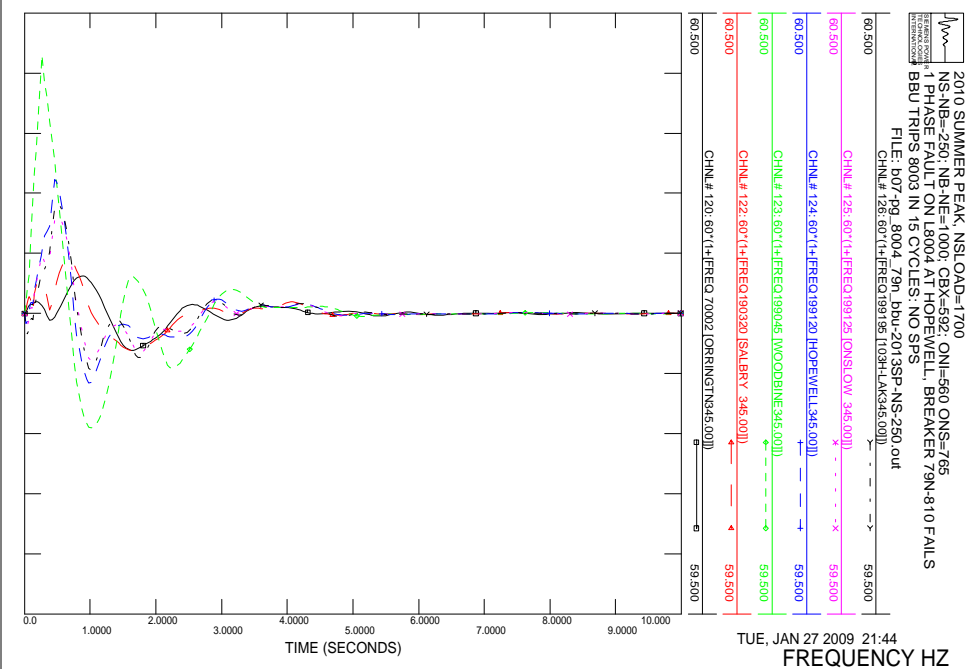
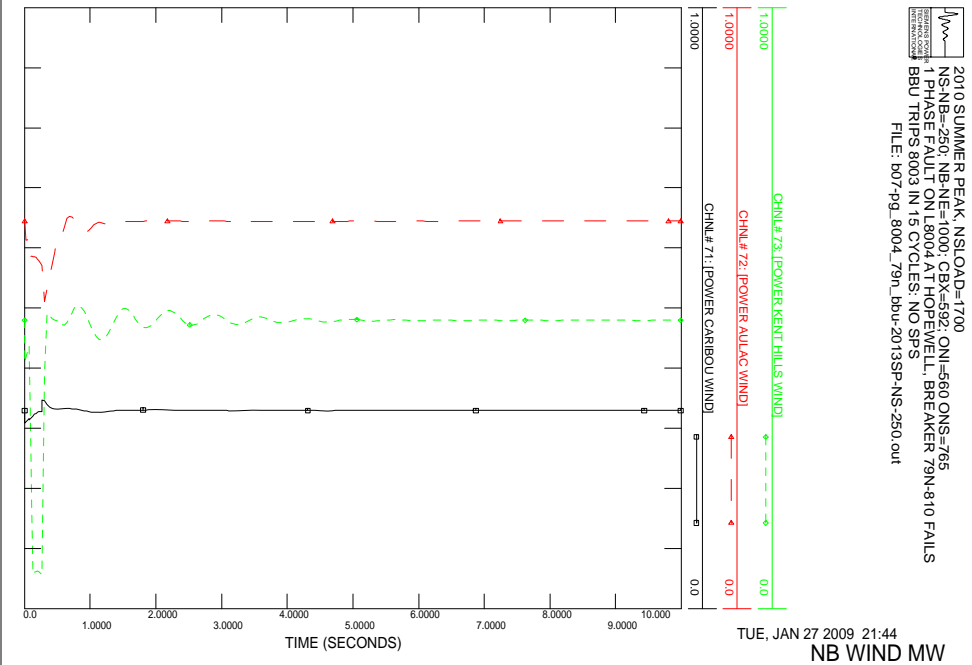
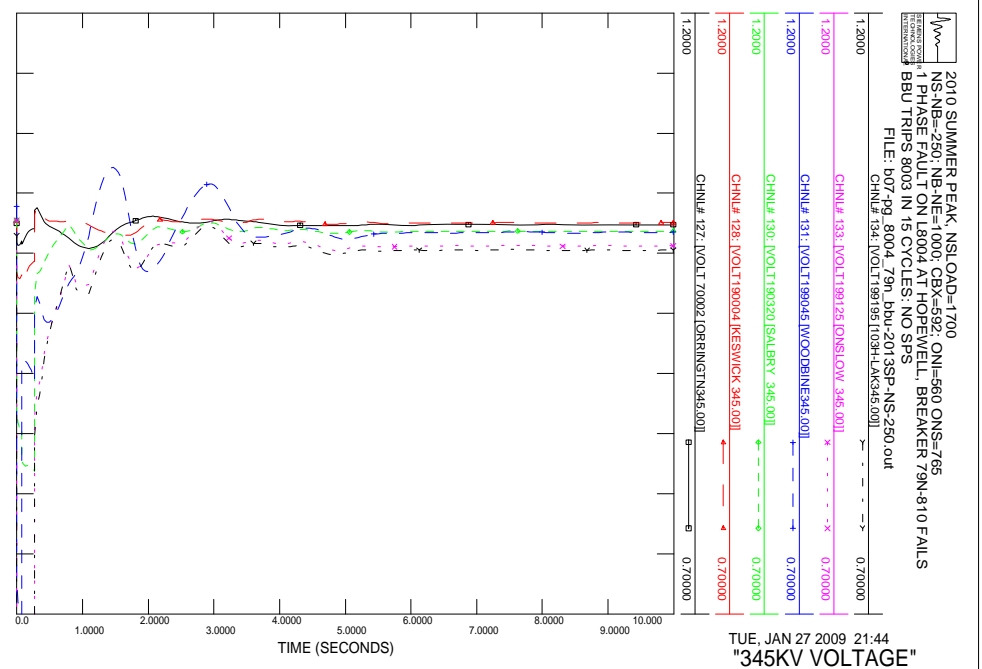
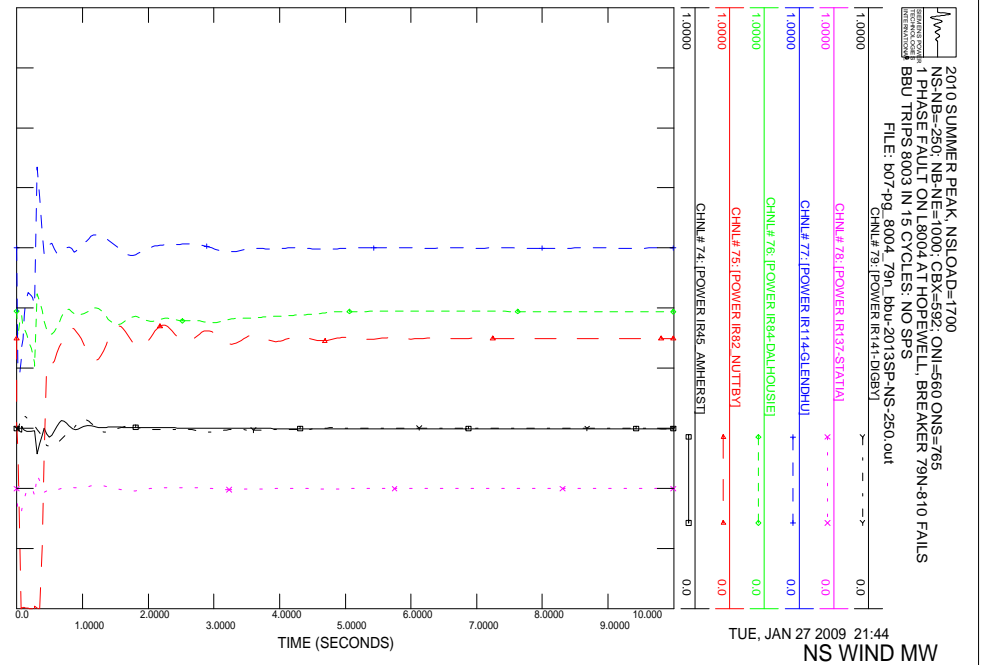

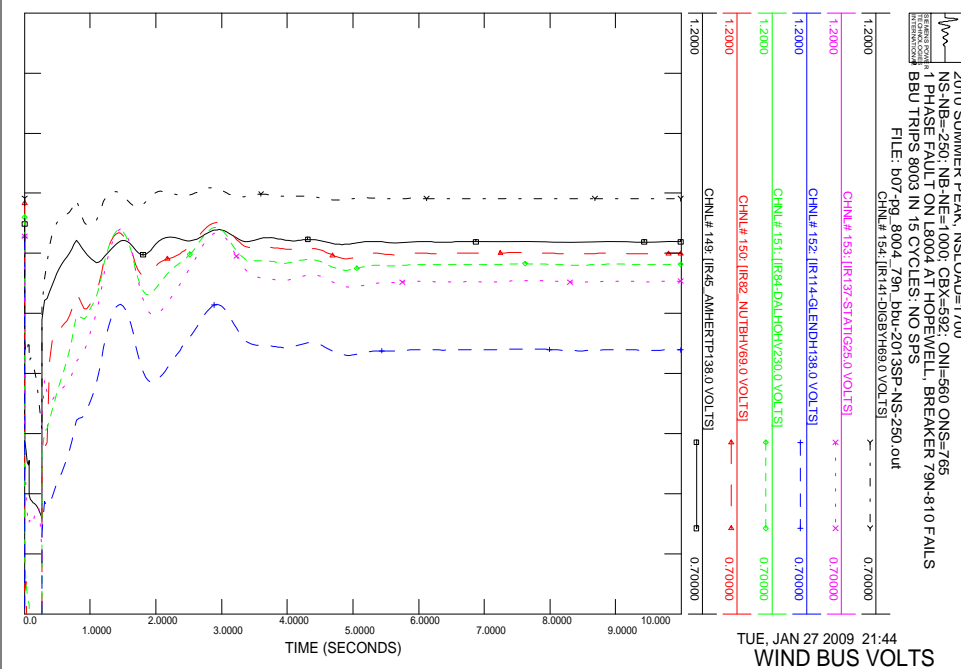
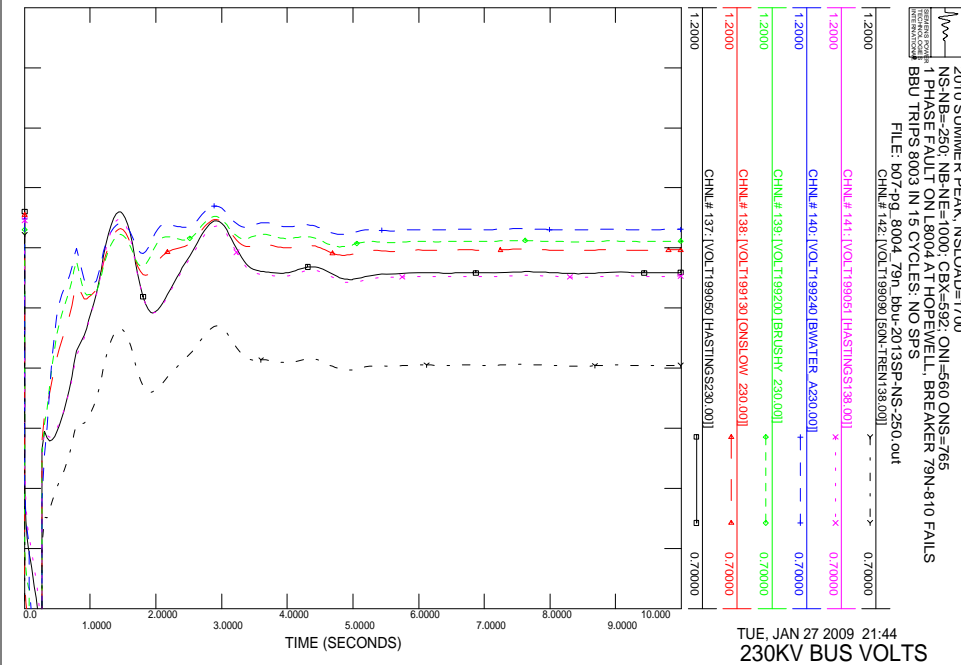
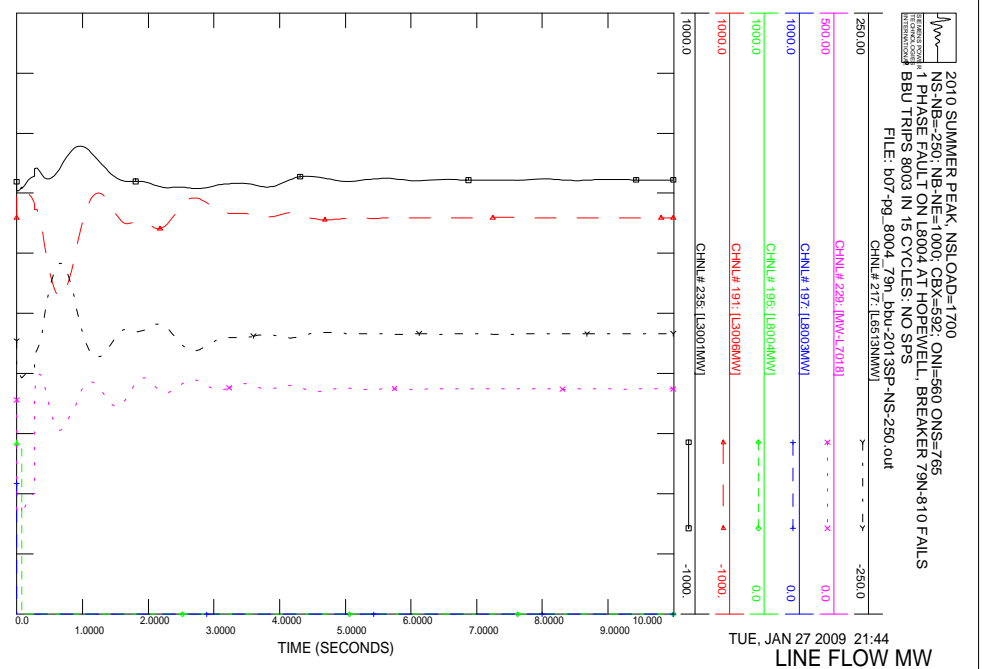
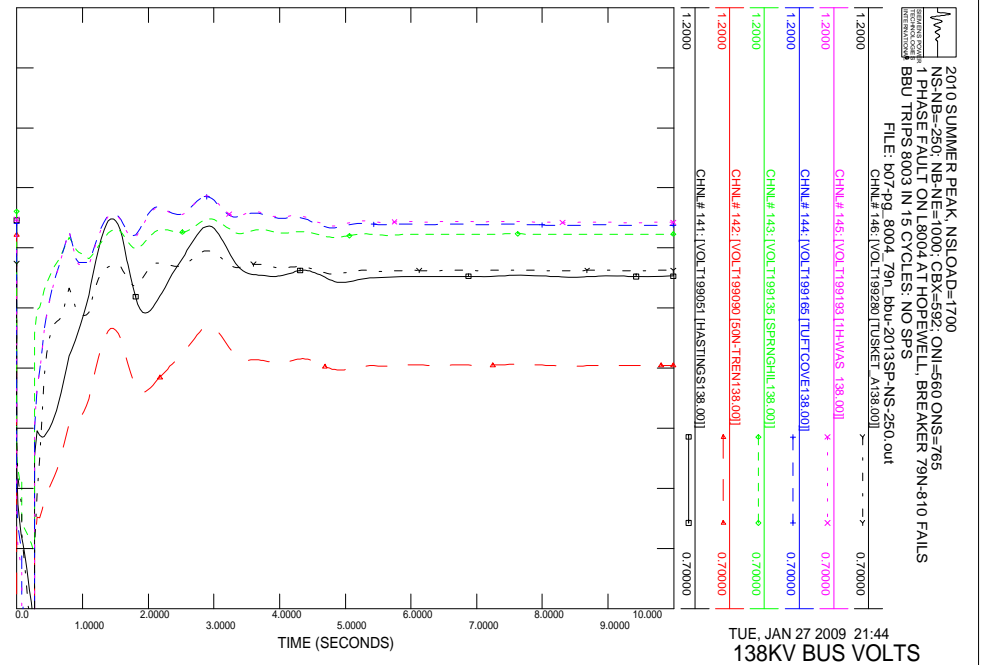

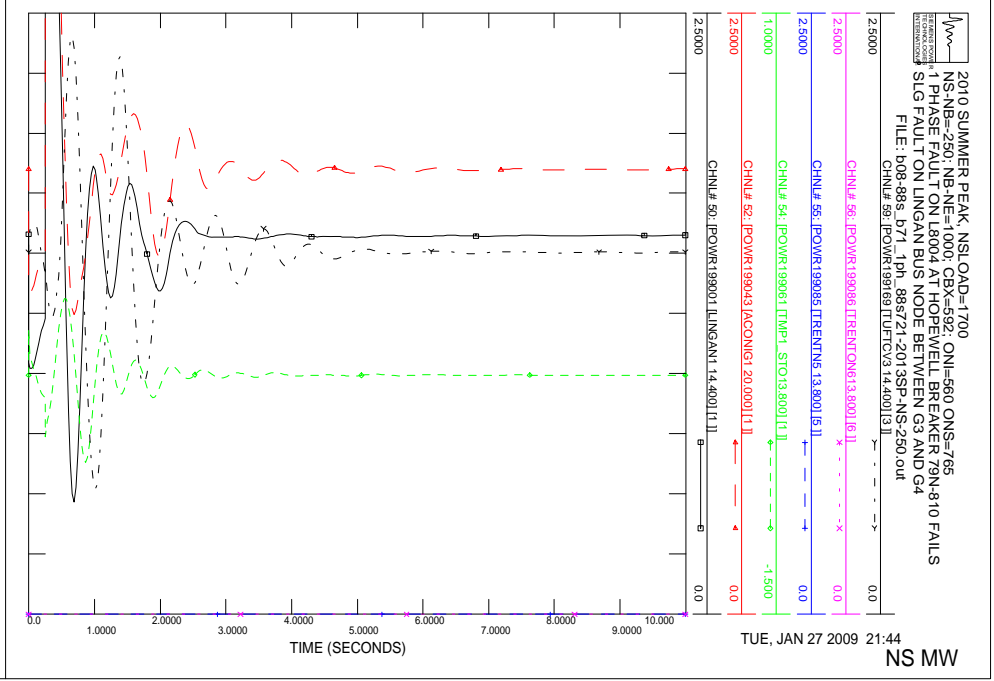
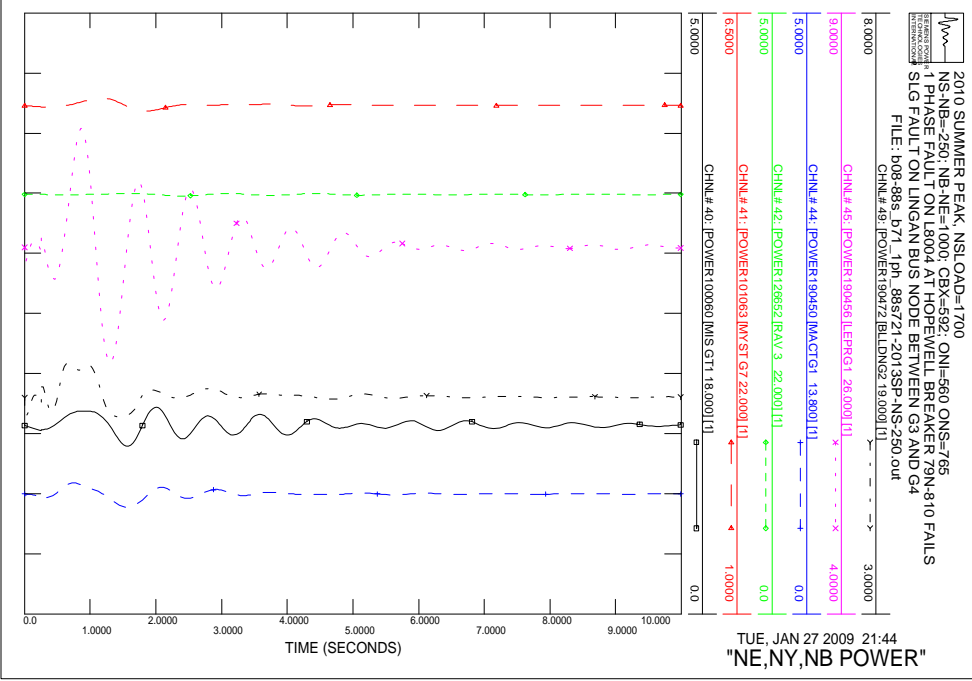
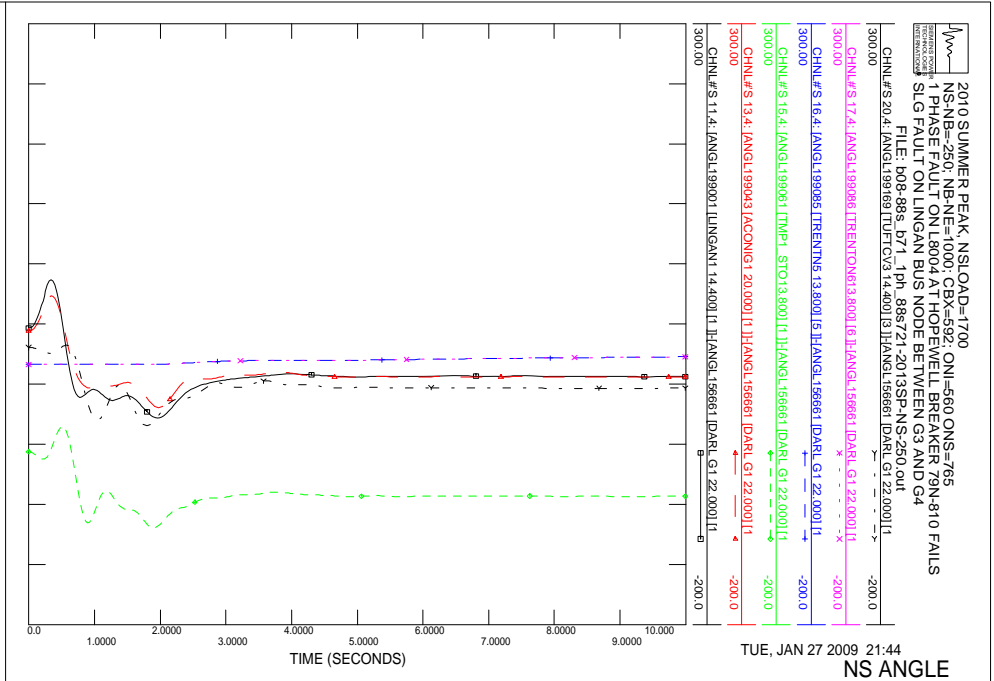
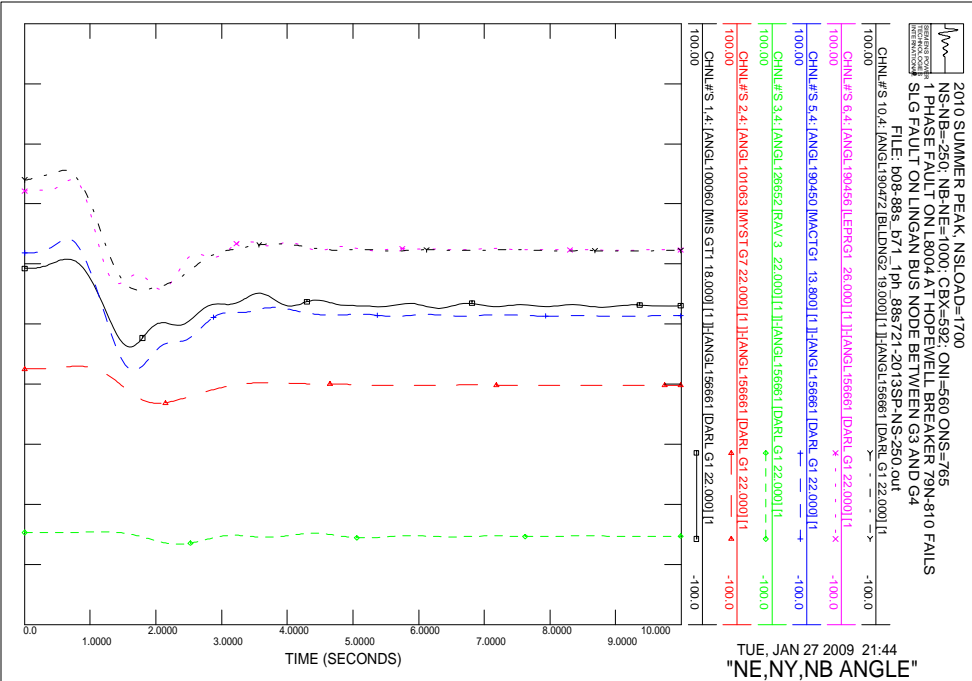

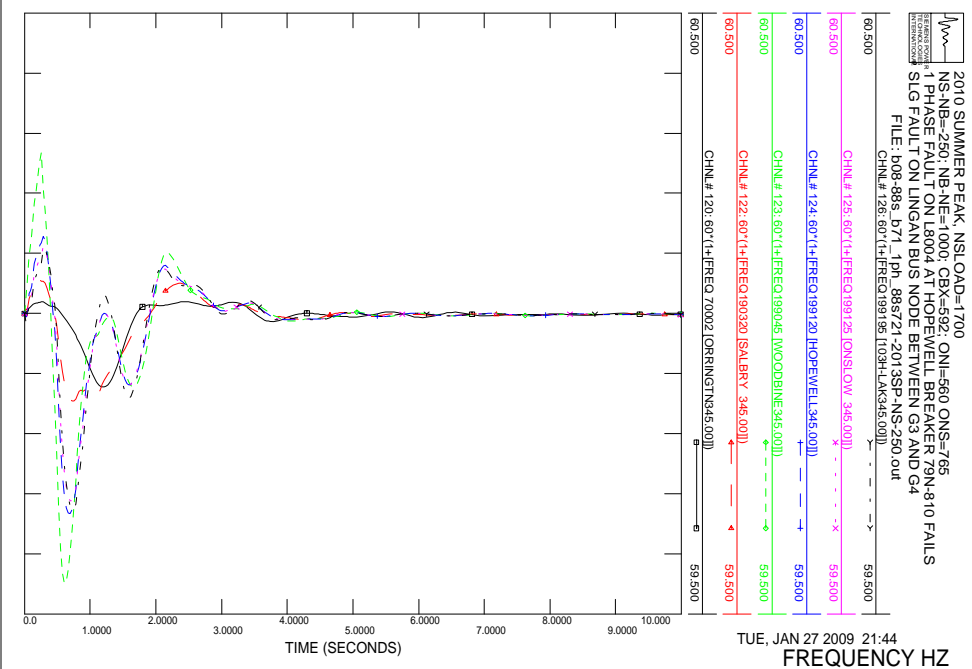
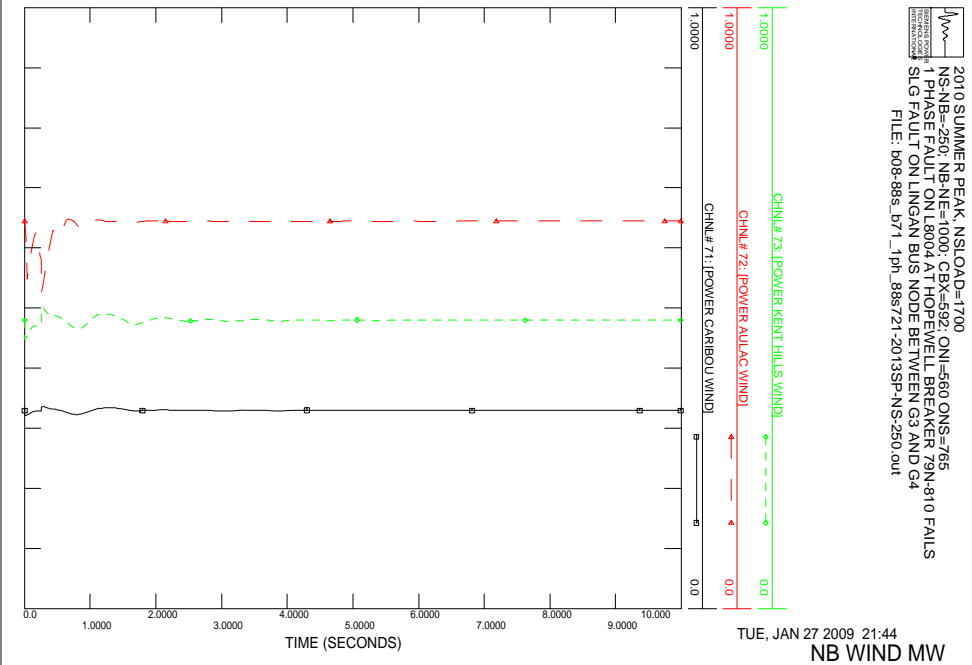
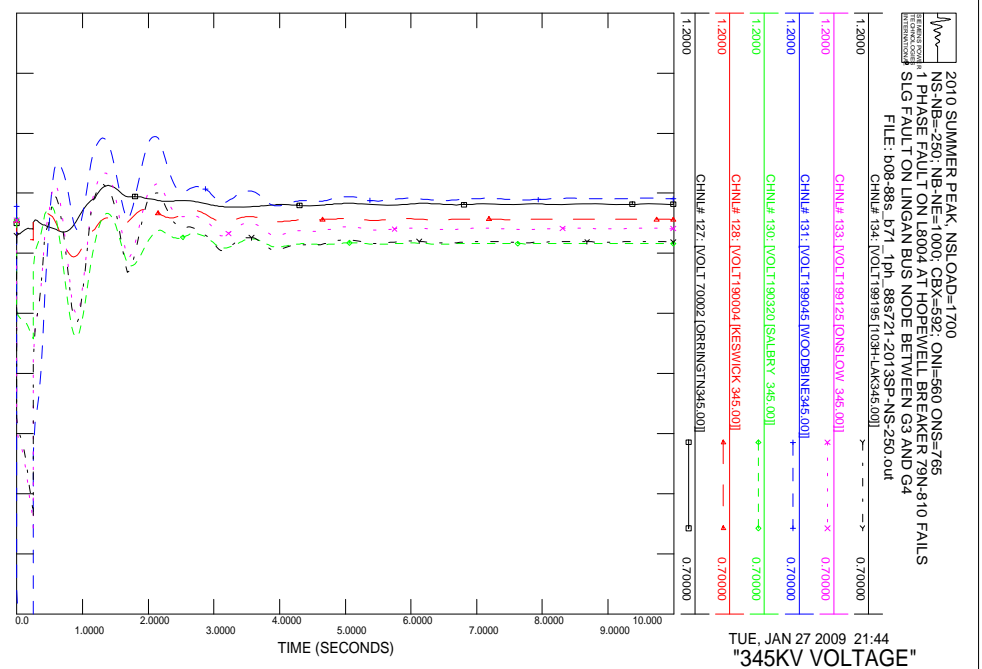
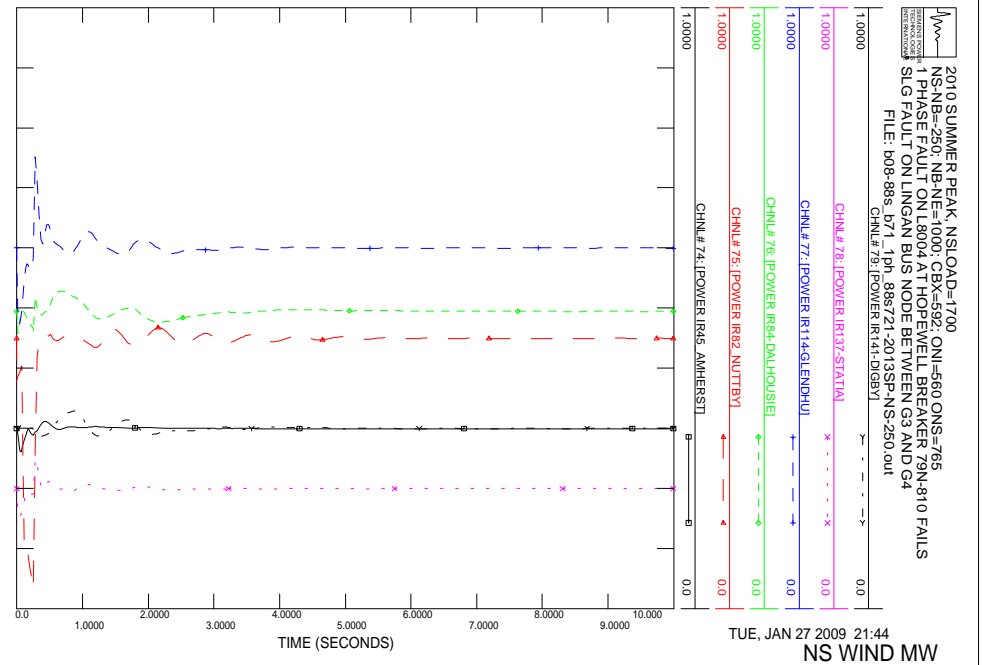

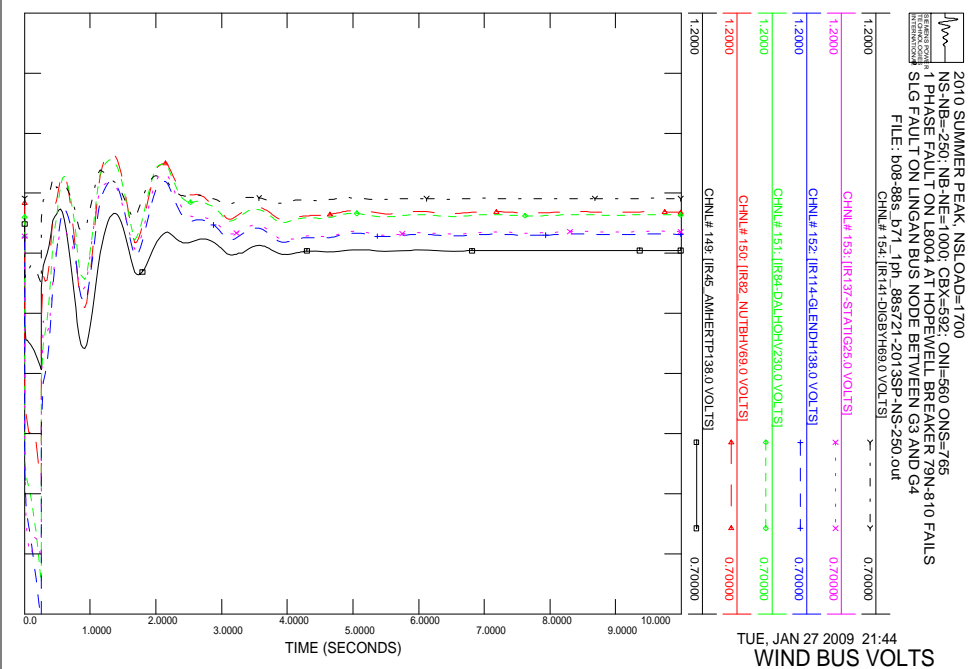
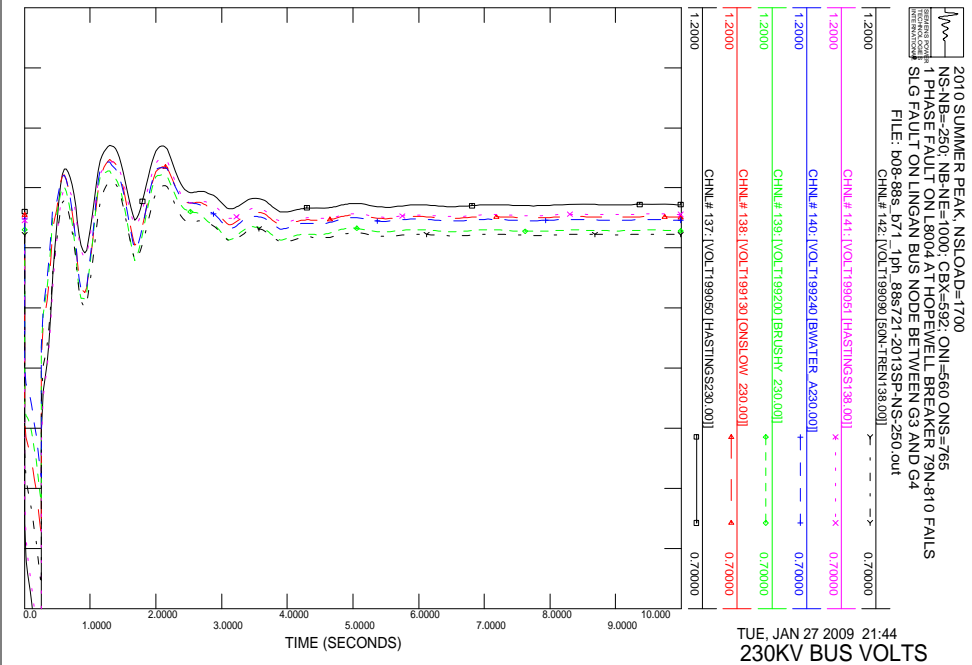
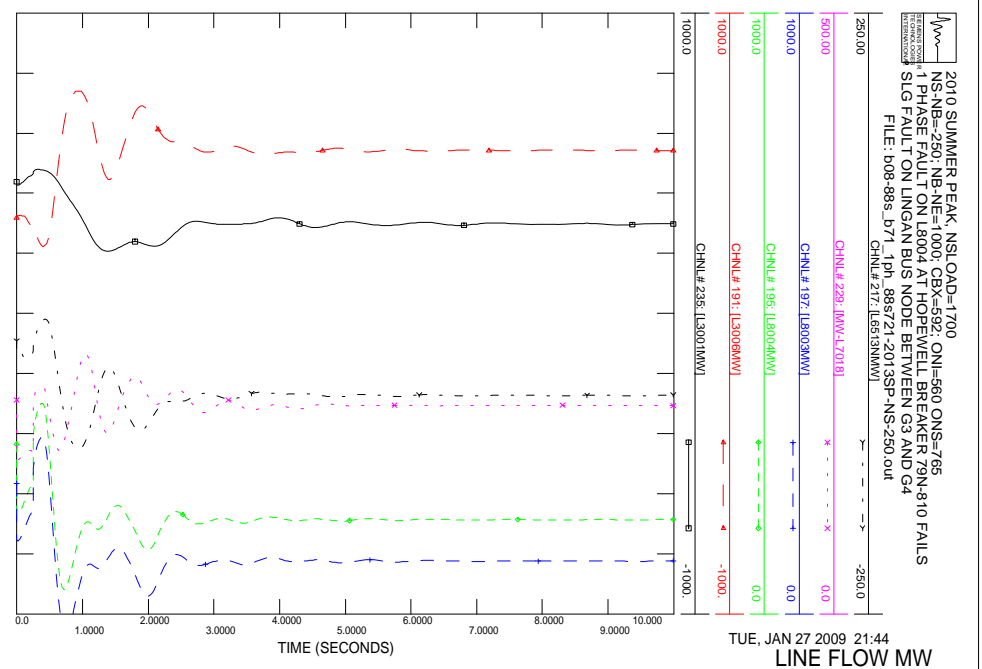
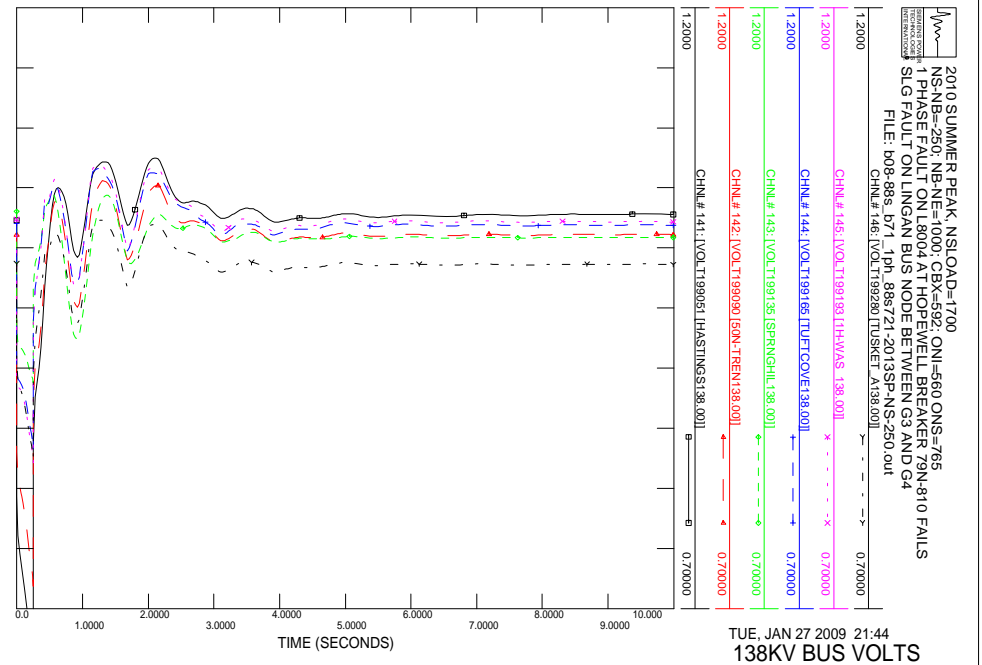

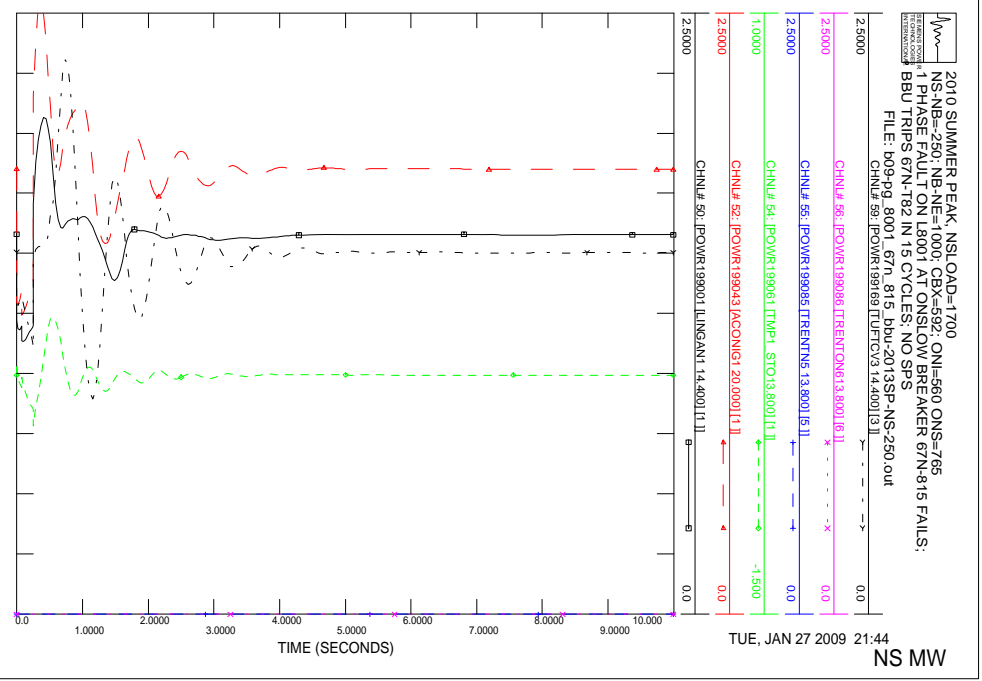
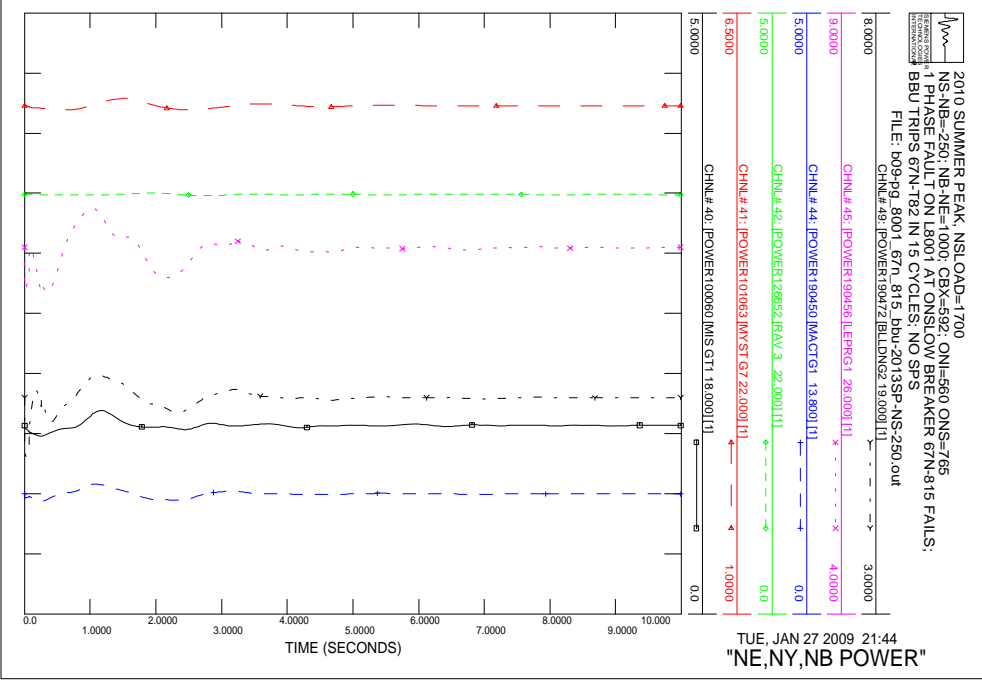
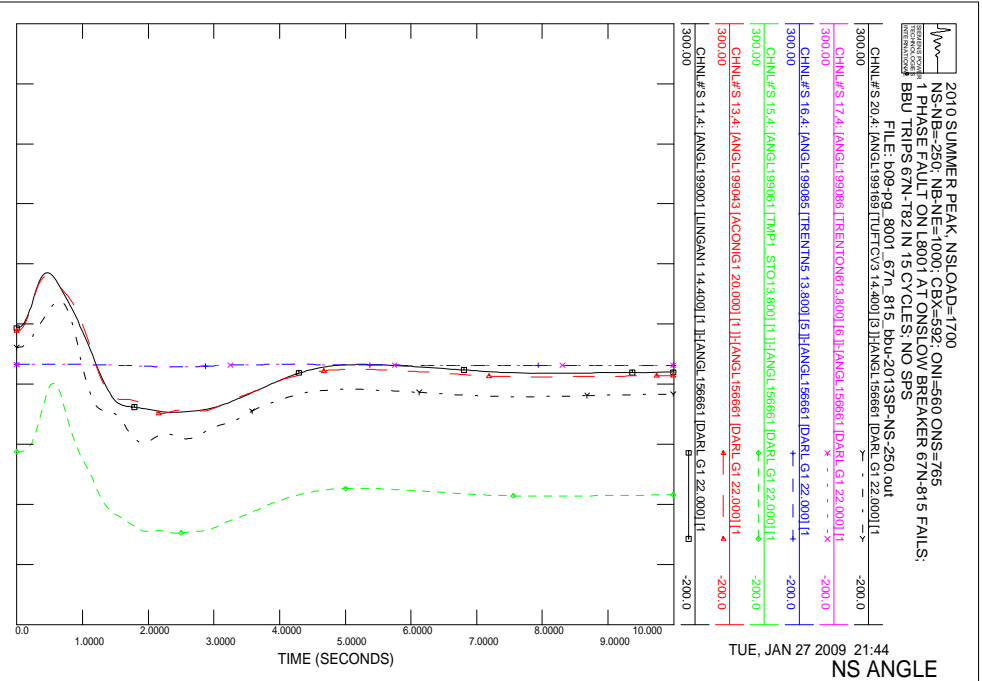
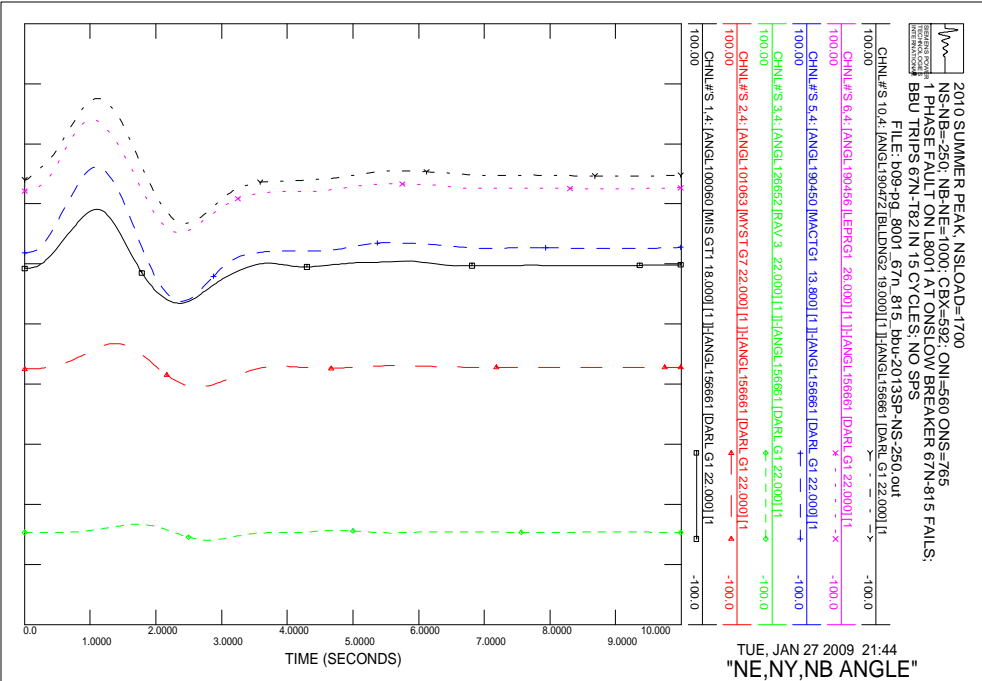

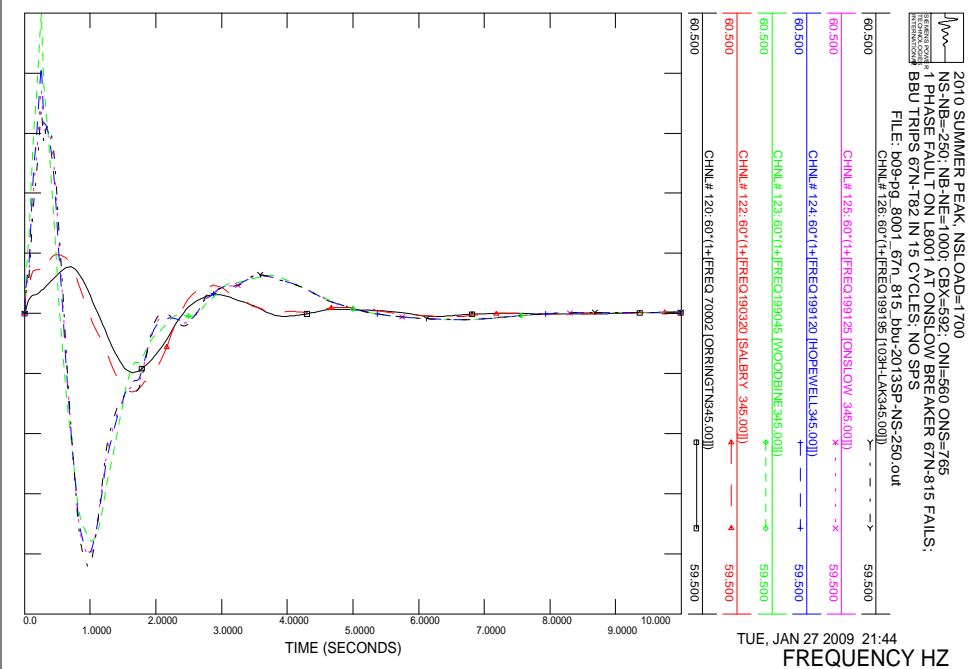
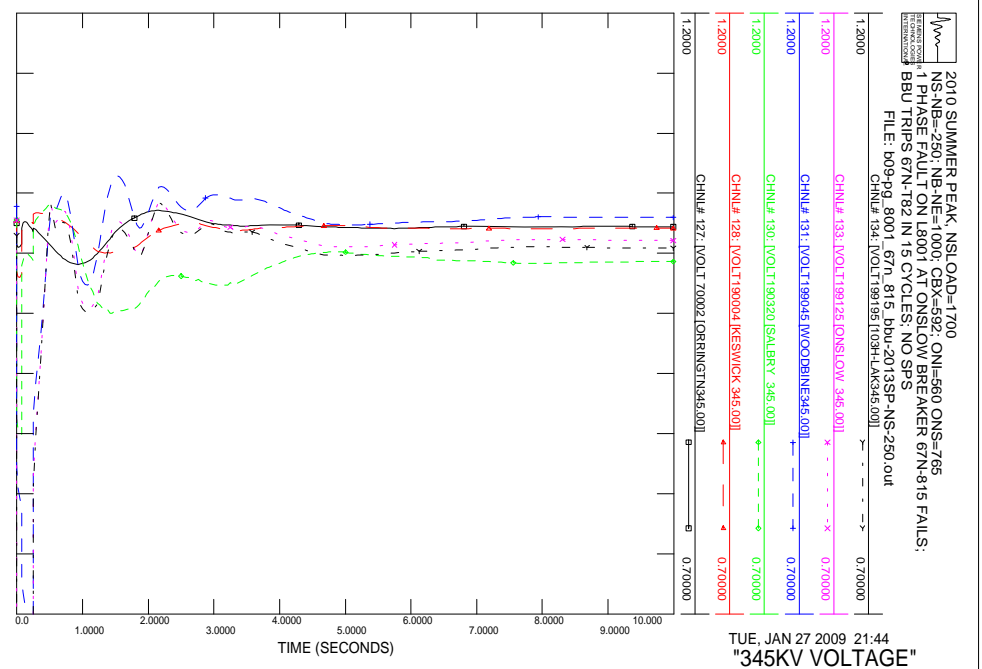
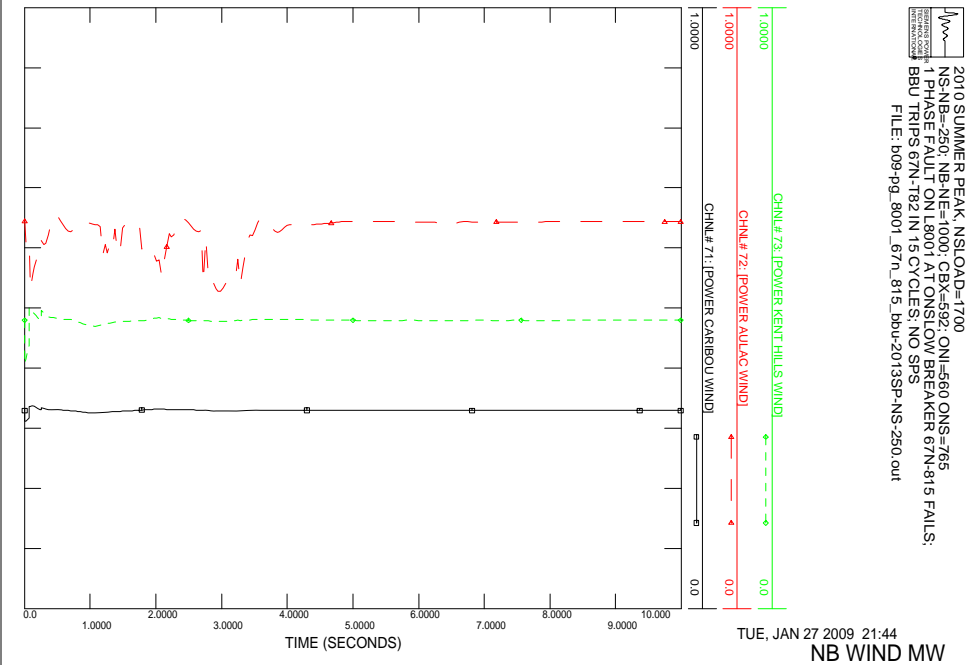
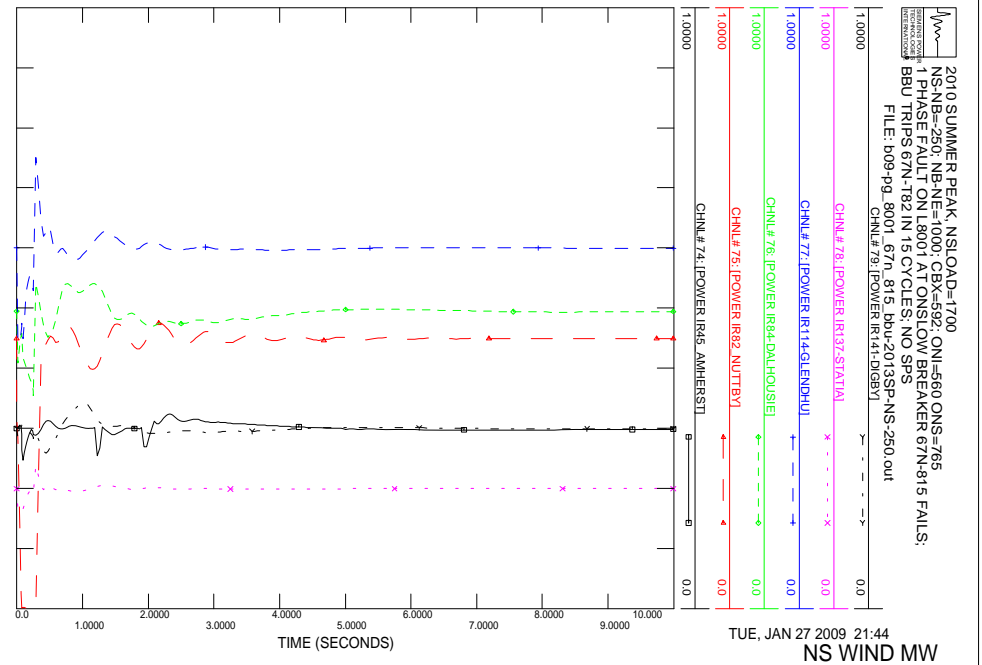

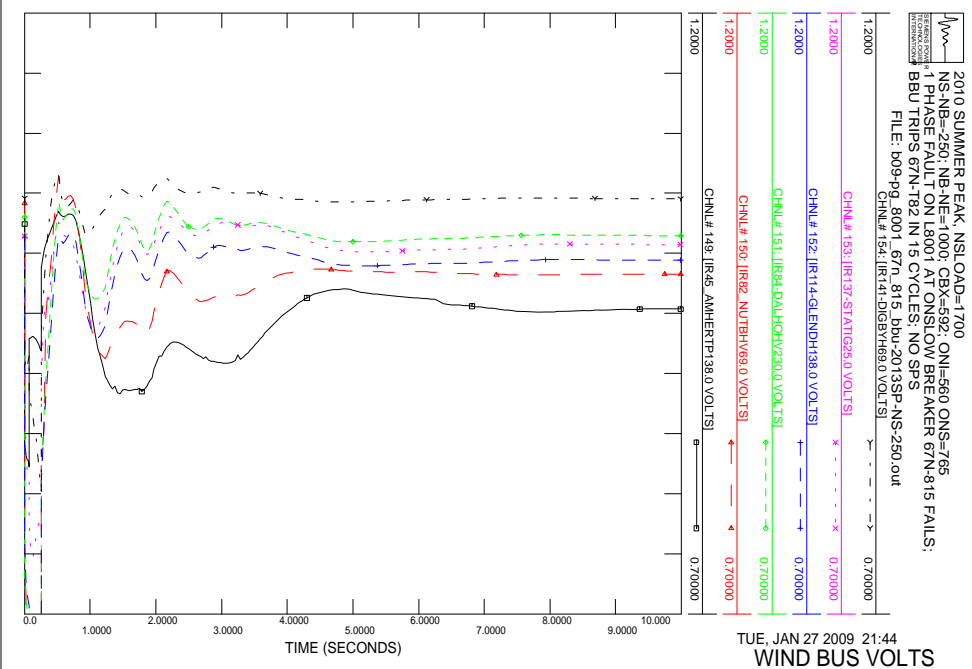
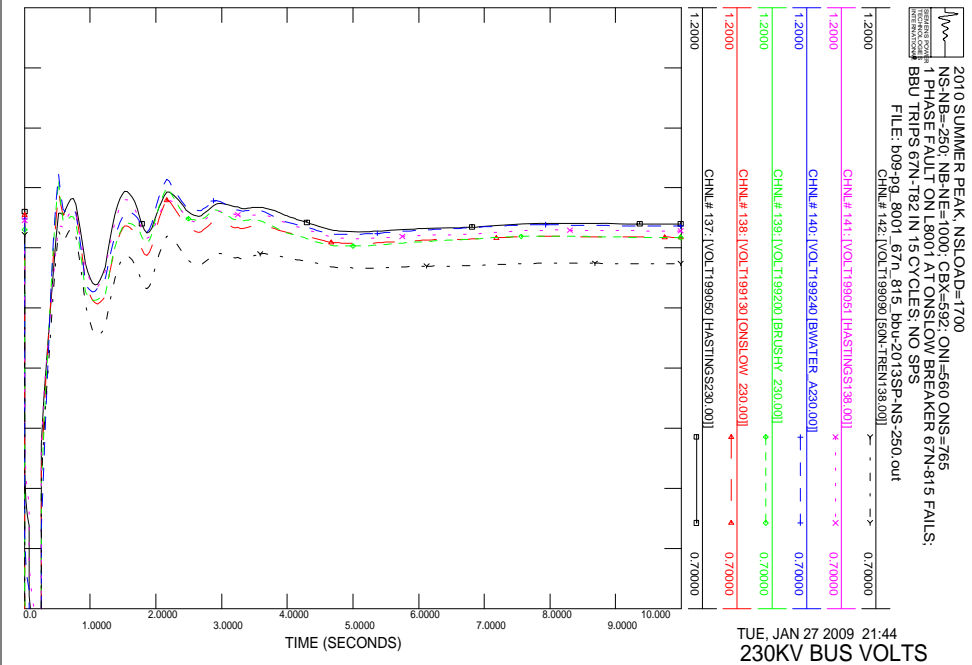
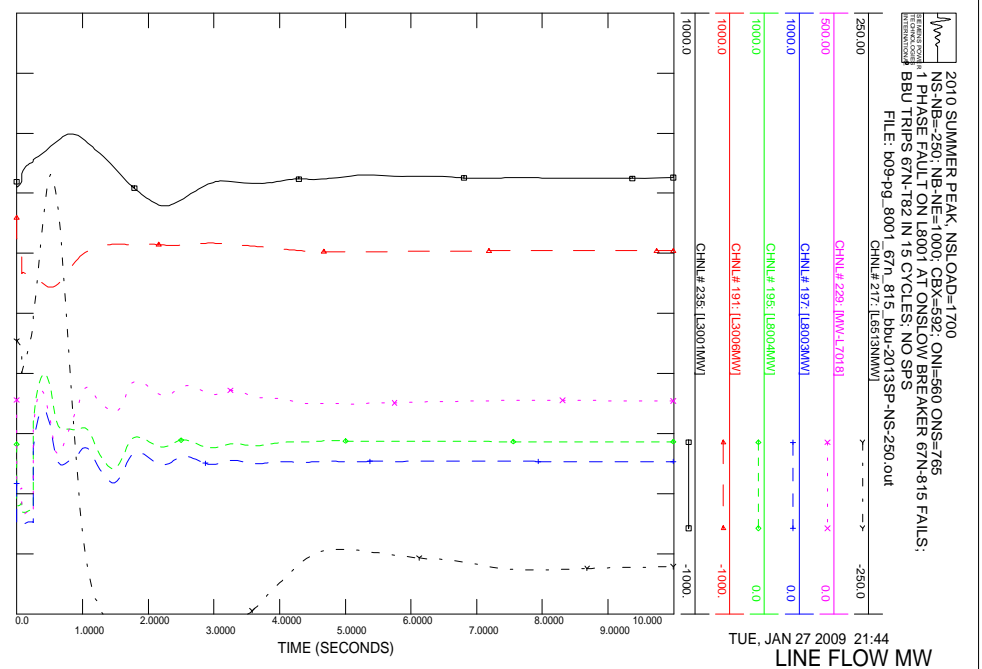
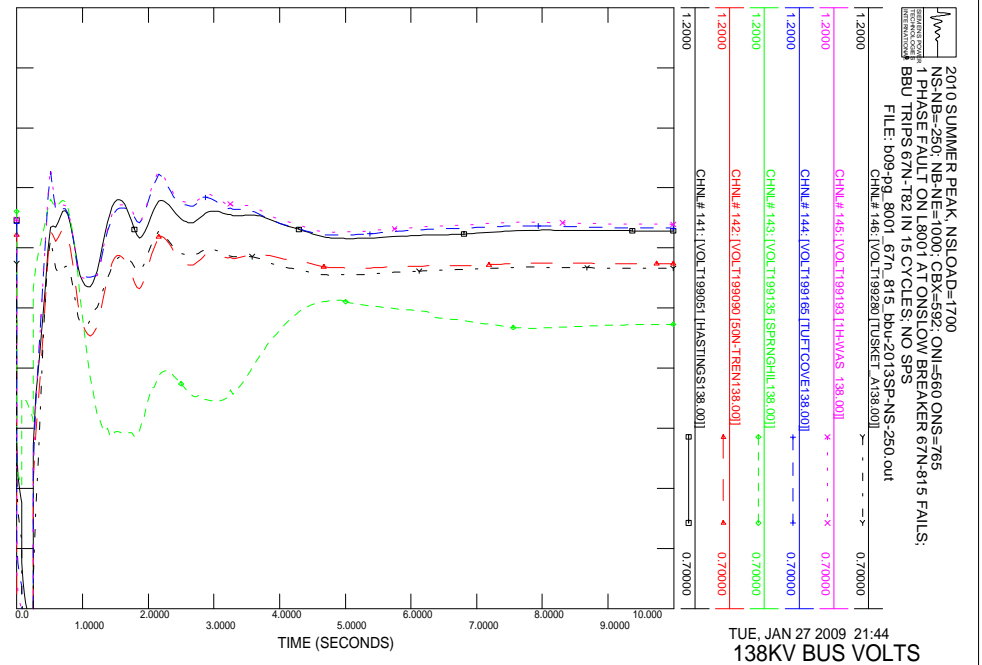

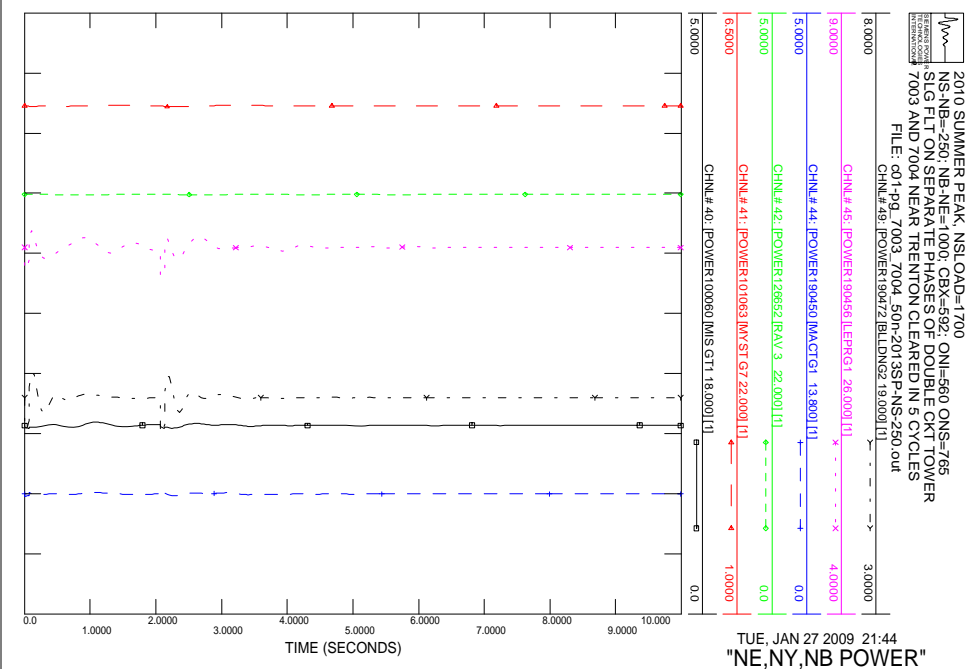
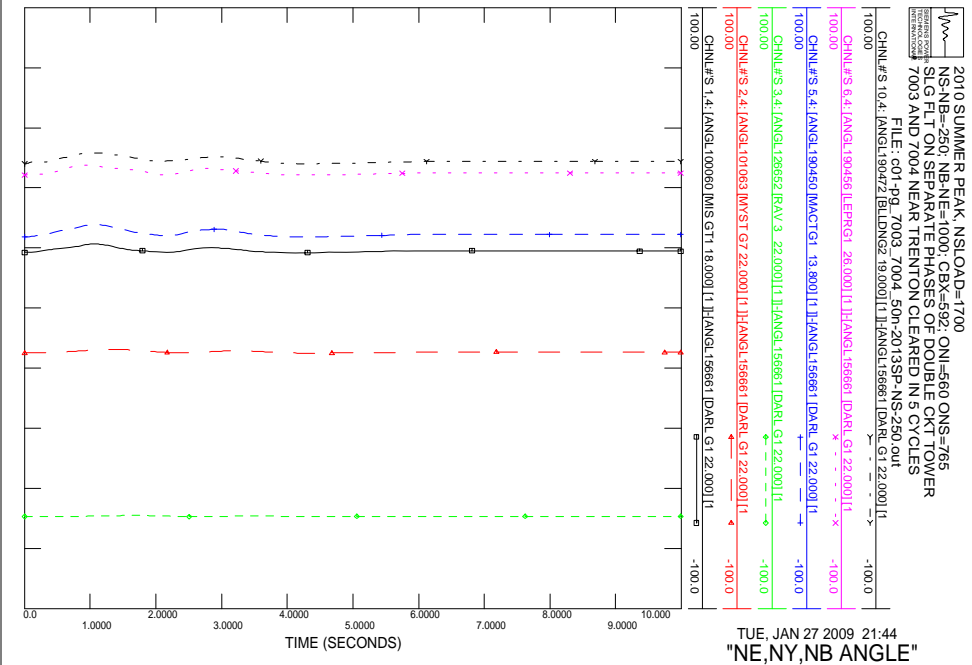
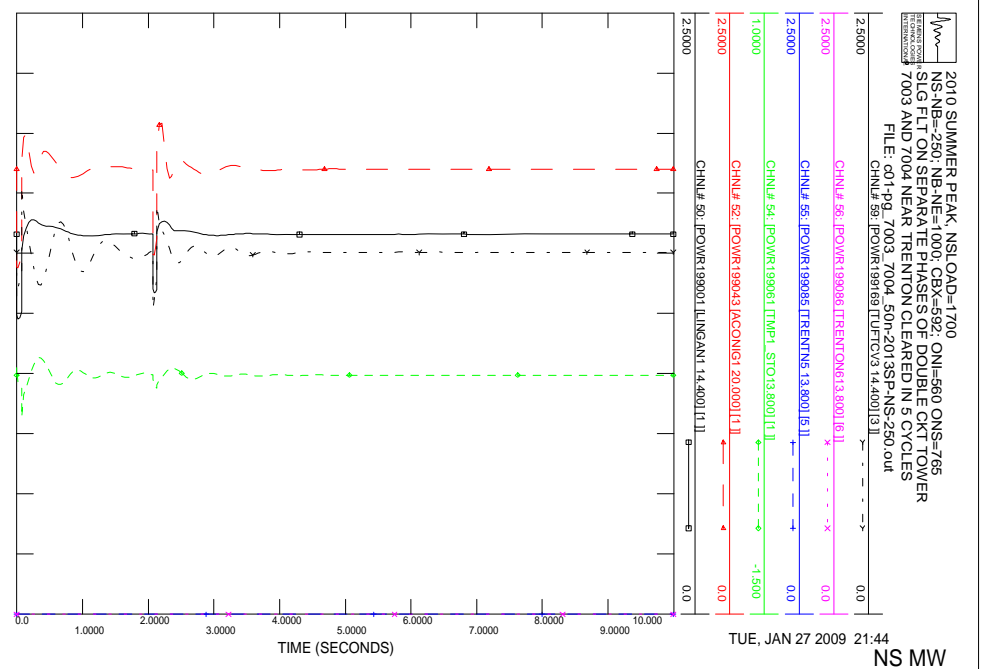
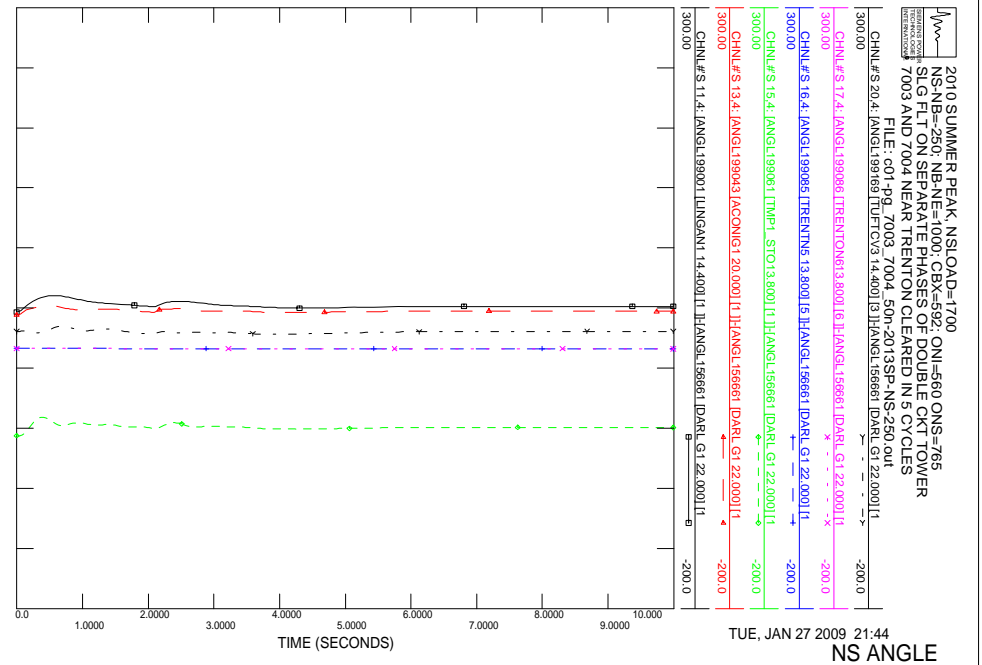

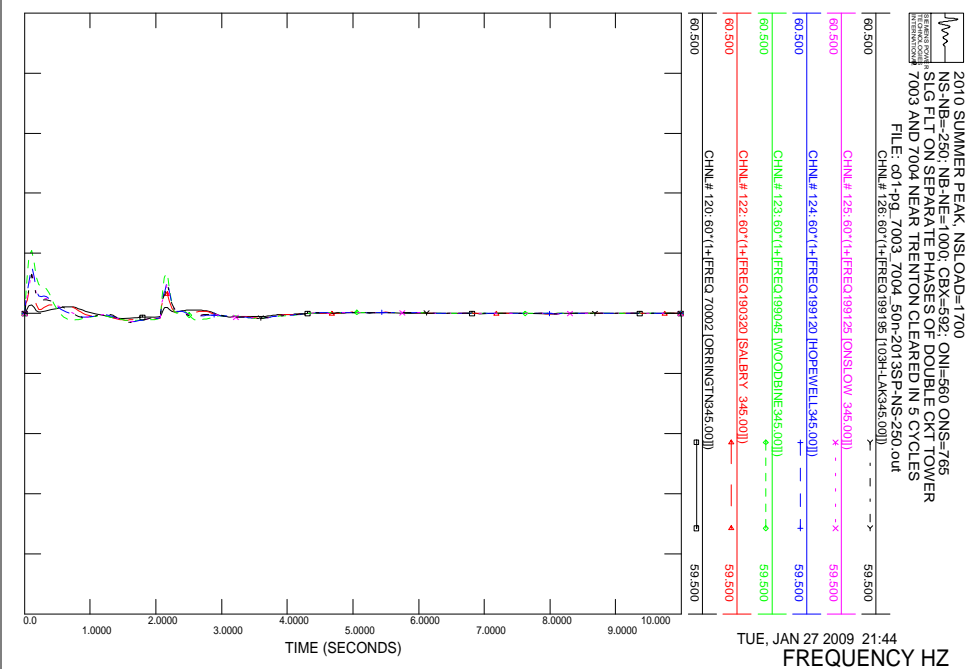
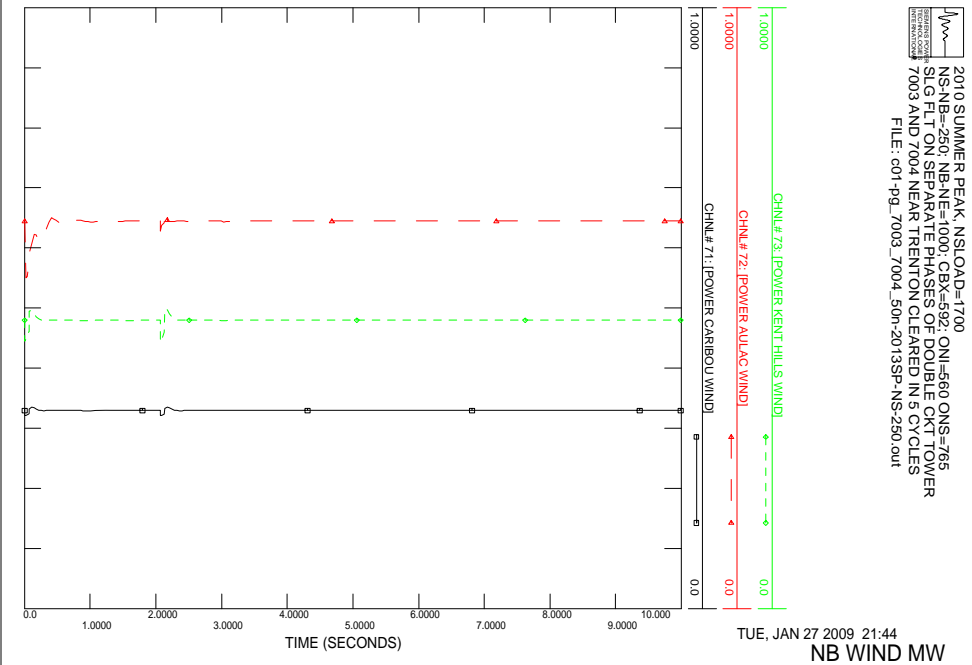
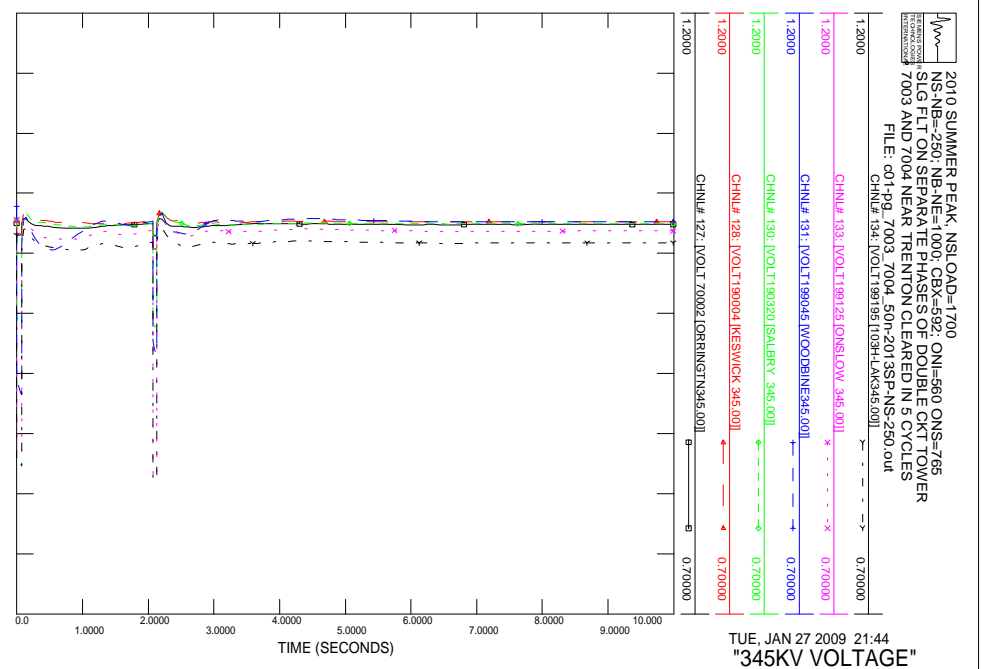
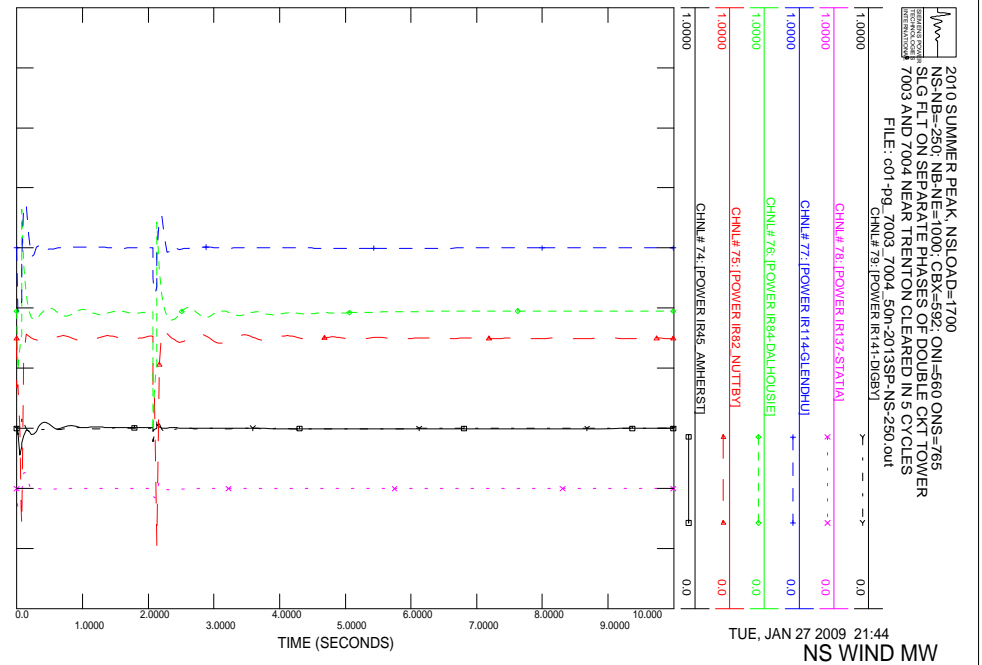

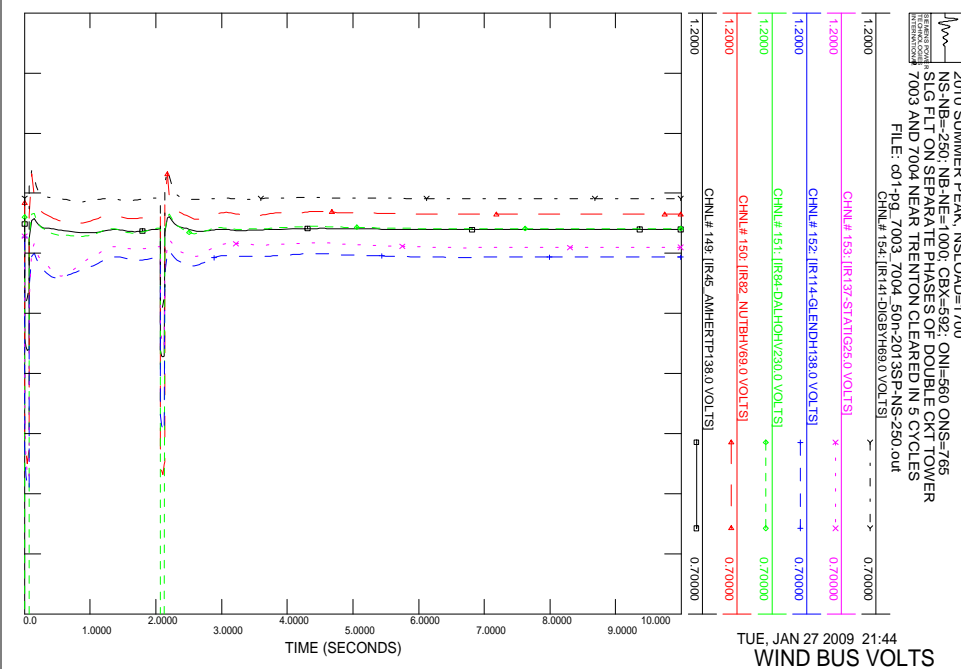
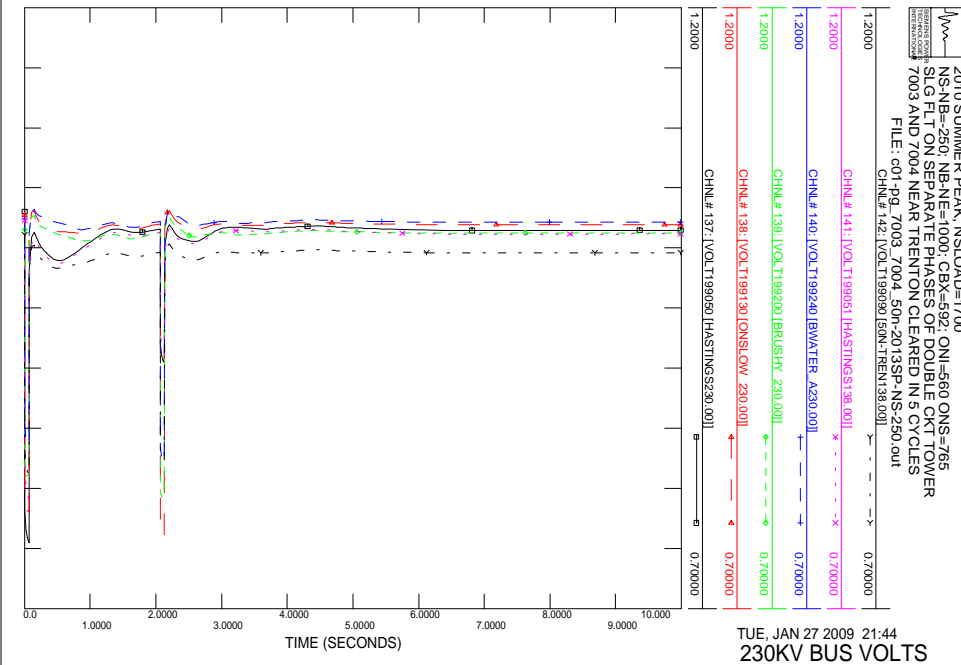
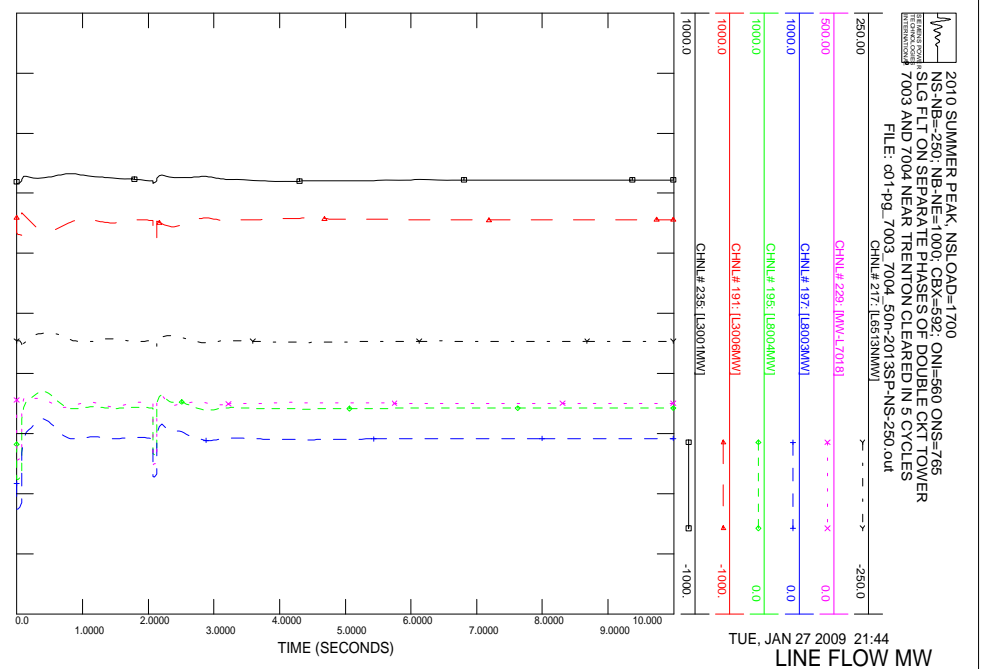
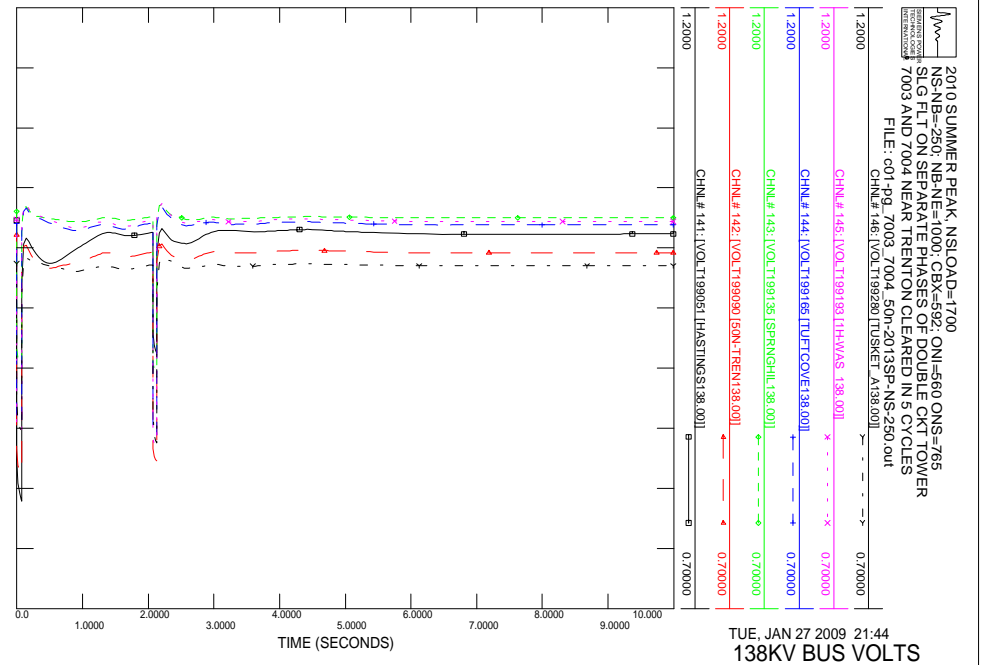

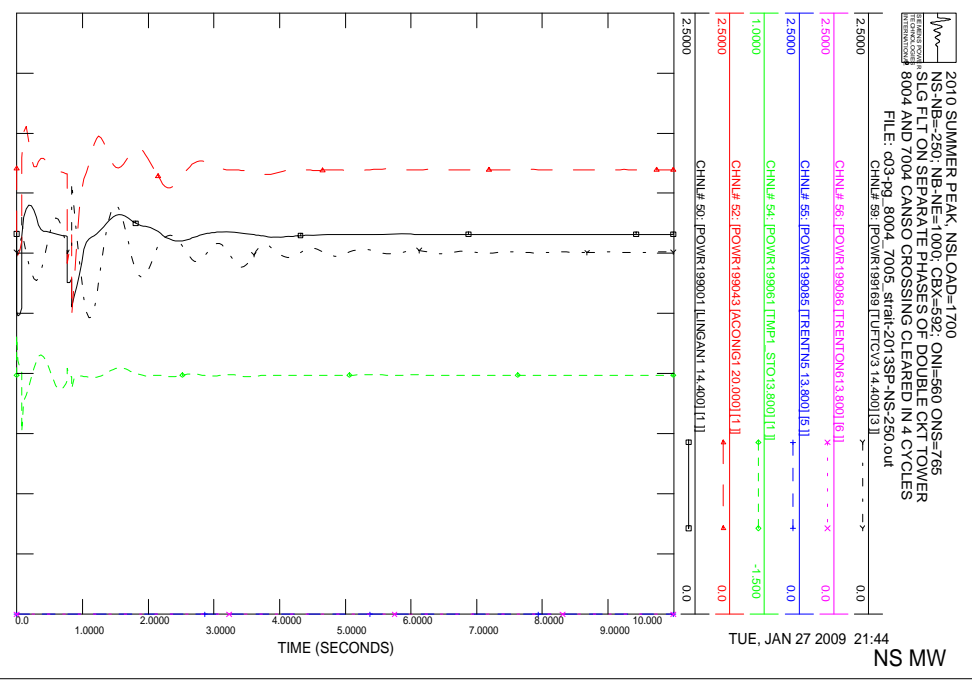
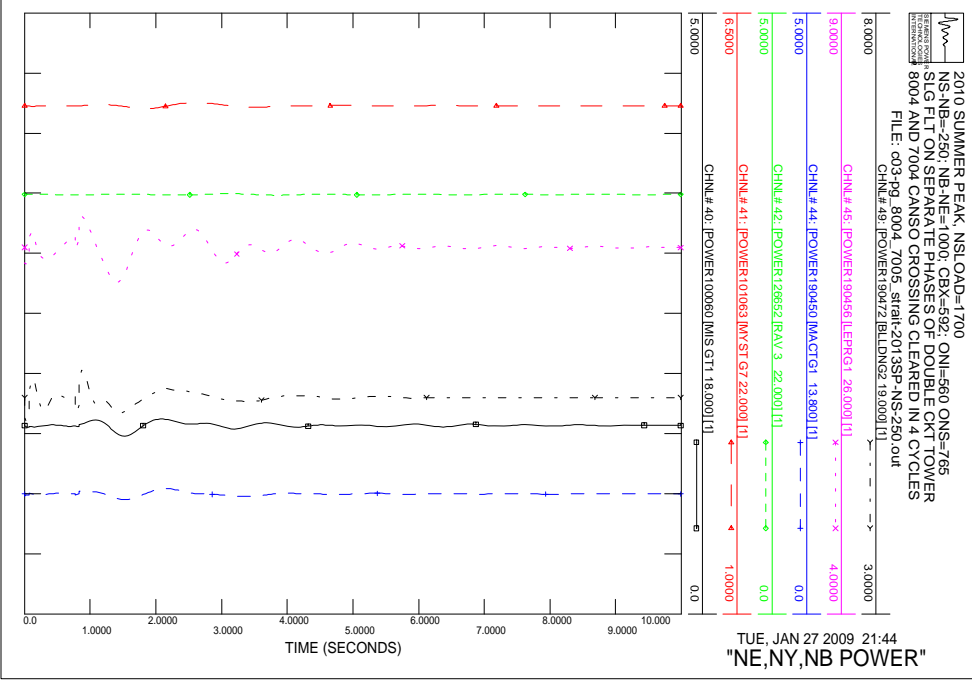
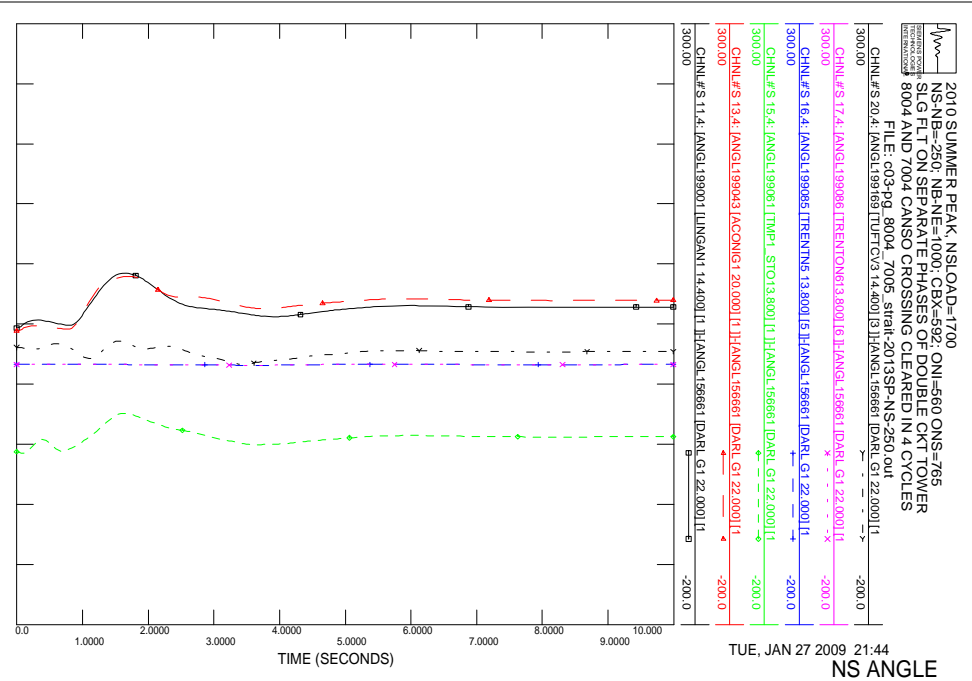
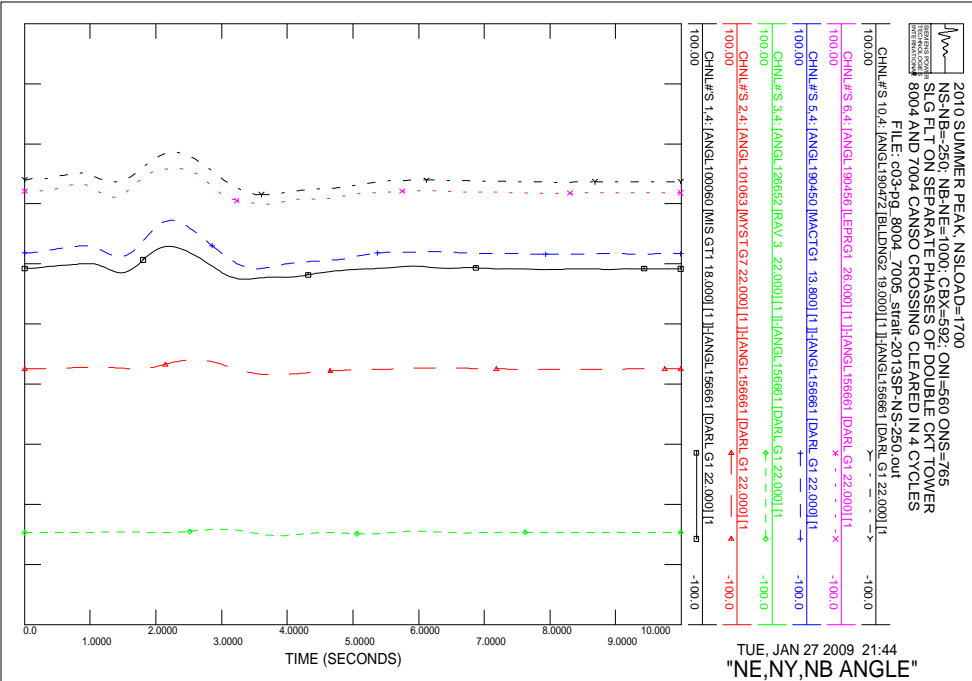

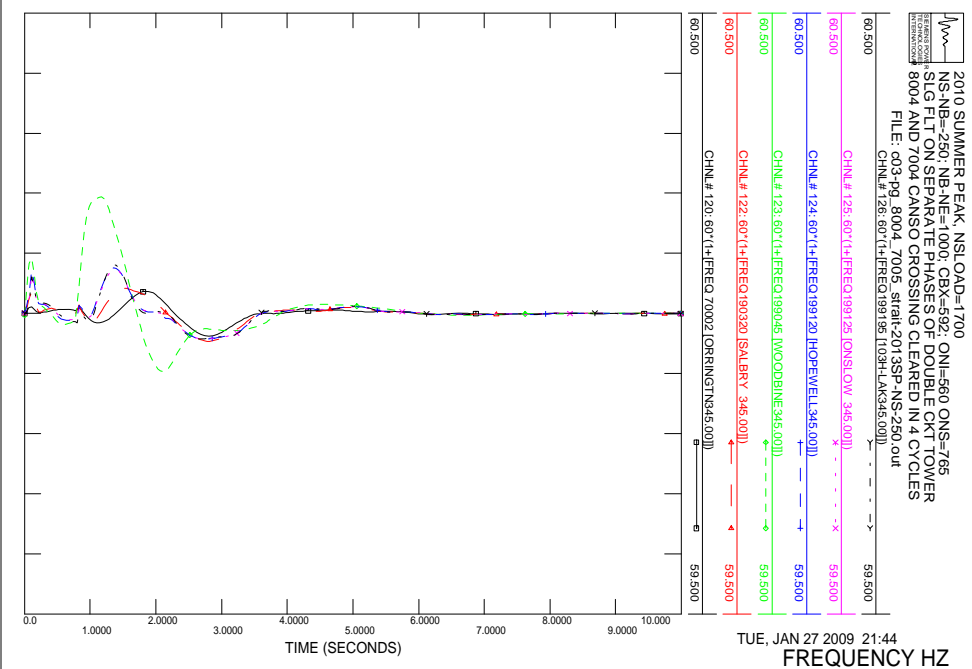
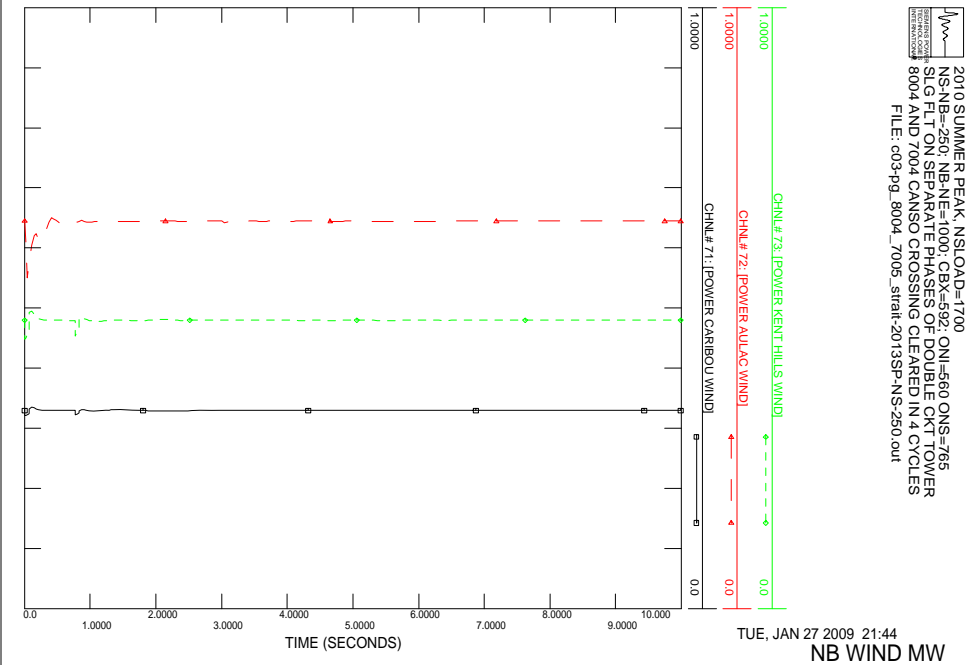
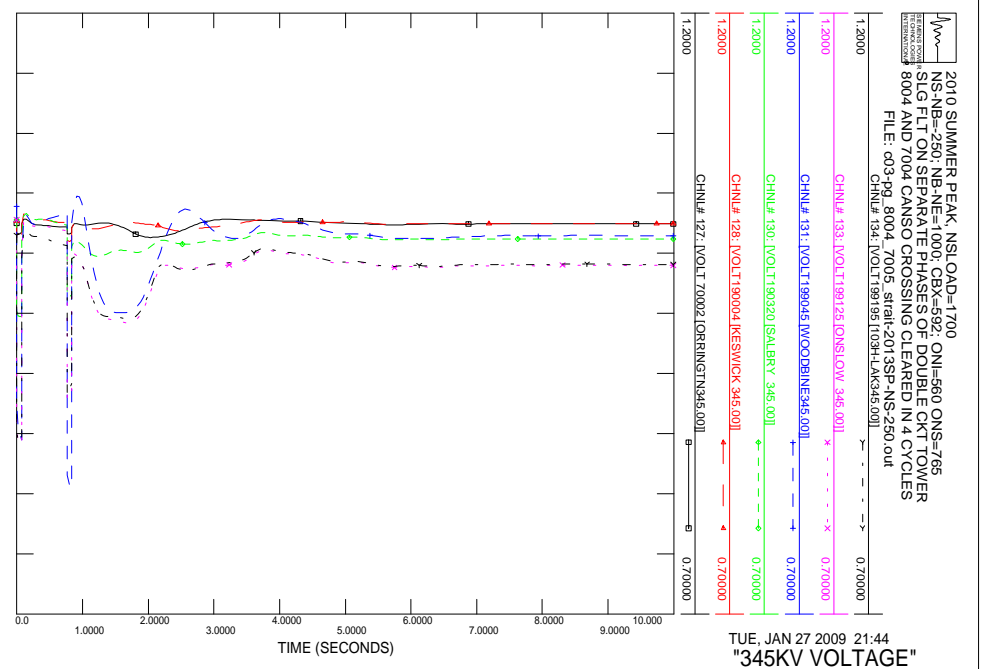
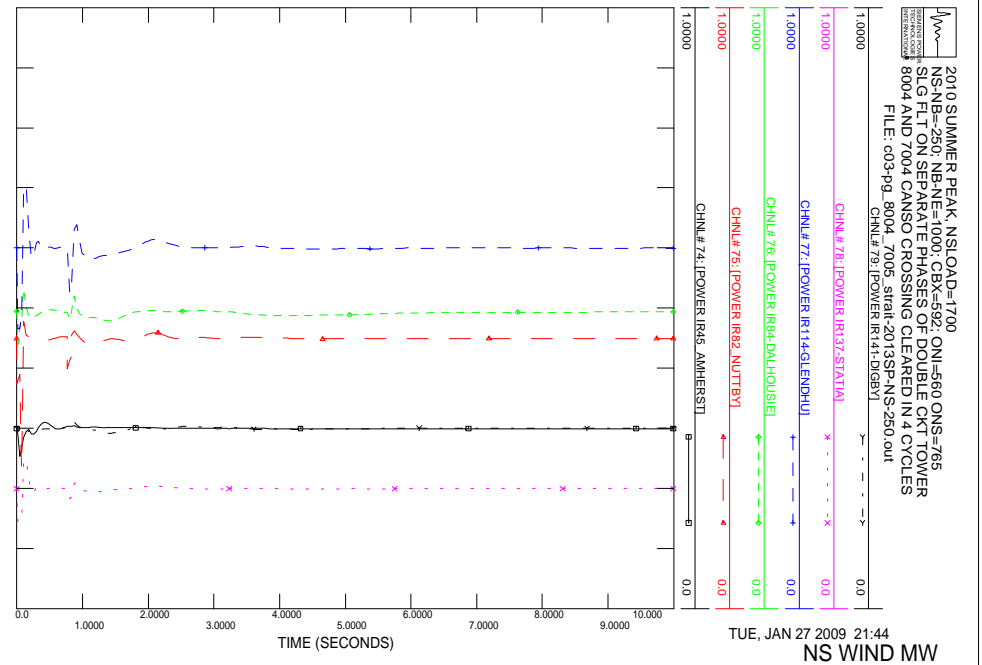

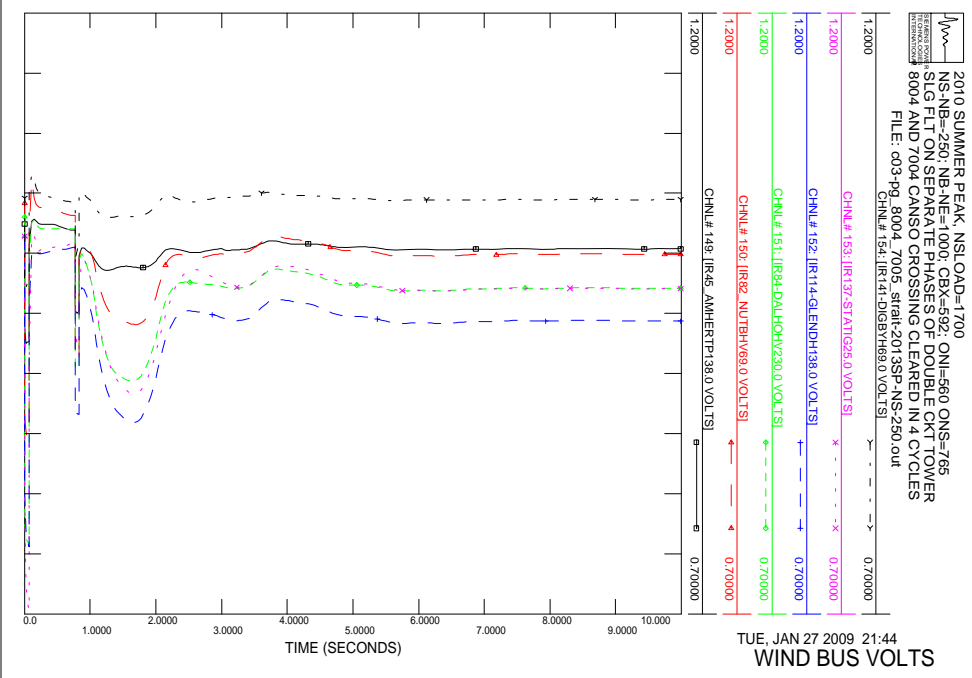
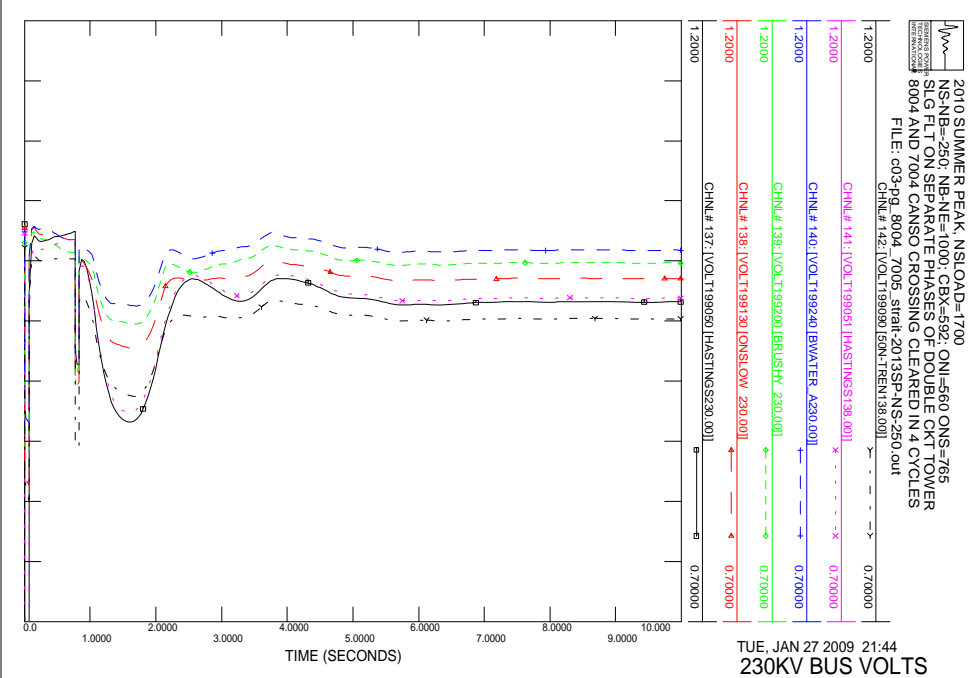
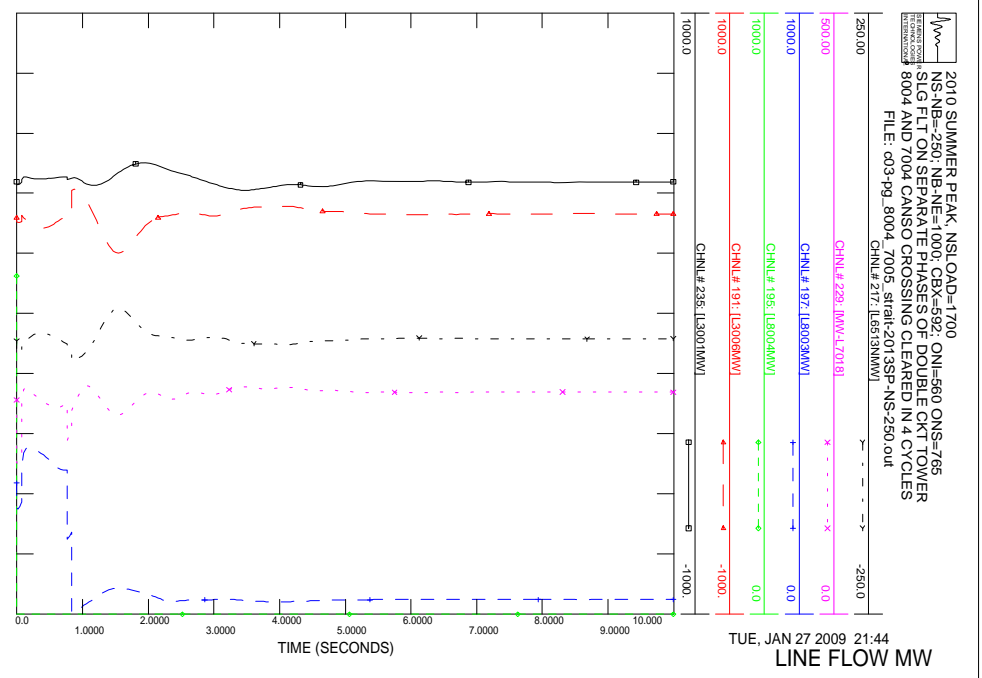
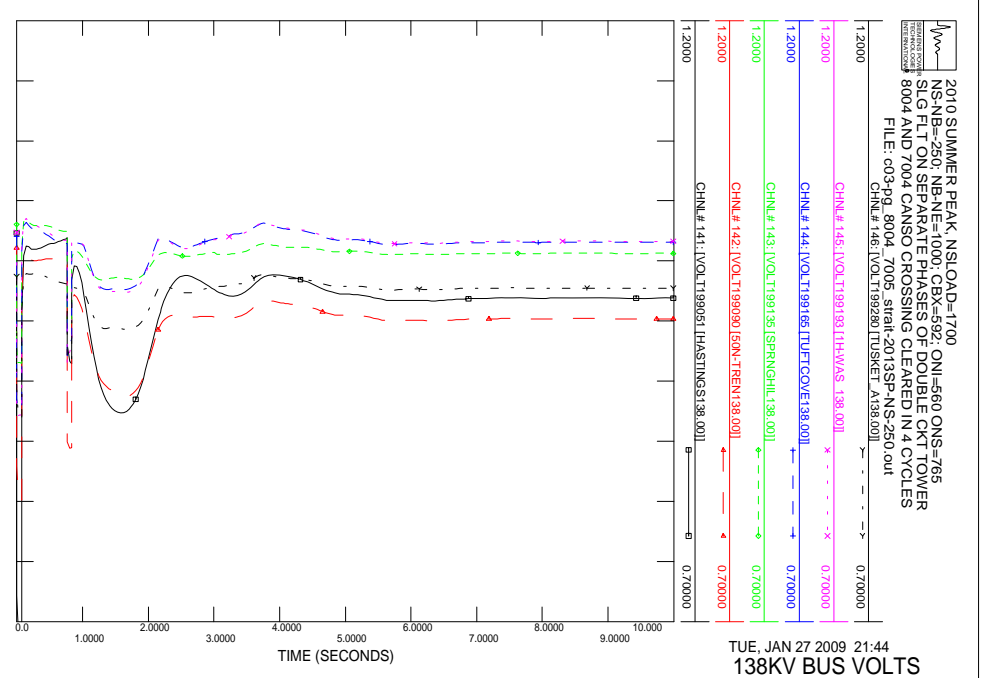

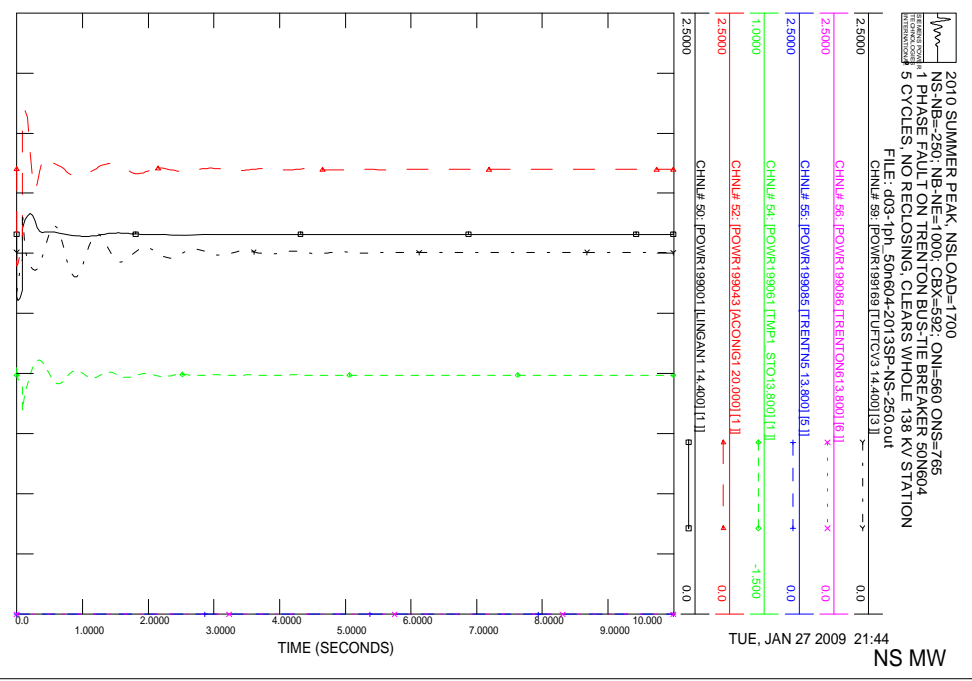
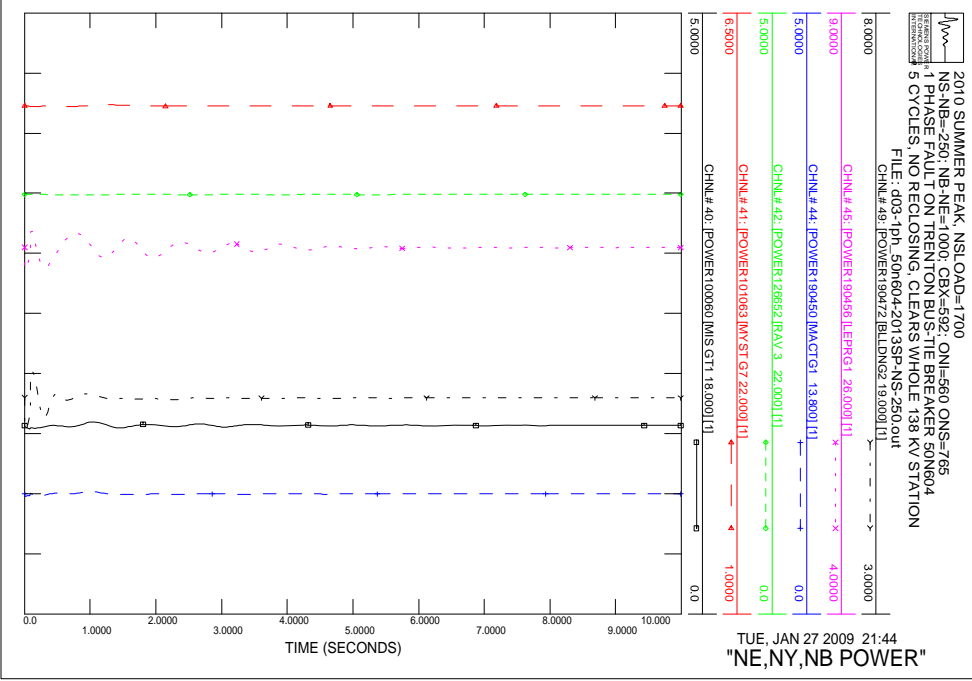
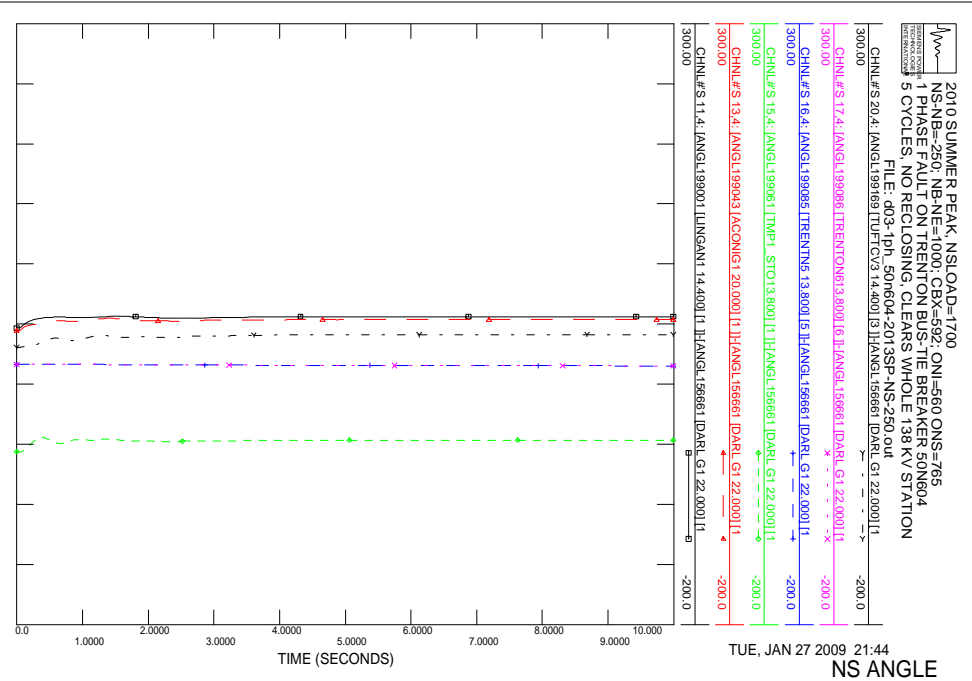
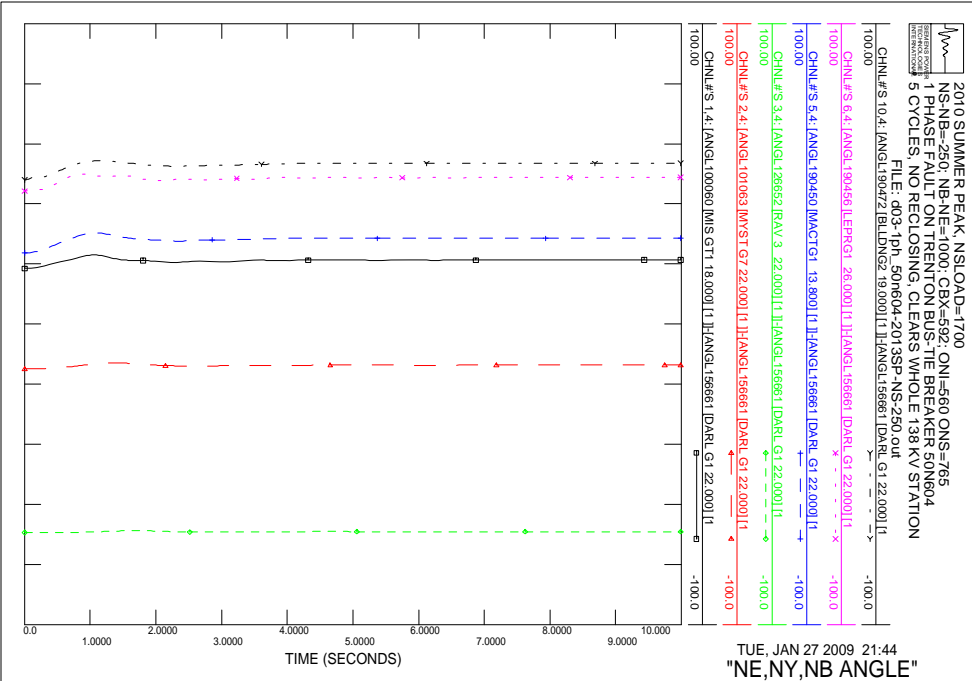

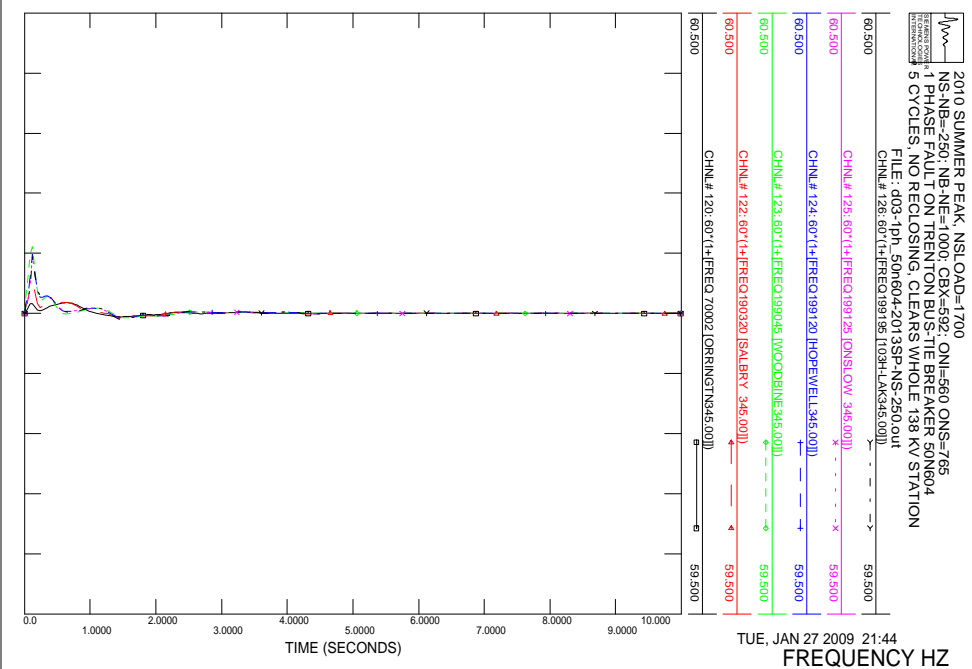
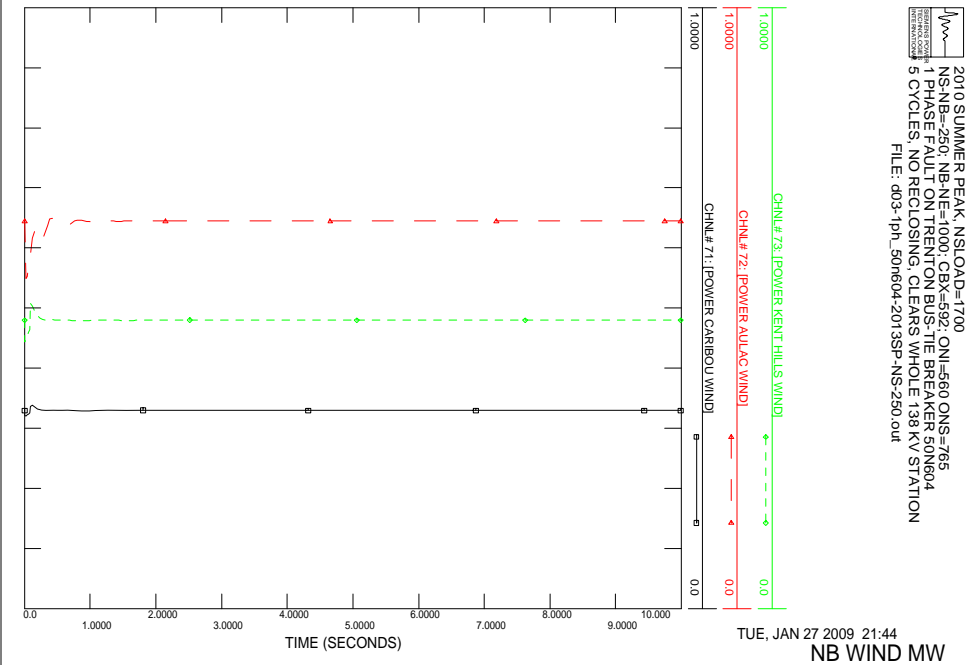
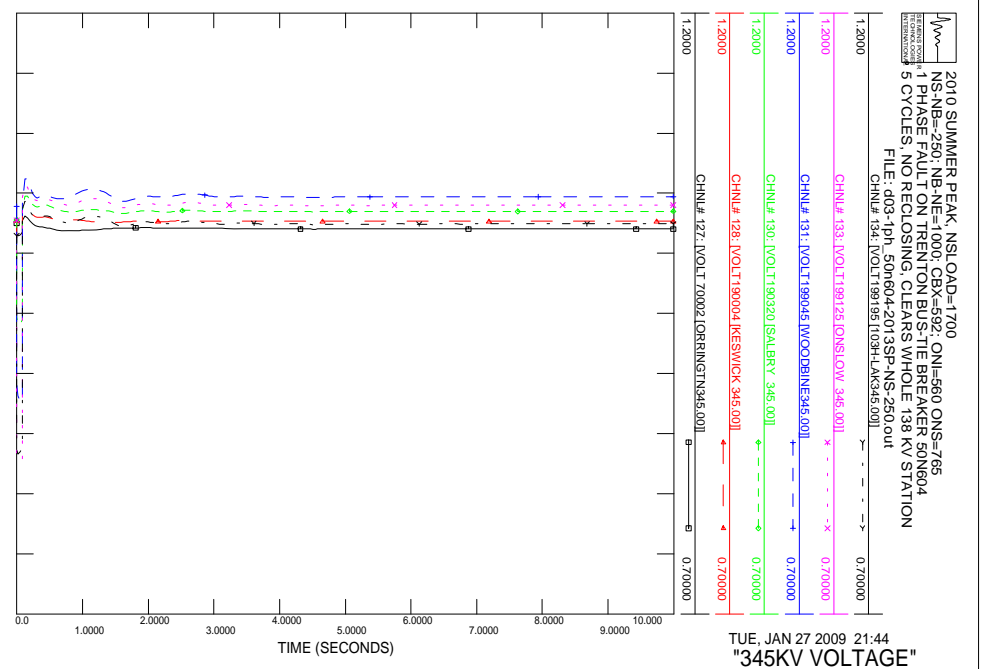
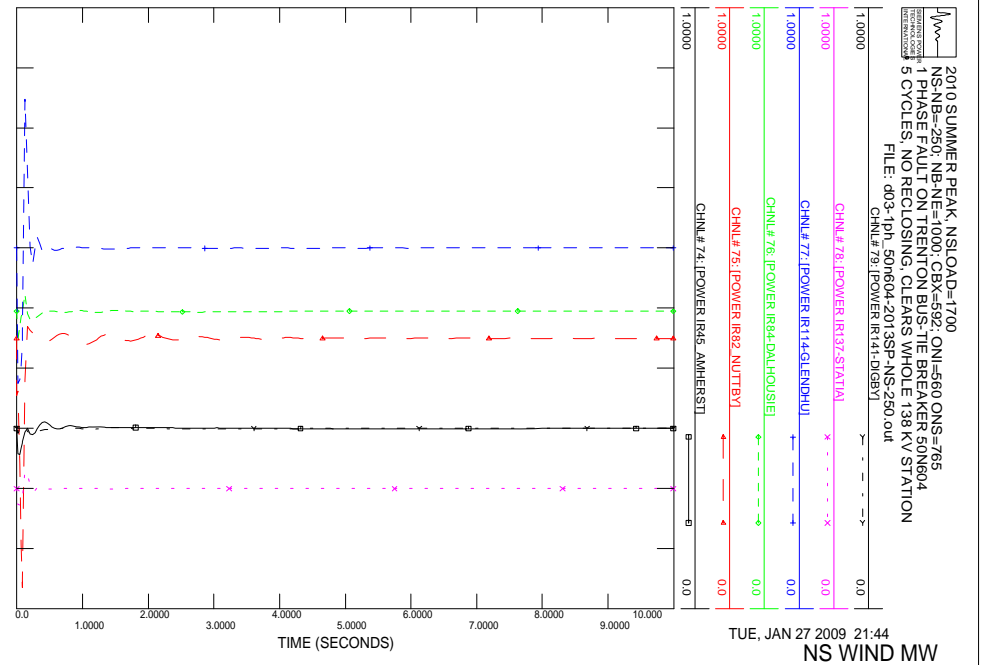

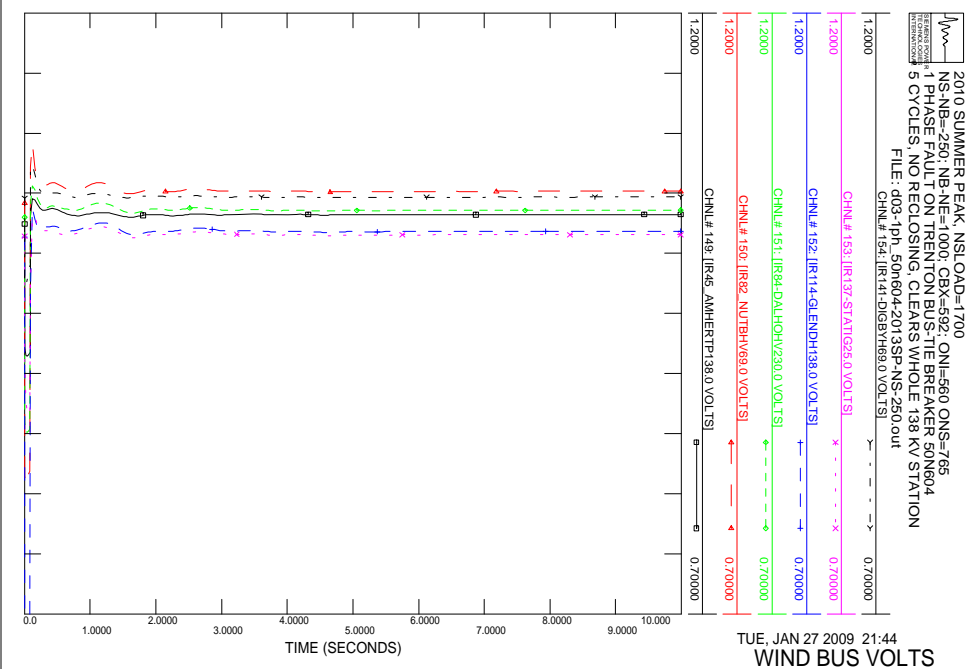
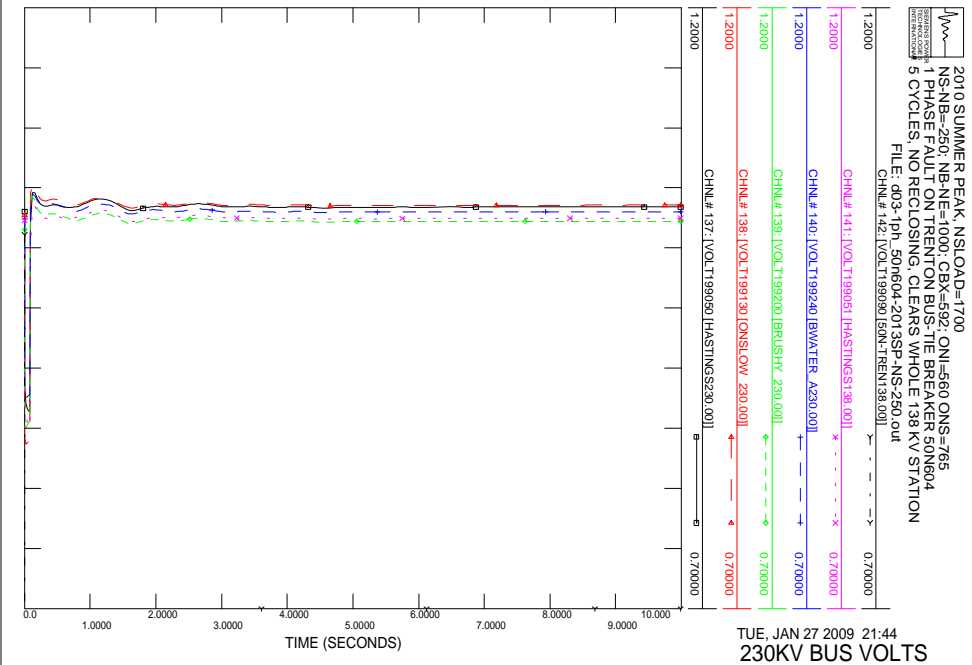
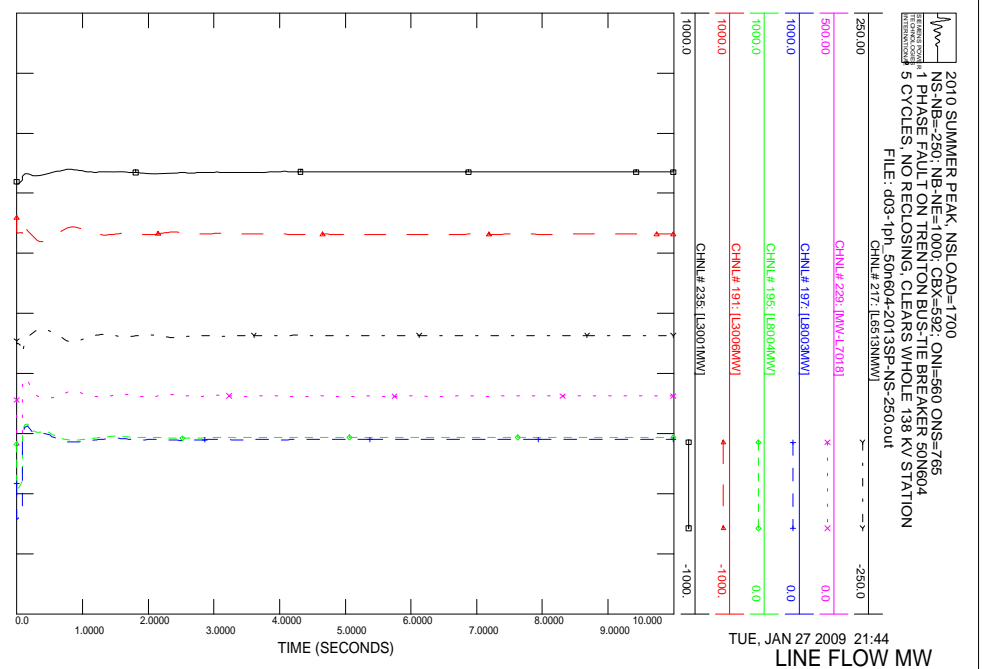
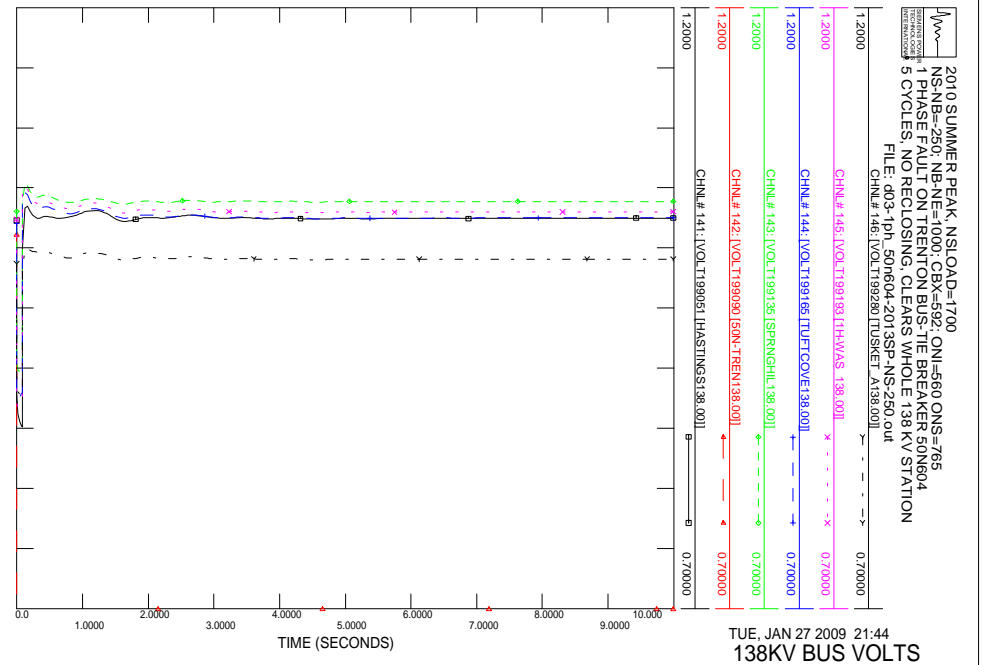

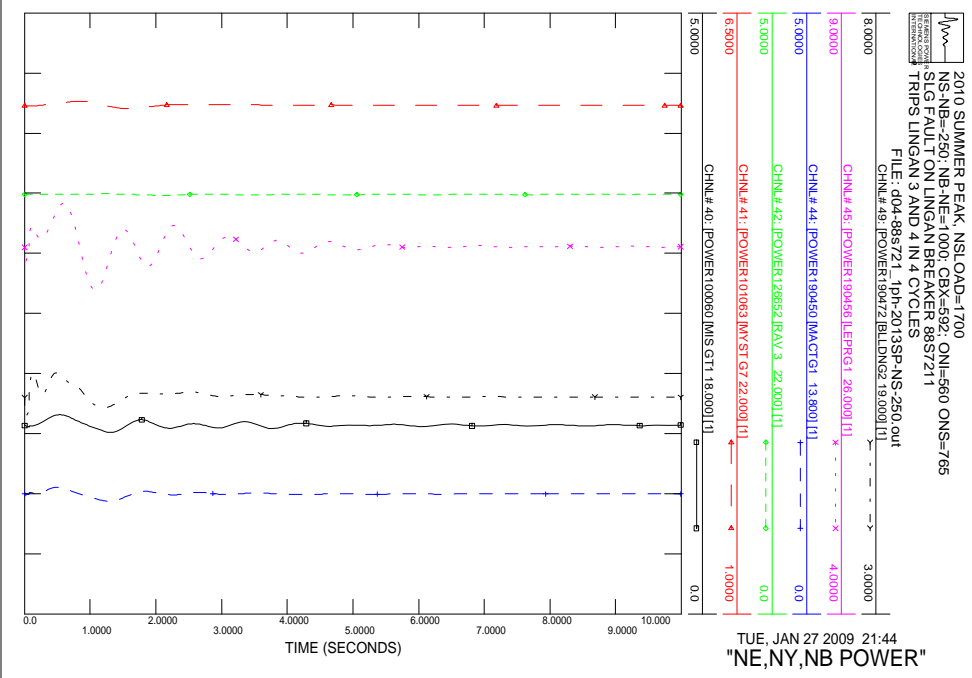
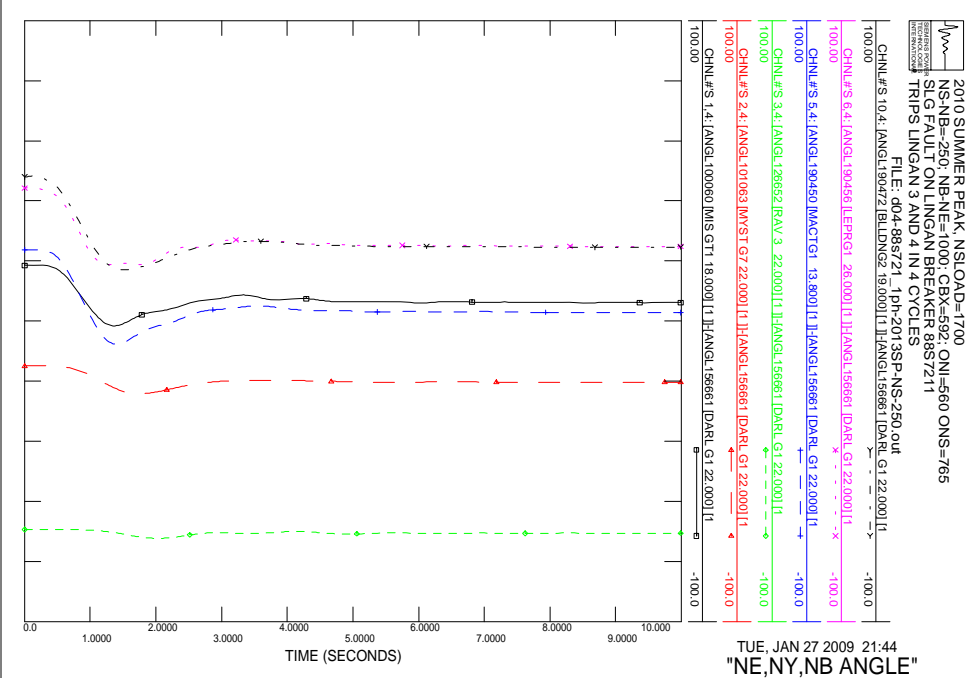
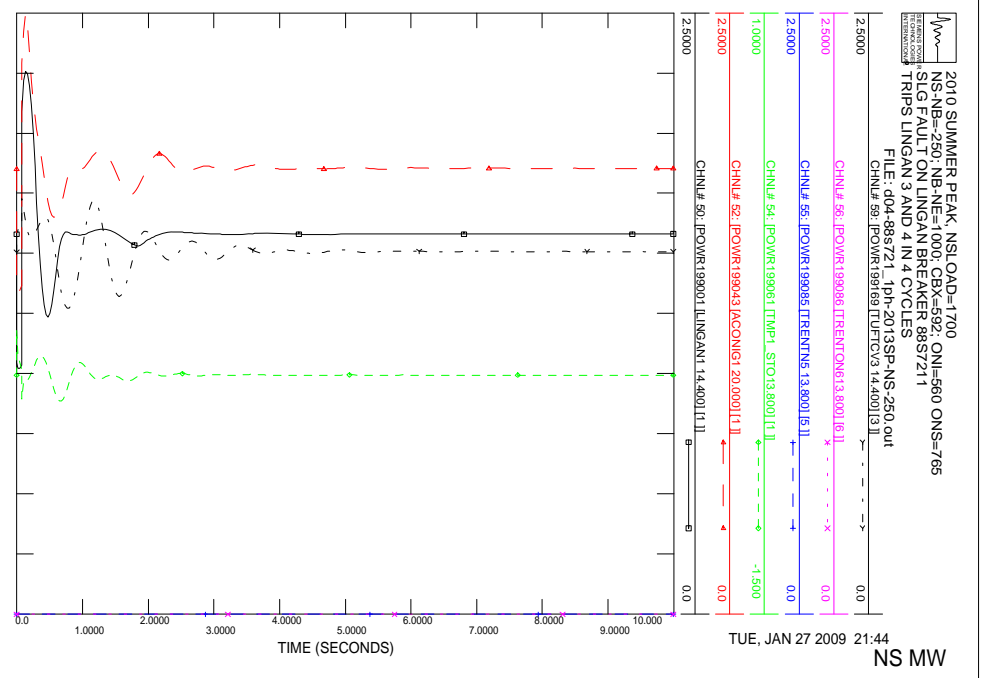
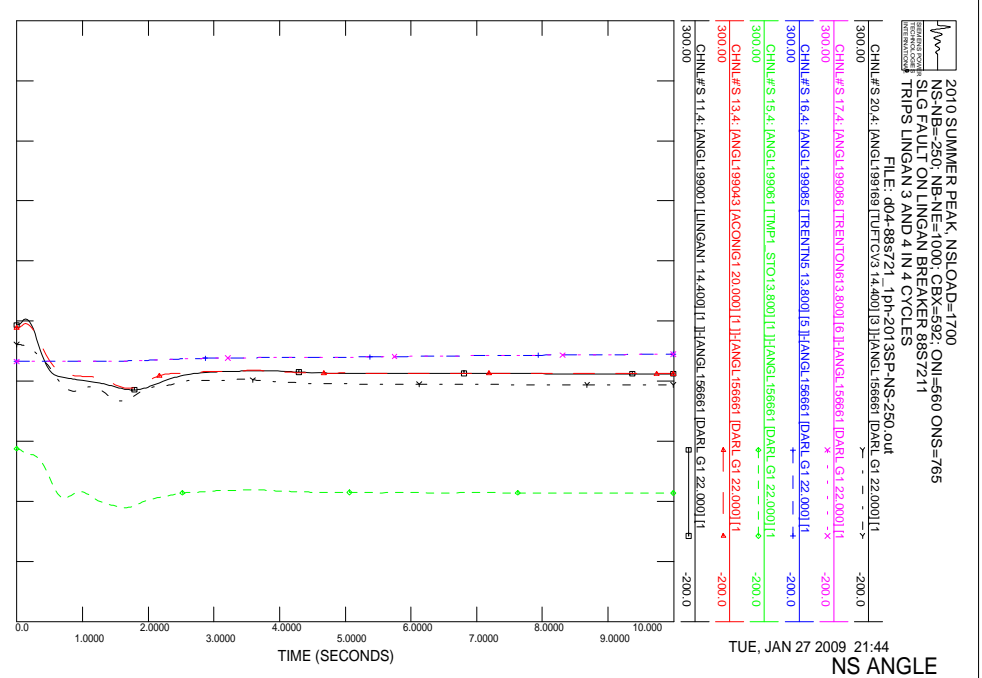

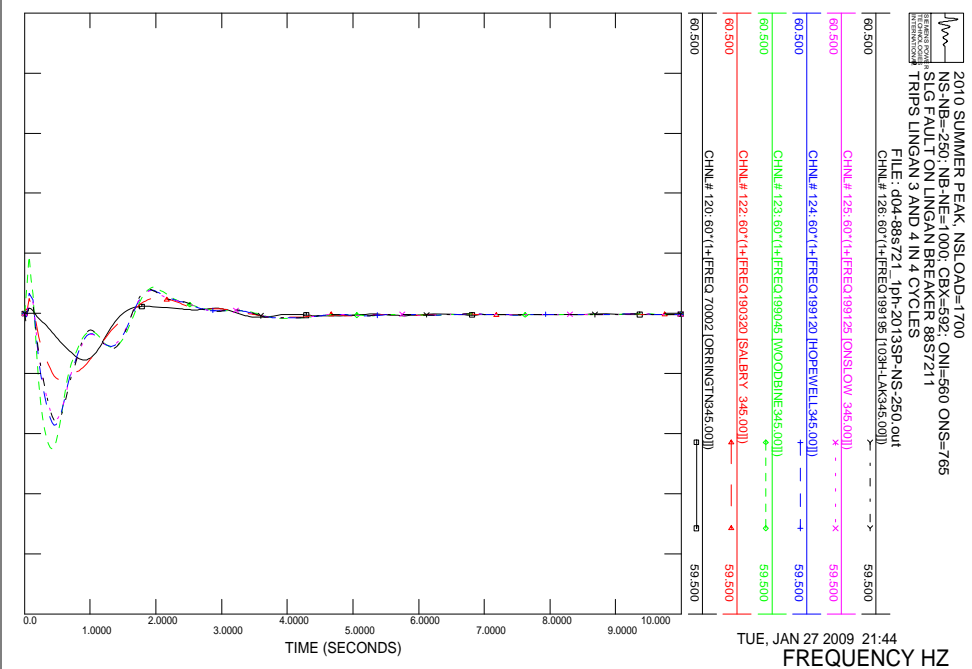
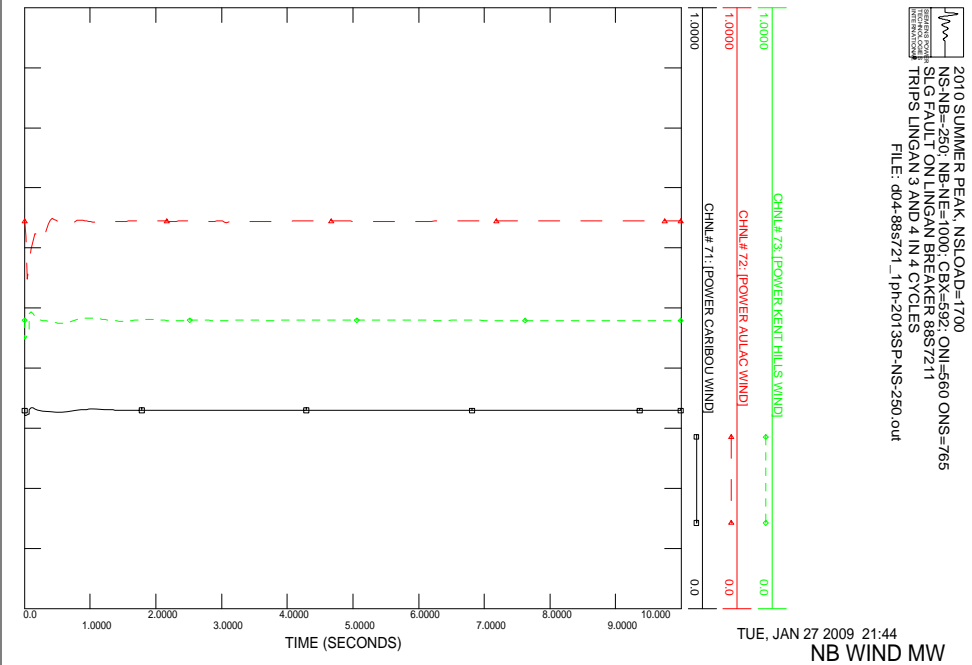
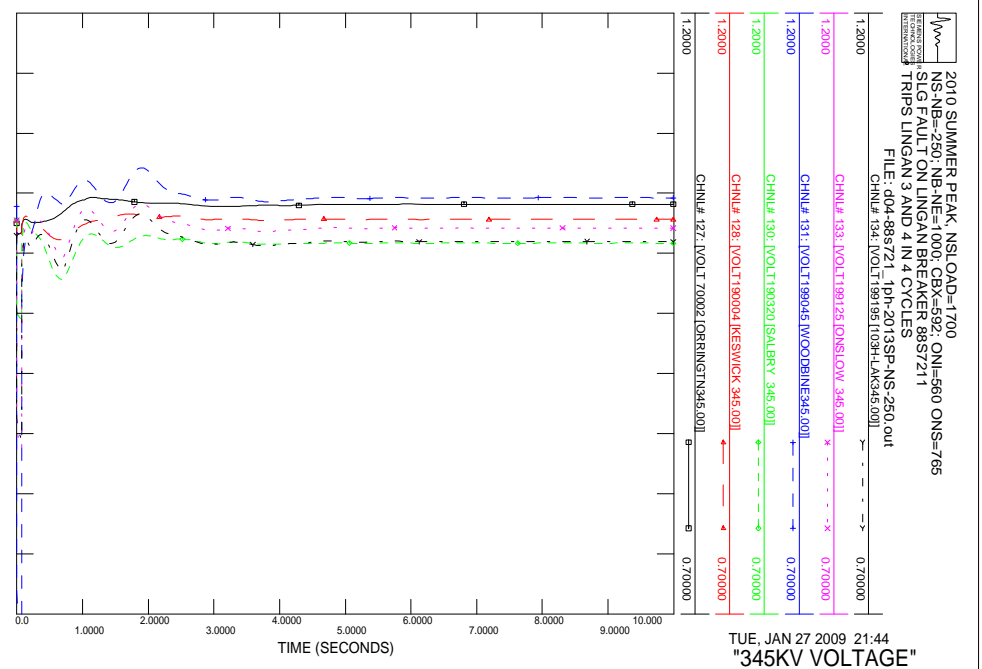
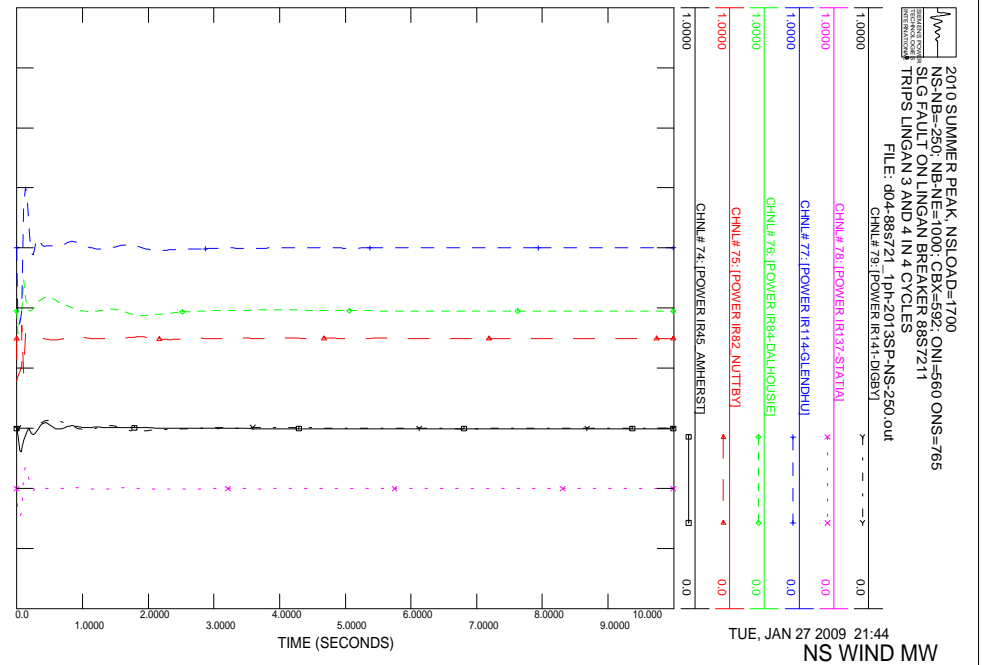

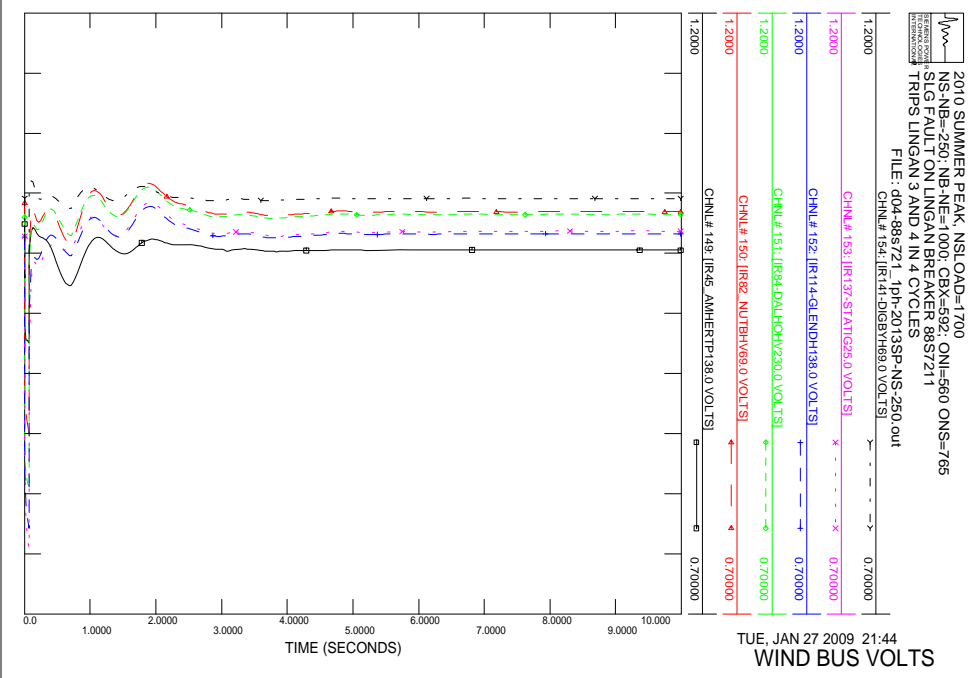
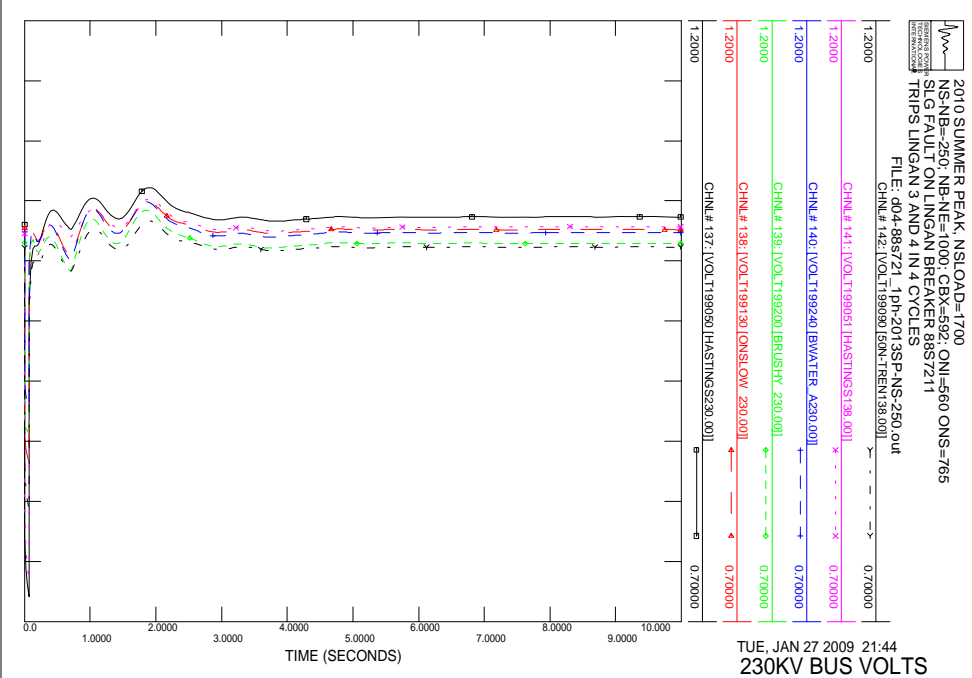
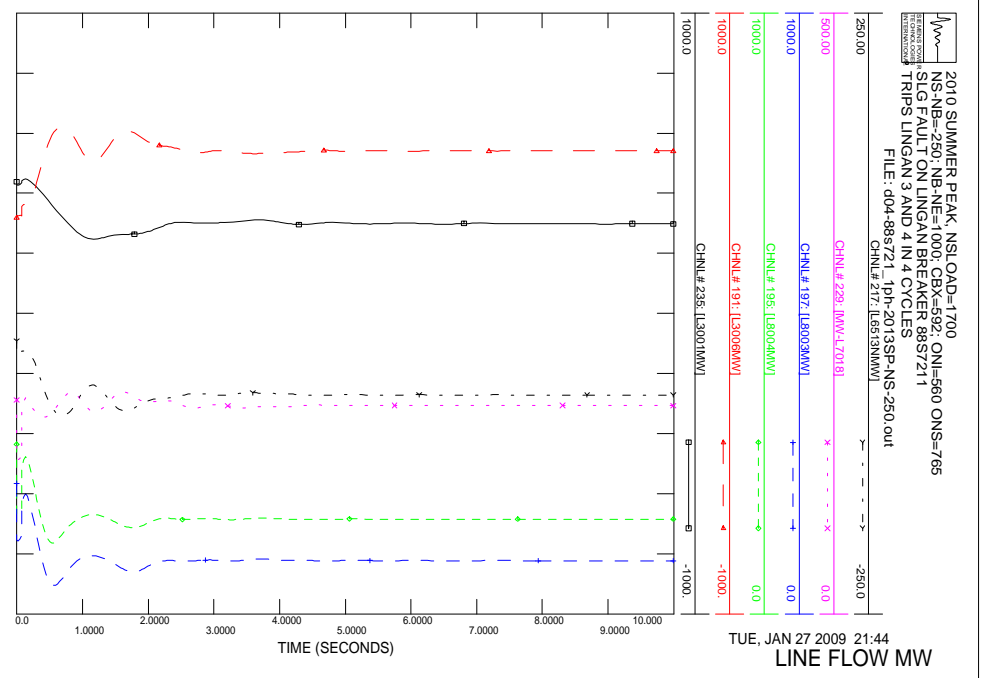
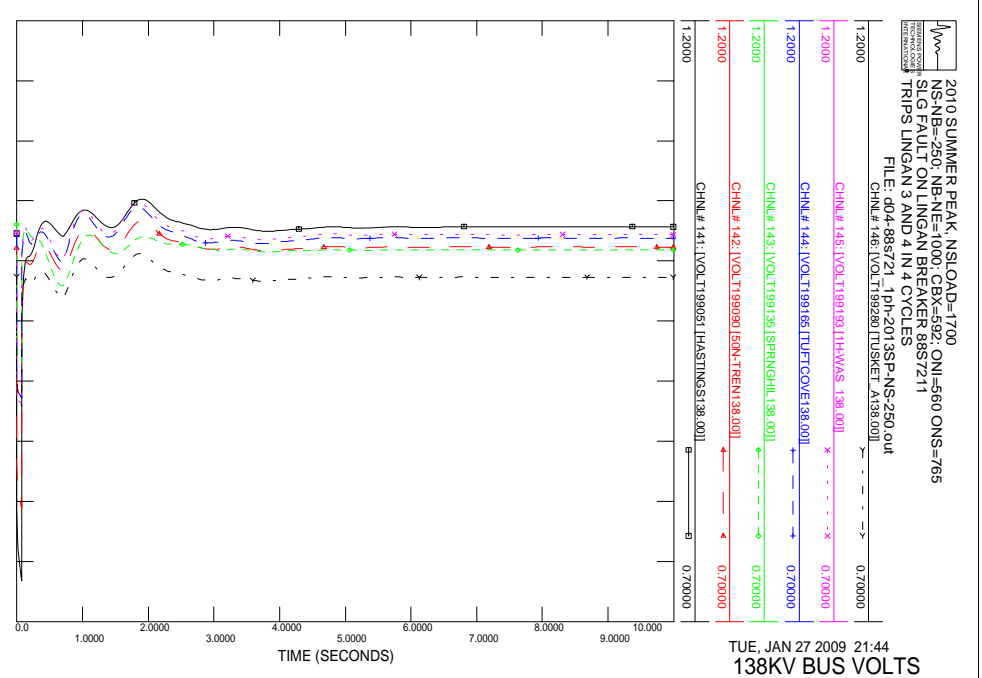

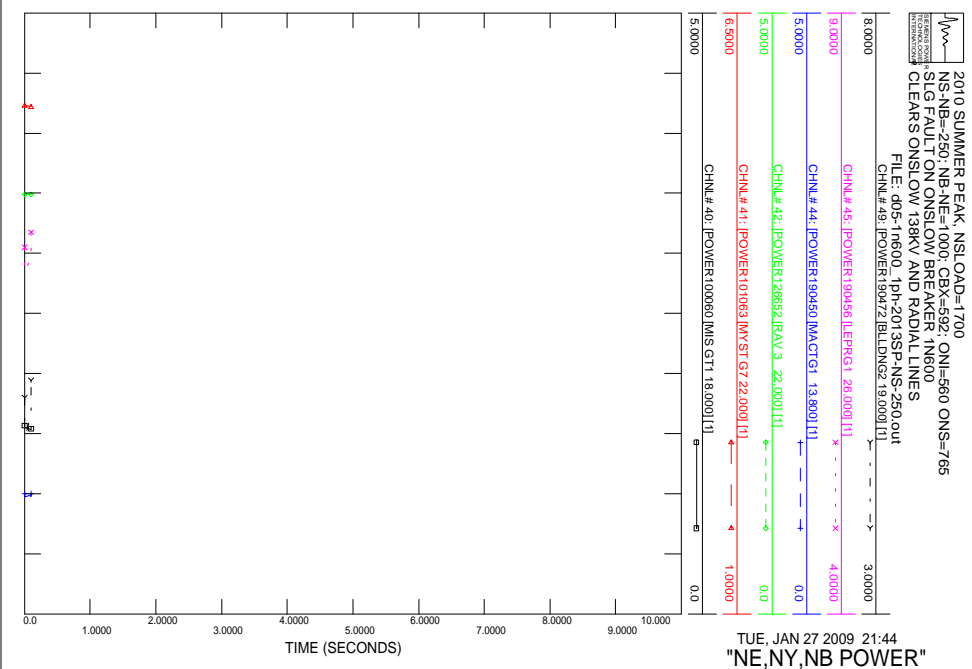
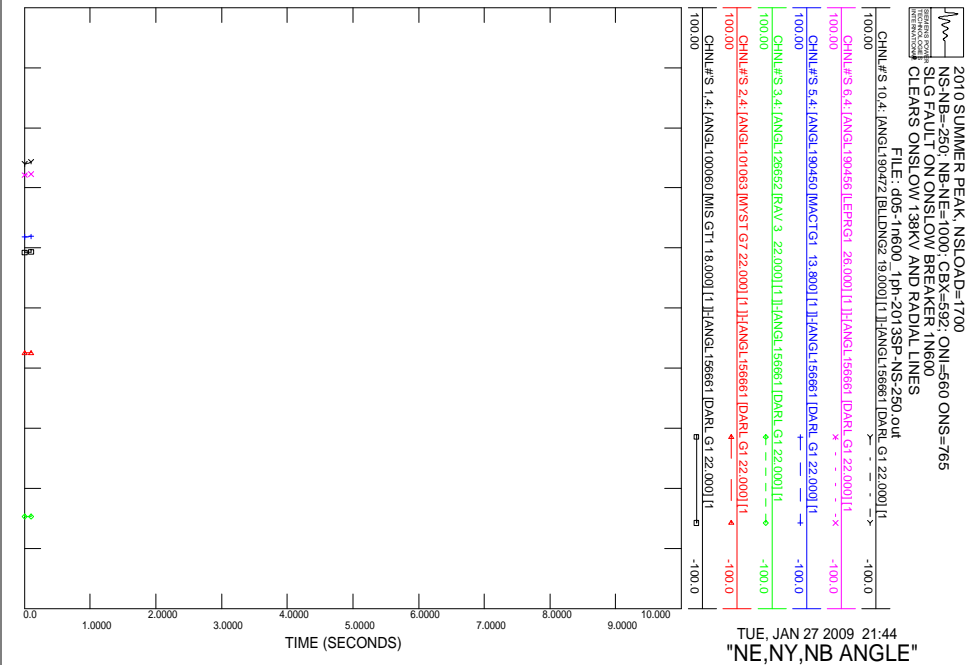
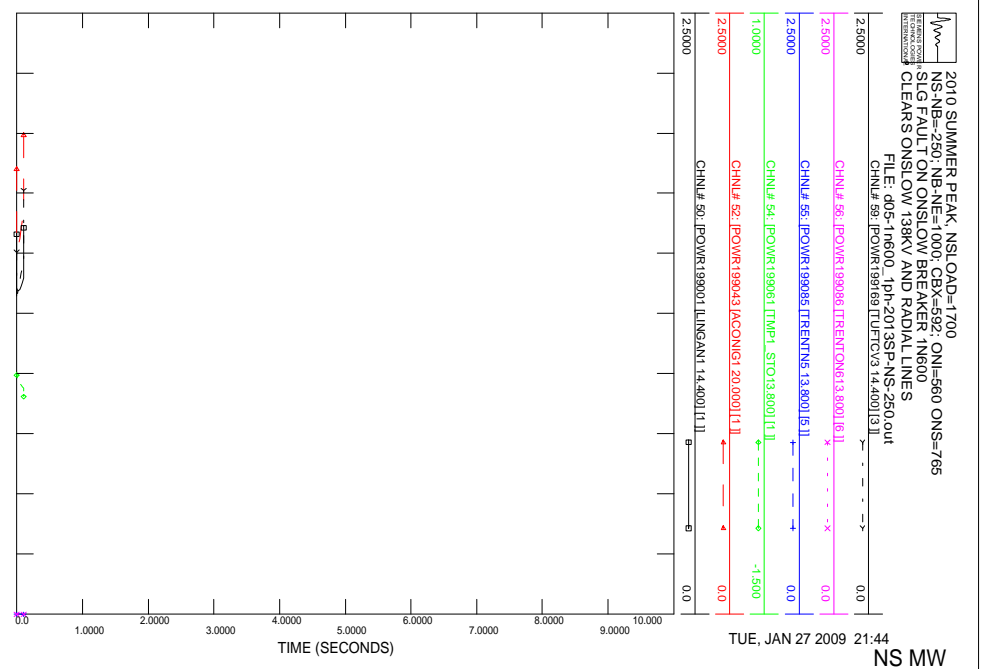
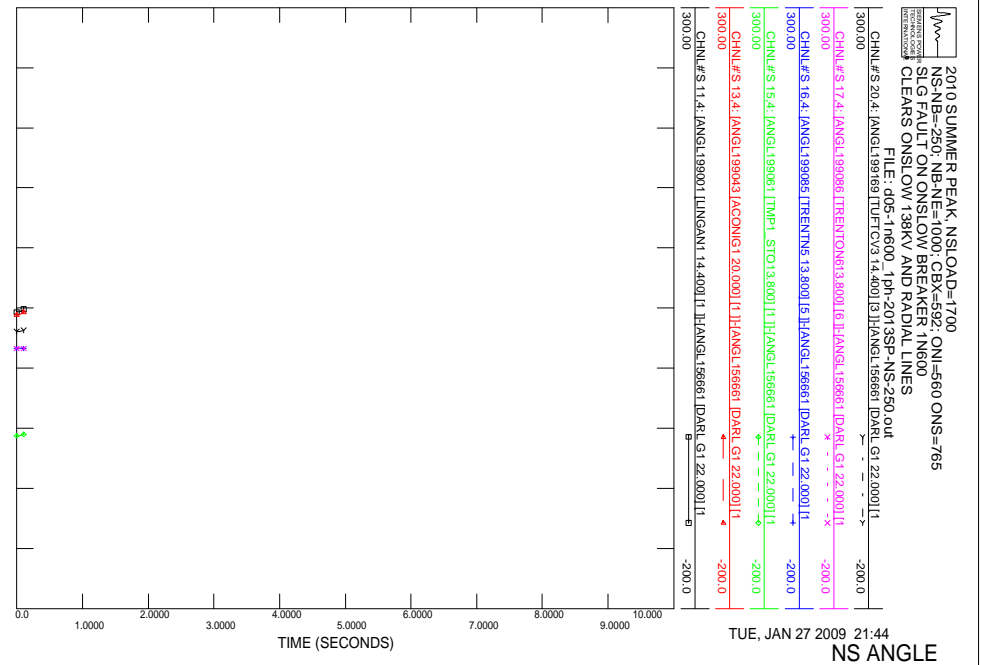

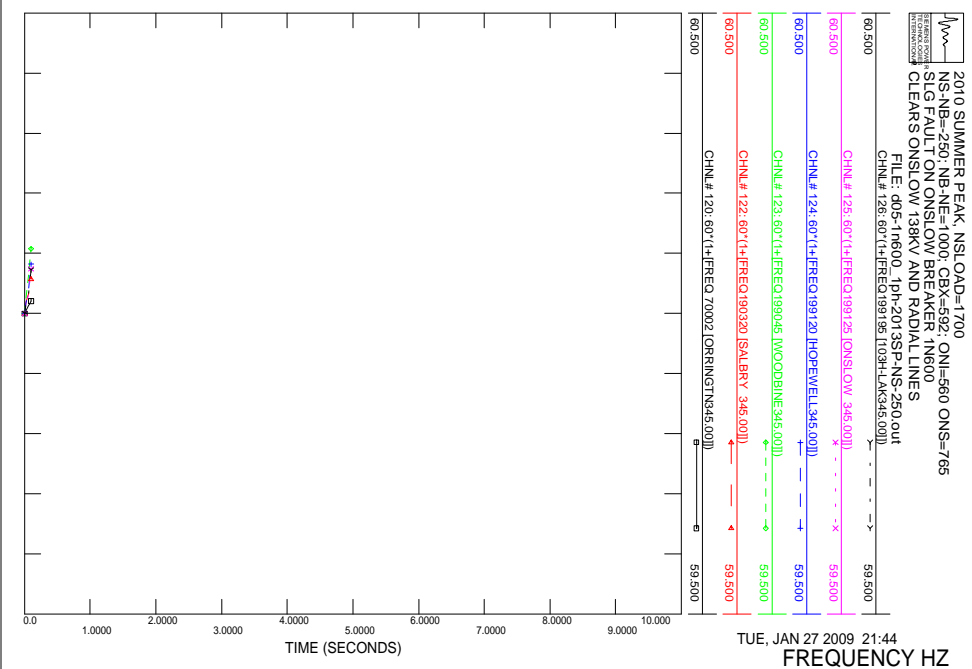
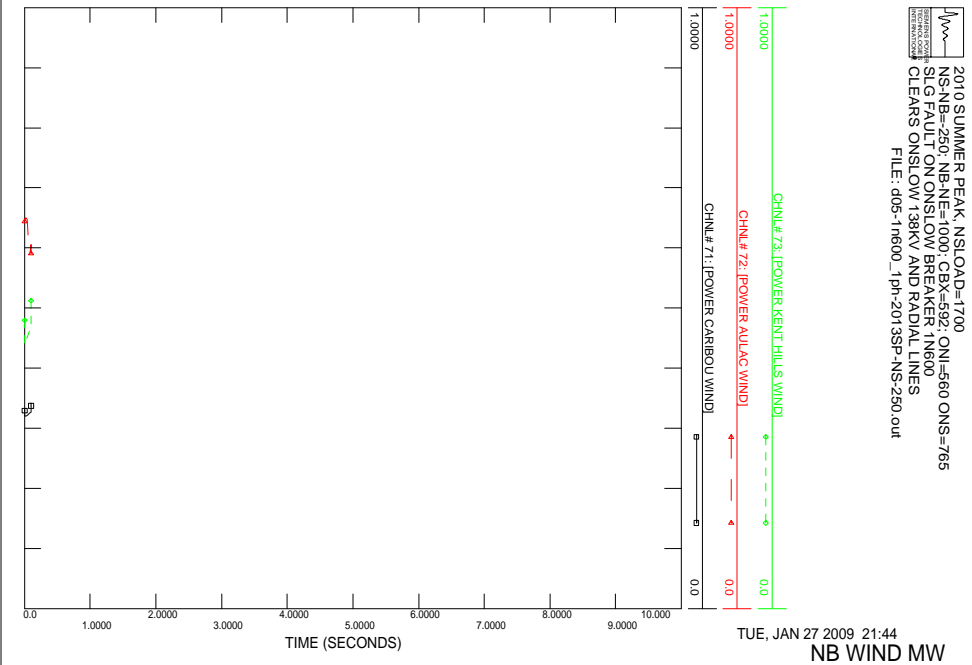
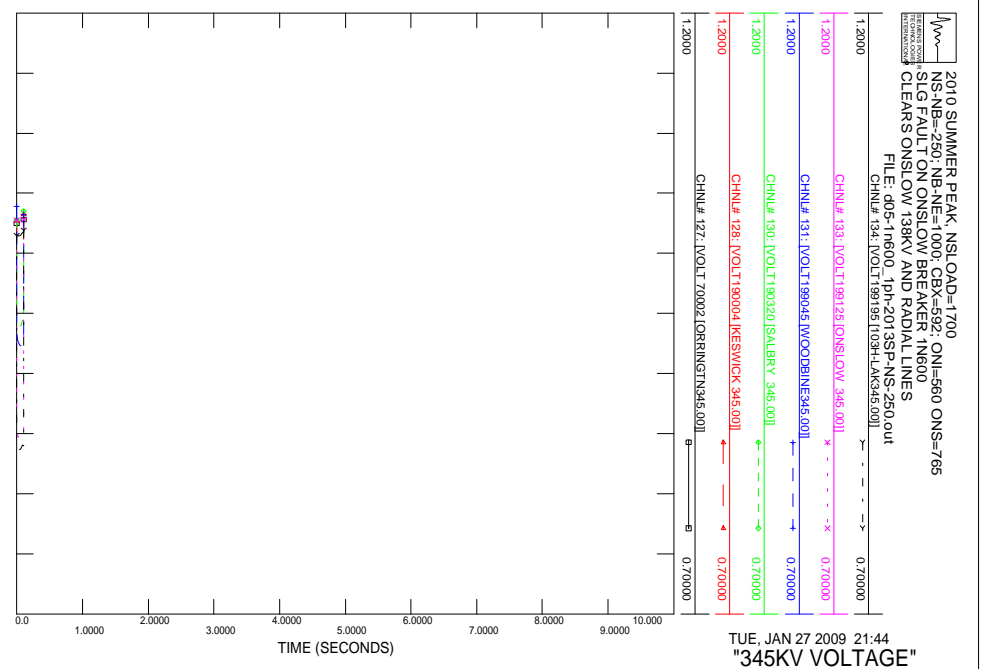
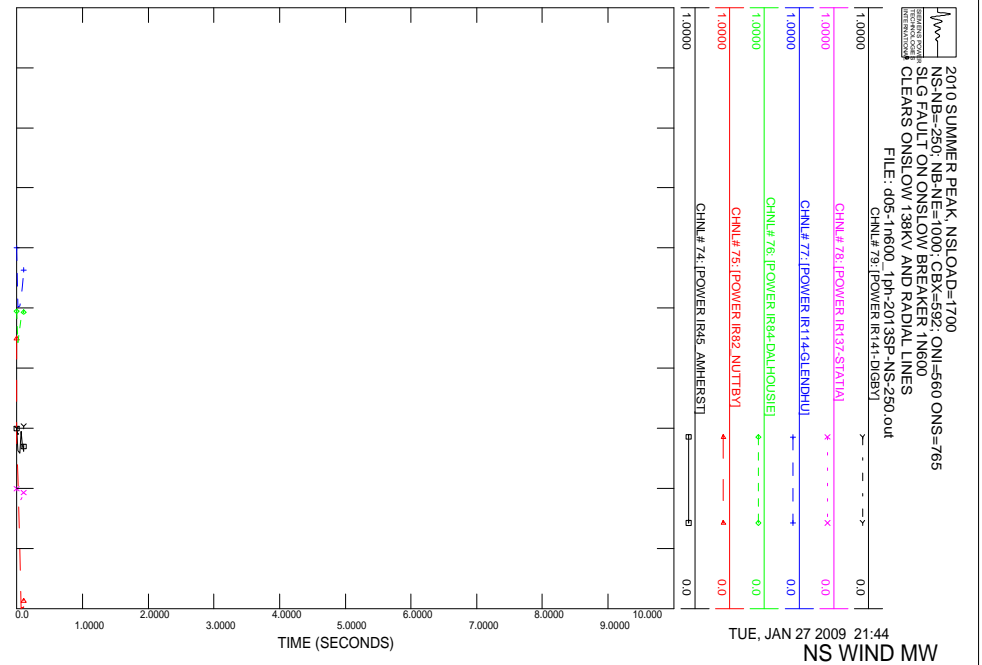

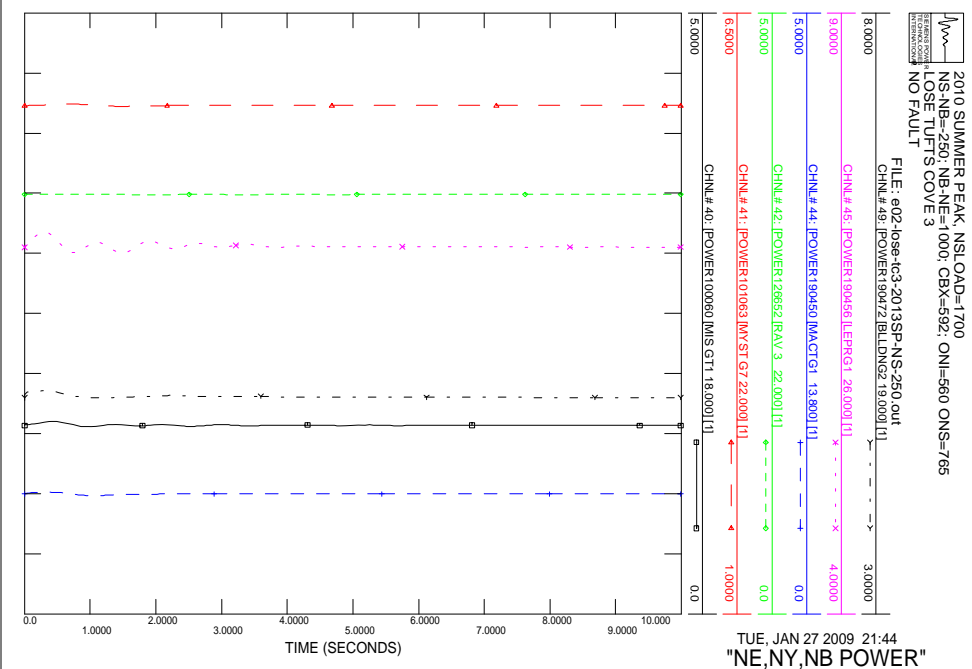
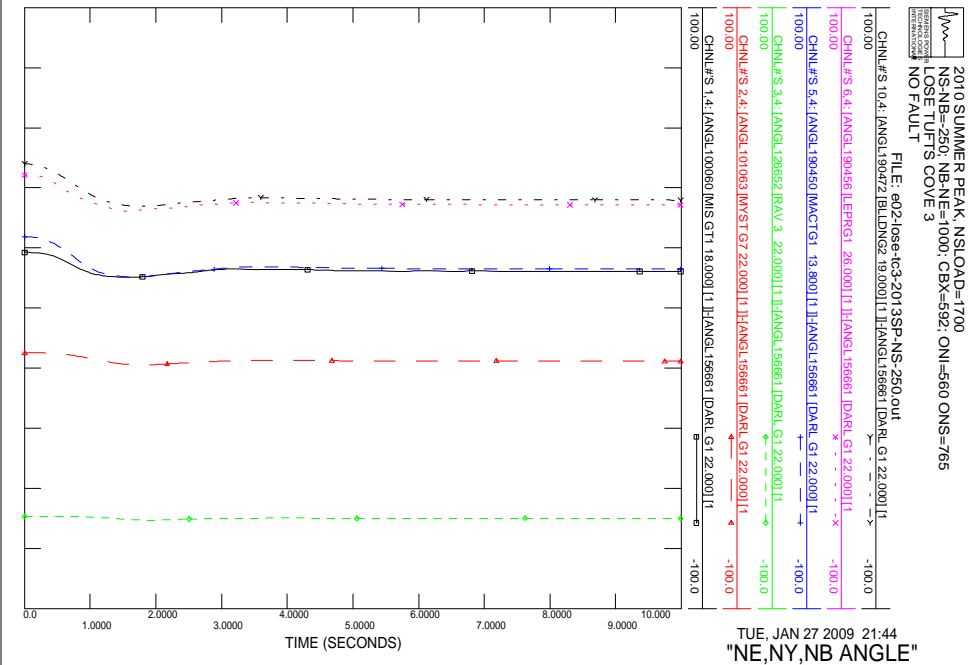
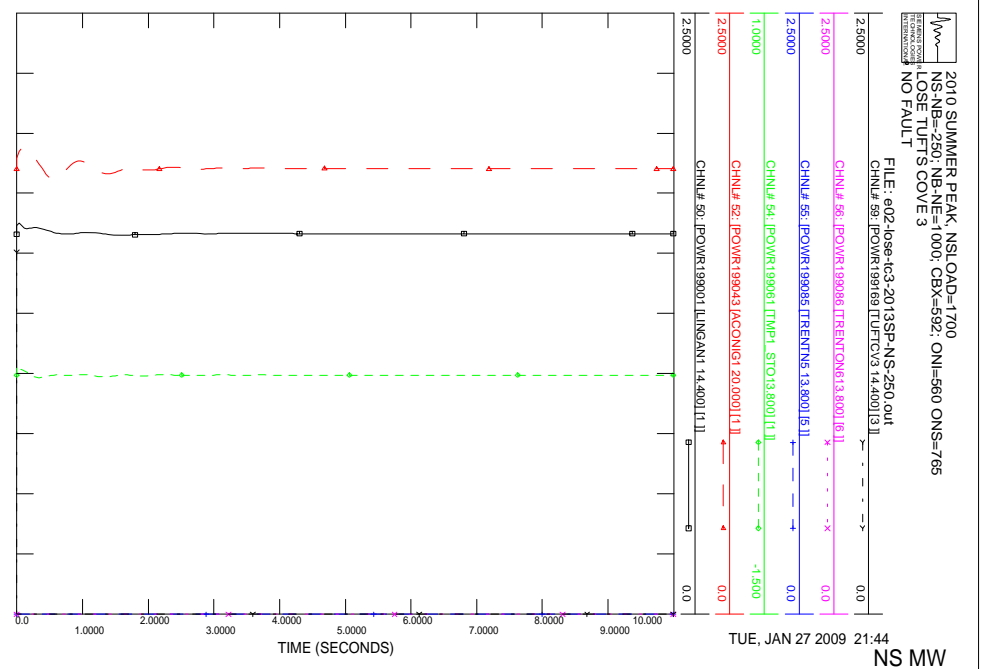
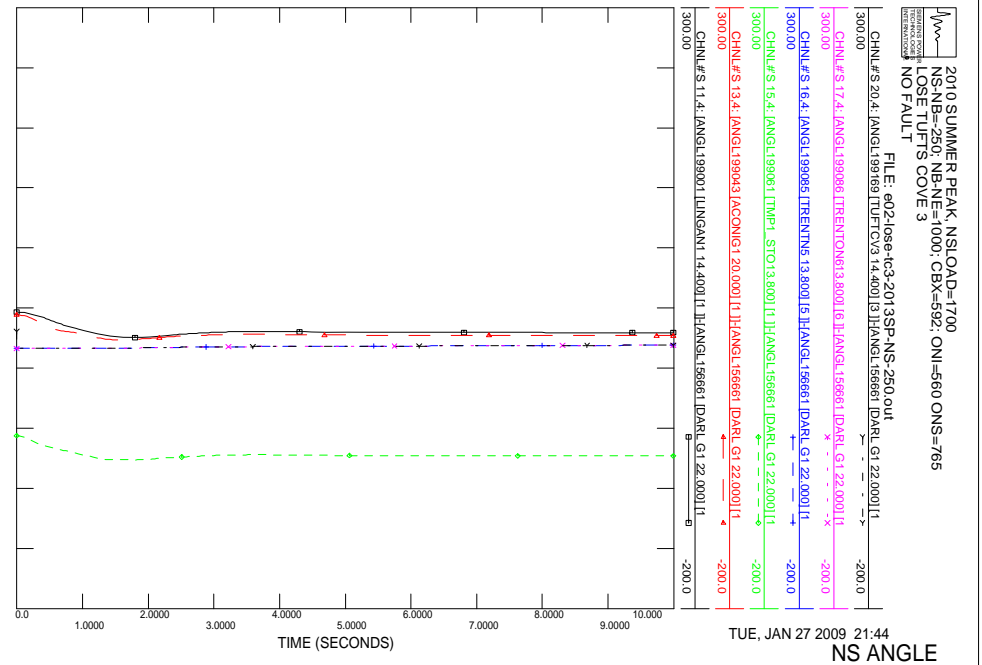

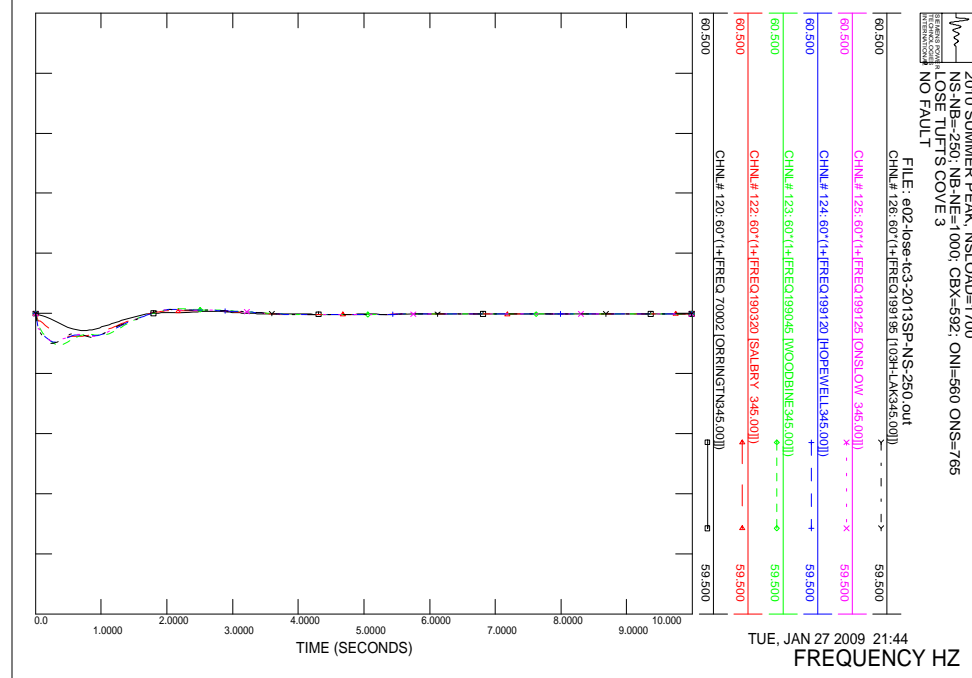
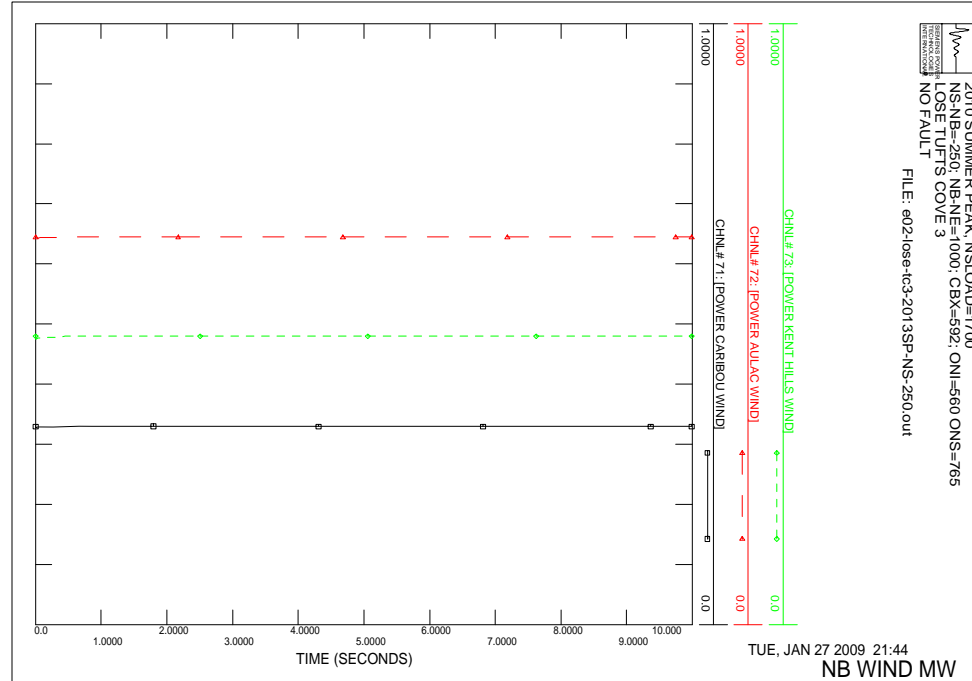
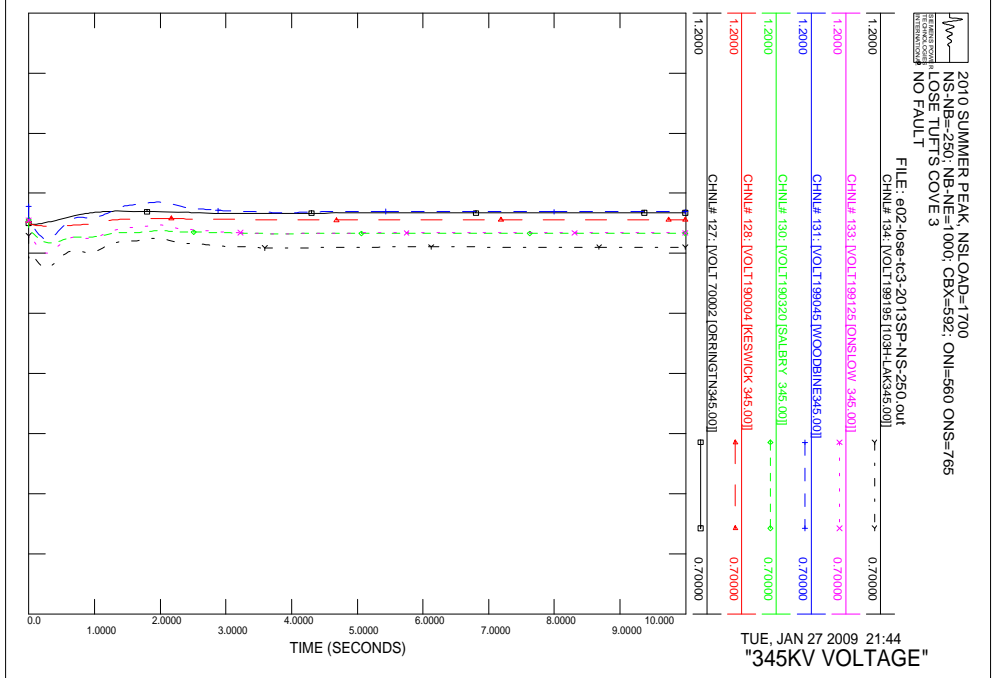
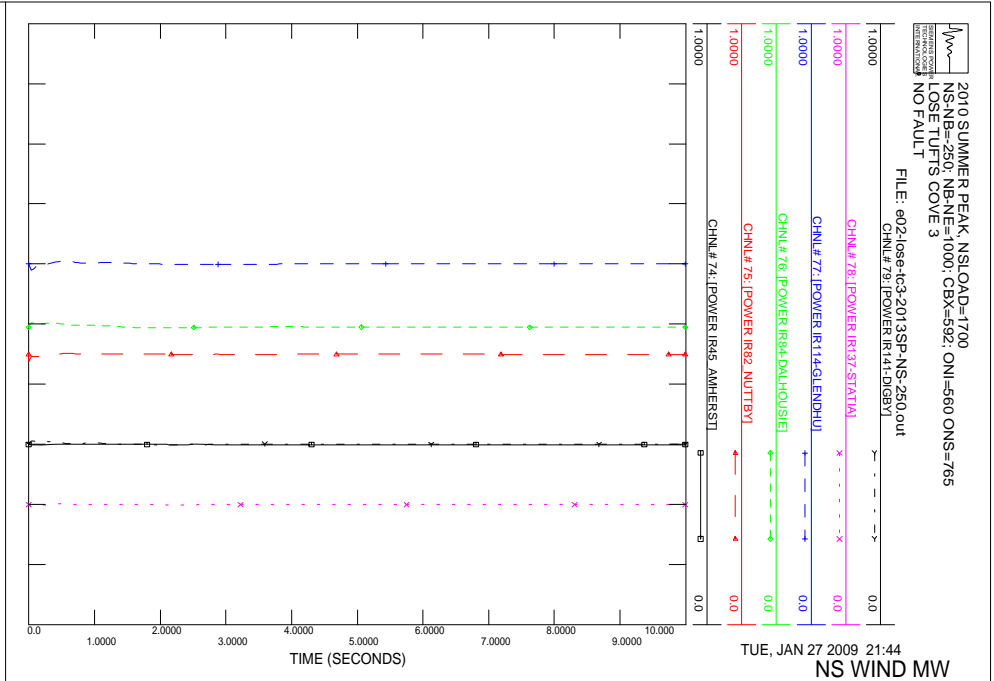

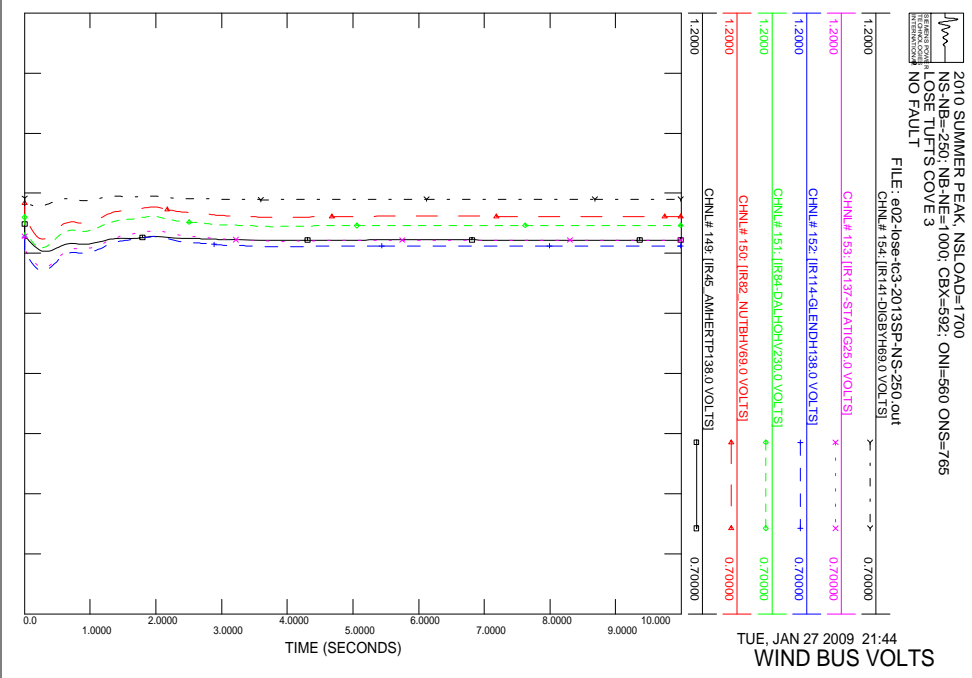
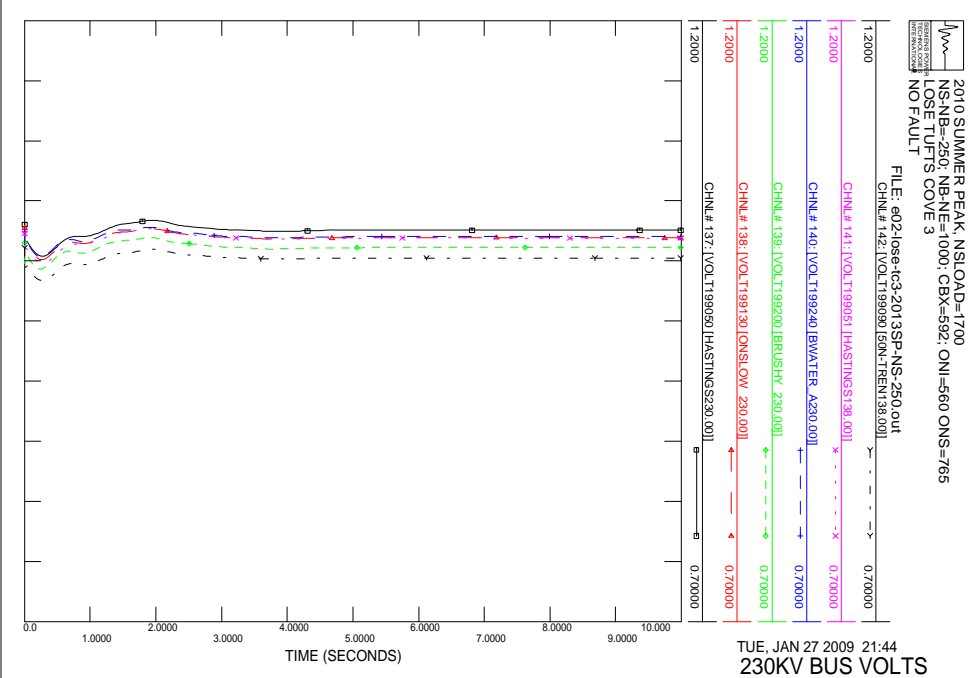
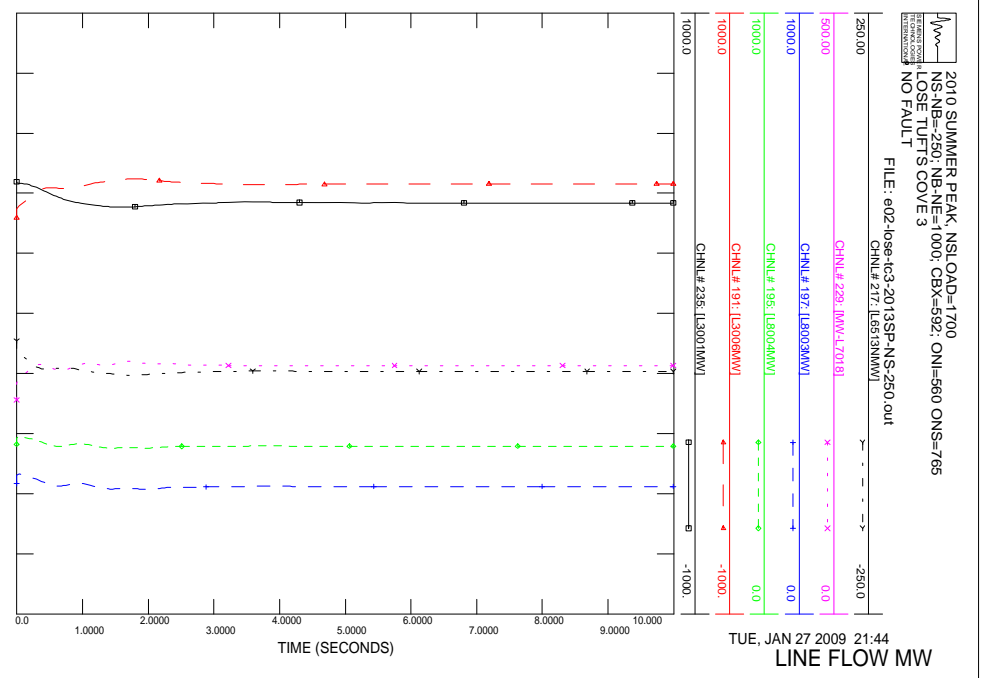
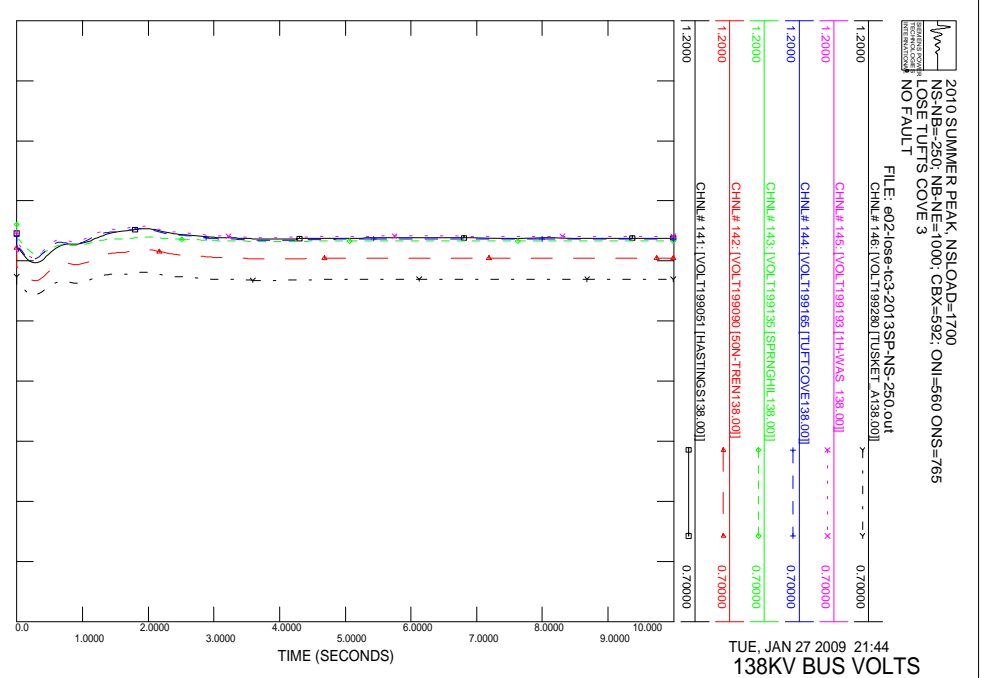

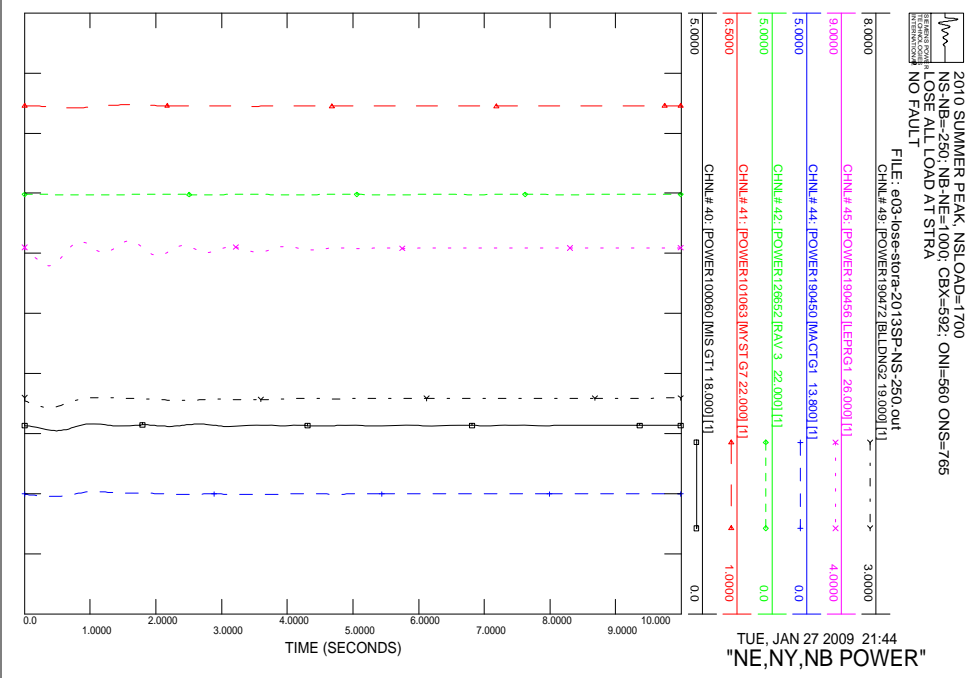
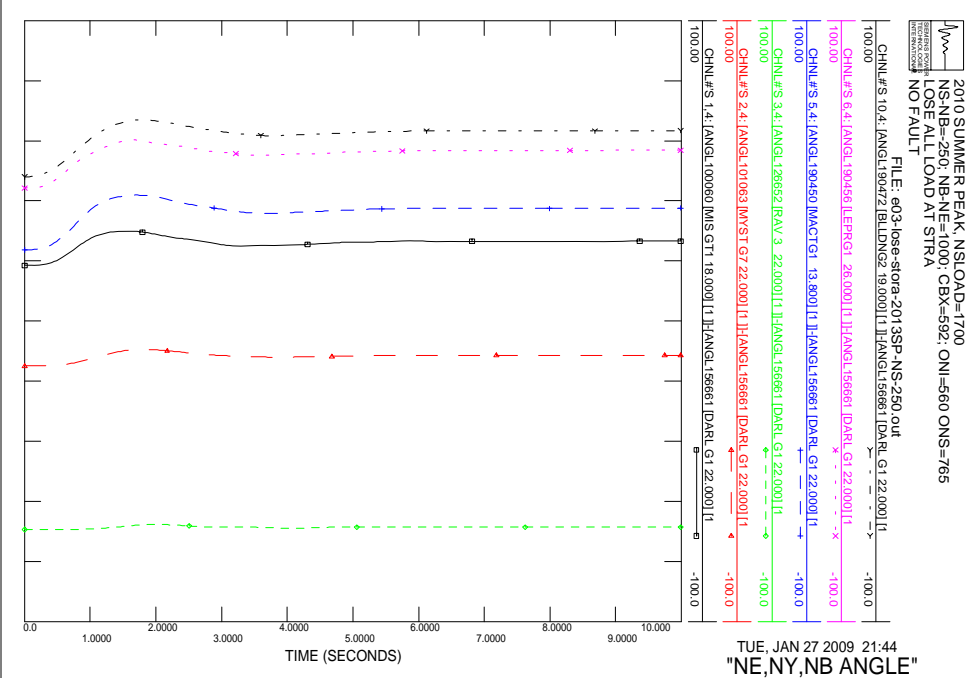
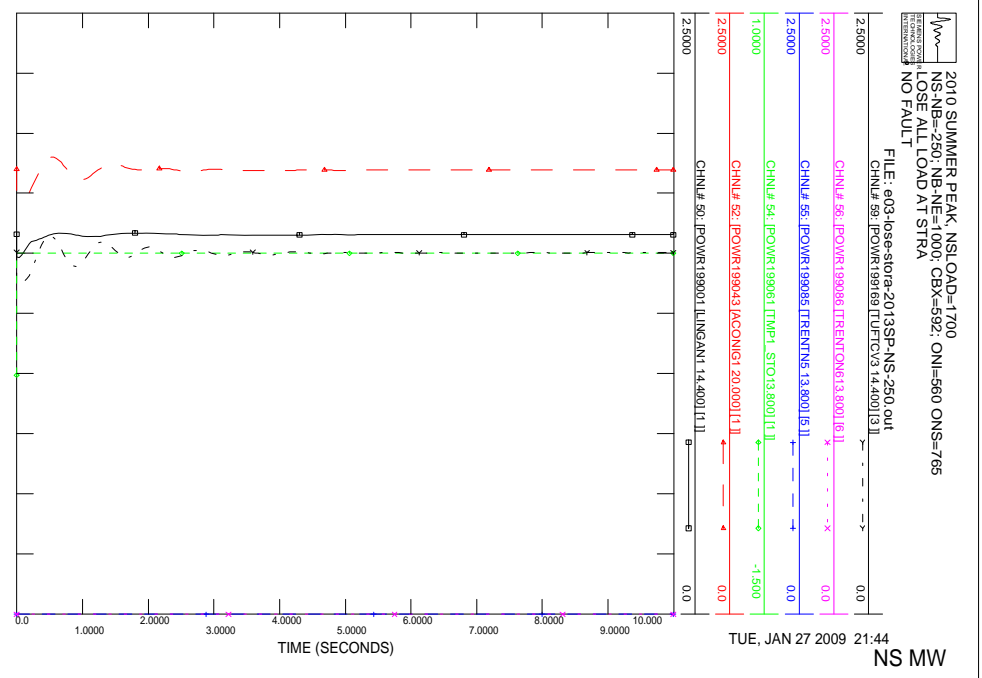
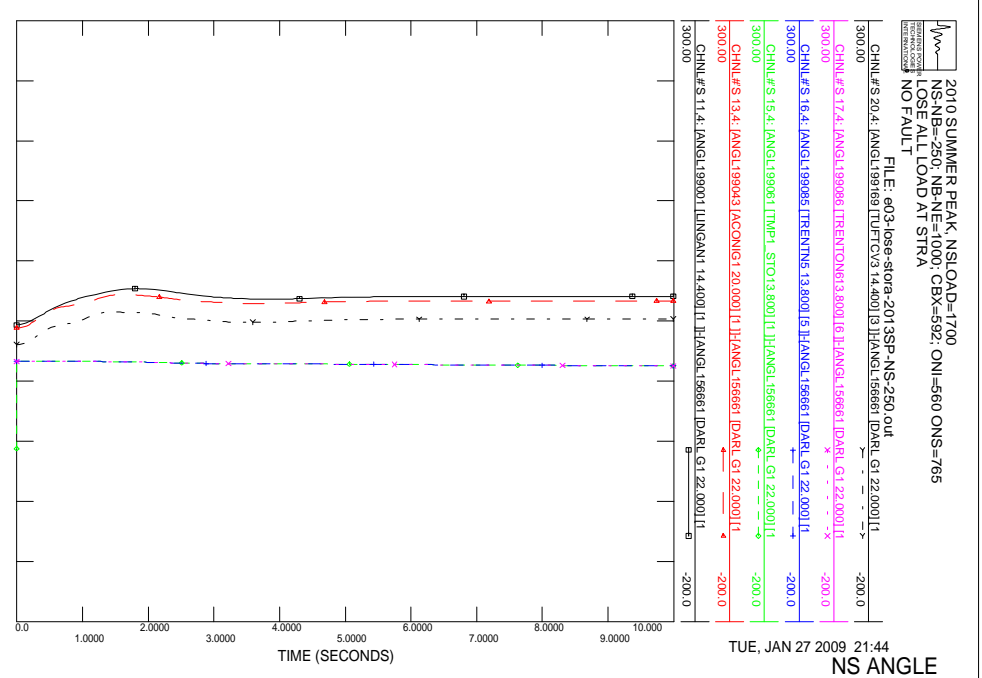

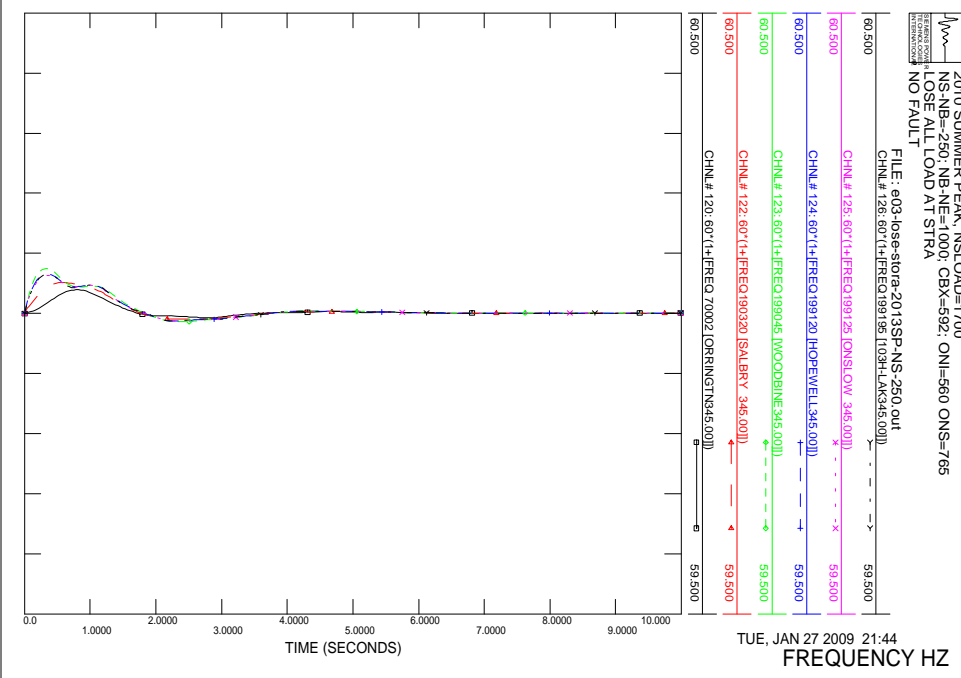
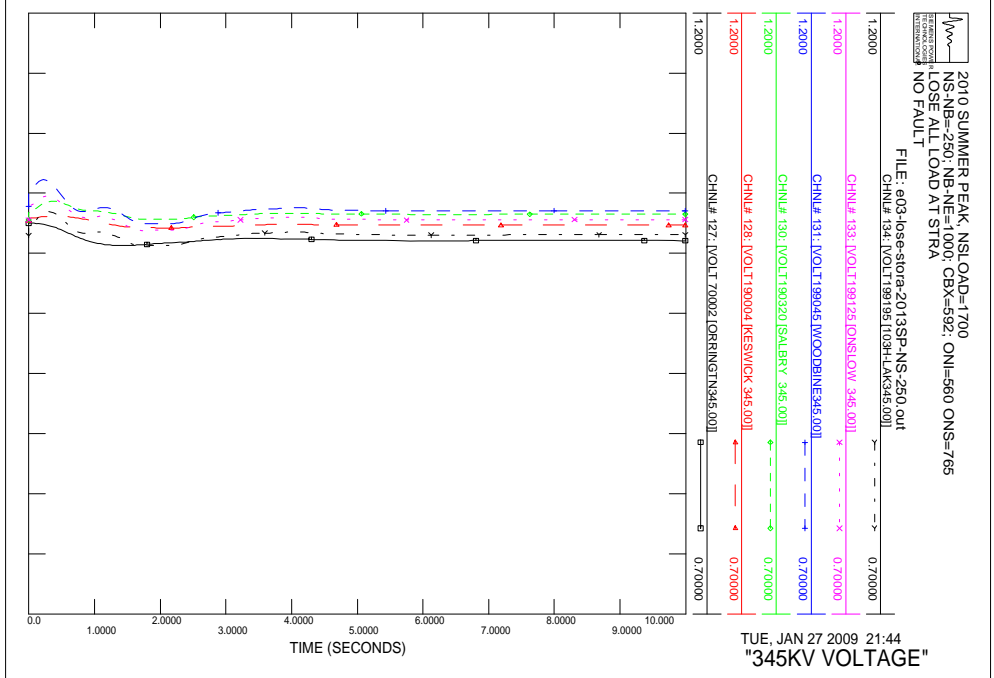
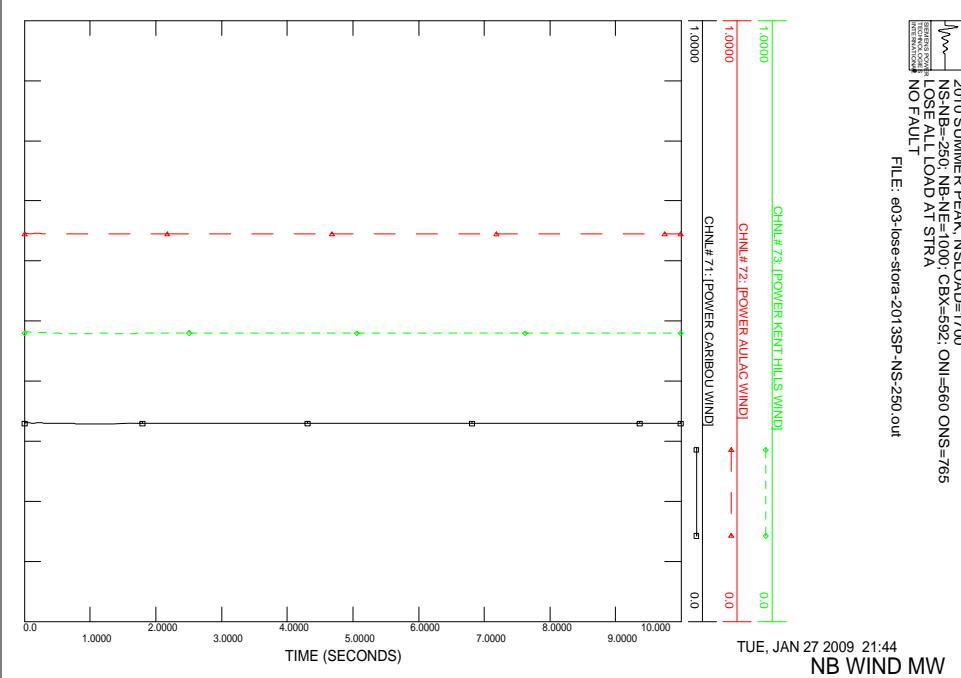
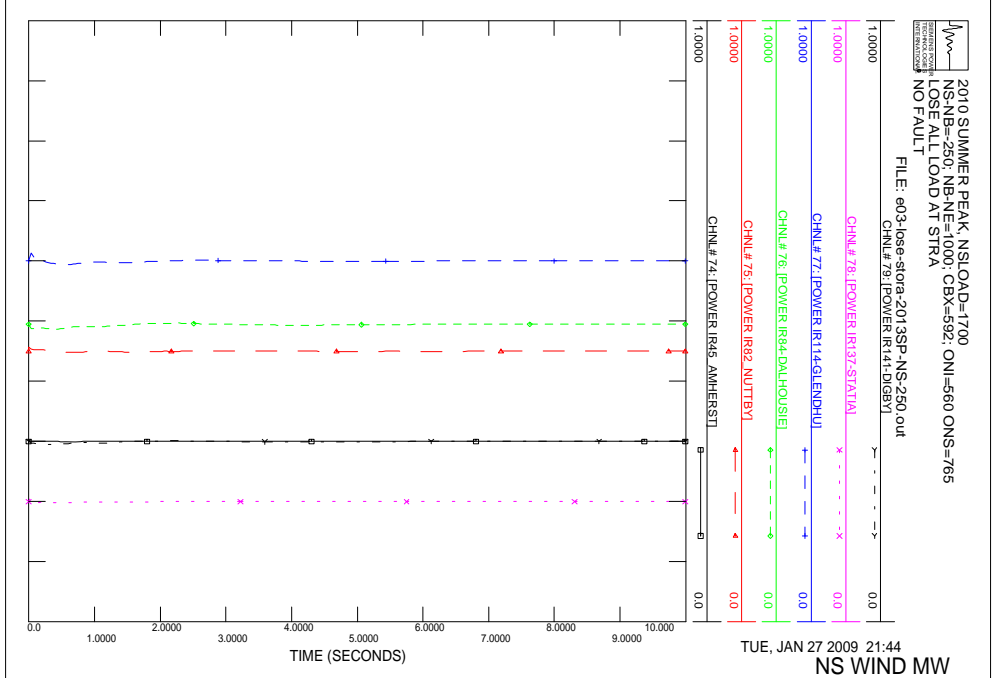

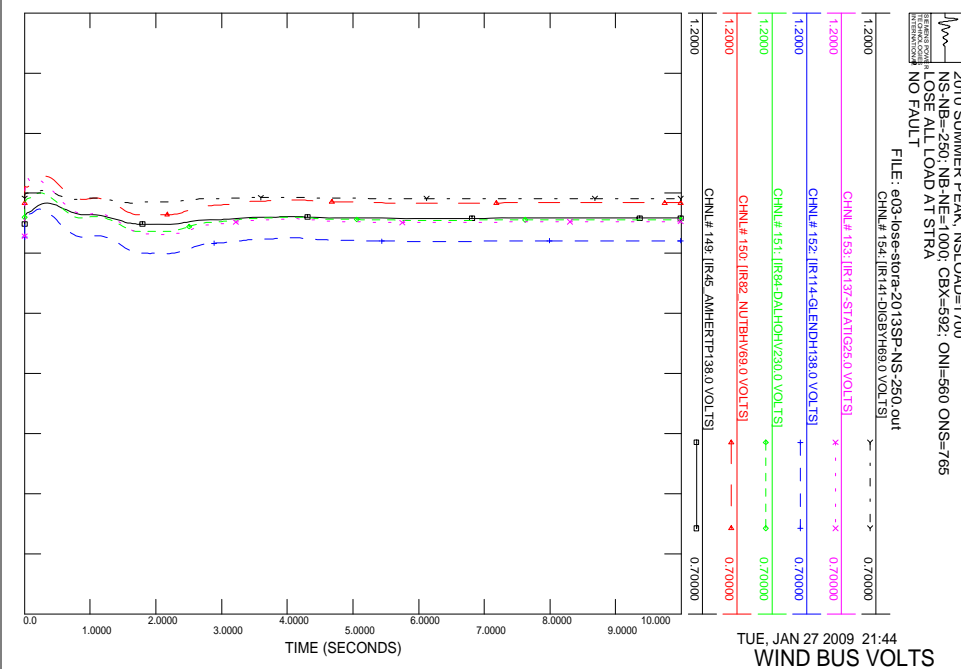
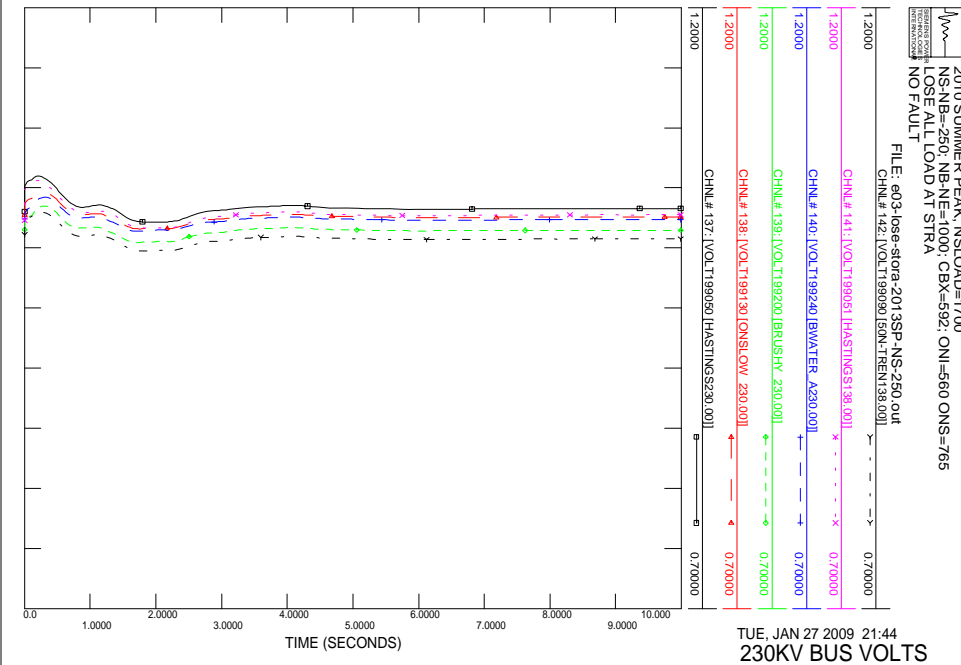
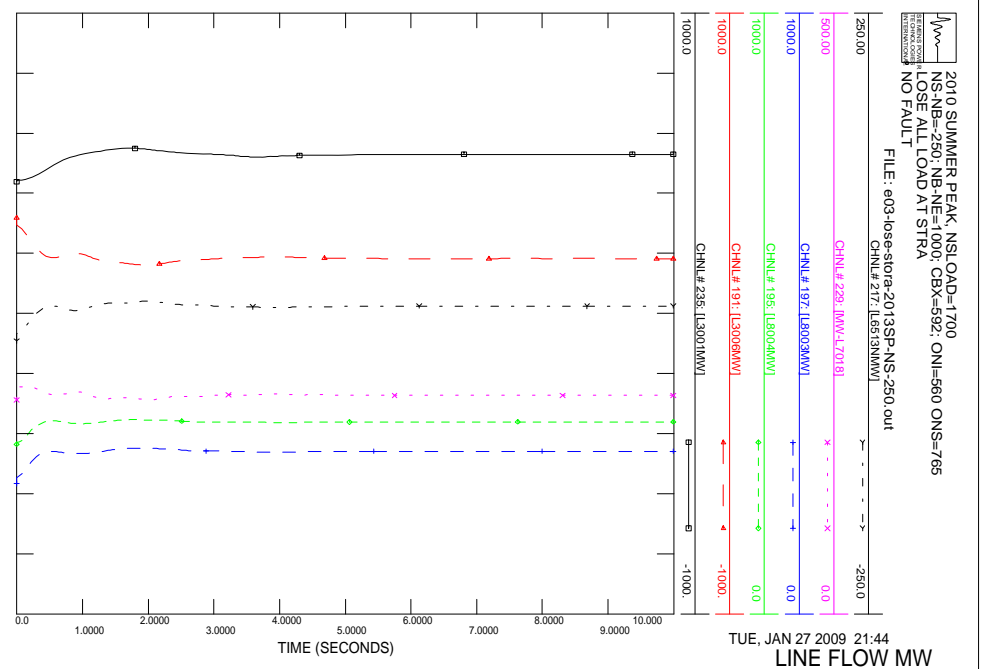
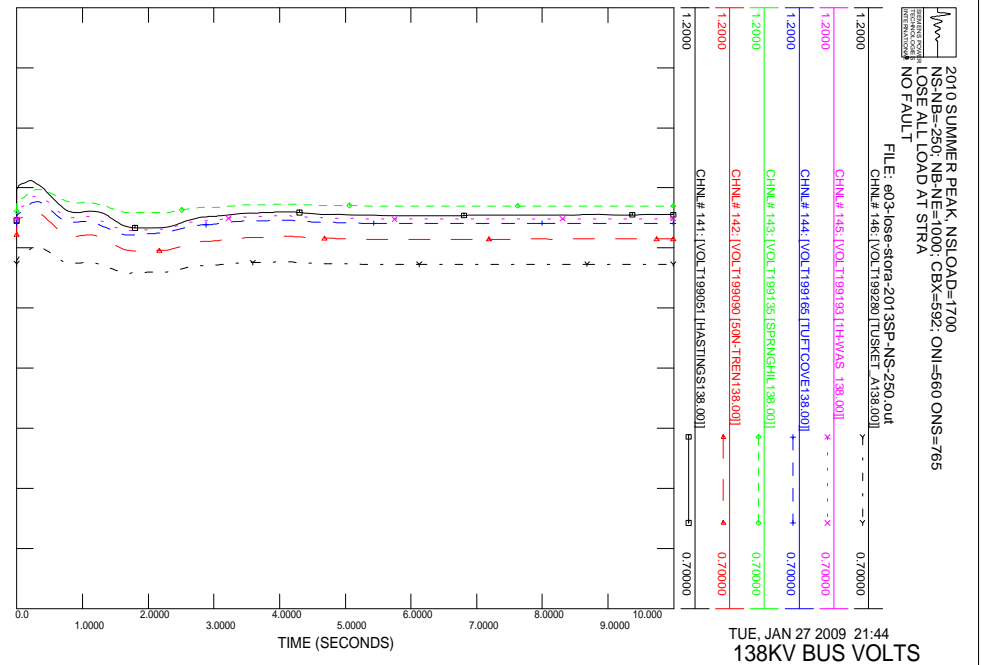

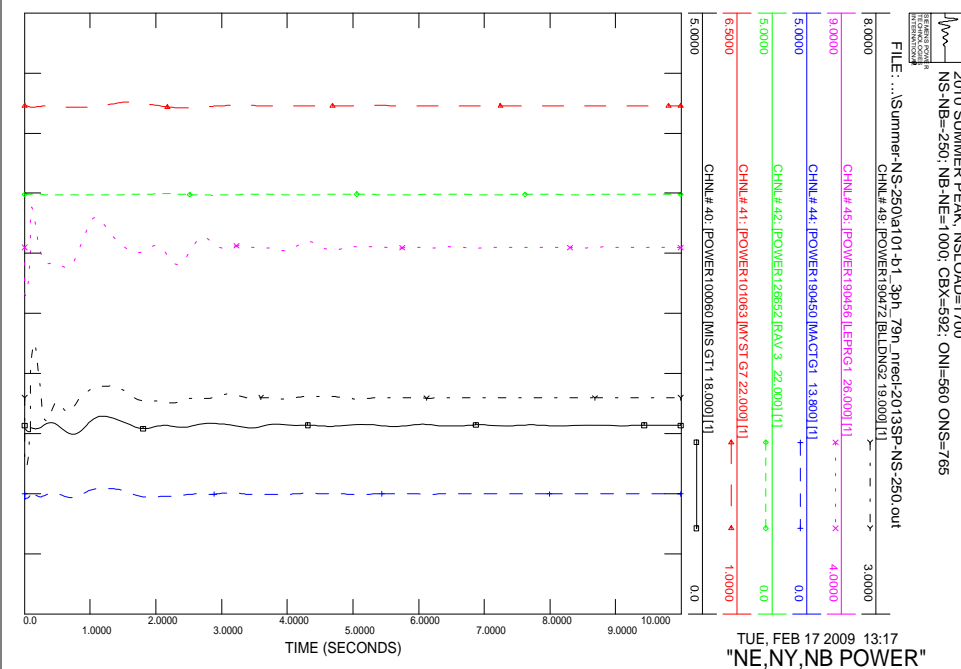
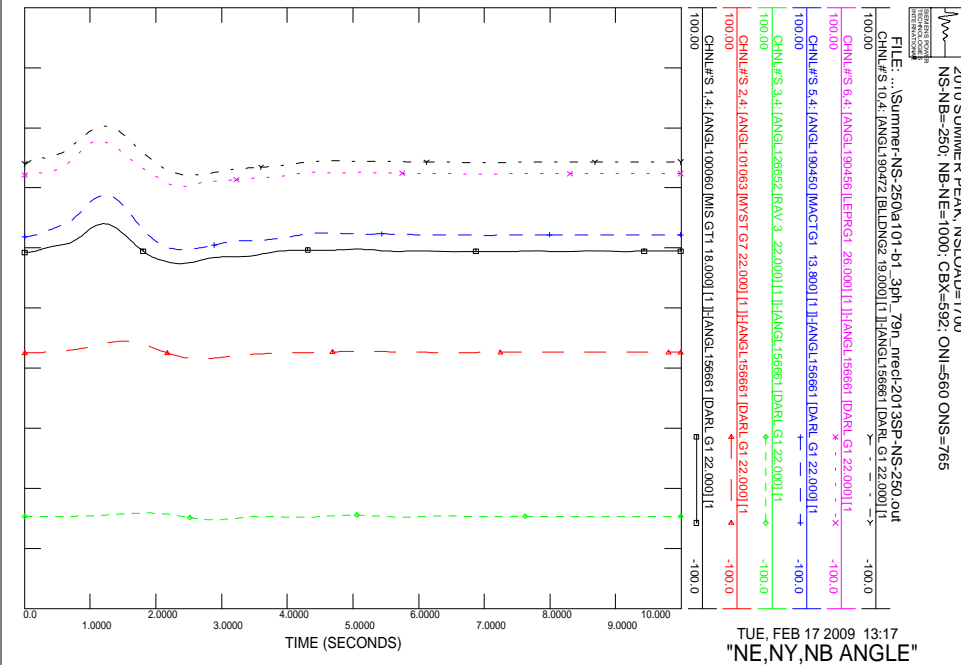
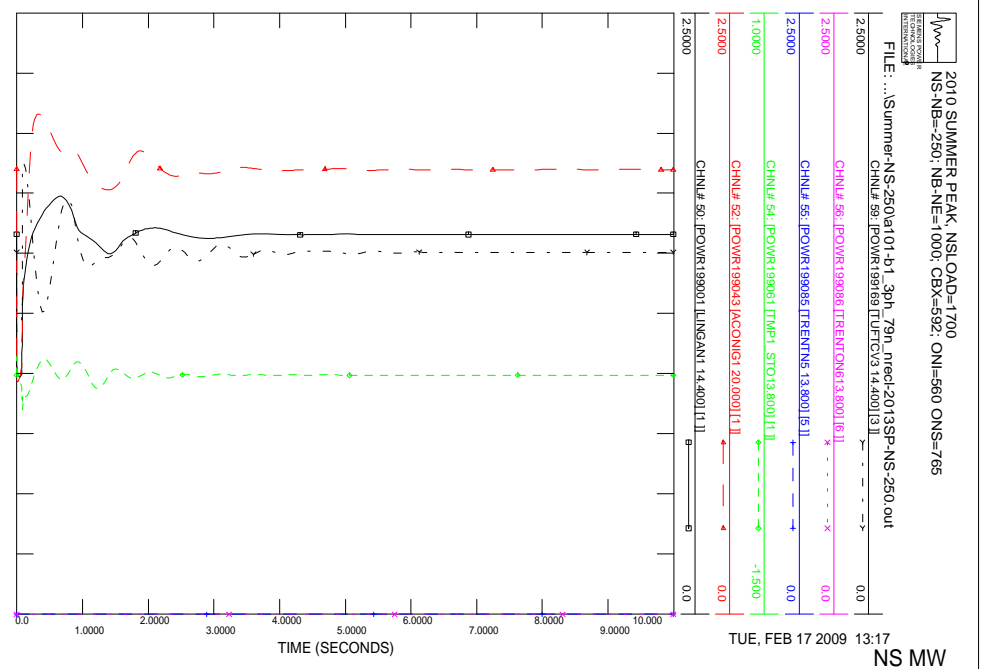
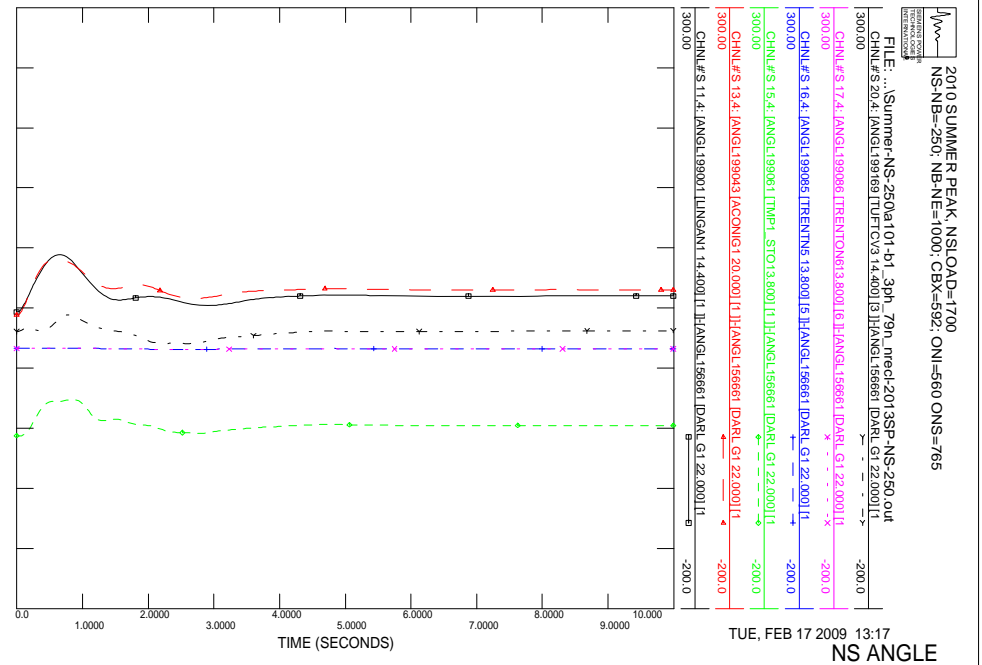

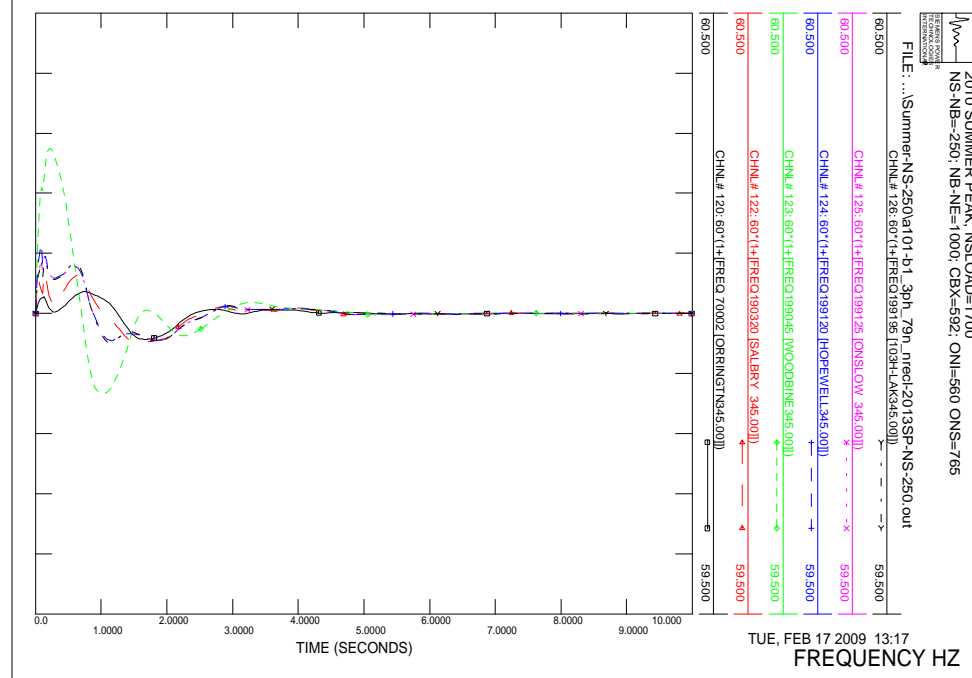
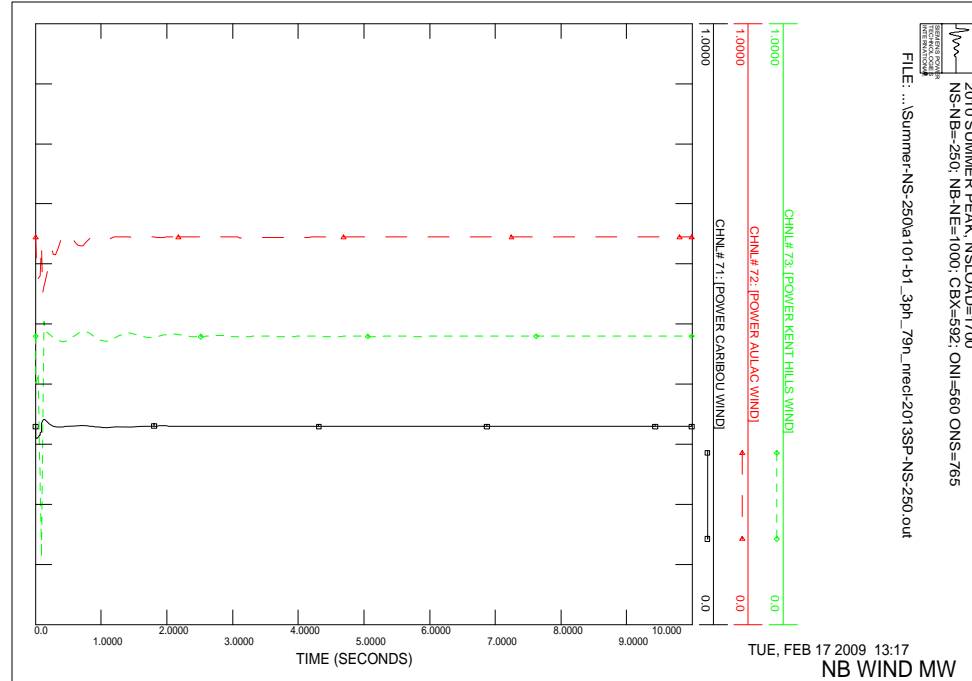
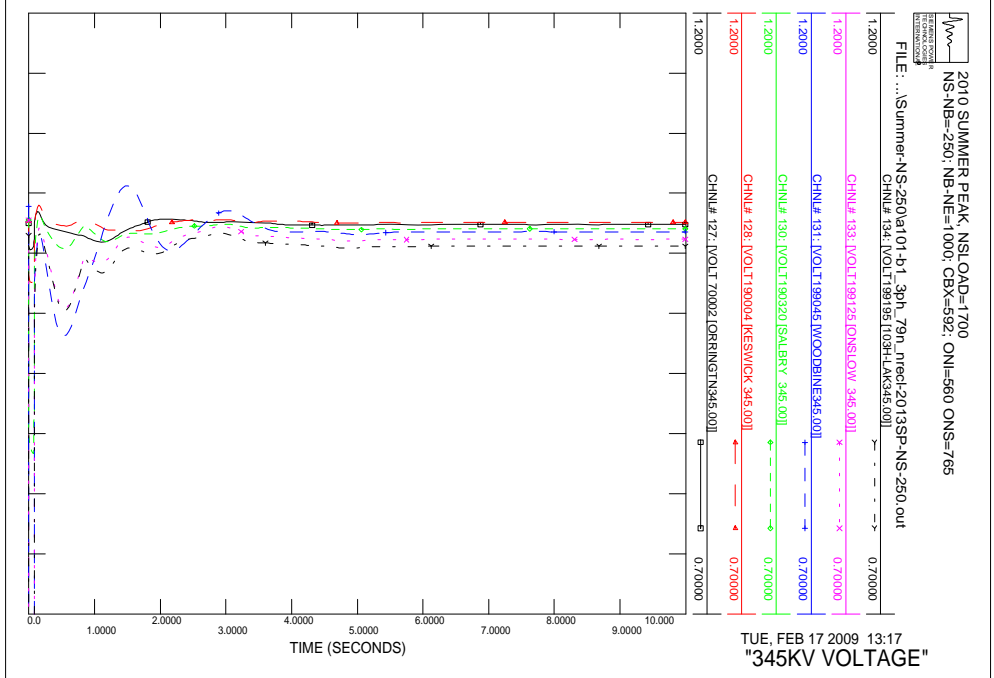
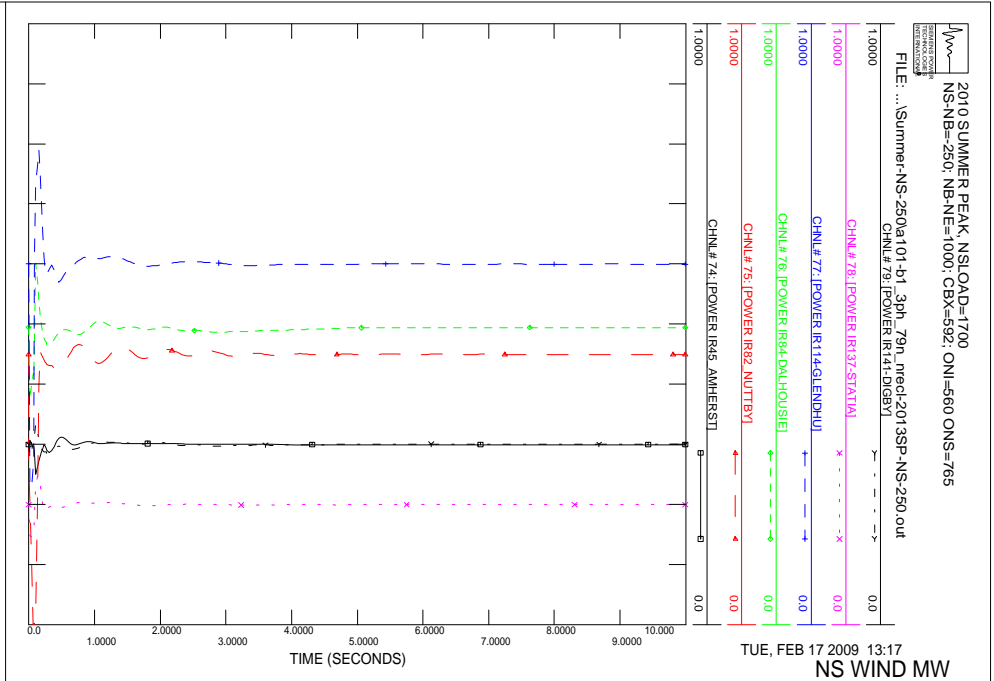

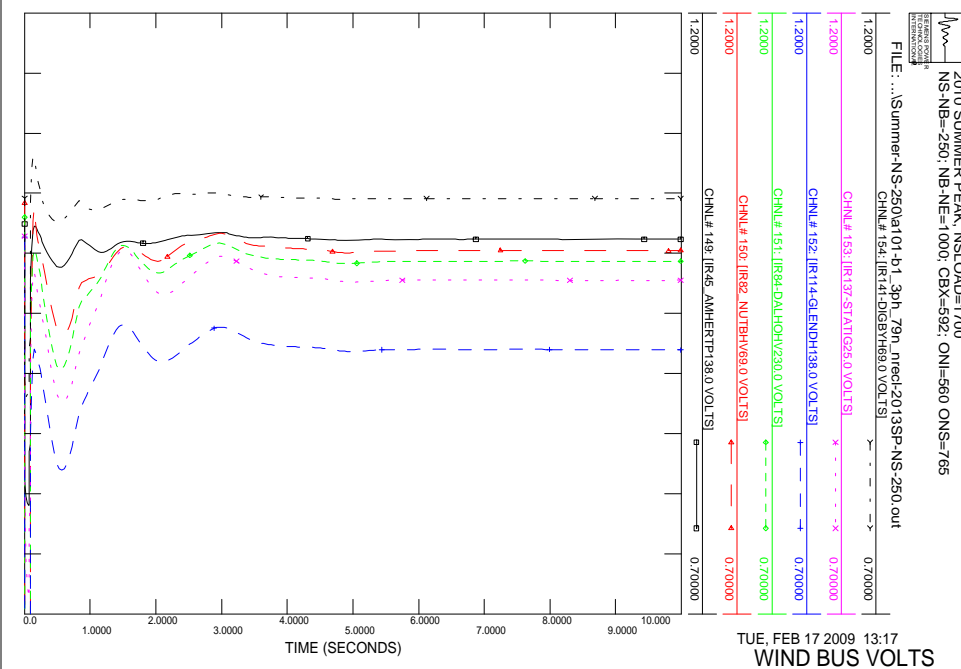
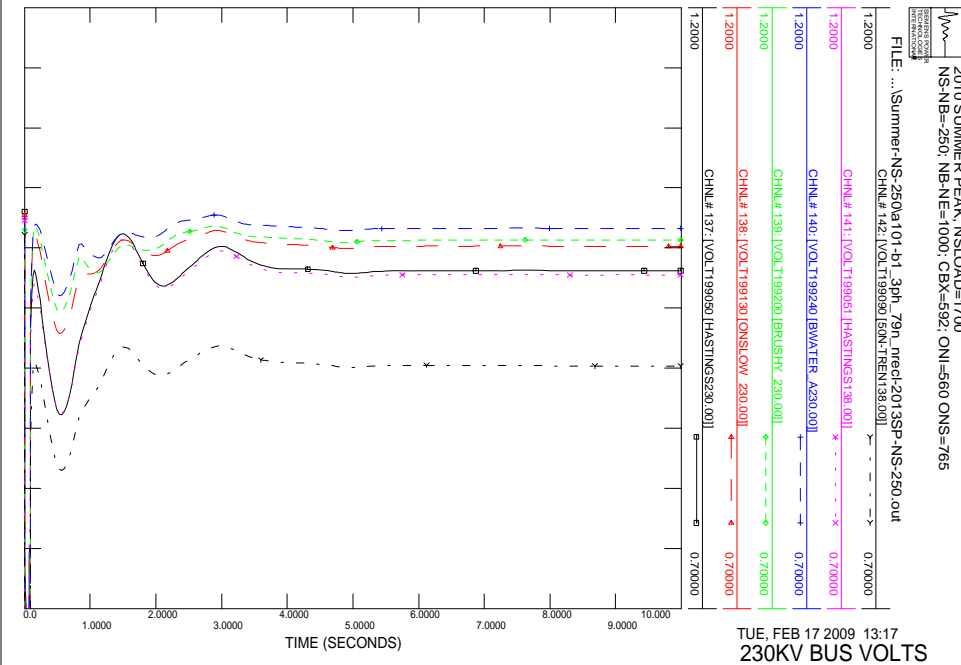
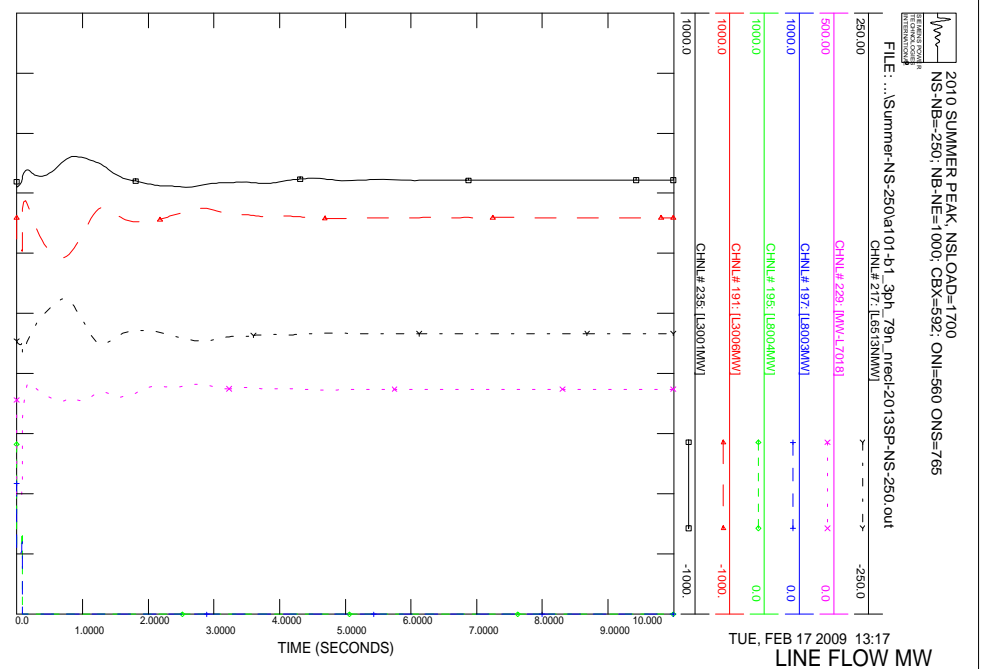
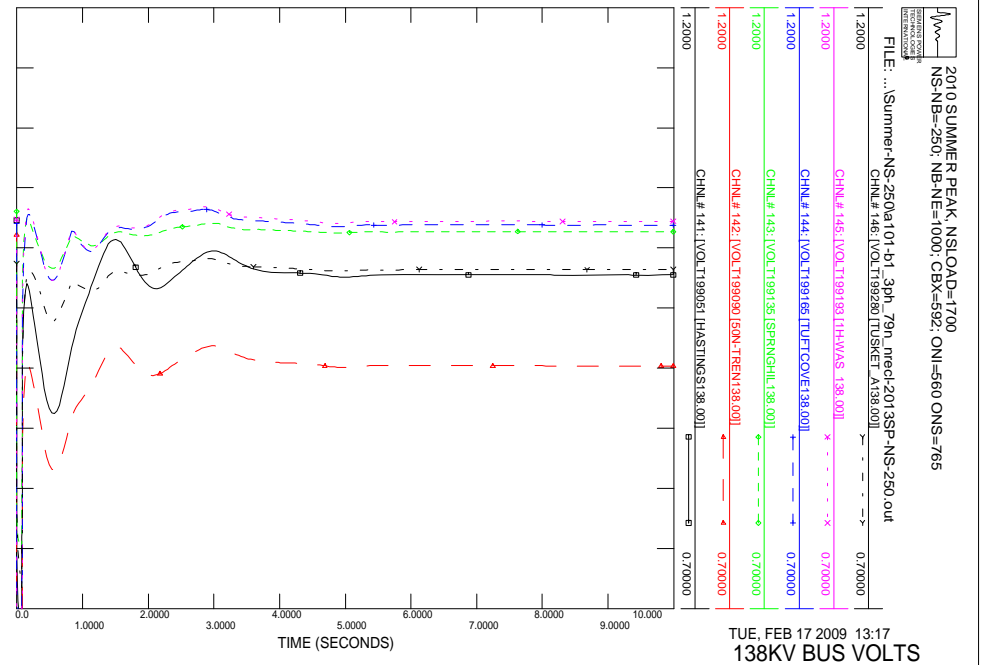

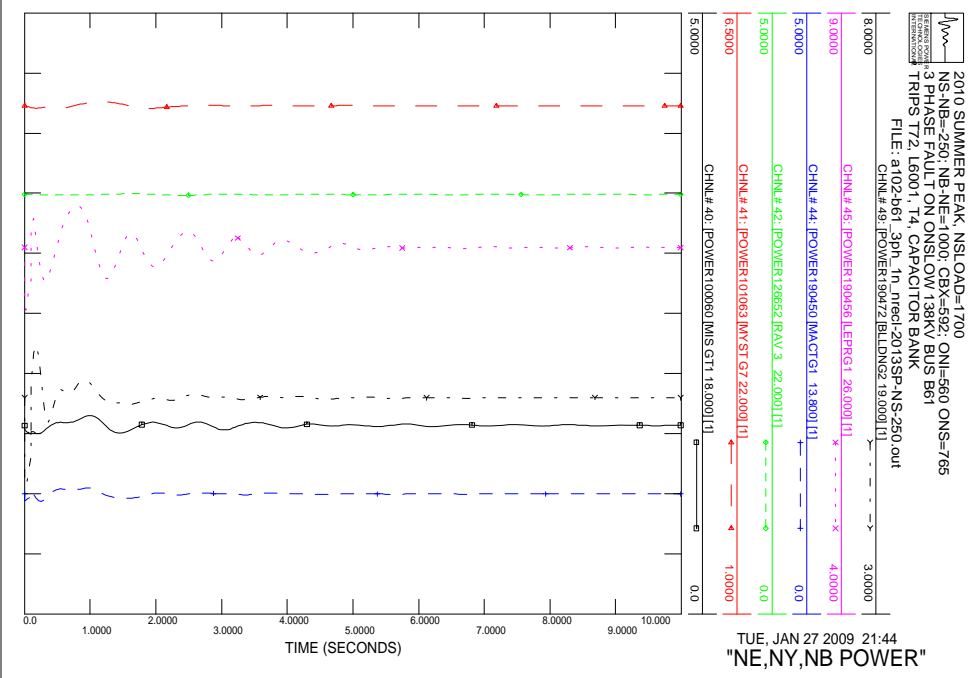
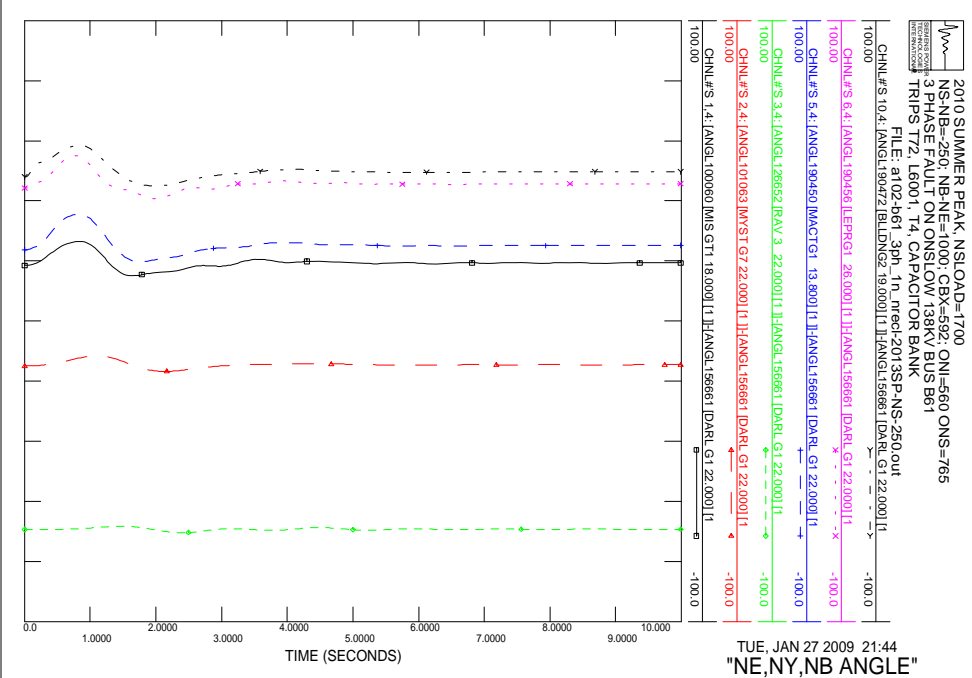
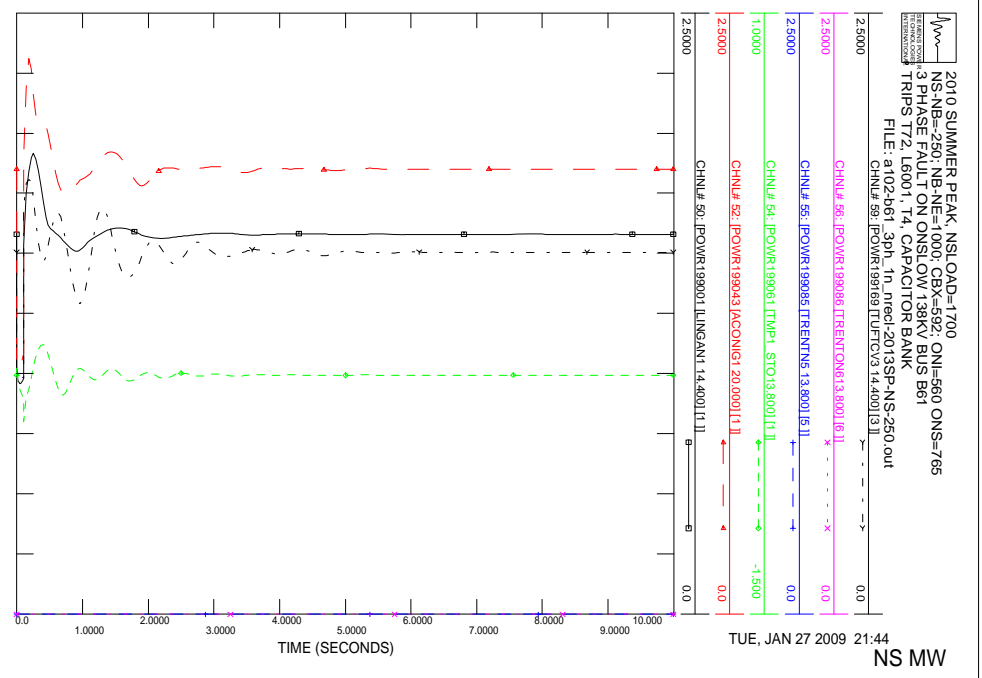
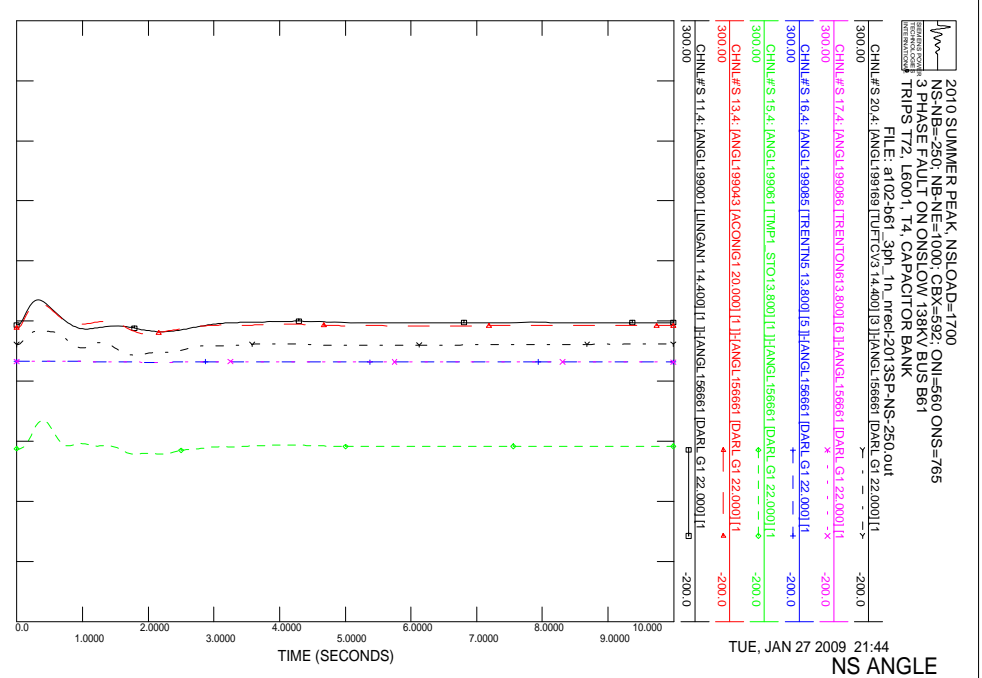

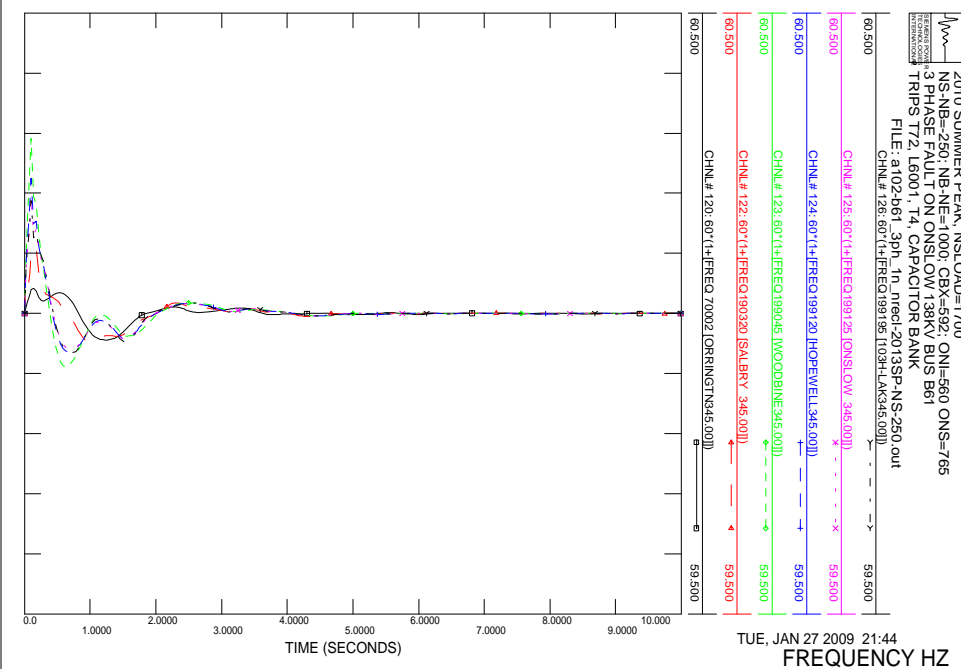
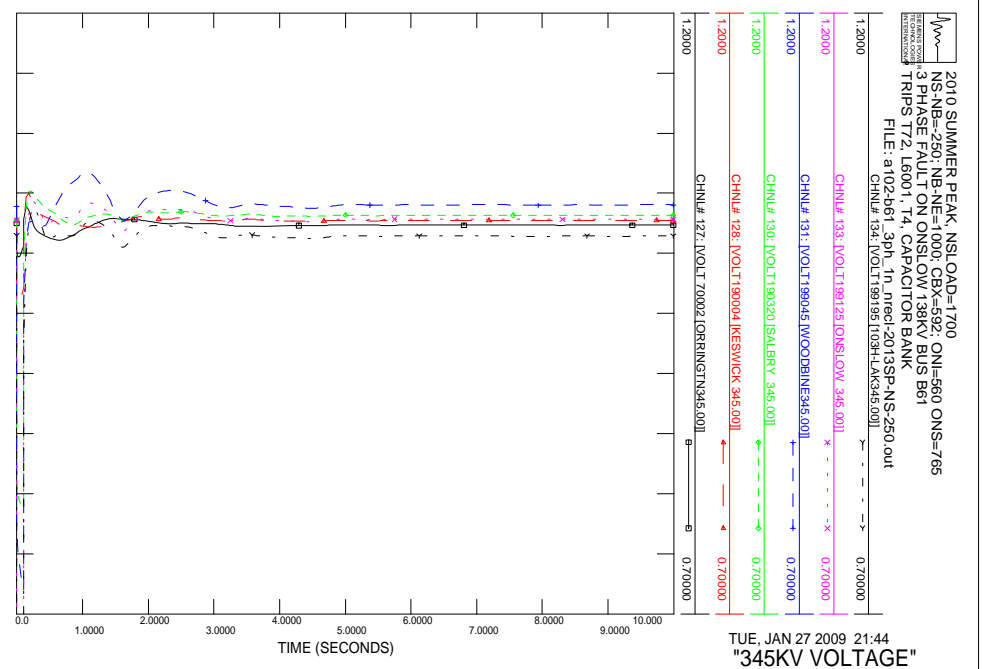
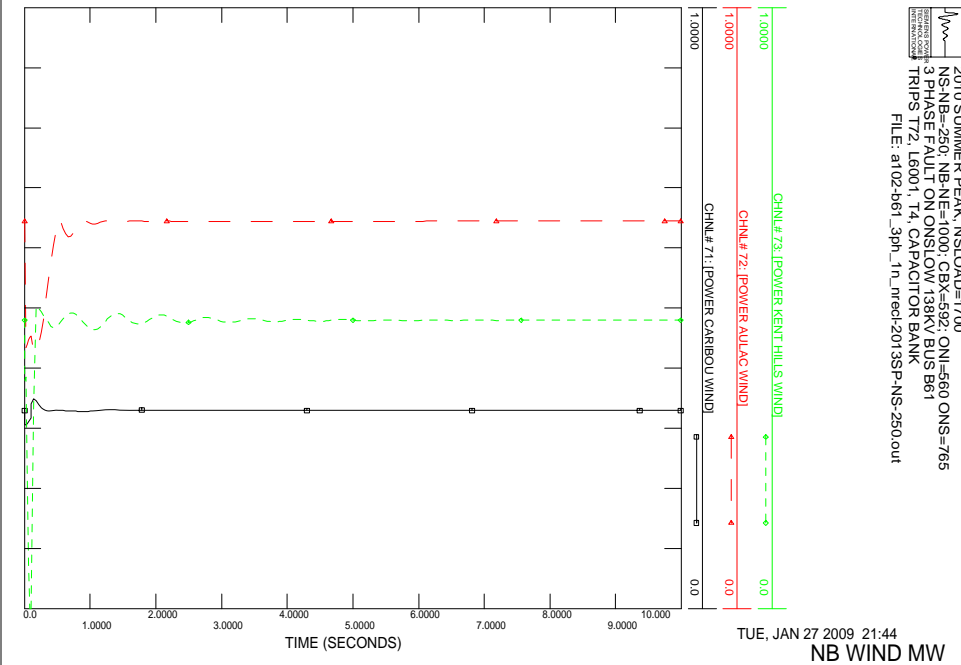
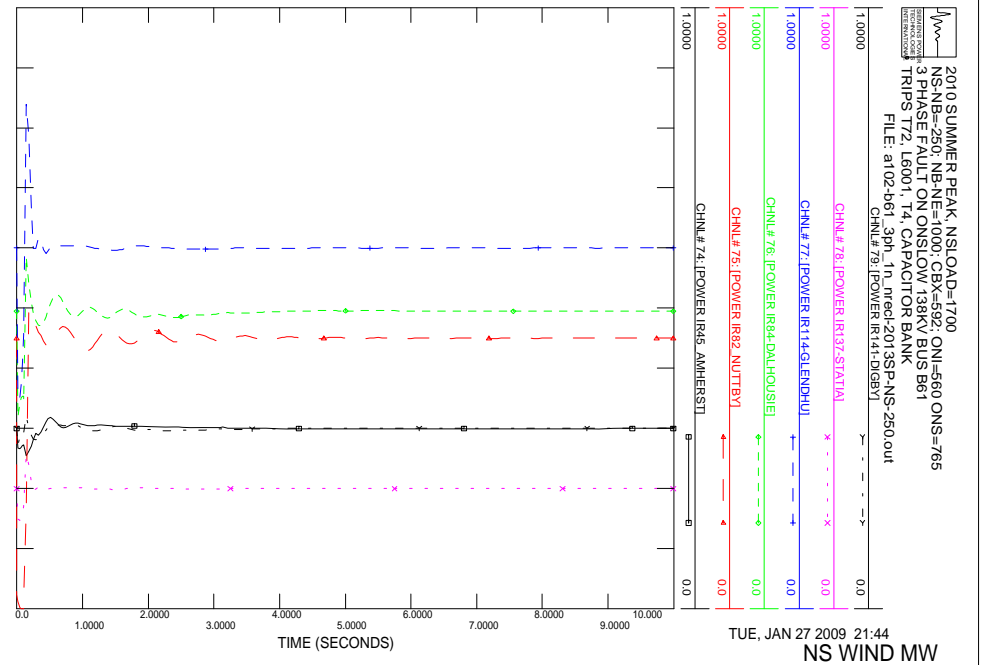

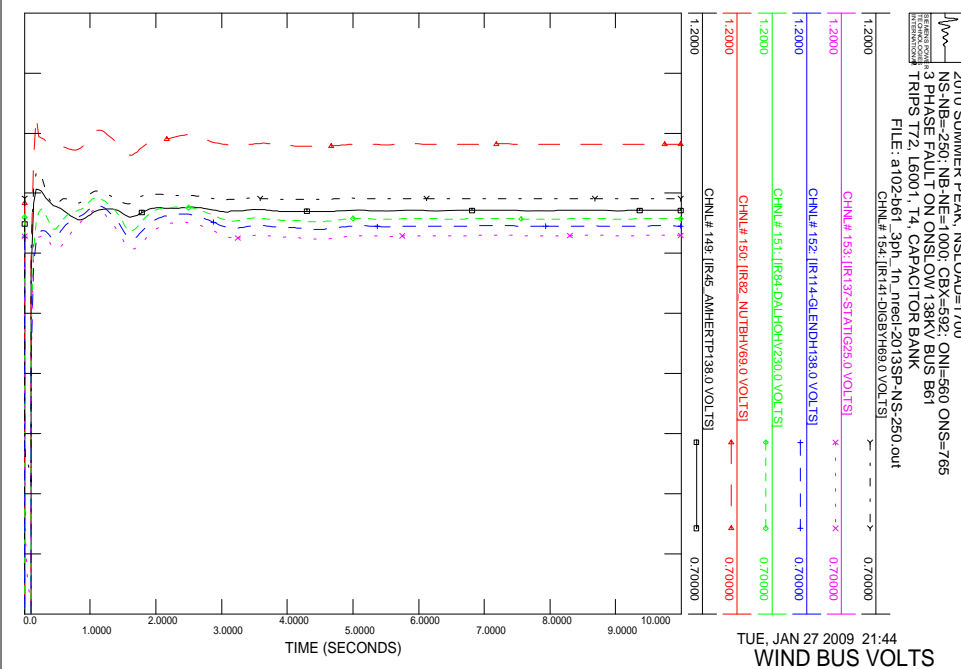
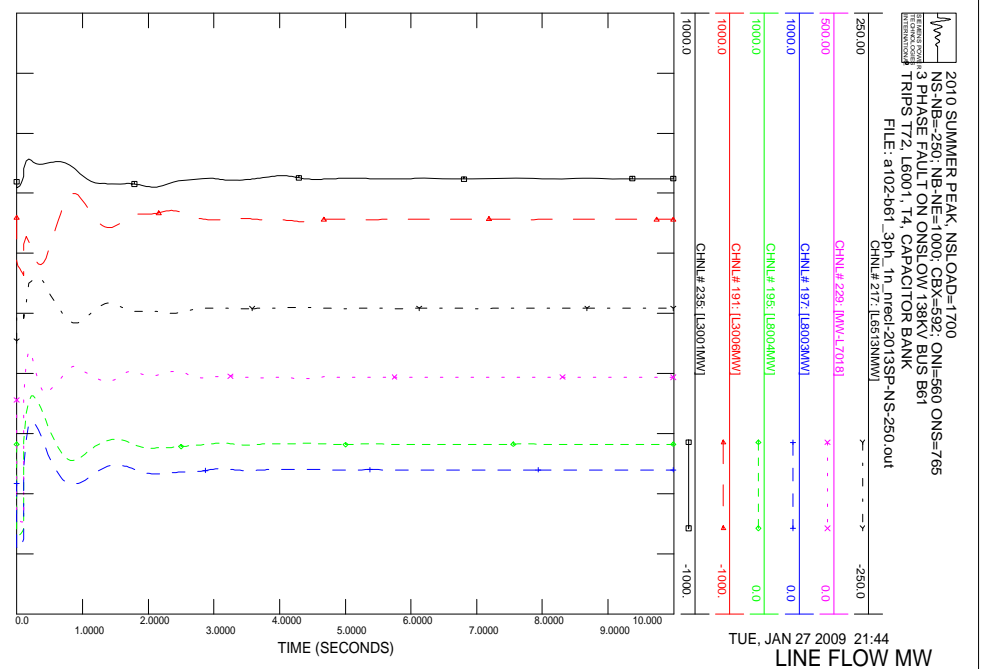
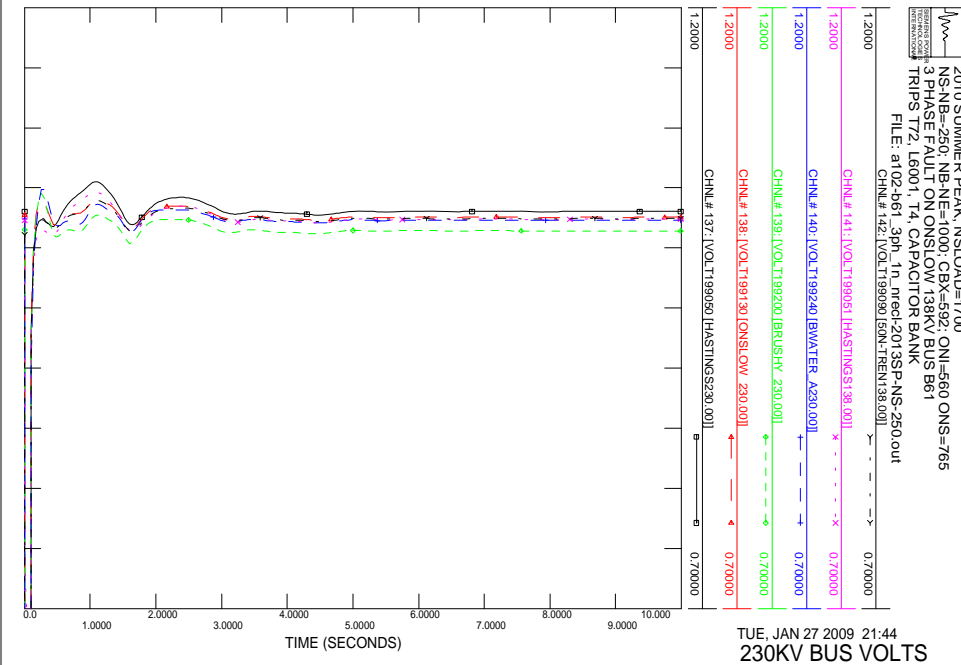
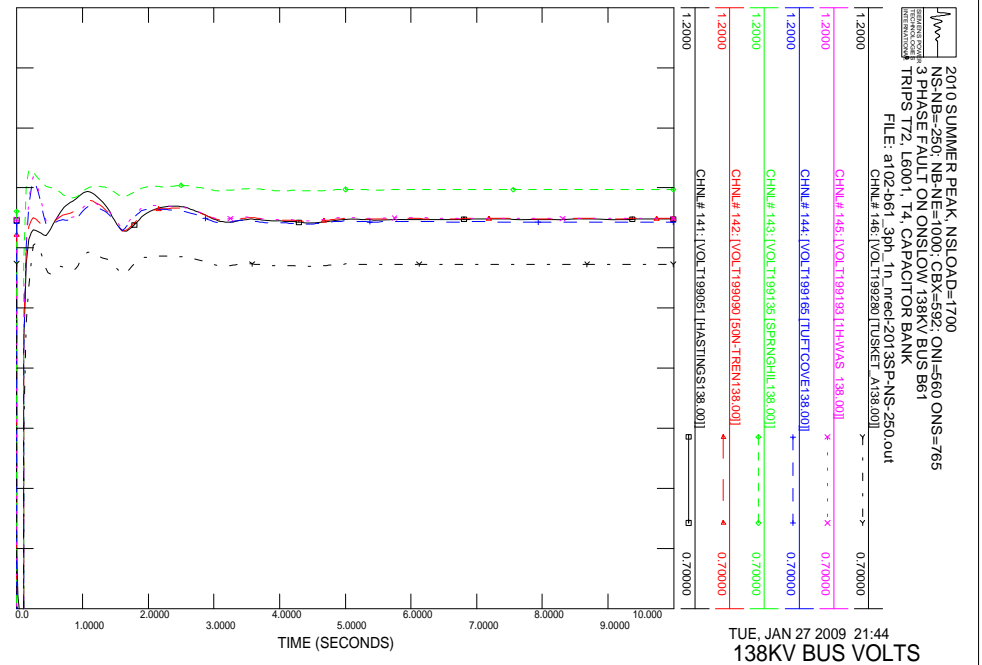

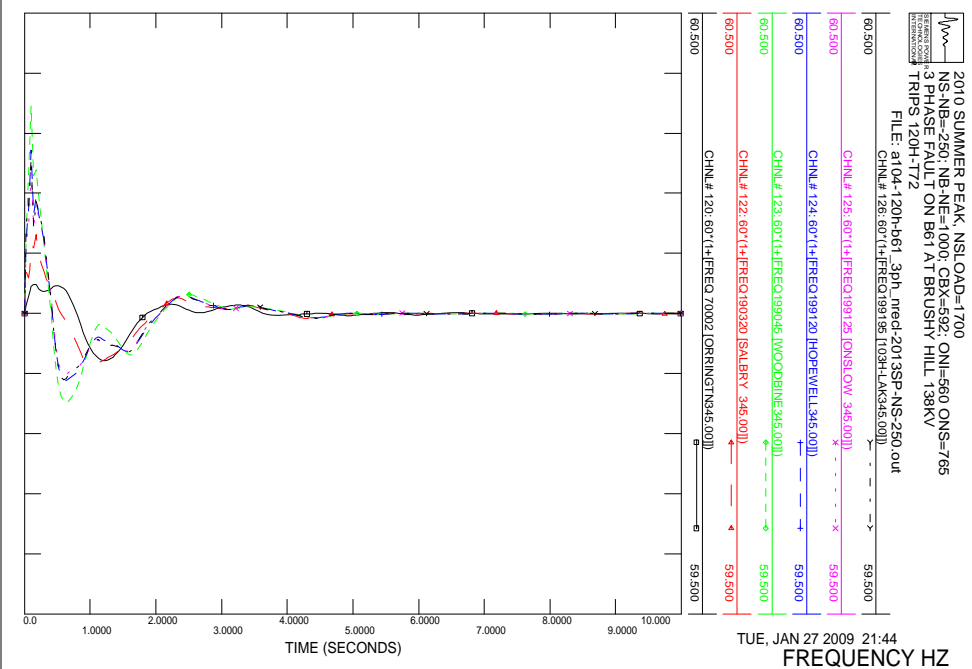
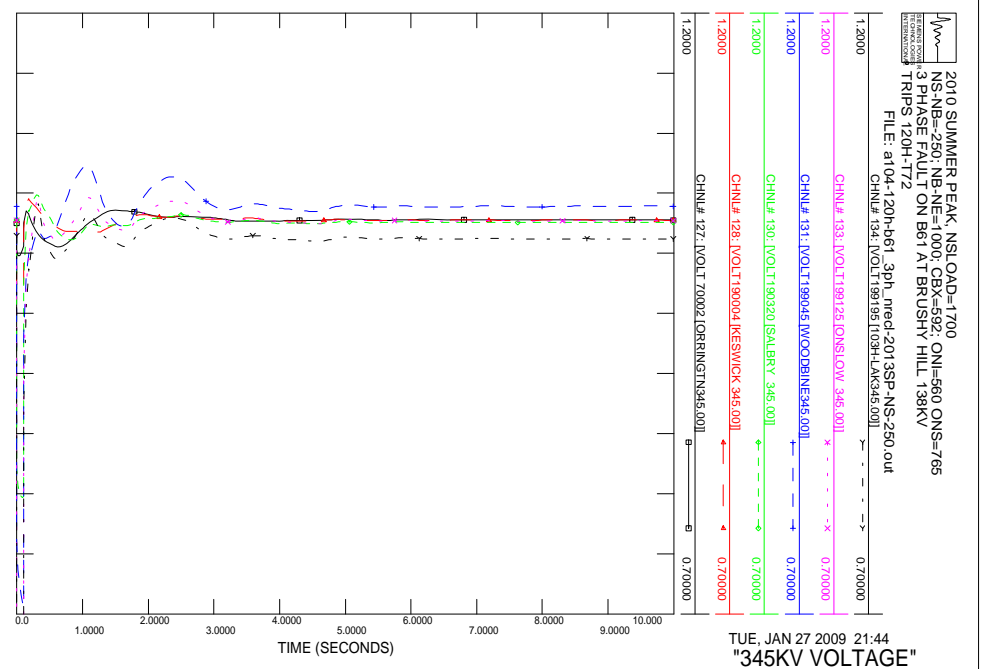
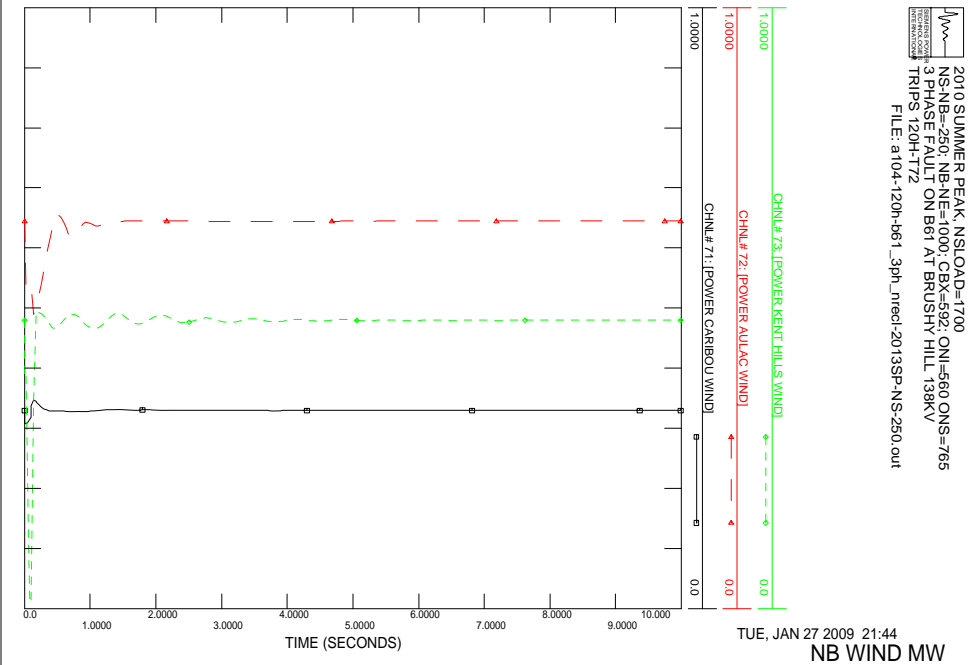
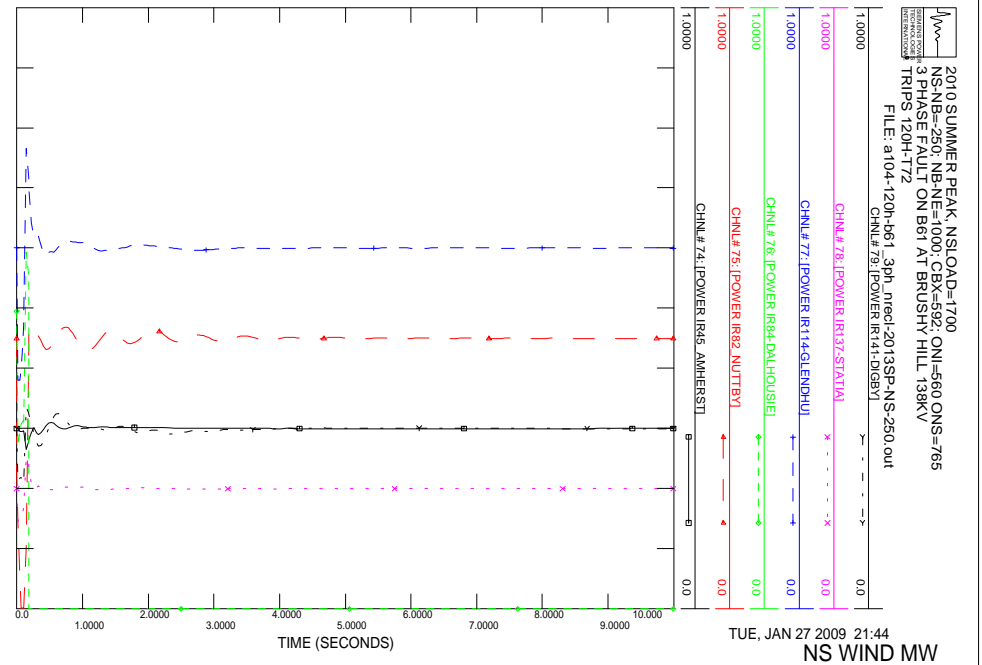

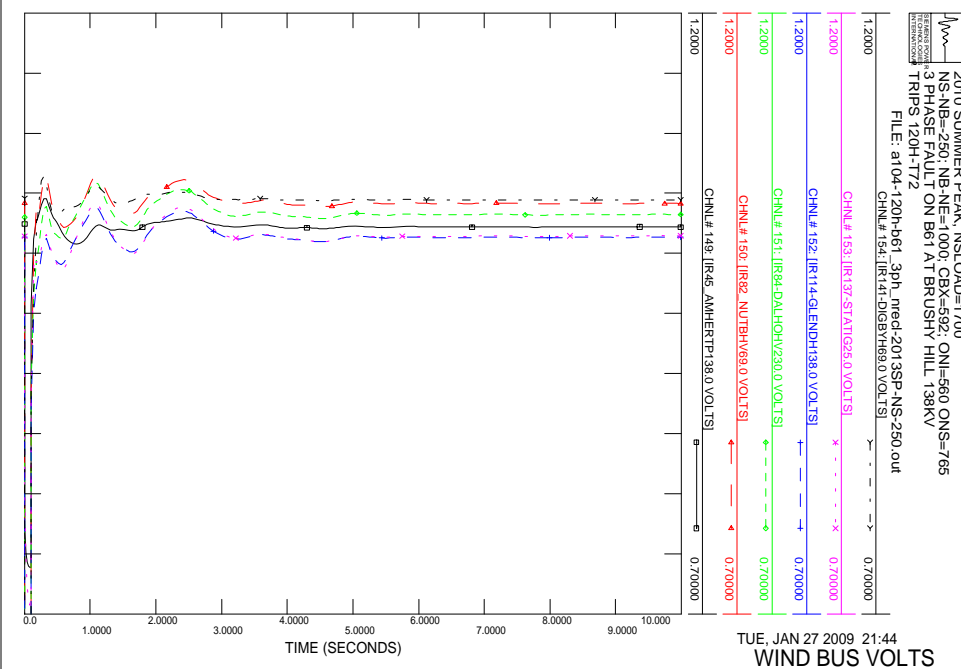
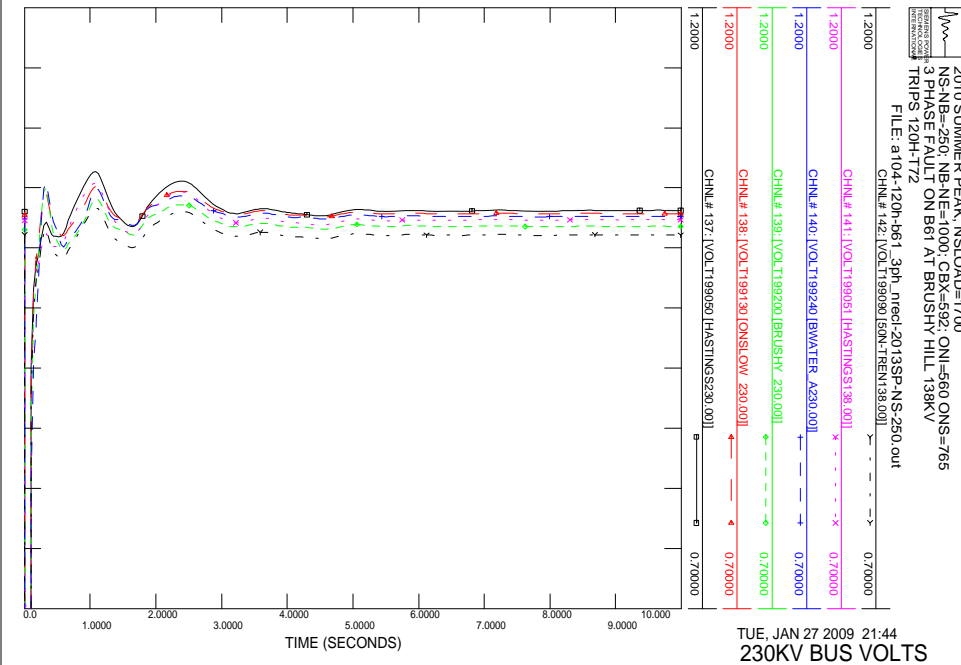
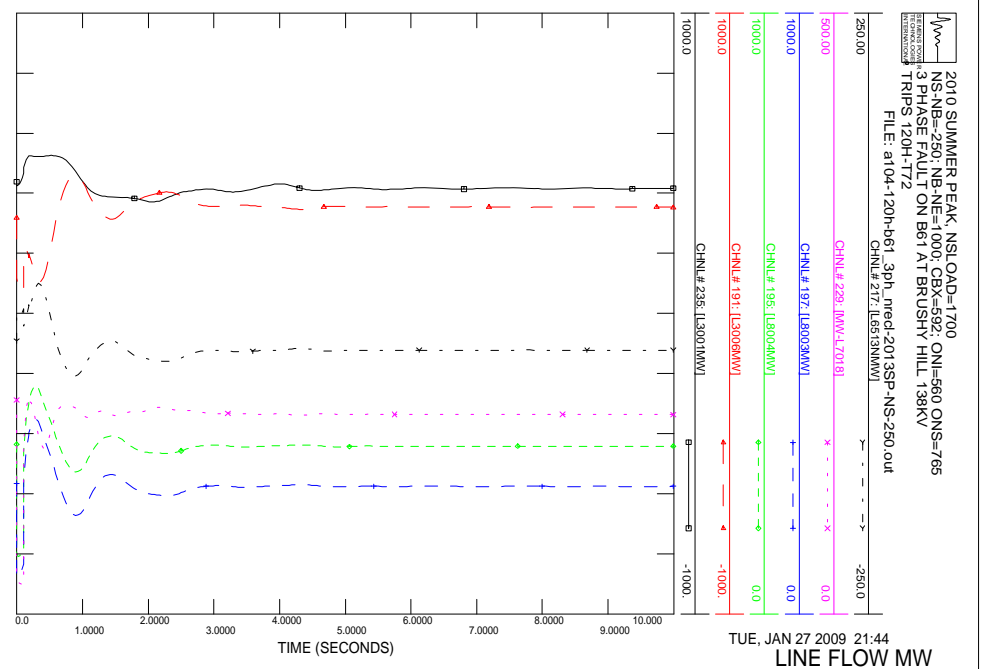
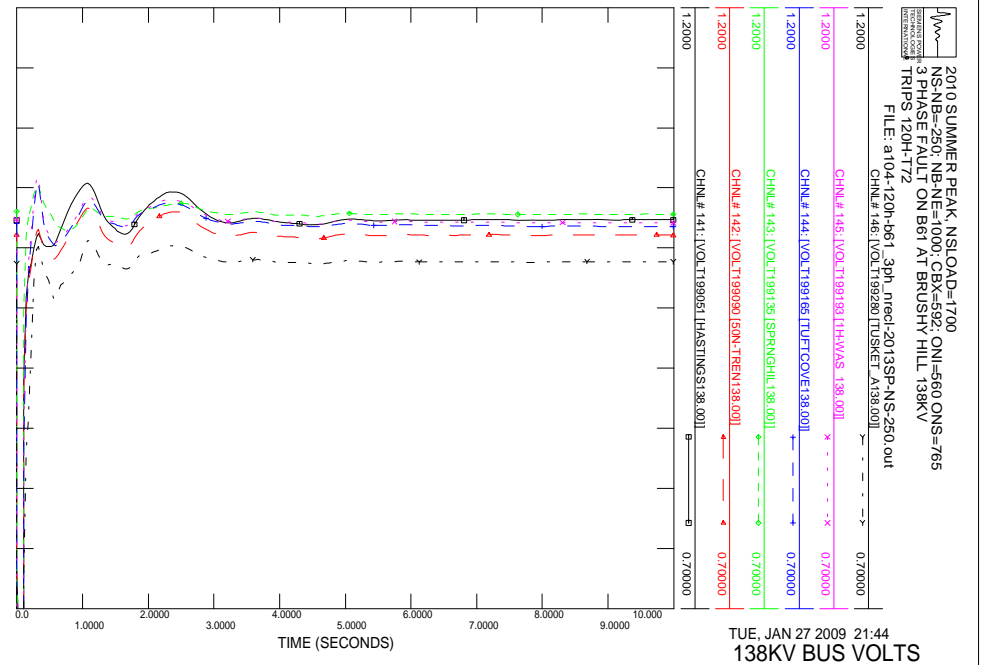

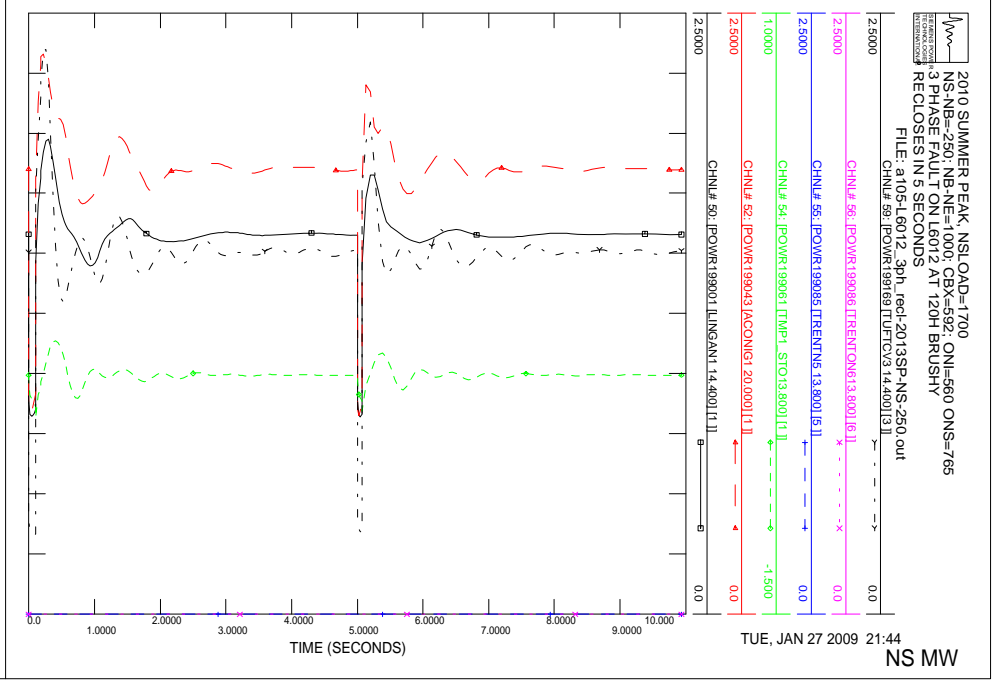
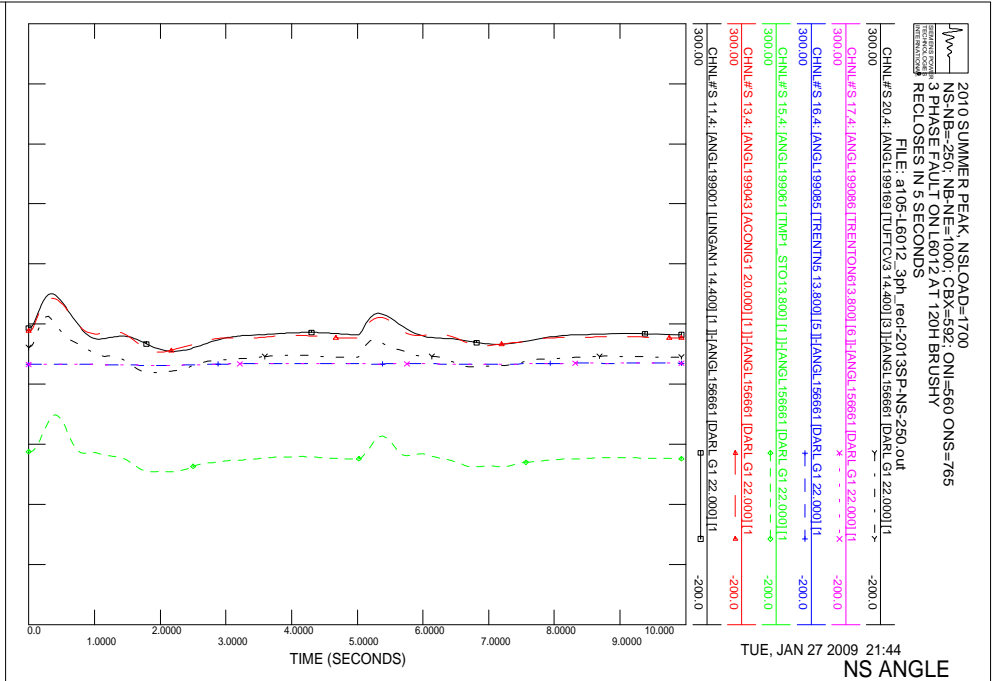
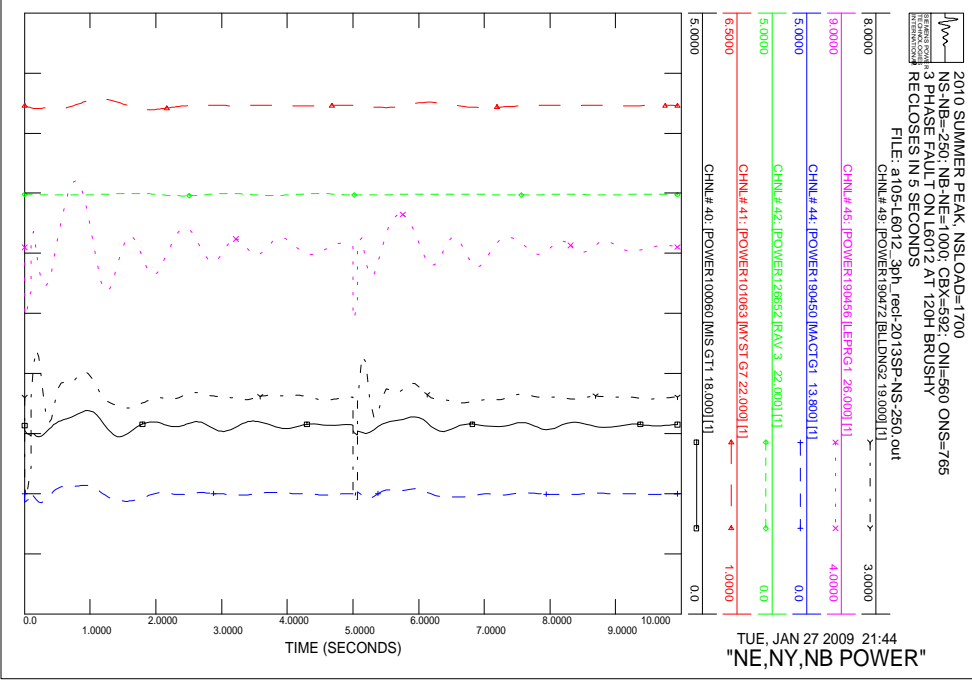
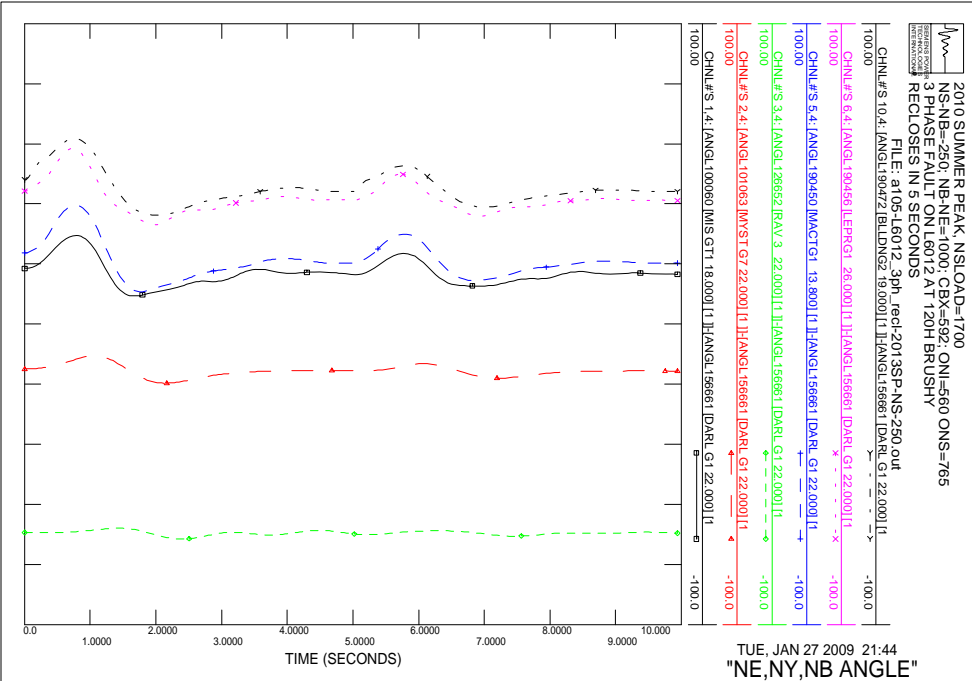

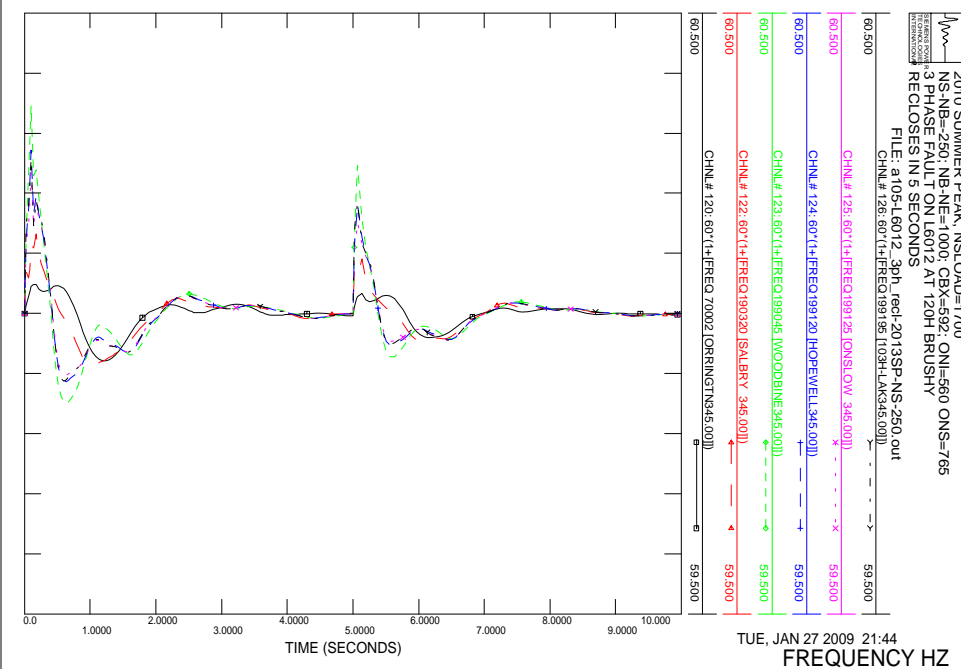
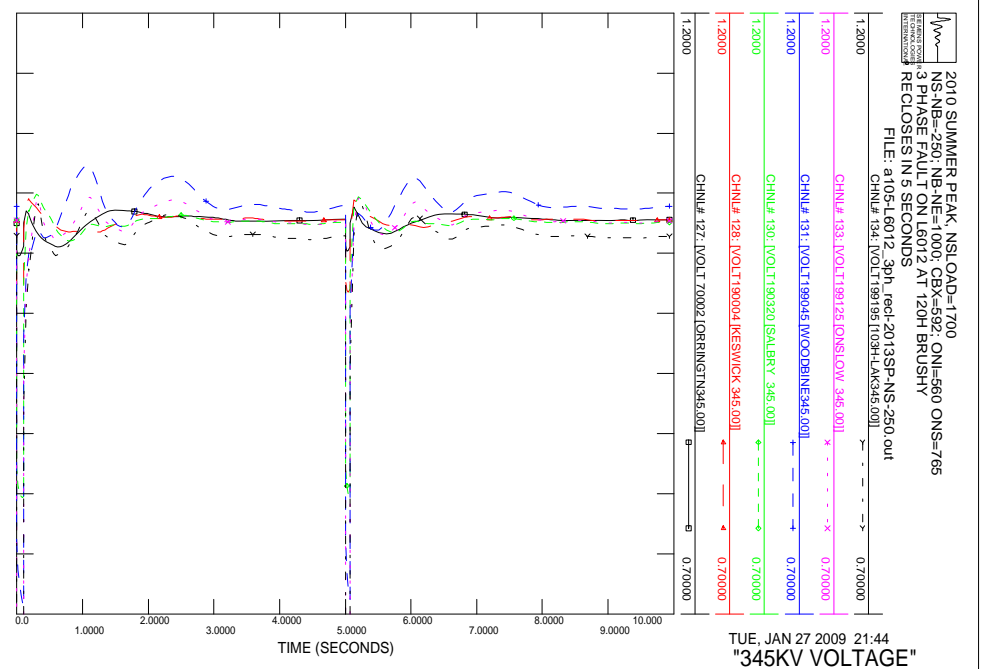
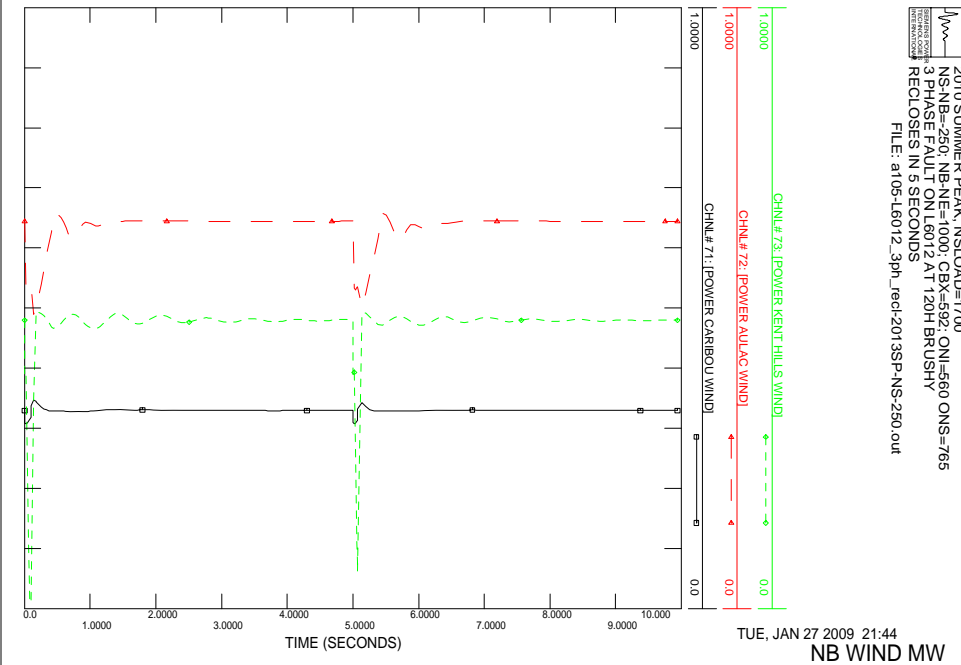
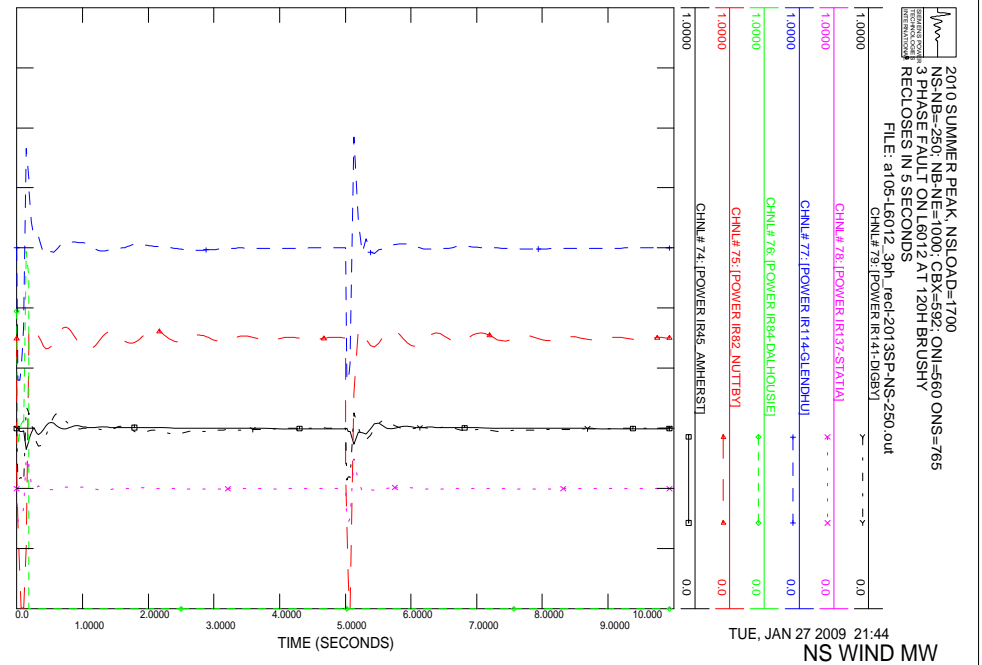

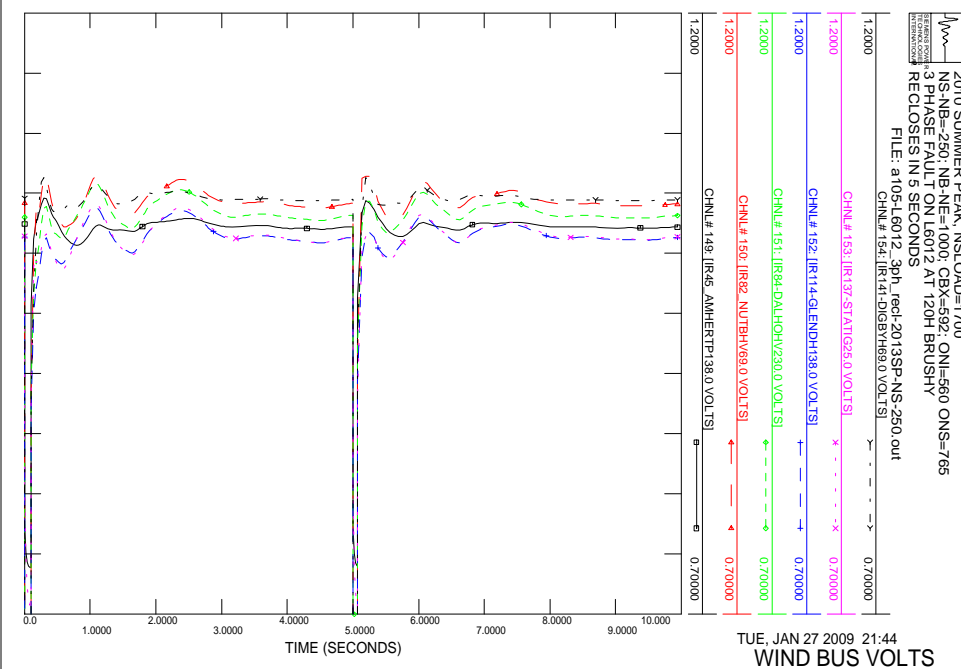
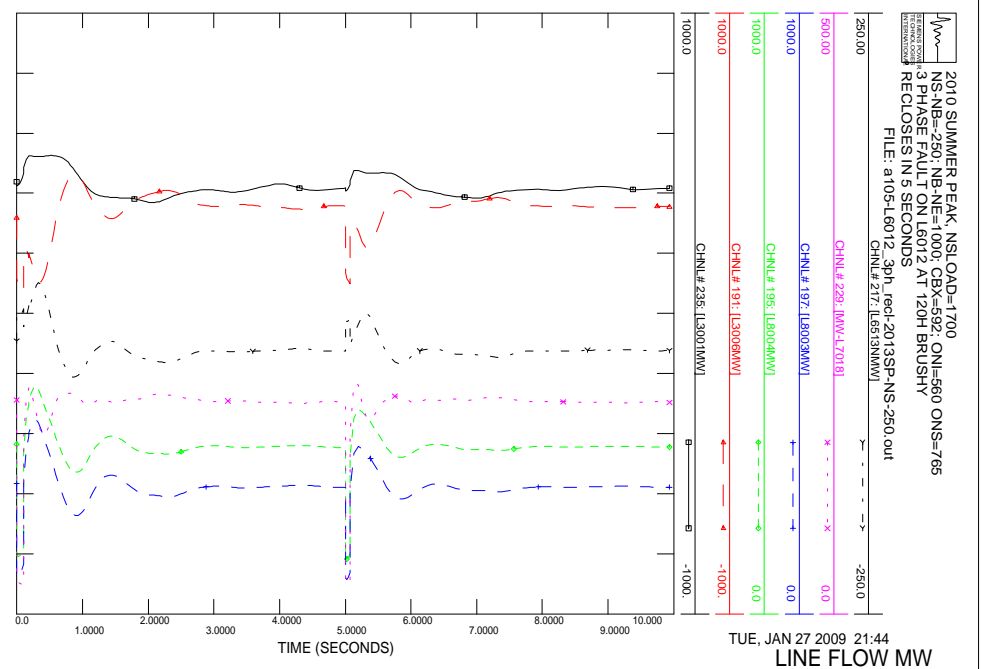
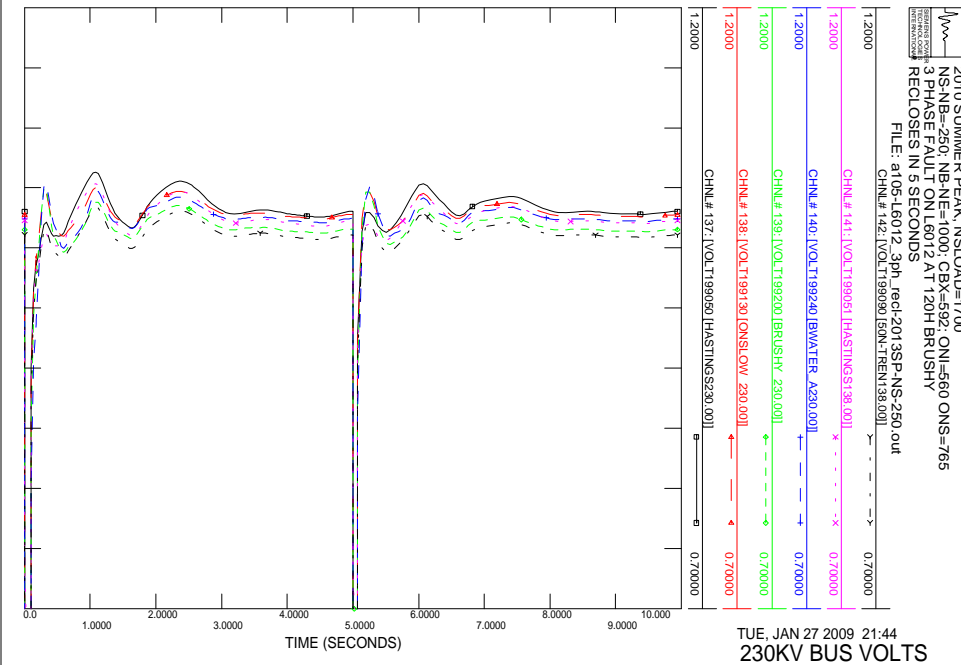
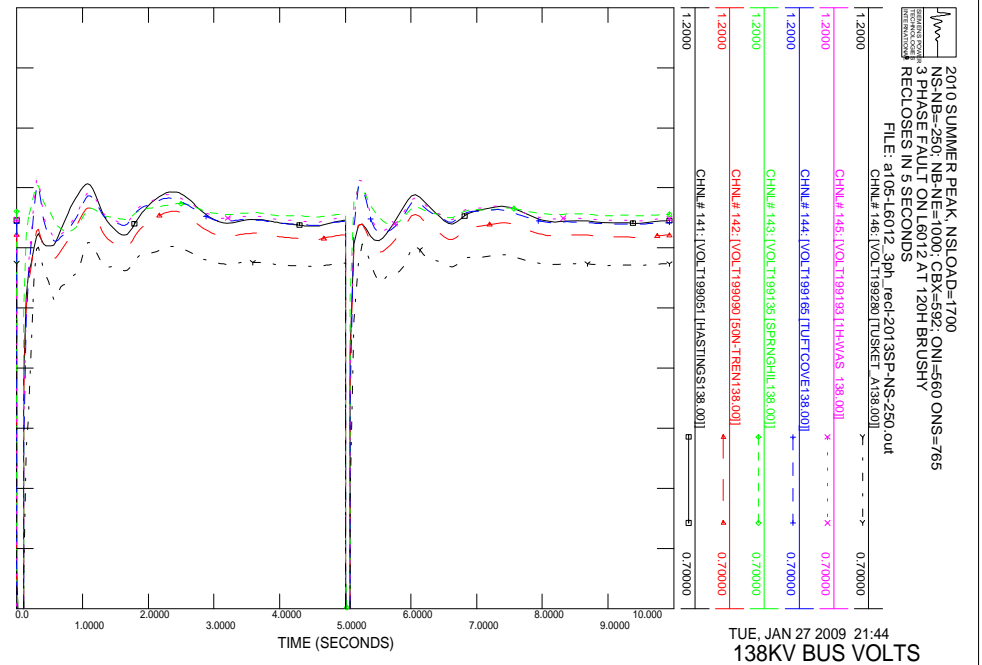

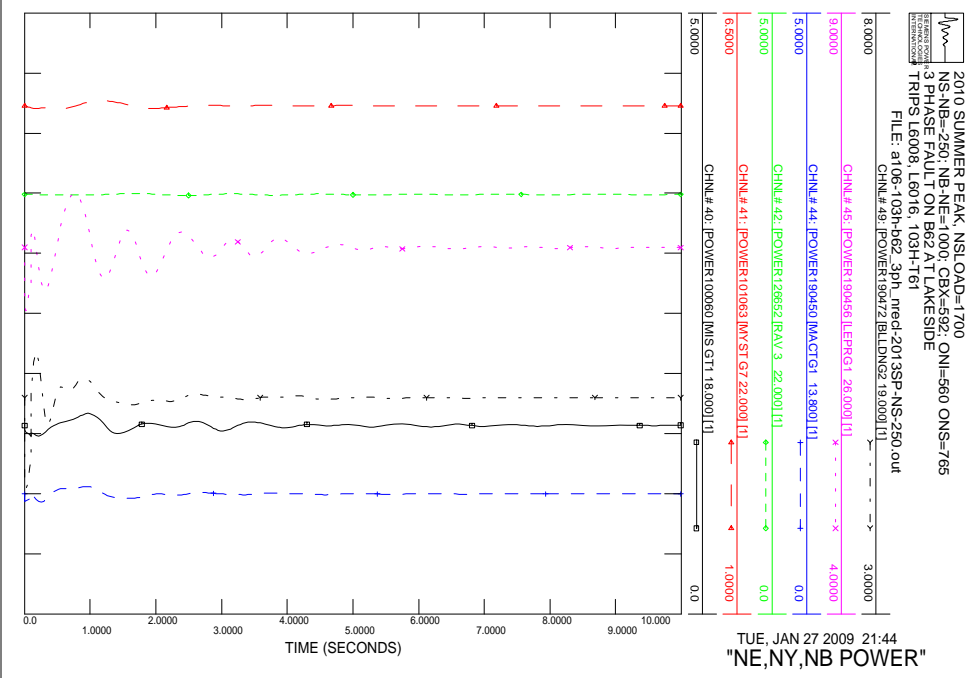
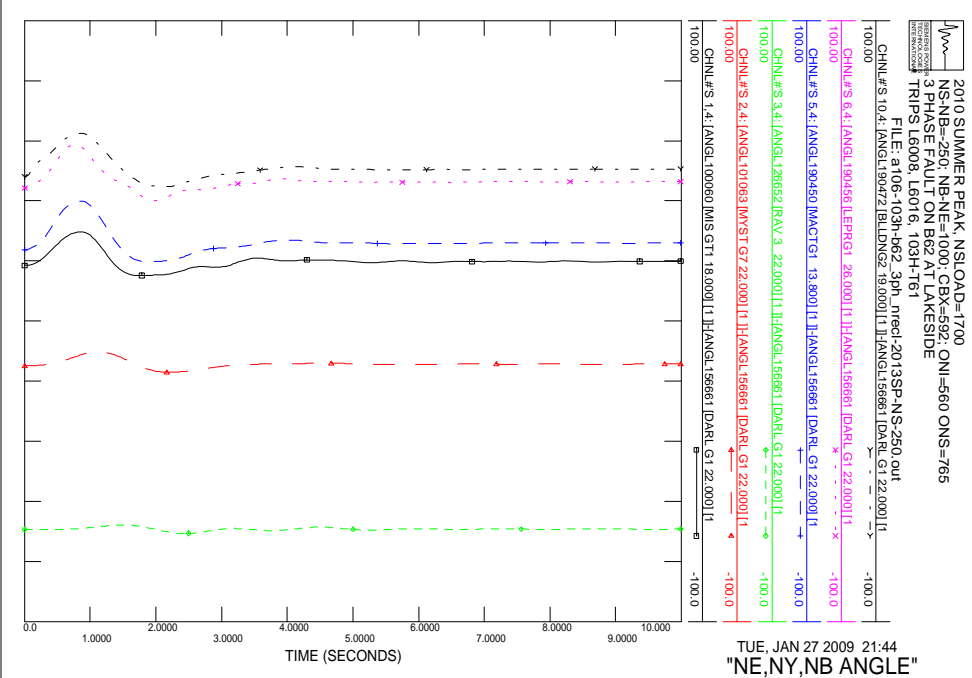
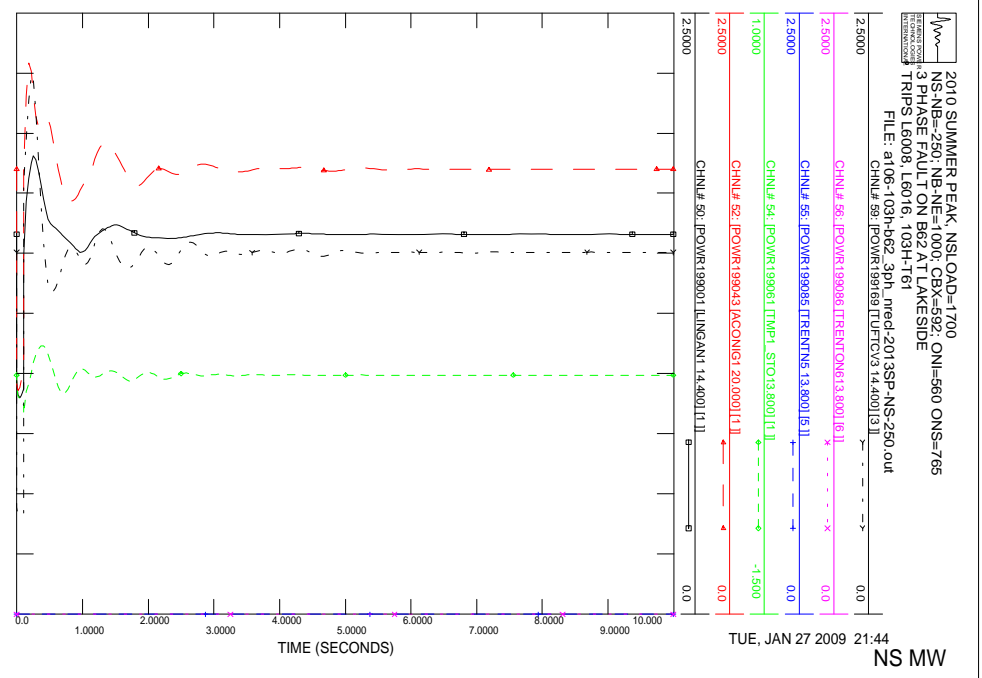
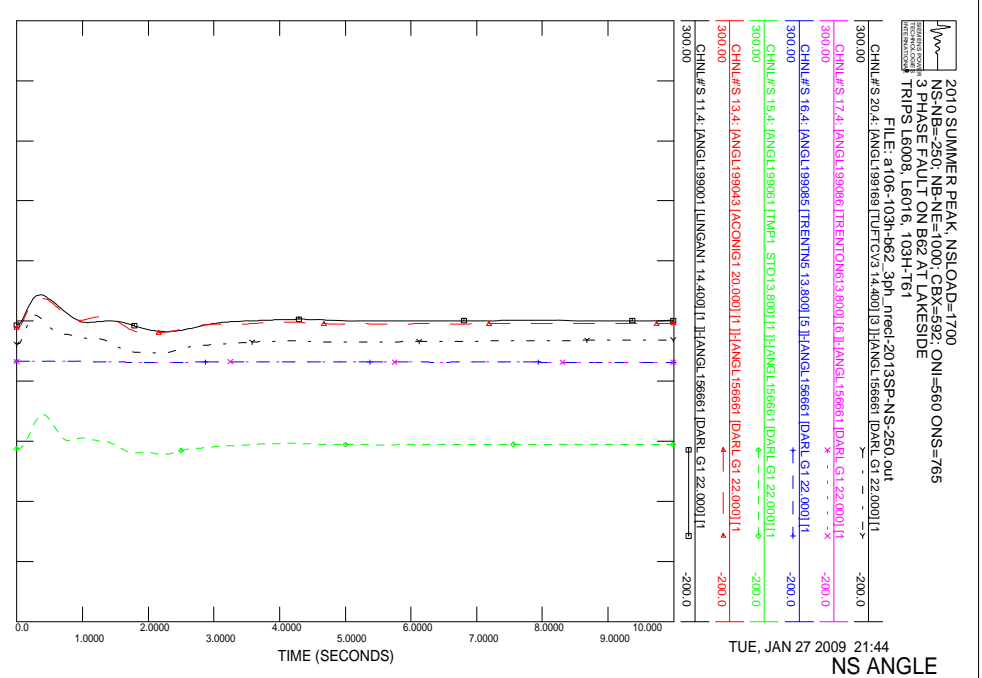

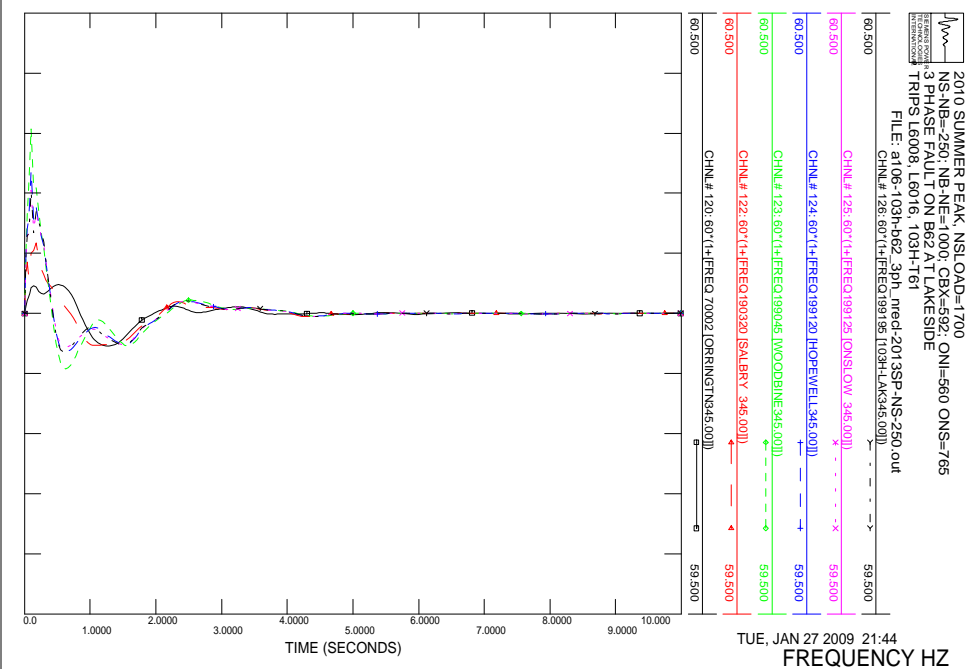
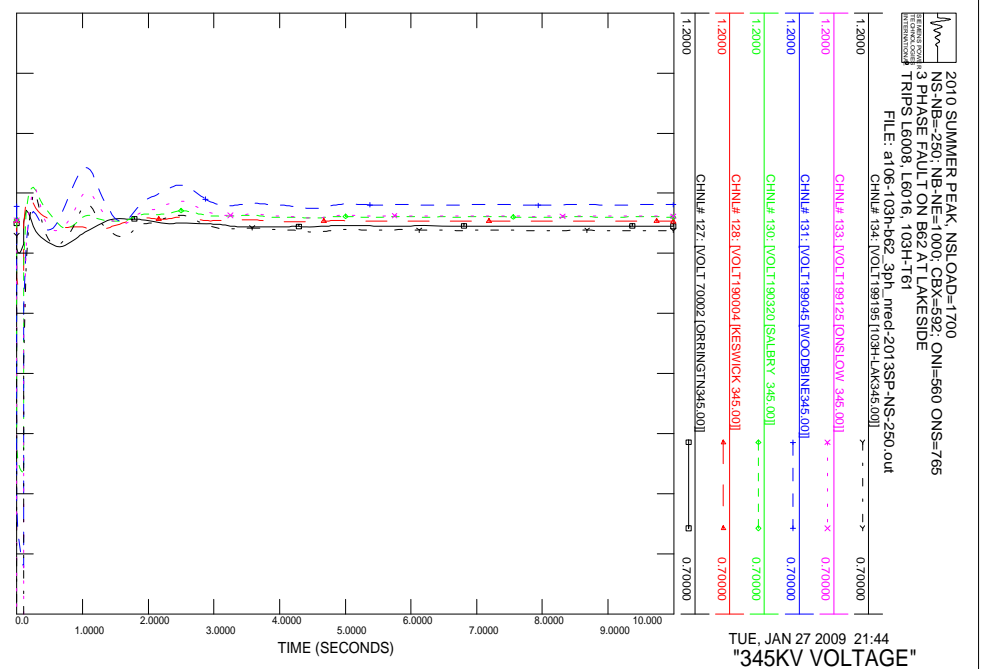
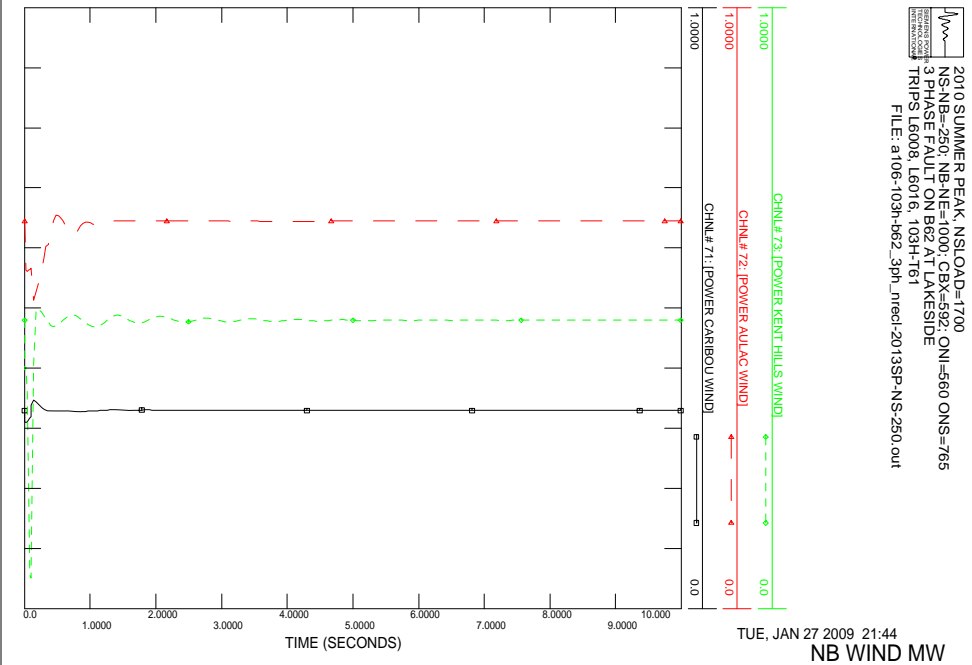
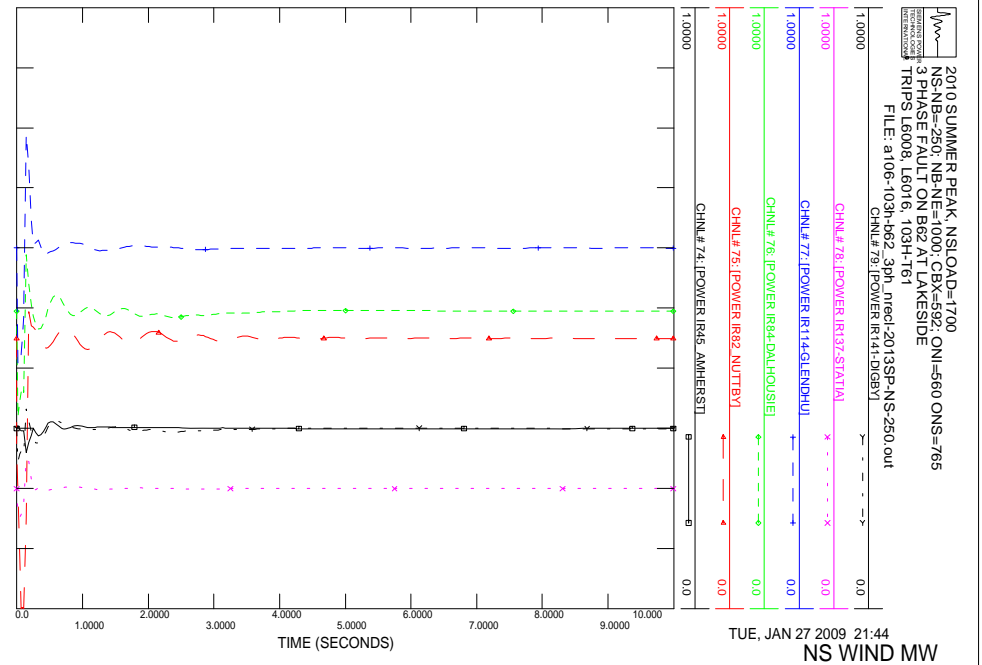

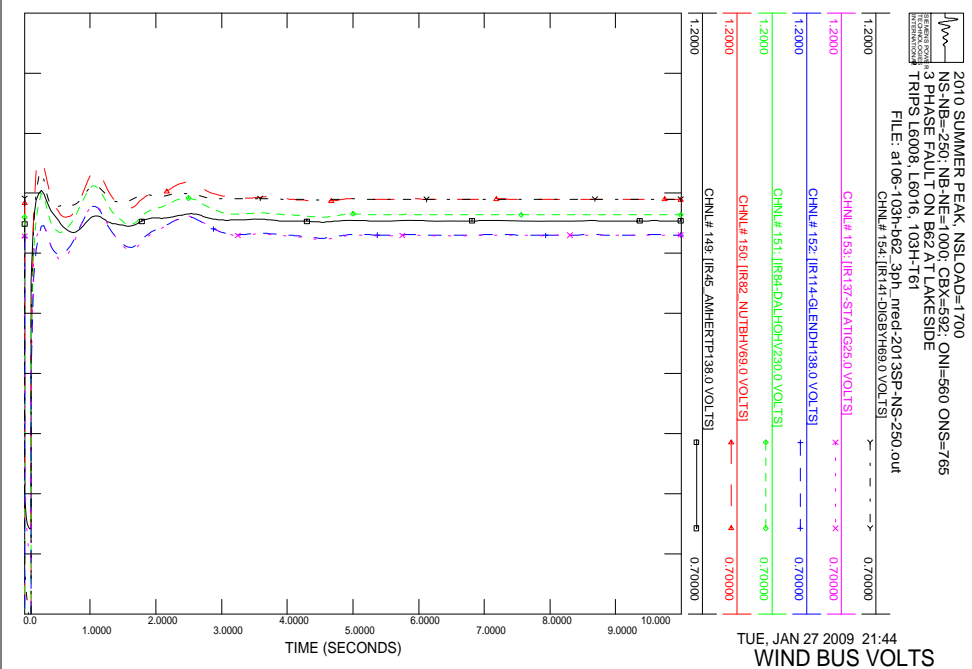
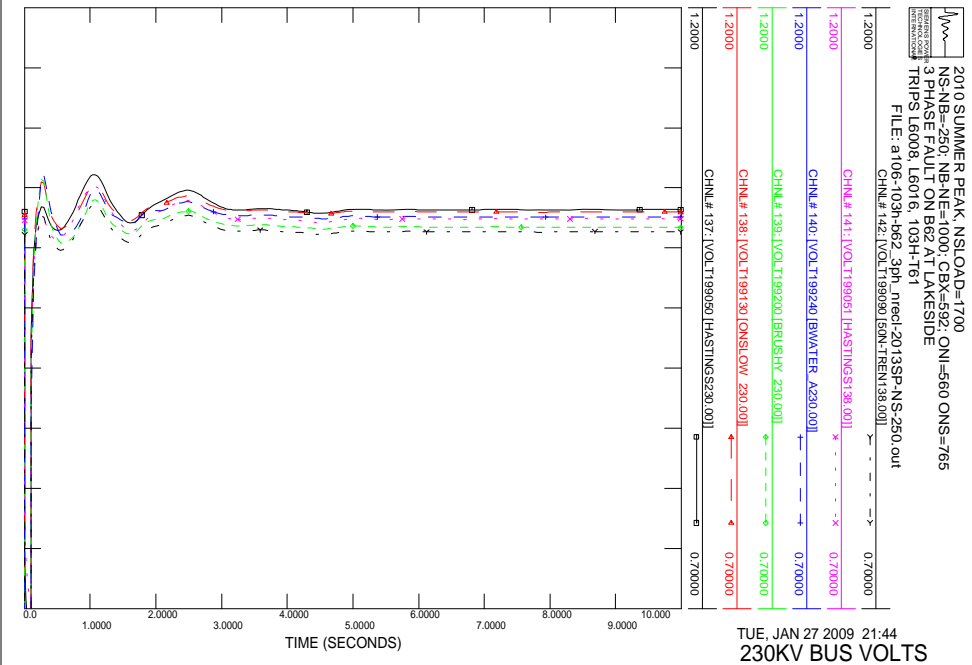
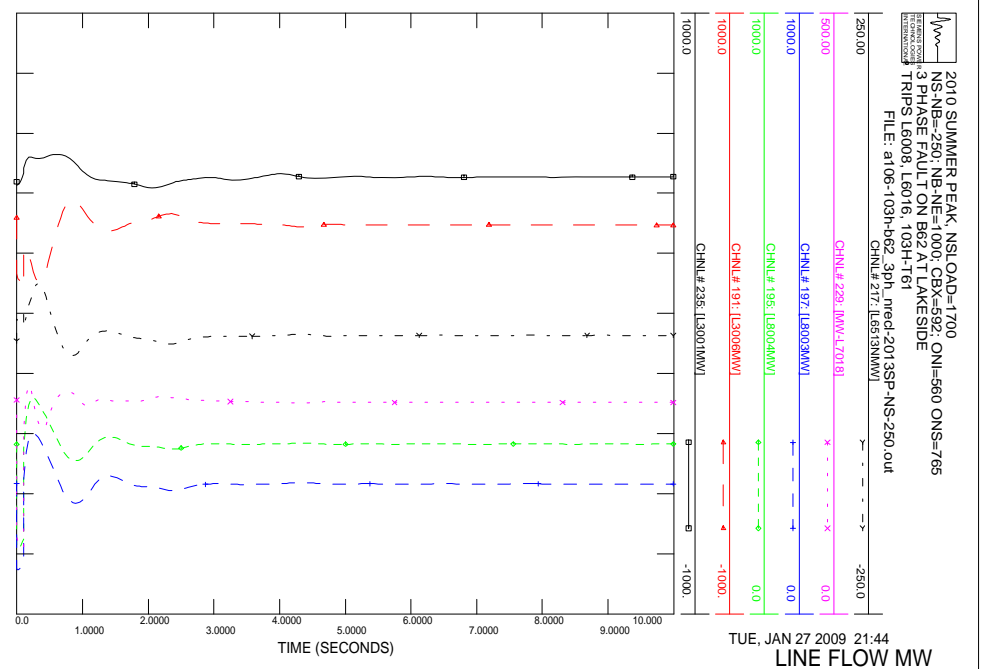
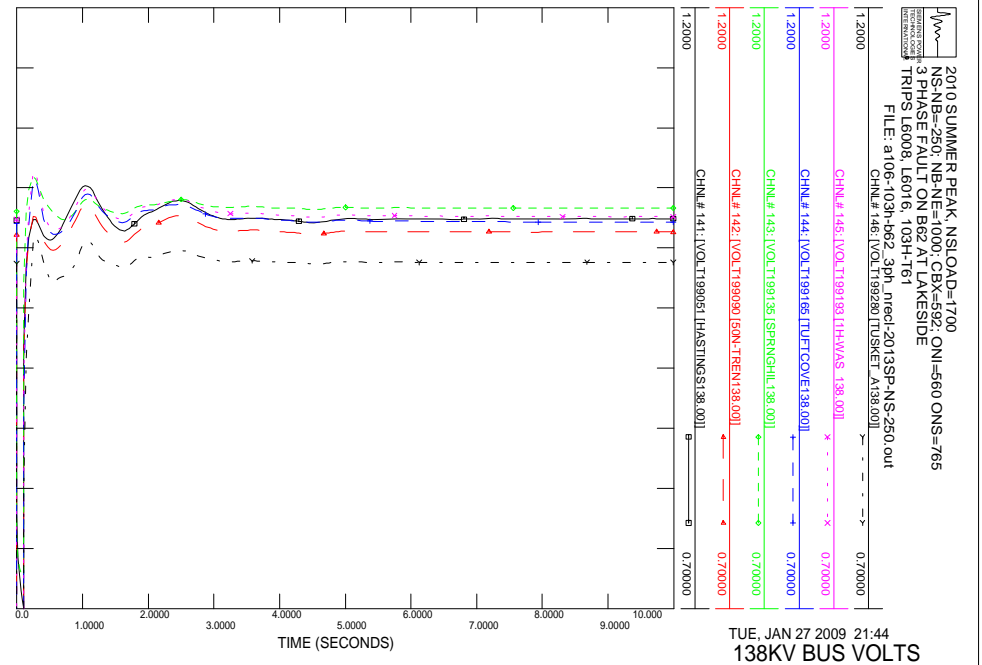

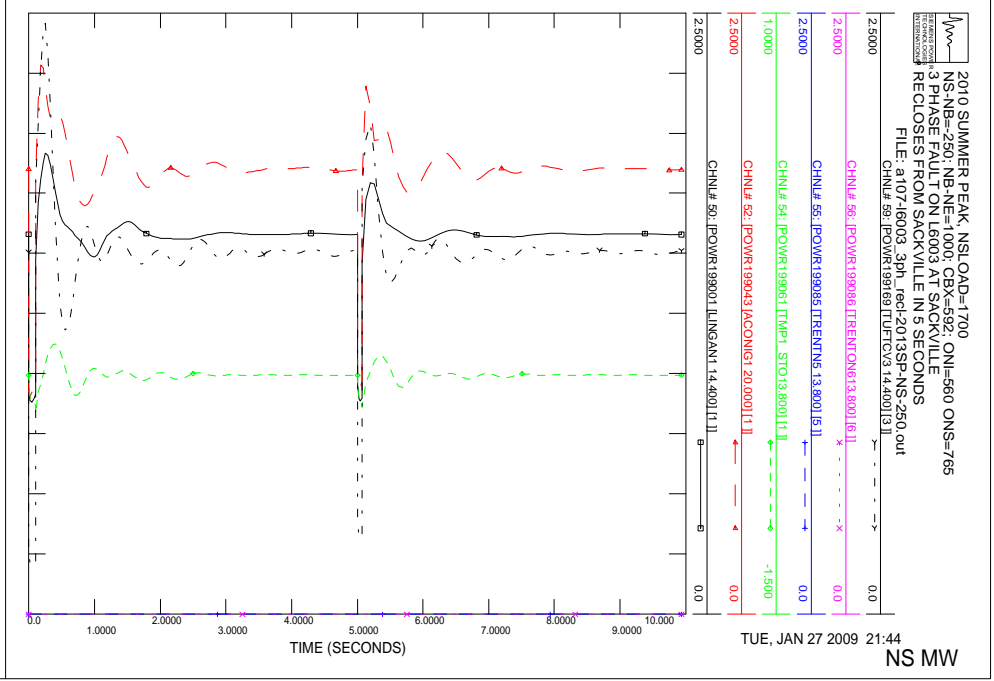
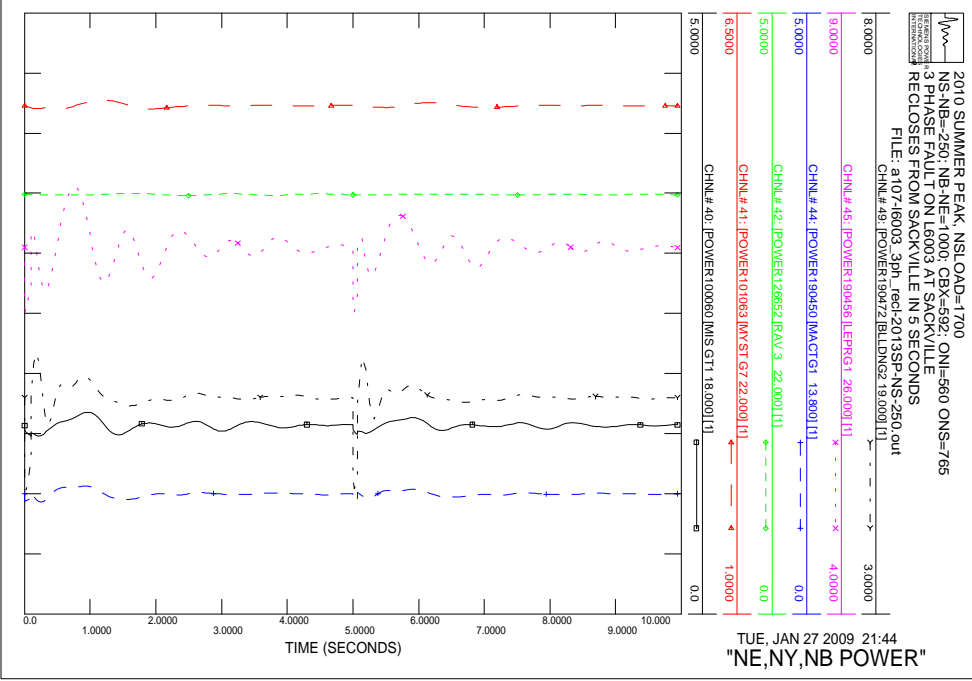
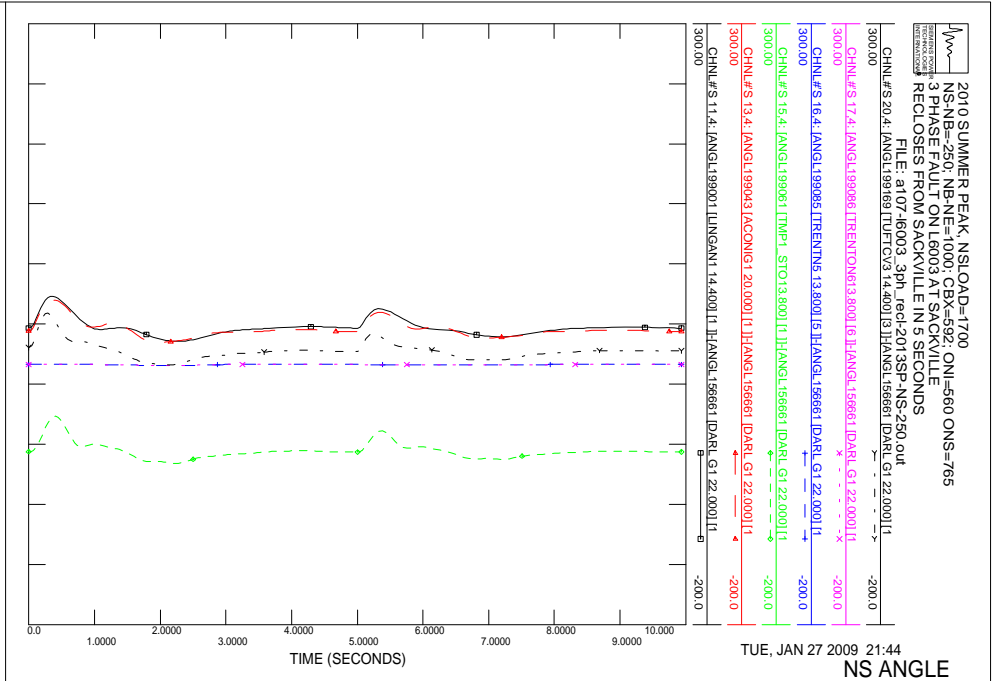
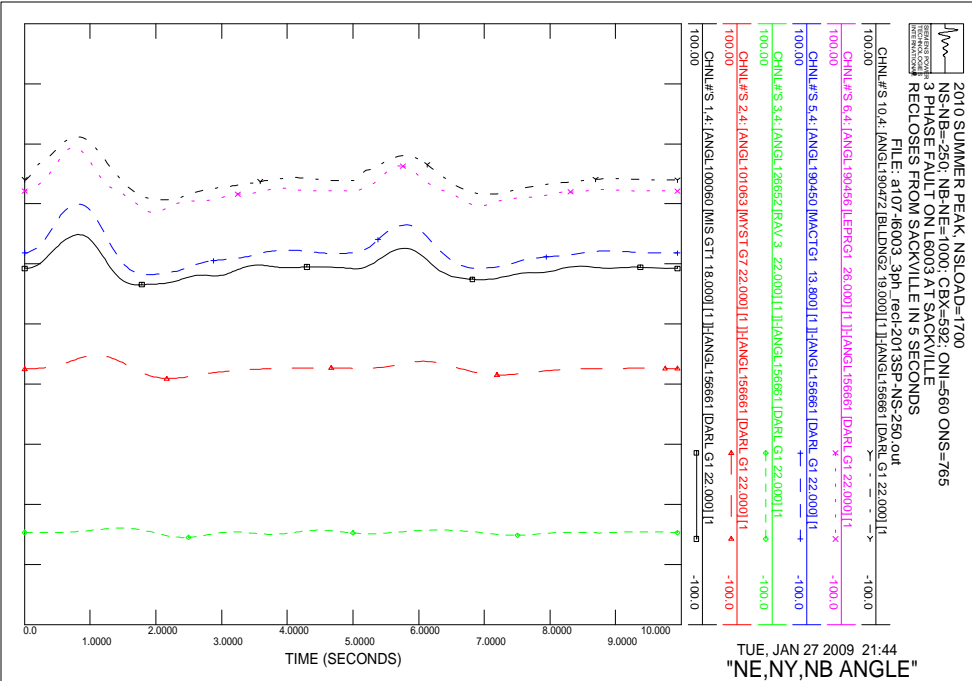

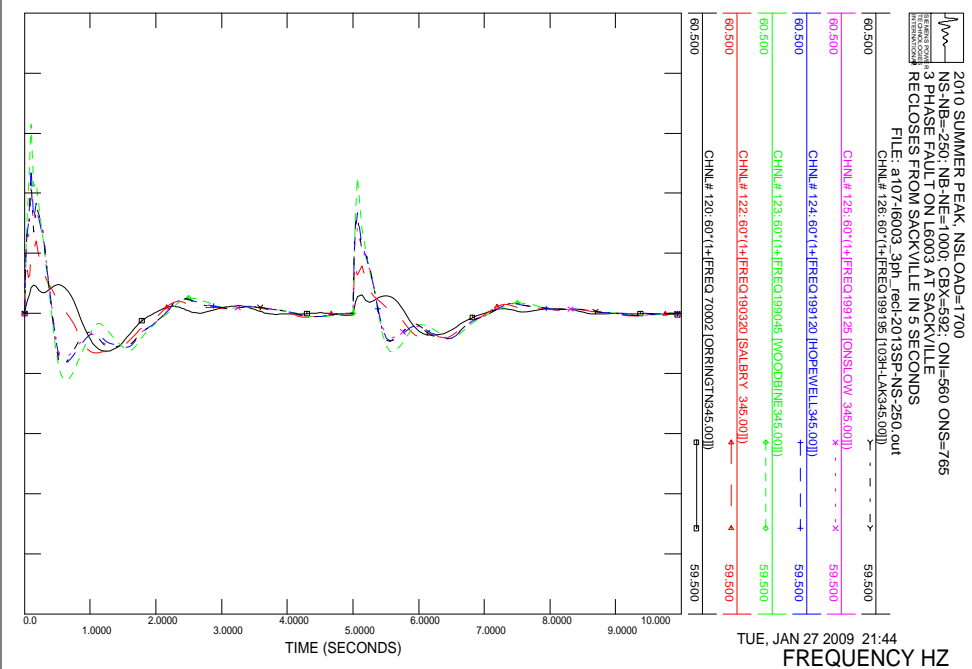
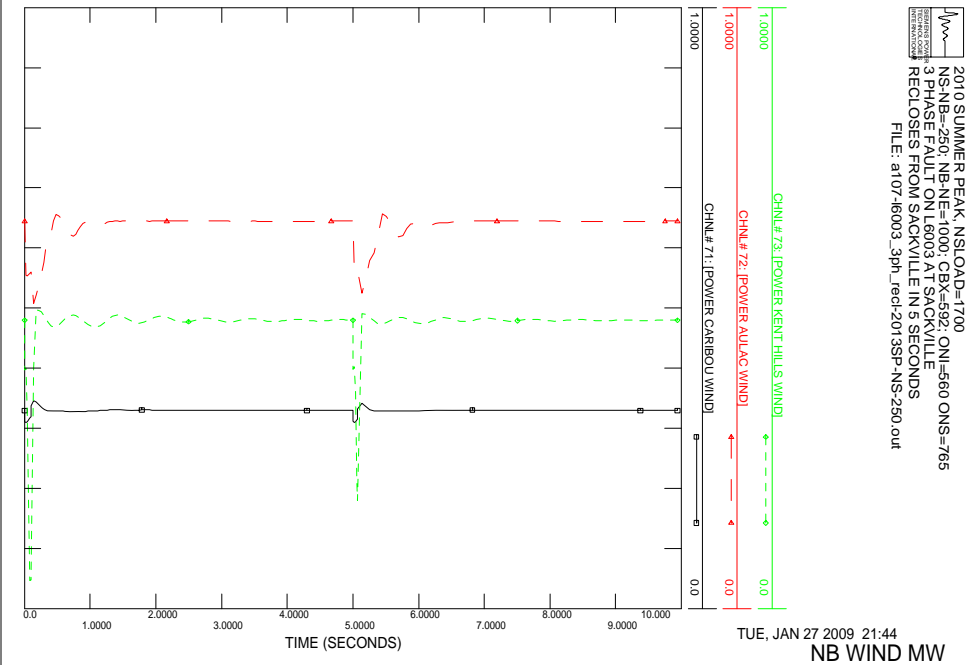
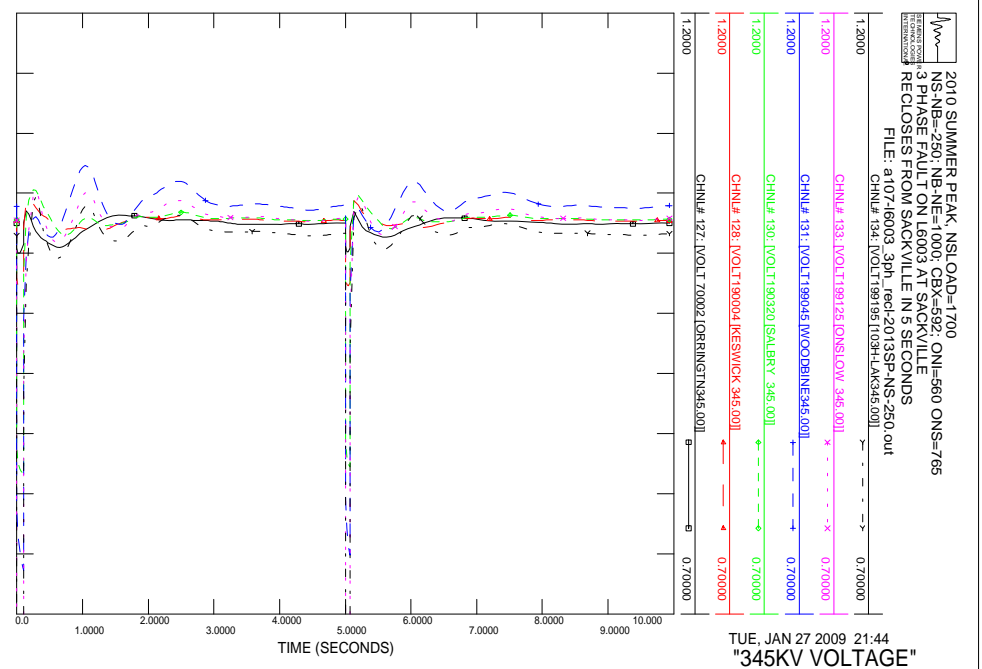
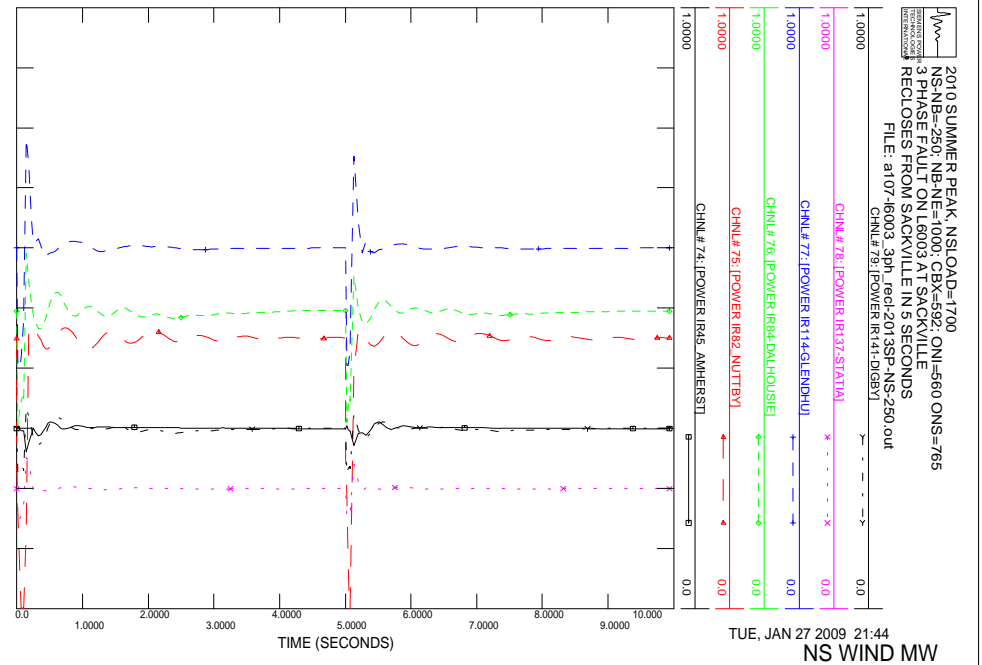

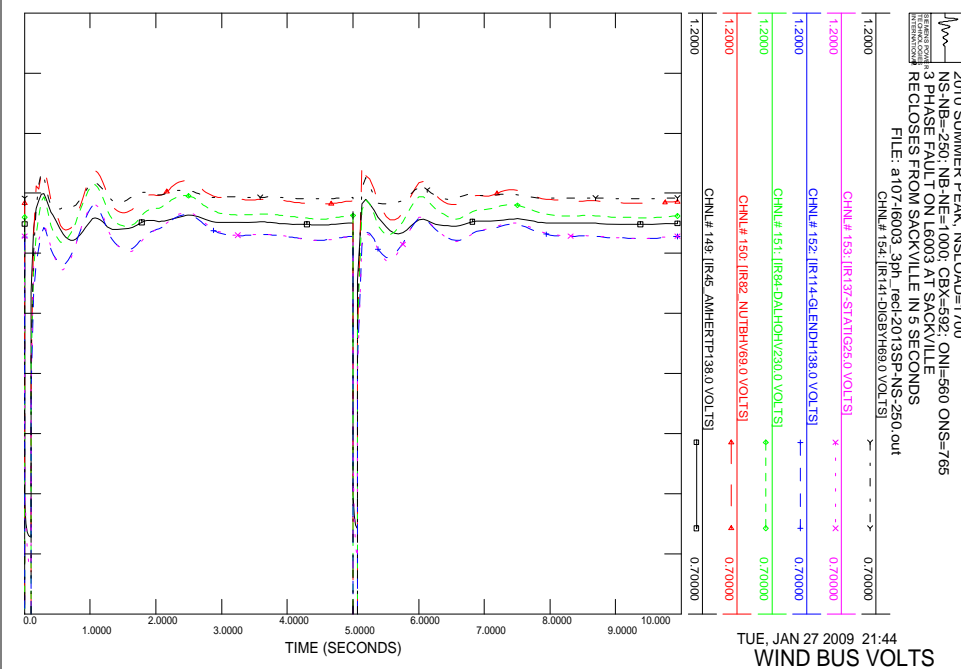
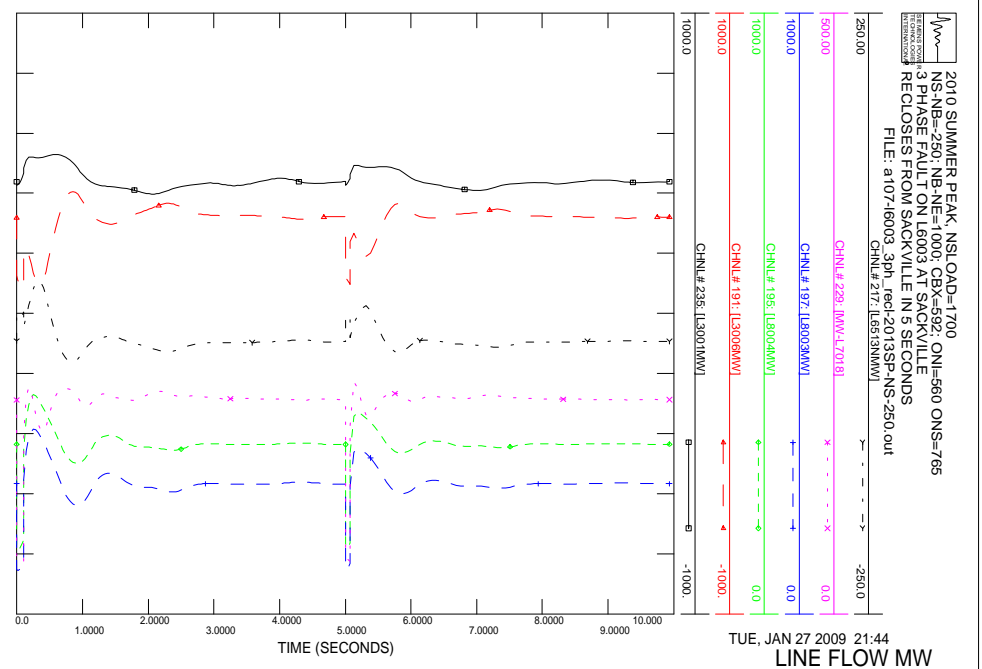
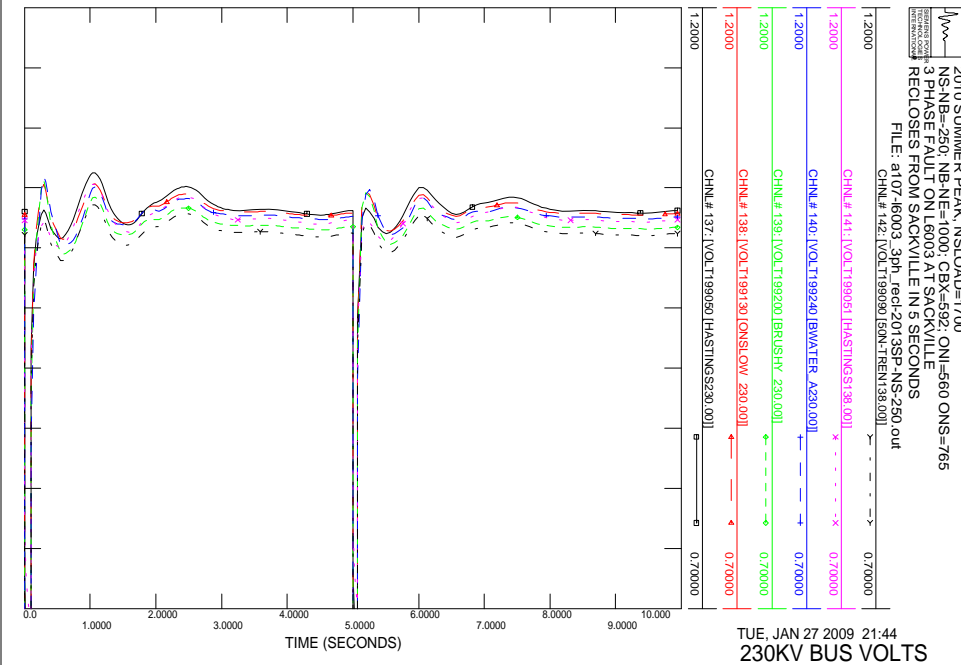
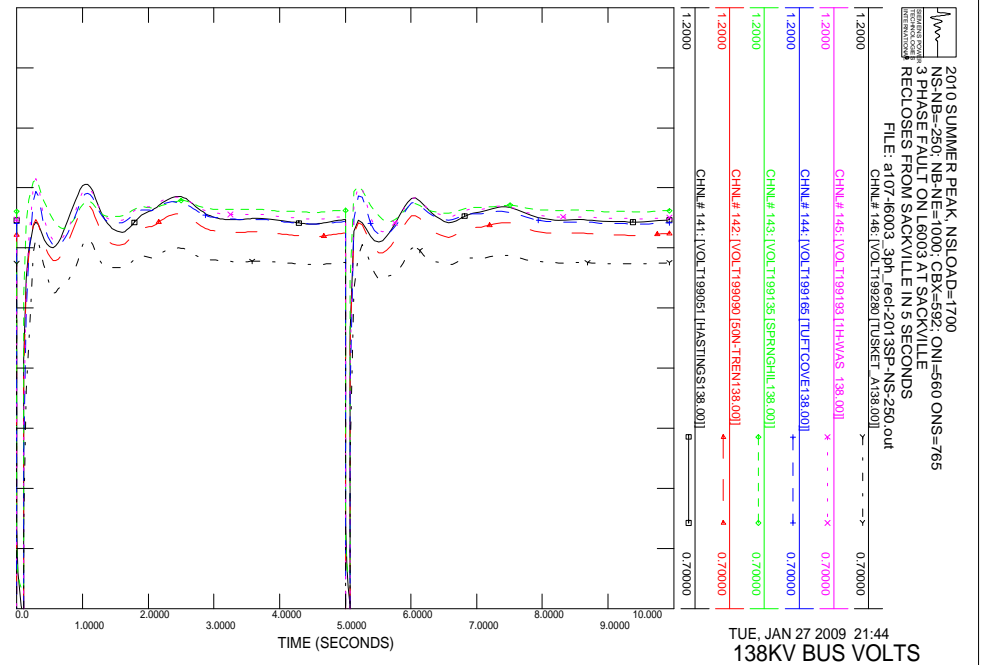

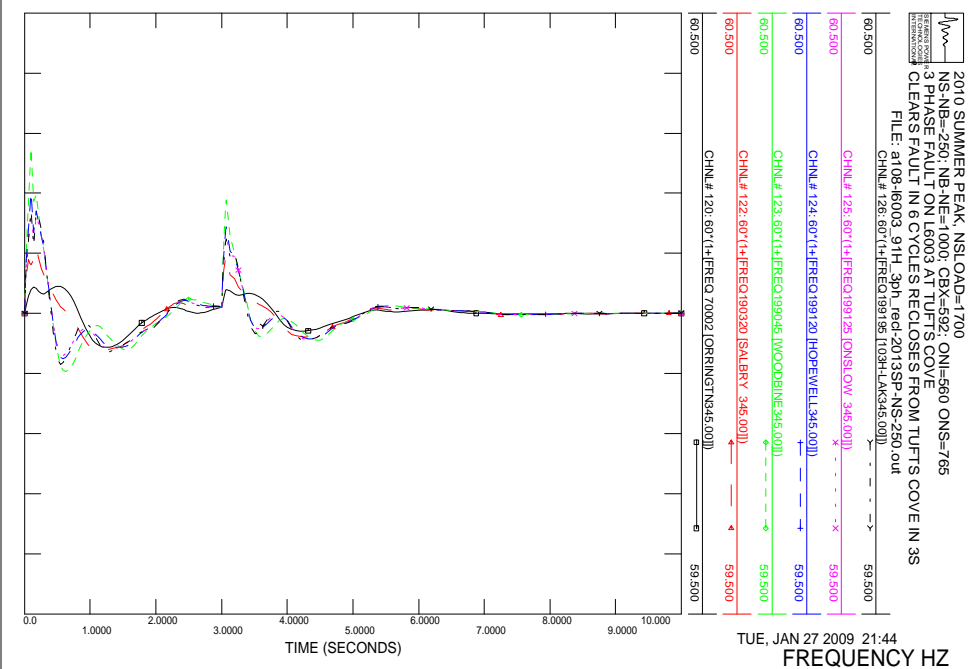
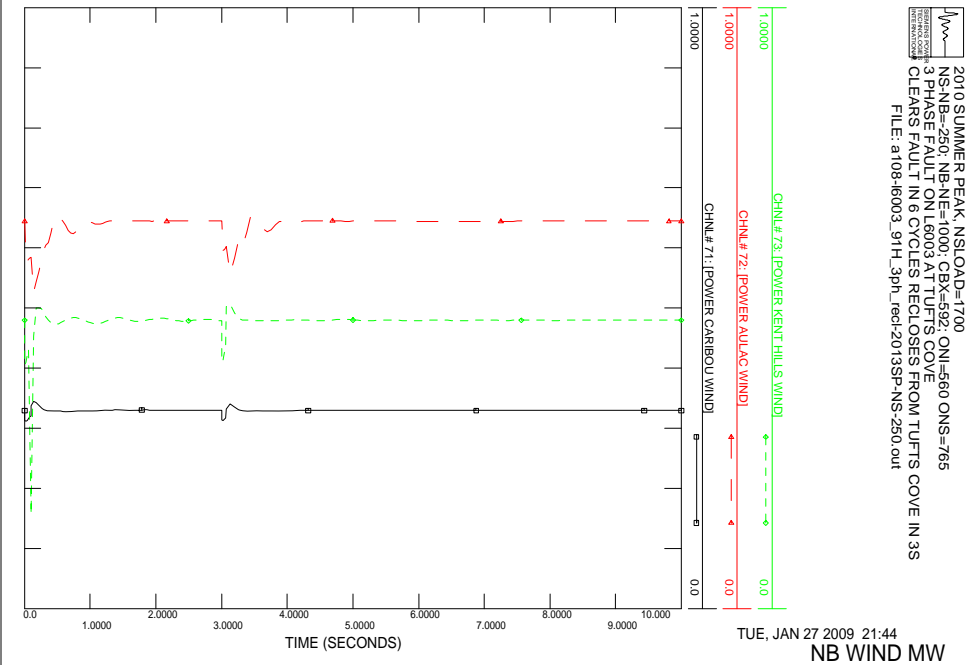
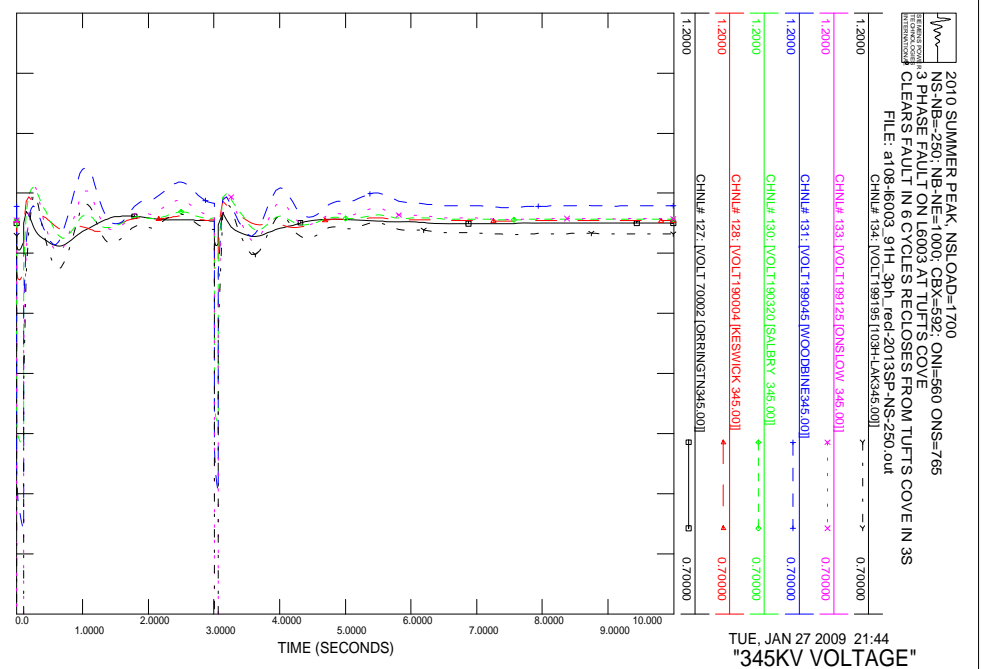
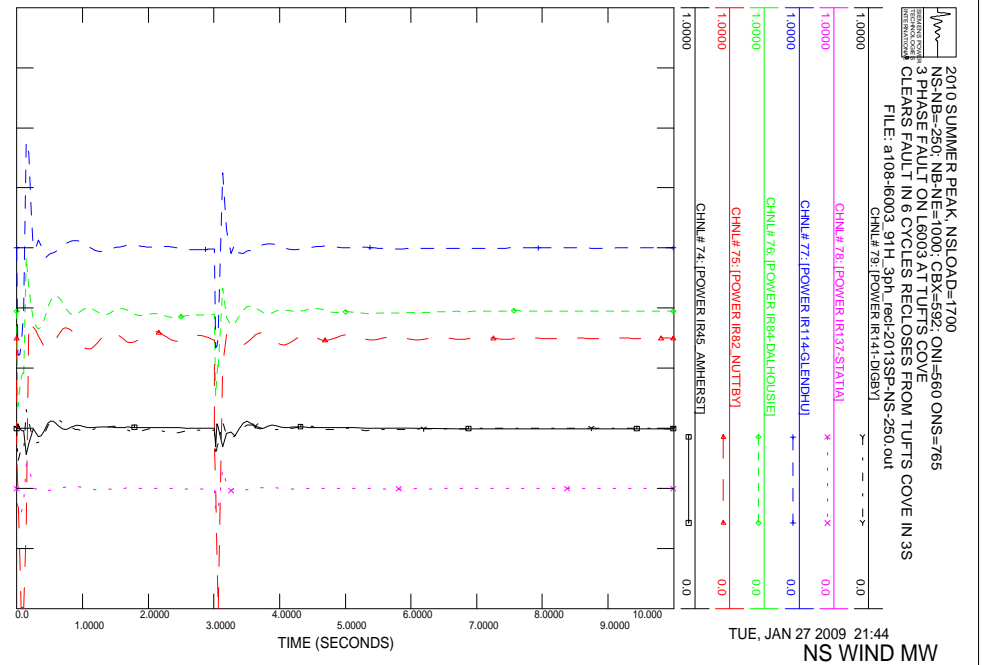

TUE, JAN 27 2009 21:44 NS WIND MW

TUE, JAN 27 2009 21:44 "345KV VOLTAGE"

TUE, JAN 27 2009 21:44 NB WIND MW

TUE, JAN 27 2009 21:44 FREQUENCY HZ

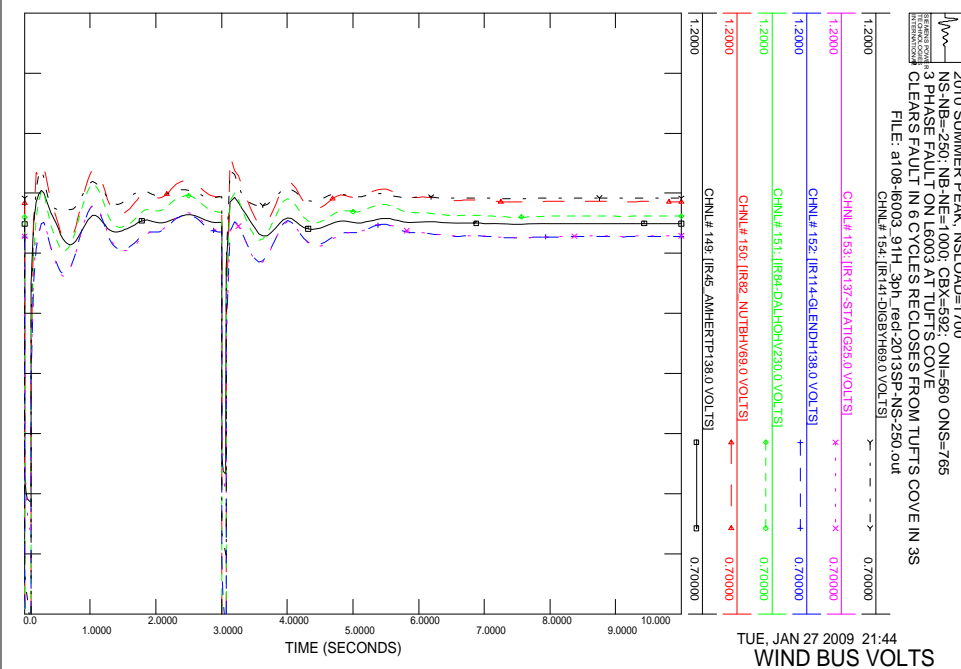
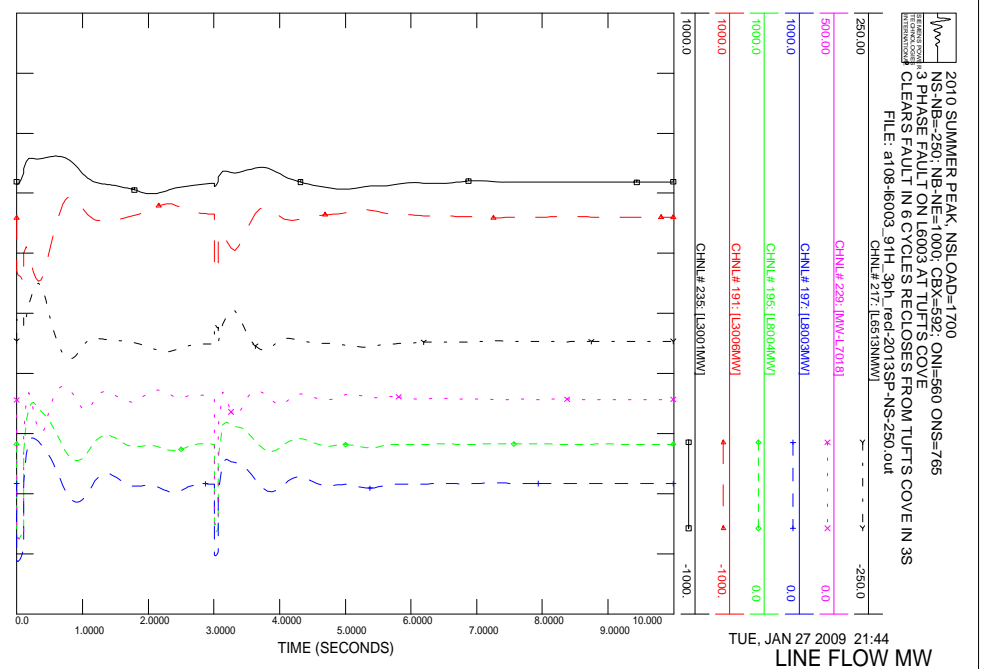
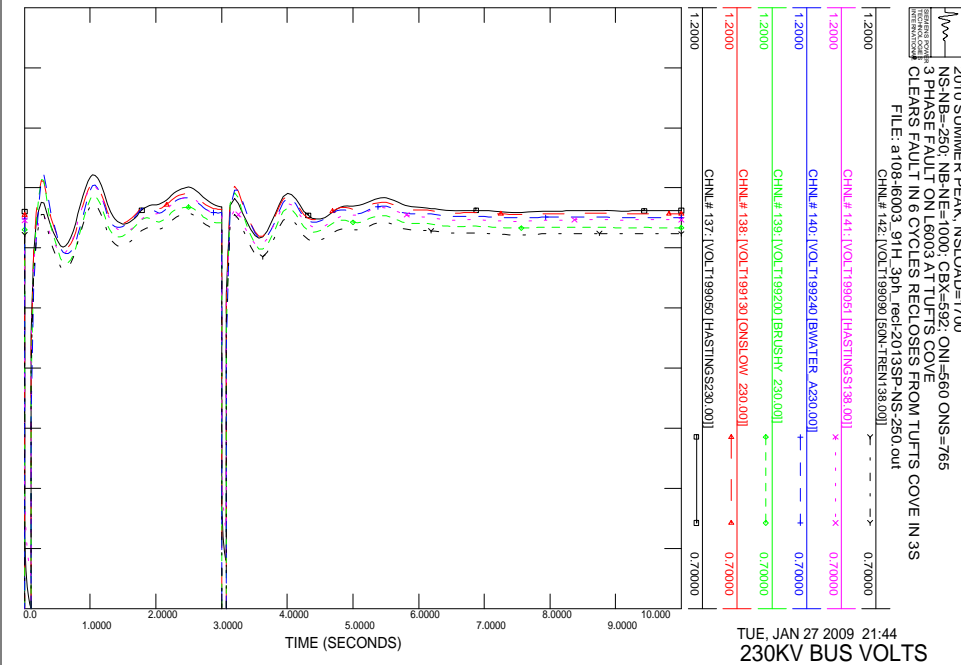
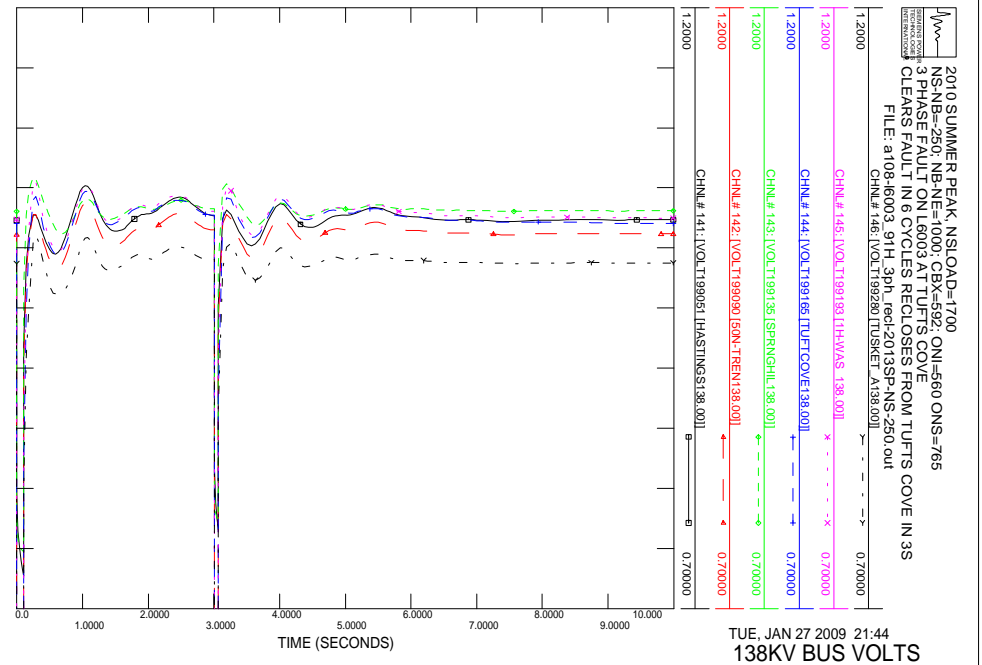

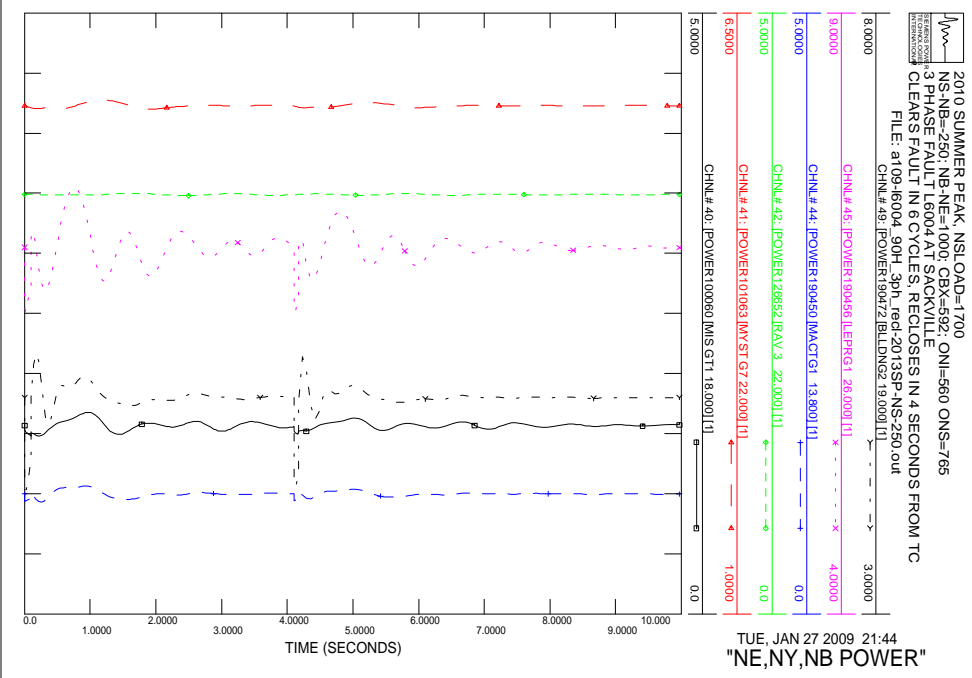
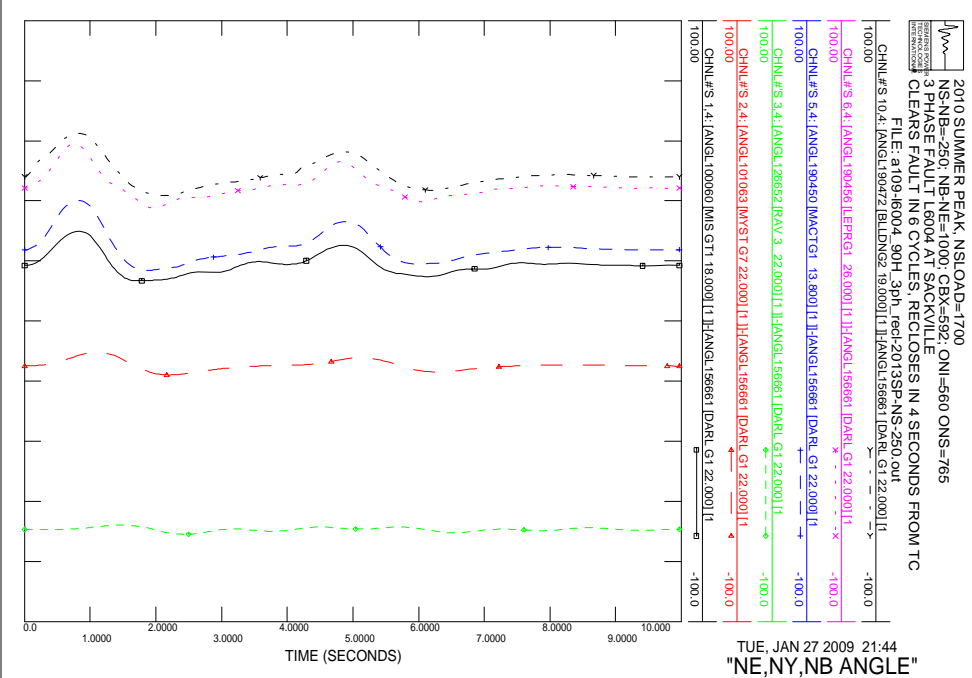
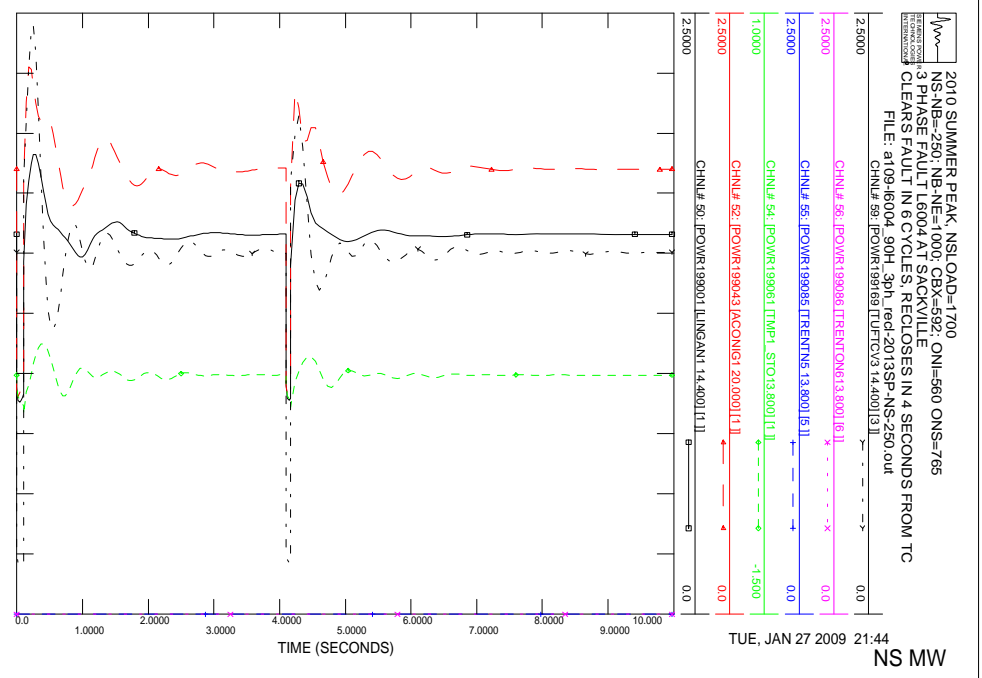
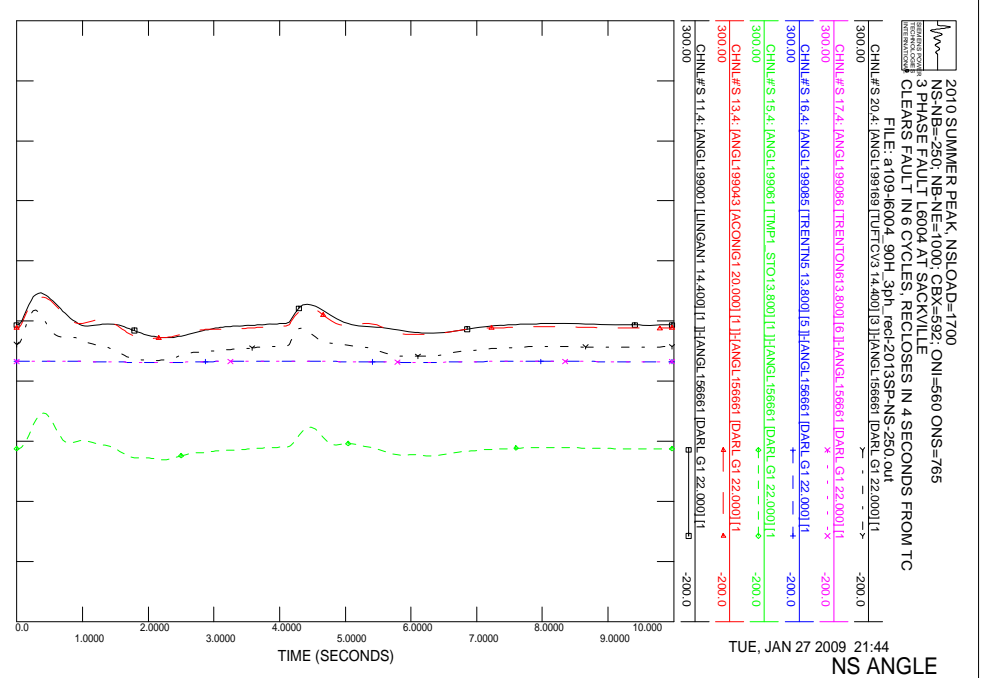

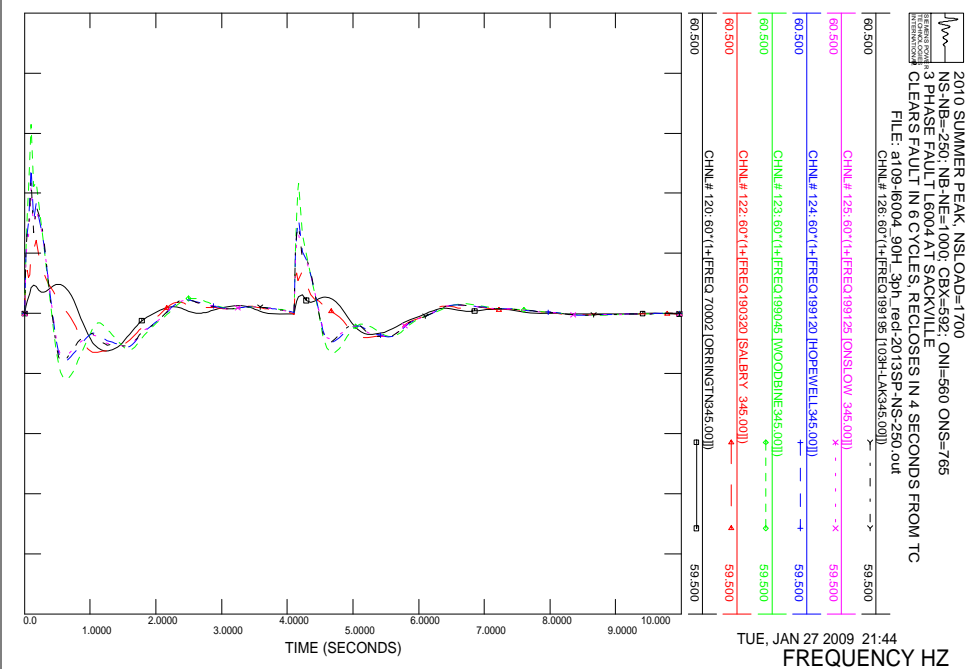
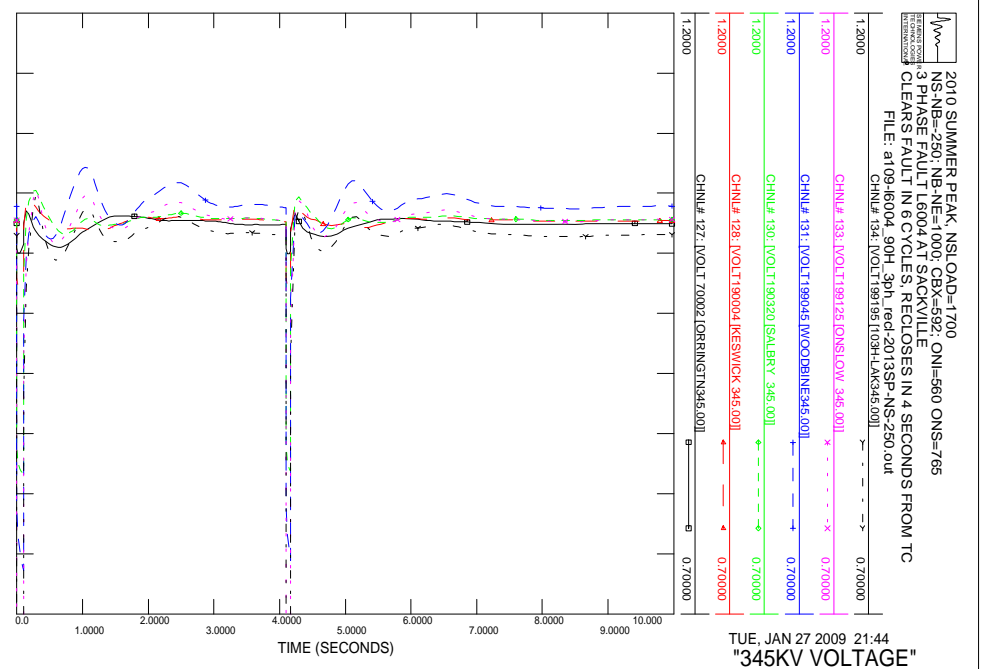
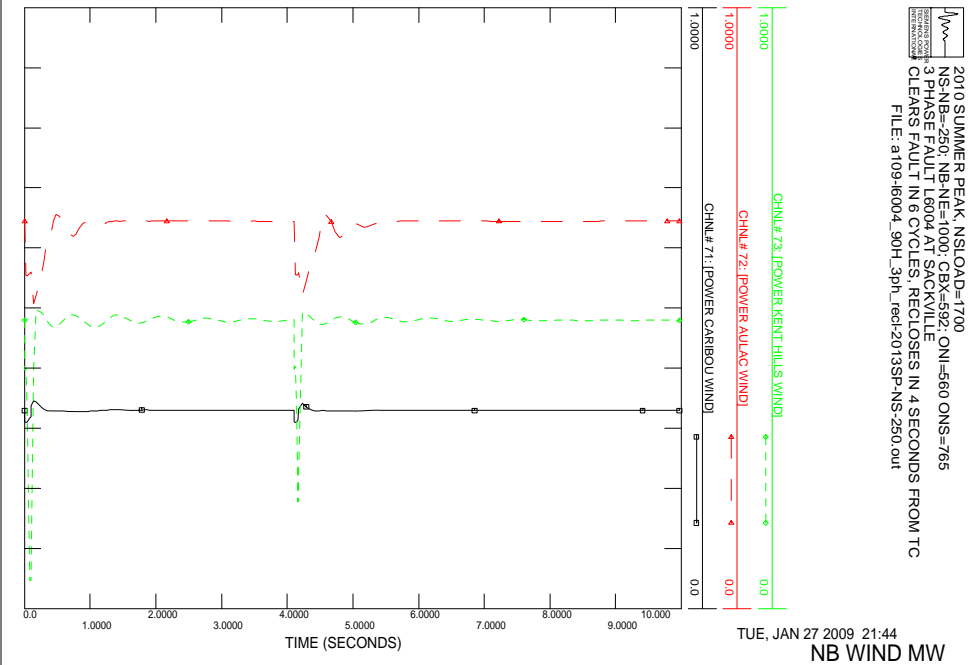
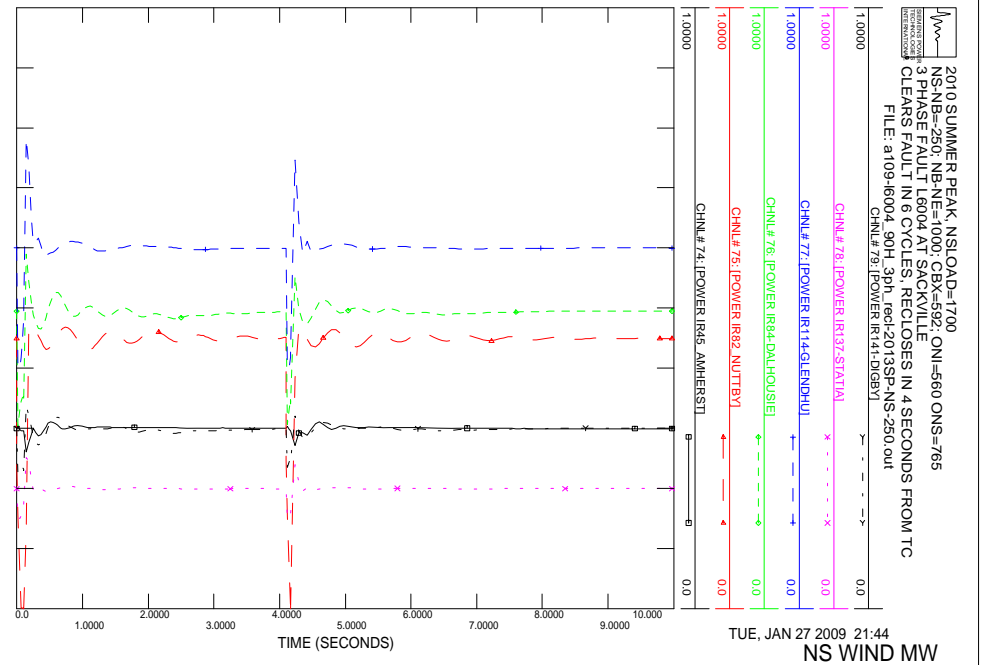

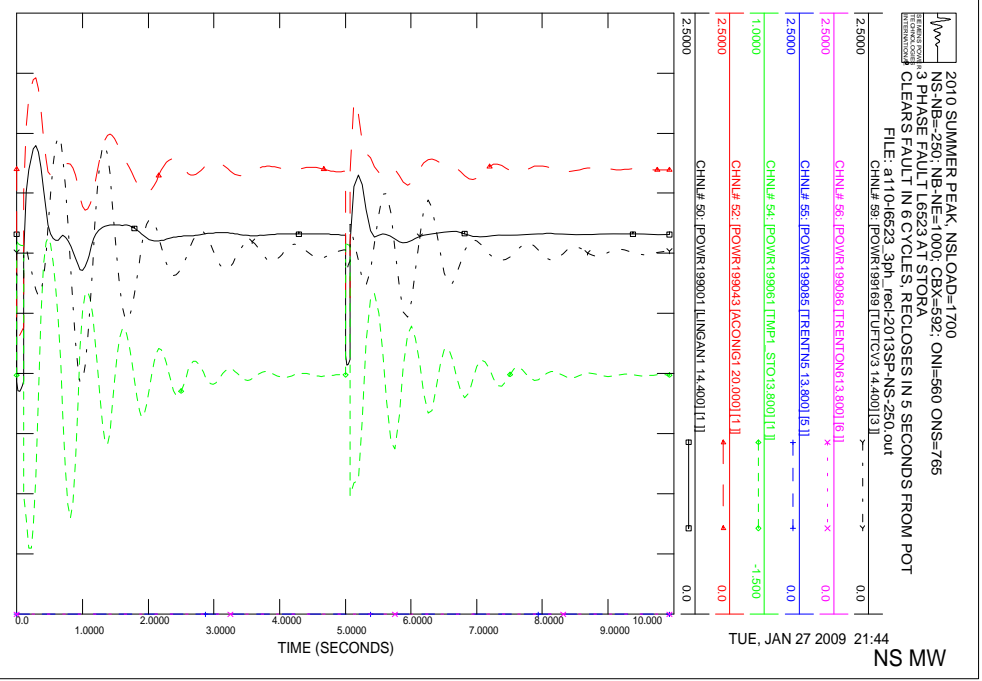
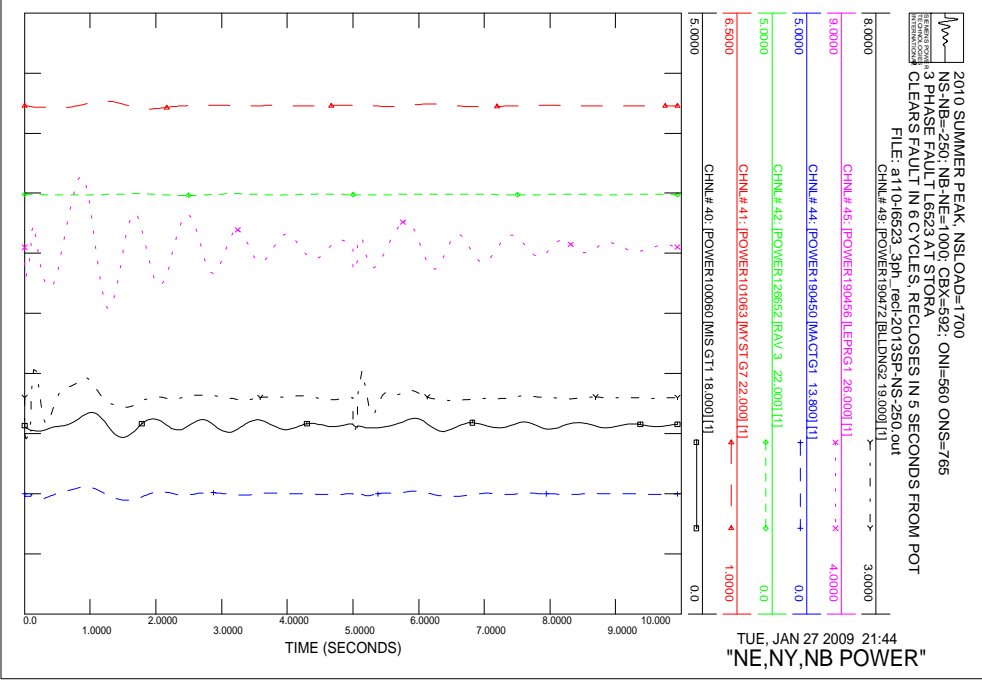
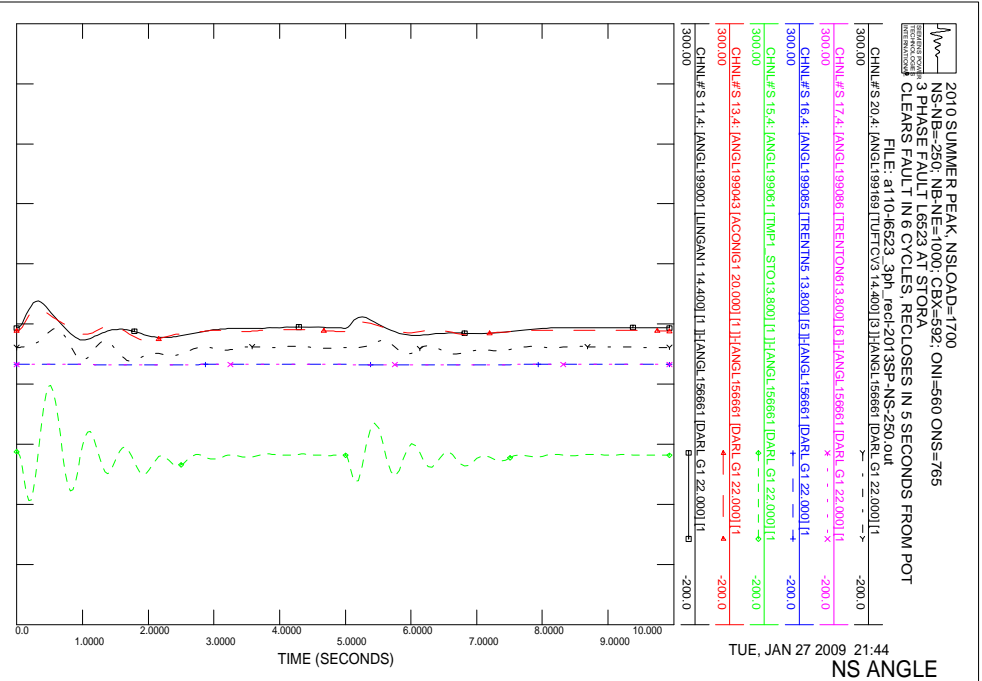
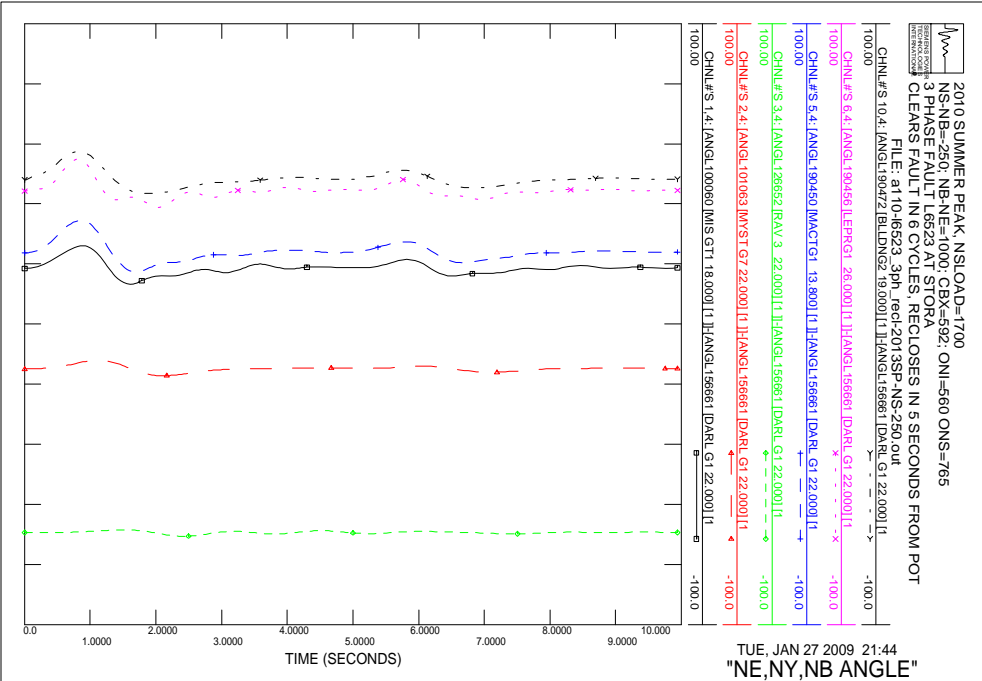

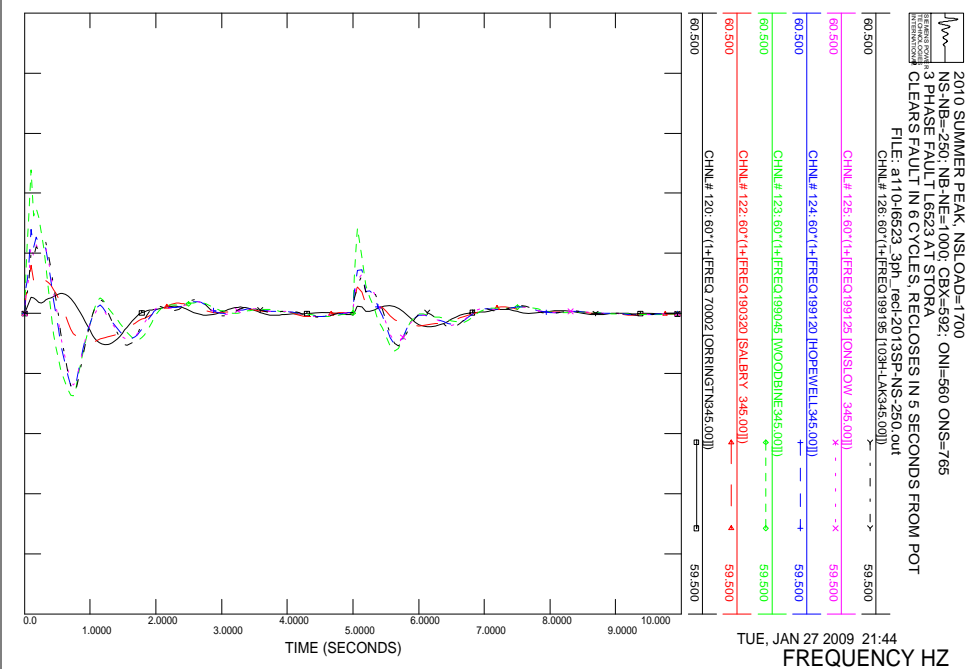
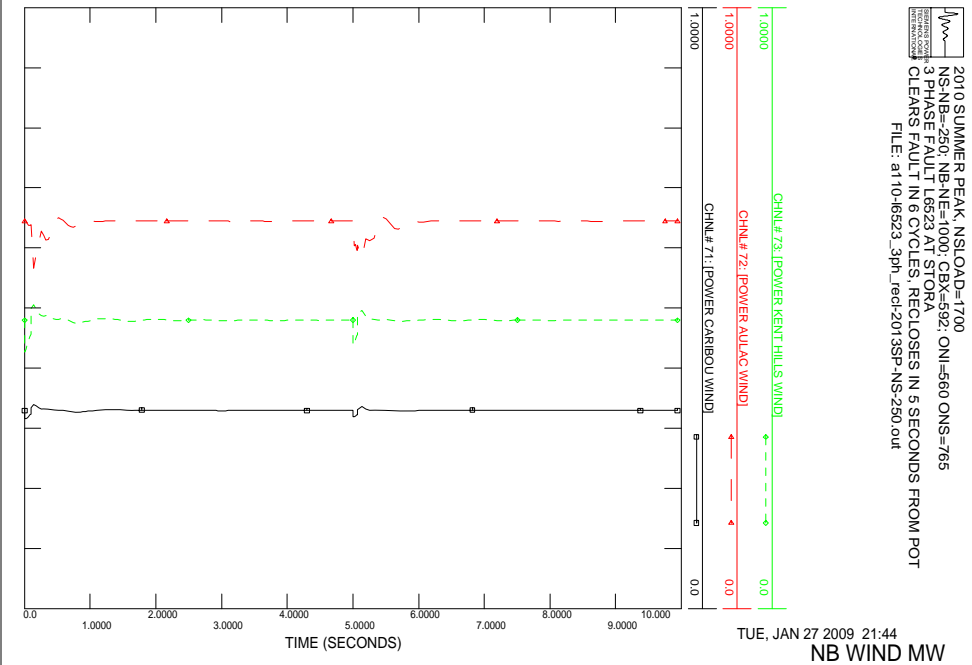
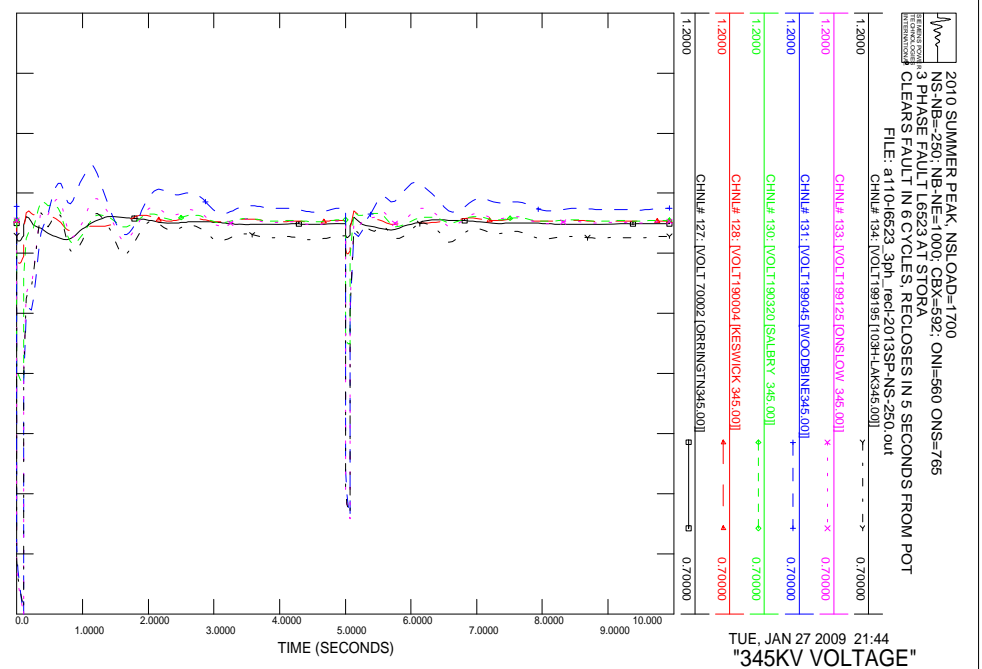
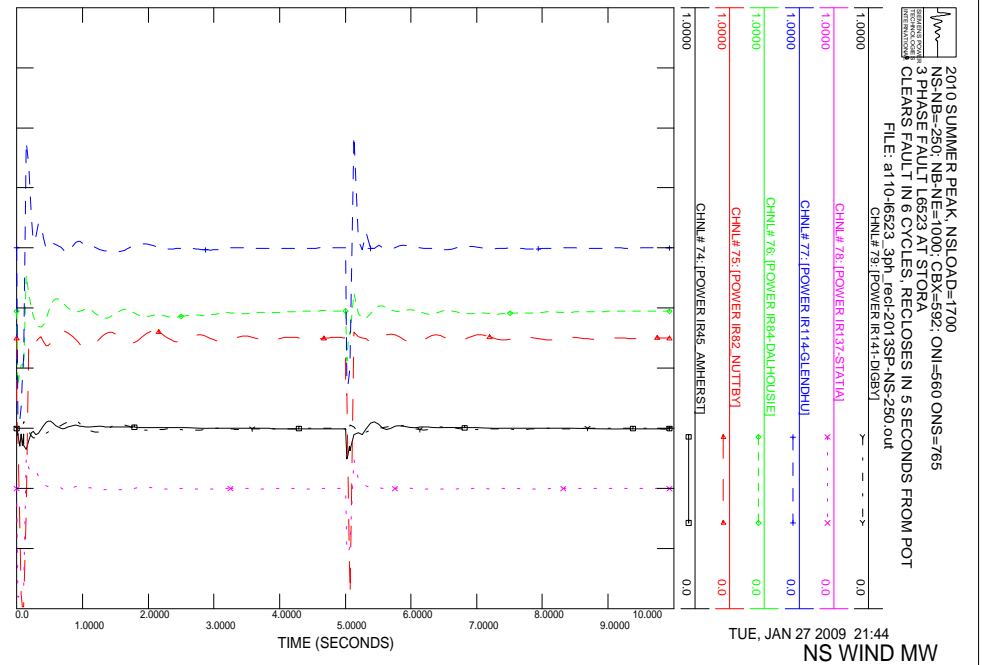

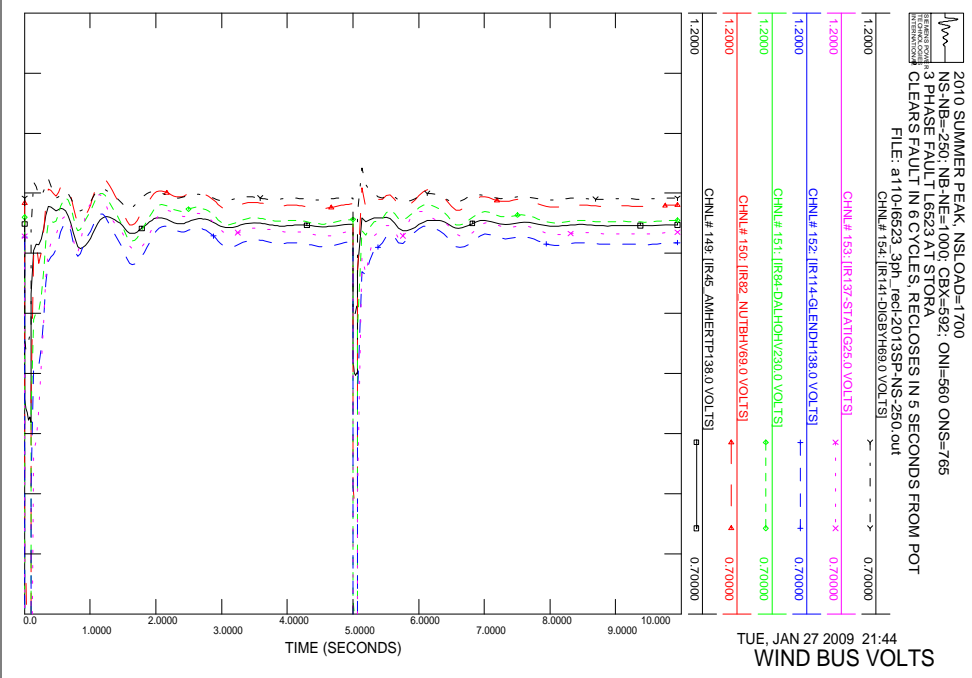
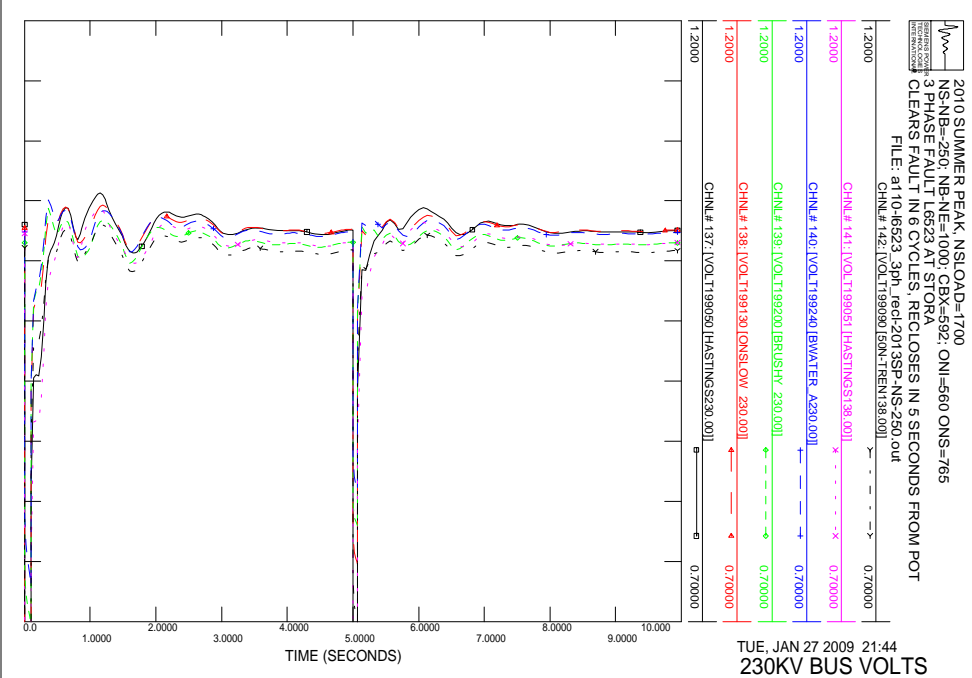
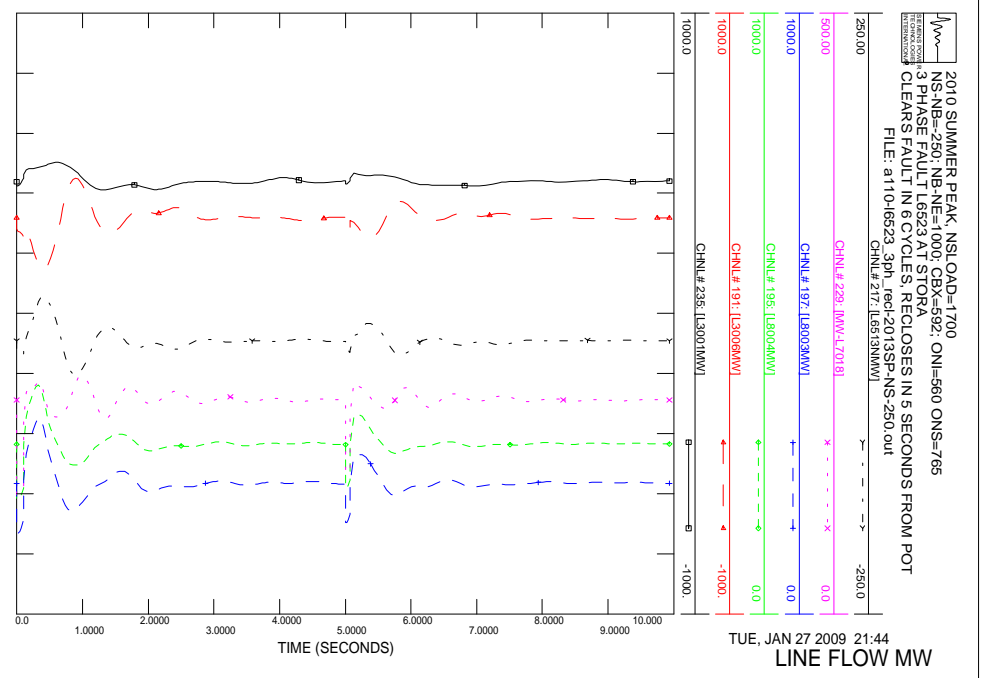
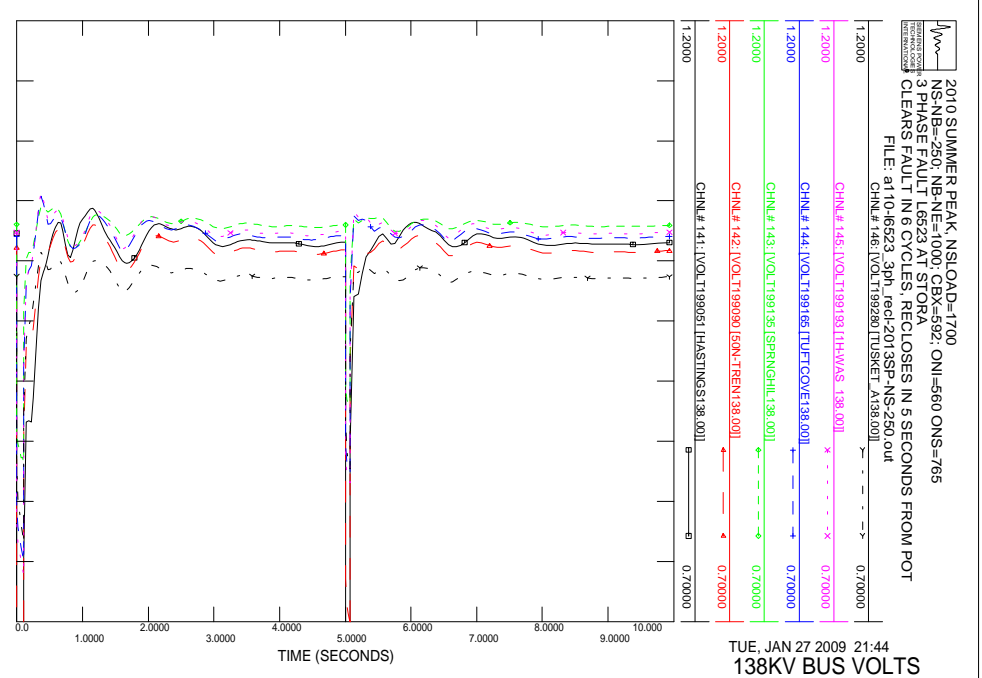

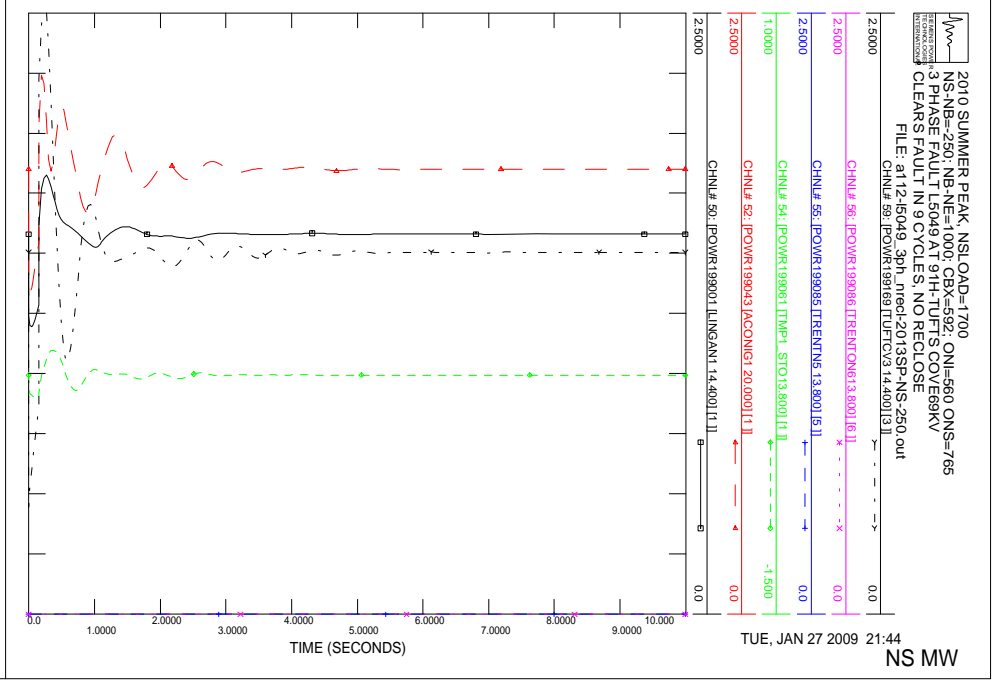
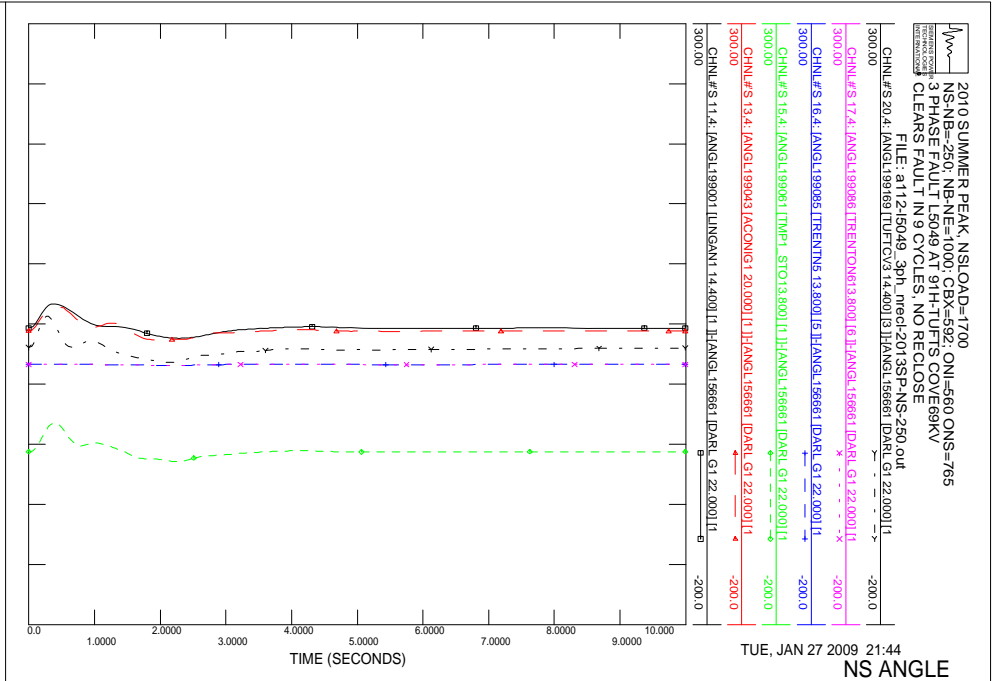
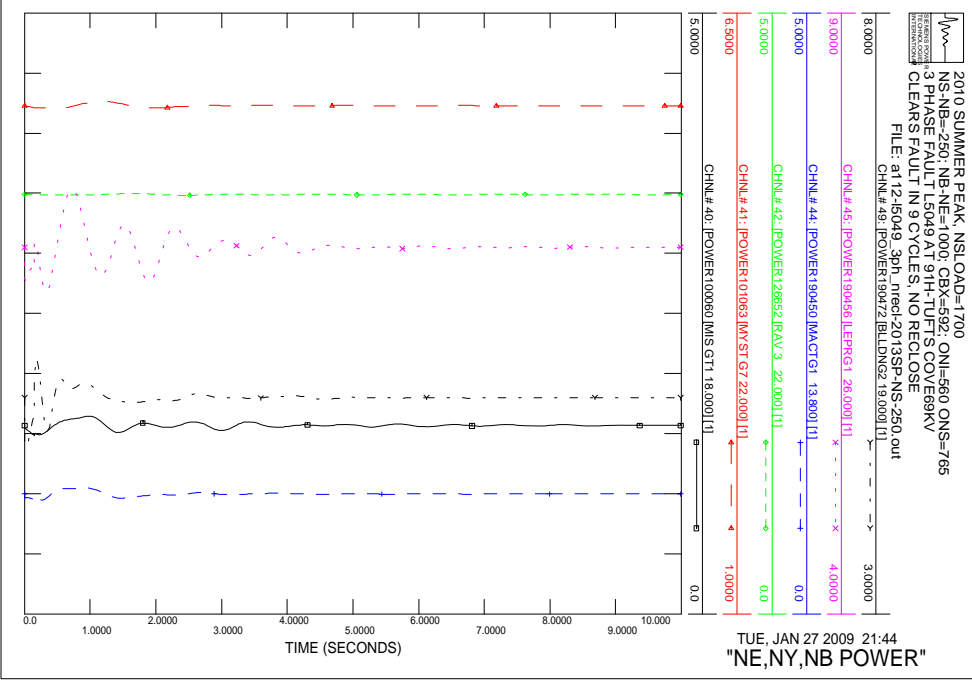
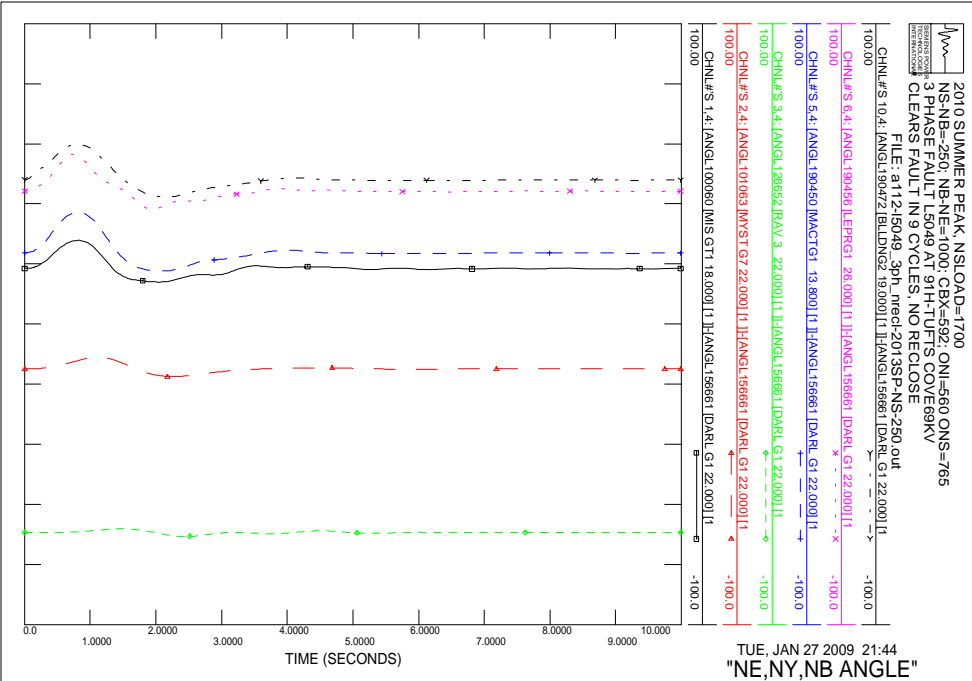

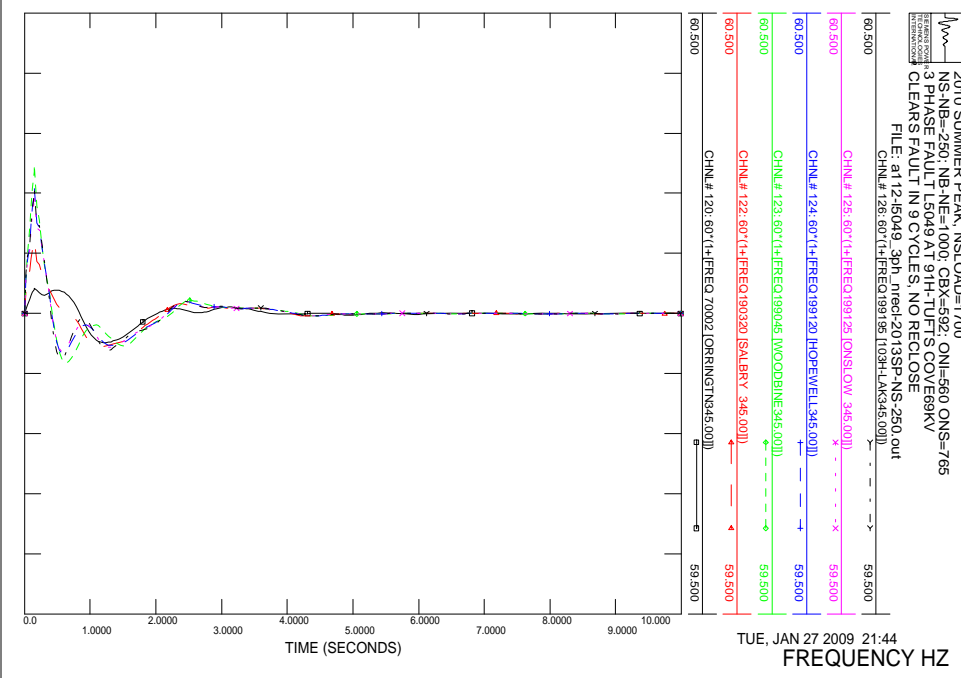
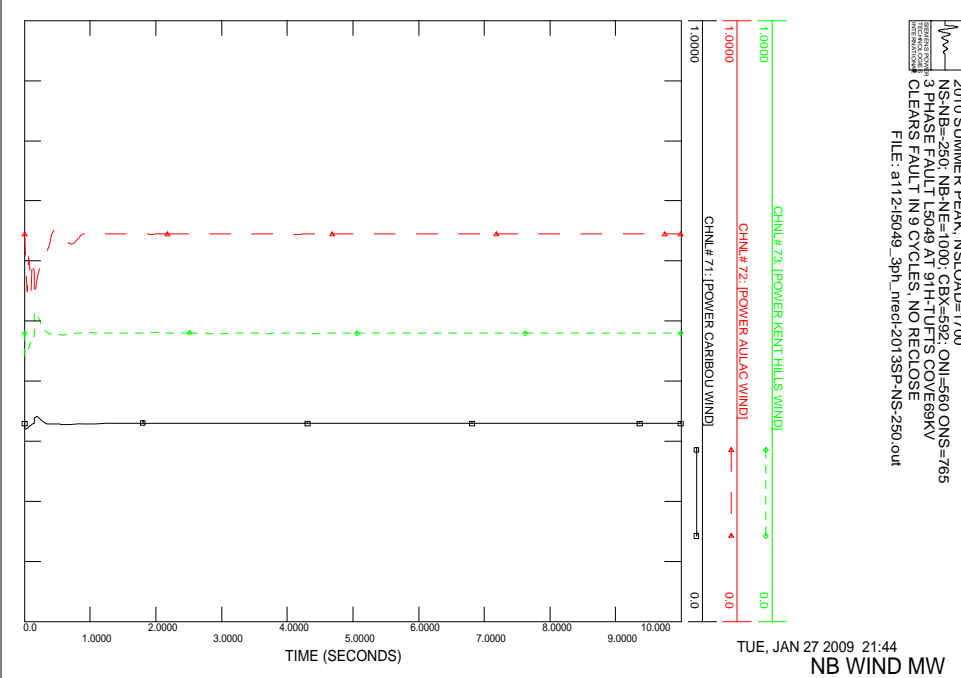
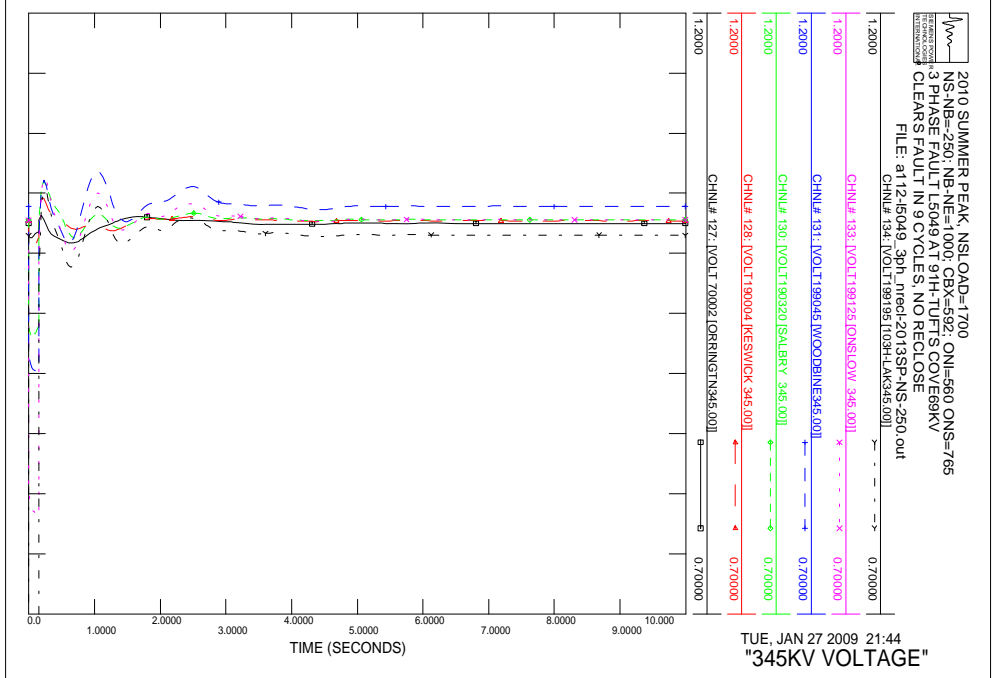
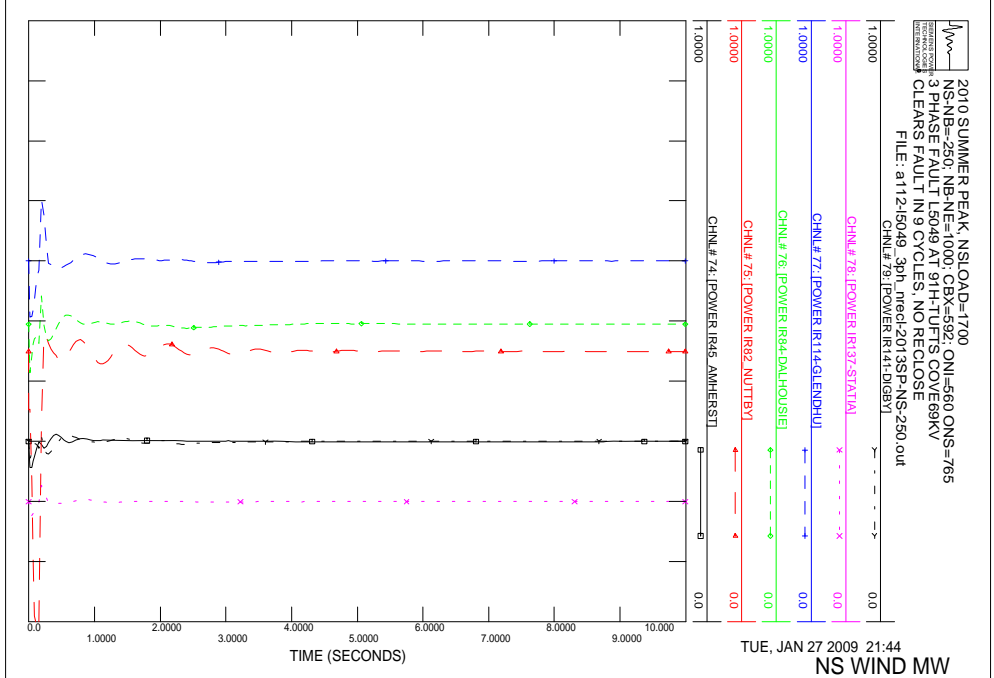

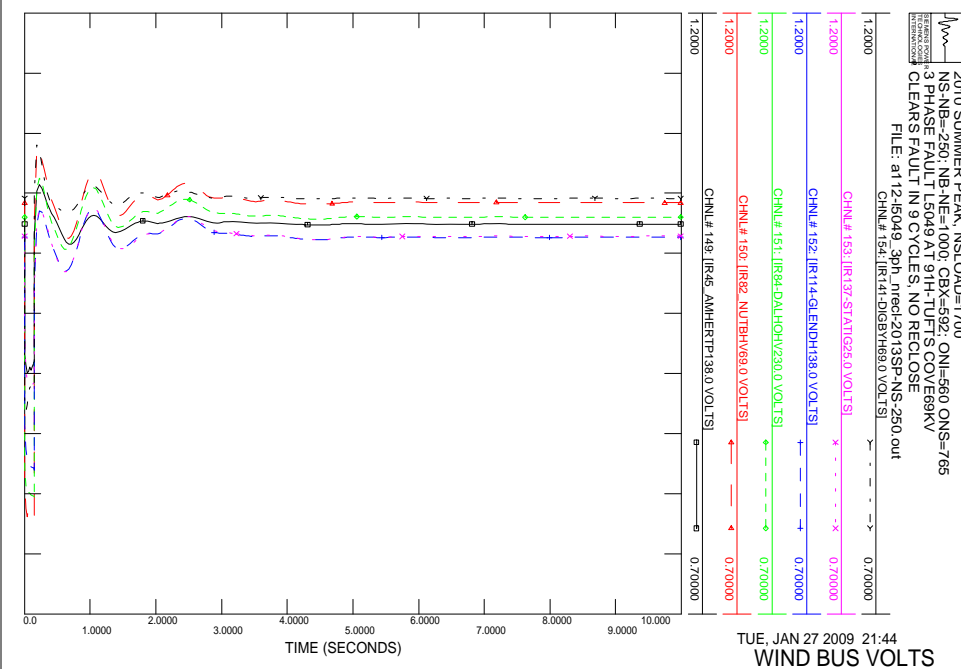
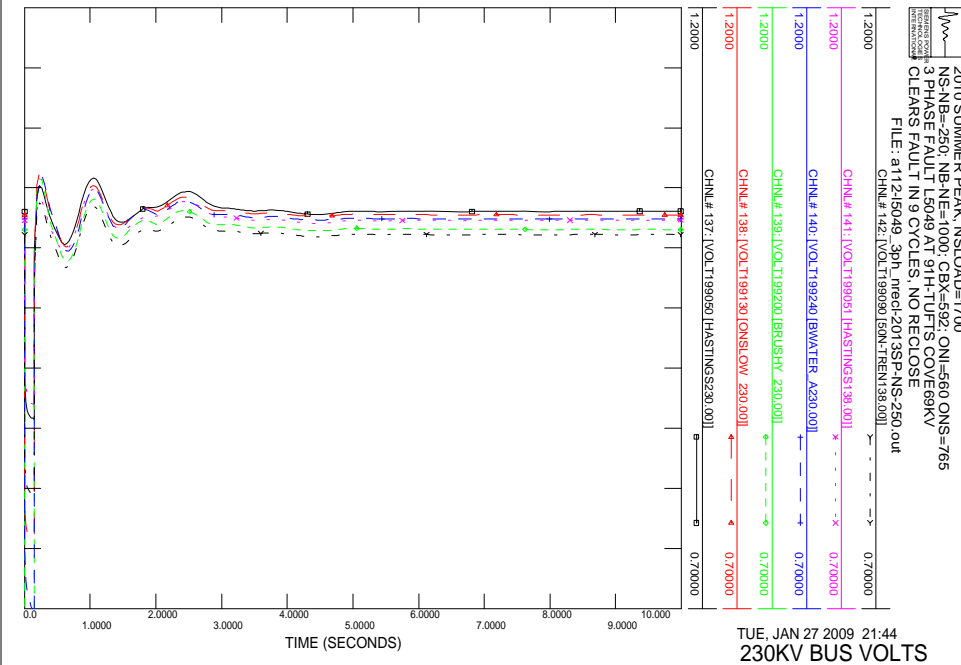
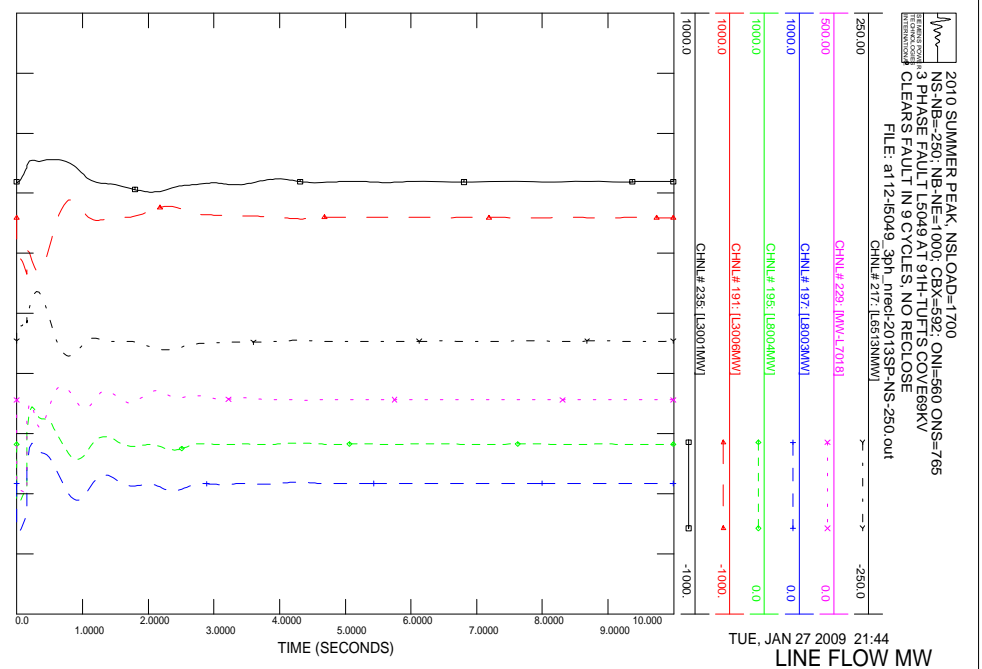
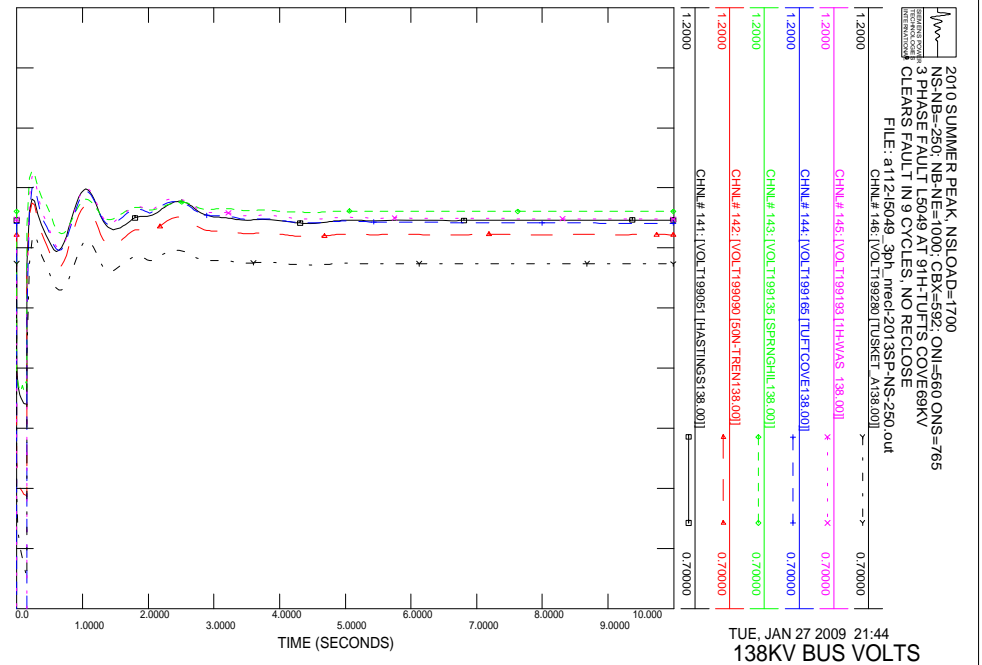

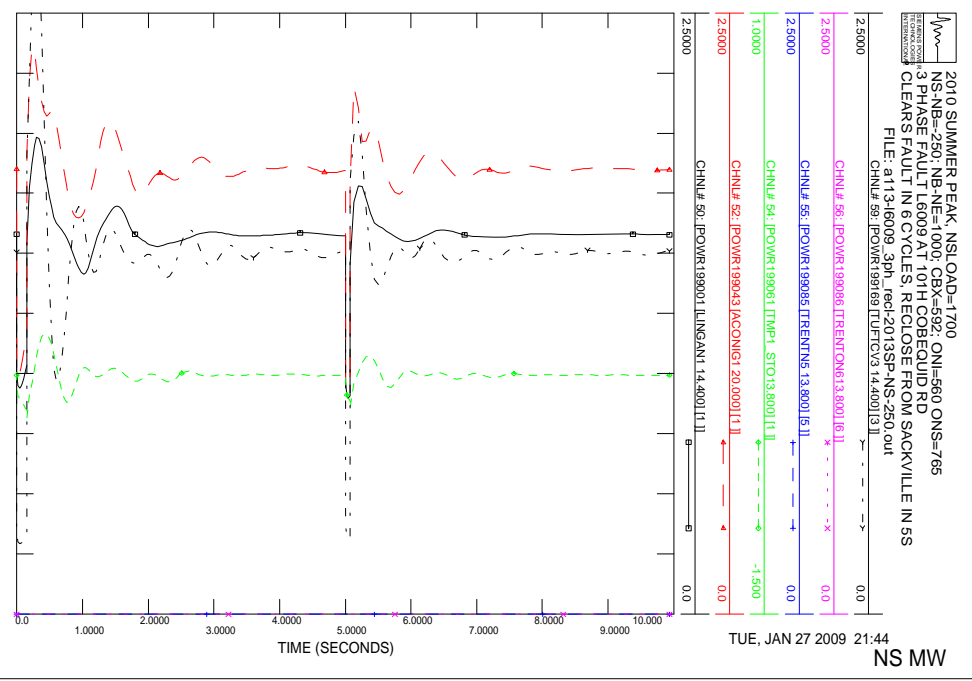
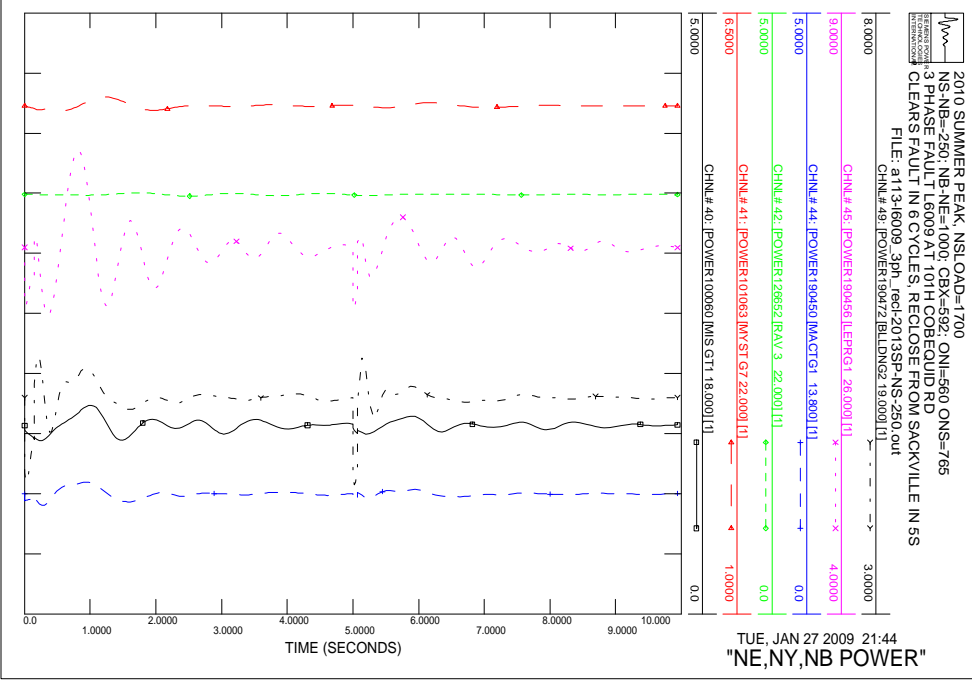
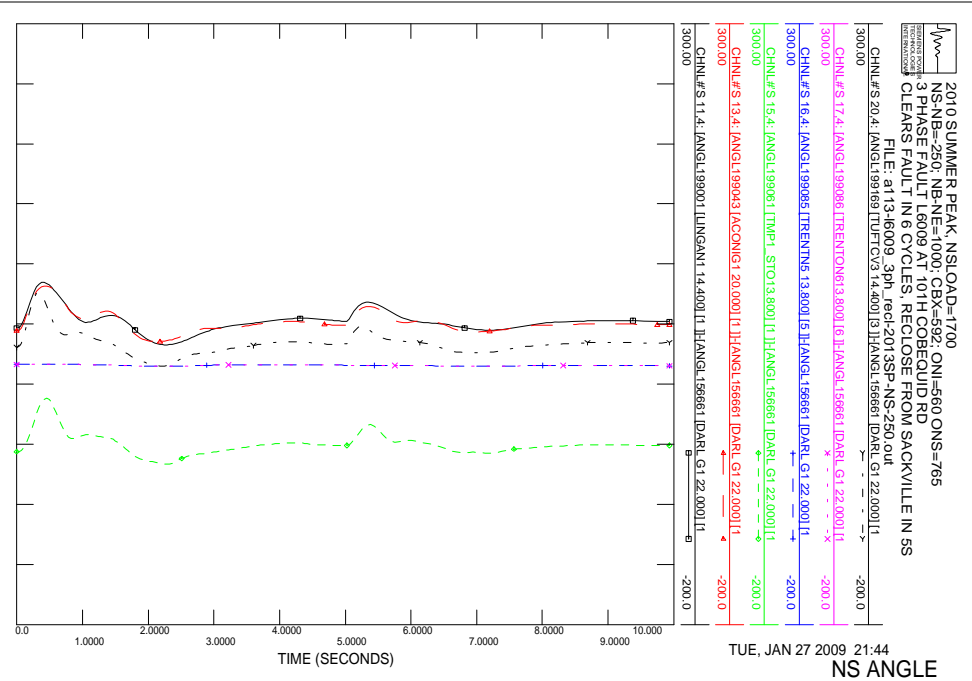
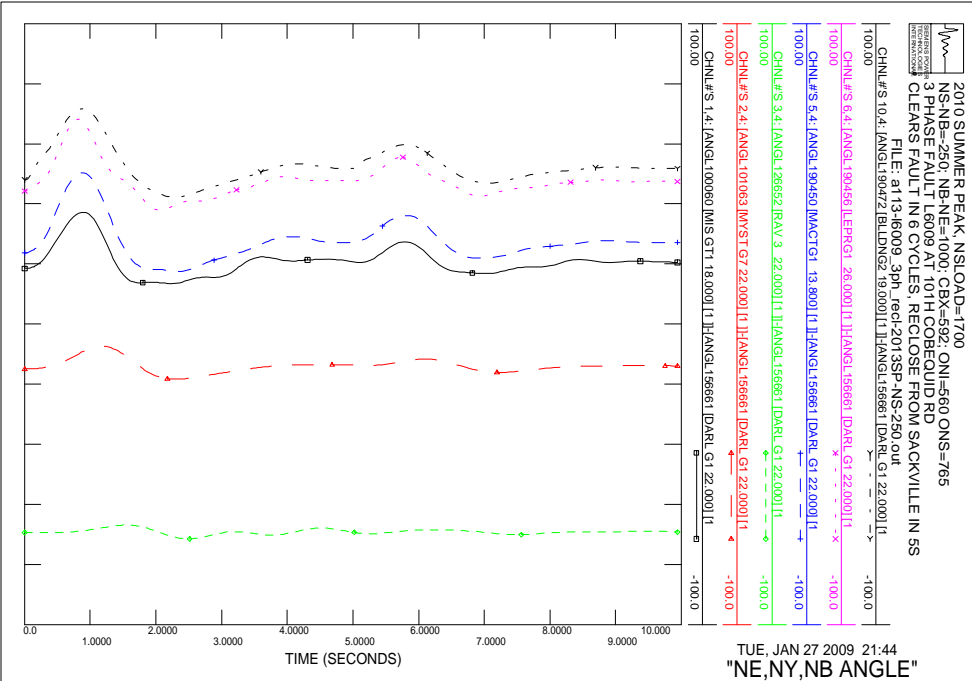

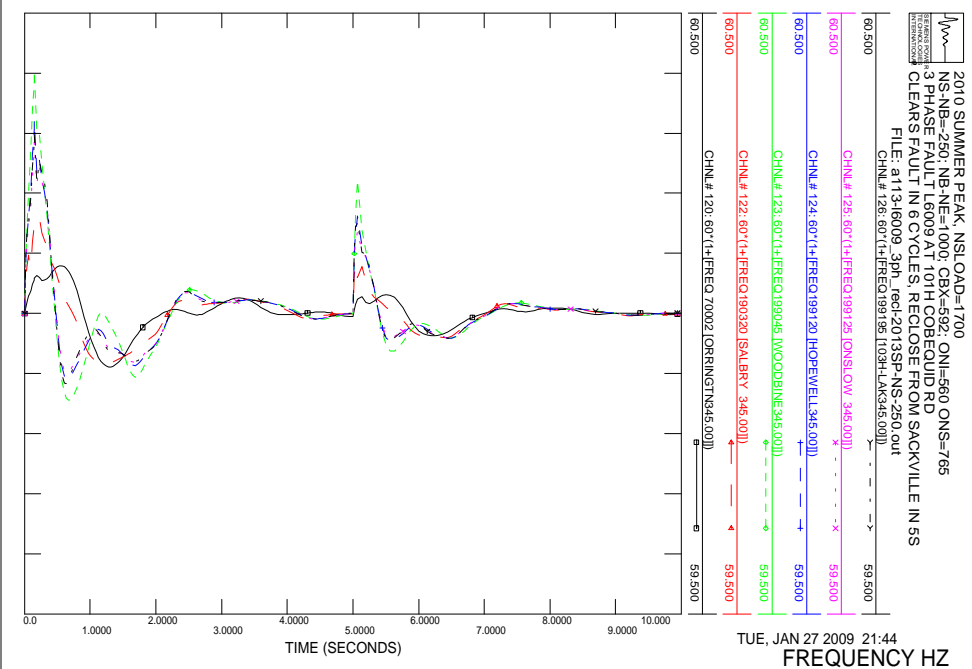
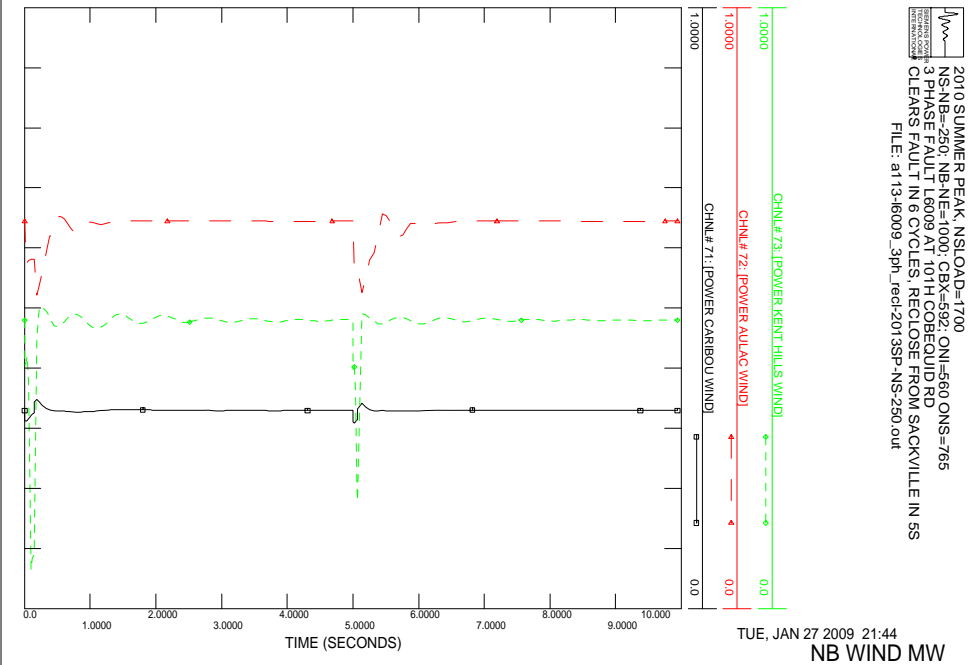
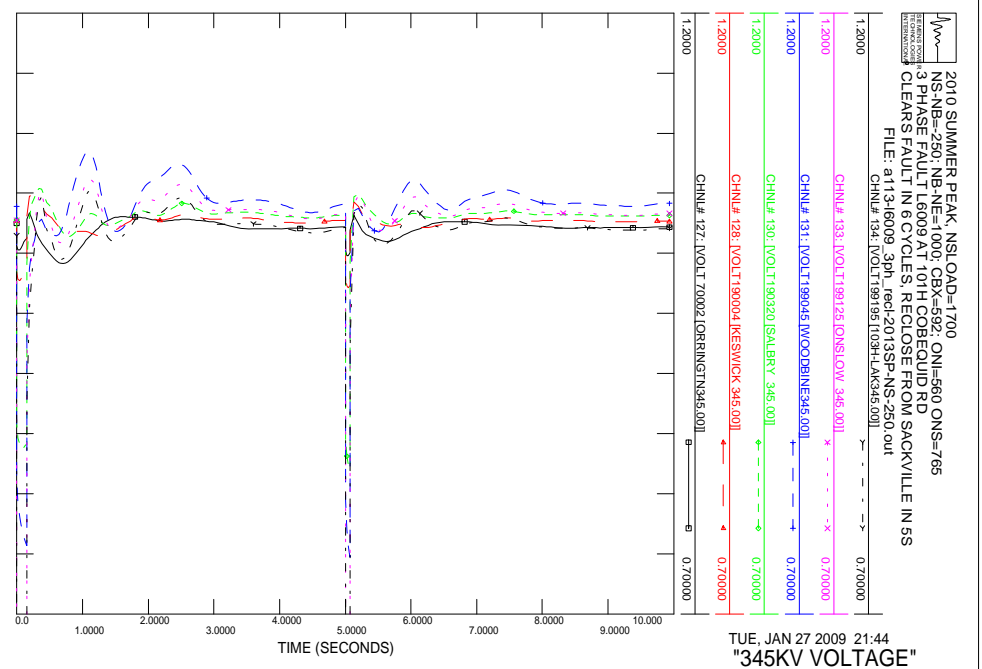
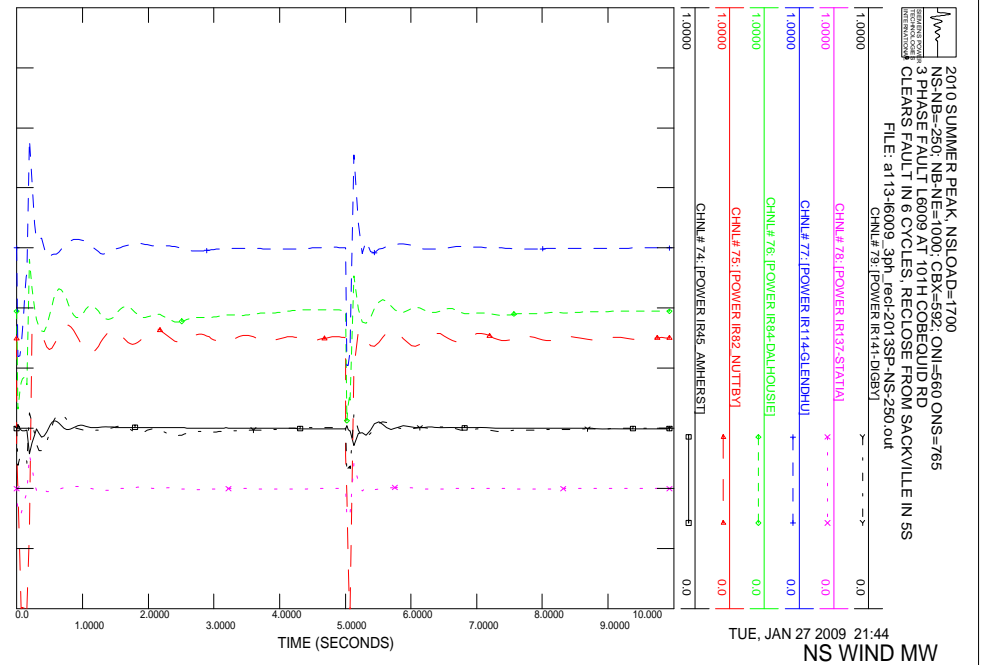

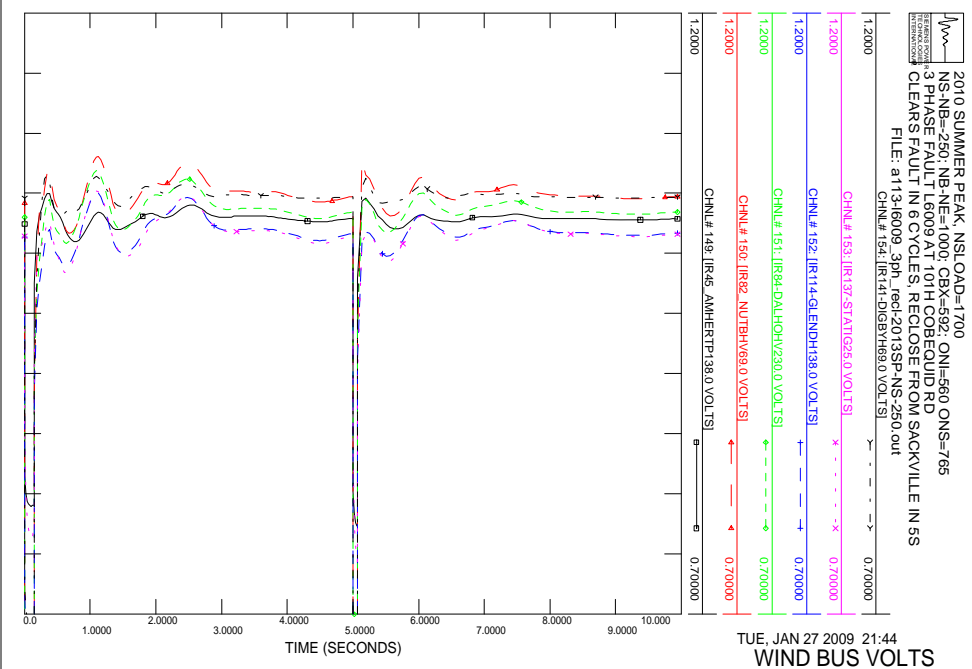
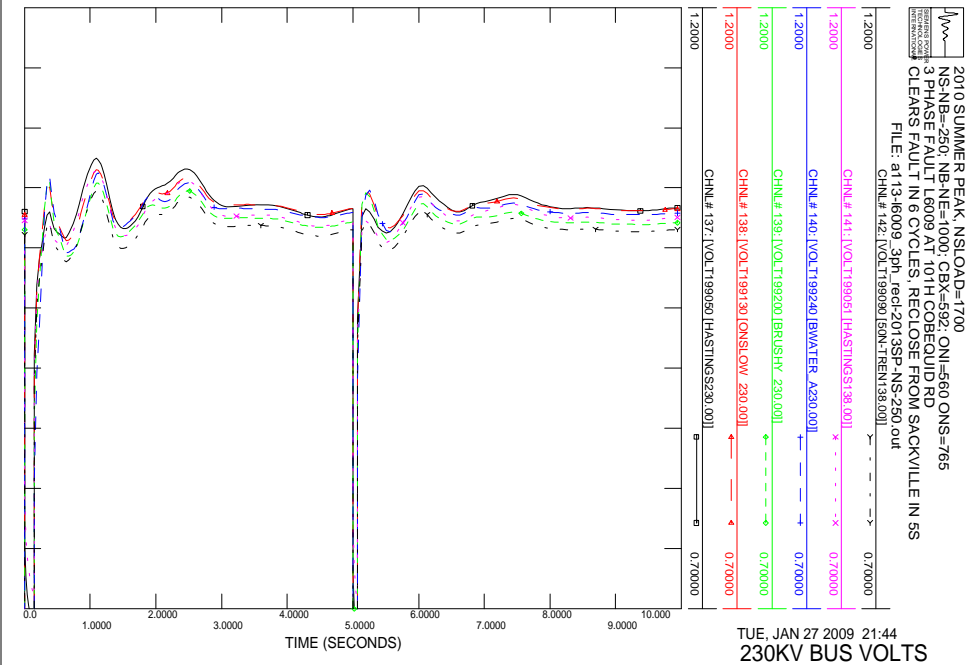
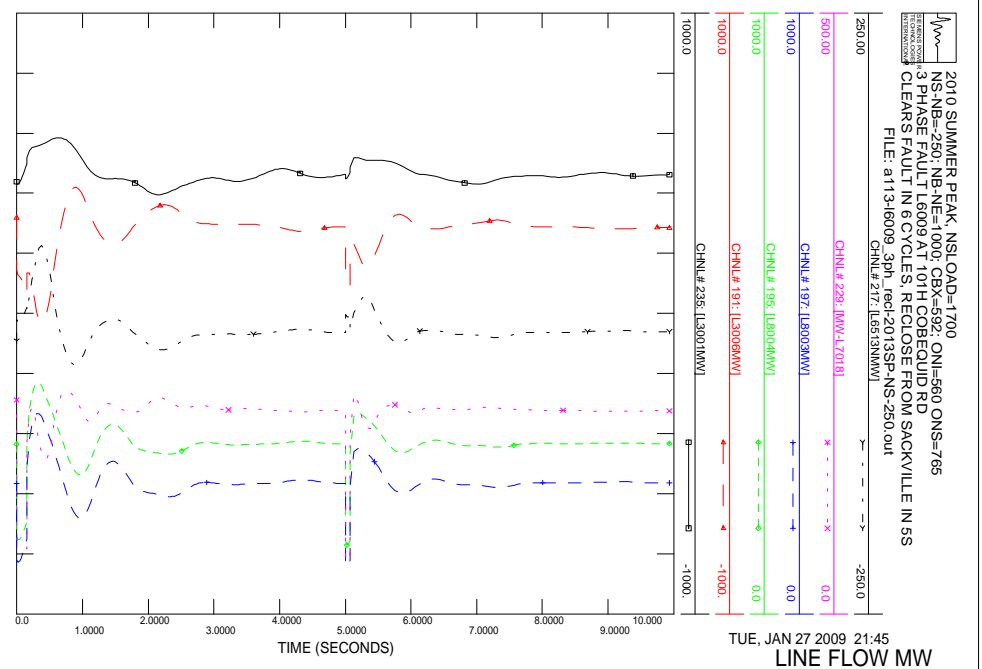
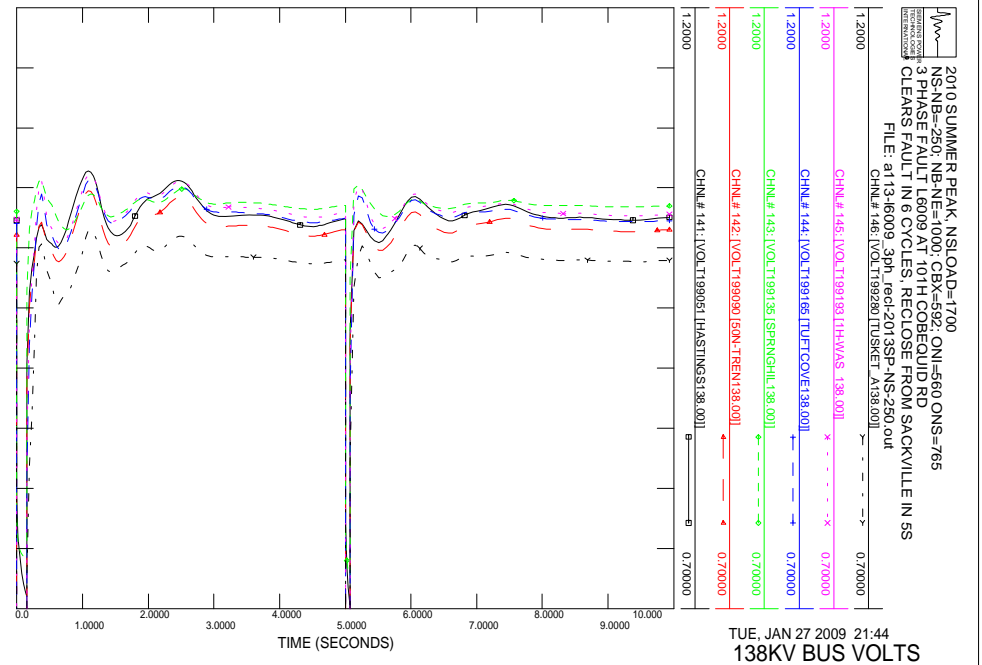

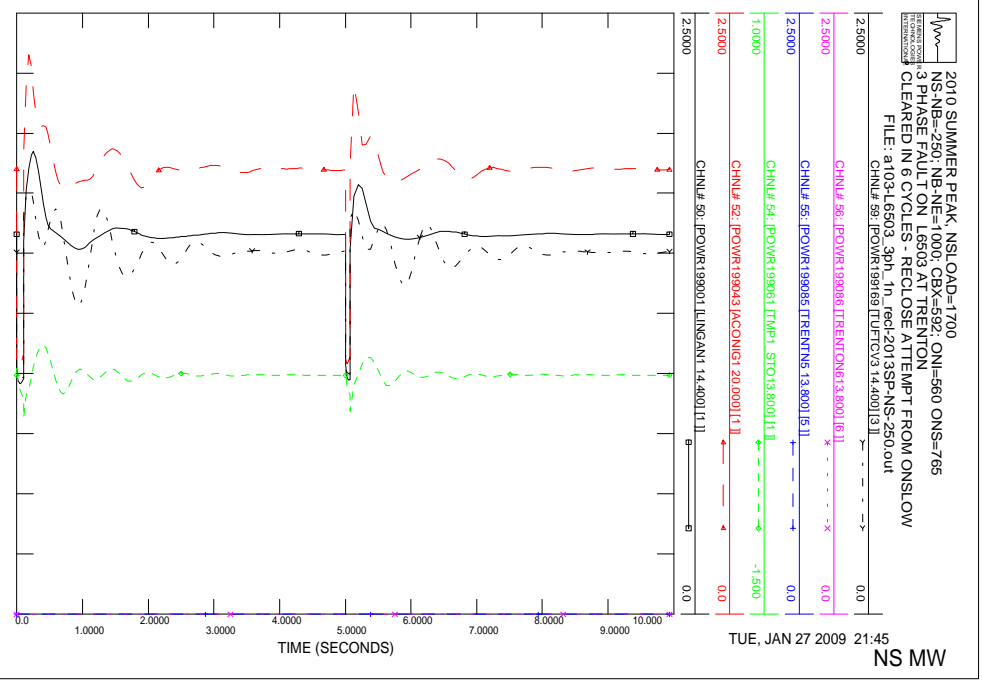
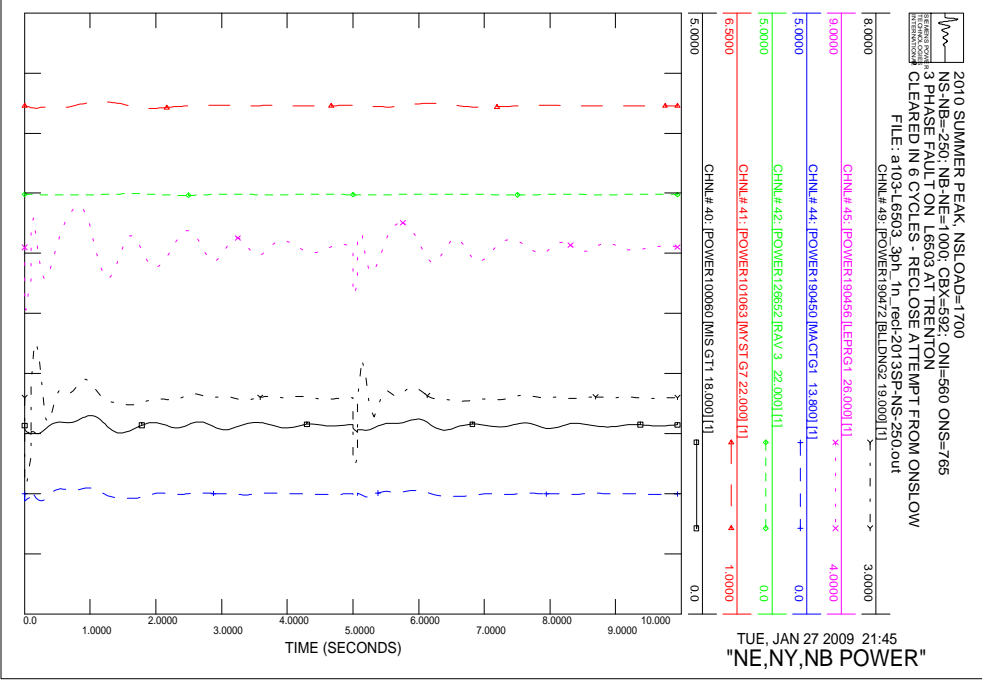
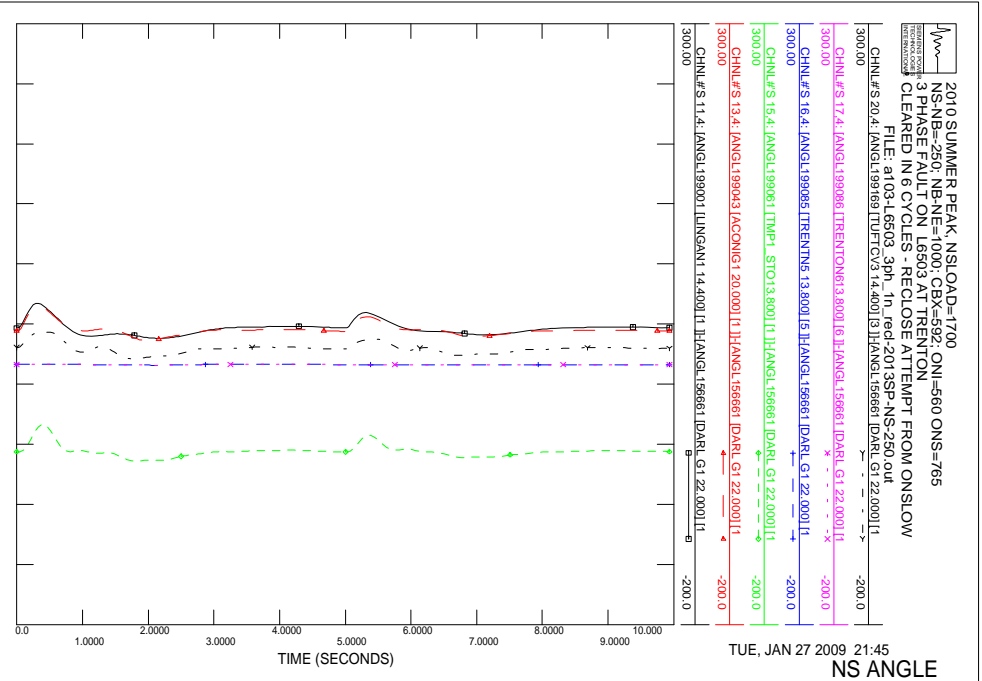
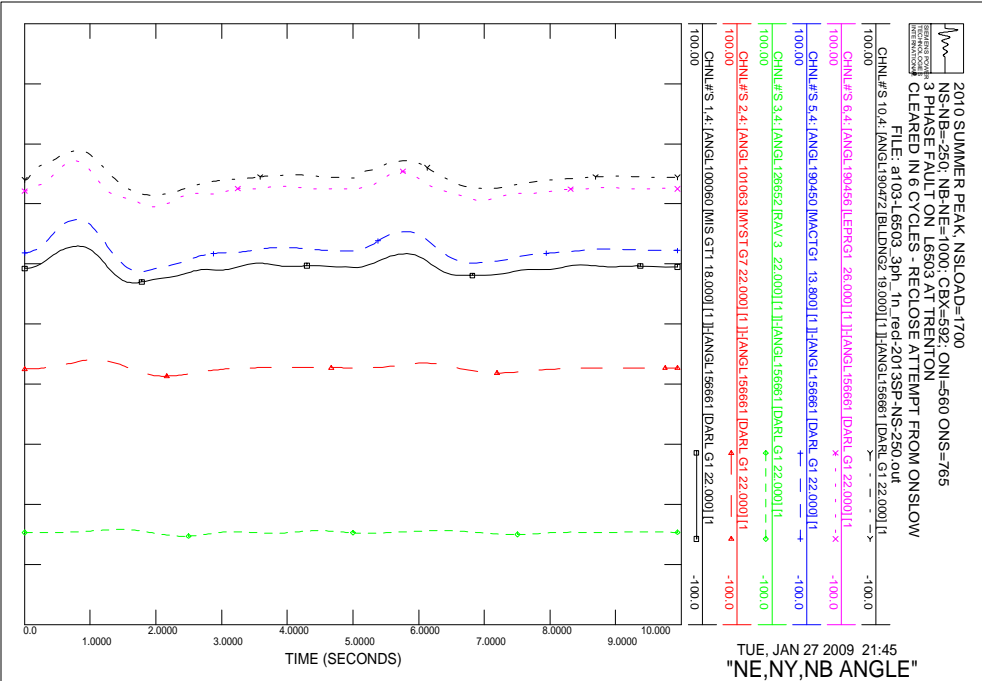

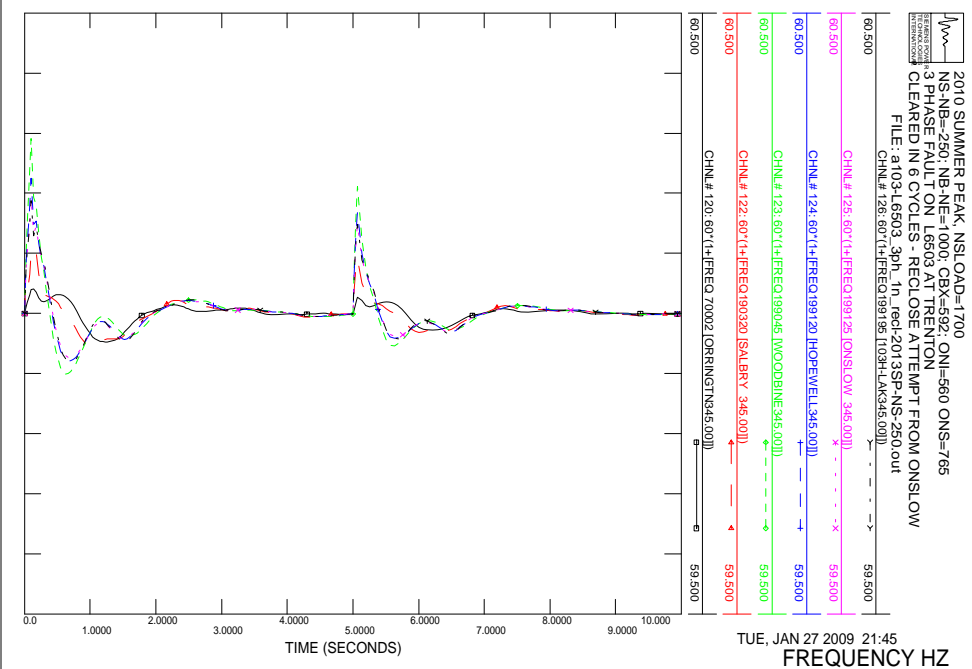
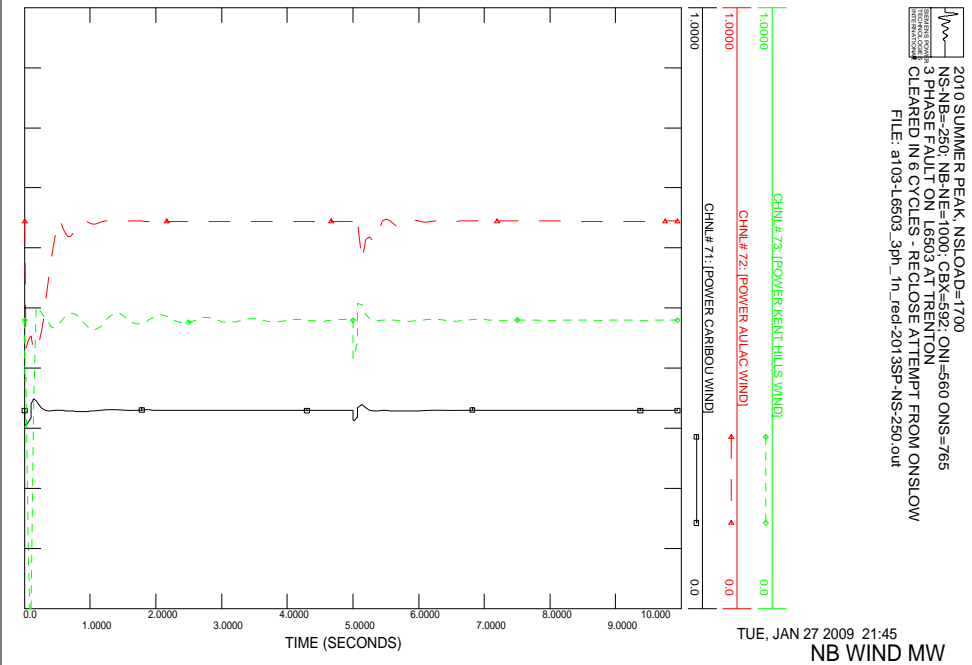
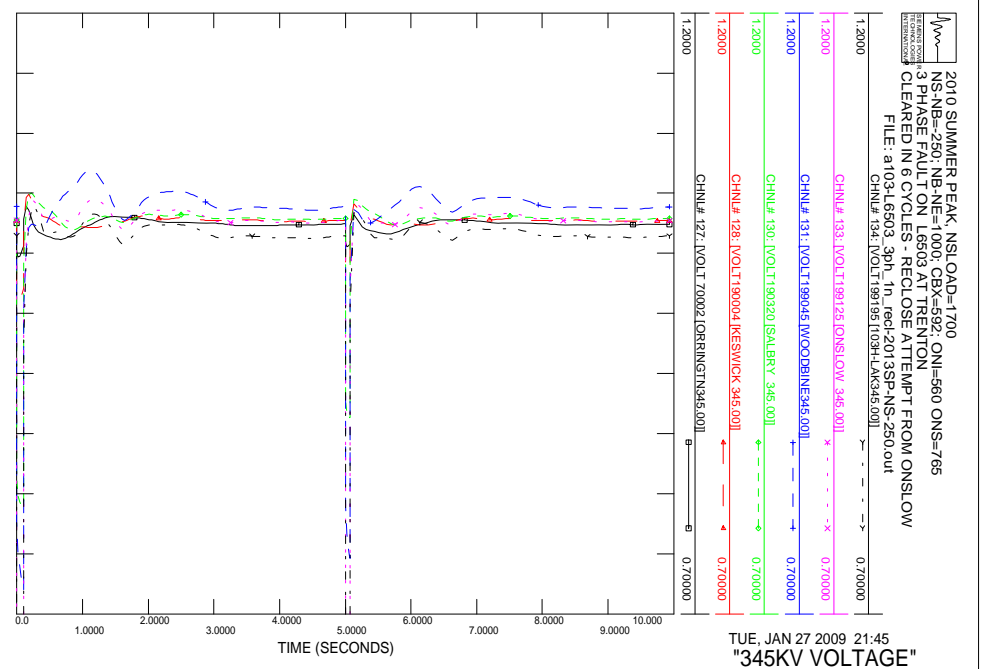
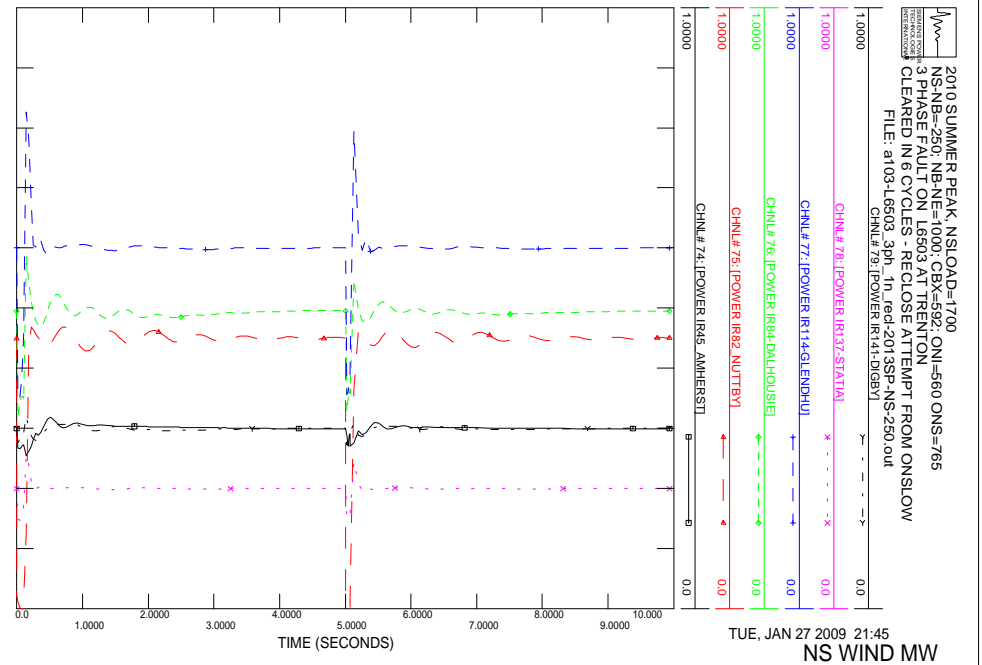

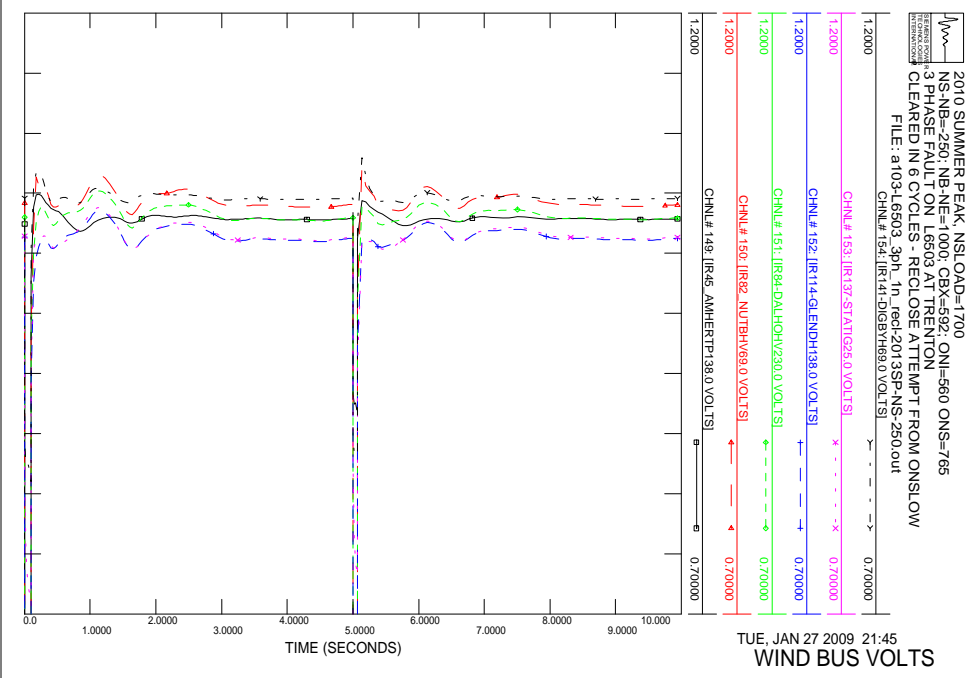
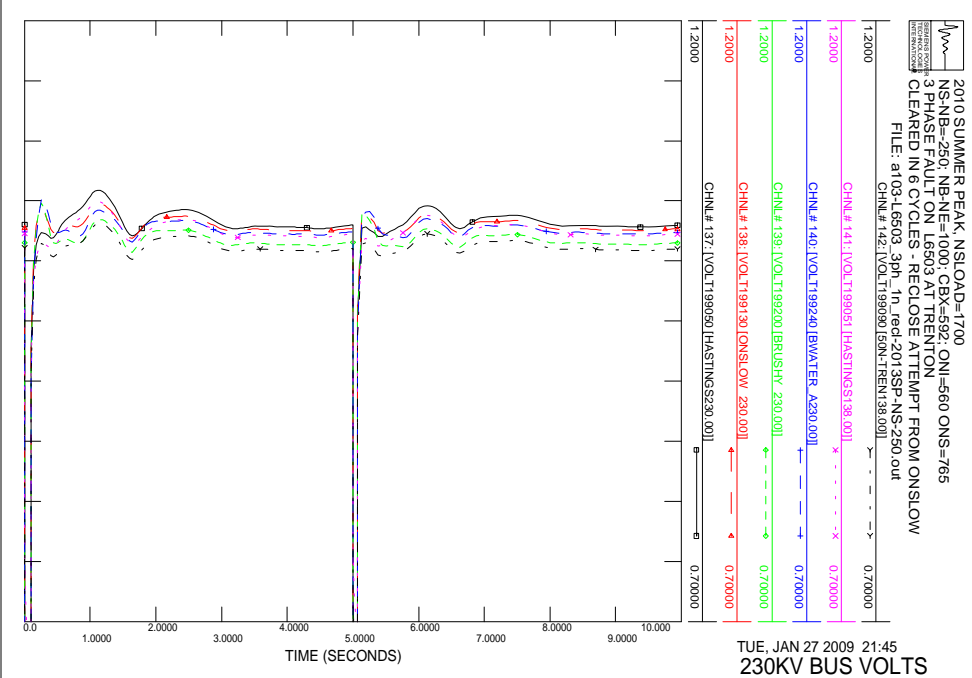
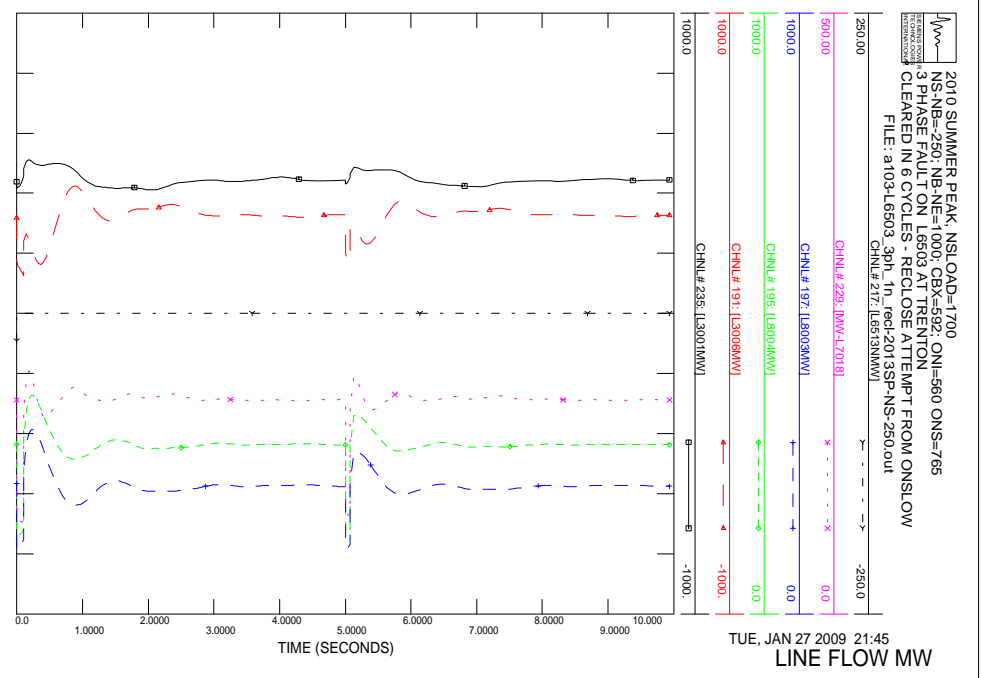
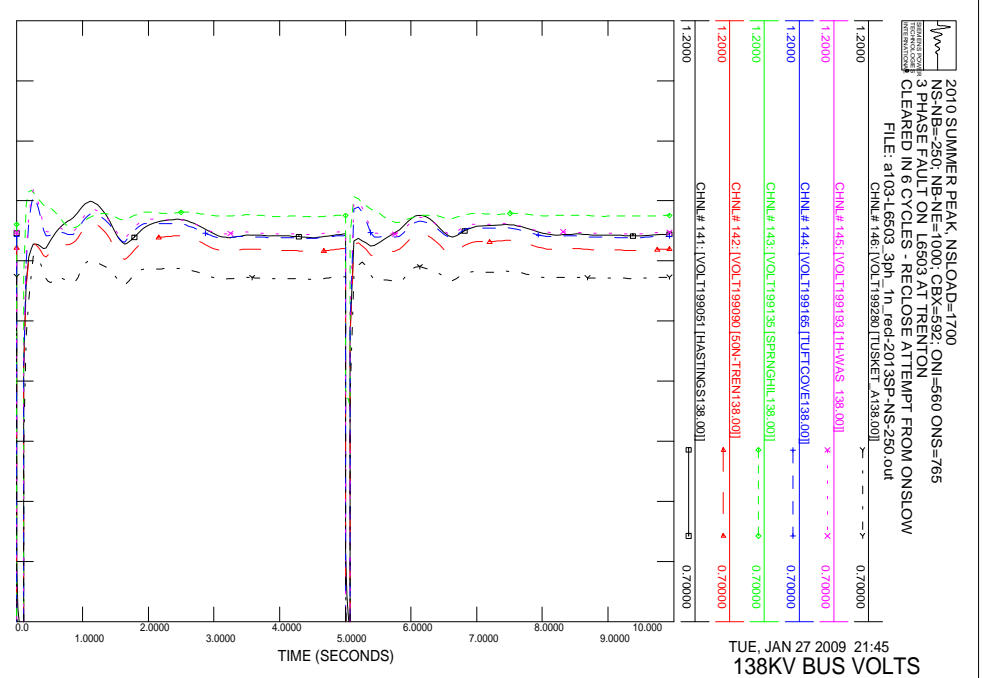

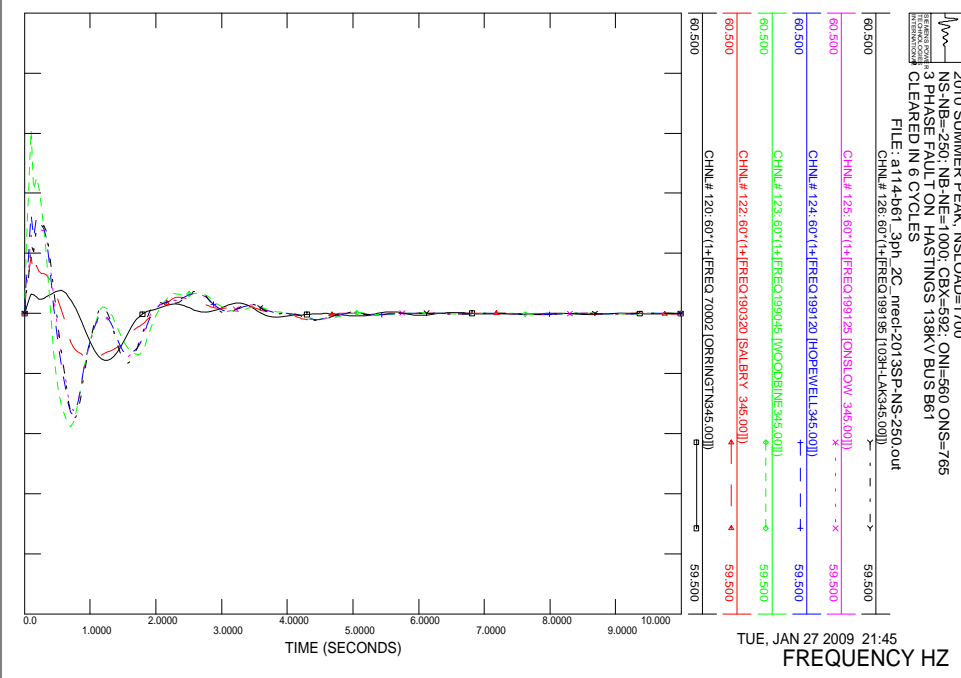
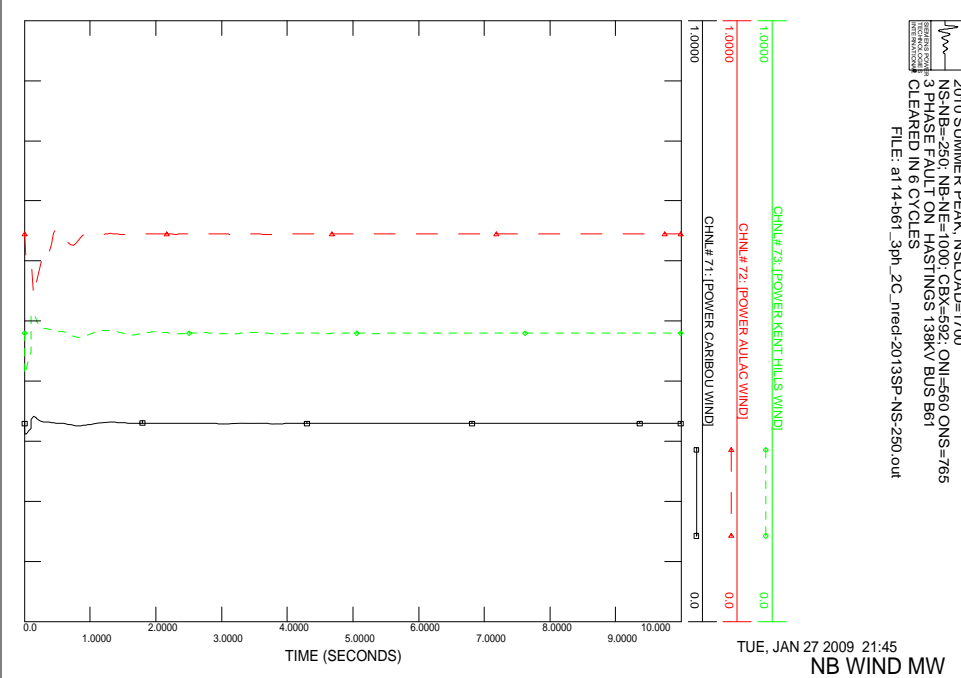
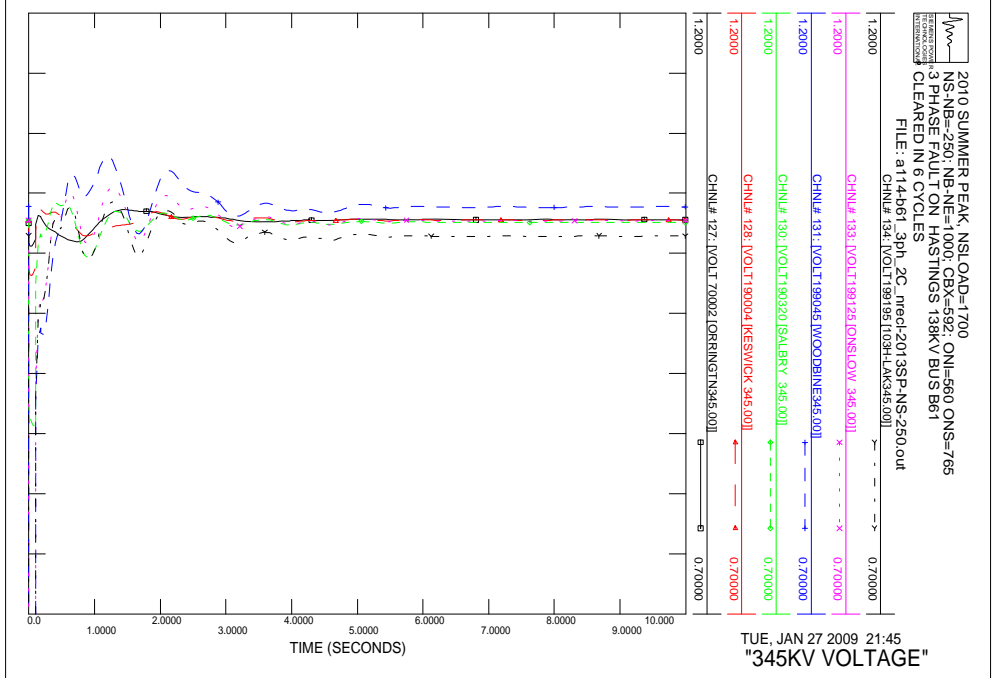
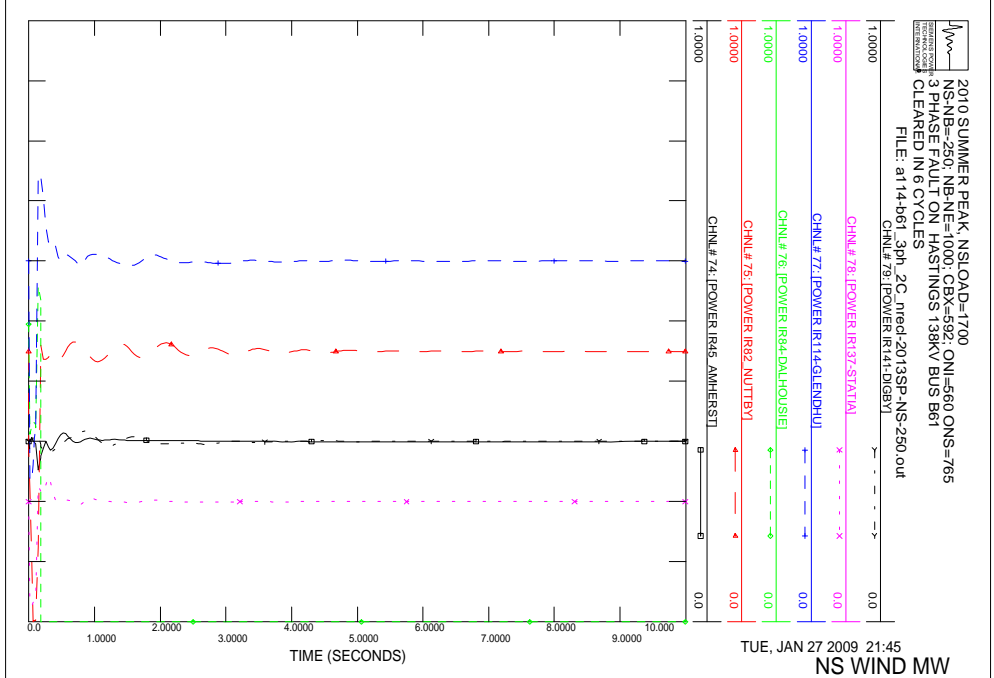

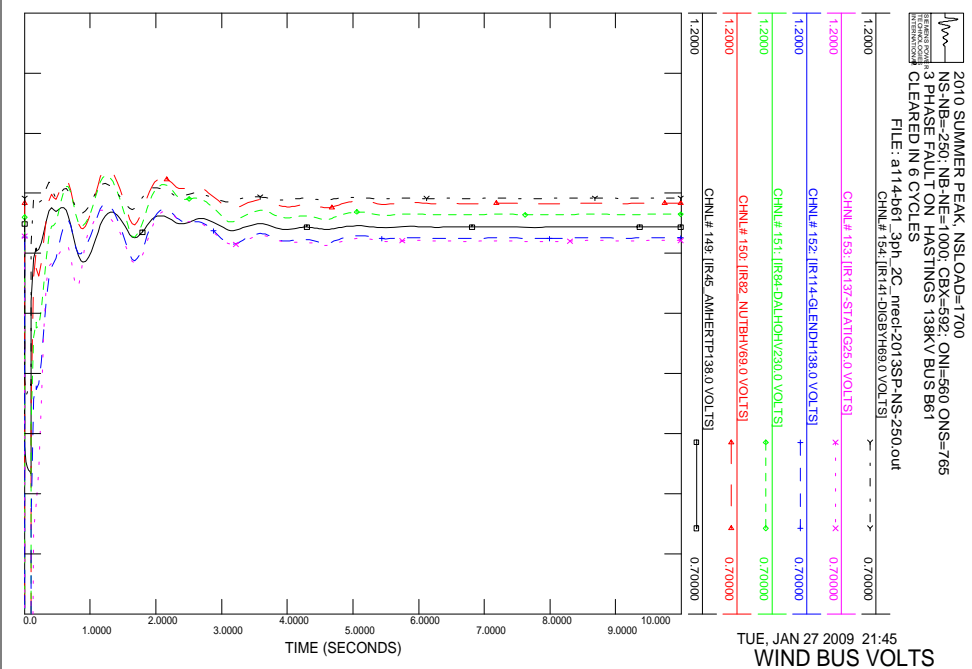
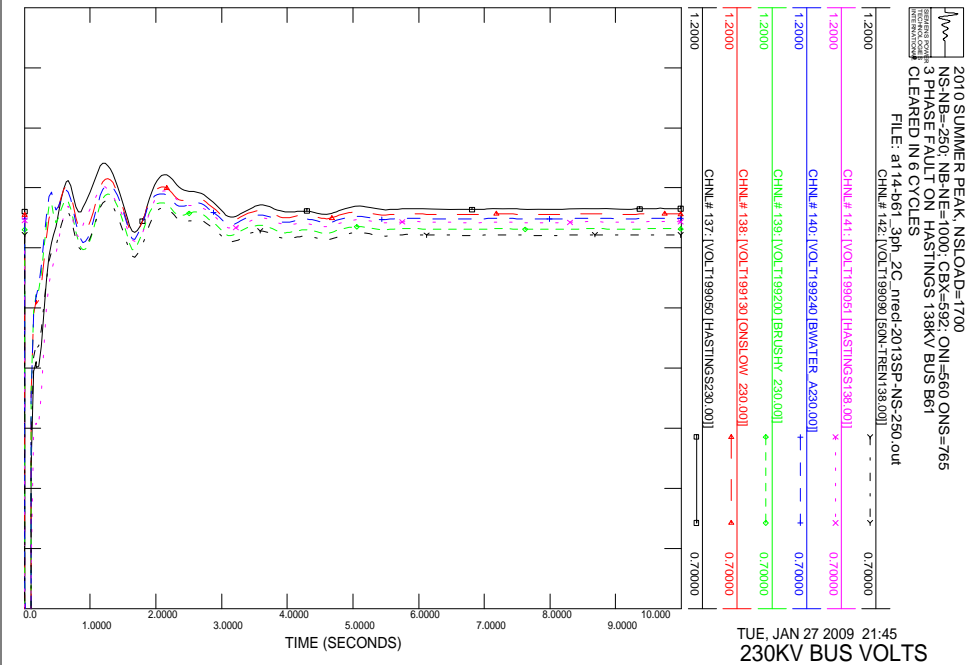
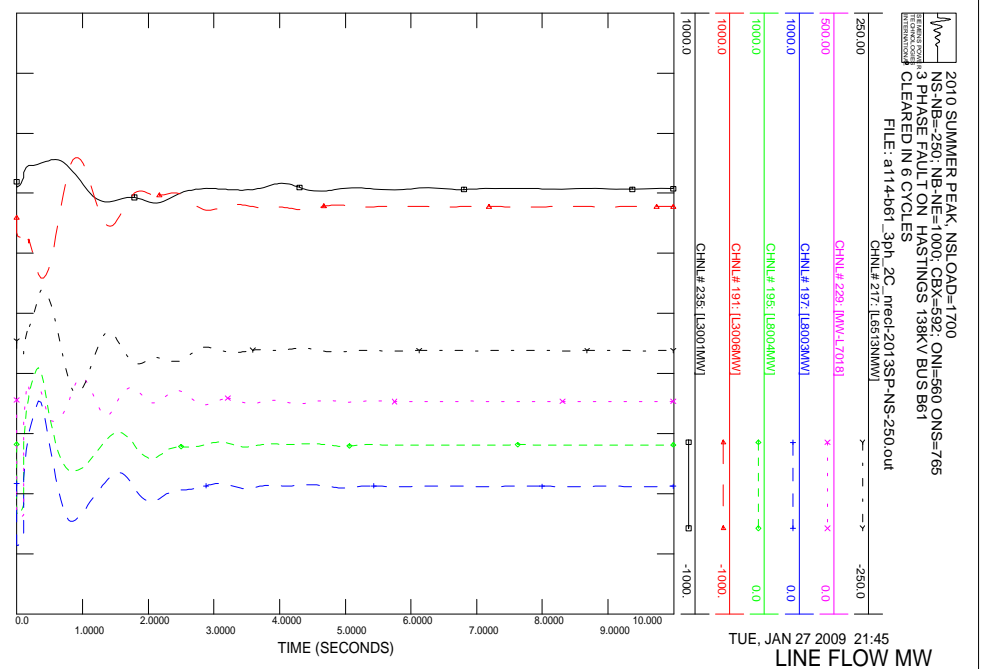
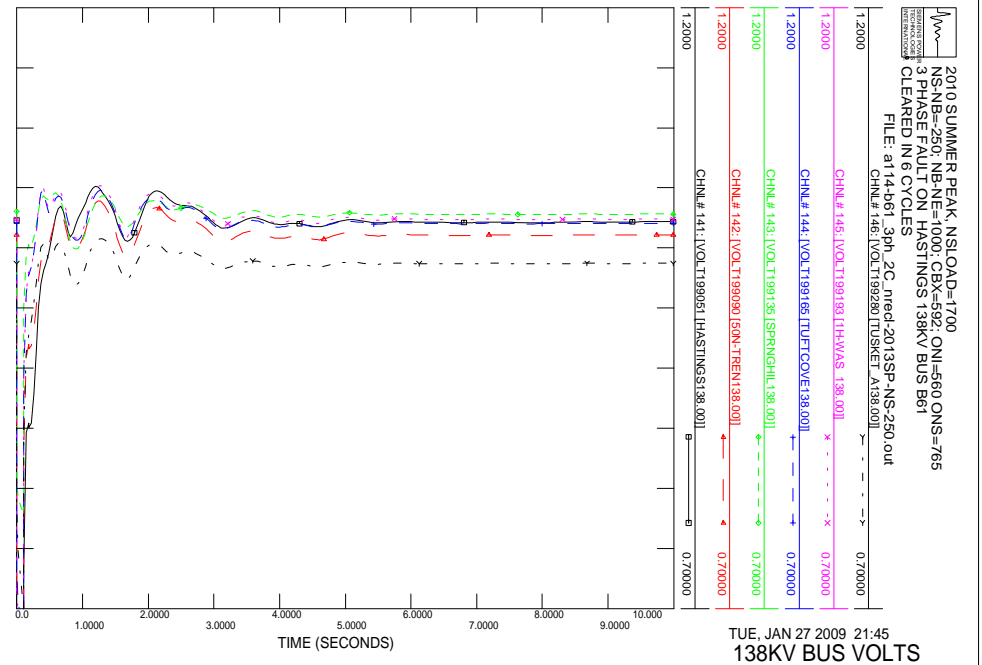

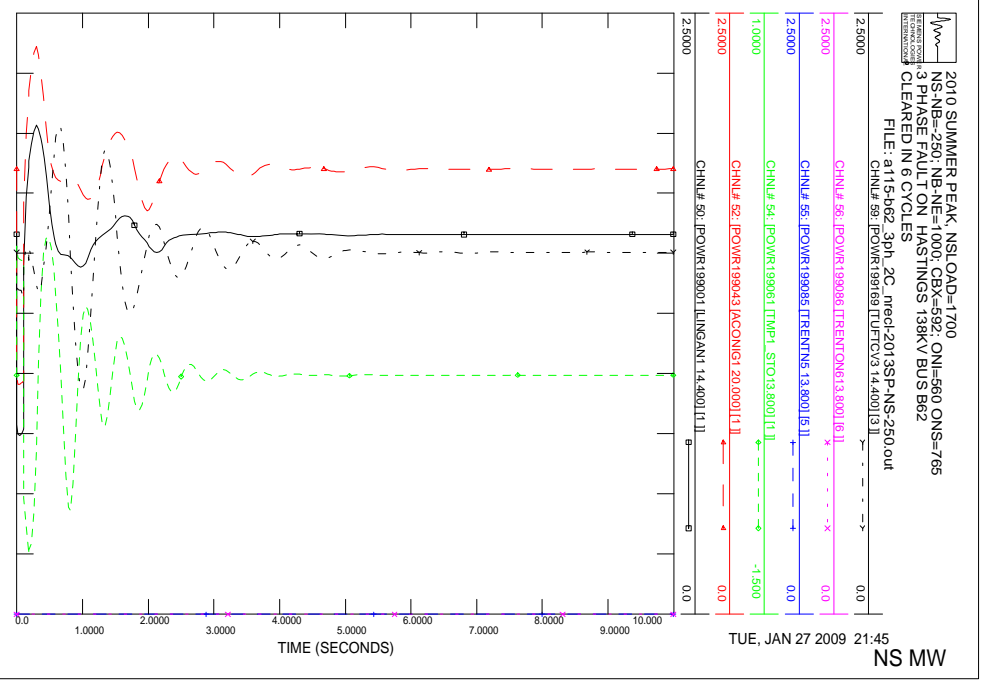
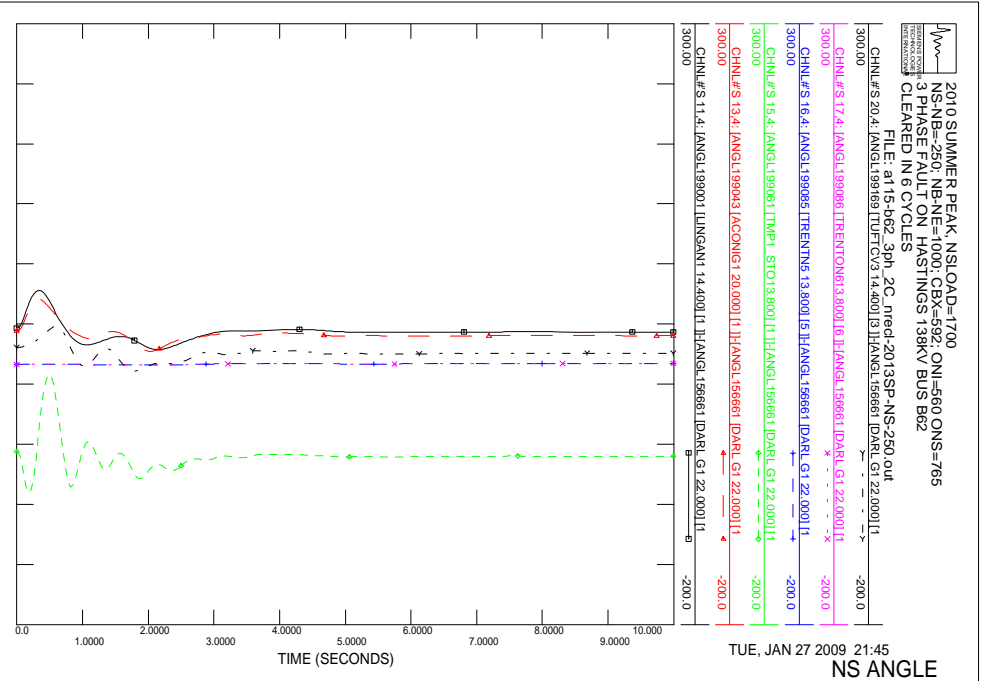
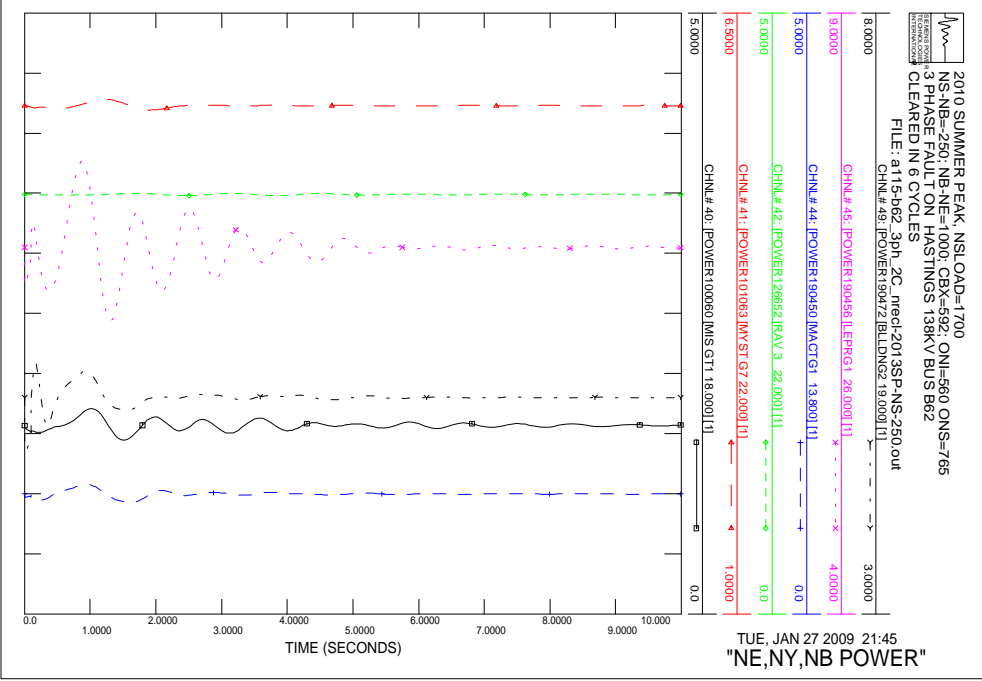
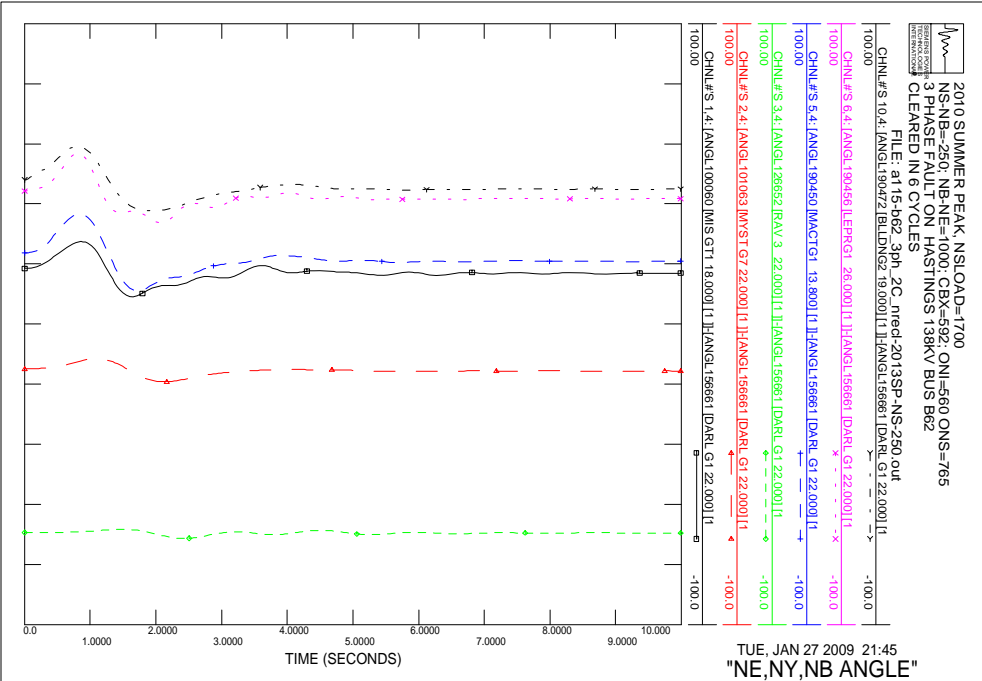

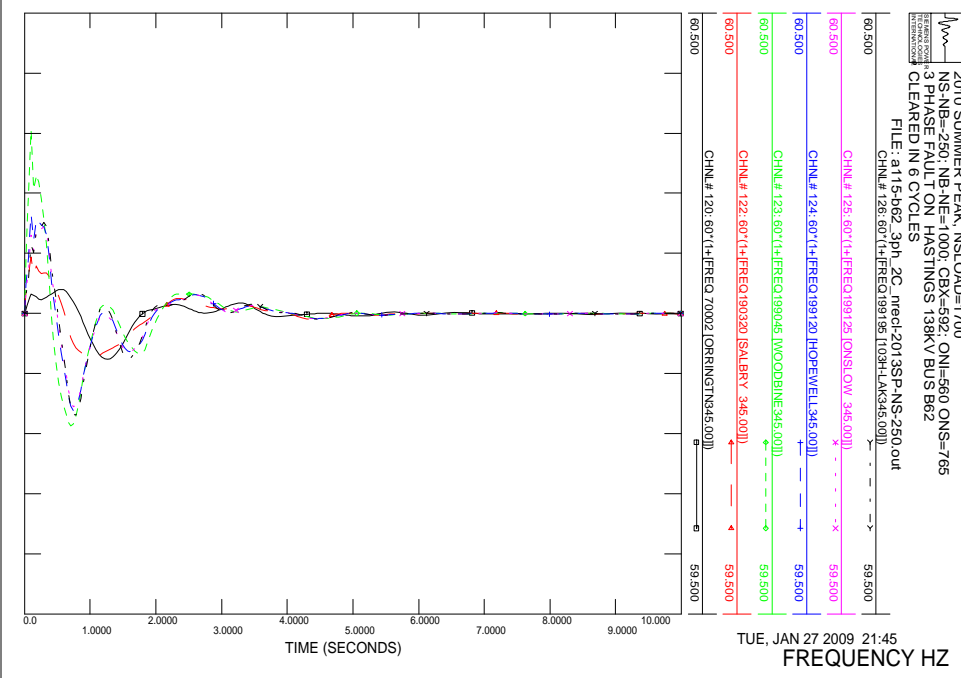
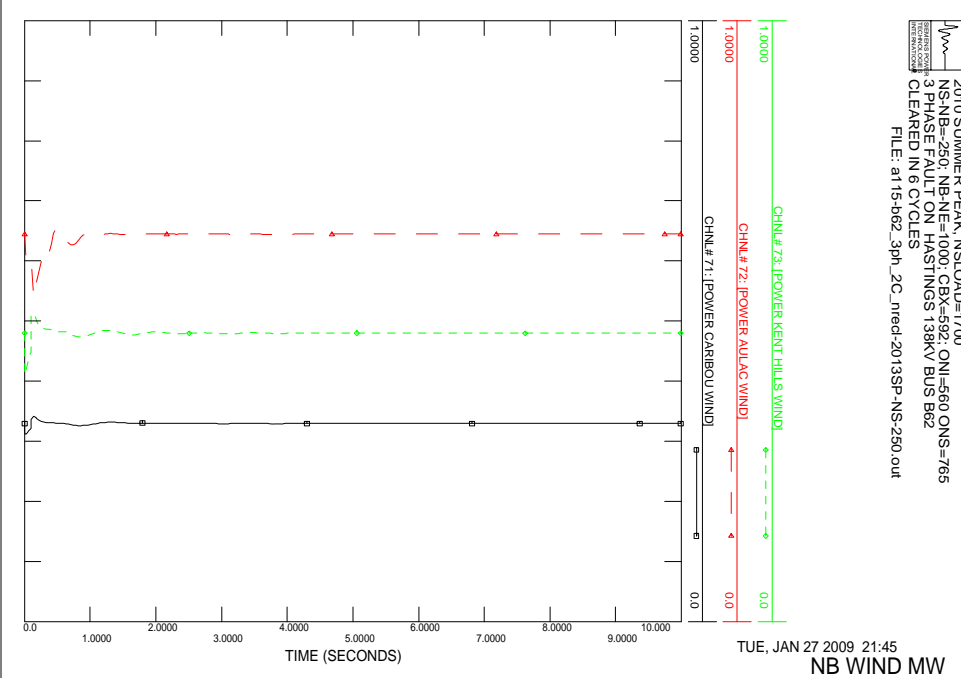
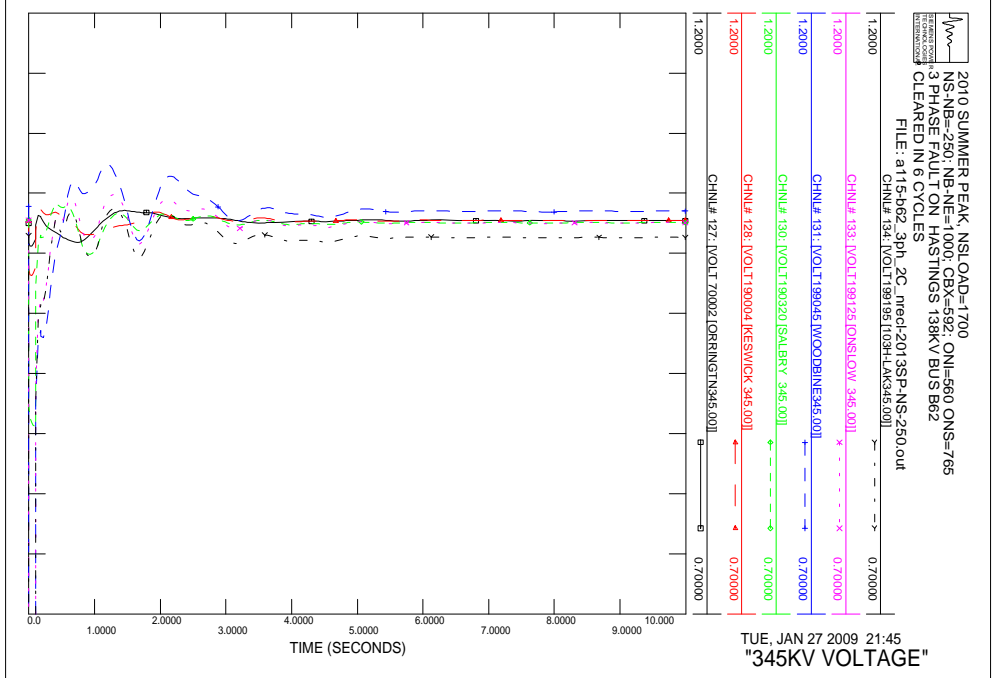
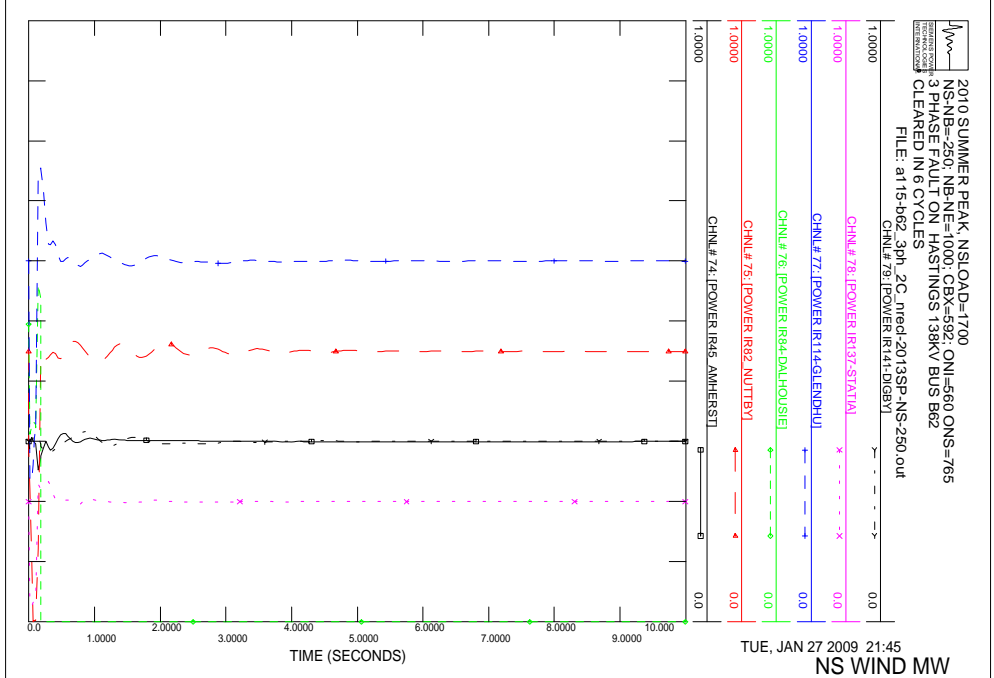

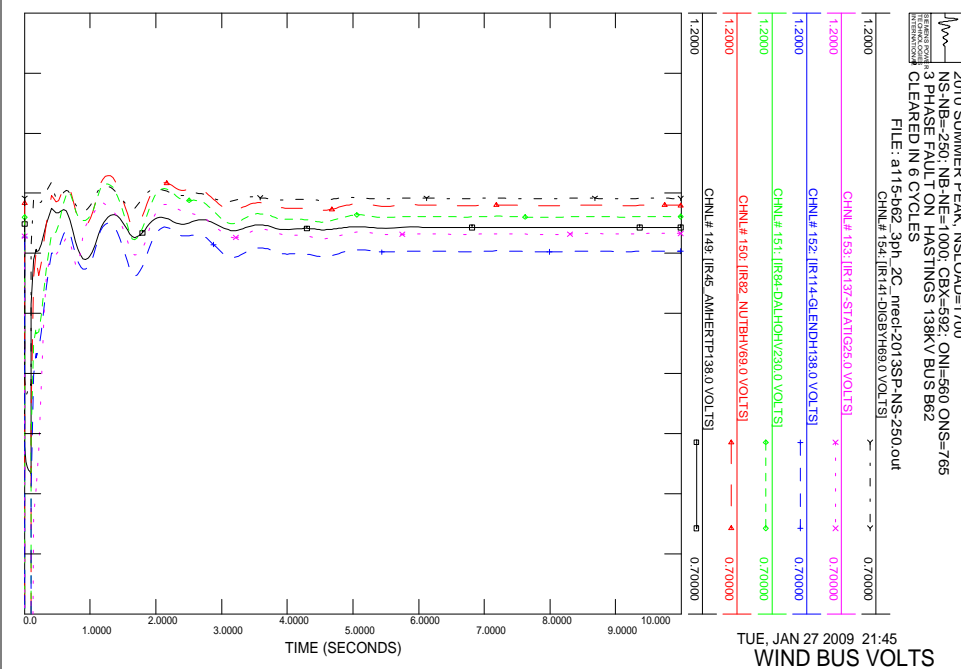
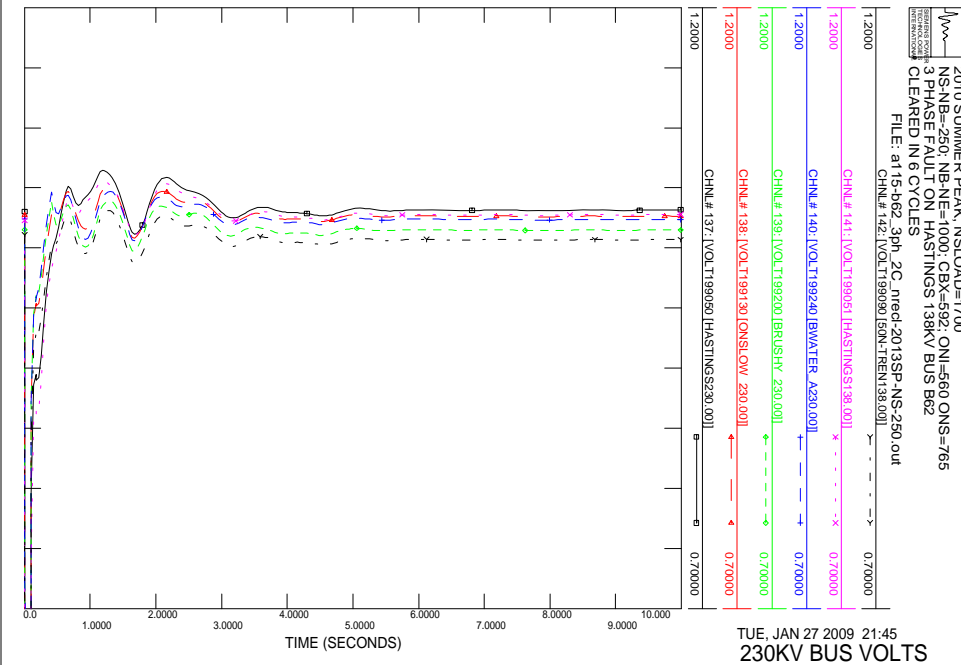
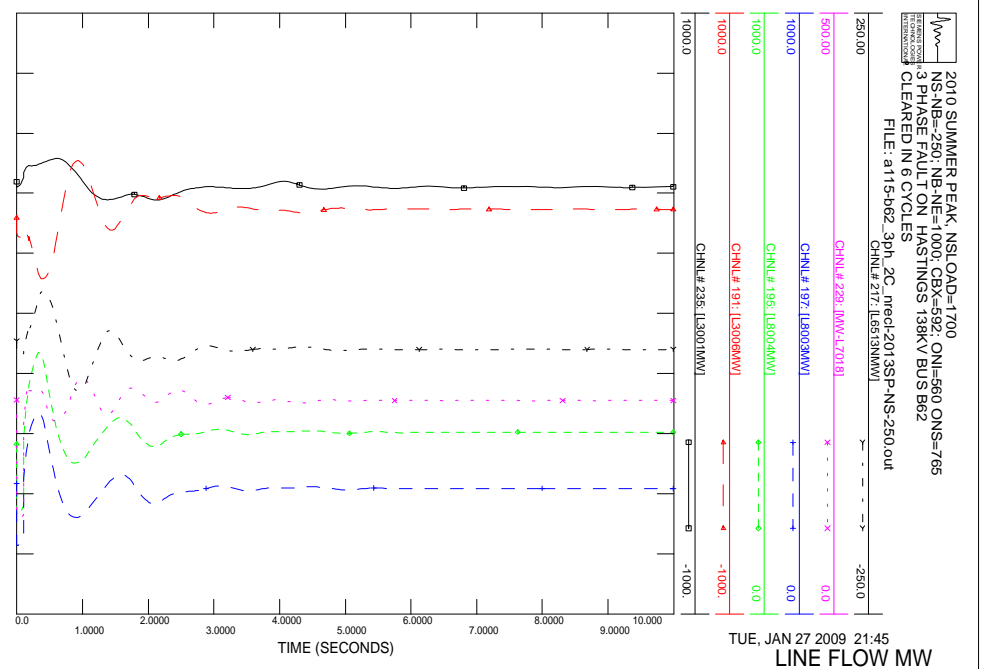
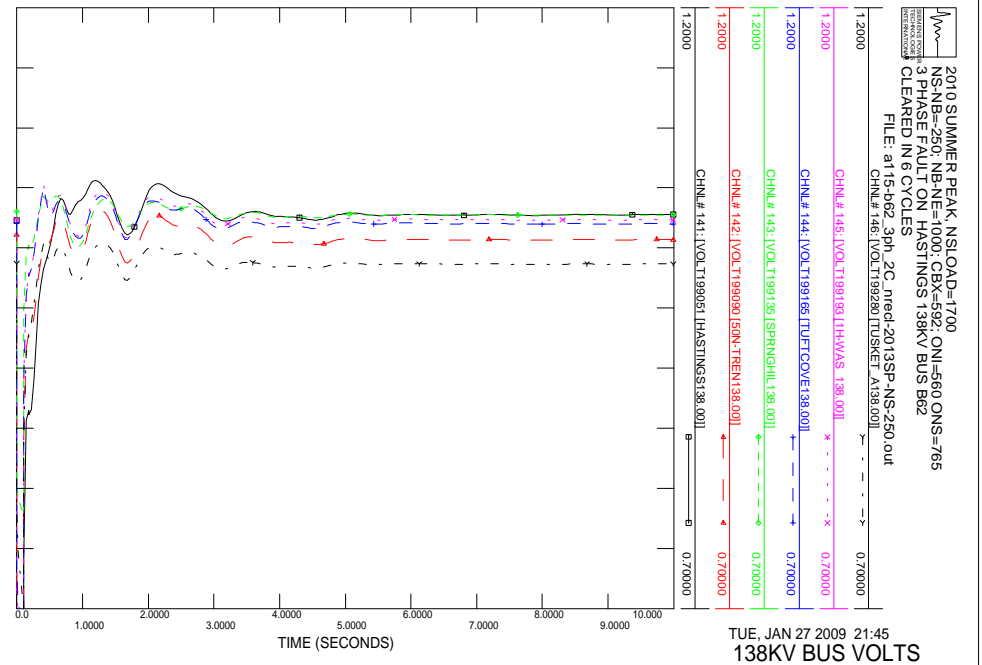

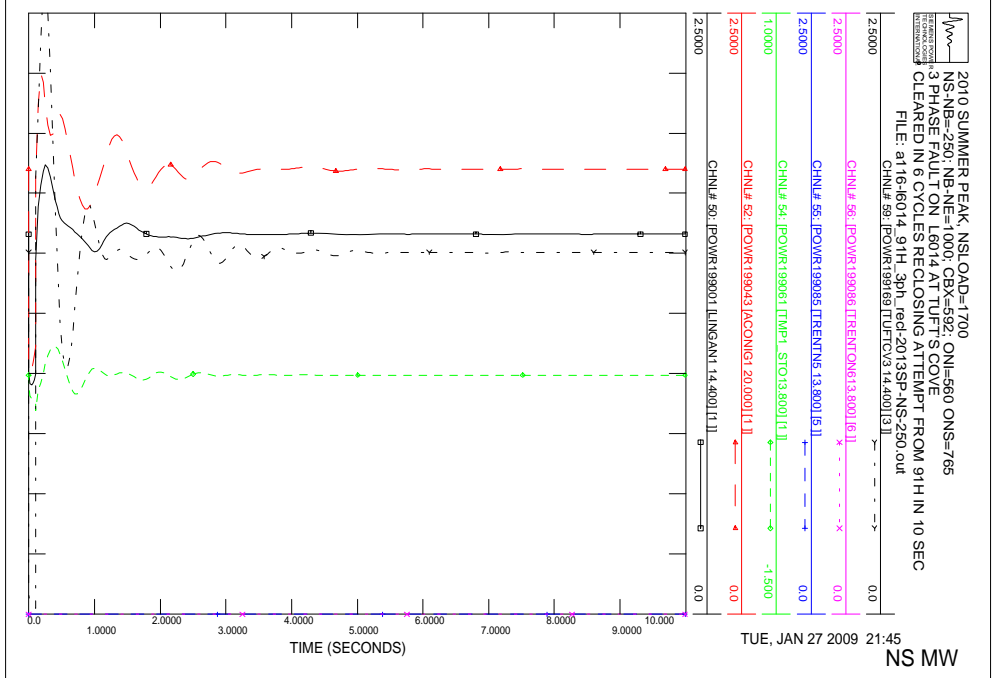
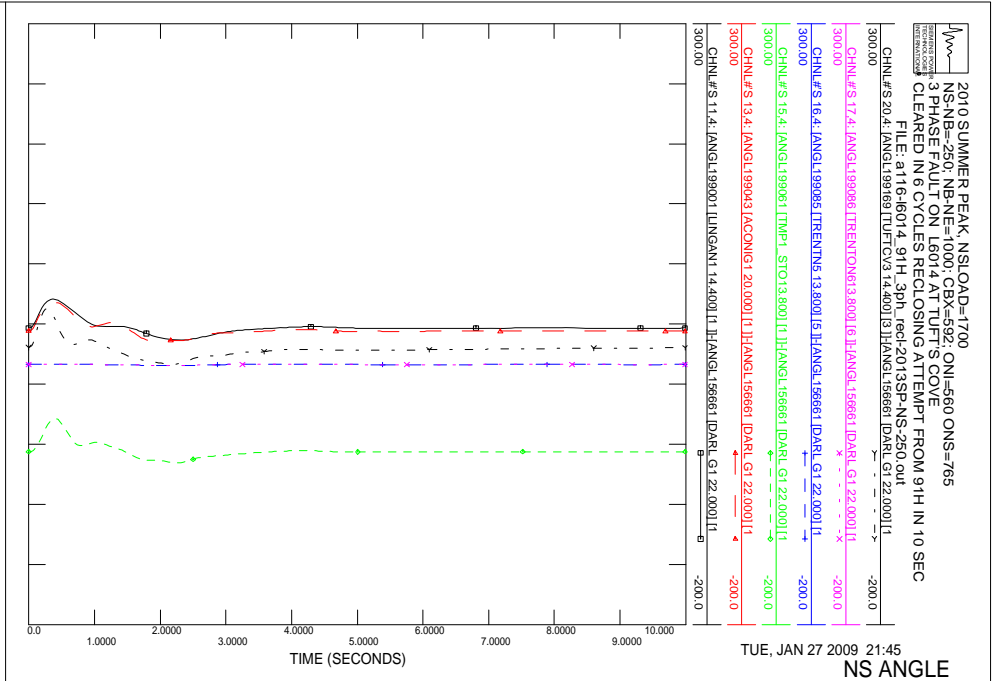
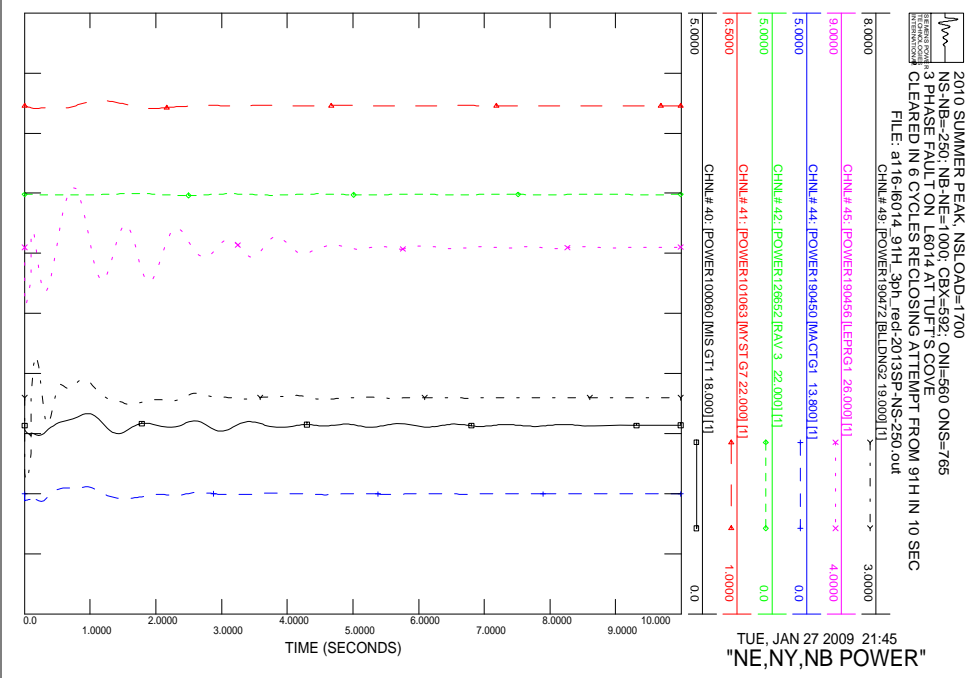
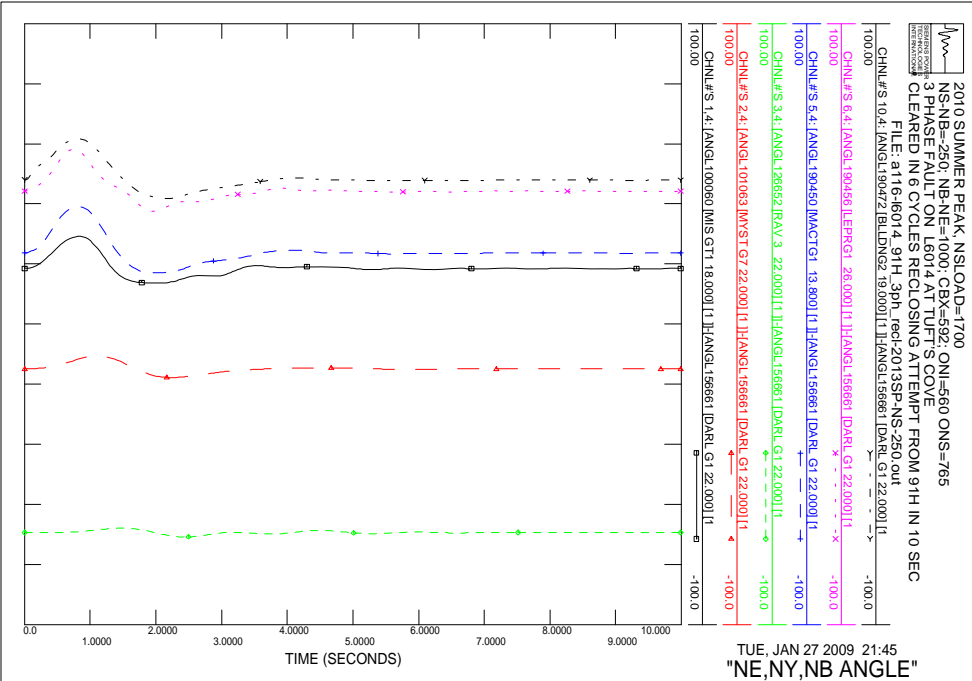

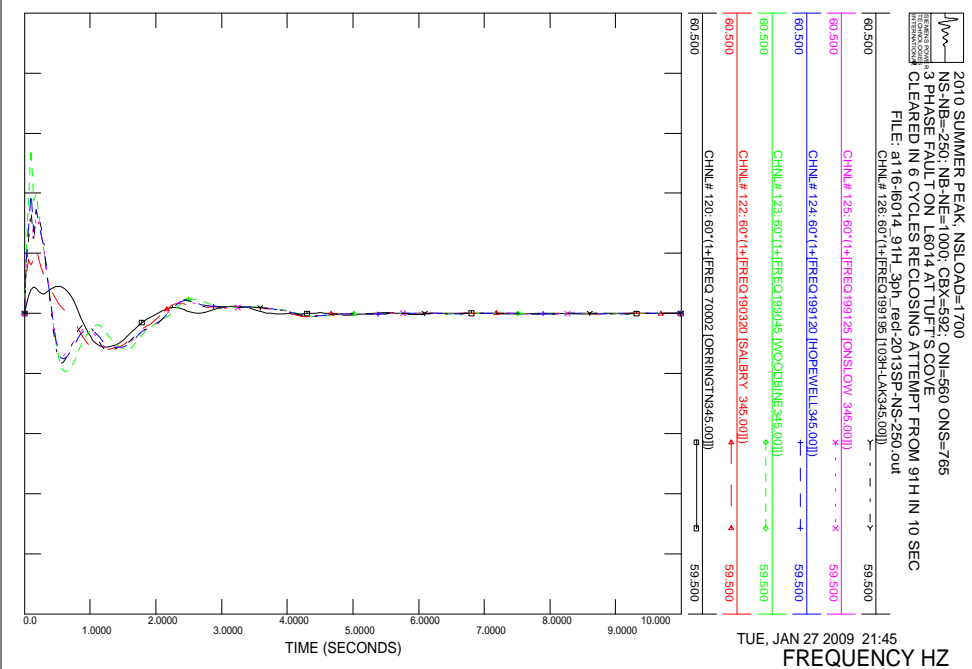
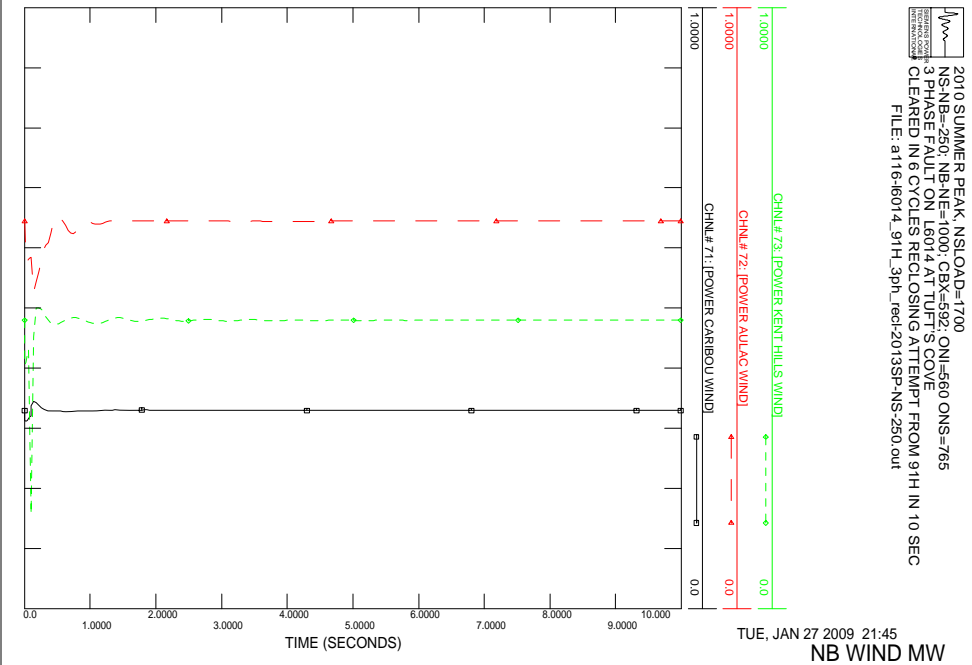
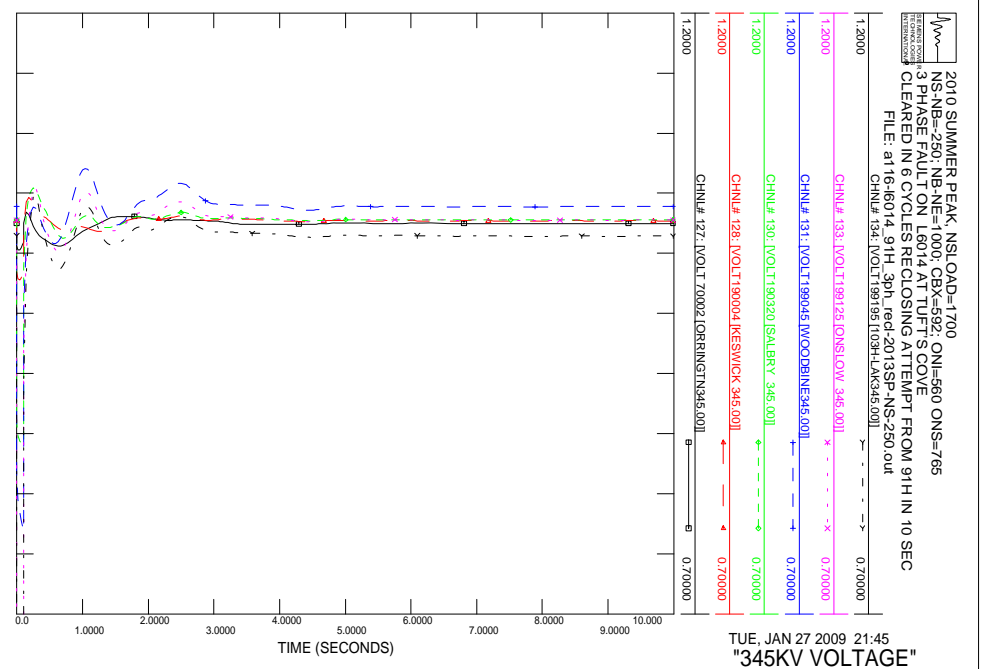
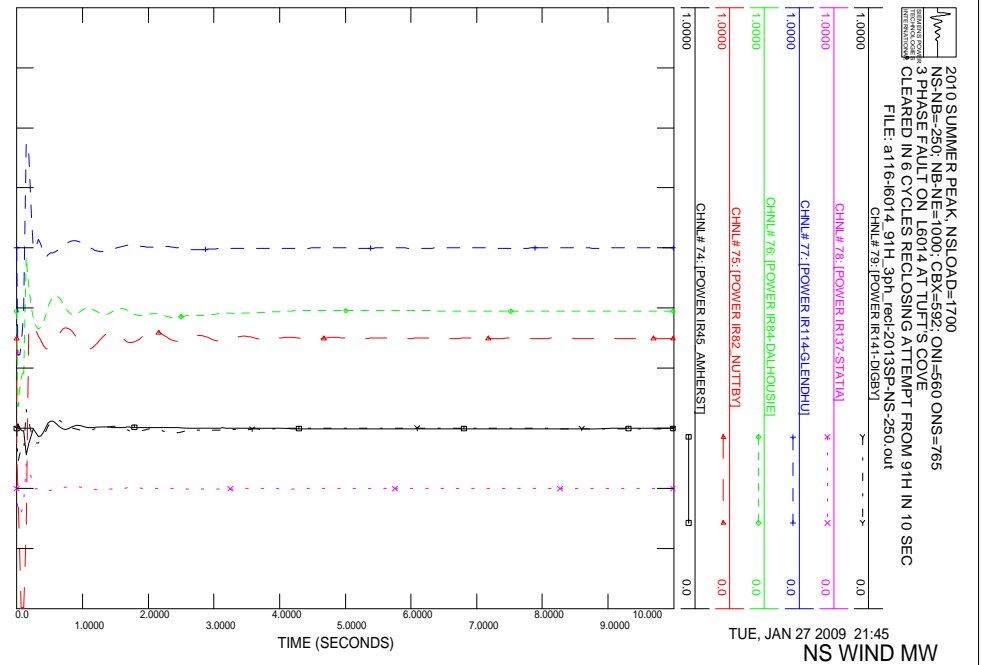

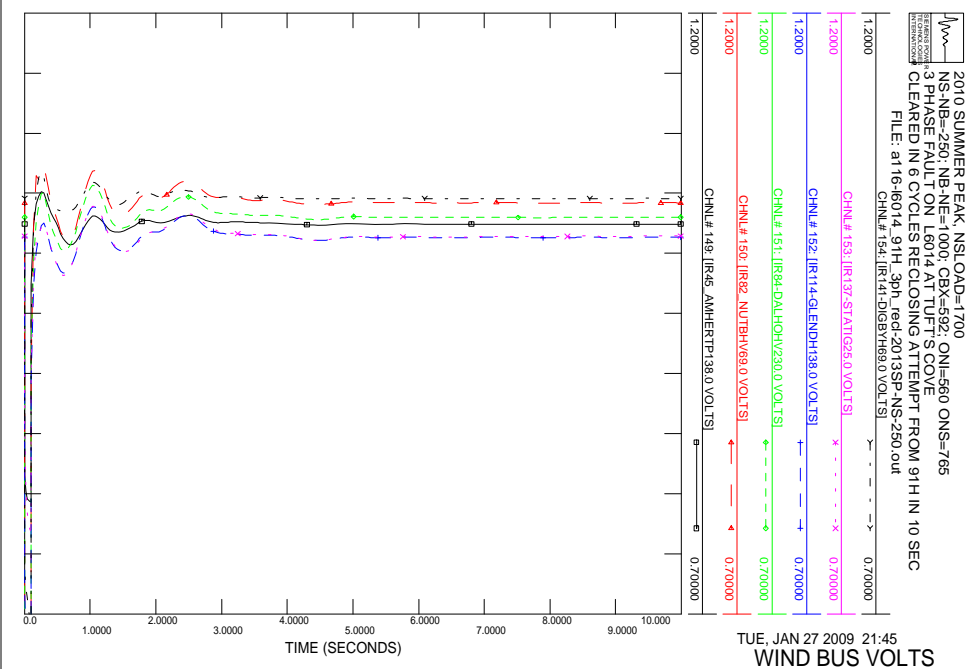
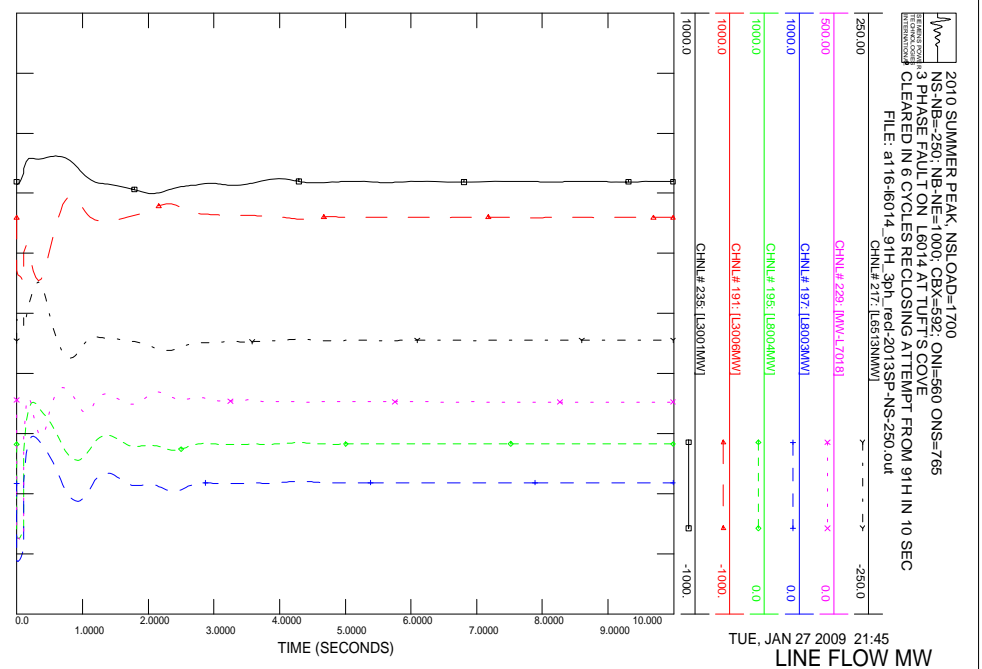
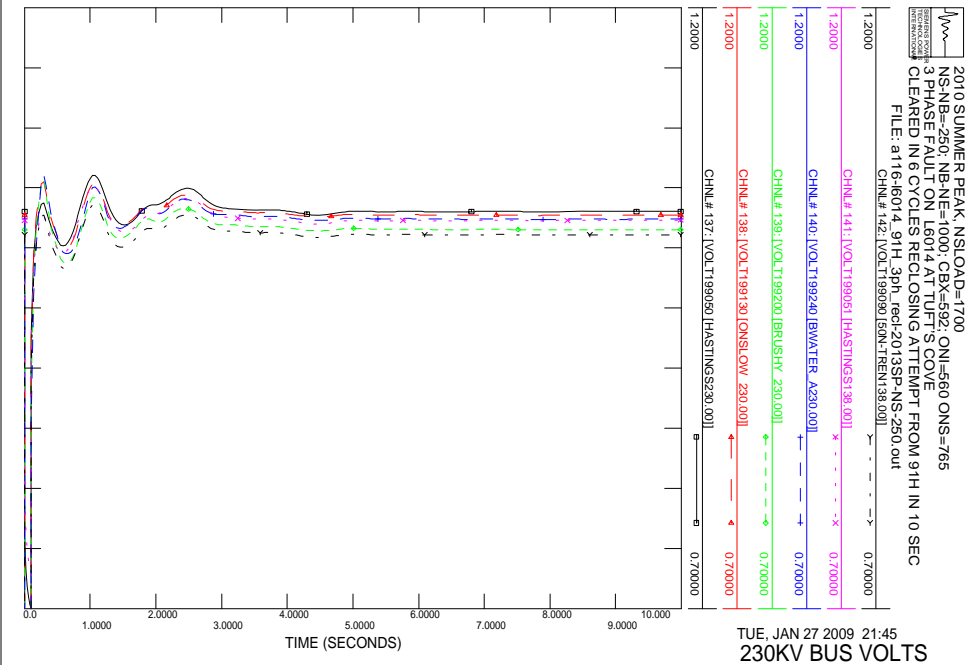
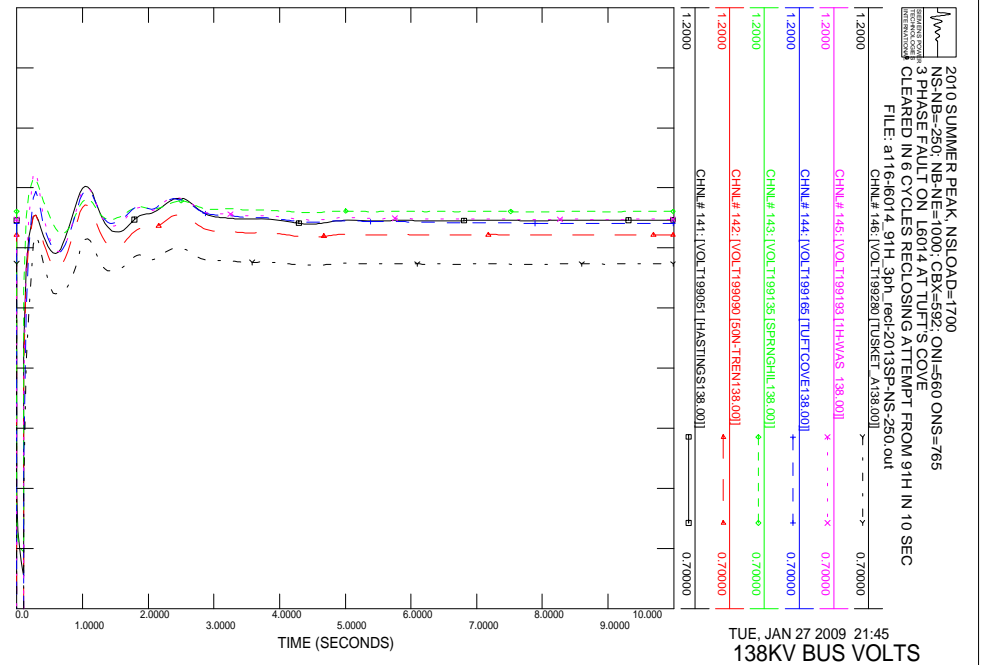

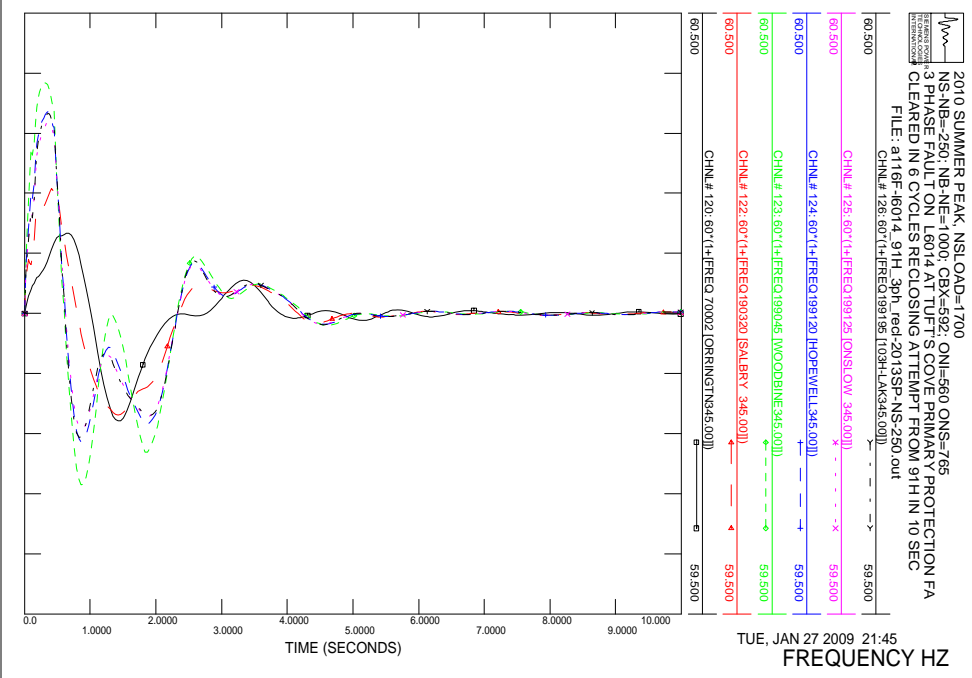
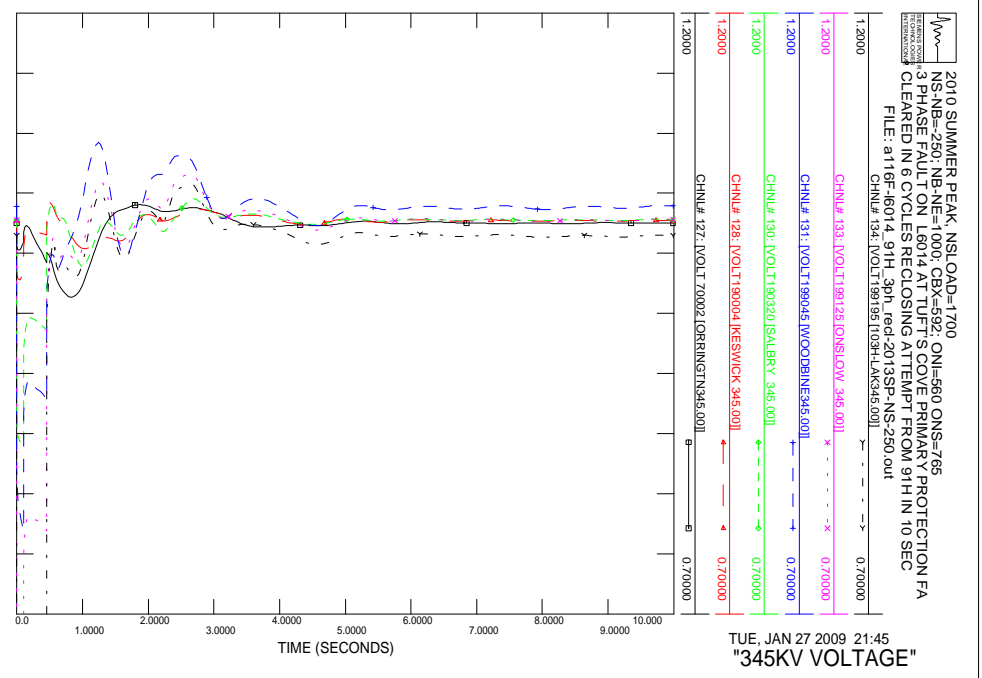
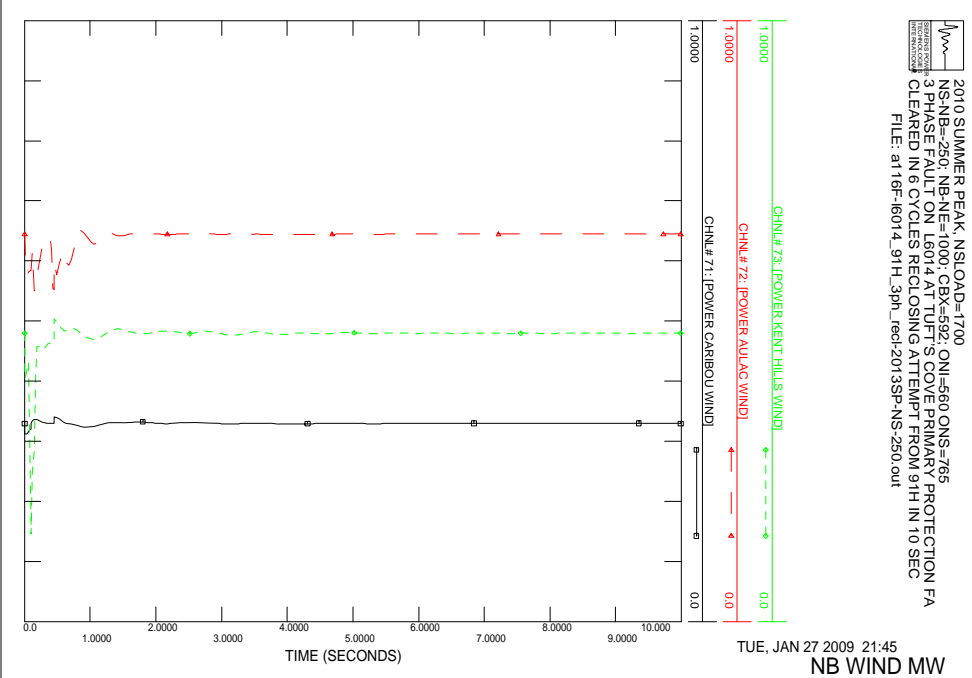
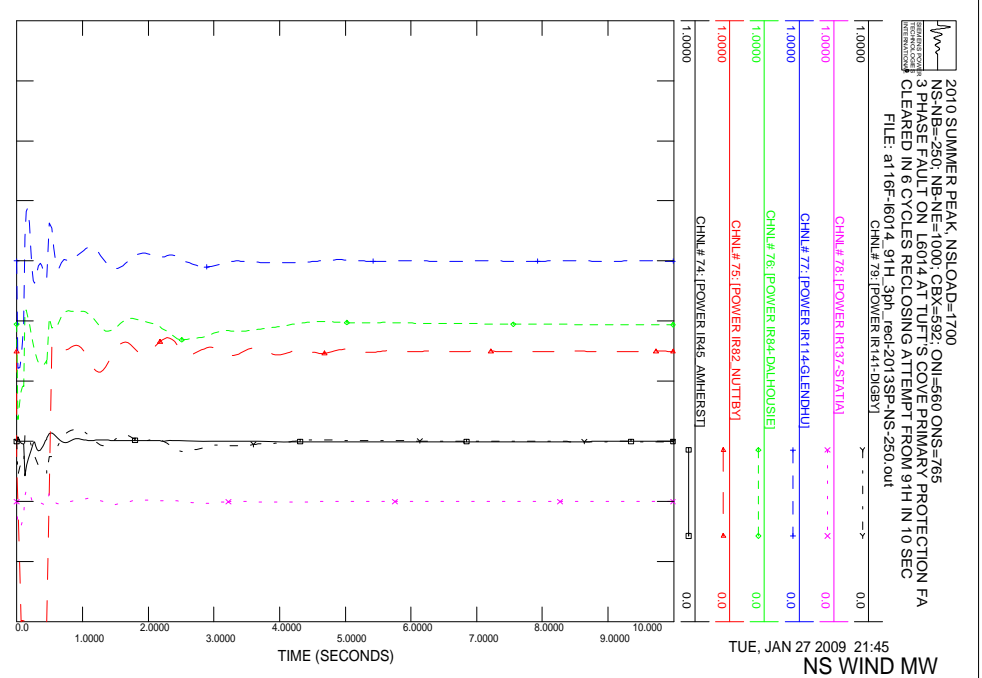

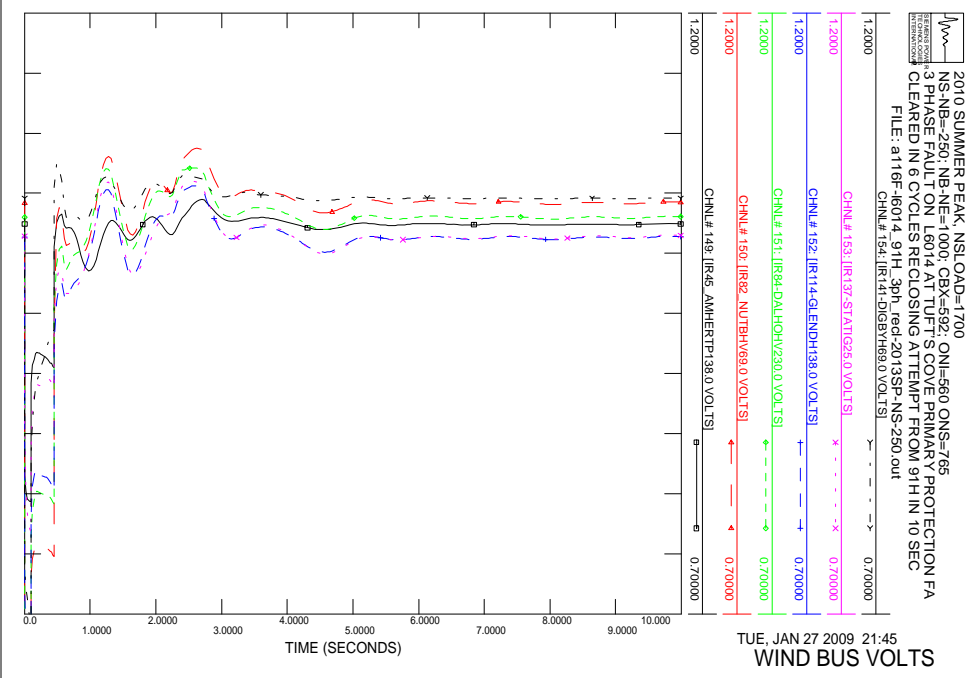
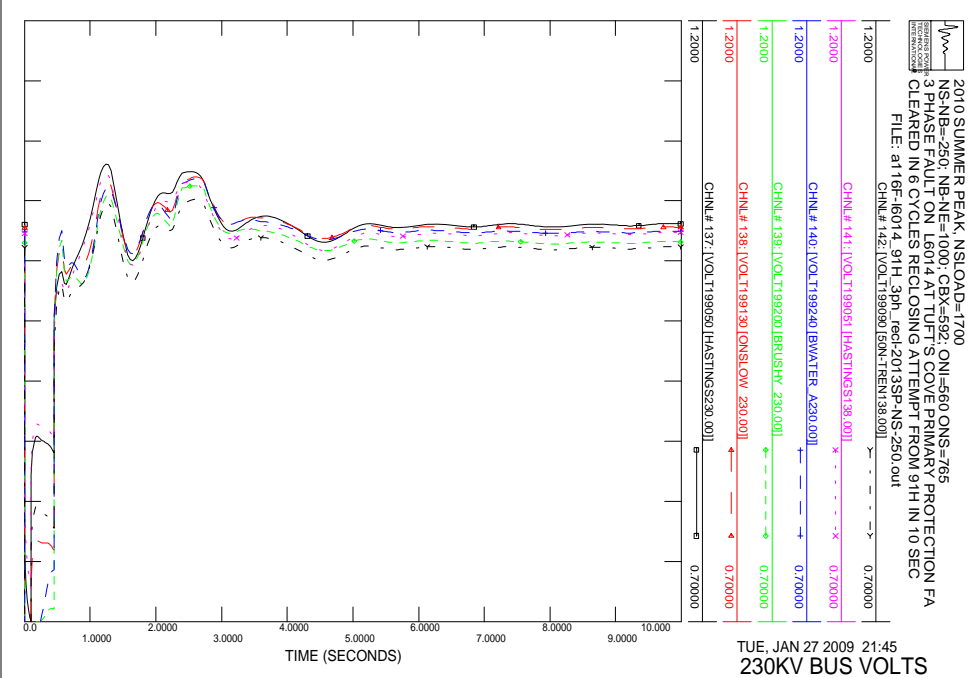
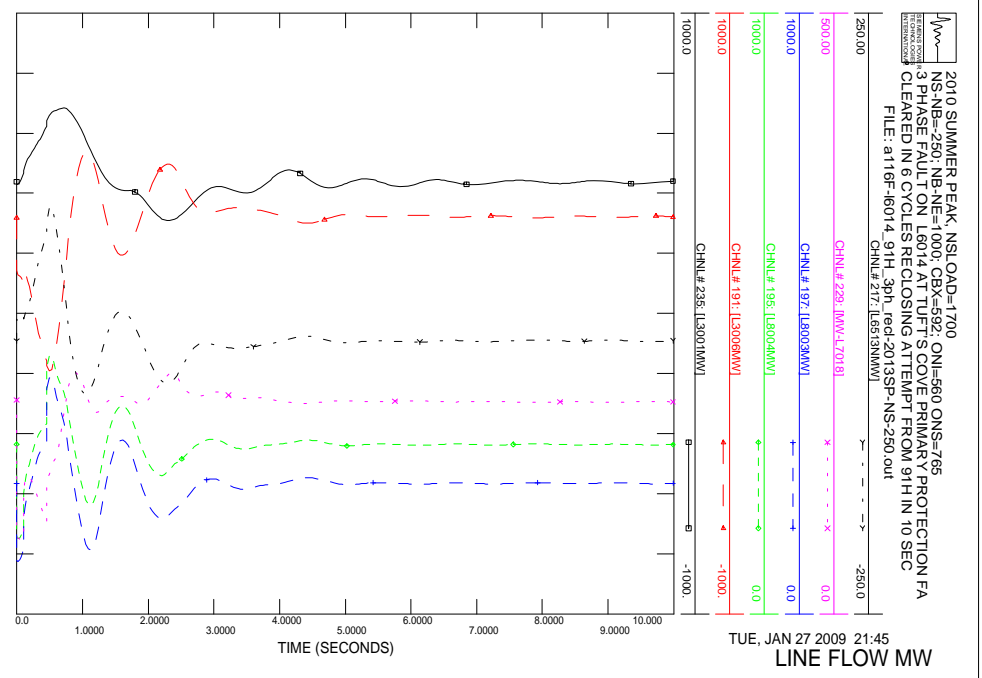
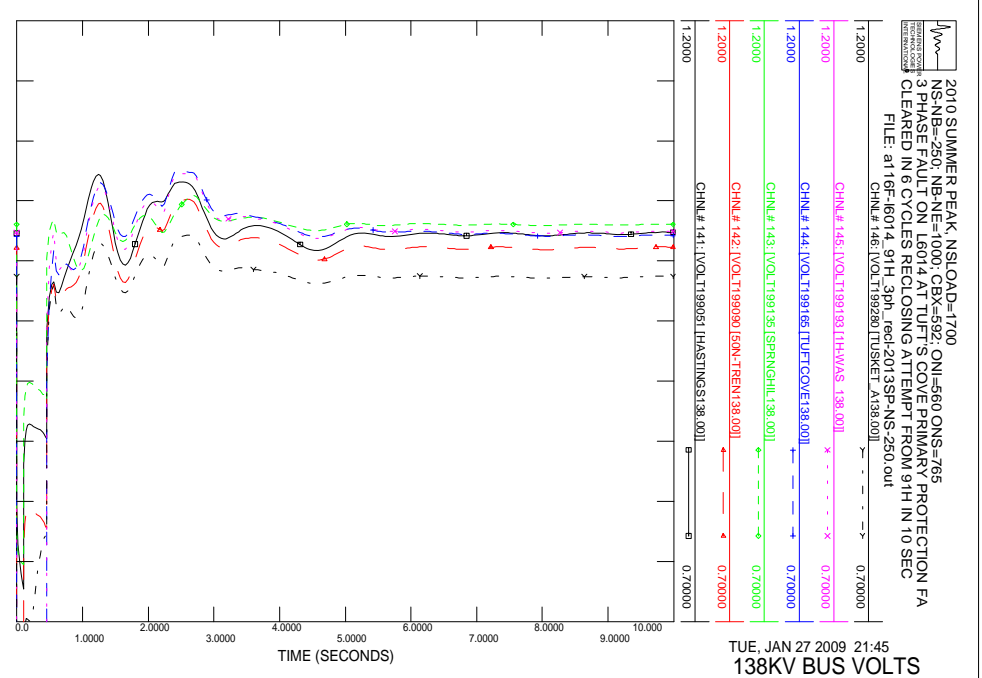

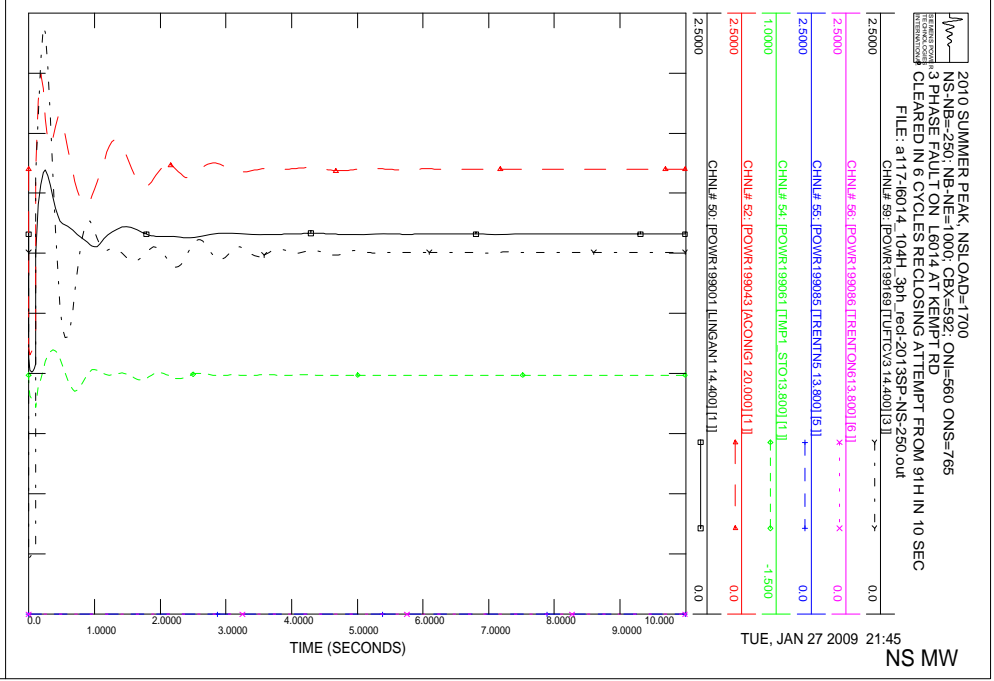
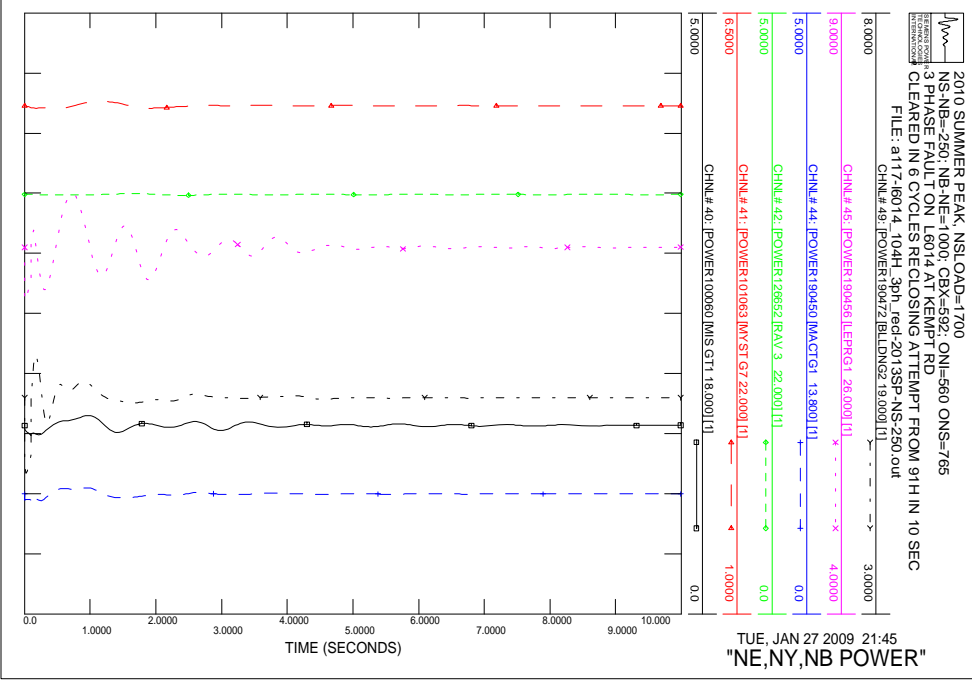
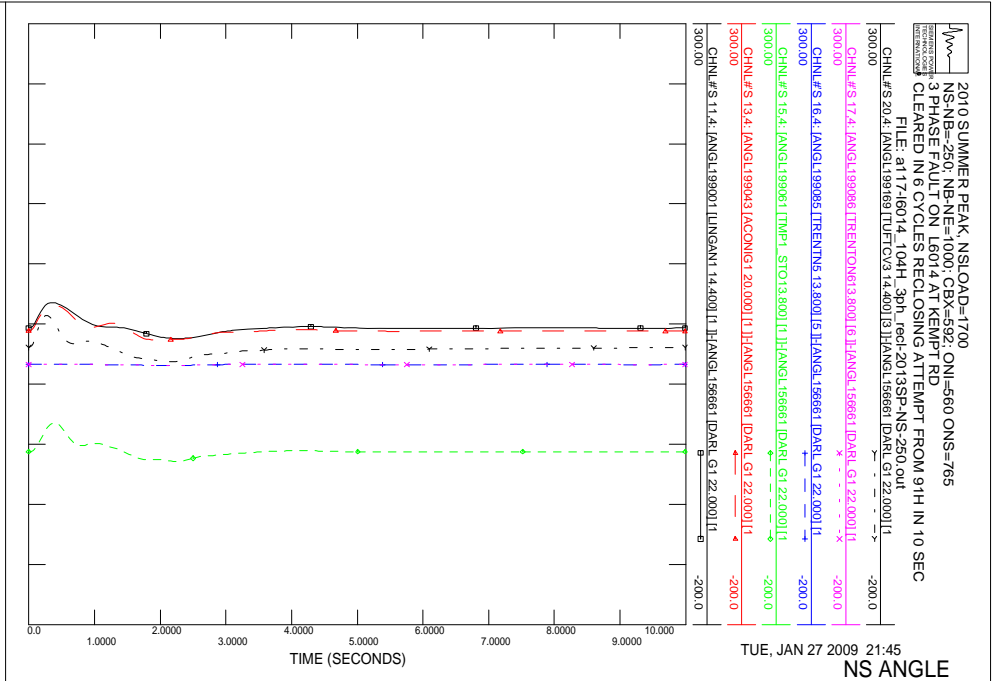
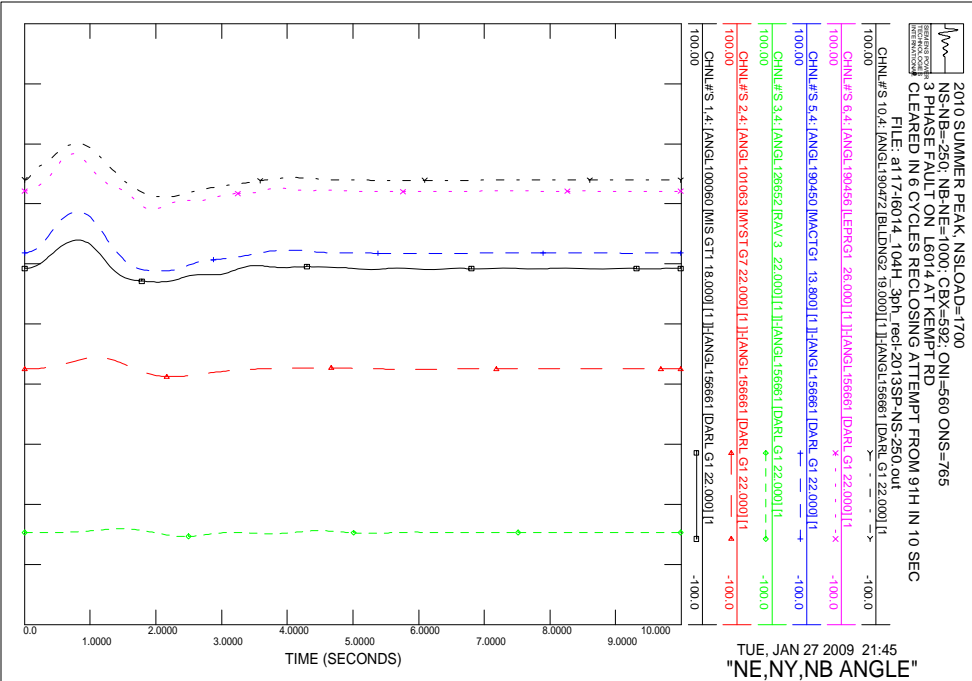

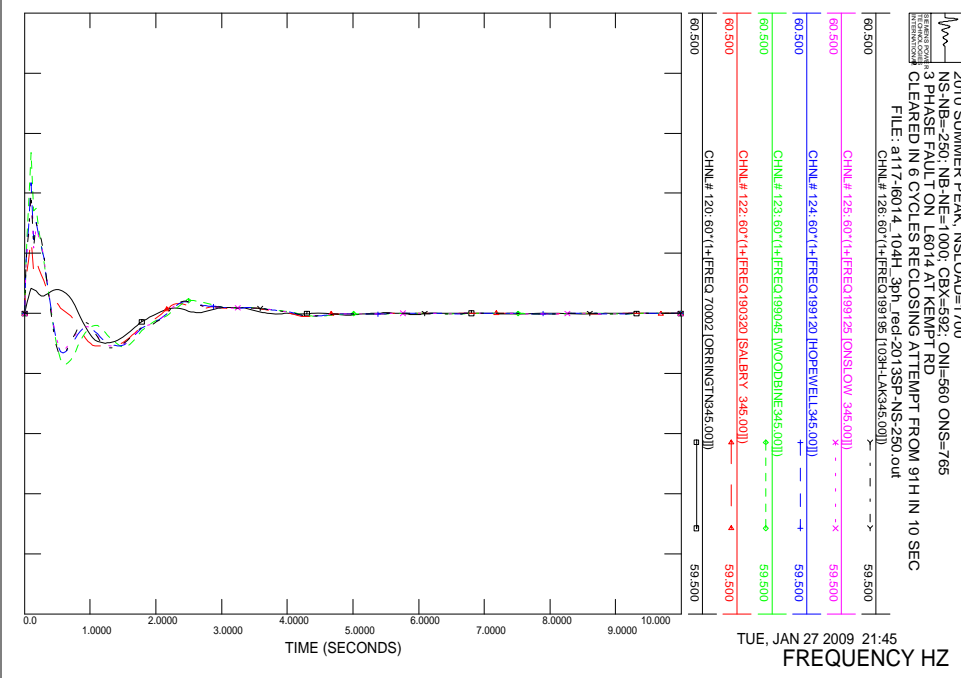
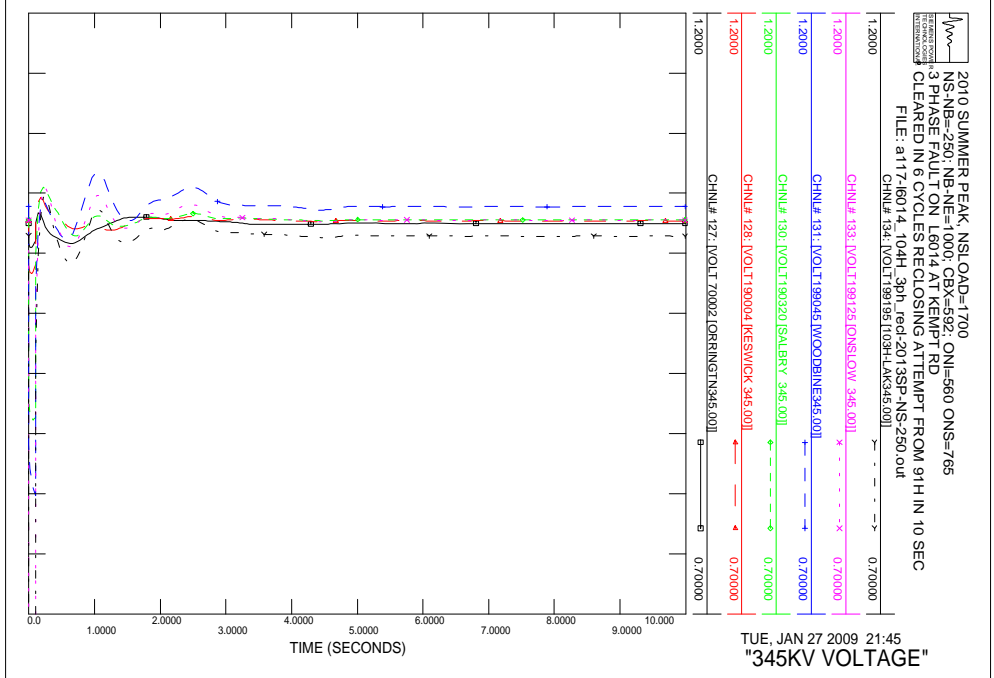
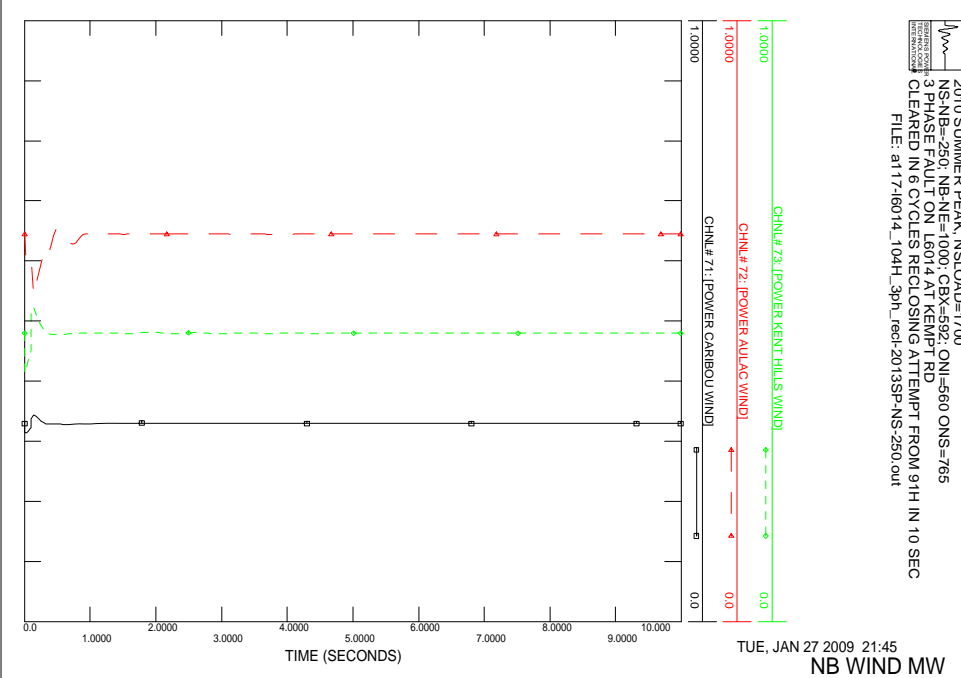
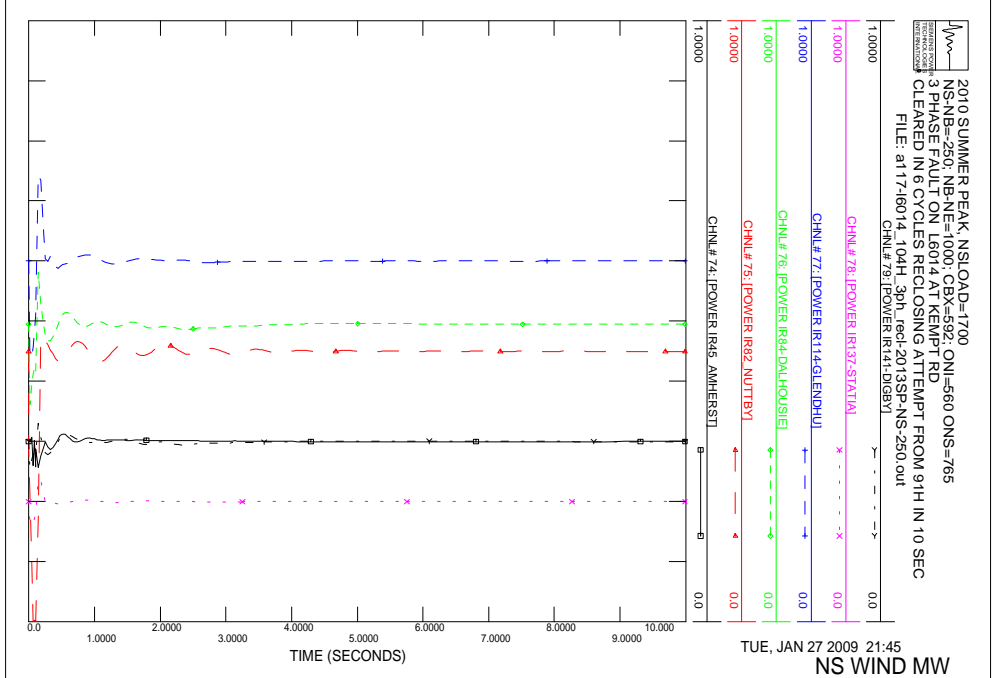

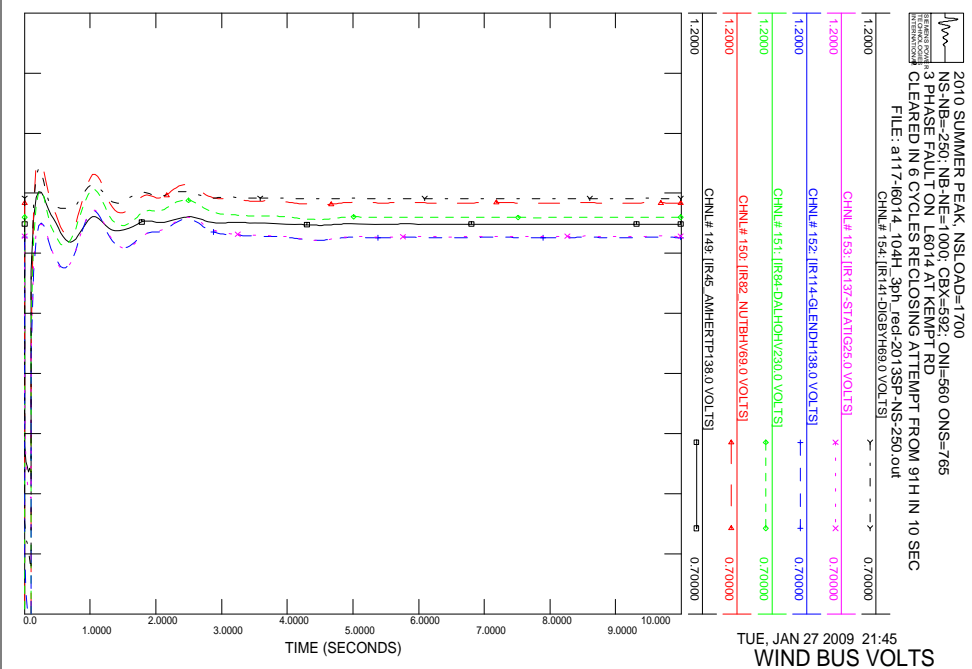
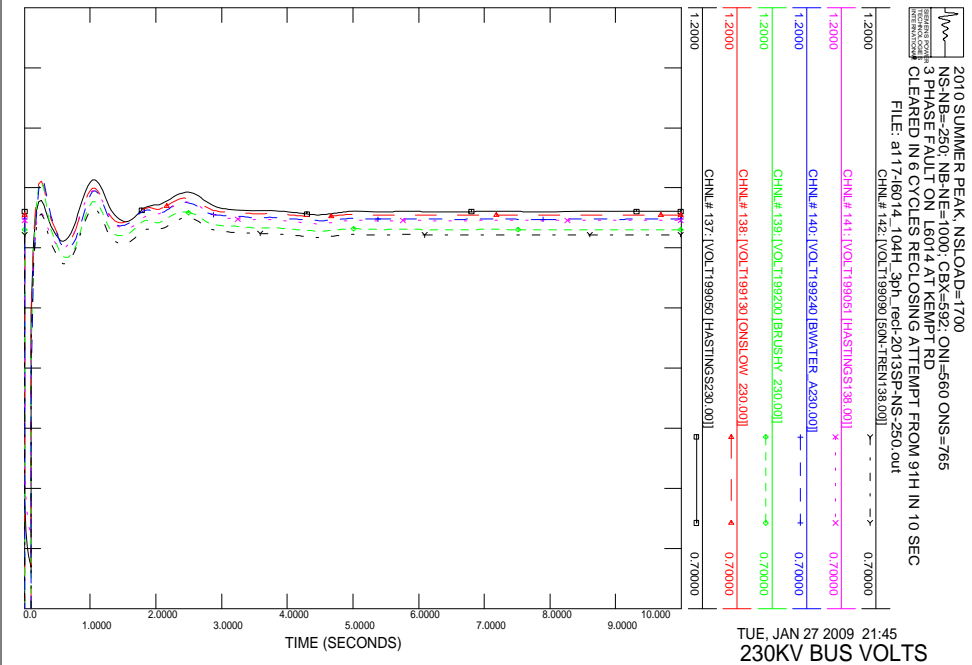
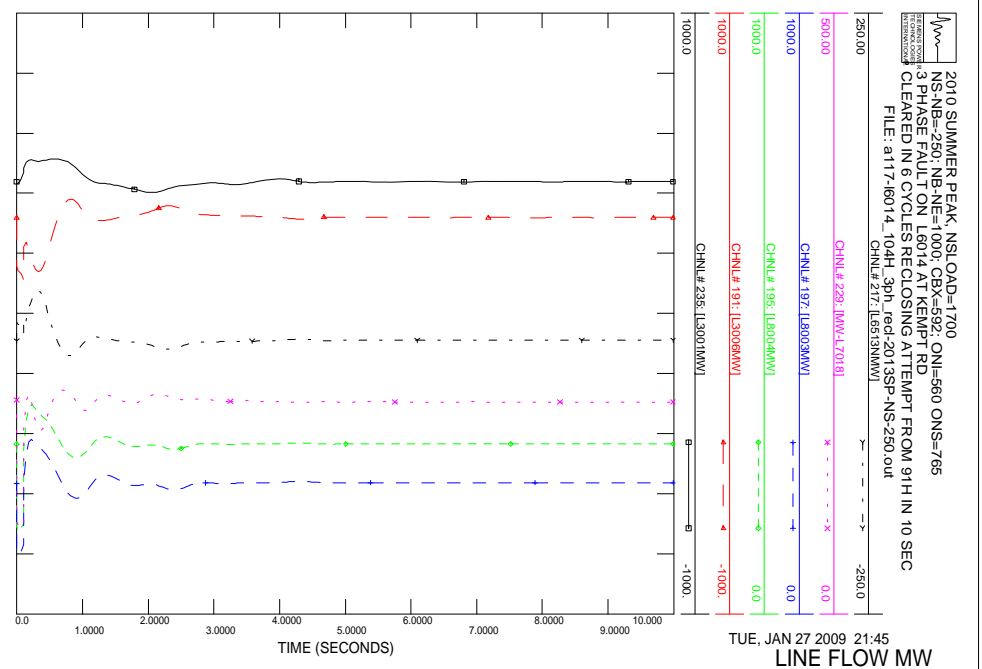
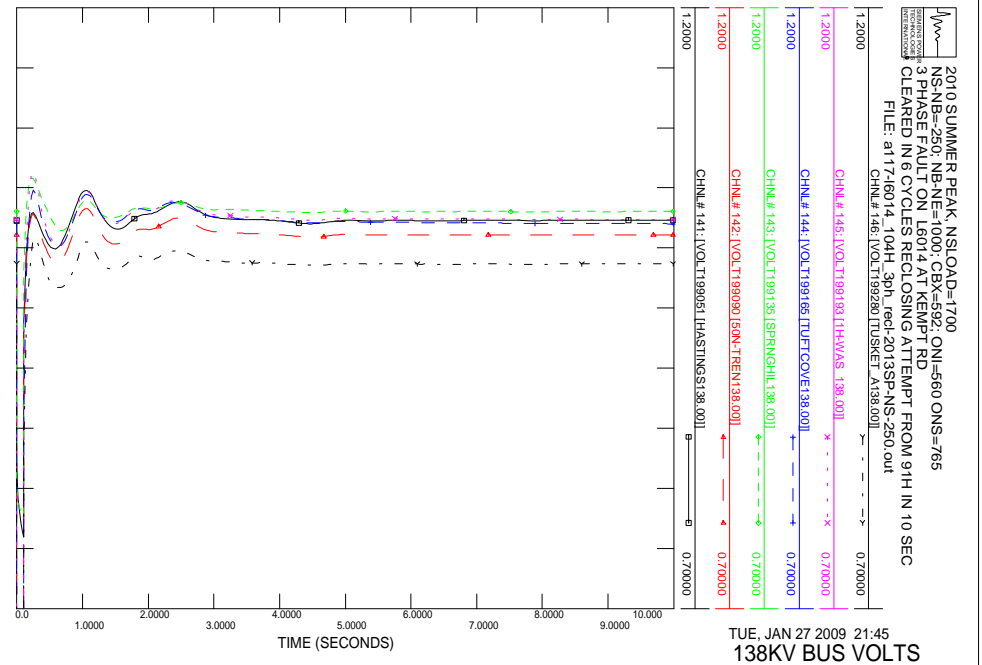

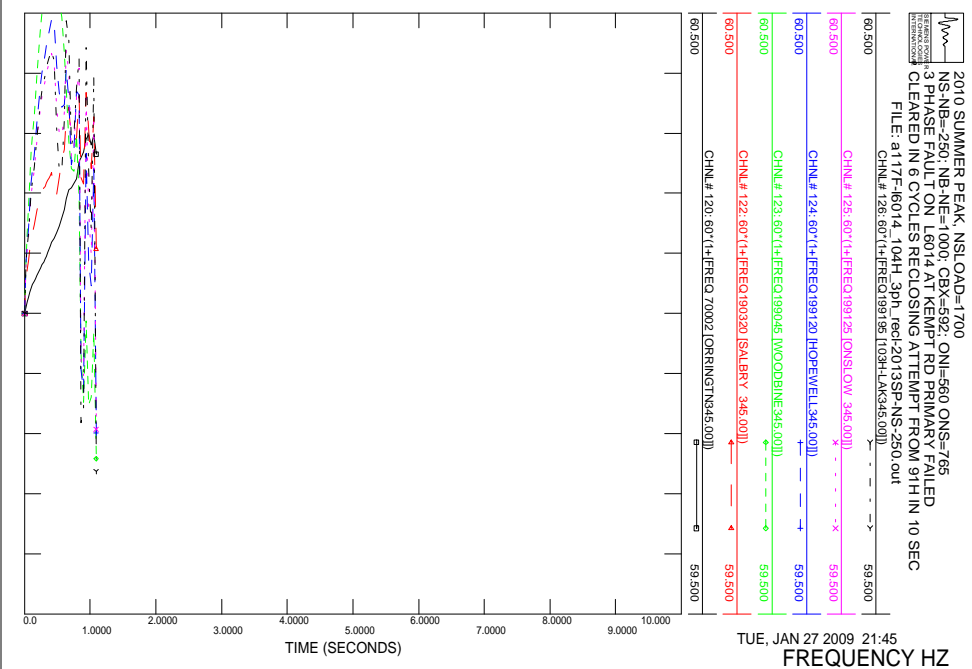
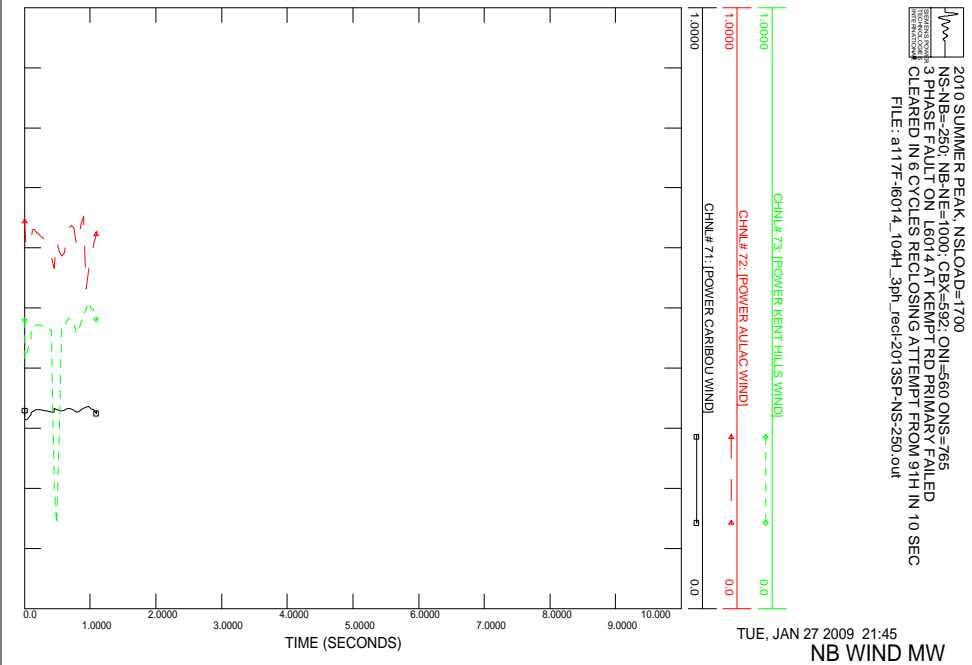
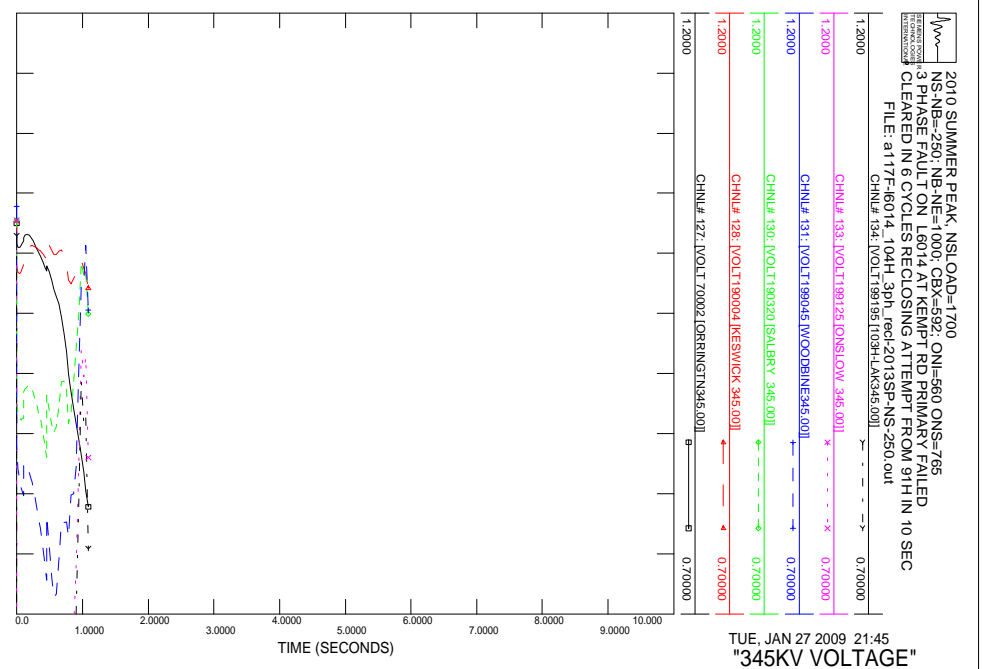
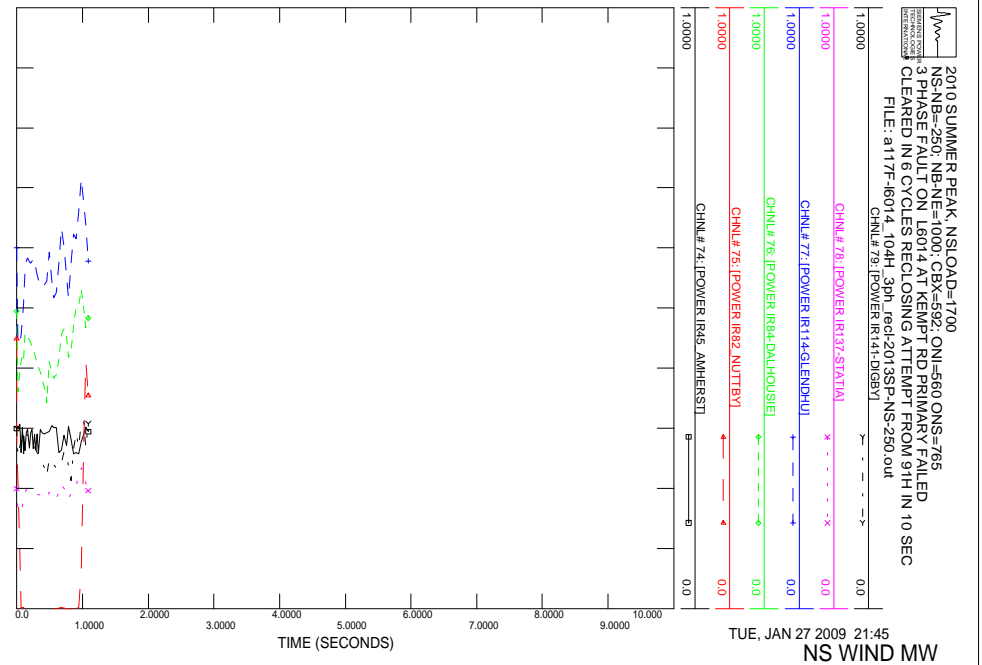

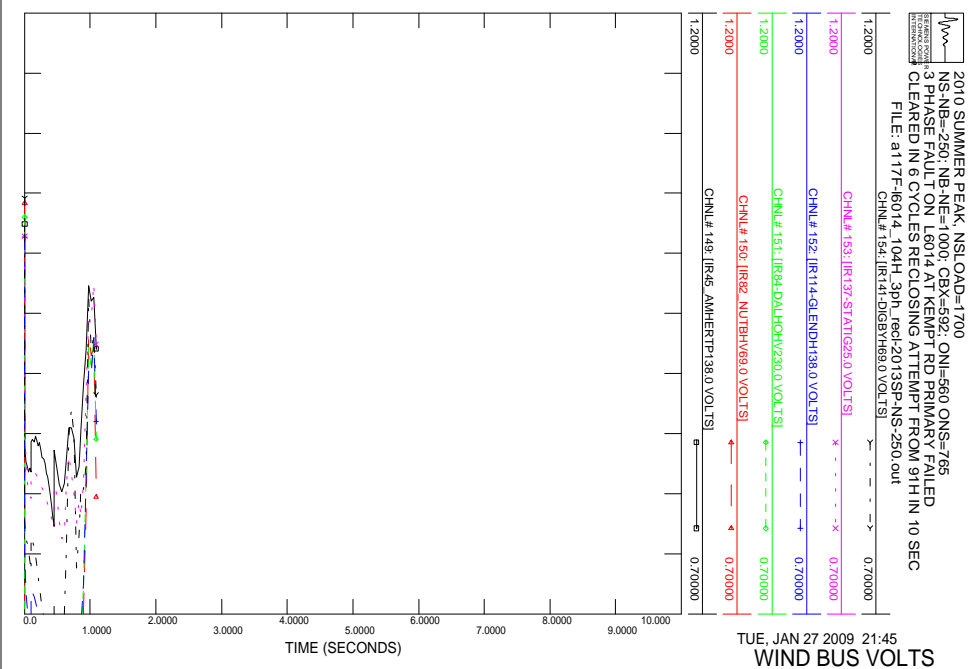
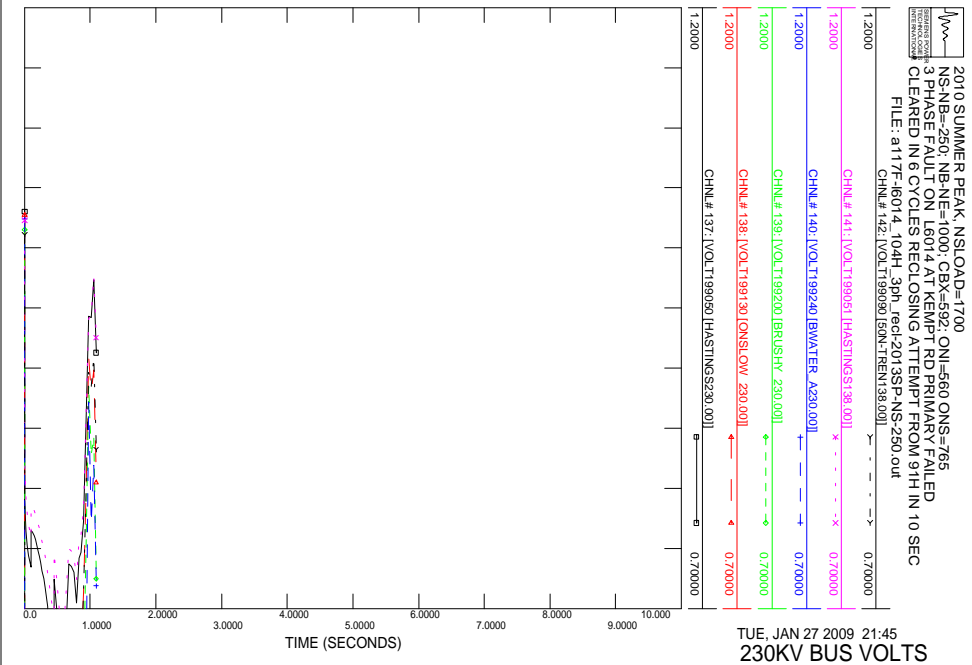
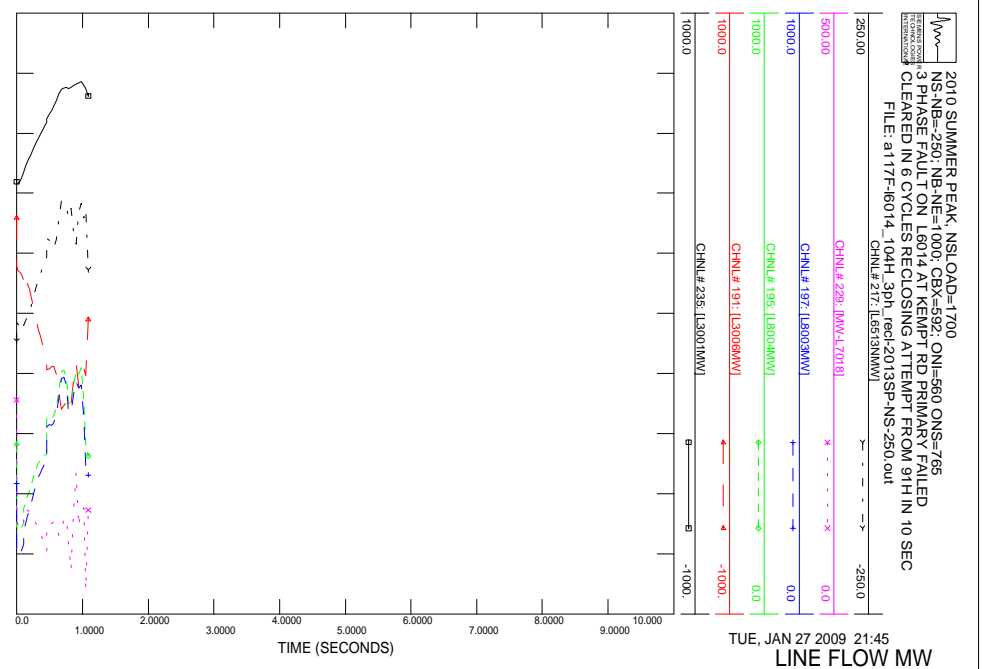
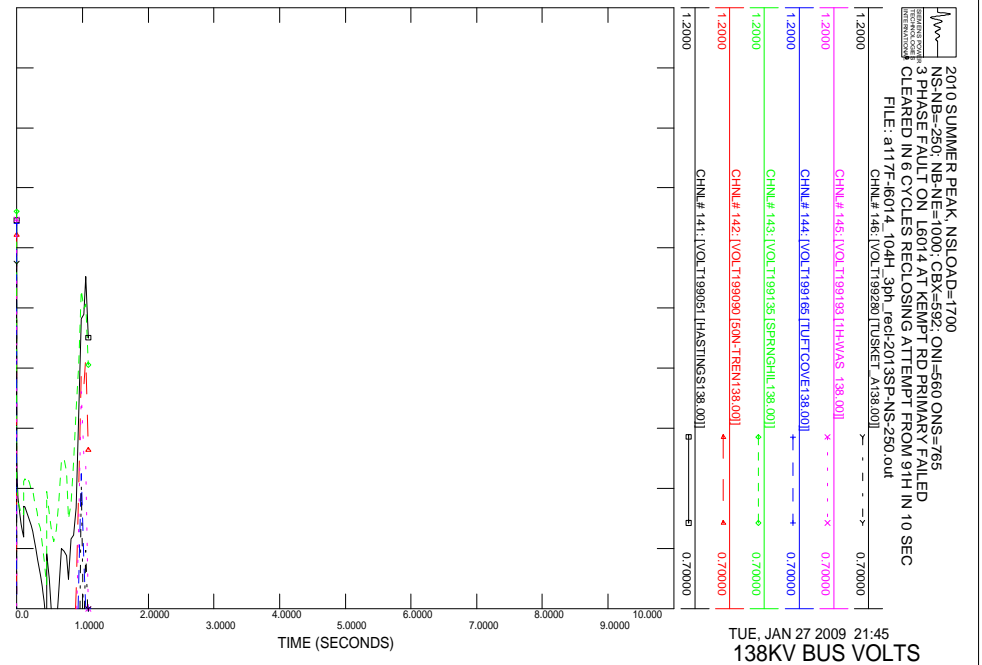

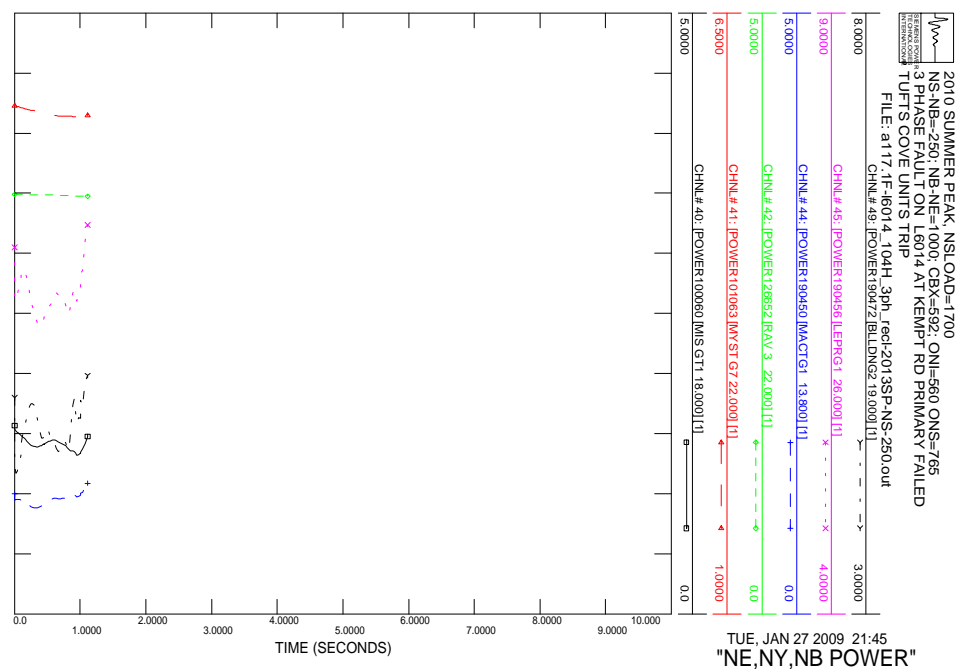
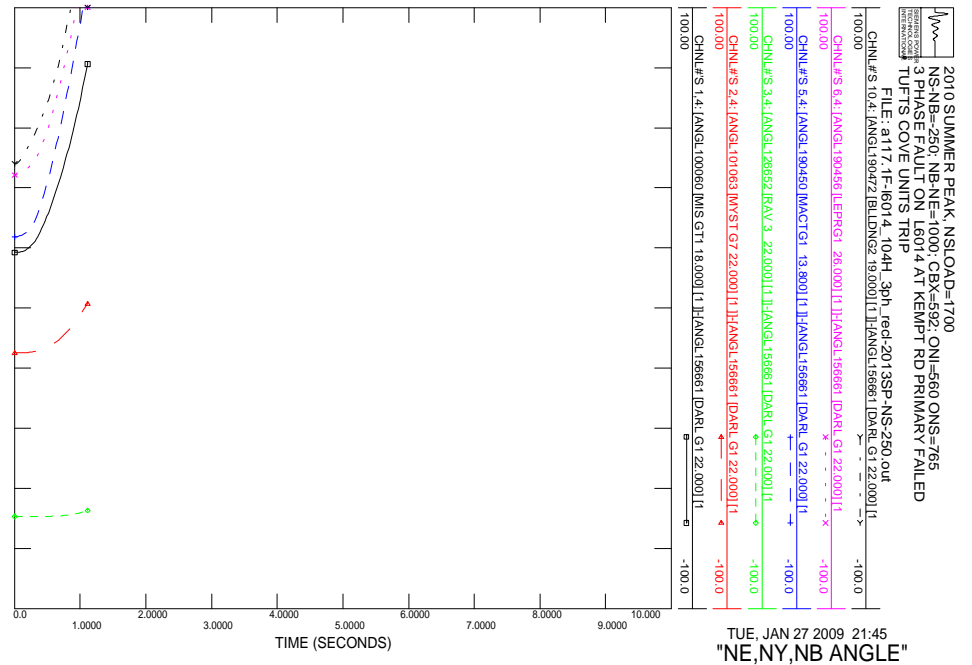
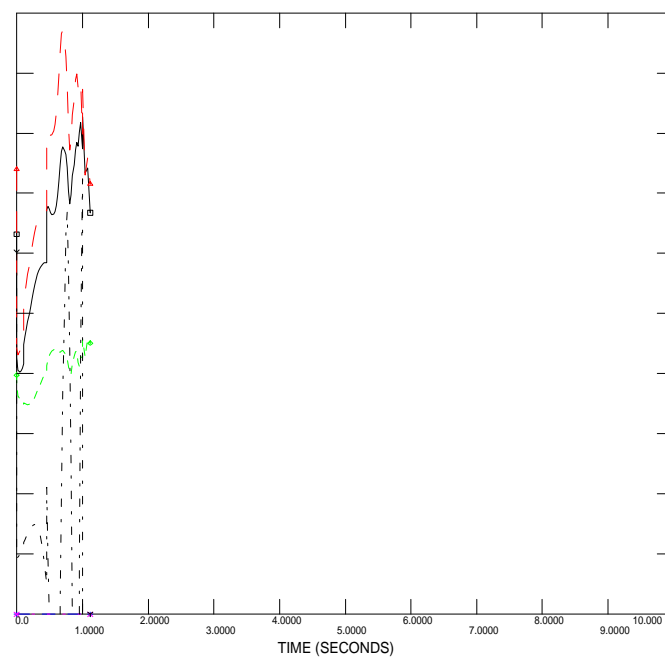
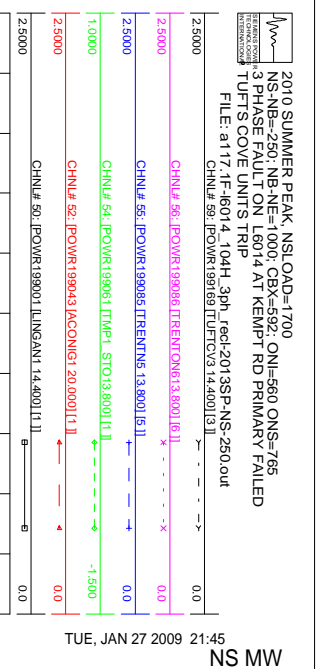
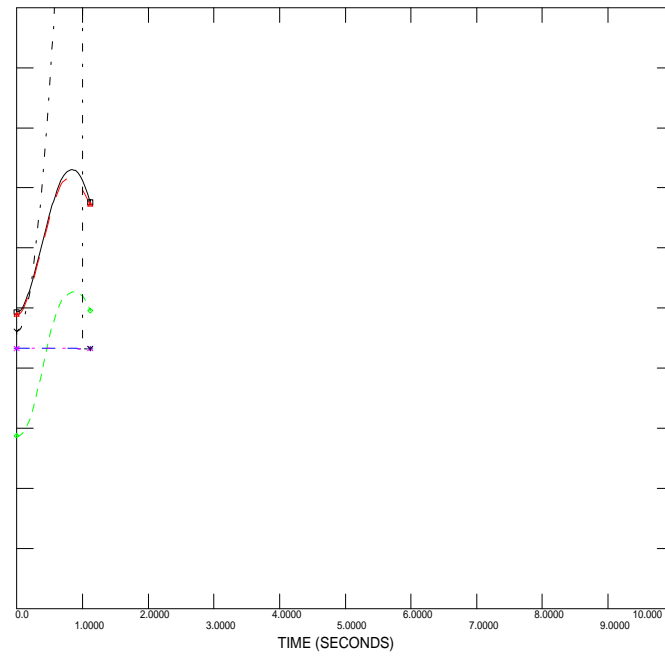
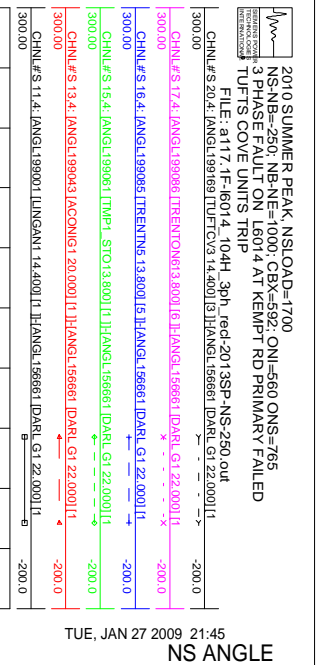

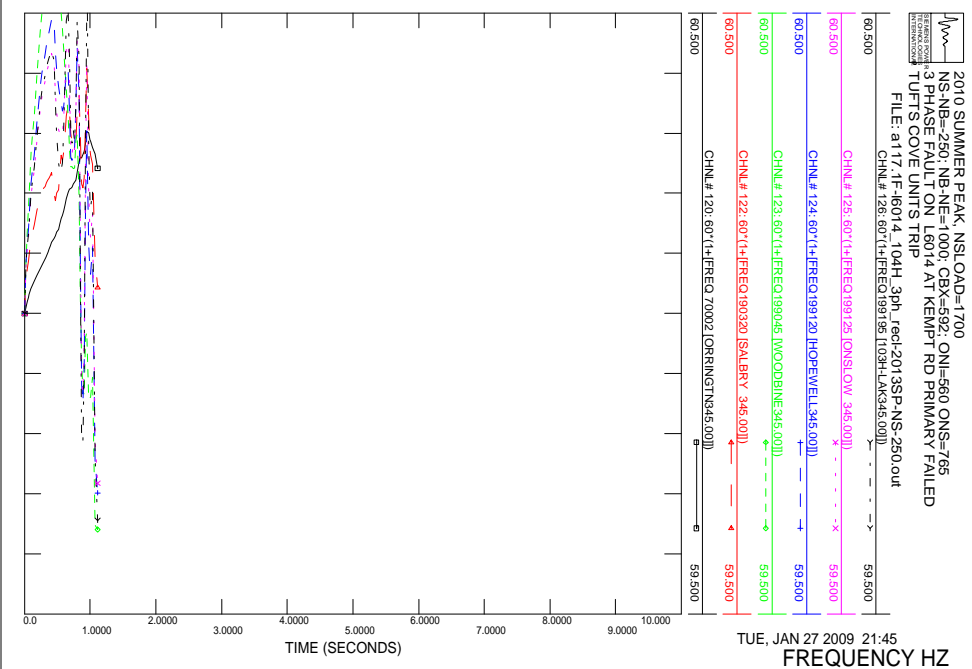
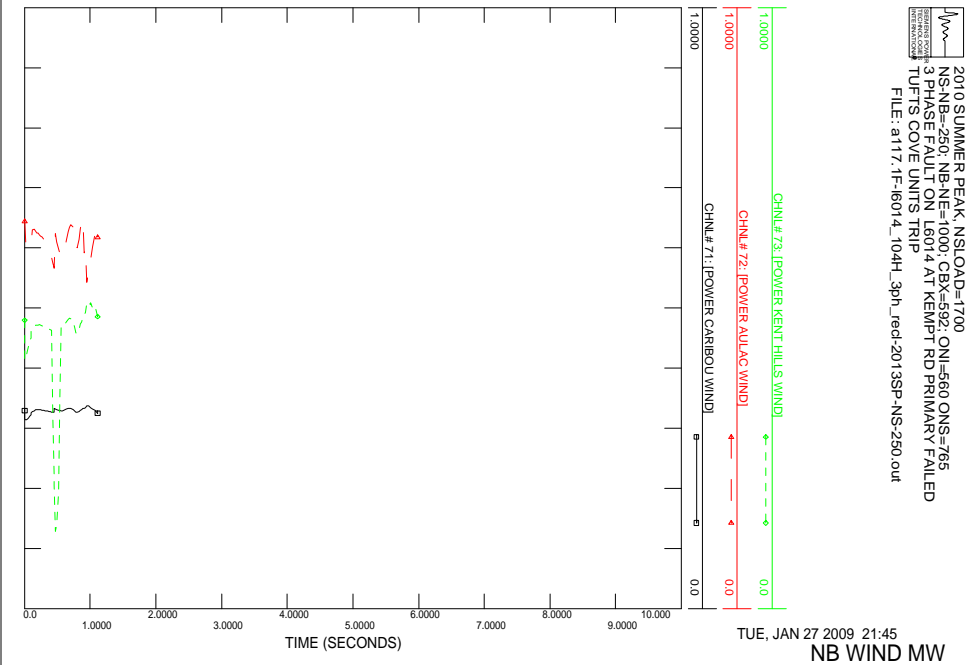
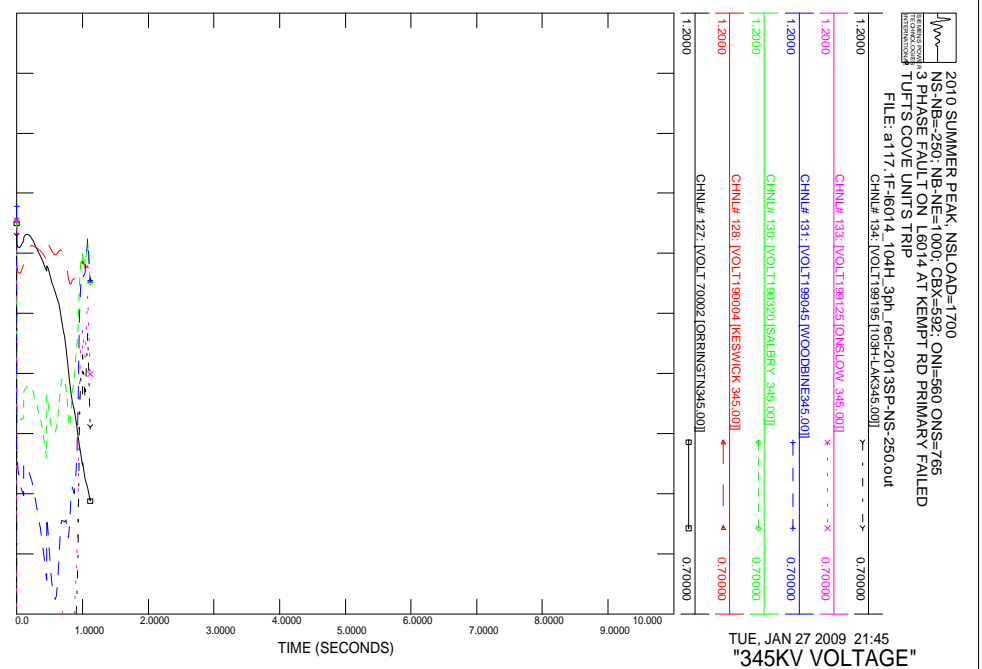
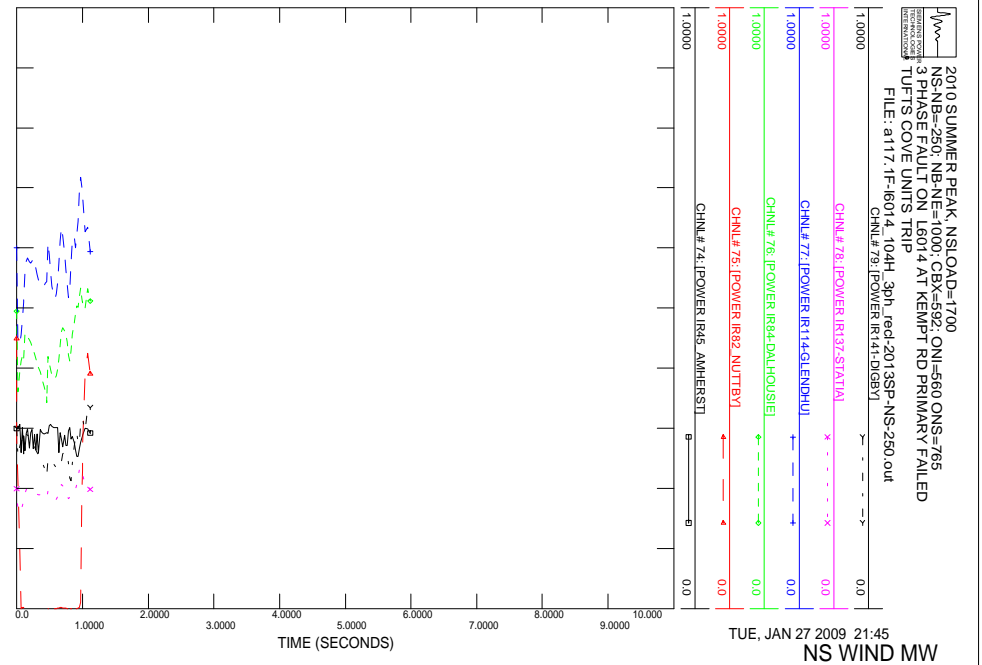

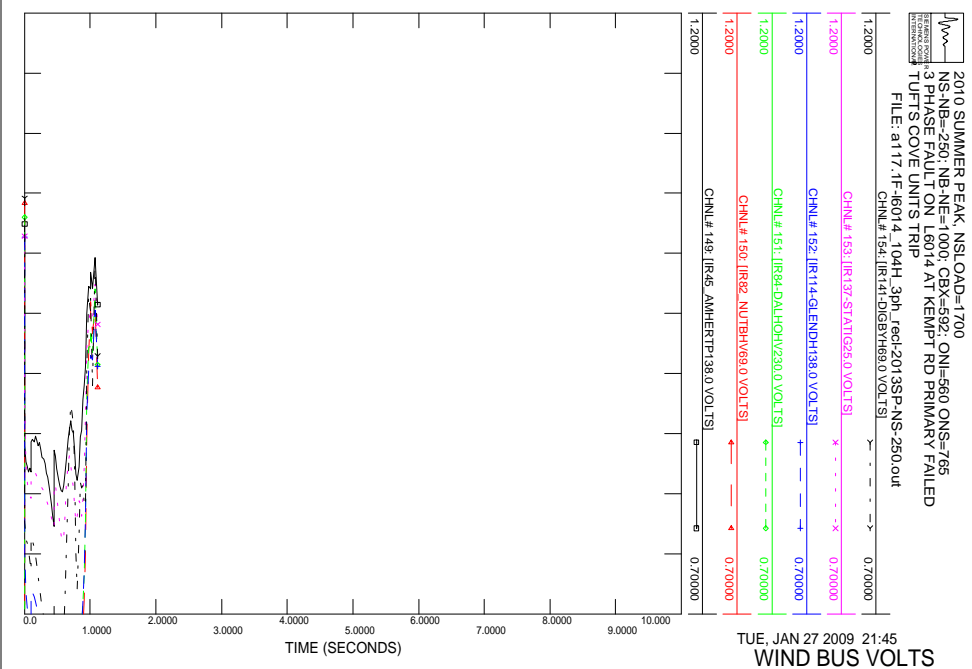
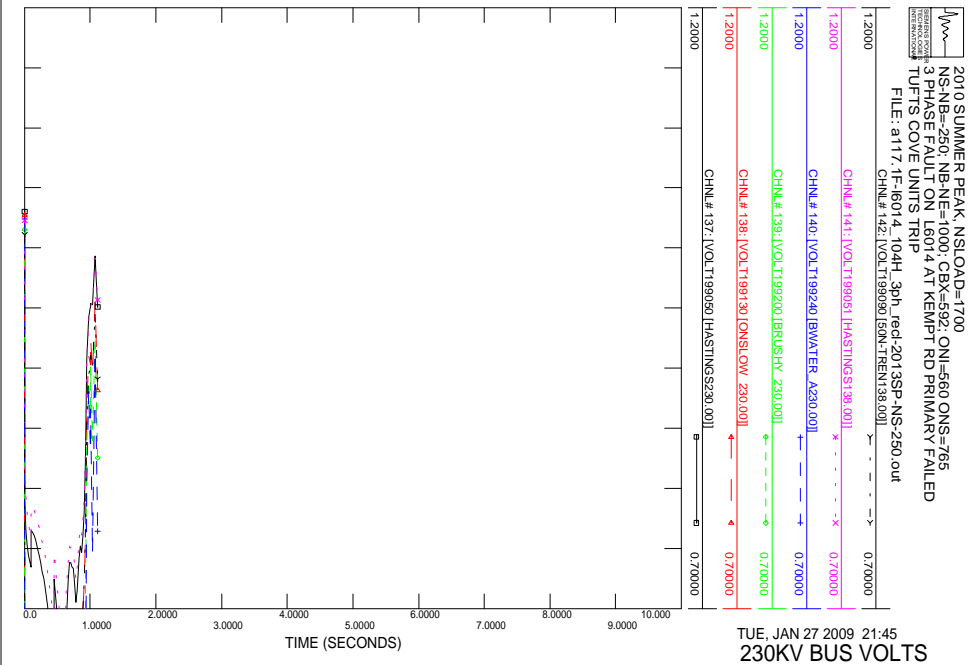
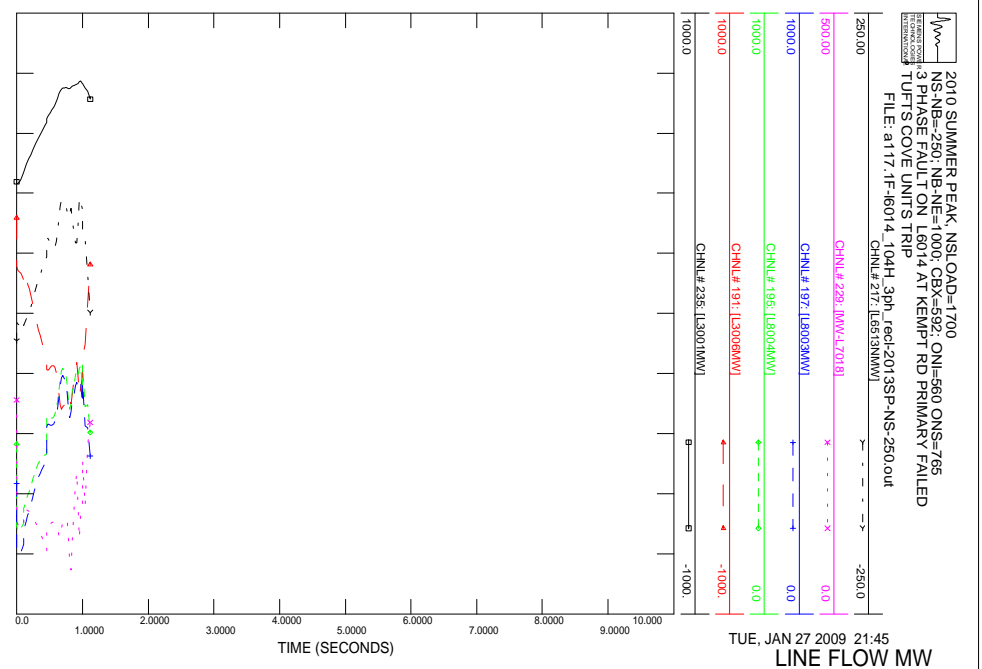
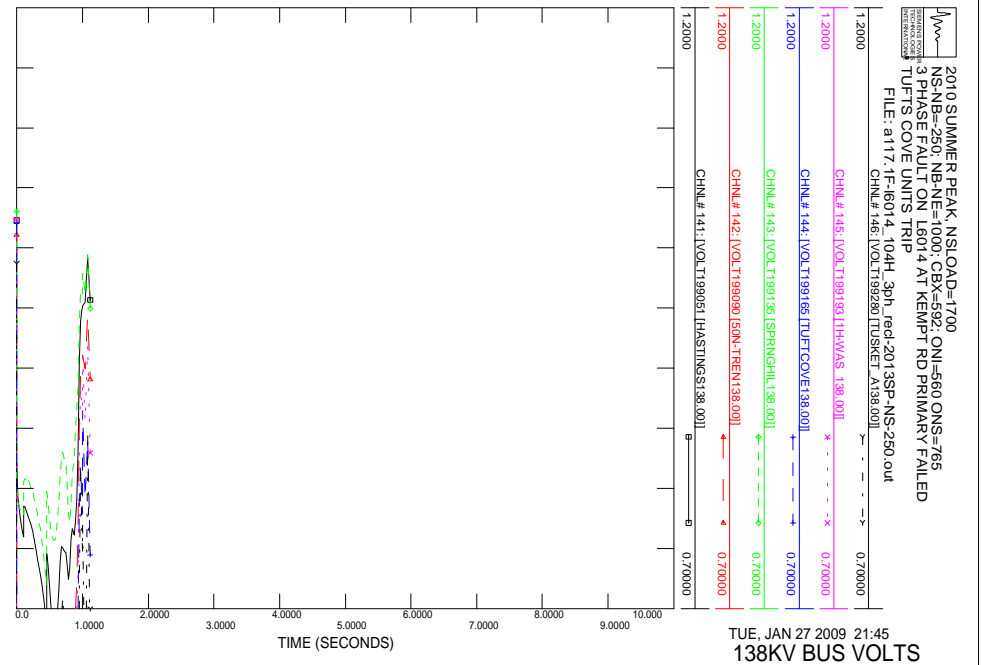

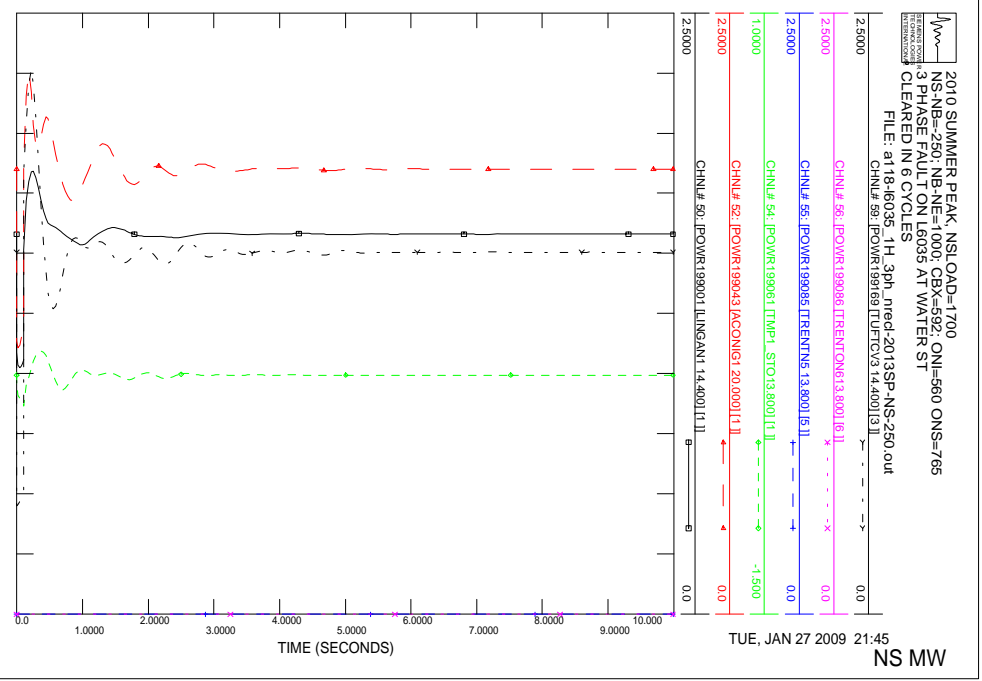
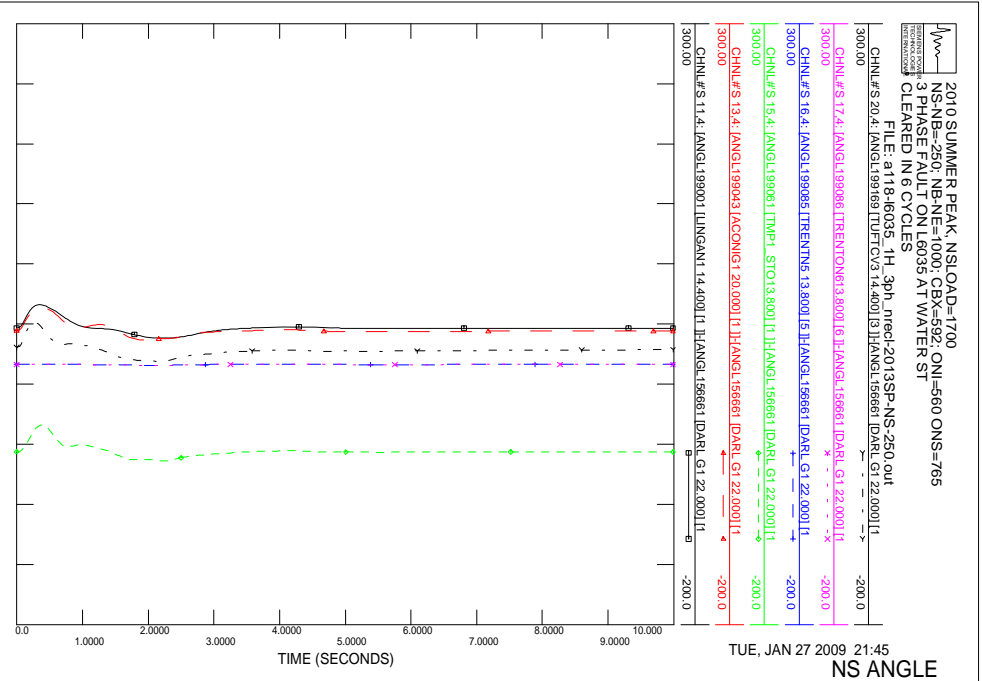
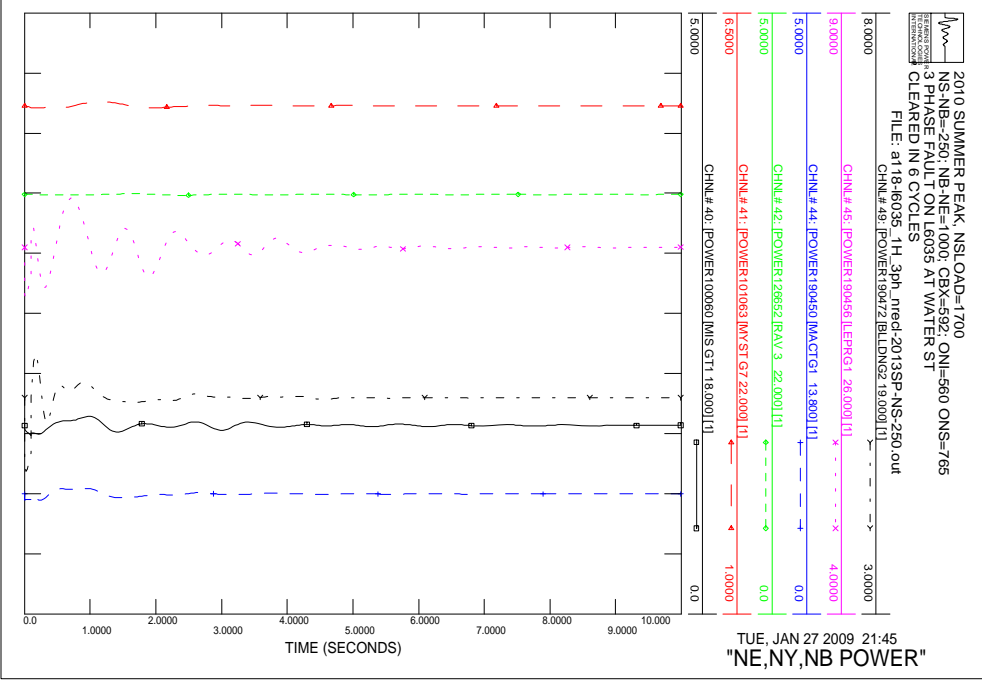
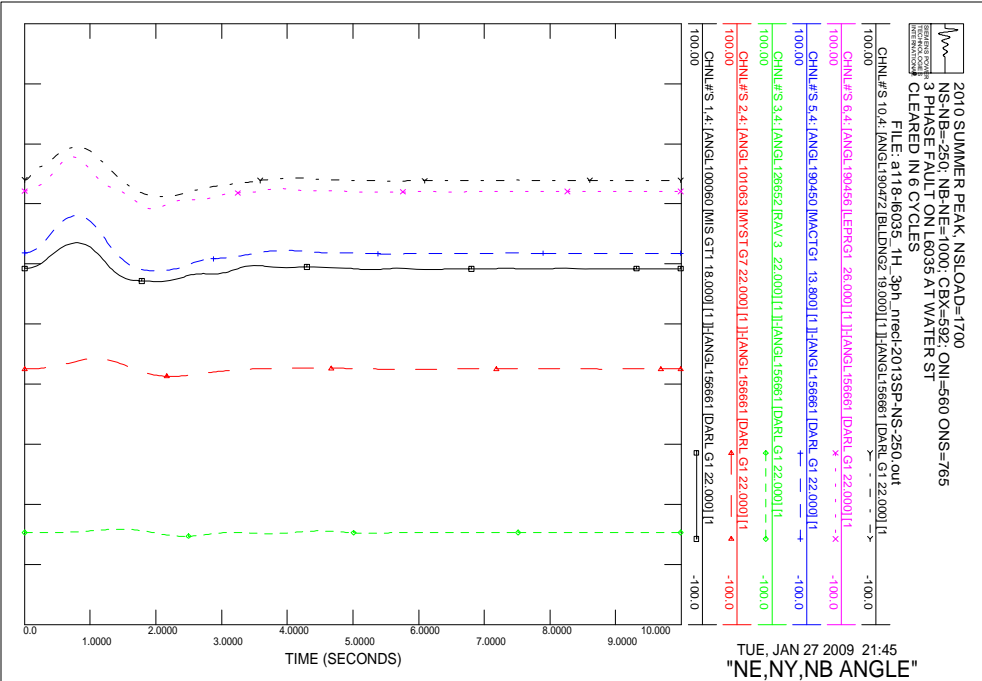

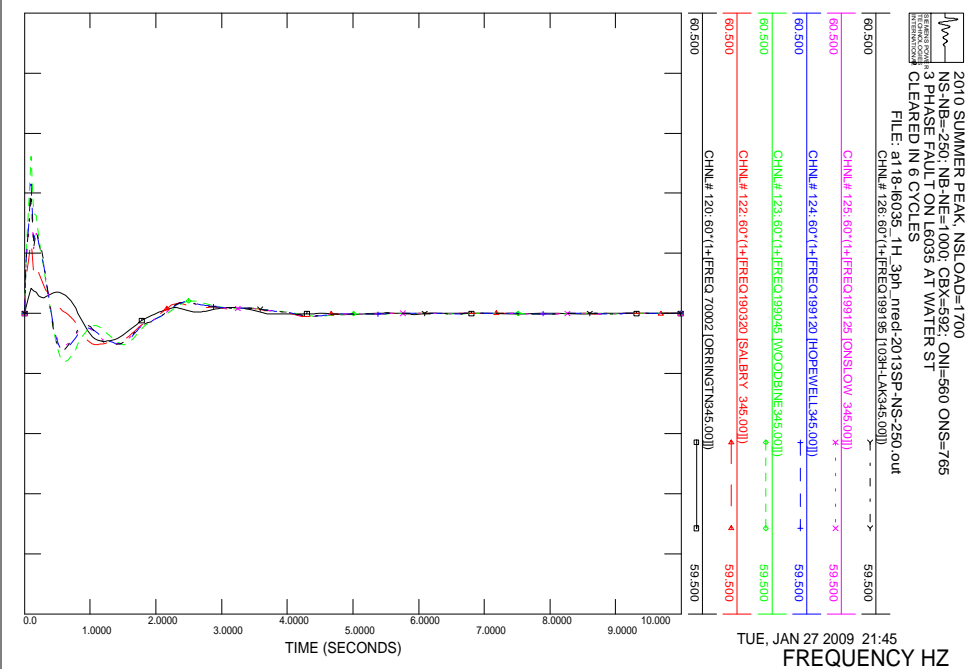
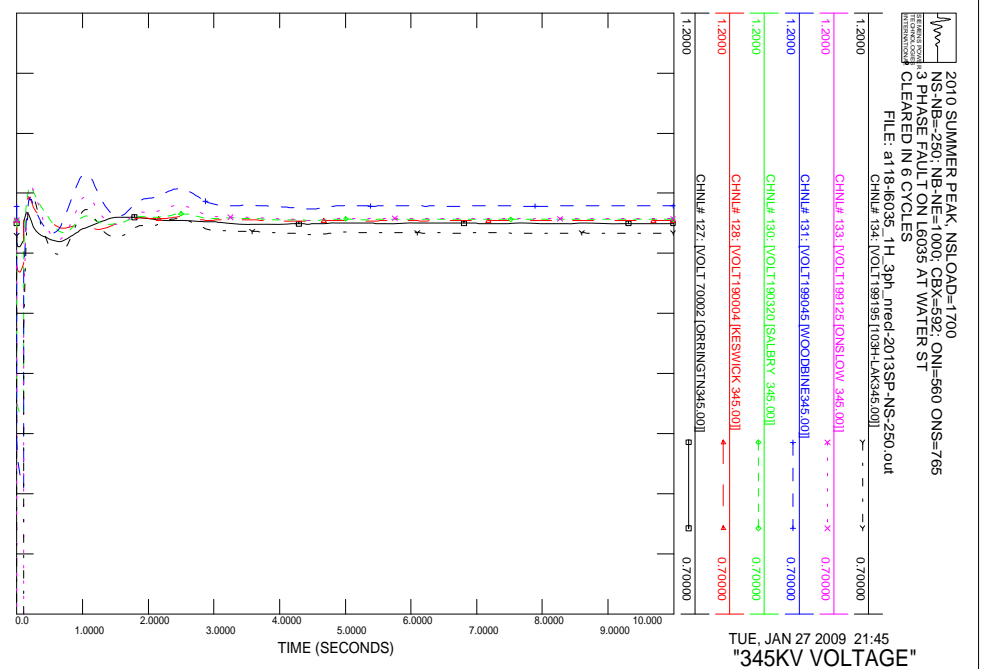
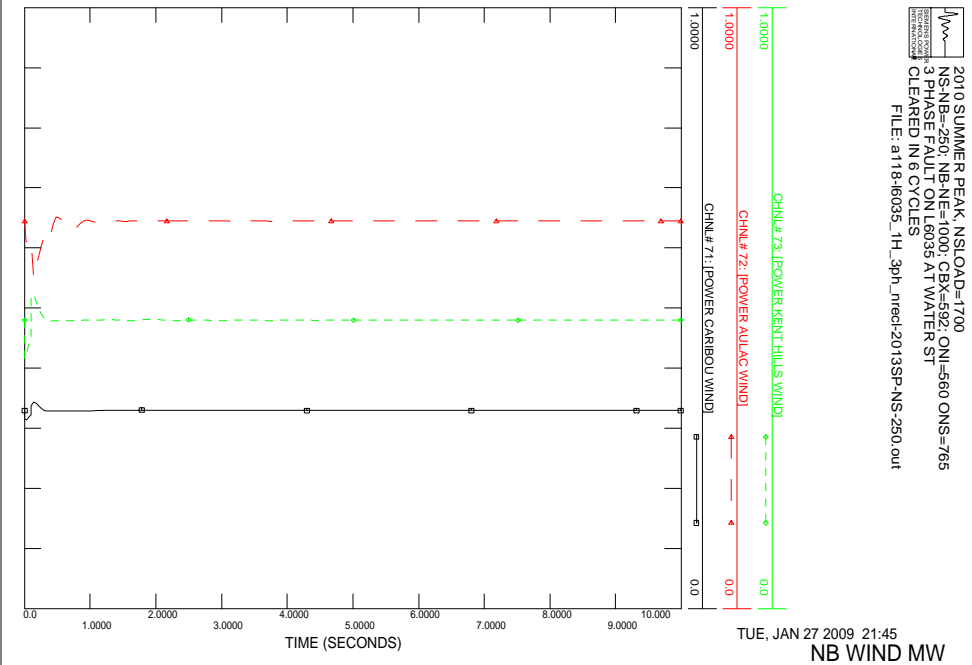
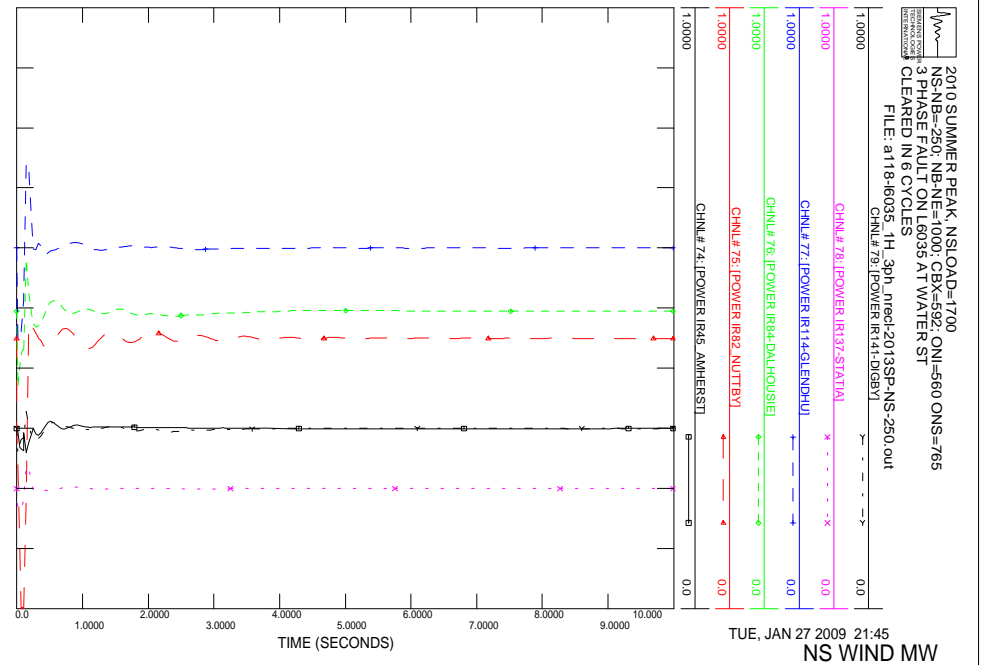

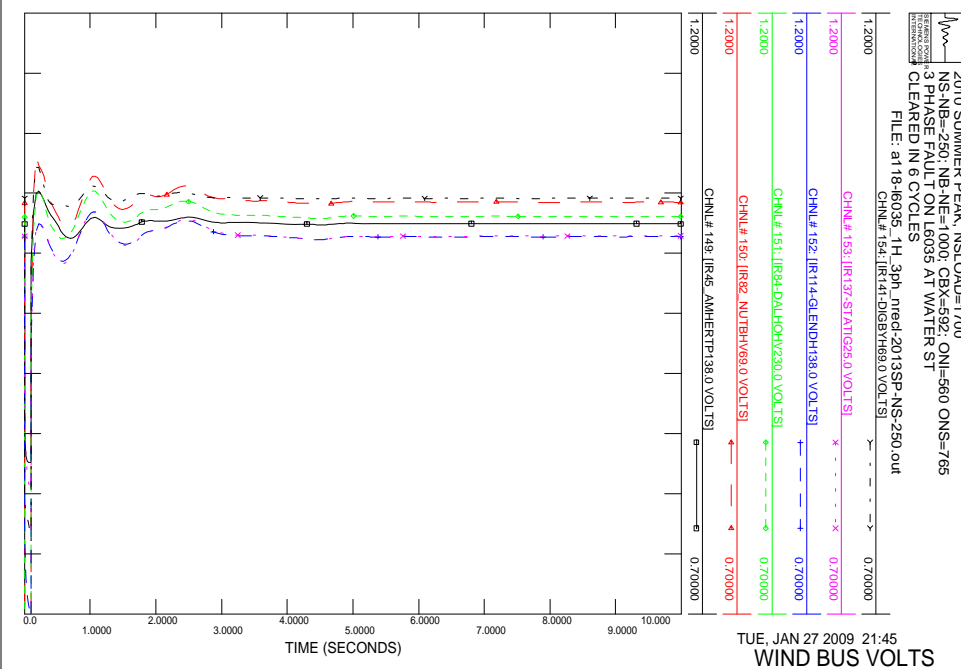
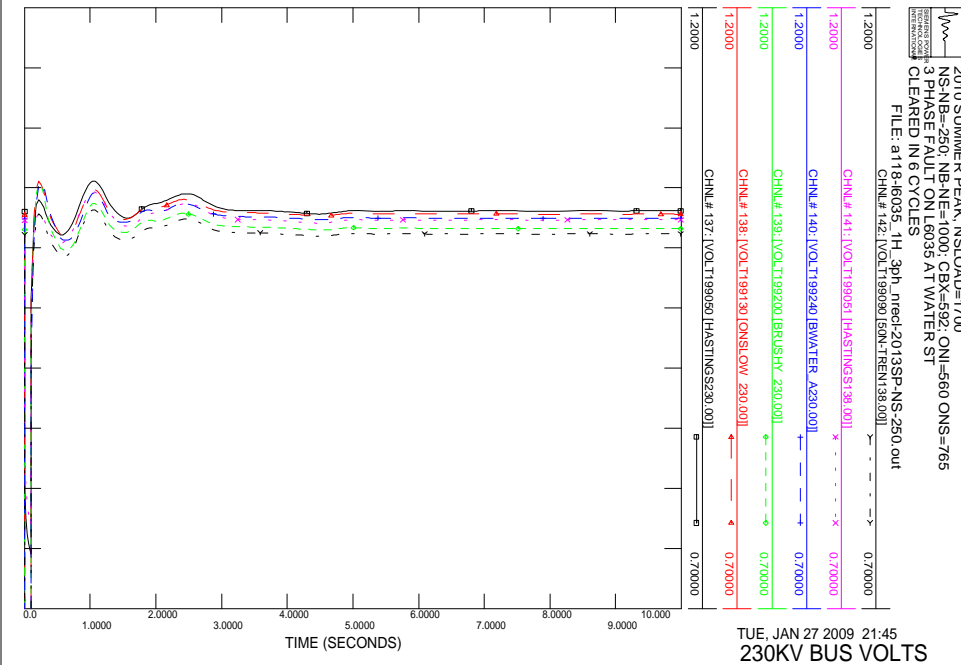
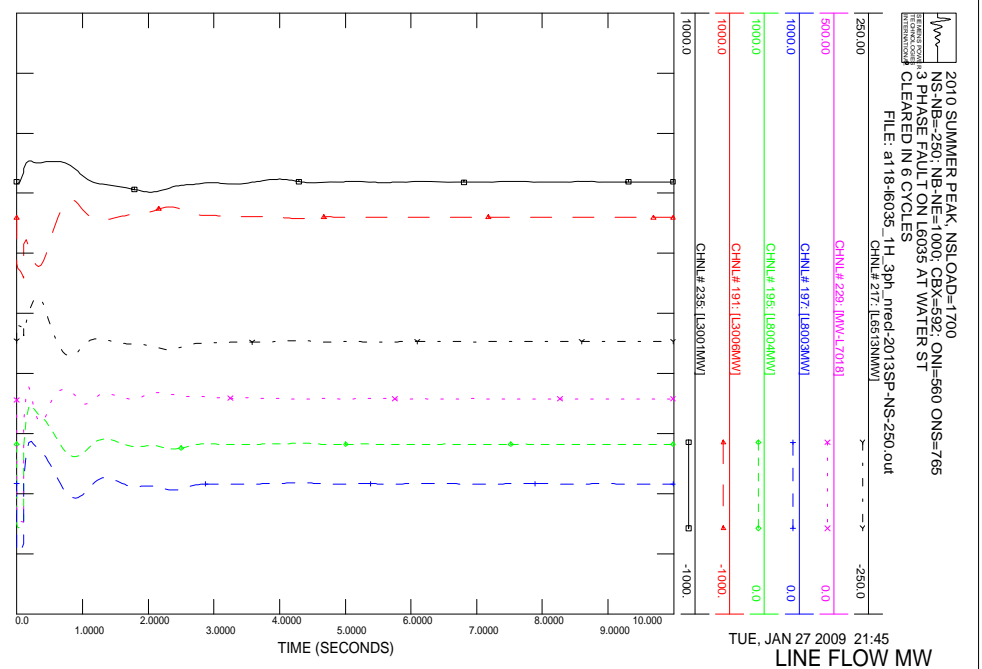
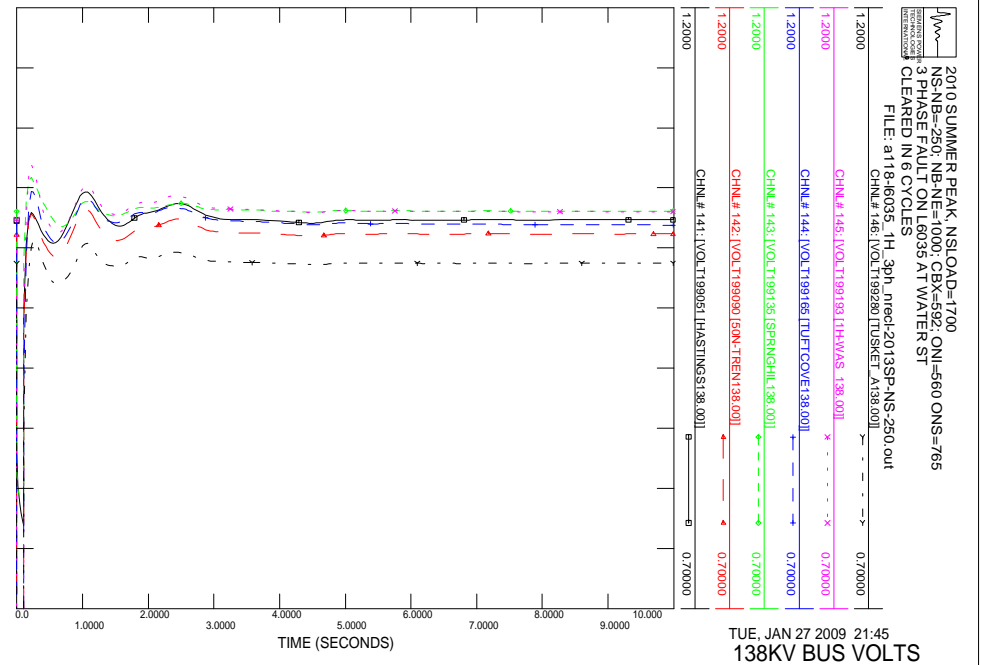

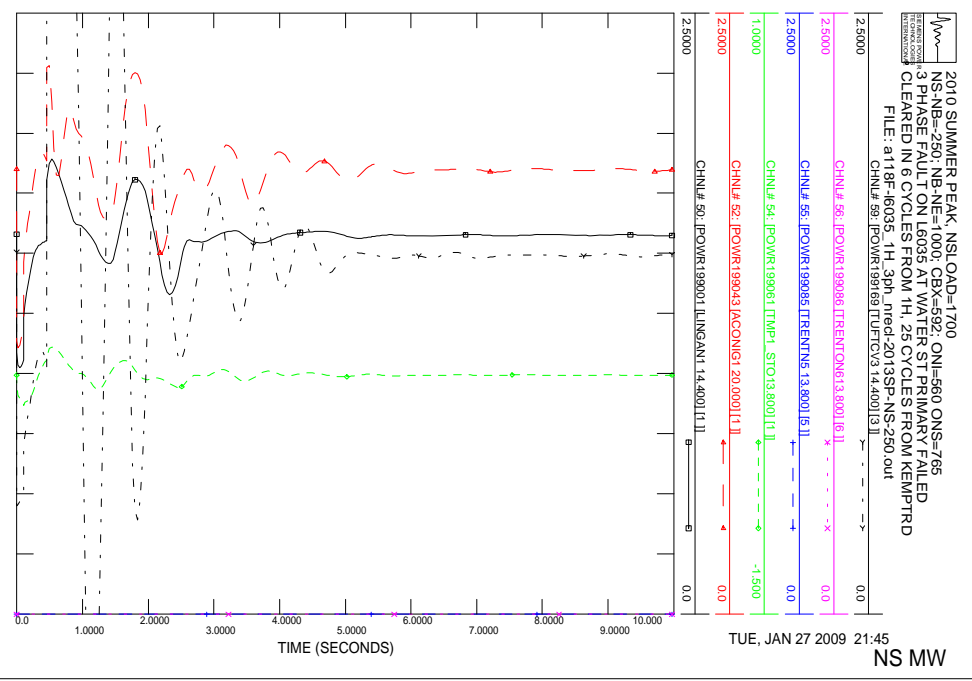
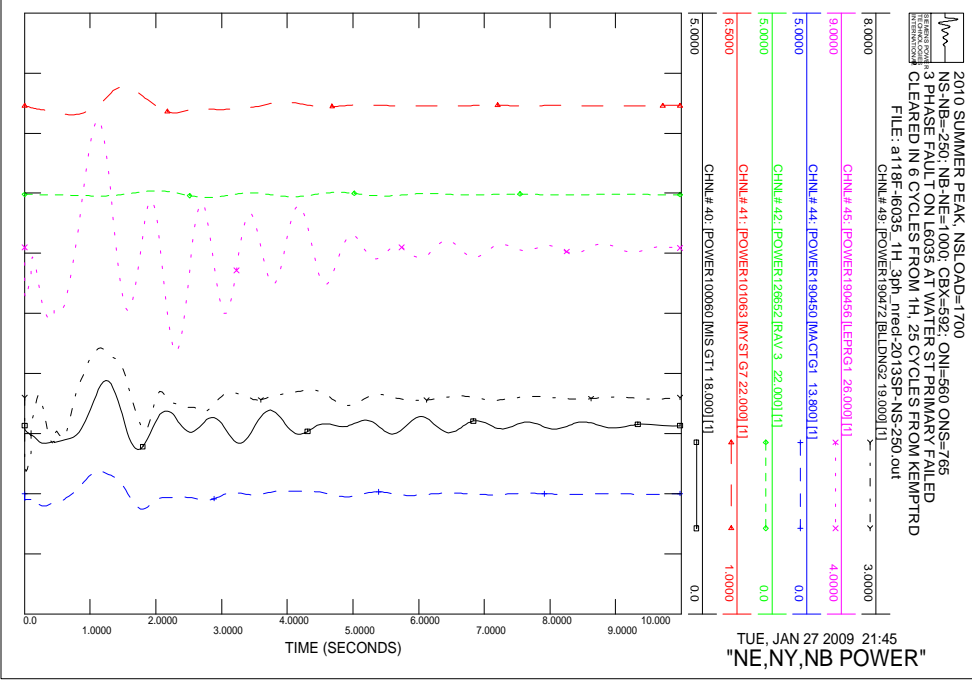
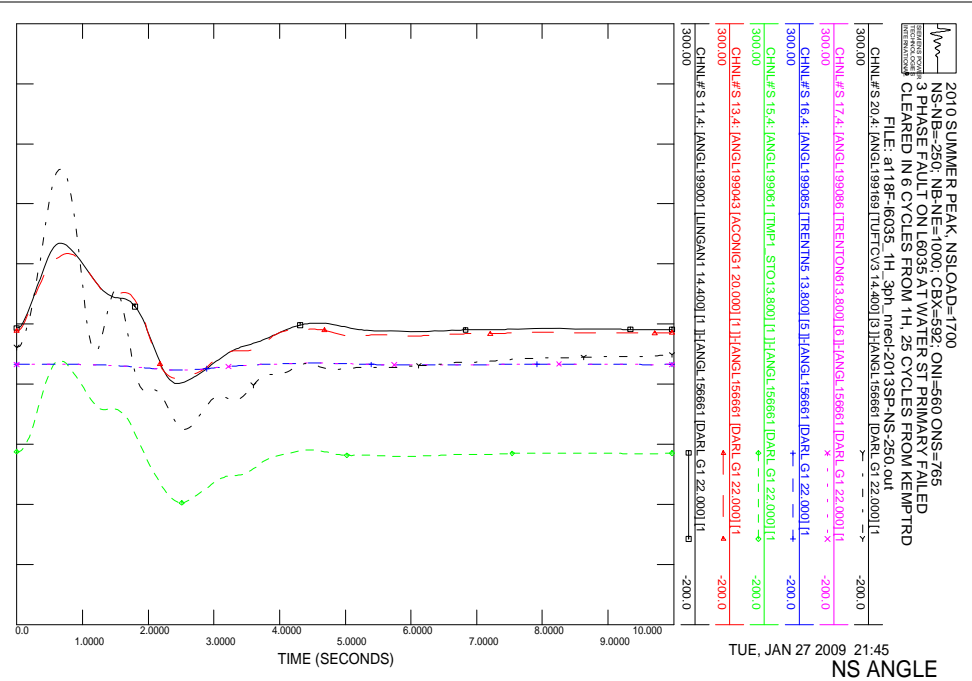
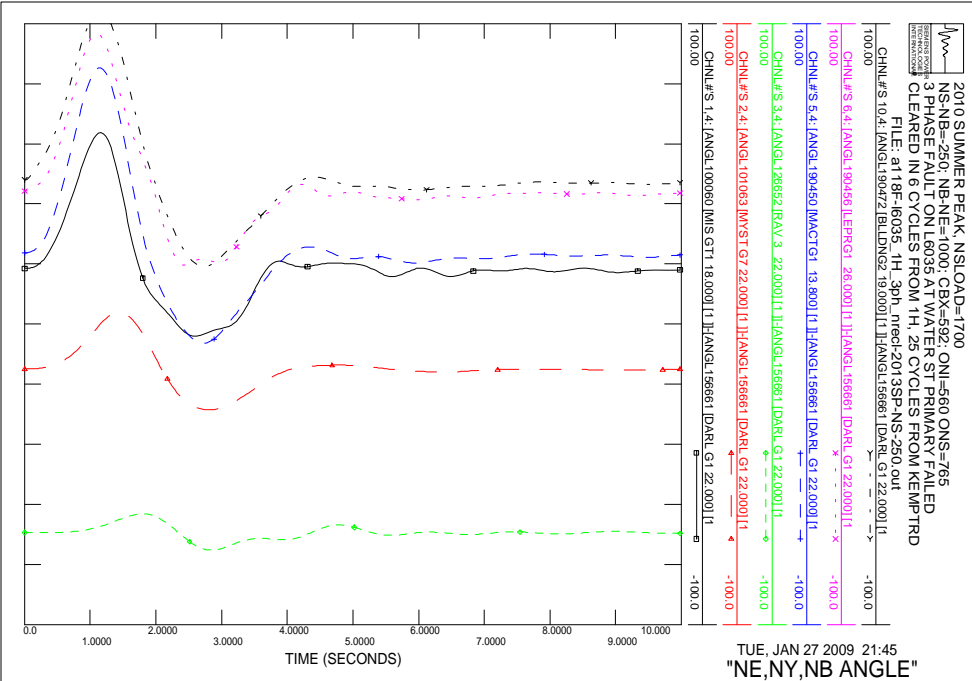

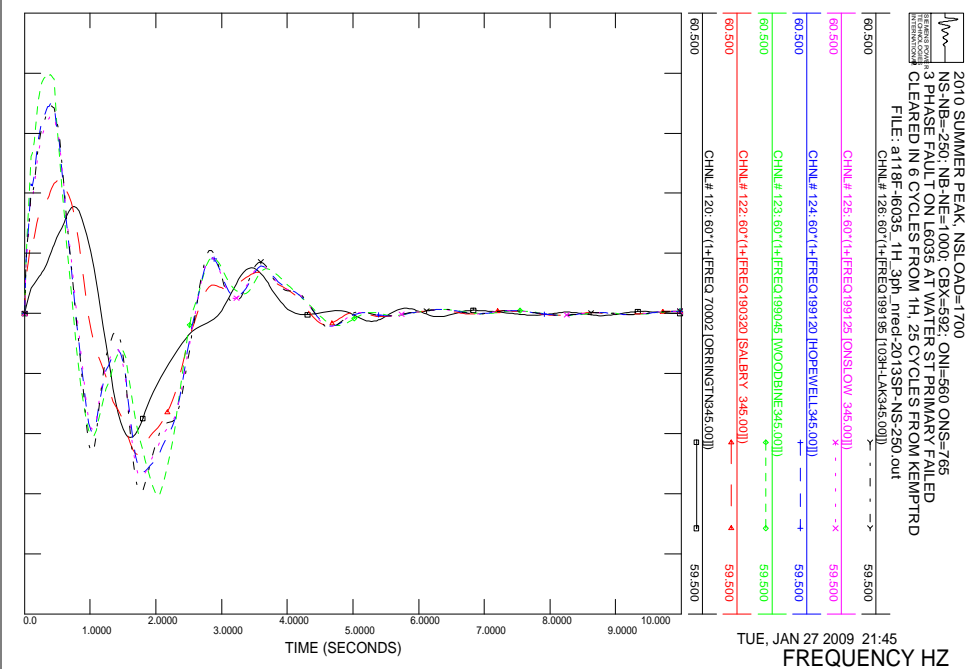
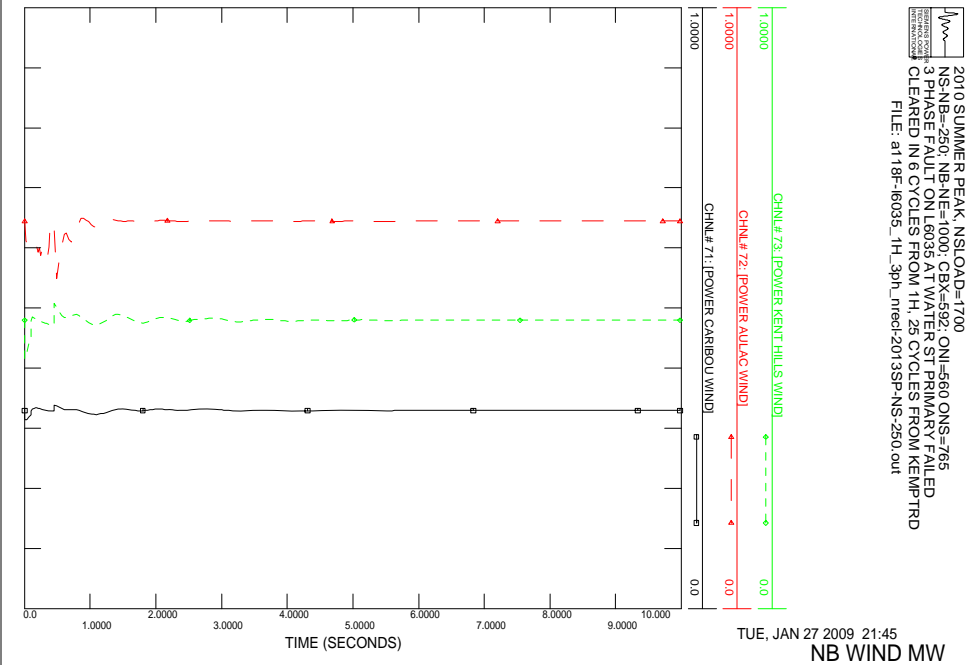
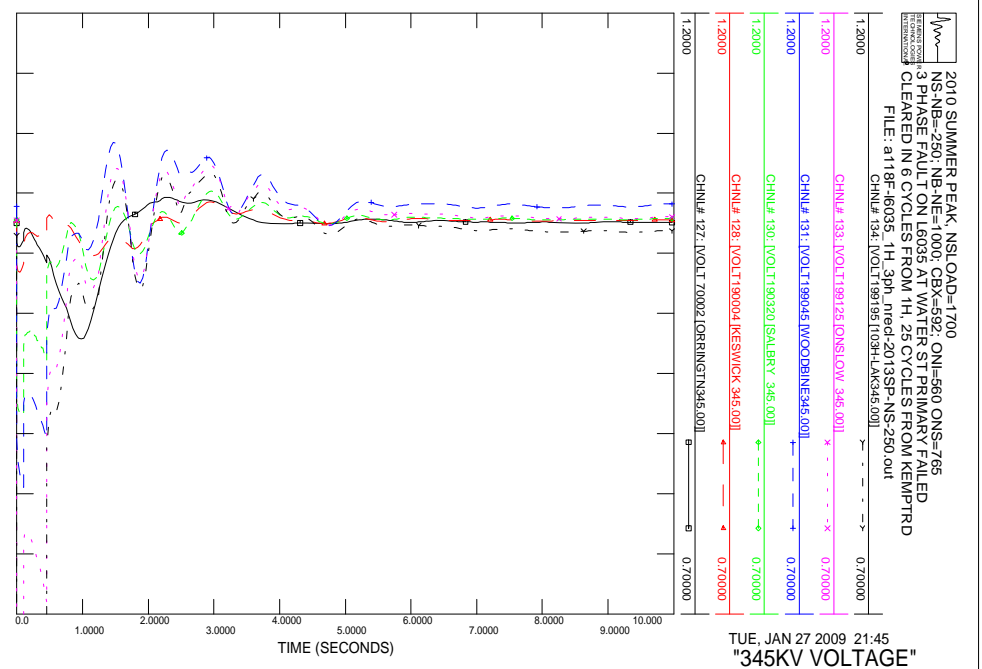
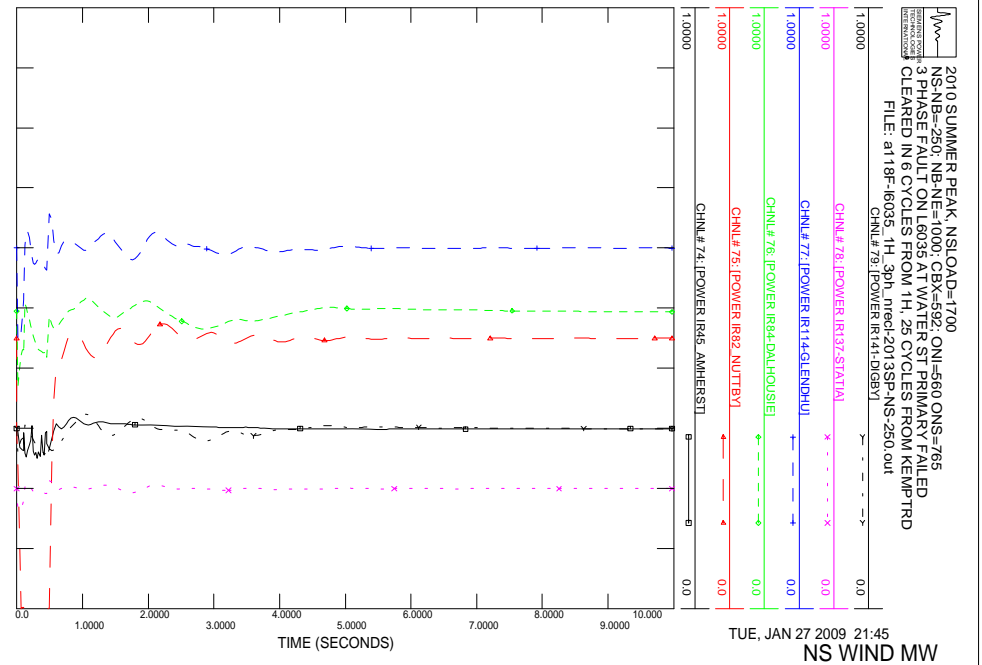

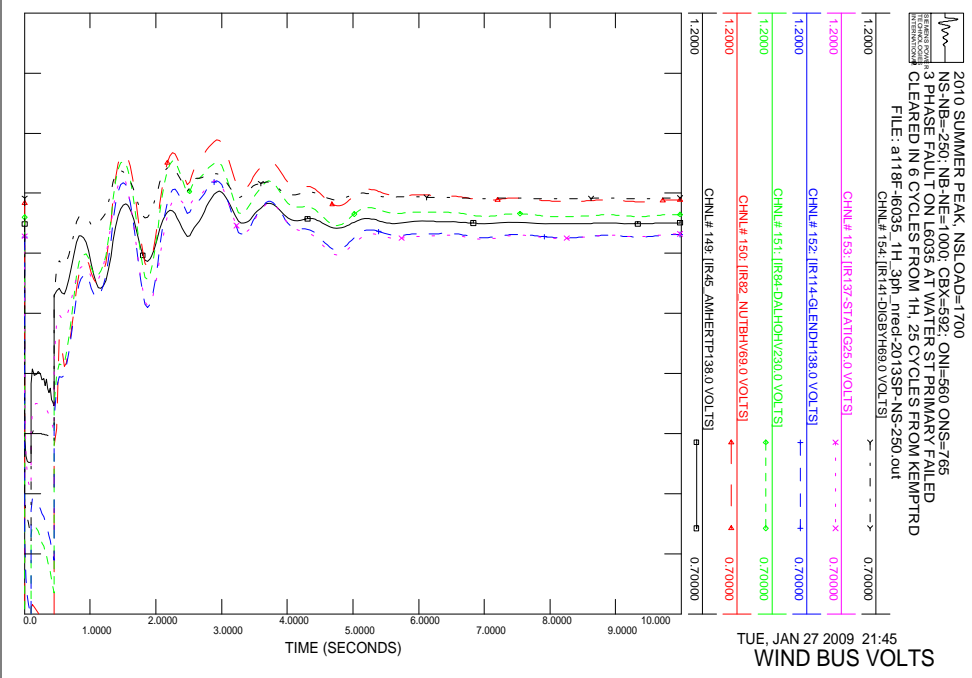
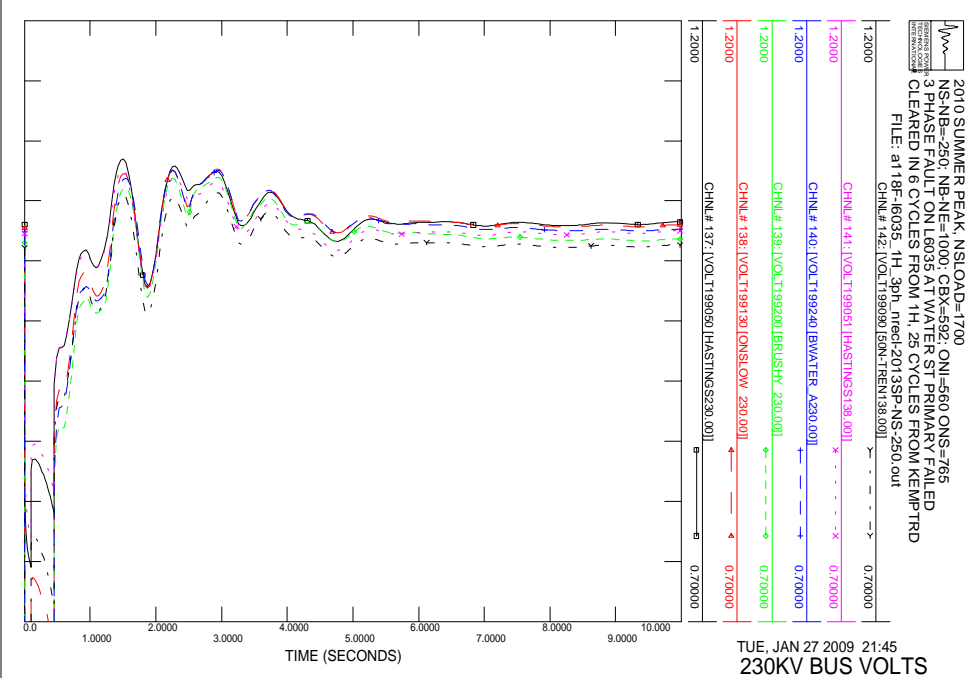
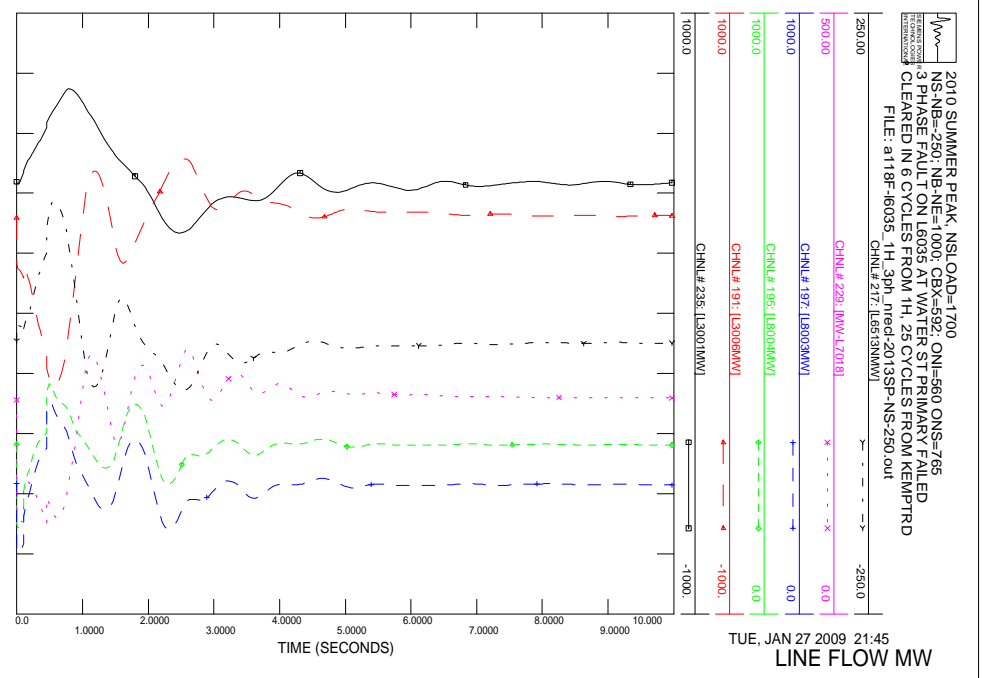
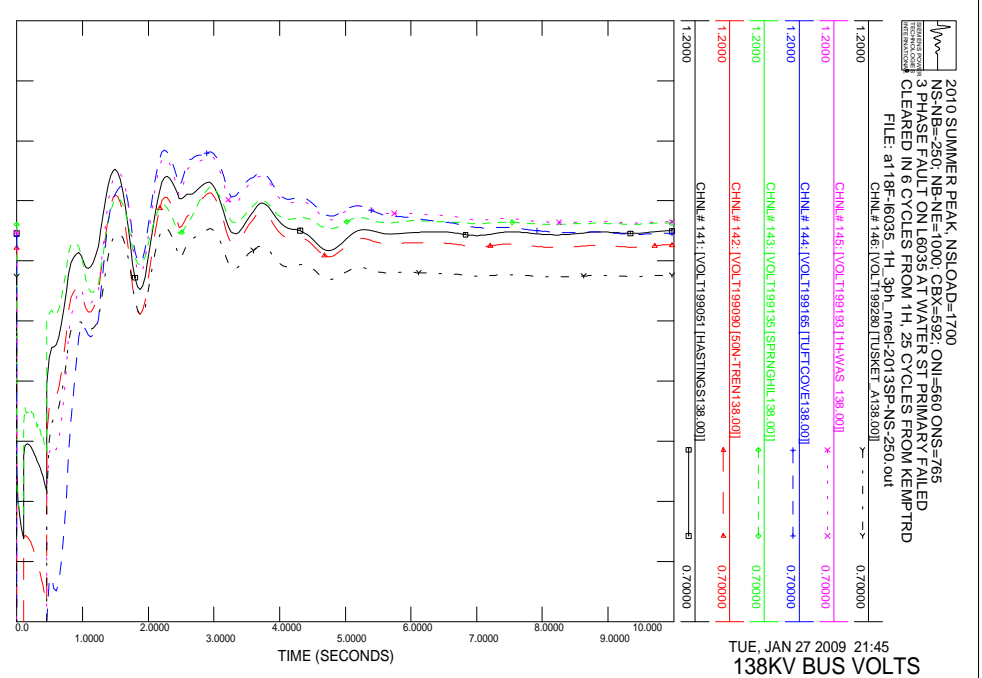

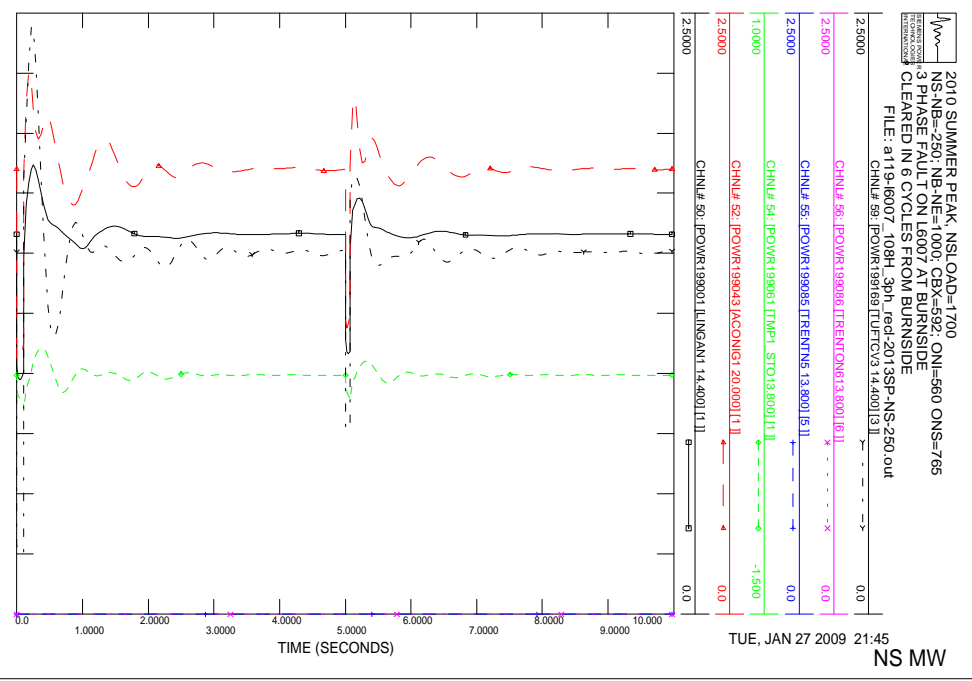
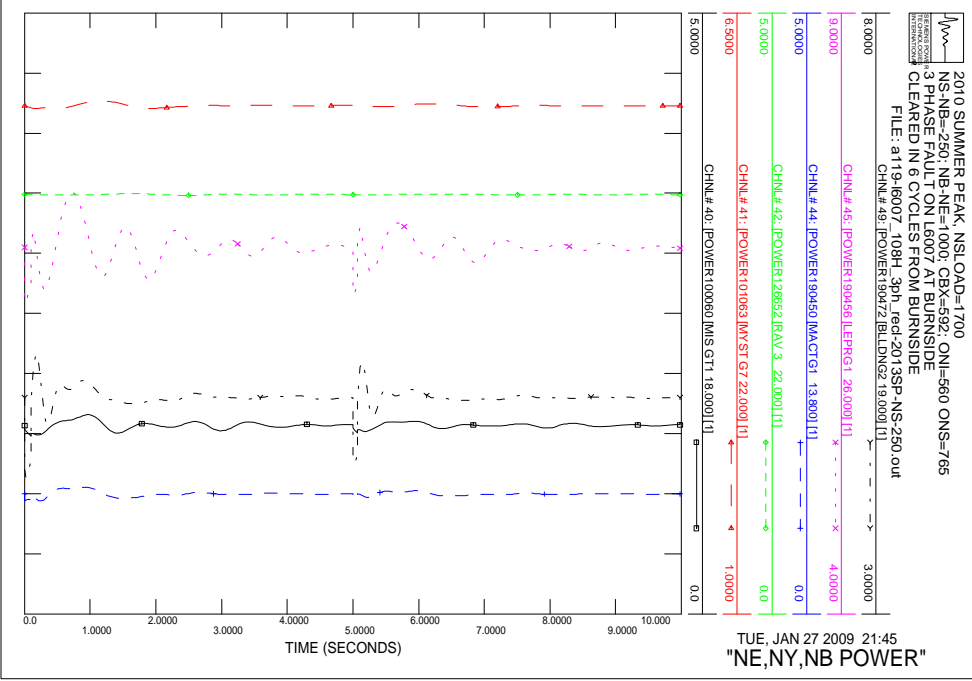
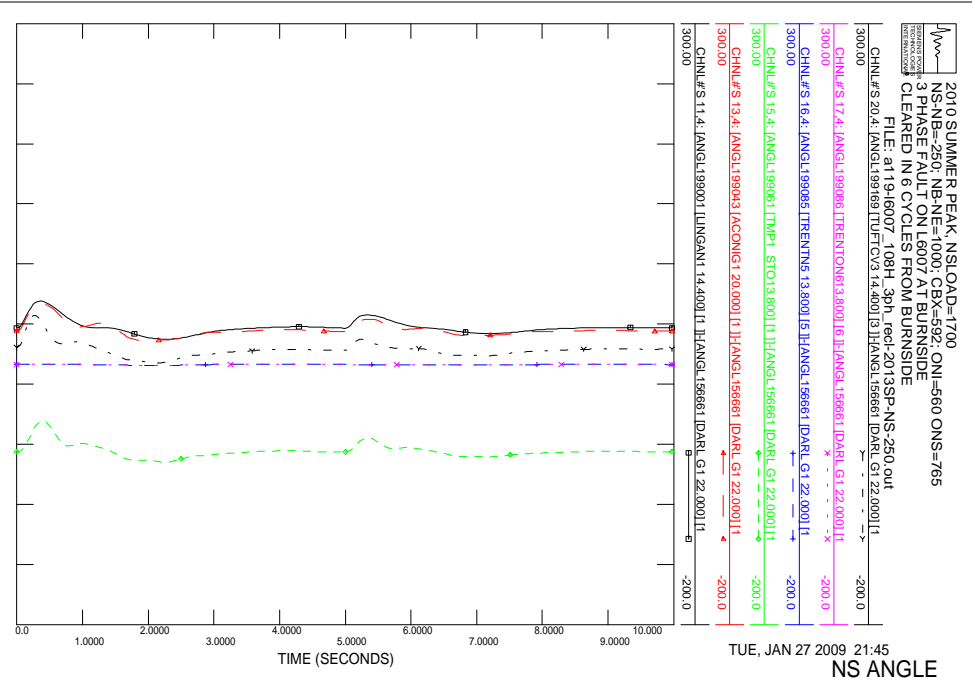
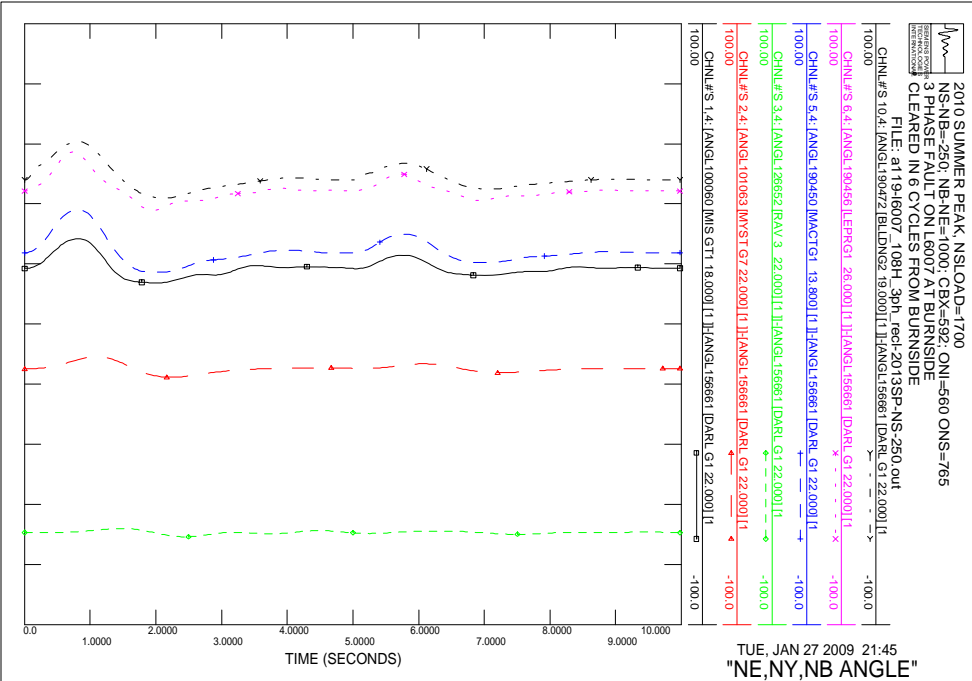

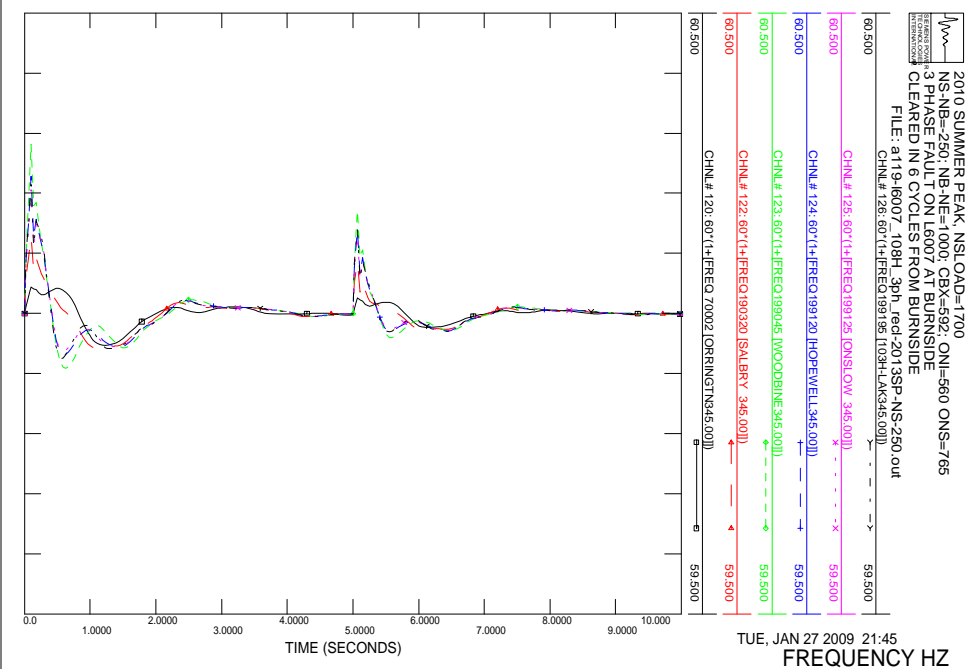
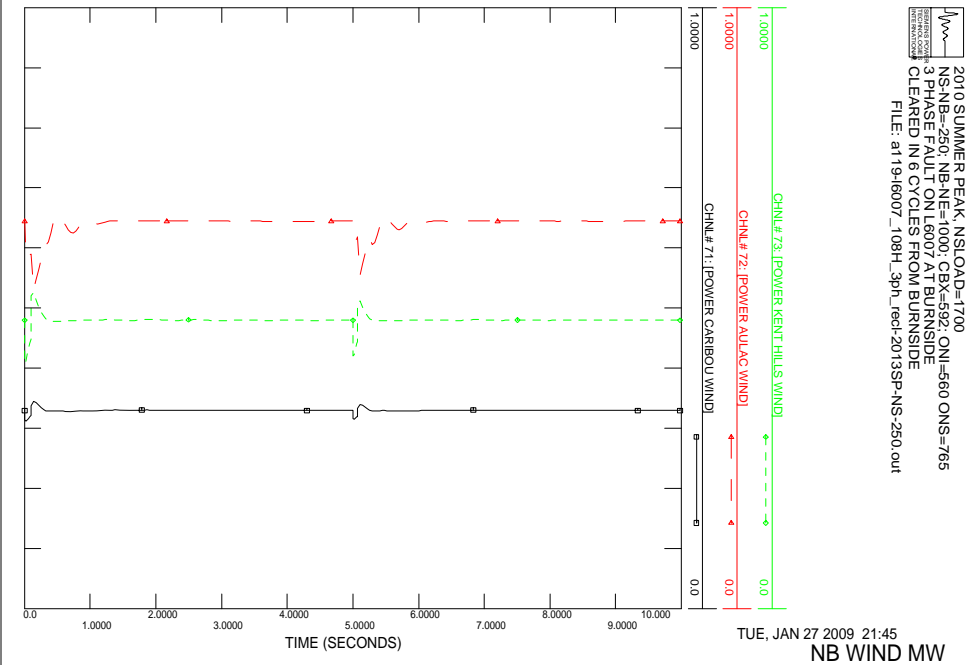
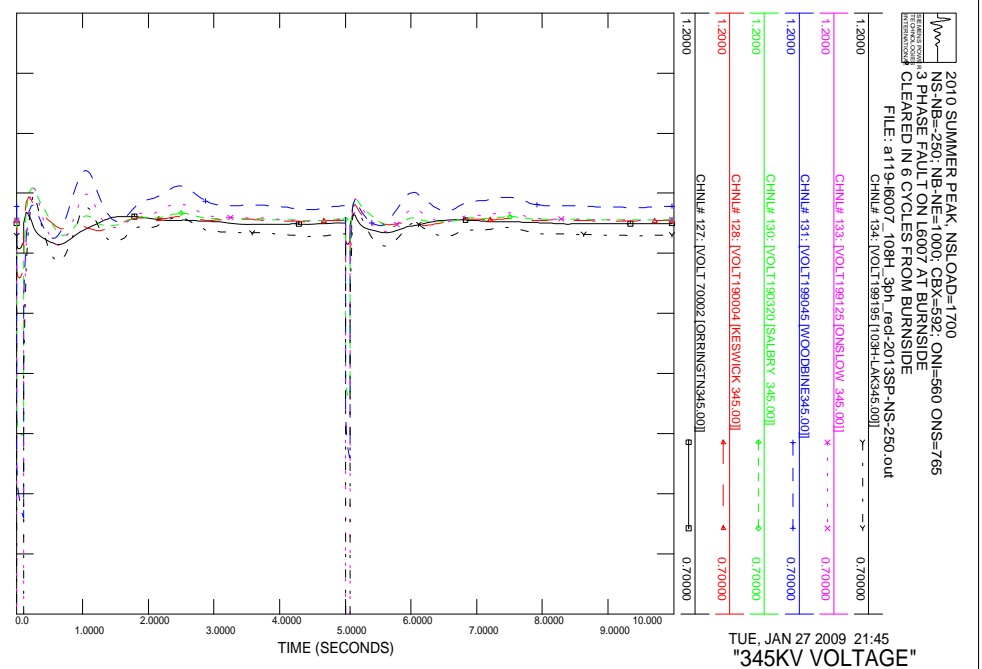
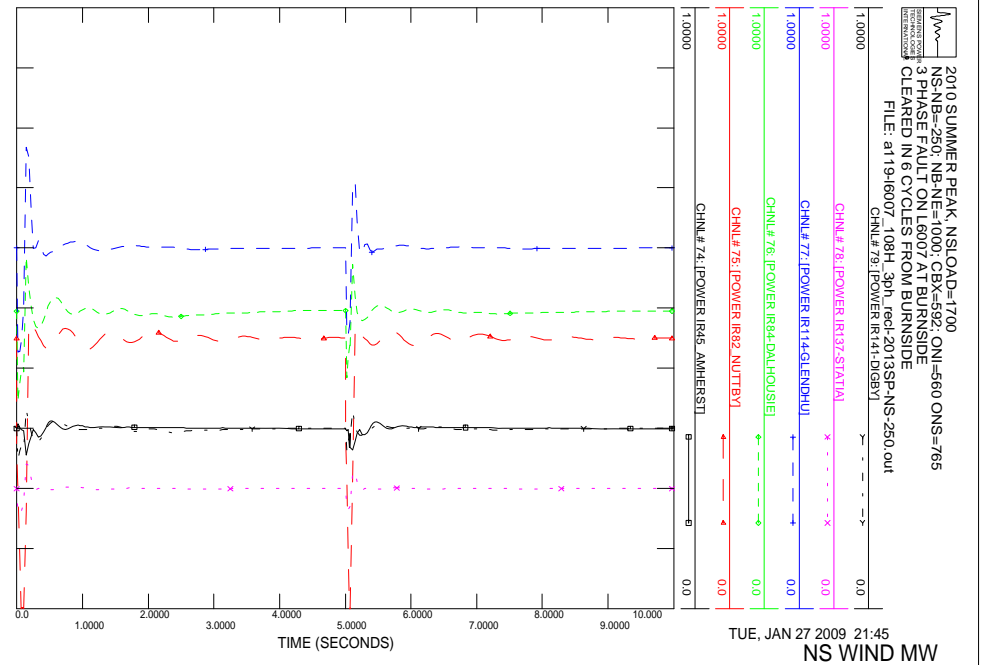

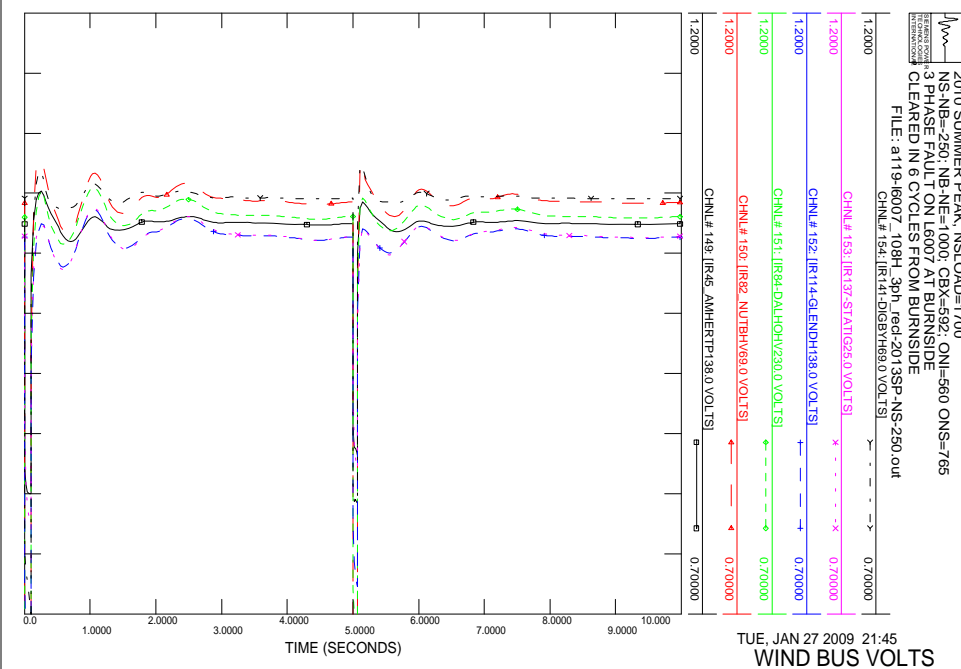
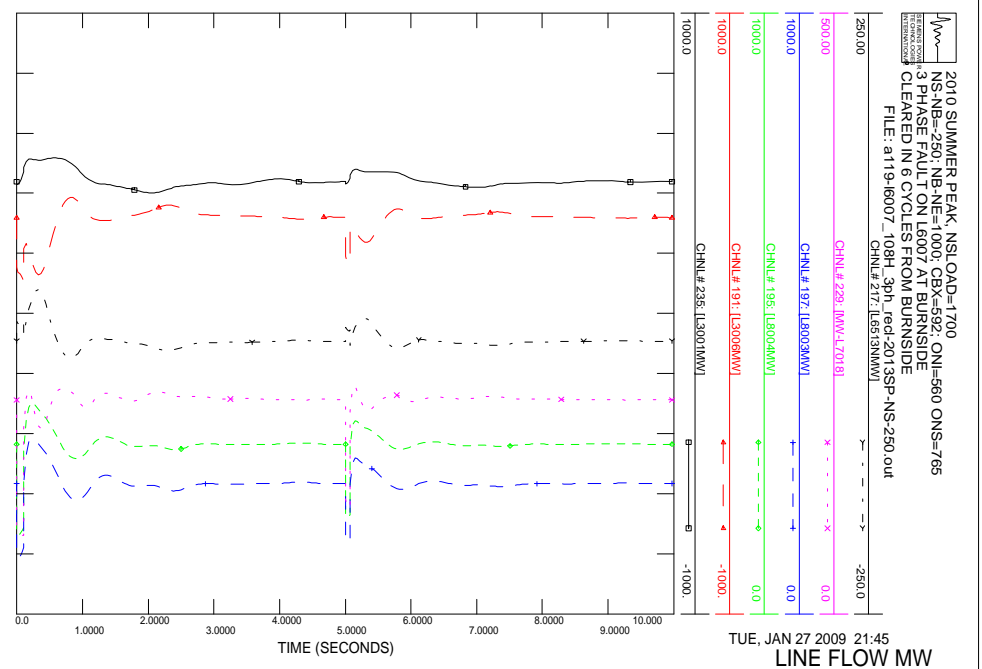
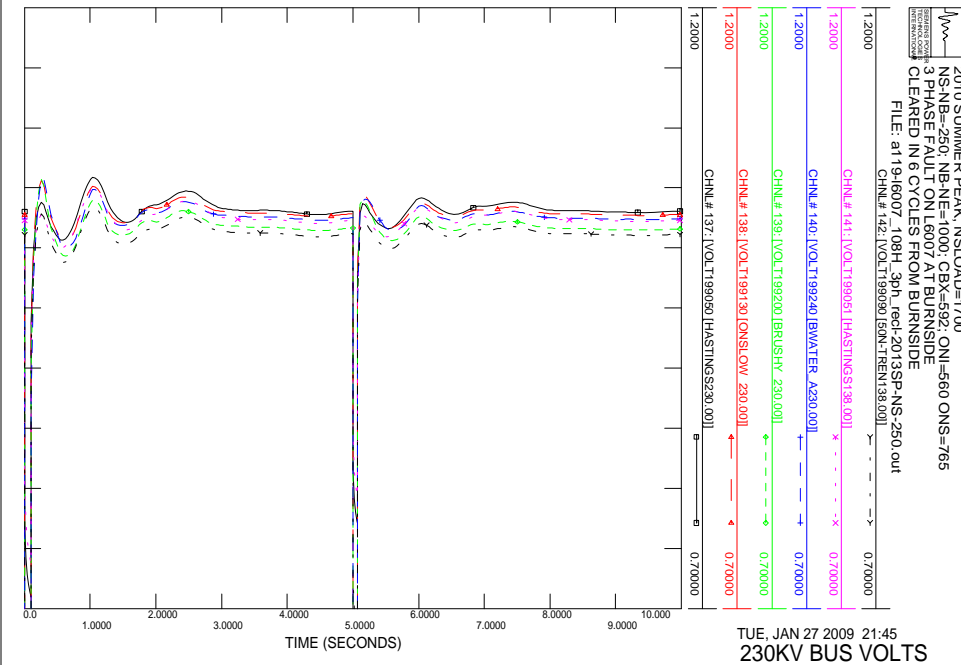
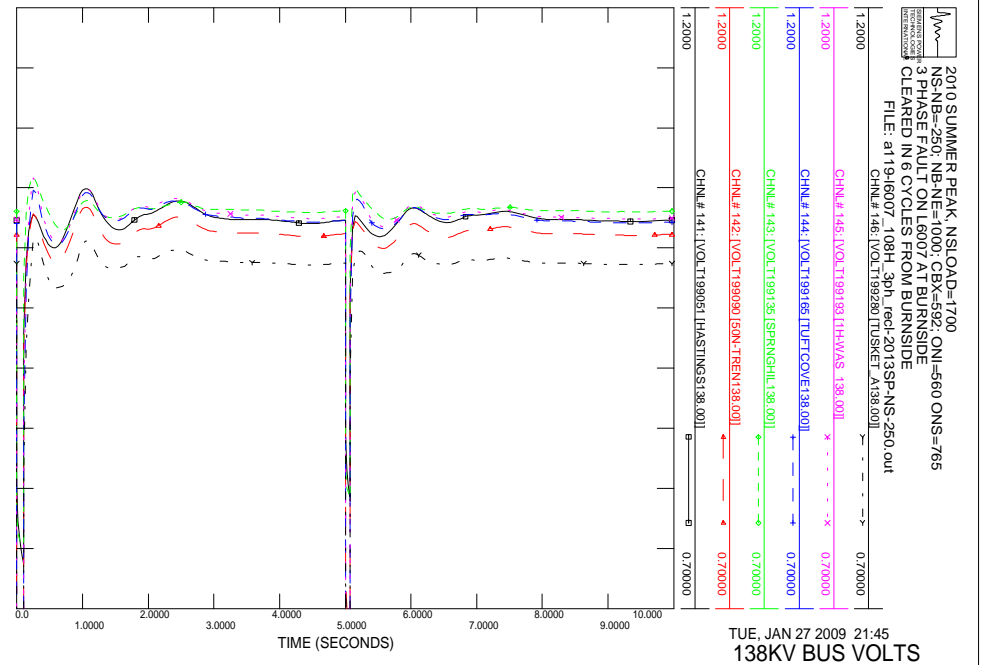

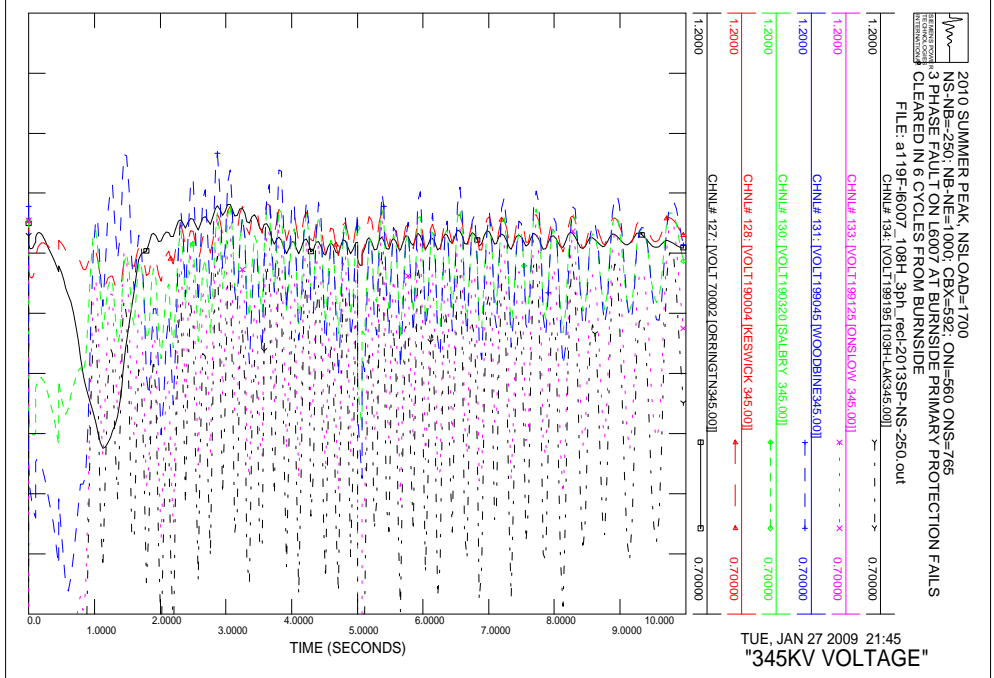
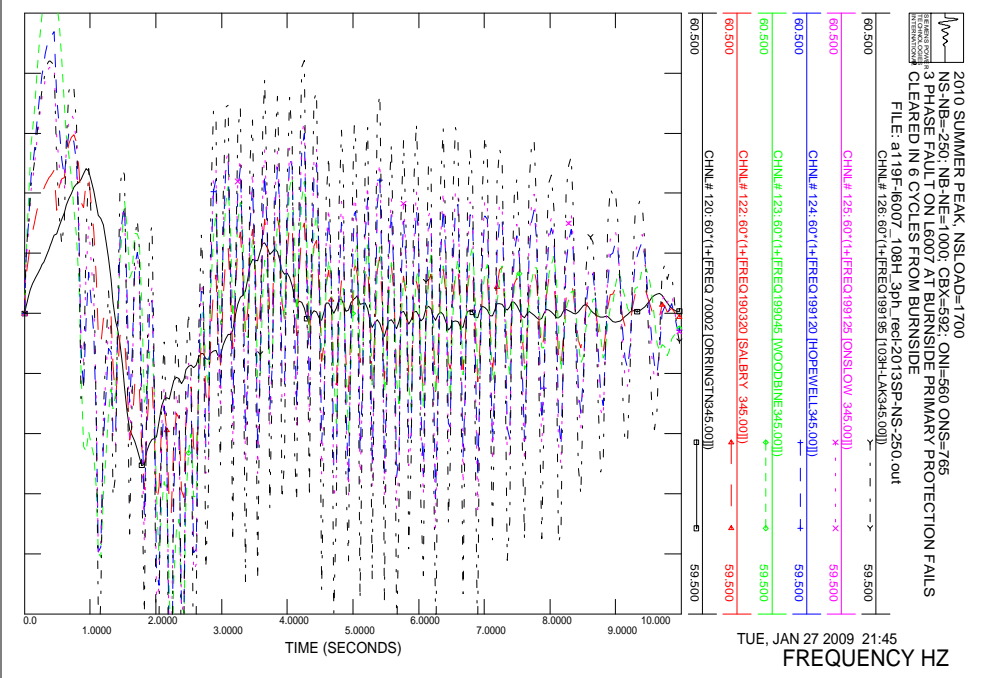
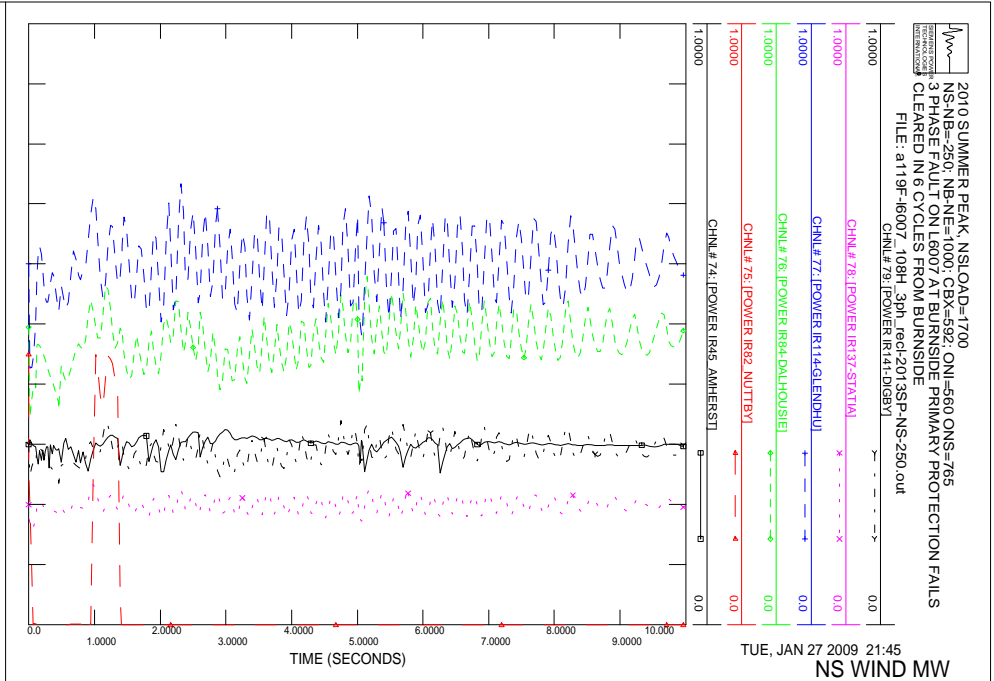
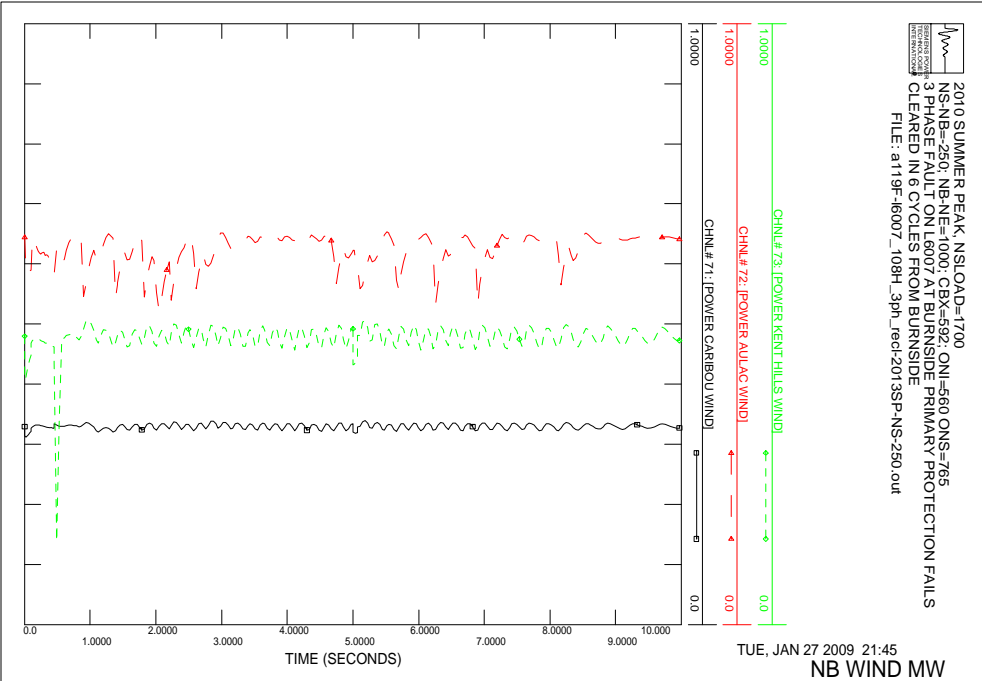

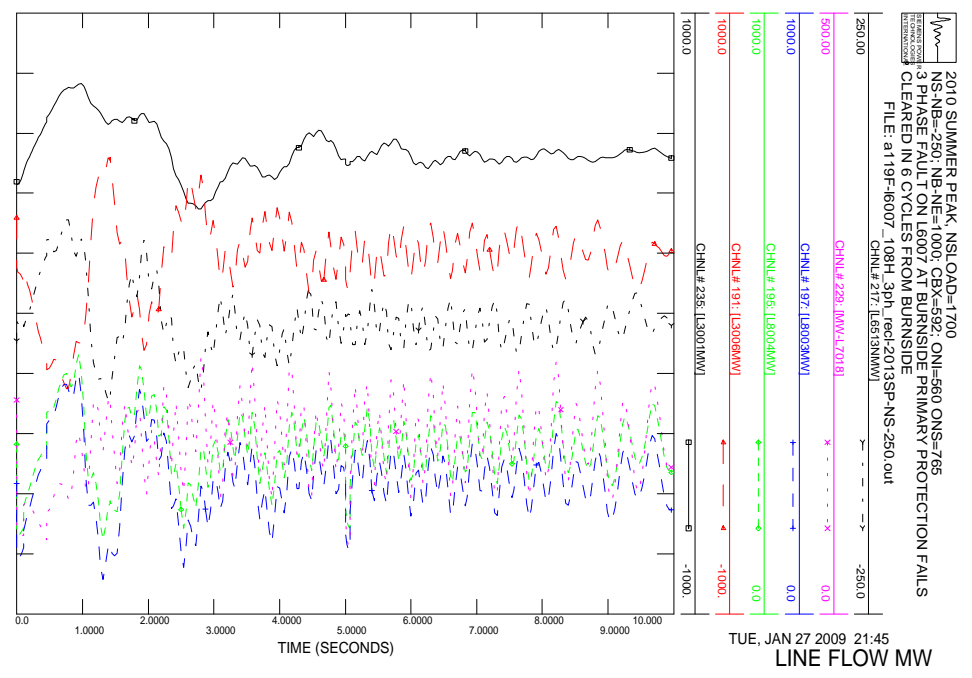
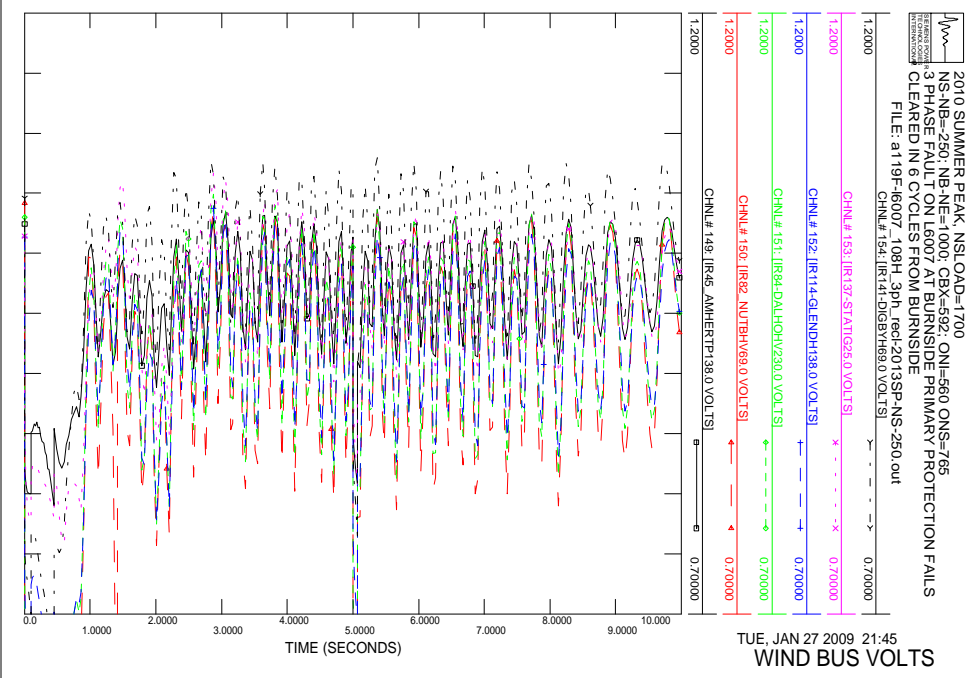
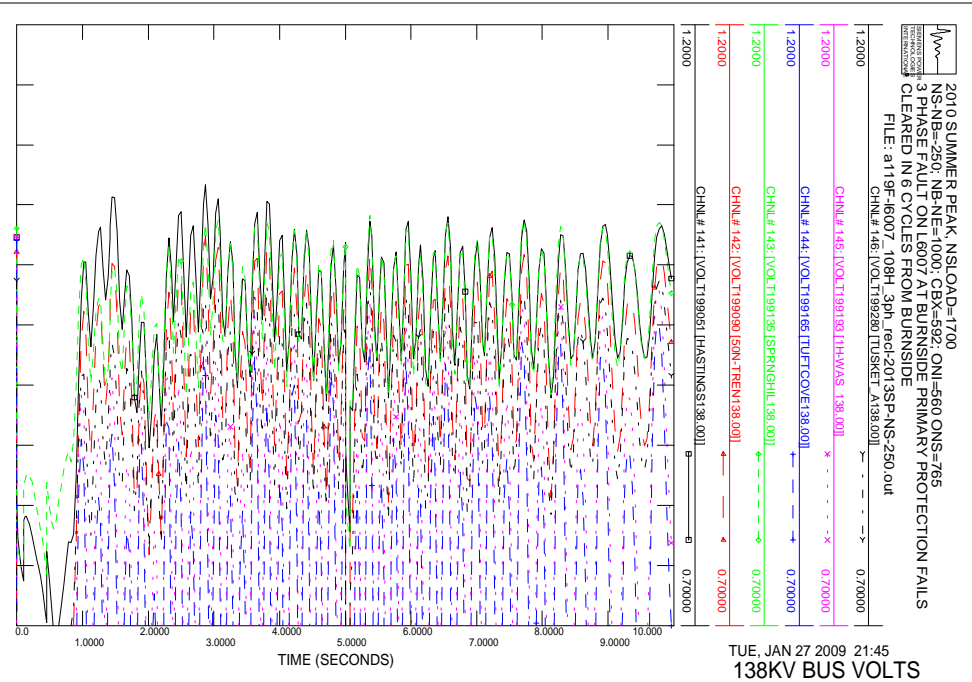
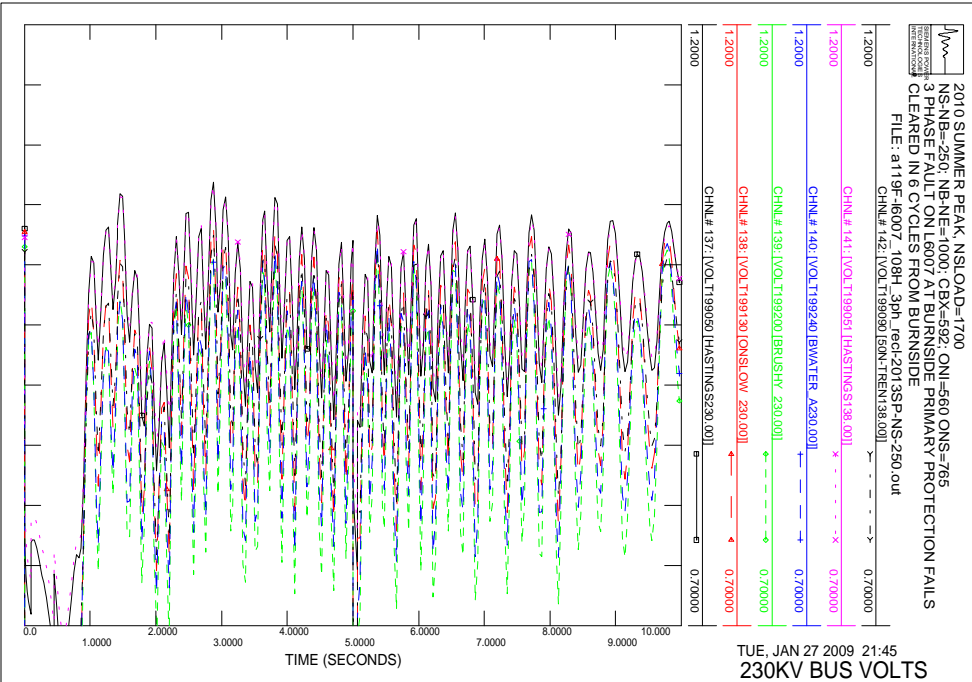

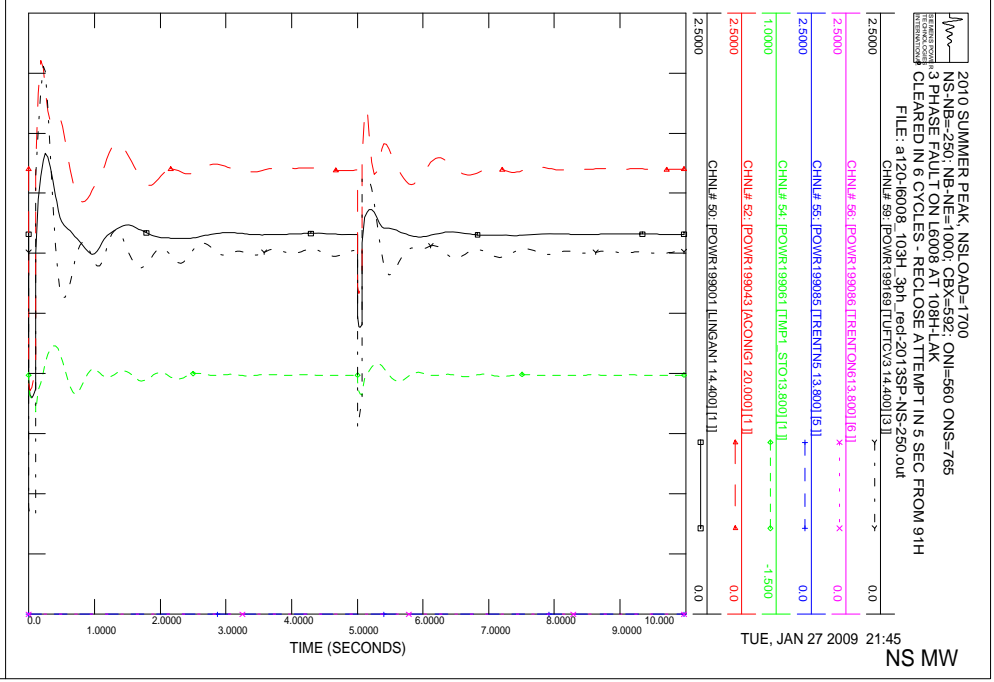
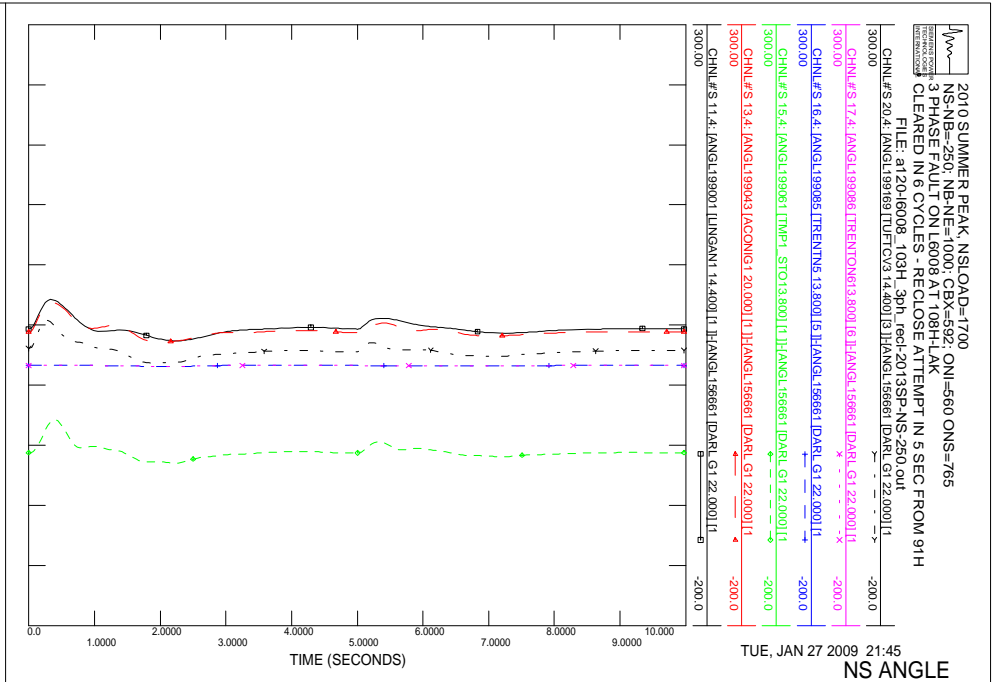
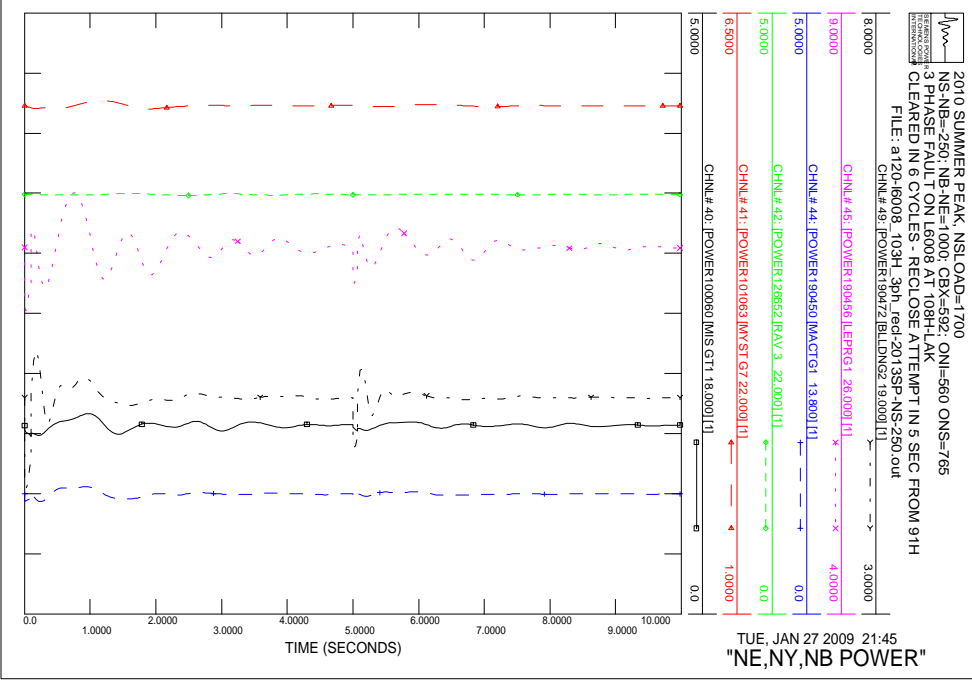
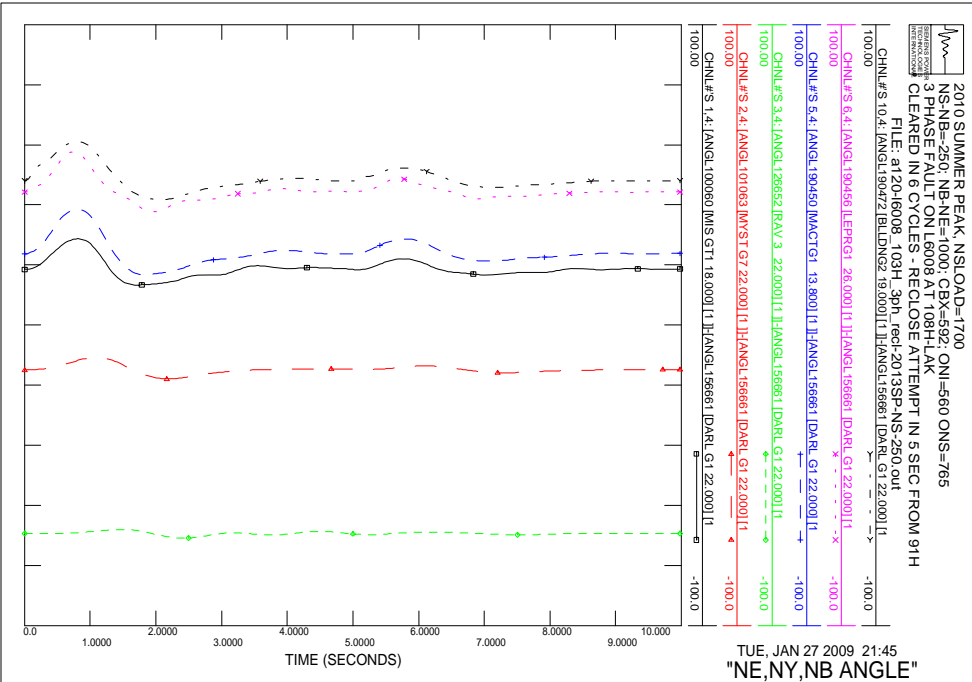

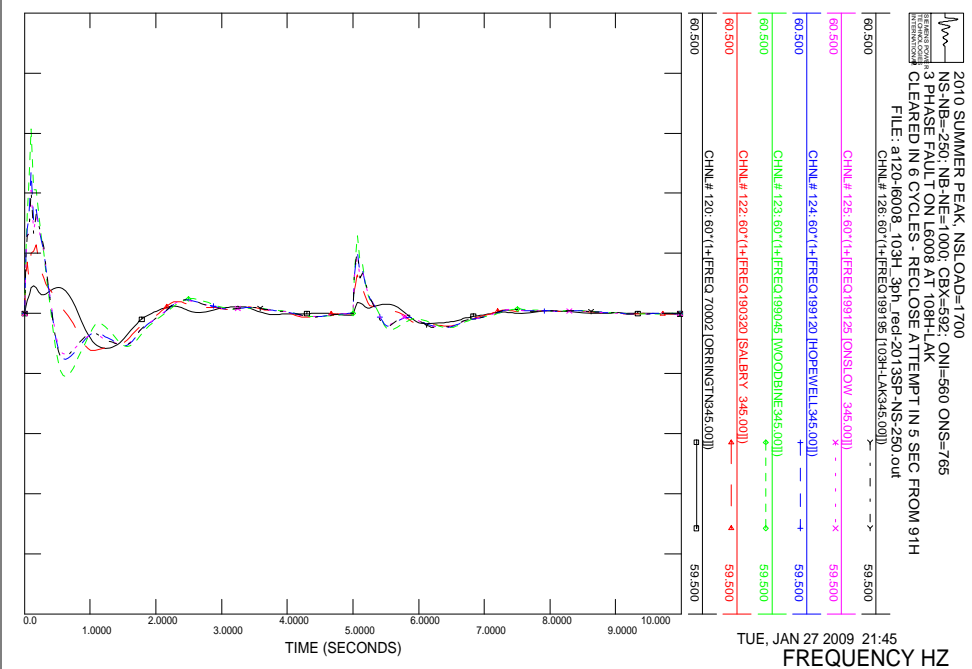
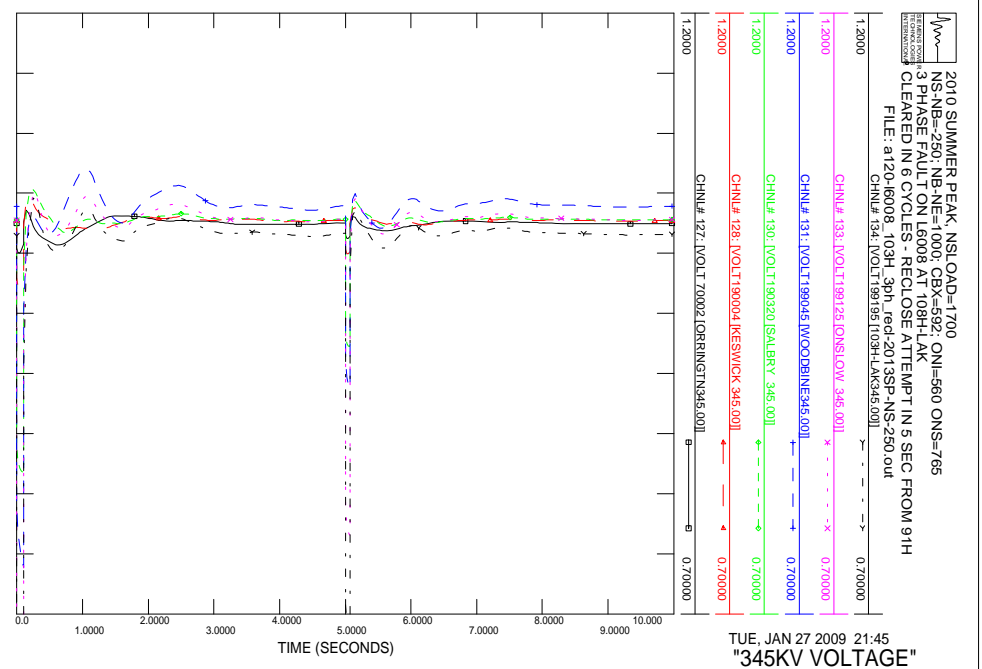
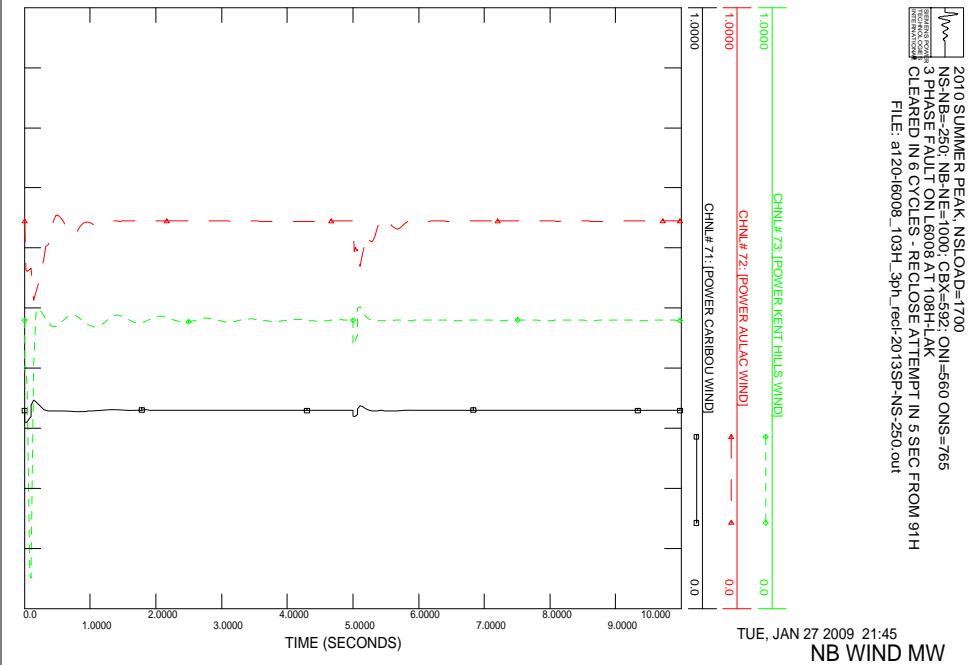
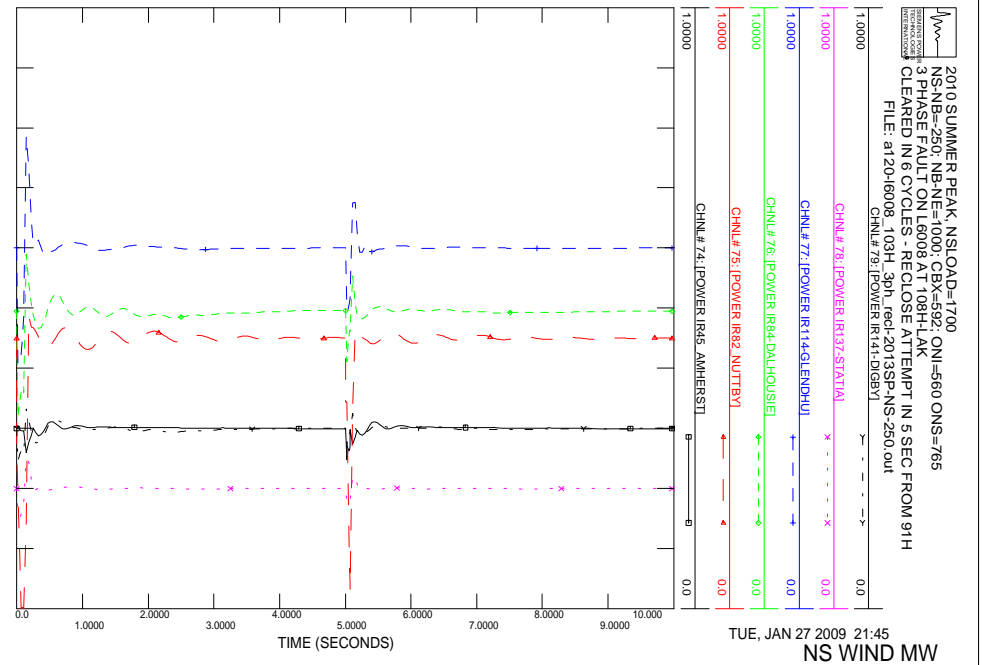

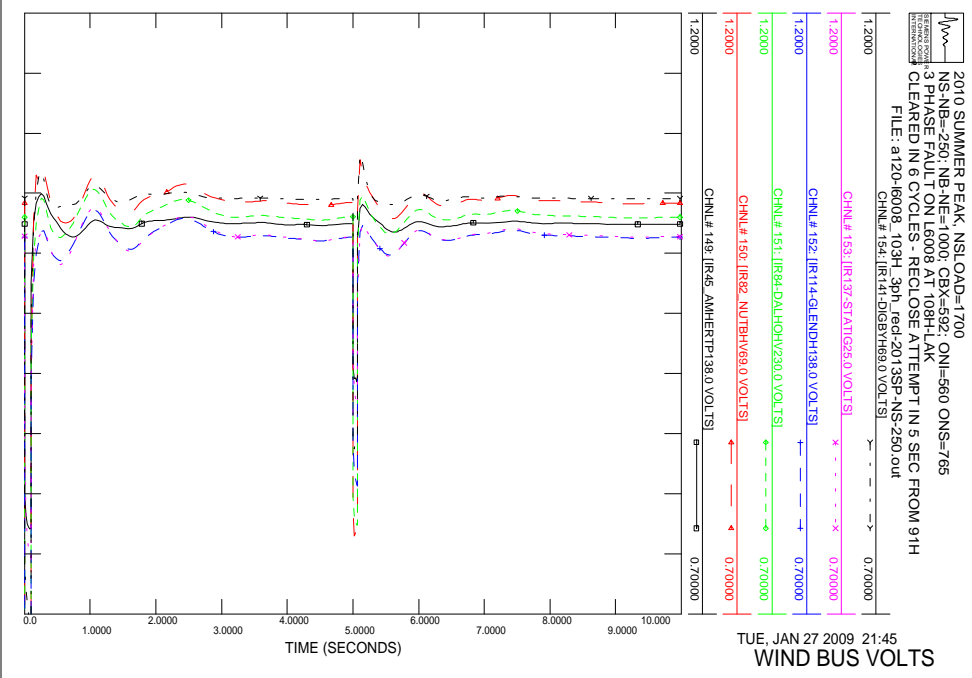
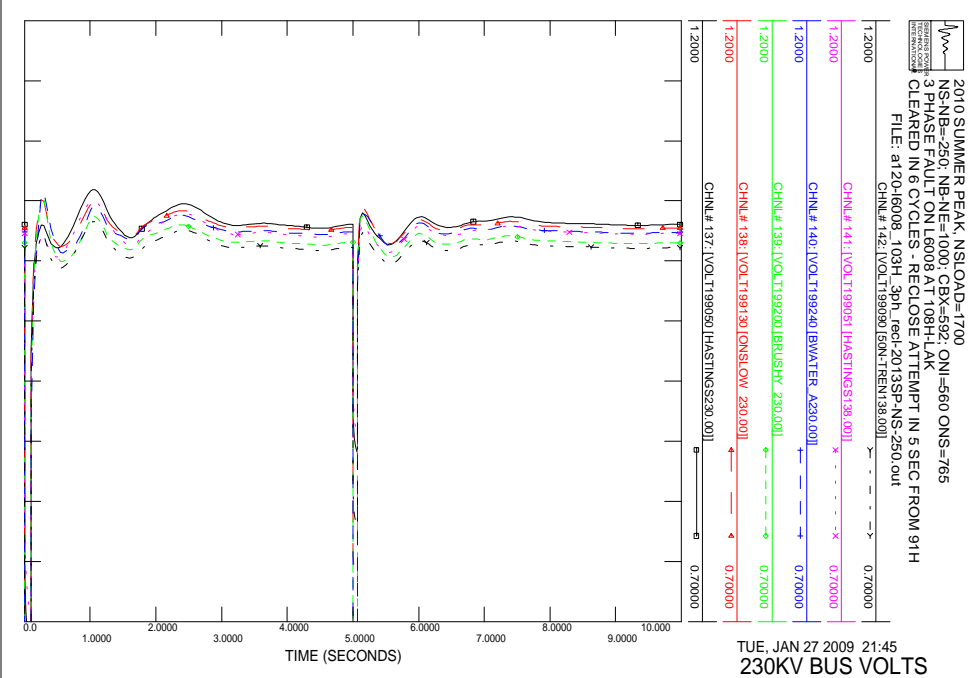
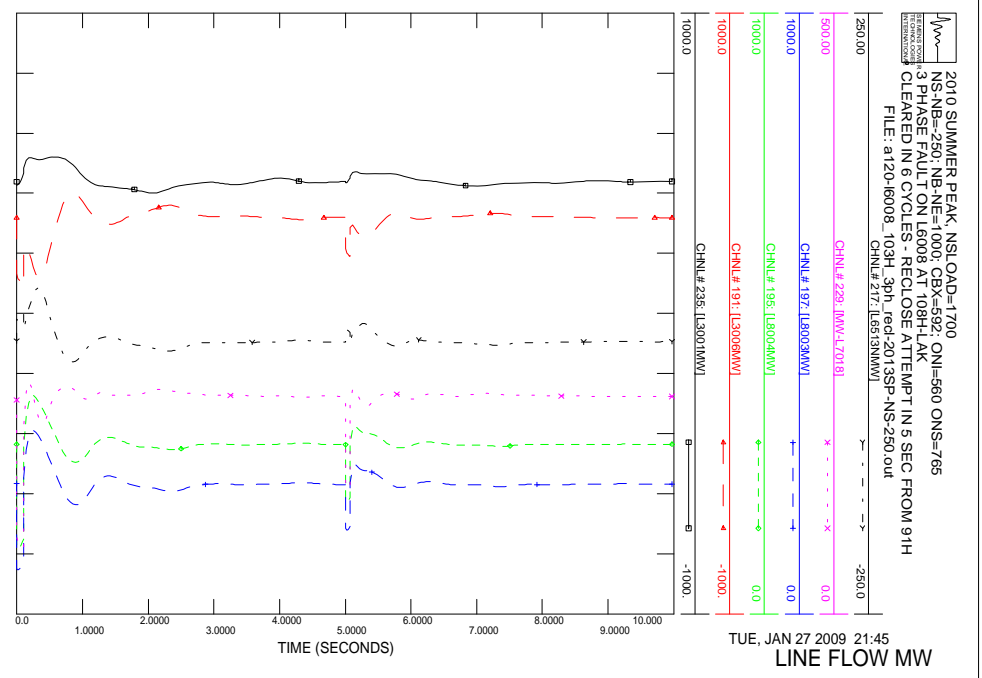
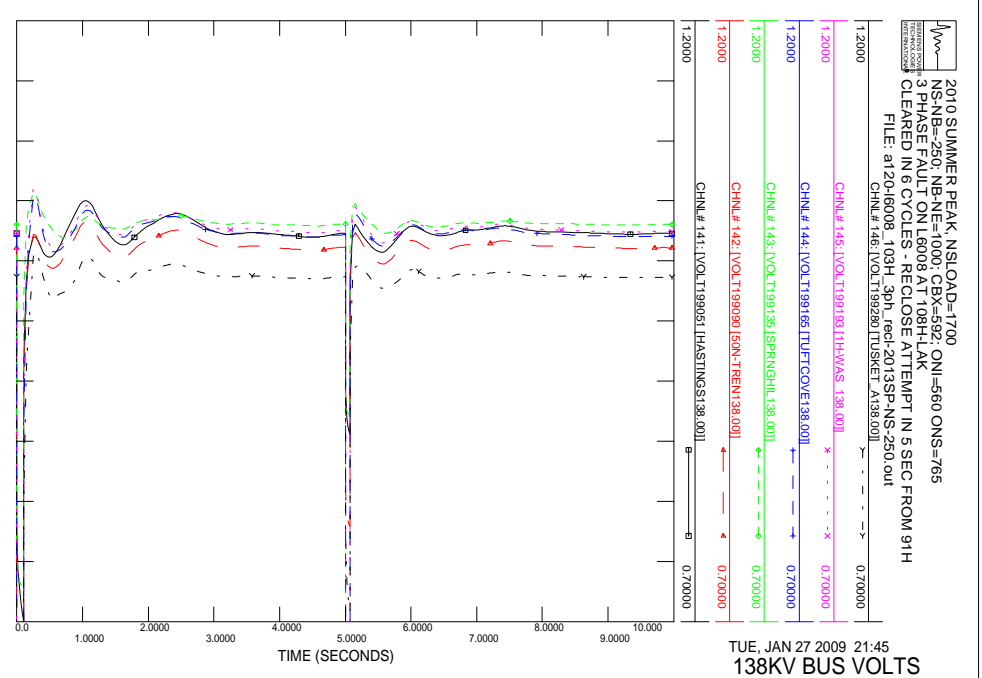

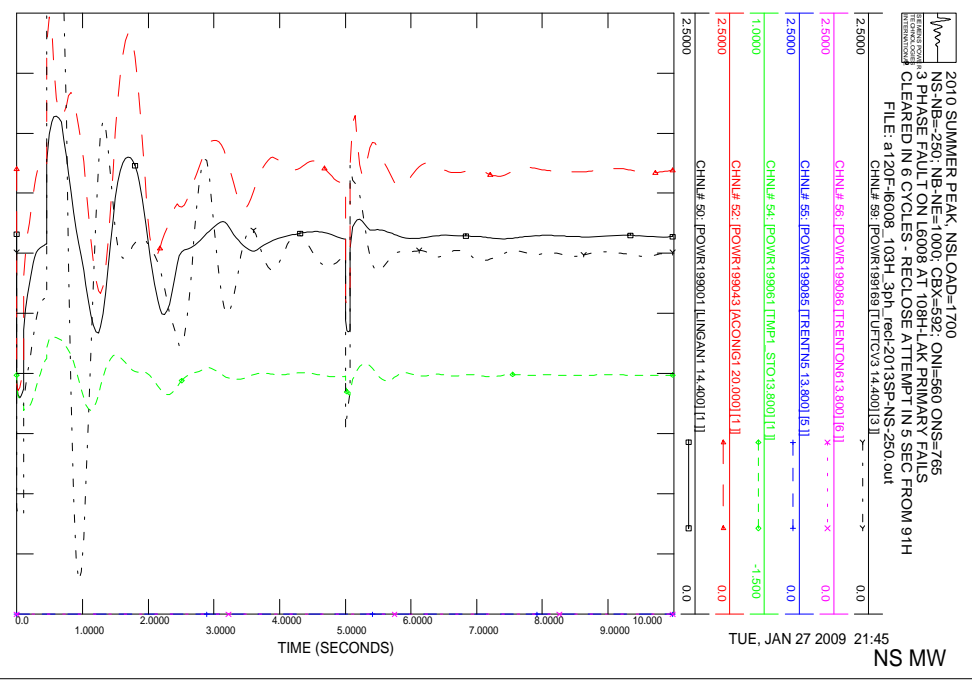
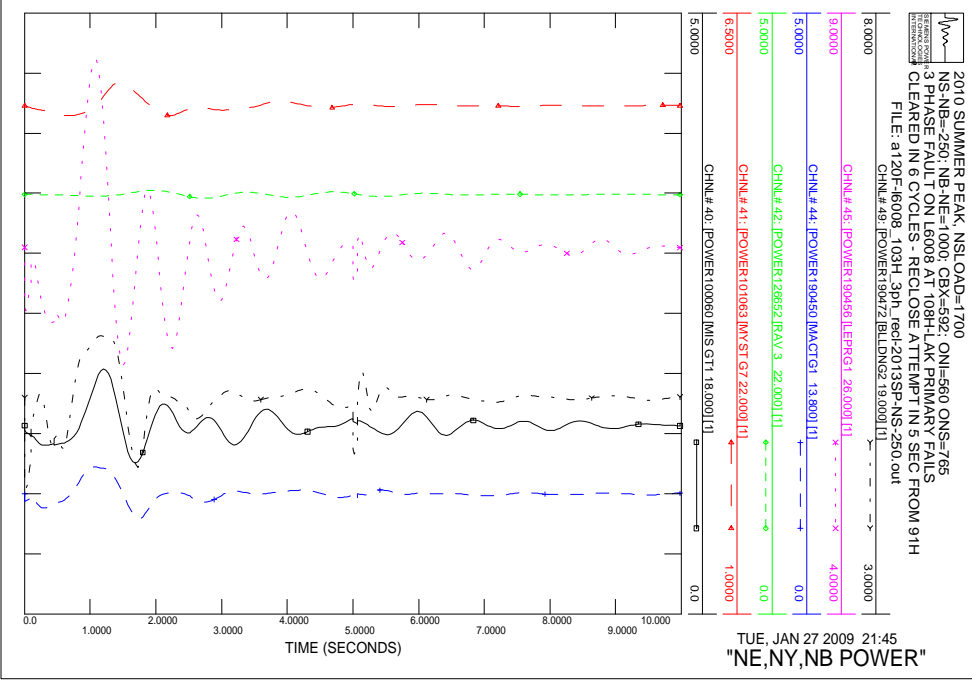
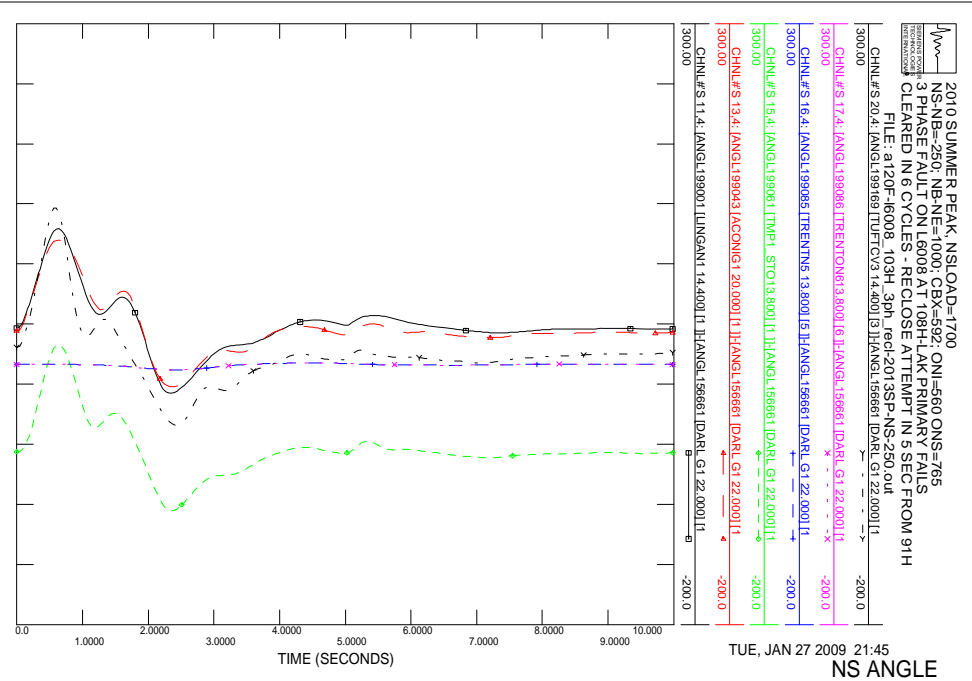
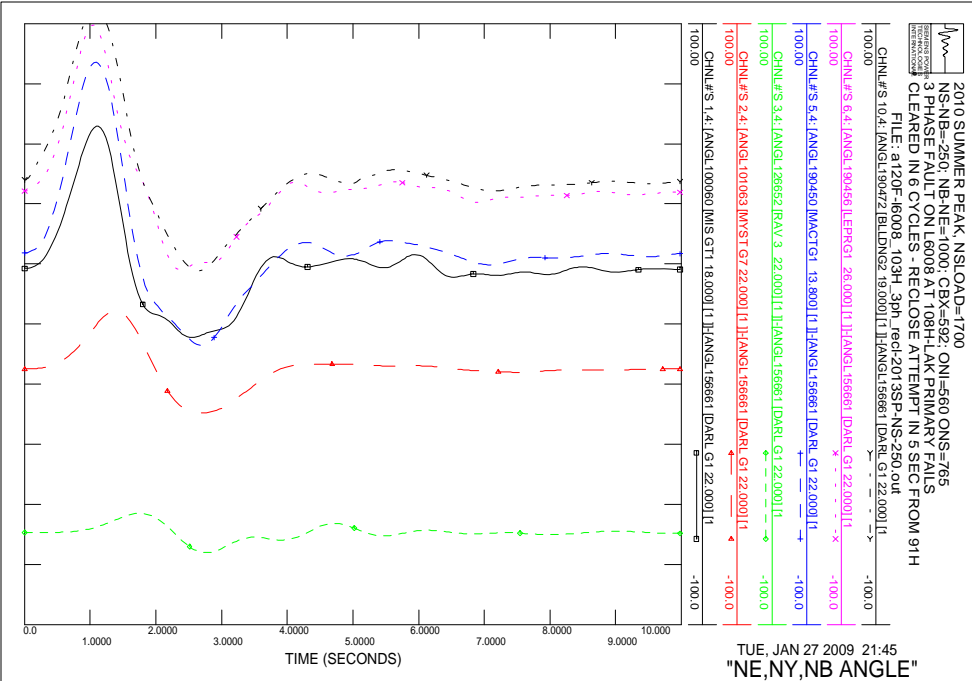

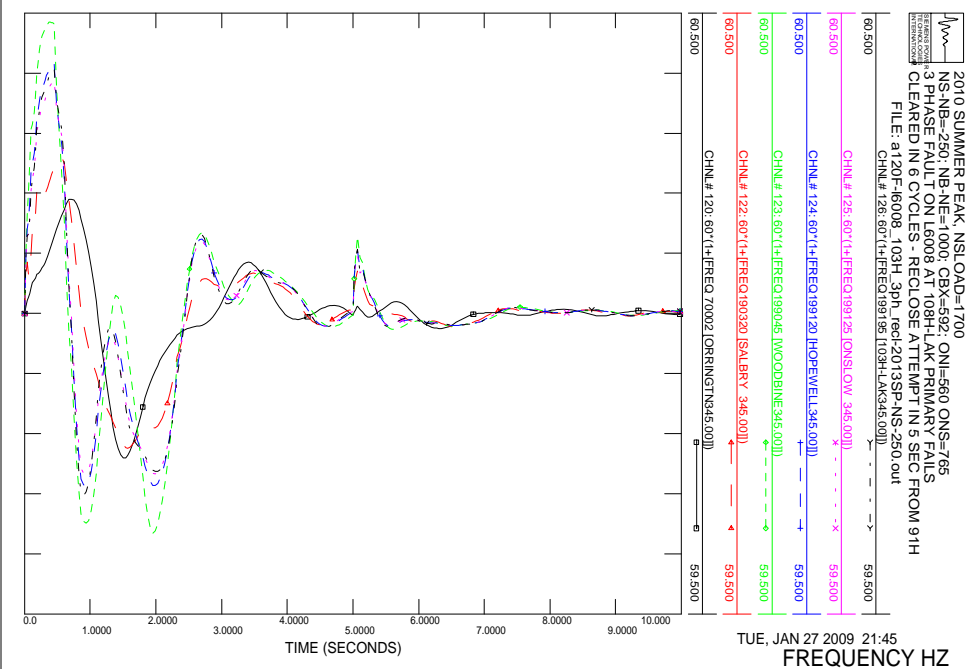
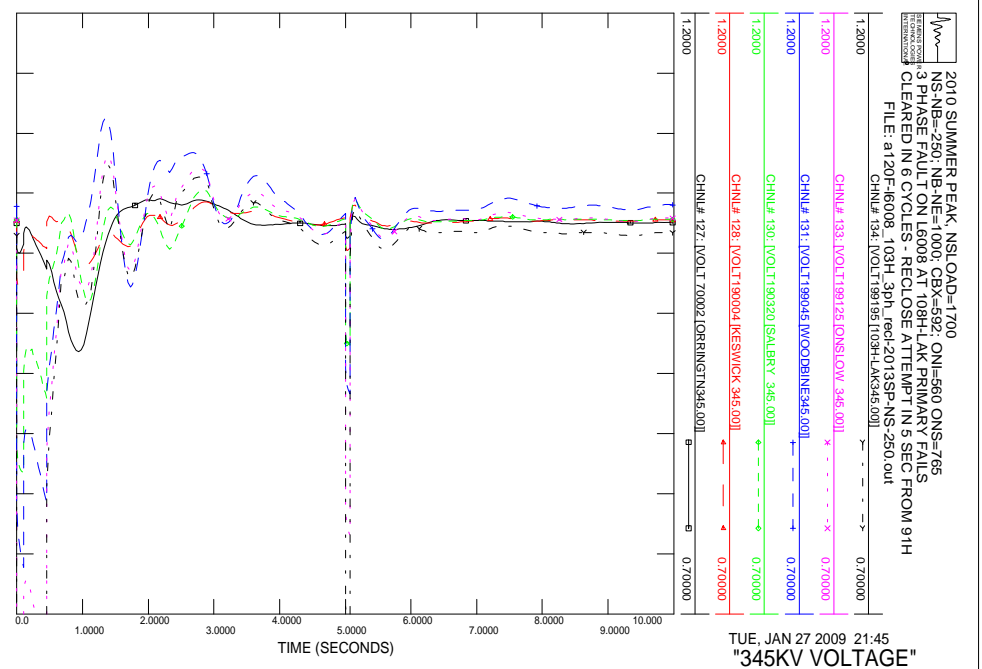
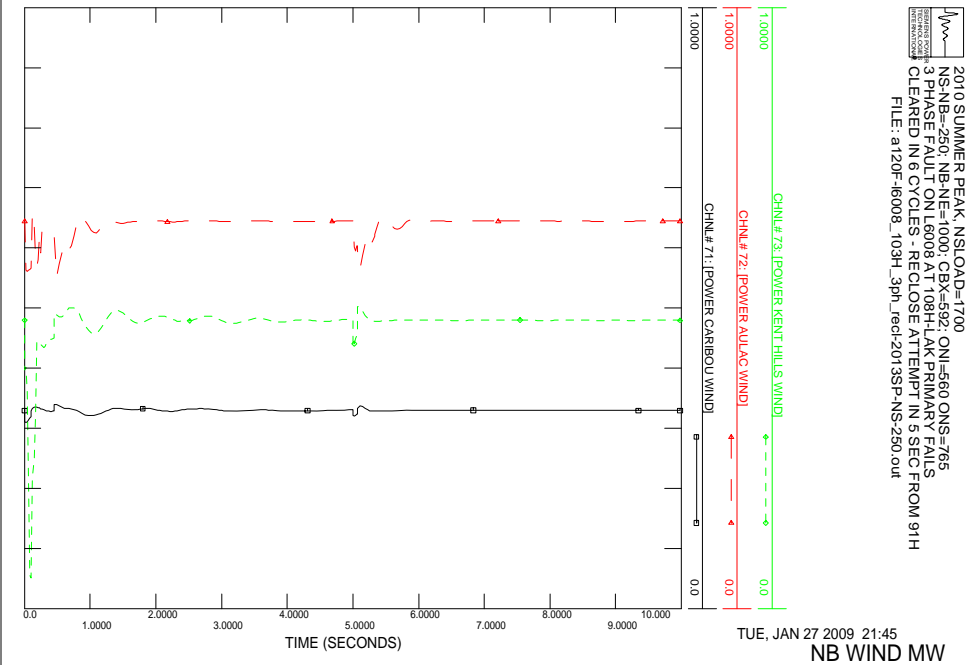
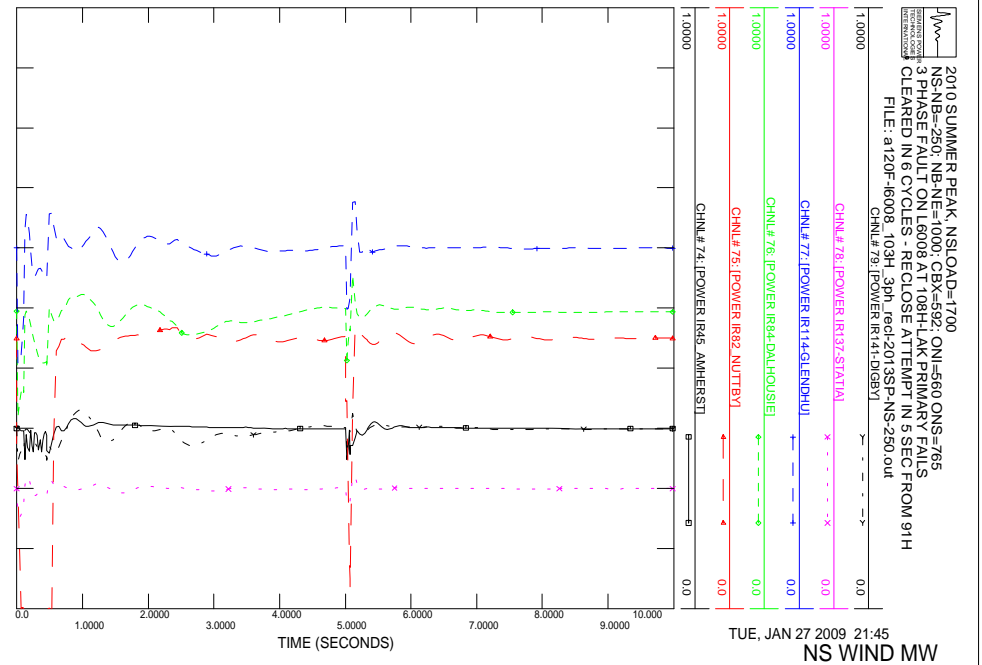

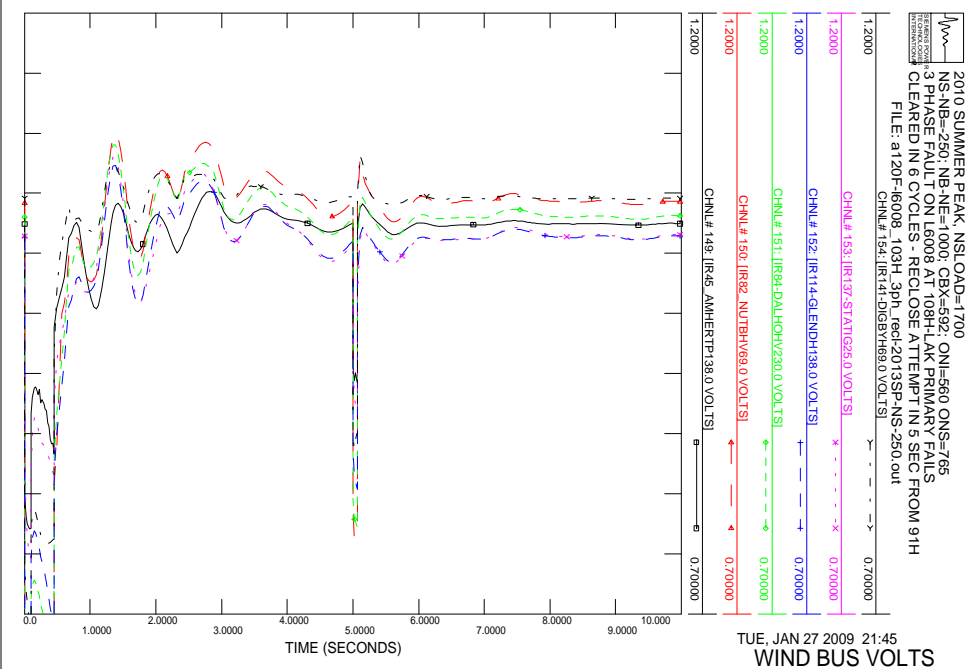
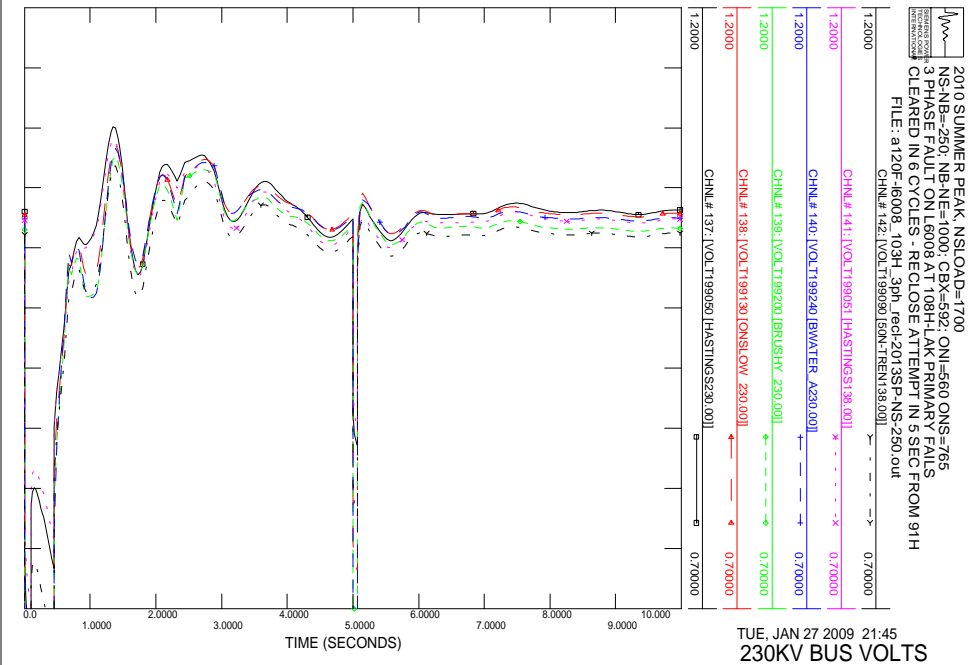
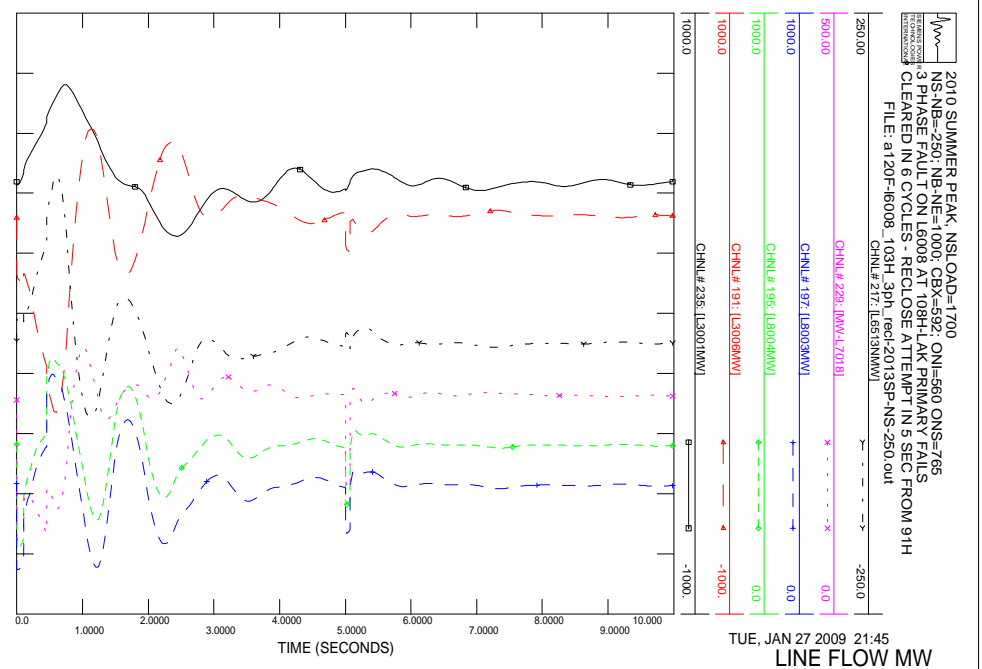
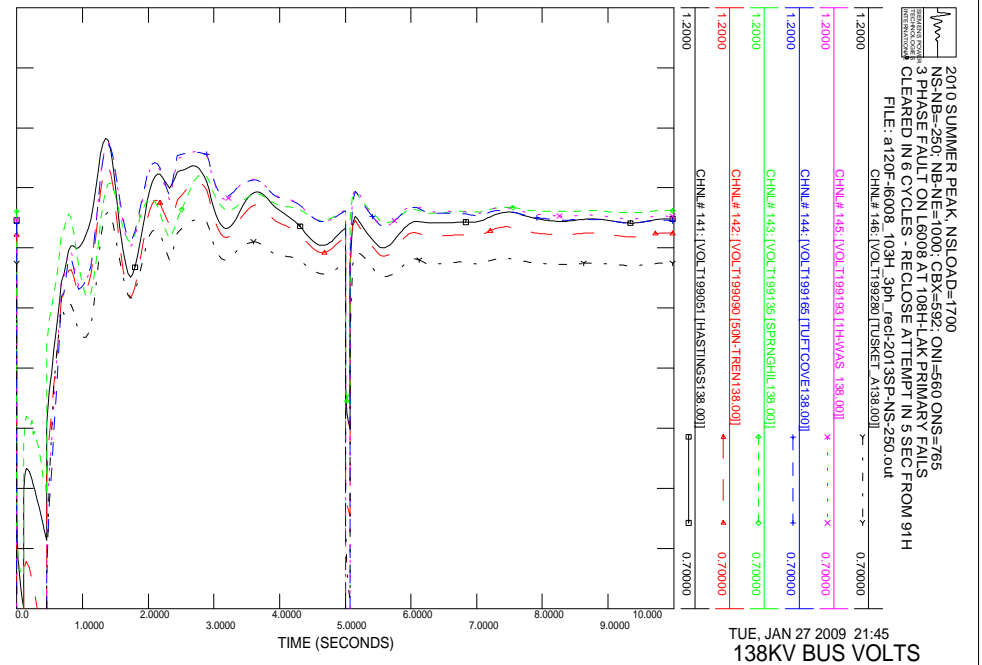

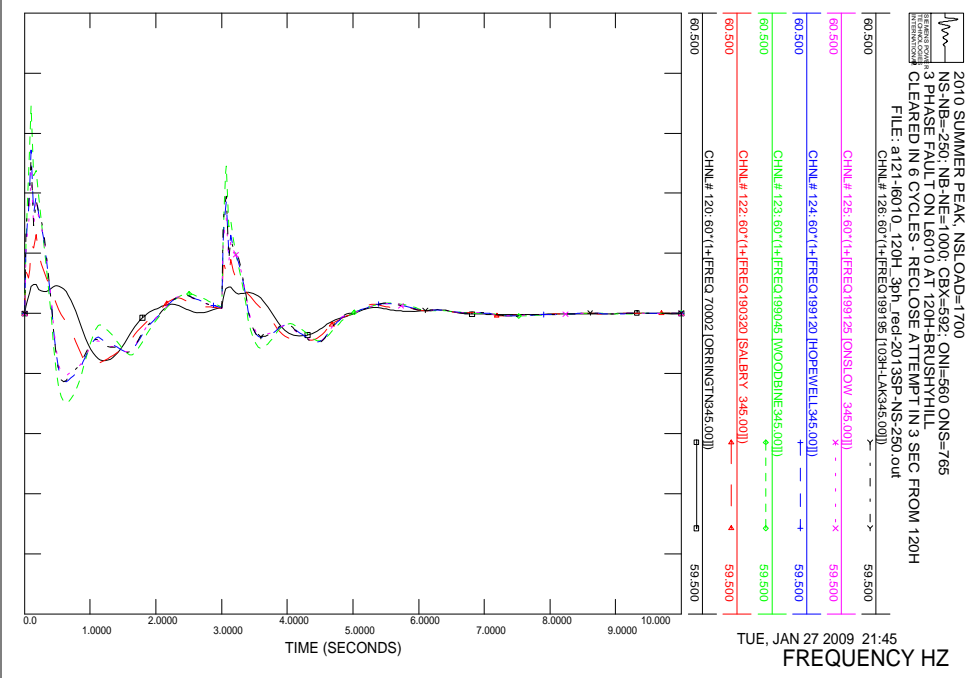
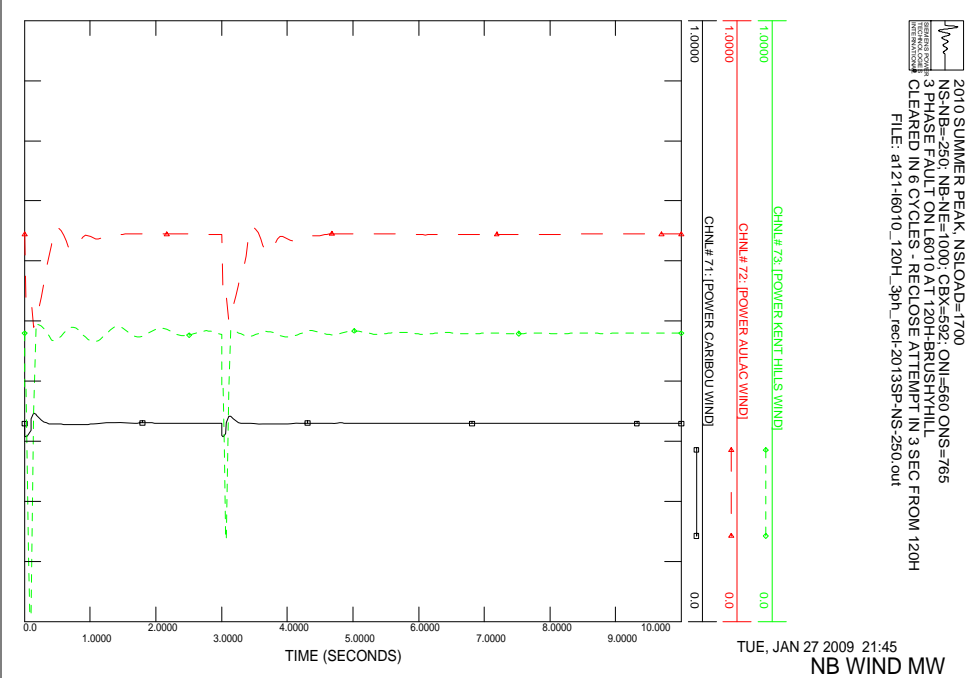
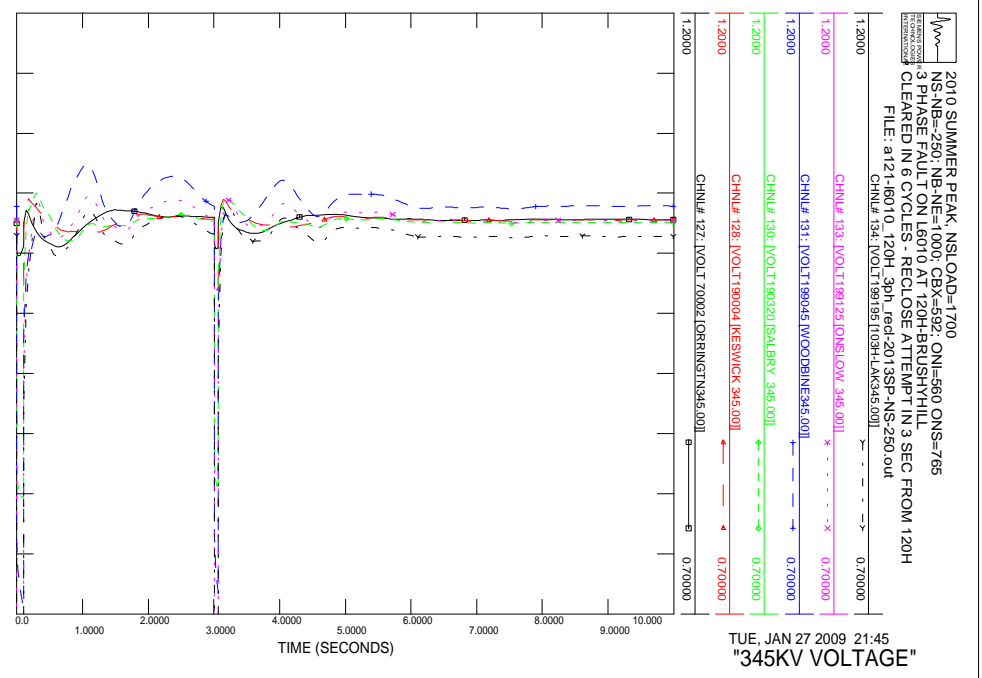
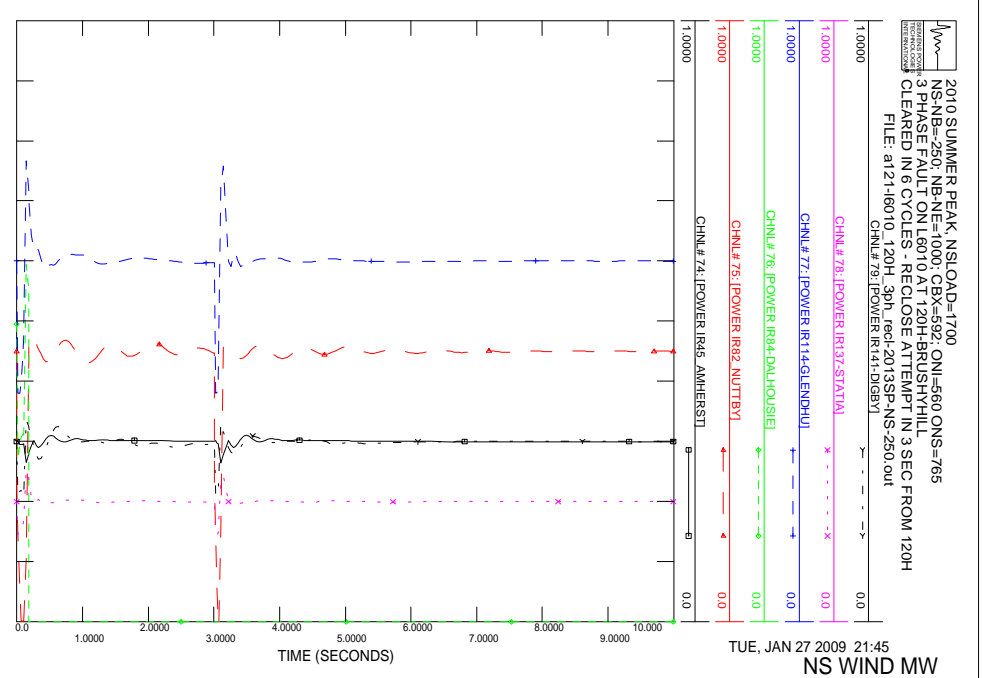

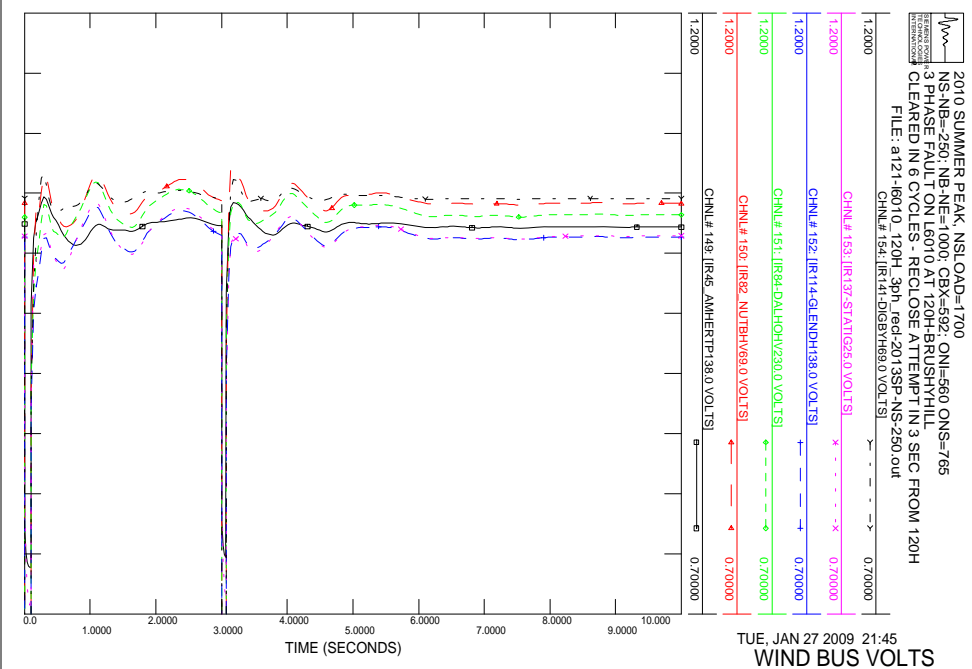
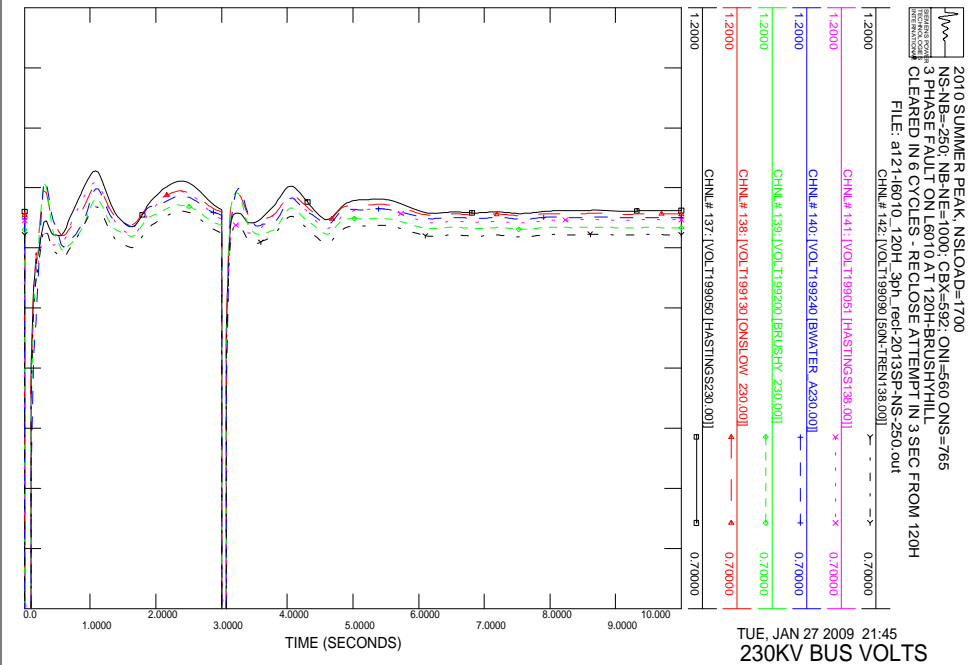
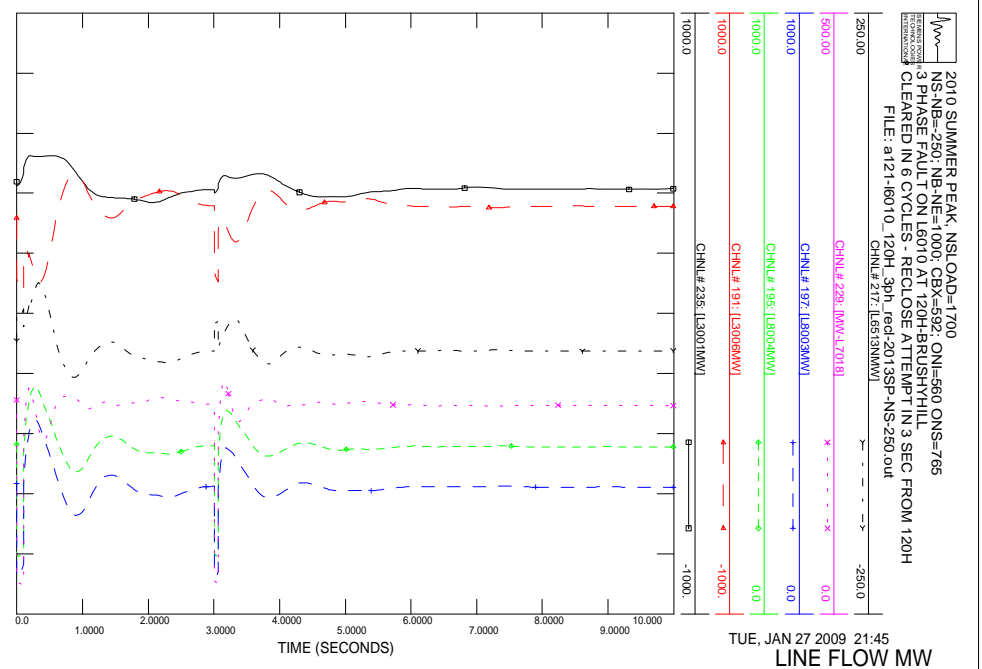
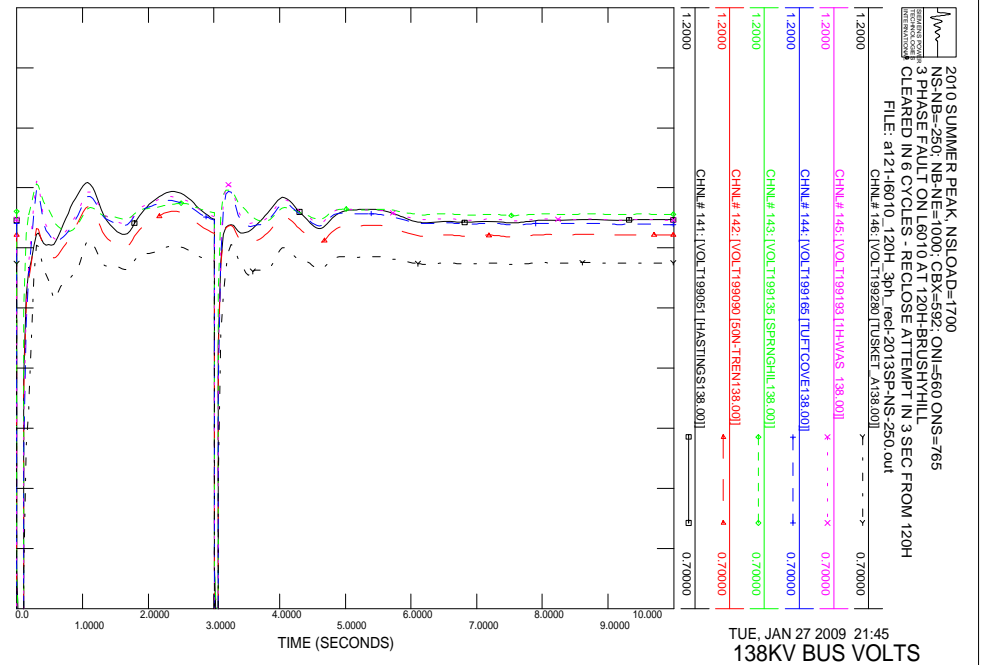

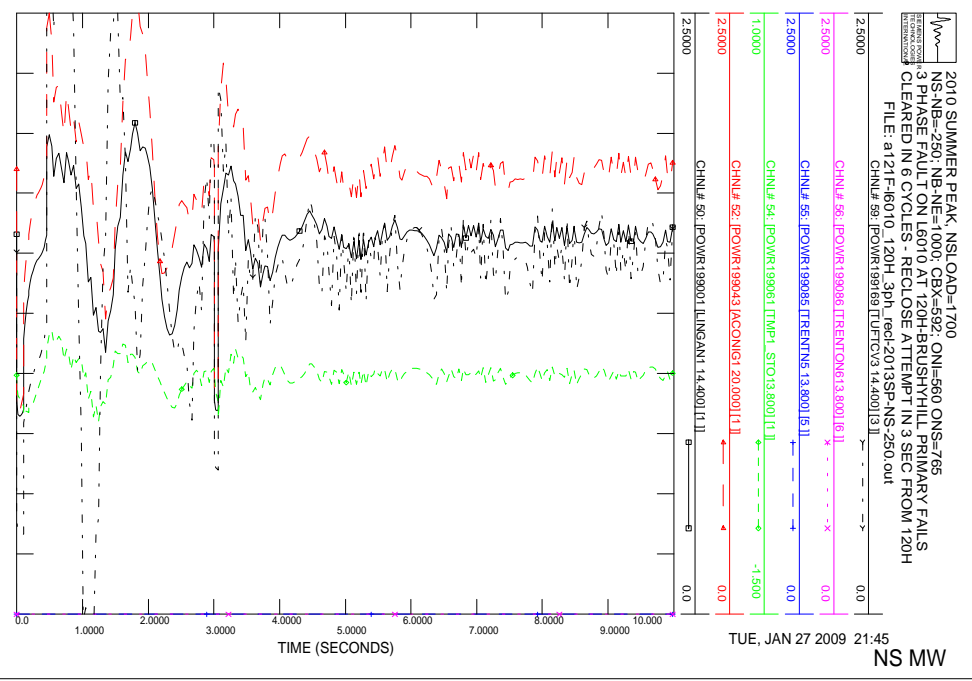
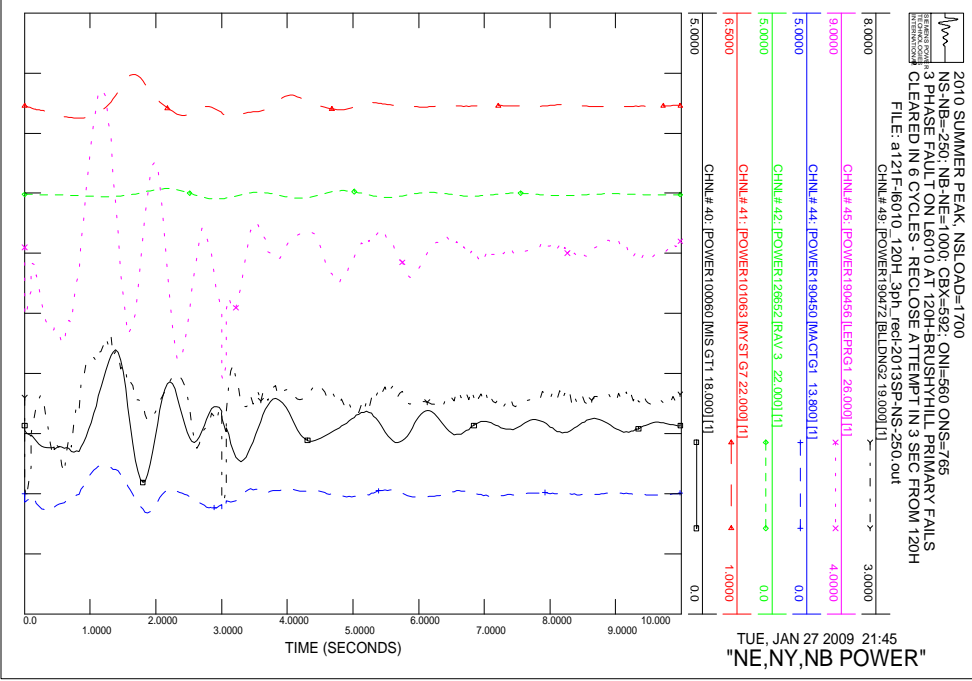
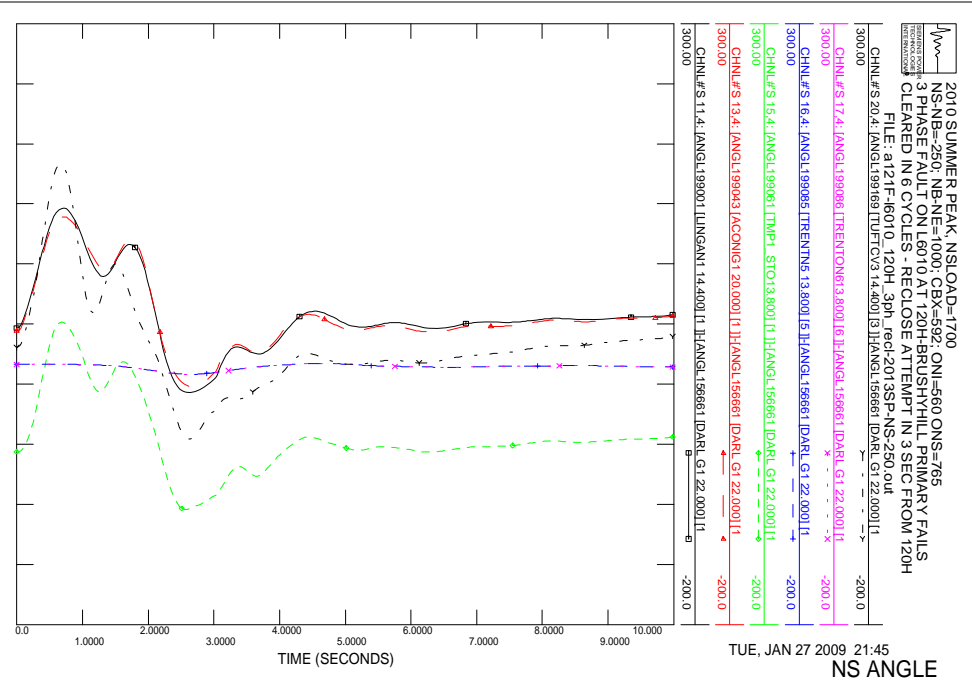
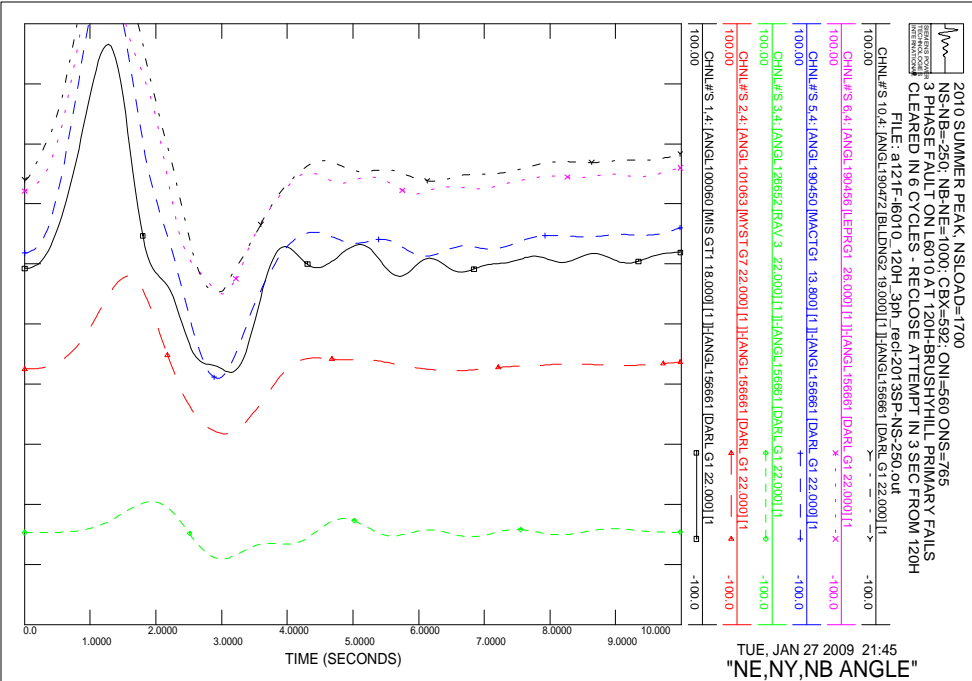

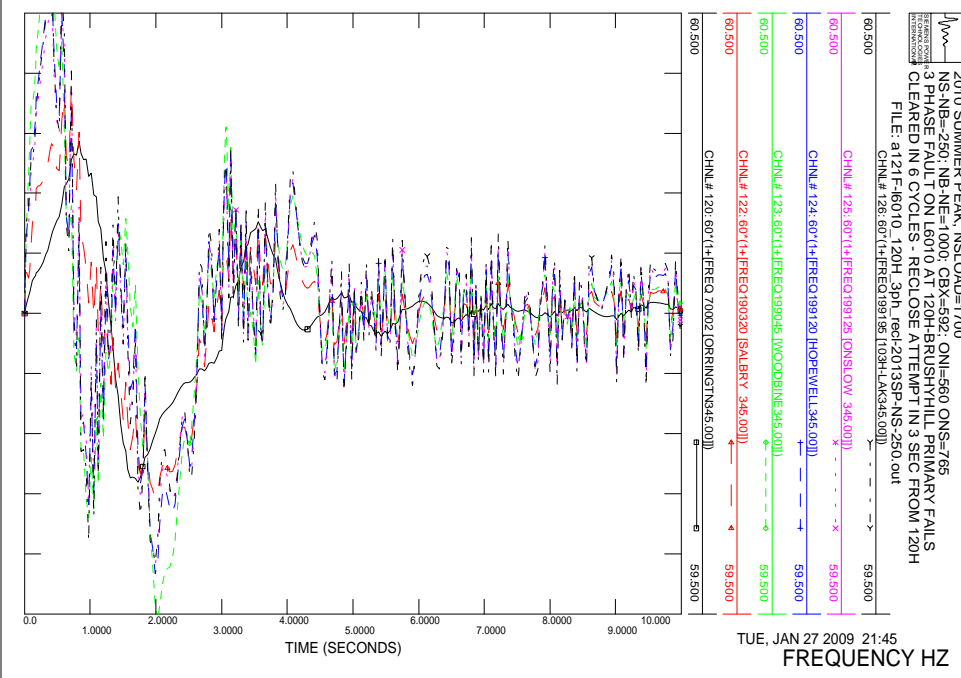
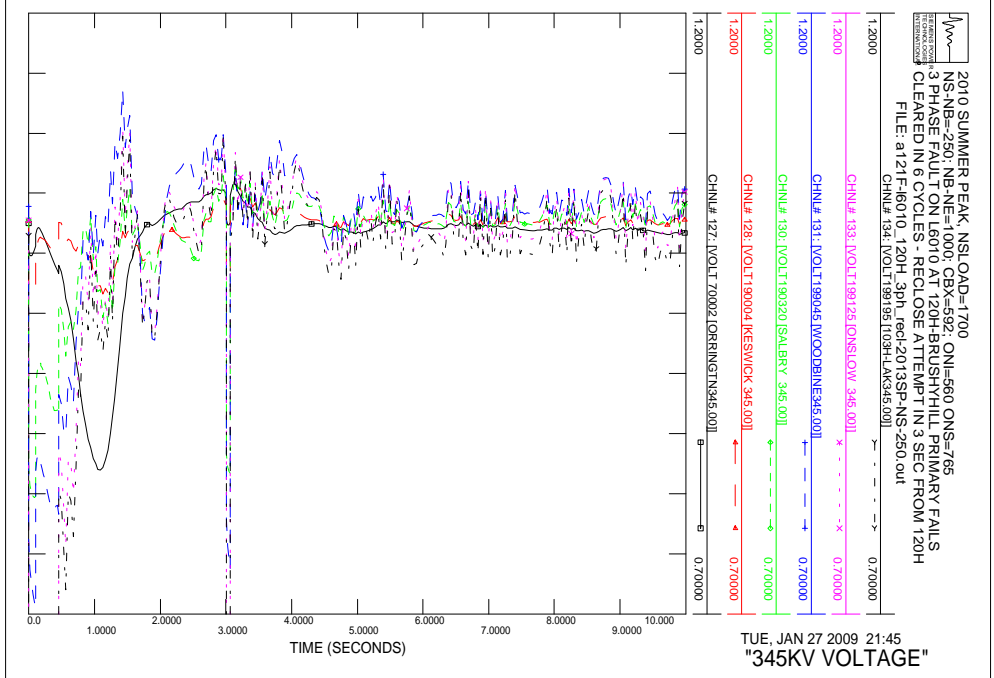
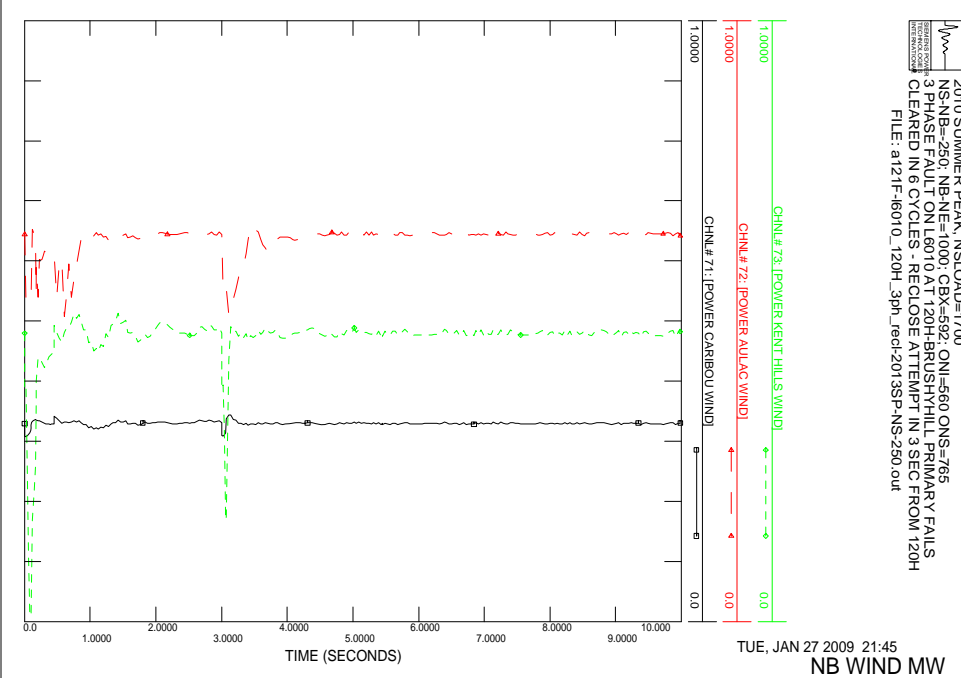
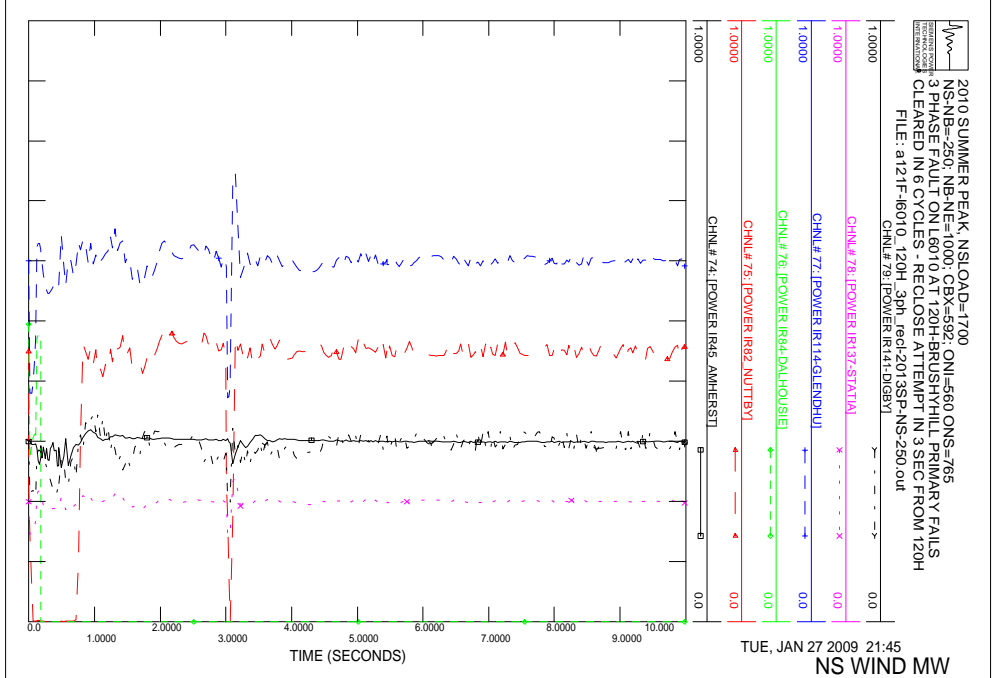

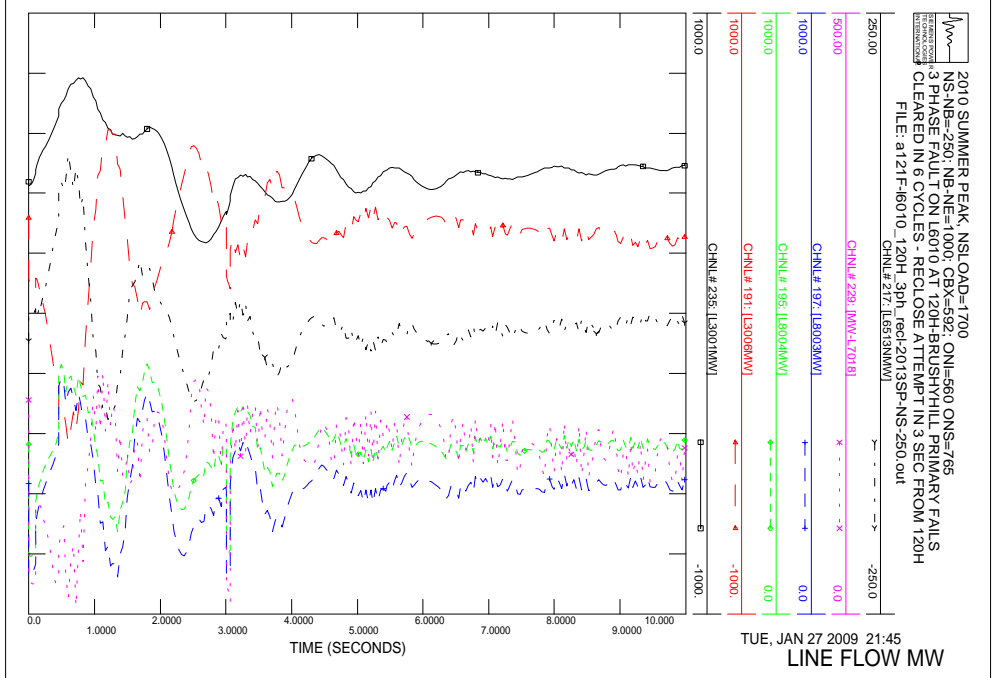
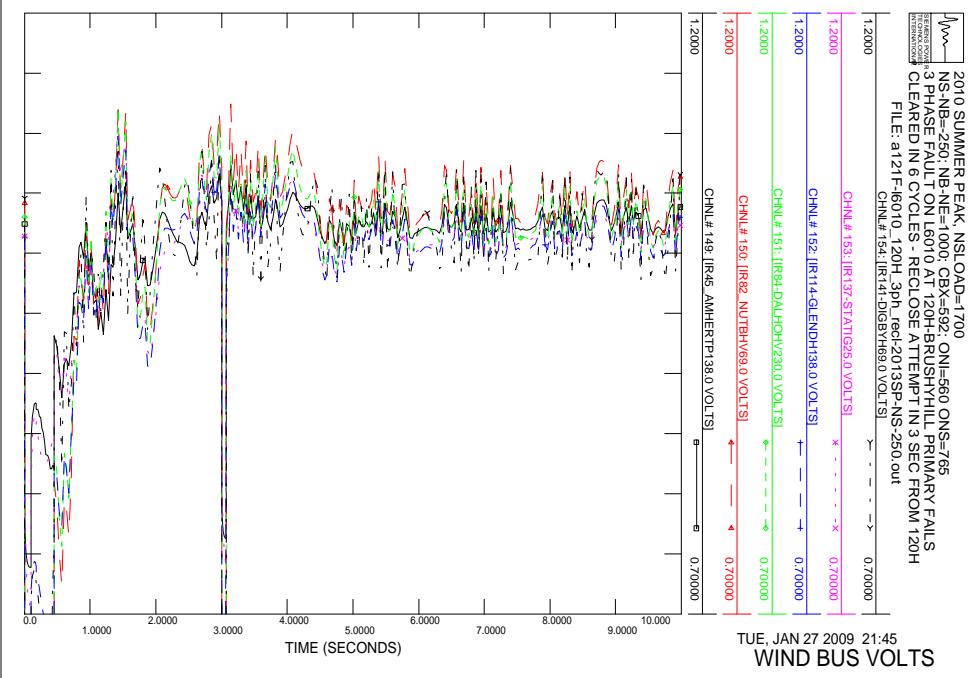
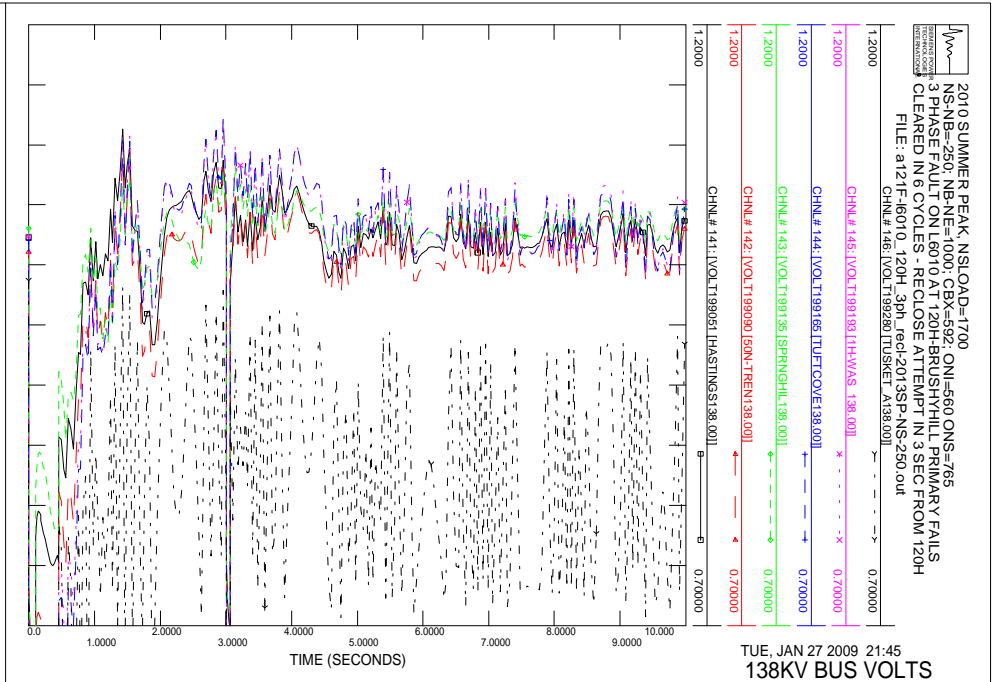
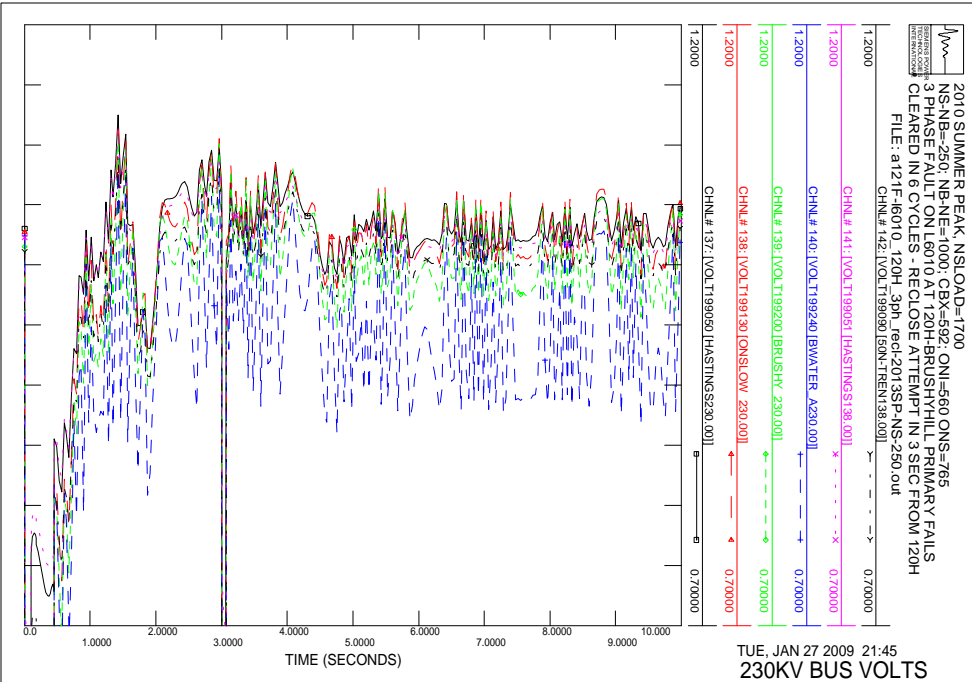

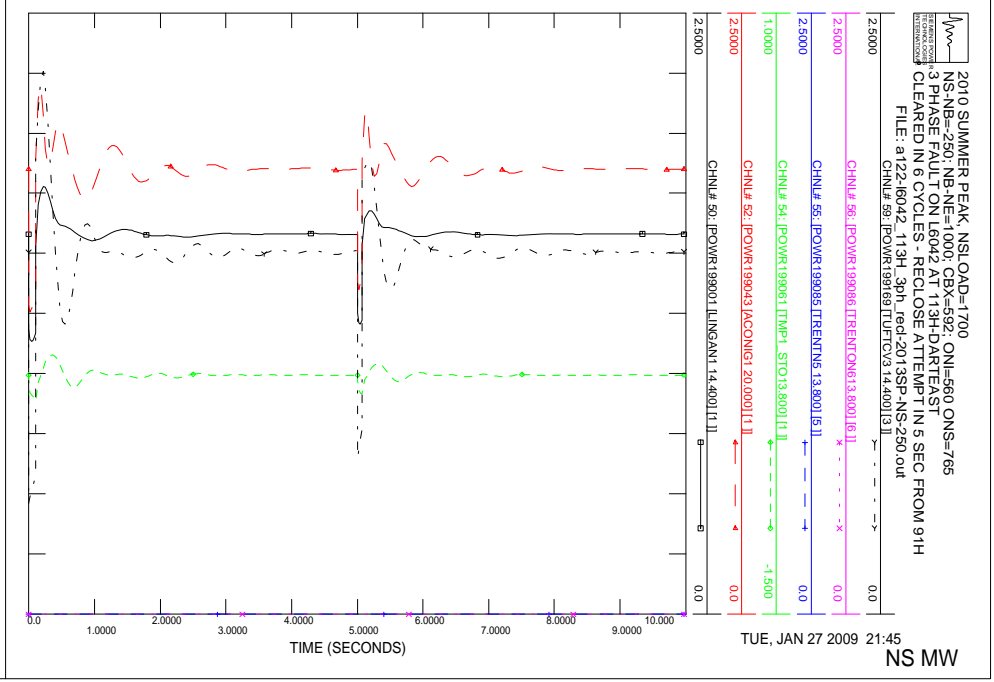
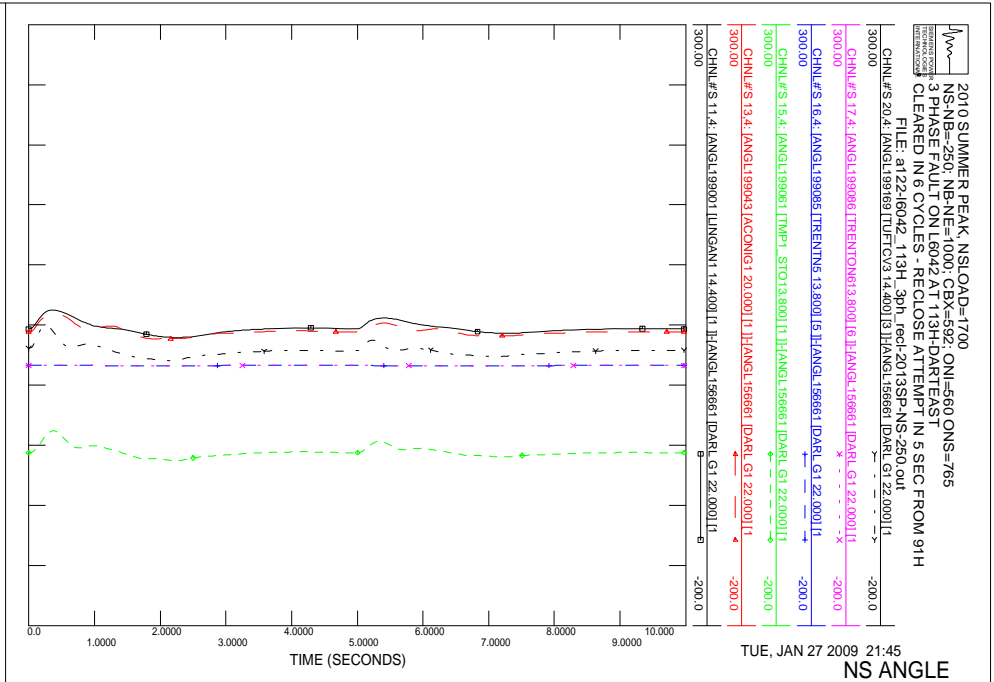
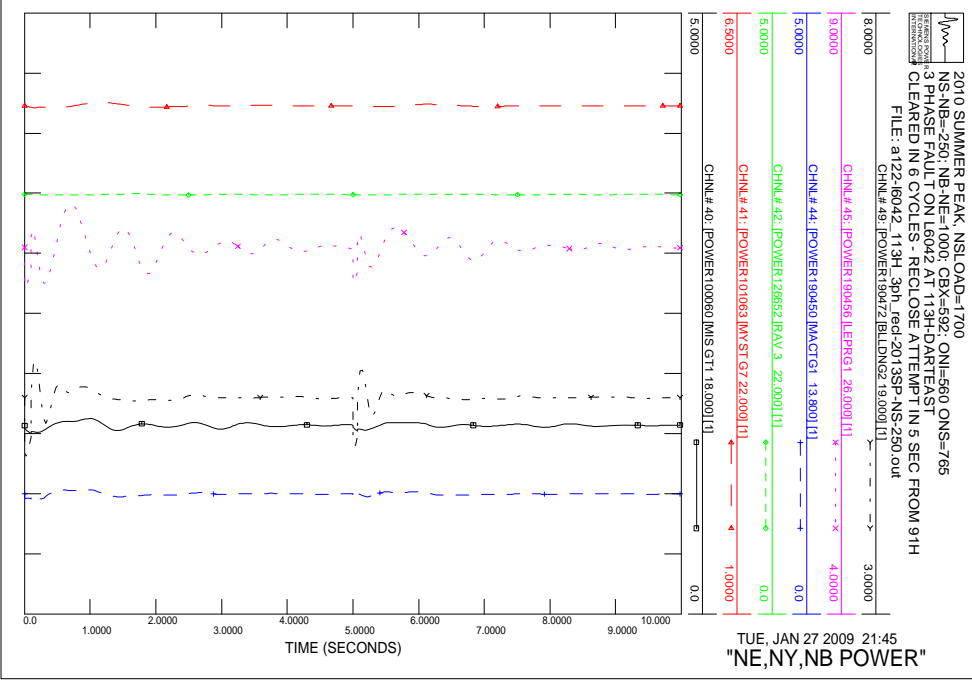
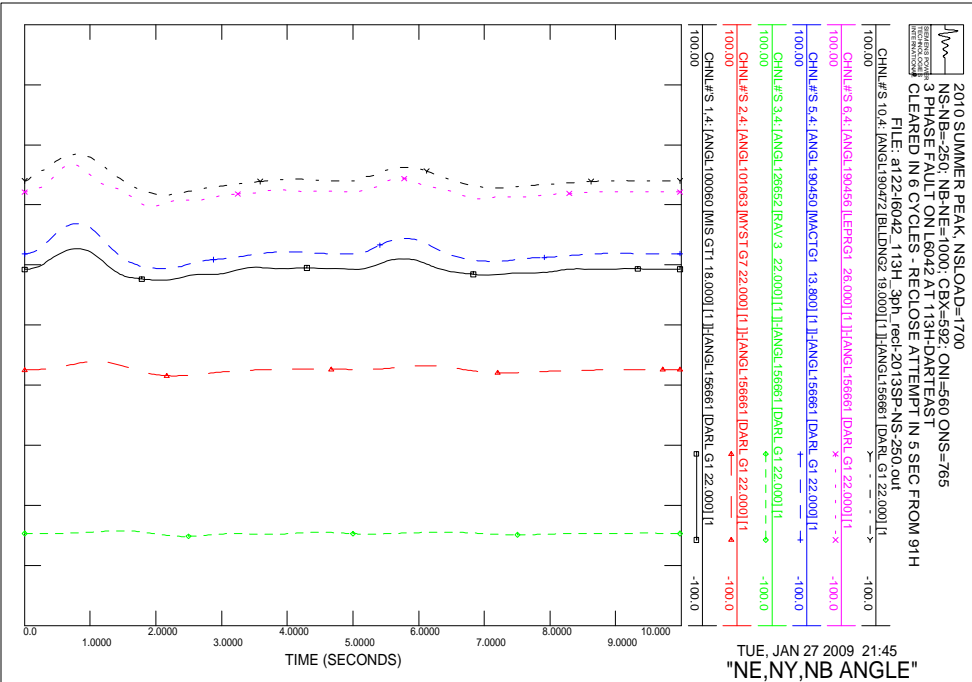

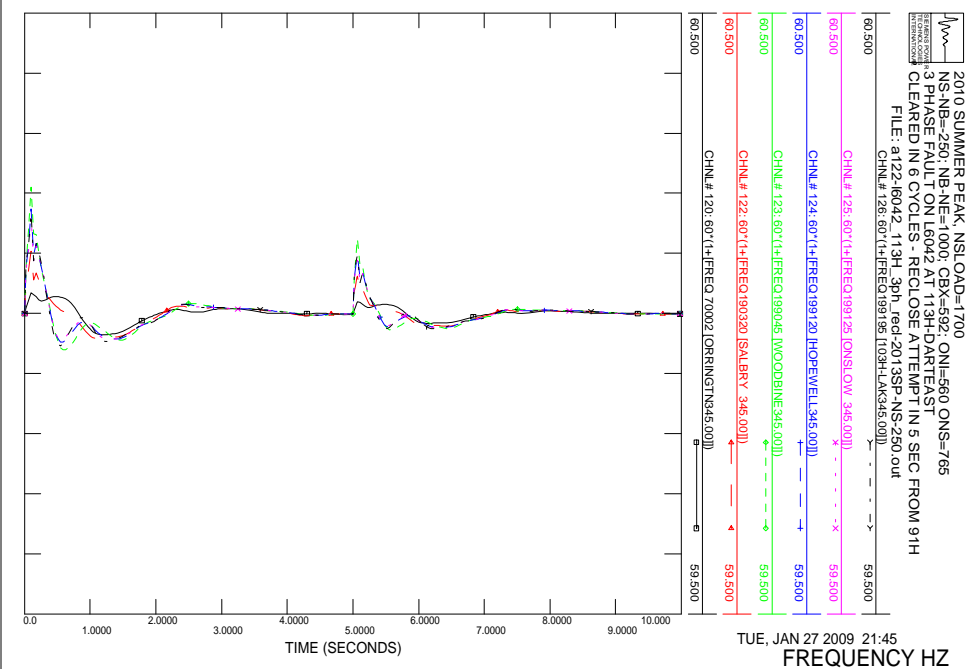
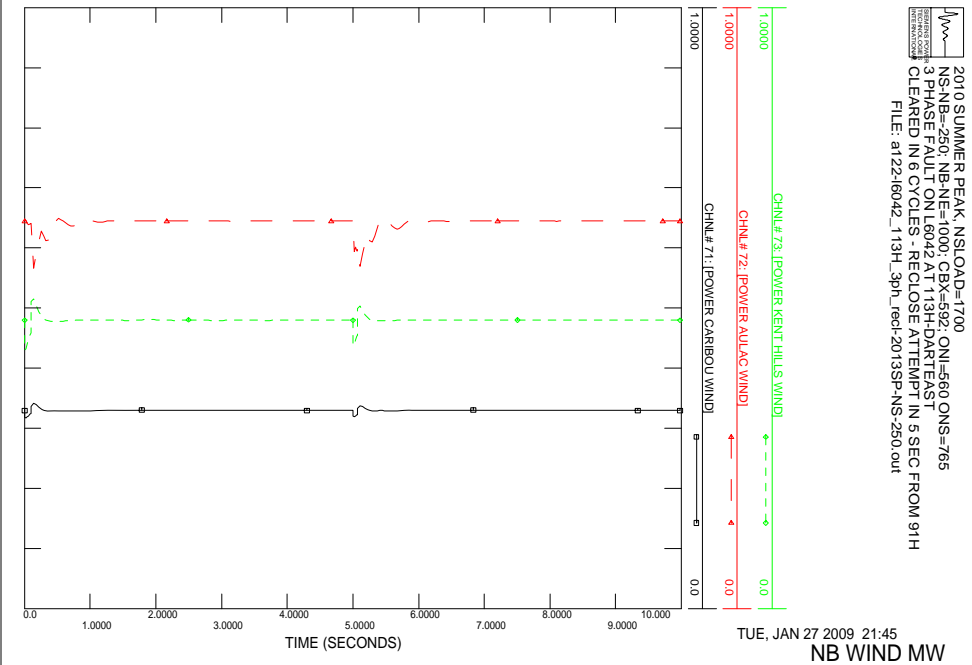
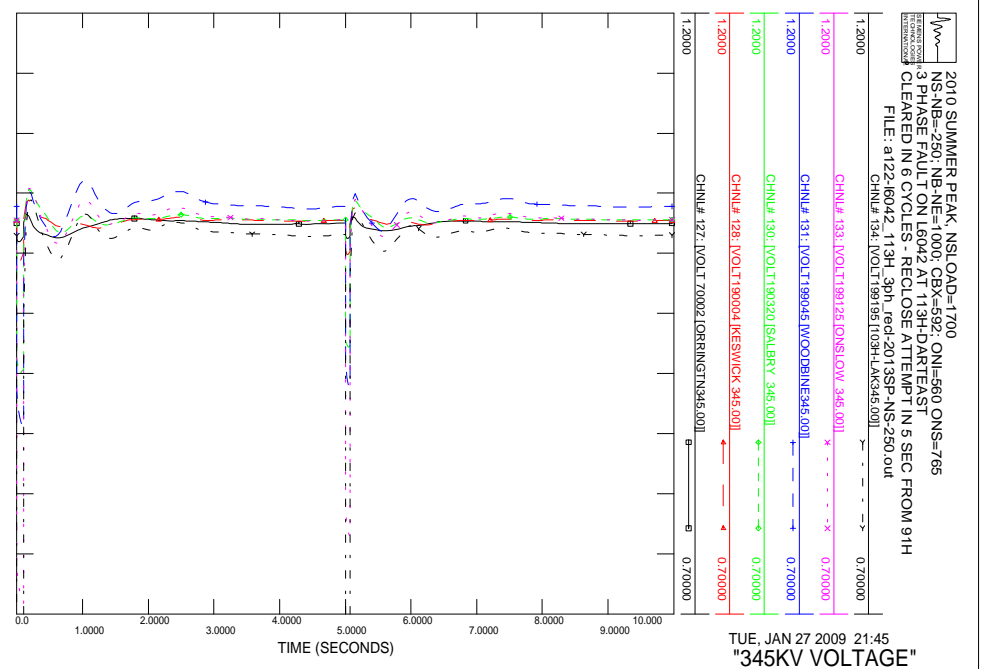
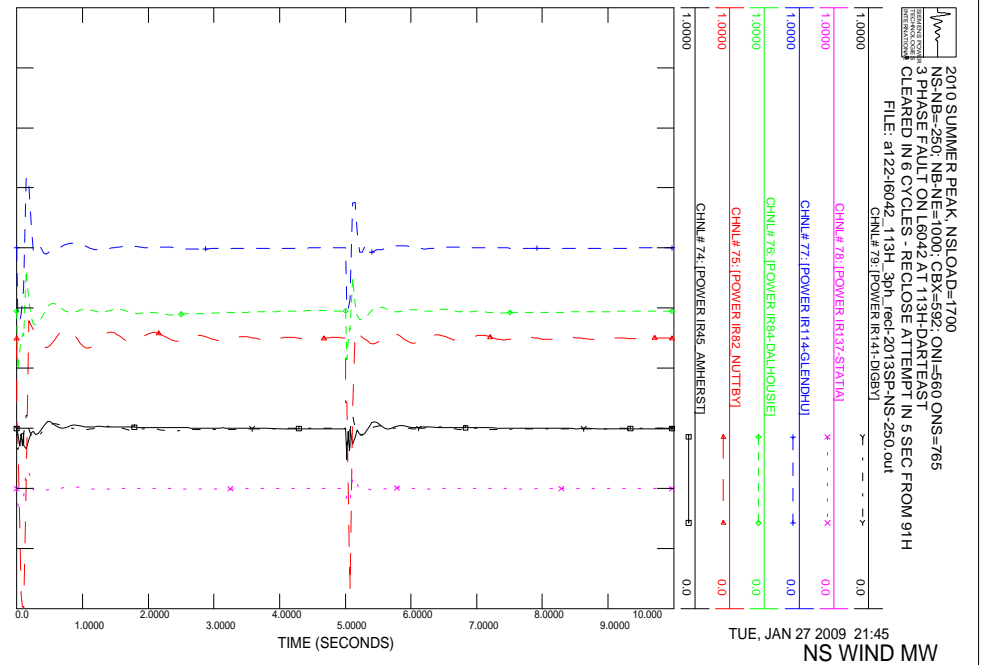

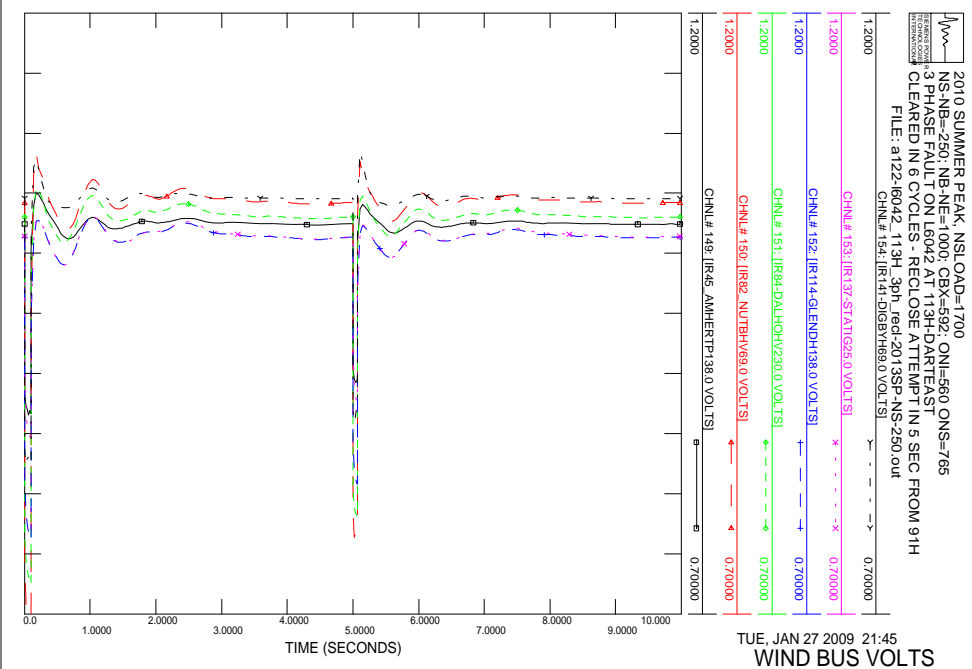
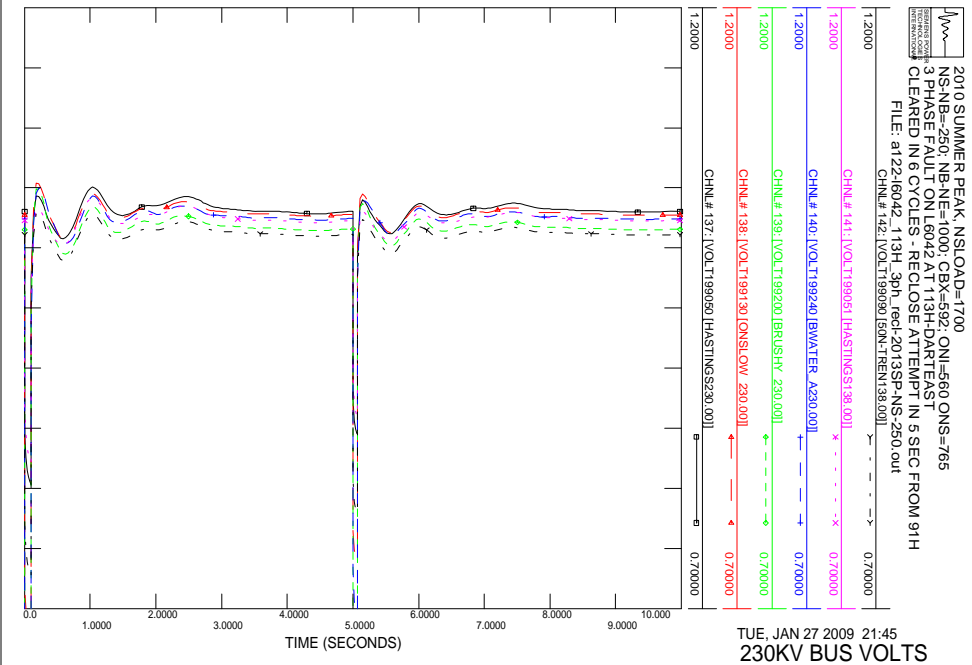
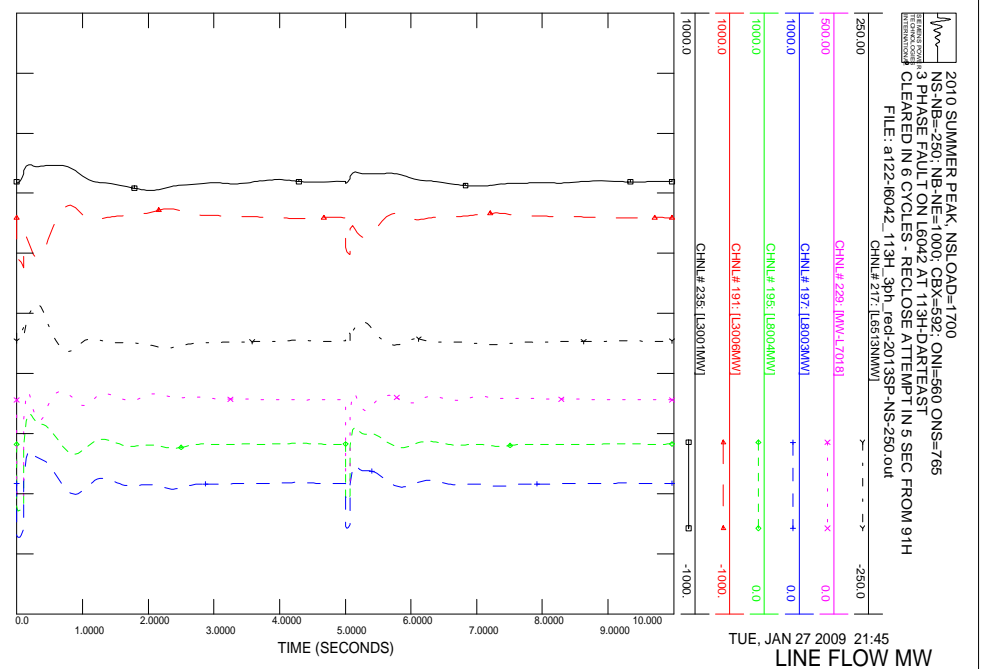
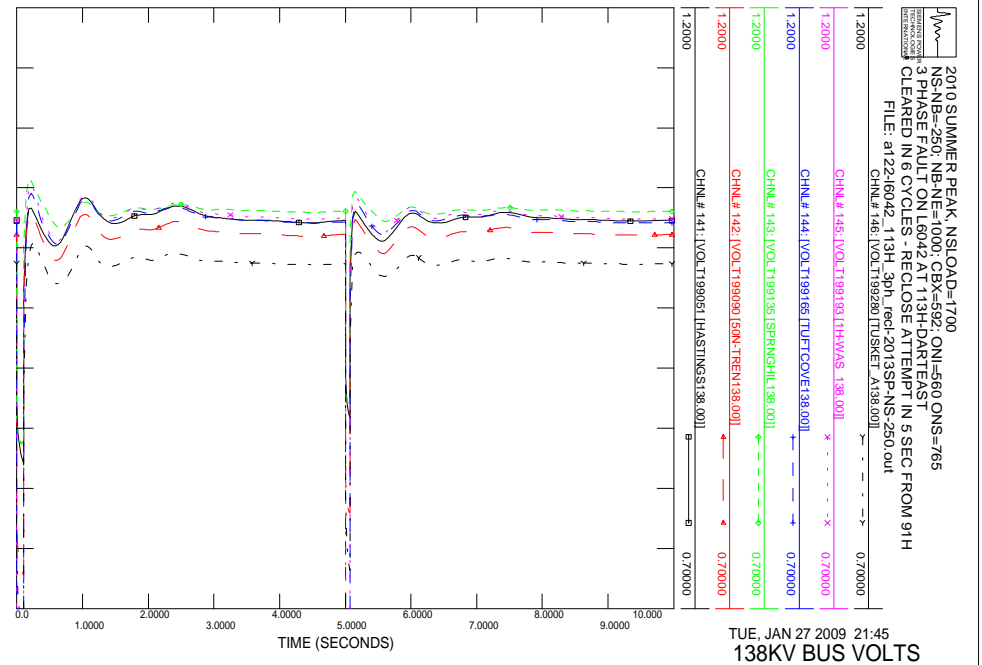

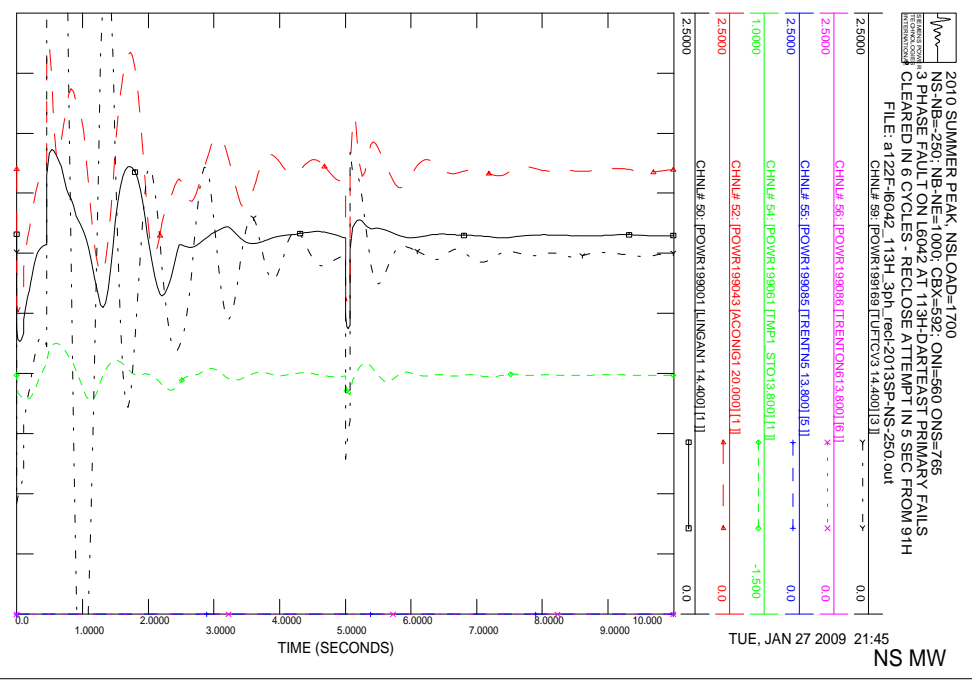
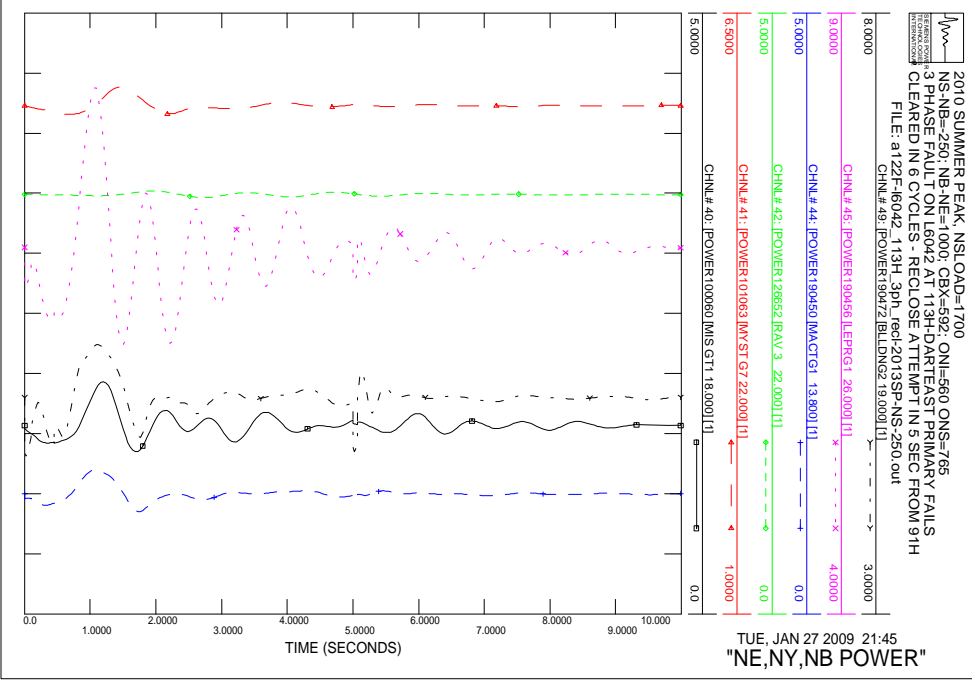
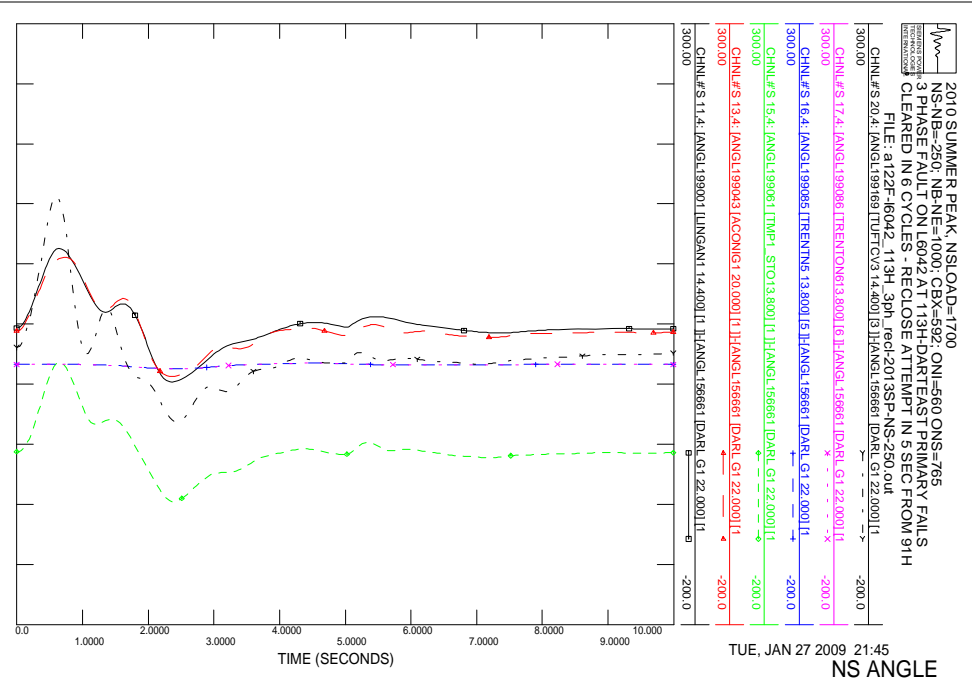
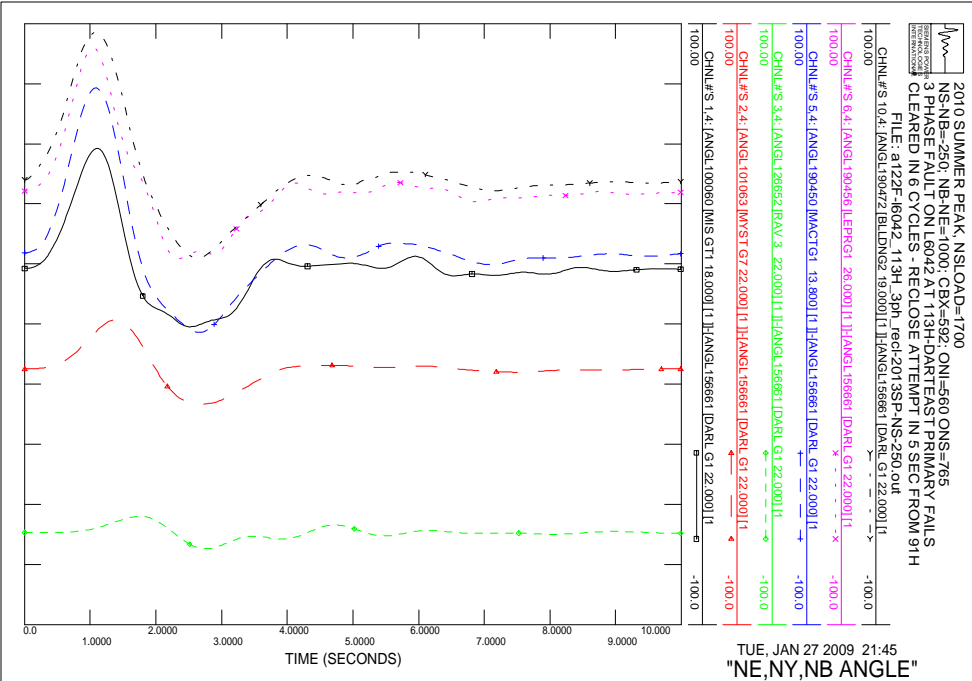

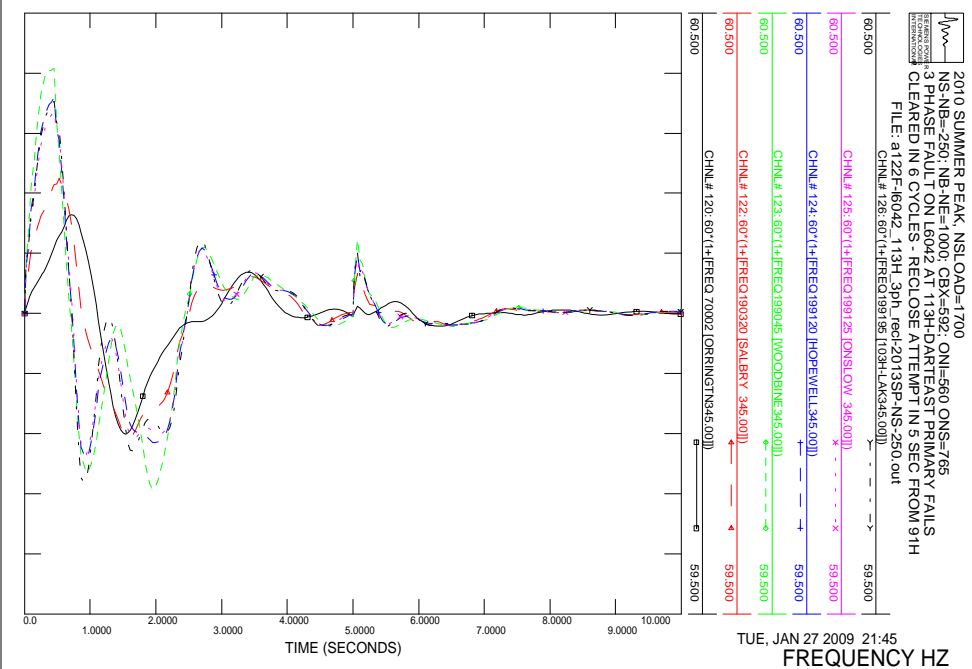
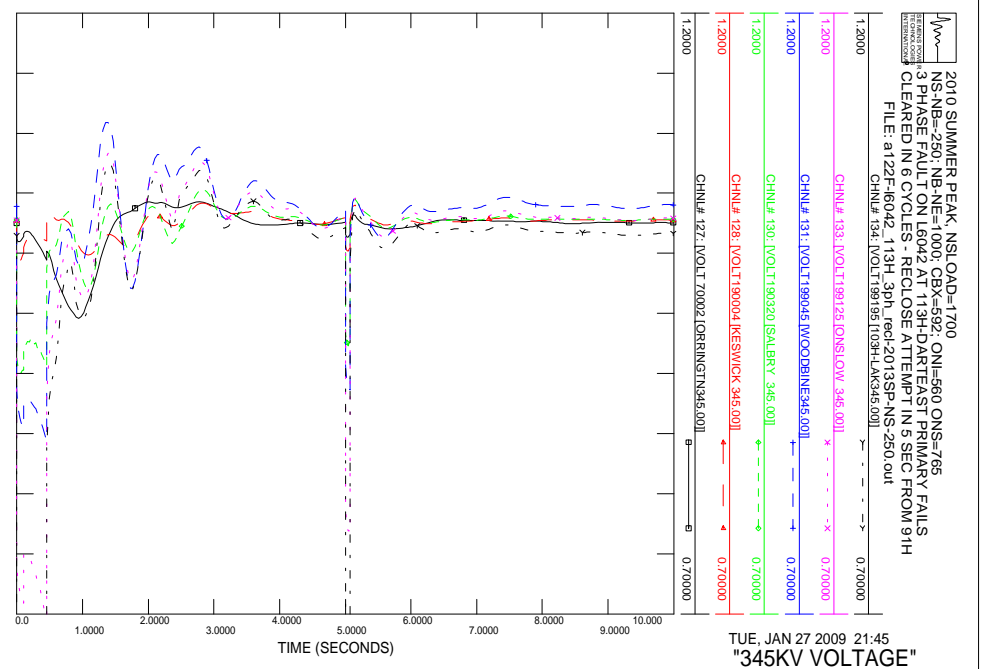
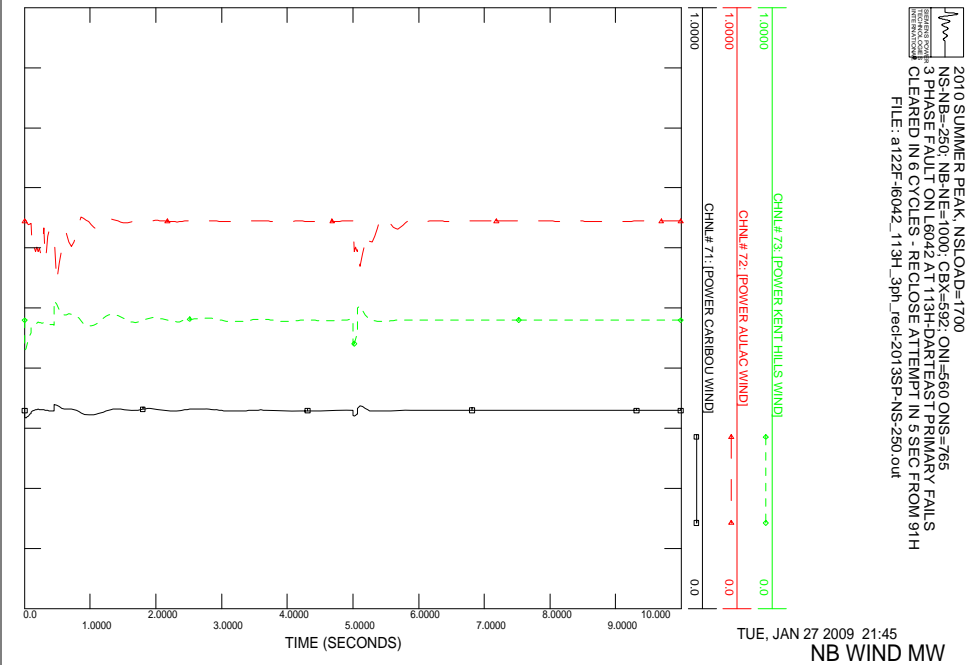
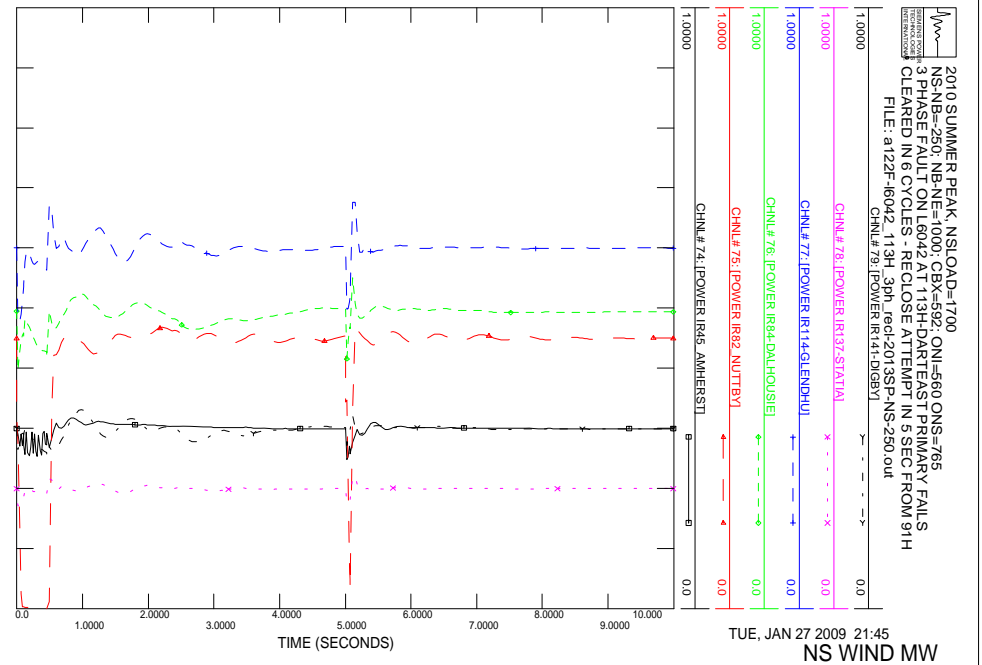

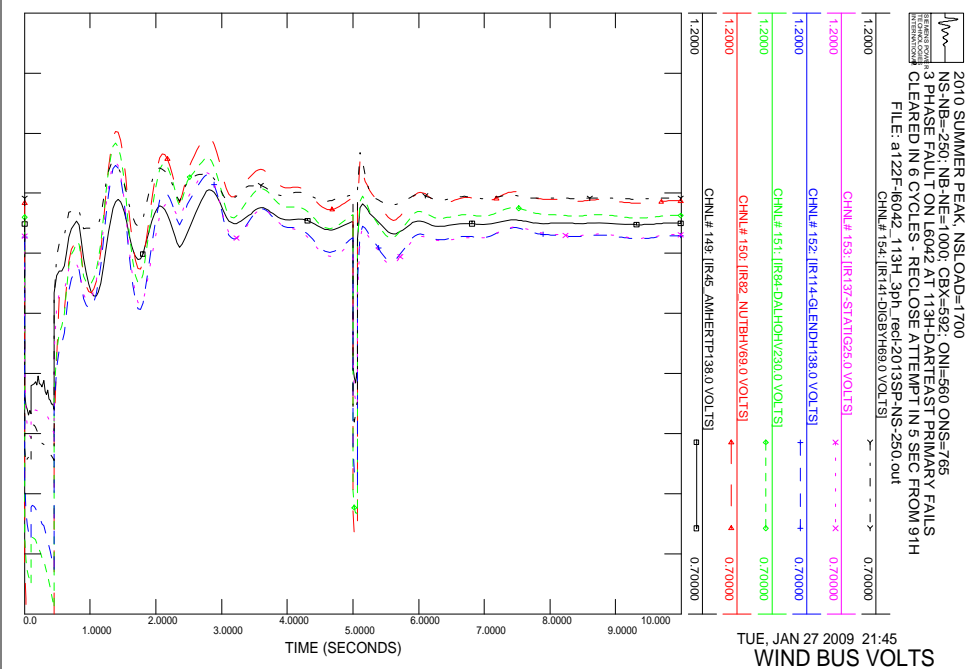
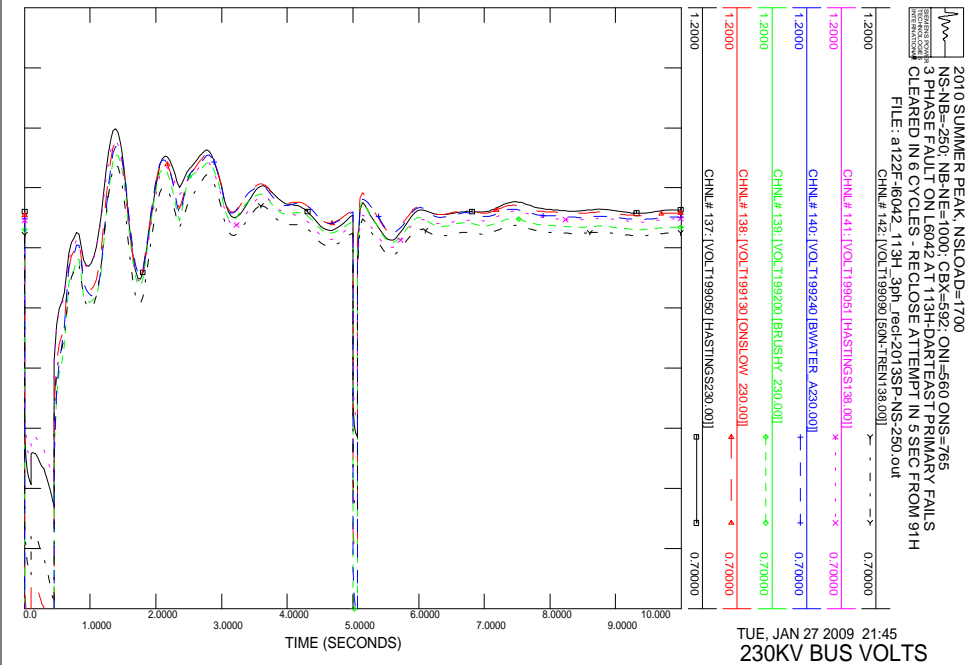
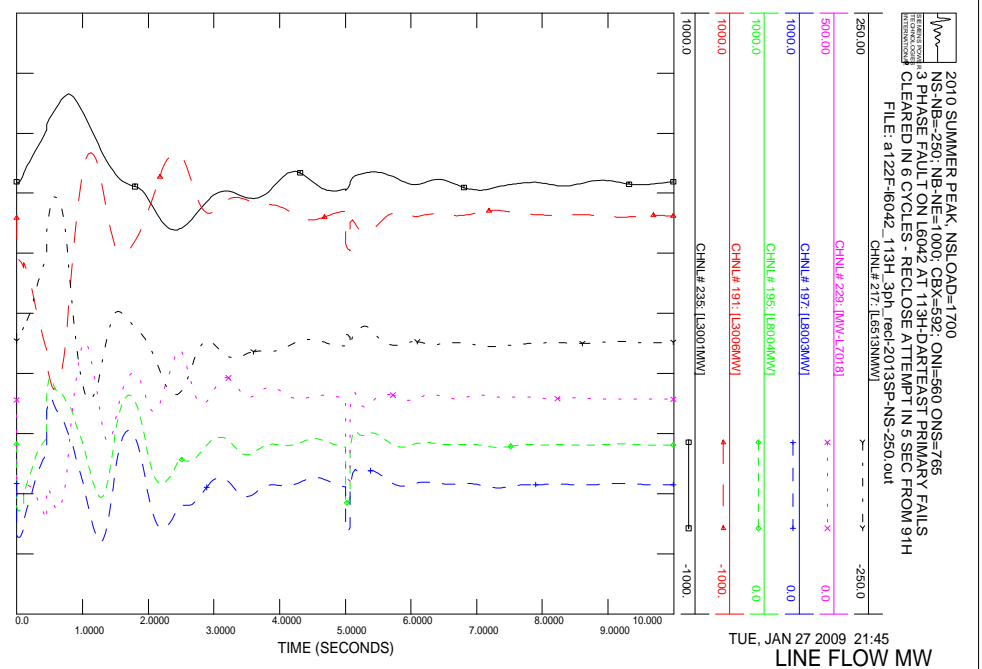
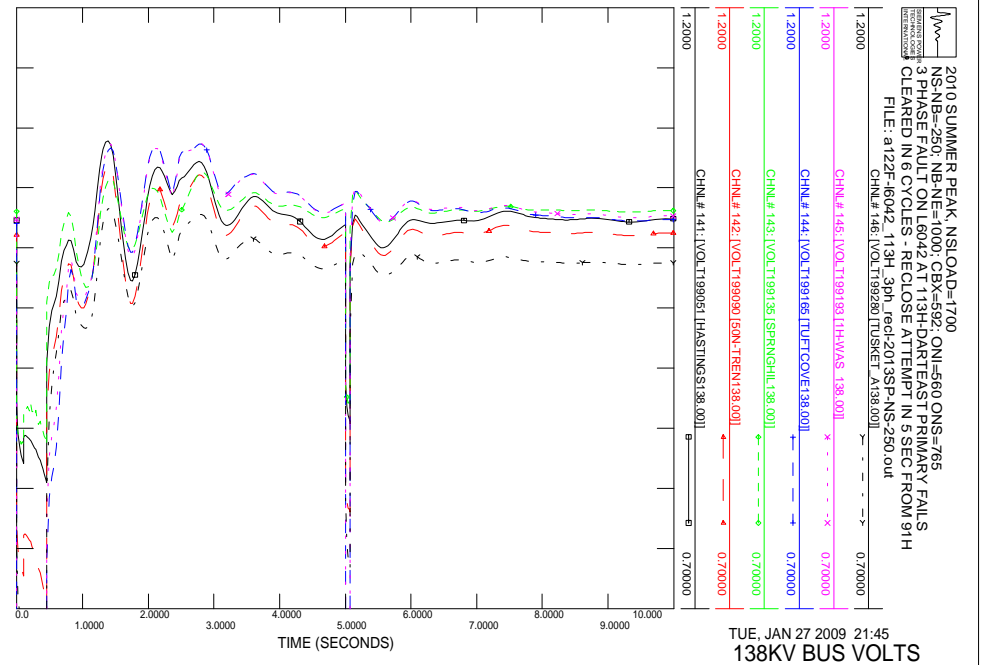

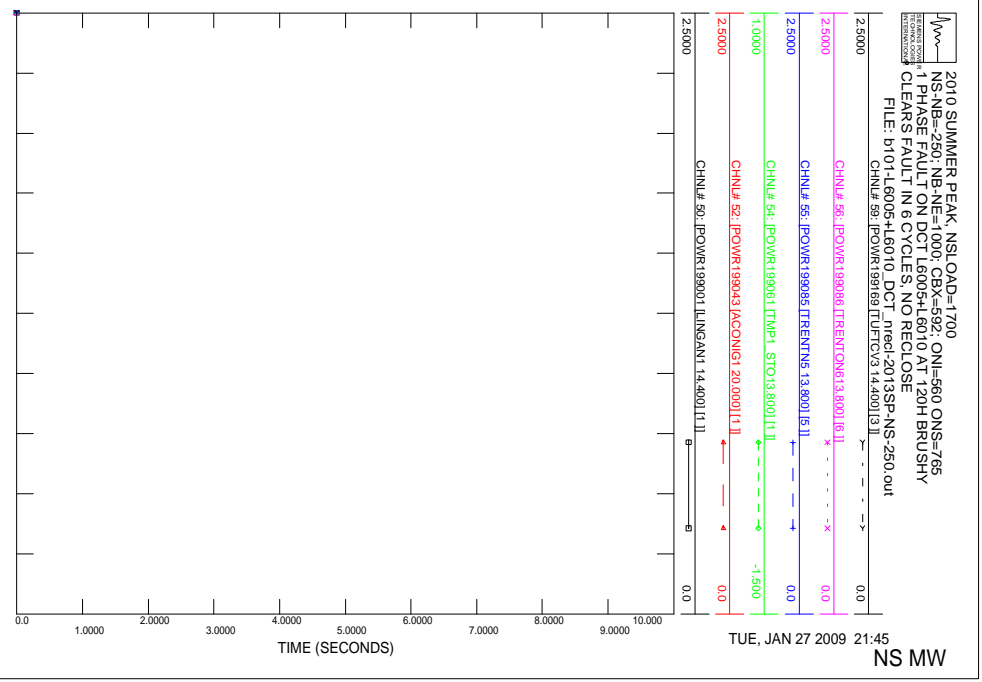
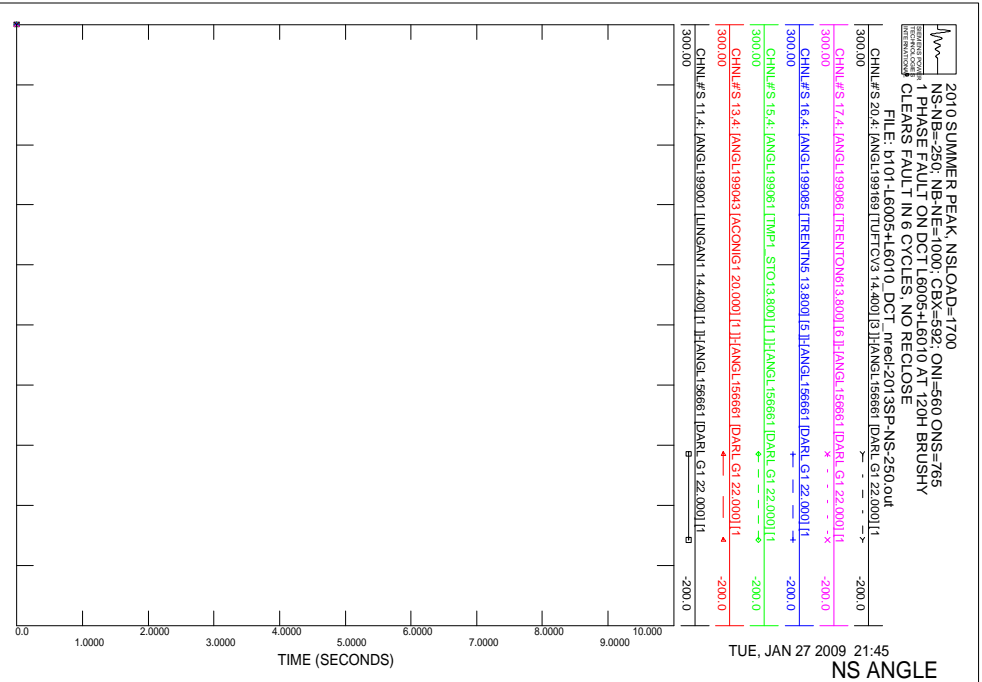
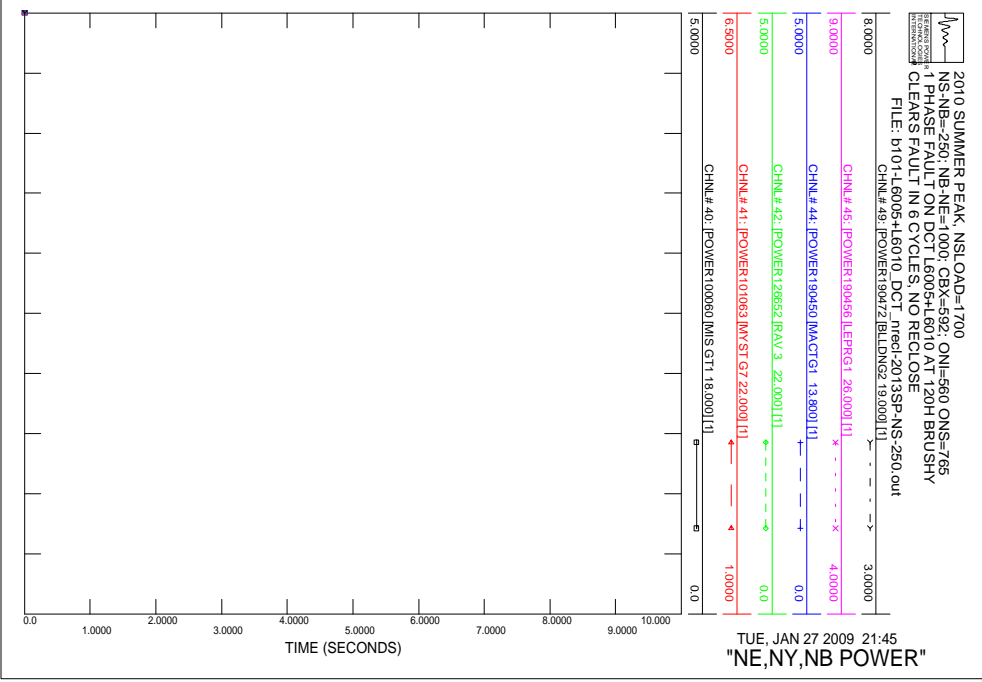
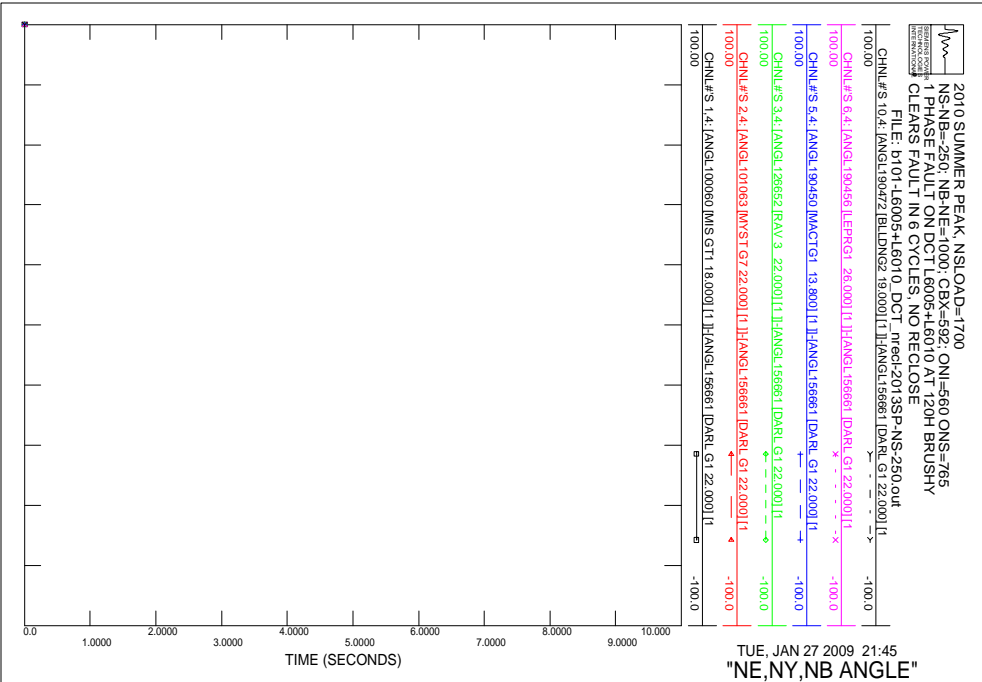

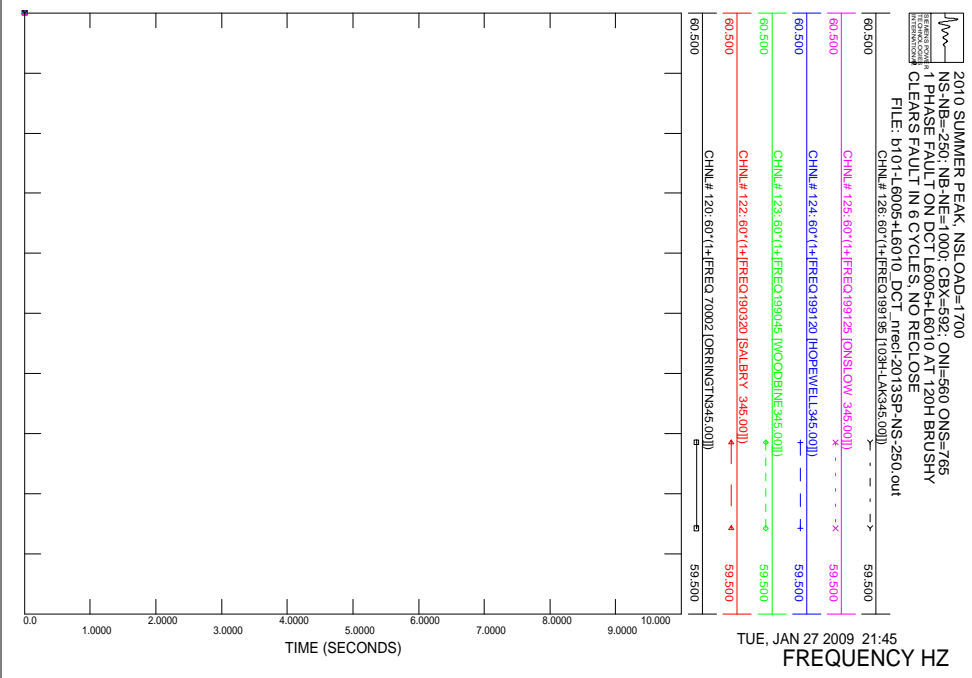
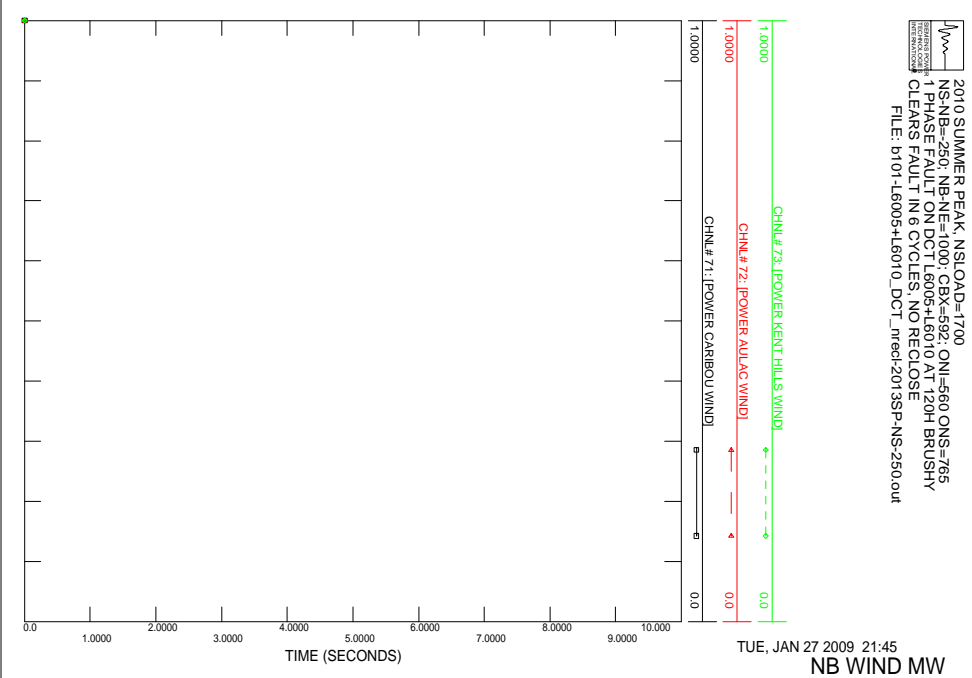
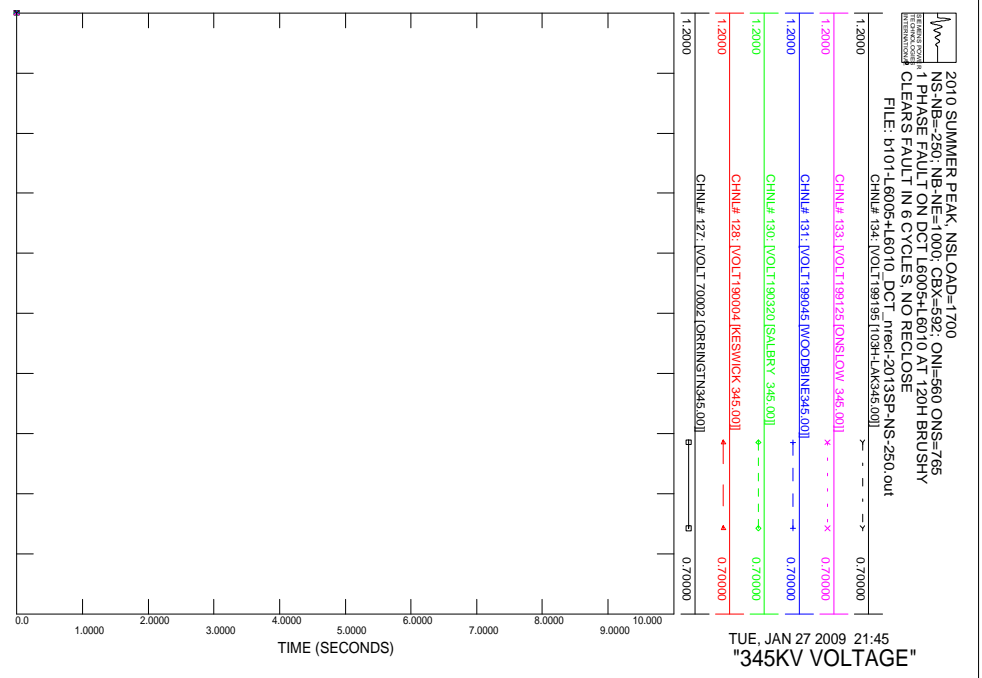
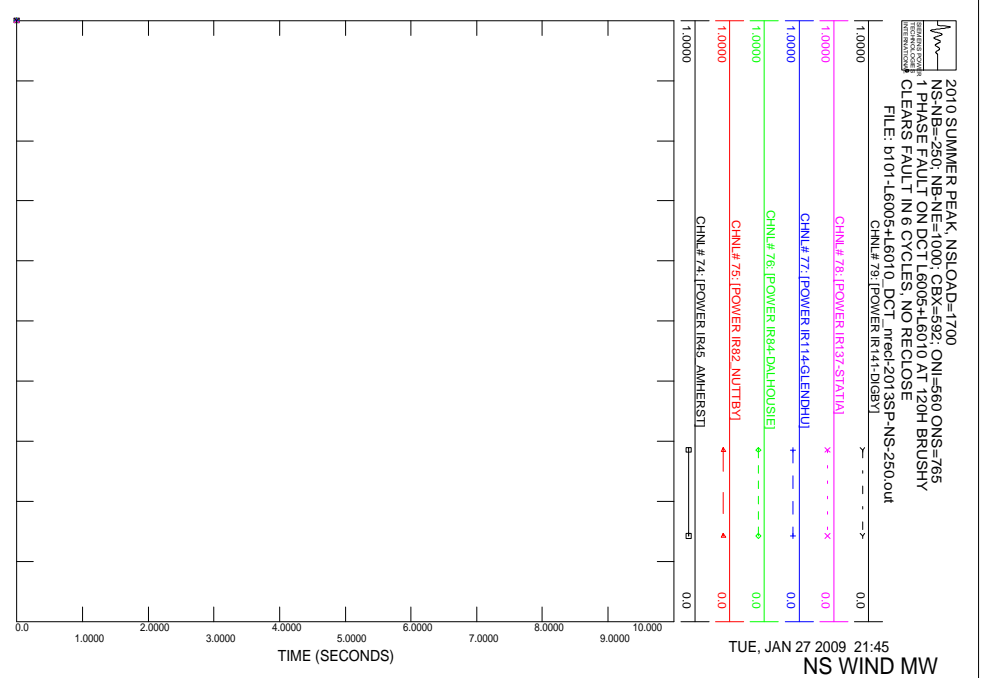

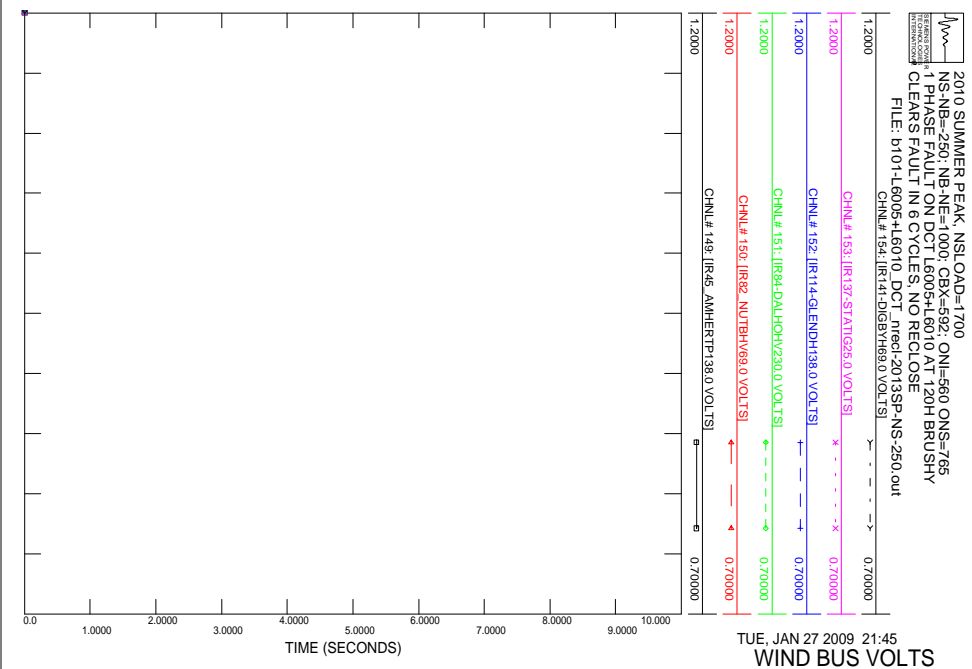
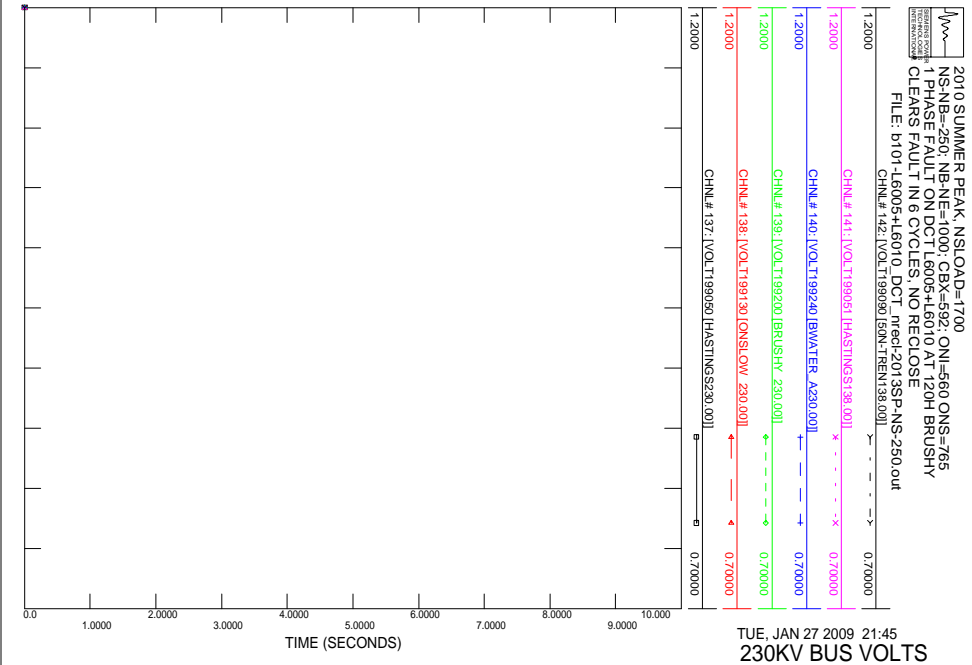
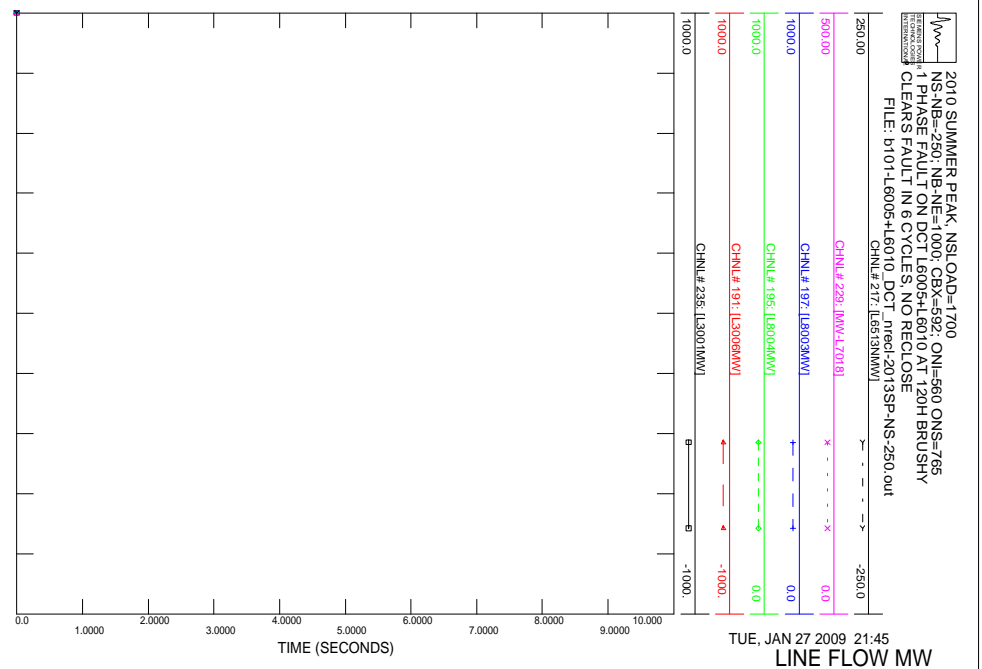
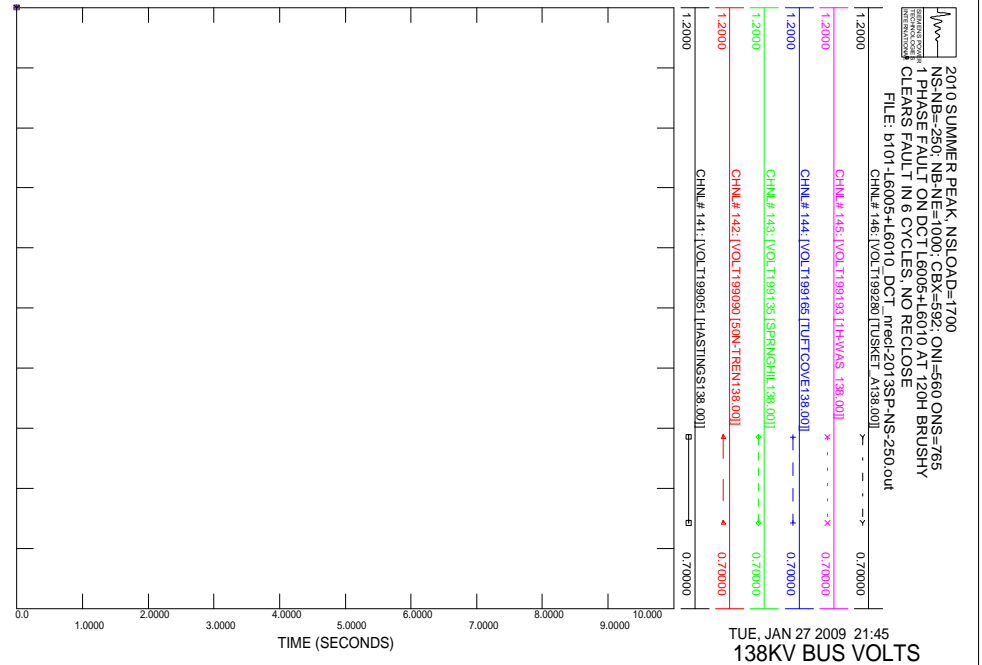

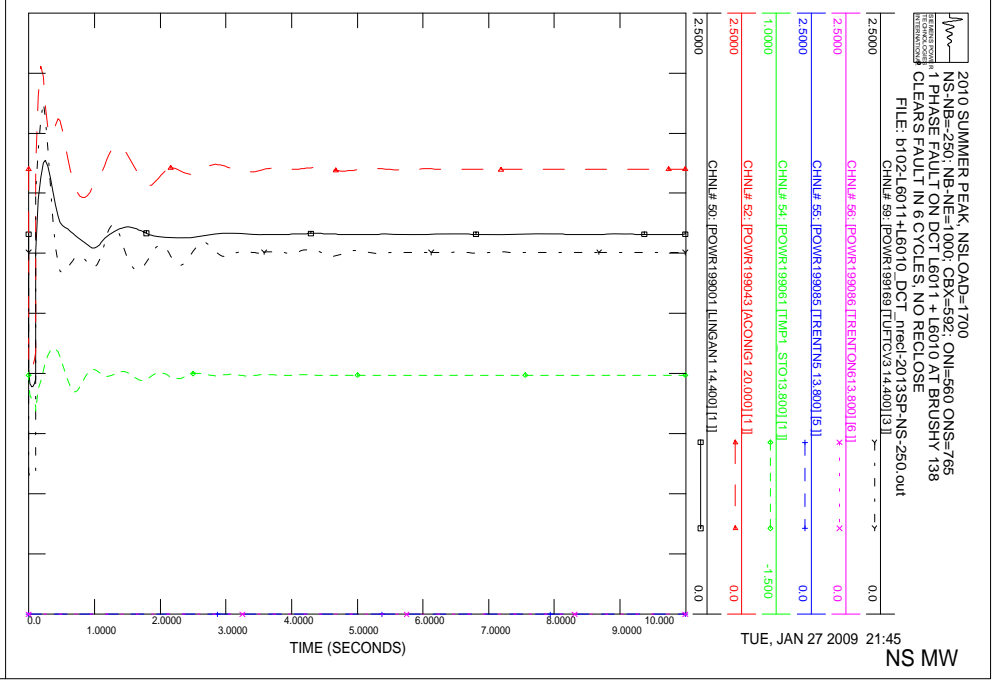
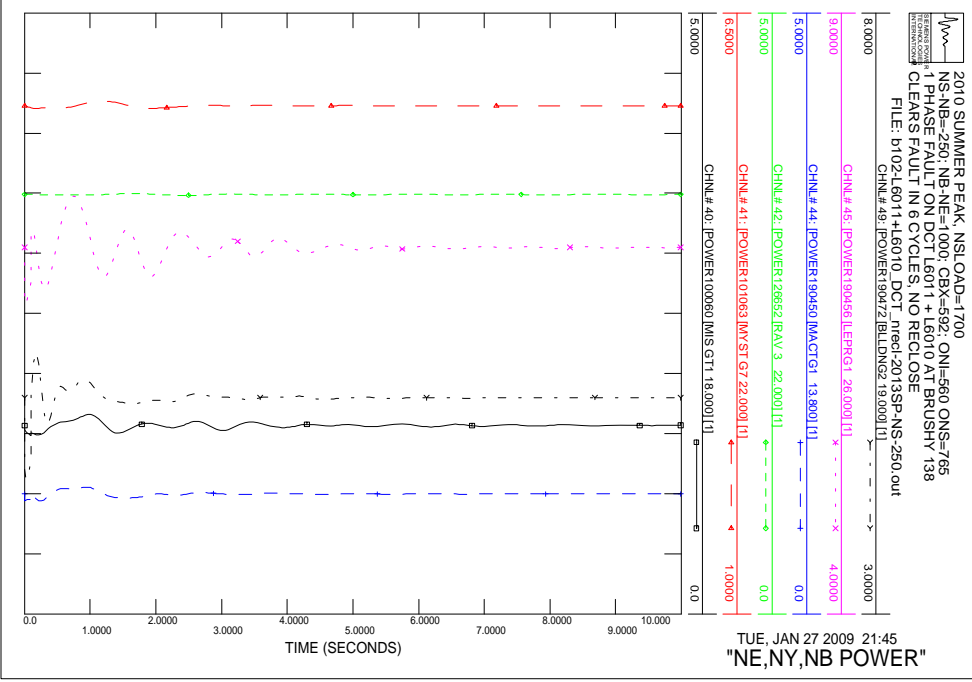
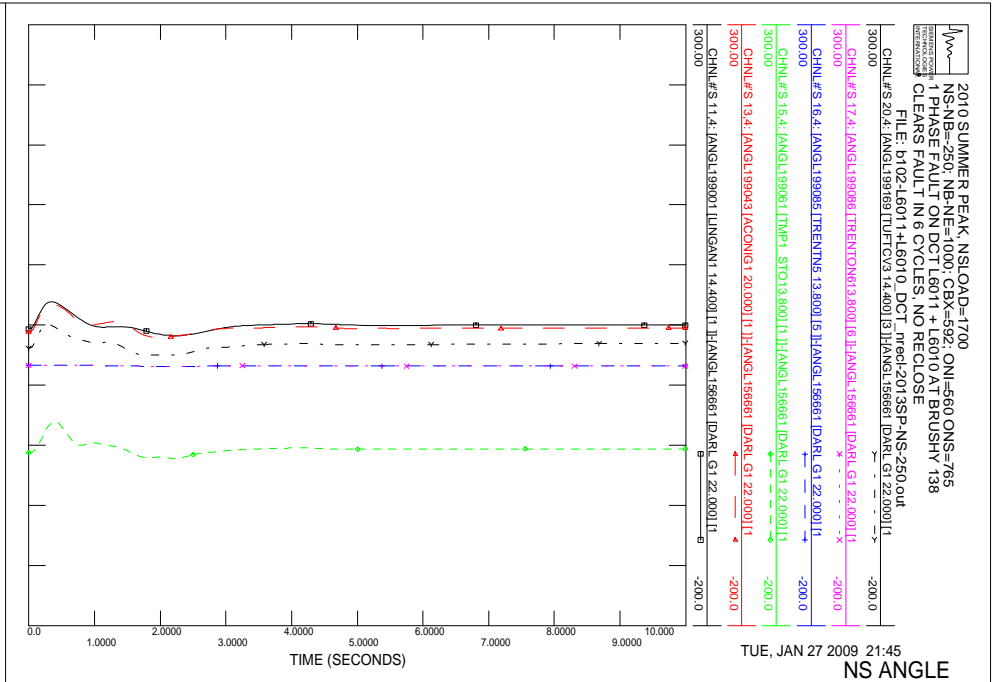
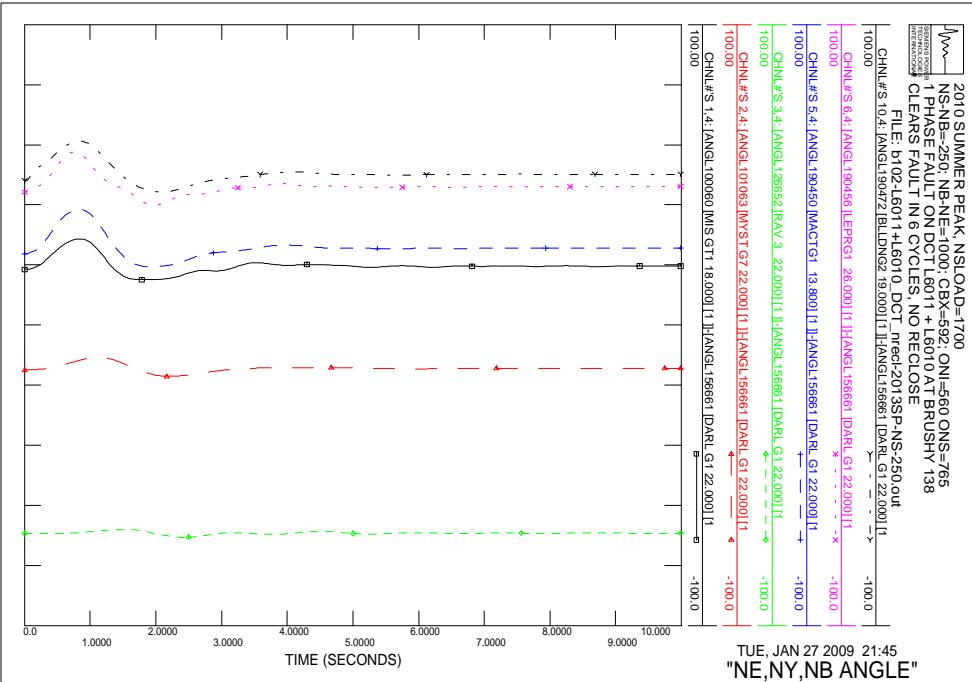

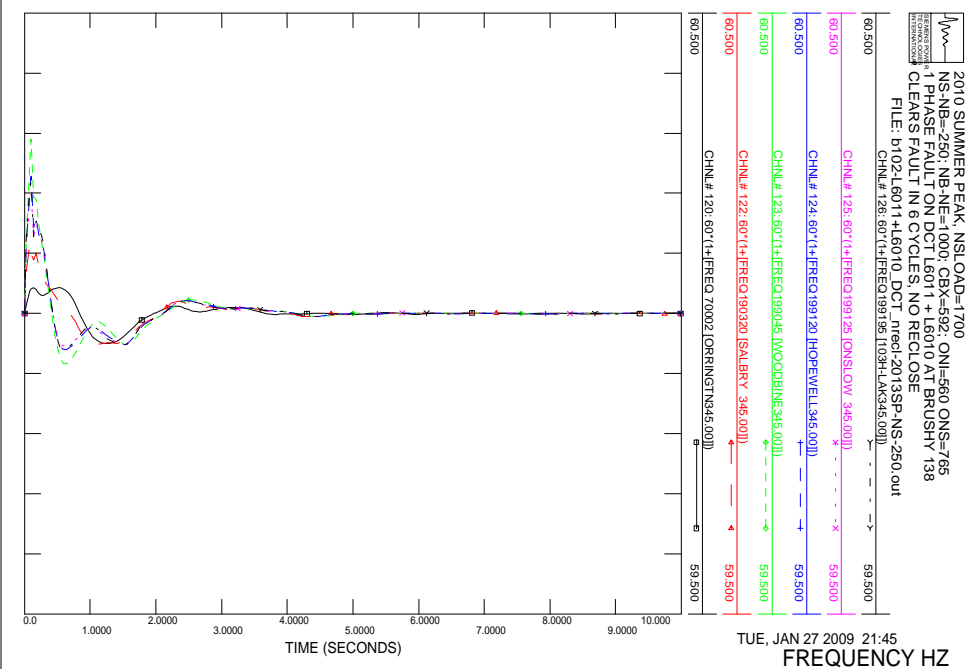
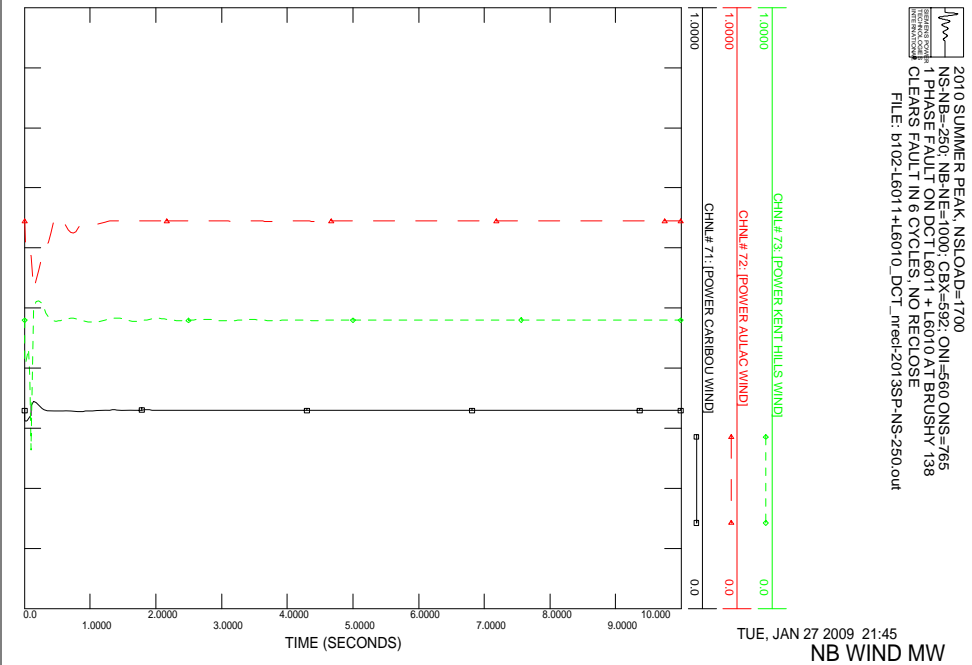
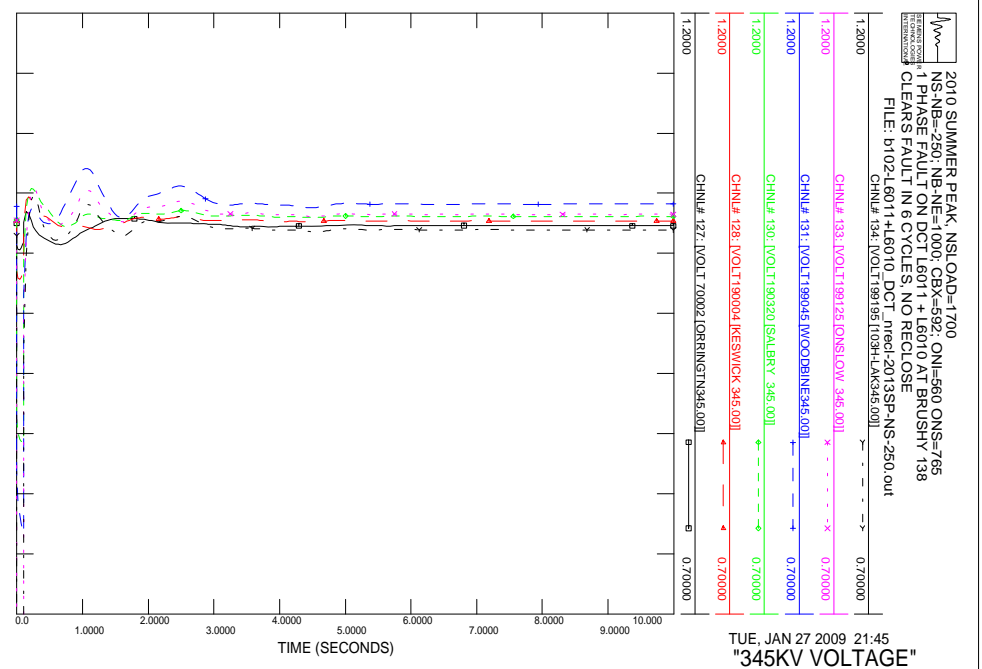
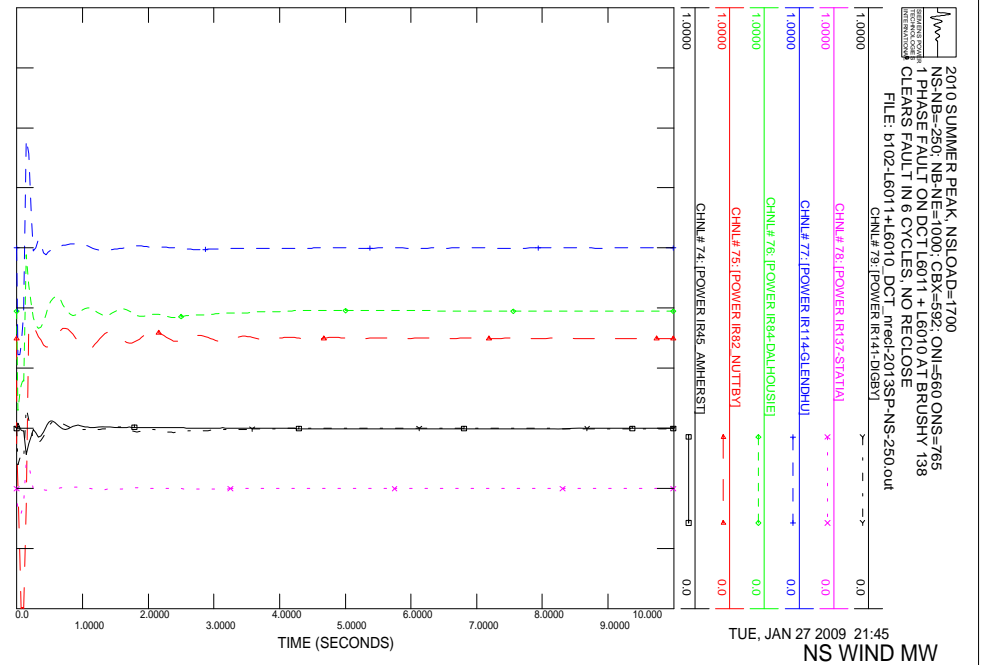

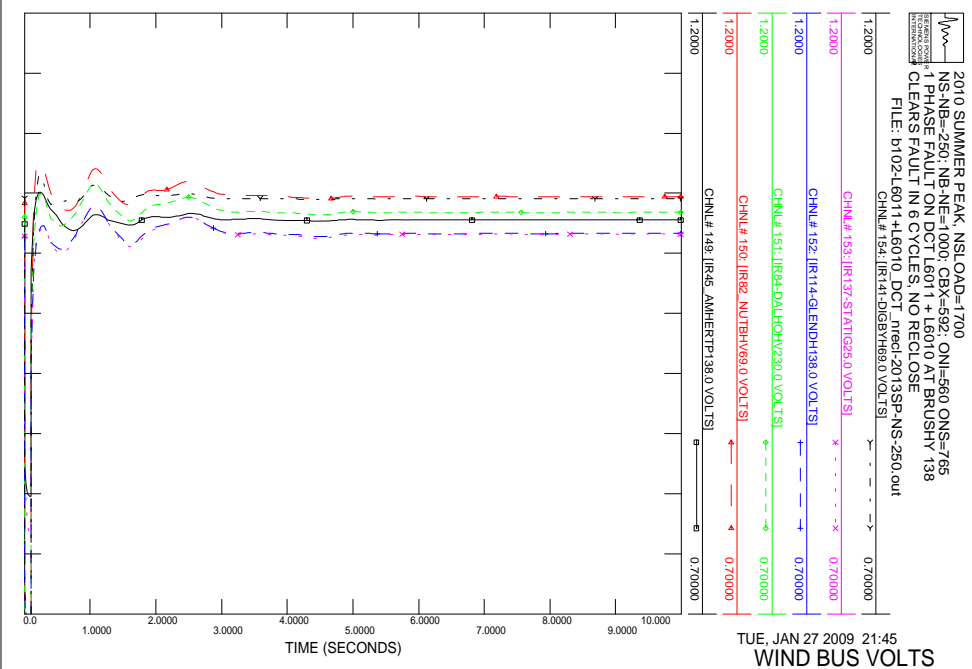
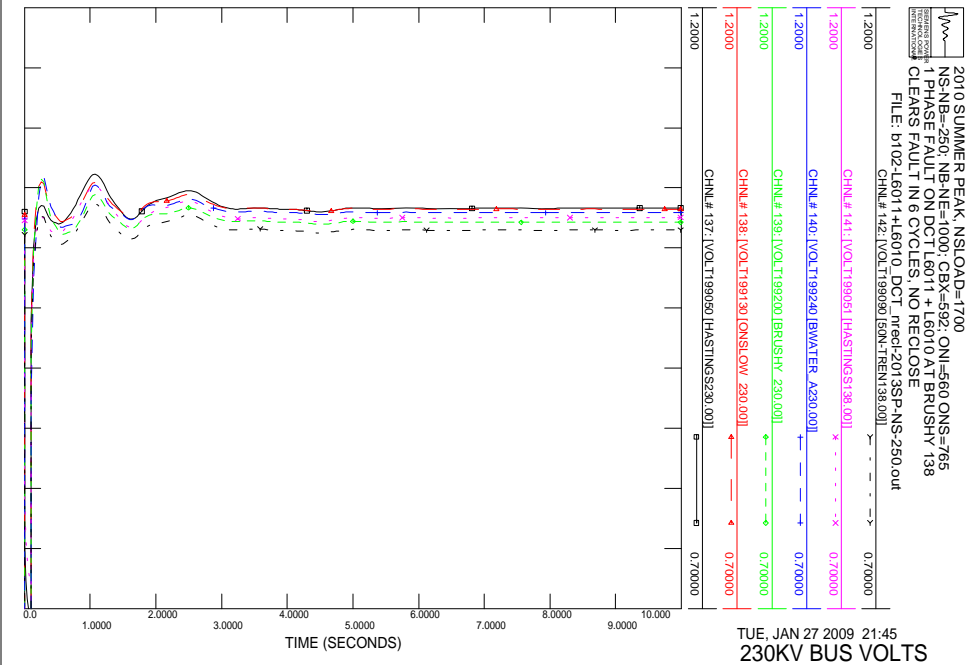
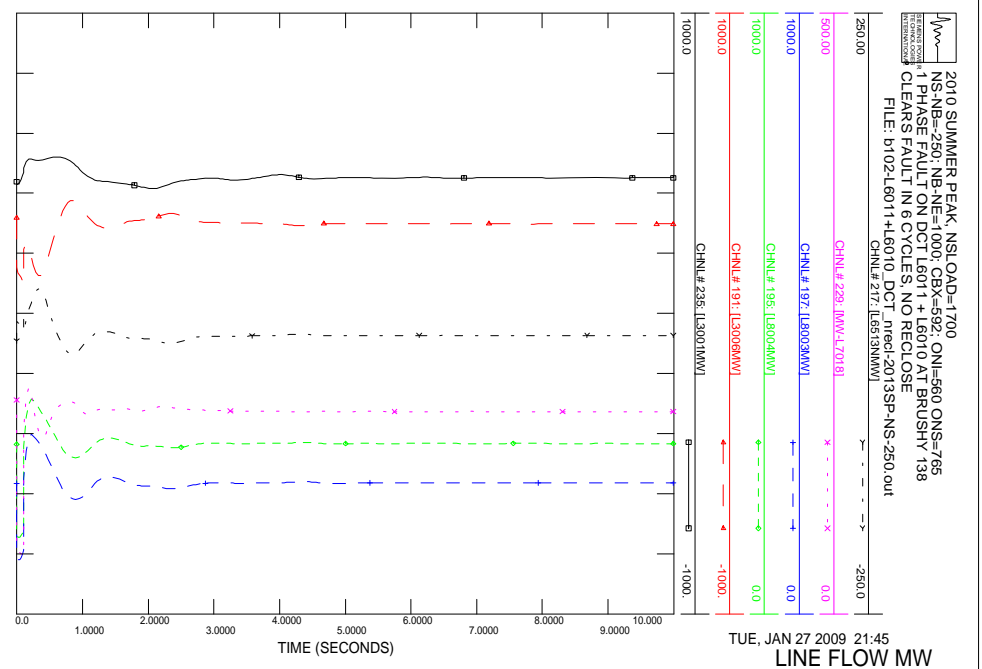
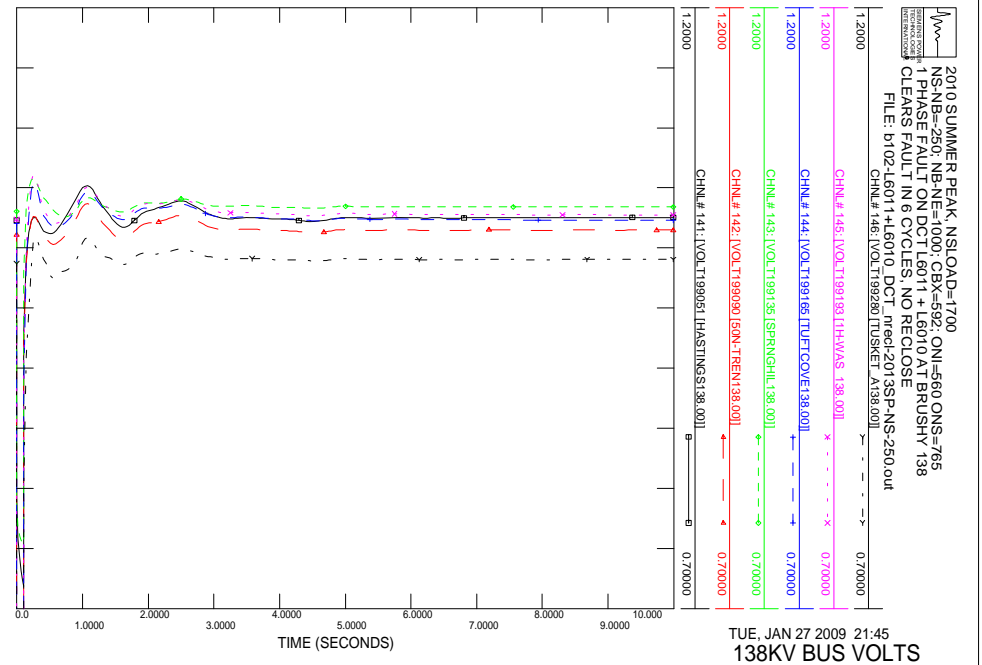

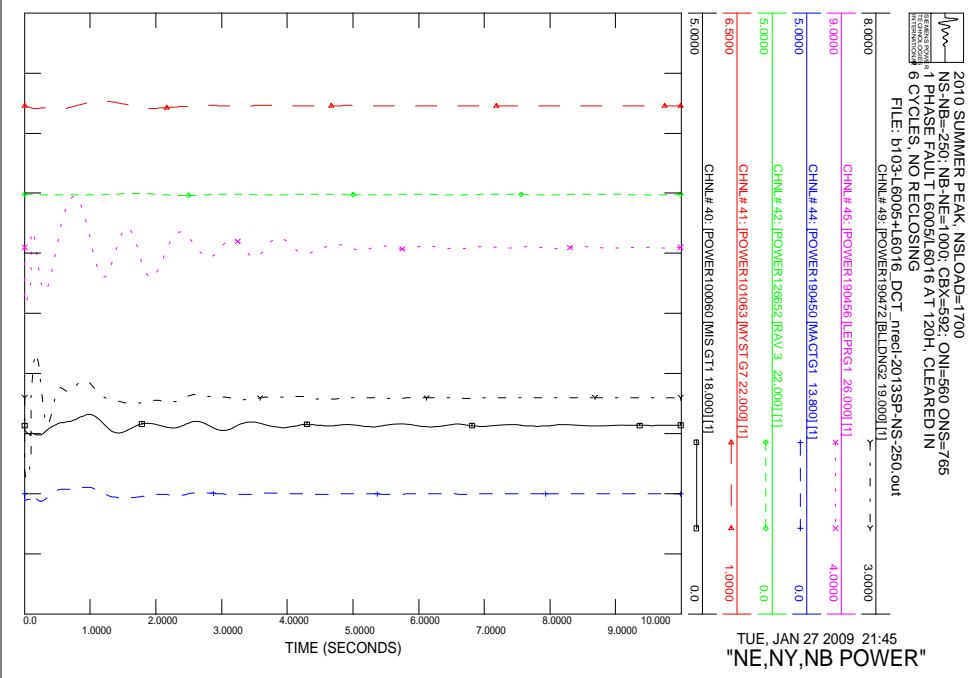
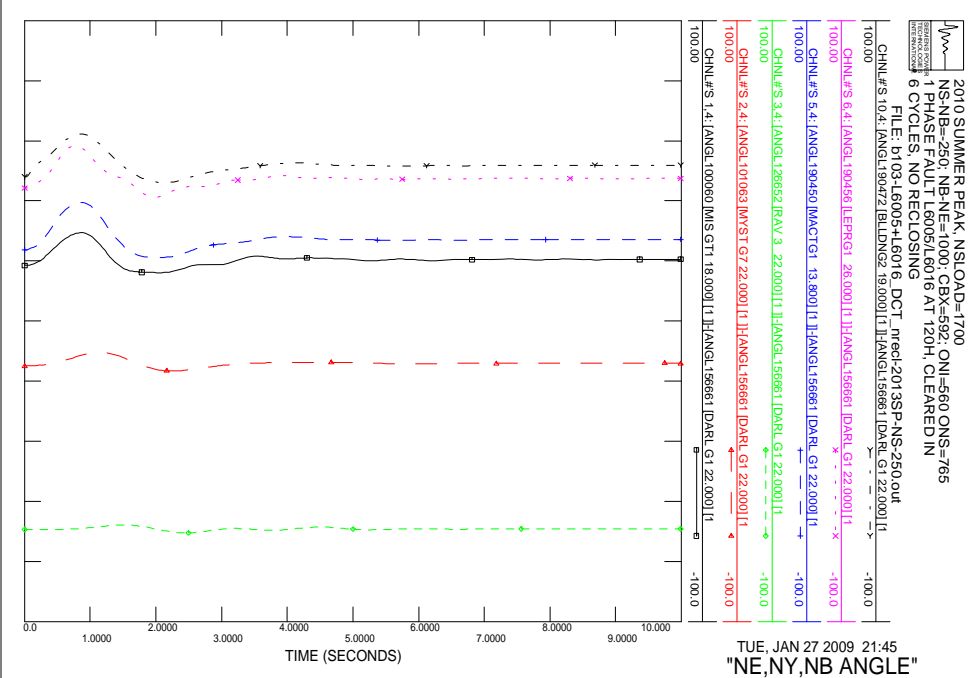
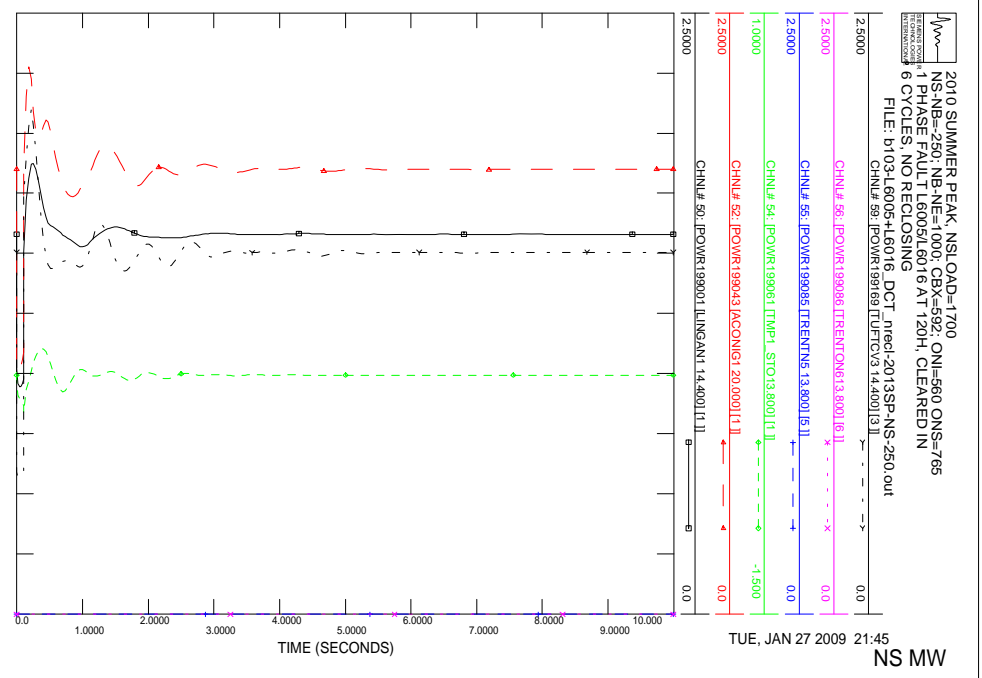
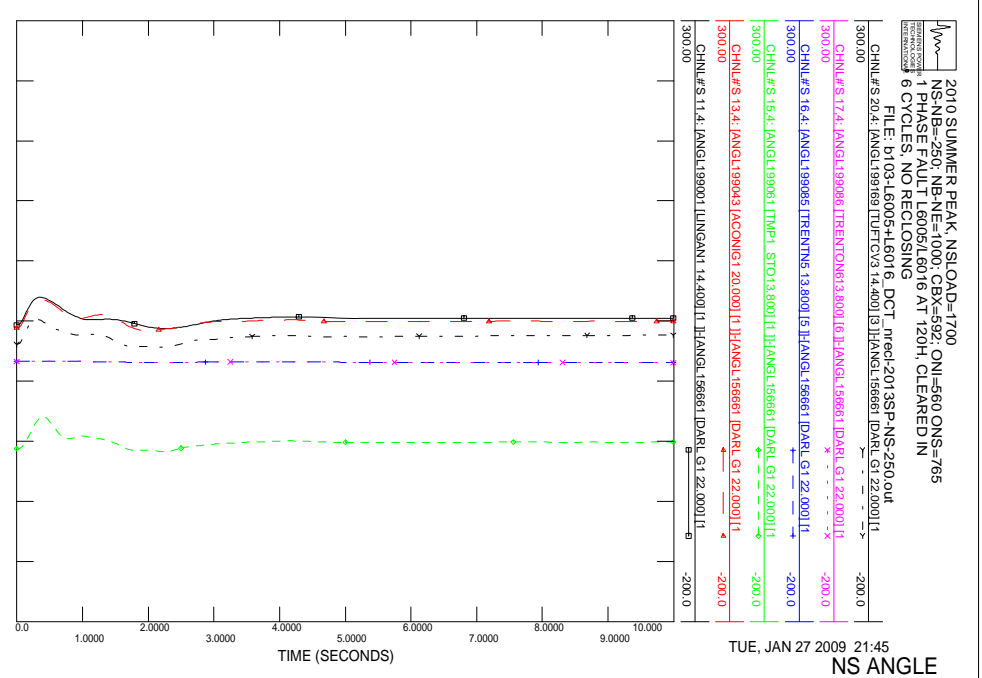

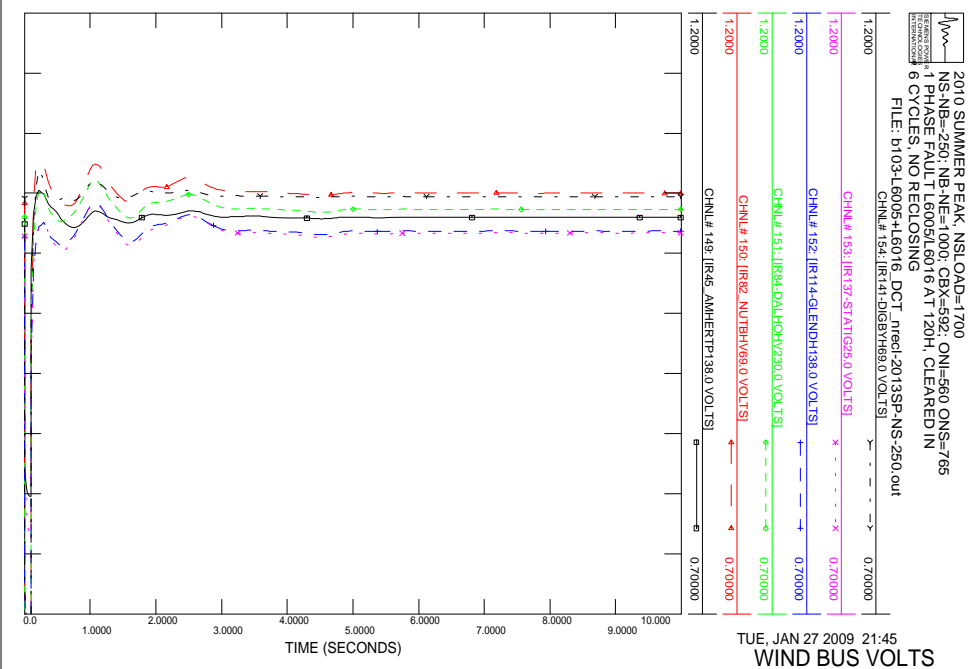
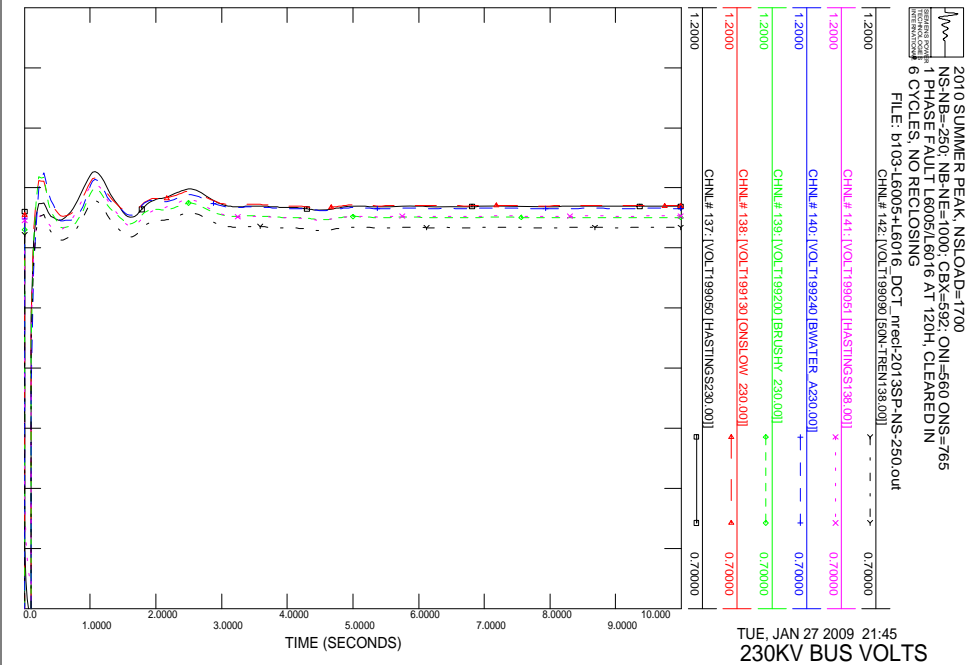
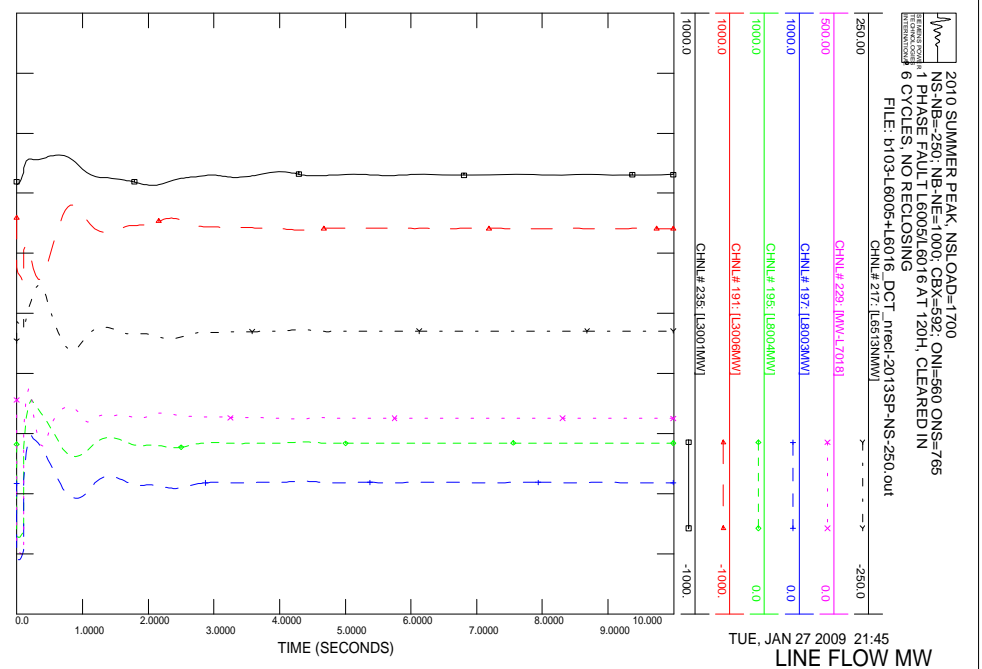
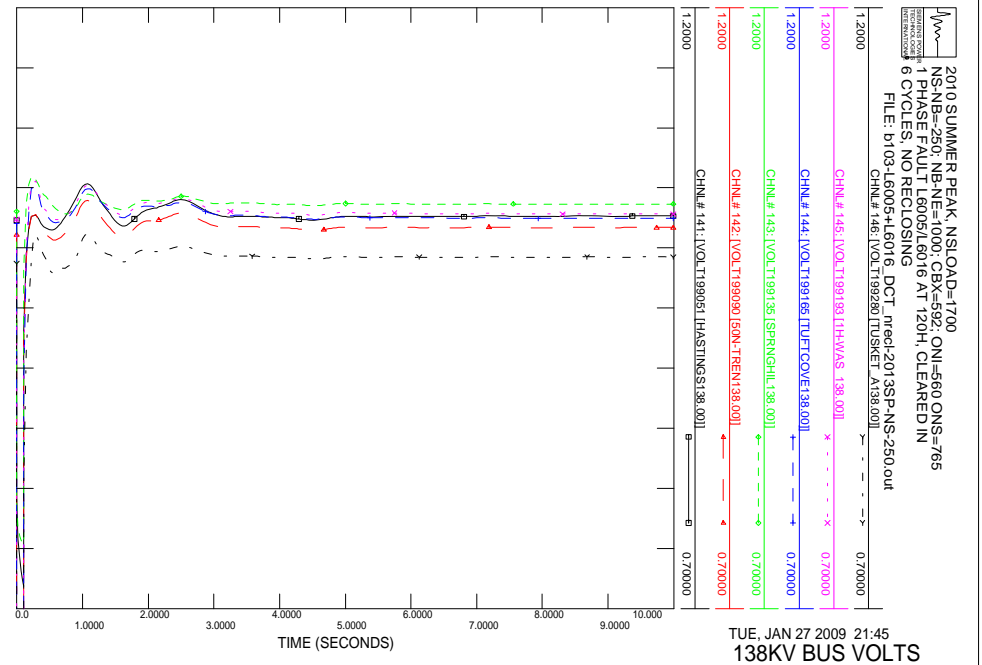

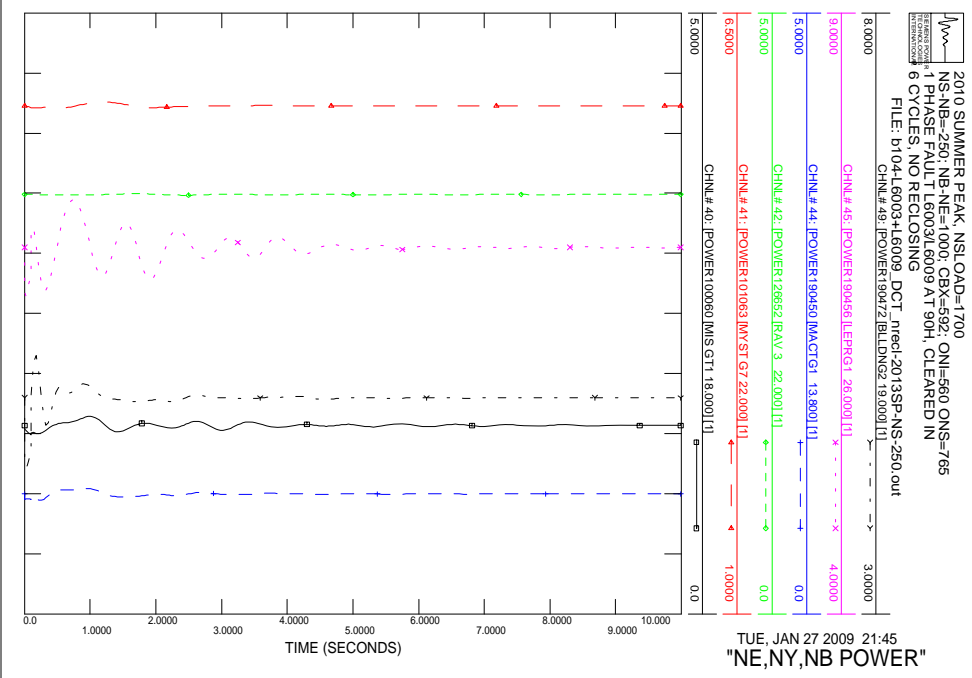
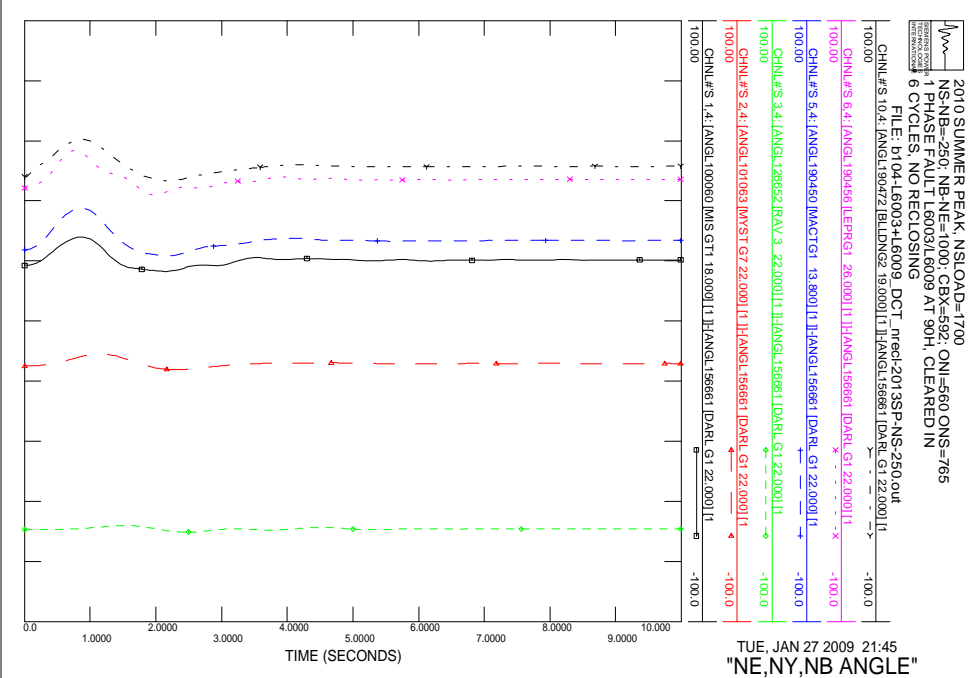
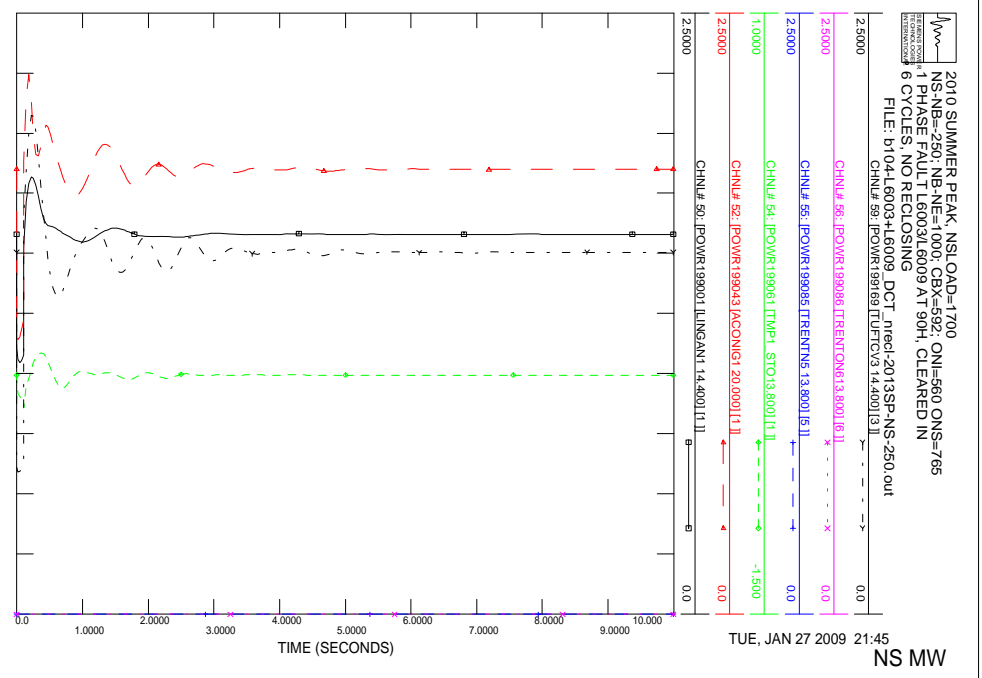
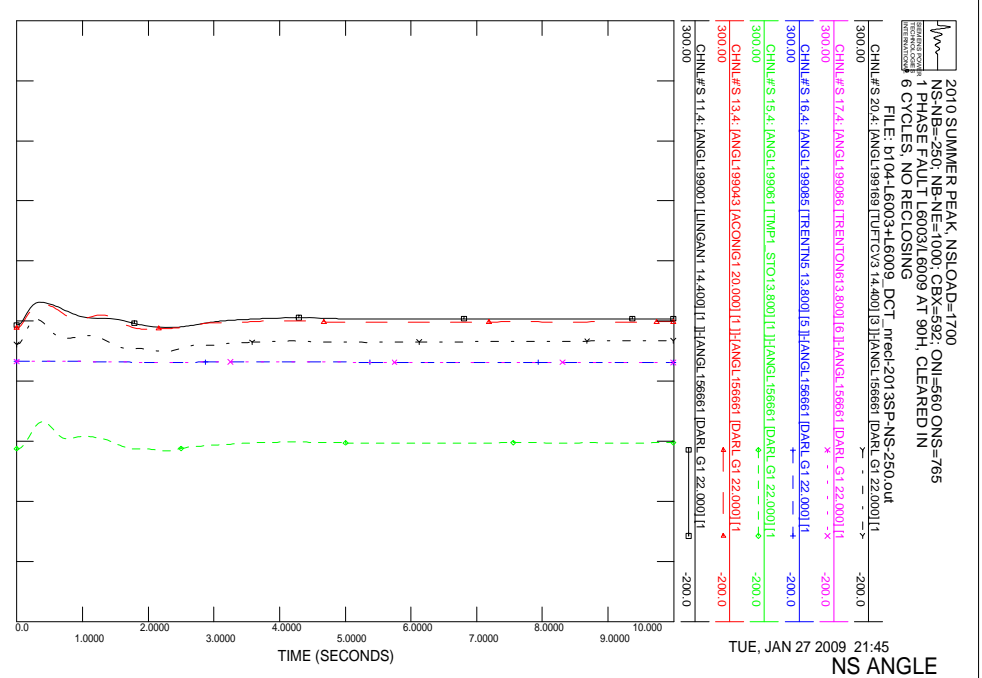

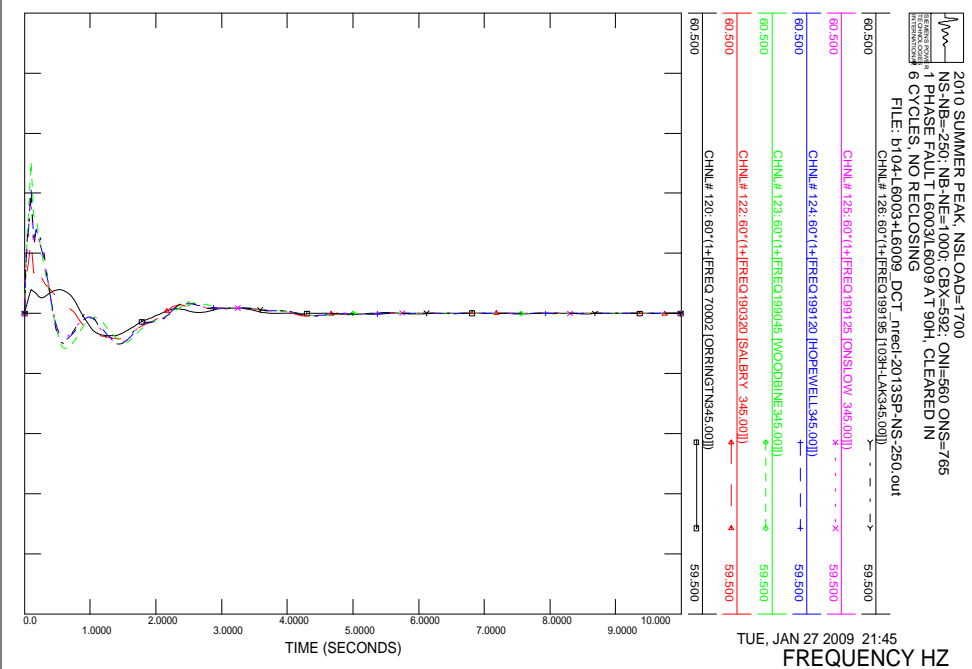
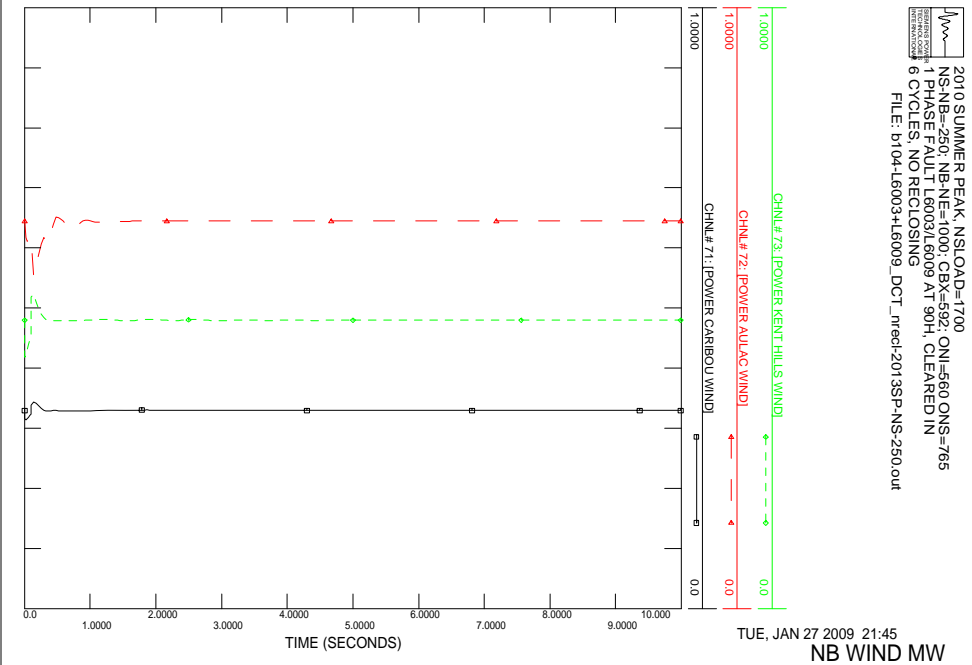
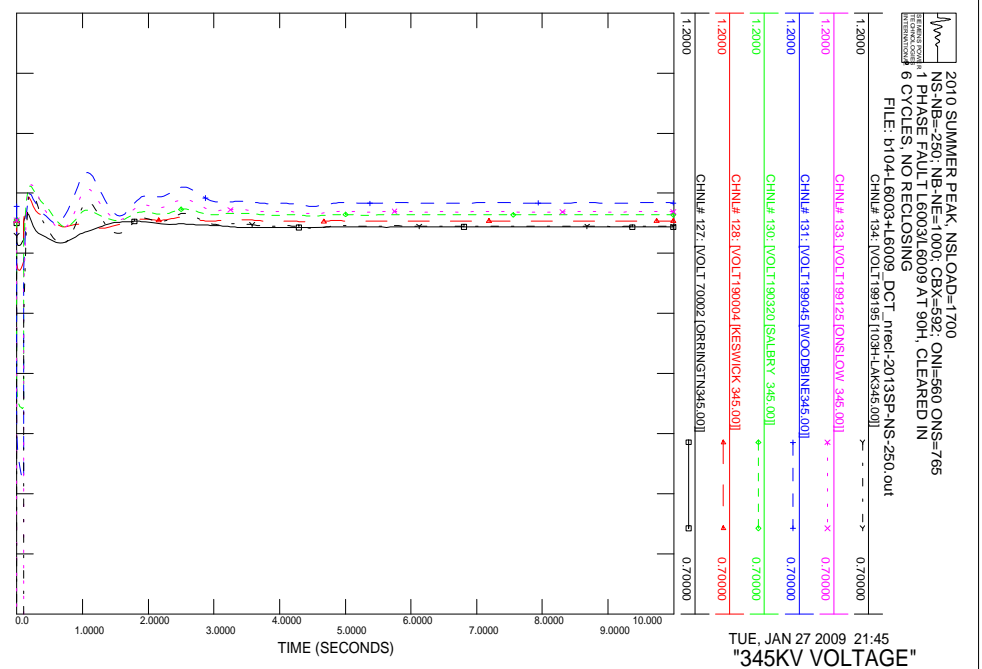
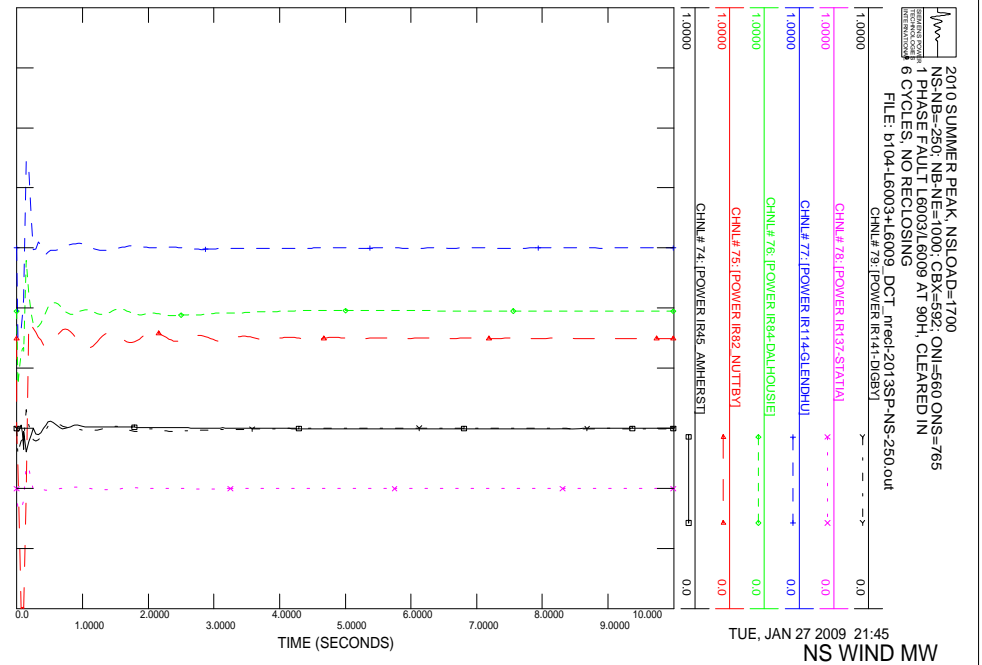

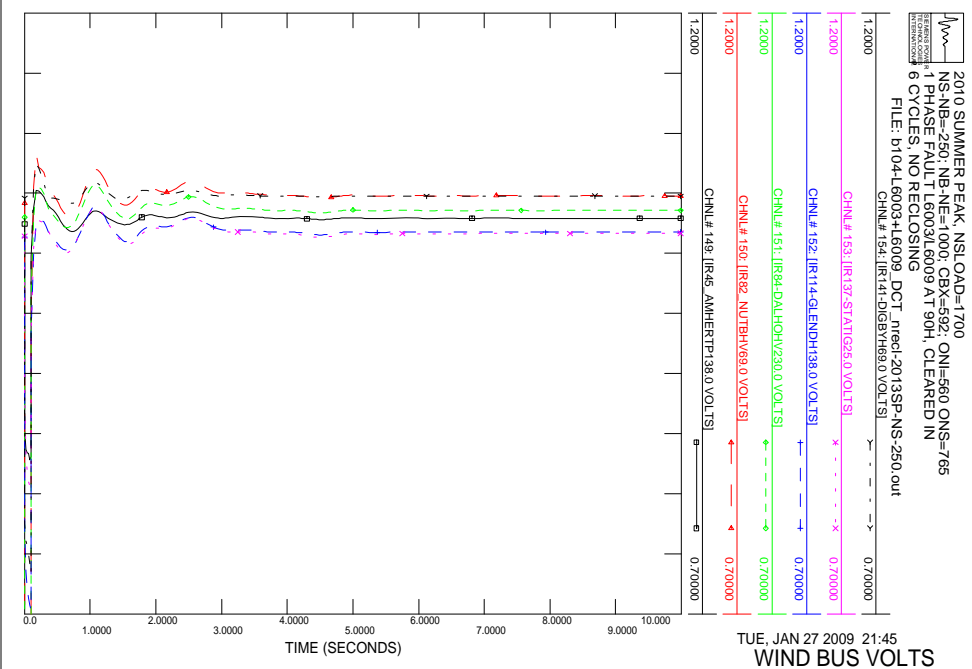
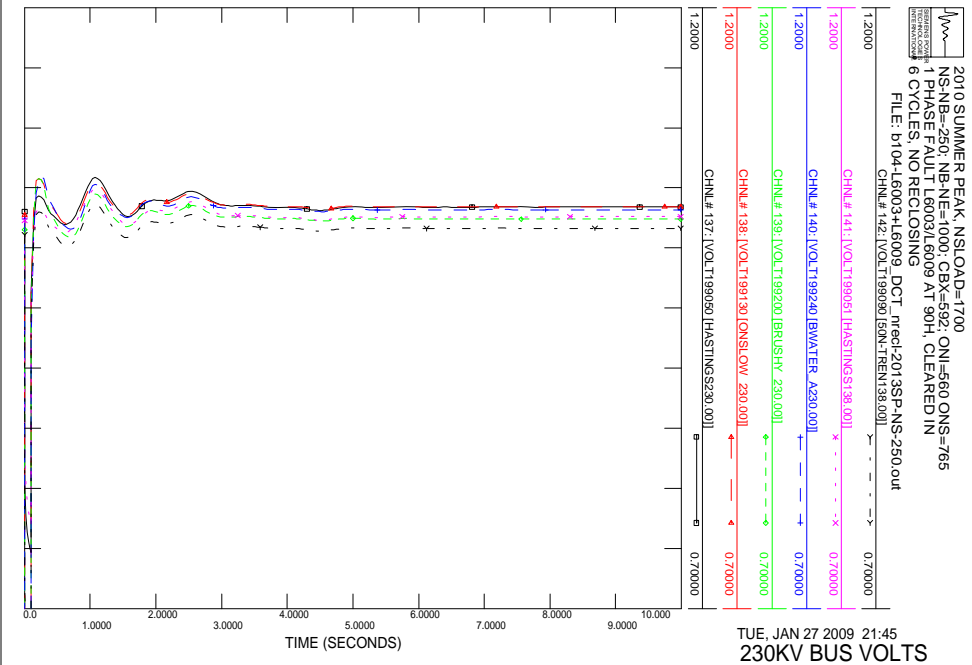
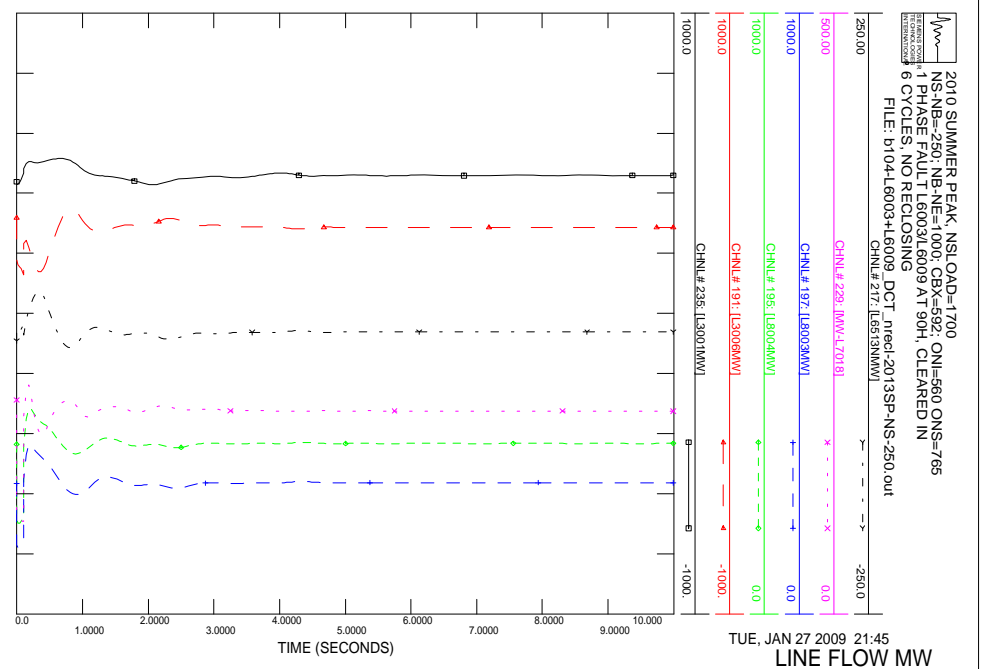
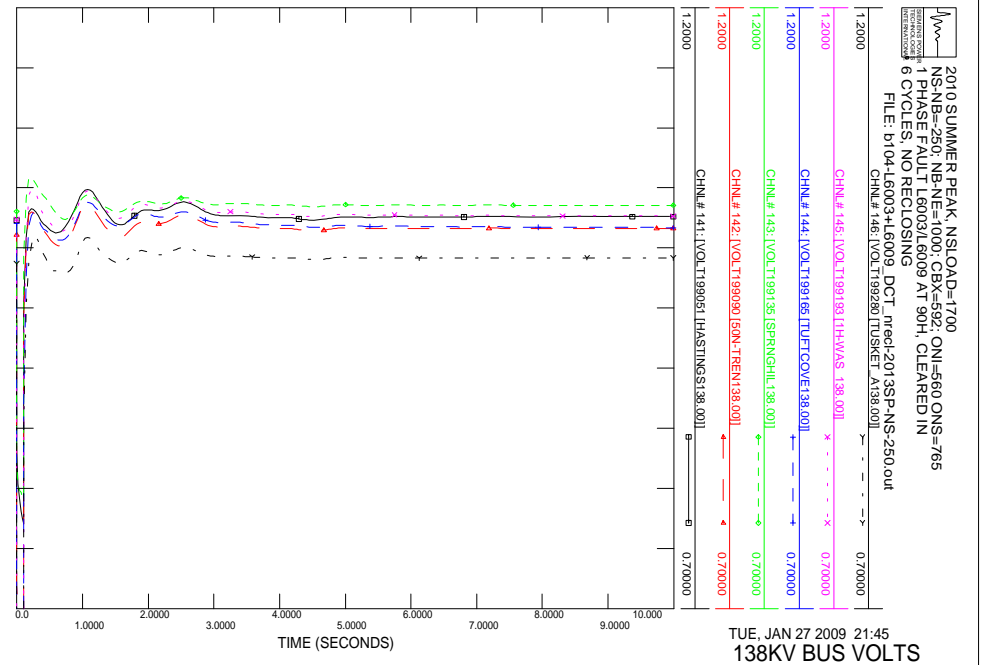

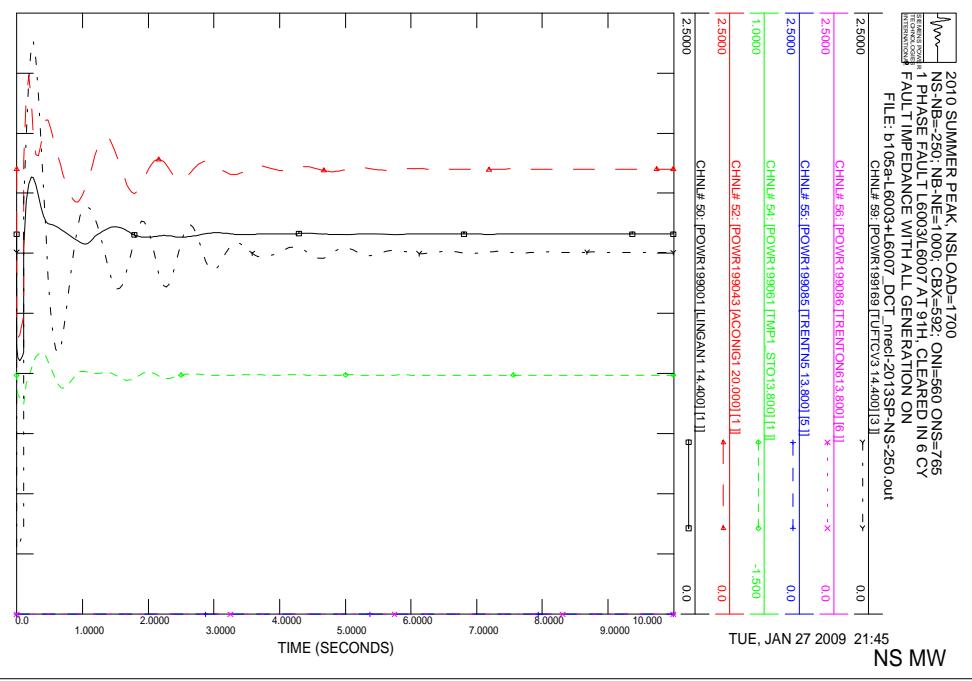
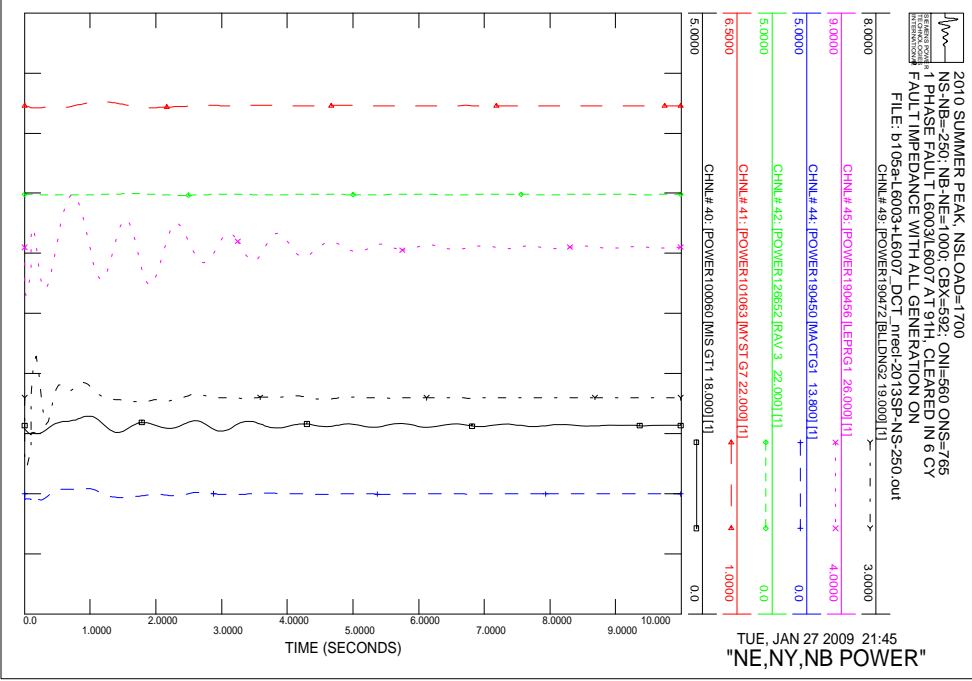
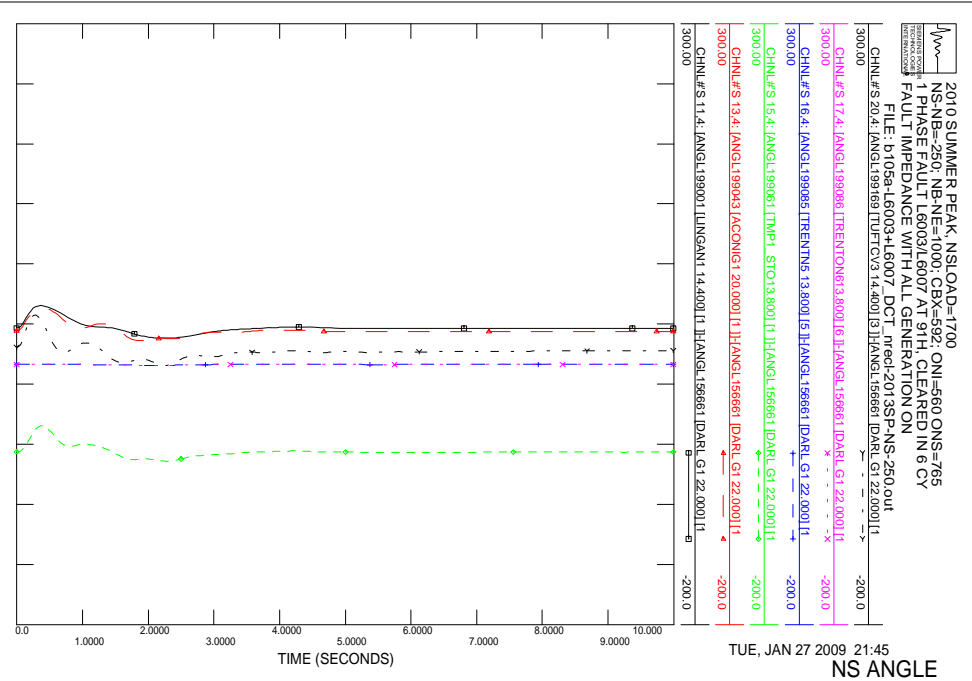
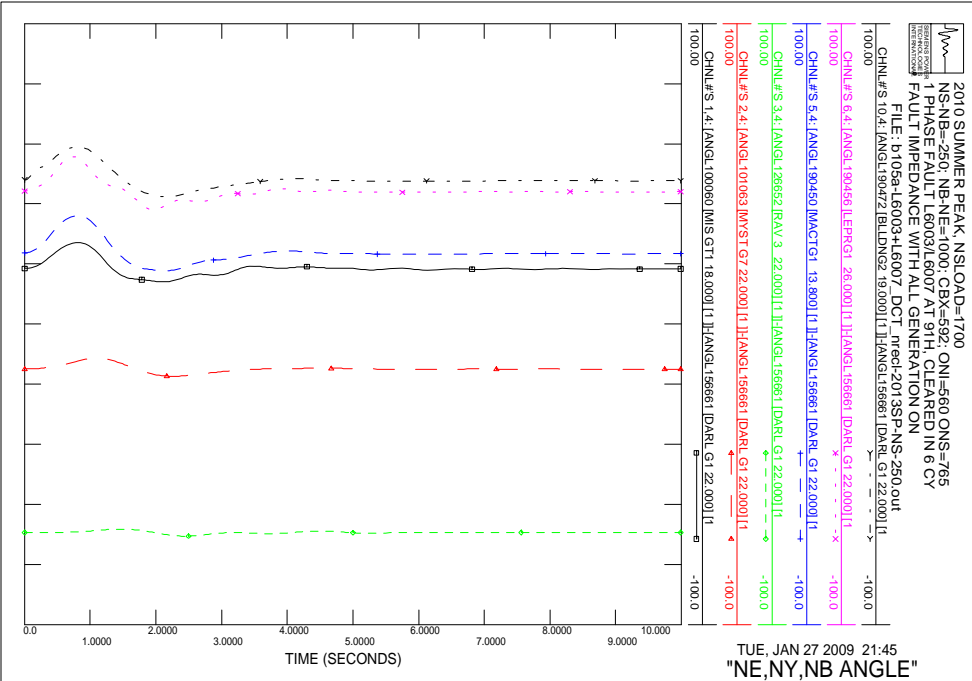

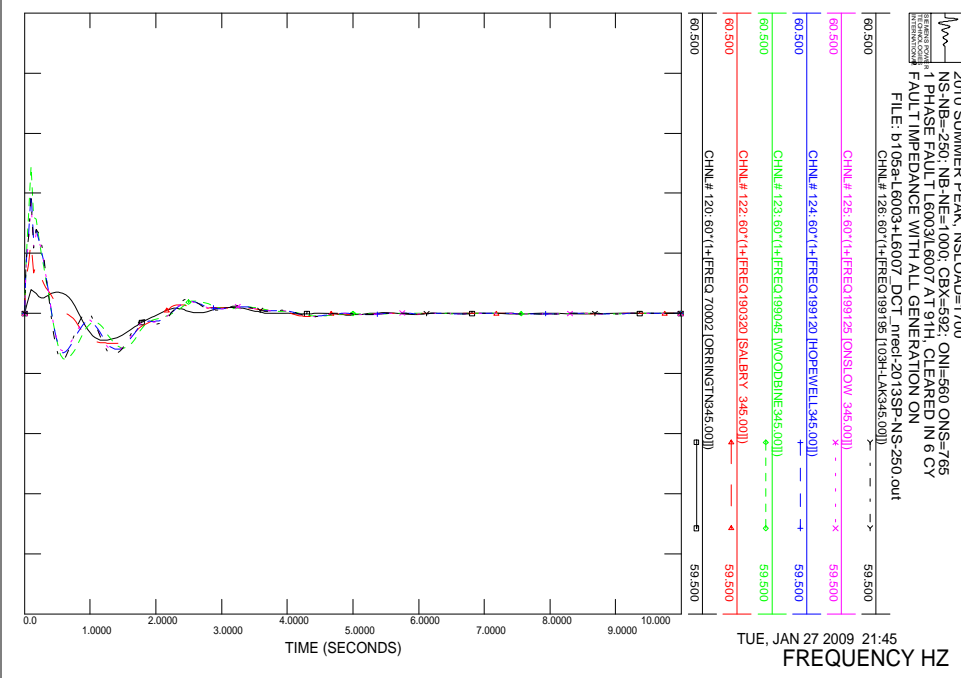
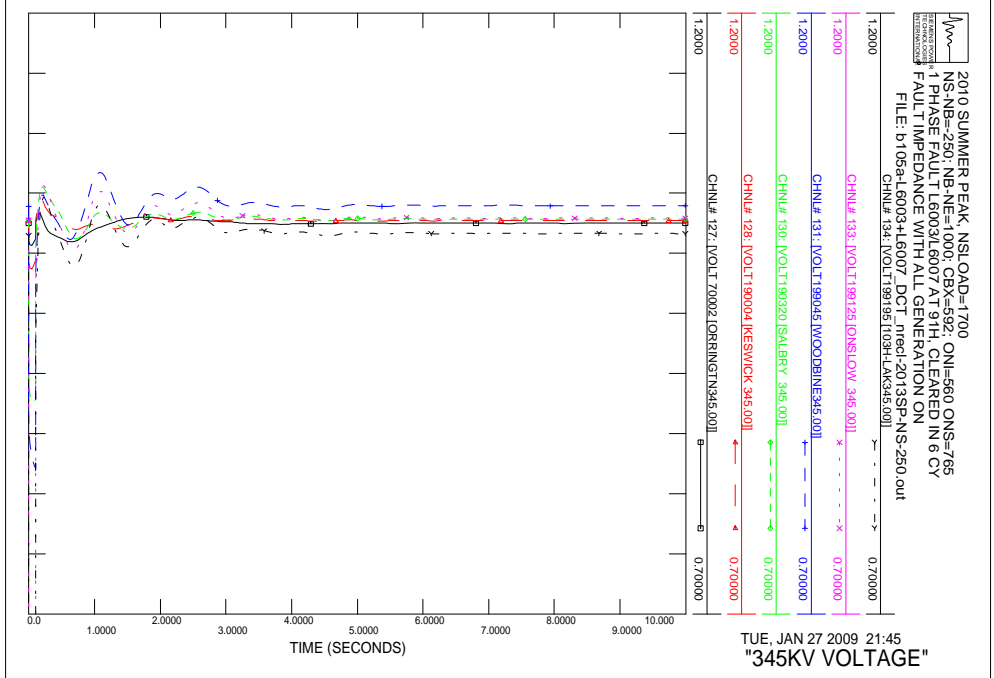
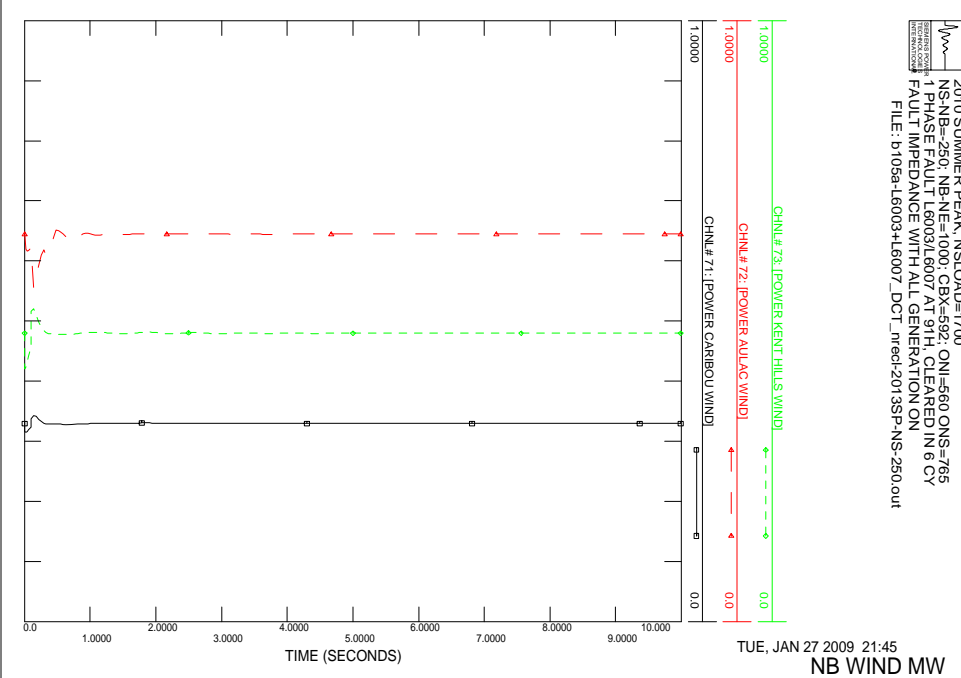
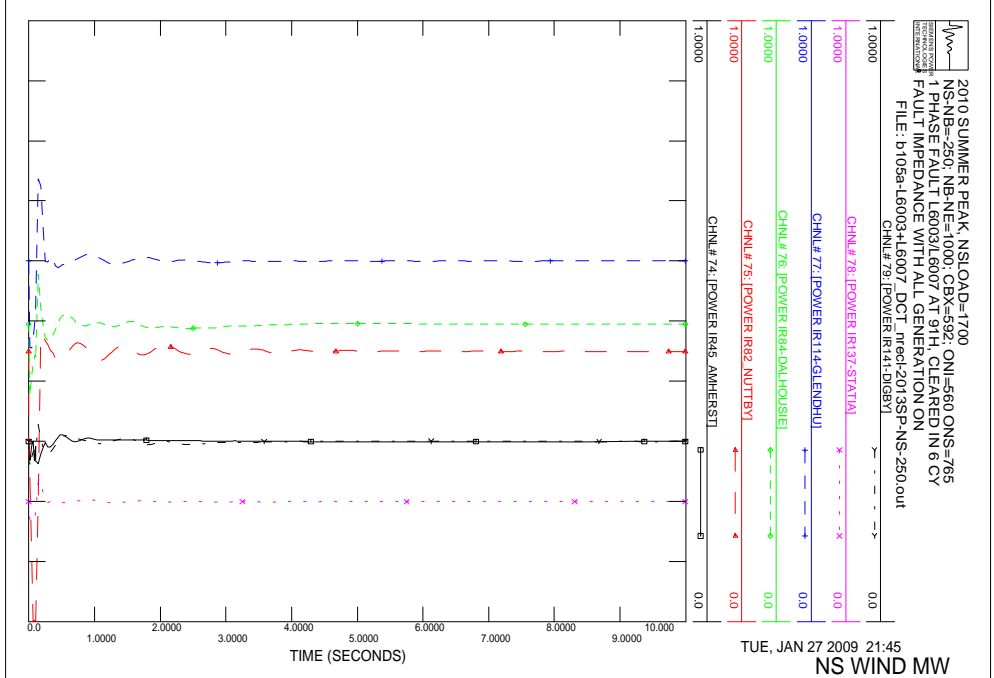

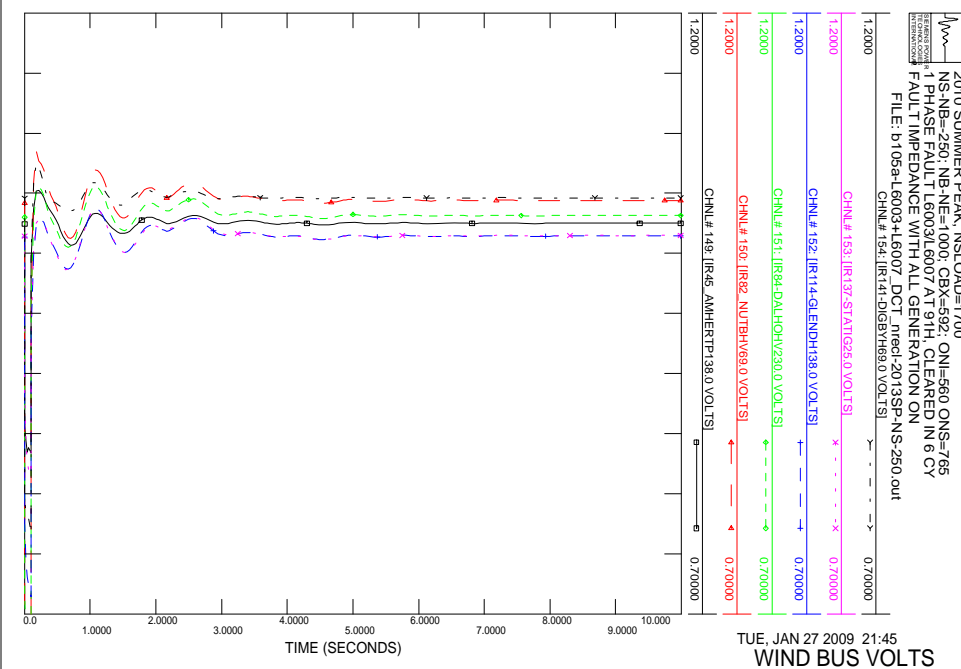
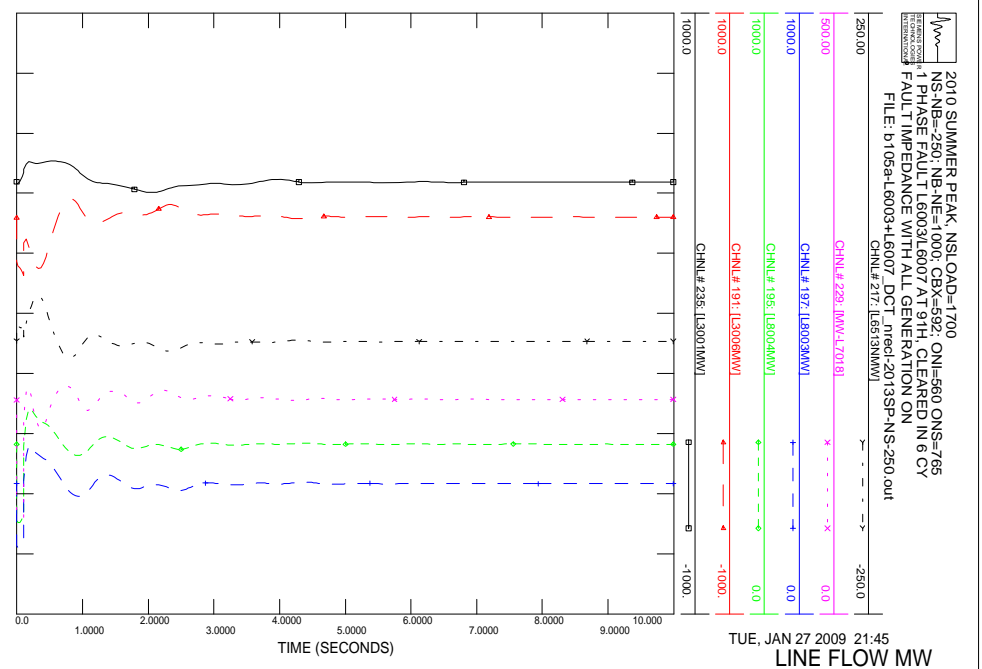
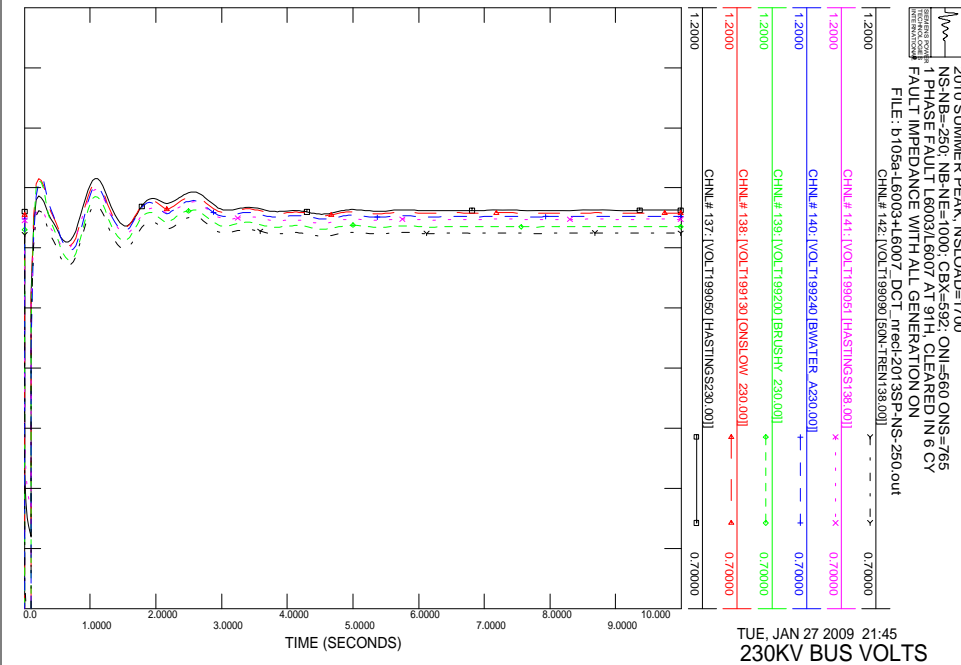
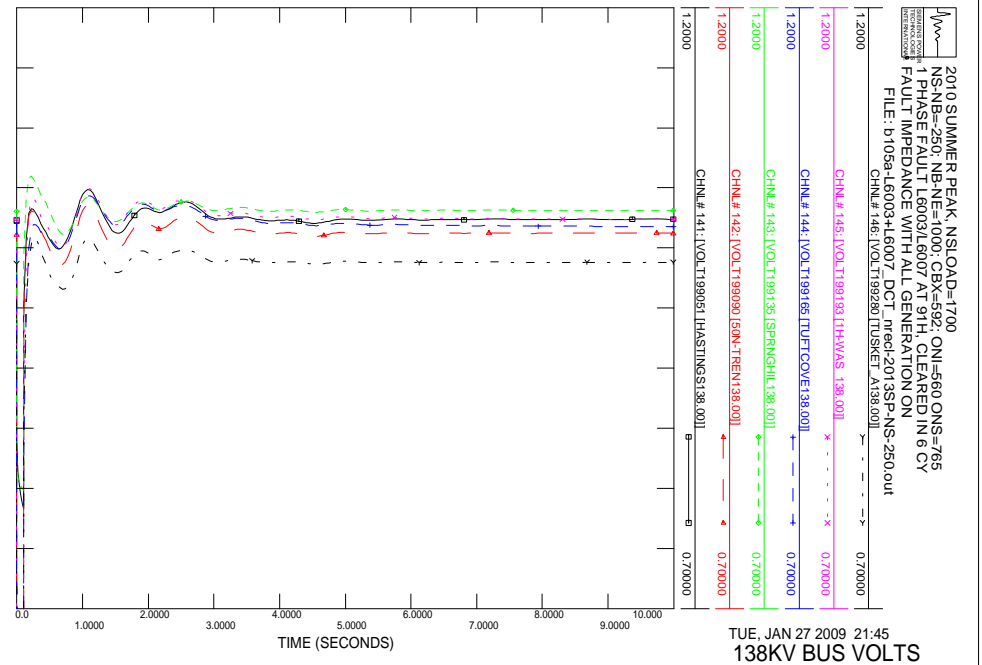

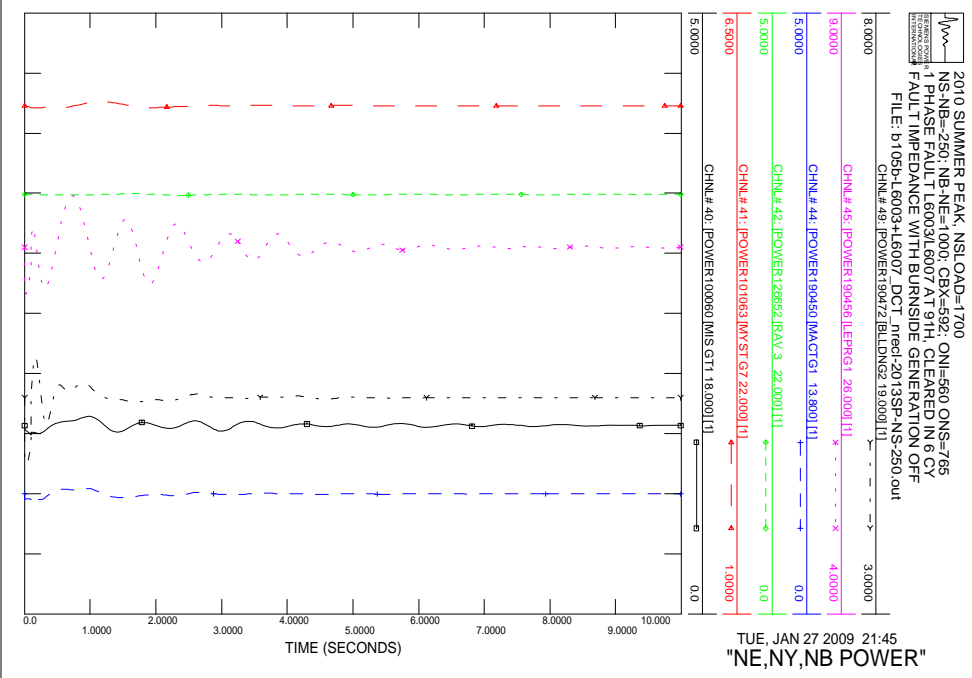
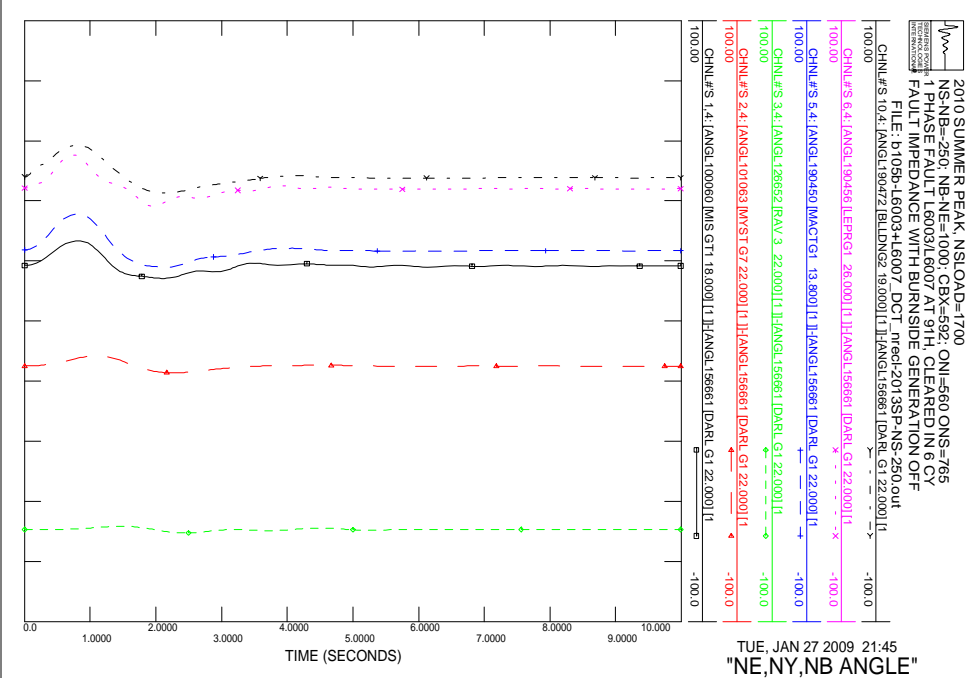
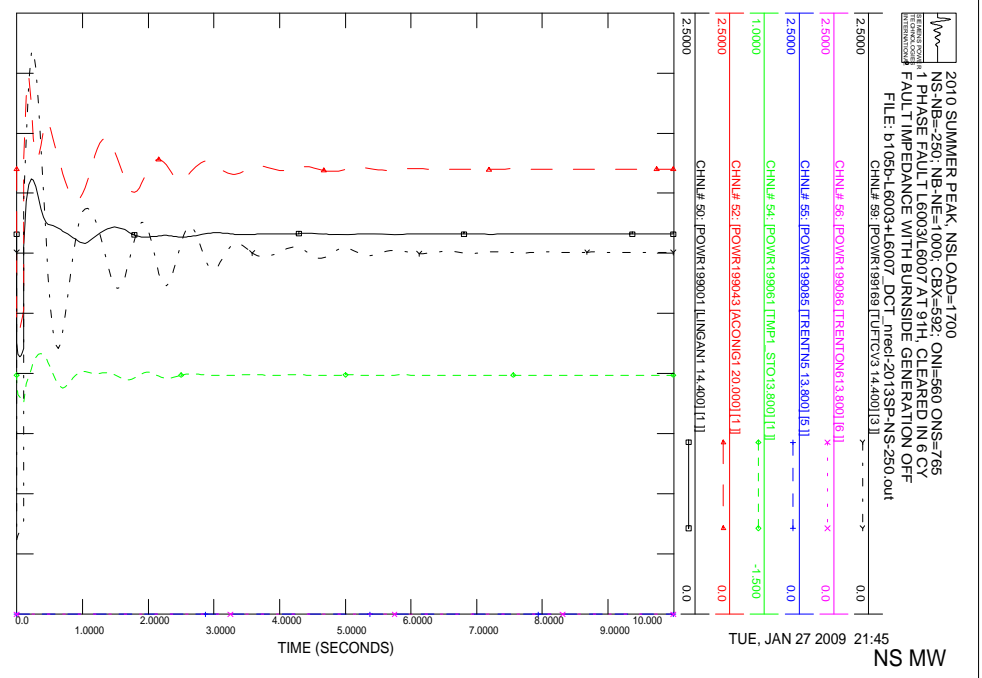
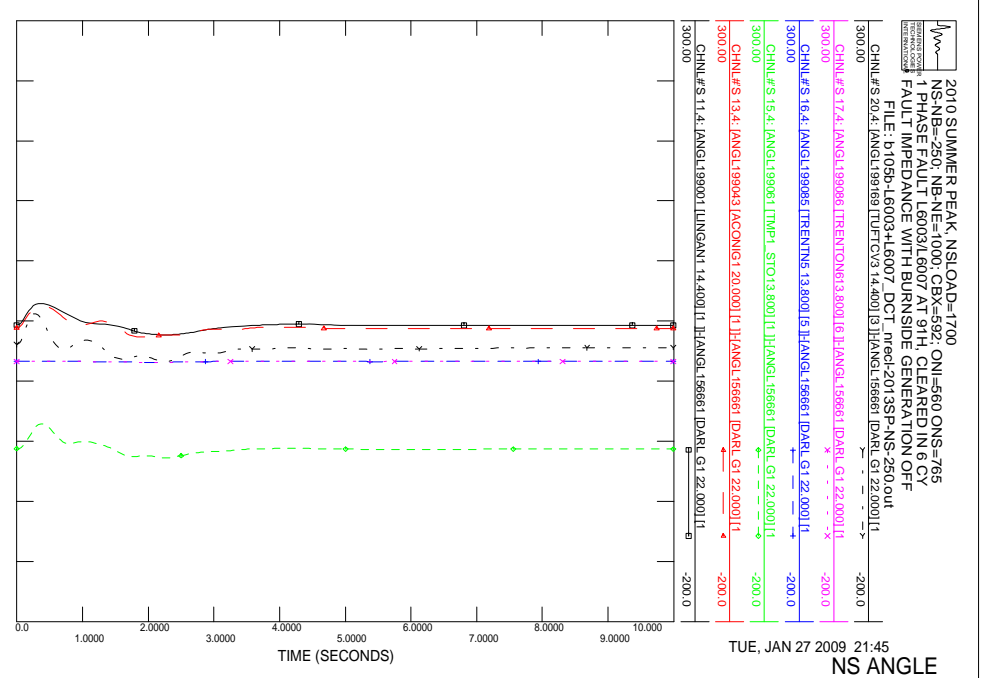

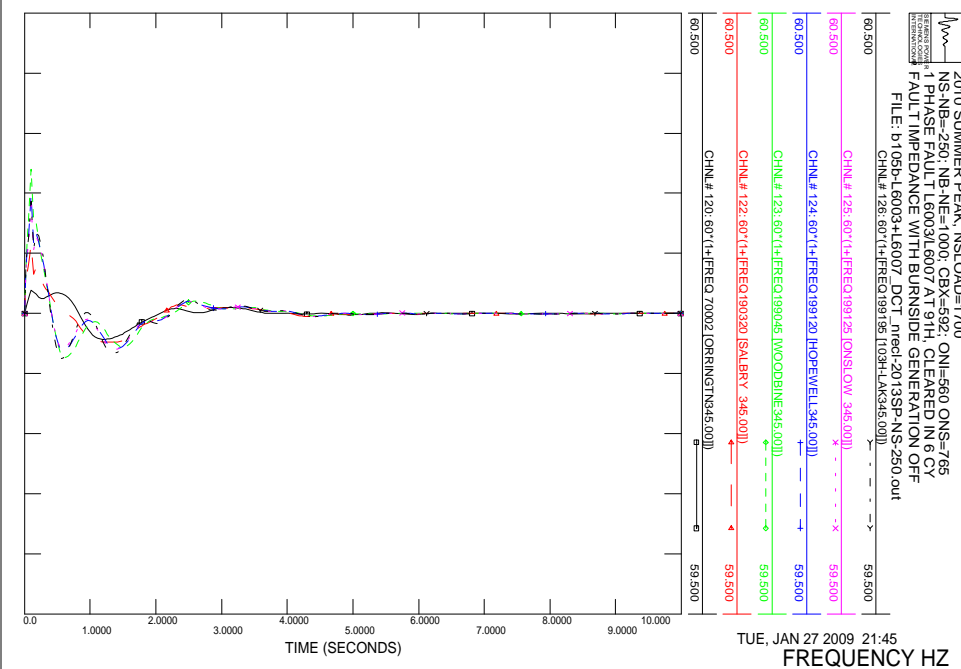
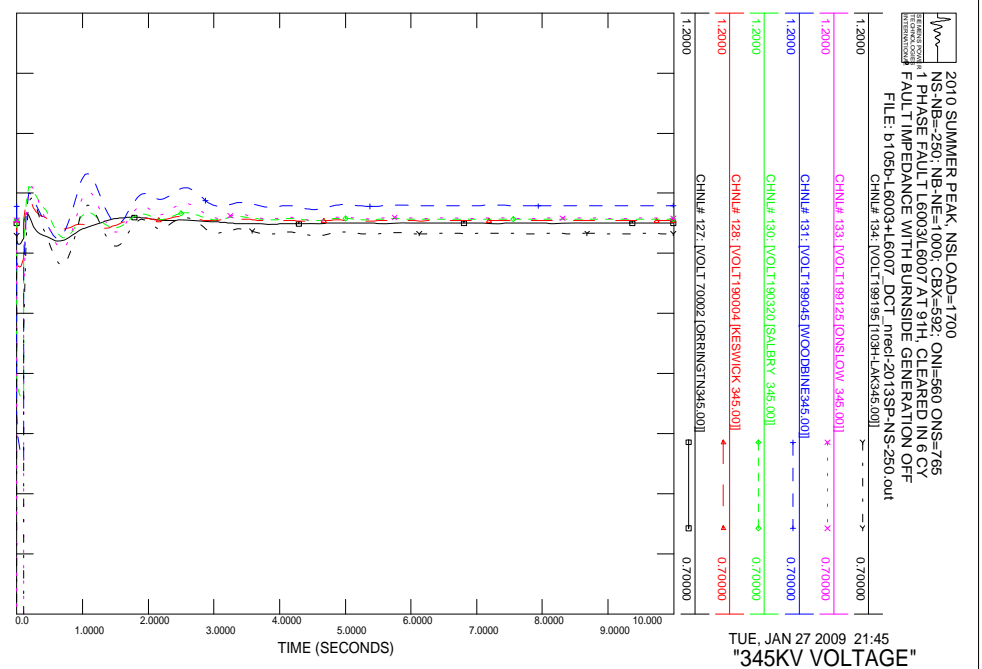
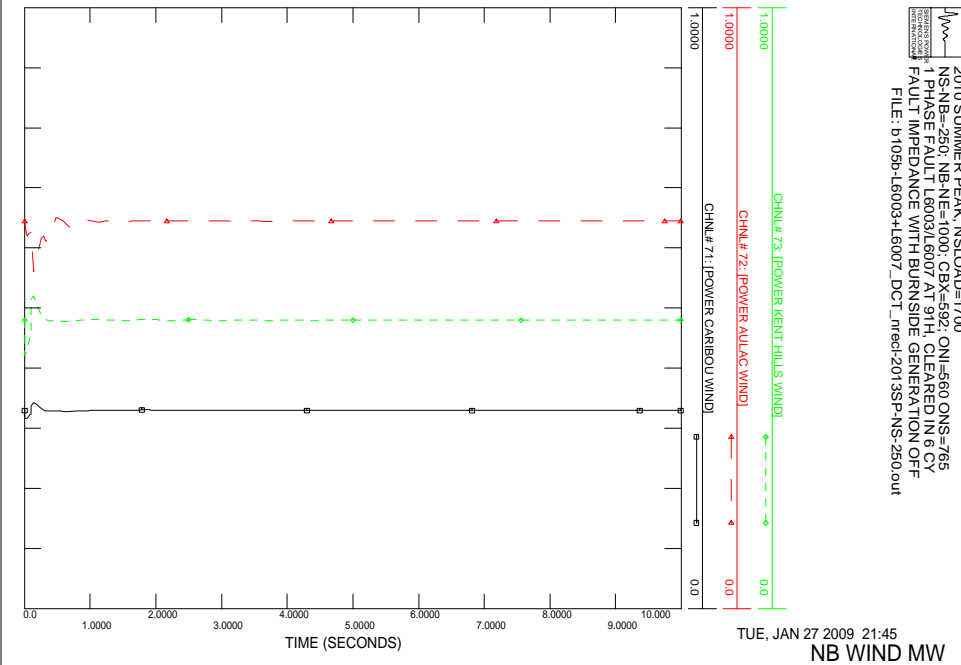
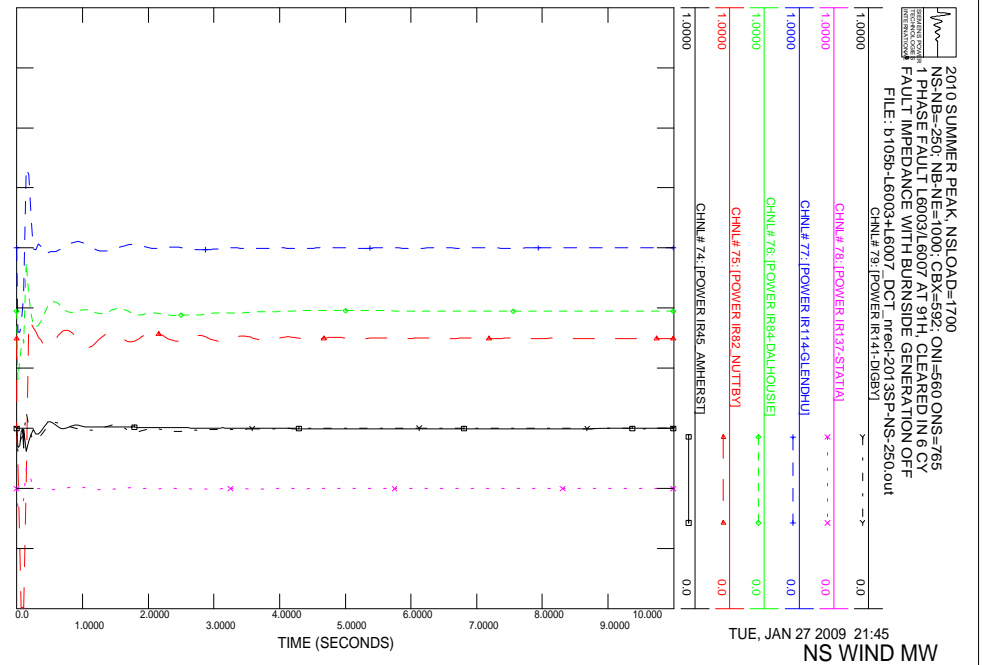

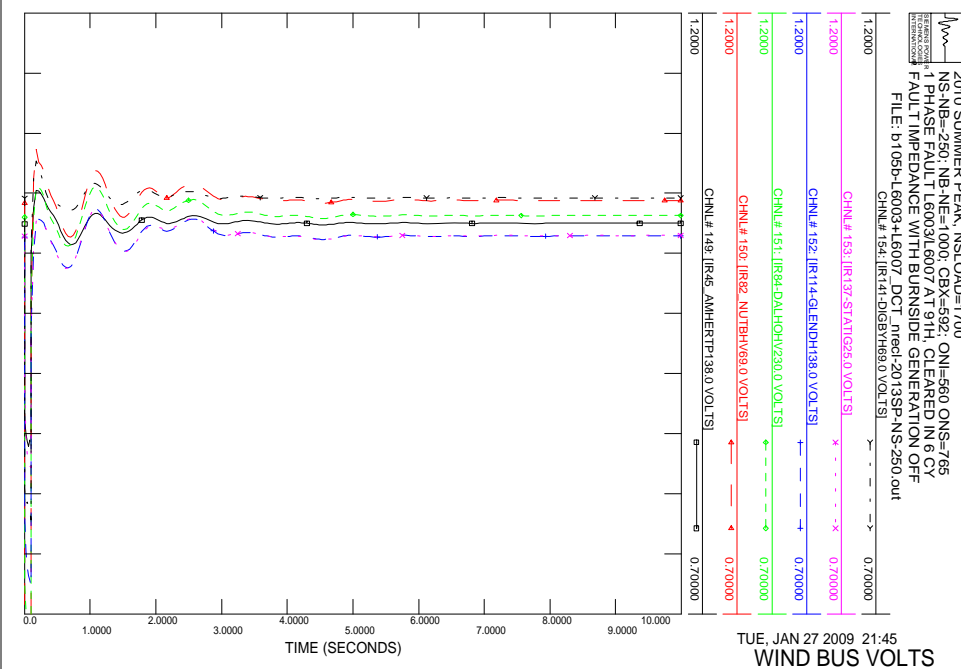
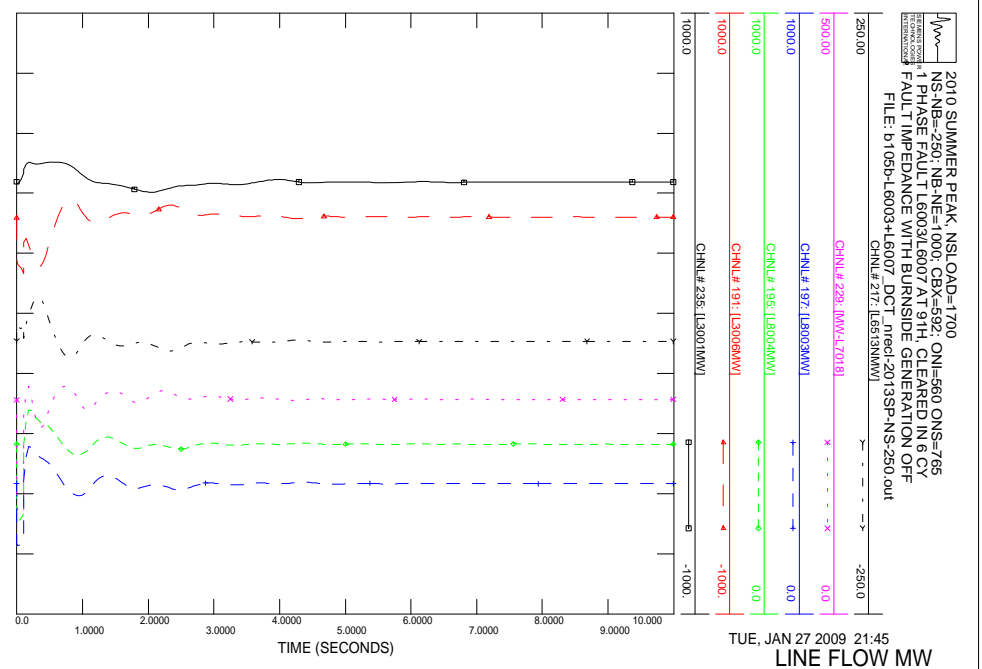
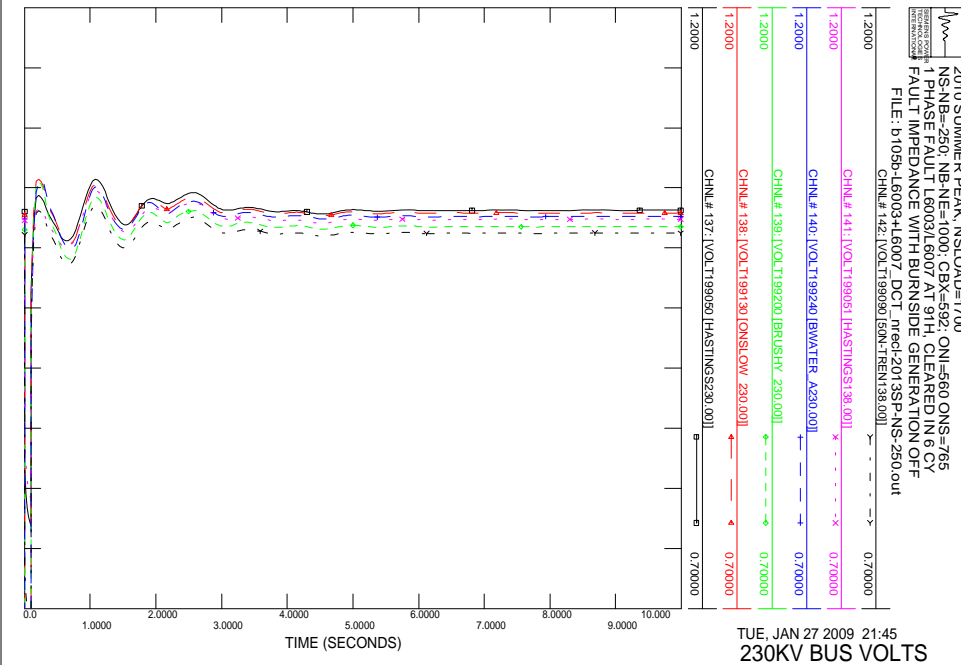
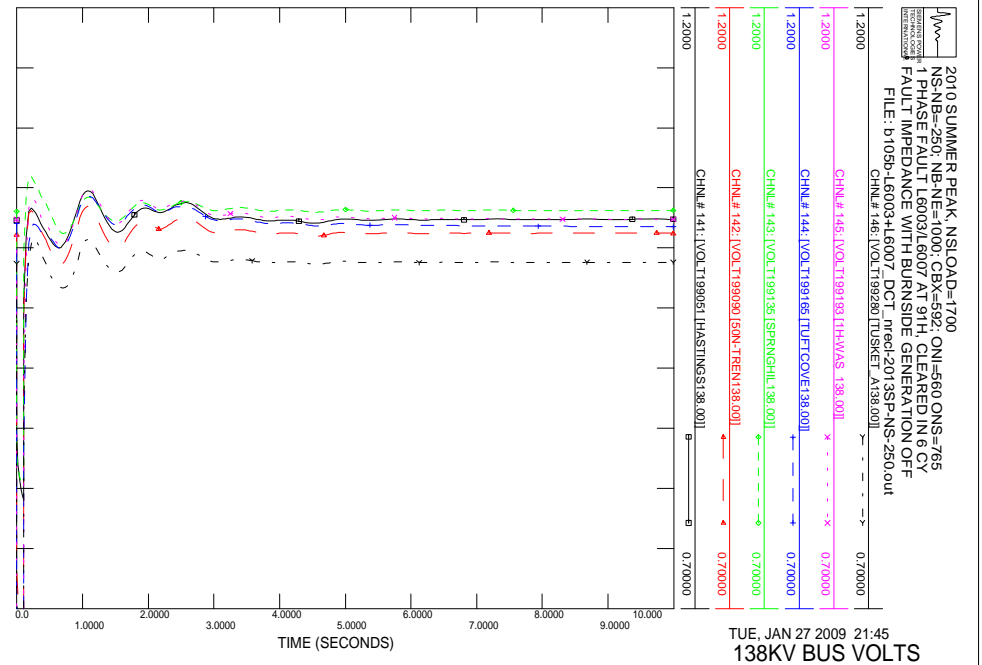

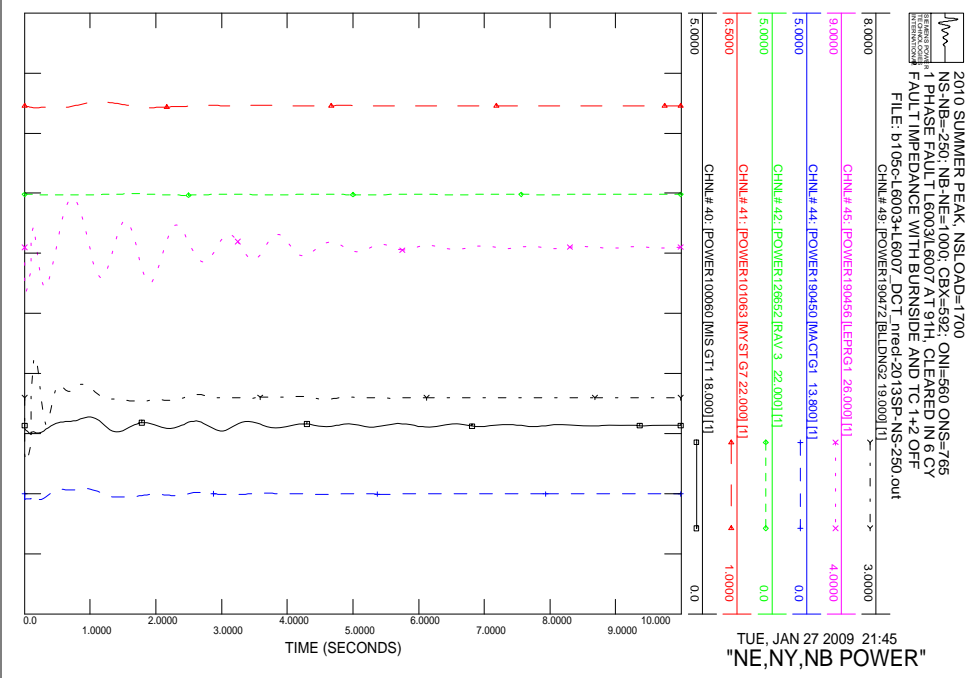
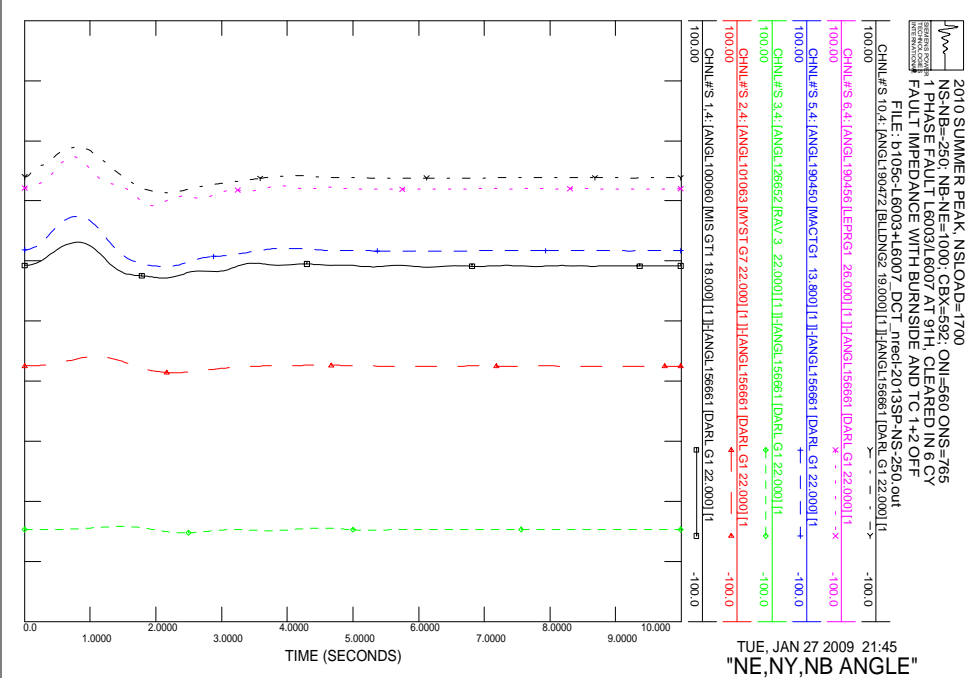
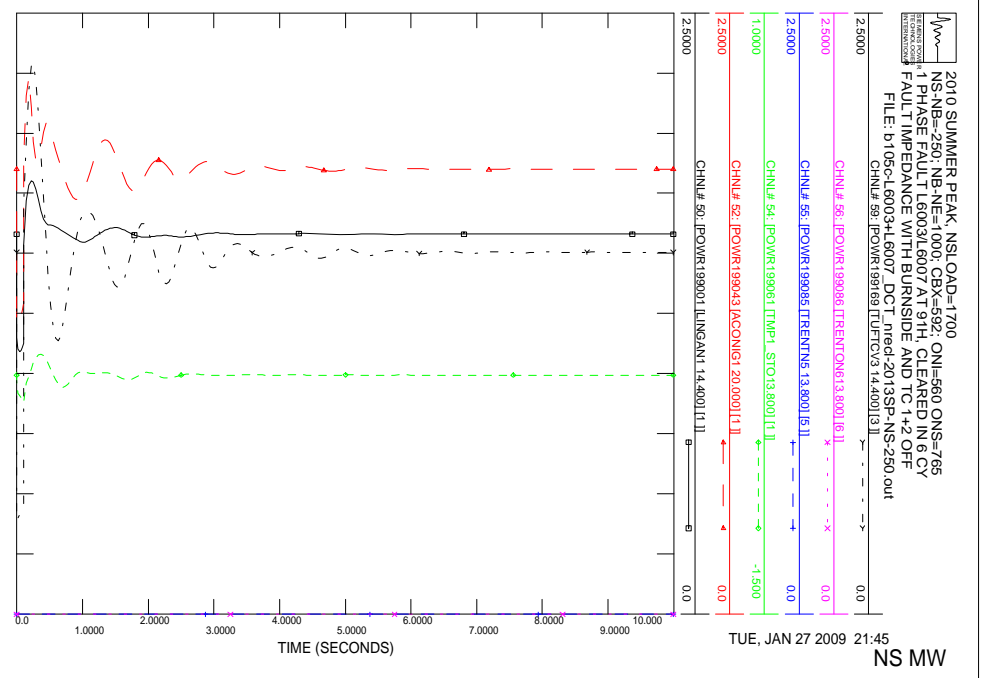
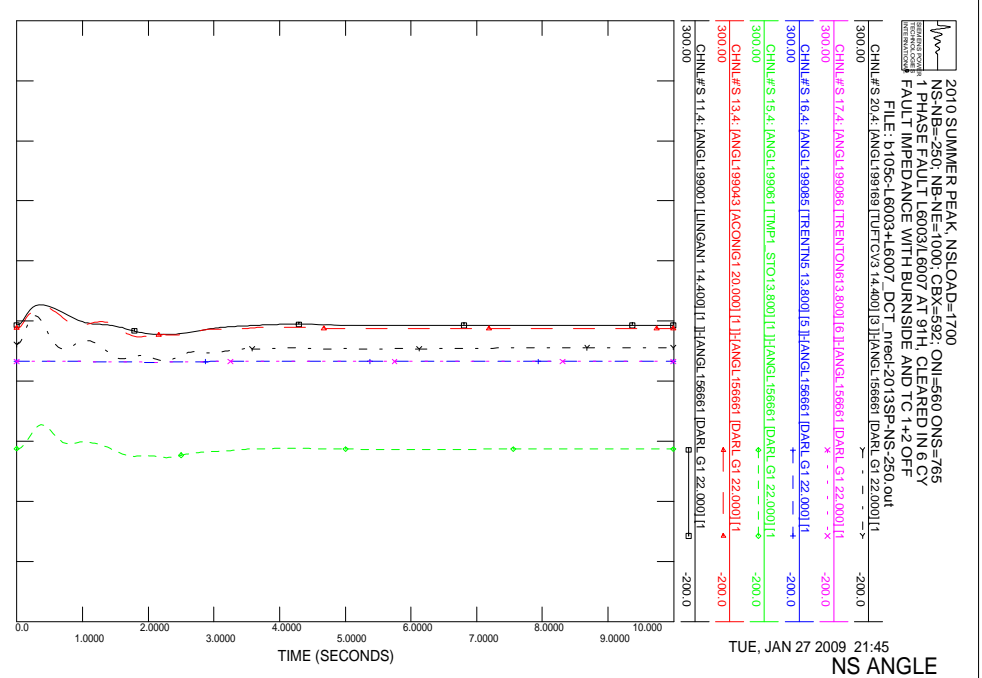

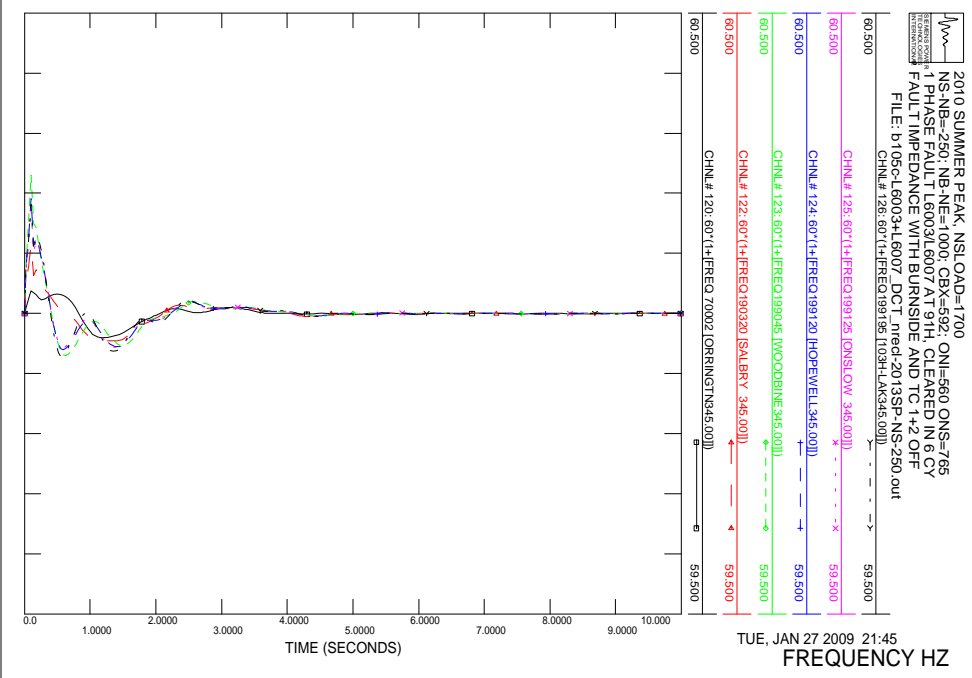
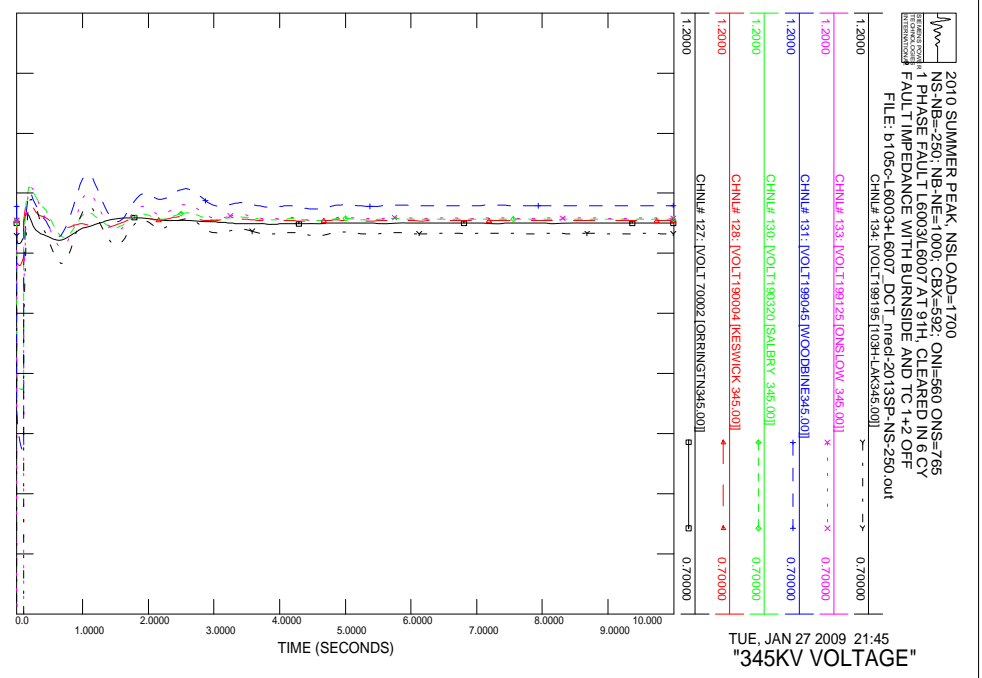
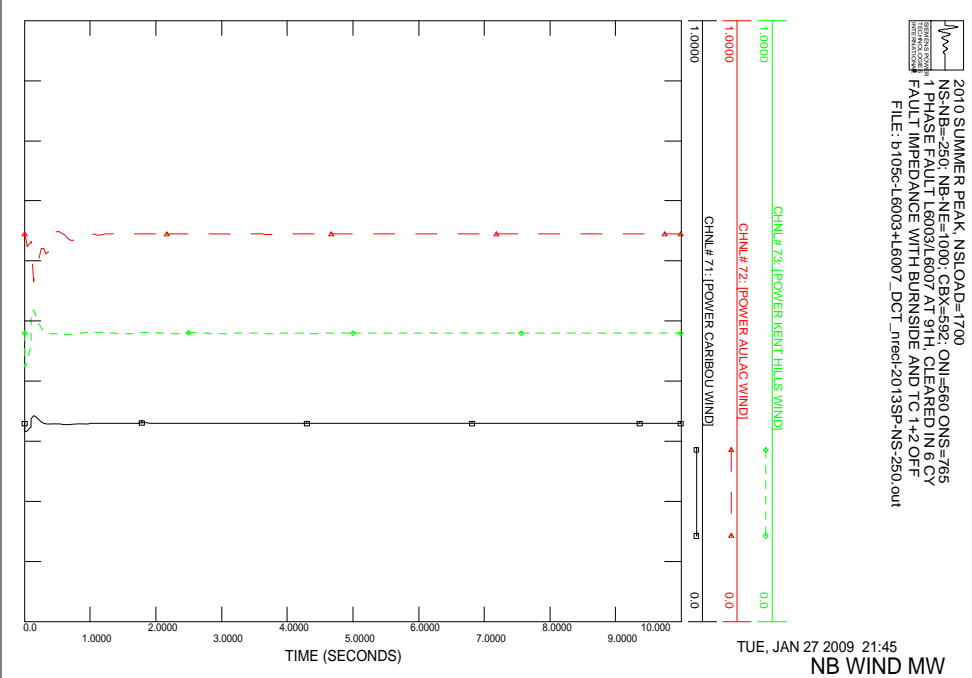
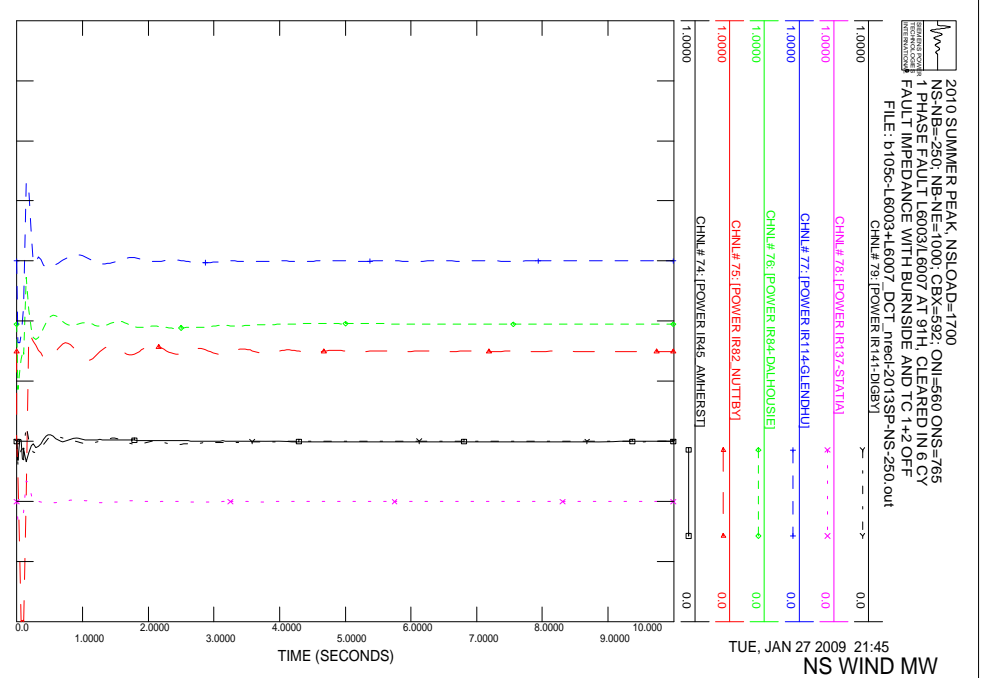

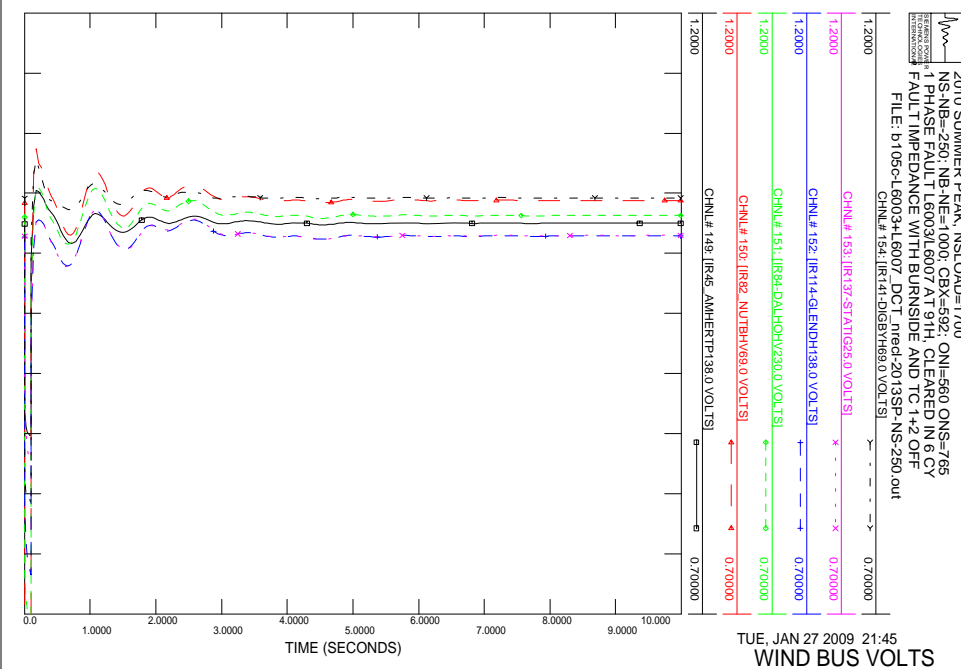
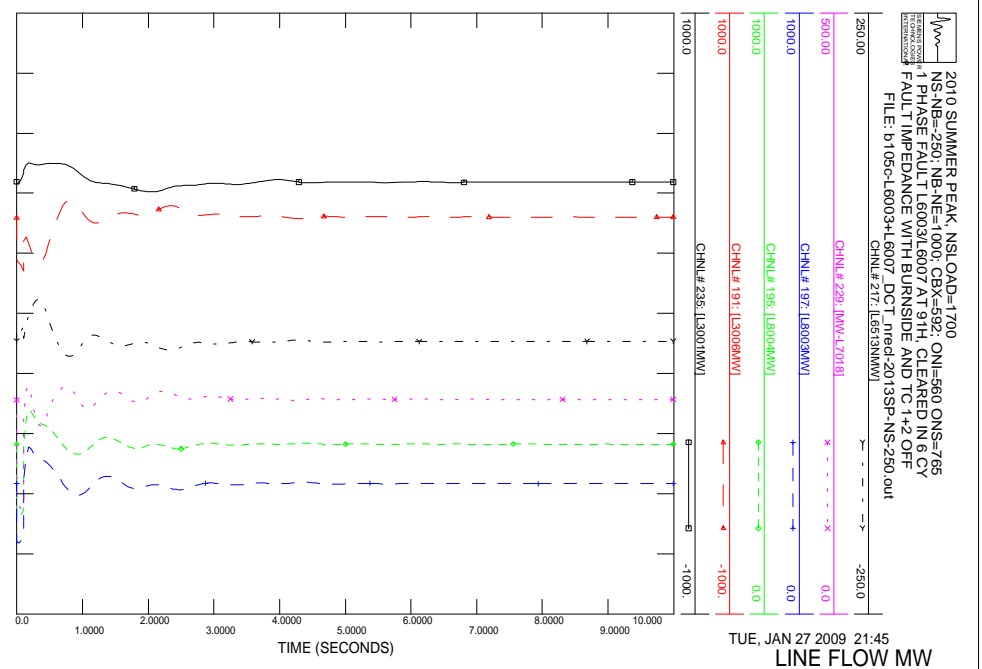
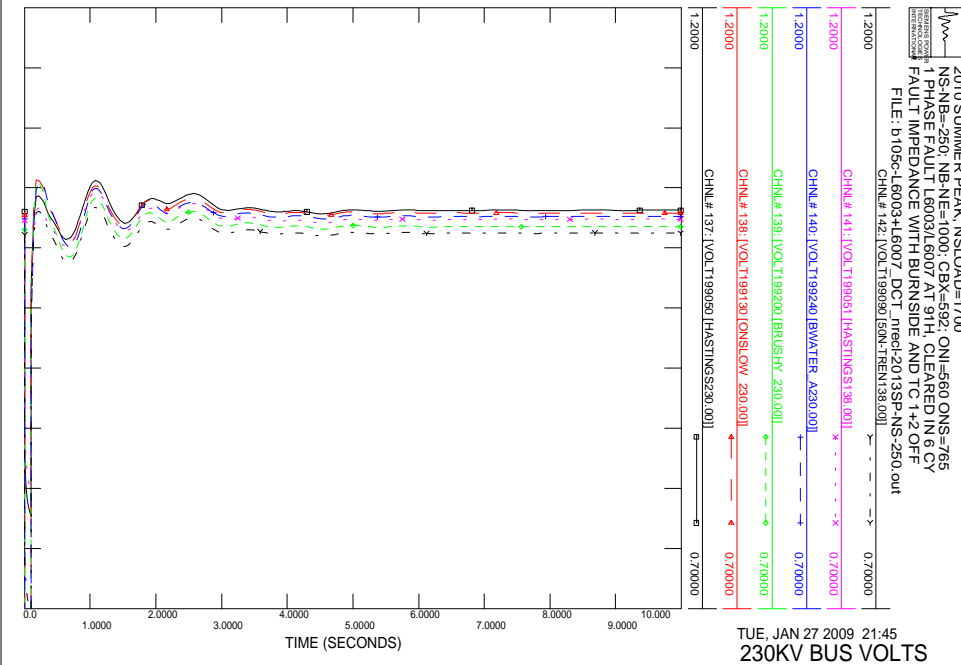
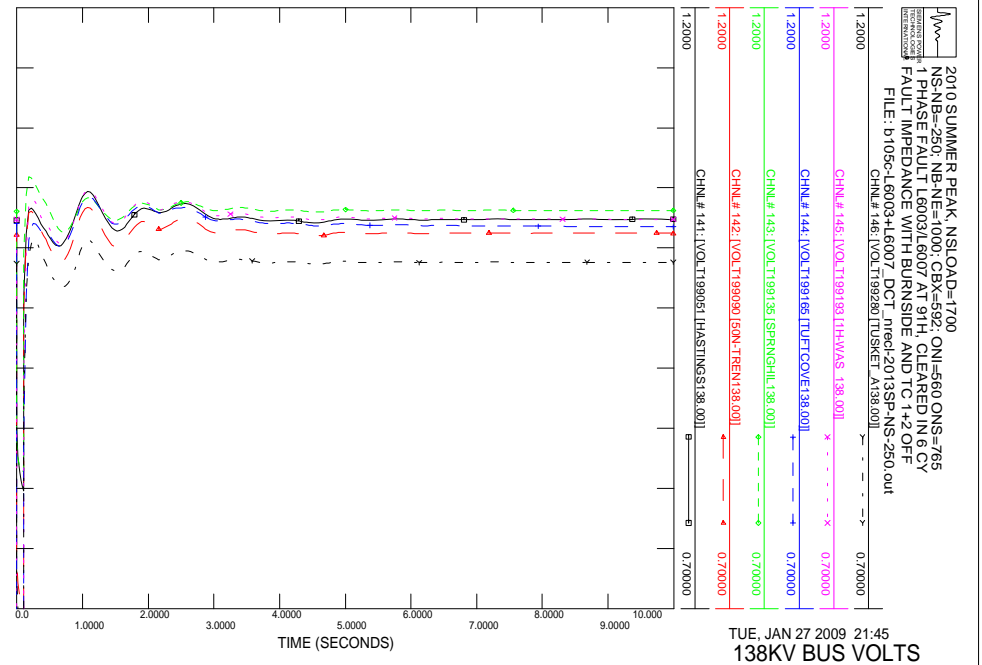

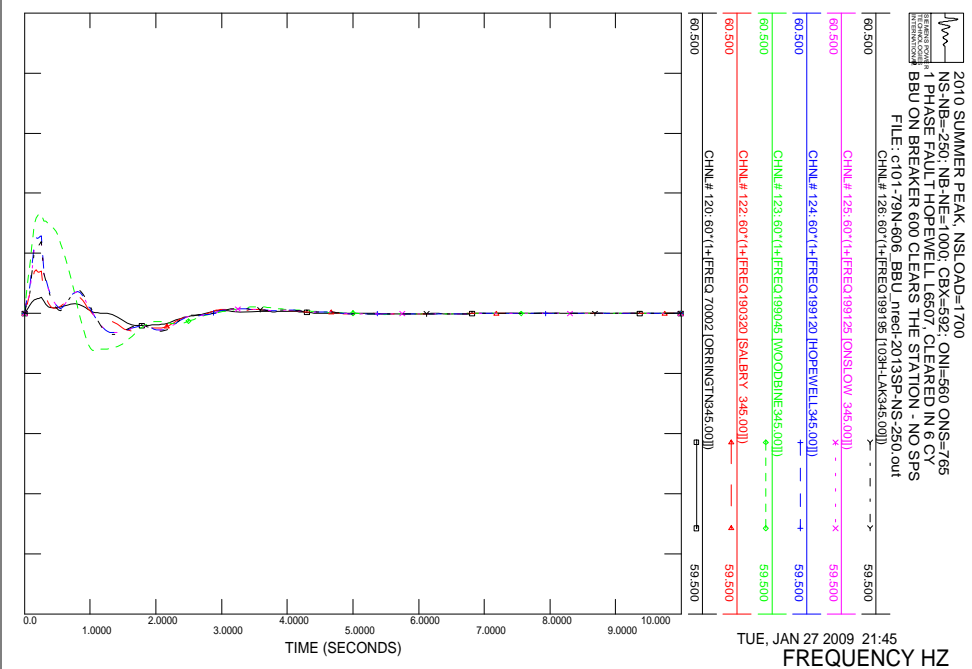
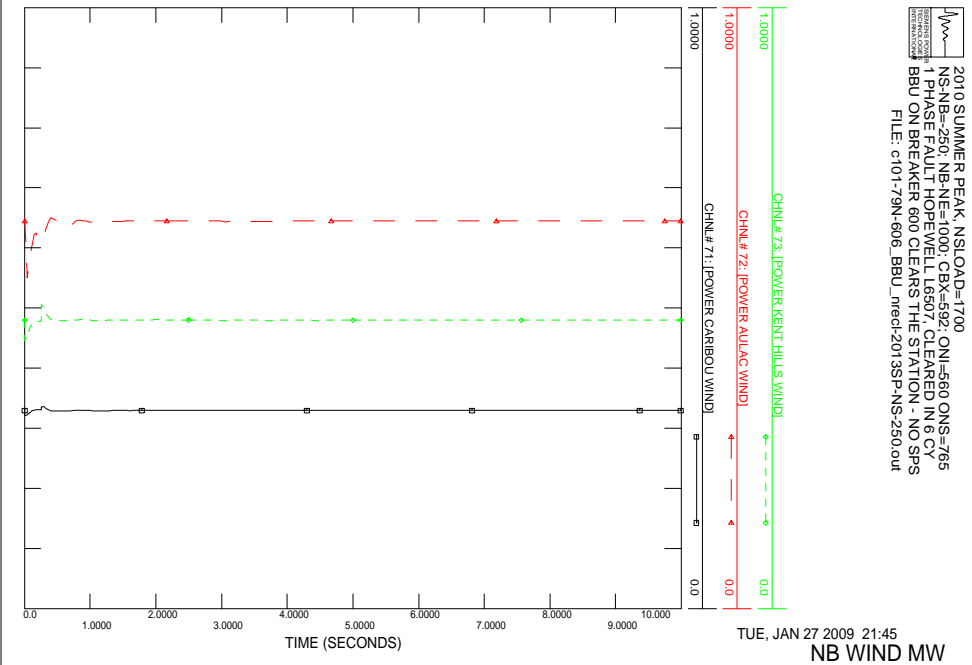
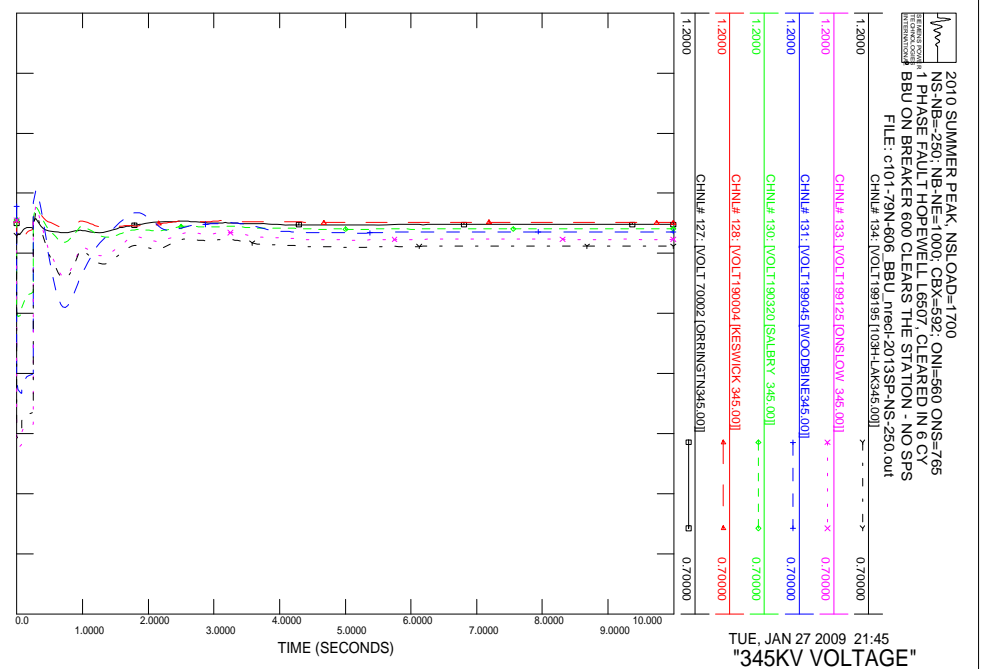
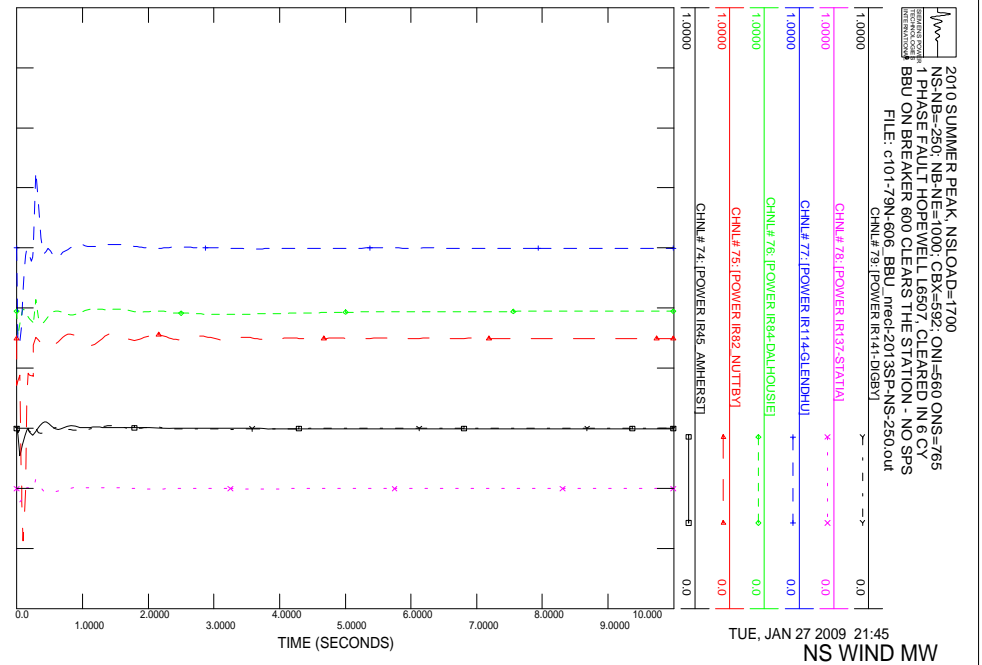

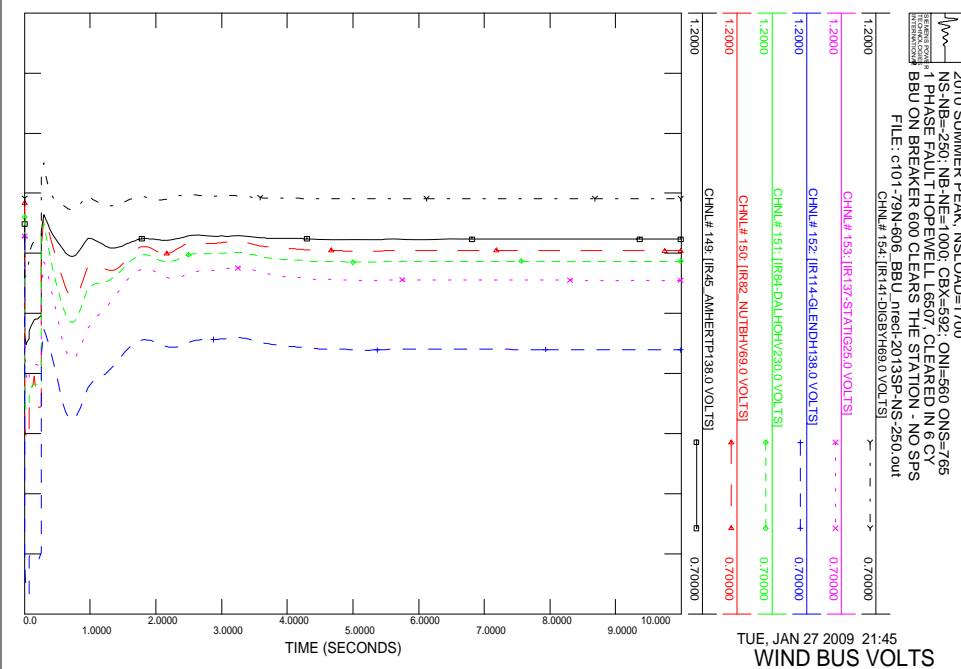
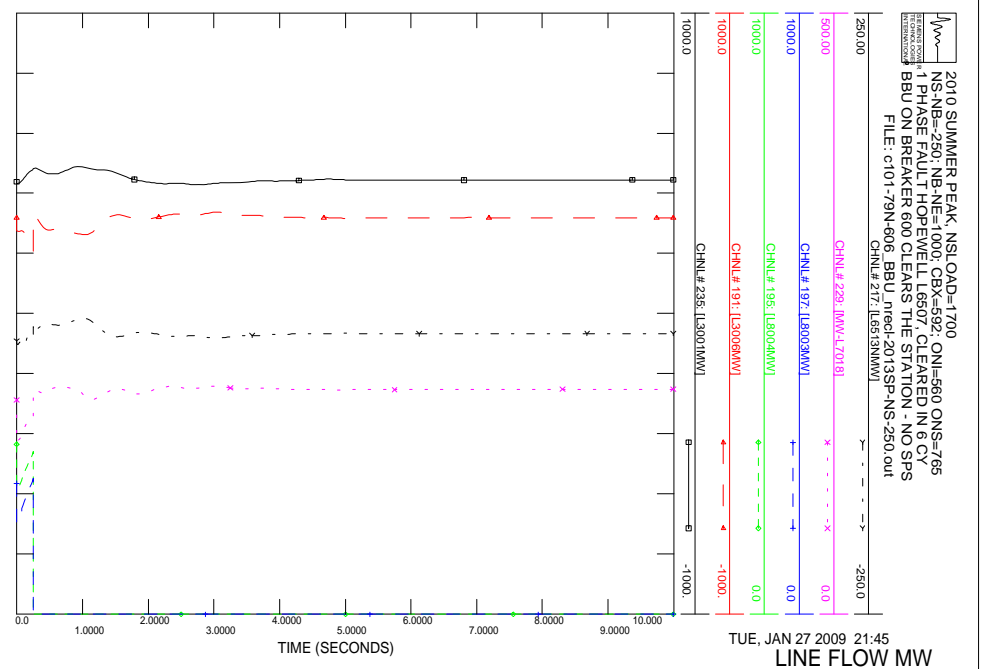
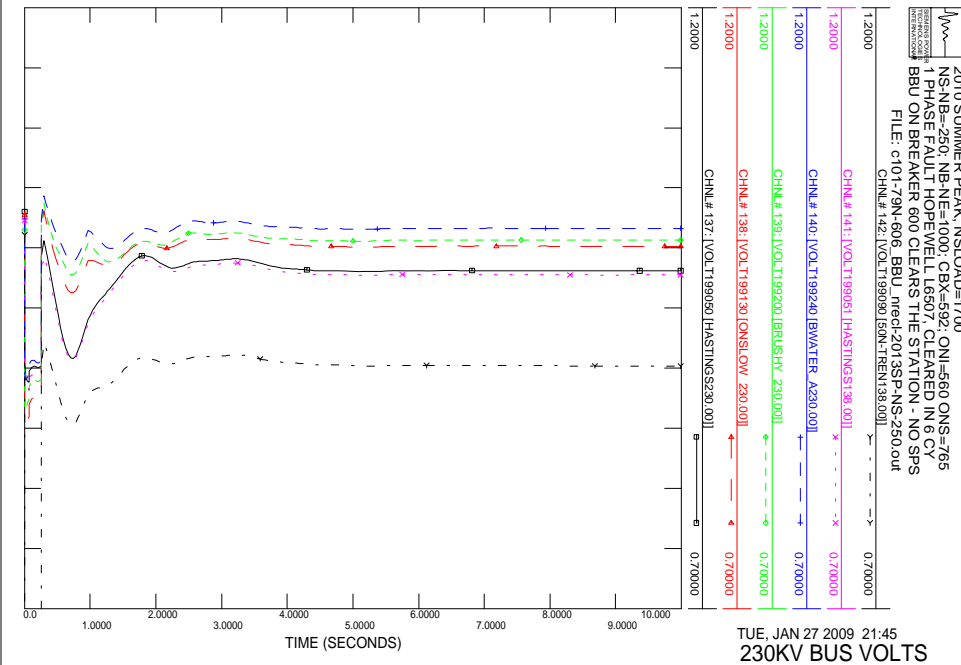
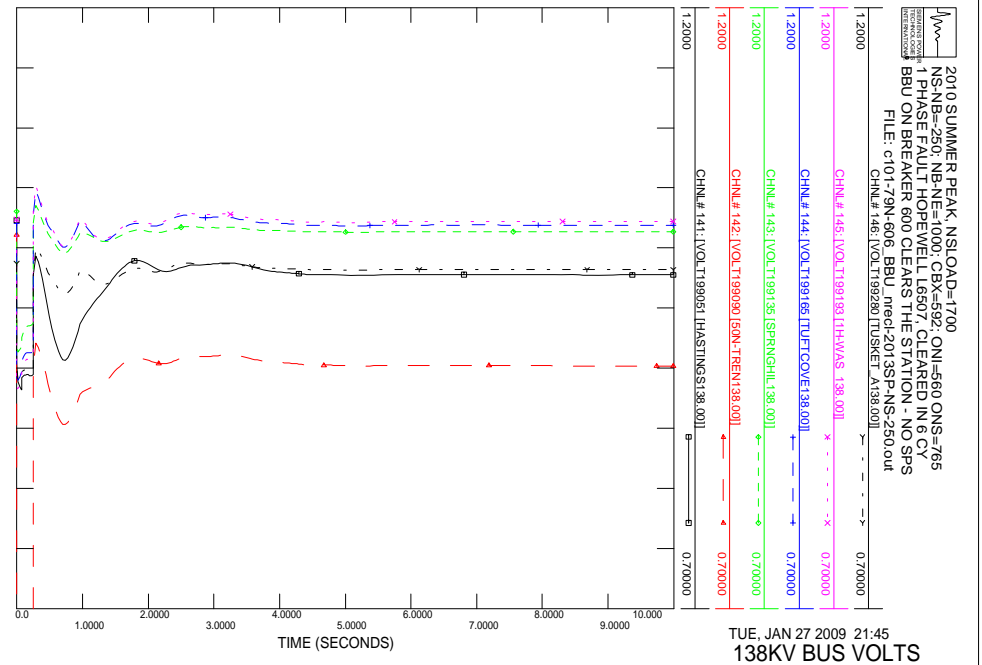

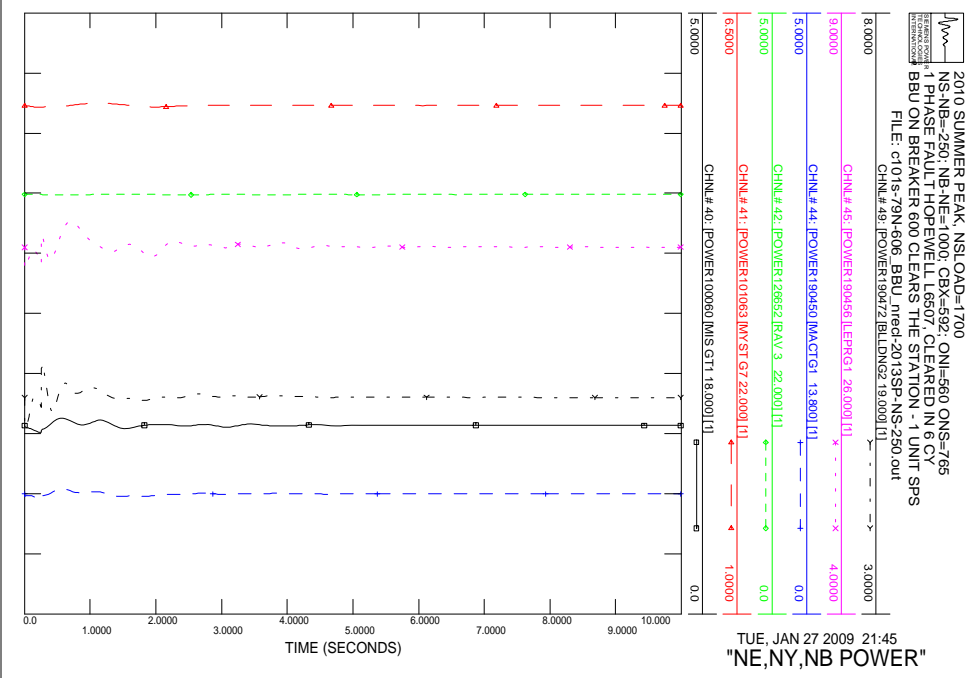
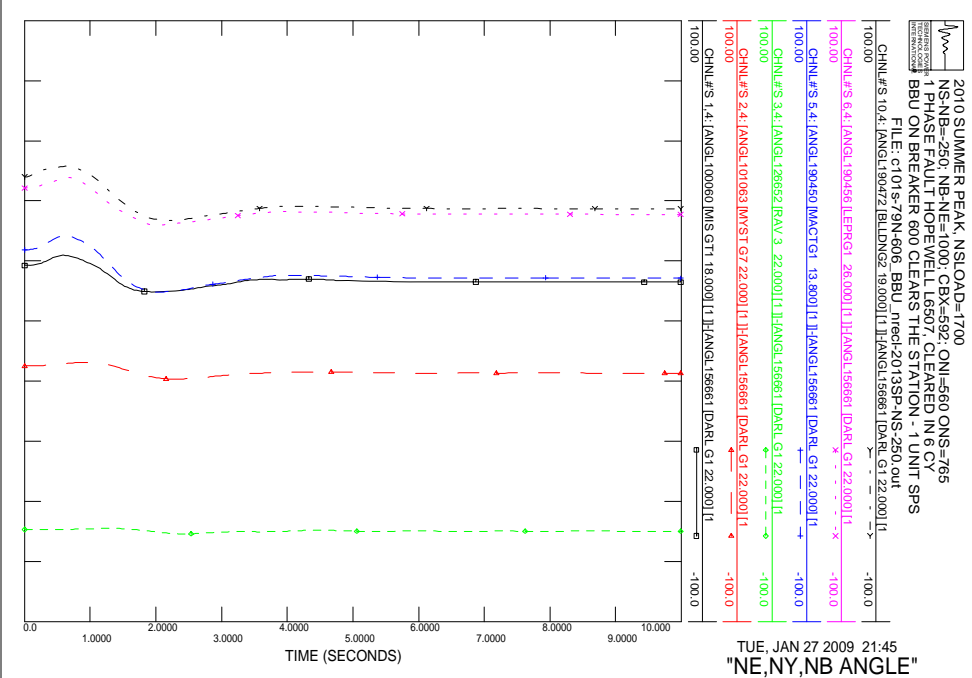
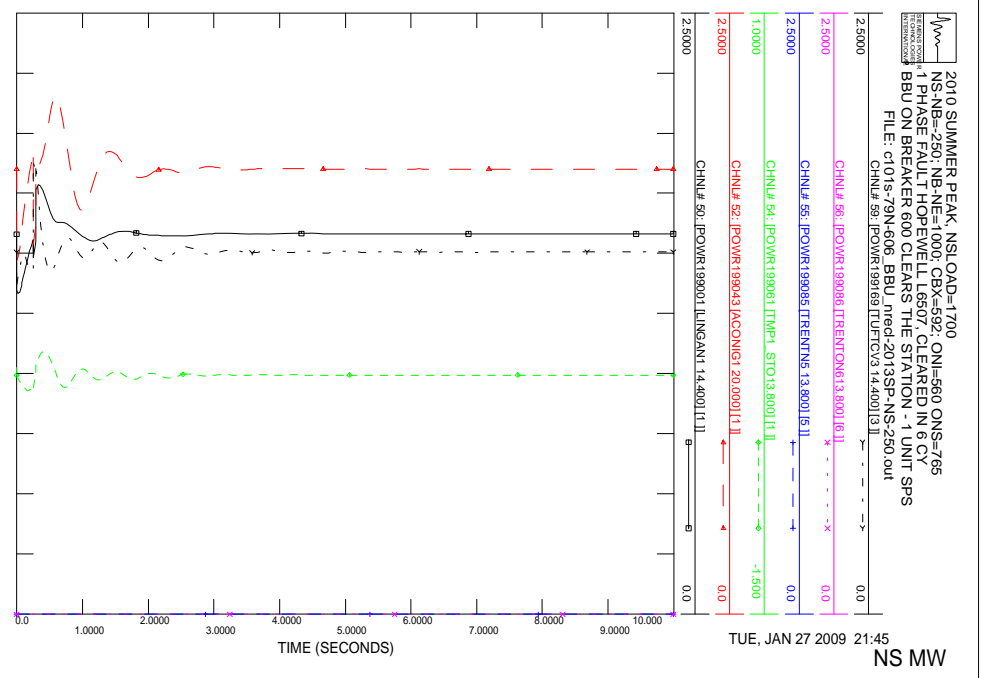
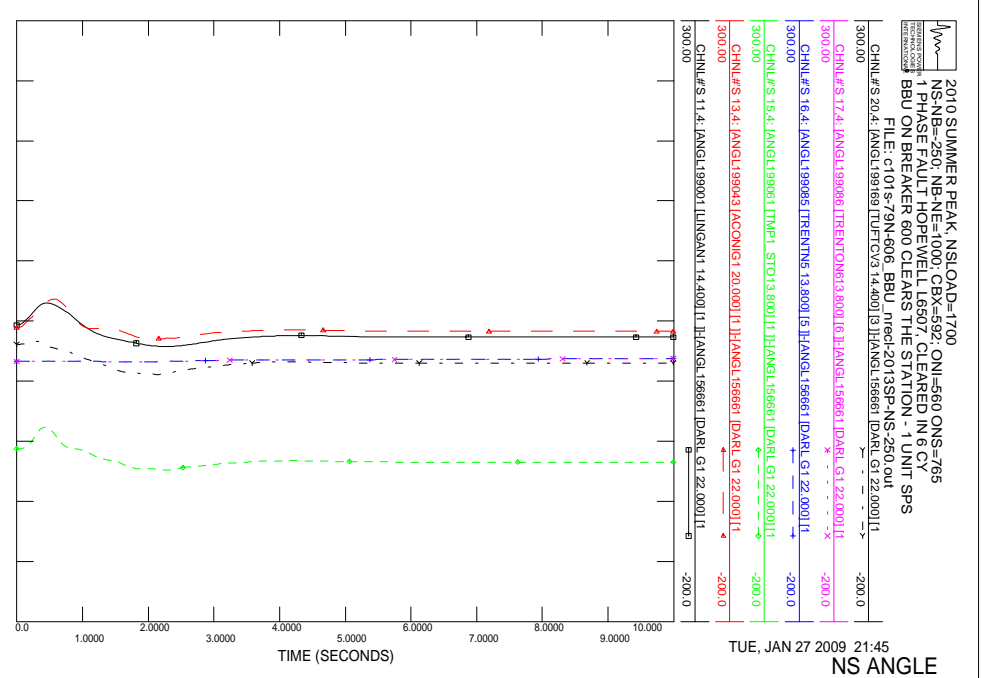

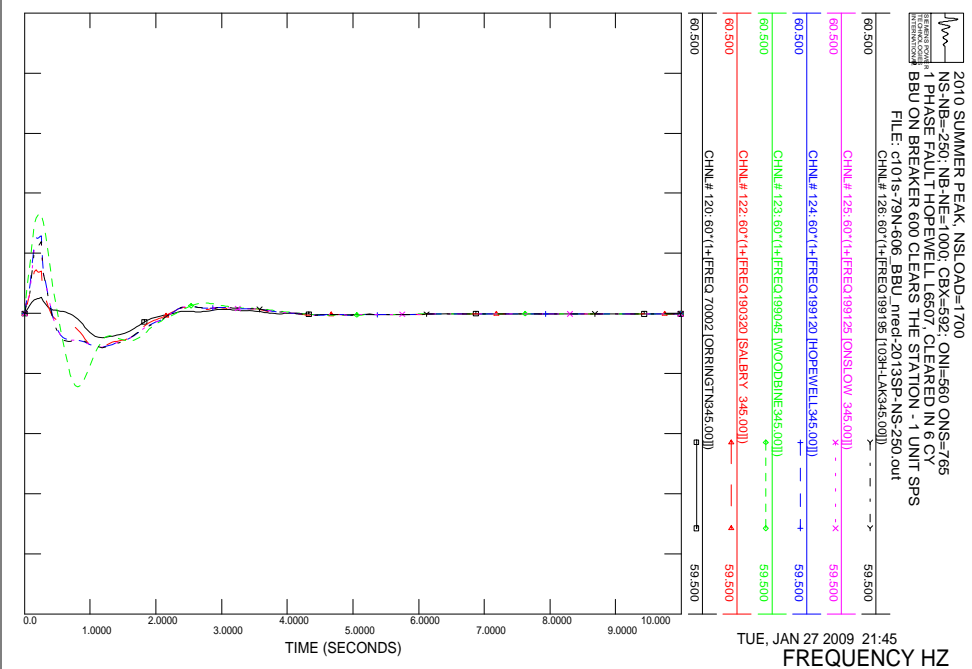
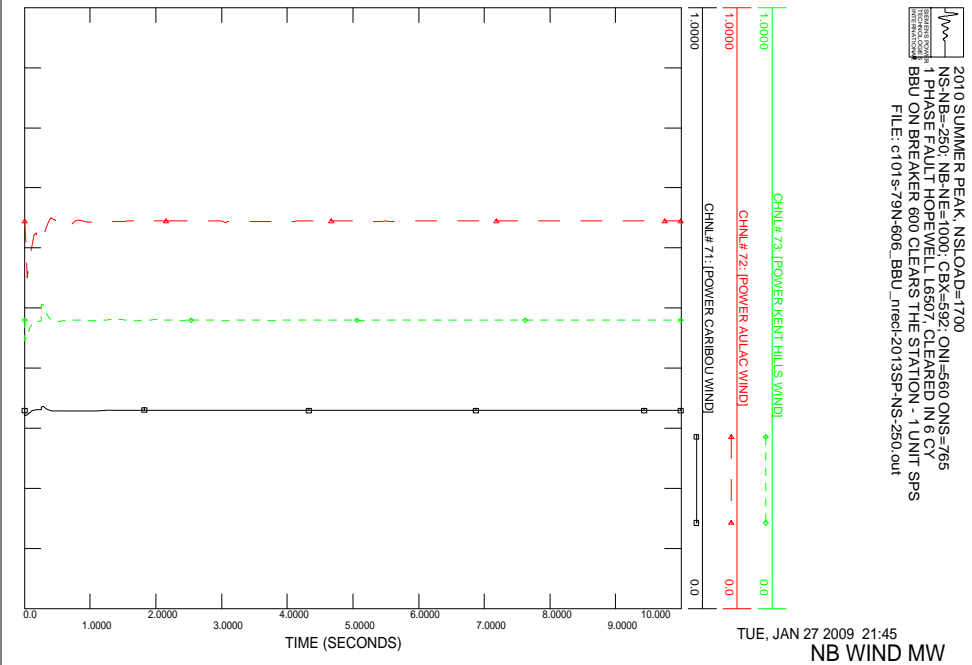
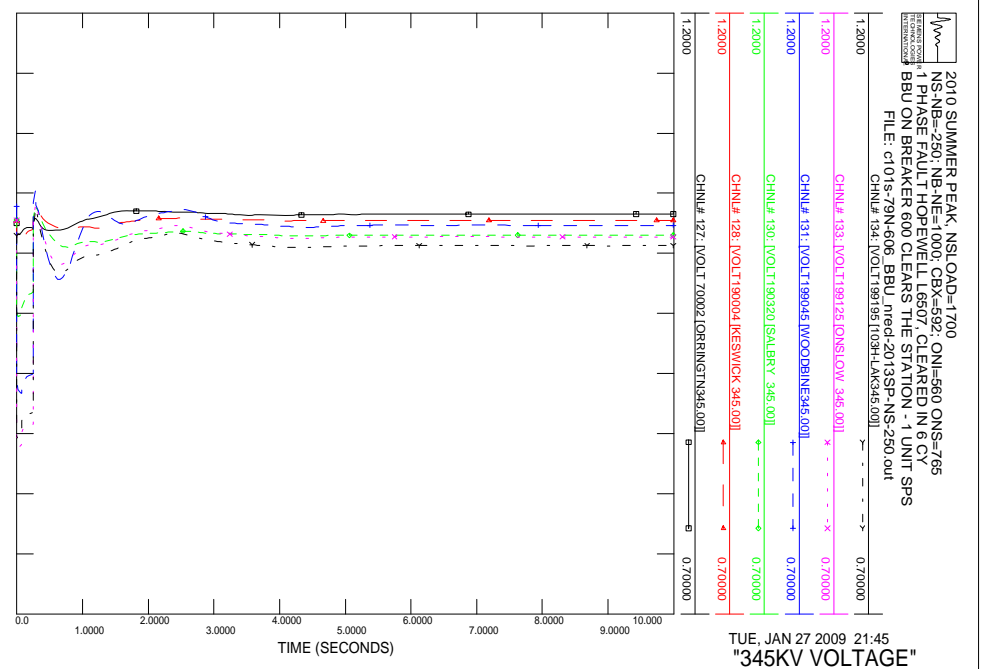
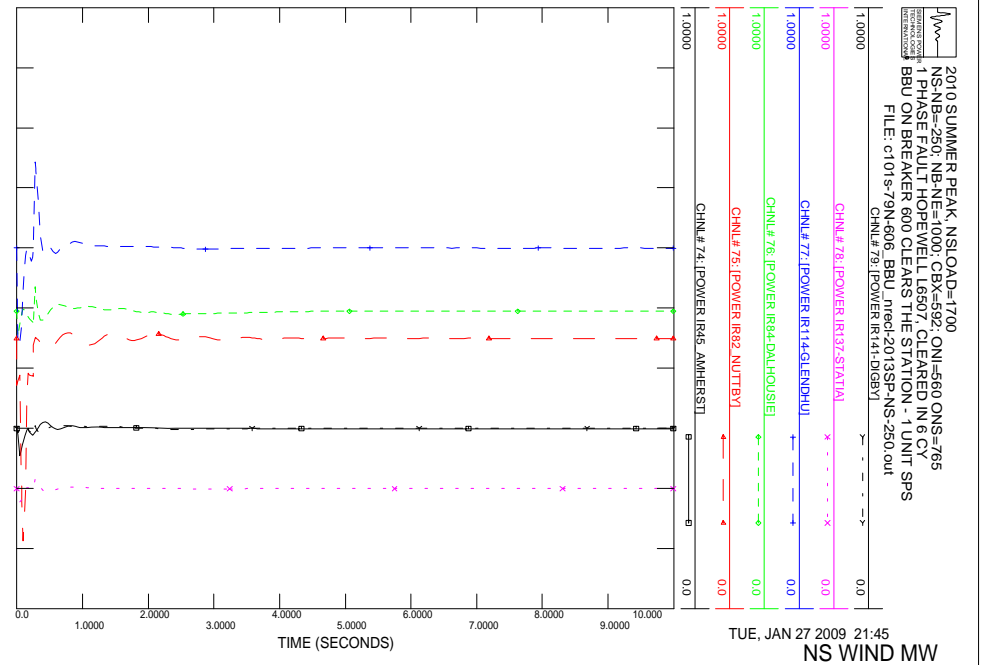

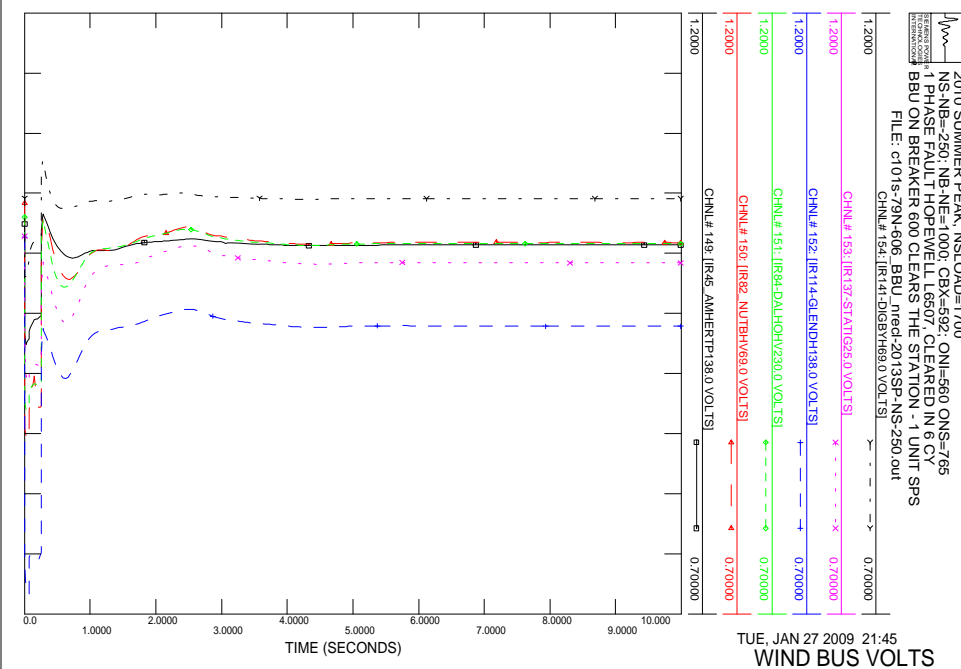
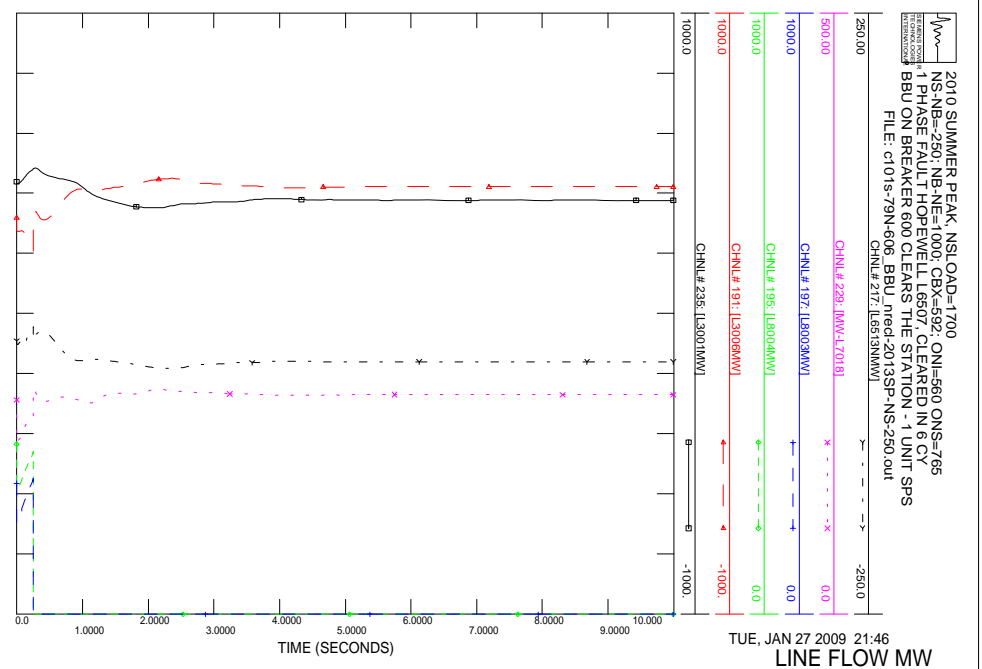
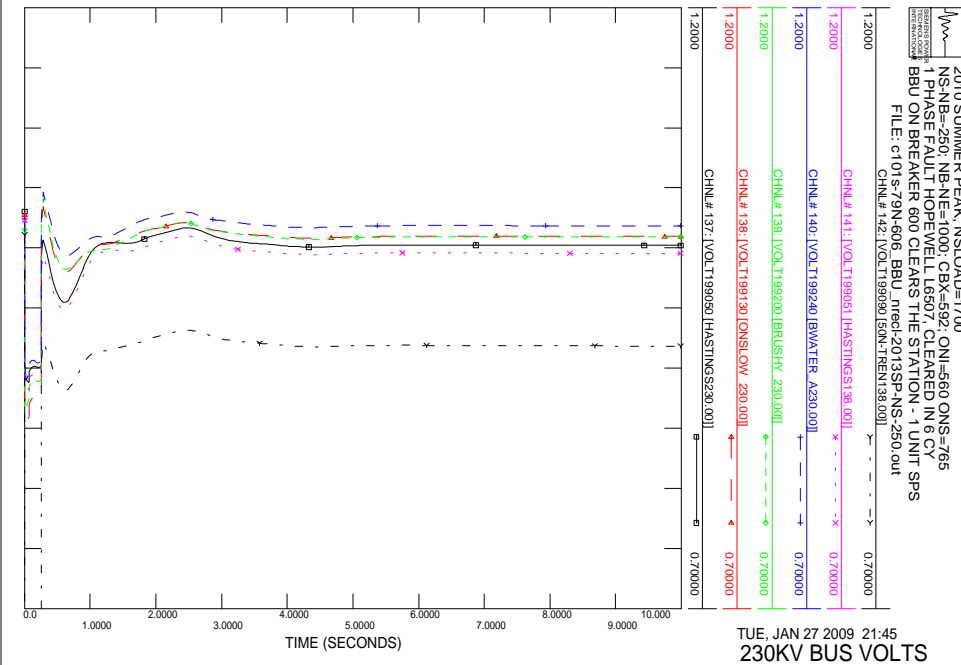
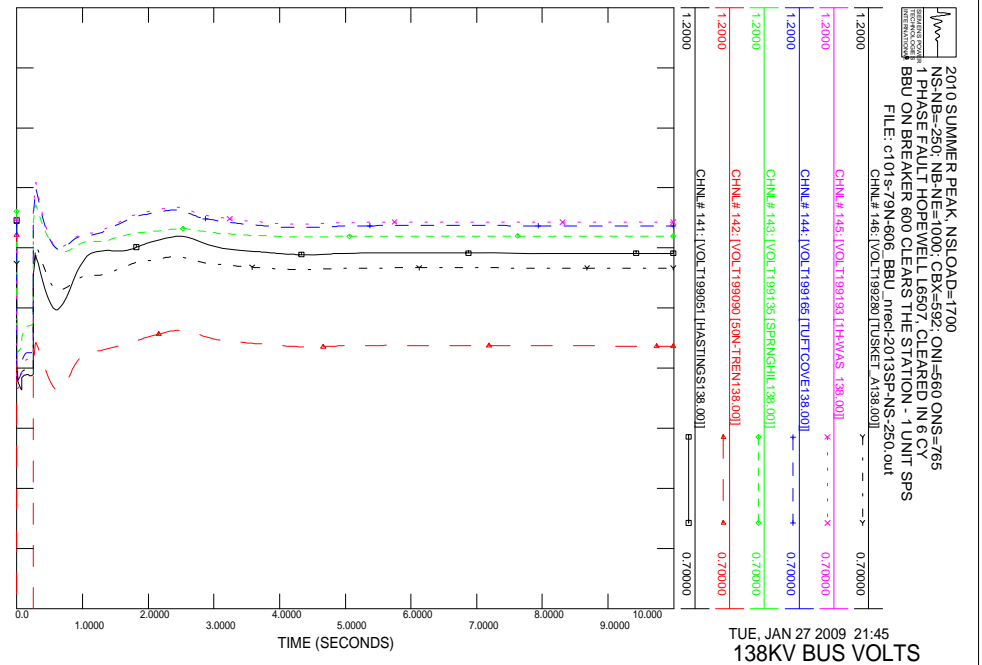

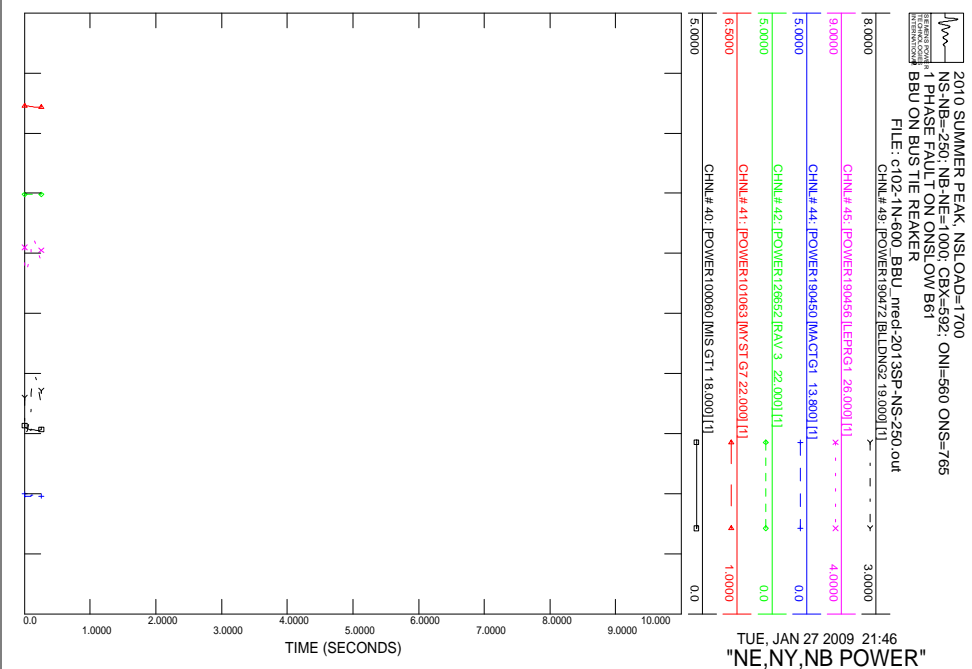
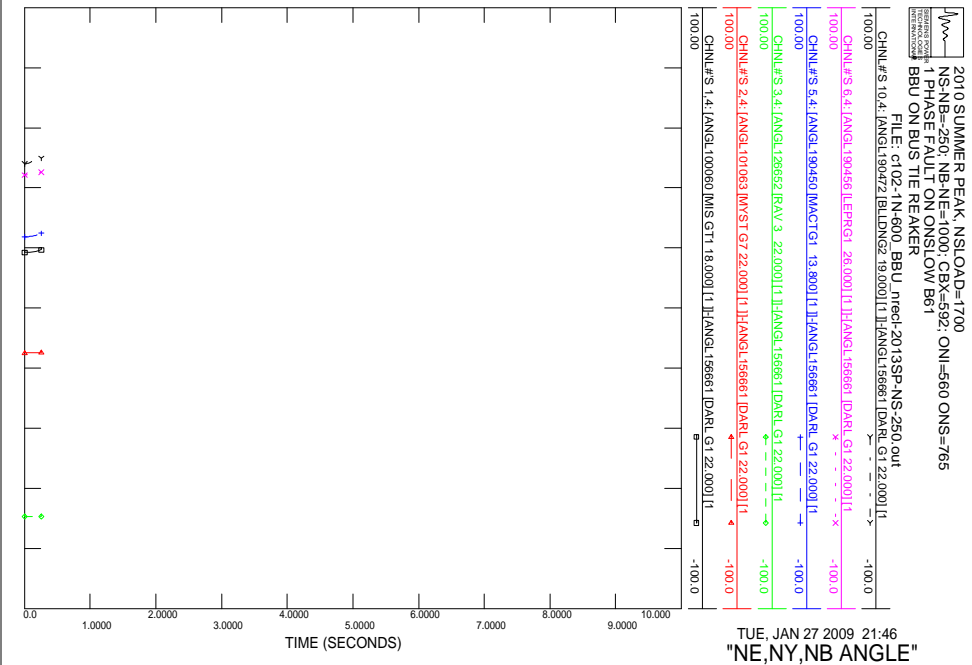
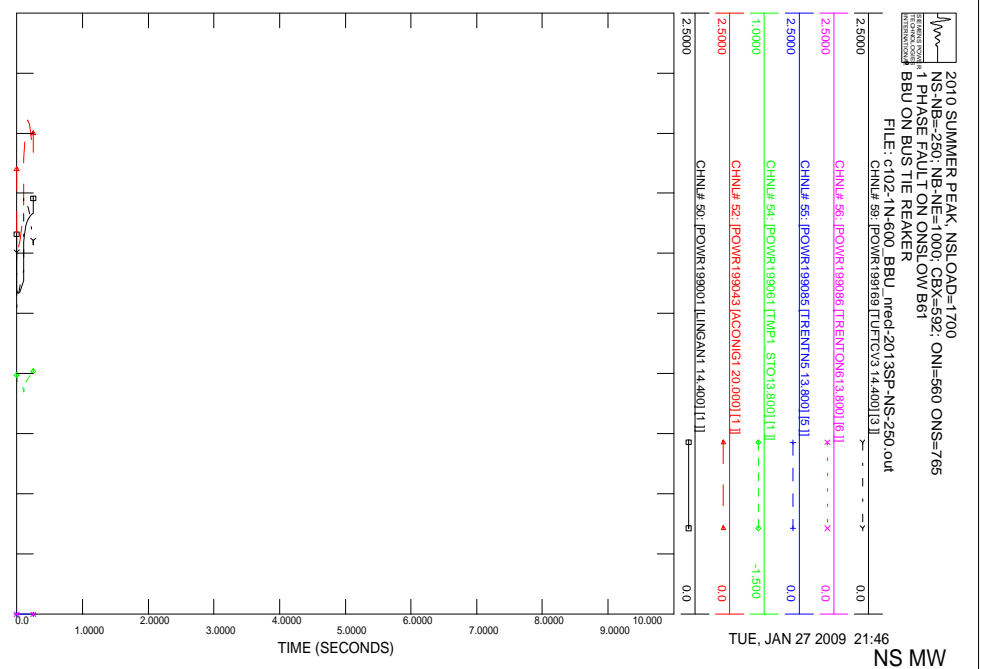
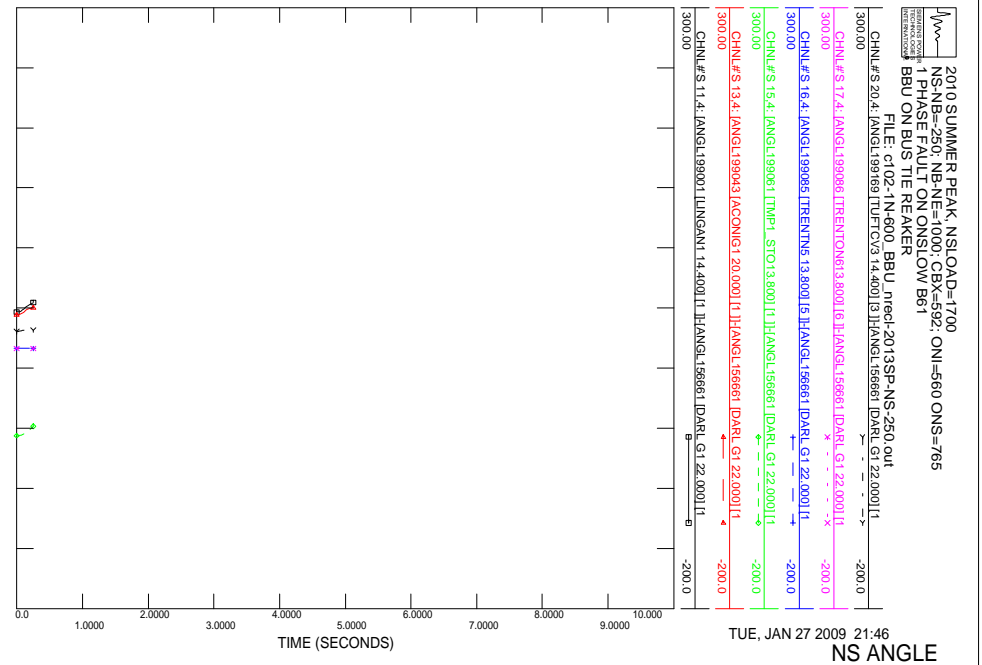

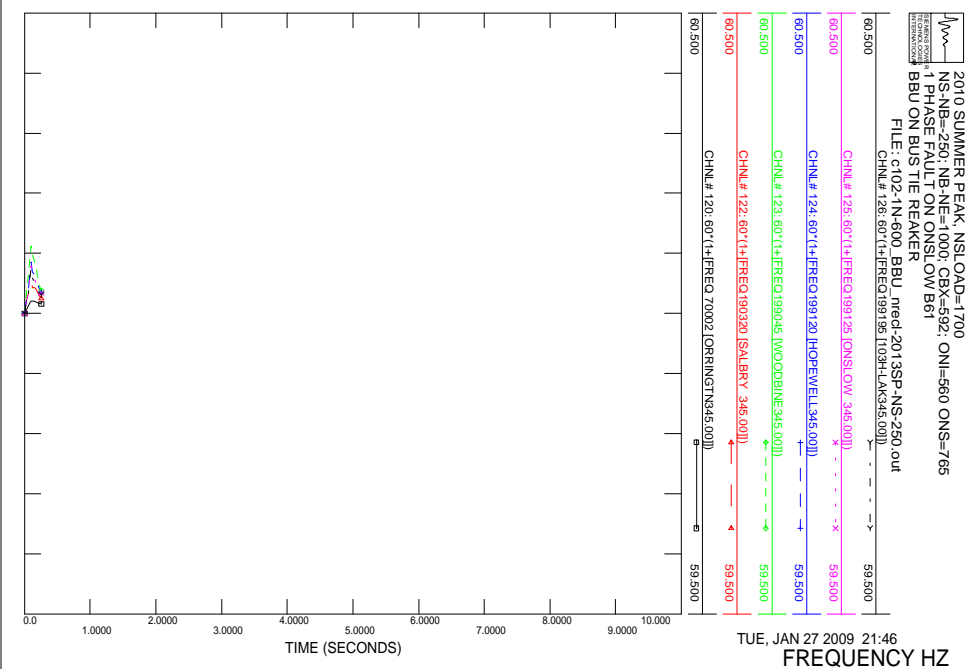
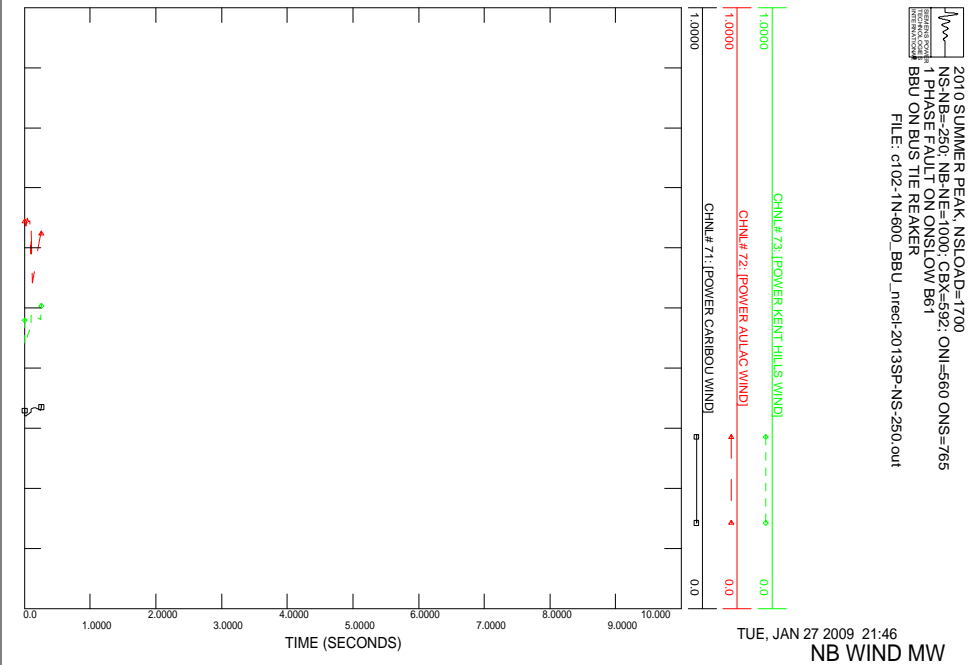
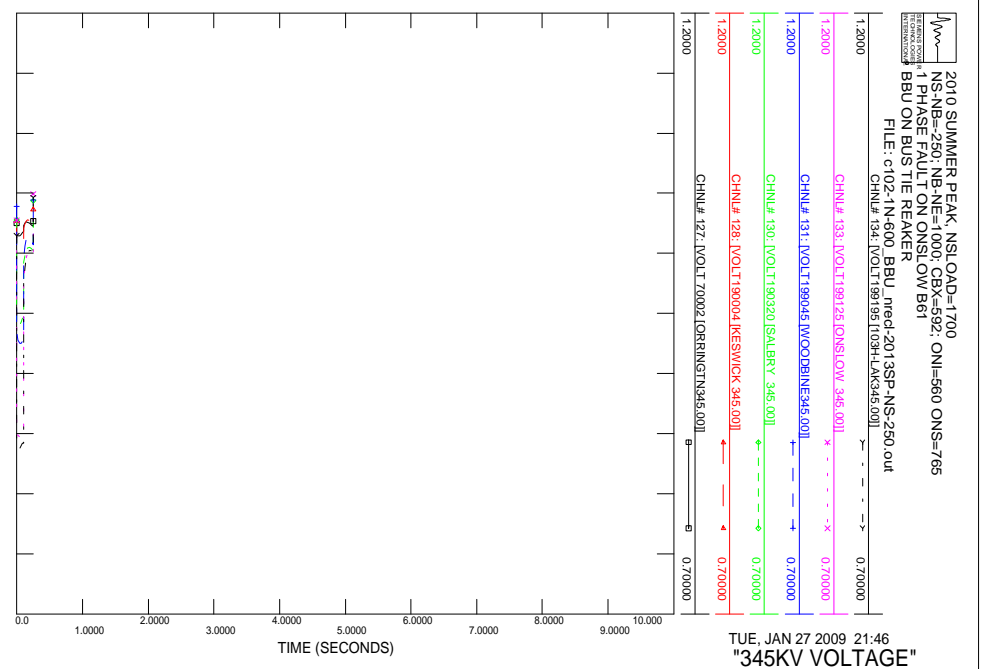
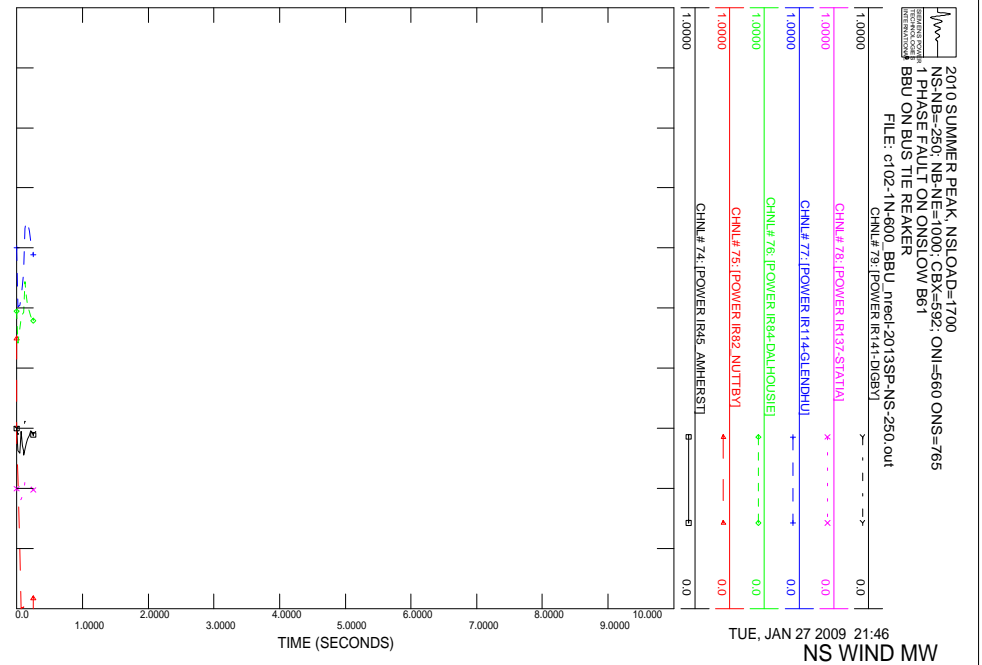

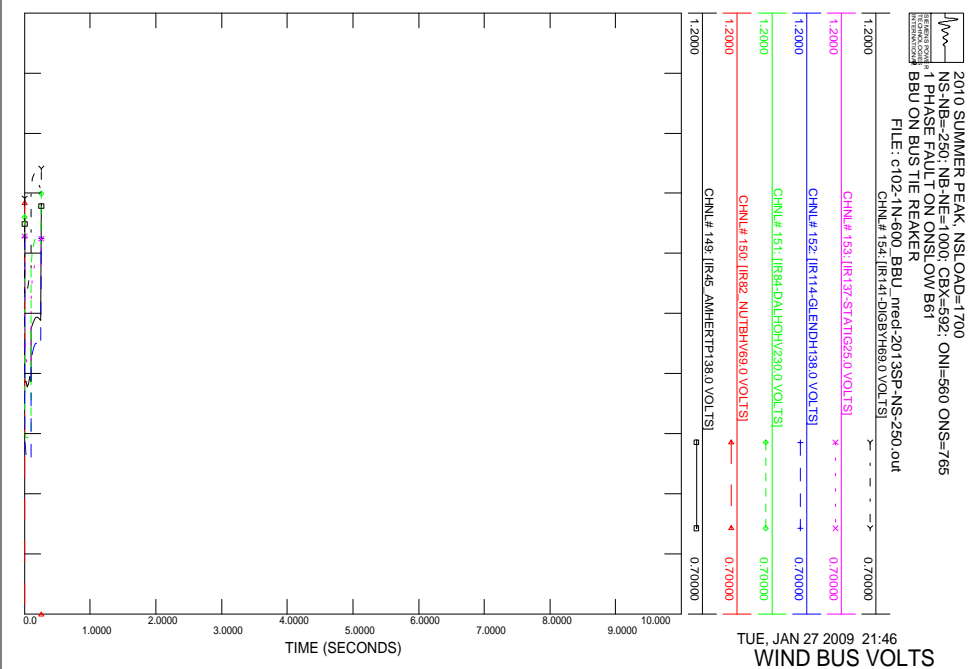
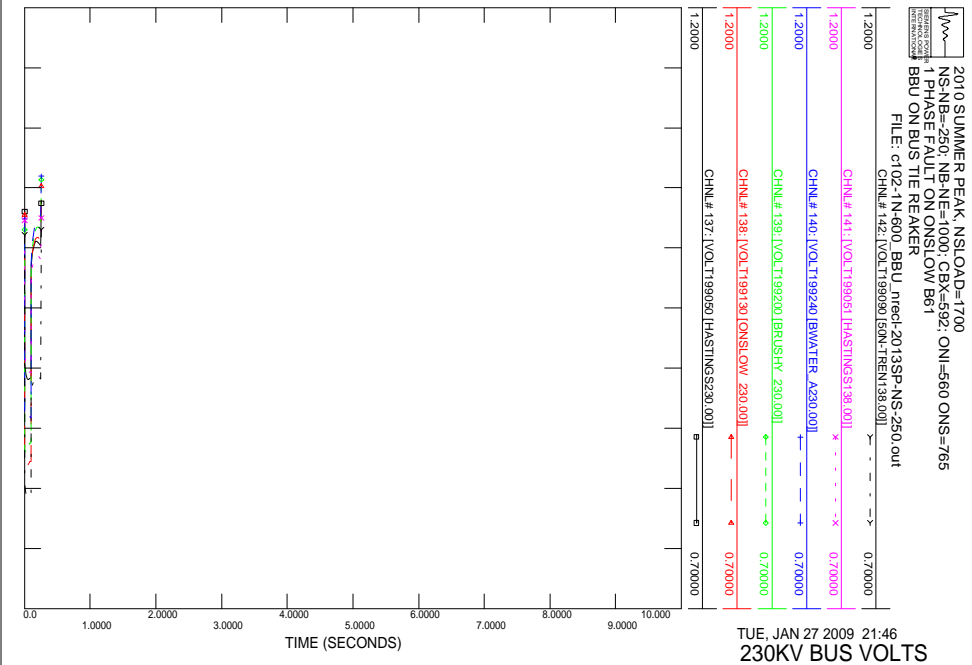
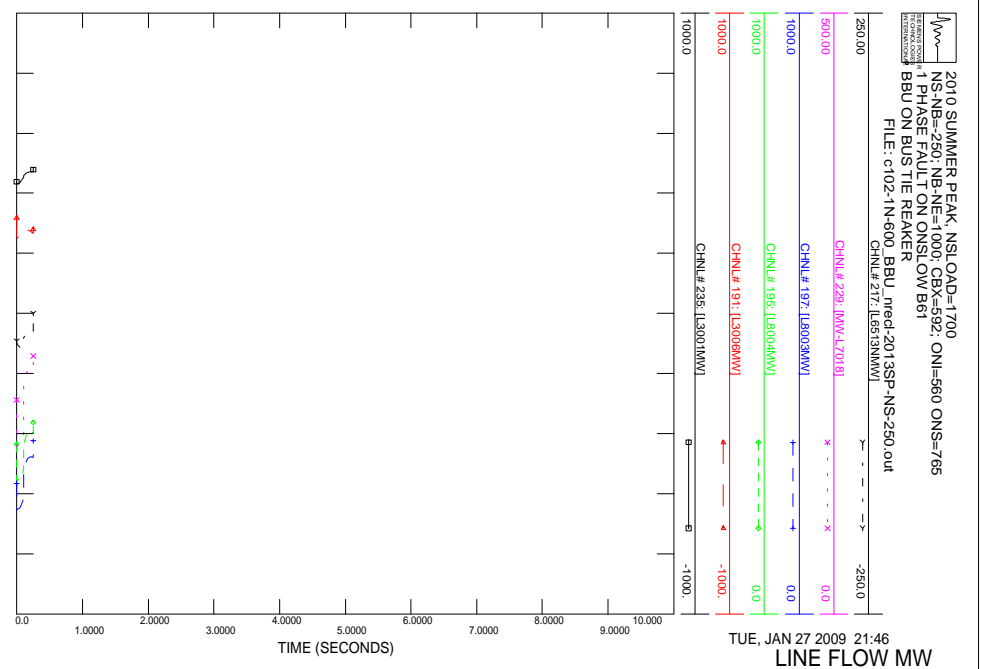
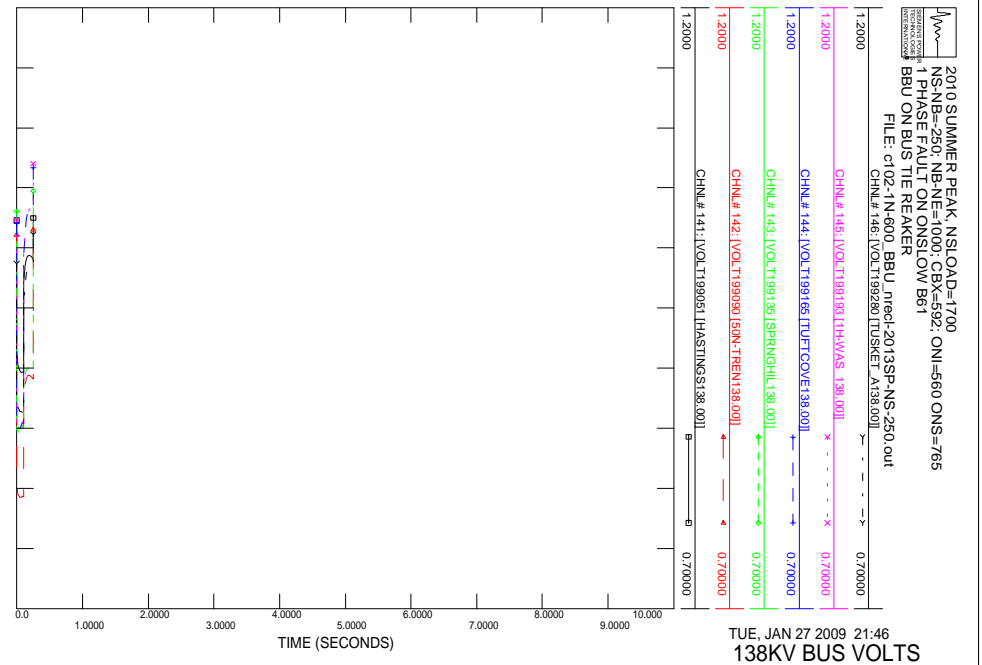

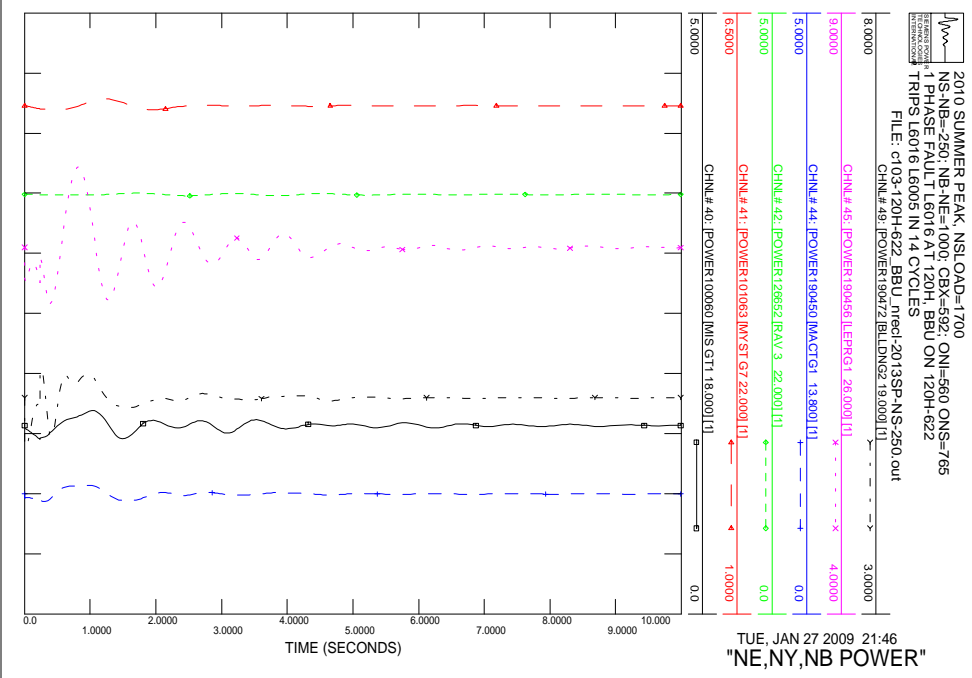
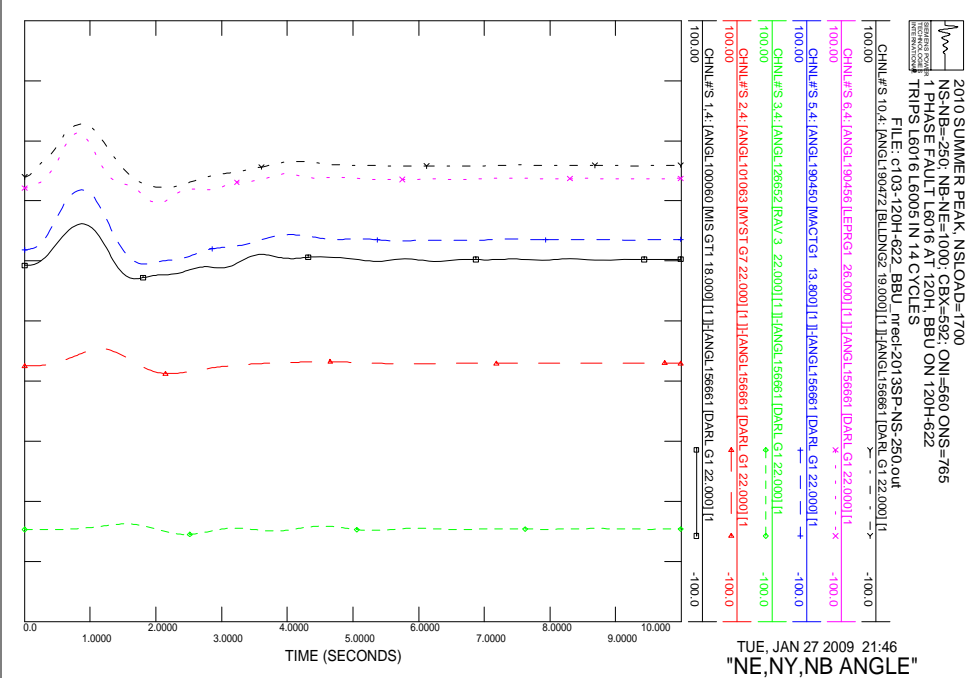
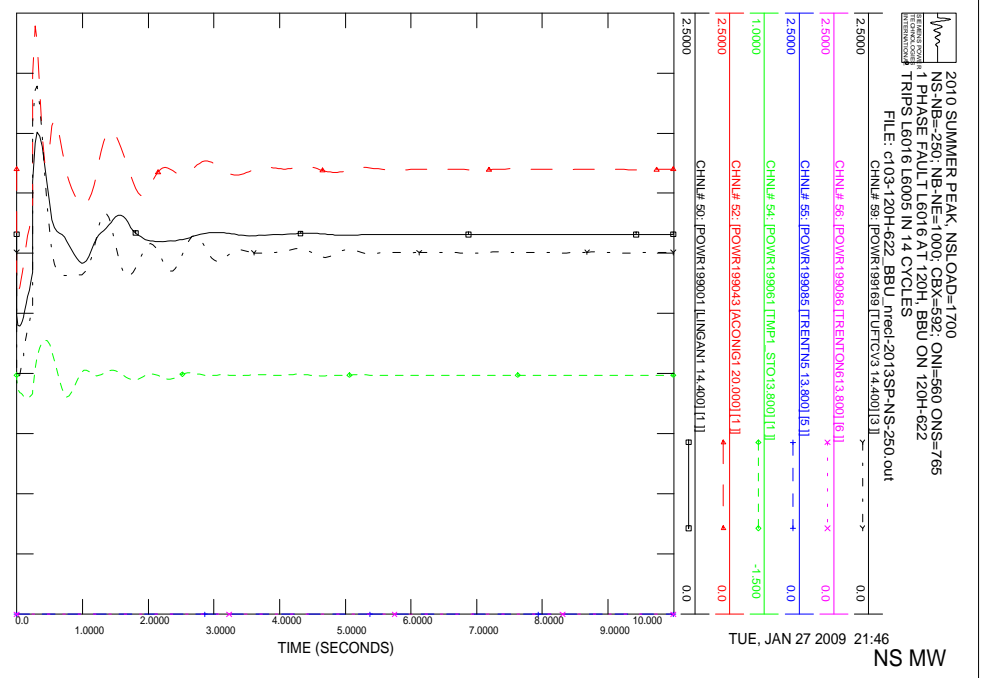
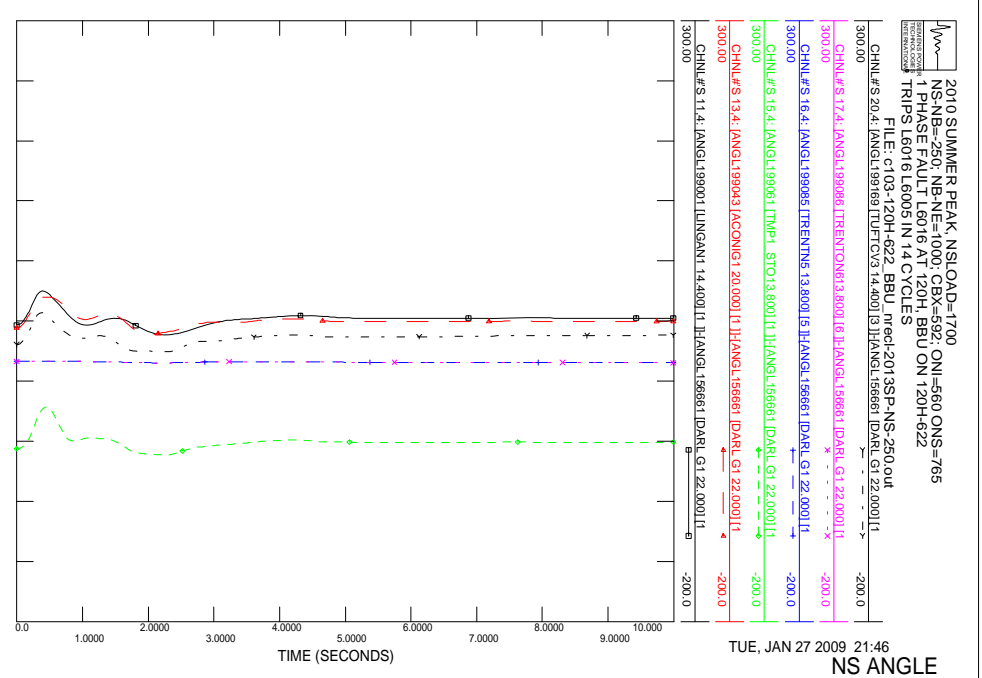

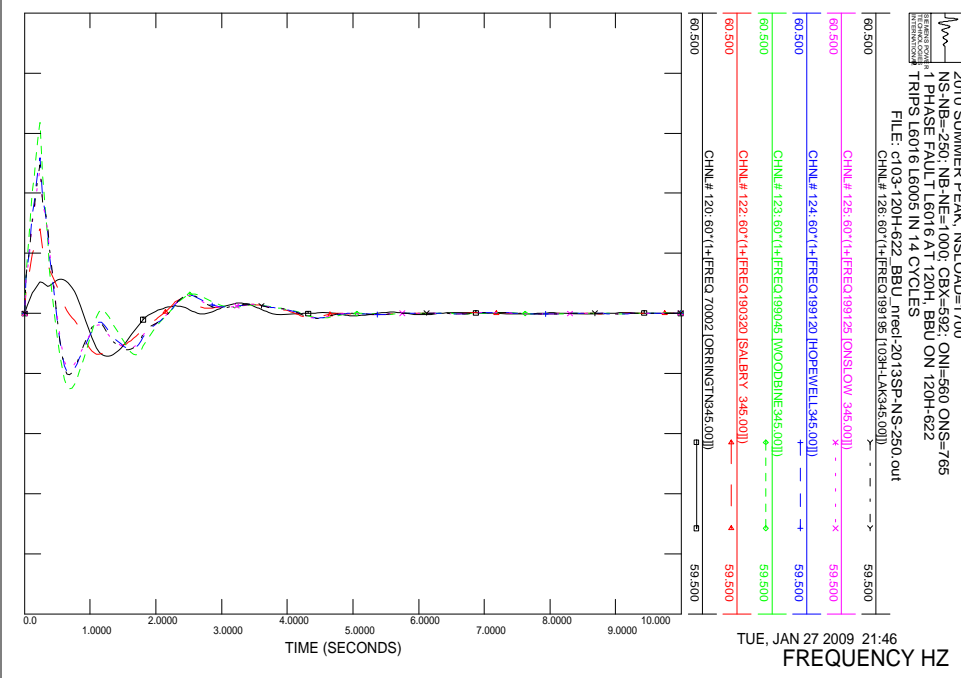
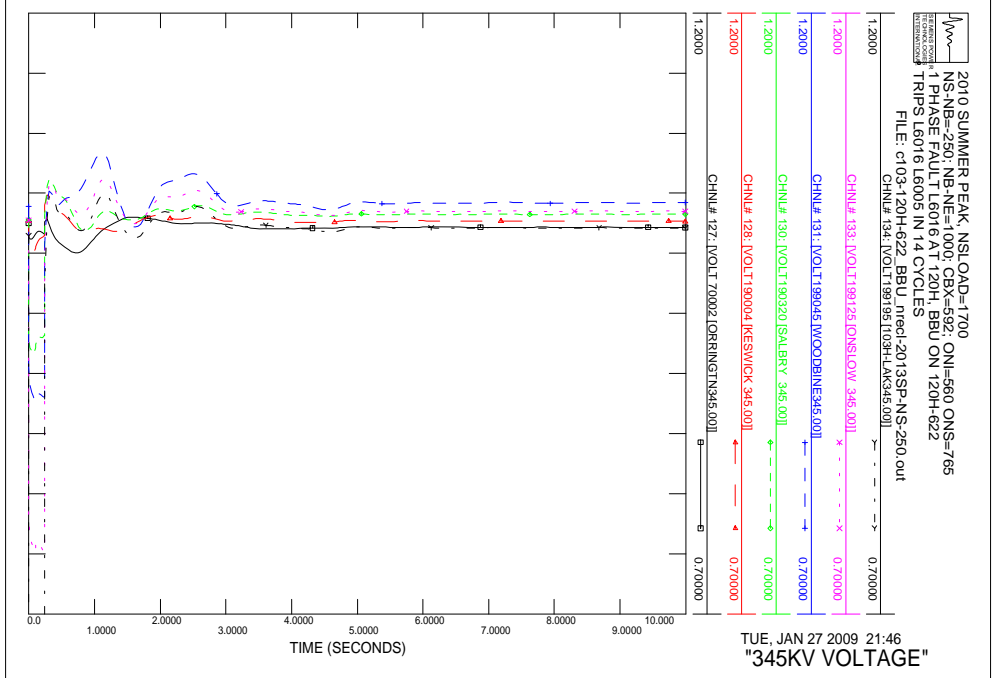
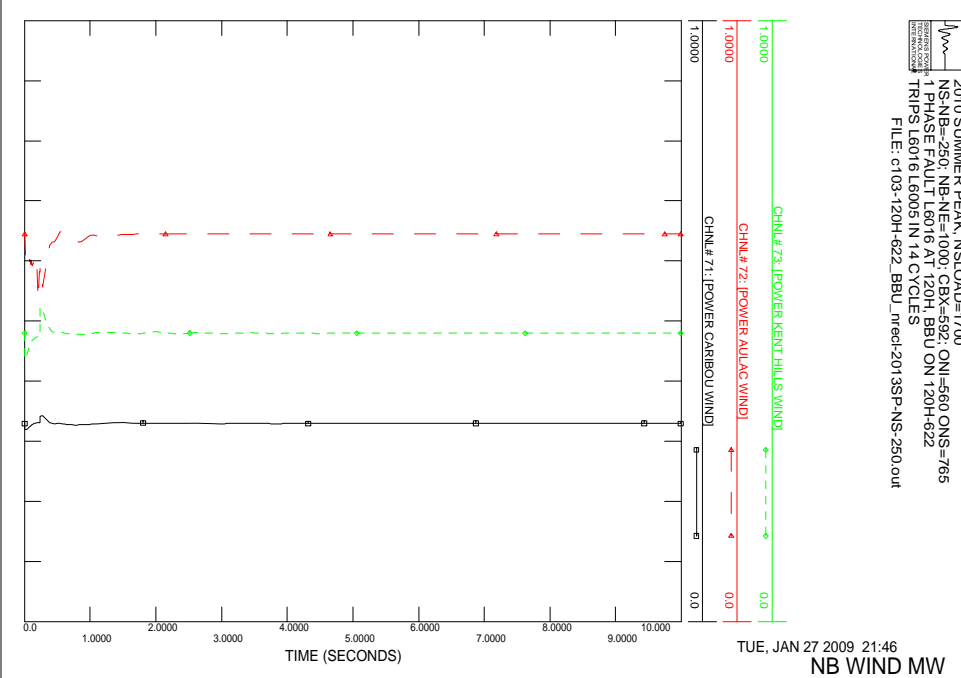
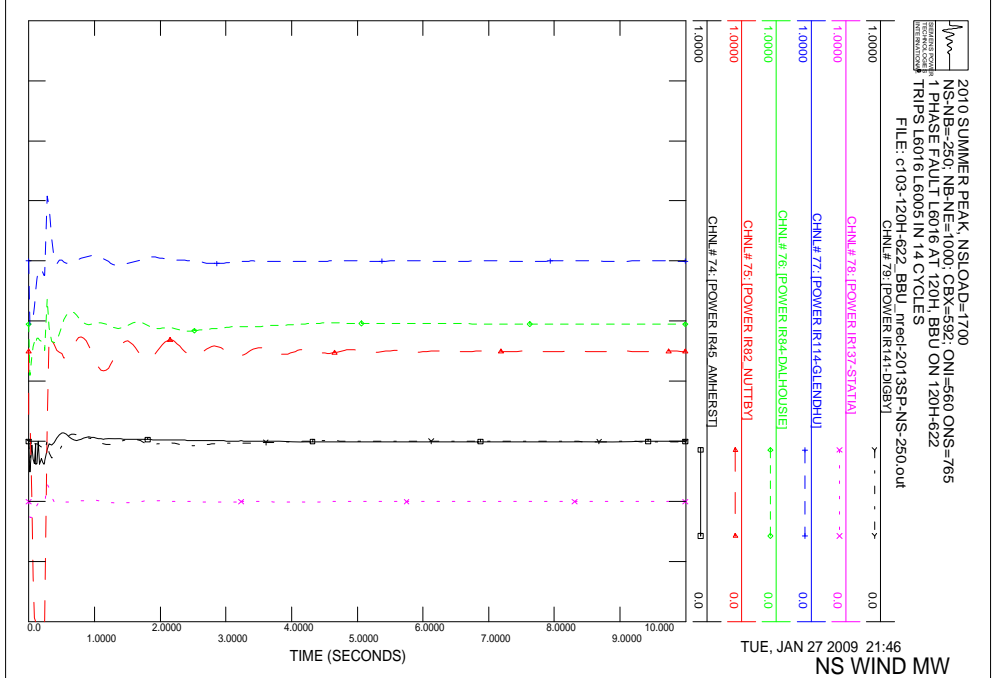

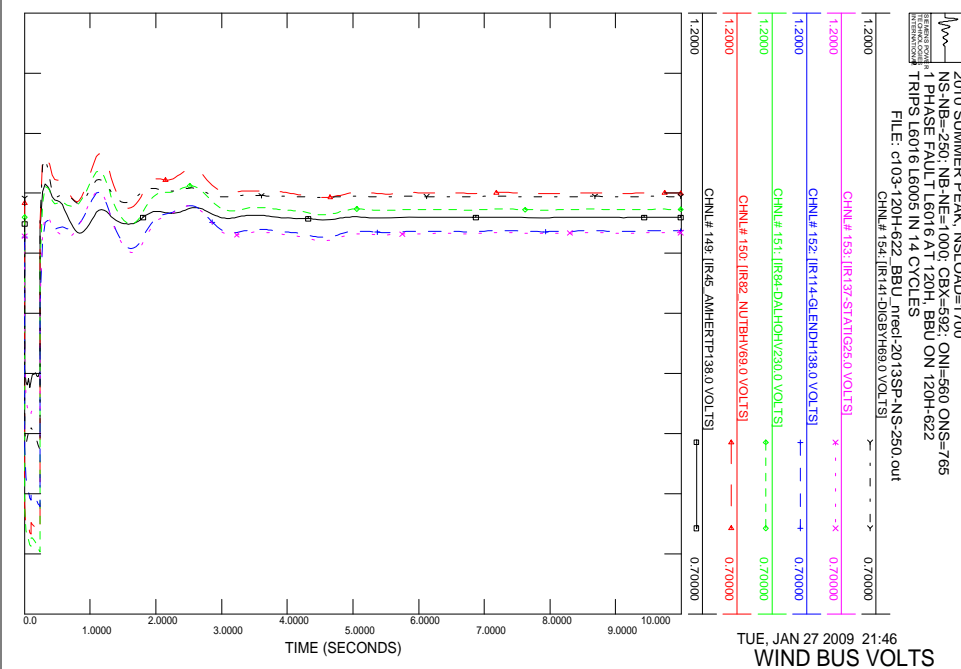
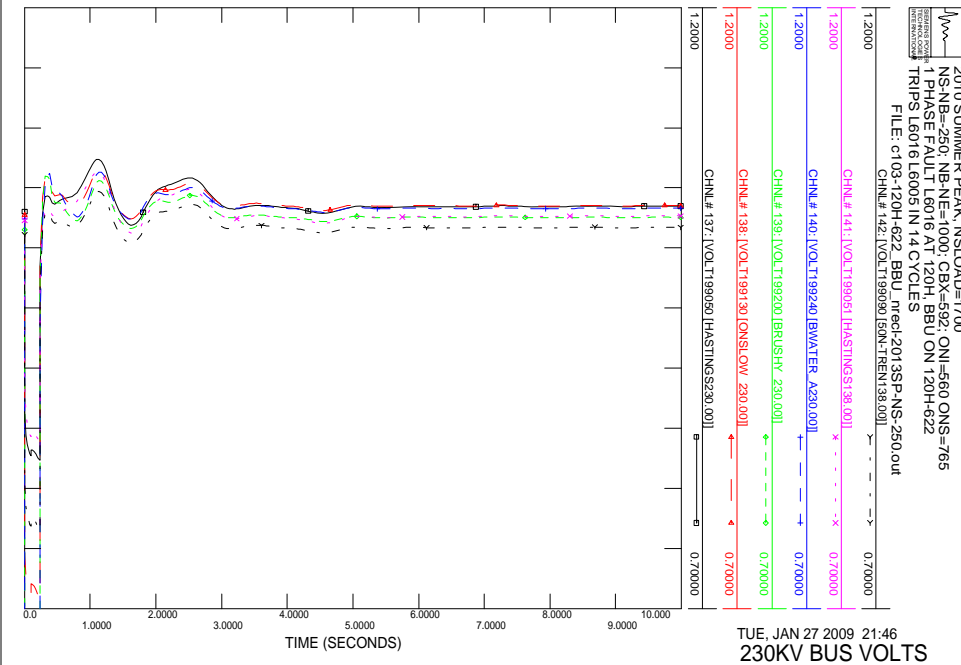
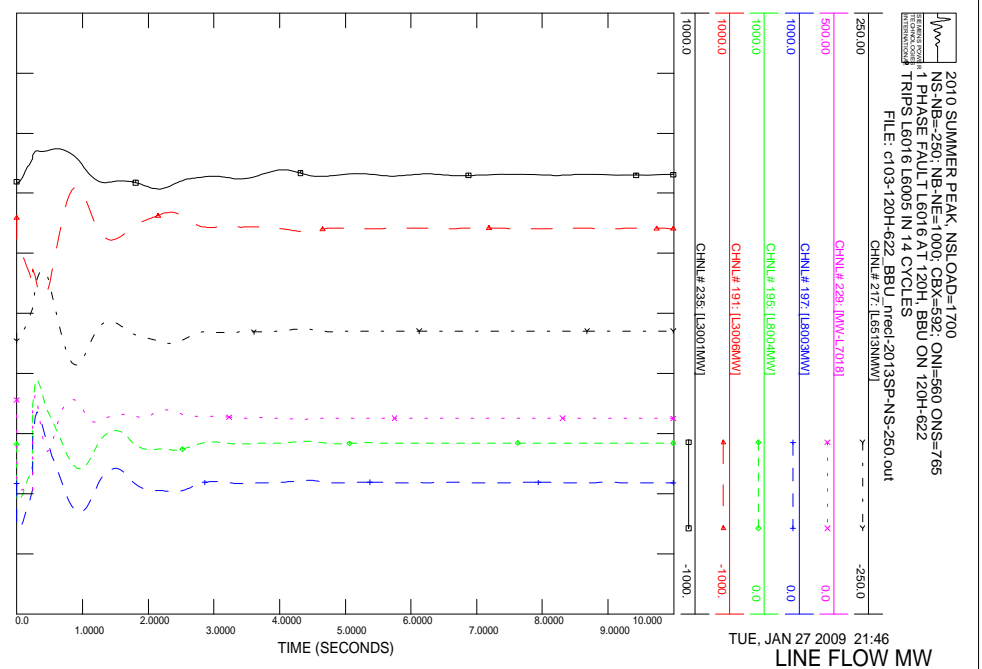
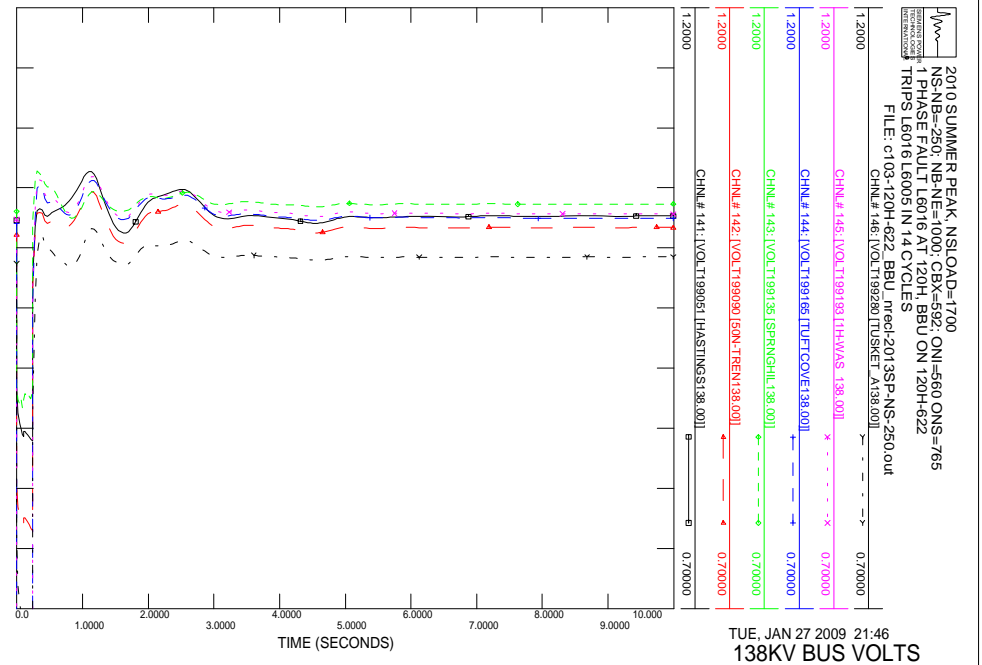

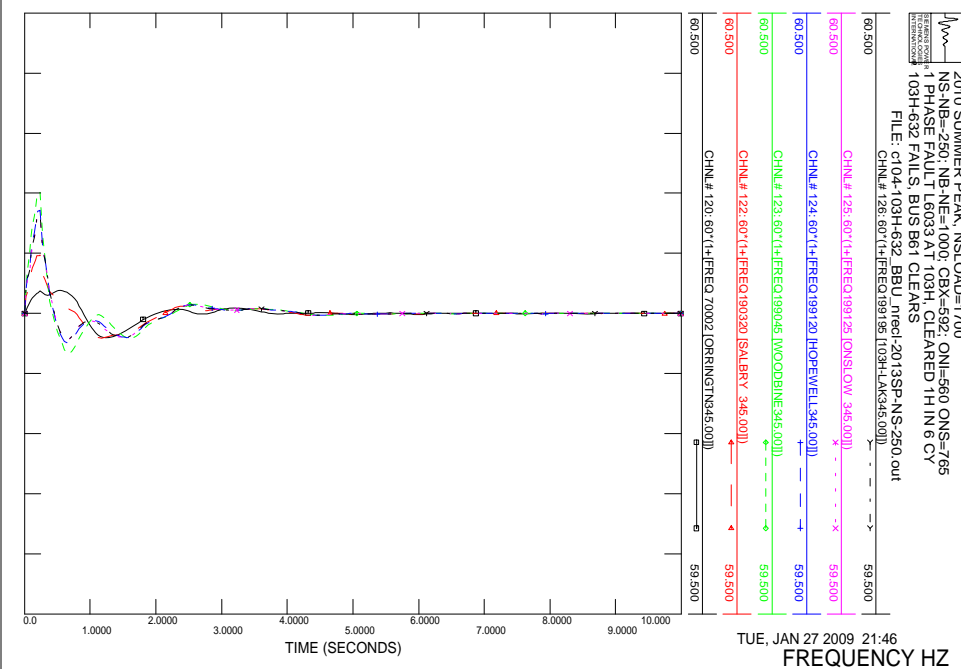
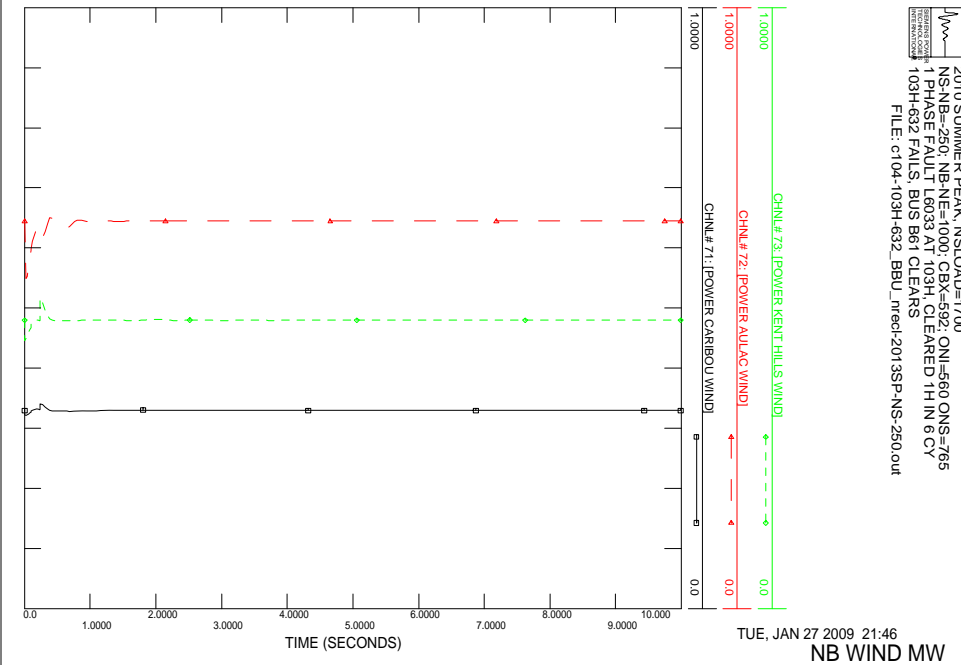
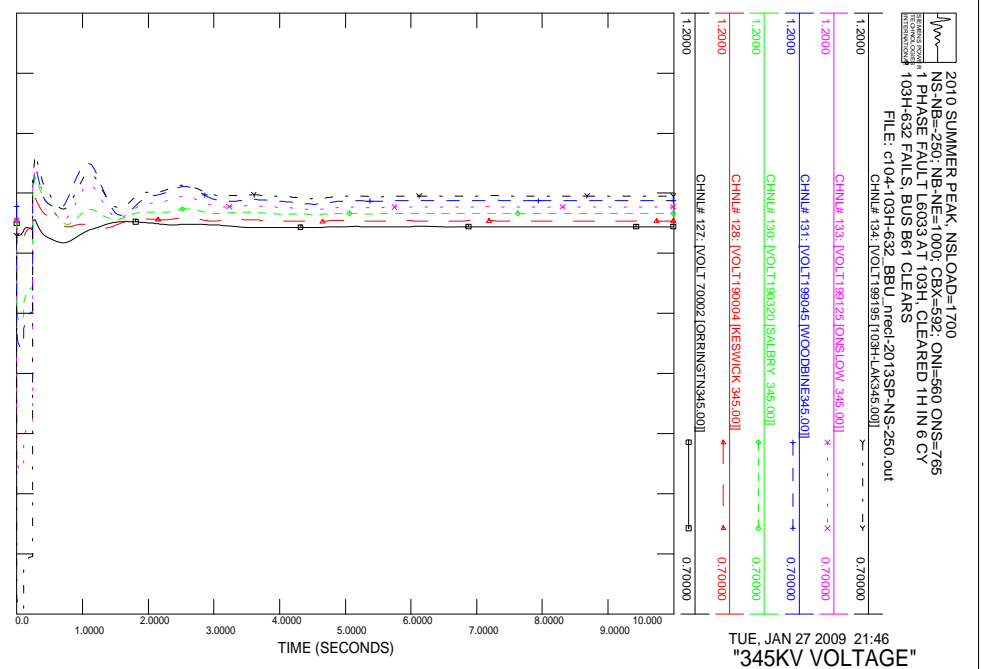
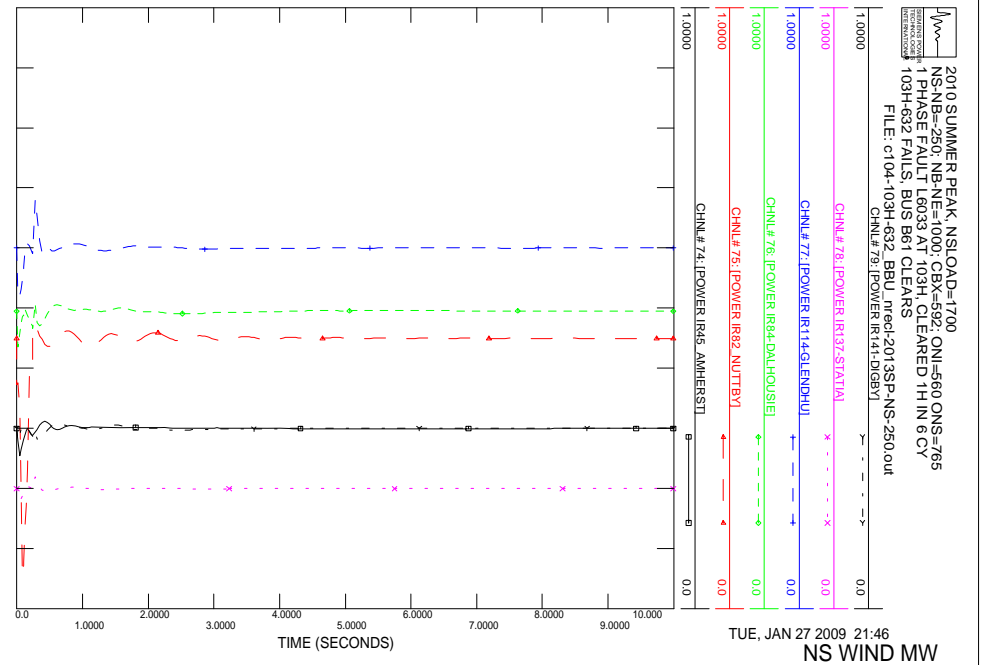

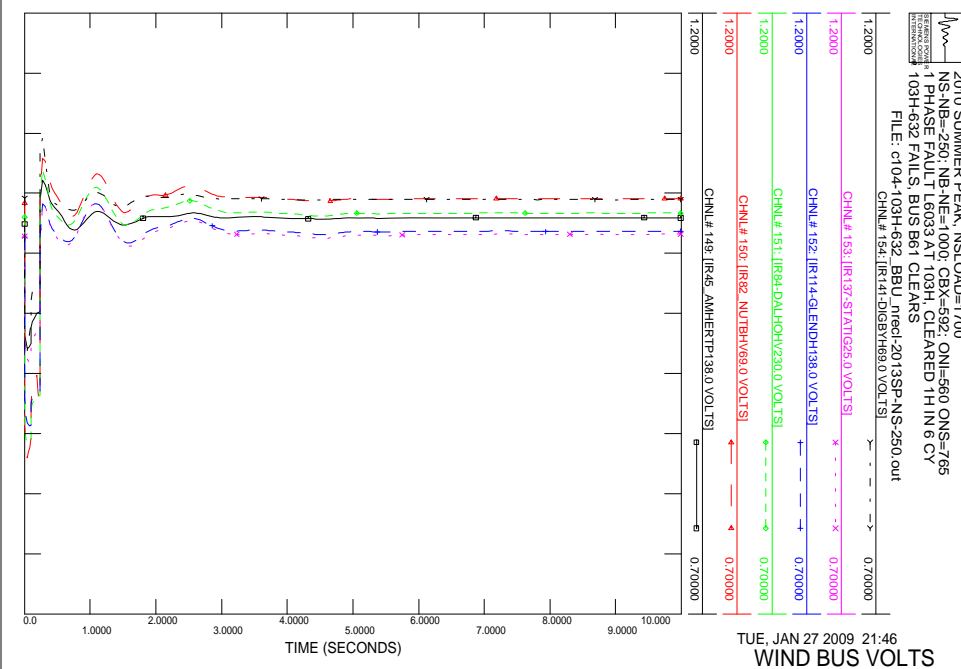
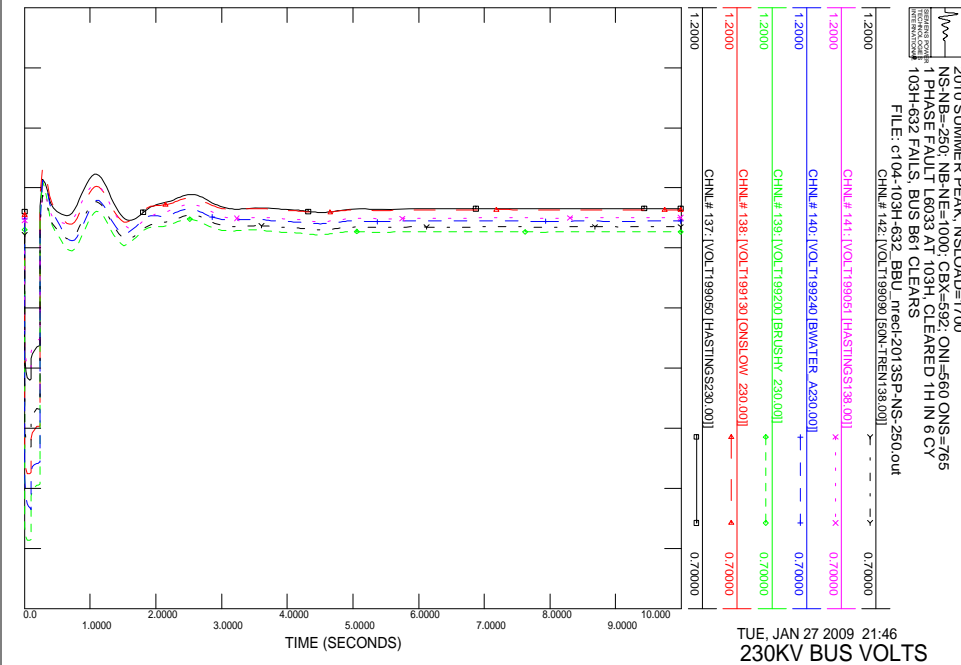
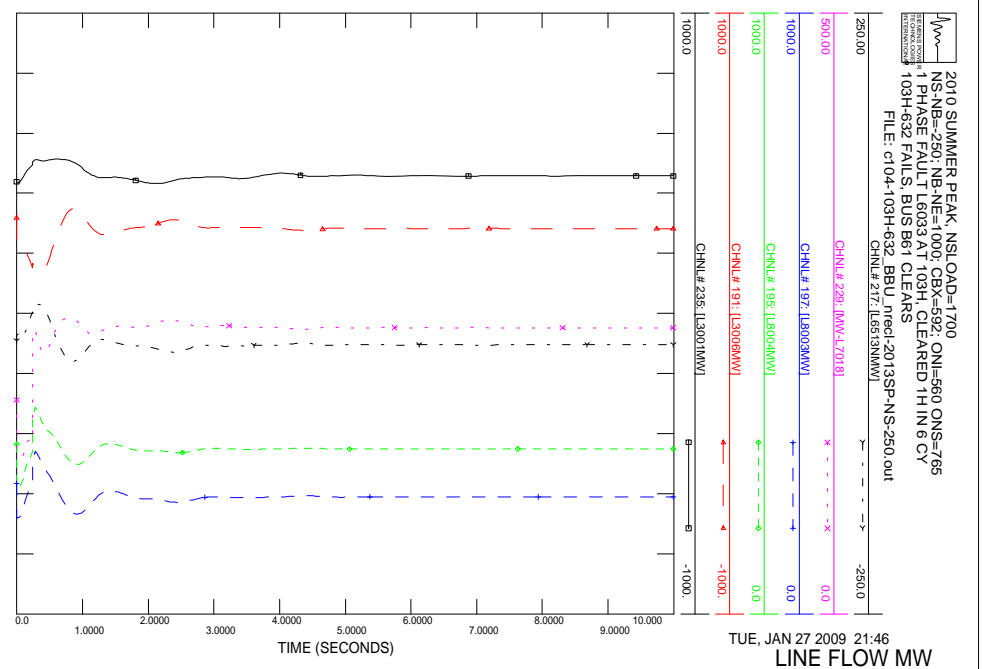
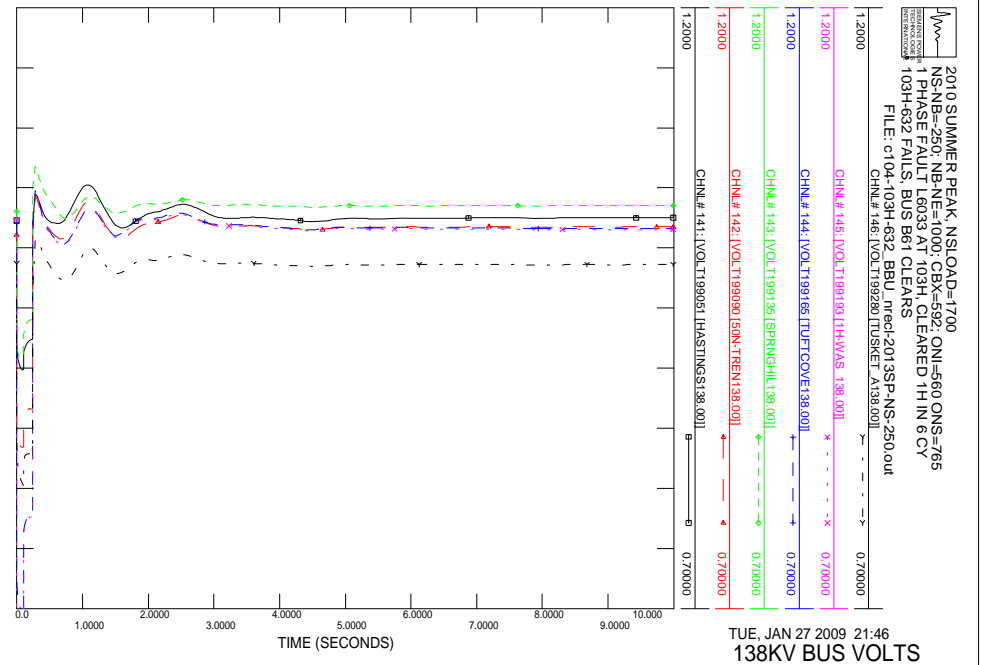

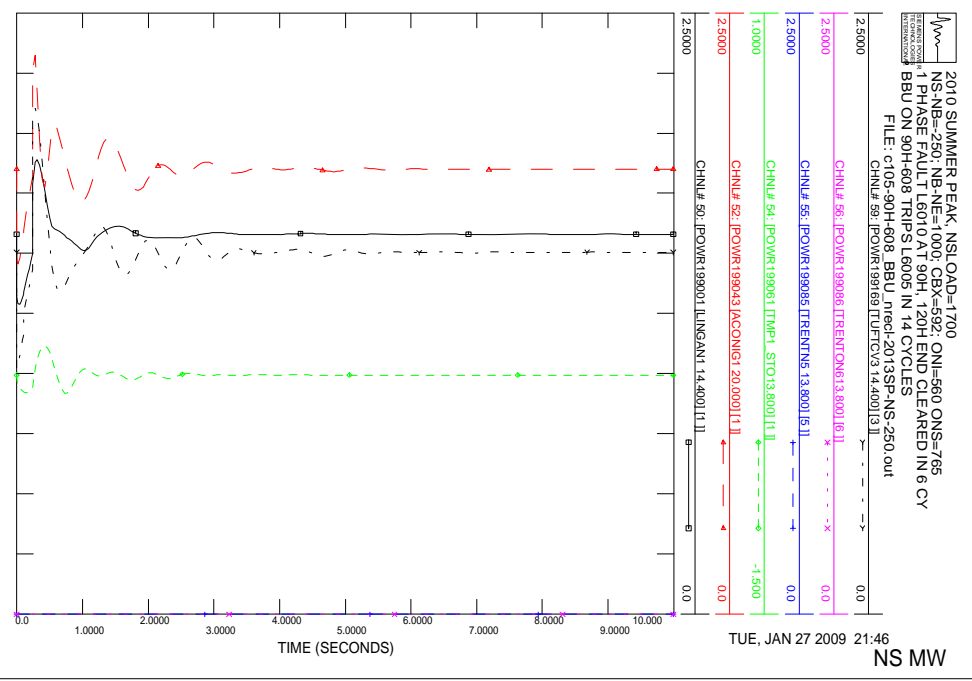
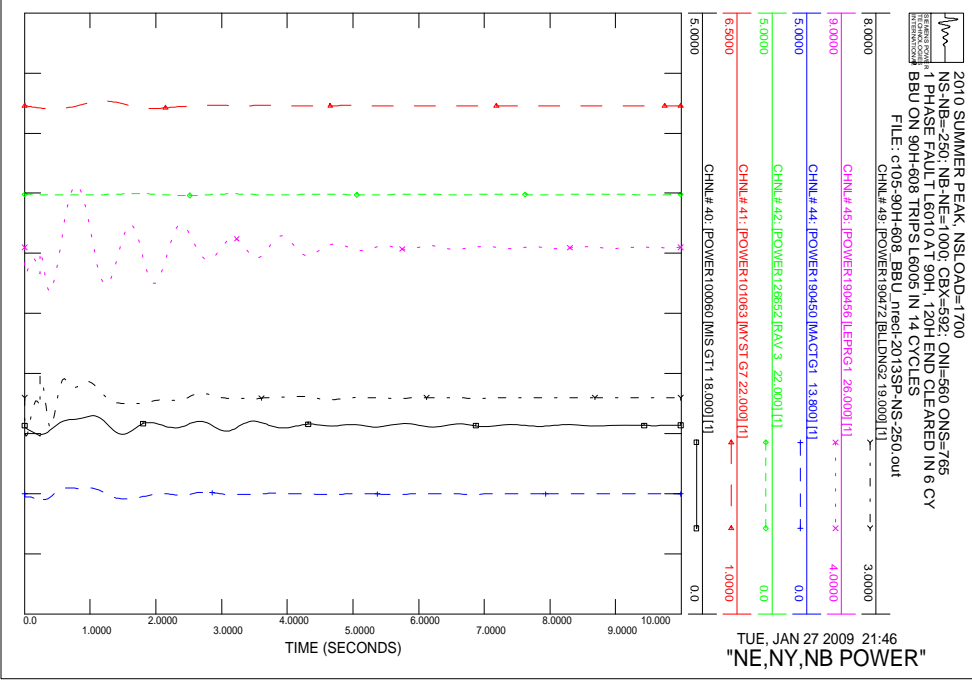
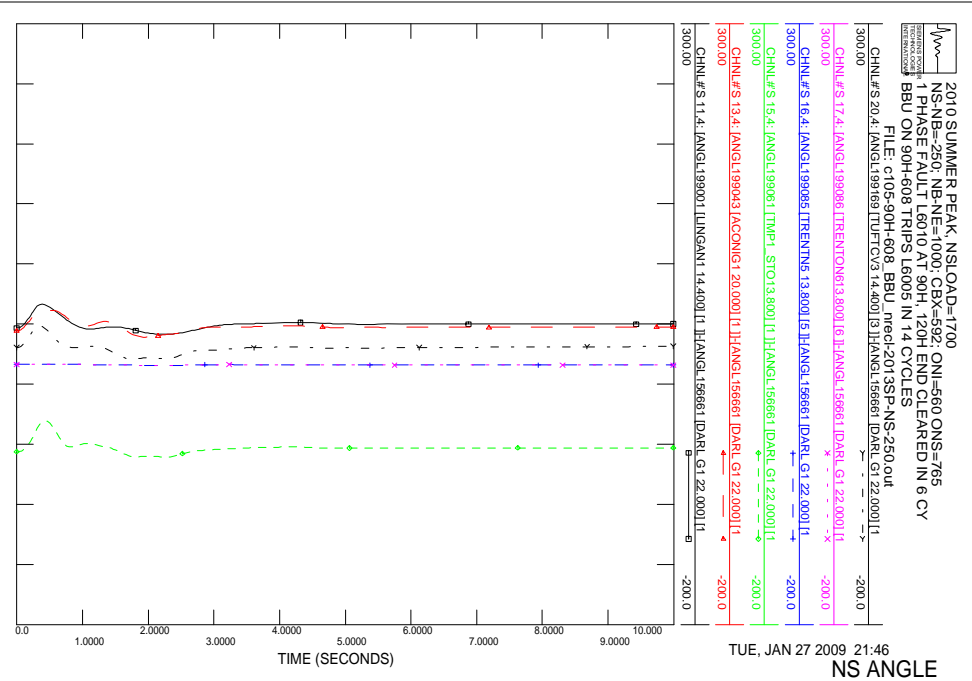
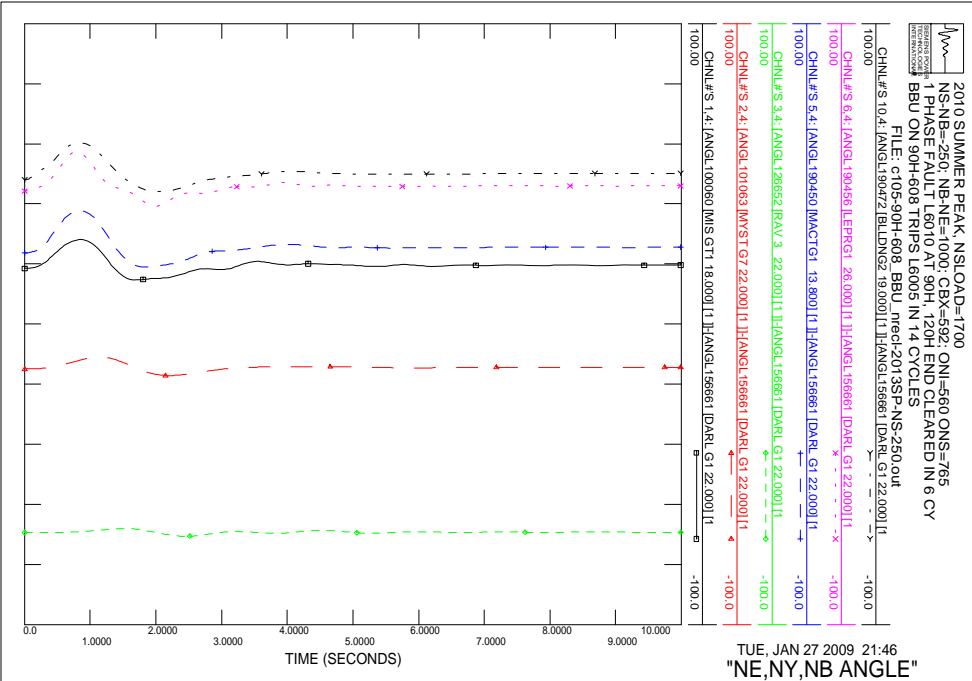

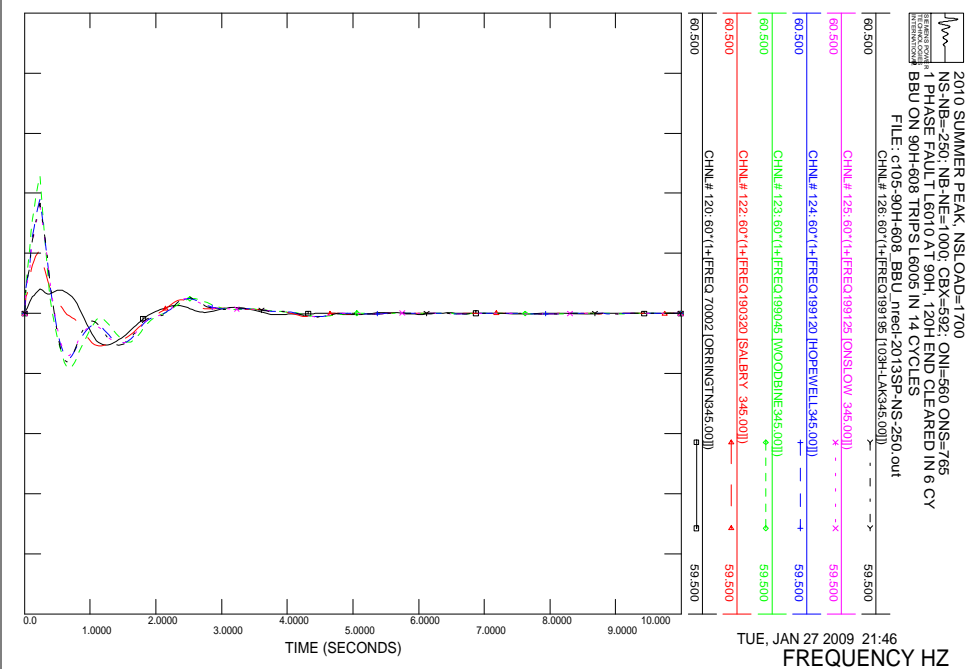
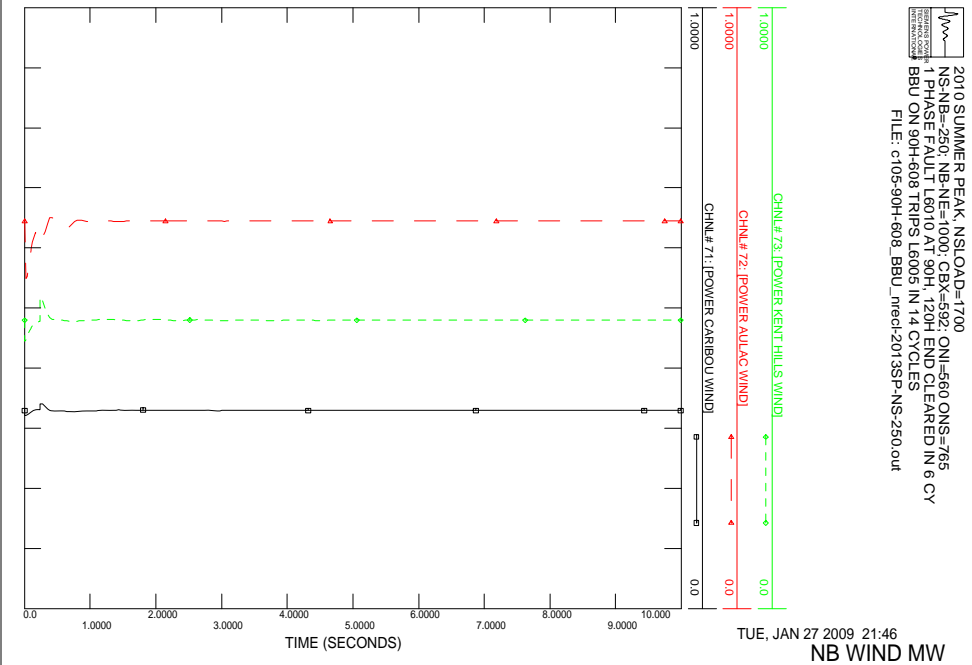
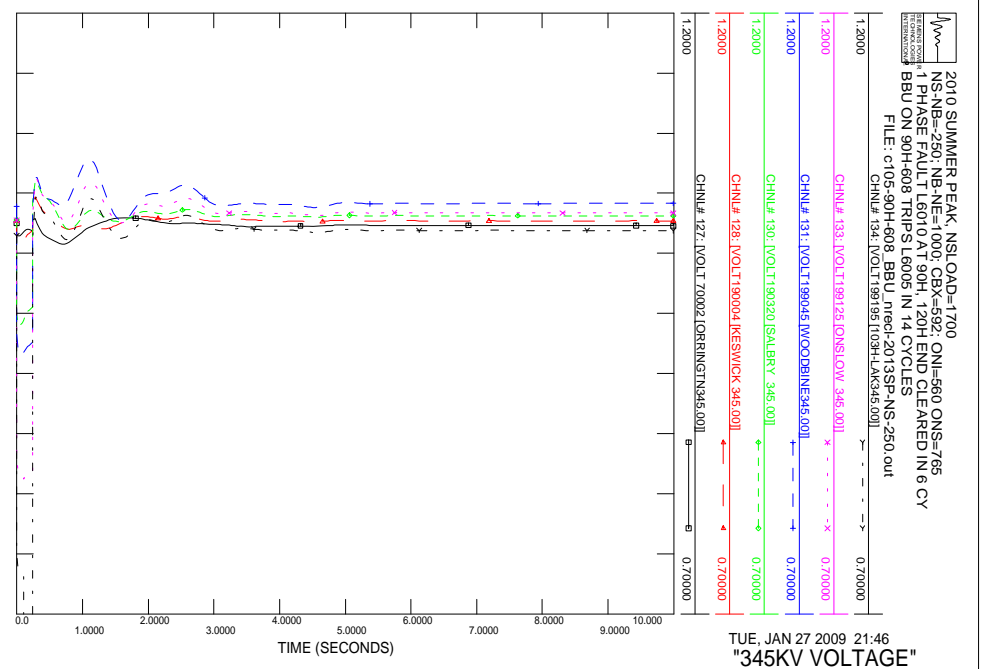
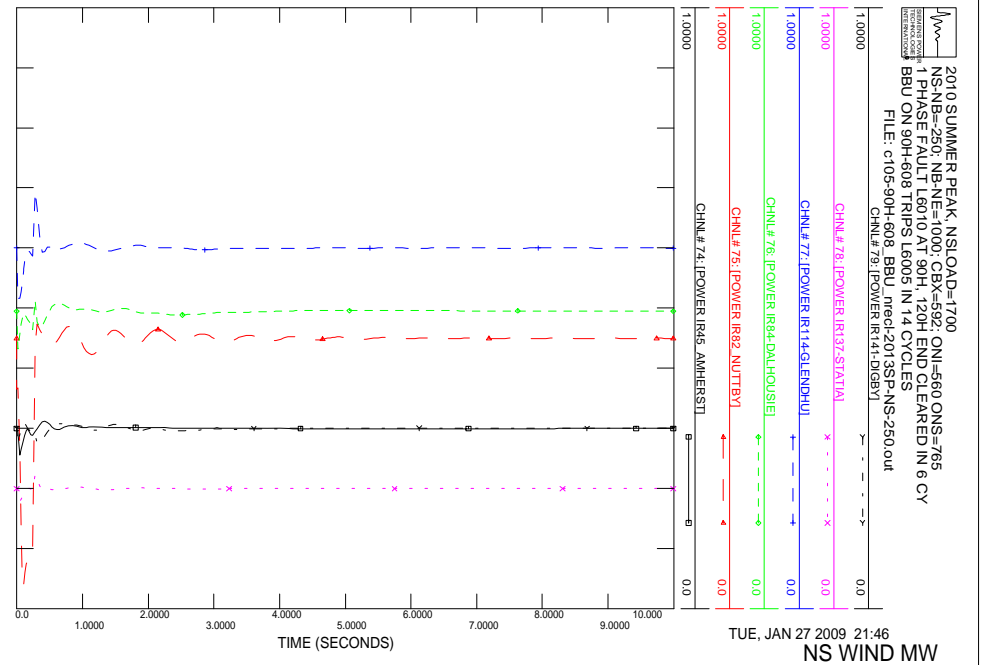

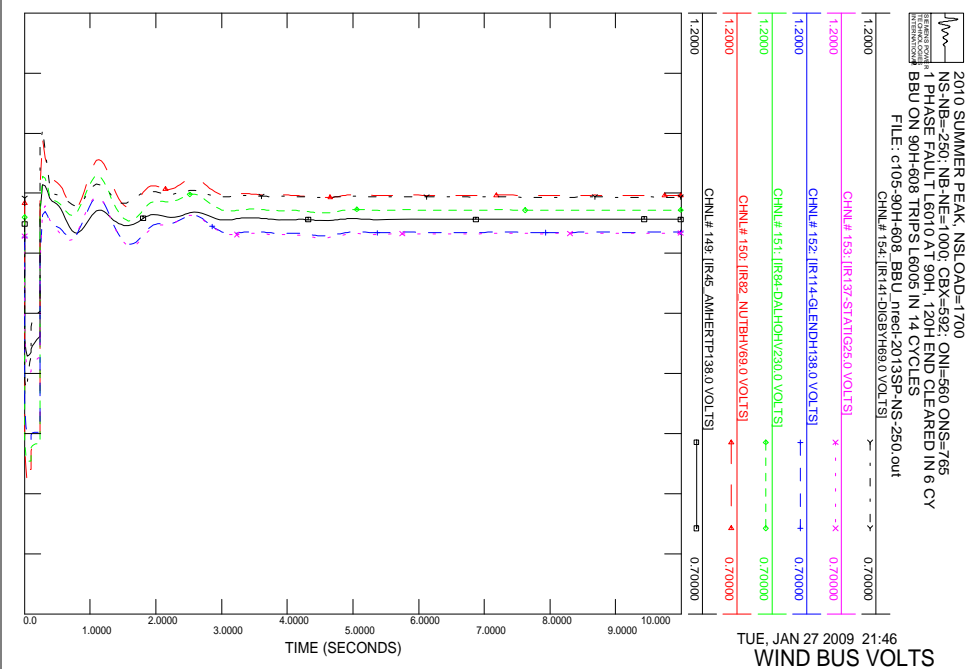
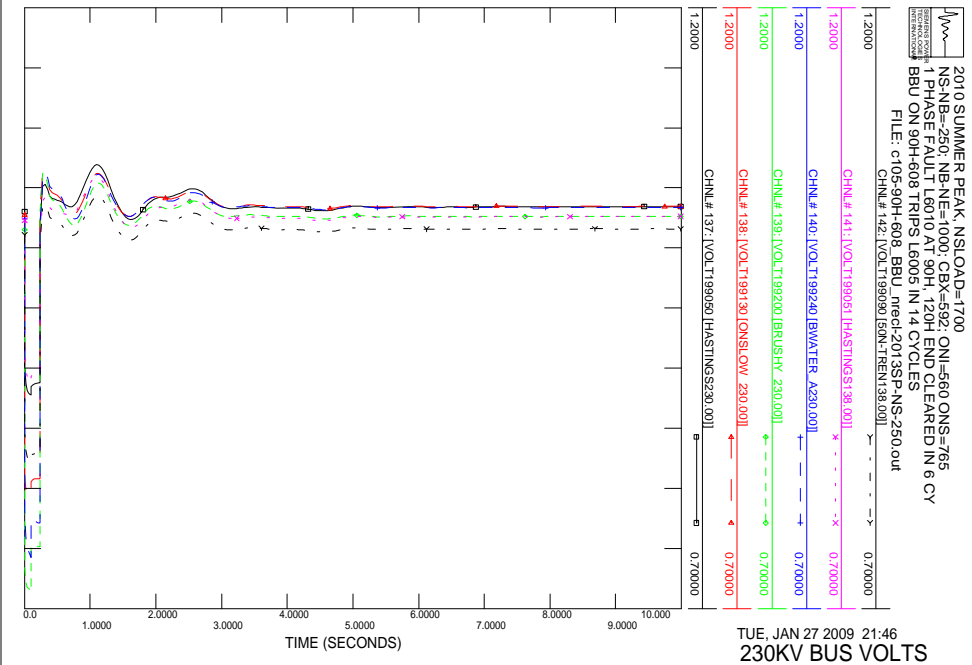
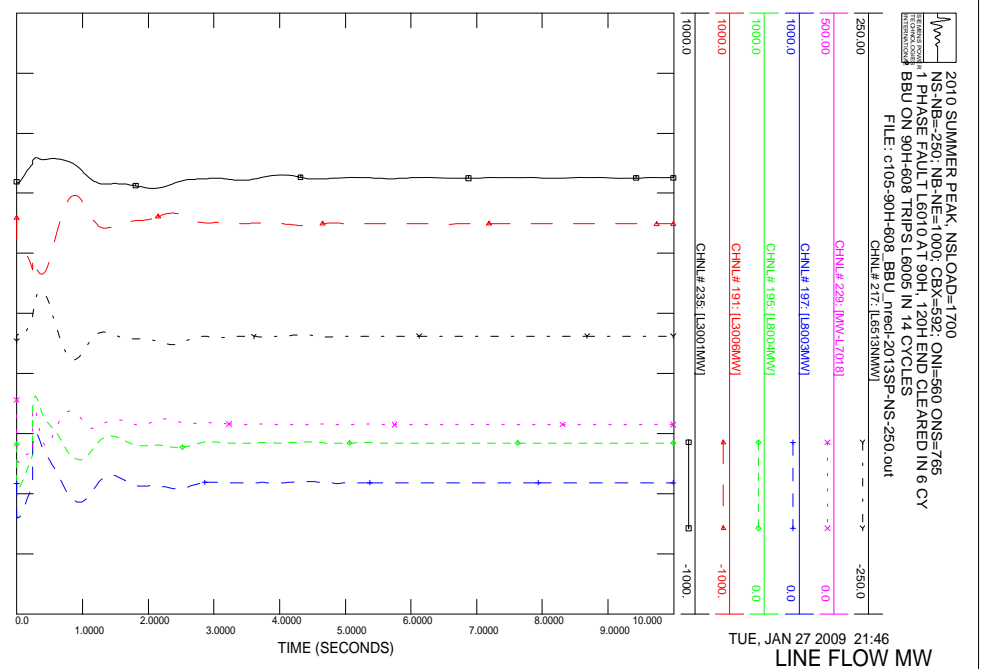
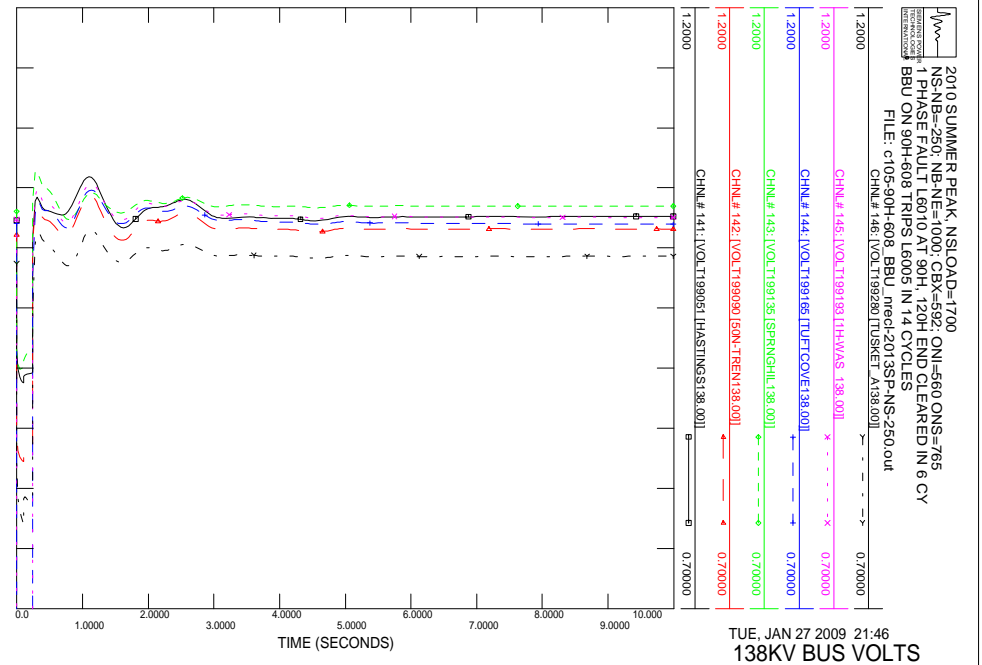

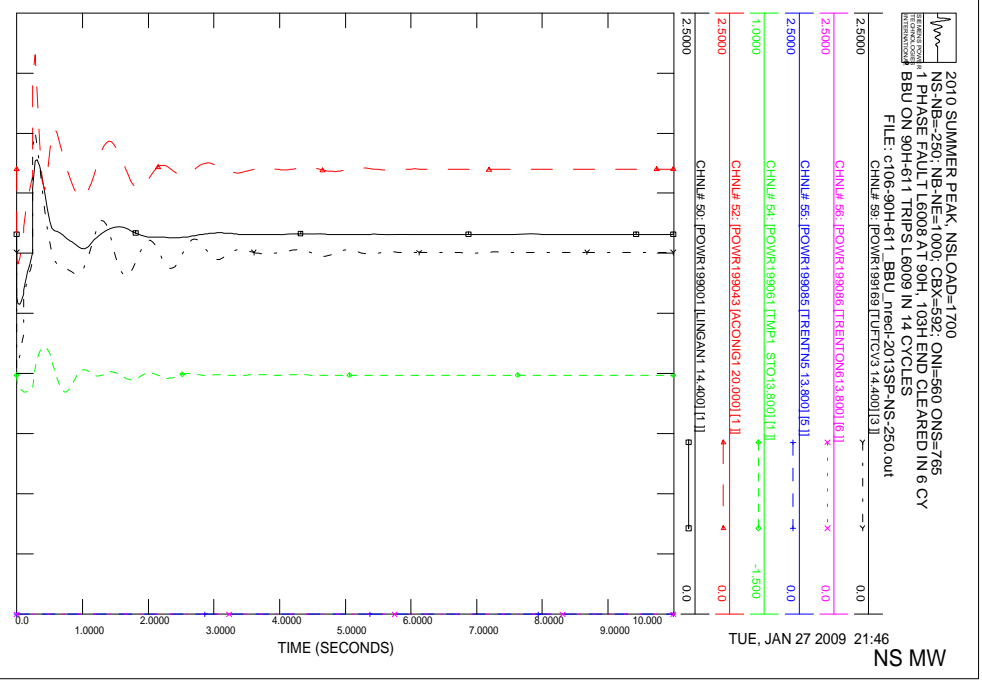
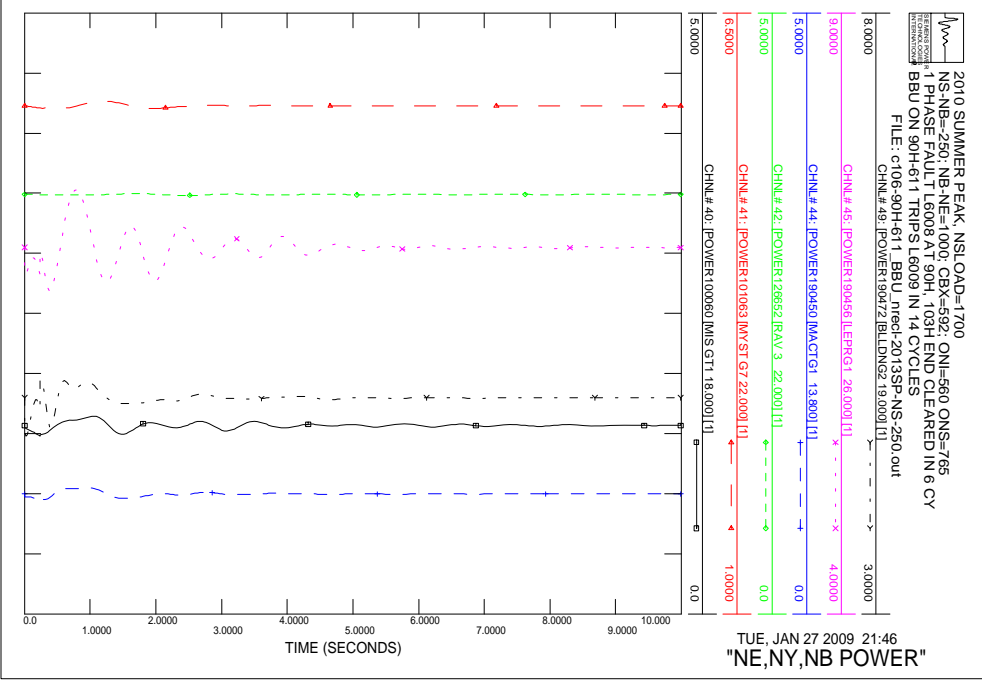
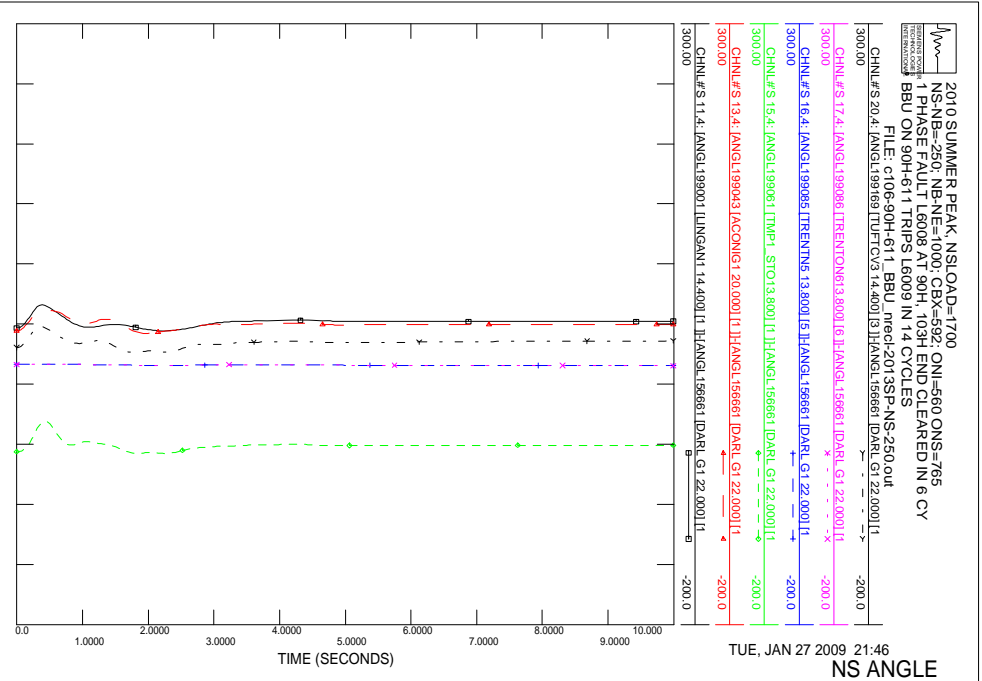
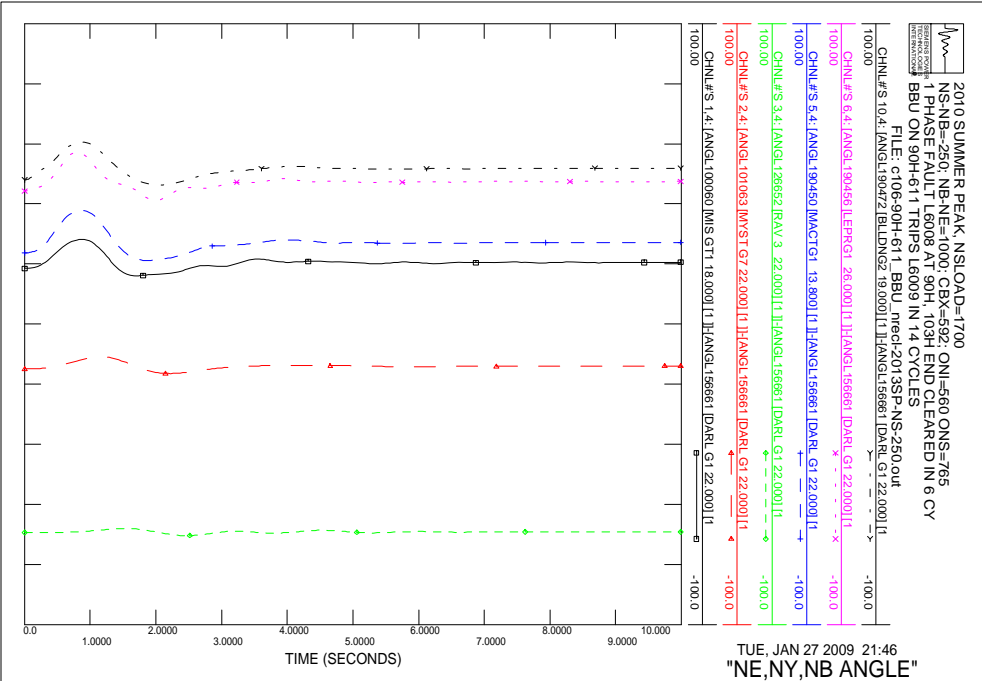

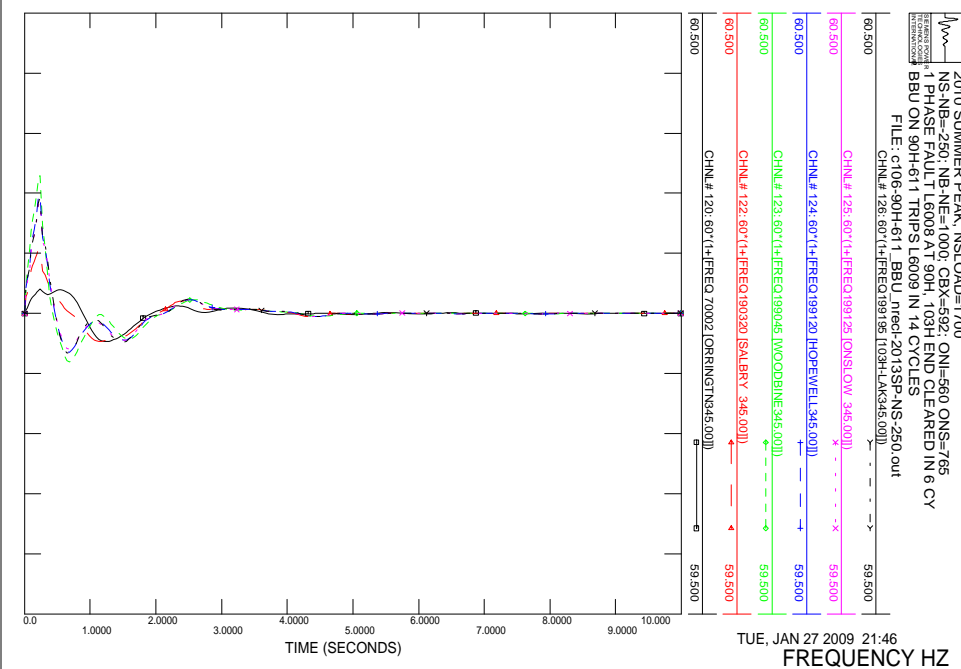
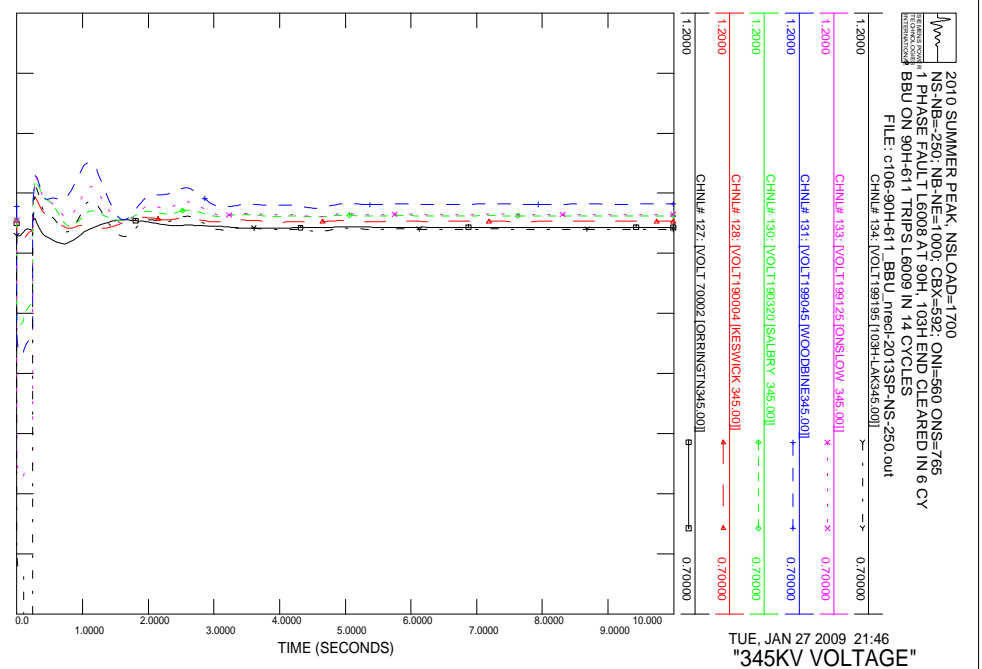
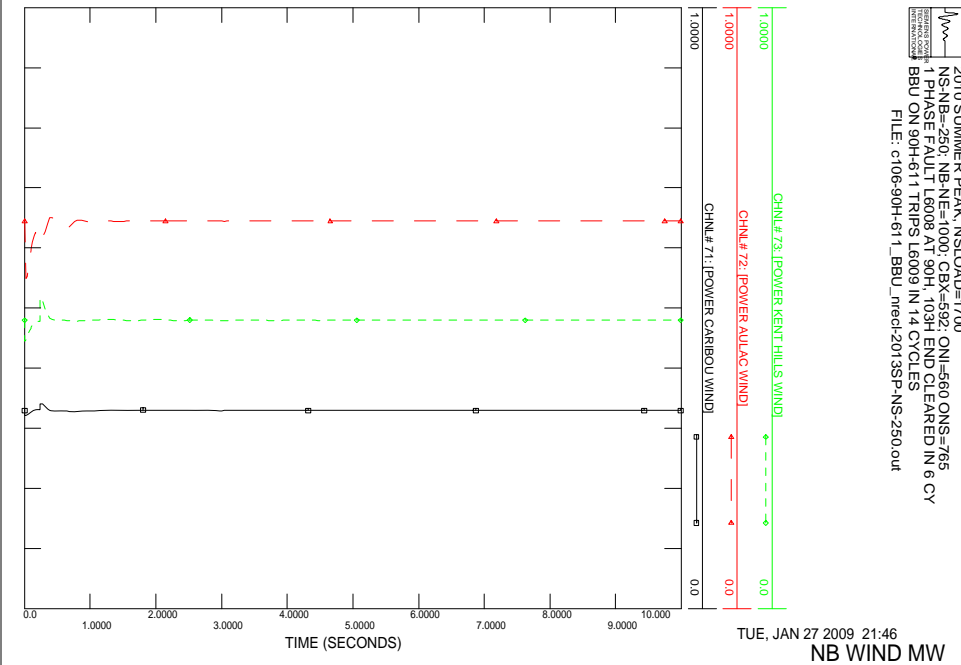
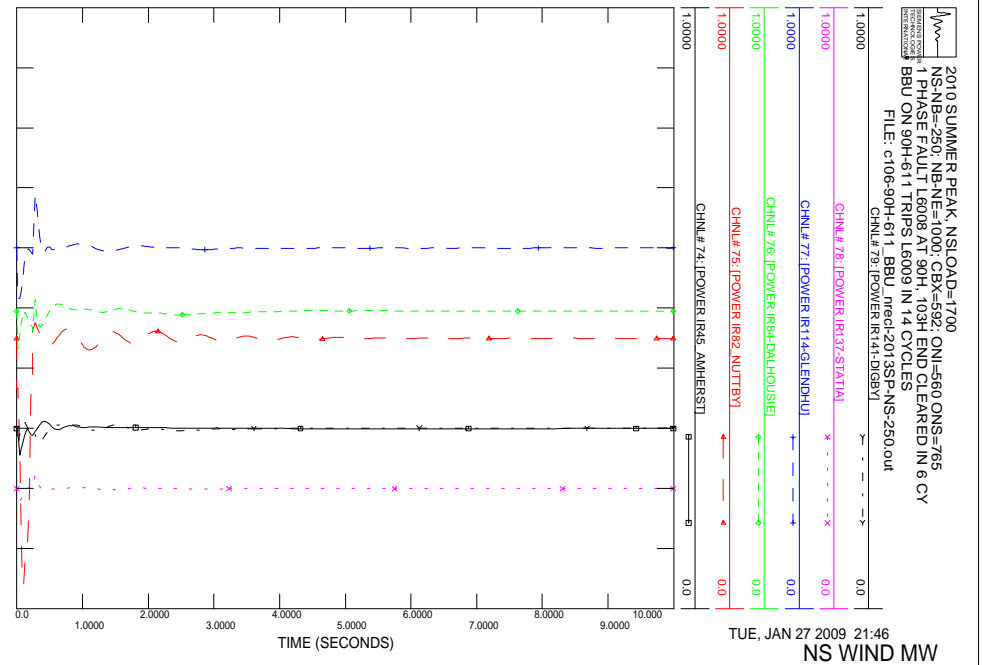

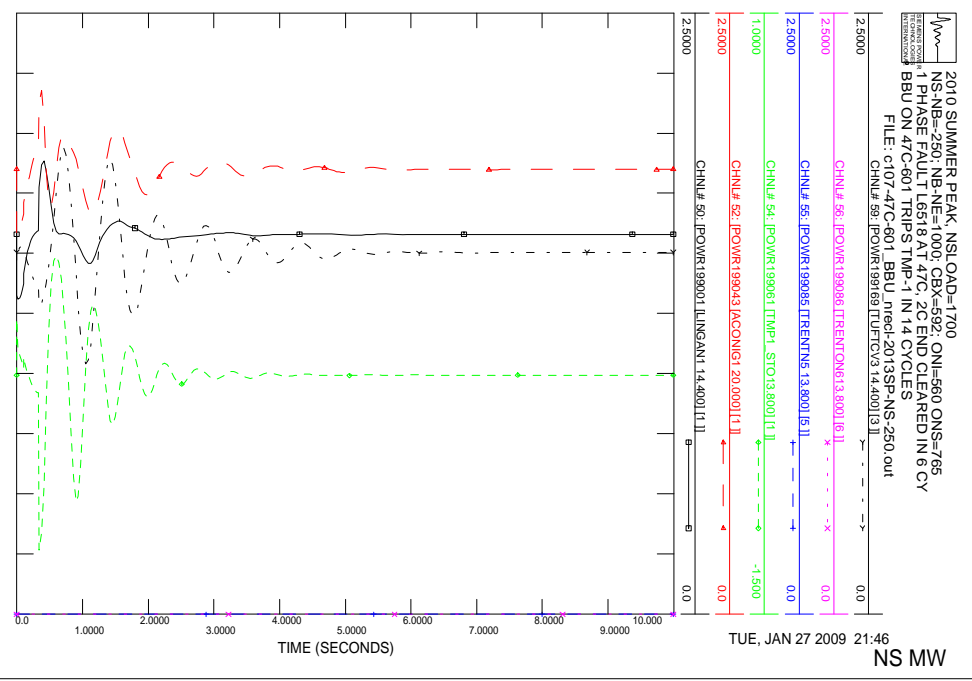
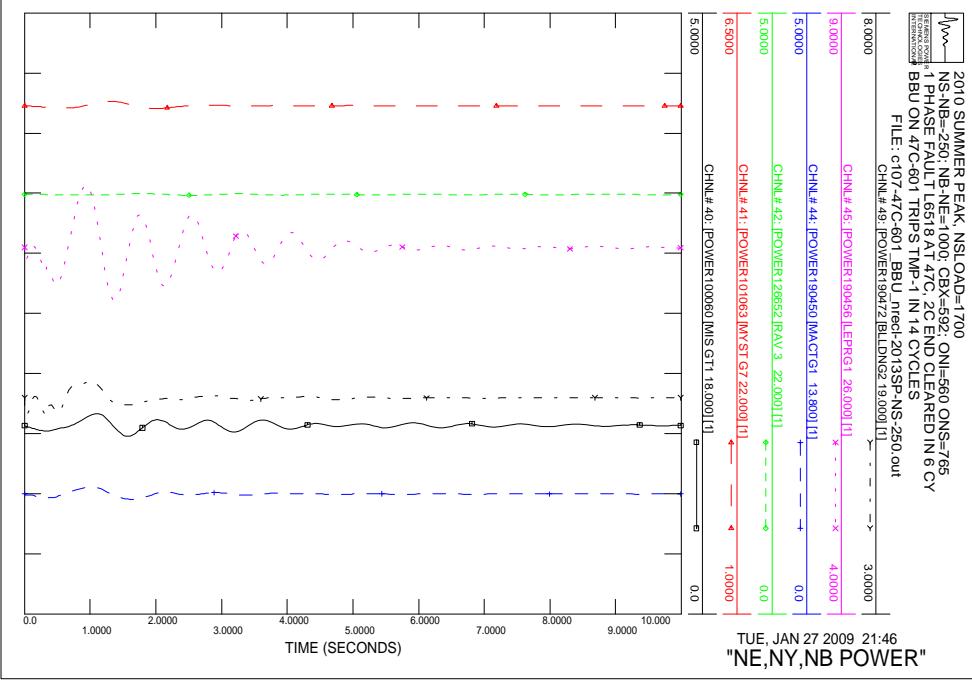
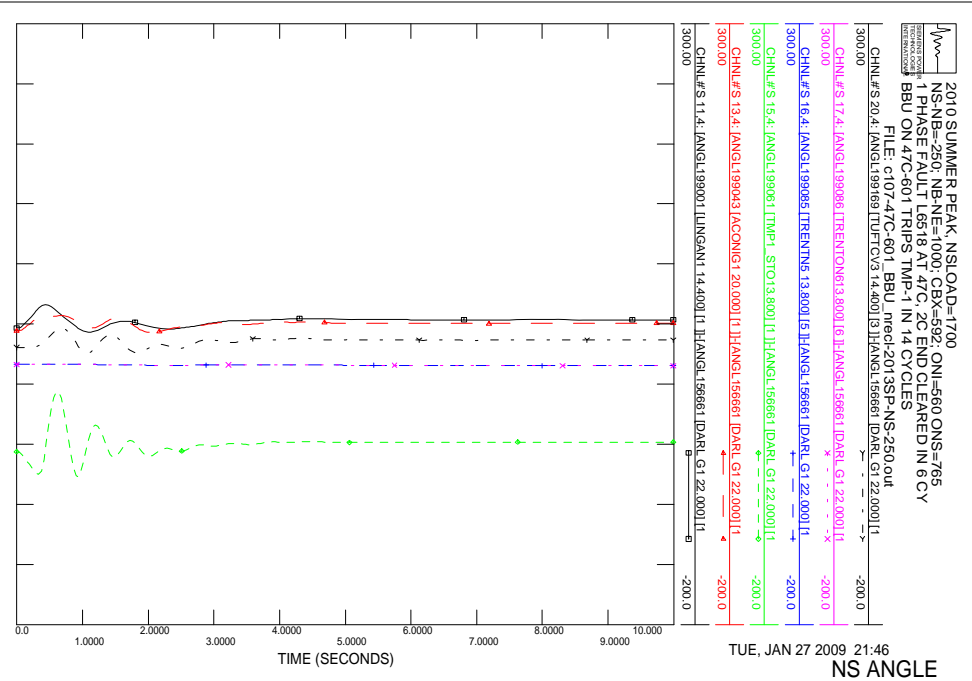
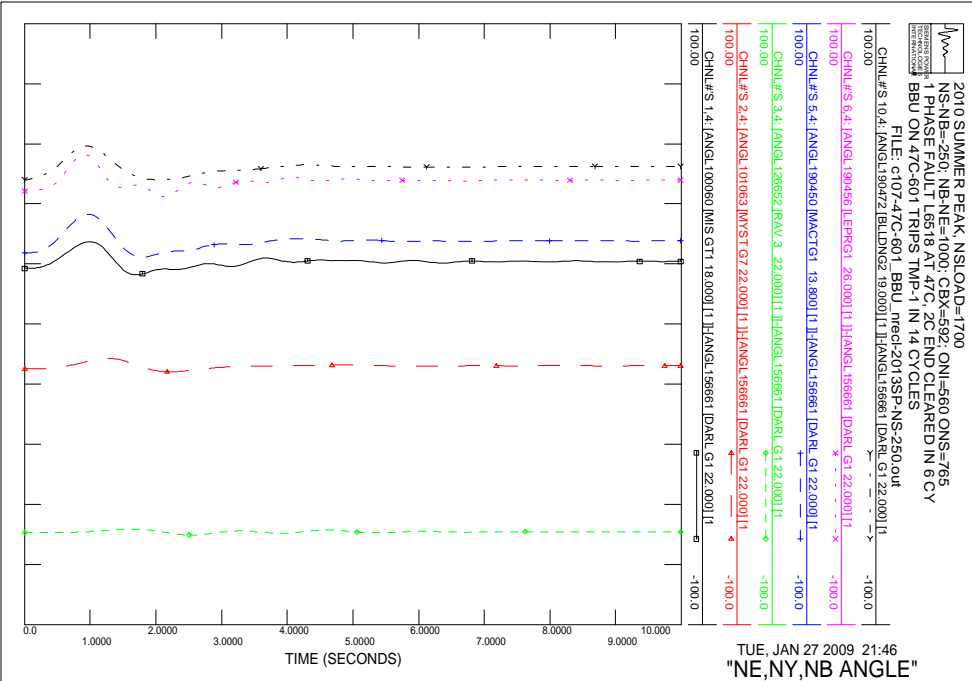

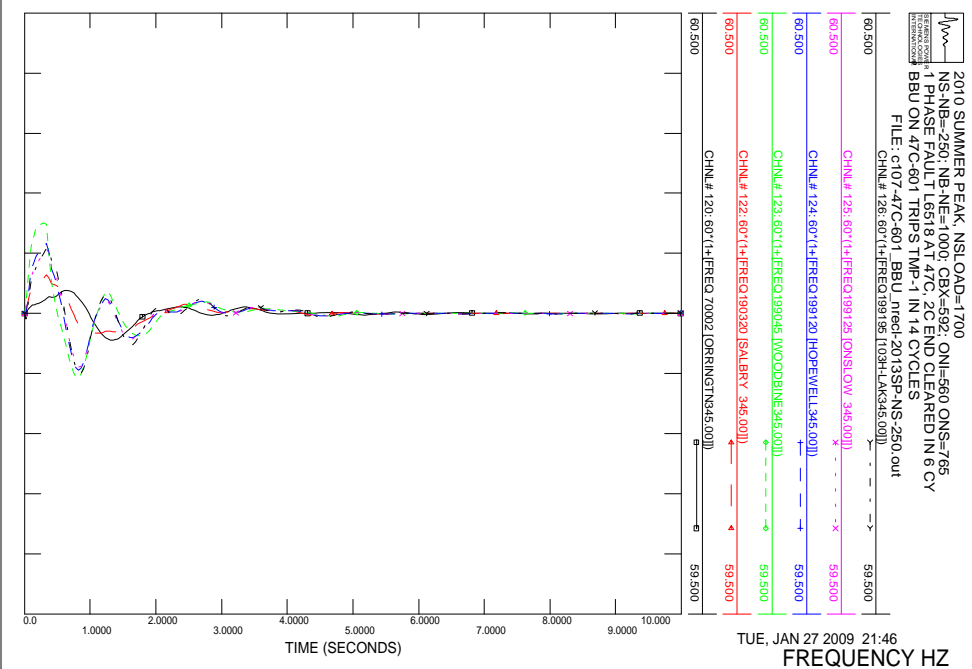
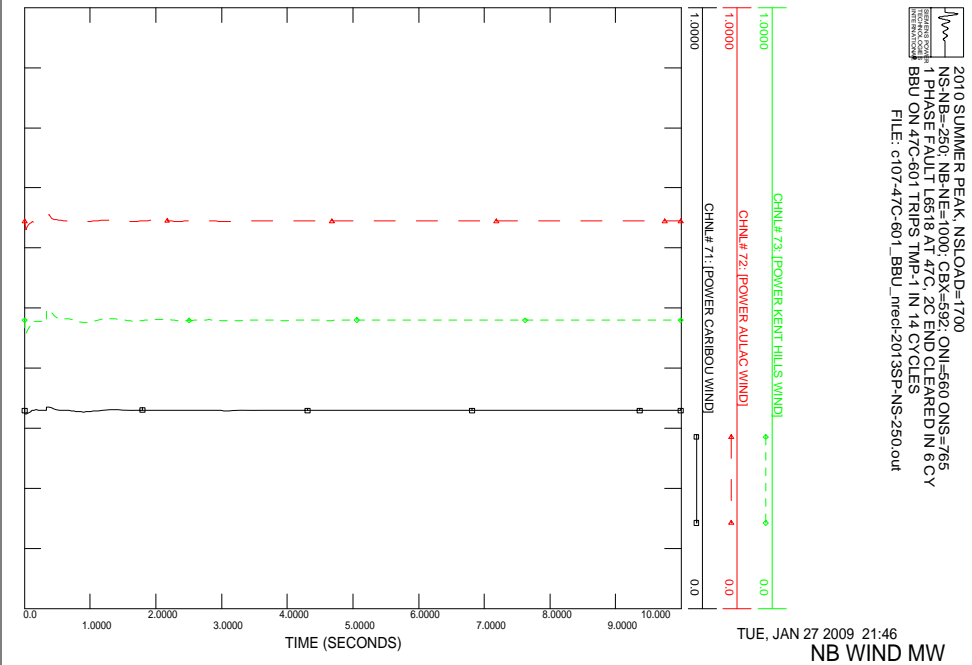
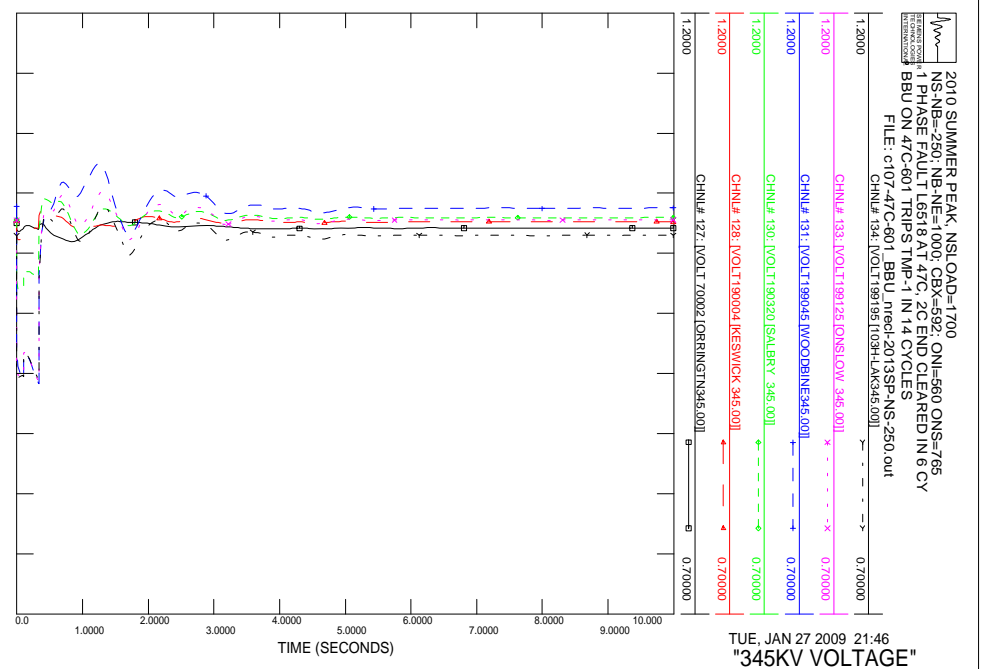
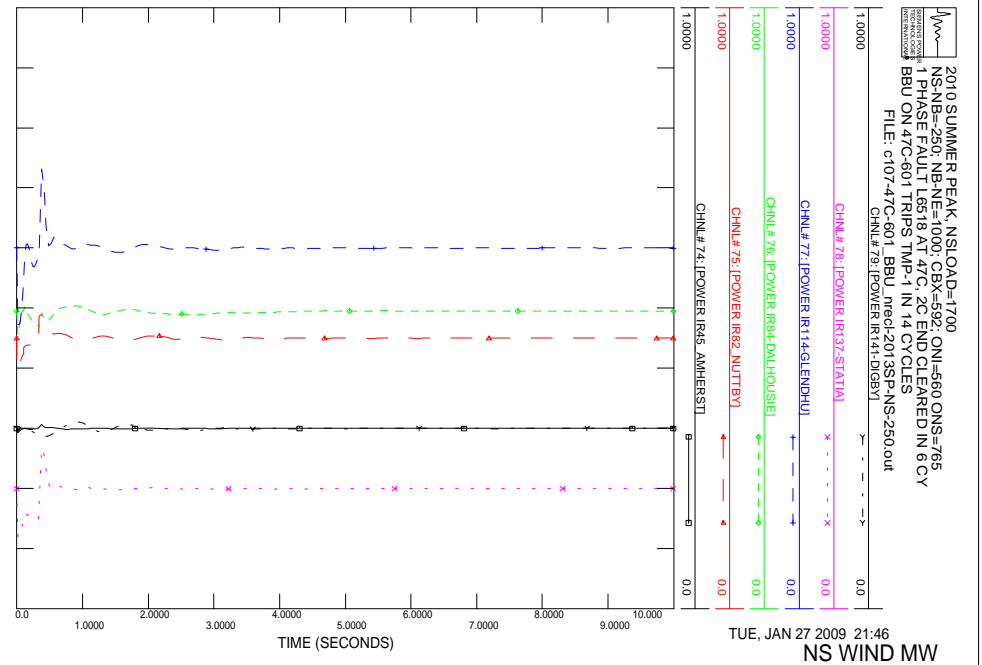

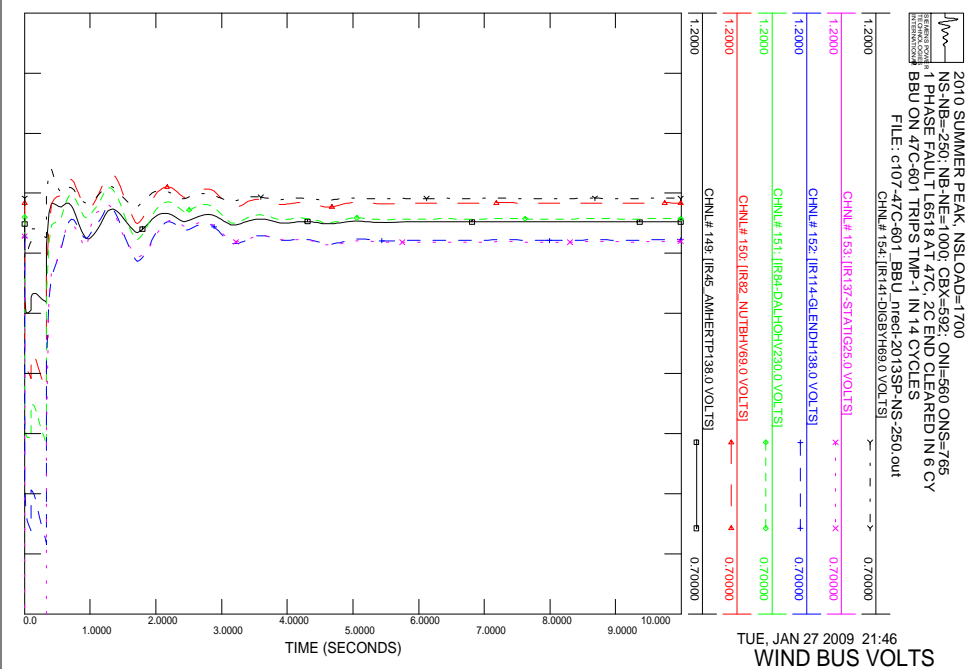
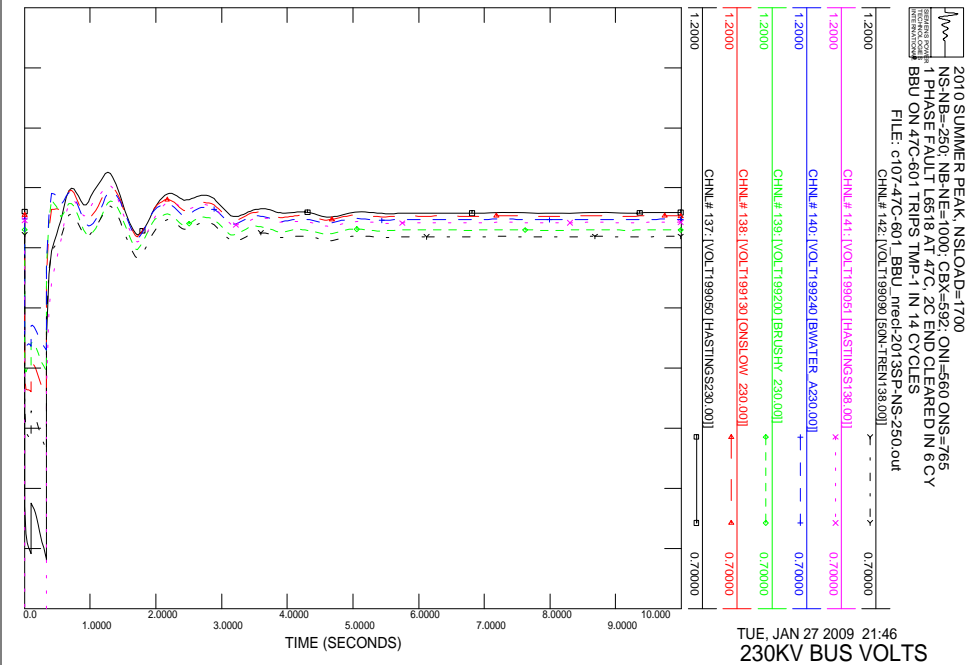
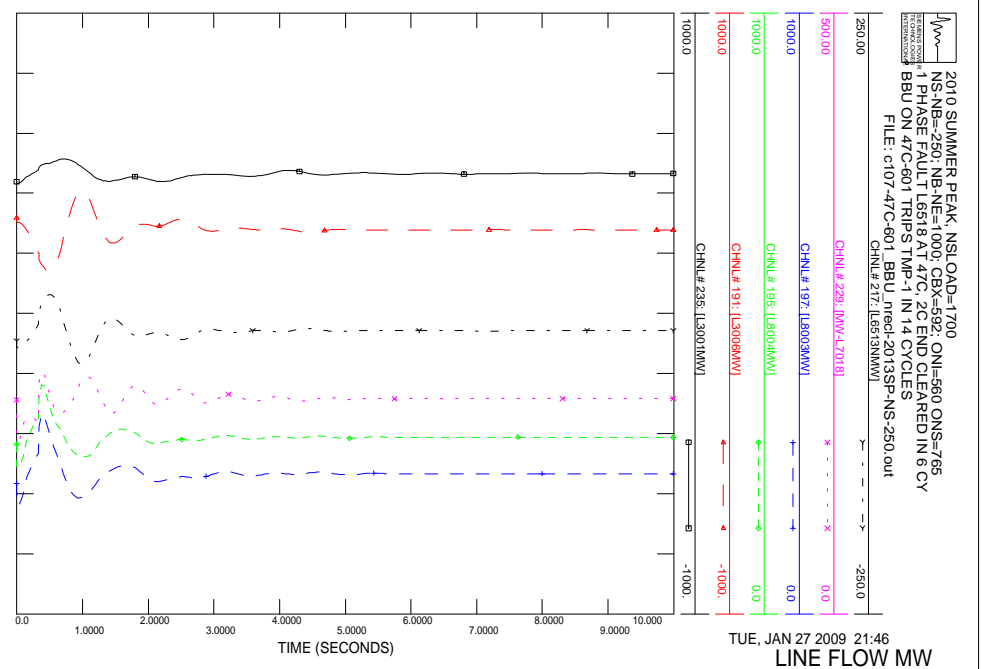
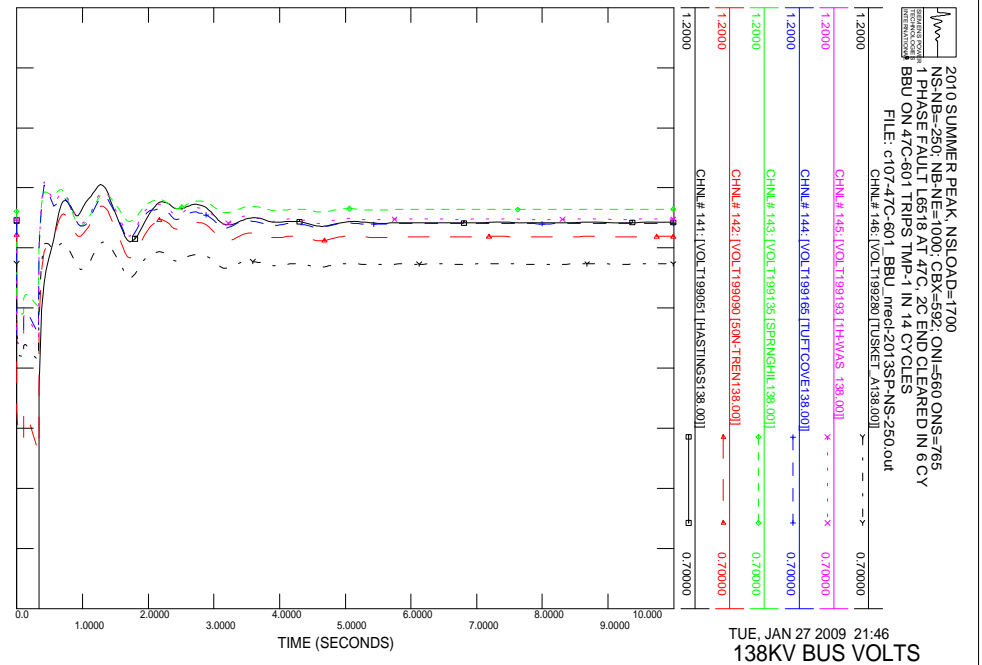

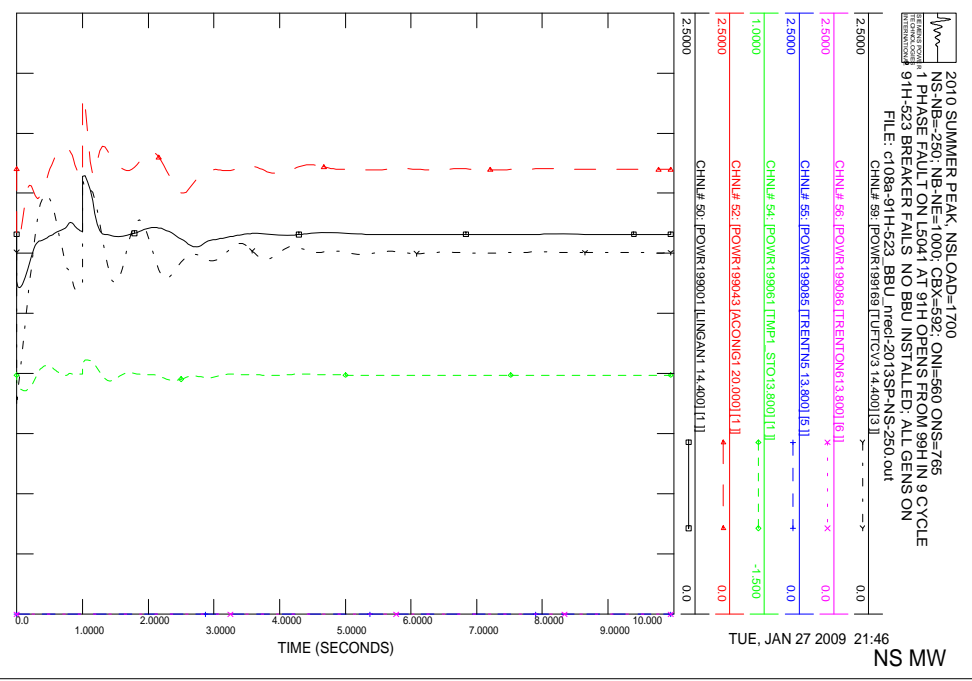
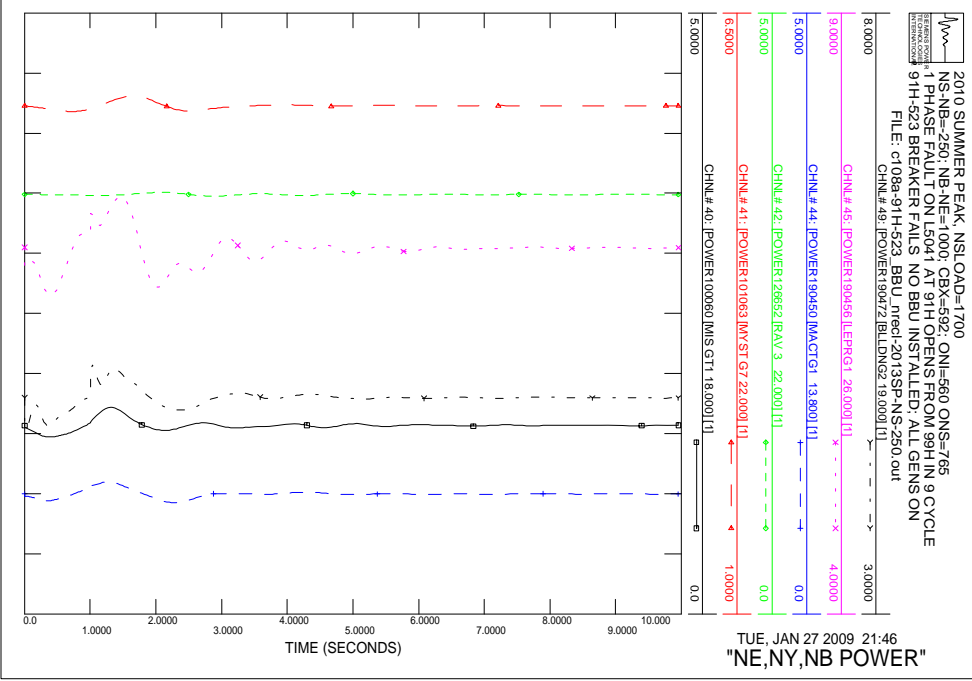
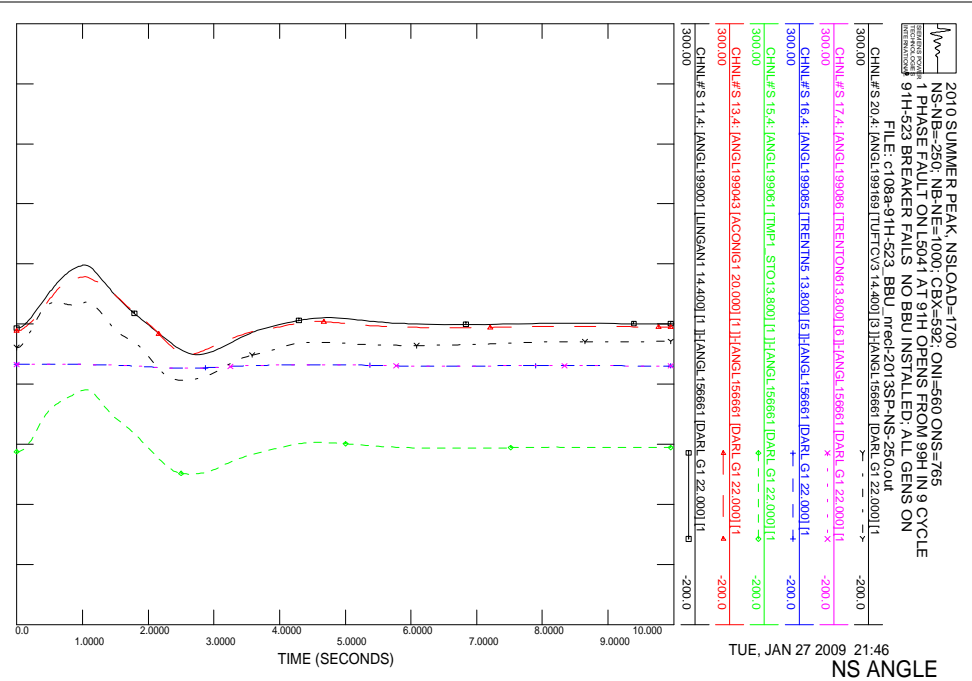
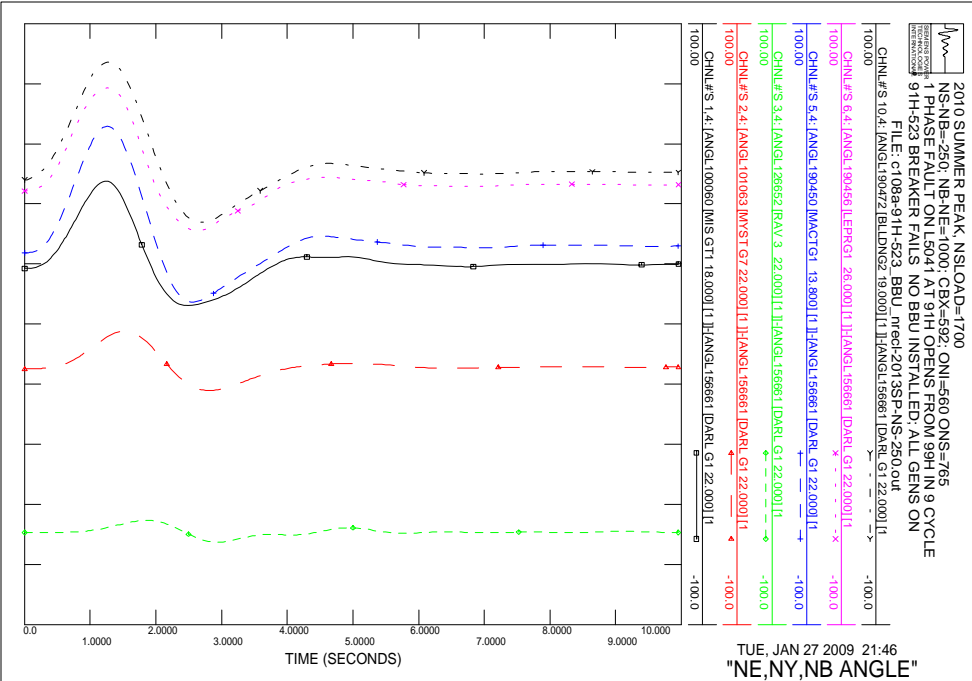

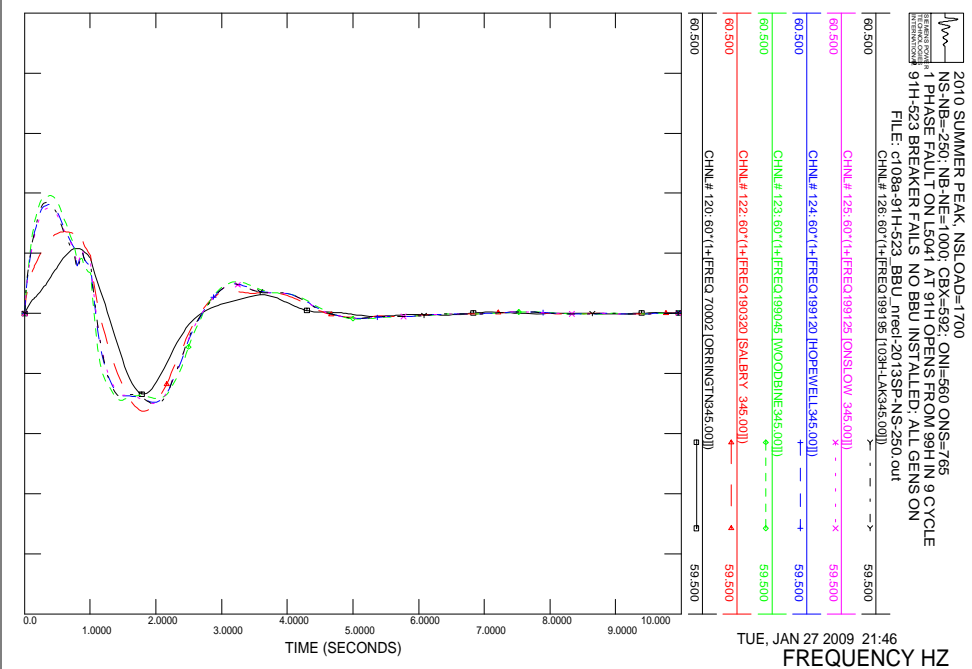
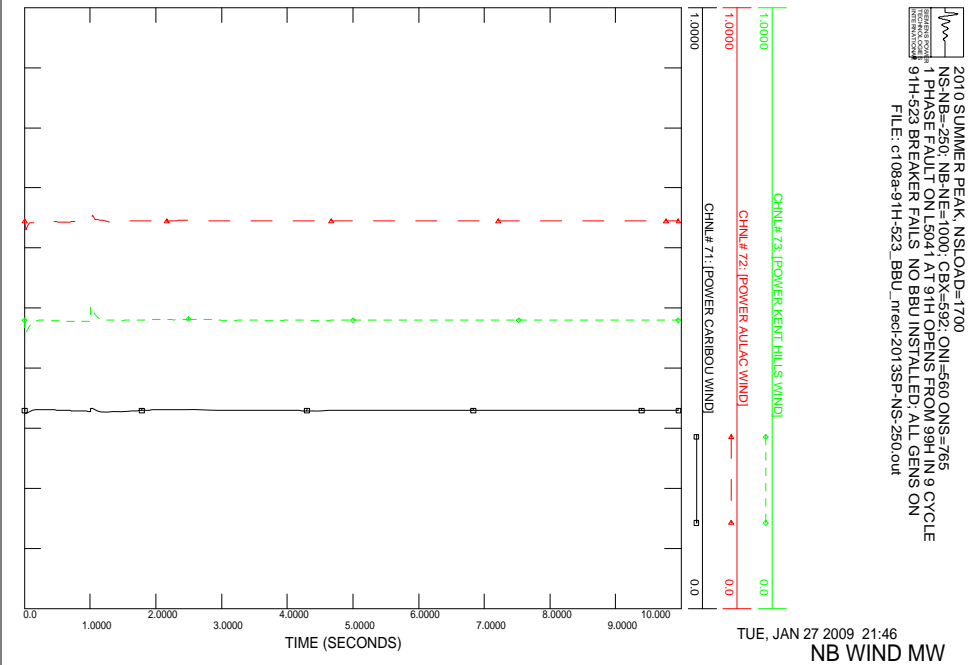
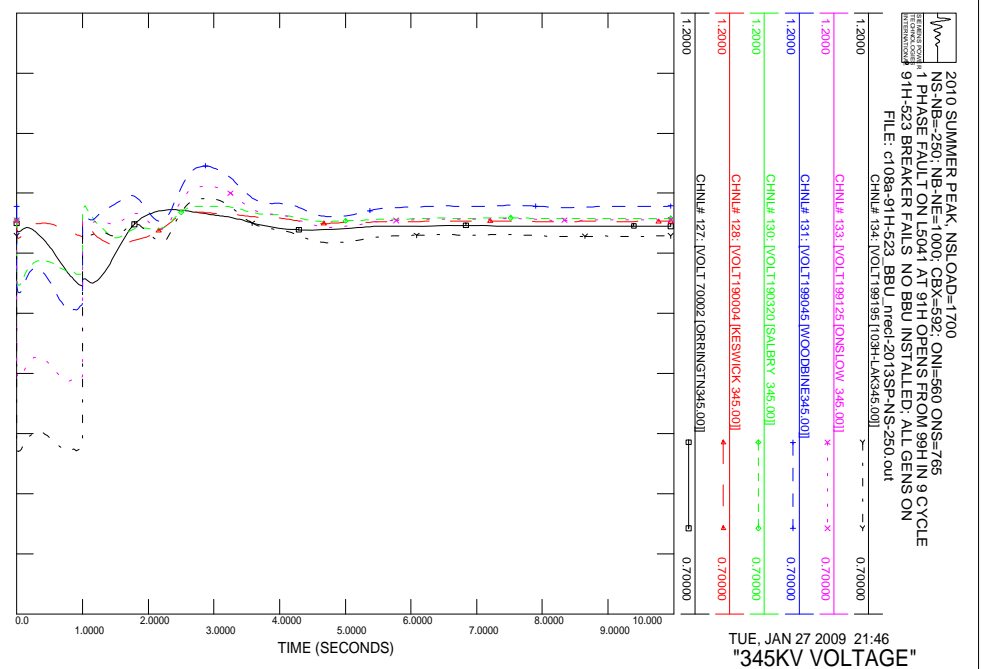
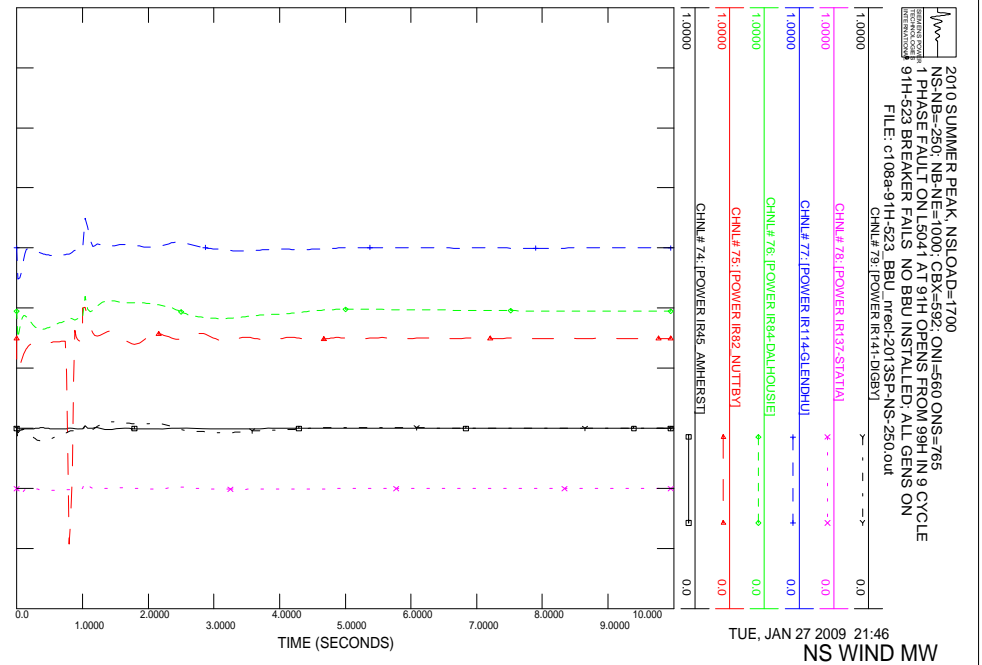

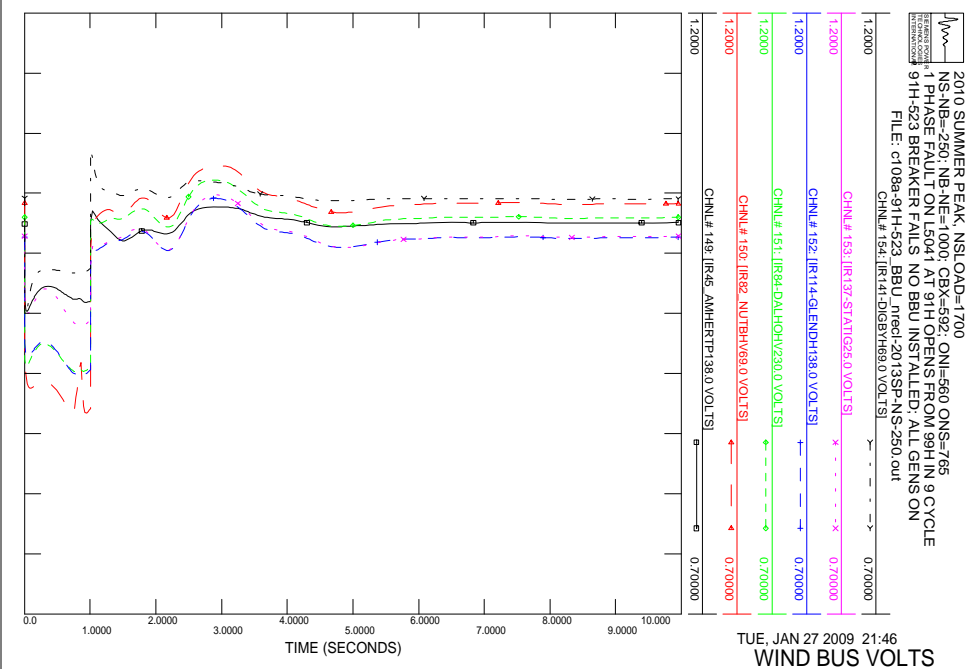
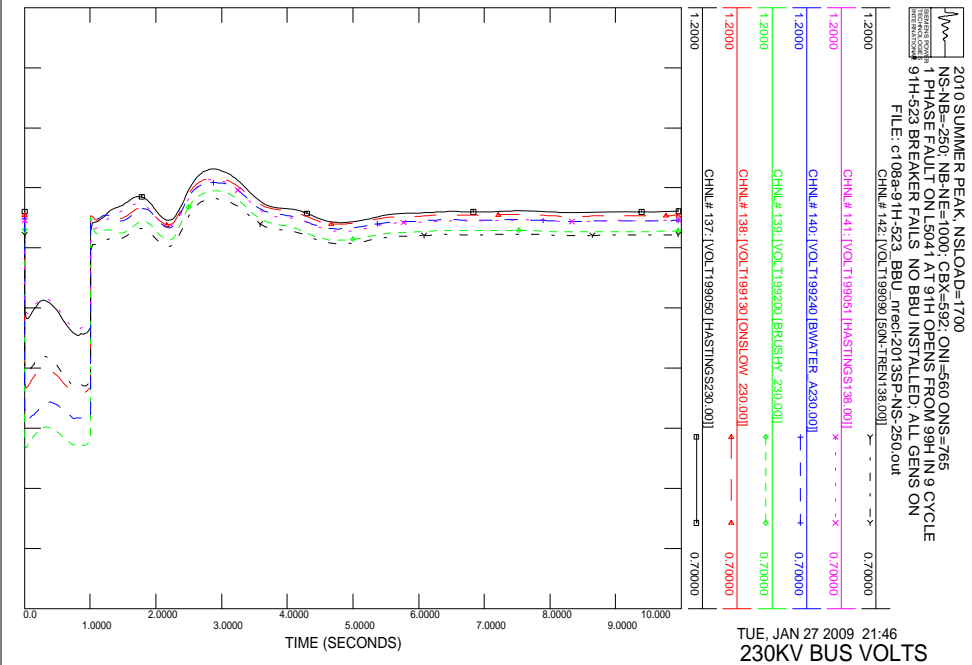
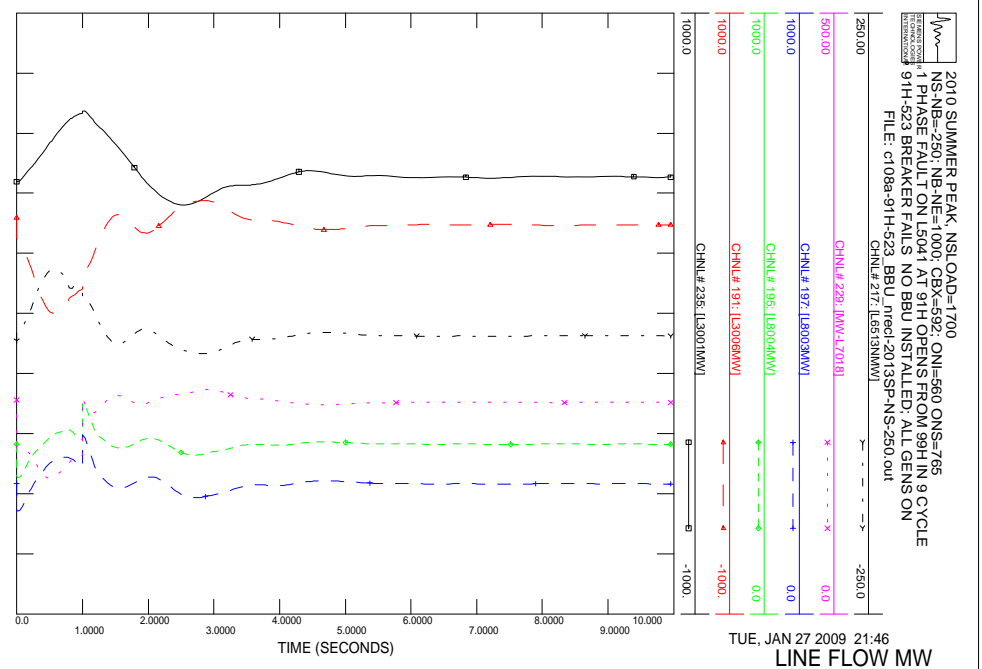
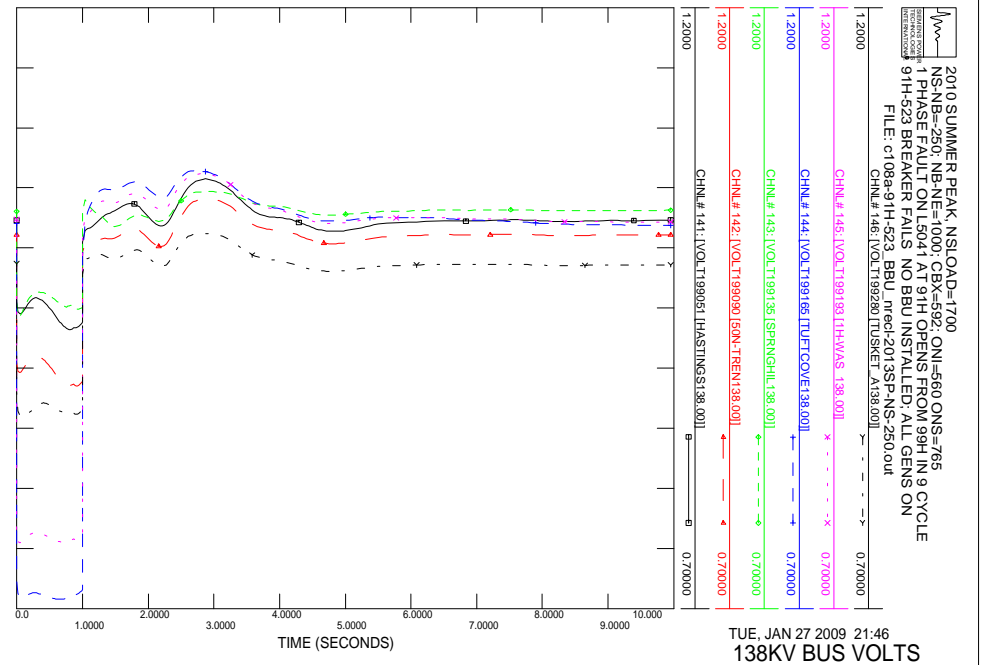

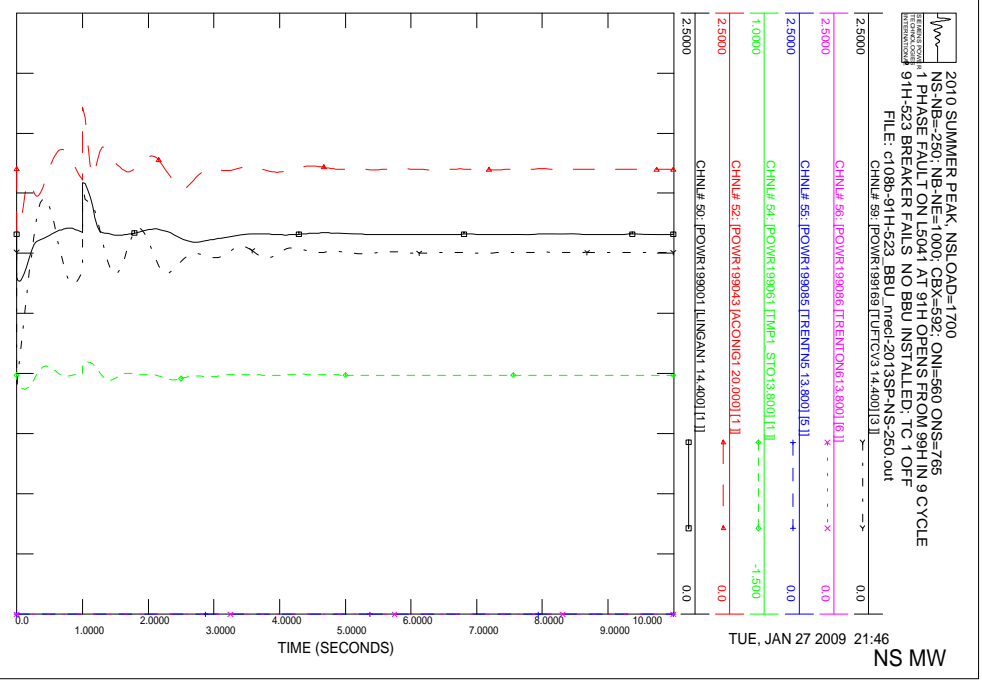
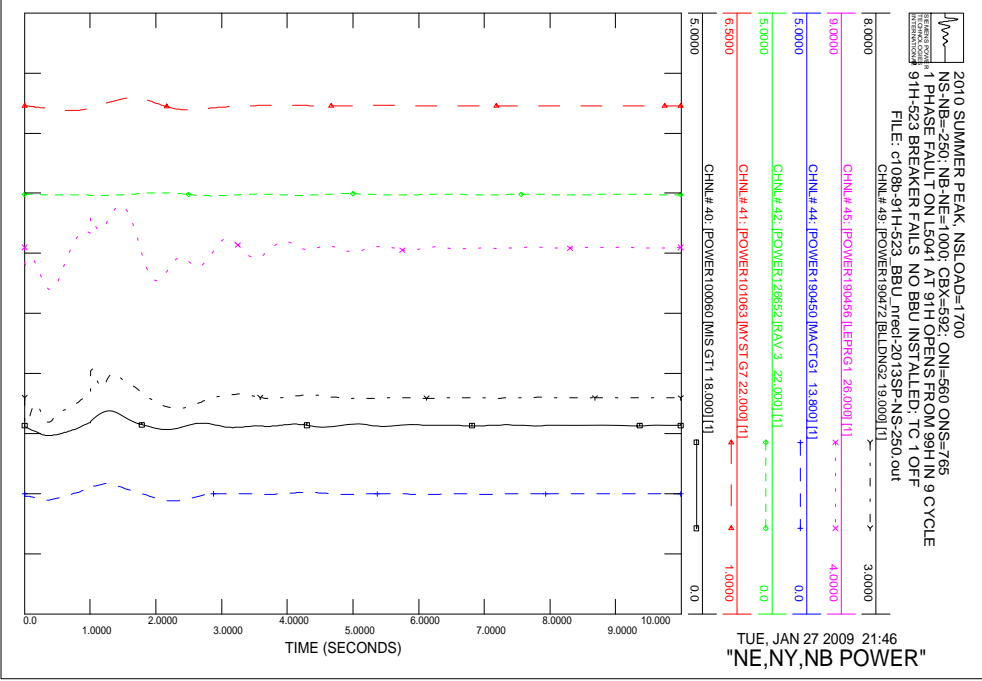
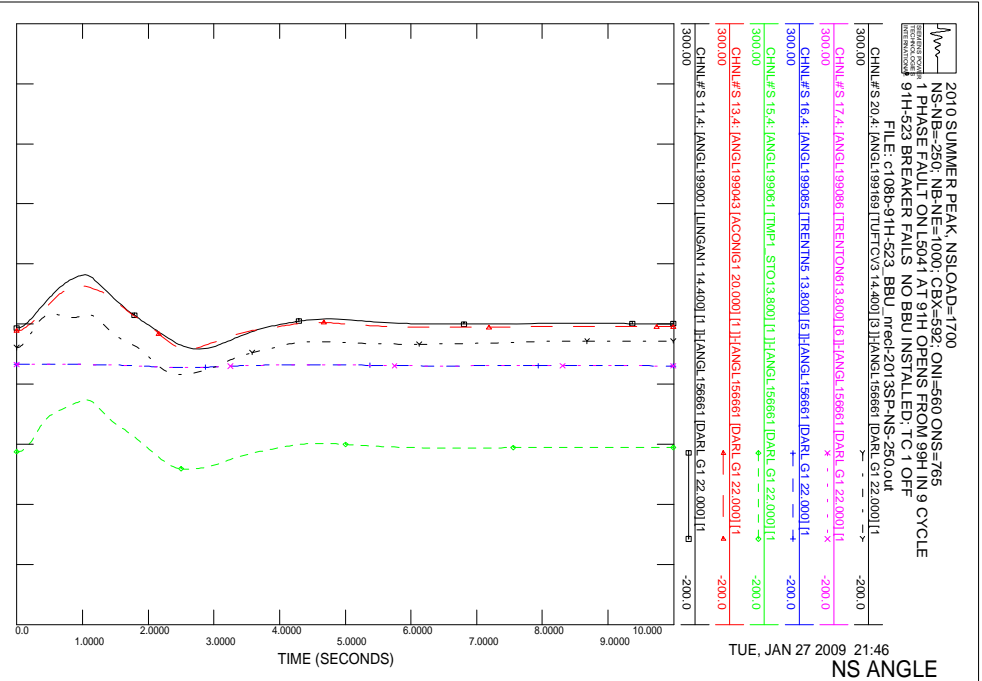
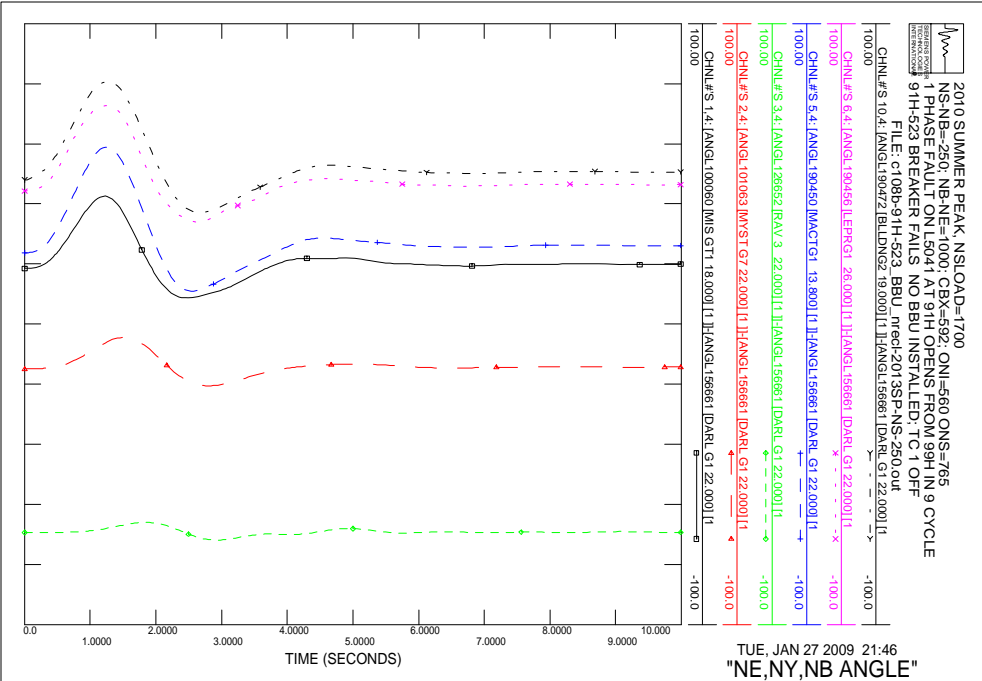

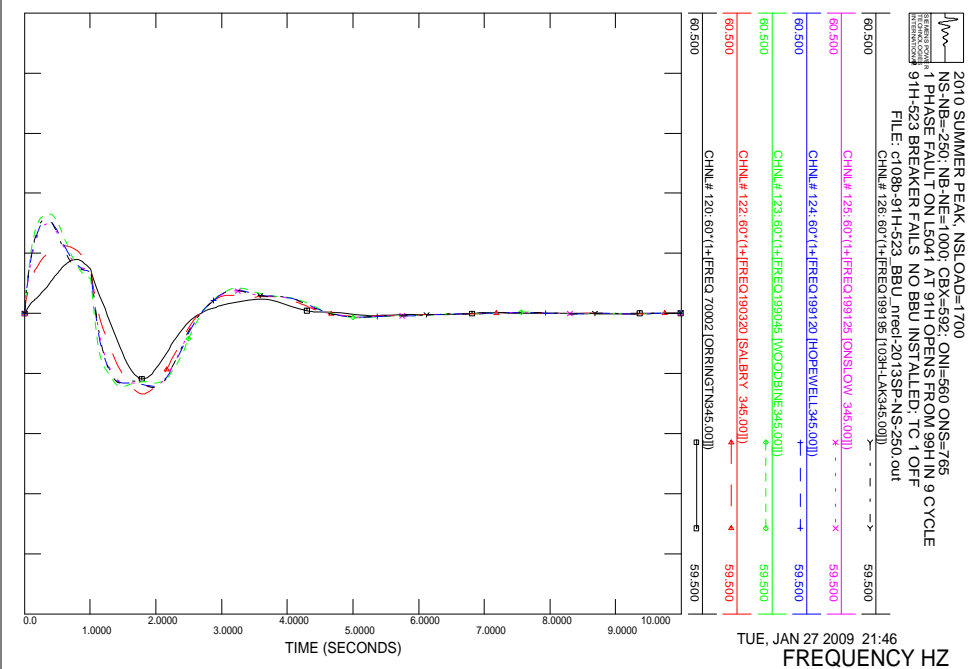
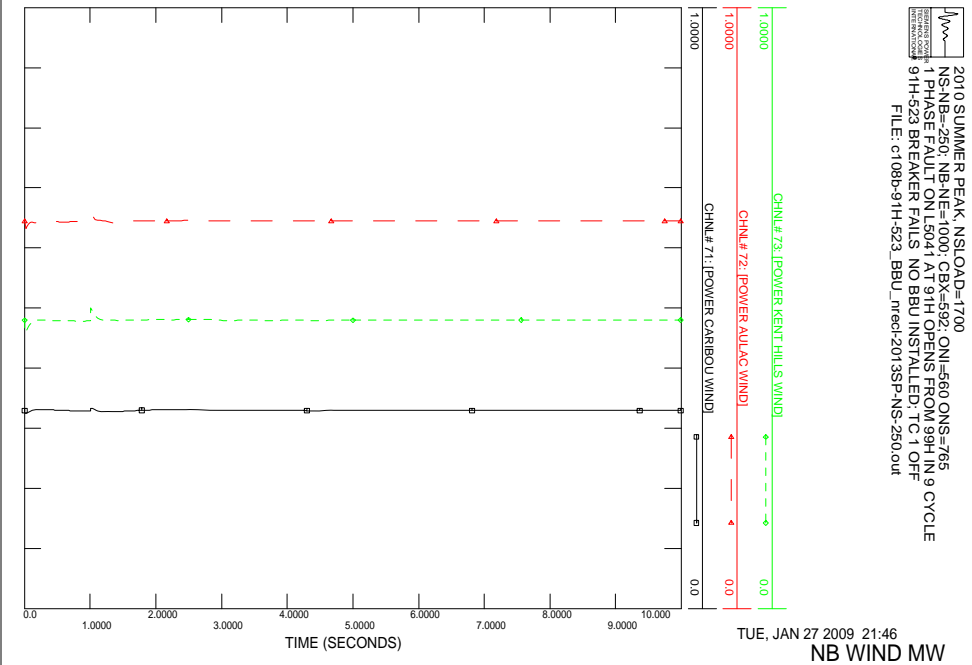
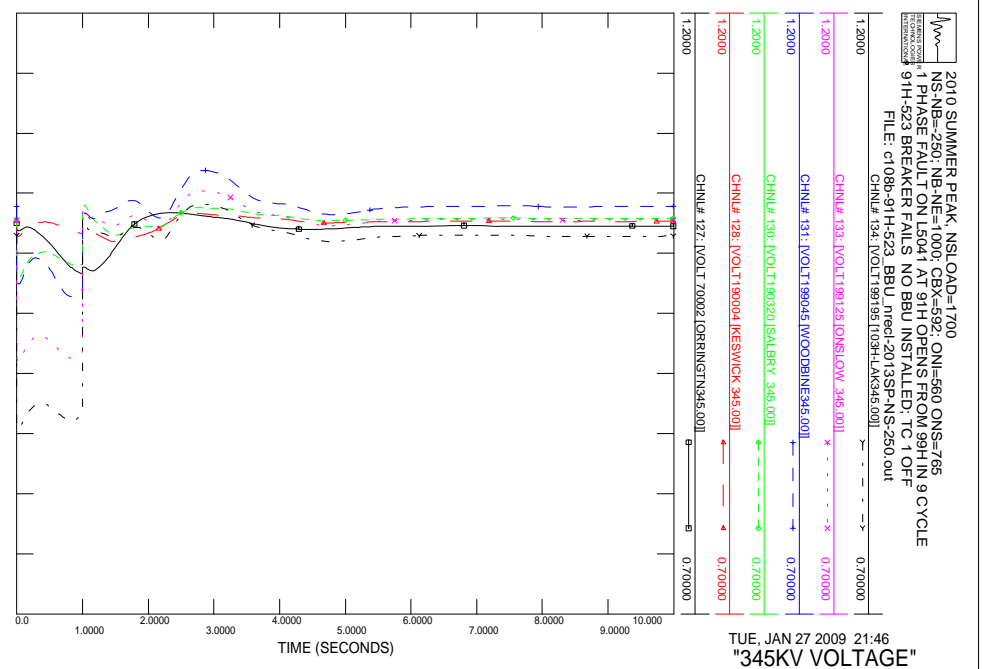
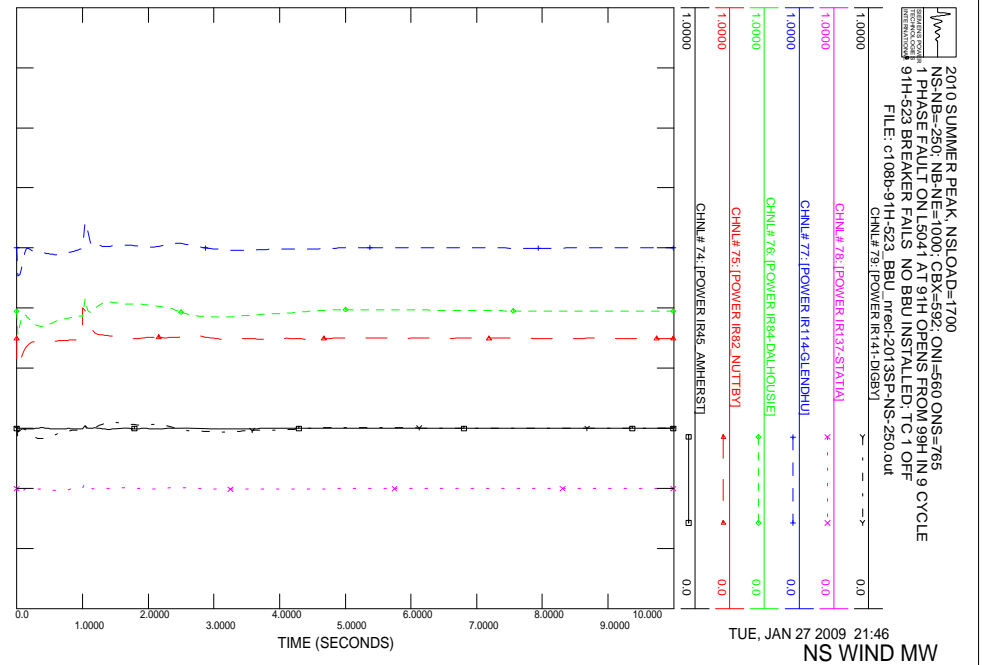

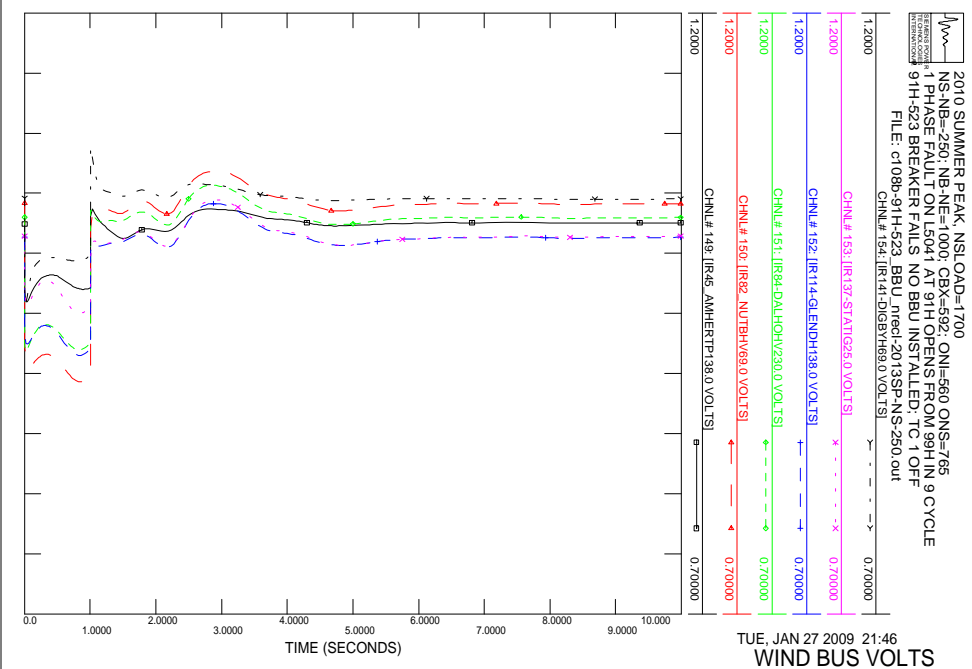
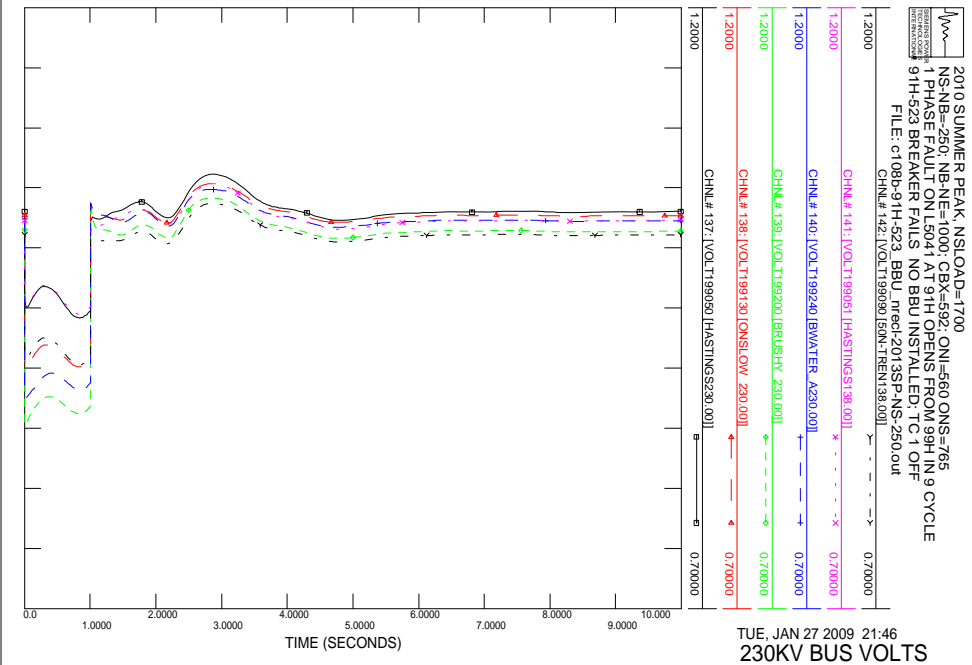
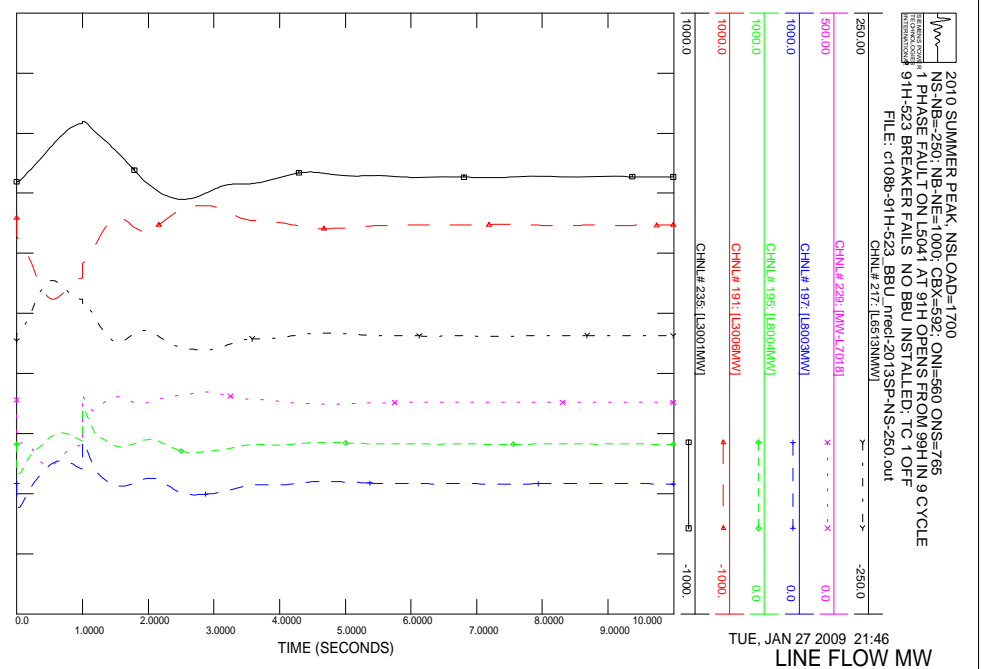
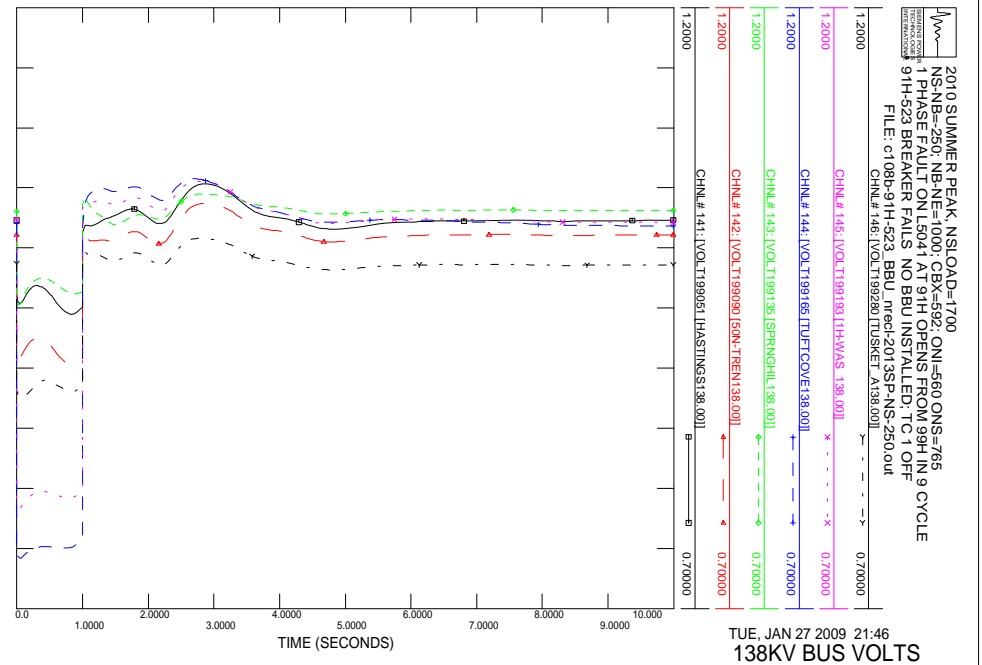

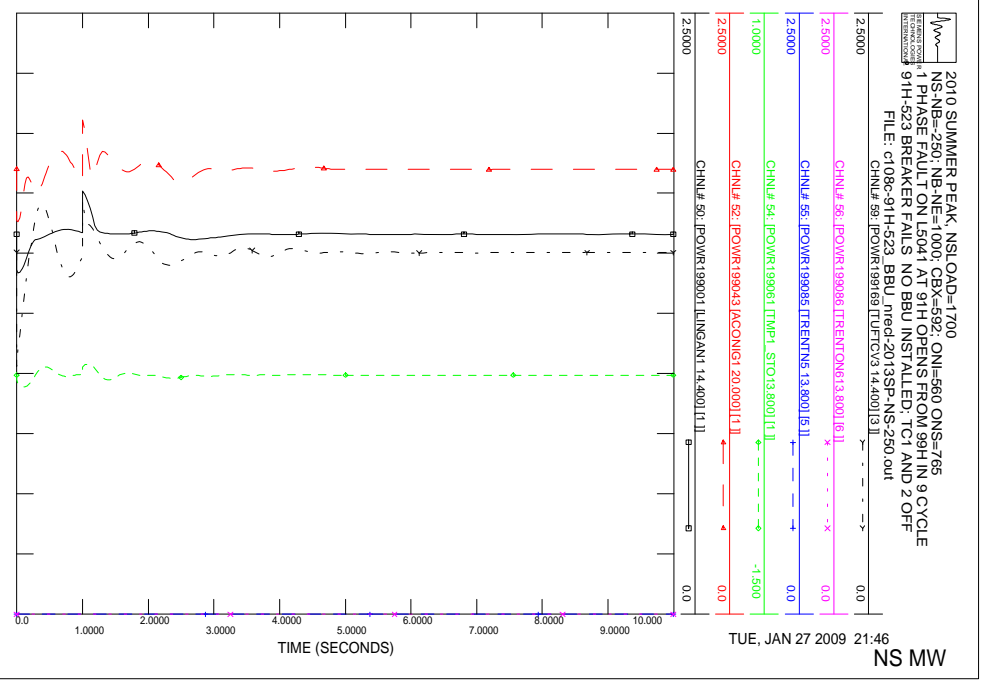
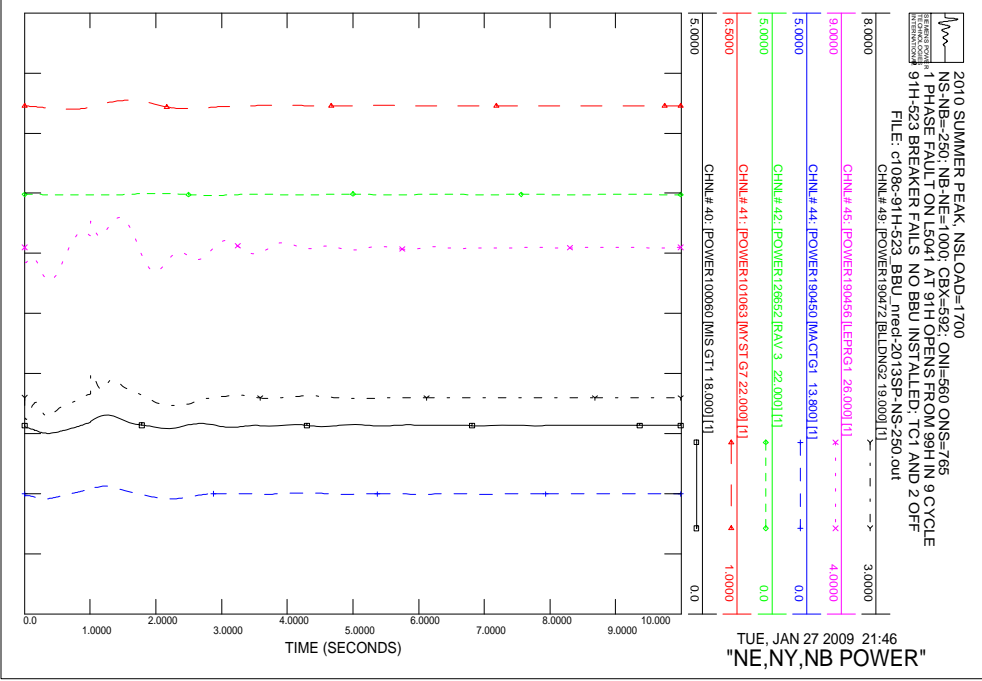
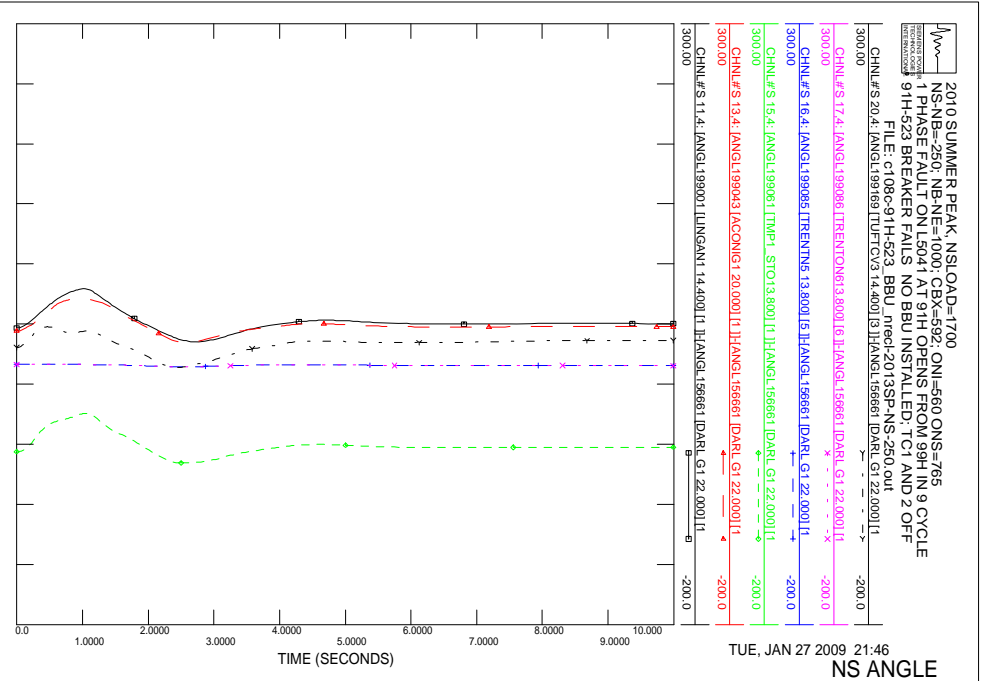
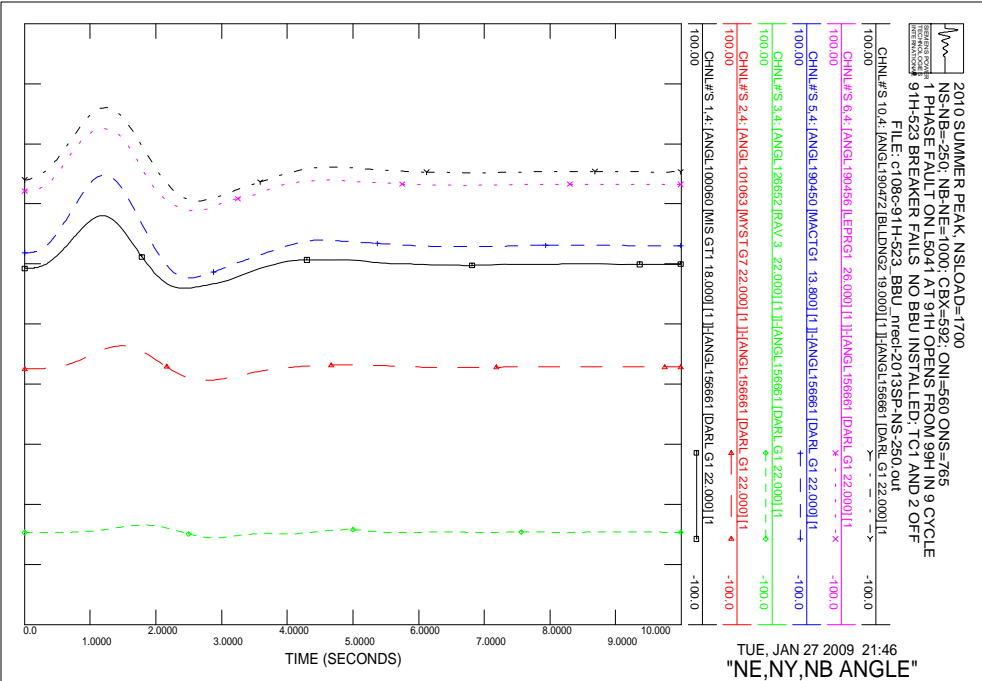

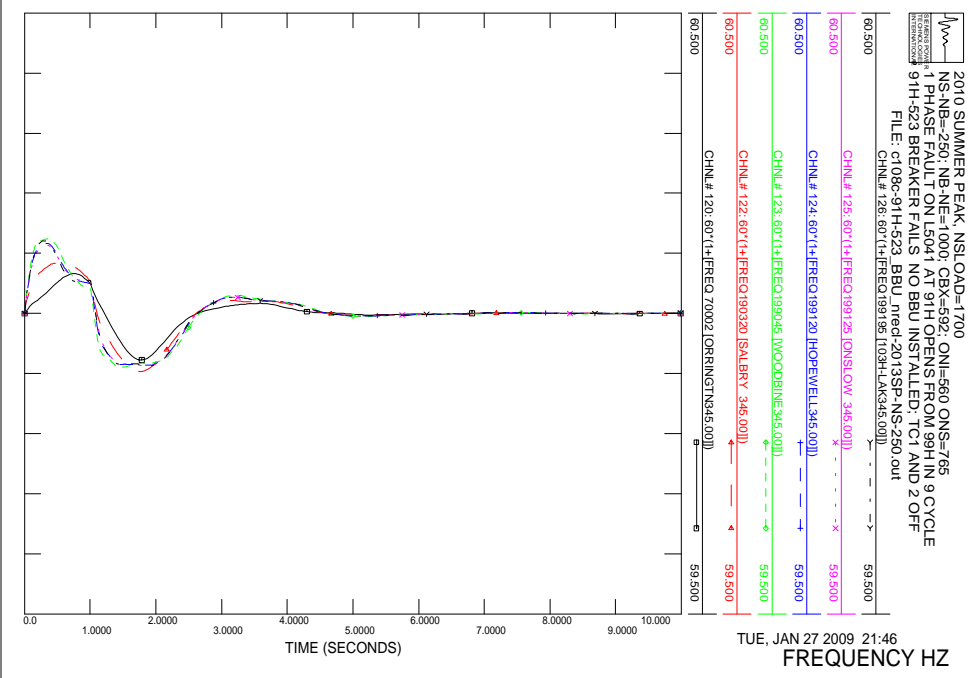
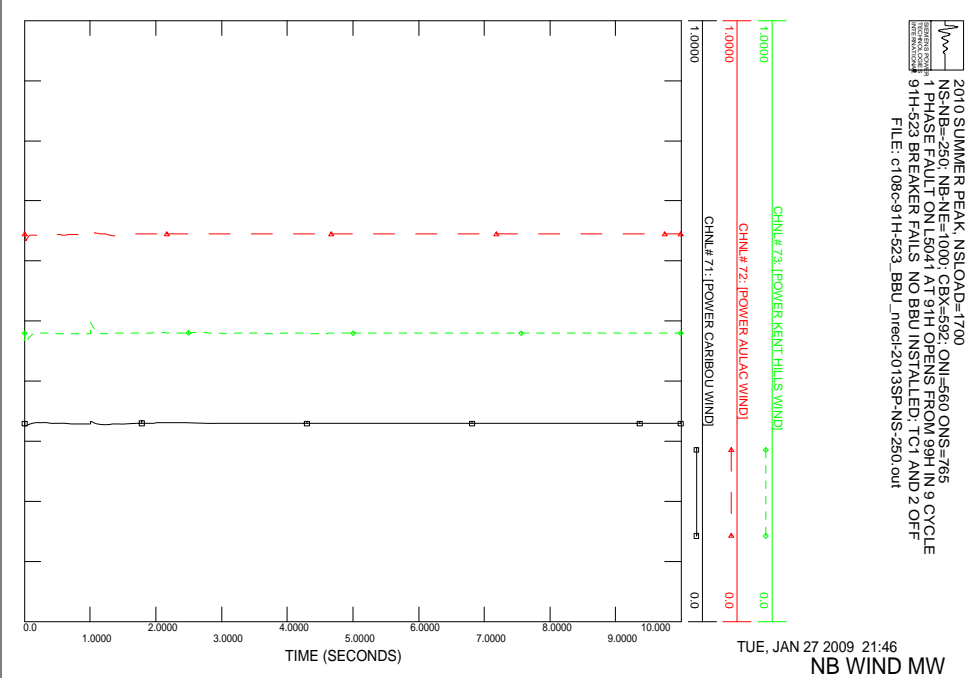
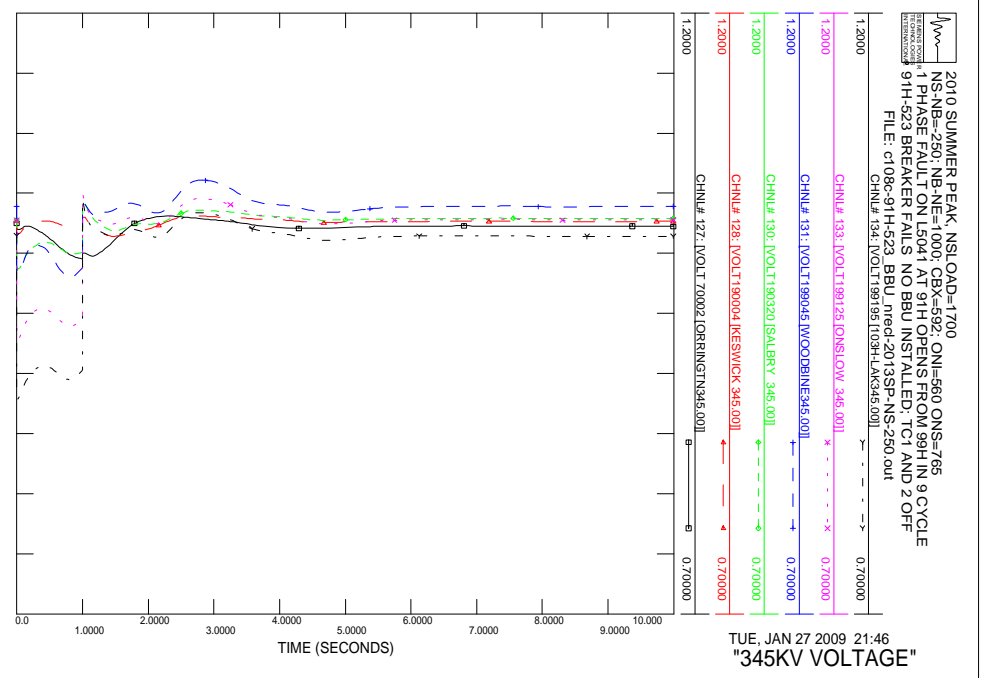
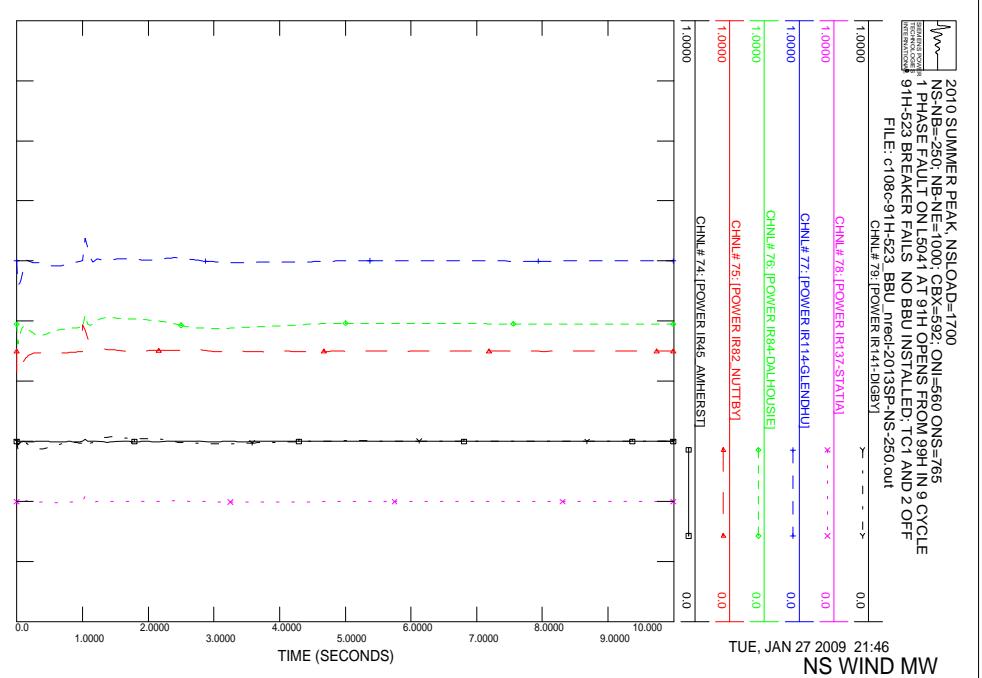

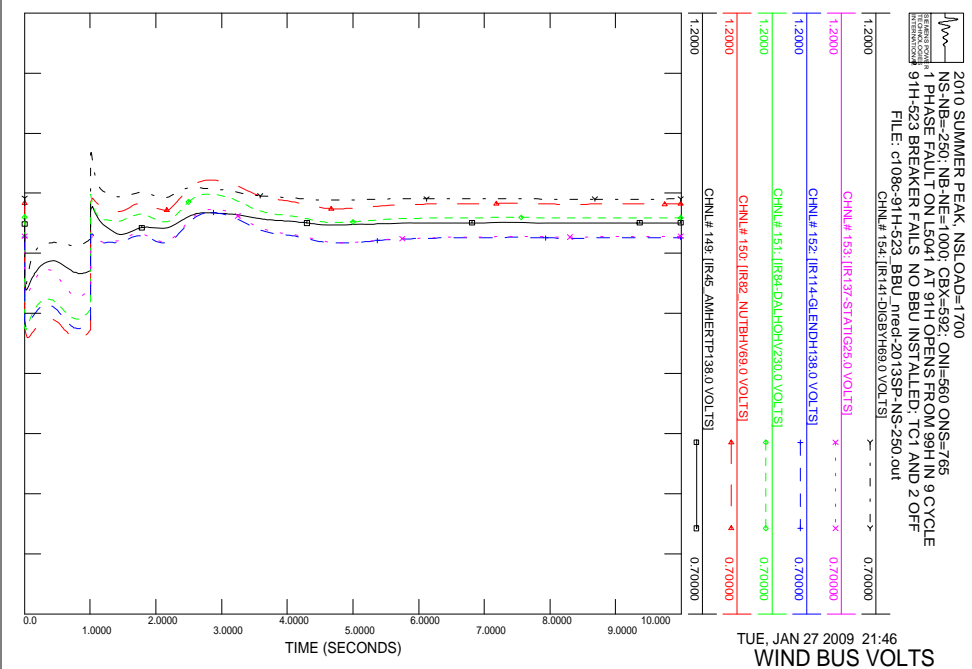
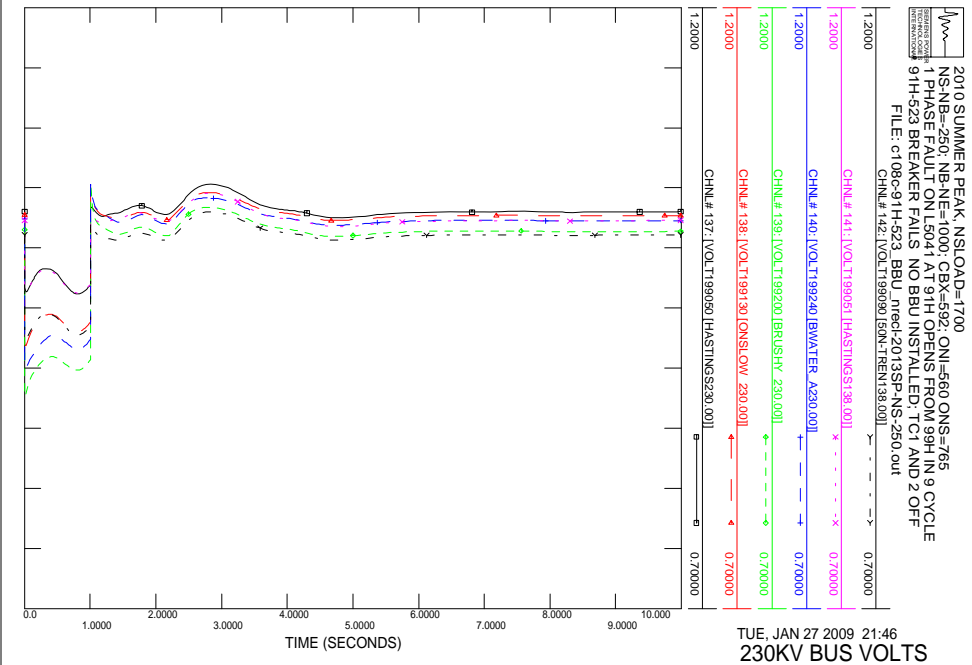
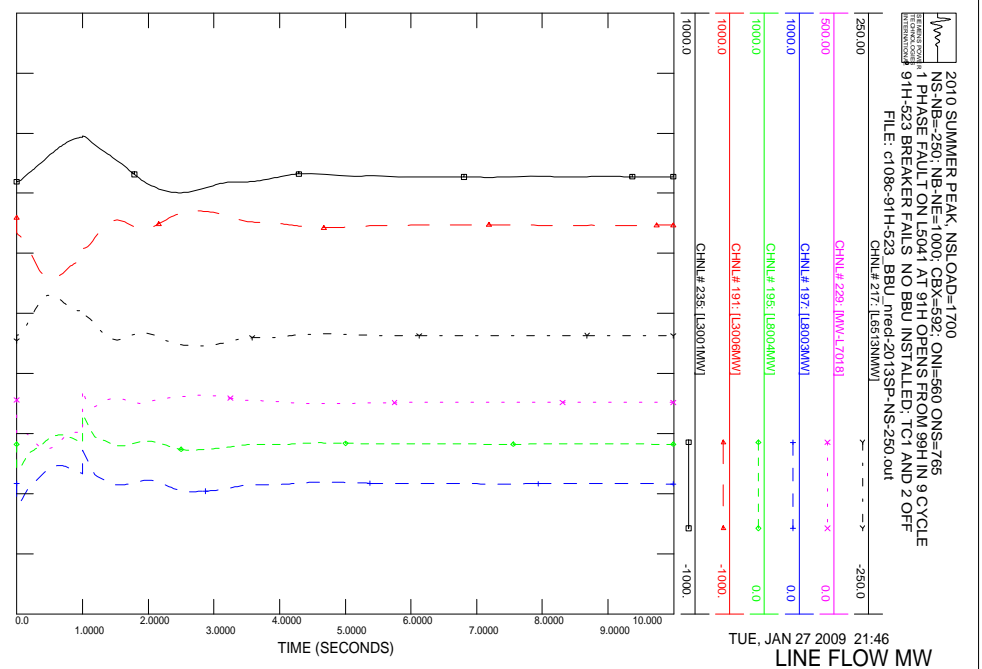
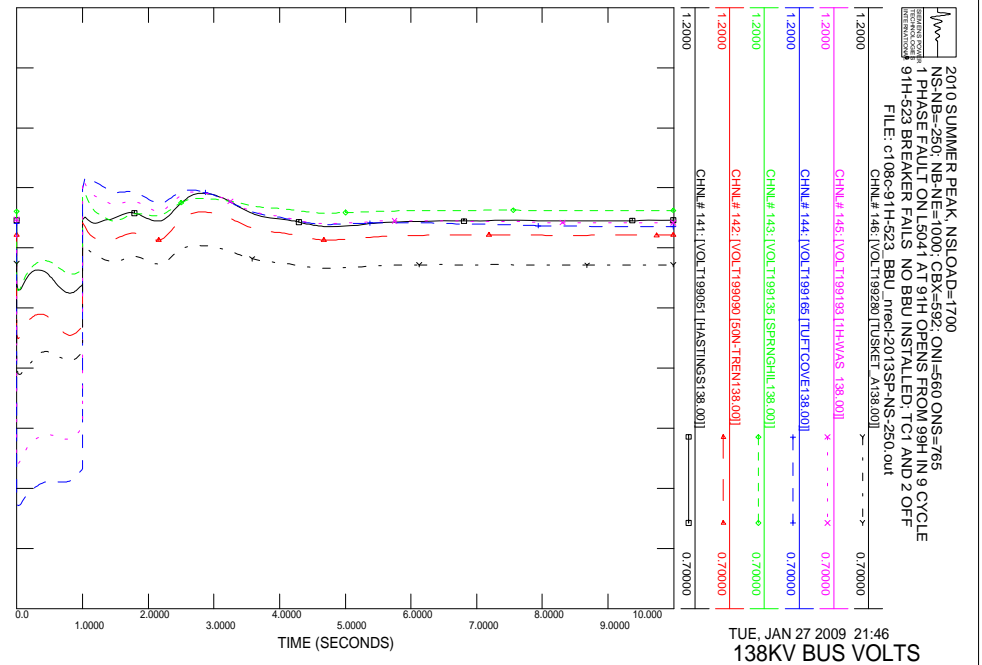

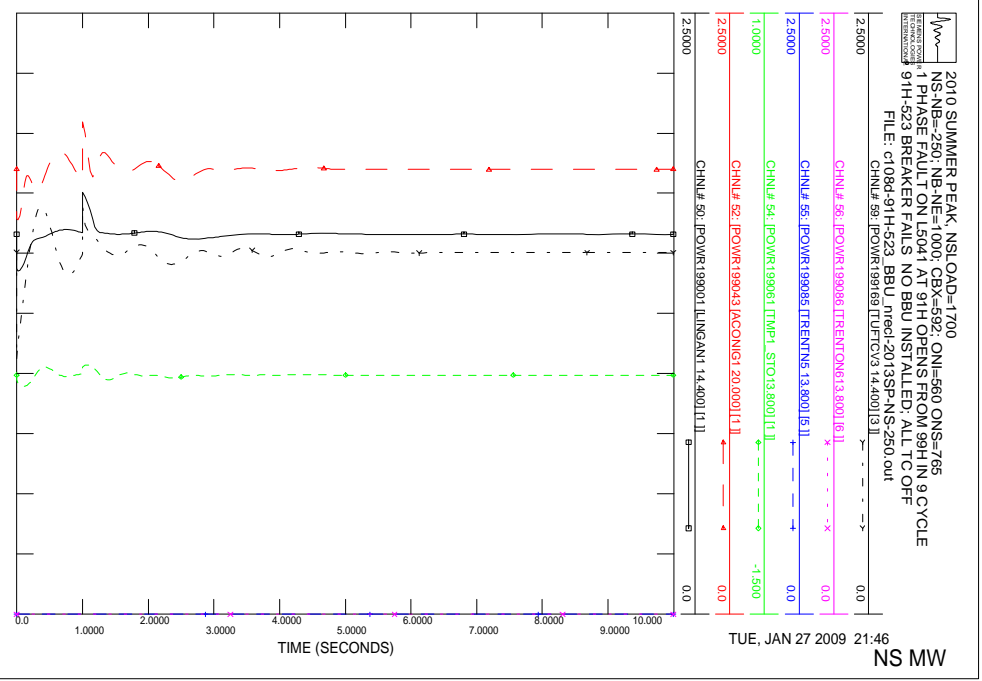
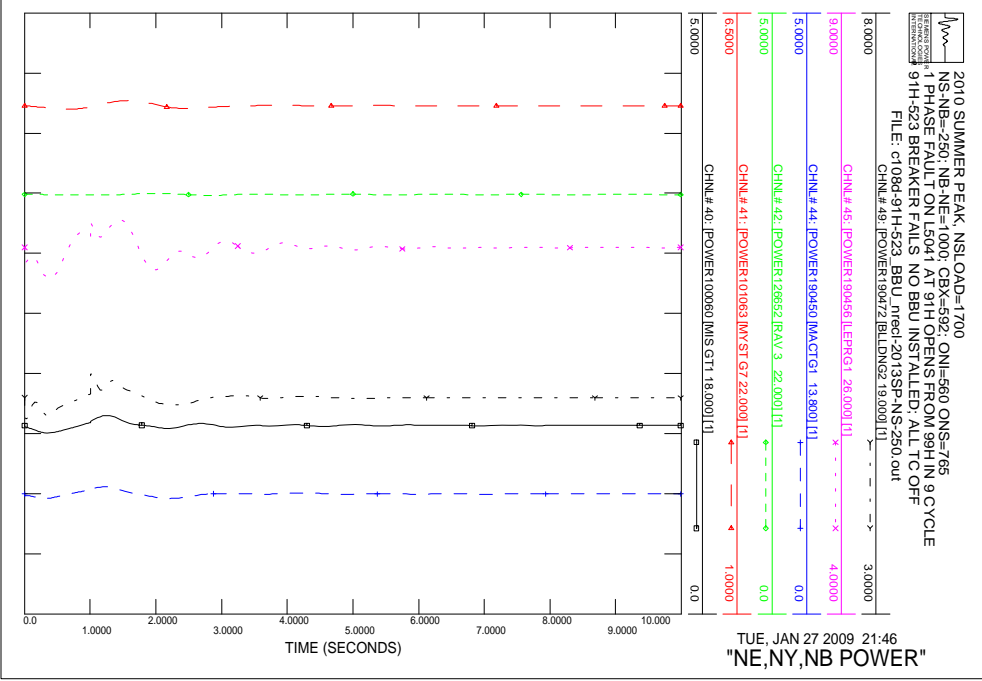
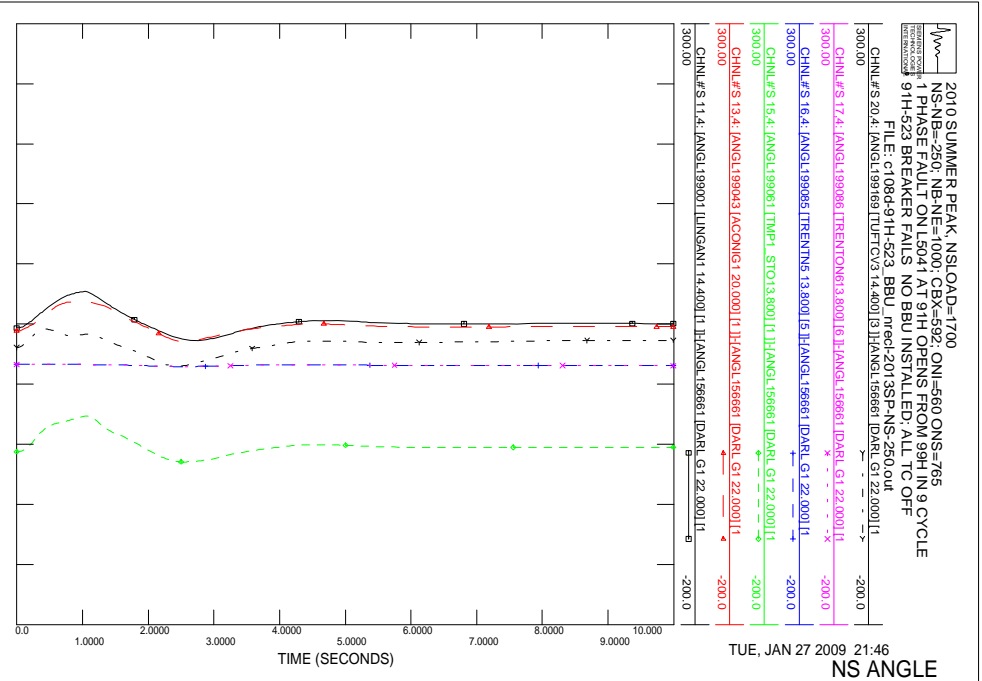
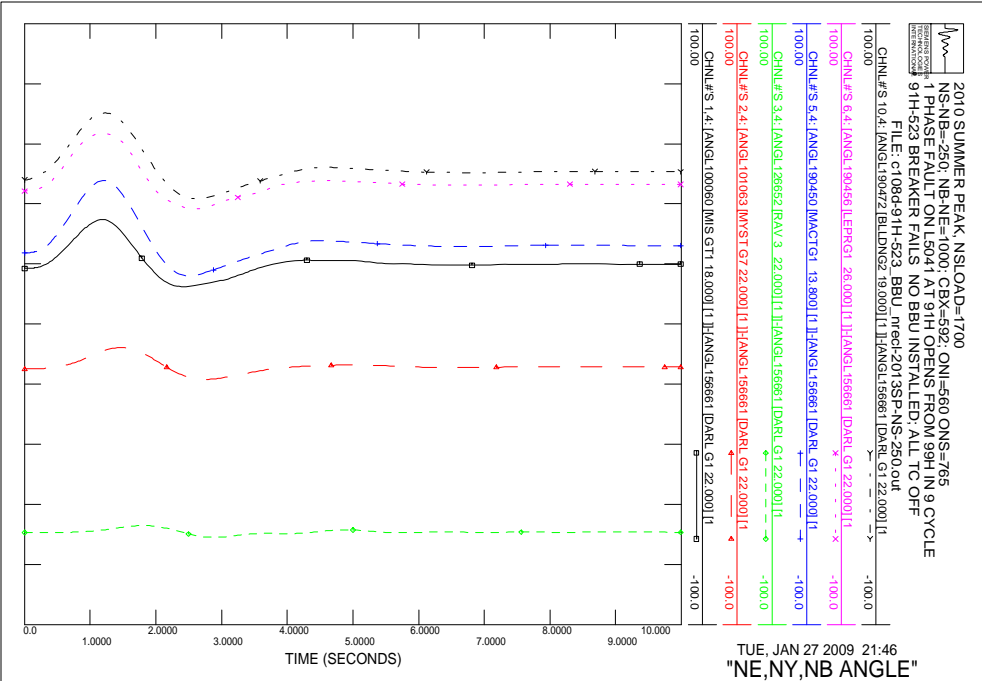

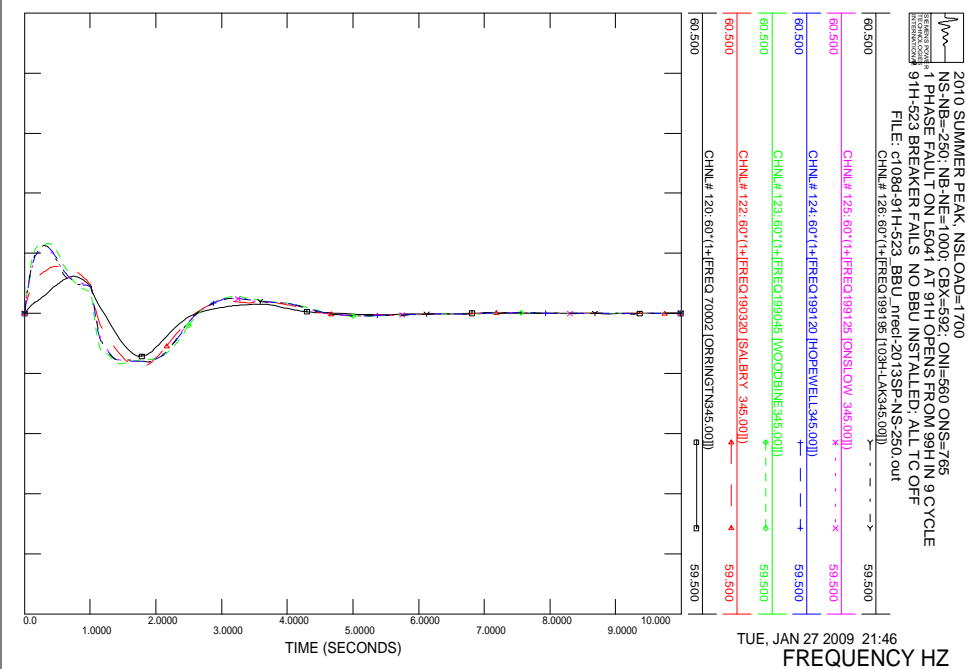
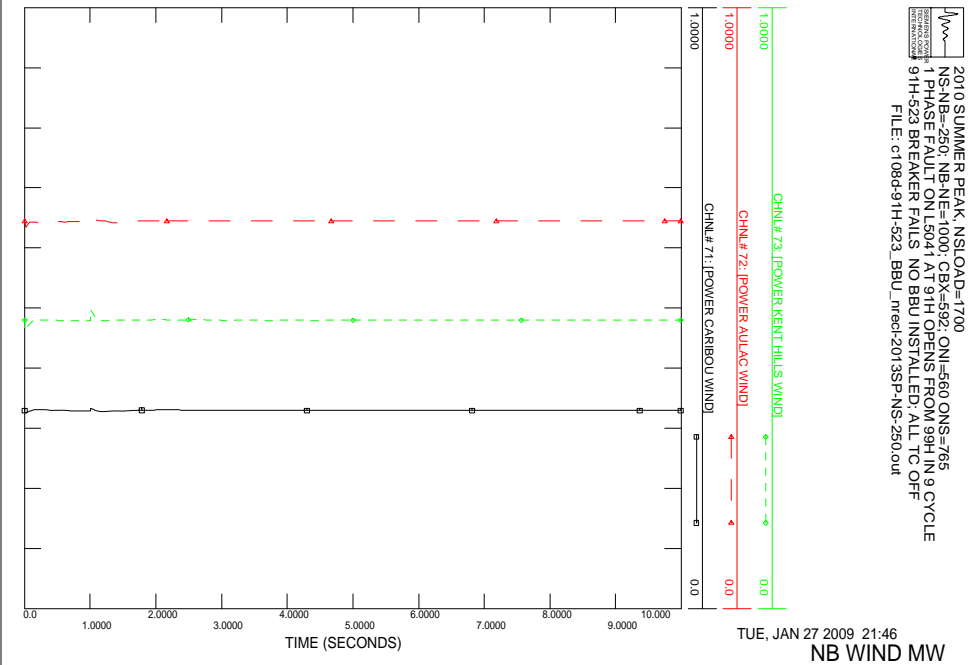
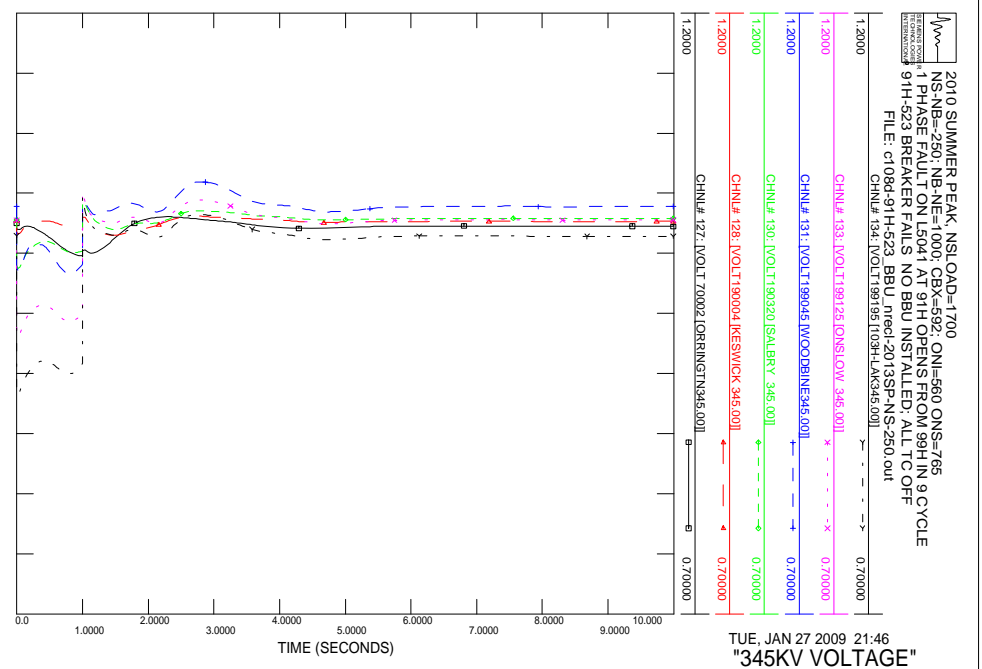
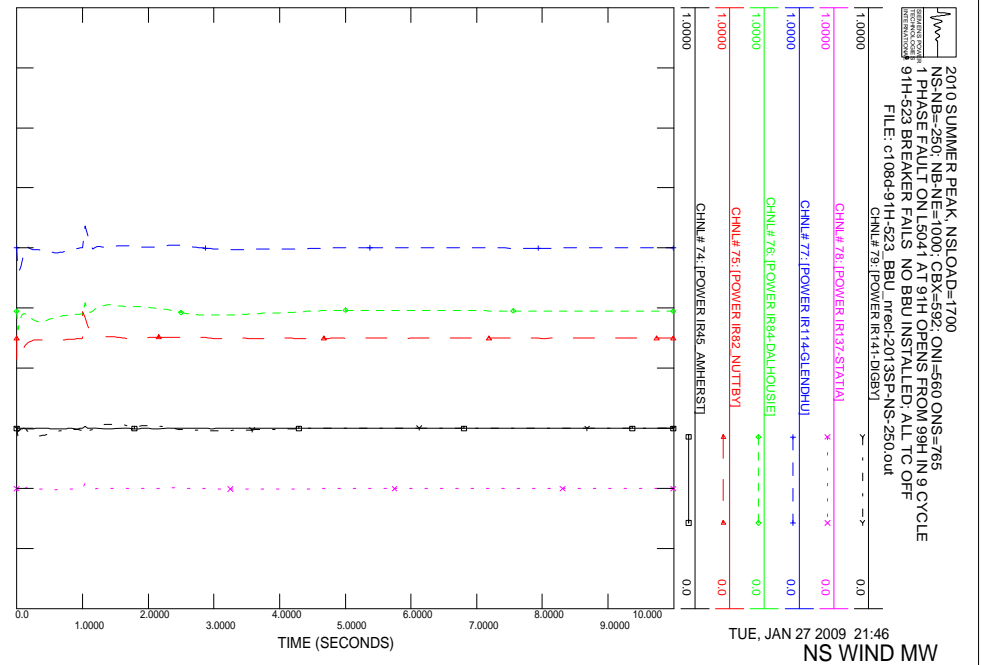

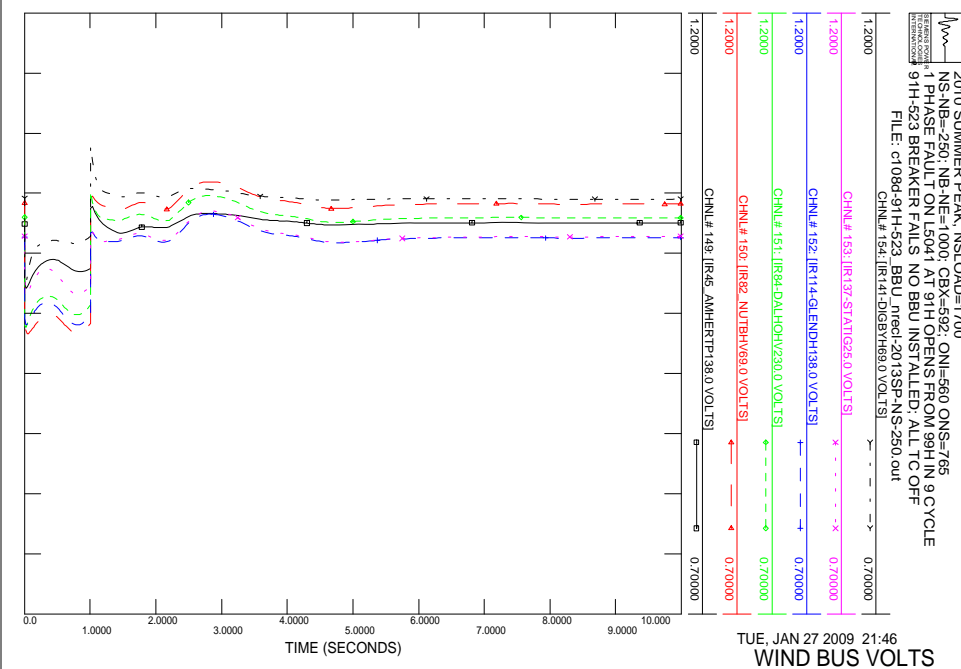
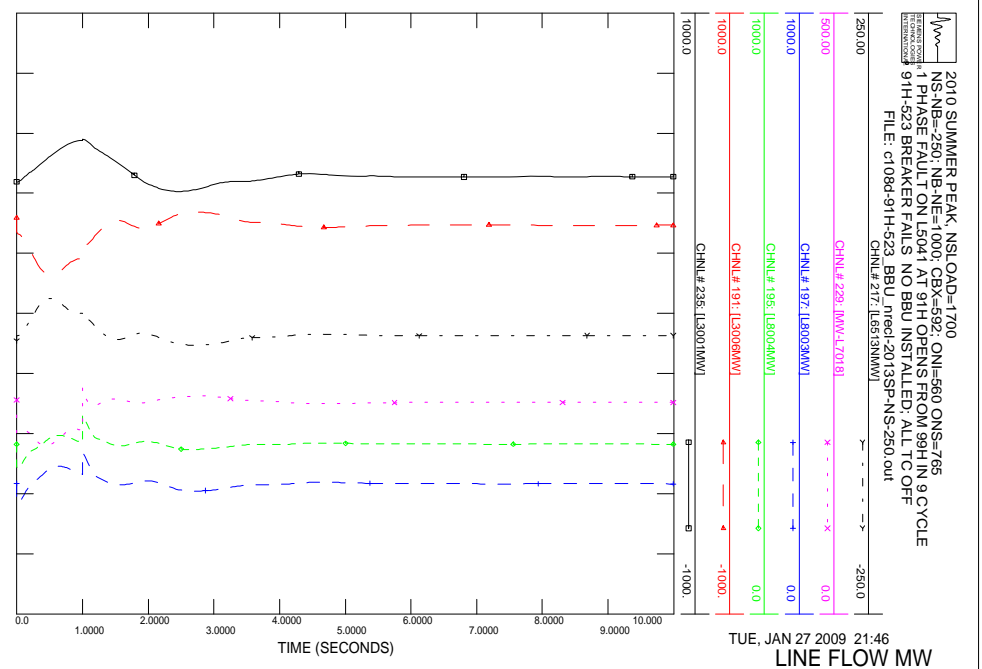
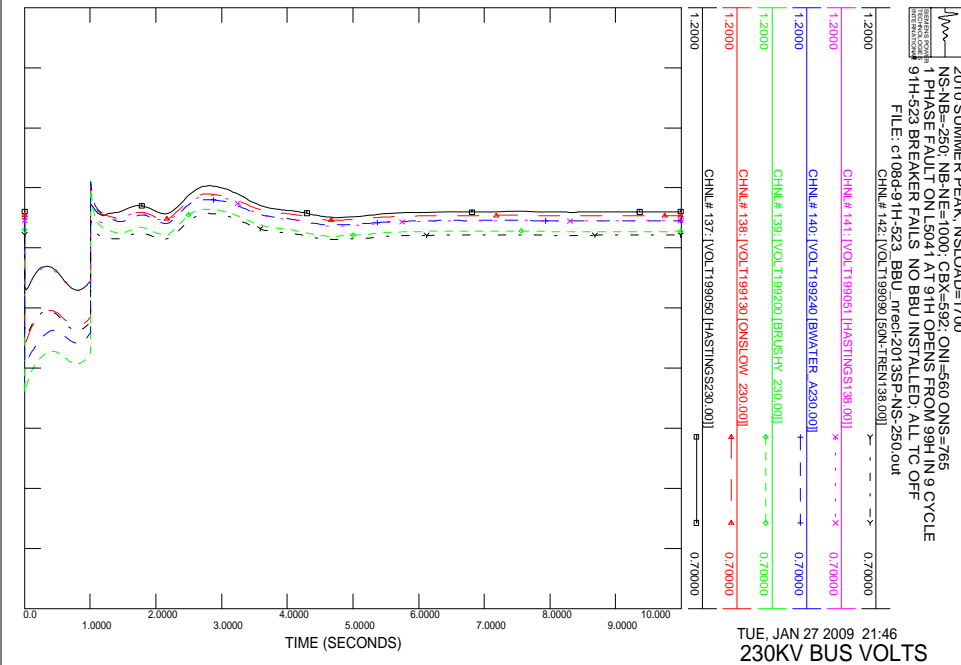
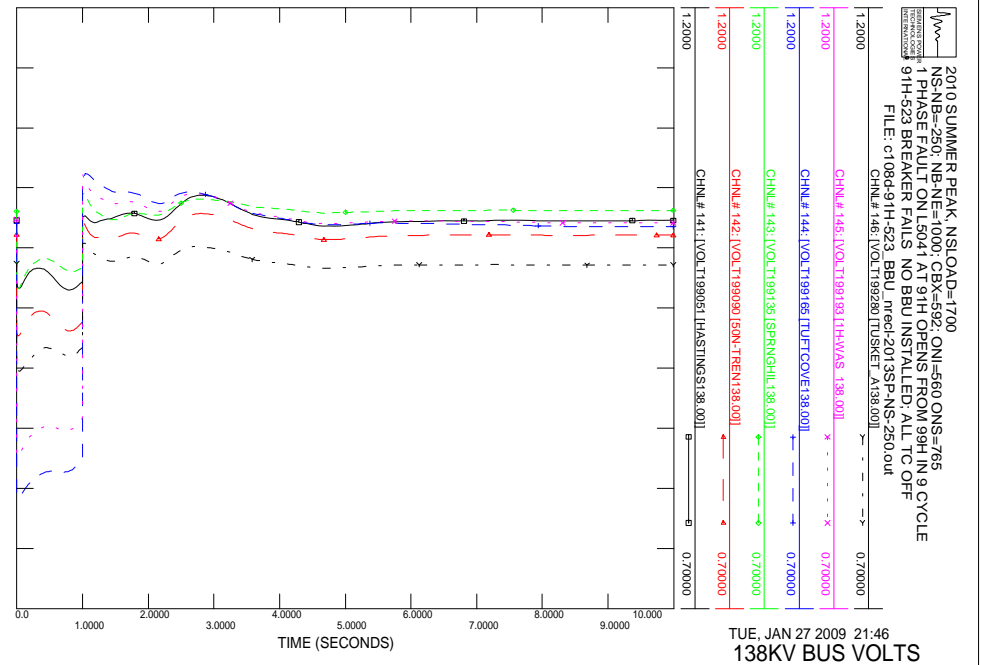

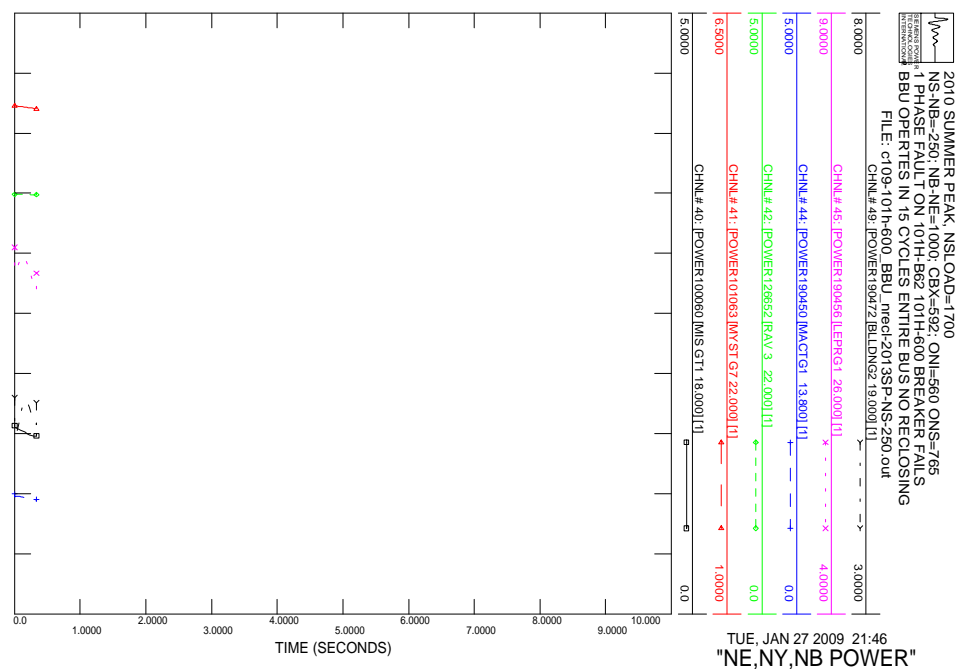
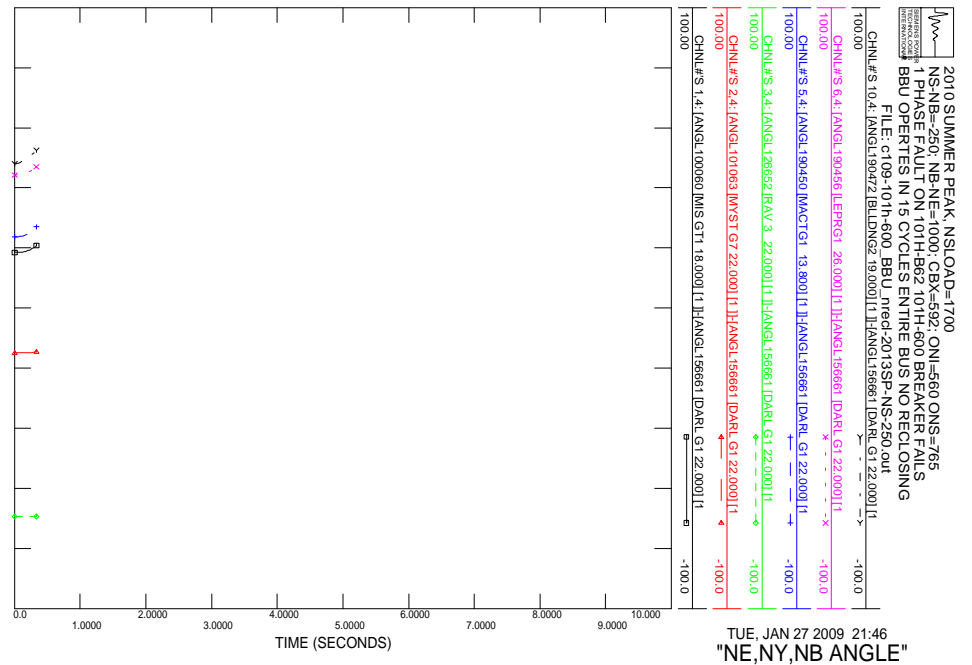
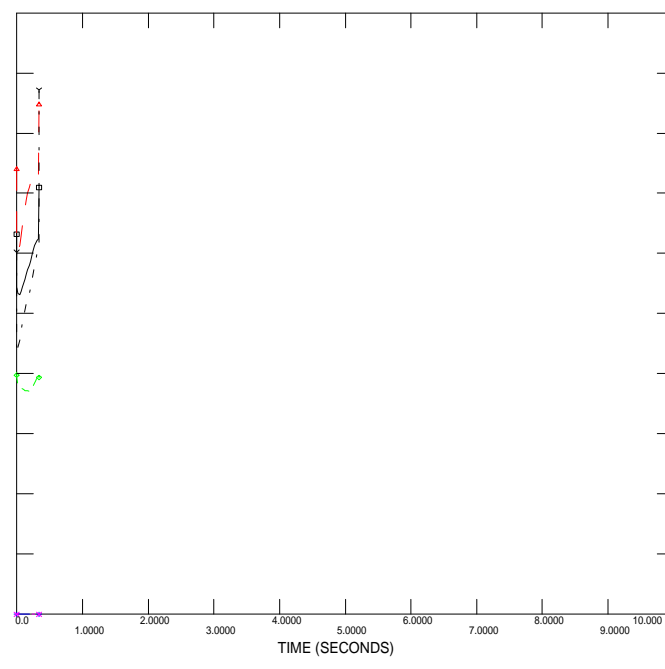
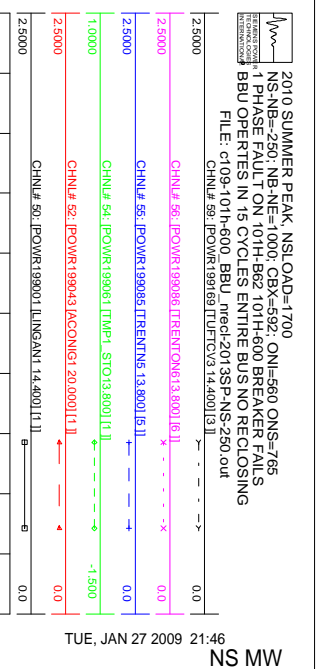
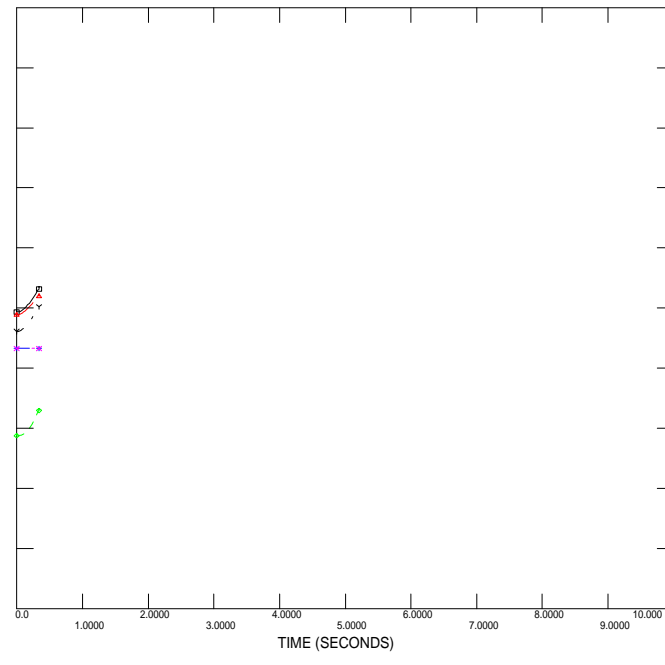
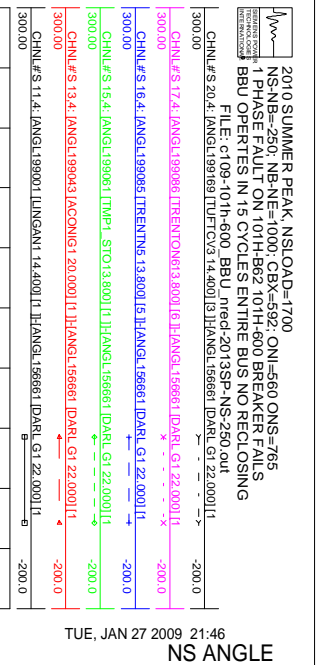

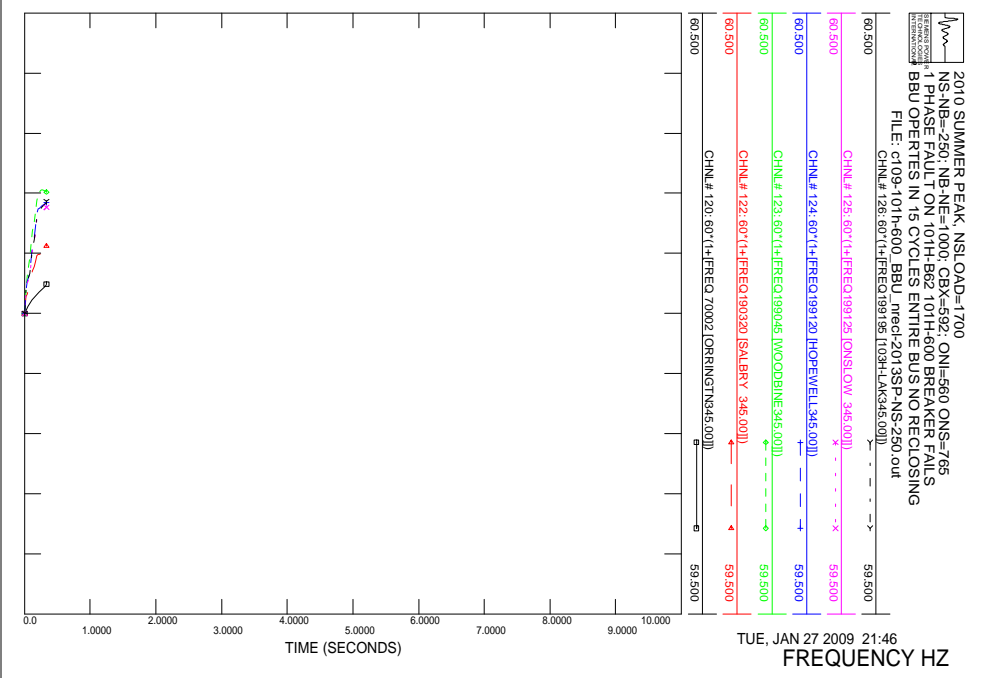
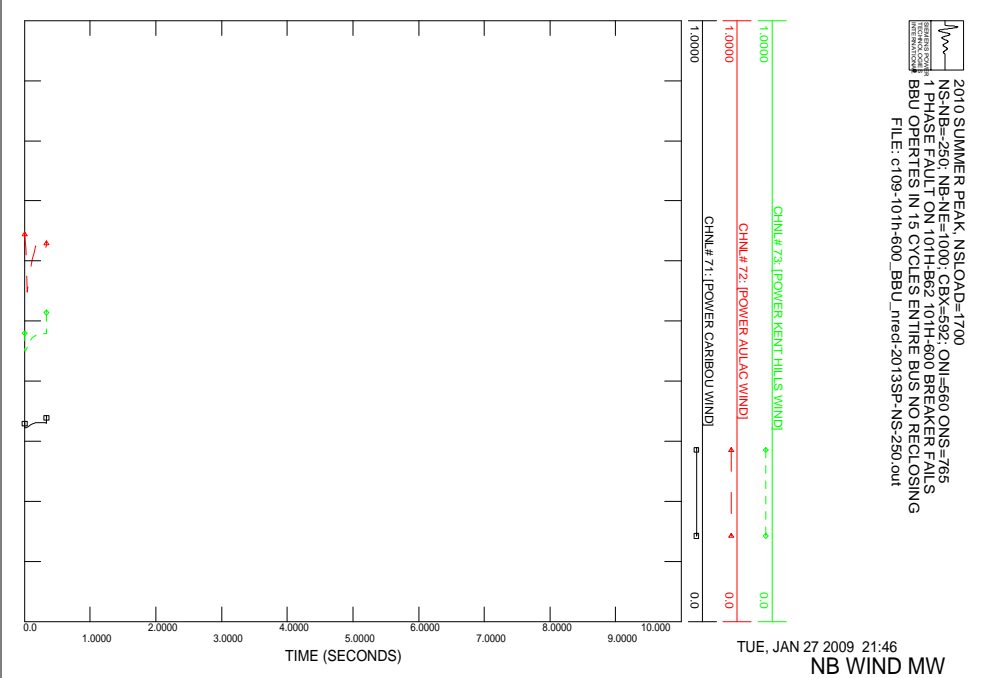
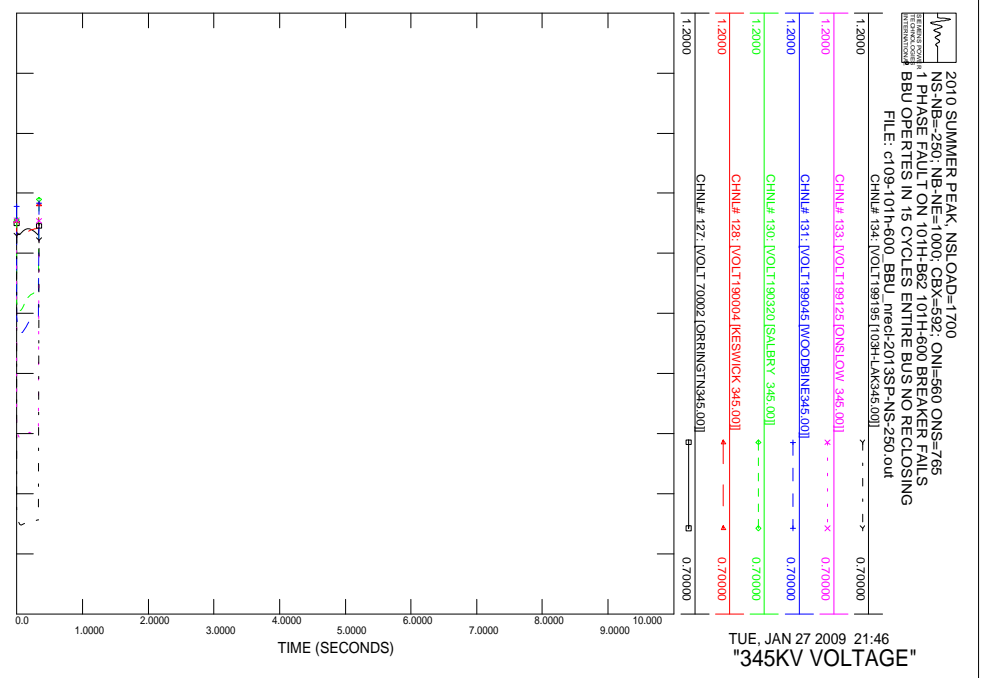
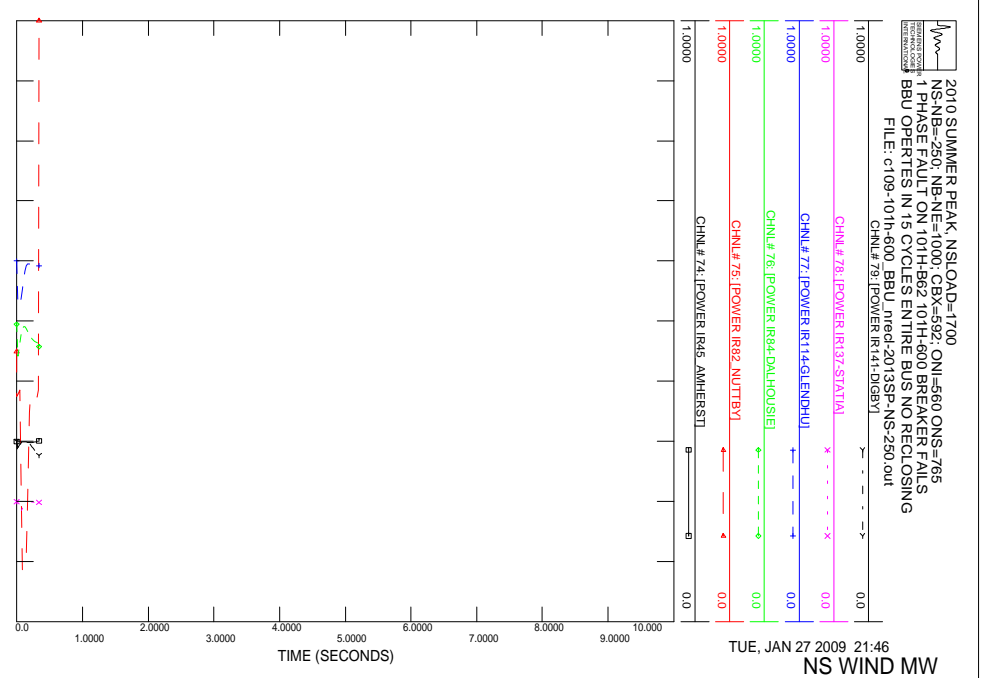

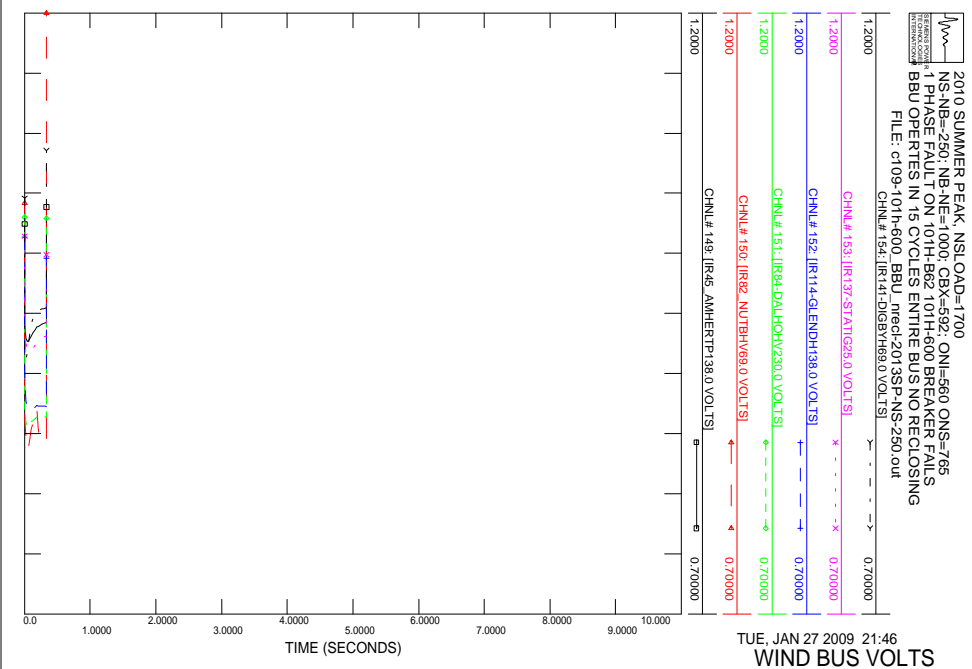
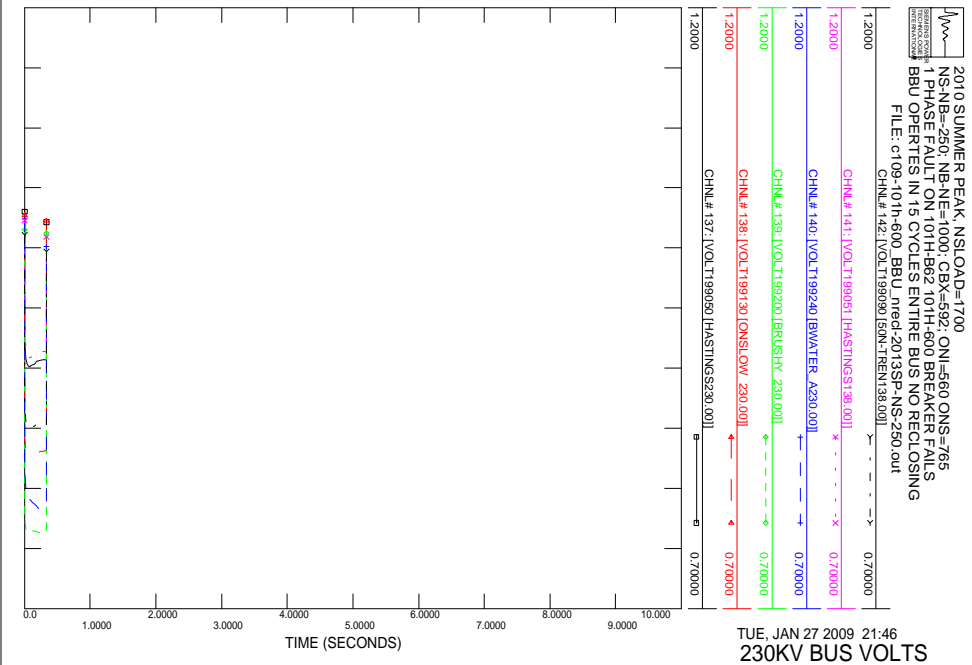
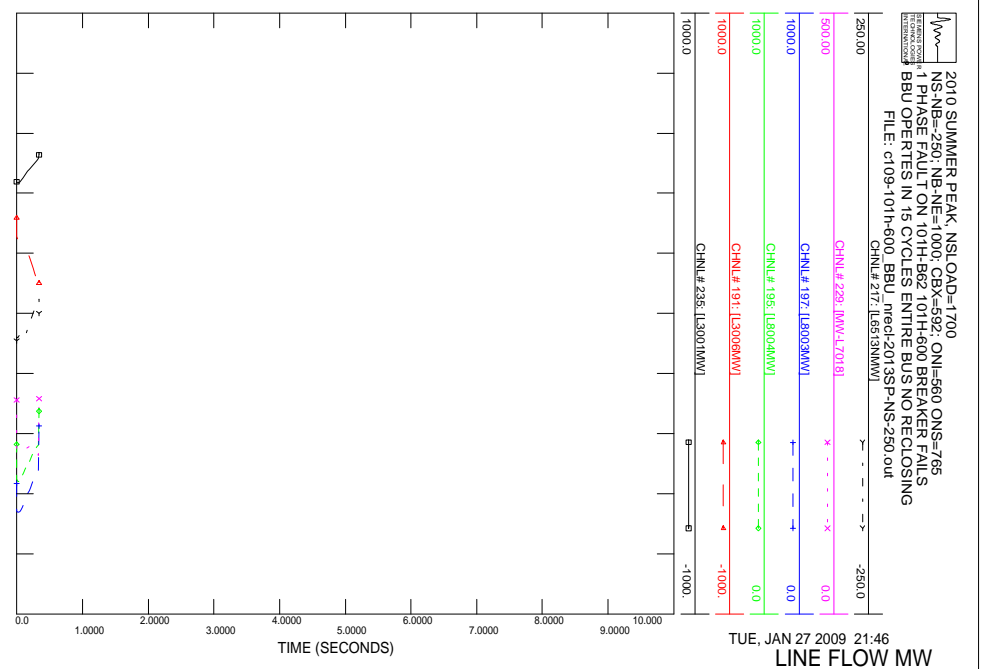
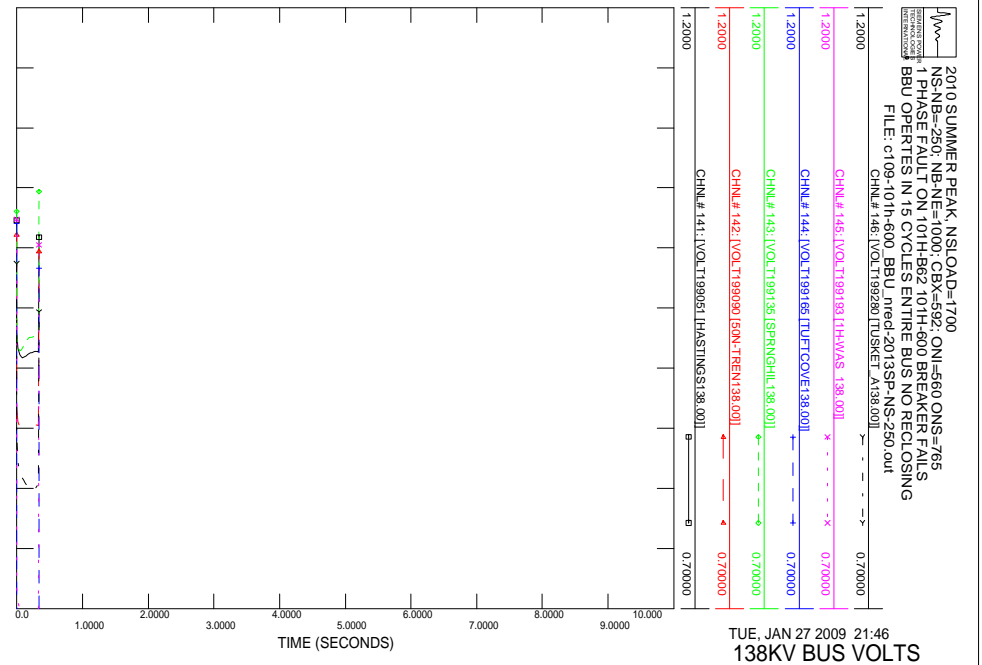

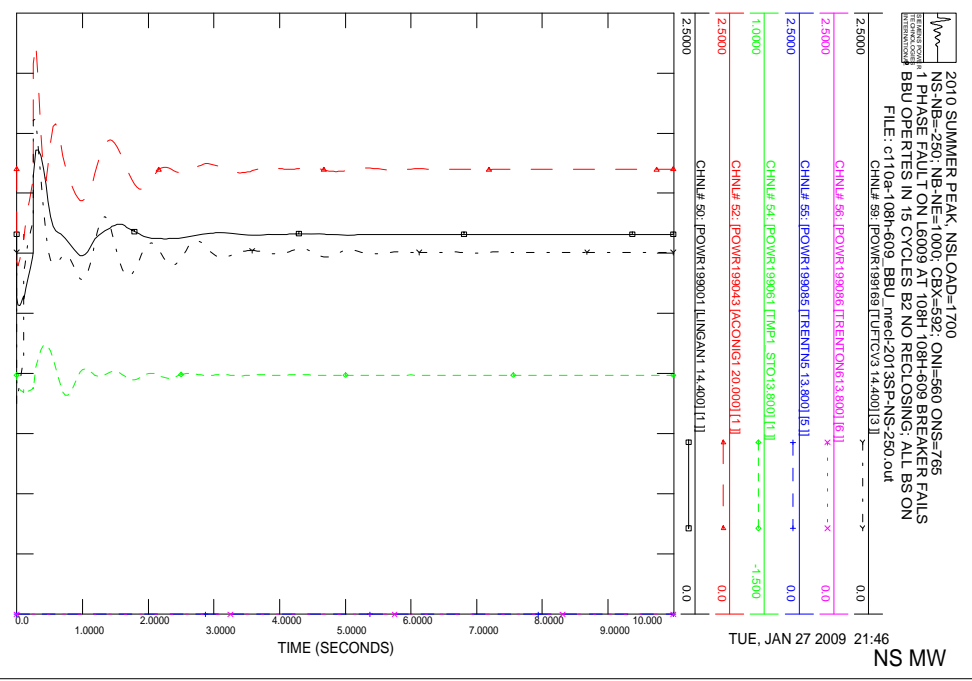
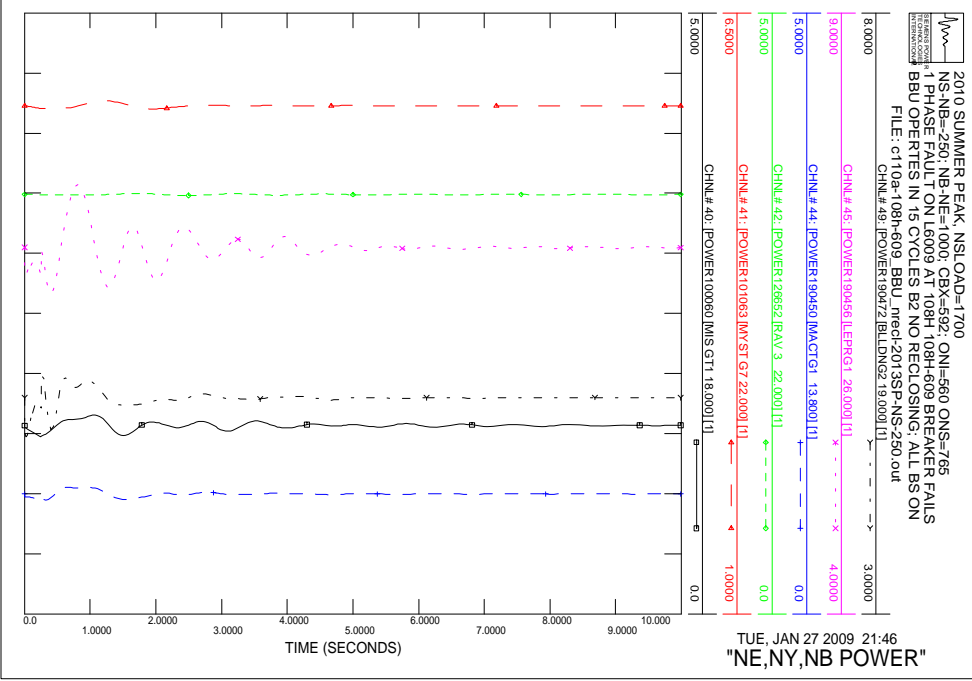
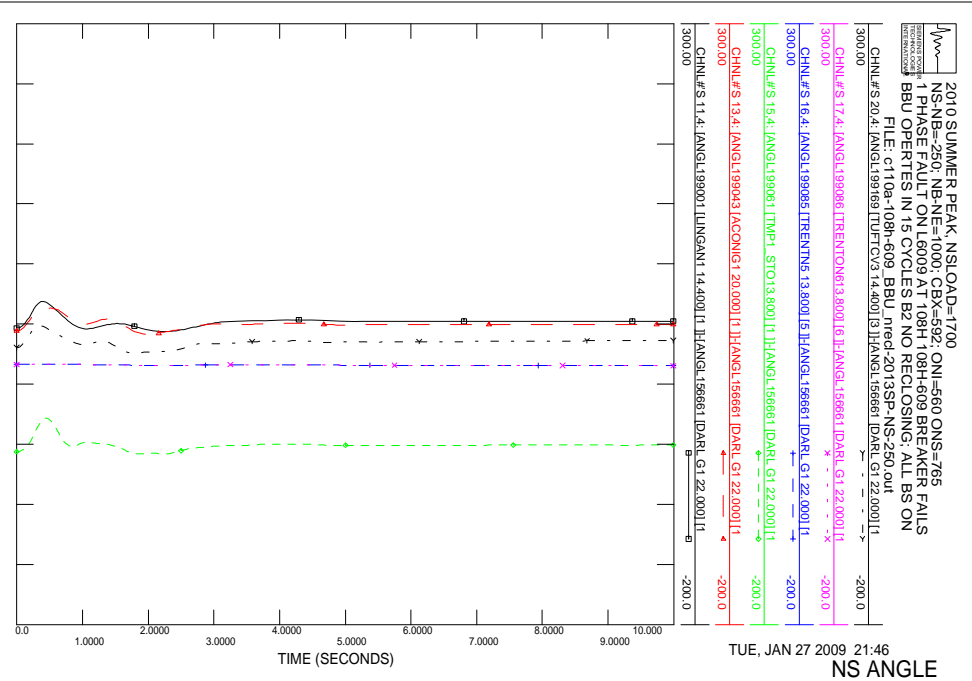
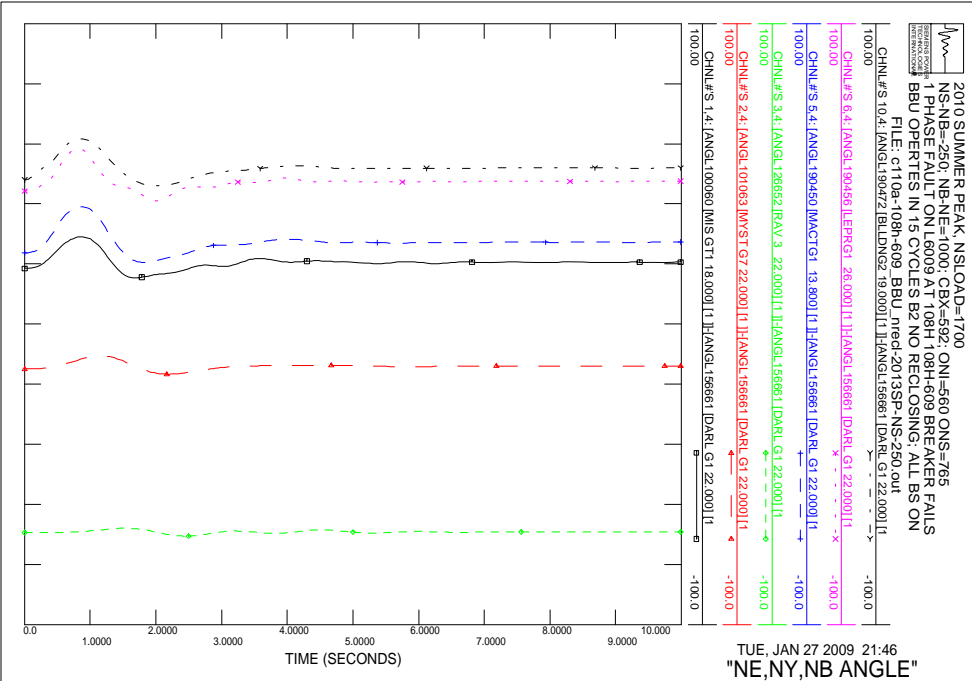

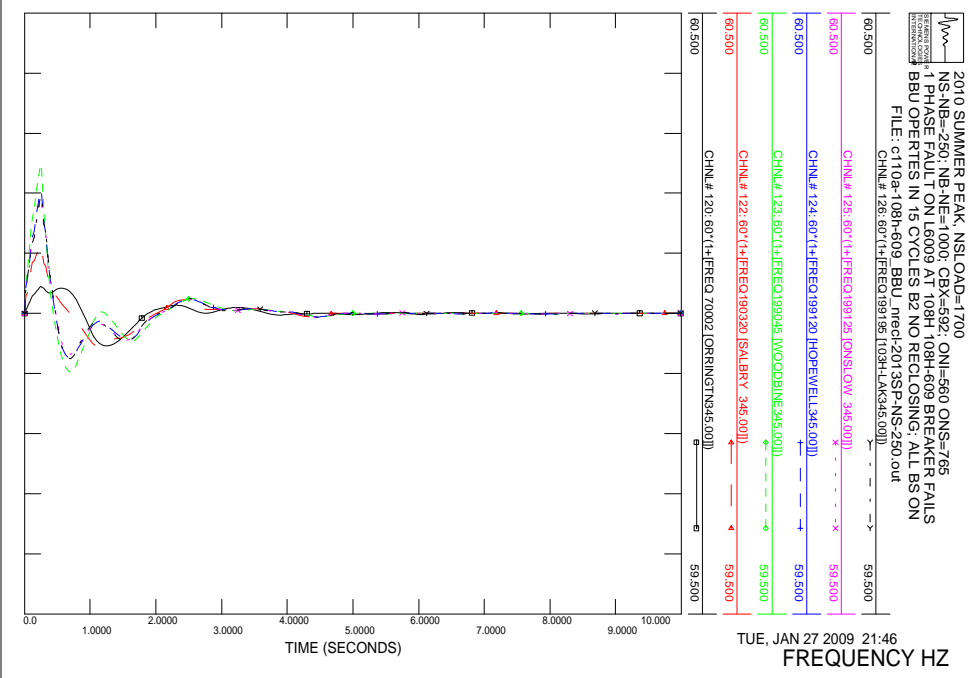
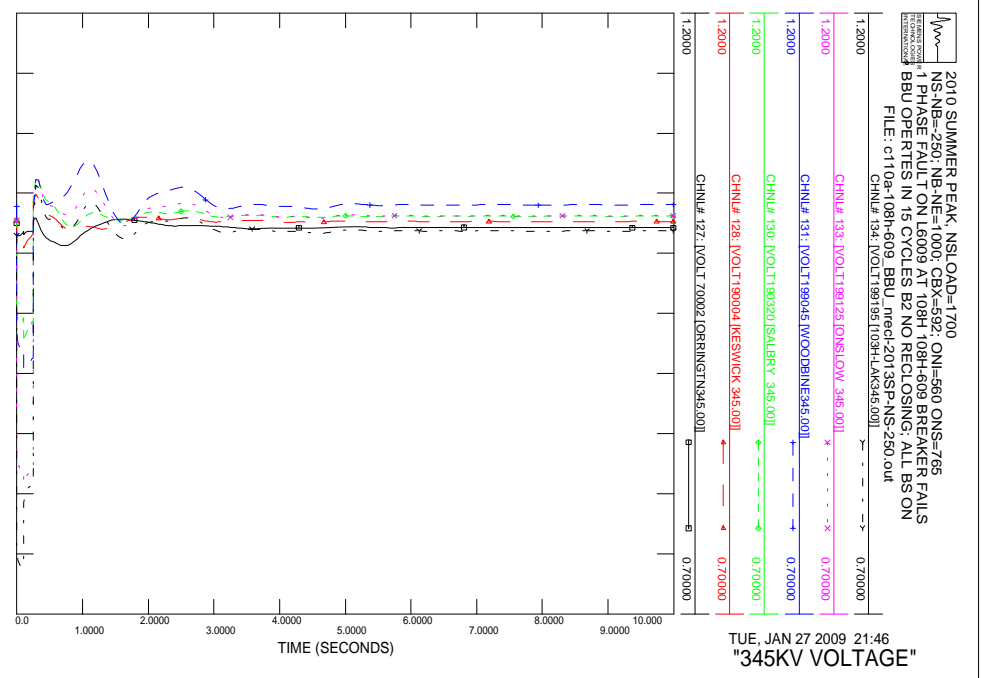
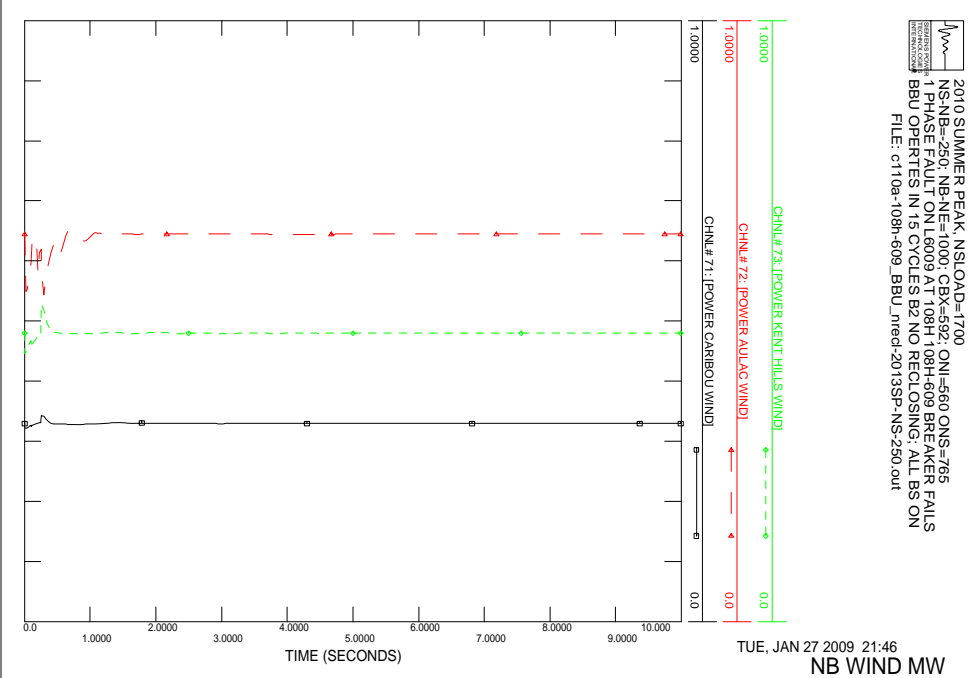
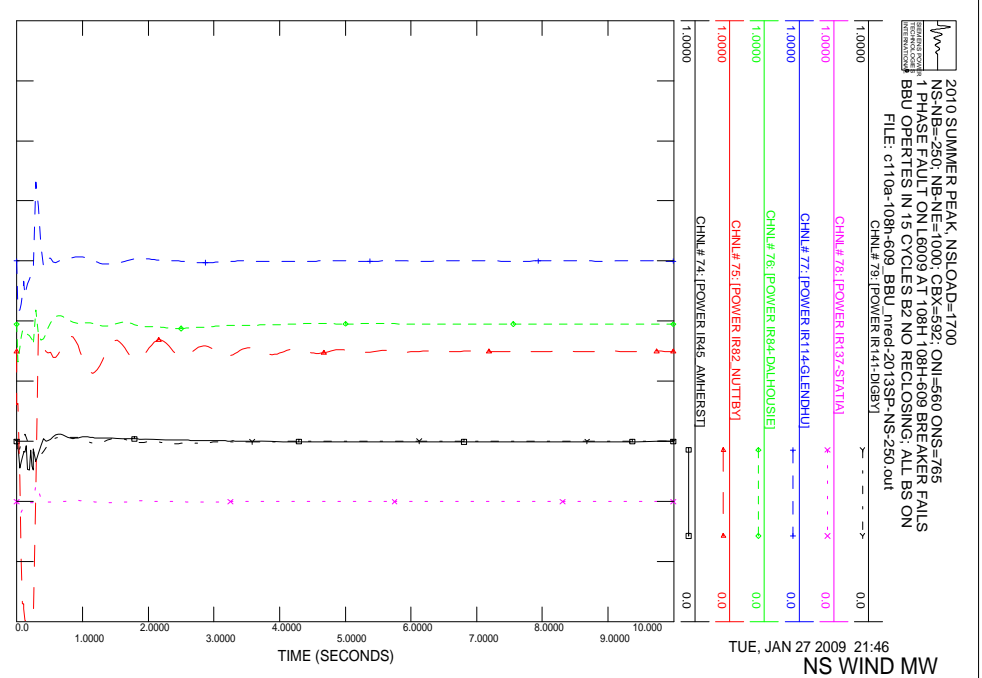

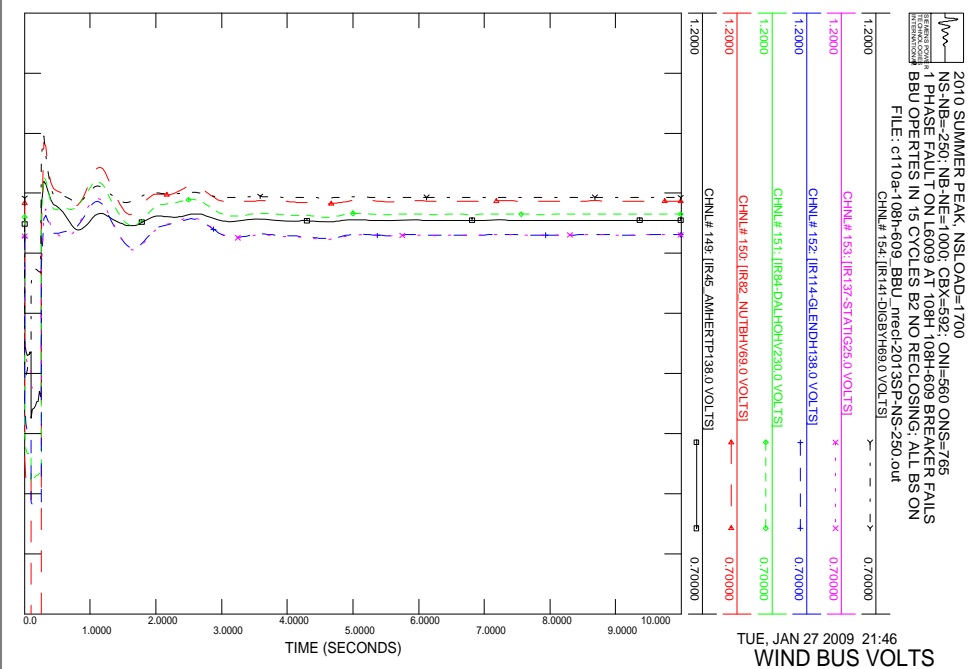
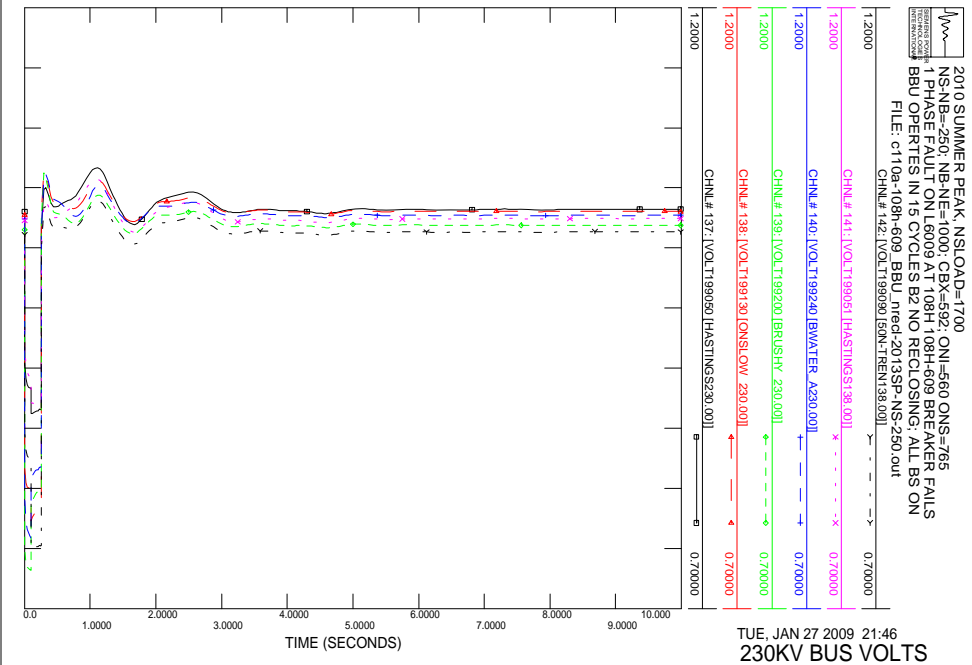
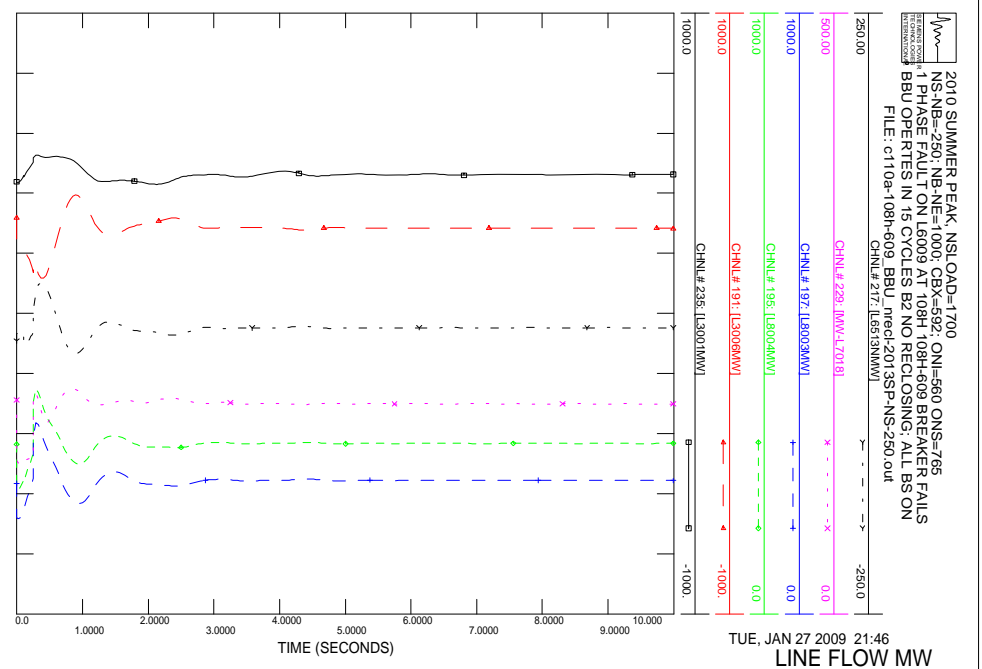
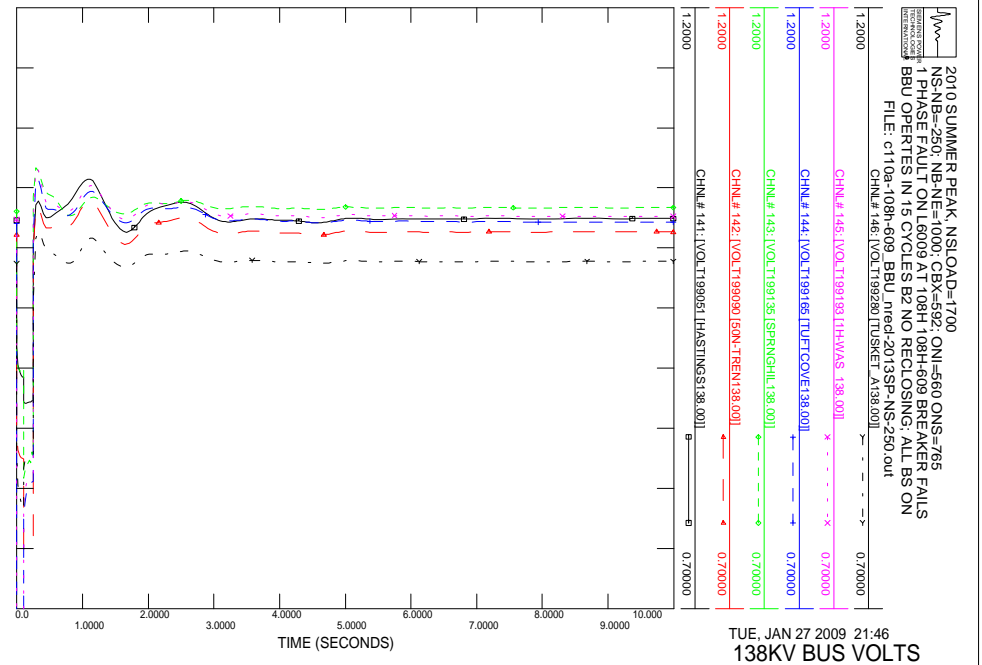

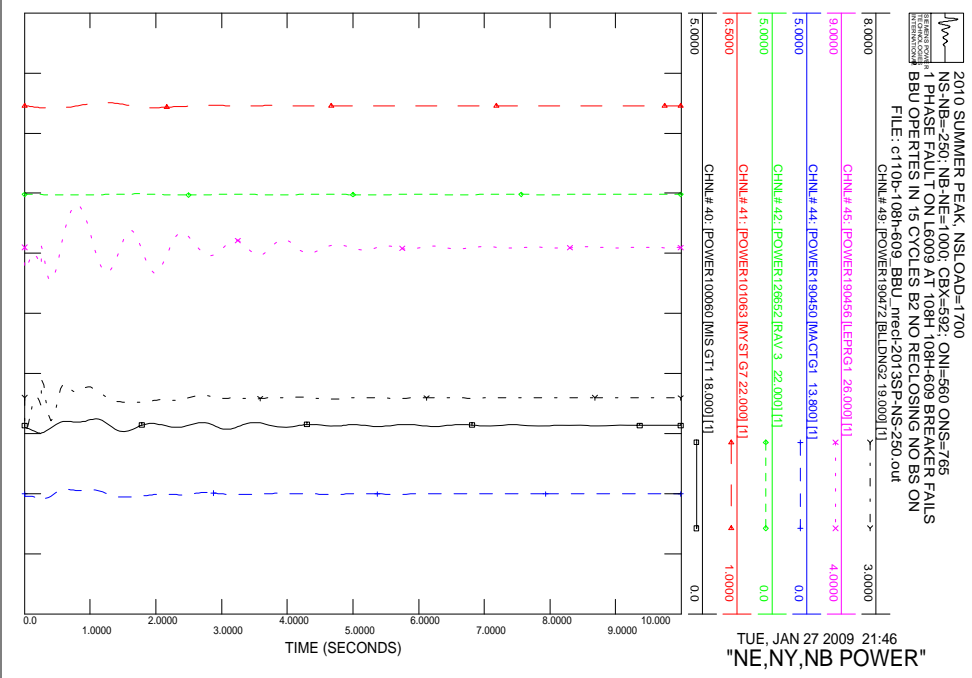
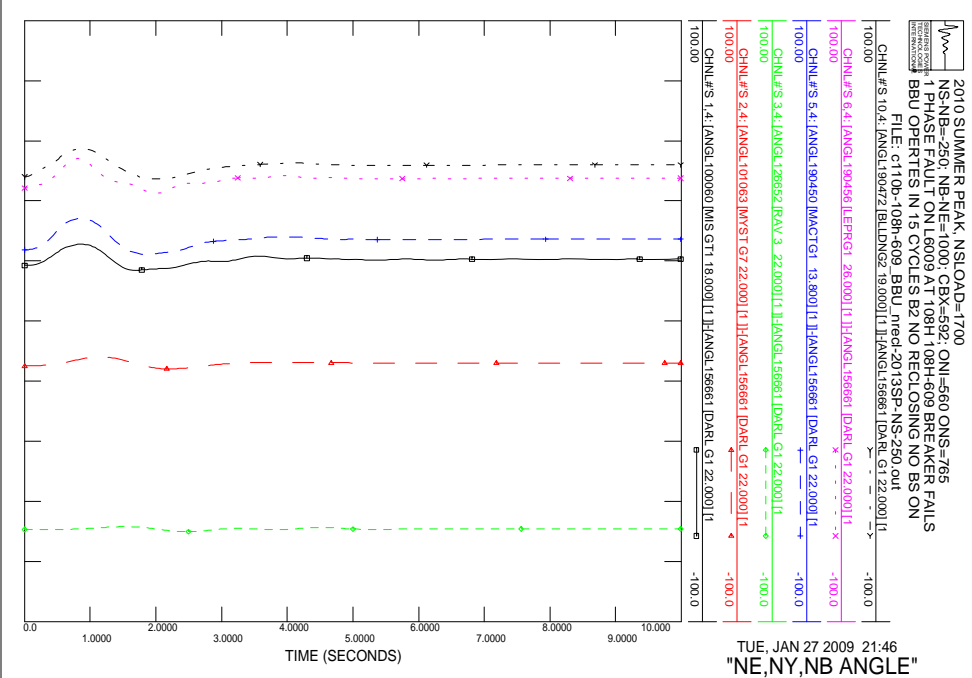
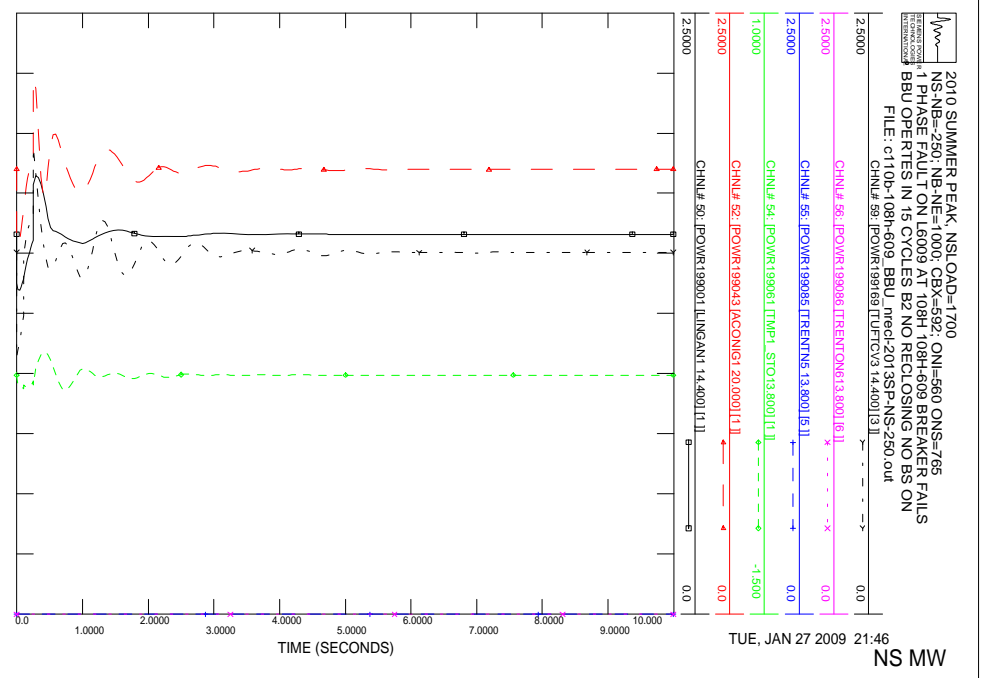
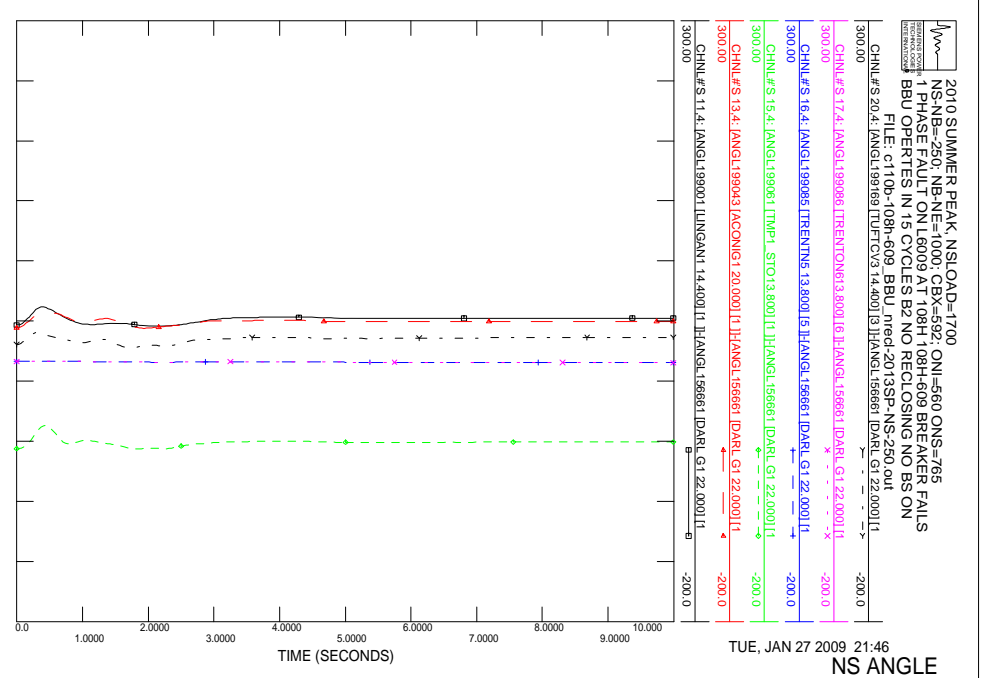

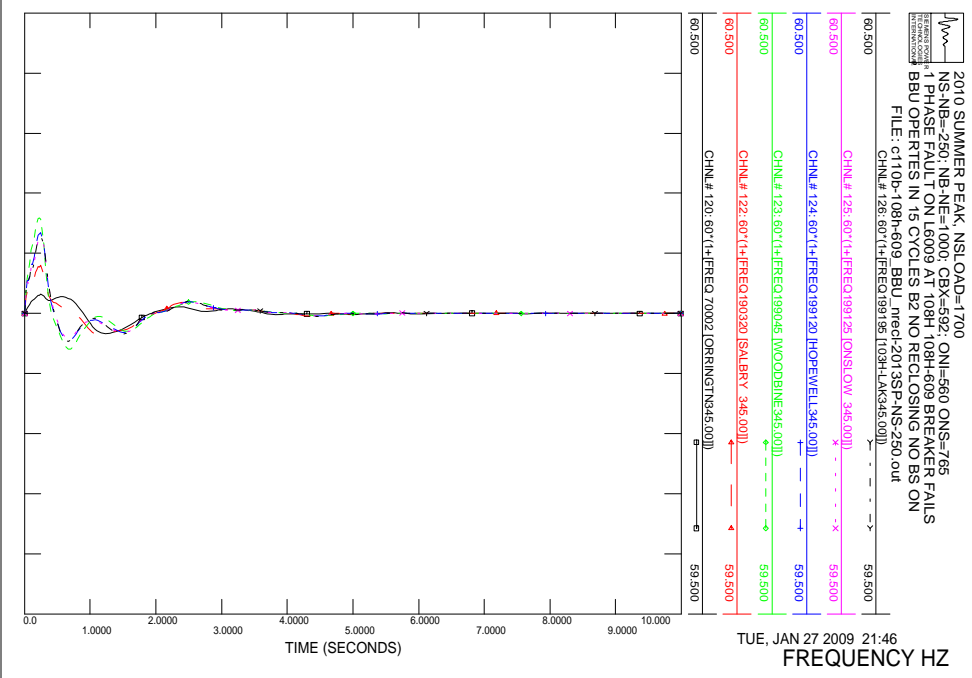
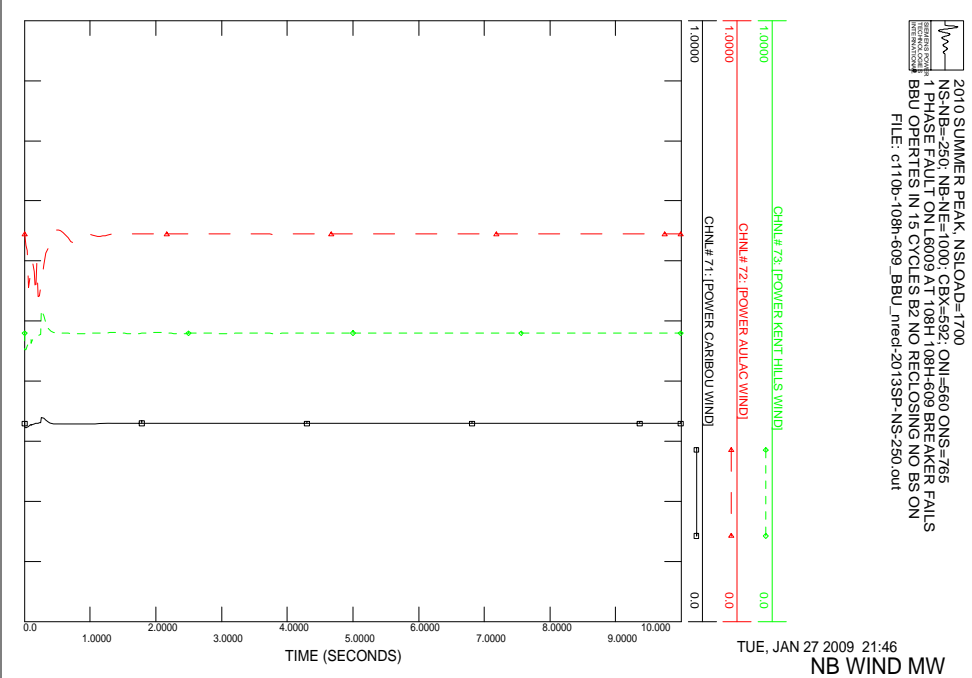
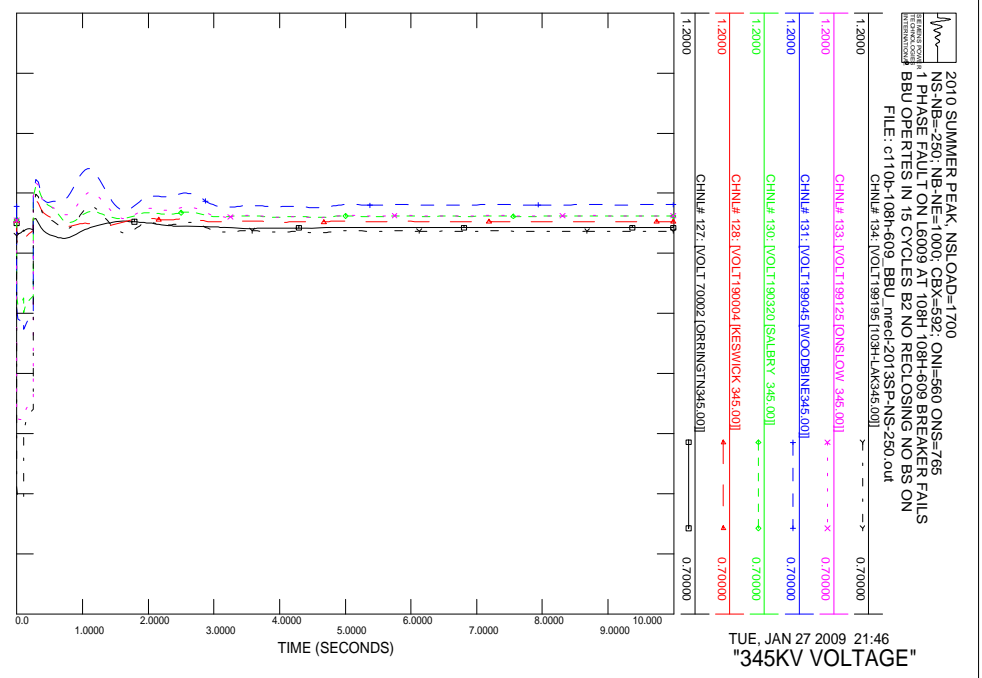
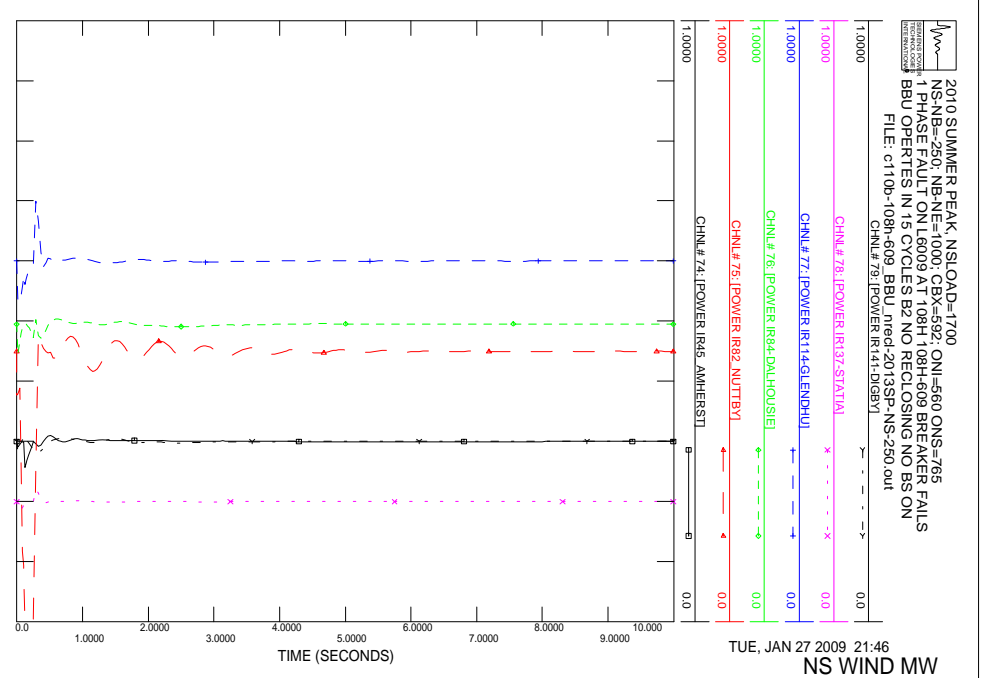

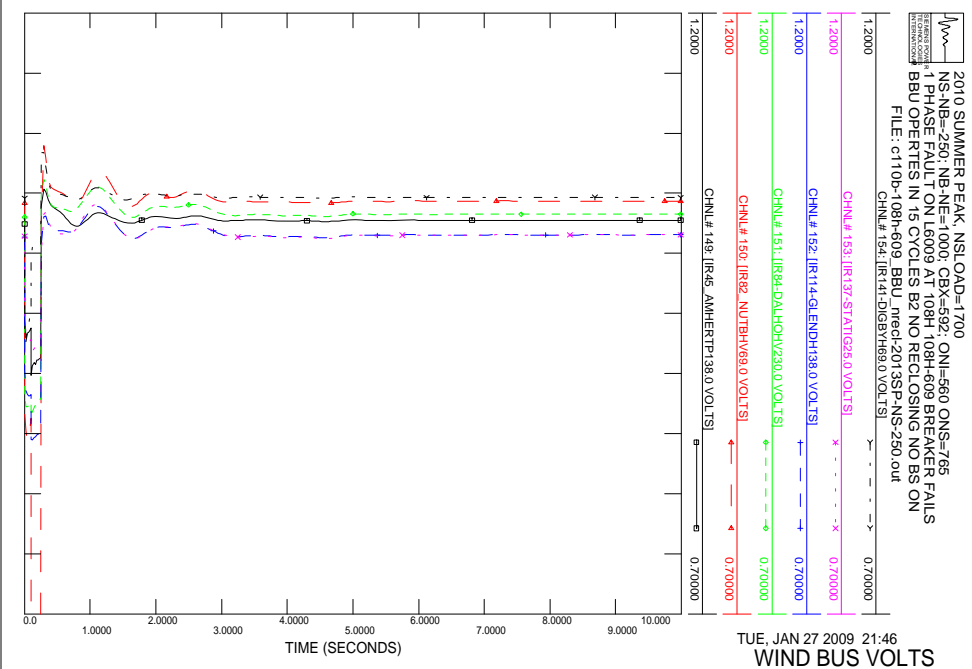
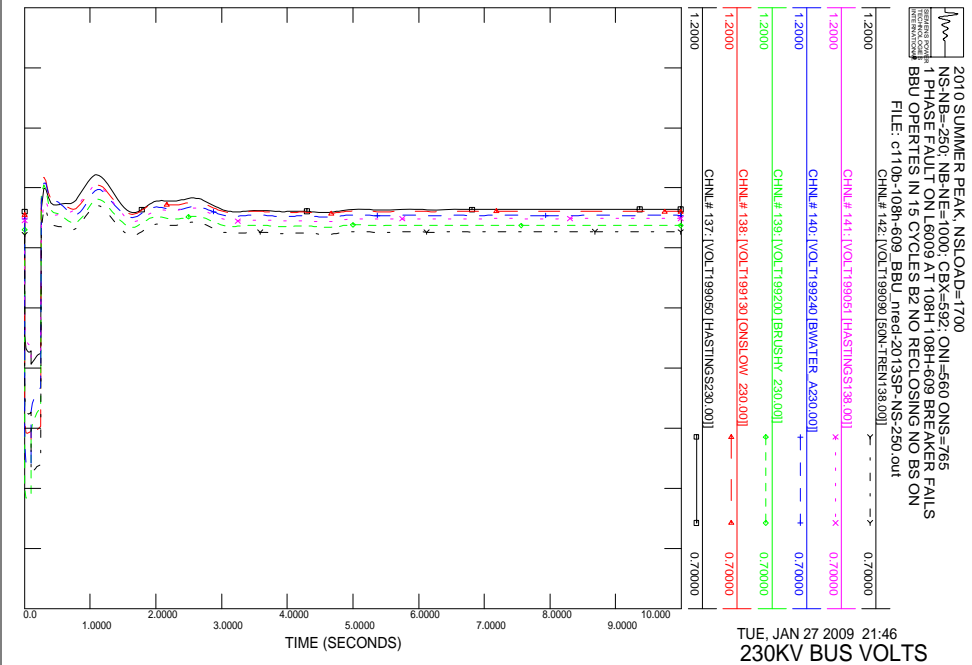
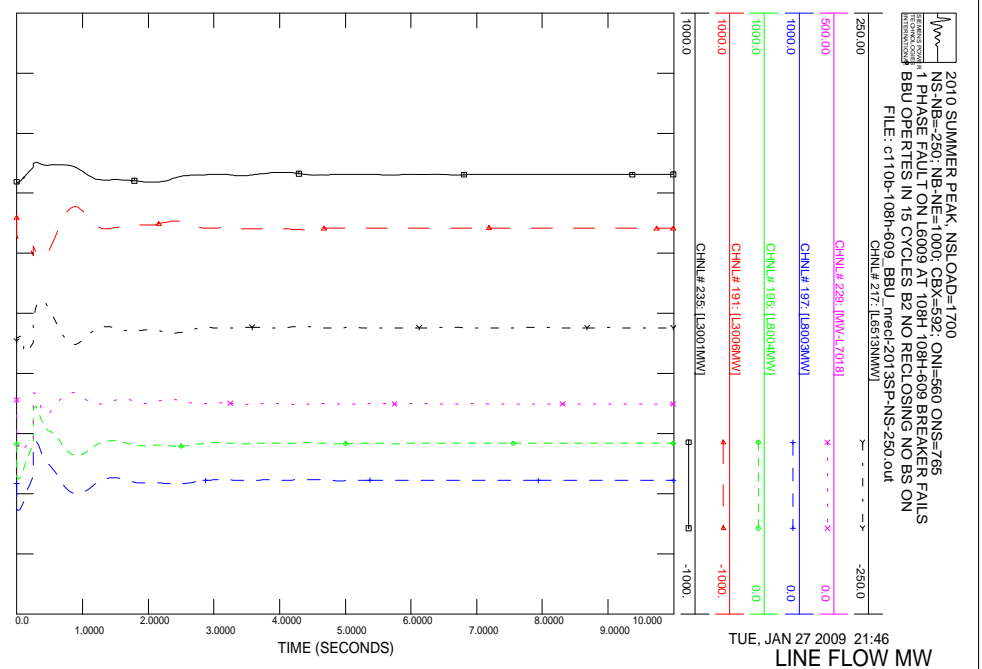
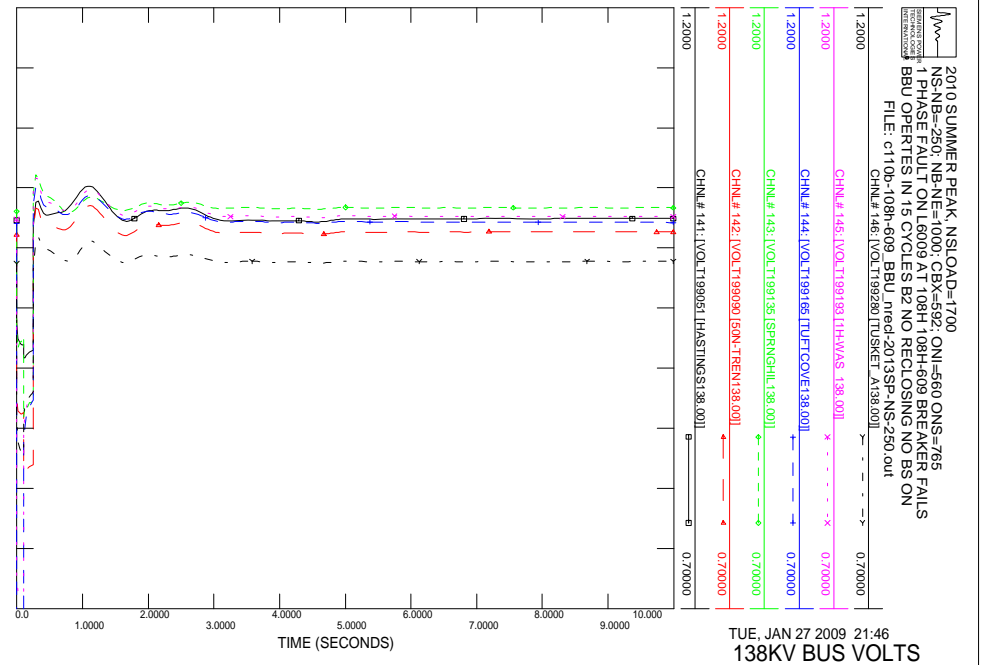

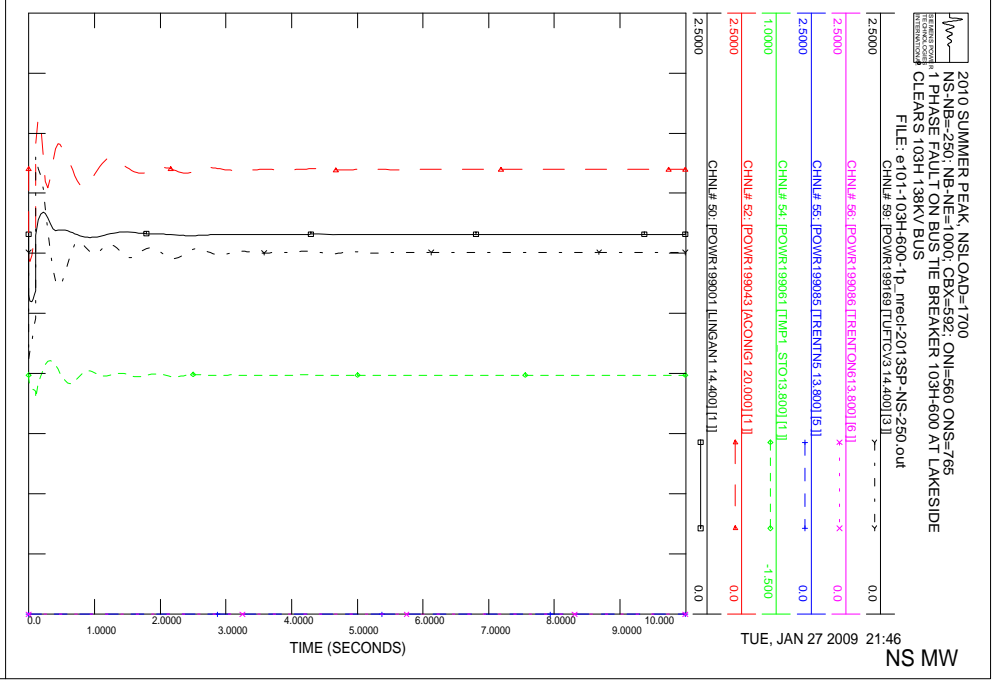
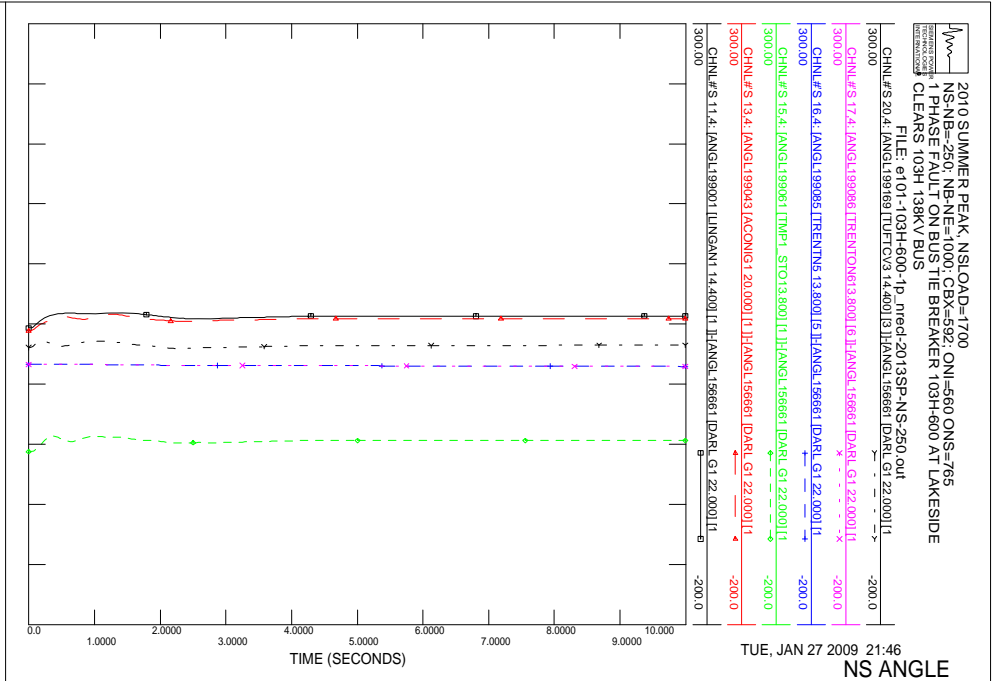
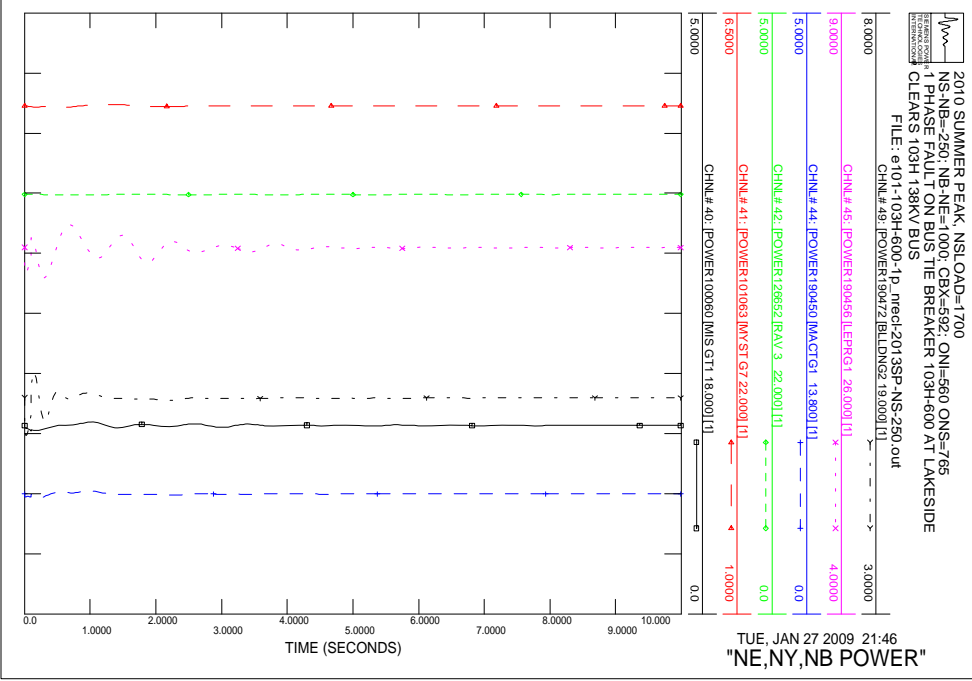
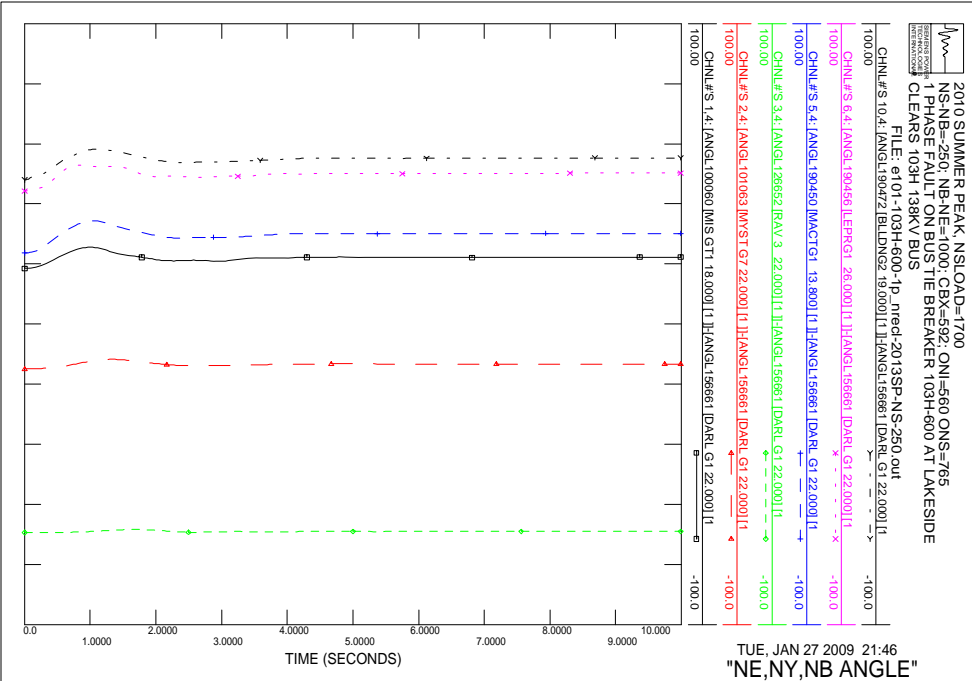

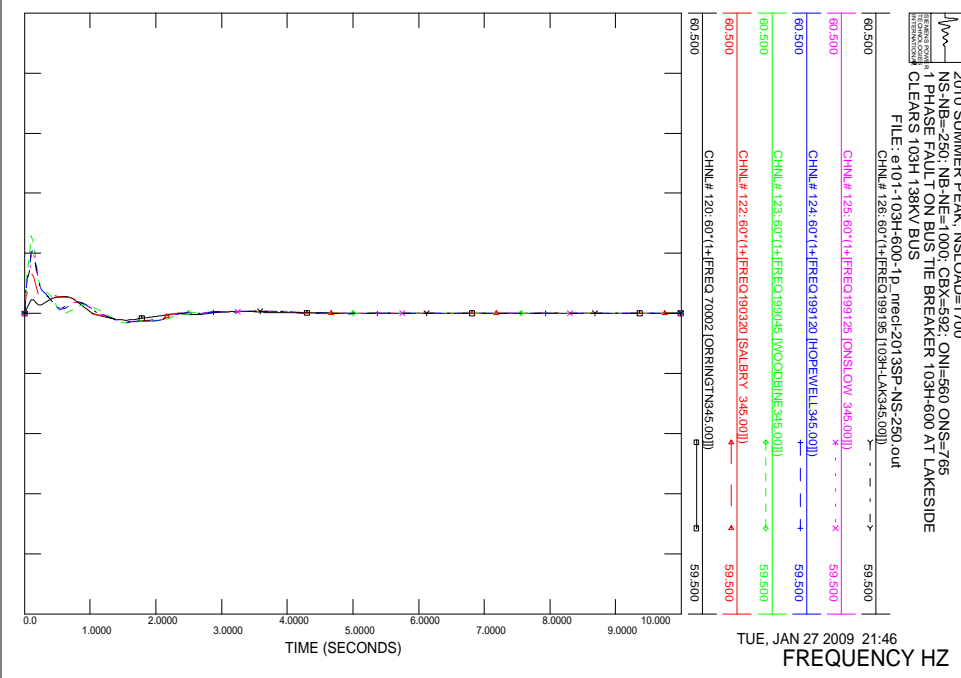
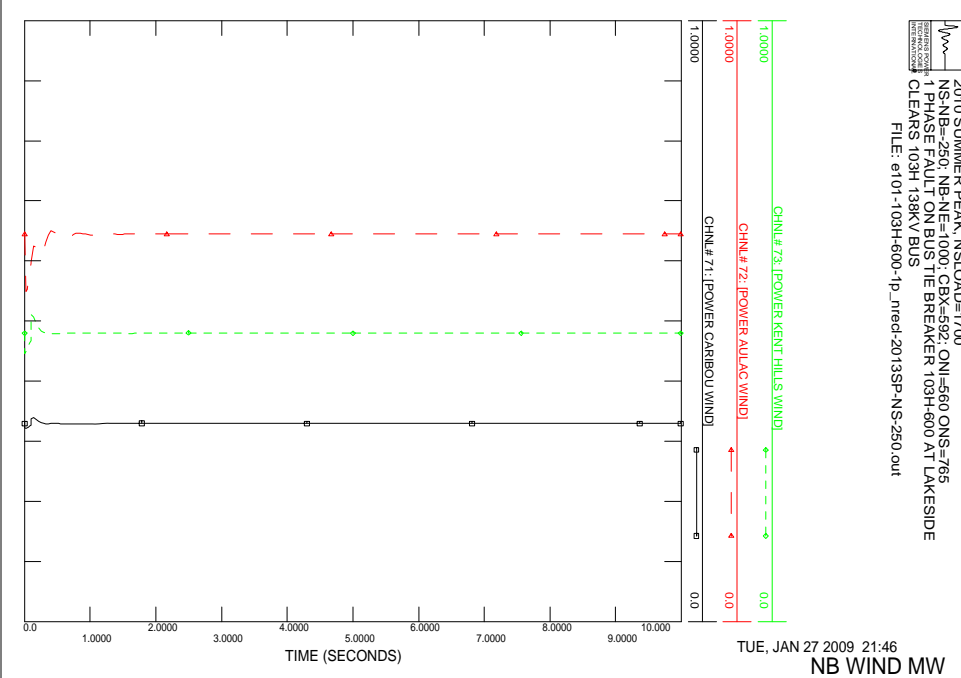
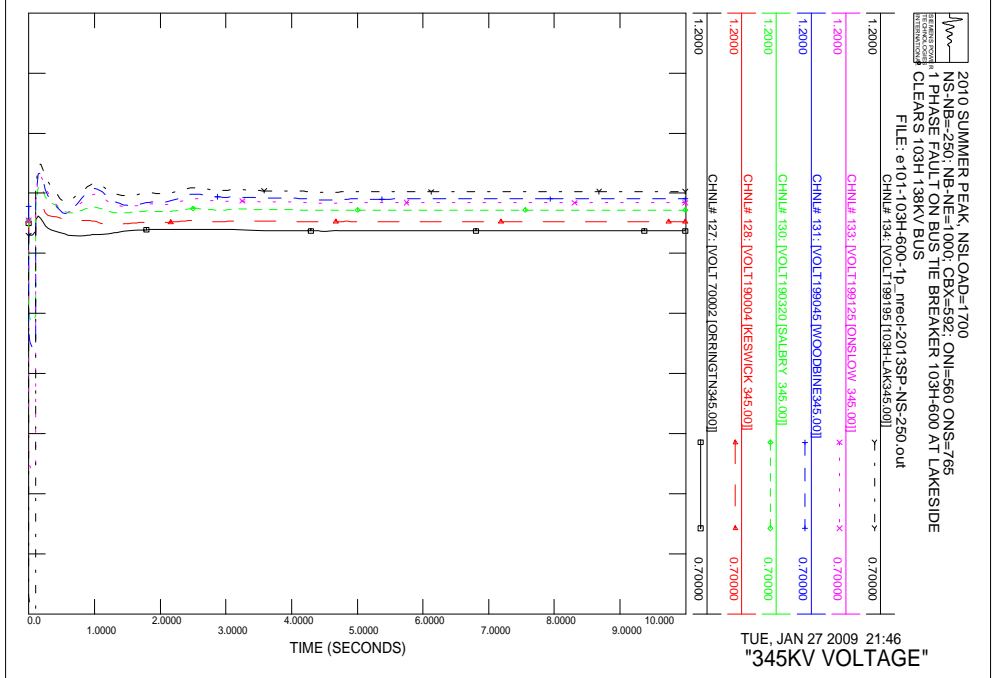
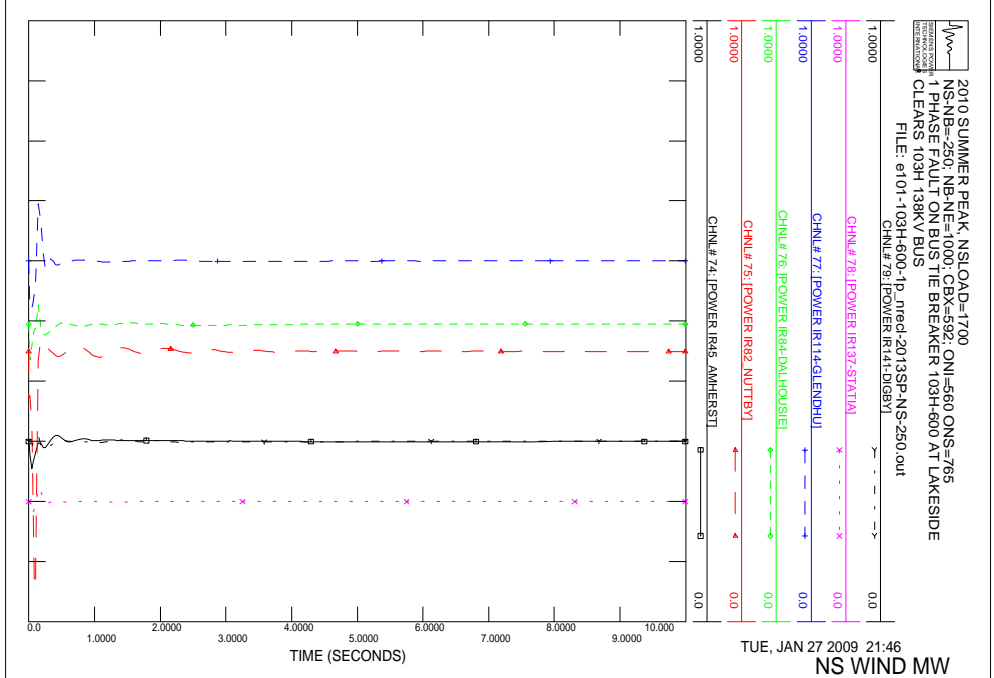

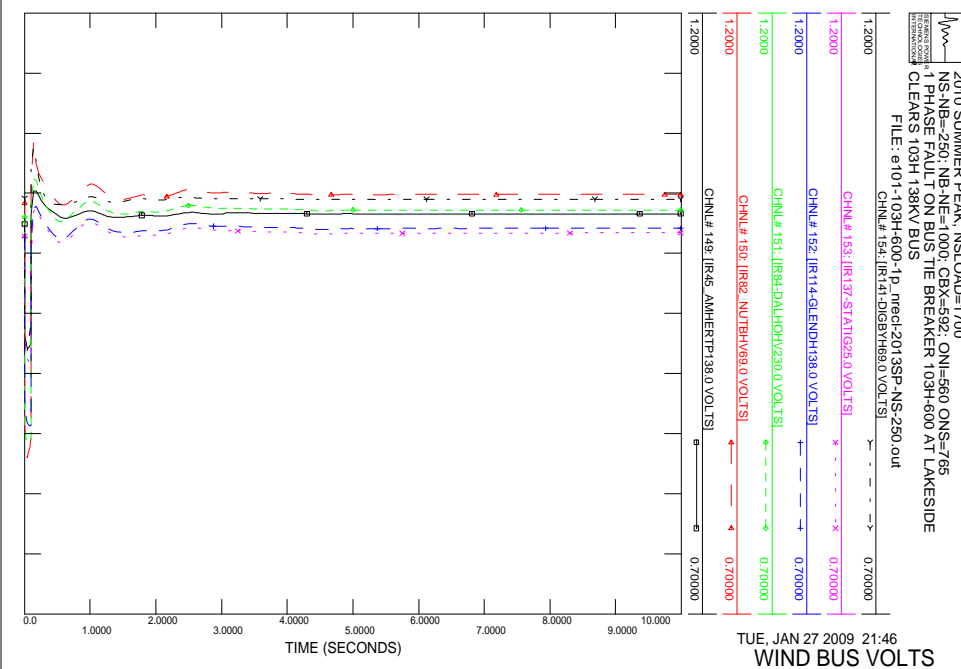
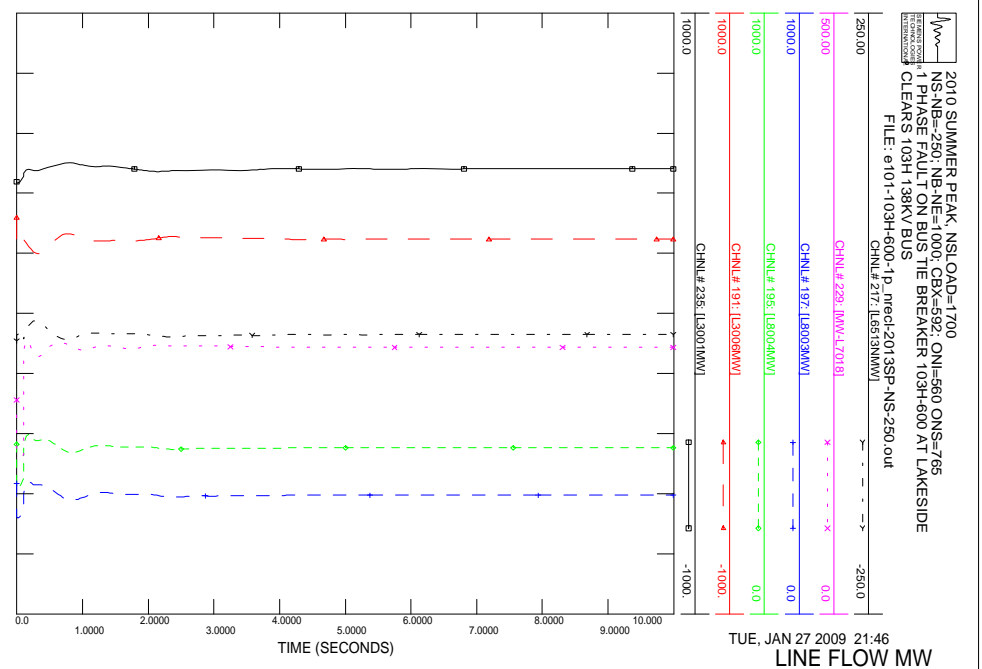
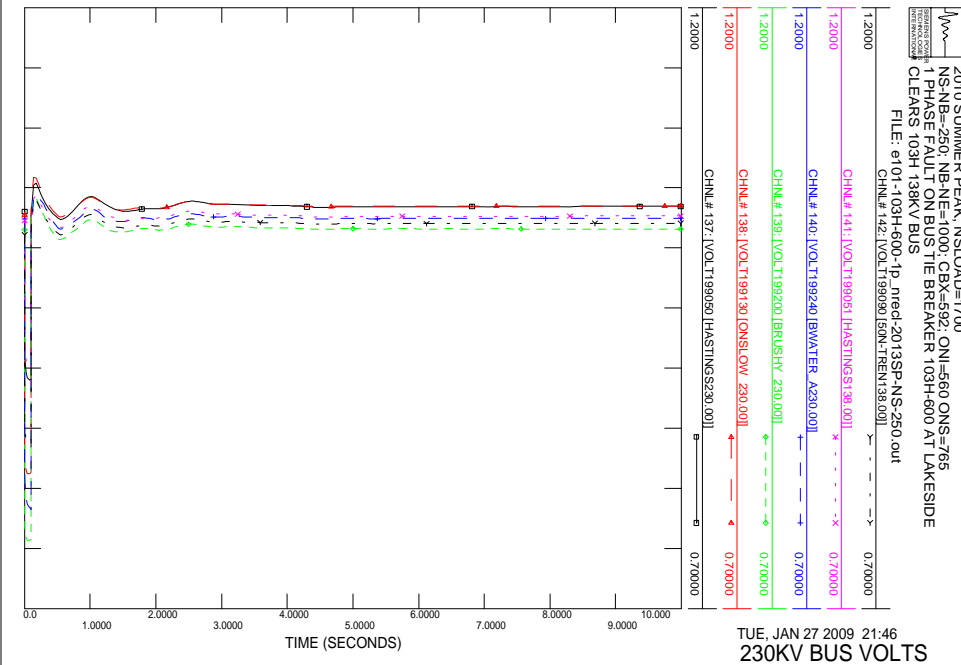
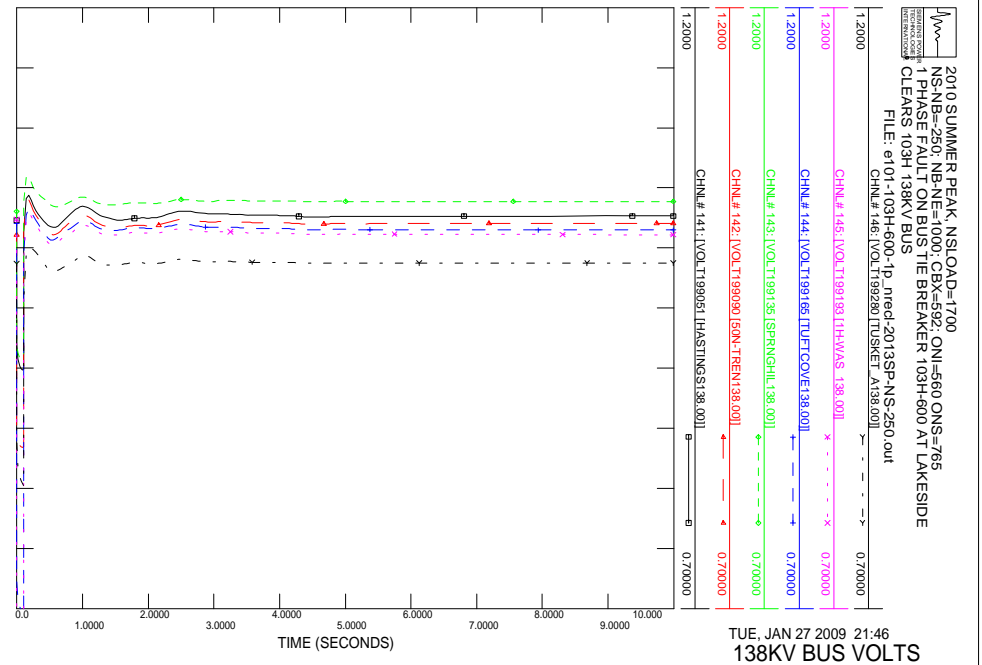

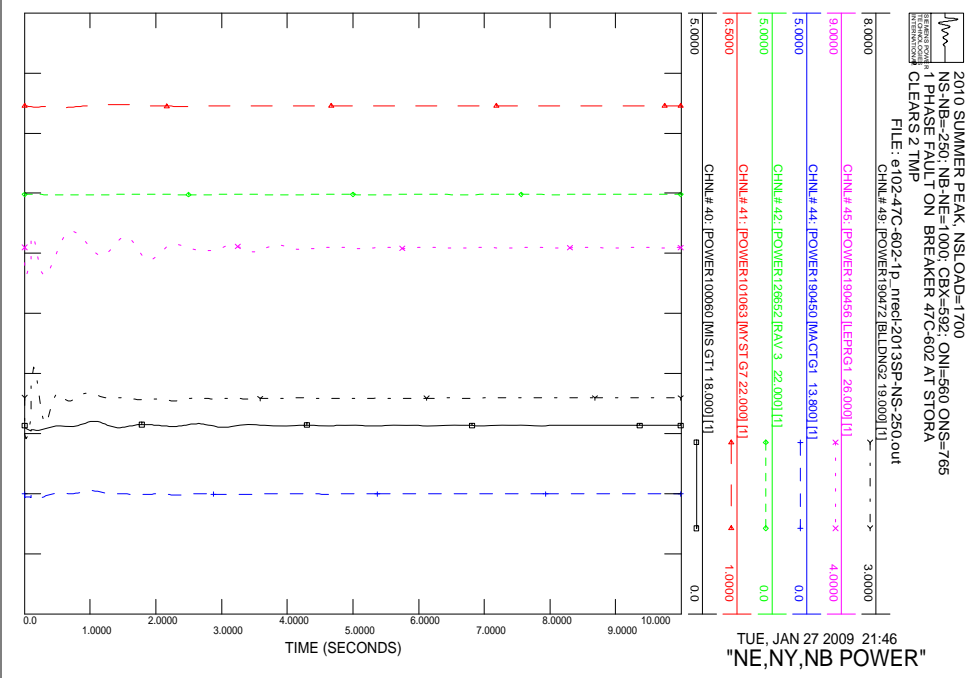
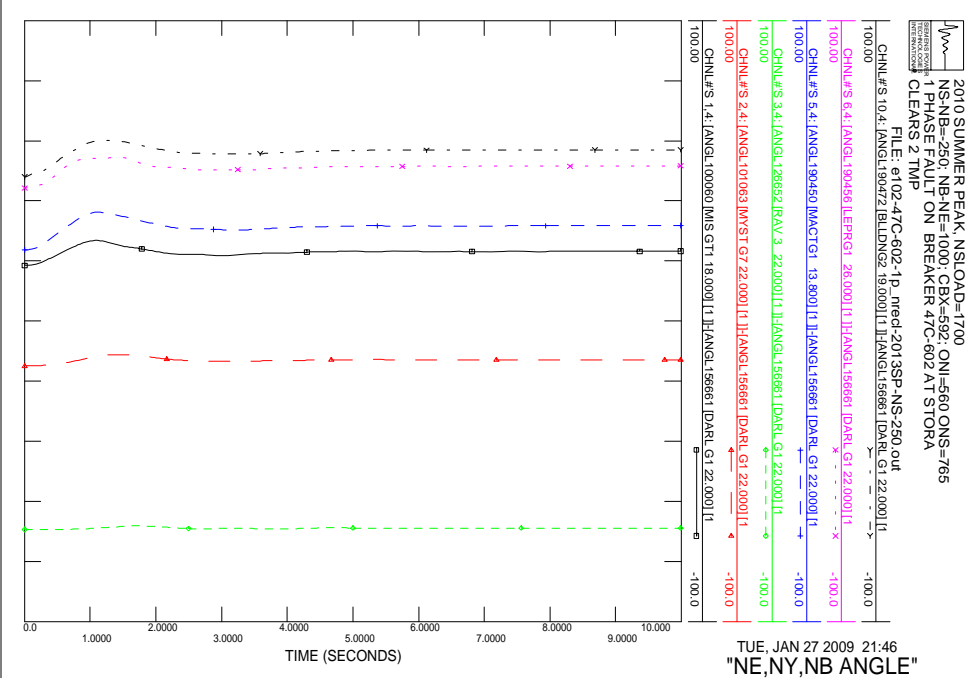
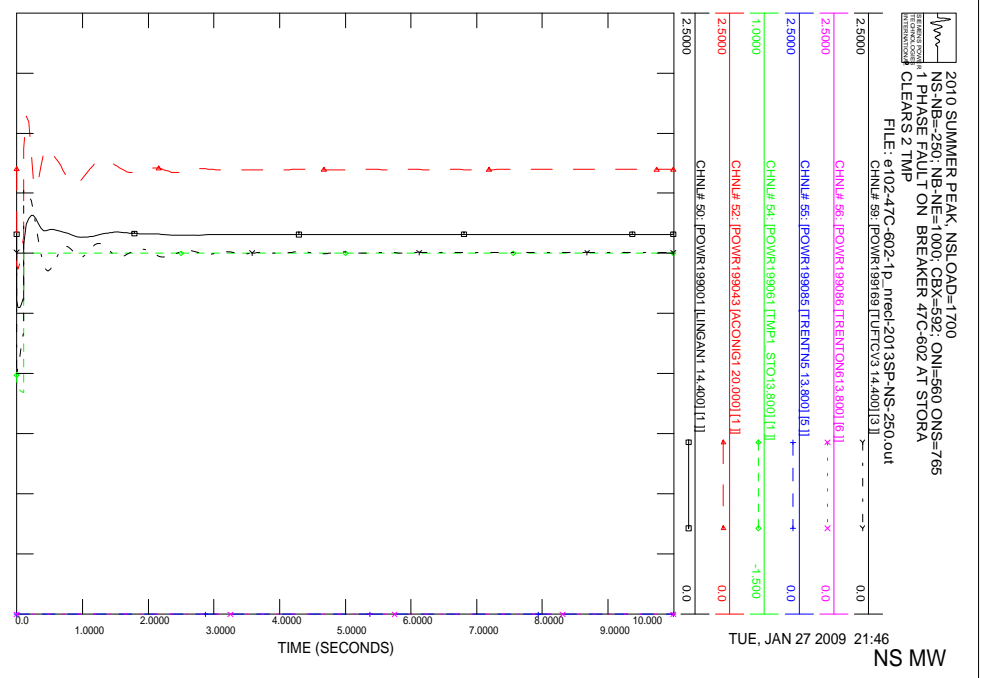
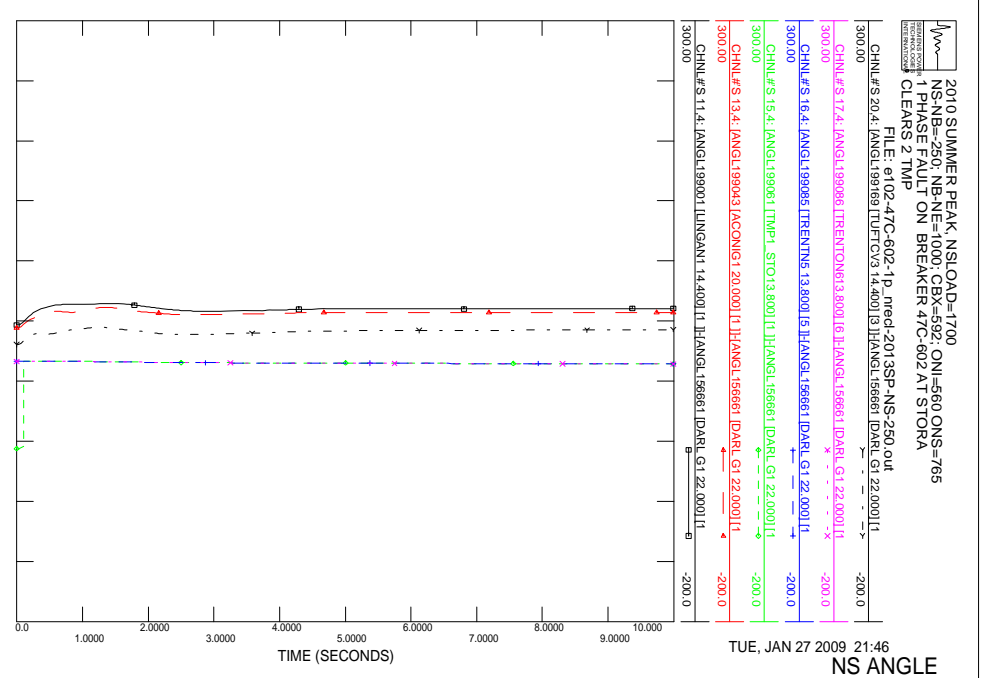

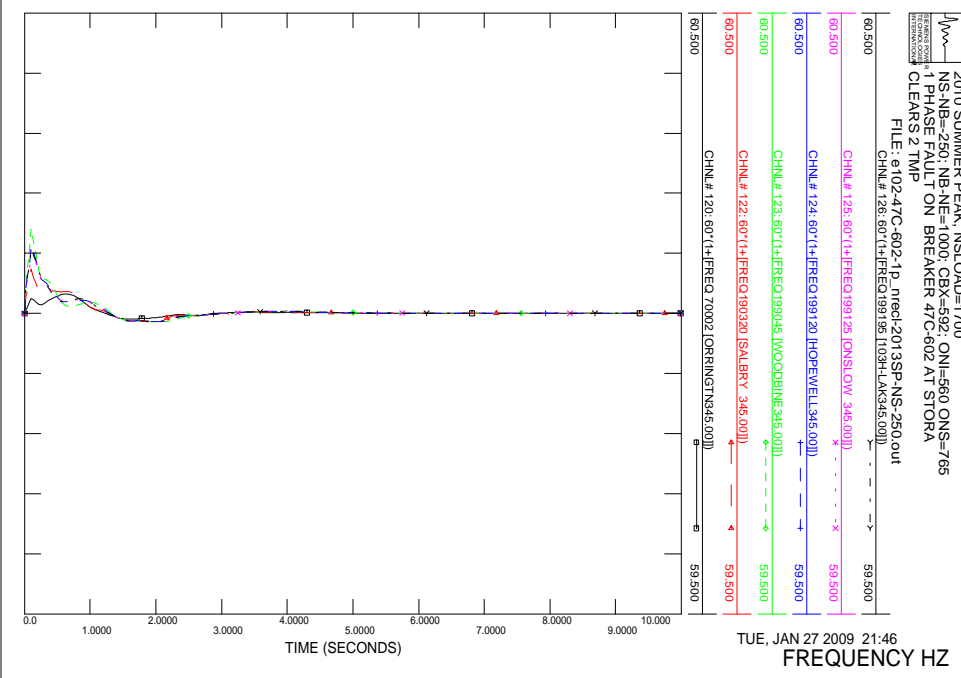
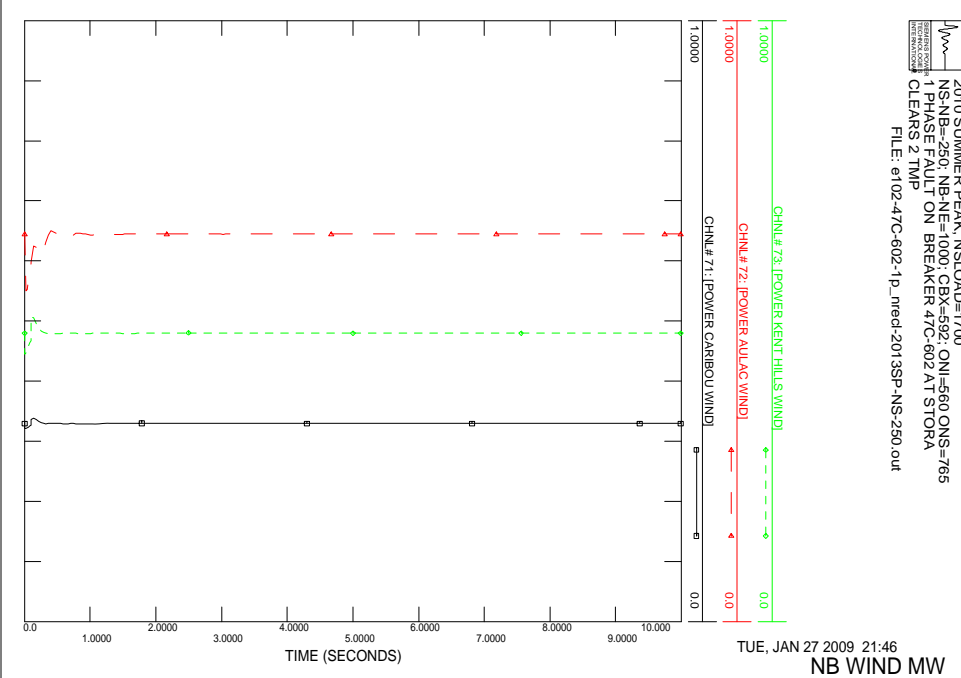
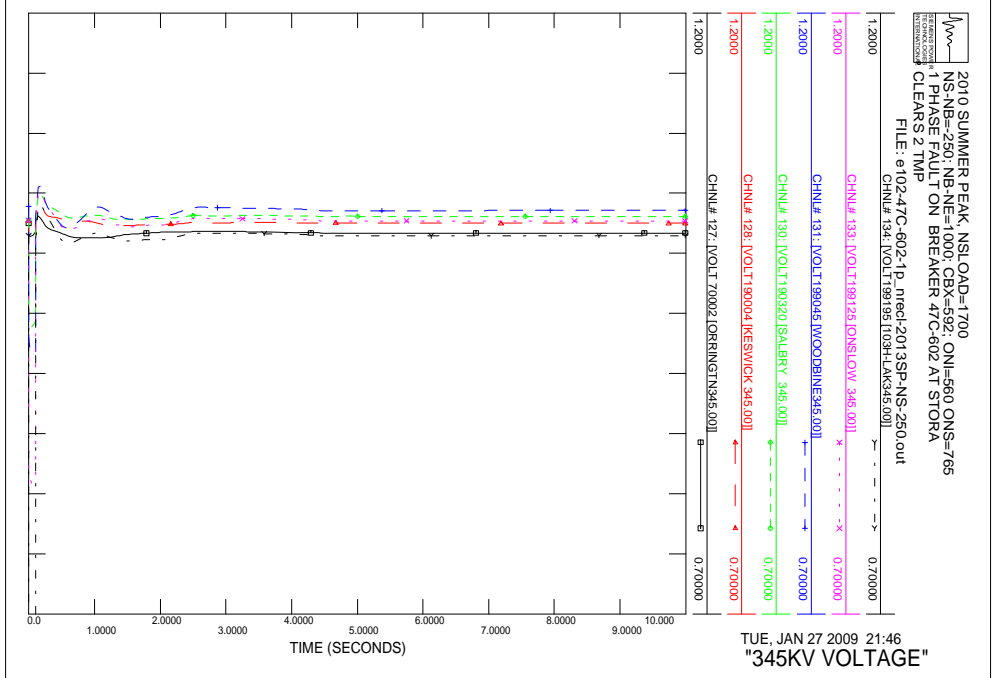
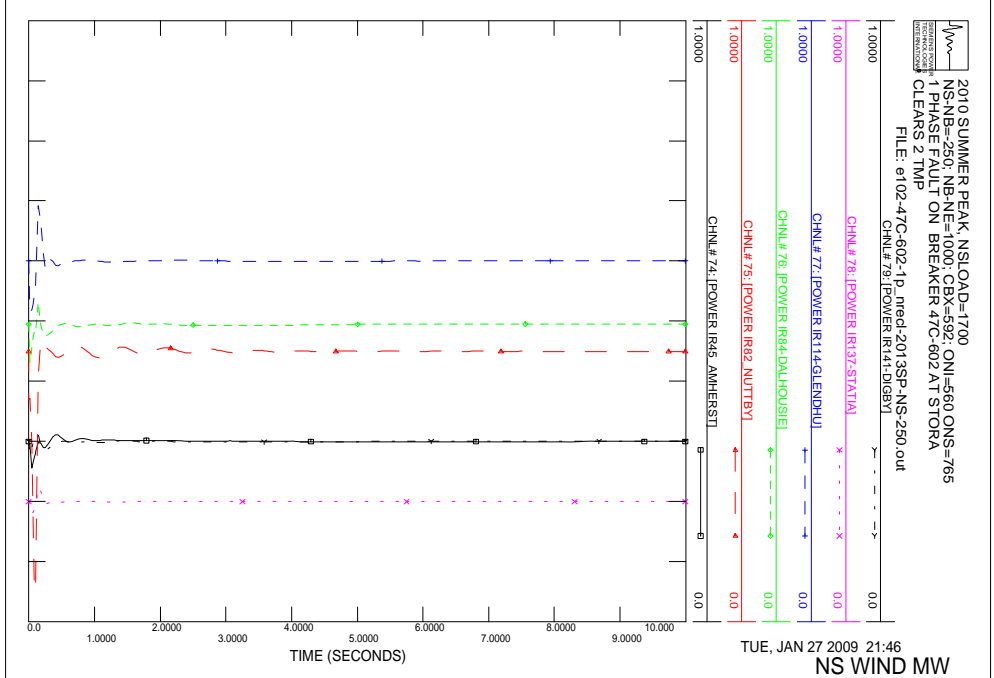

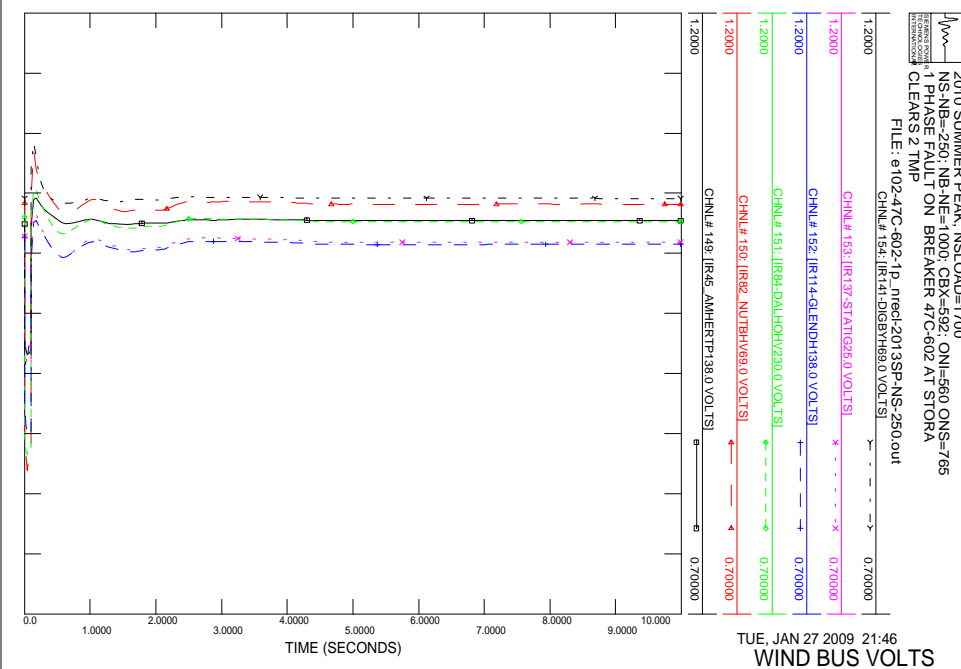
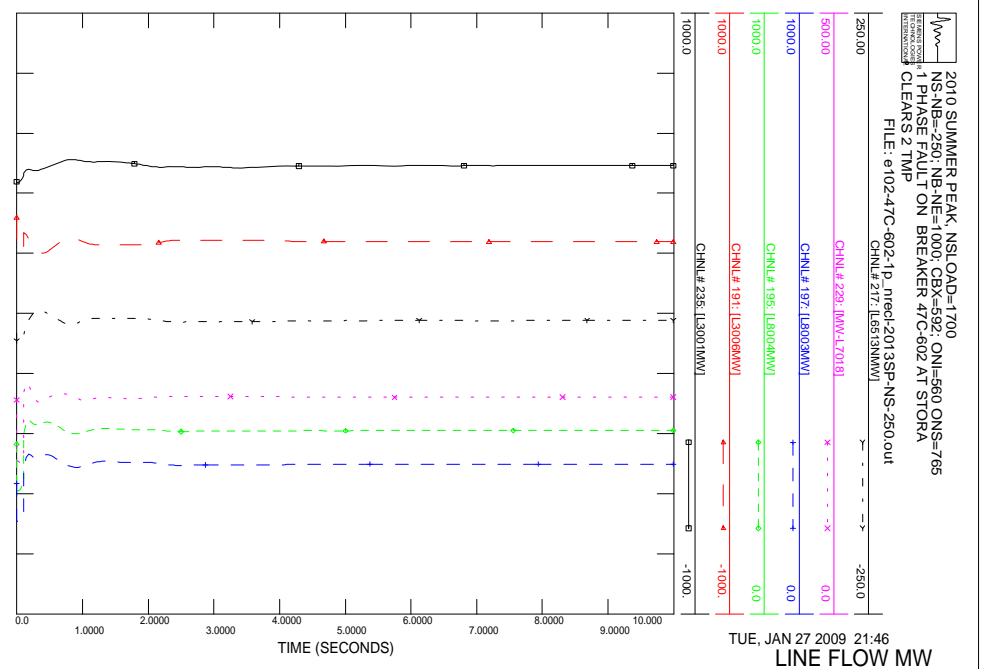
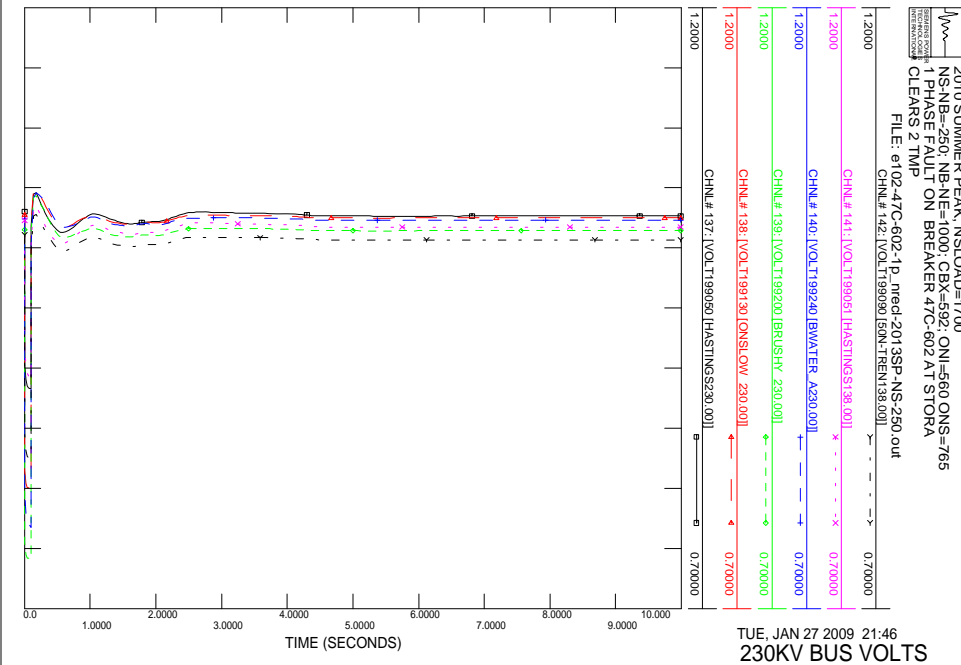
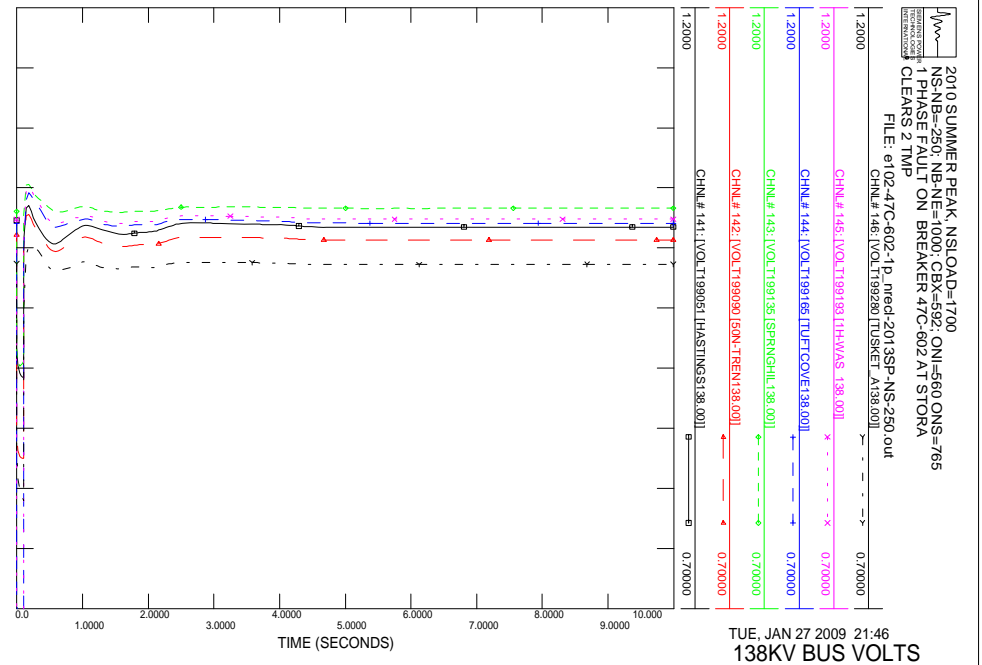

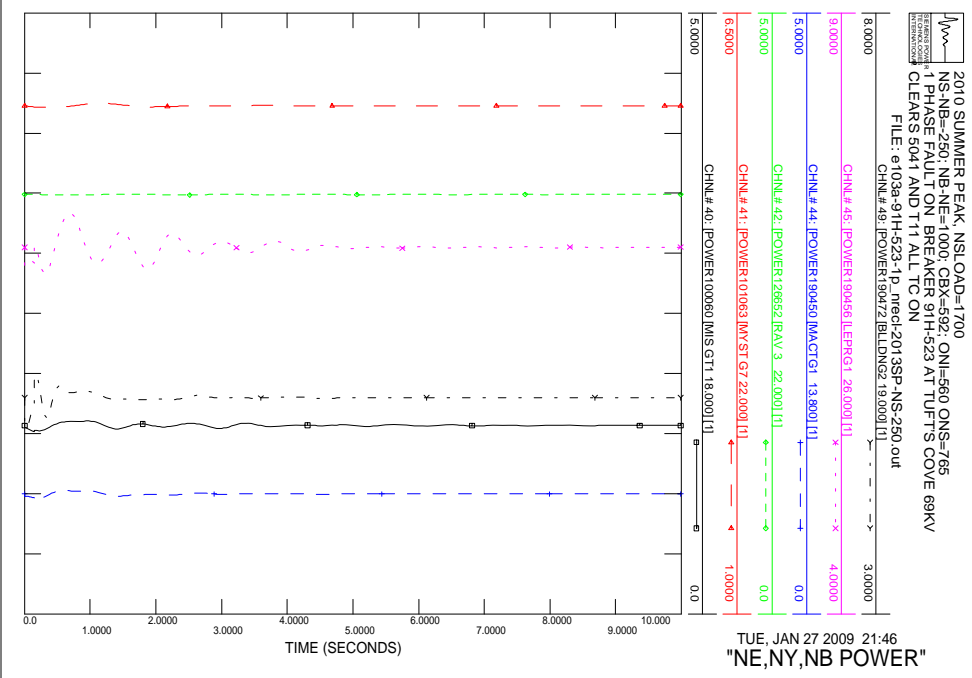
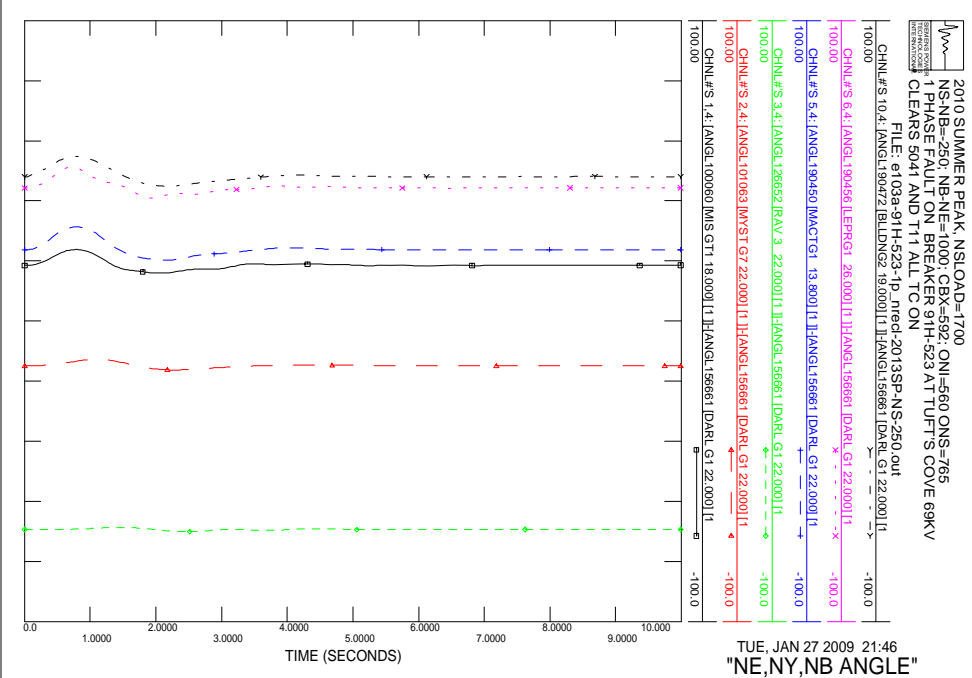
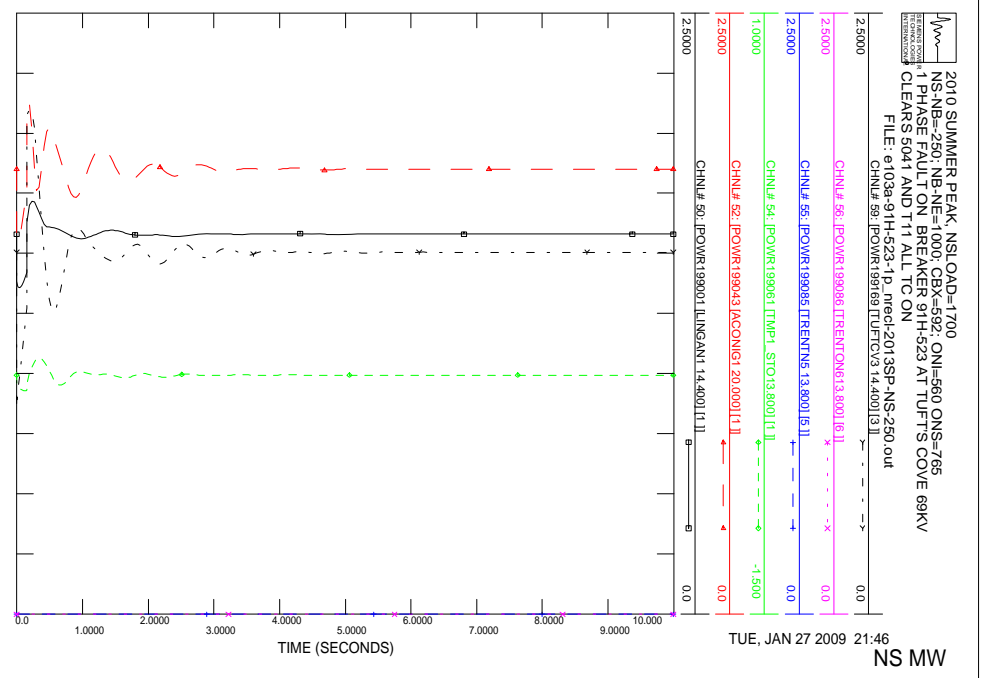
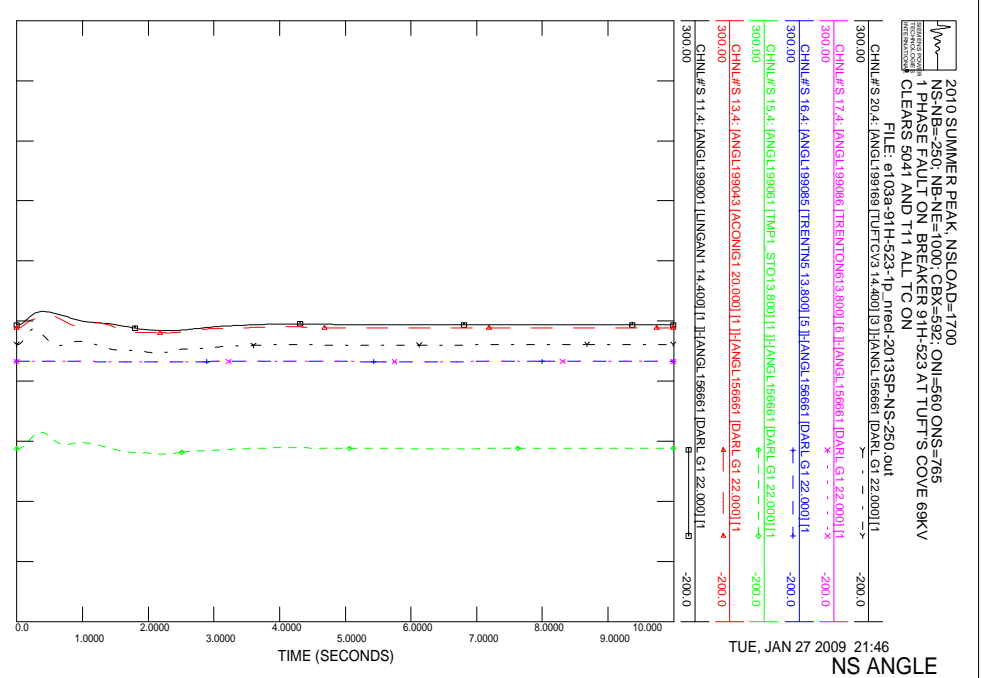

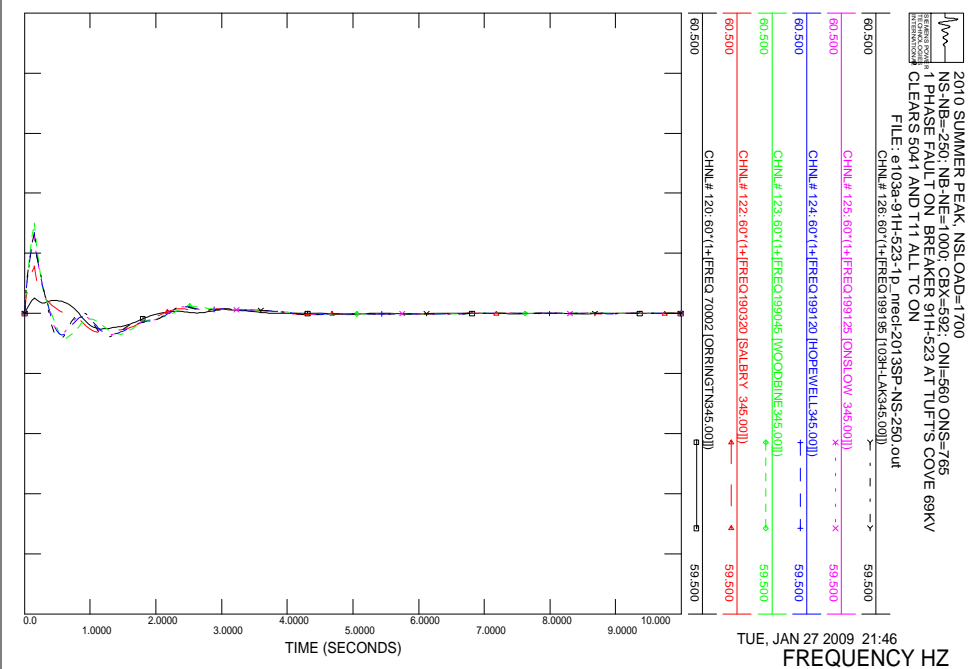
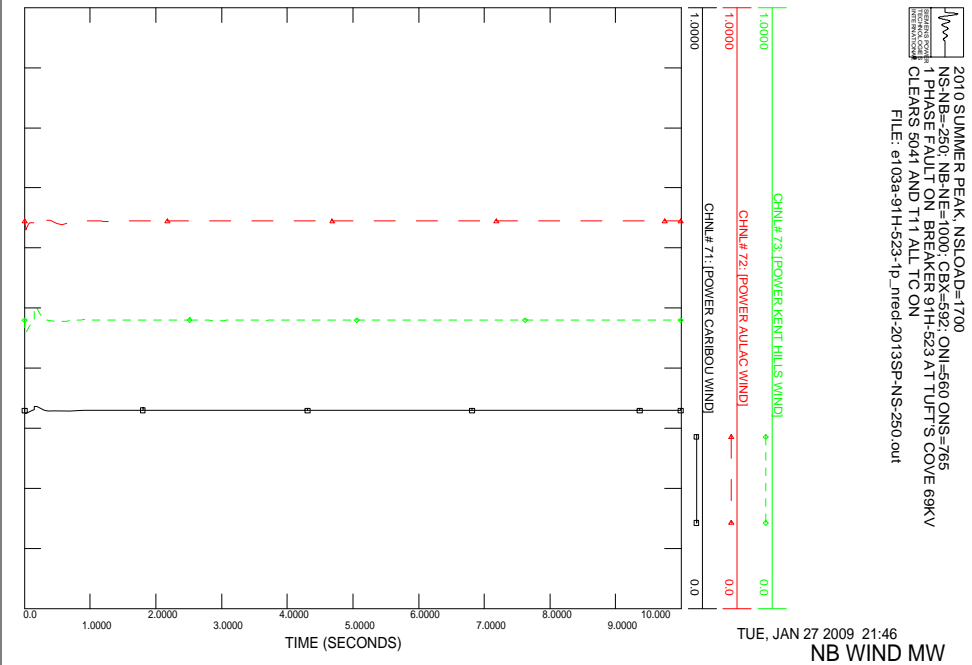
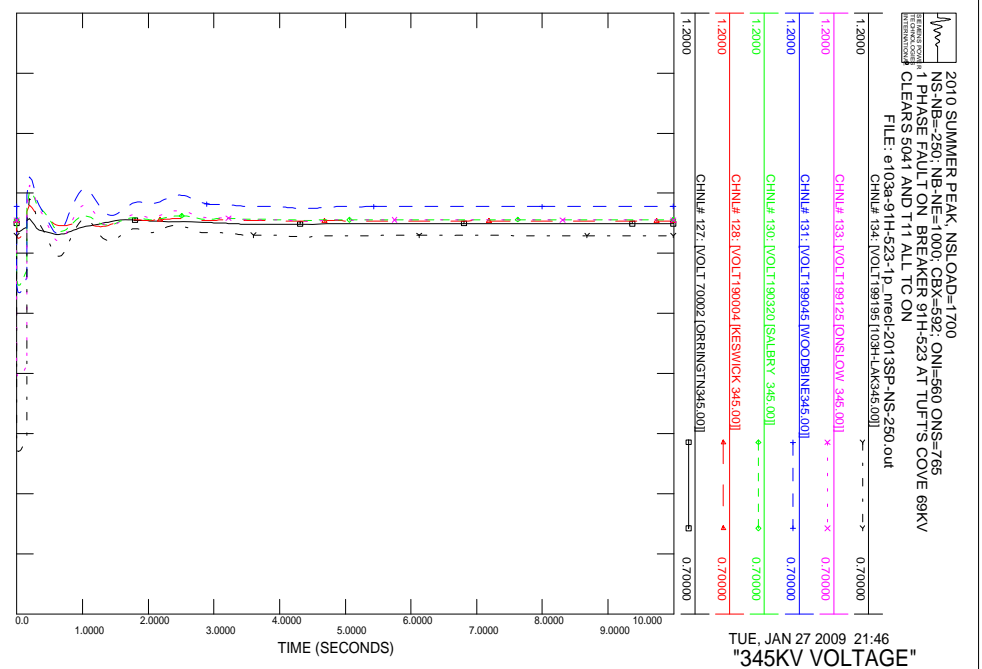
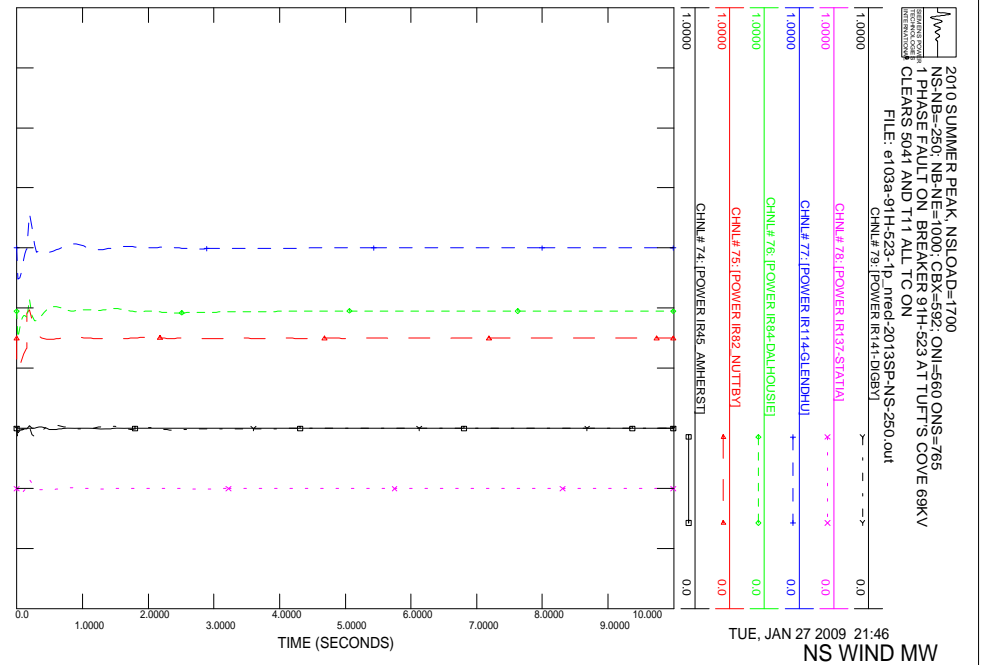

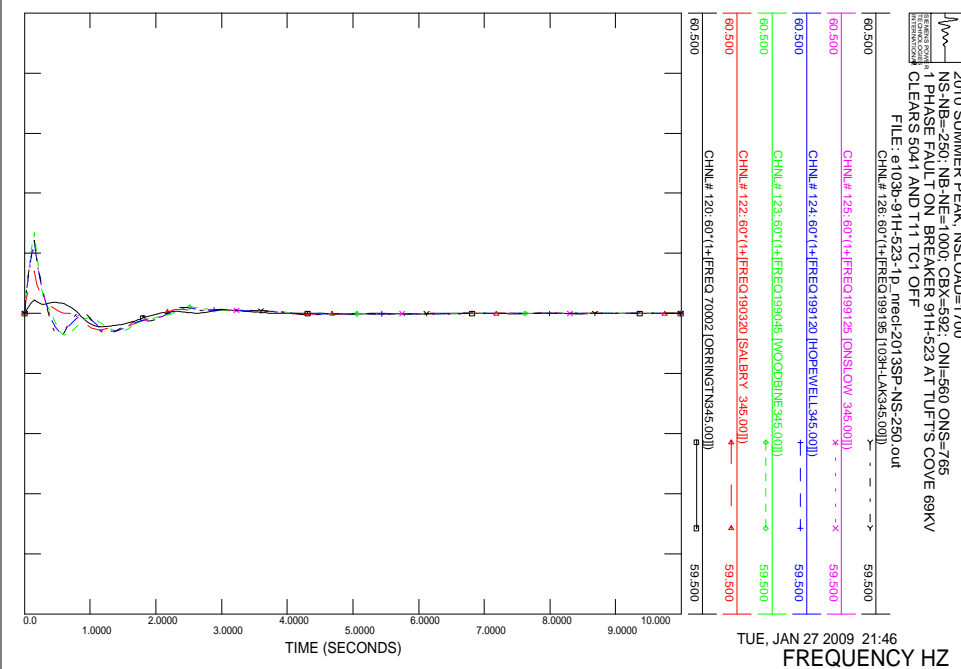
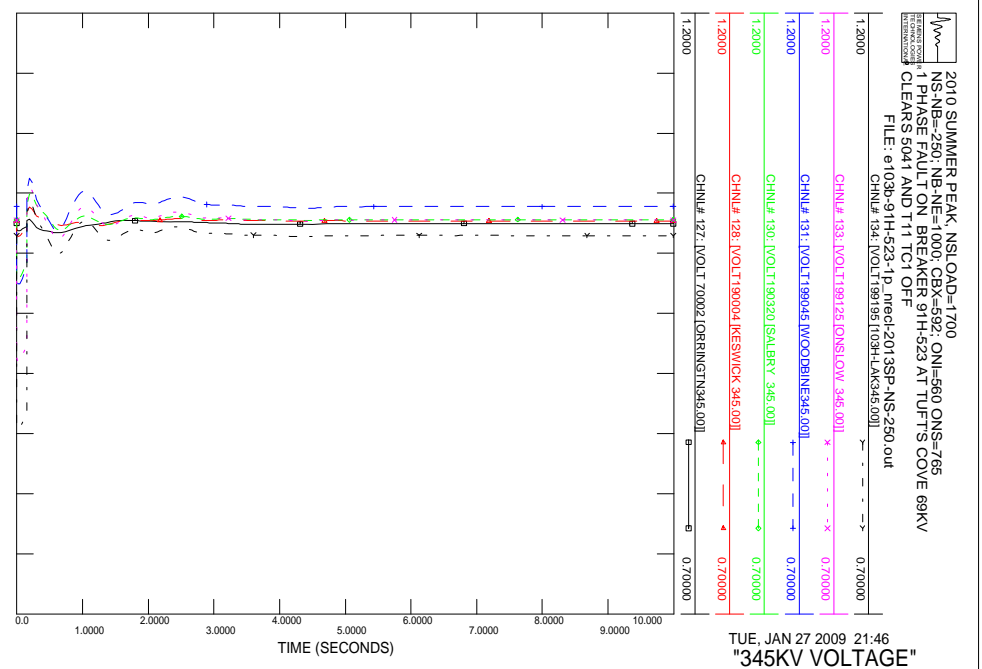
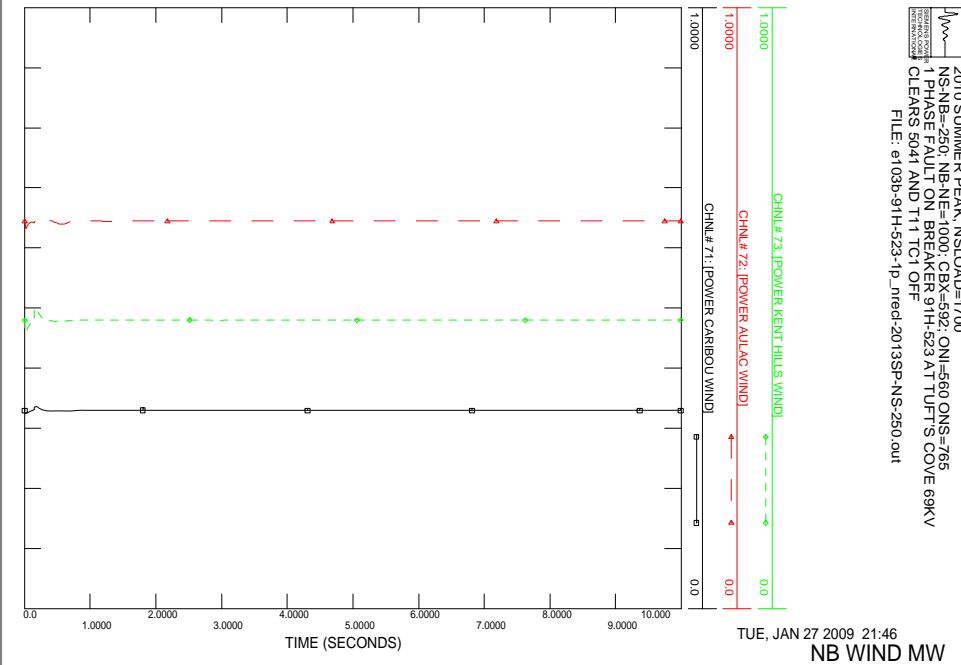
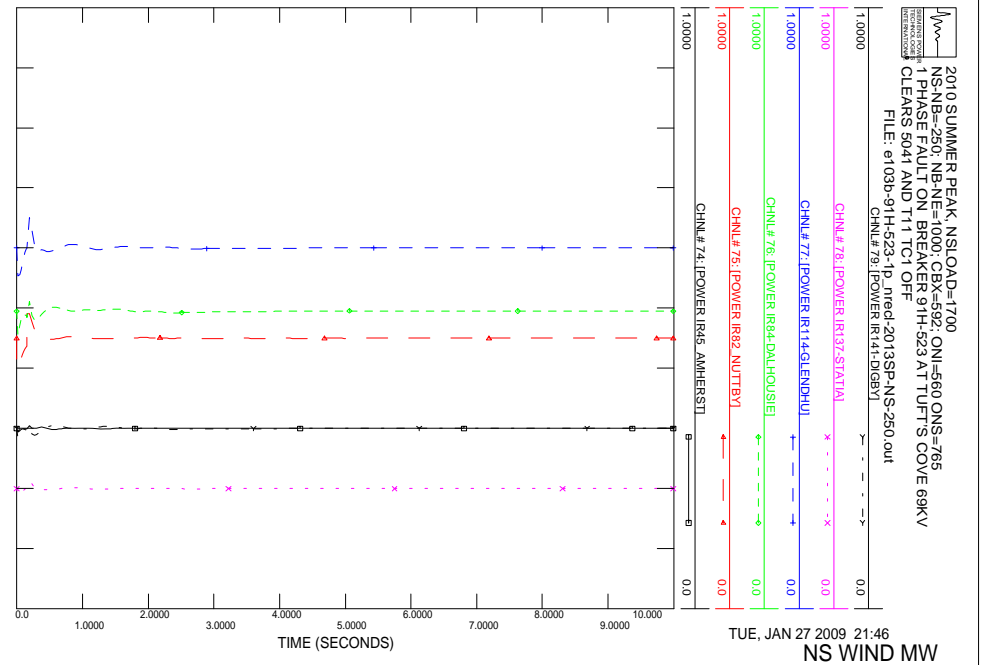

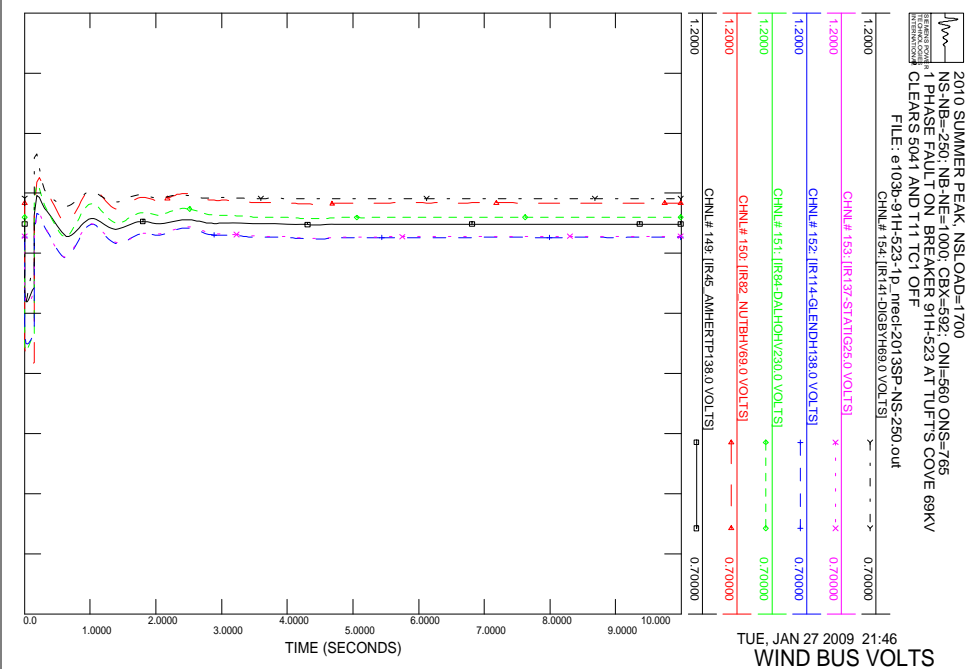
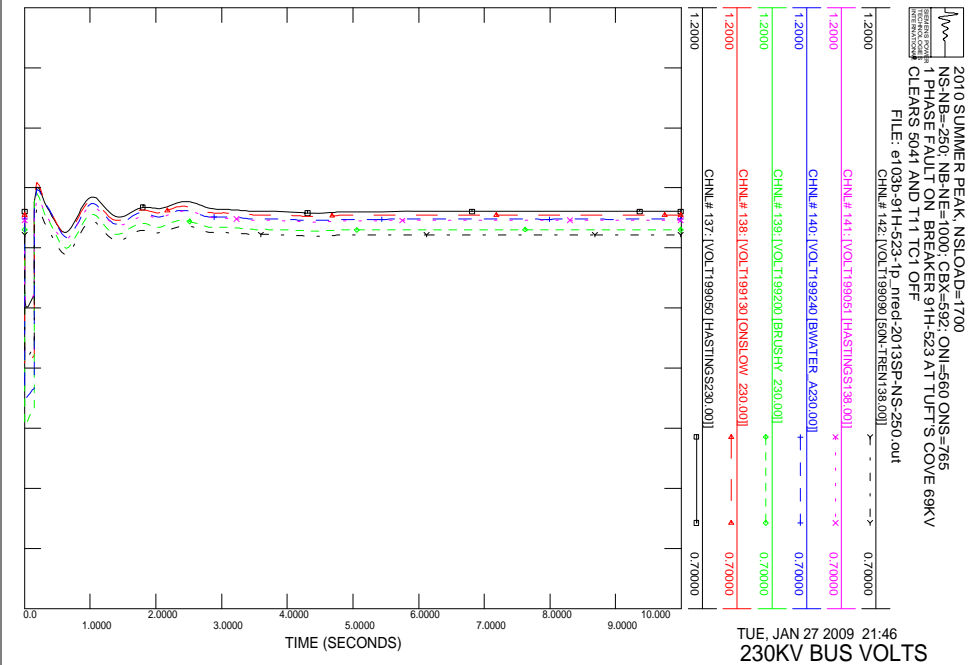
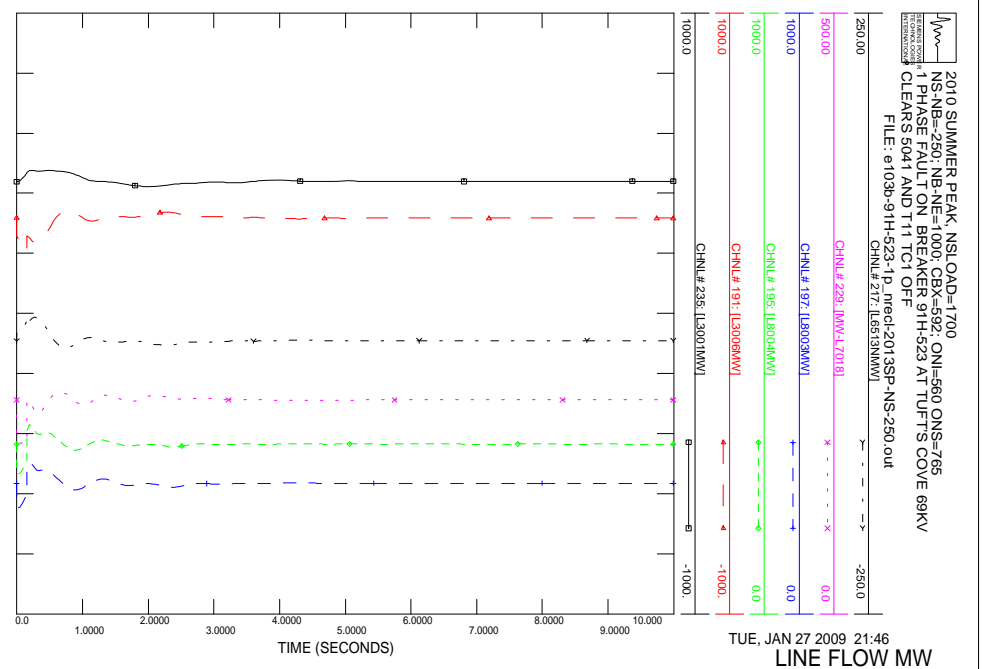
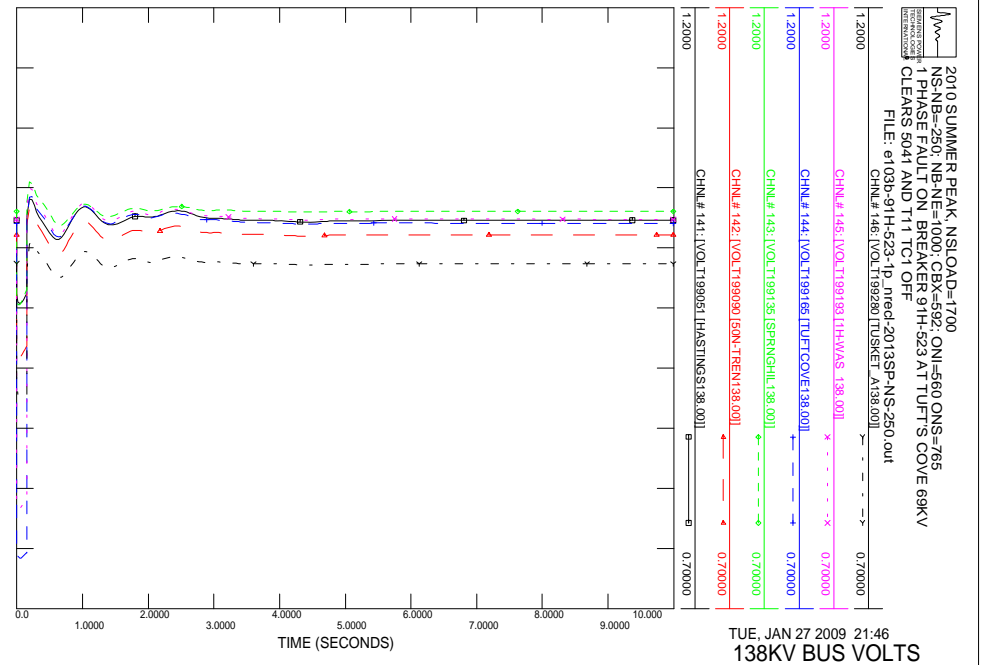

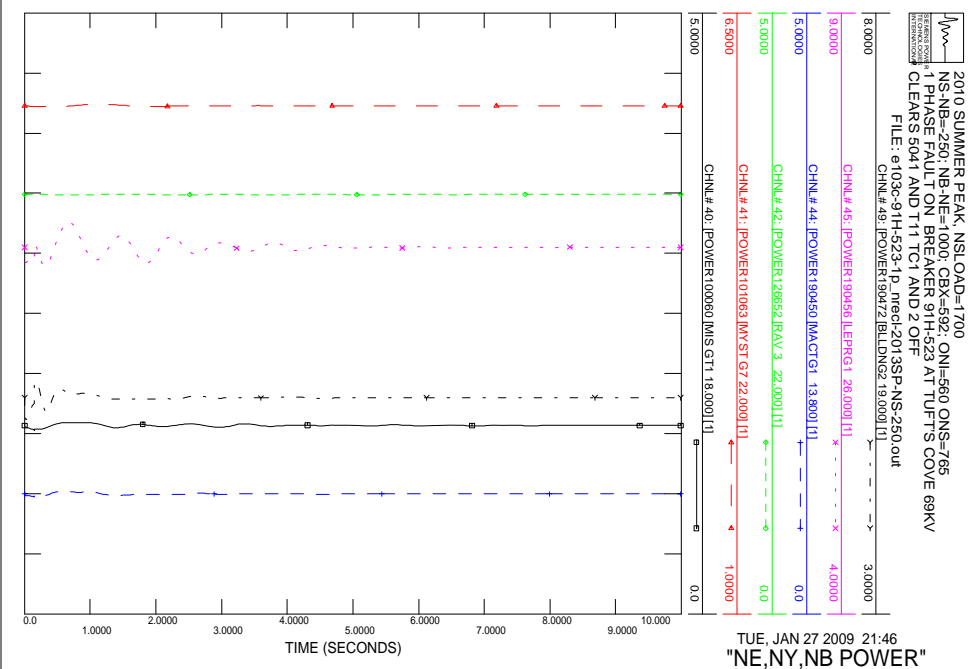
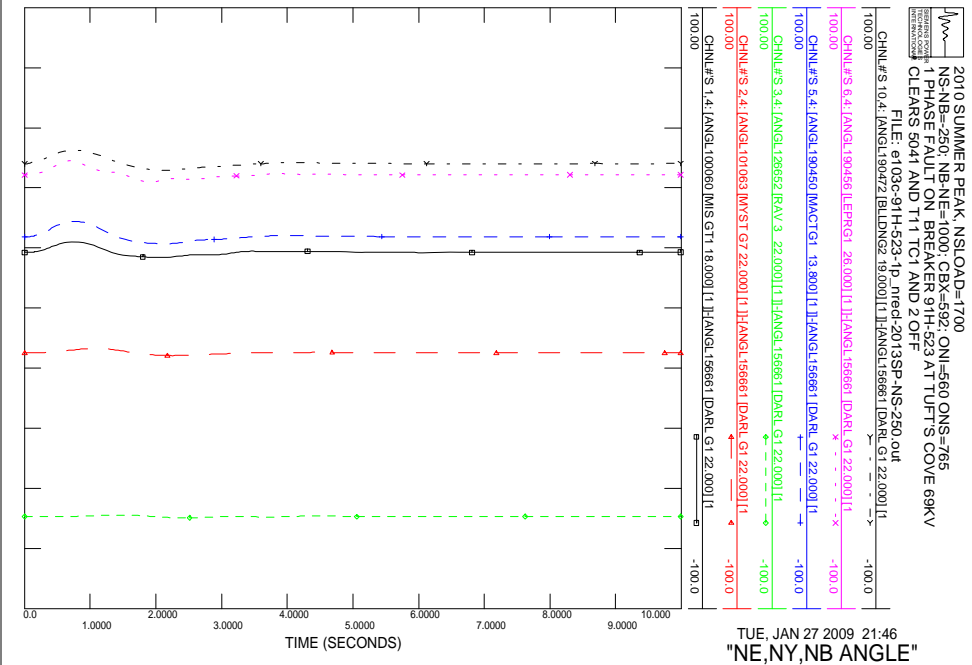
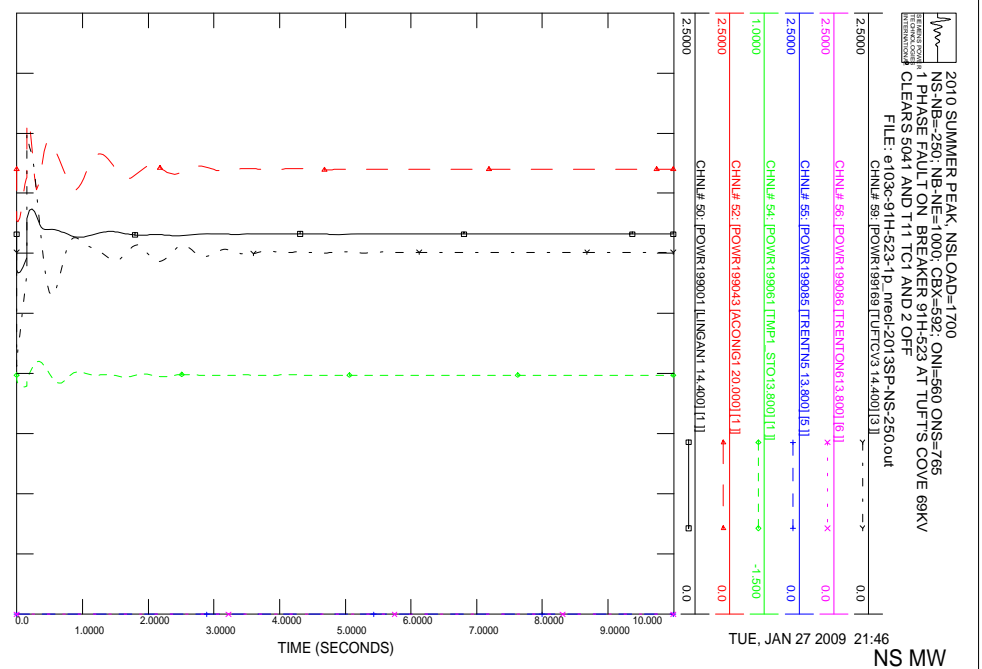
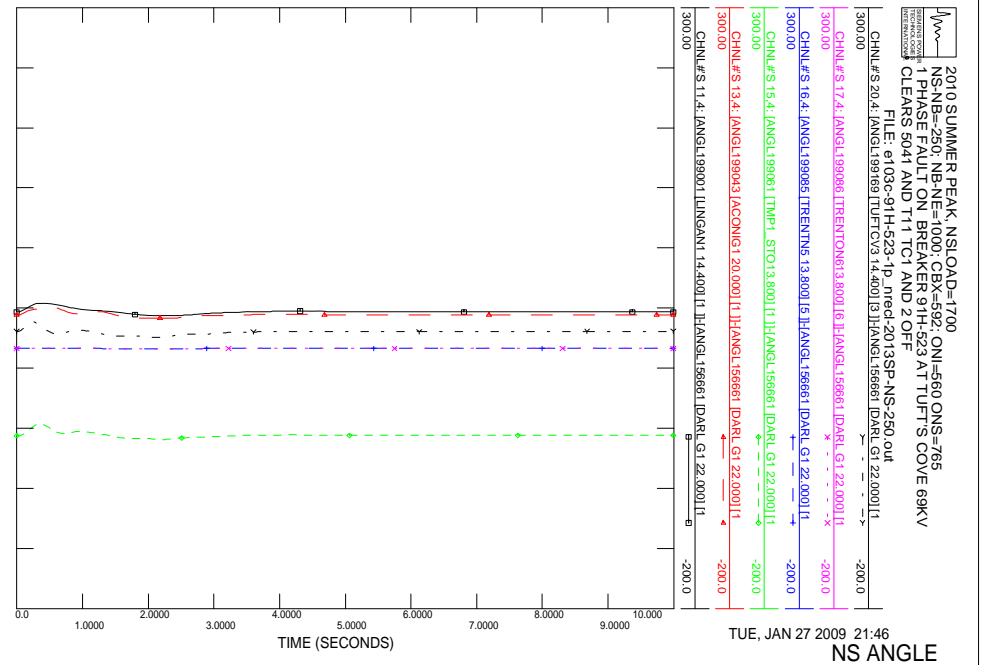

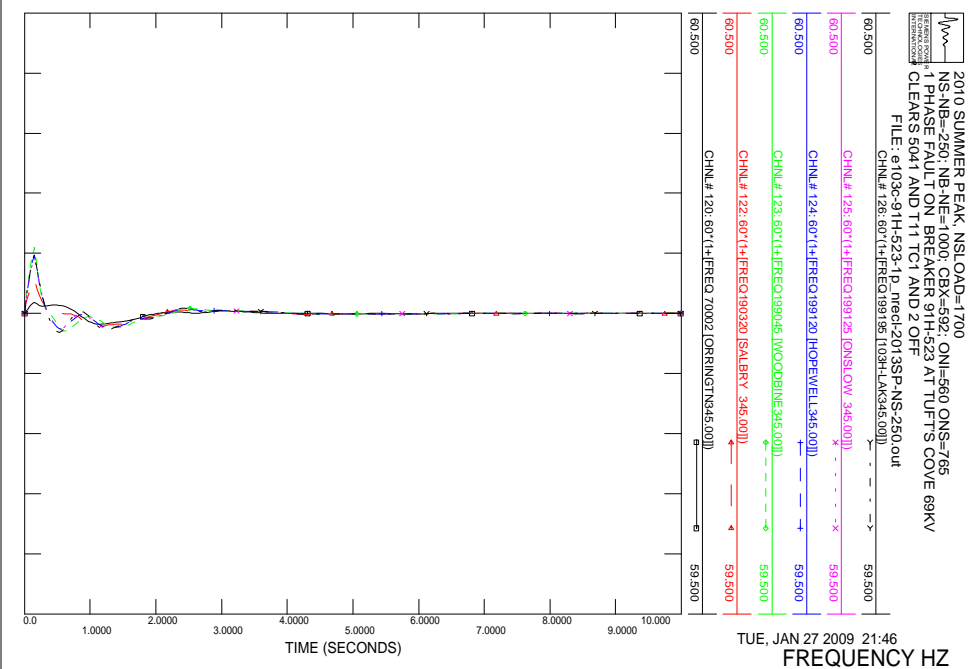
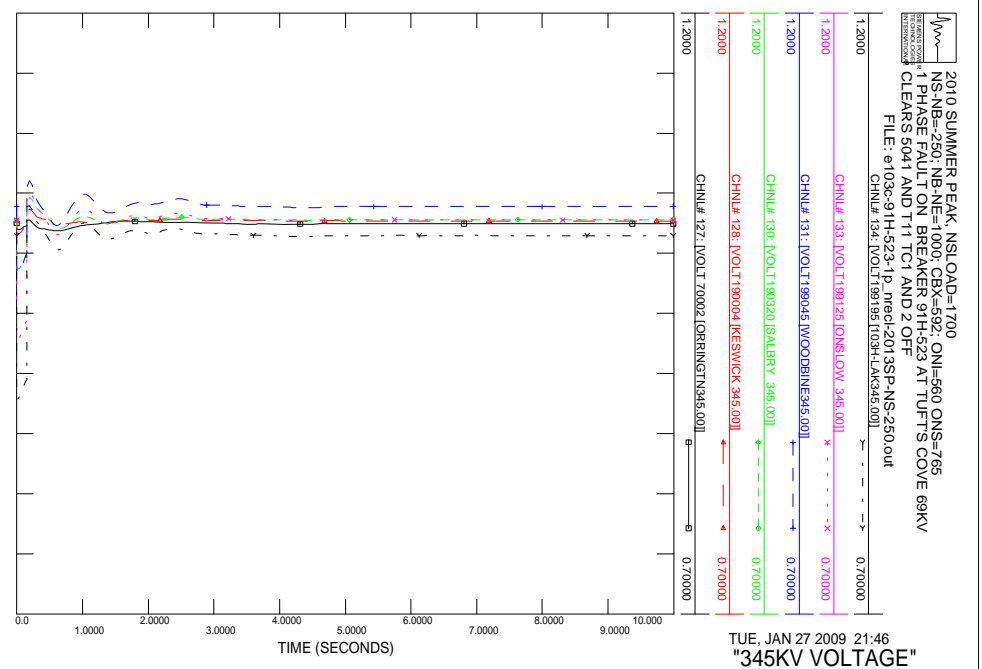
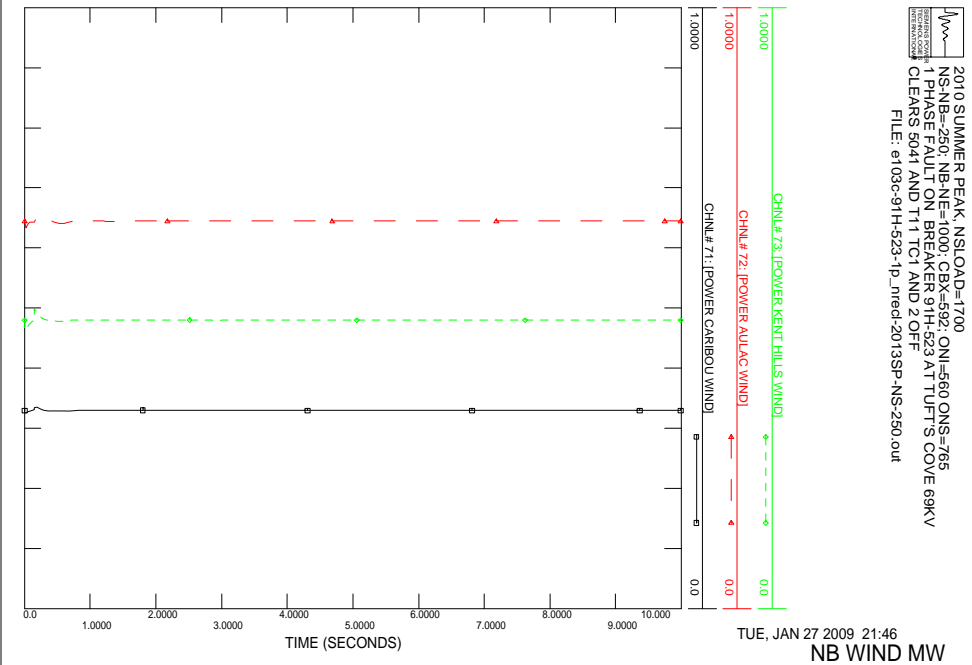
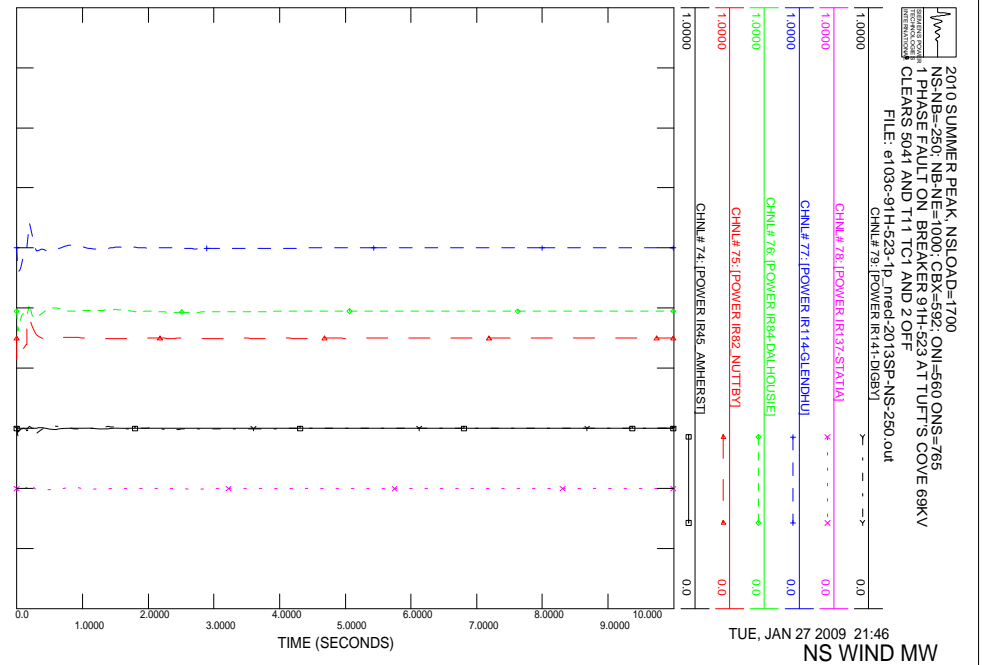

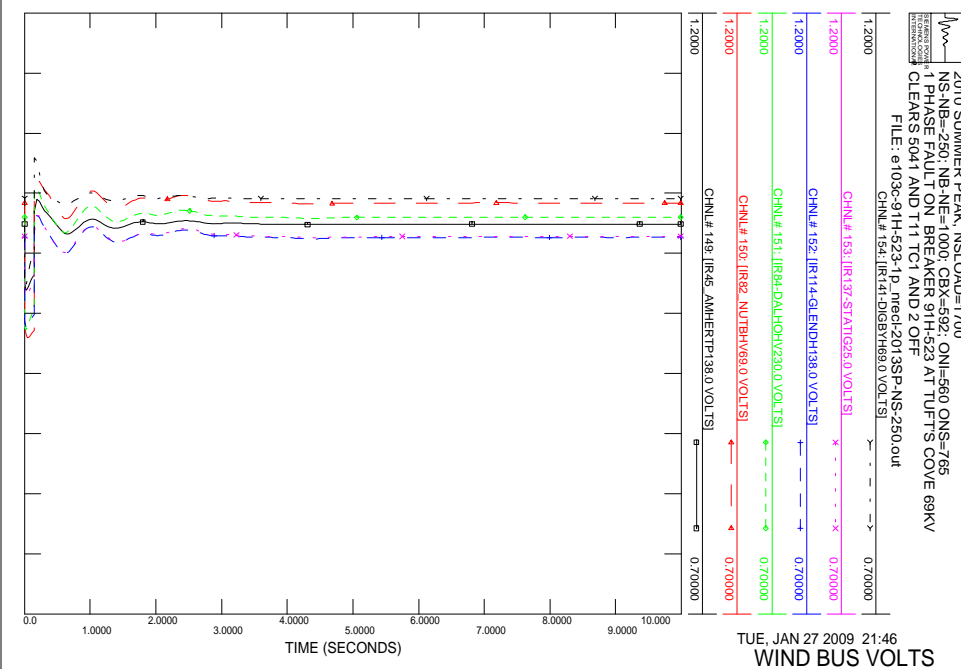
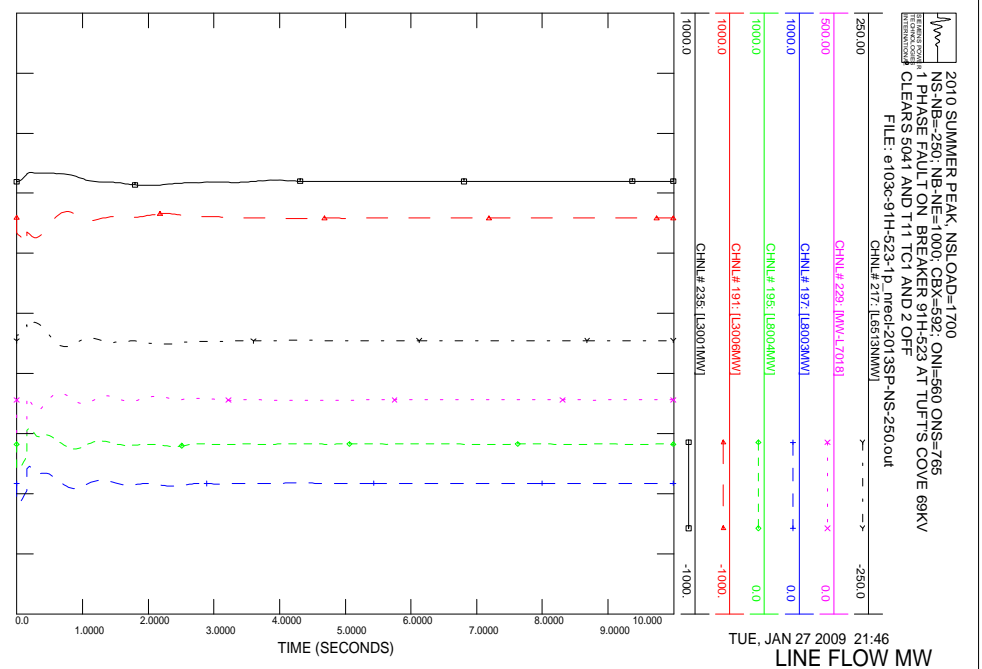
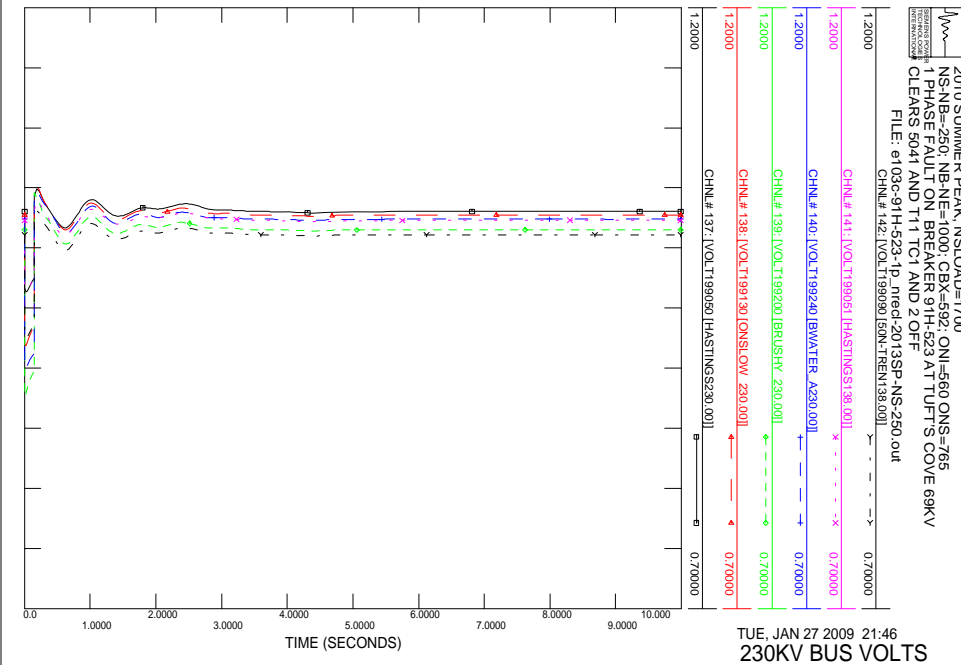
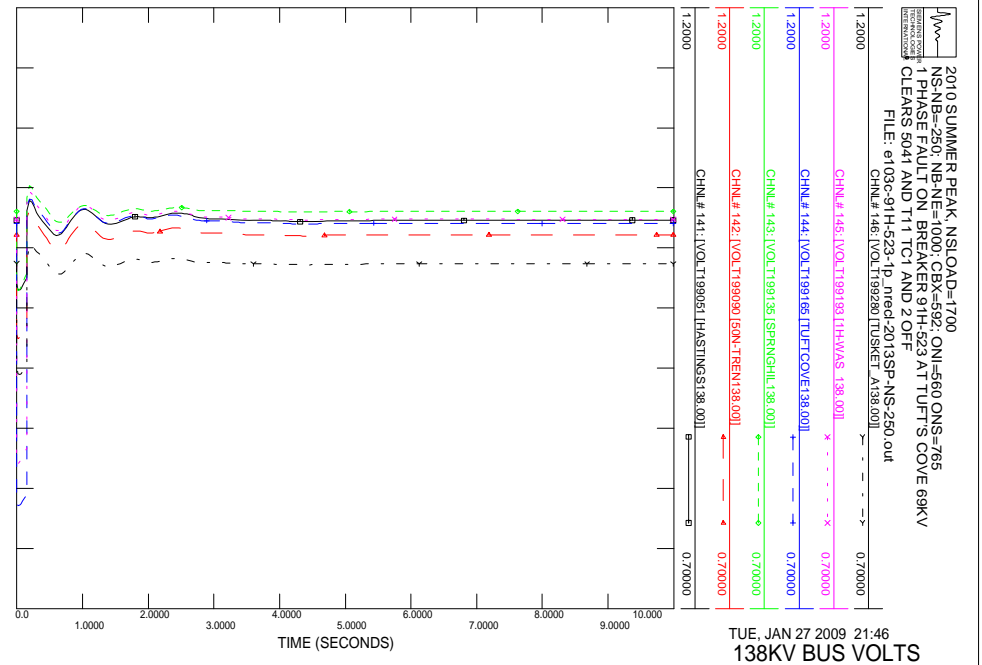

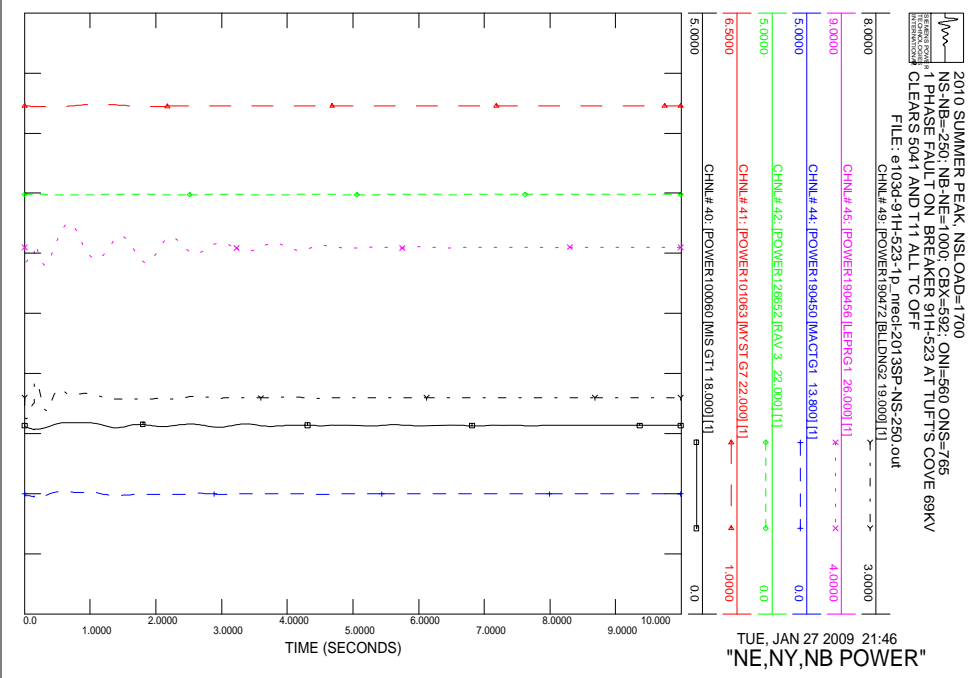
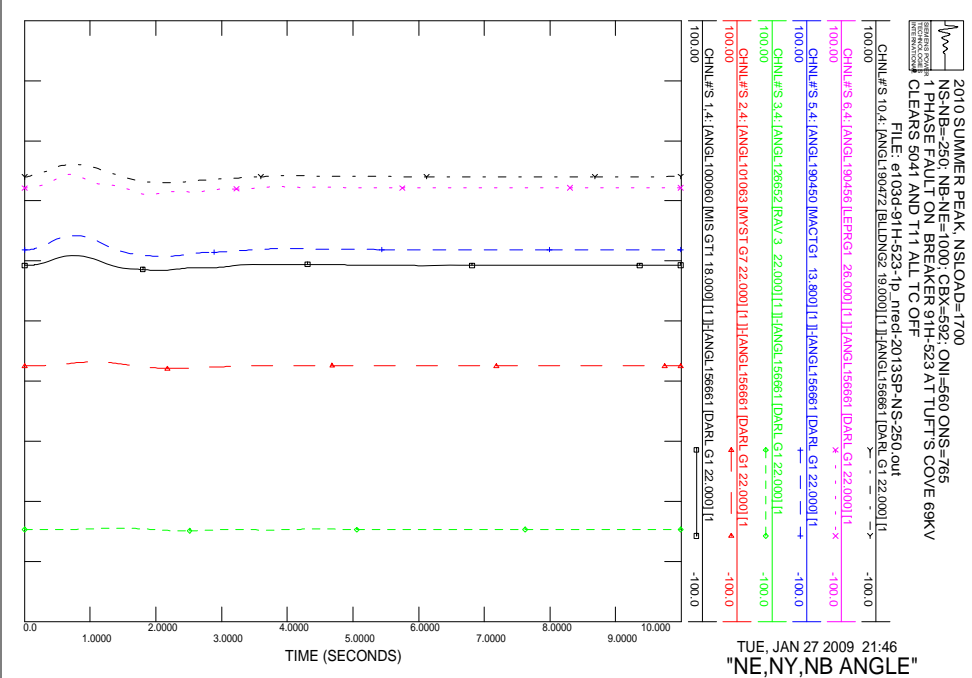
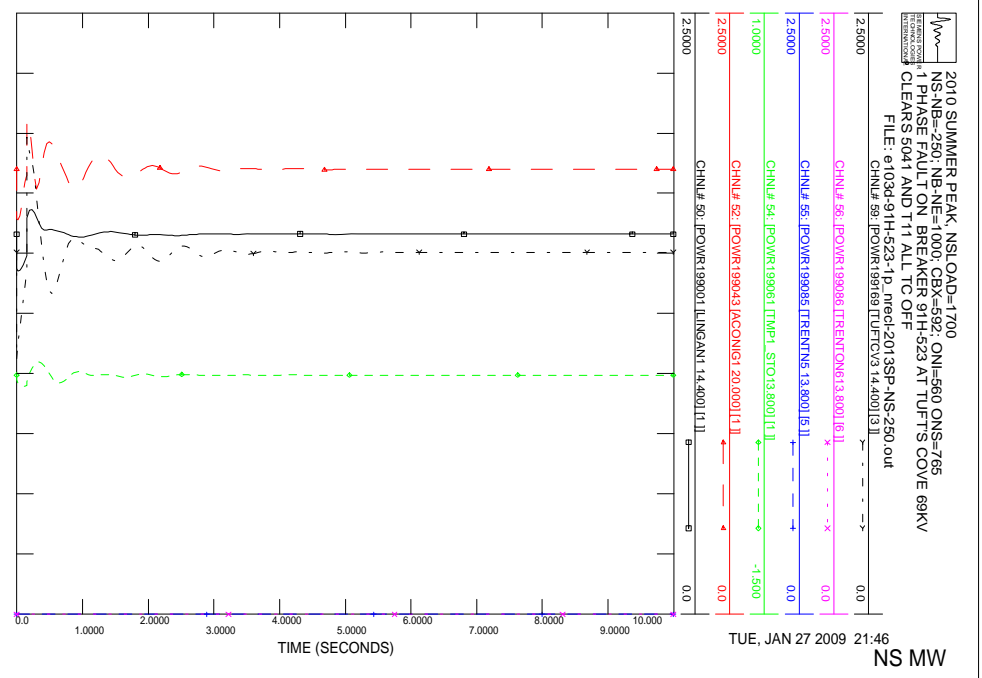
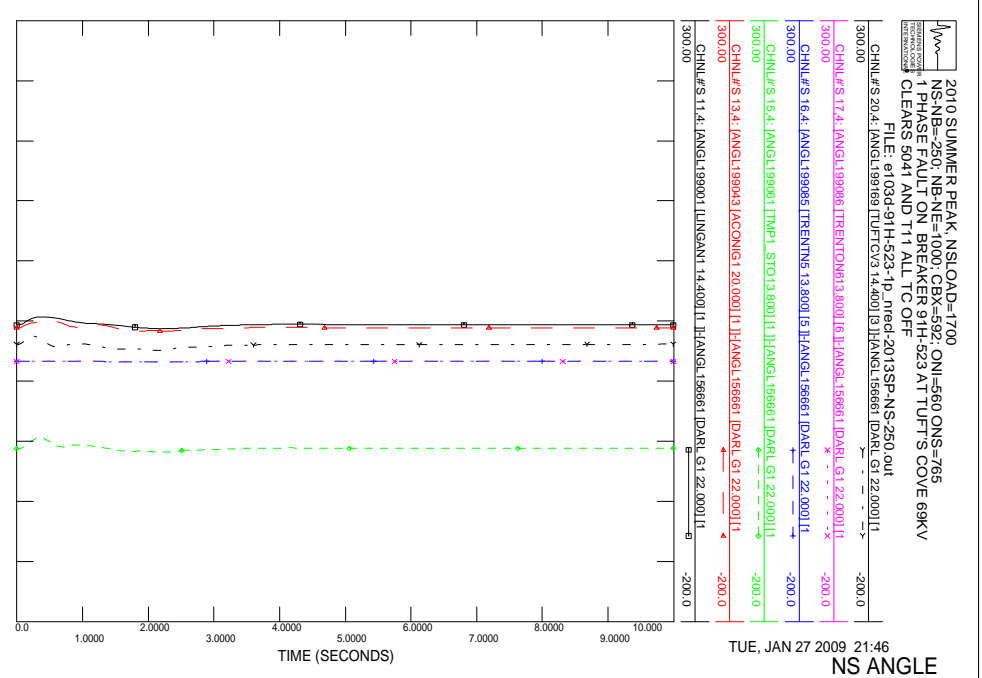

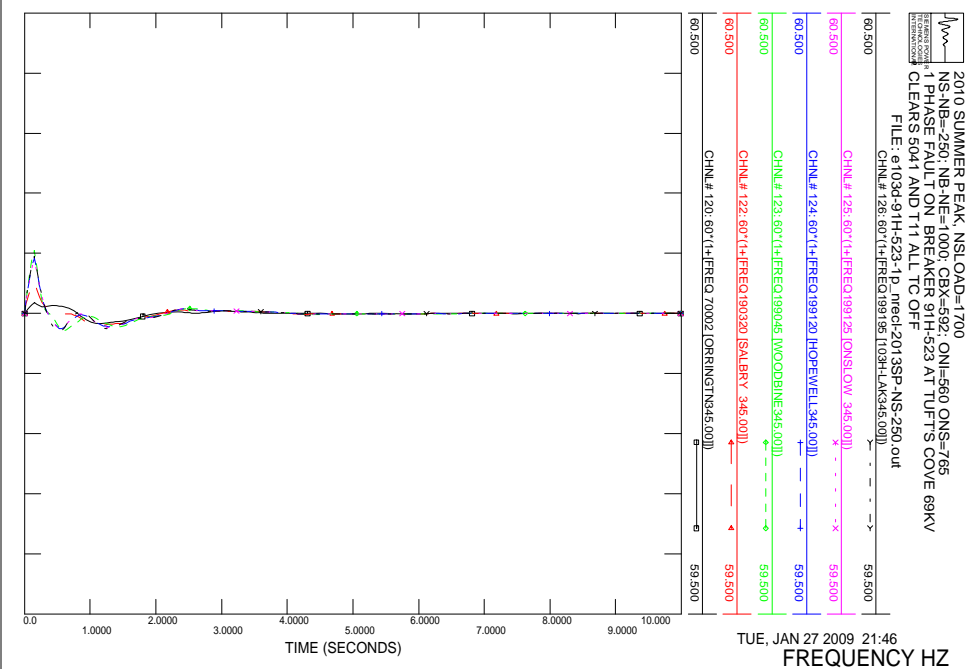
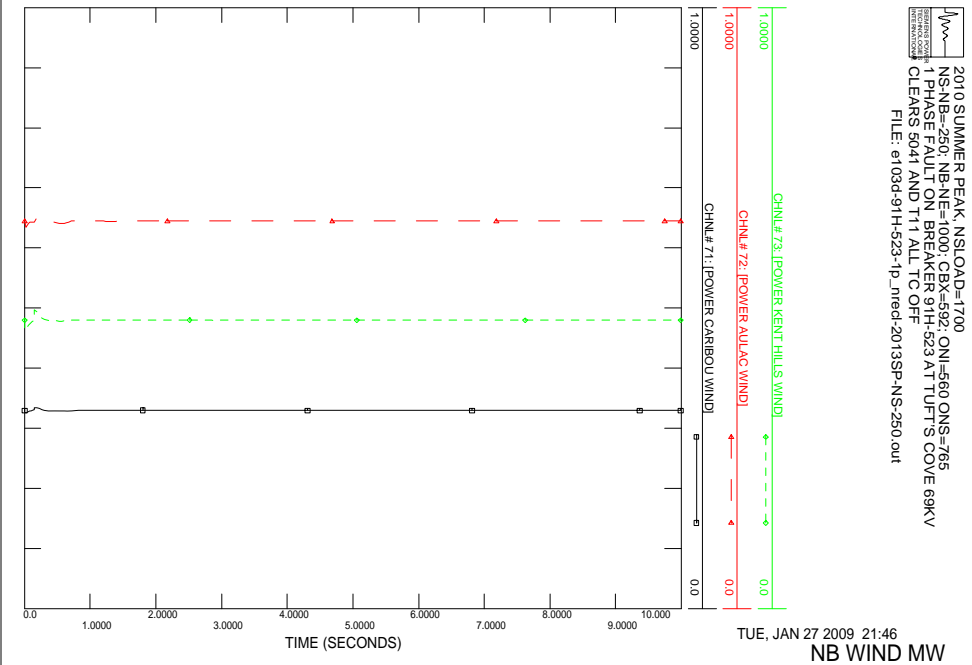
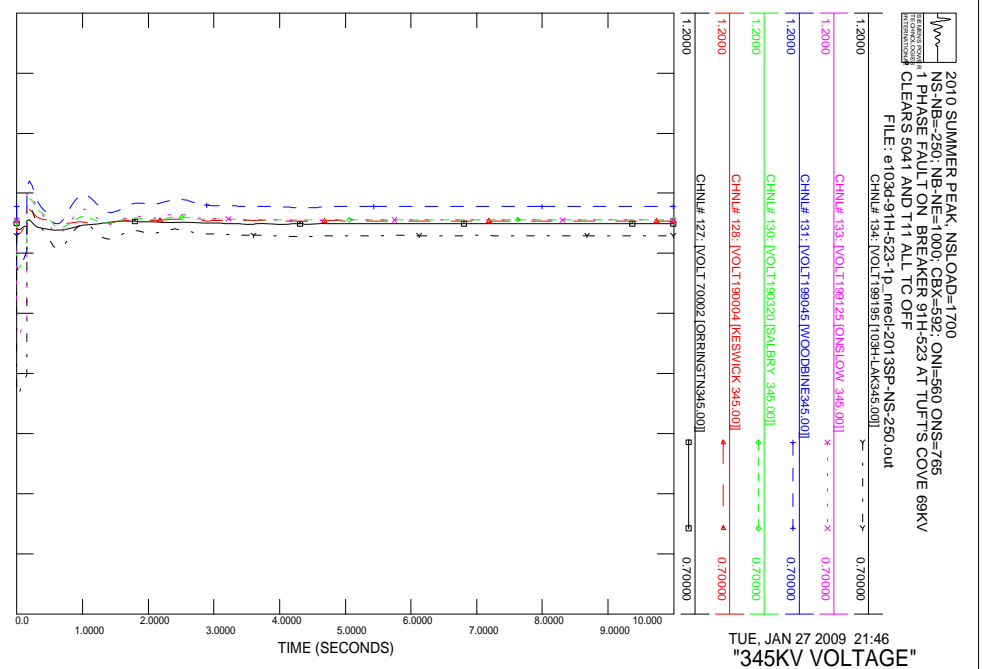
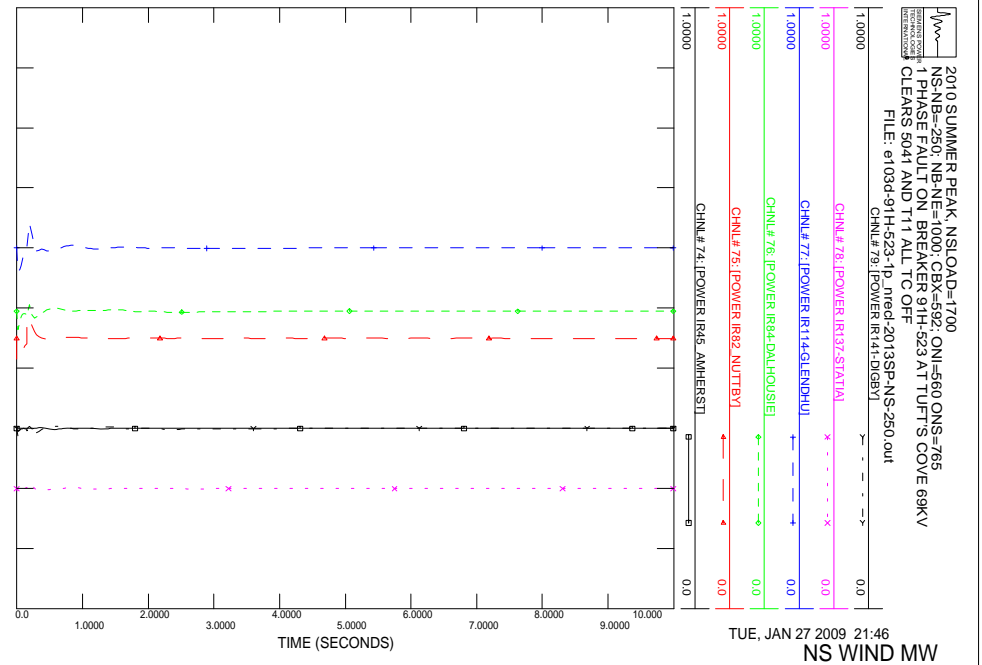

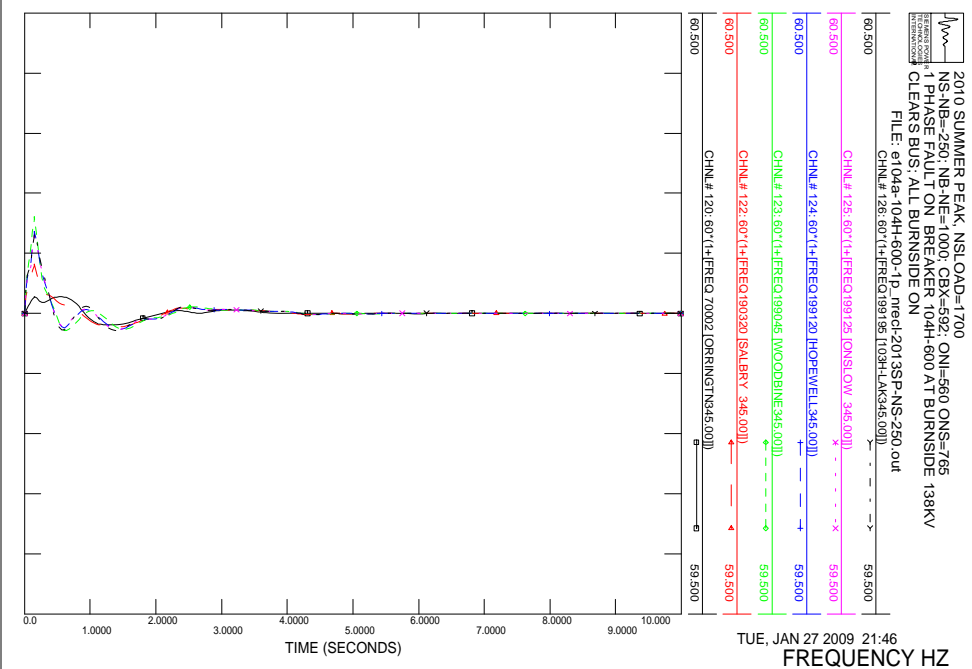
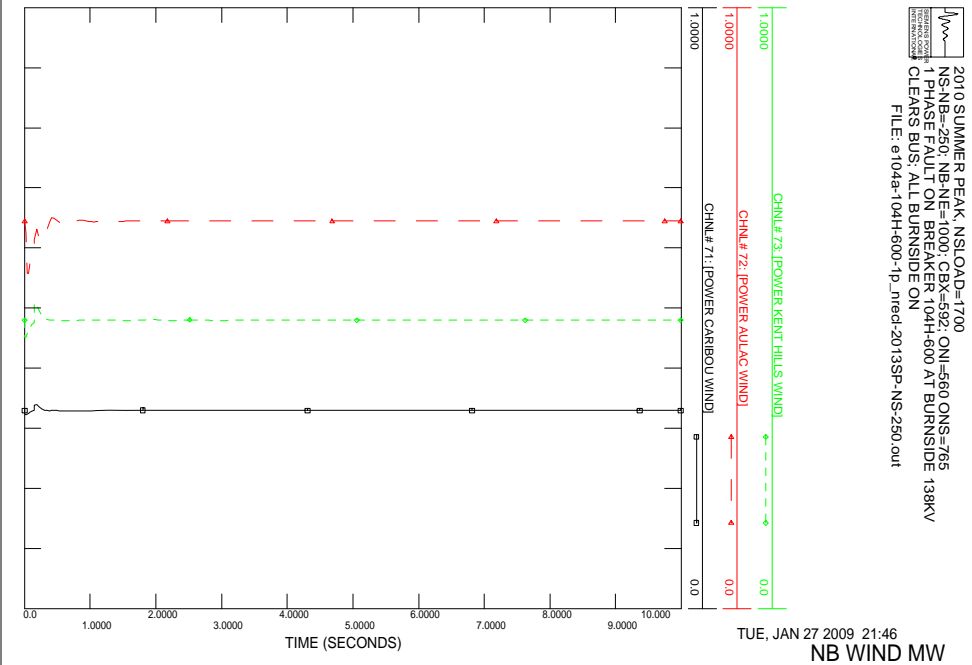
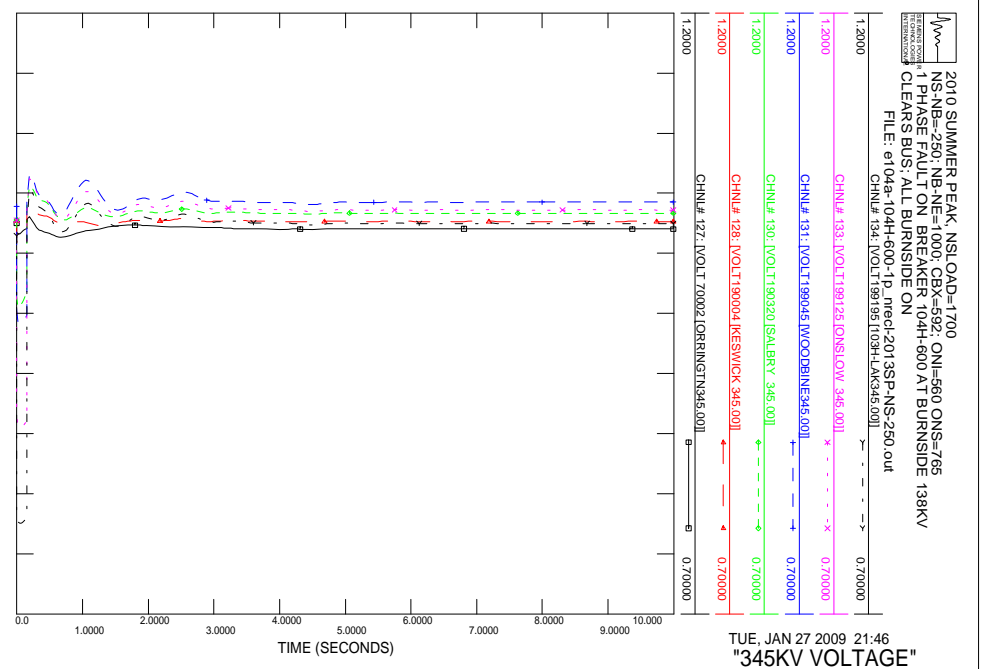
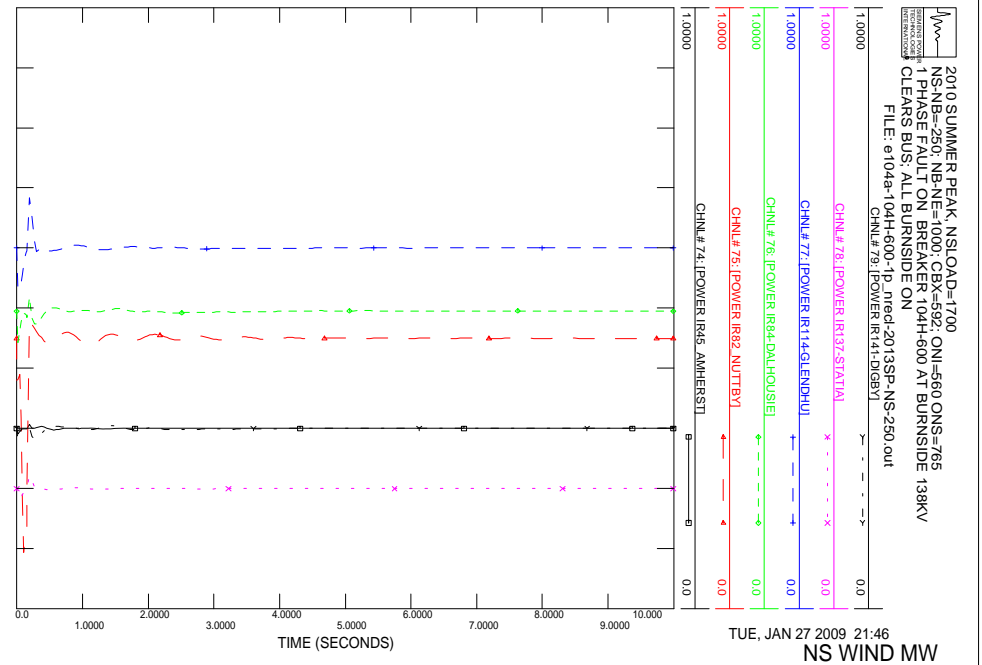

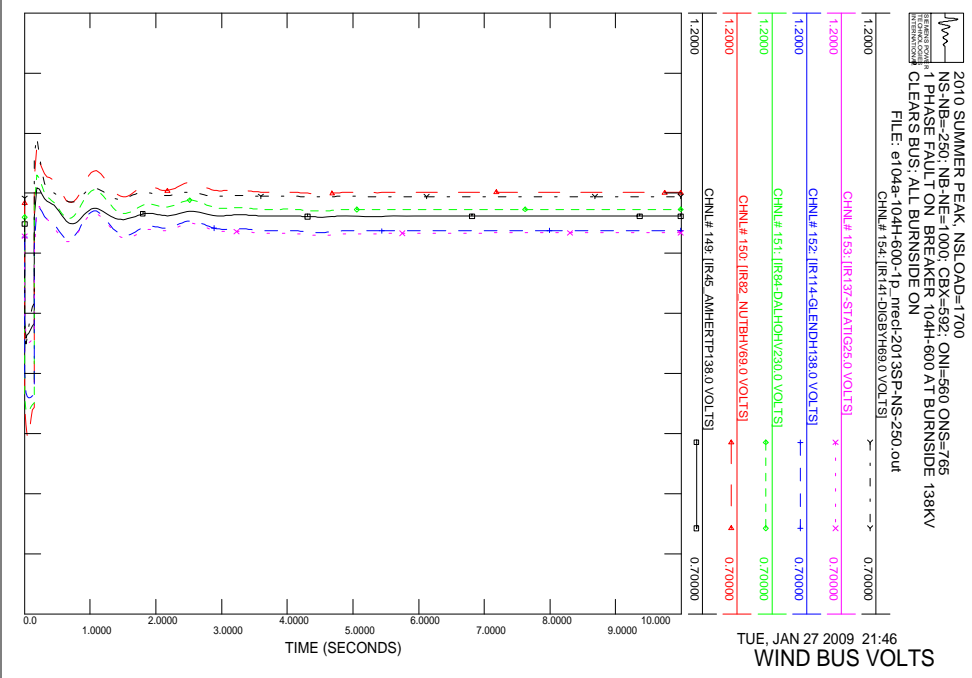
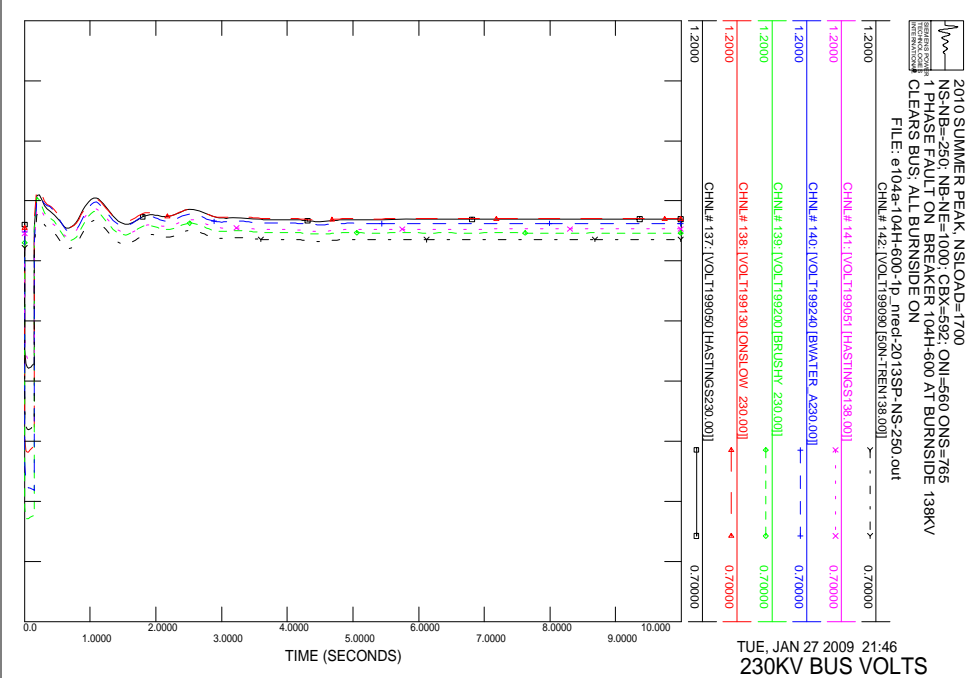
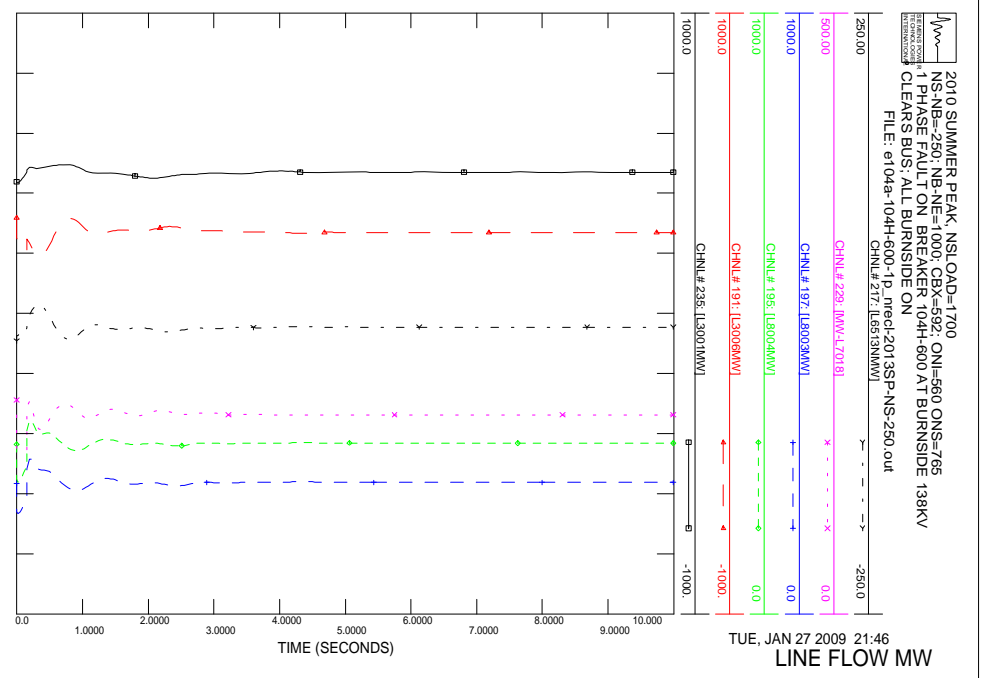
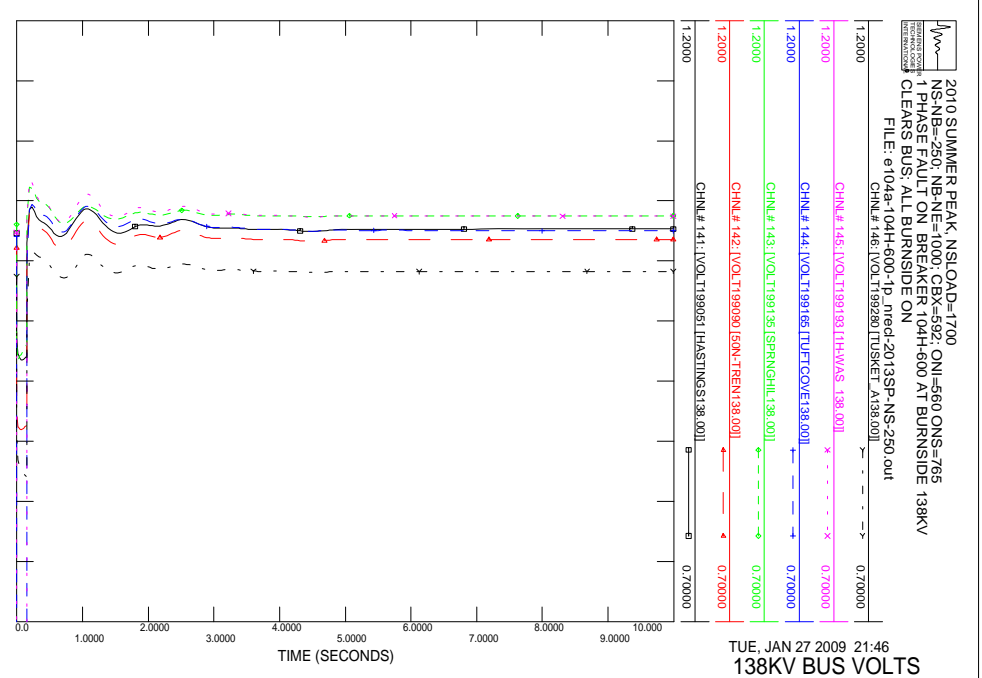

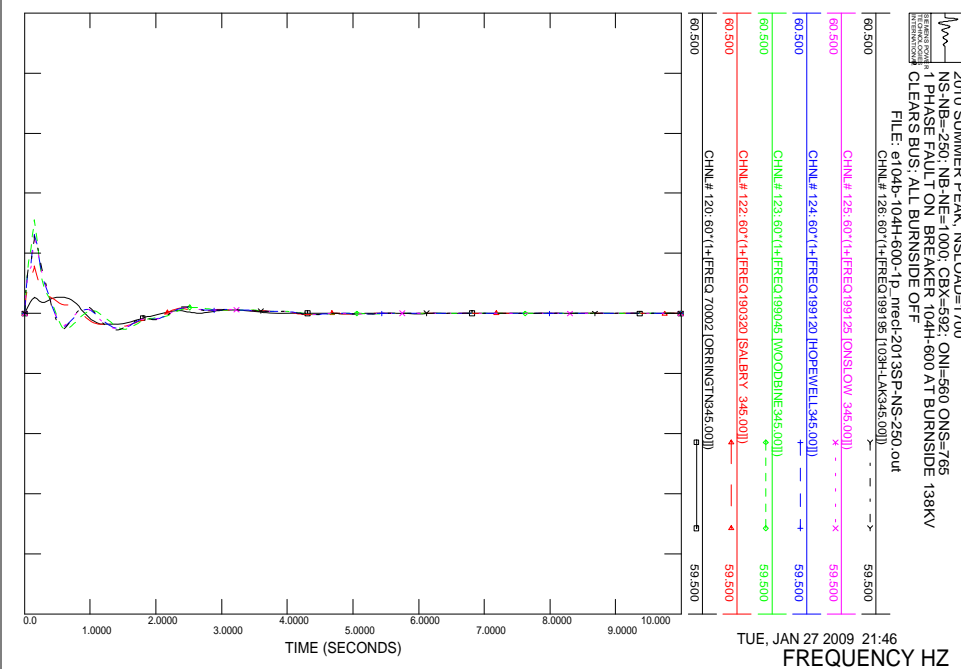
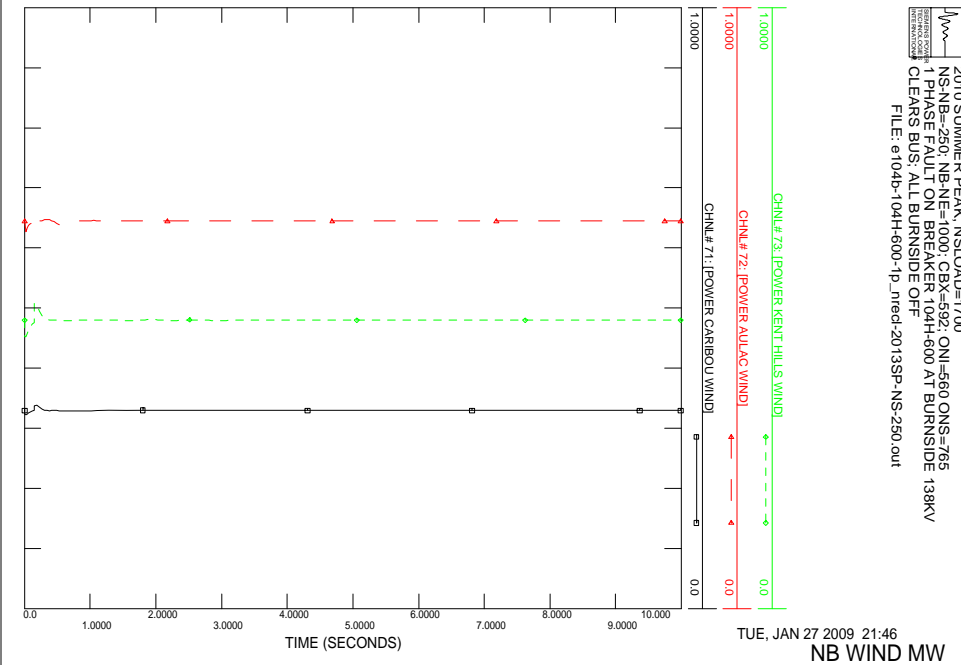
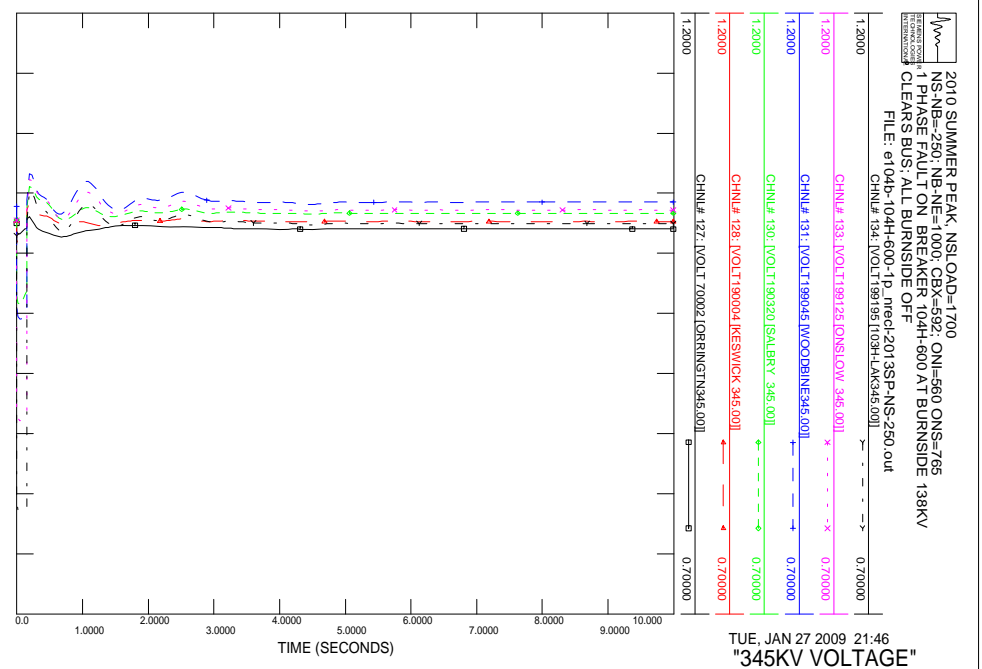
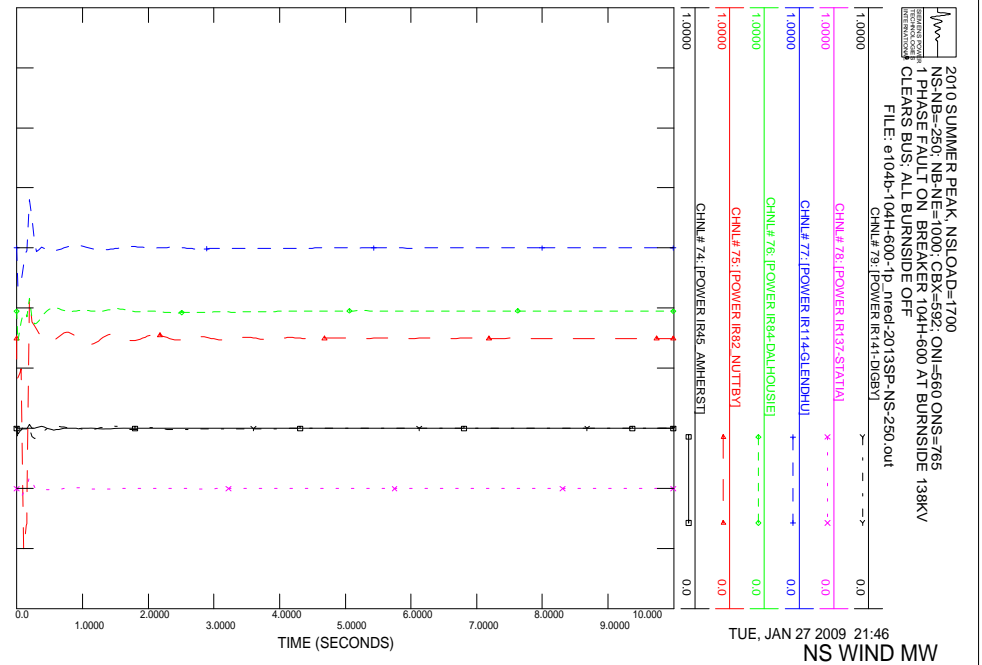

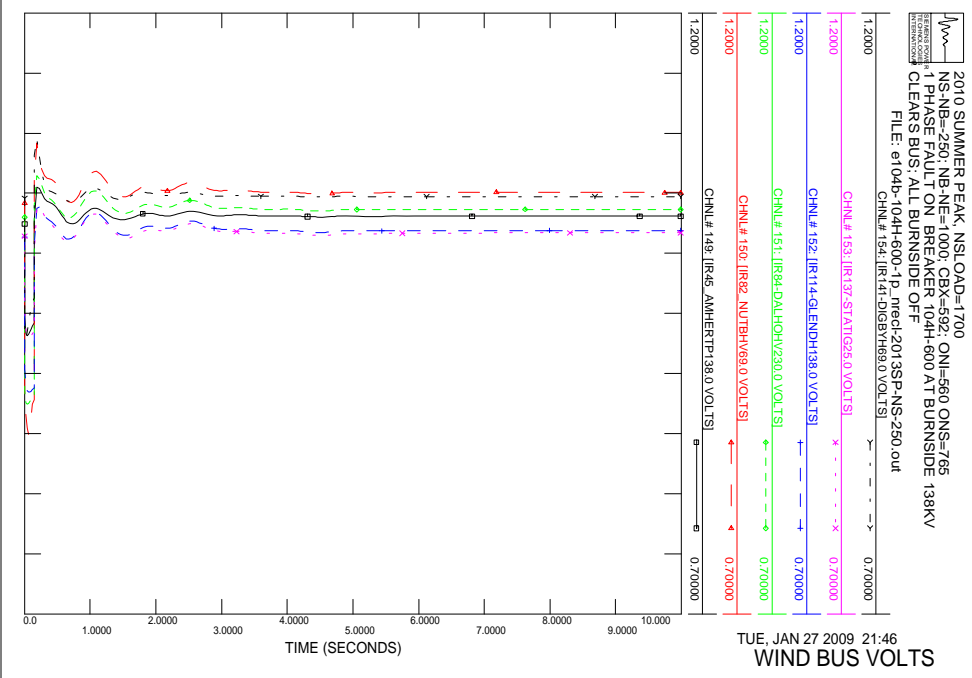
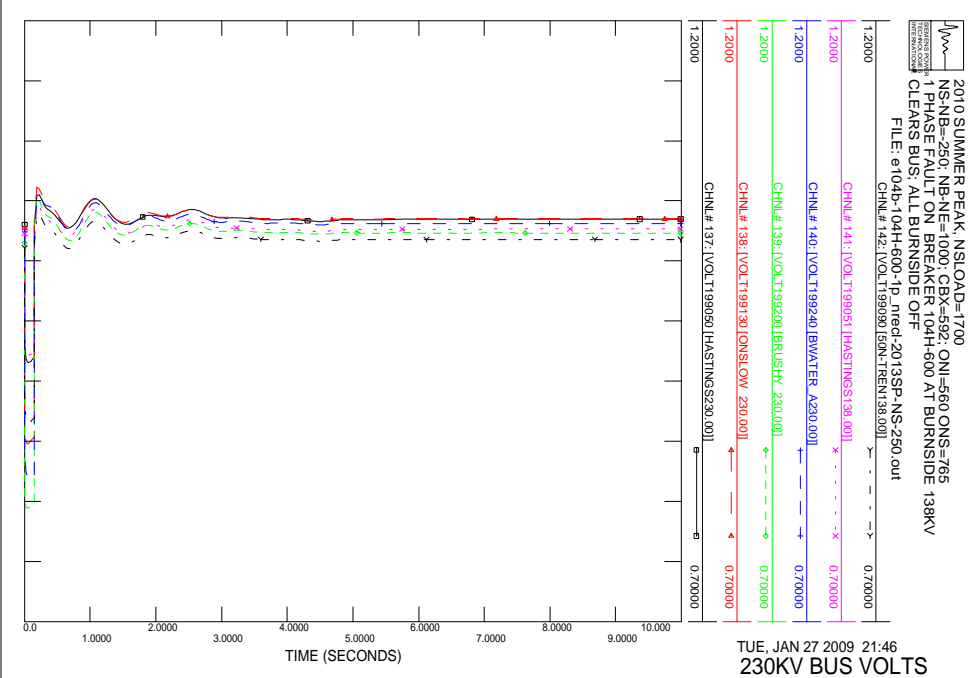
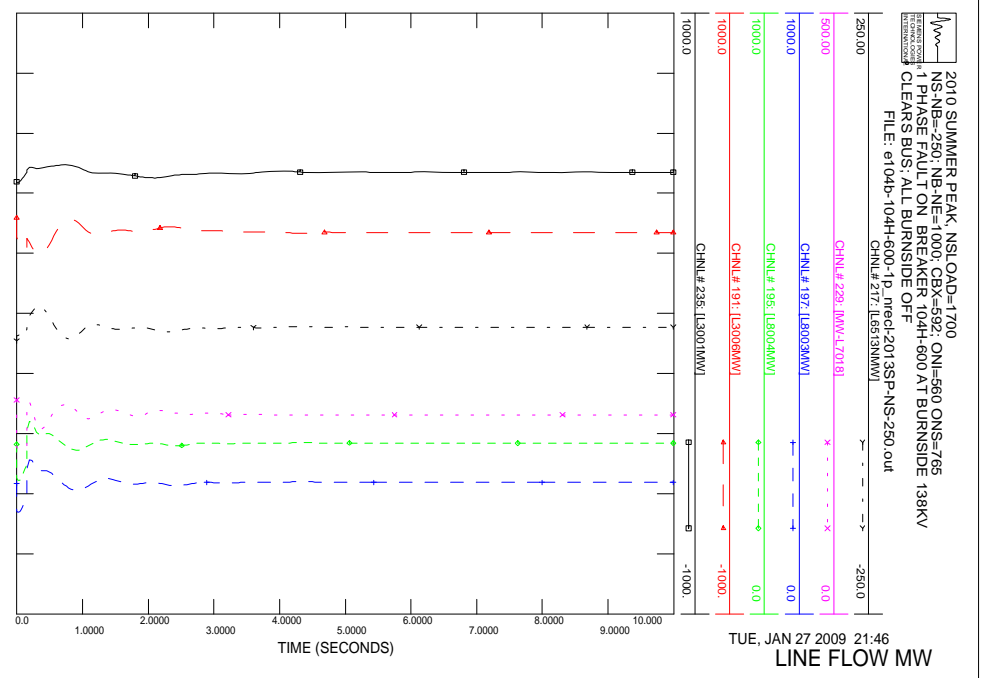
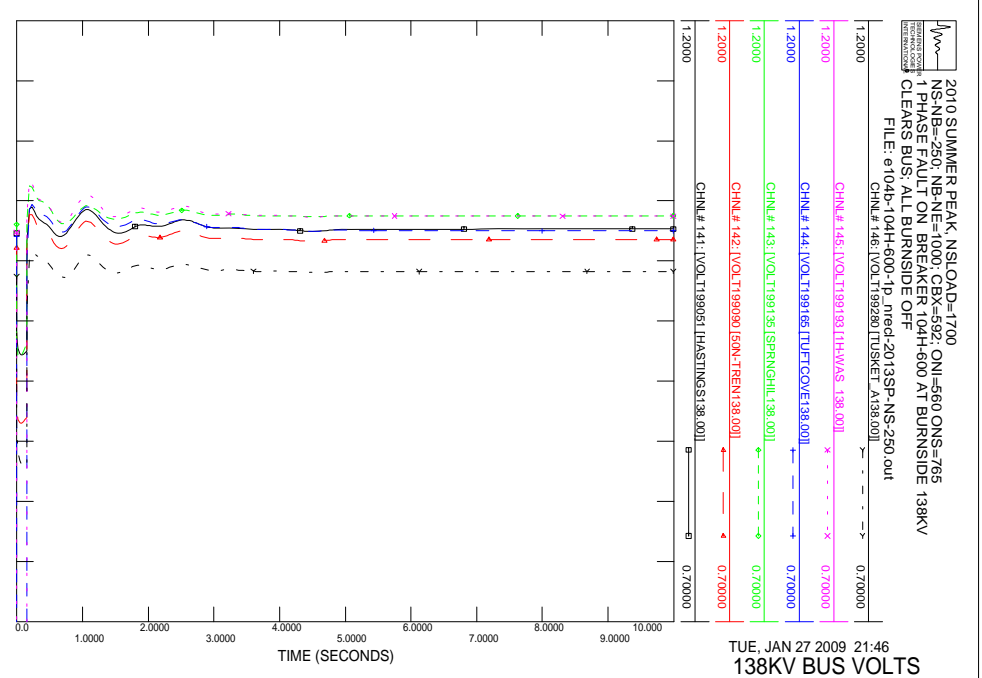

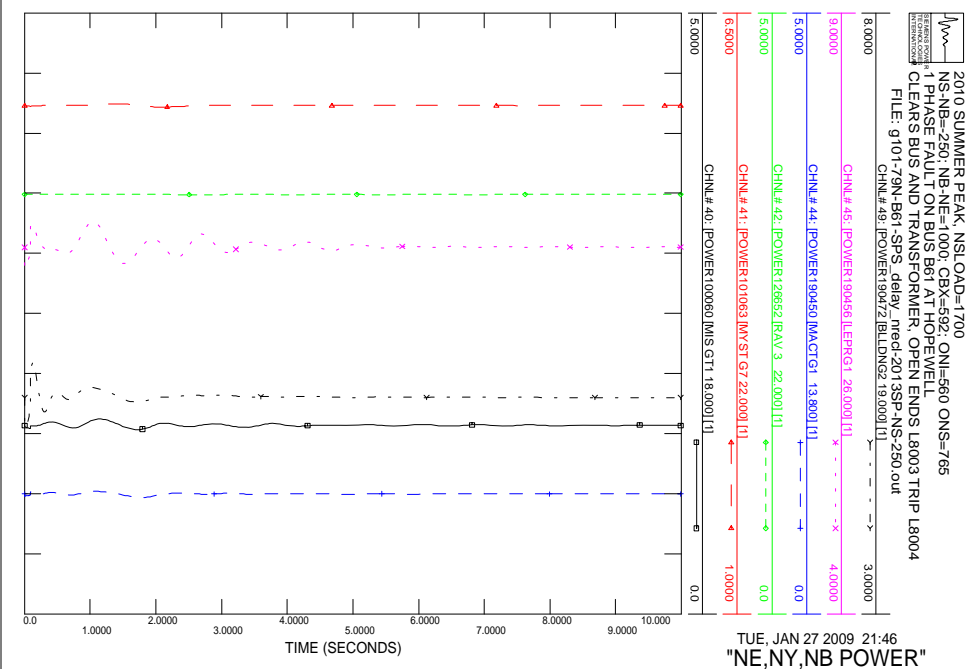
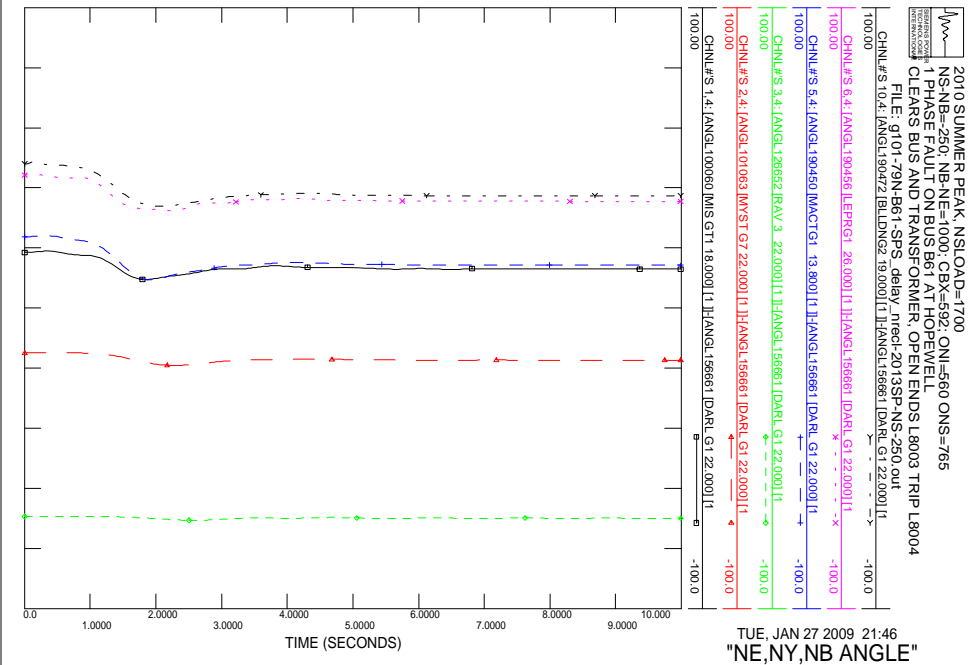
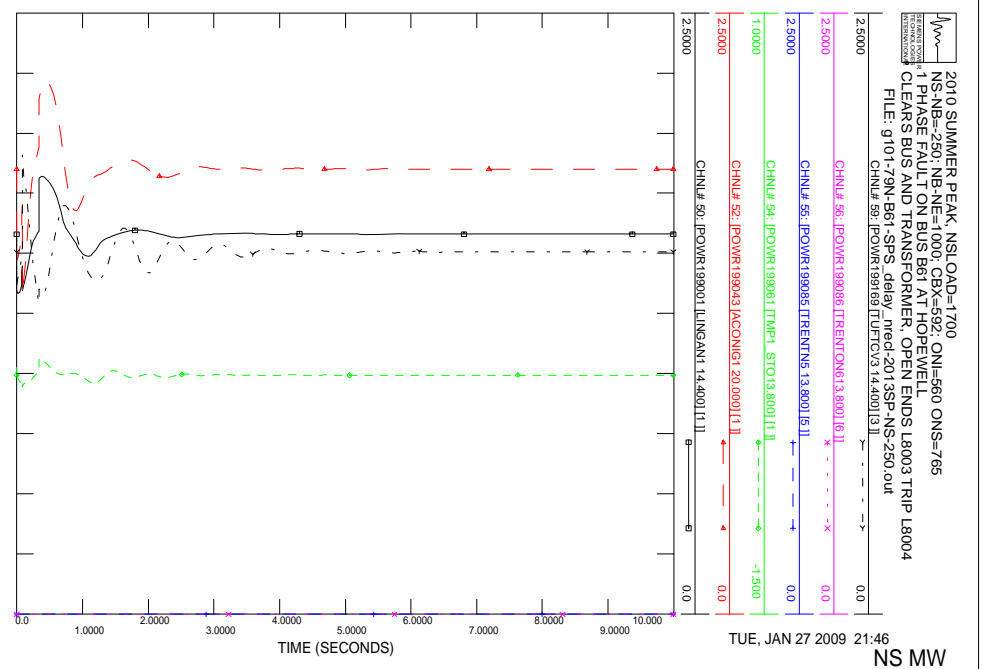
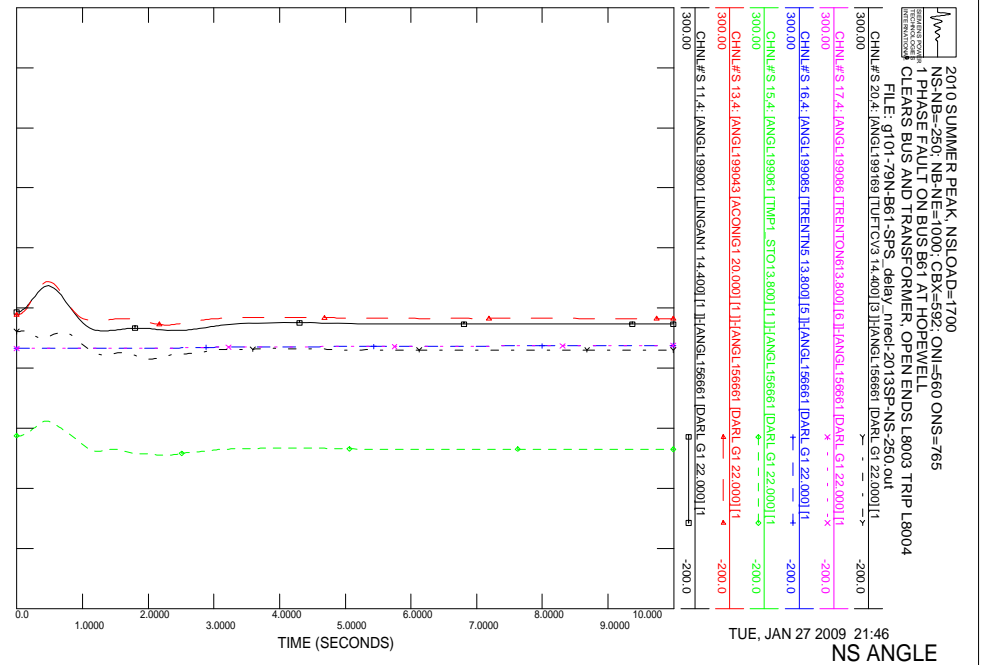

TUE, JAN 27 2009 21:46
 "NE,NY,NB ANGLE"

TUE, JAN 27 2009 21:46
 "NE,NY,NB POWER"

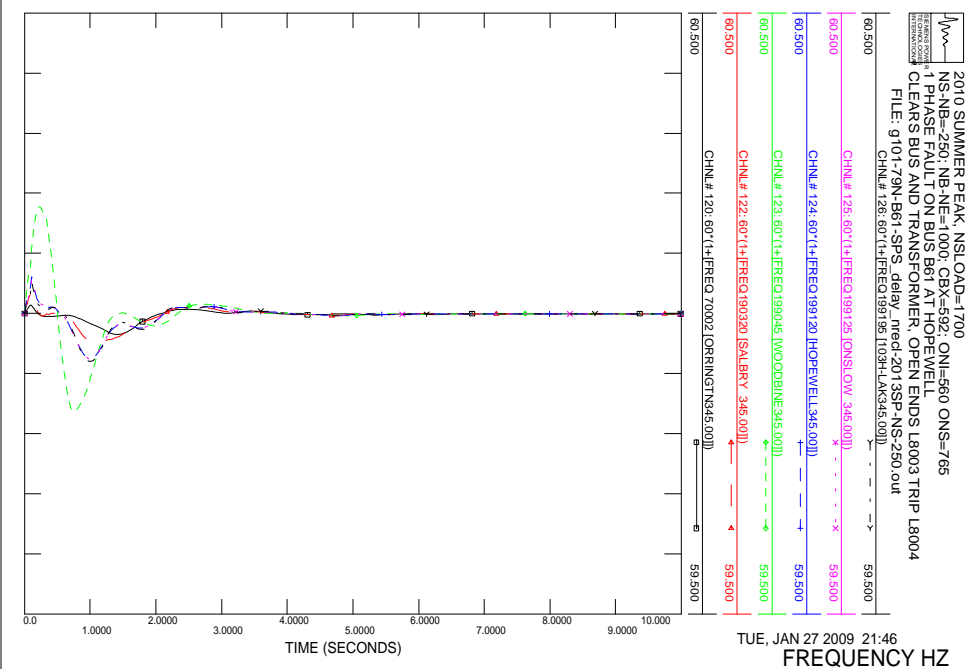
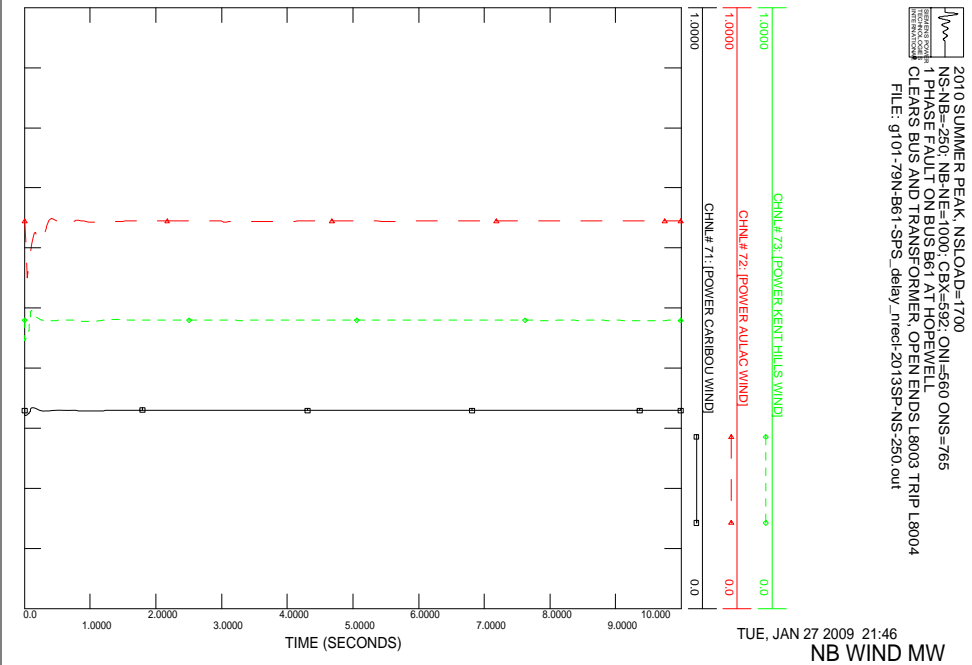
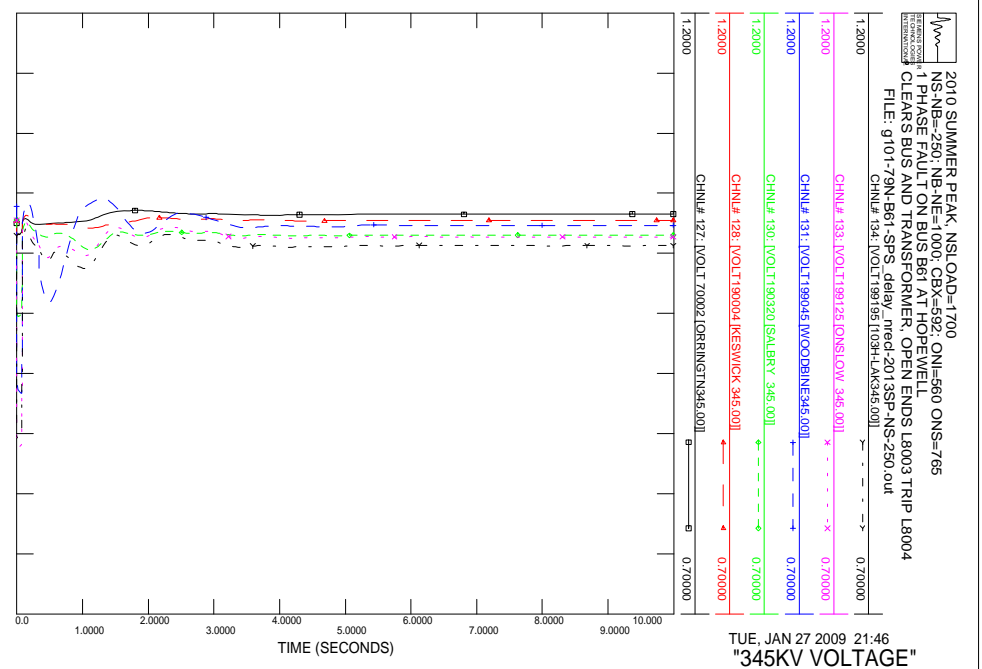
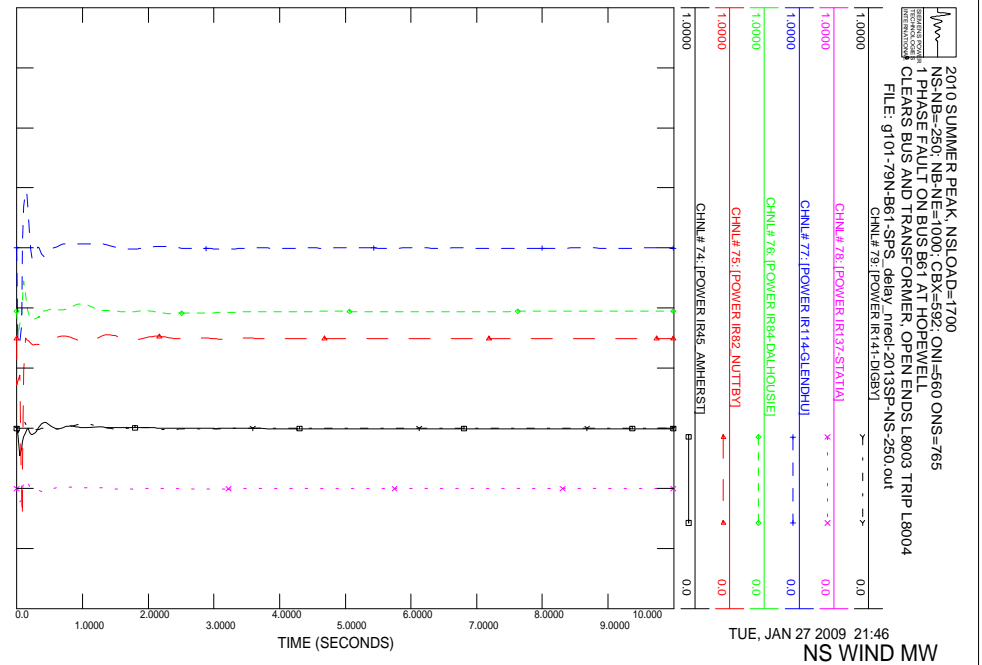

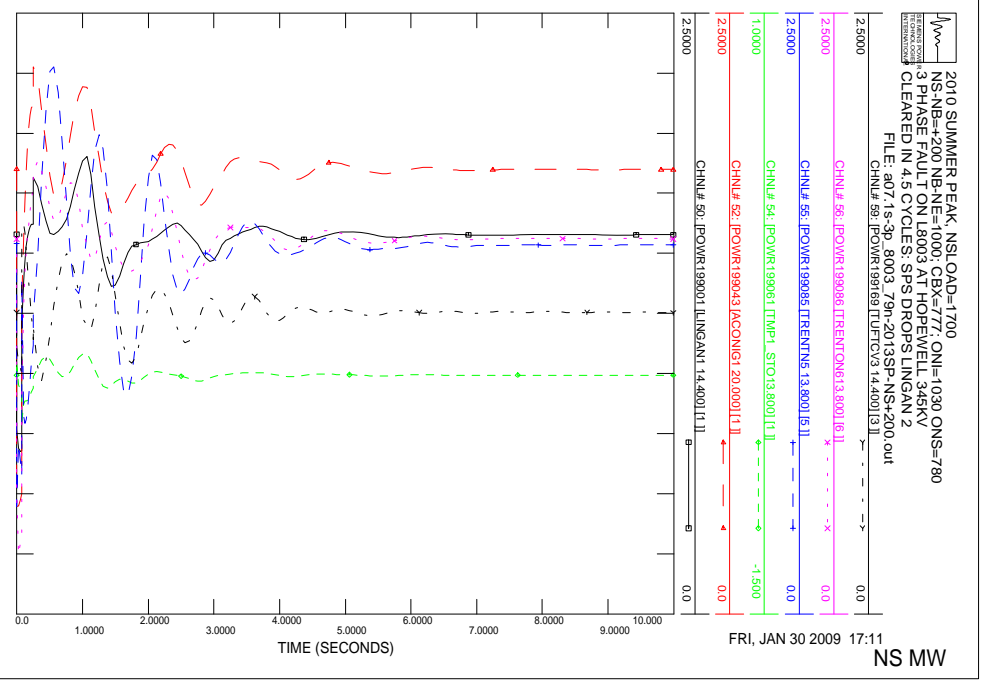
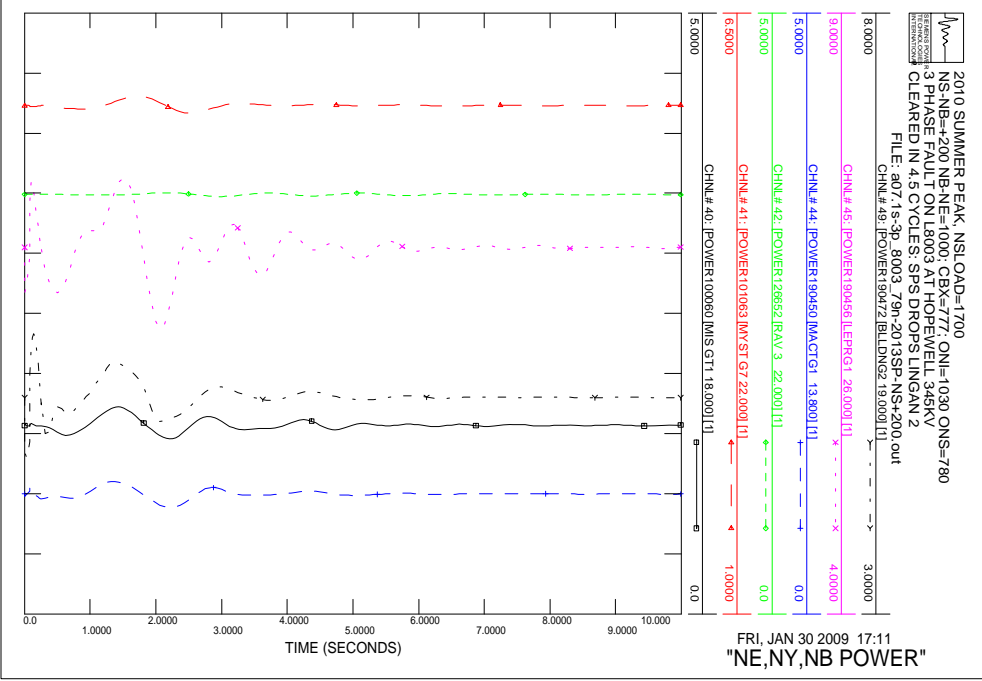
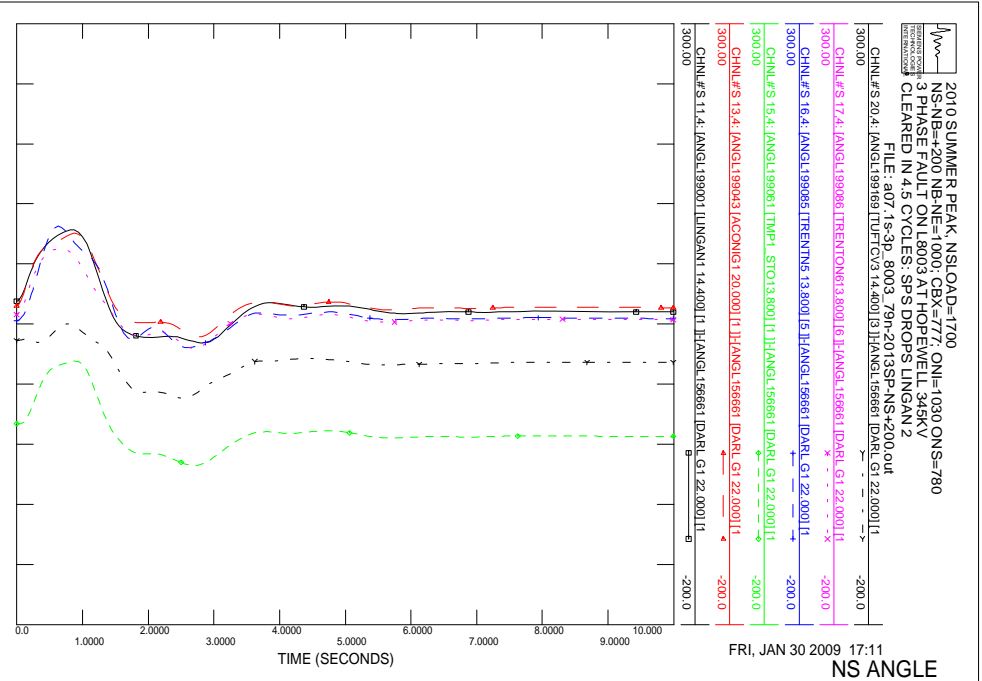
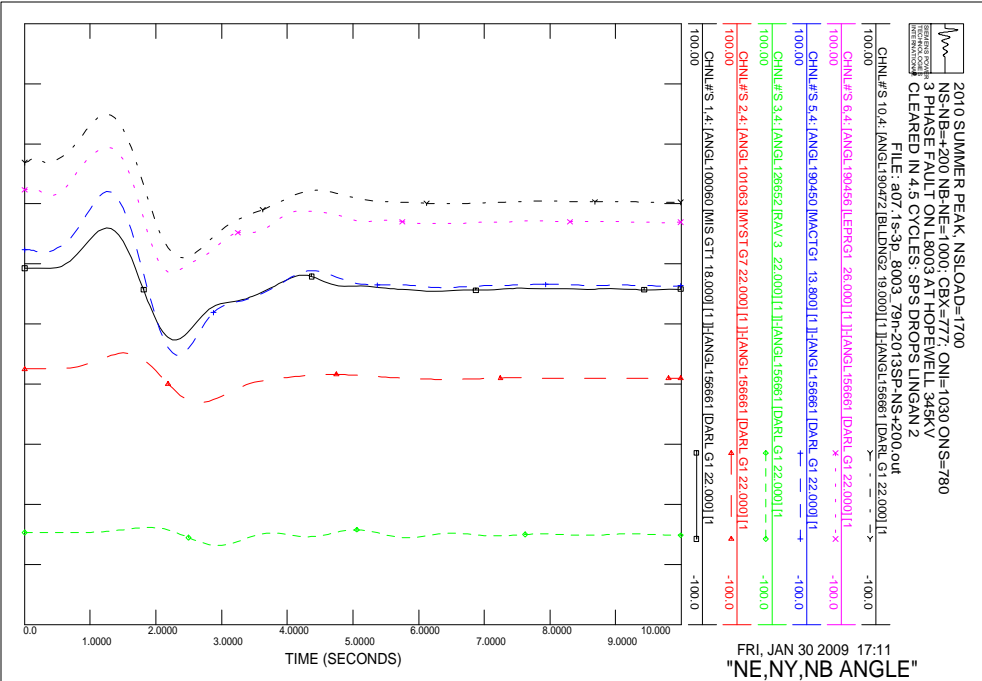

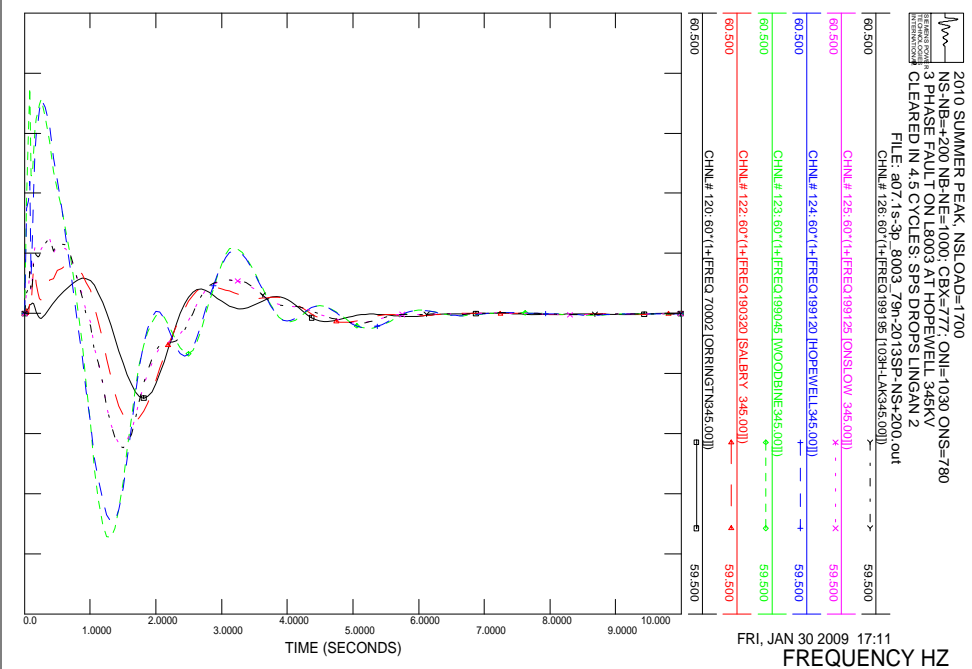
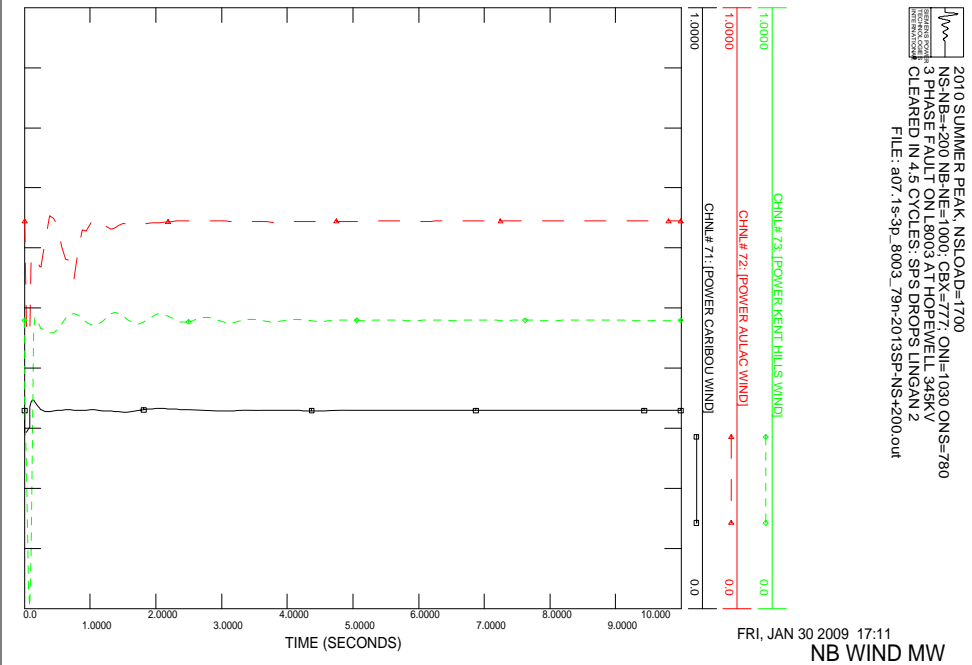
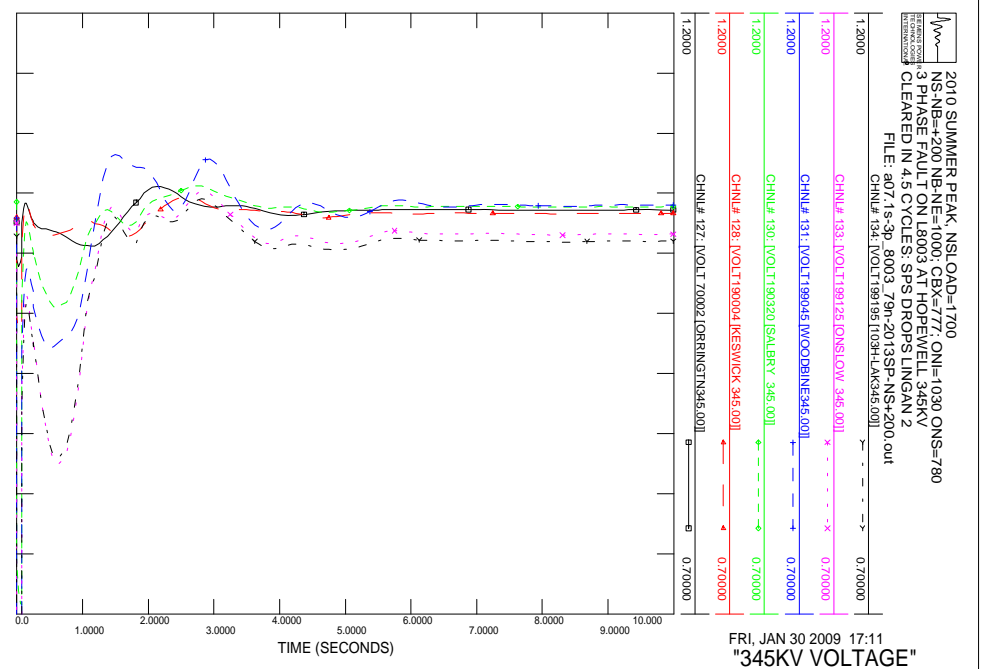
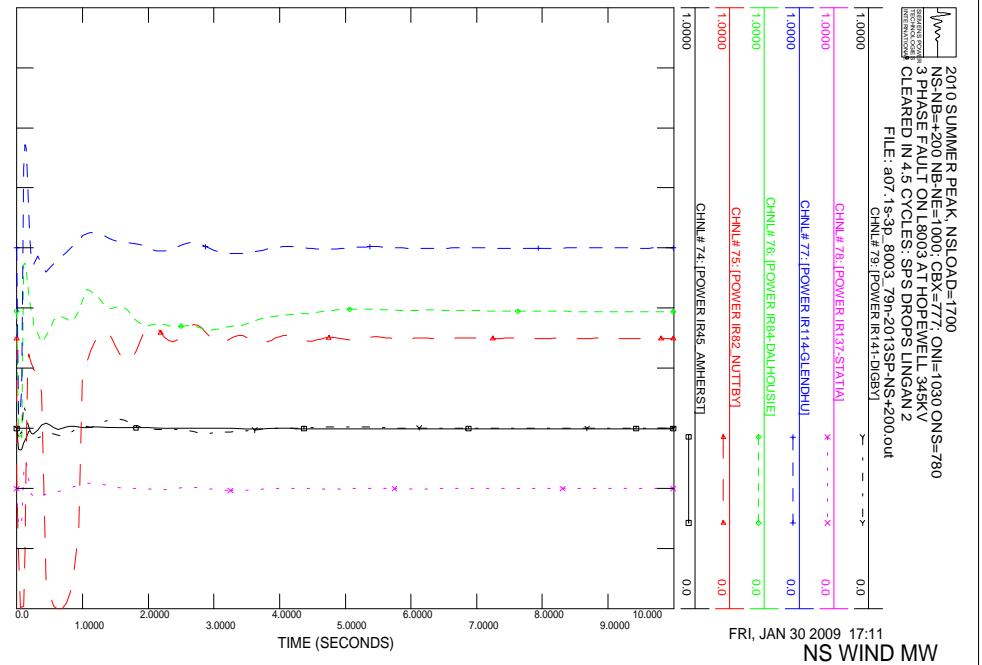

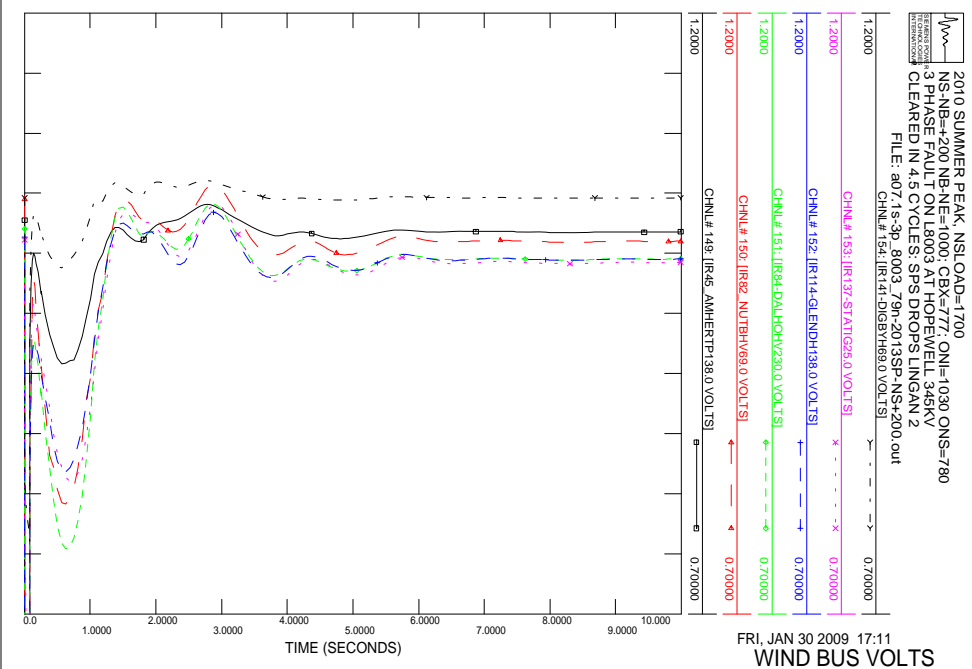
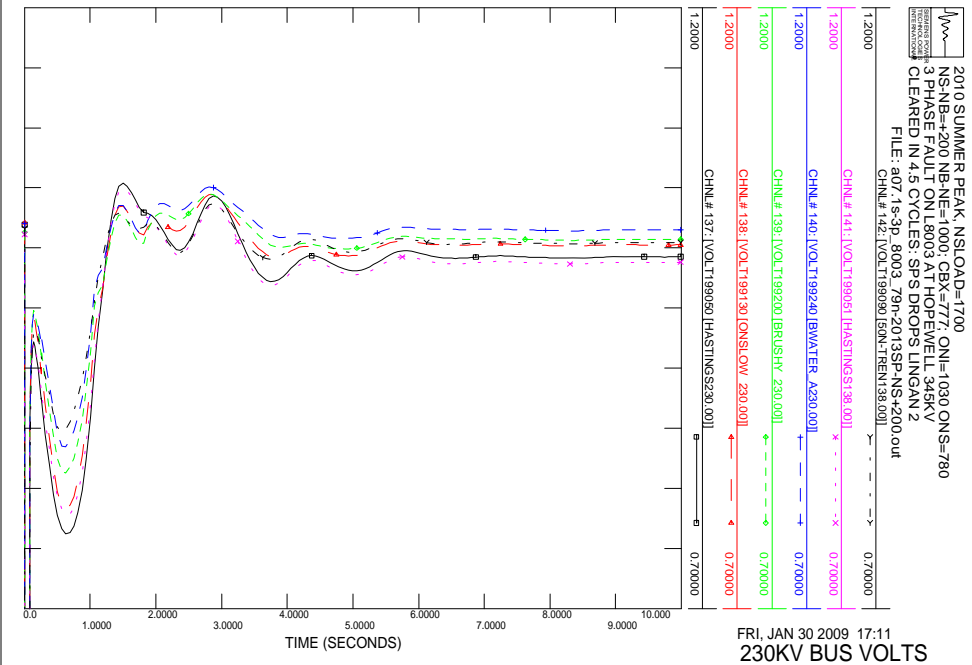
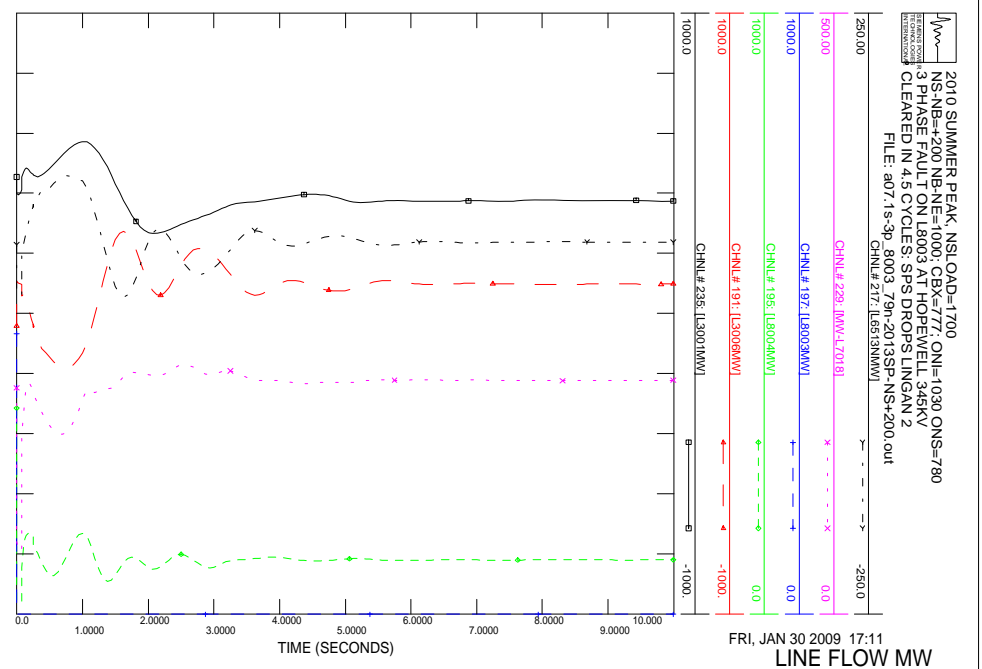
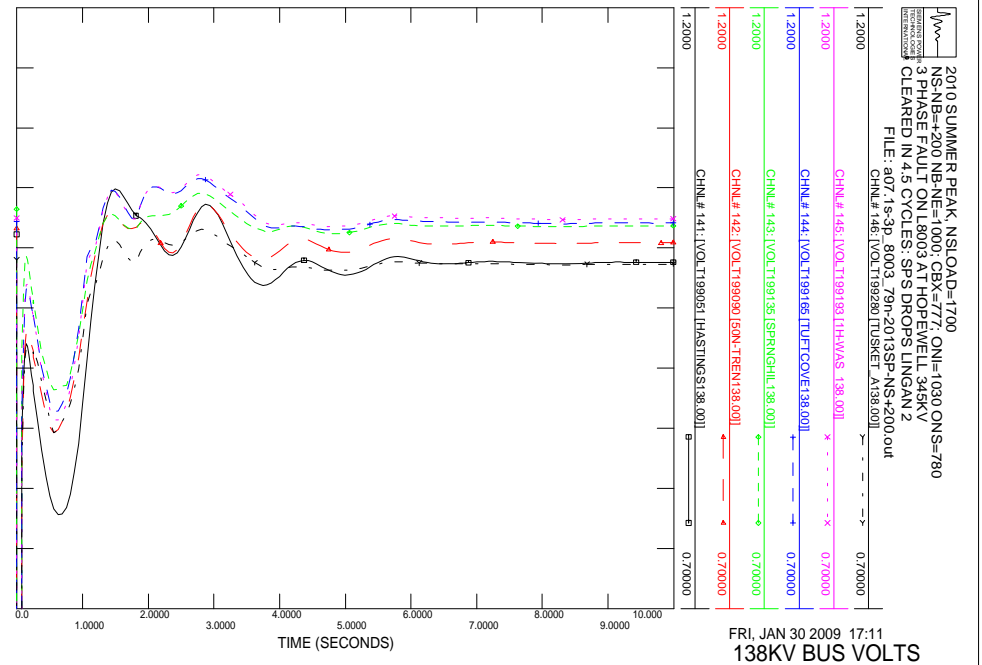

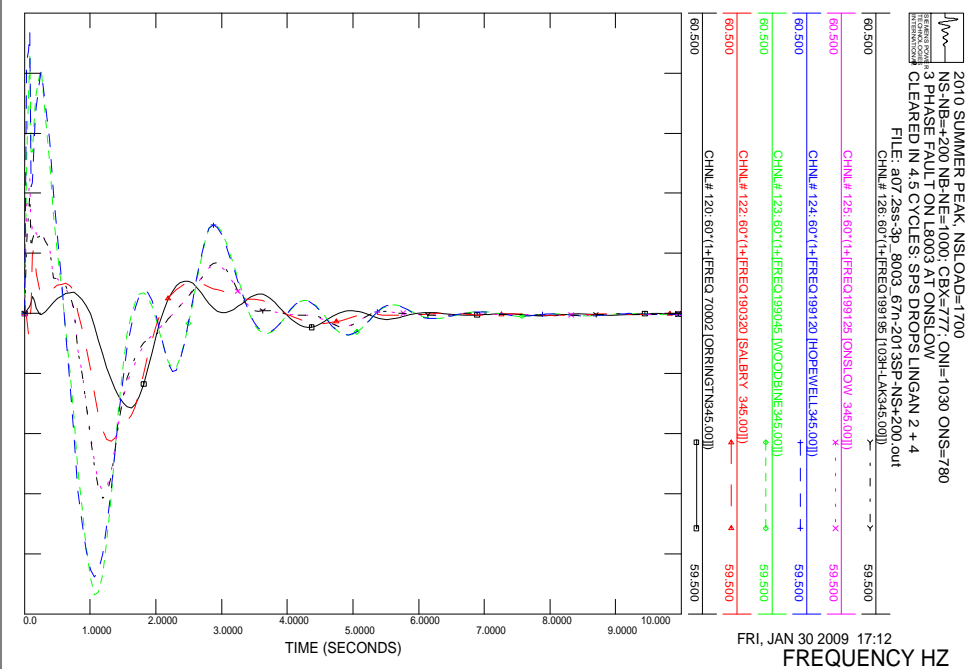
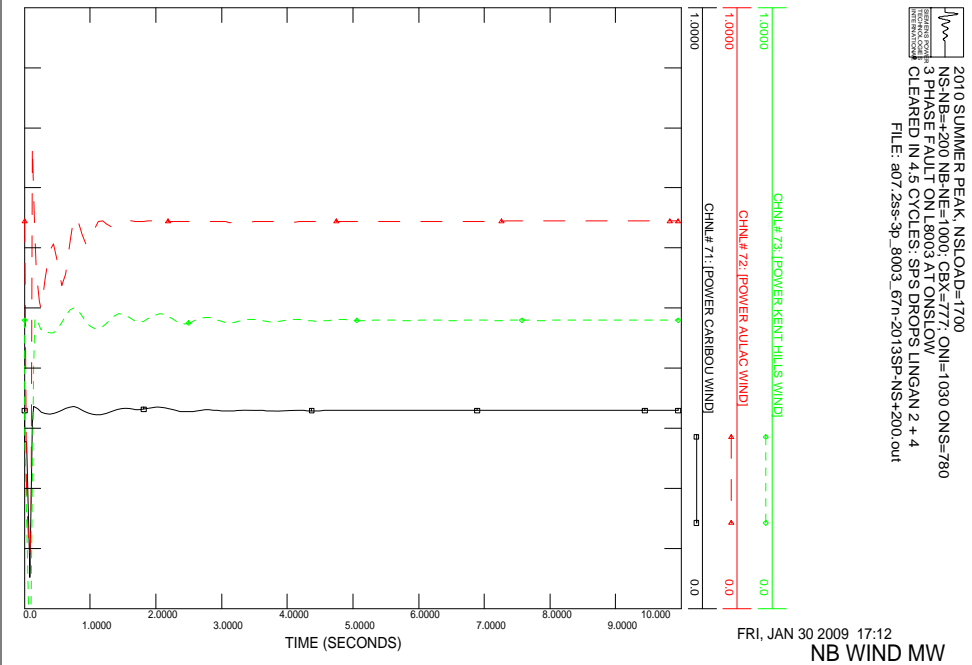
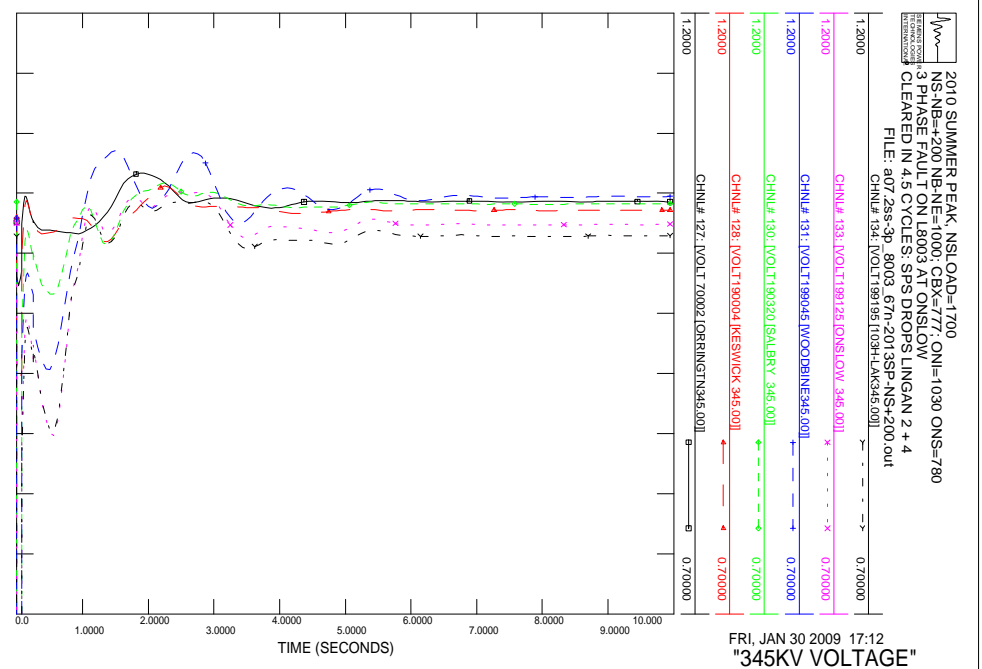
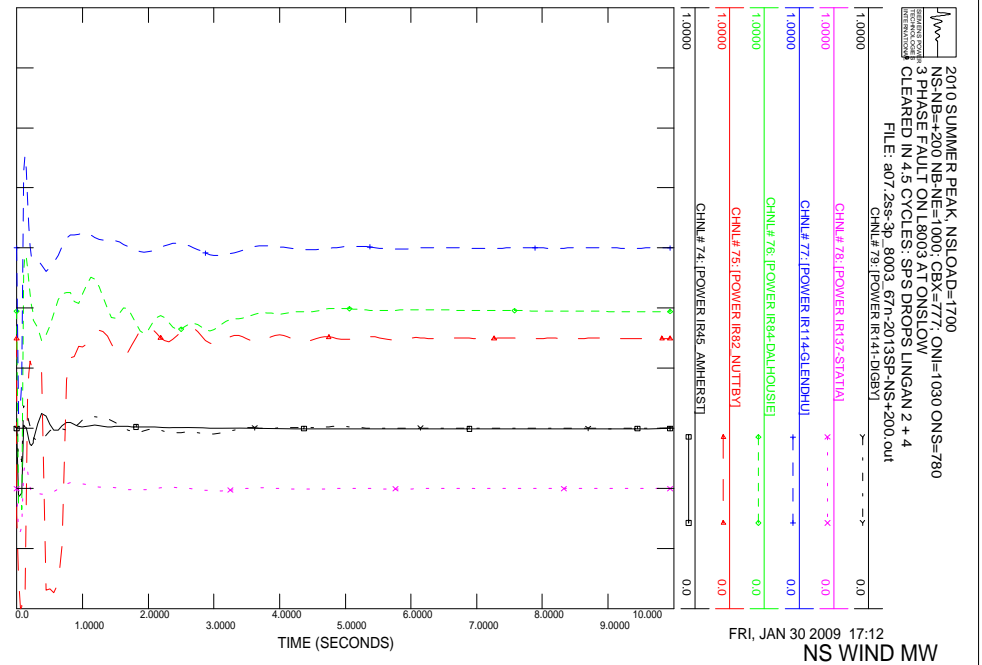

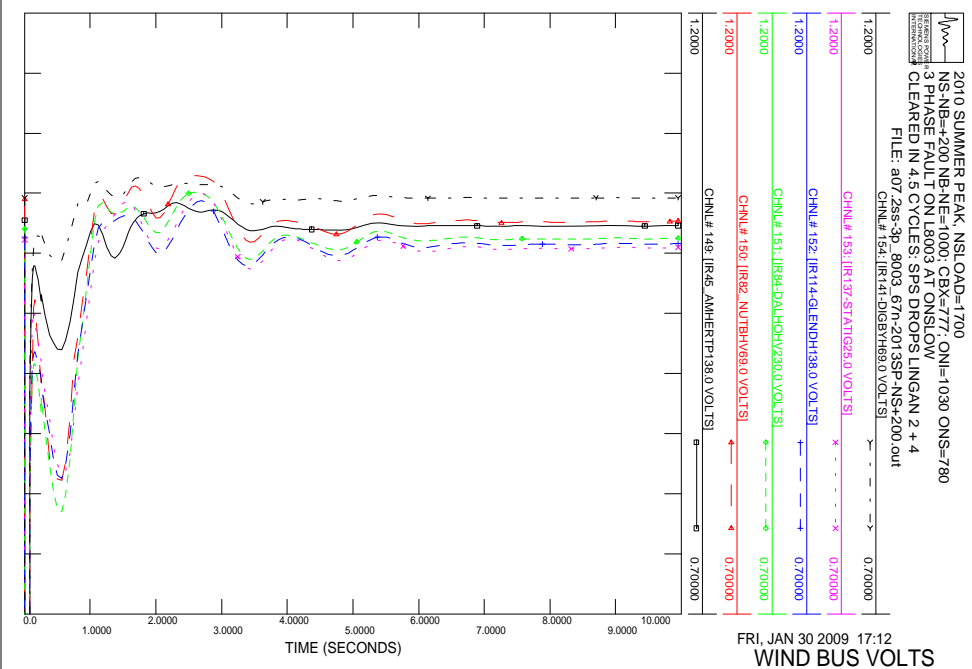
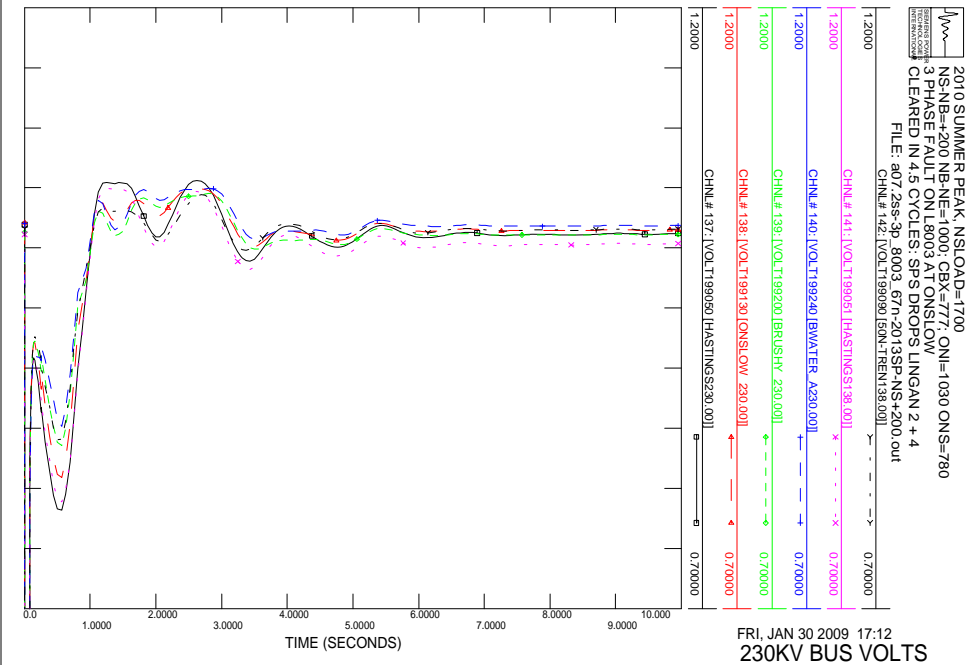
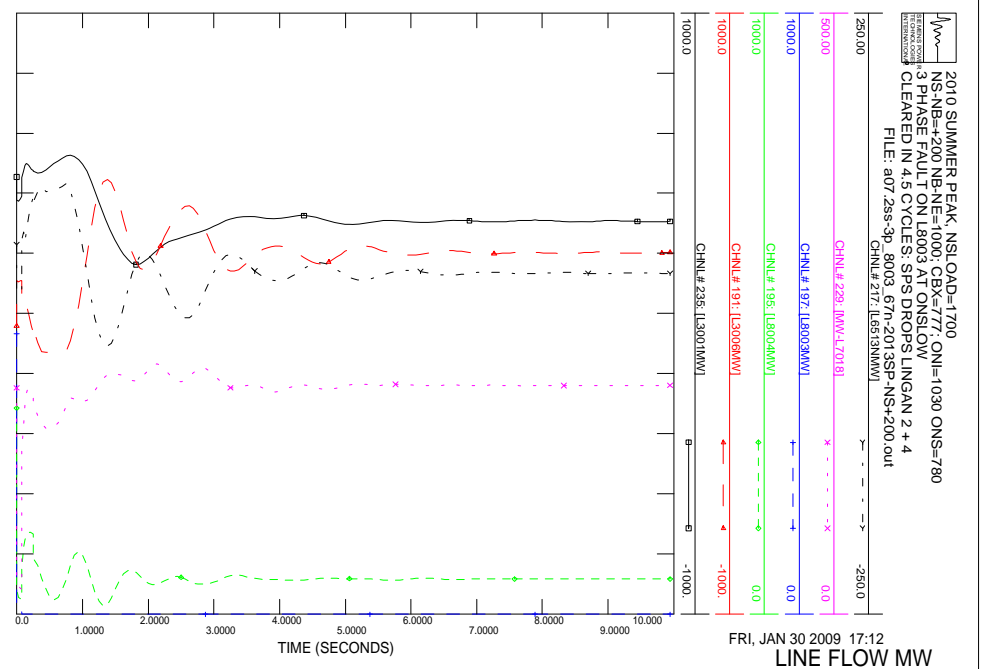
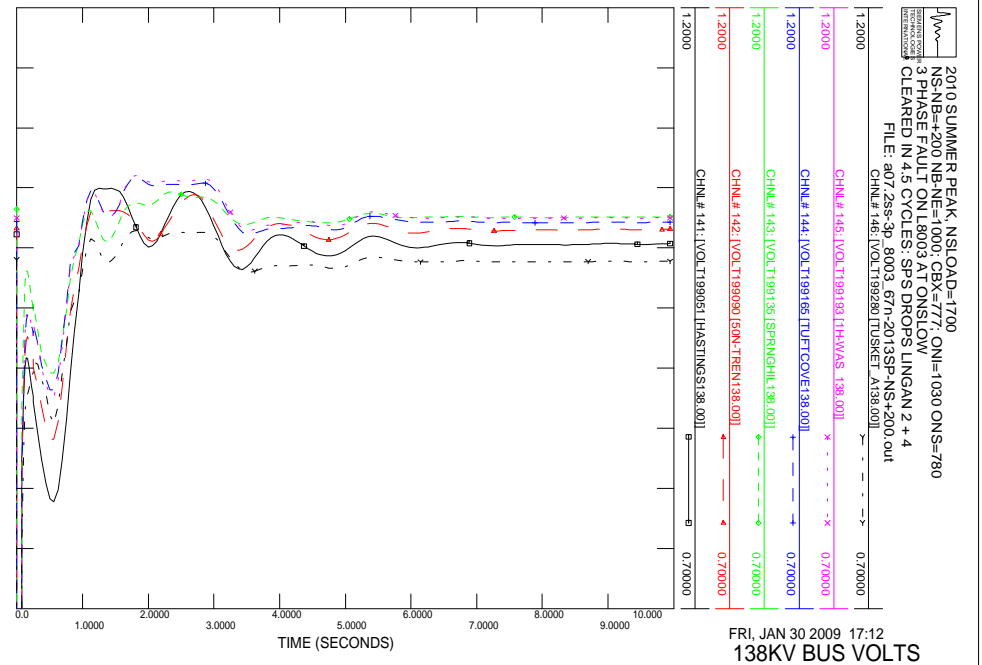

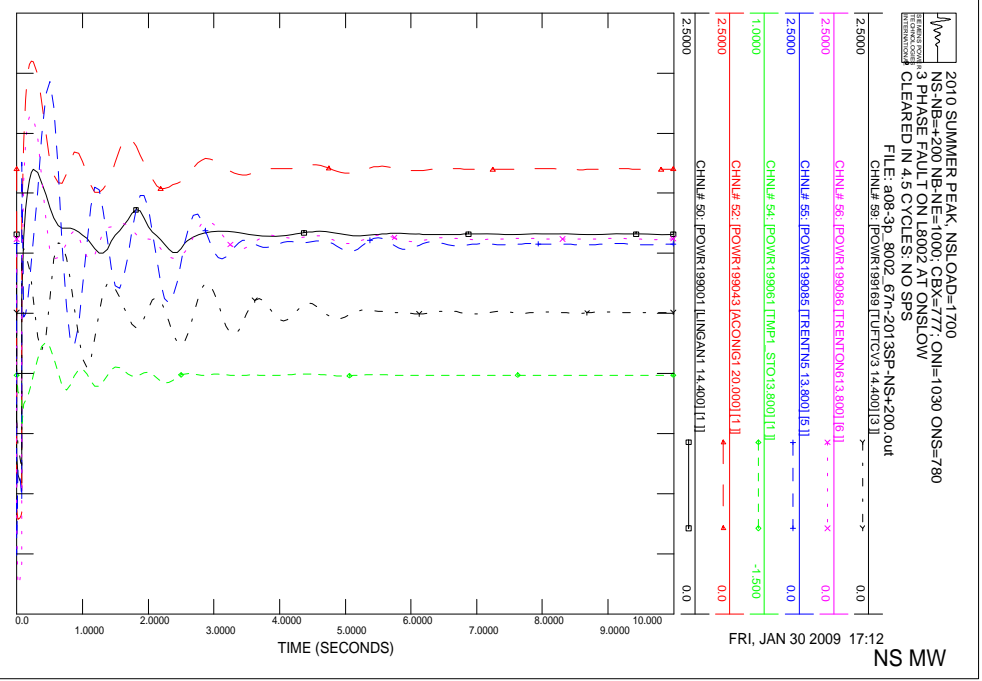
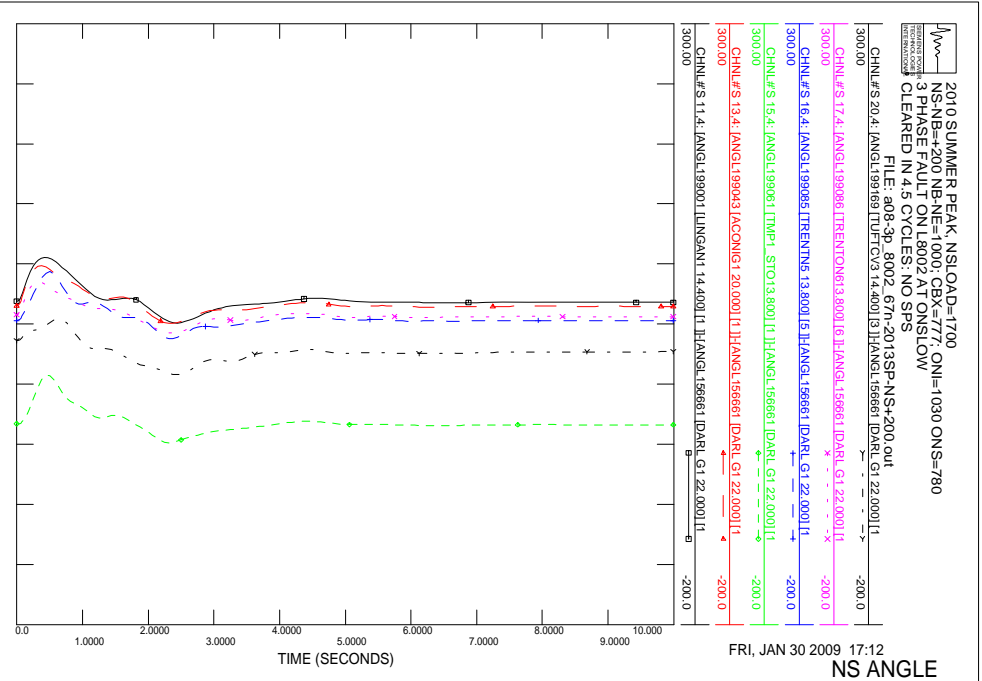
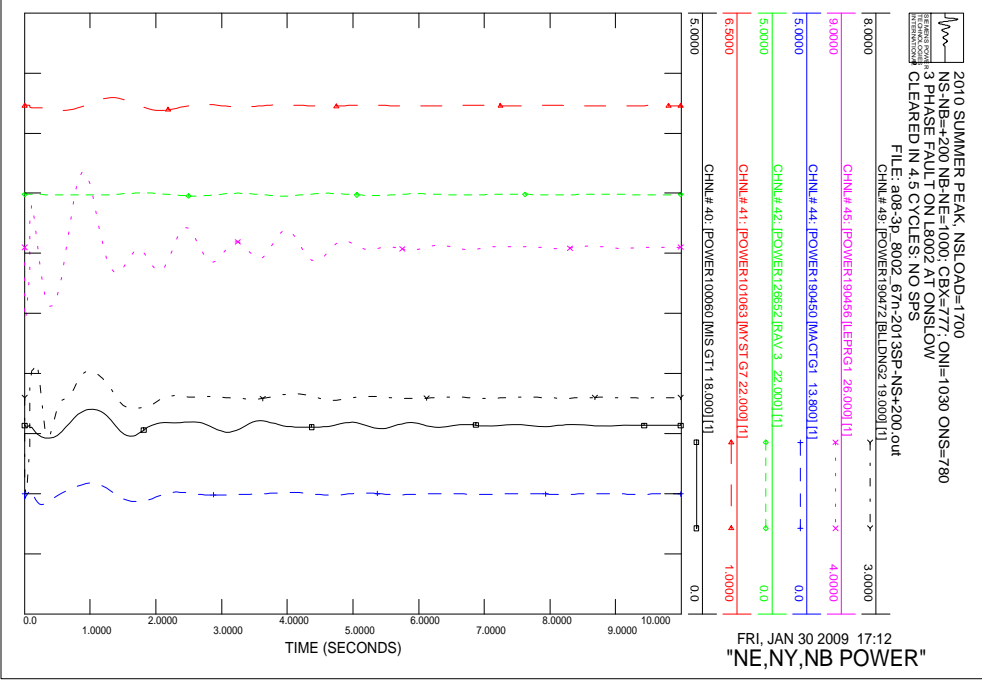
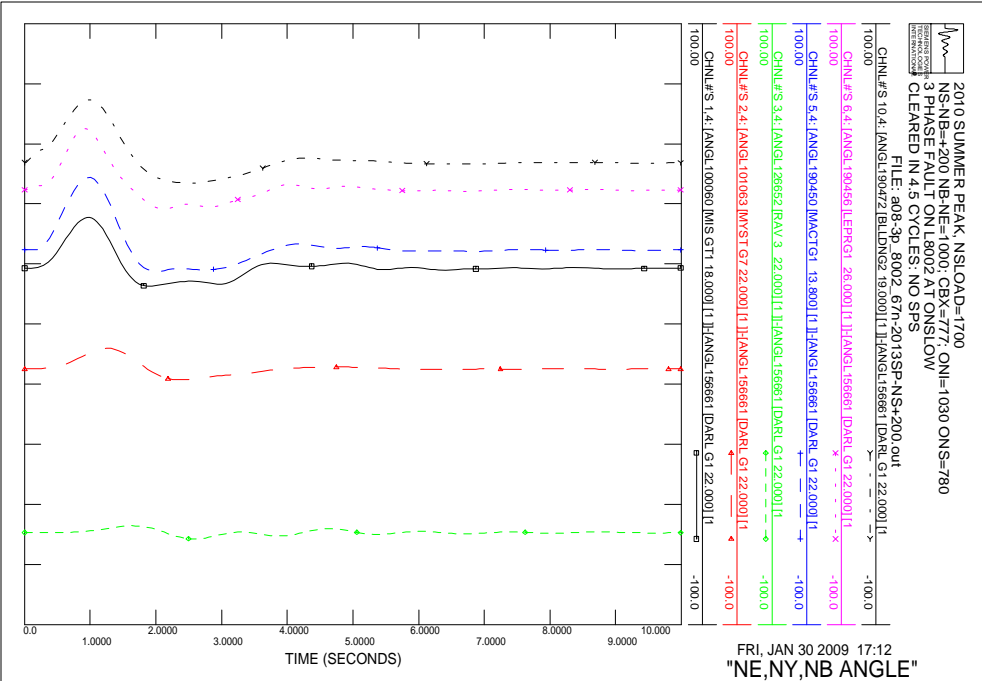

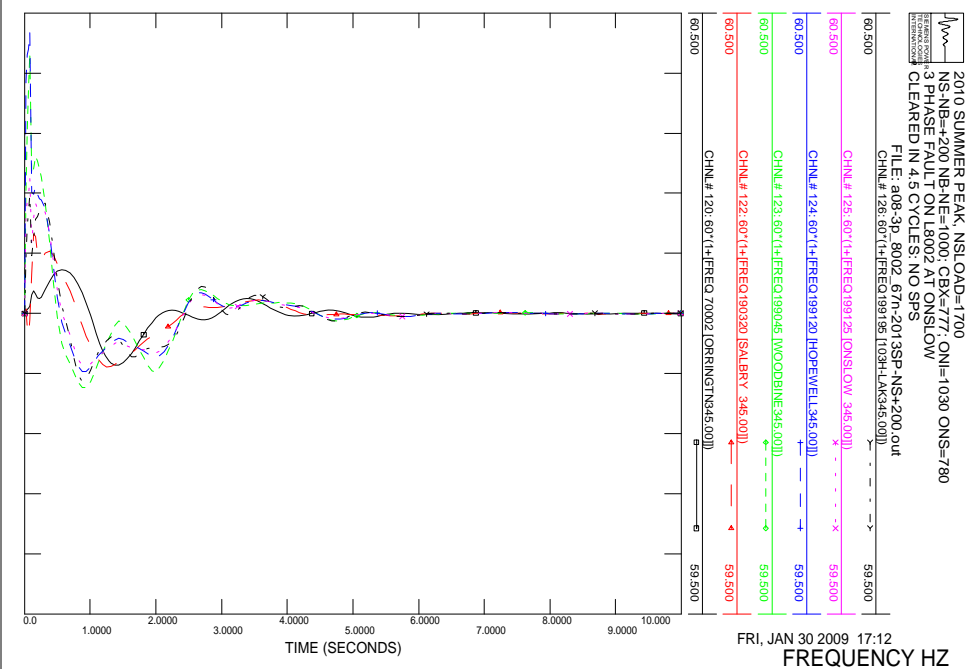
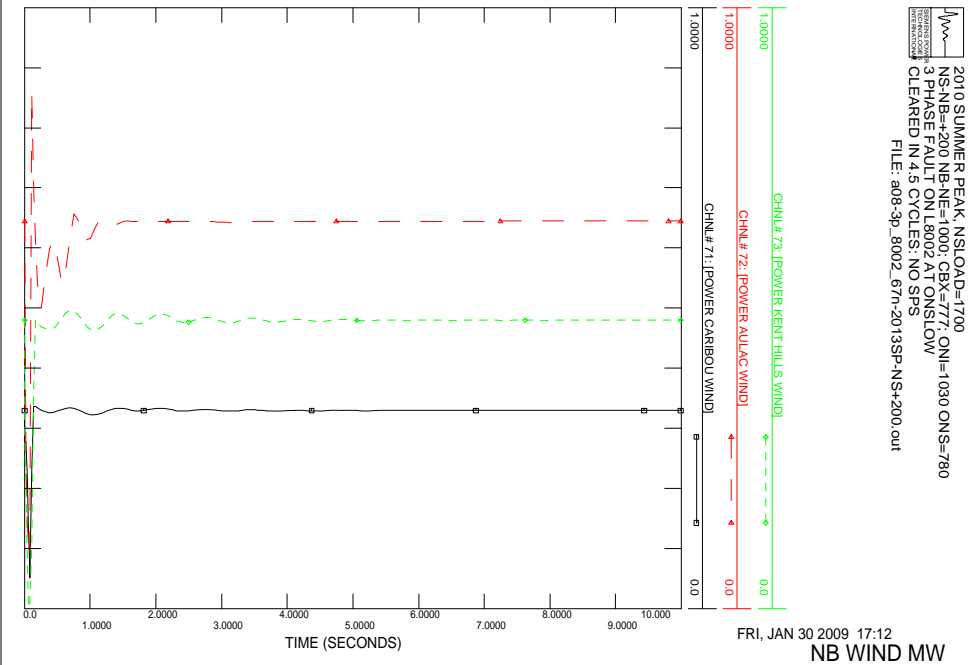
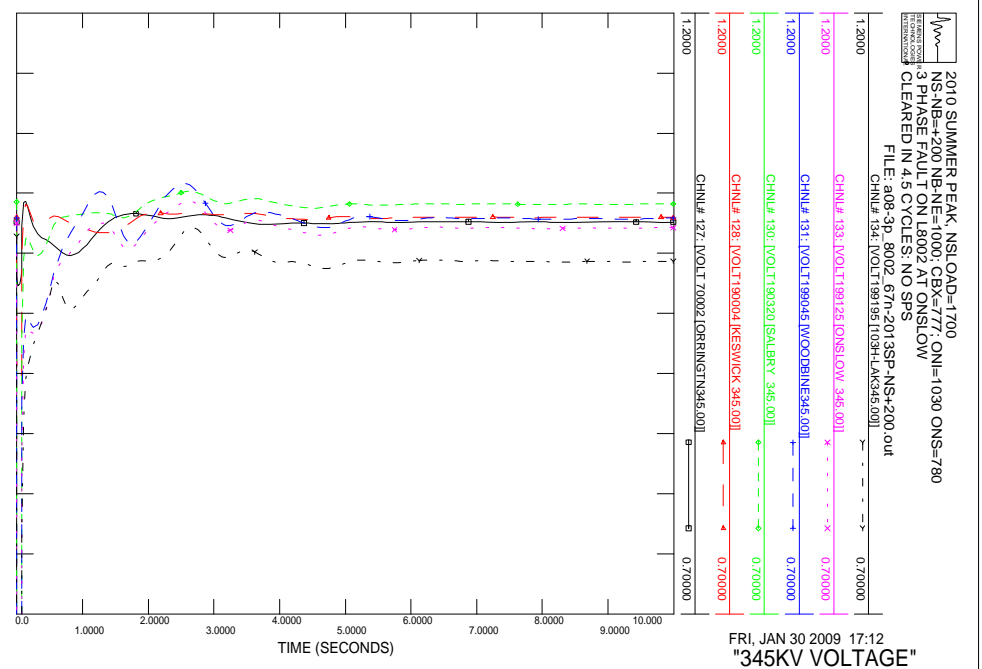
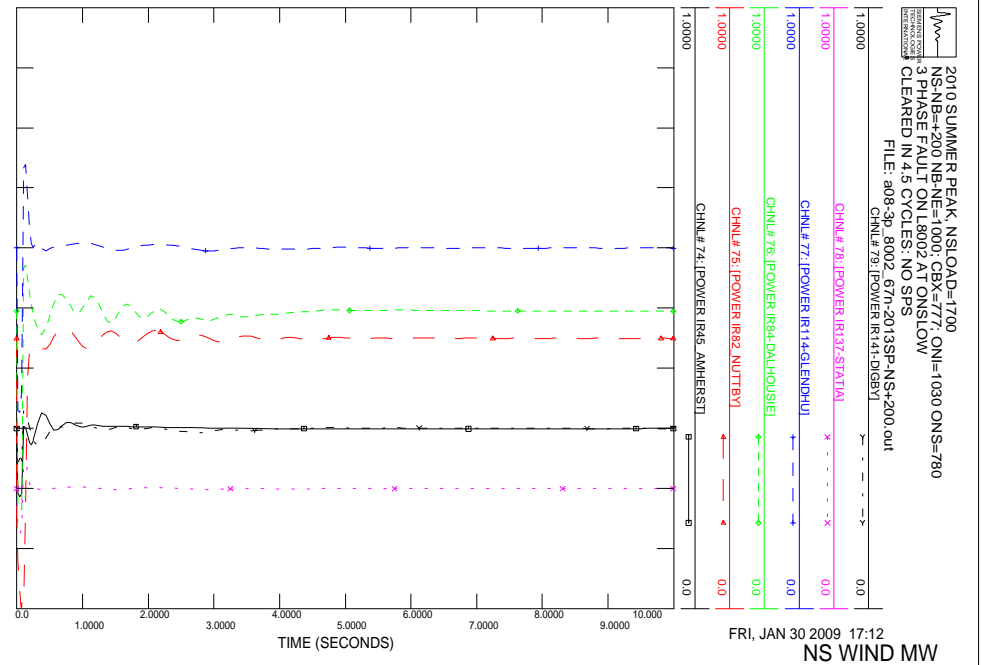

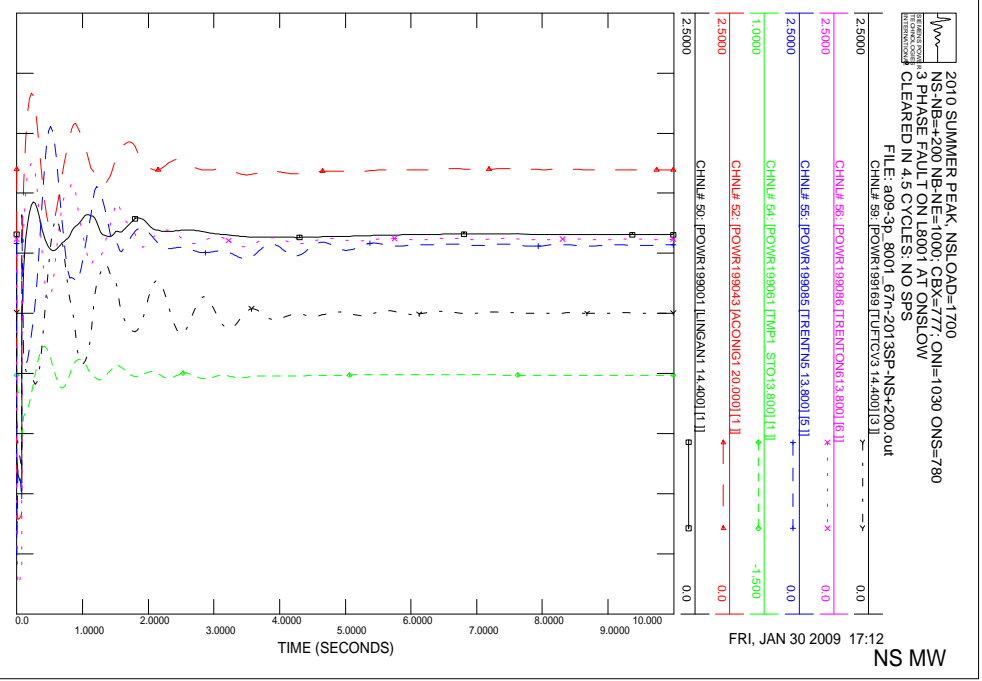
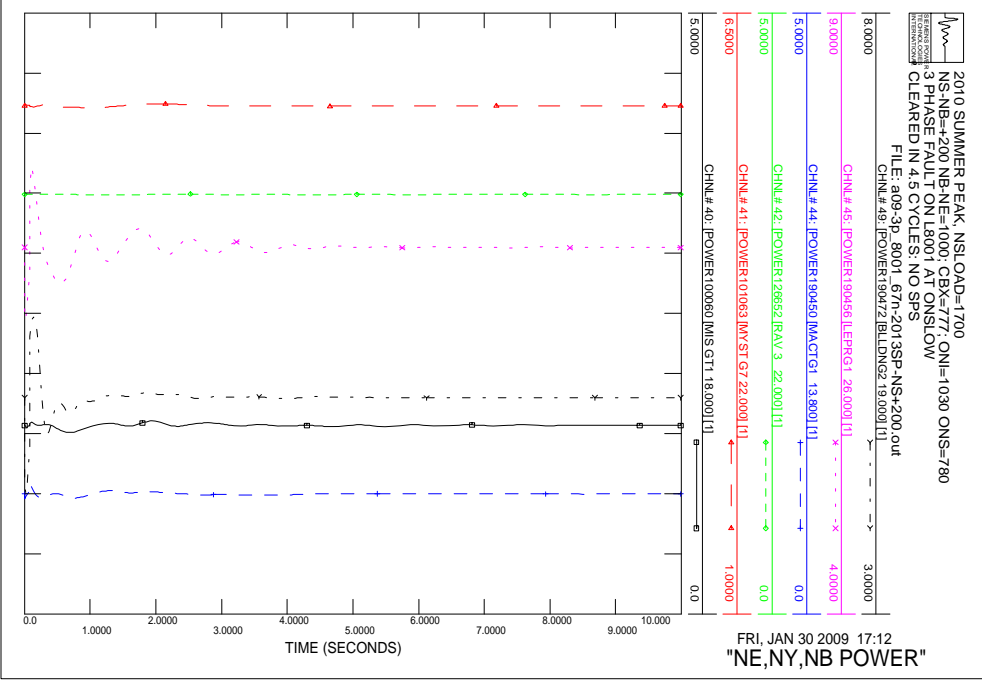
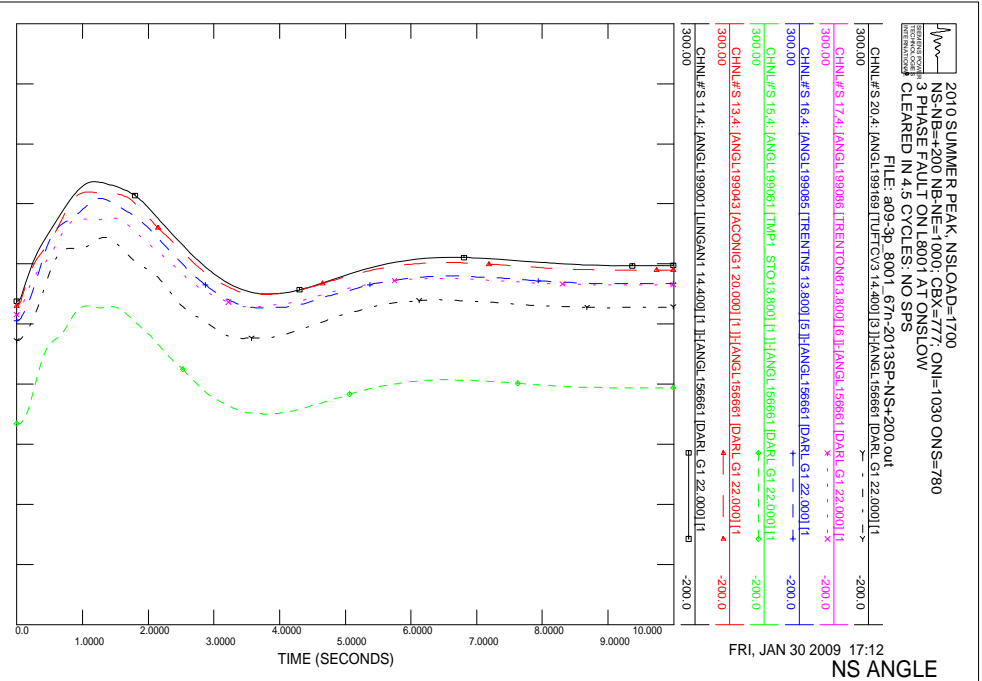
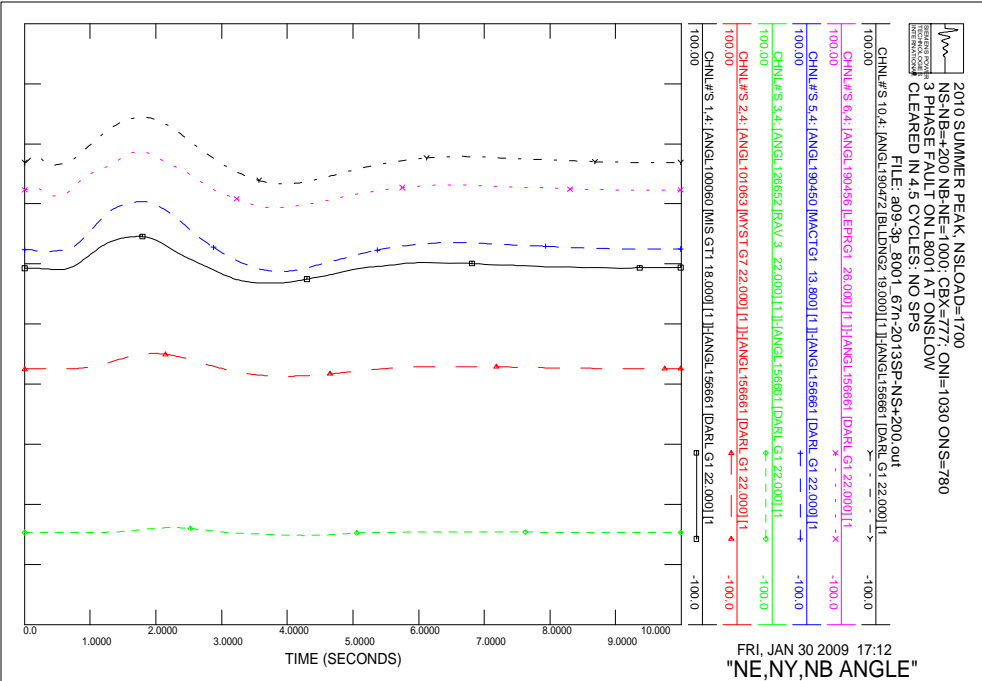

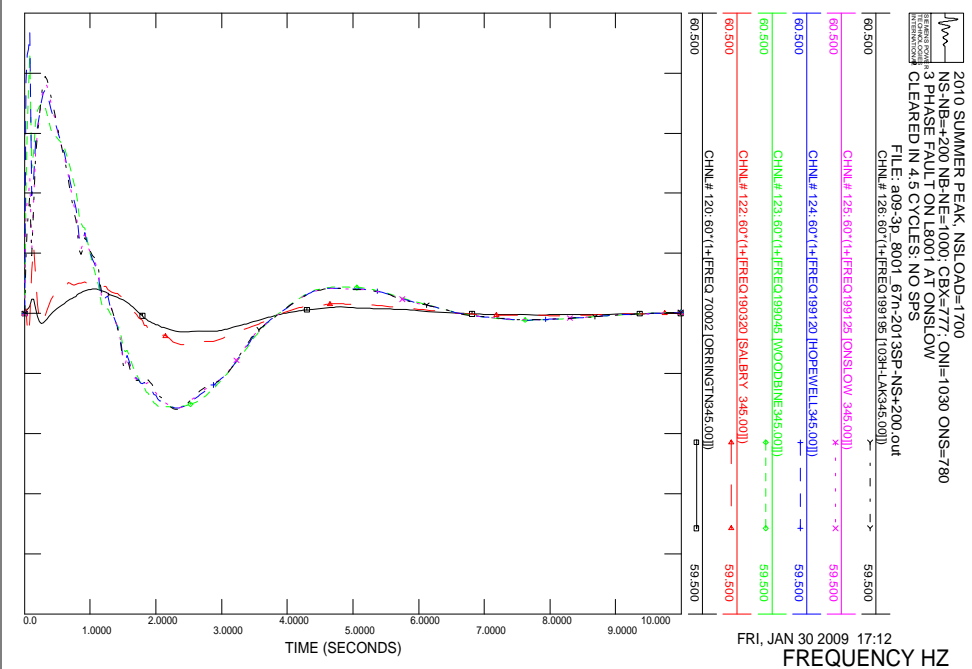
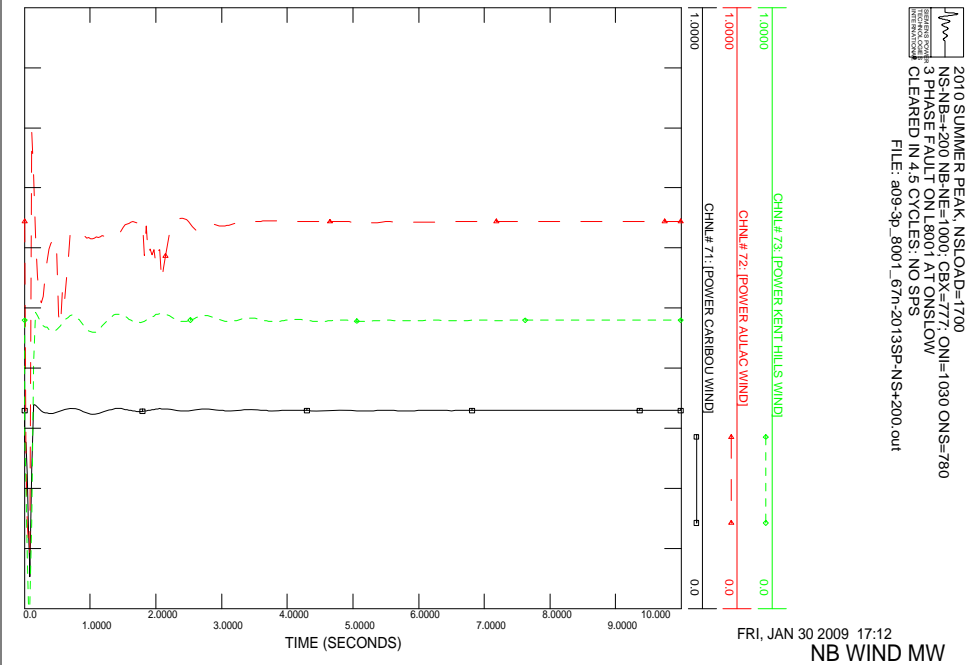
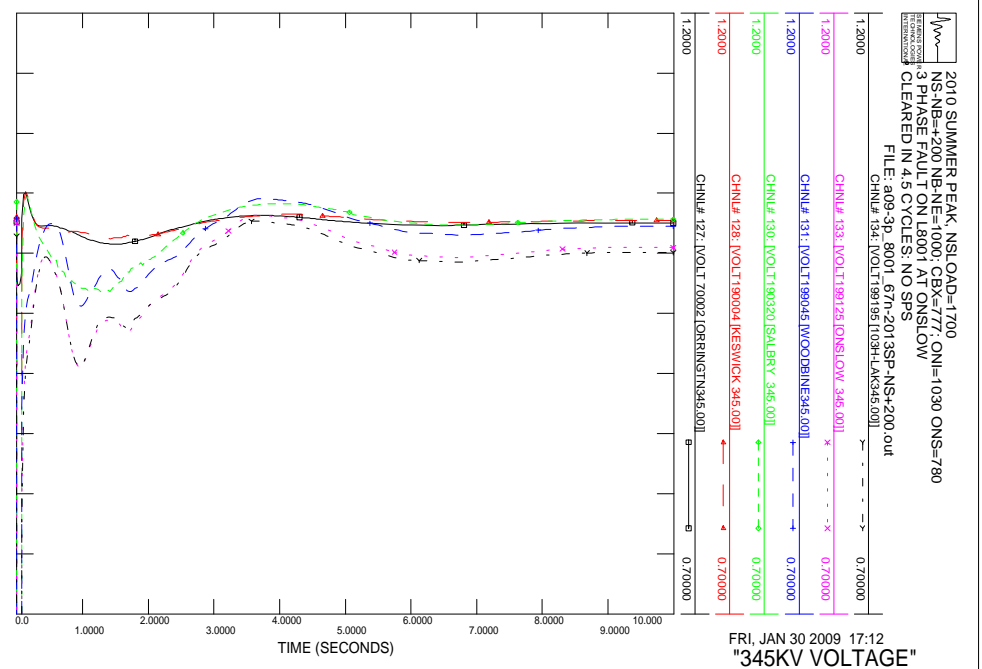
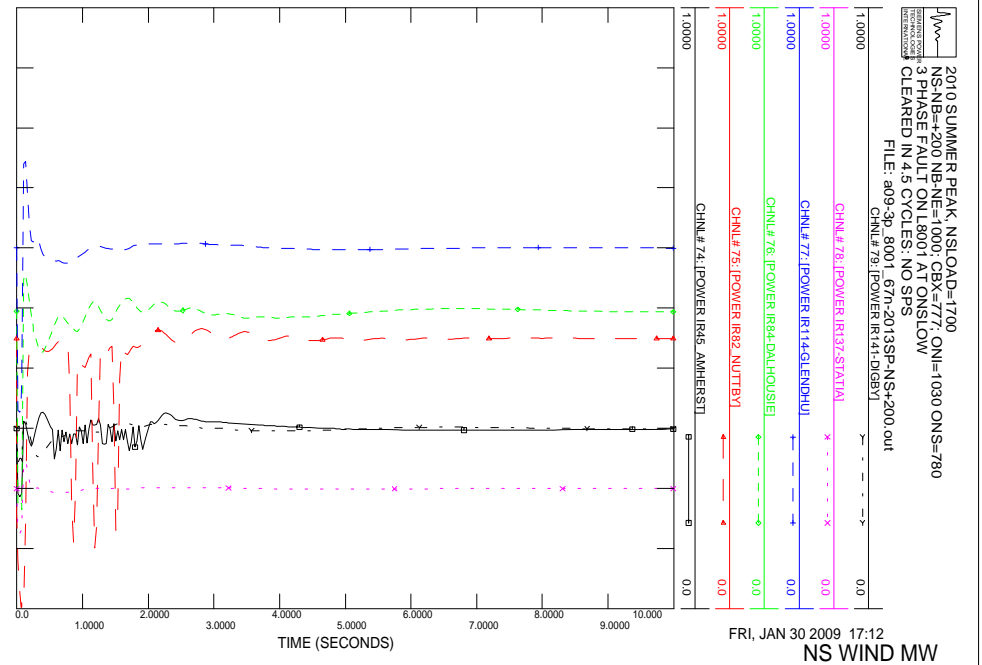

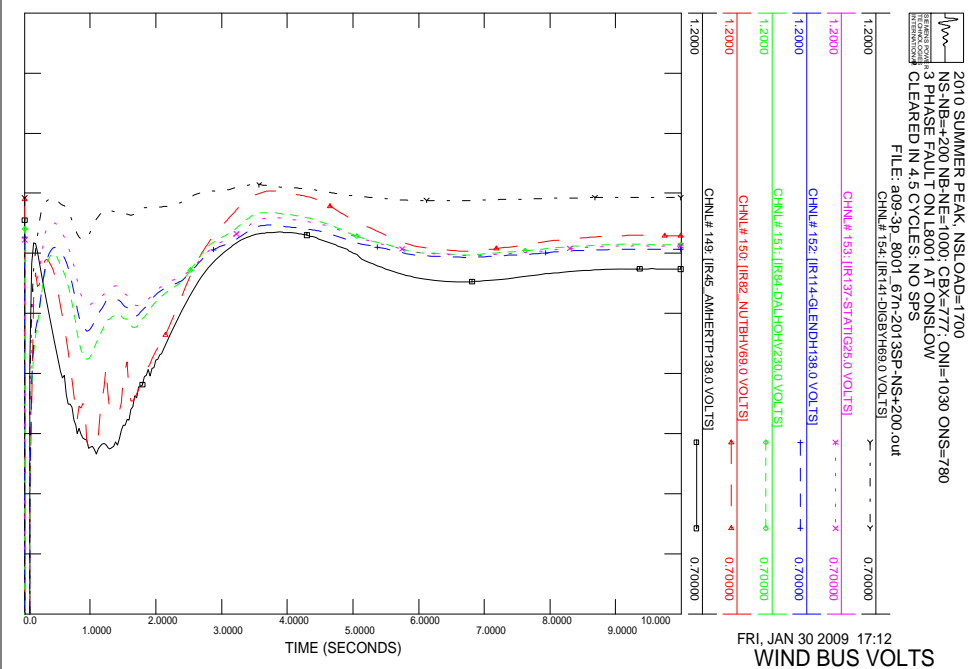
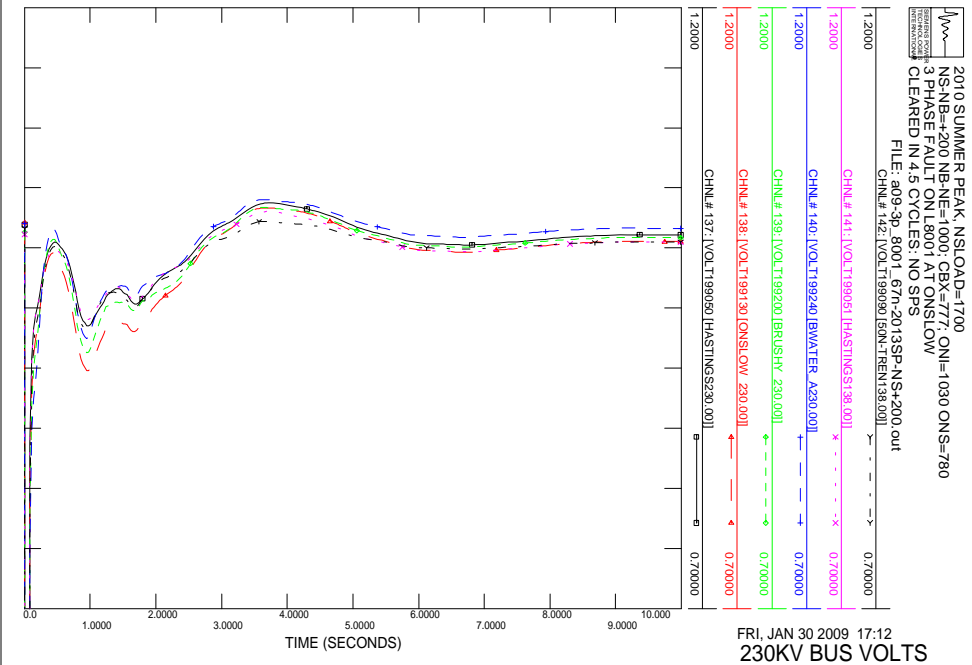
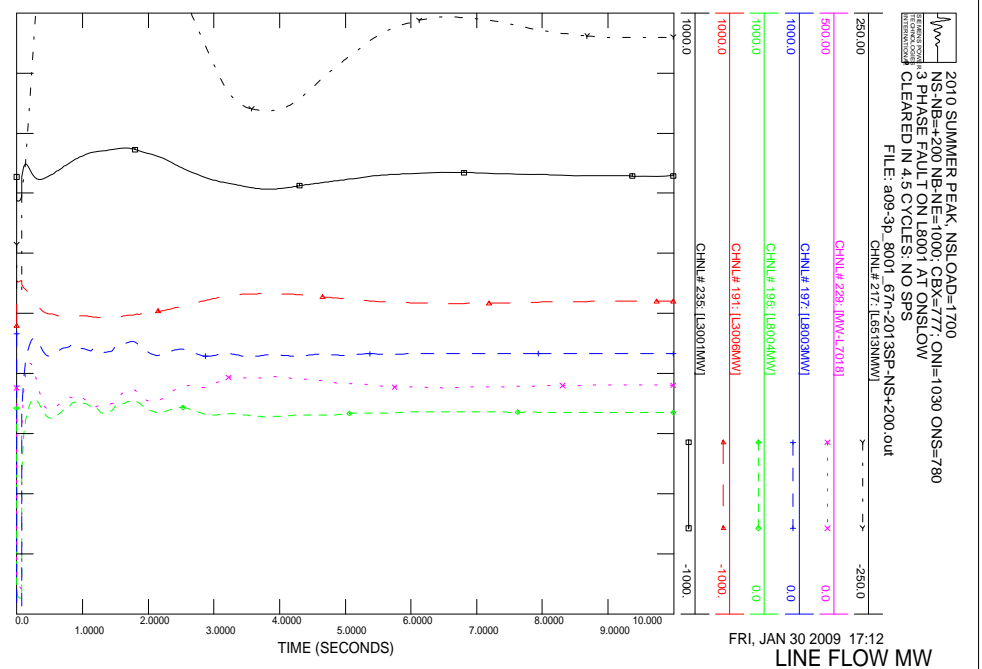
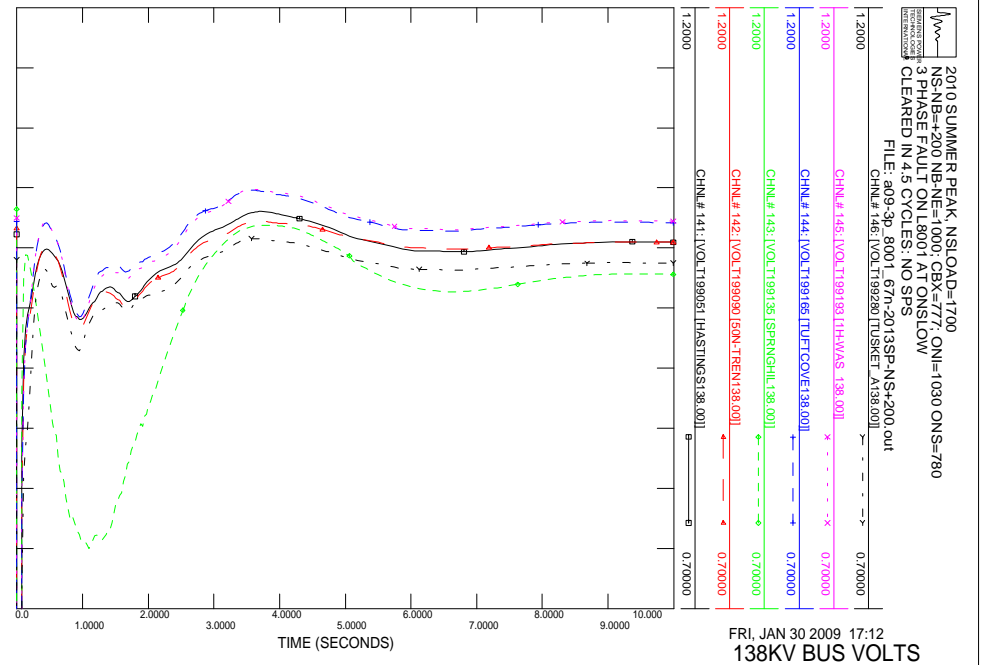

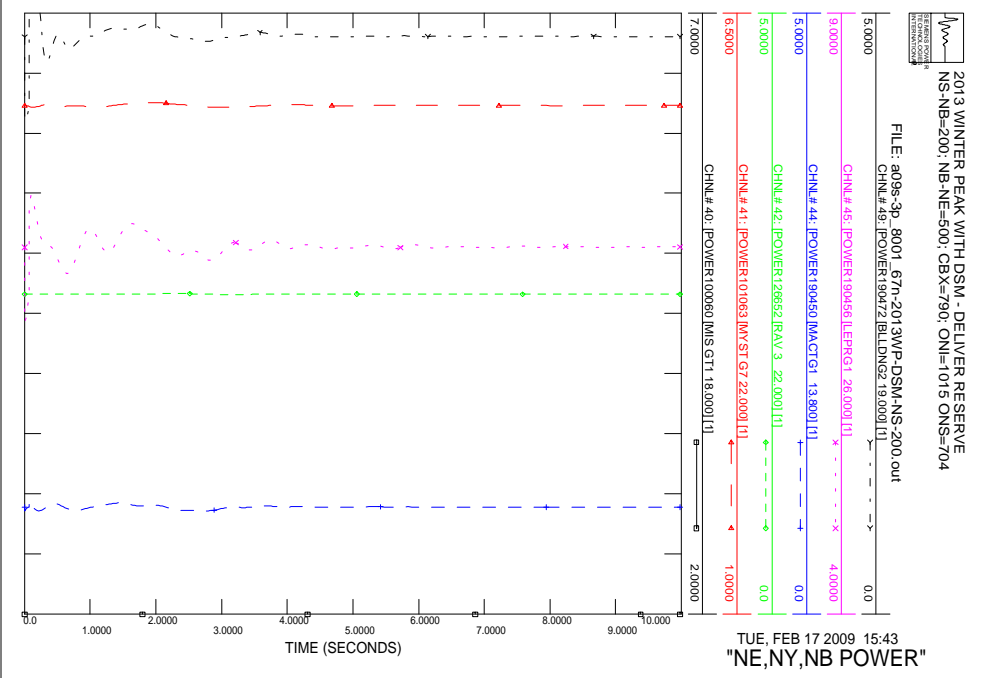
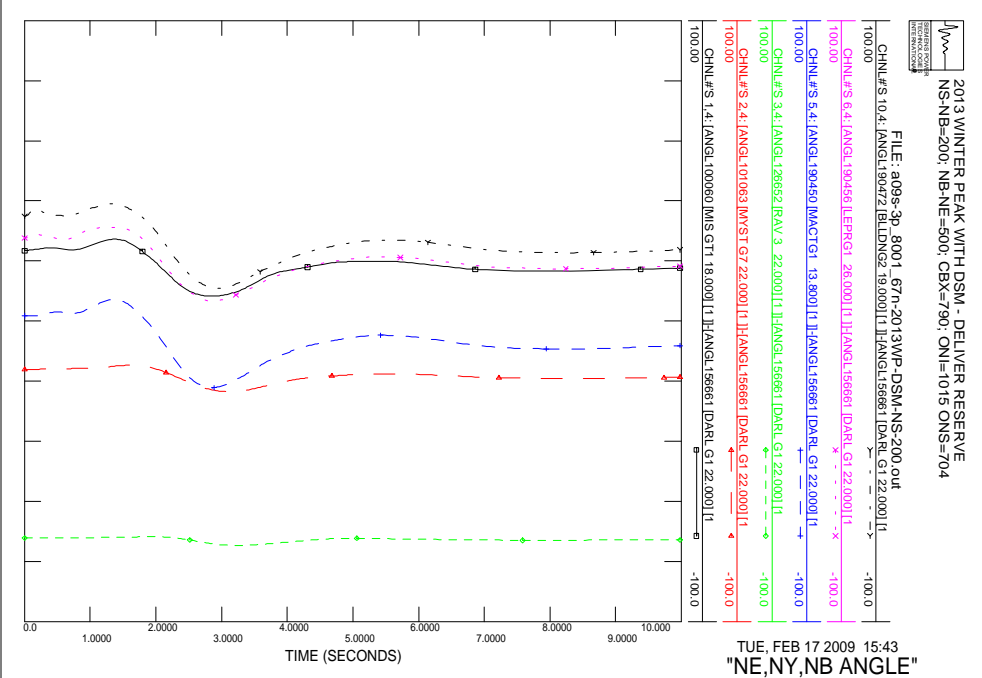
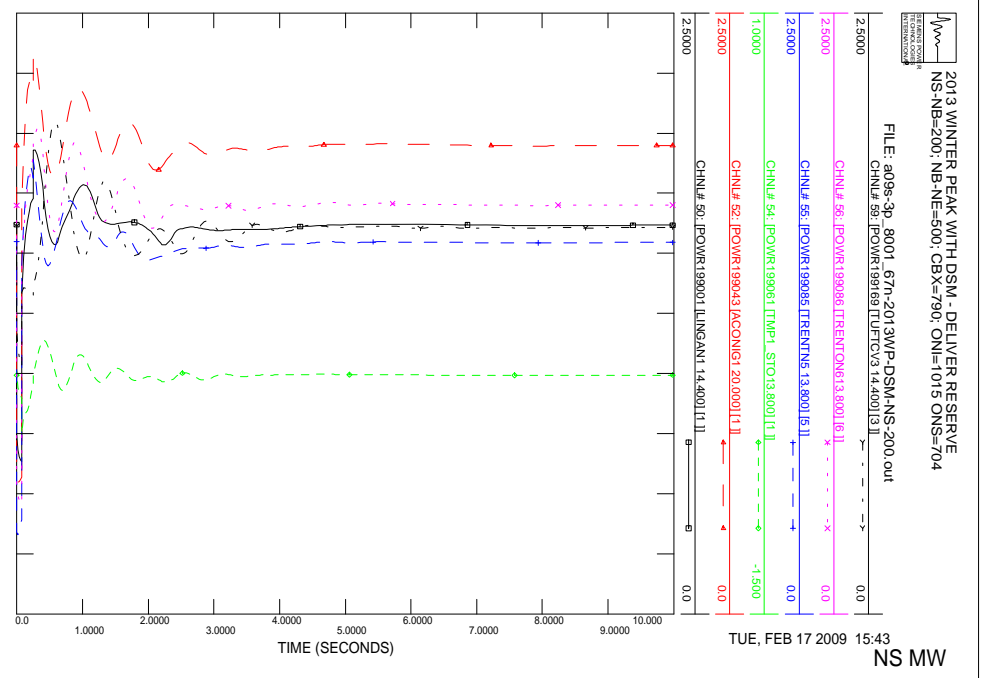
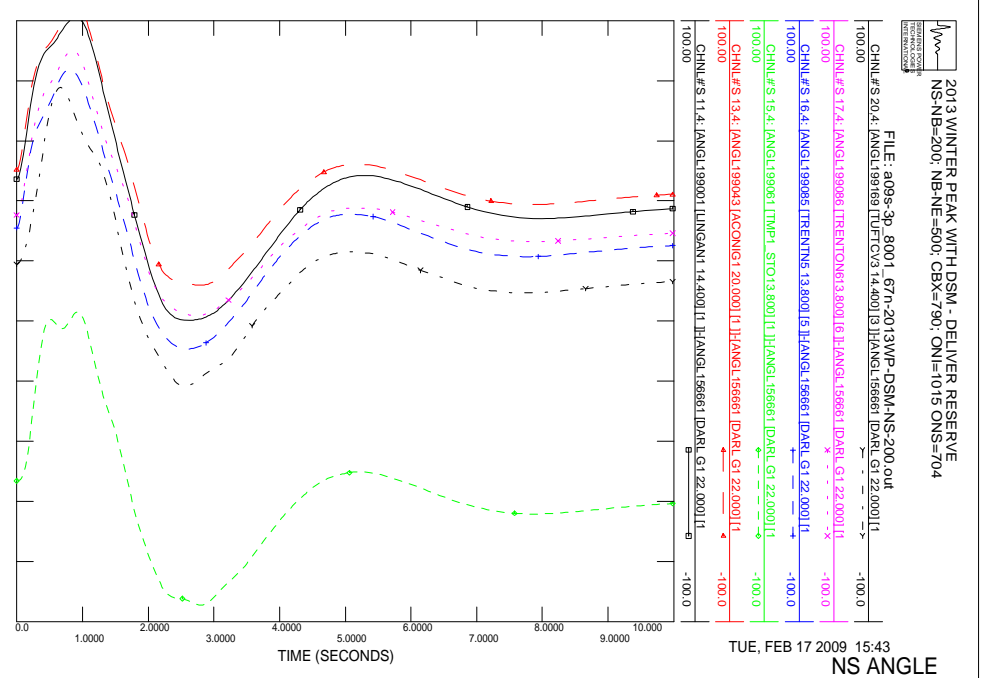

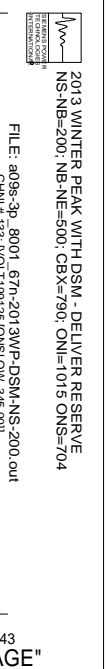
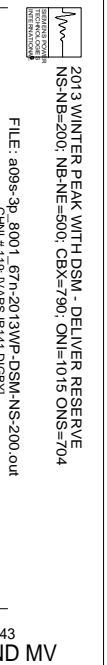
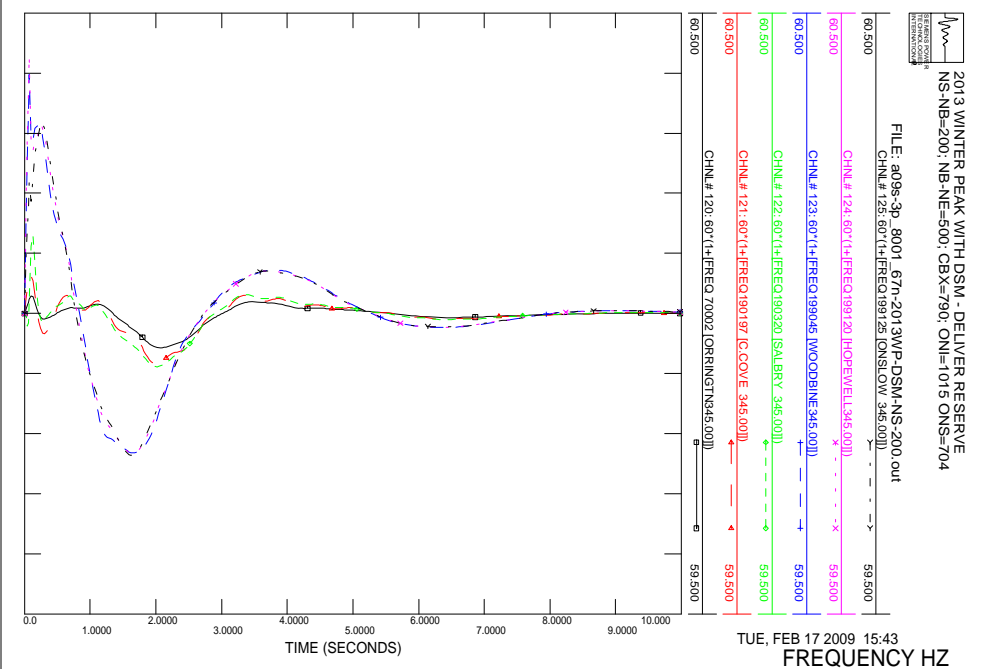
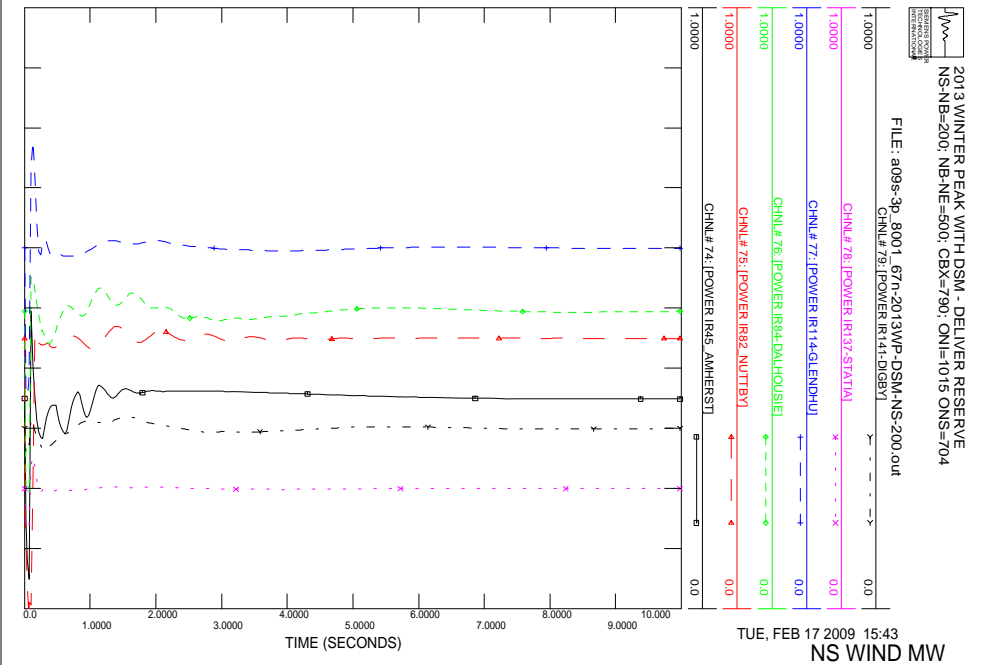
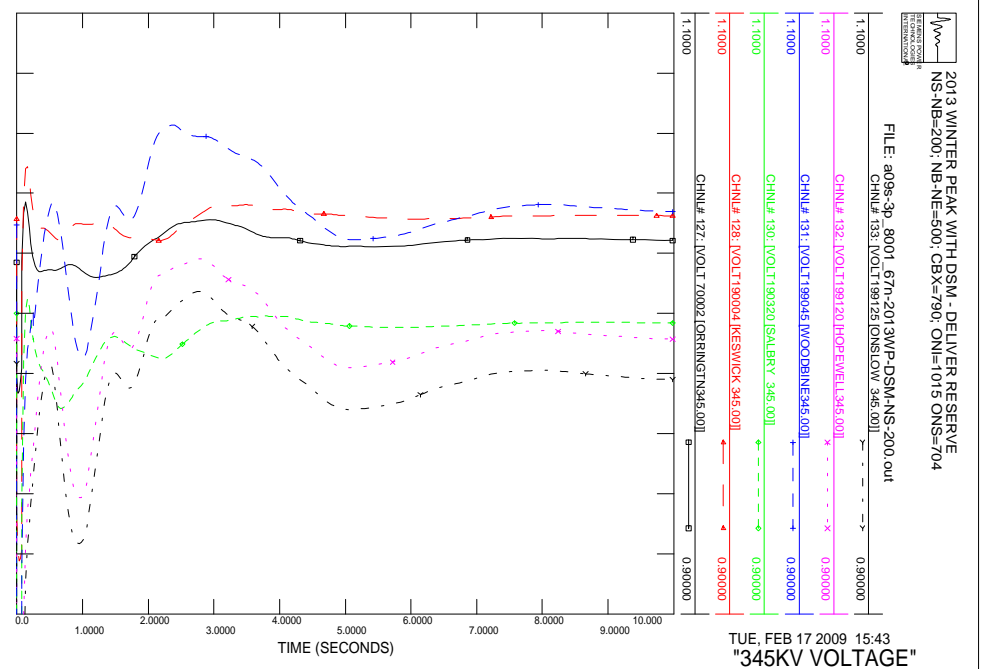
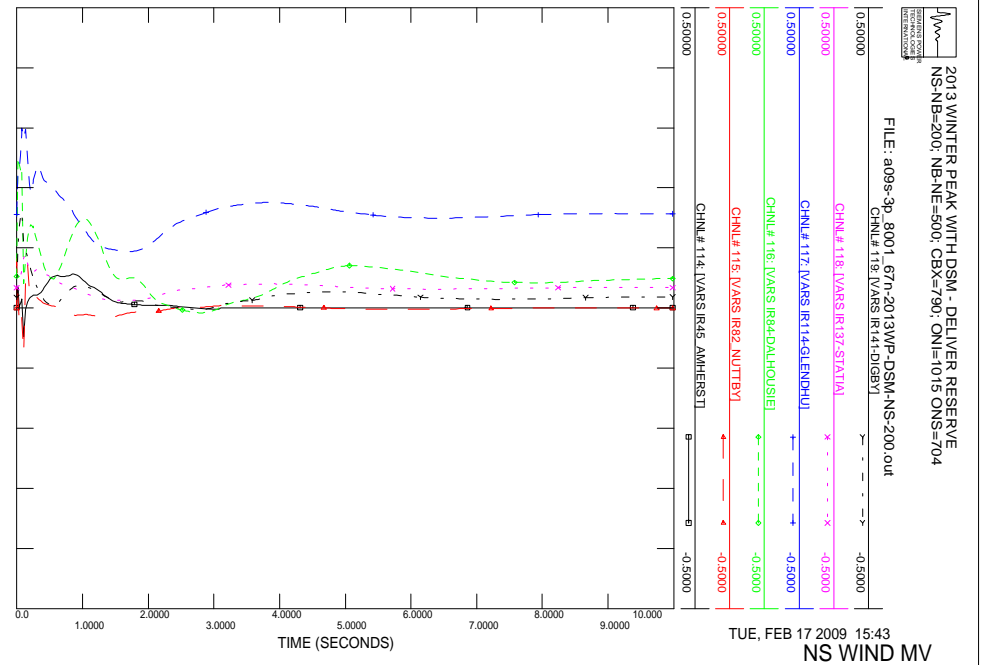

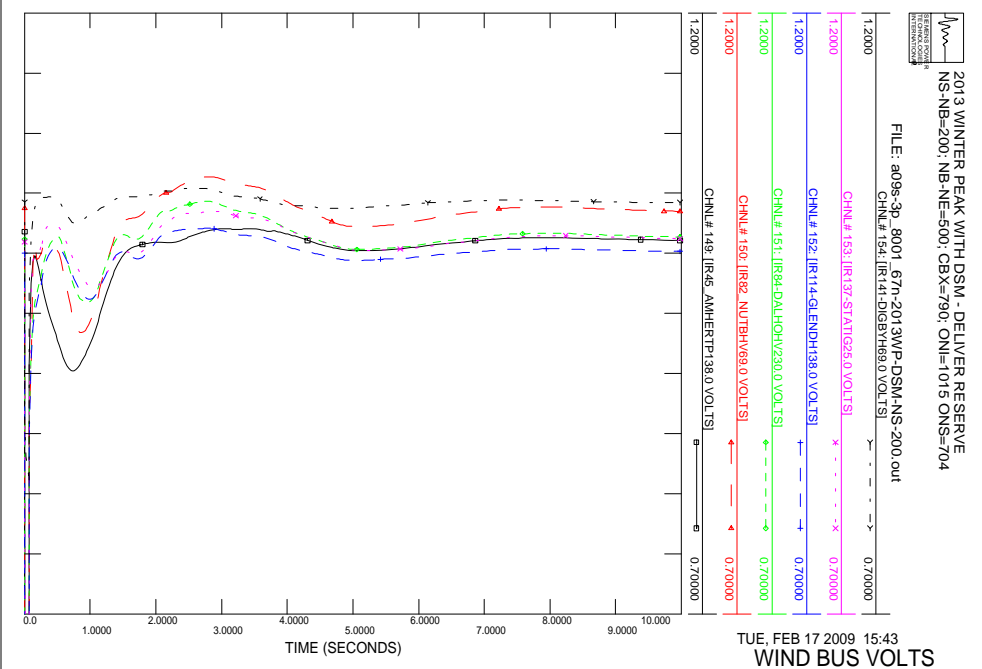
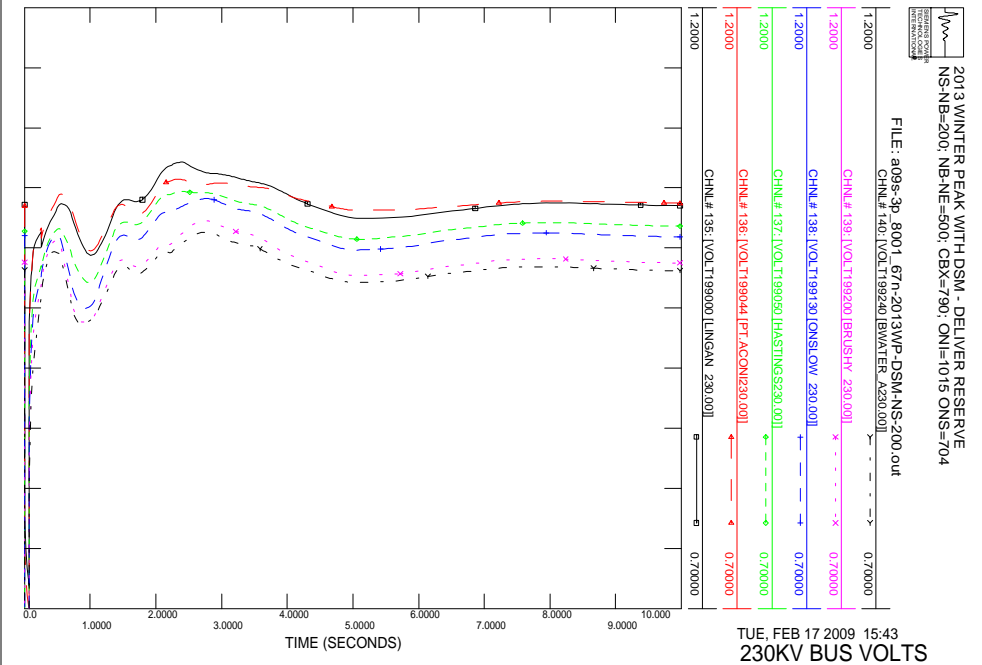
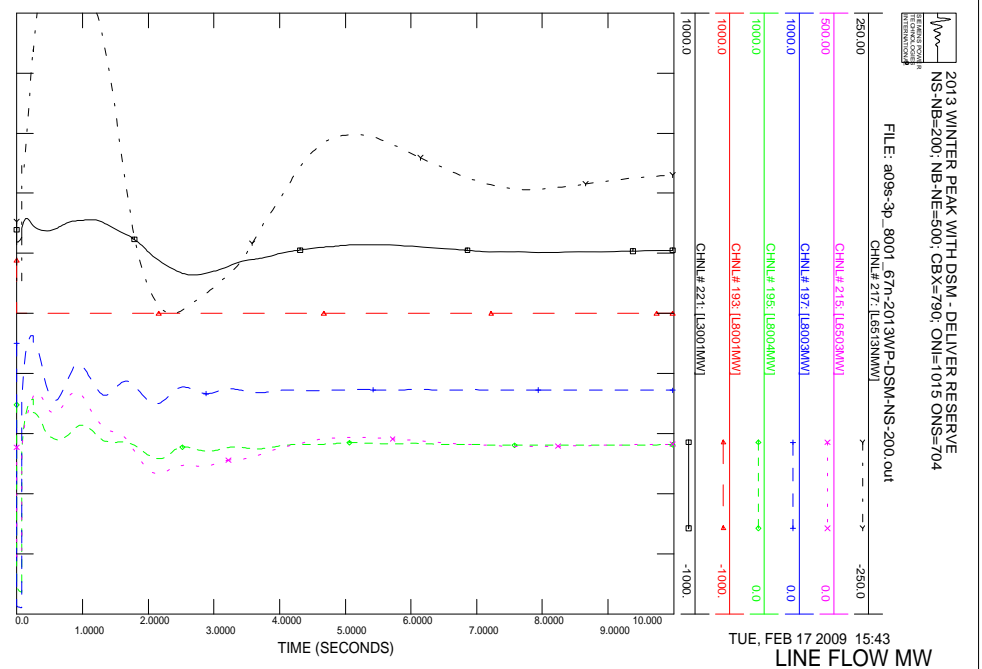
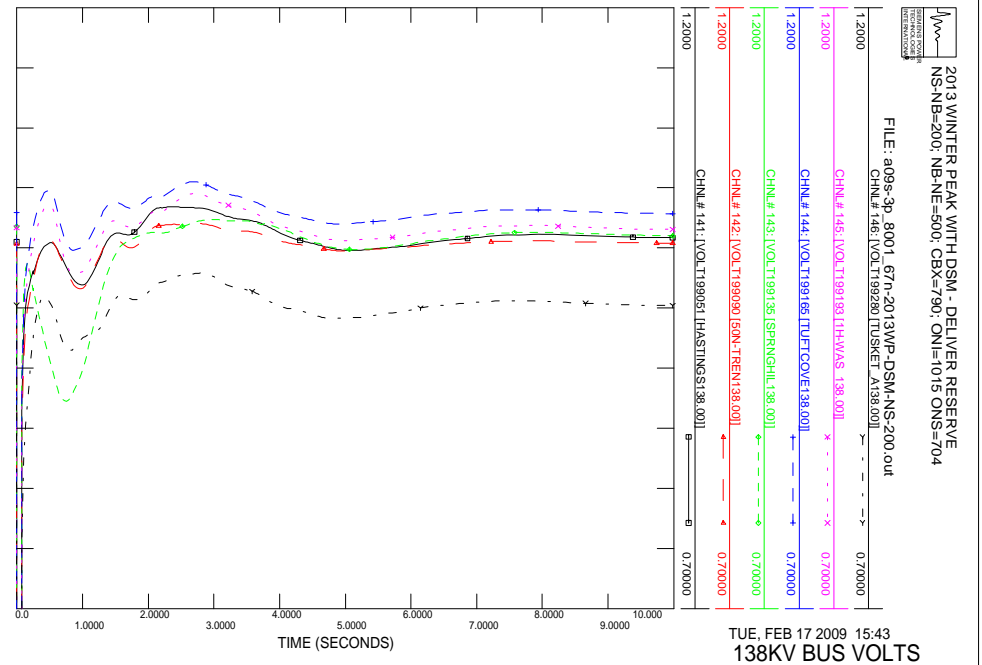

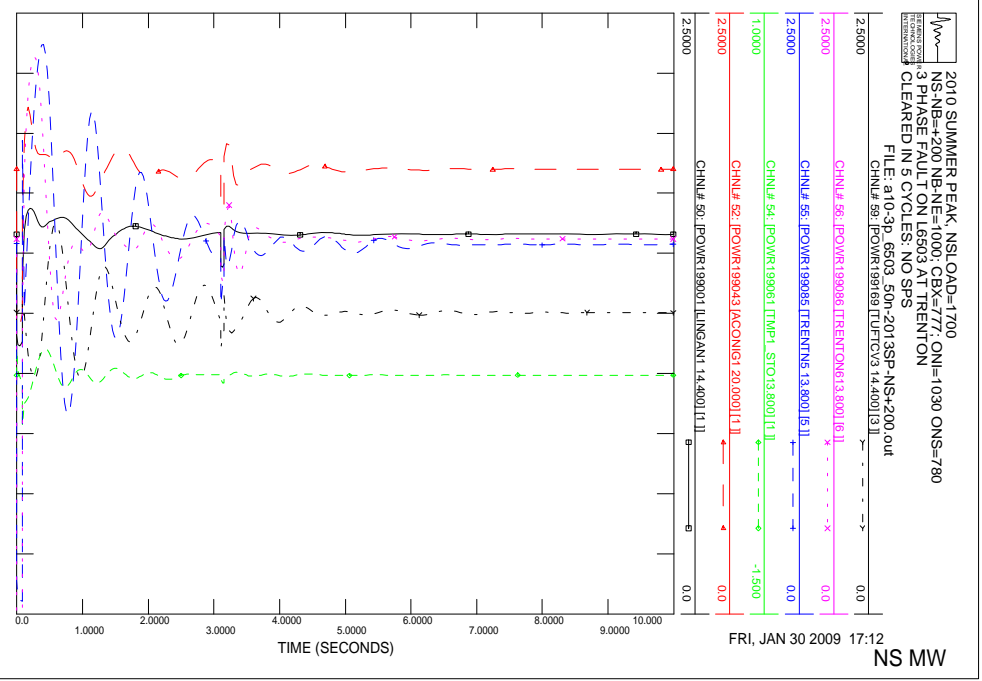
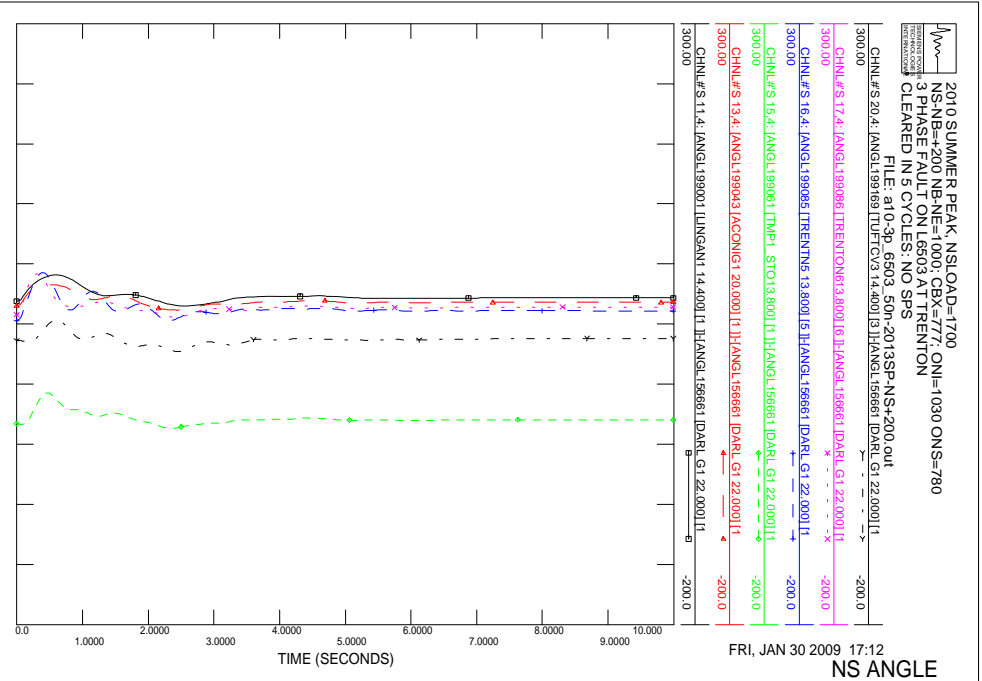
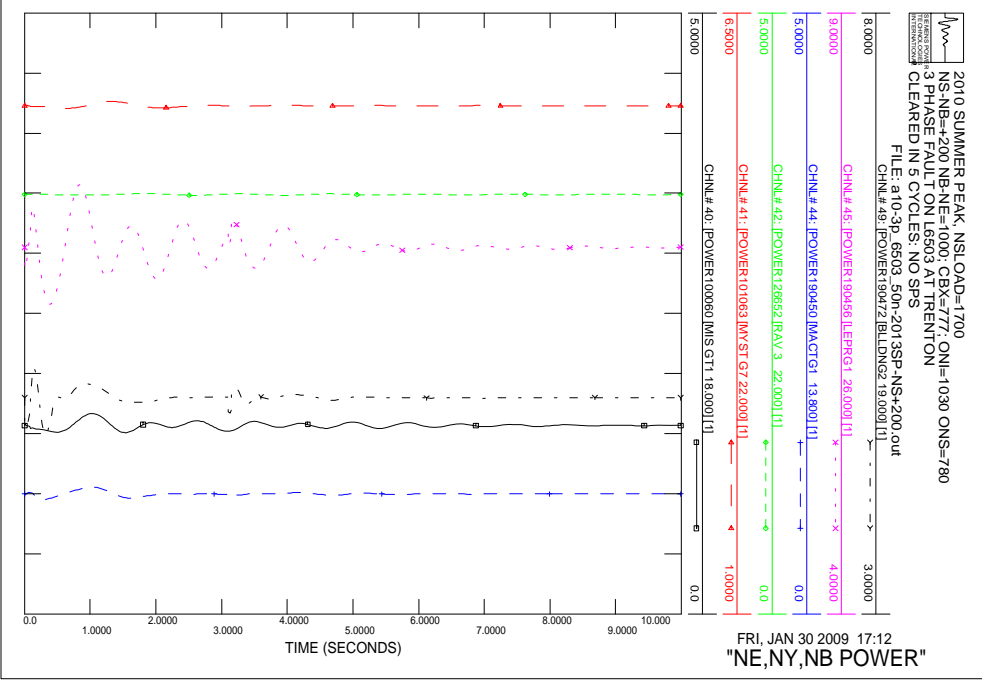
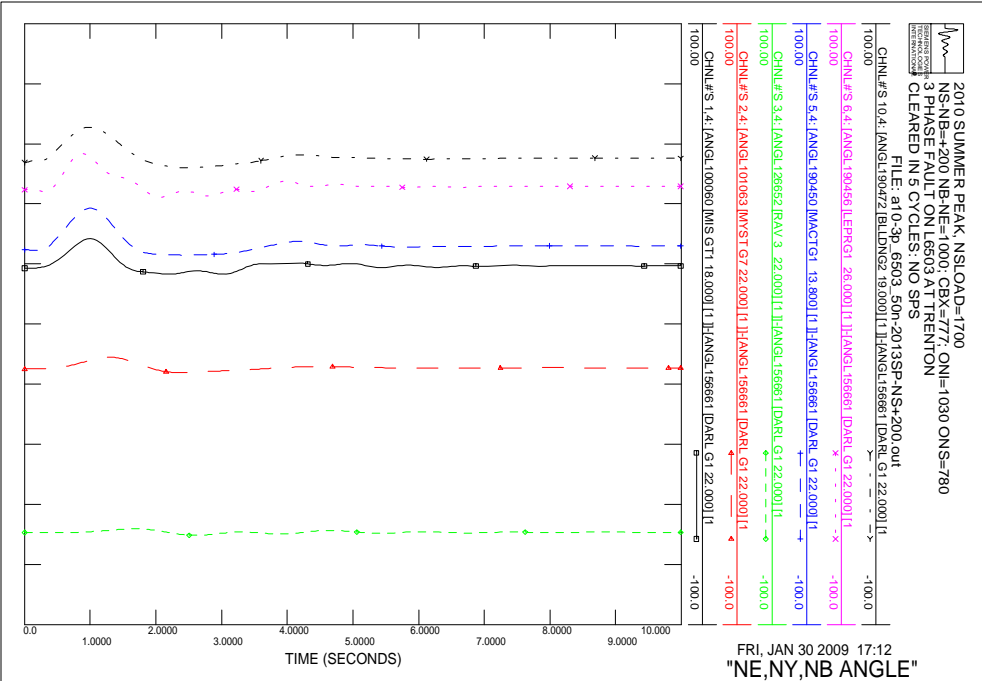

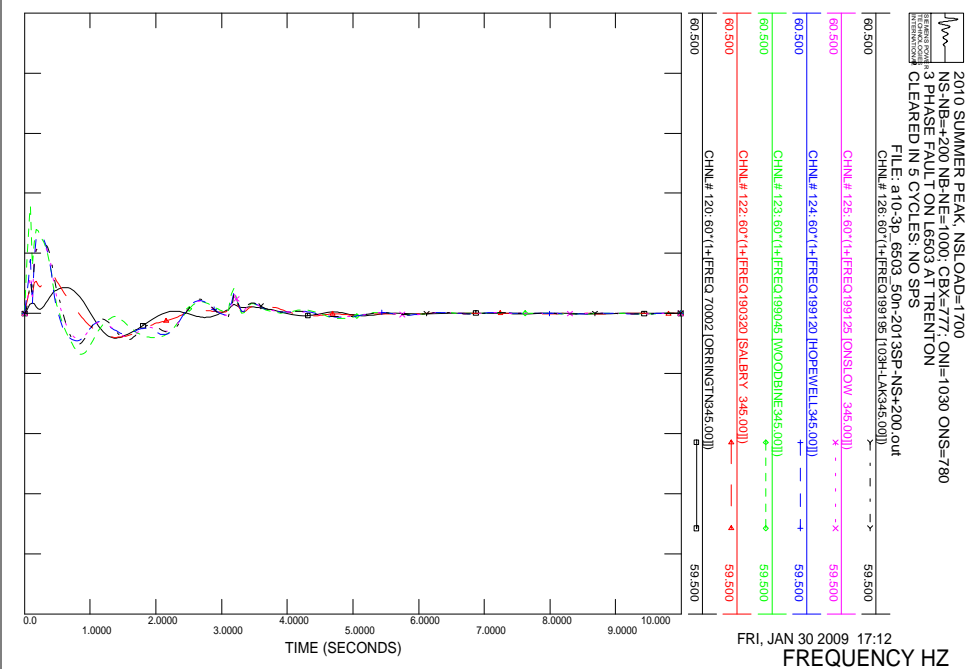
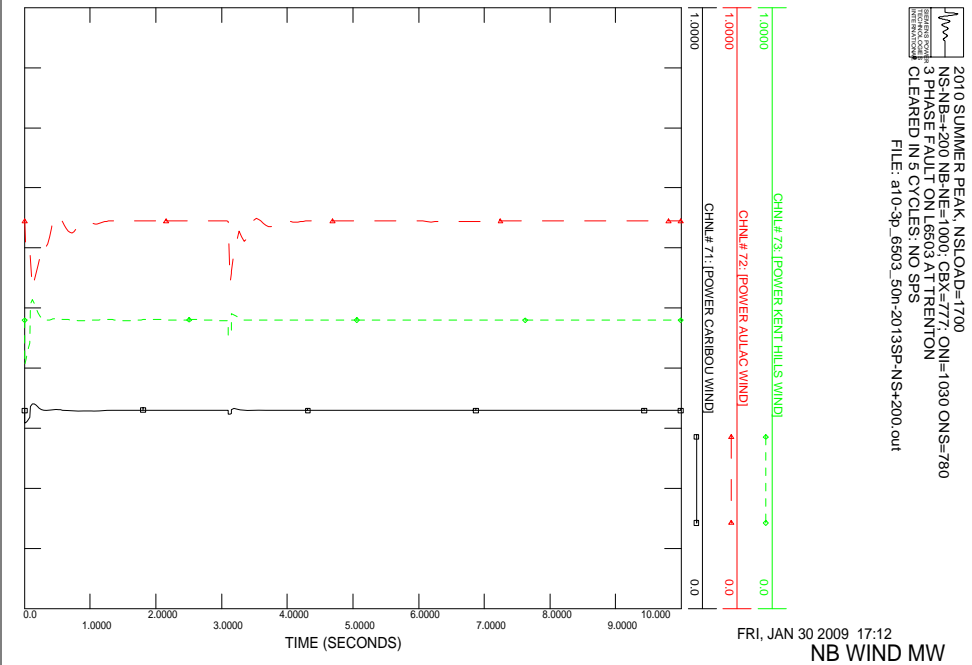
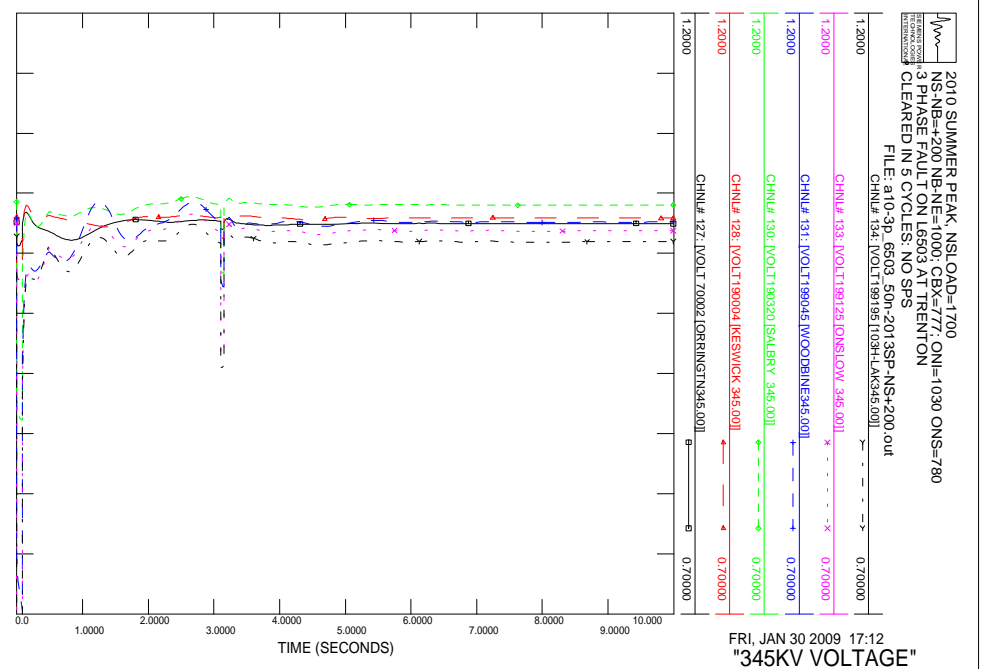
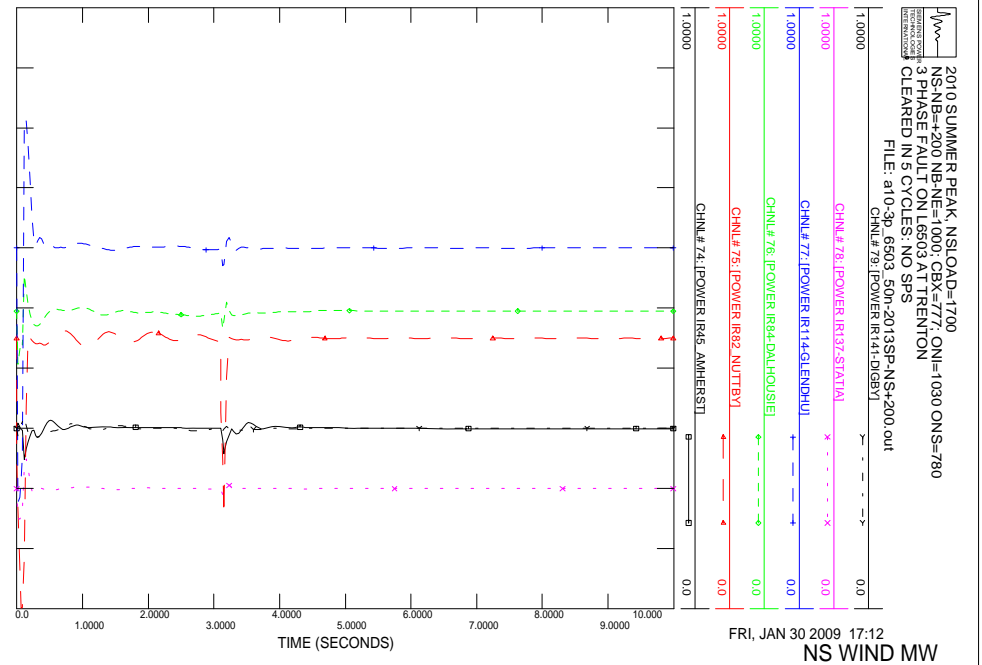

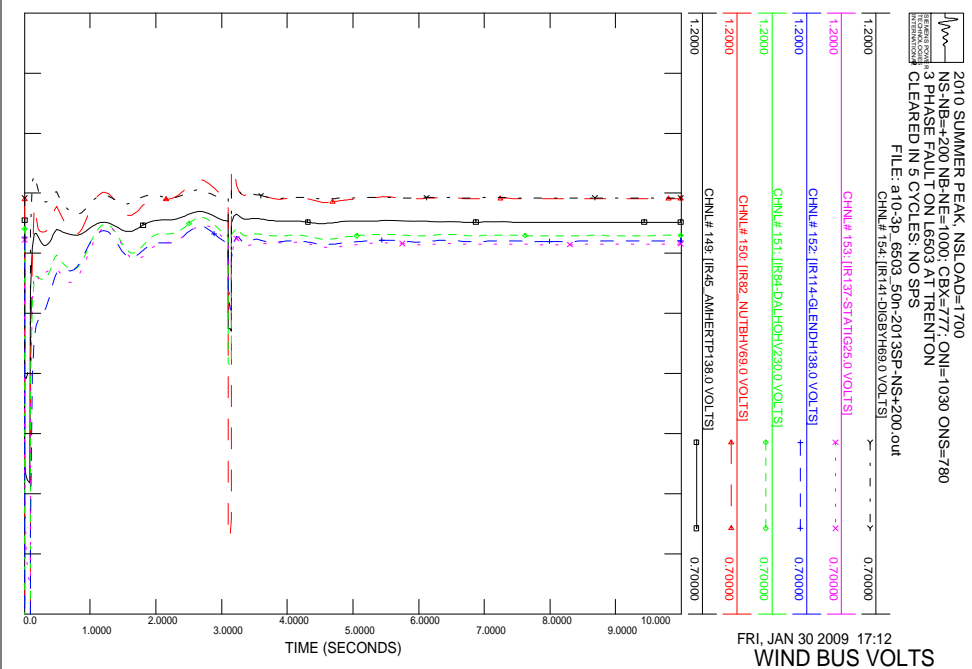
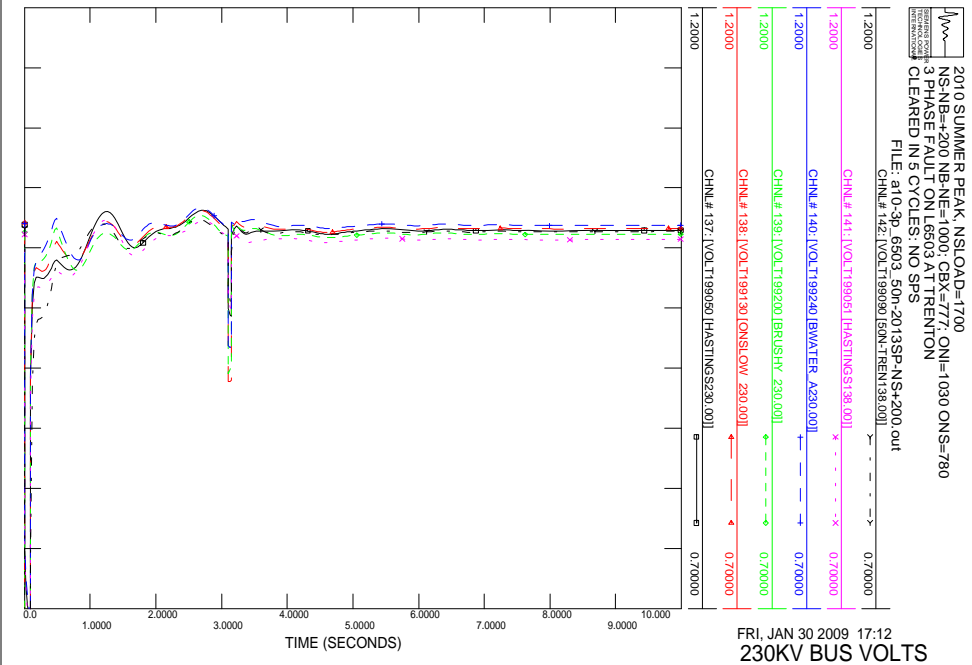
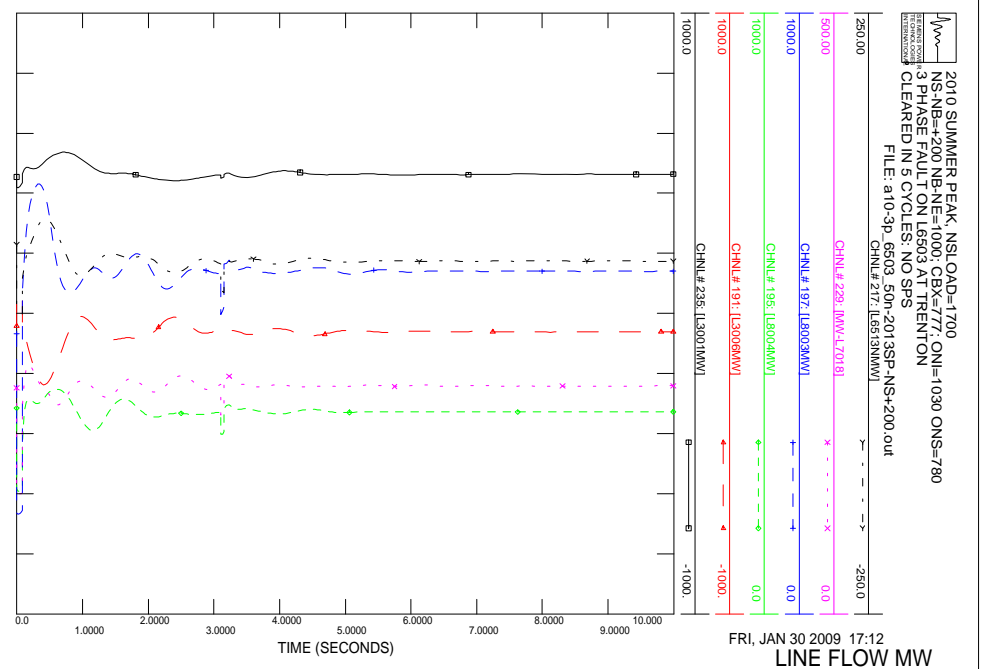
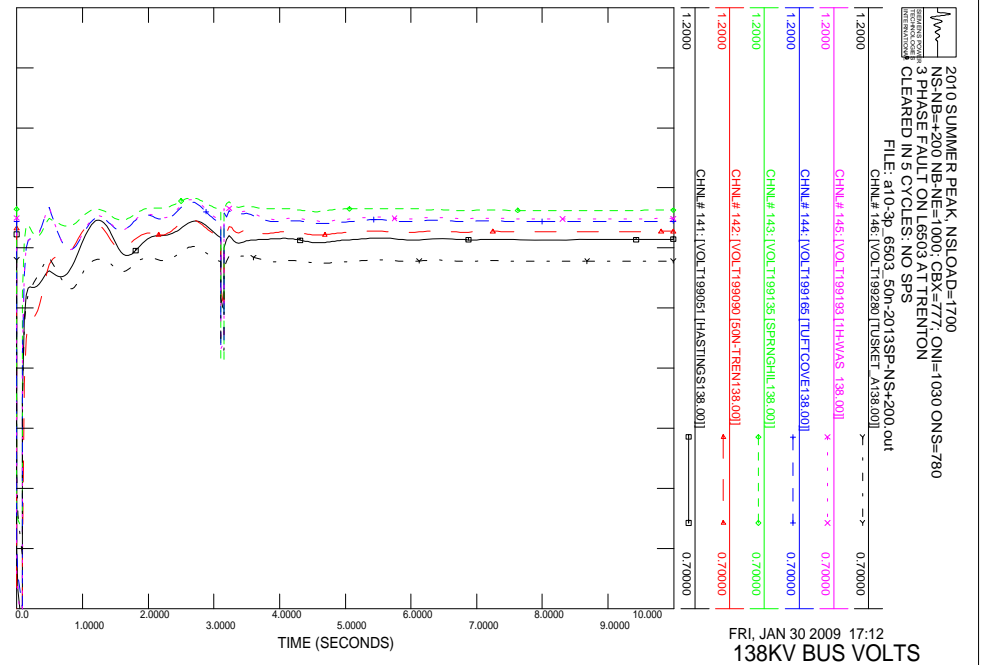

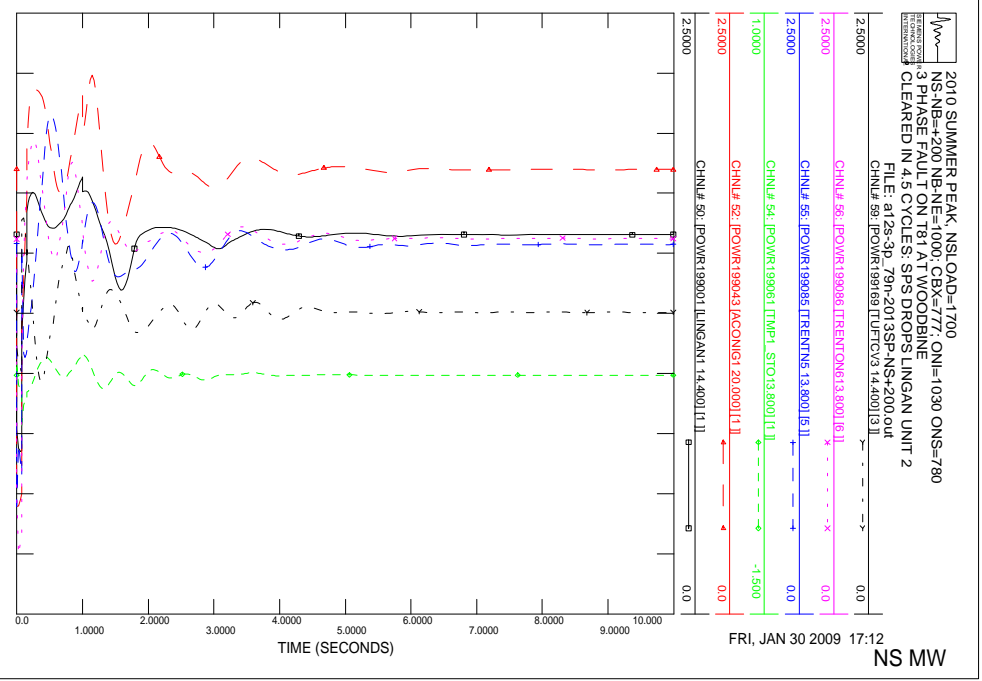
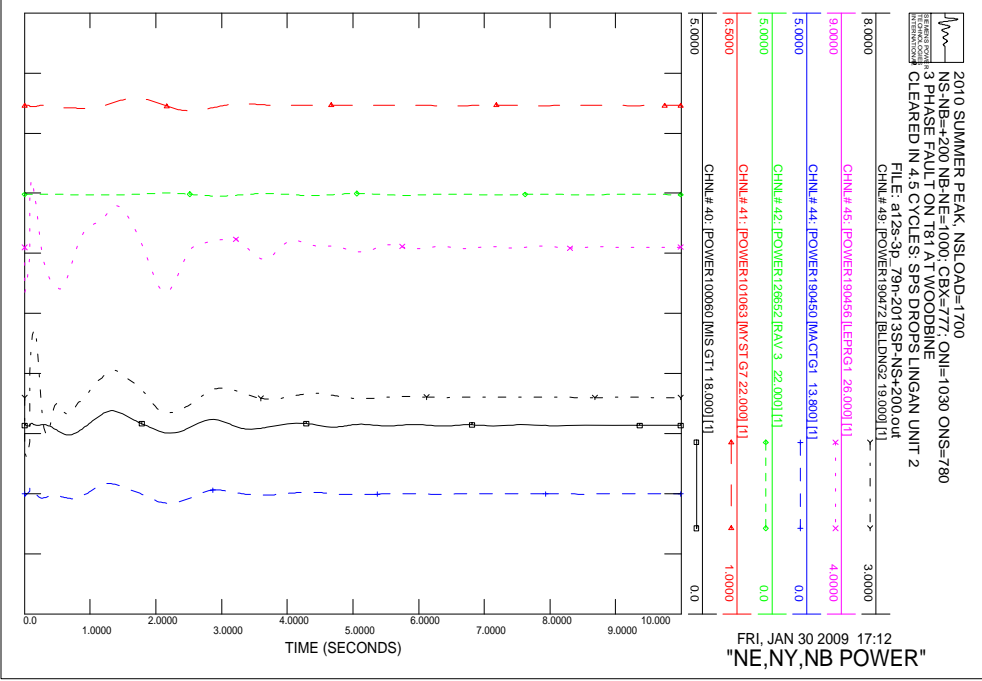
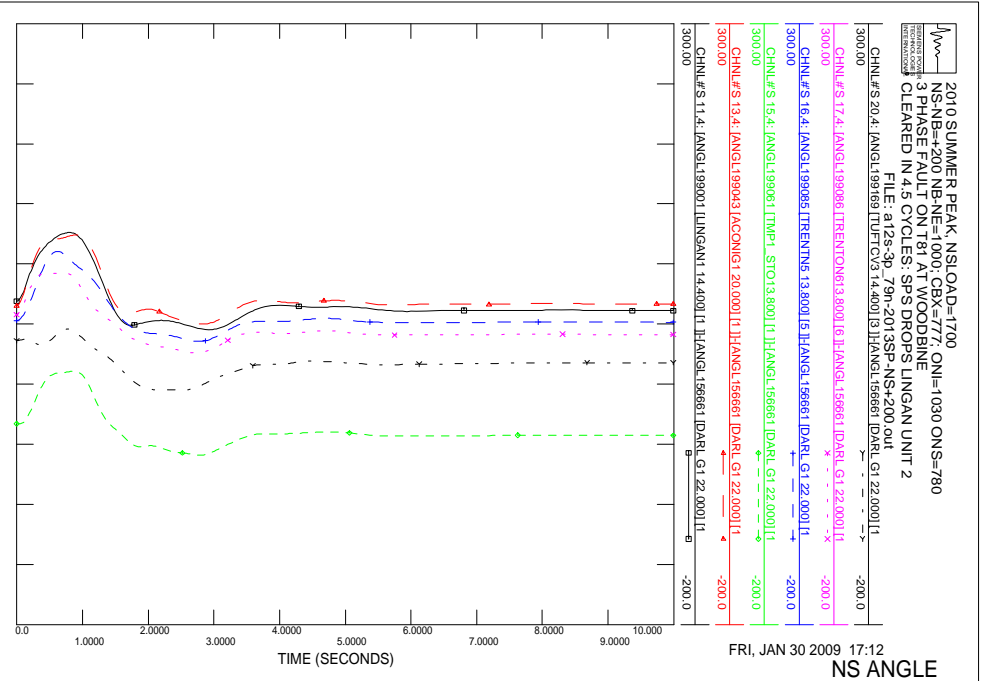
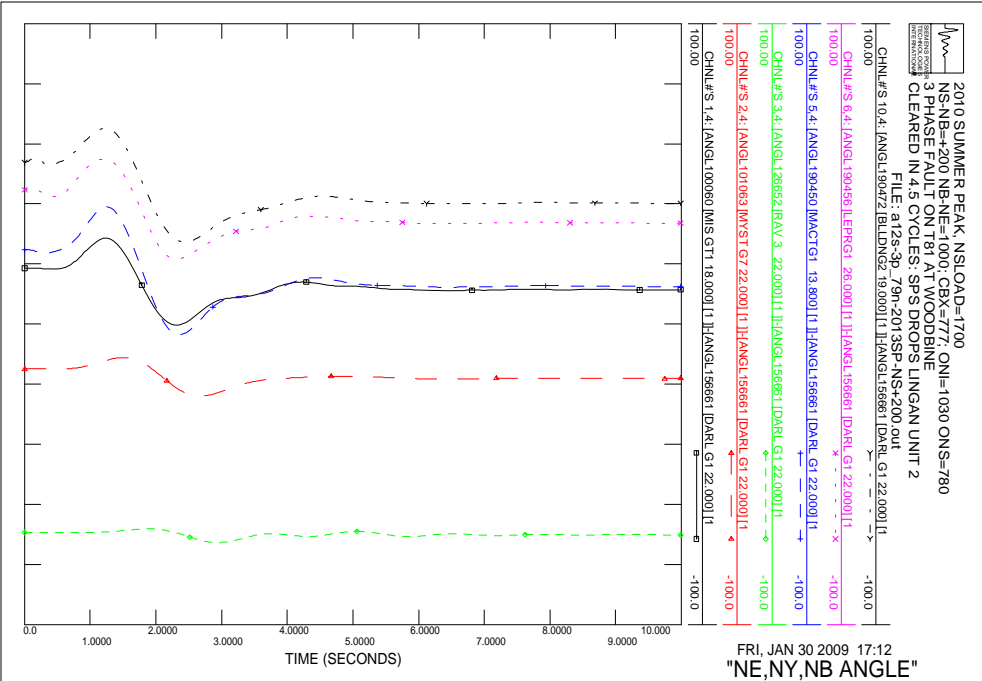

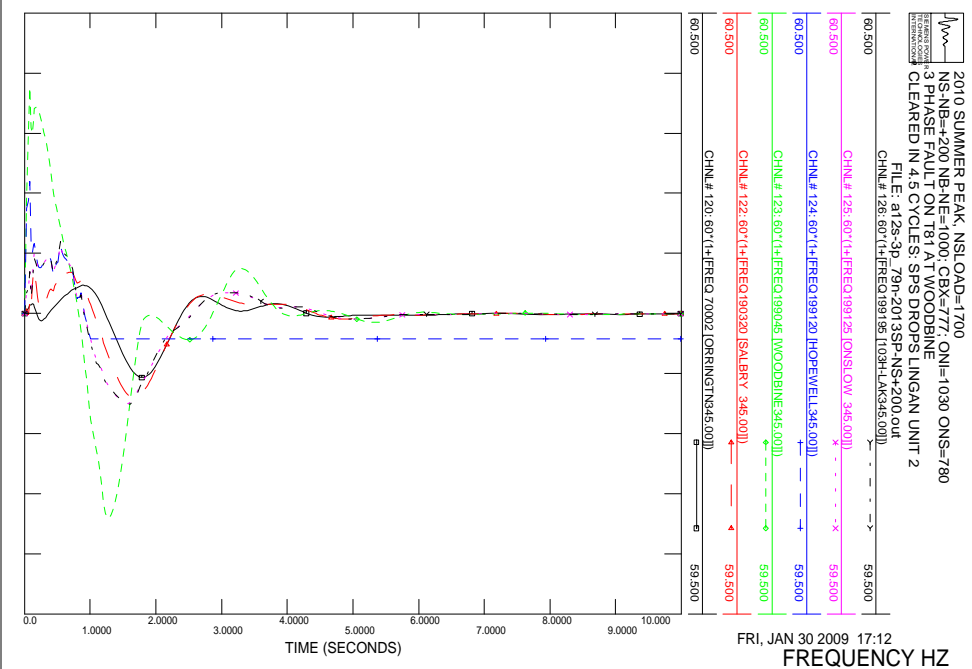
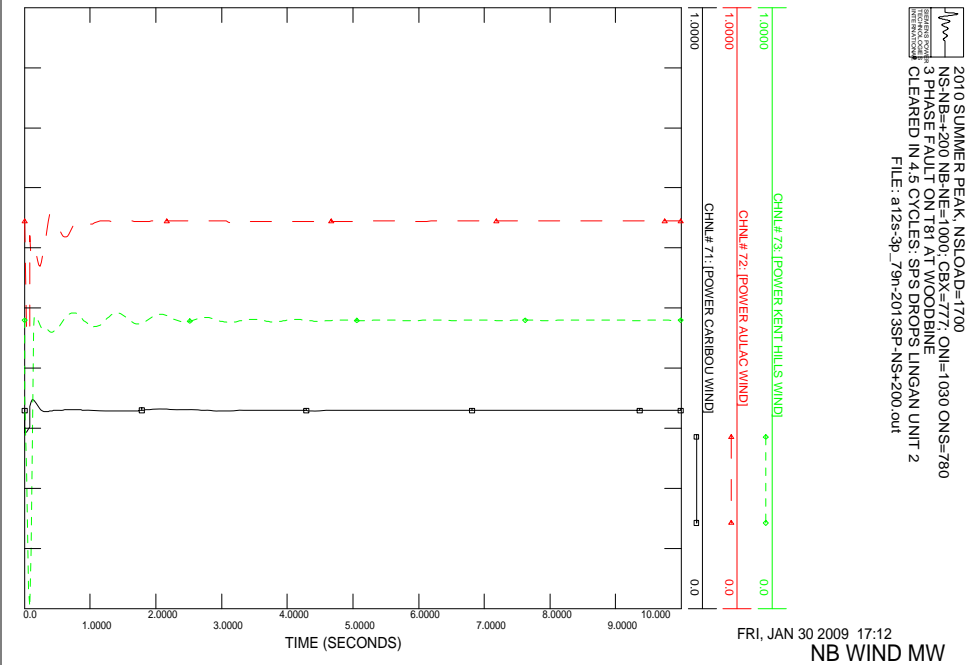
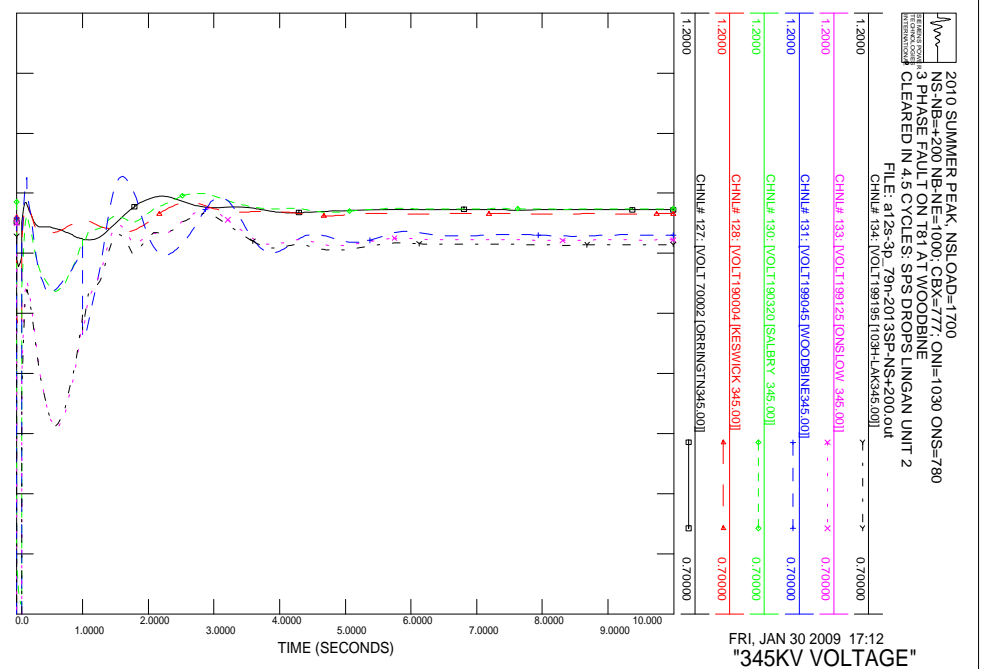
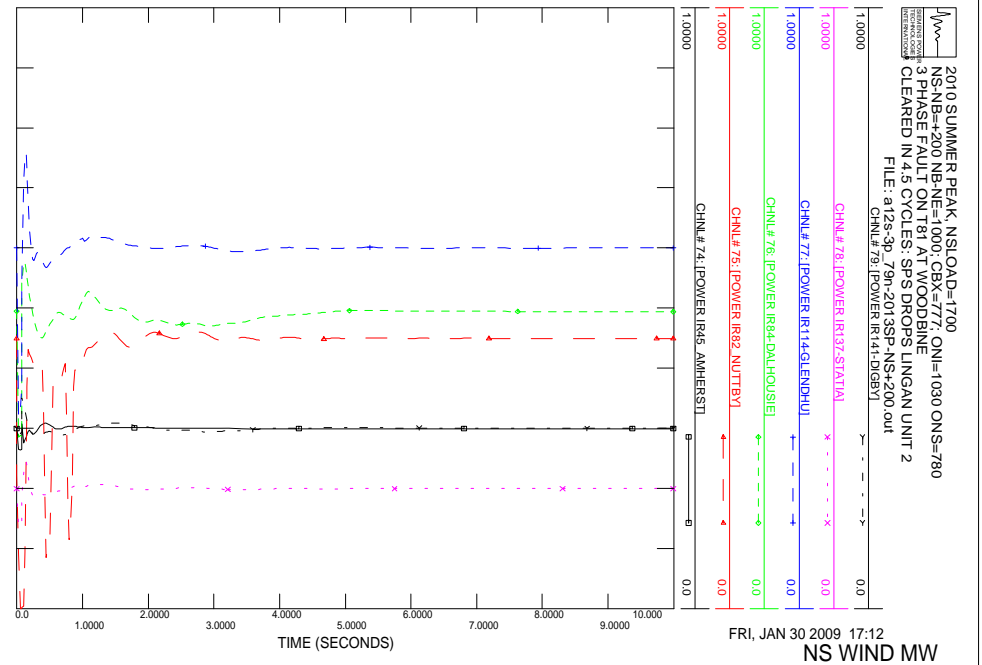

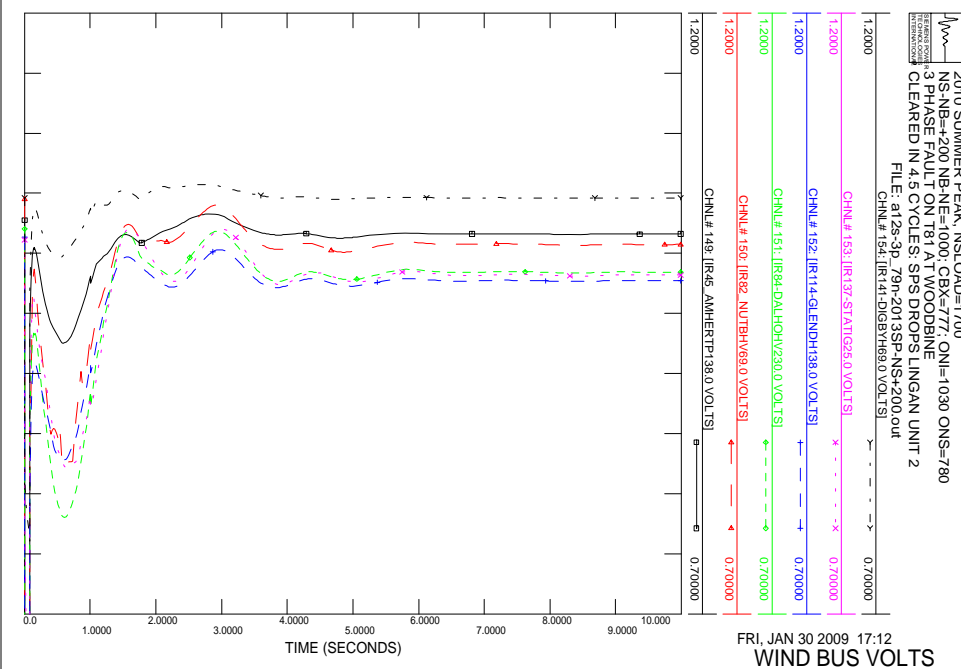
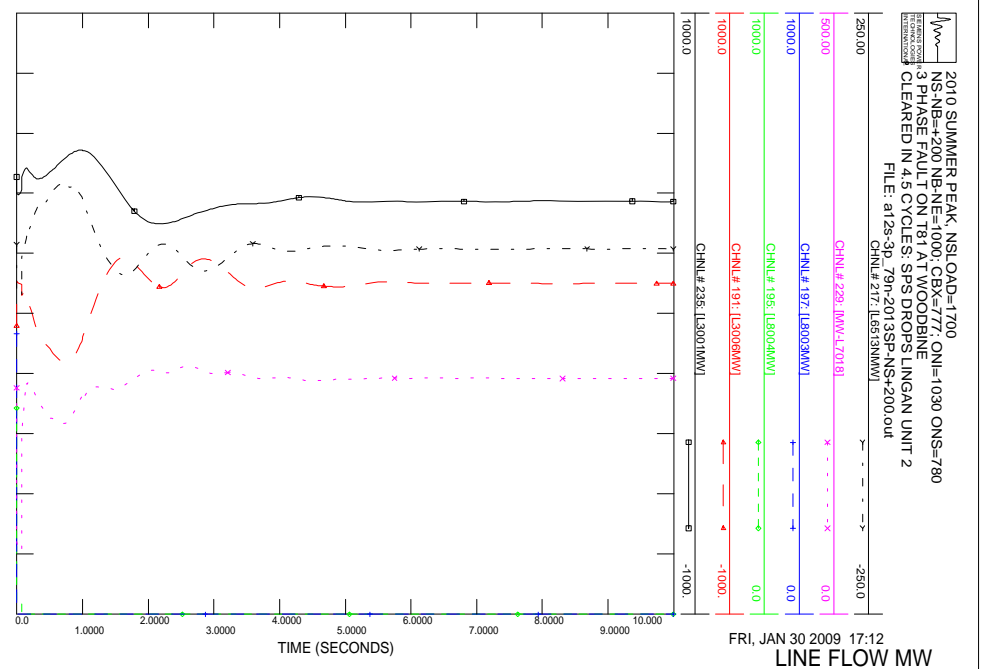
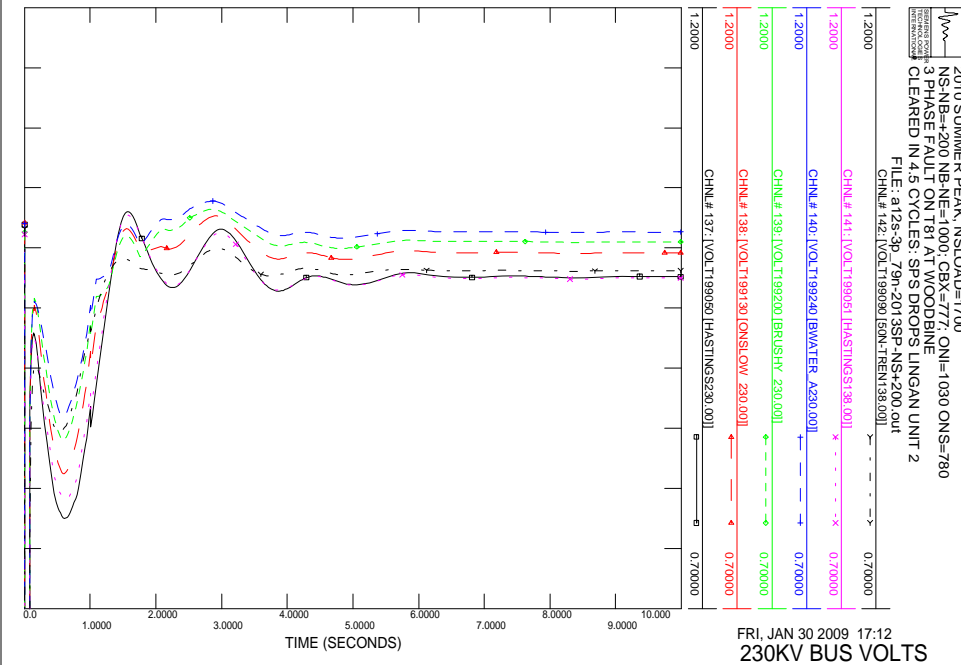
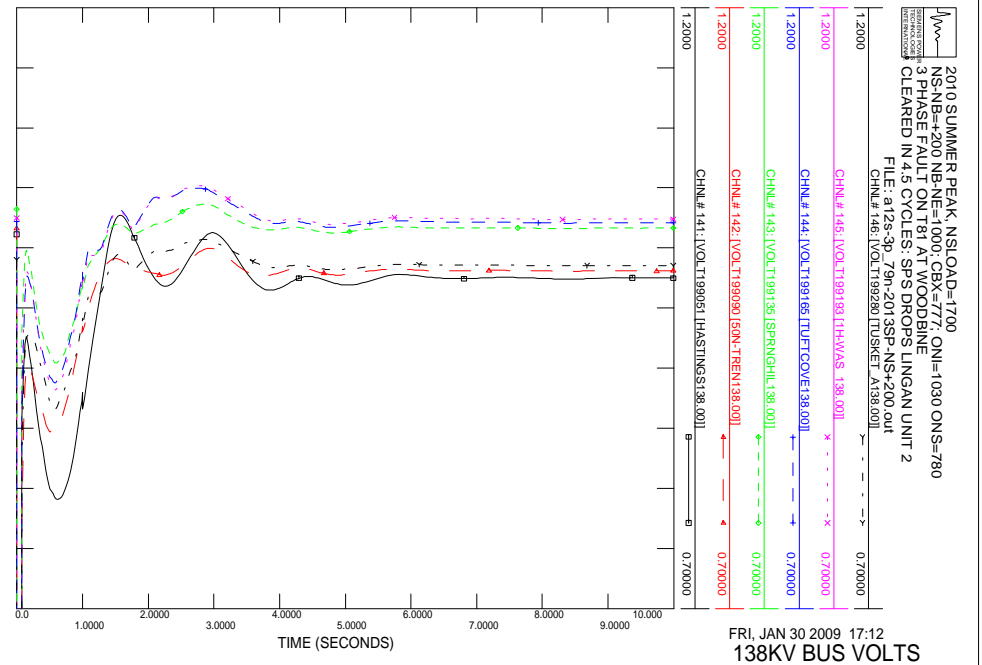

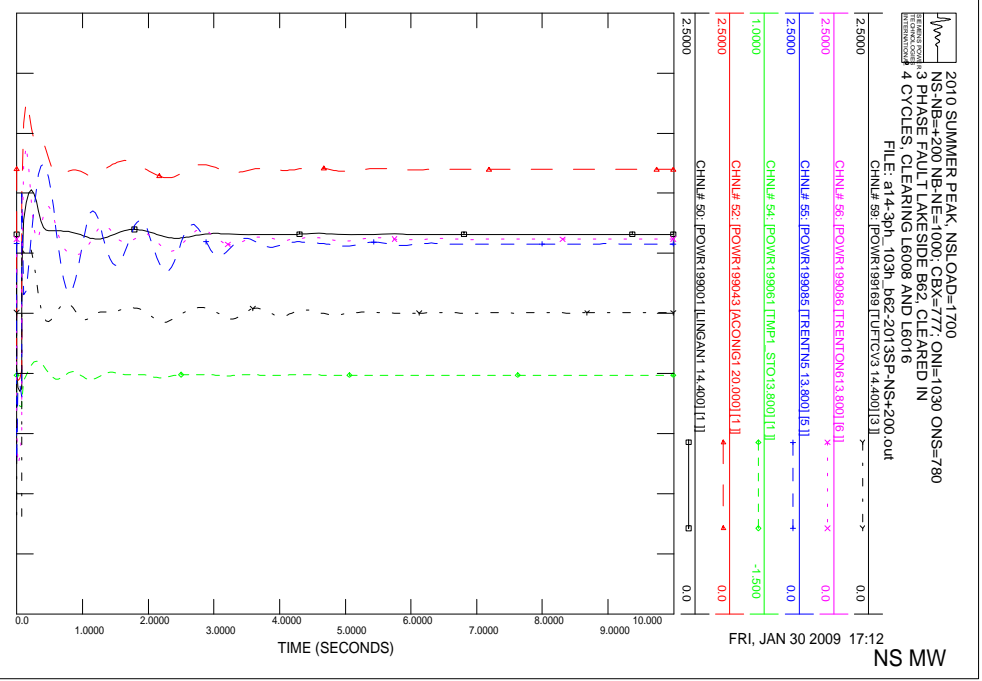
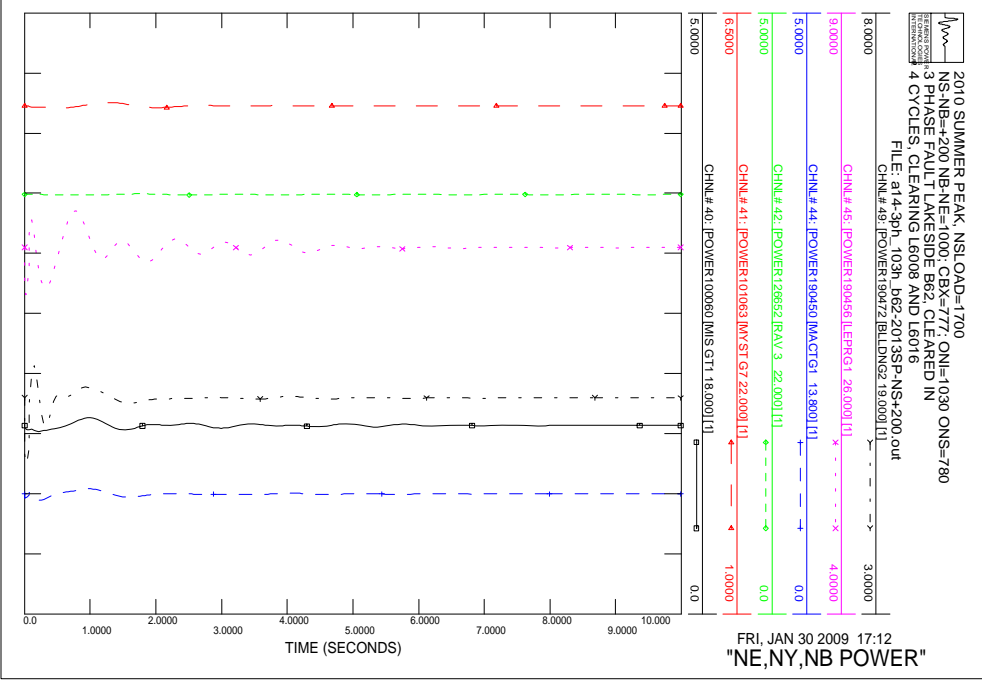
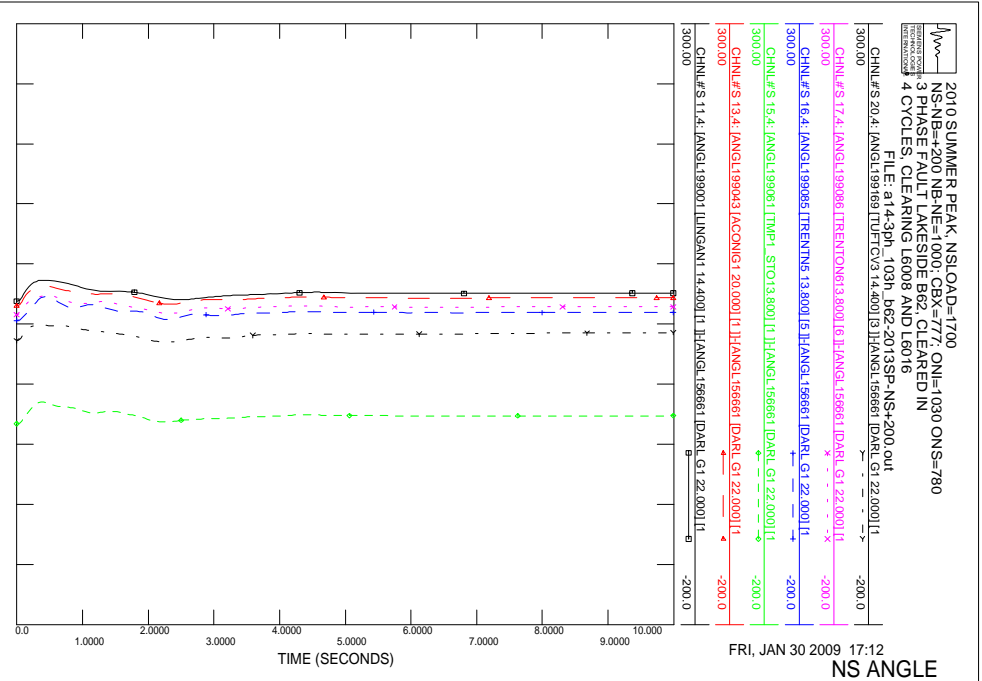
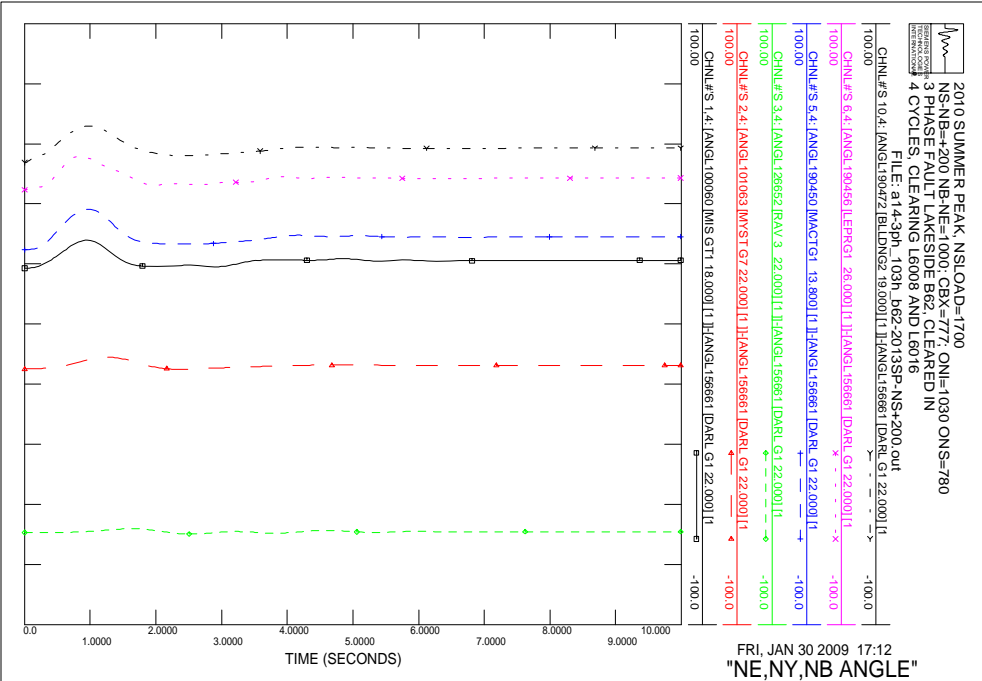

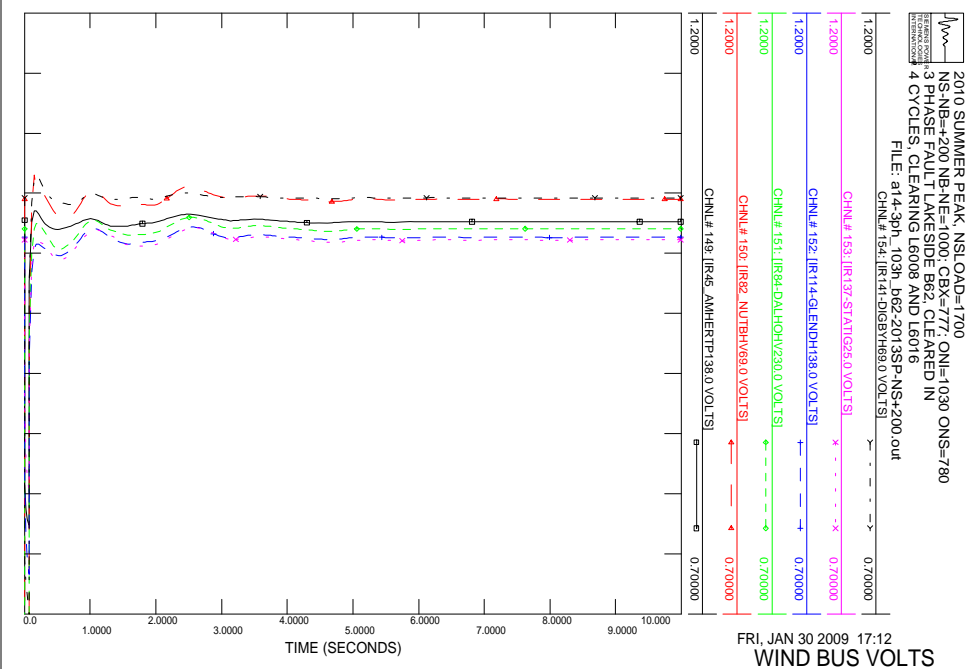
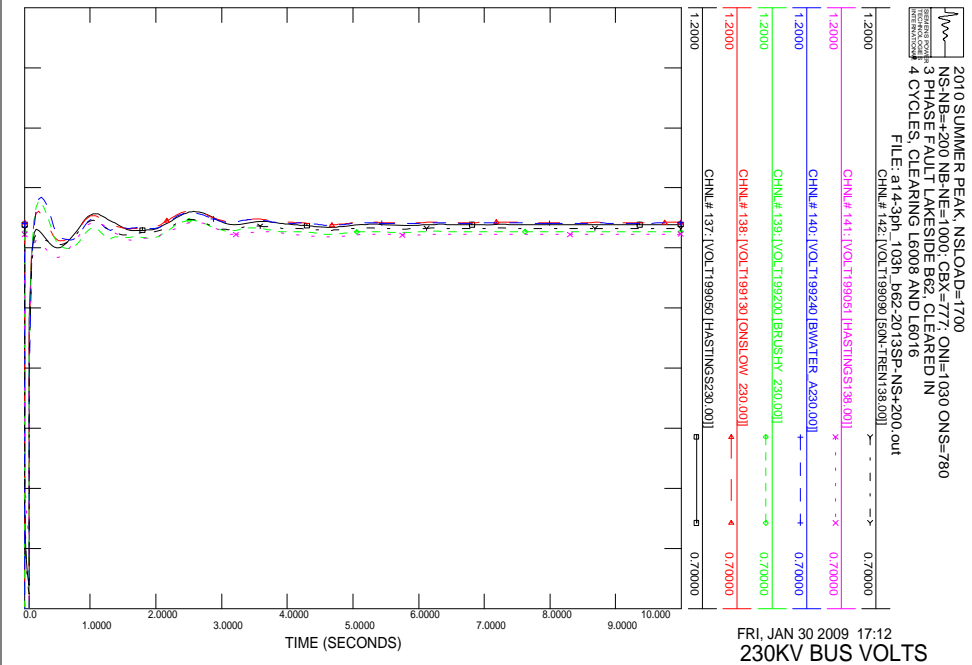
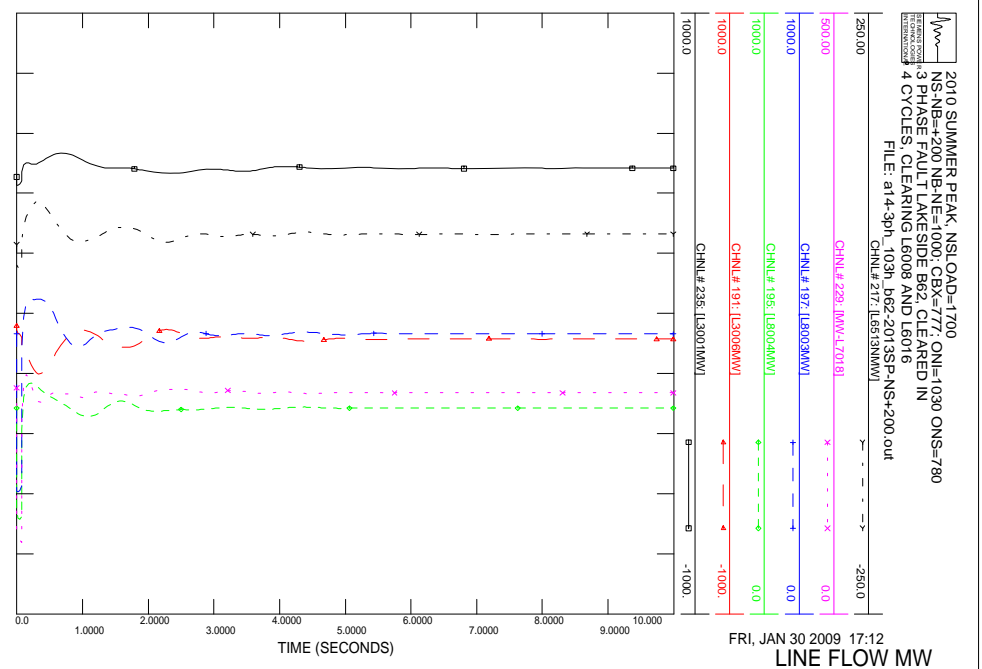
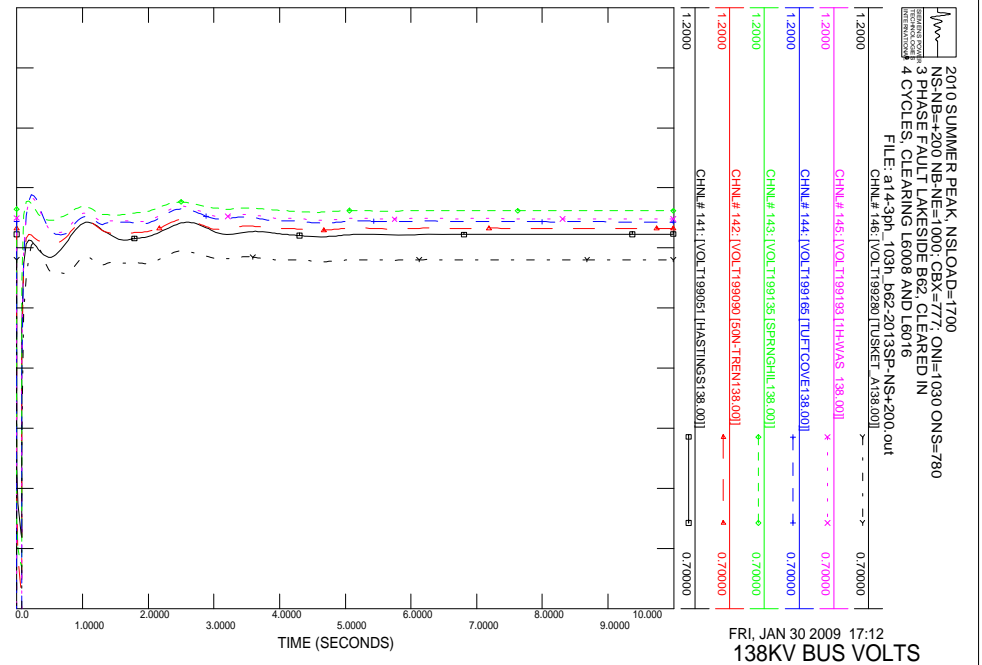

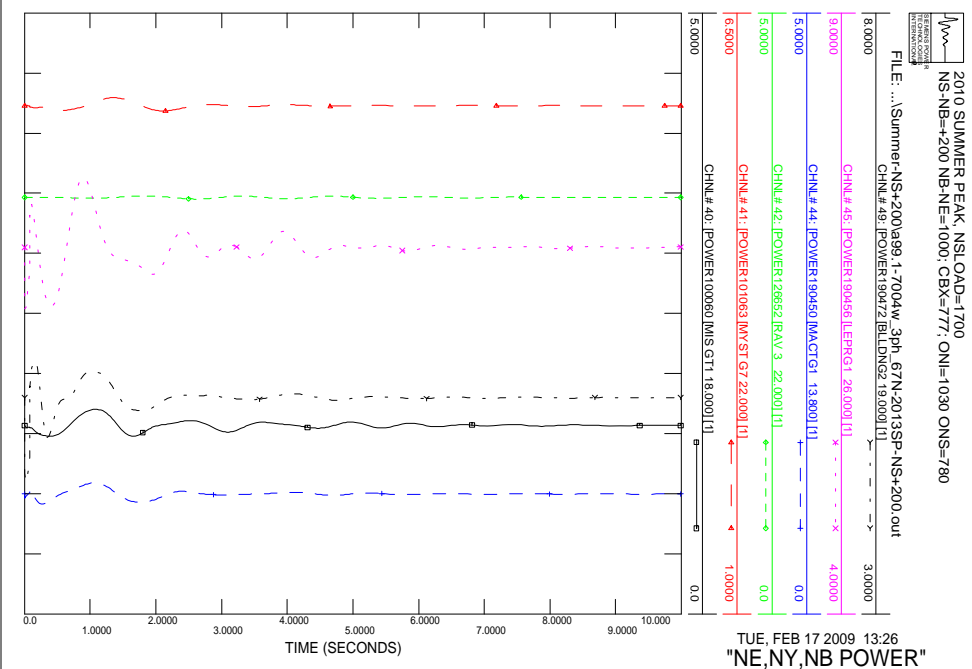
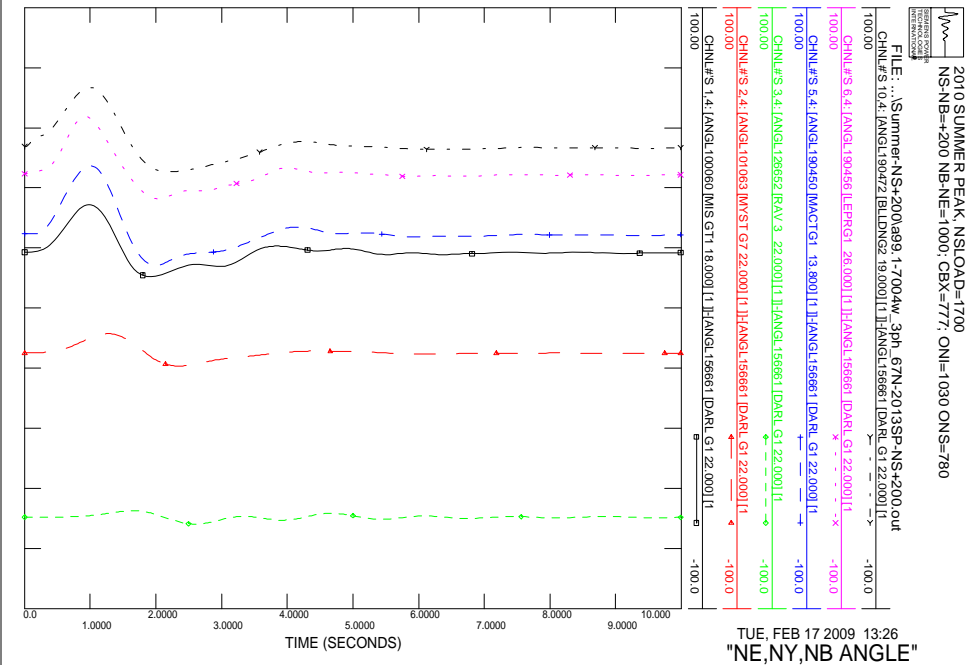
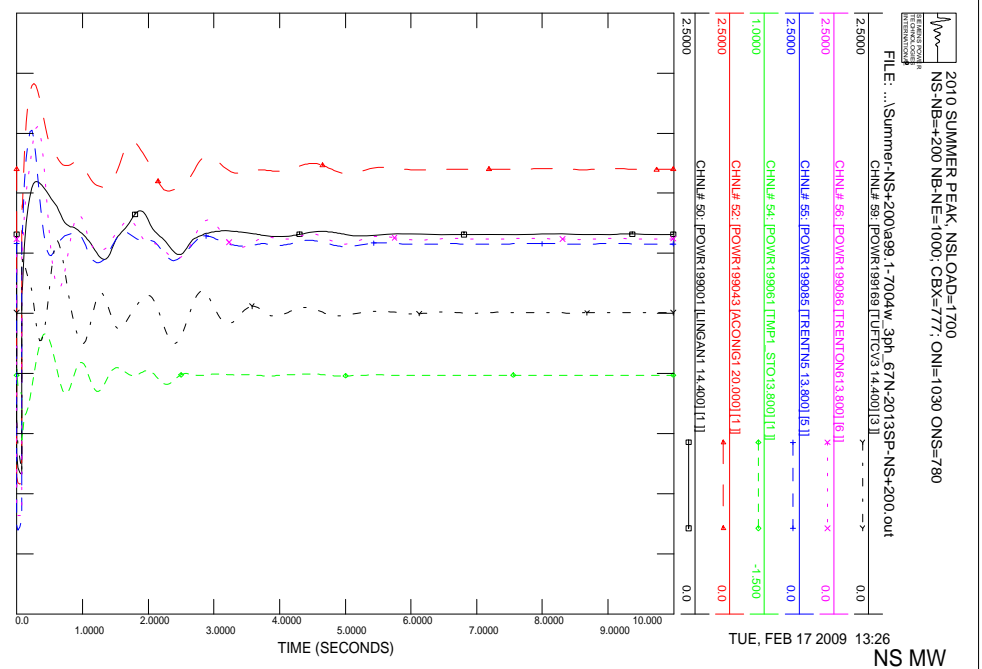
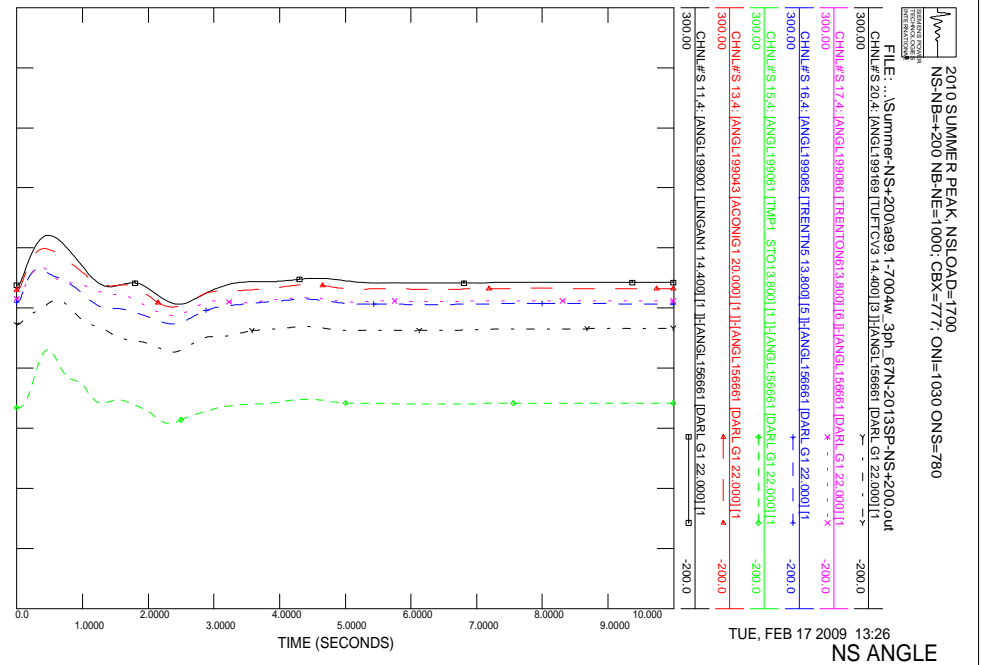

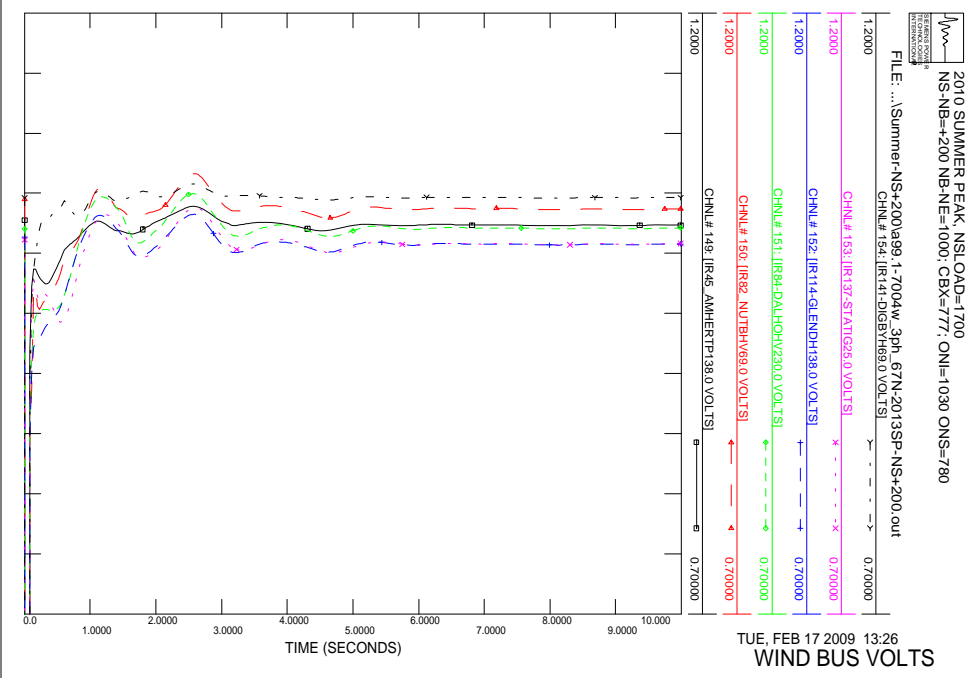
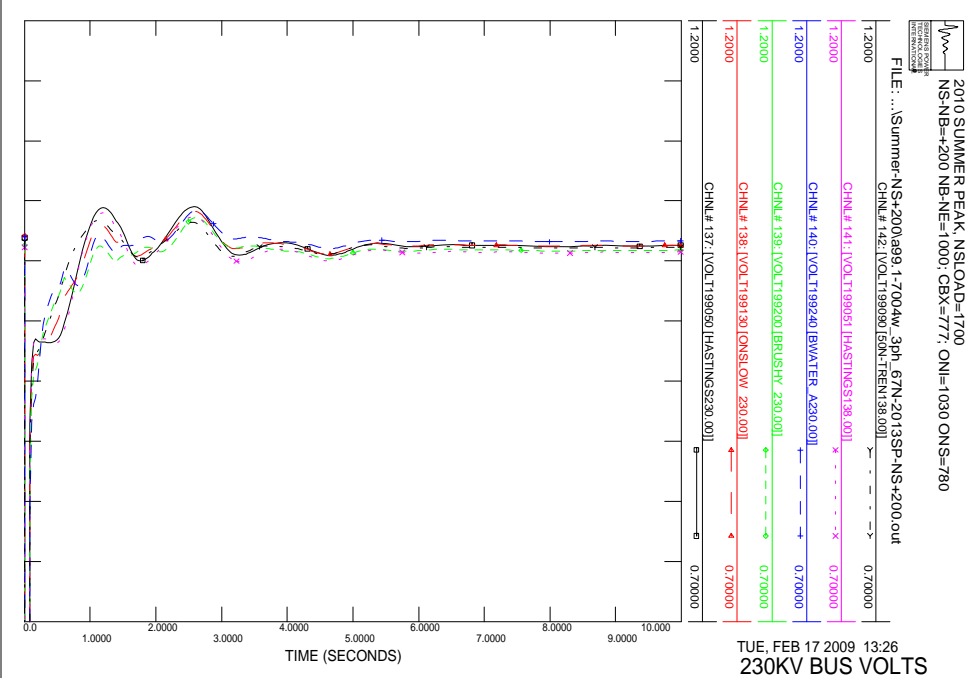
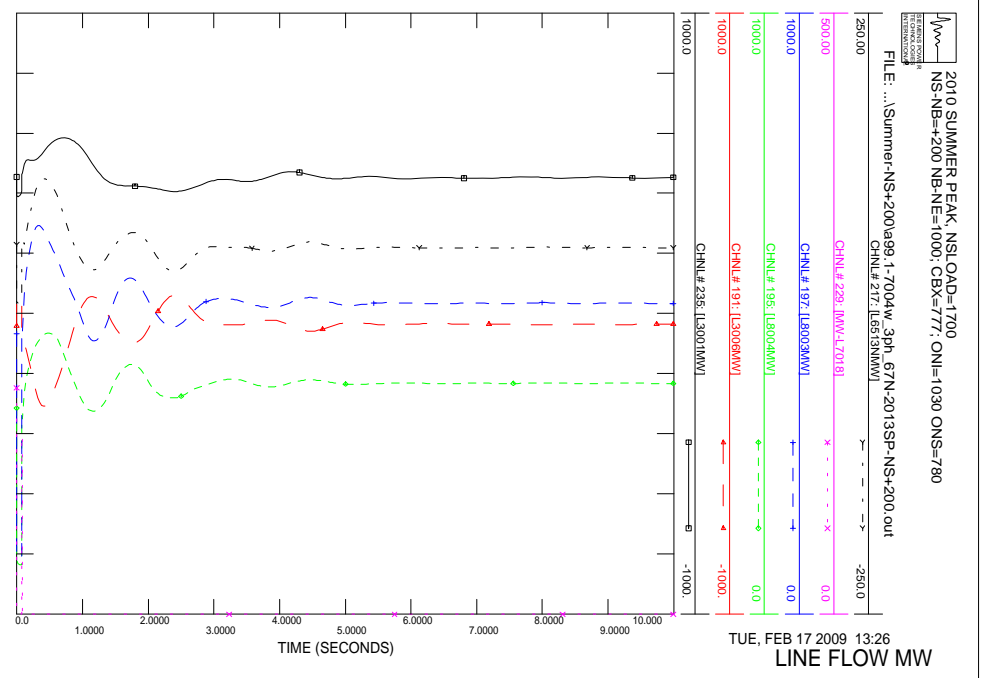
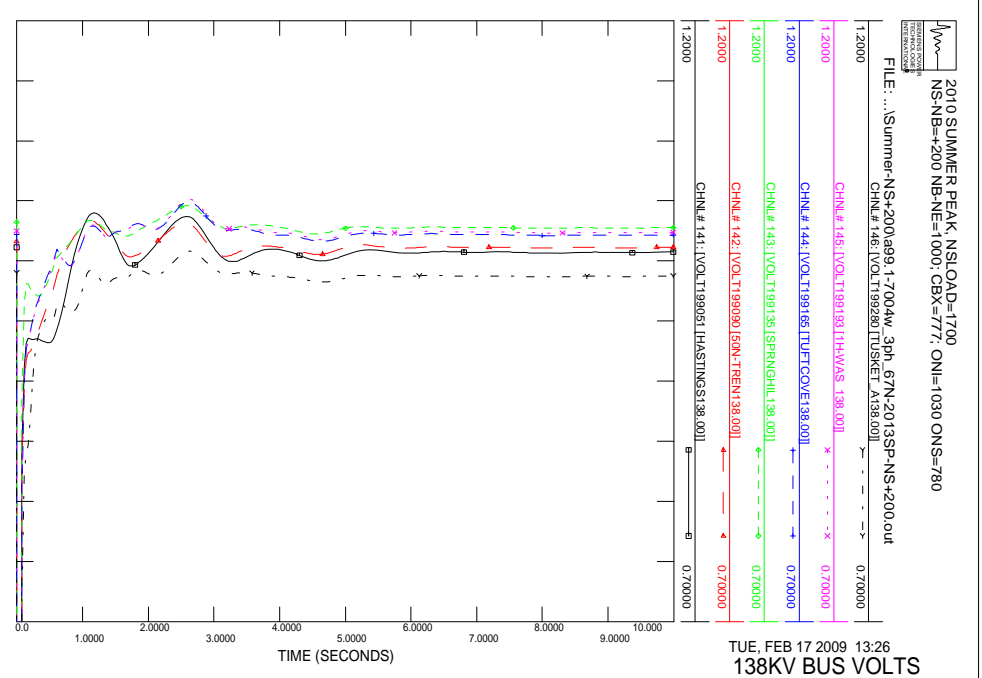

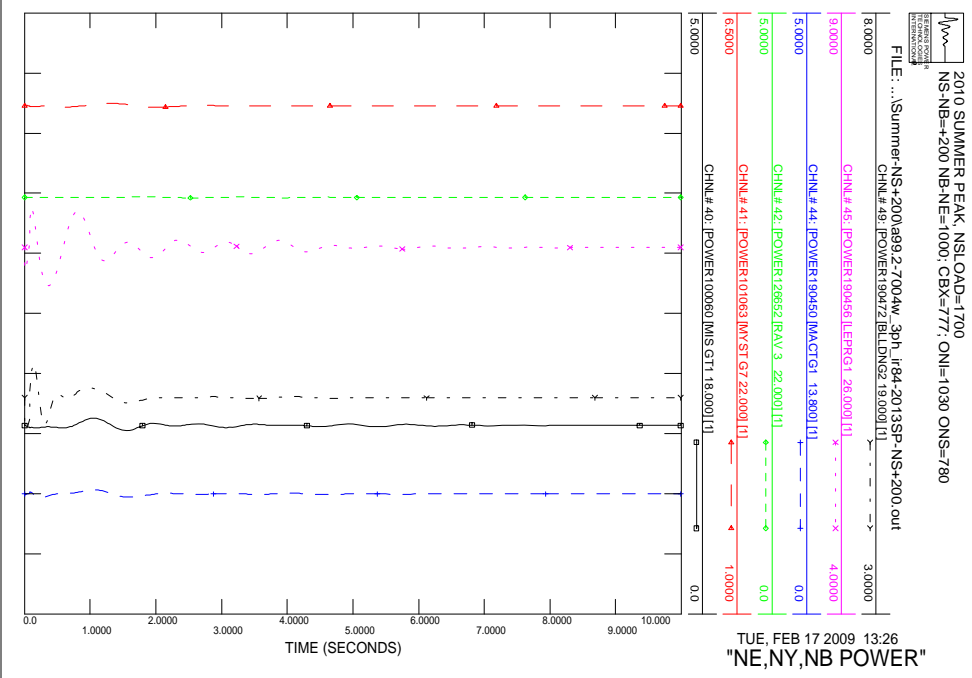
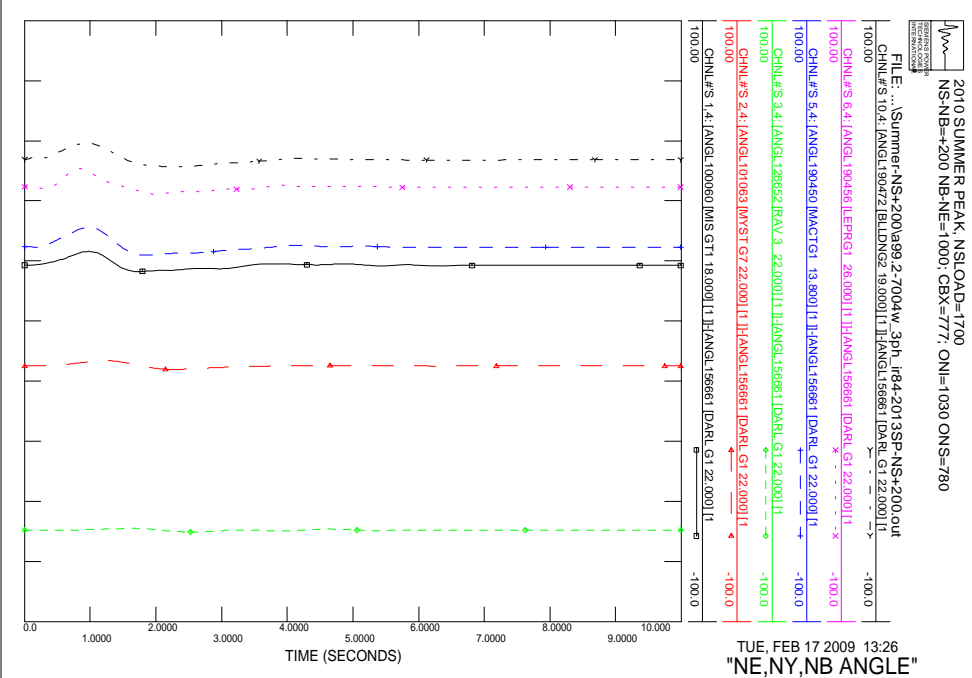
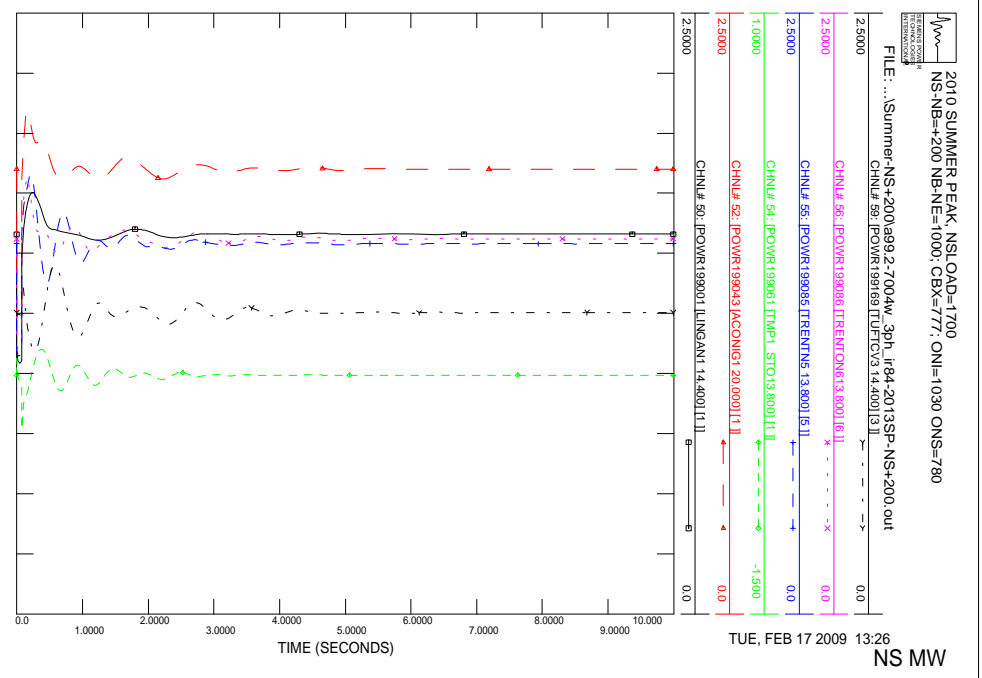
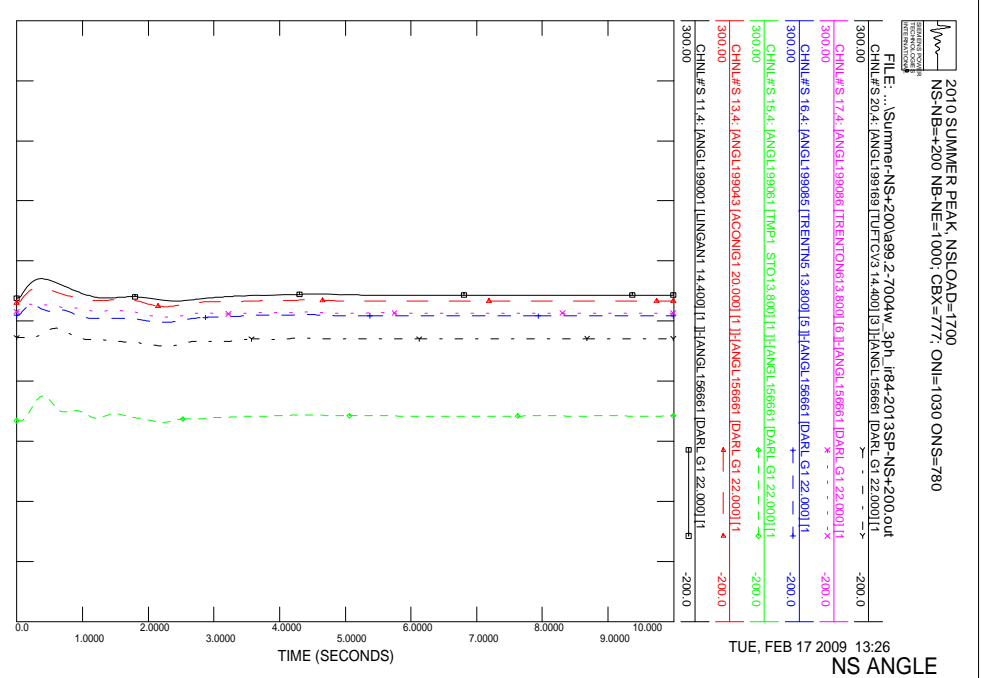

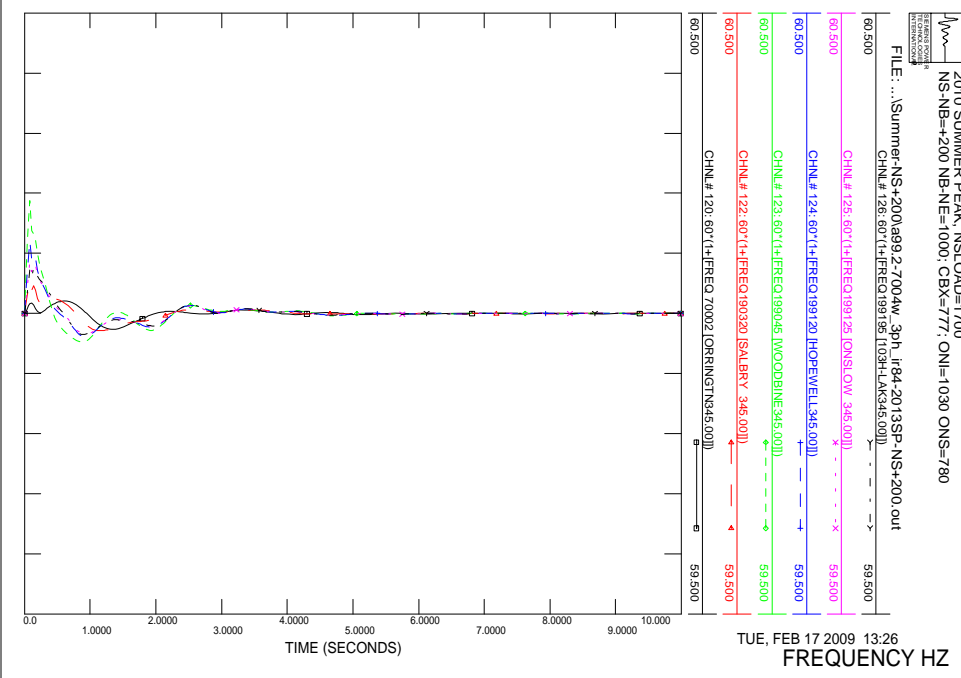
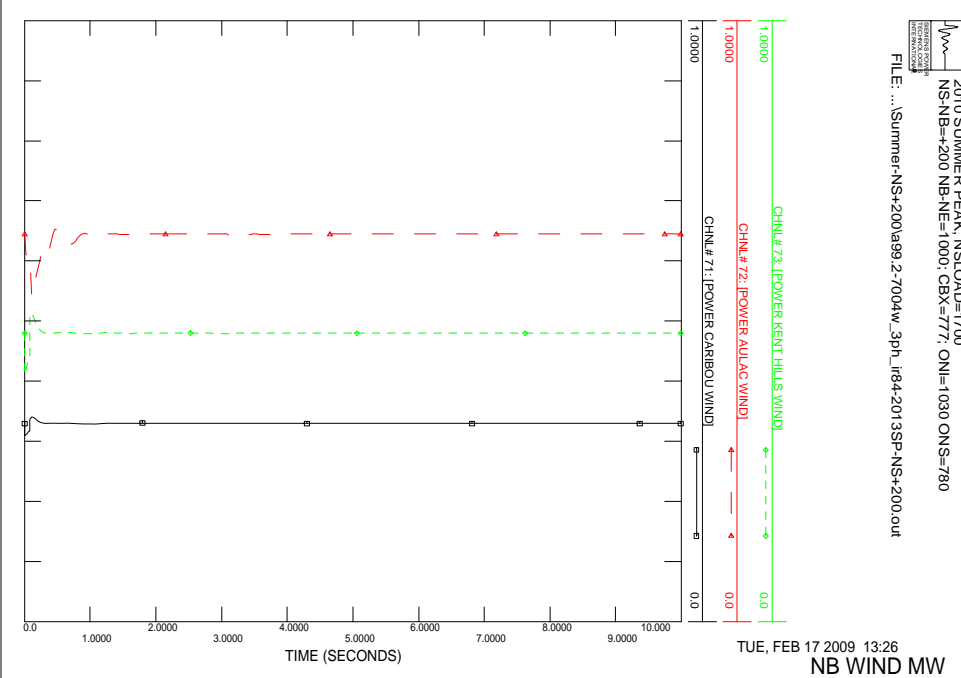
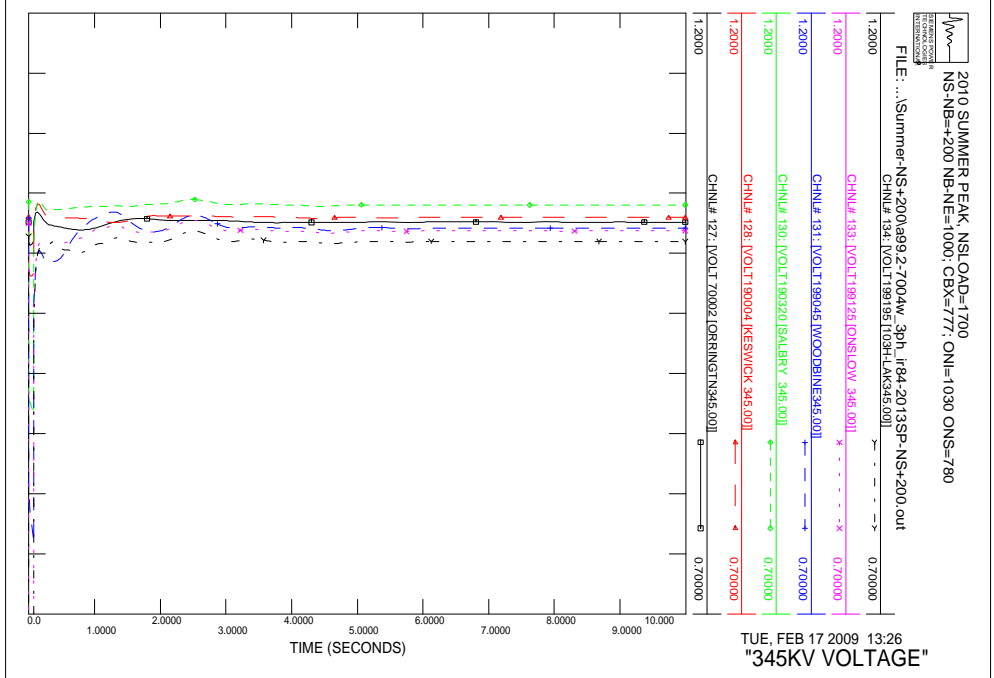
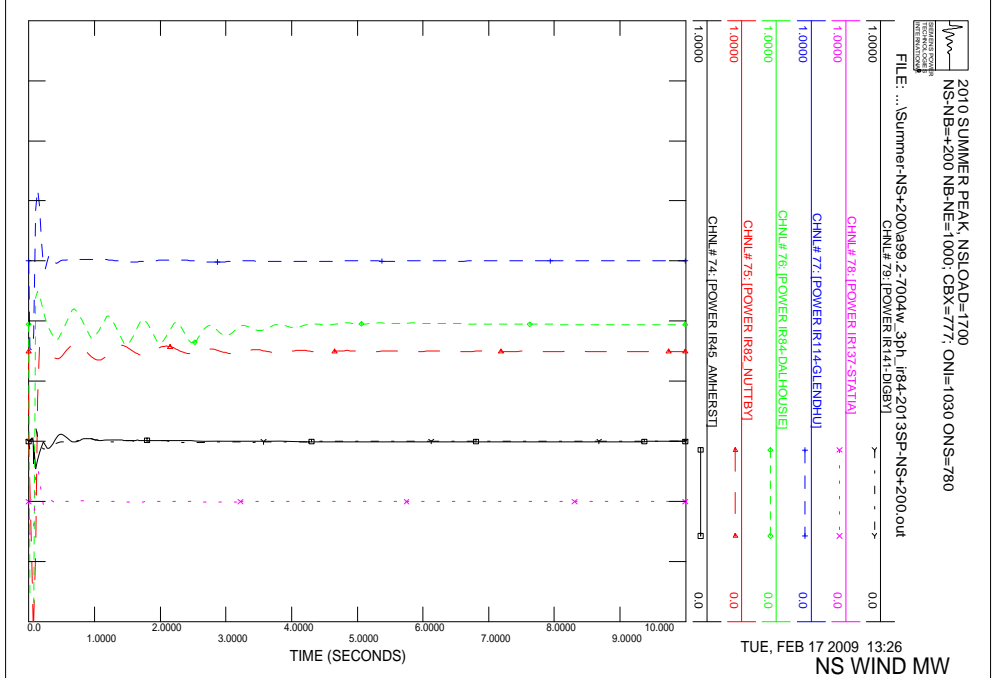

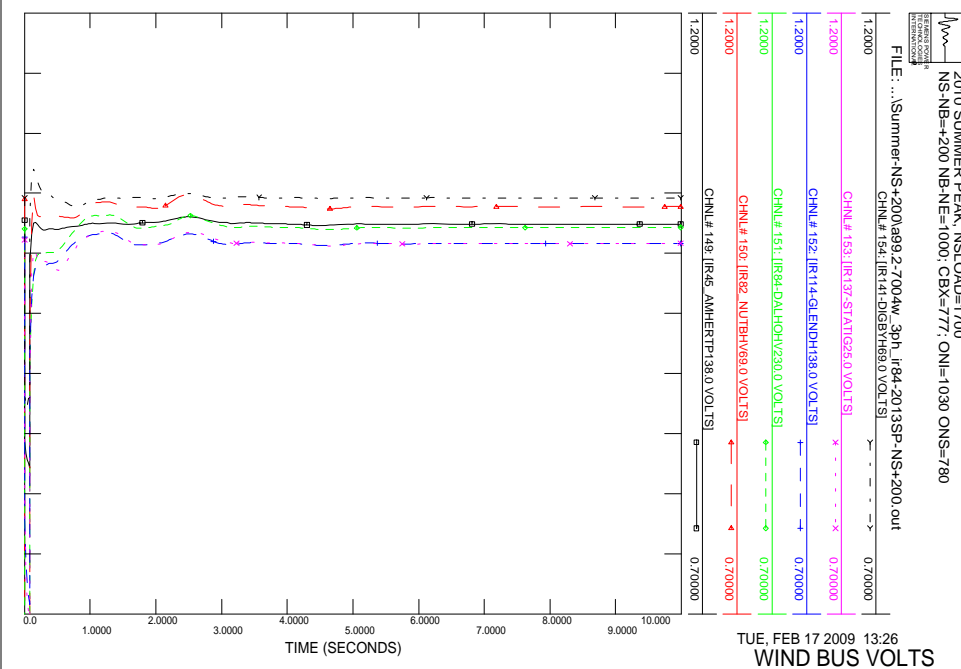
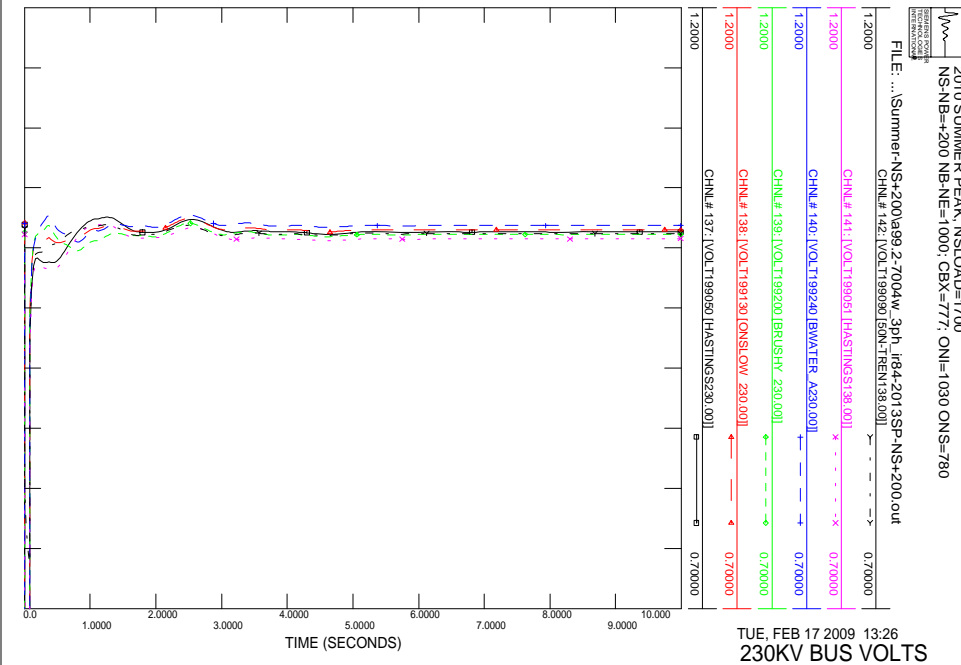
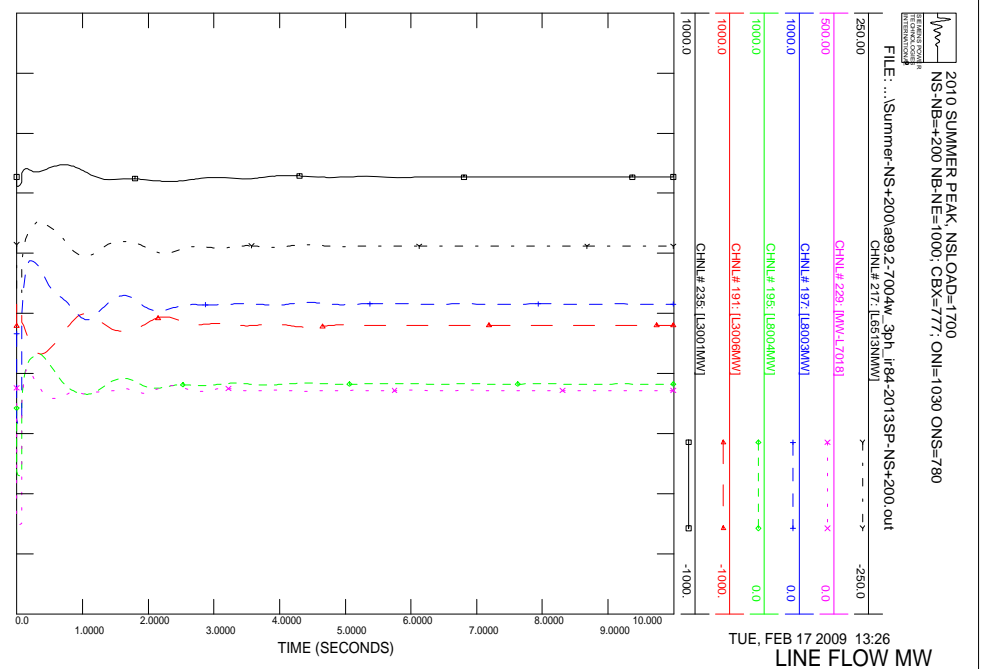
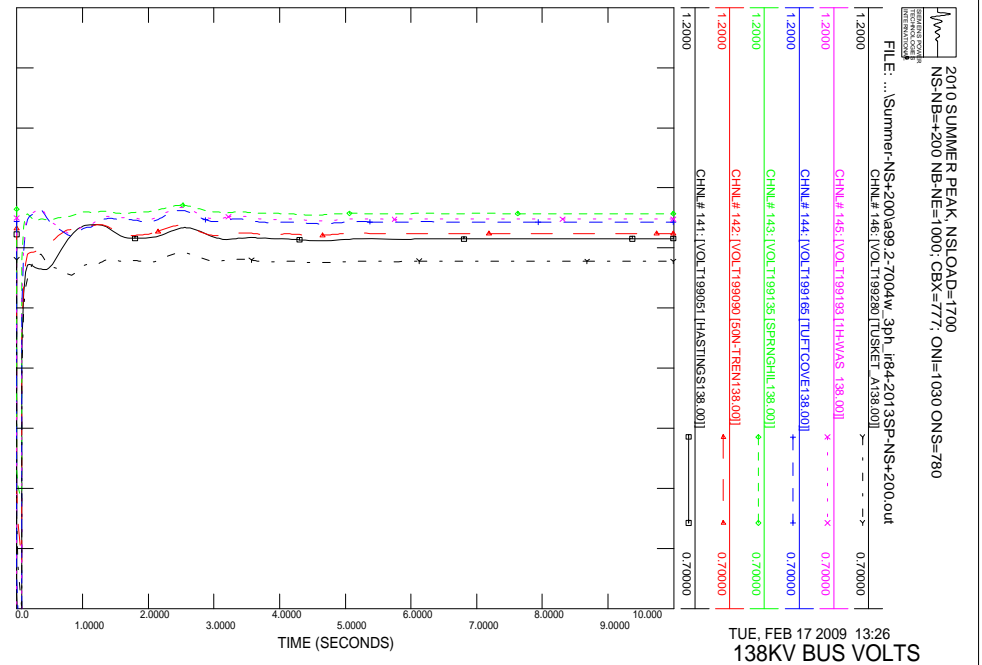

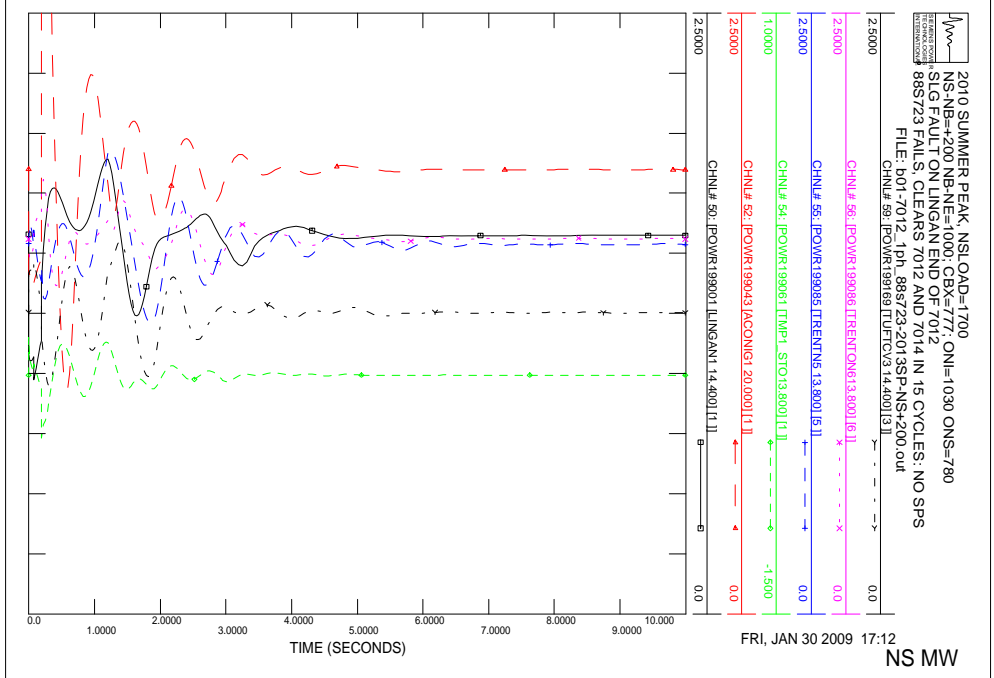
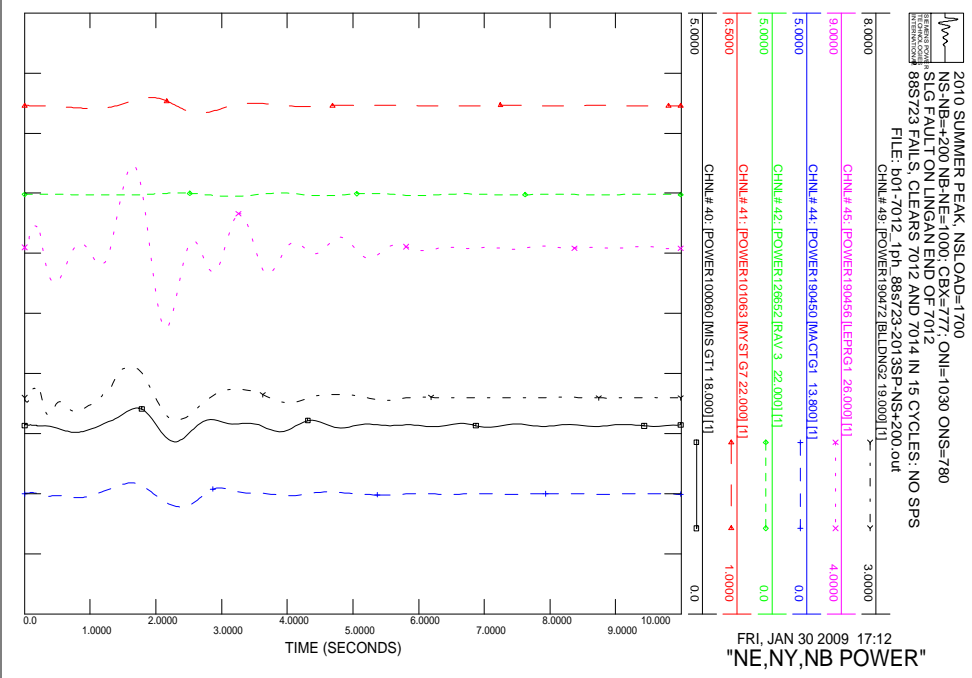
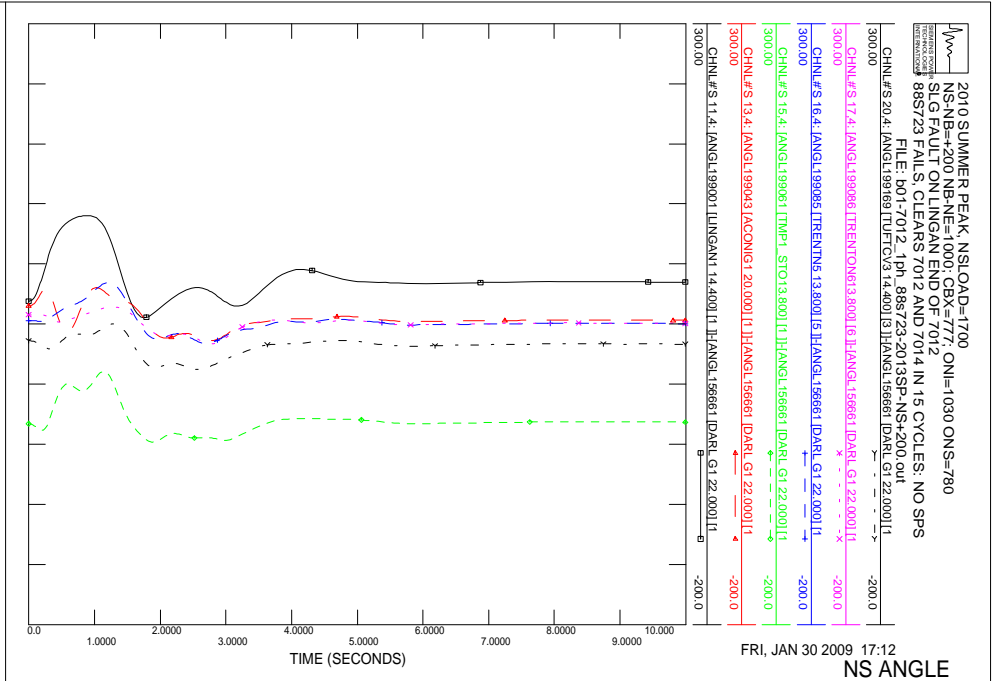
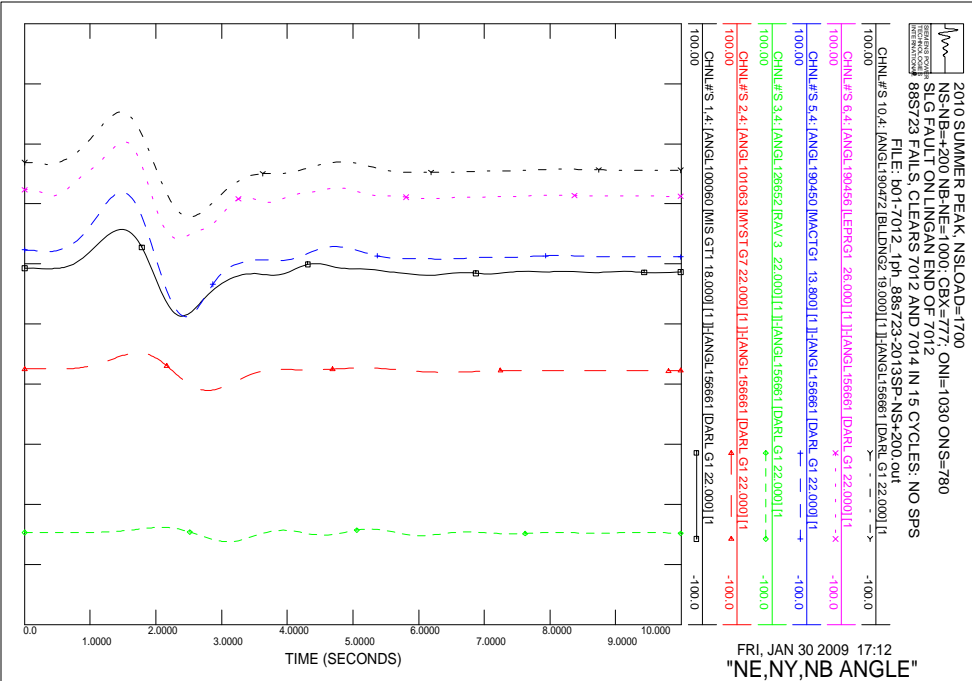

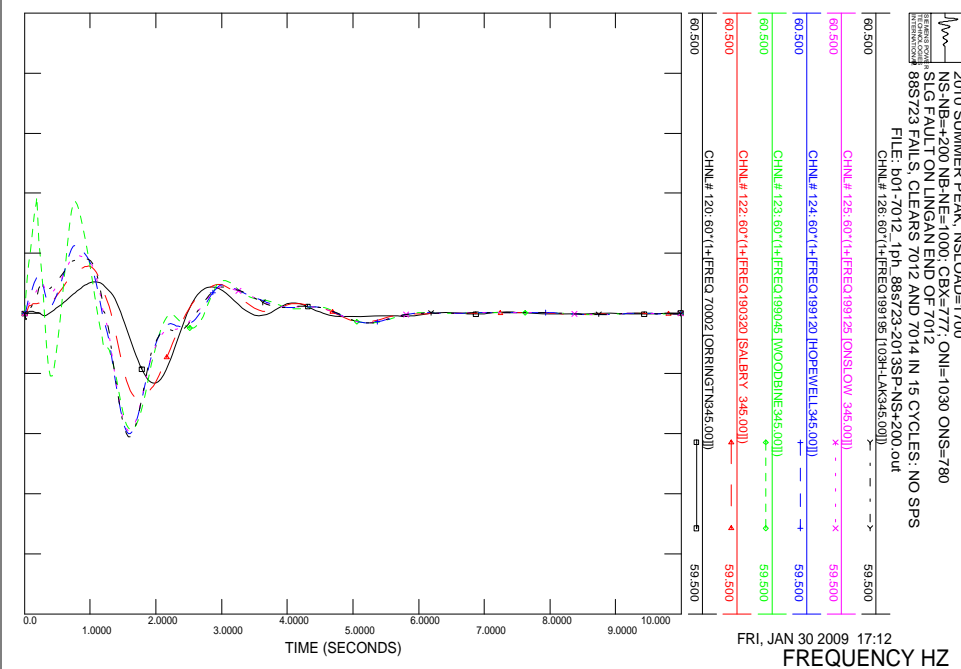
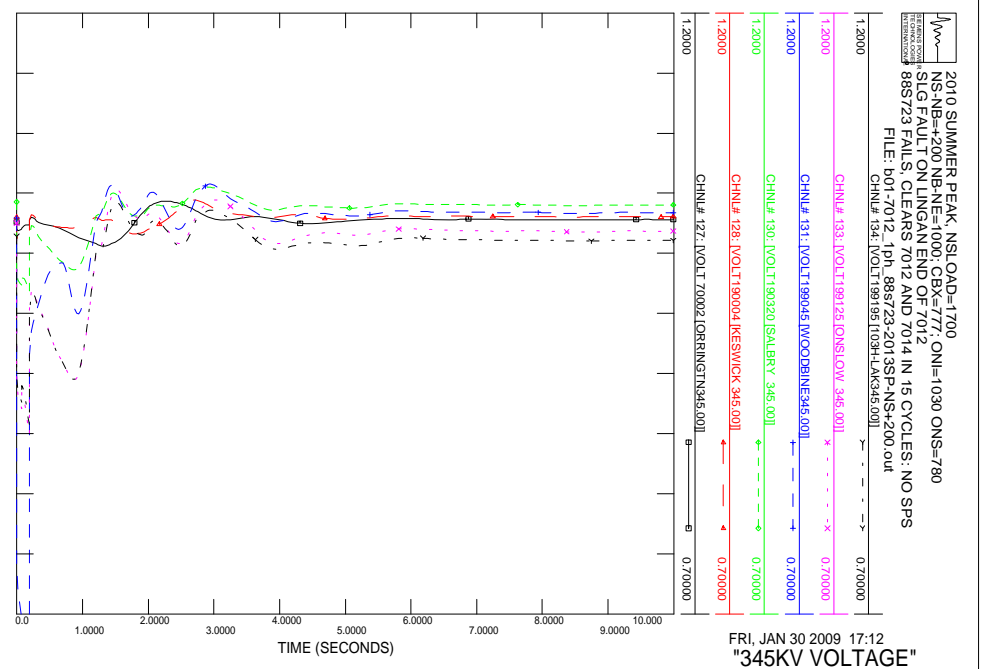
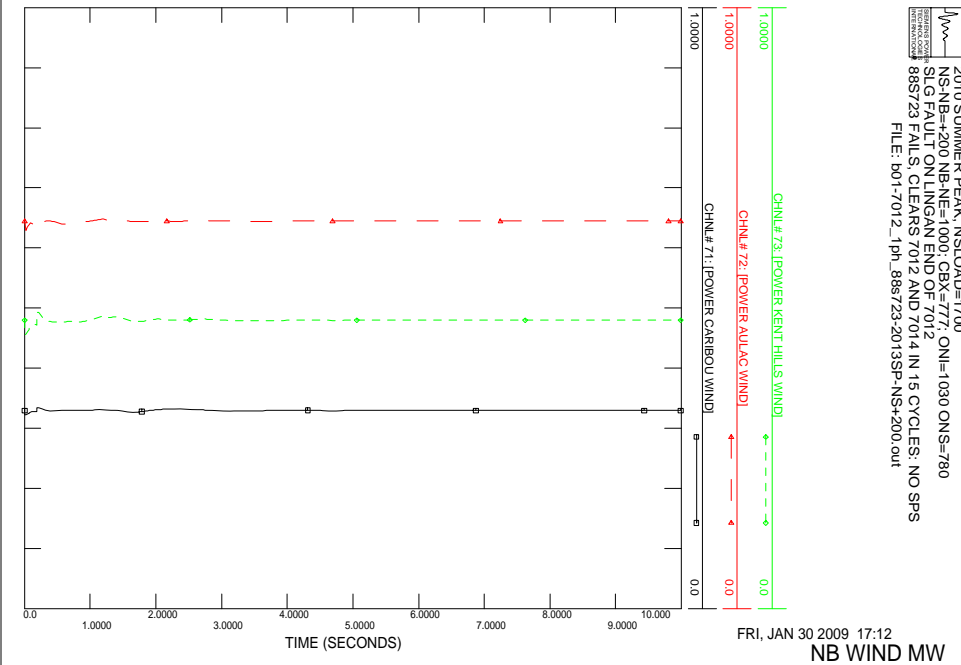
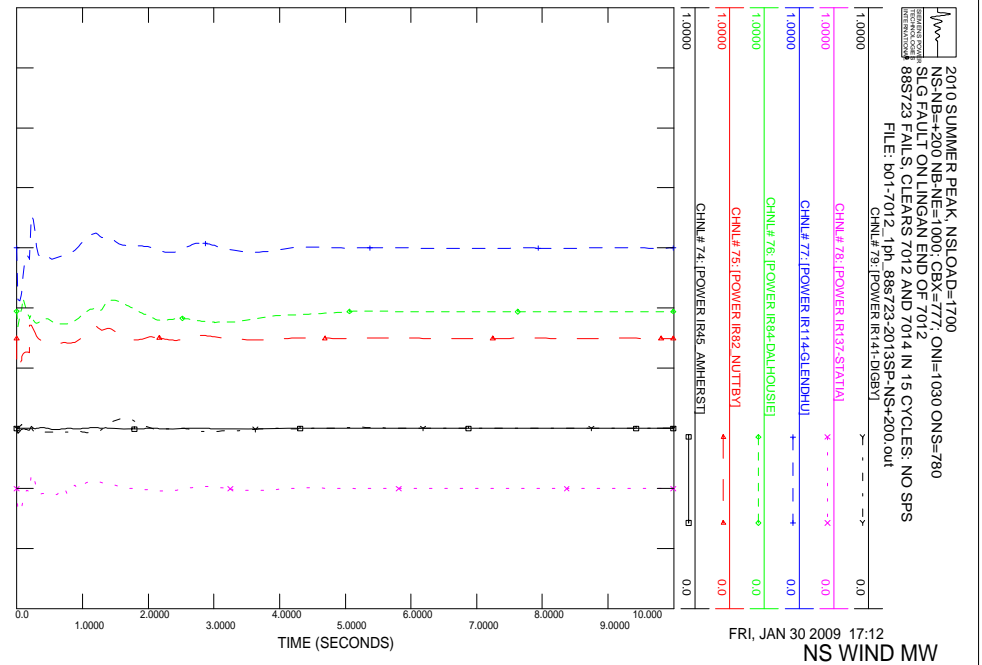

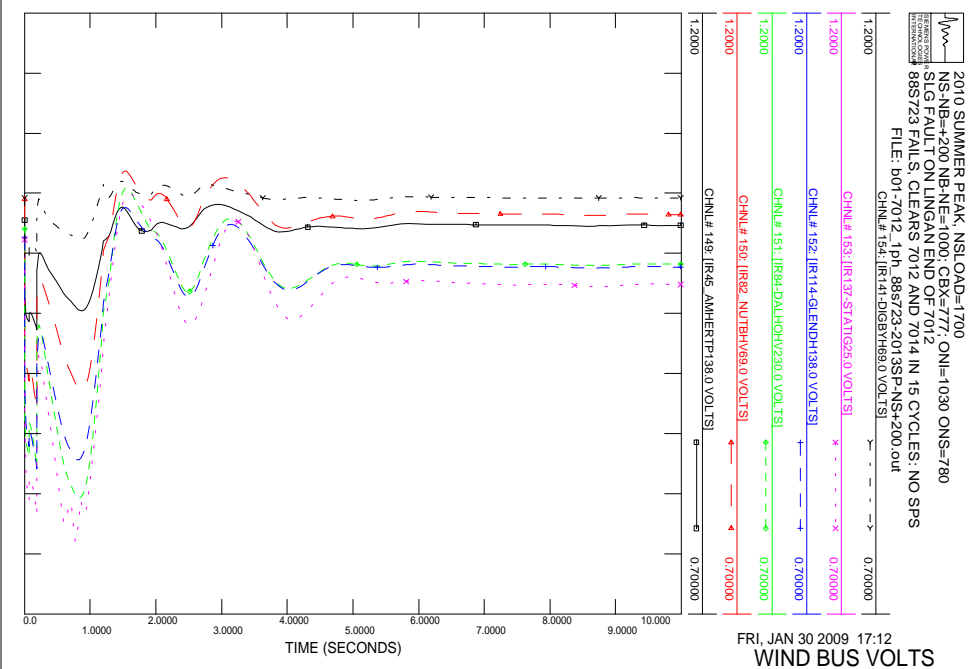
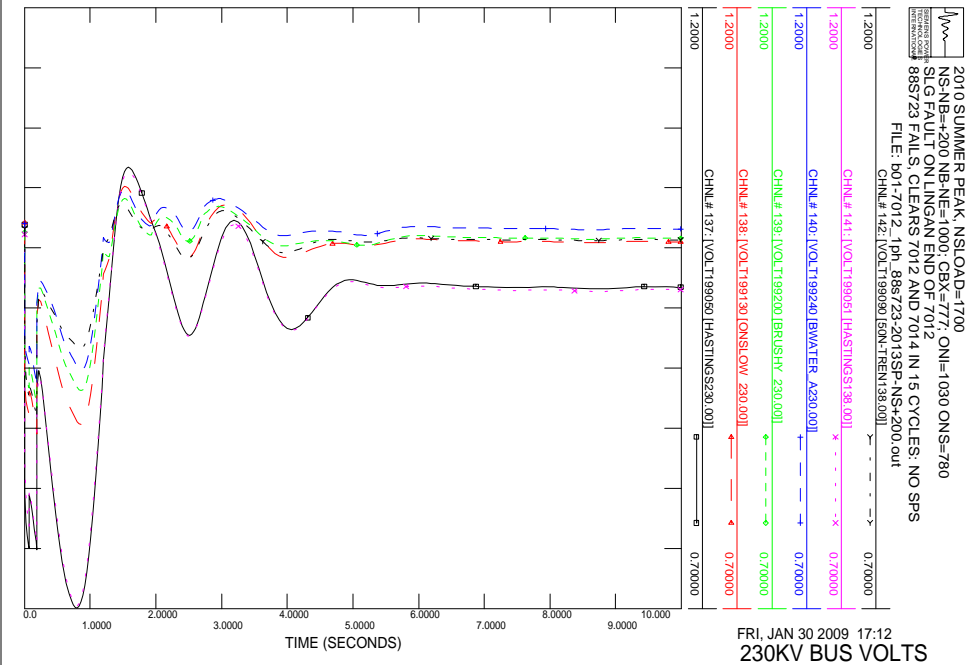
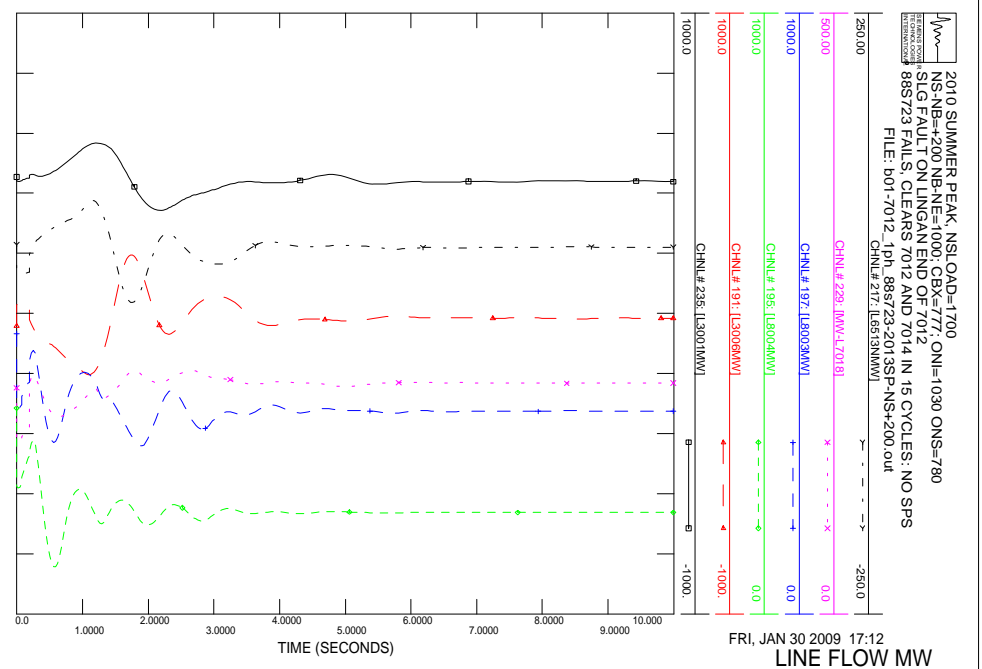
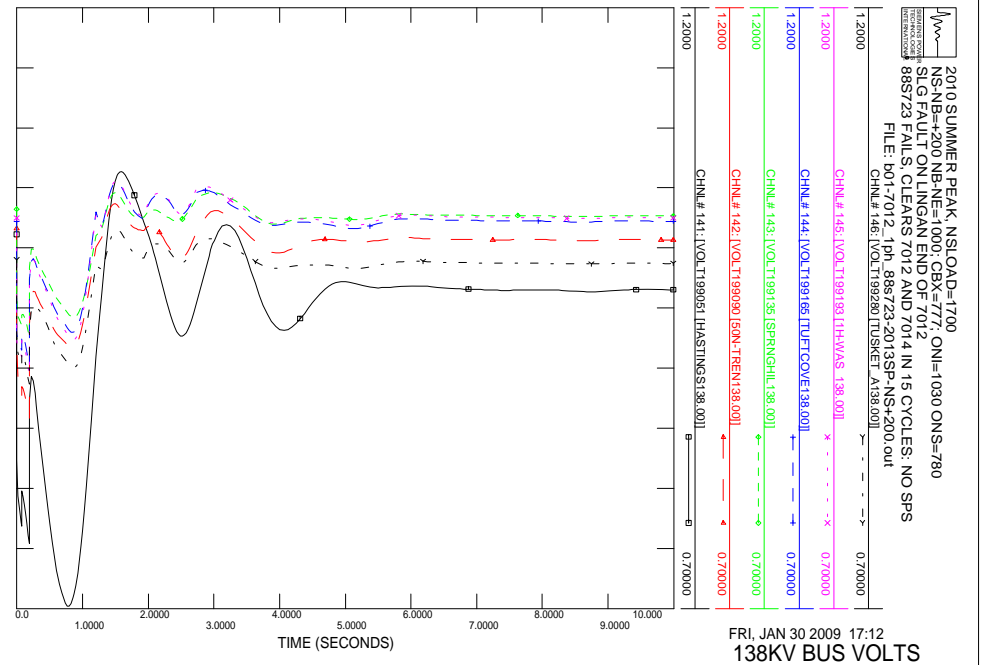

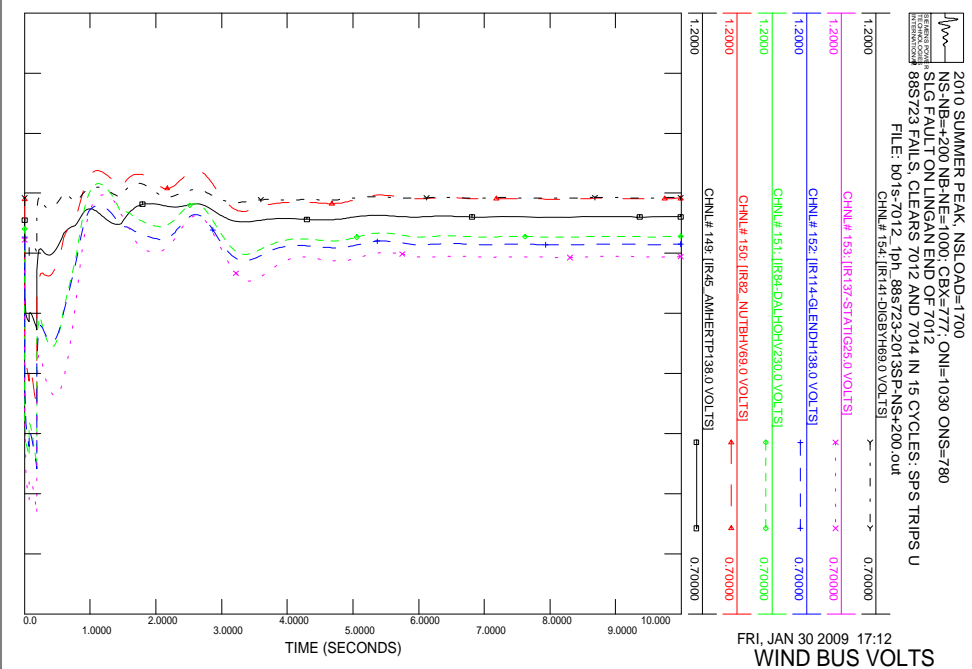
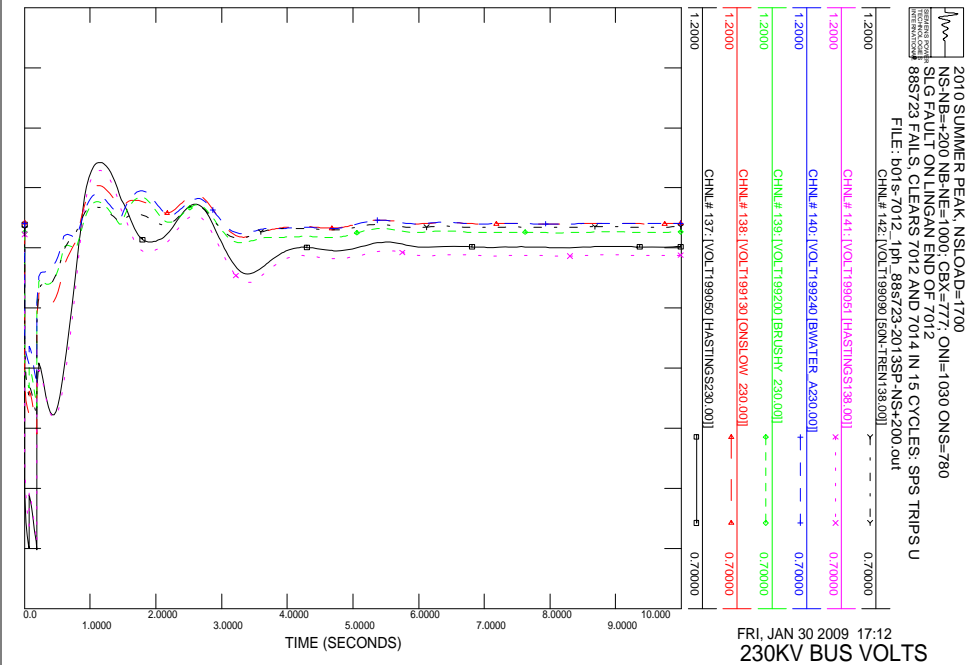
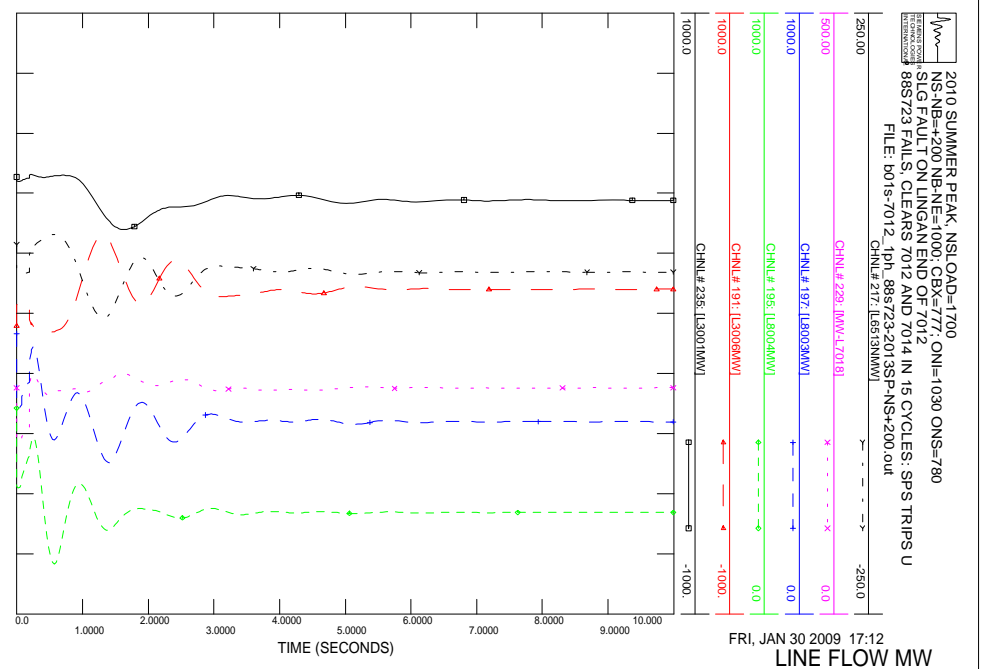
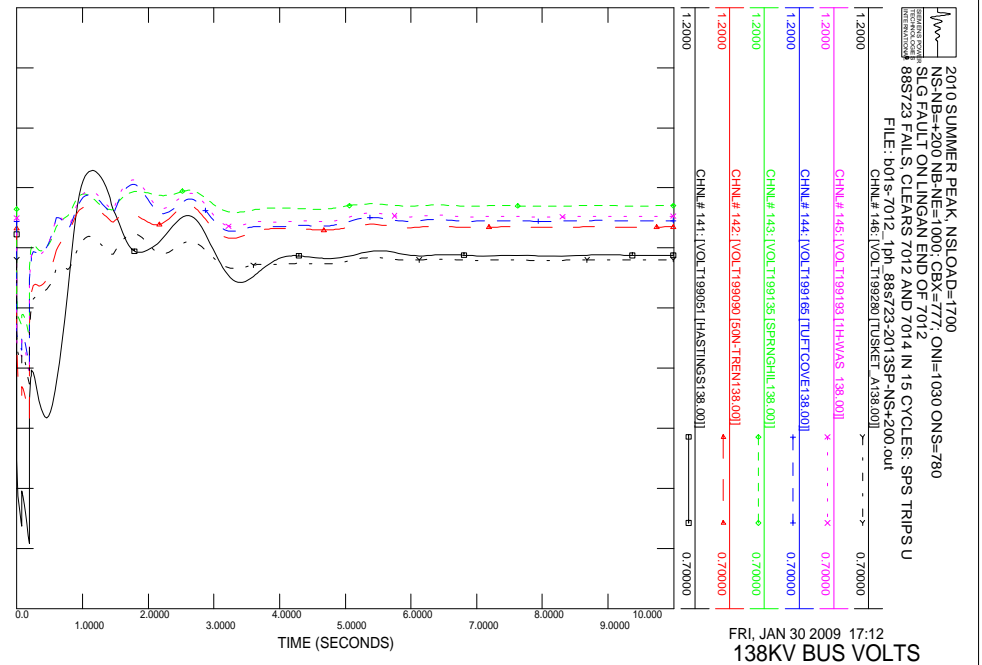

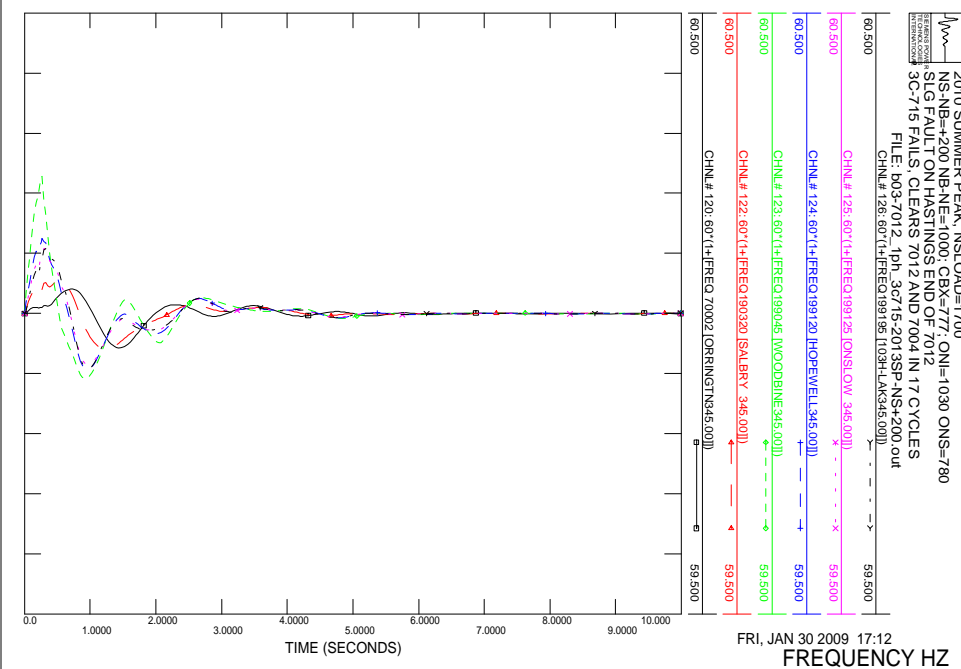
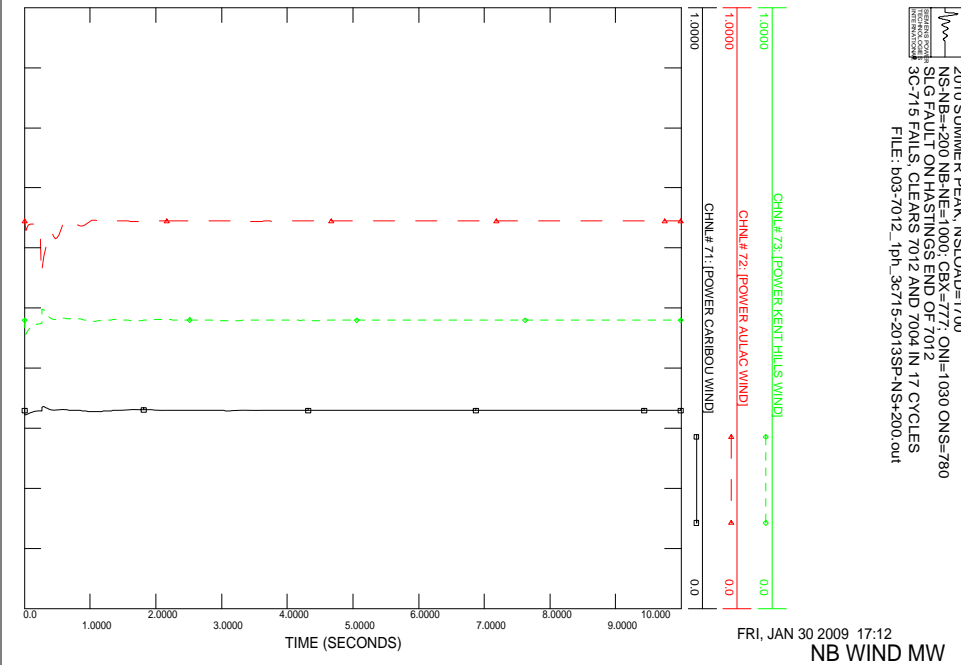
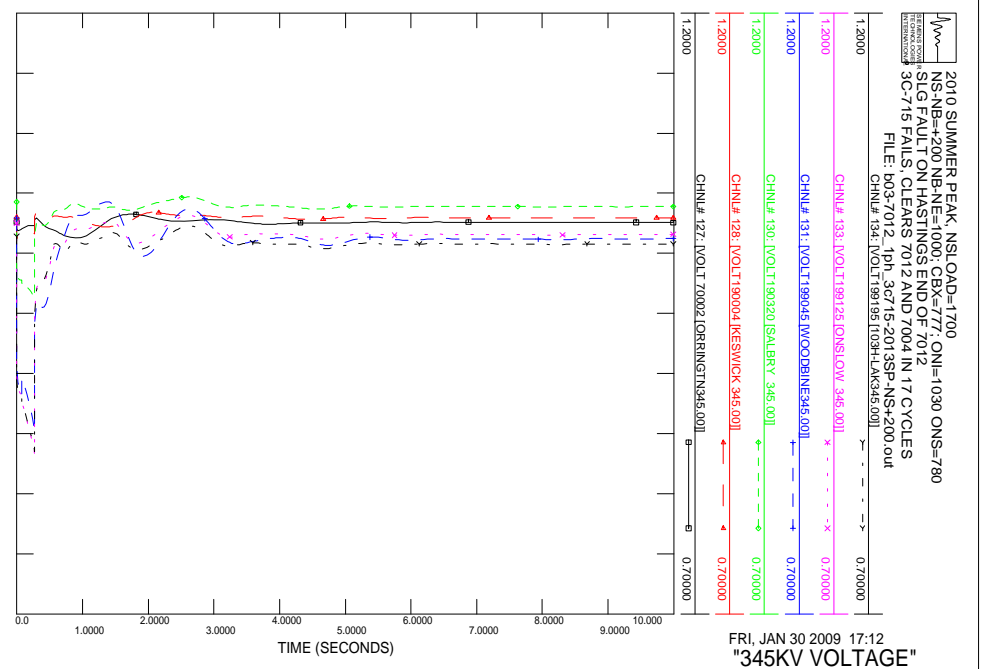
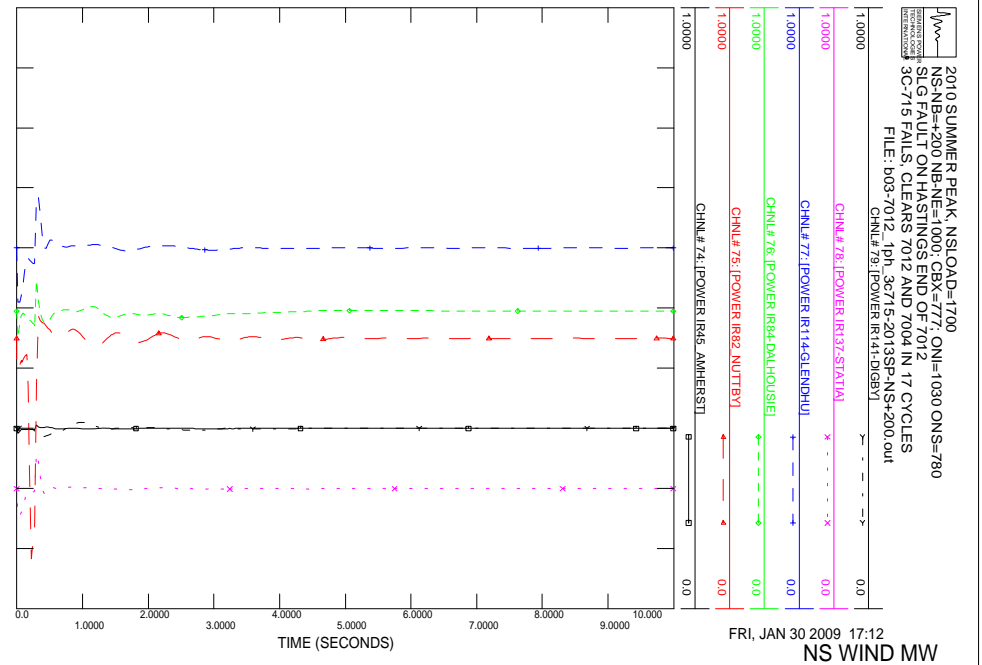

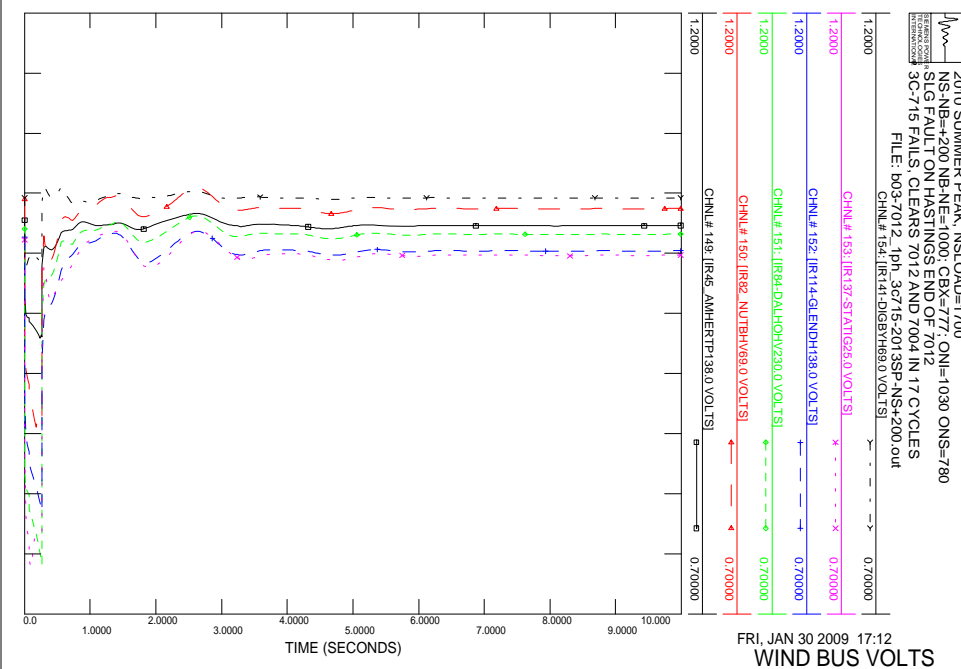
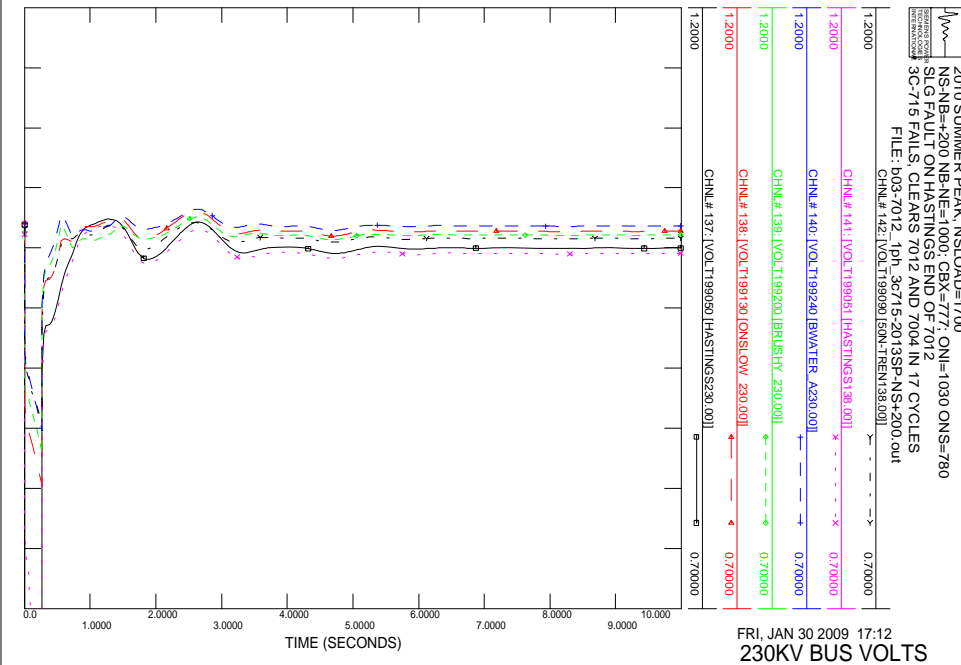
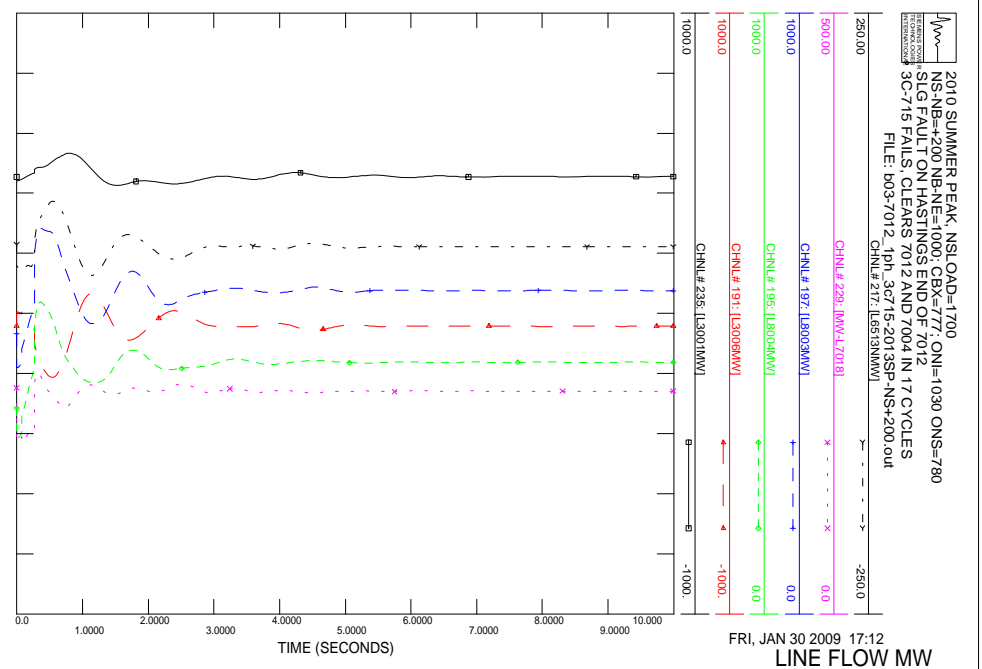
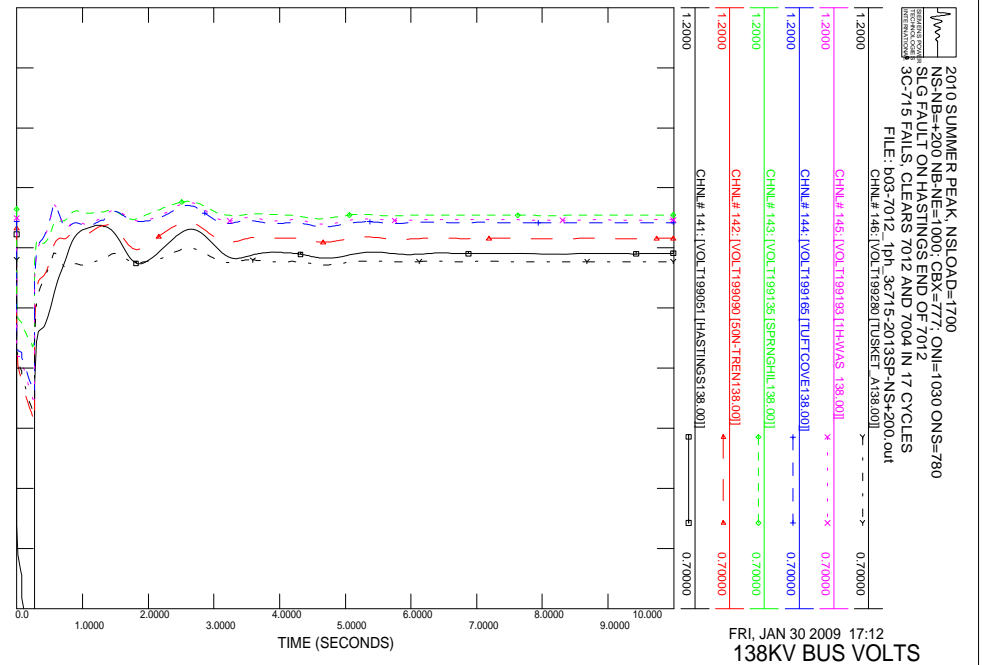

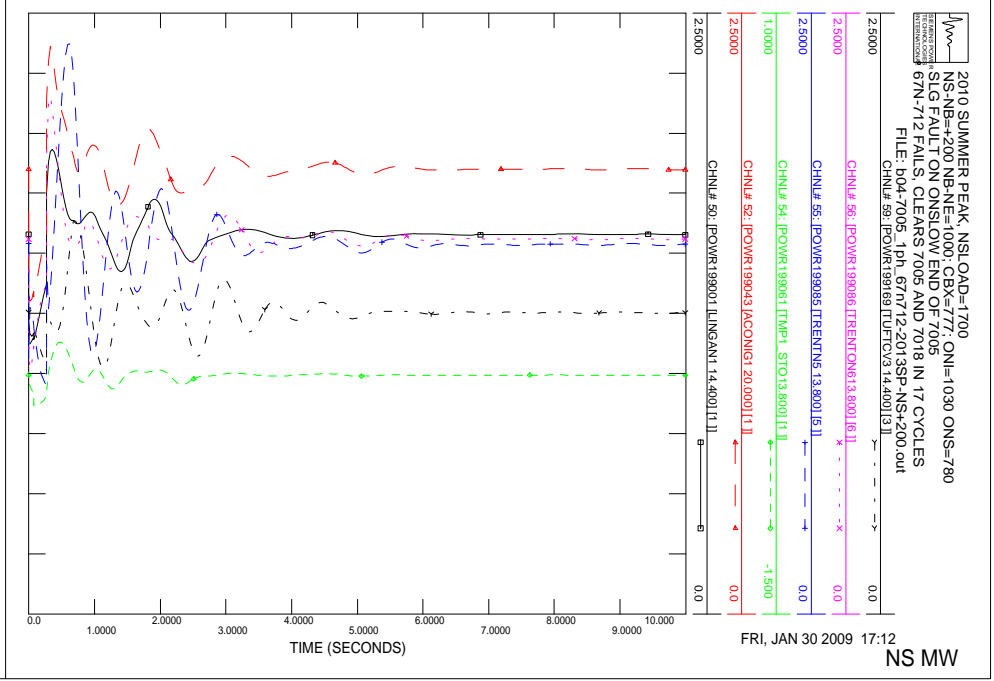
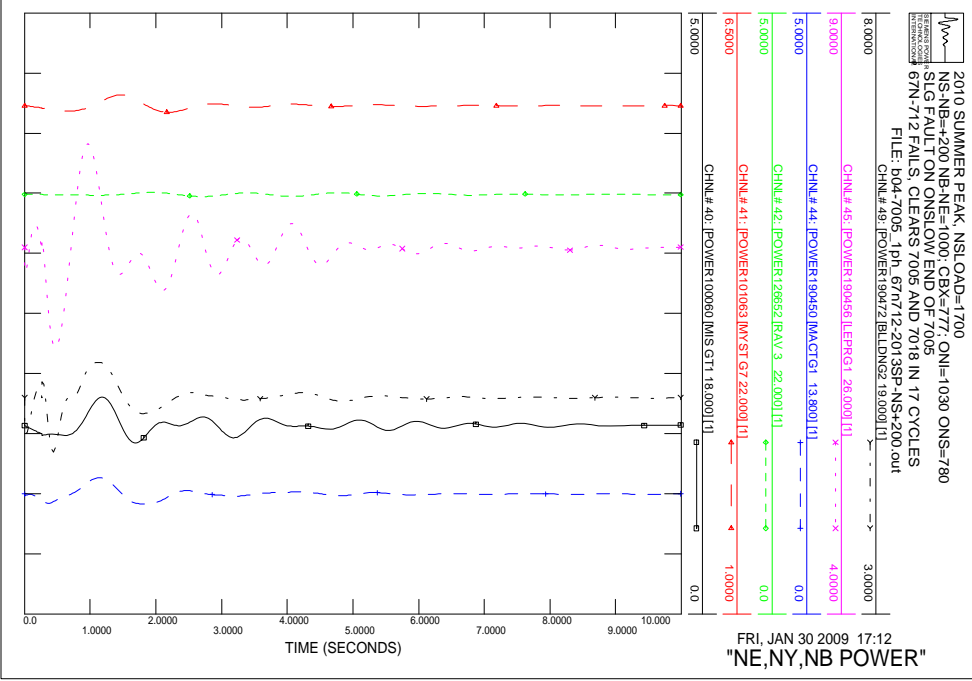
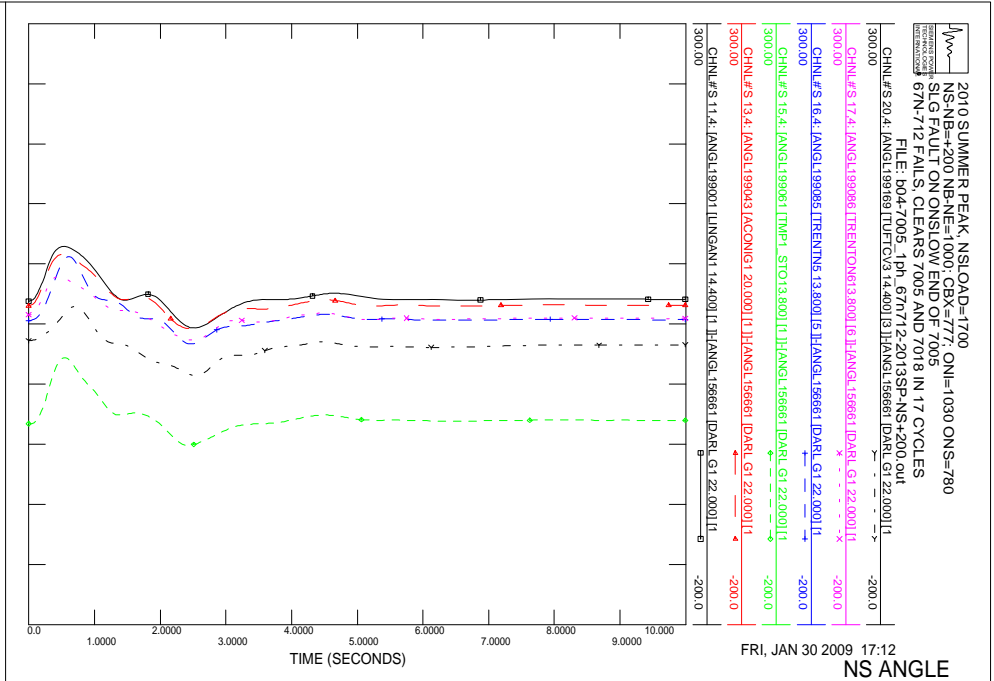
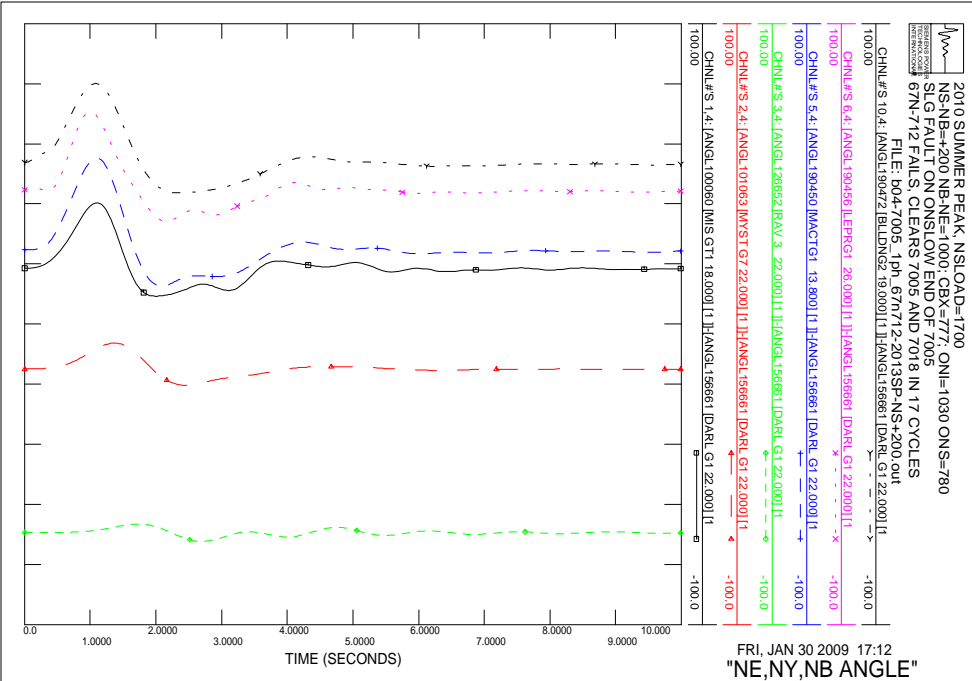

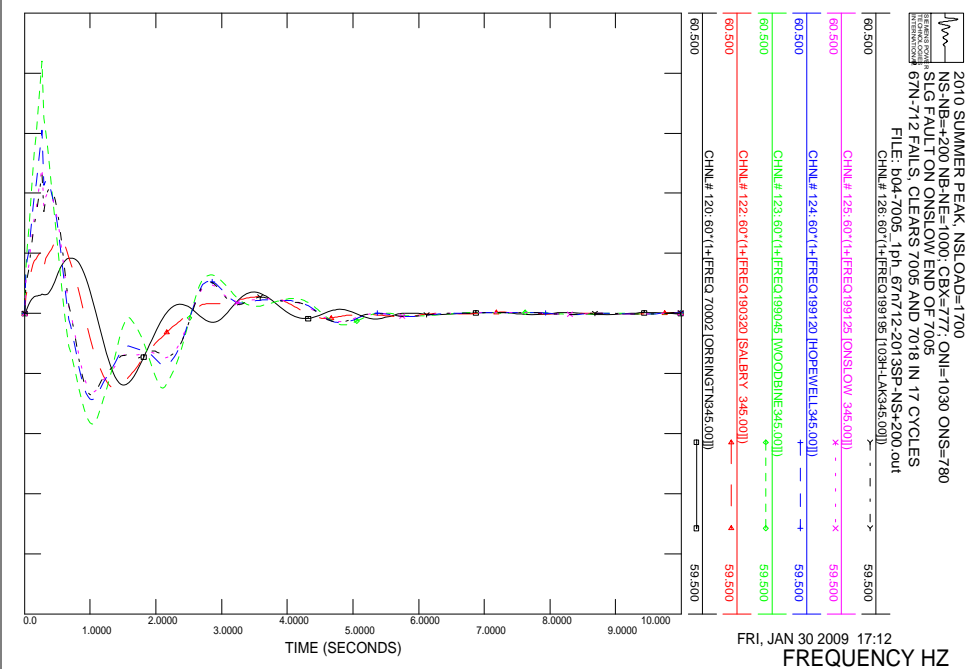
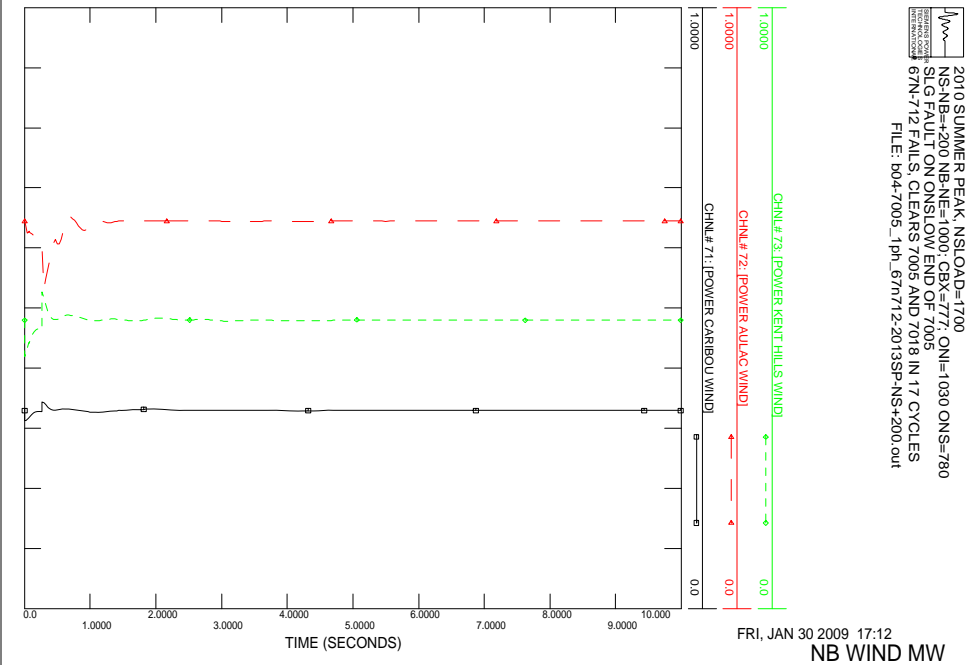
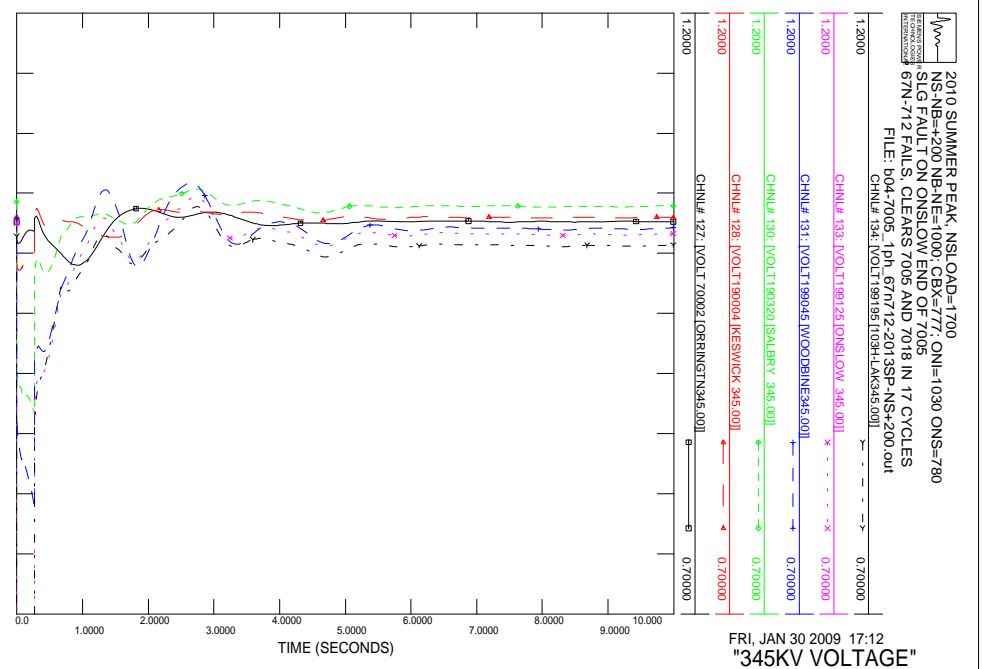
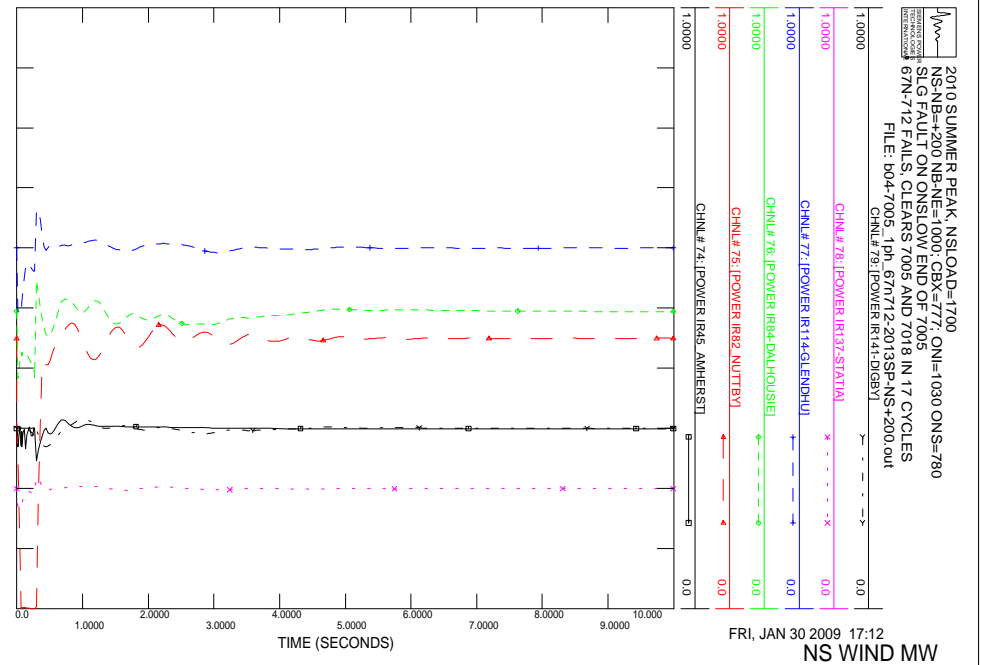

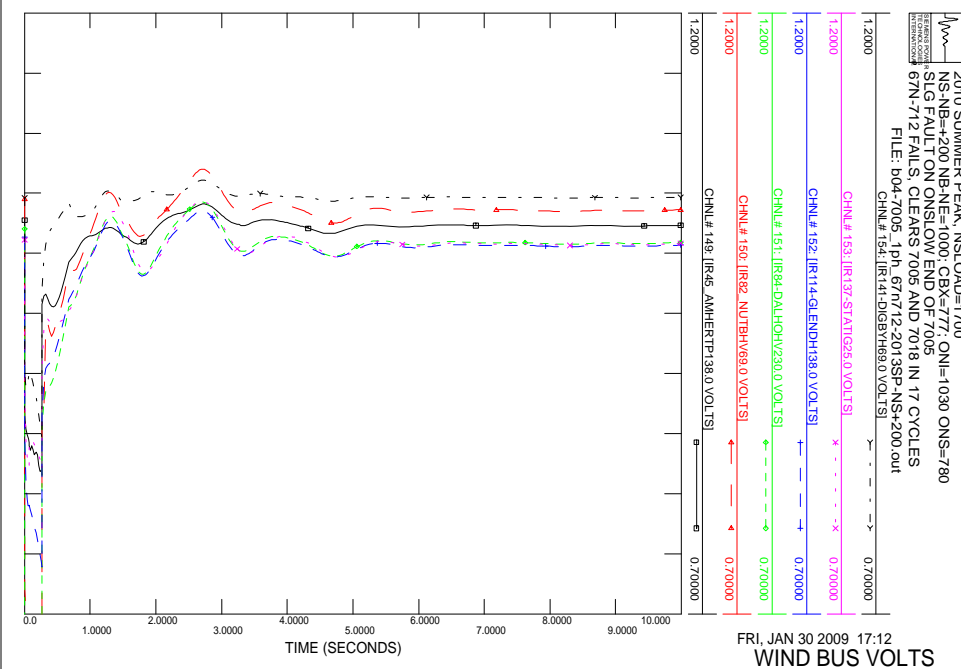
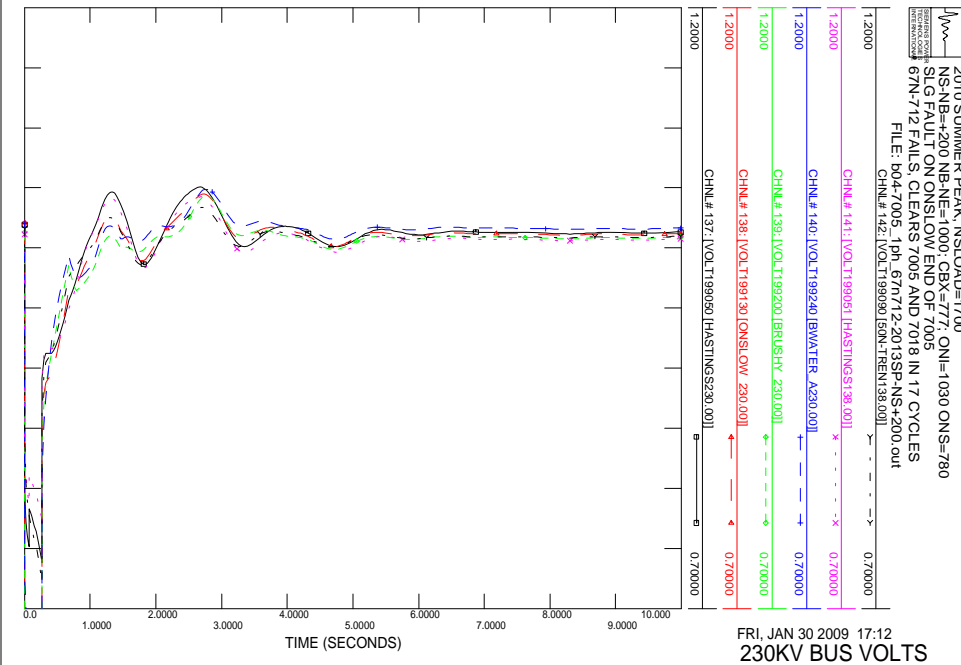
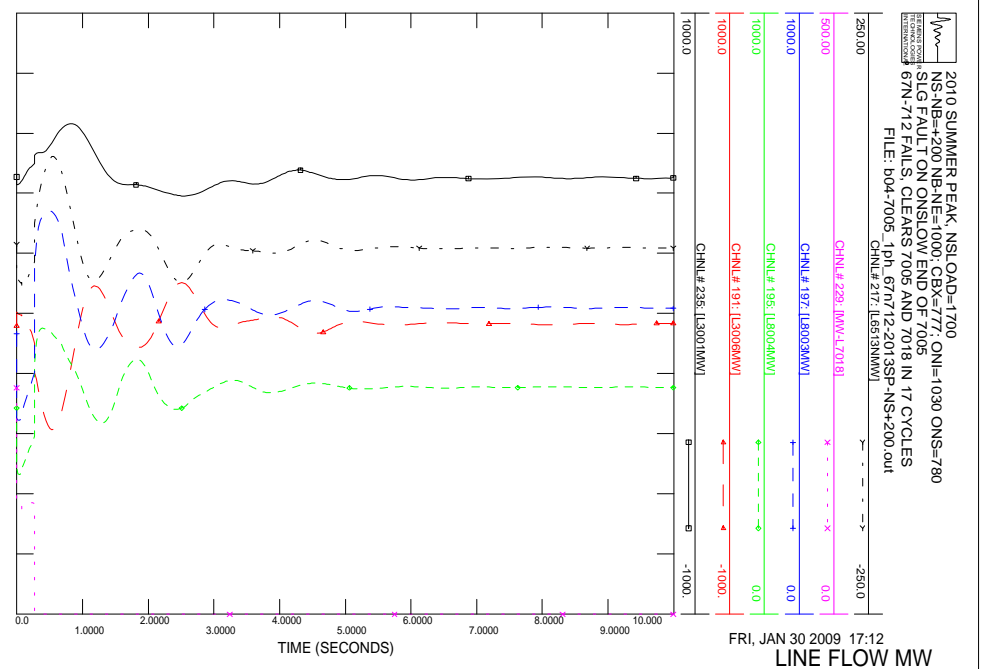
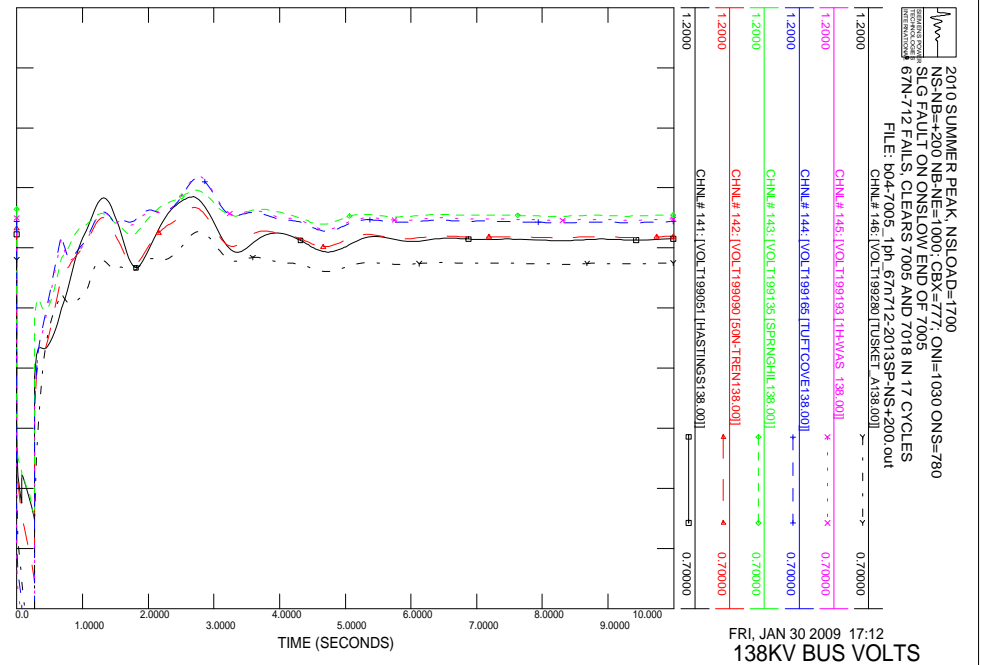

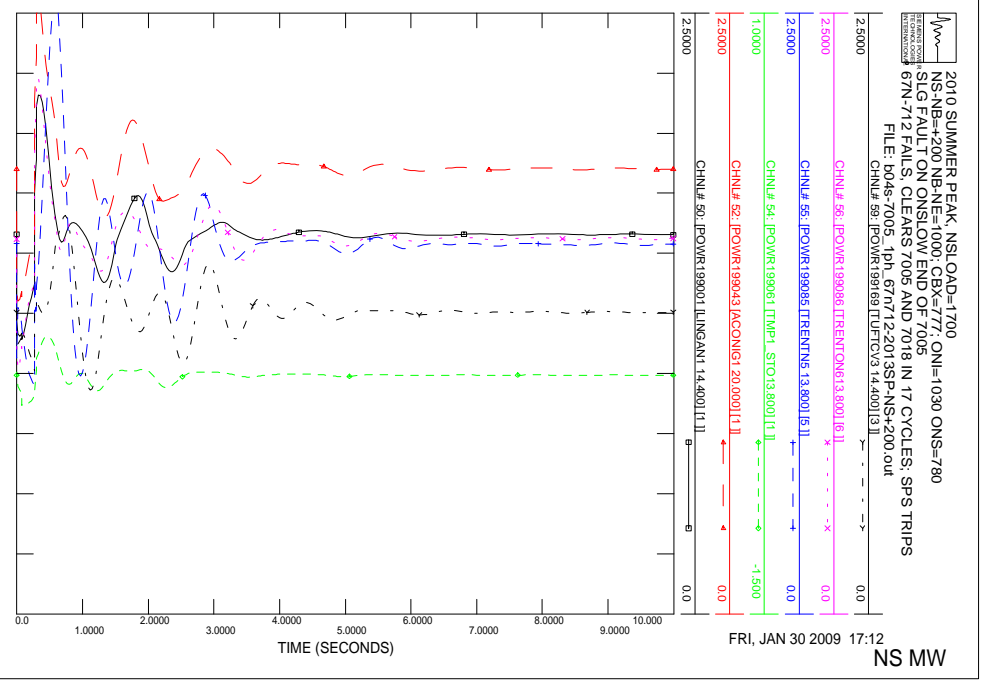
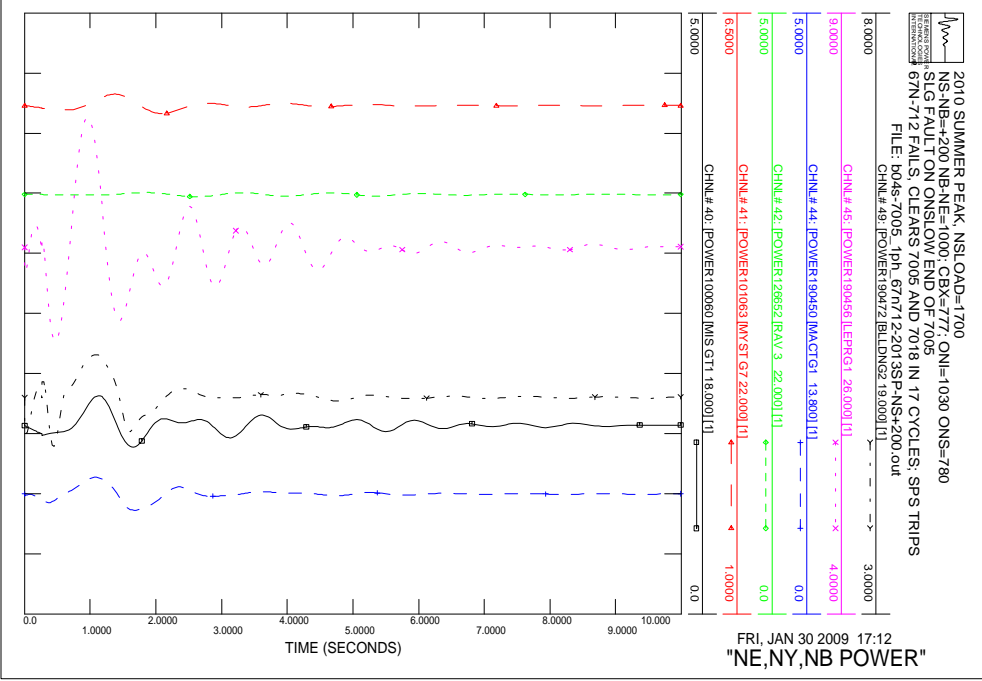
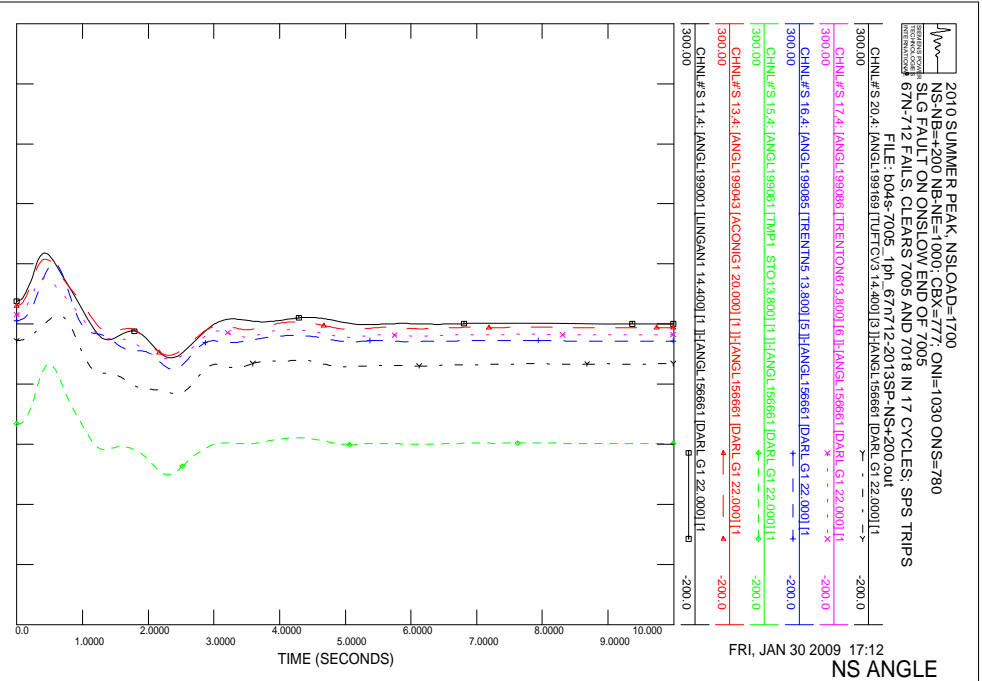
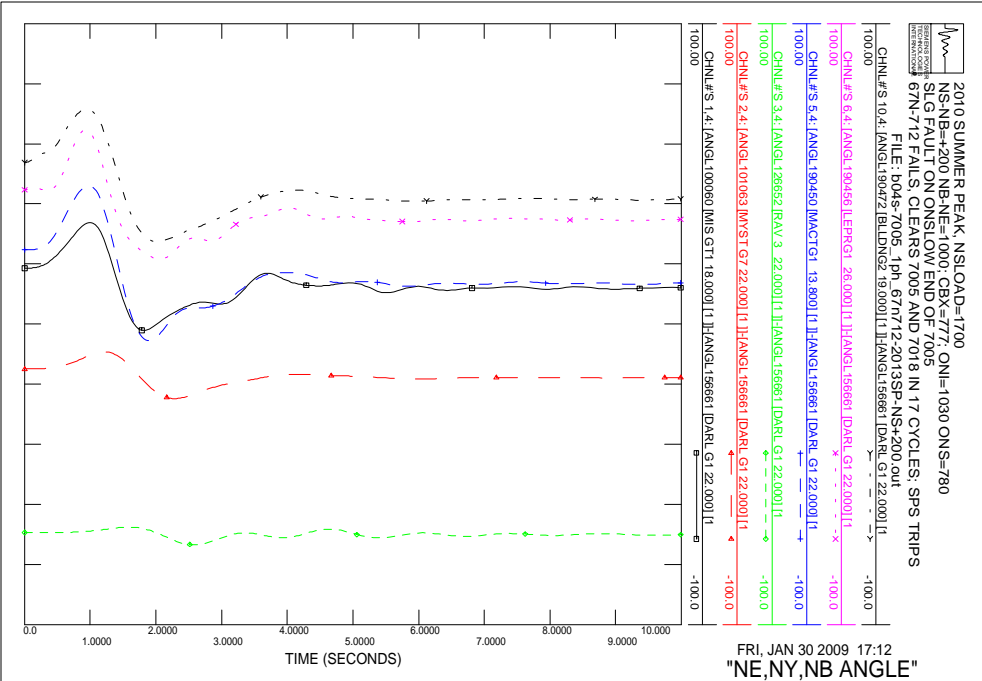

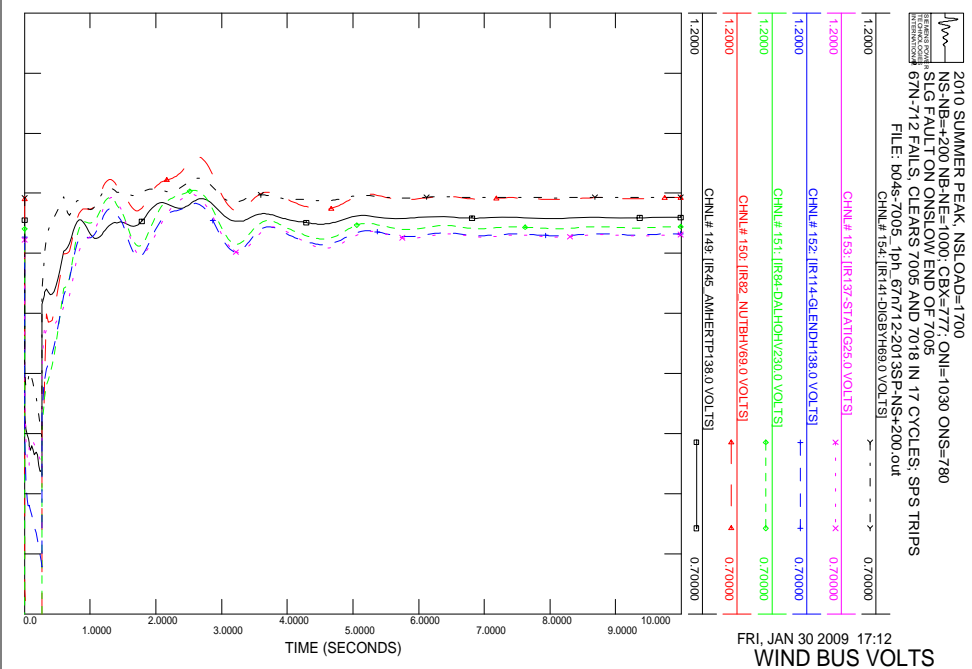
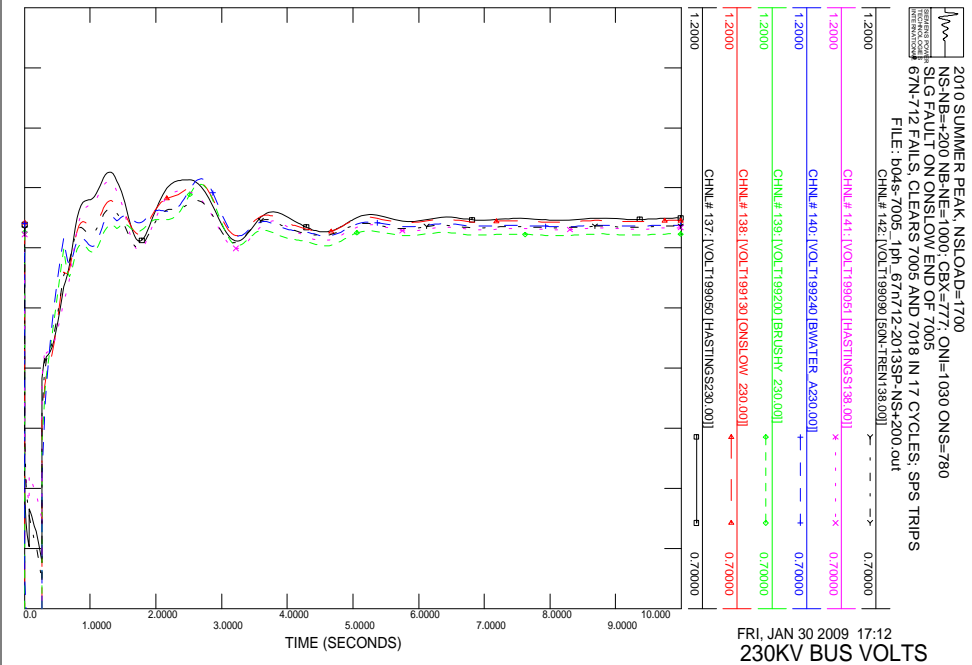
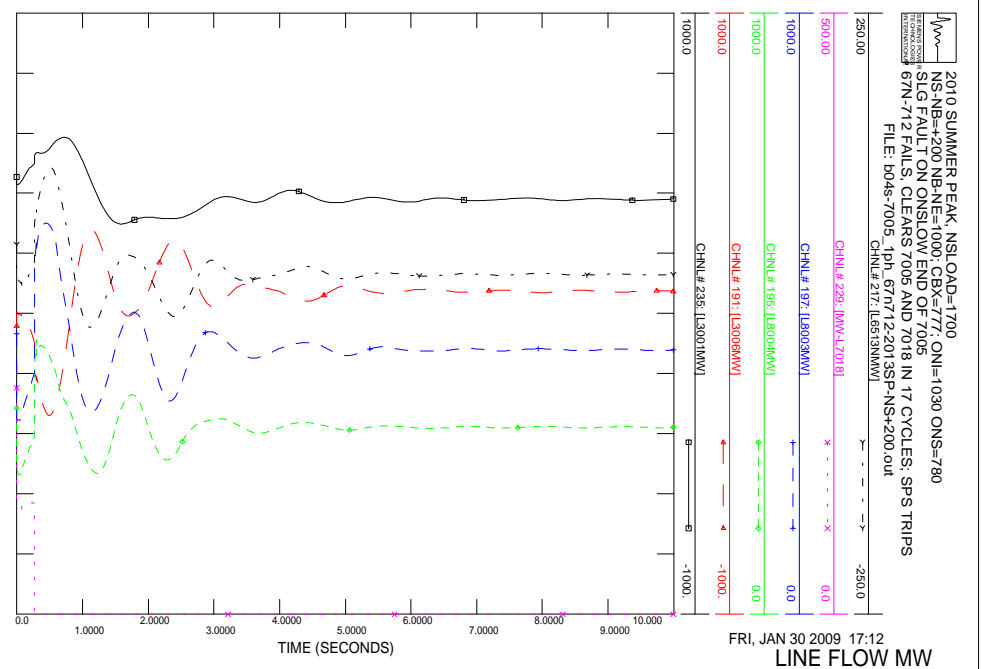
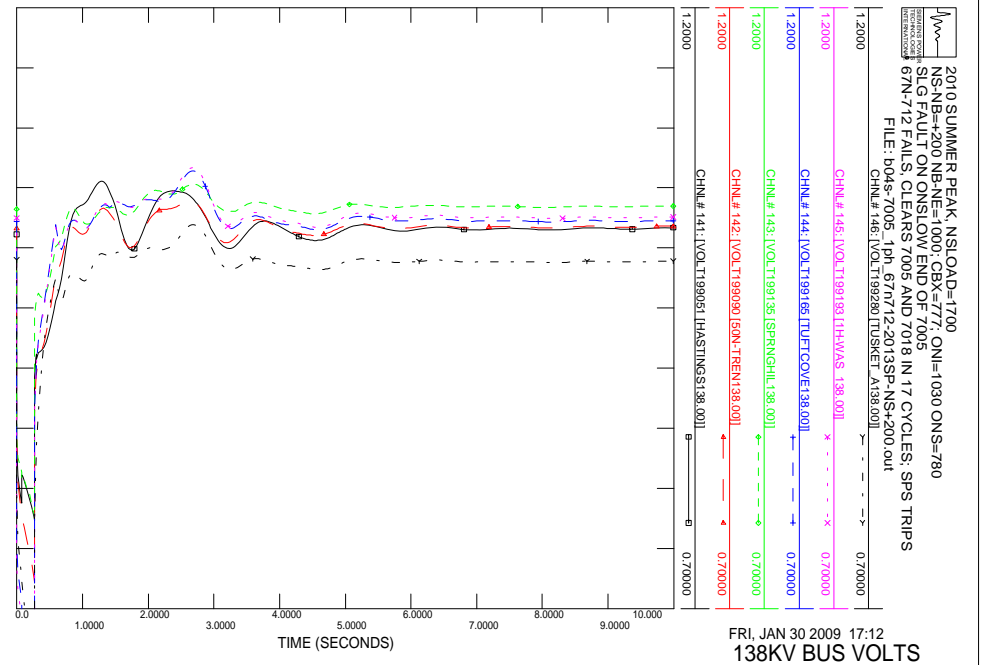

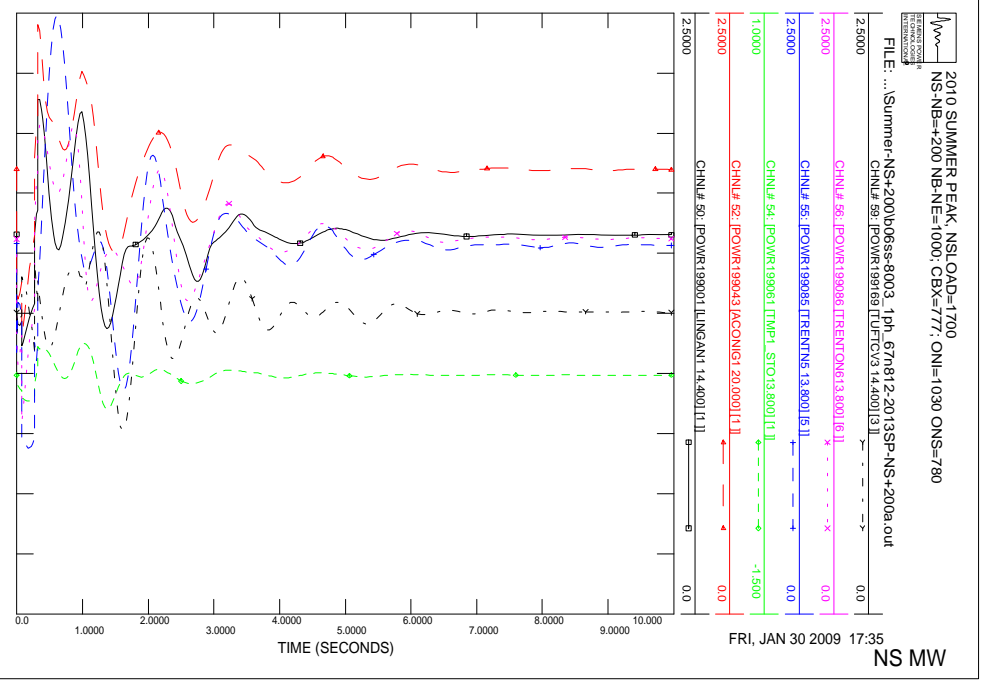
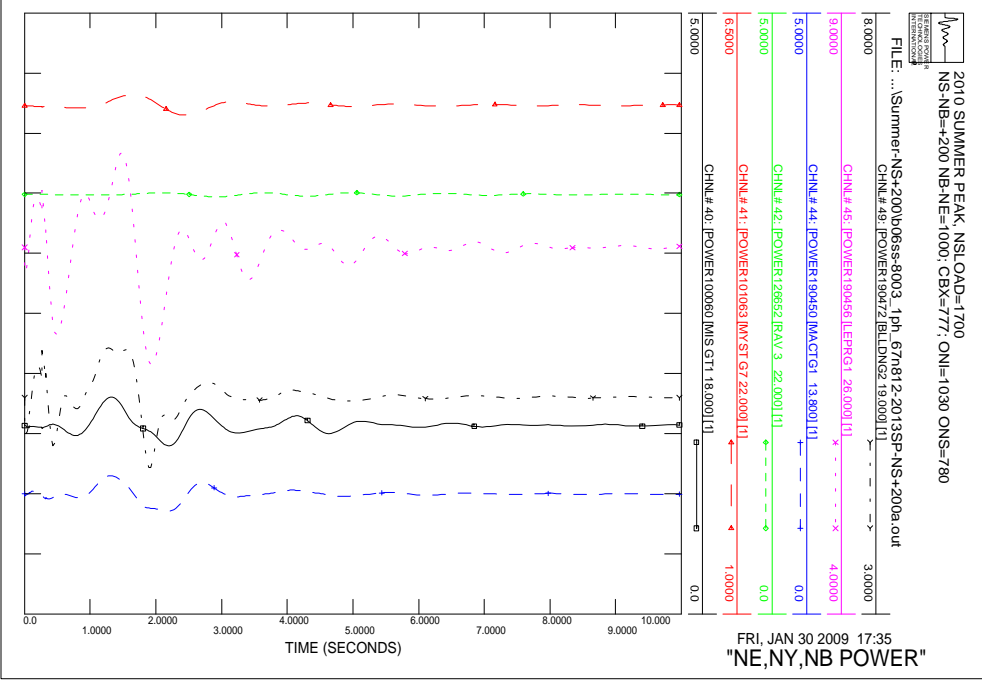
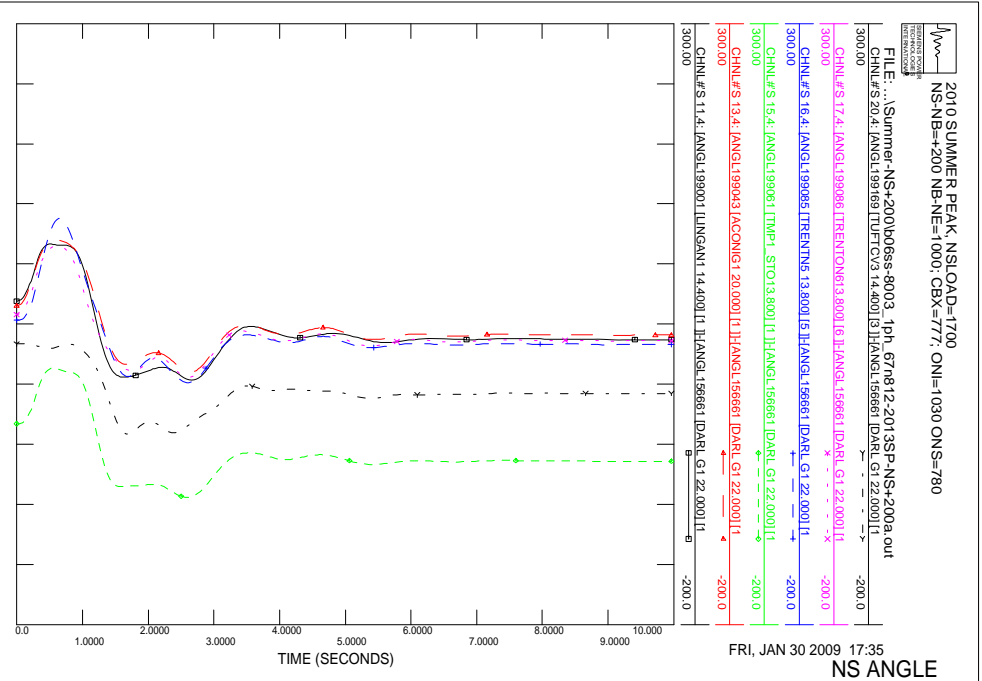
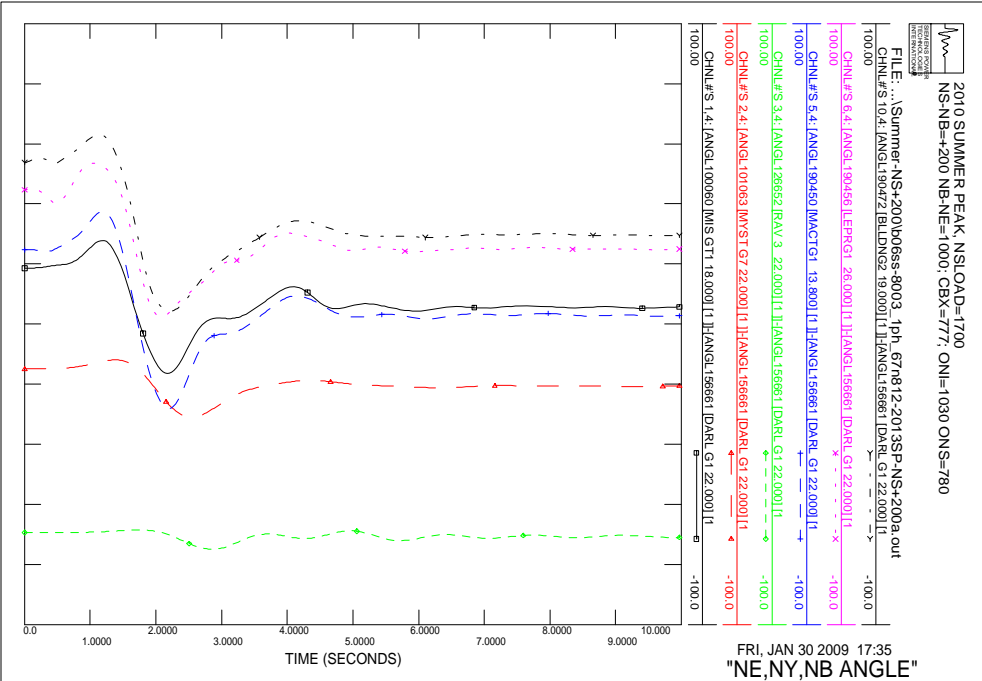

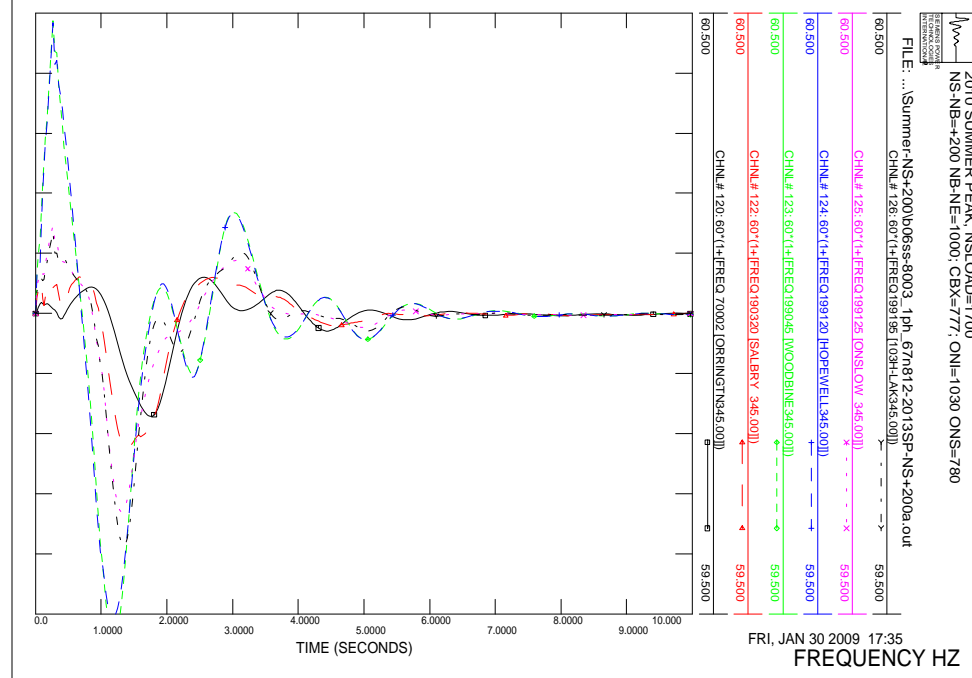
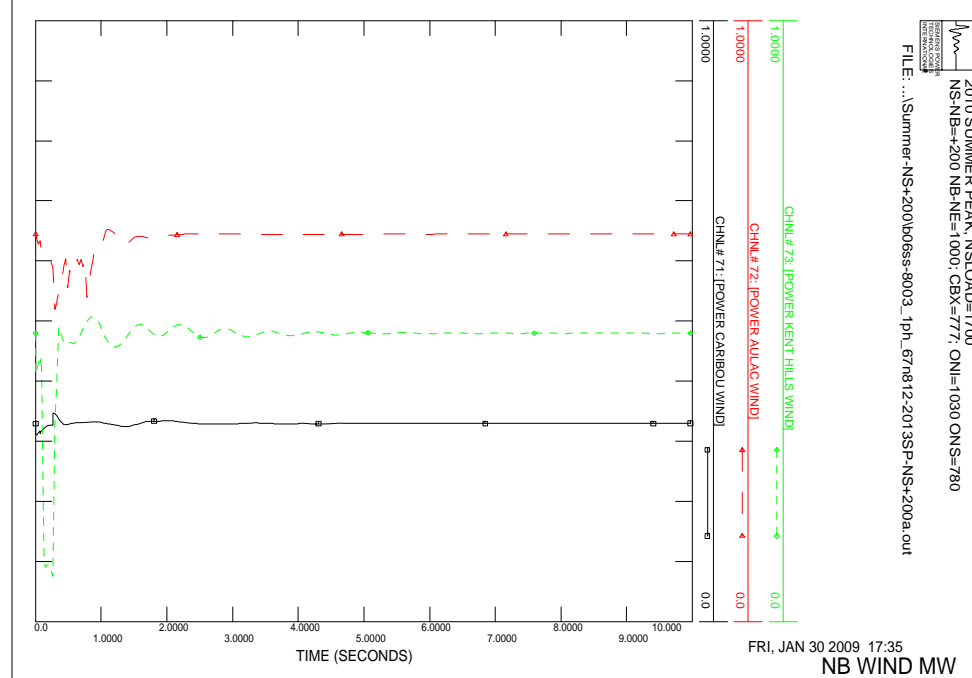
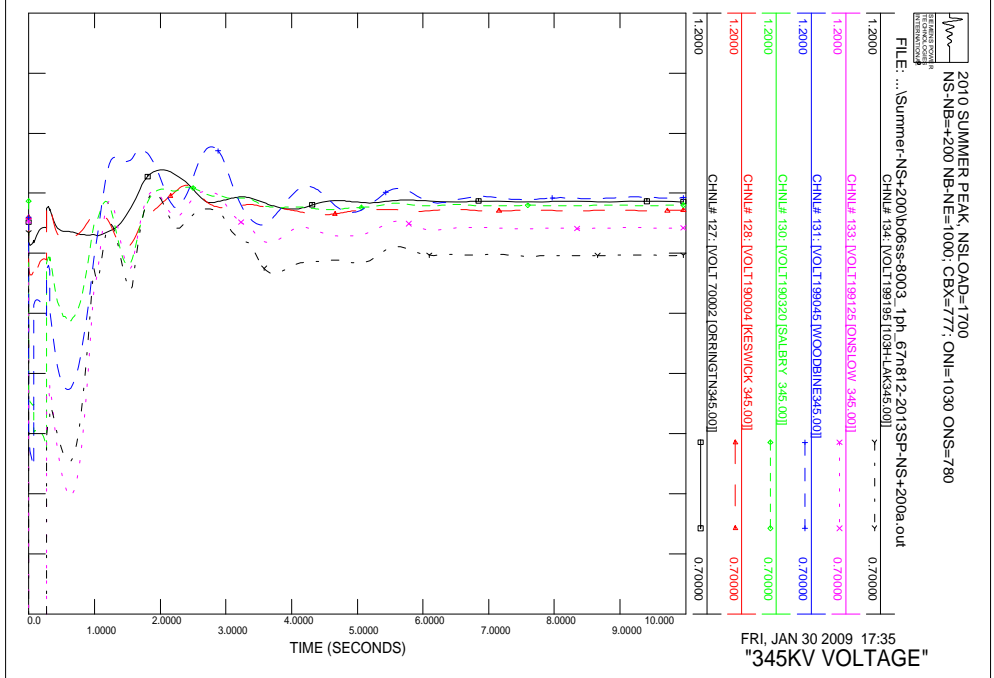
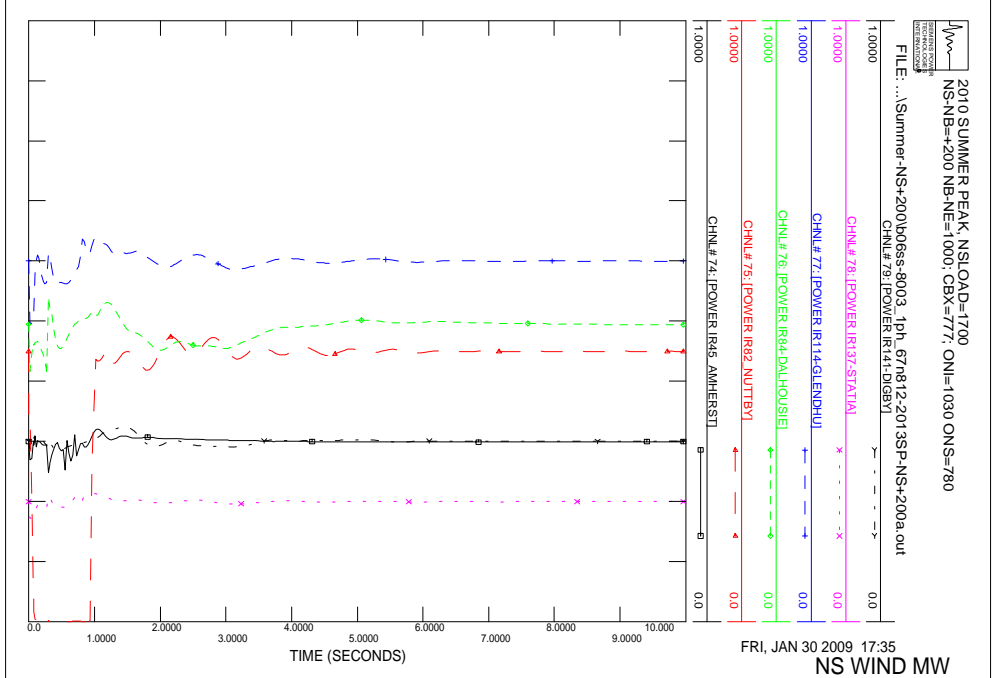

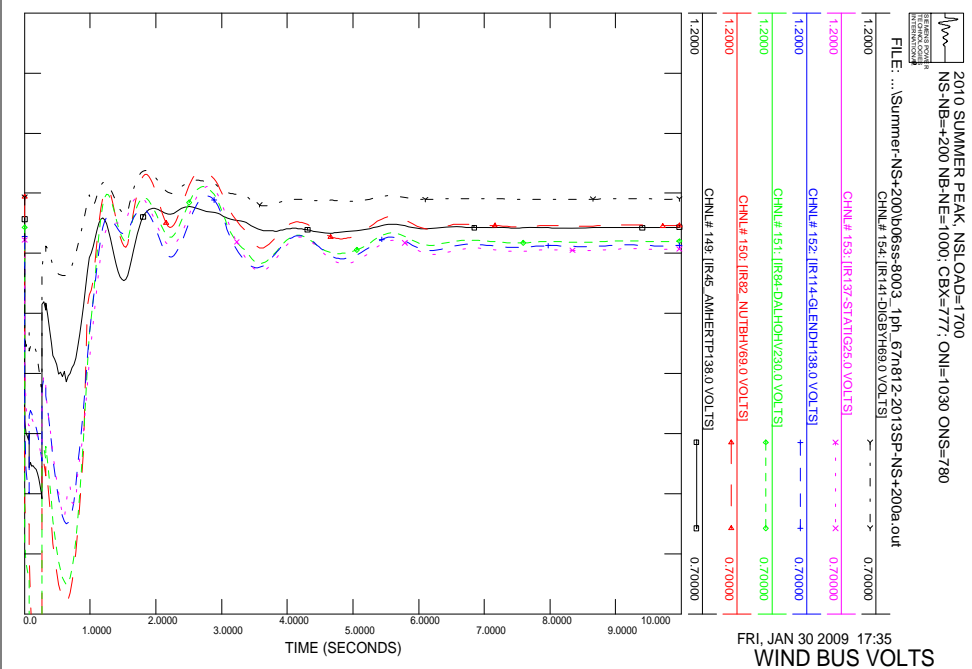
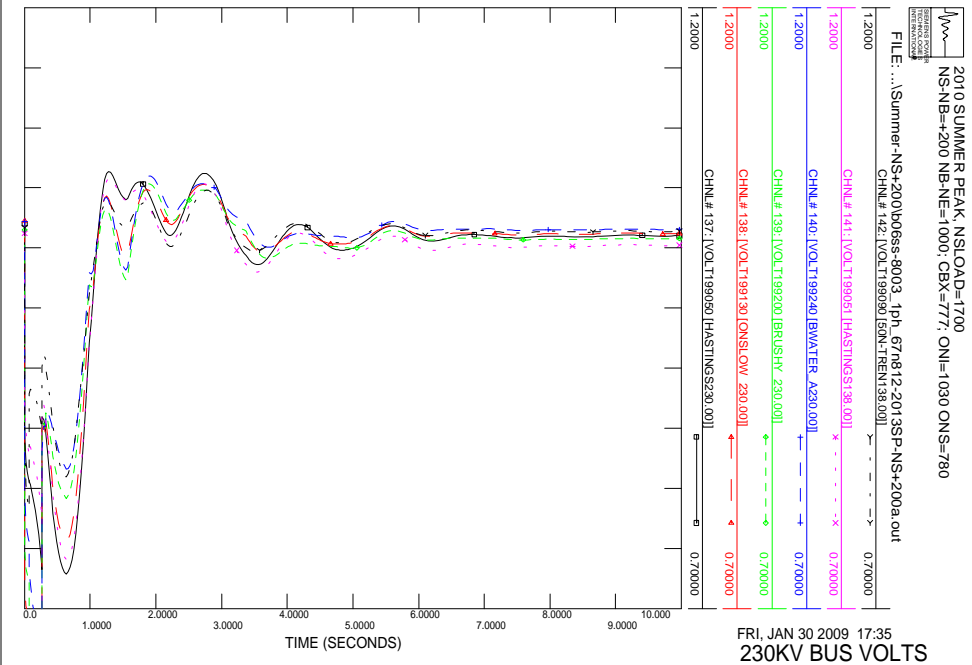
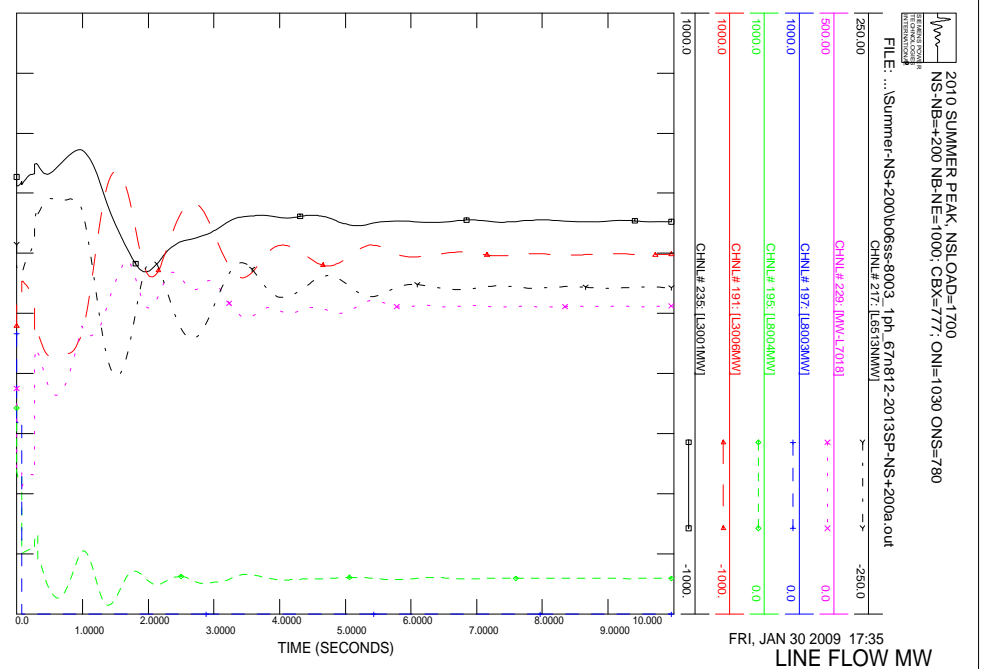
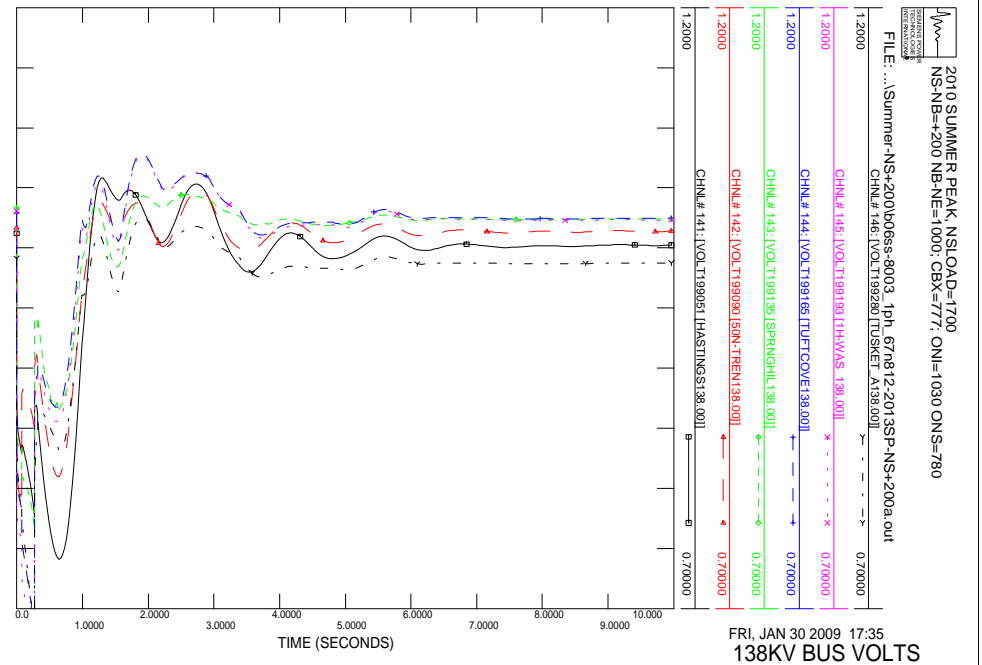

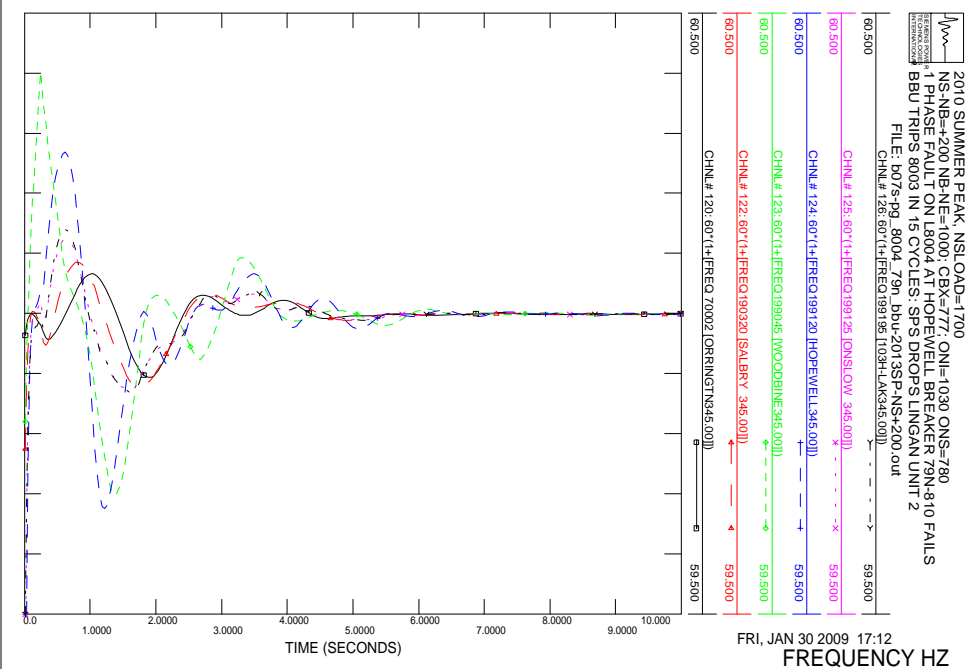
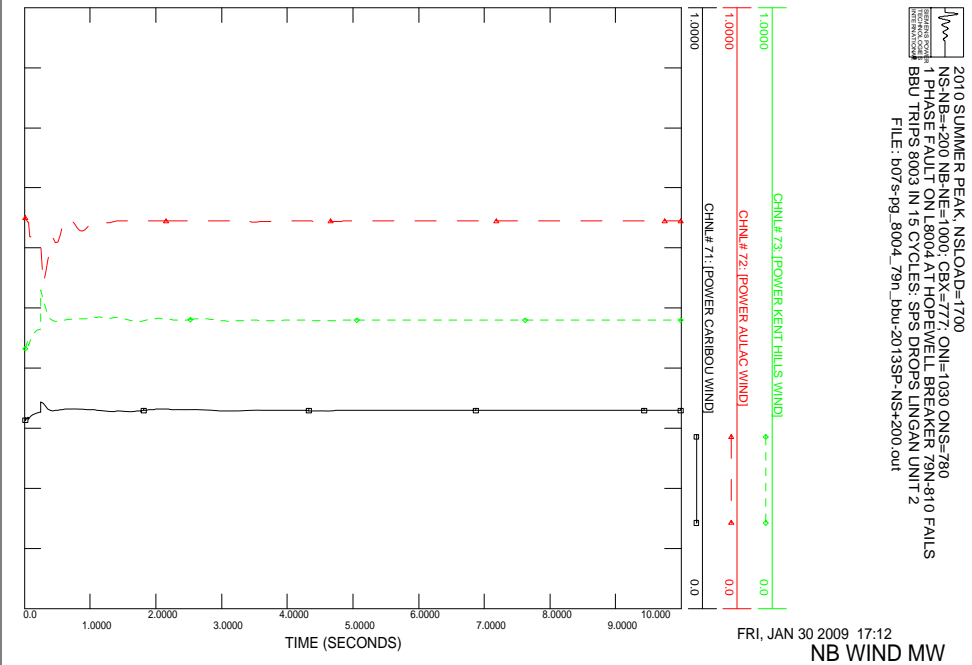
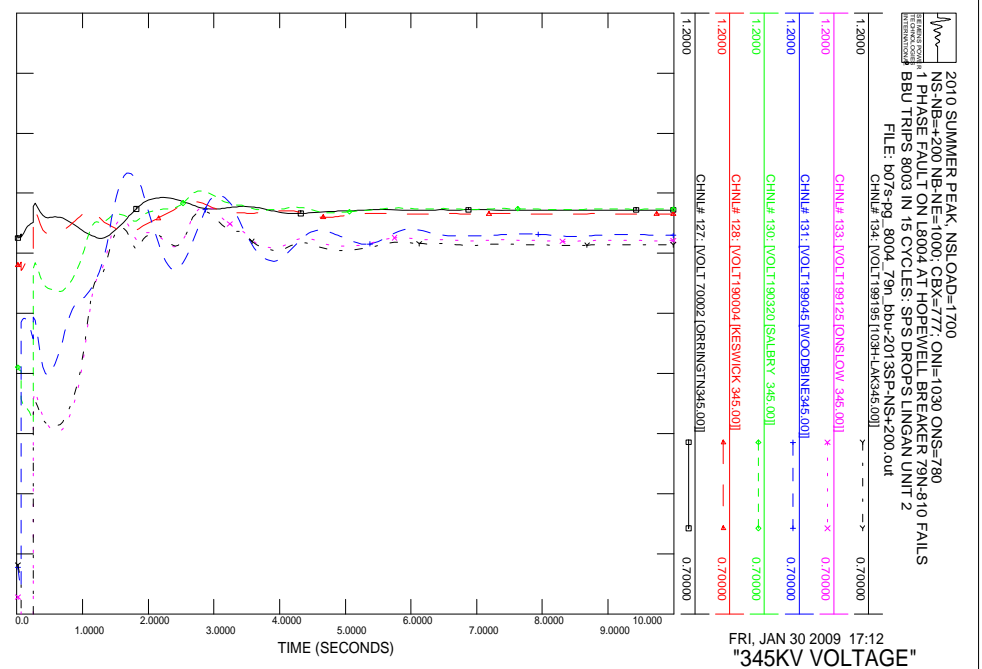
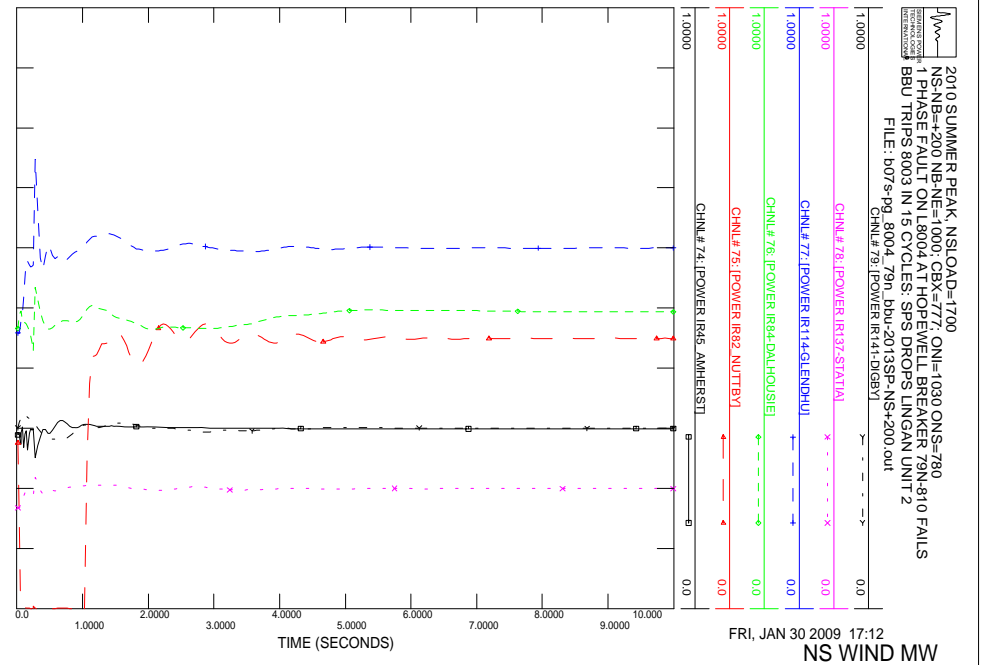

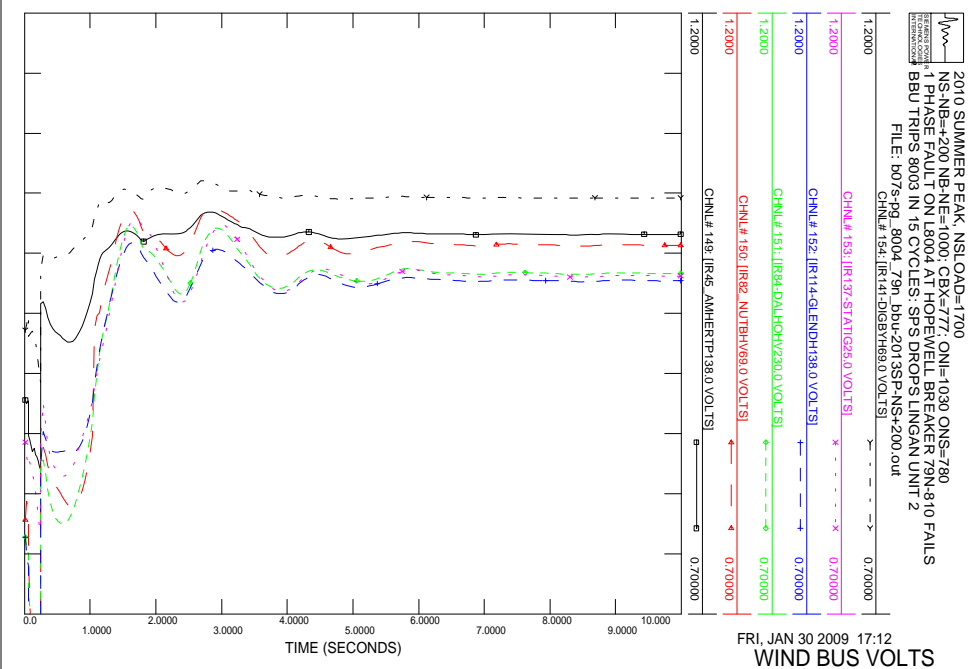
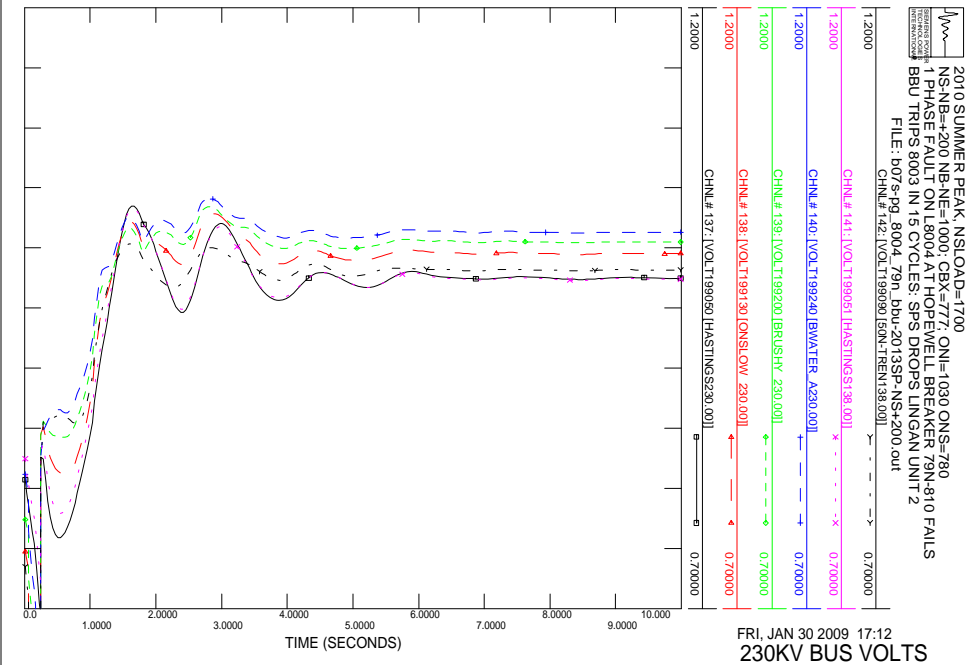
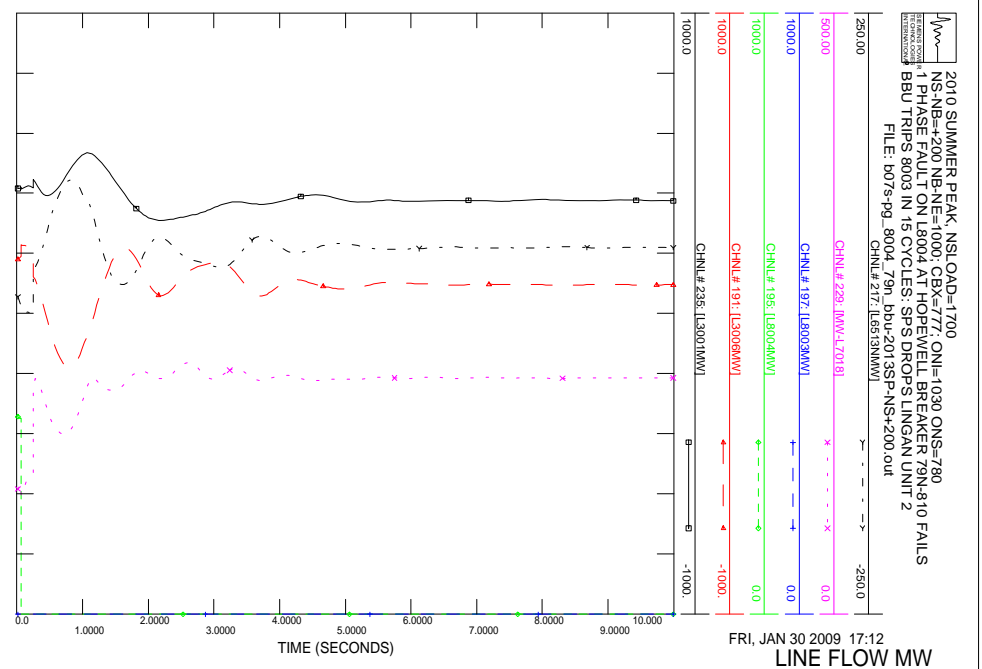
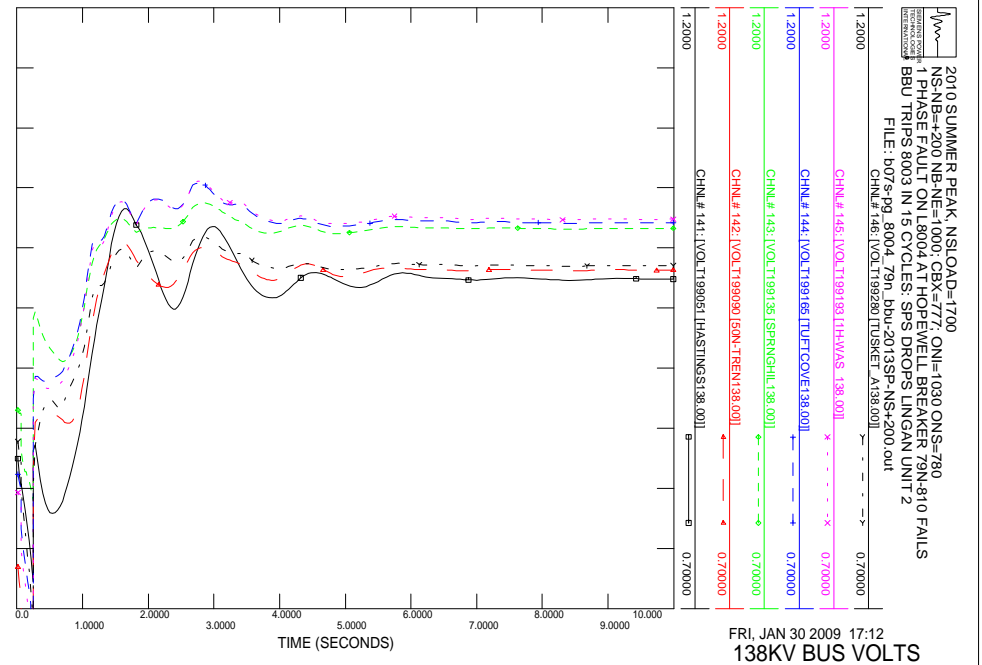

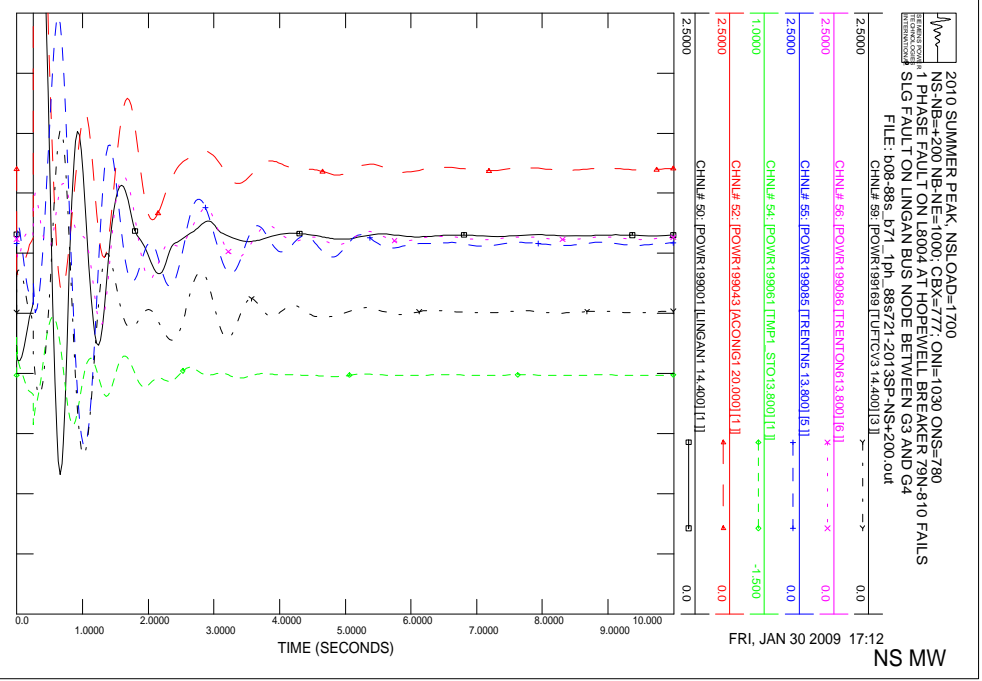
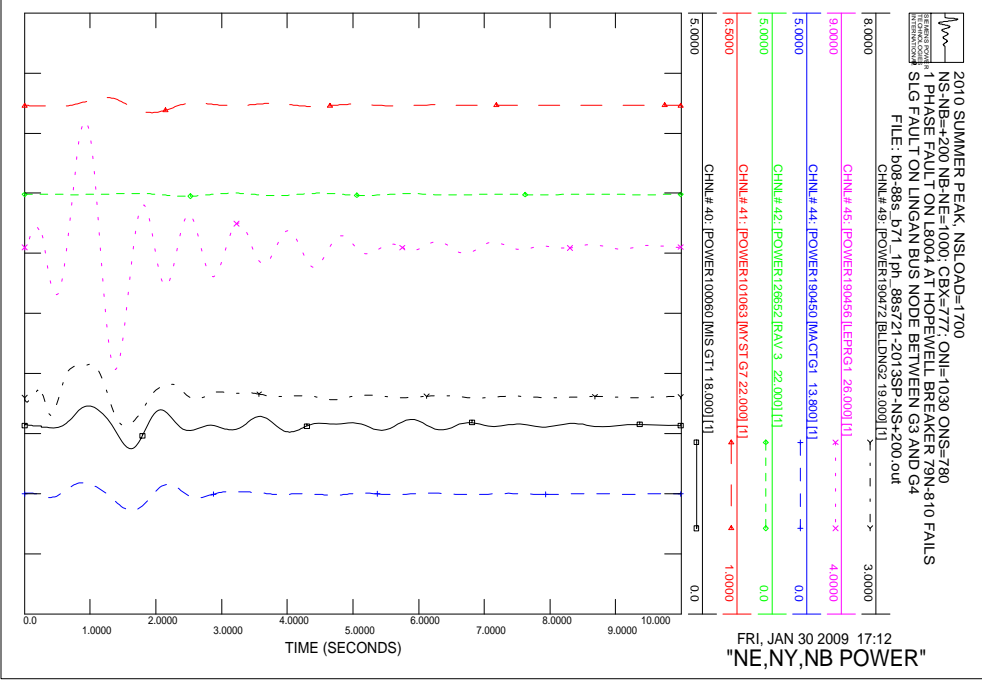
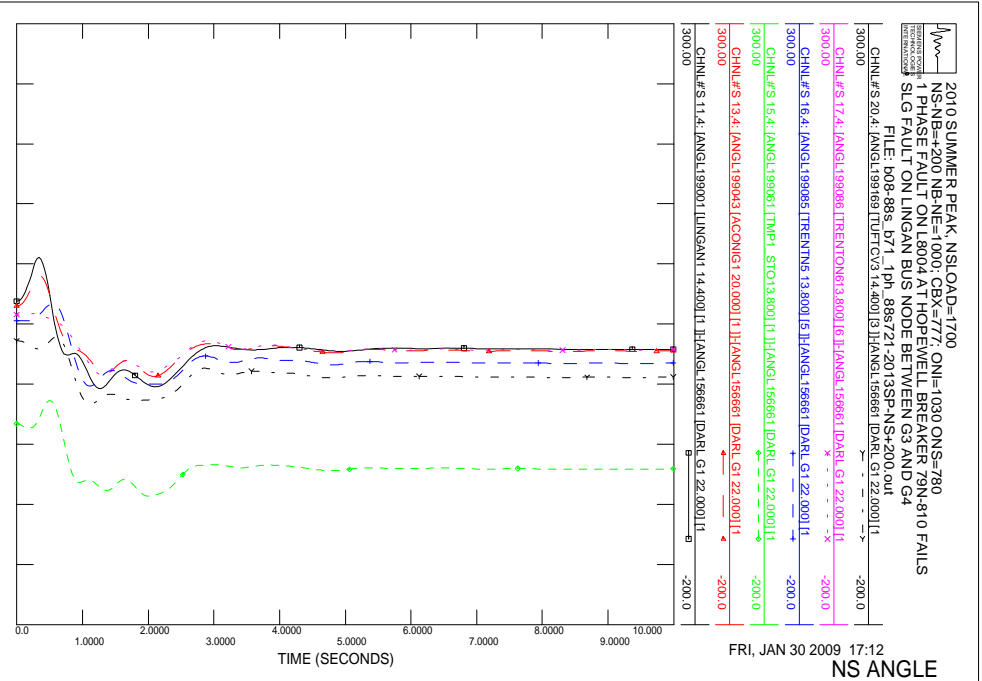
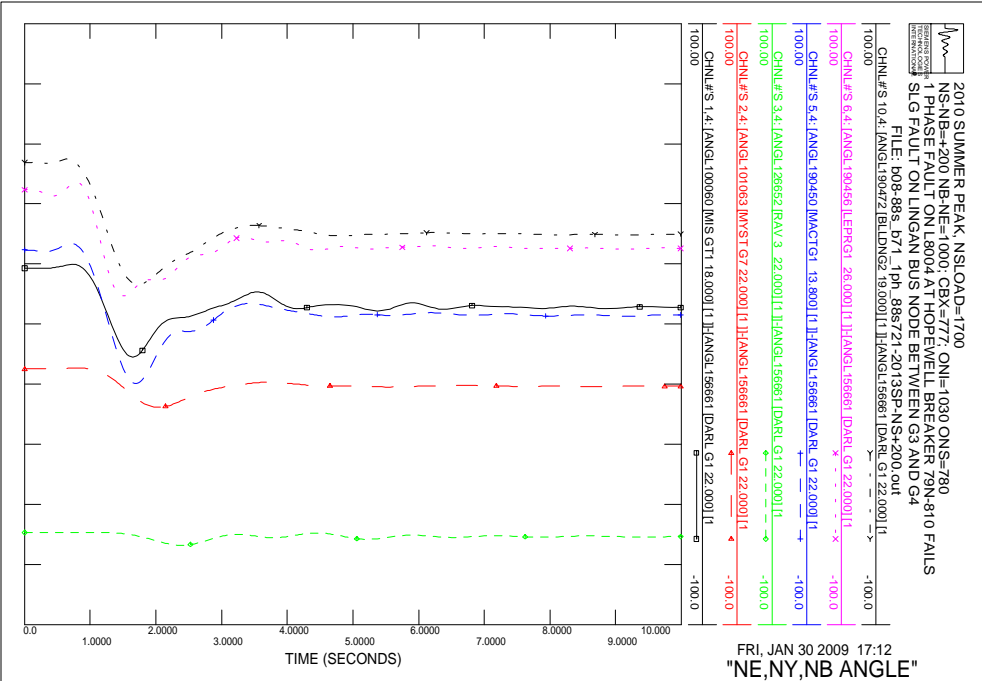

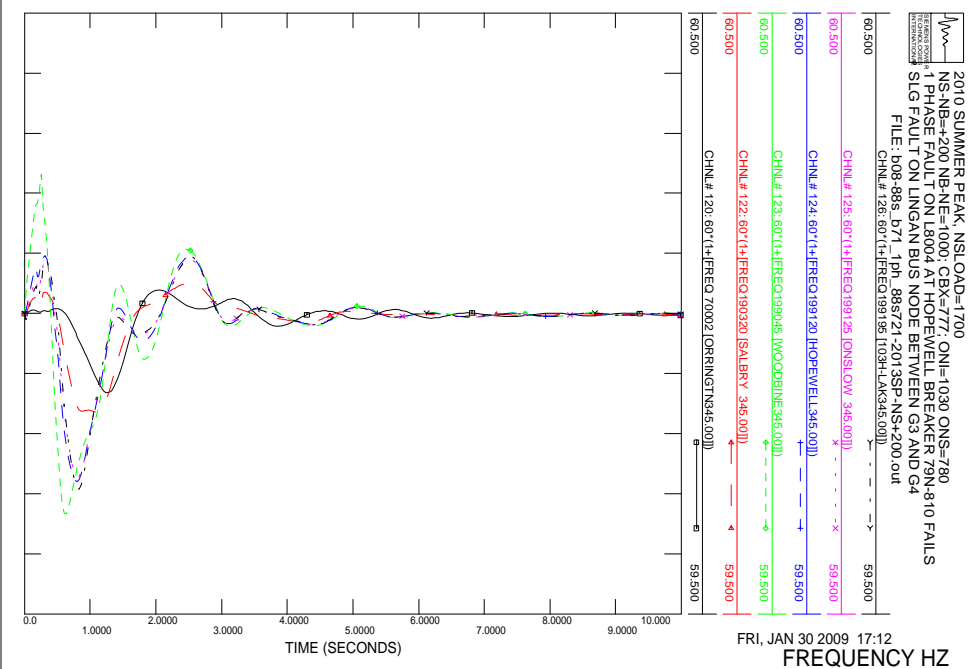
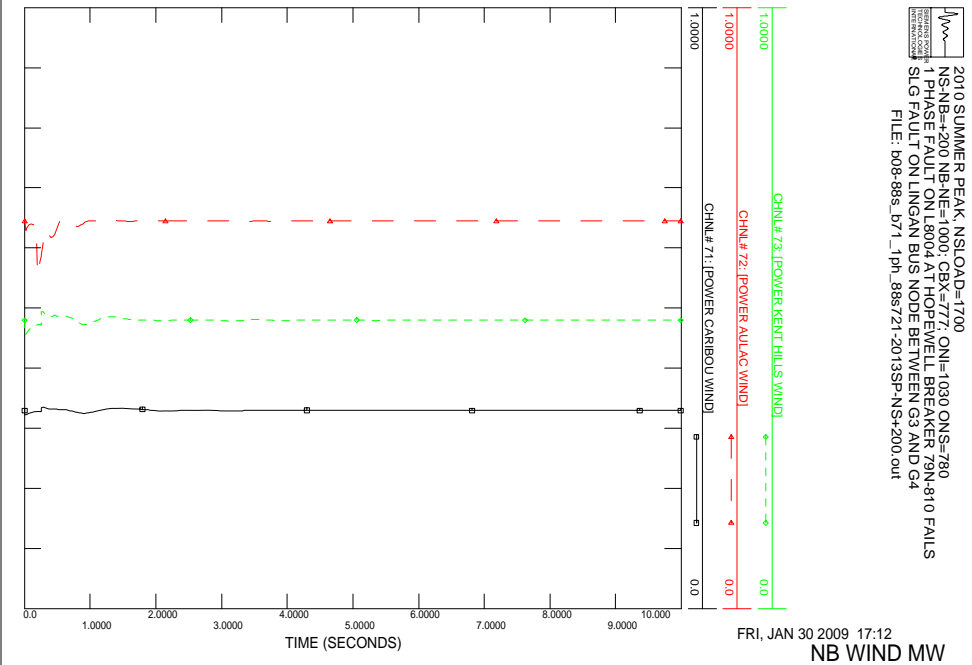
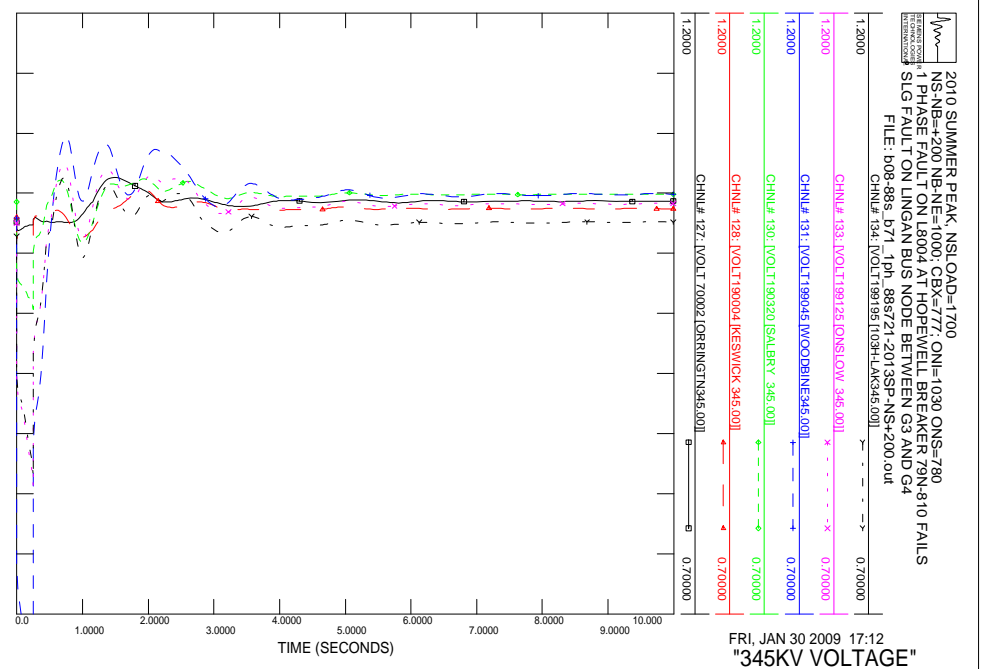
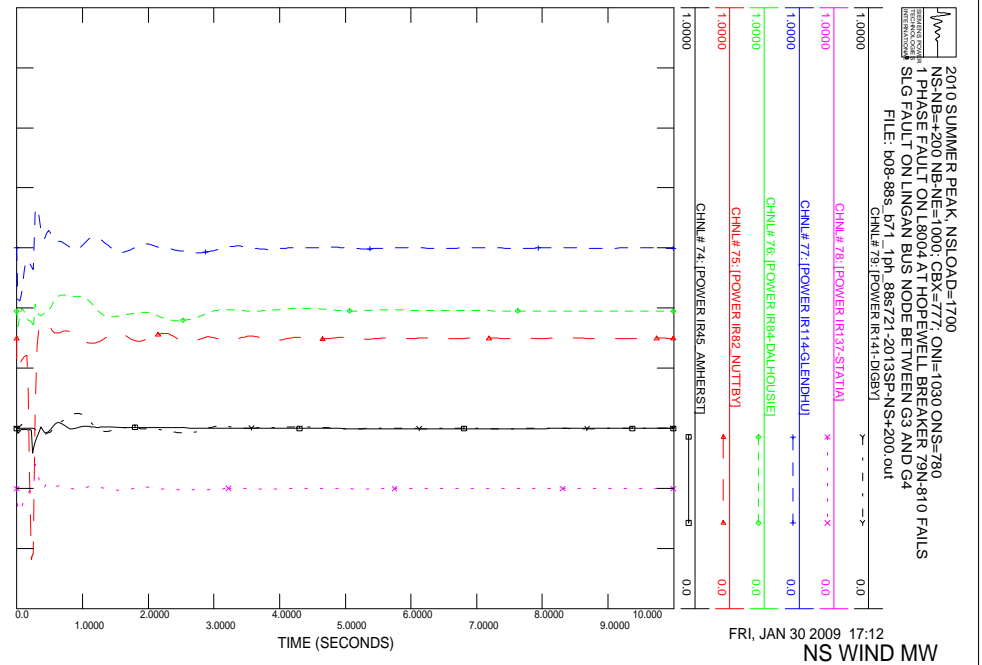

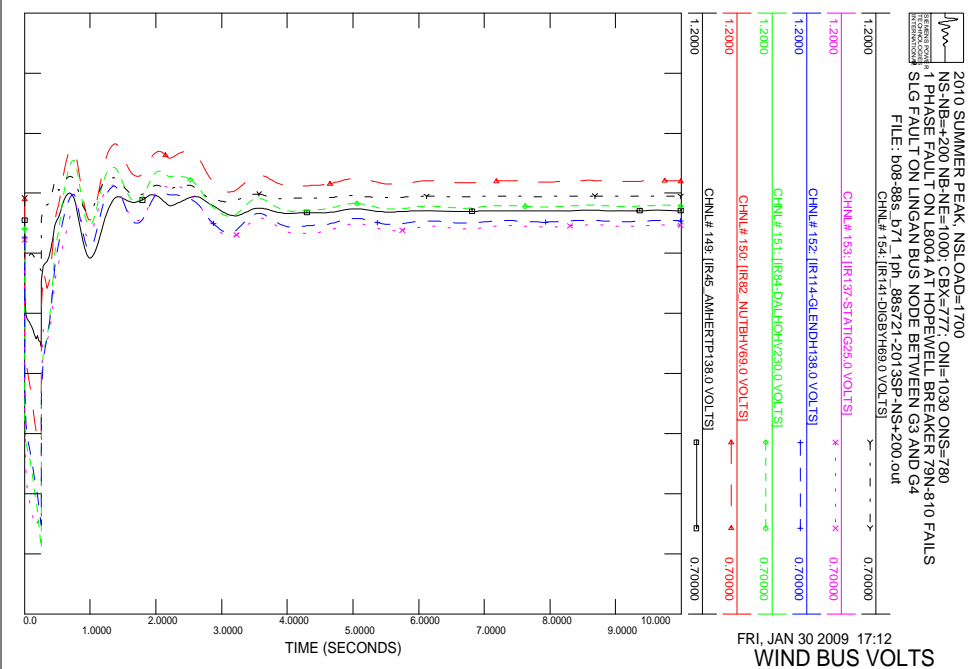
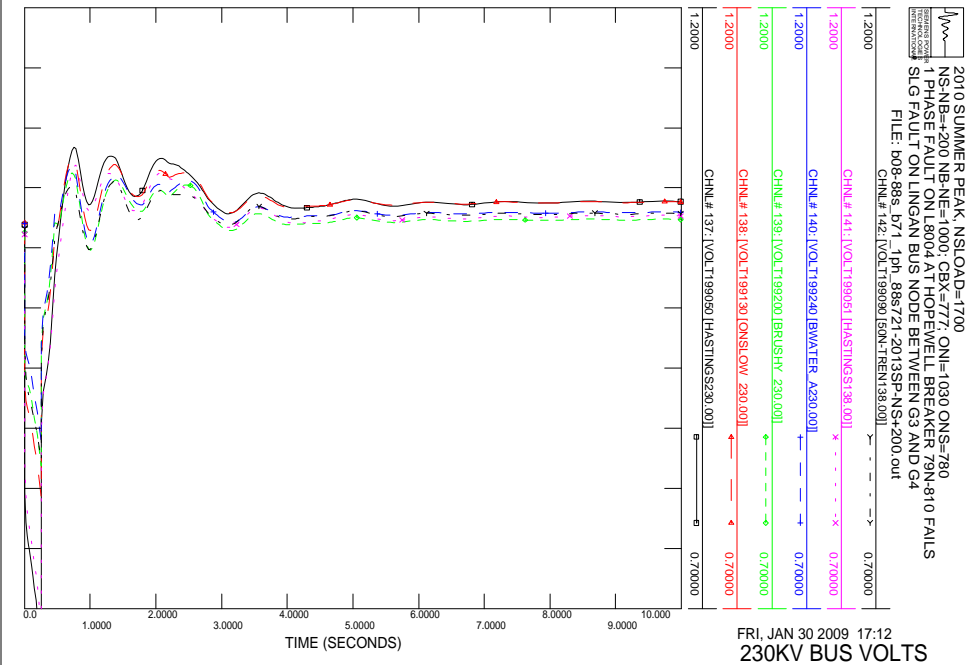
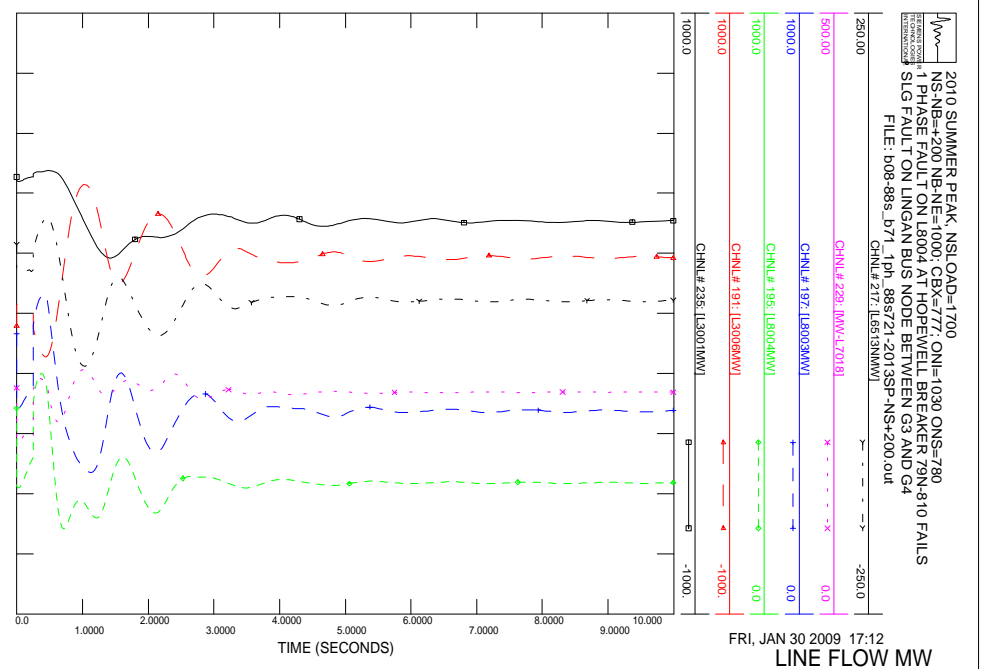
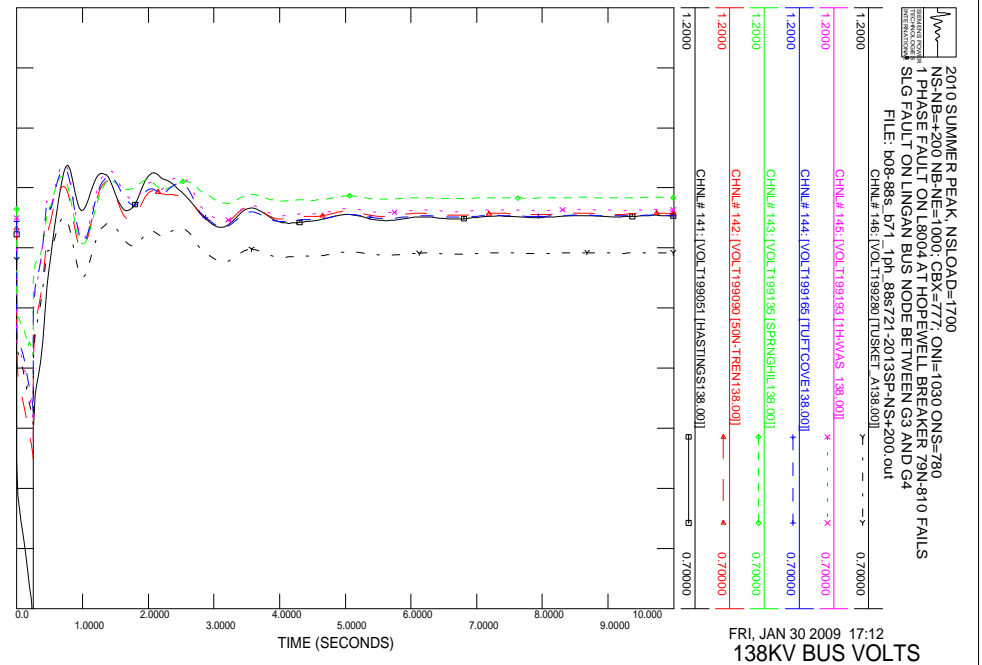

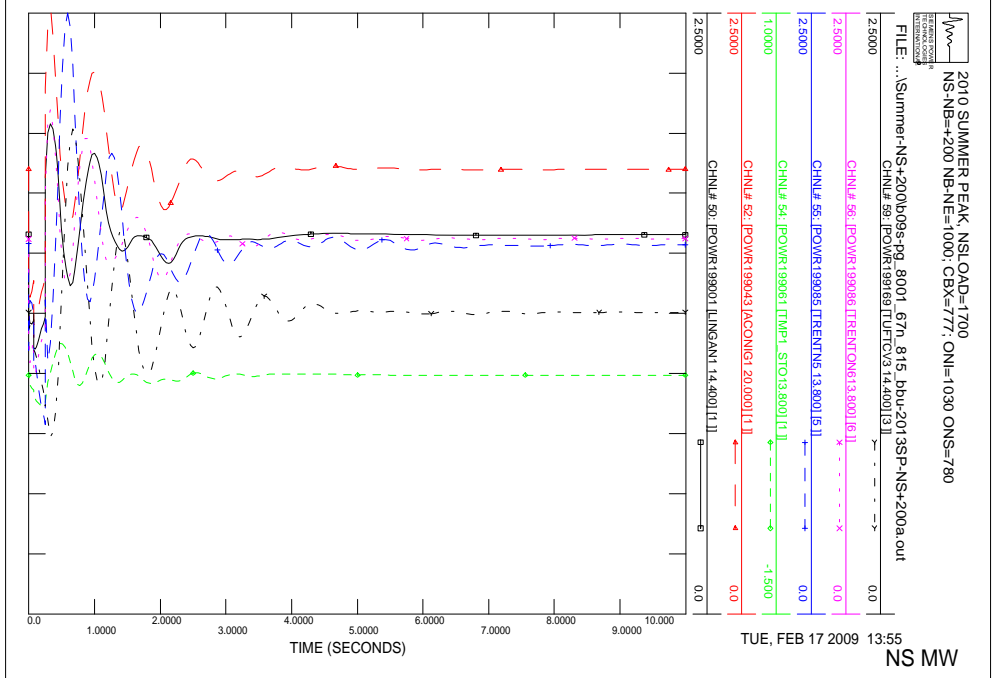
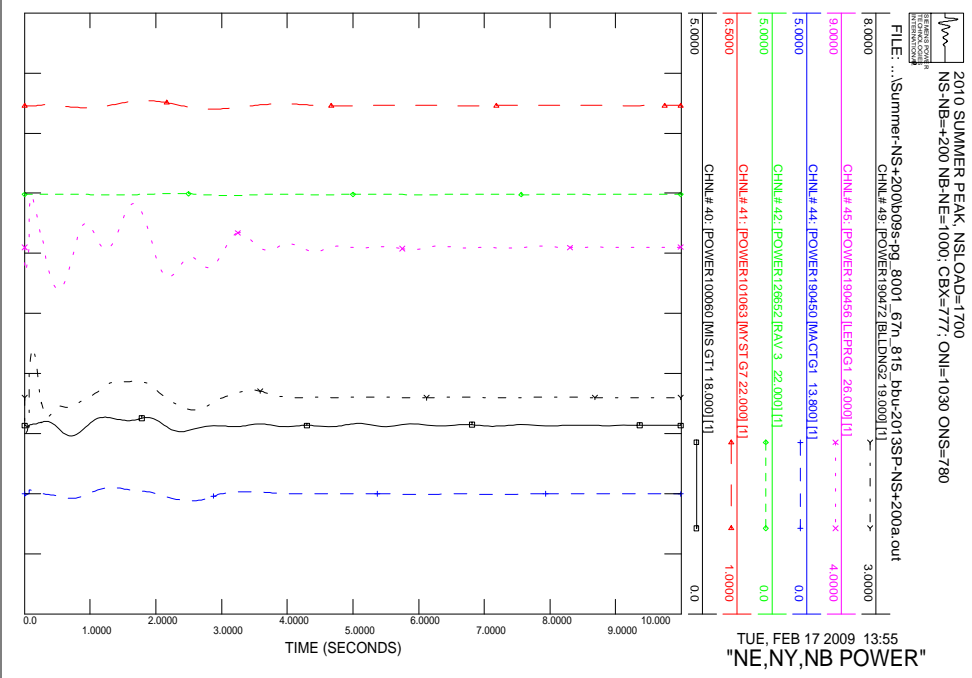
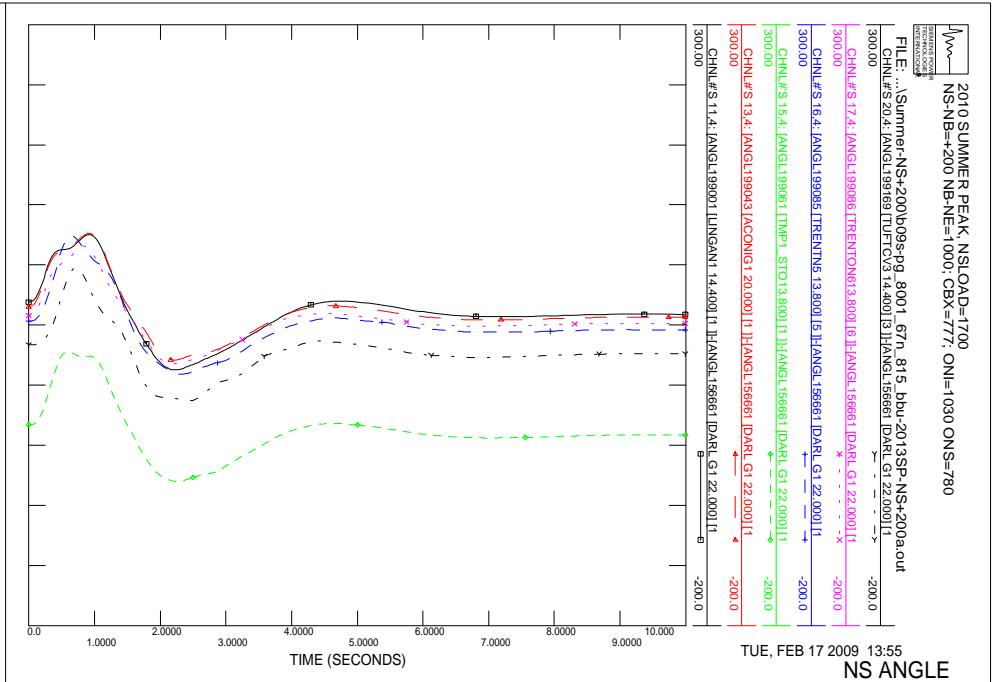
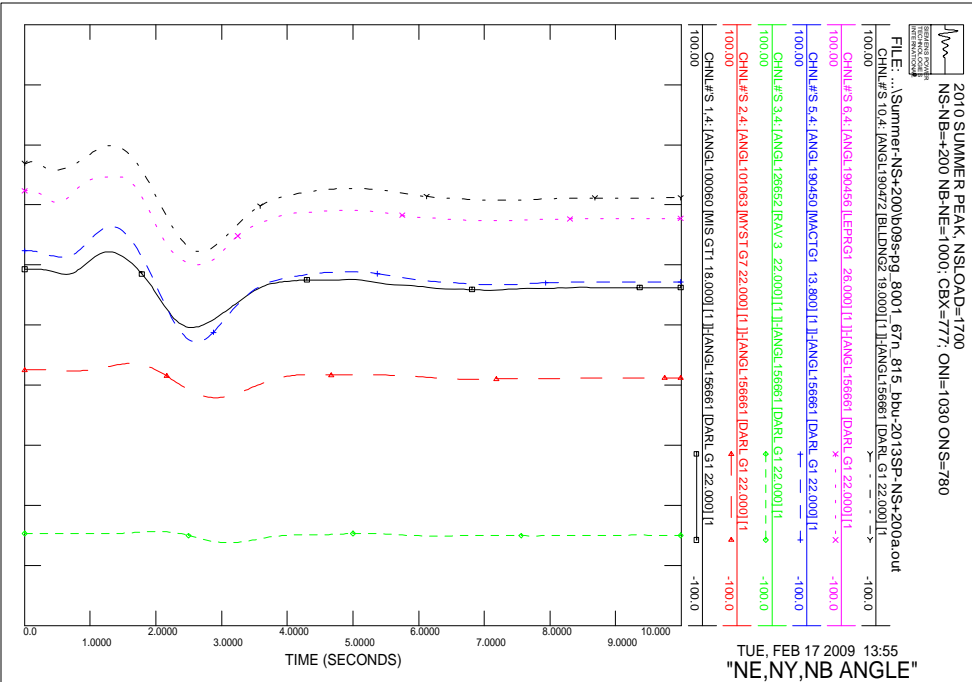

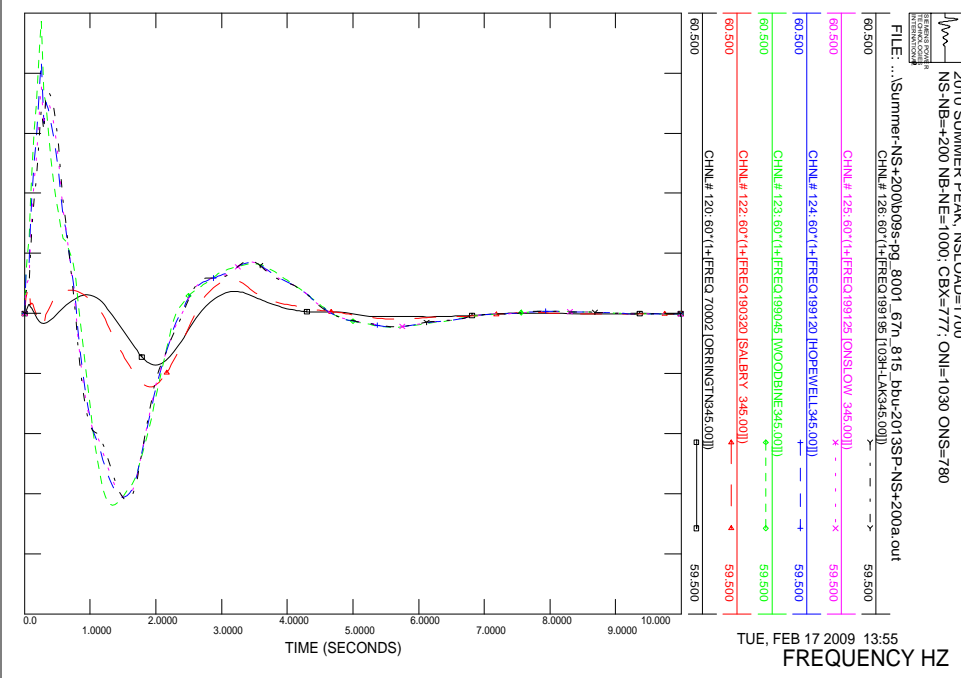
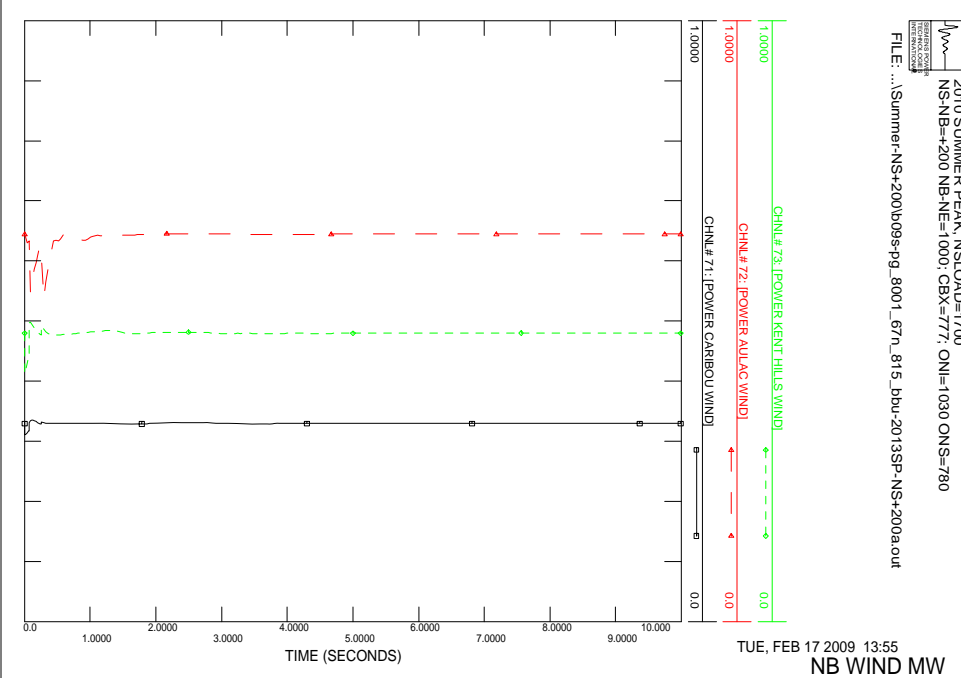
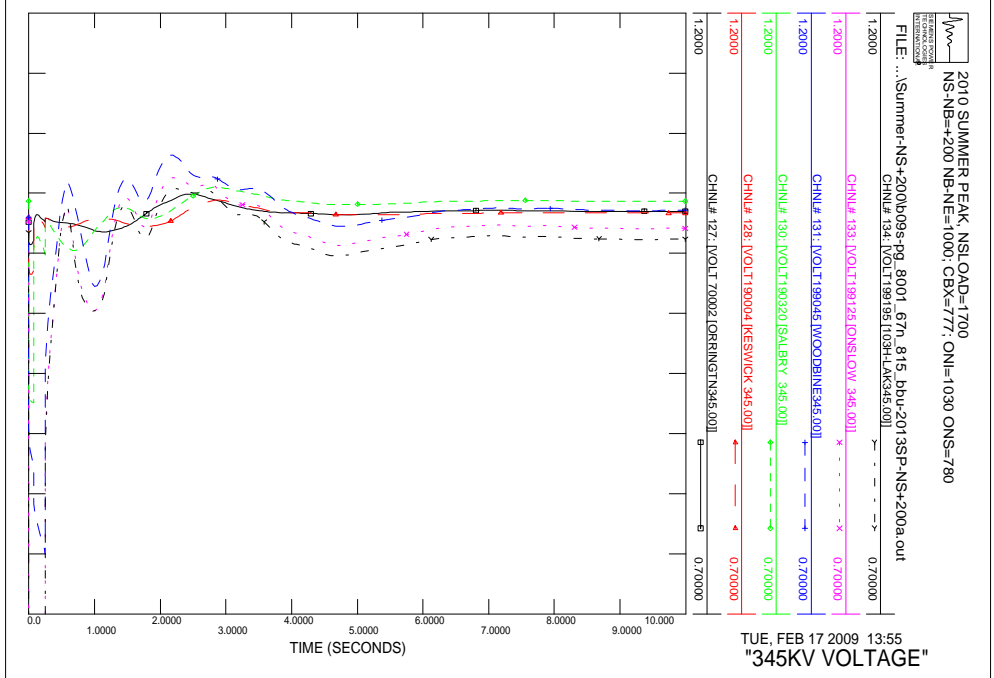
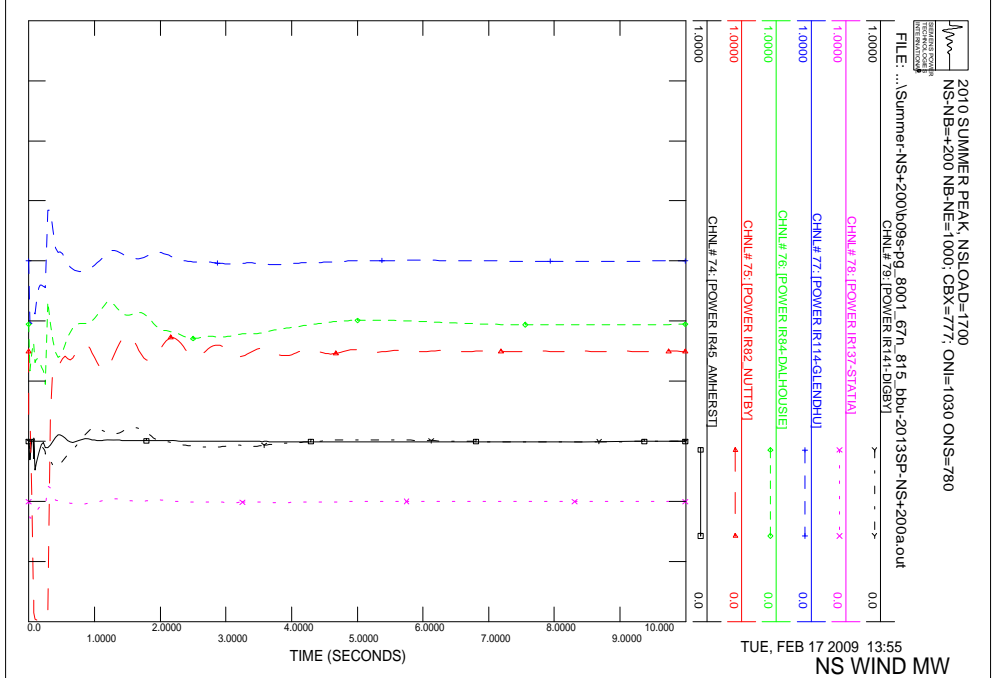

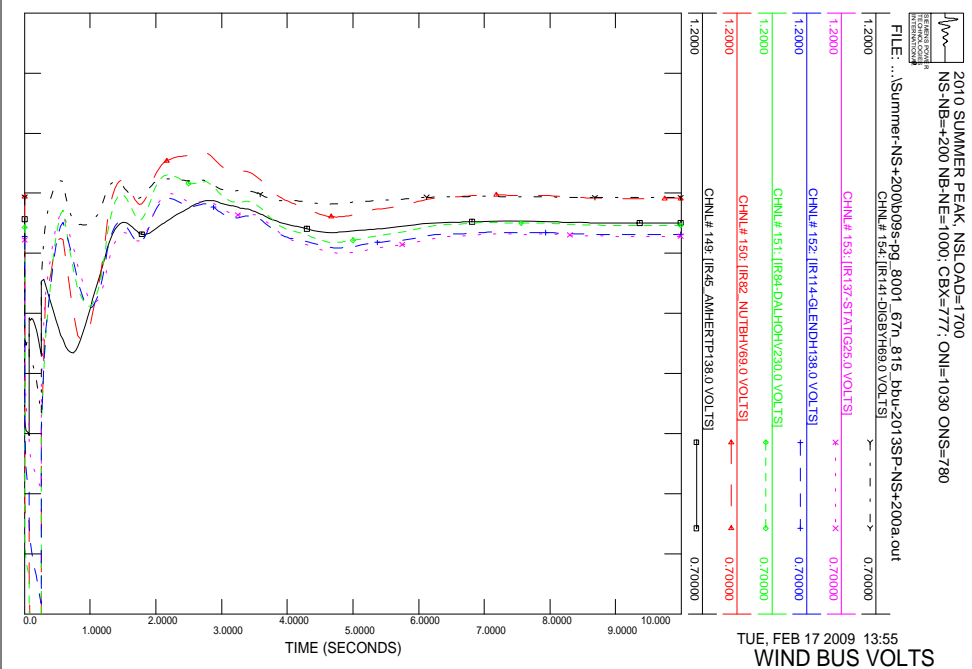
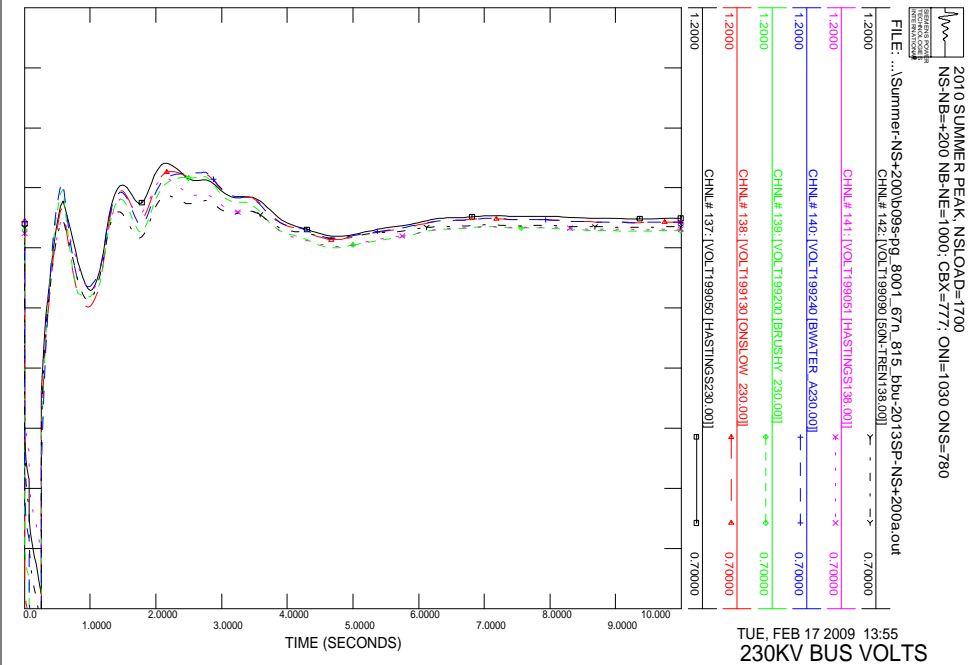
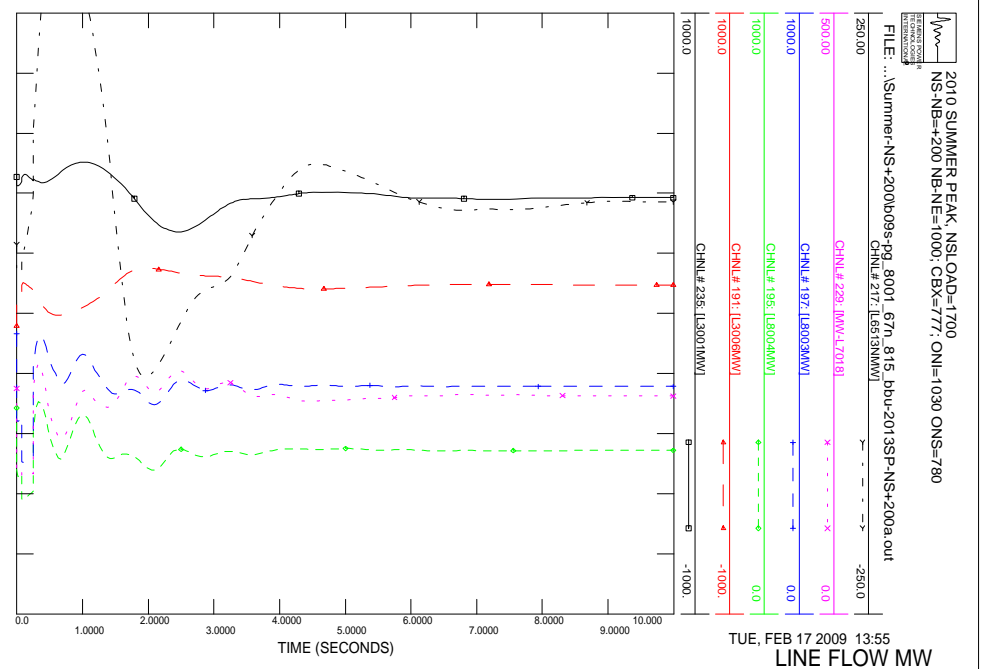
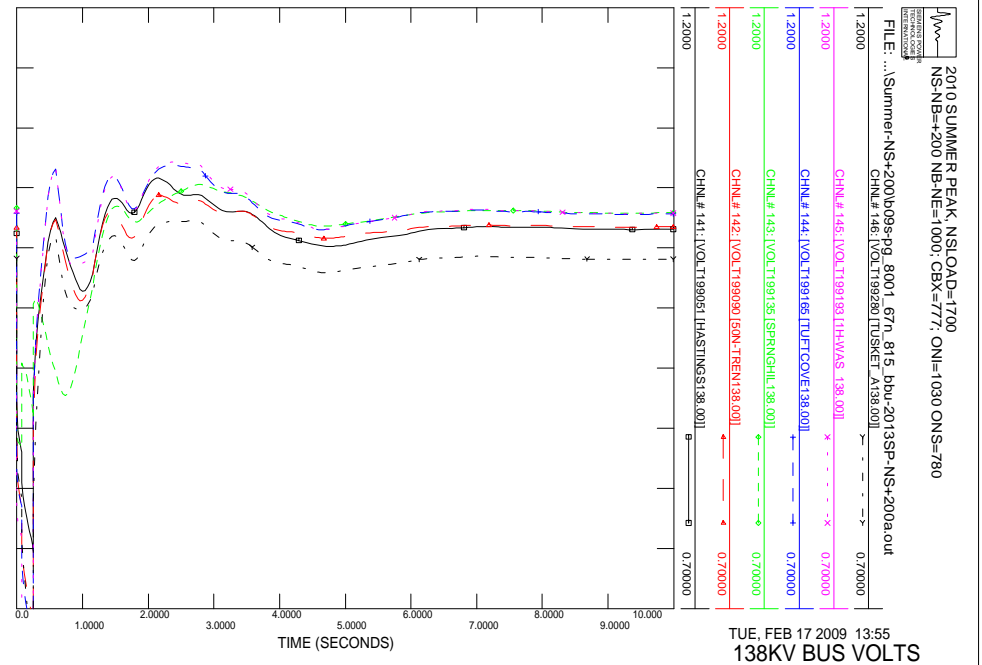

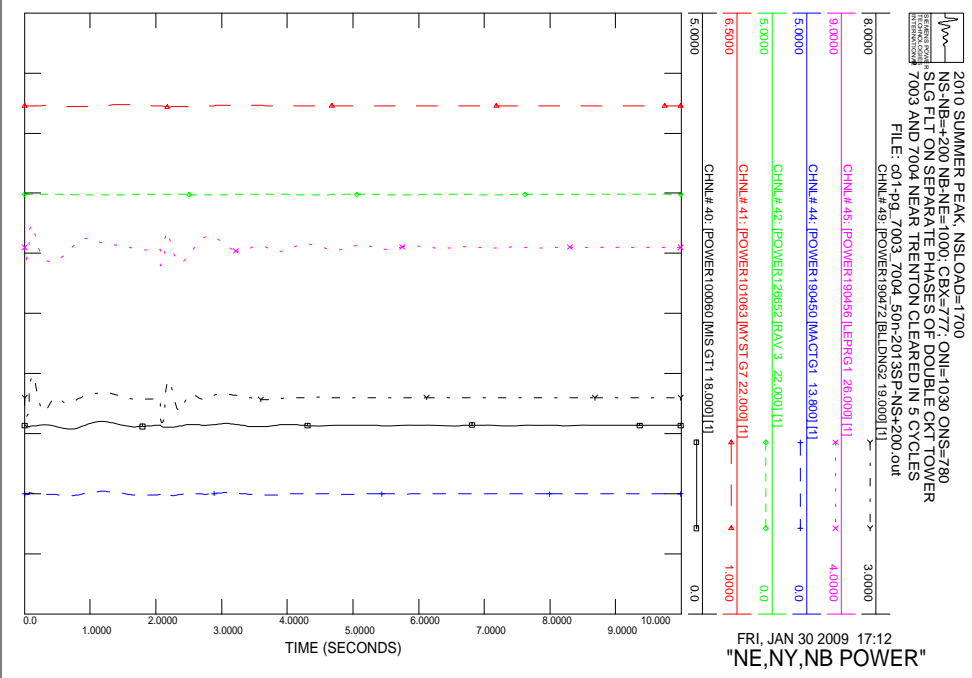
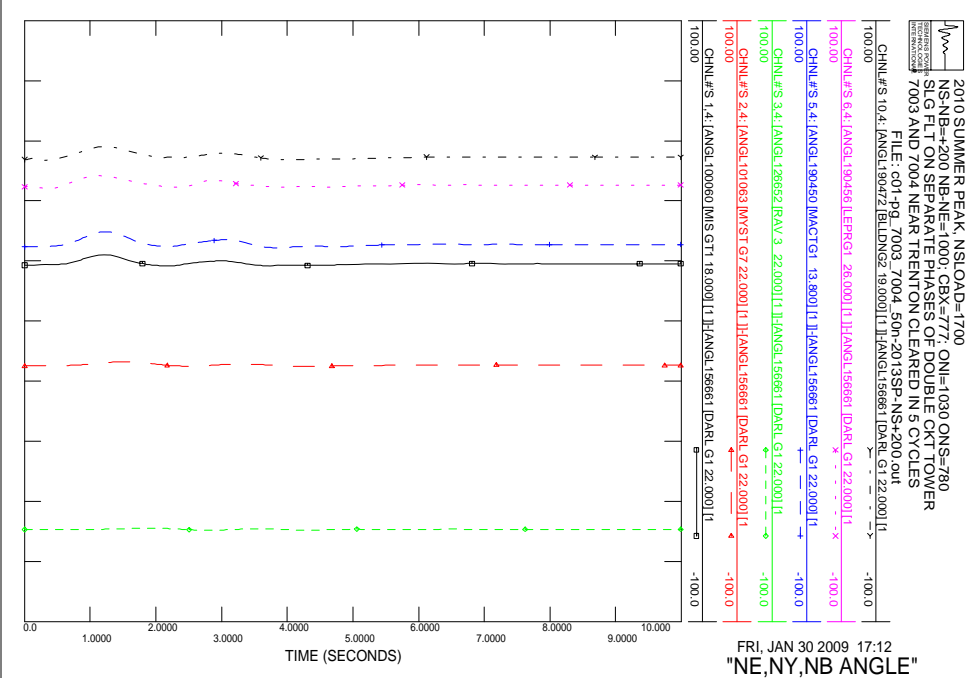
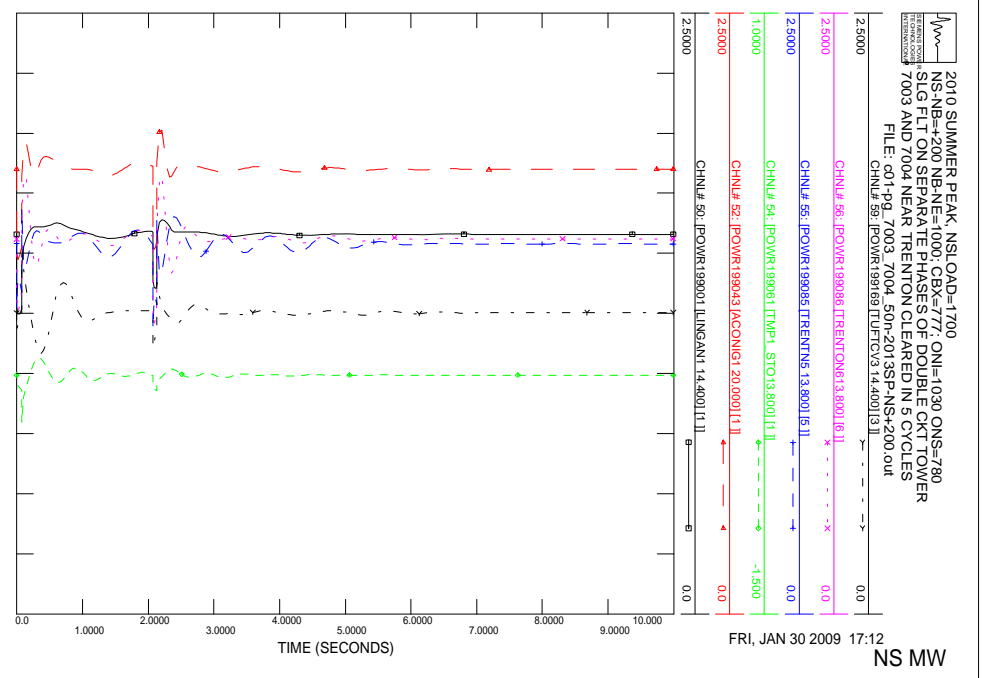
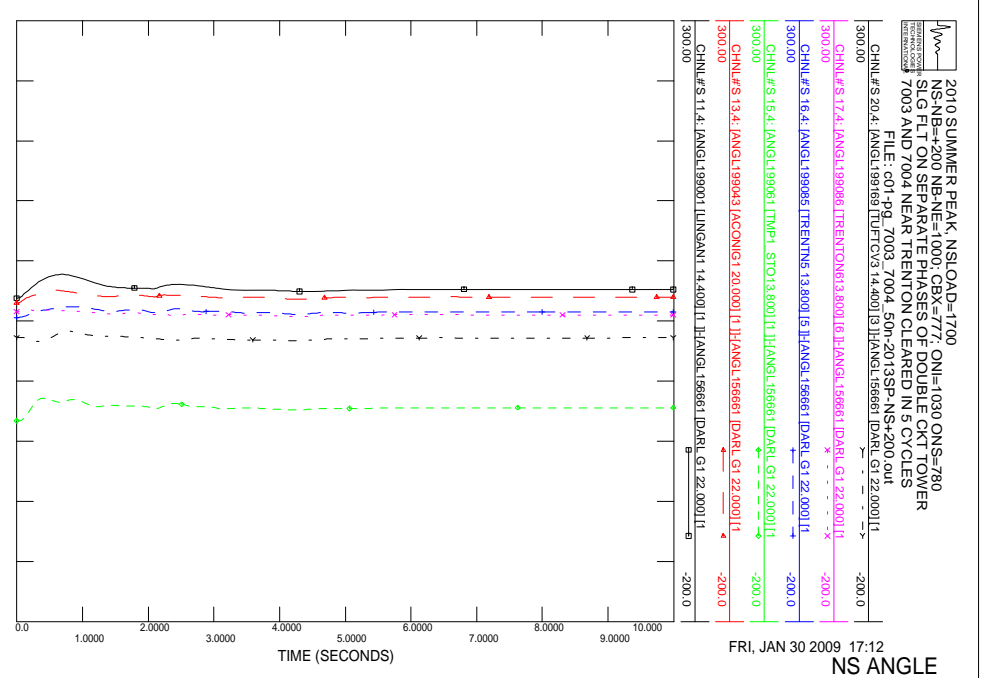

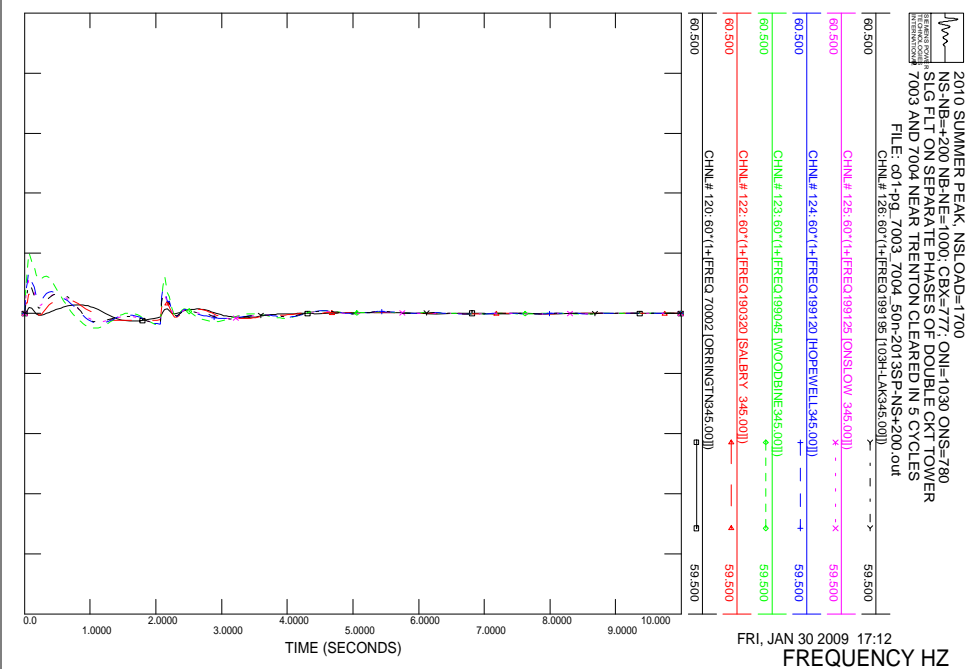
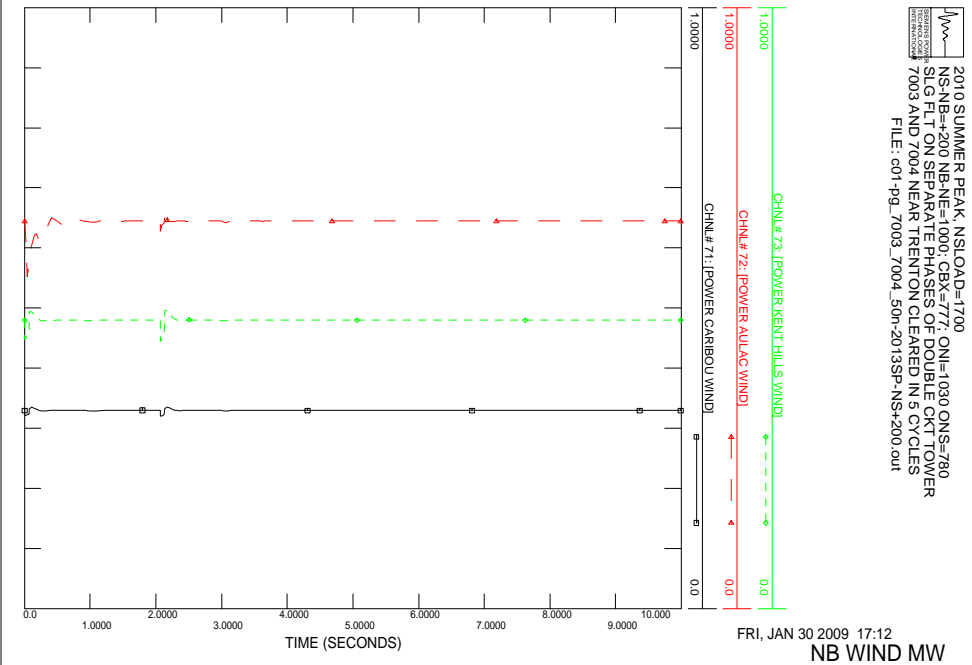
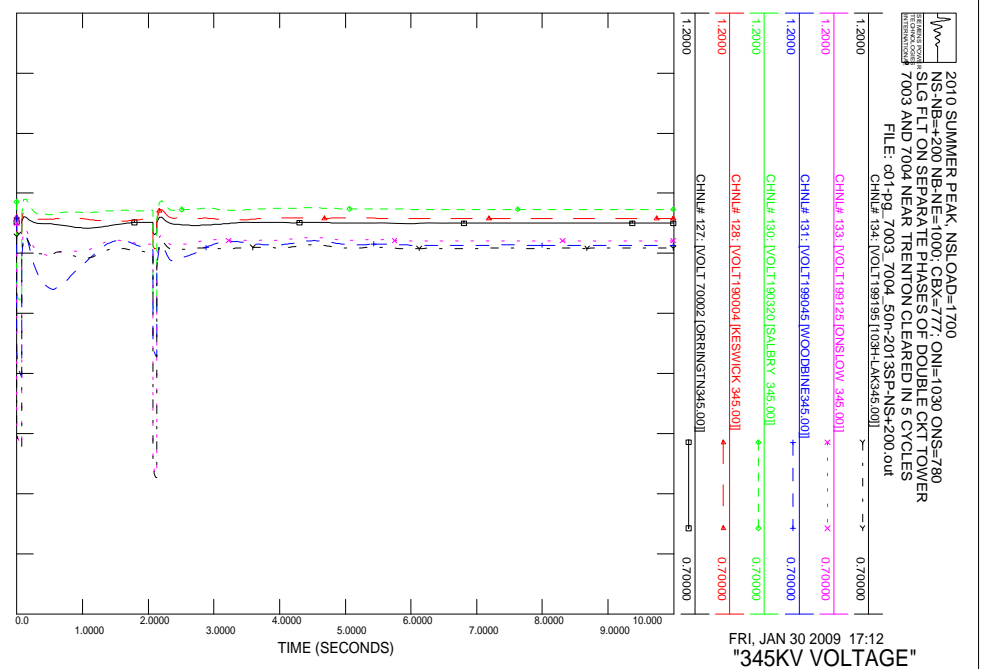
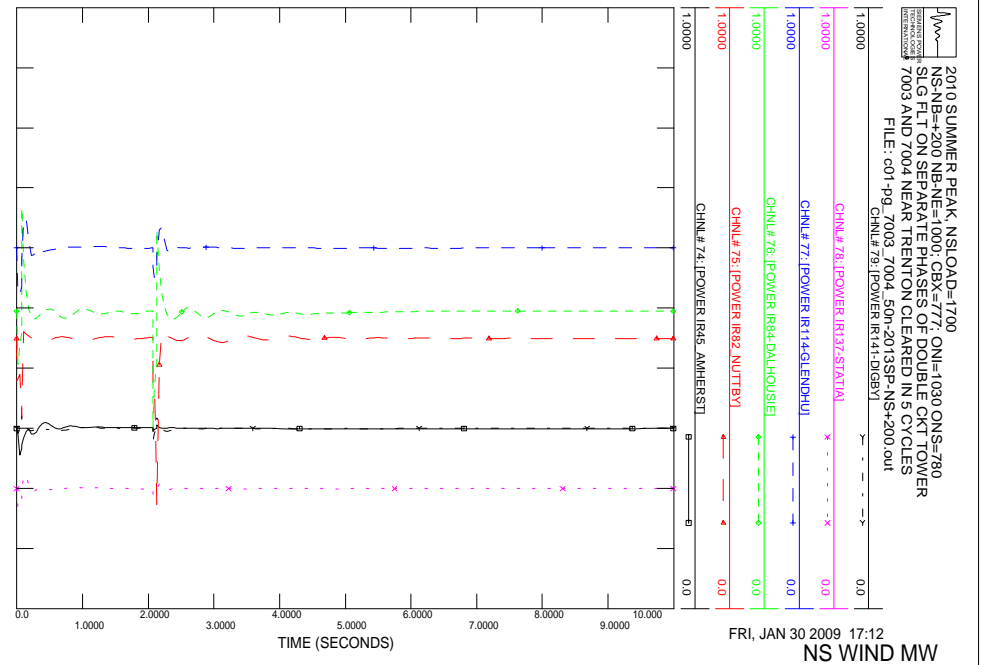

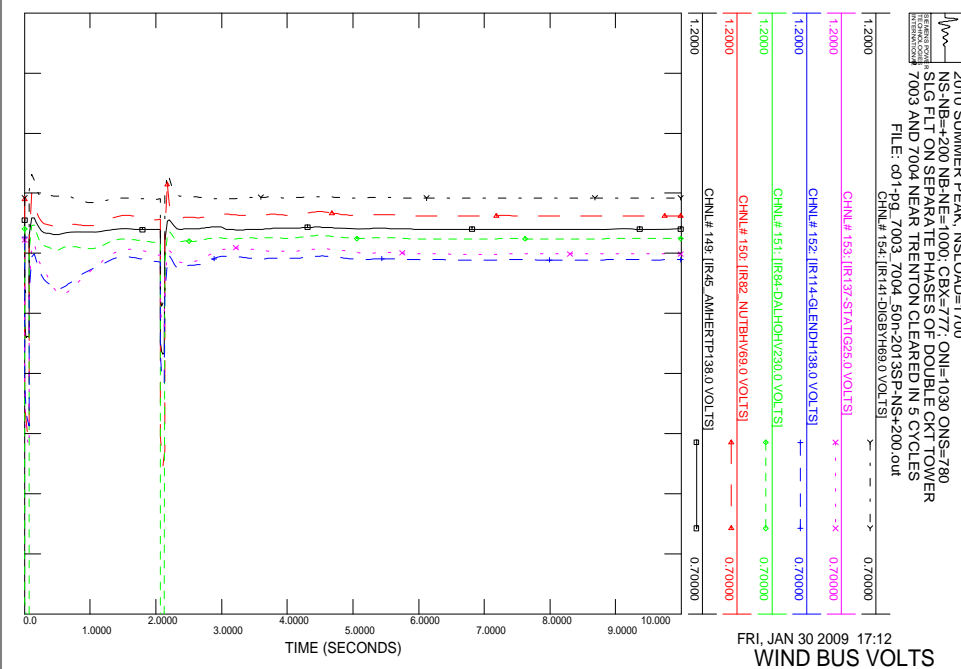
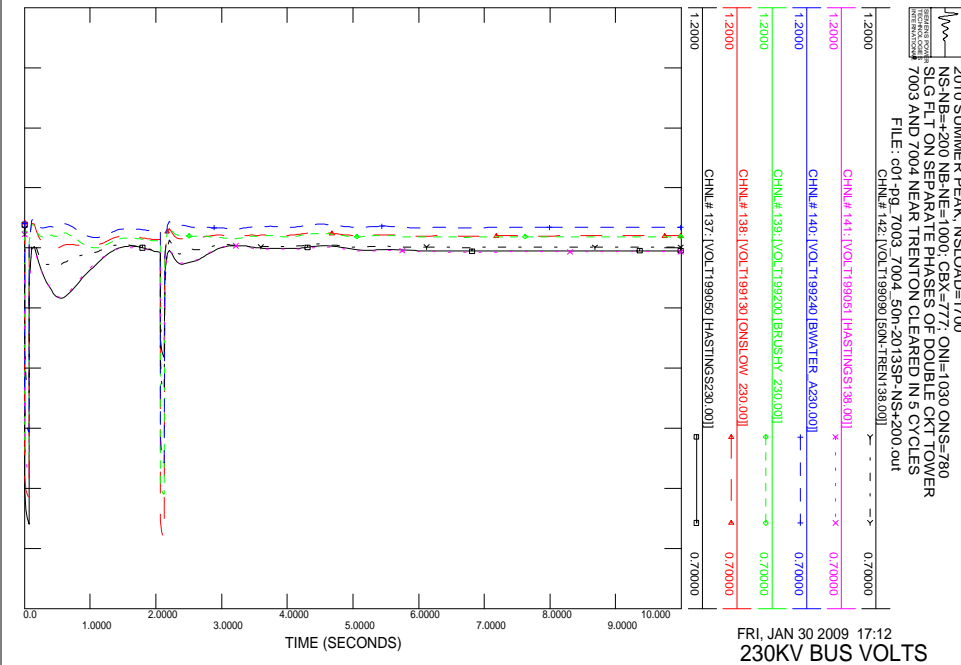
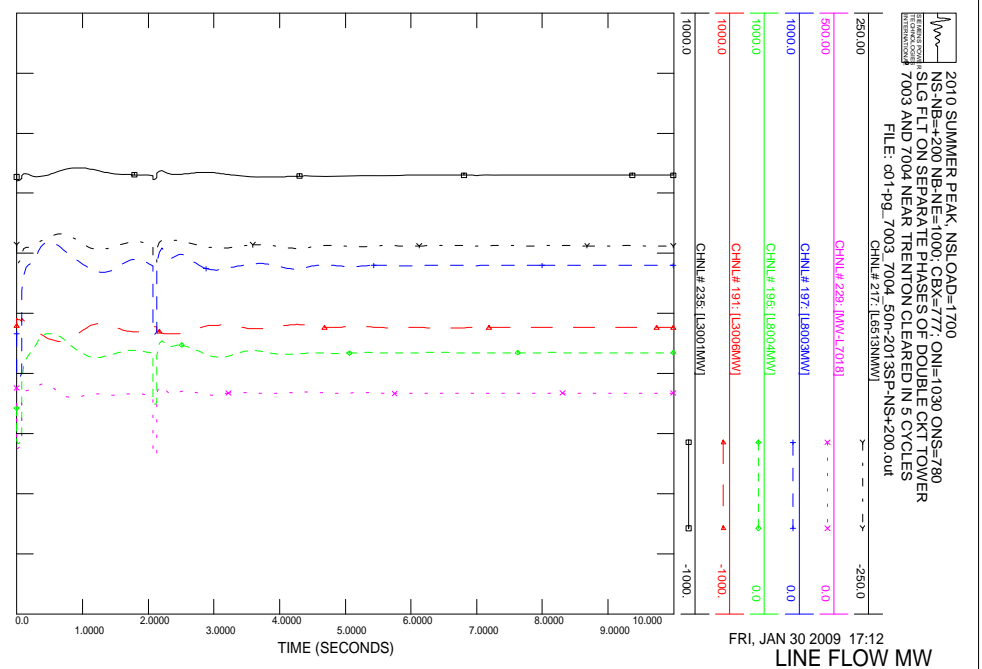
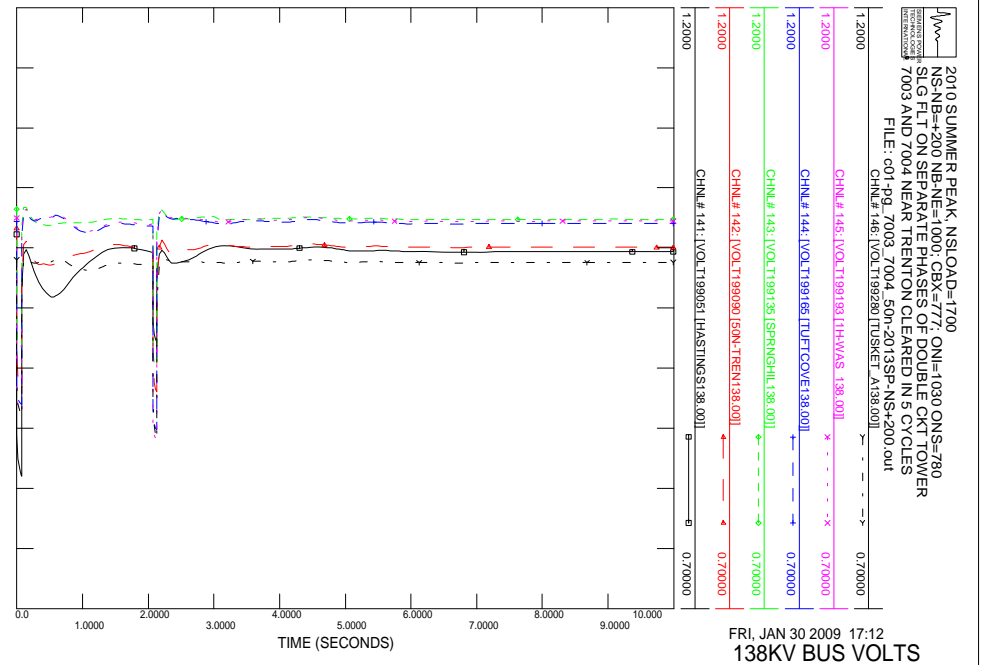

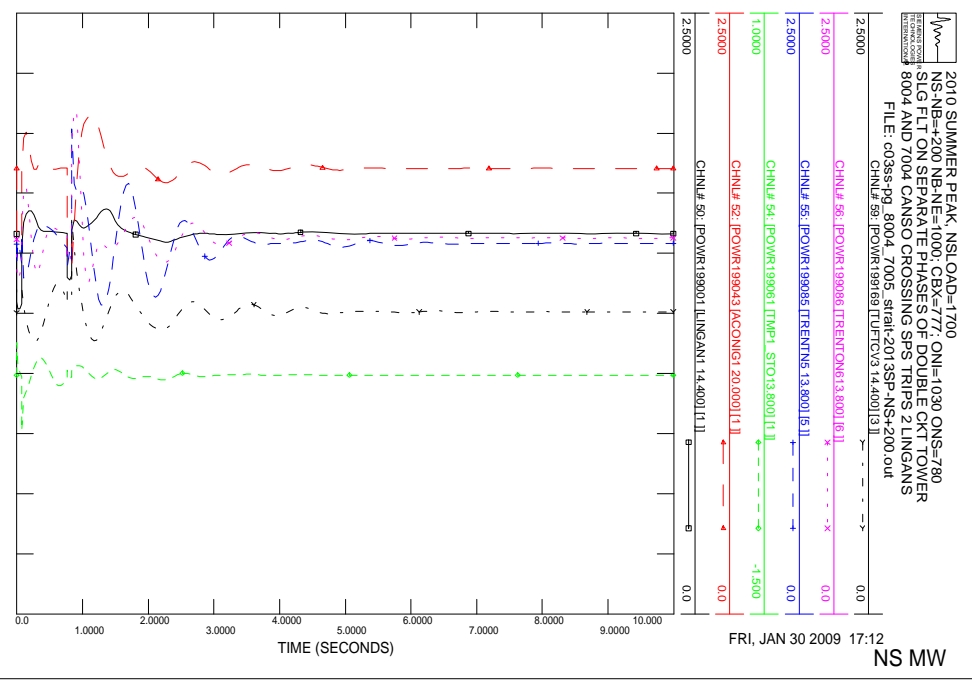
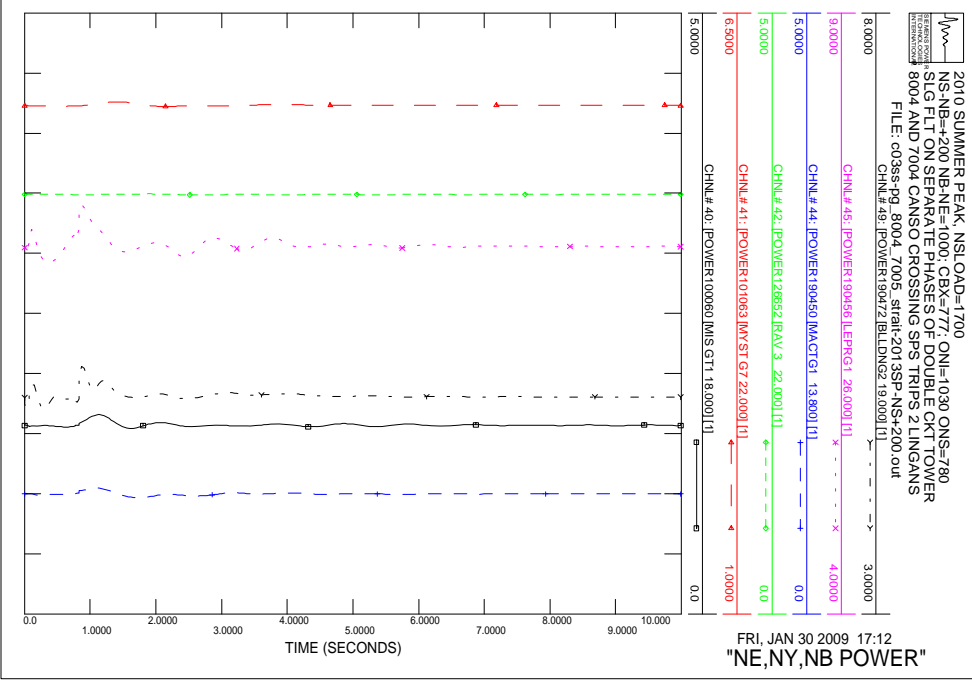
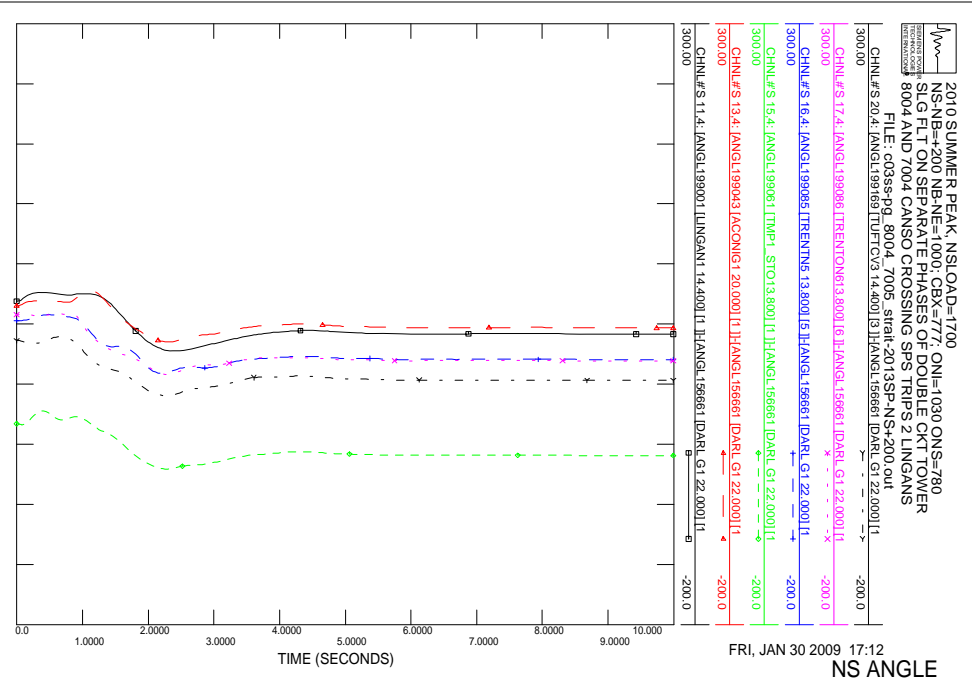
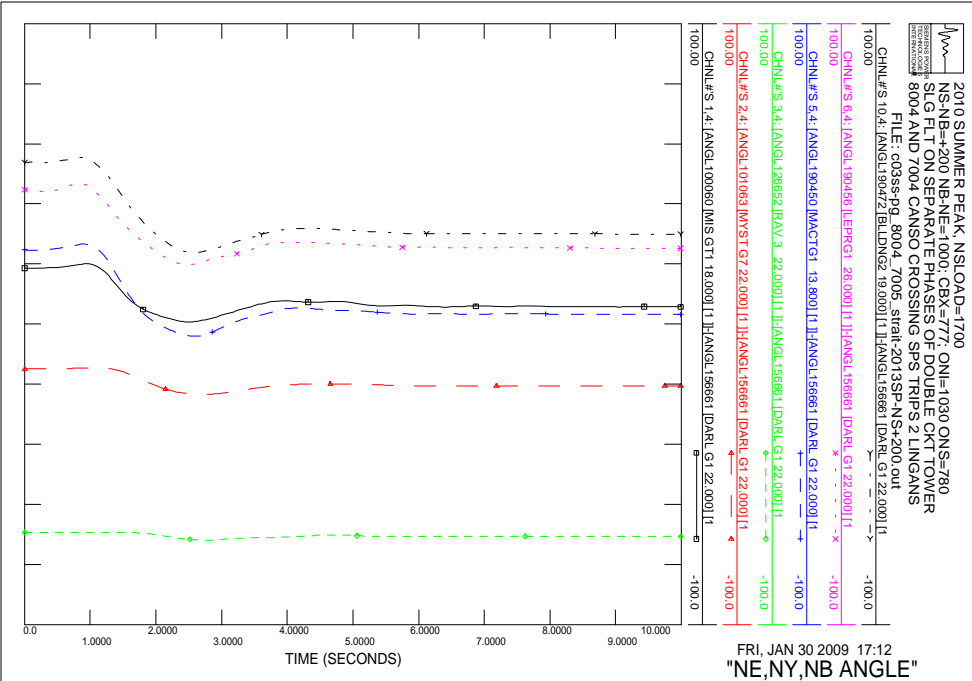

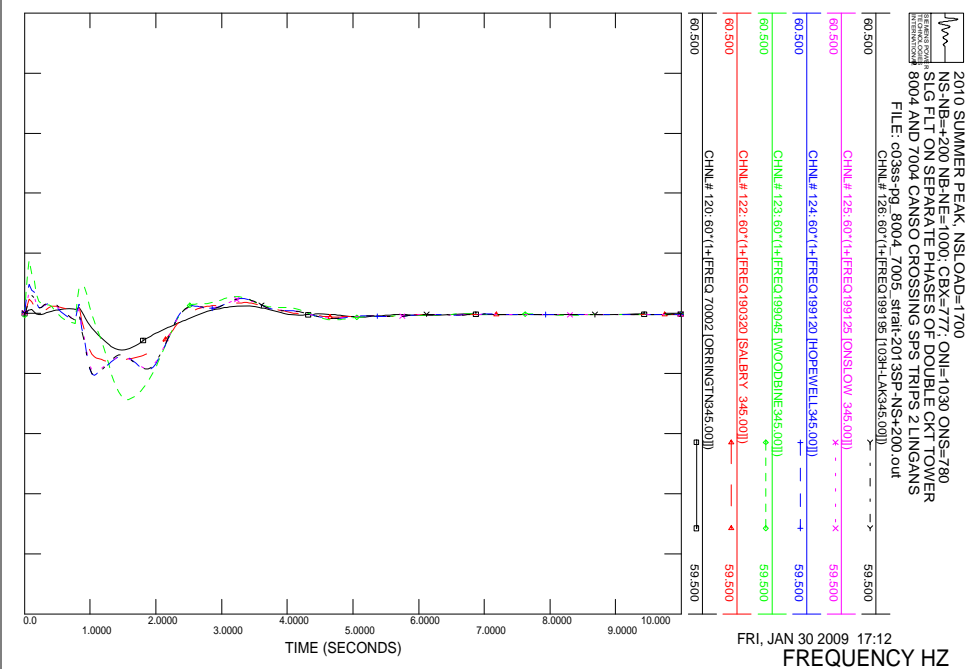
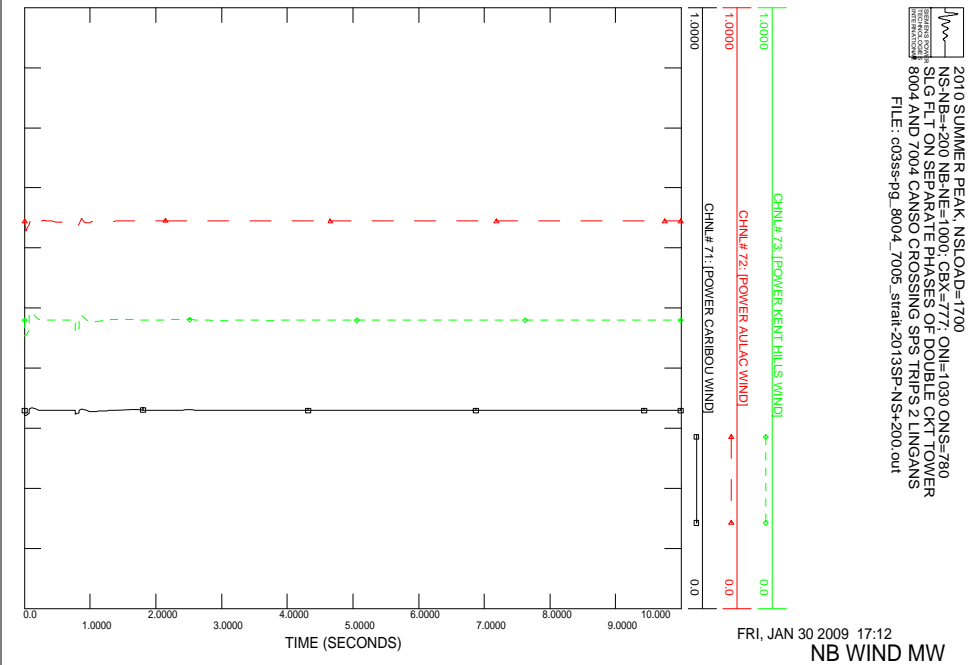
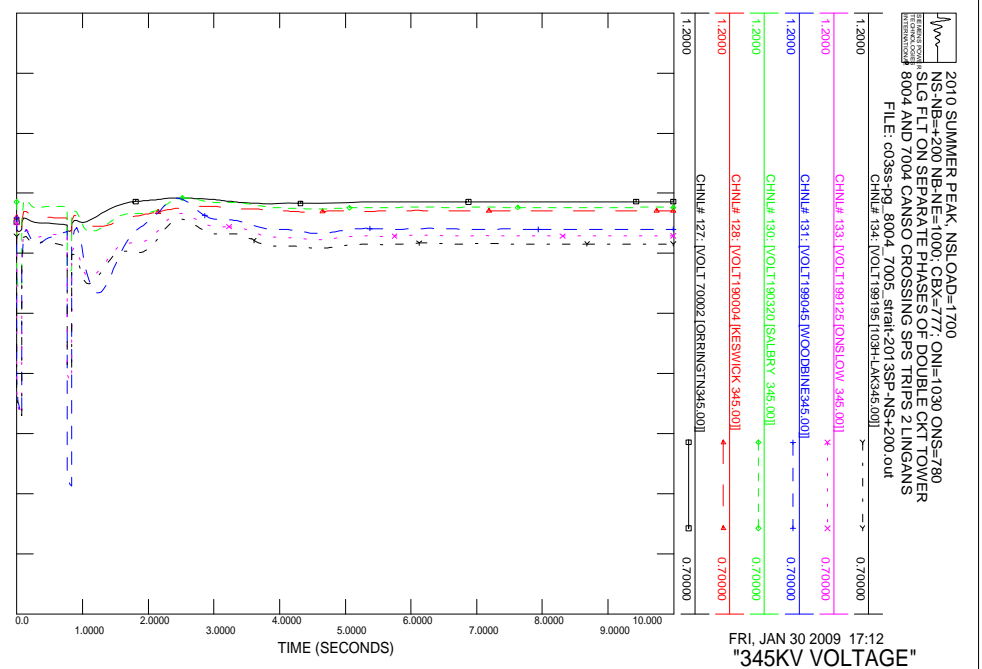
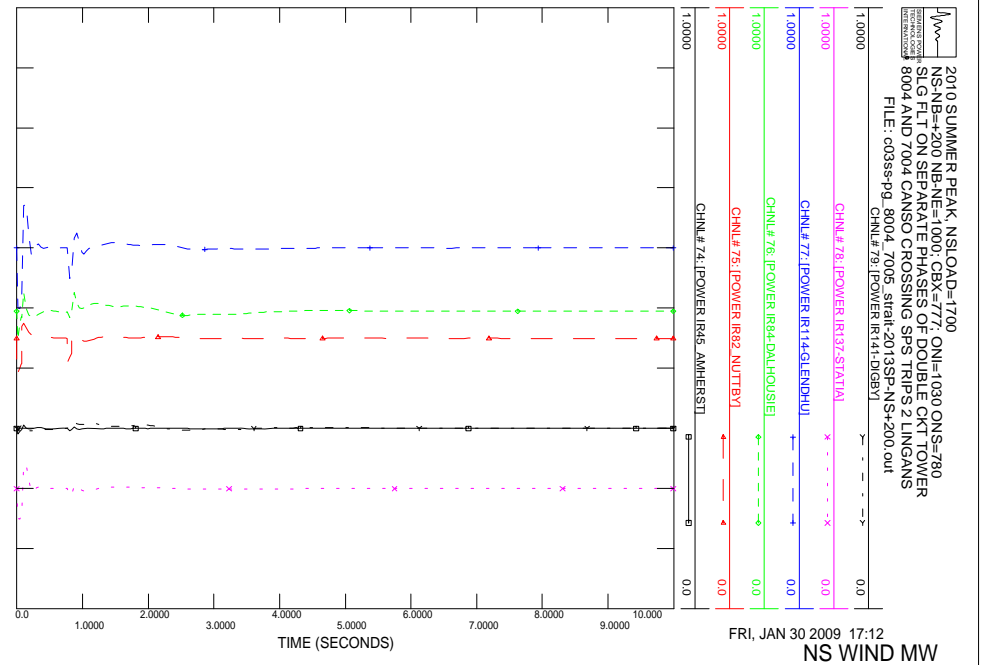

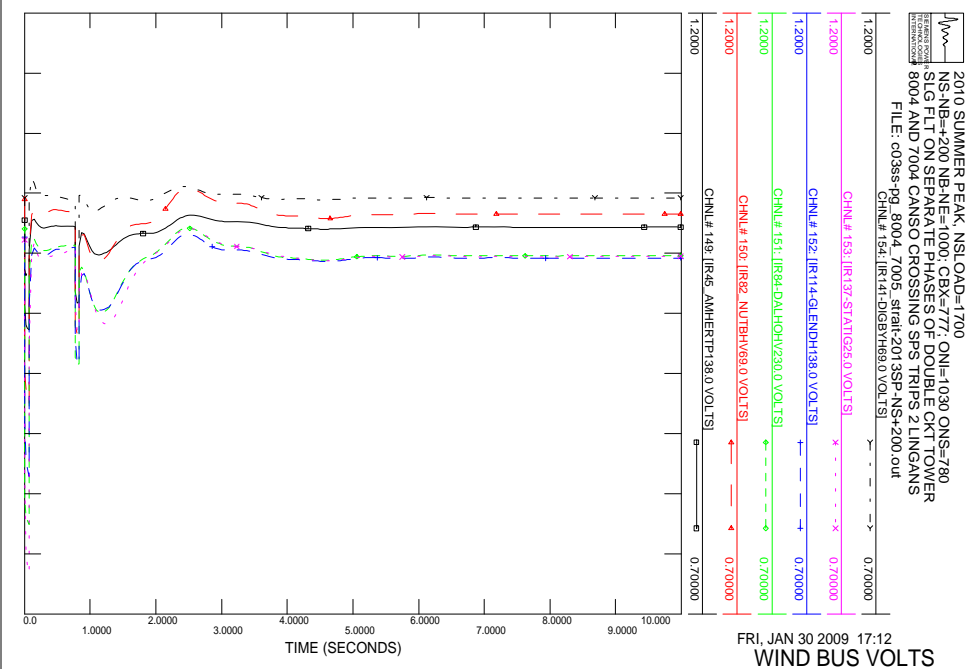
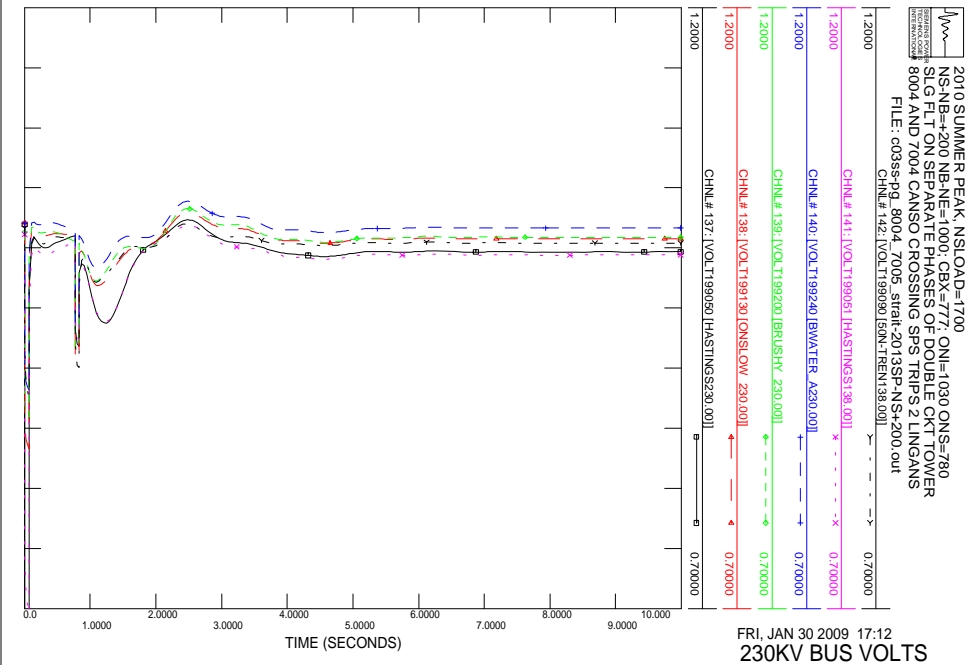
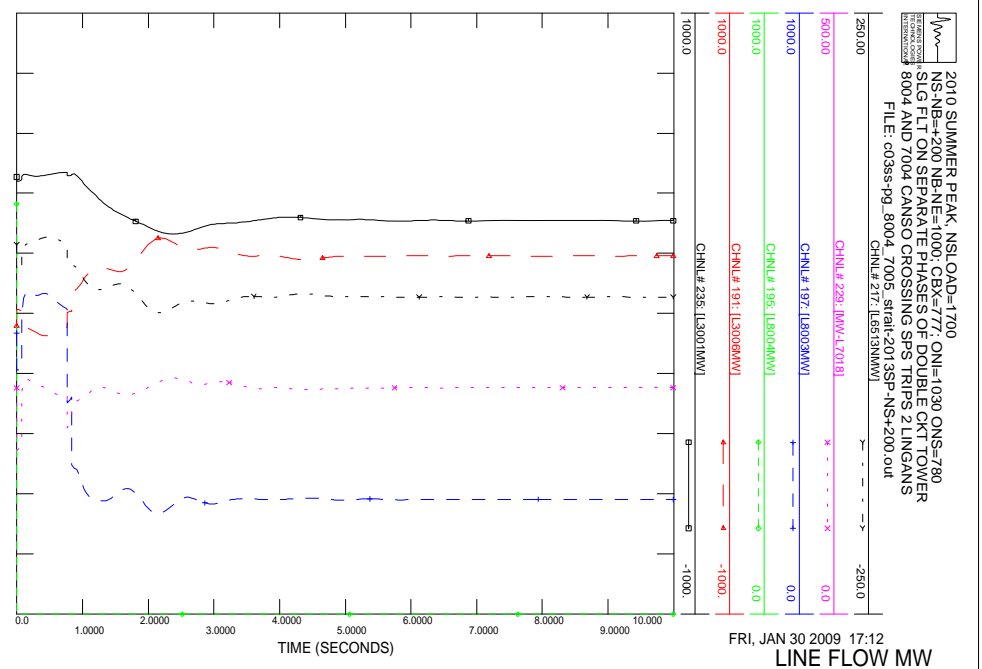
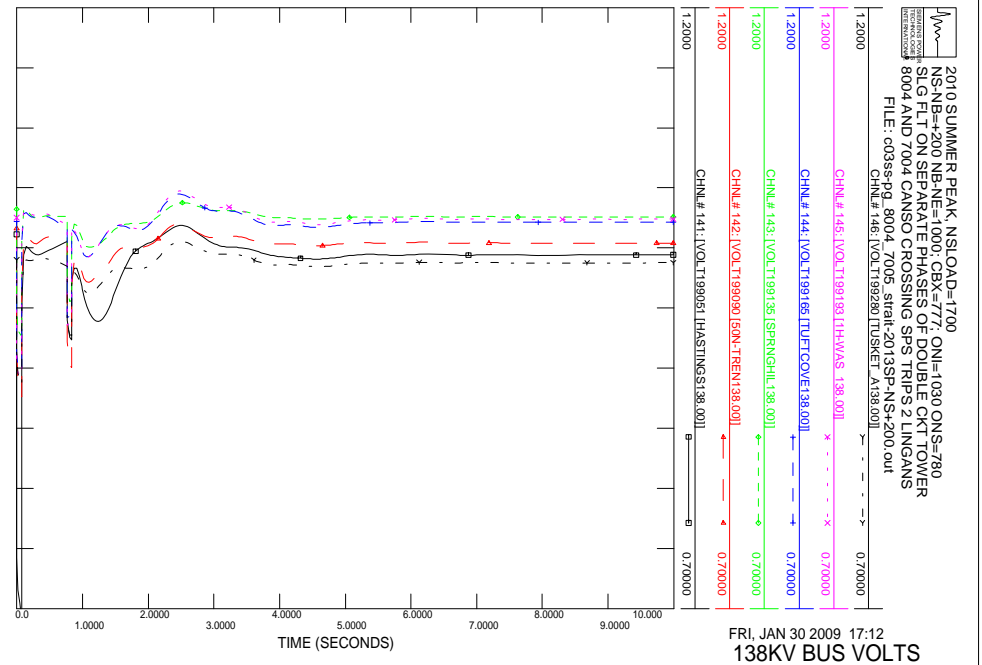

FRI, JAN 30 2009 17:12
 138KV BUS VOLTS

FRI, JAN 30 2009 17:12
 230KV BUS VOLTS

FRI, JAN 30 2009 17:12
 LINE FLOW MW

FRI, JAN 30 2009 17:12
 WIND BUS VOLTS

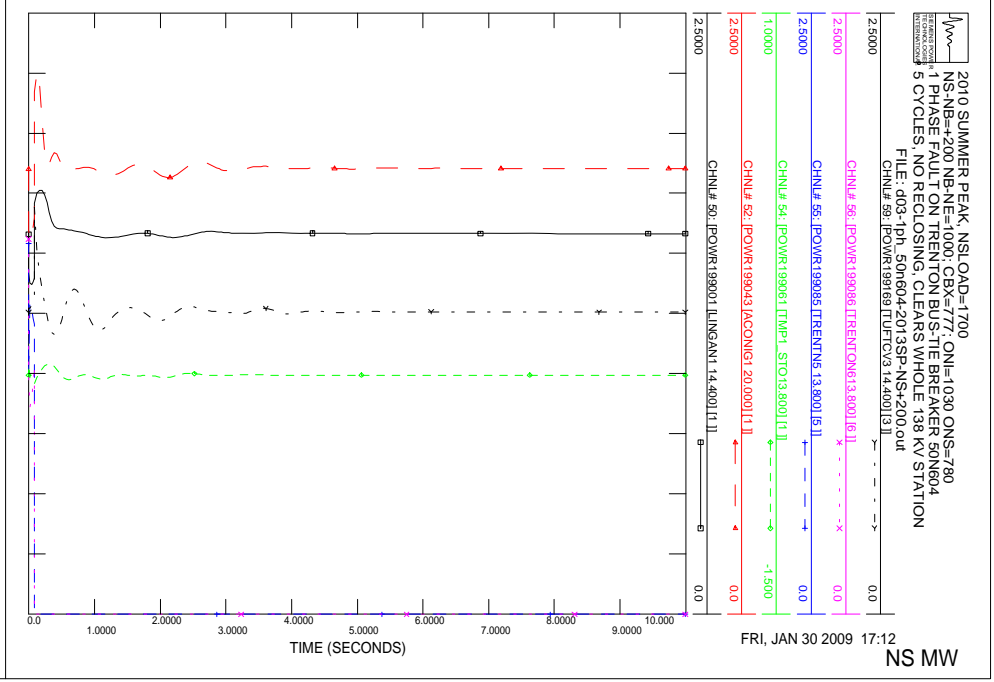
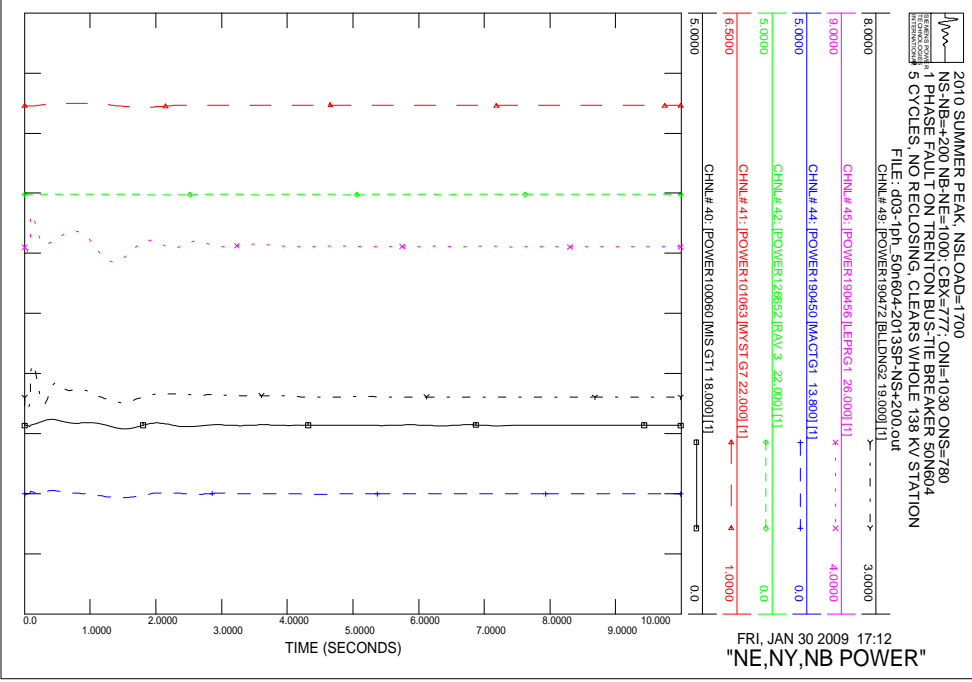
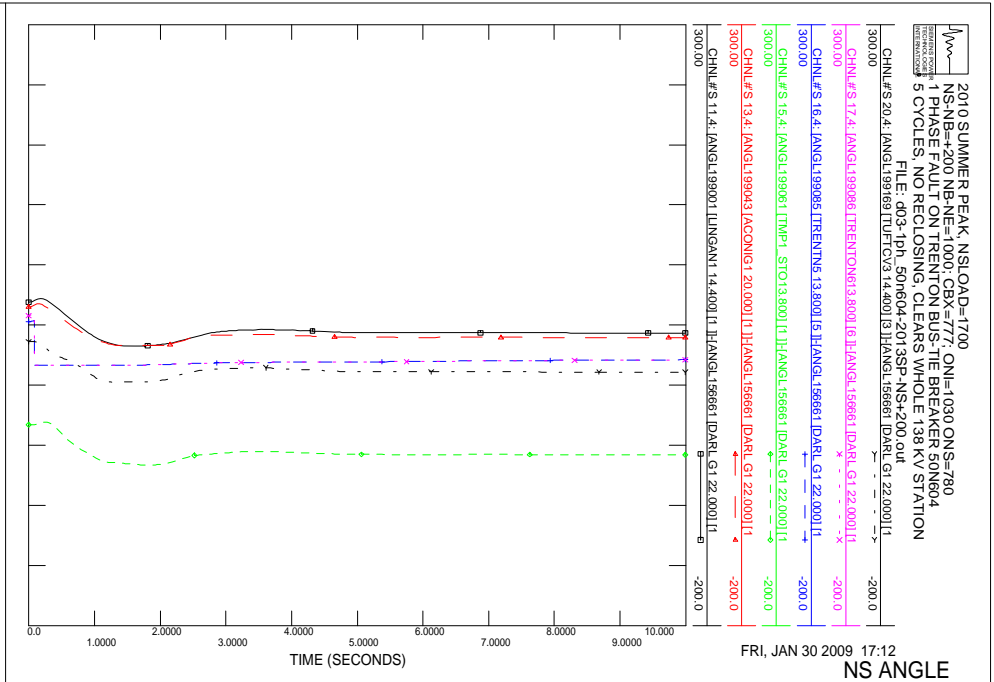
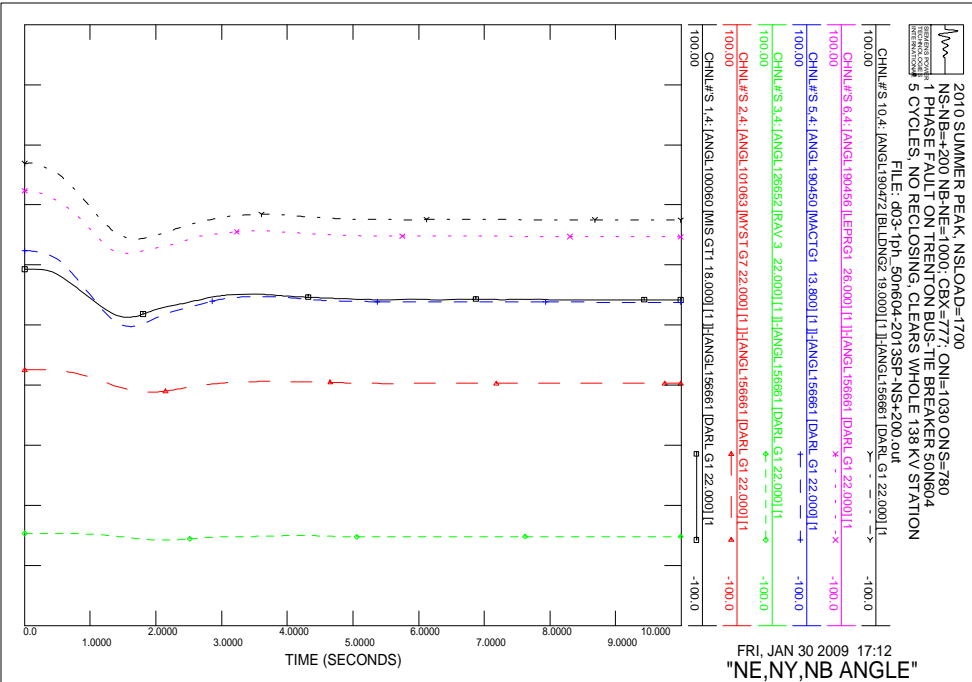

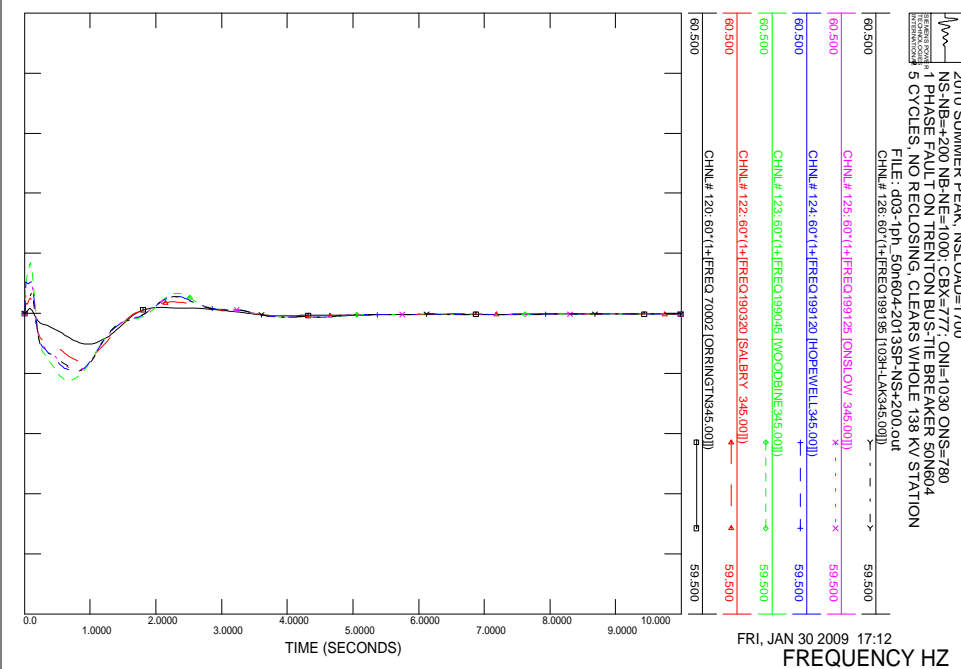
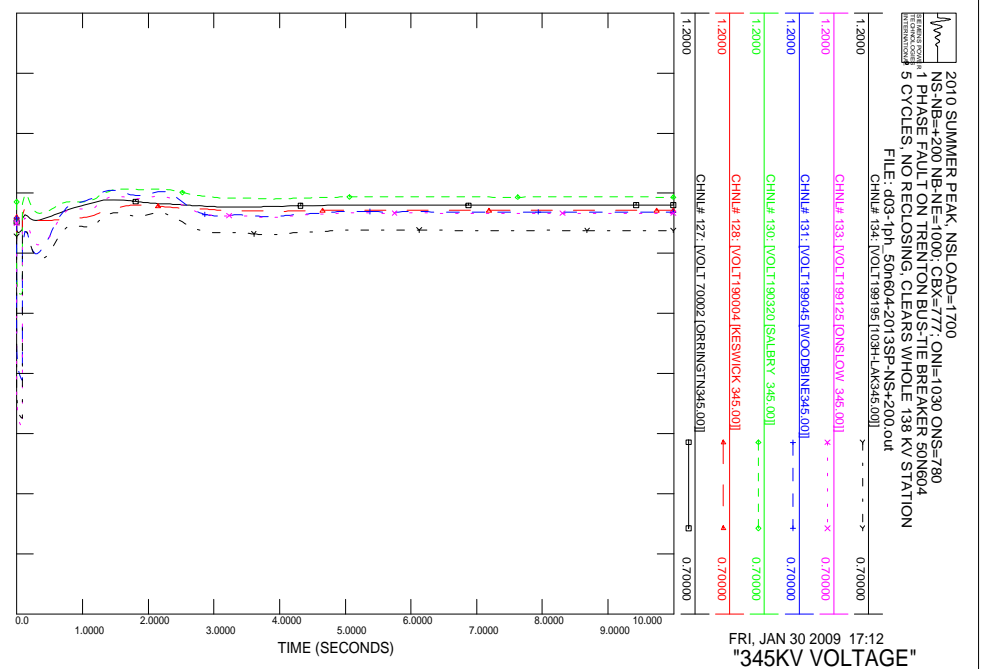
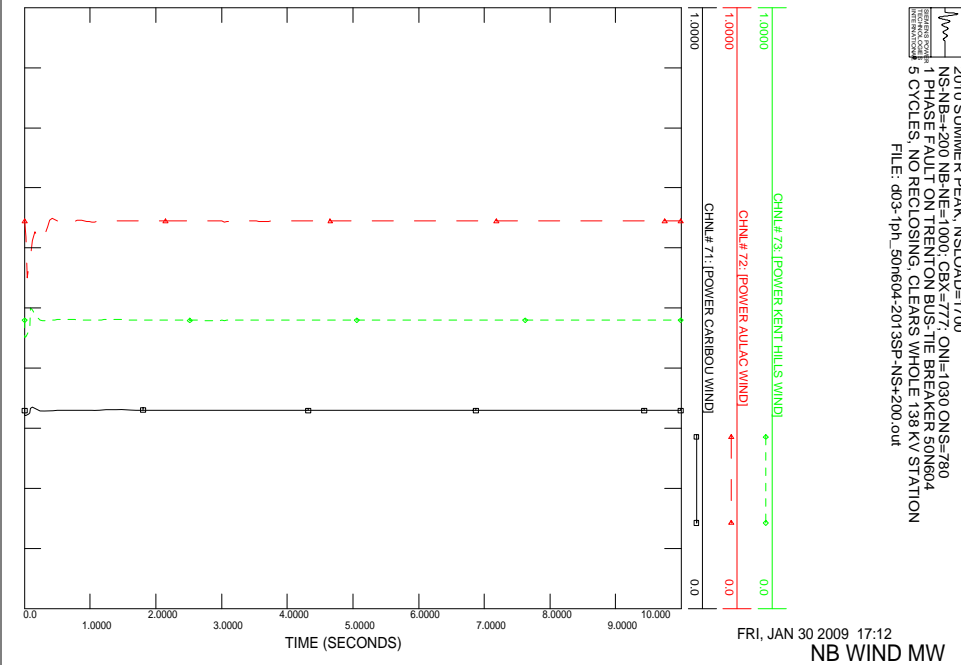
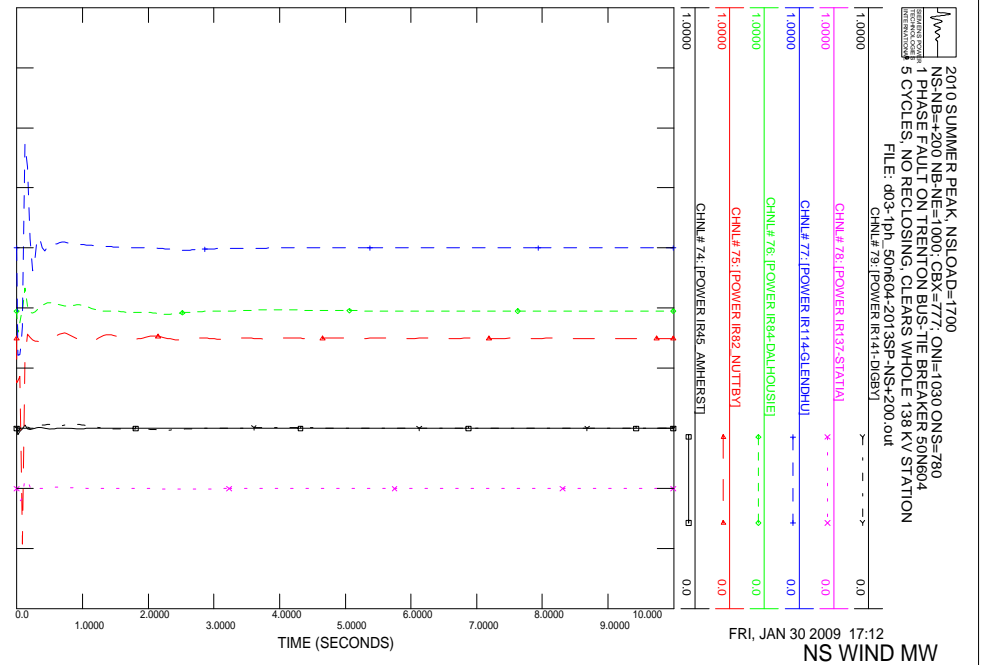

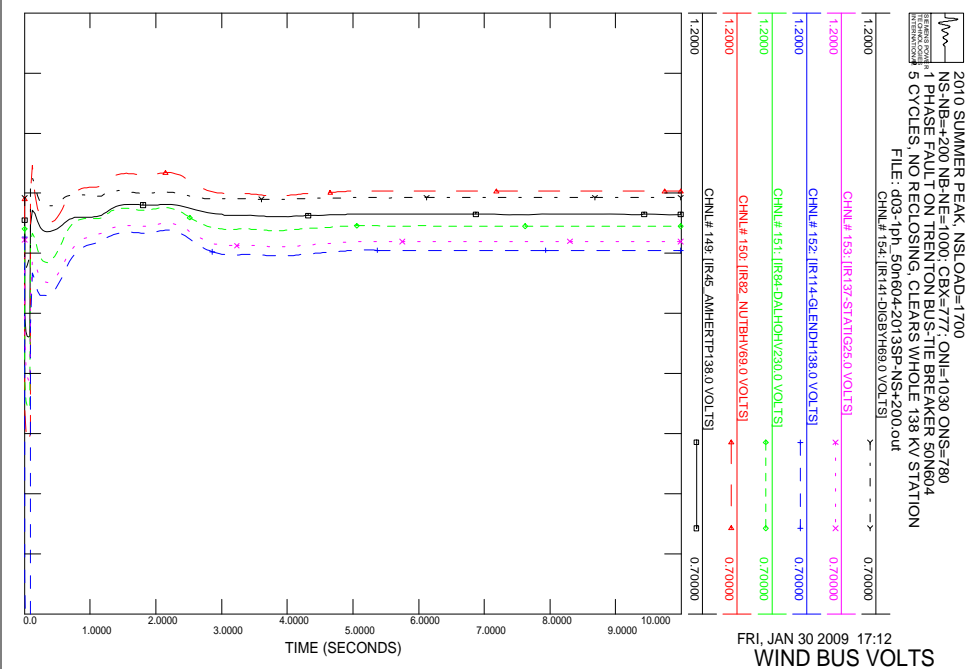
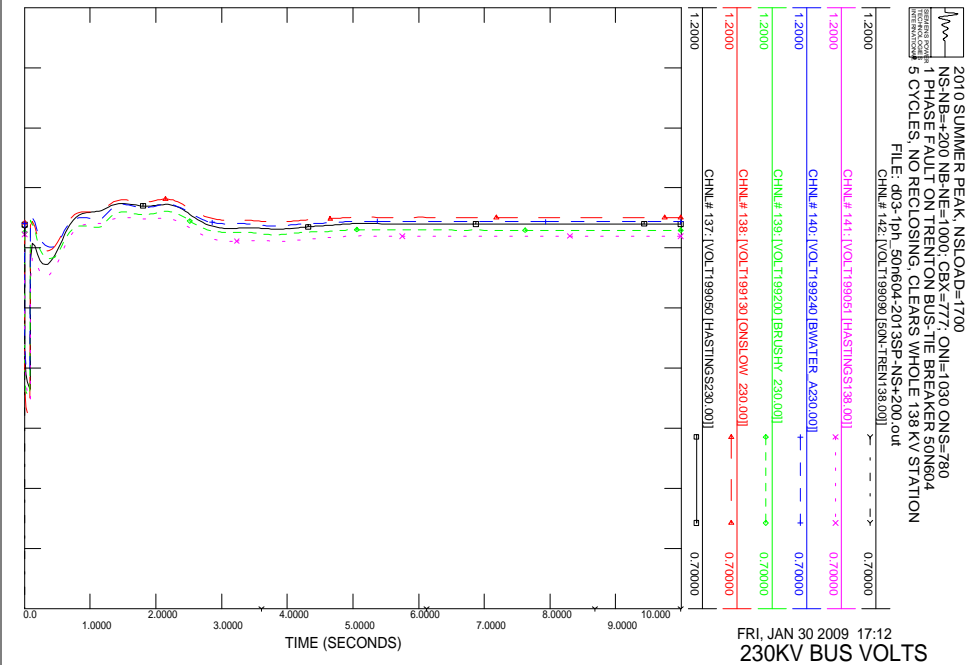
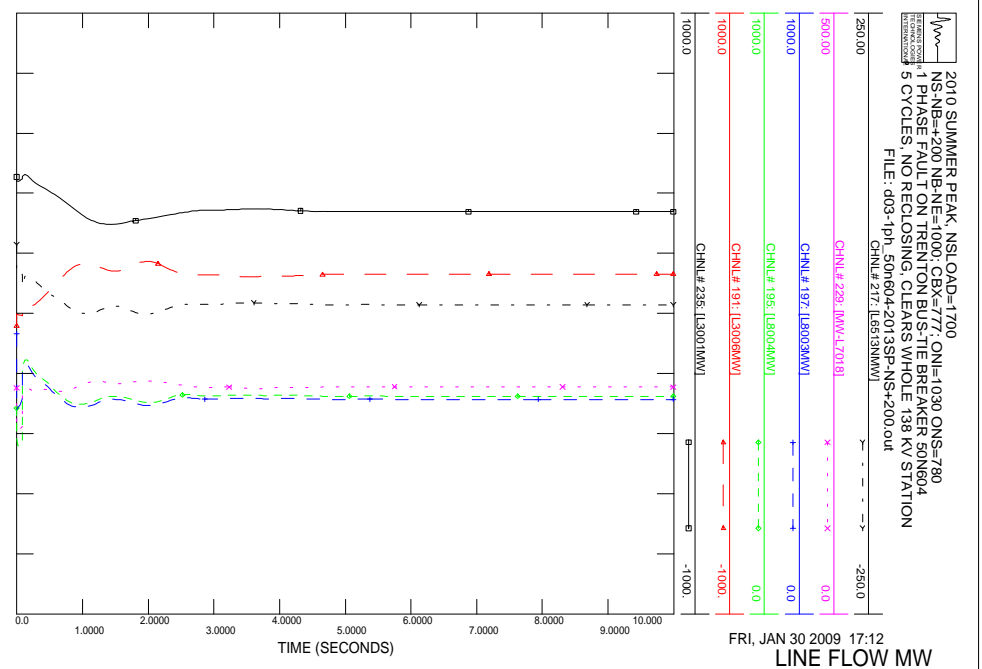
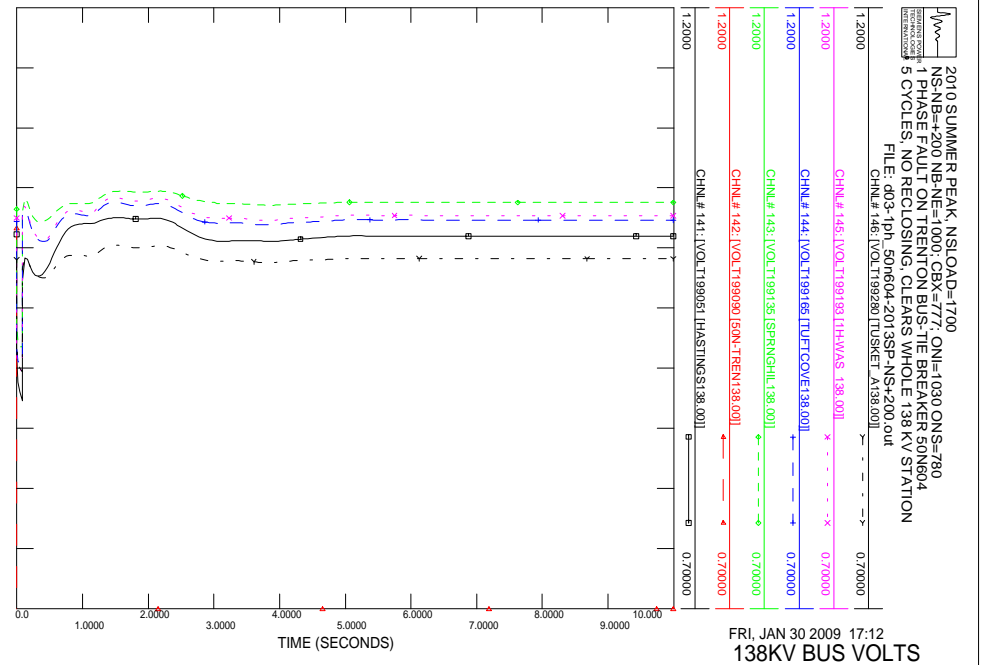

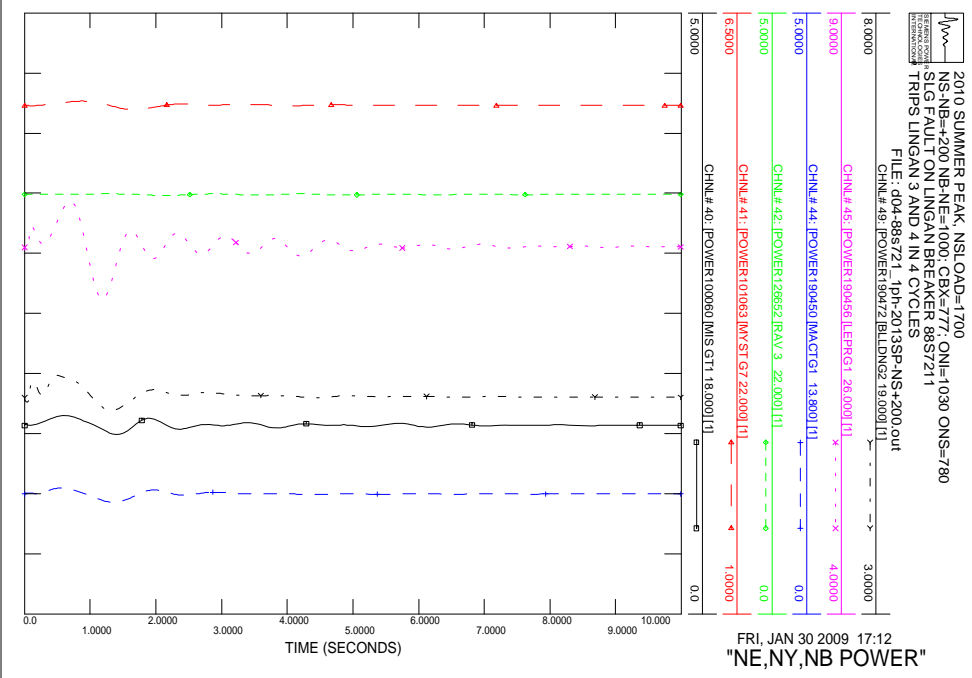
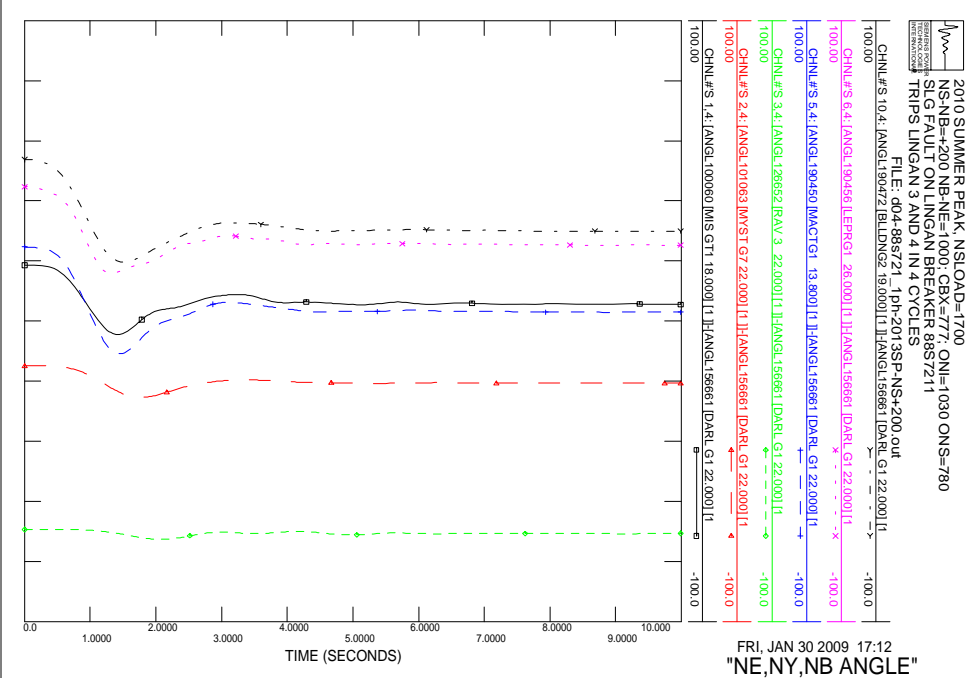
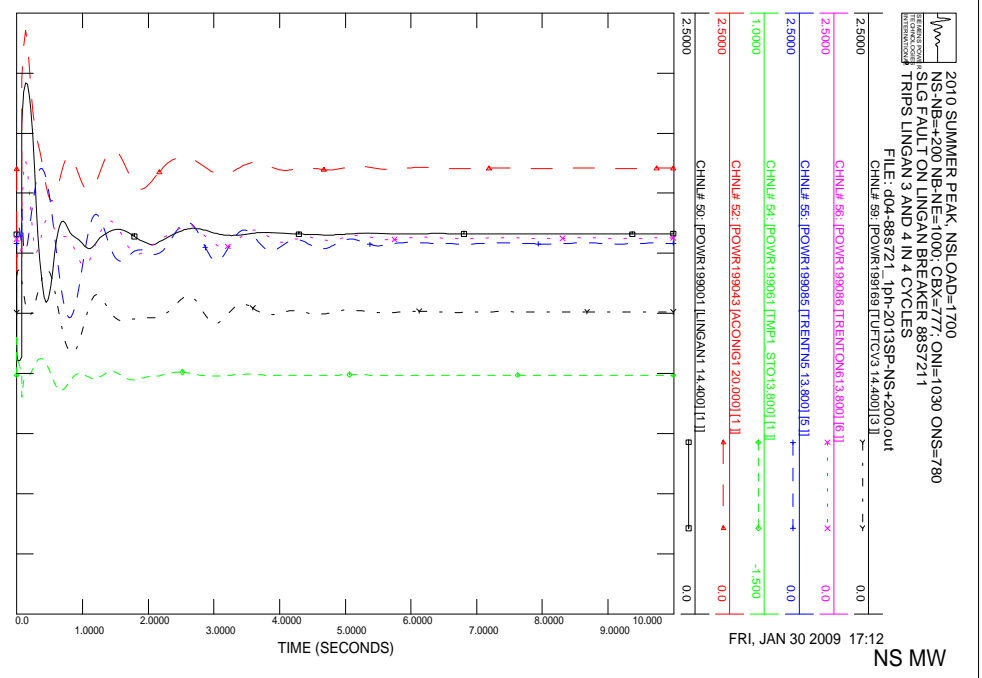
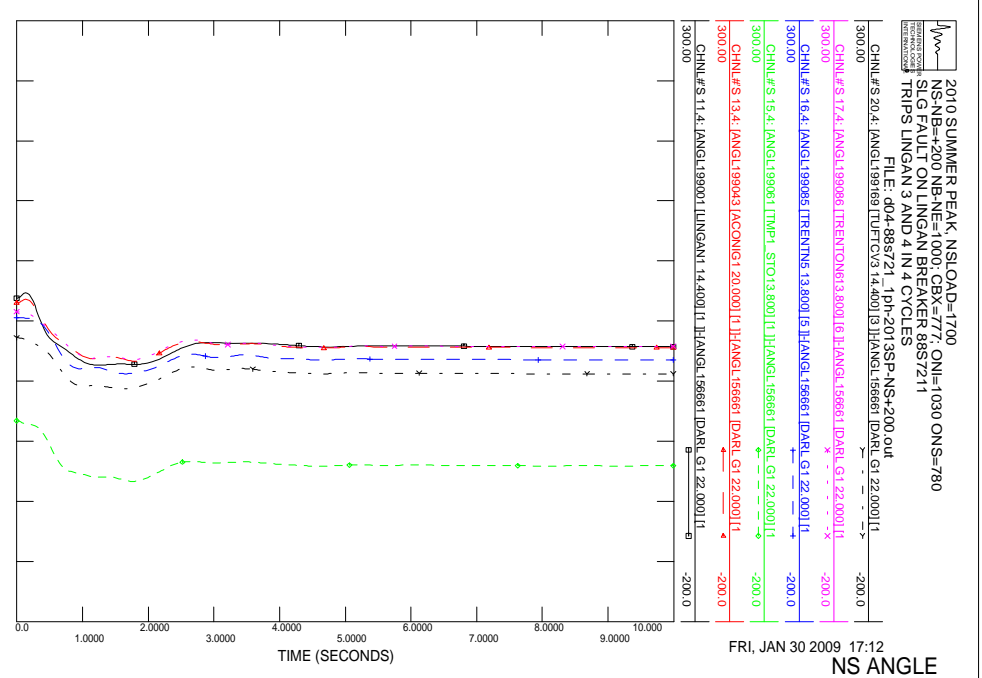

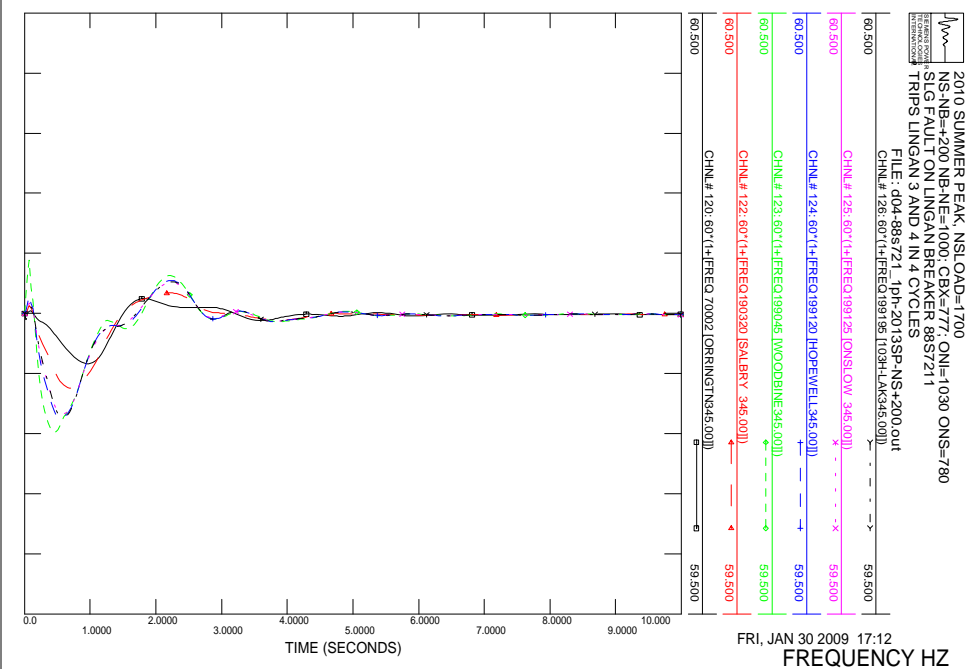
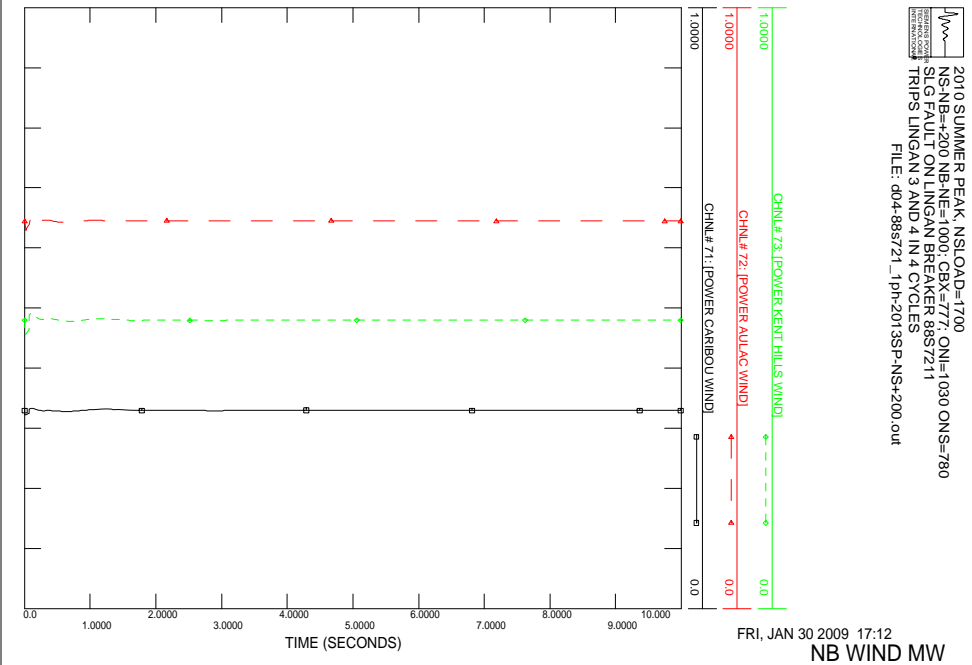
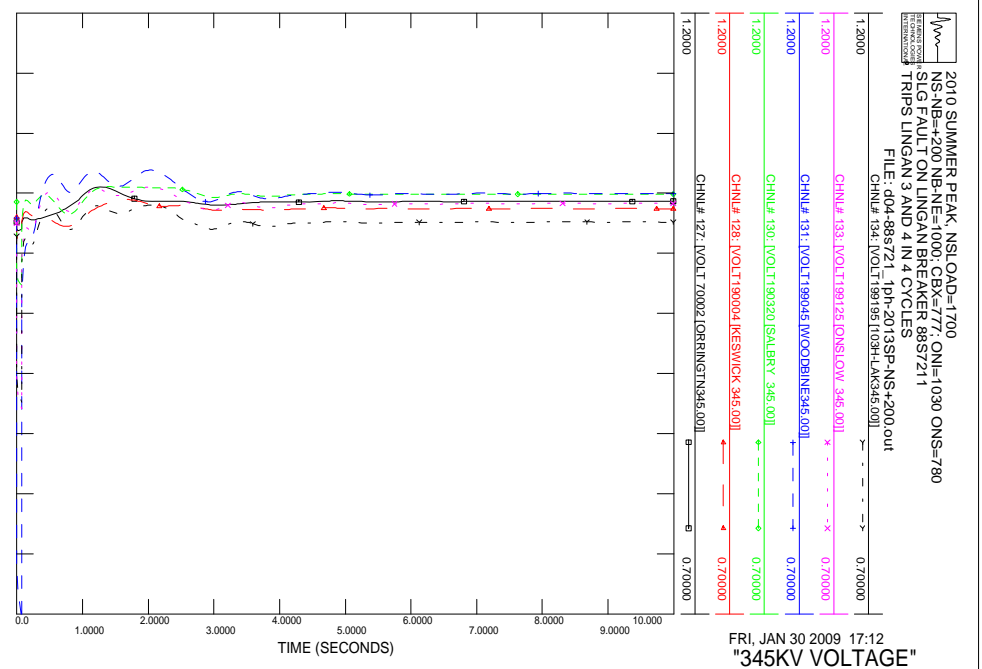
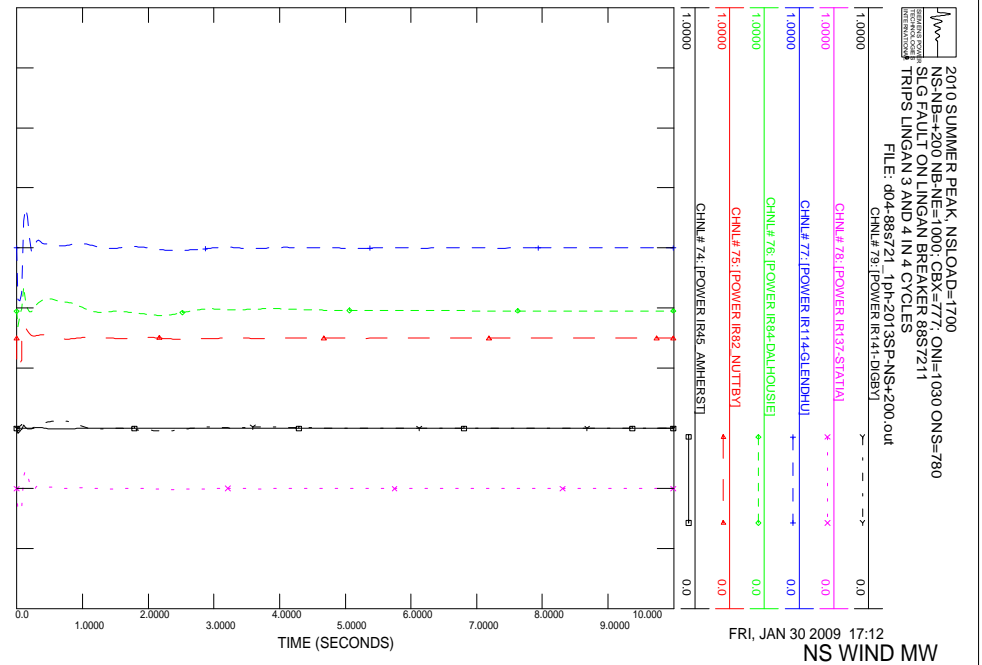

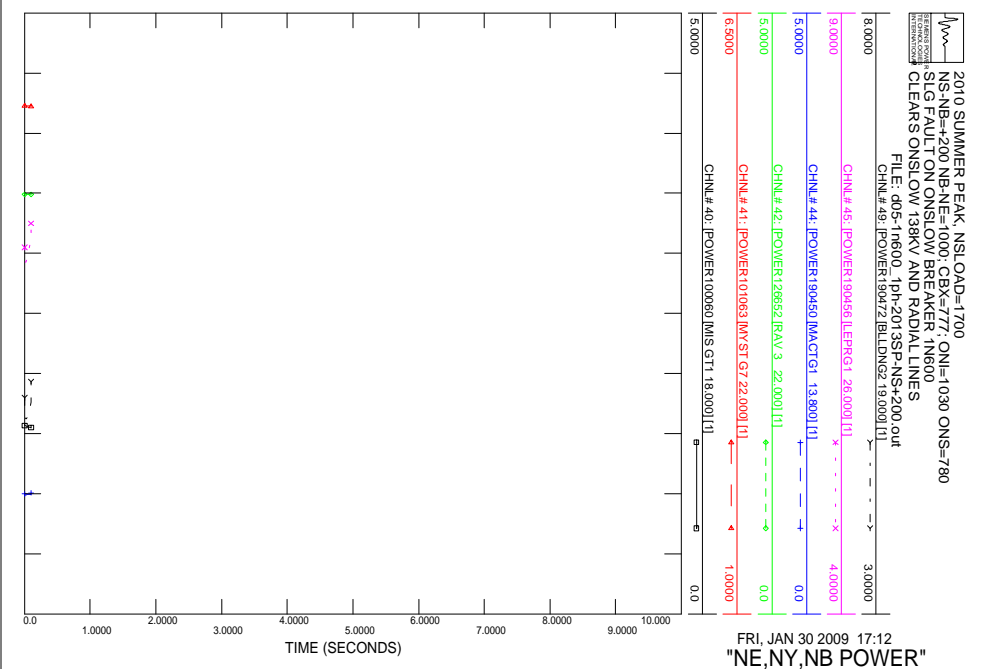
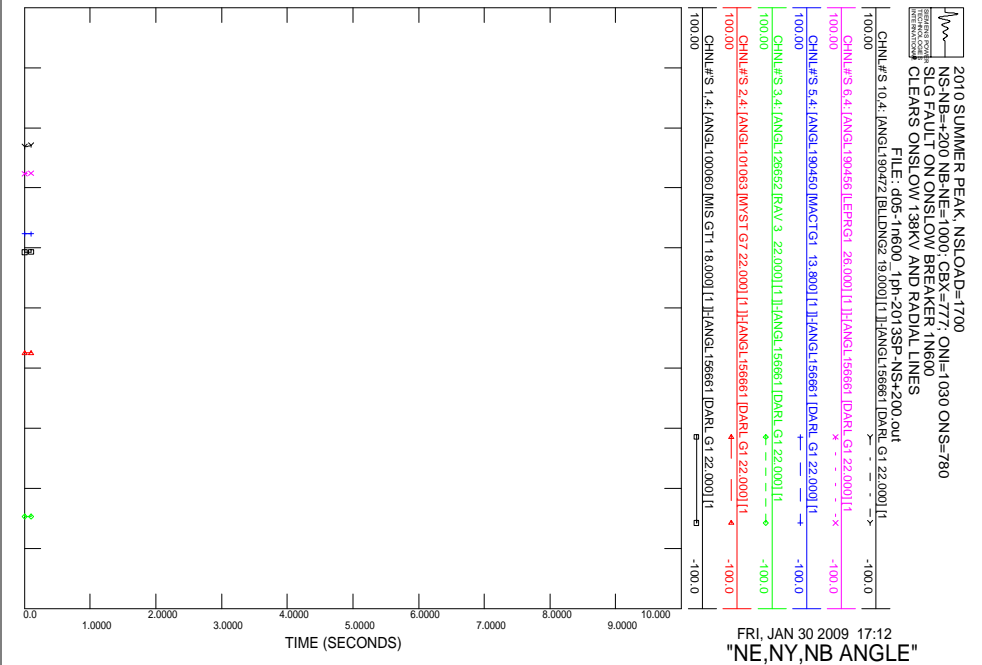
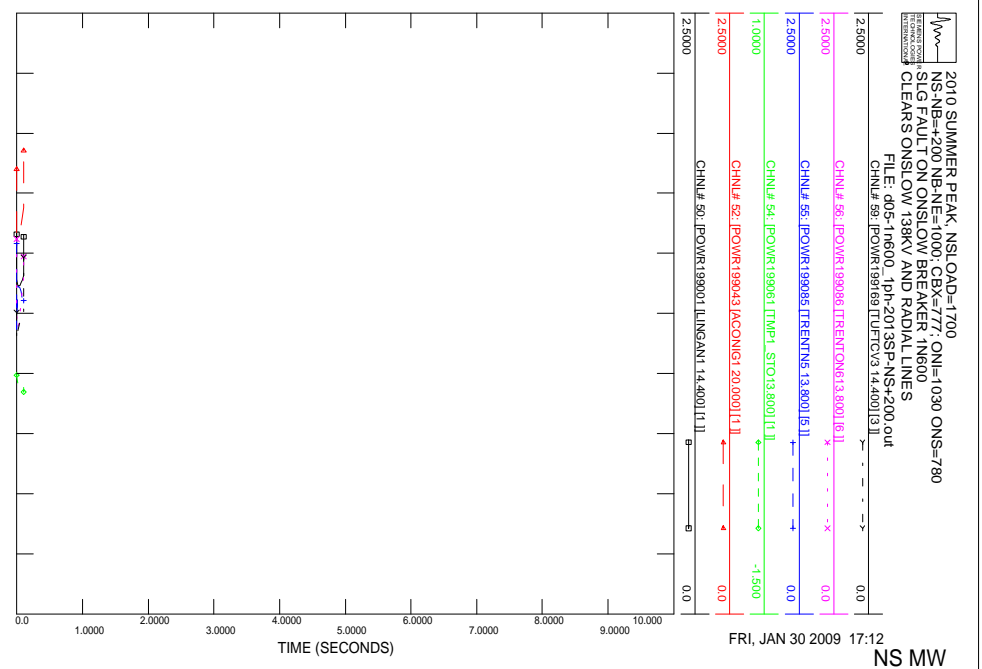
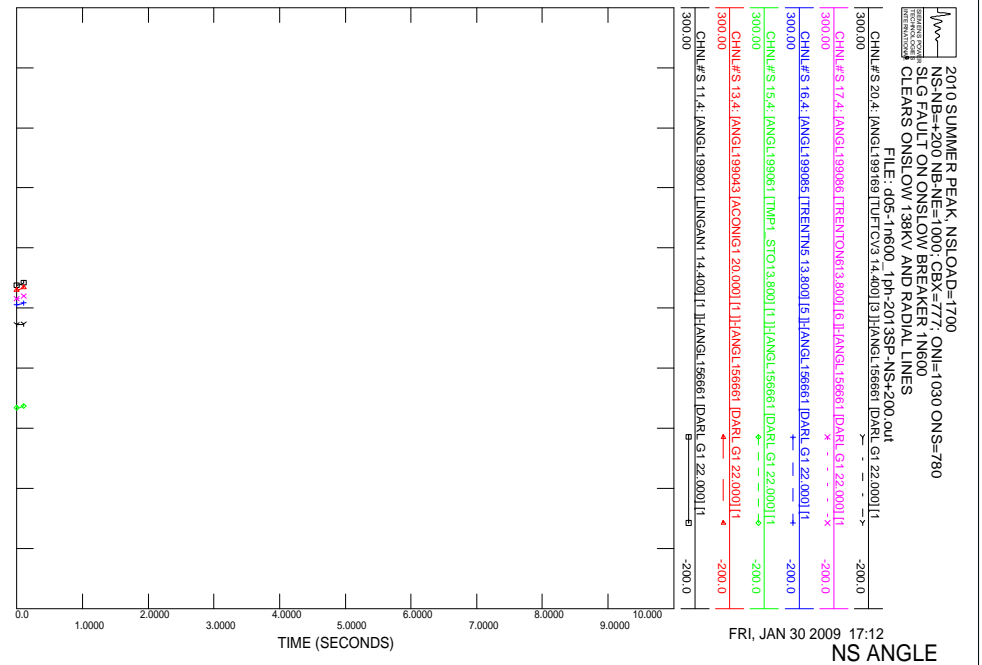

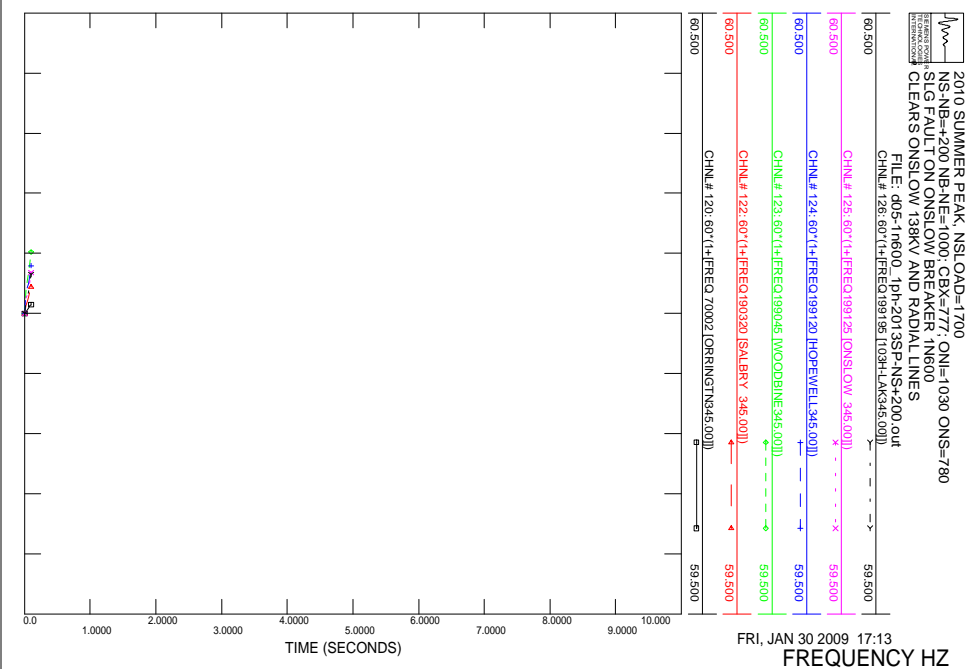
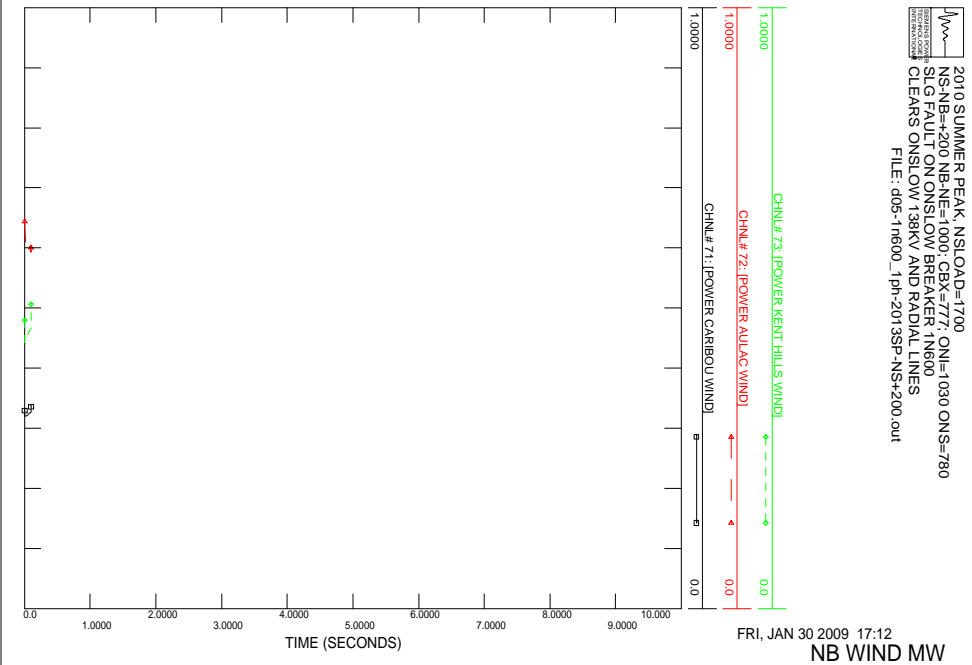
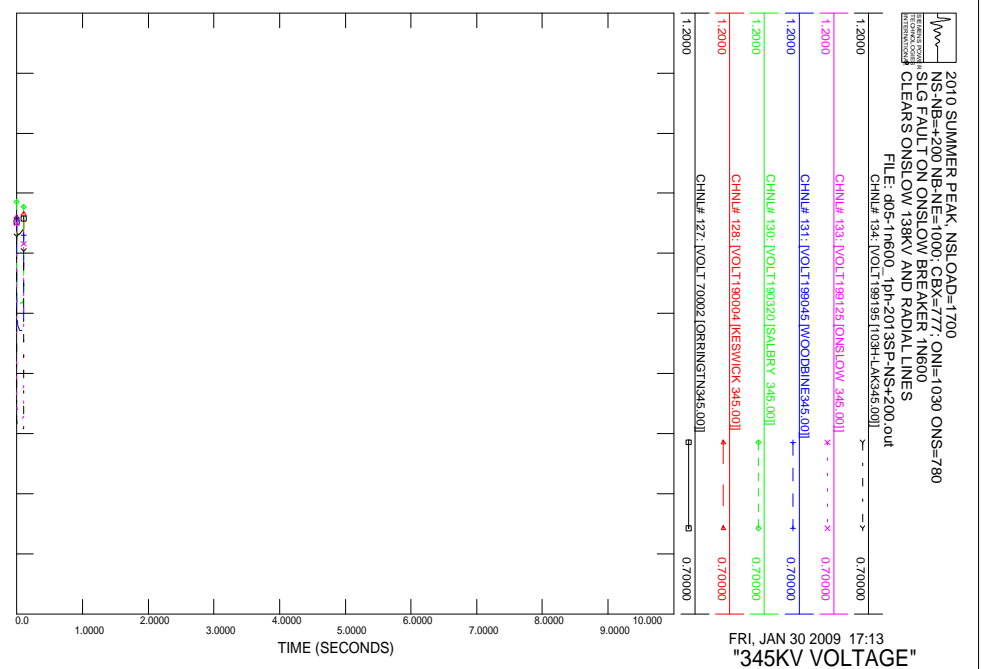
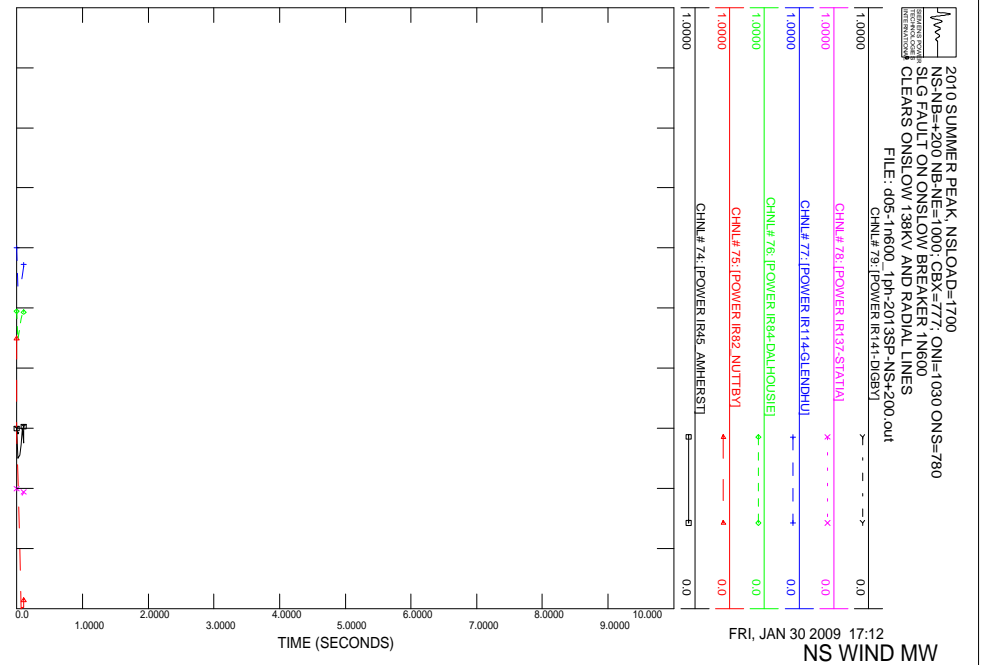

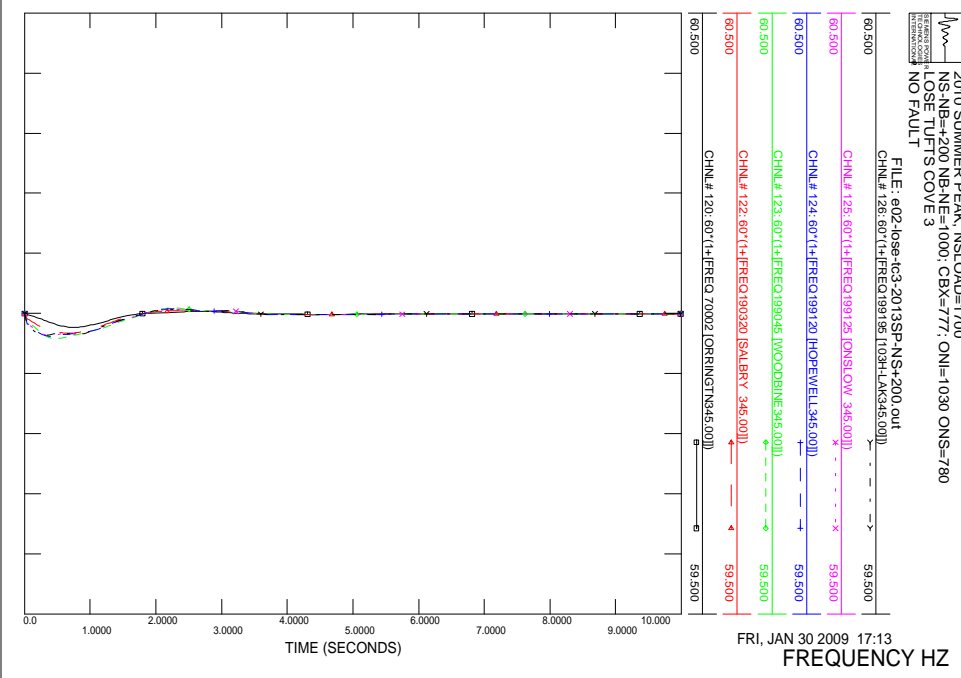
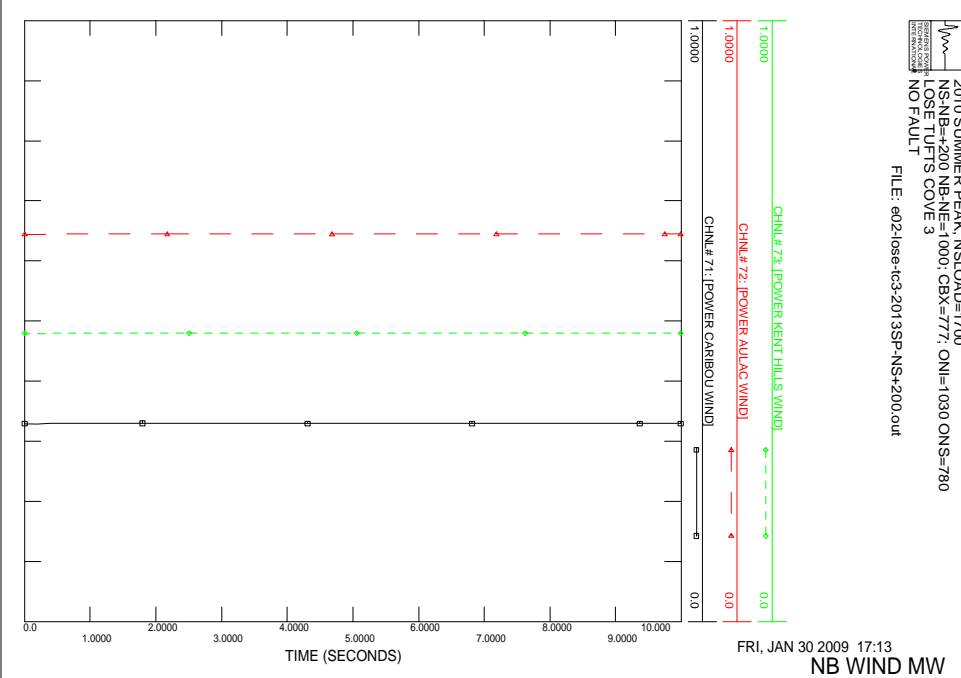
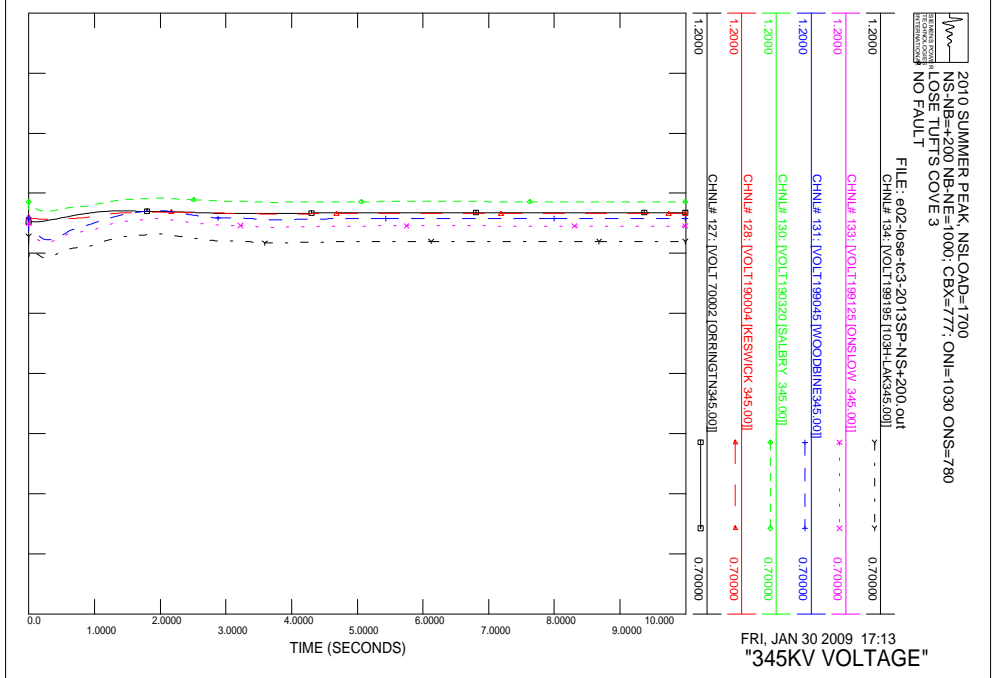
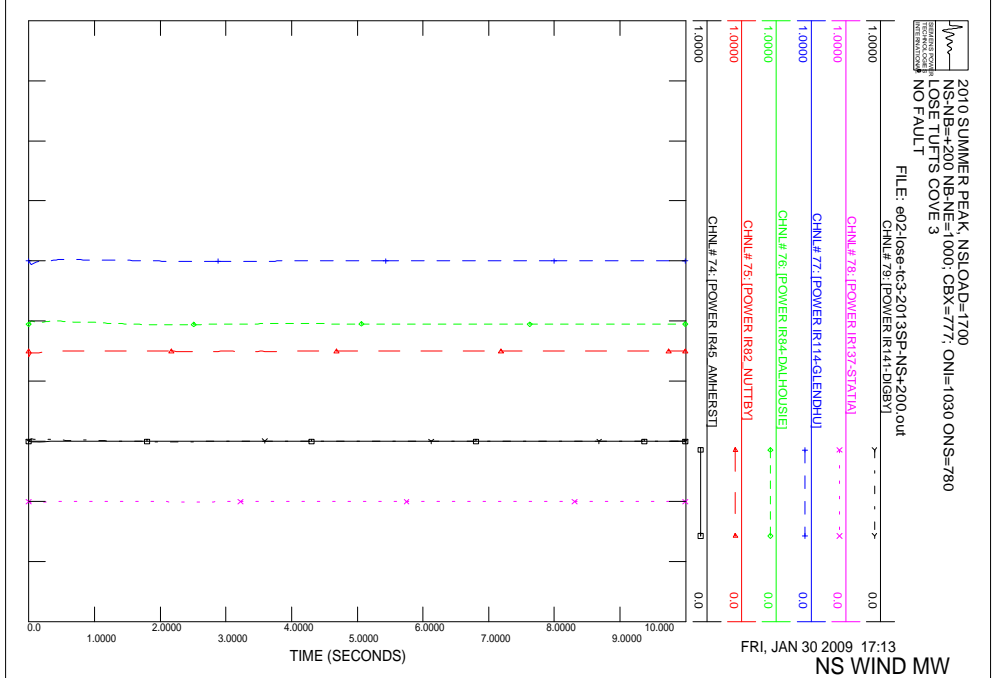

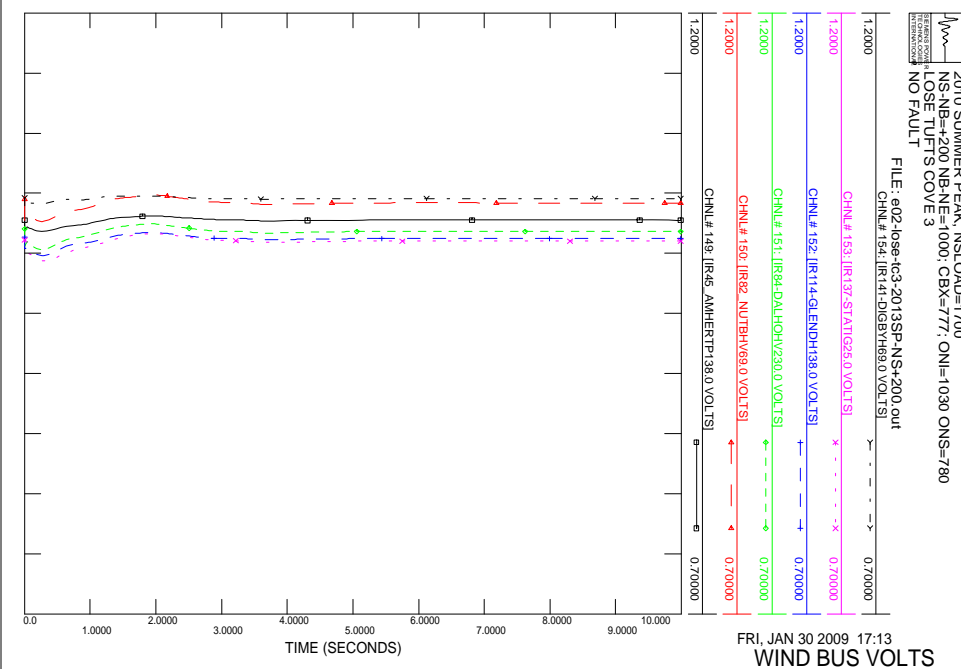
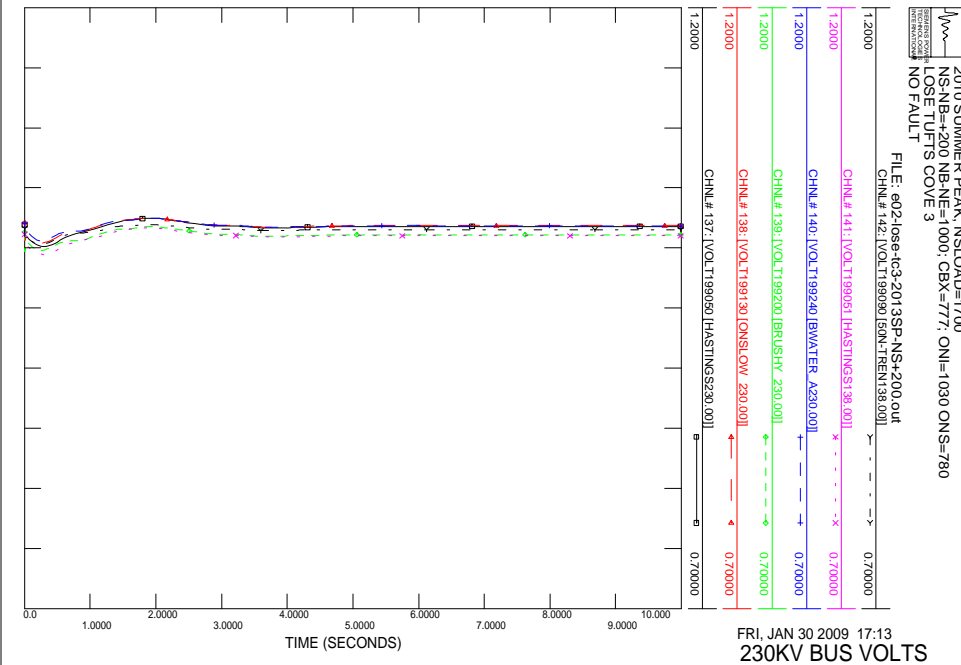
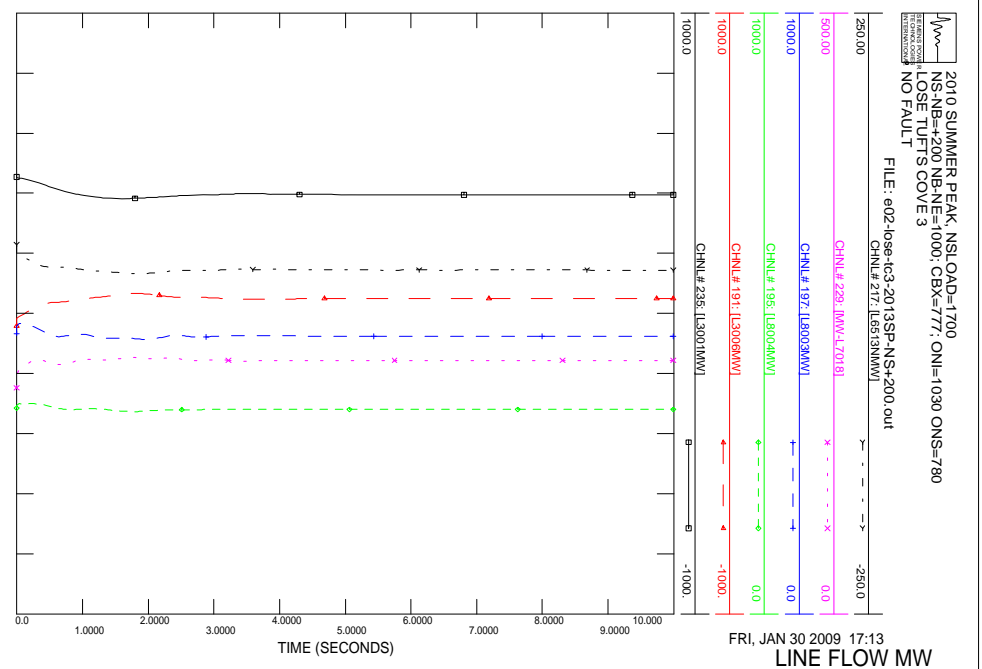
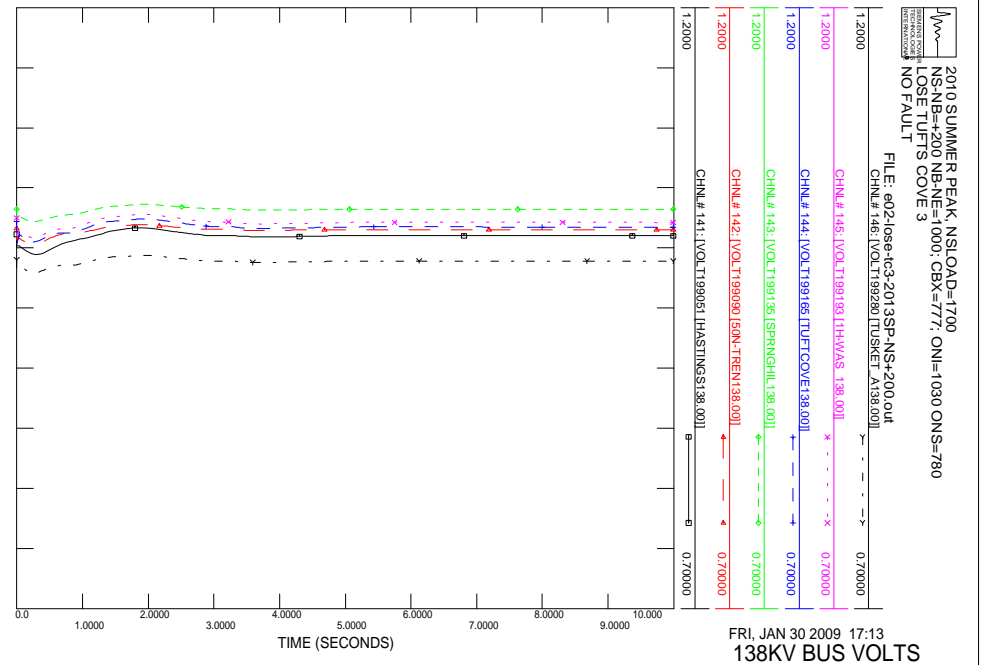

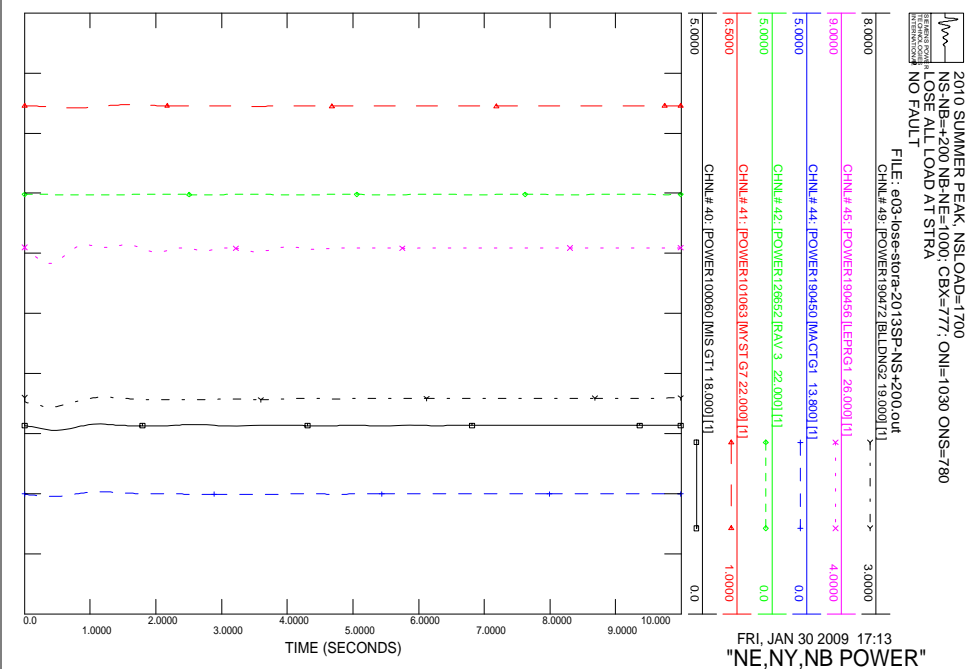
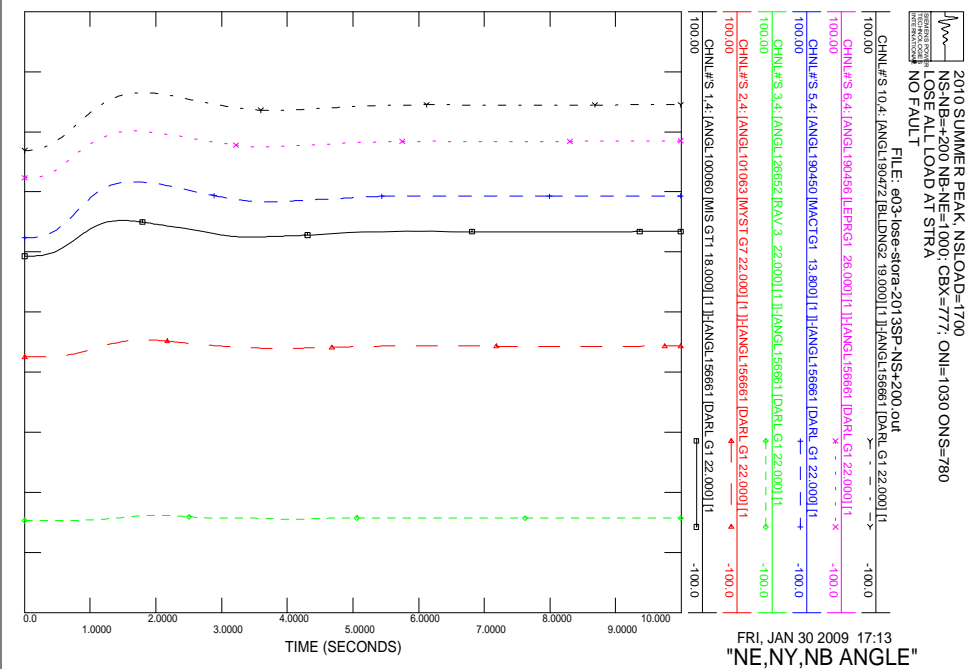
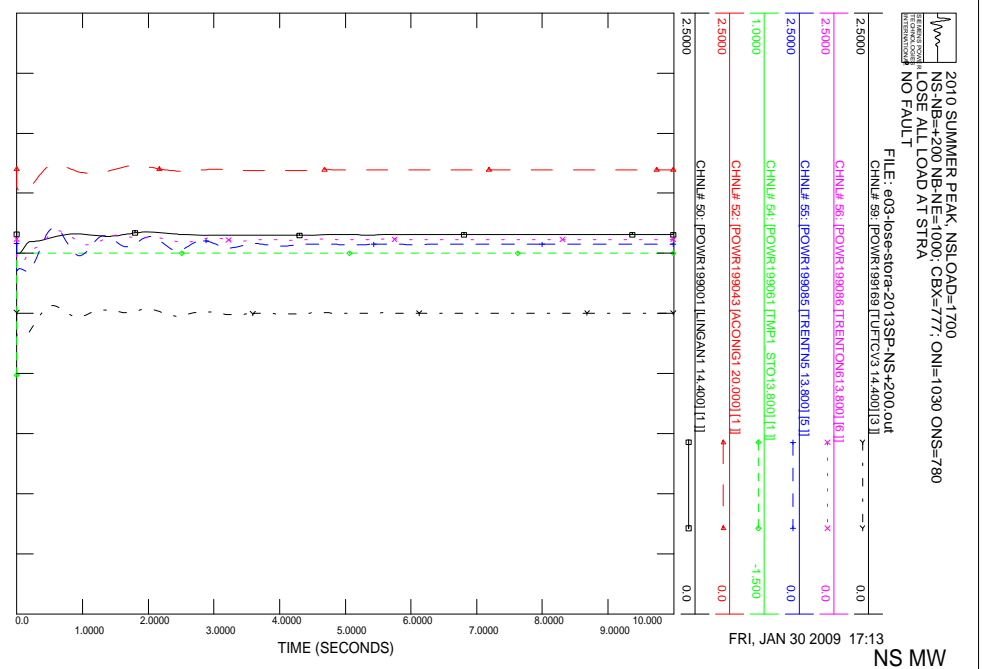
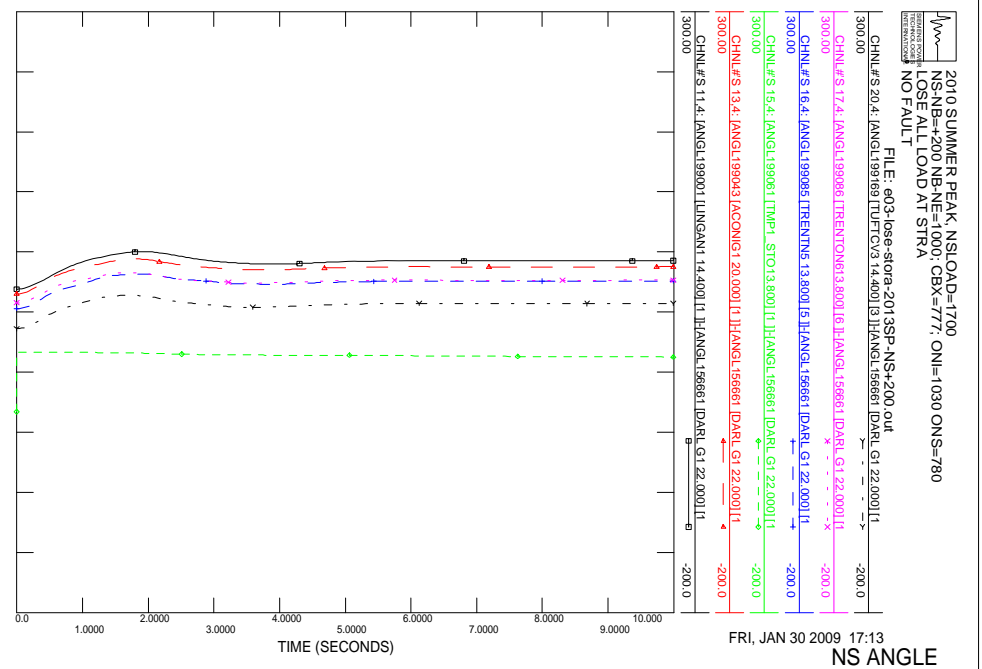

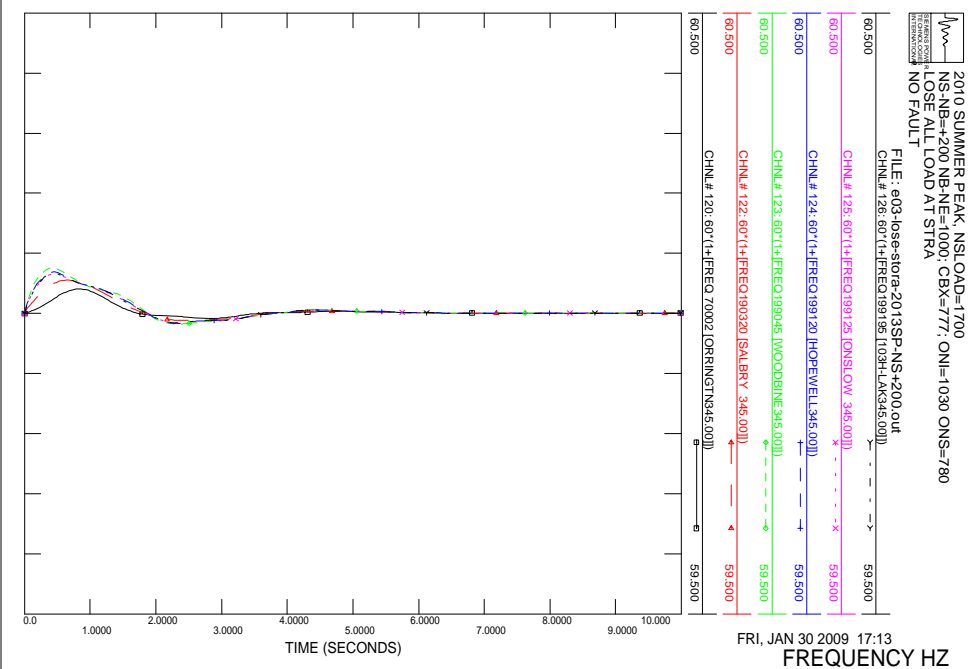
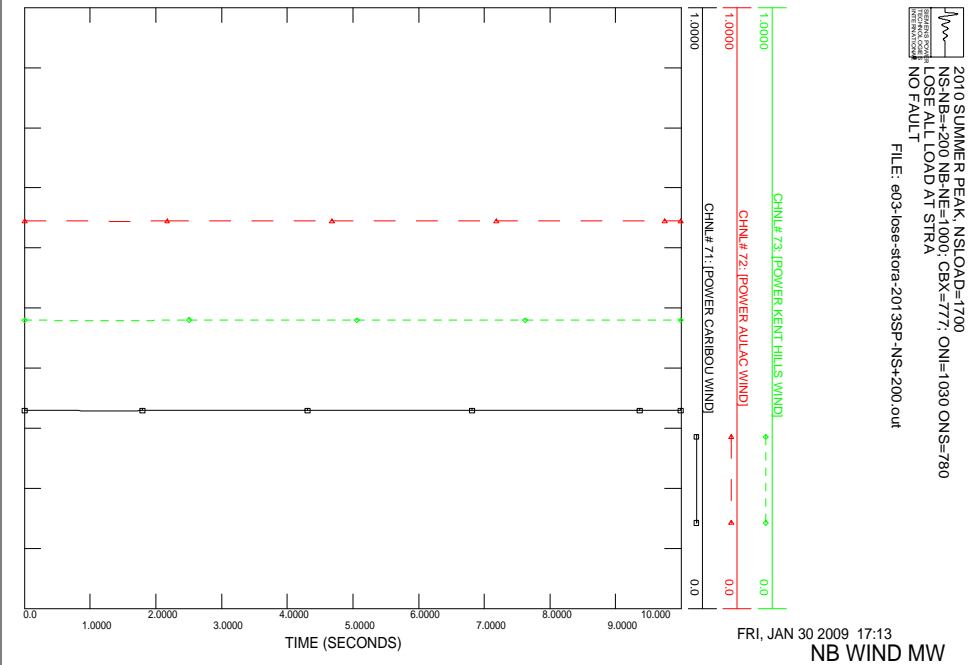
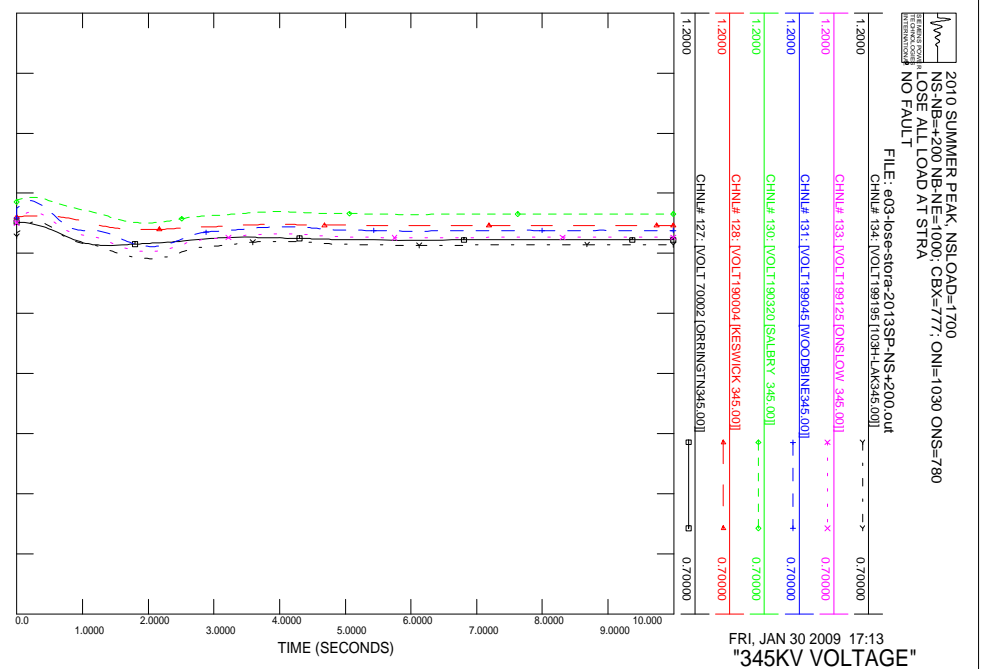
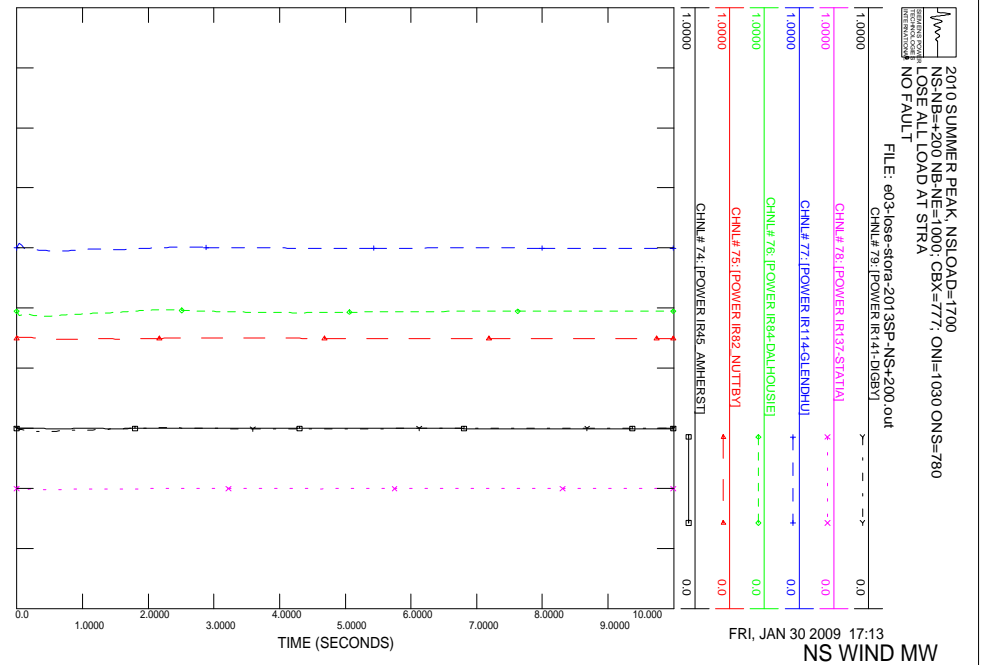

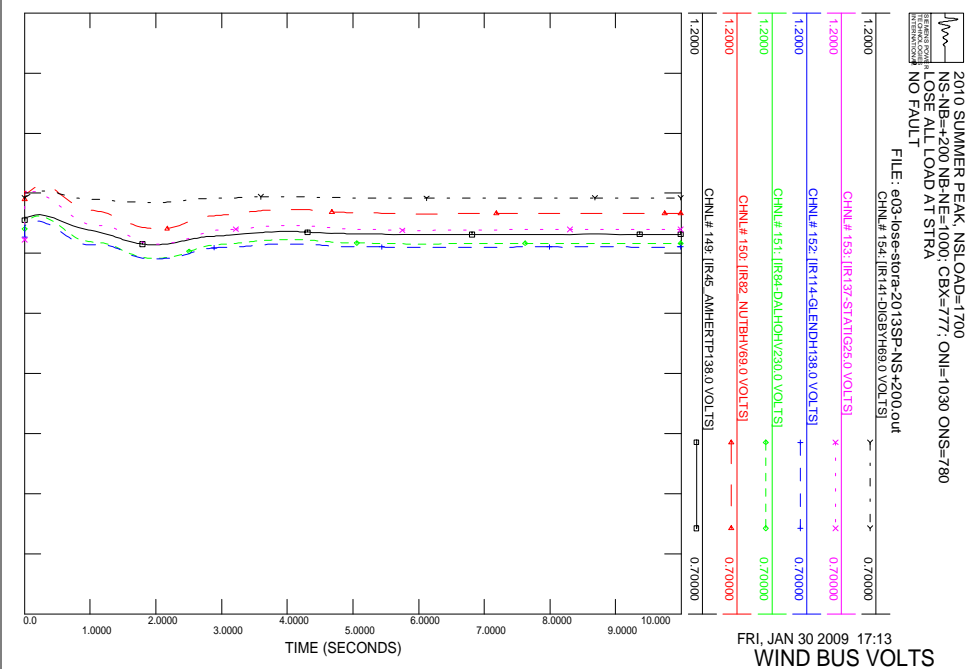
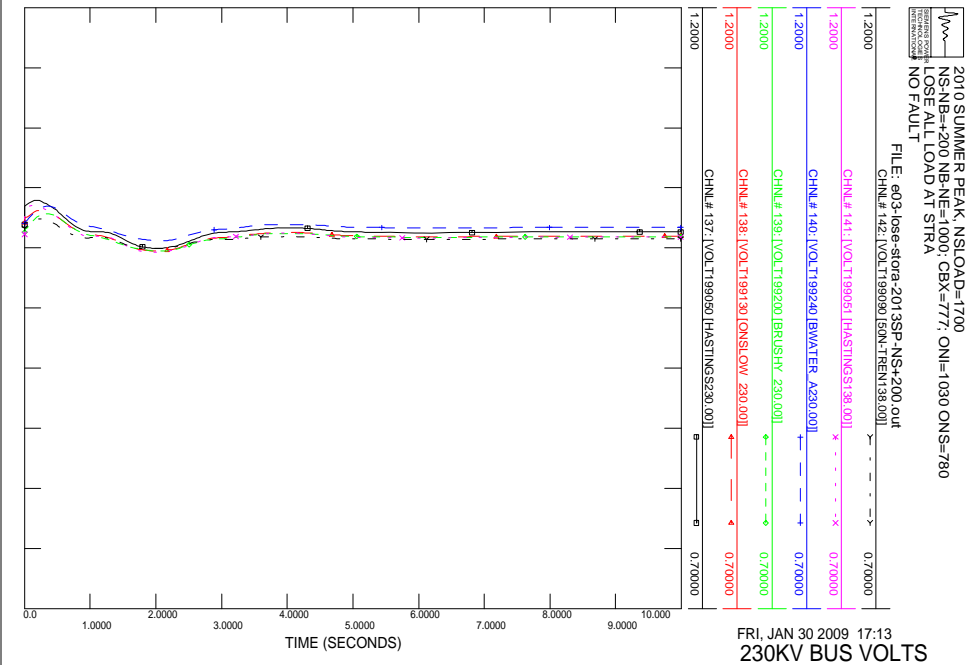
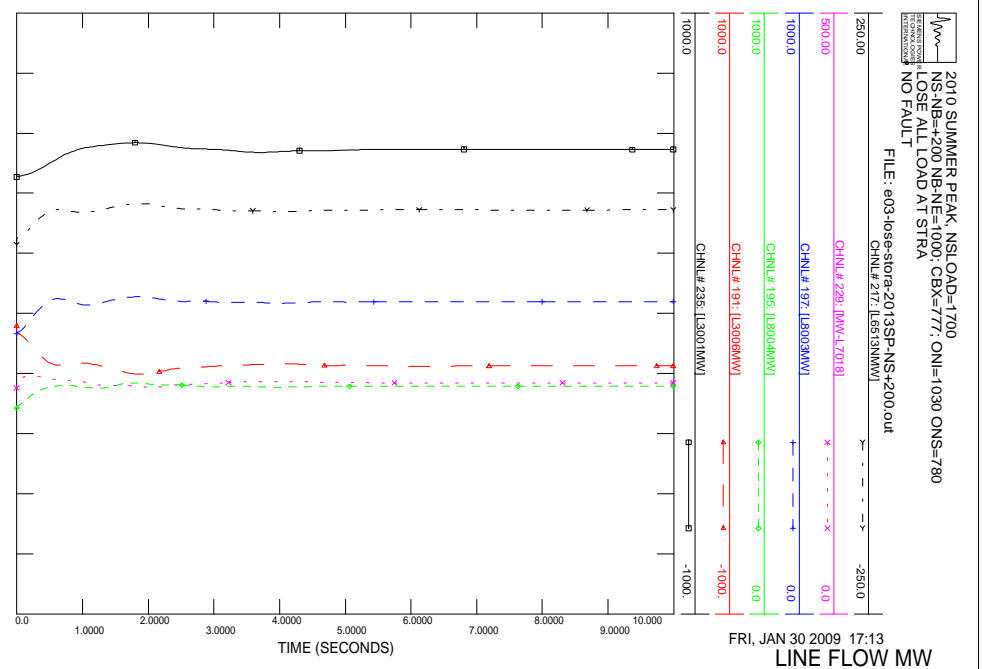
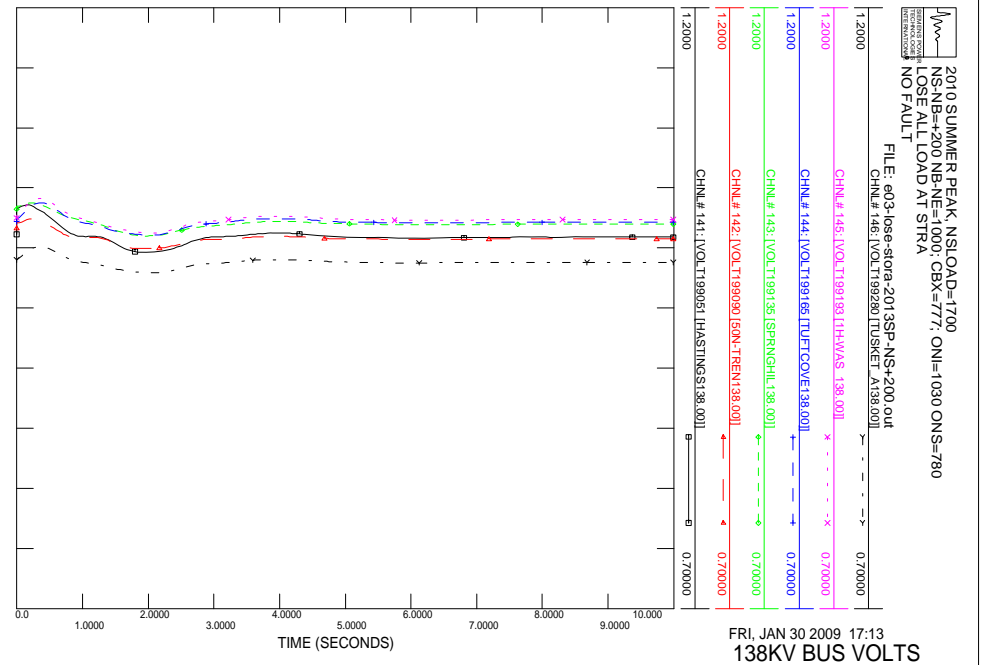

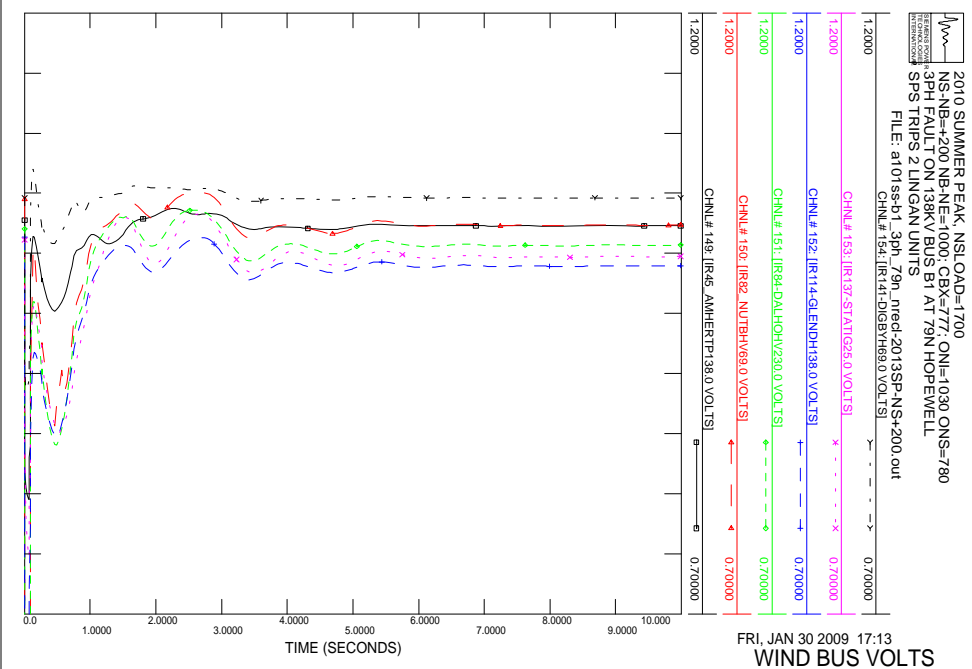
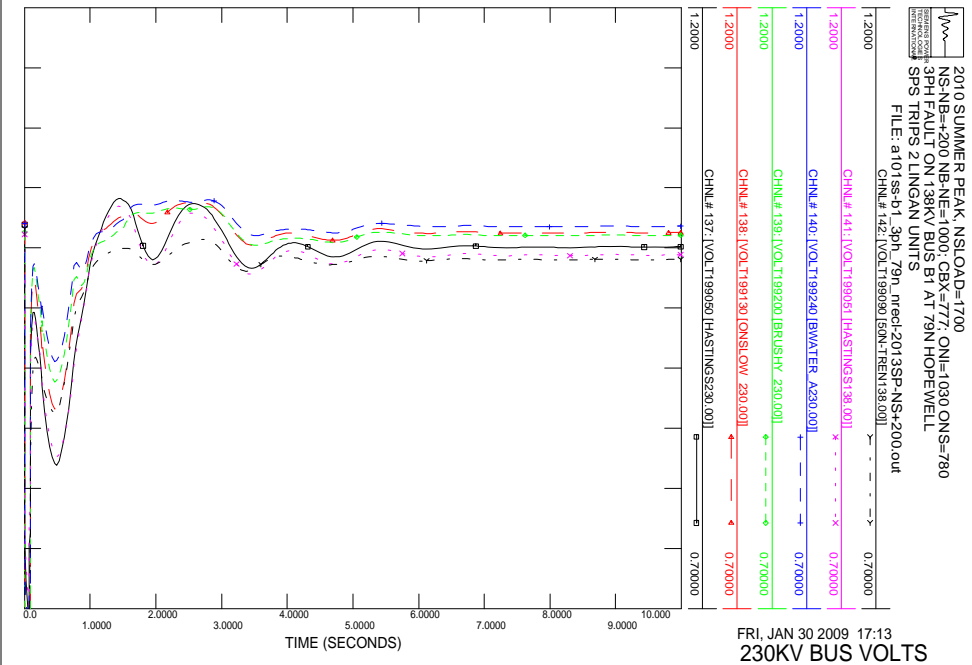
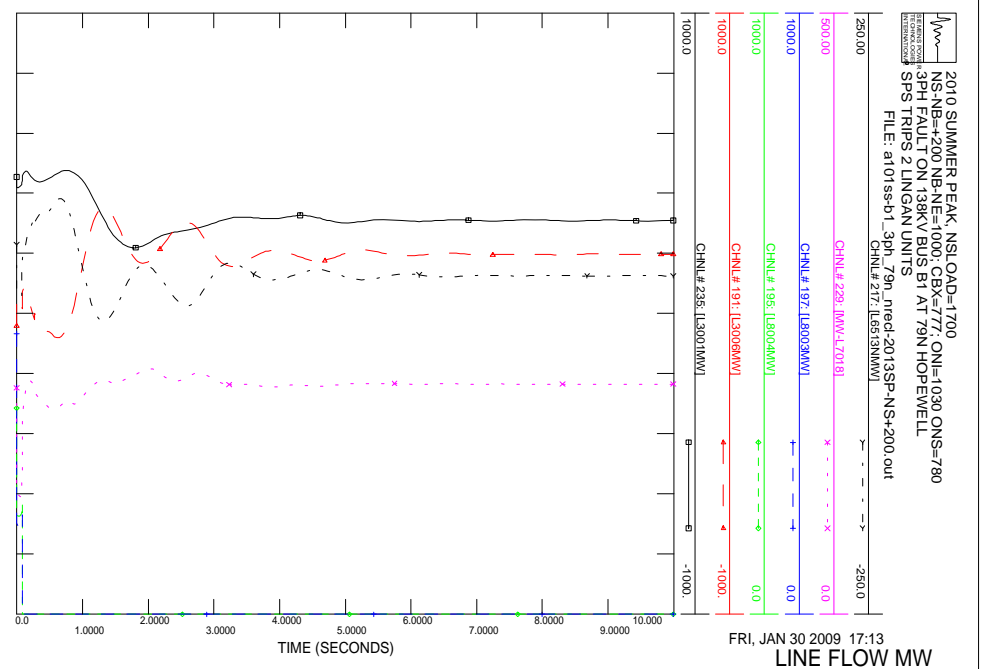
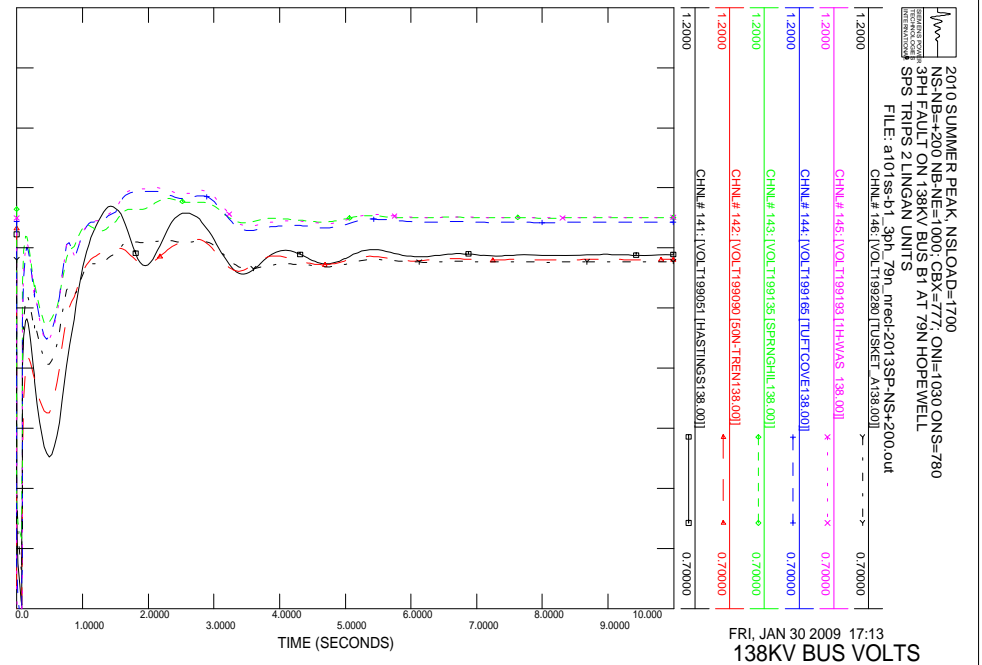

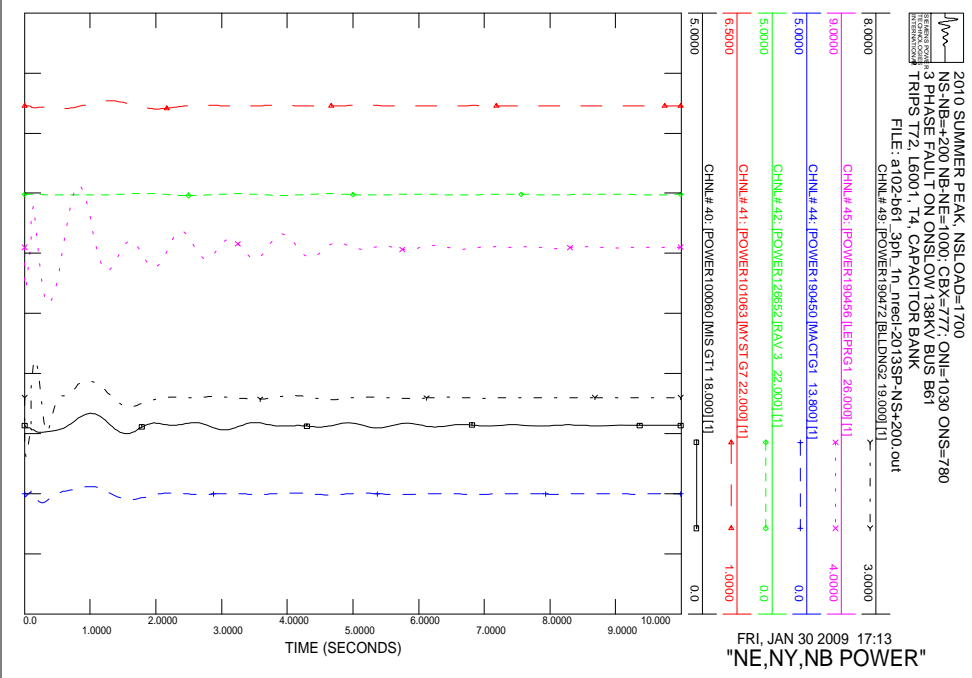
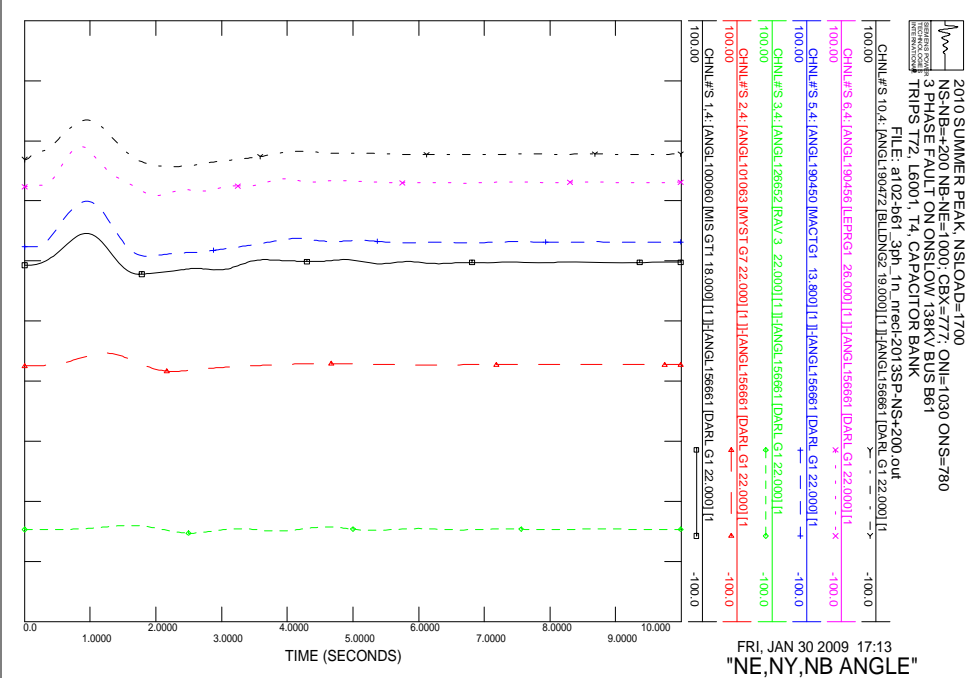
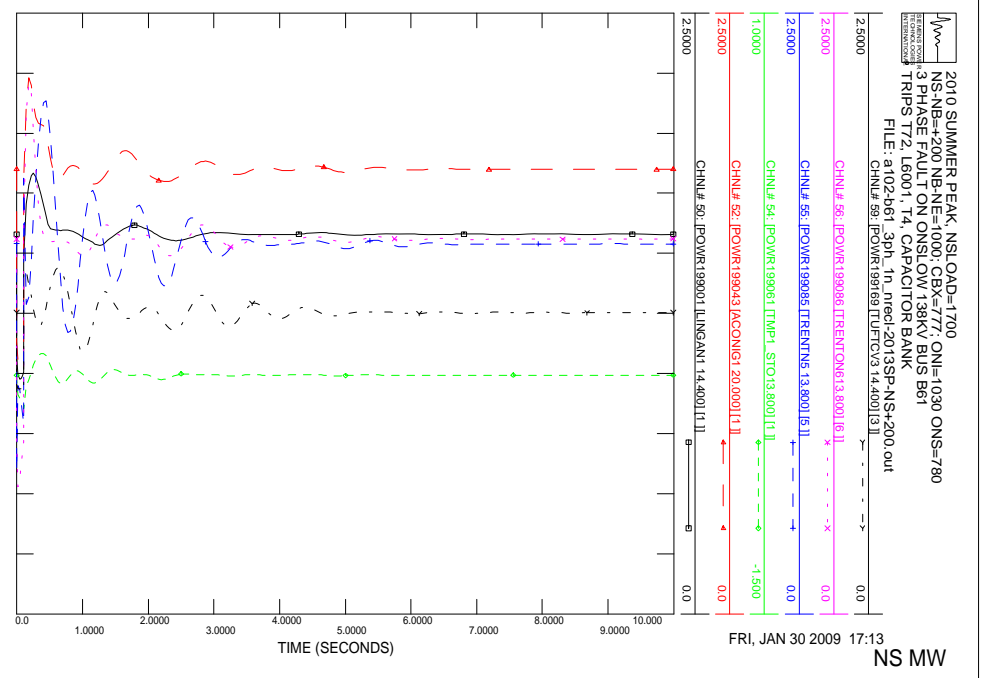
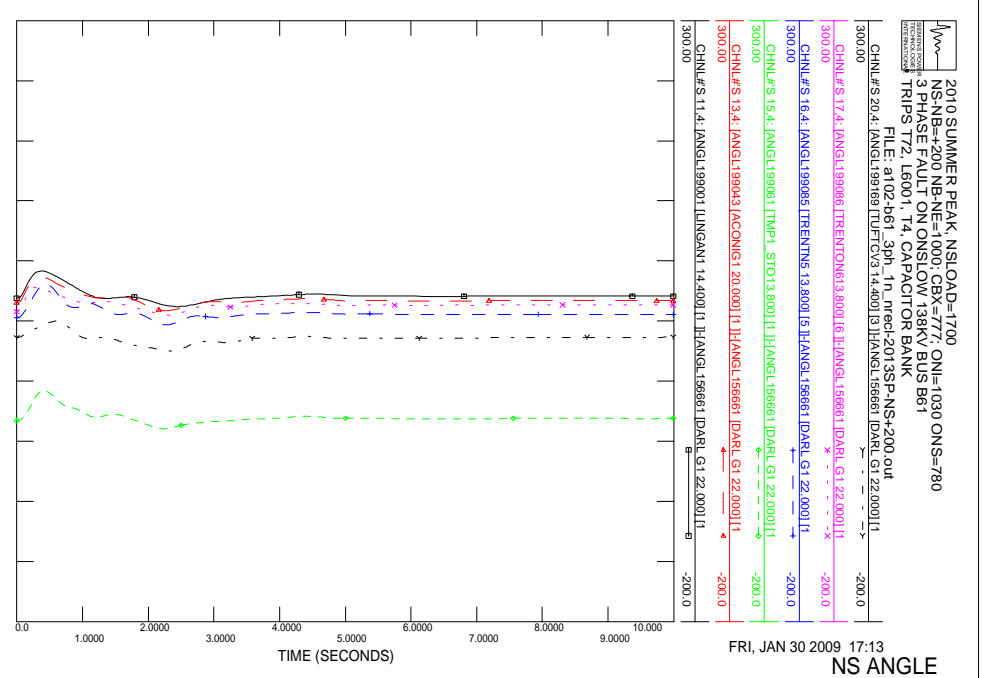

FRI, JAN 30 2009 17:13
 "NS ANGLE"

FRI, JAN 30 2009 17:13
 "NS MW"

FRI, JAN 30 2009 17:13
 "NE, NY, NB ANGLE"

FRI, JAN 30 2009 17:13
 "NE, NY, NB POWER"

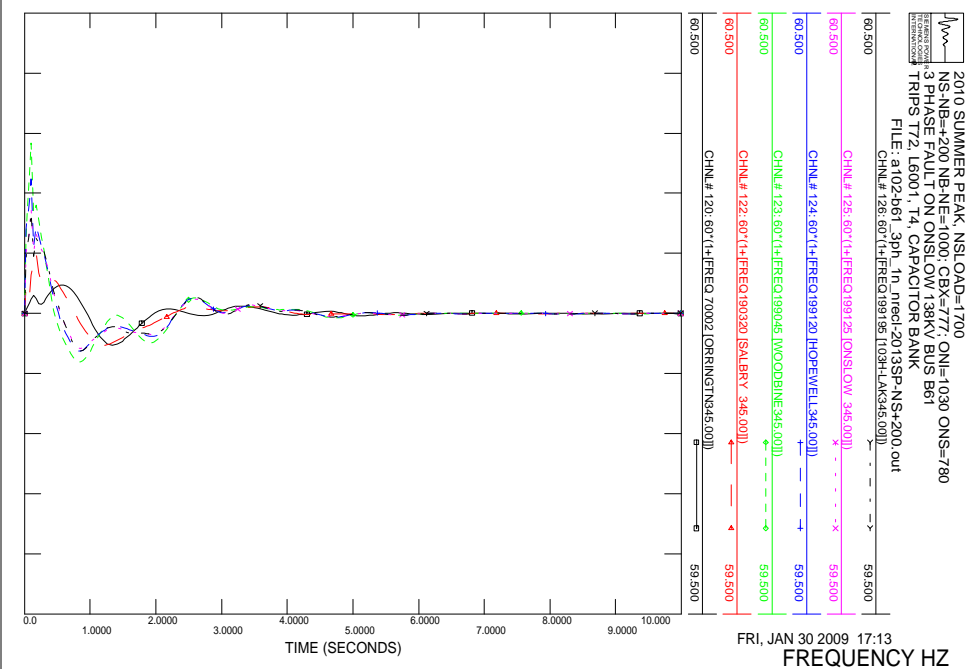
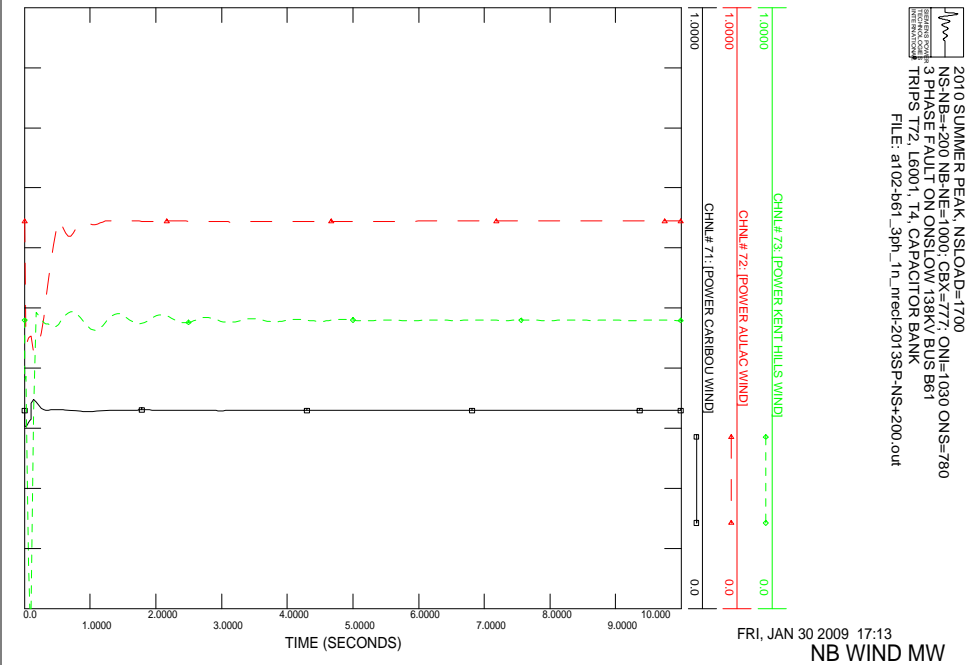
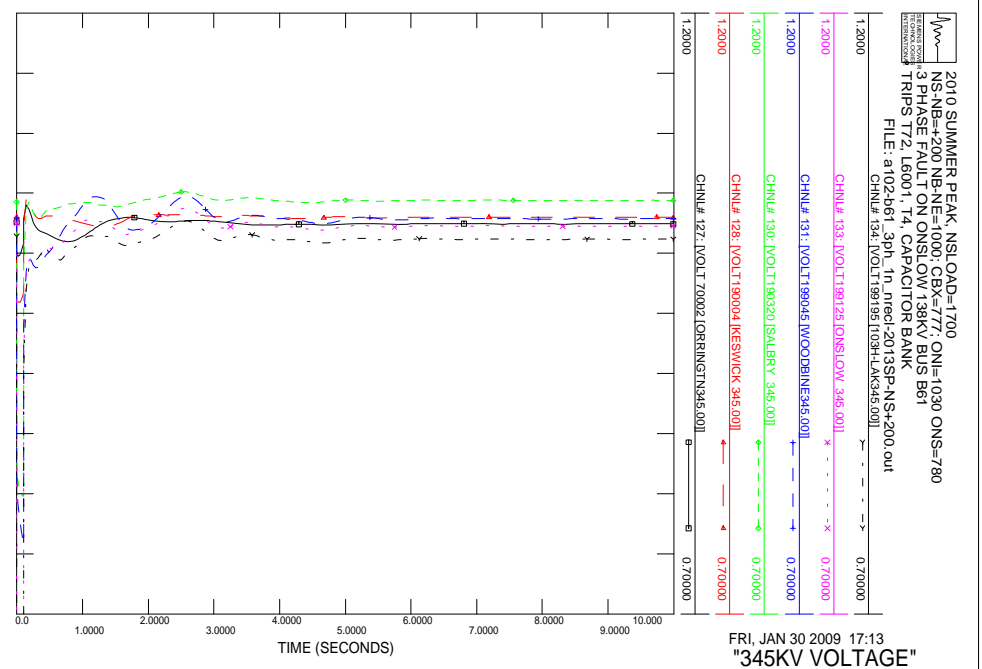
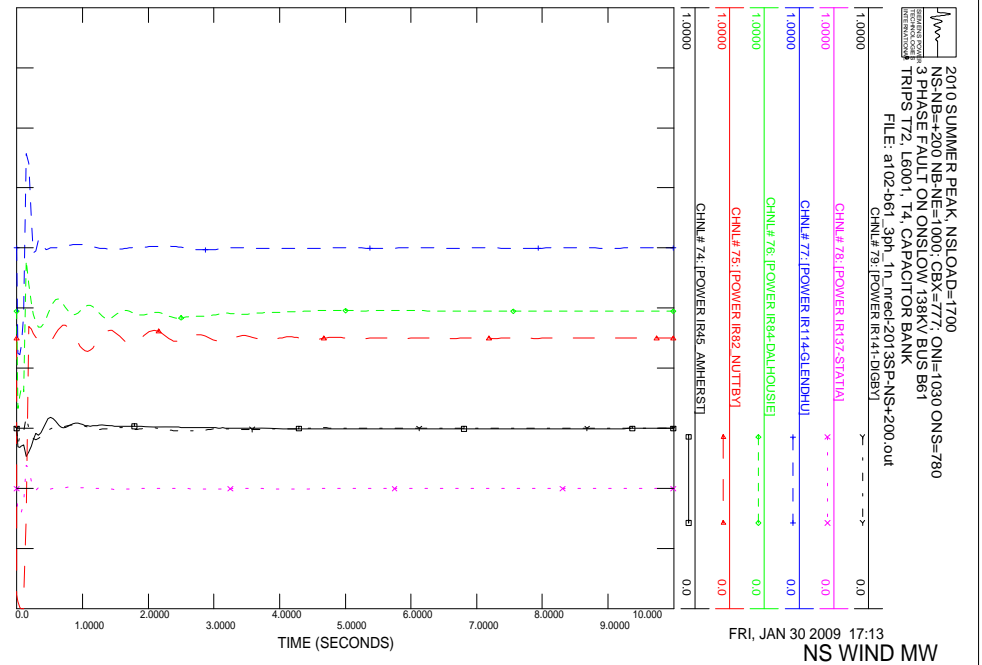

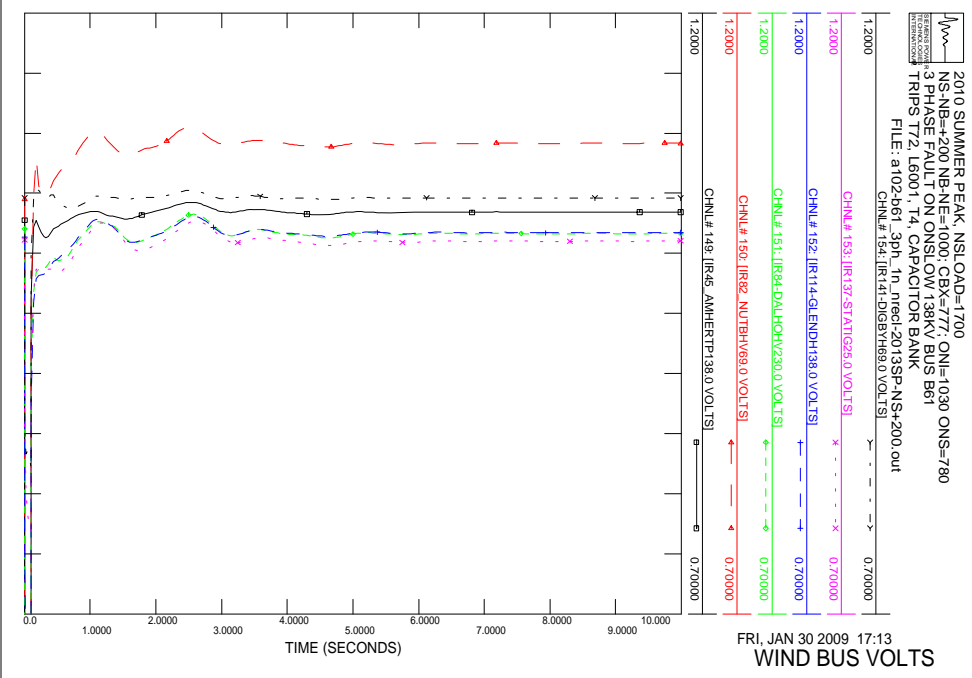
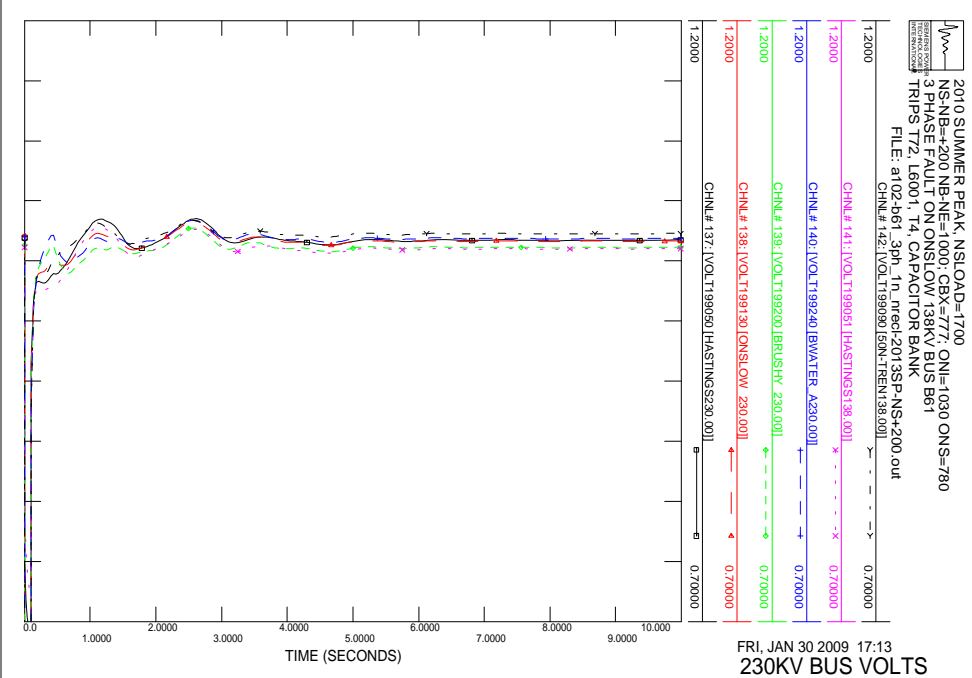
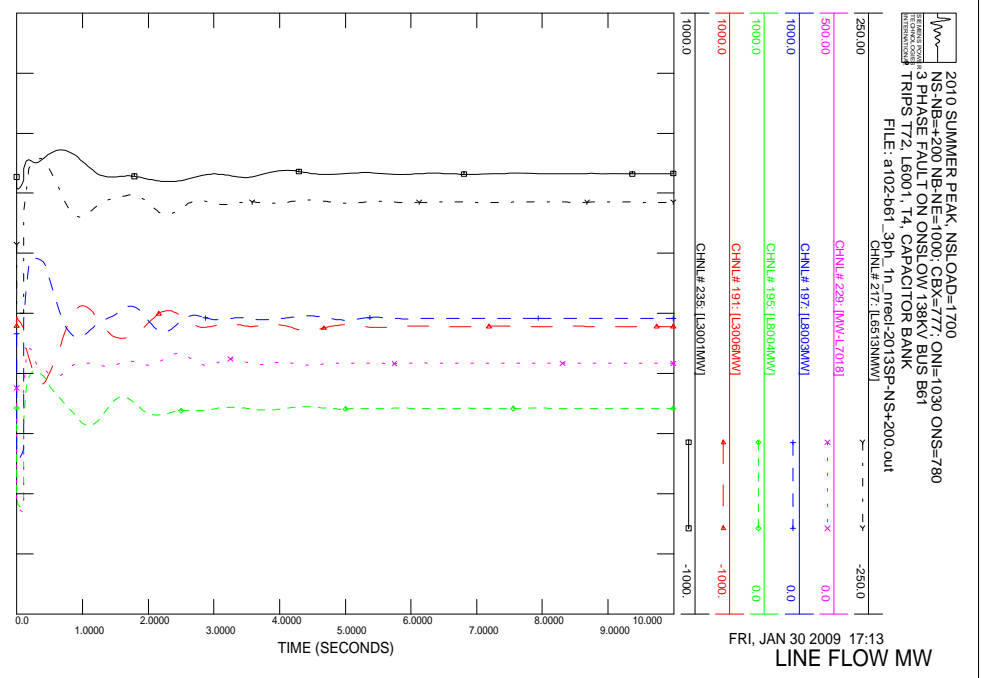
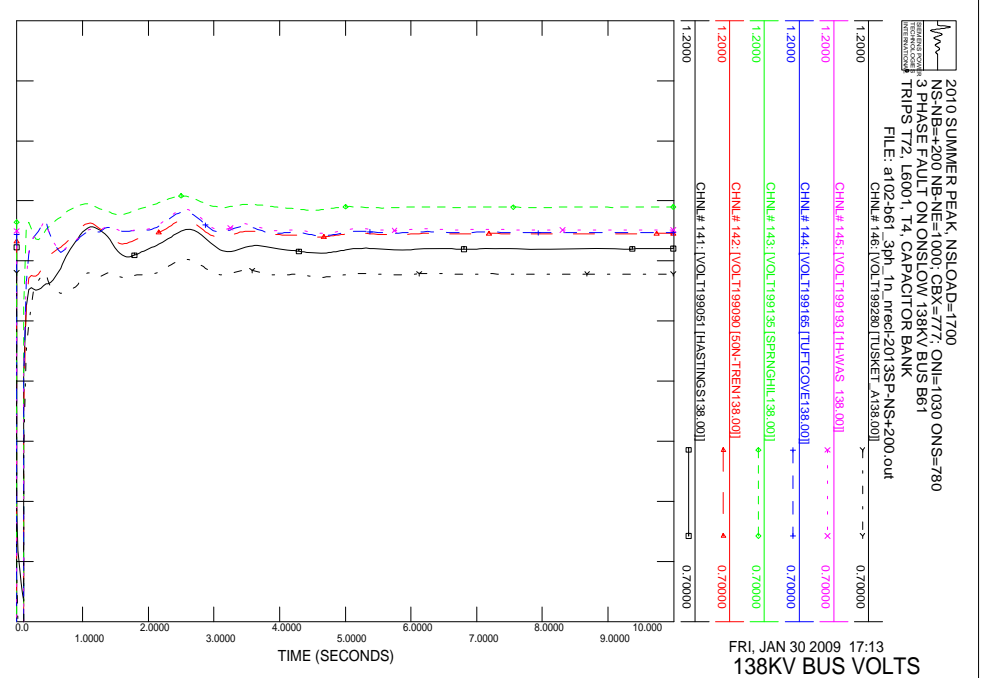

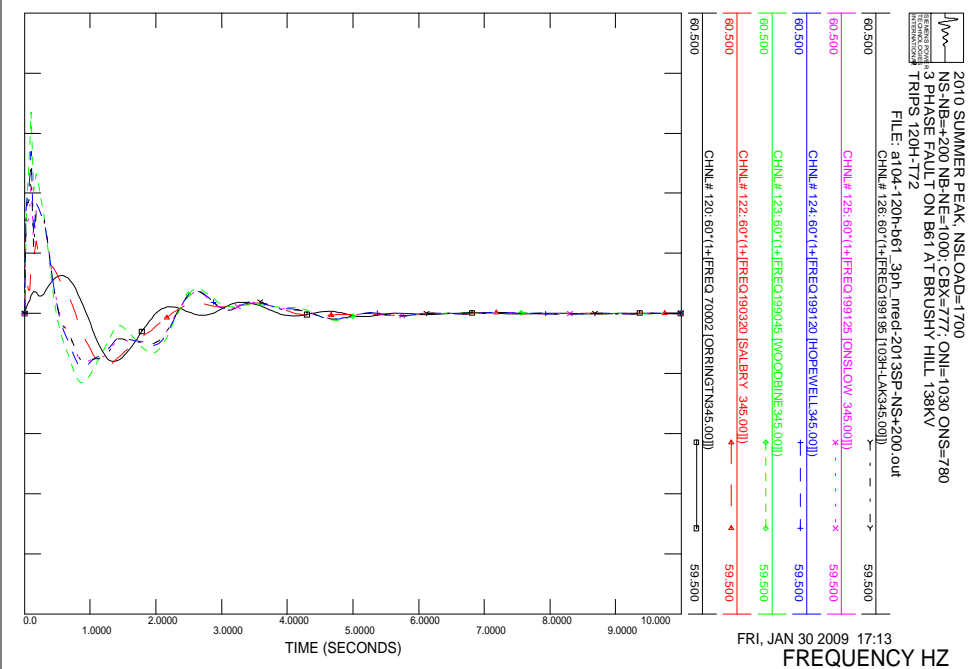
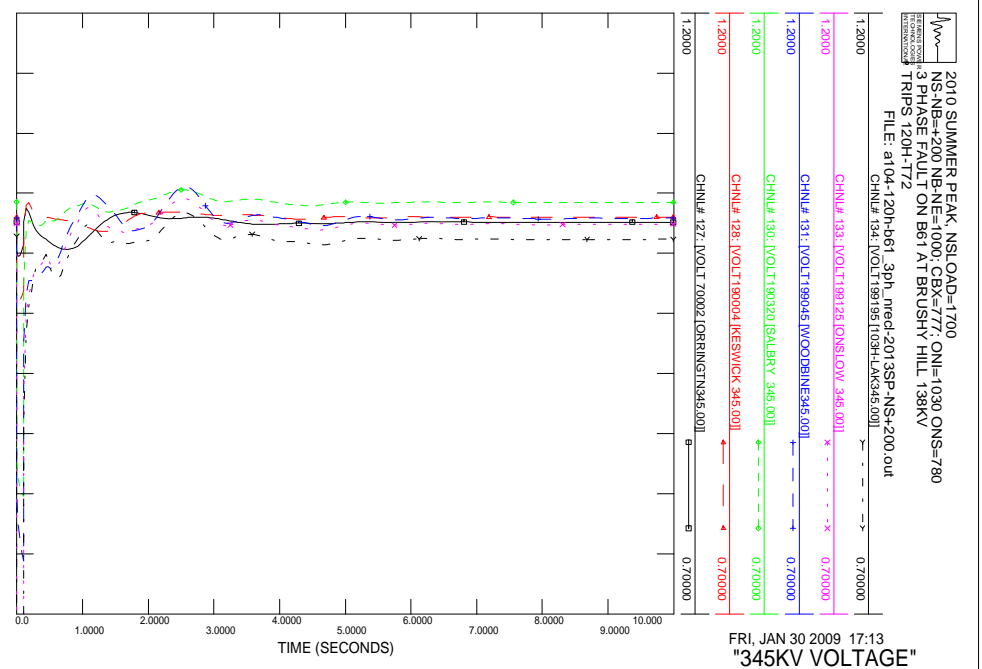
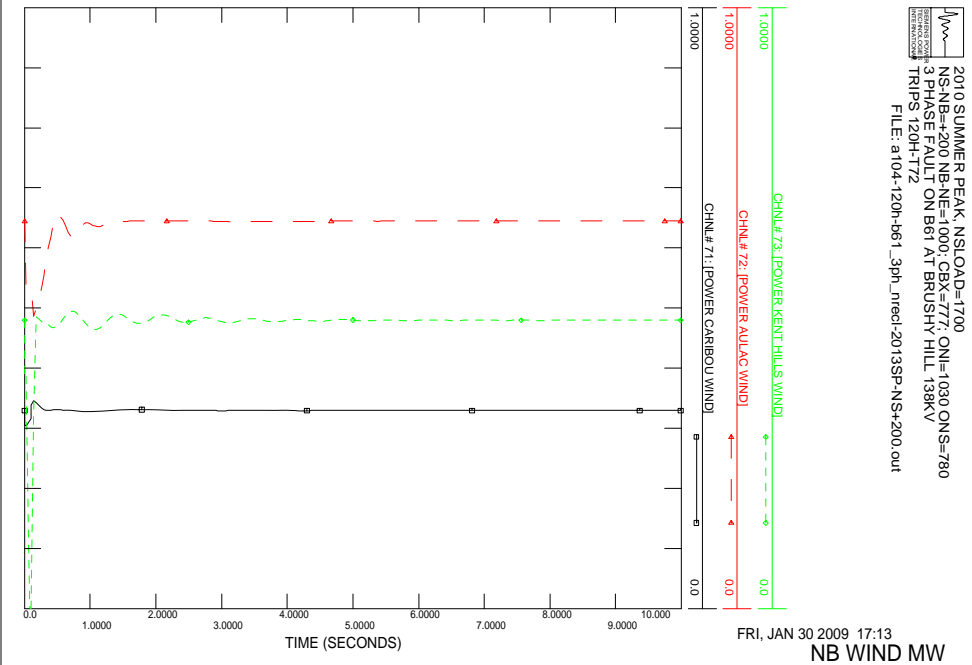
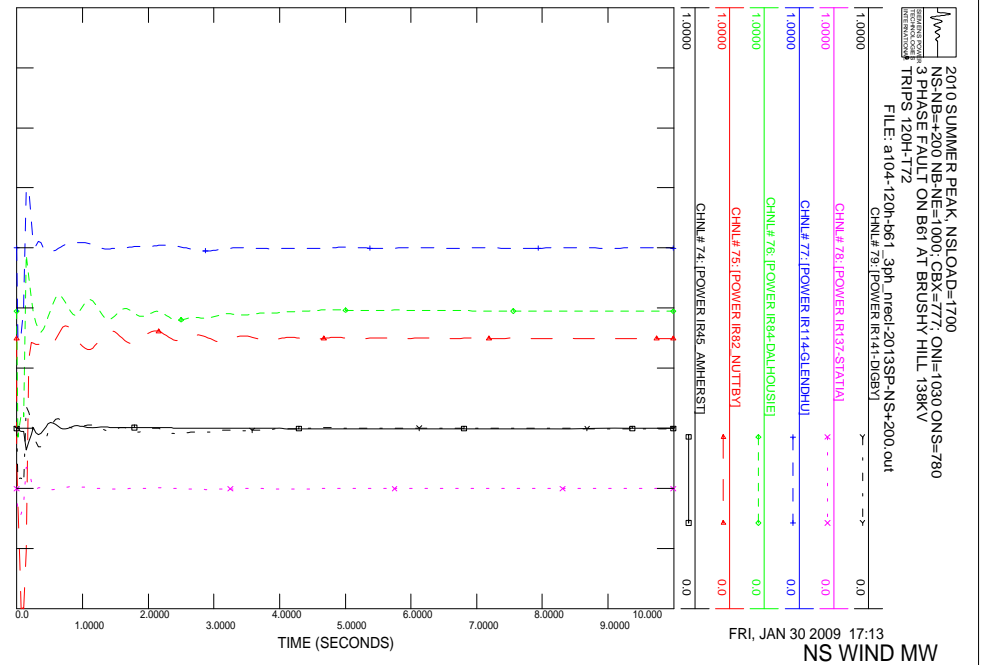

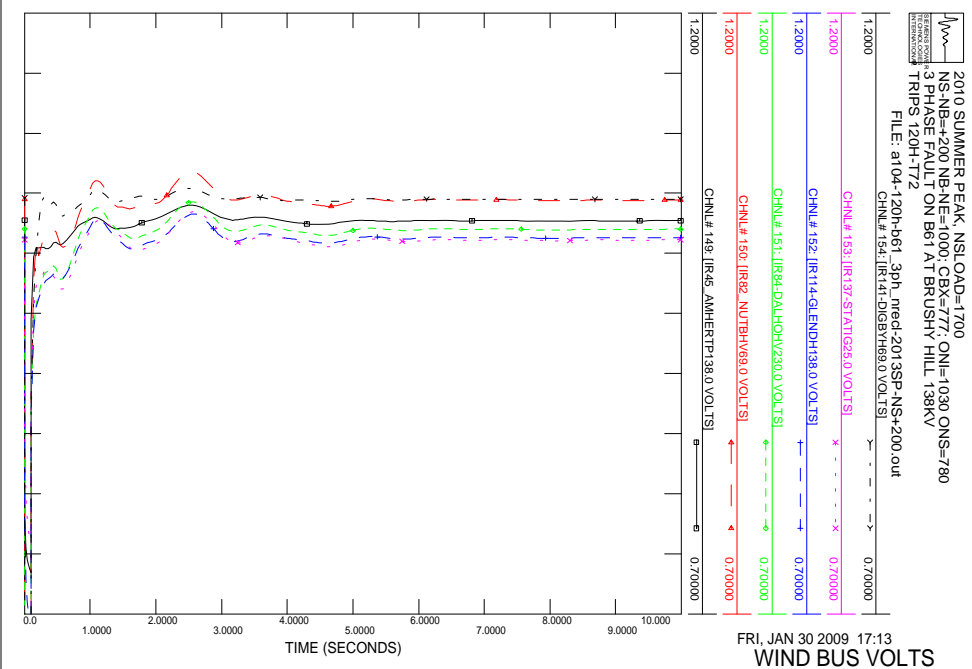
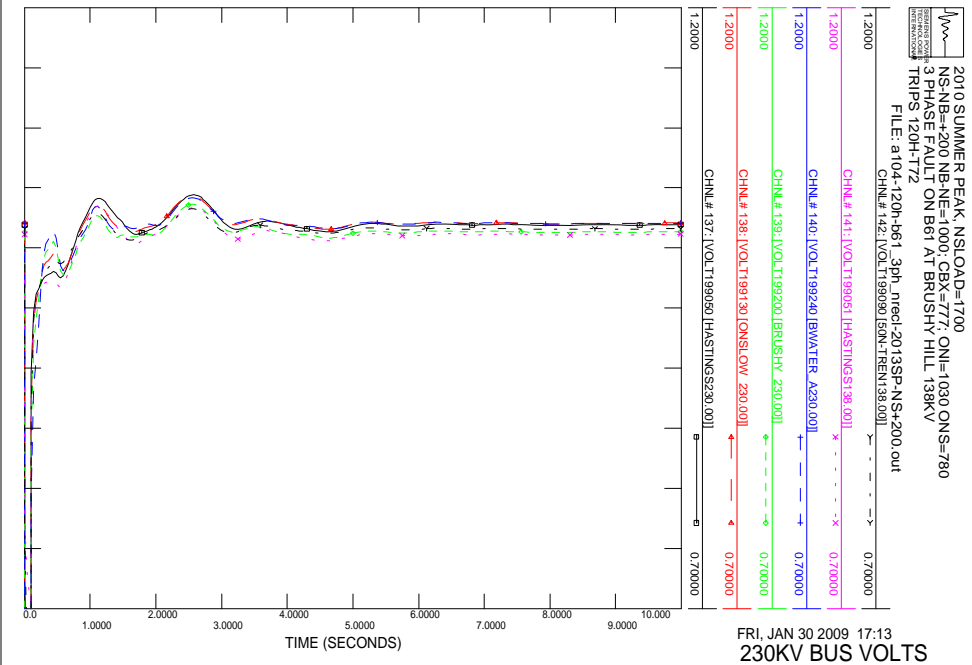
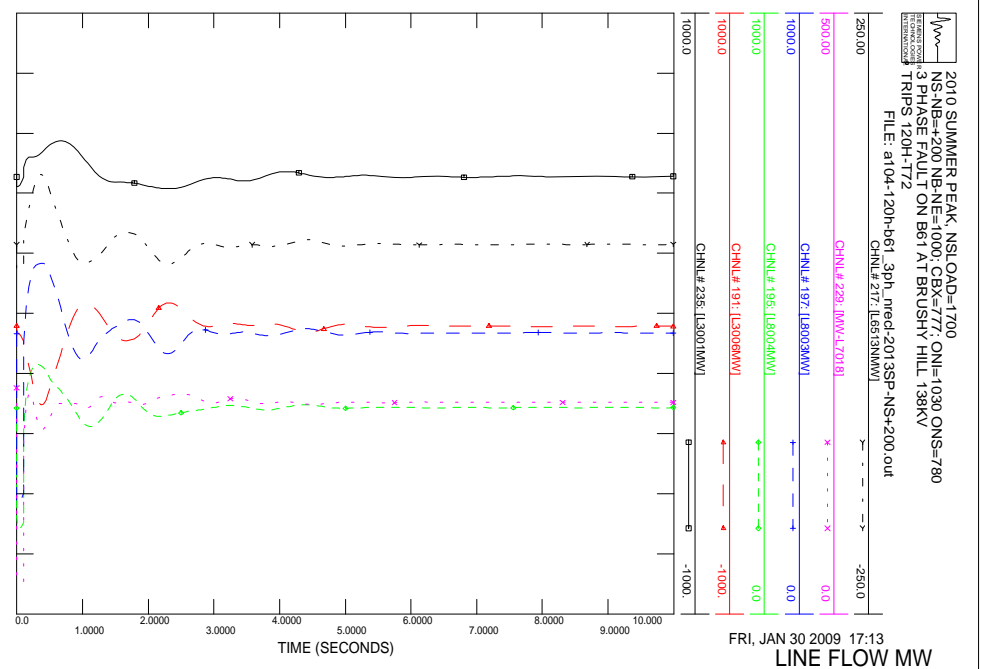
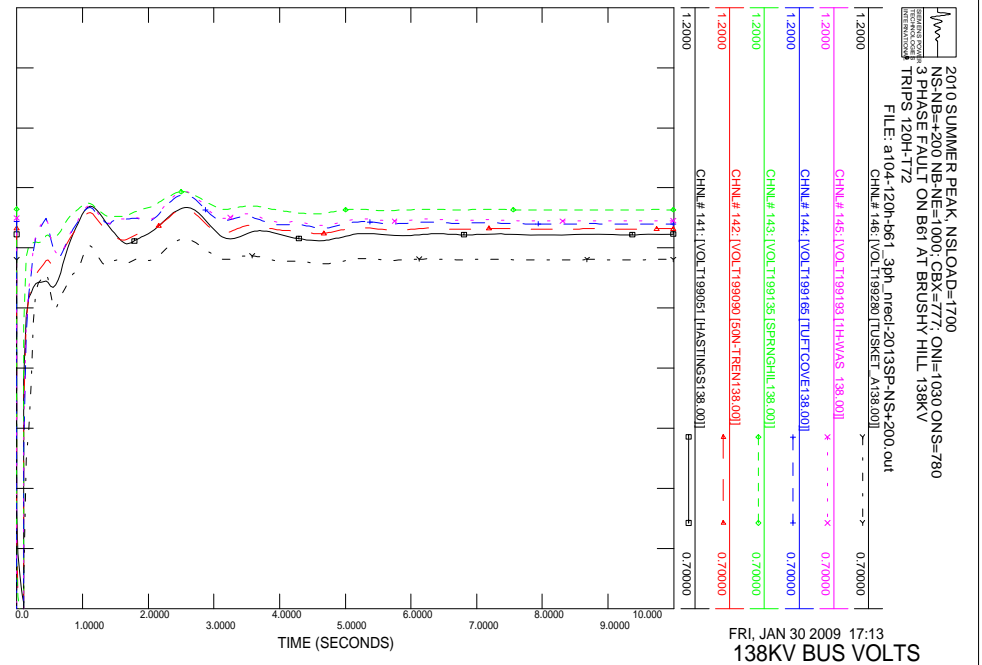

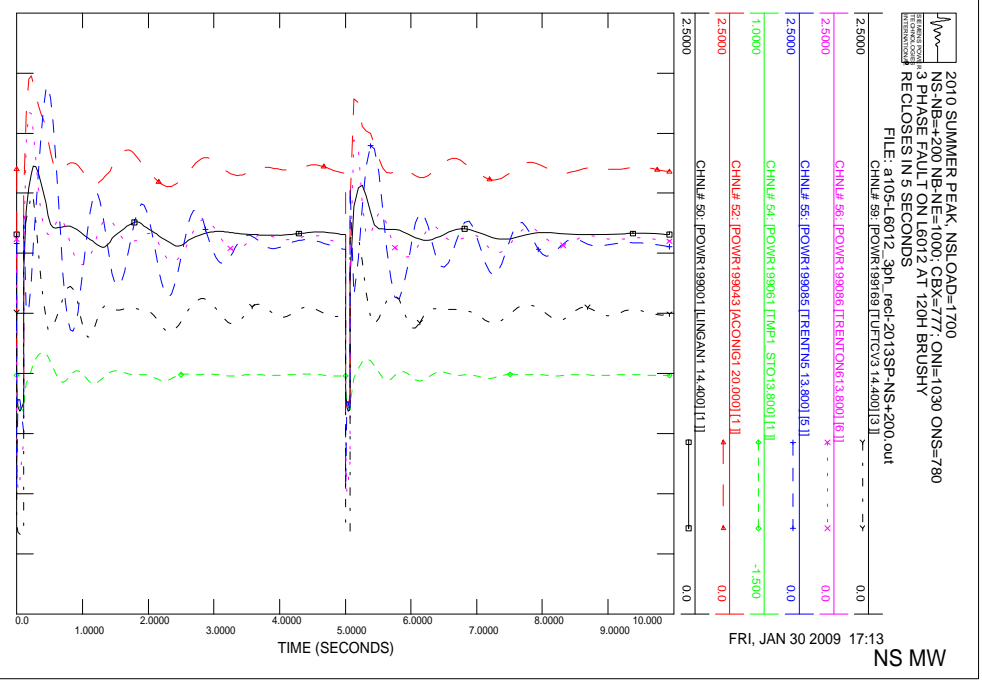
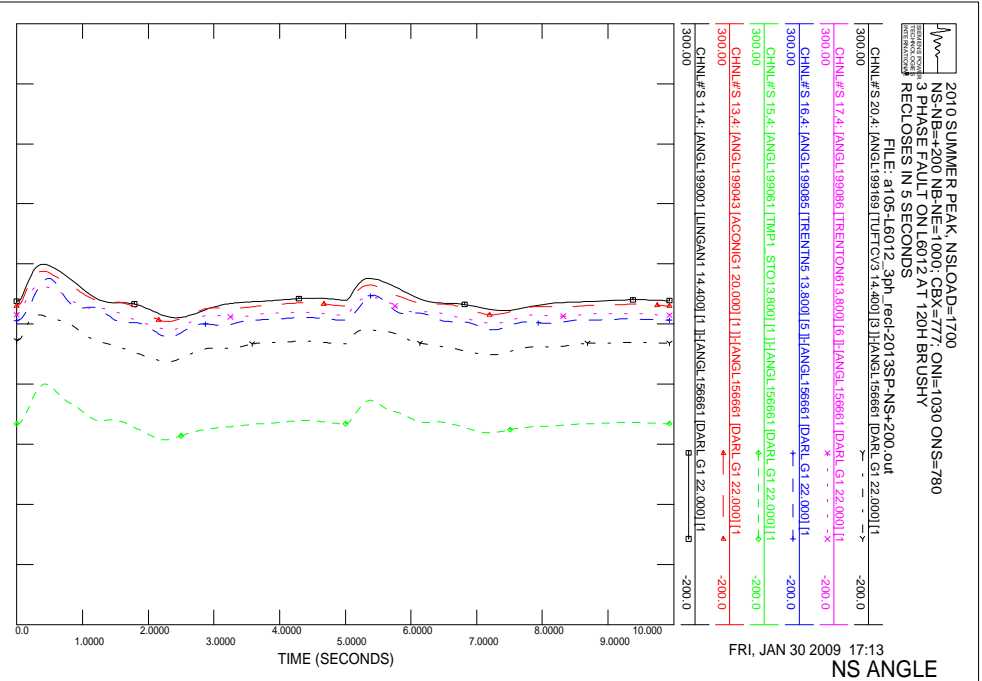
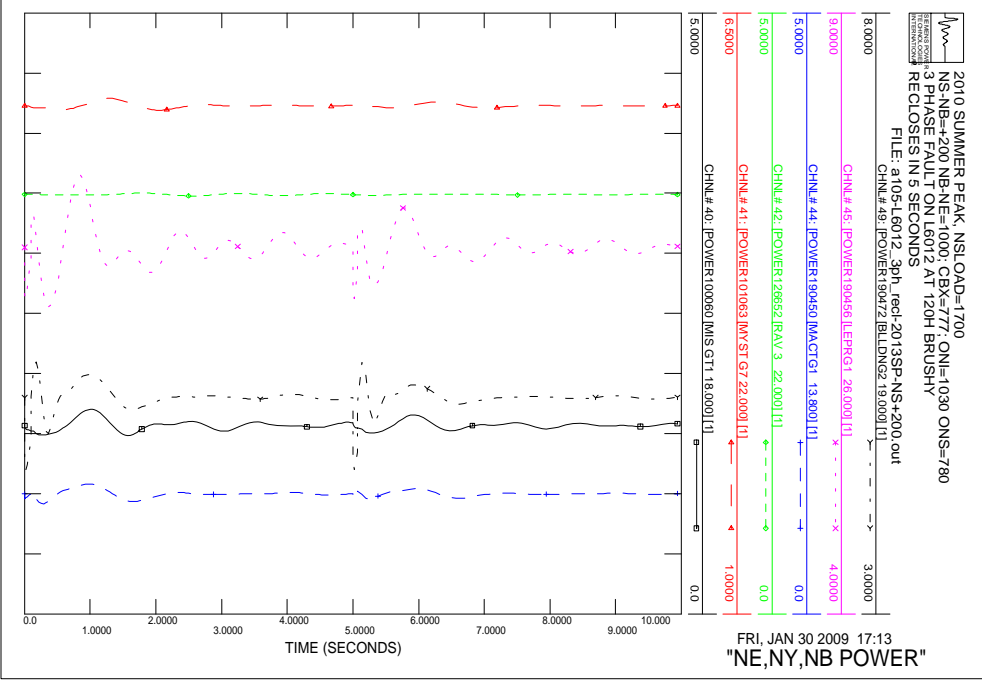
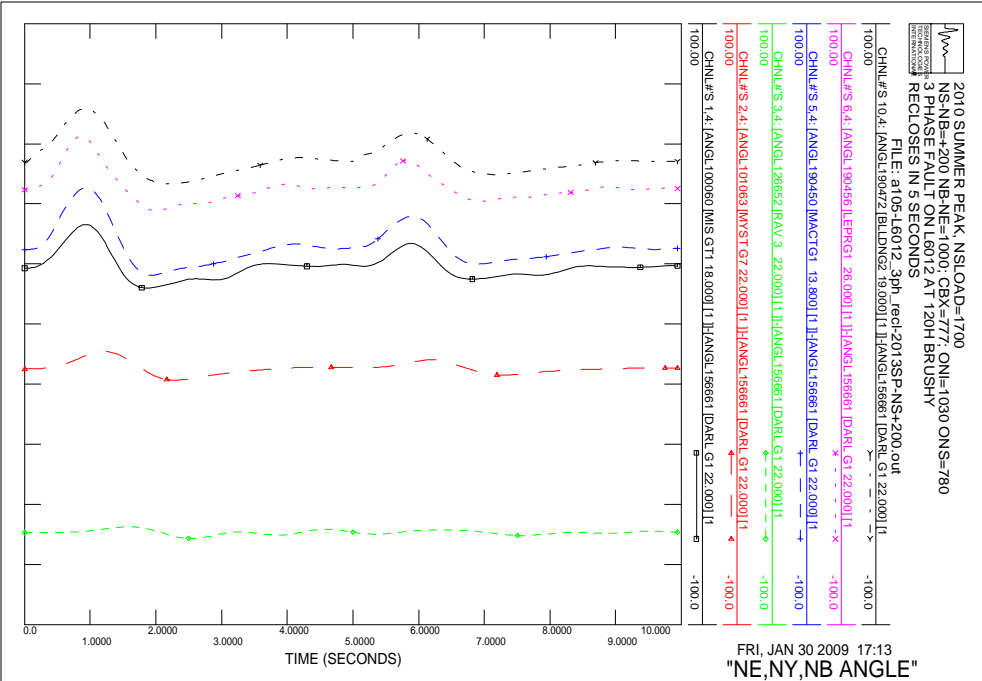

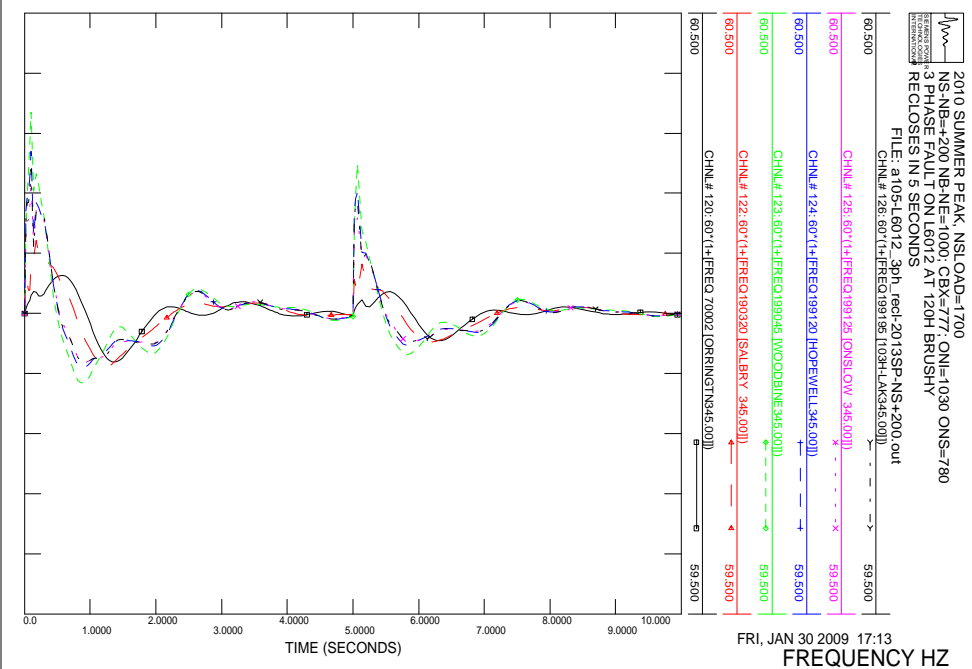
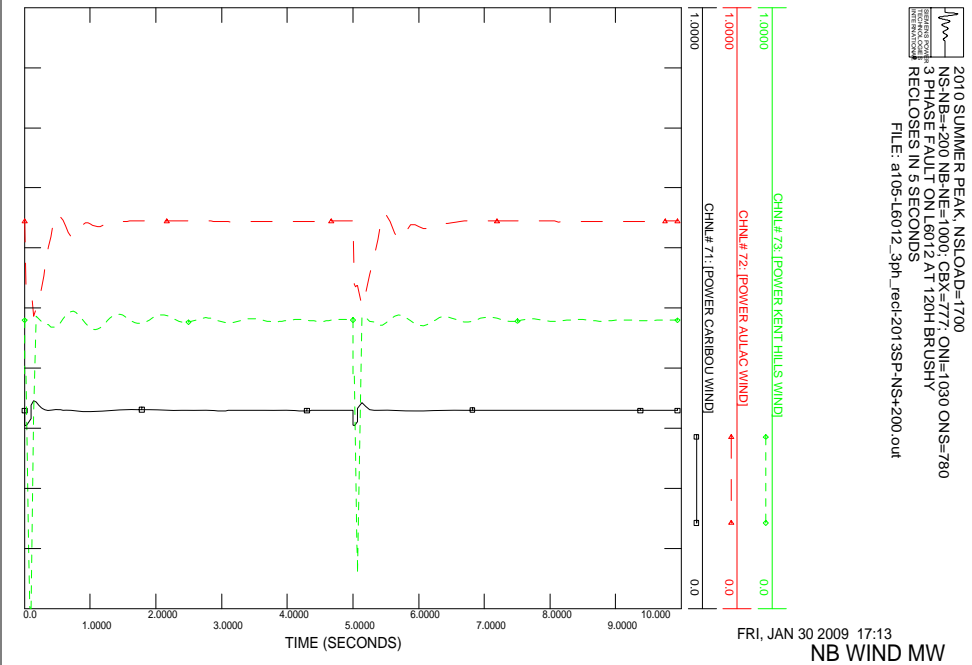
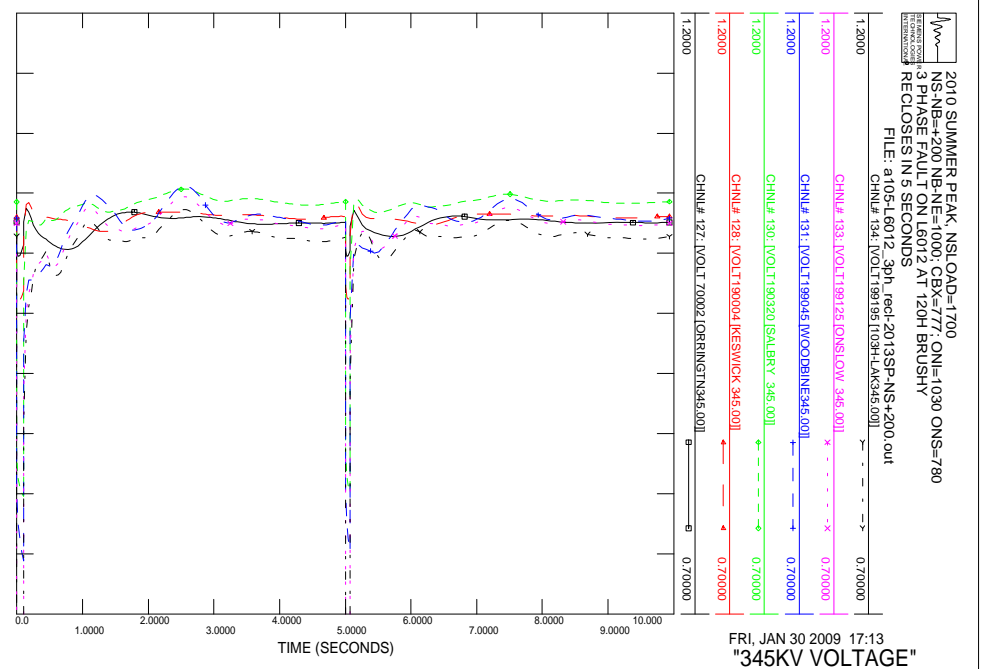
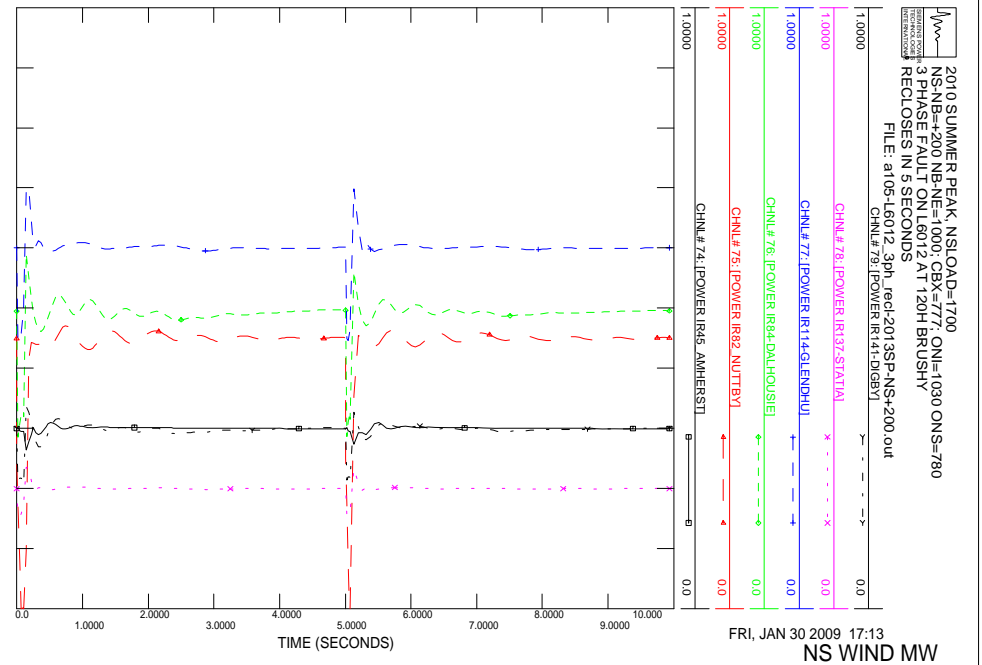

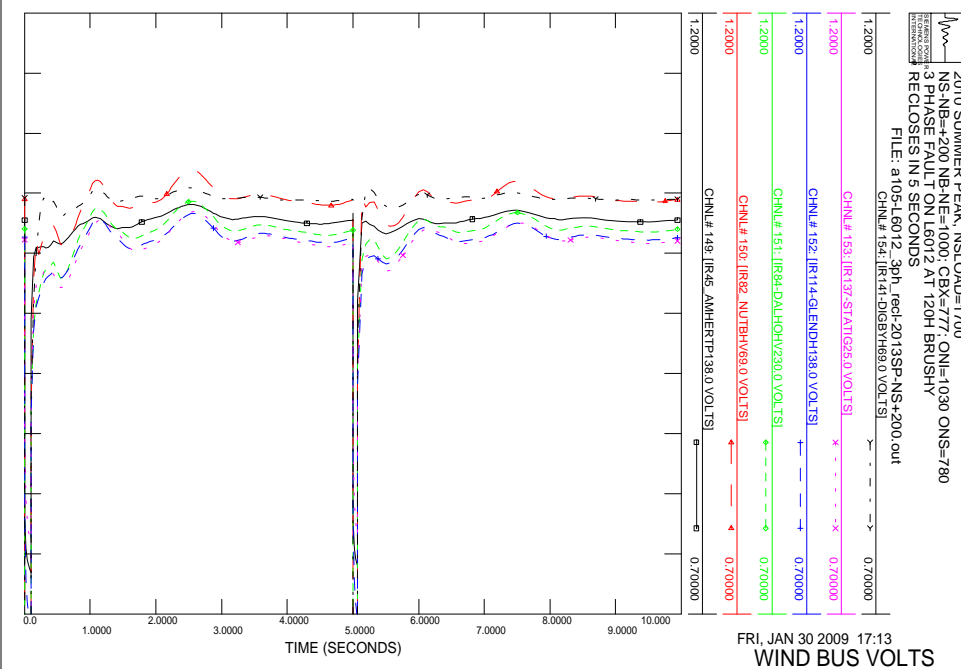
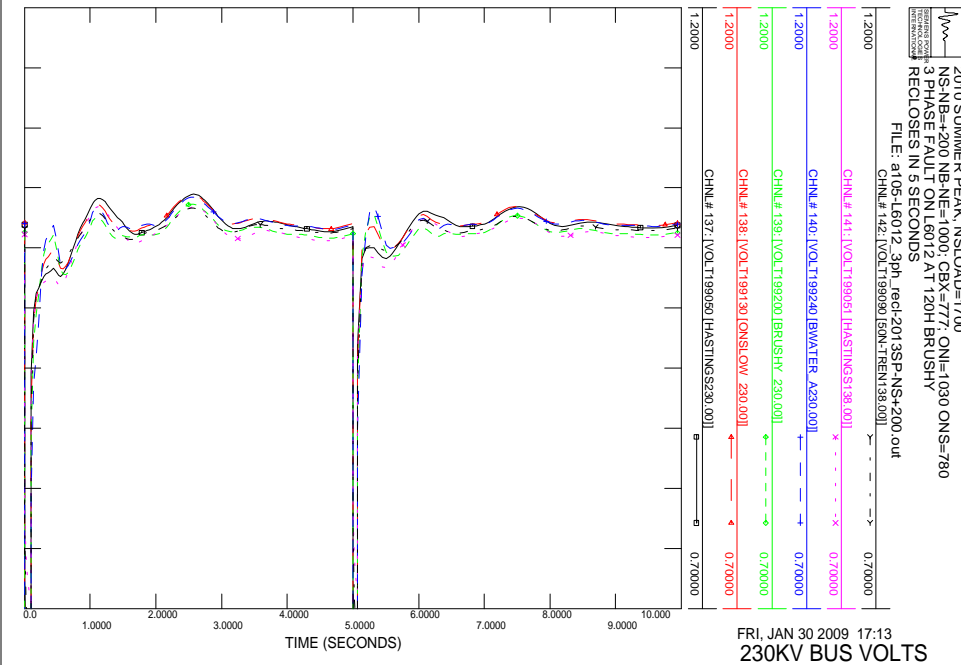
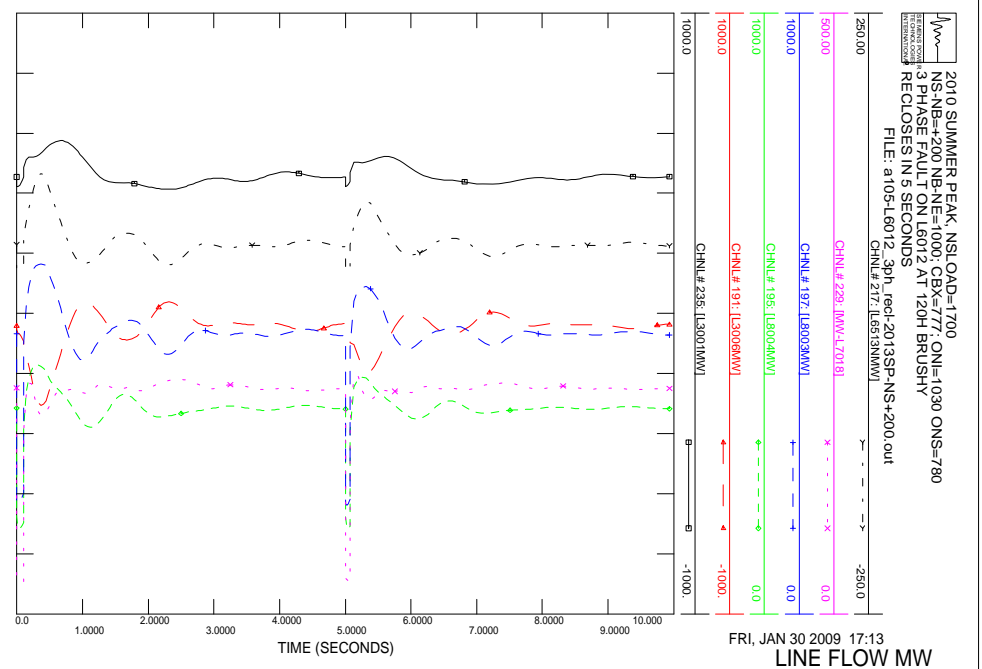
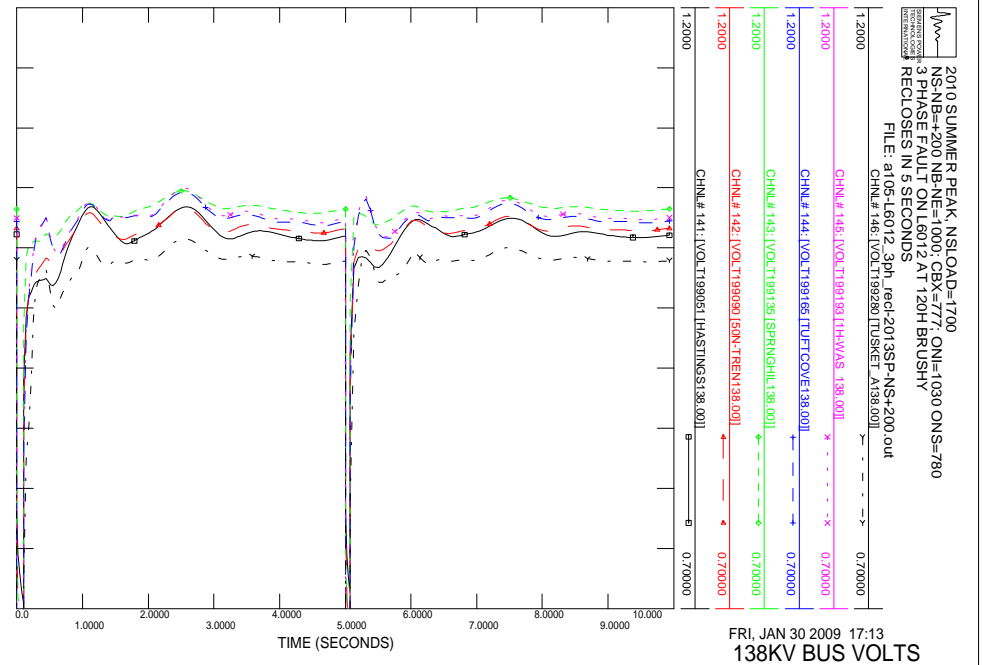

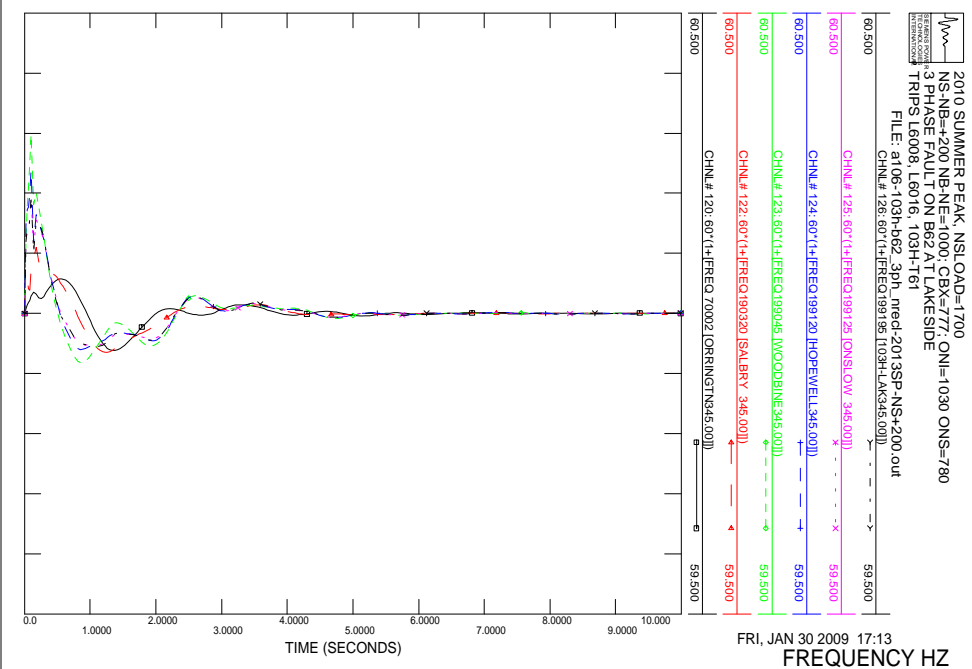
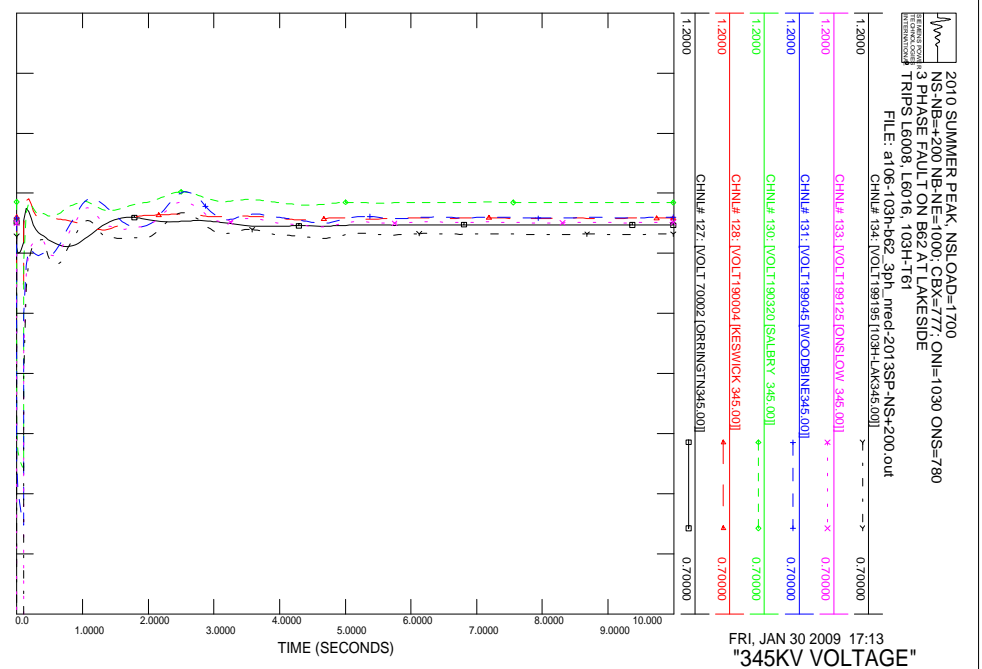
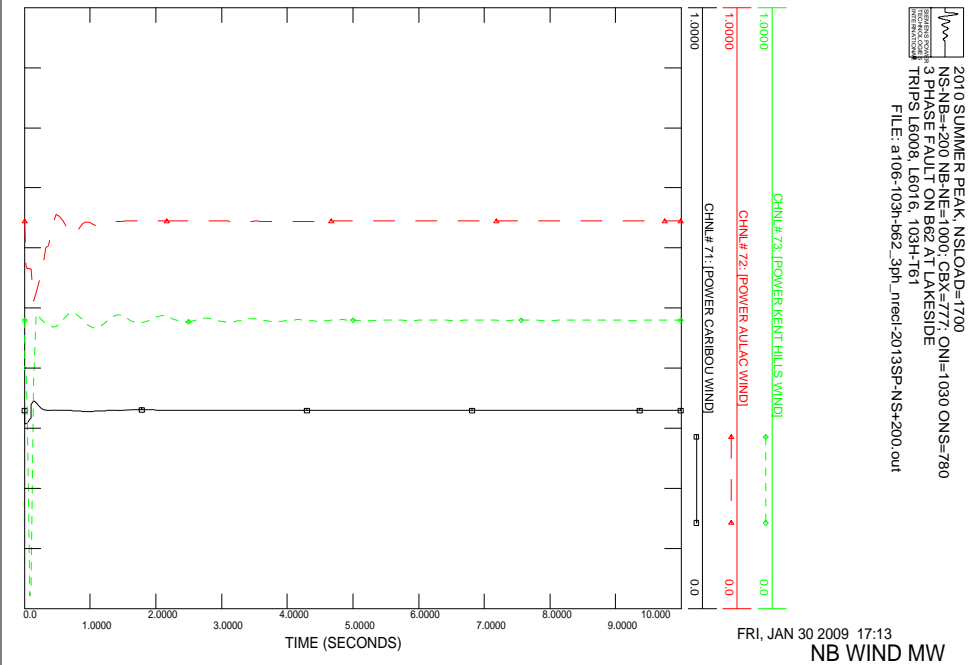
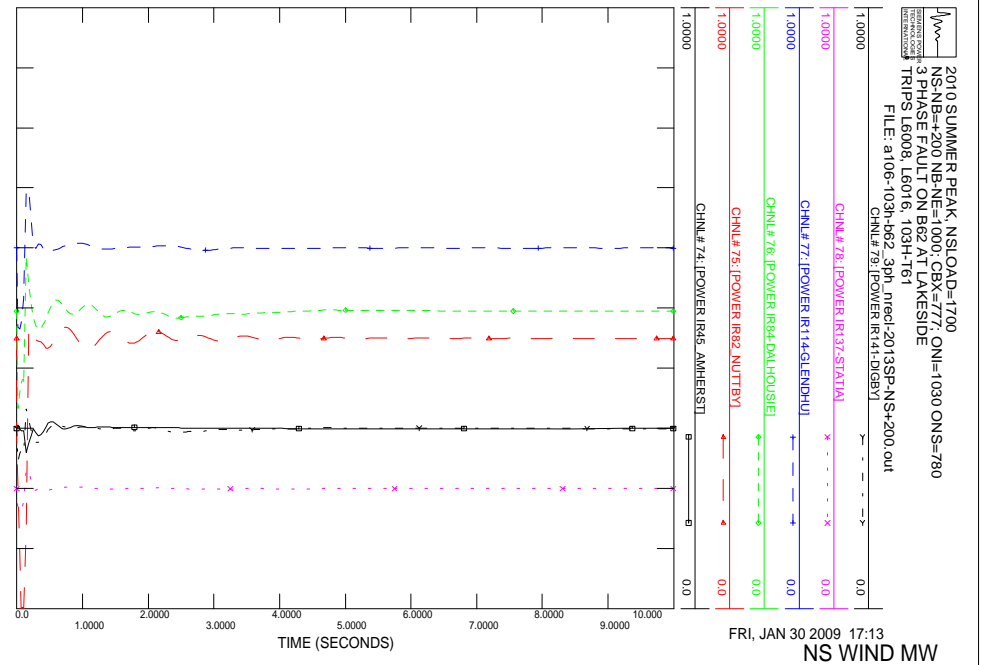

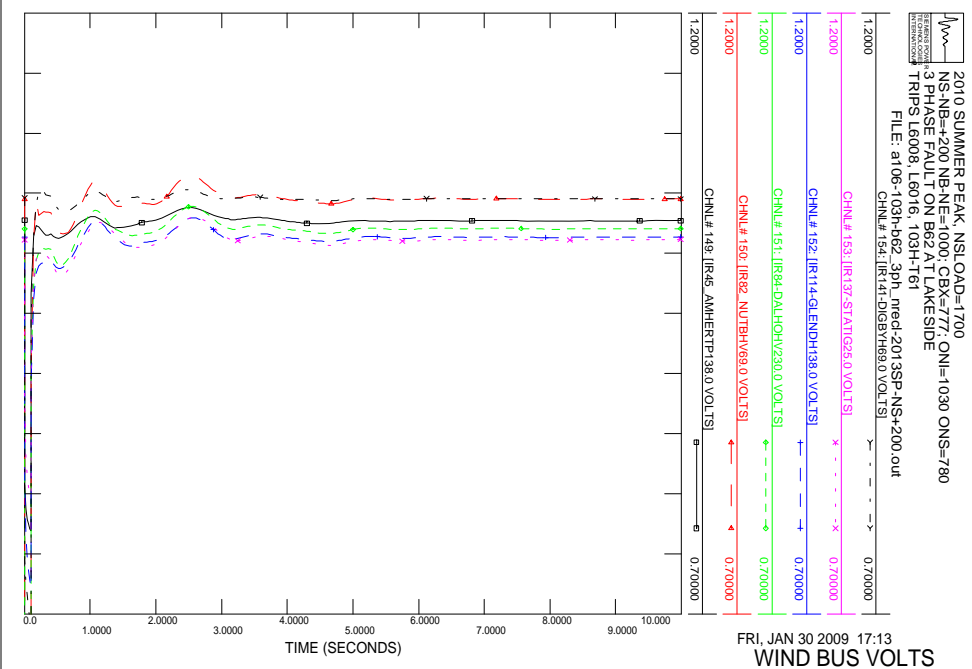
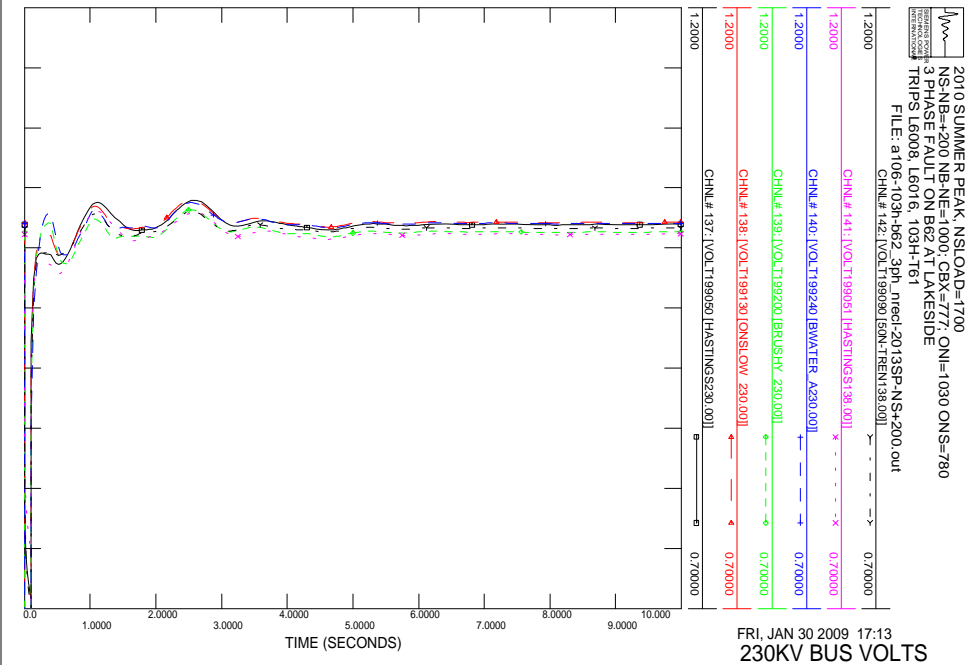
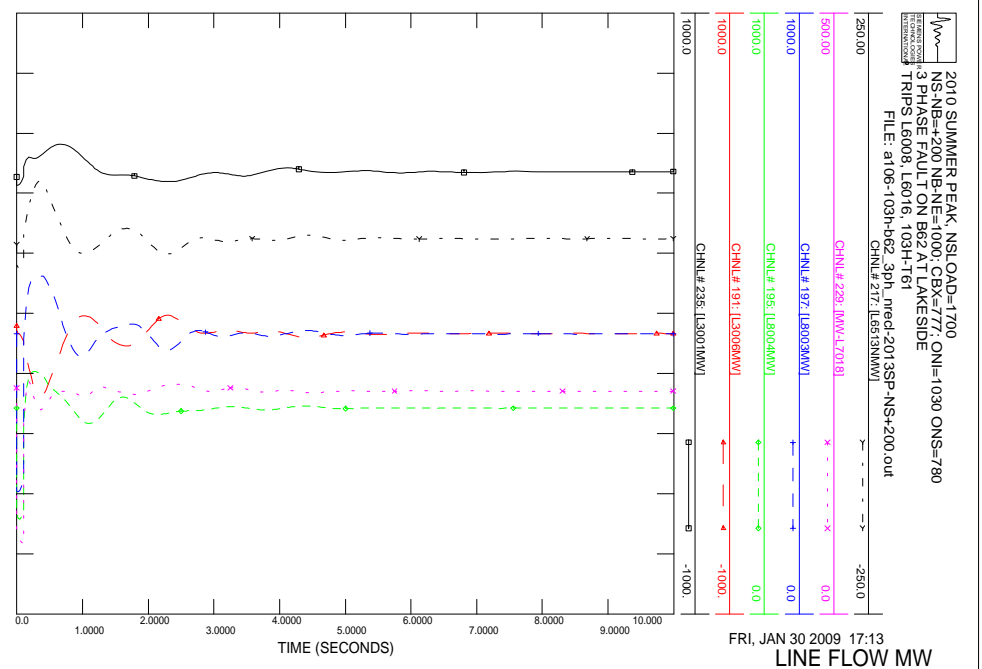
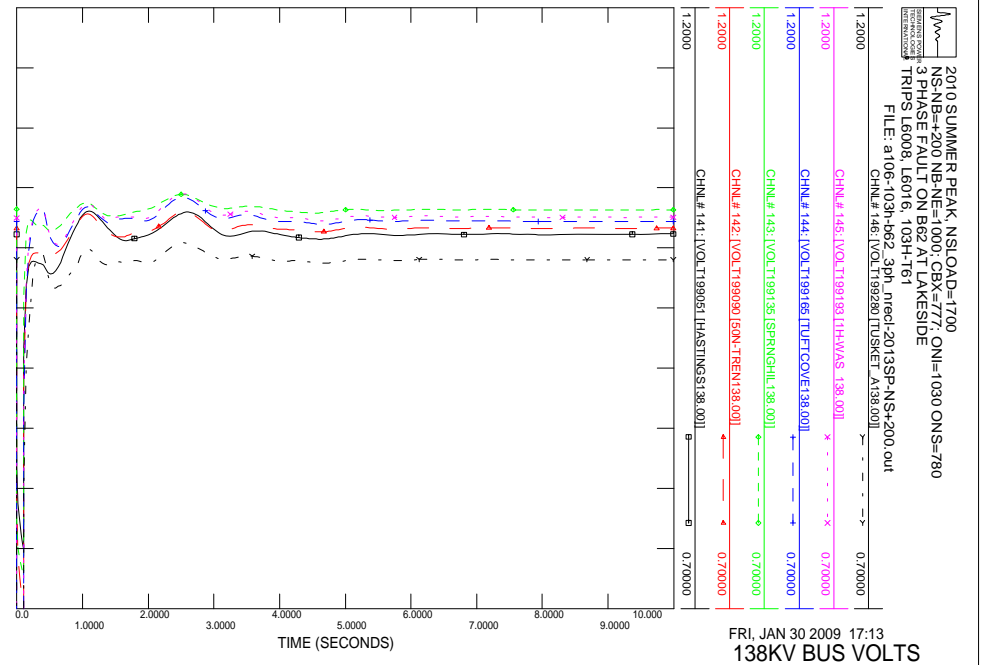

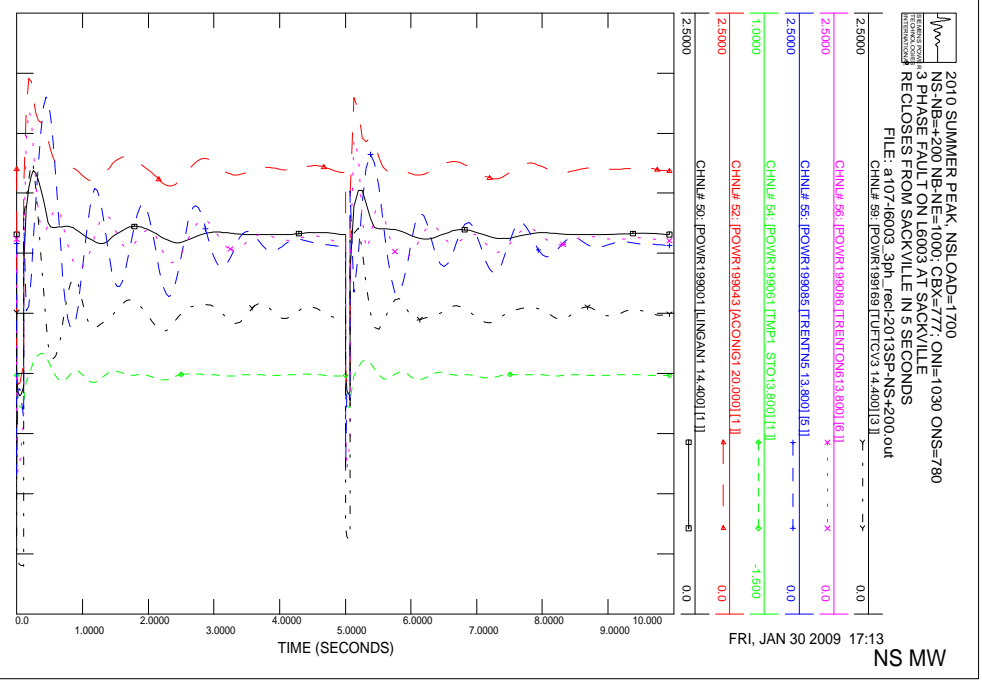
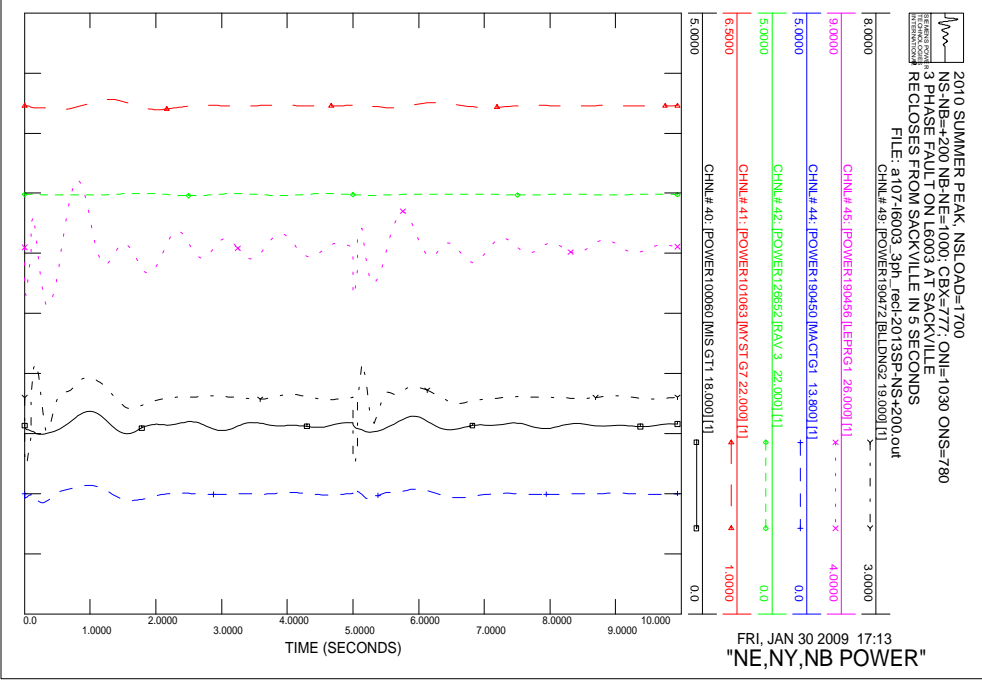
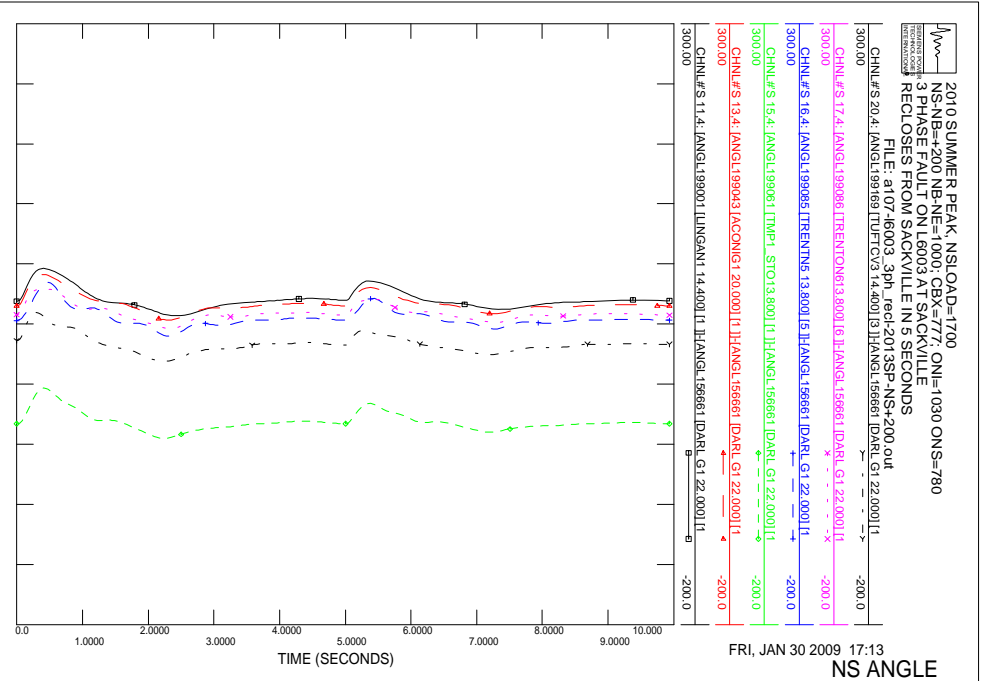
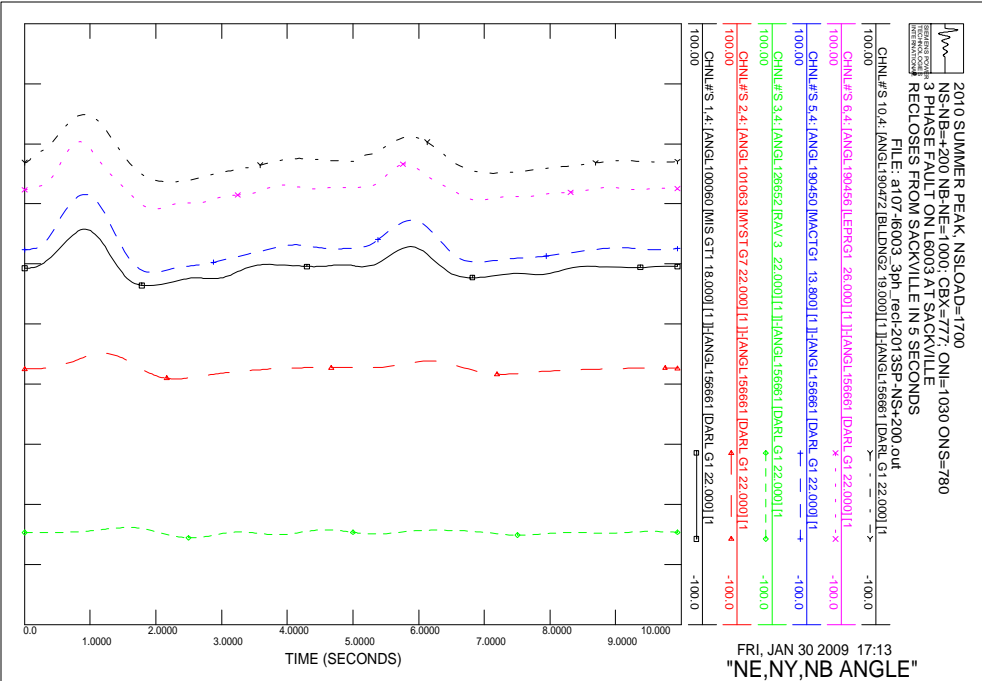

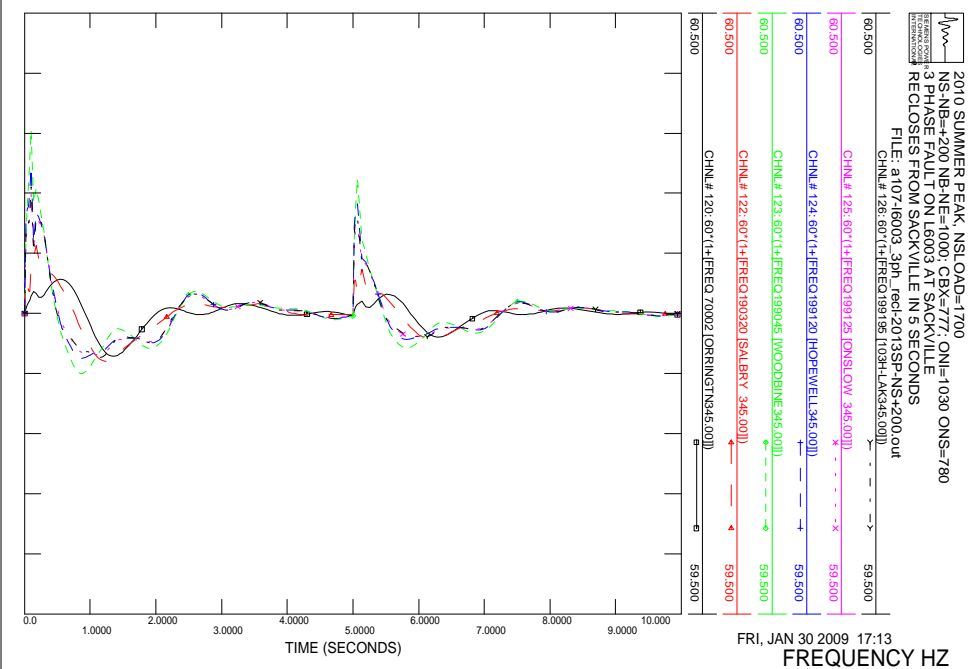
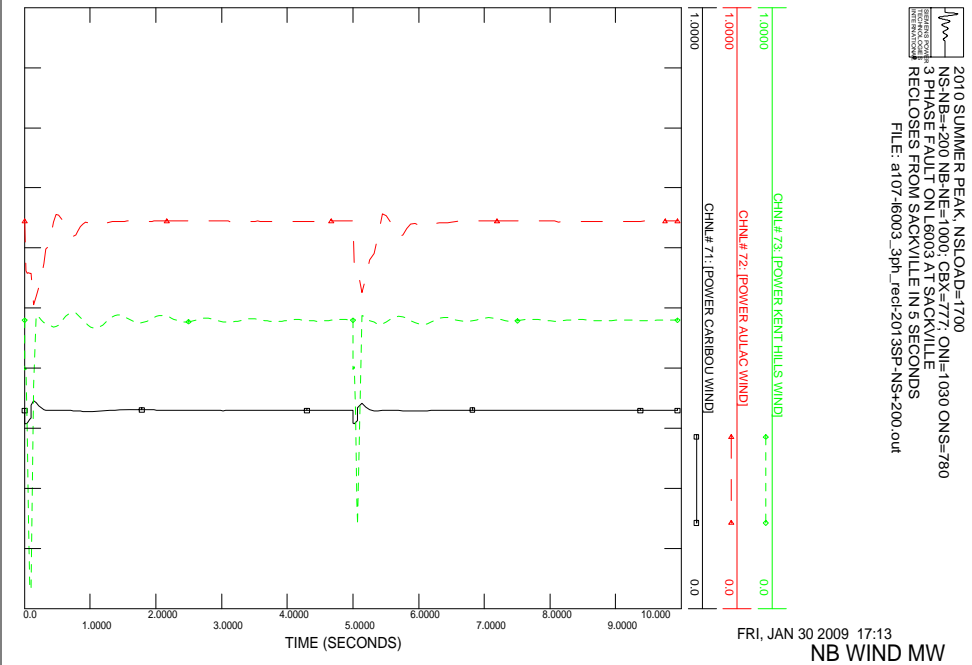
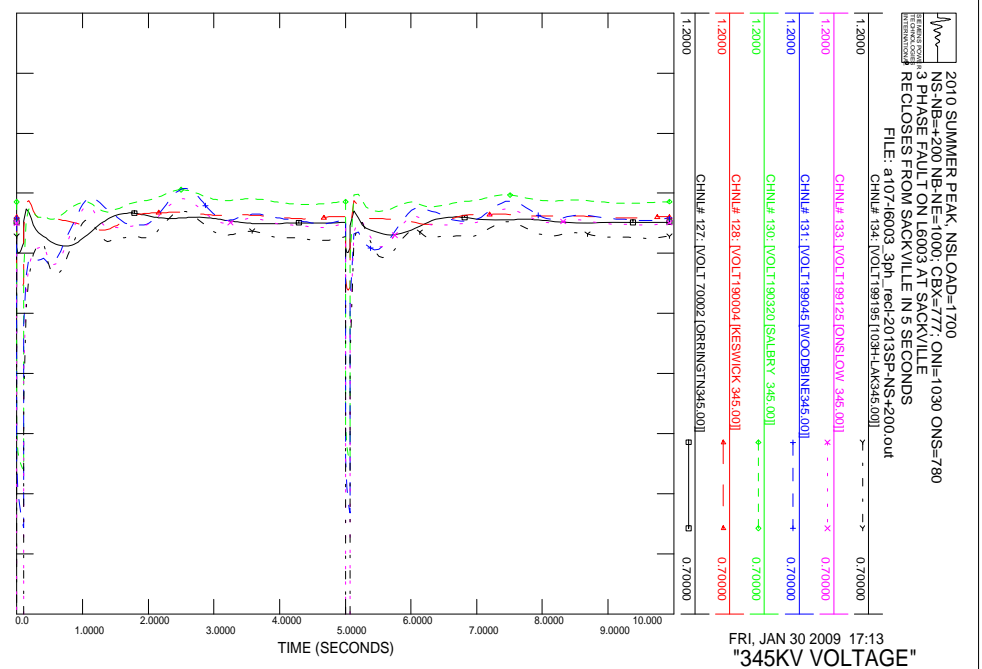
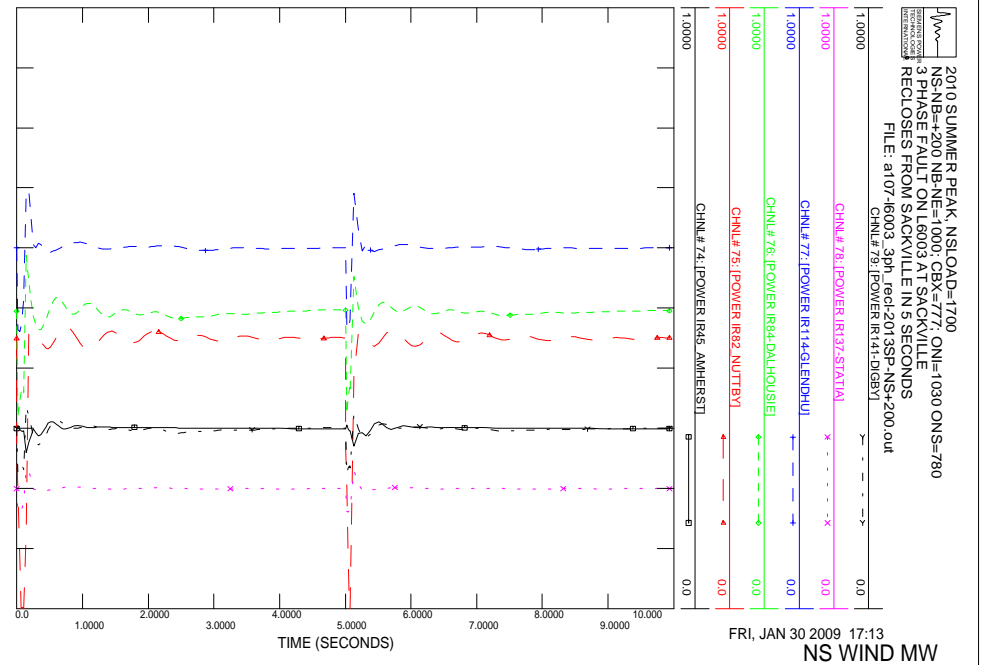

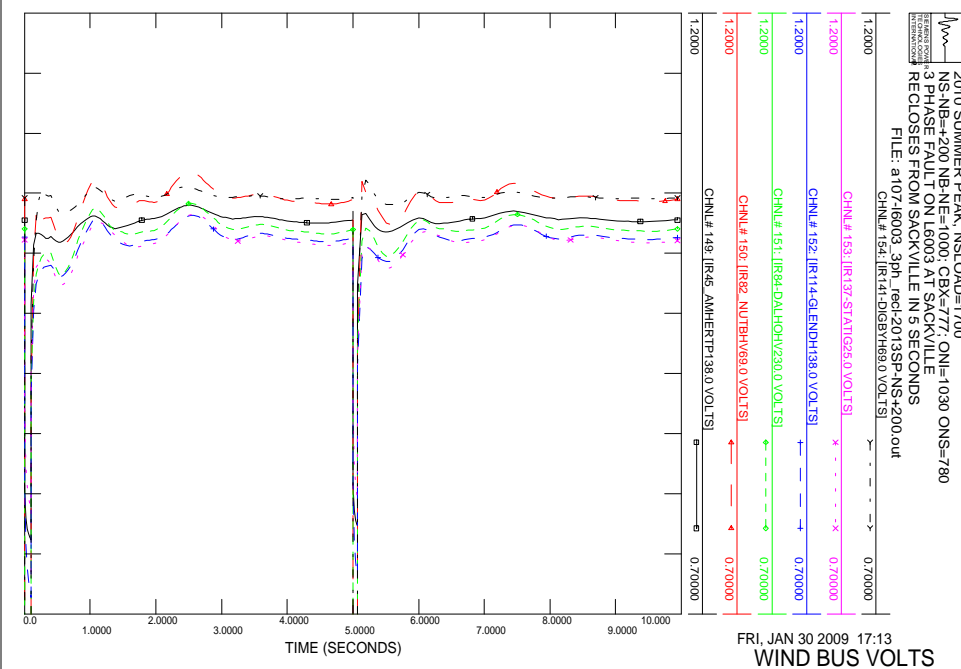
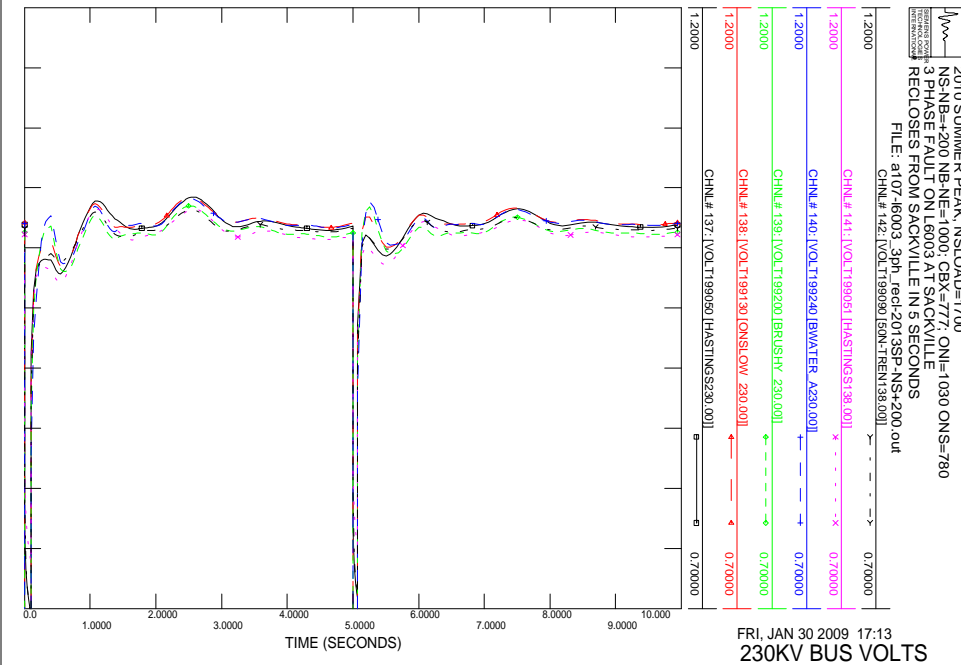
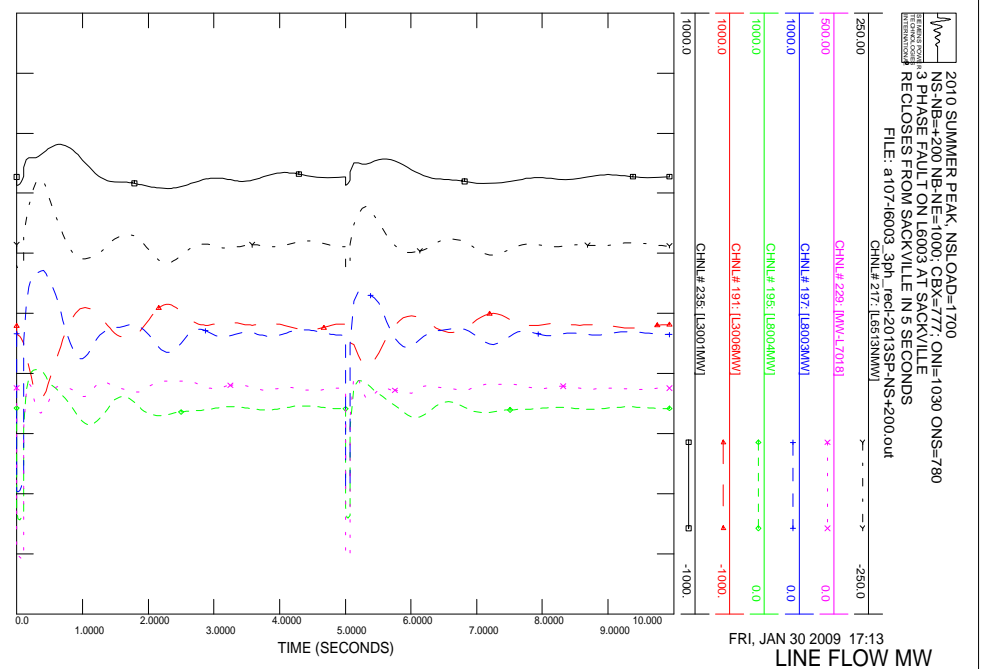
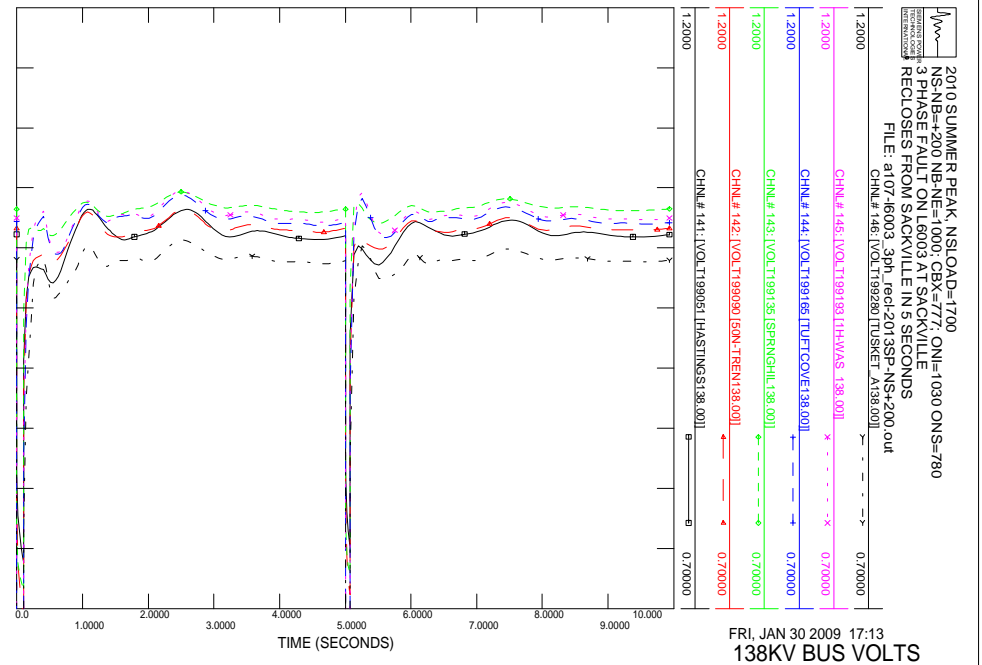

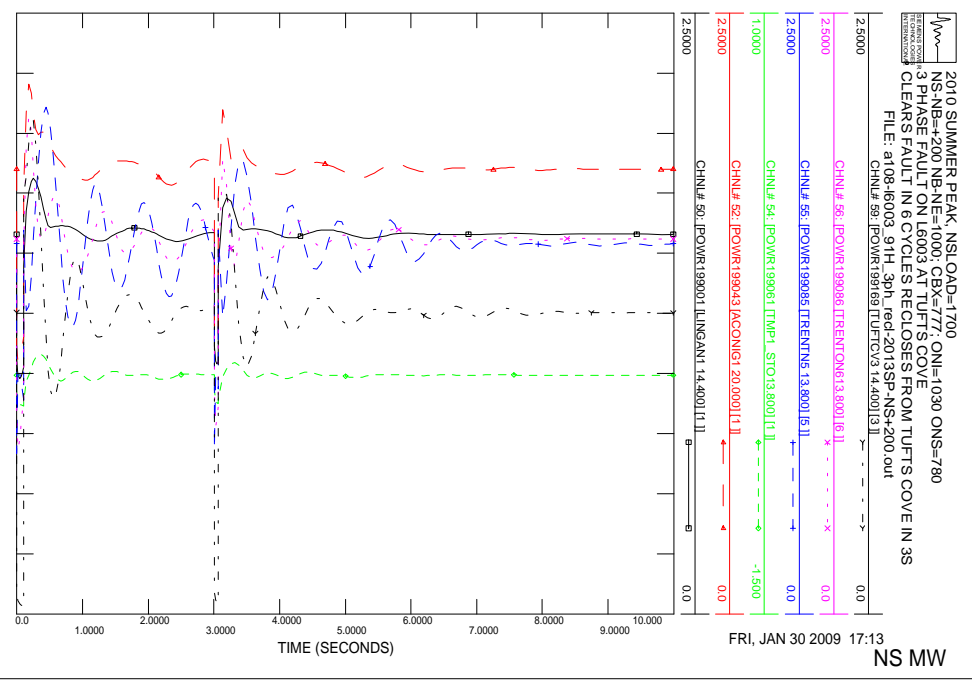
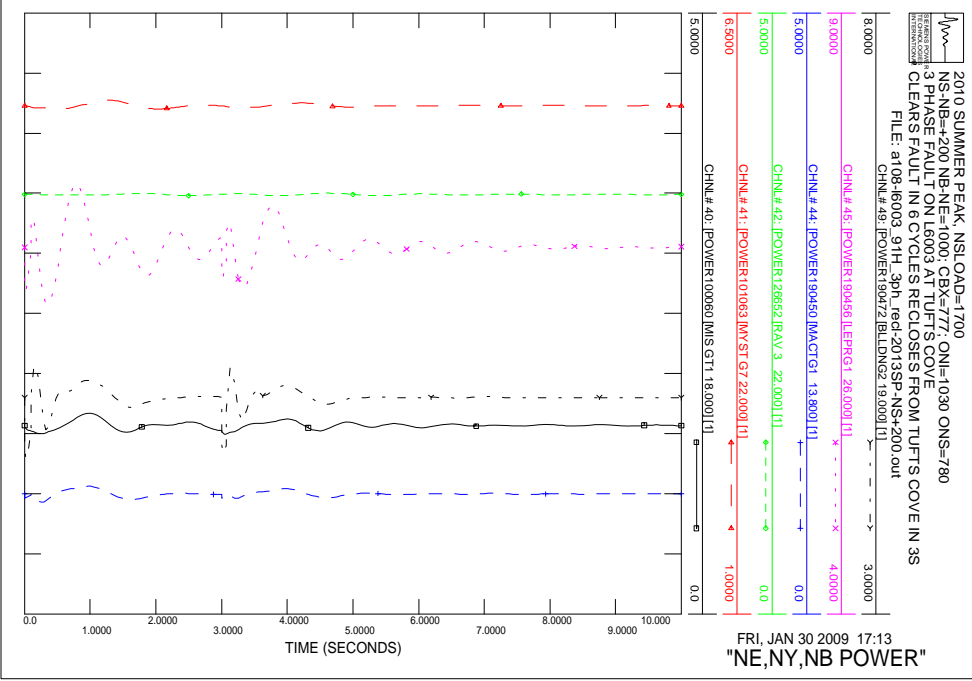
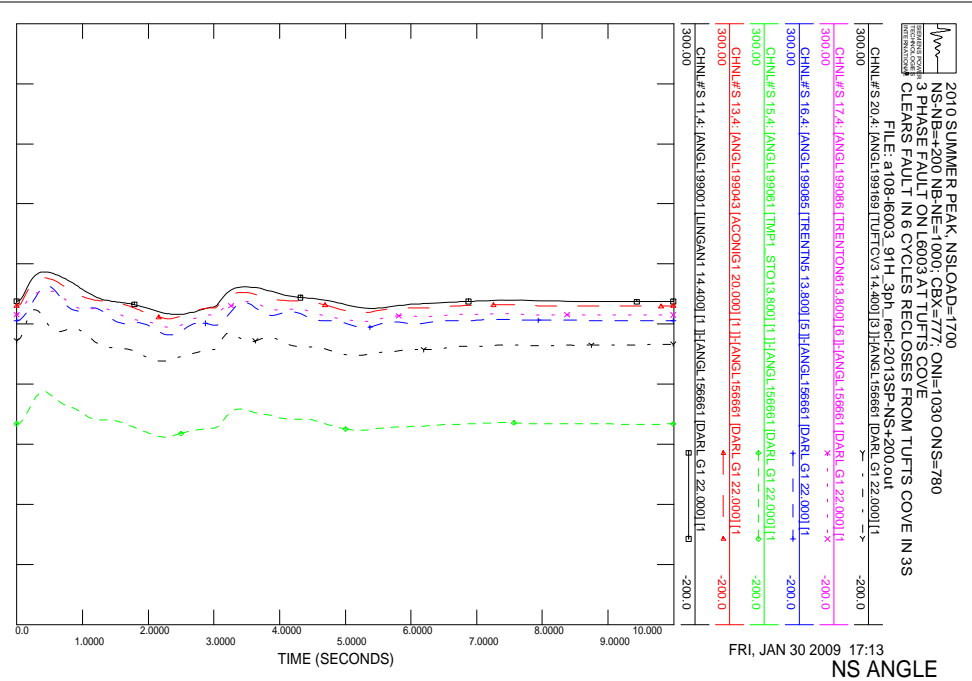
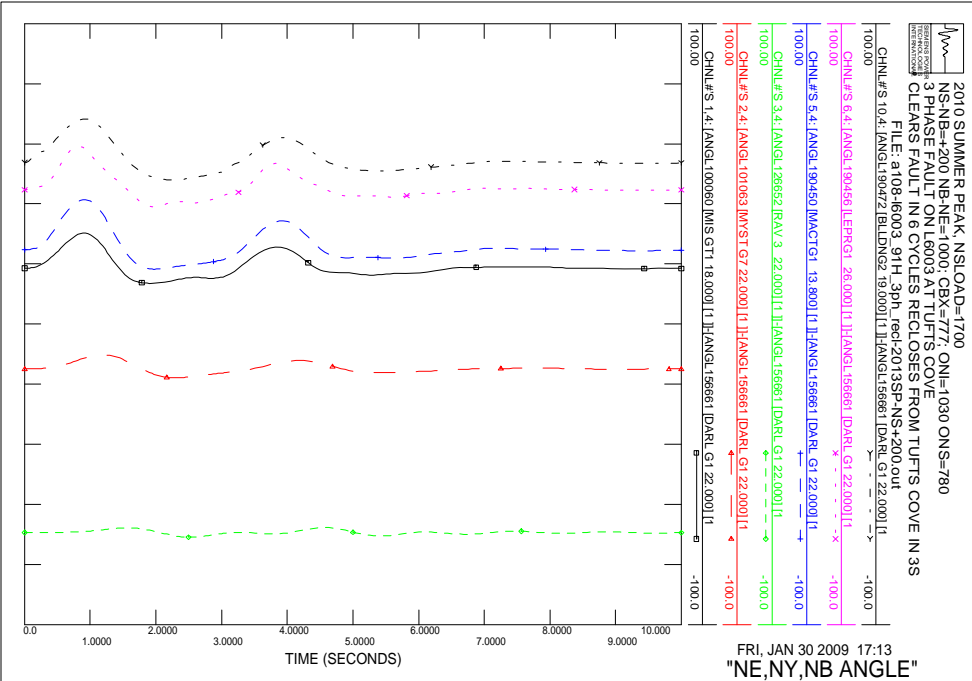

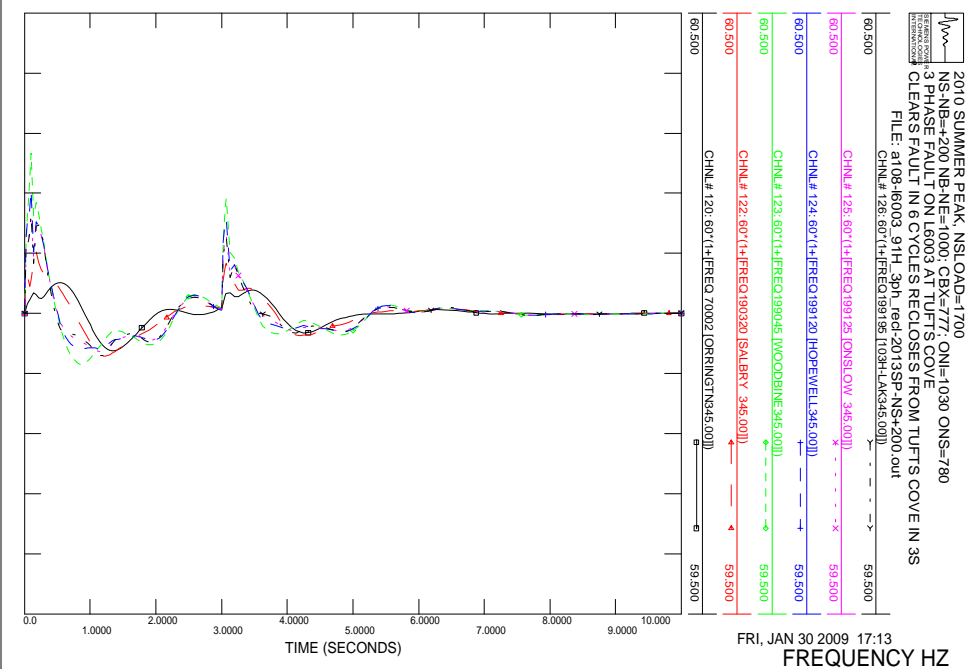
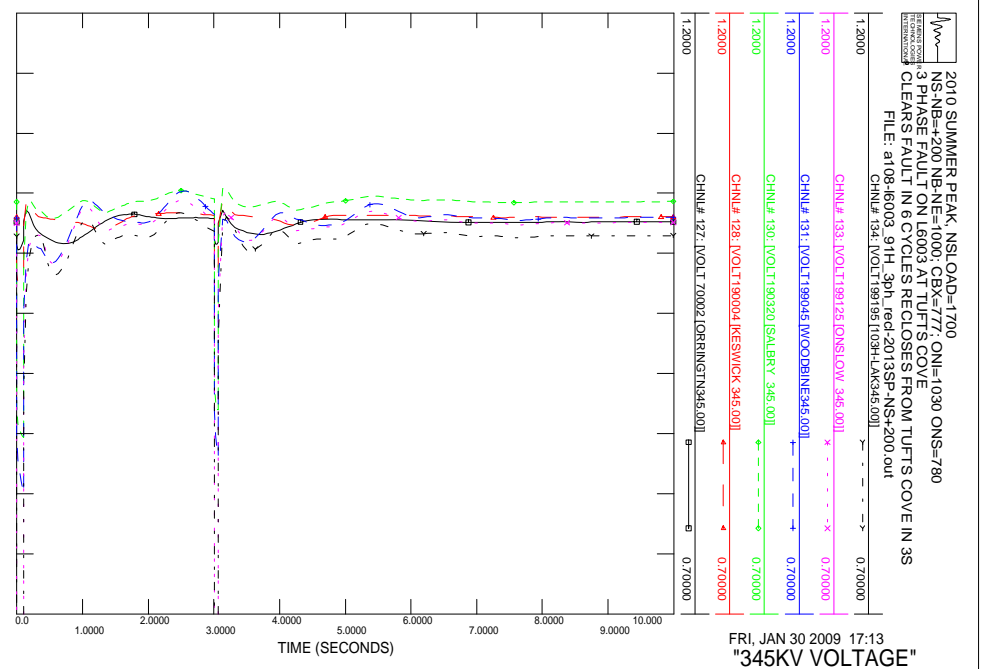
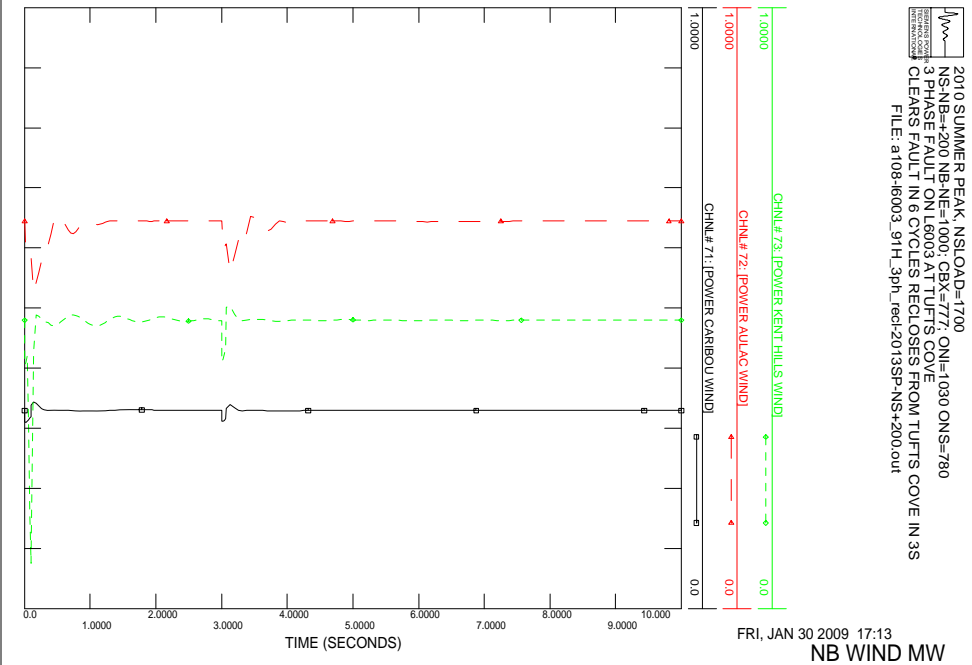
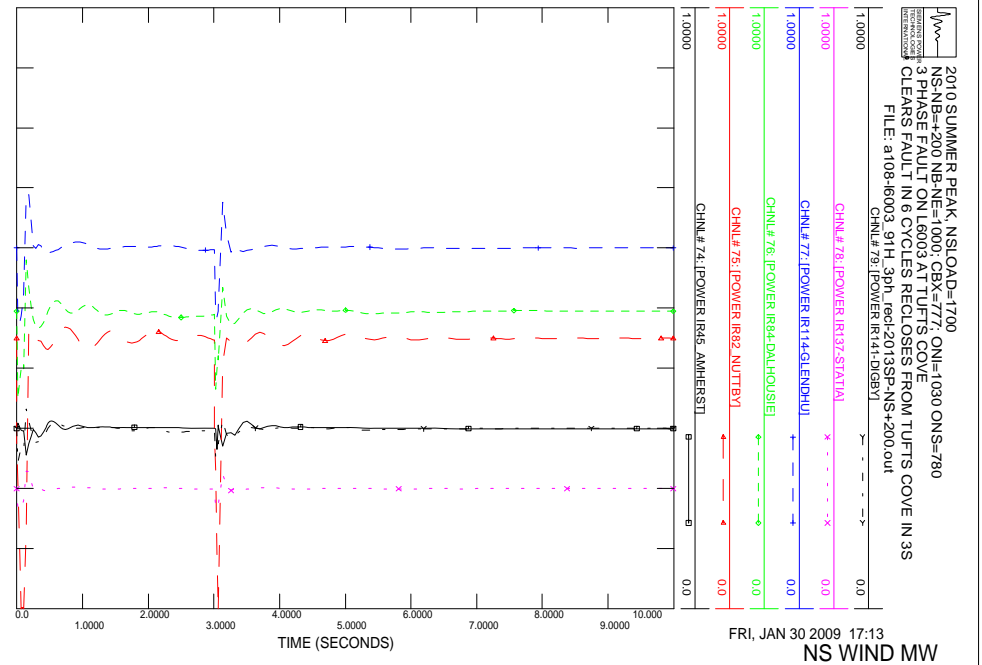

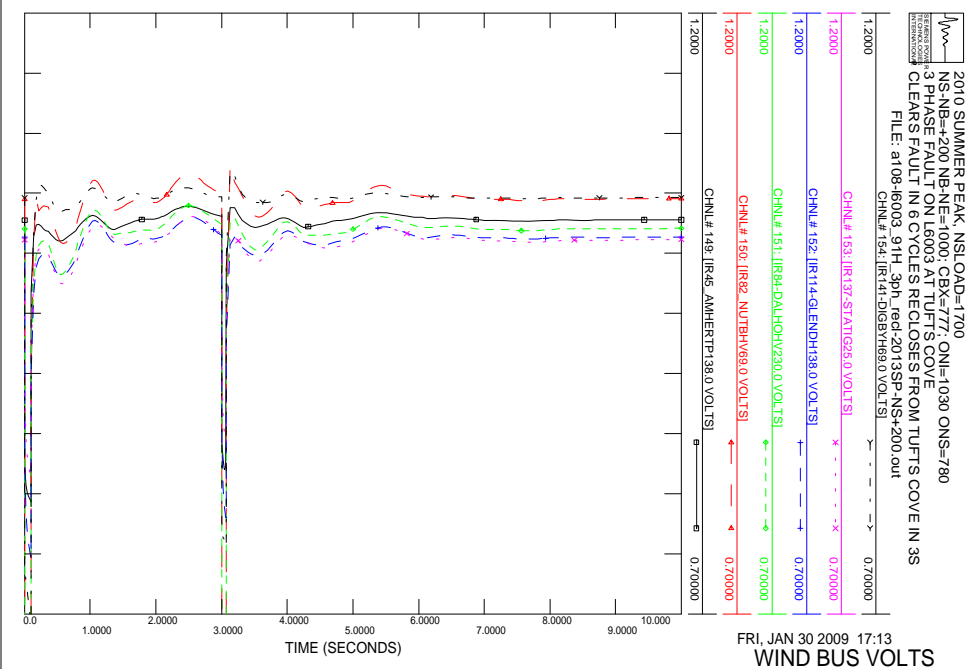
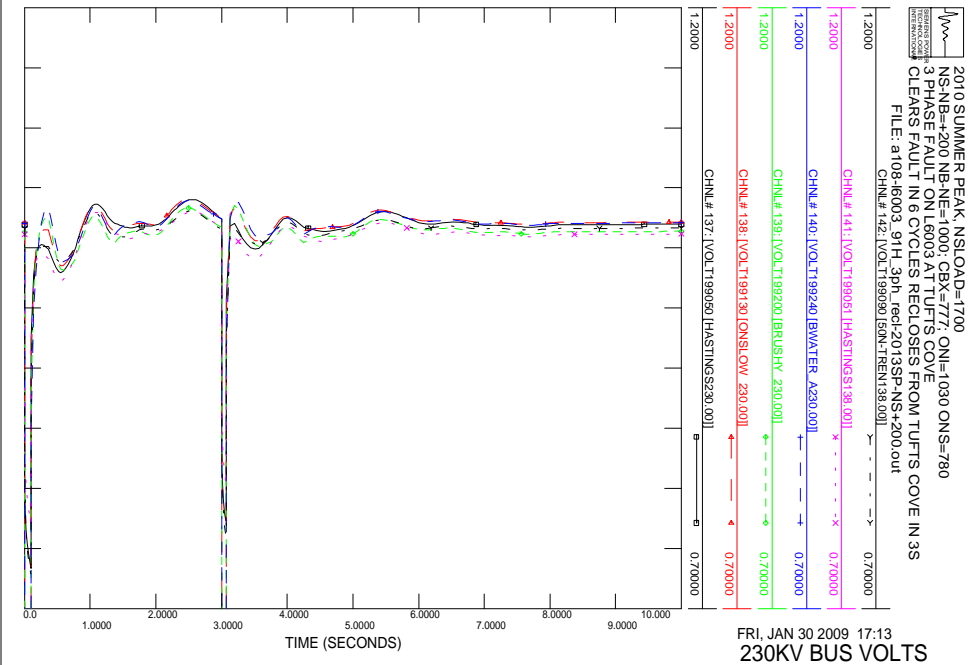
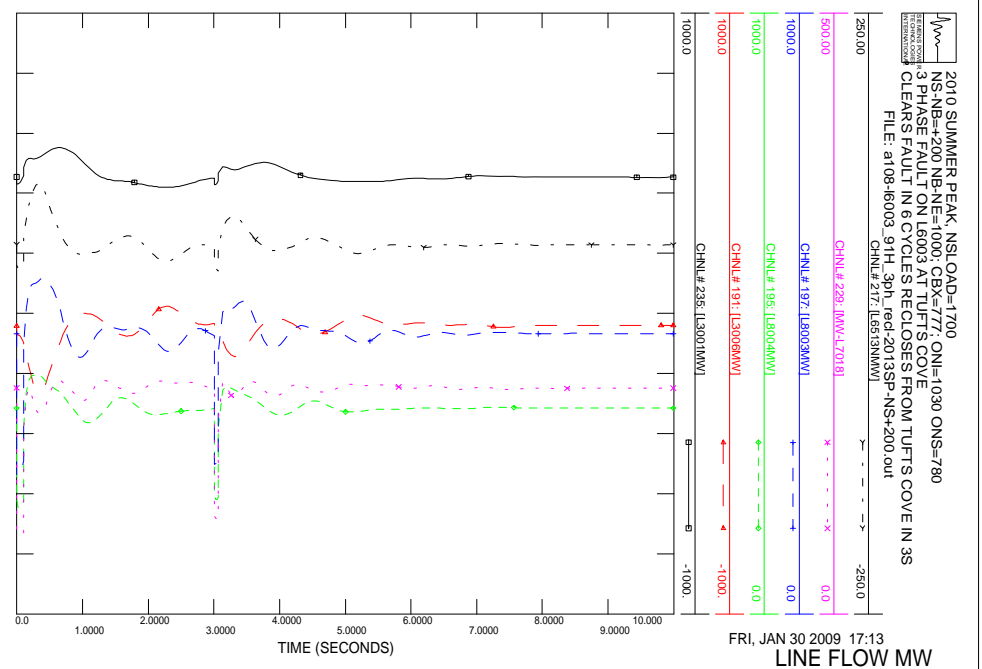
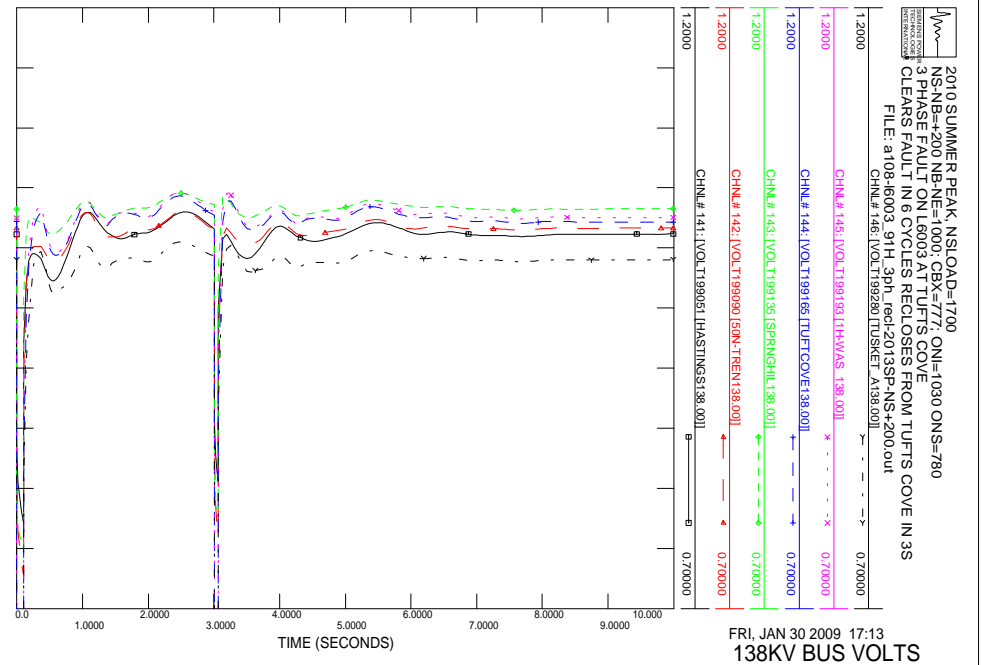

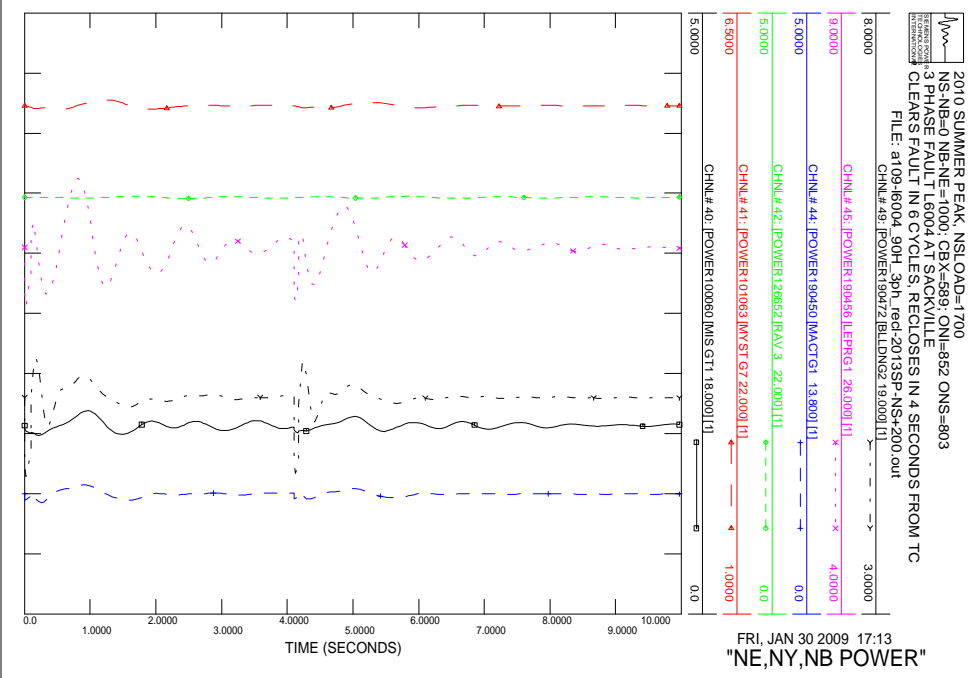
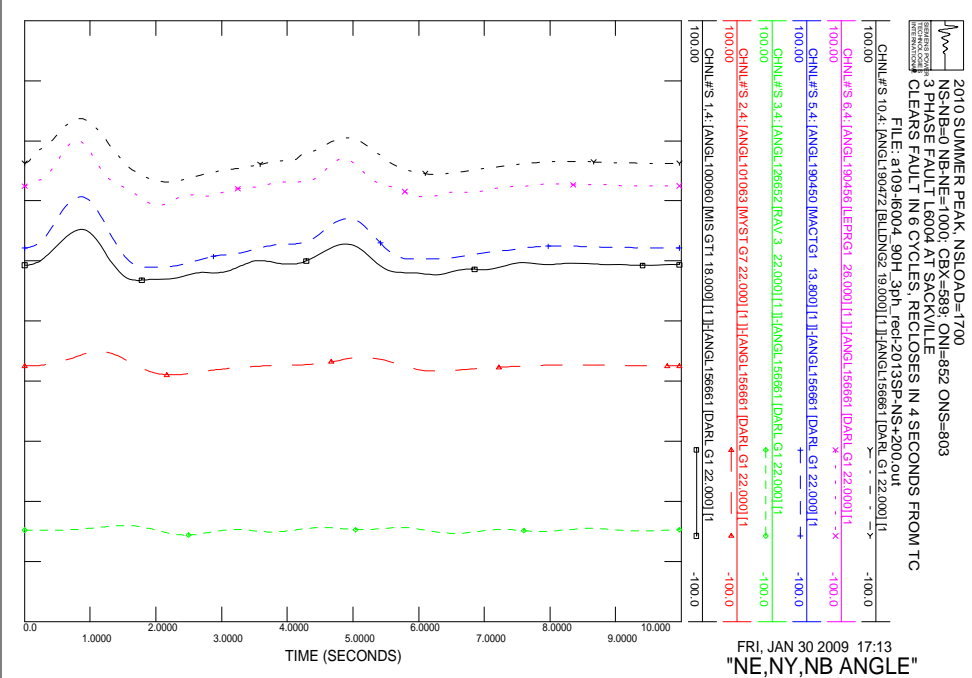
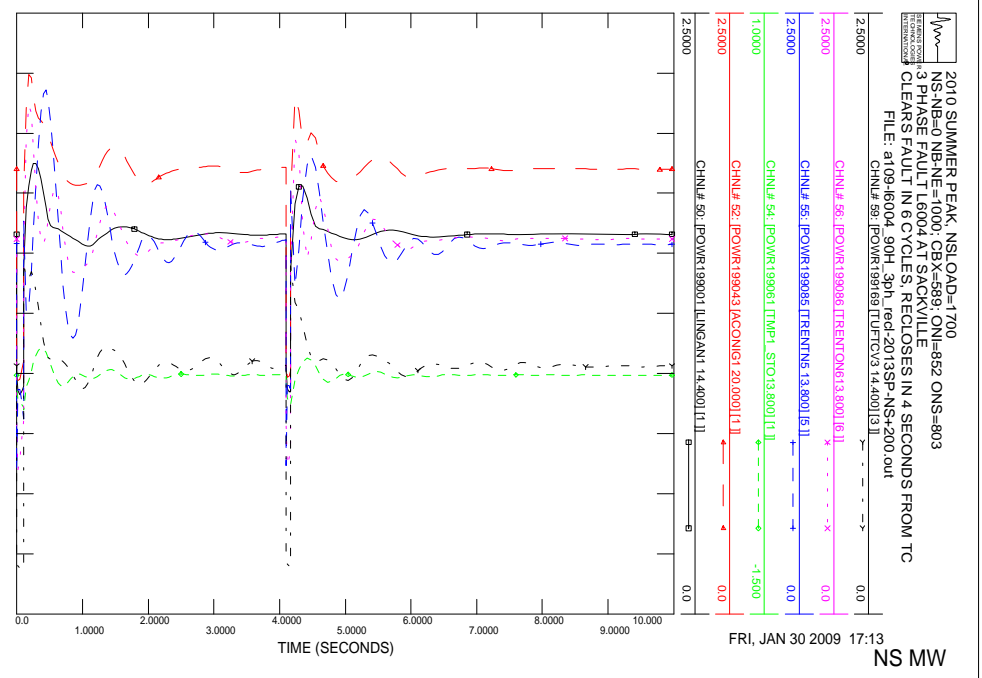
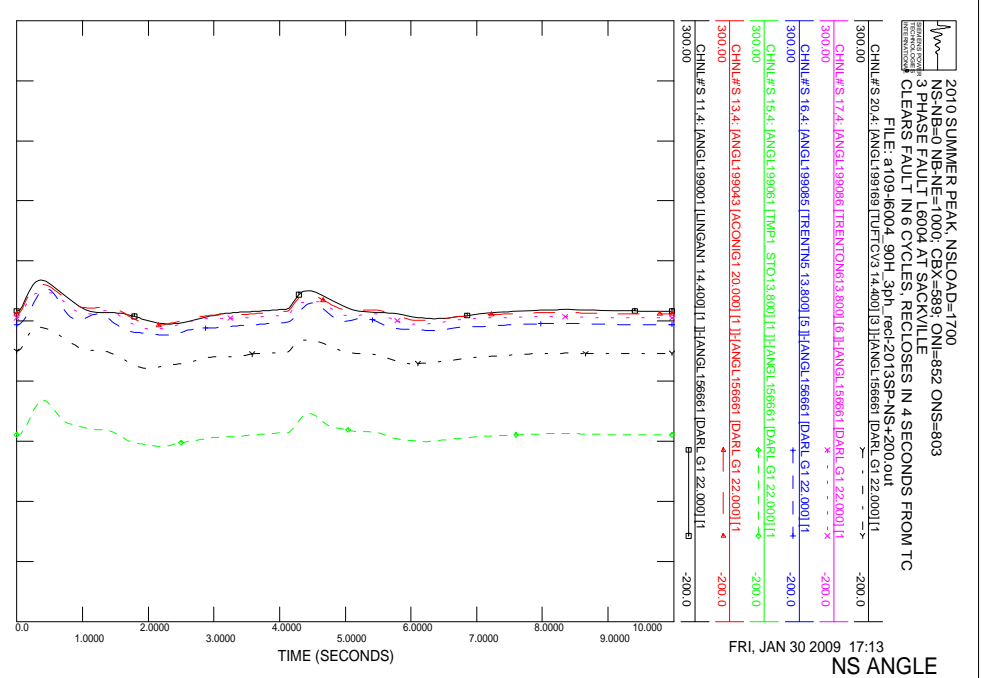

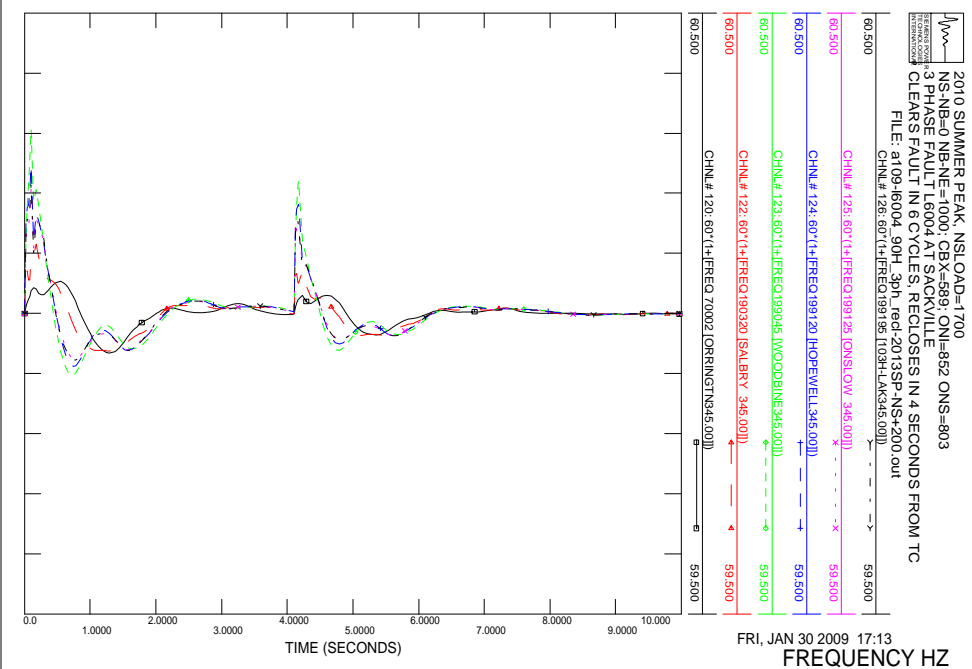
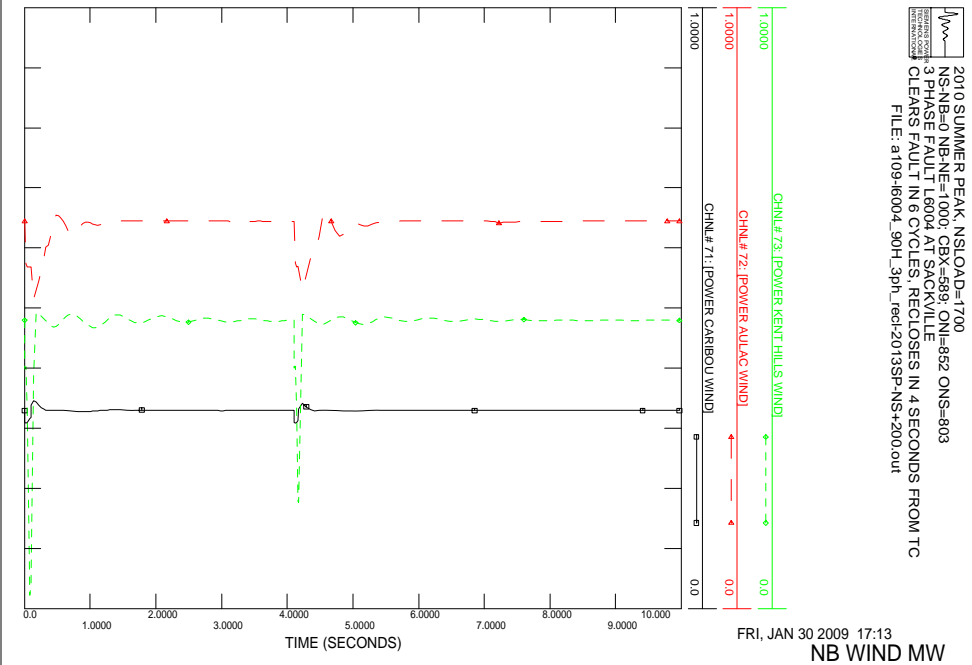
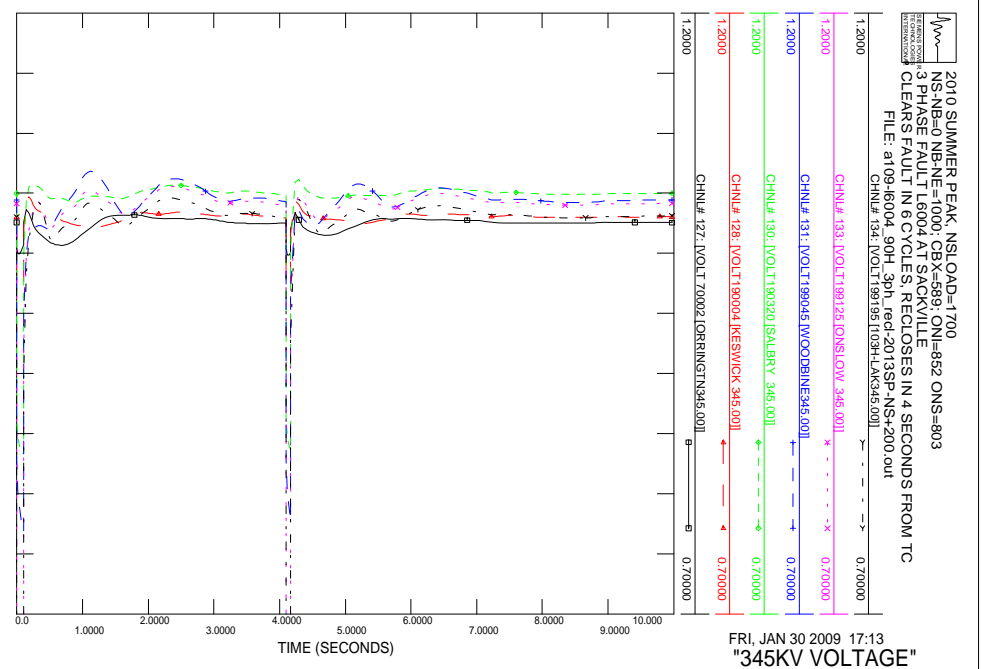
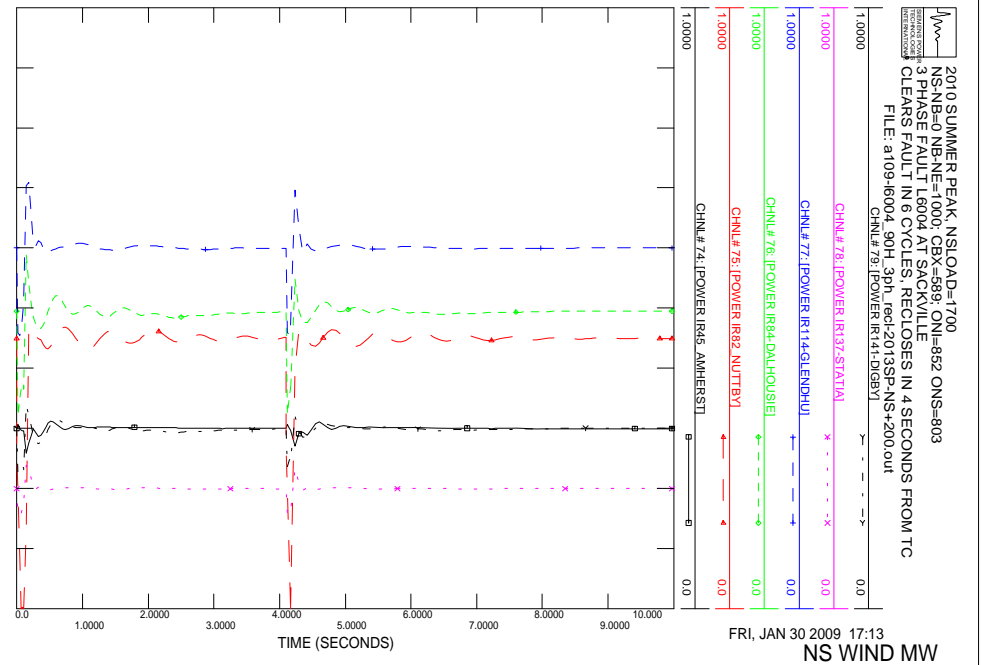

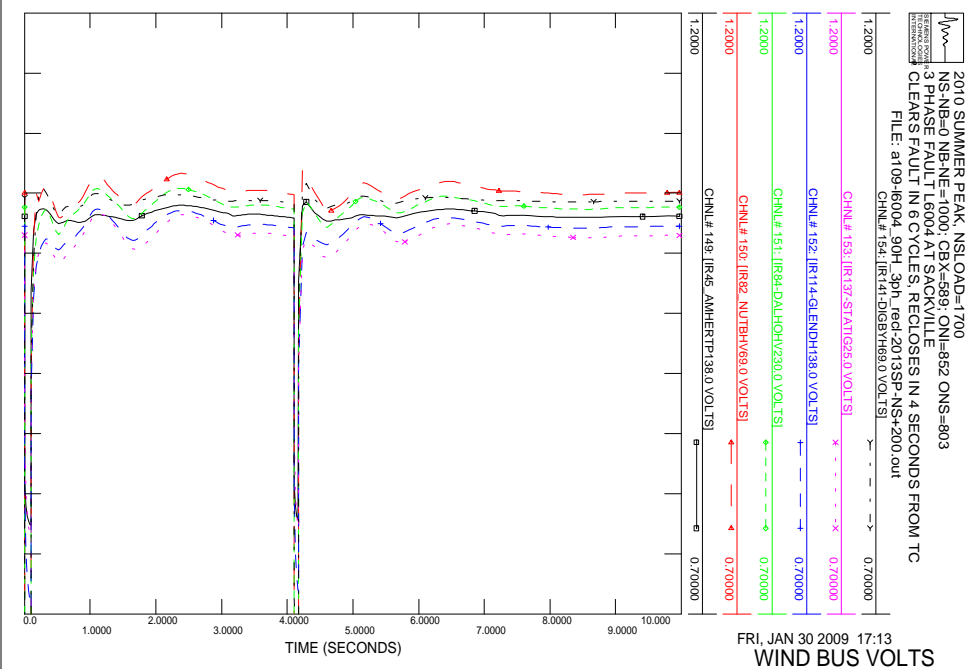
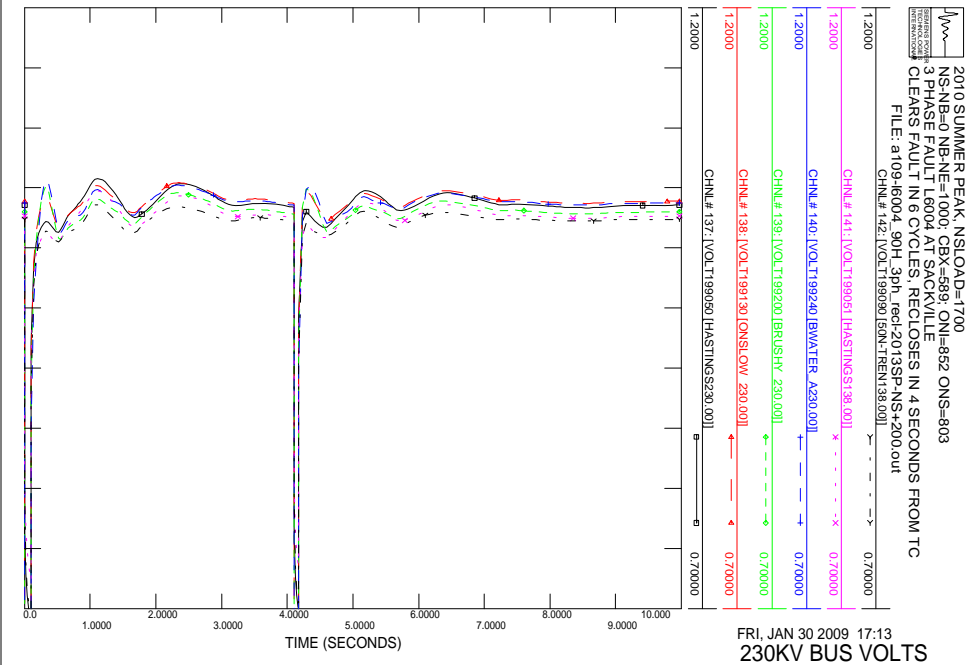
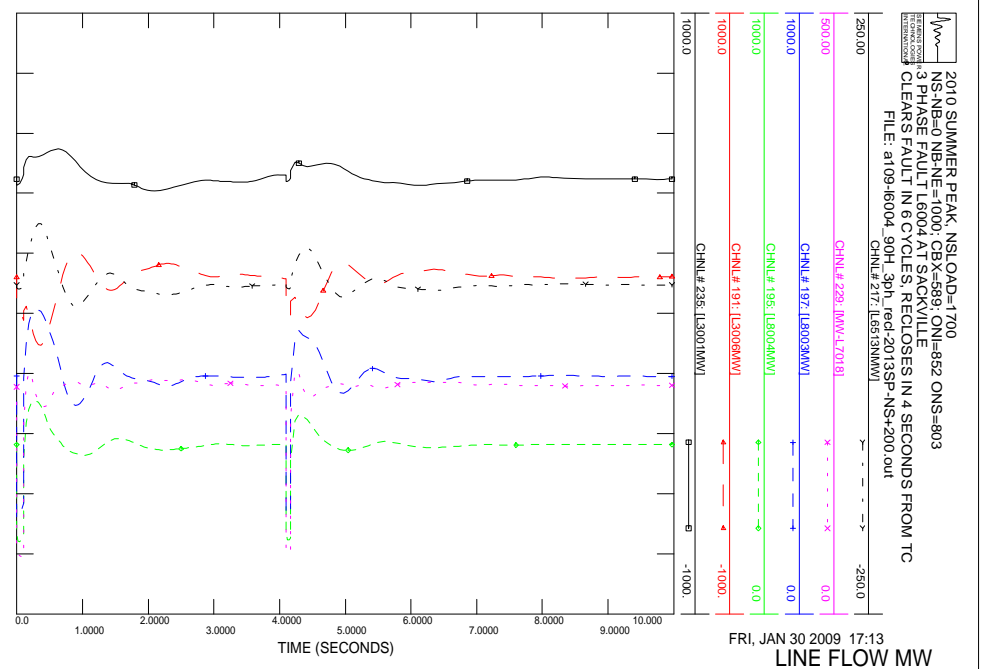
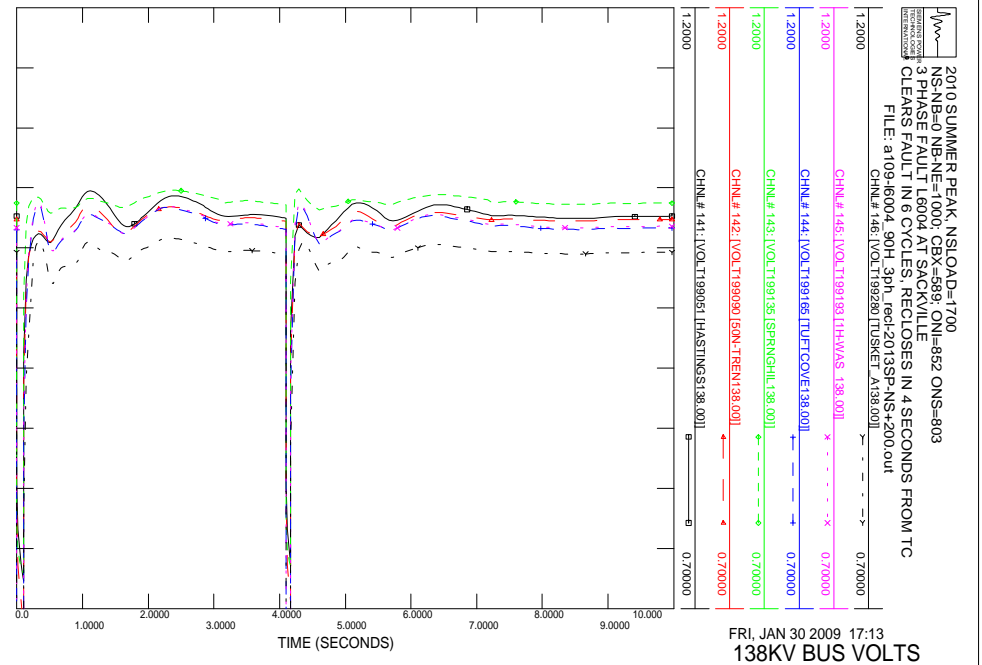

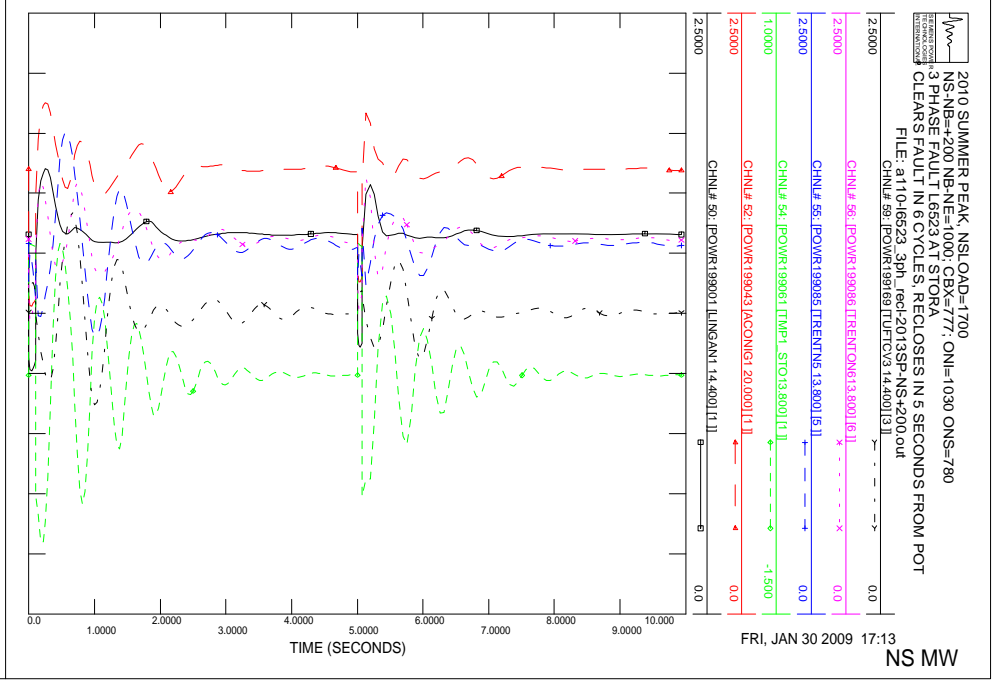
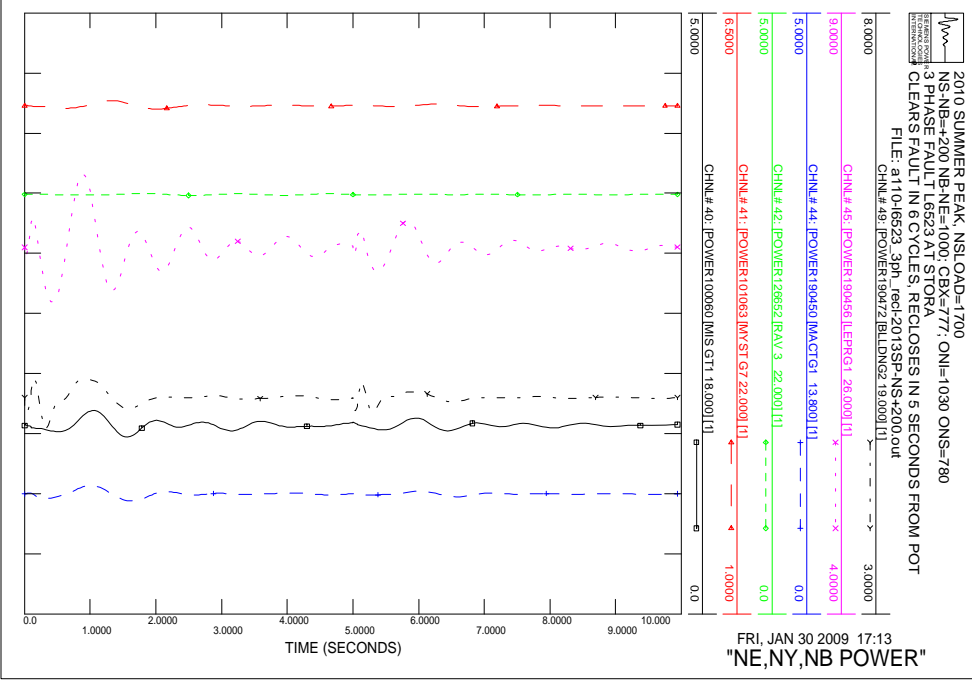
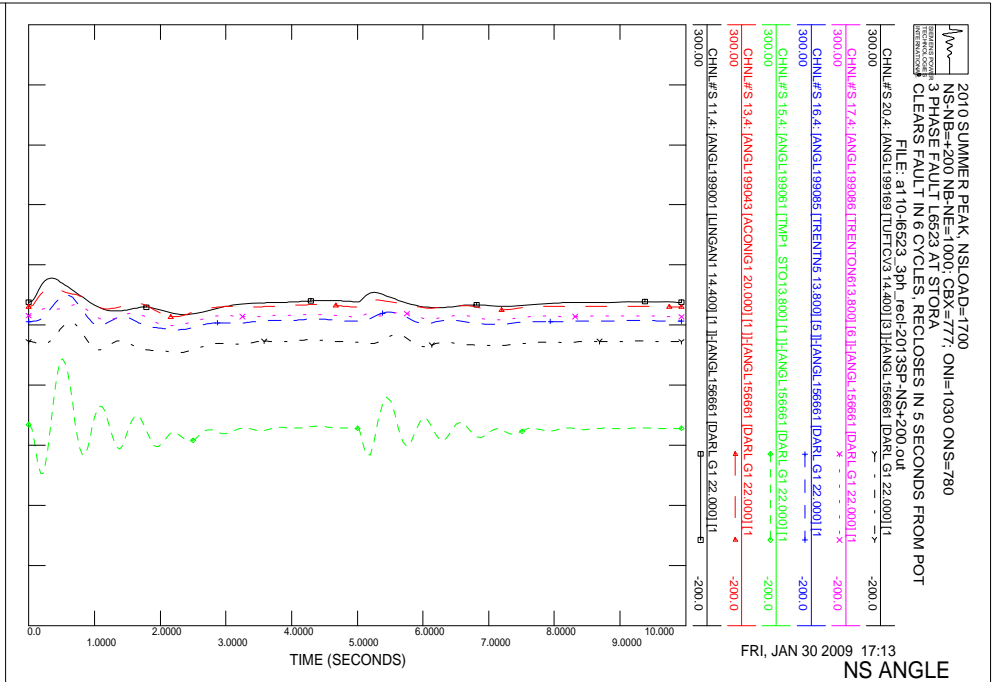
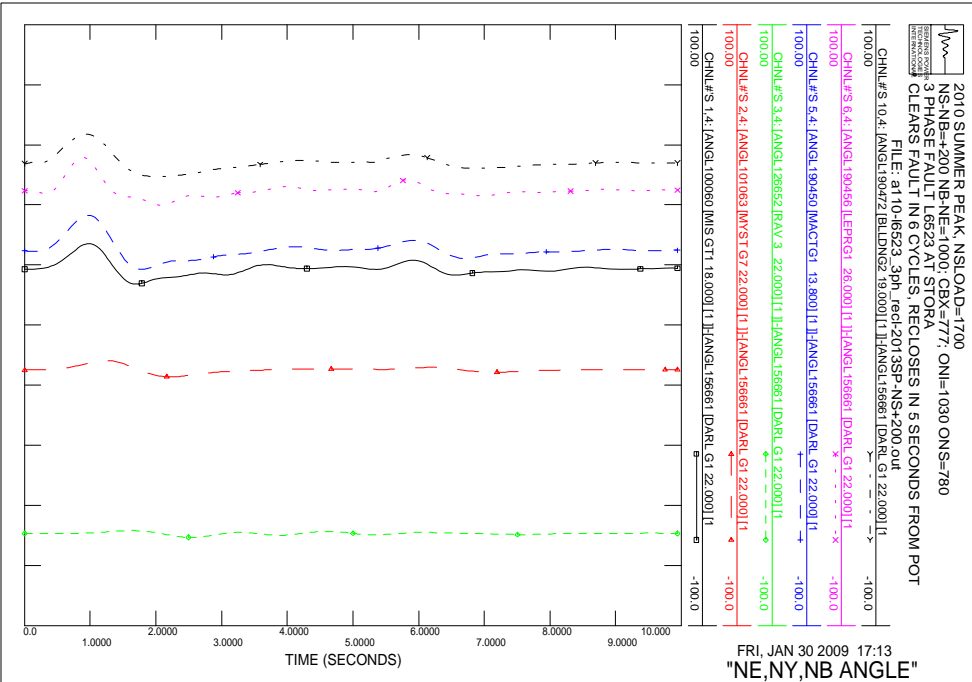

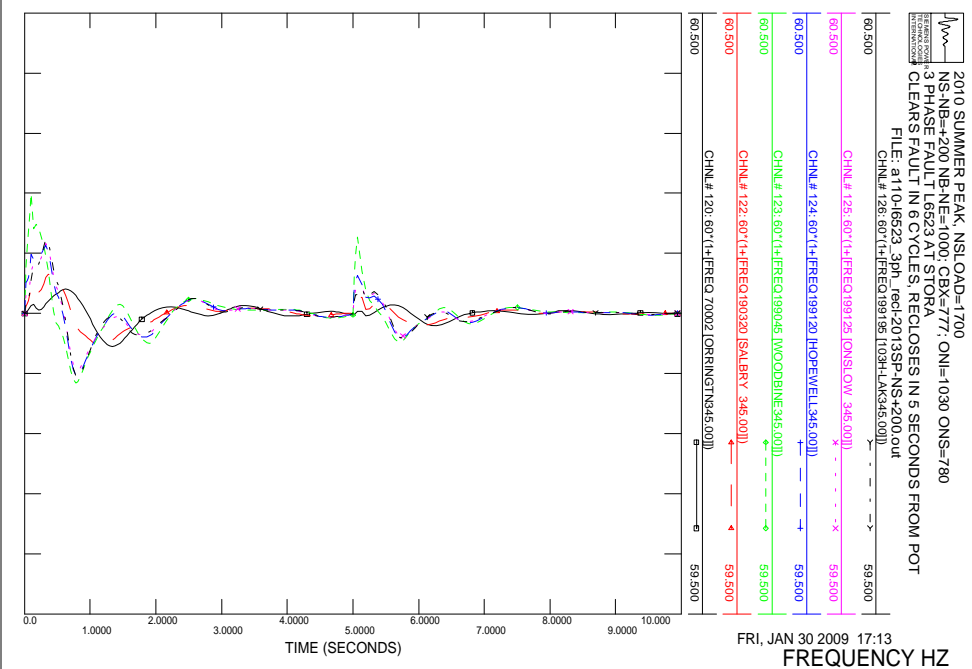
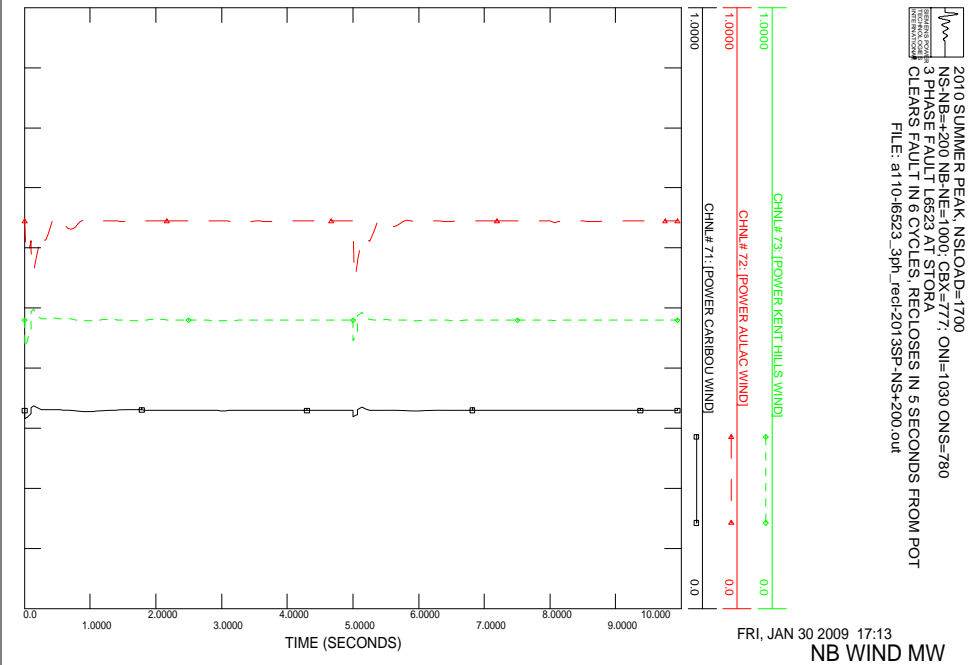
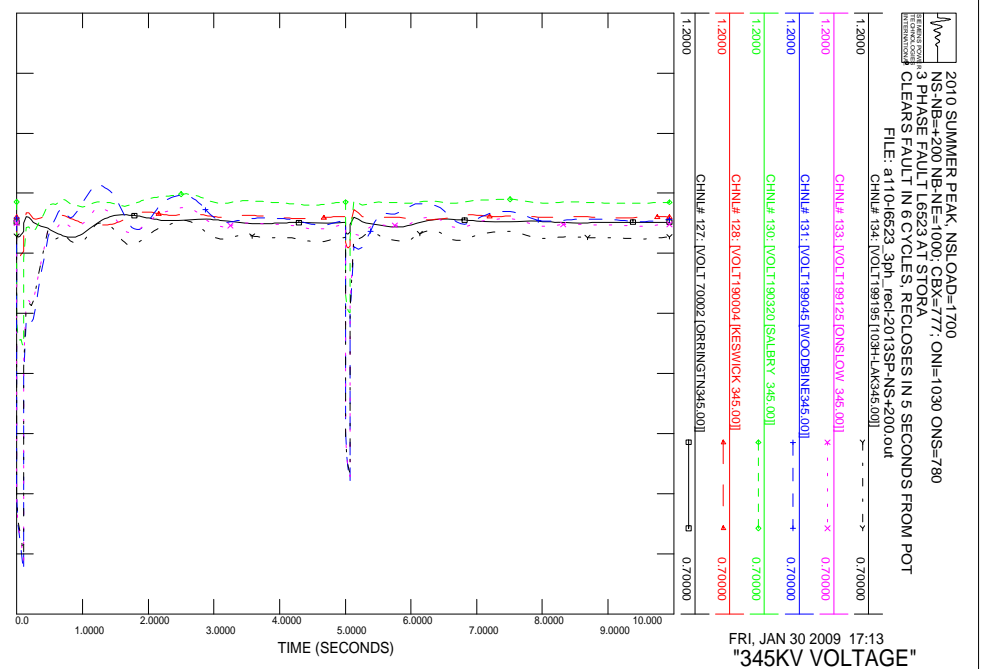
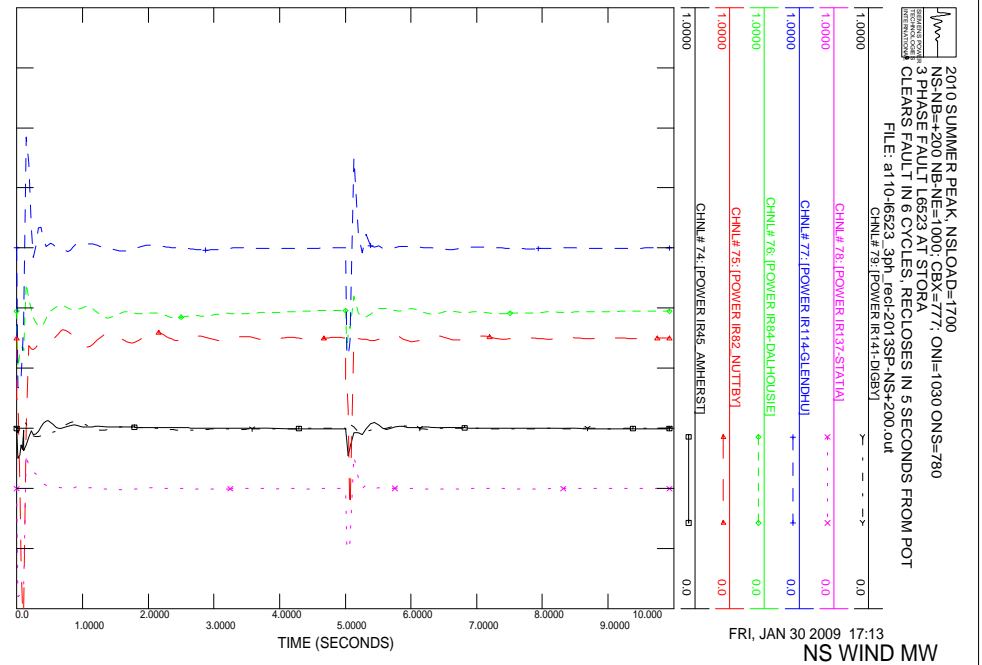

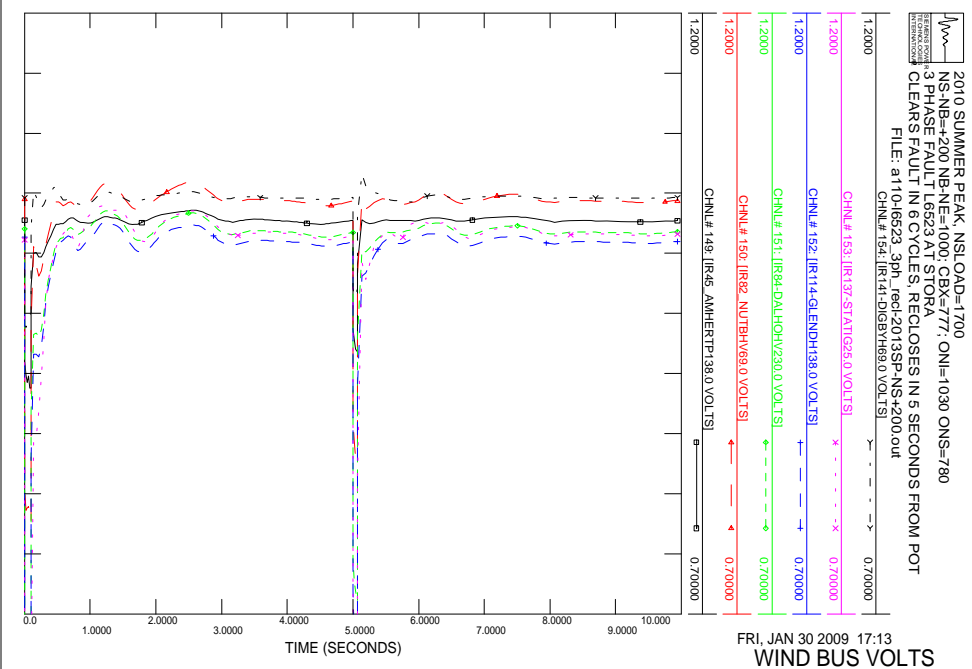
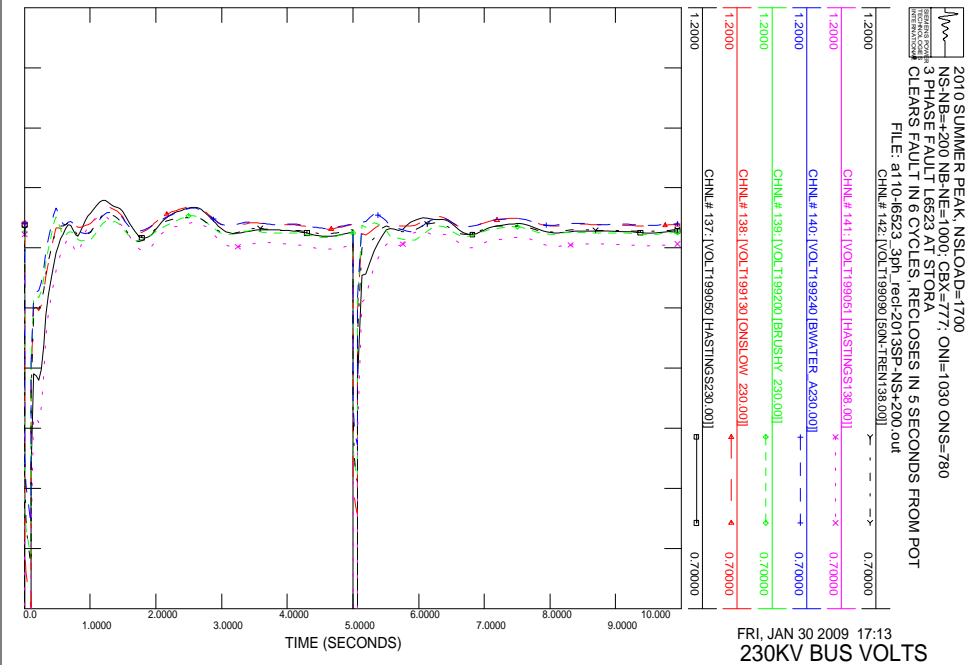
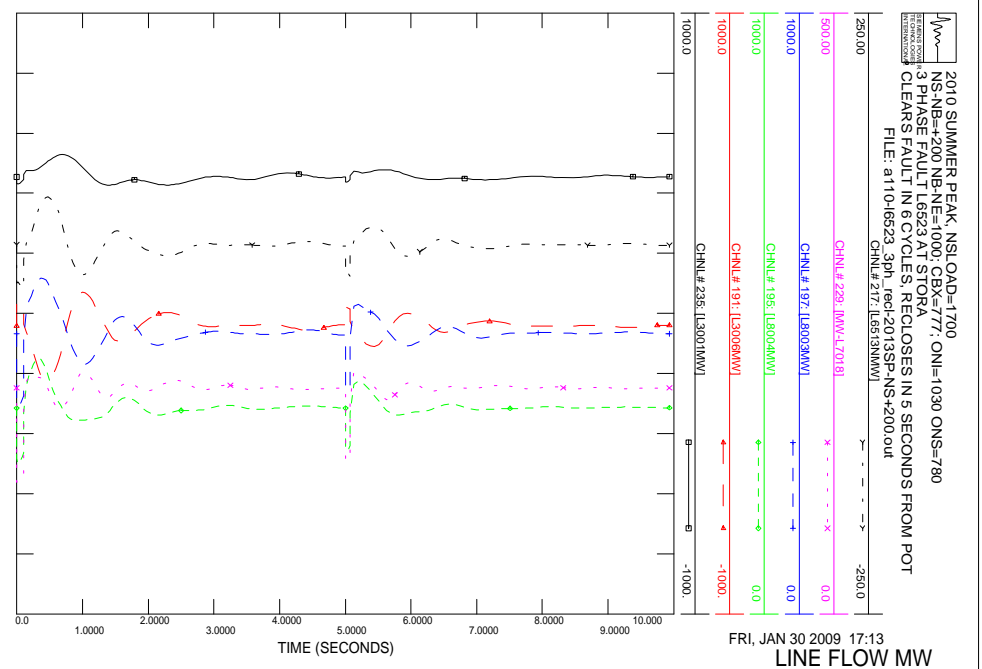
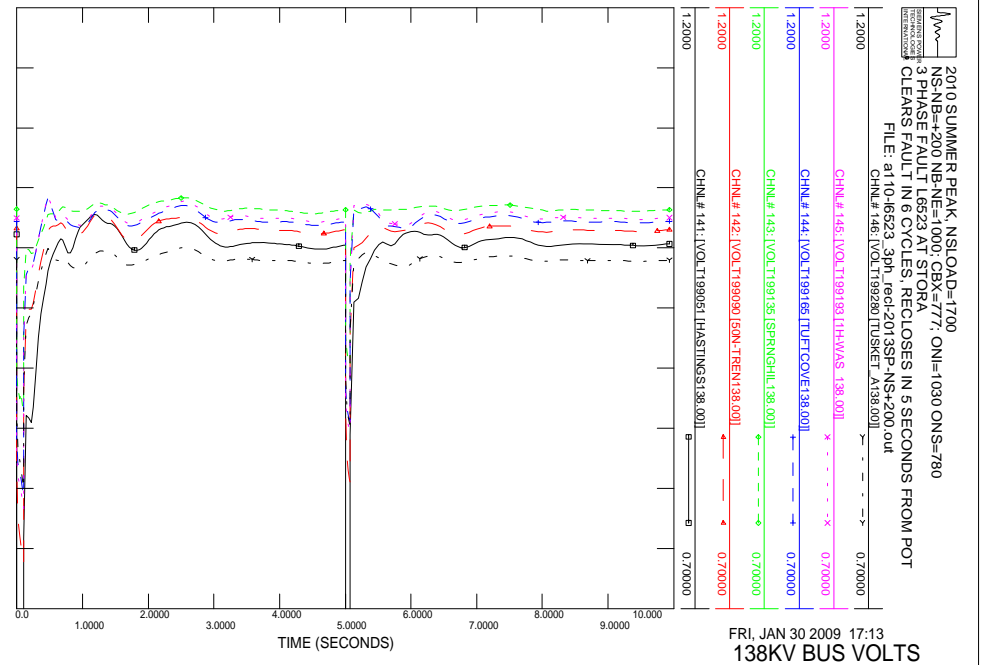

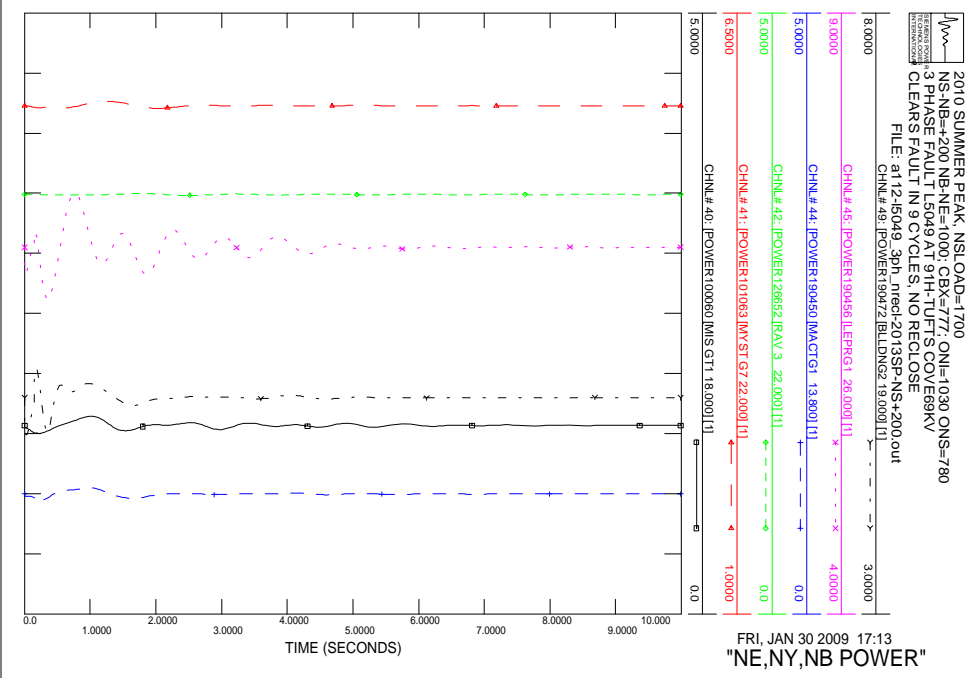
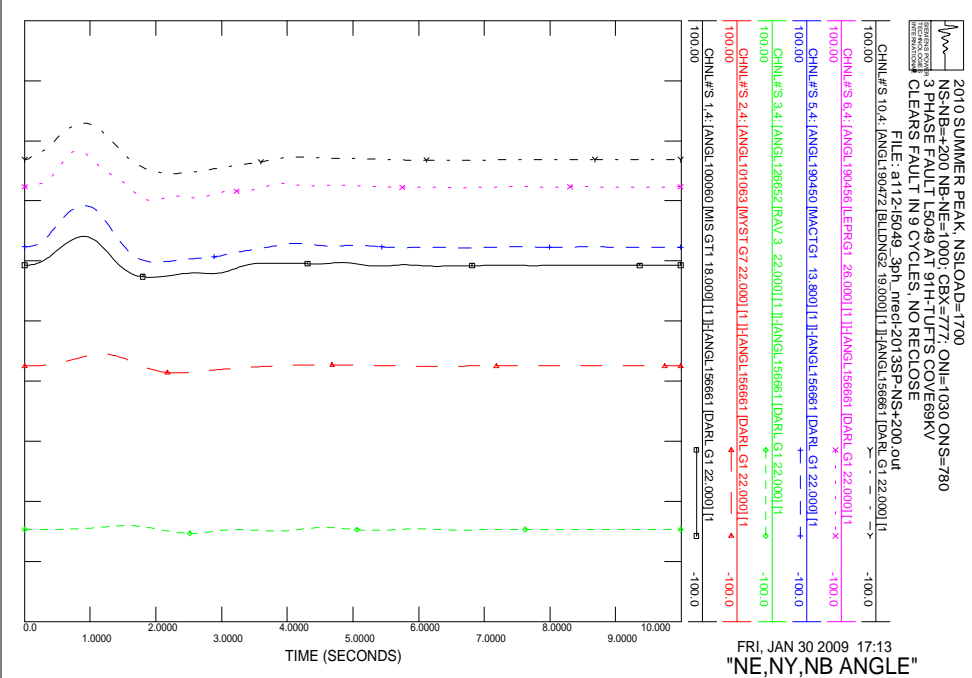
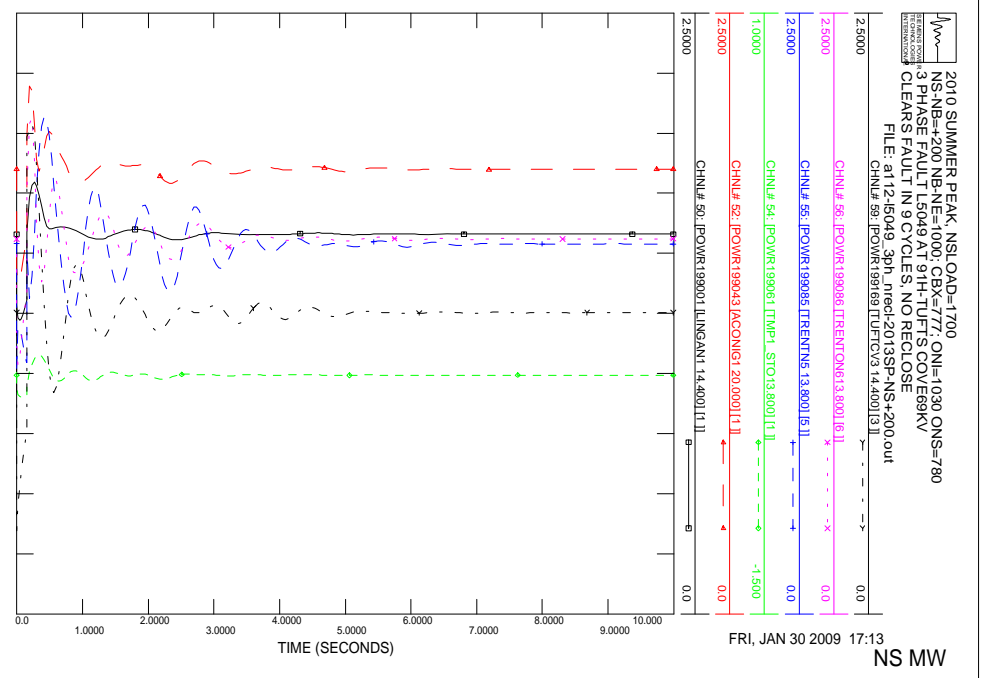
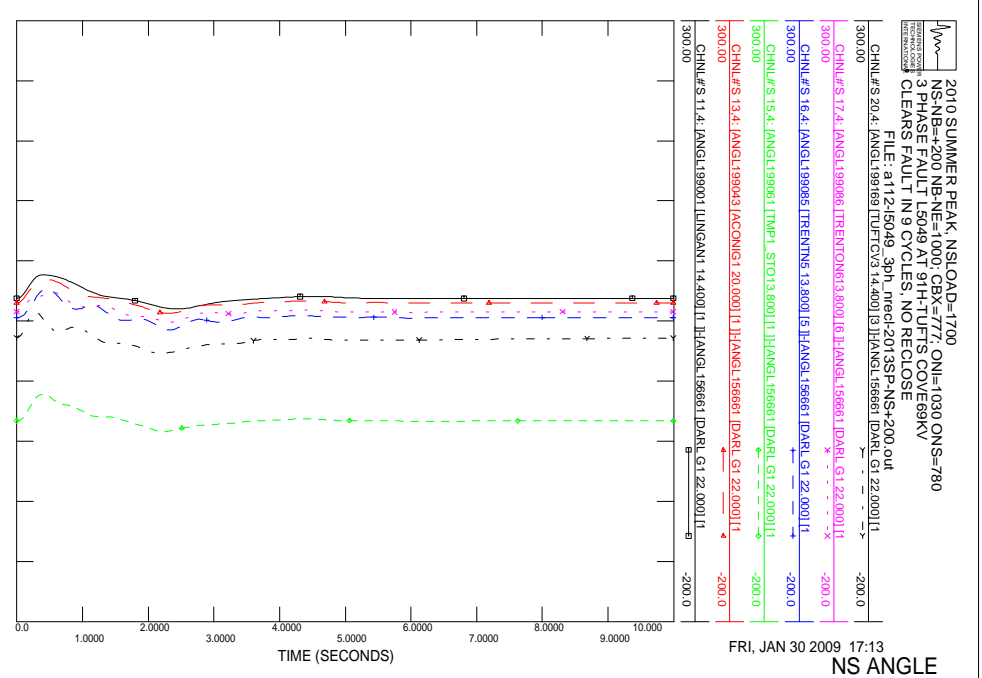

FRI, JAN 30 2009 17:13 "NS ANGLE"

FRI, JAN 30 2009 17:13 "NS MW"

FRI, JAN 30 2009 17:13 "NE,NY,NB ANGLE"

FRI, JAN 30 2009 17:13 "NE,NY,NB POWER"

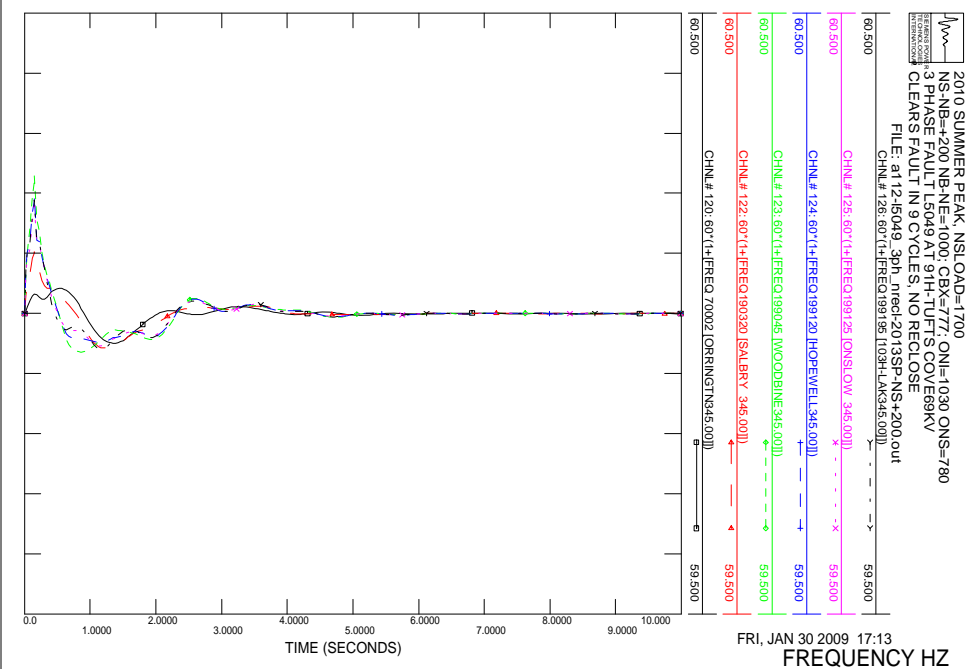
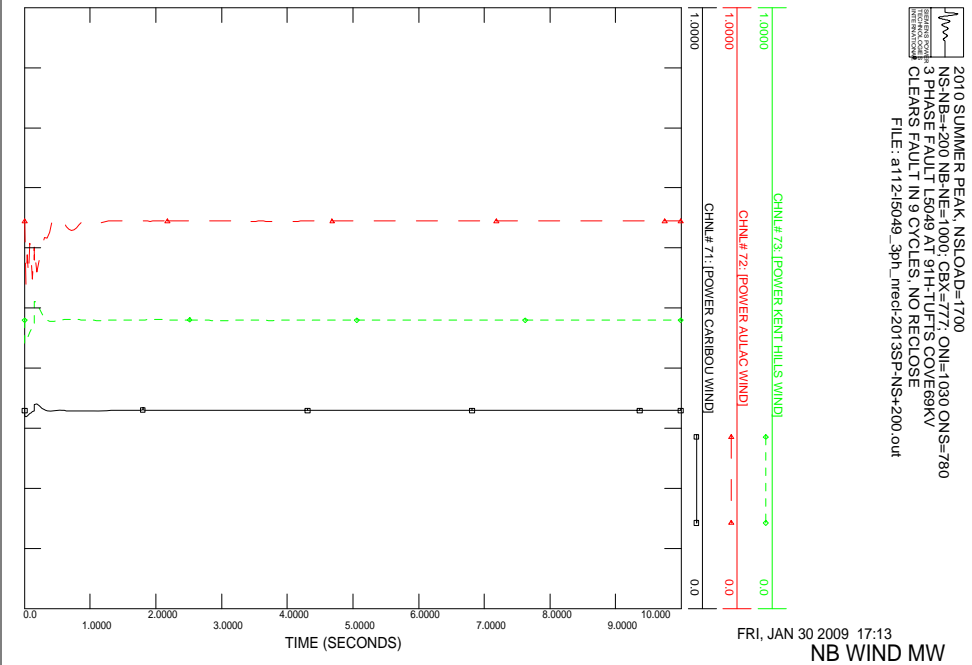
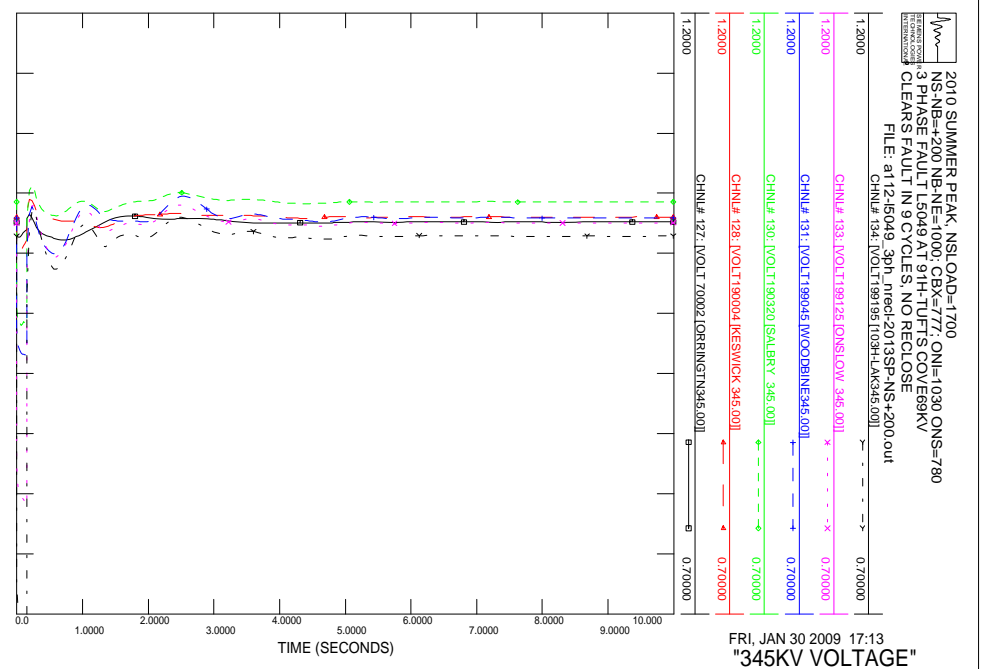
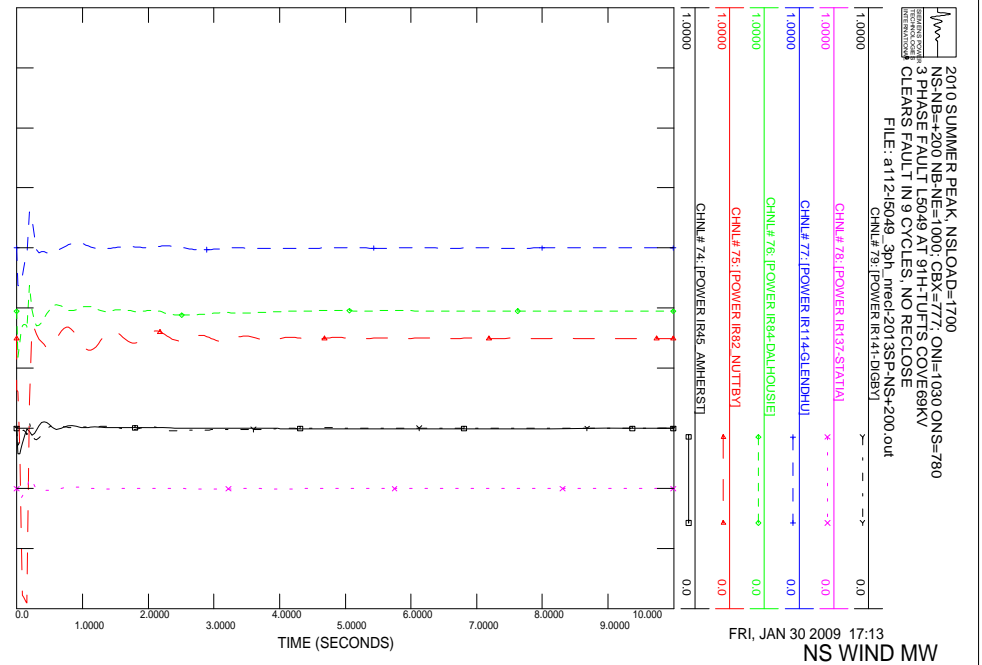

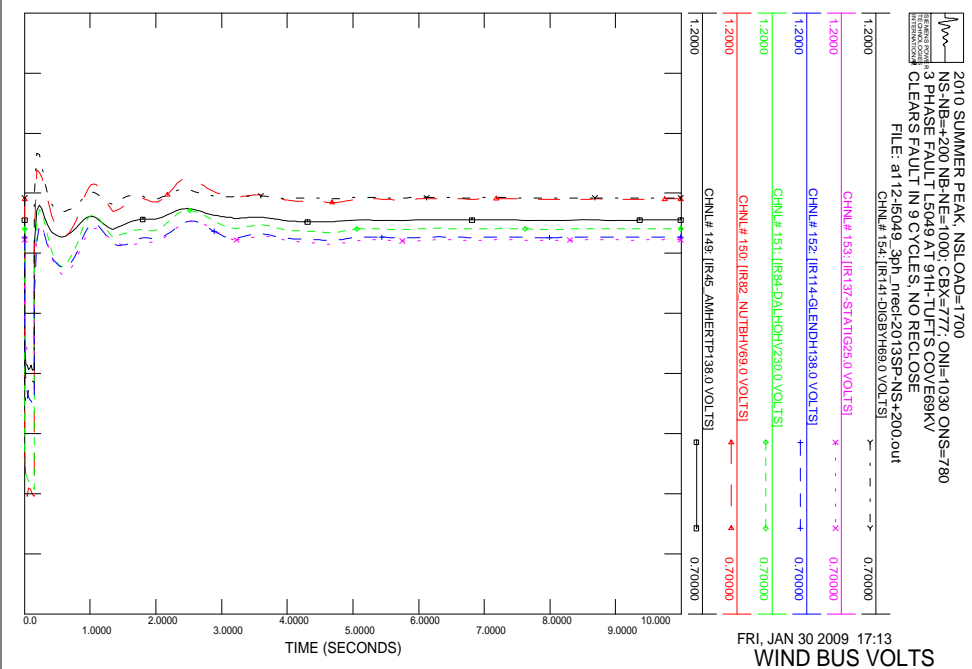
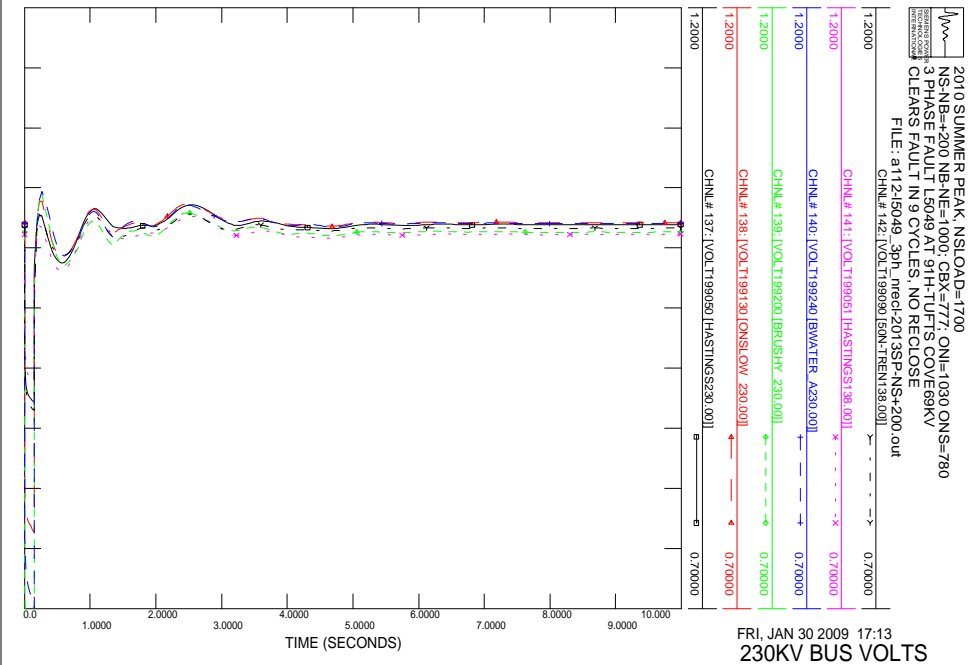
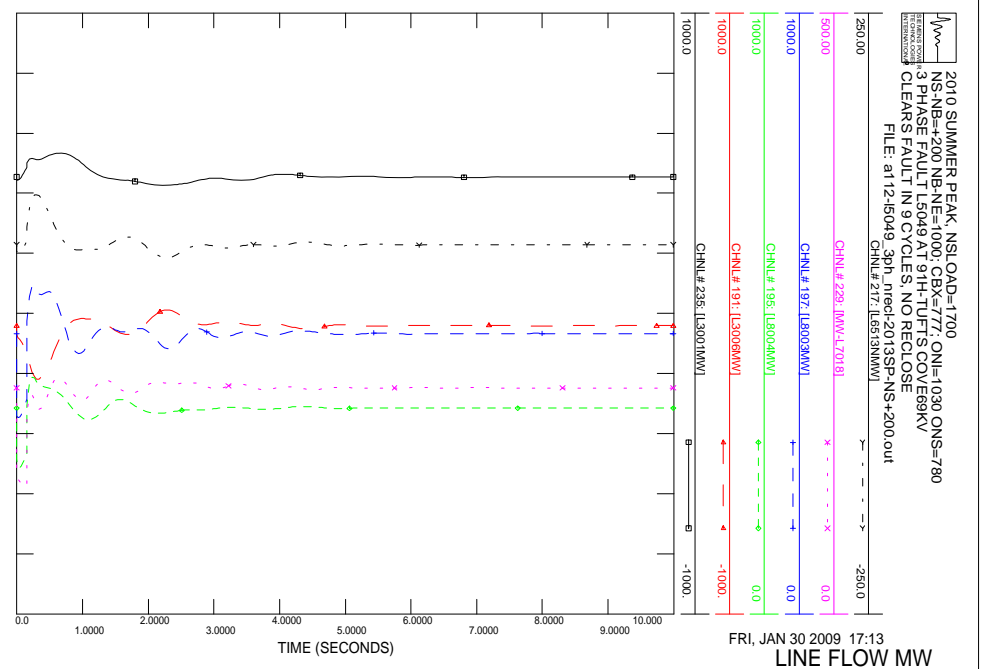
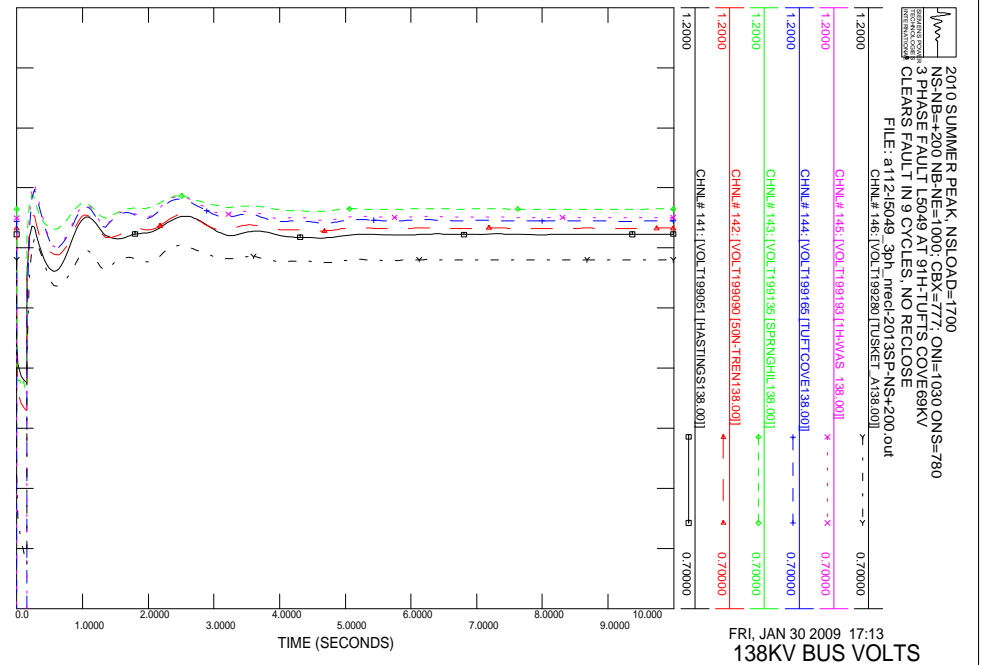

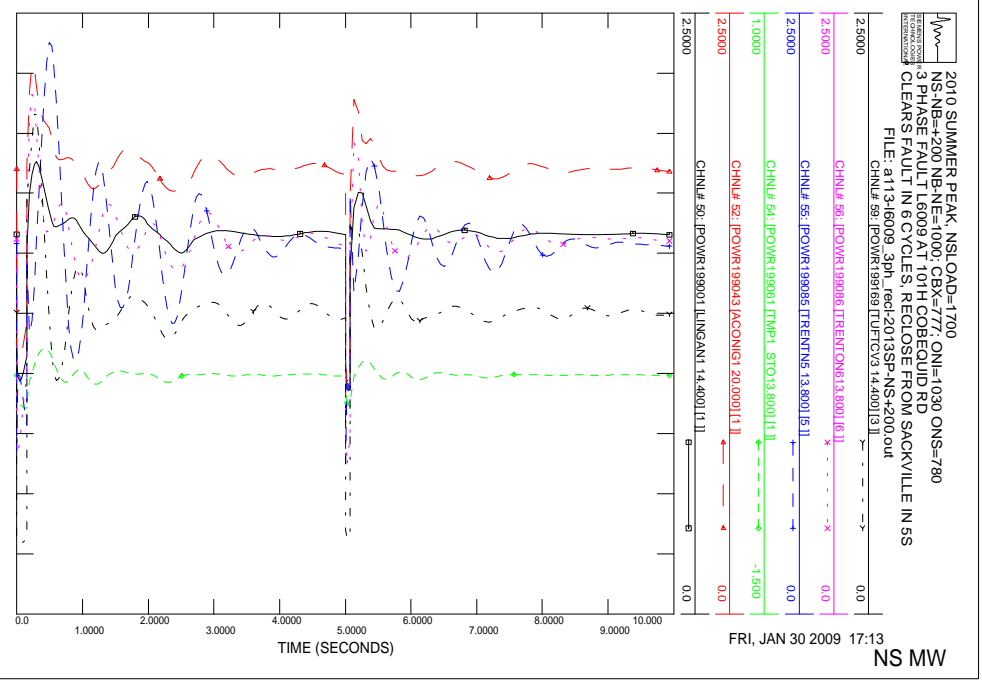
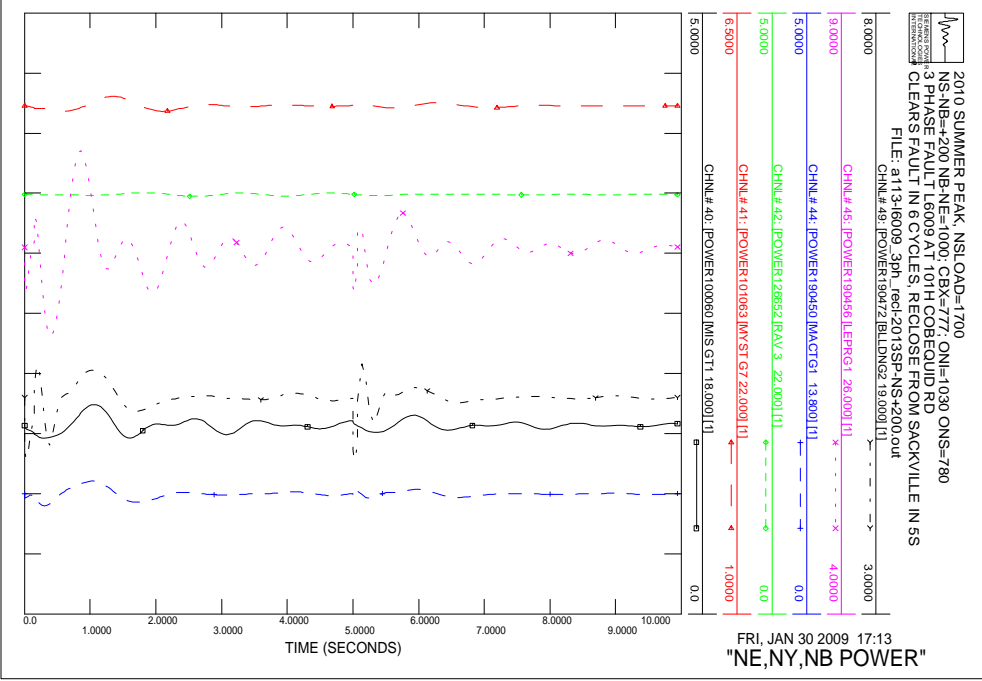
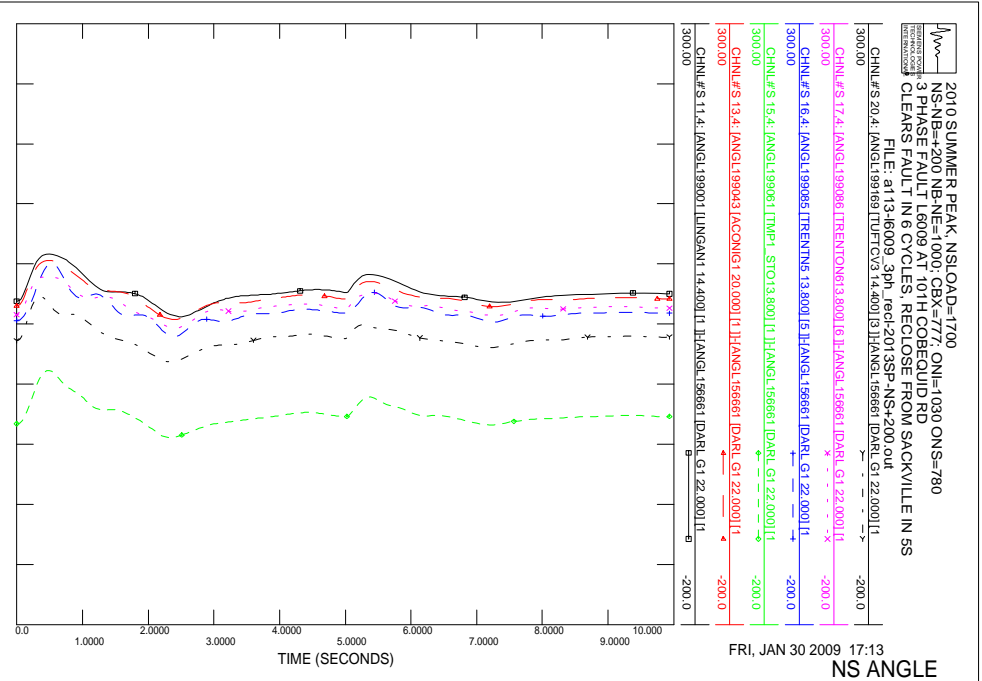
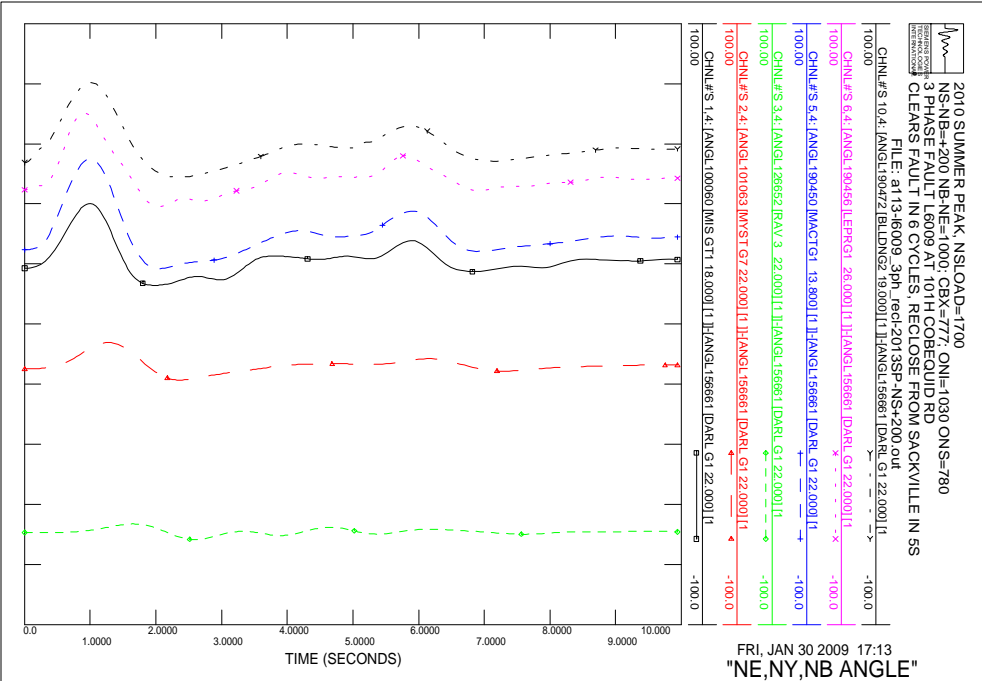

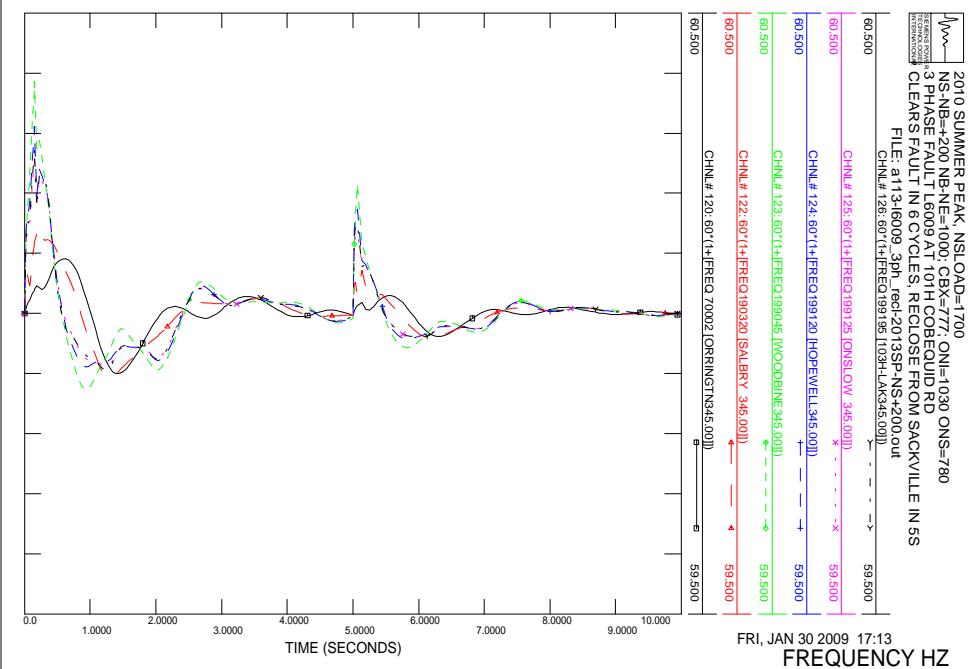
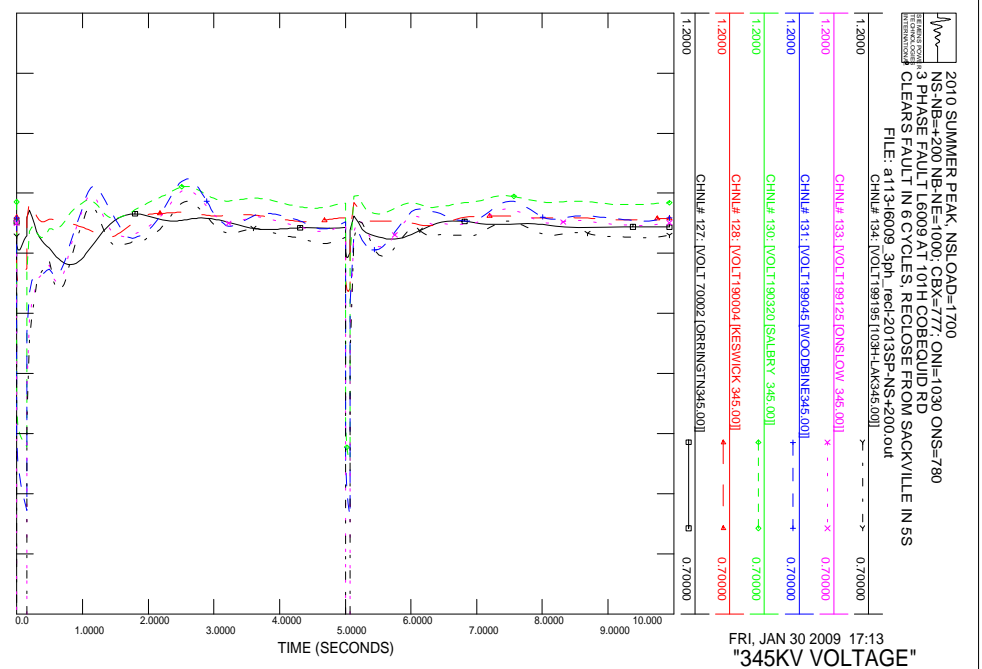
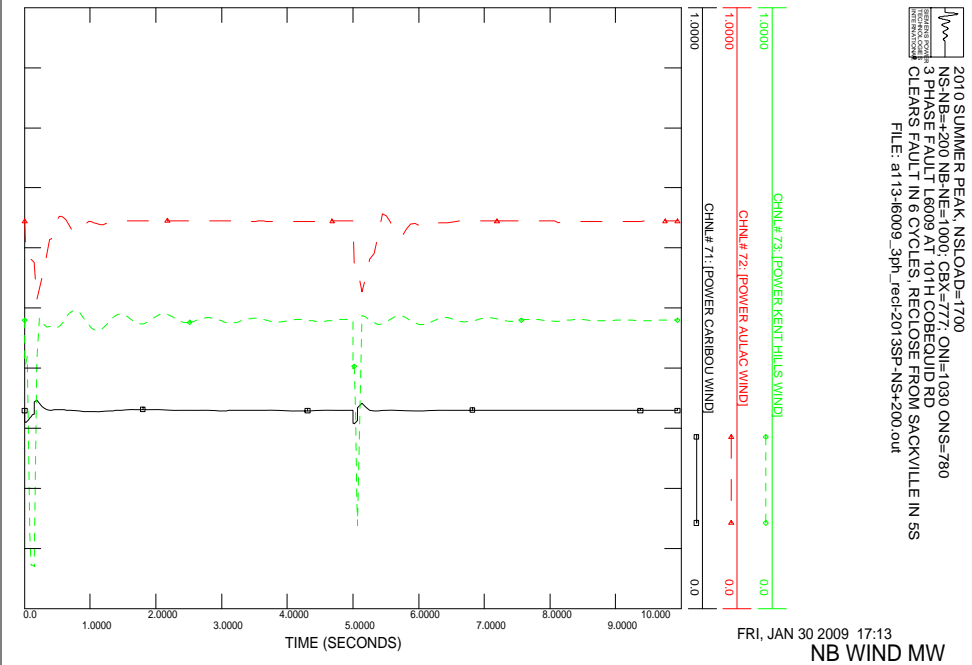
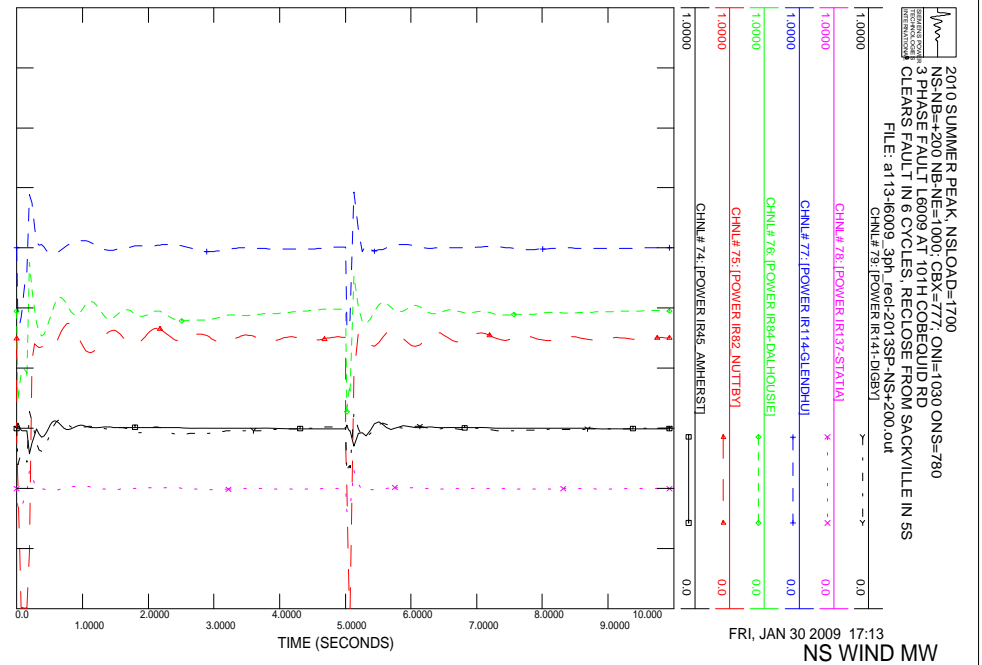

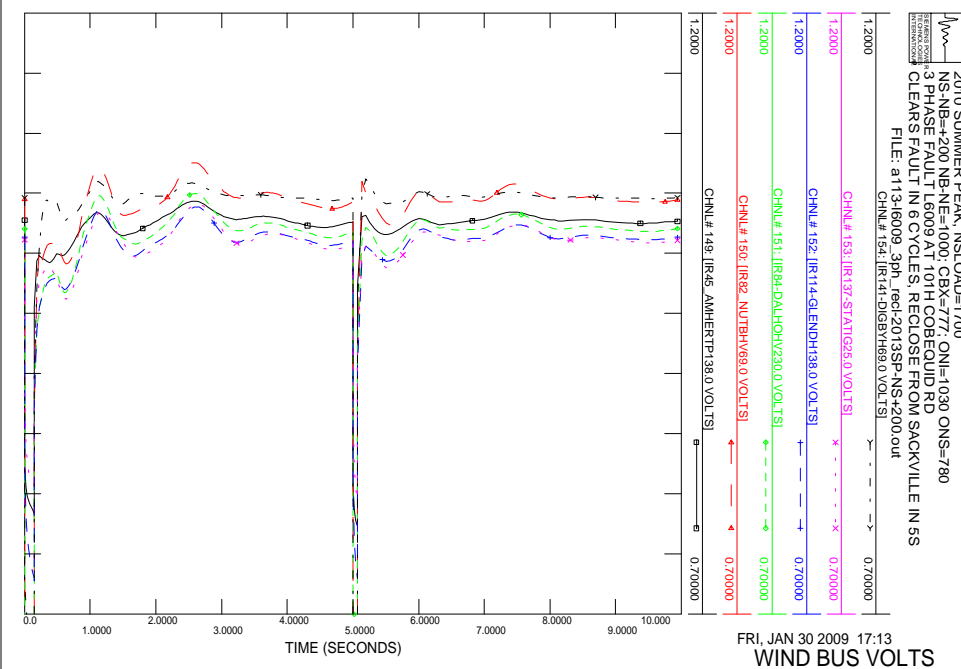
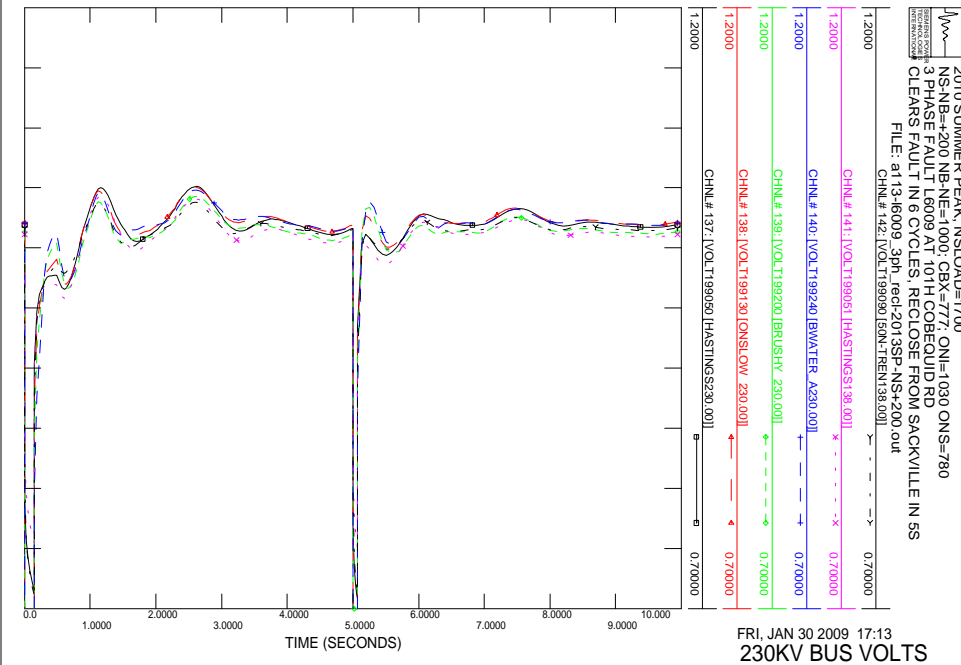
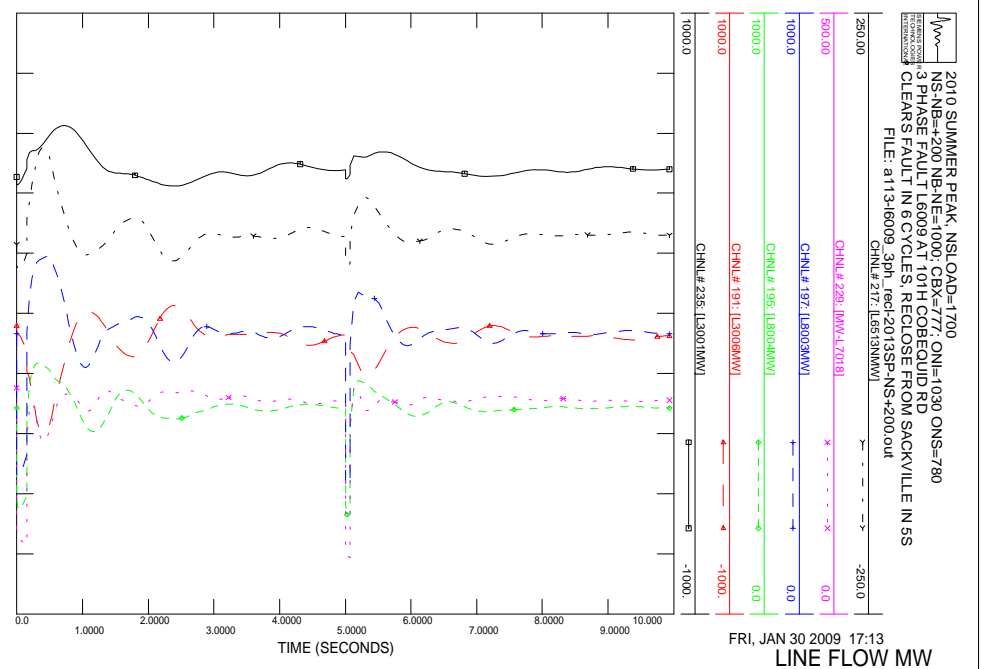
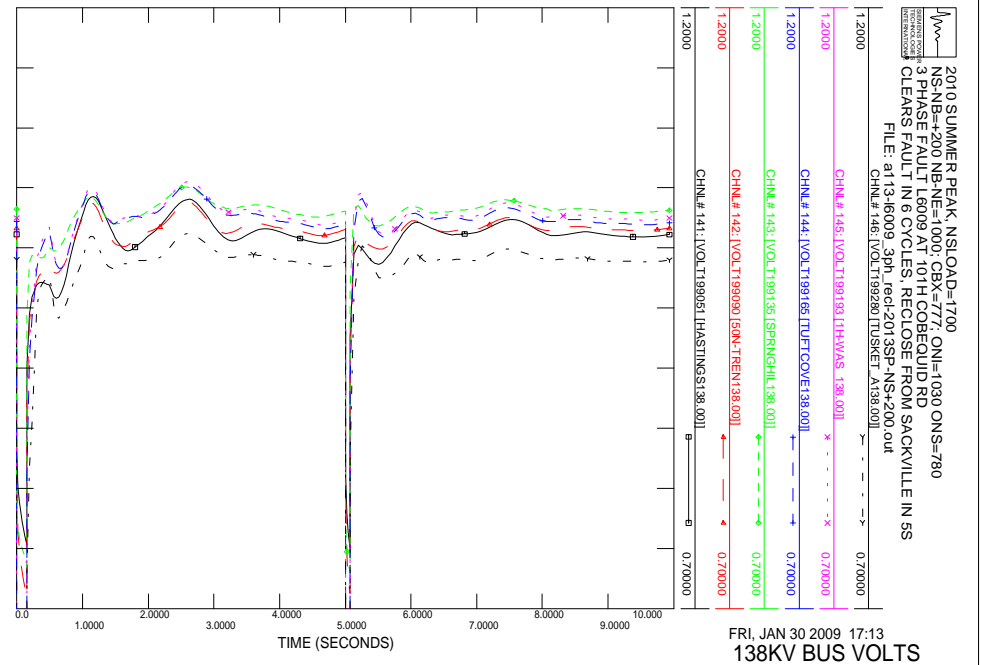

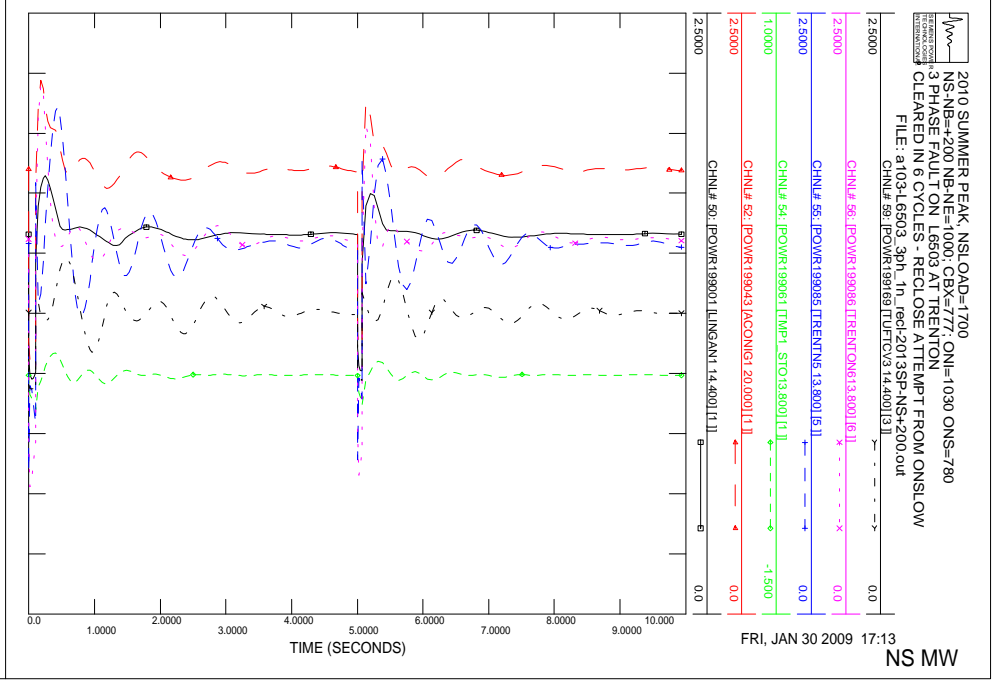
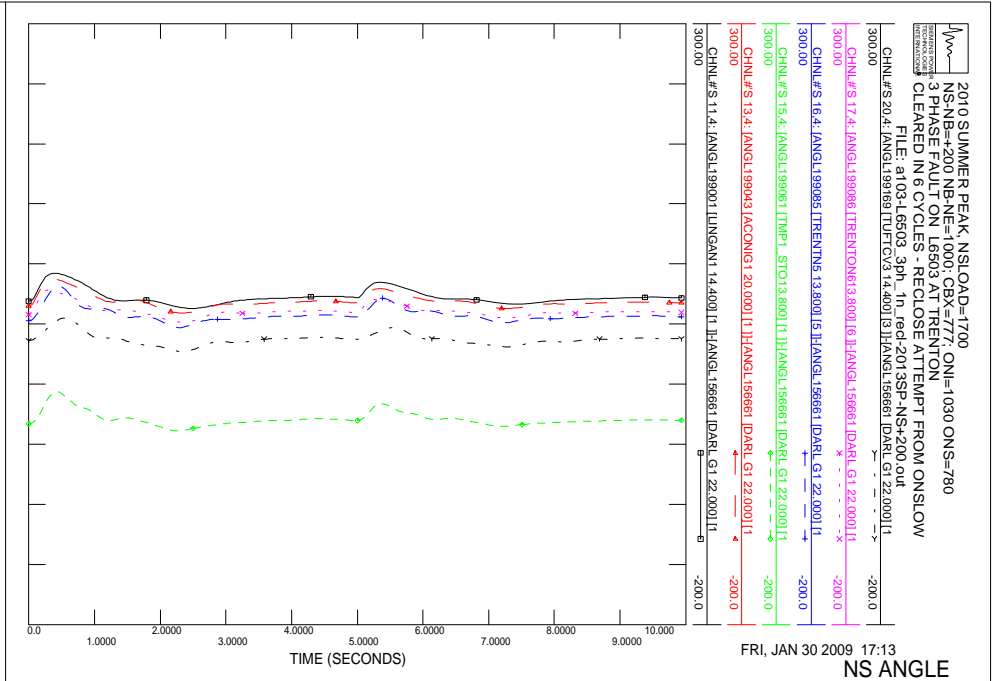
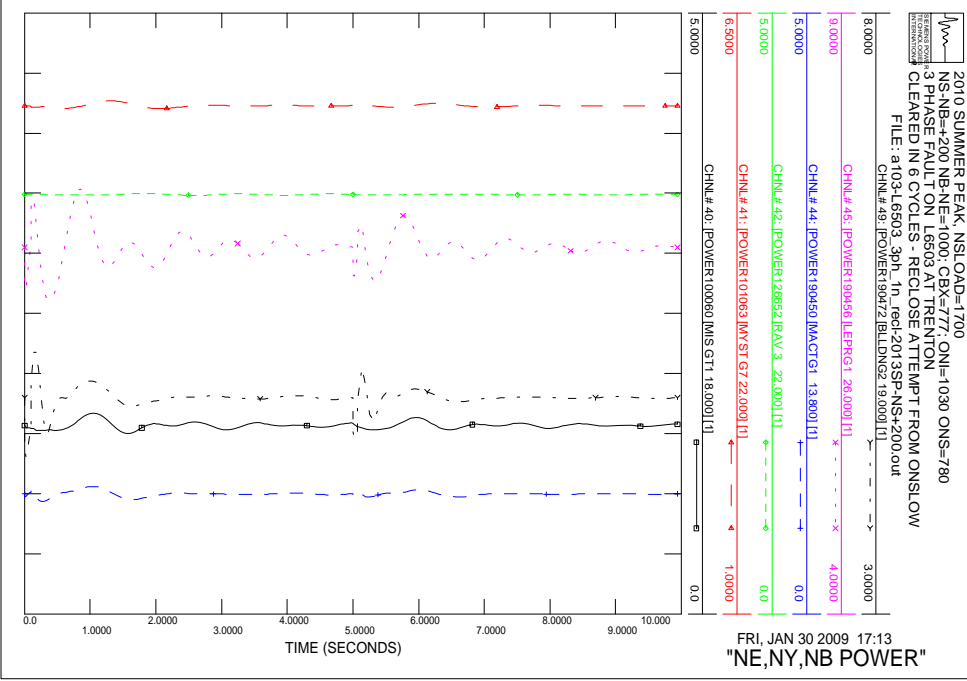
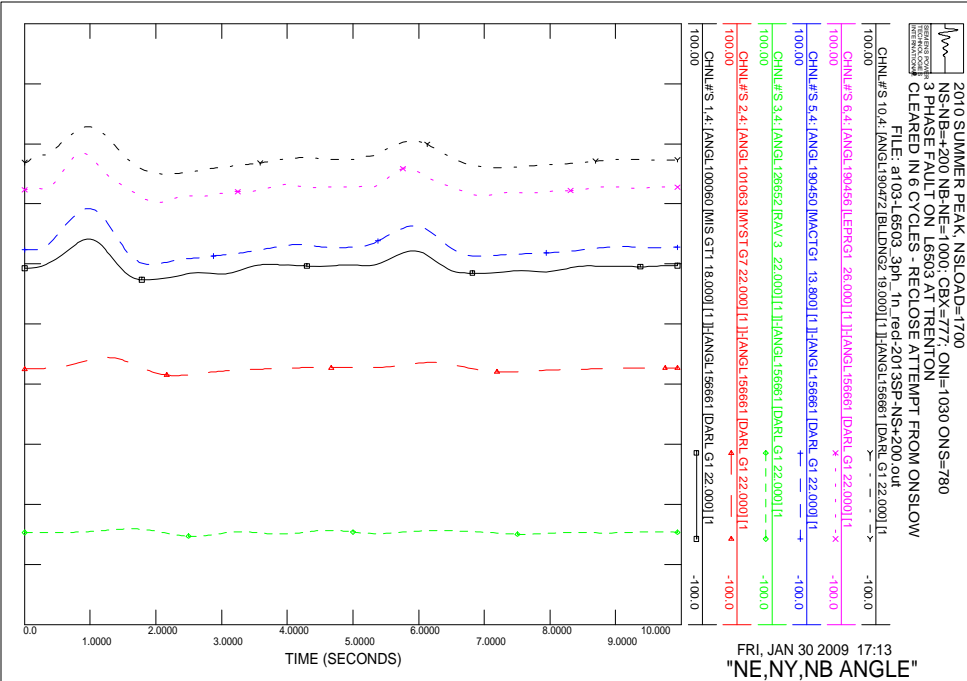

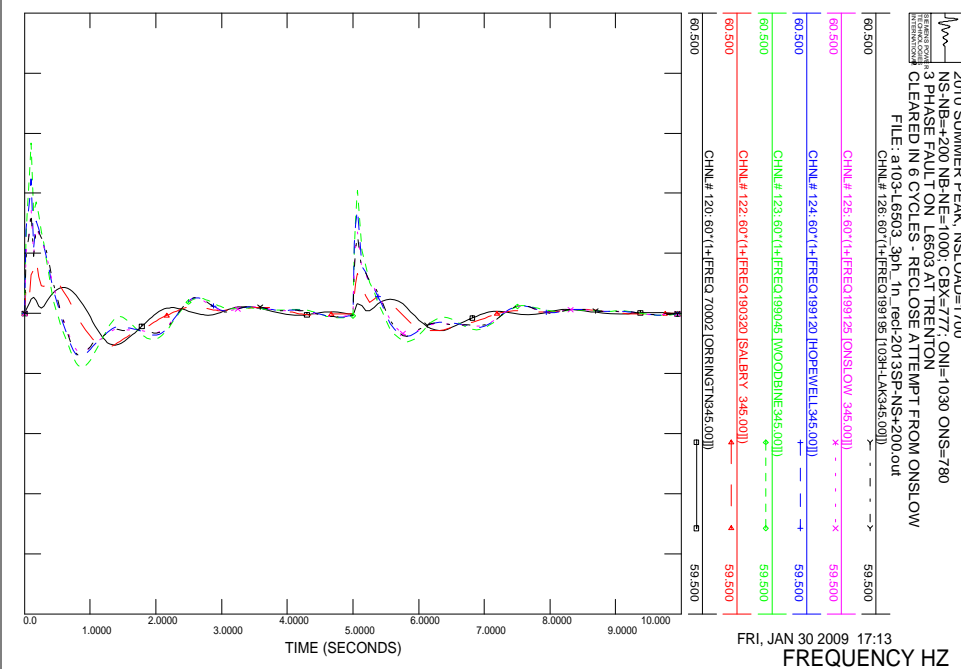
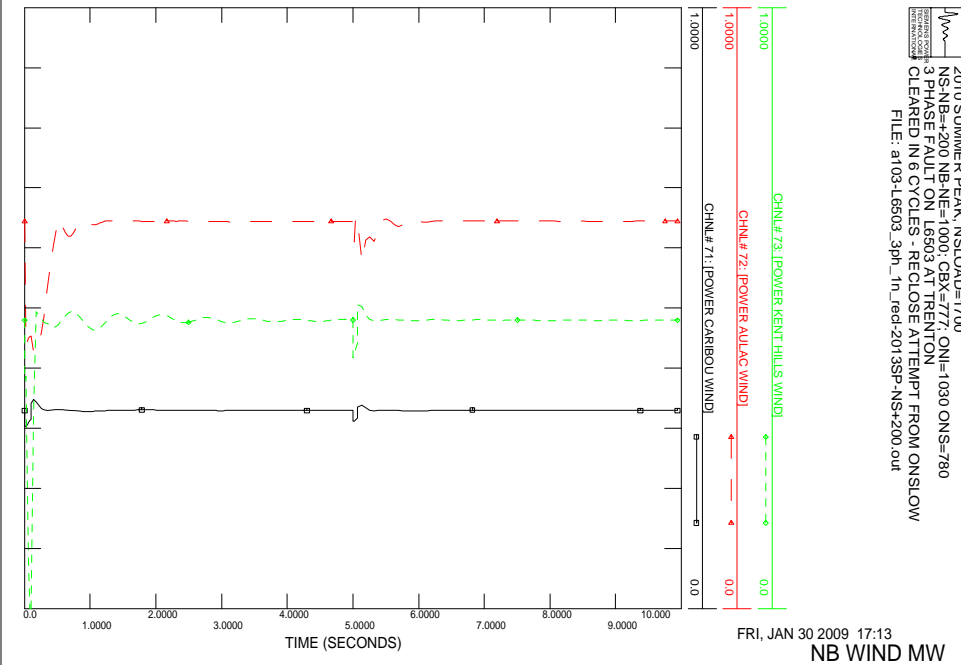
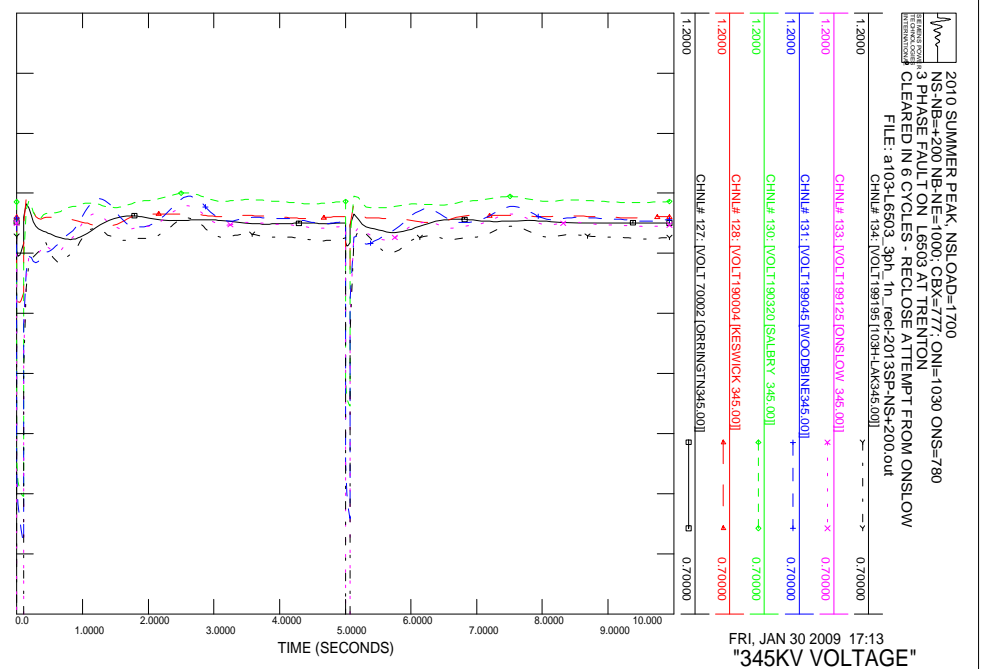
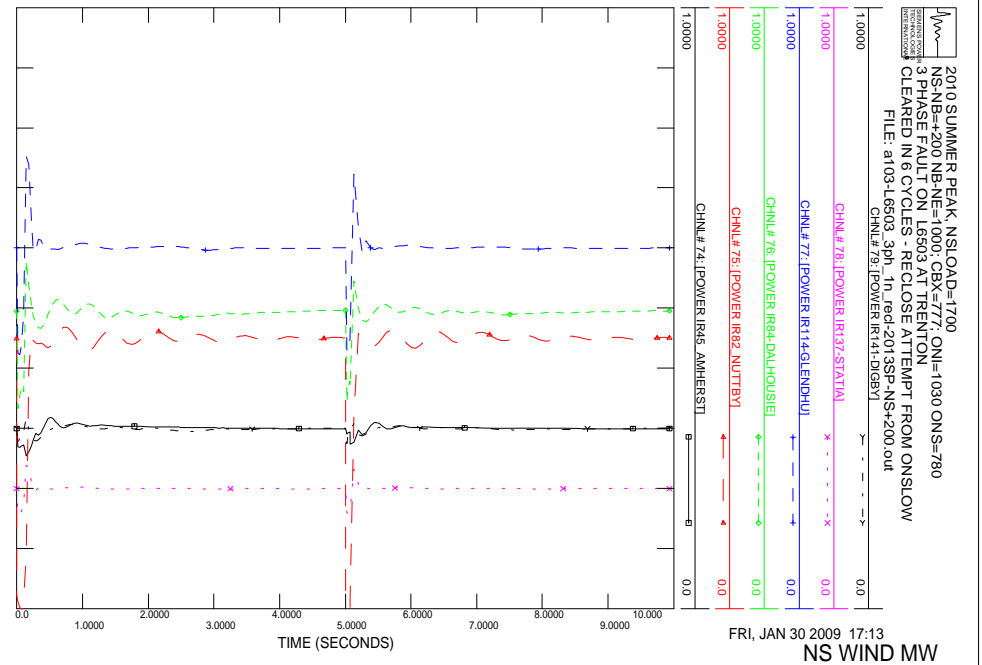

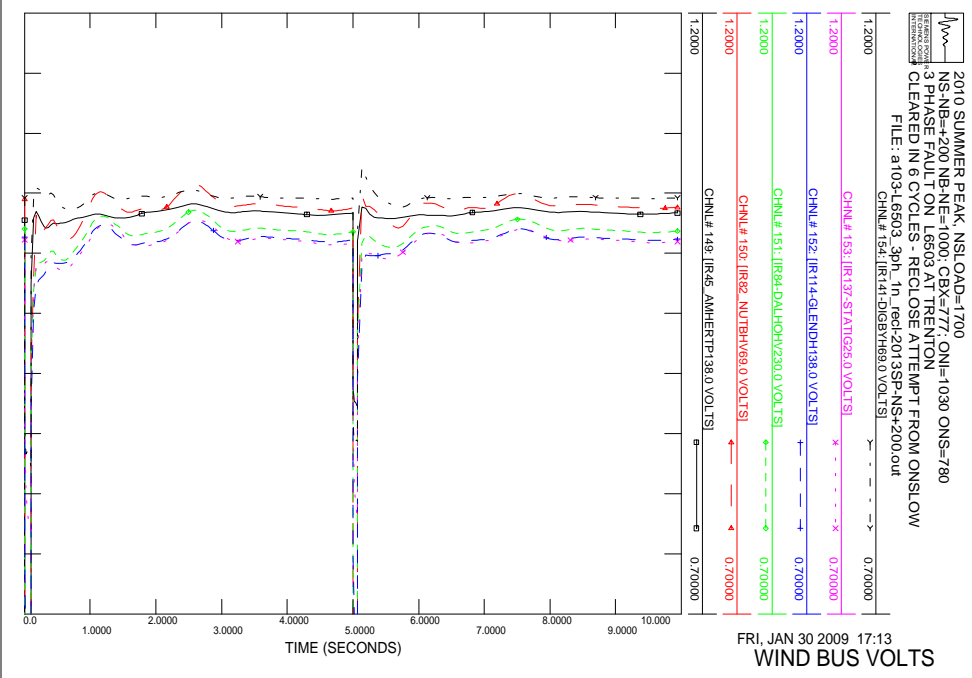
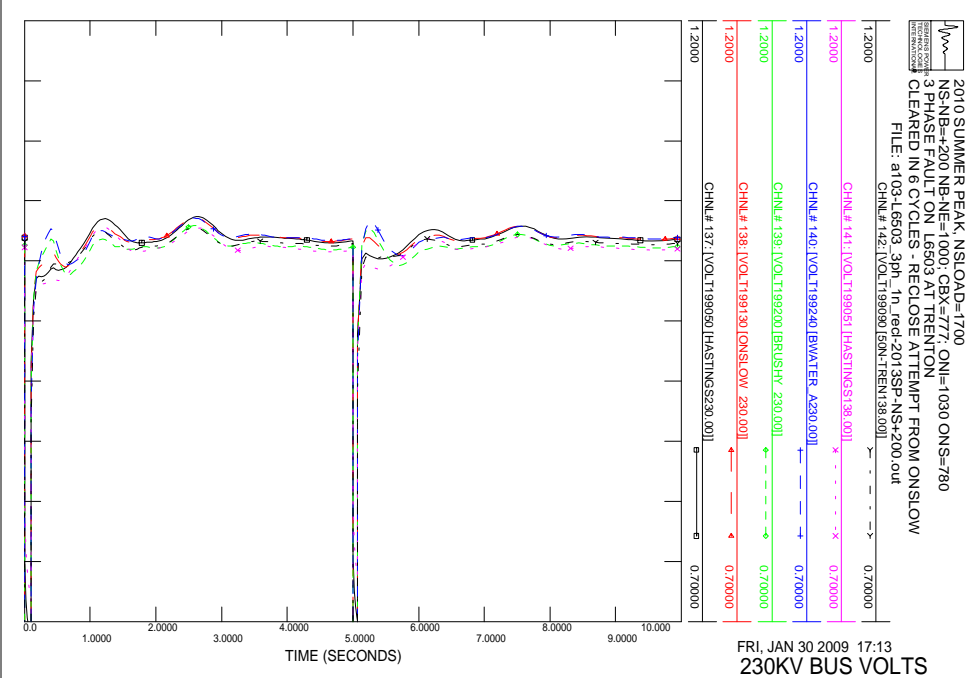
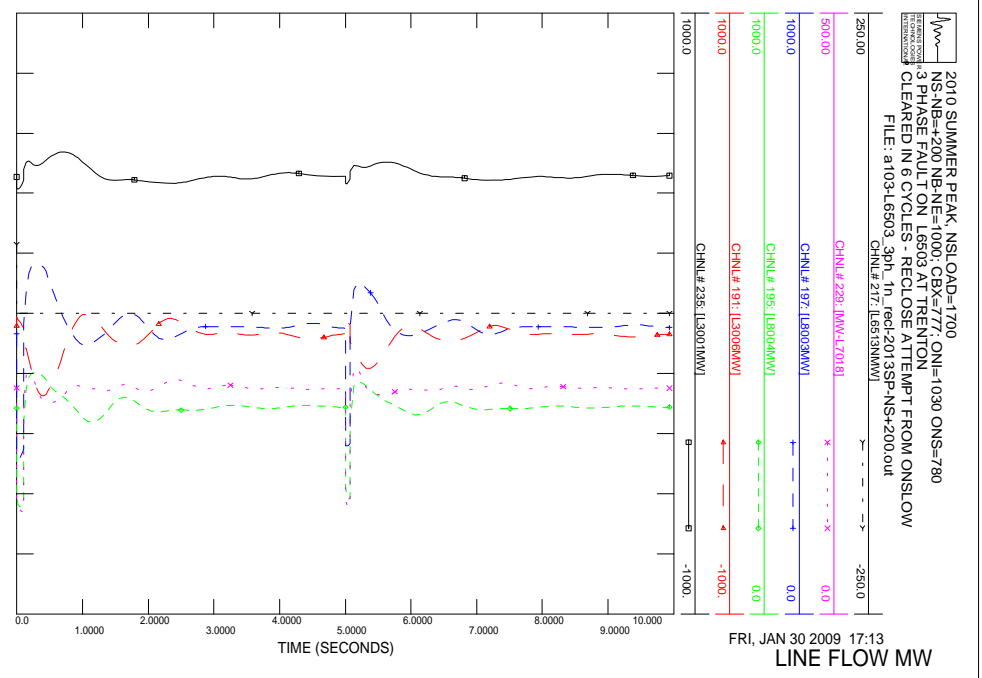
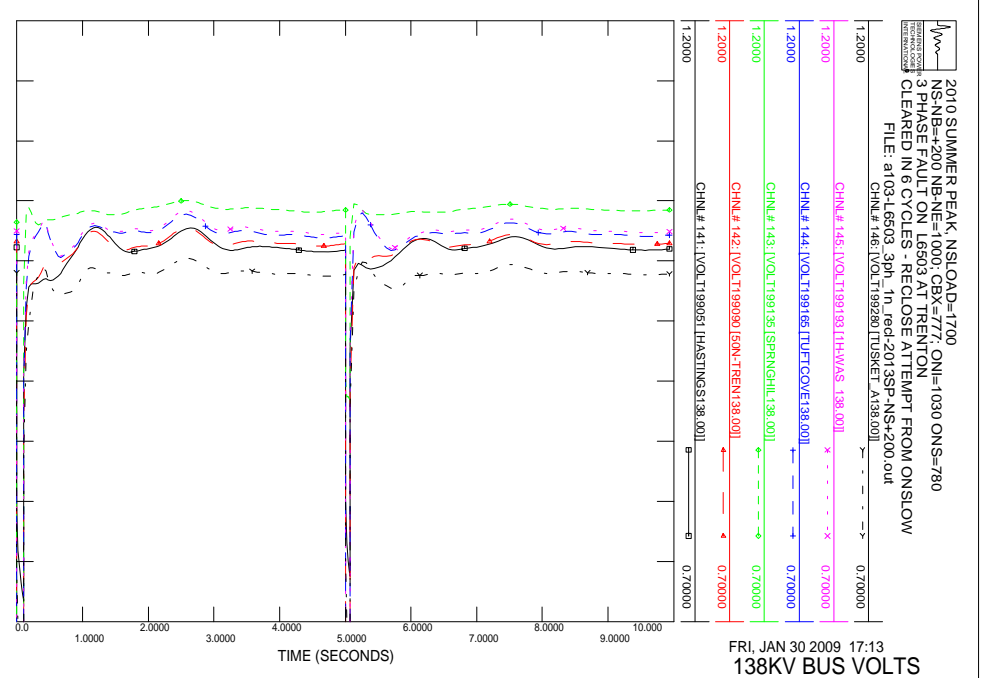

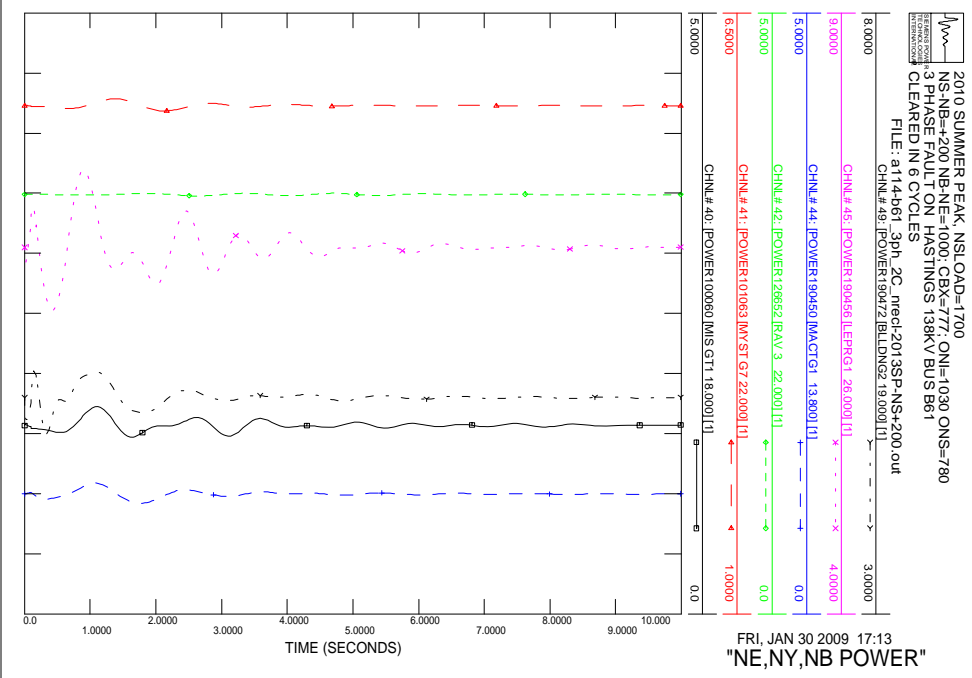
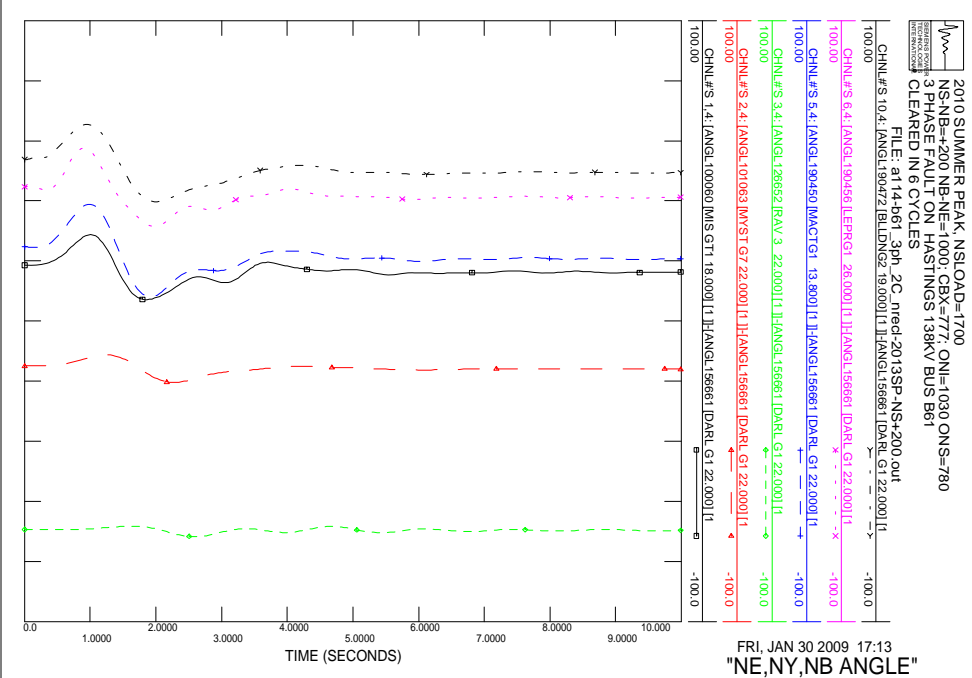
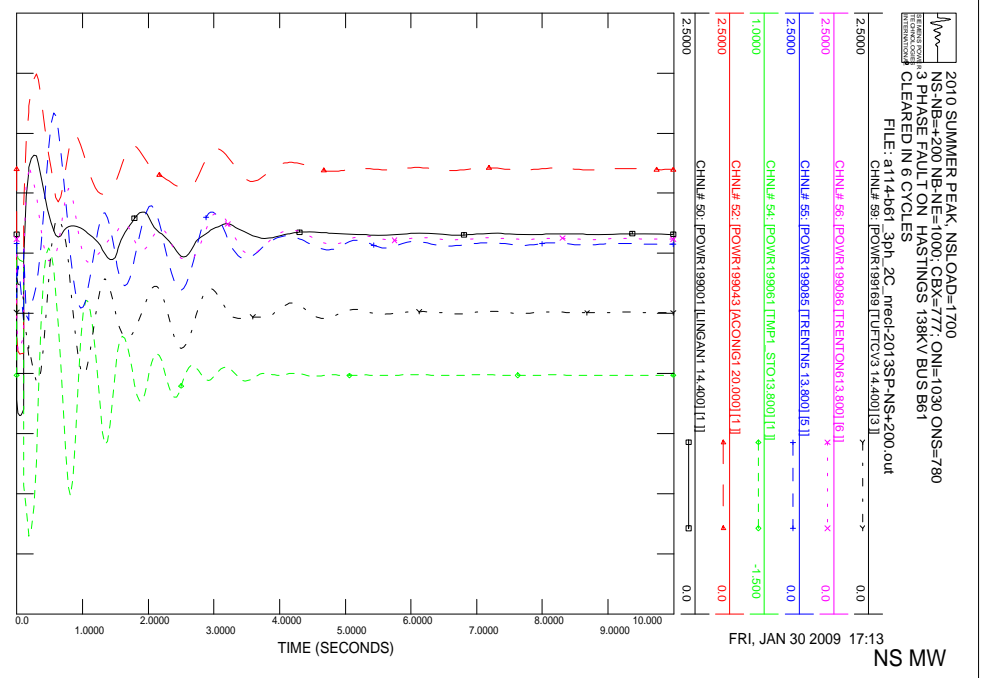
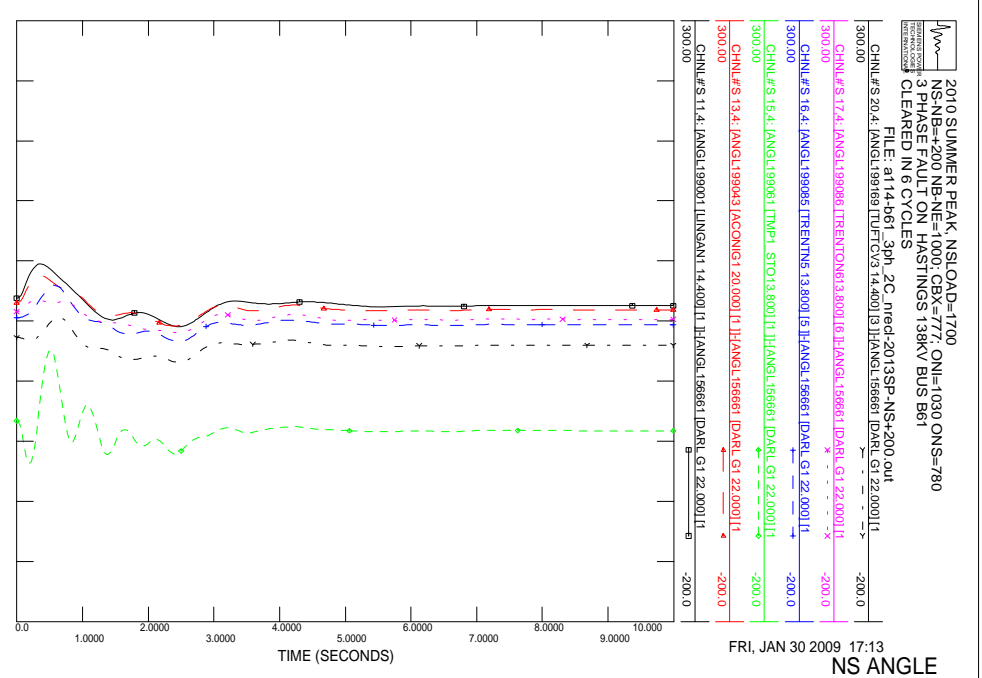

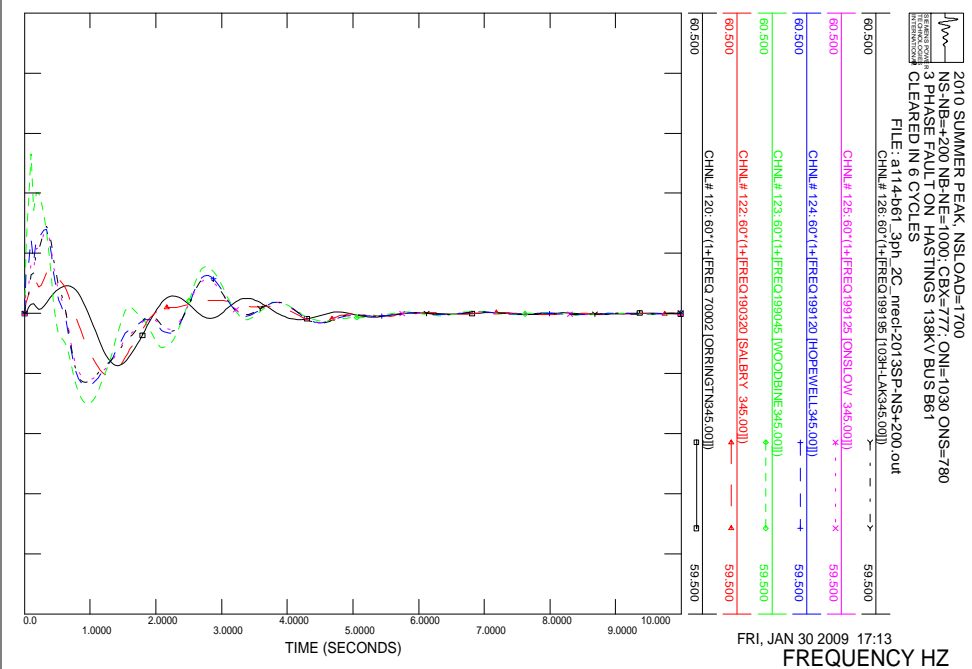
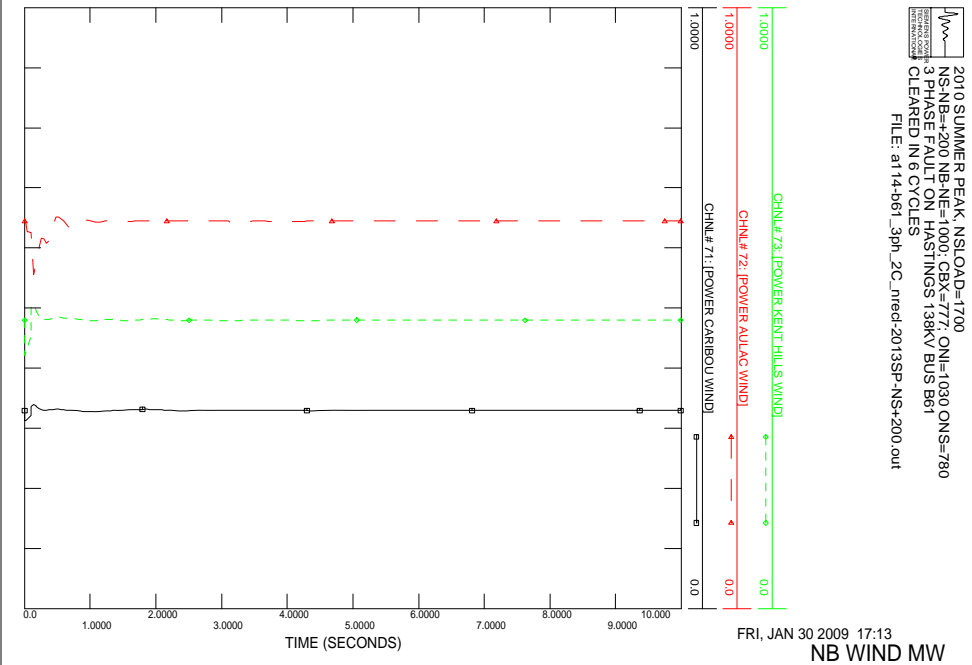
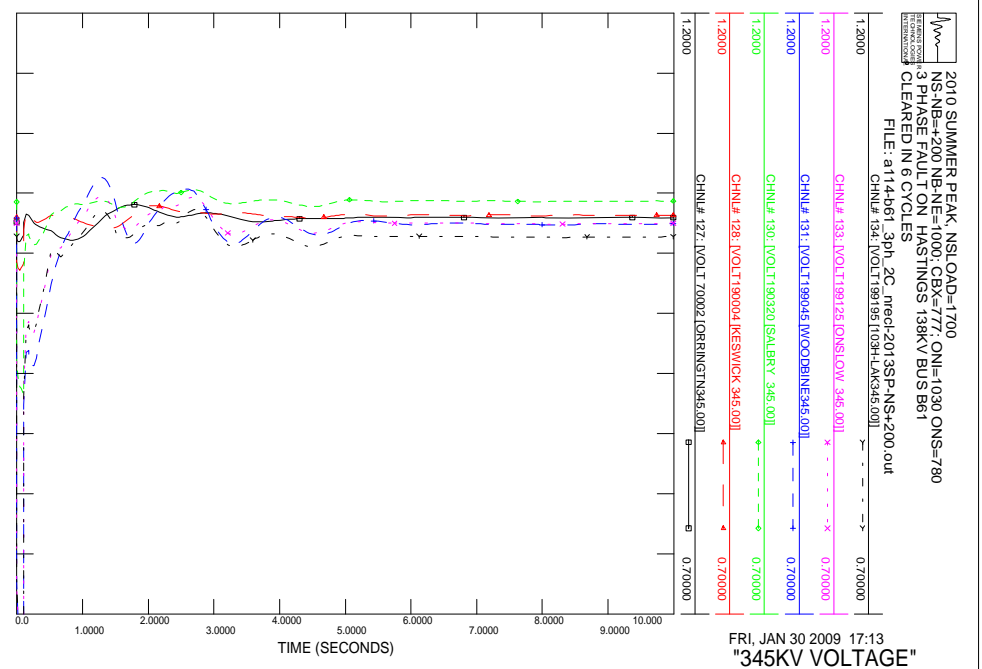
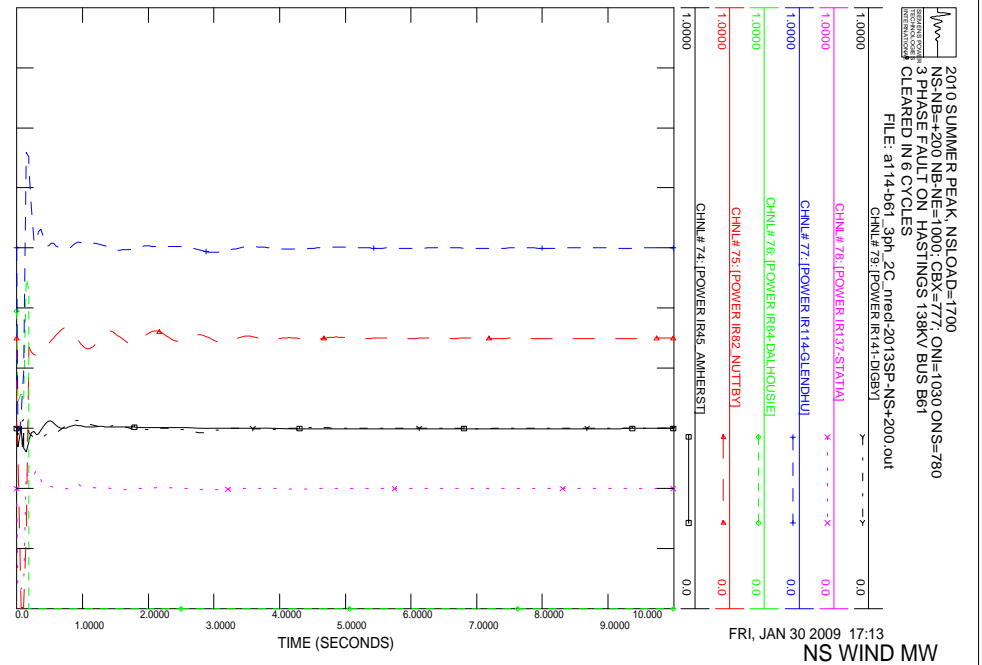

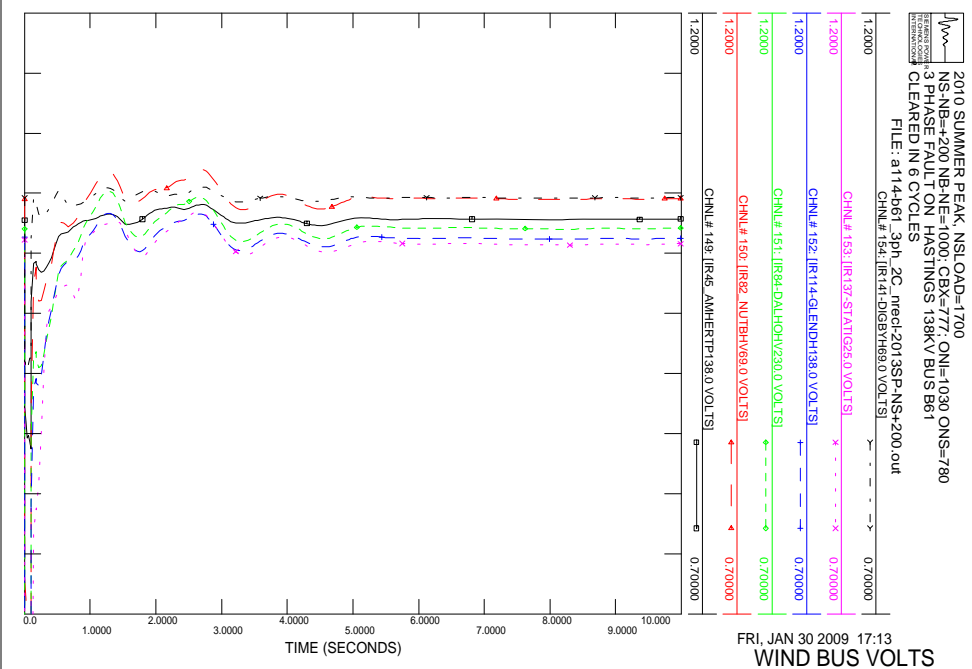
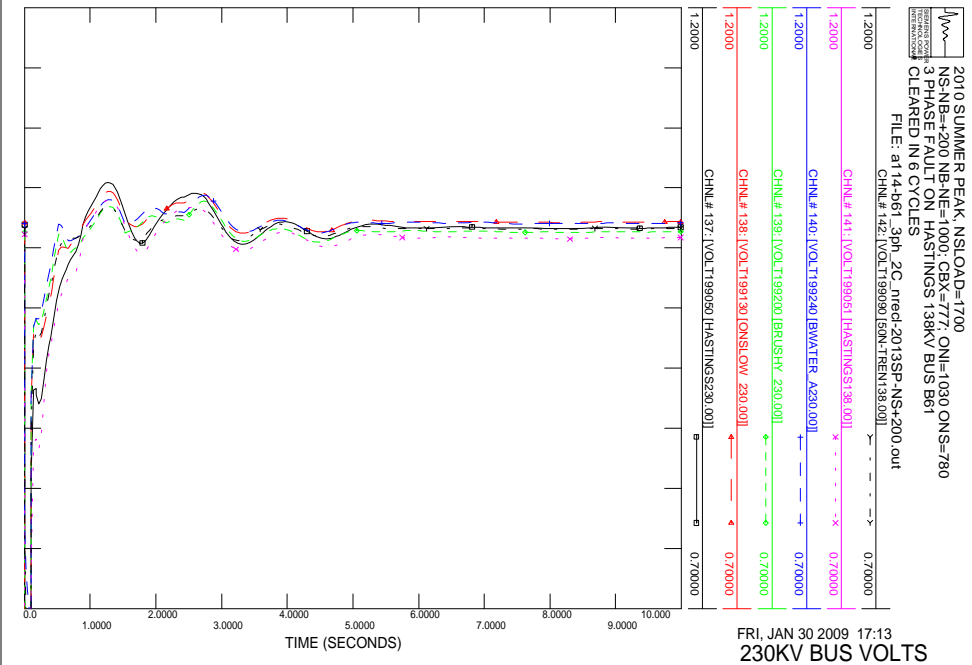
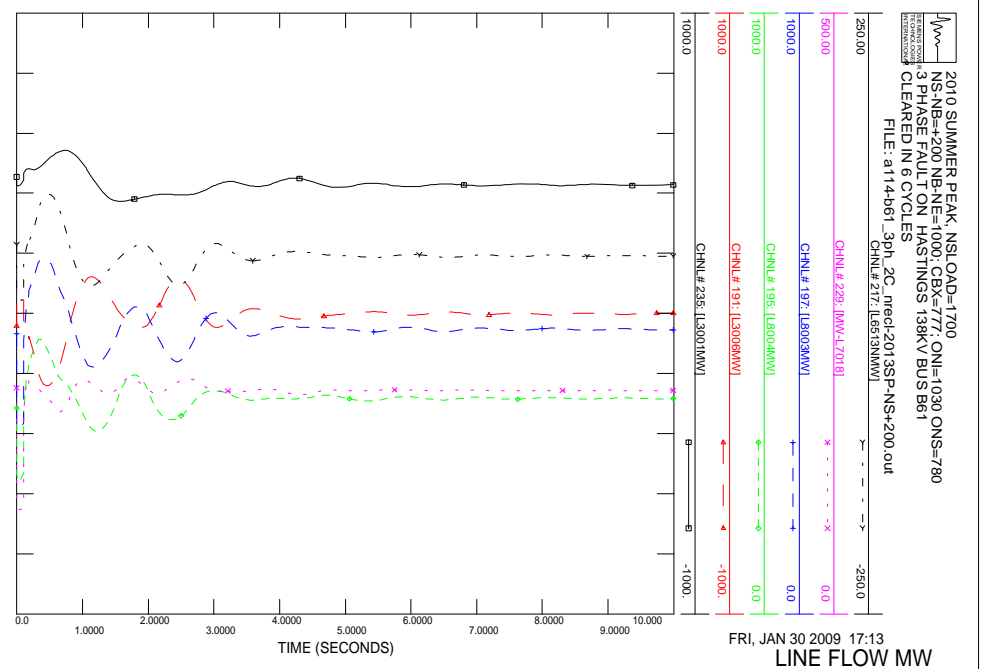
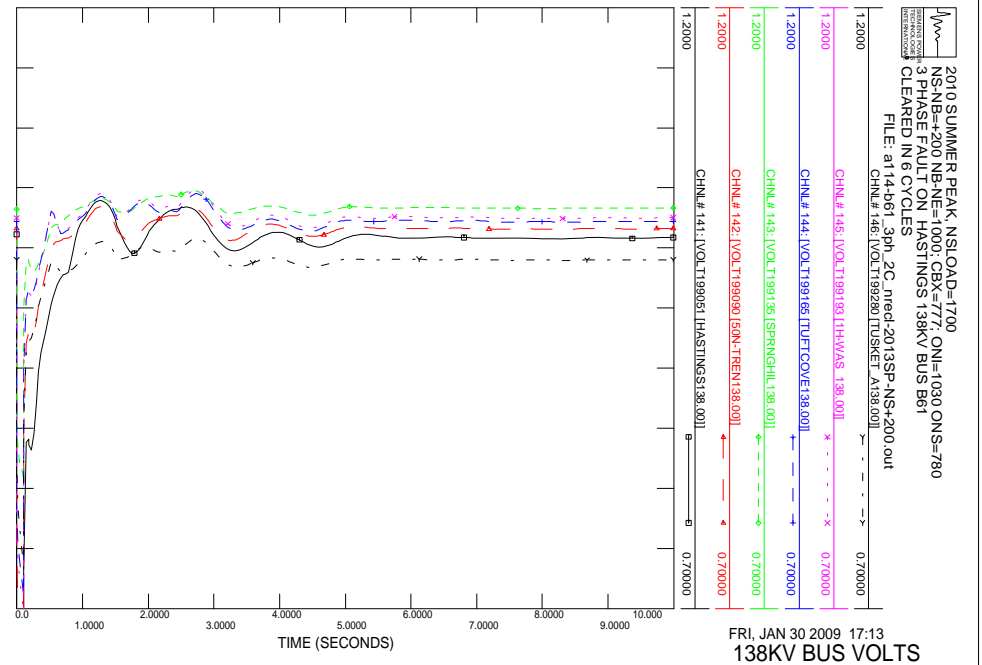

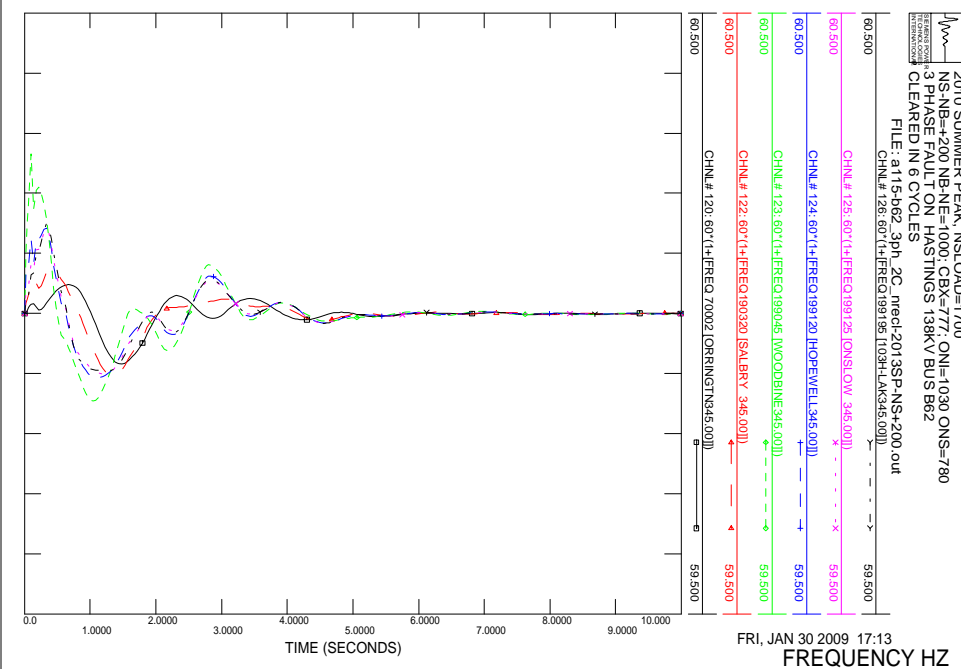
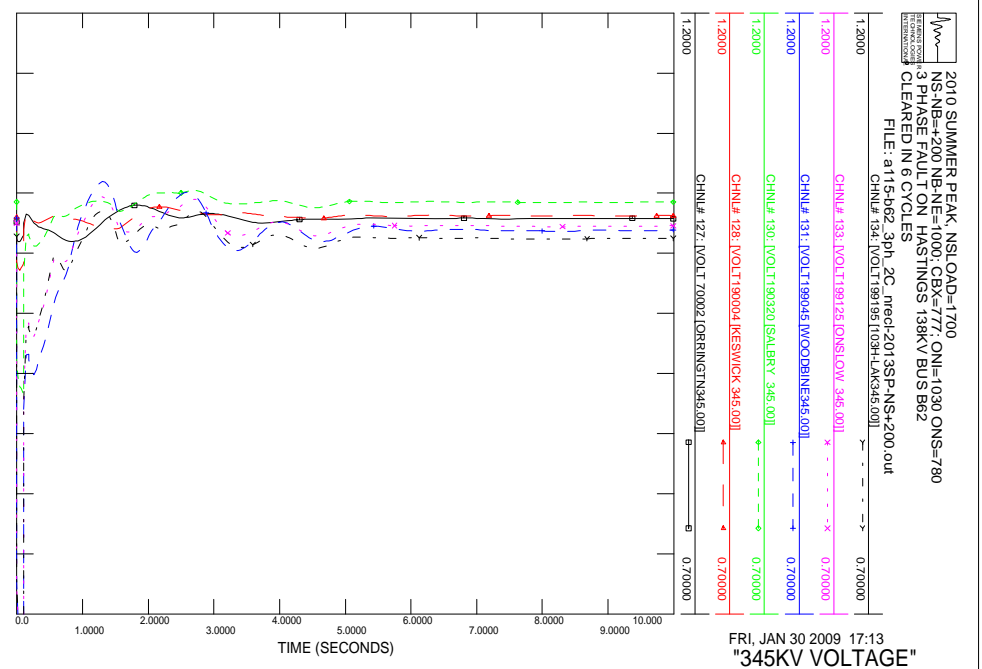
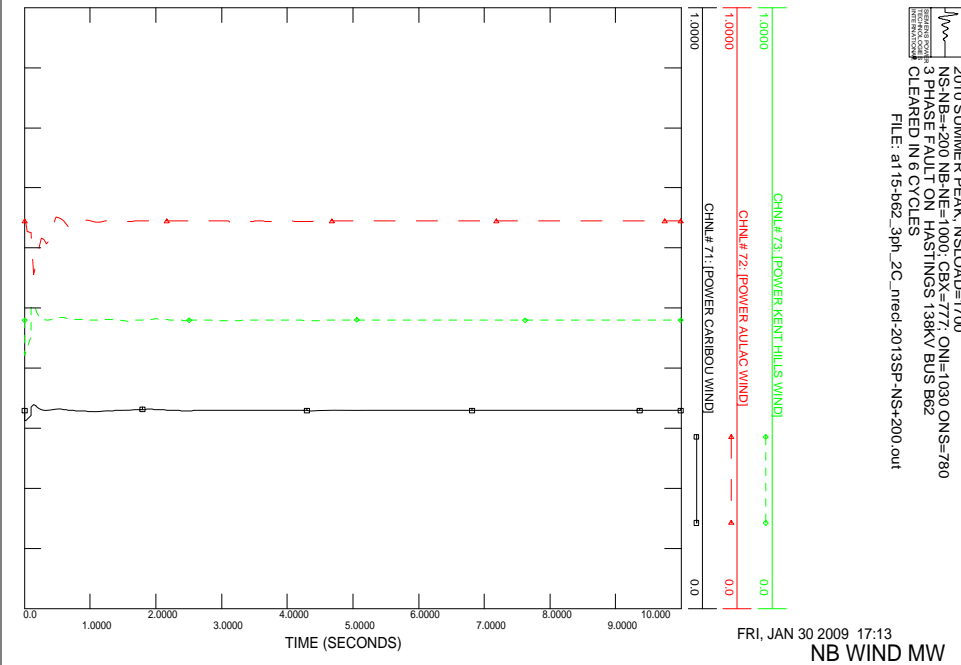
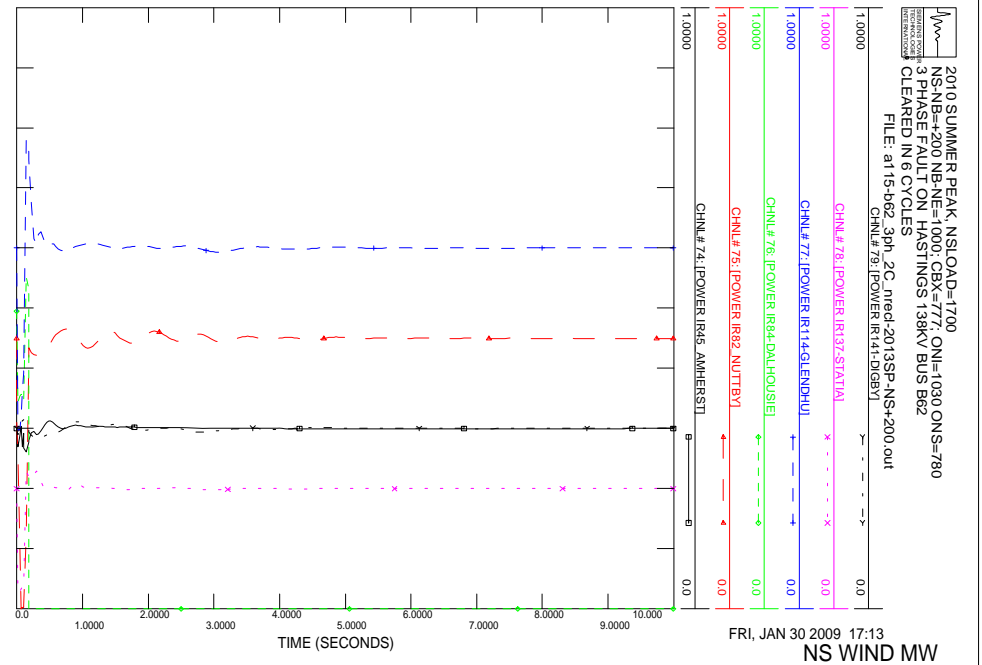

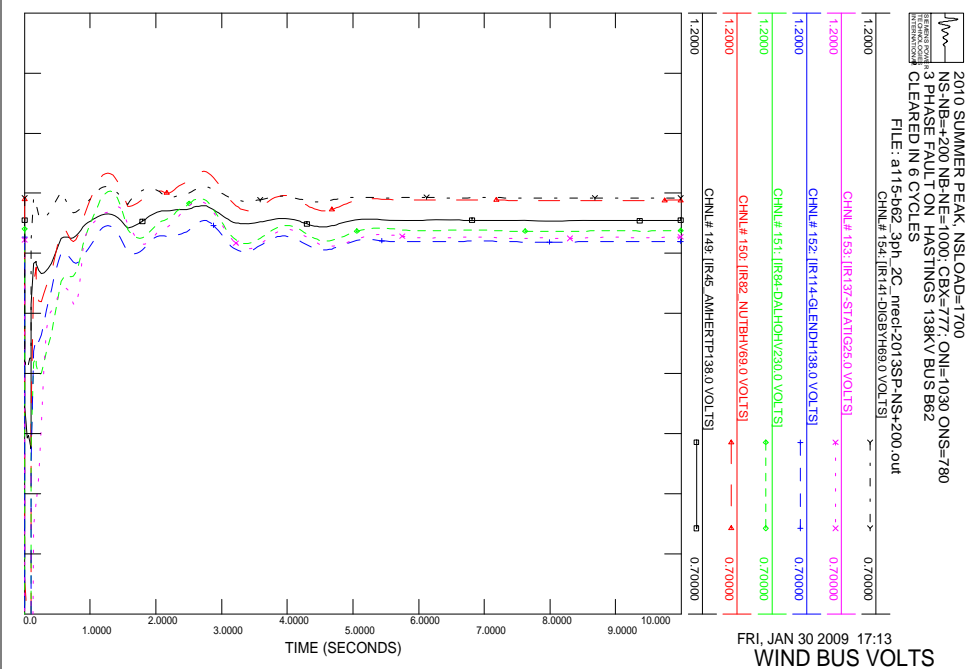
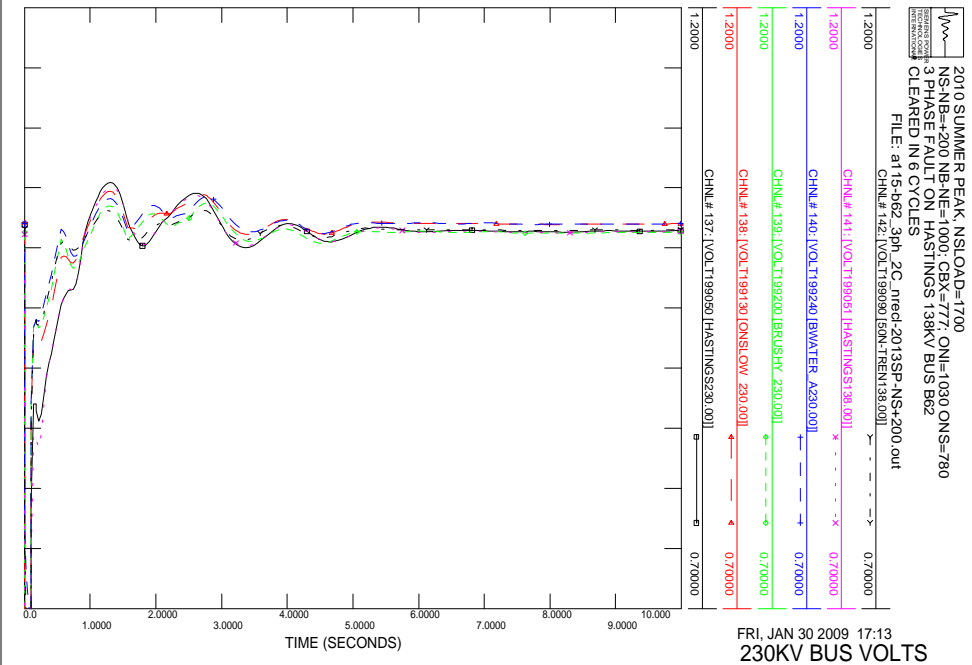
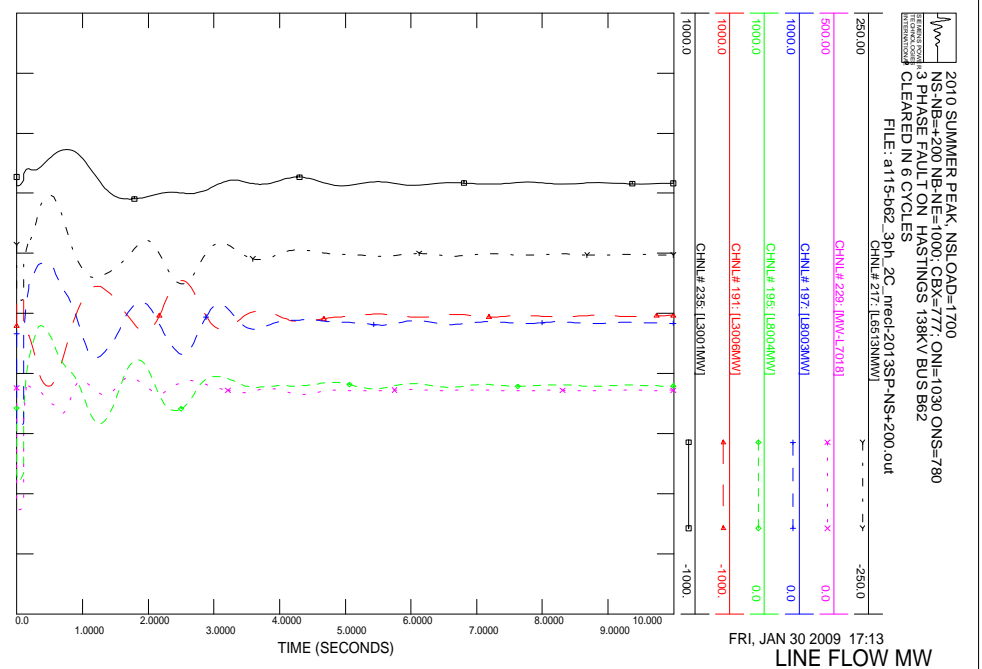
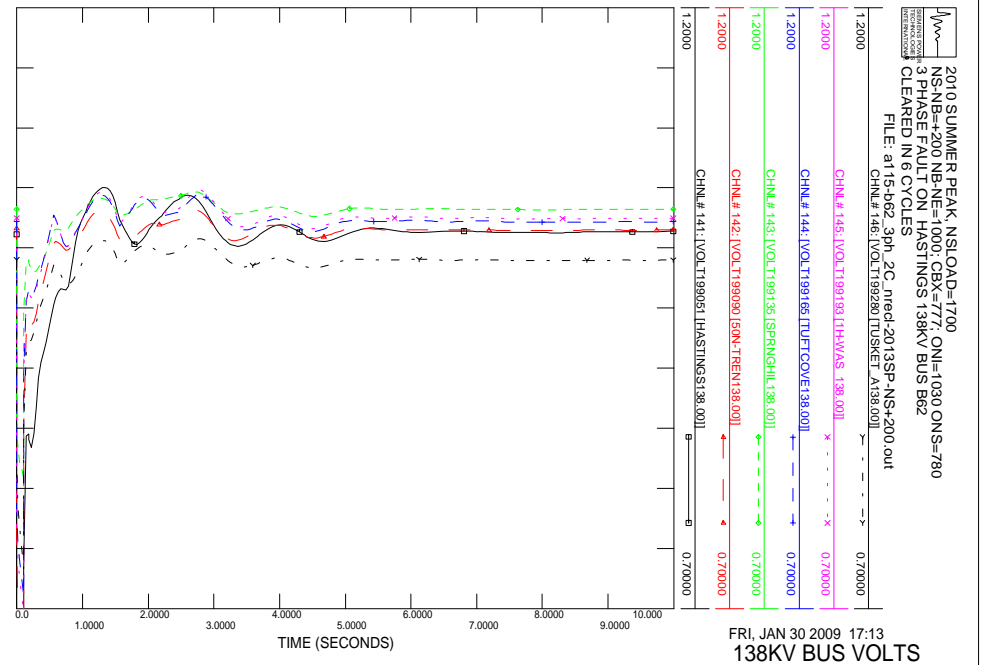

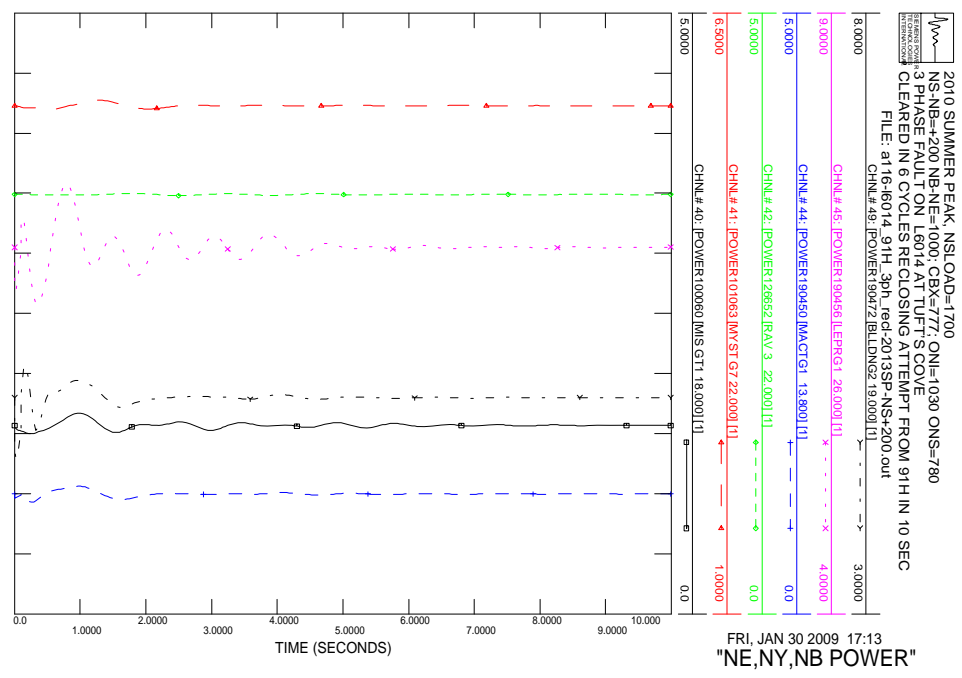
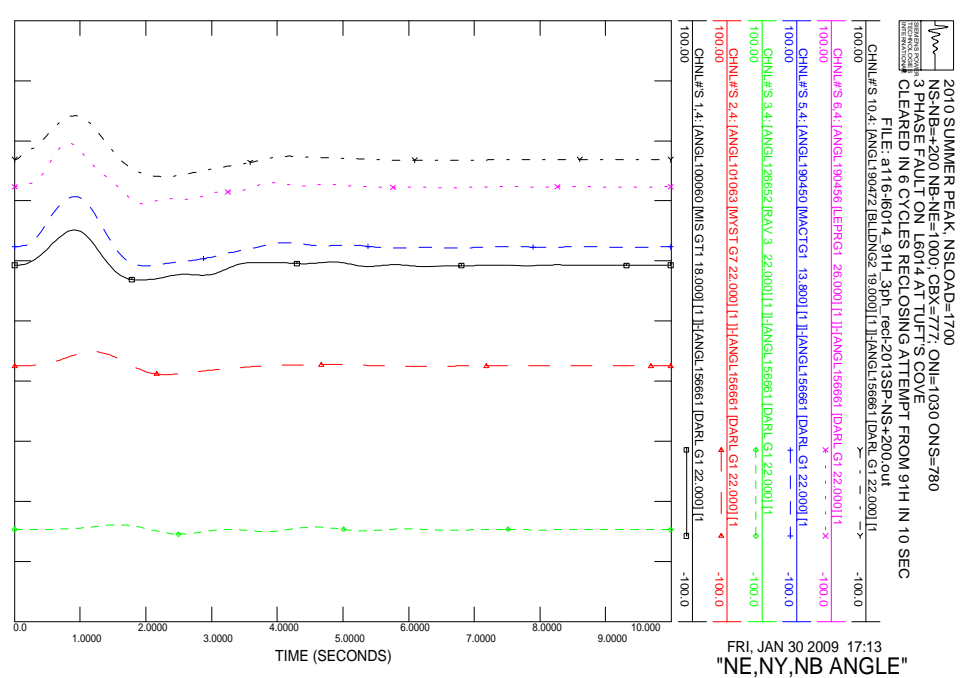
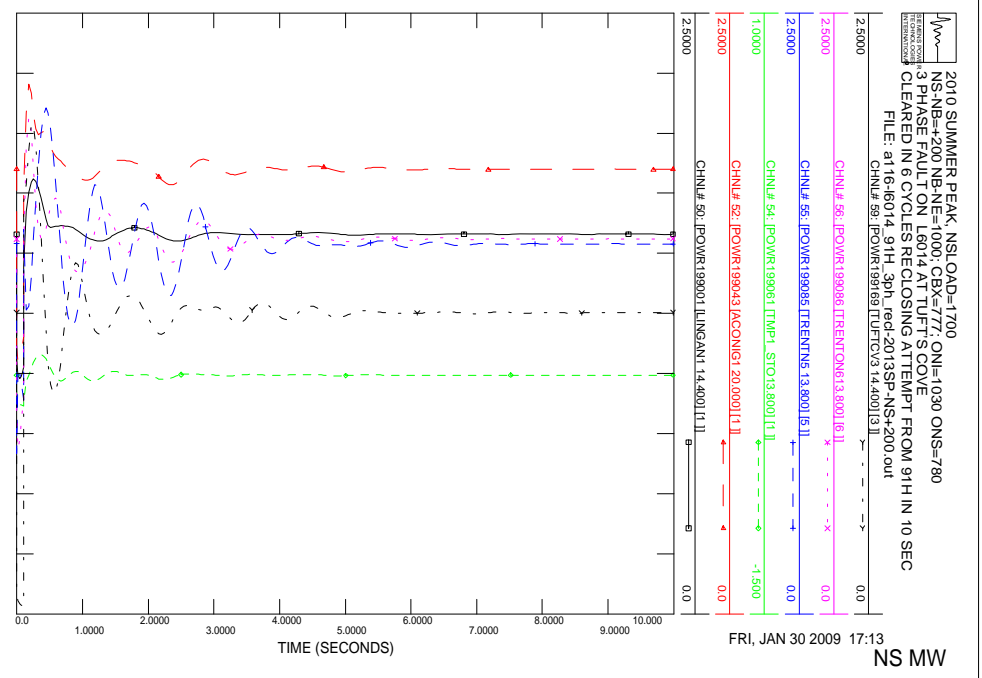
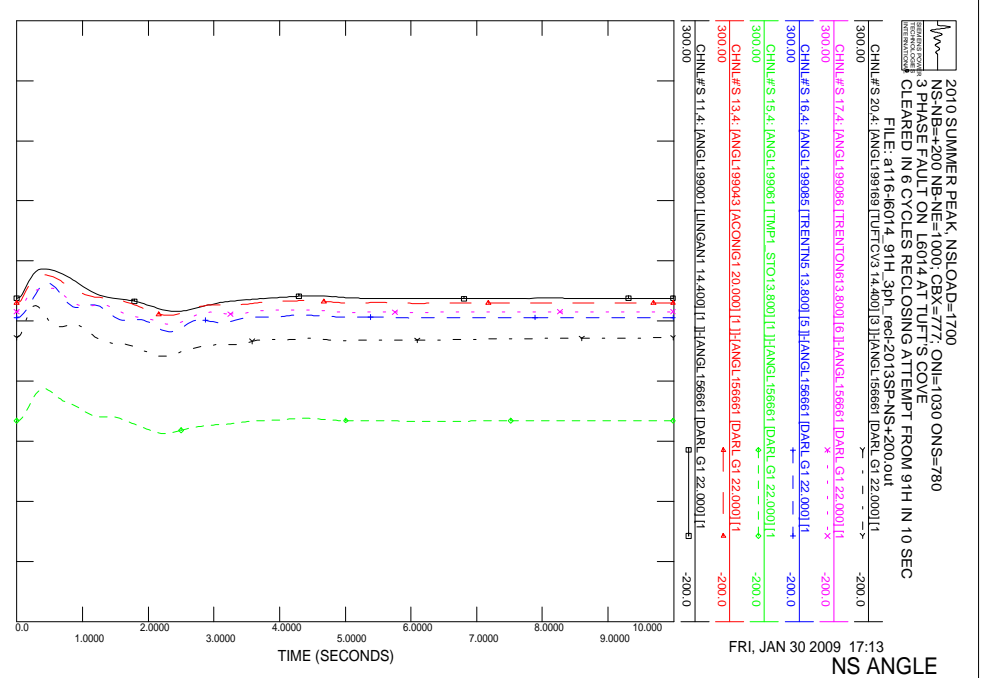

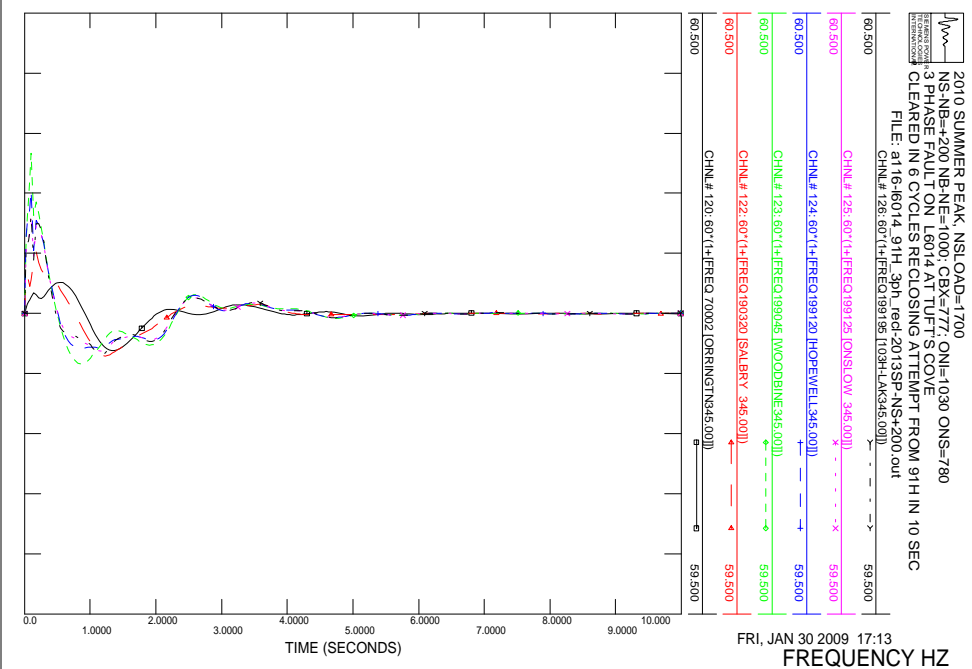
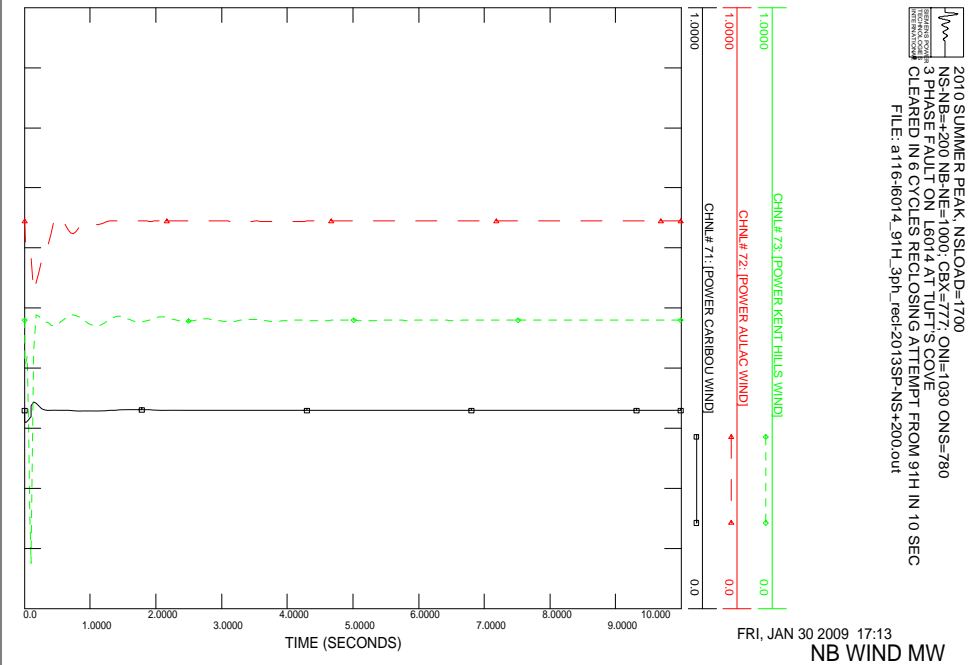
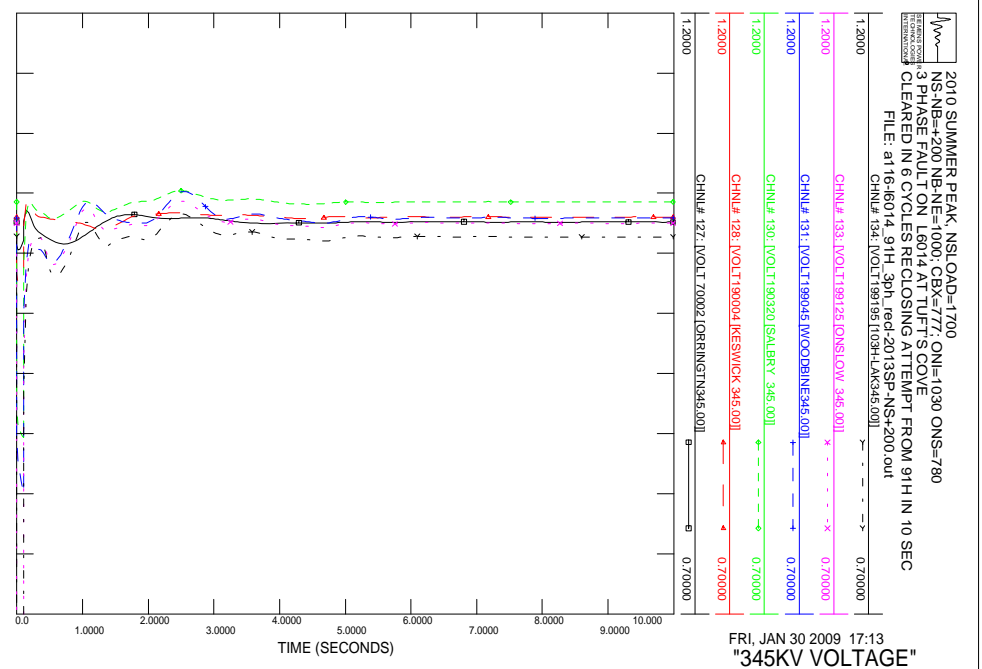
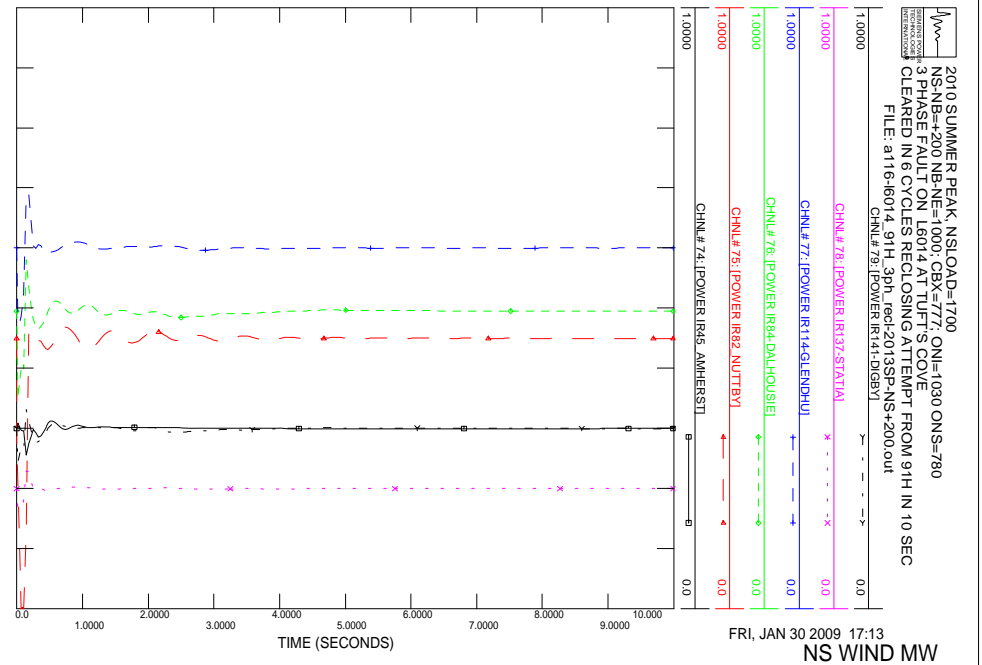

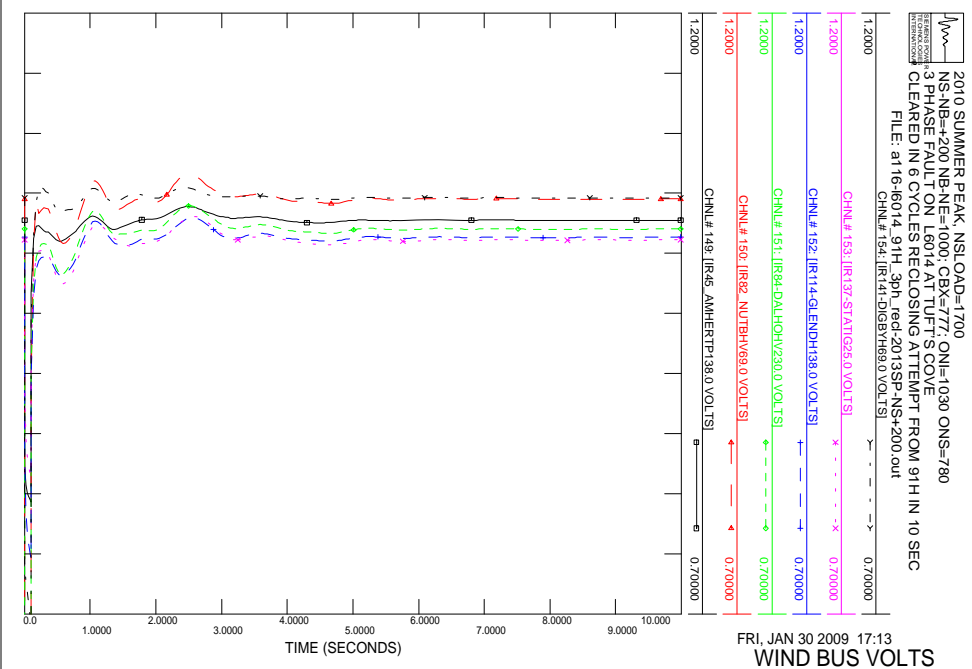
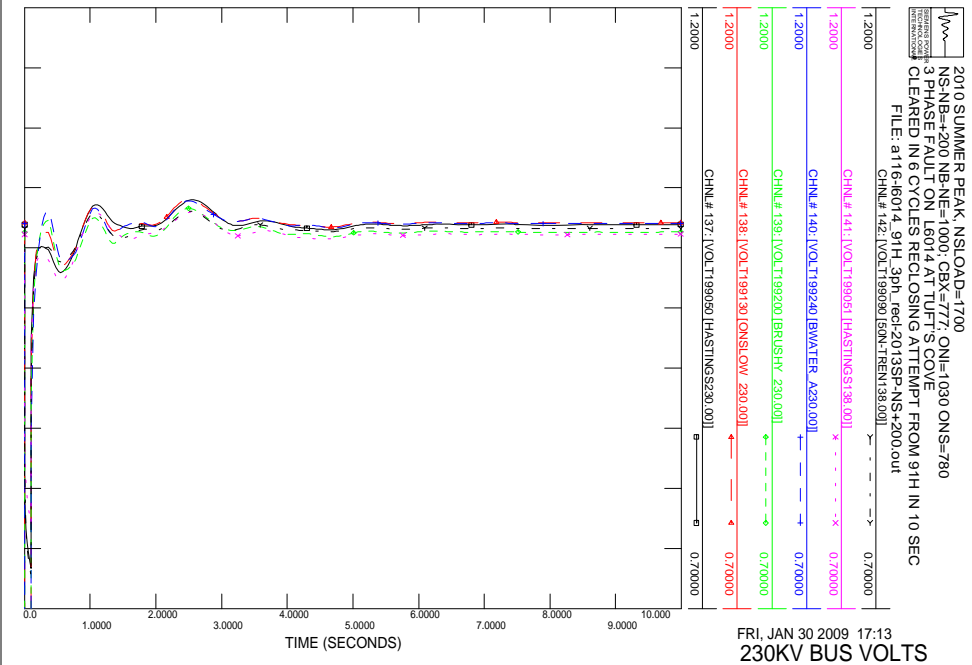
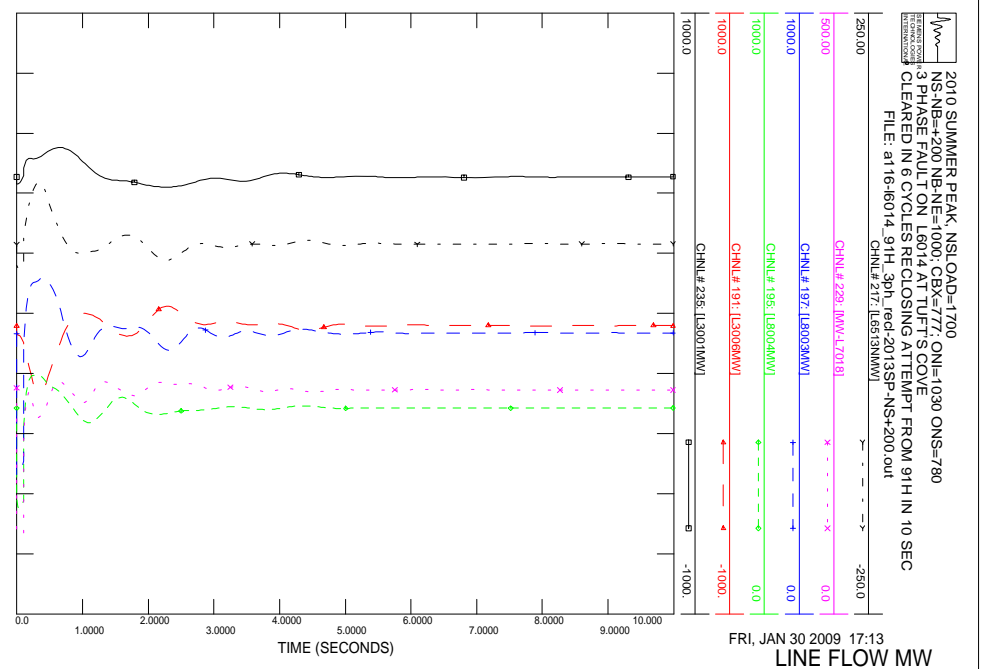
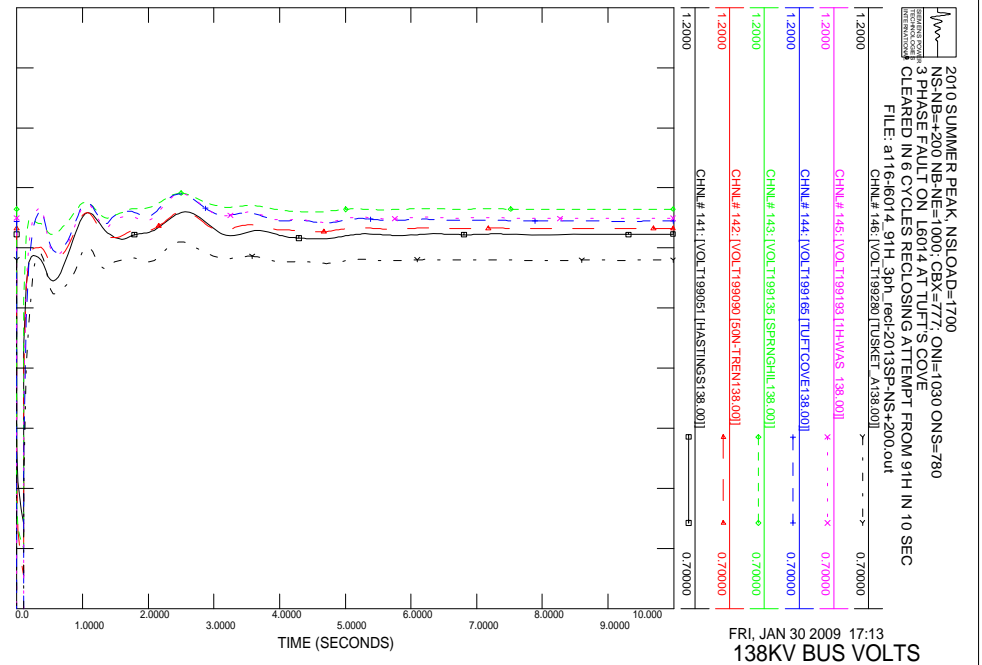

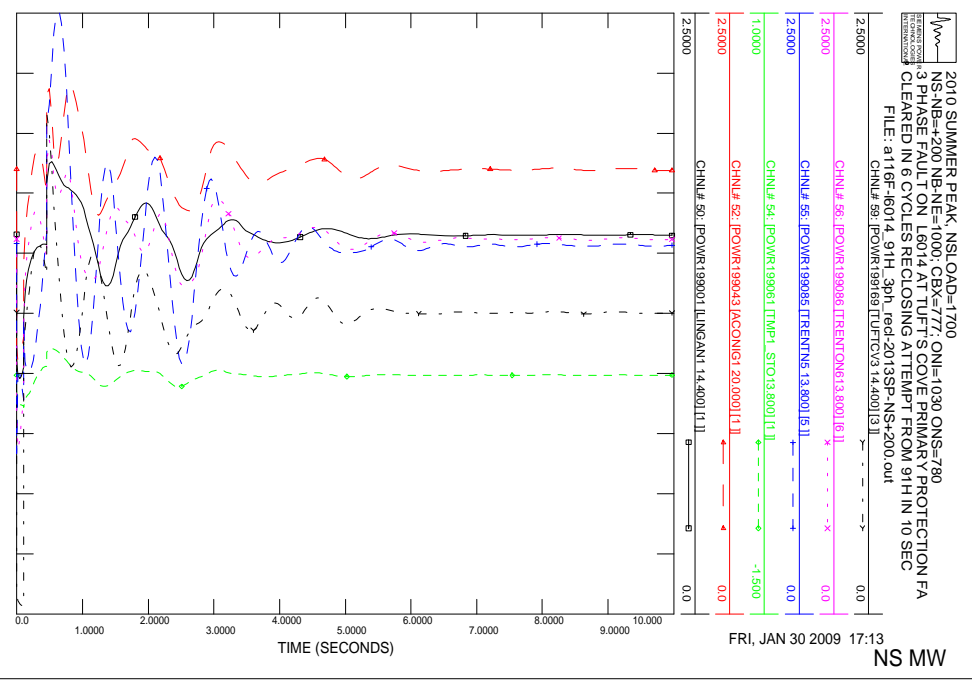
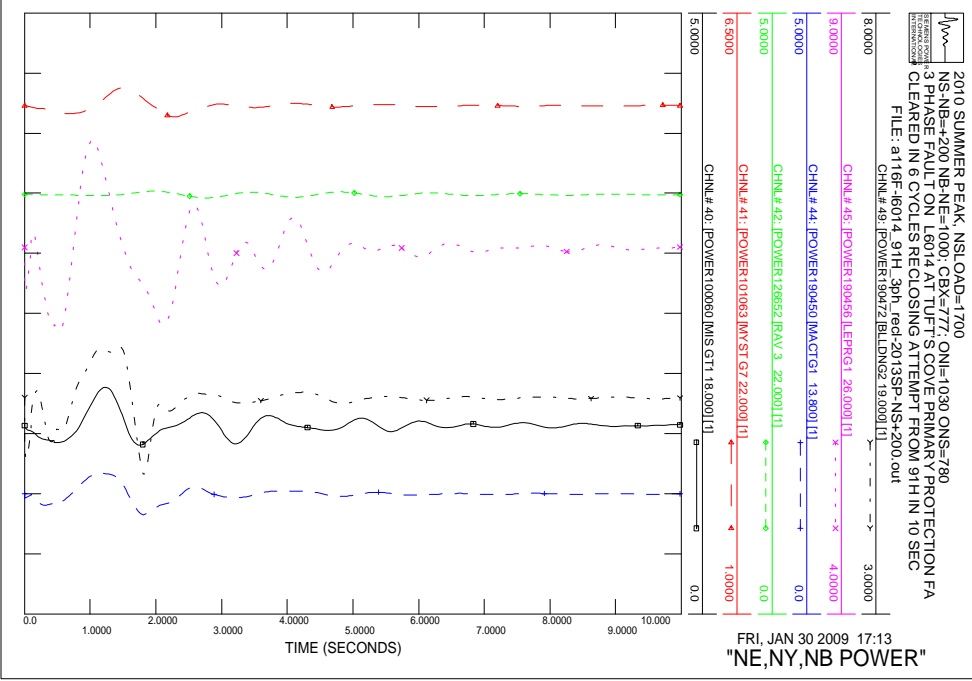
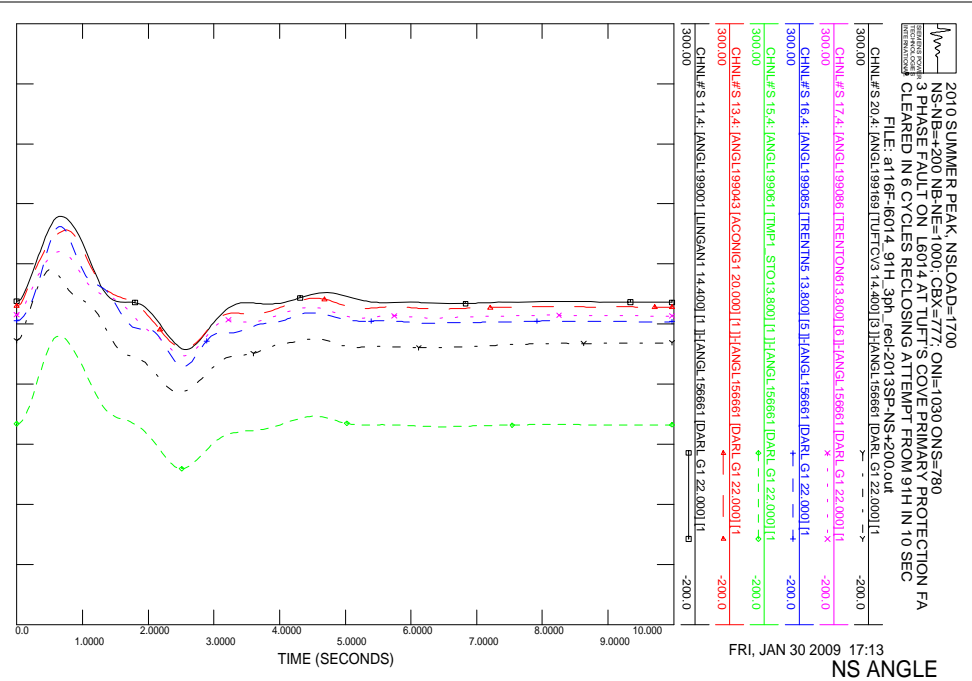
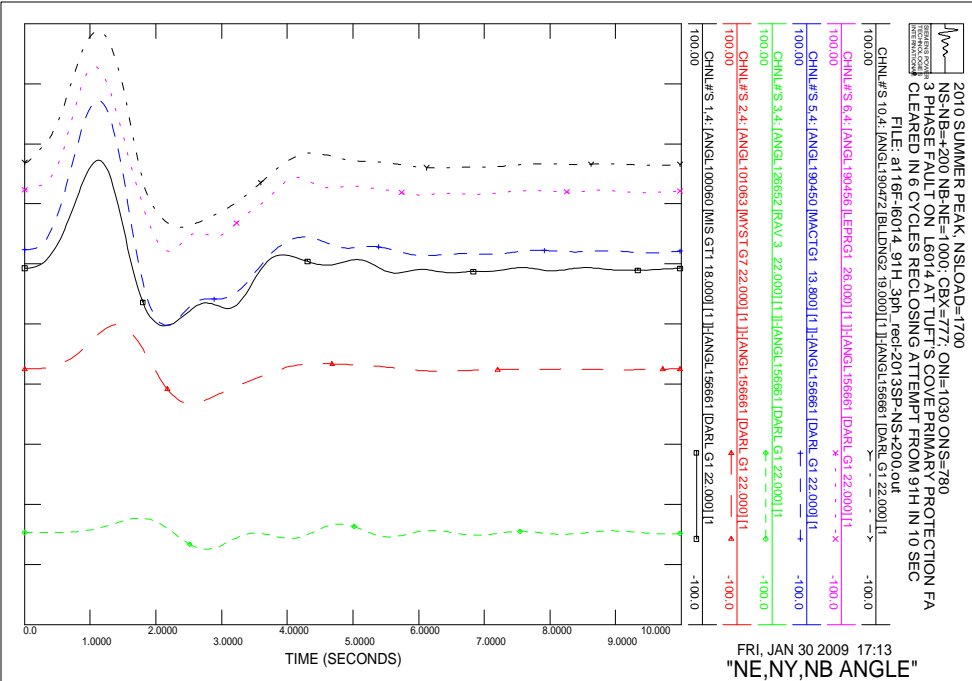

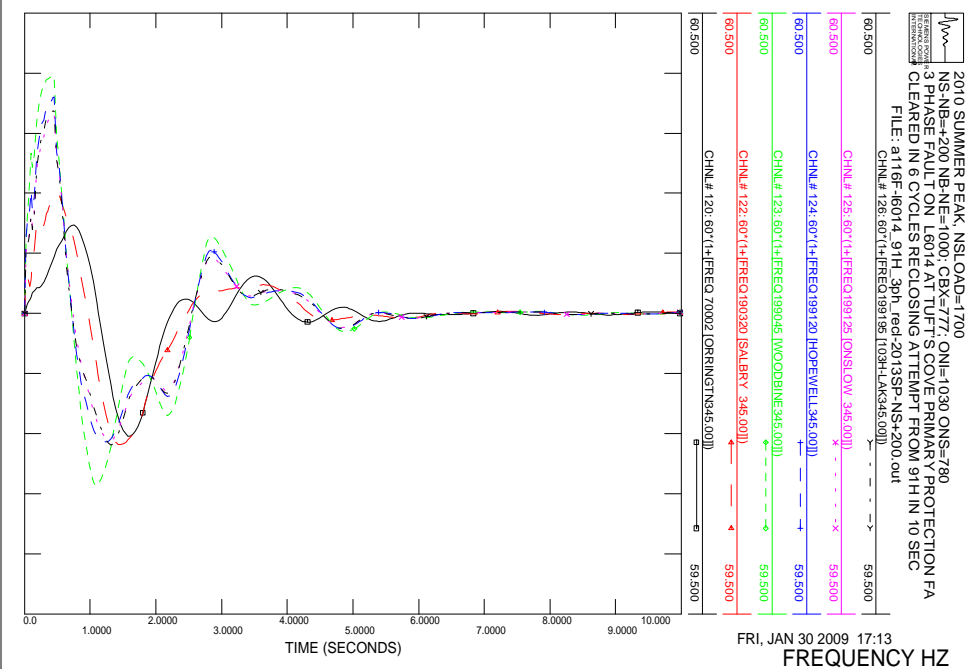
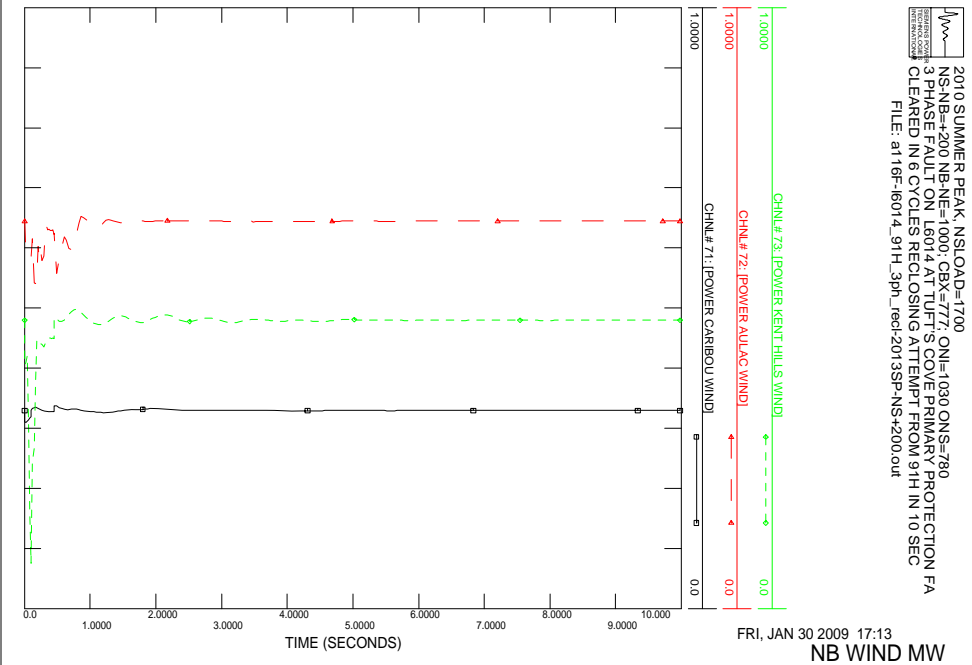
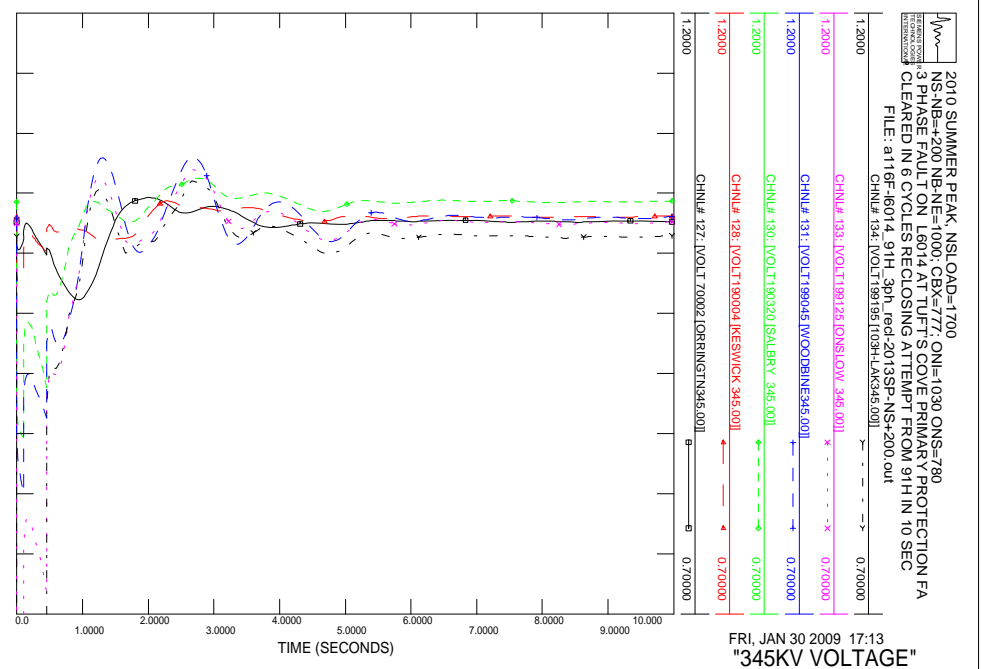
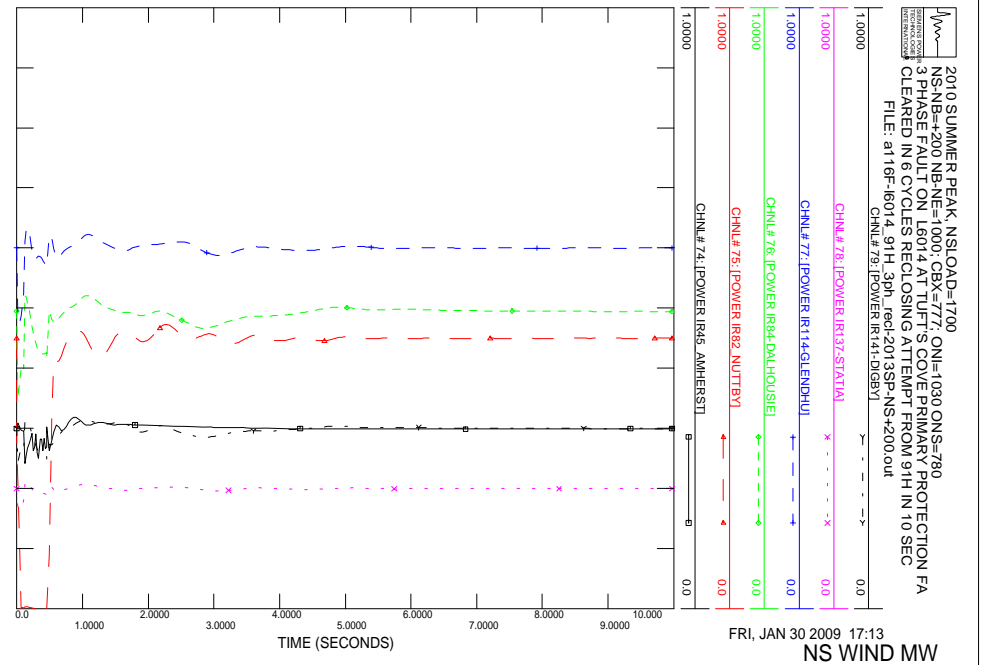

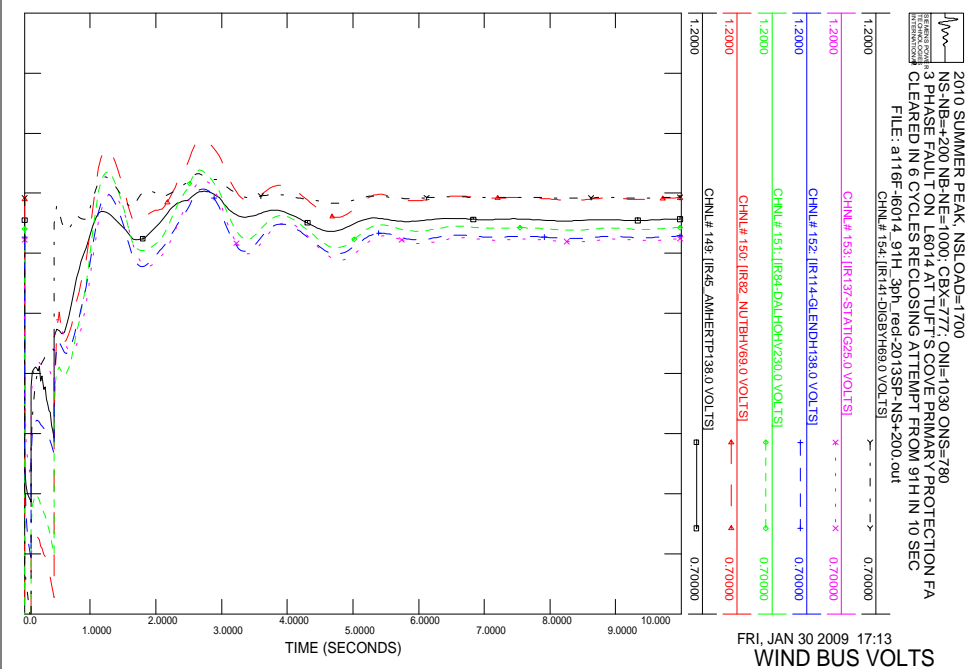
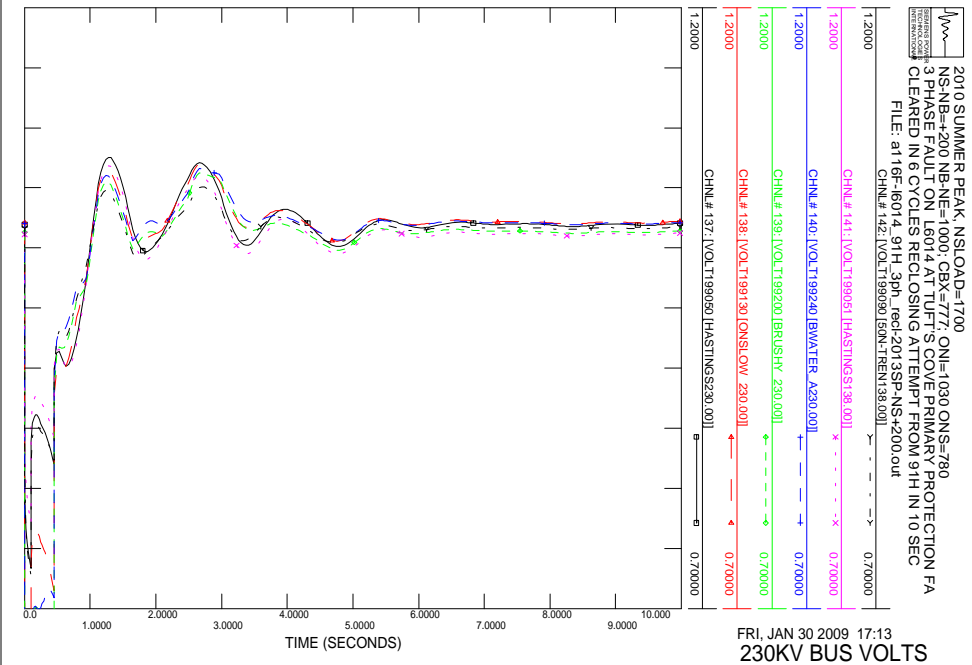
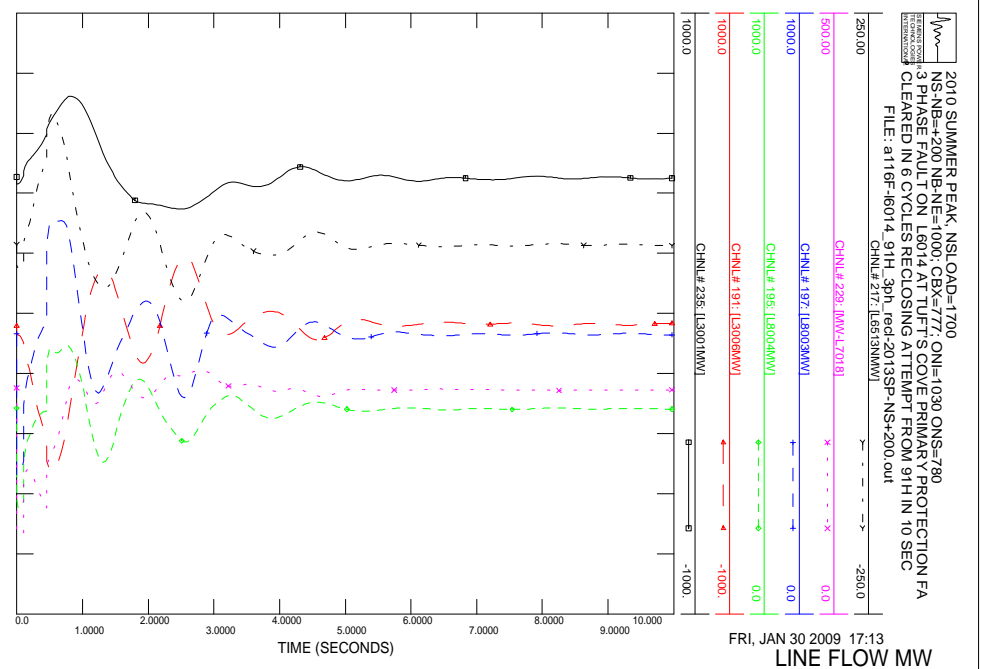
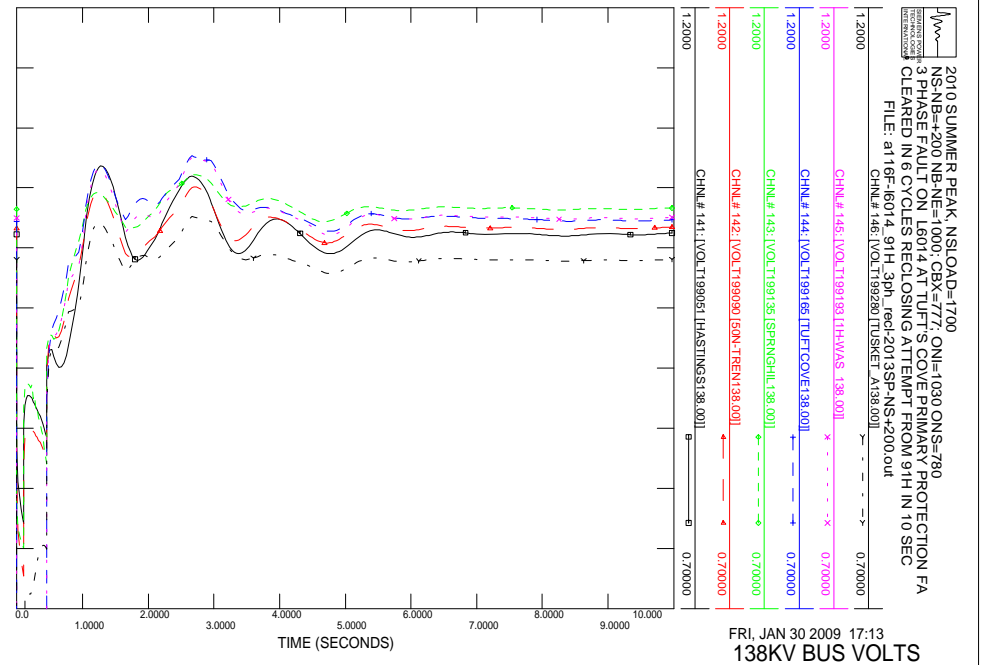

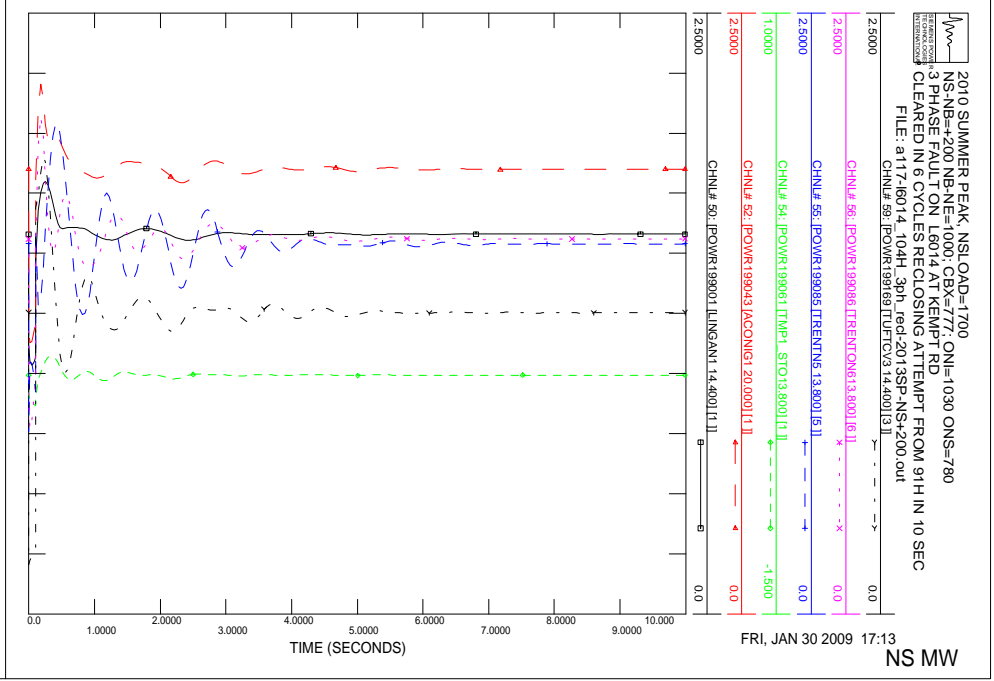
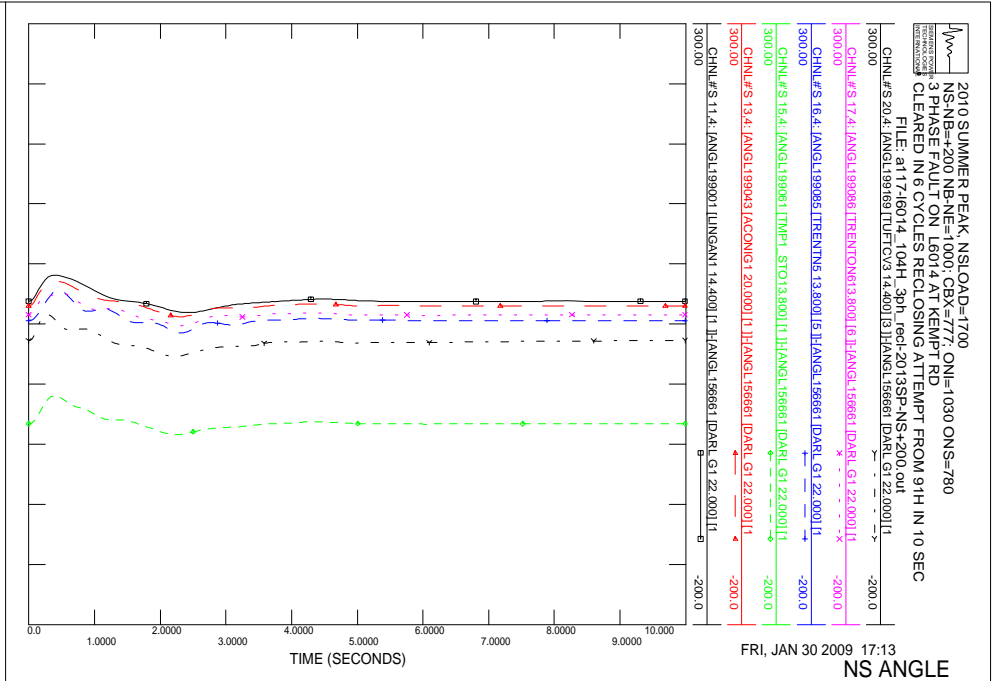
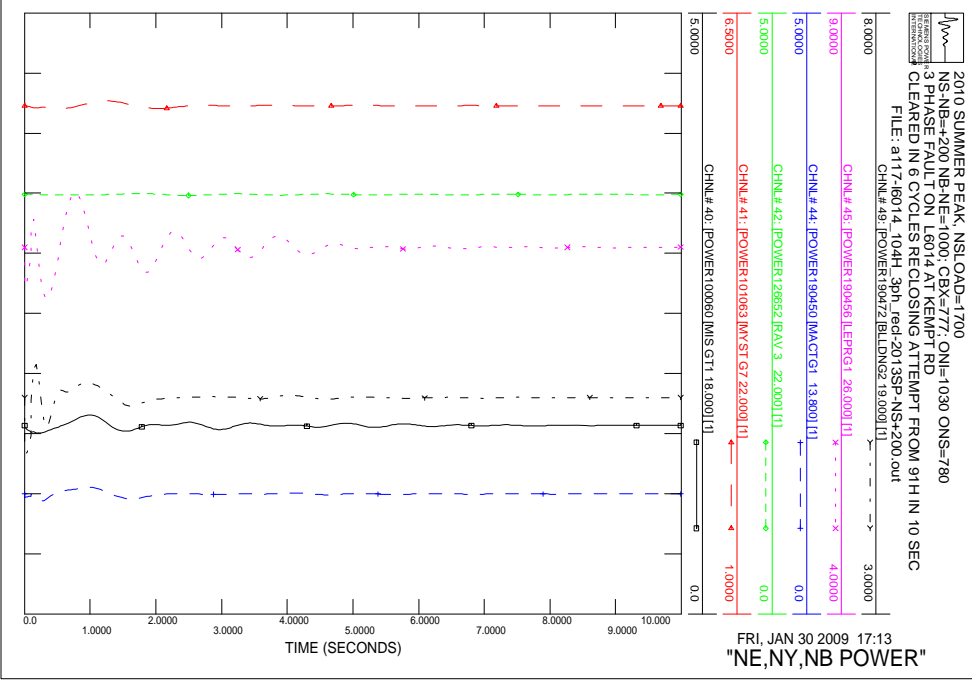
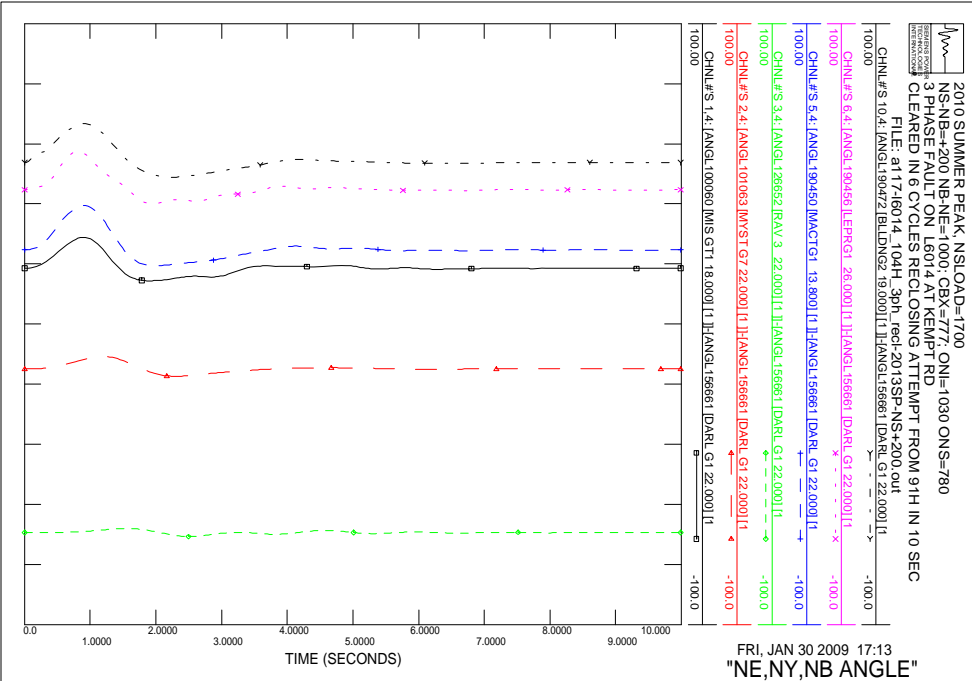

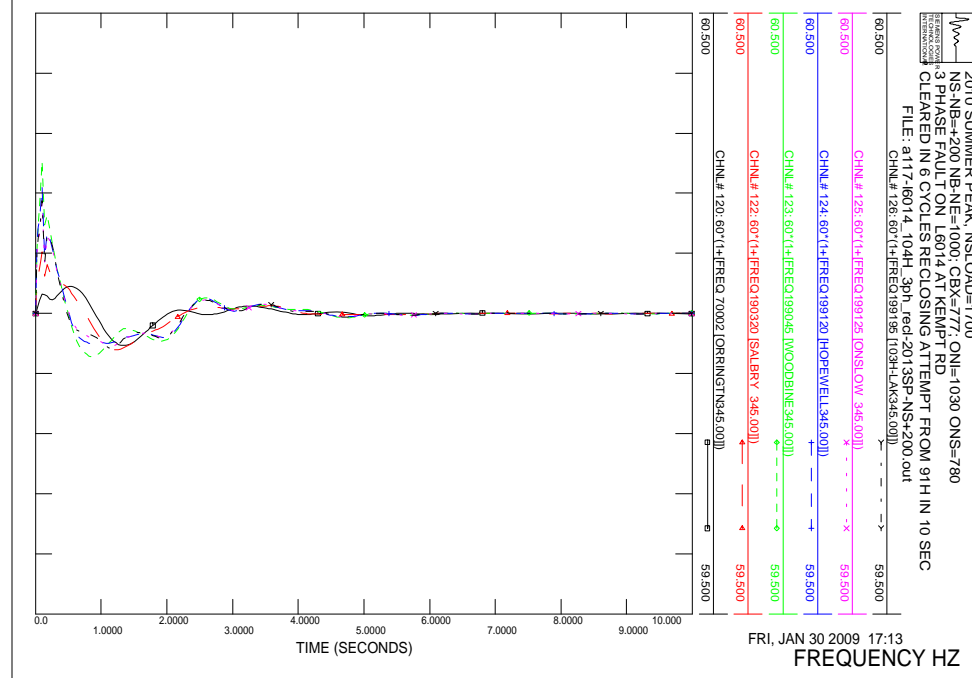
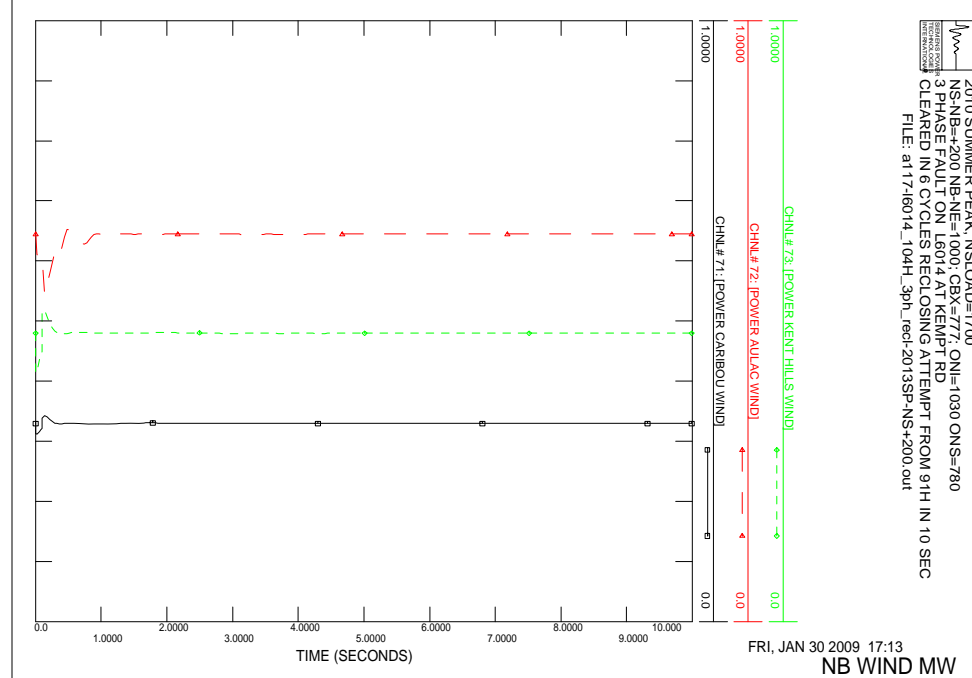
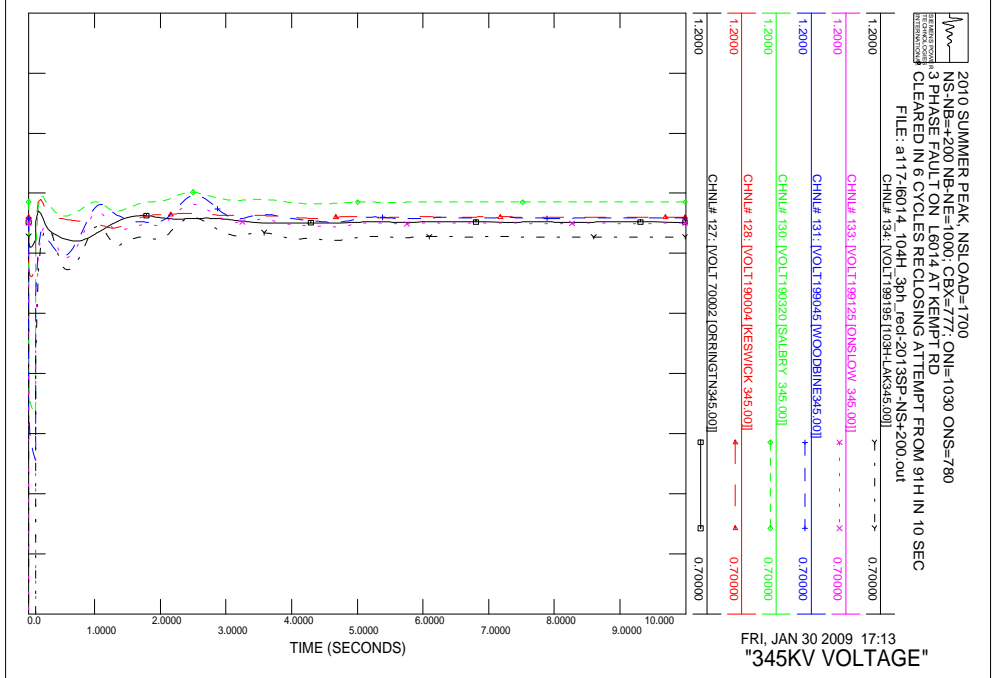
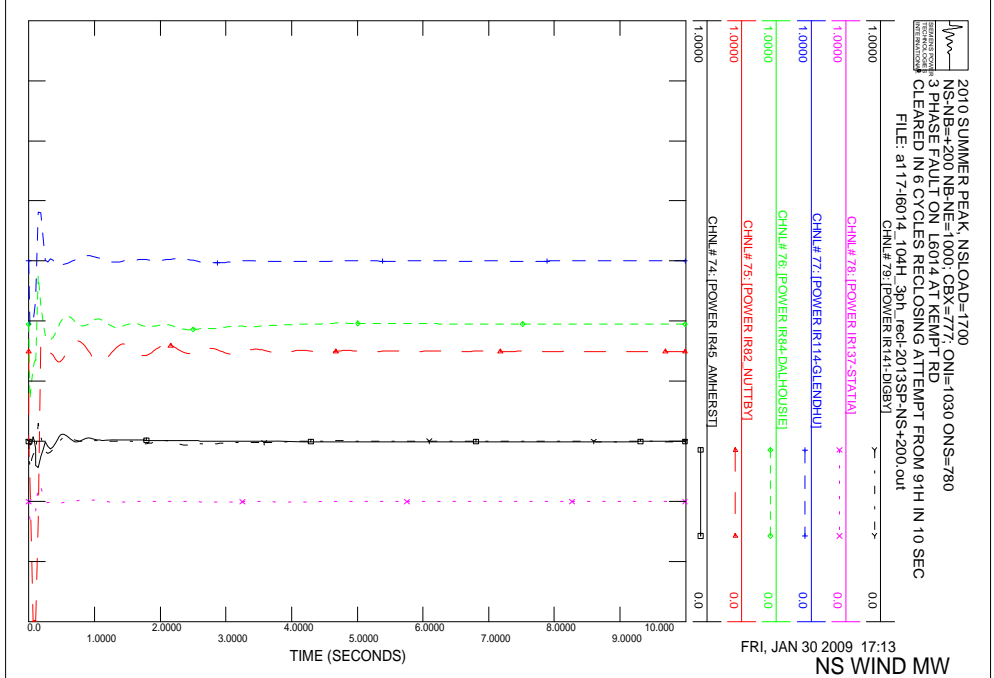

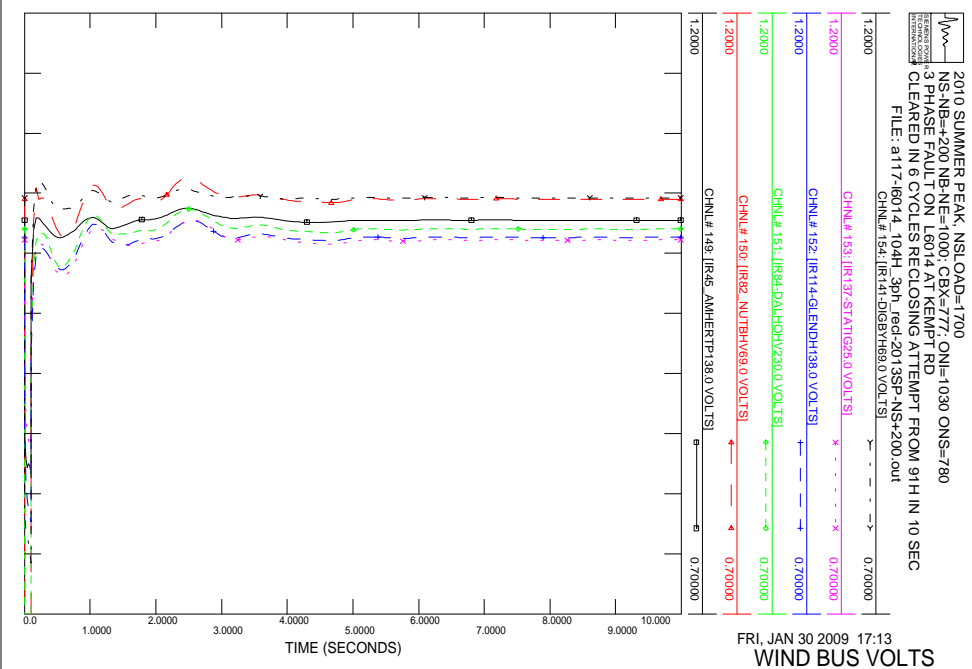
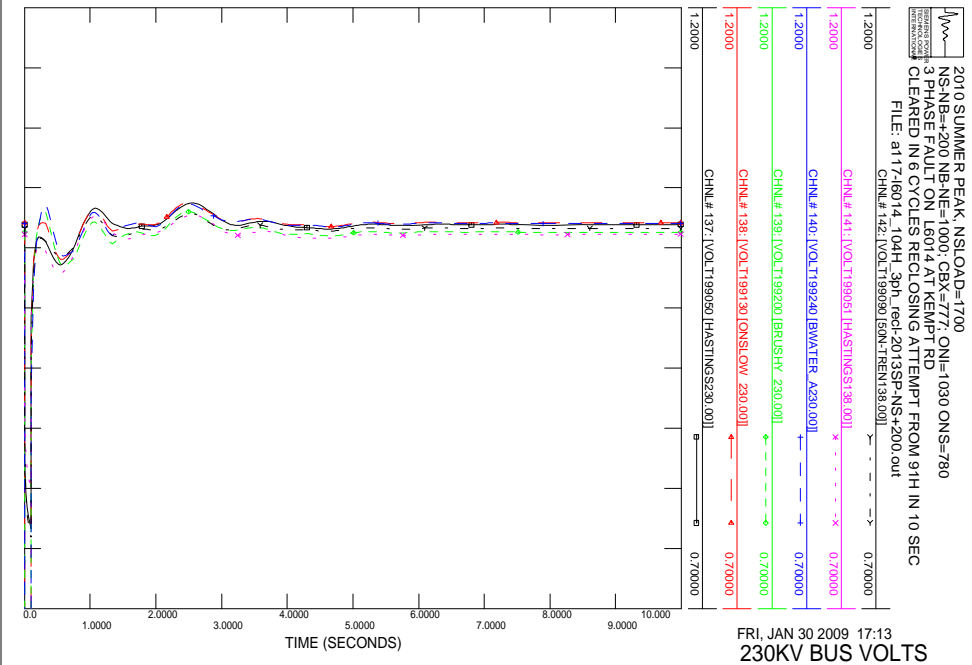
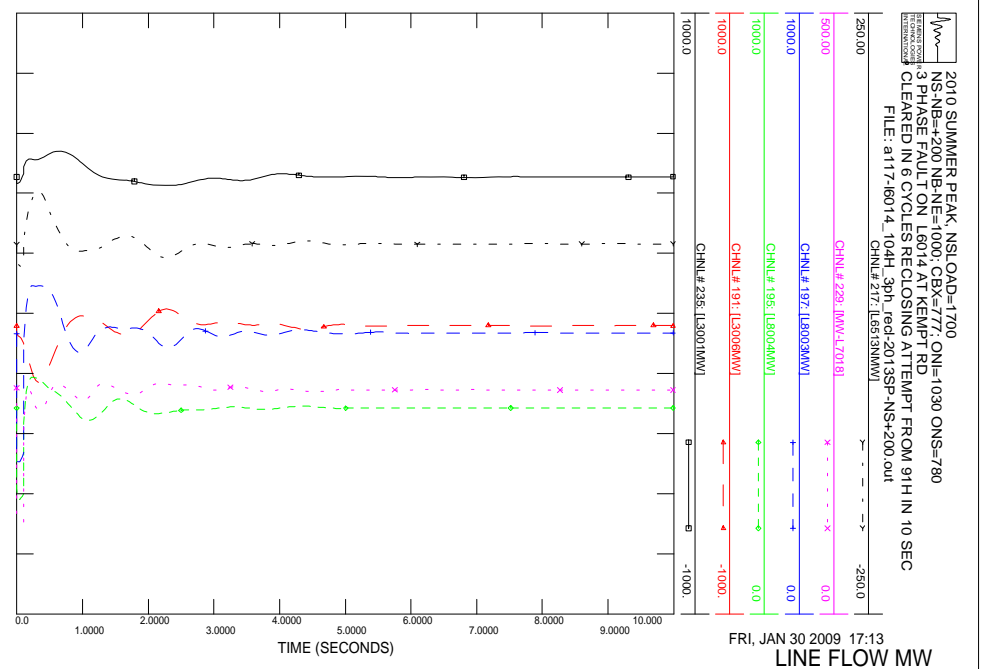
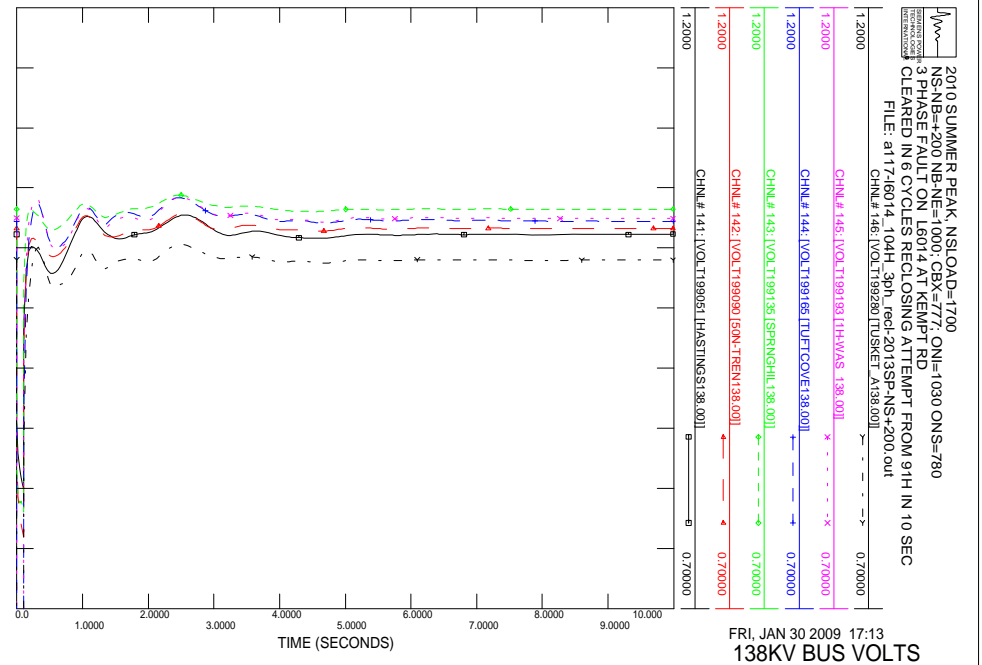

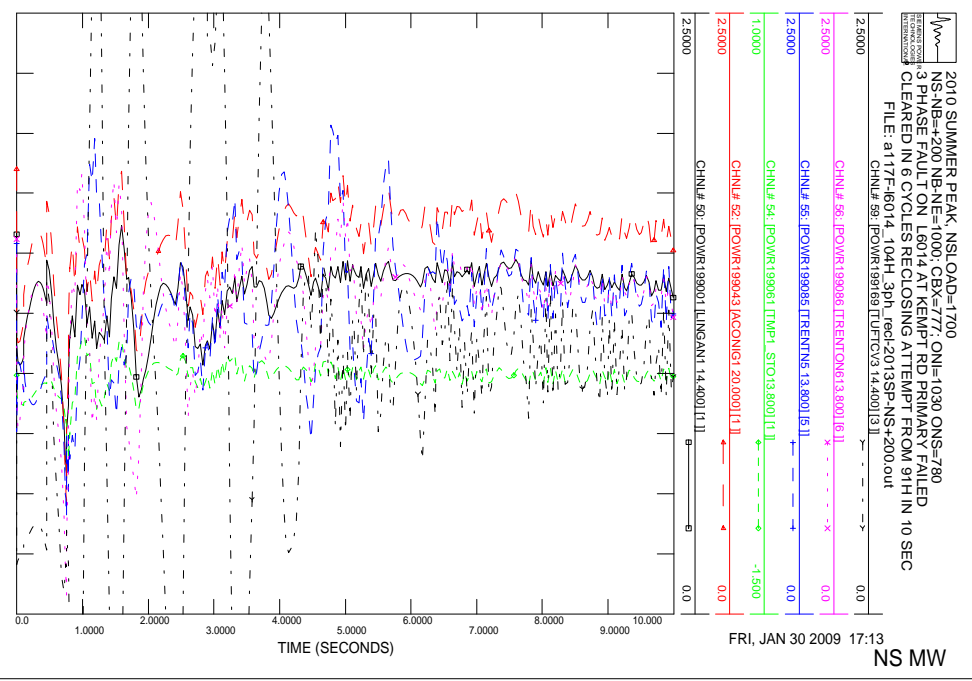
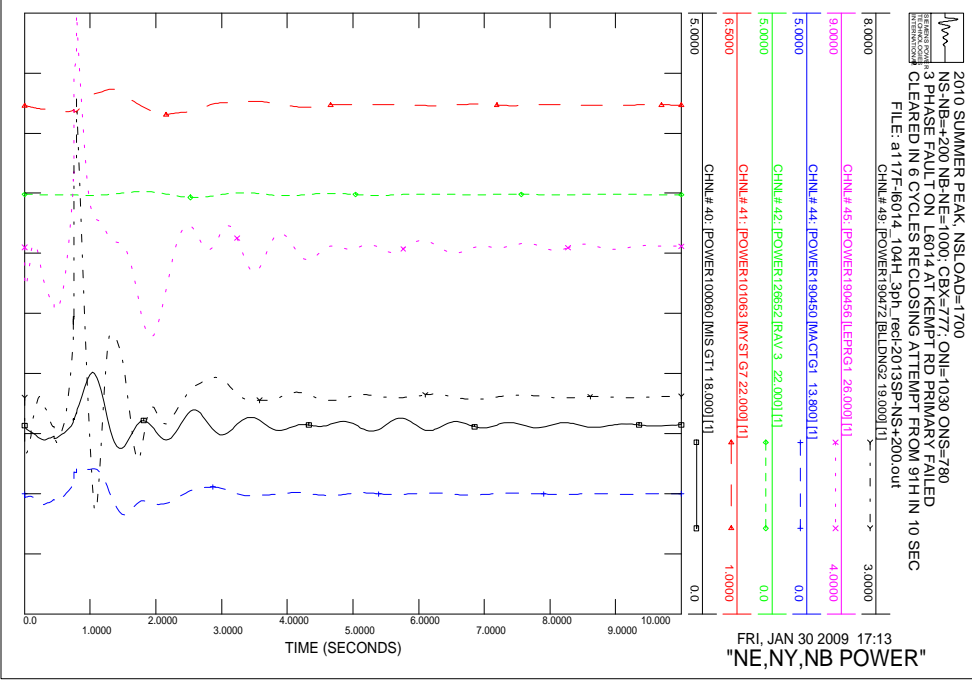
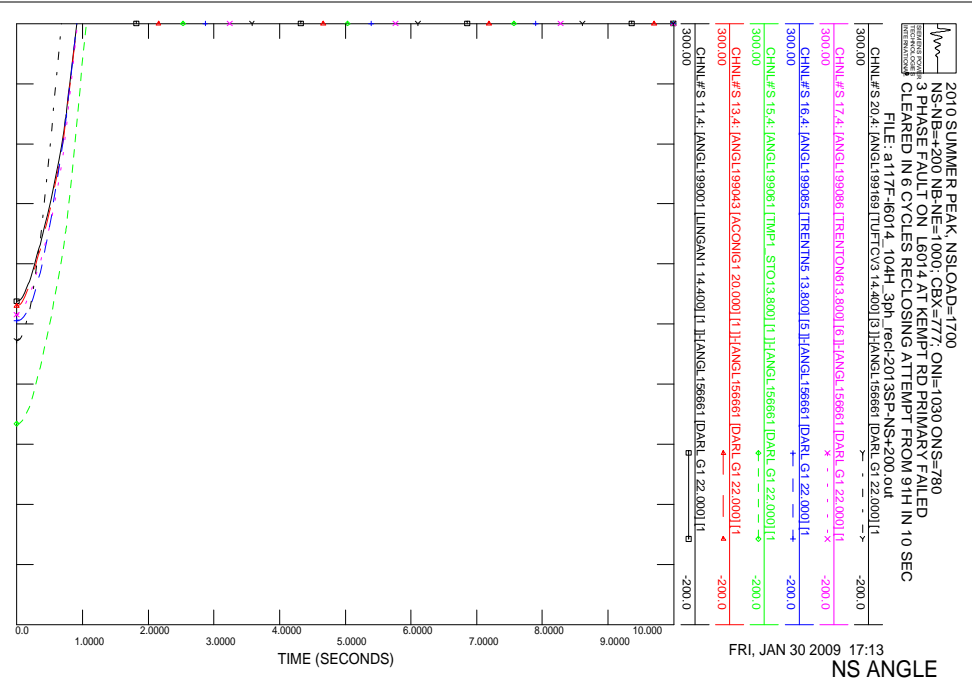
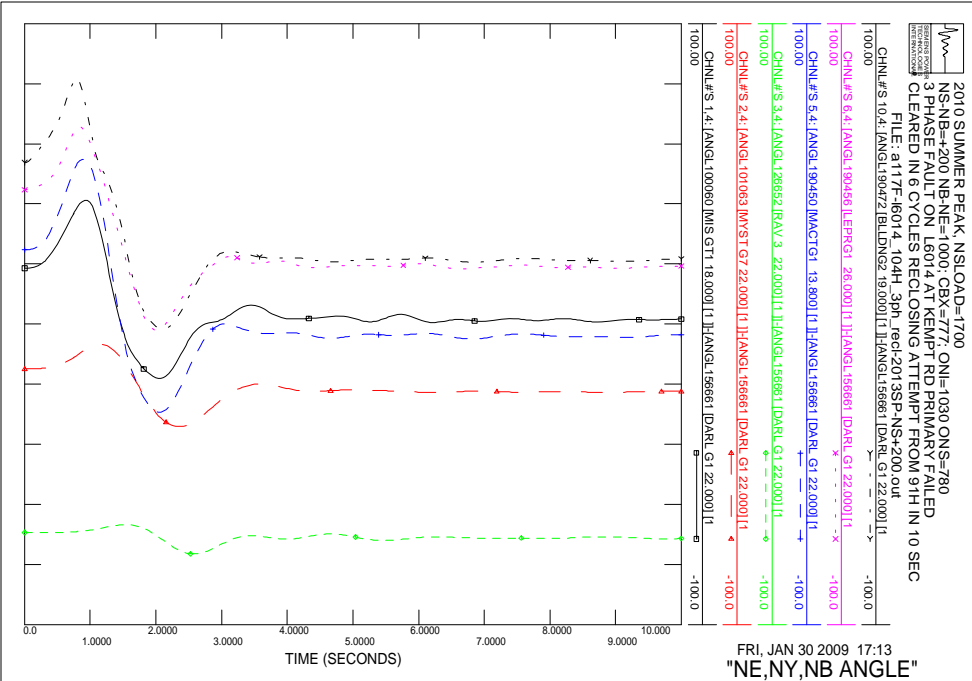

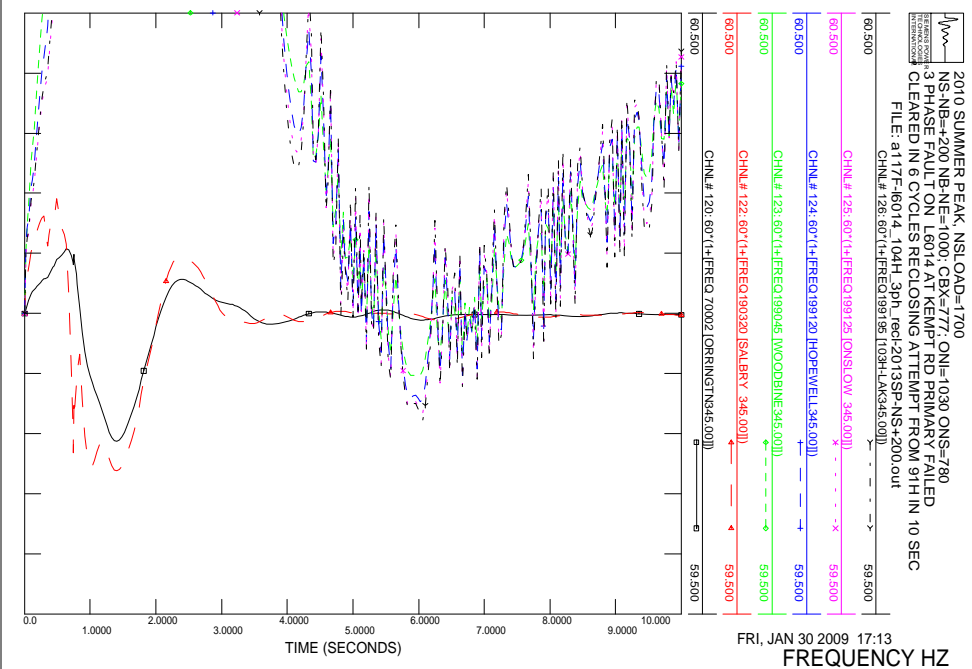
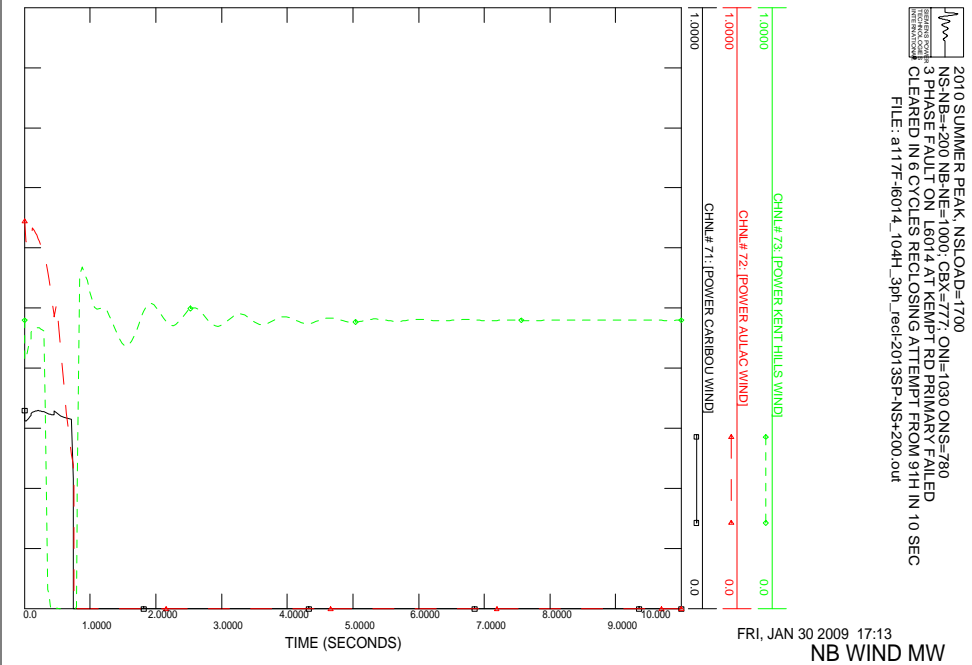
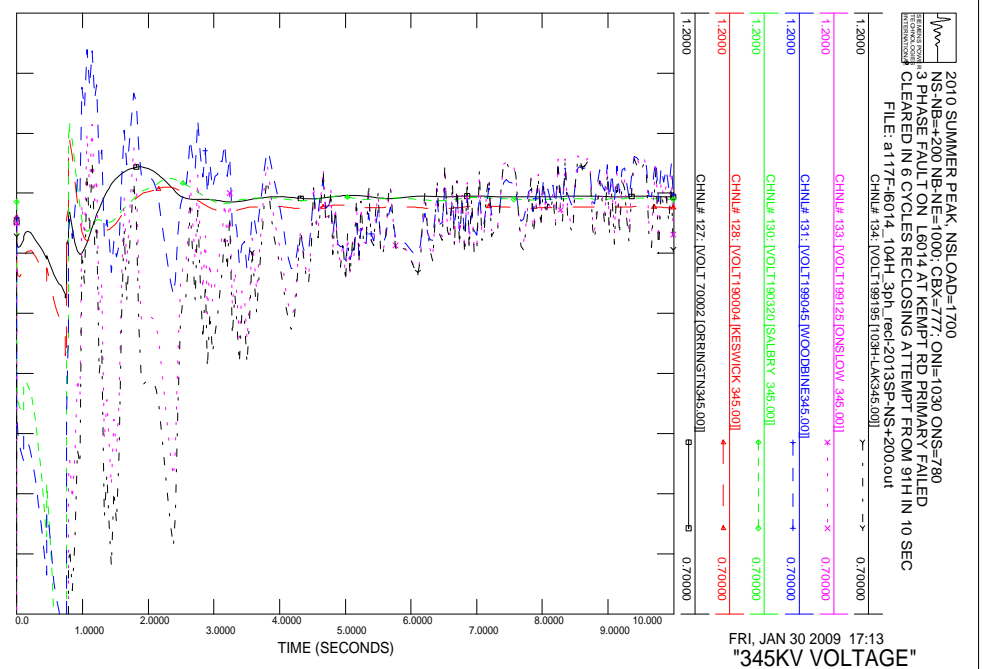
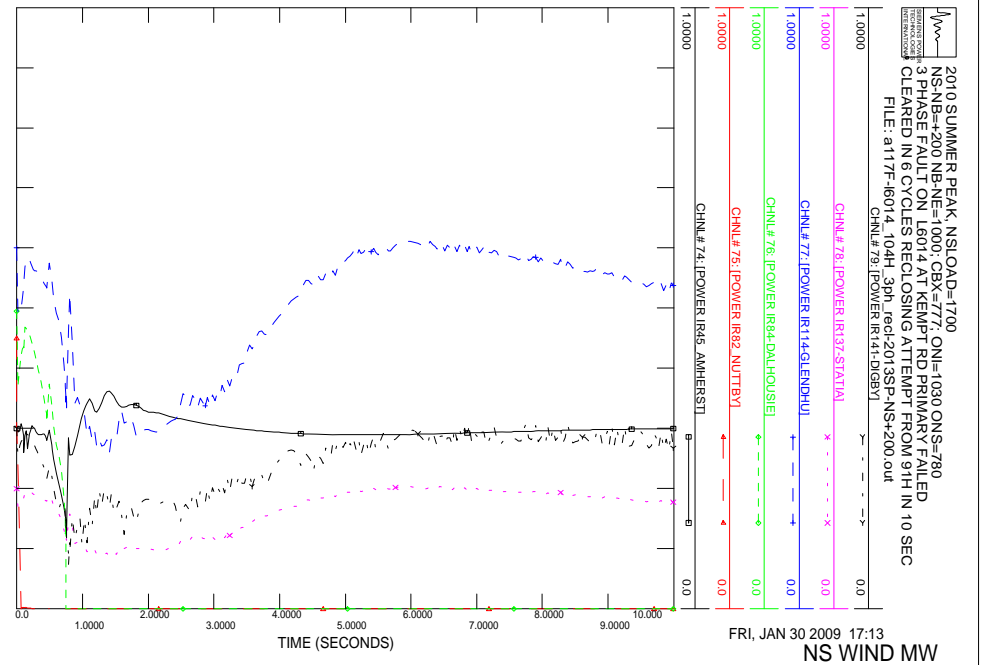

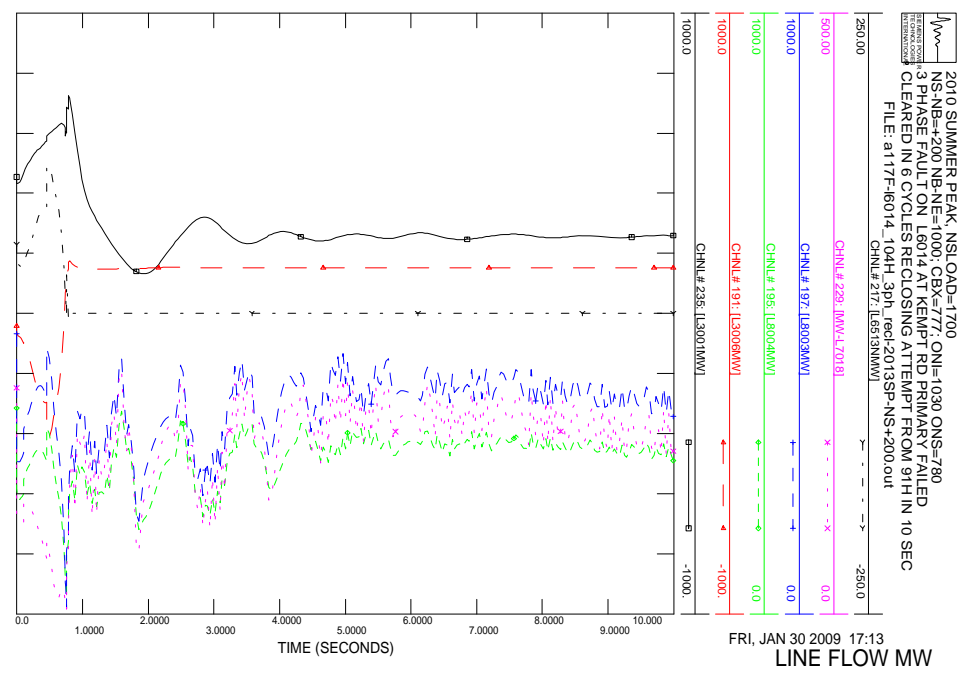
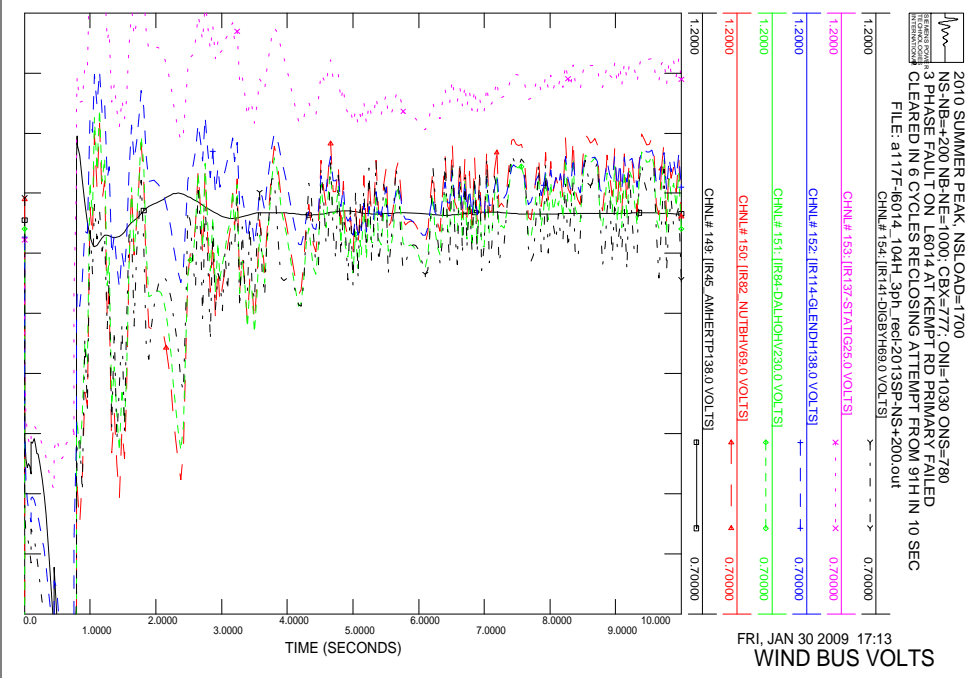
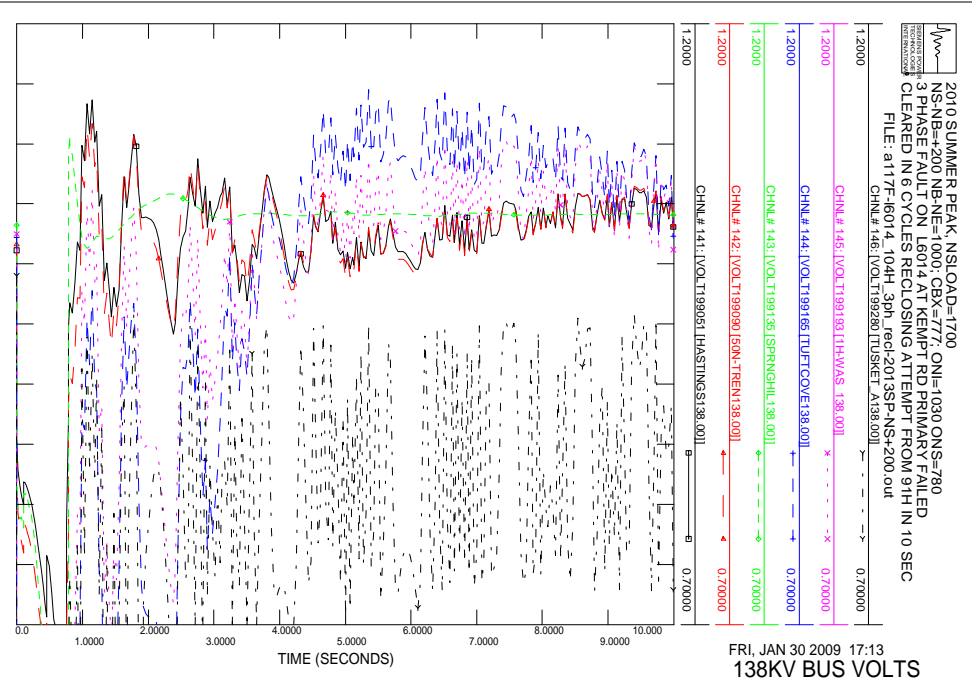
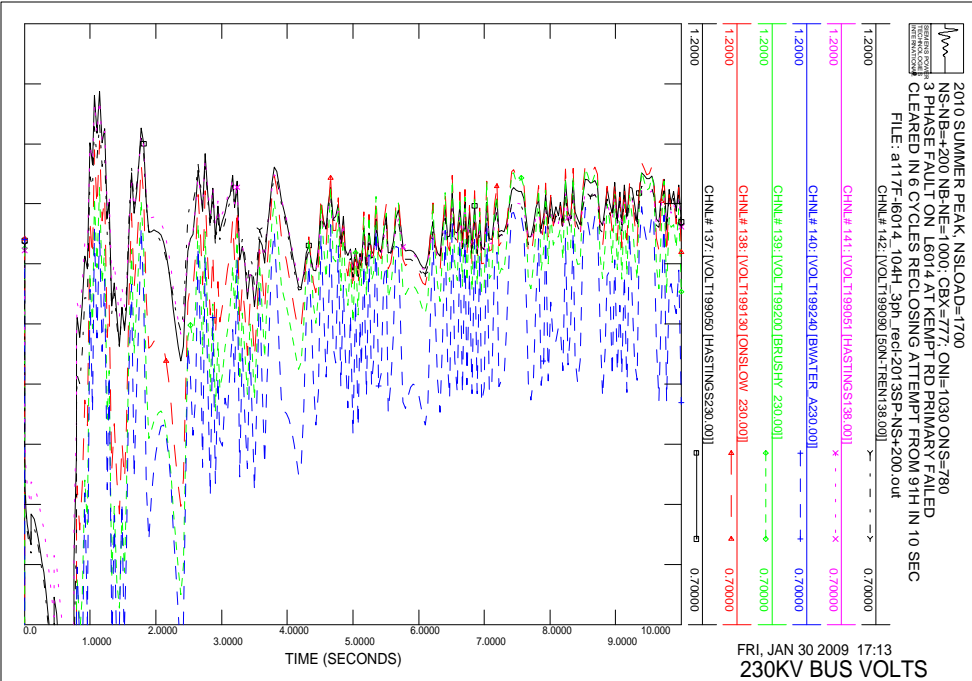

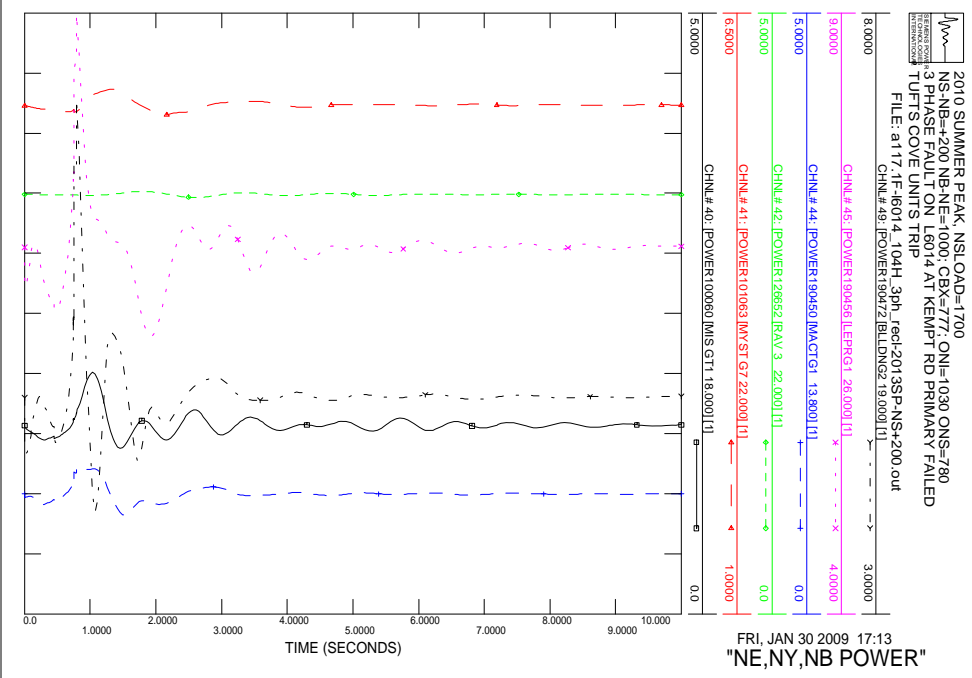
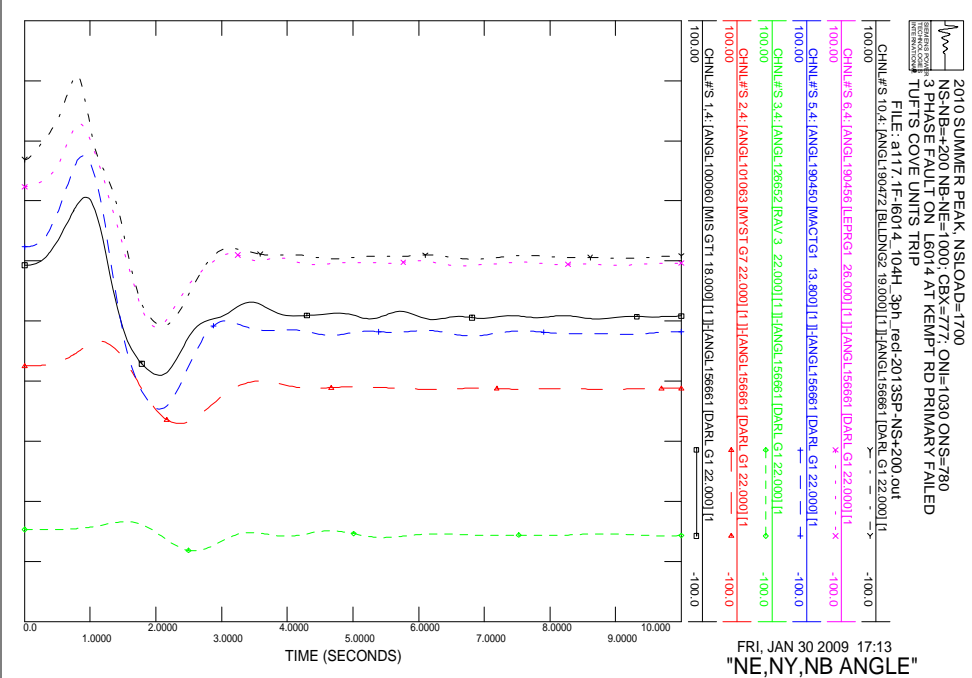
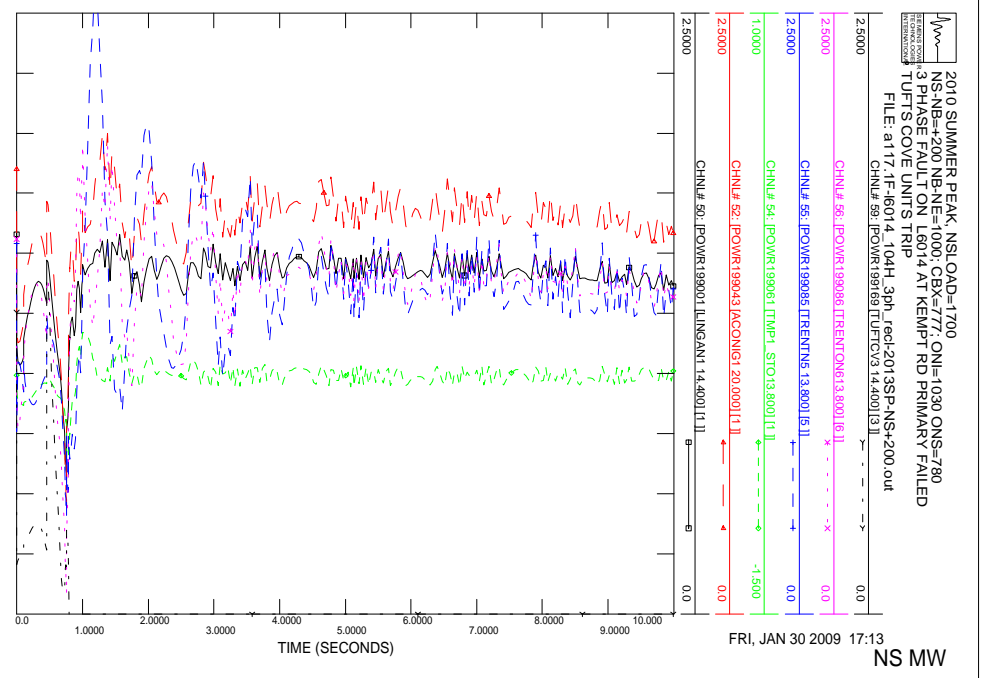
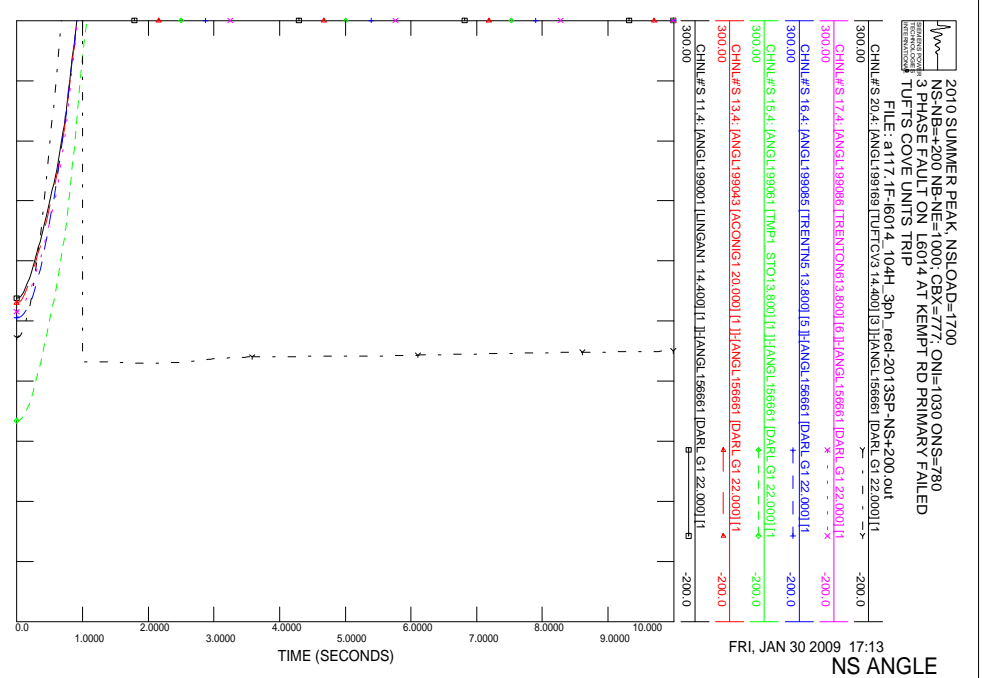

FRI, JAN 30 2009 17:13
 NS ANGLE

FRI, JAN 30 2009 17:13
 "NE,NY,NB ANGLE"

FRI, JAN 30 2009 17:13
 NS MW

FRI, JAN 30 2009 17:13
 "NE,NY,NB POWER"

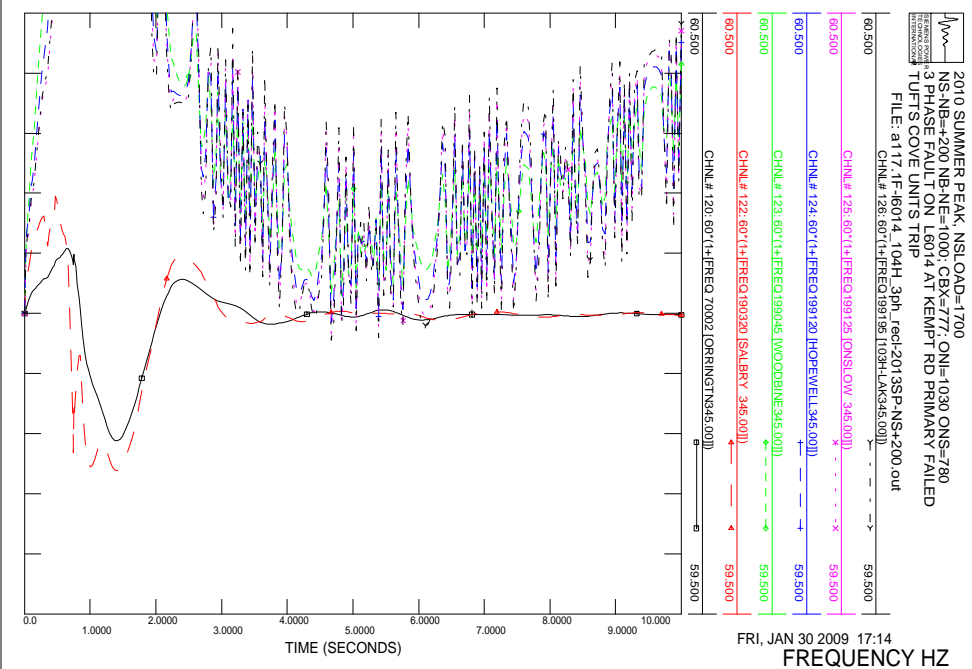
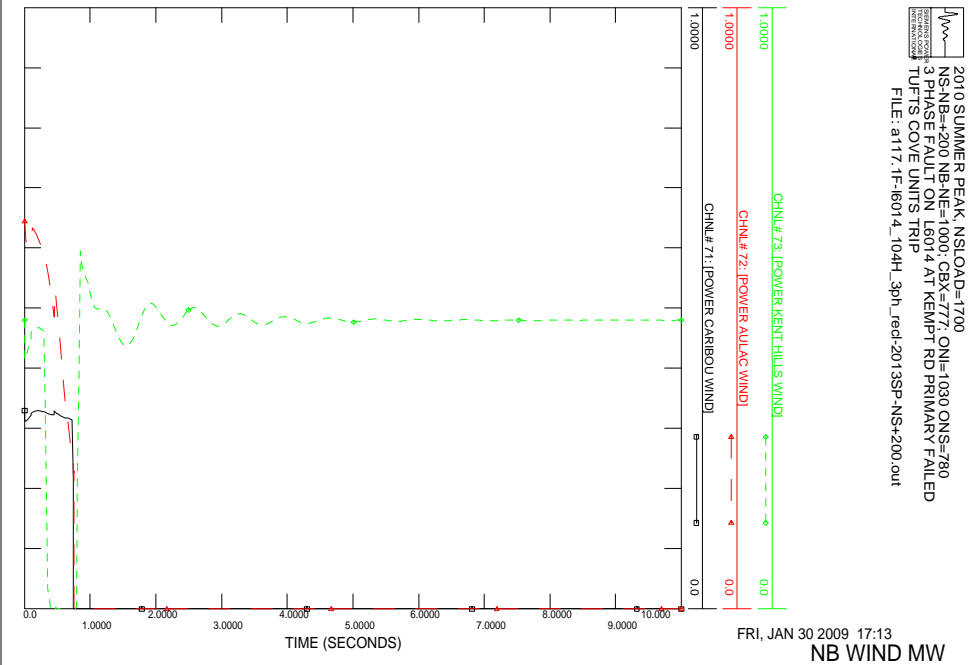
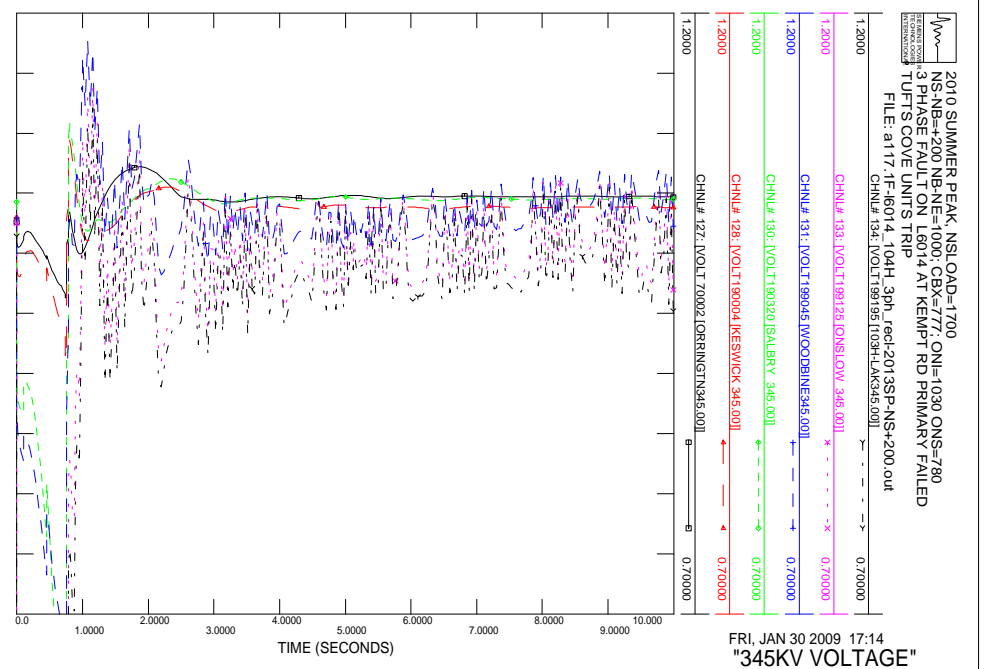
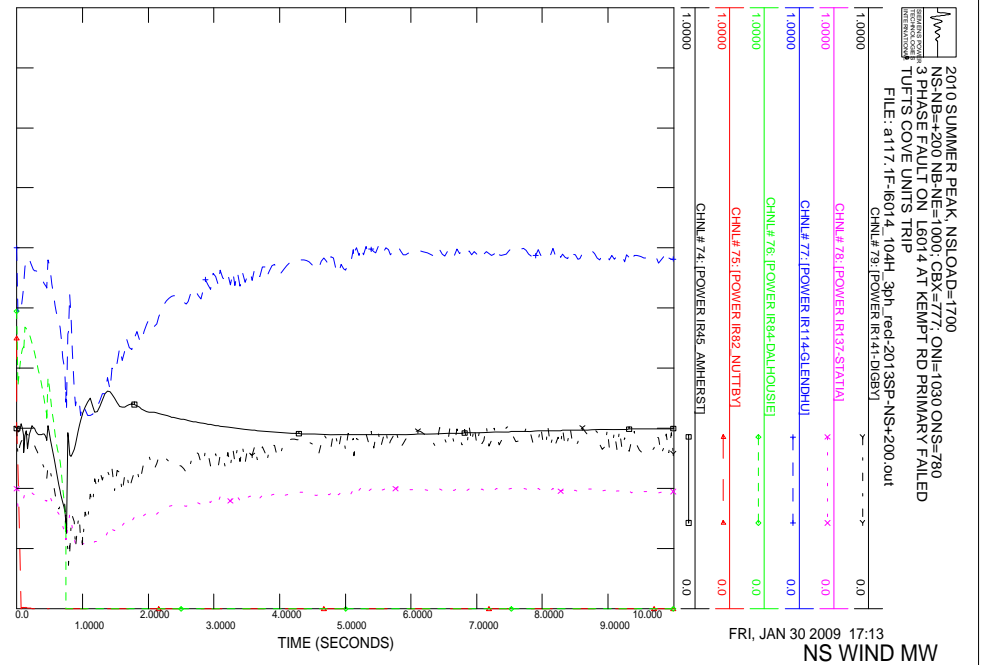

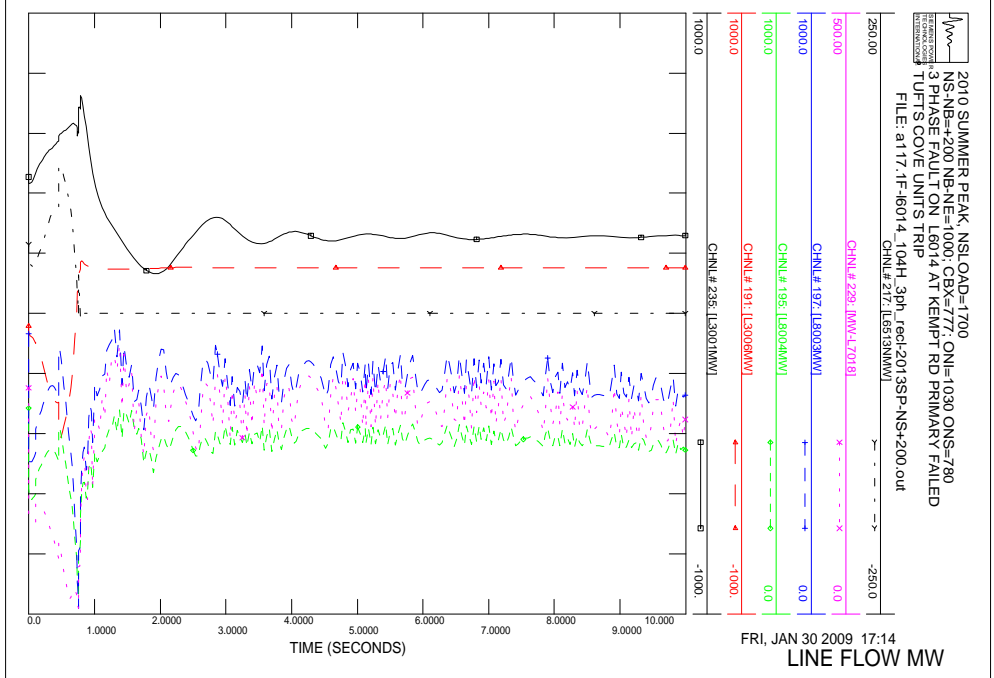
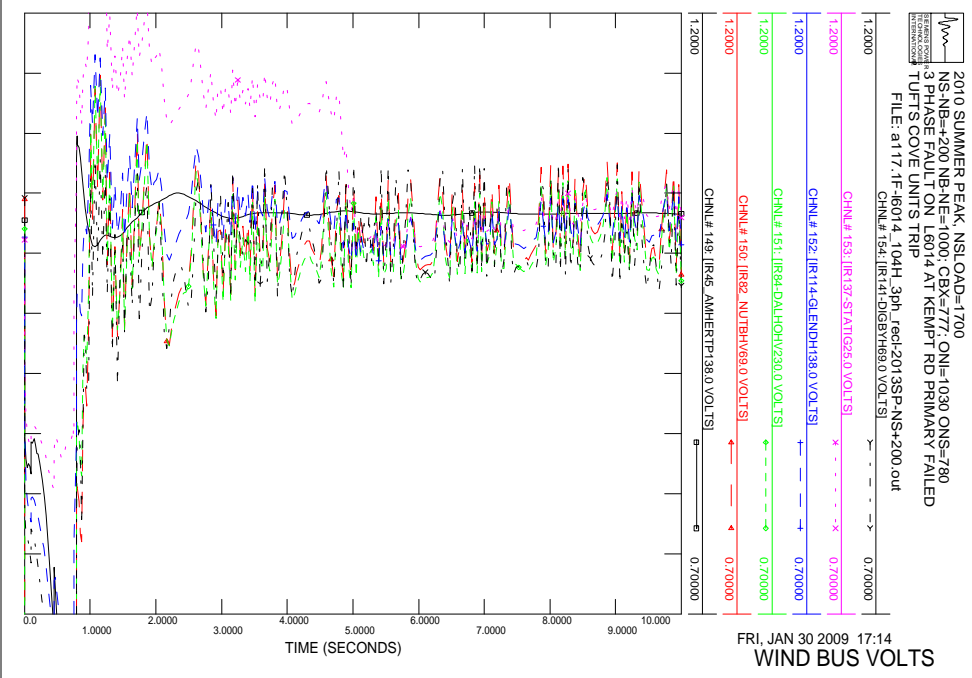
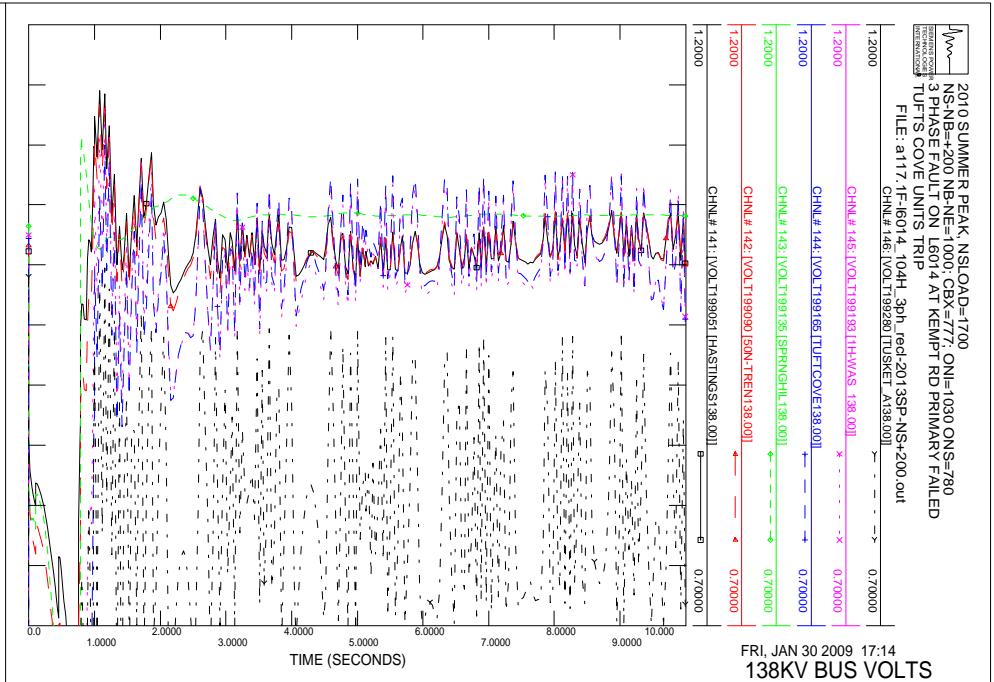
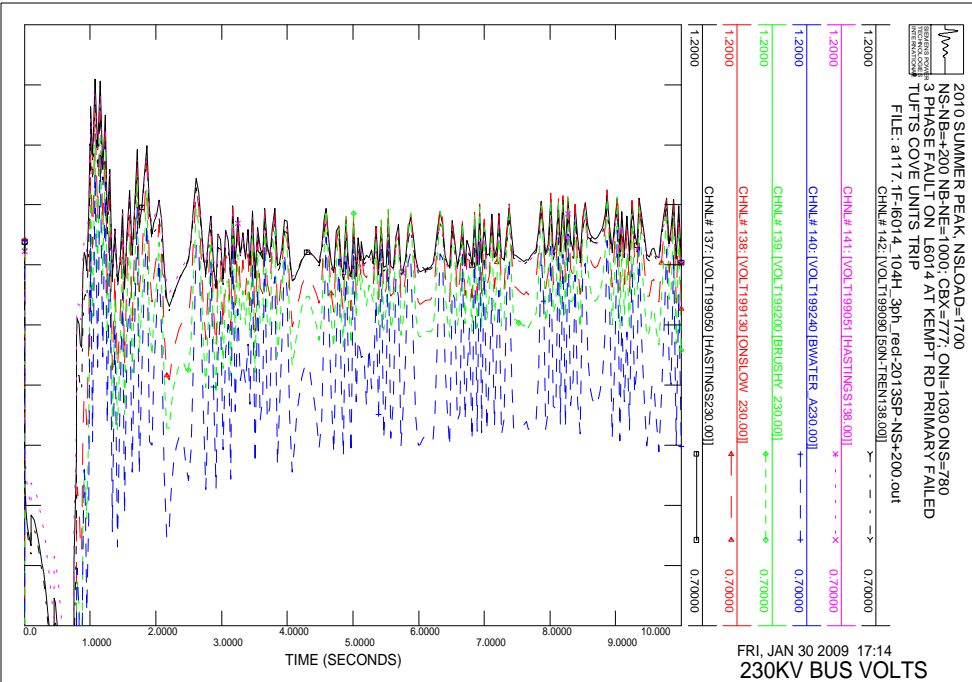

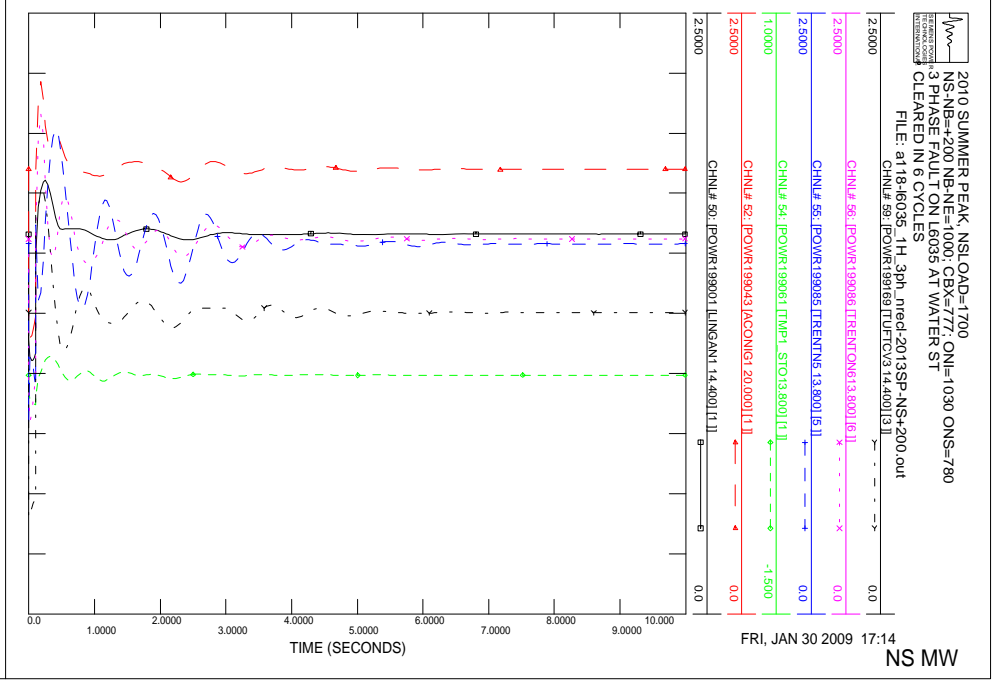
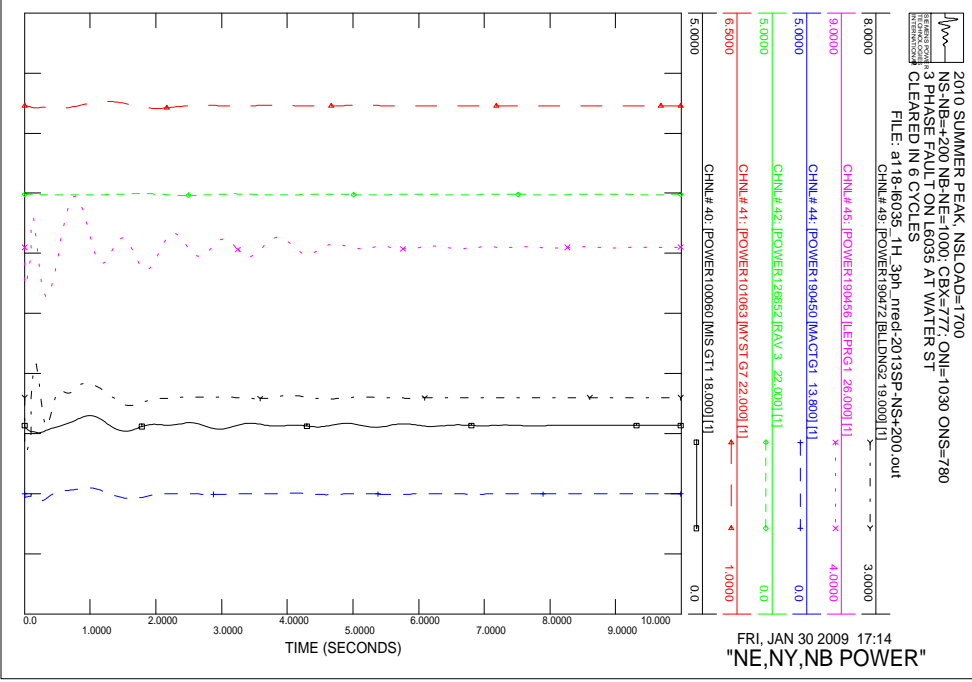
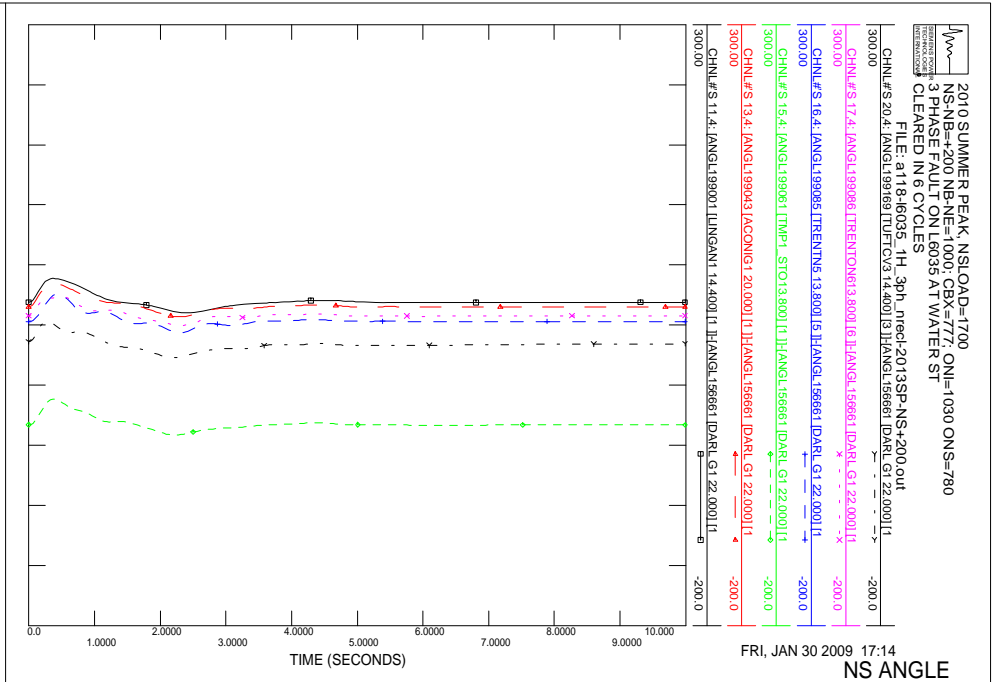
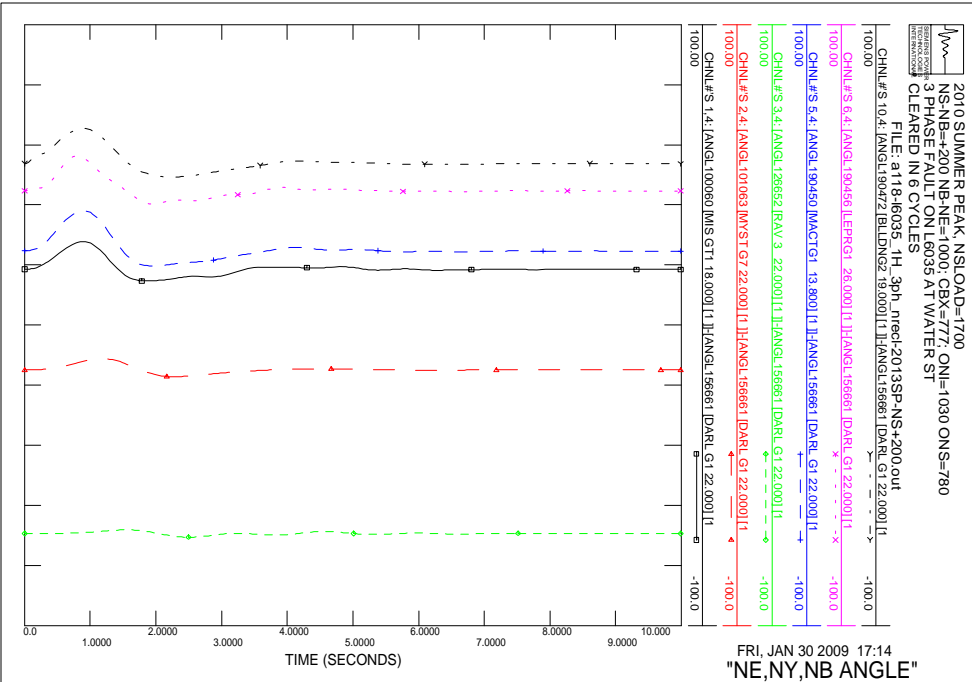

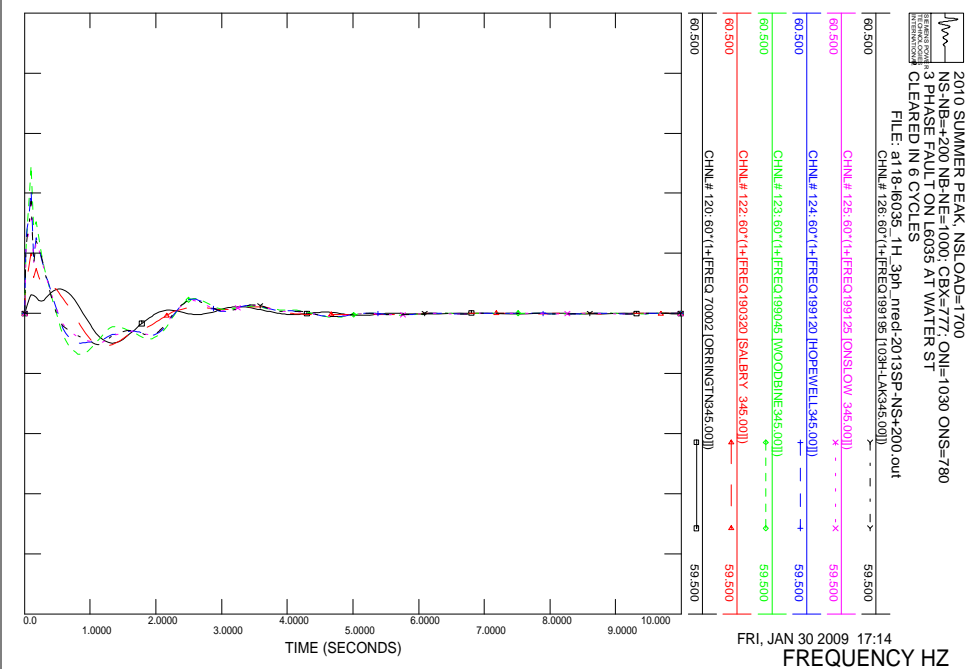
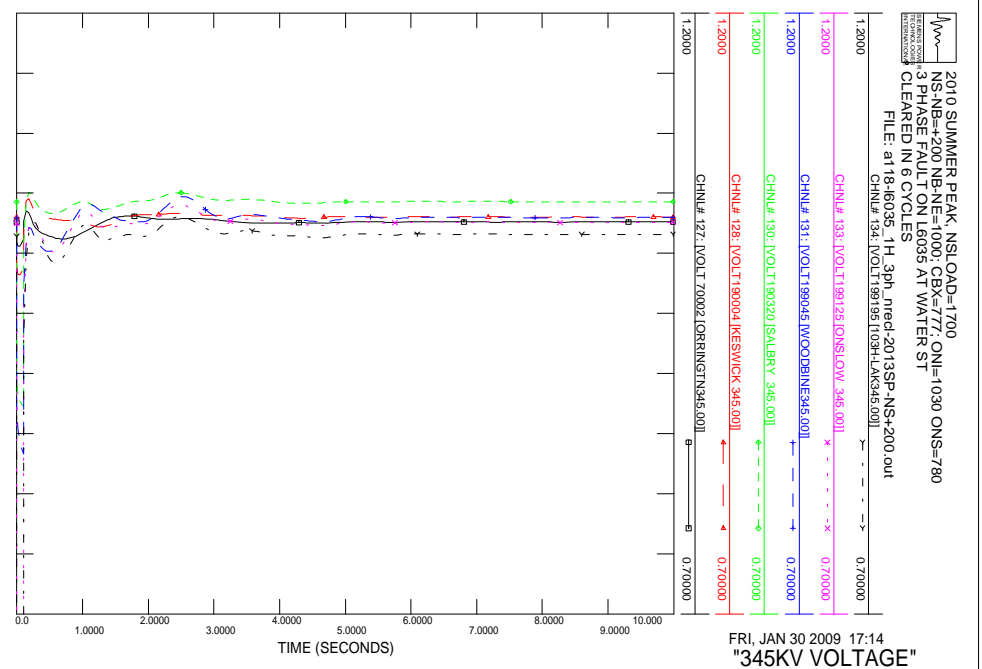
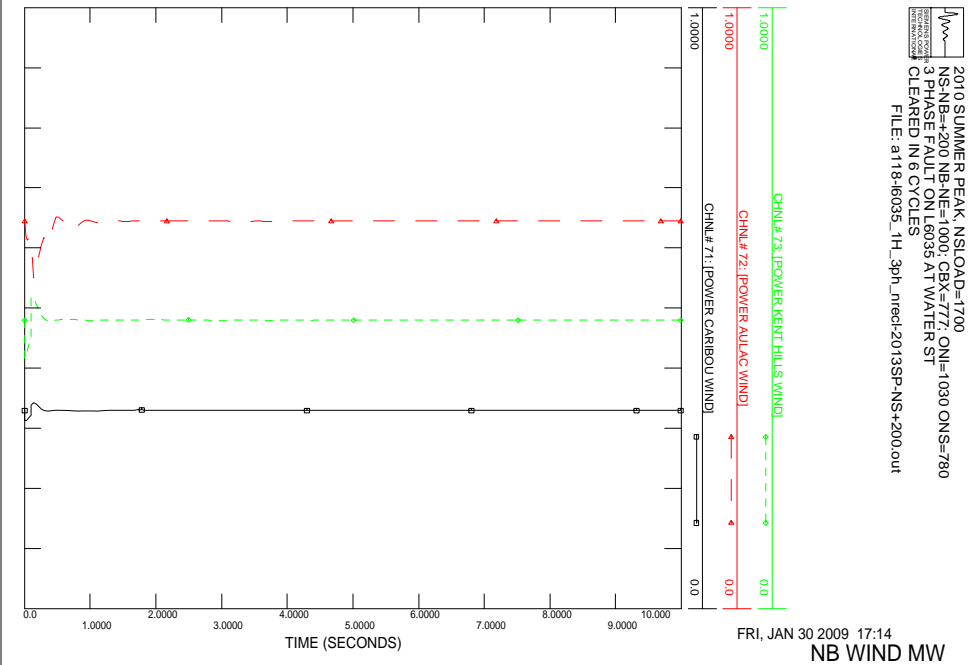
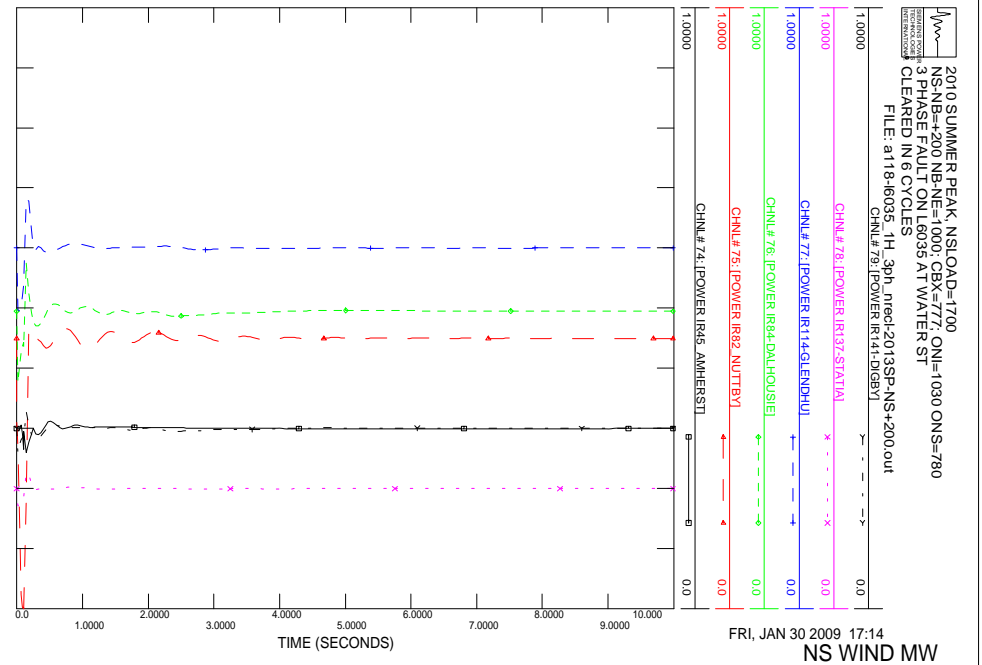

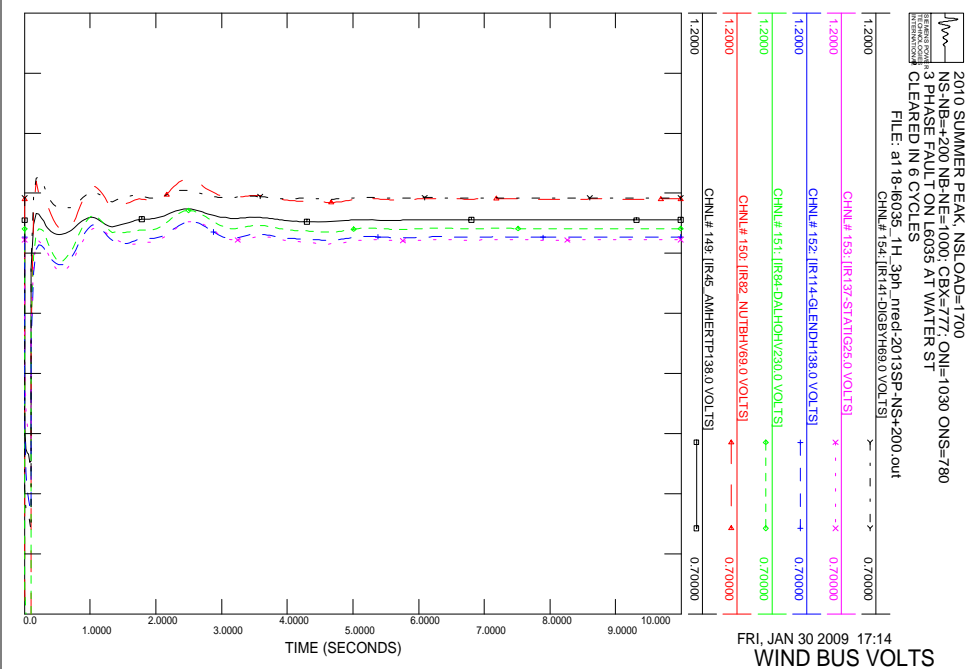
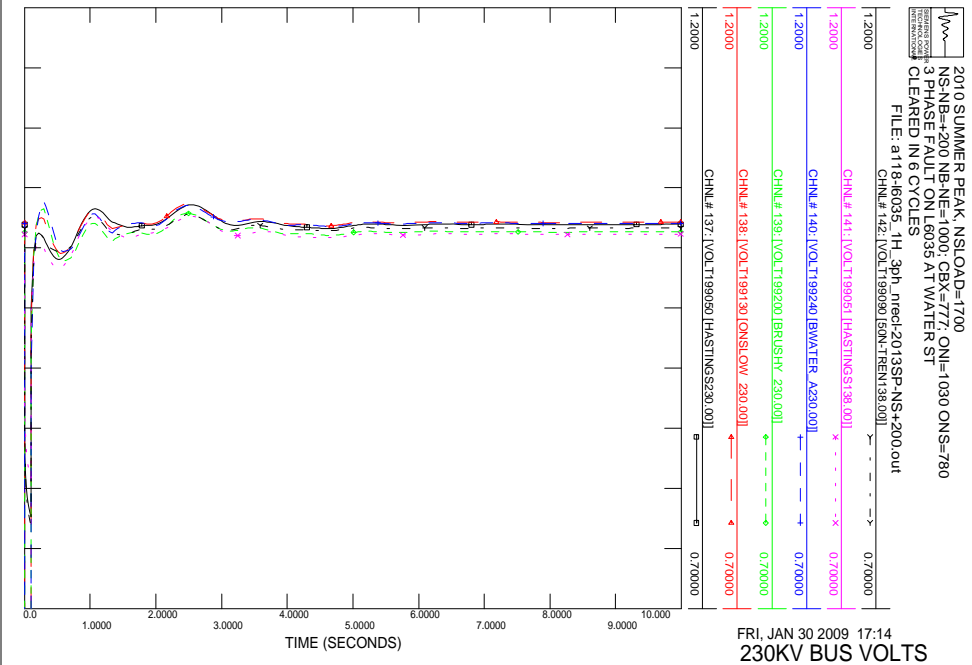
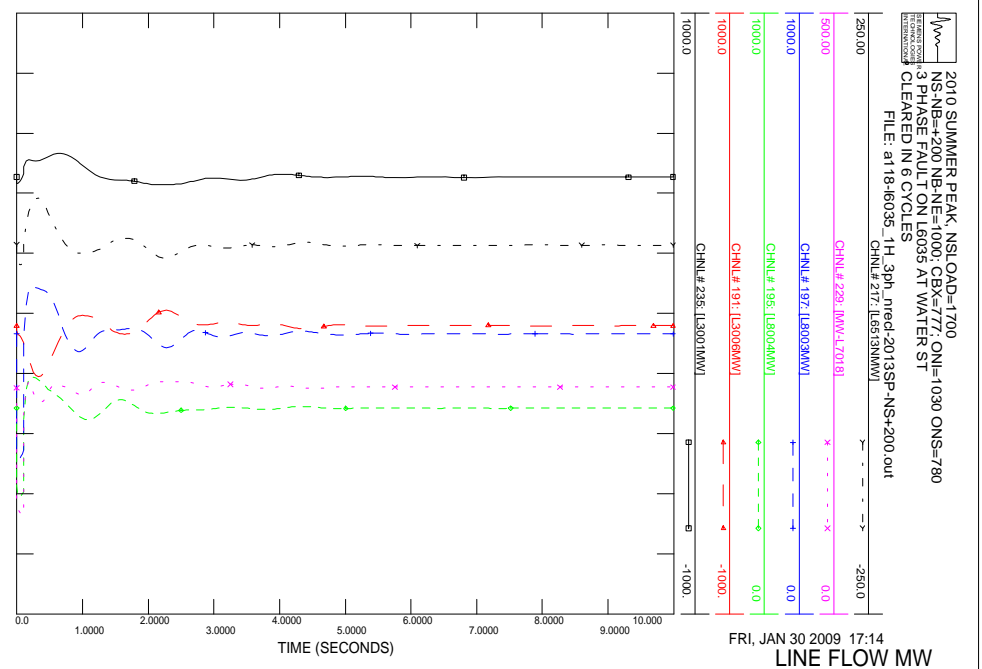
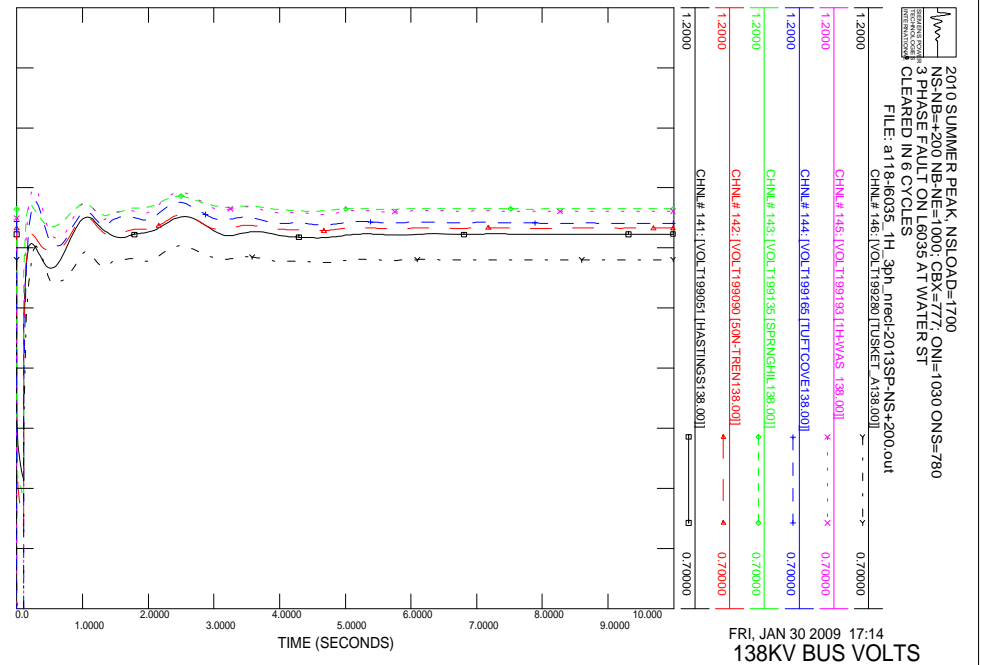

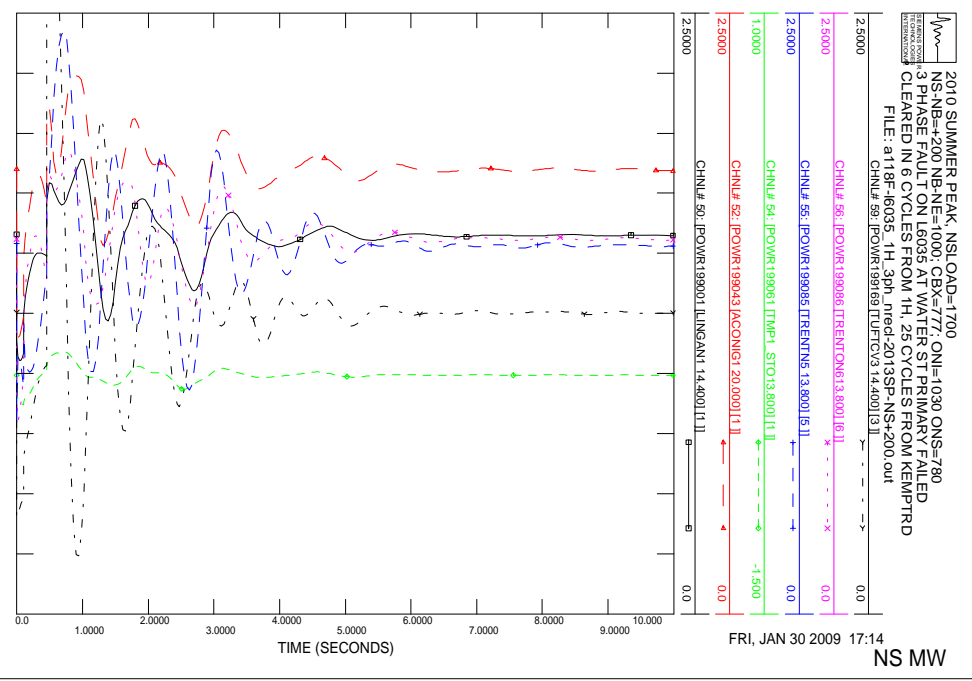
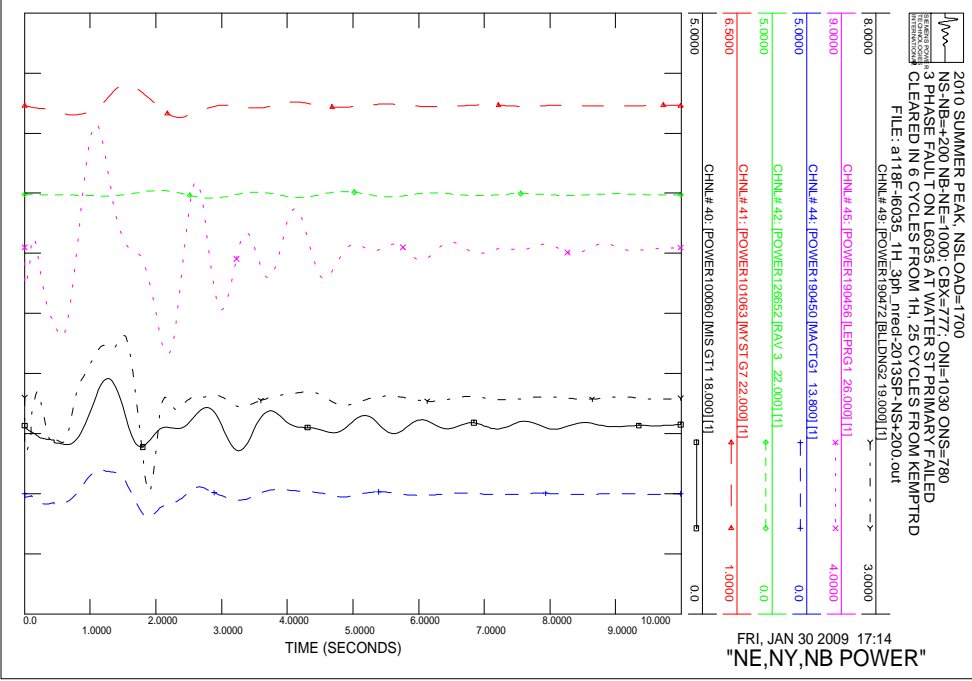
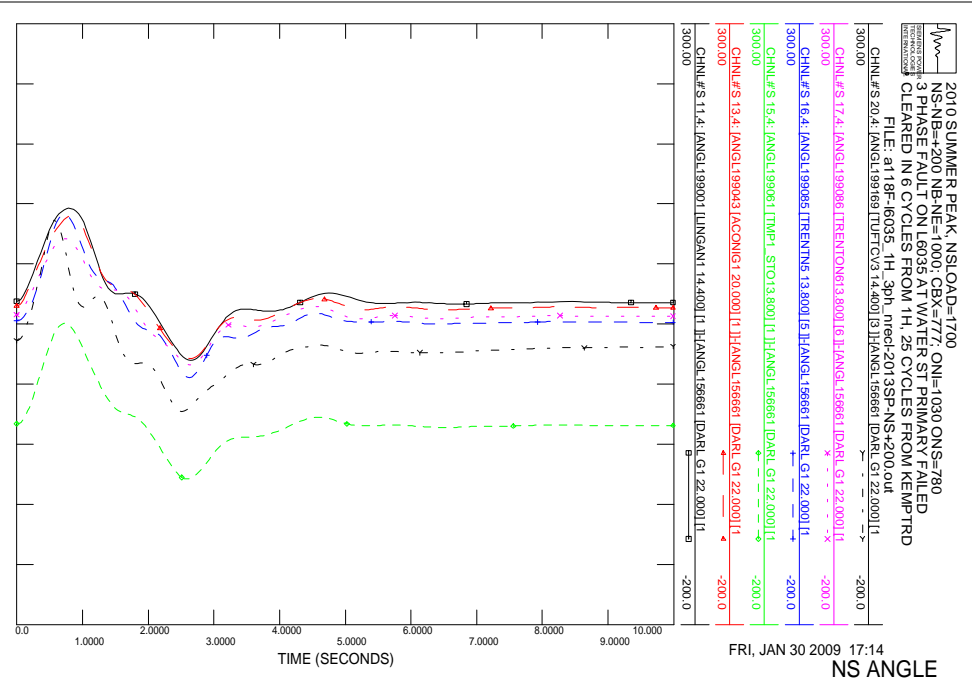
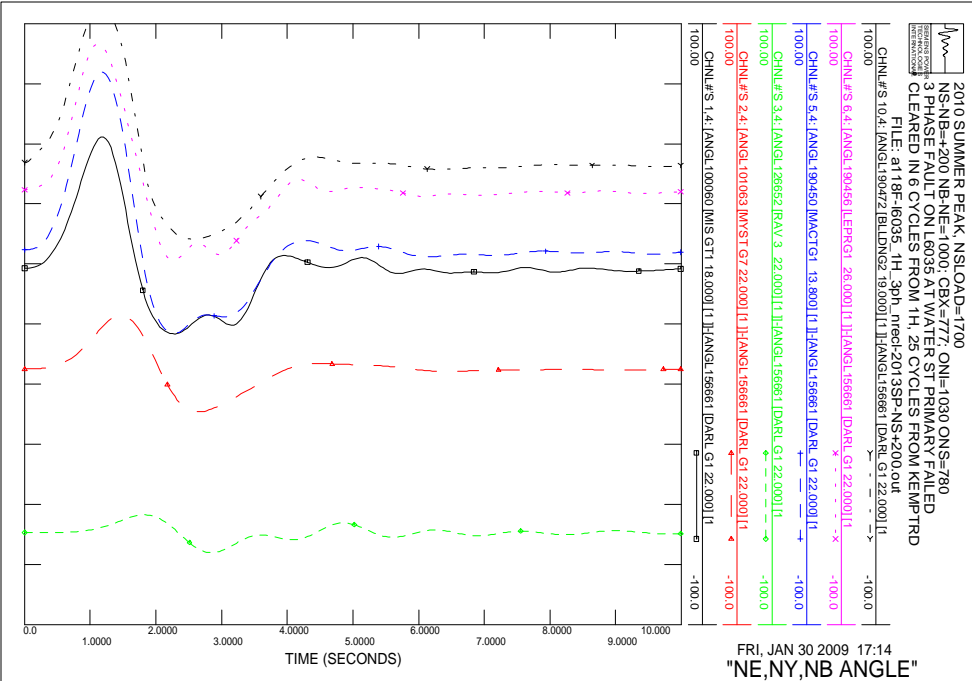

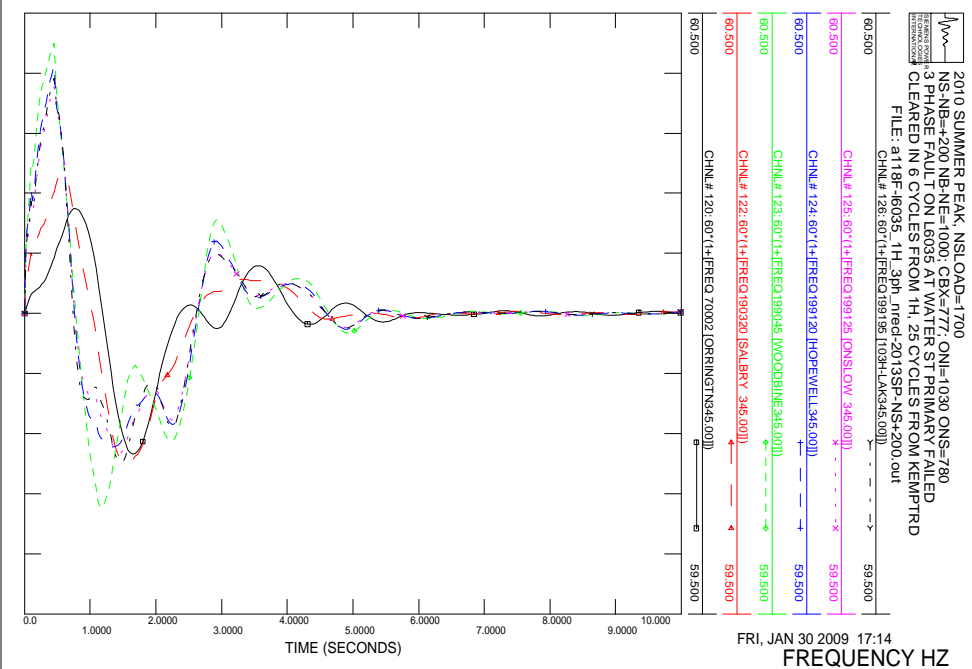
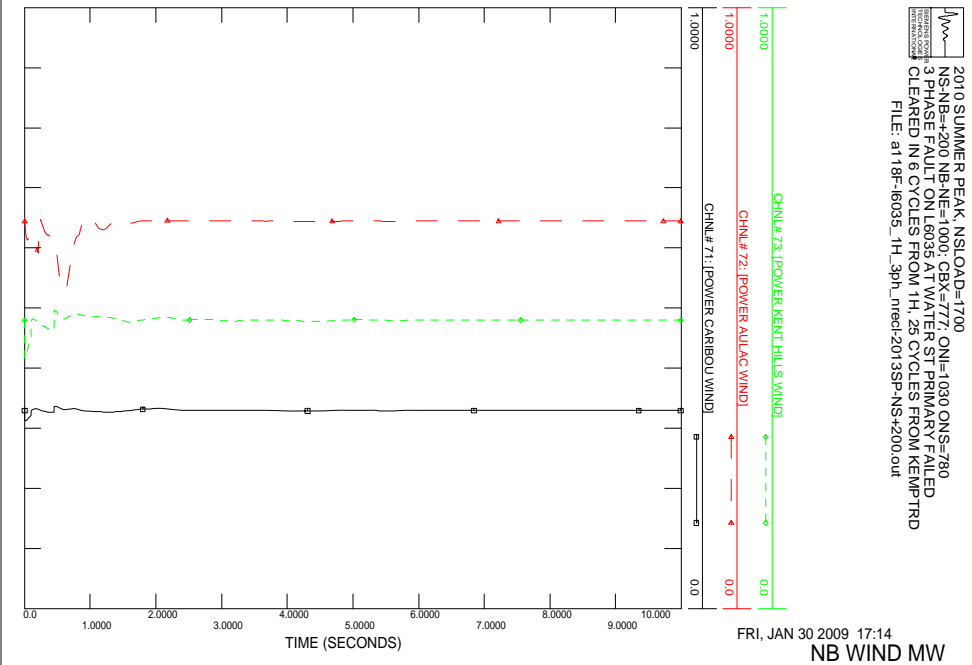
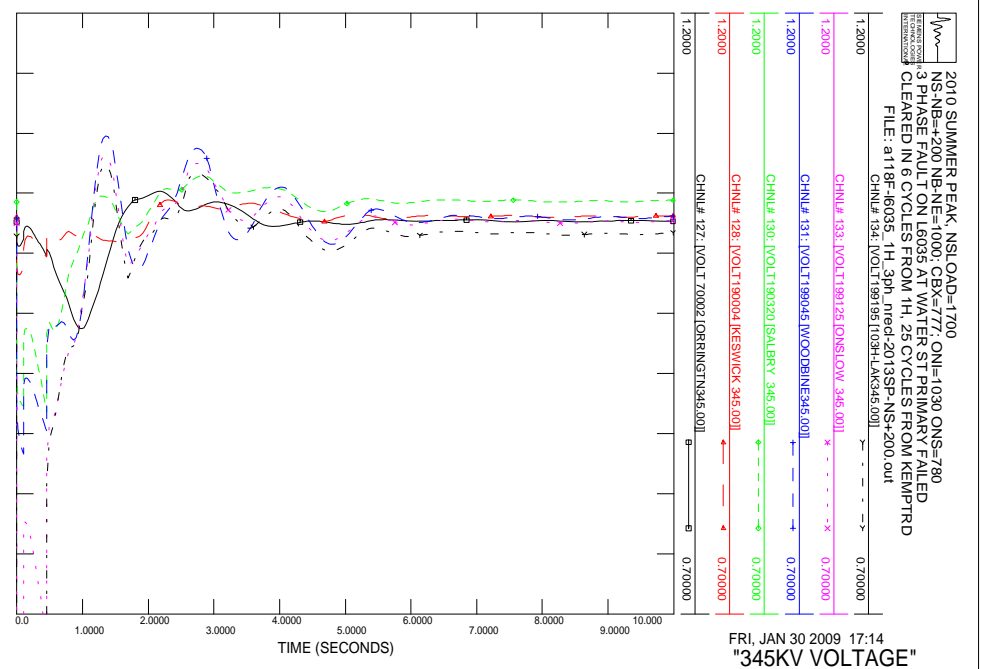
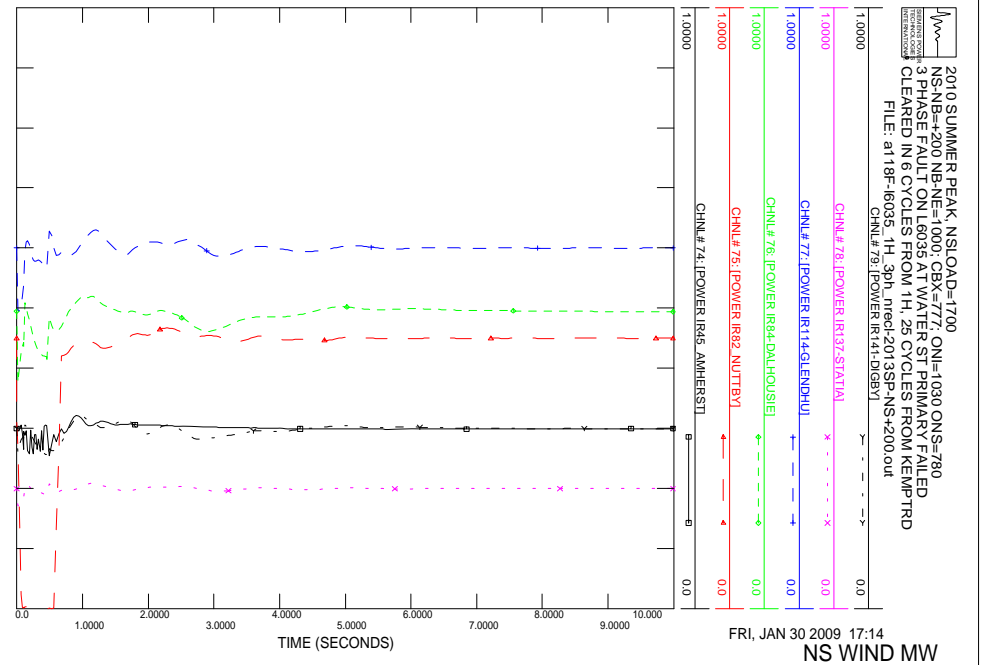

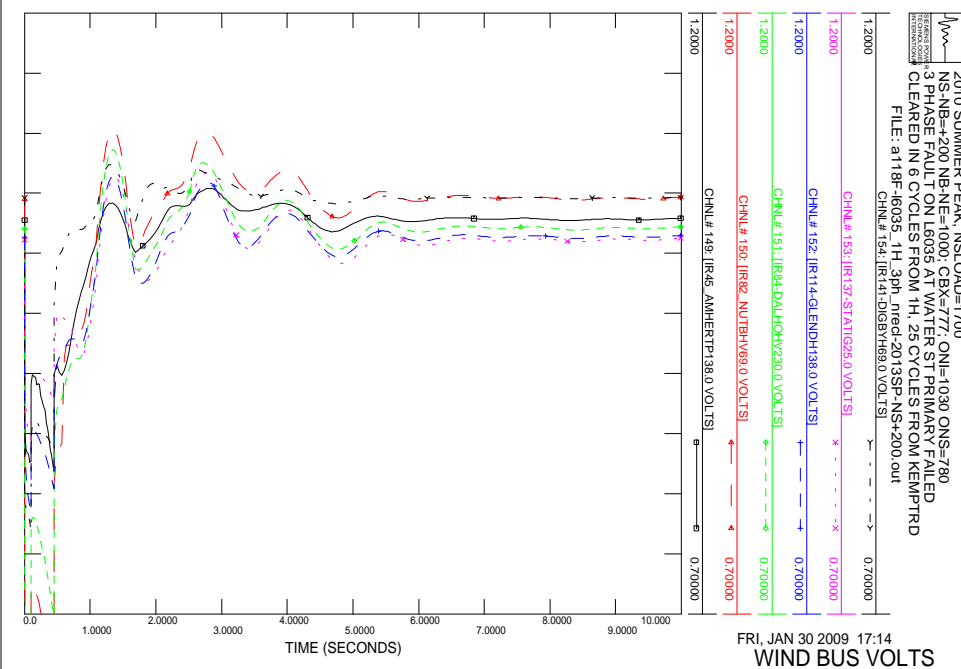
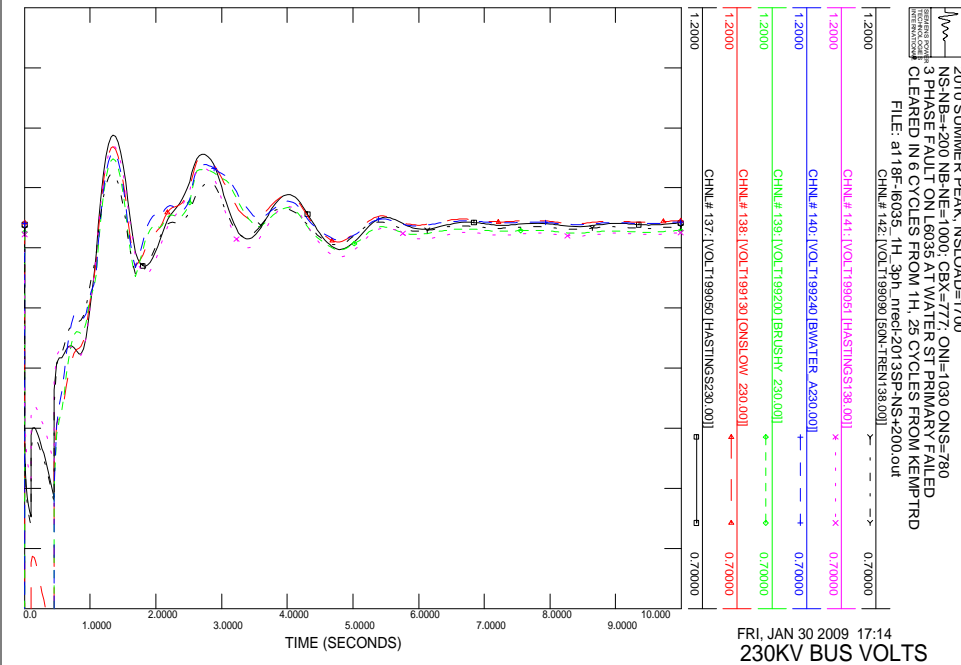
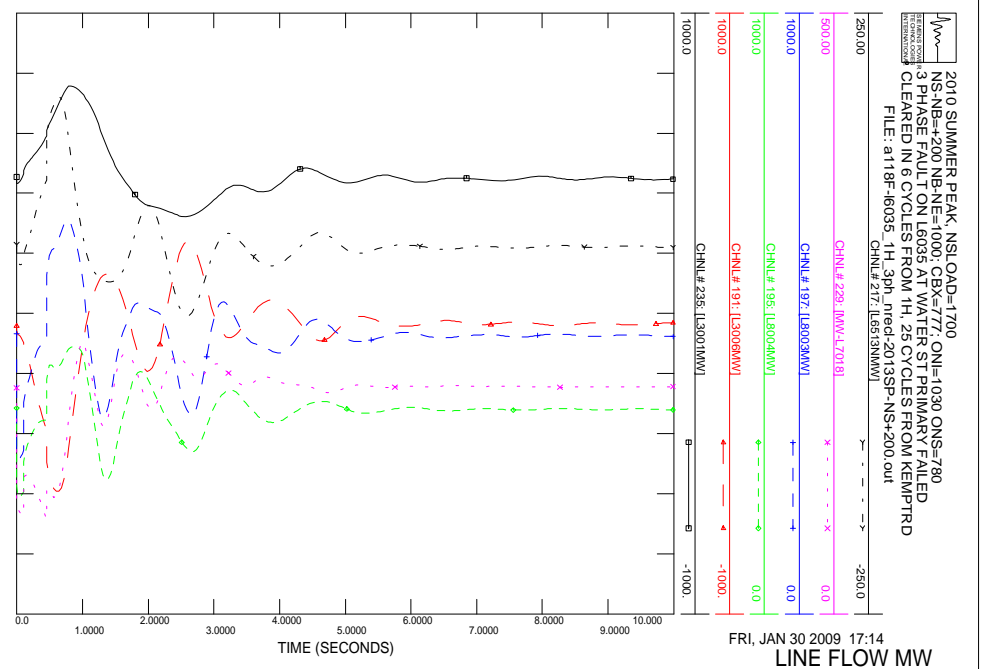
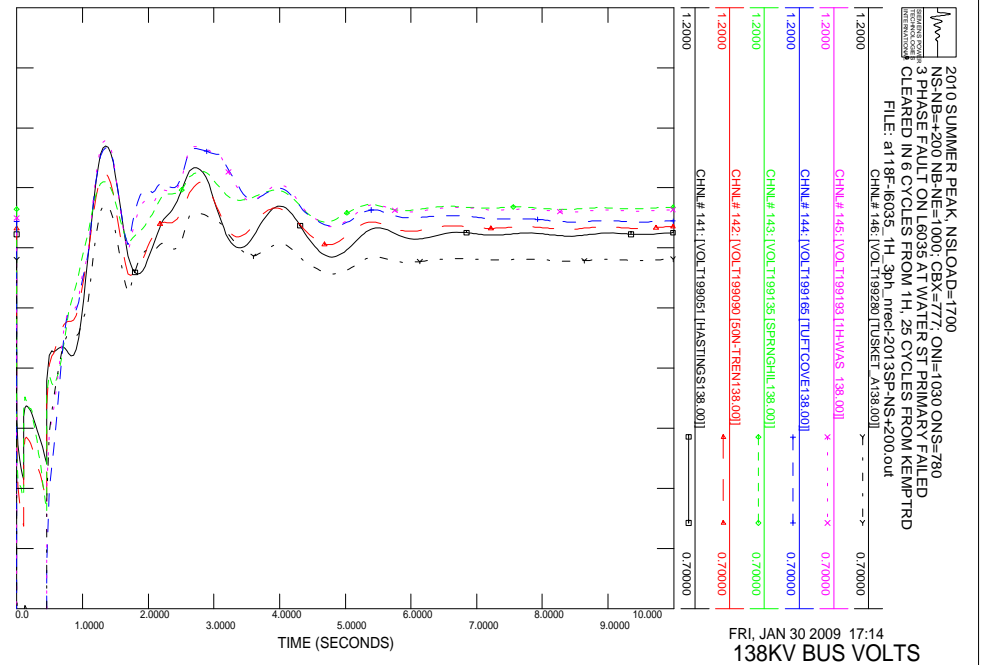

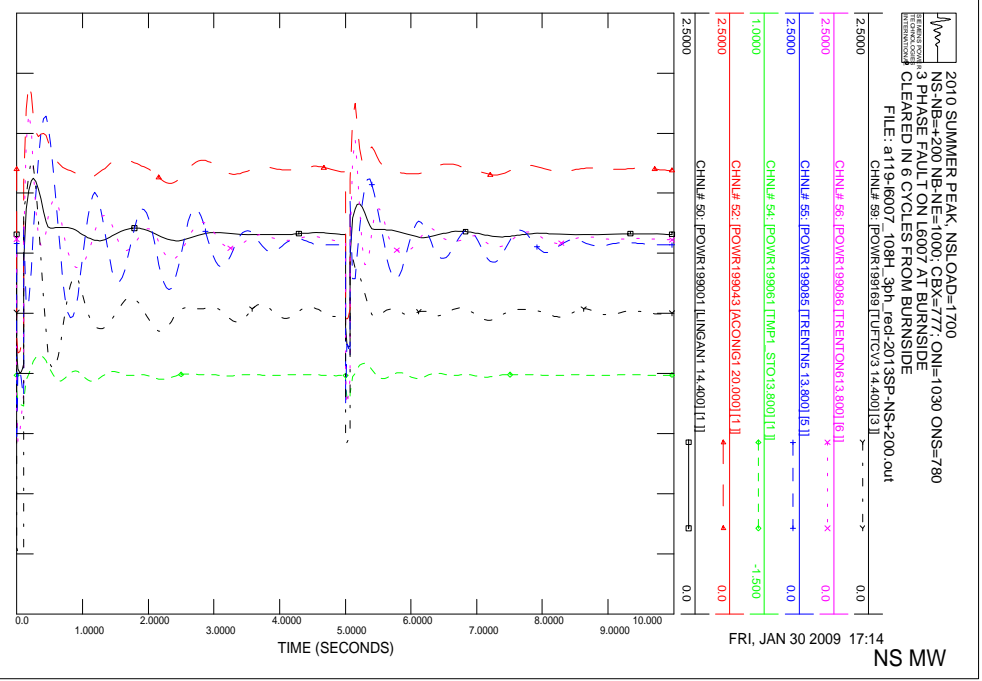
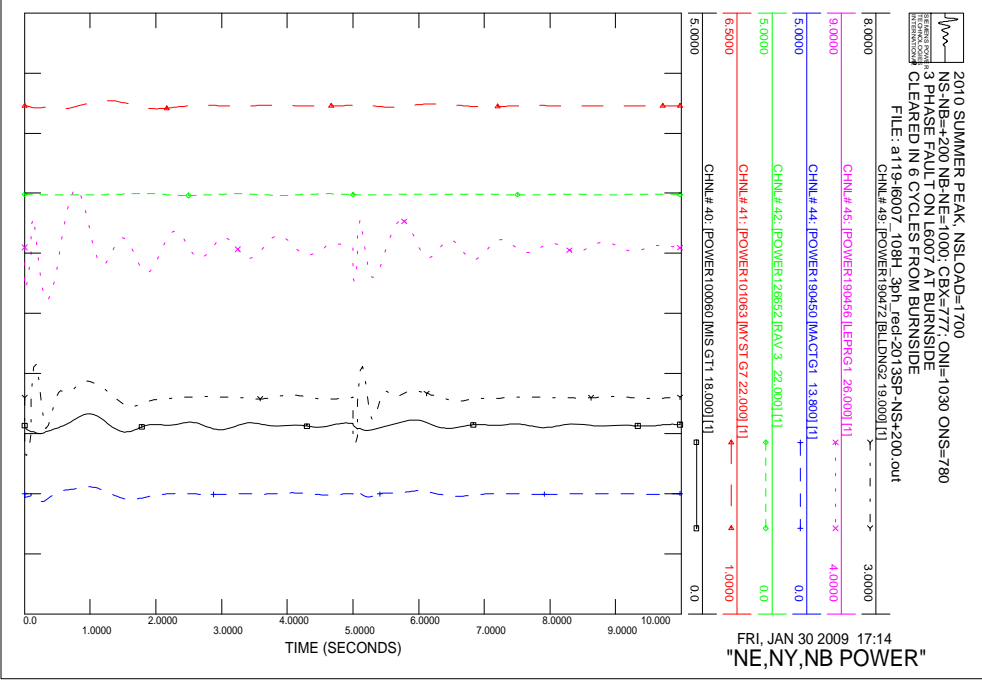
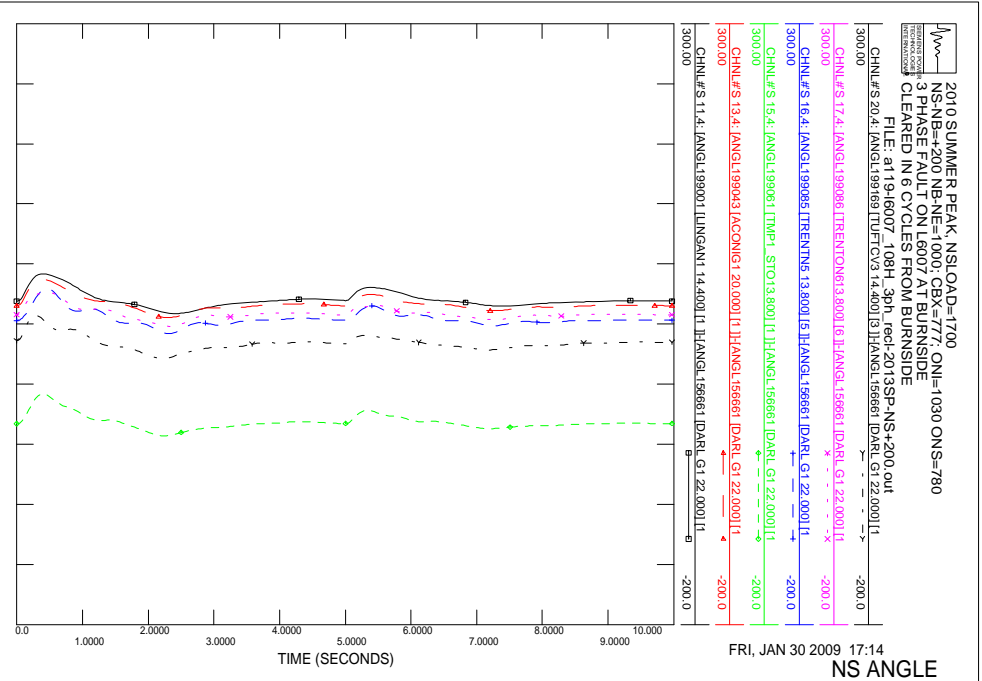
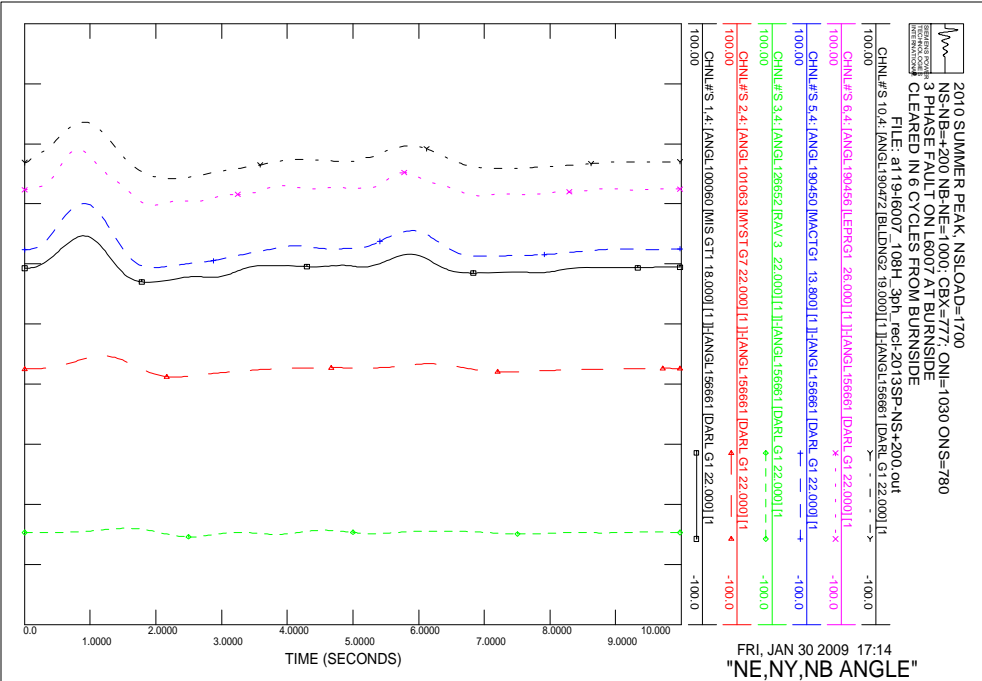

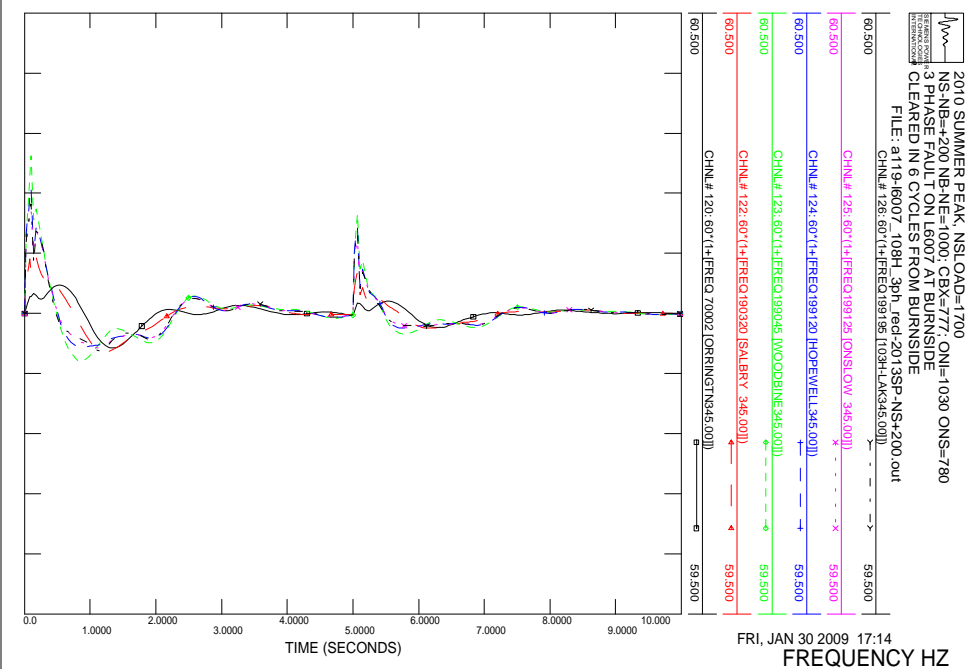
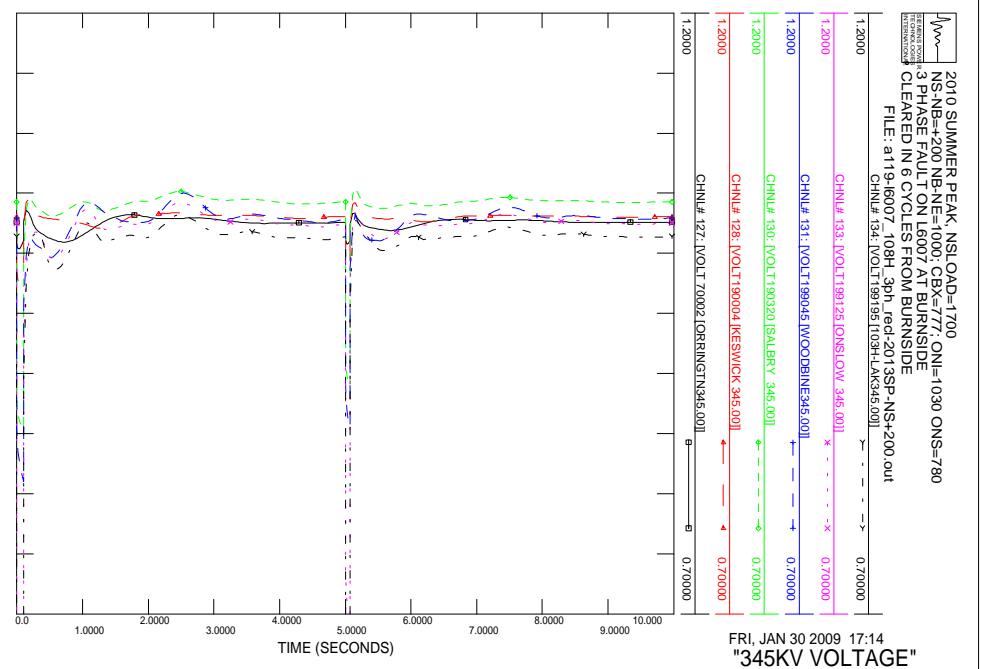
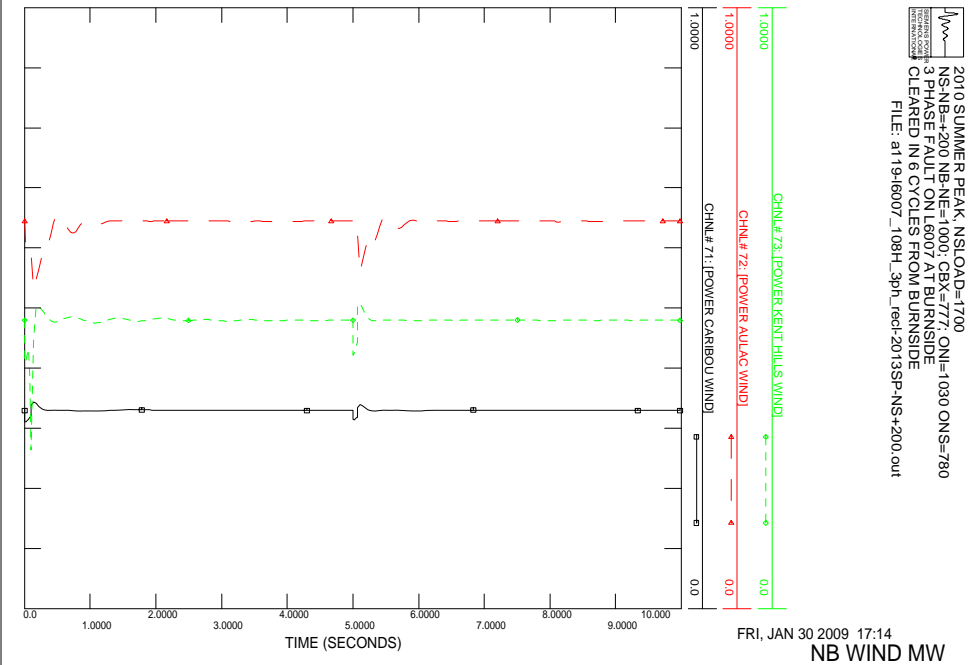
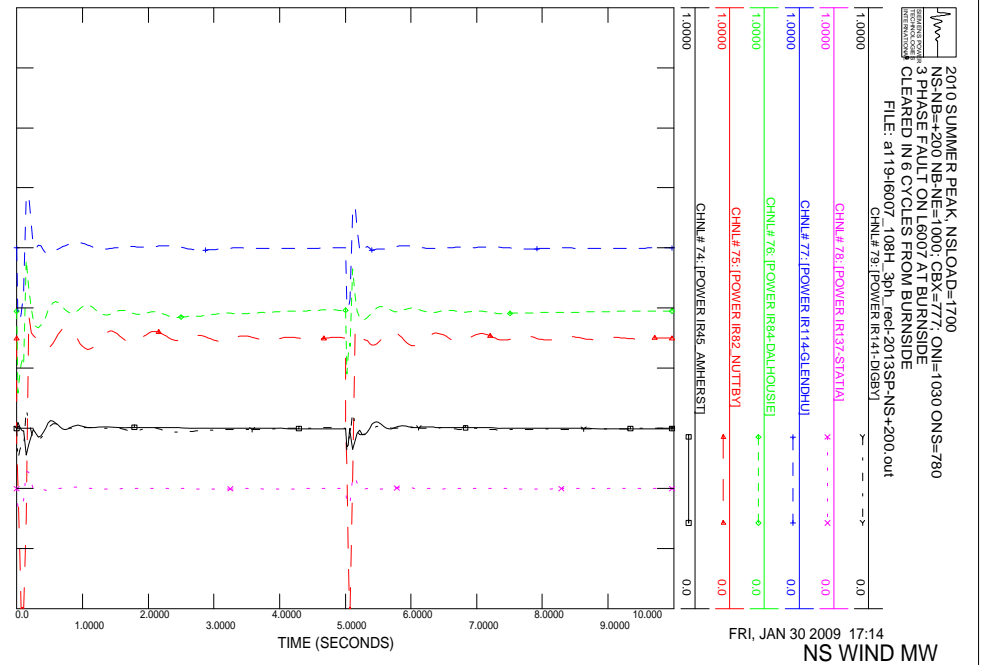

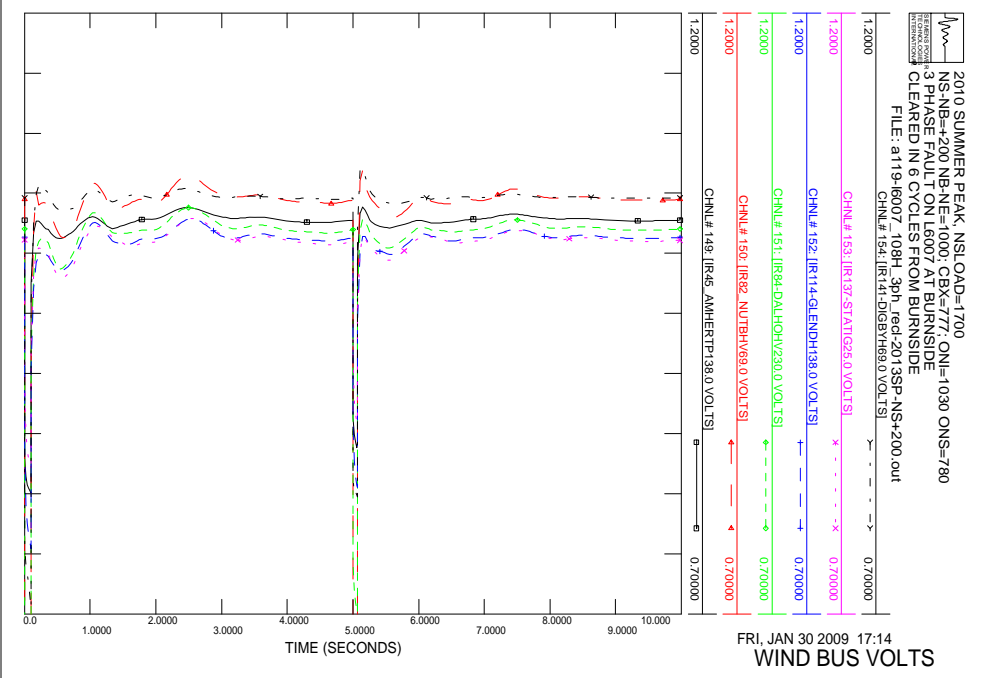
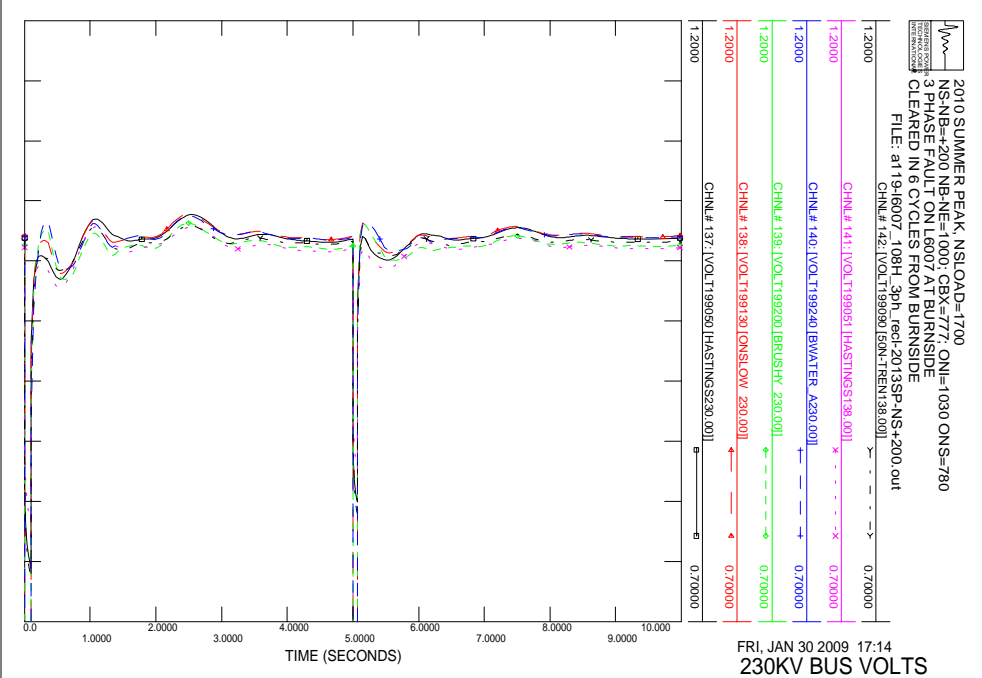
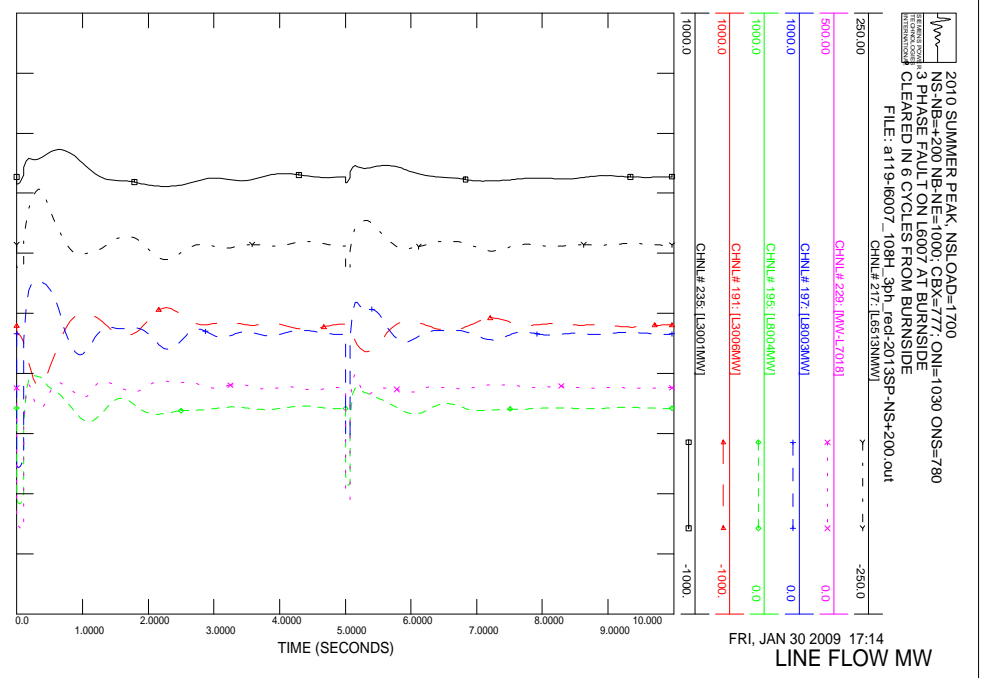
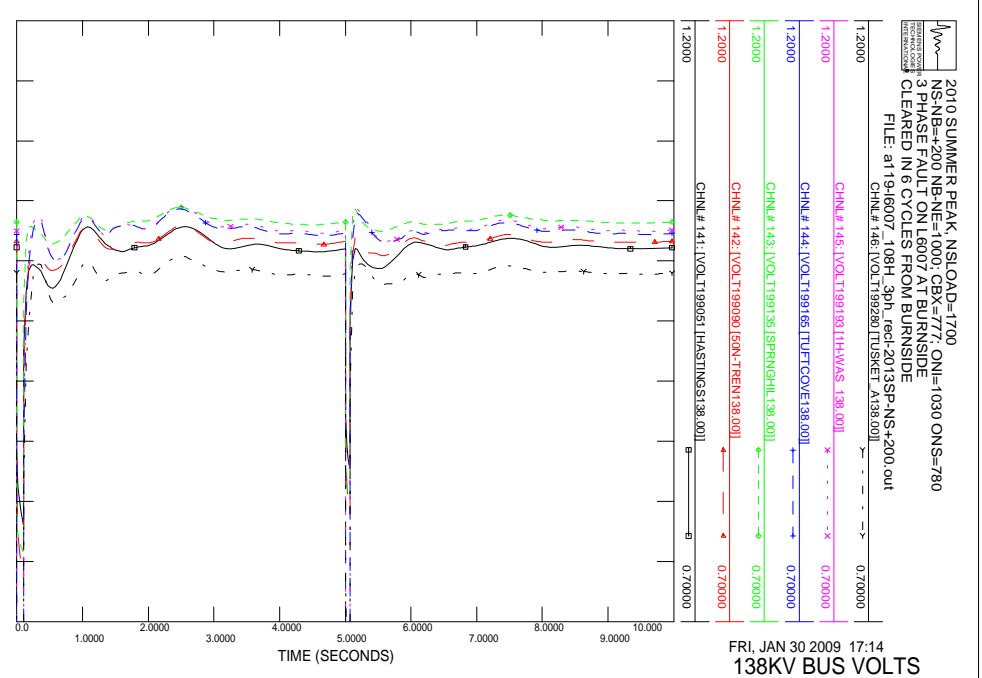

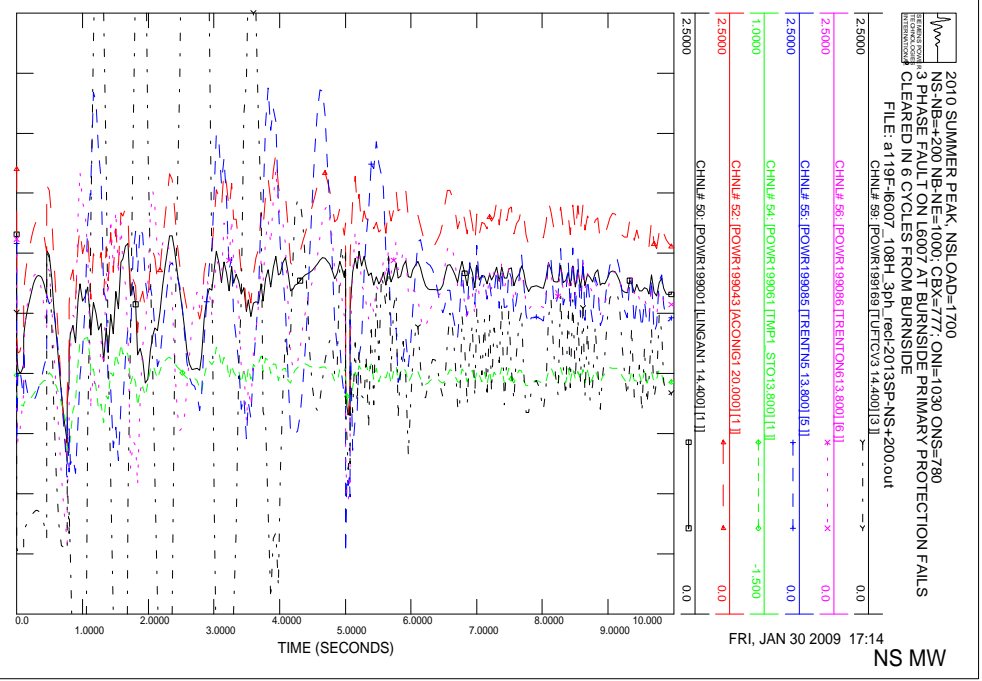
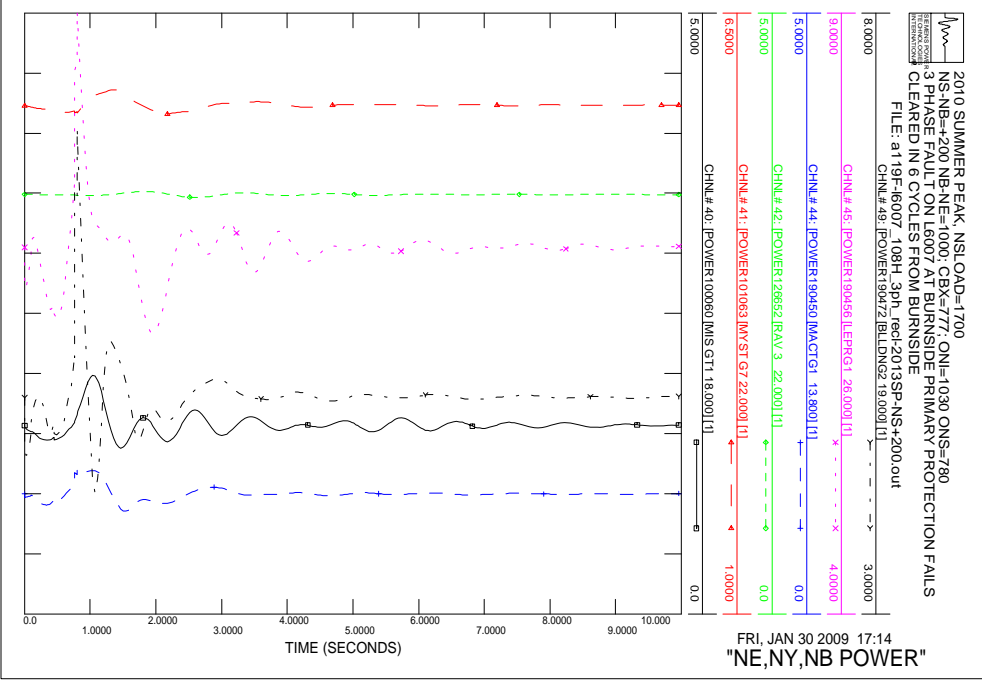
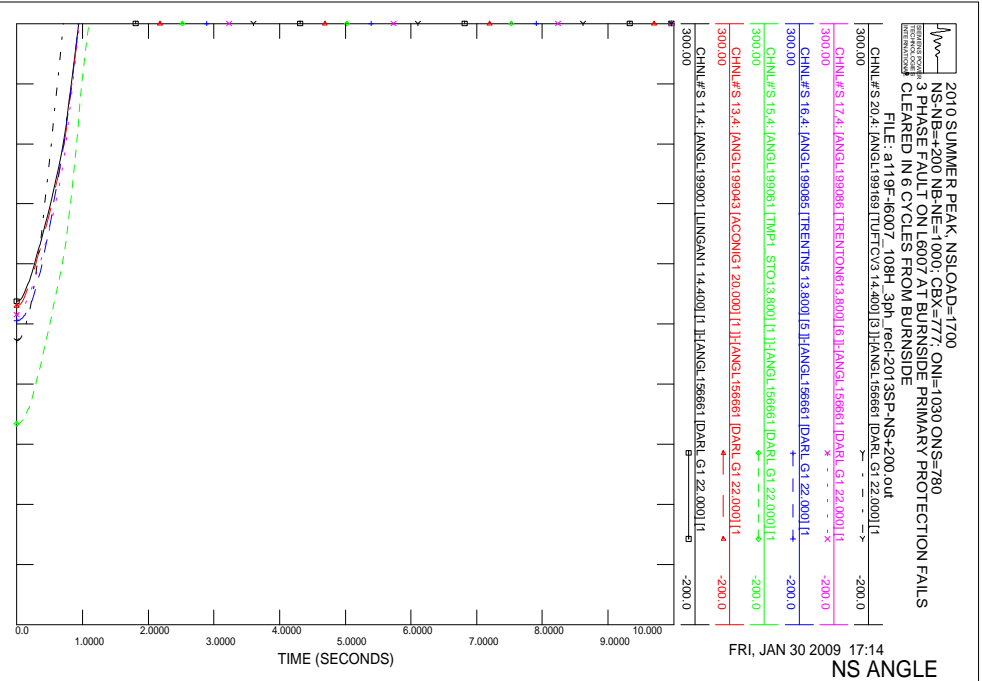
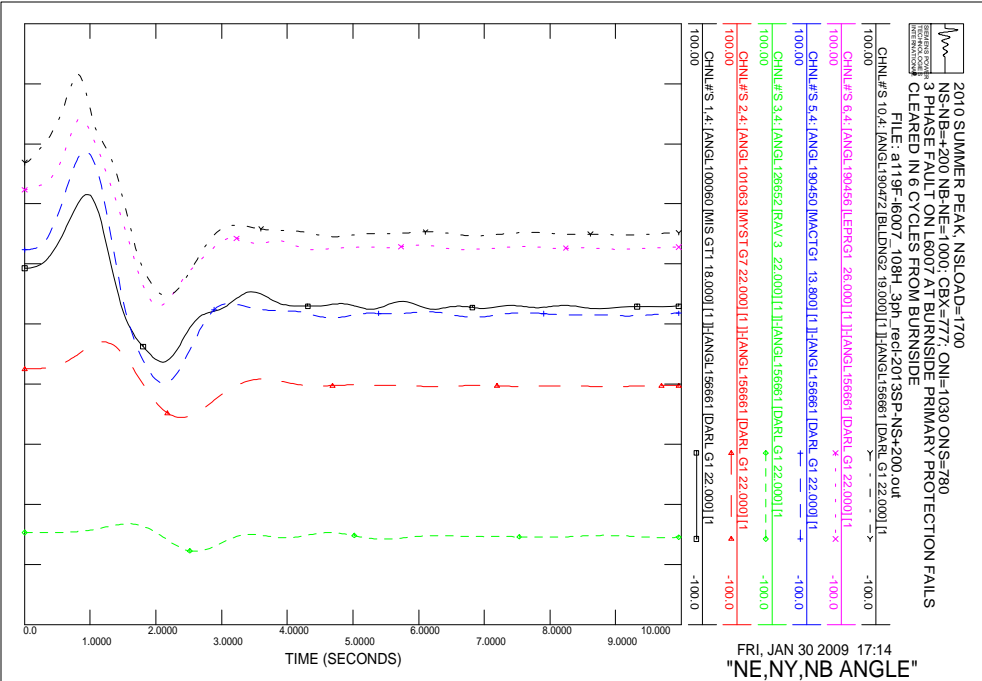

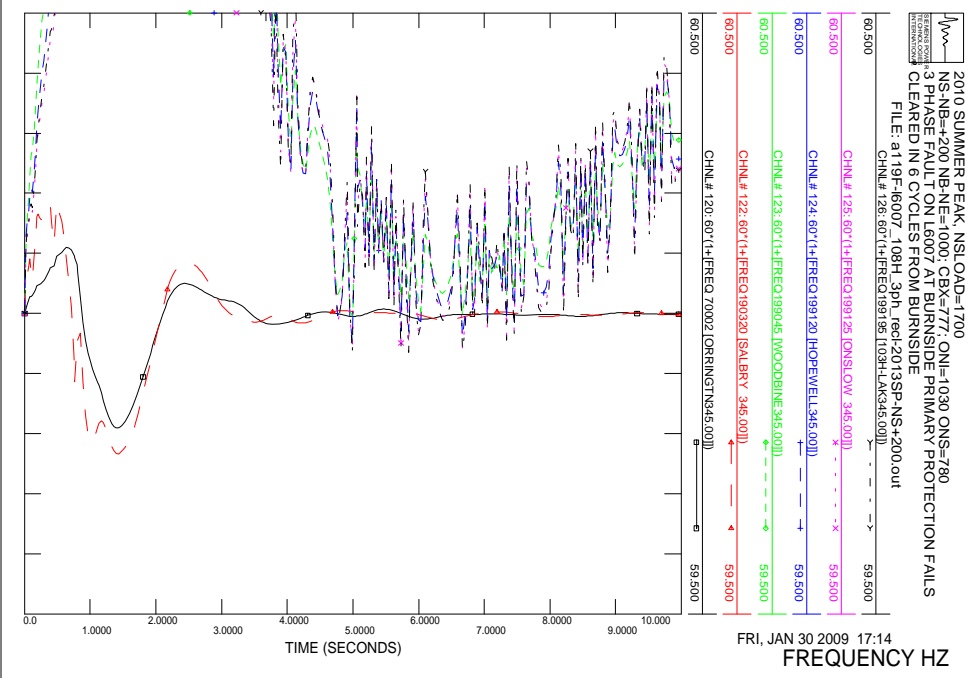
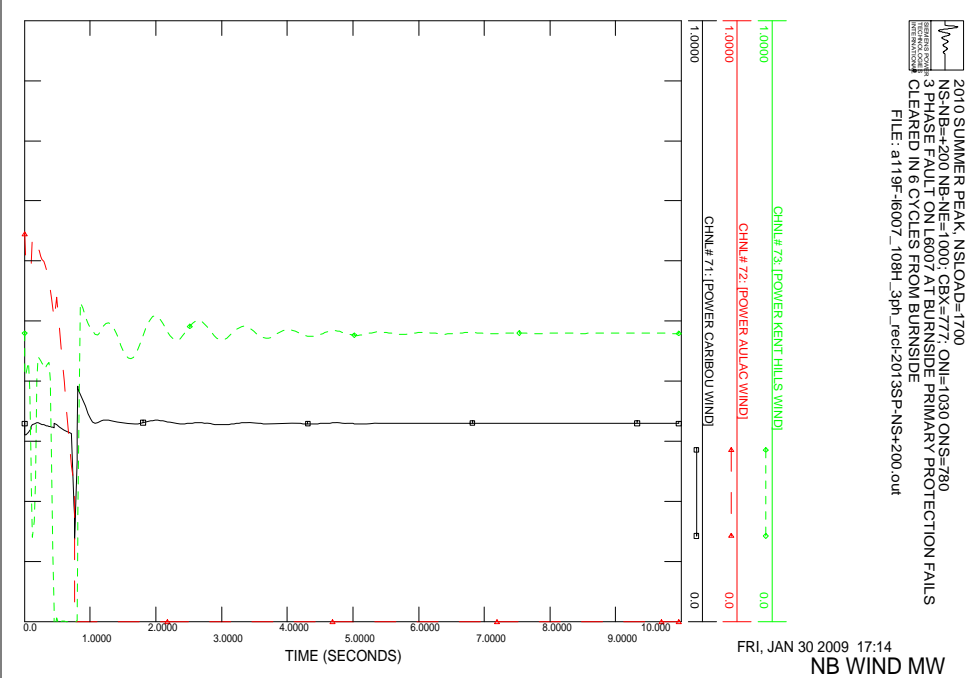
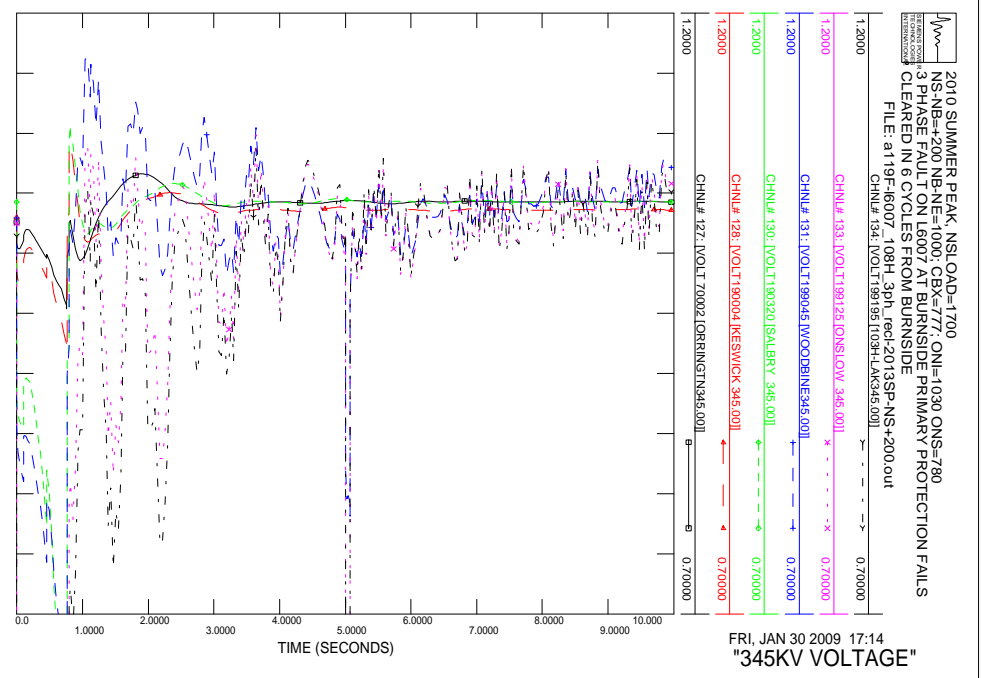
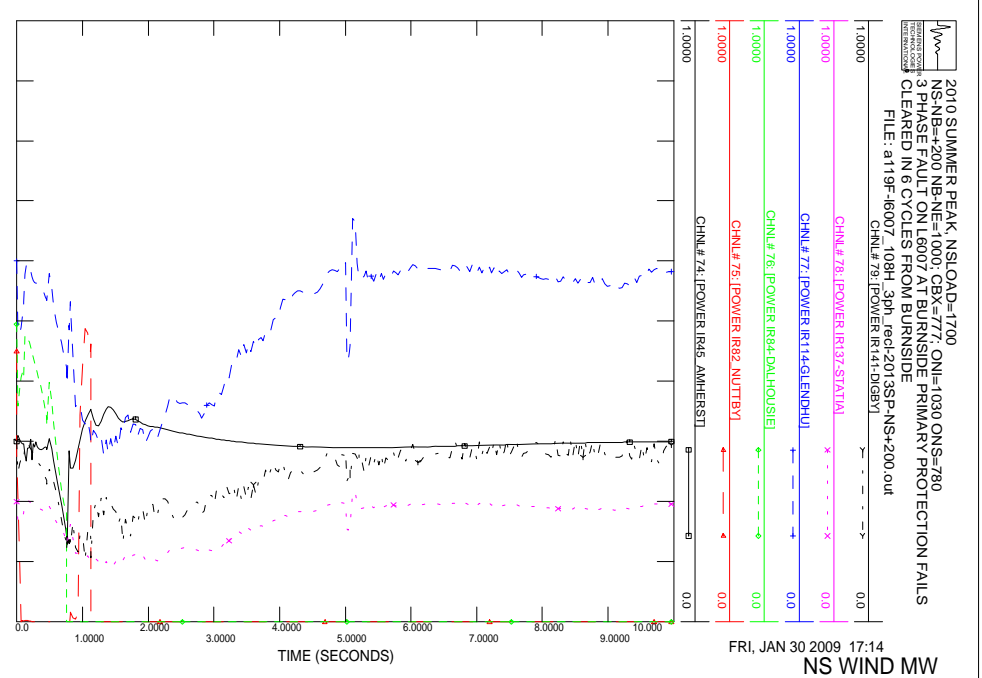

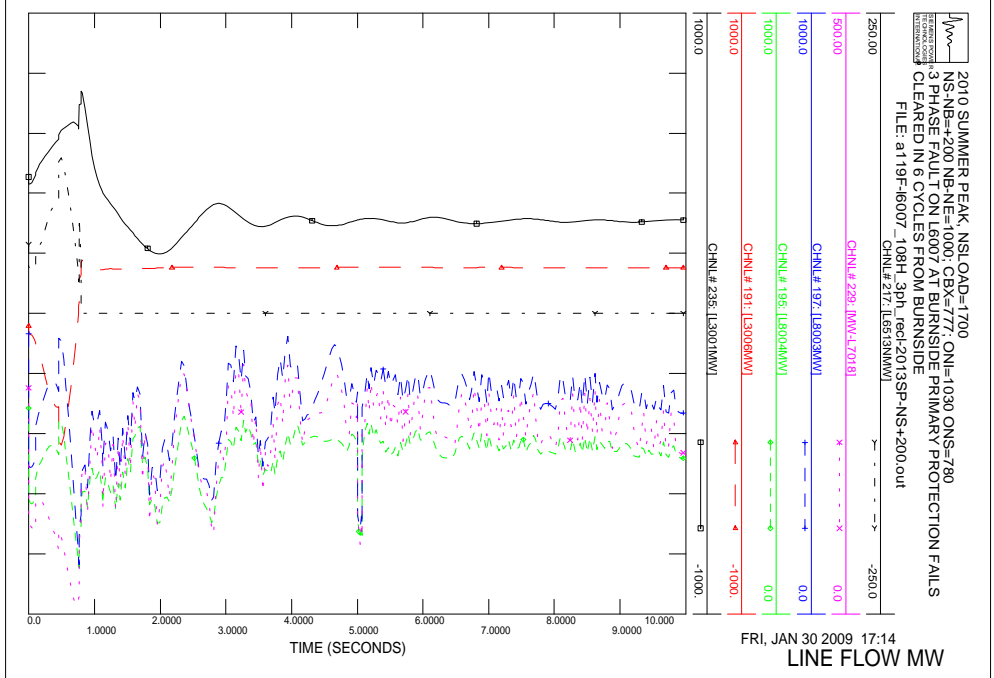
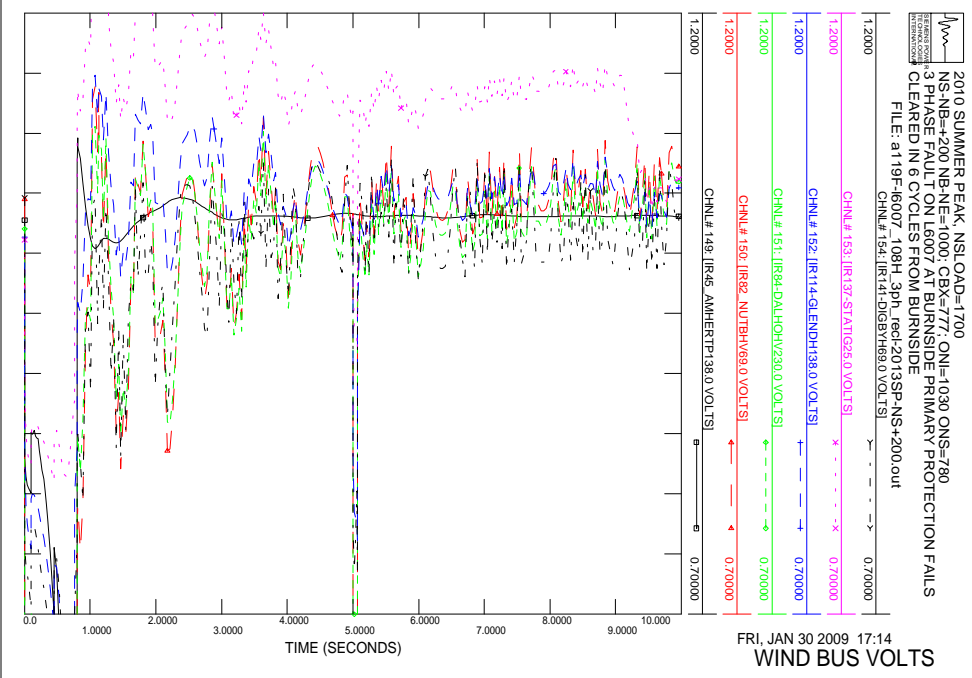
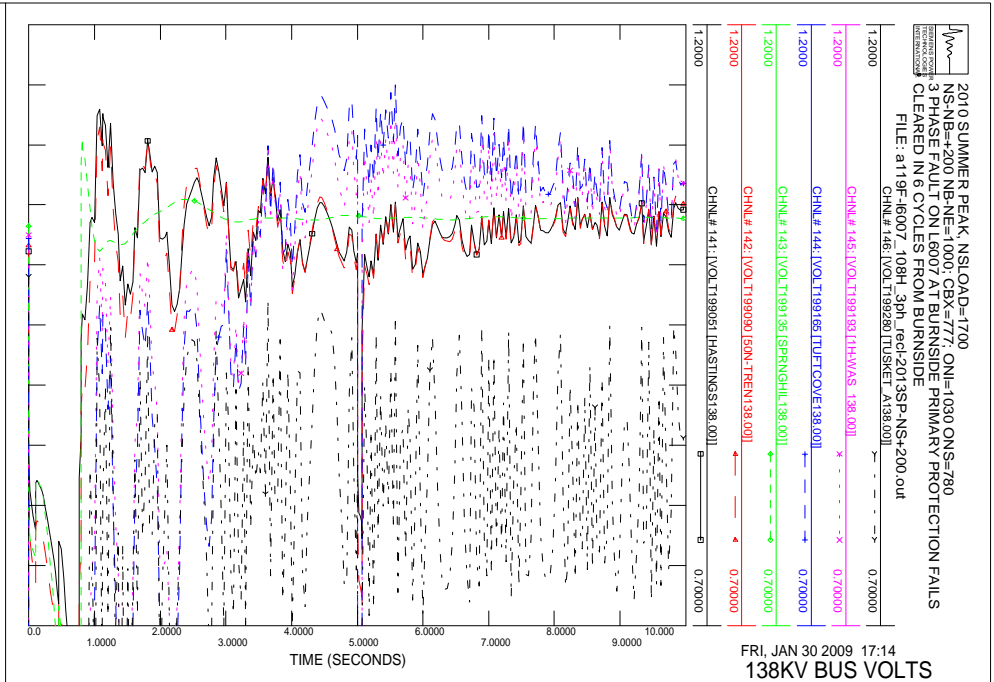
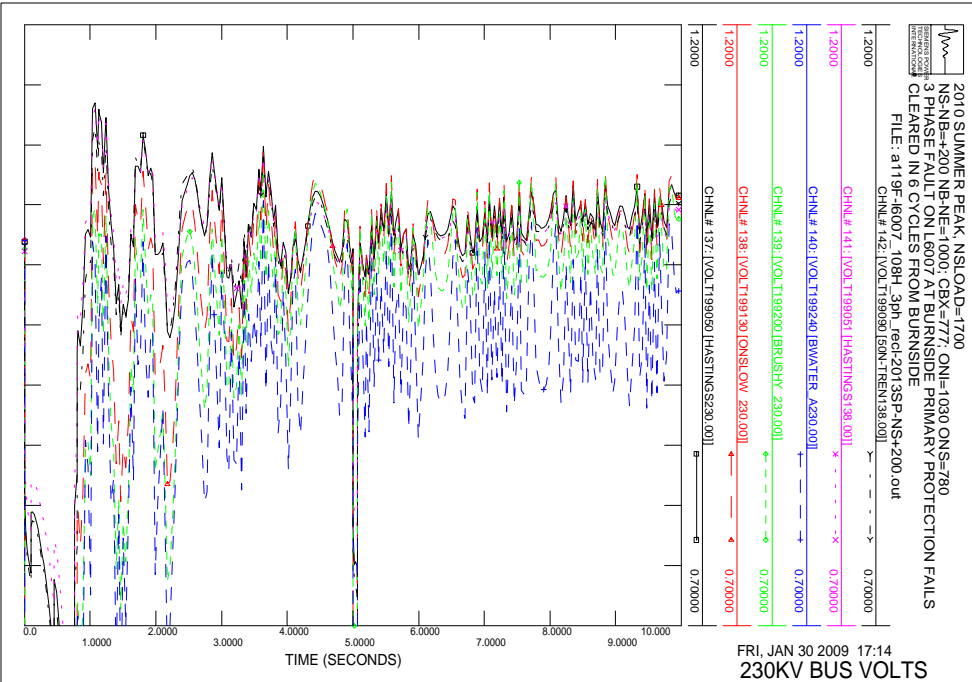

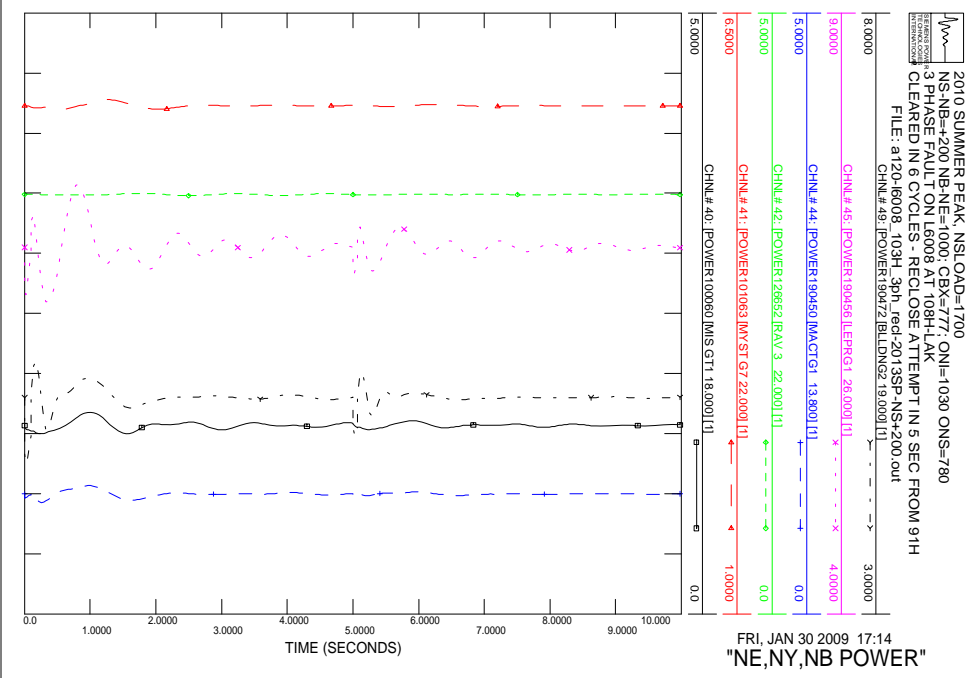
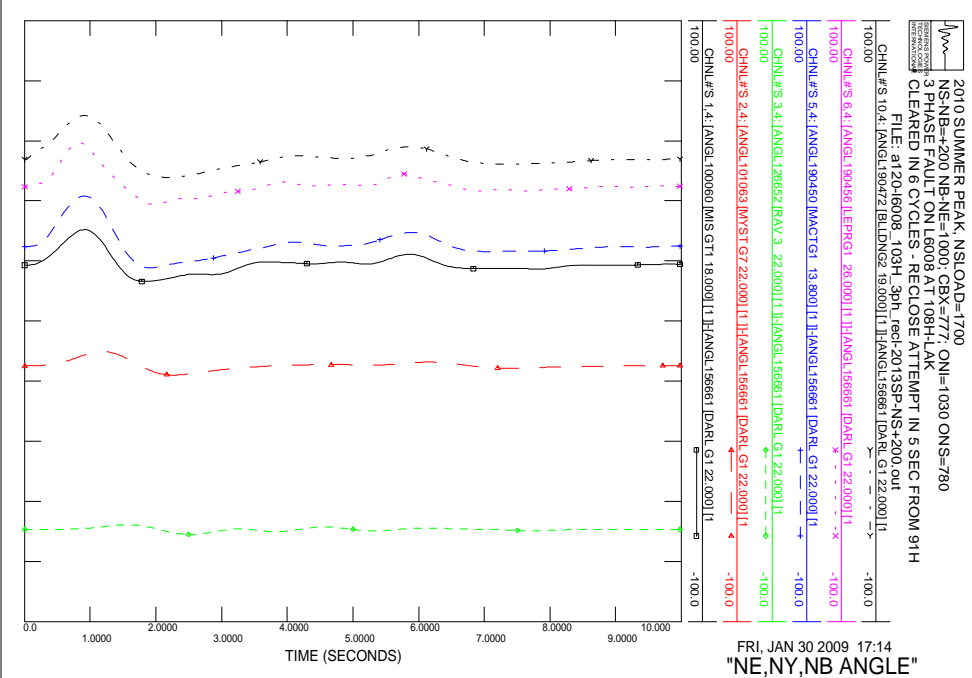
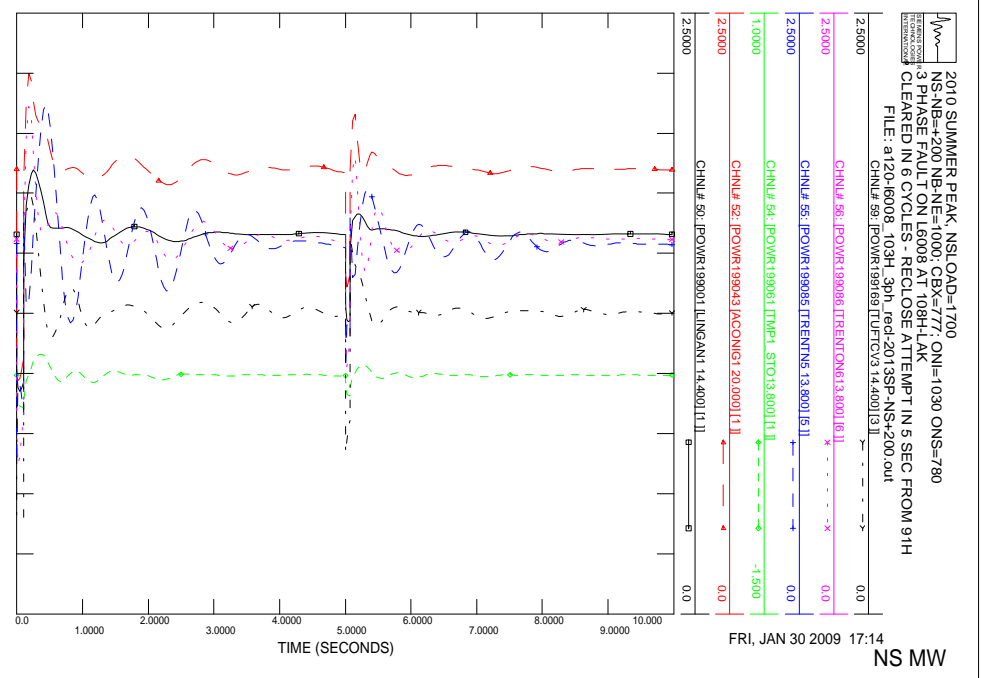
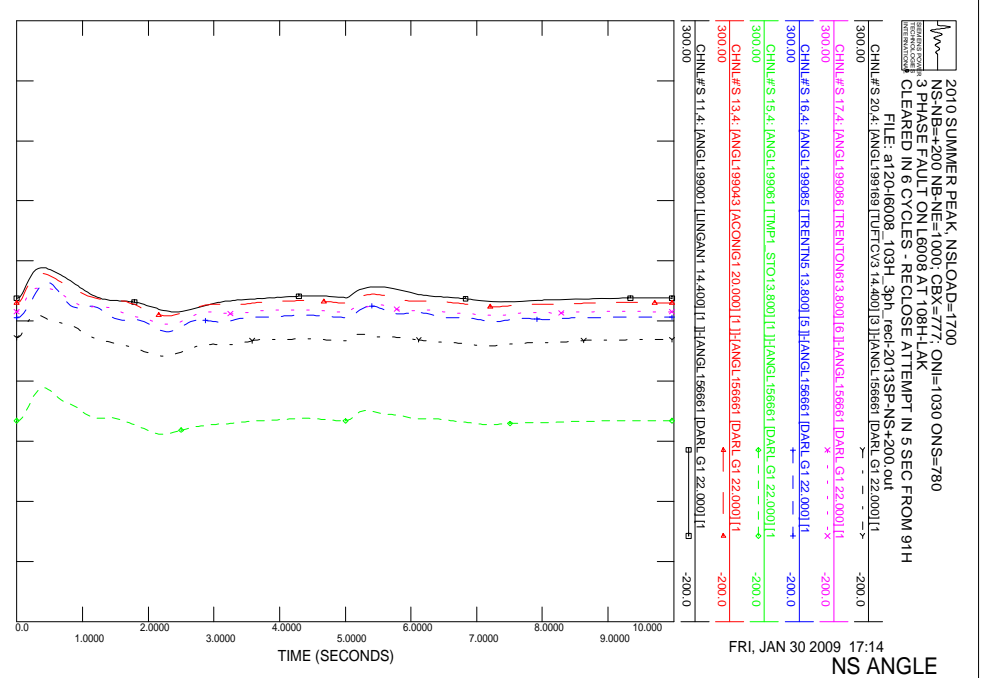

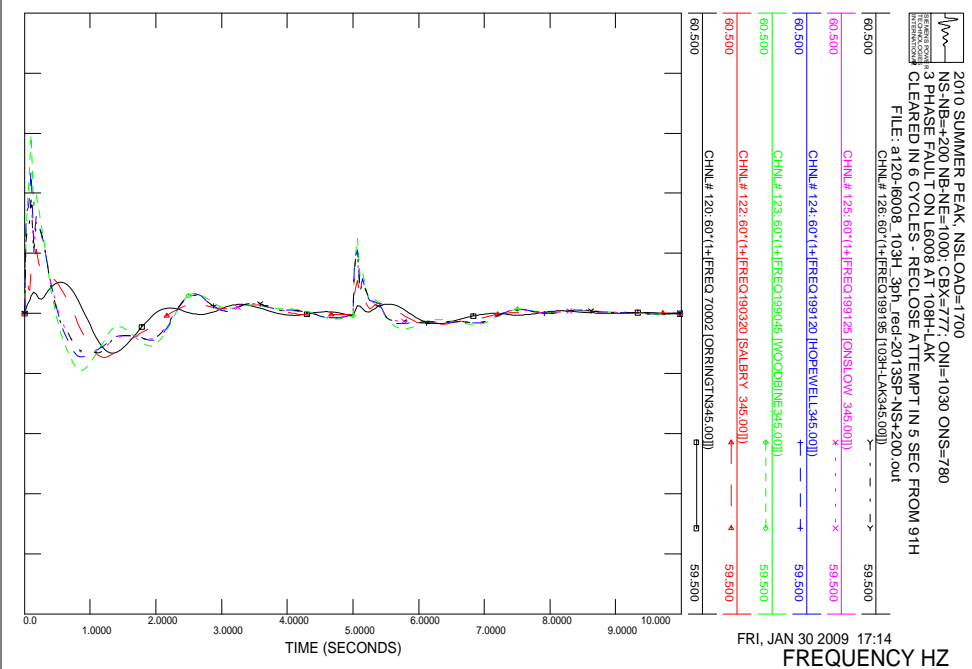
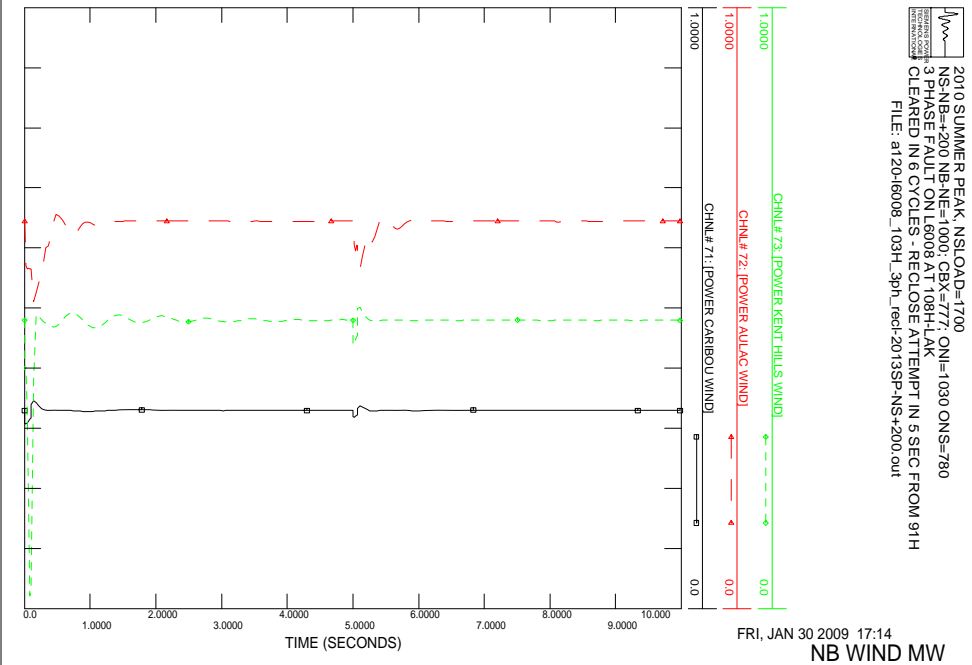
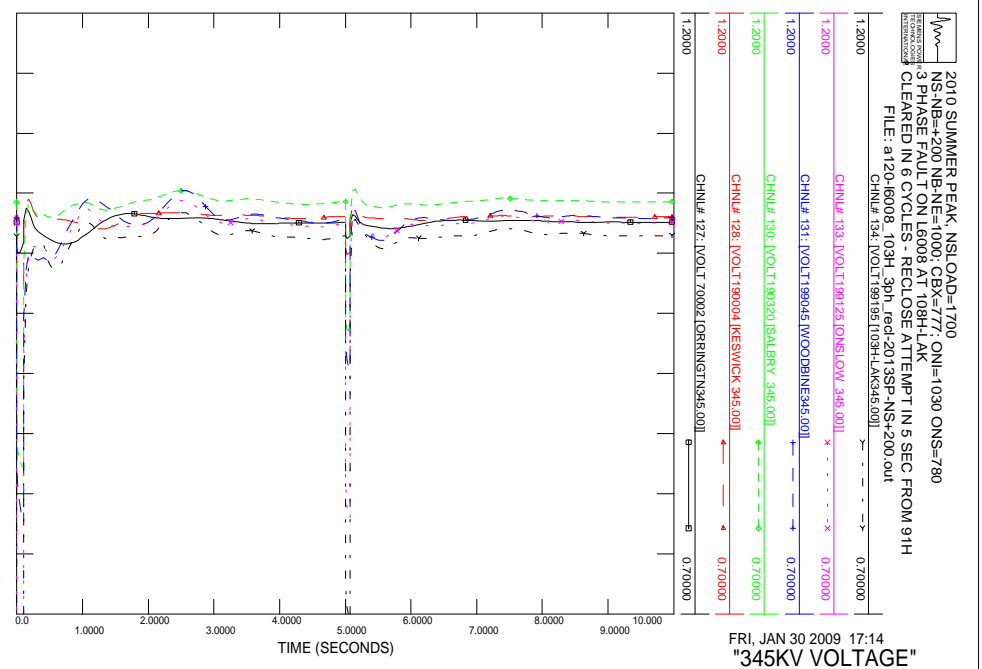
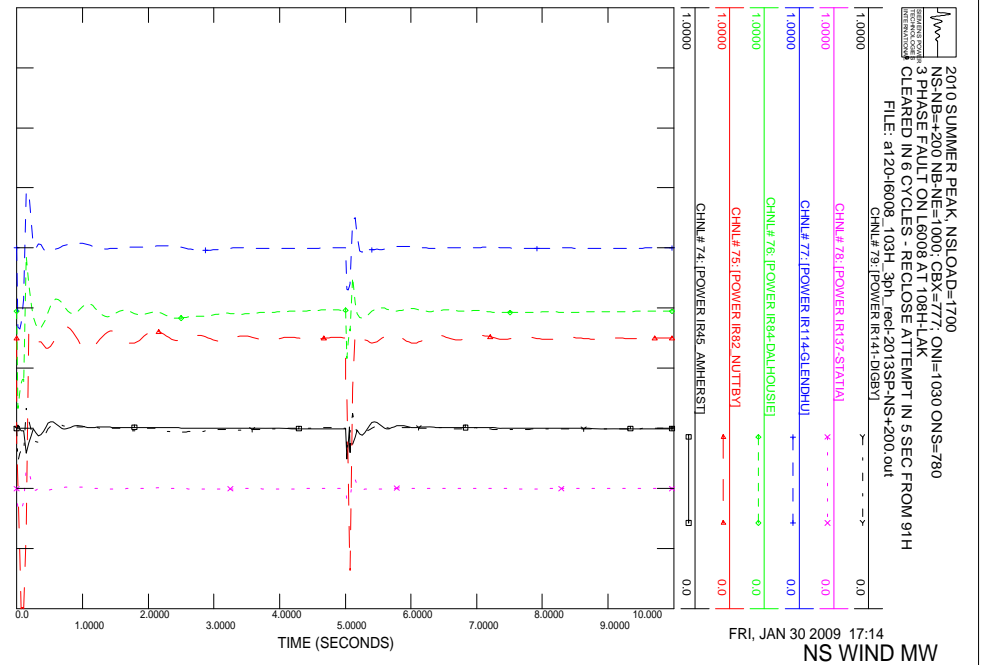

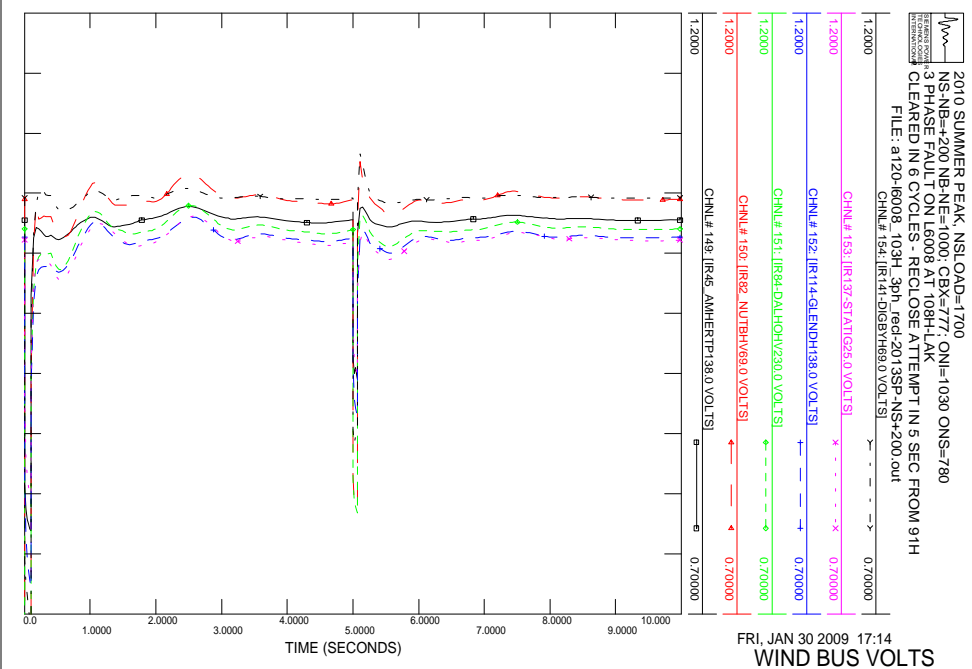
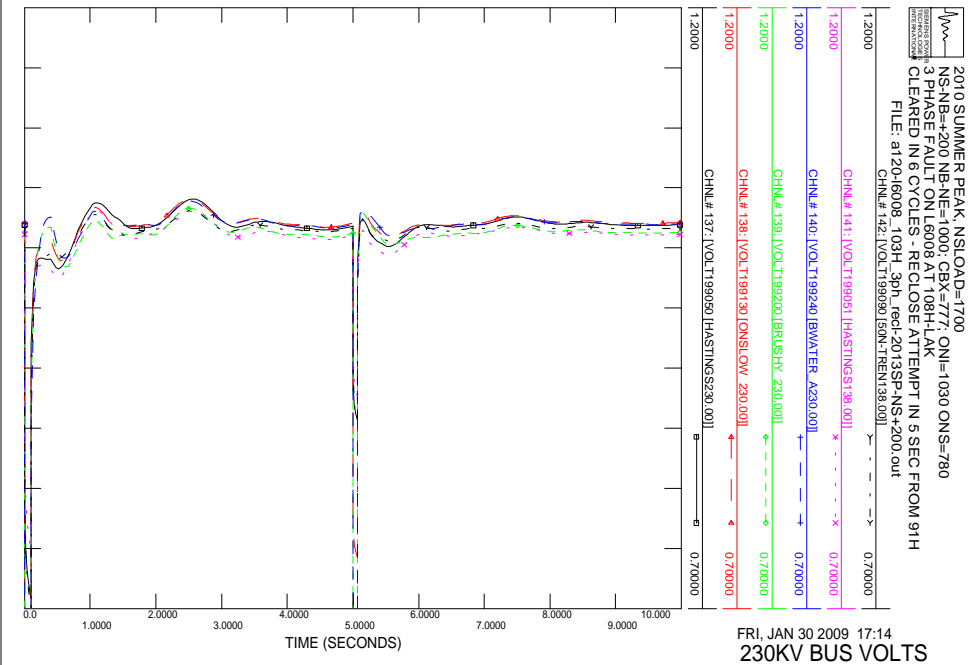
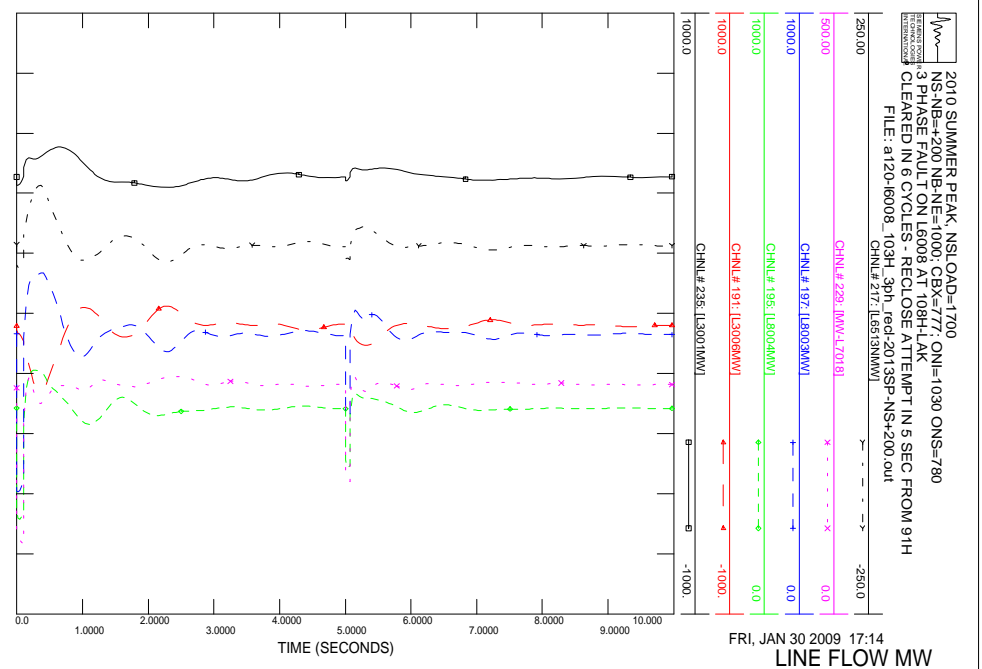
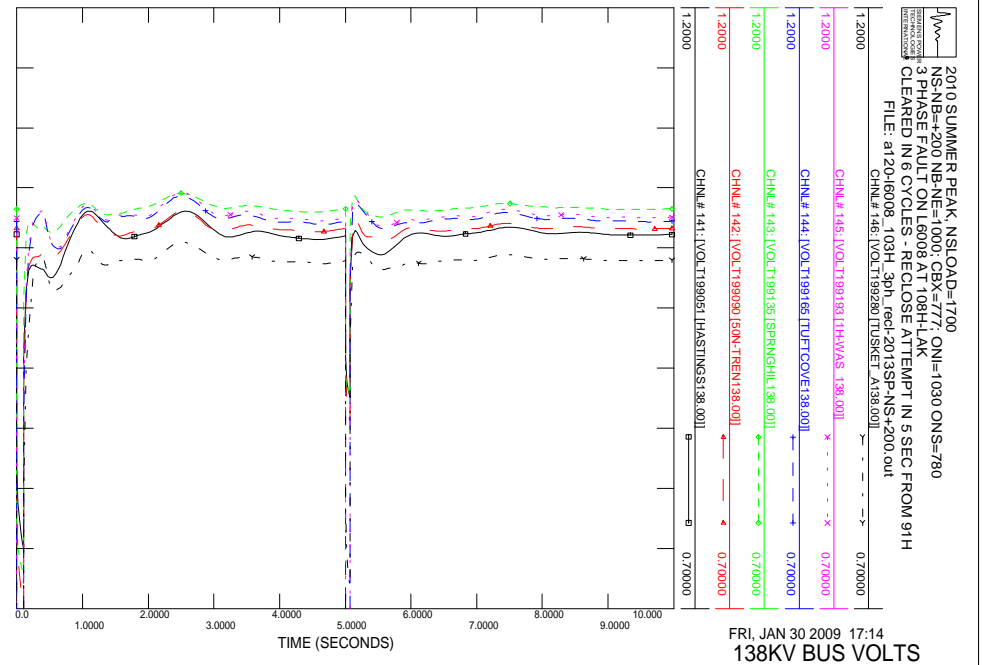

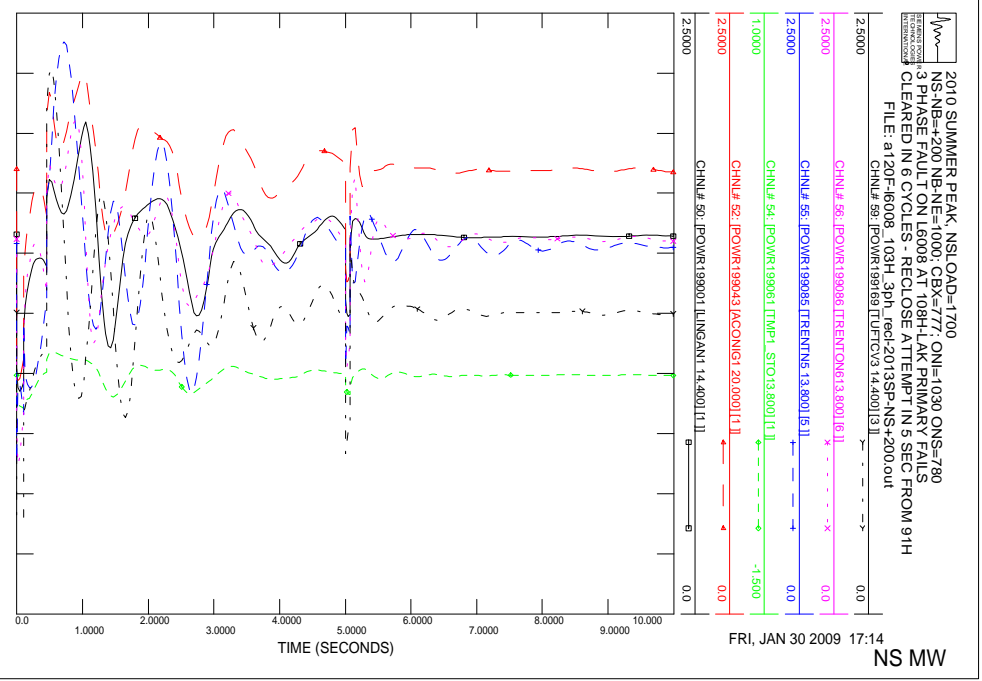
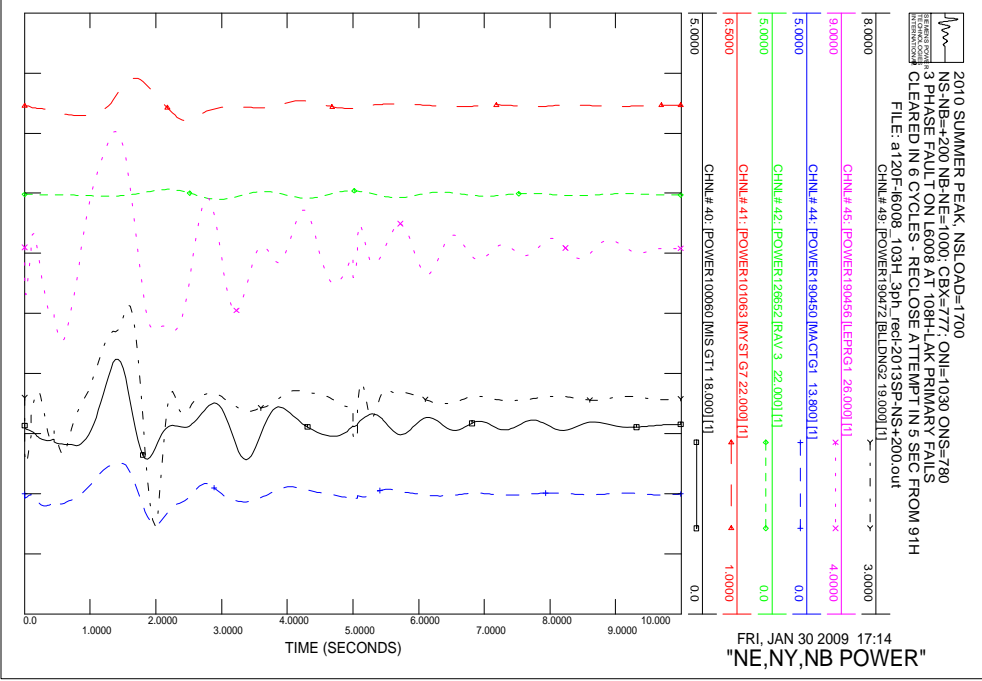
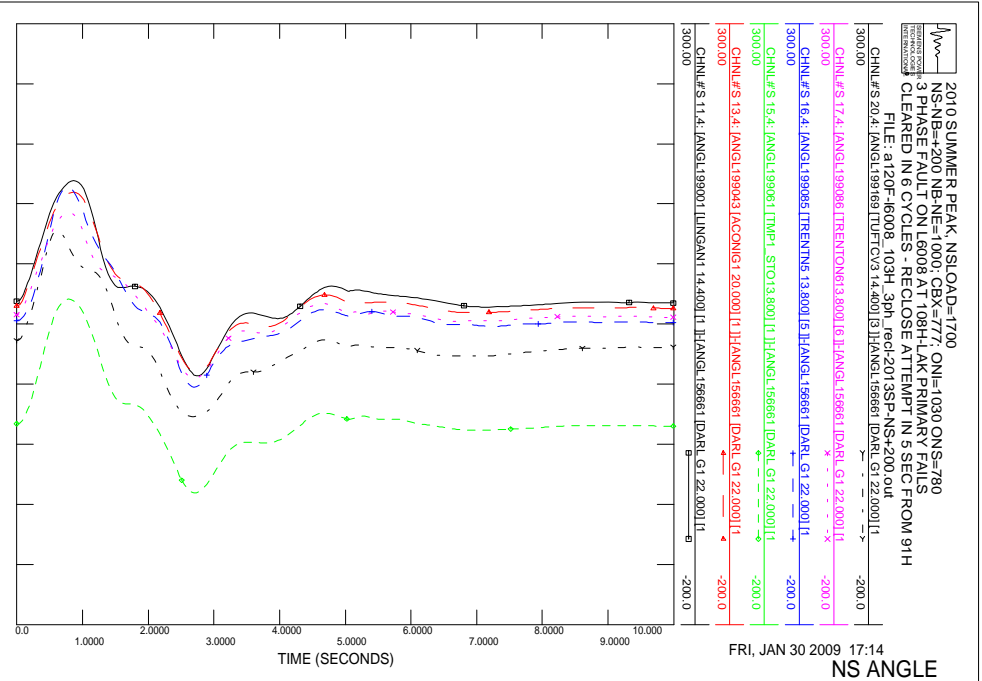
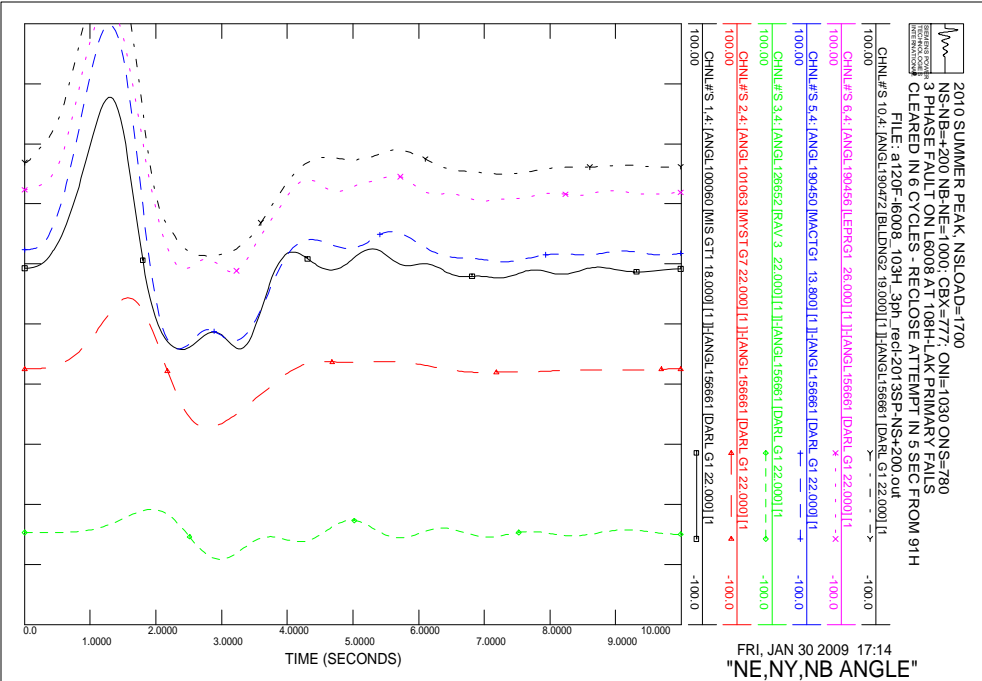

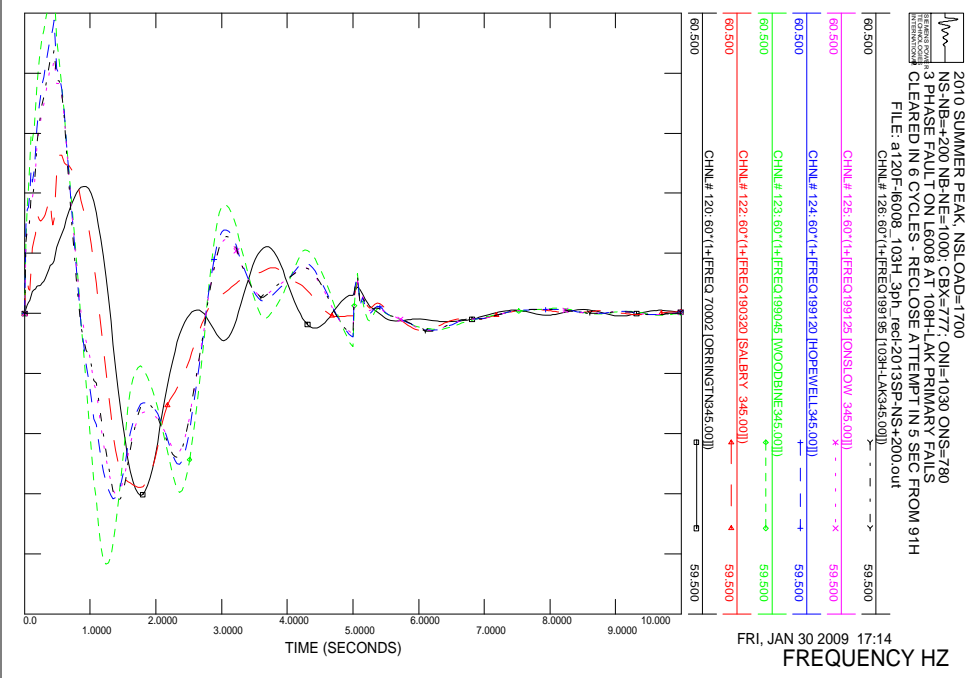
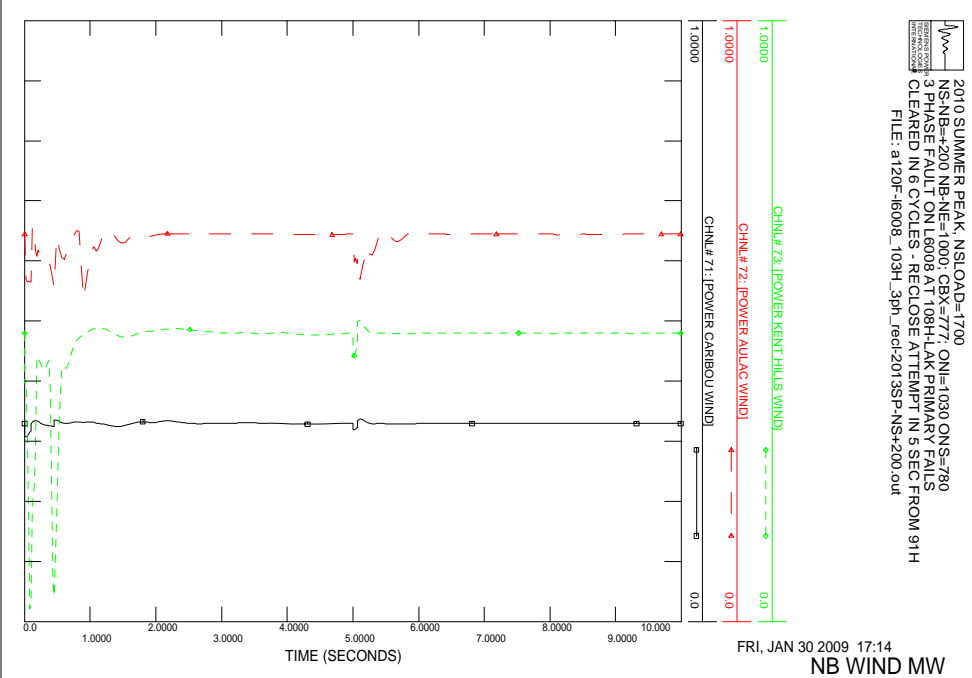
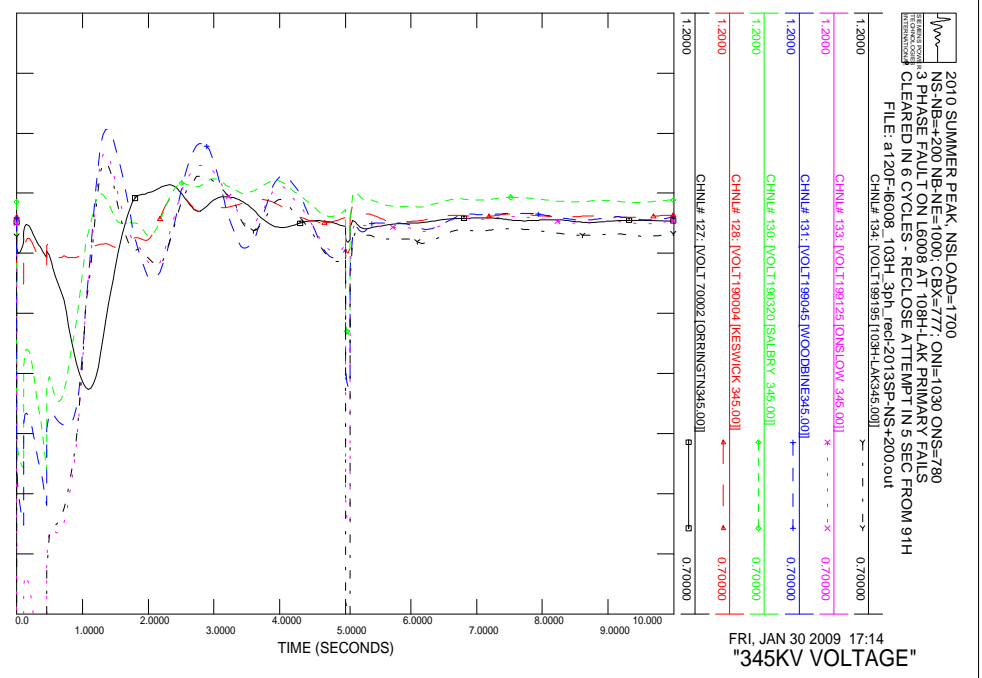
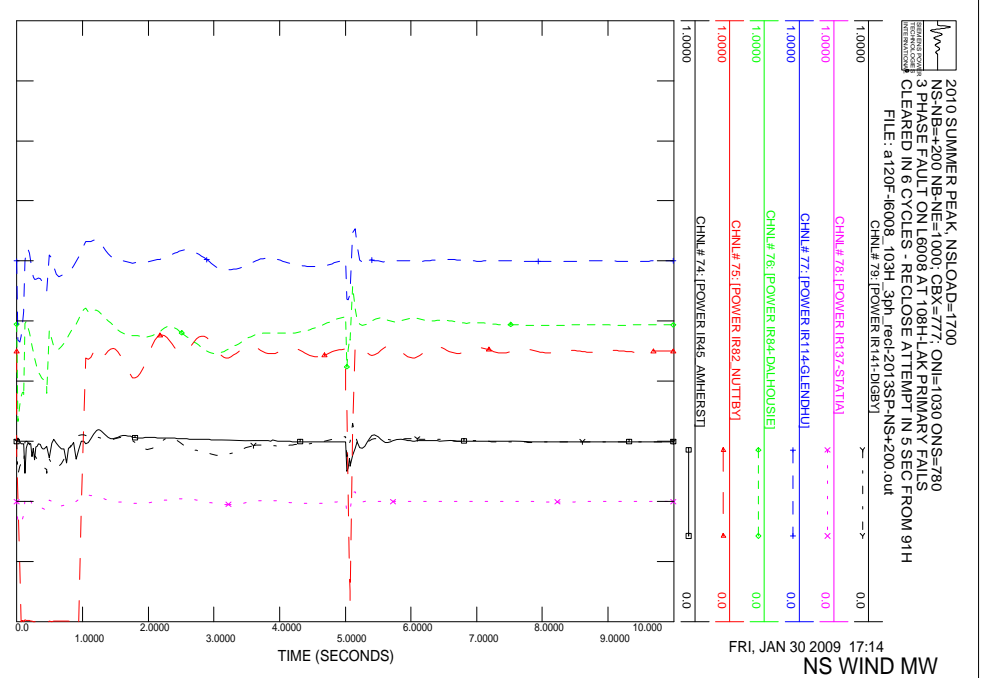

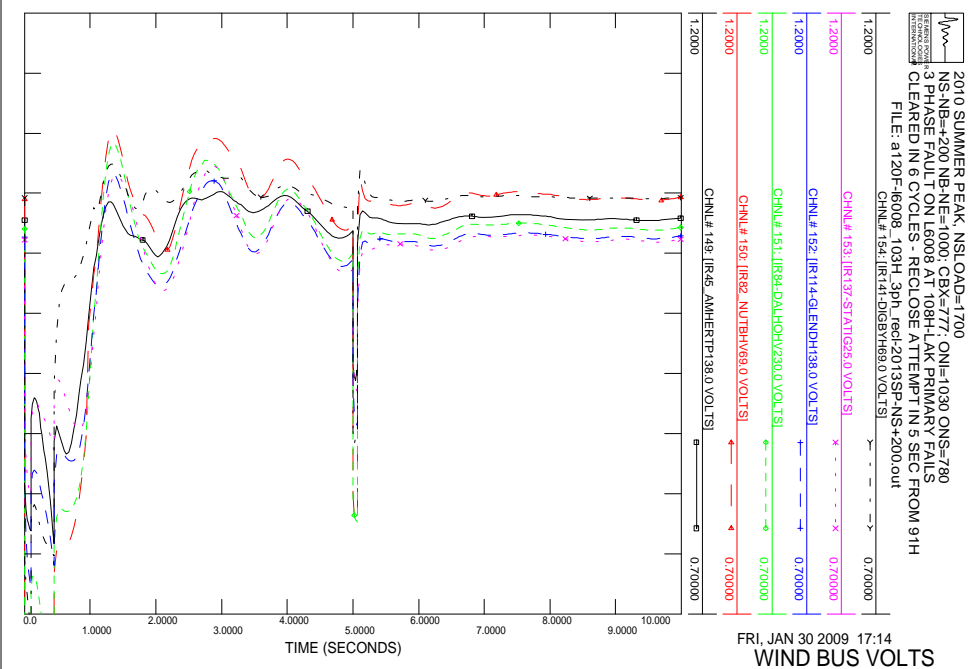
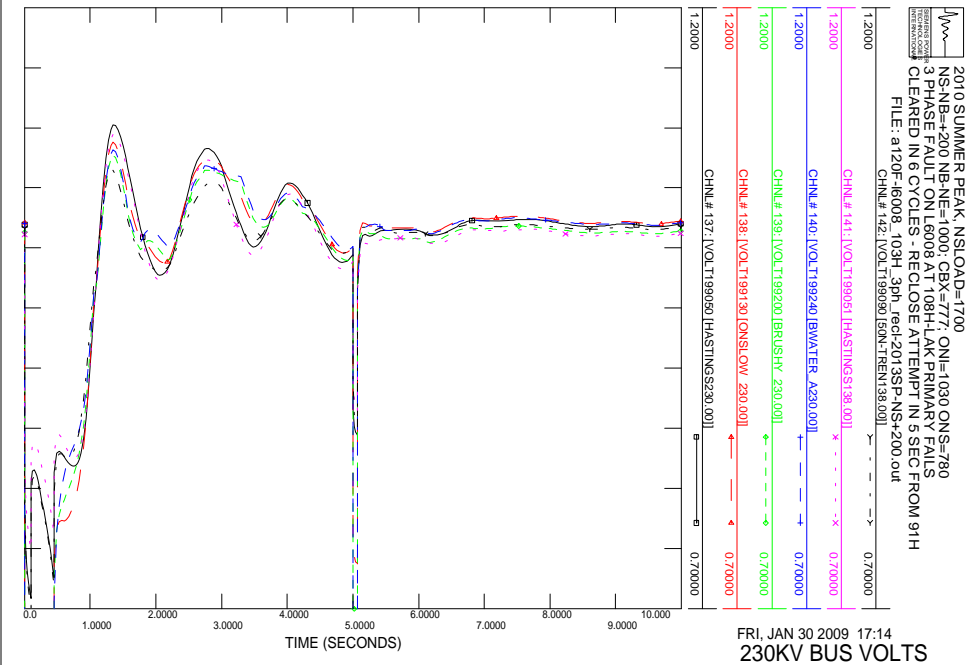
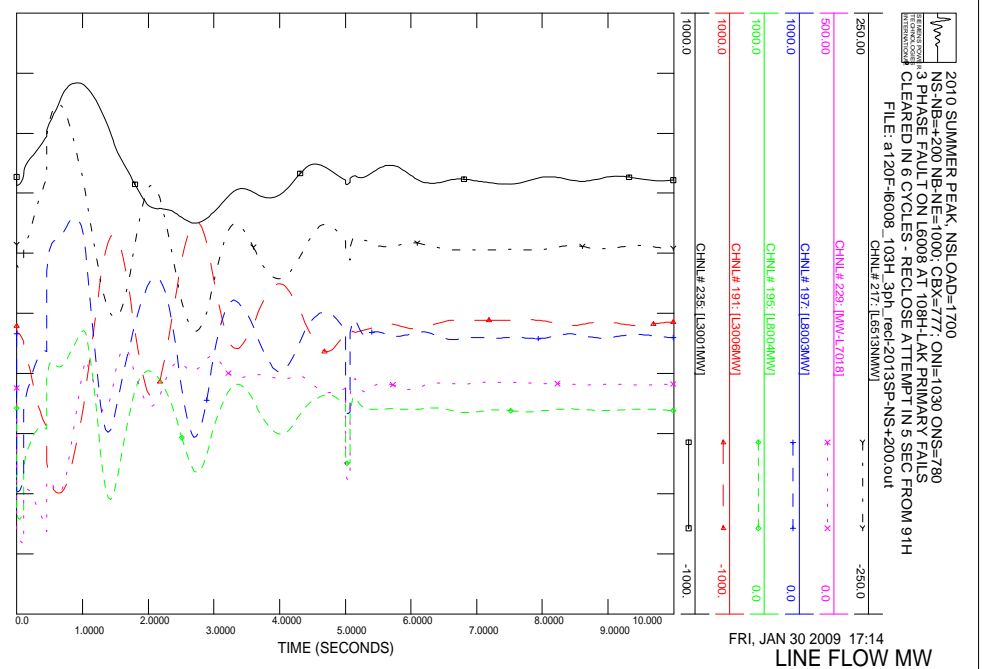
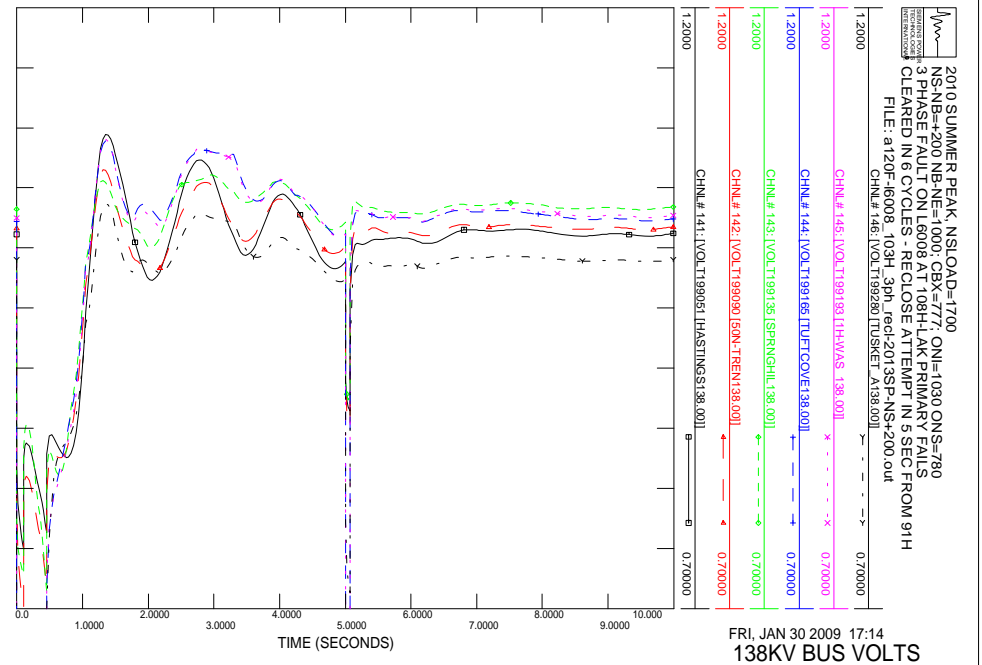

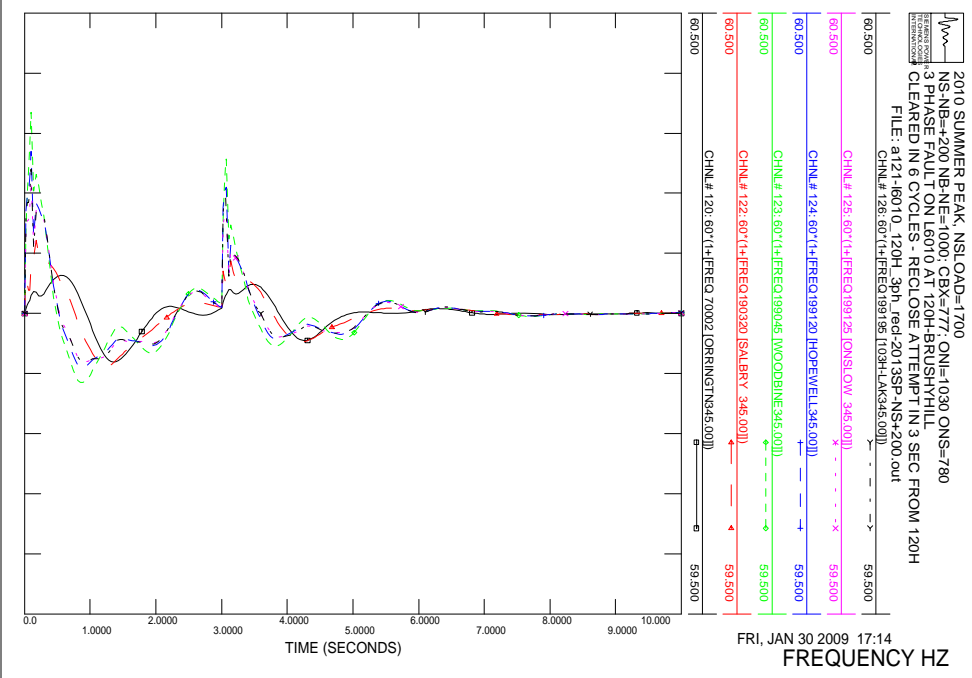
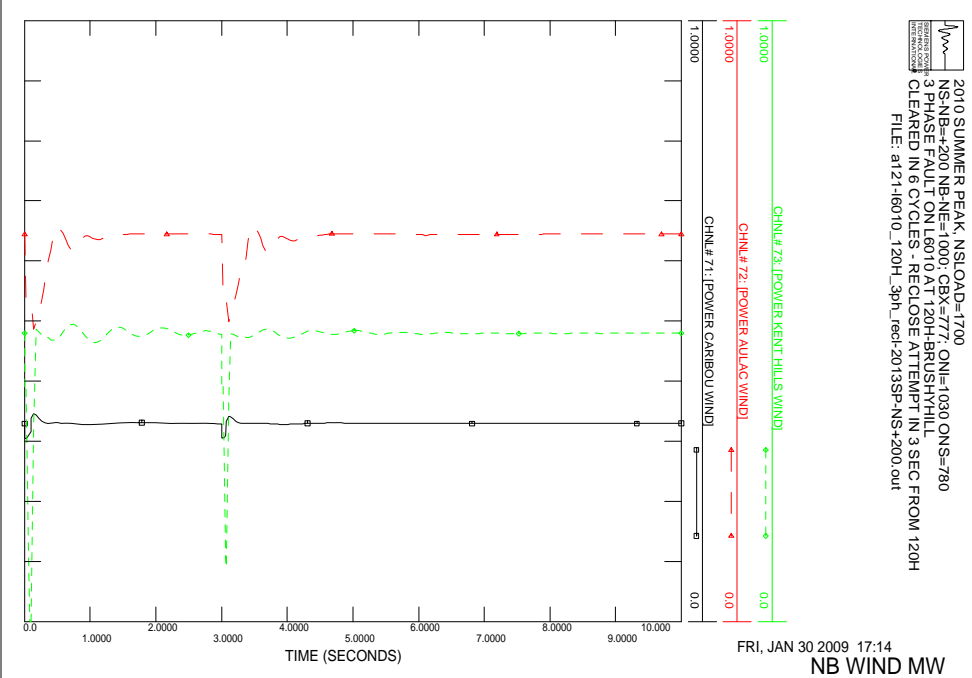
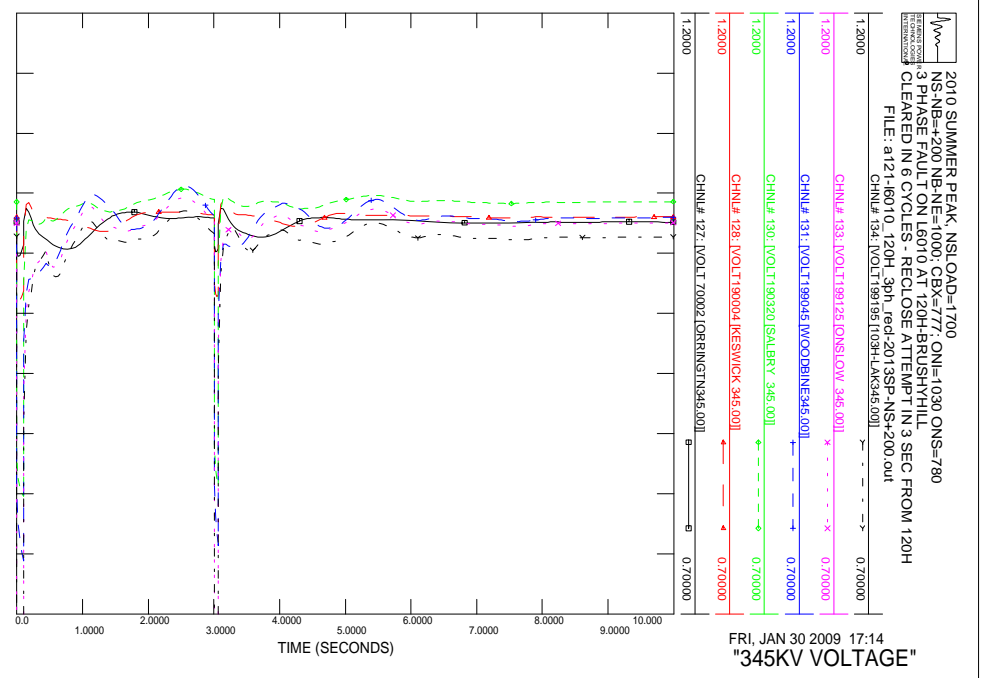
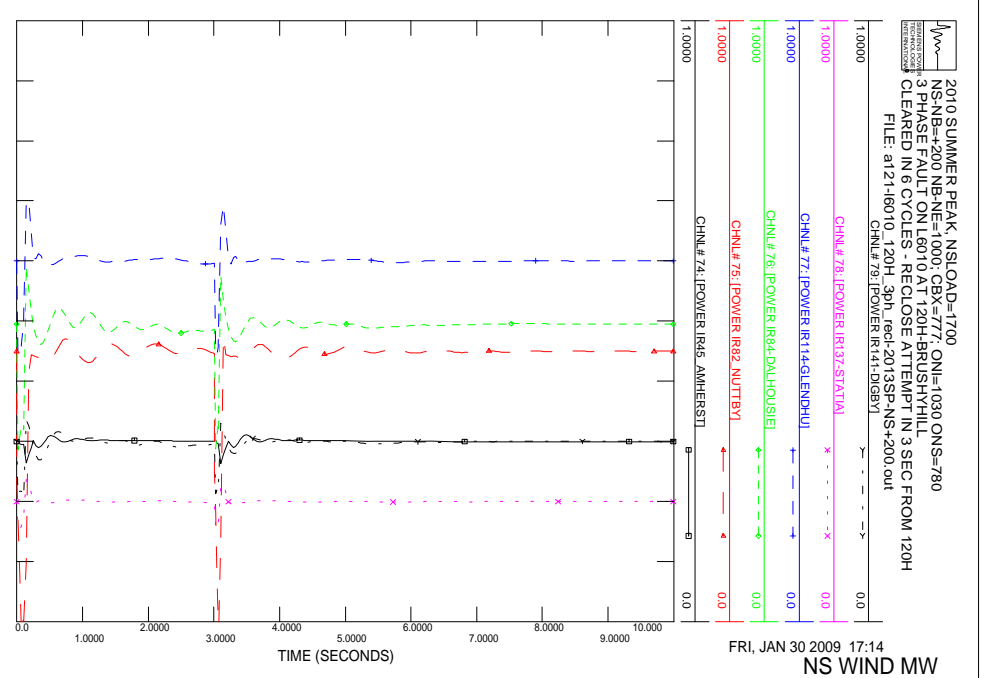

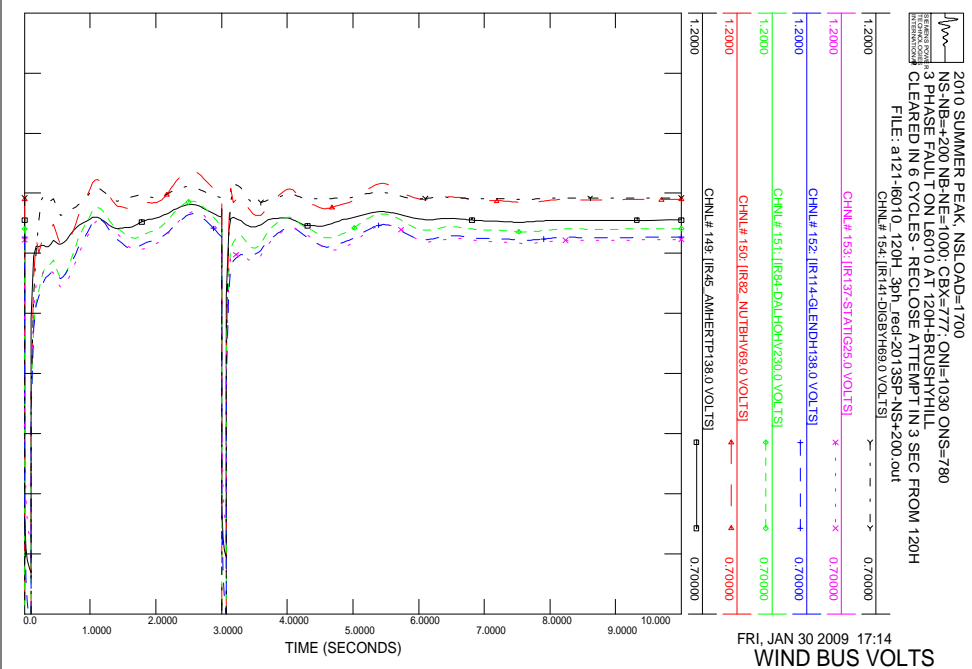
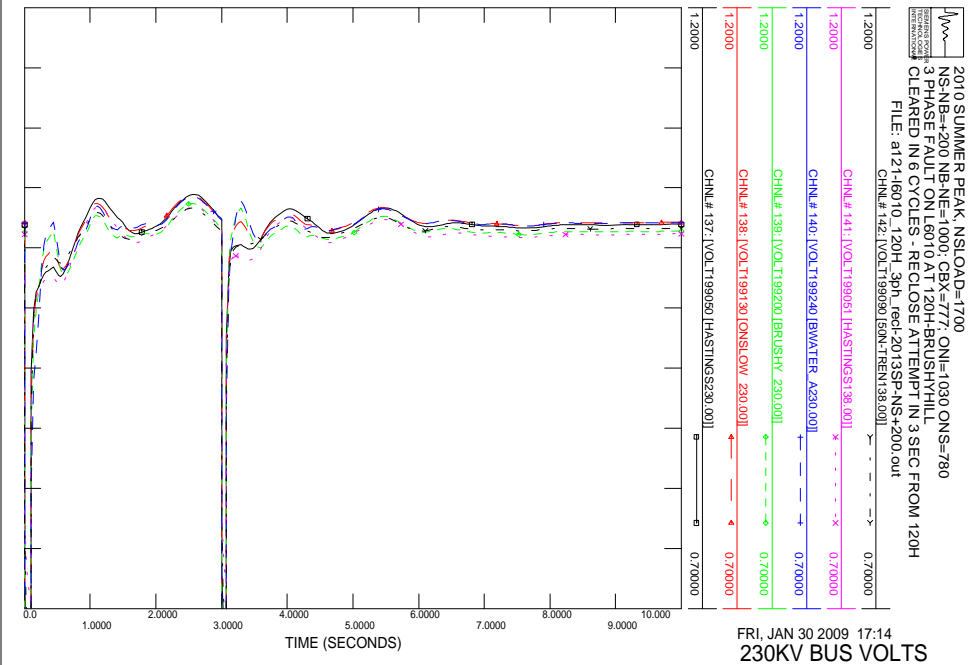
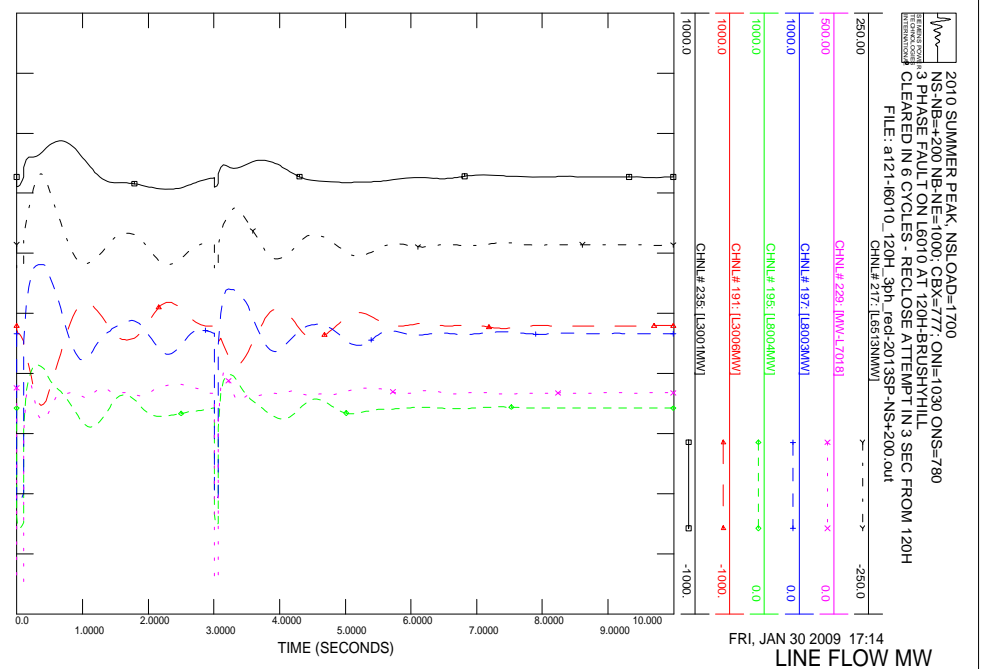
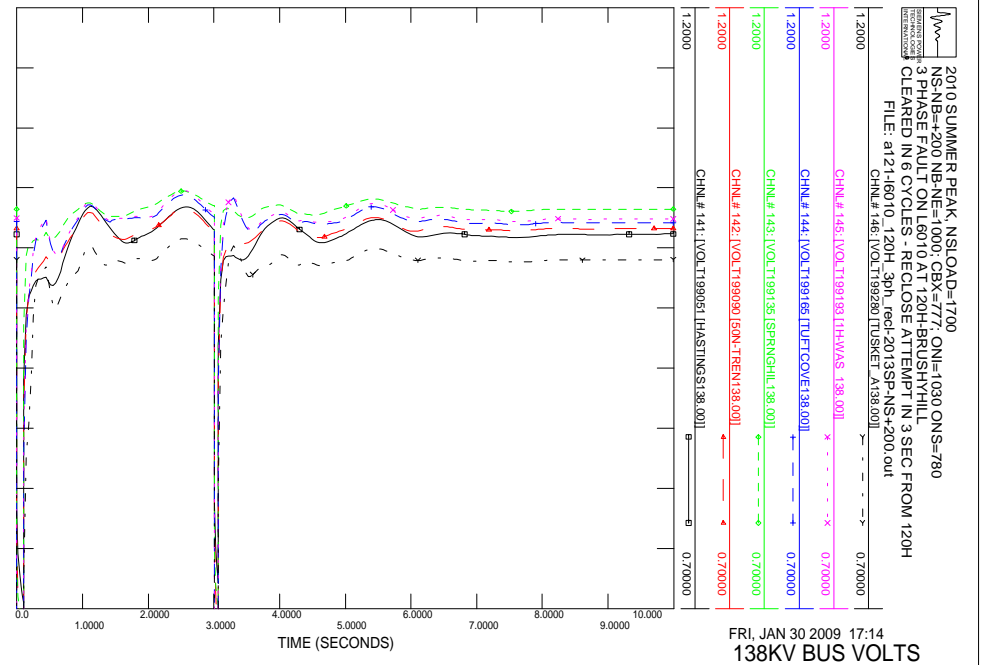

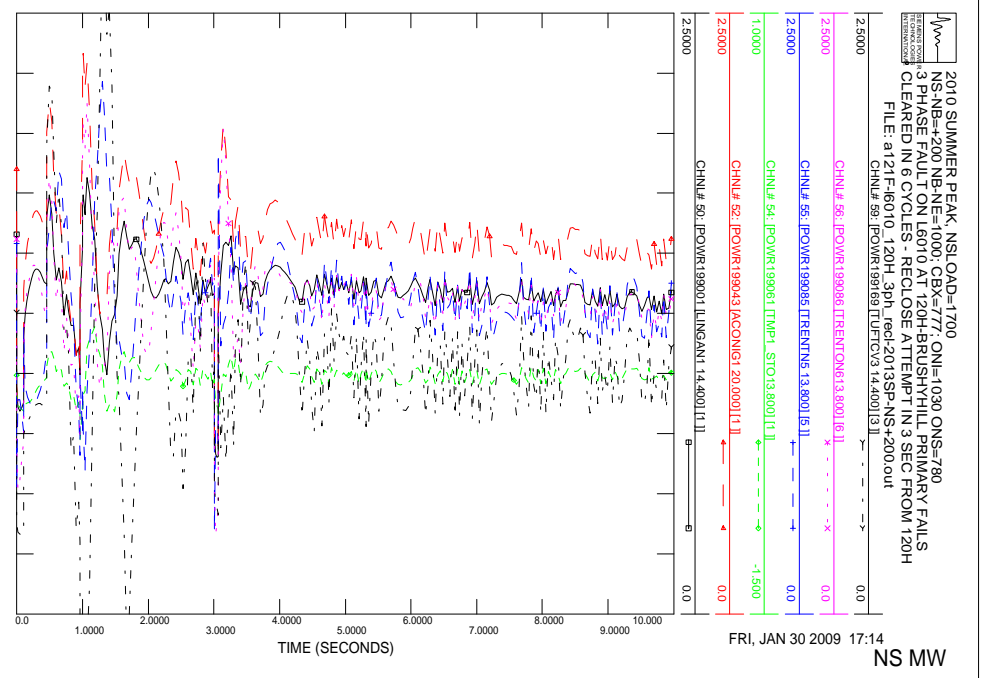
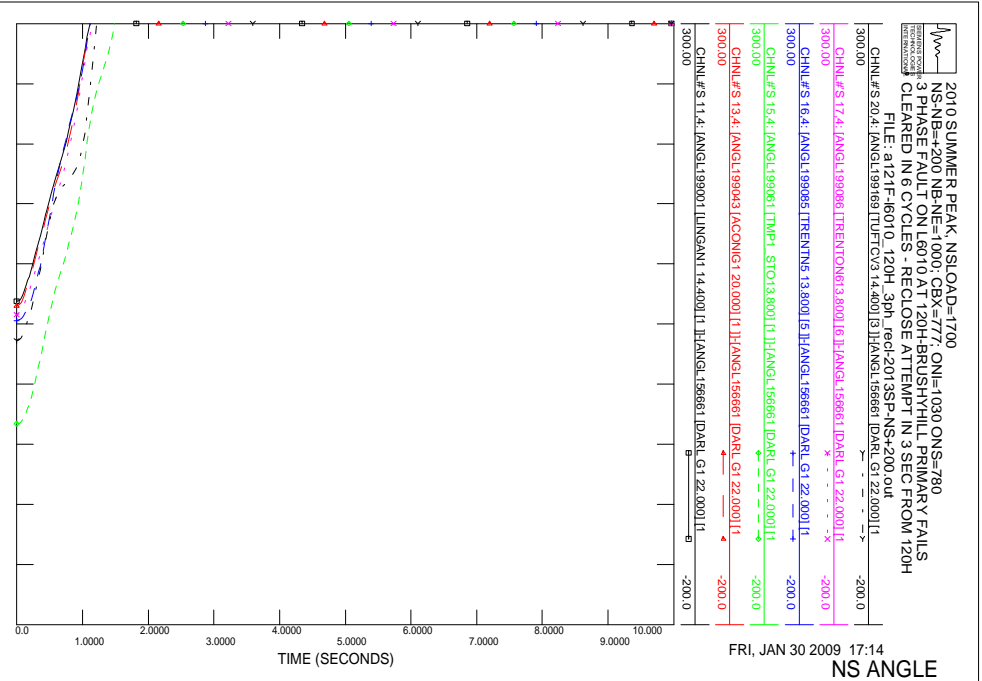
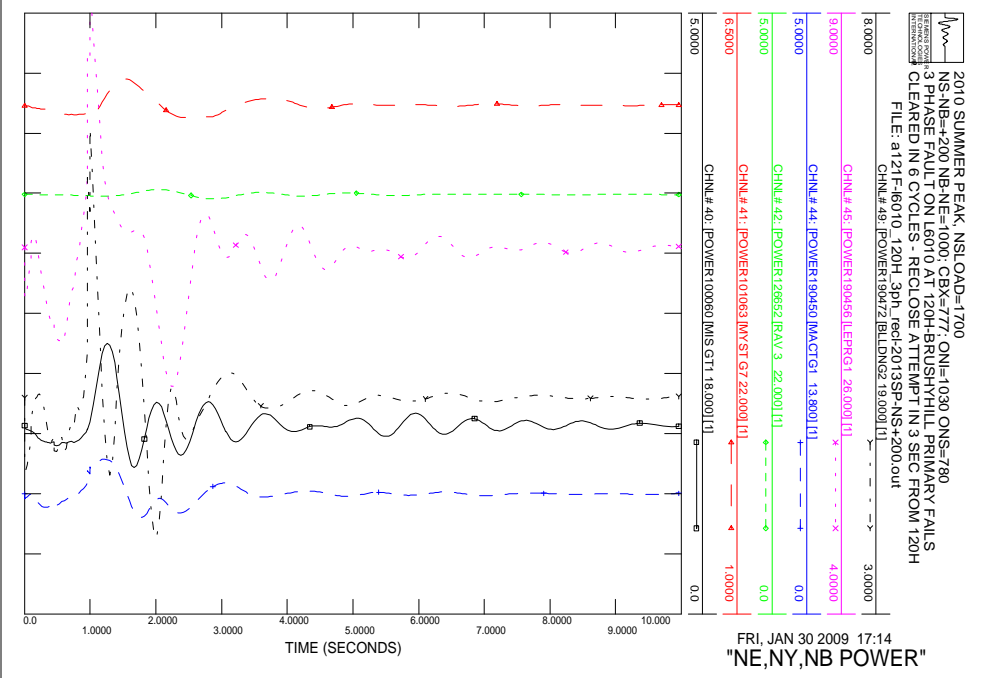
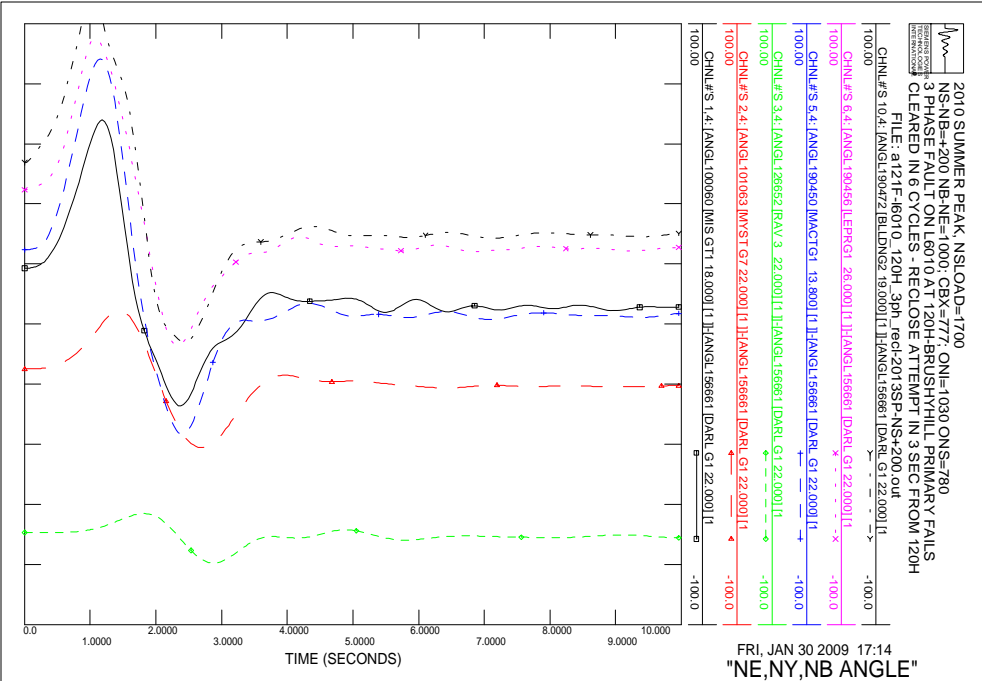

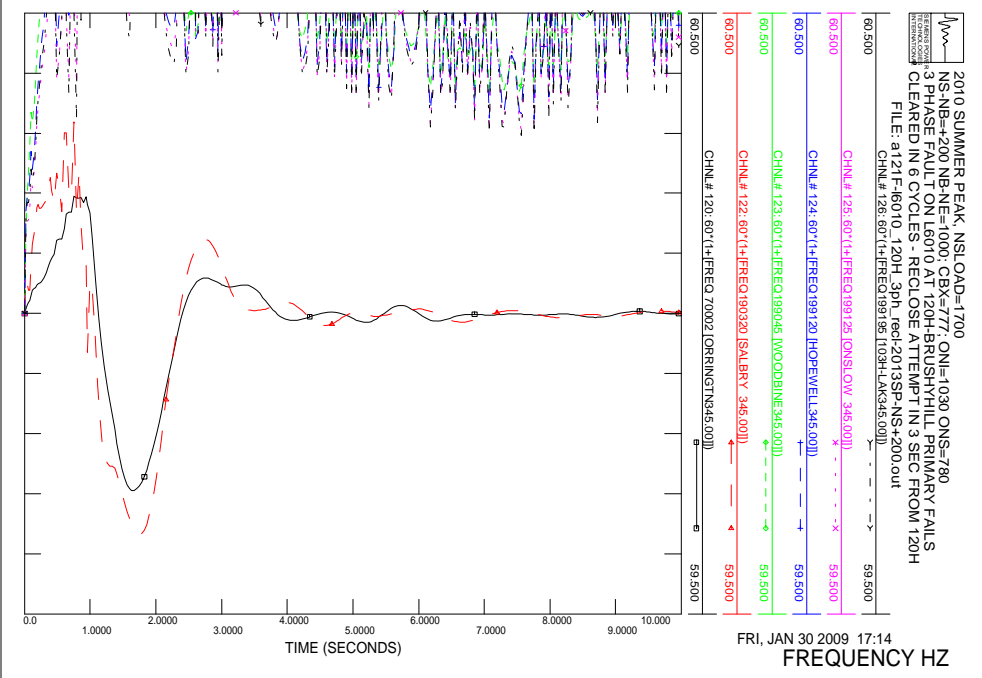
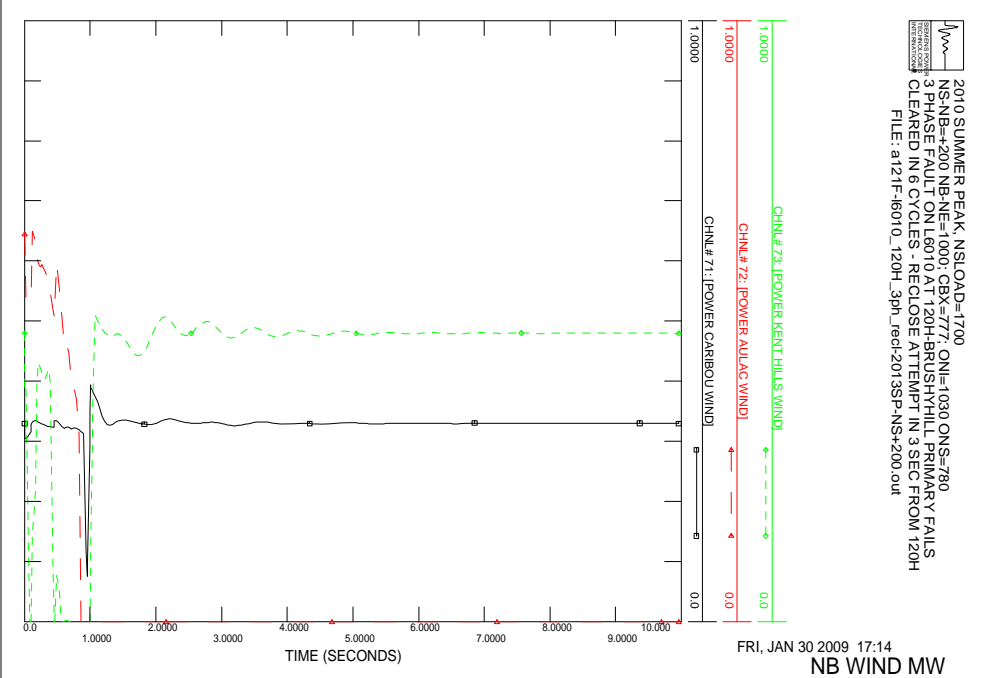
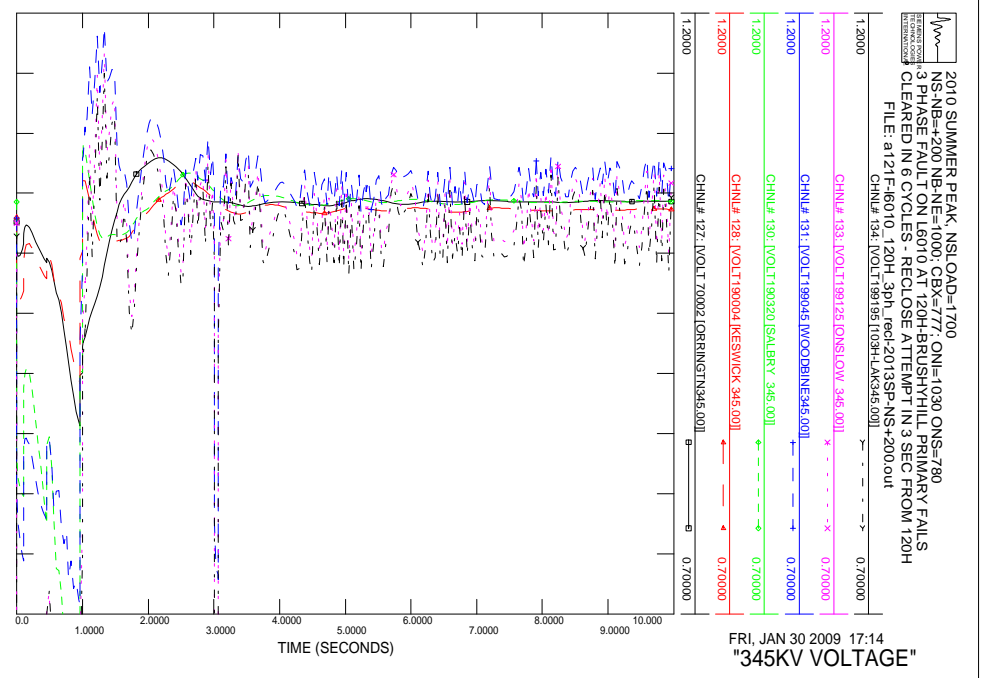
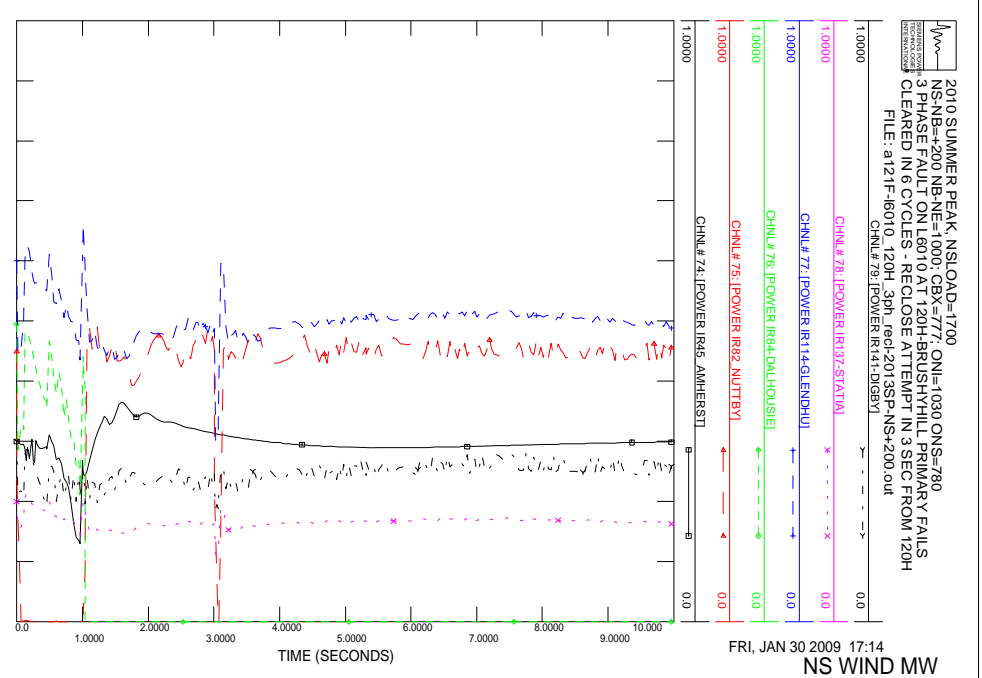

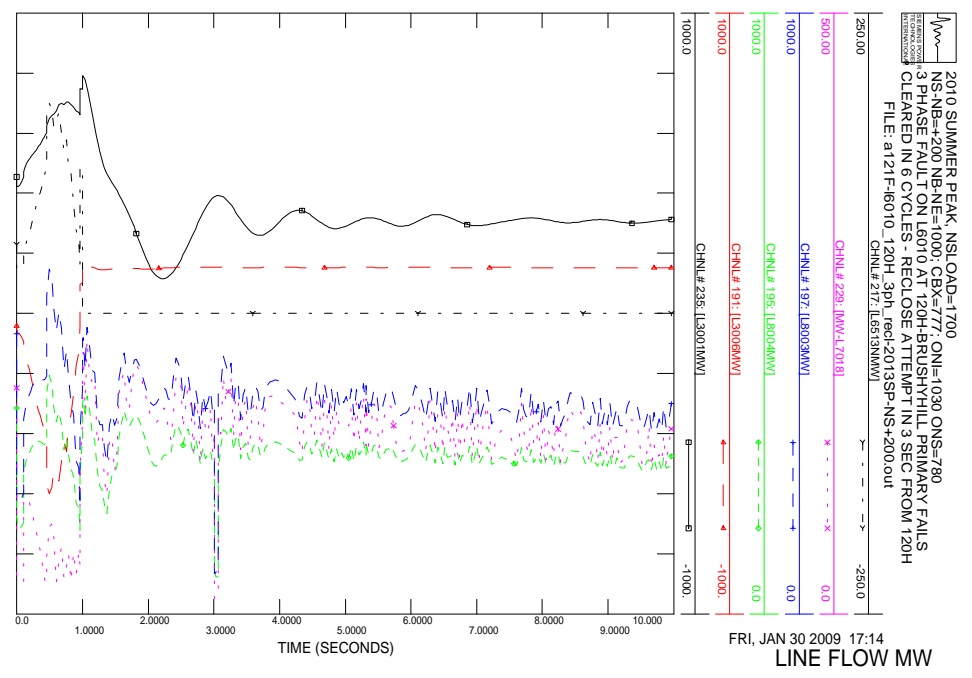
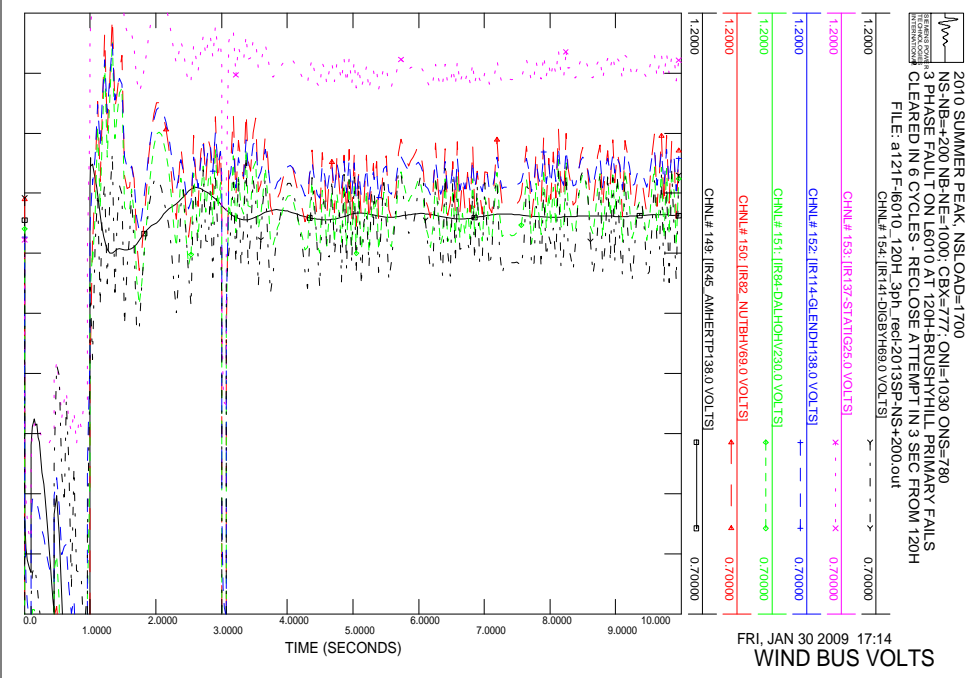
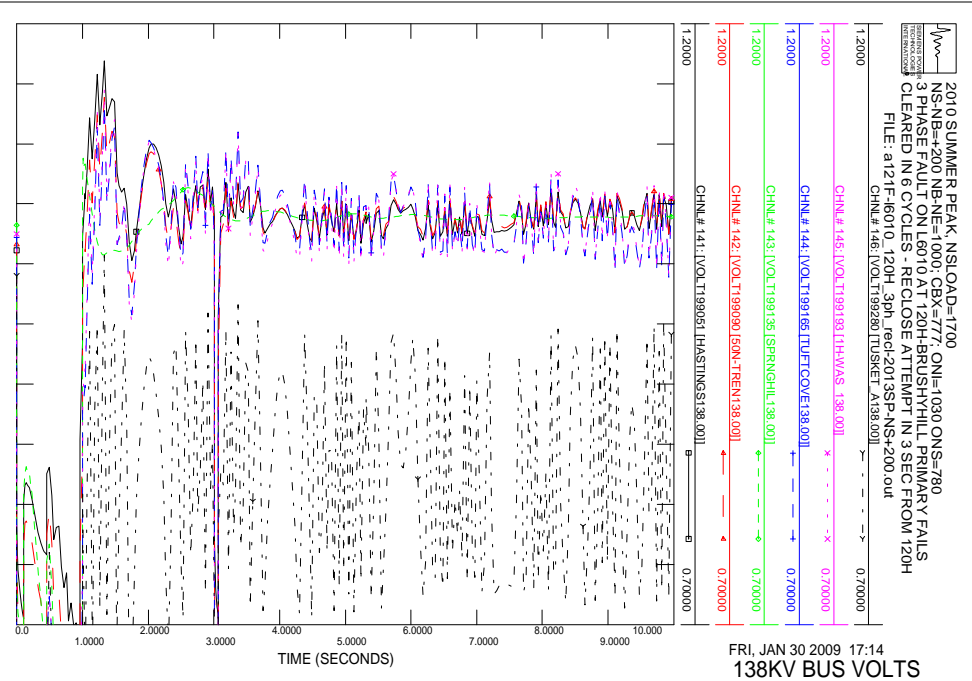
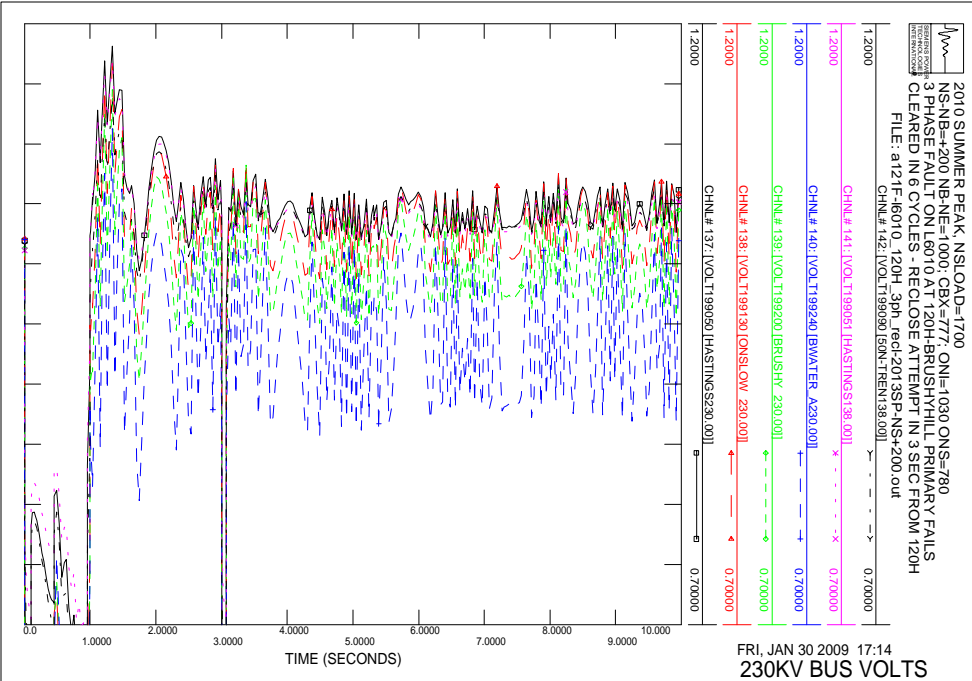

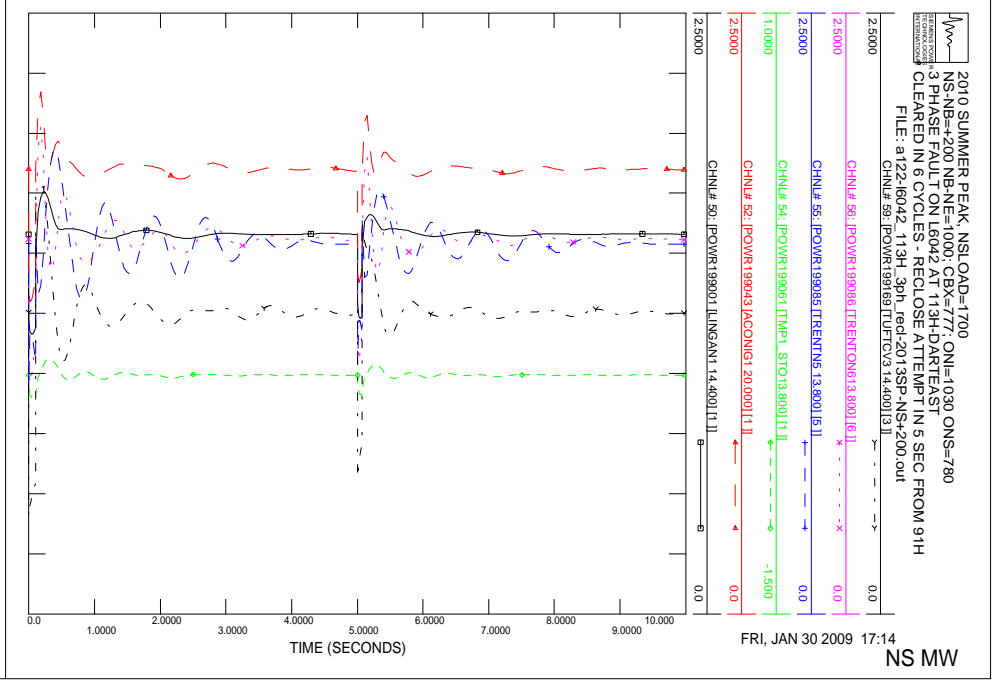
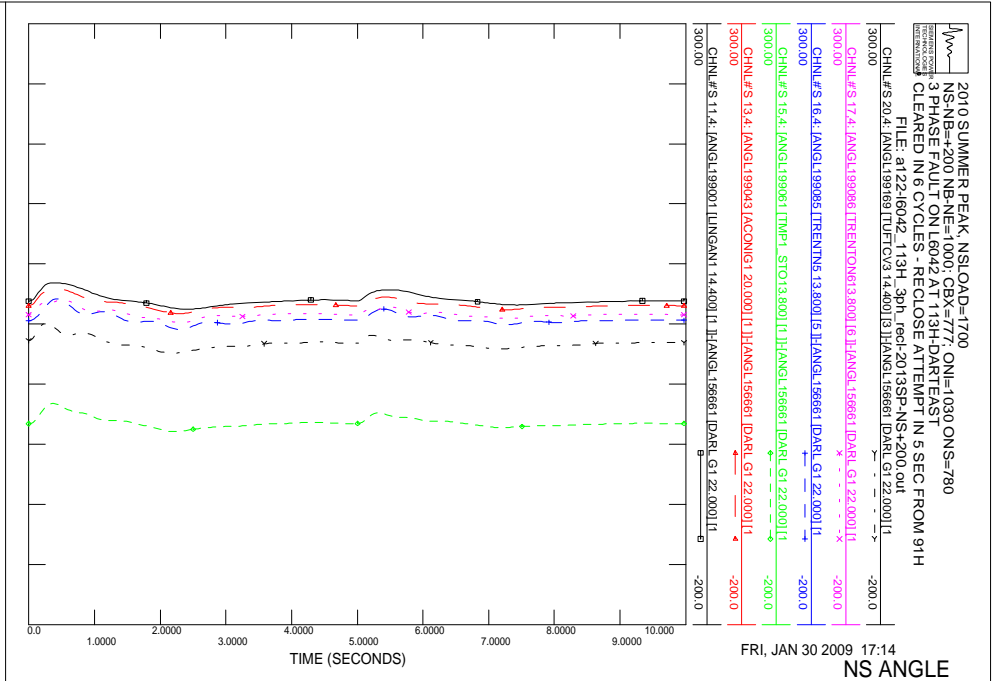
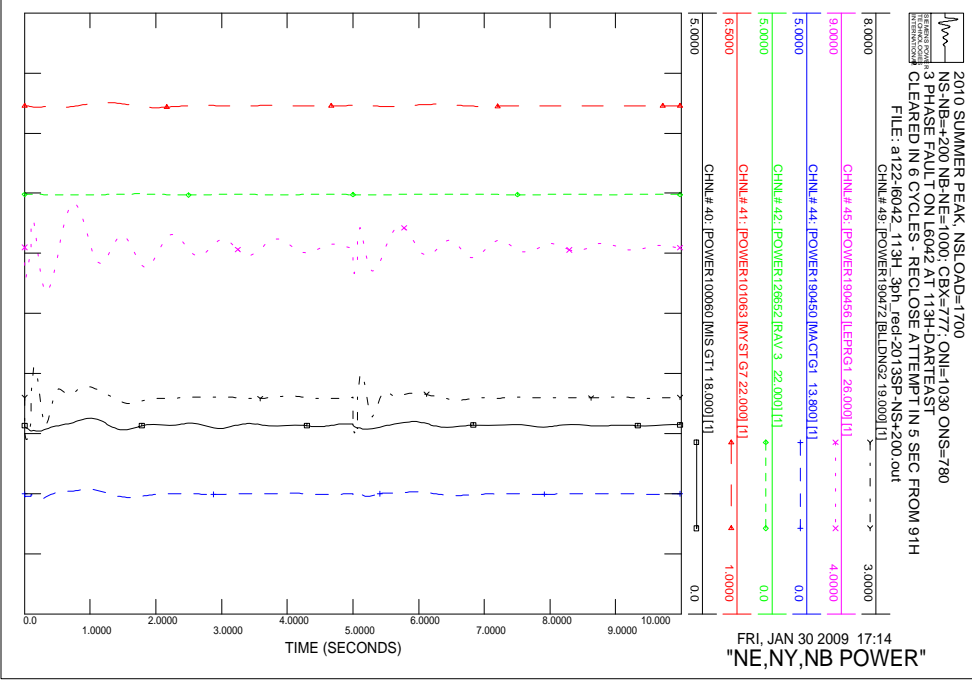
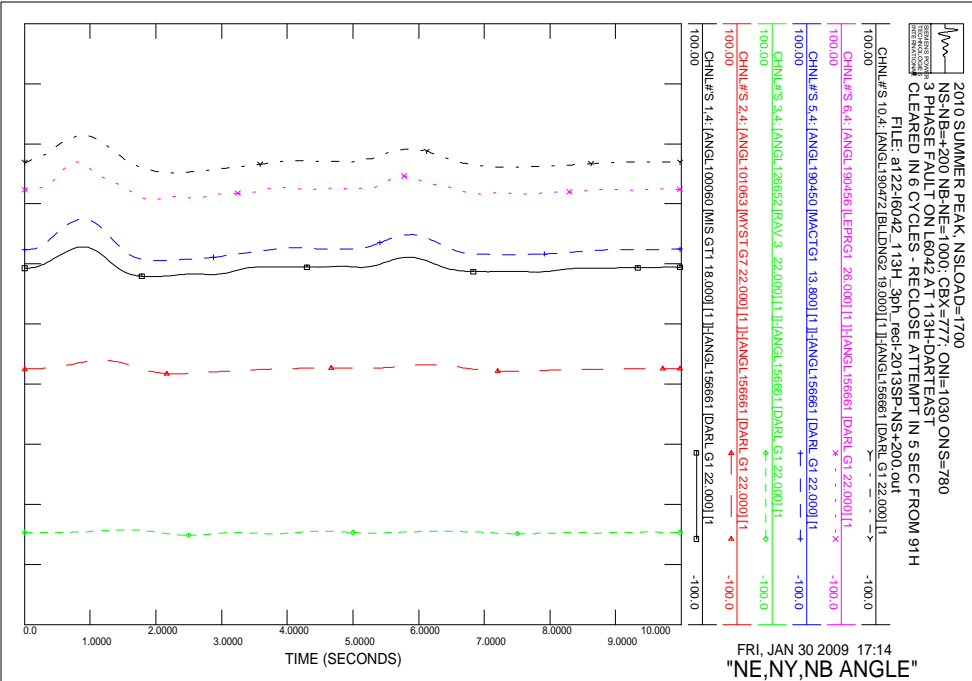

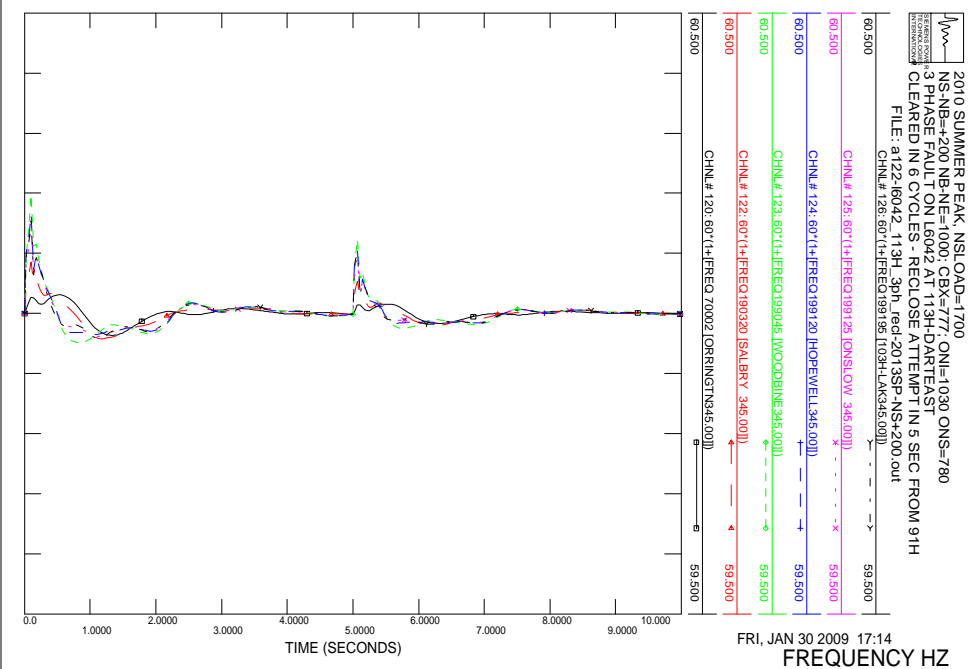
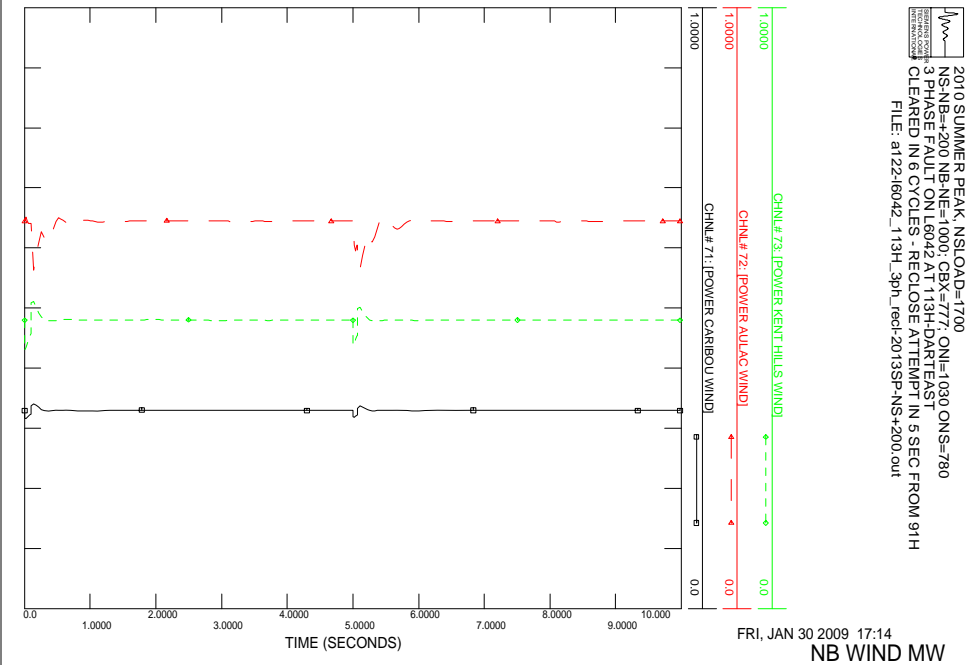
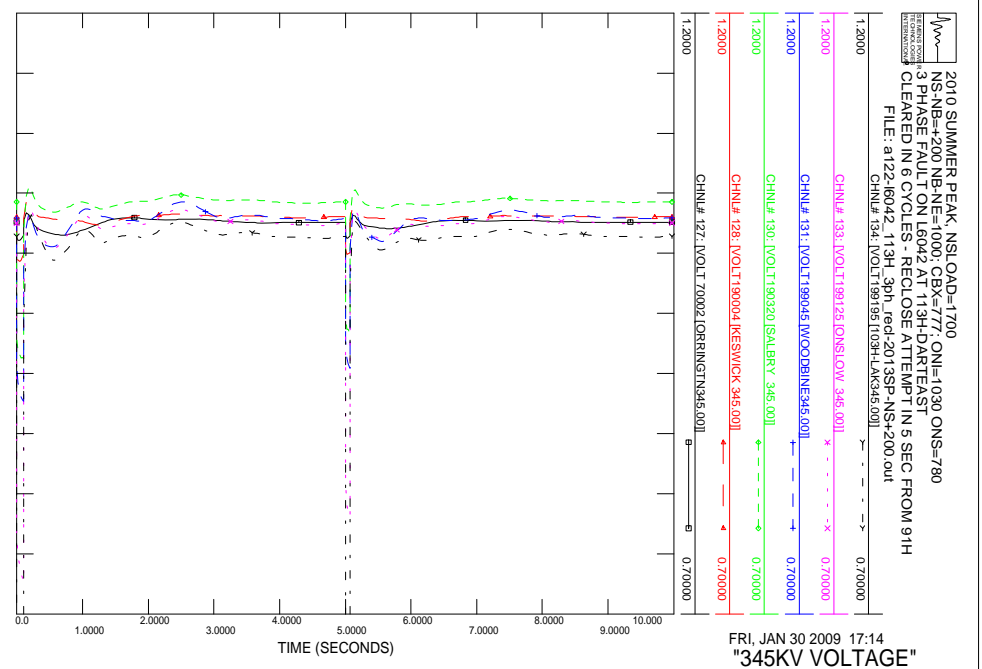
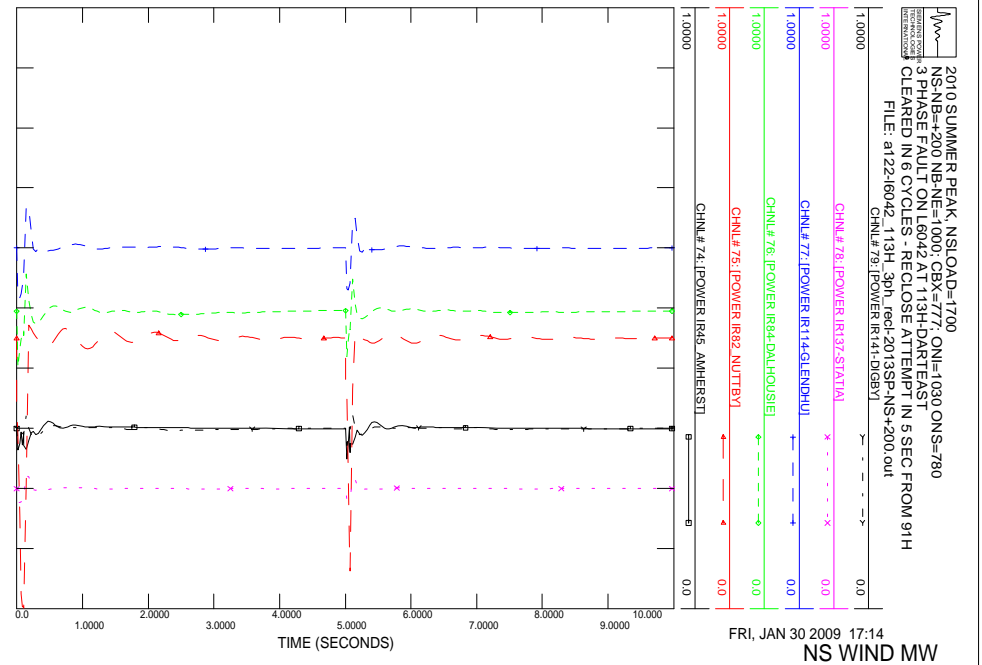

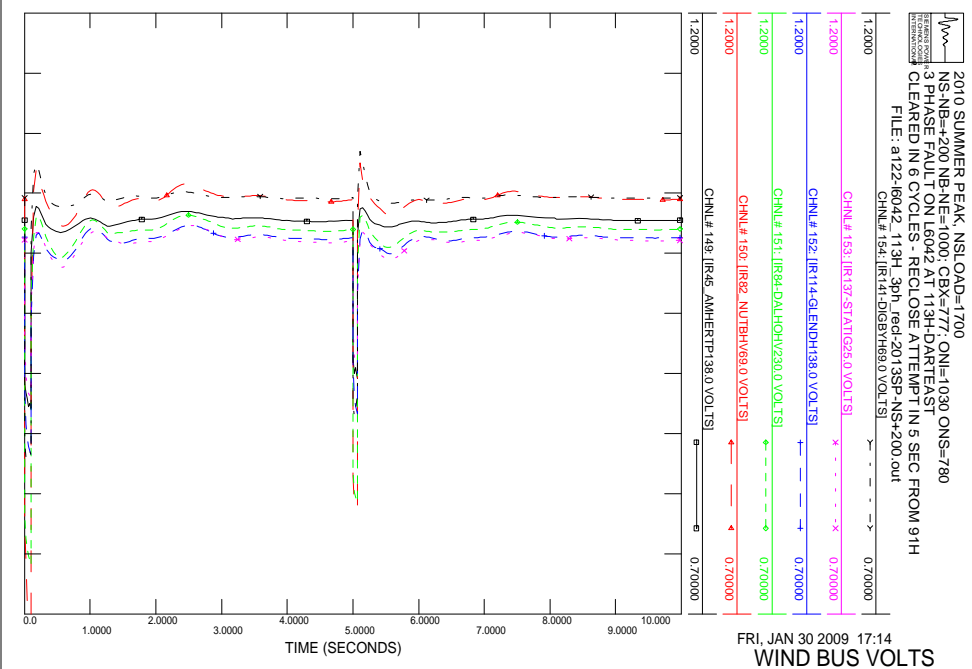
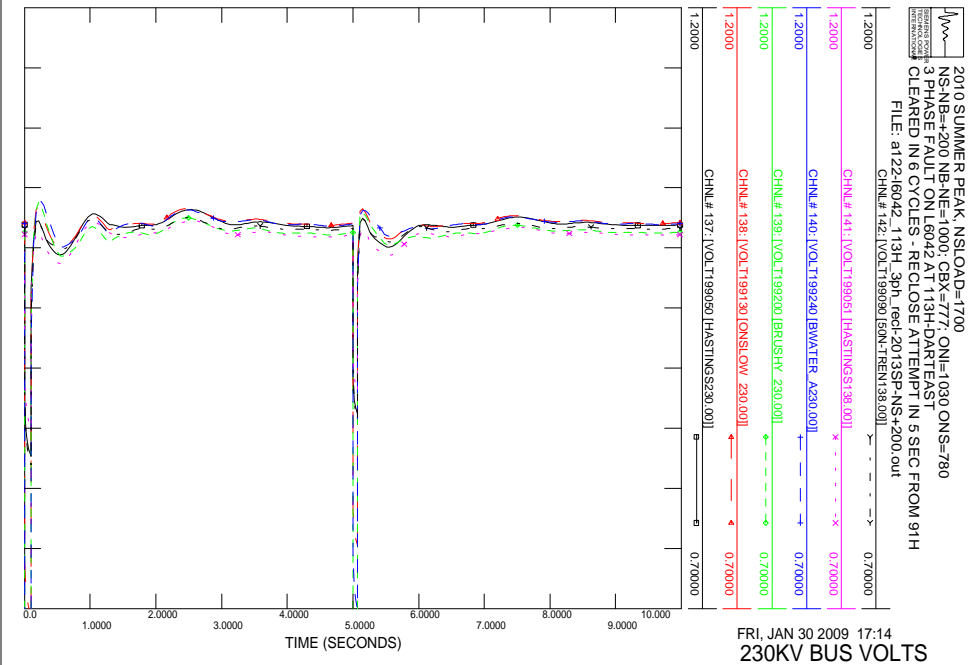
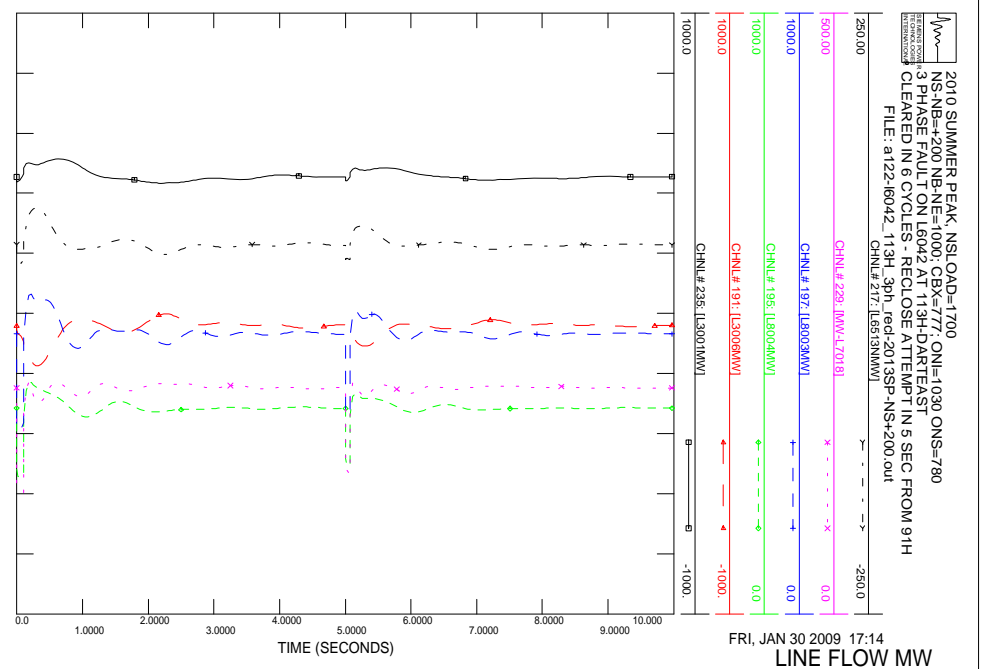
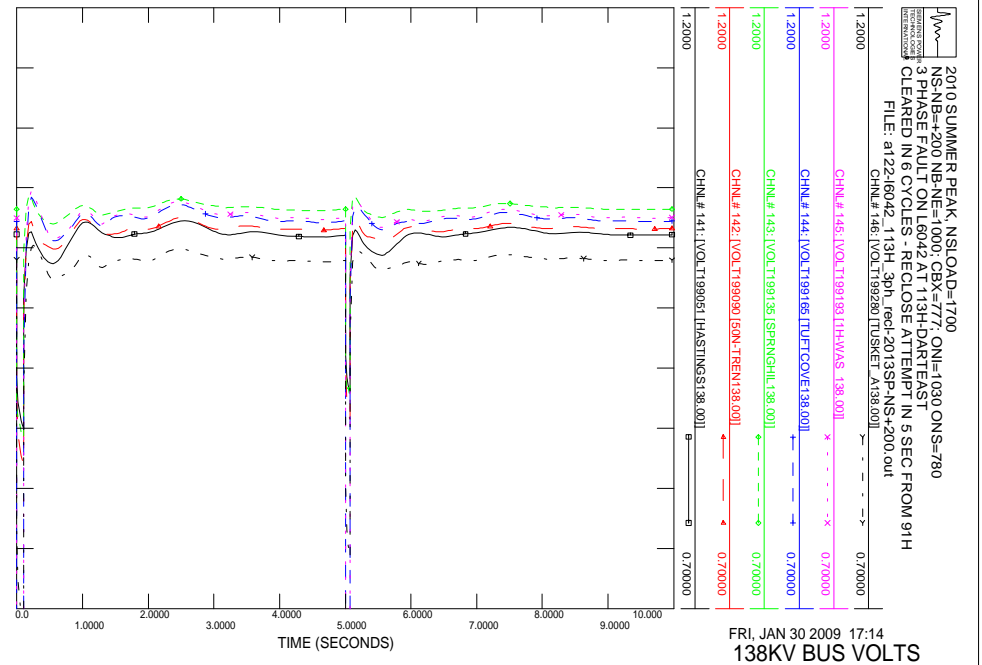

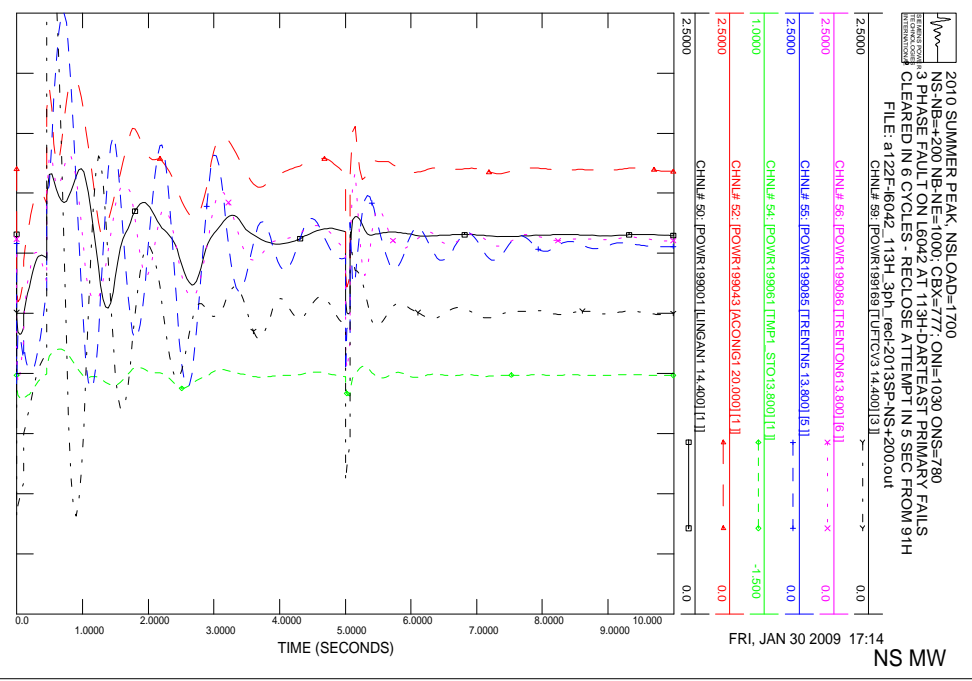
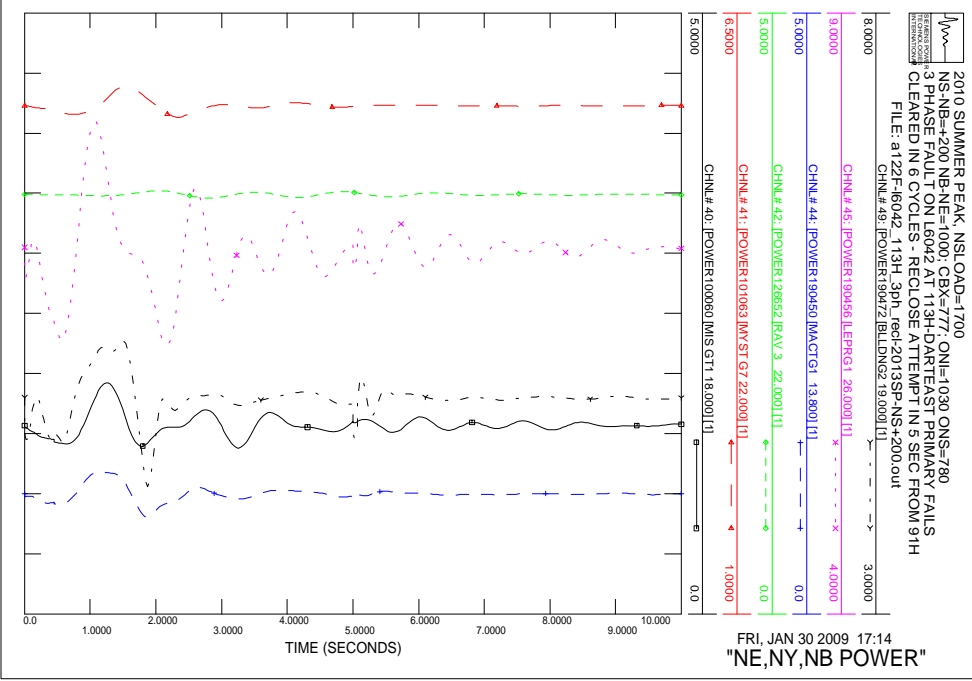
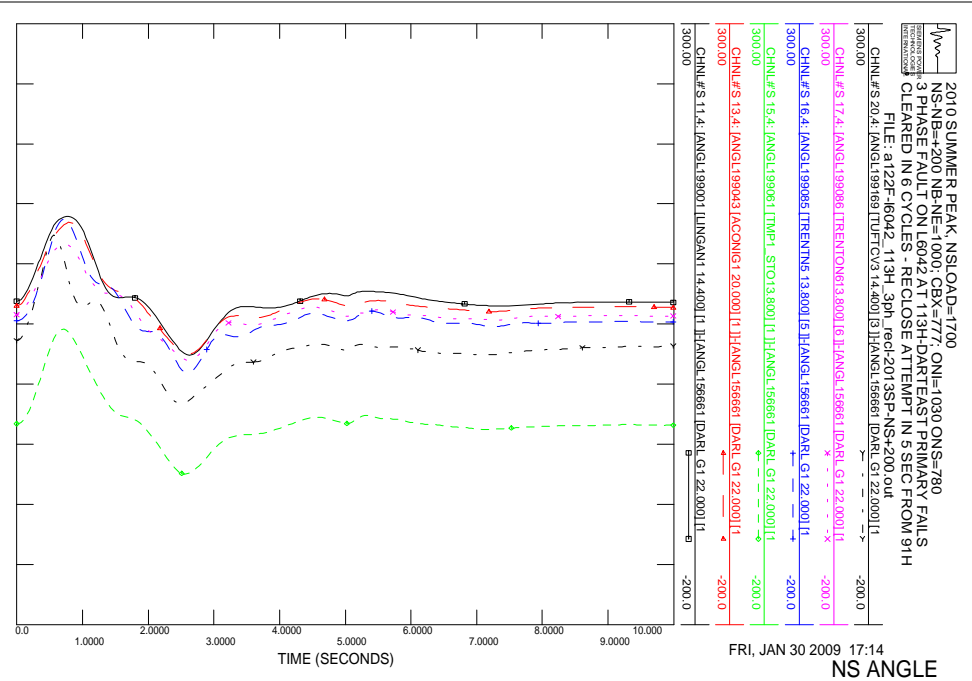
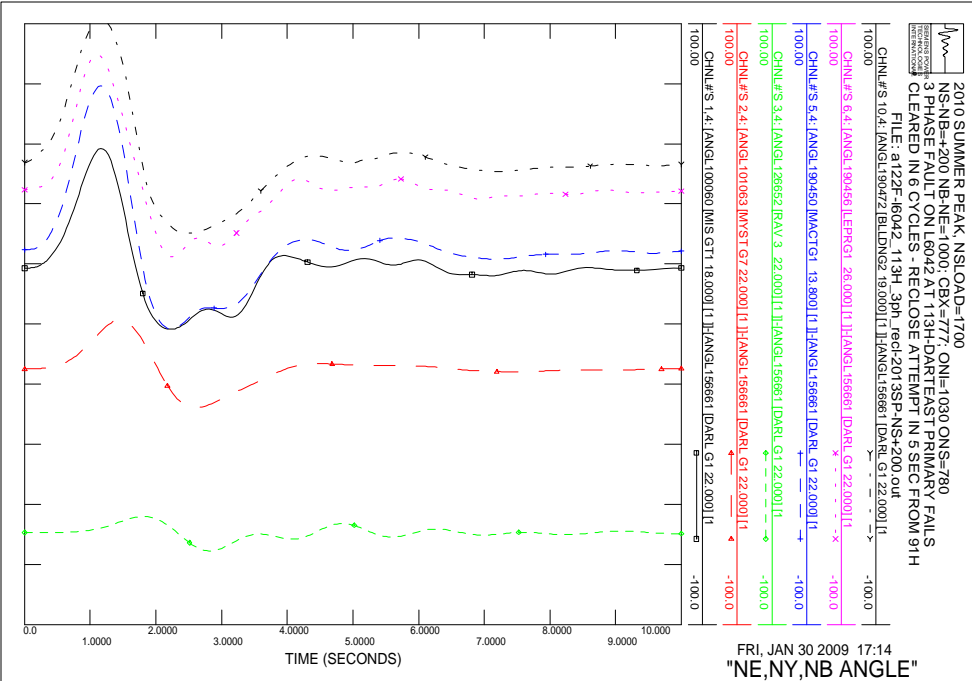

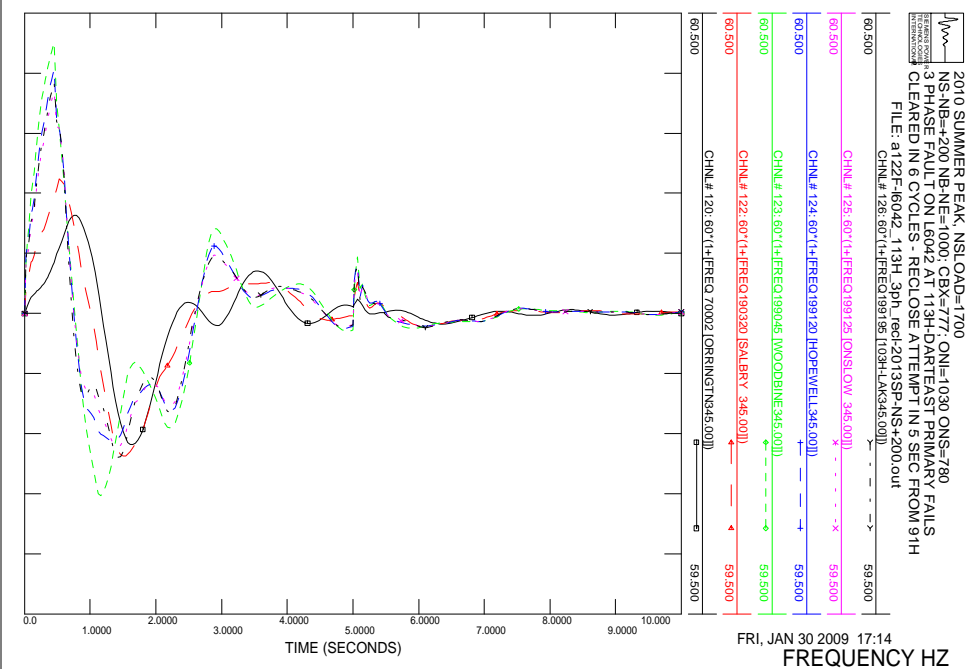
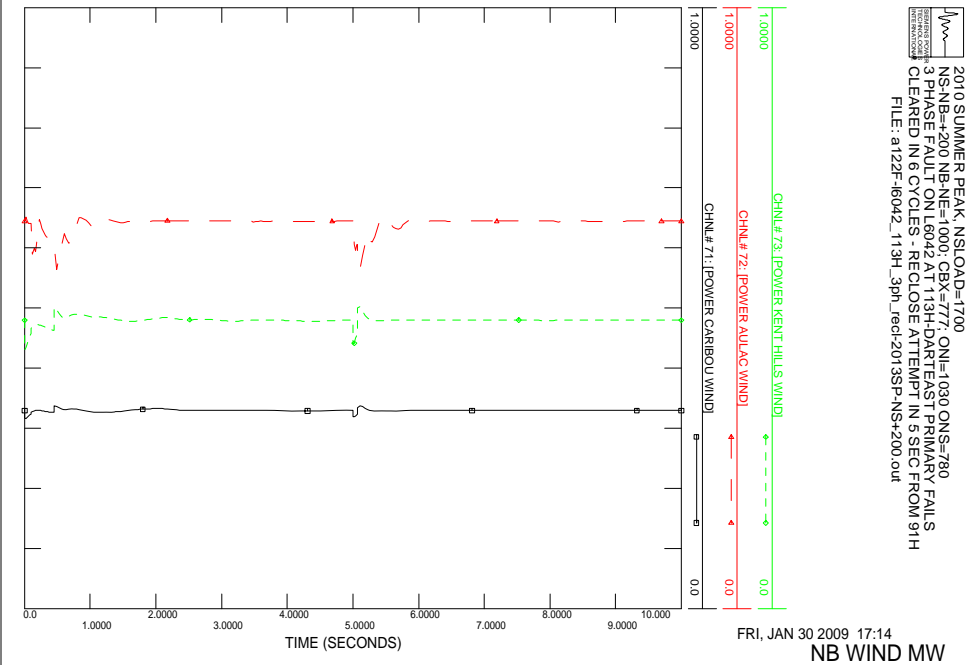
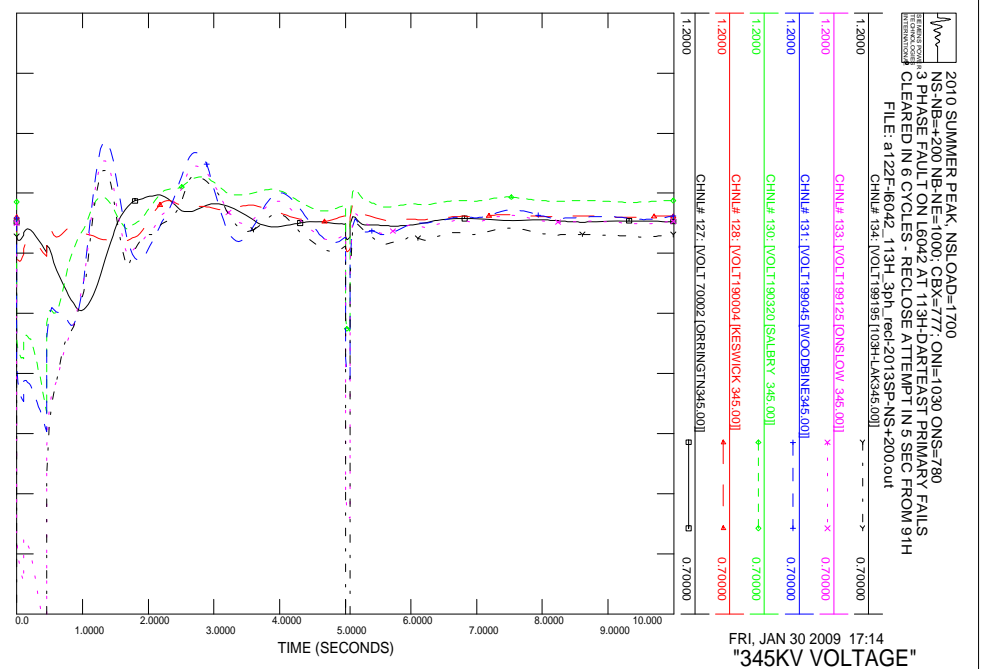
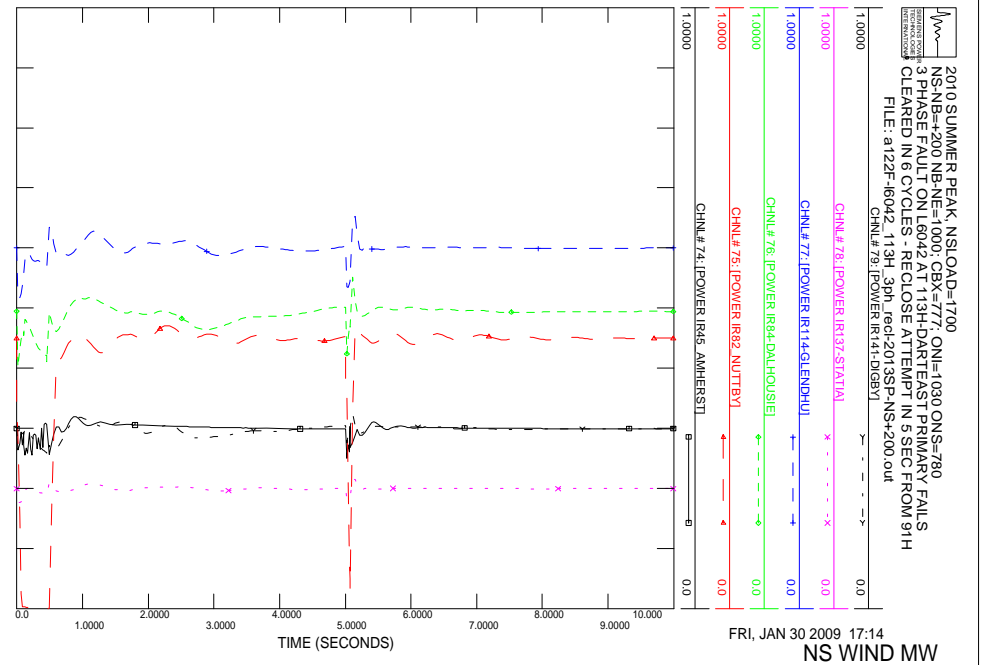

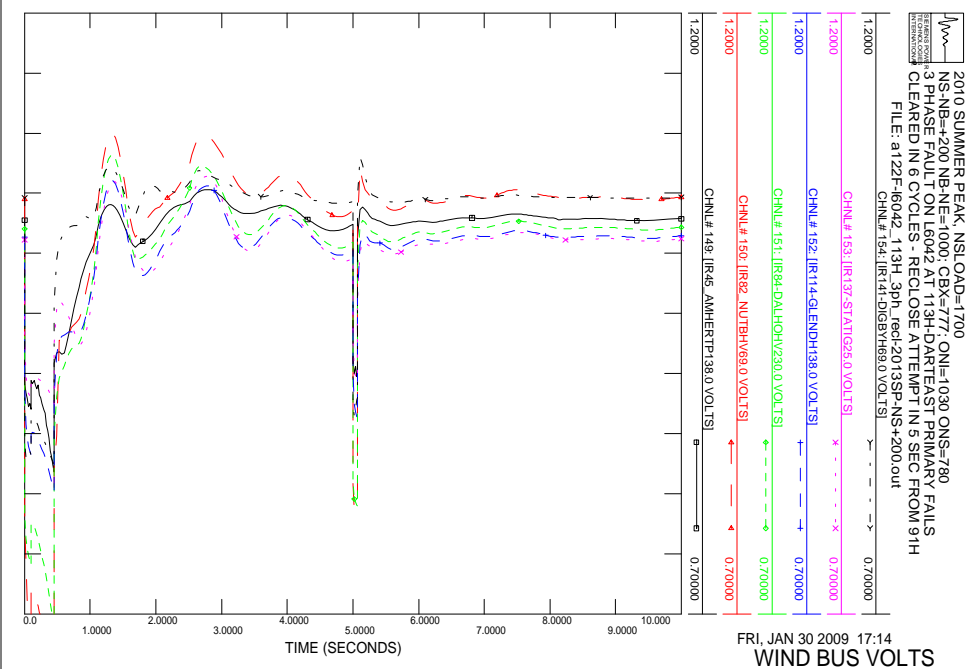
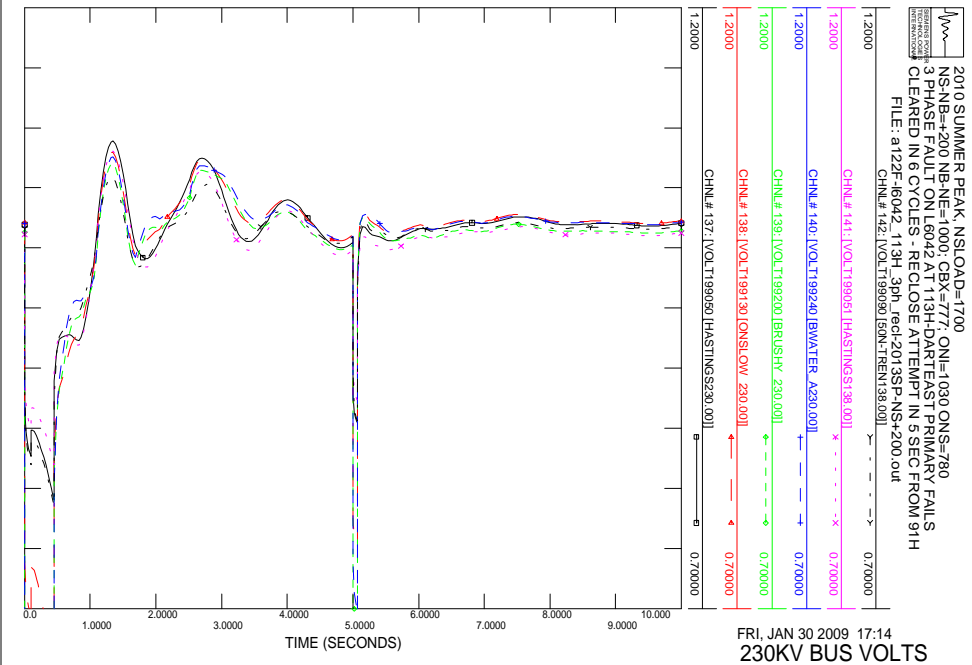
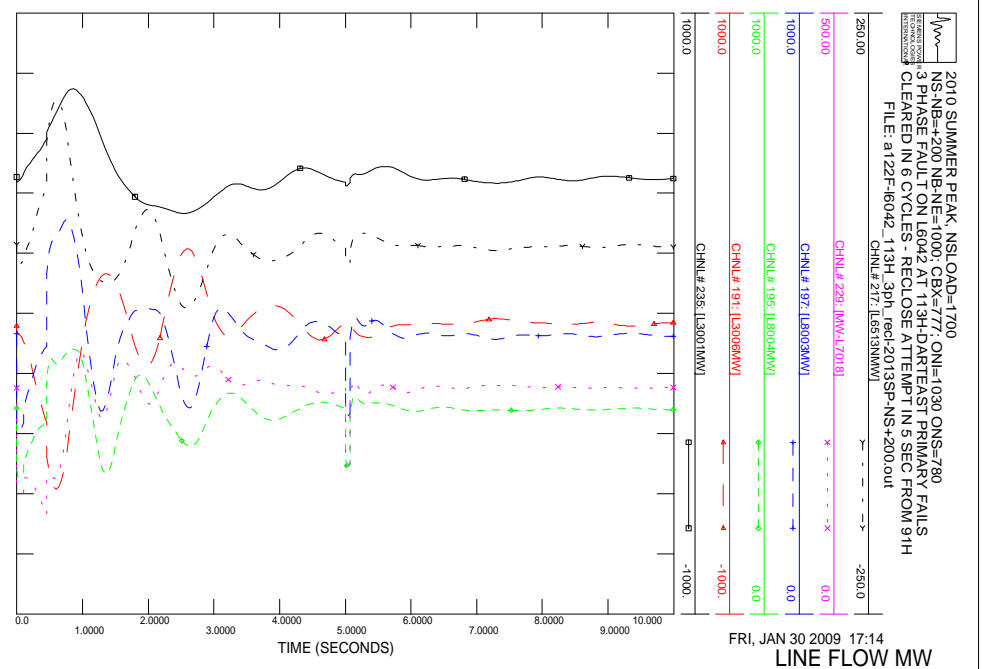
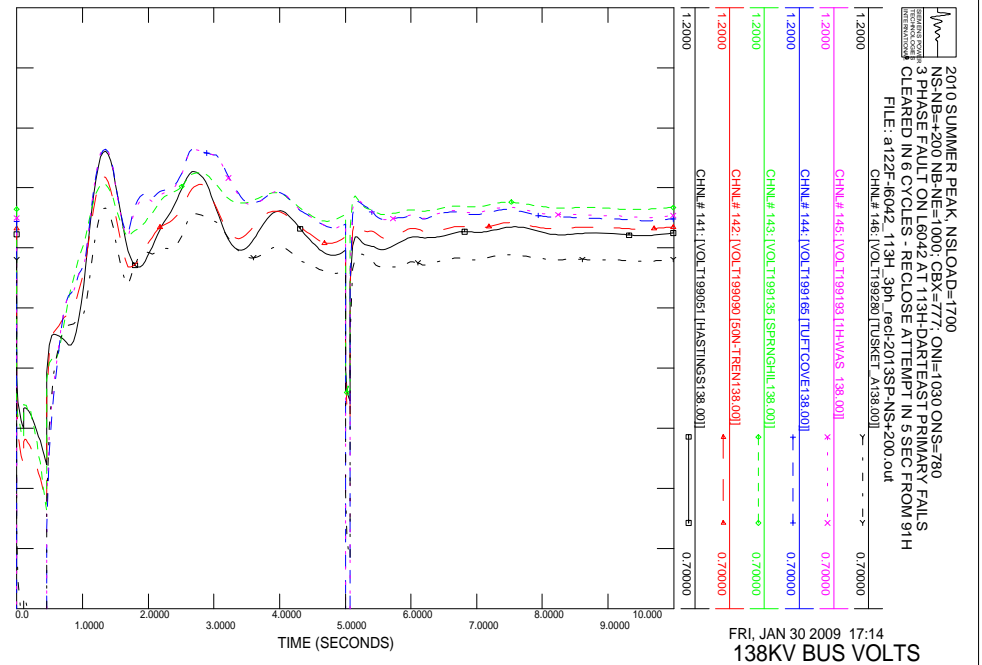

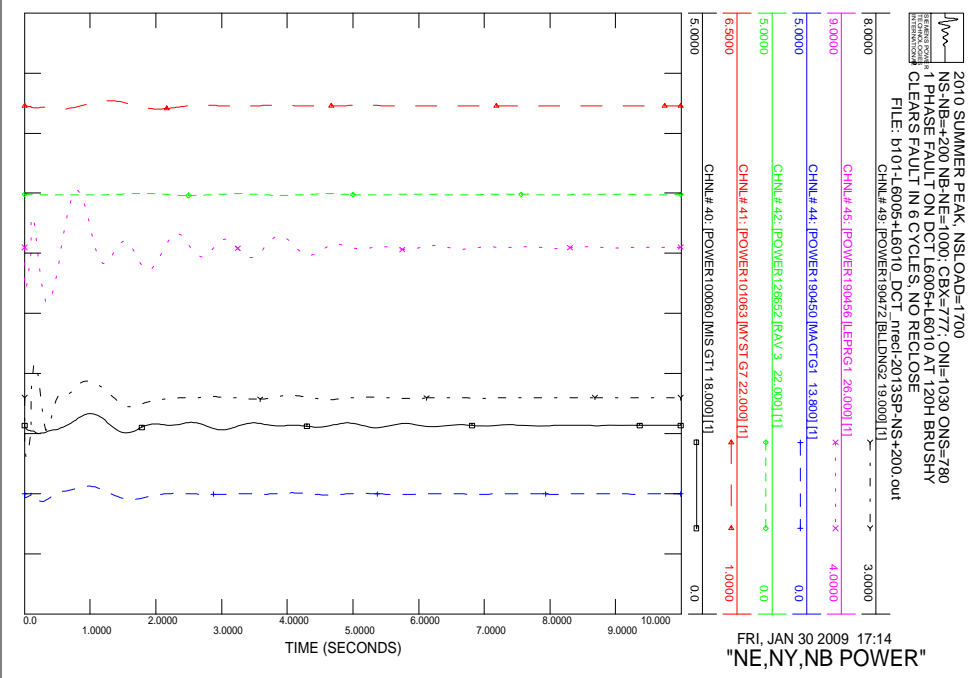
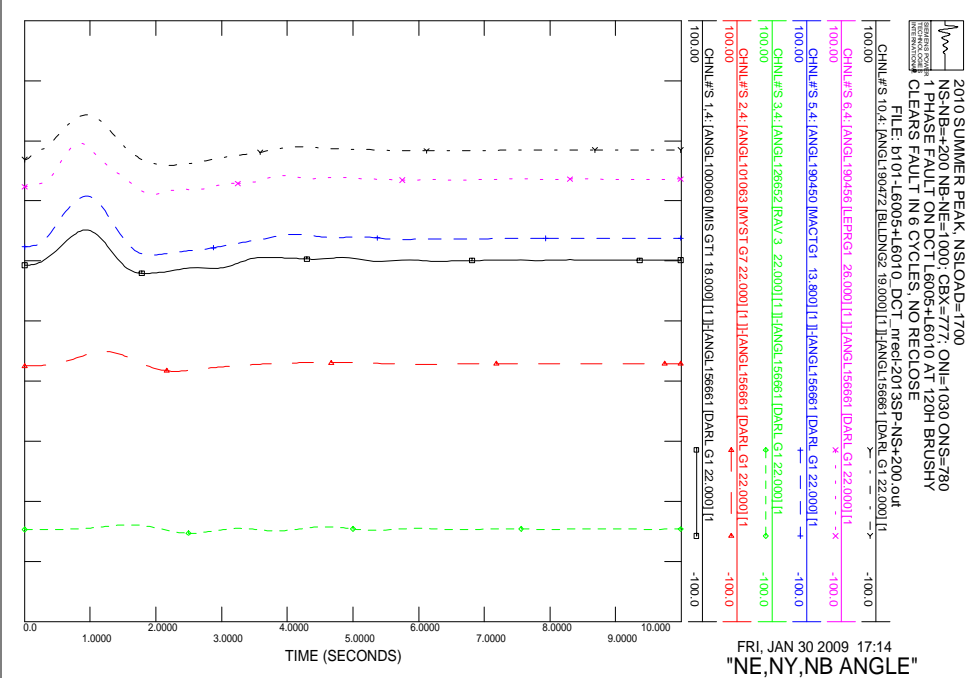
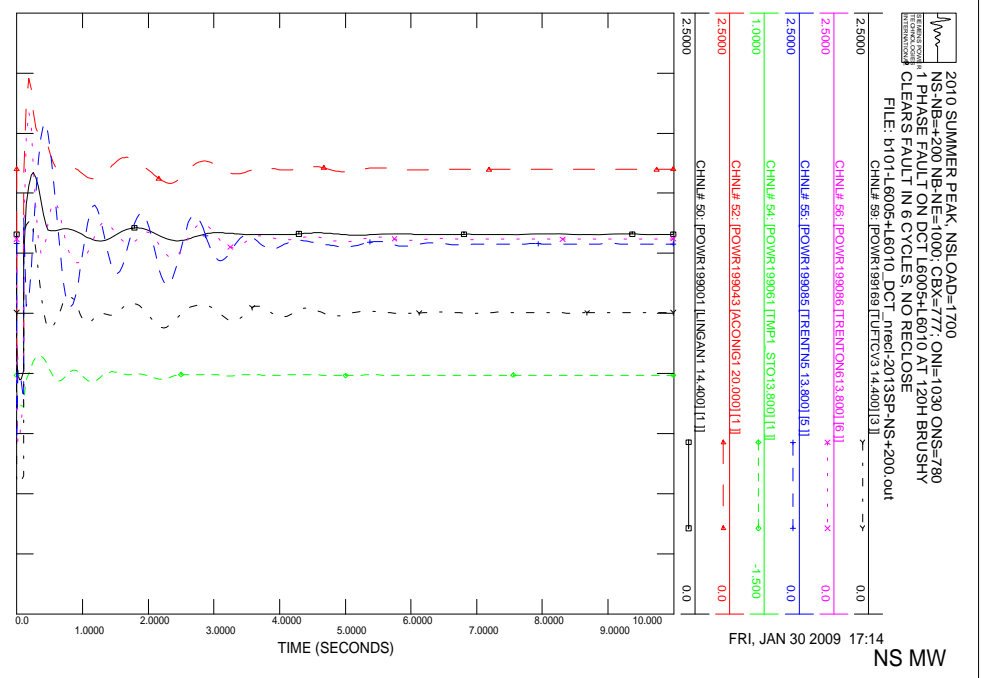
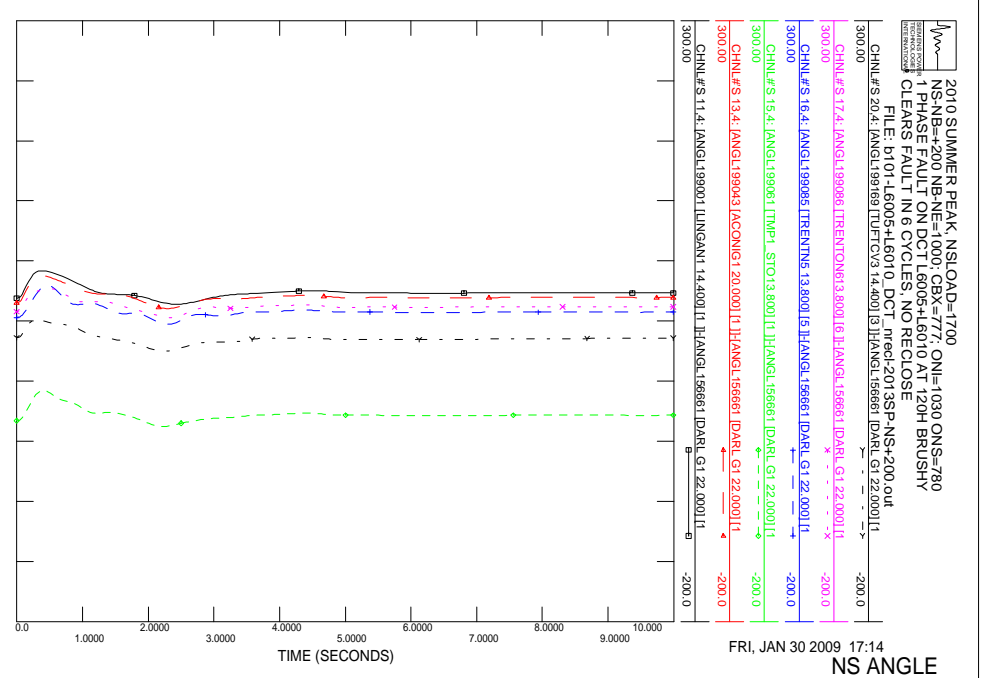

FRI, JAN 30 2009 17:14
 NS ANGLE

FRI, JAN 30 2009 17:14
 NS MW

FRI, JAN 30 2009 17:14
 "NE,NY,NB ANGLE"

FRI, JAN 30 2009 17:14
 "NE,NY,NB POWER"

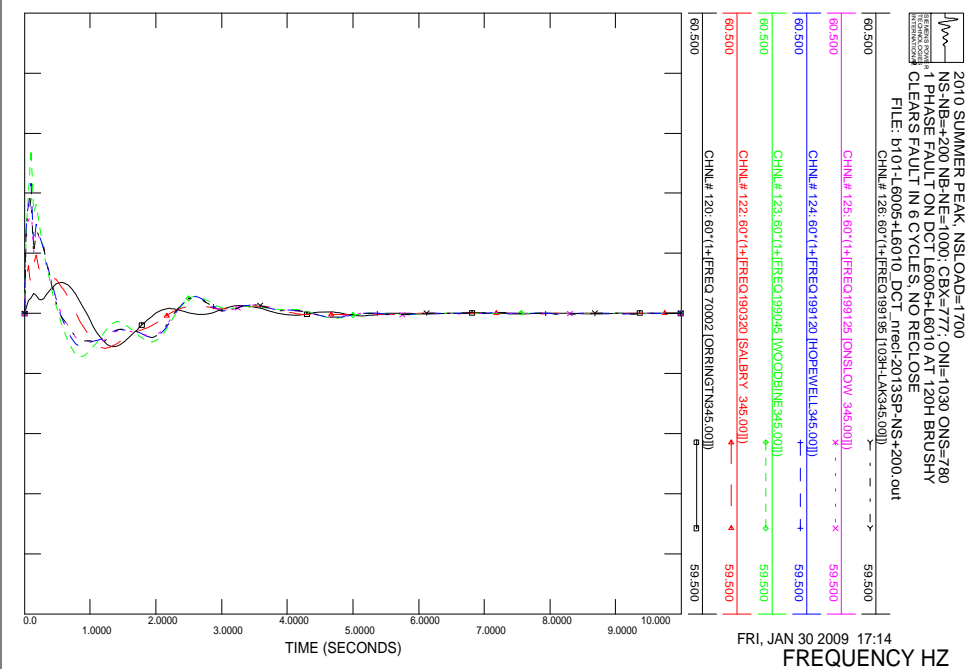
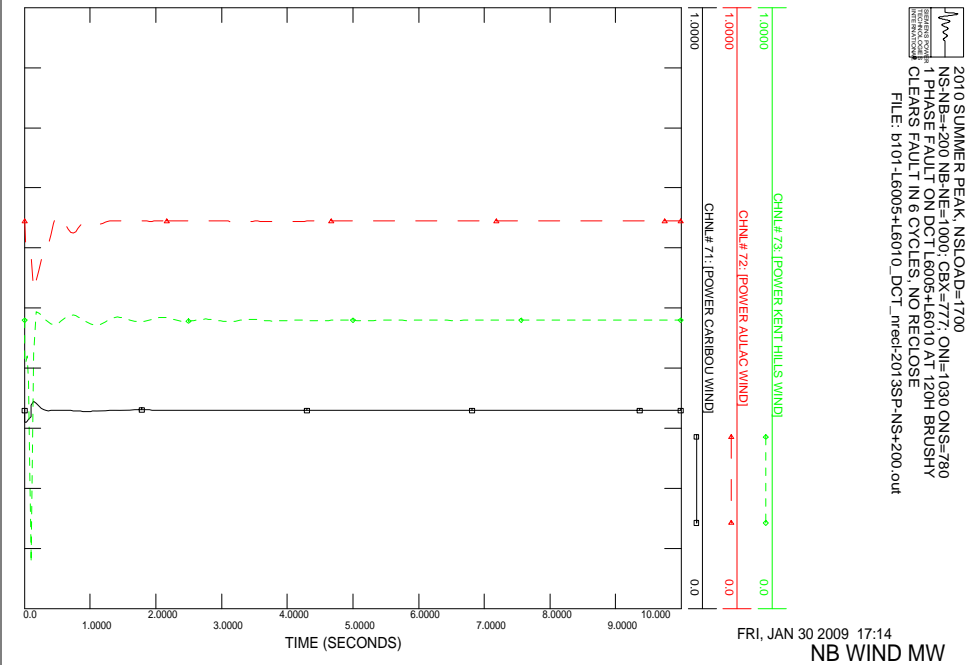
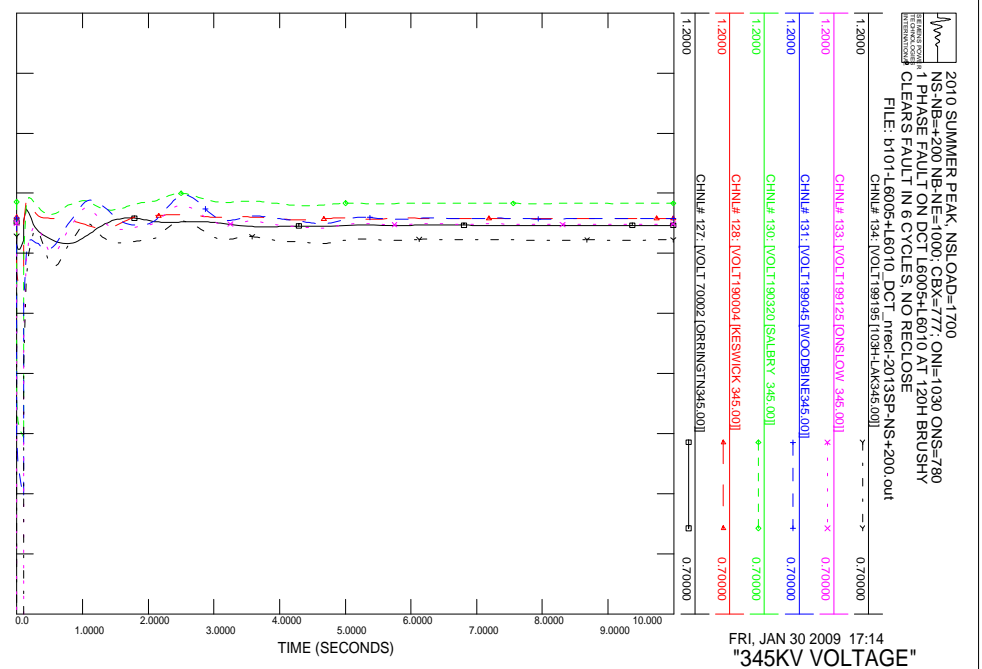
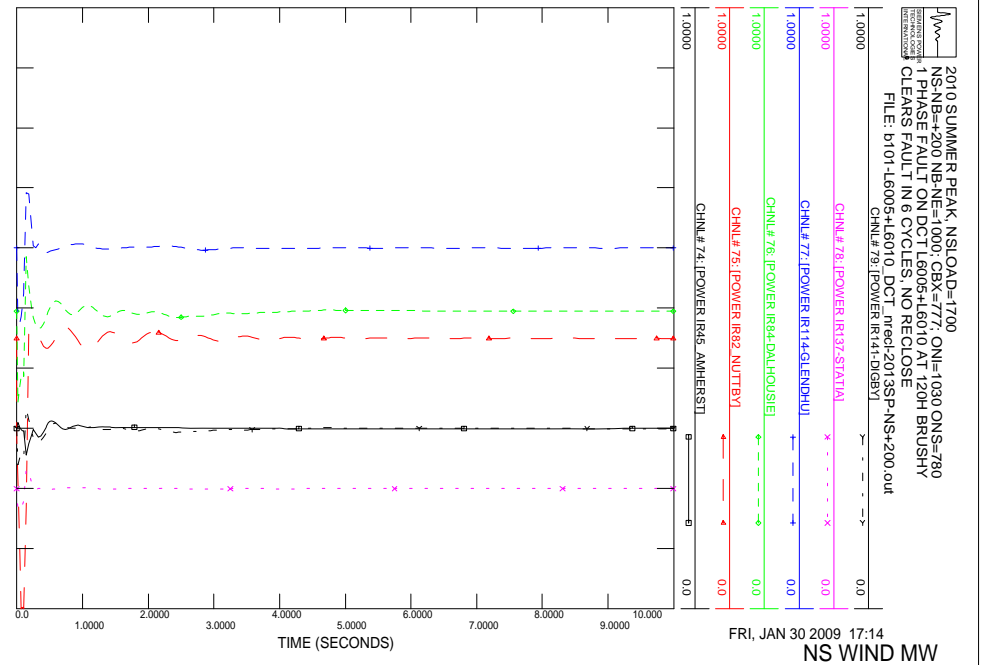

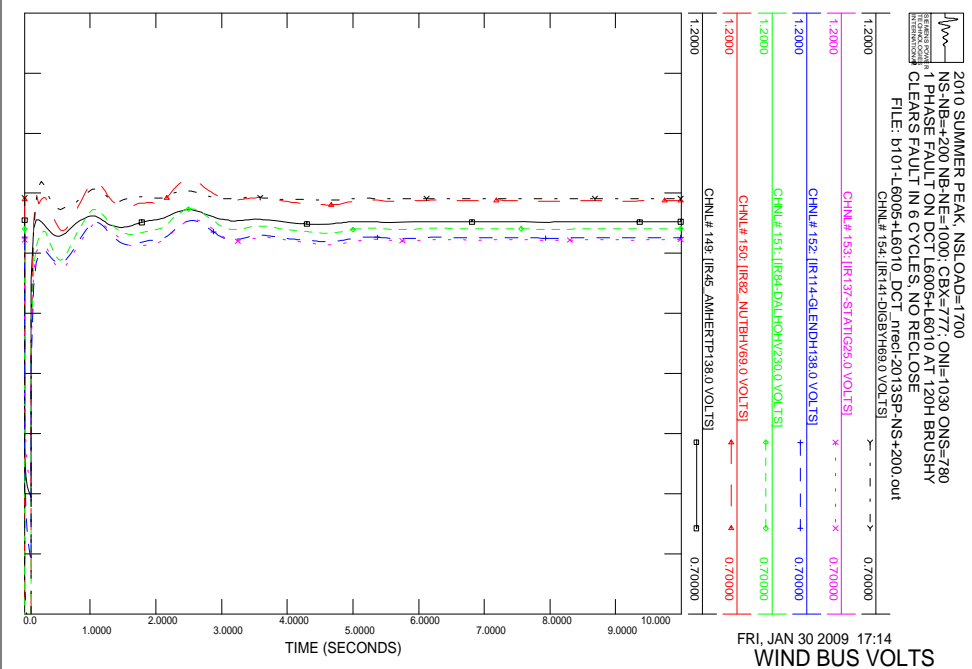
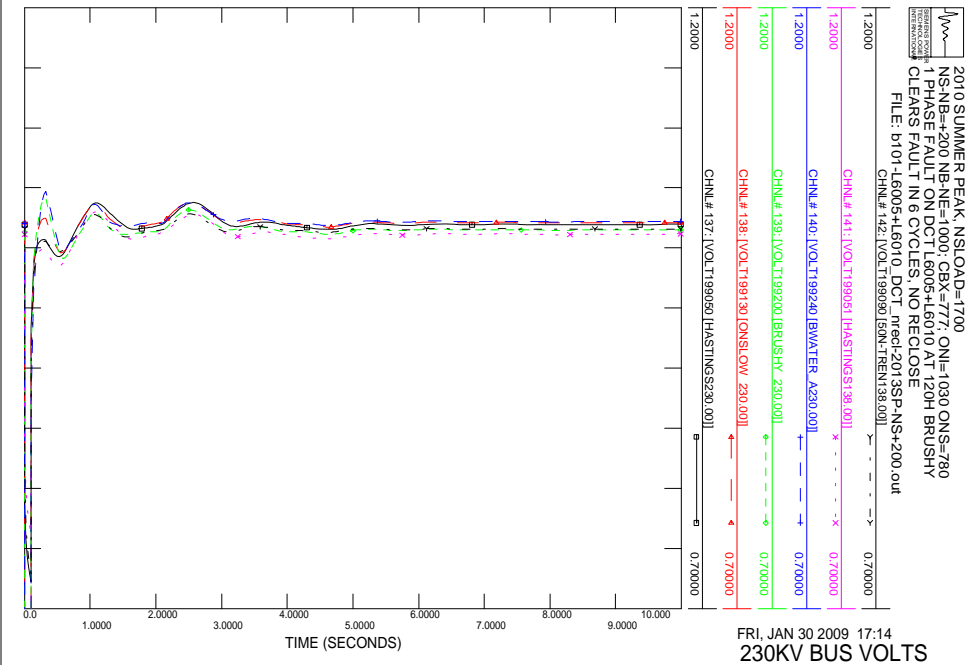
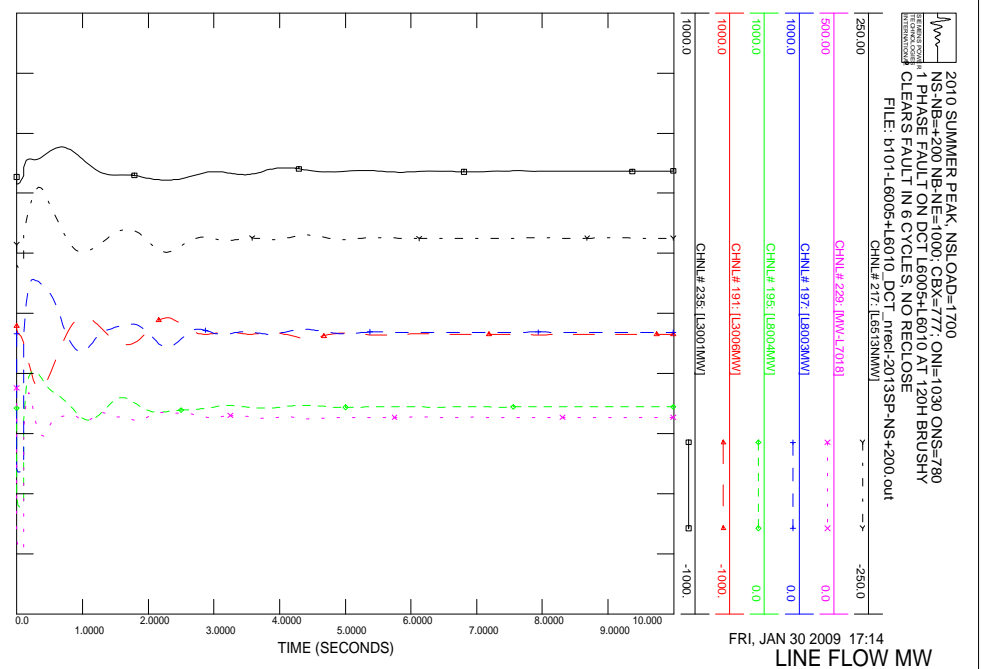
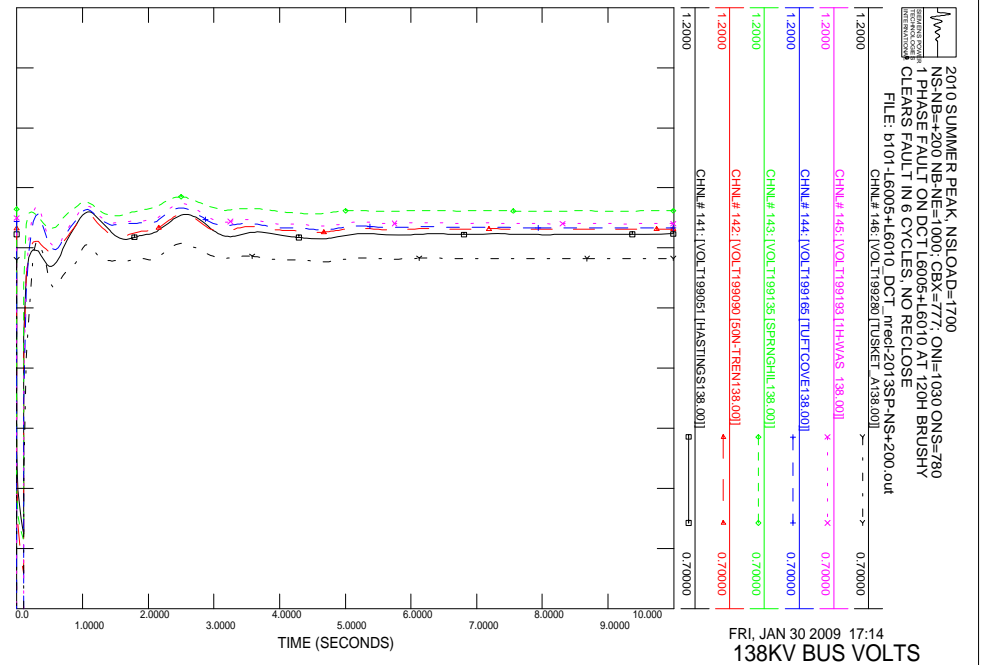

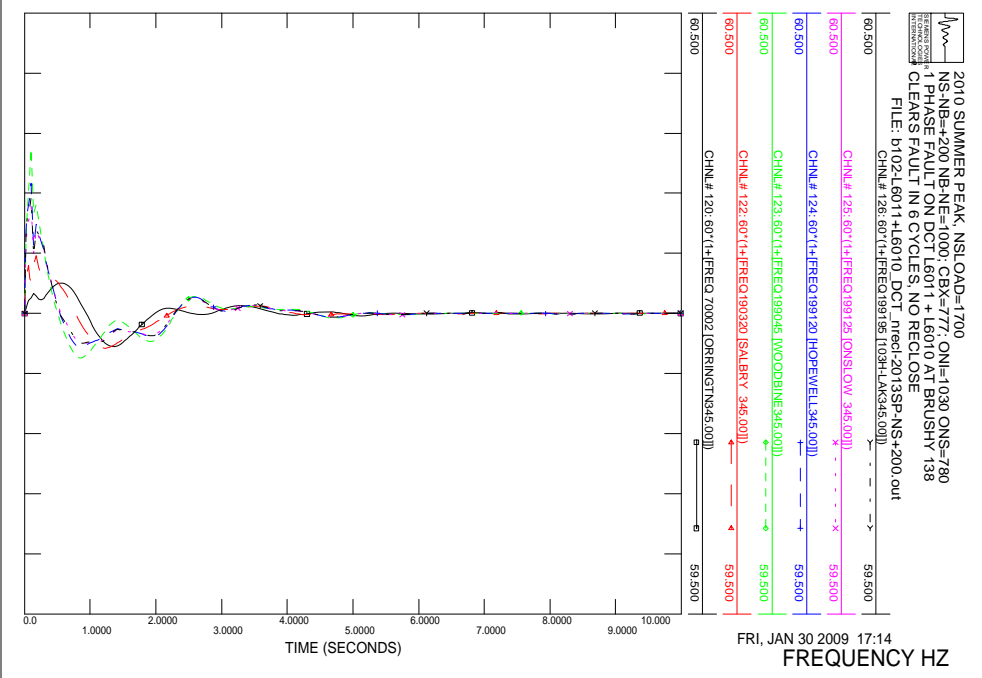
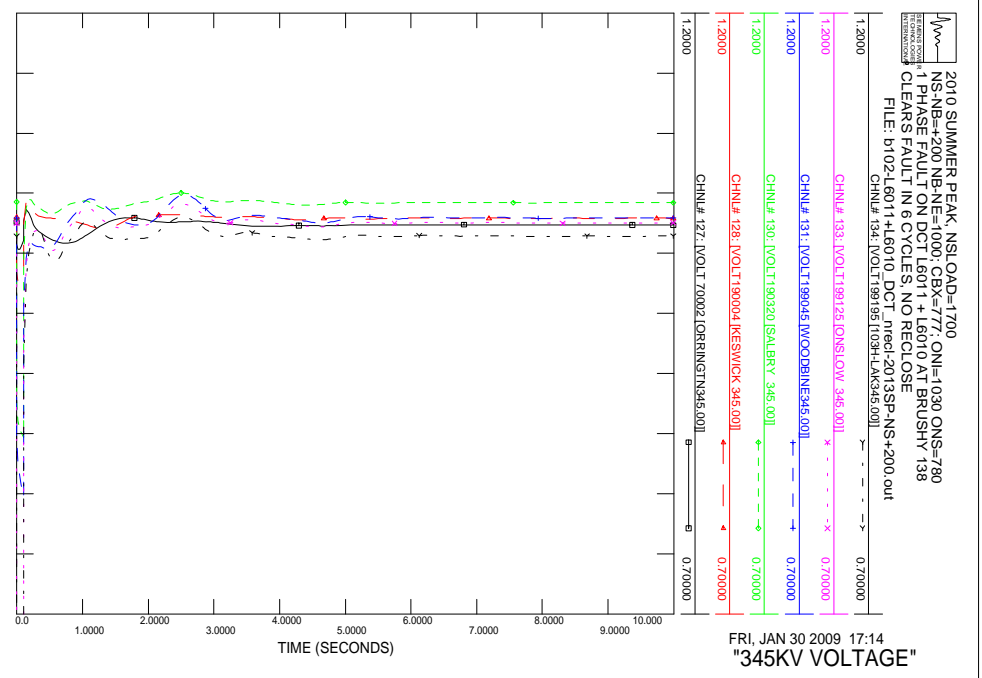
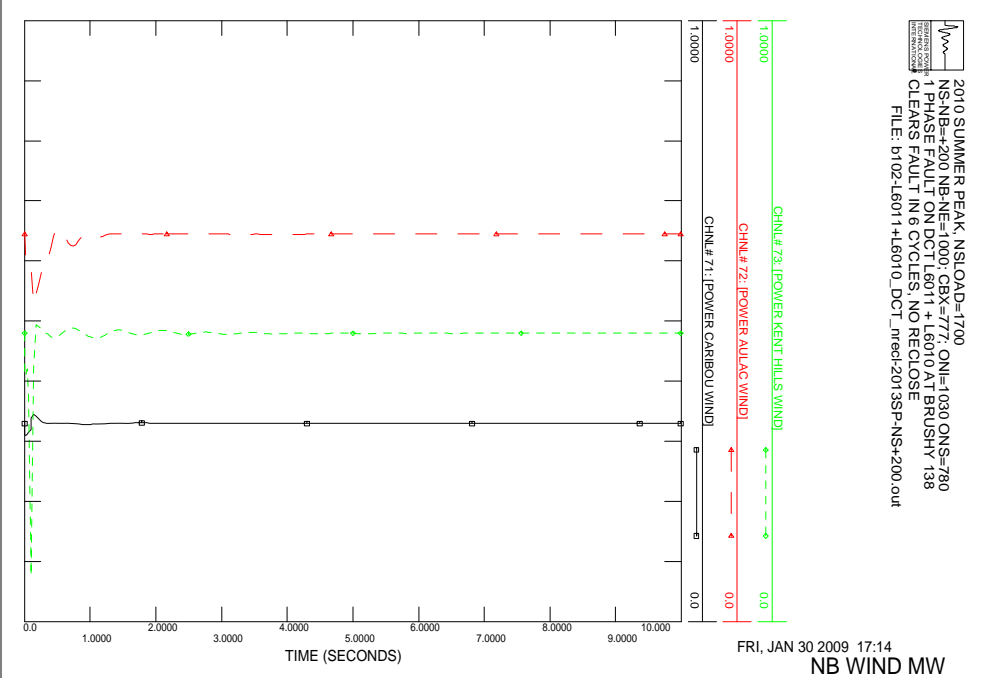
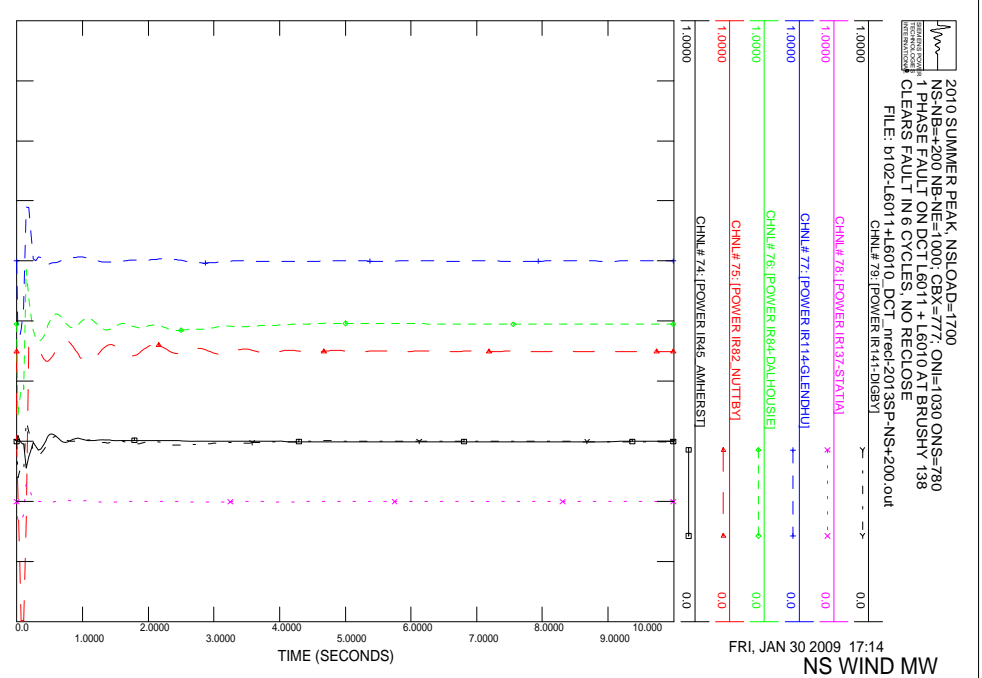

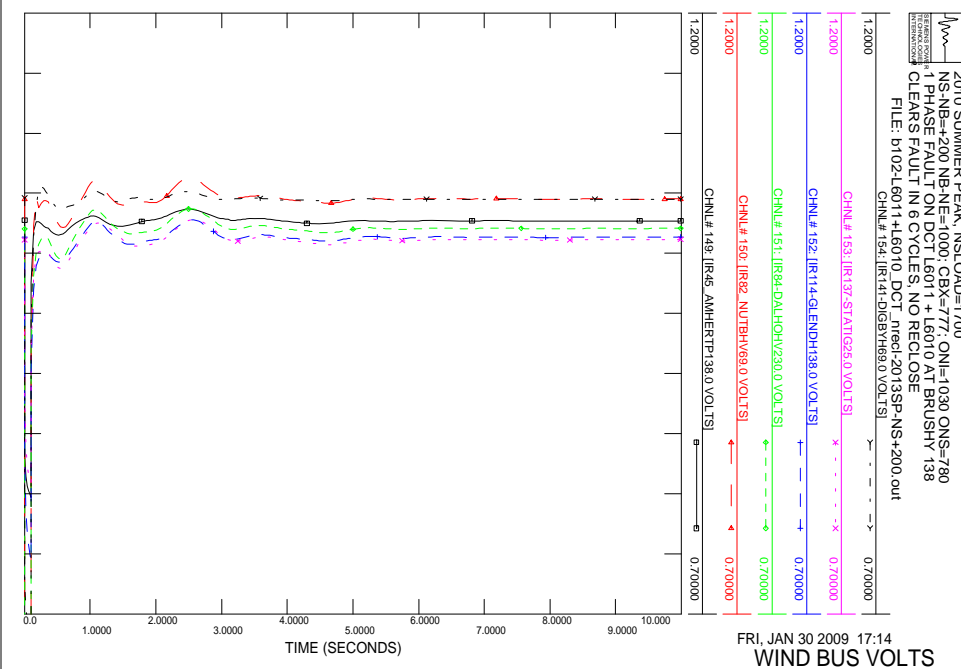
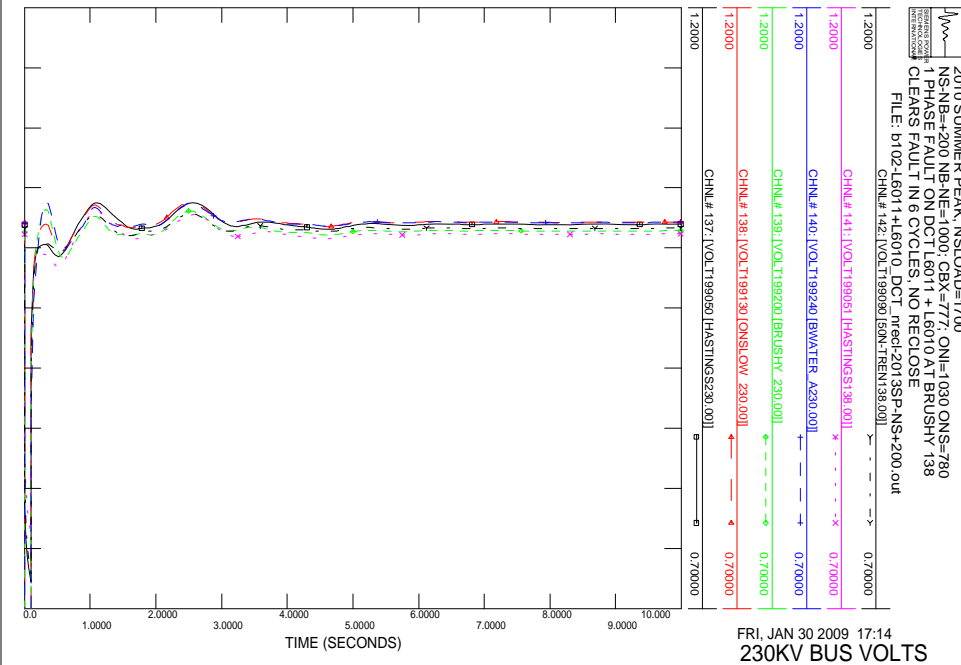
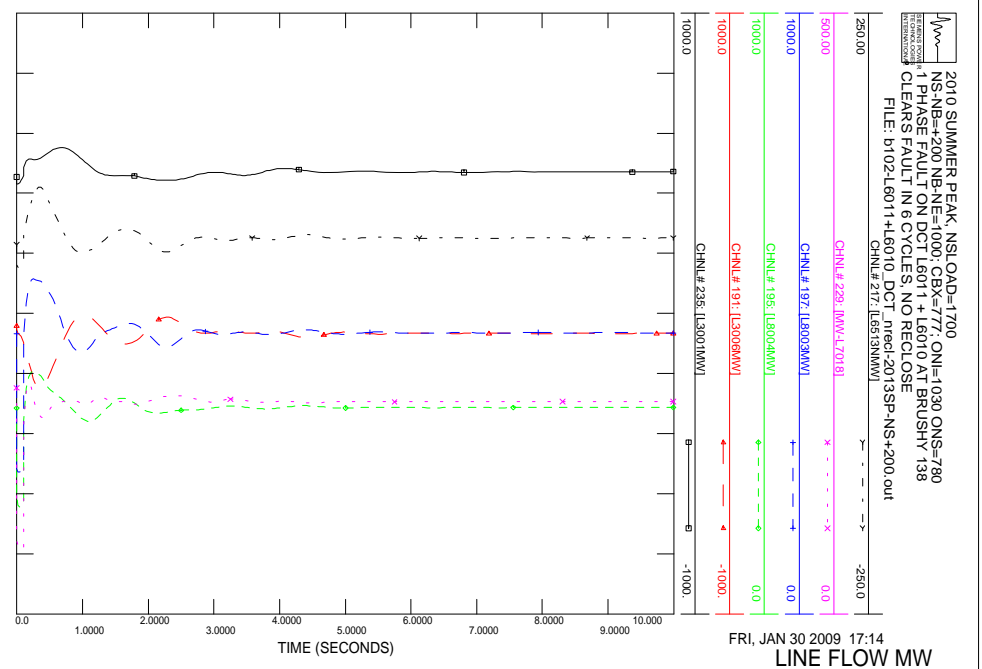
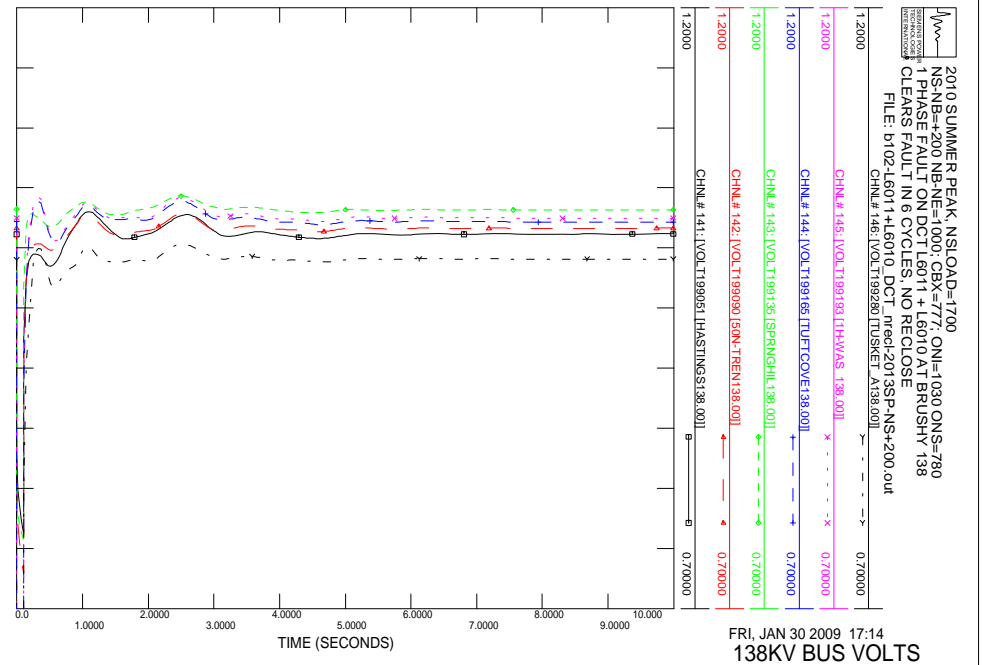

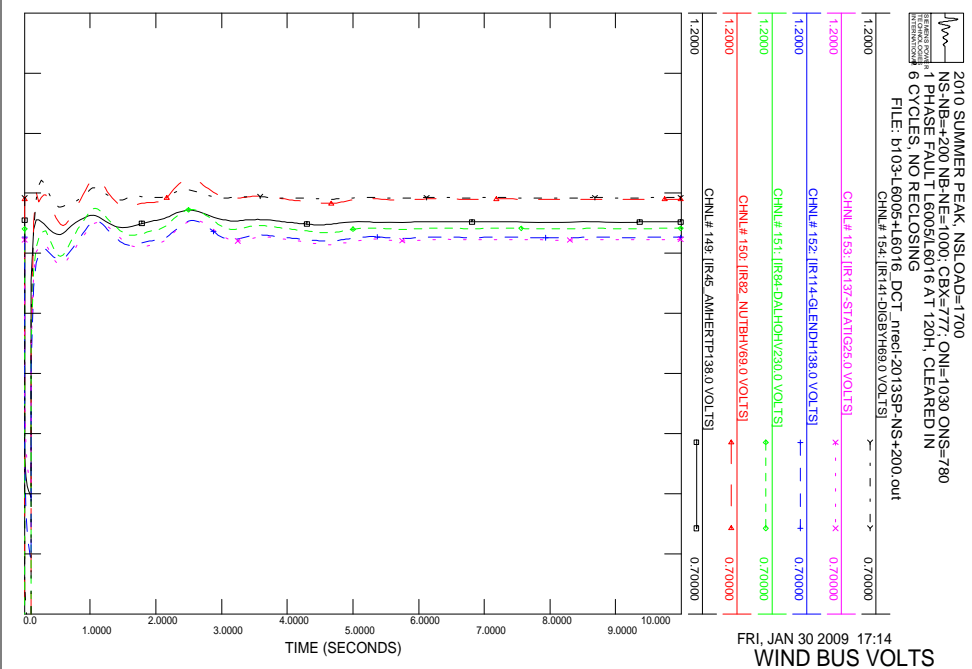
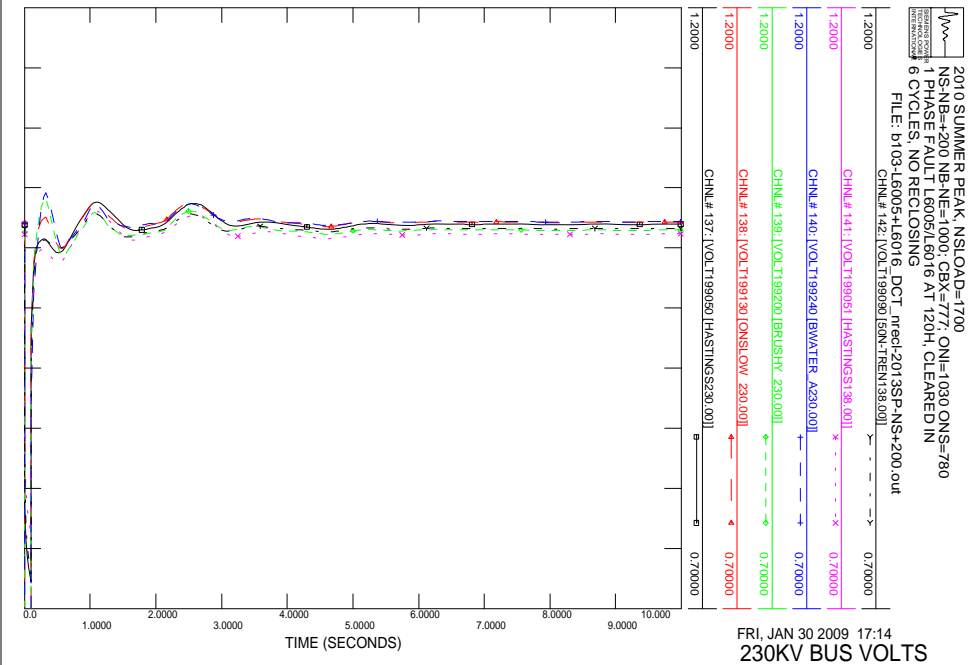
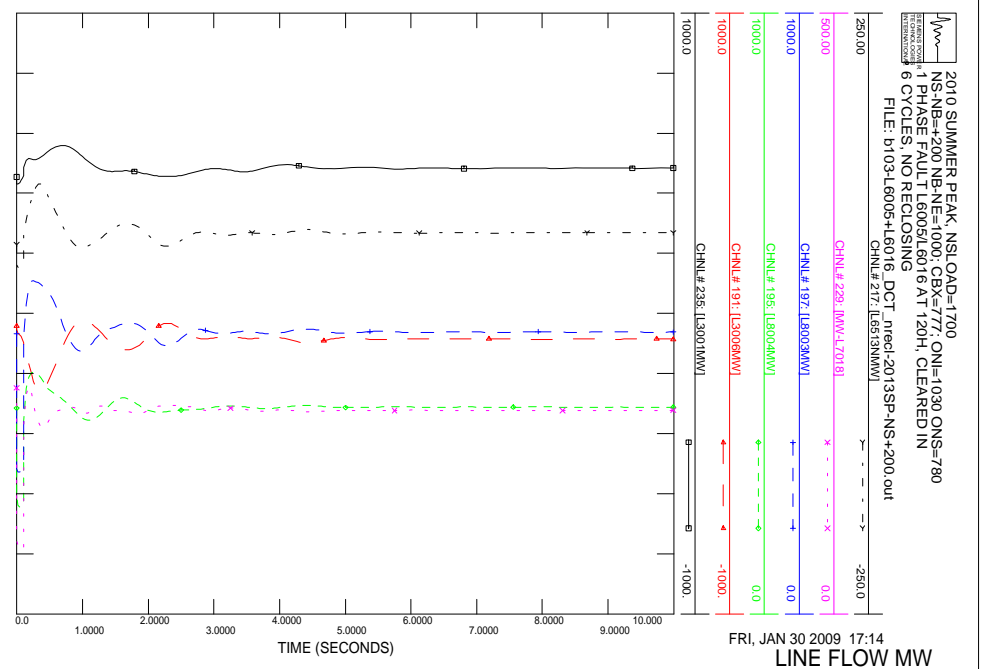
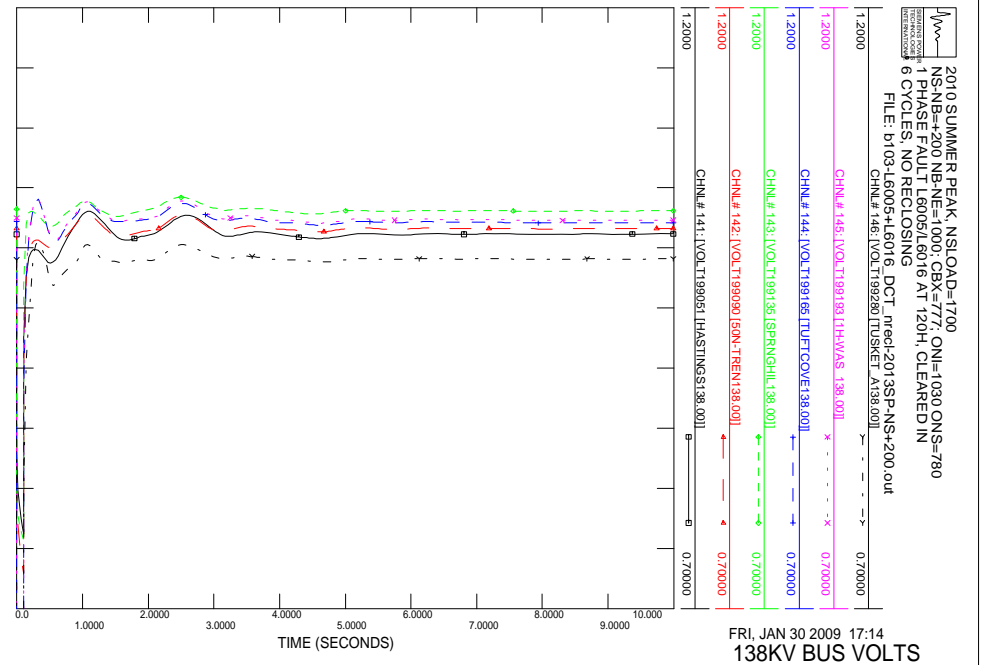

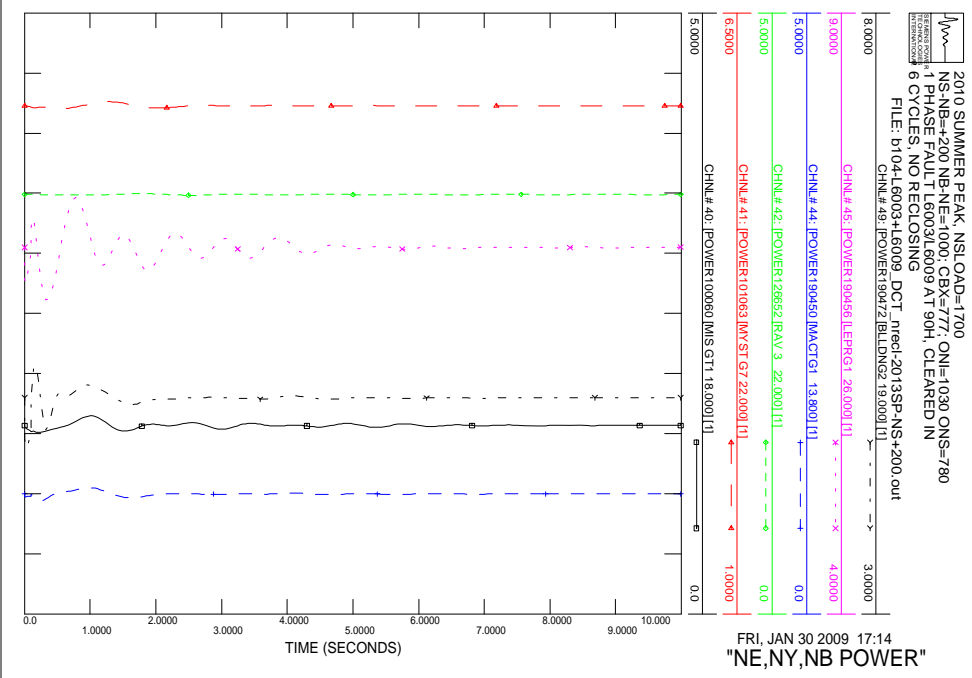
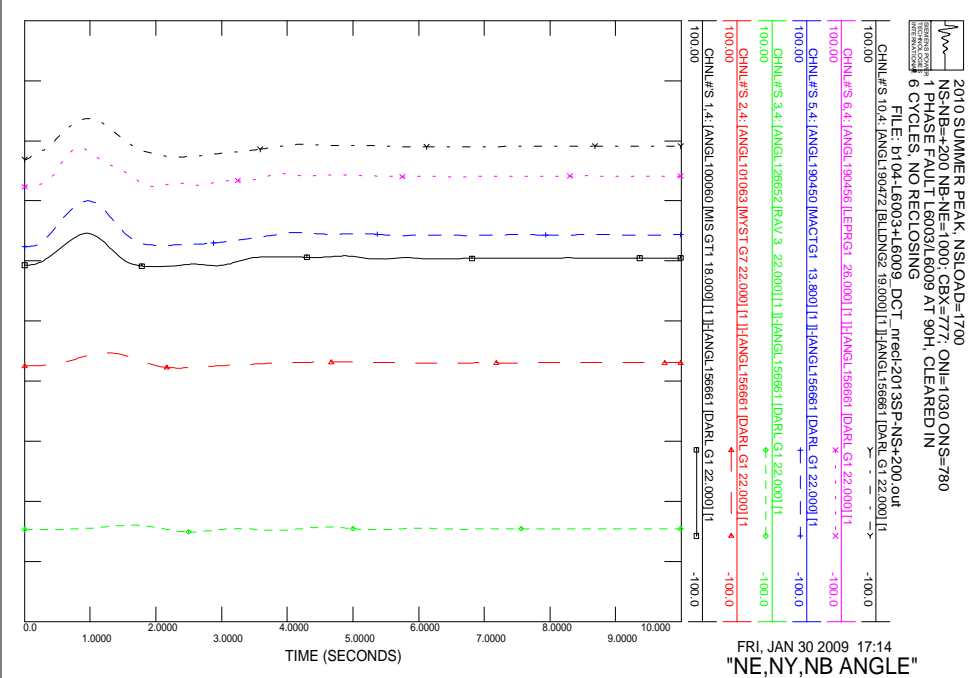
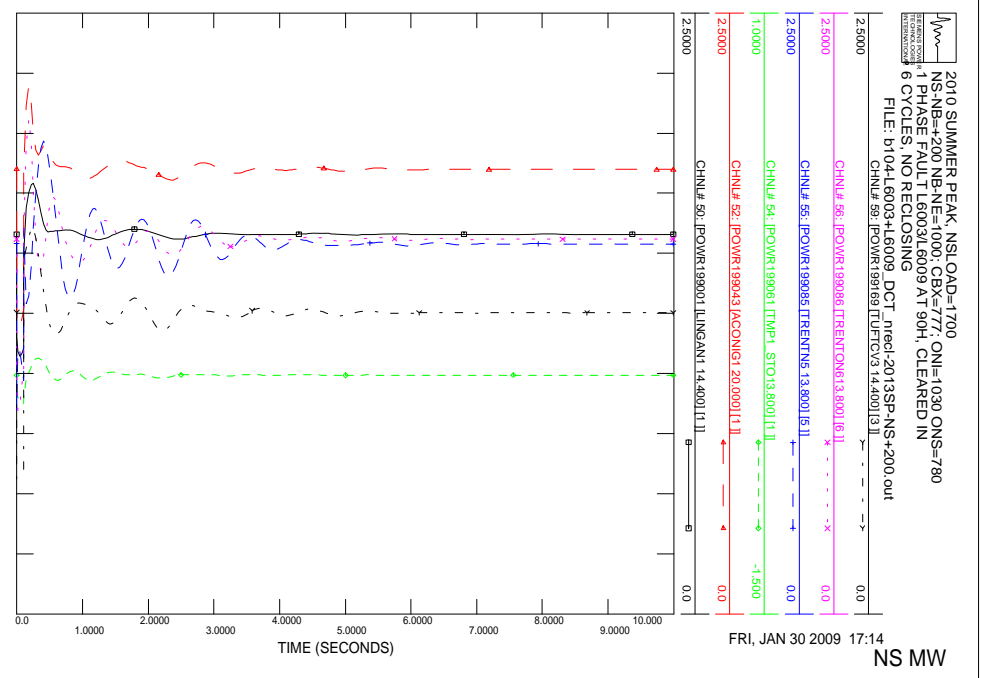
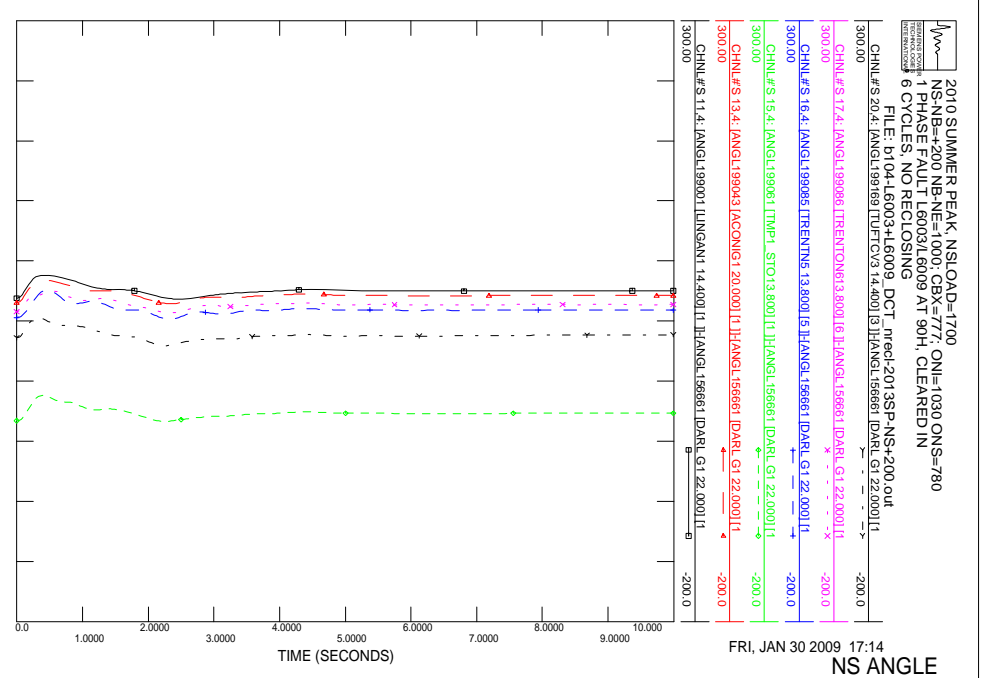

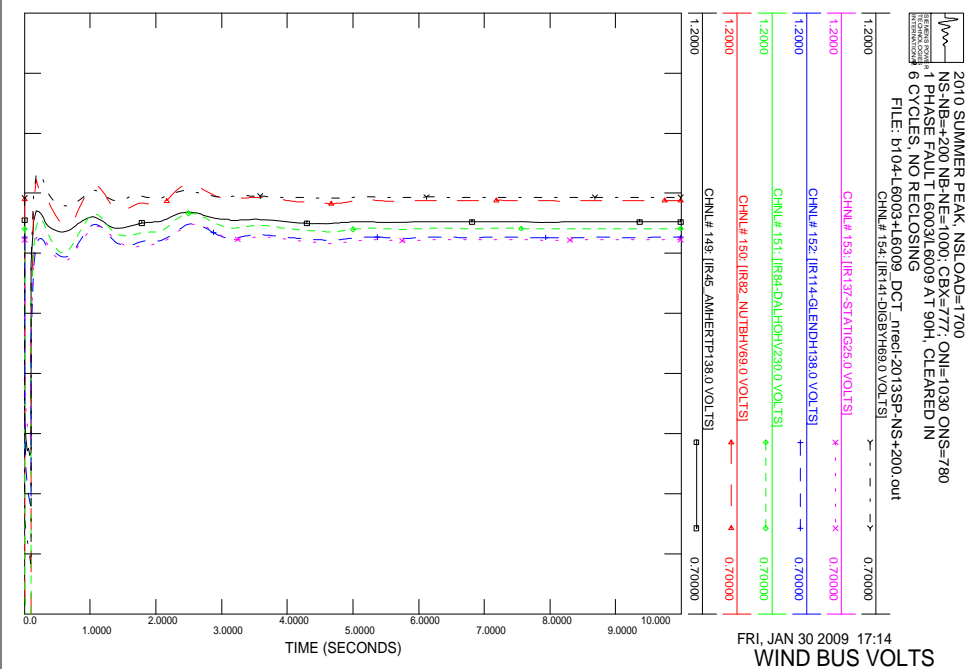
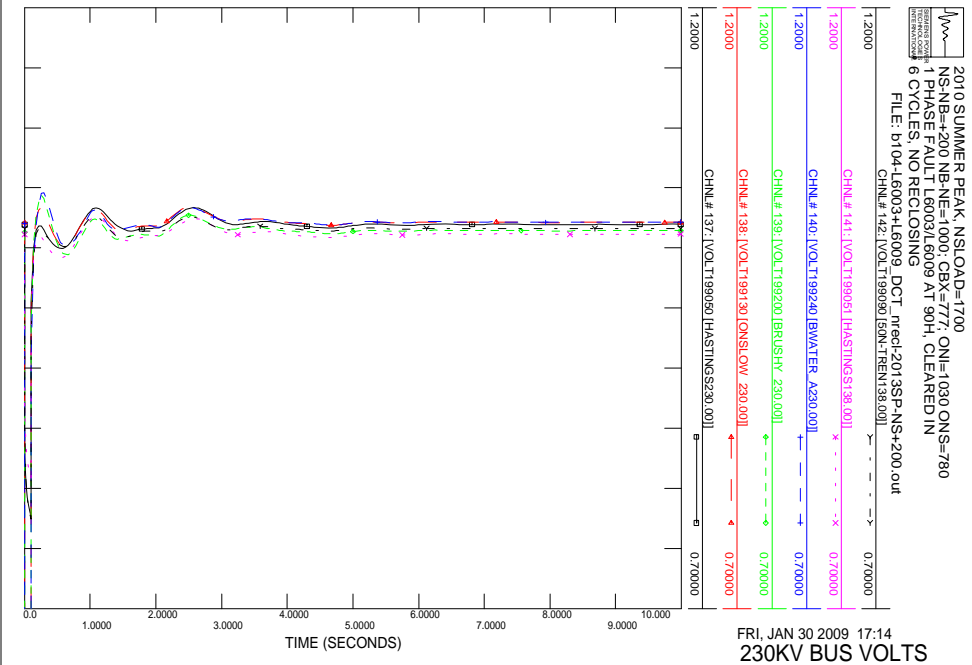
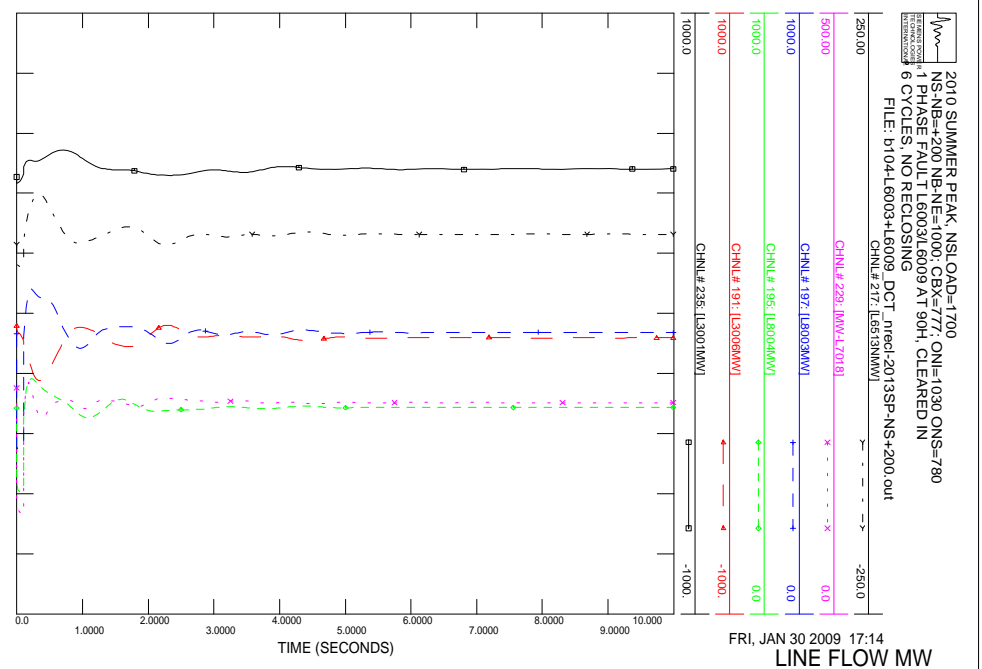
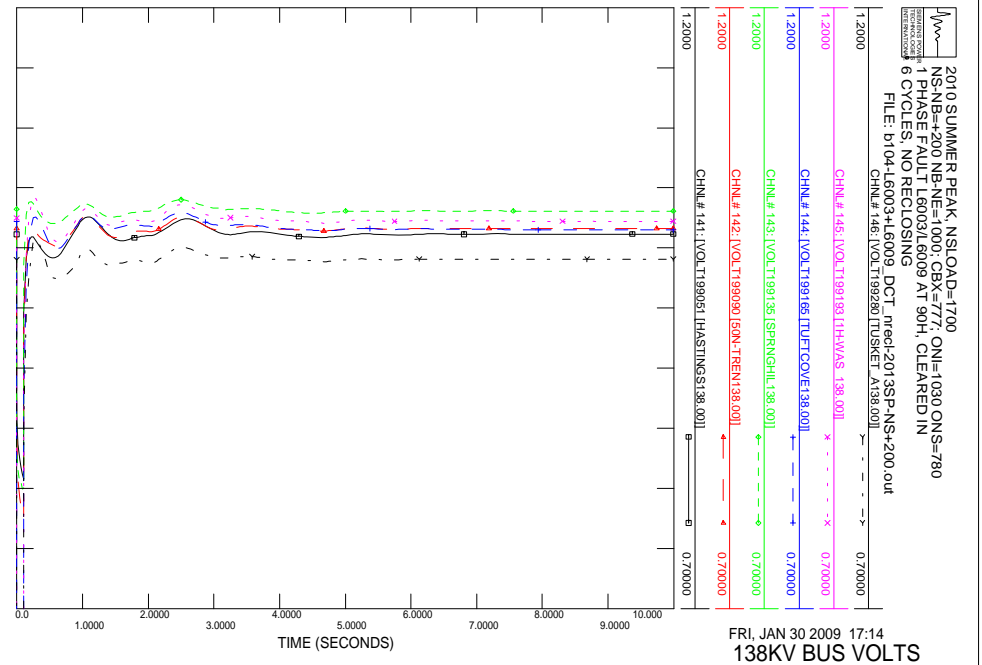

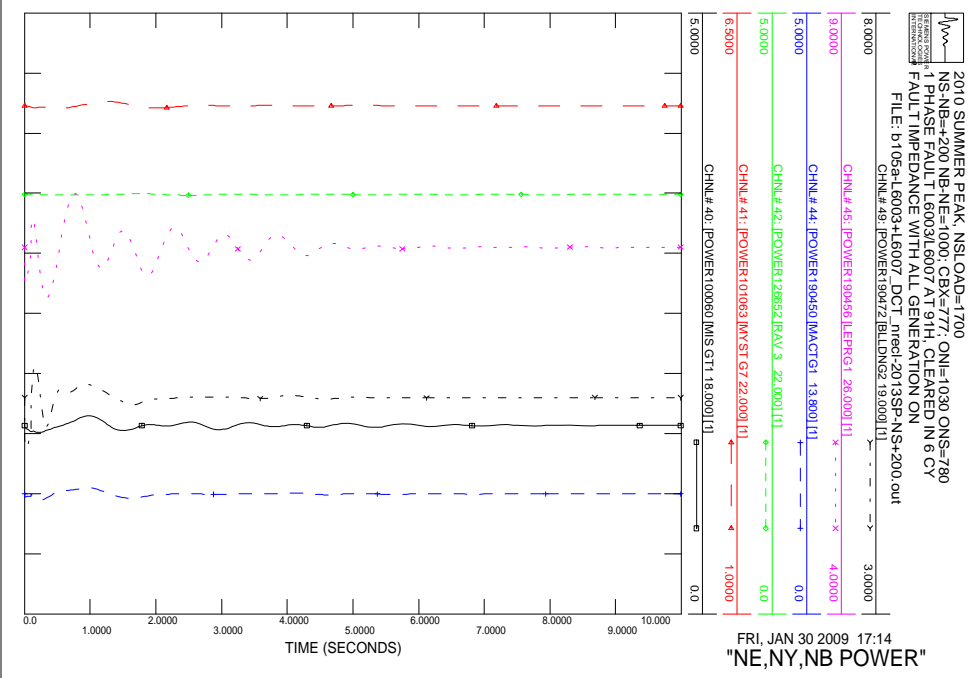
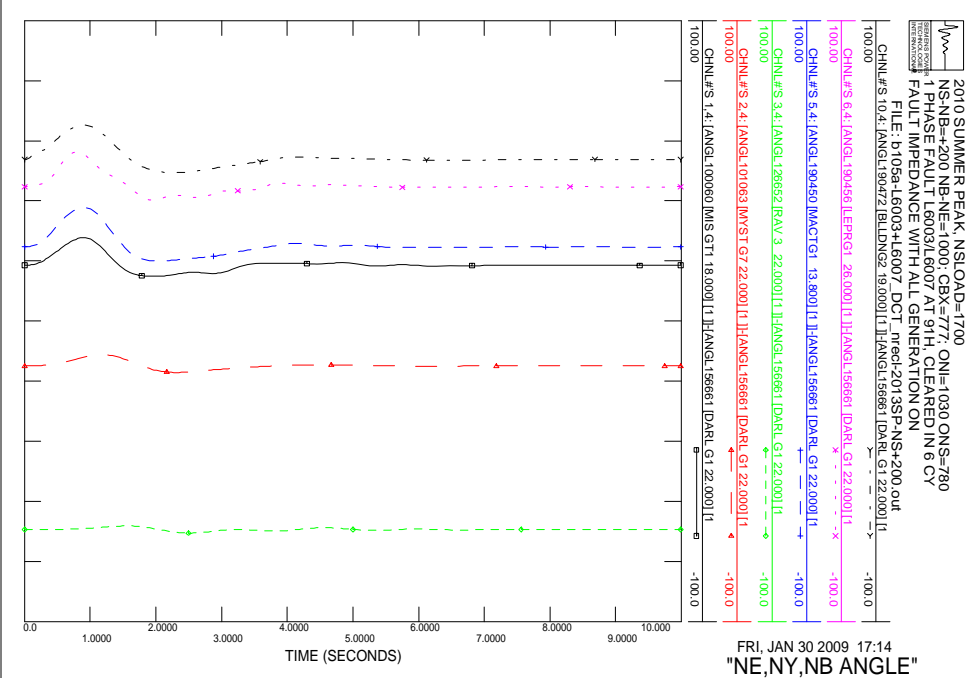
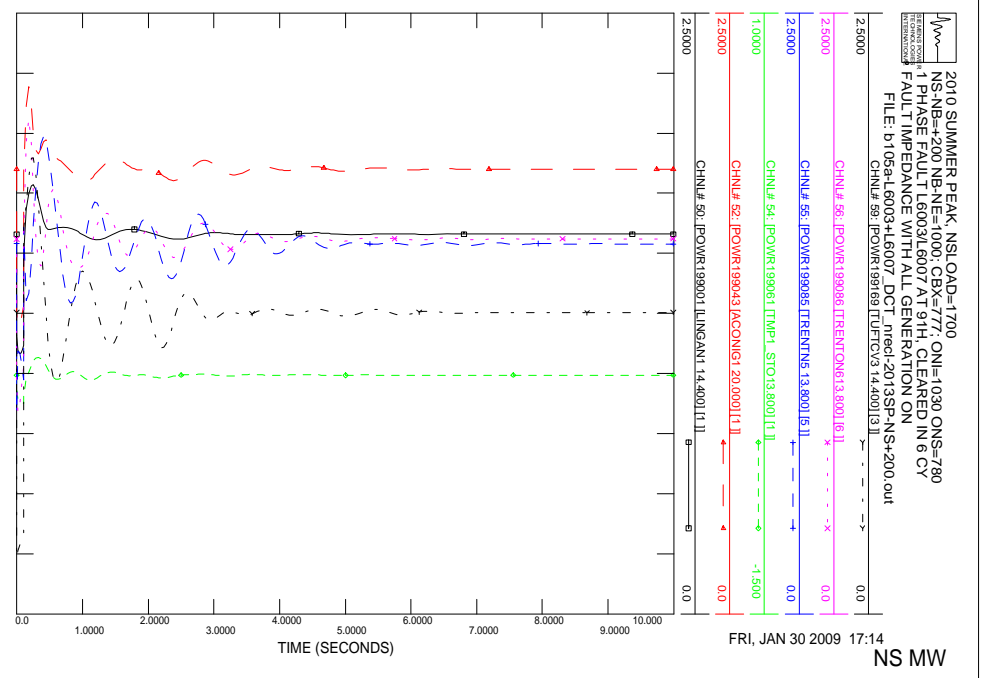
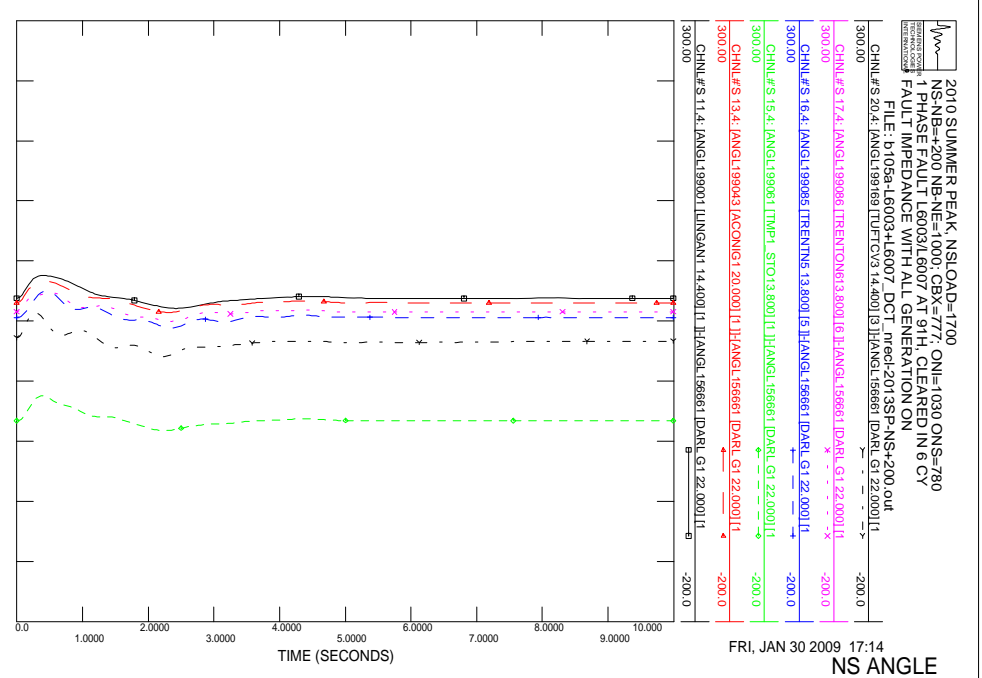

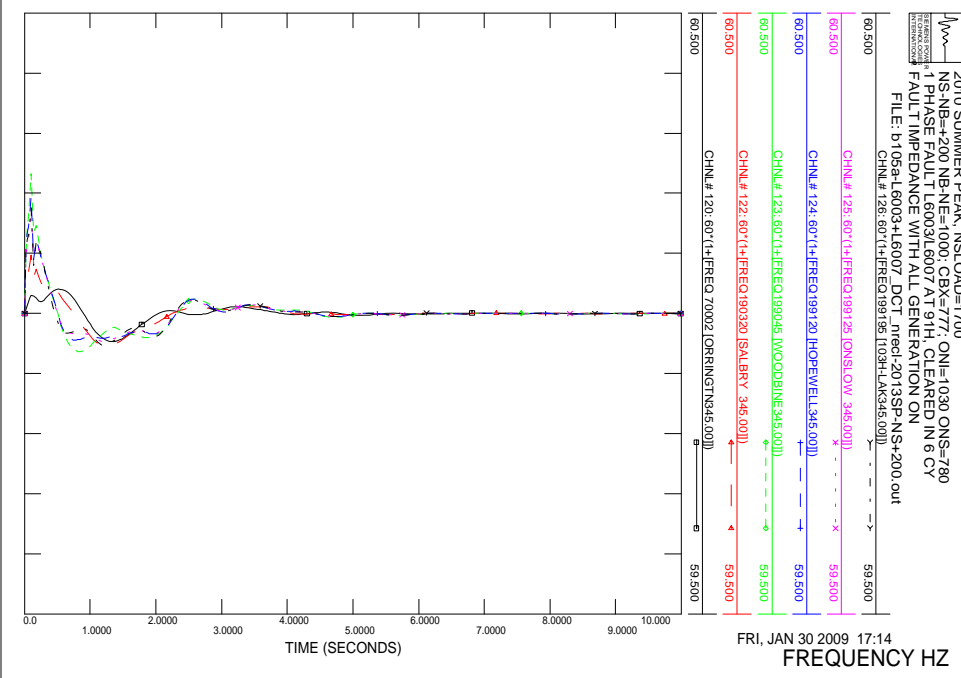
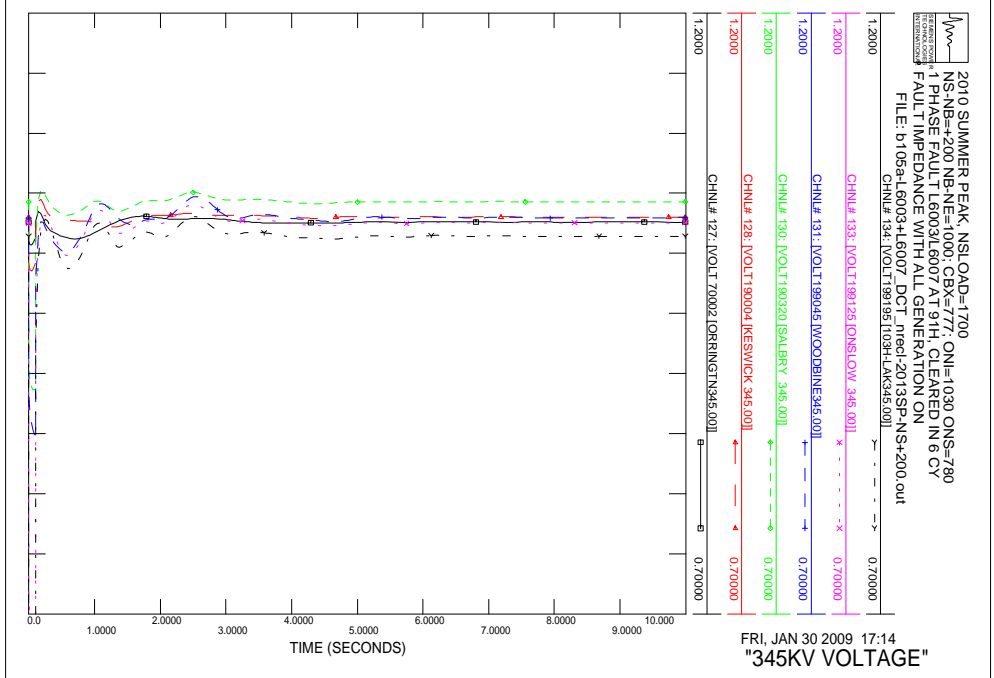
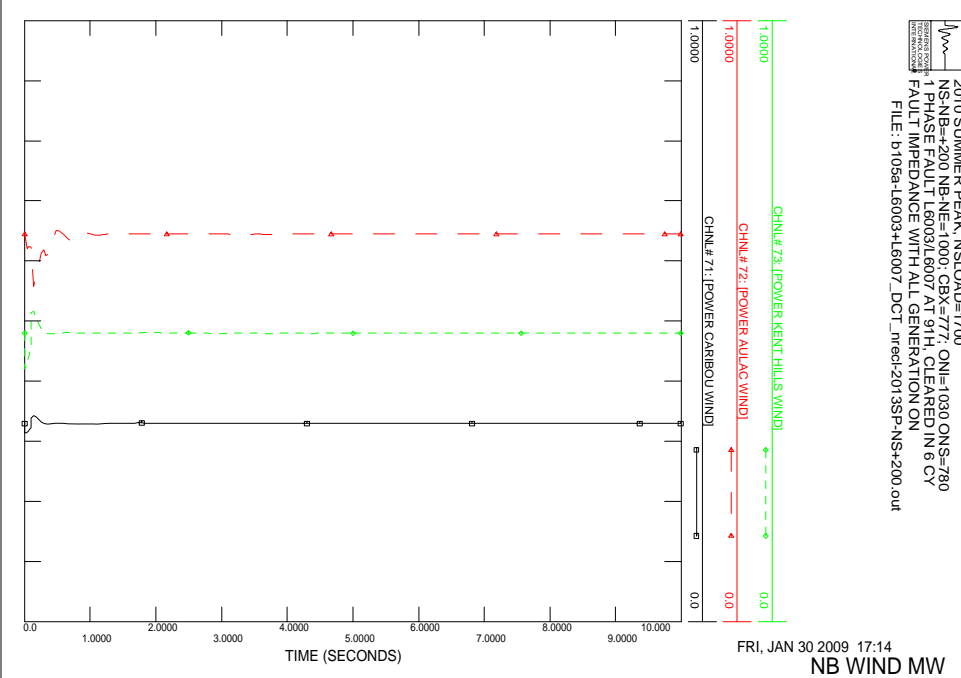
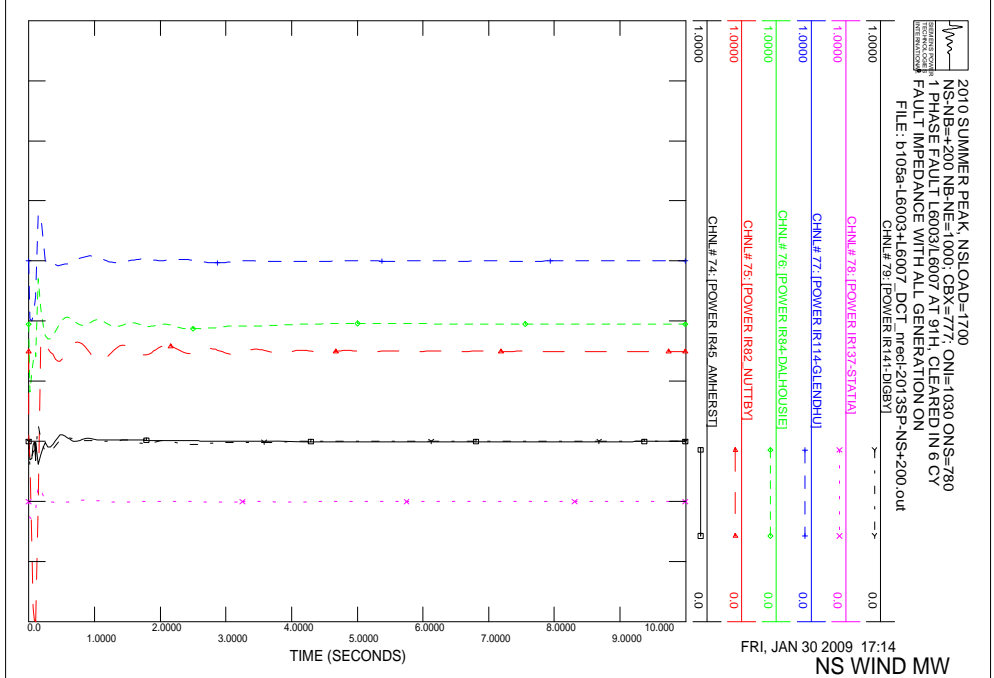

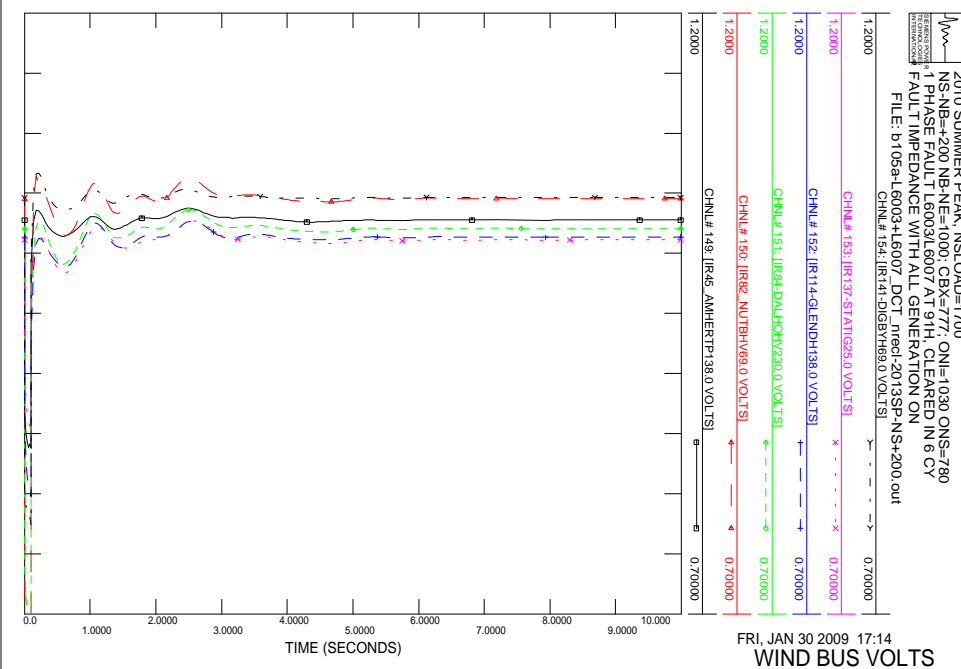
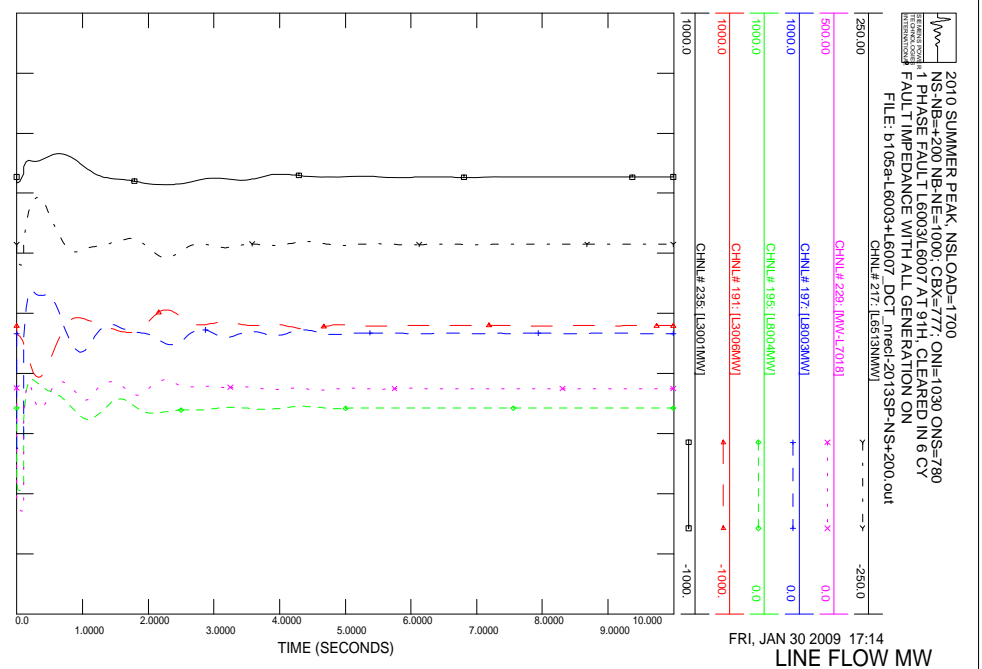
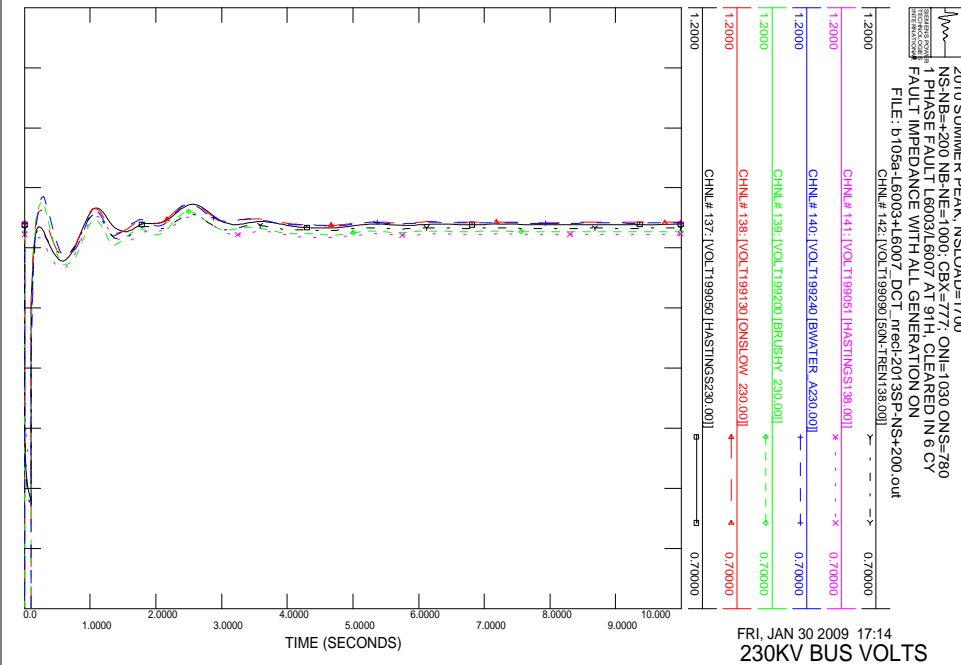
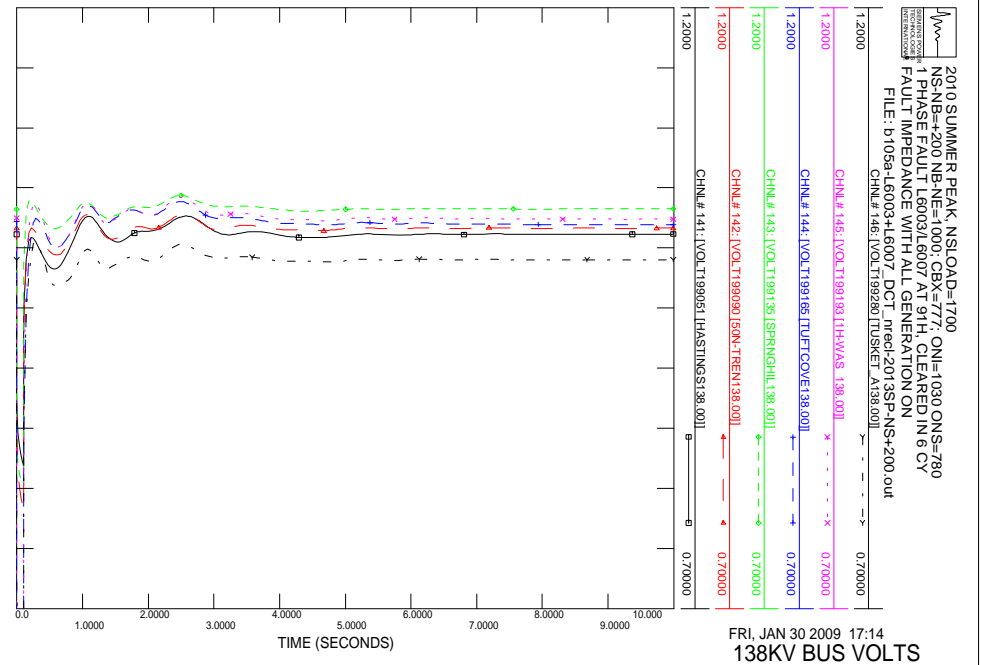

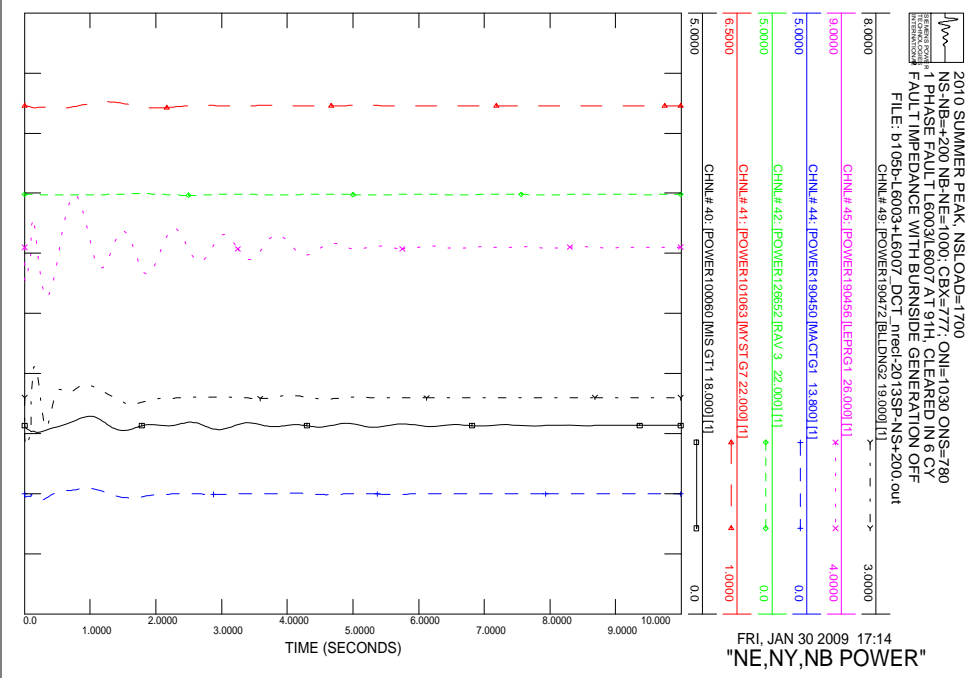
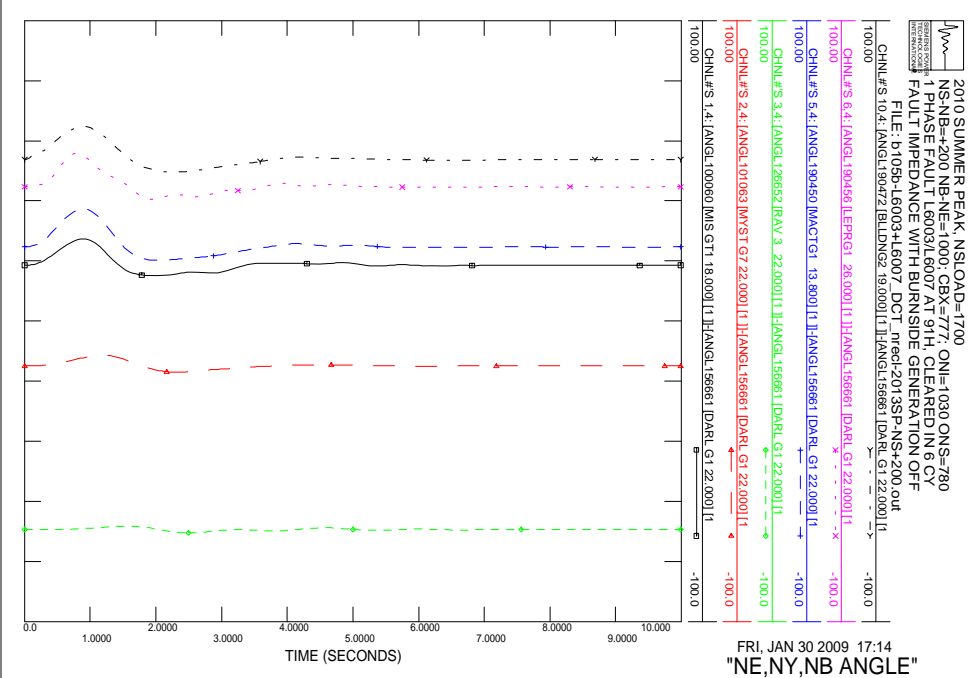
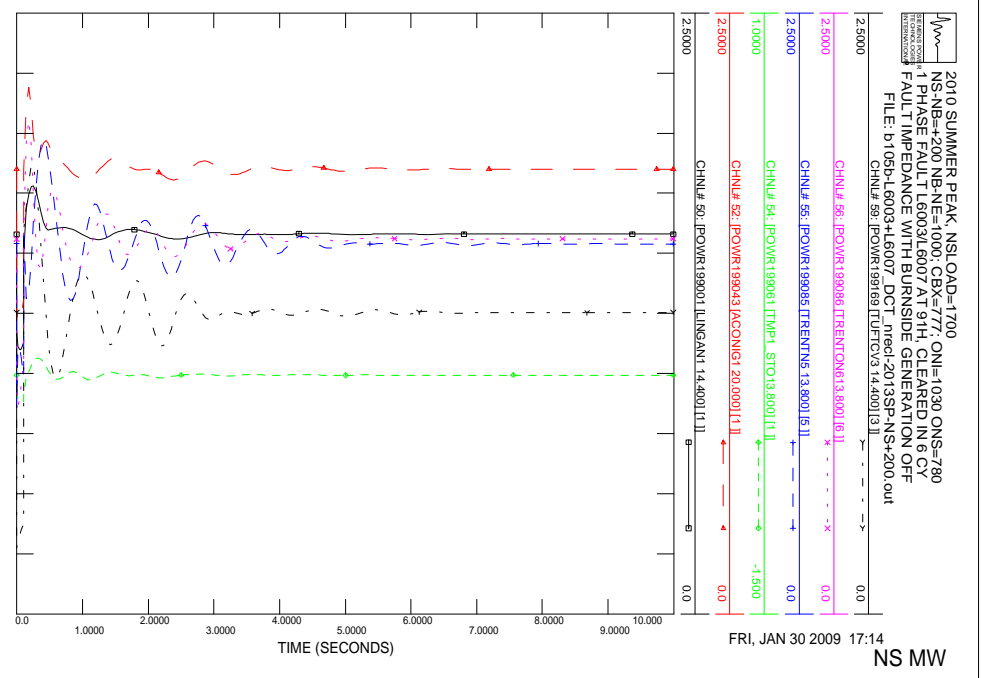
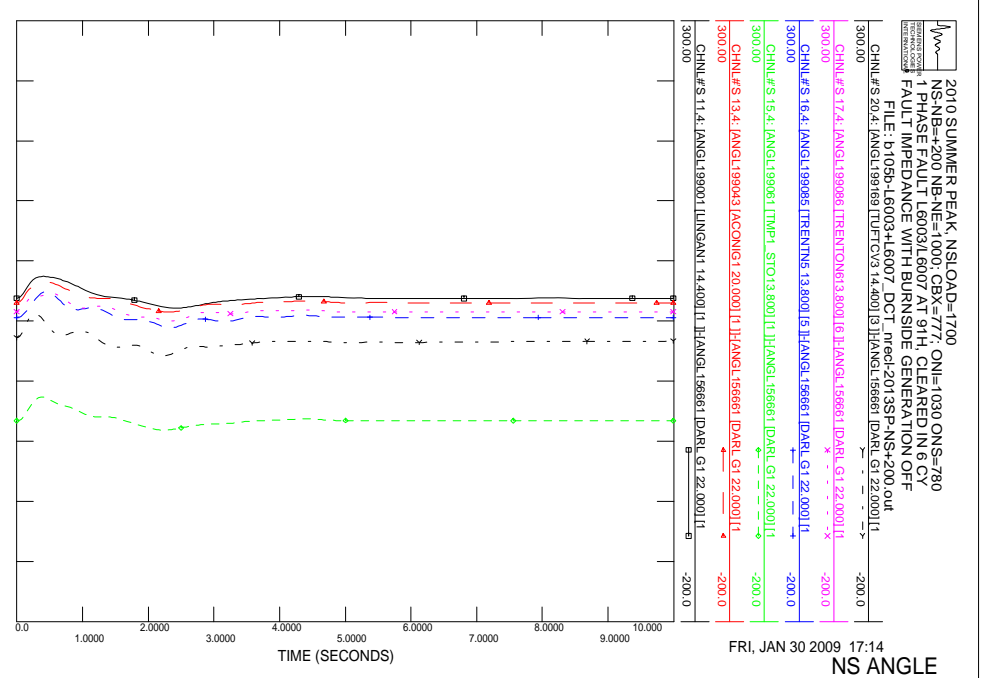

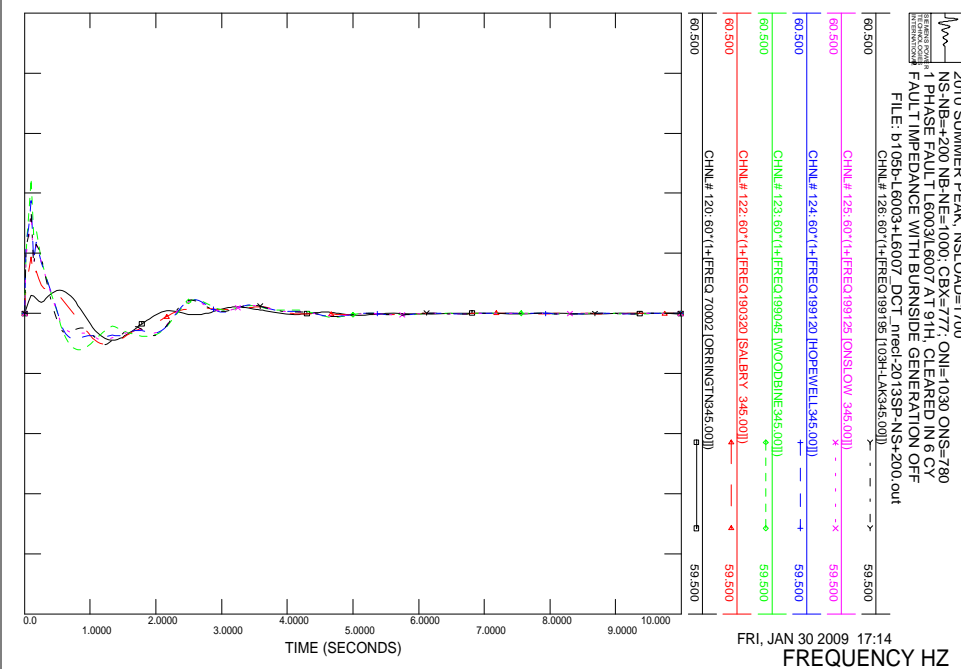
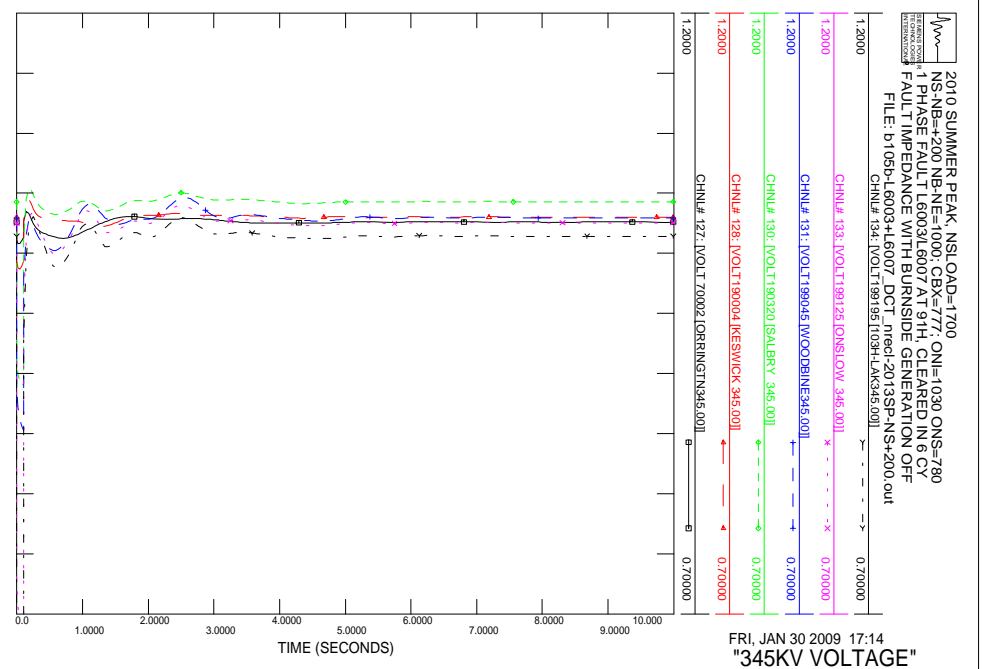
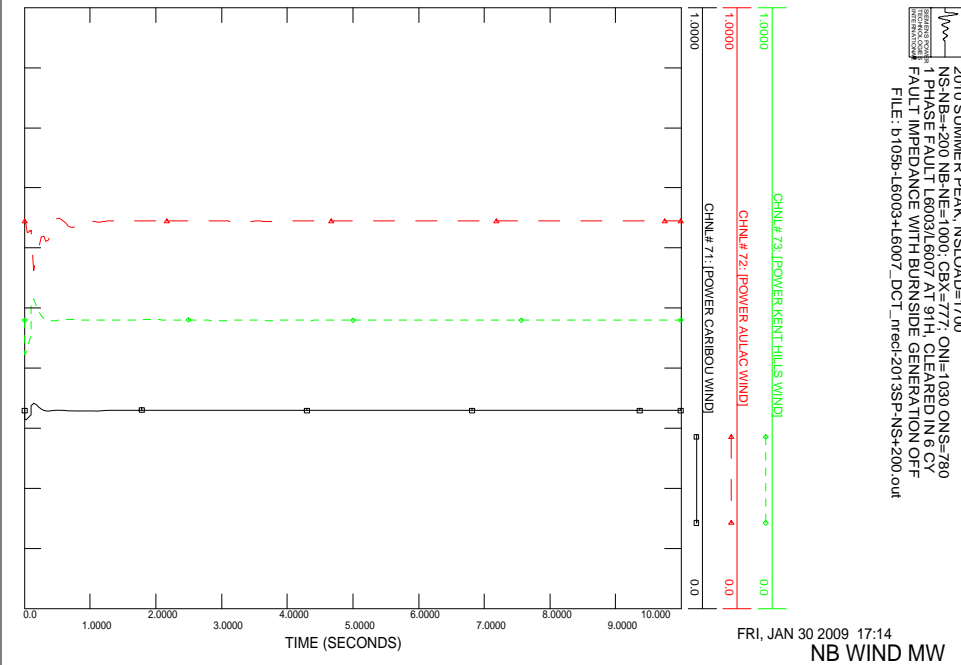
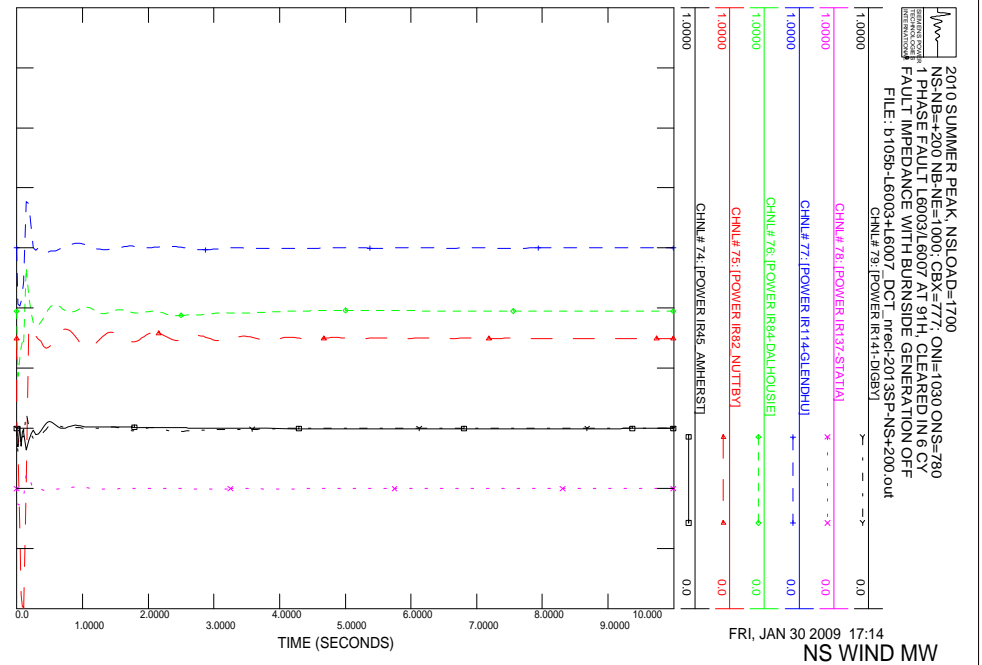

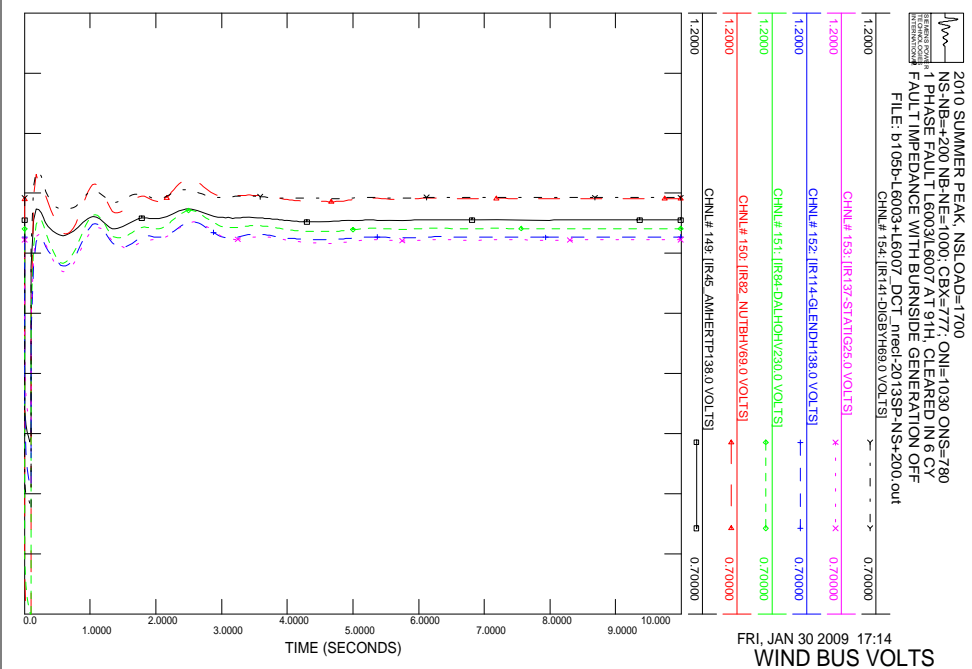
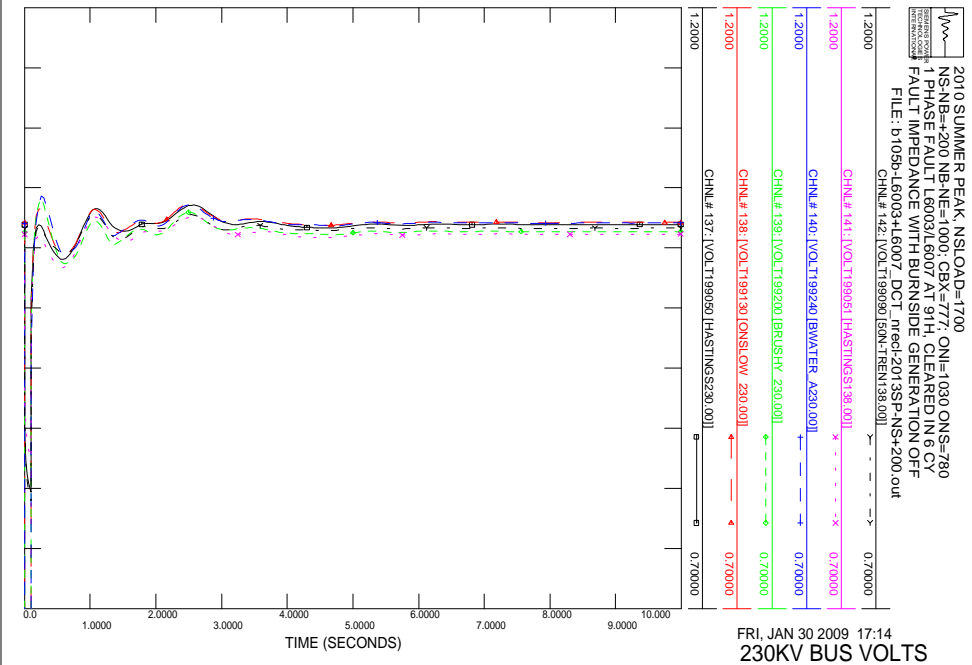
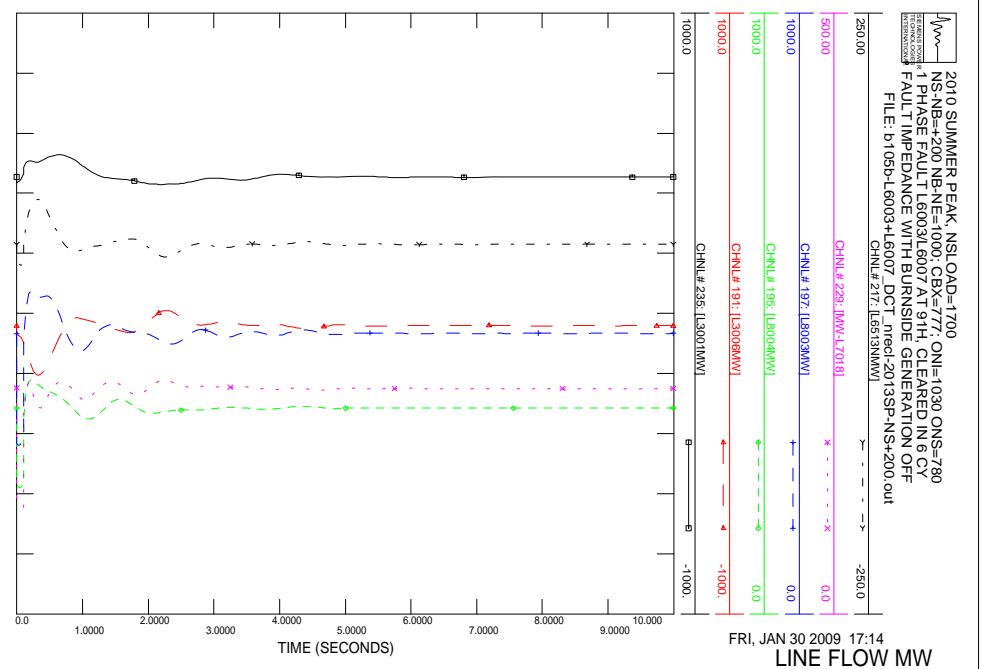
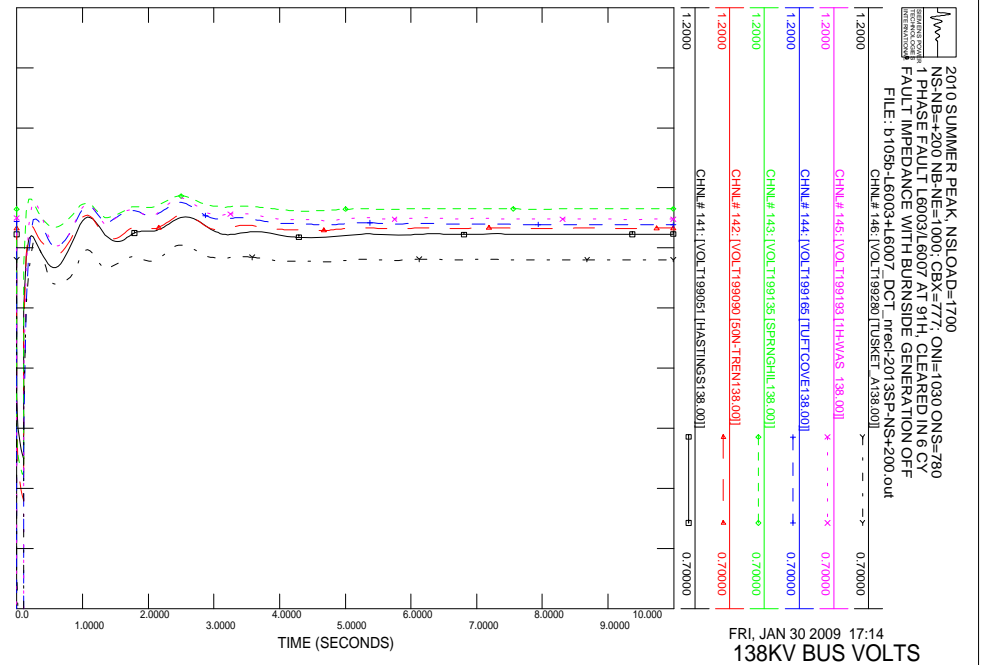

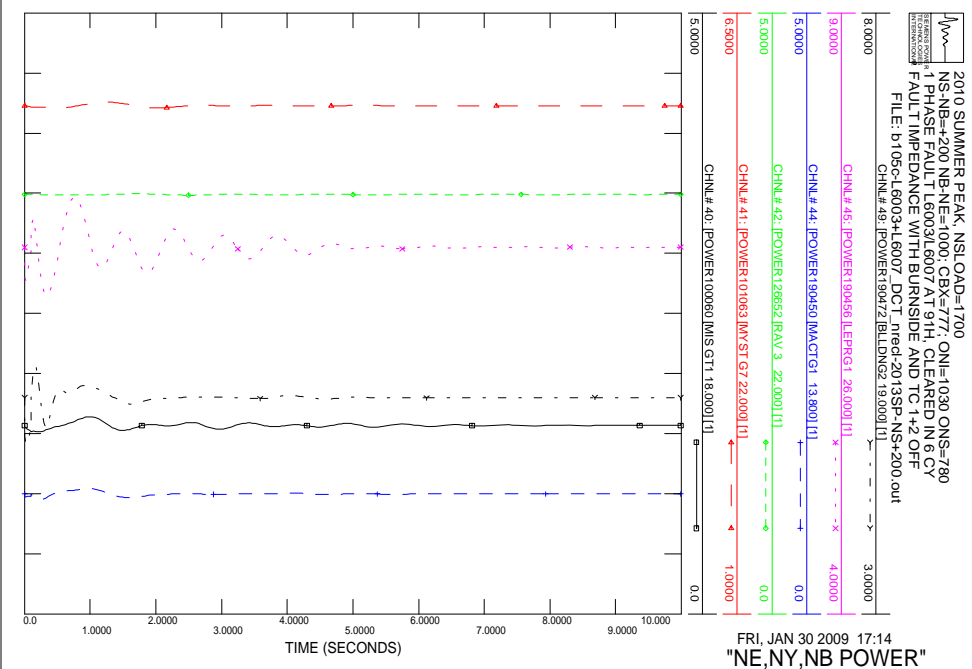
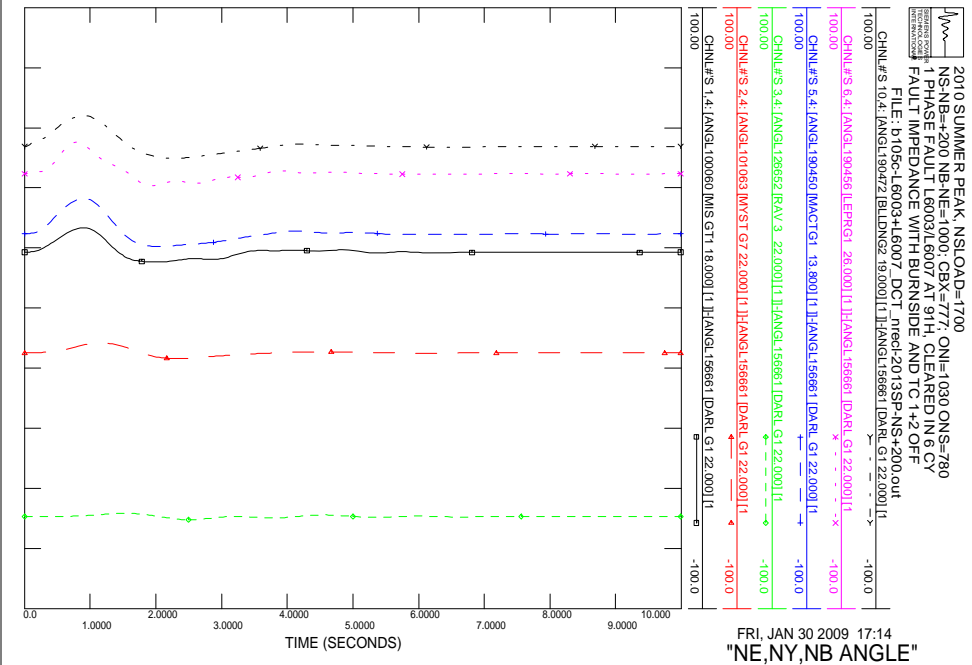
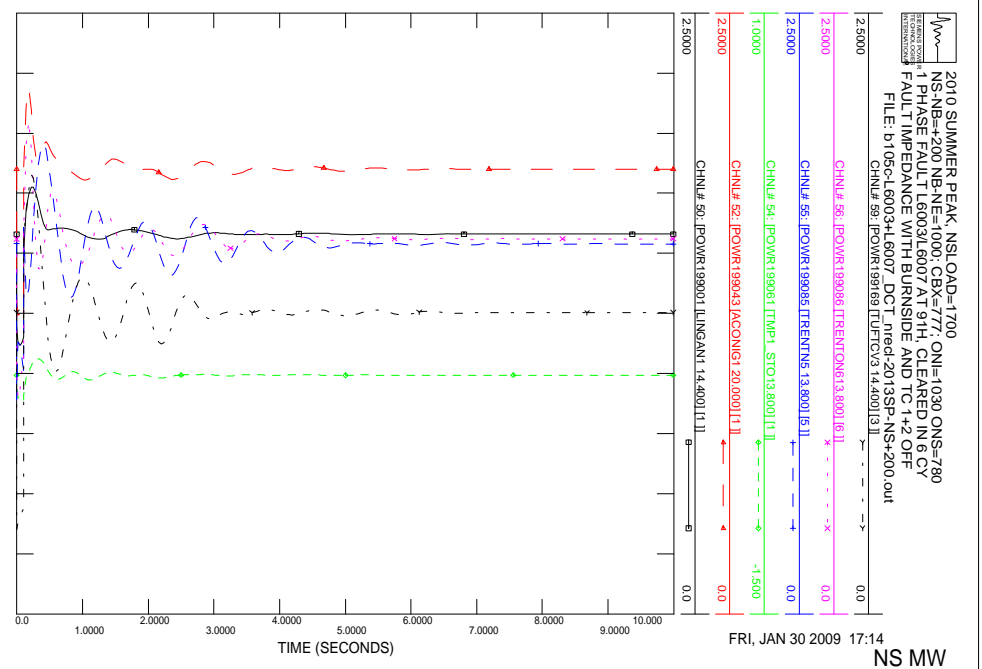
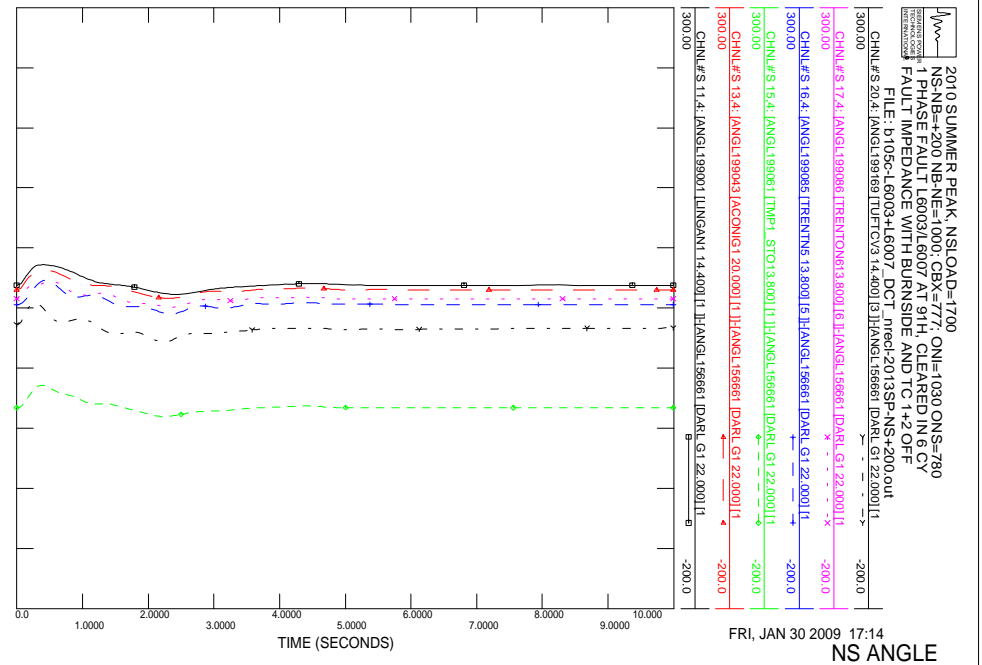

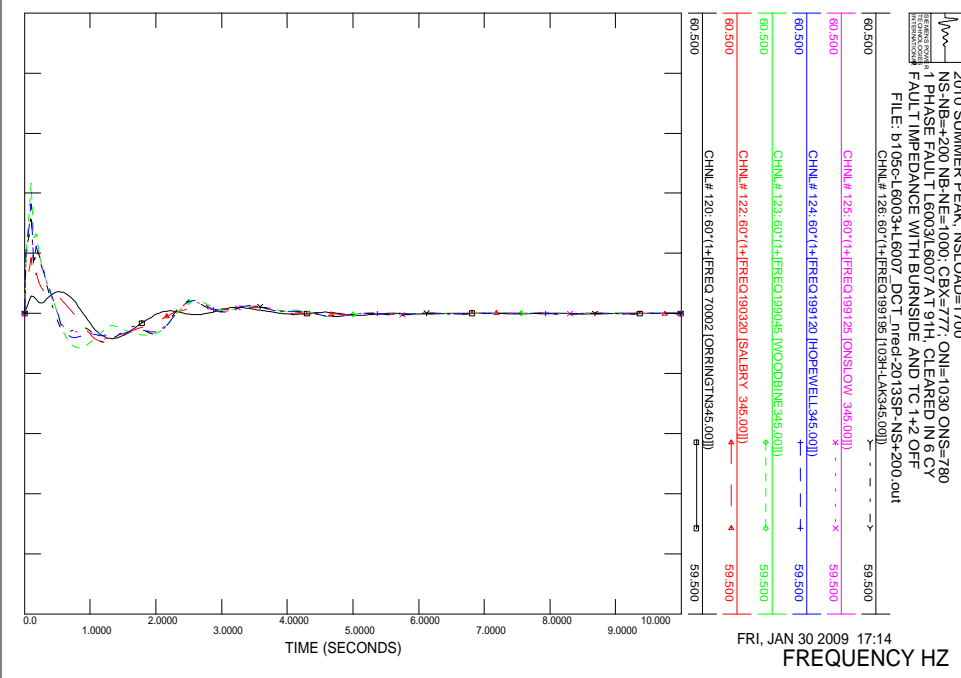
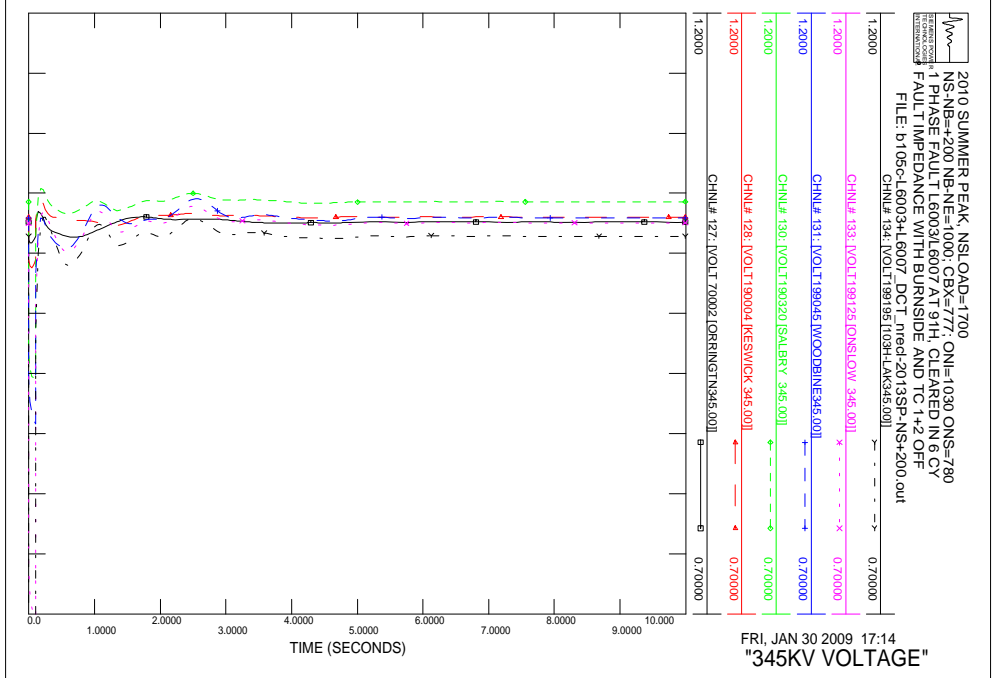
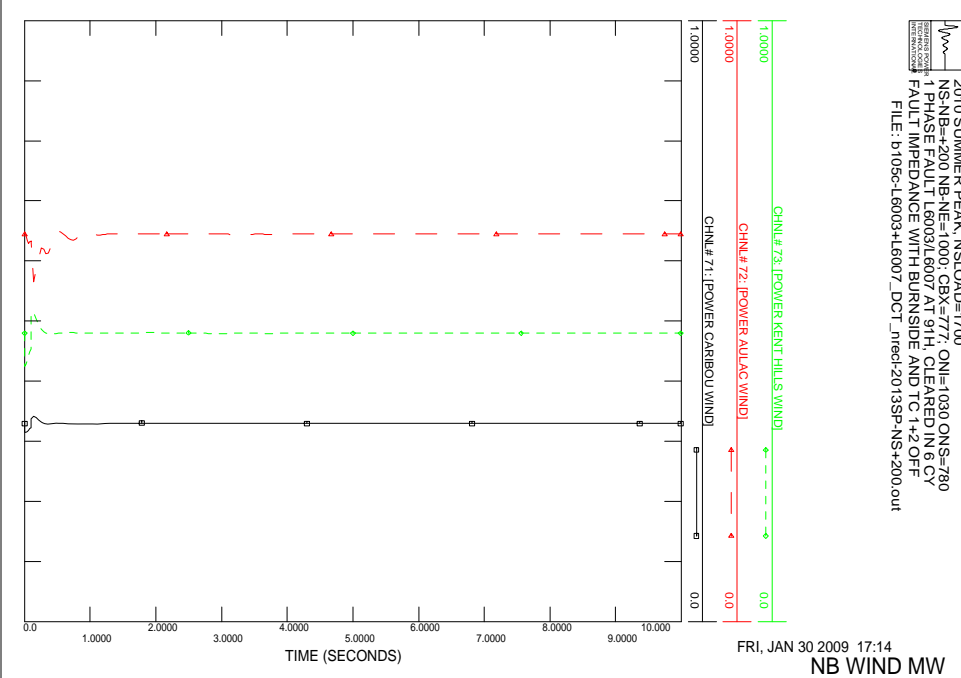
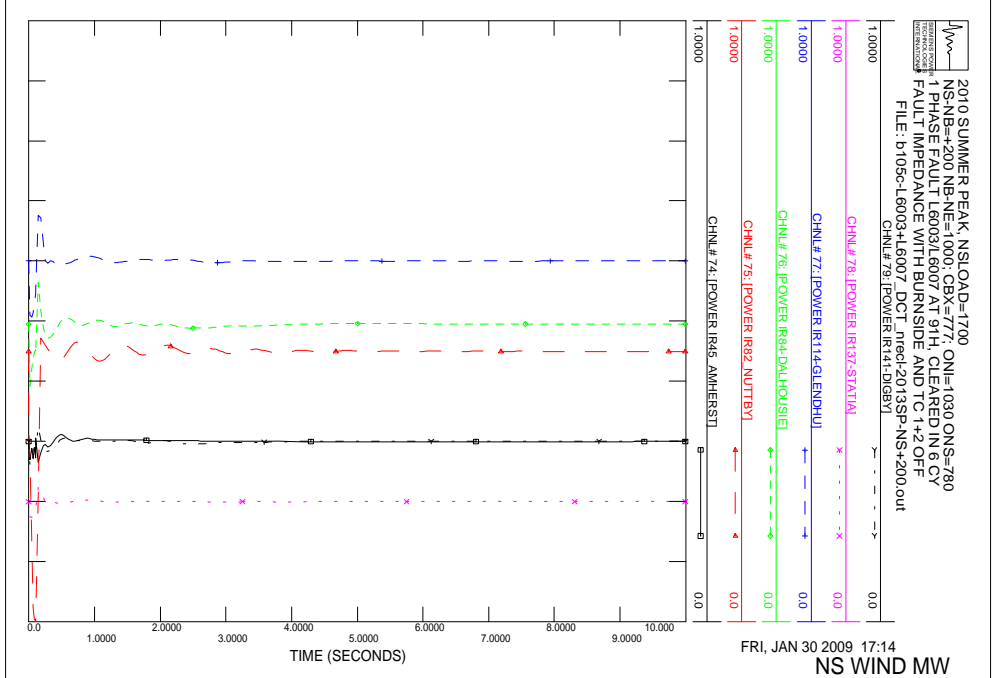

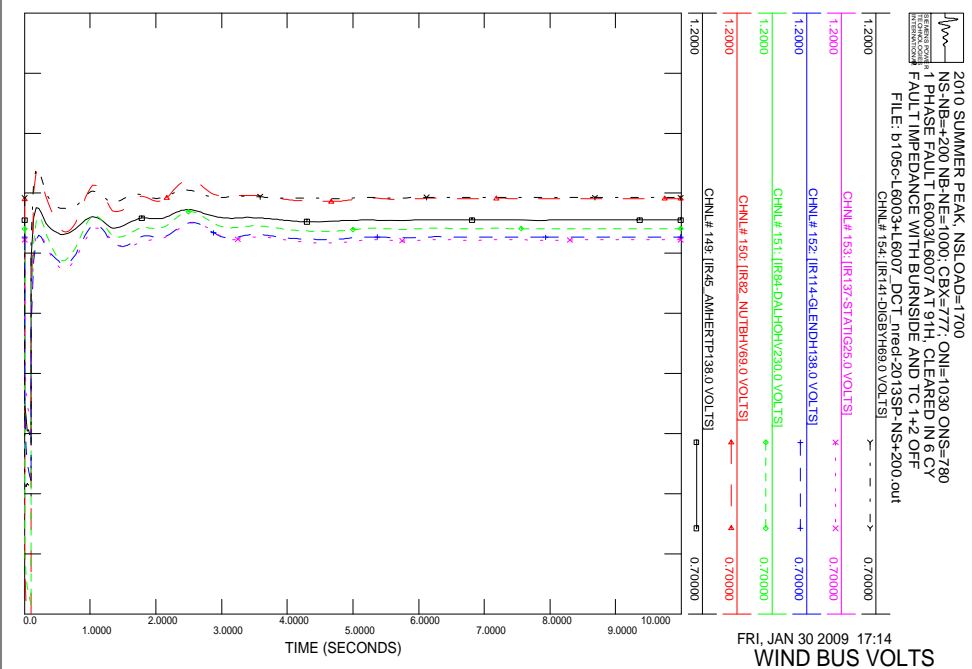
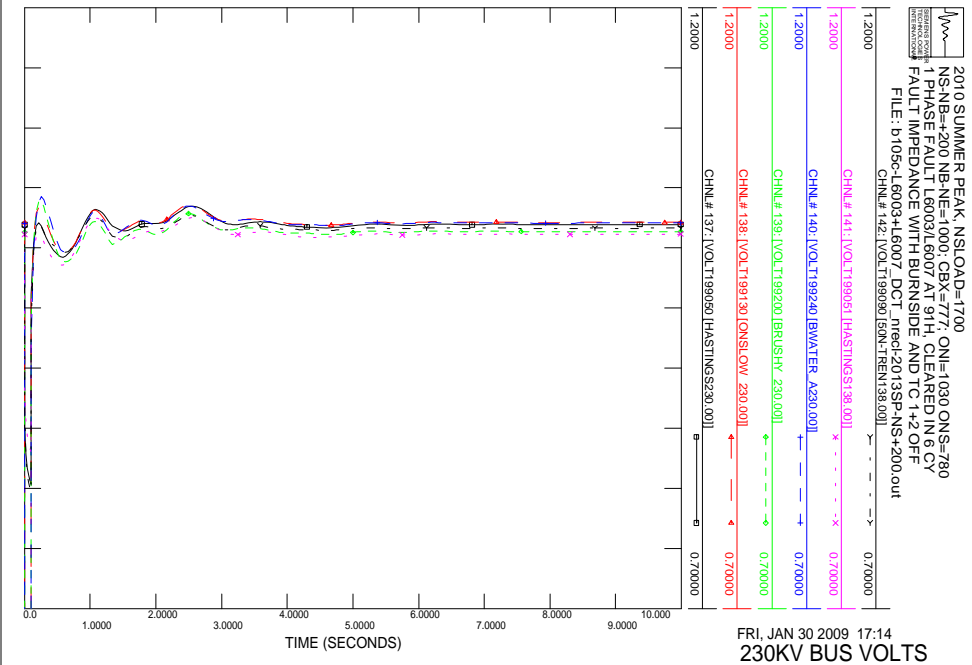
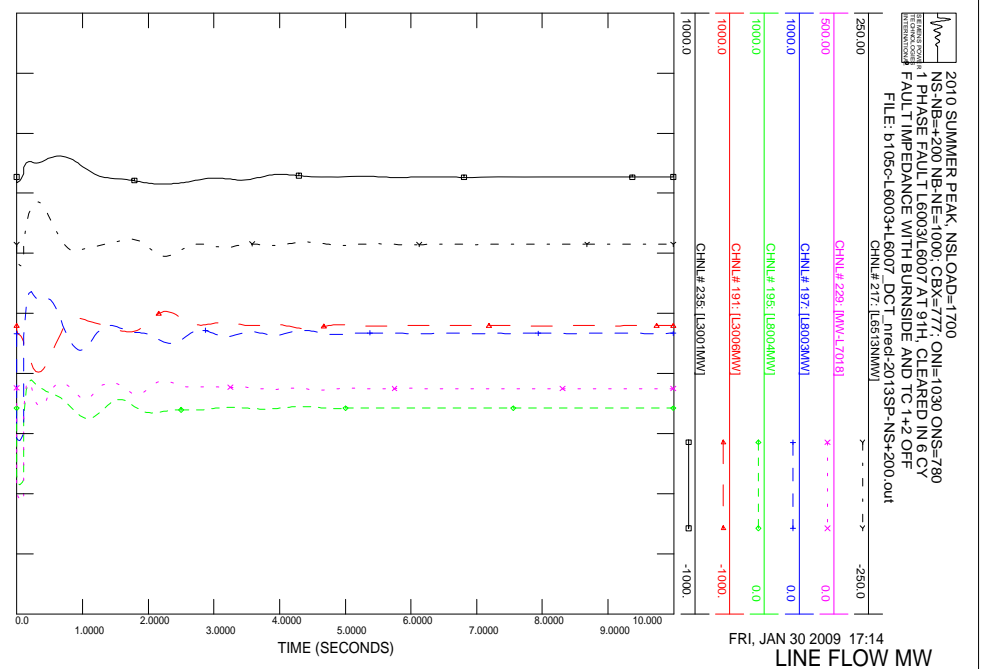
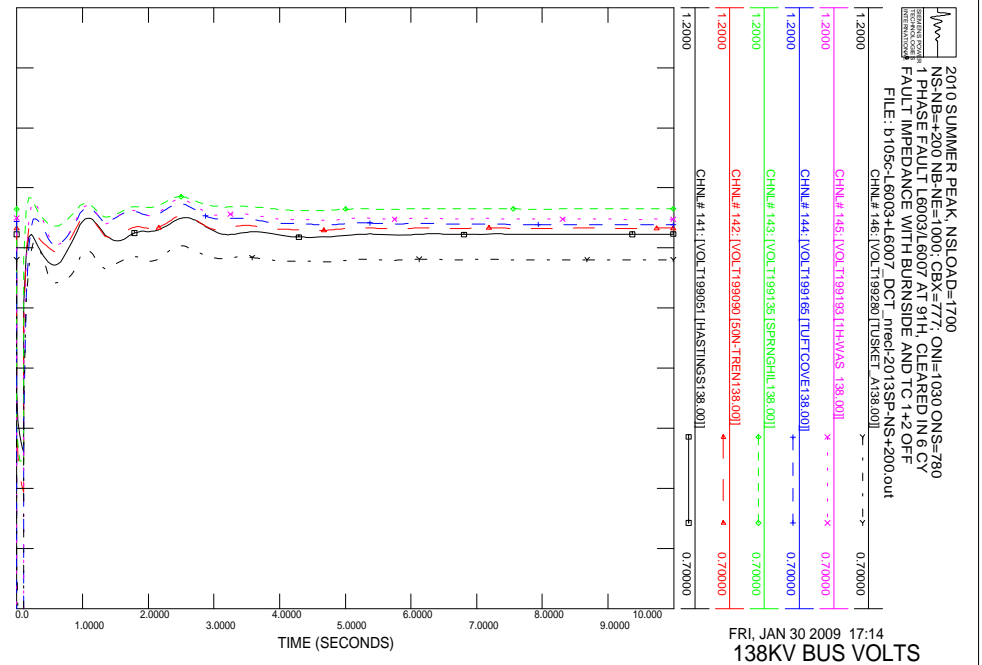

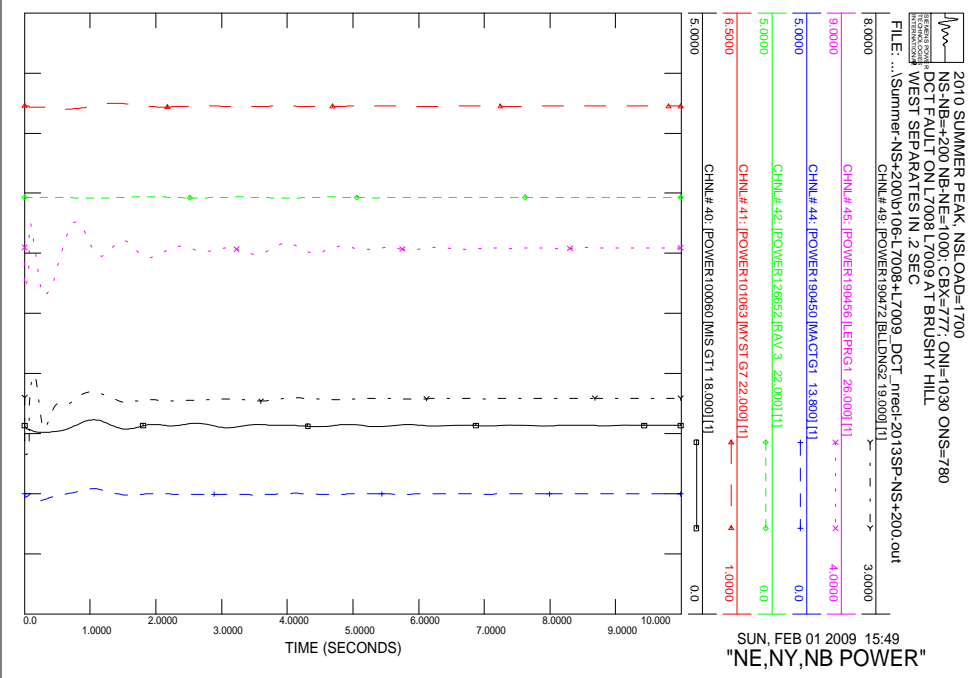
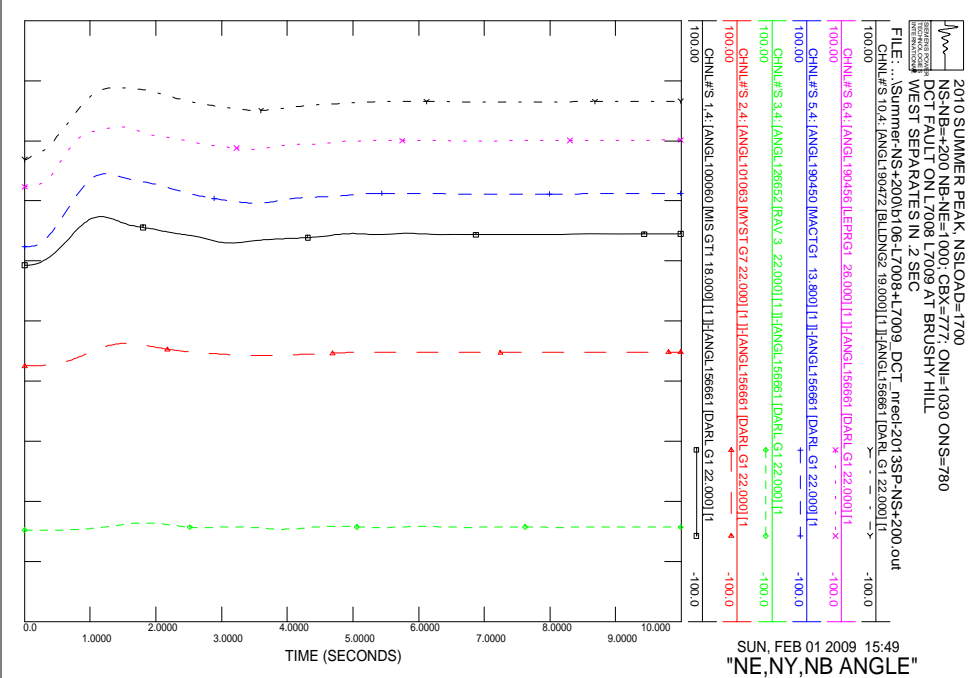
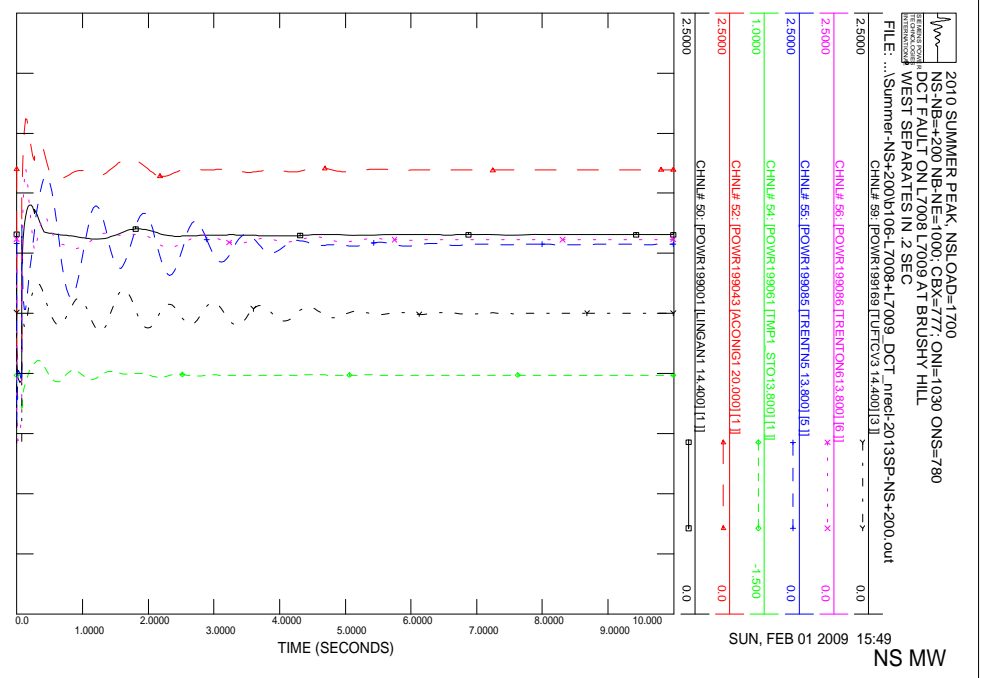
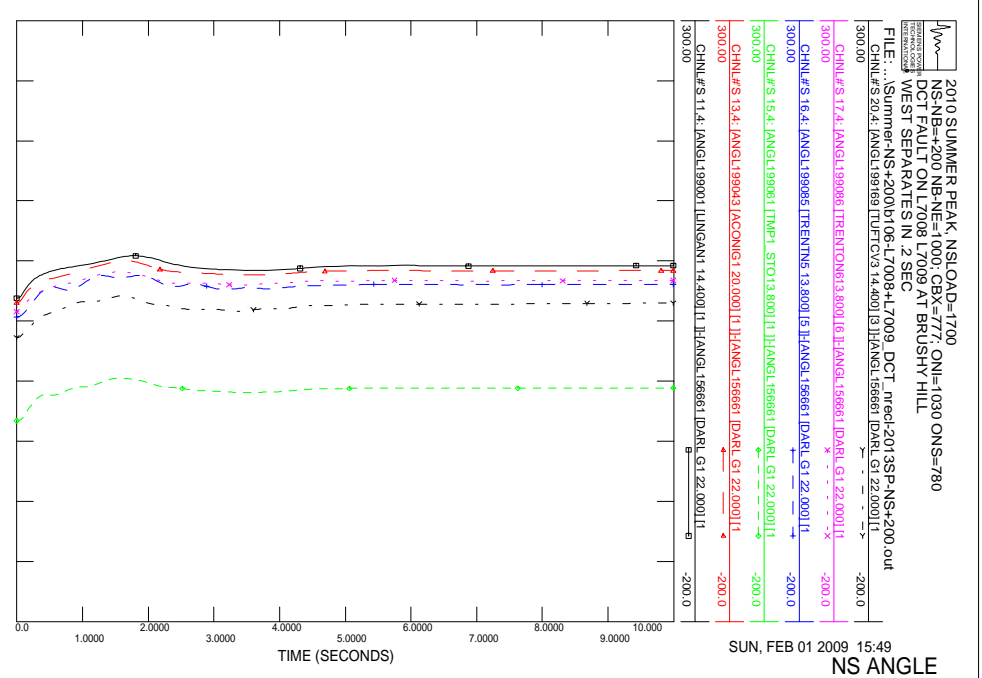

SUN, FEB 01 2009 15:49
 "NE,NY,NB ANGLE"

SUN, FEB 01 2009 15:49
 "NE,NY,NB POWER"

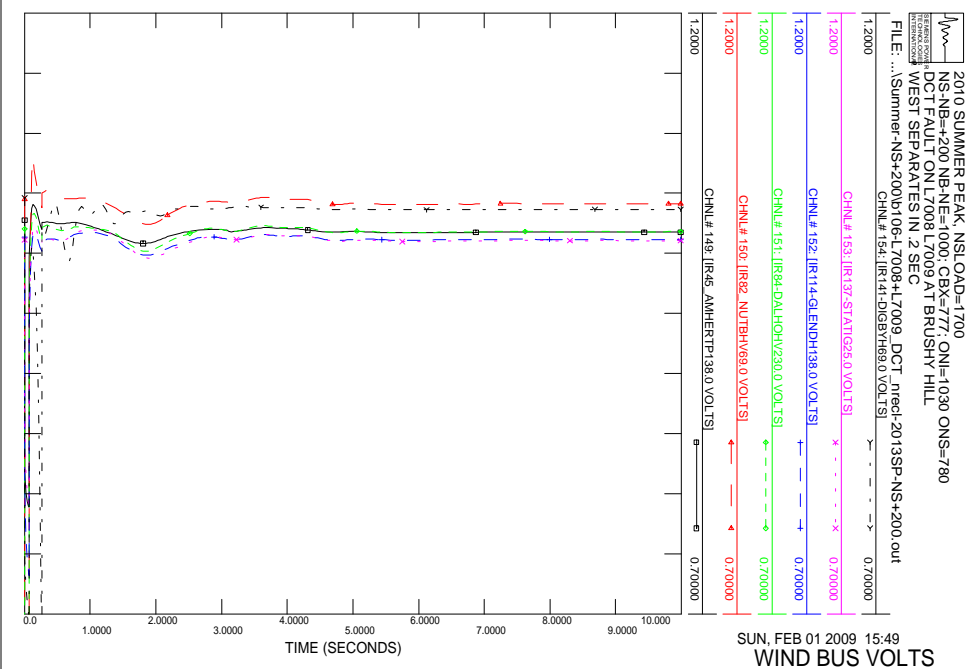
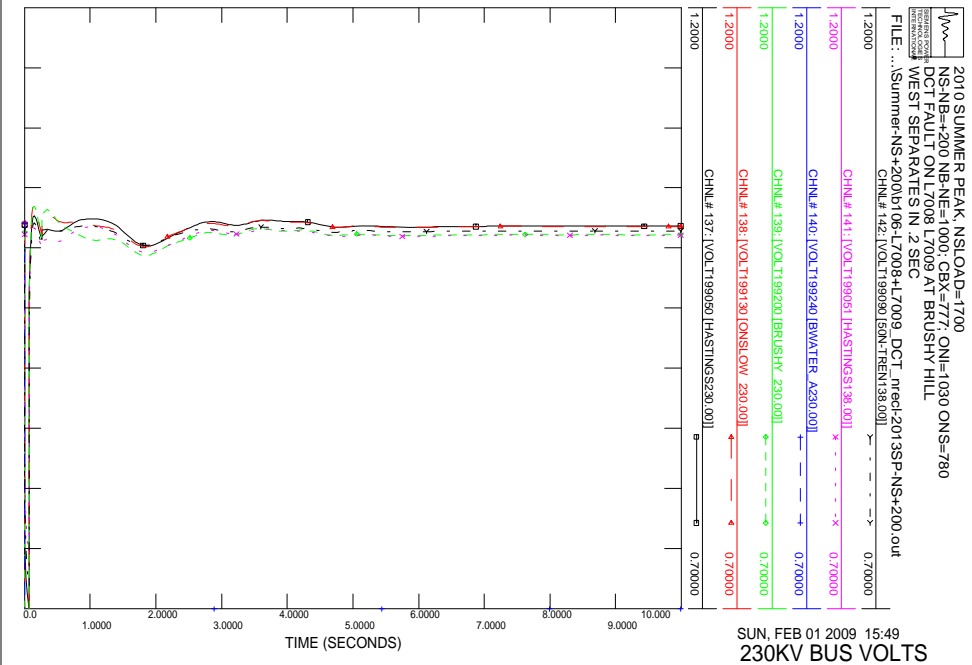
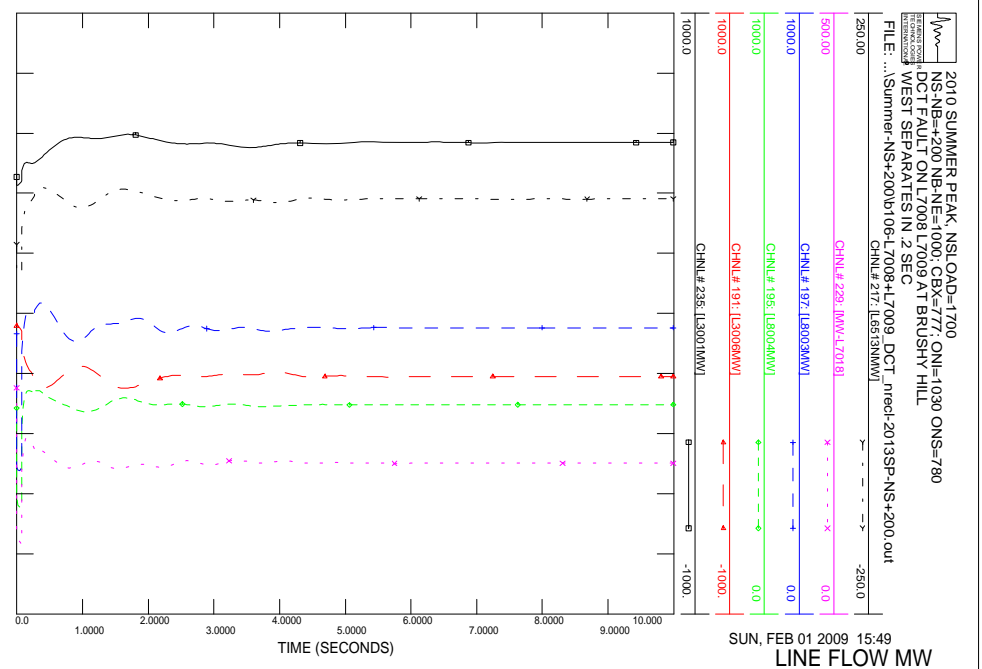
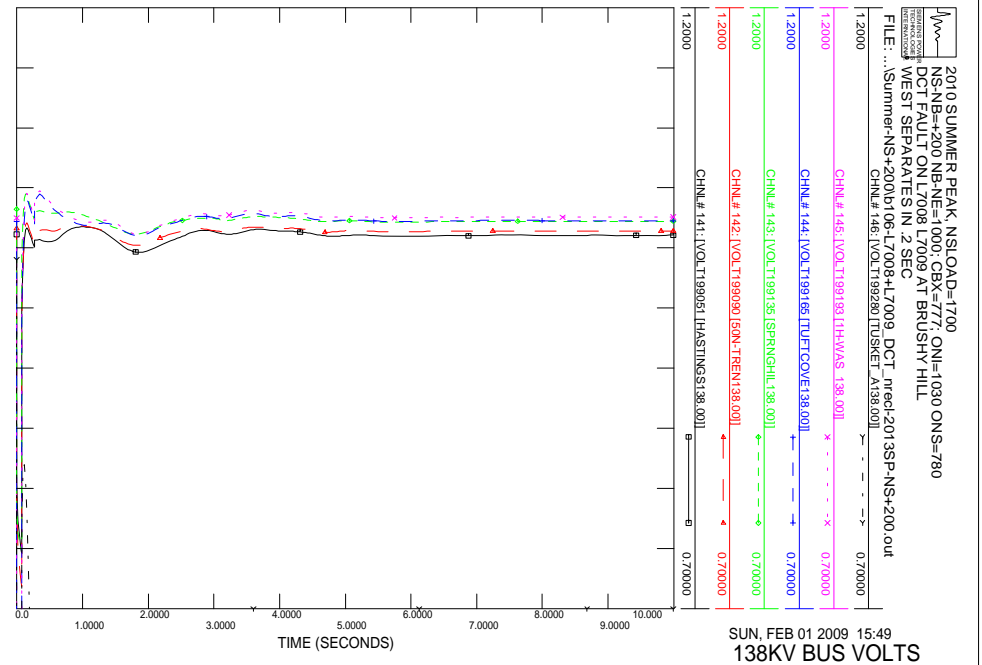

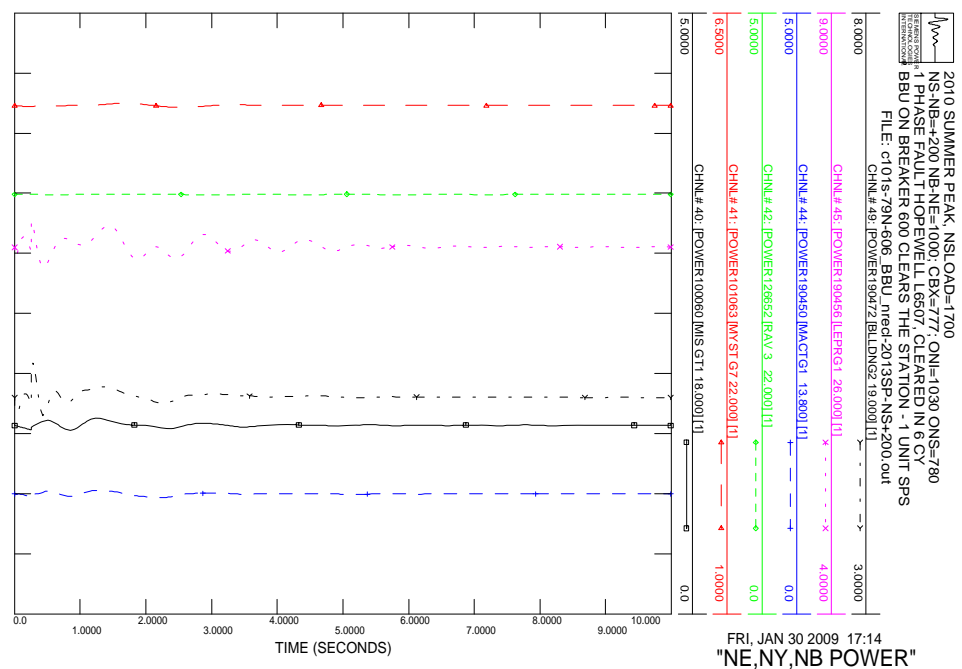
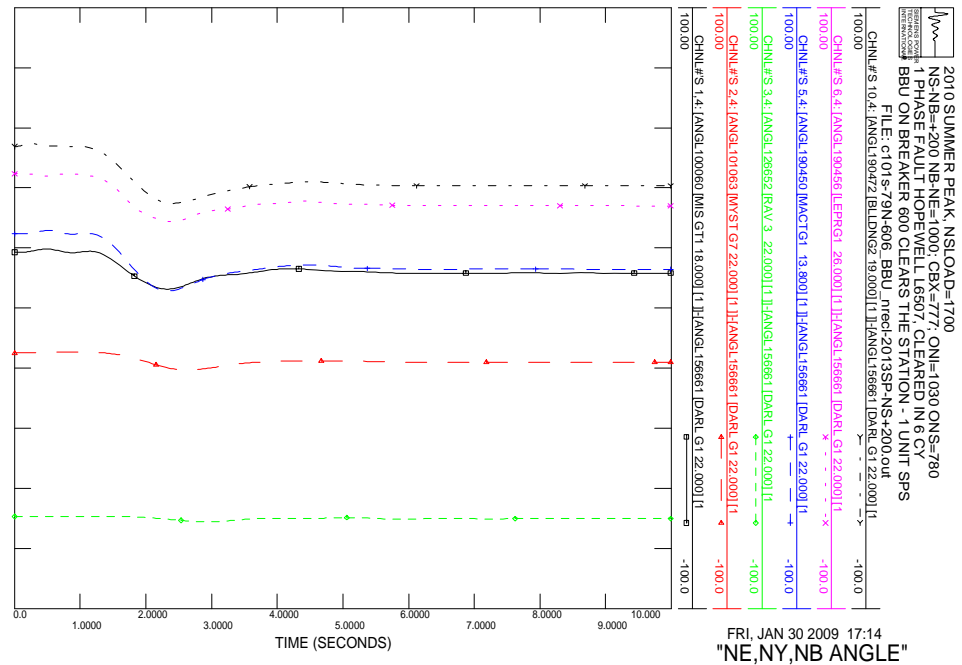
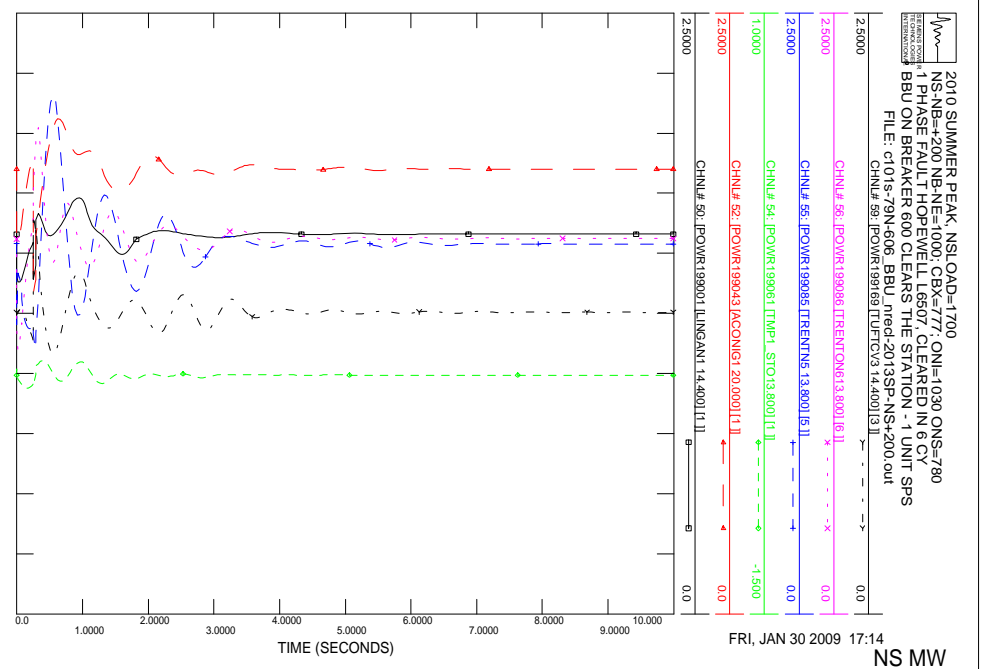
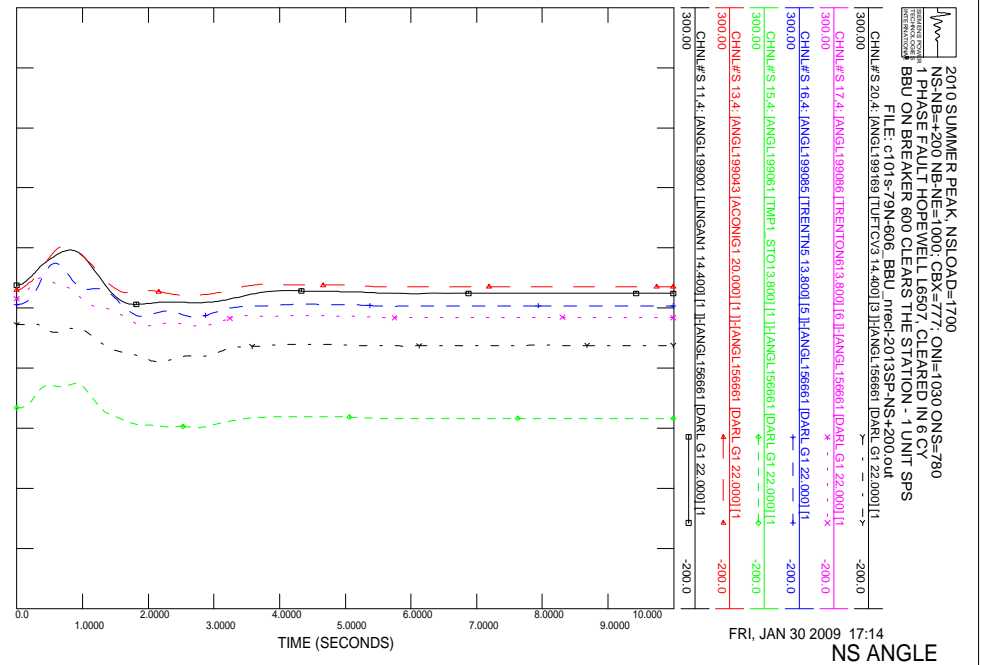

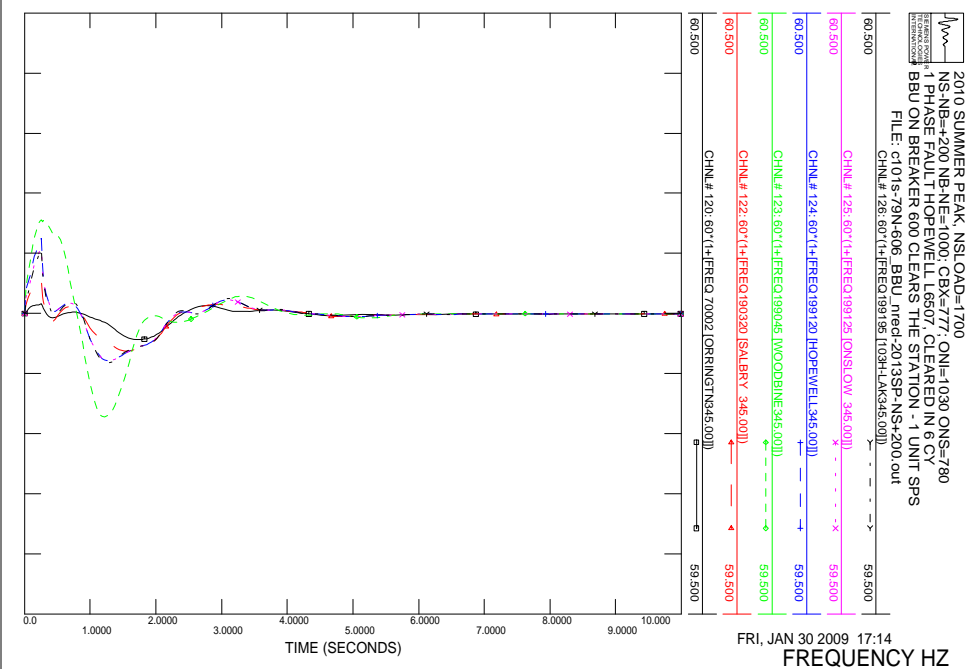
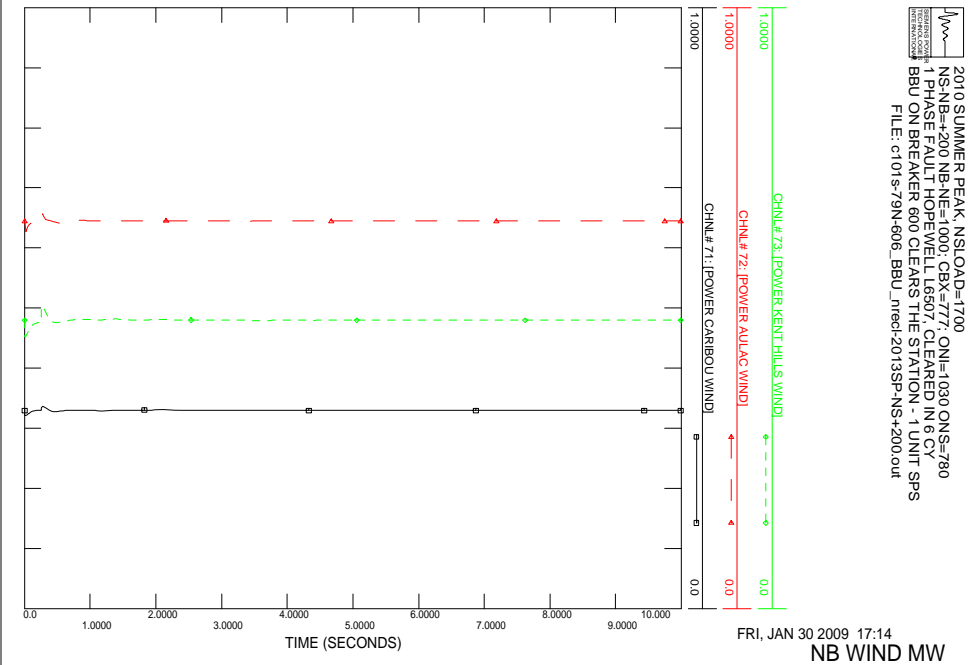
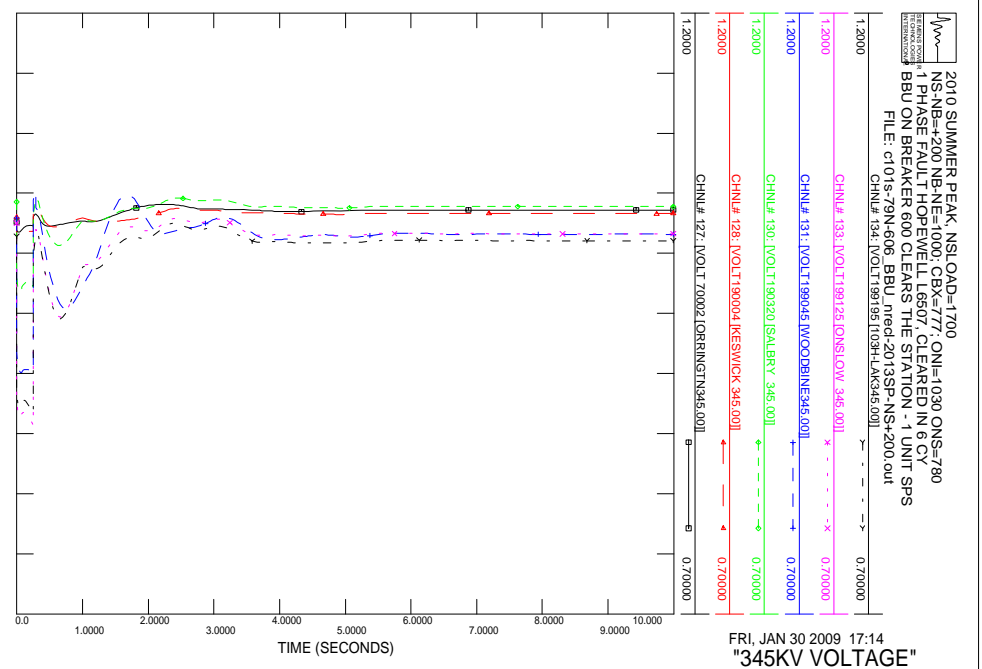
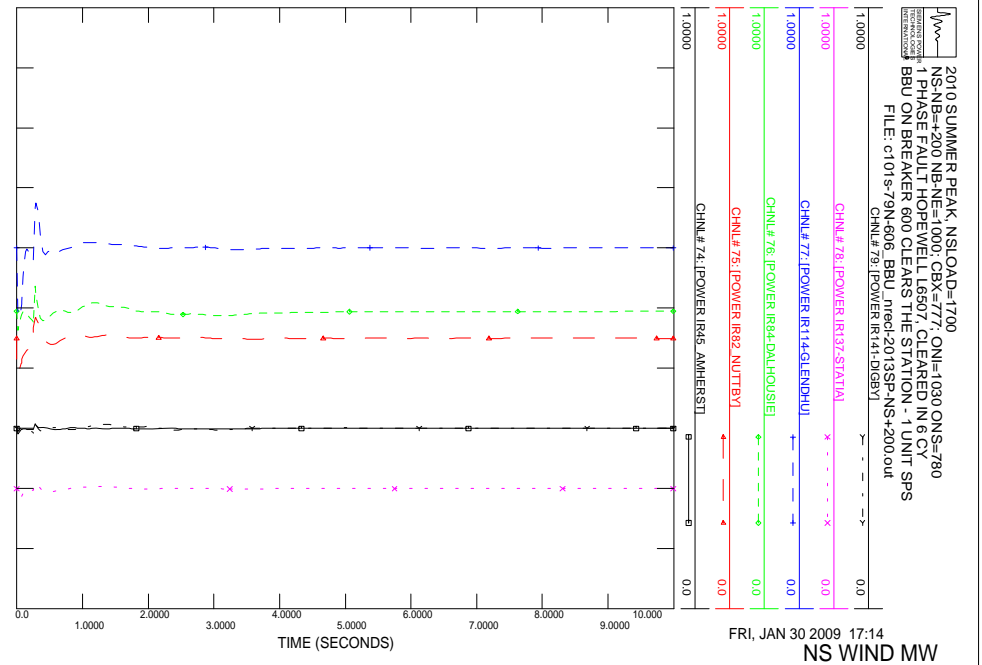

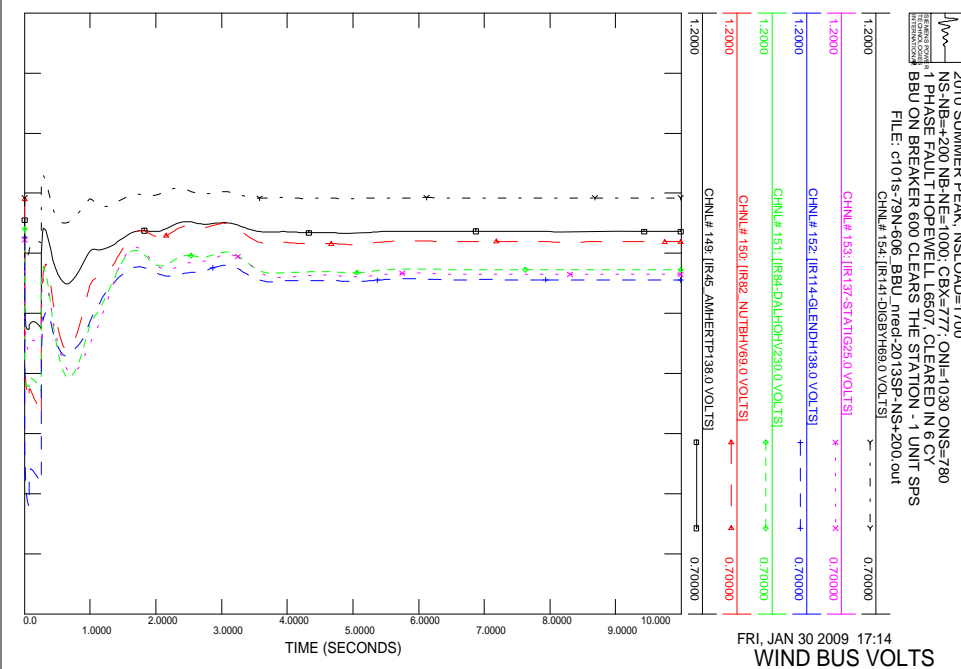
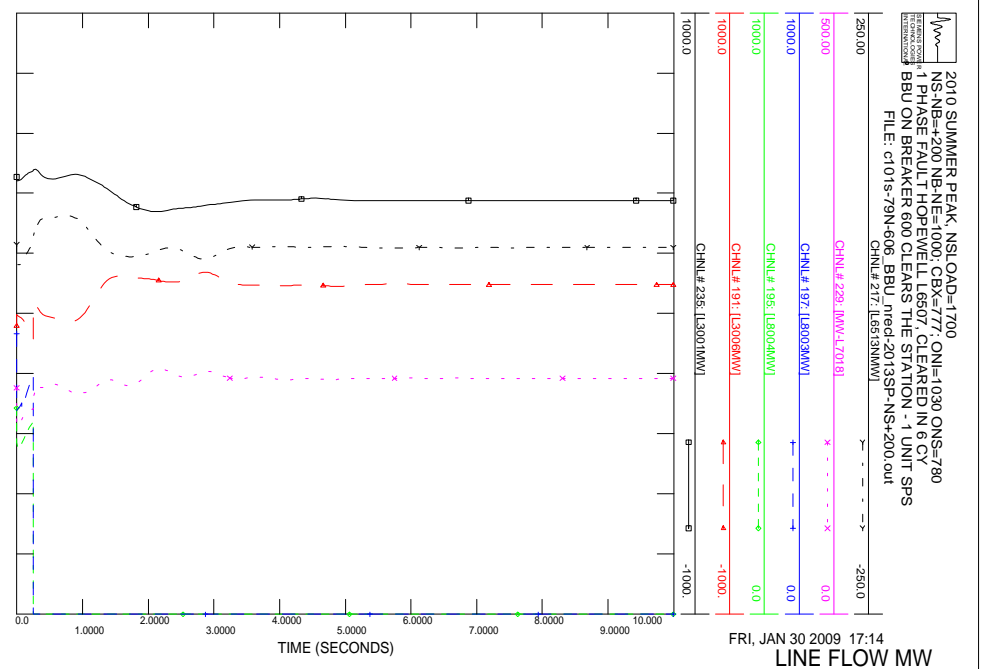
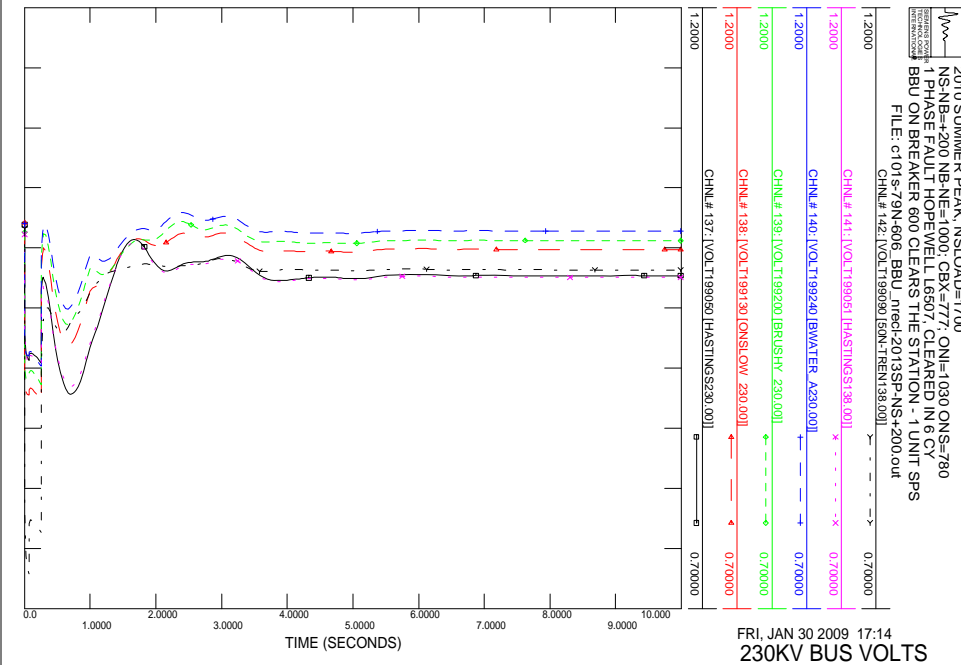
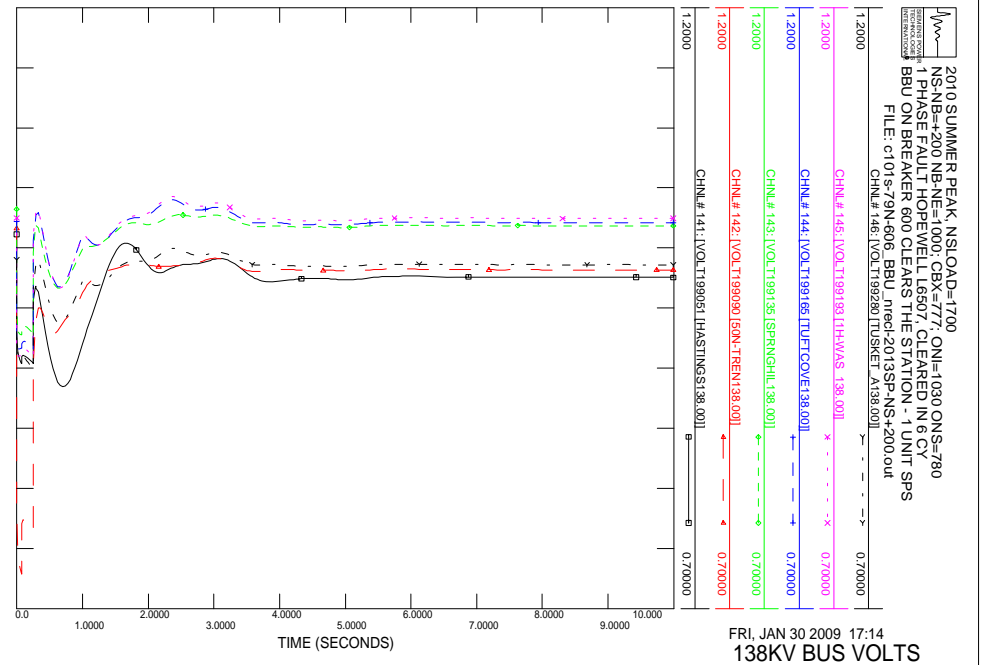

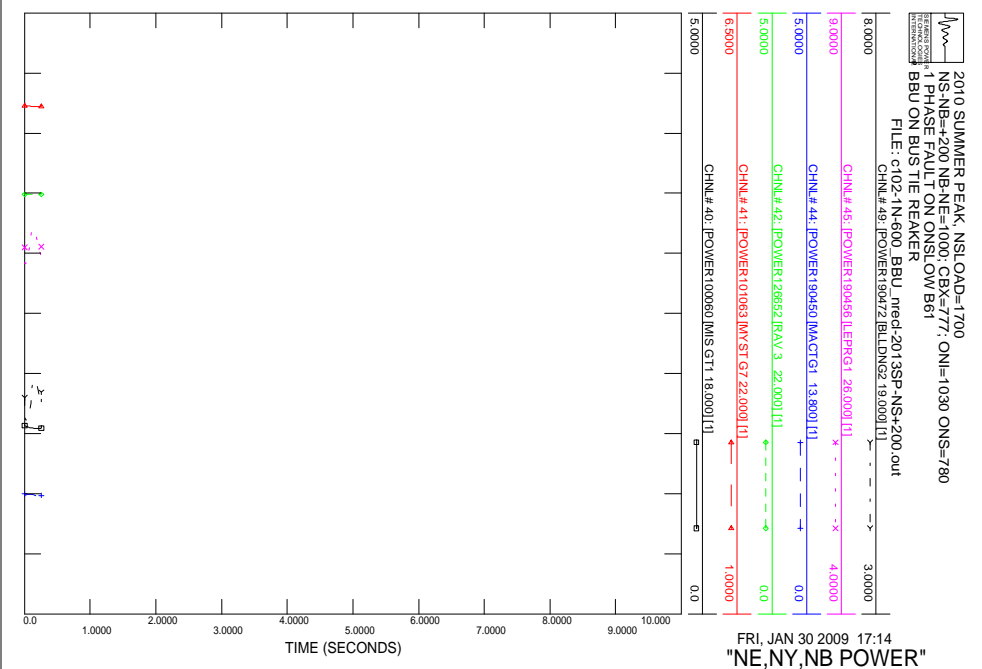
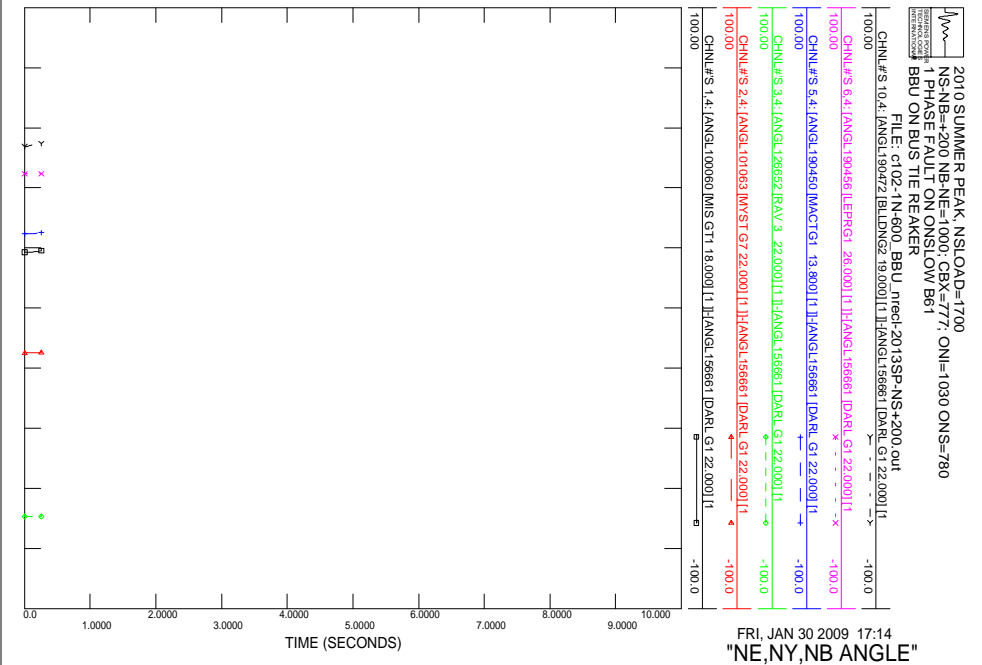
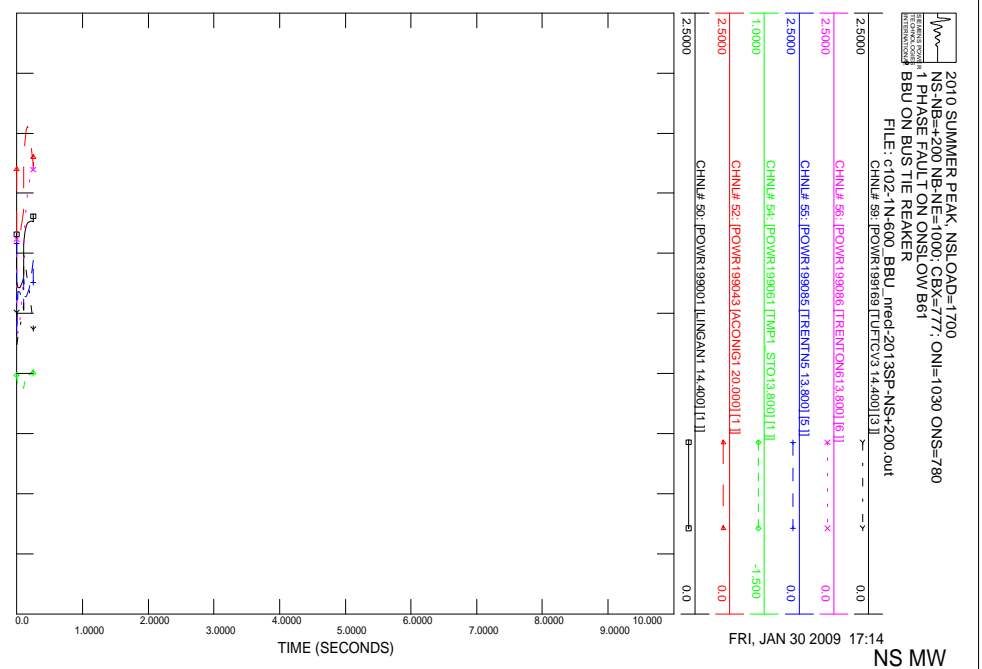
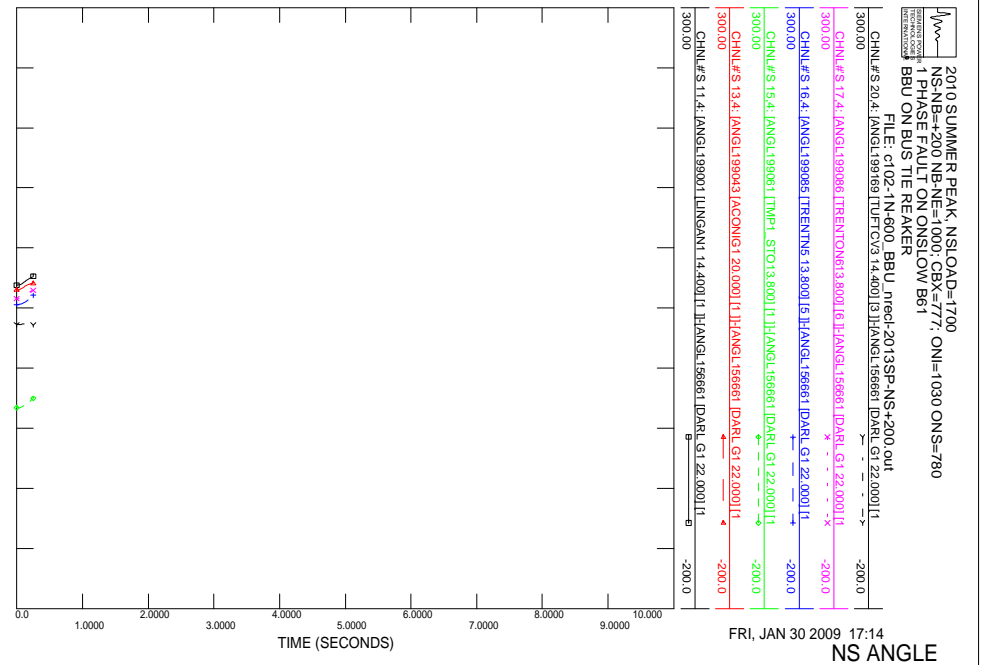

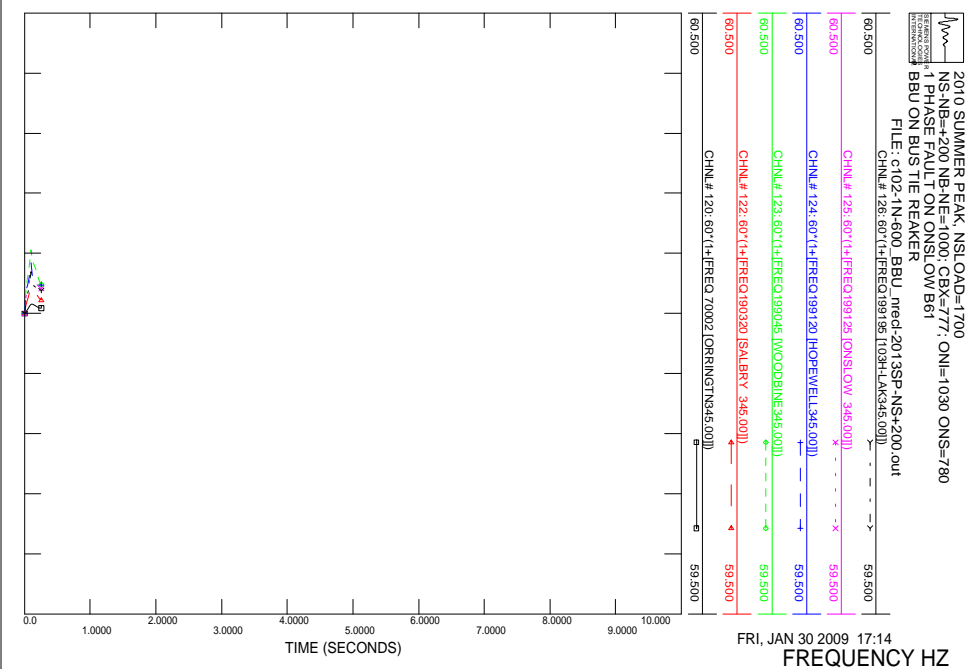
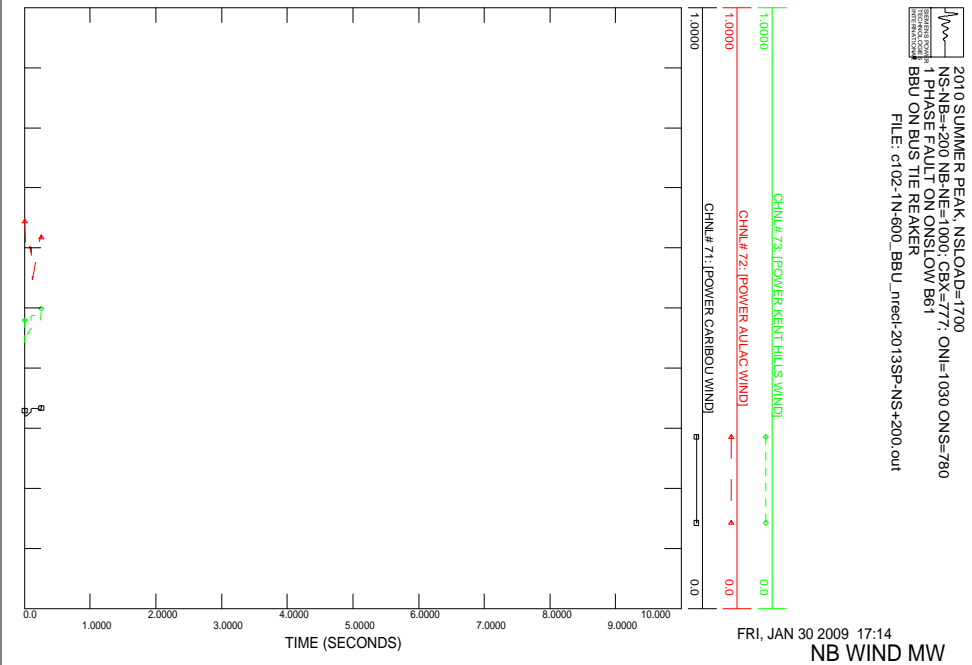
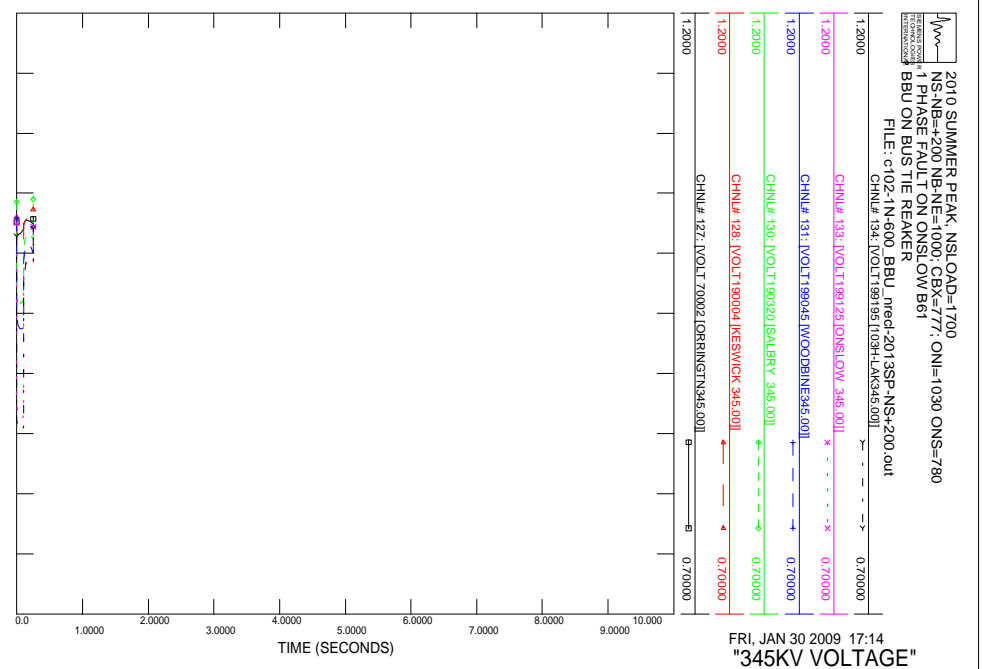
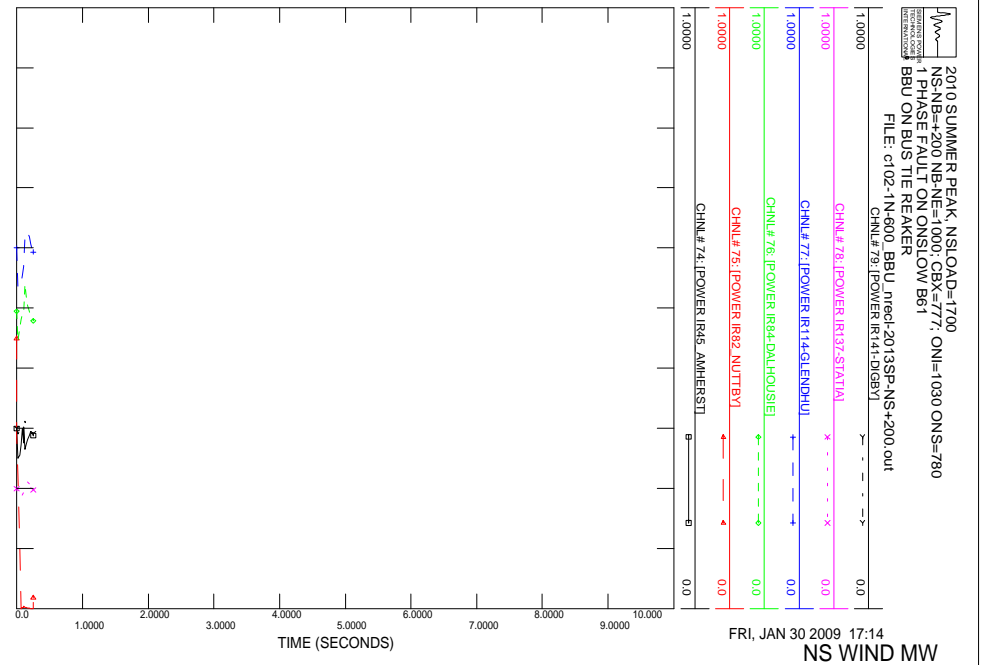

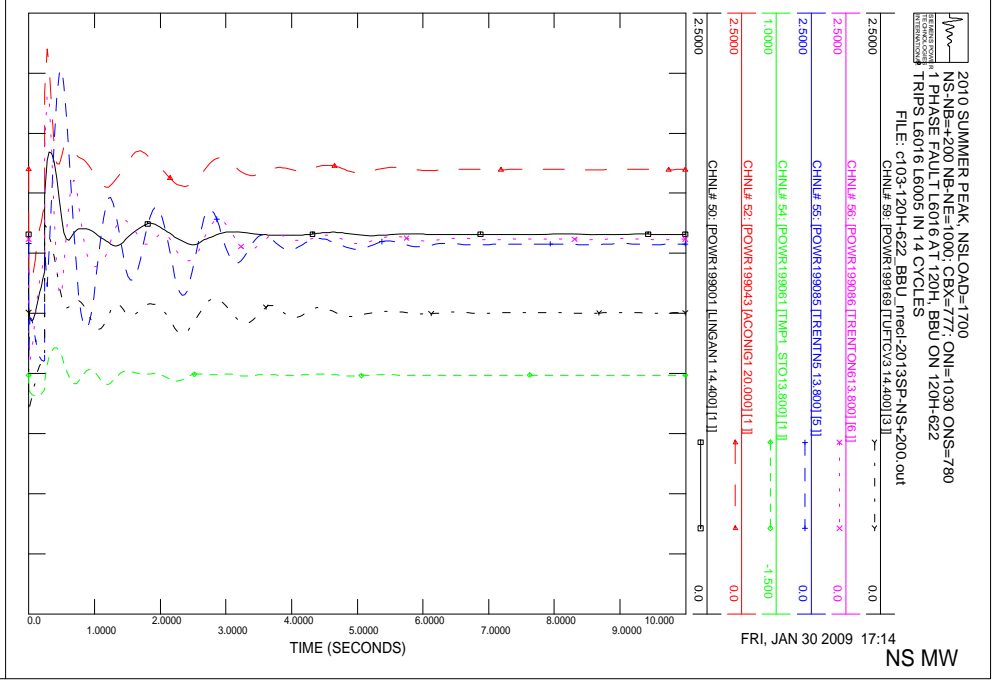
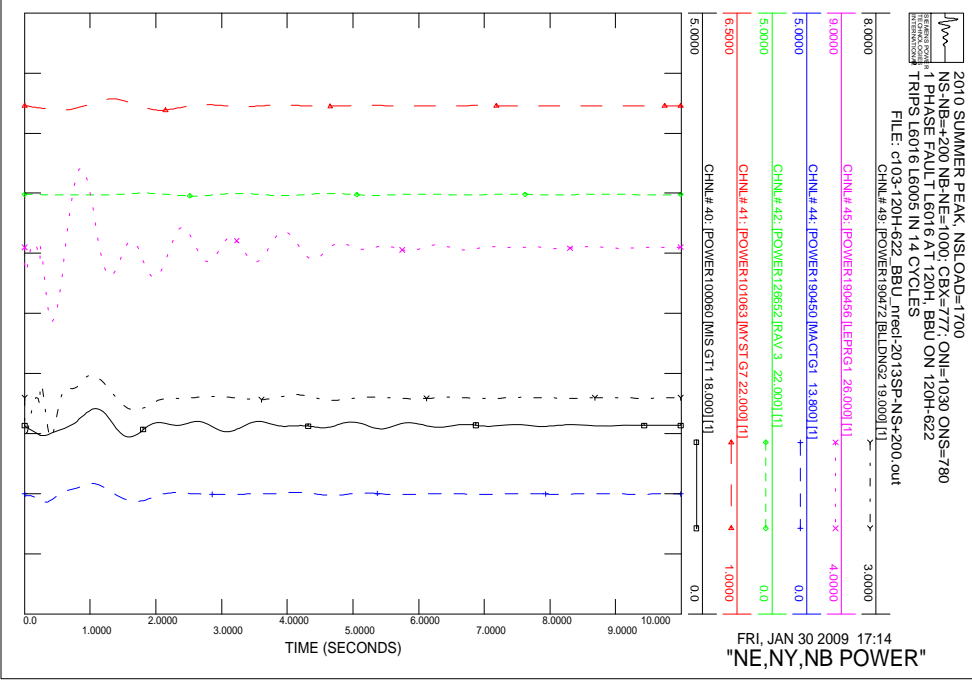
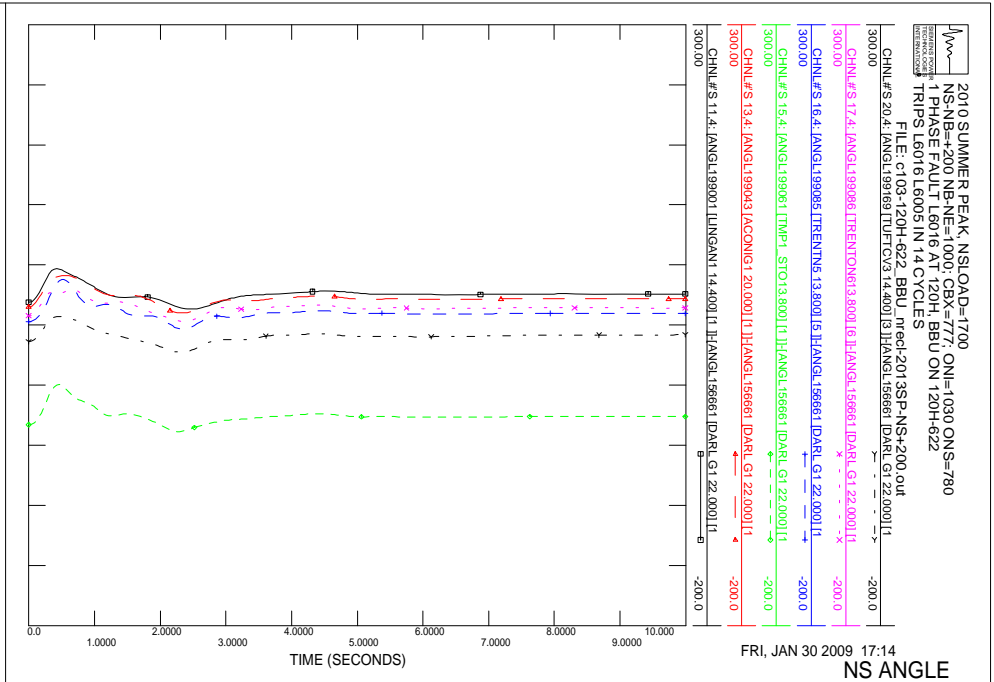
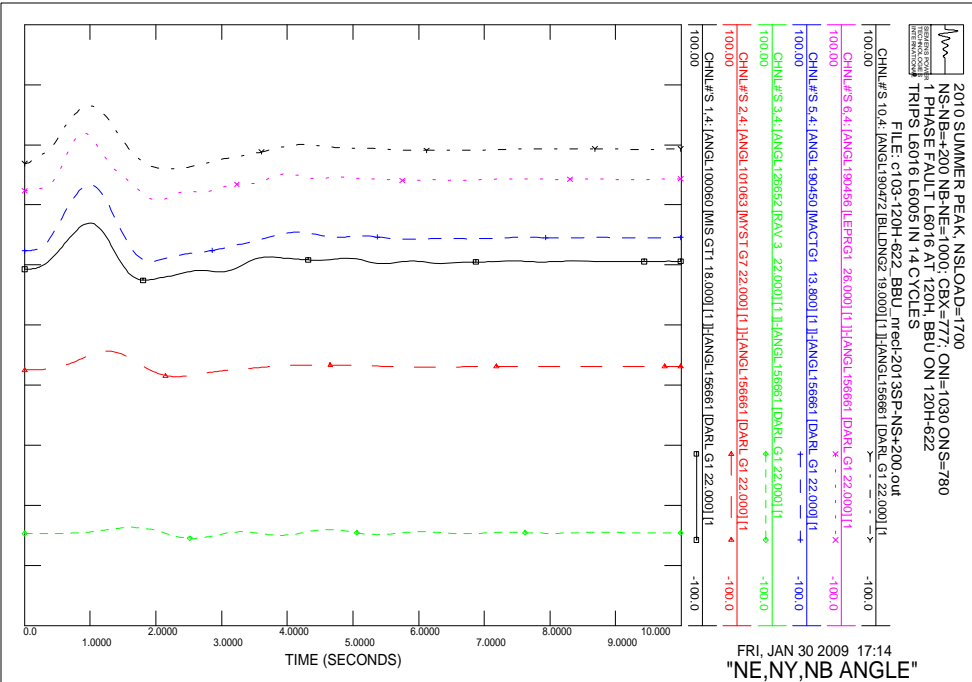

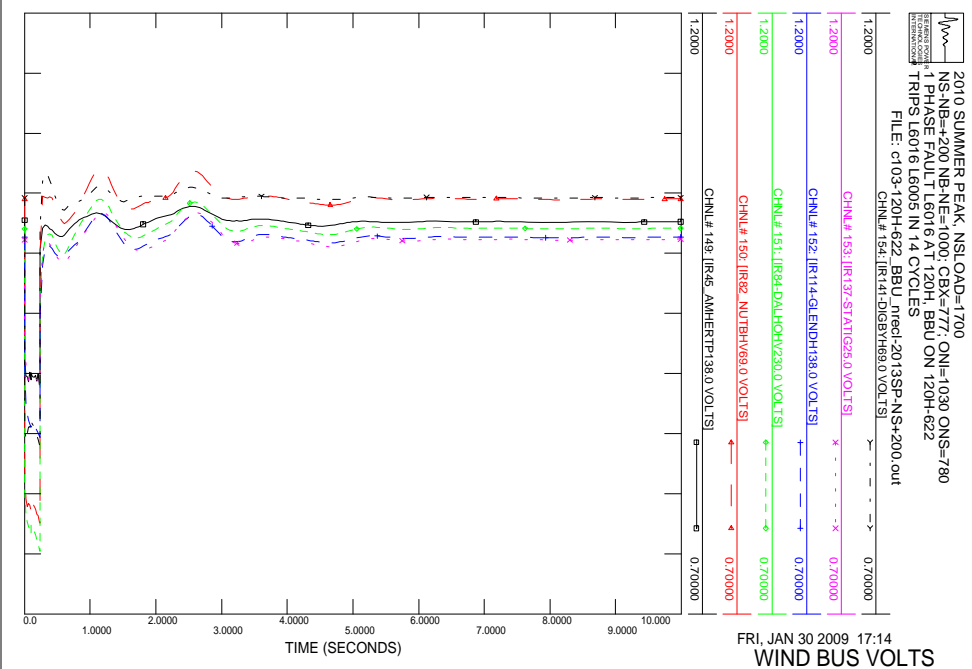
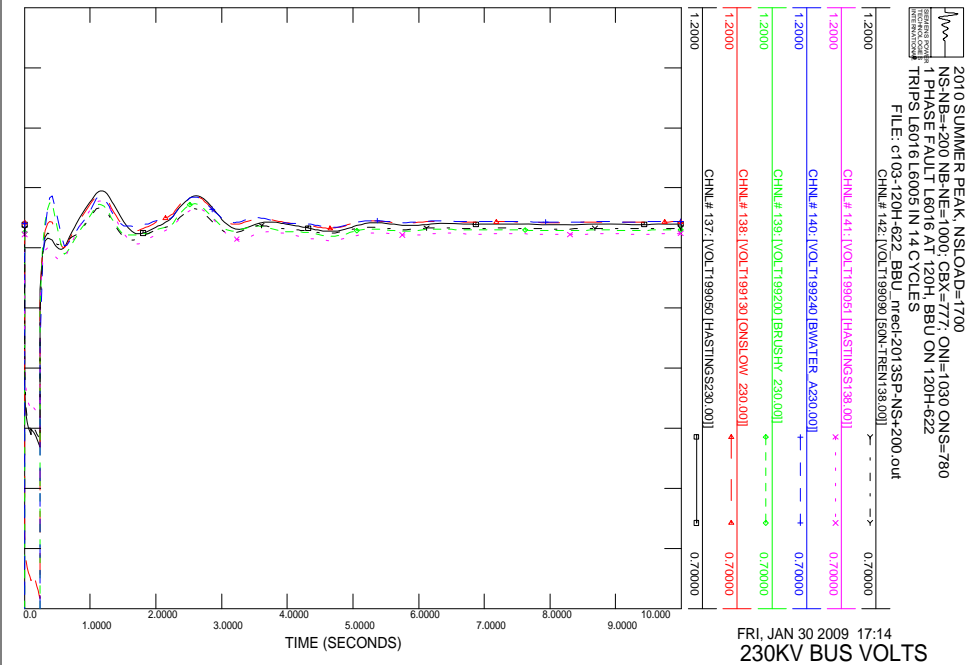
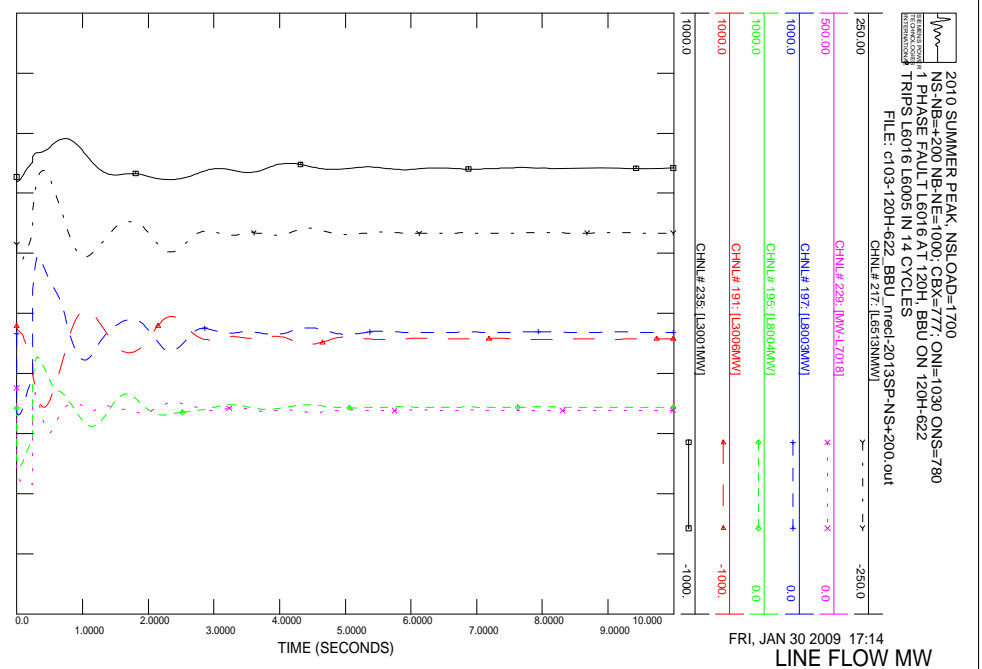
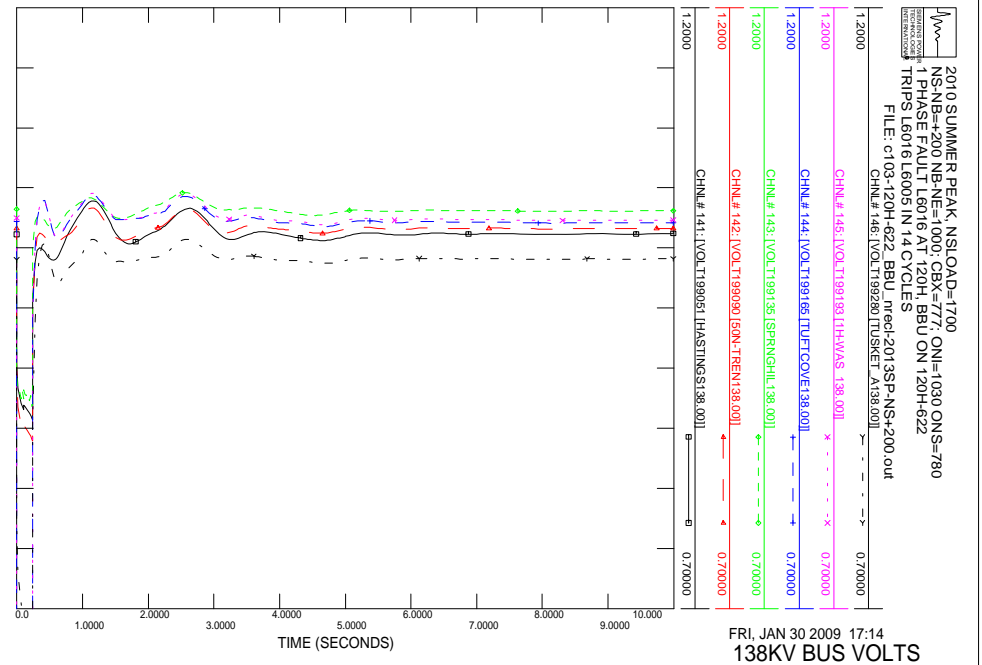

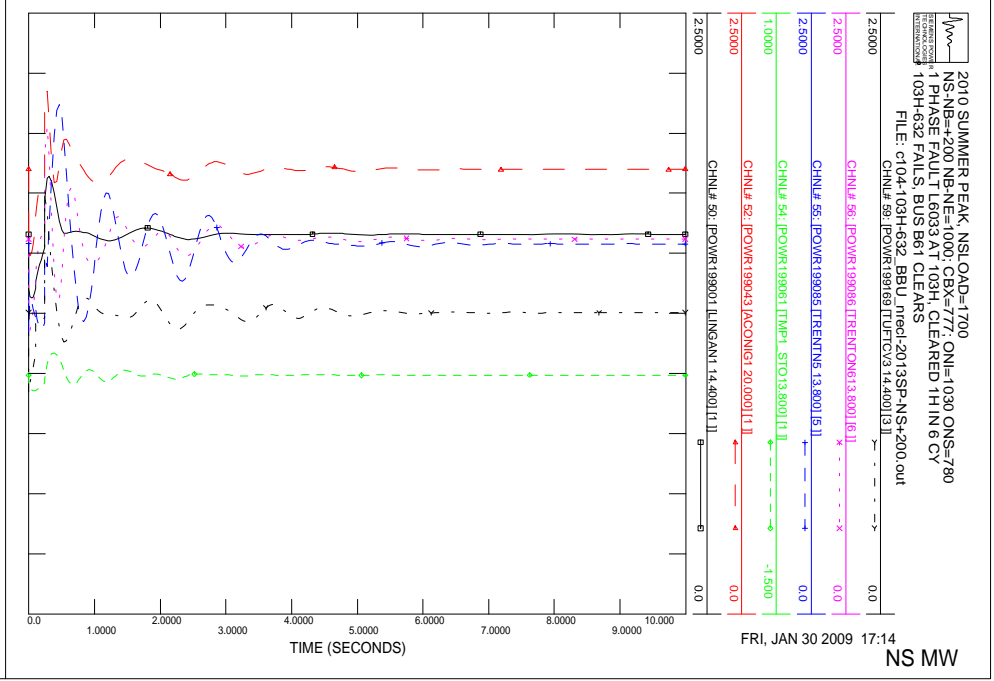
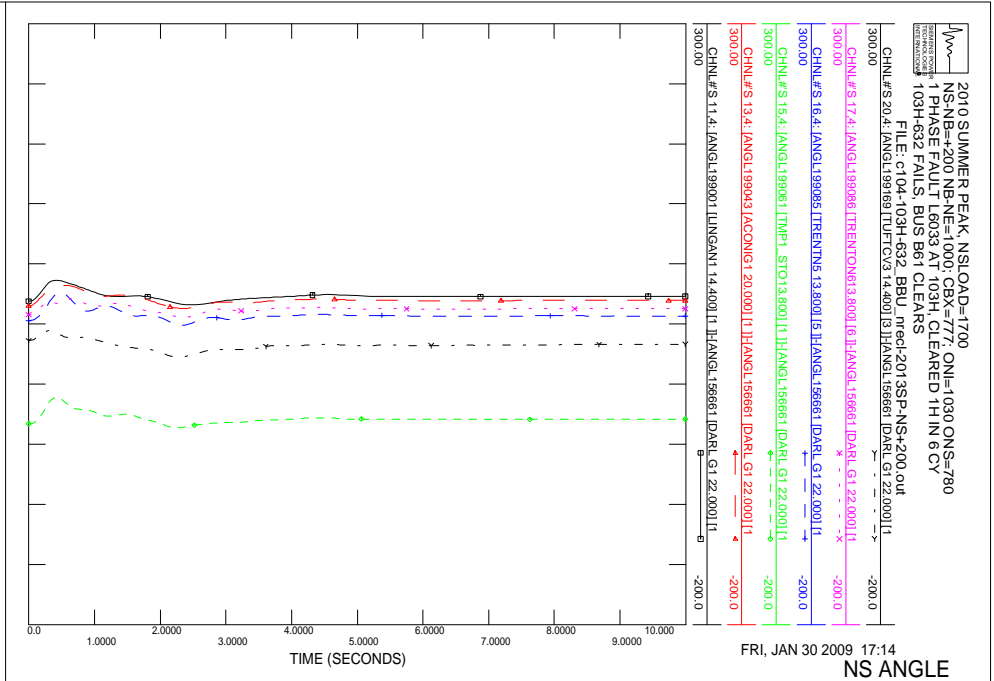
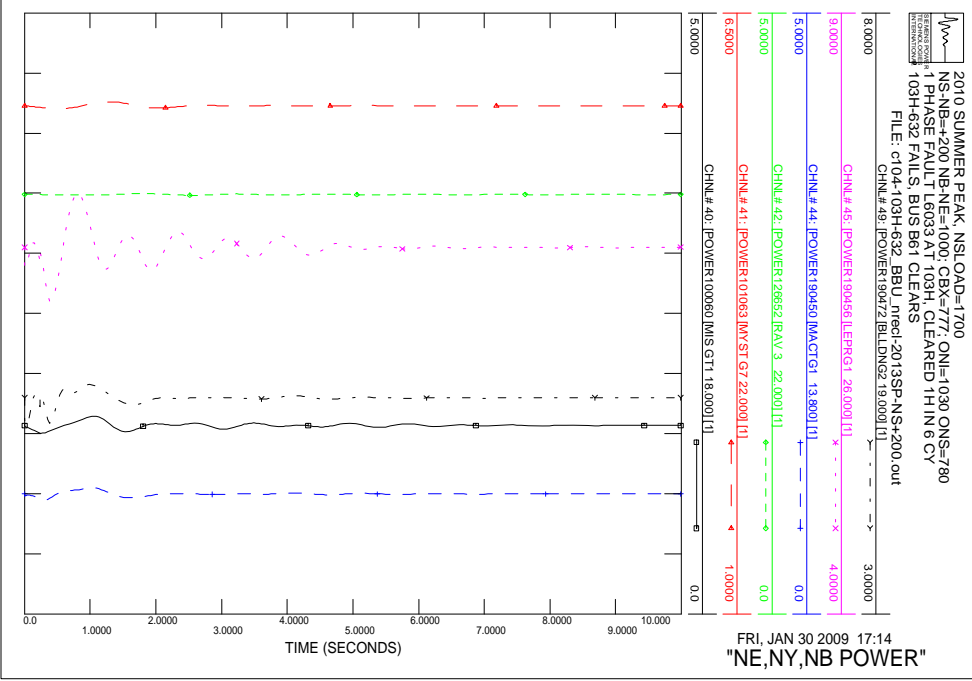
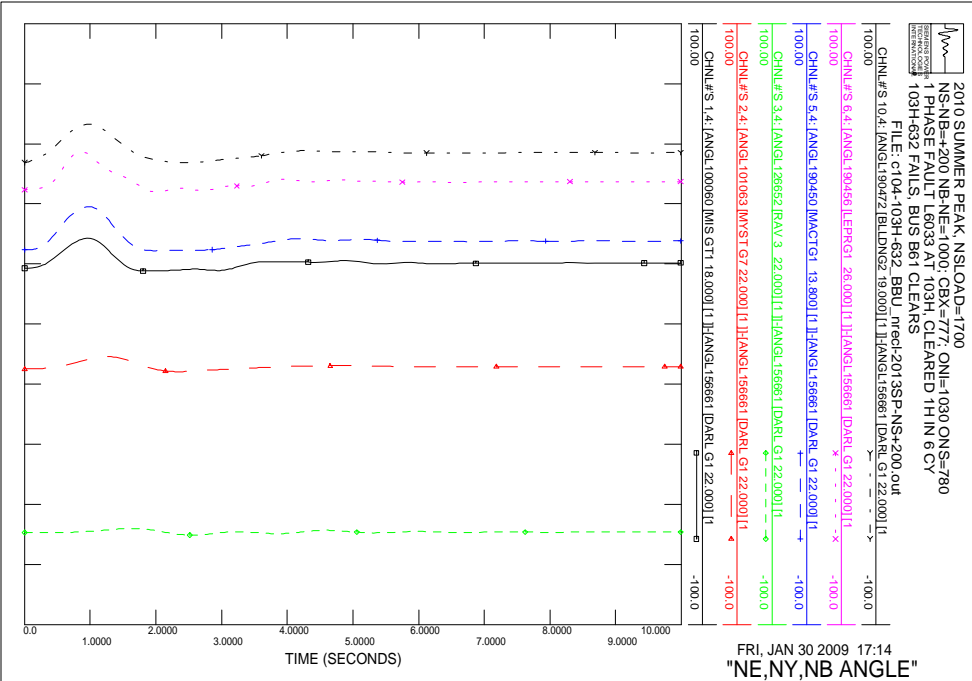

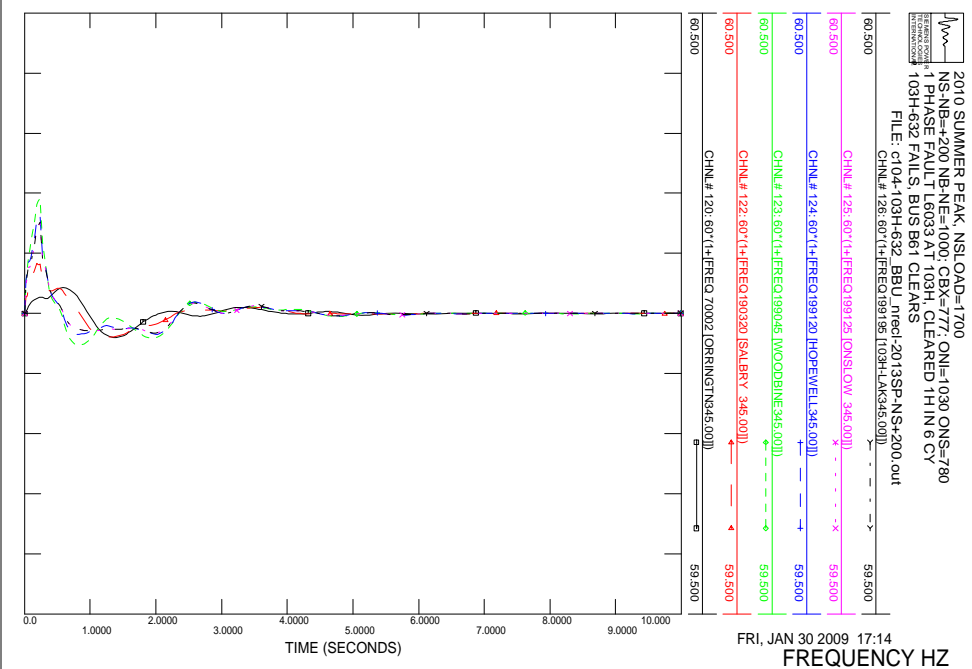
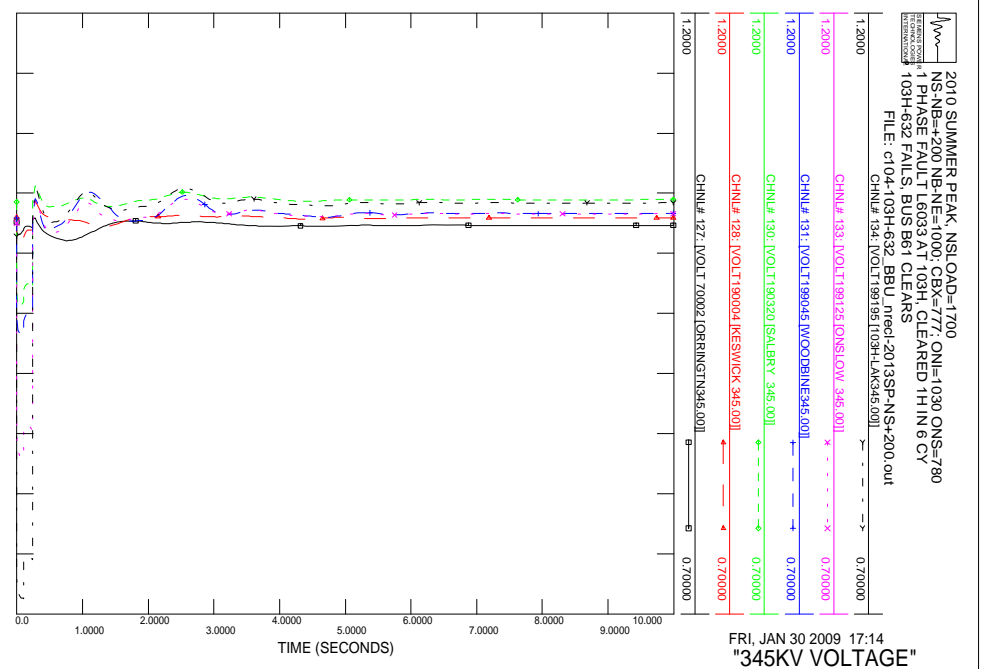
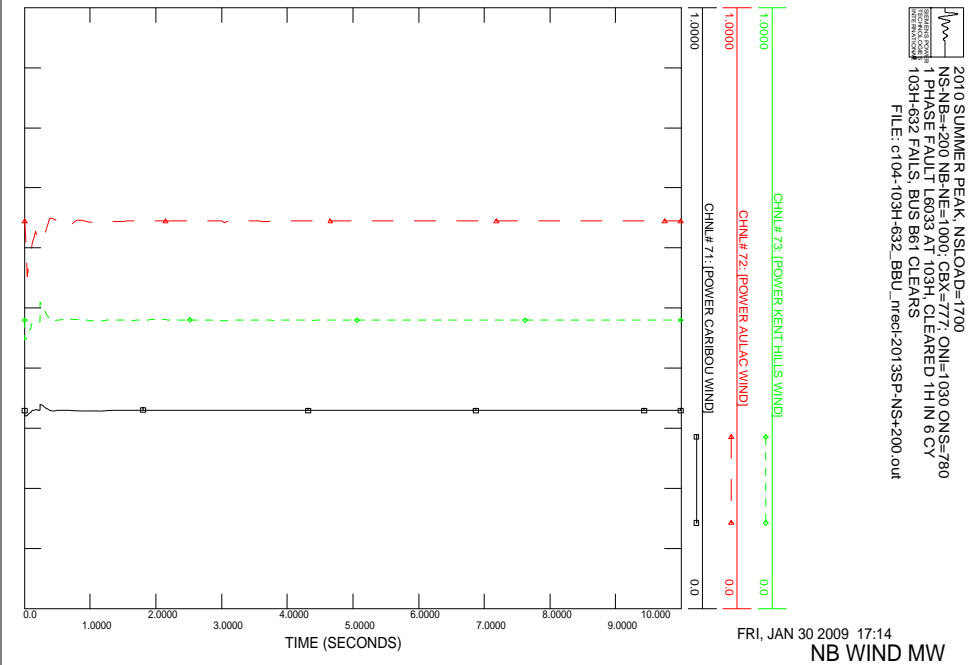
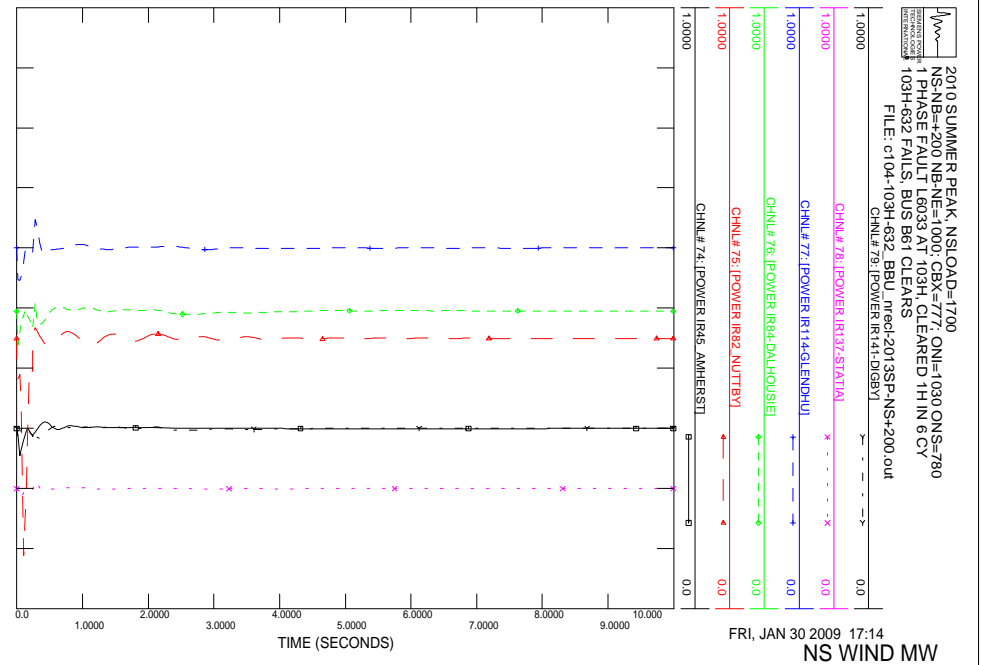

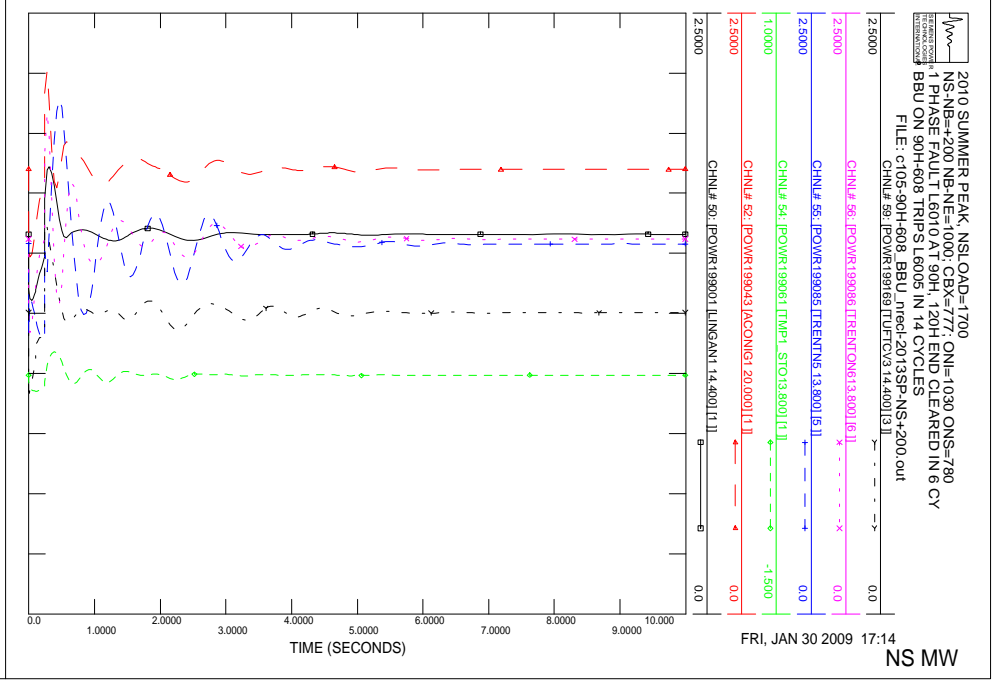
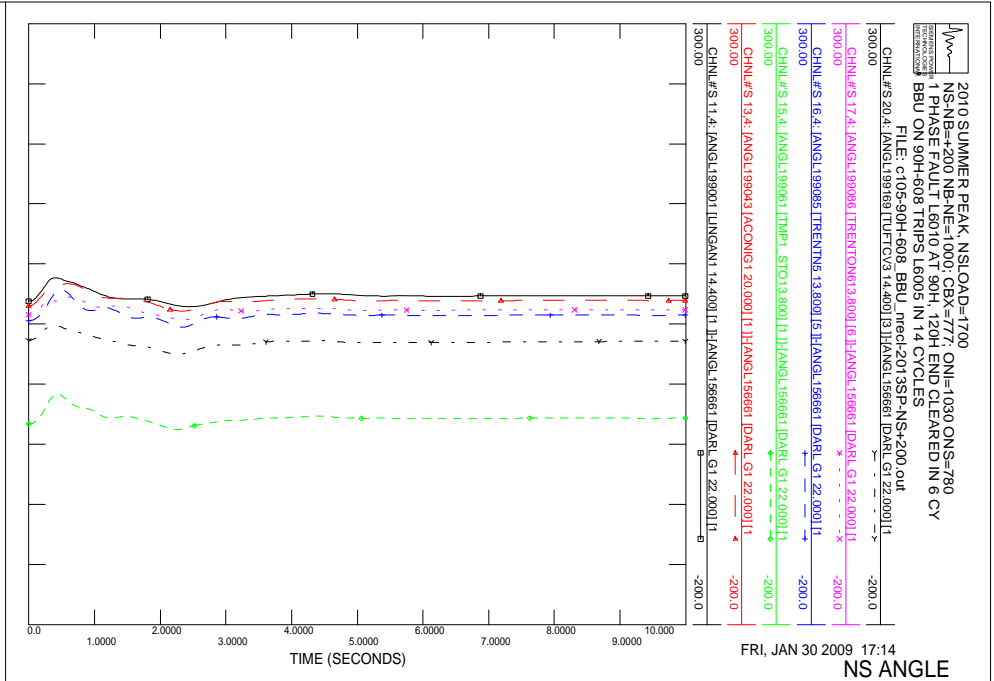
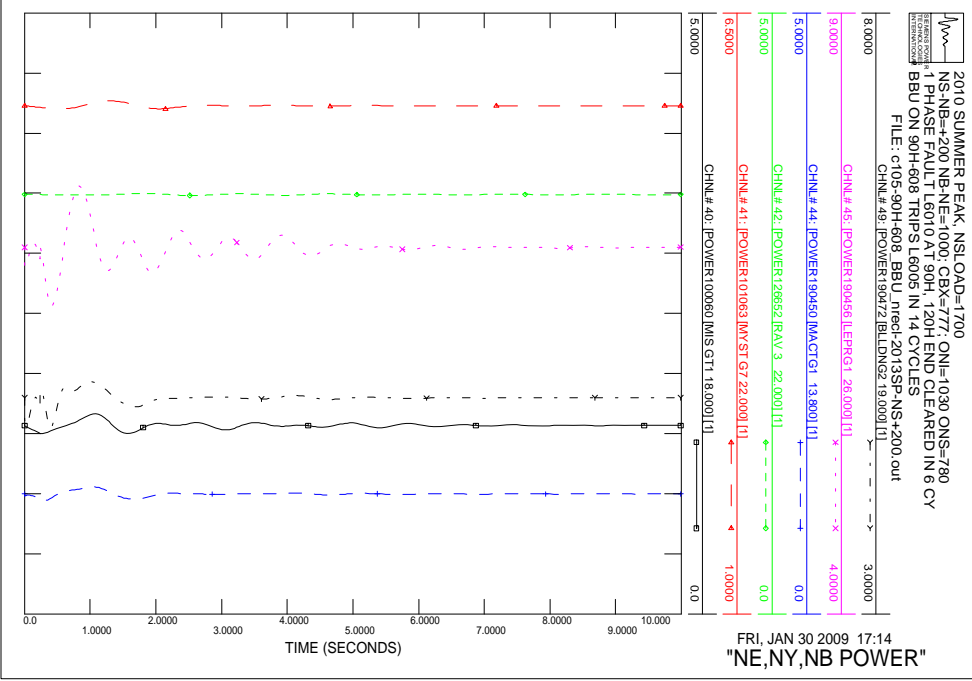
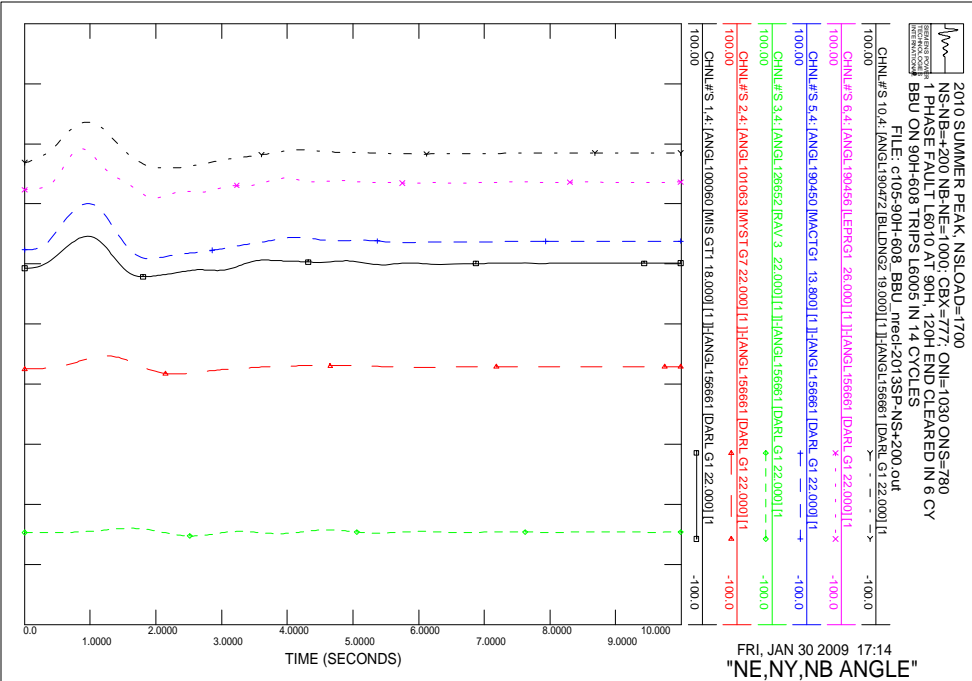

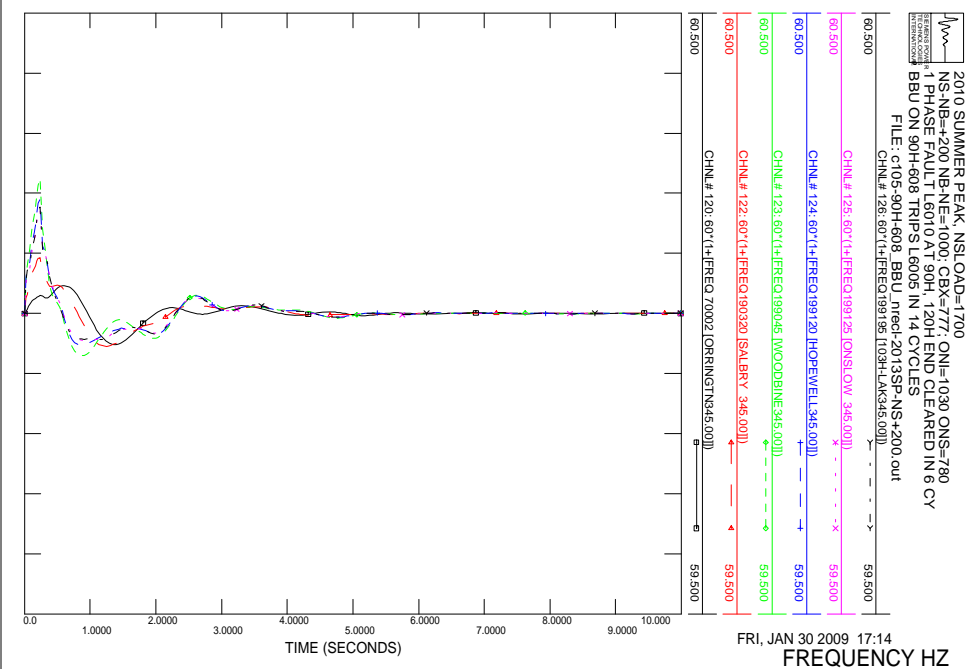
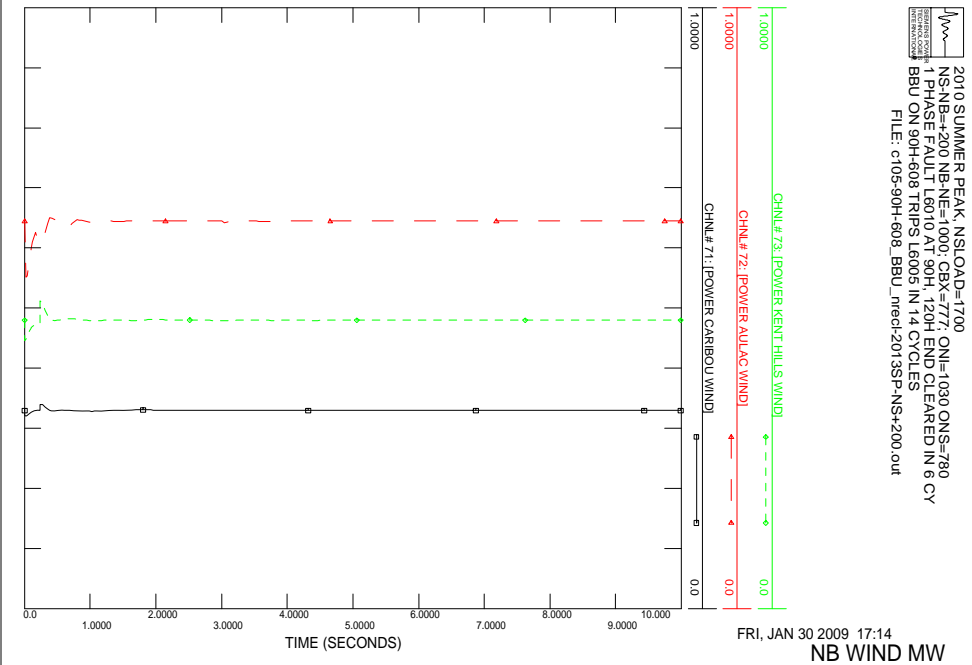
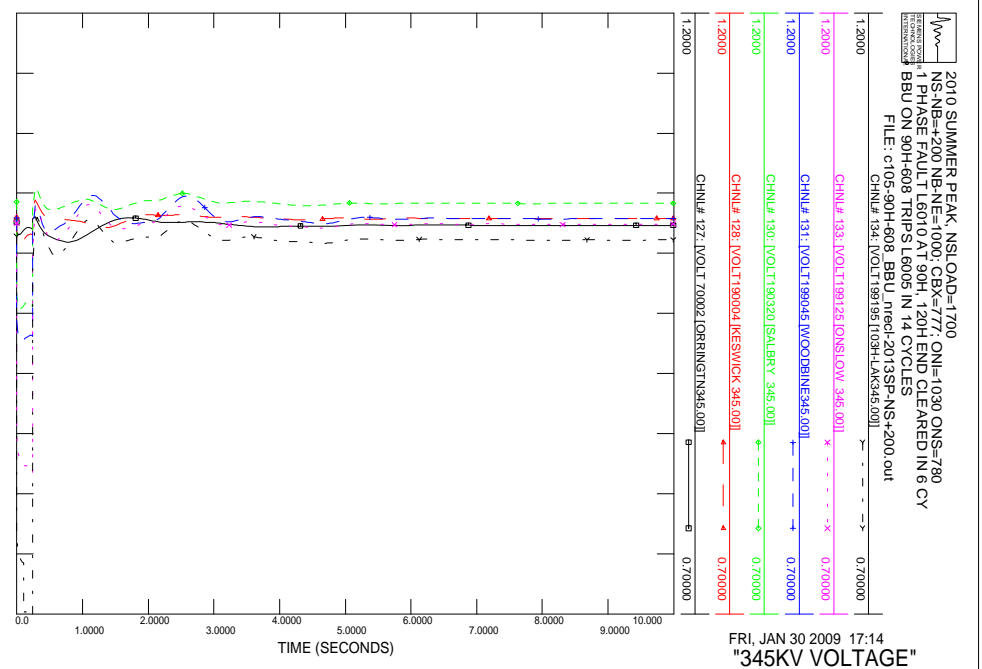
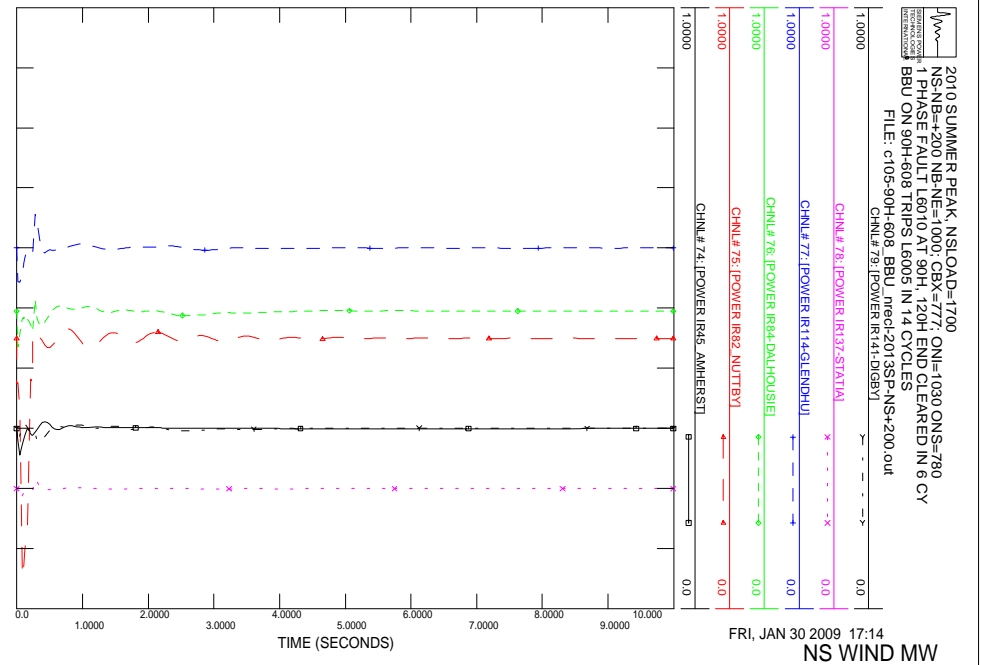

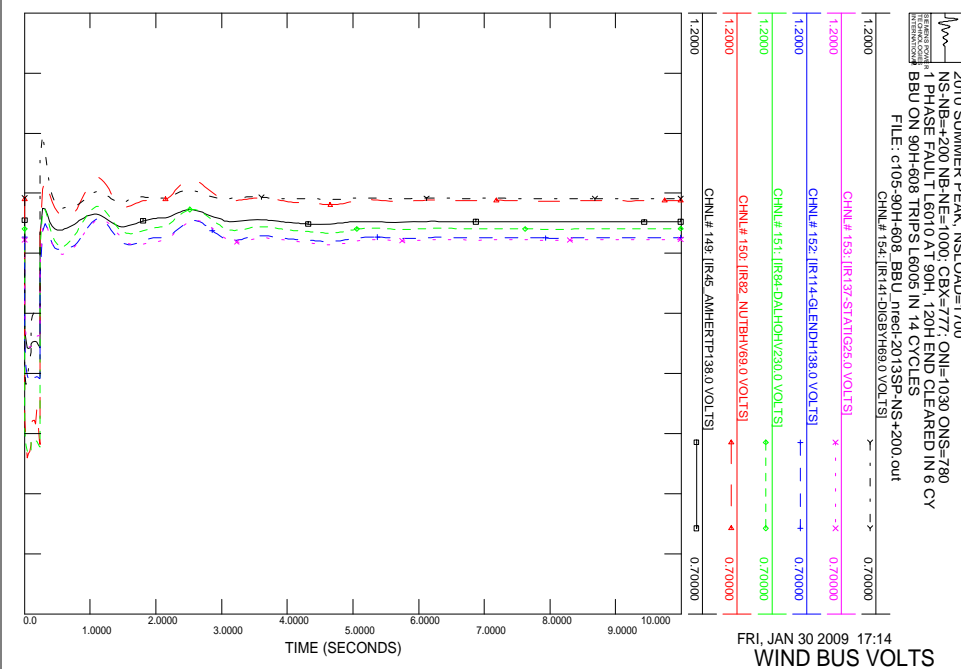
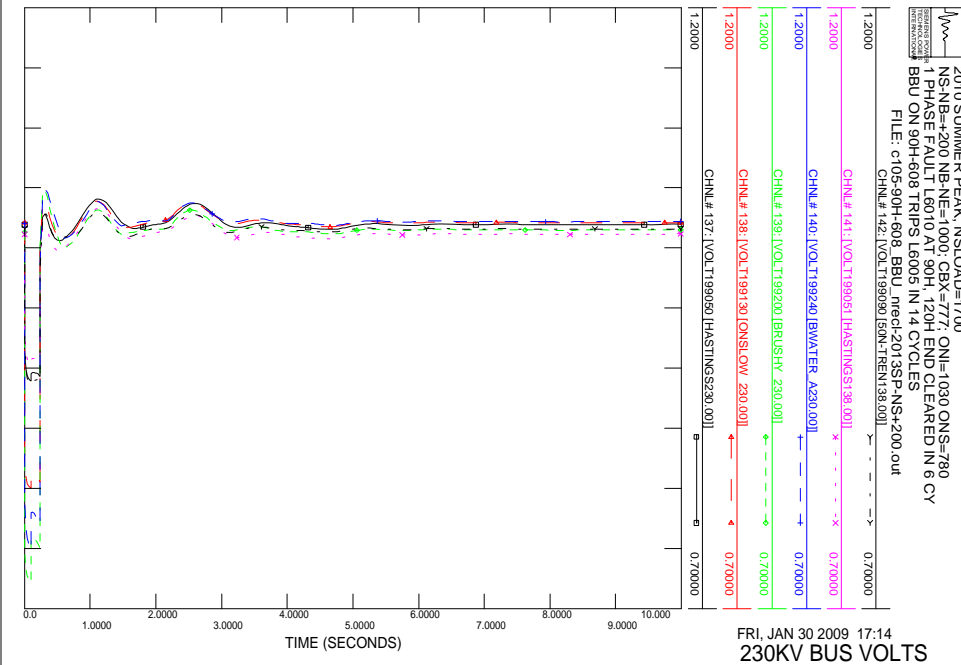
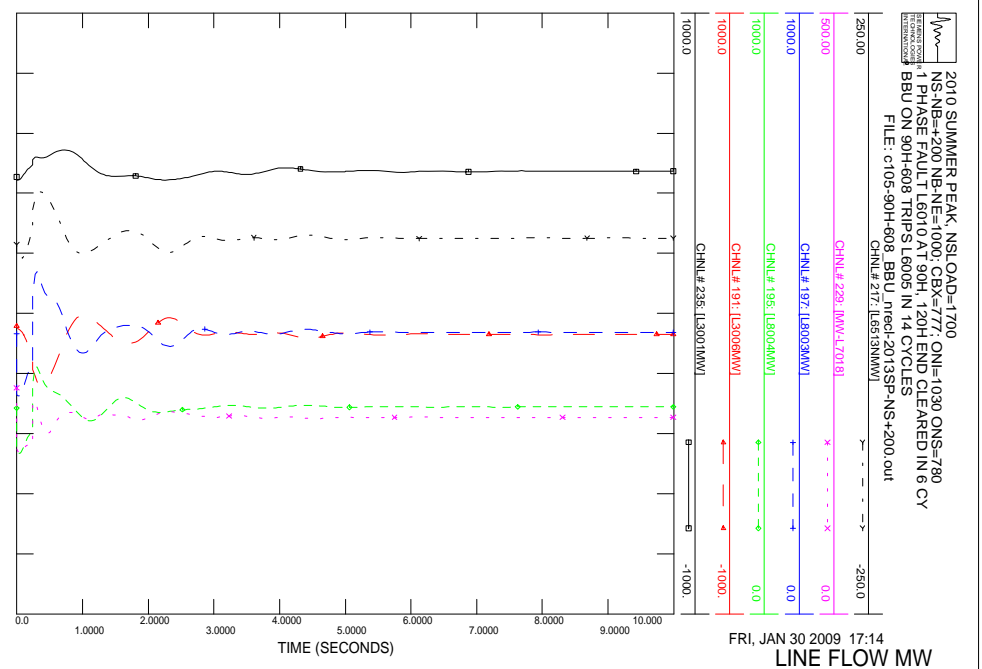
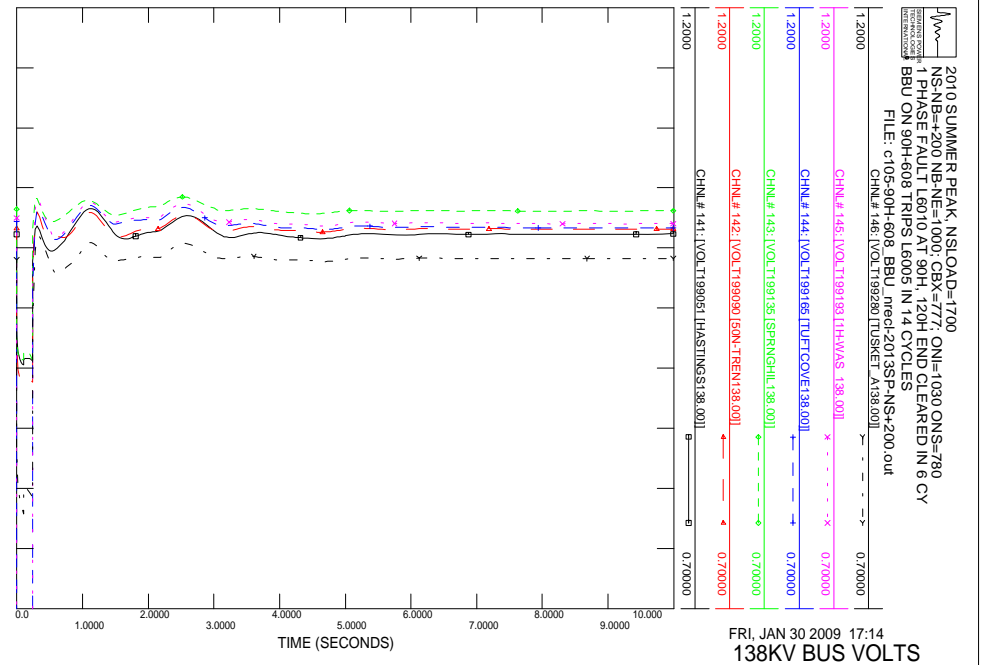

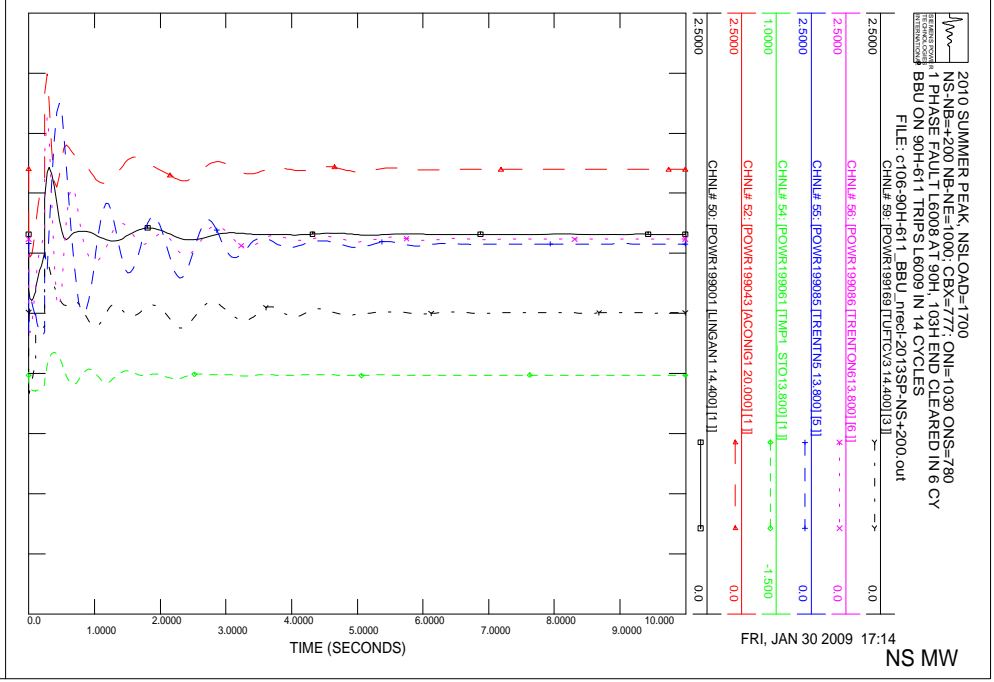
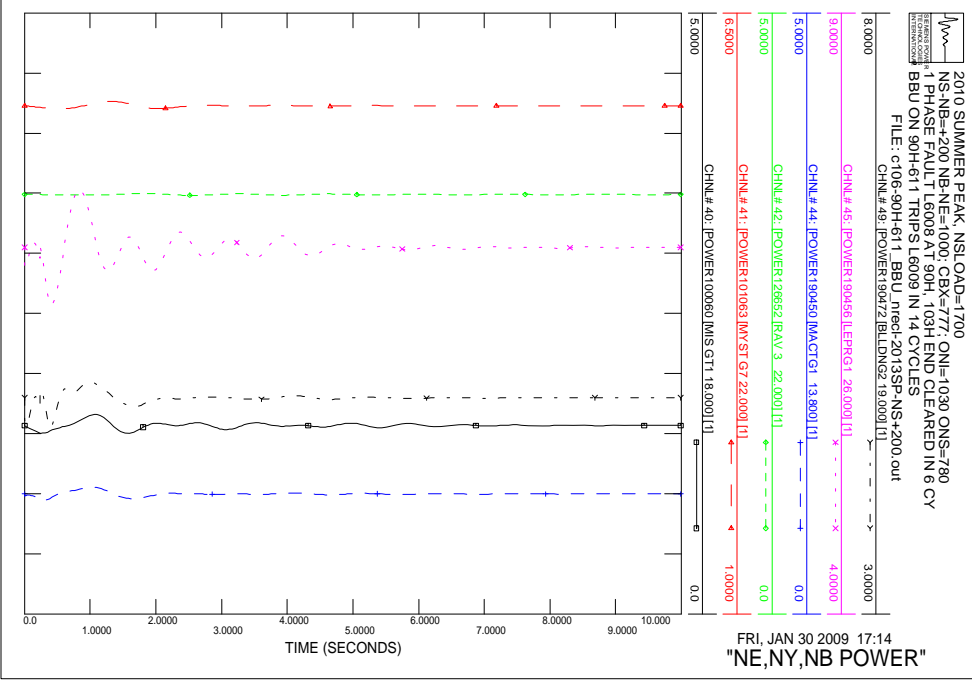
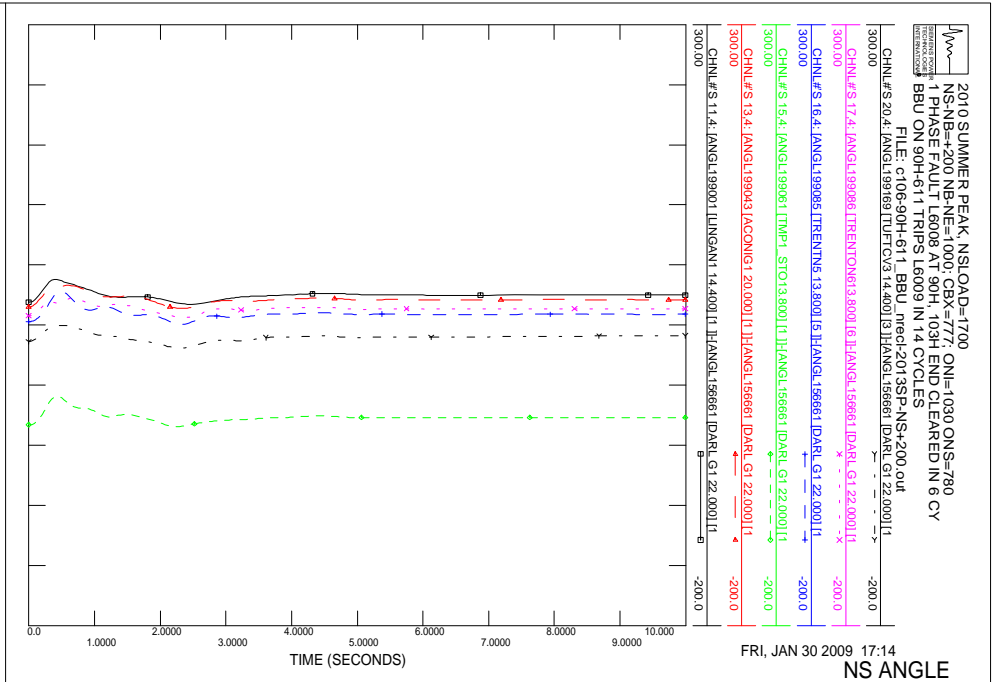
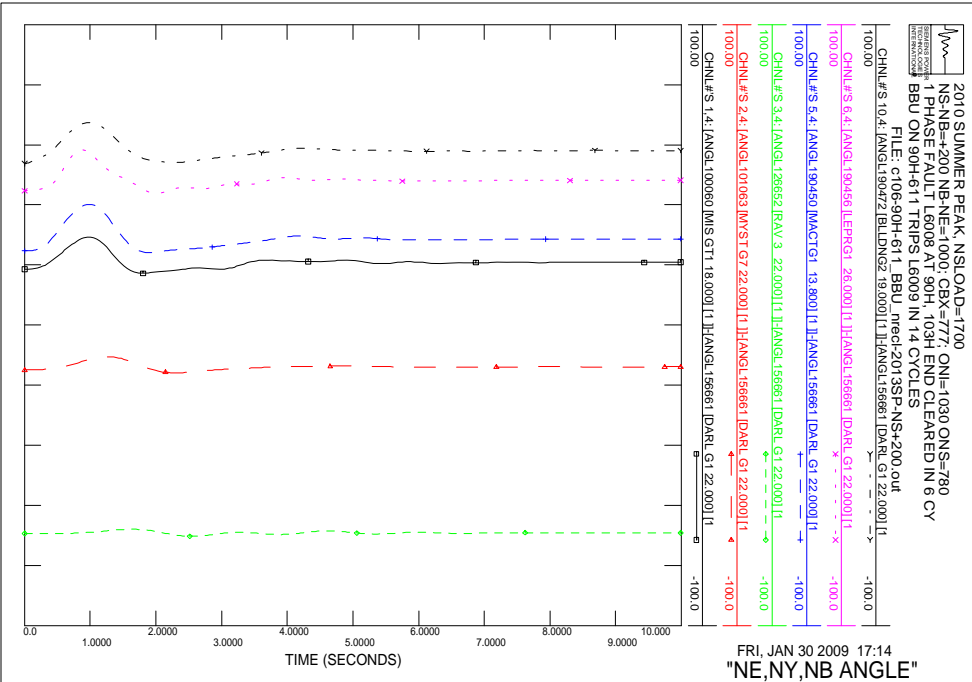

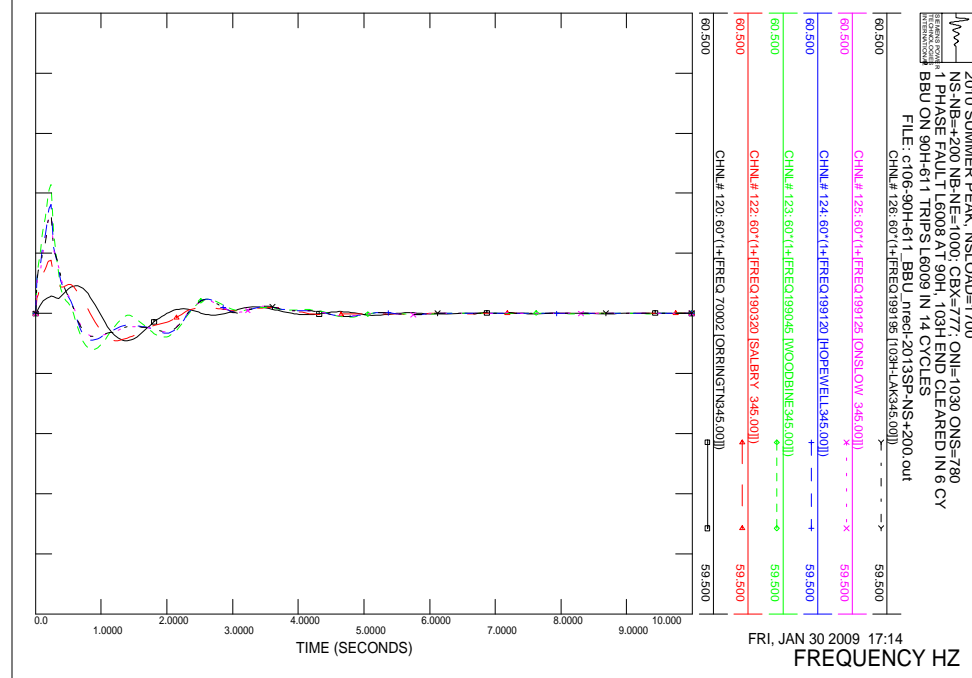
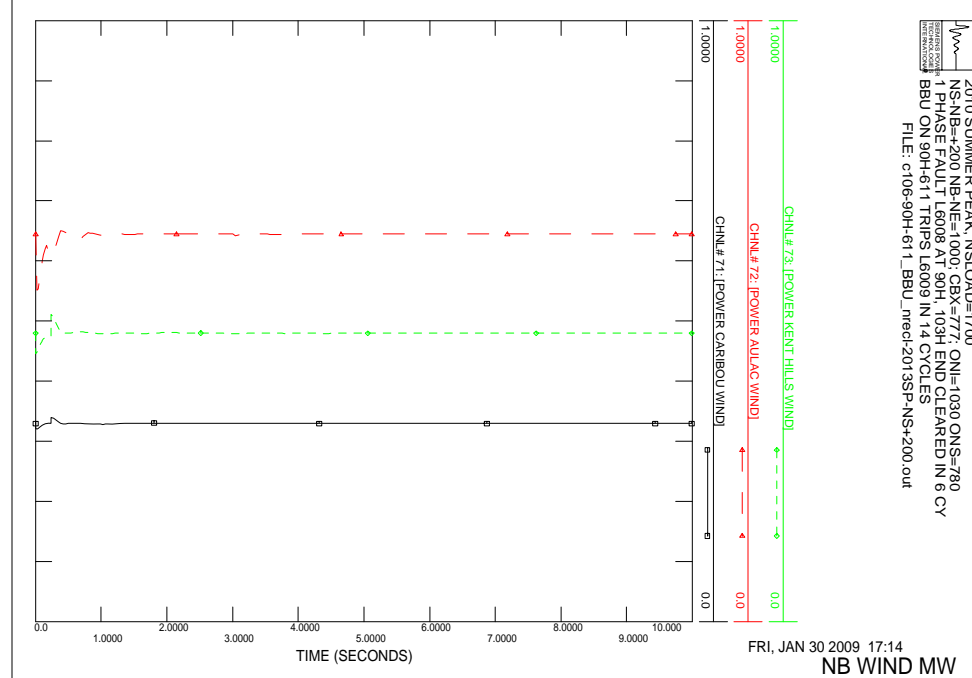
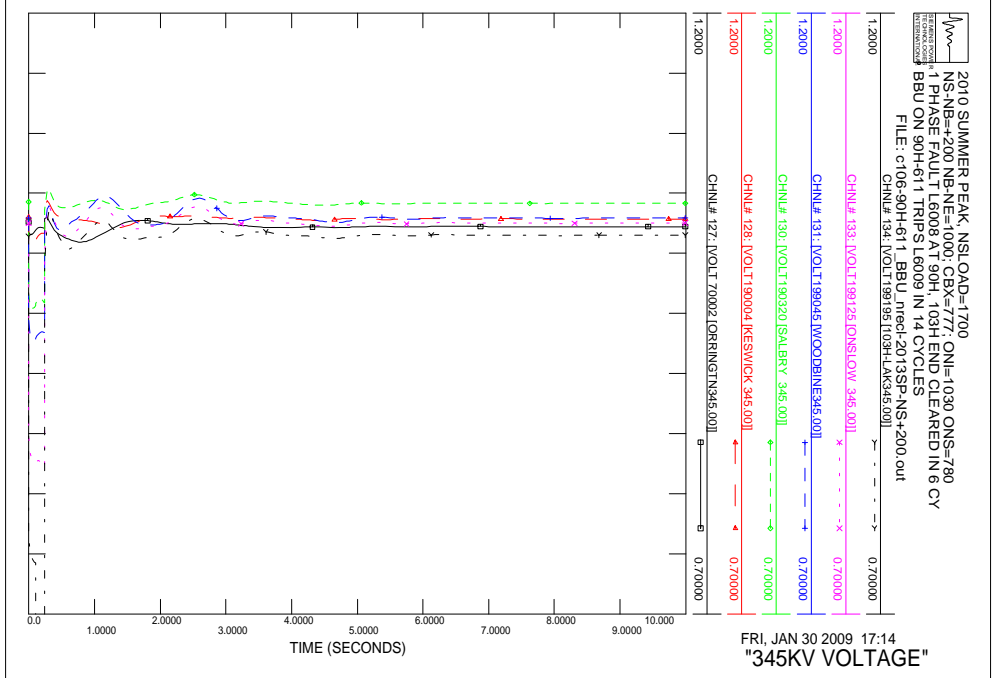
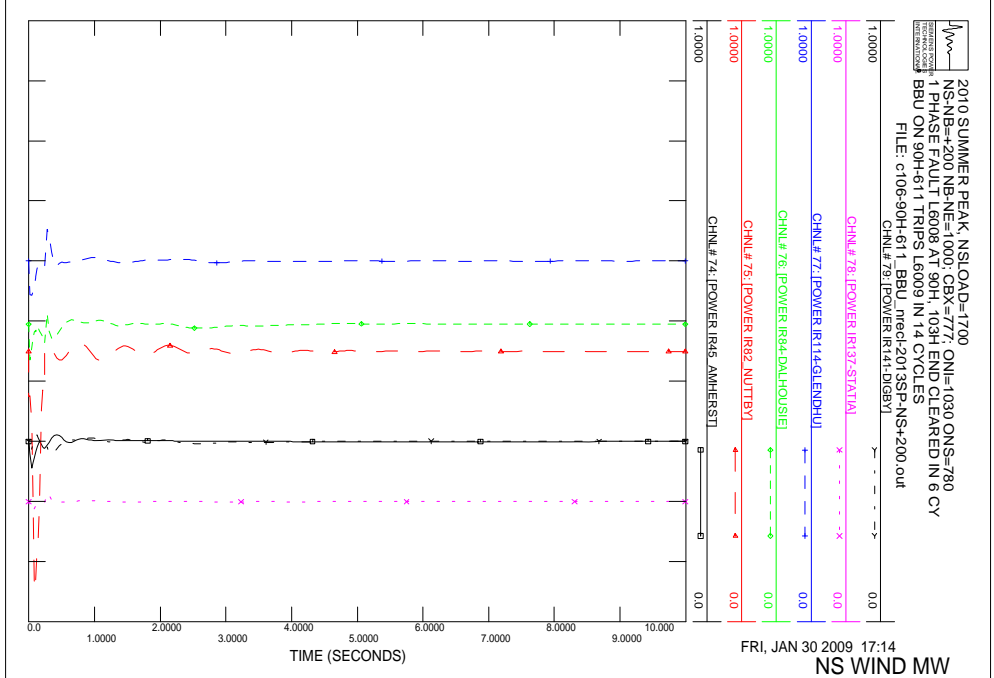

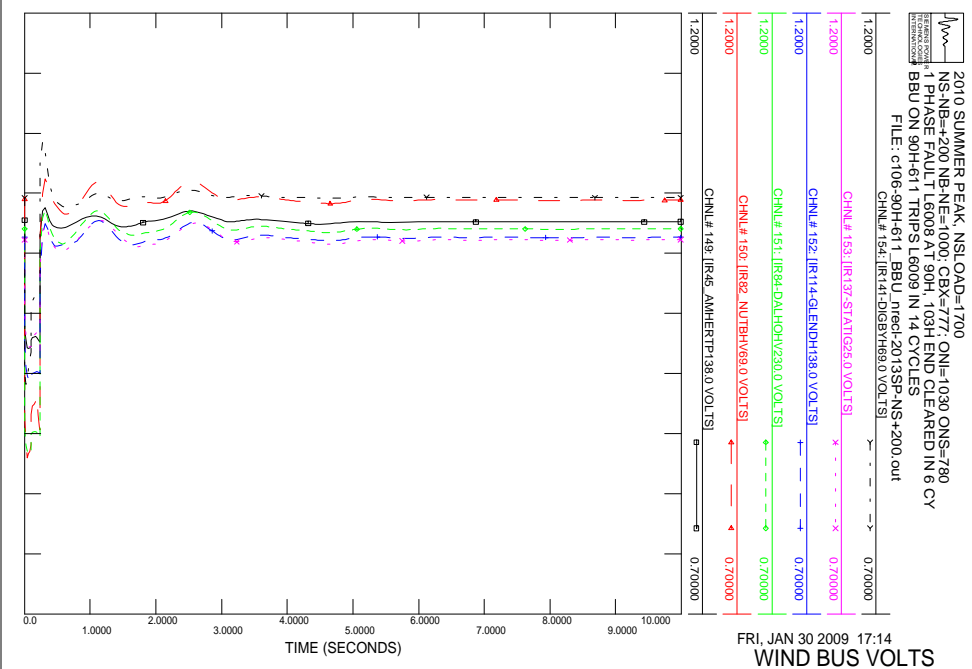
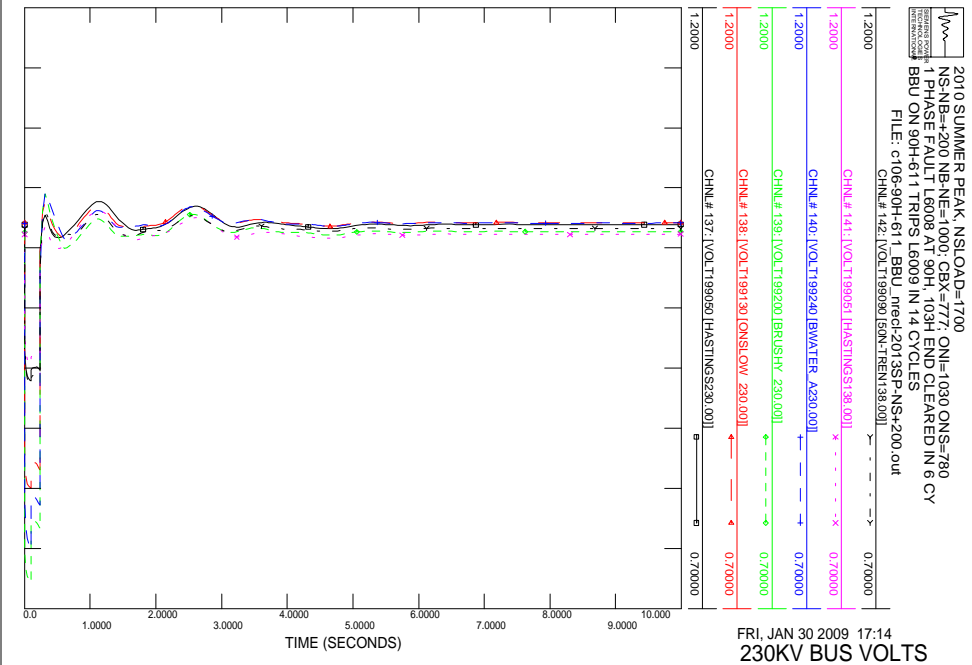
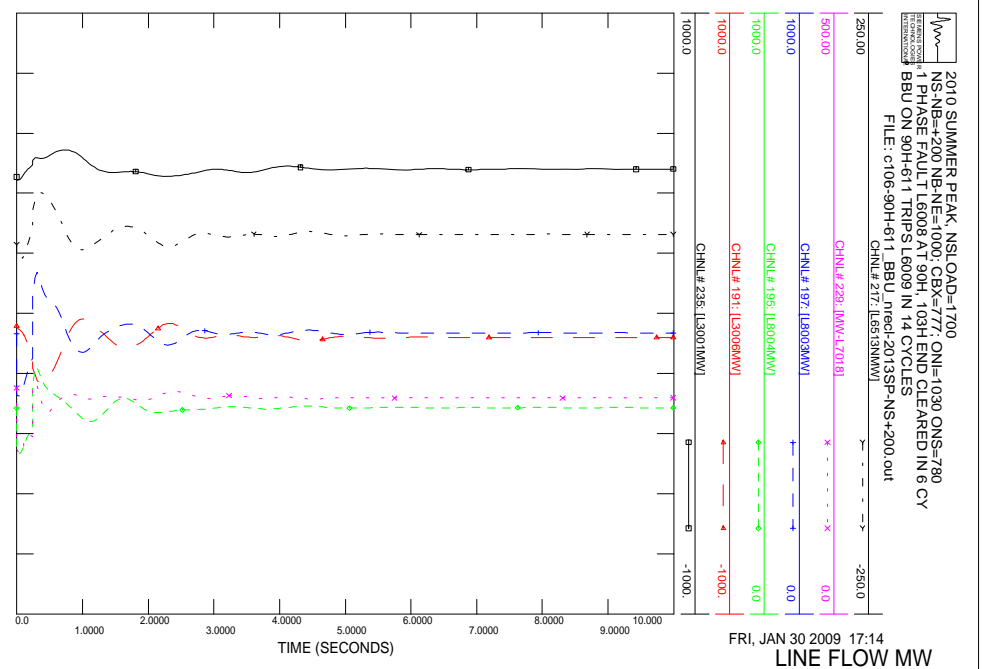
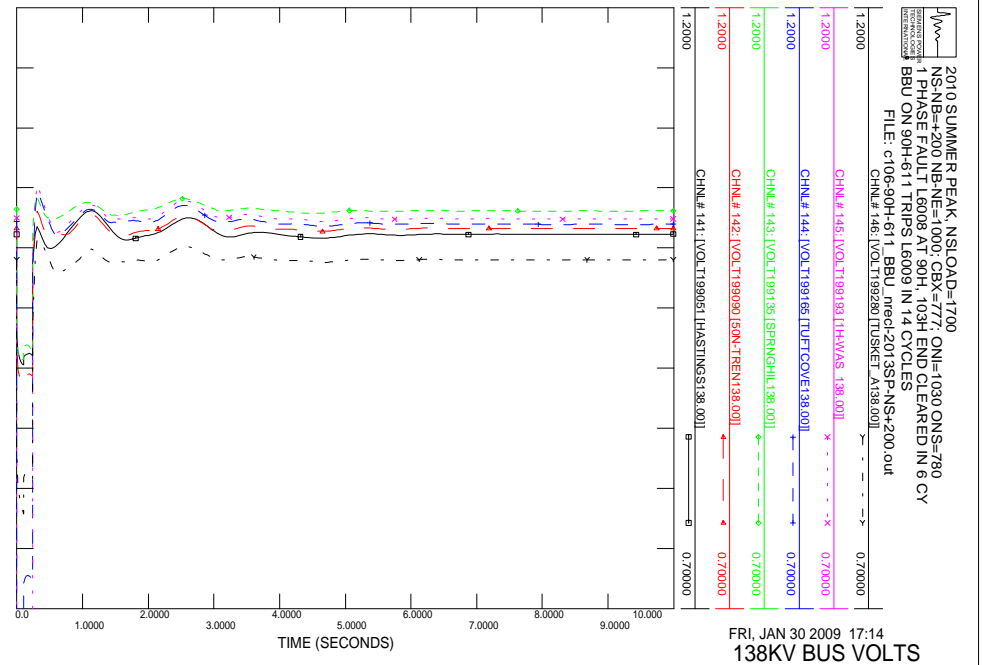

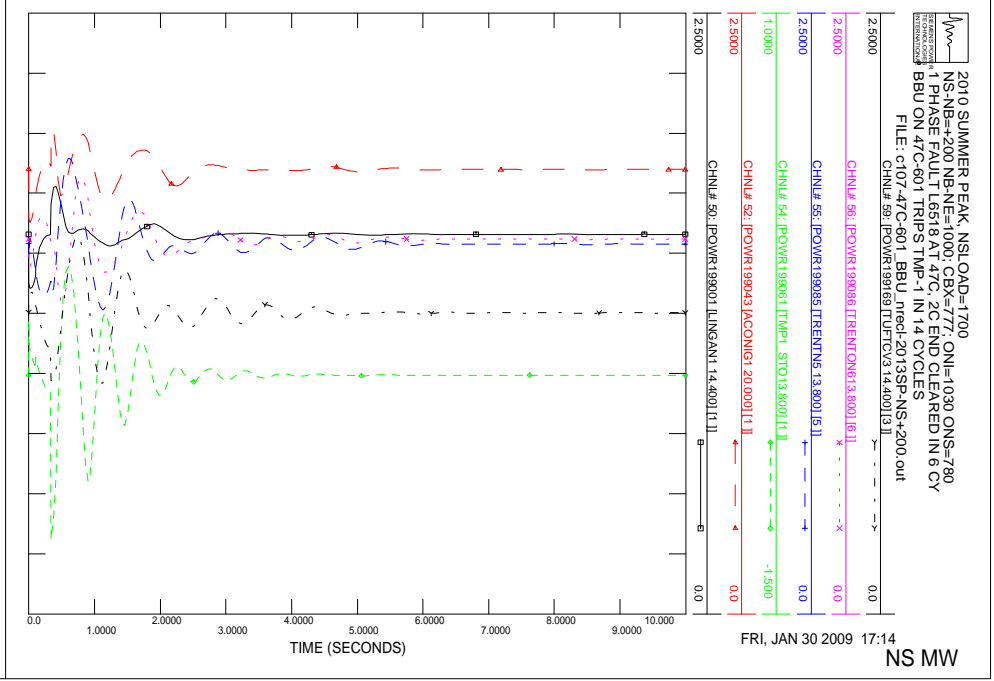
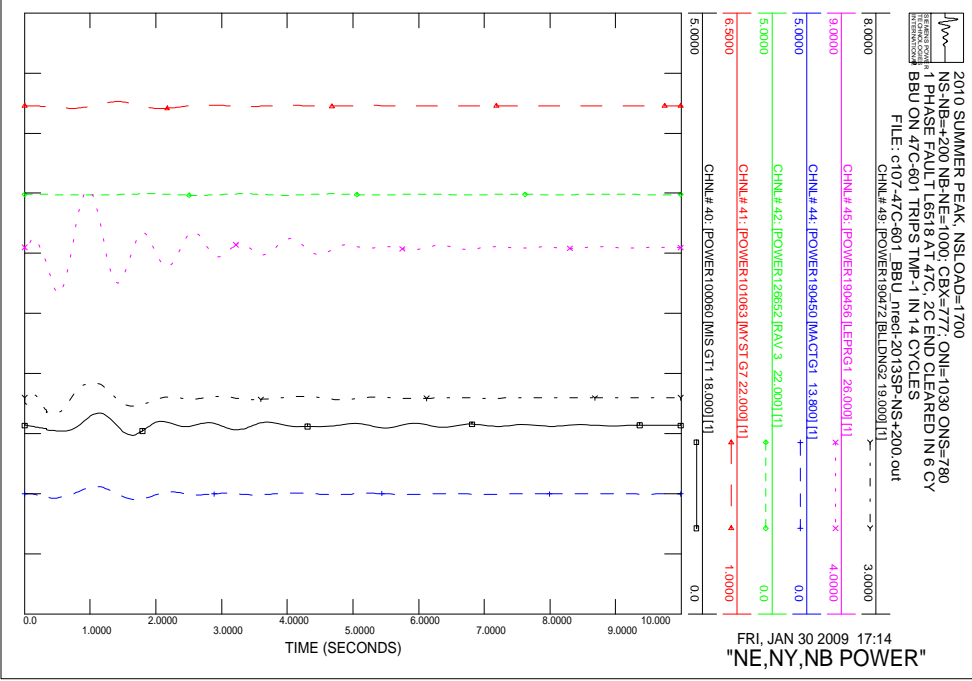
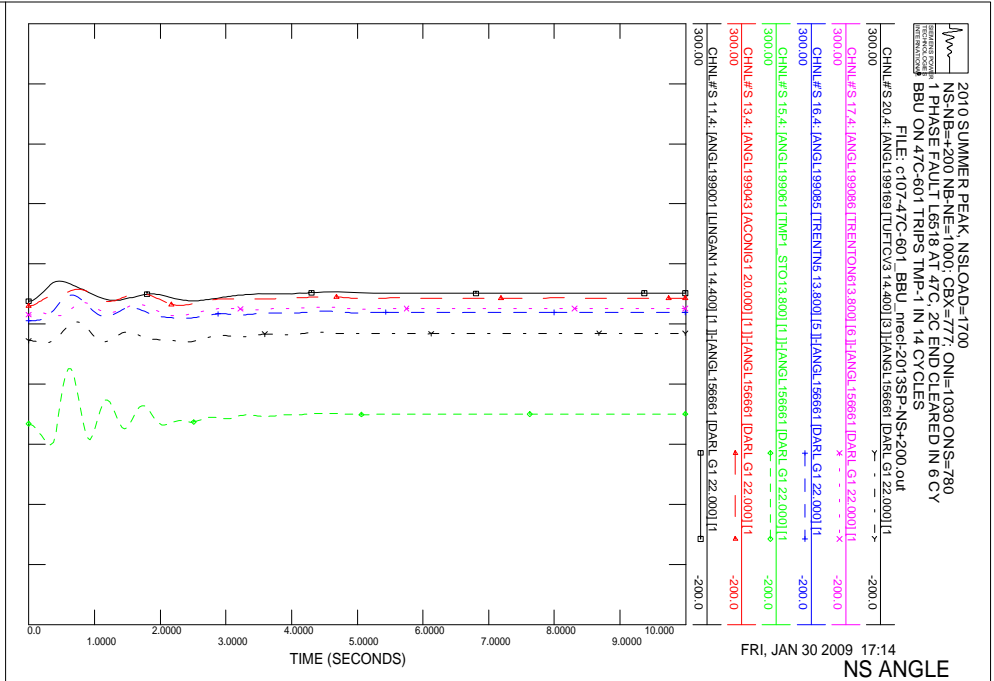
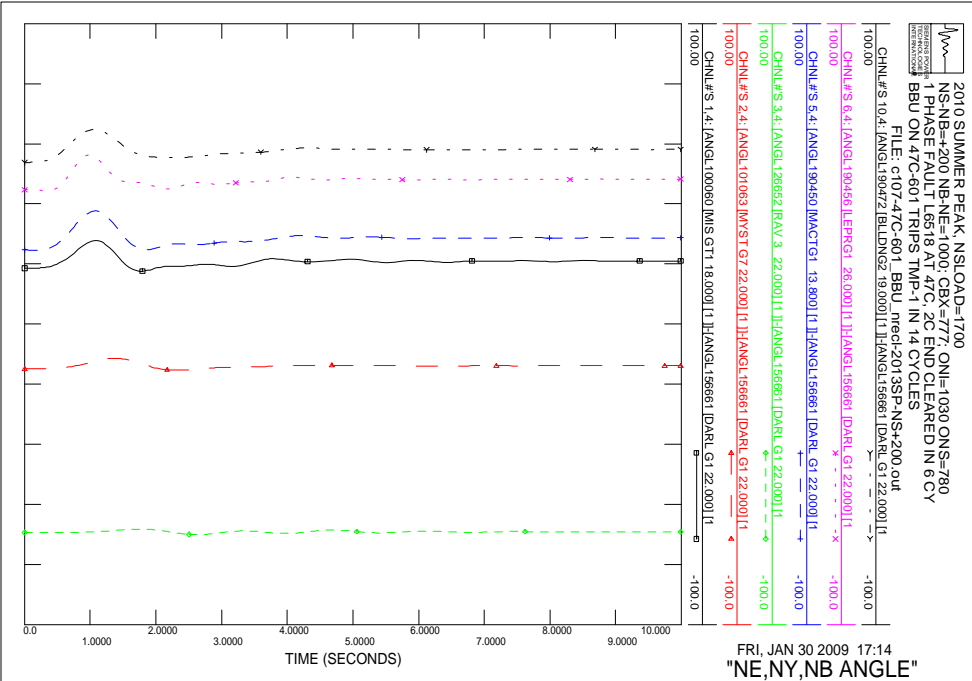

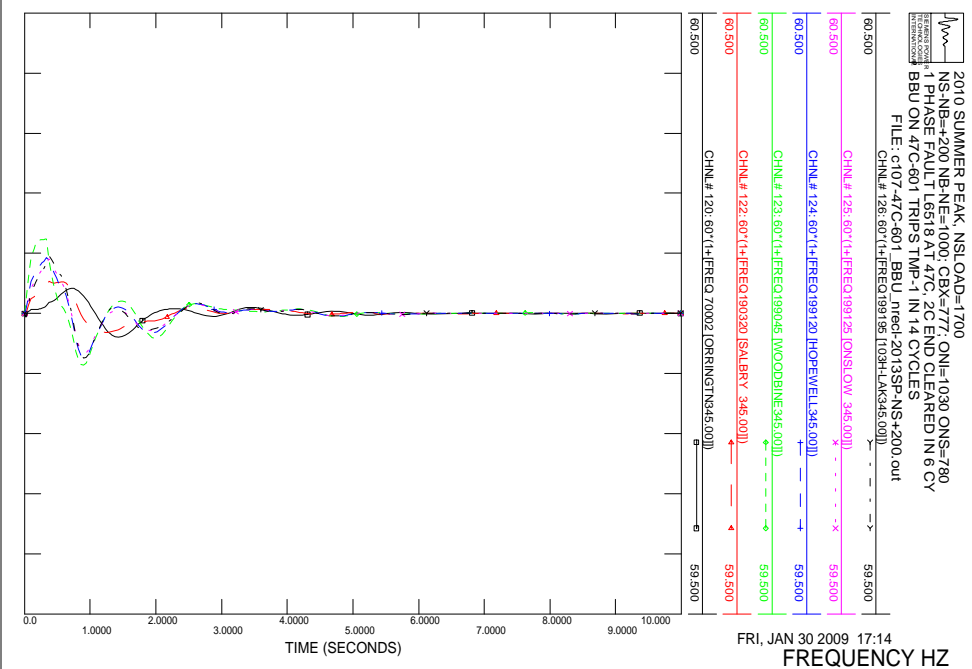
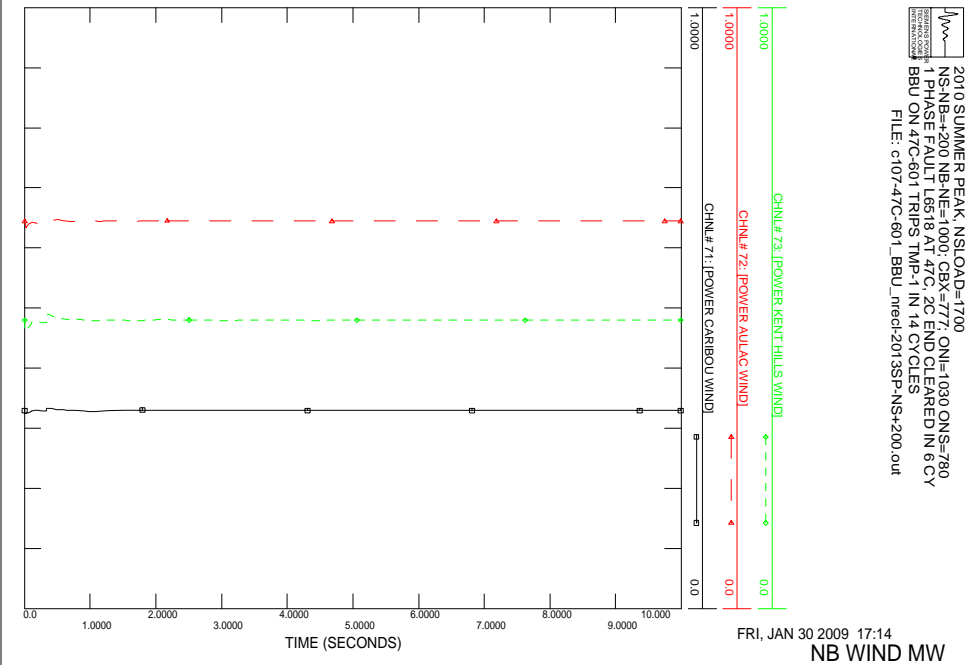
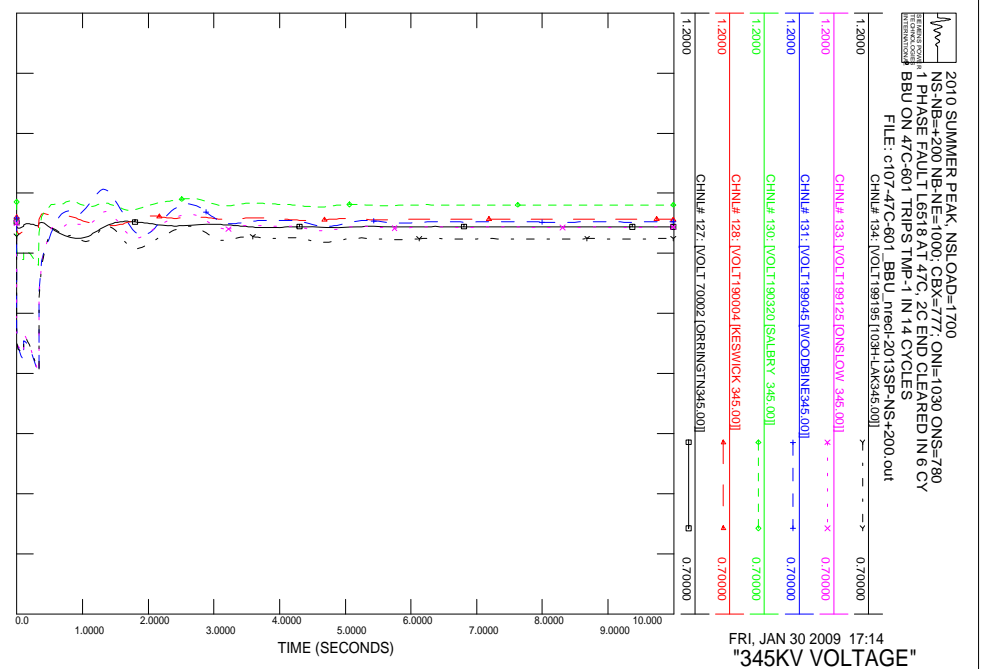
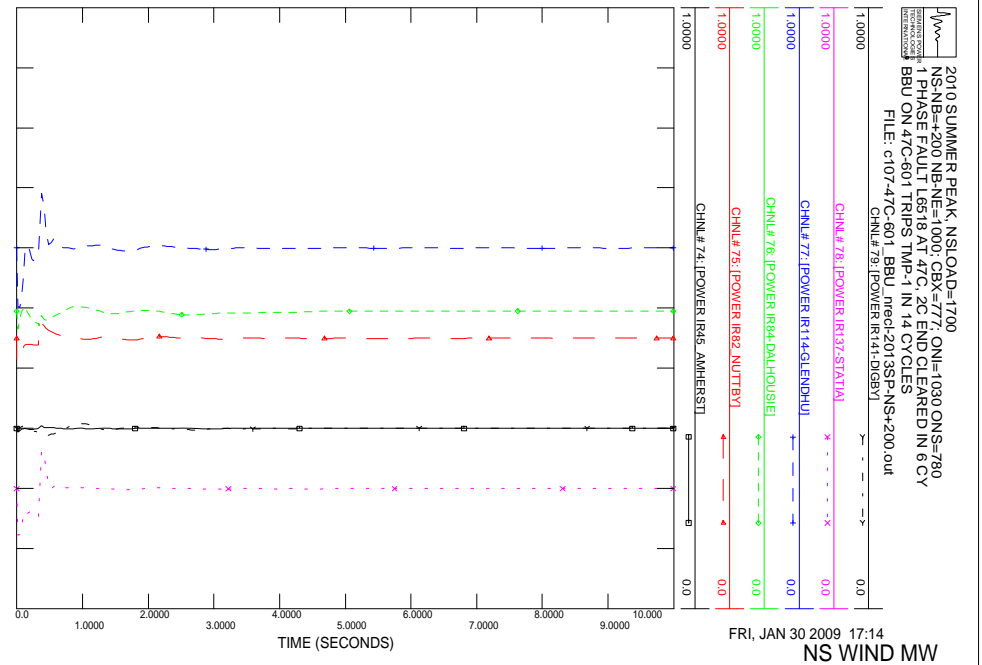

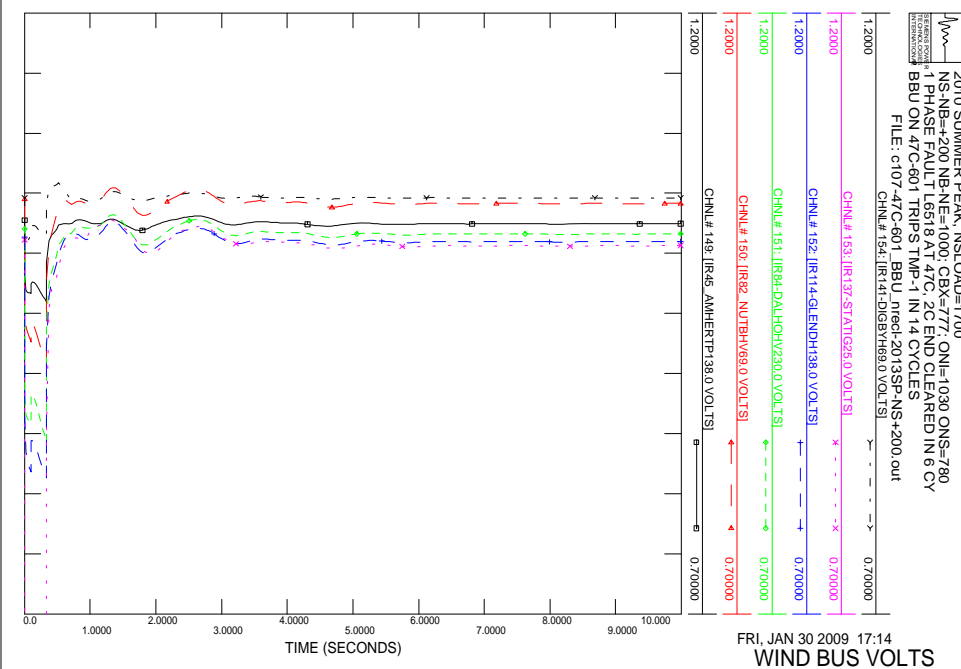
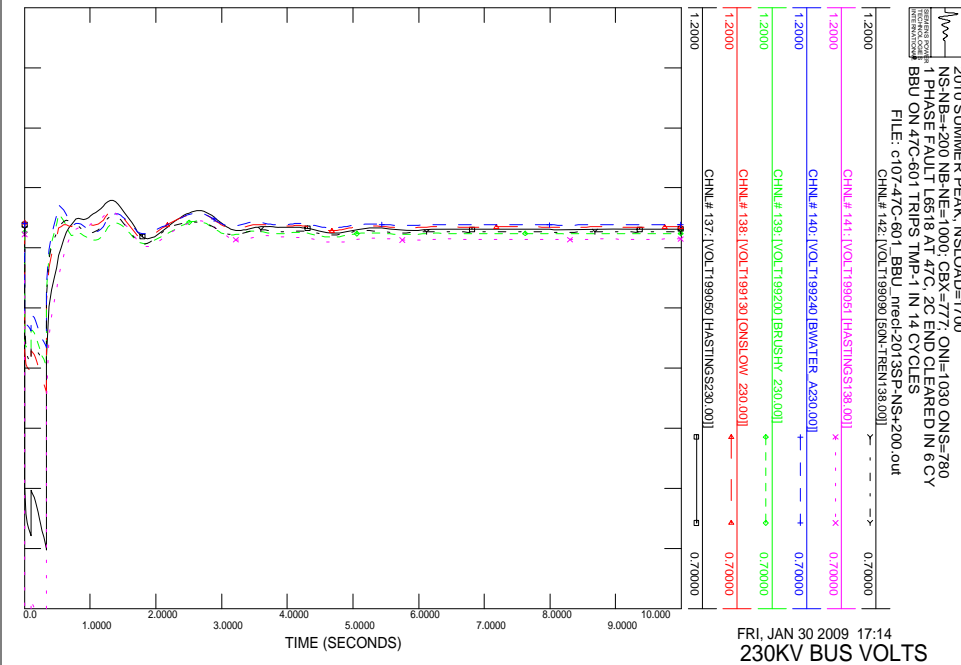
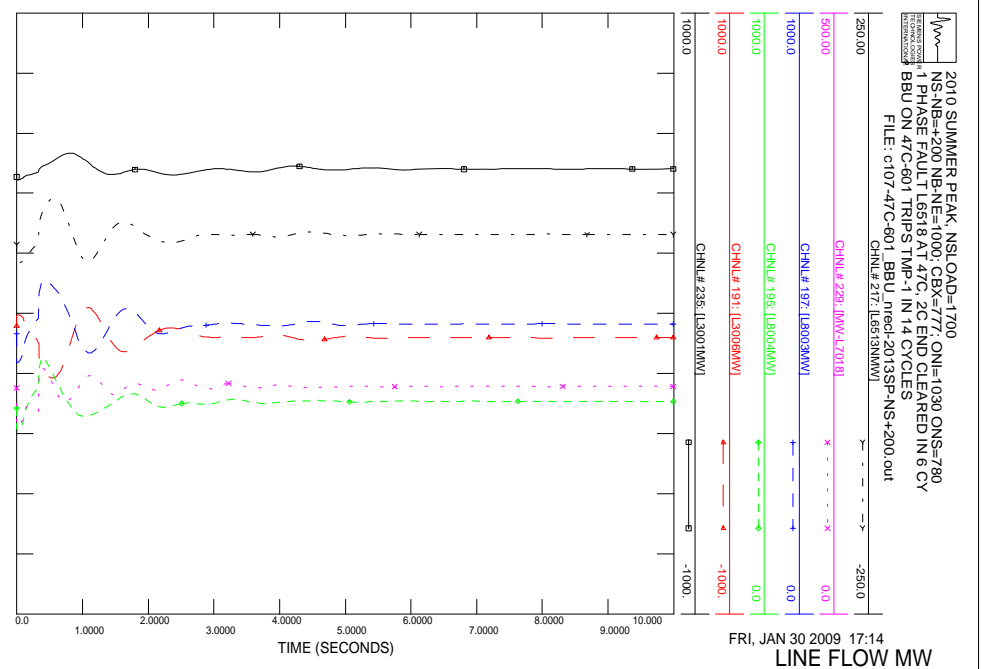
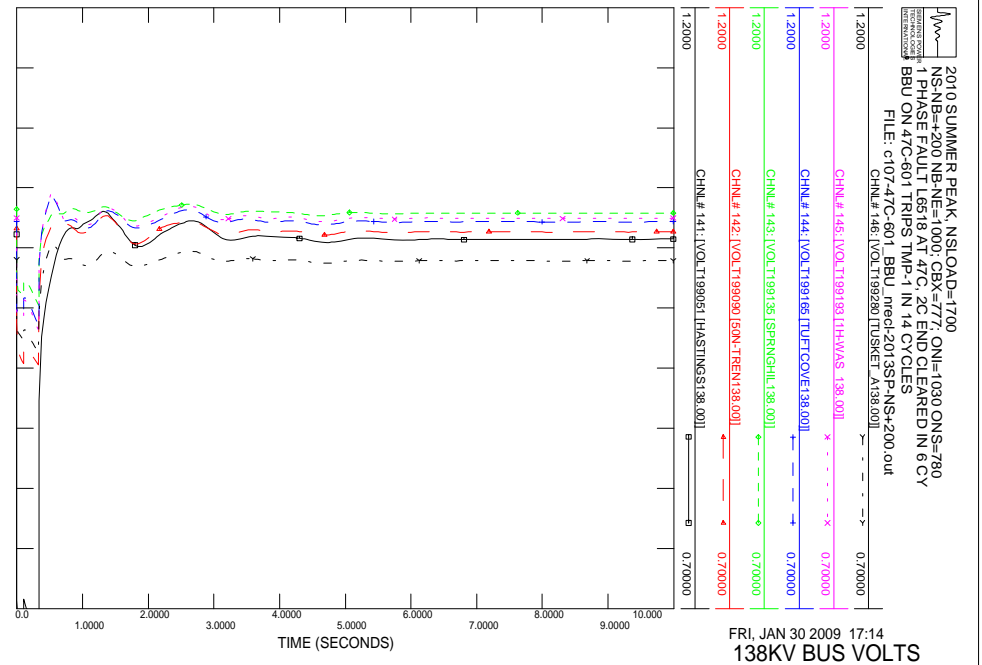

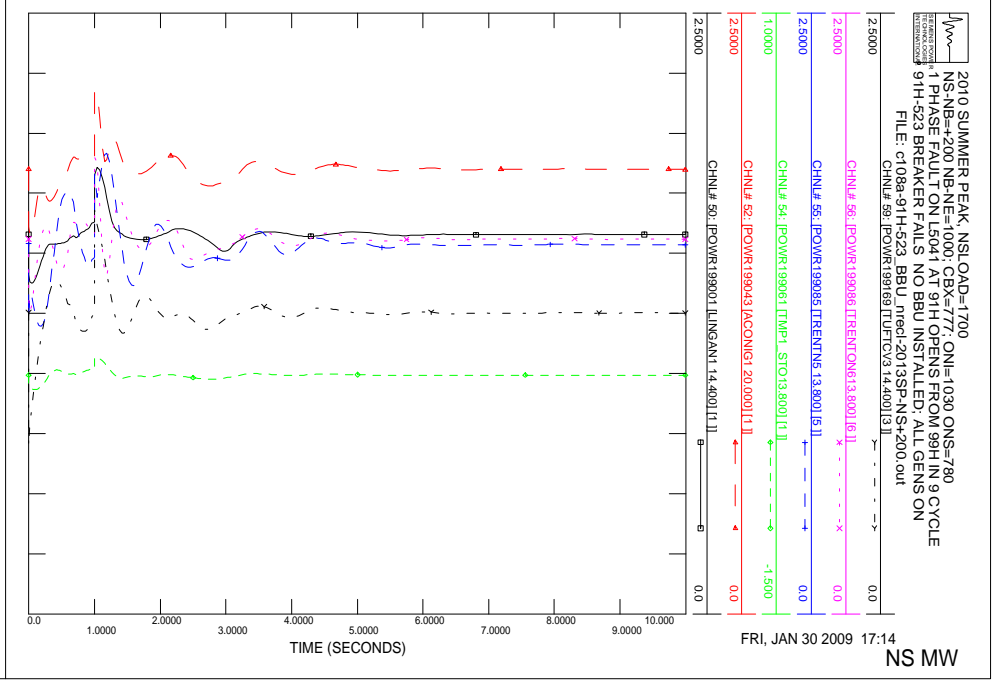
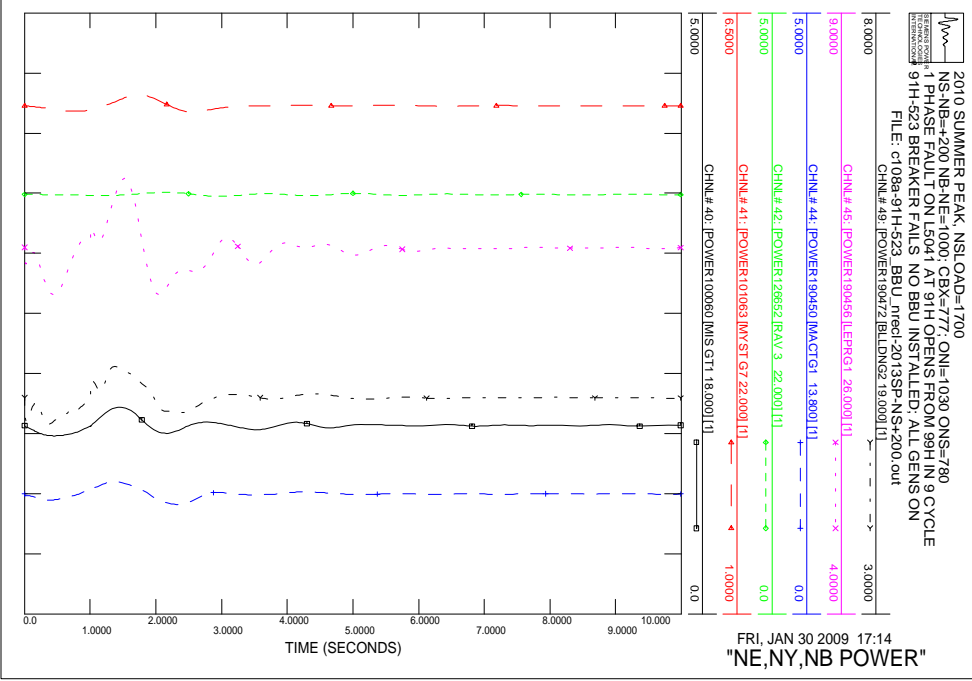
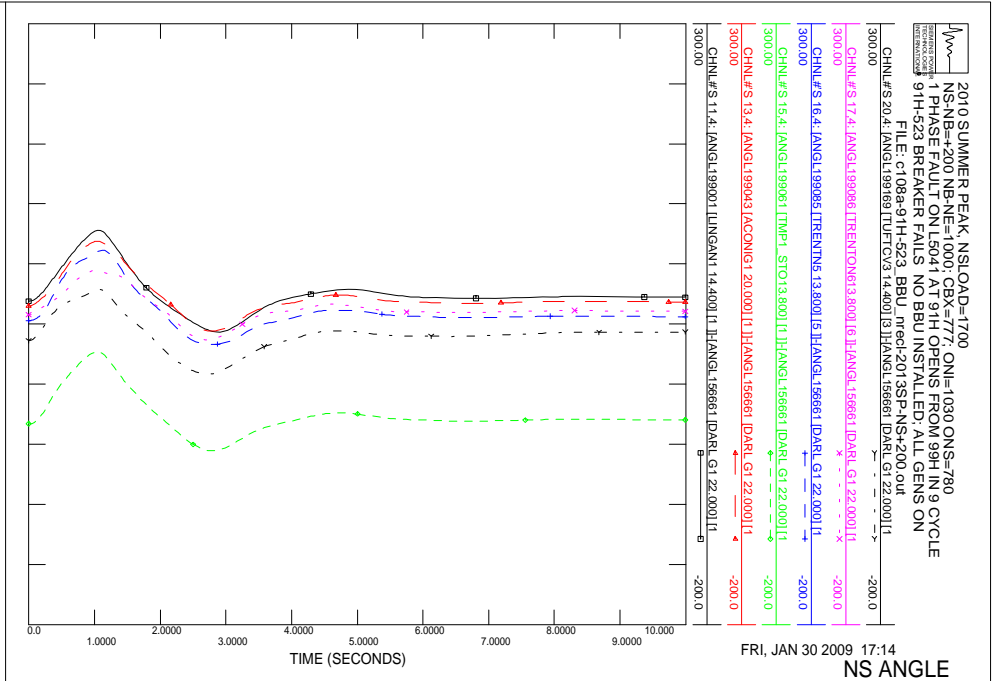
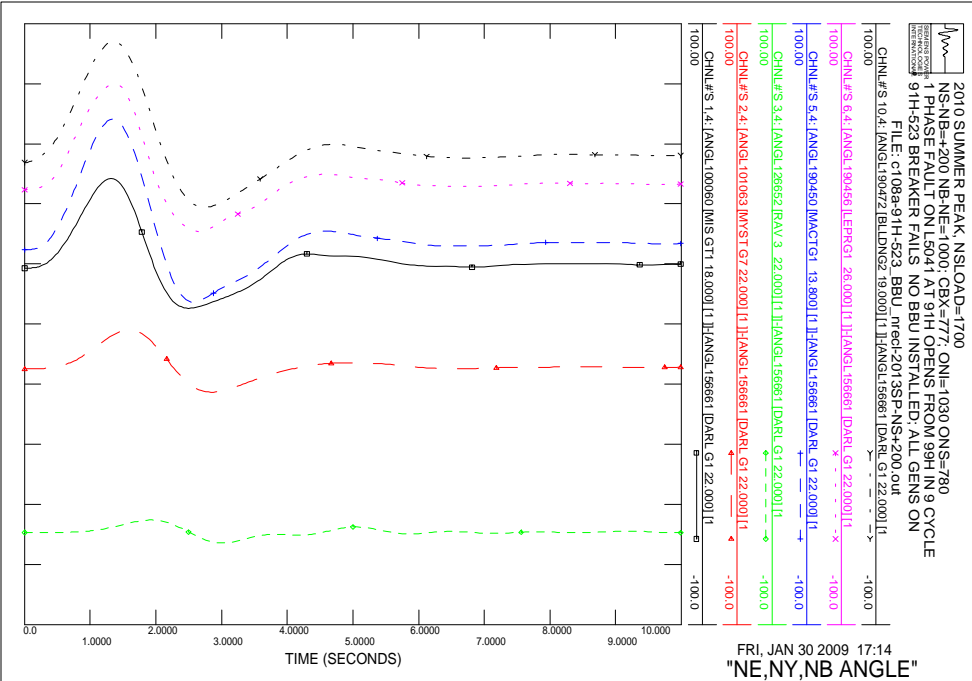

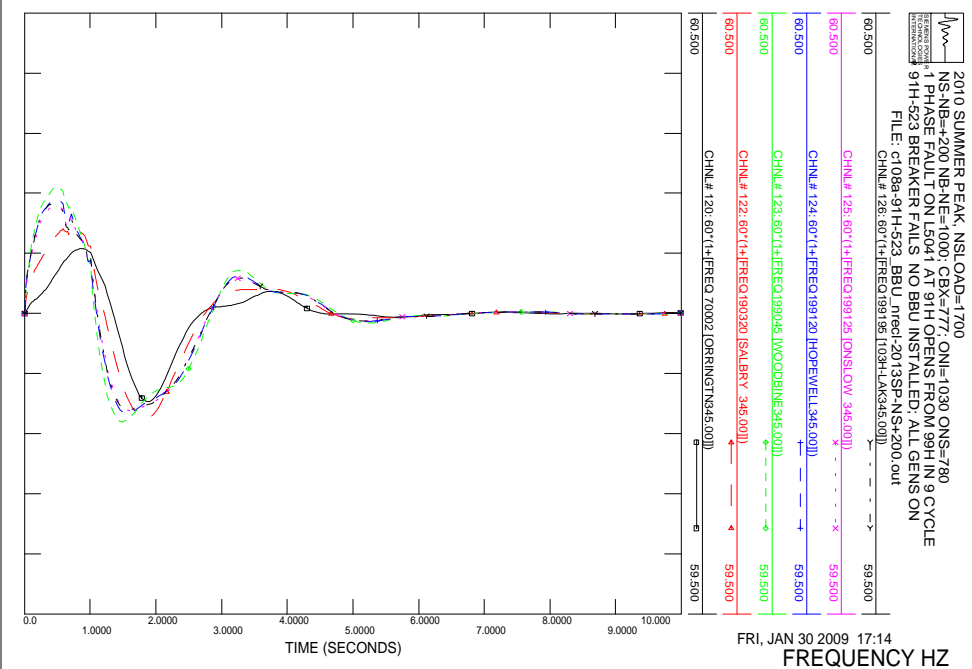
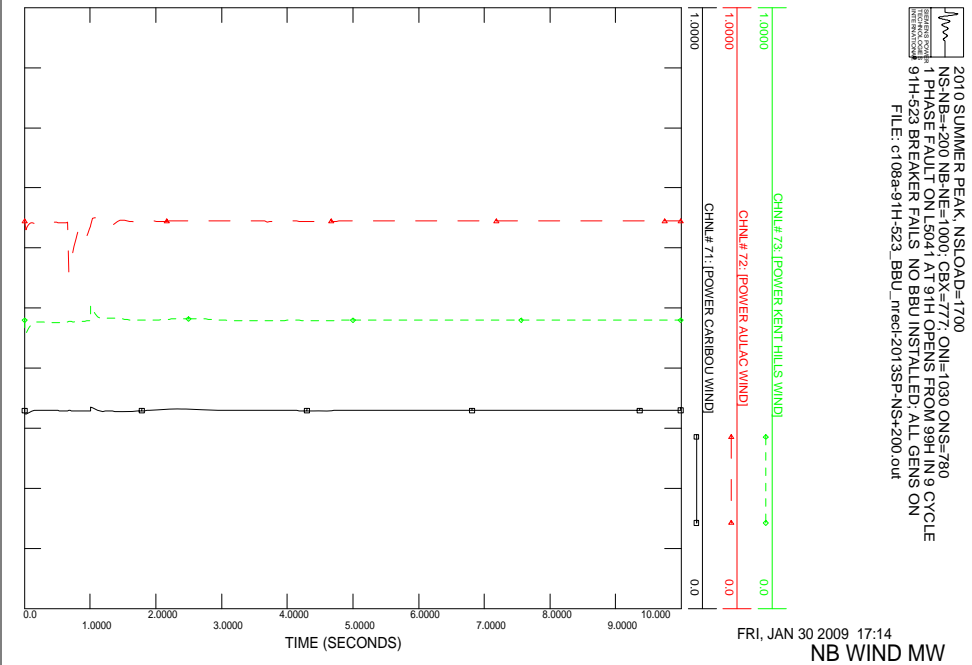
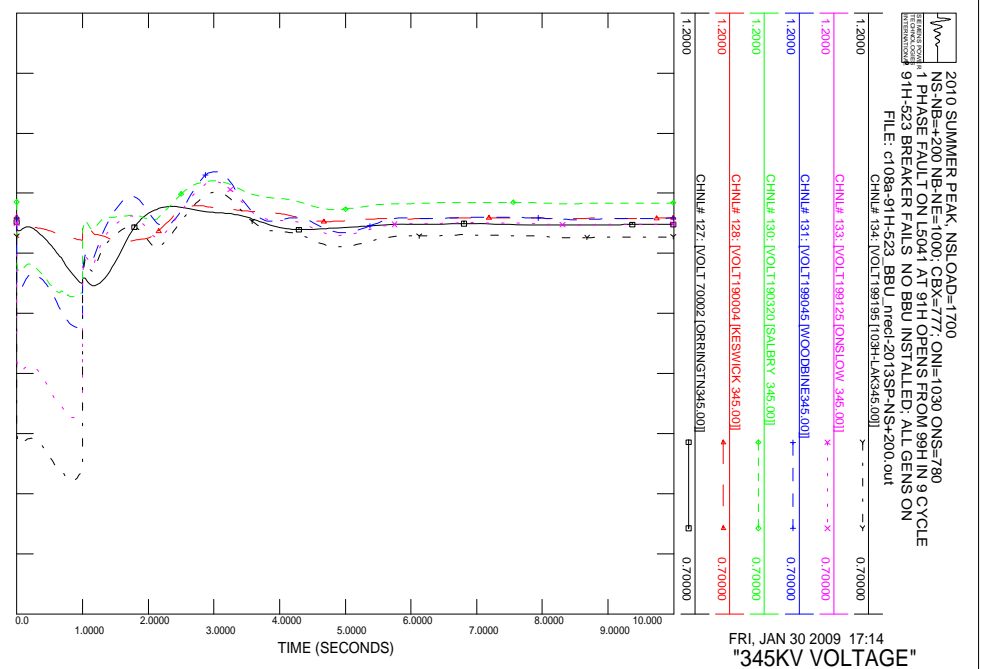
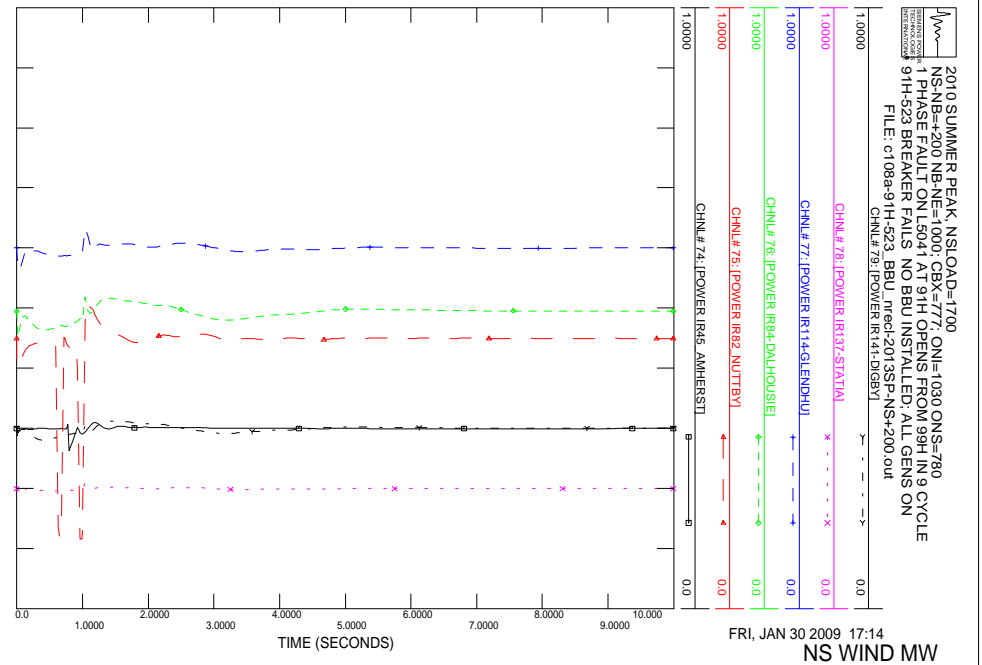

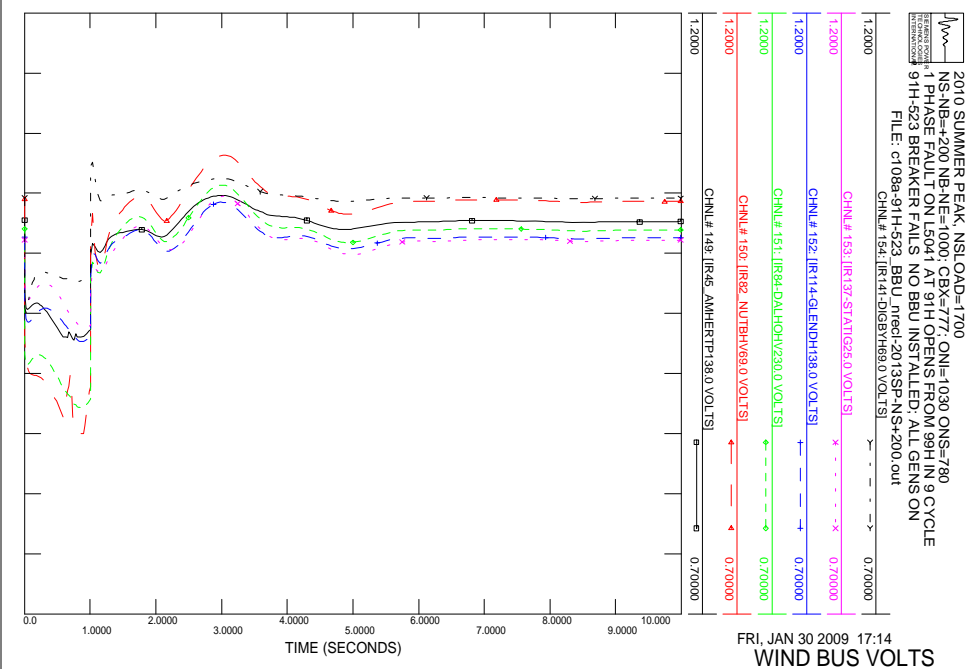
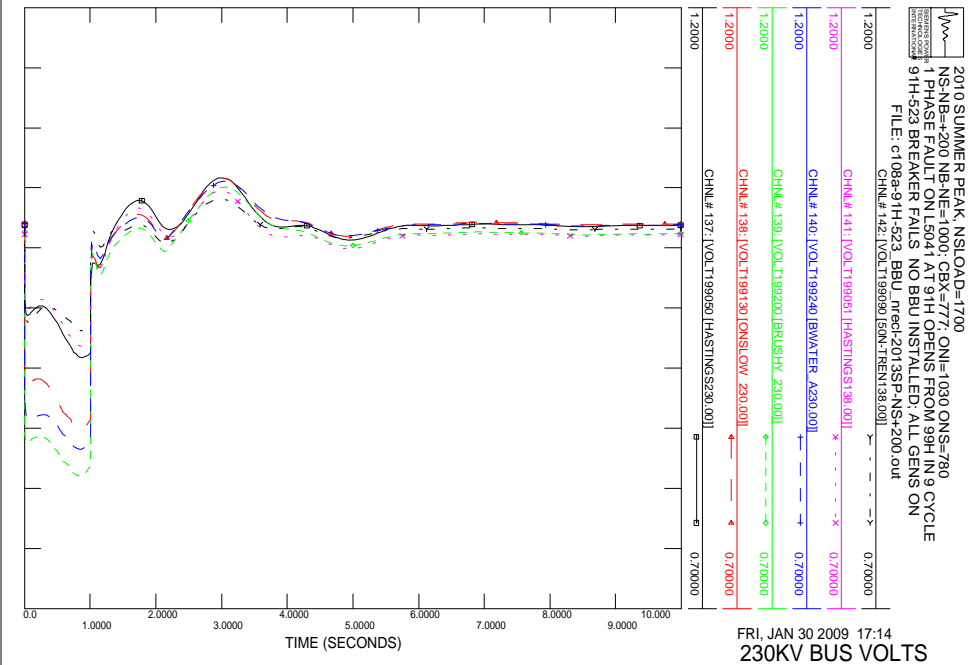
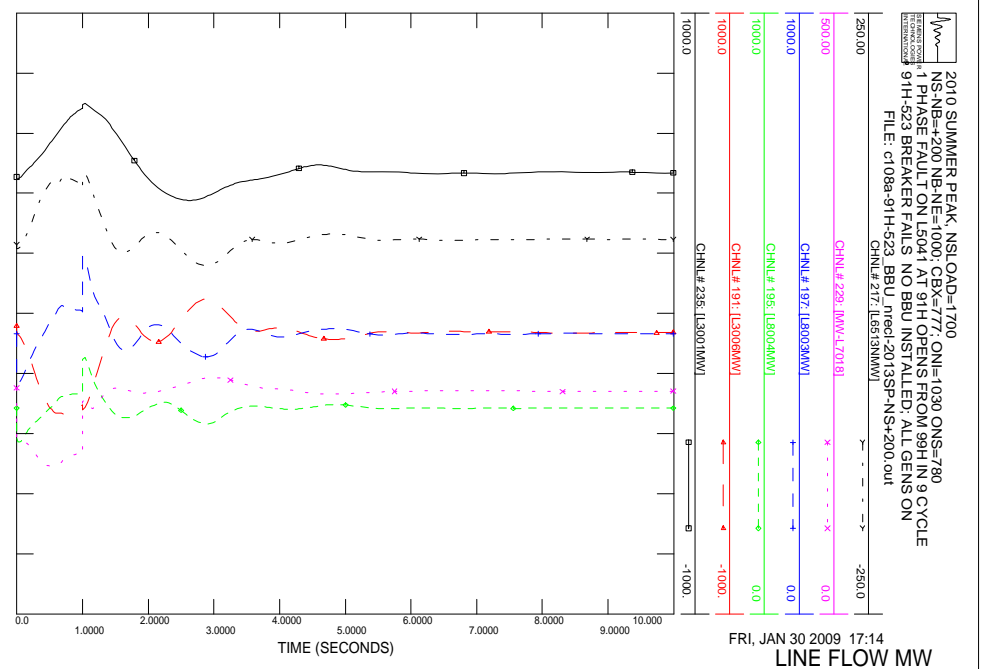
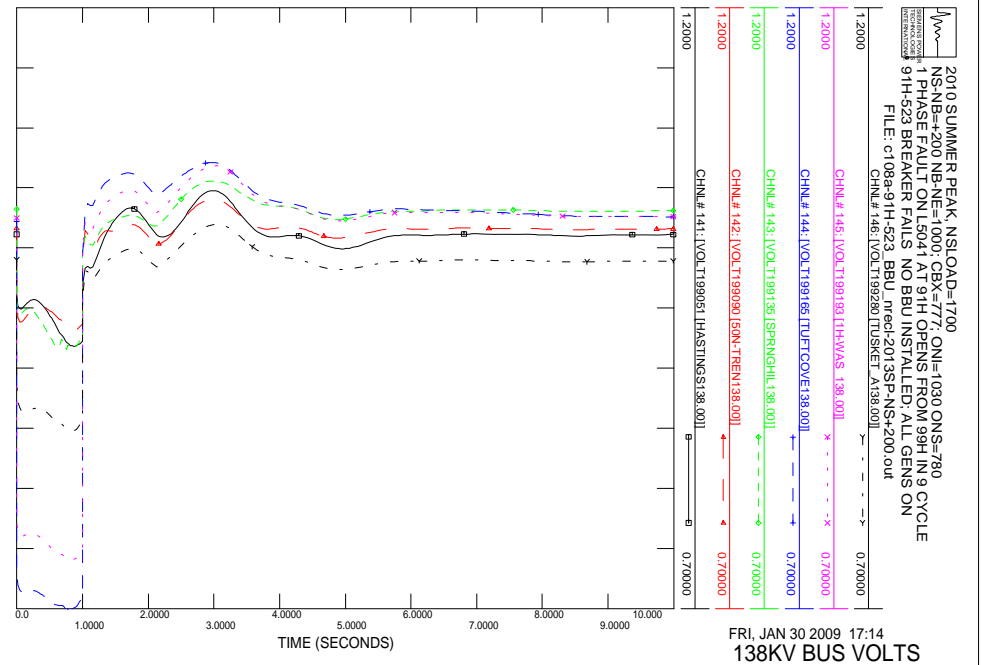

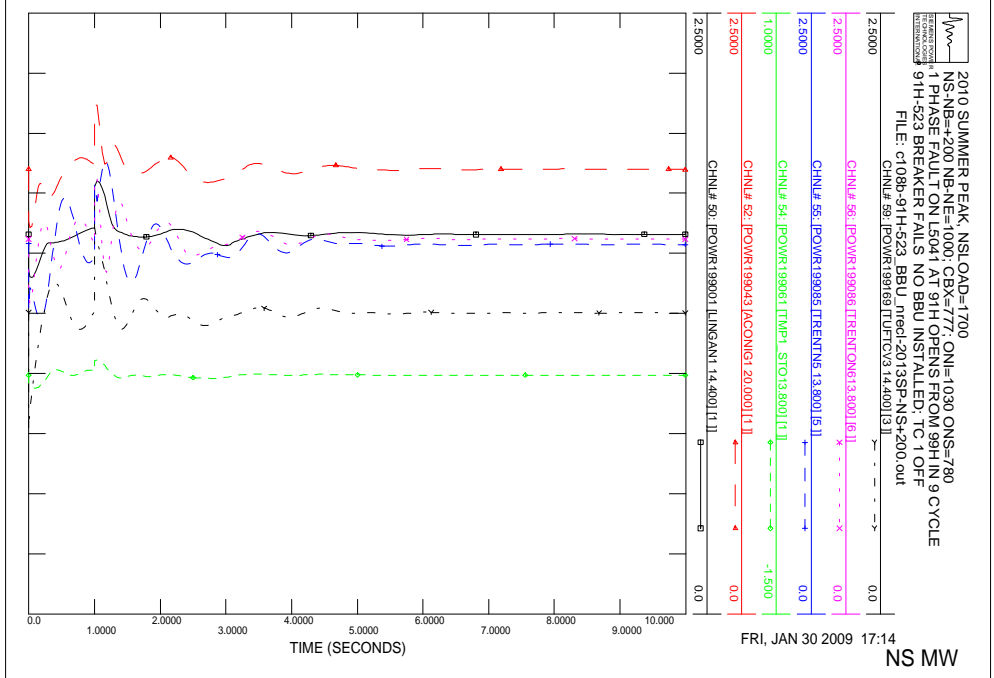
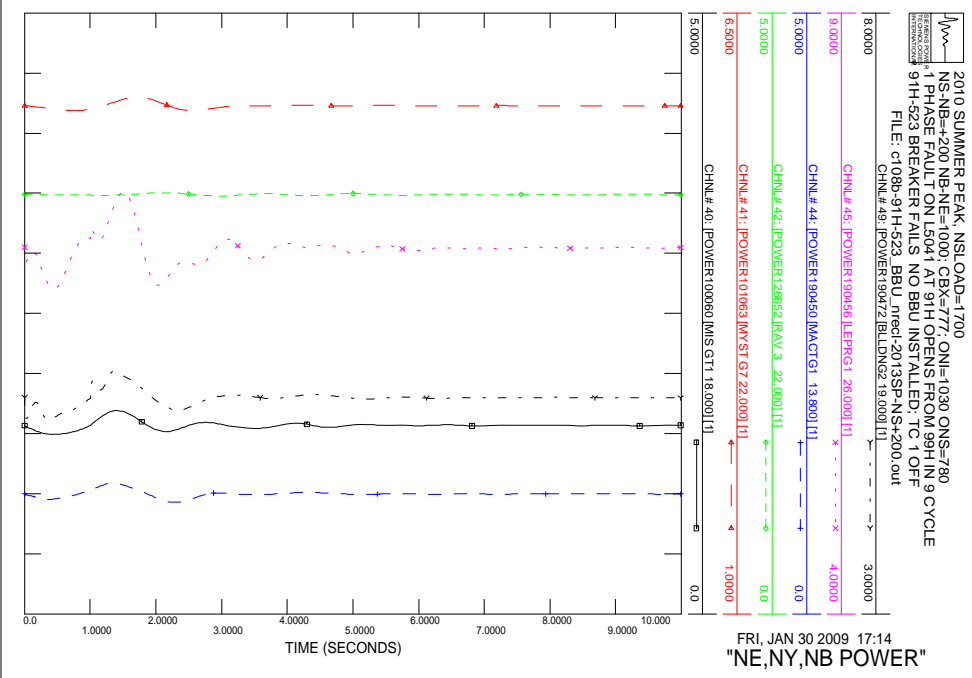
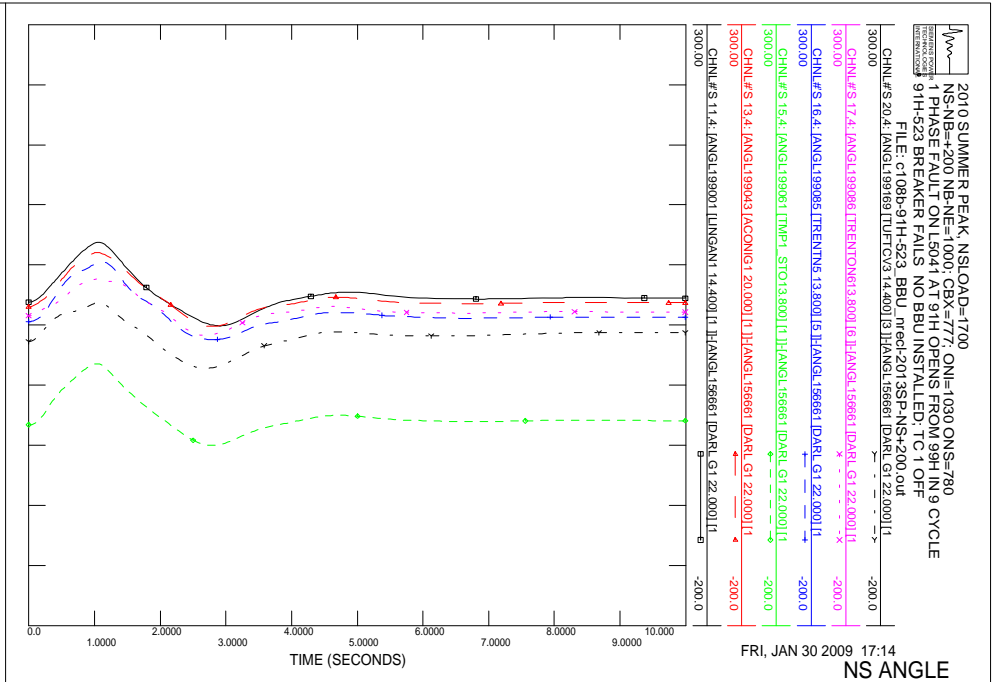
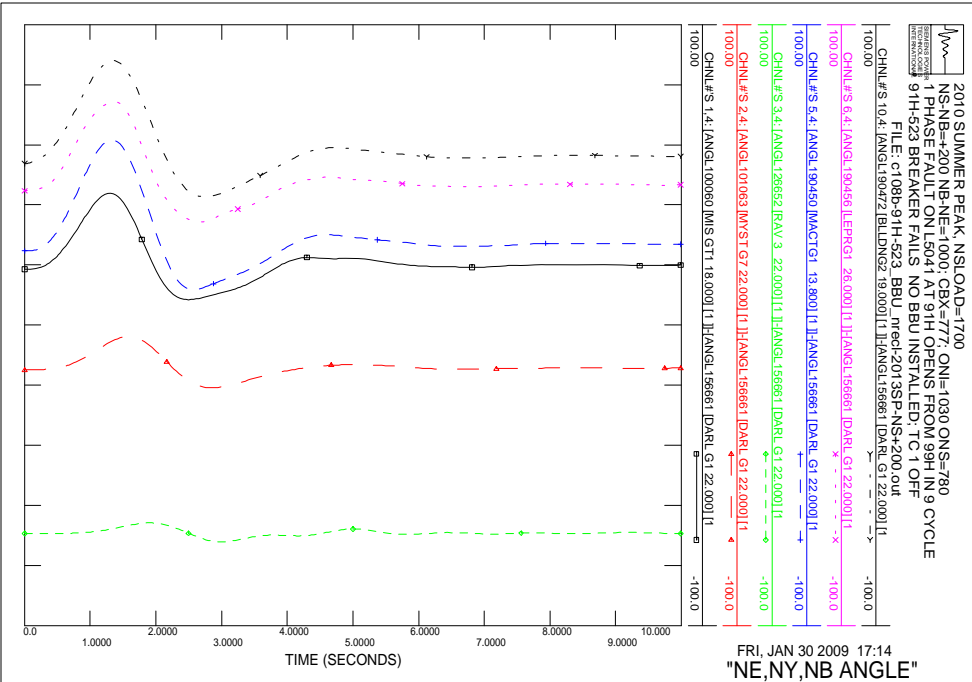

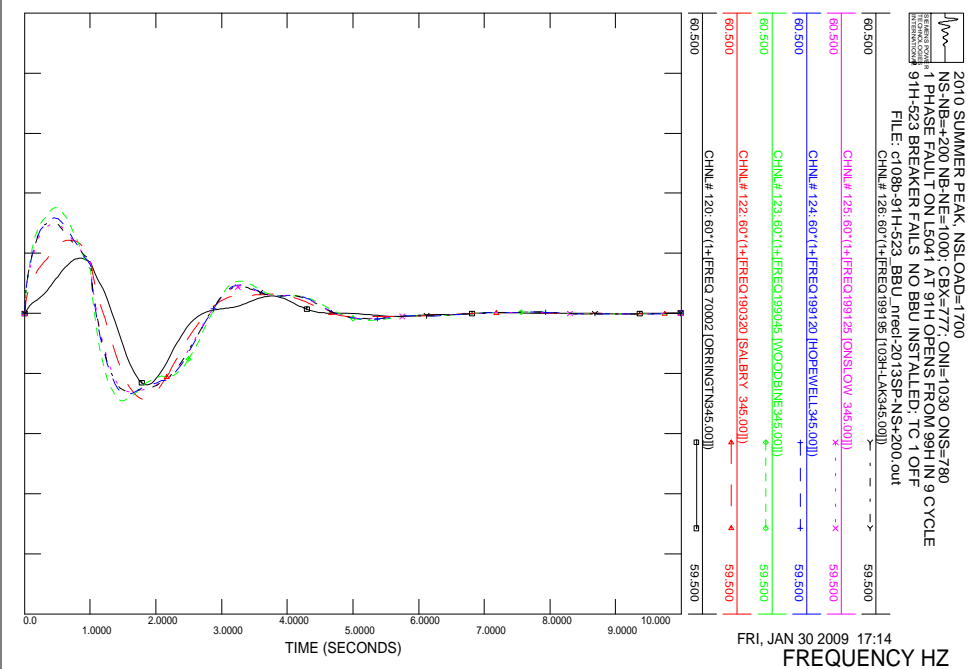
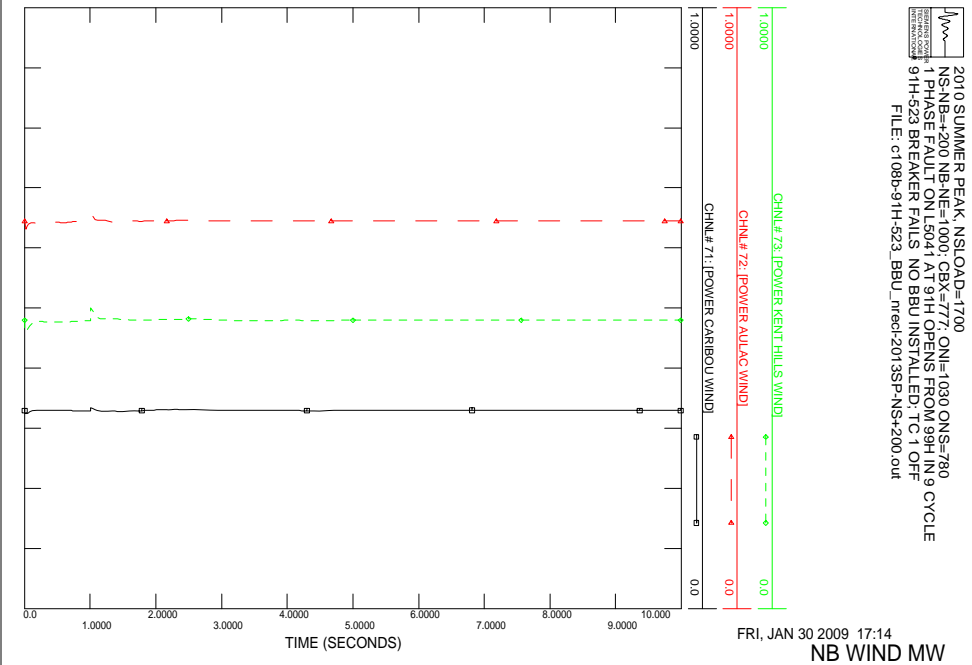
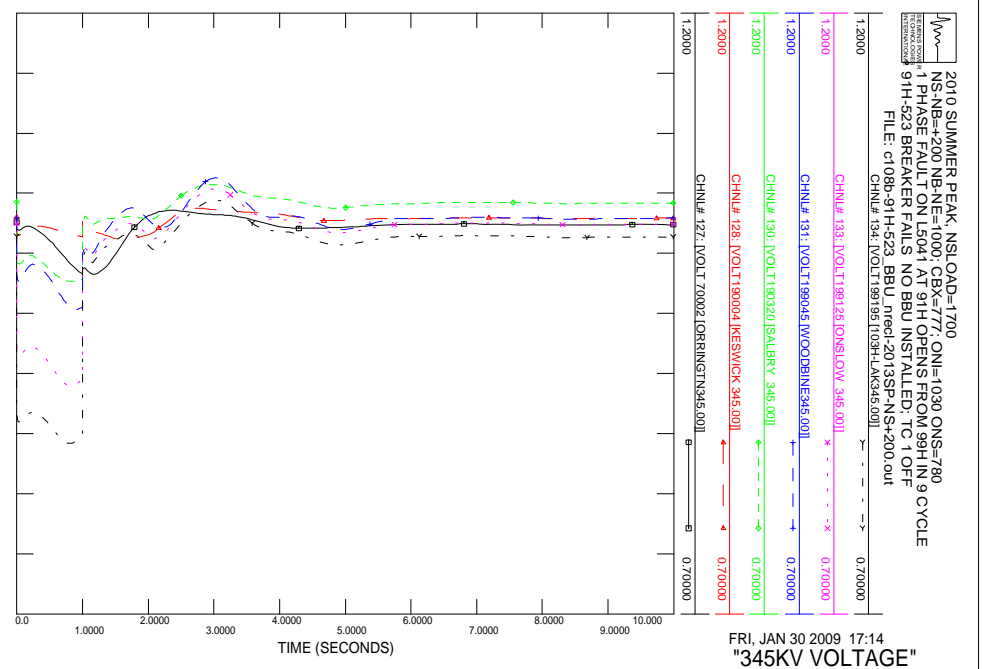
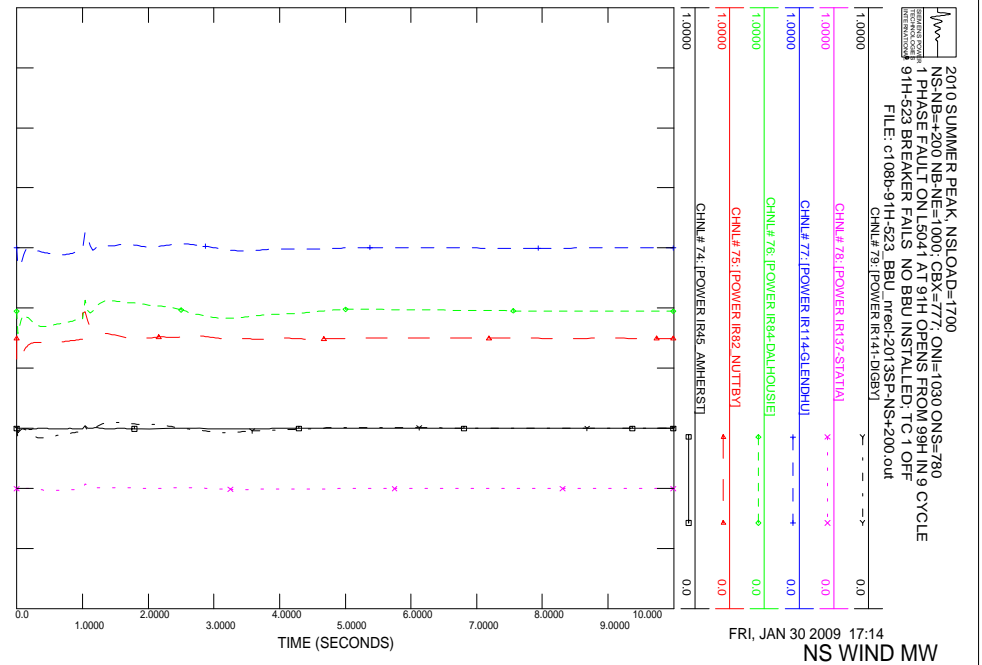

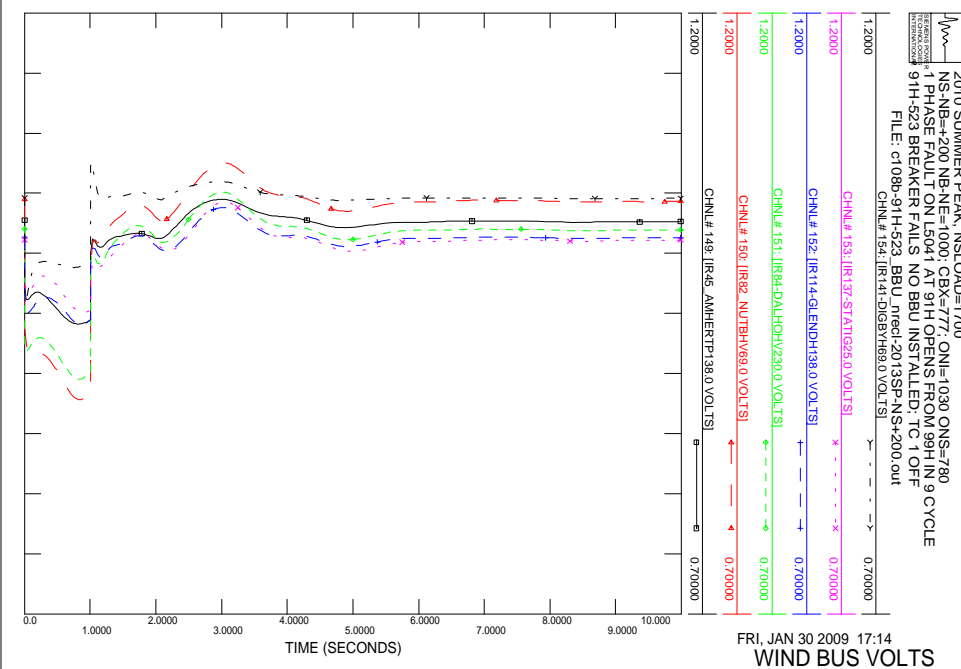
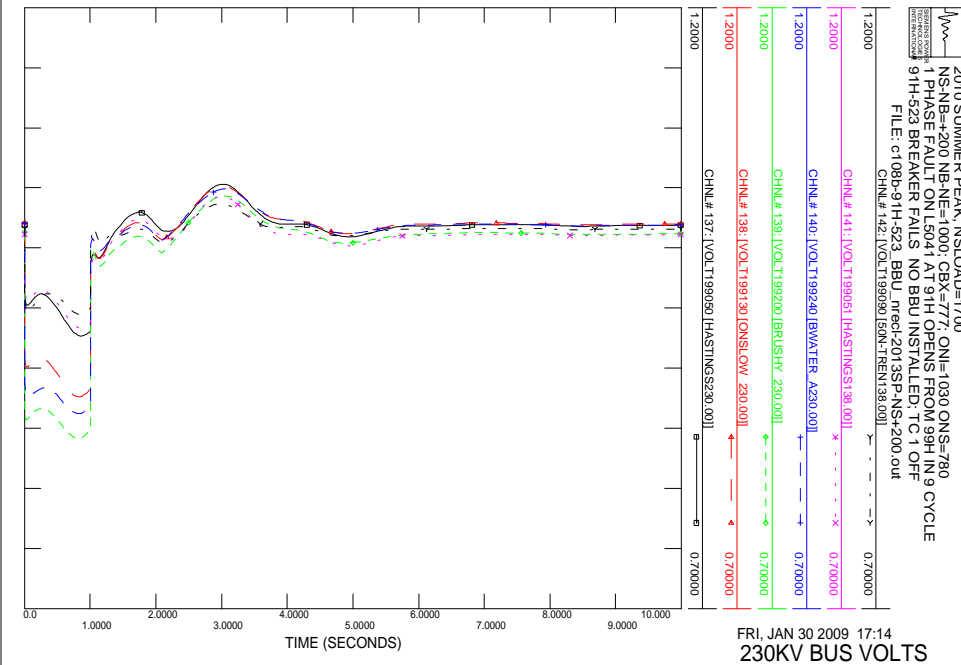
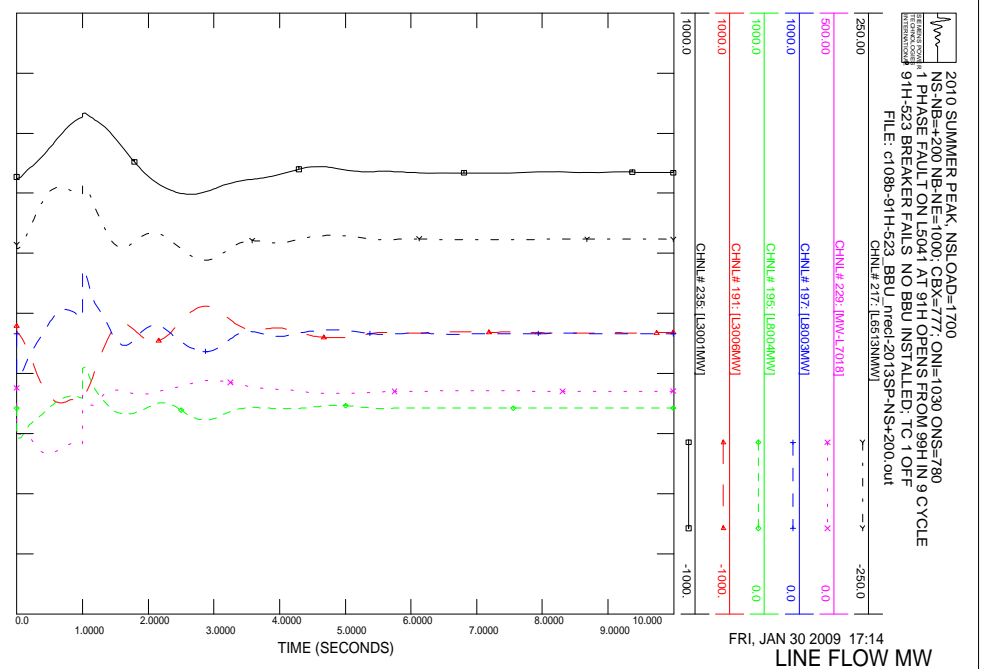
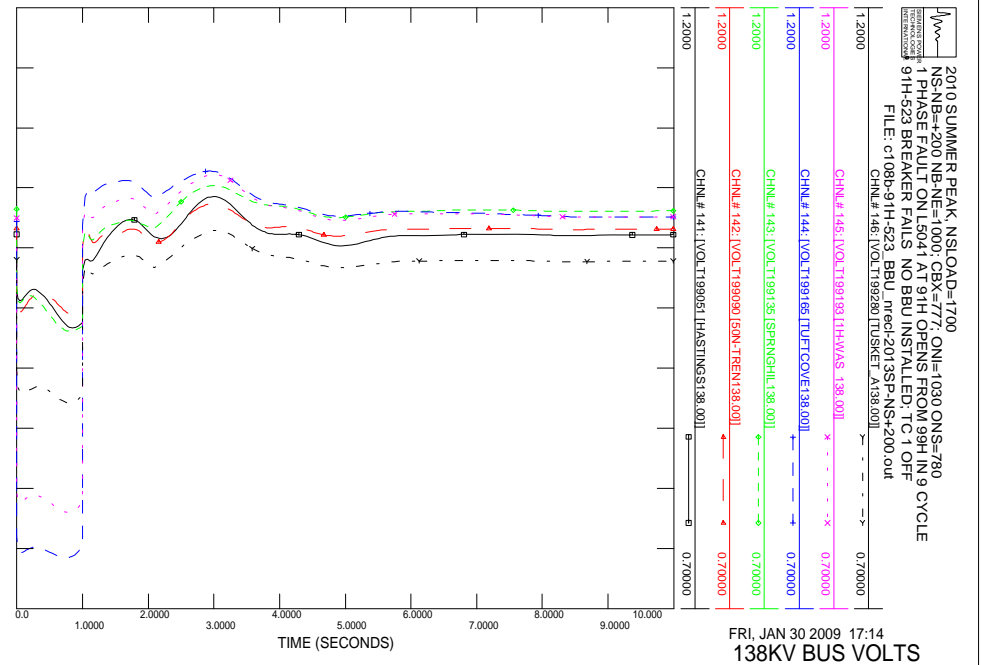

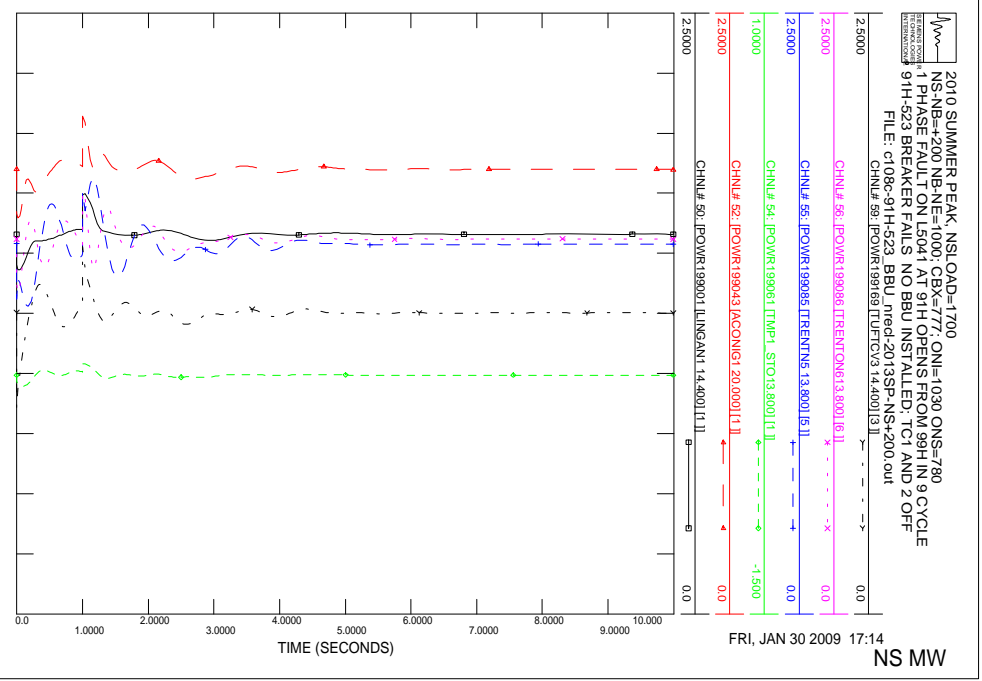
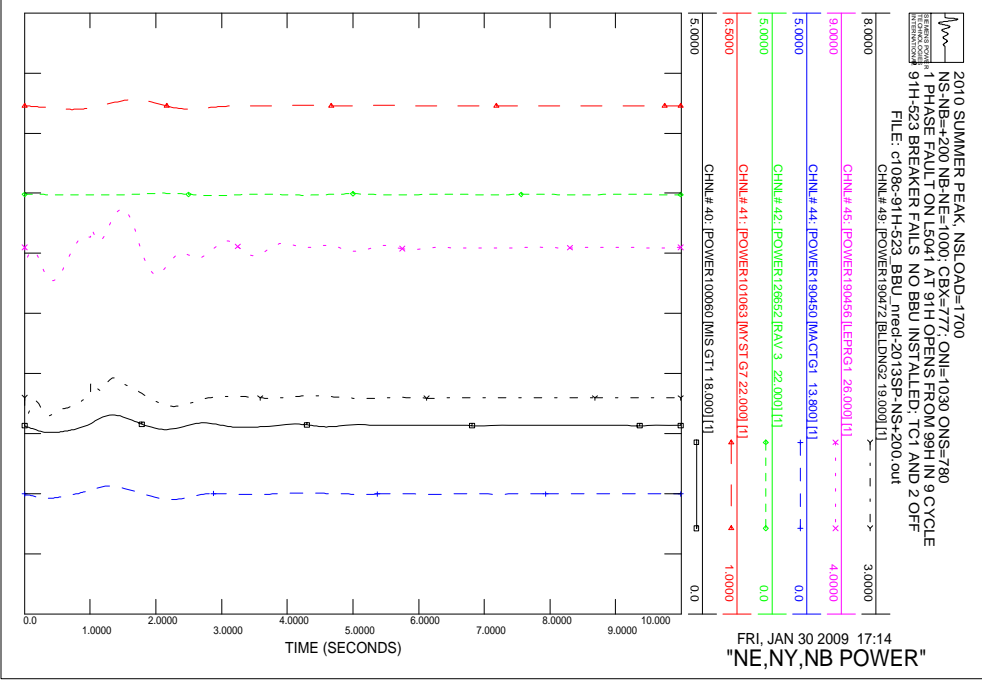
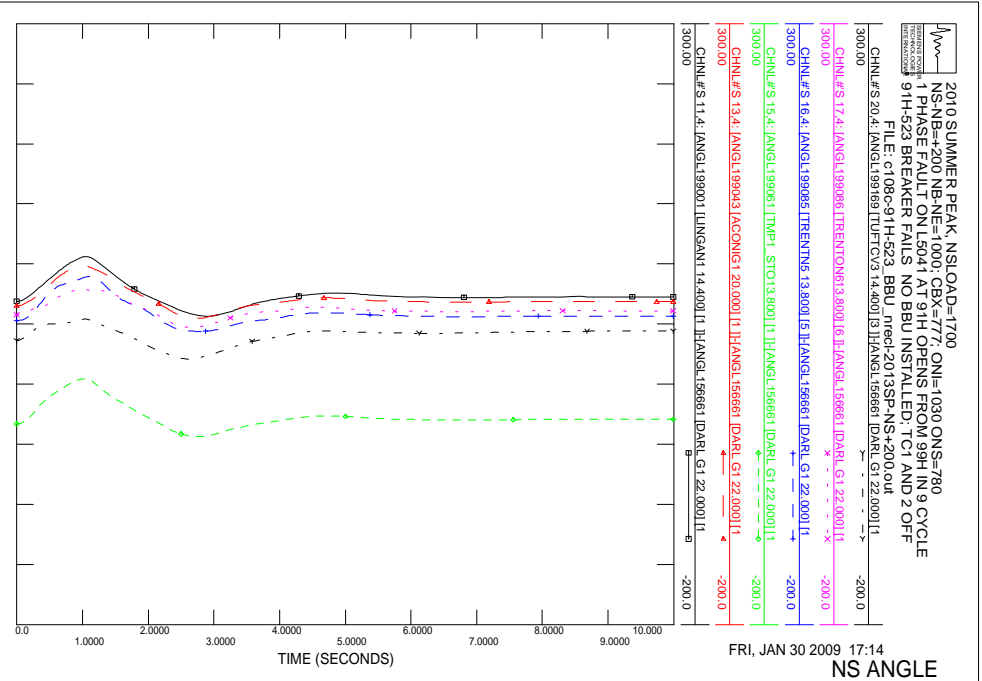
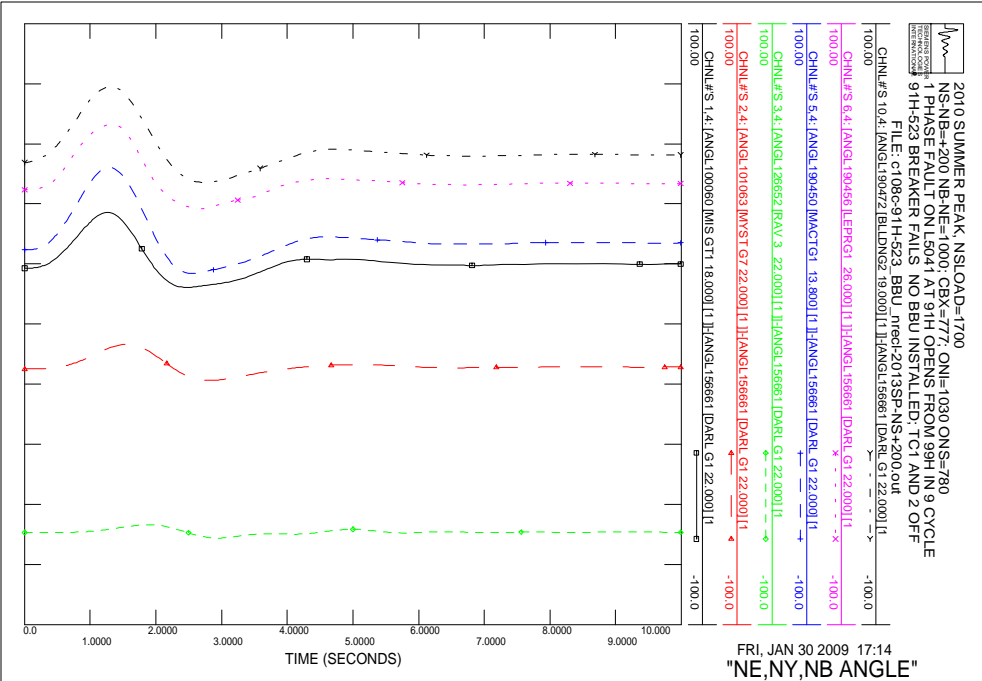

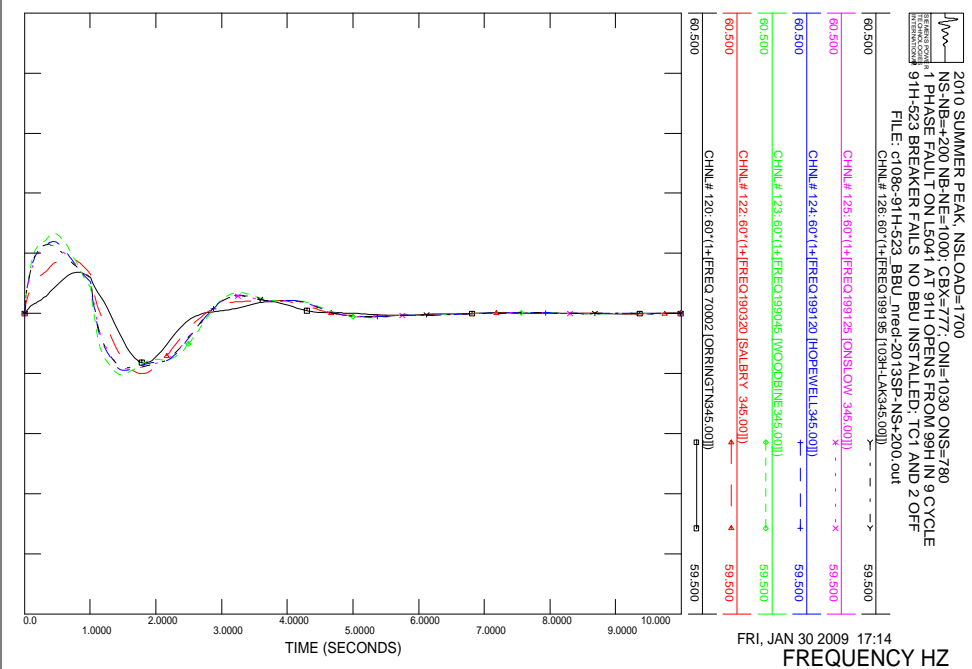
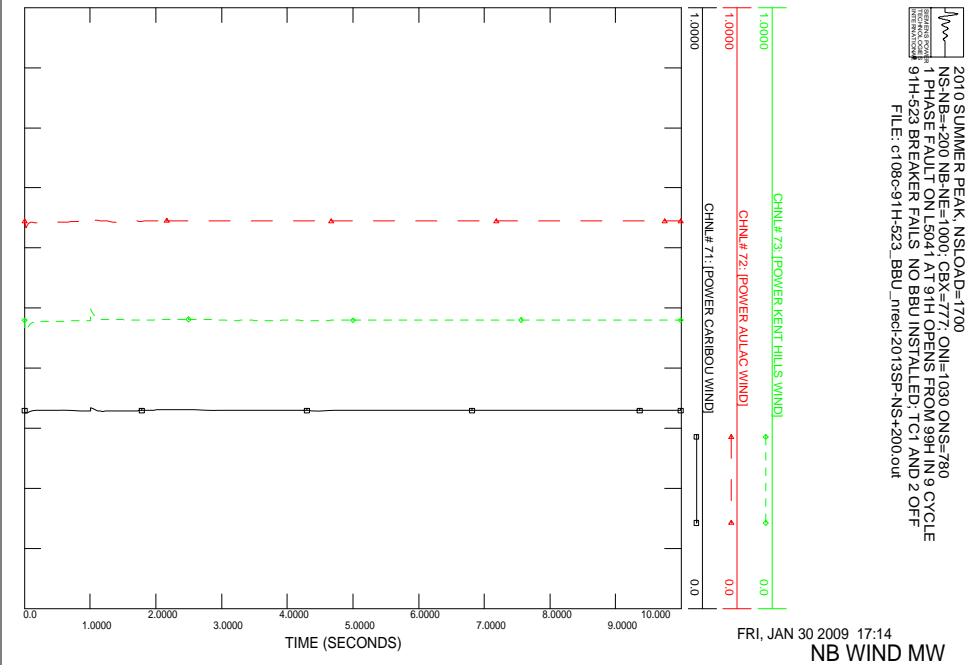
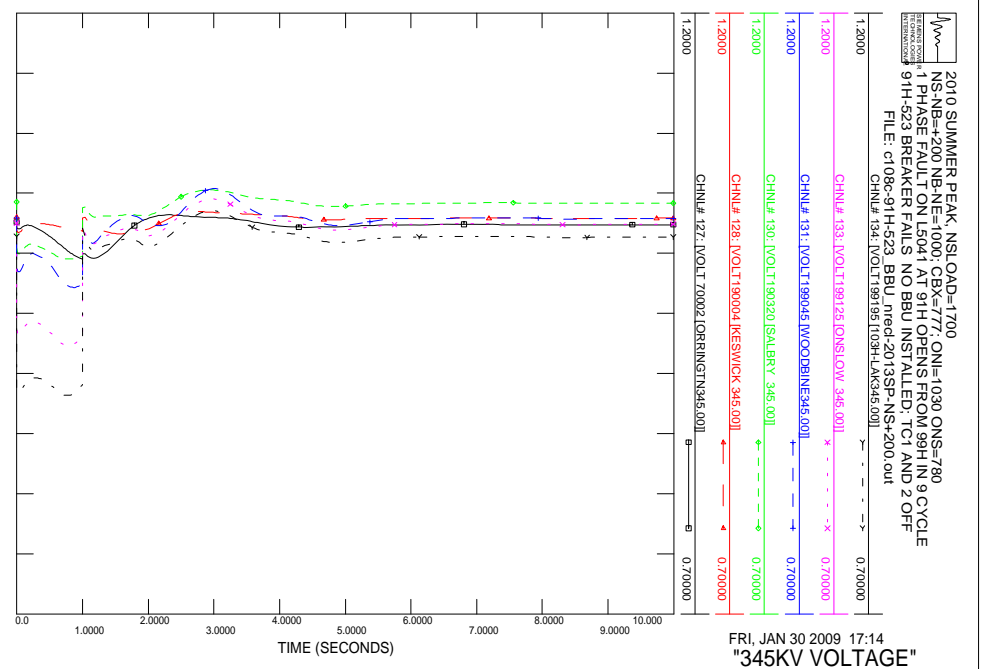
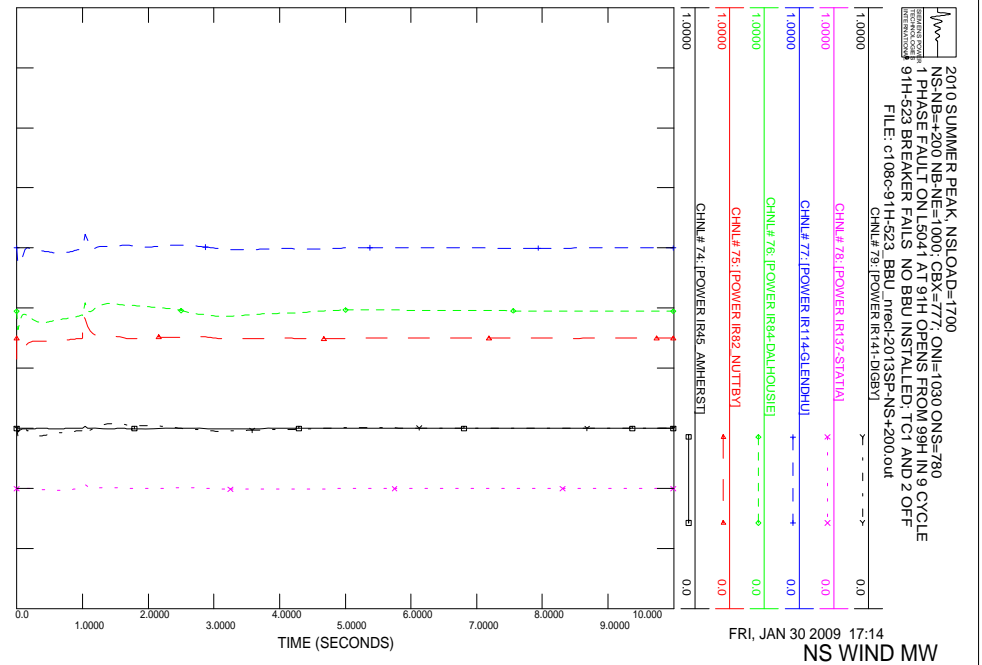

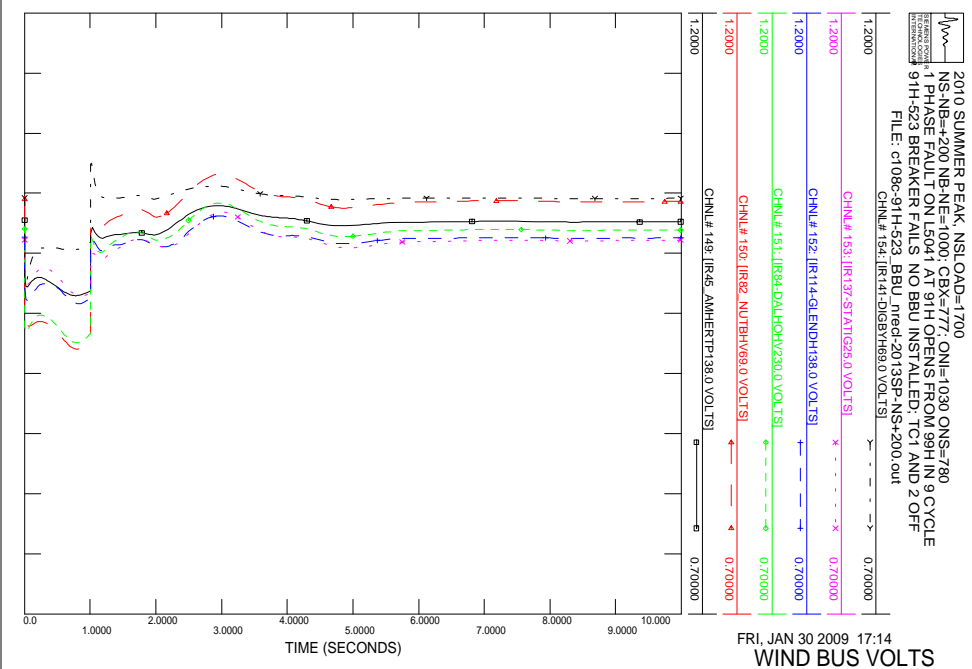
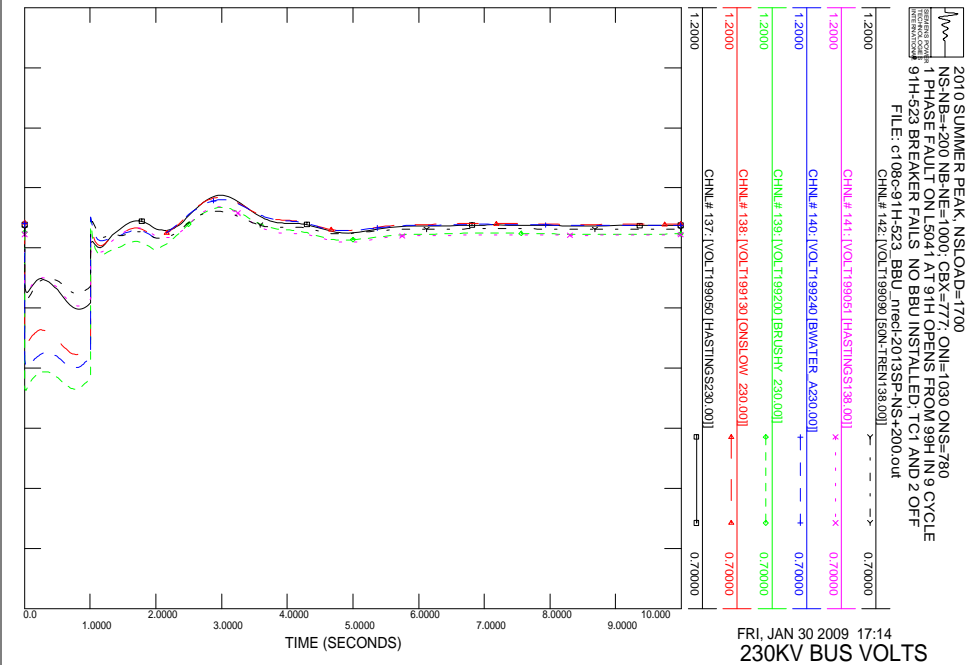
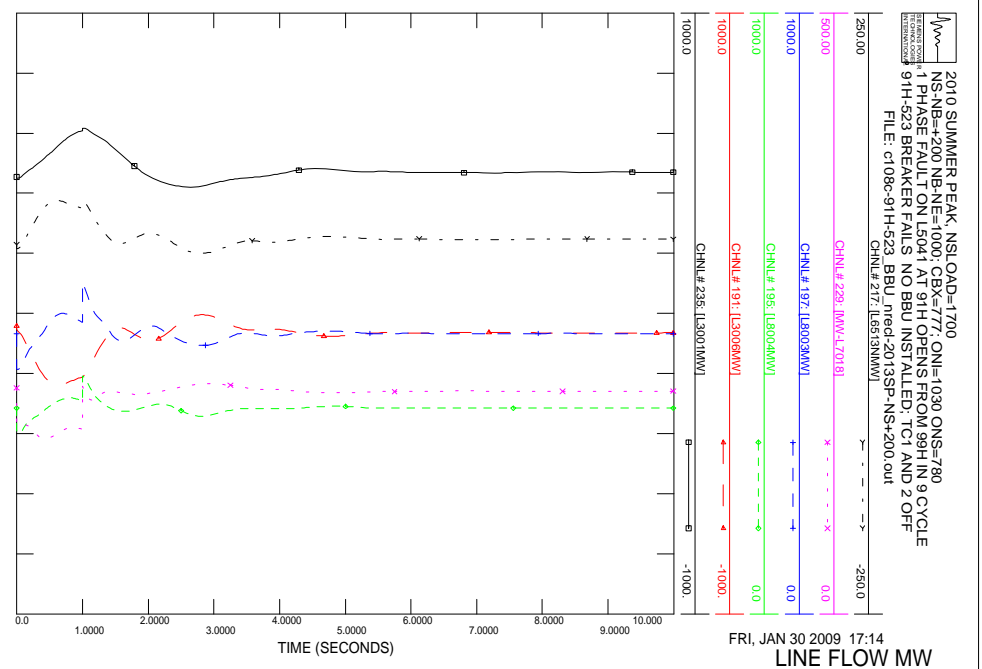
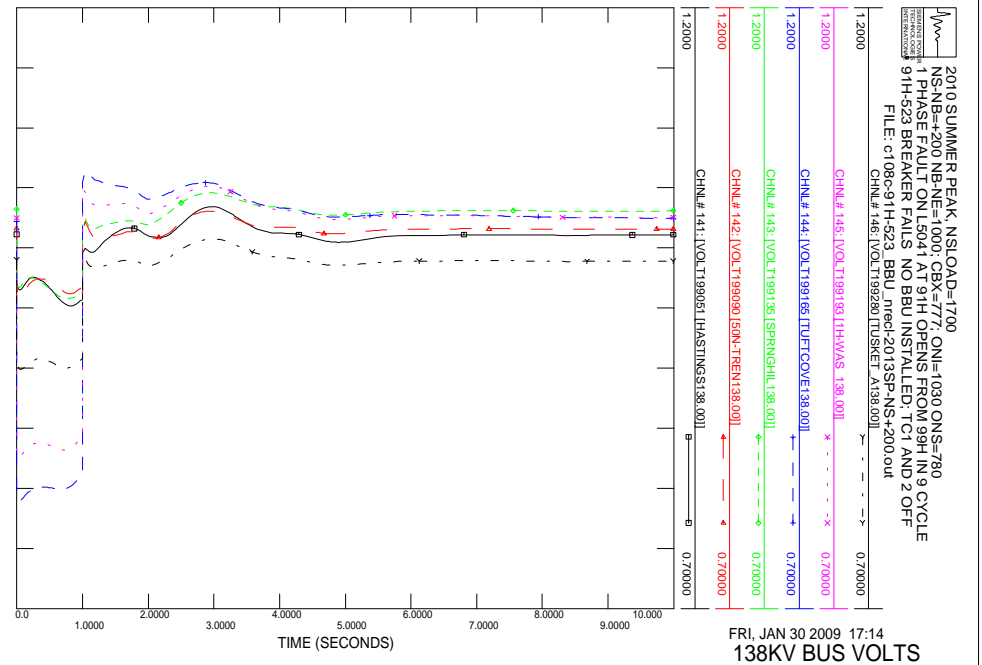

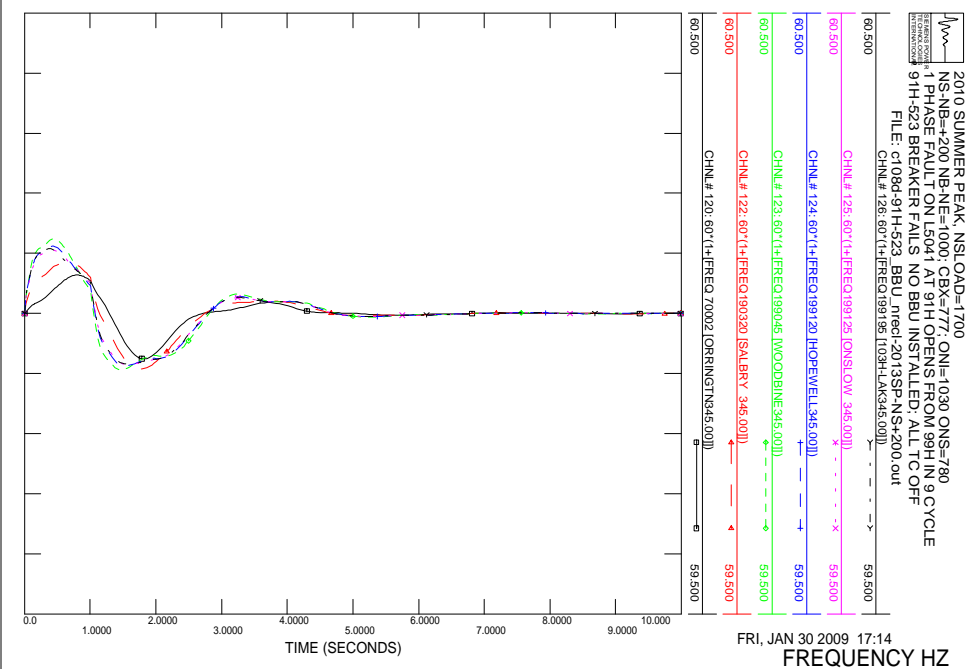
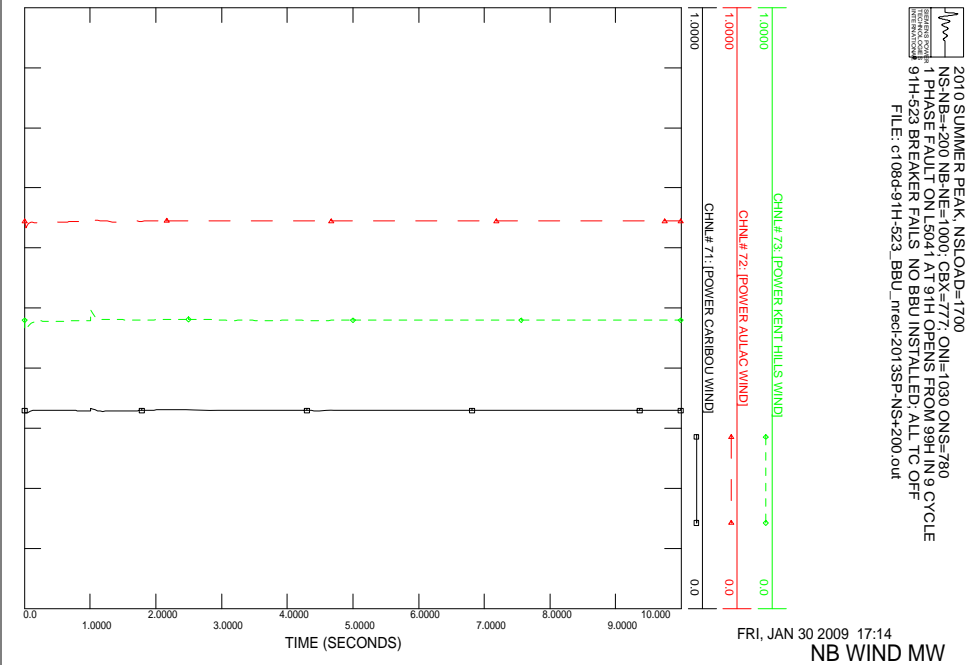
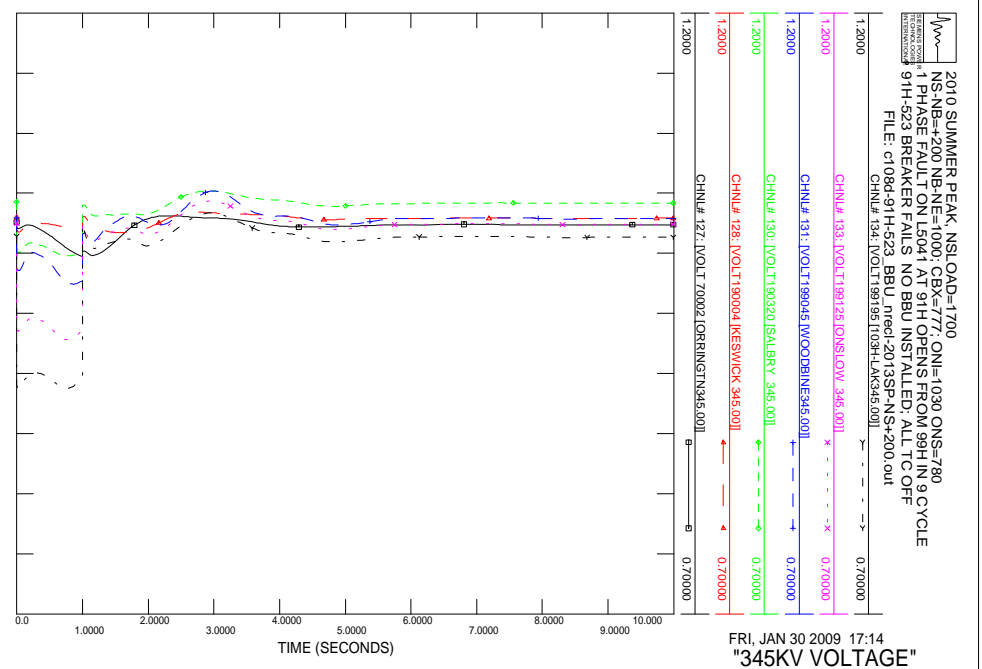
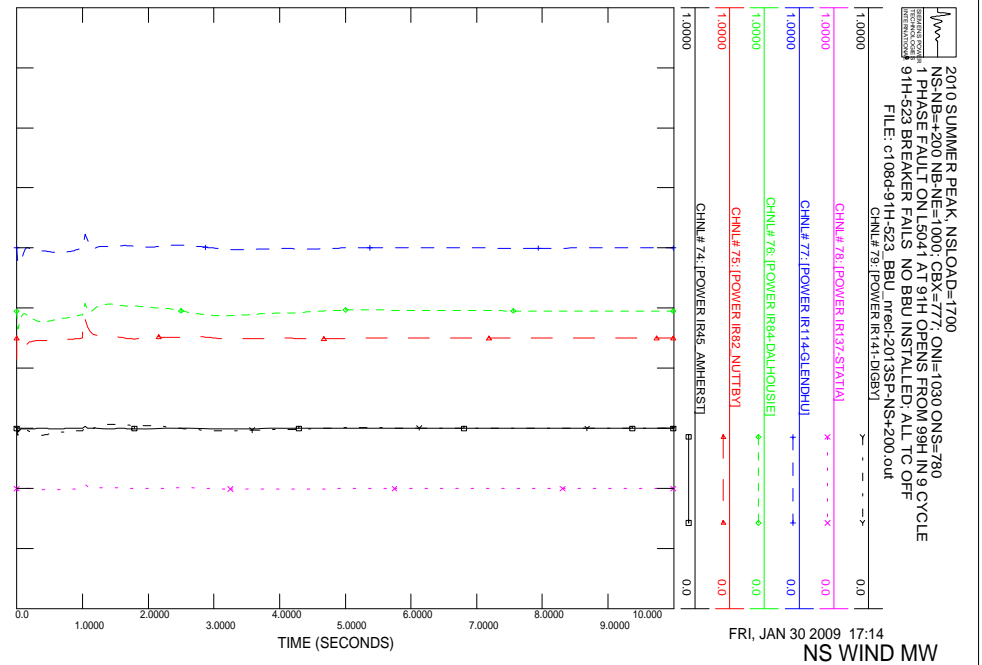

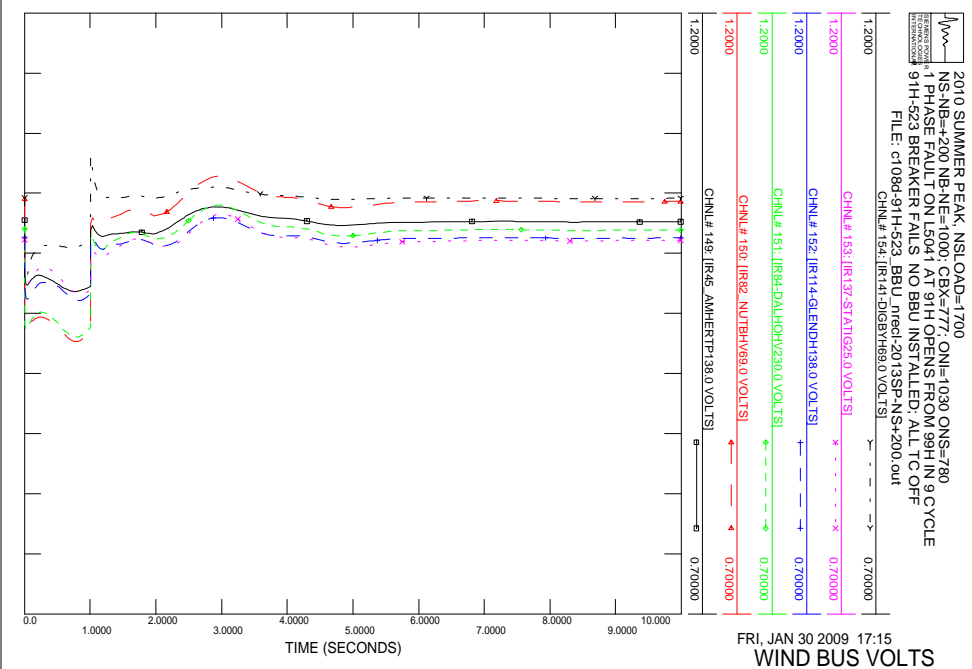
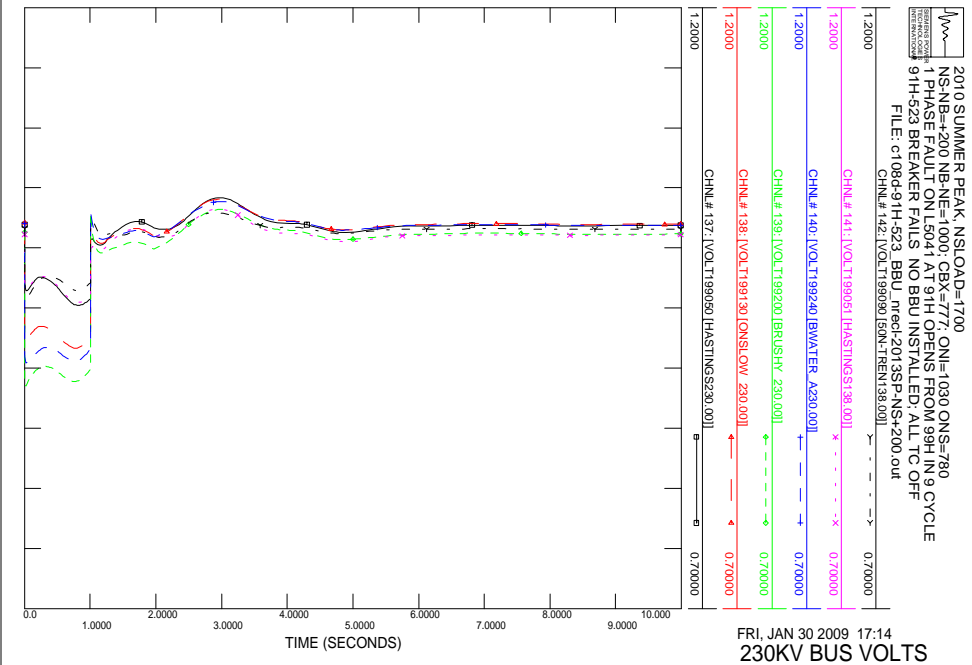
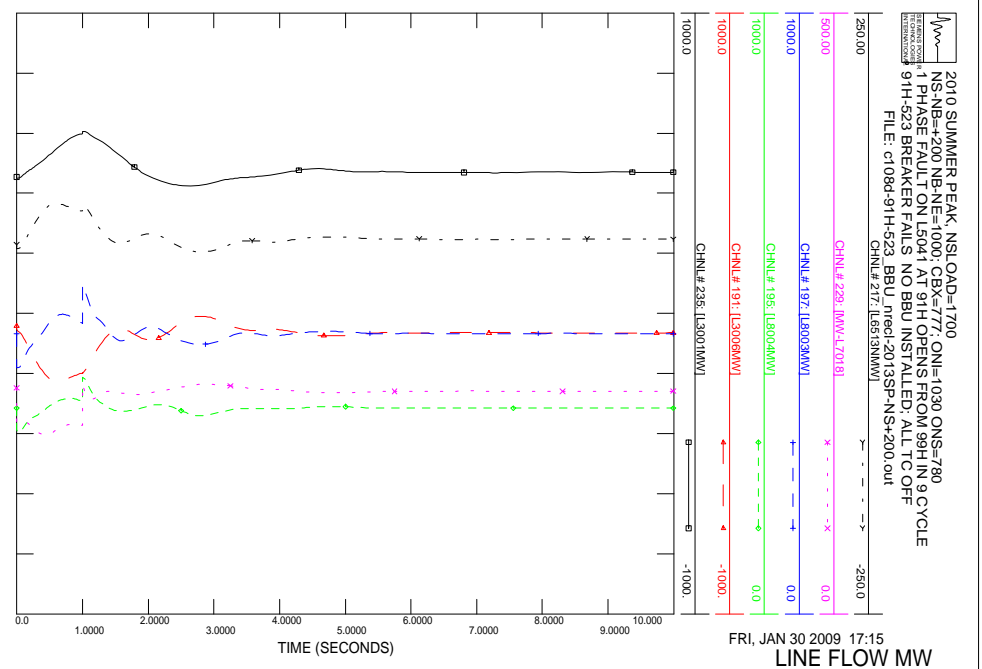
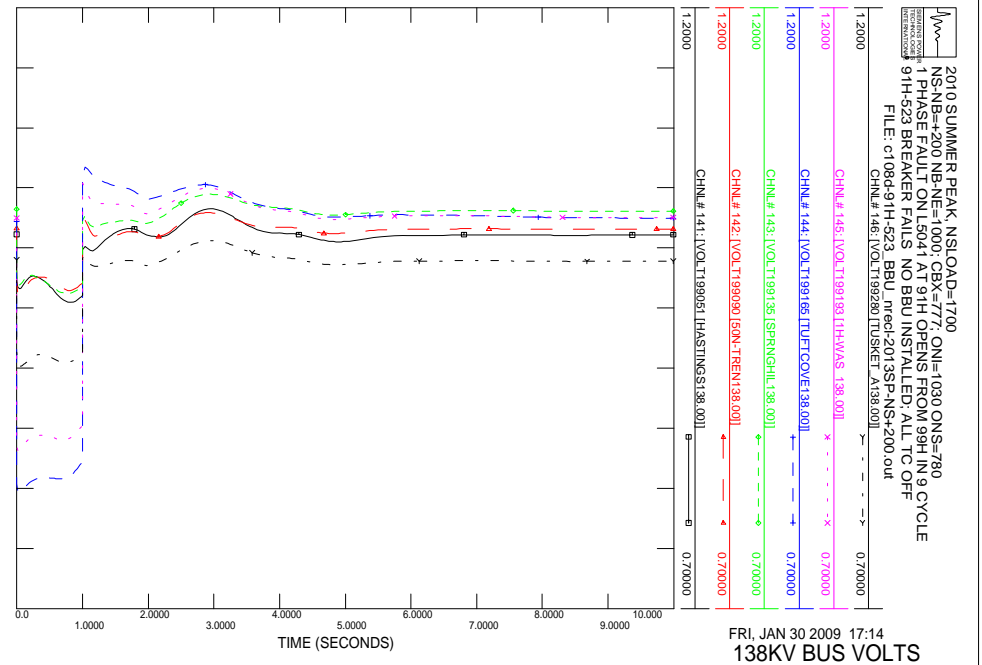

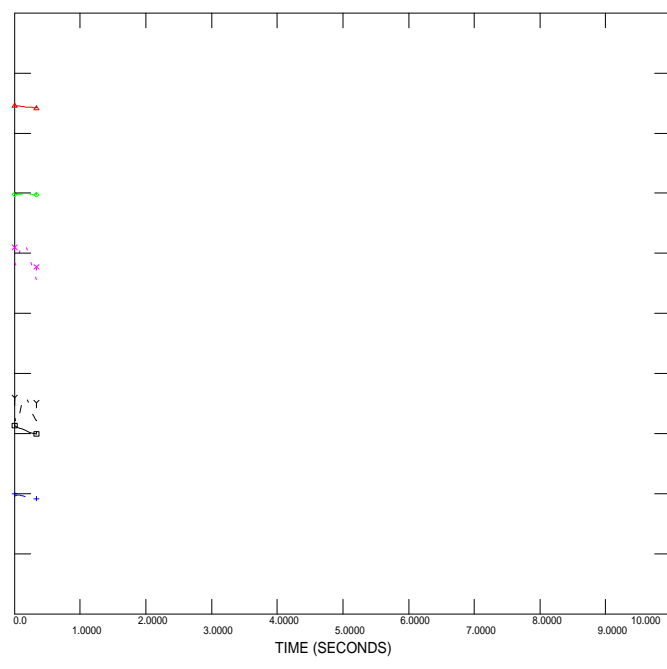
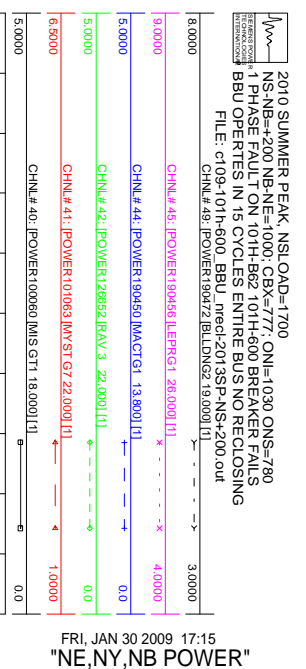
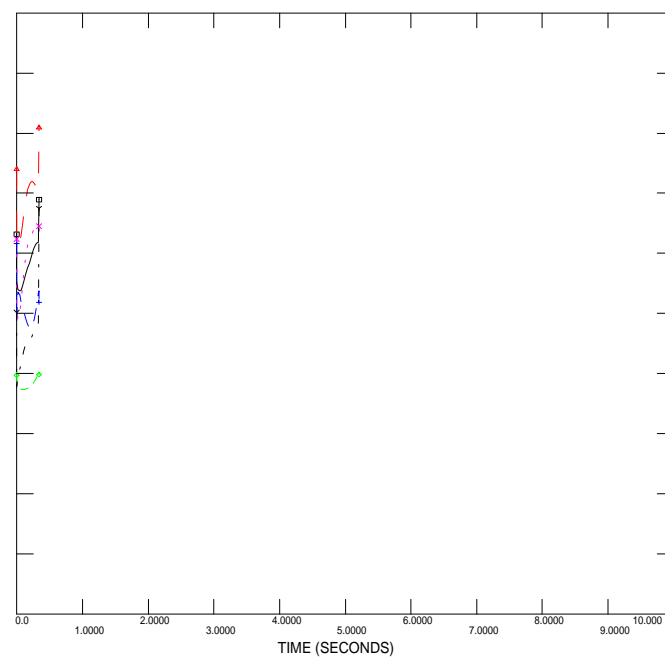
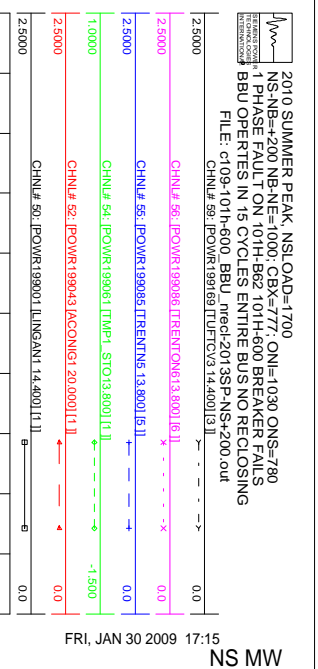
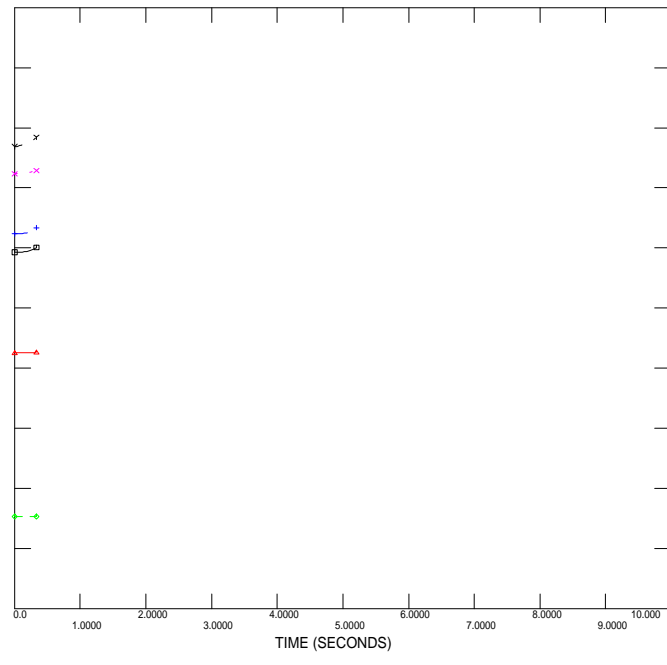
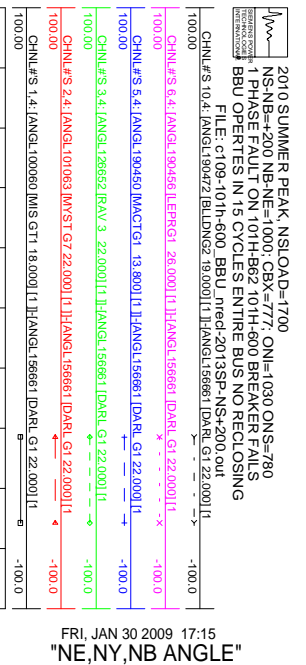
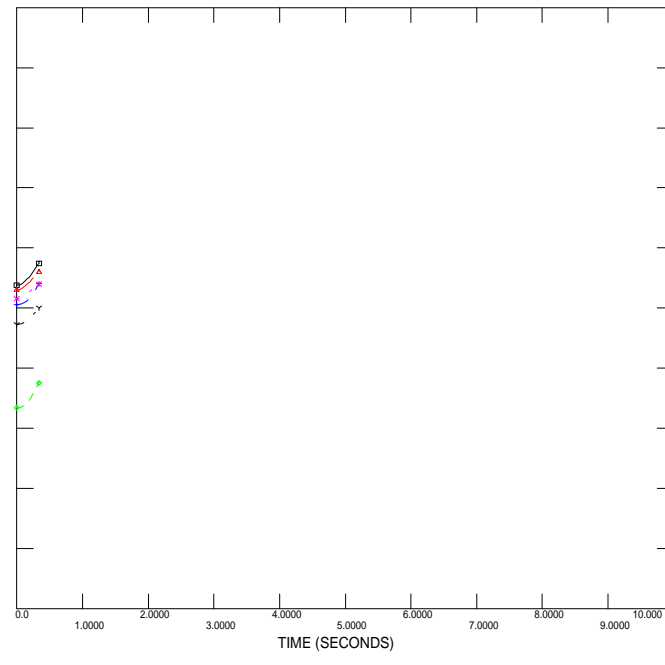
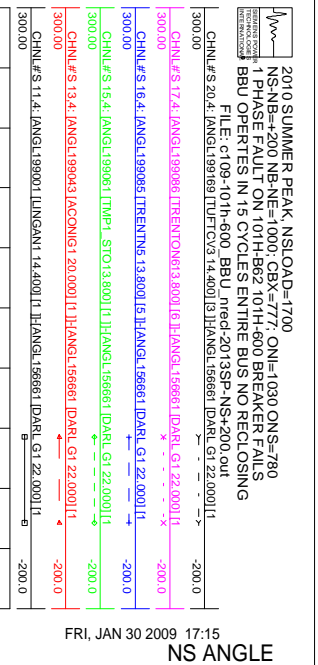

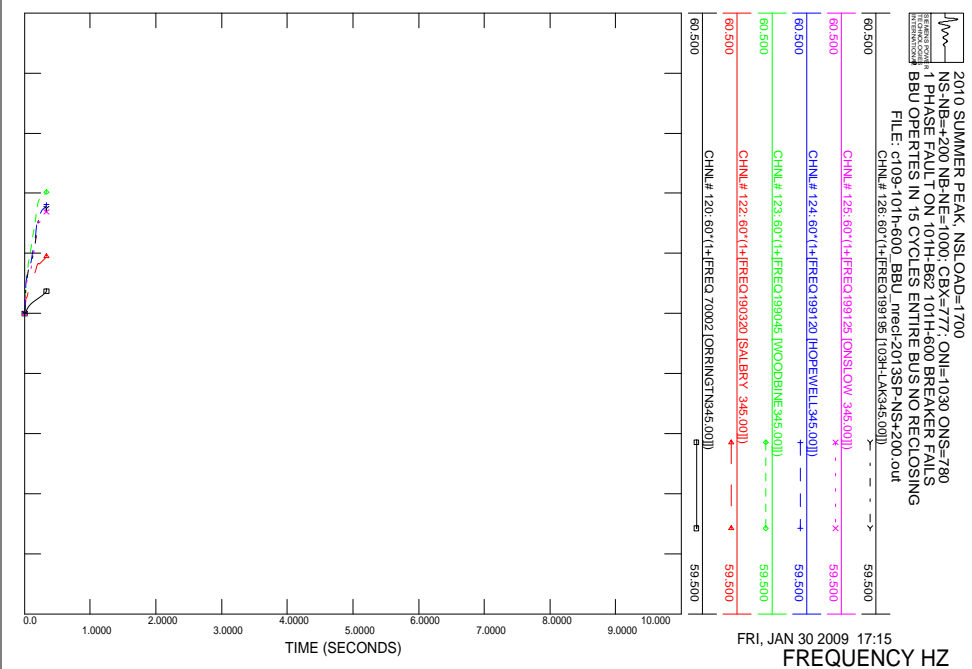
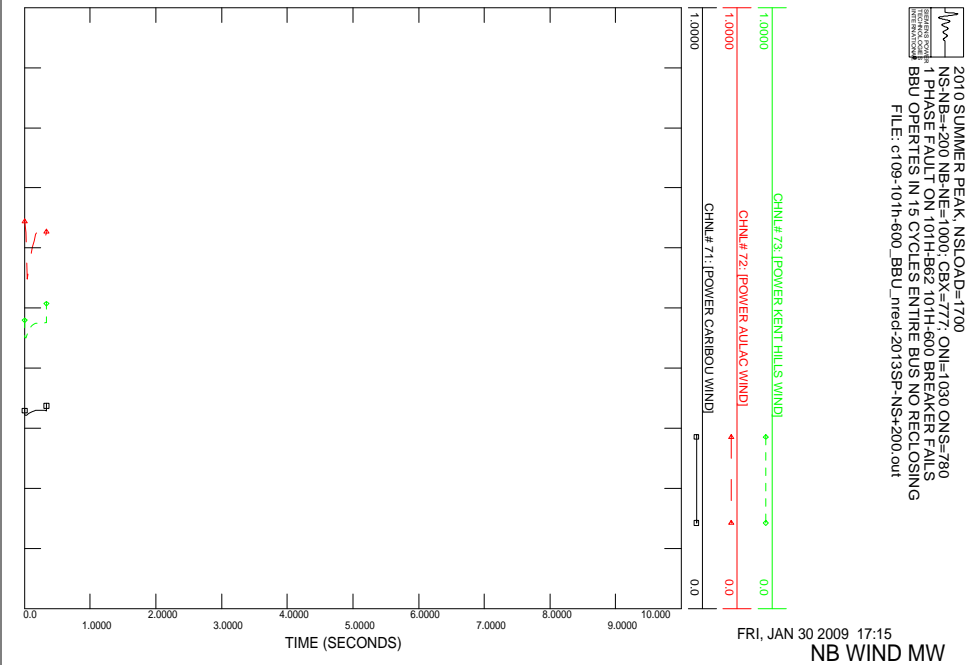
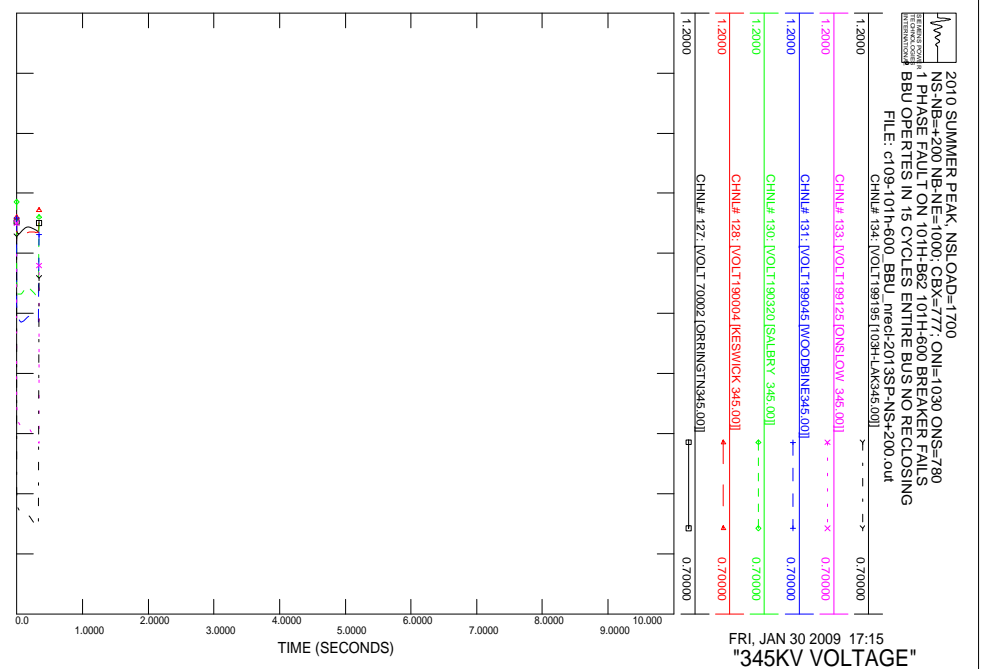
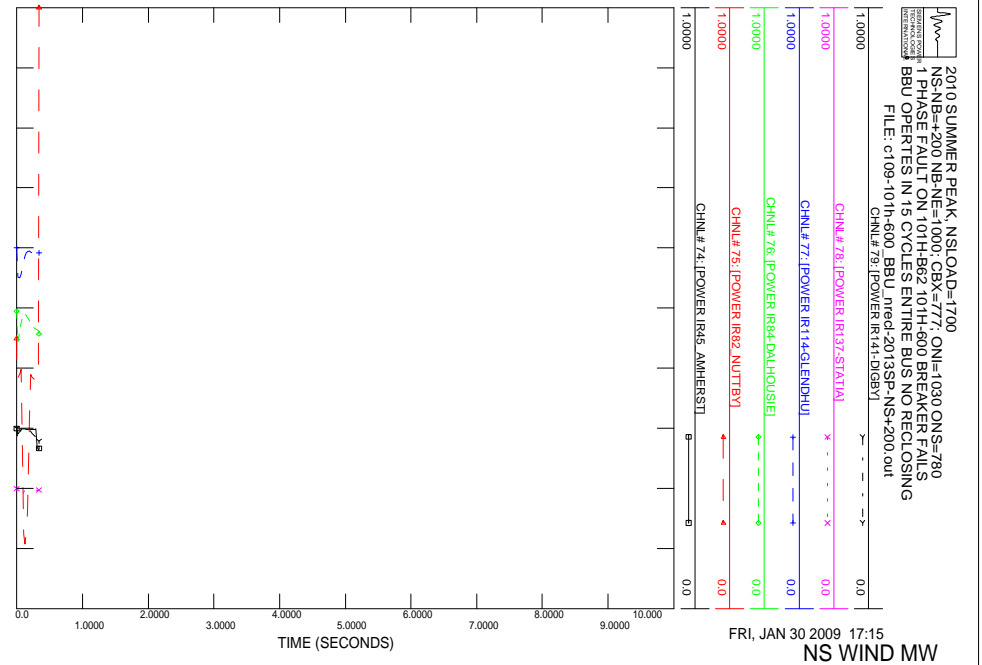

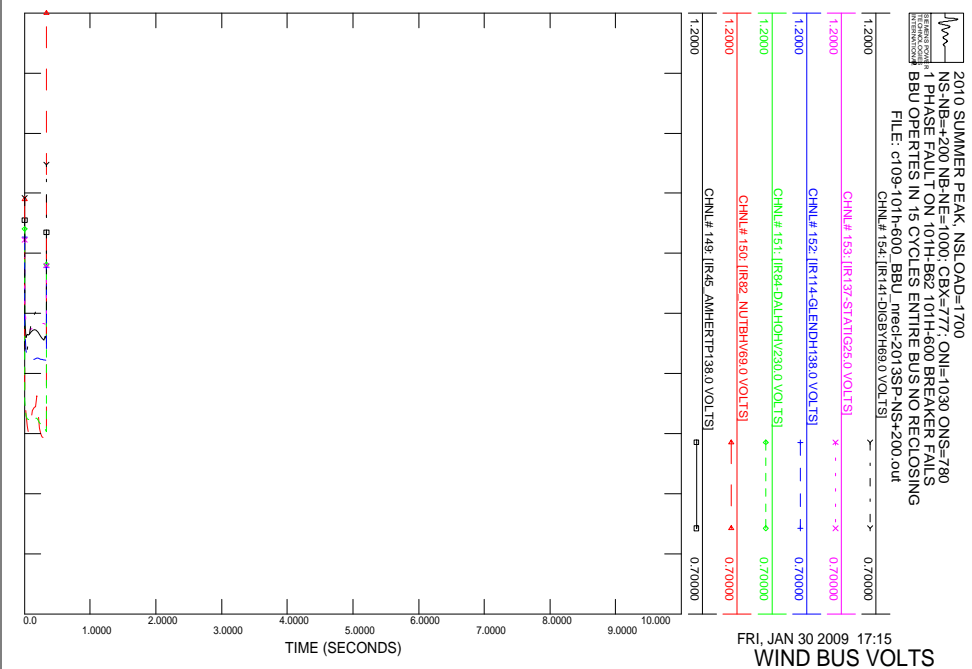
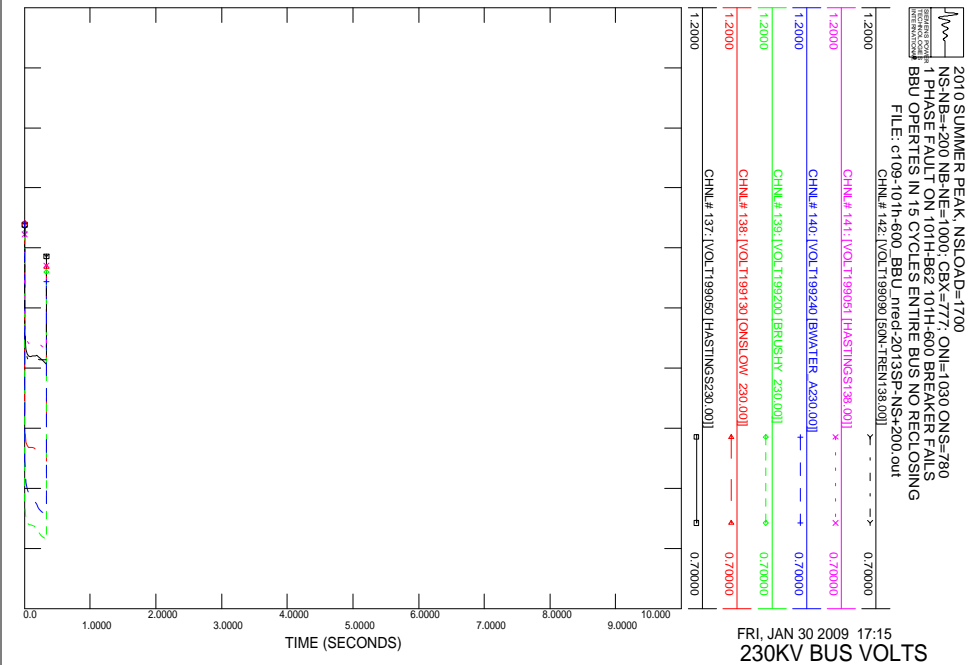
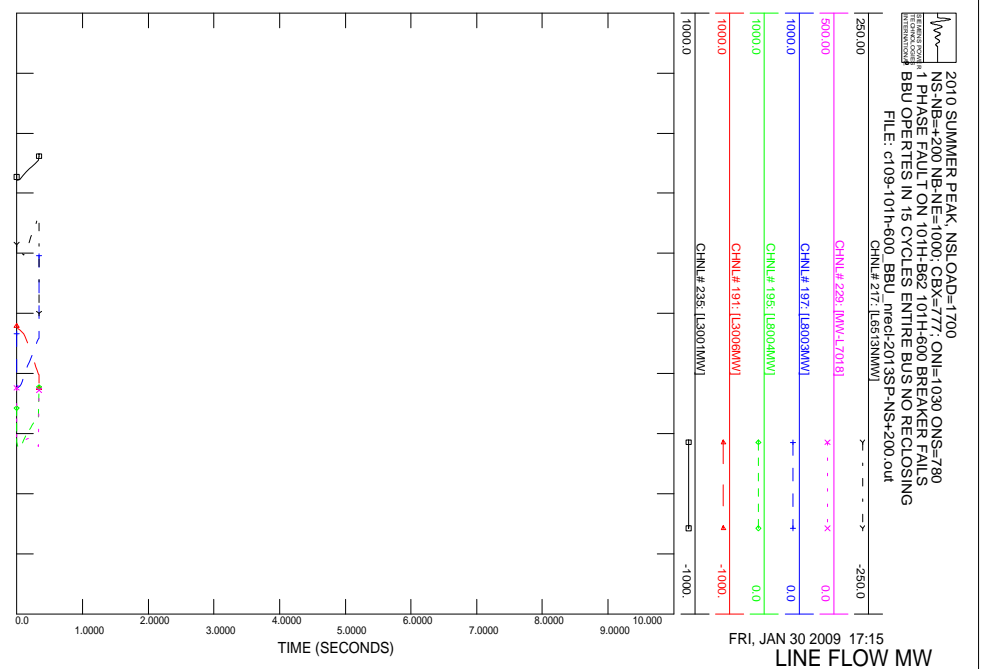
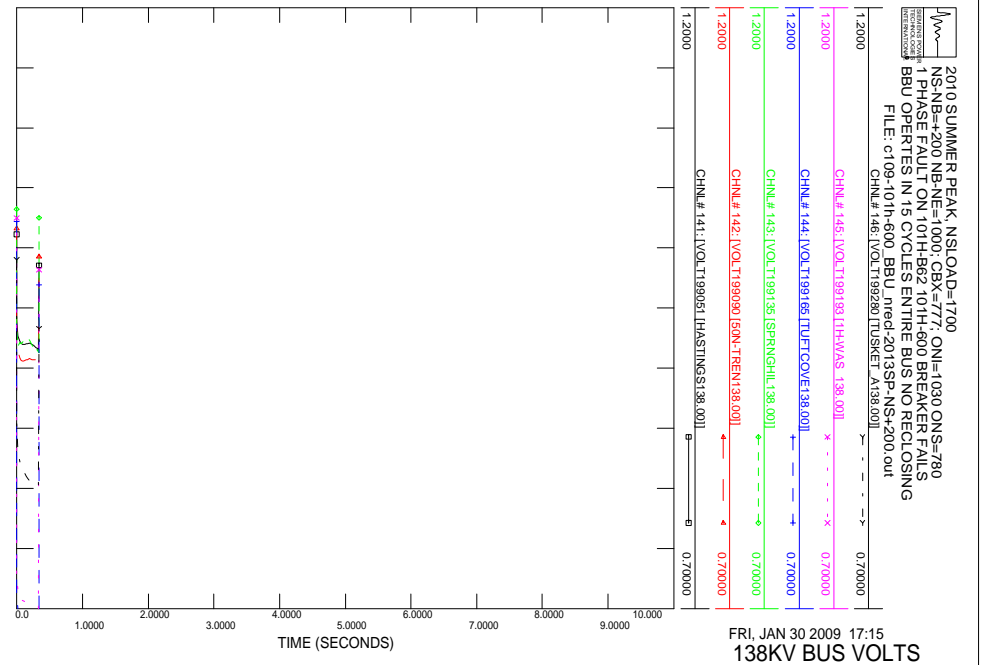

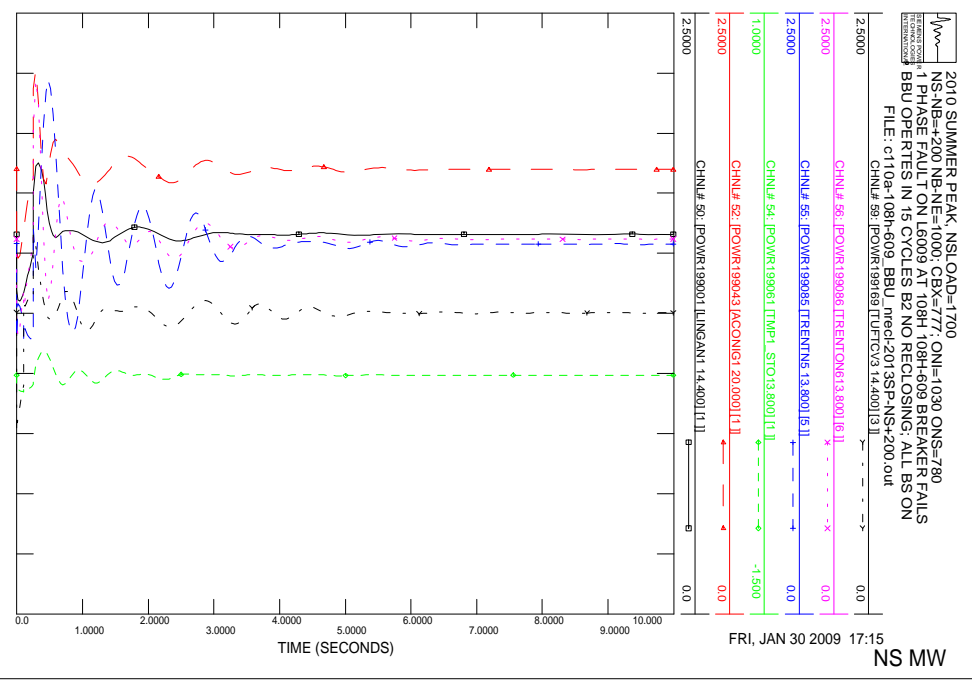
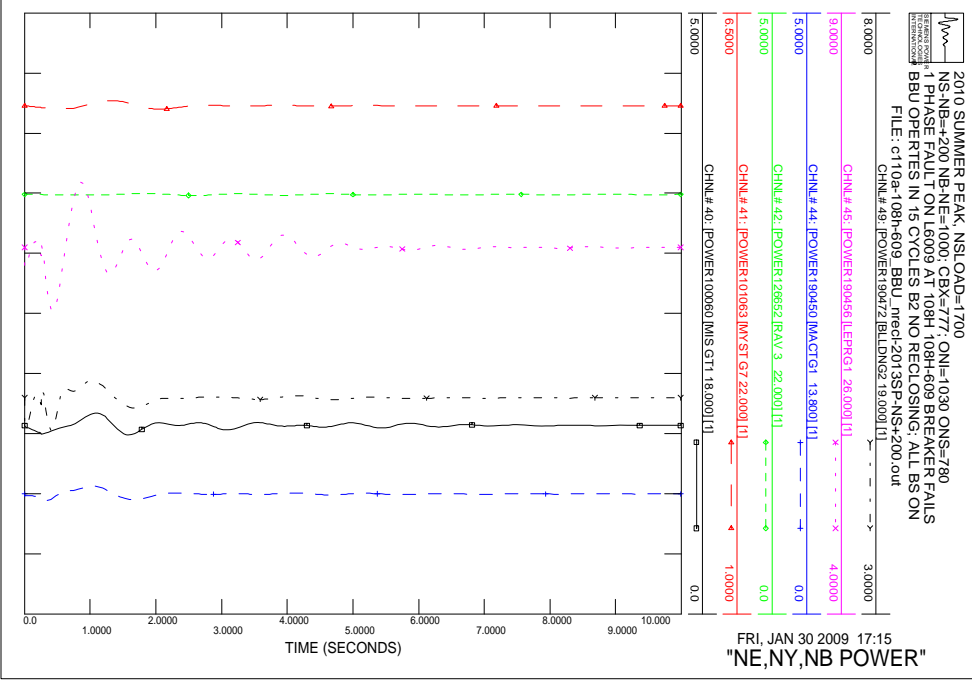
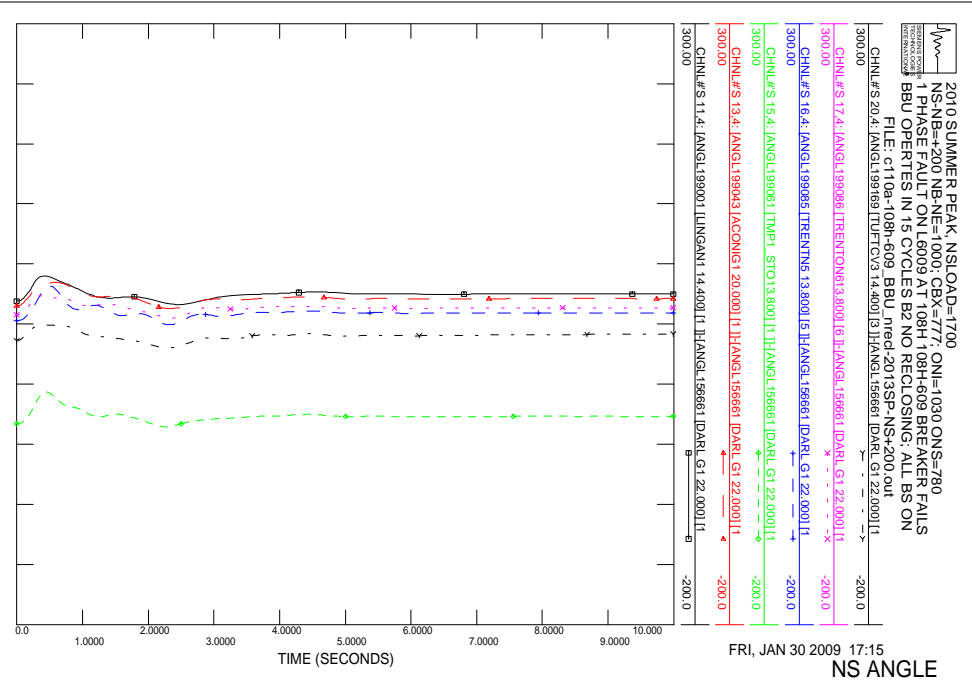
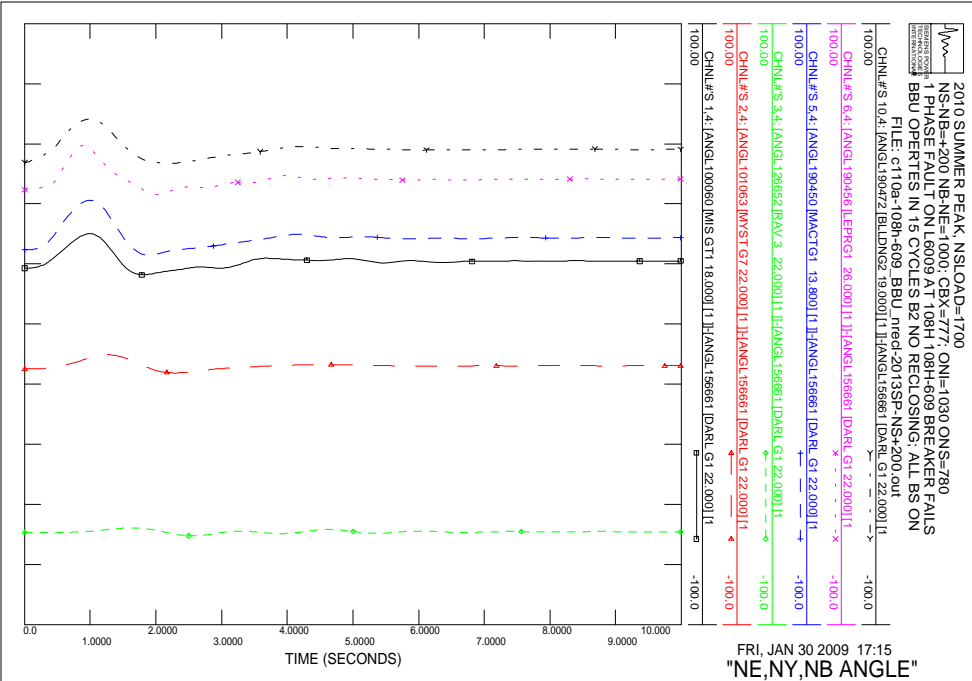

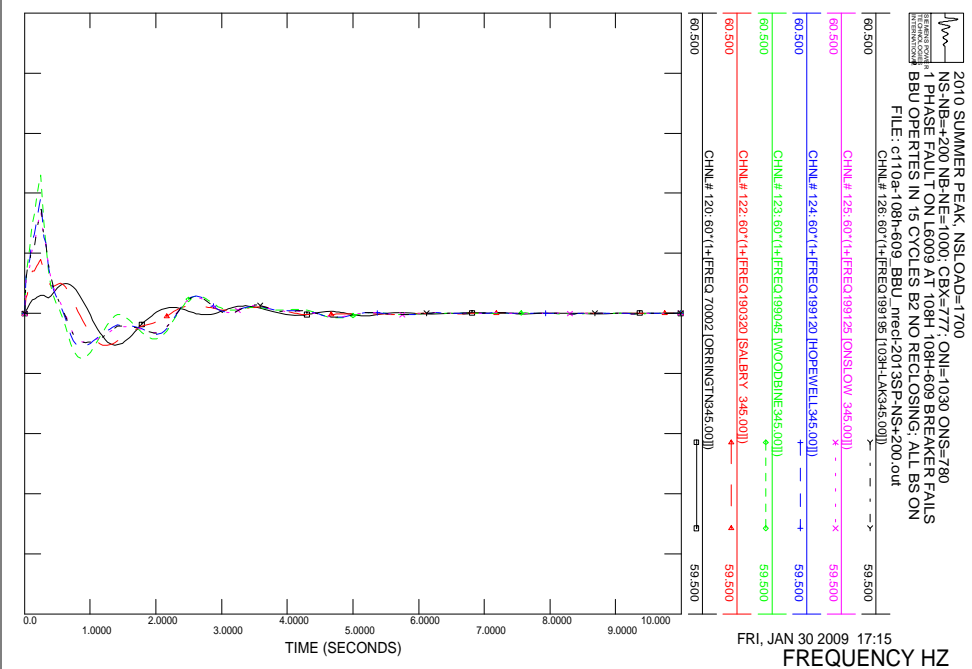
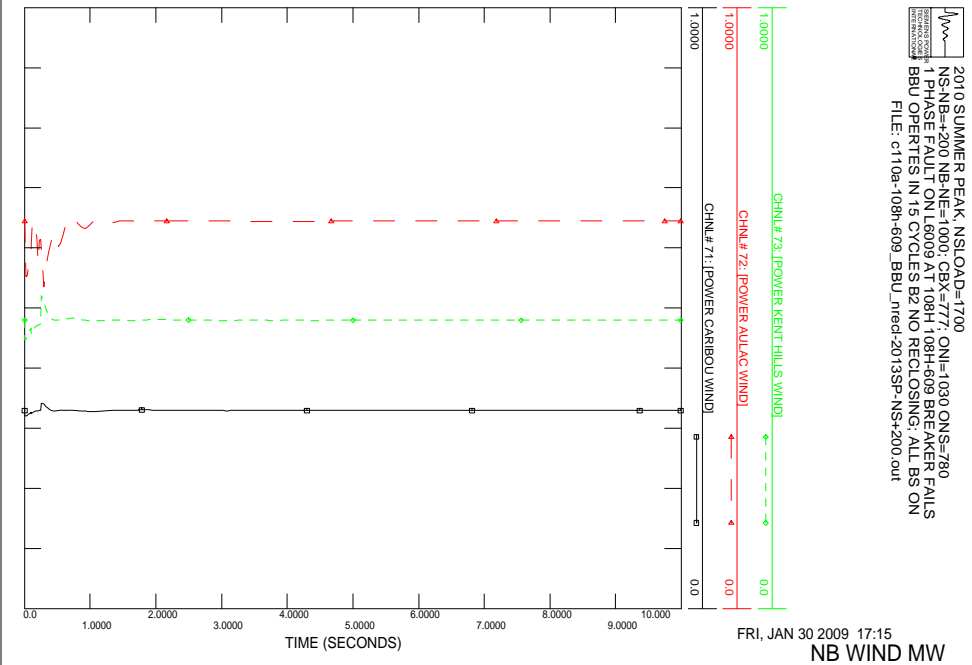
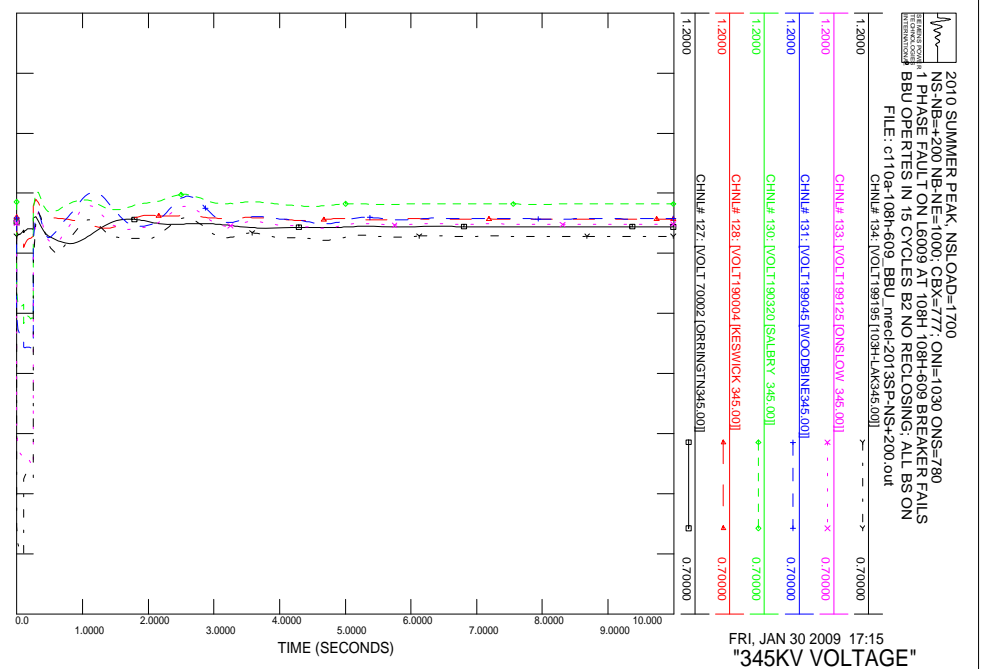
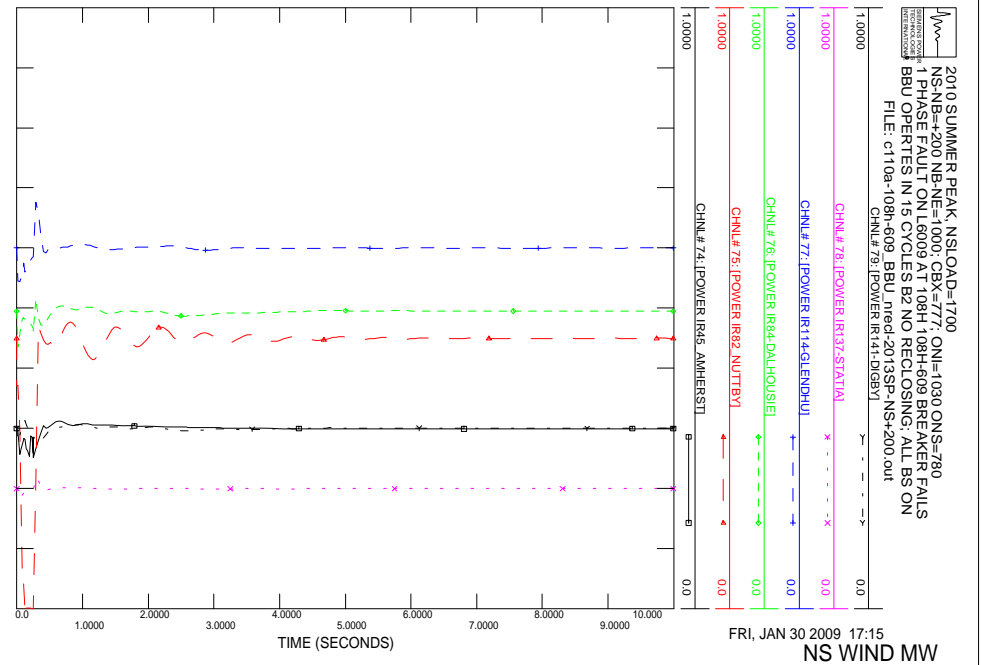

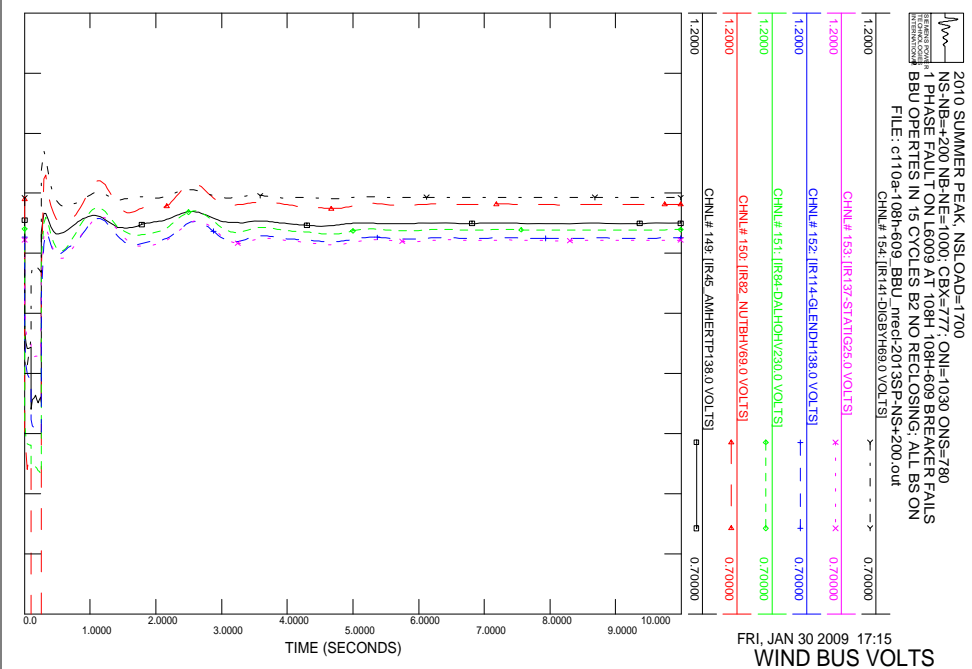
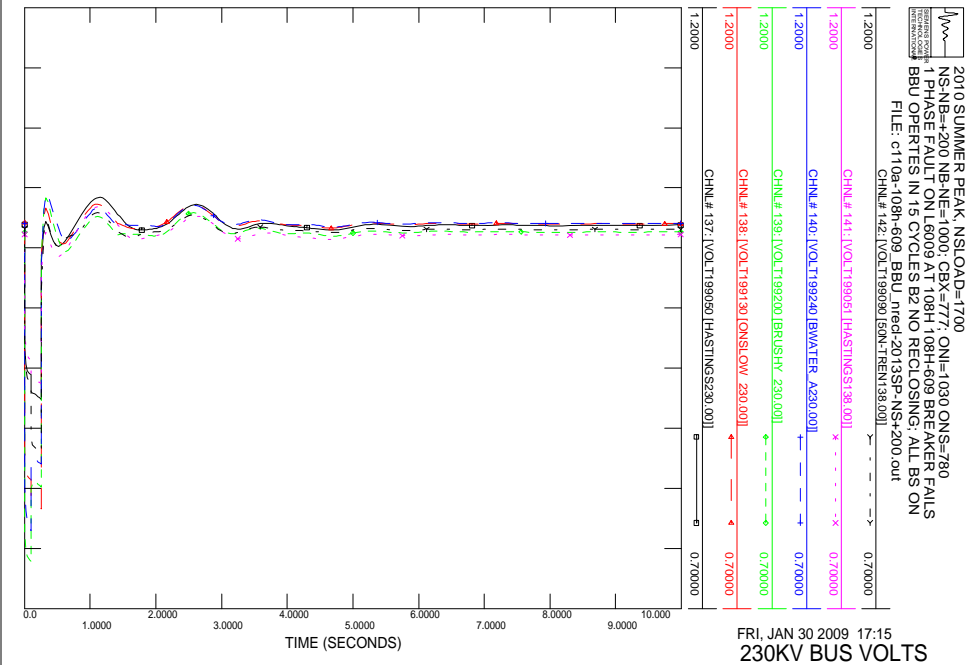
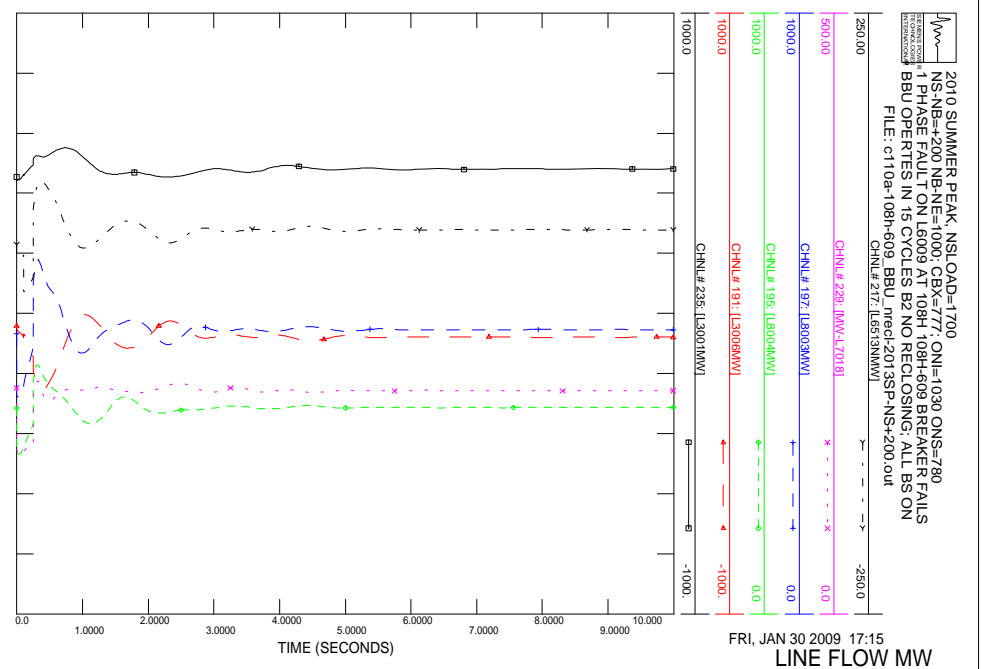
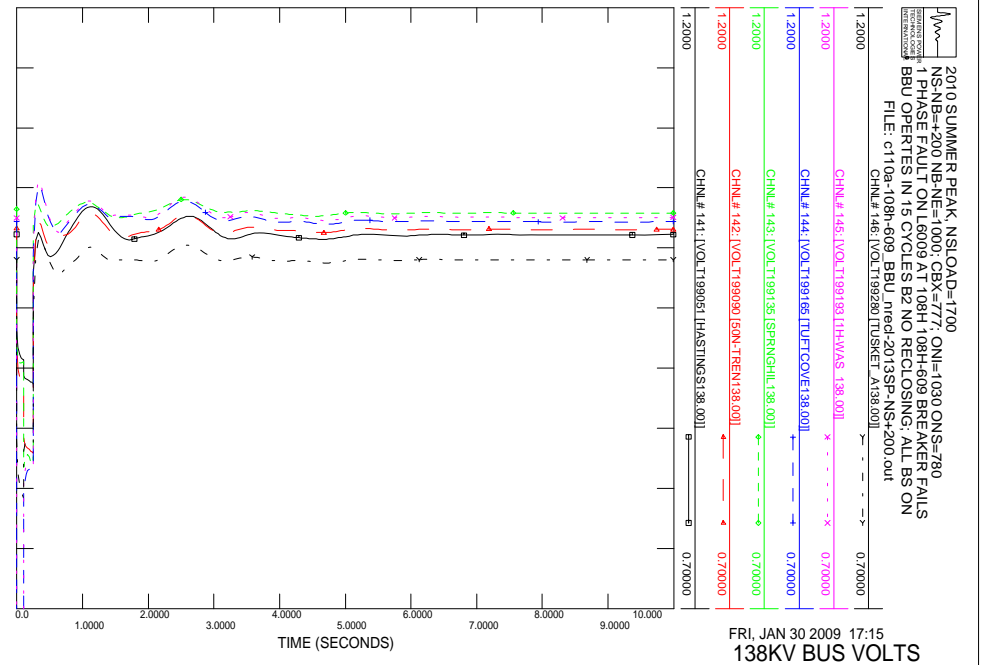

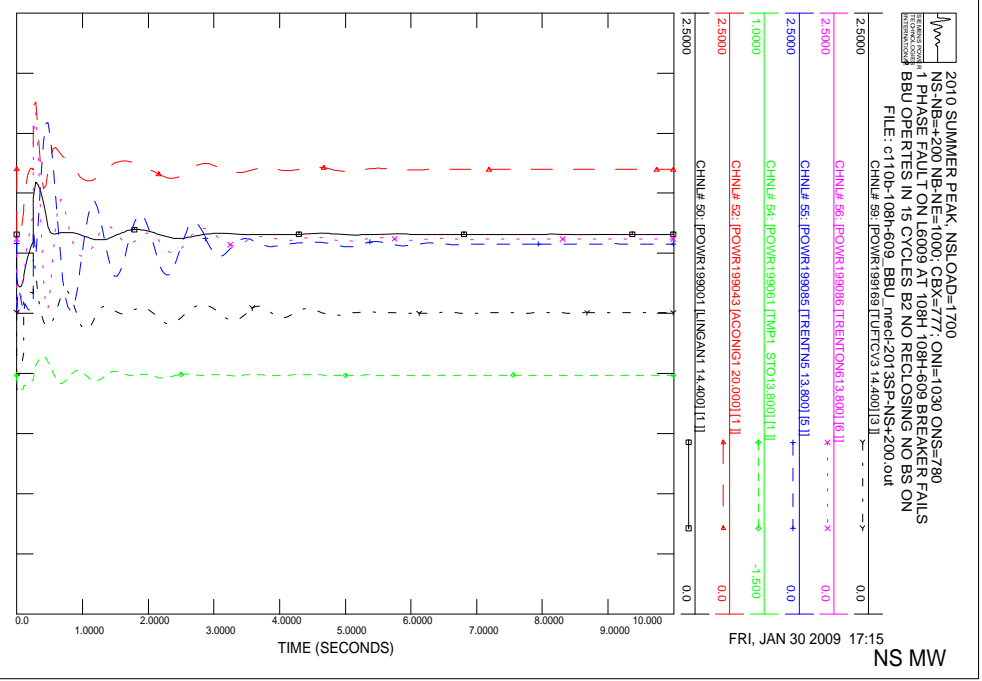
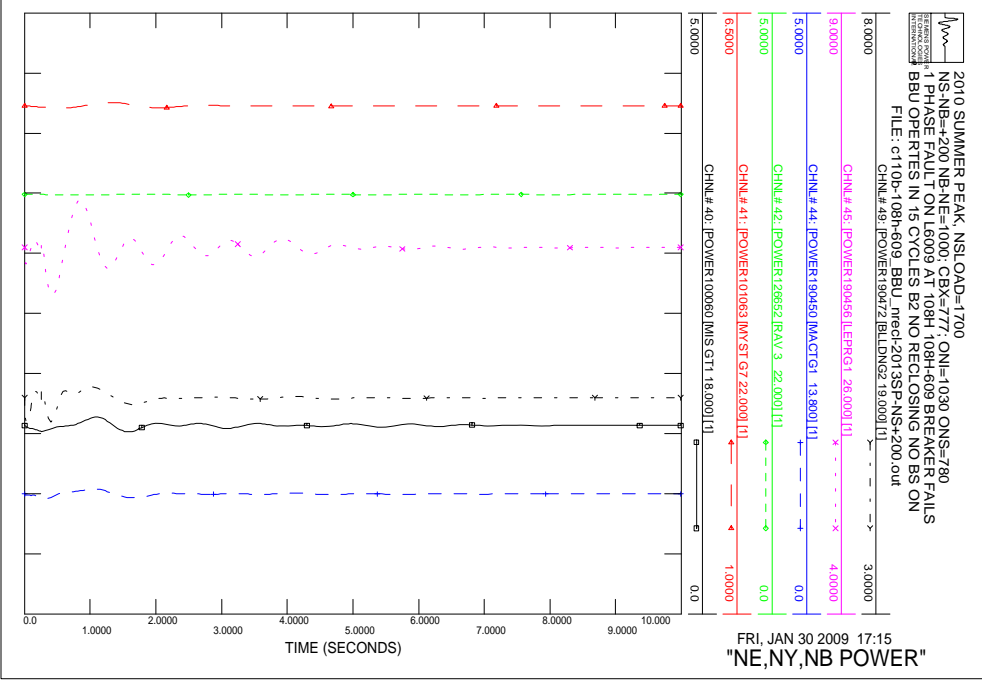
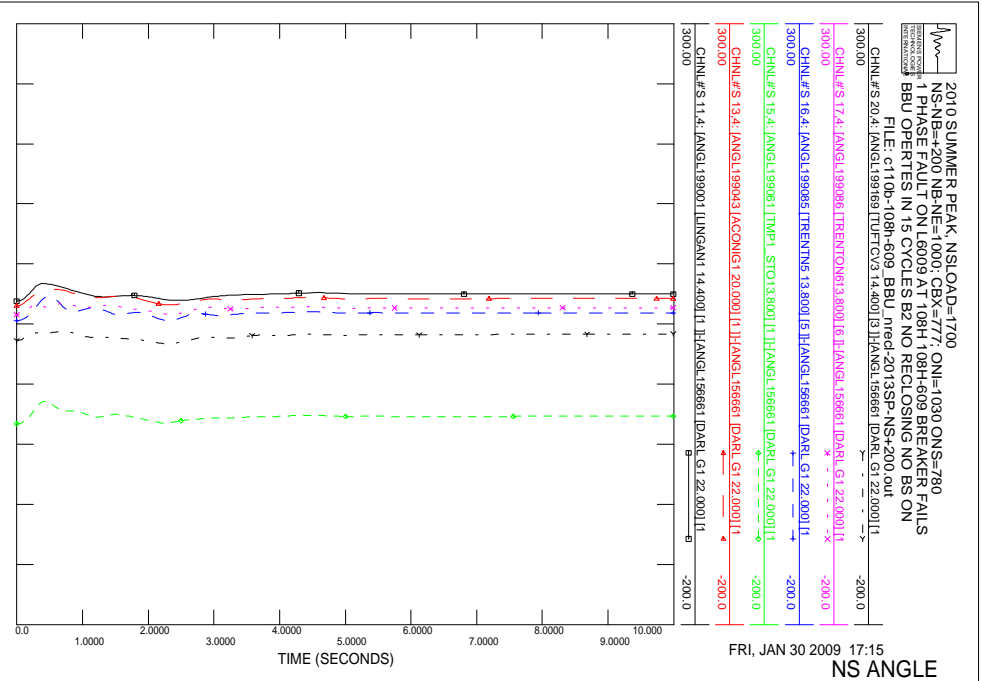
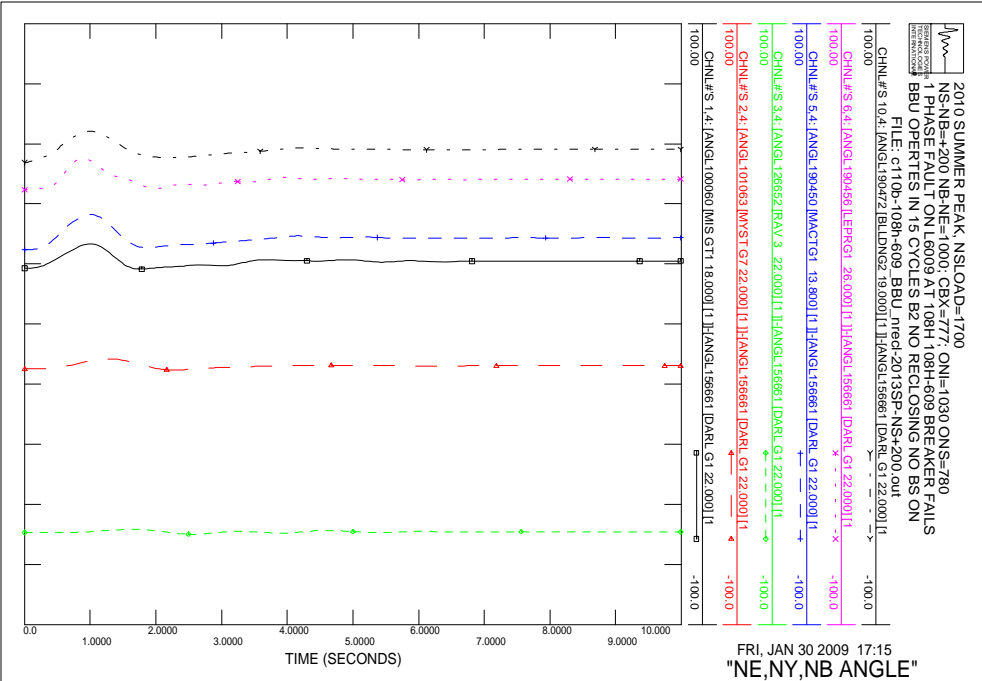

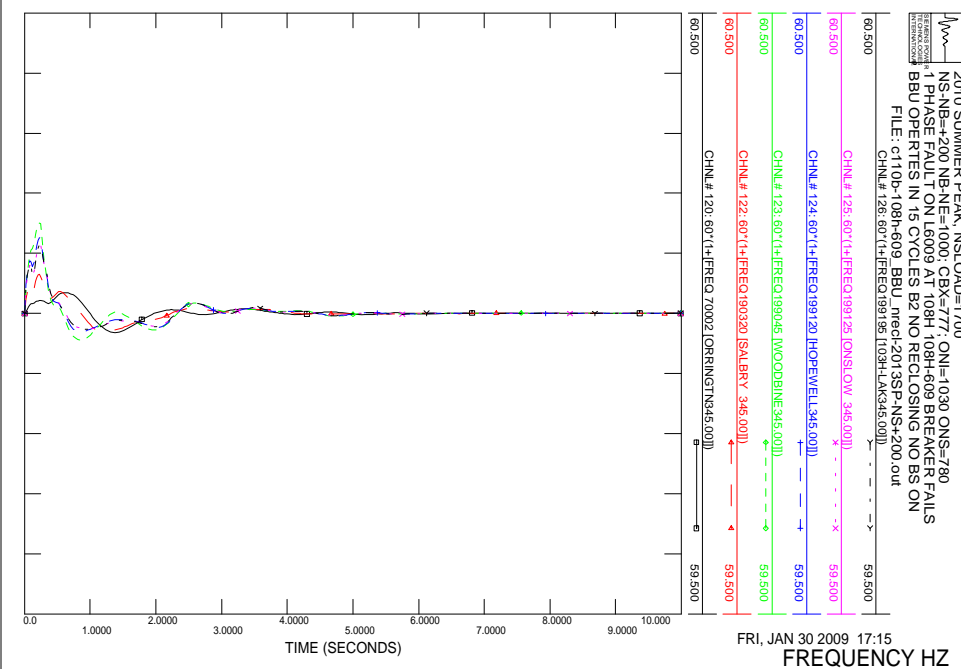
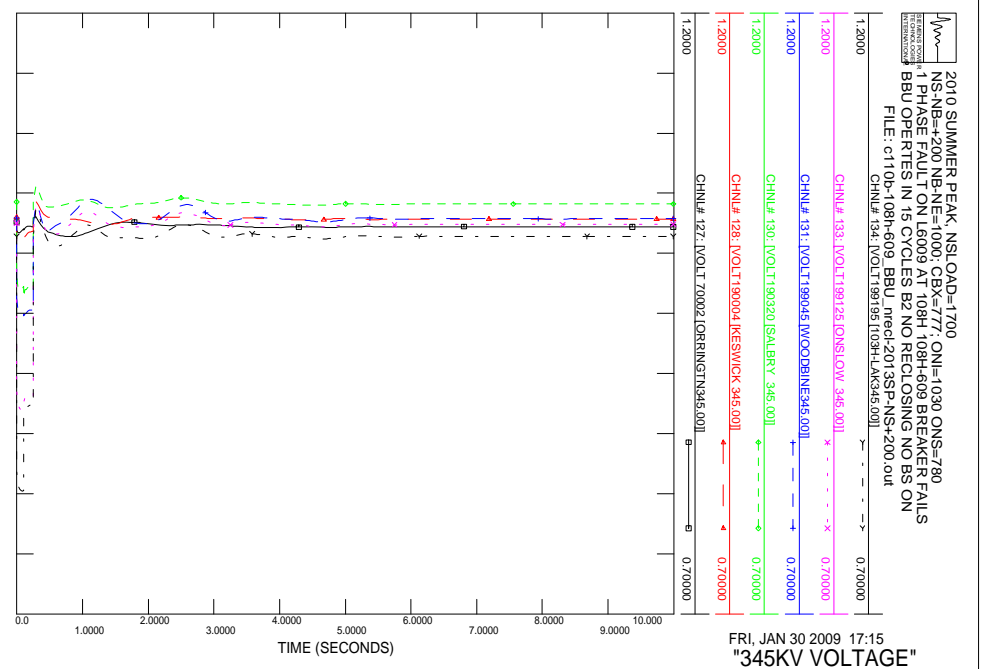
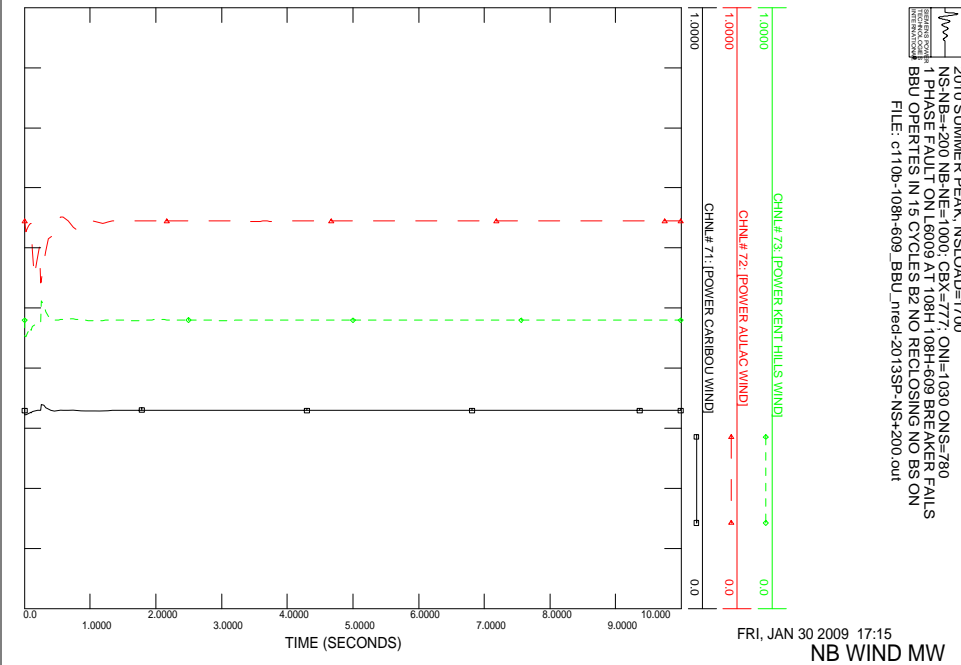
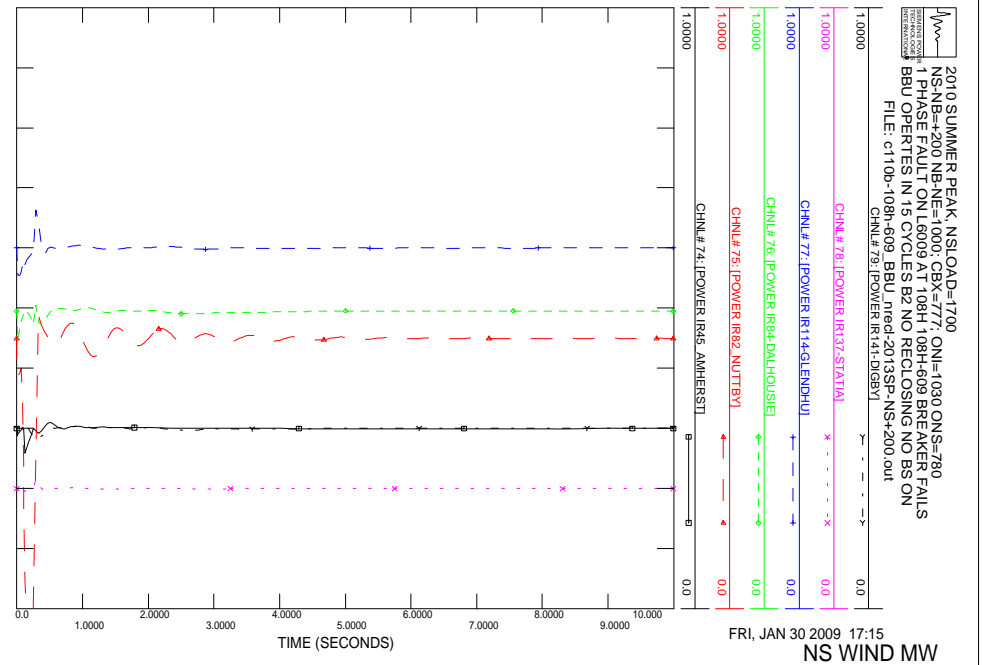

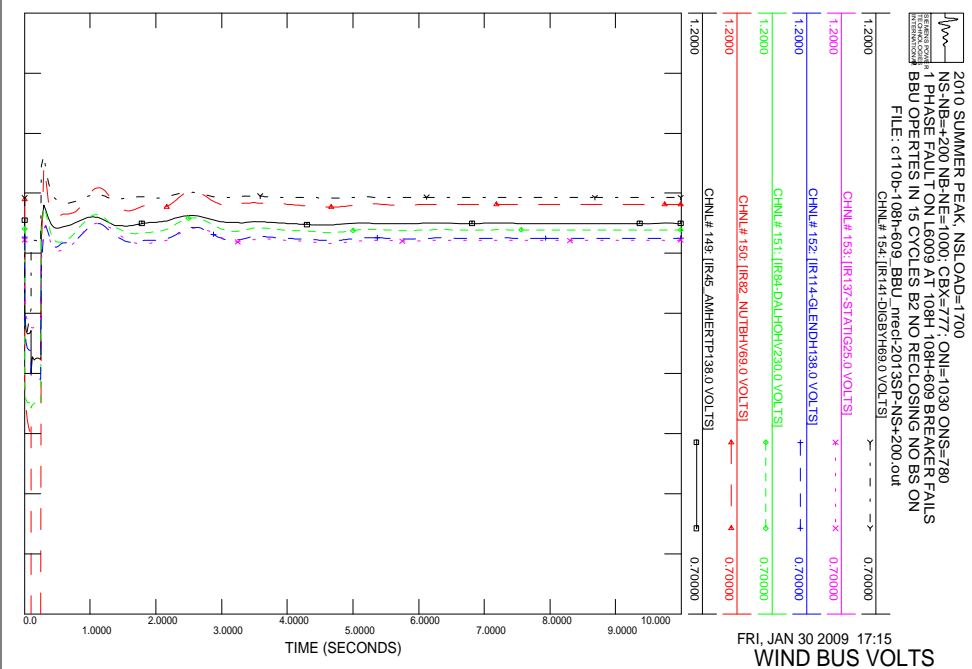
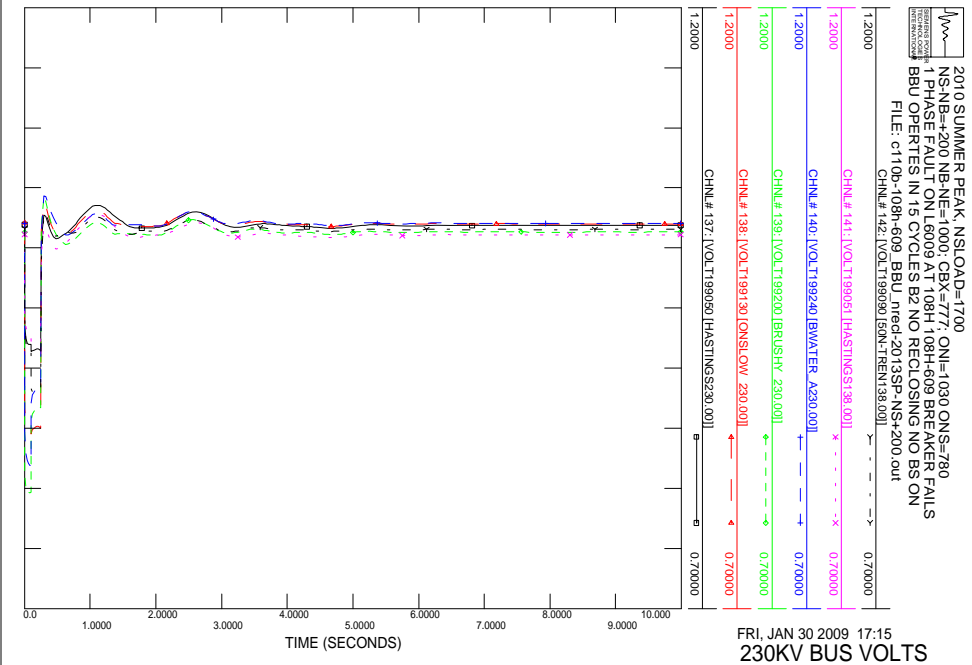
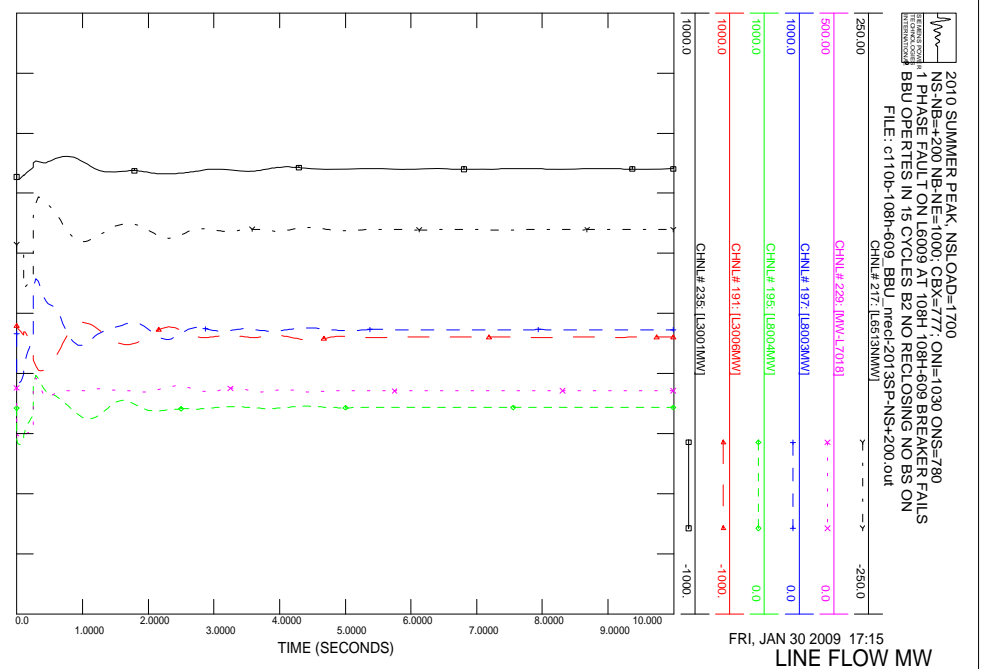
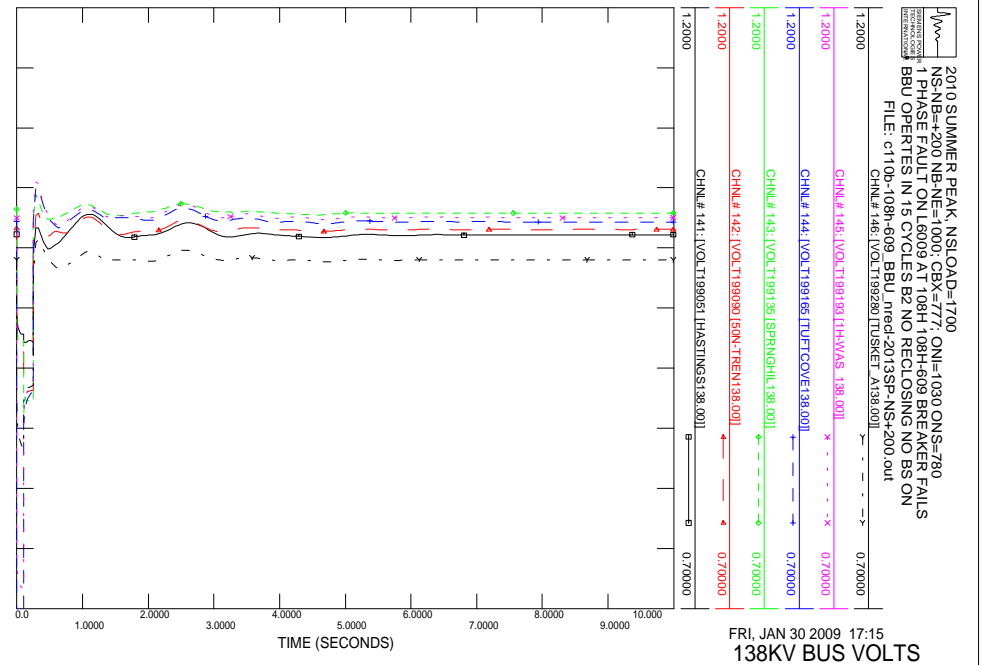

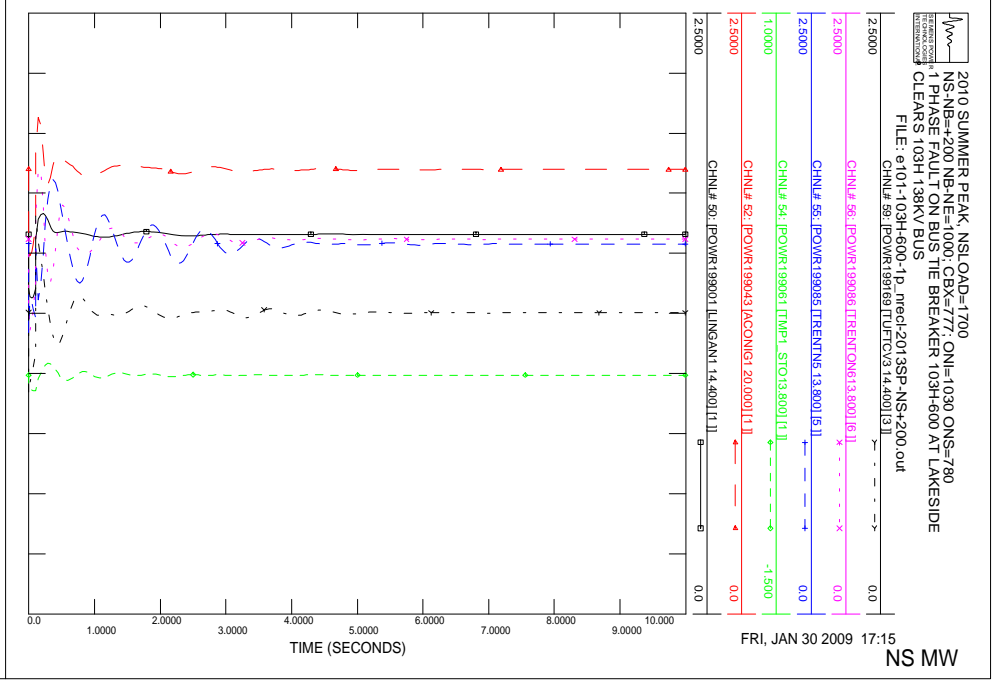
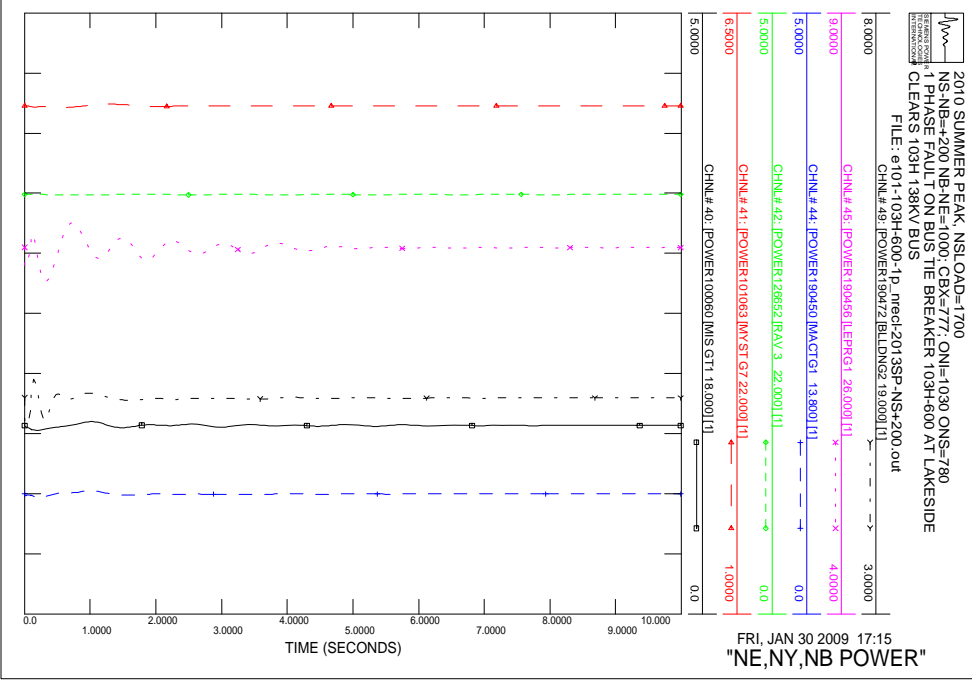
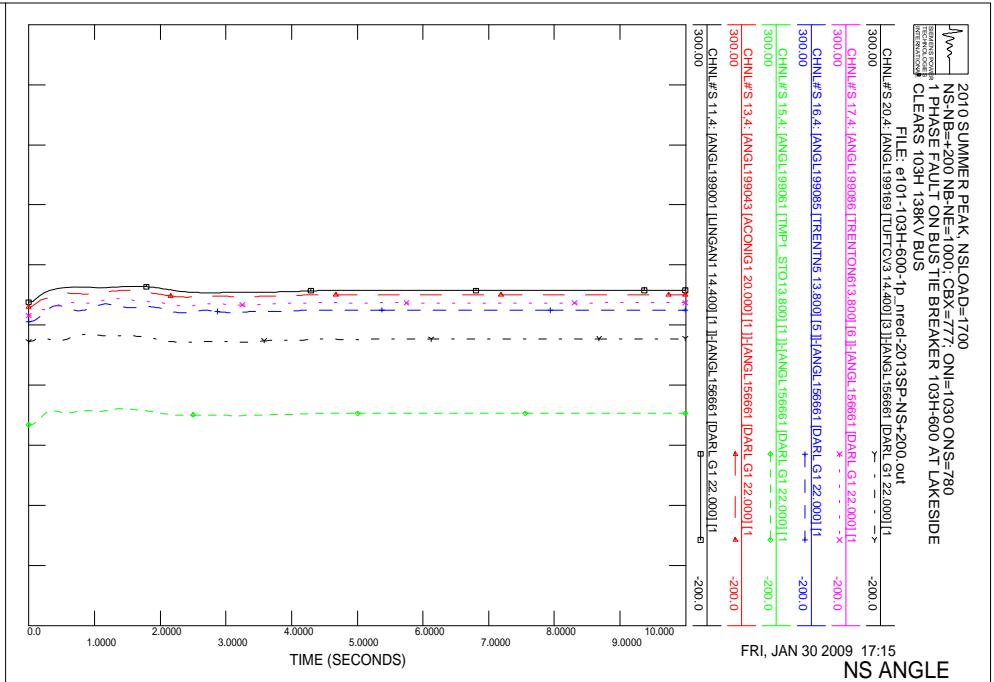
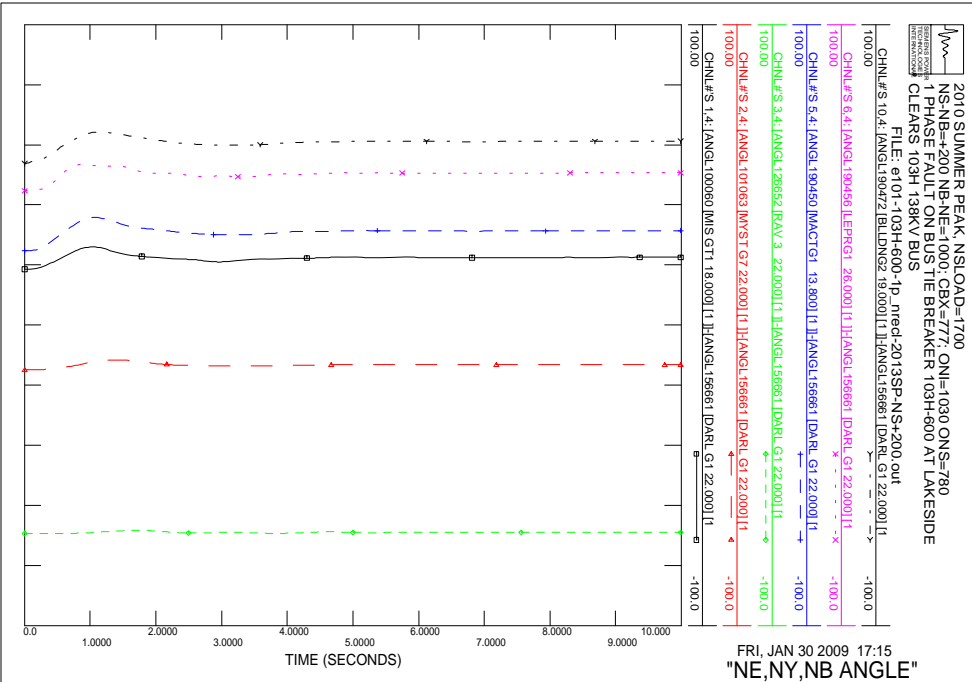

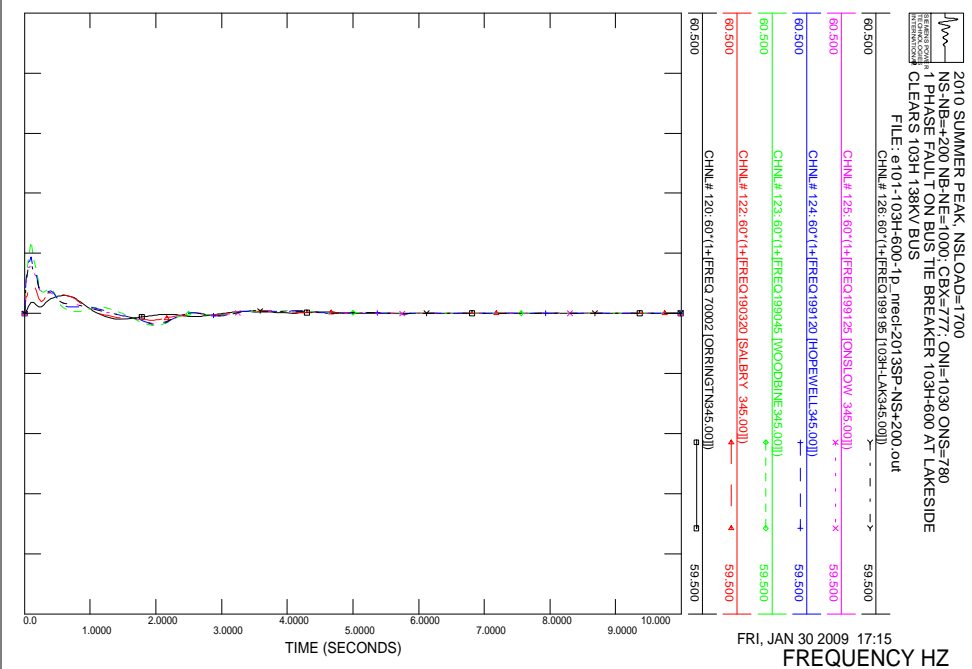
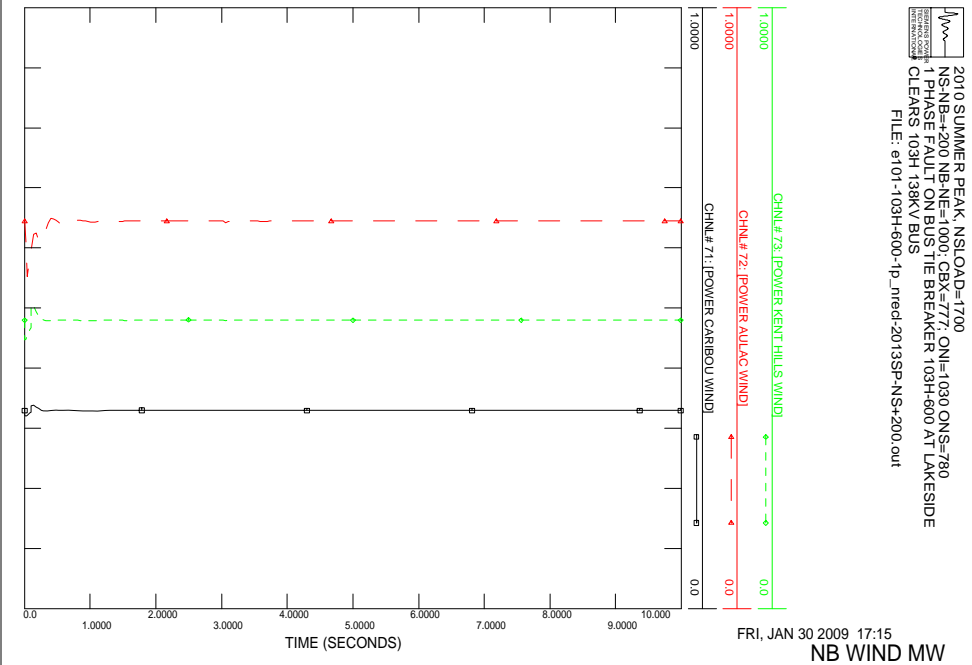
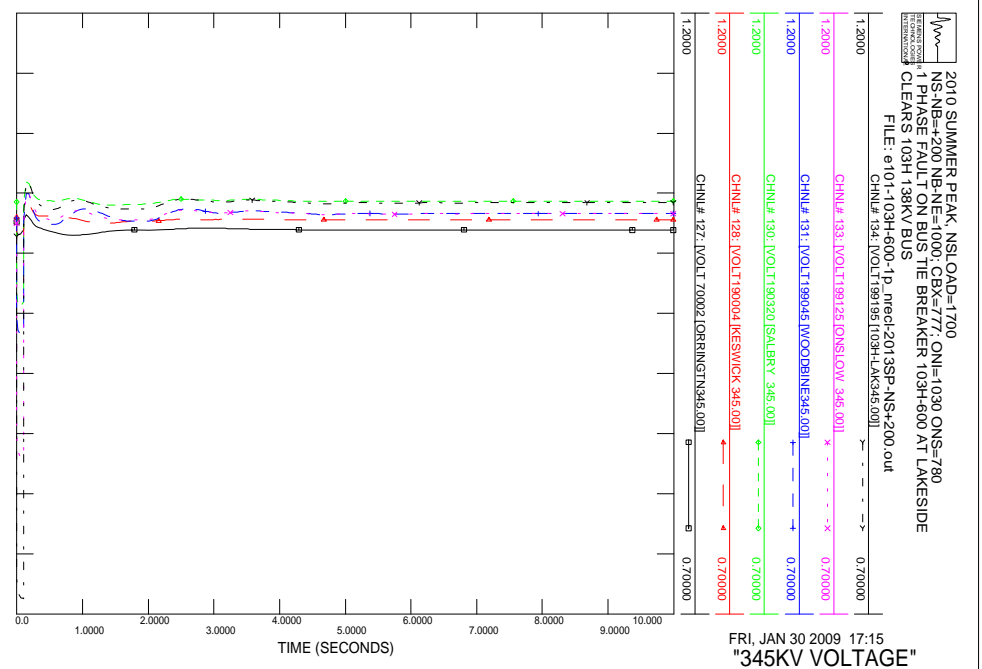
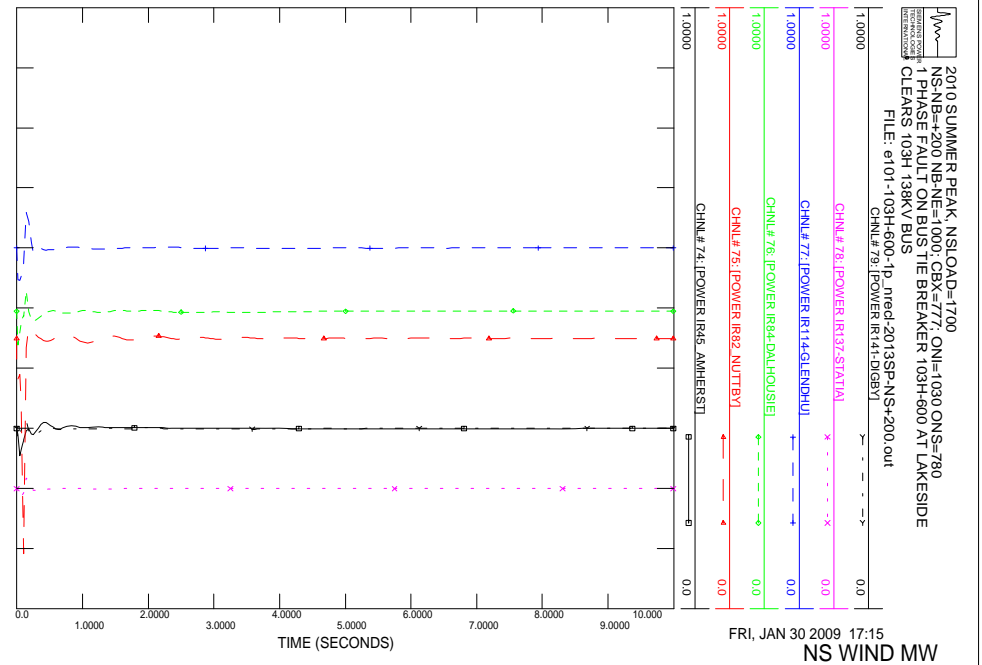

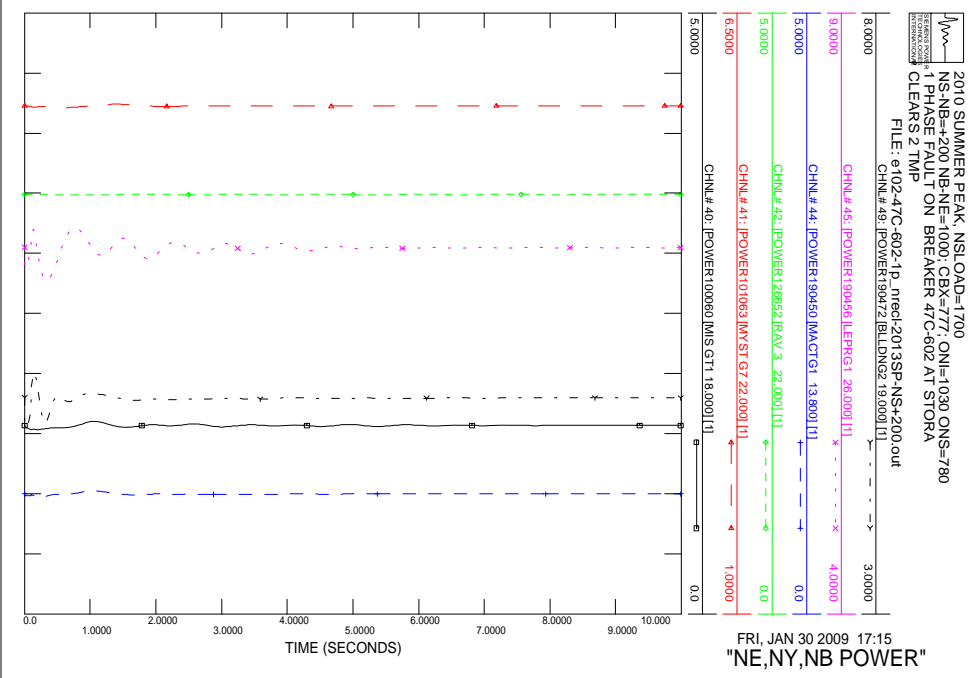
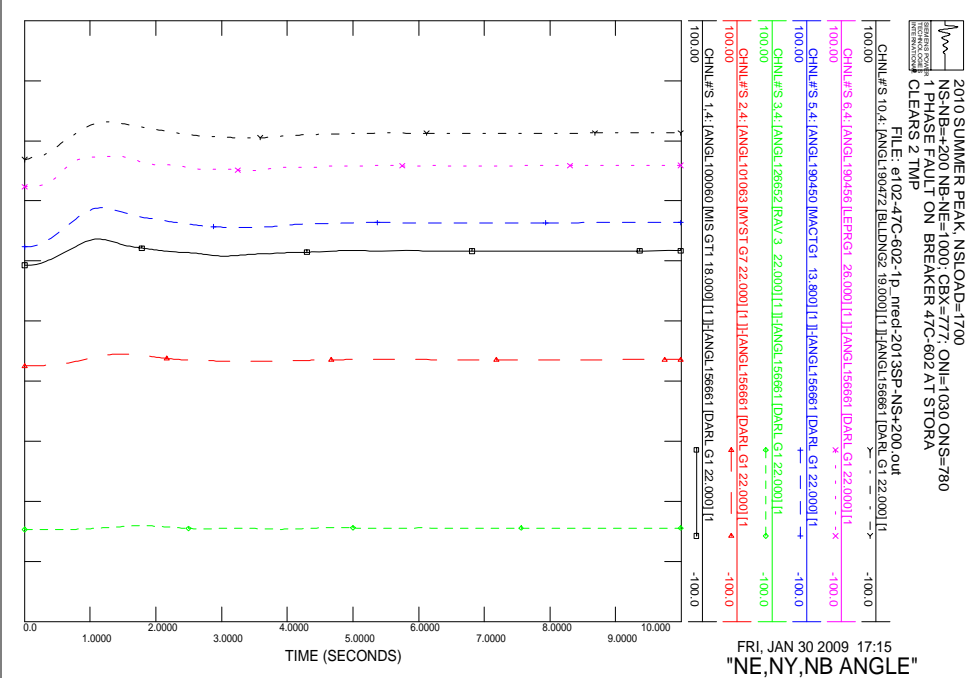
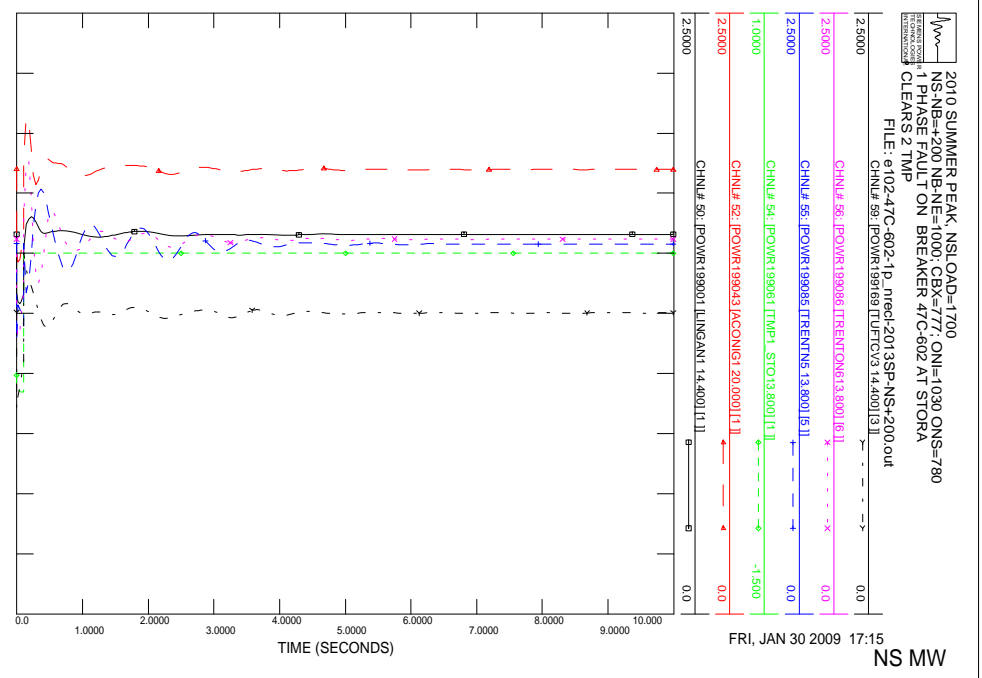
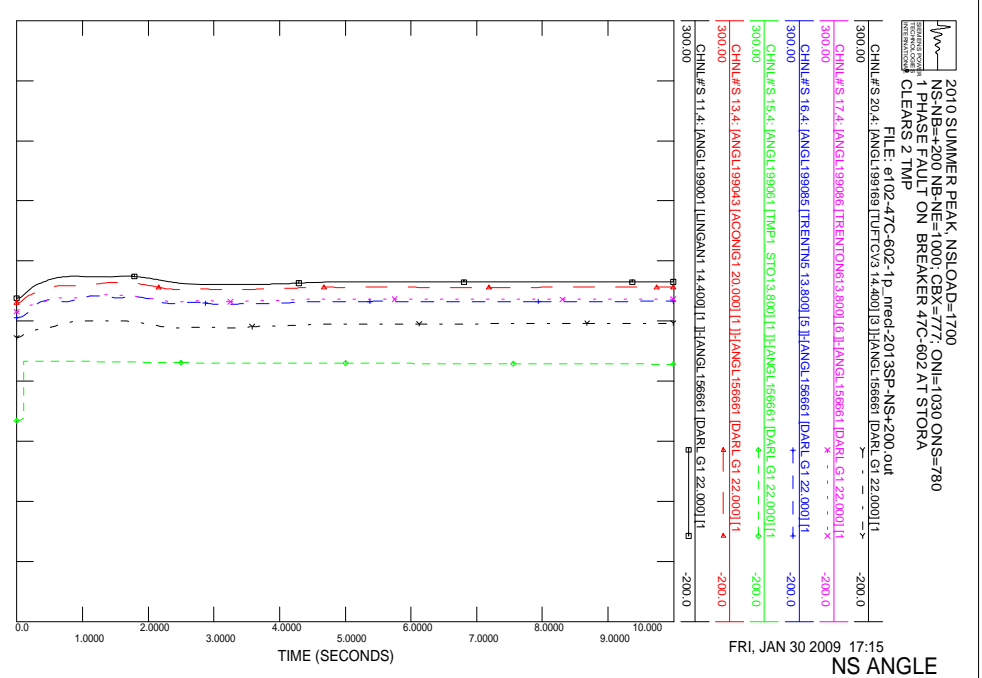

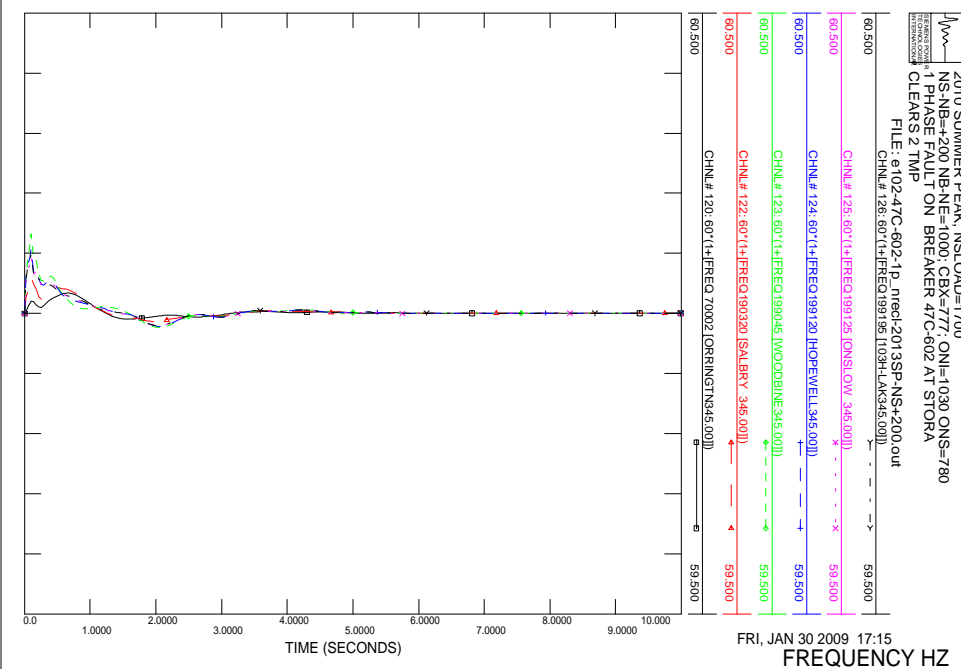
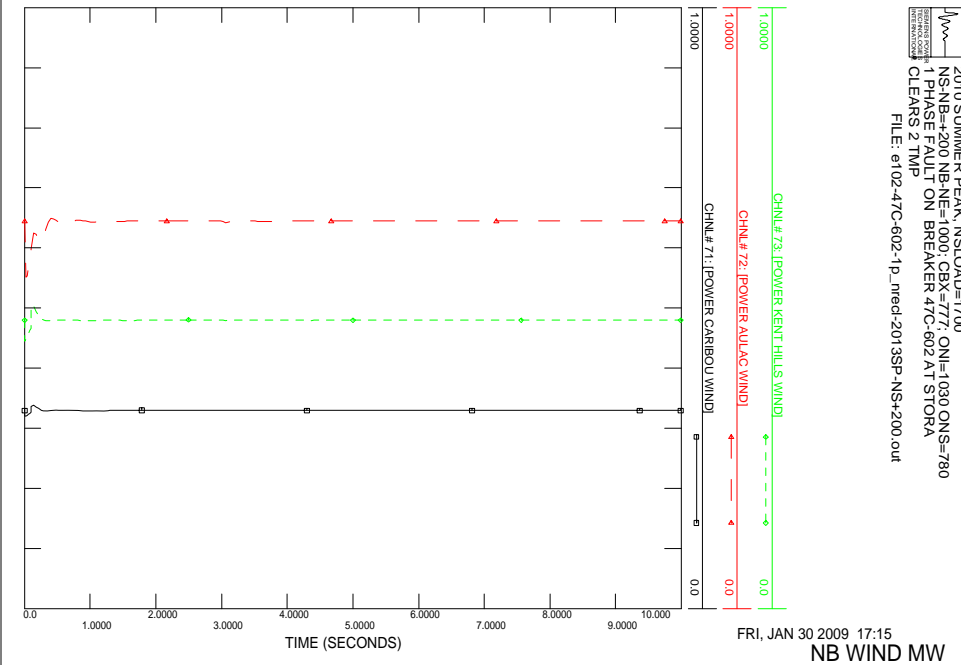
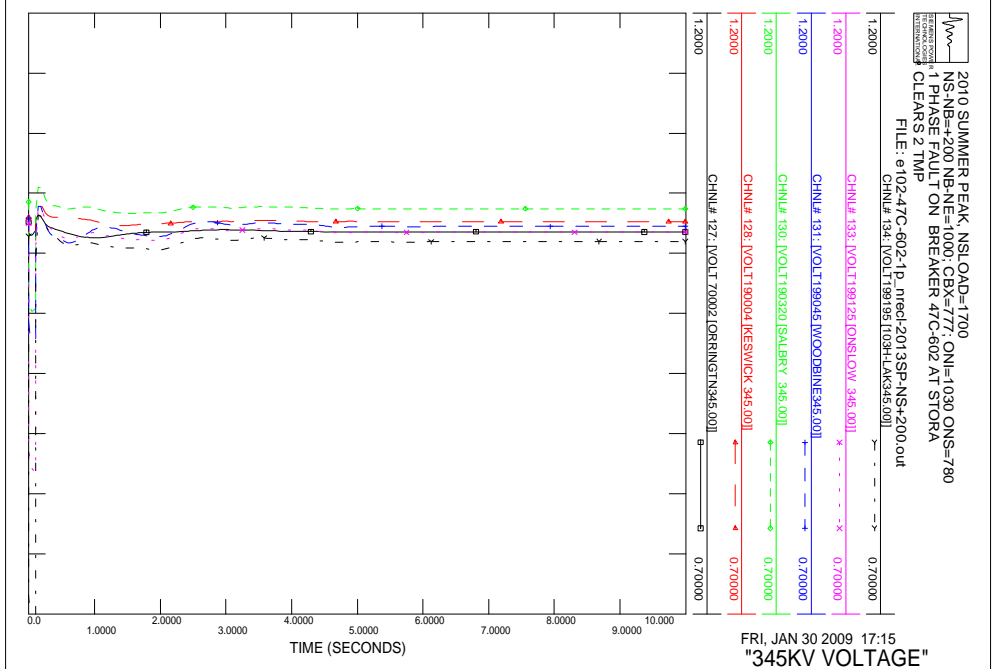
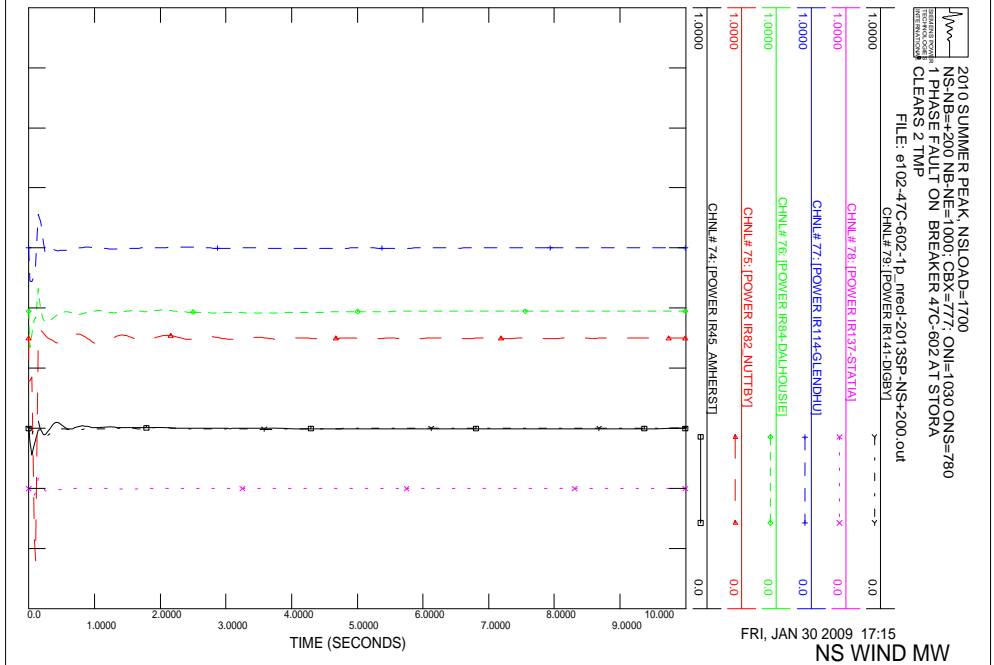

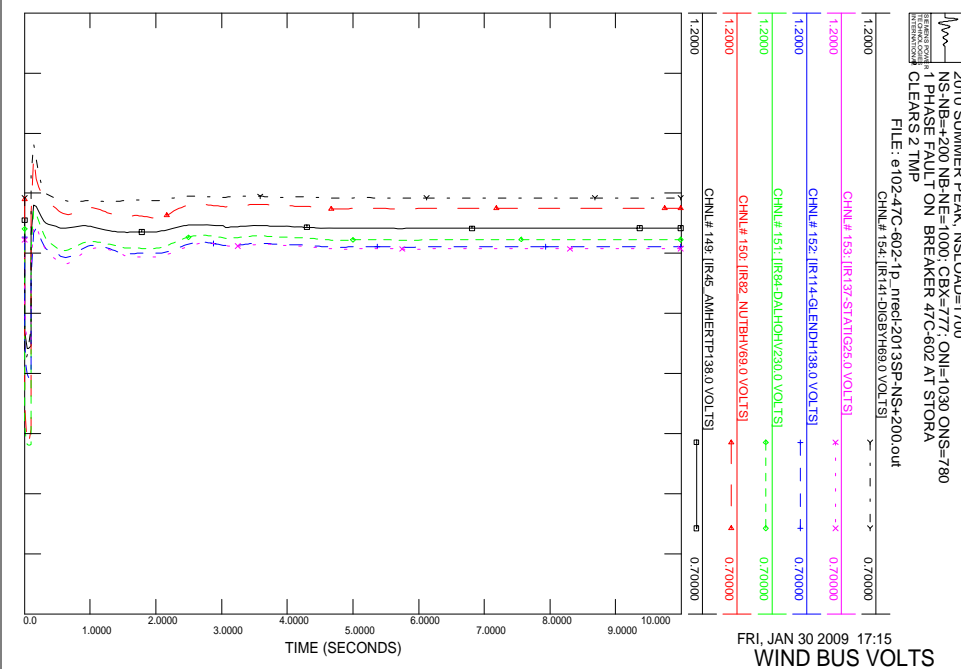
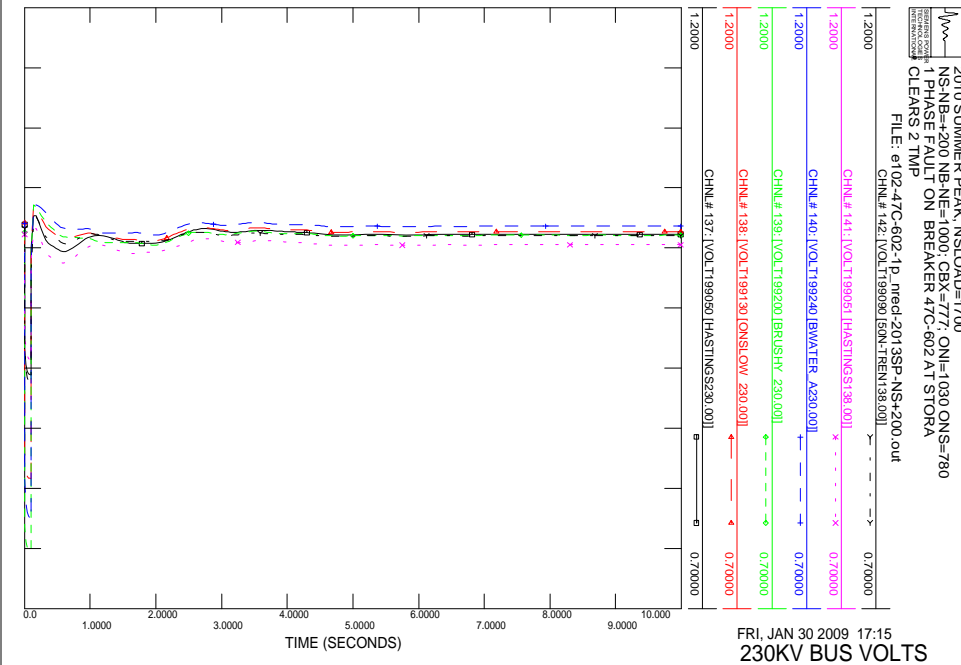
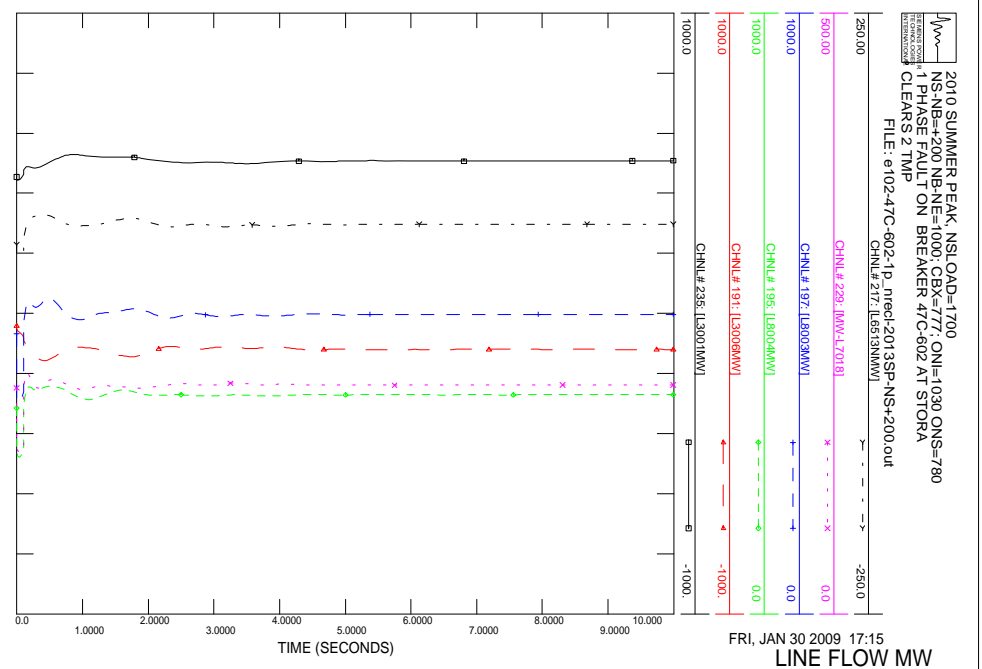
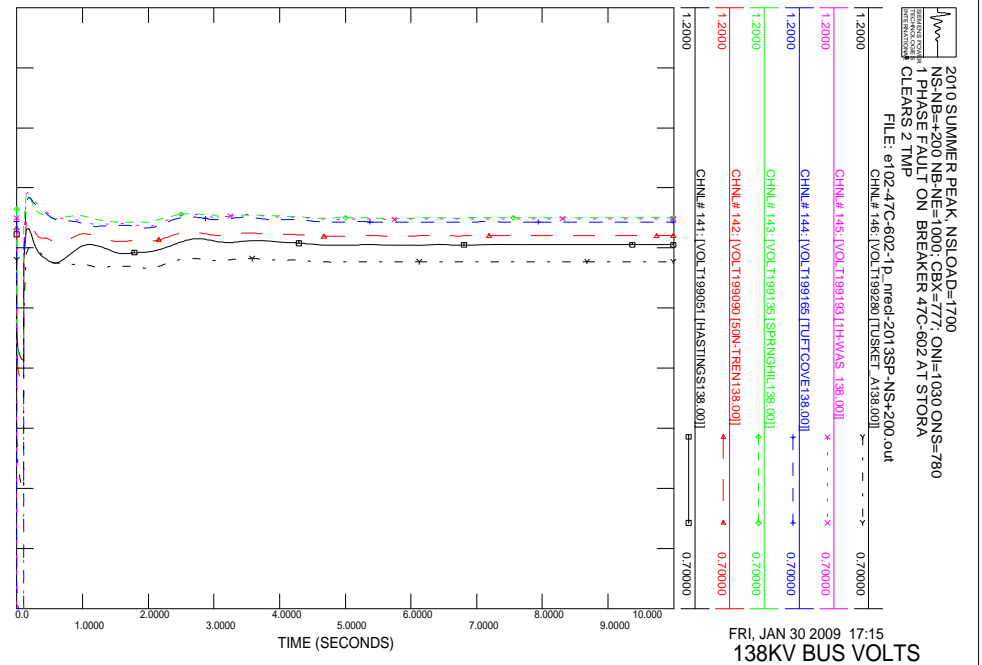

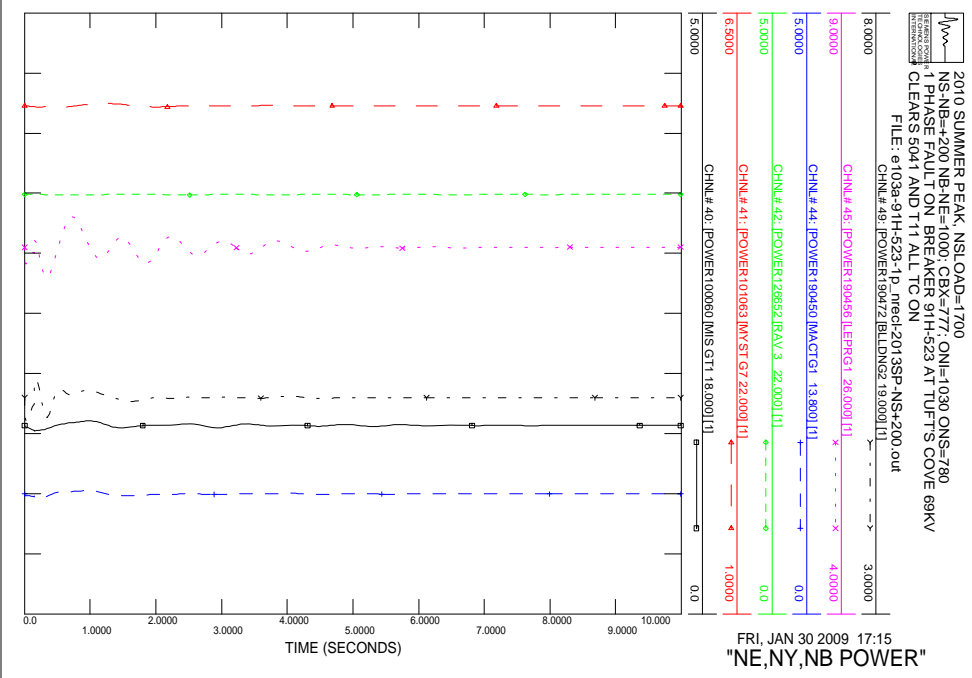
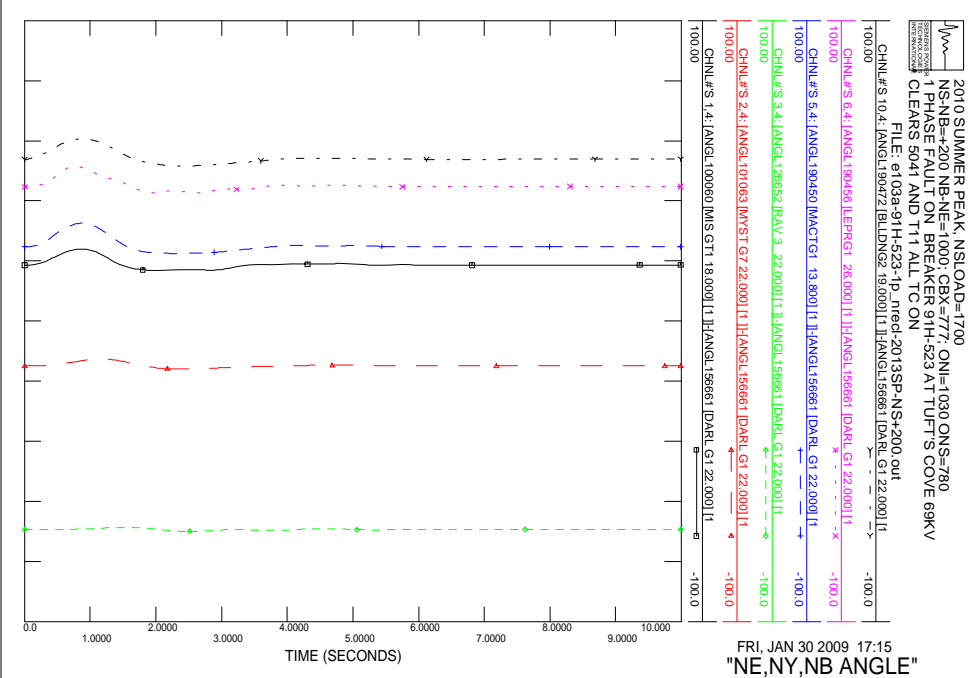
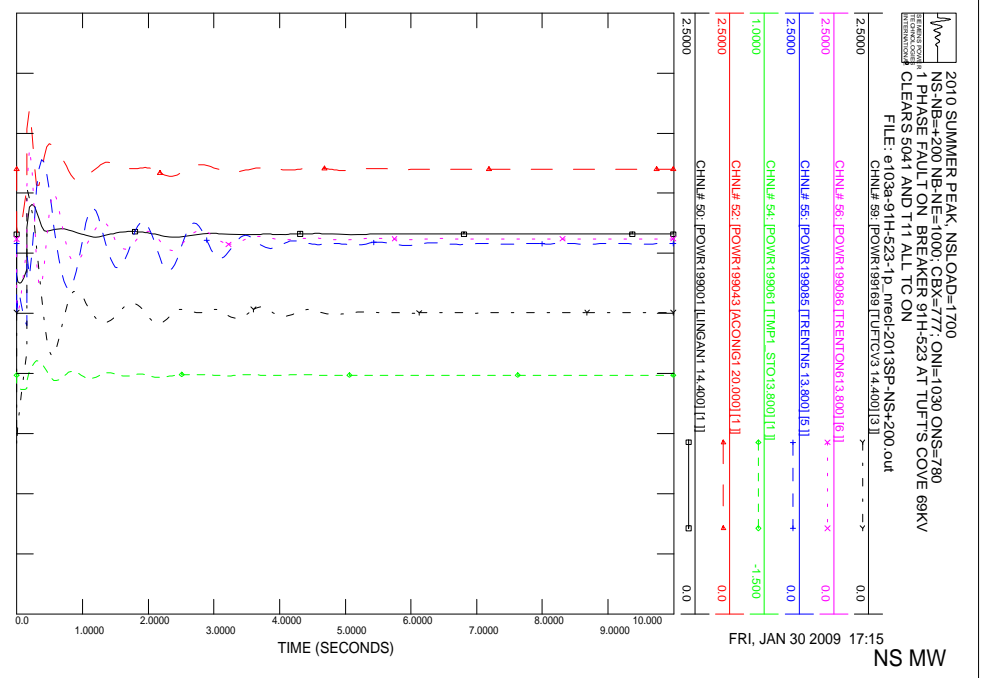
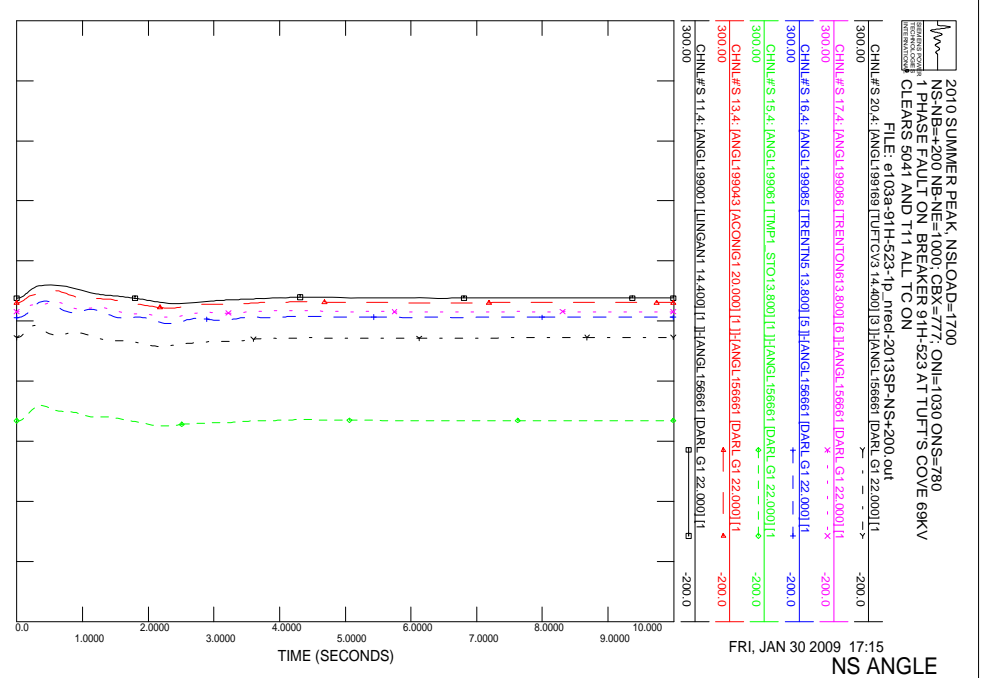

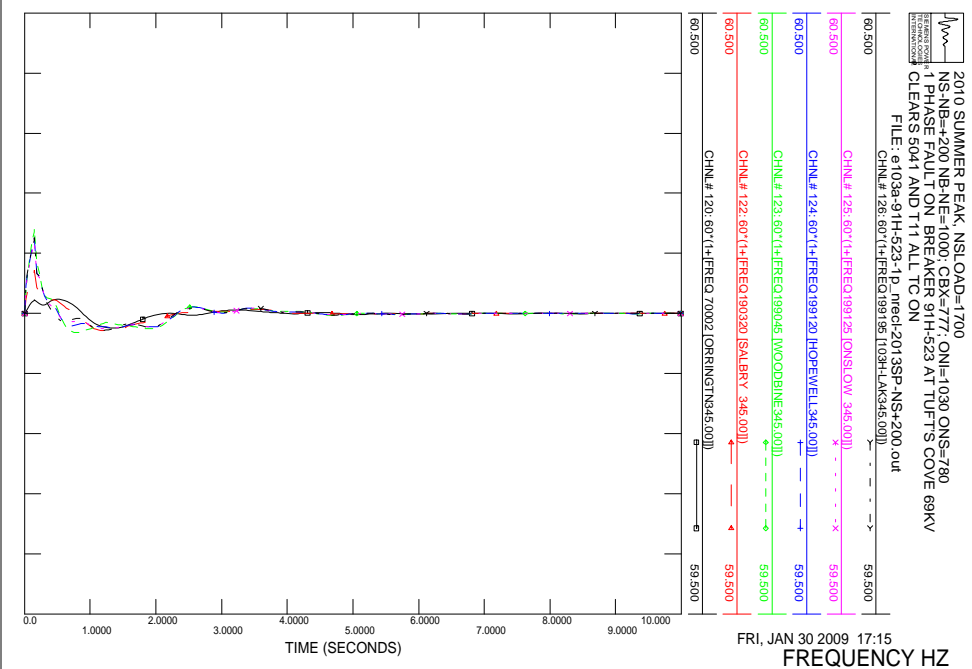
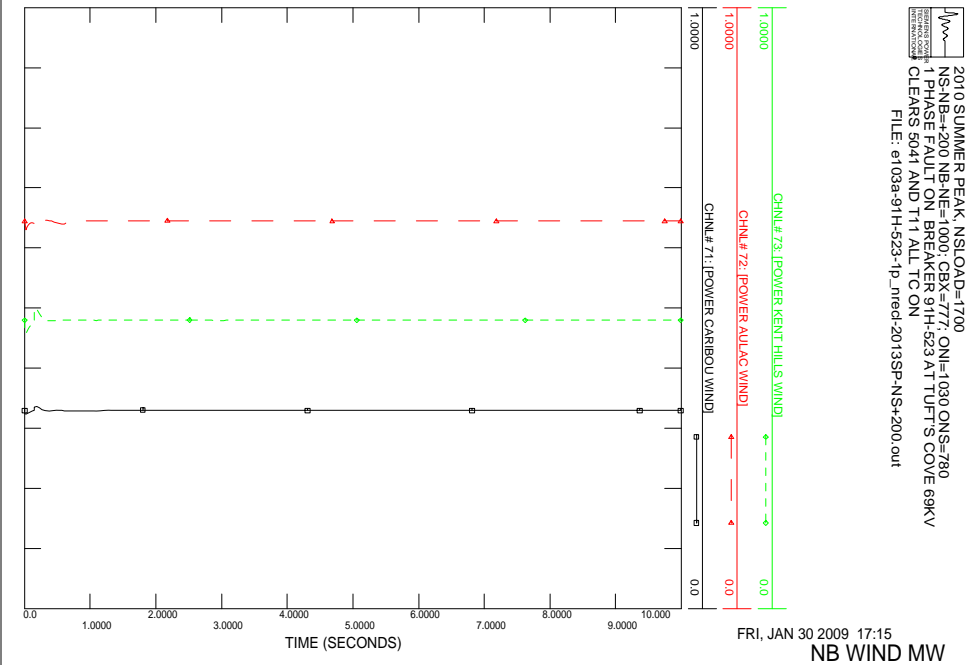
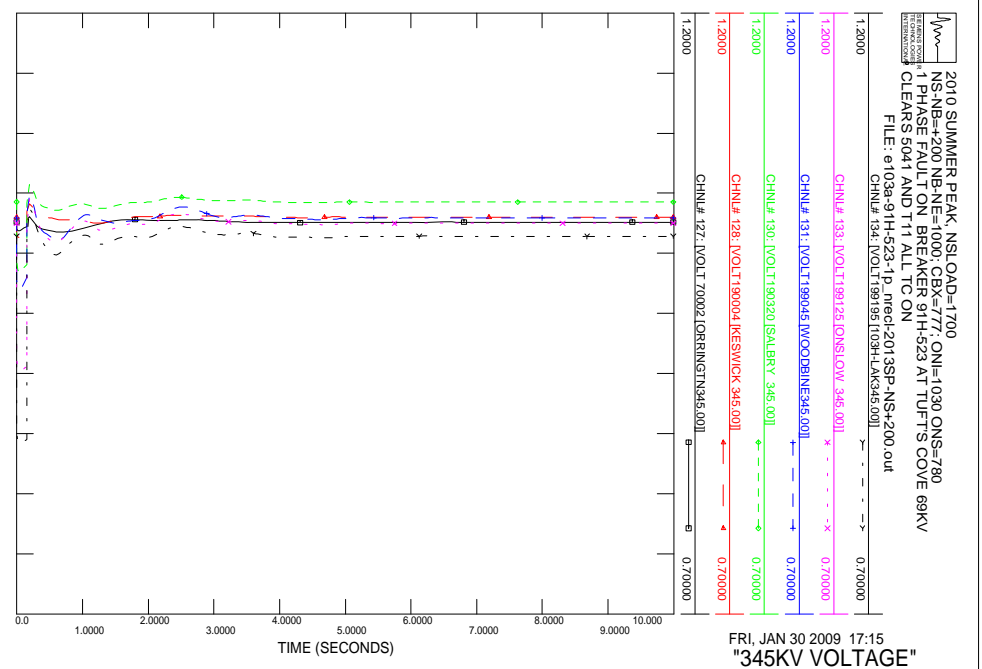
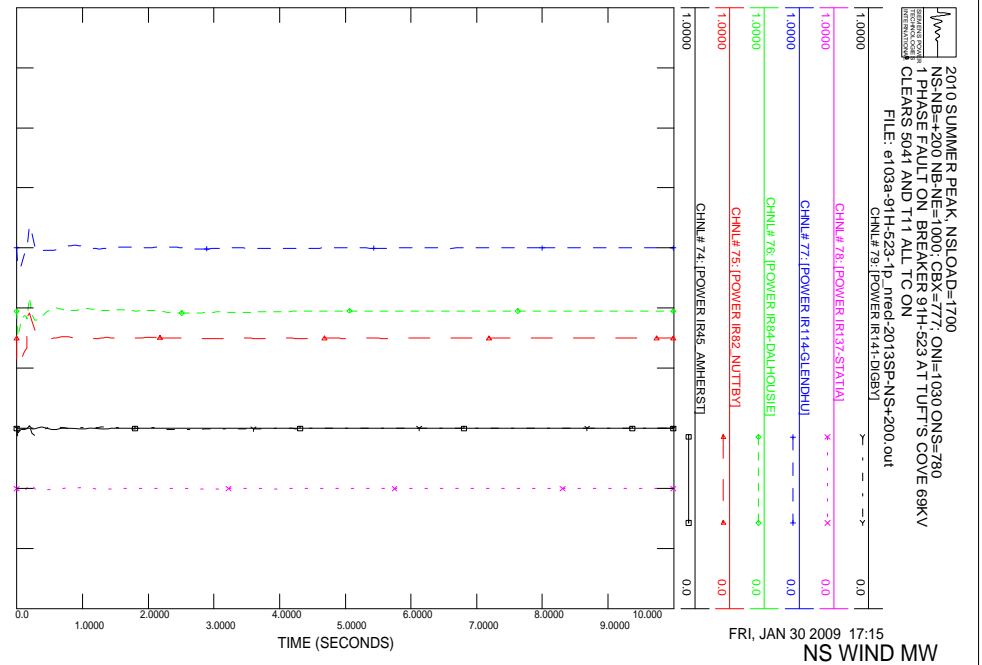

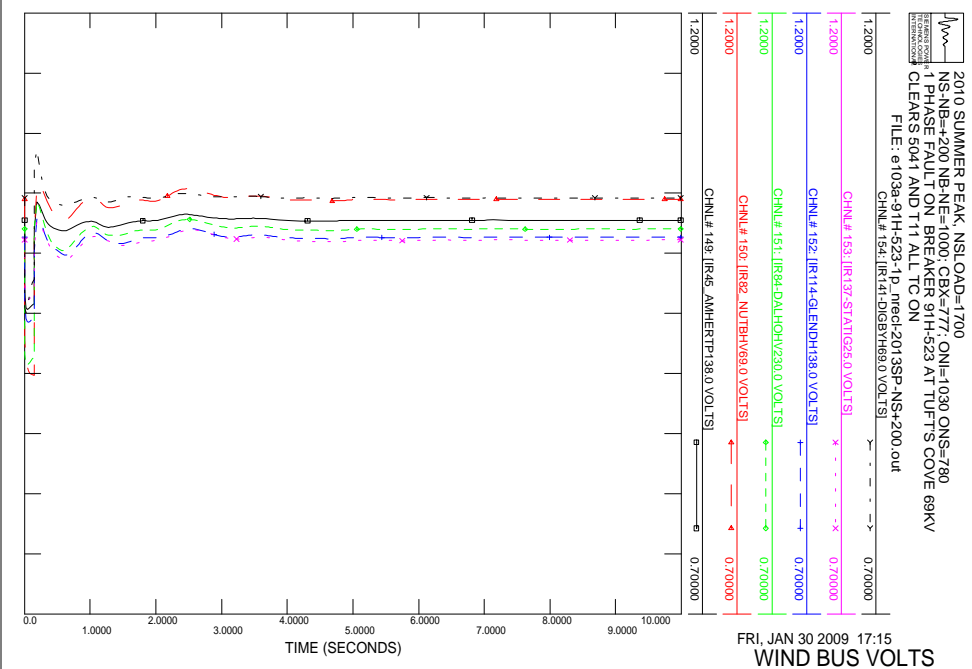
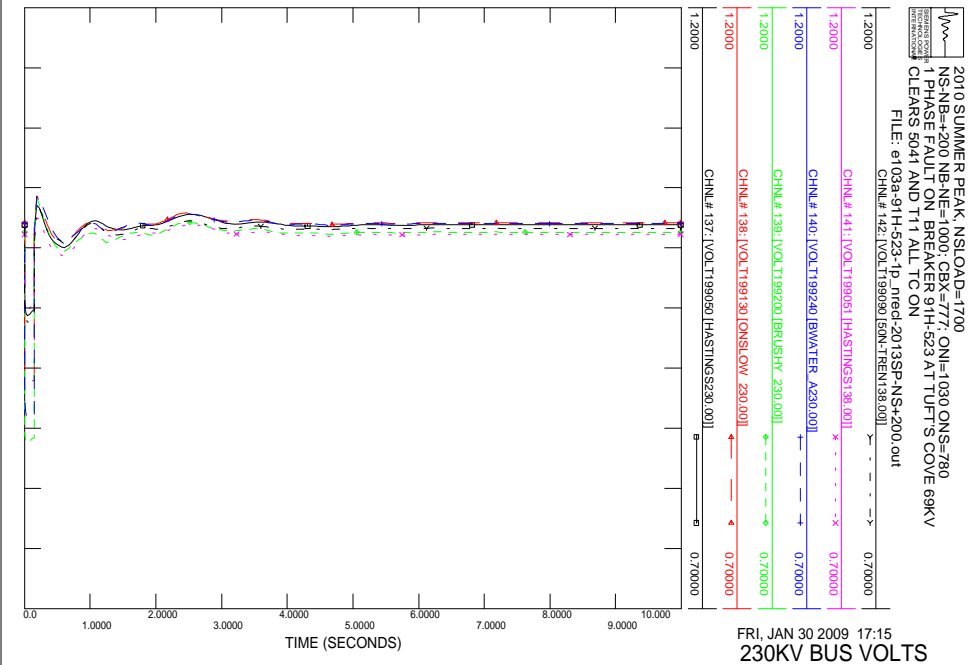
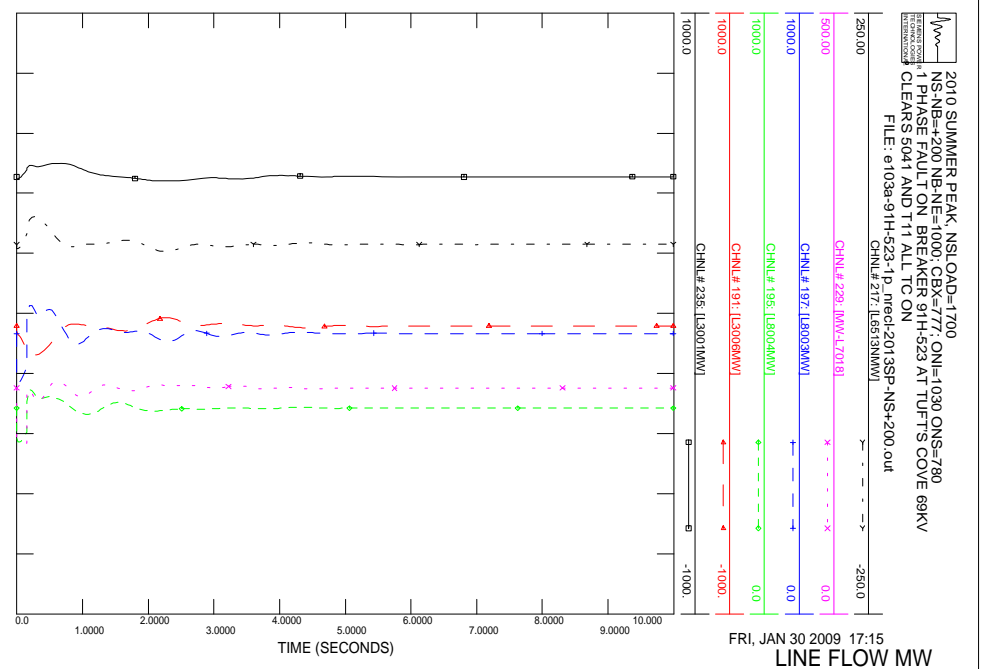
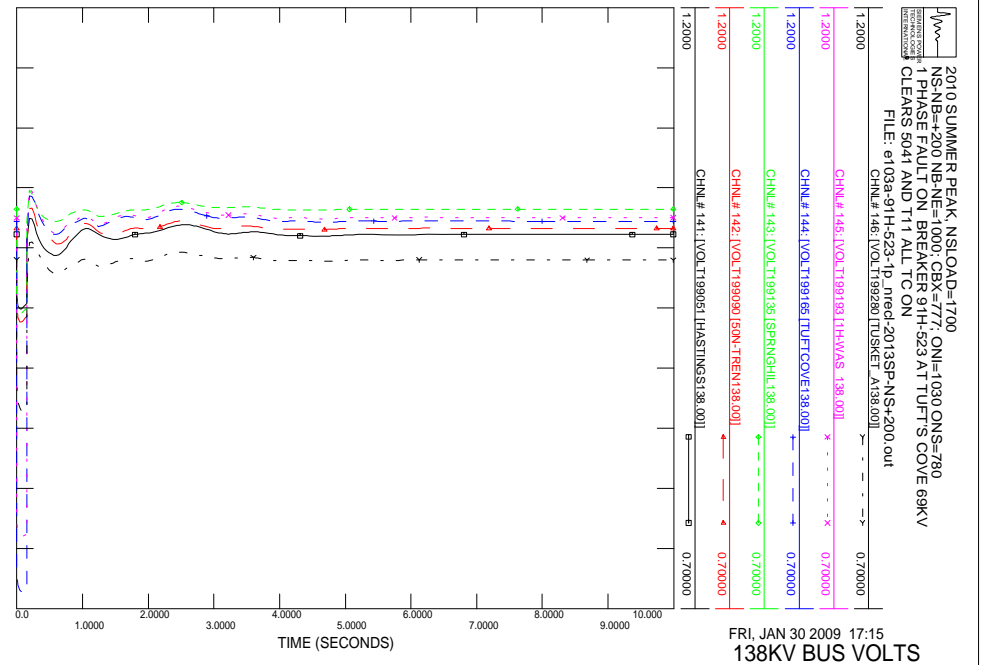

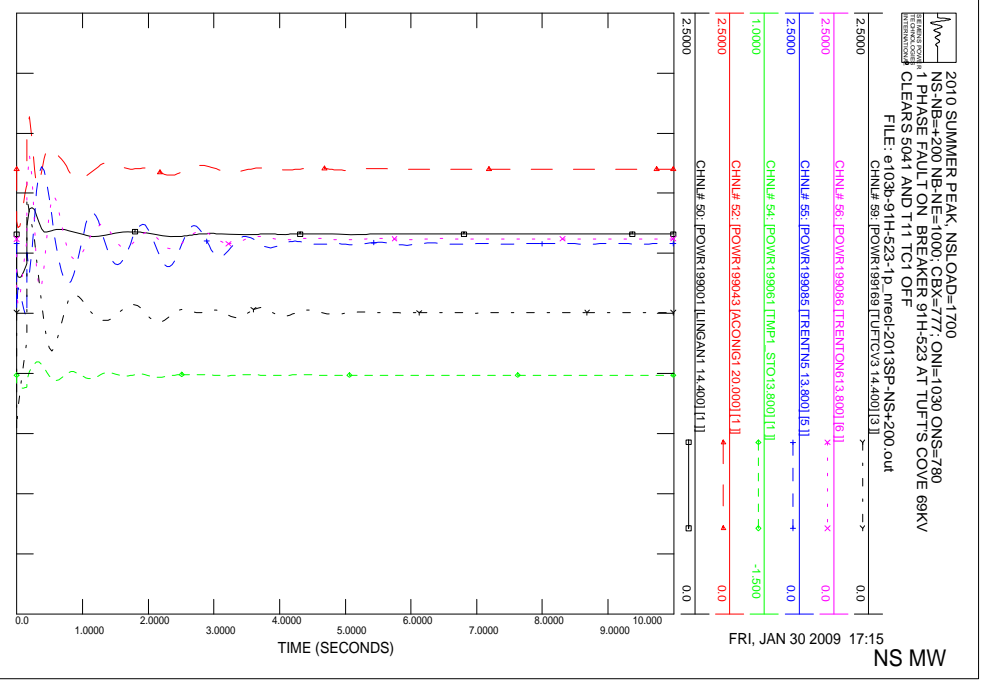
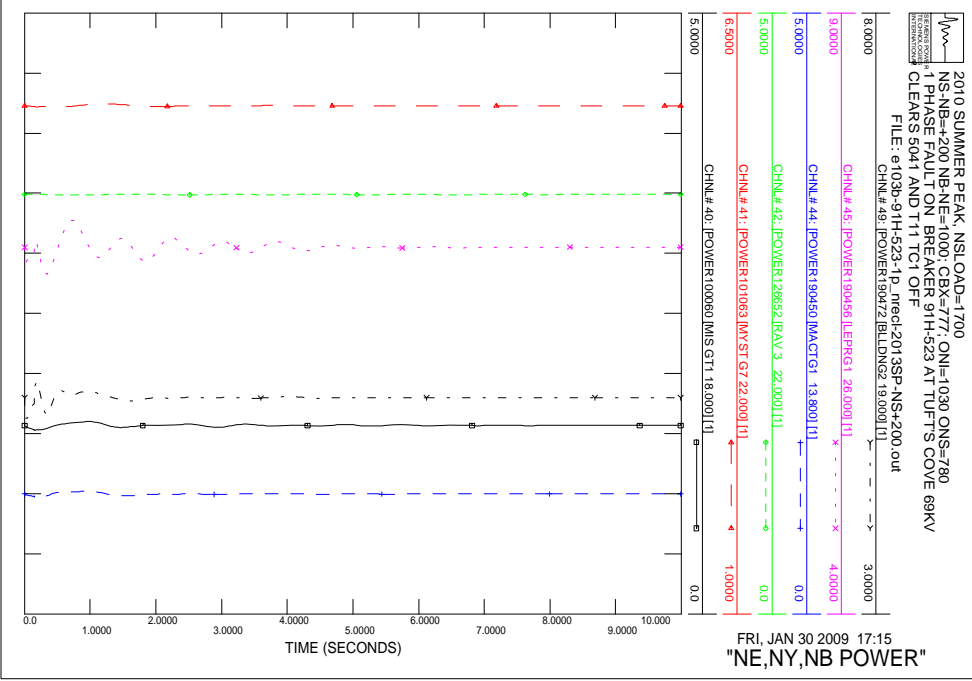
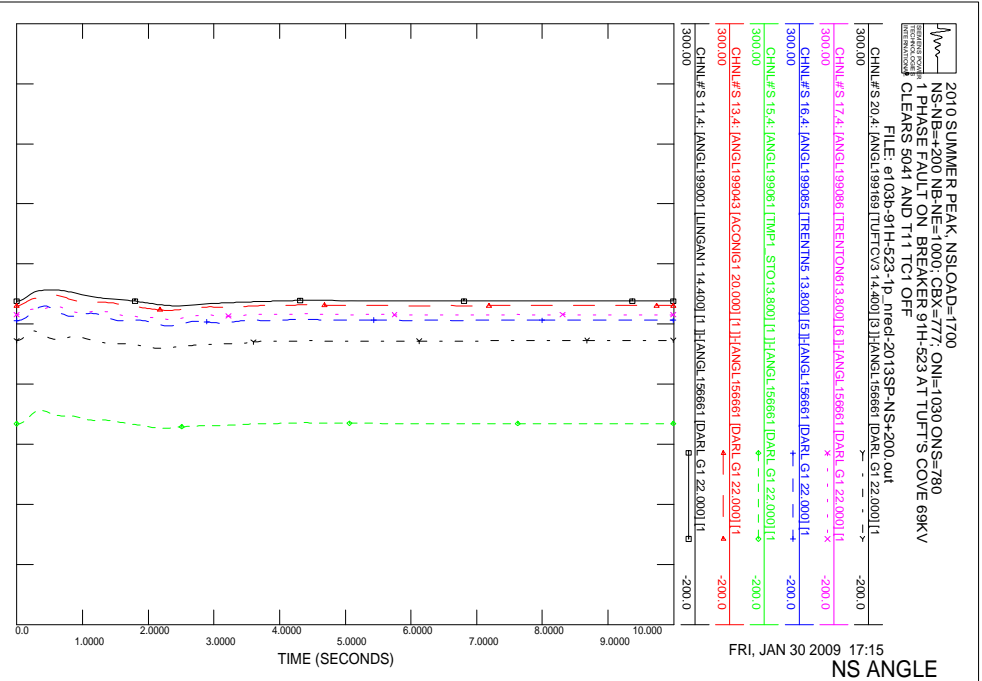
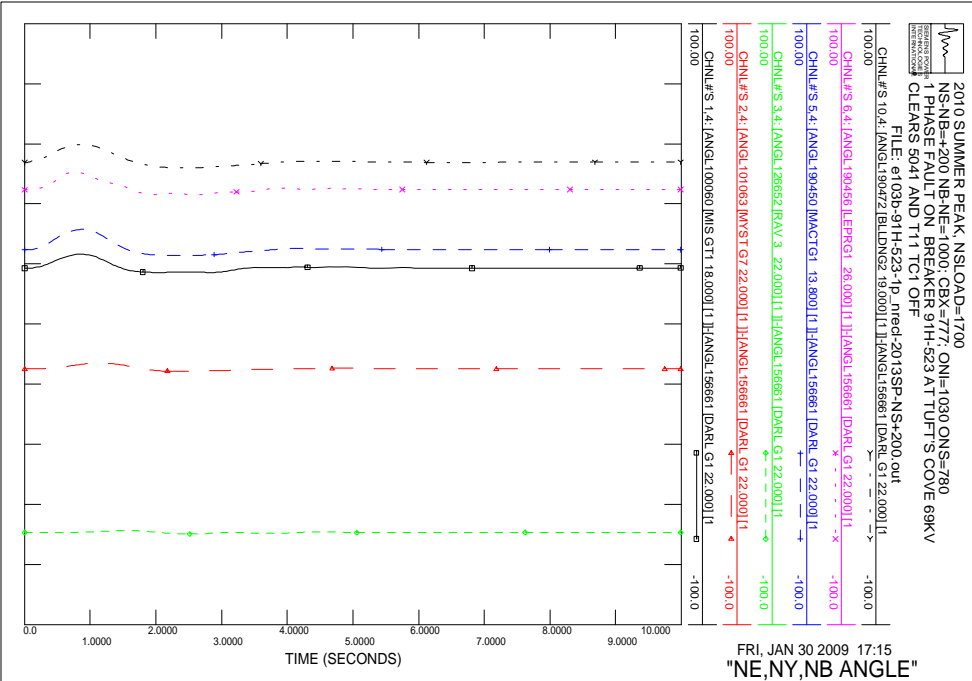

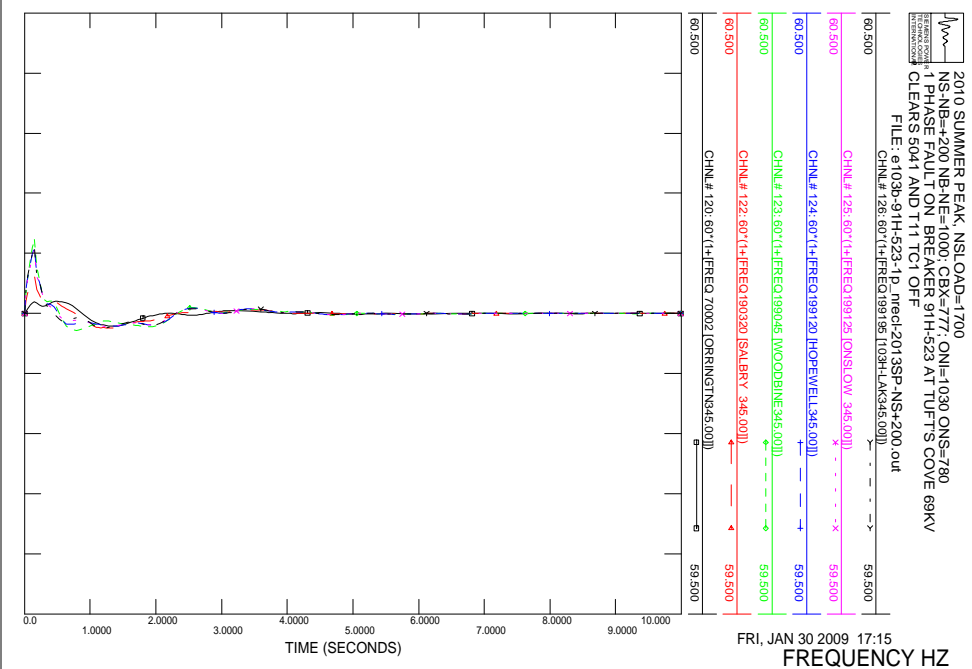
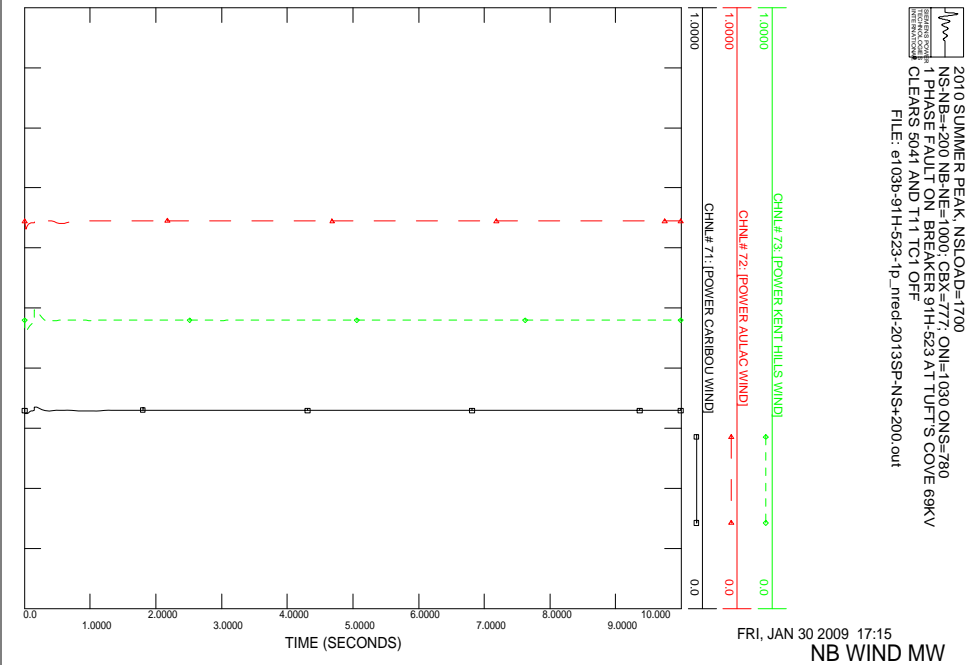
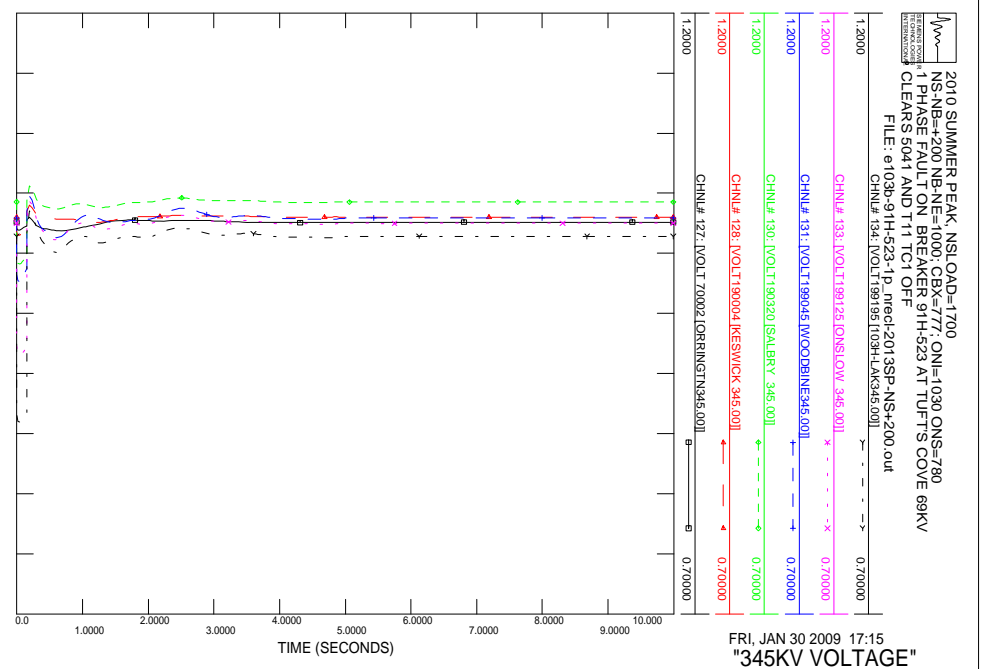
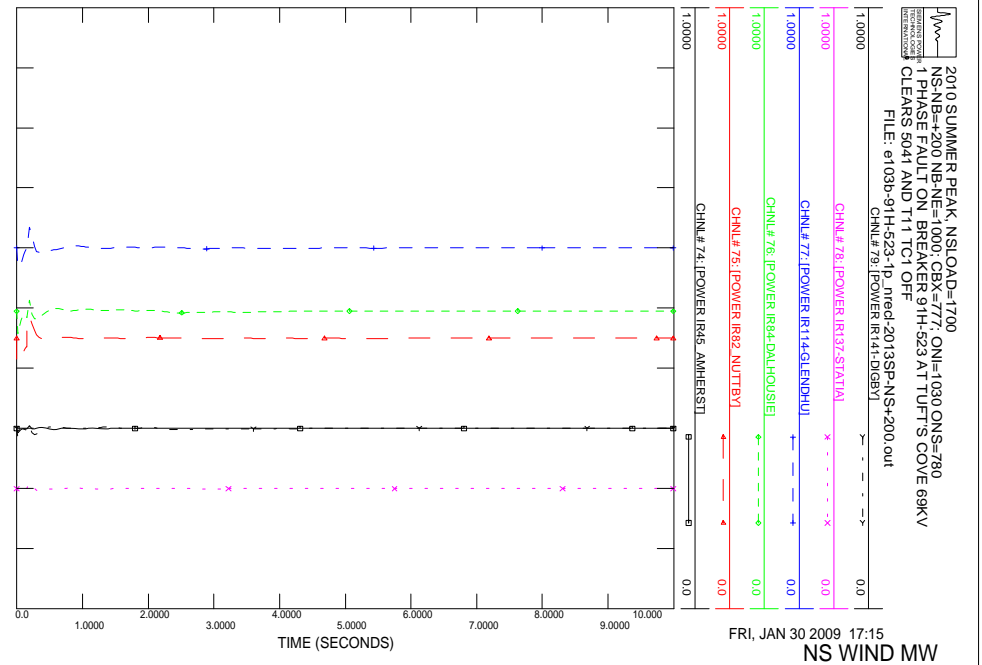

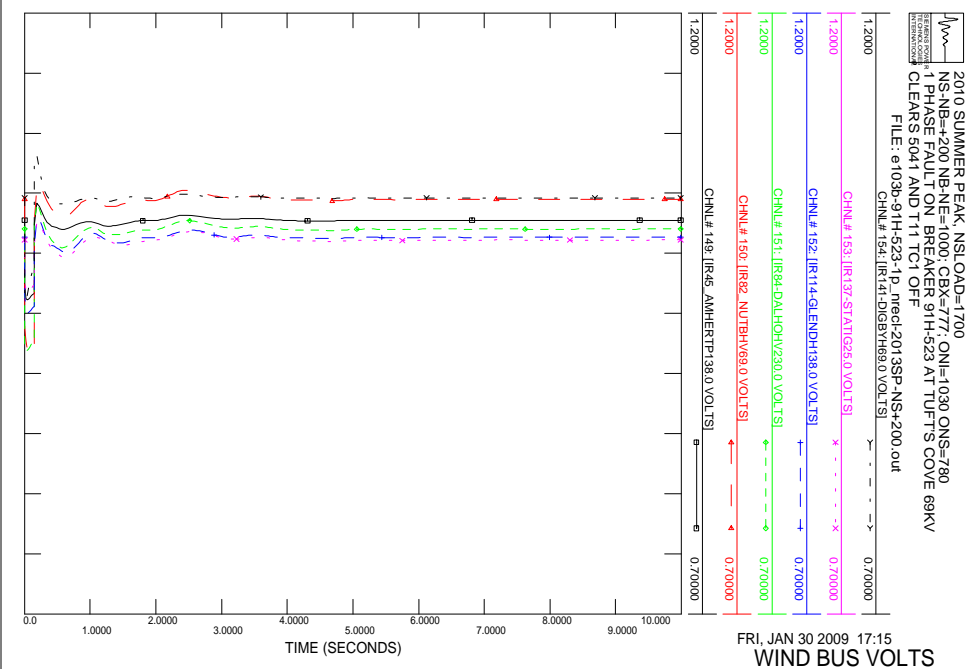
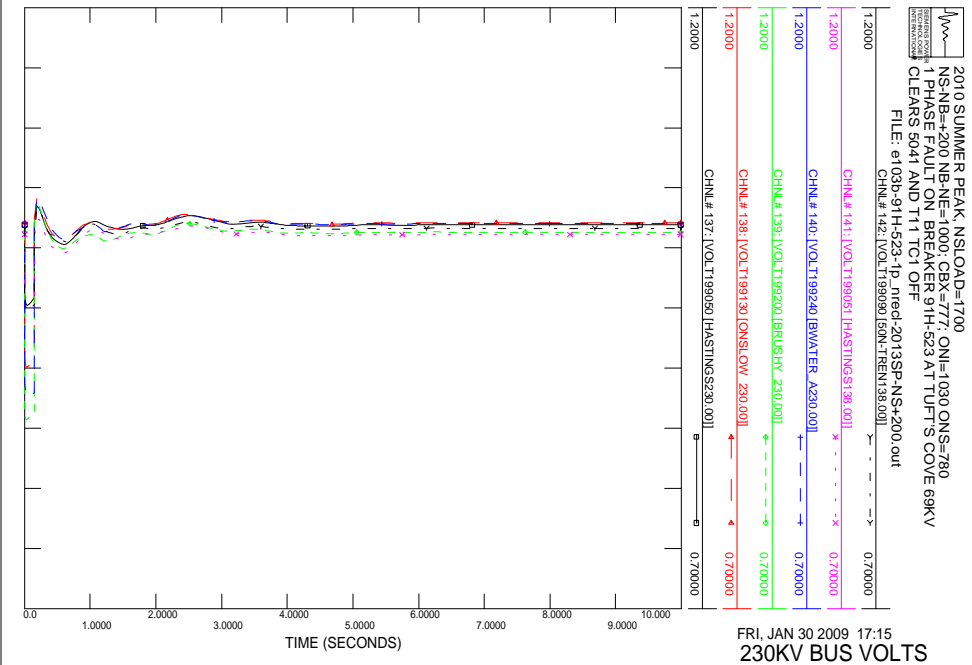
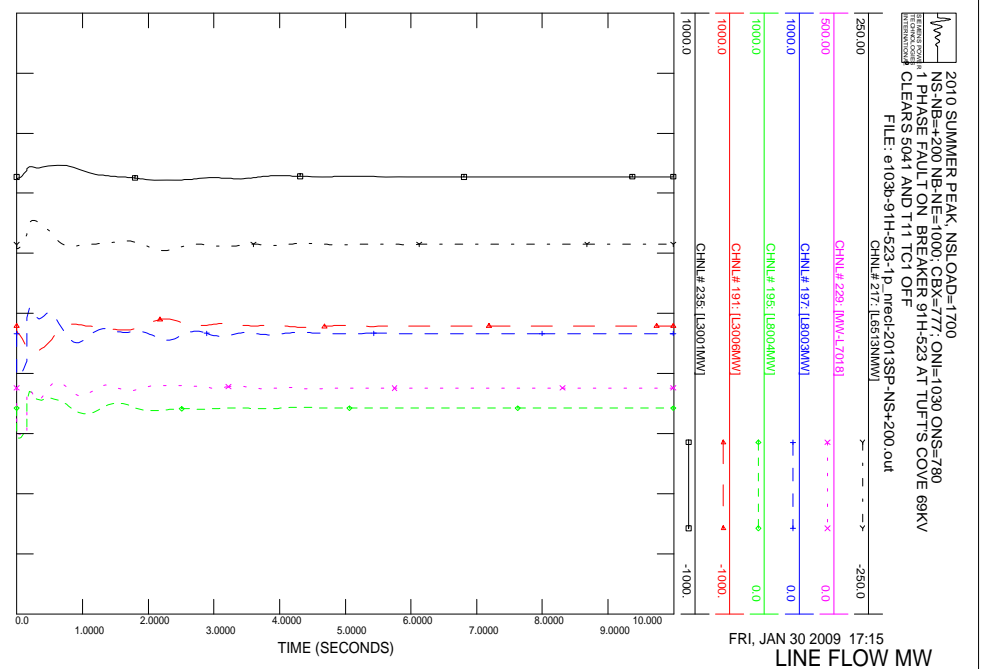
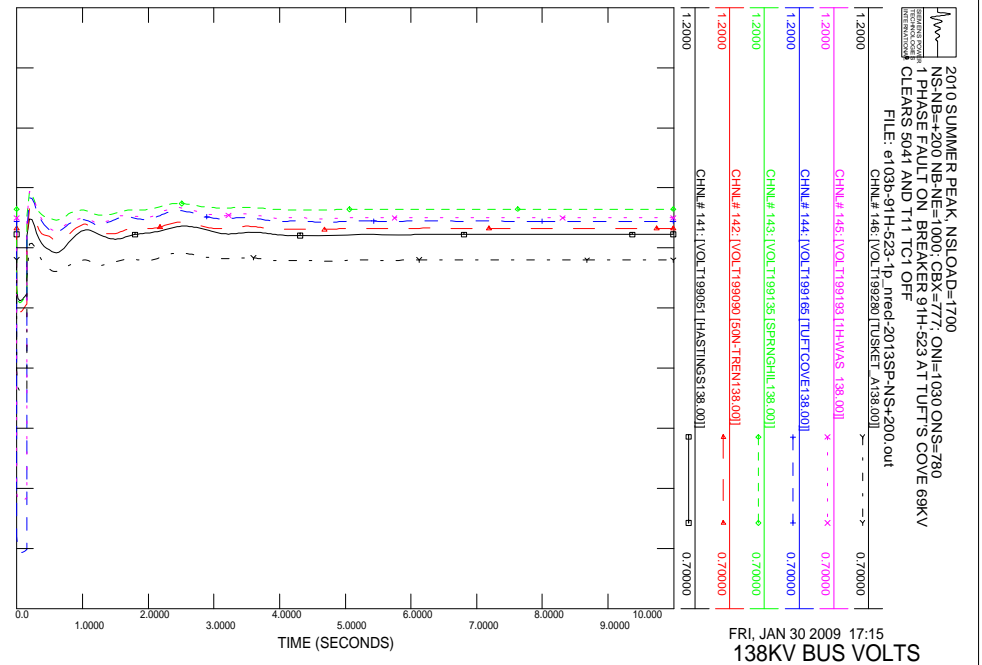

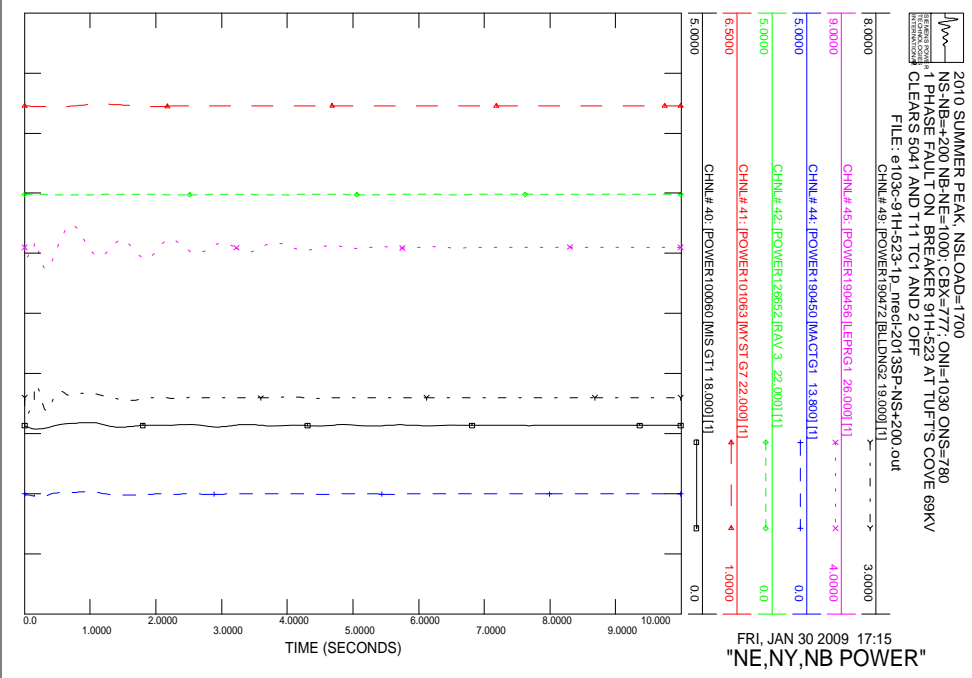
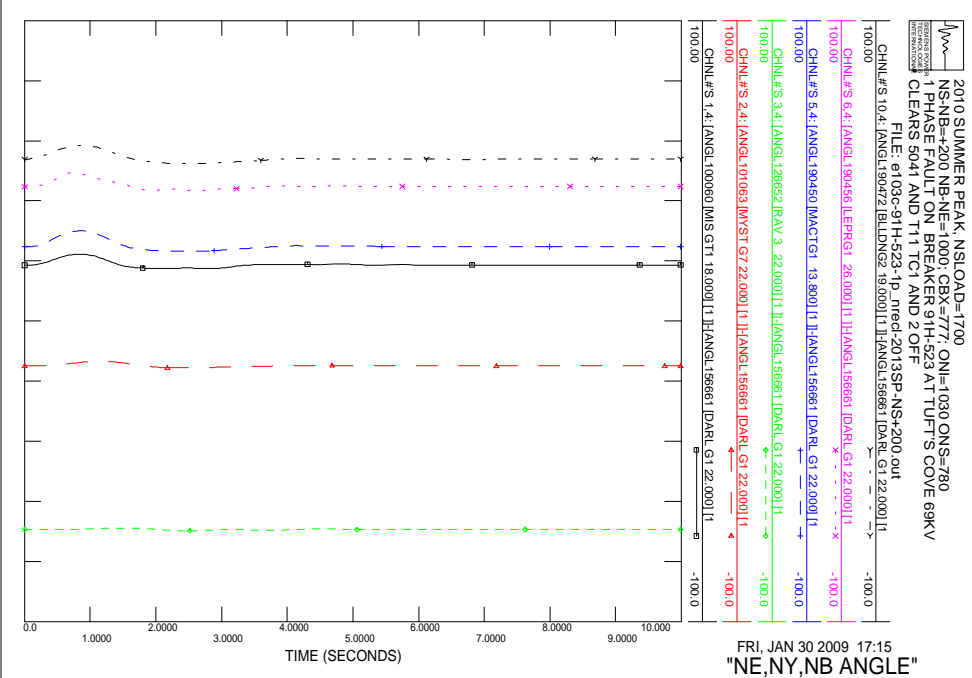
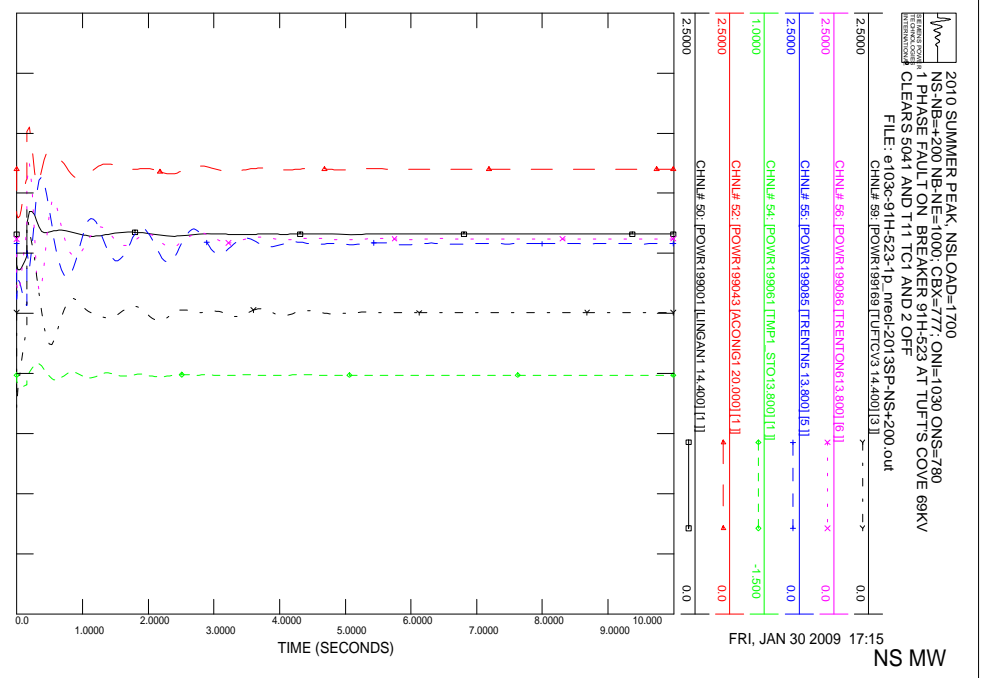
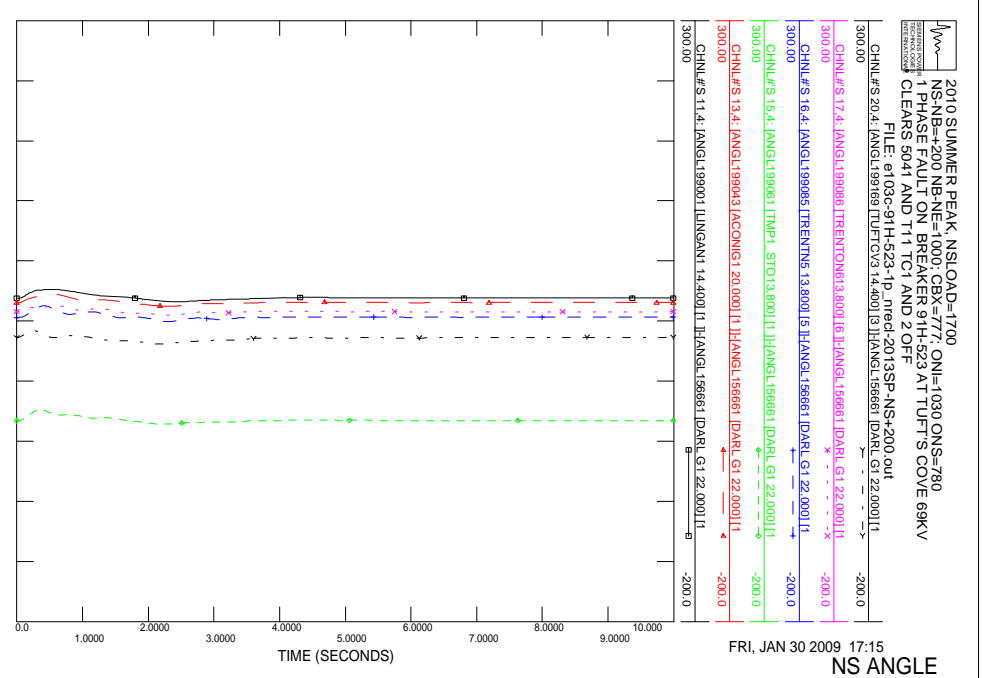

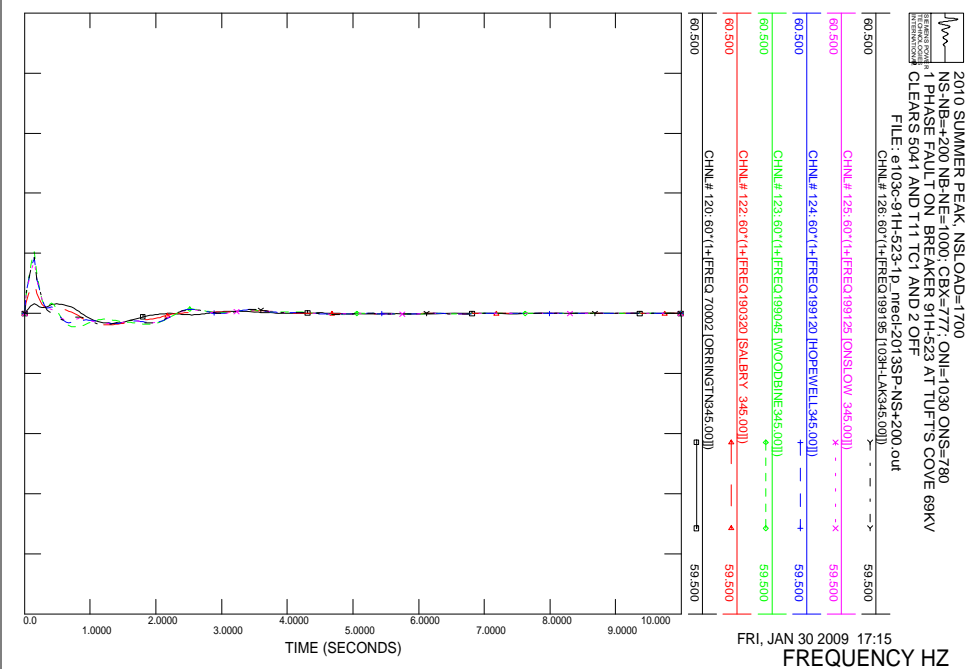
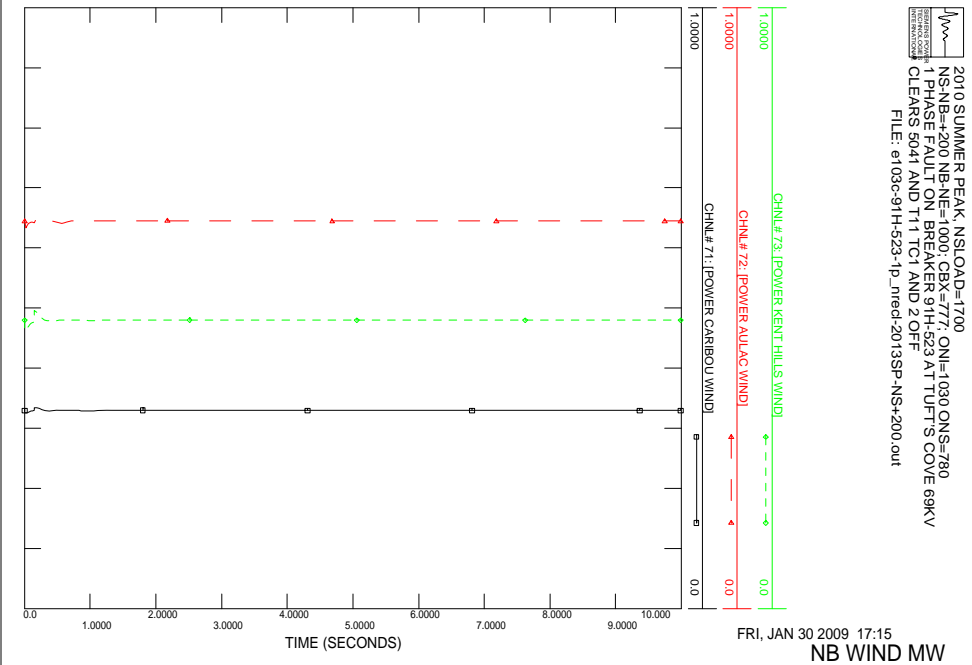
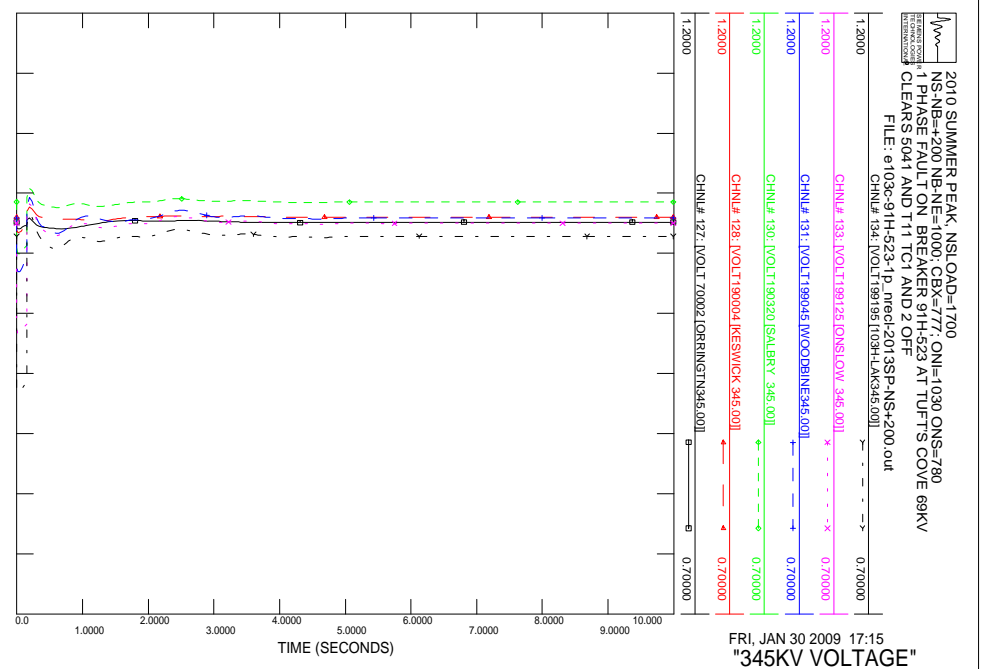
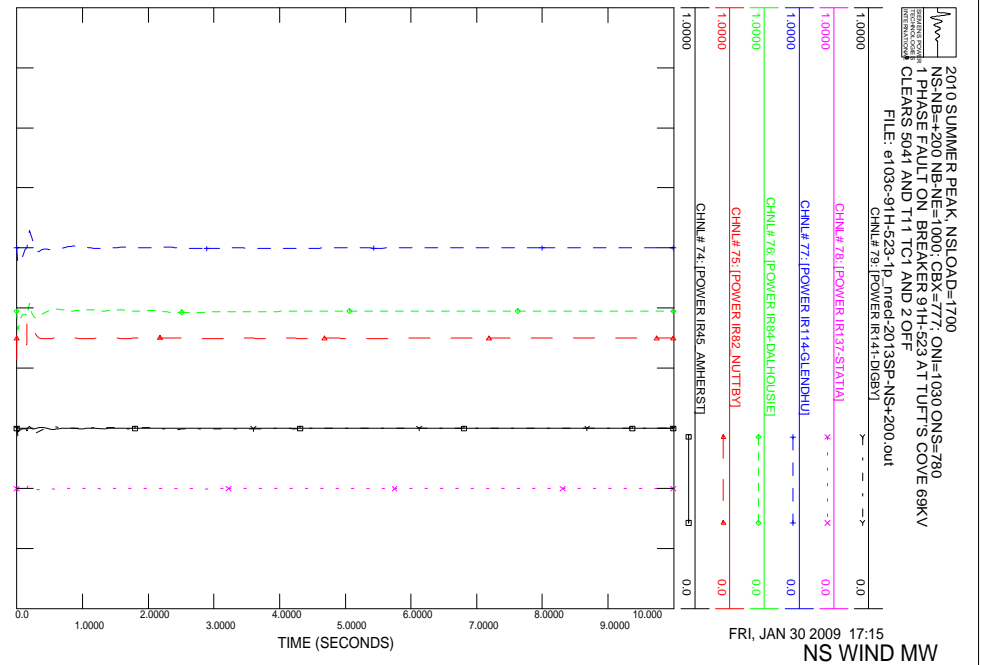

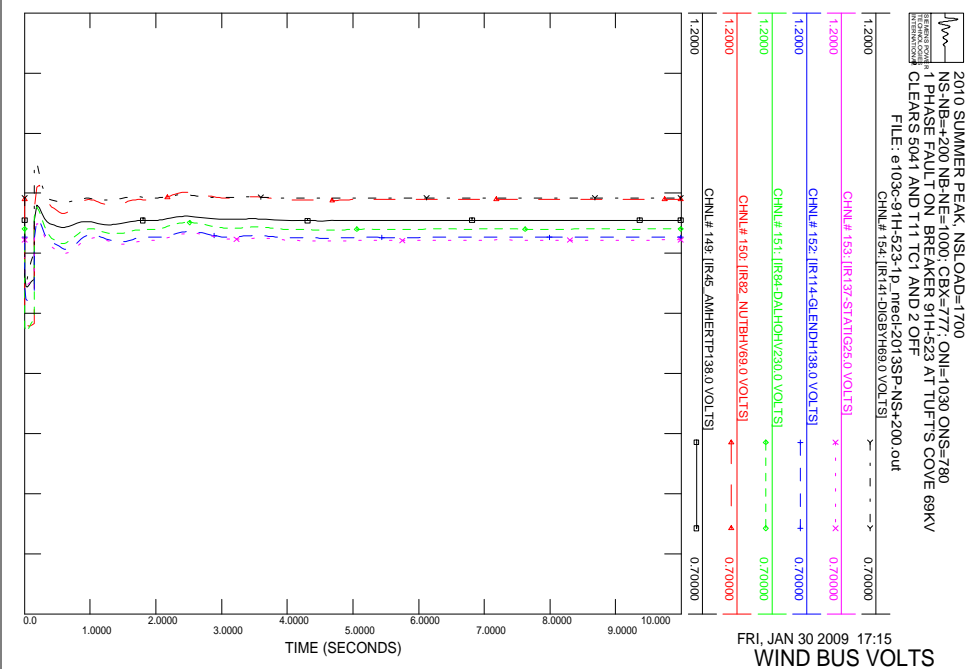
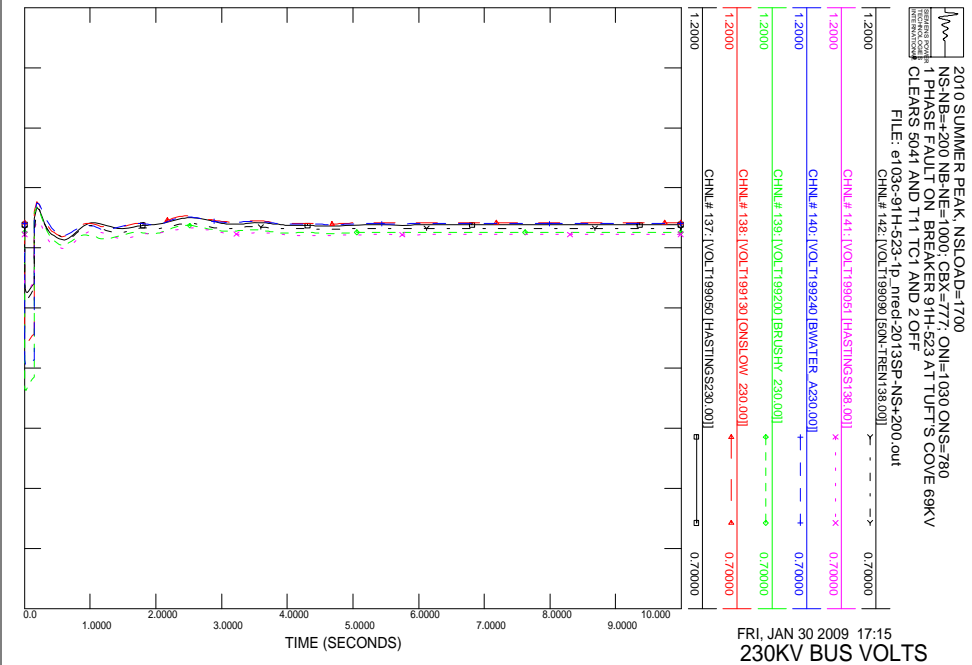
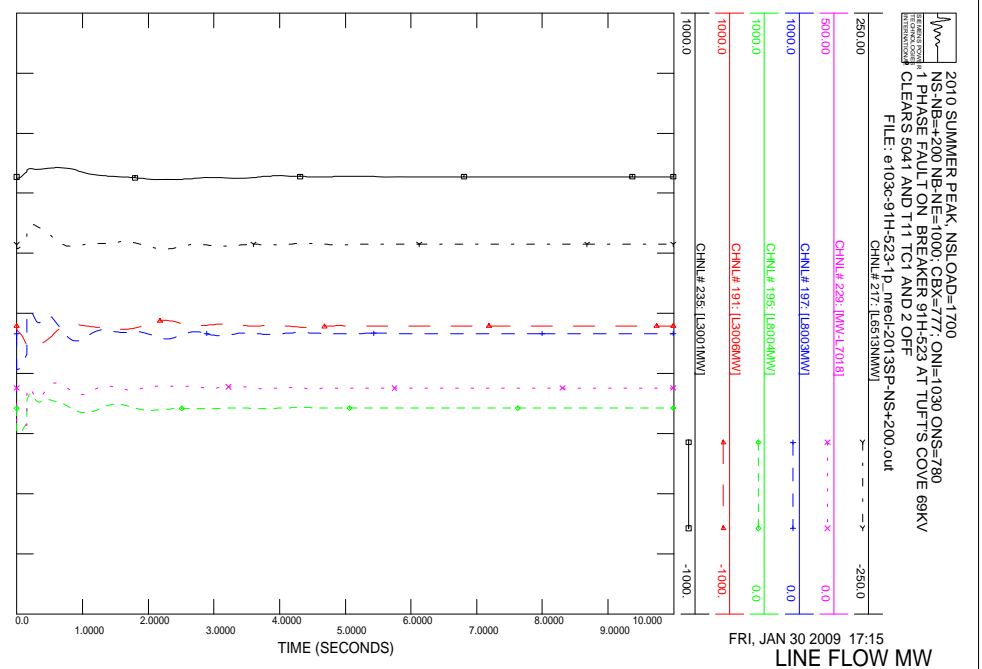
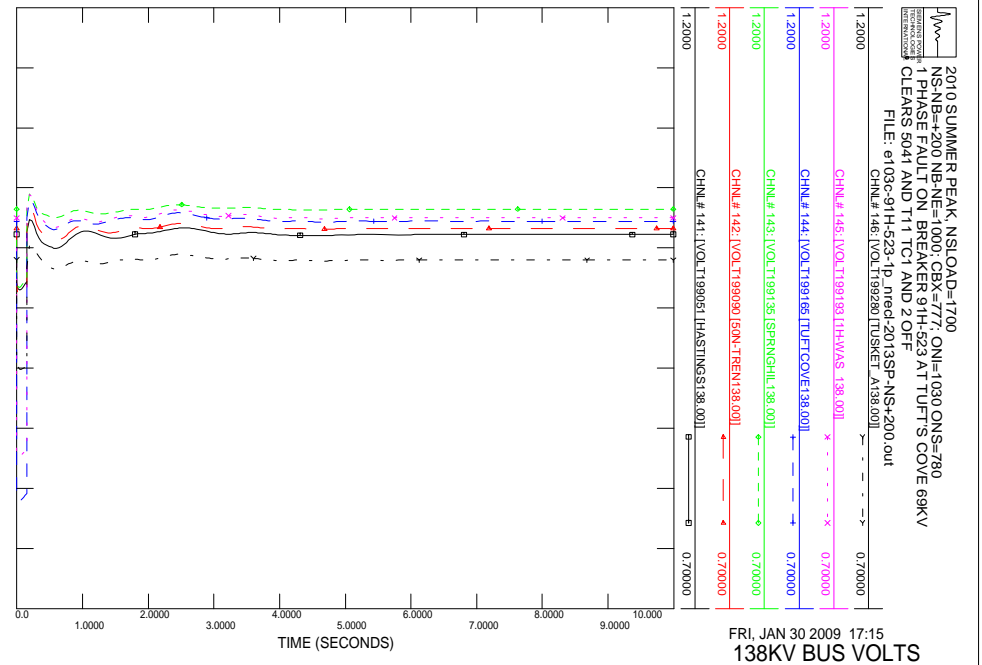

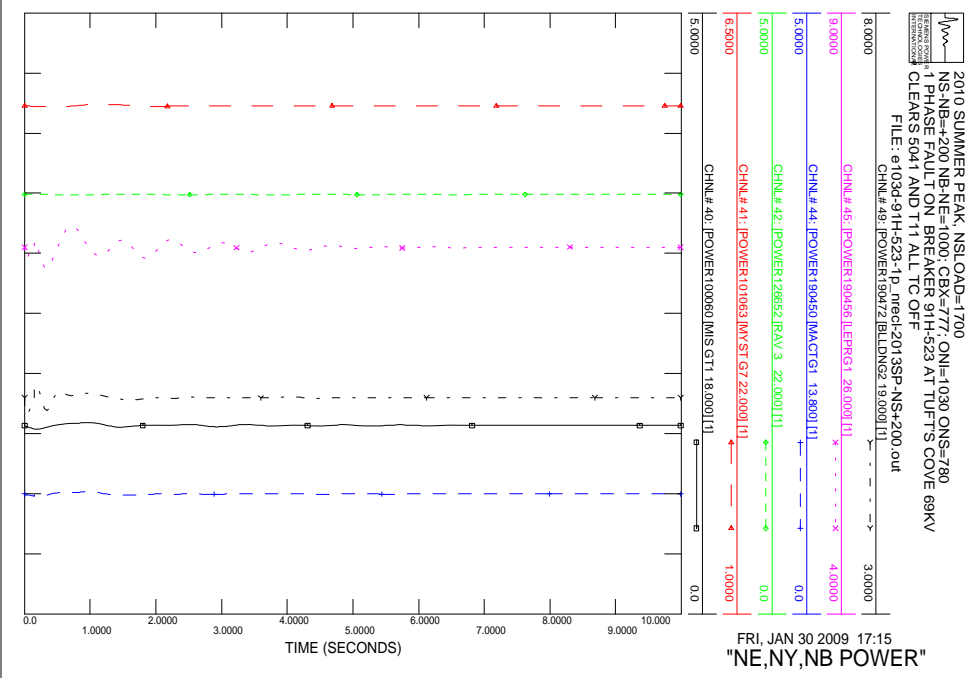
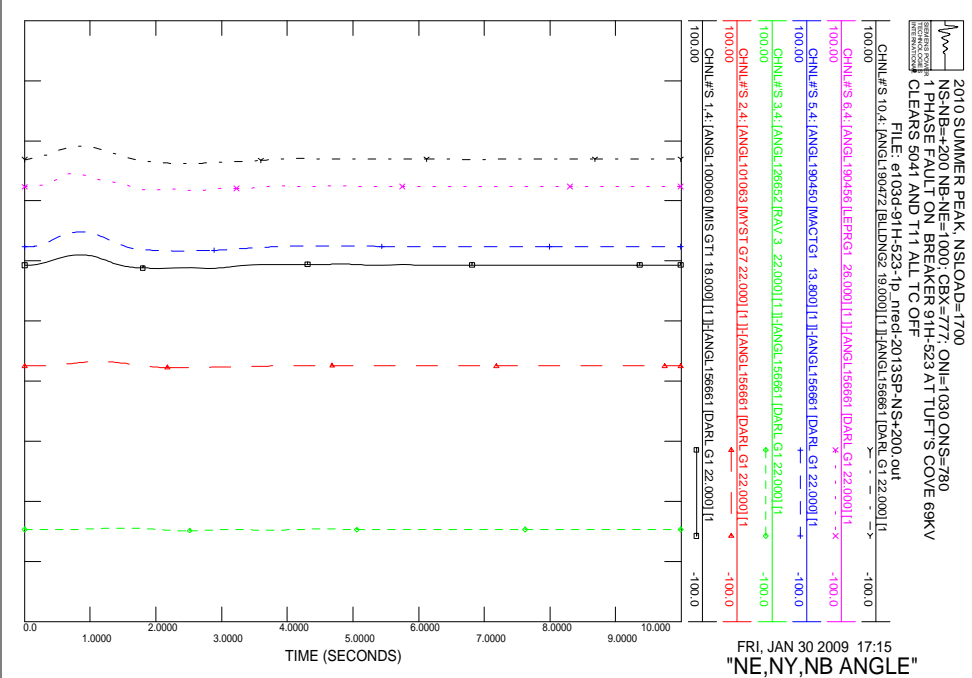
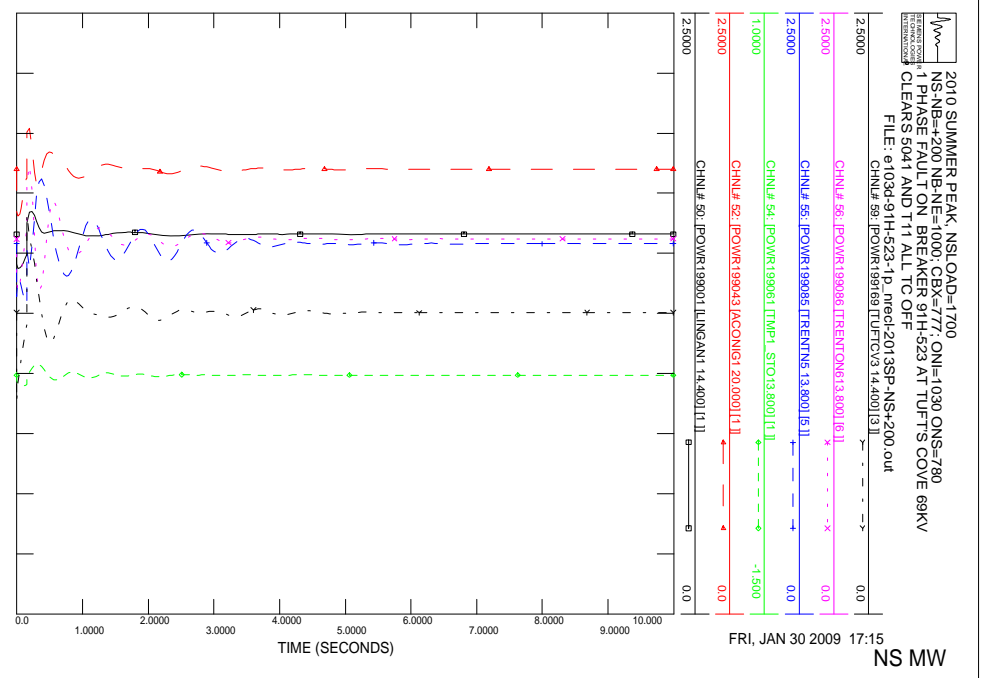
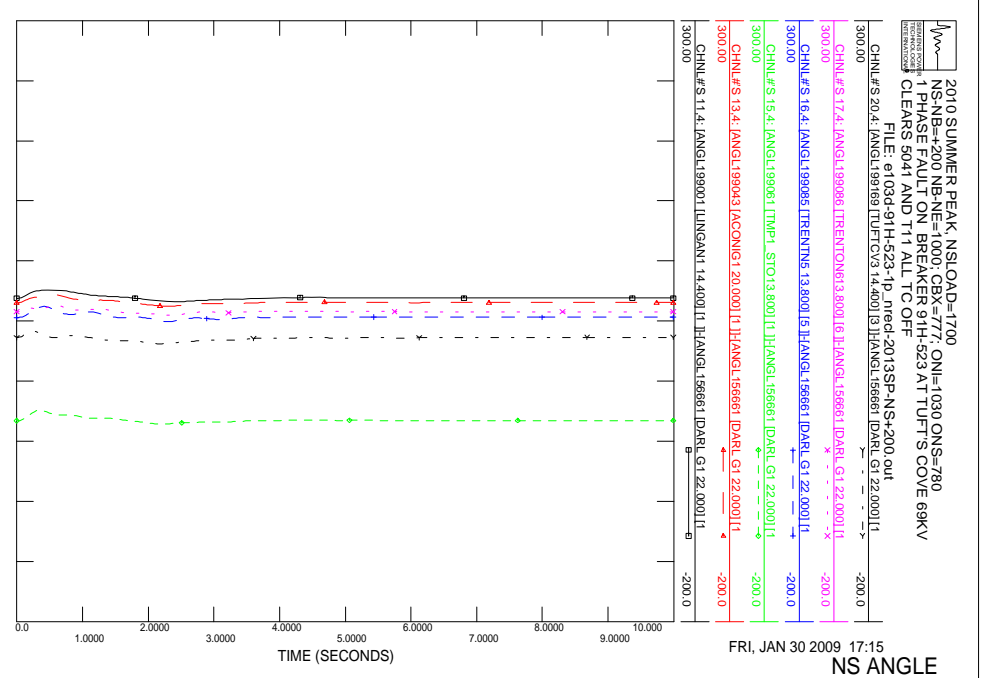

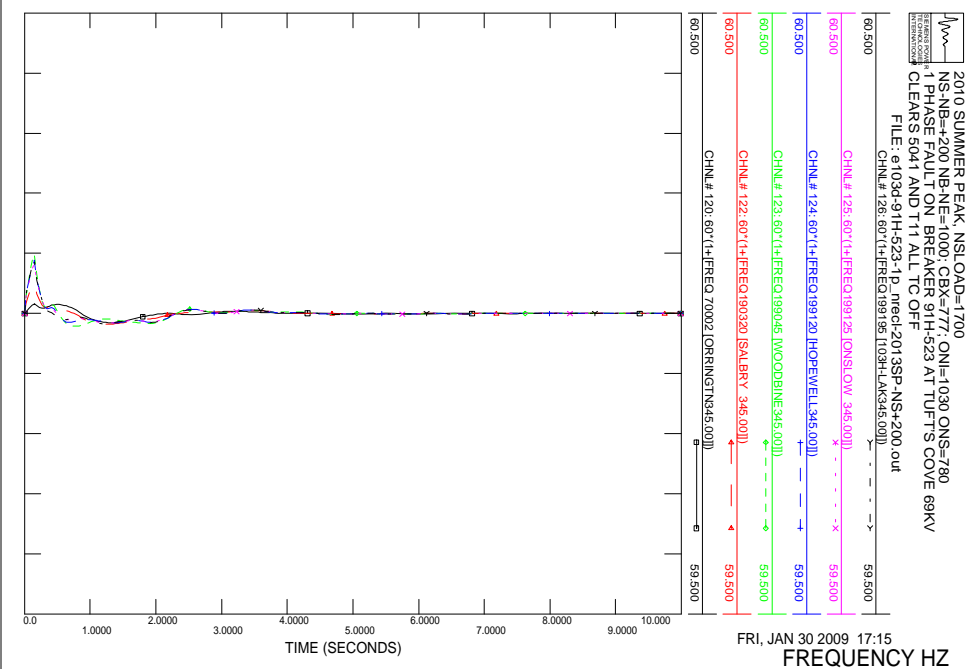
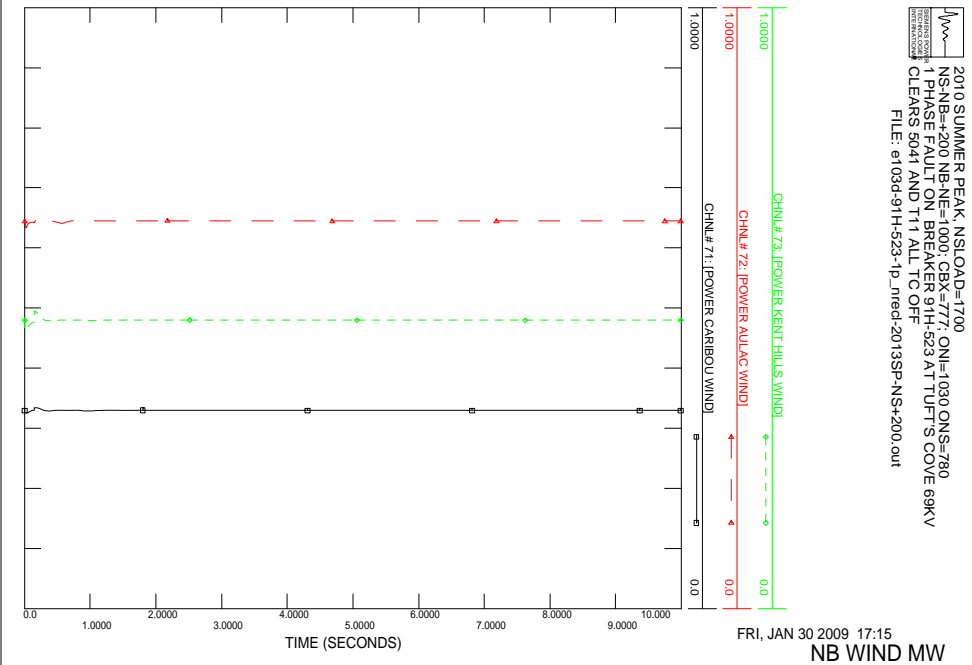
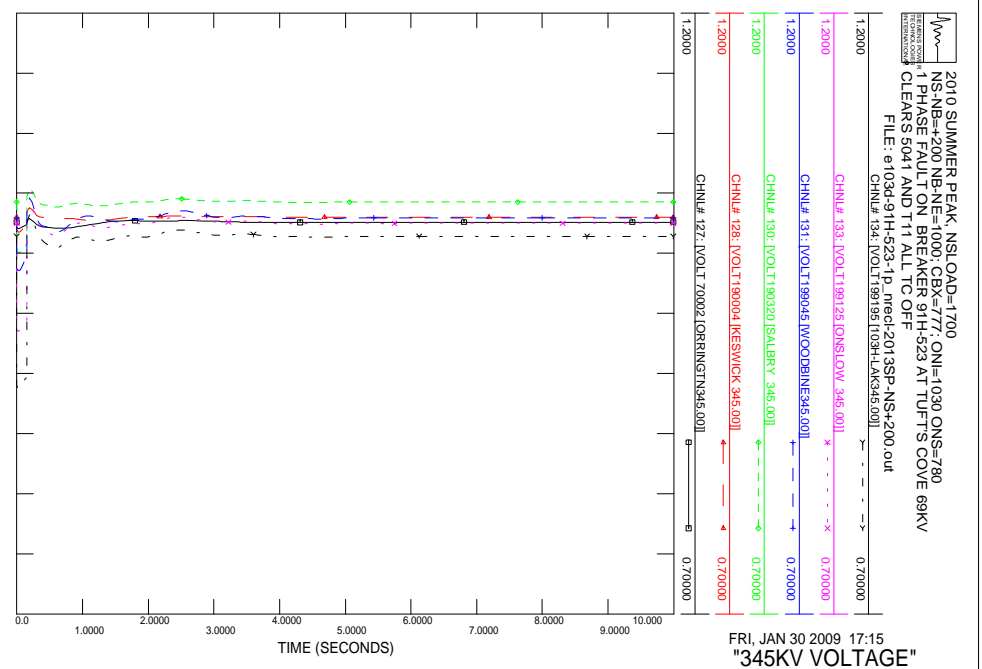
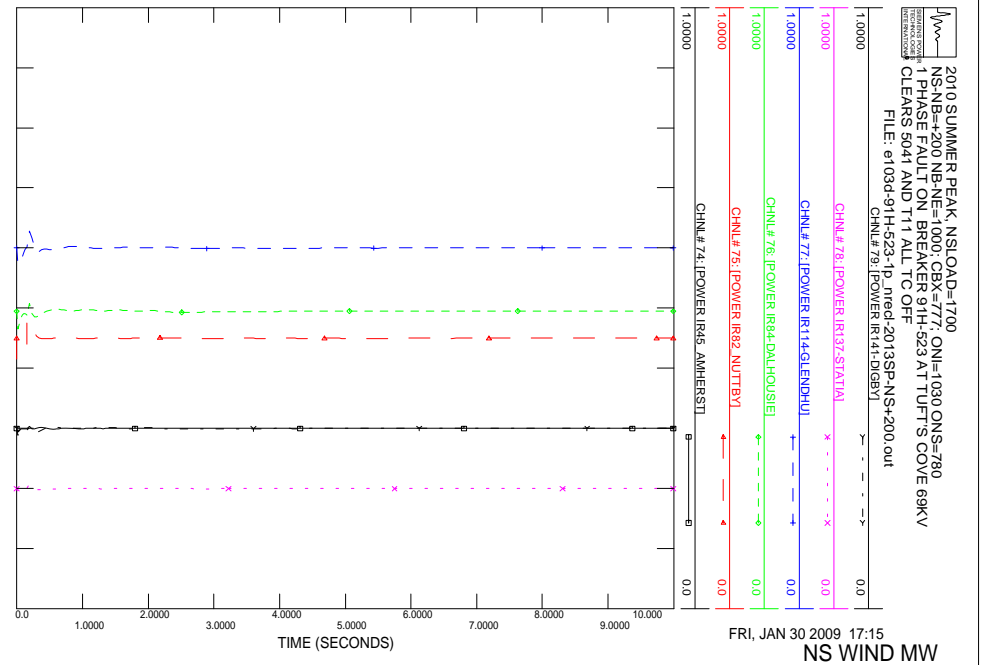

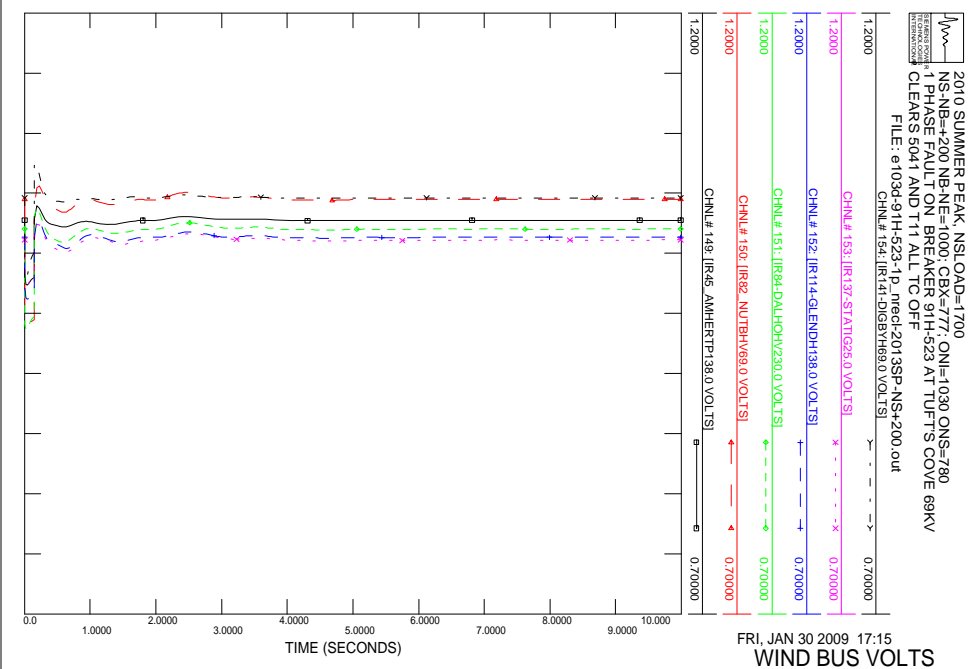
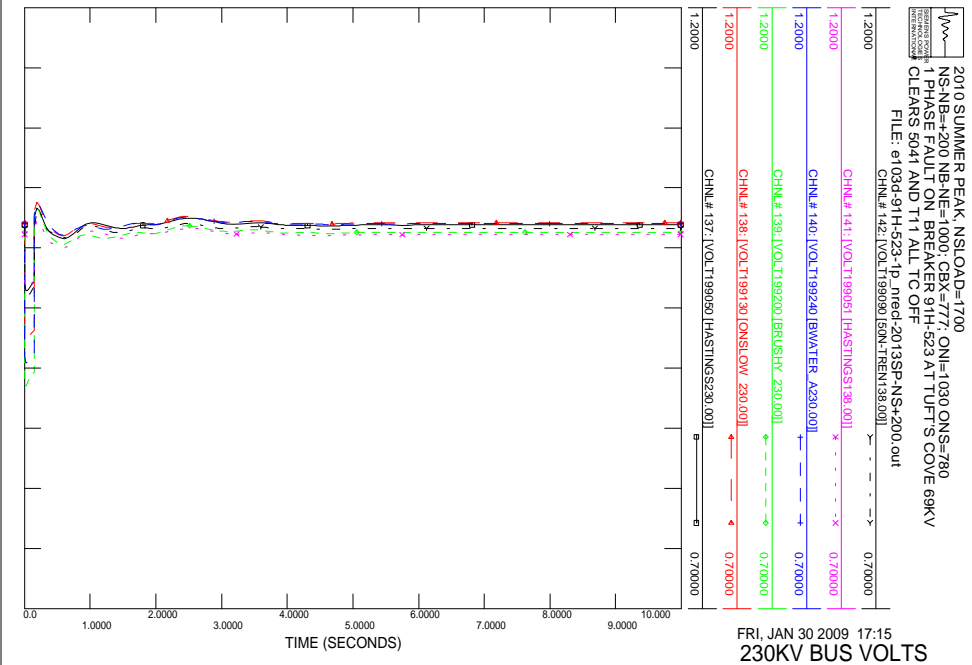
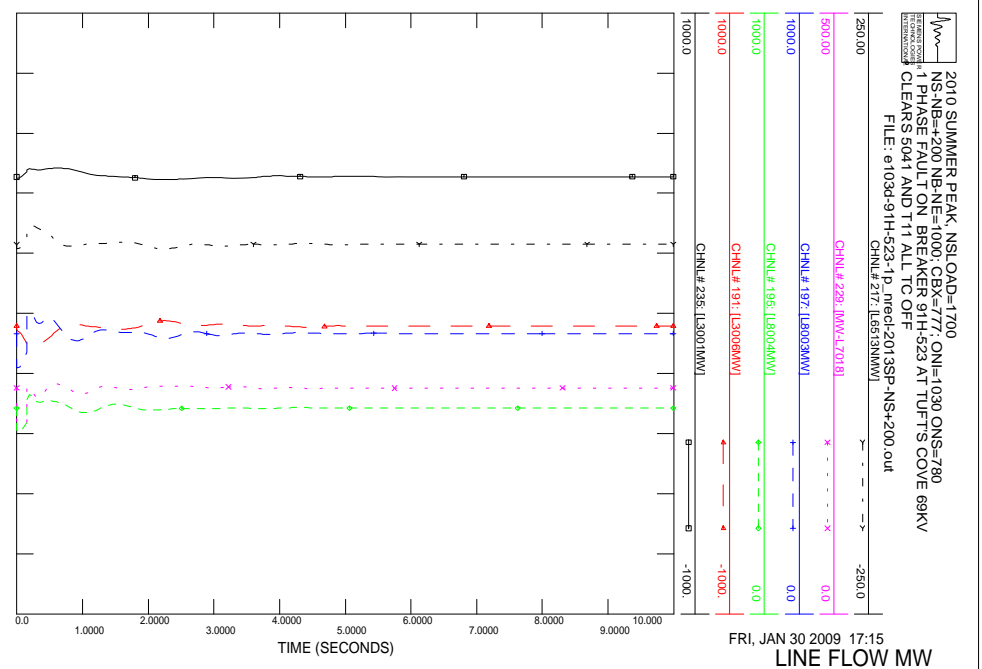
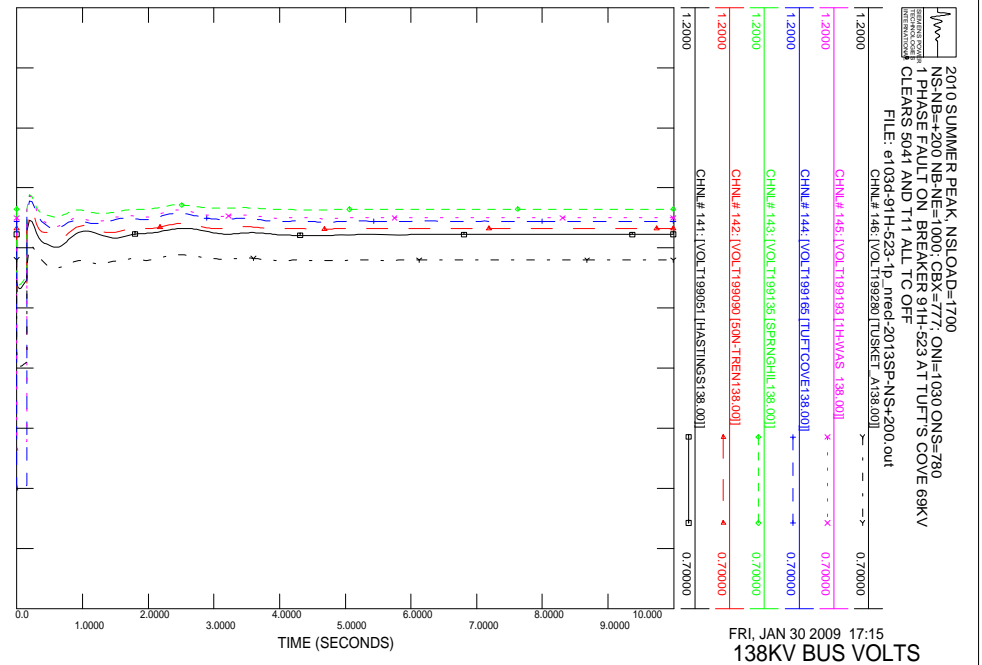

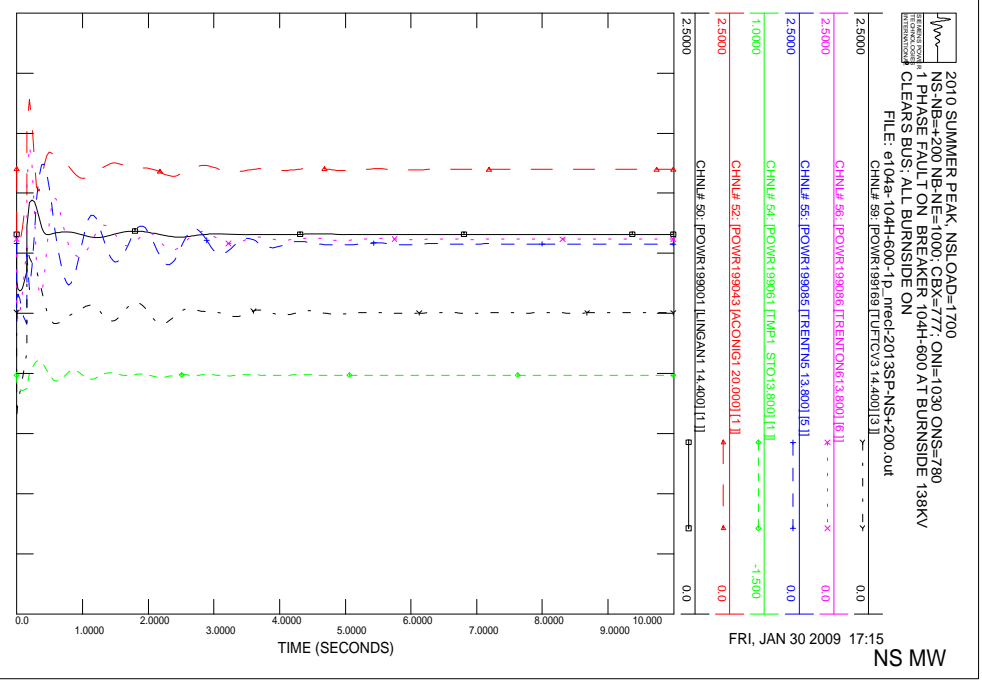
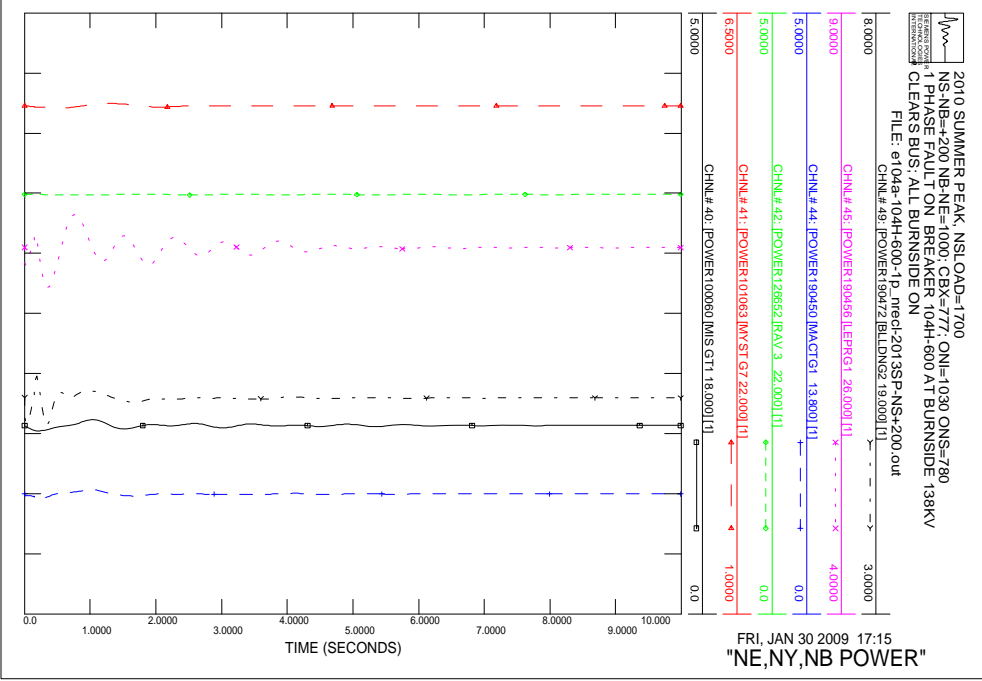
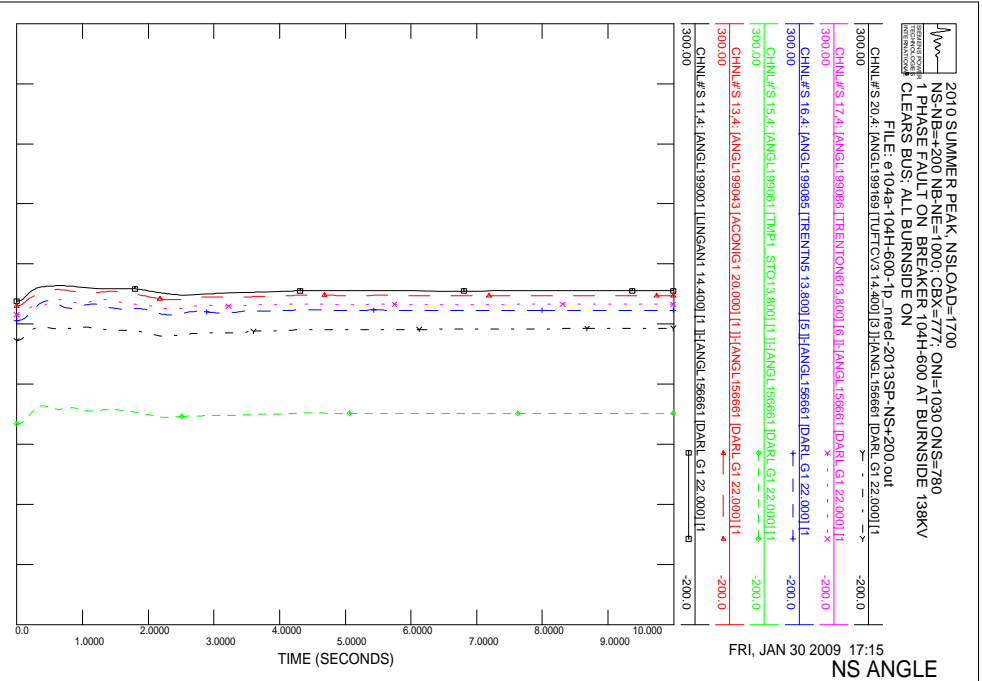
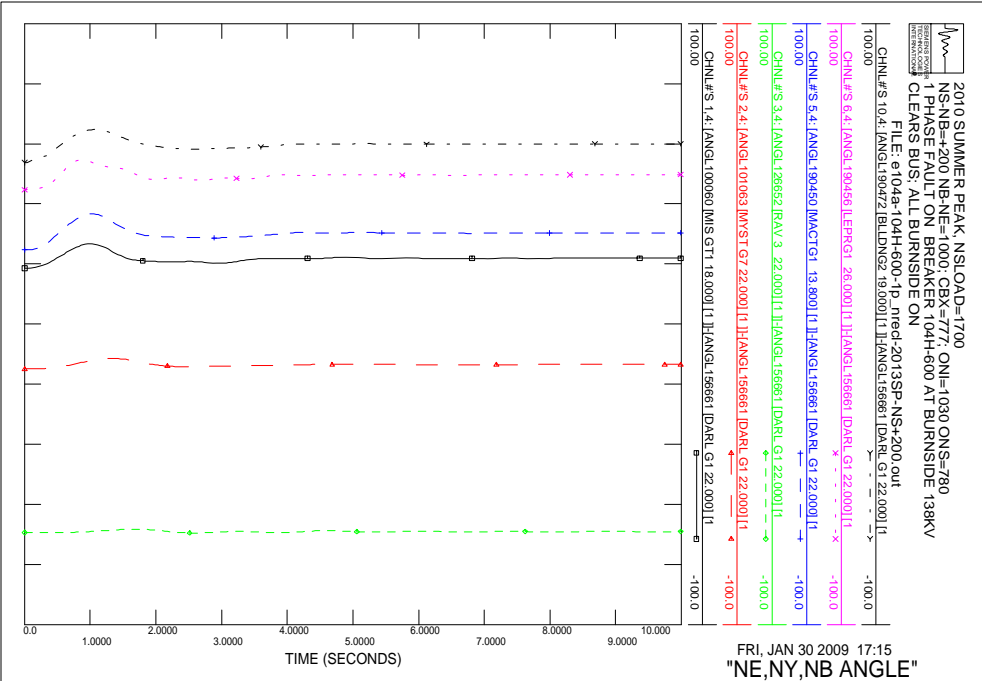

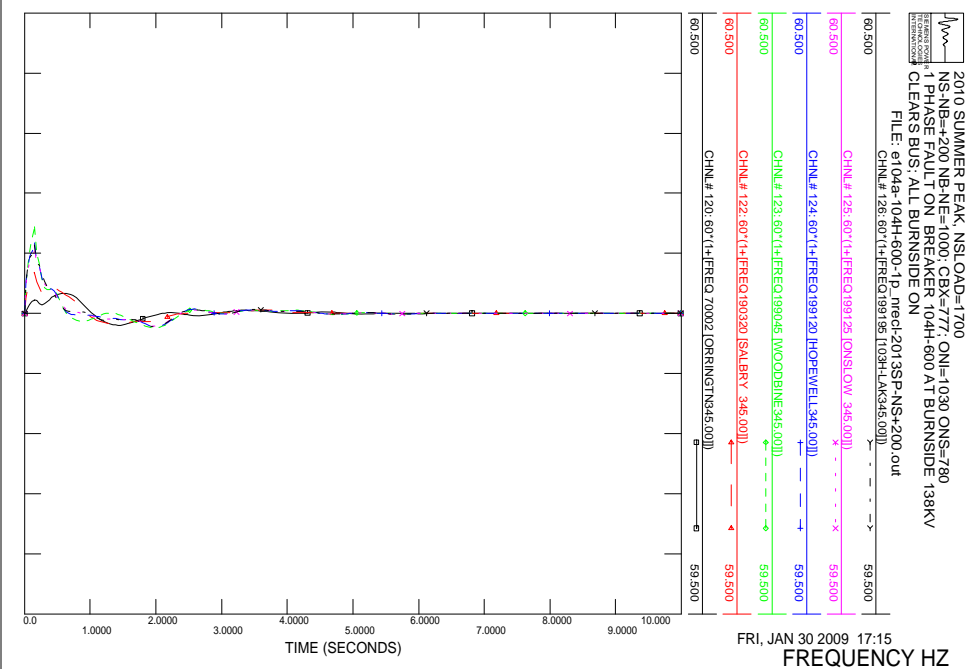
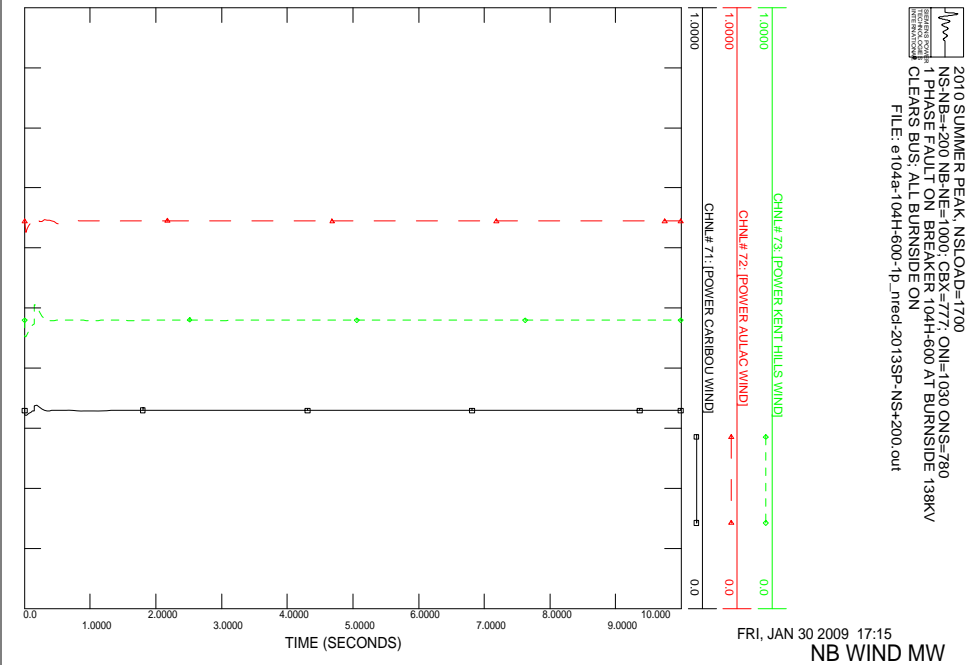
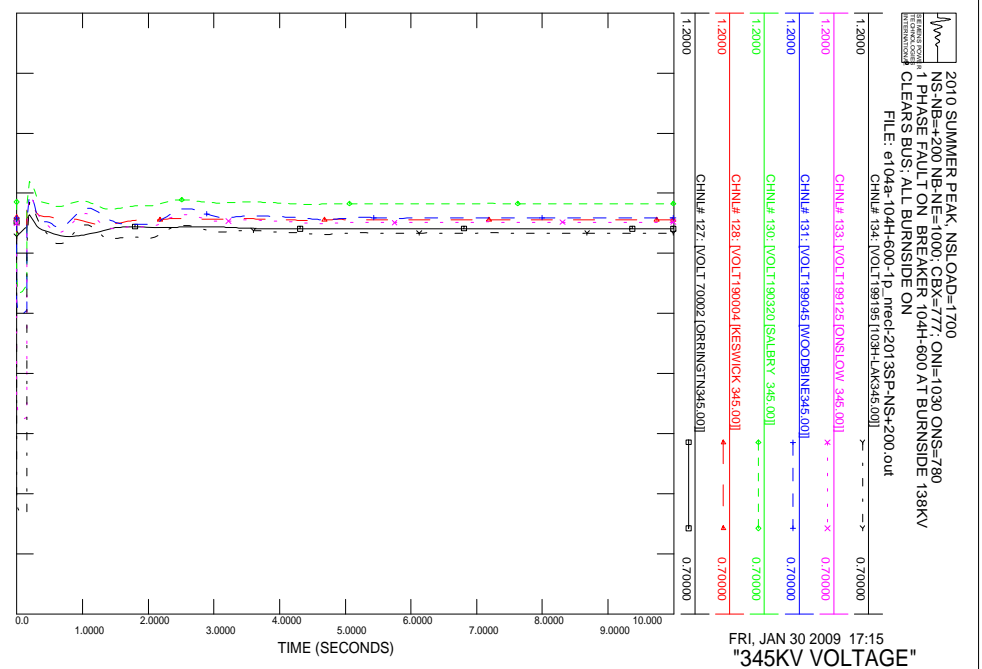
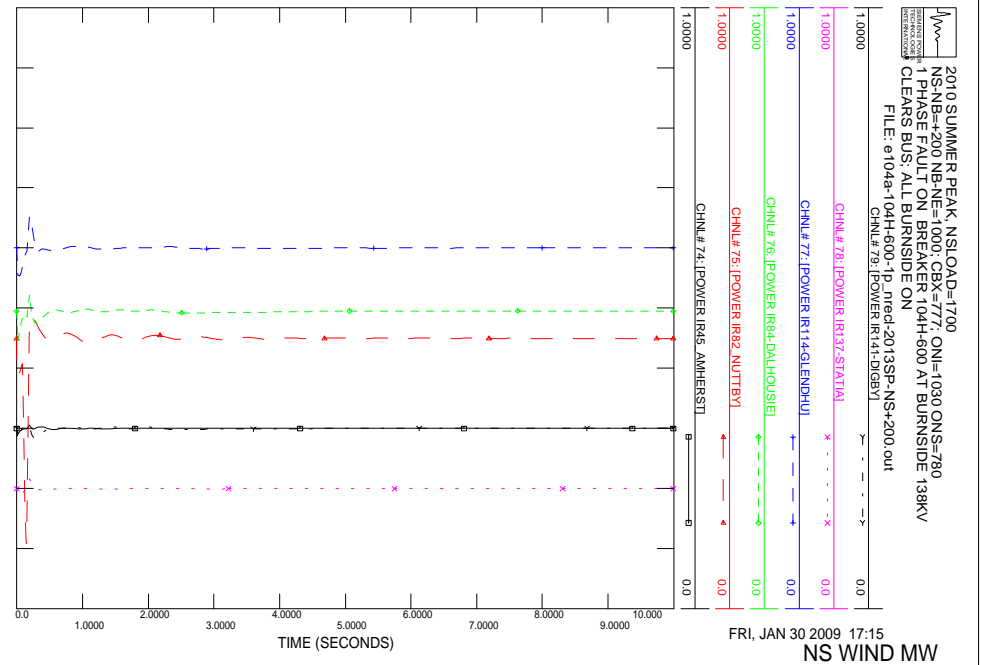

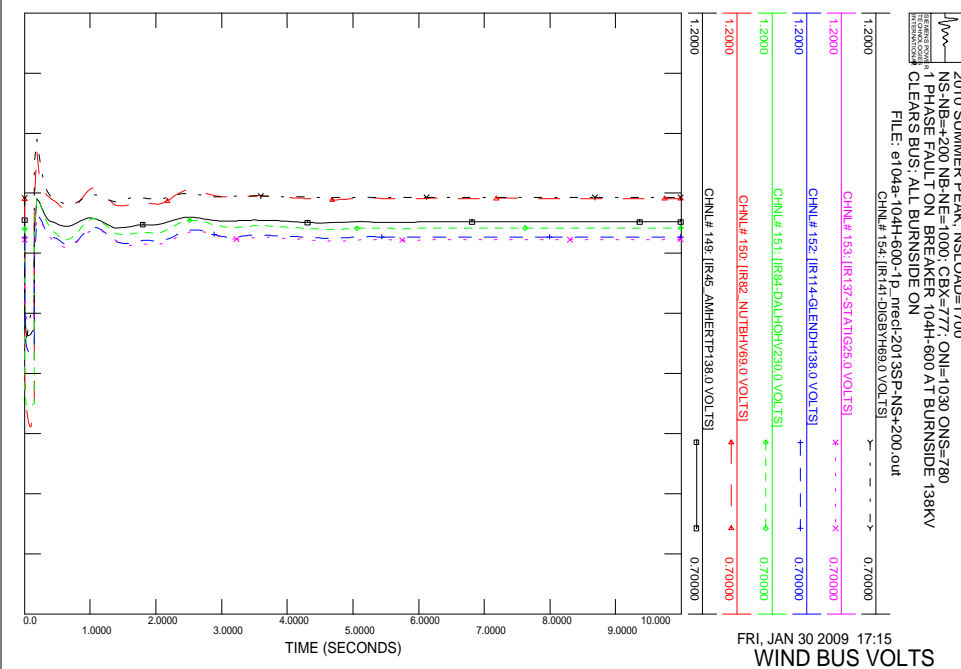
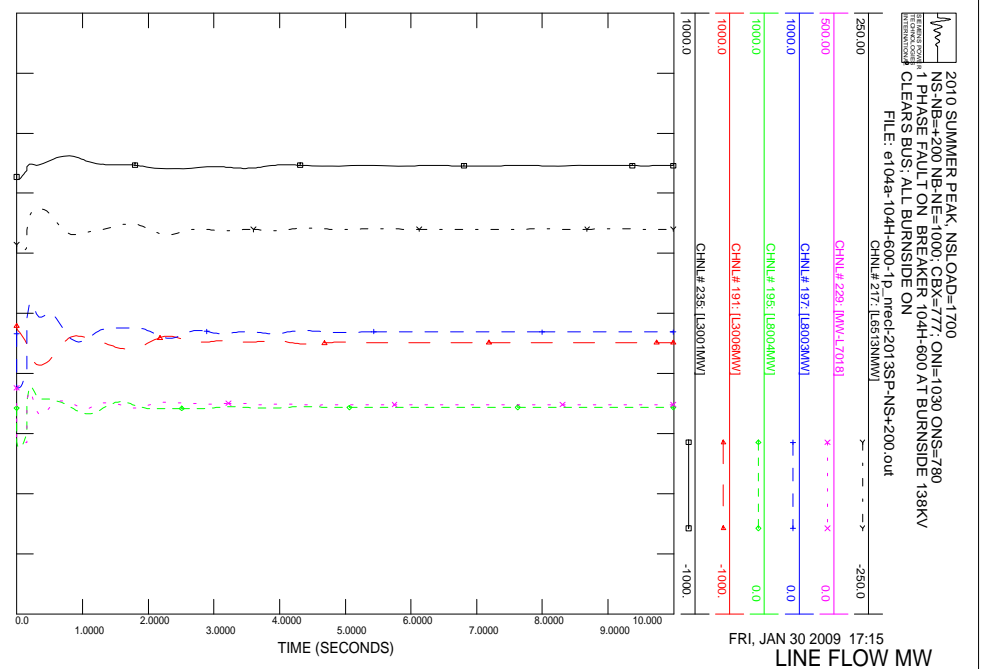
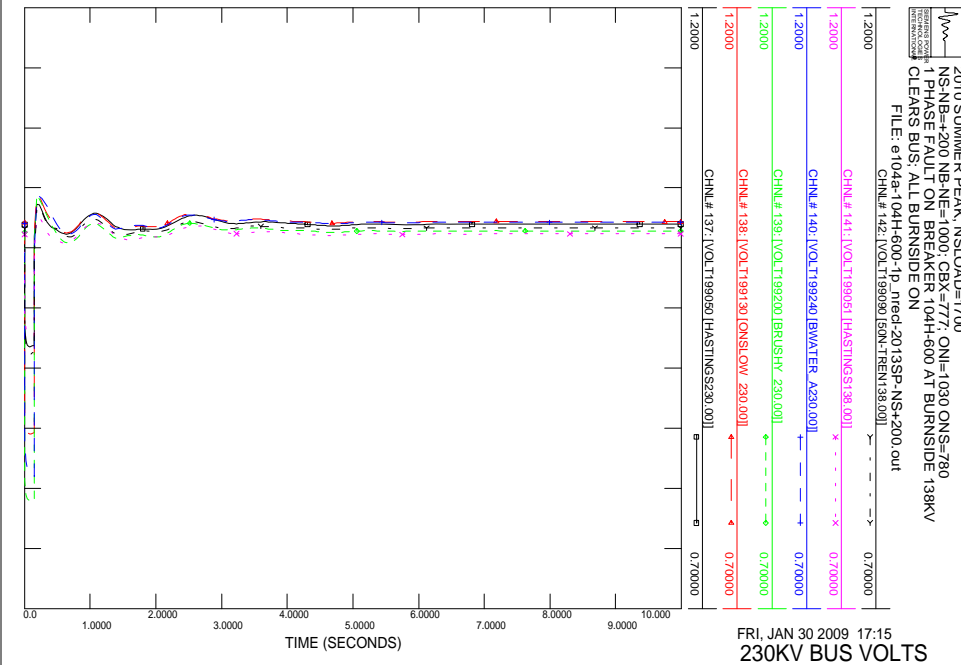
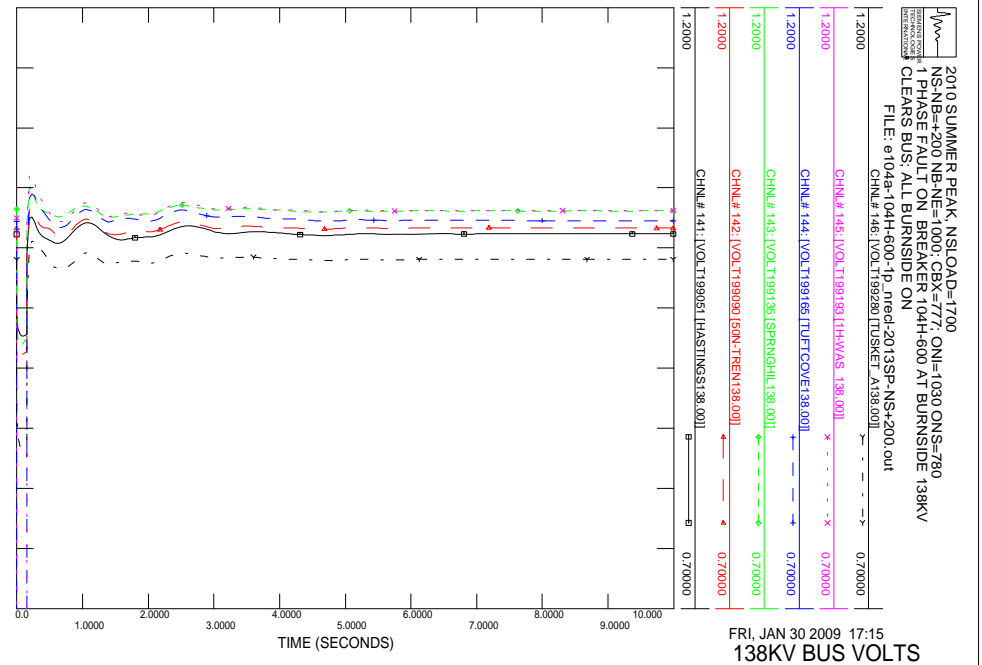

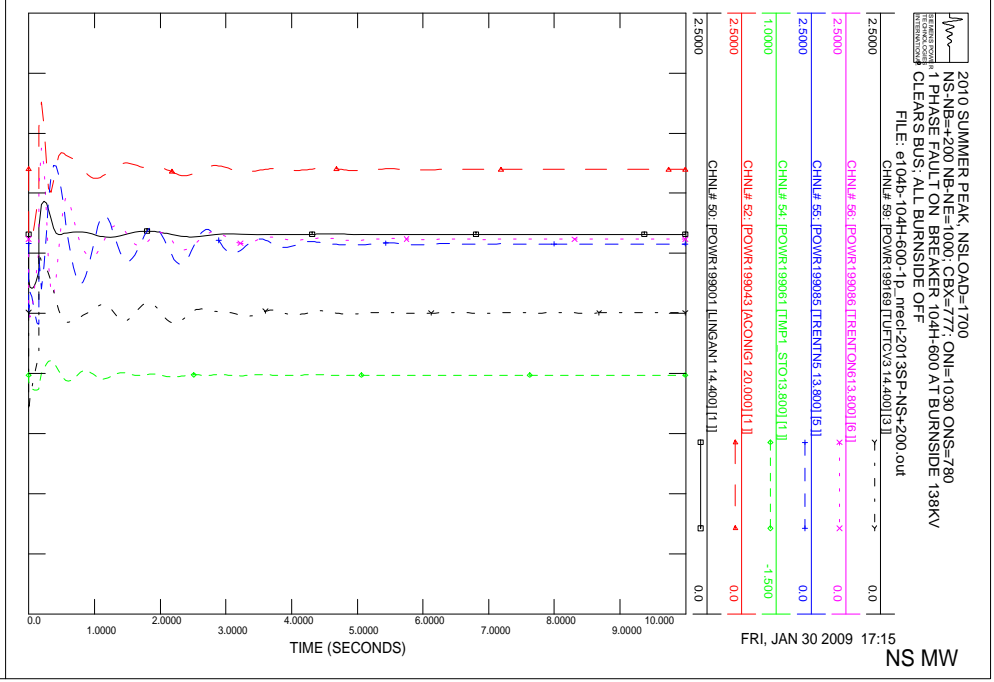
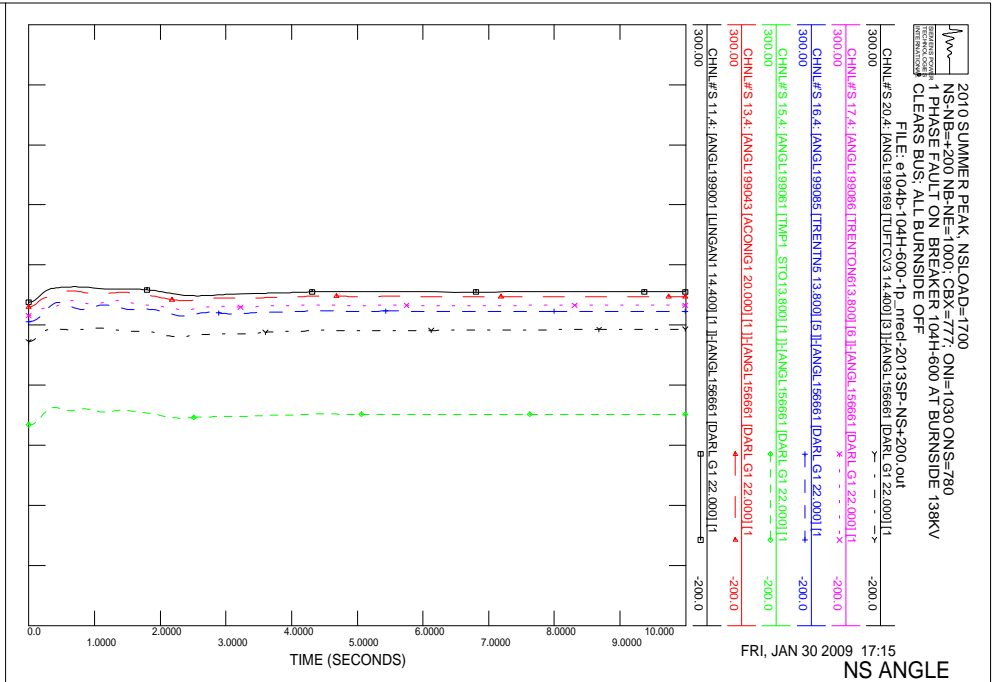
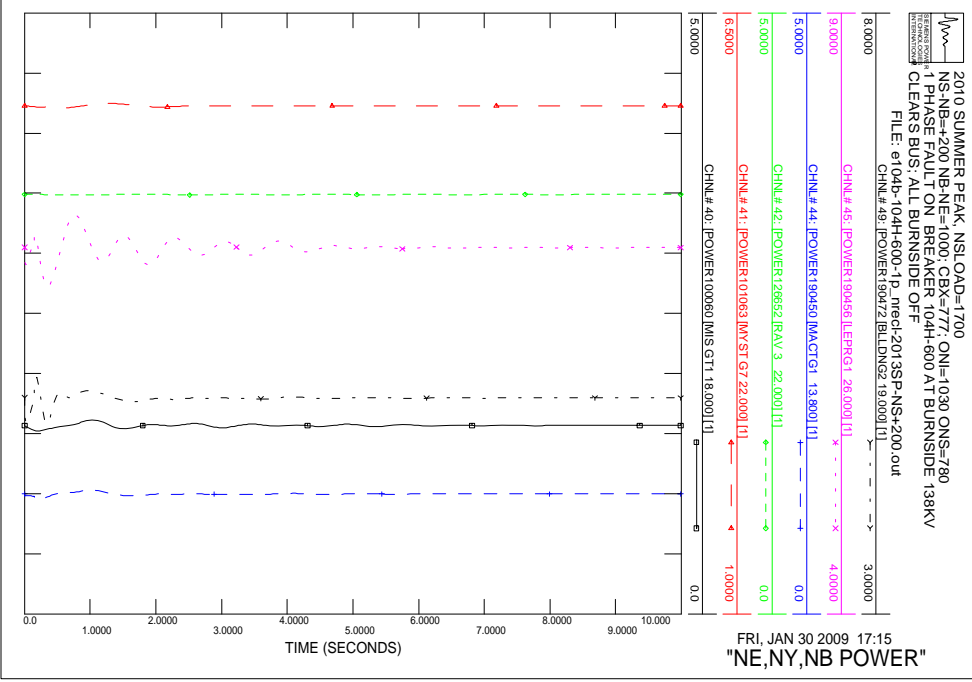
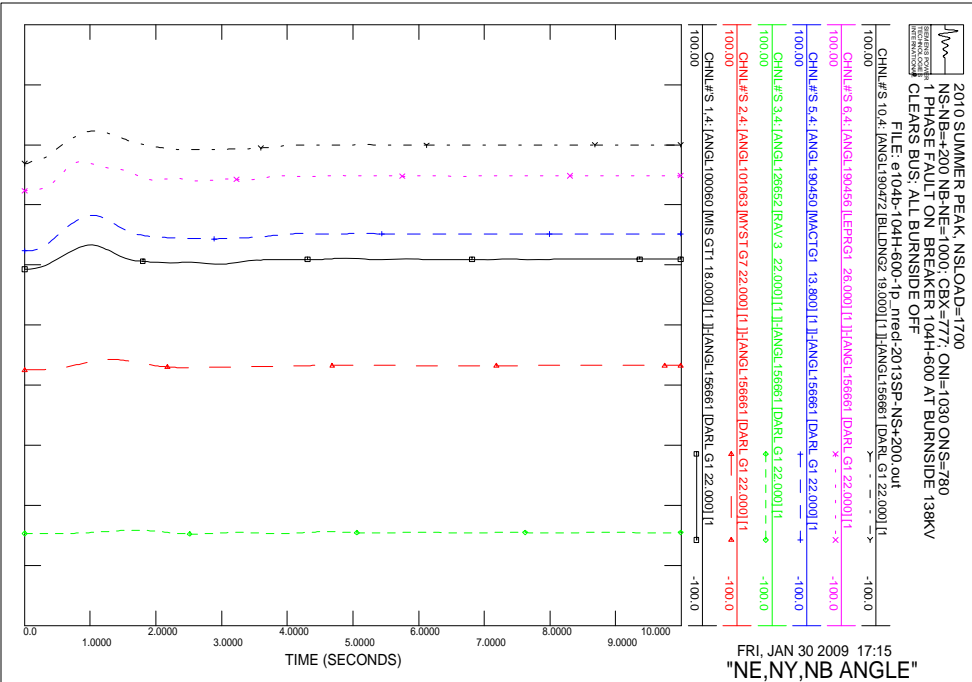

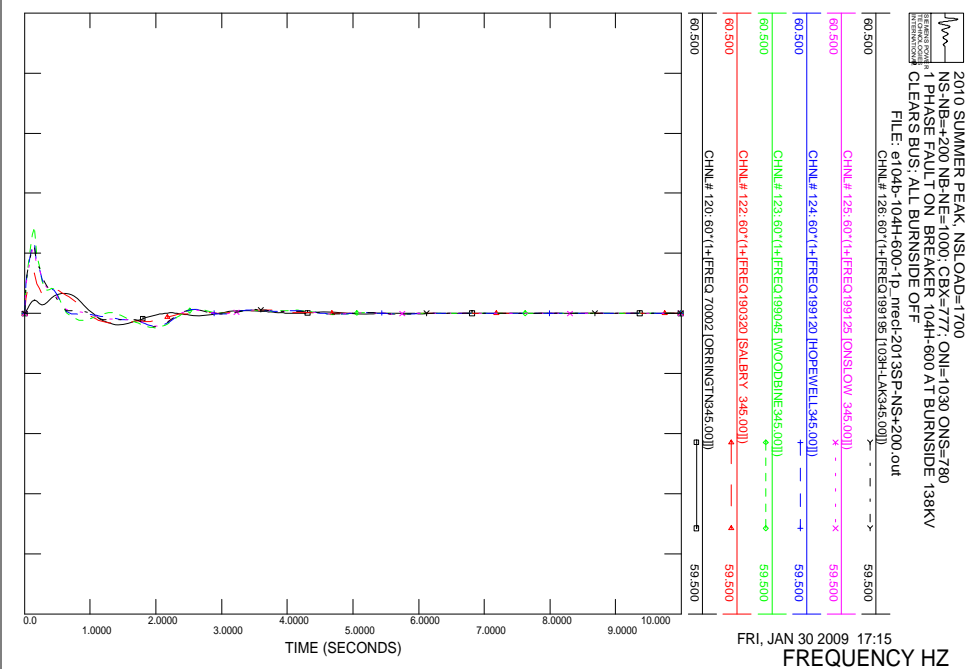
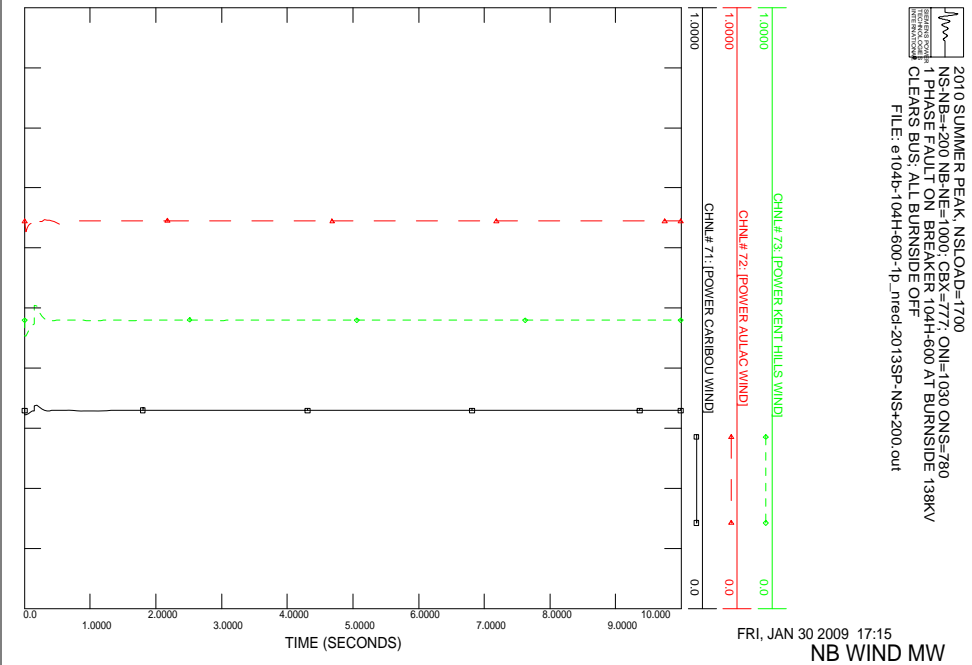
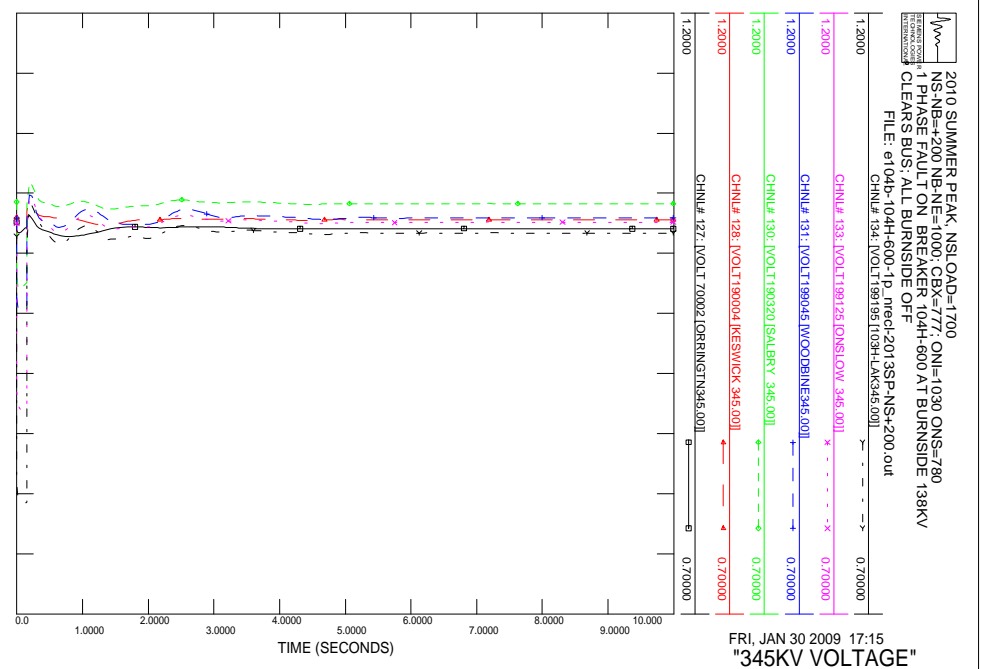
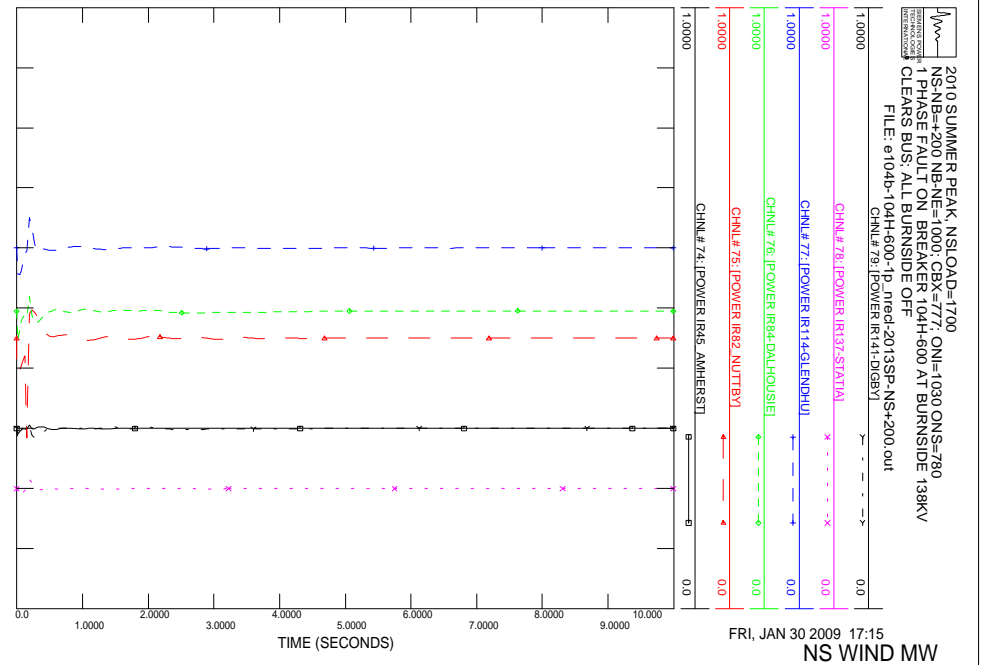

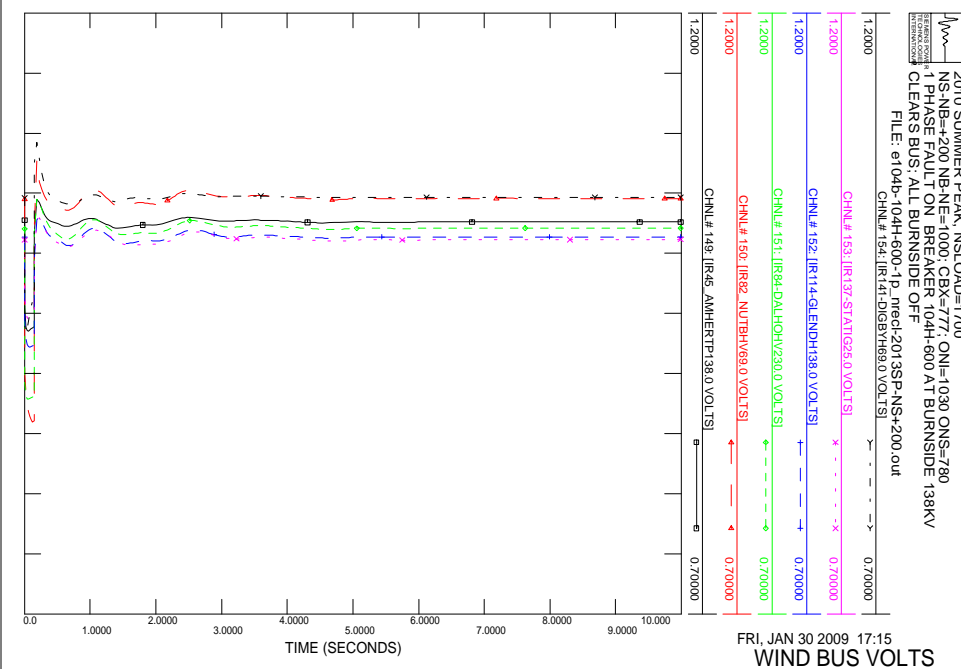
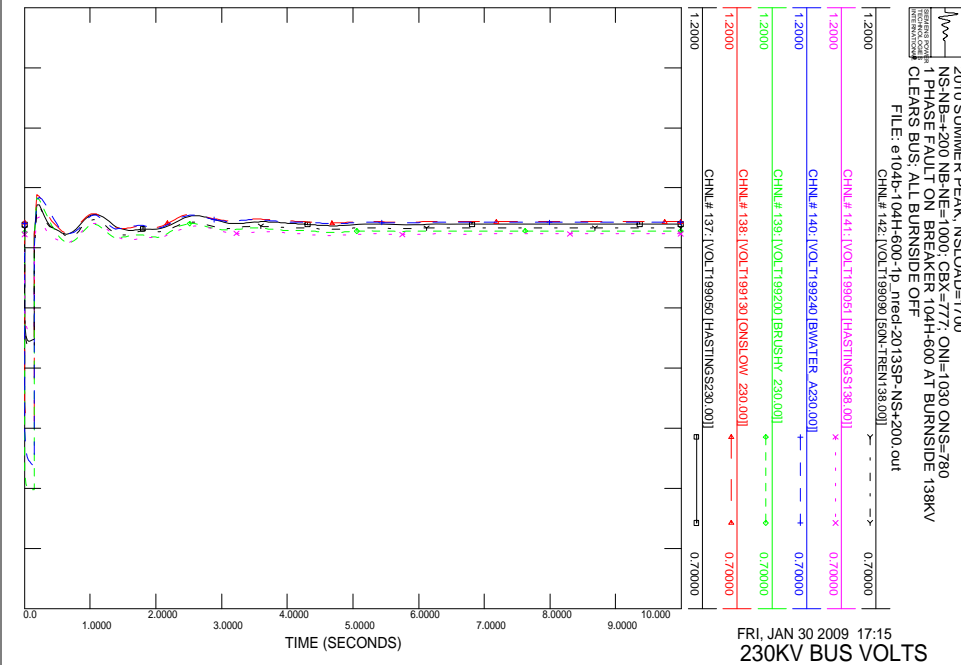
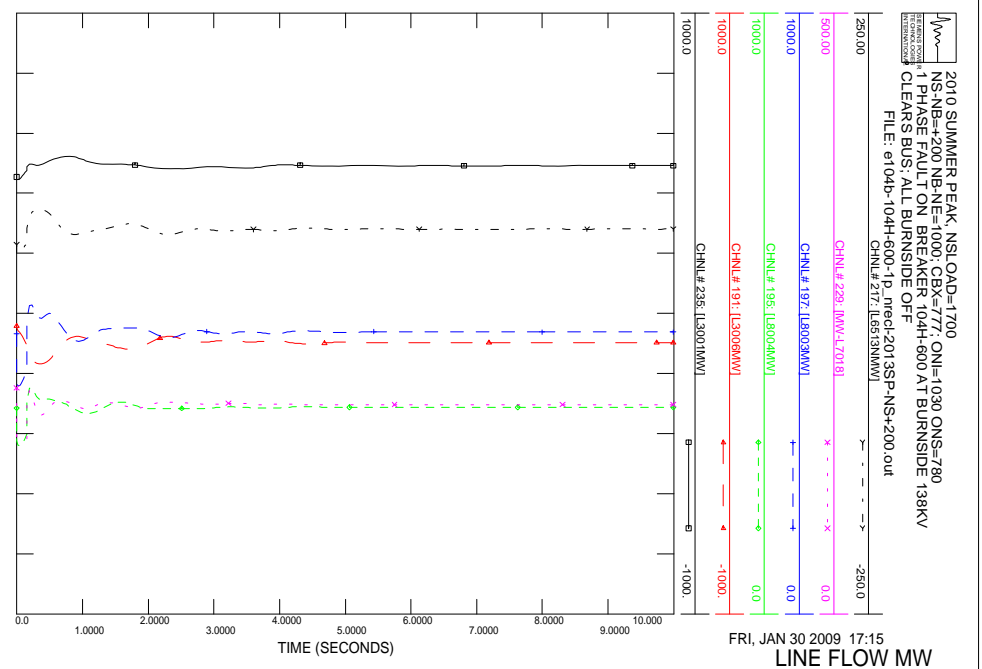
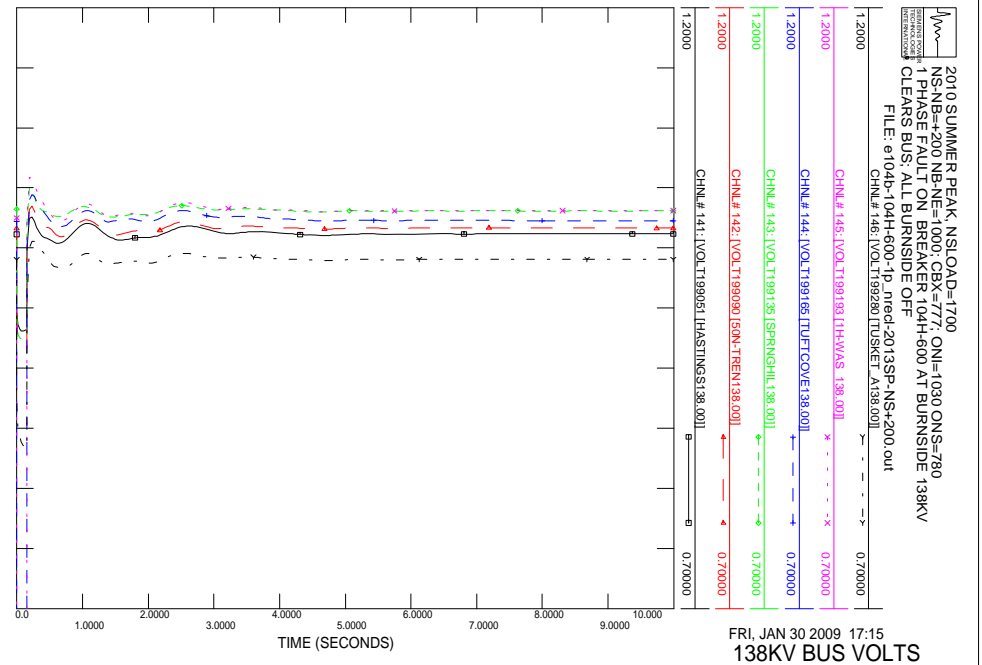

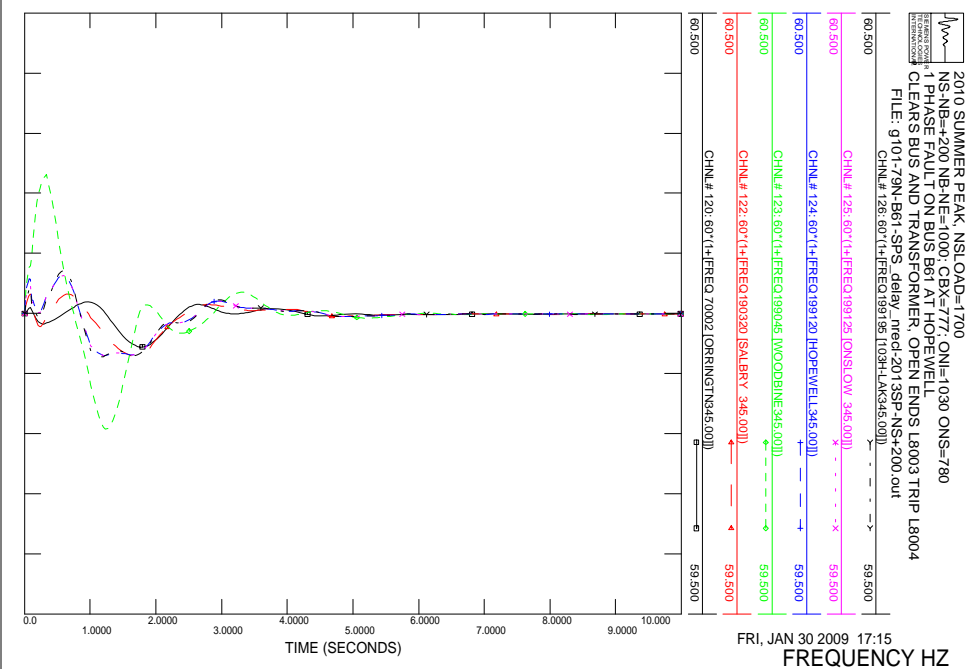
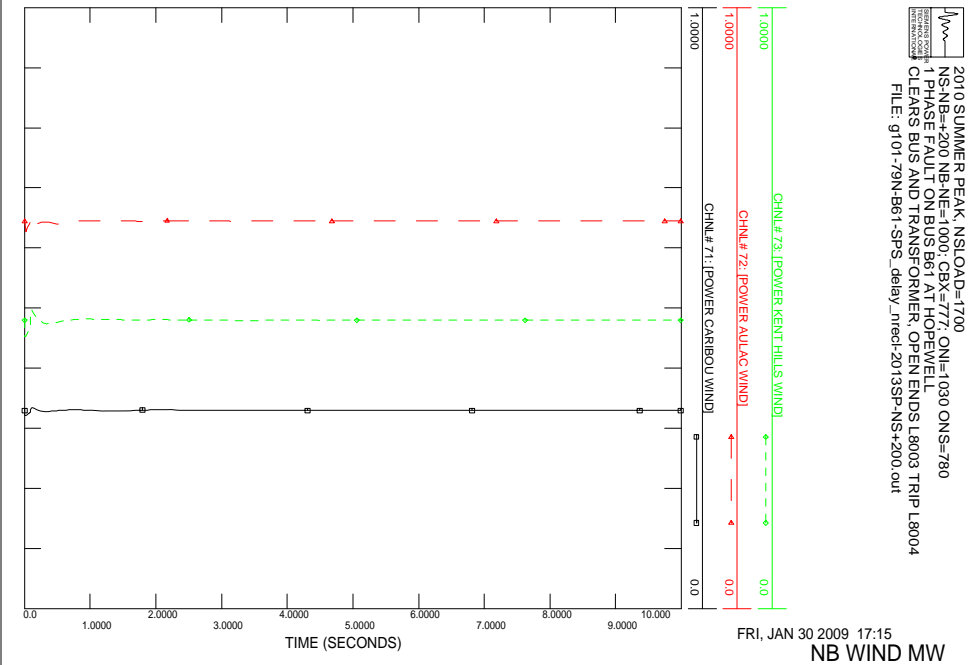
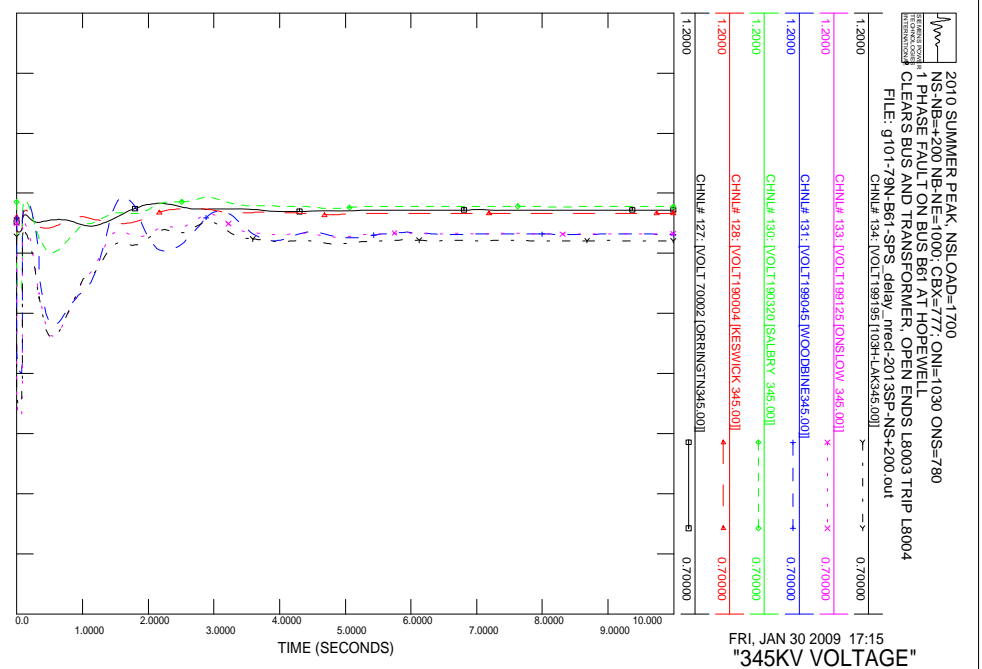
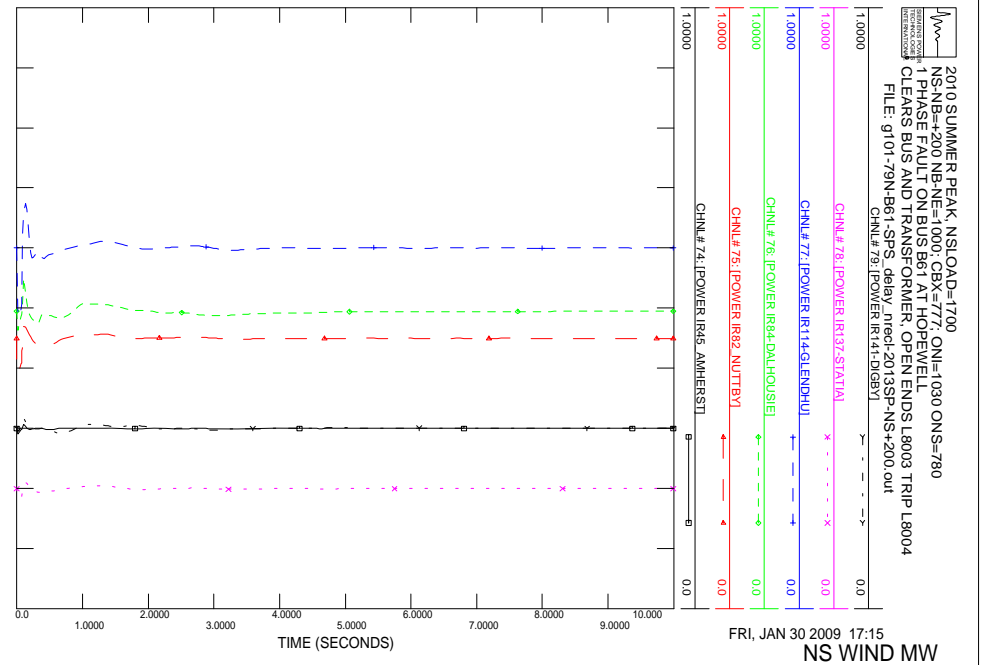

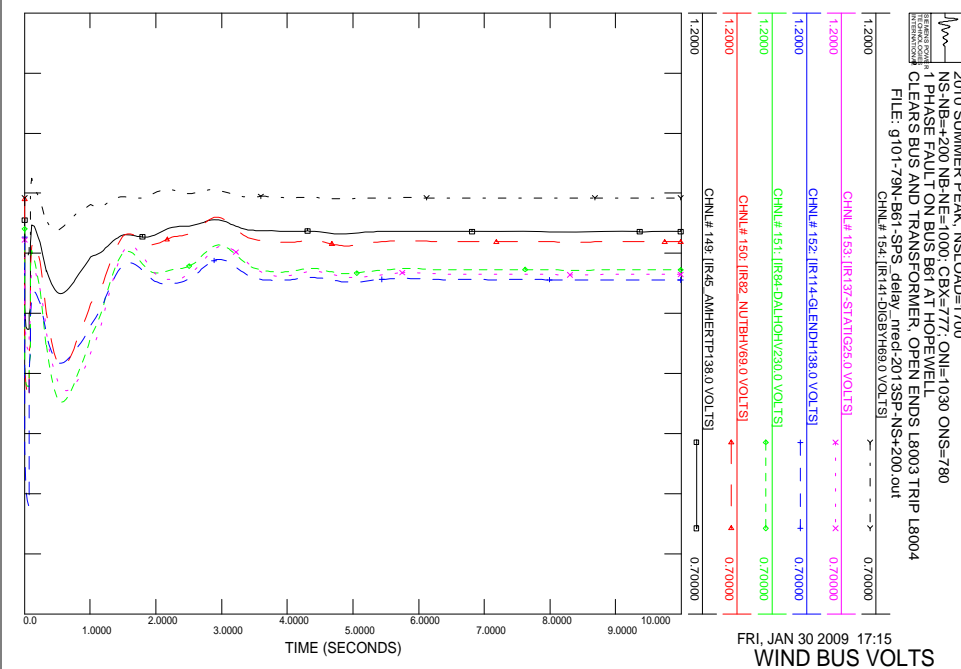
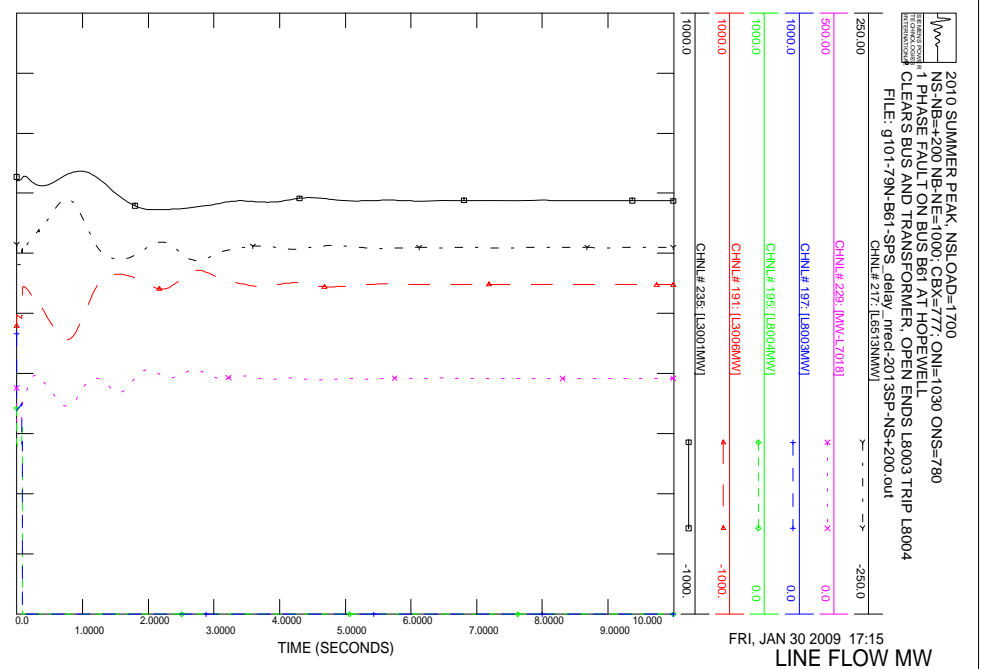
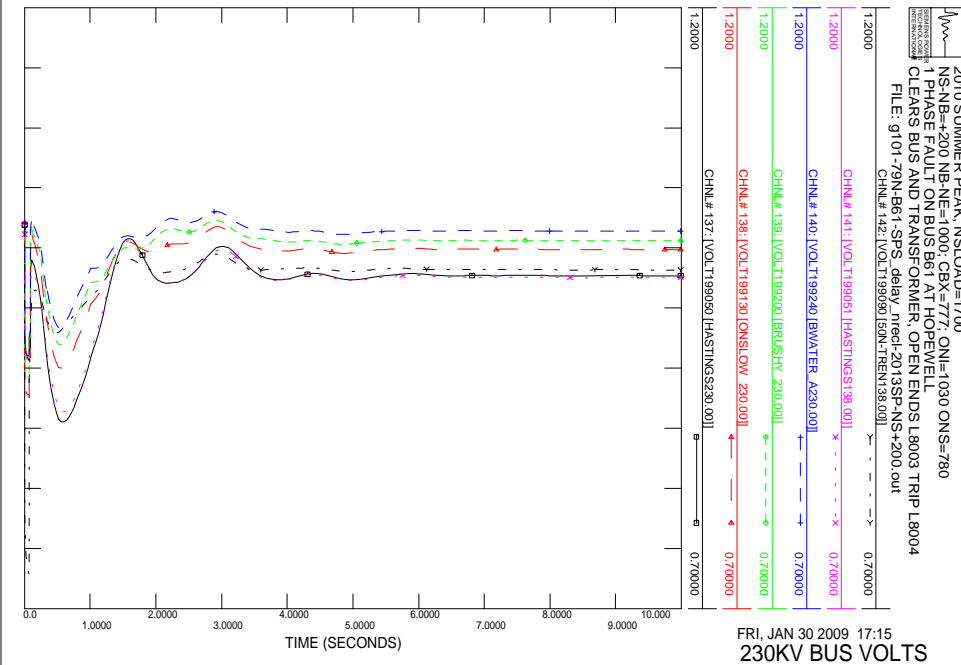
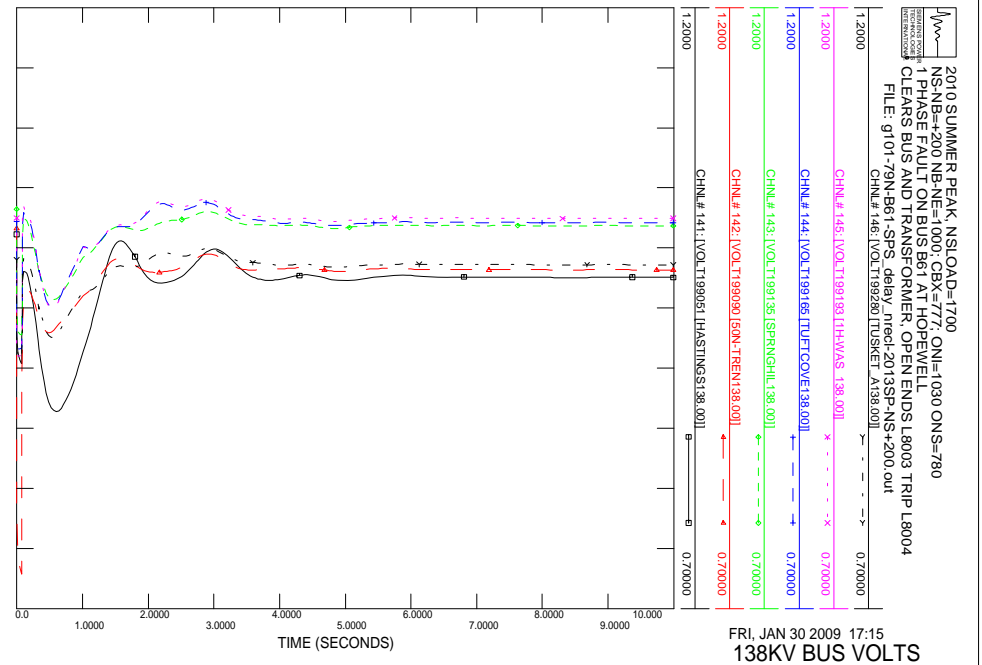

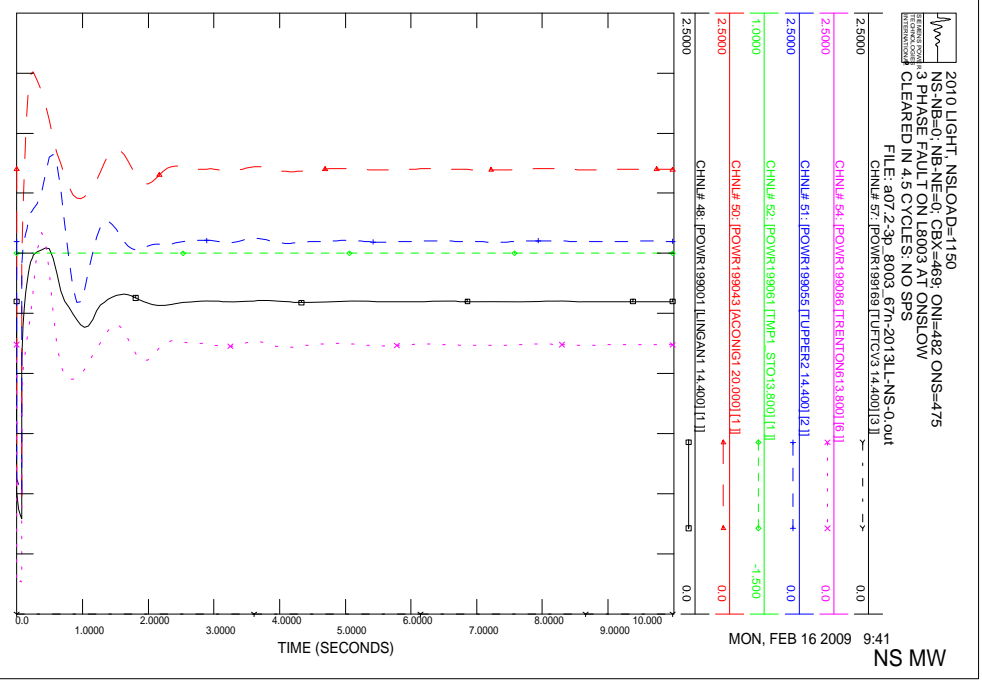
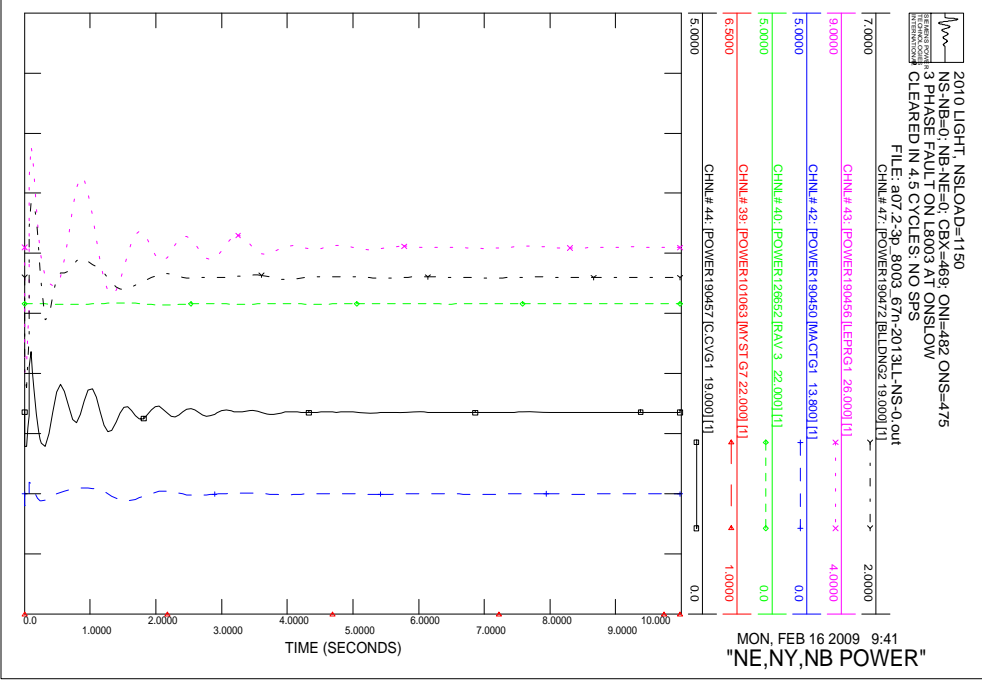
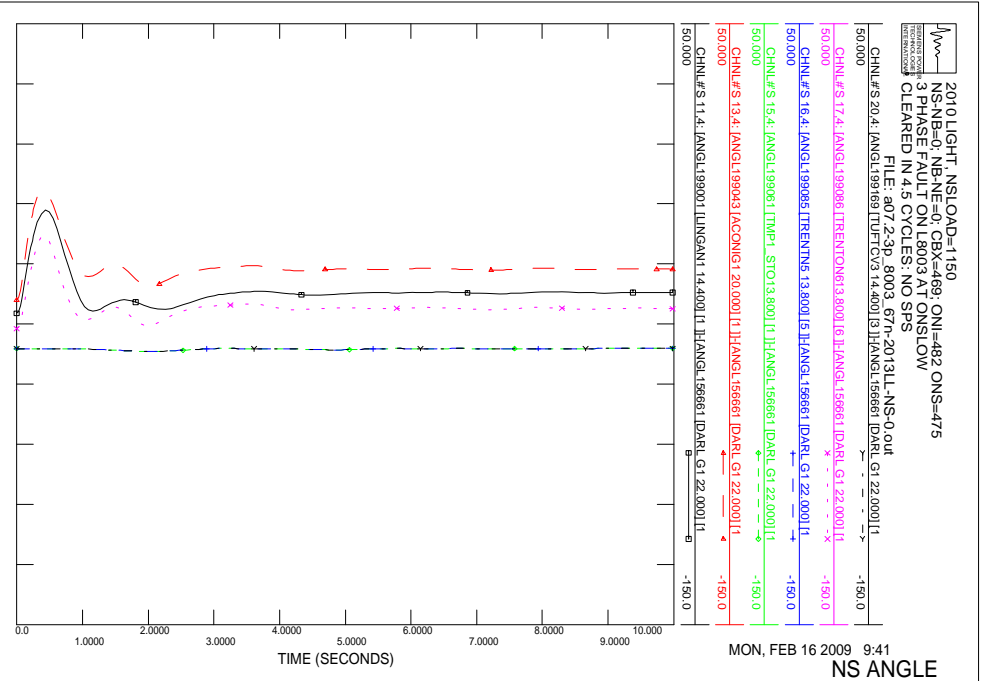
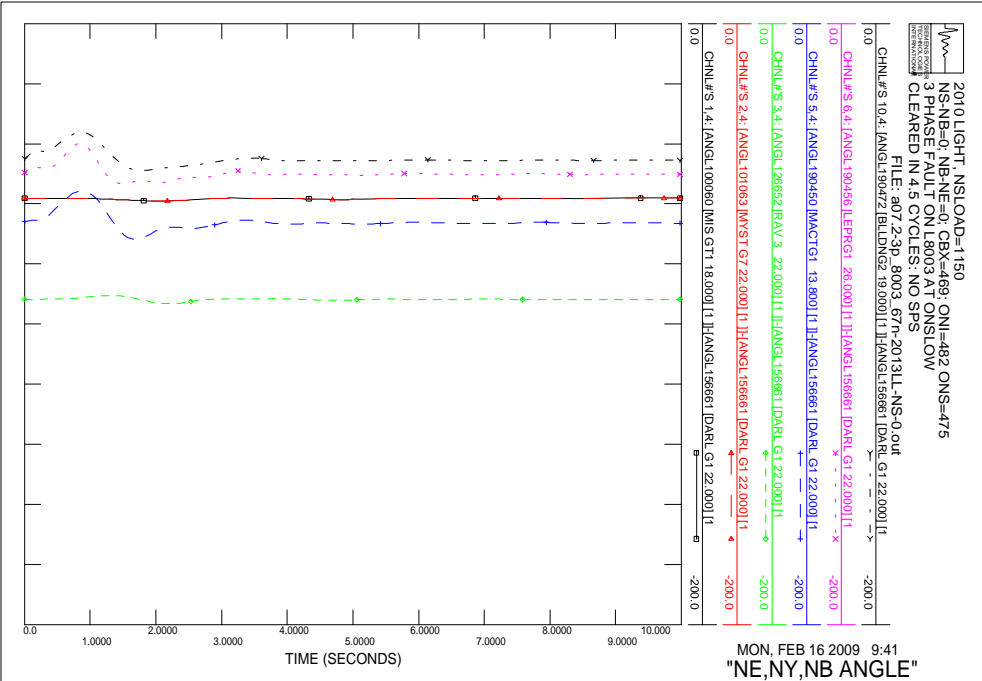

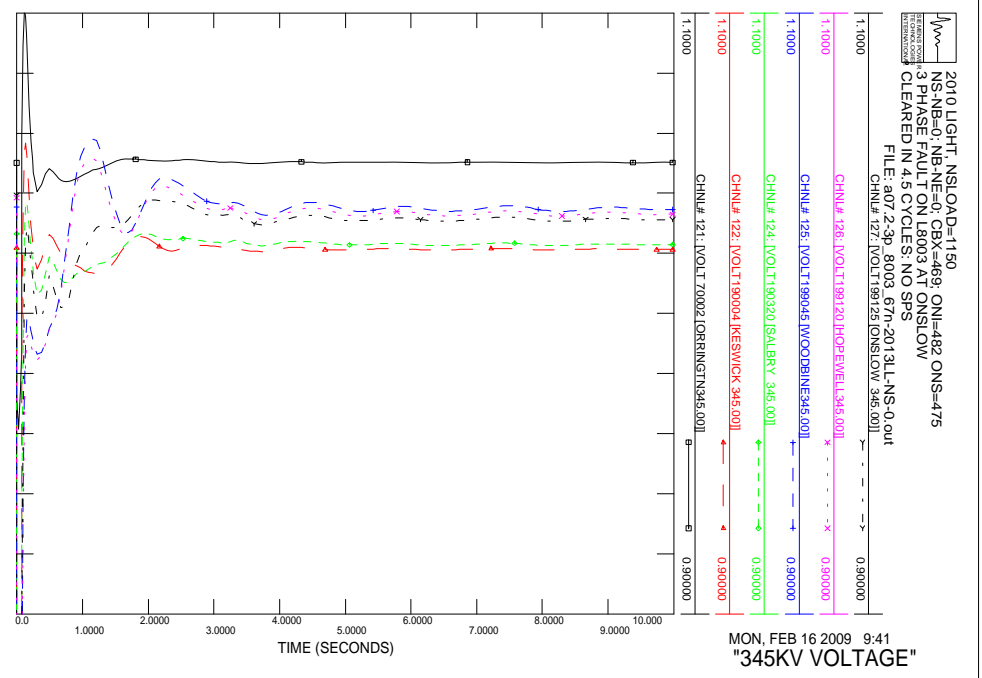
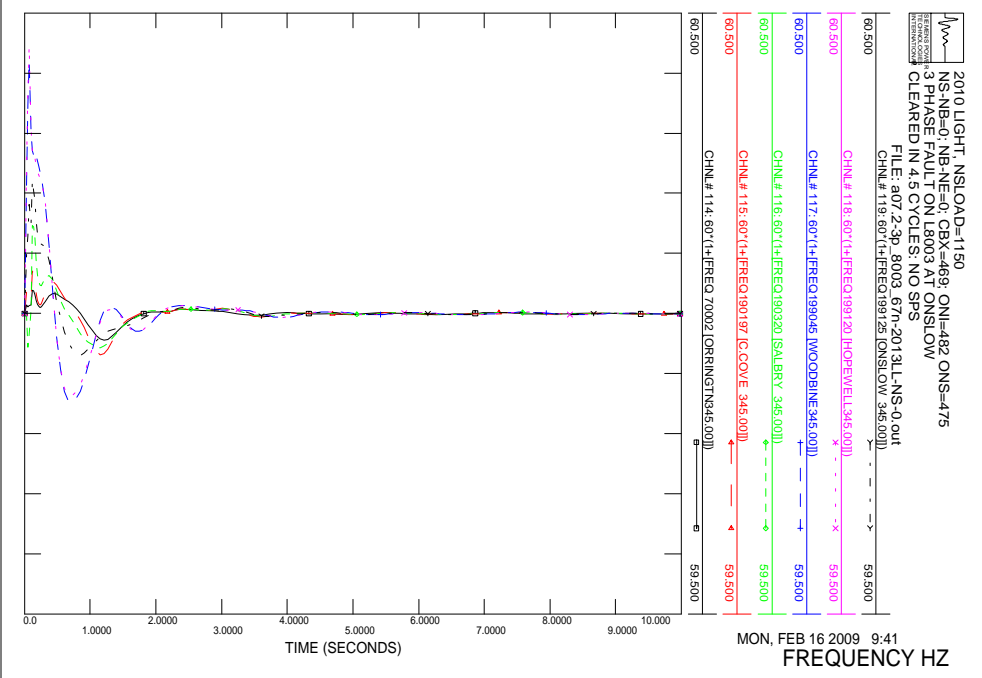
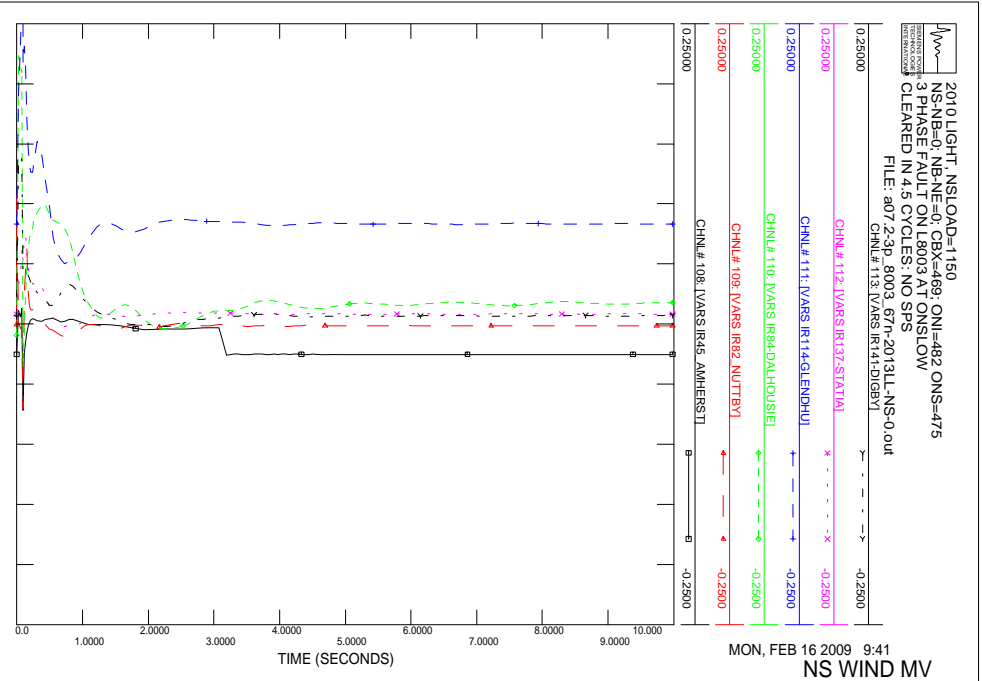
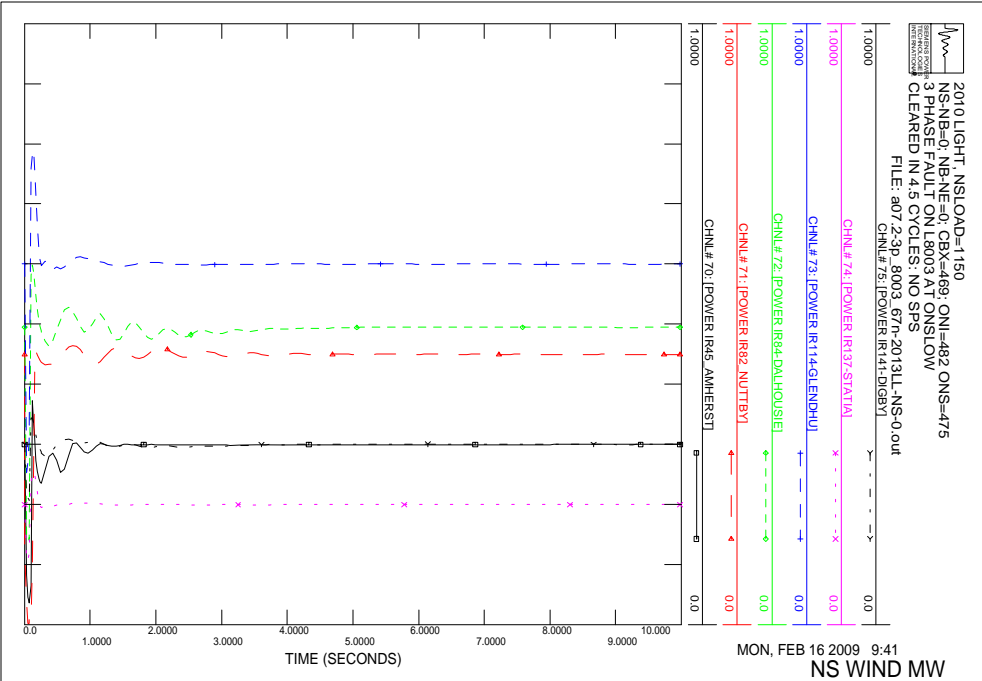

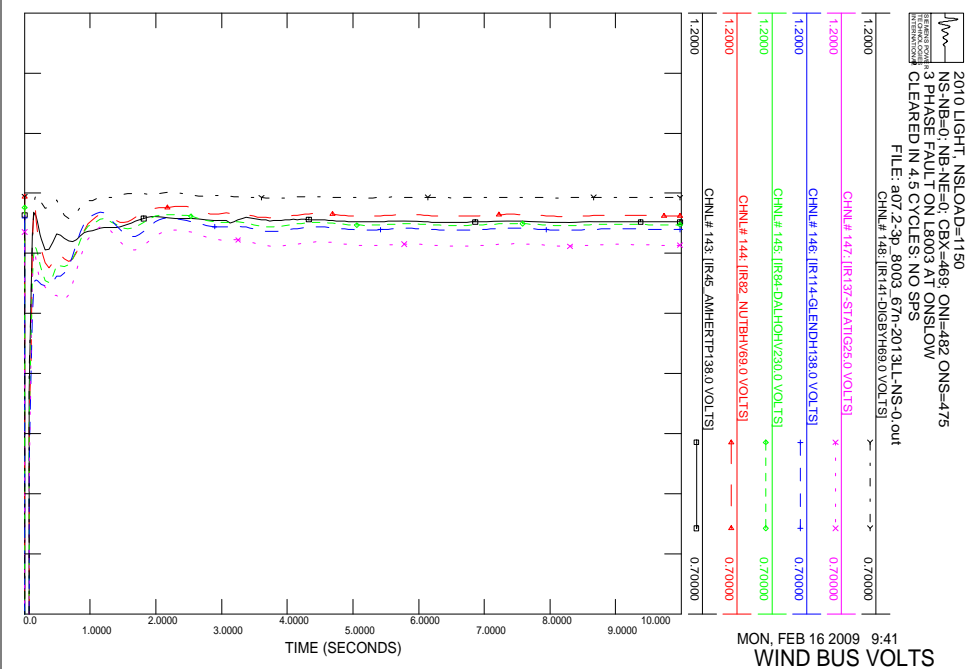
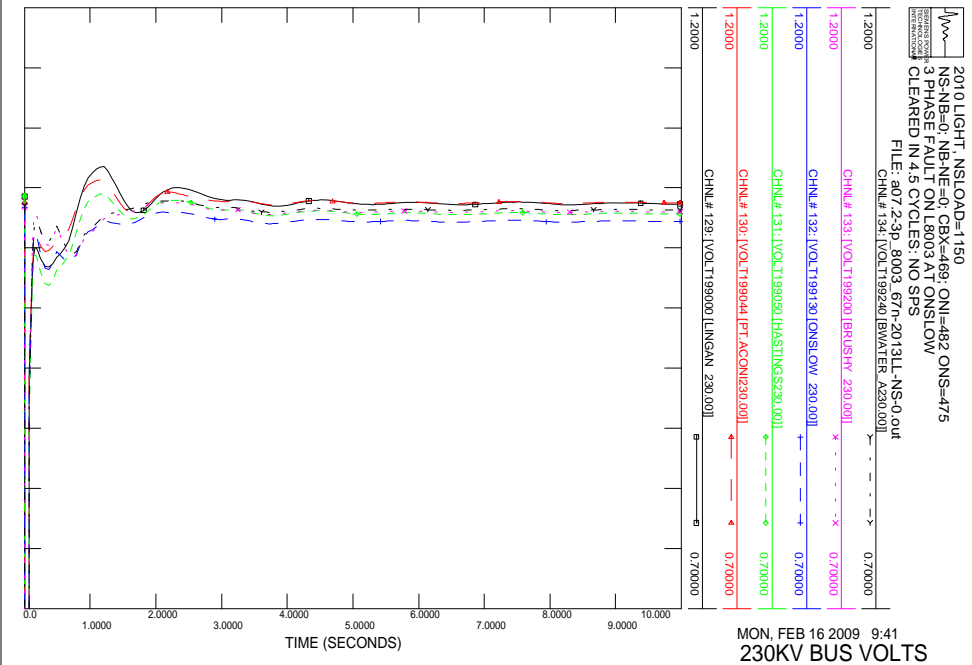
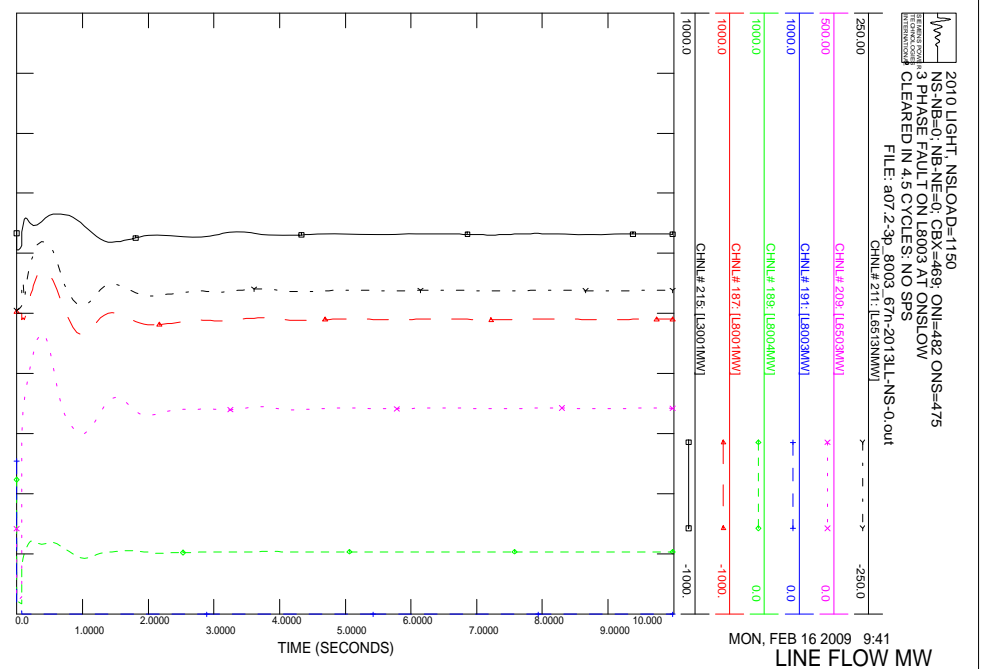
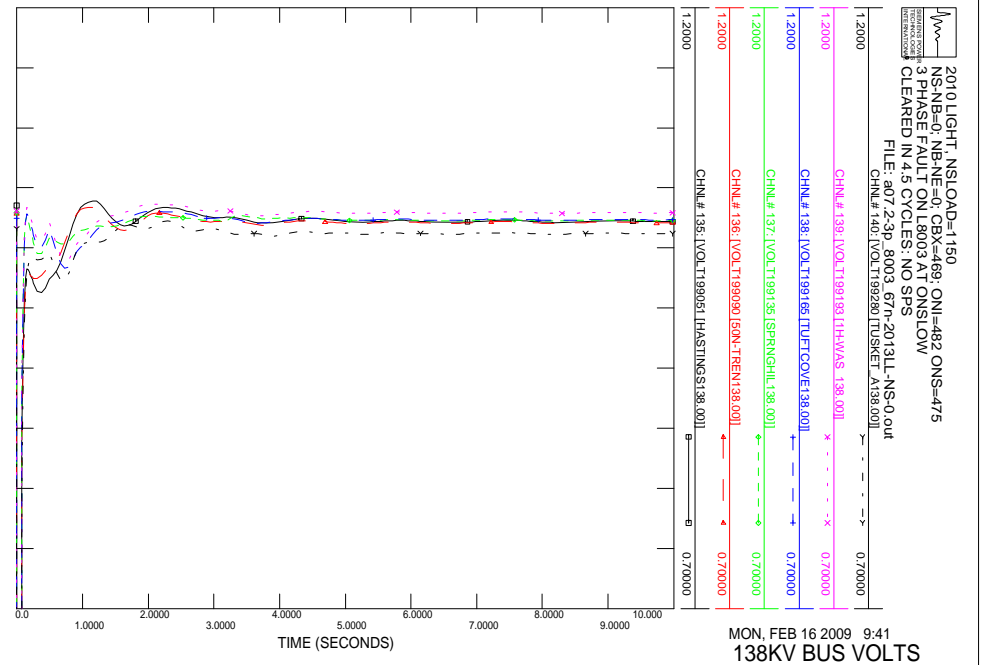

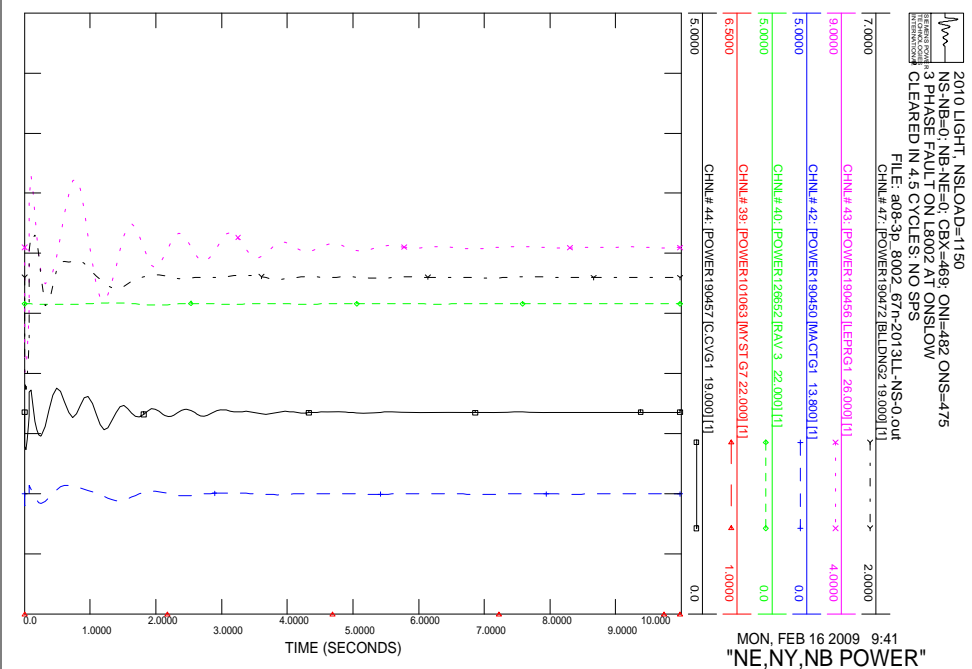
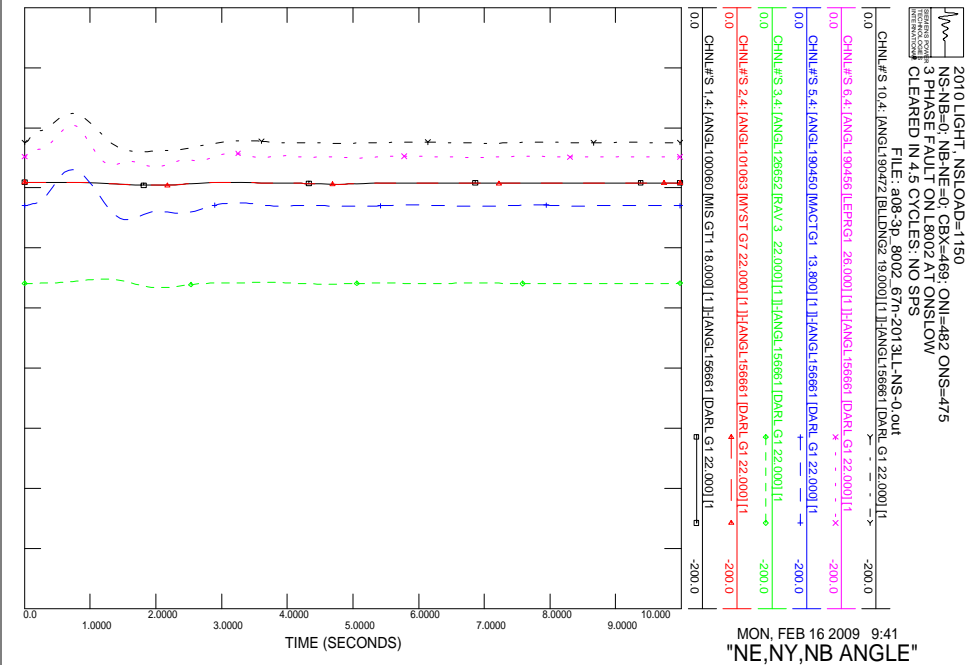
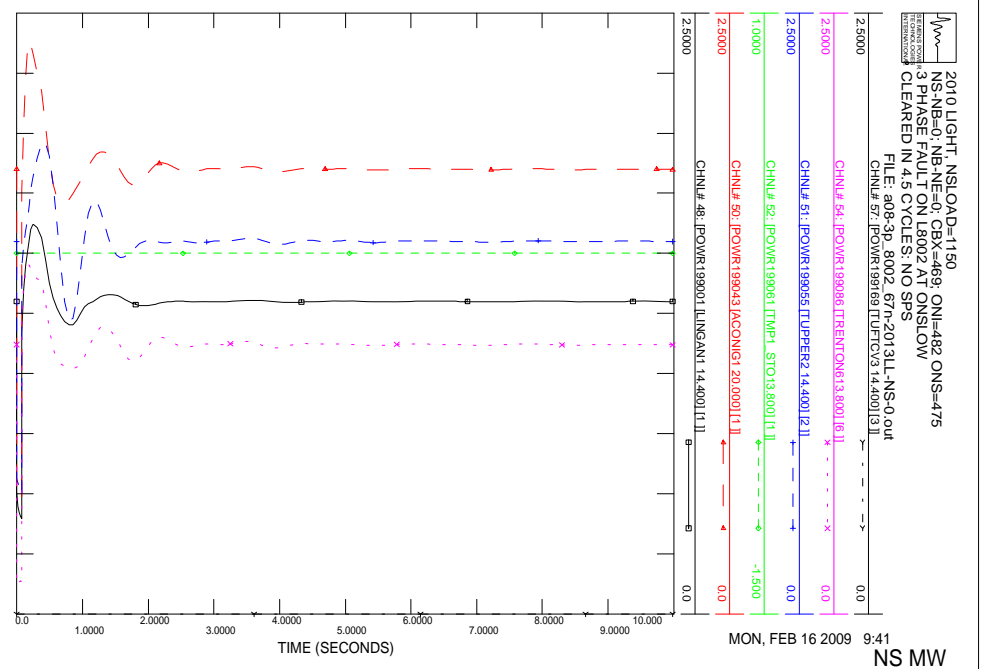
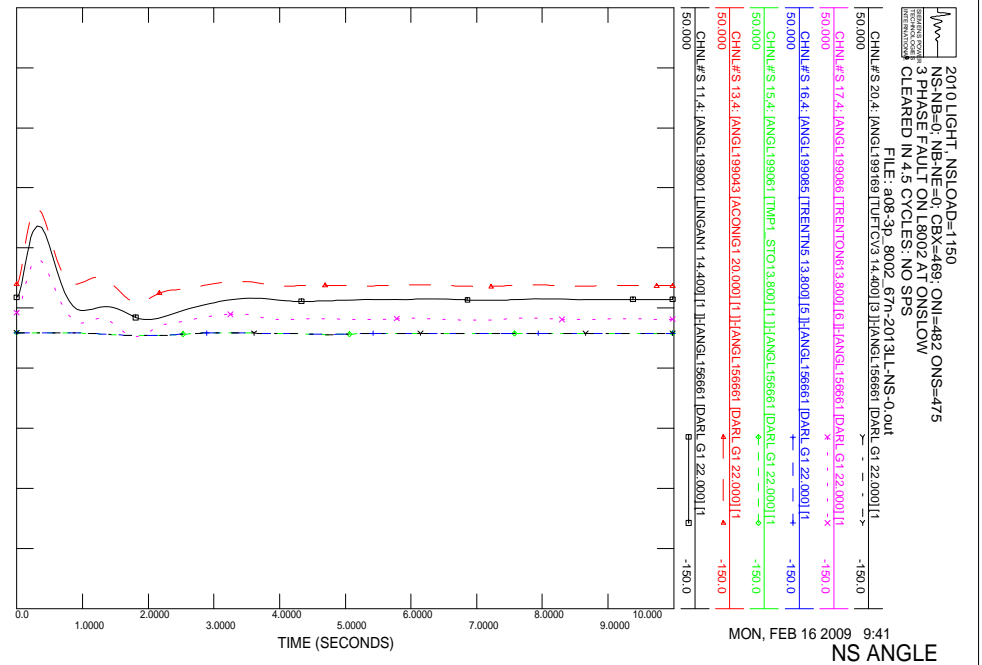

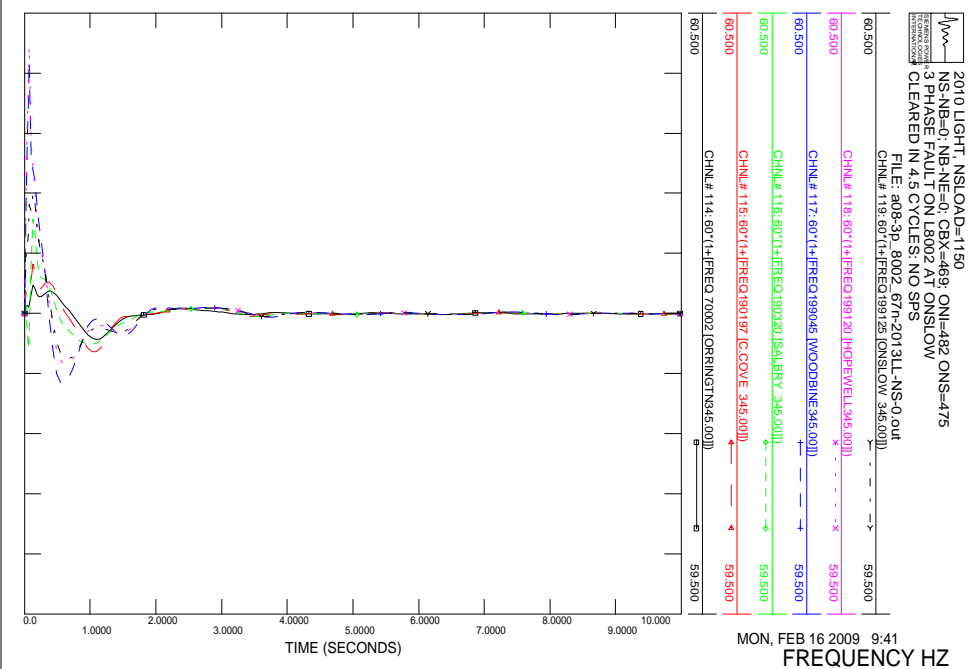
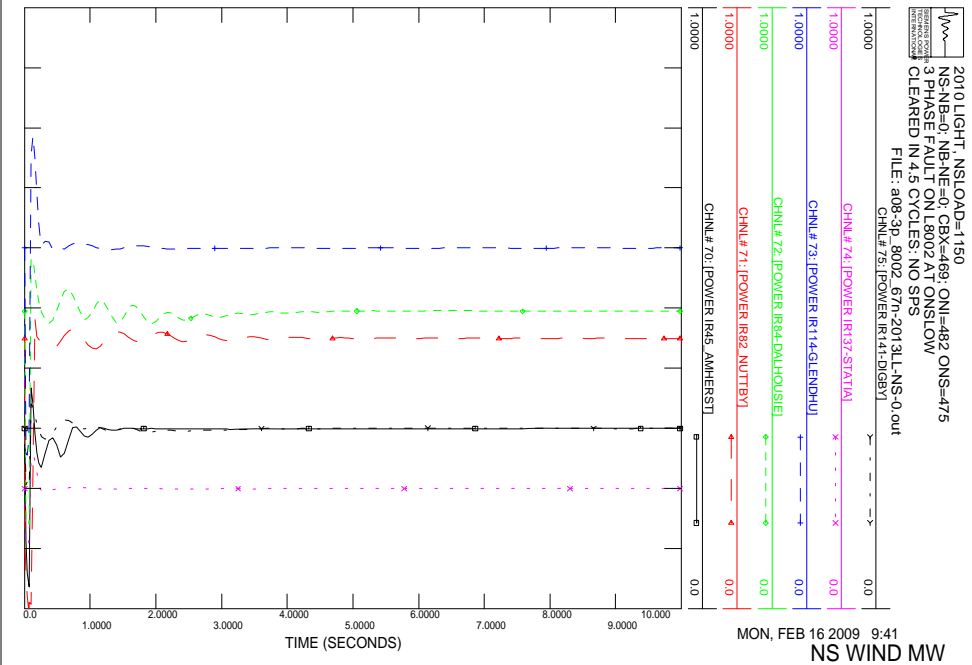
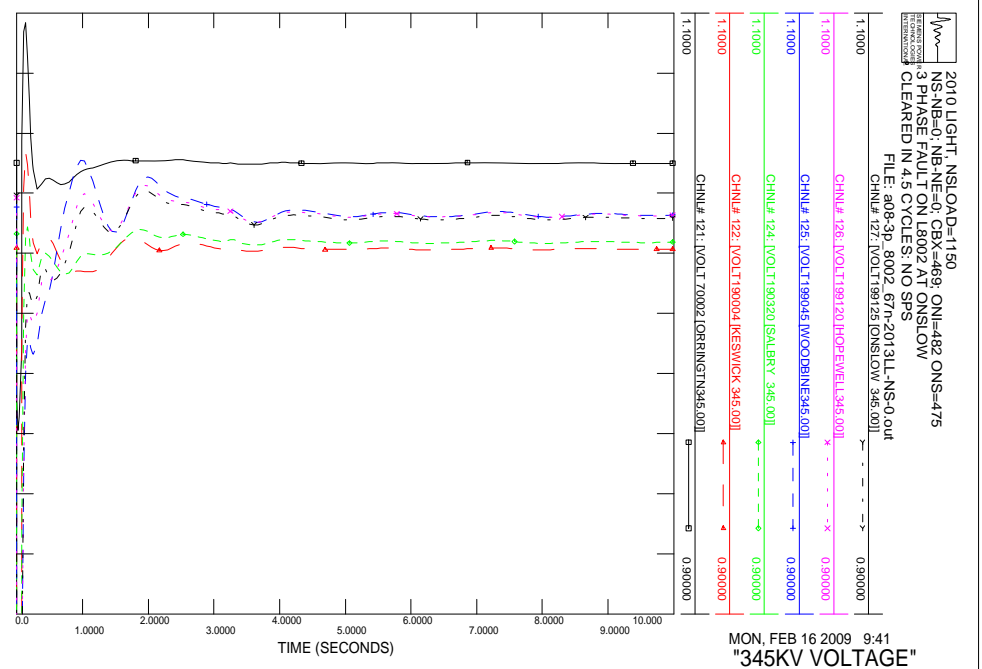
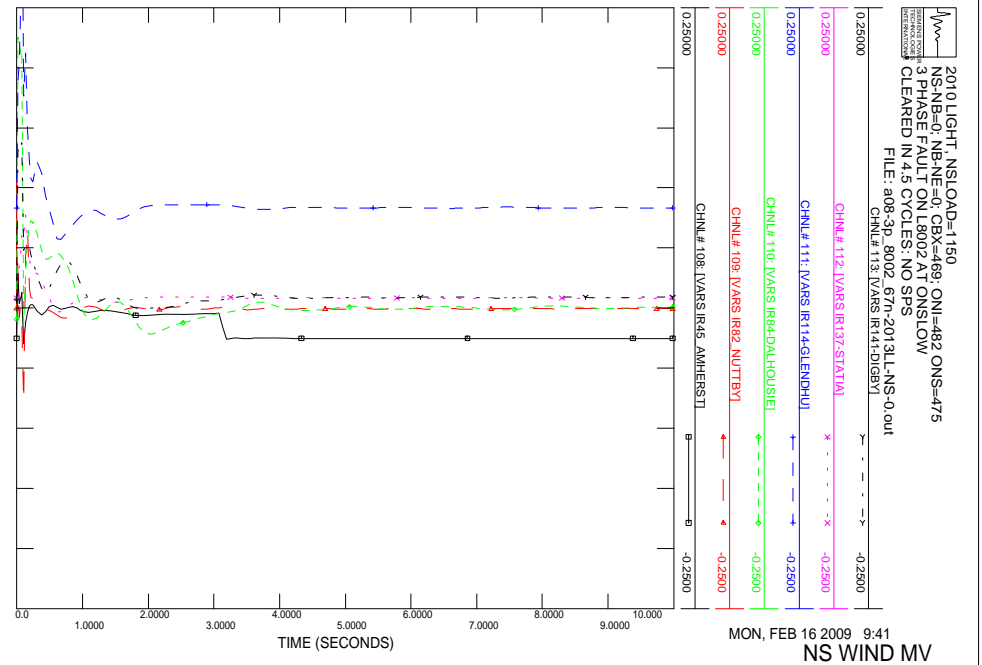

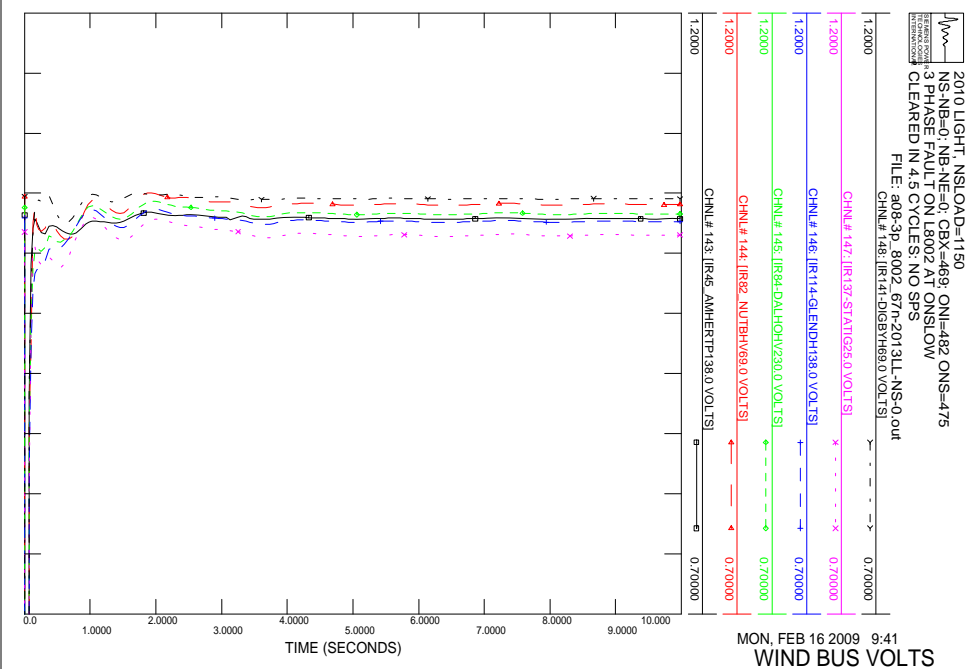
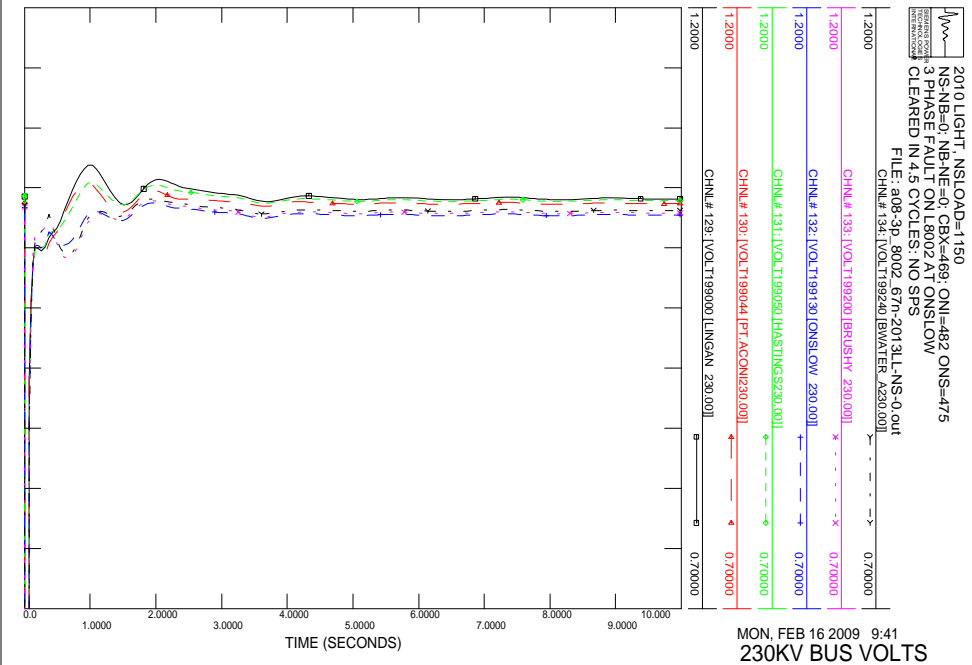
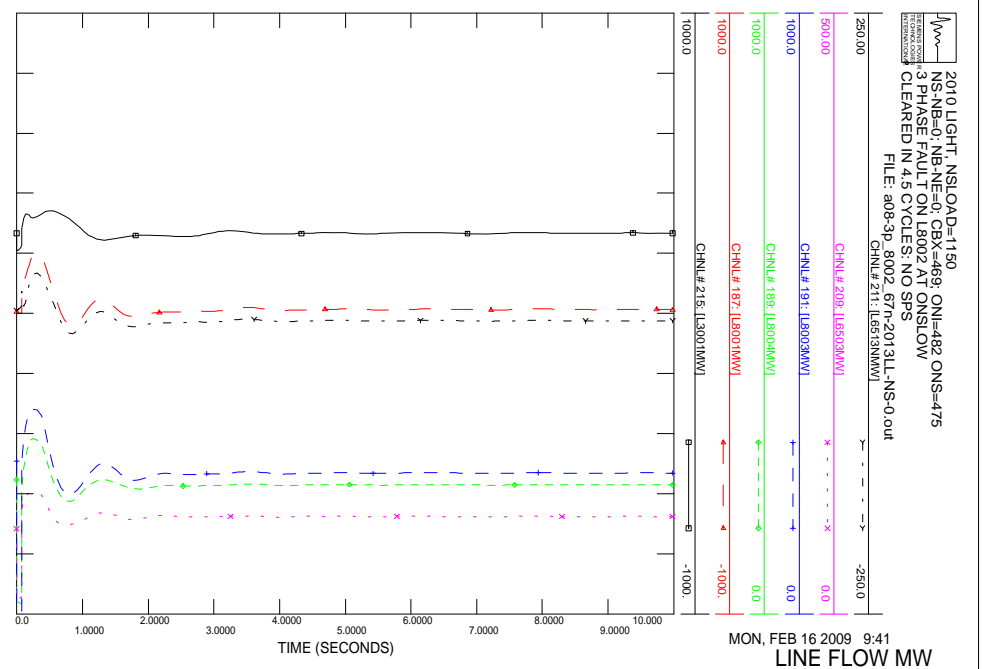
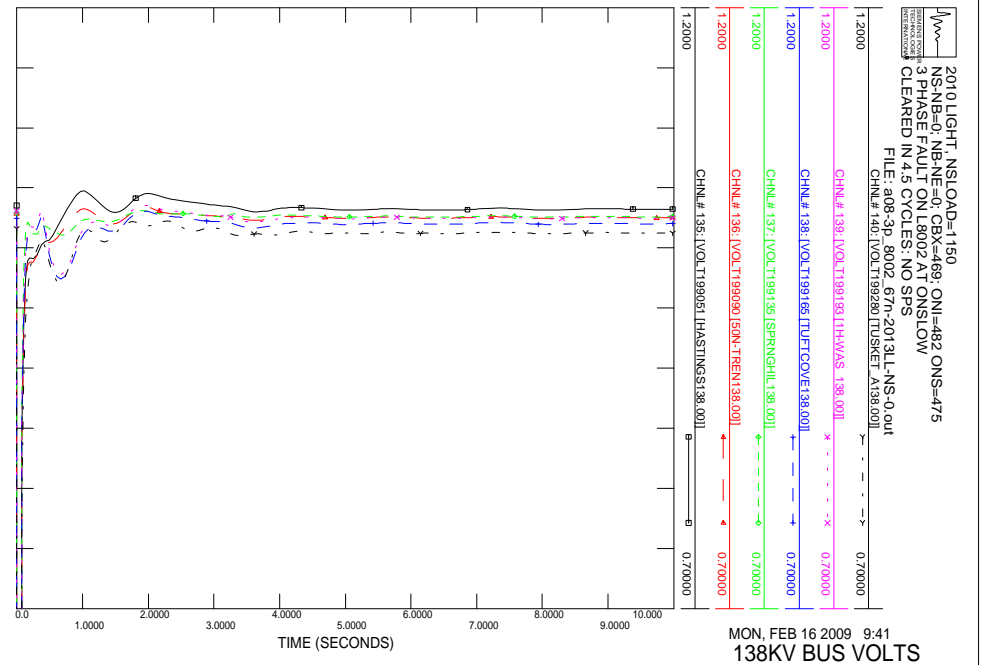

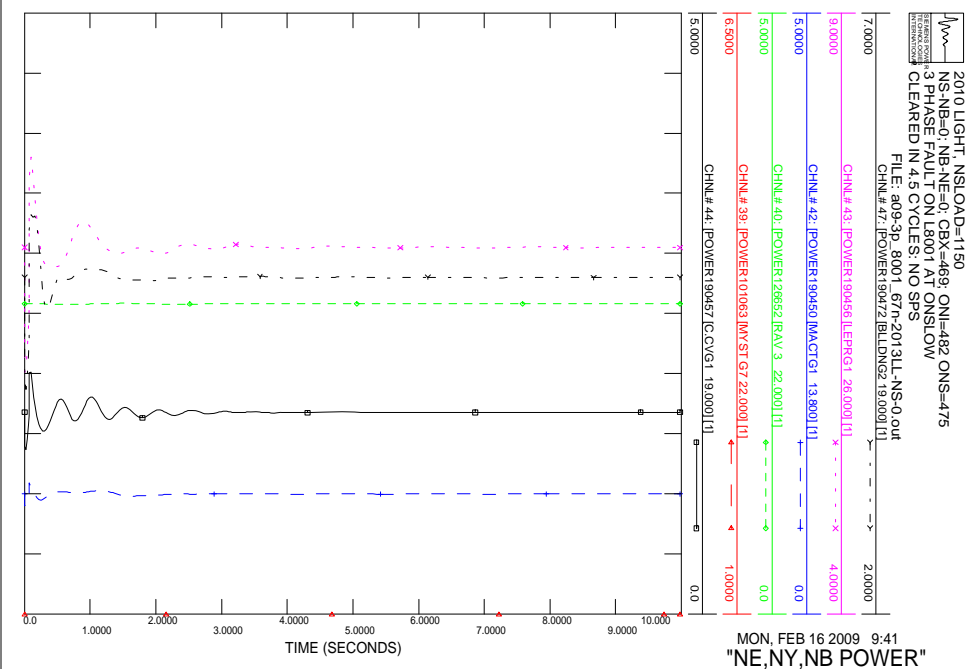
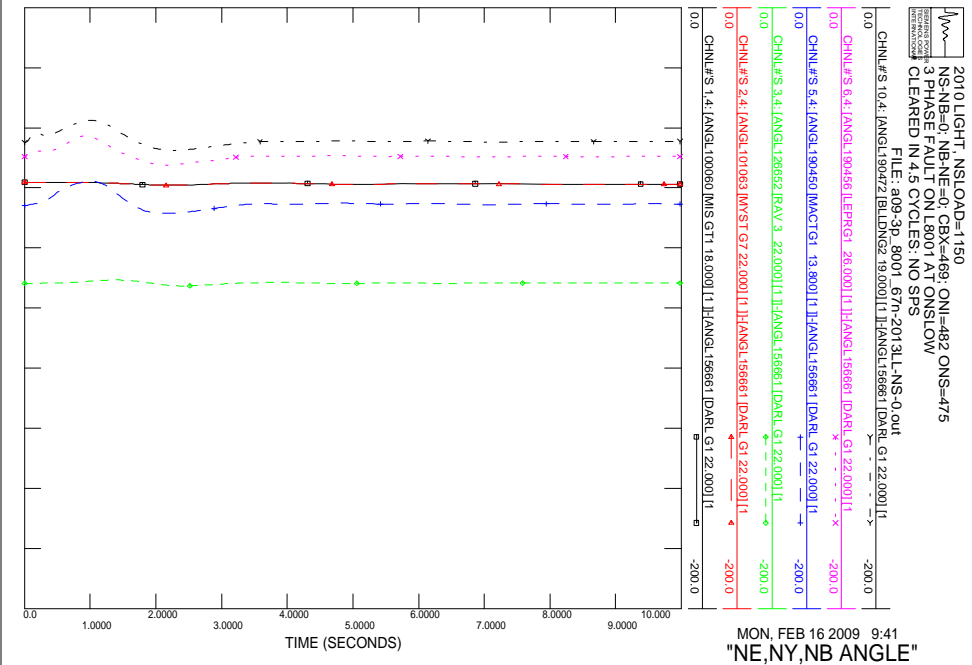
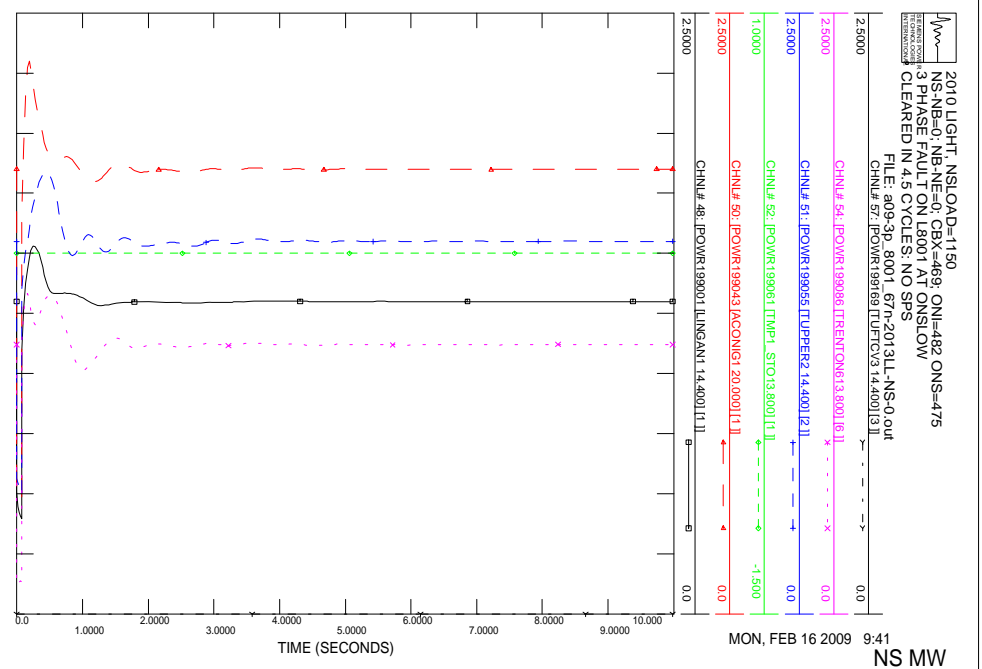
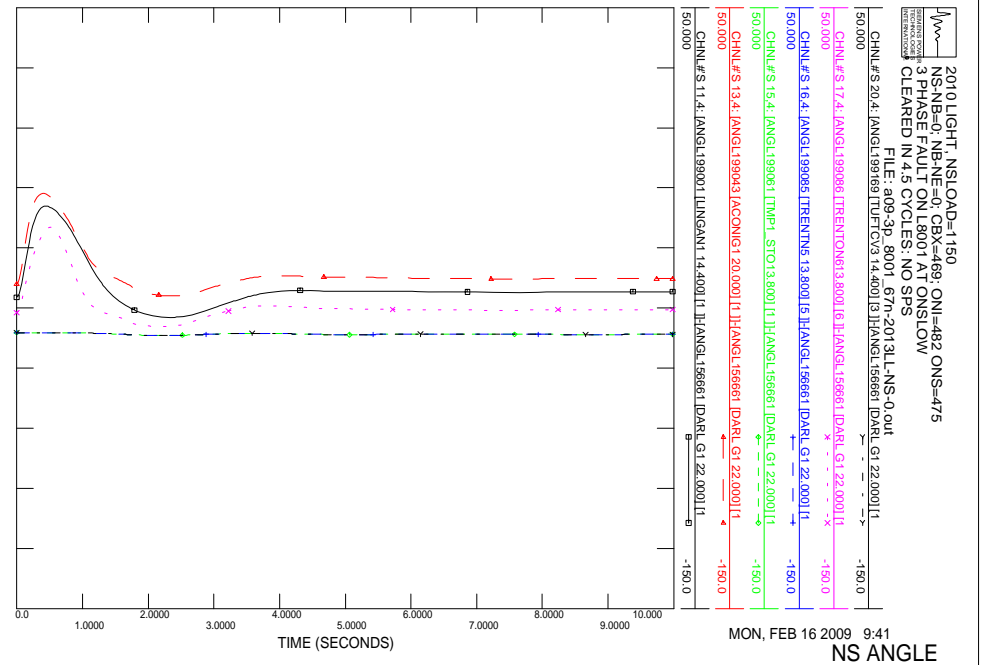

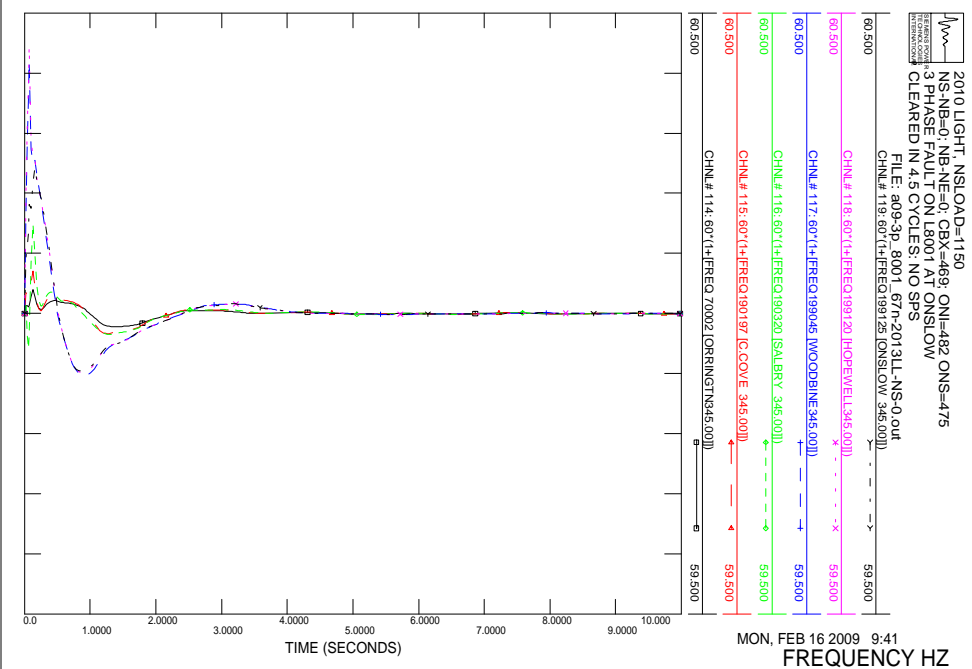
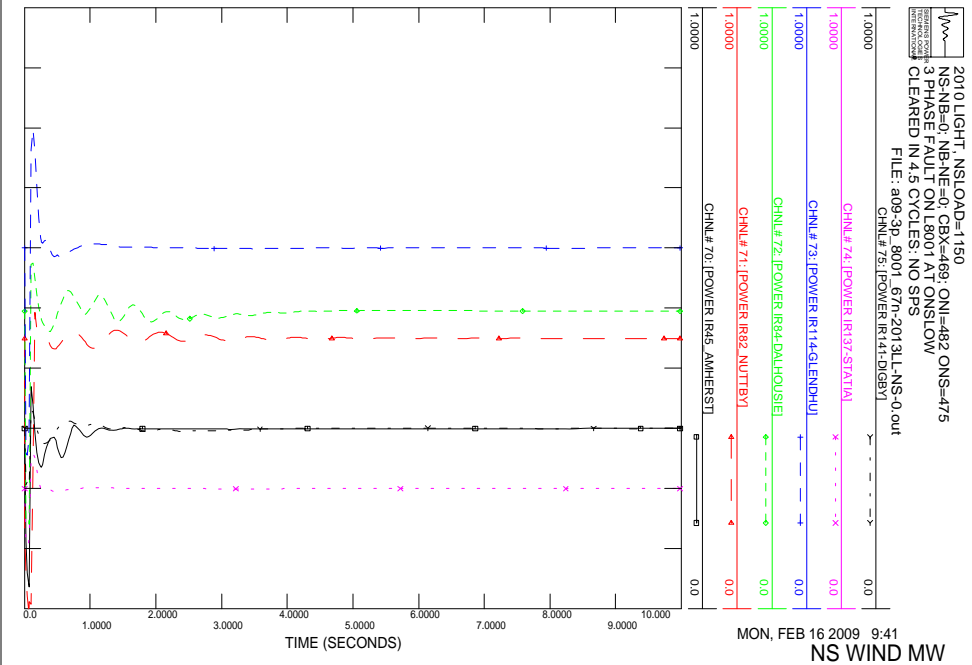
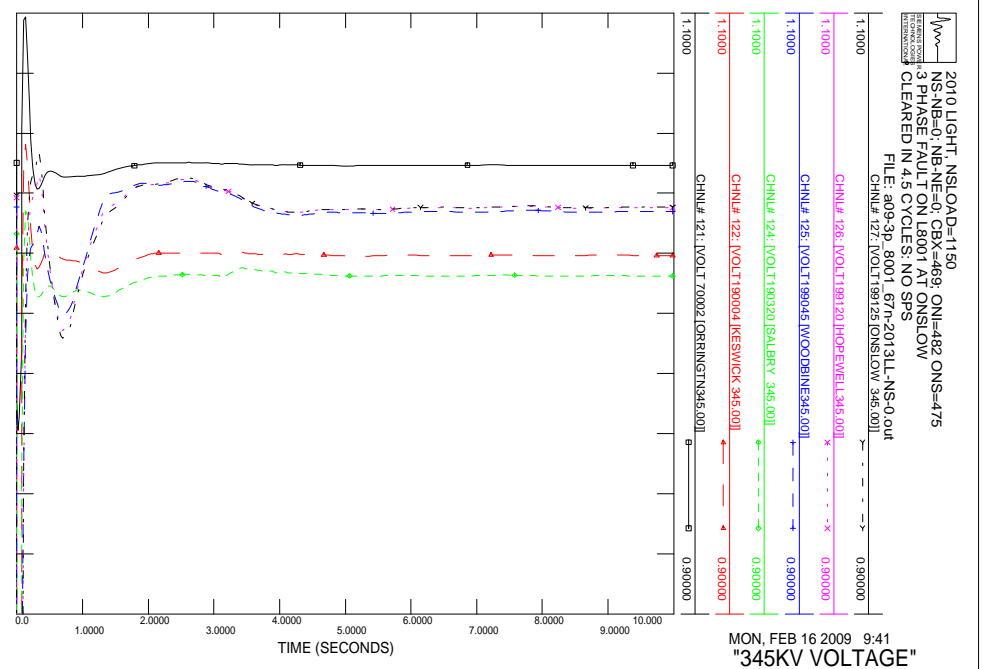
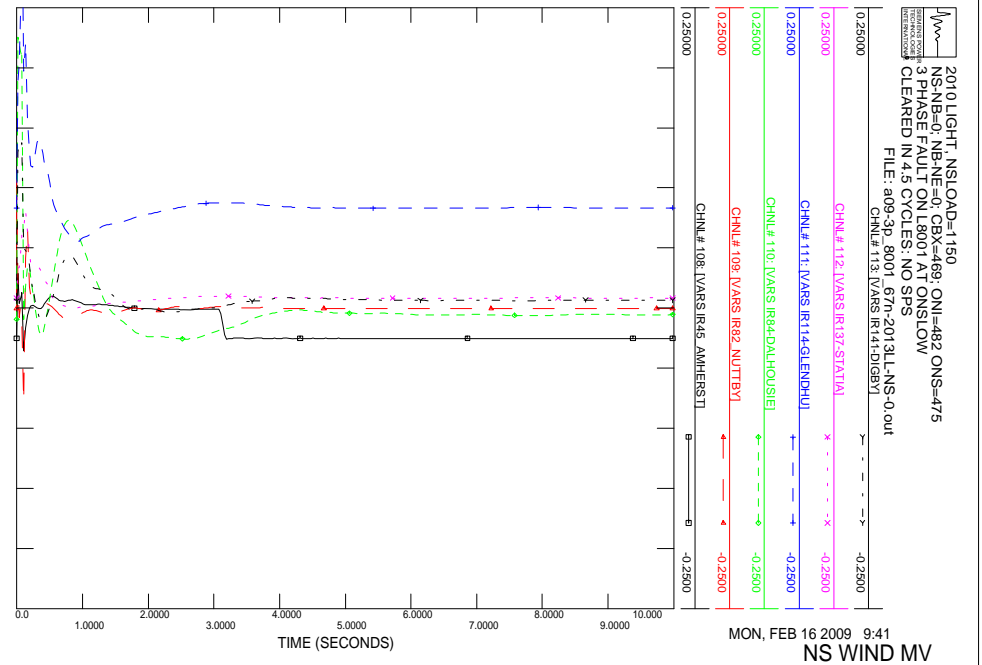

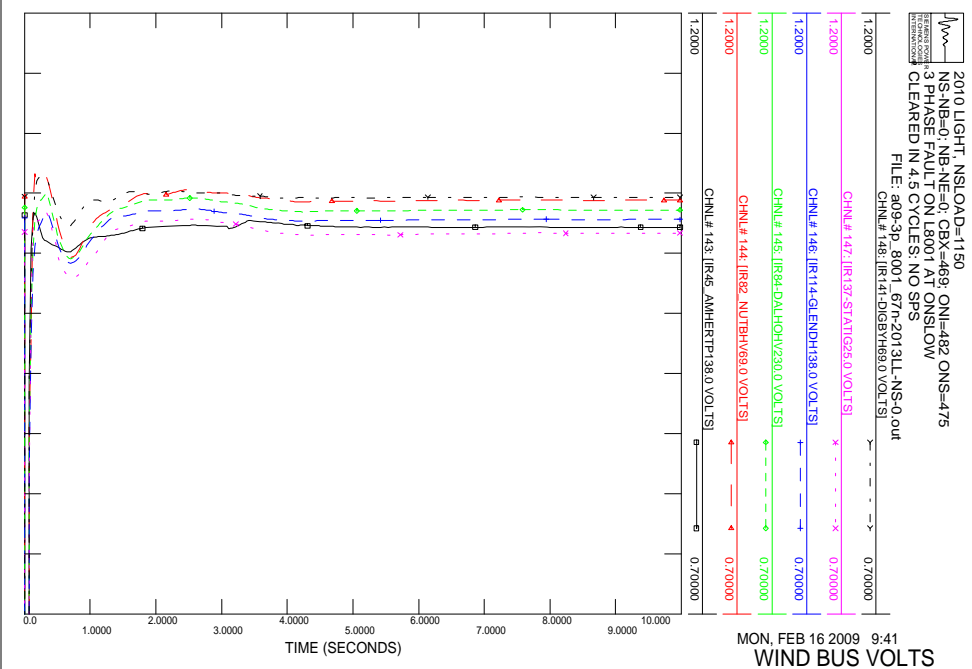
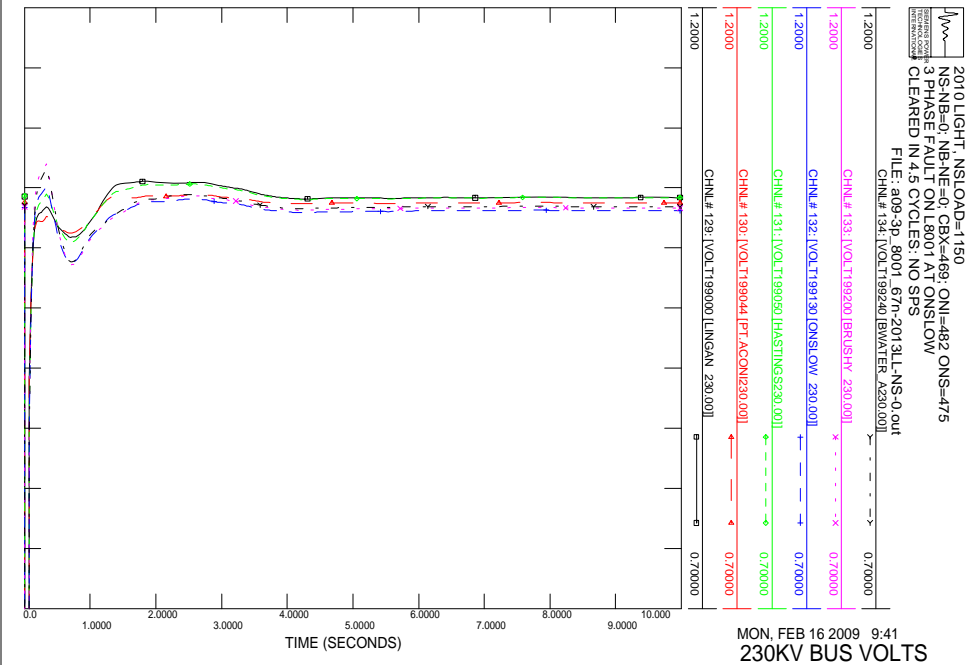
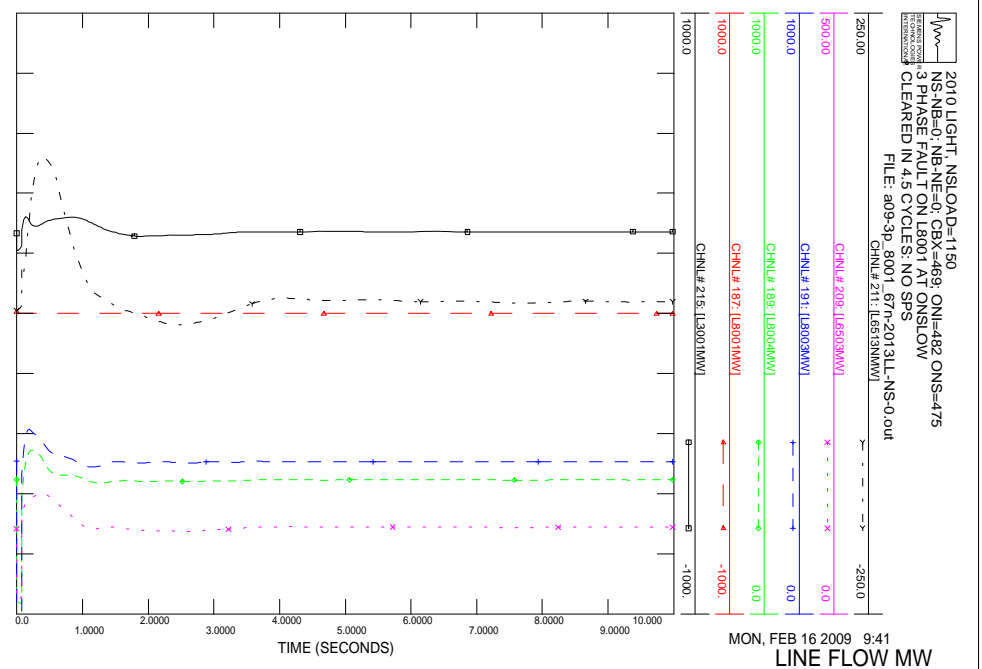
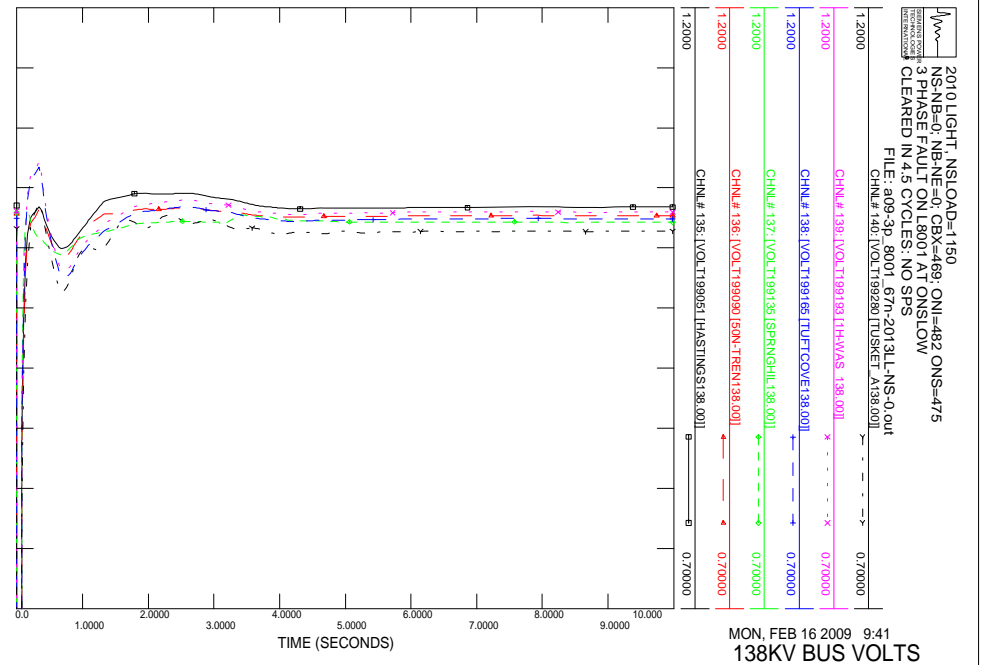

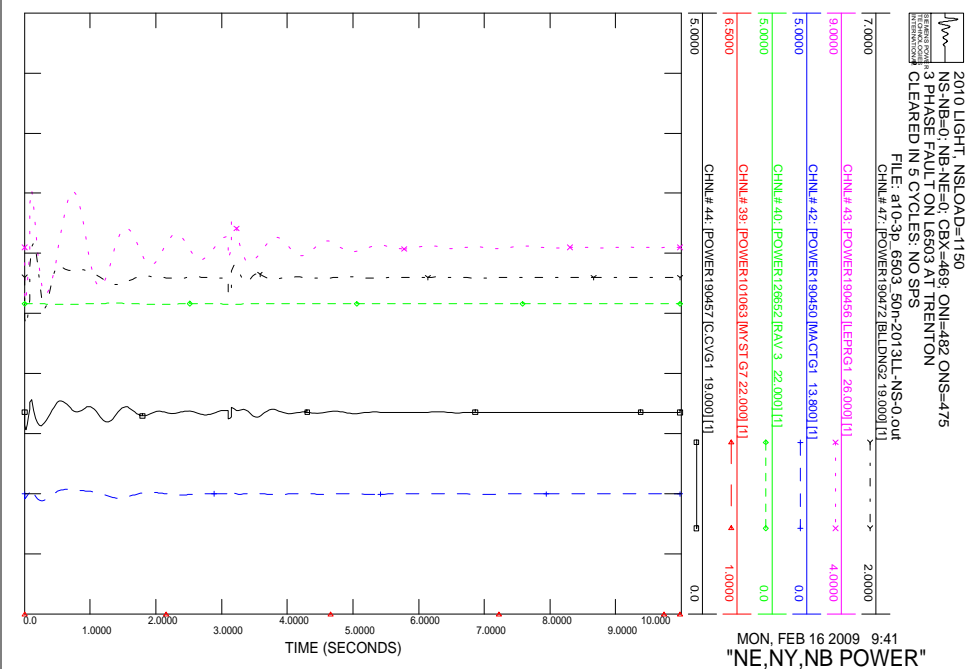
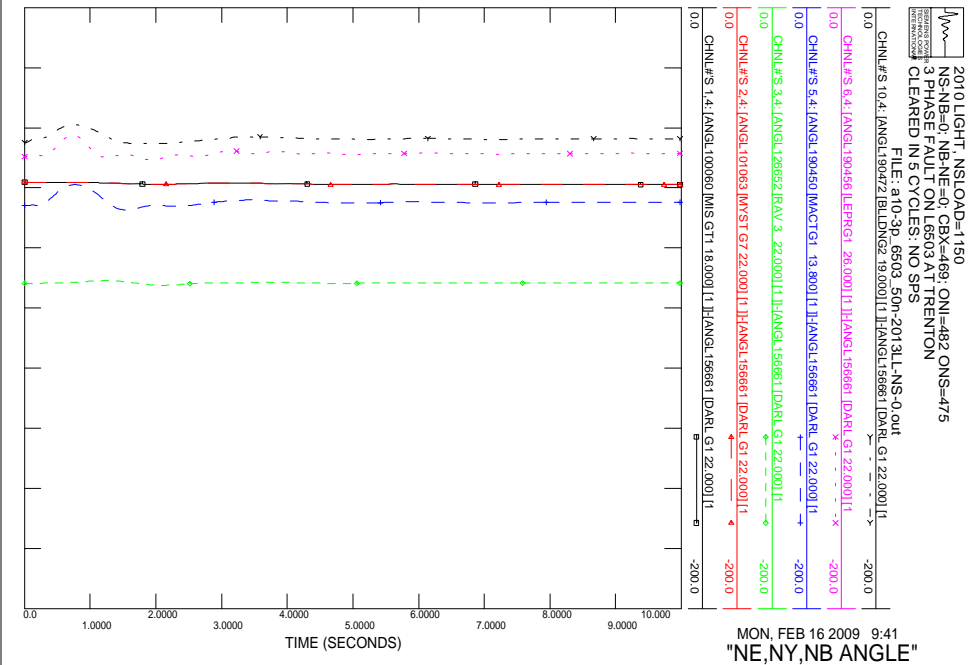
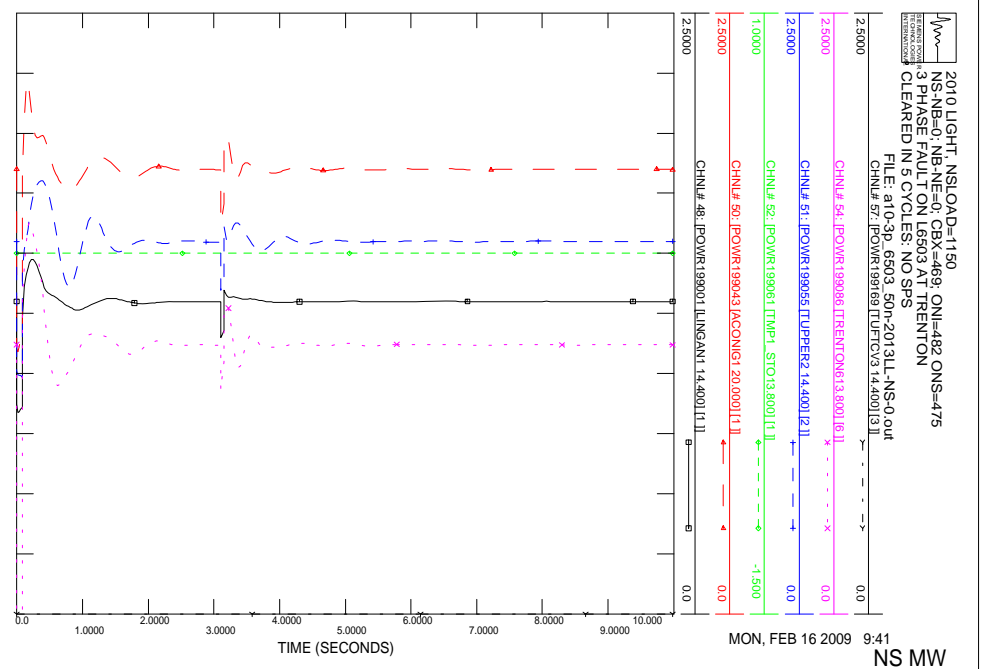
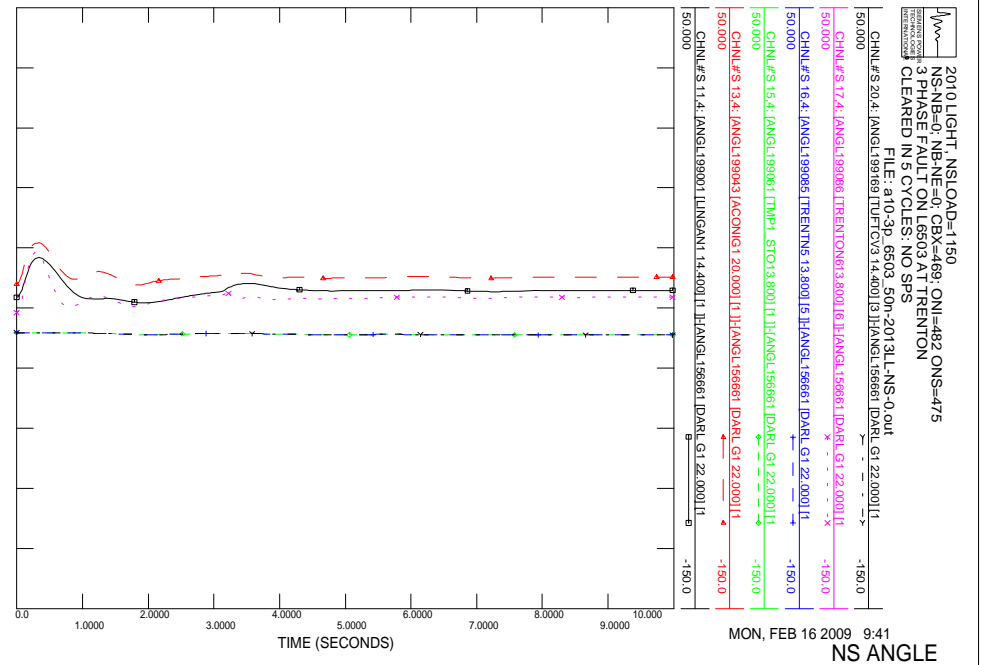

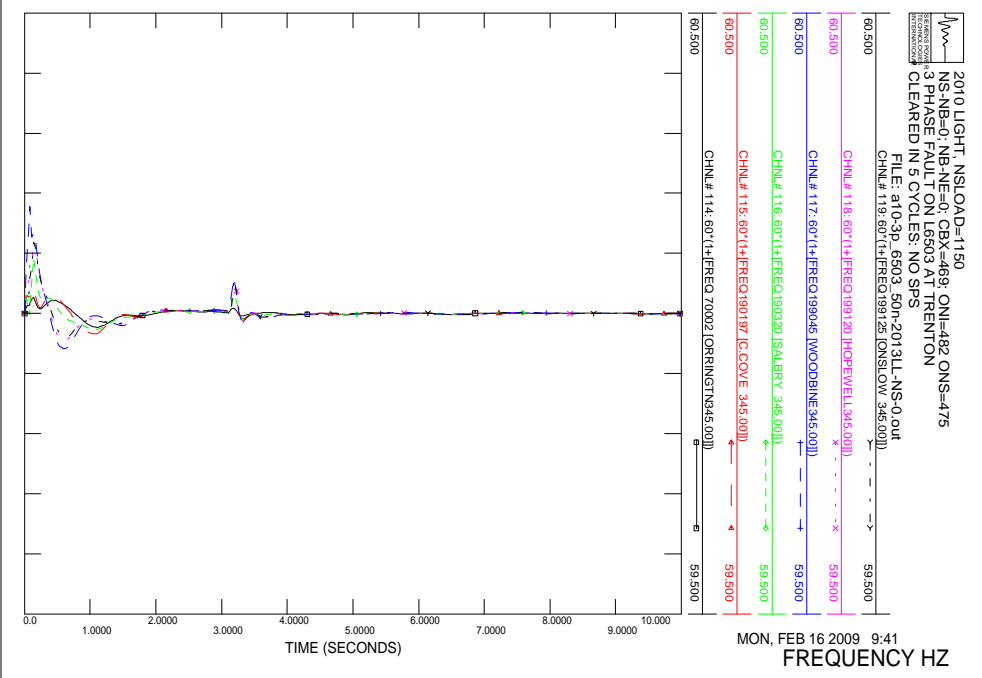
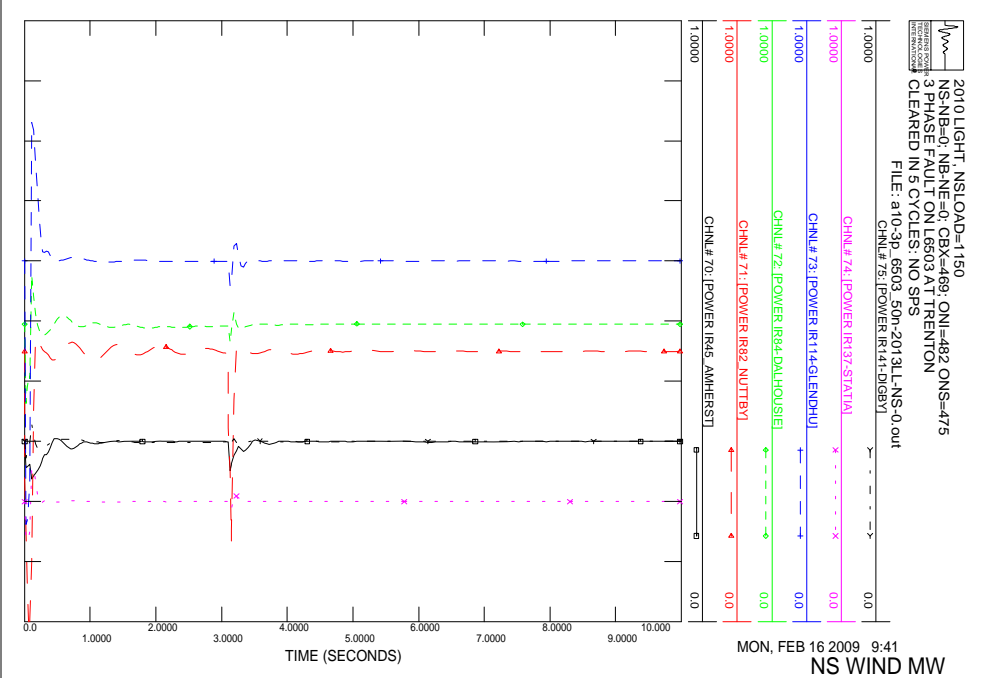
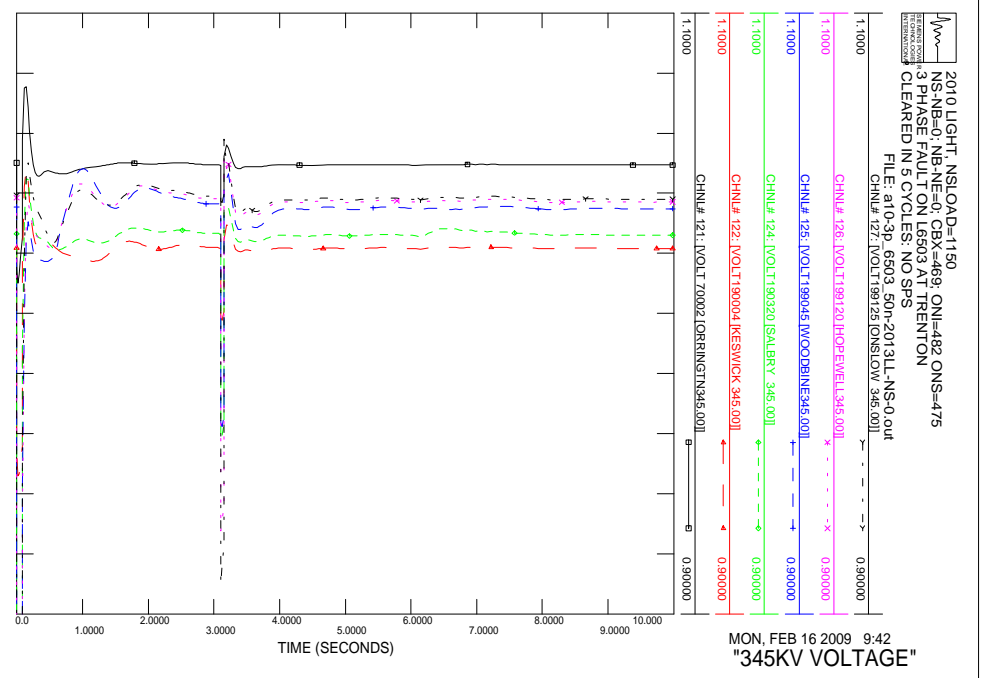
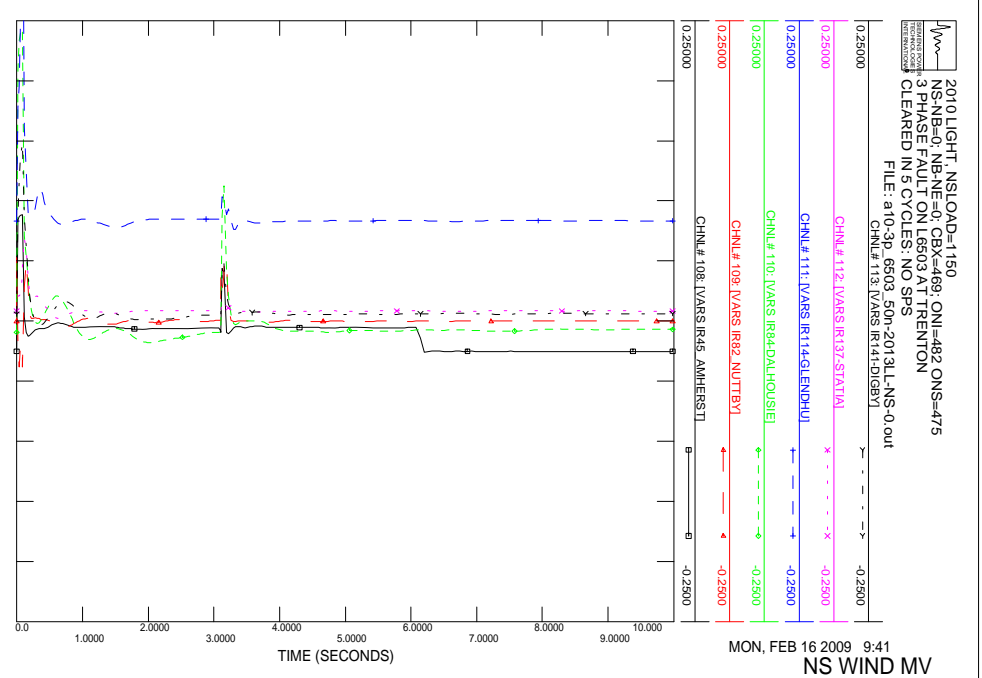

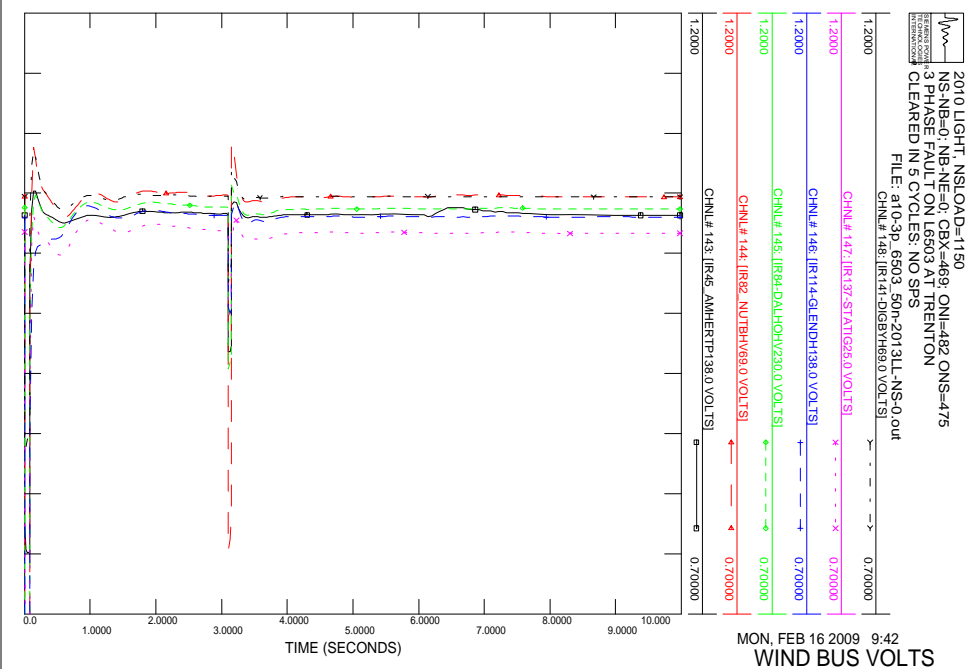
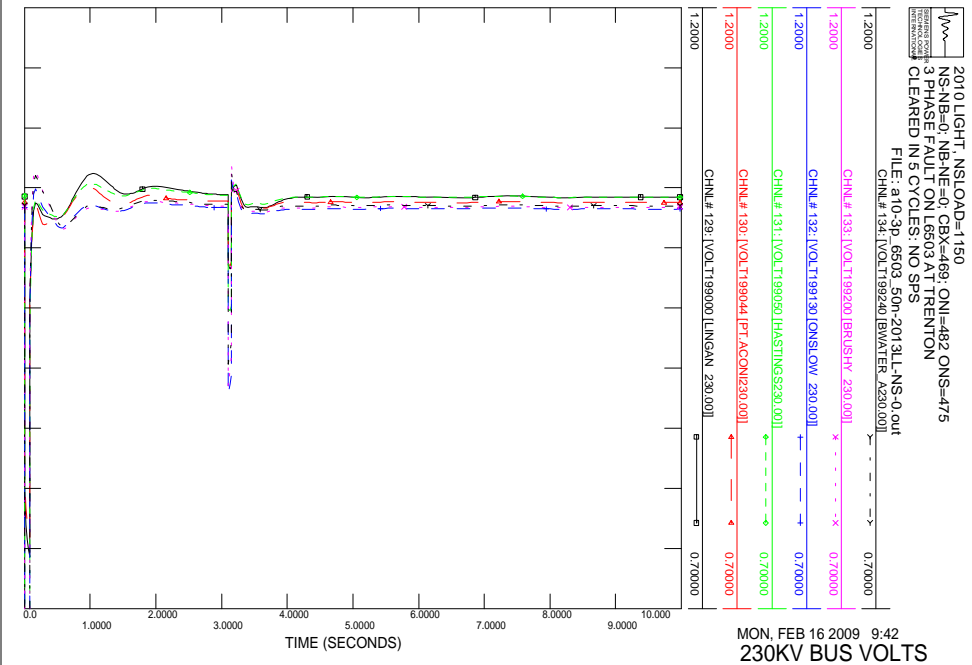
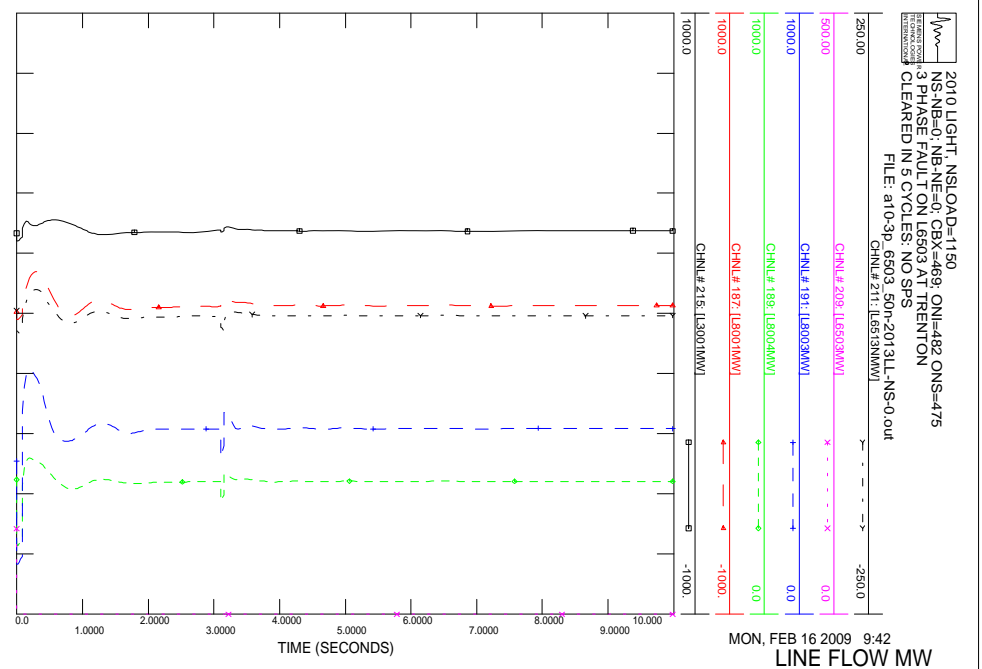
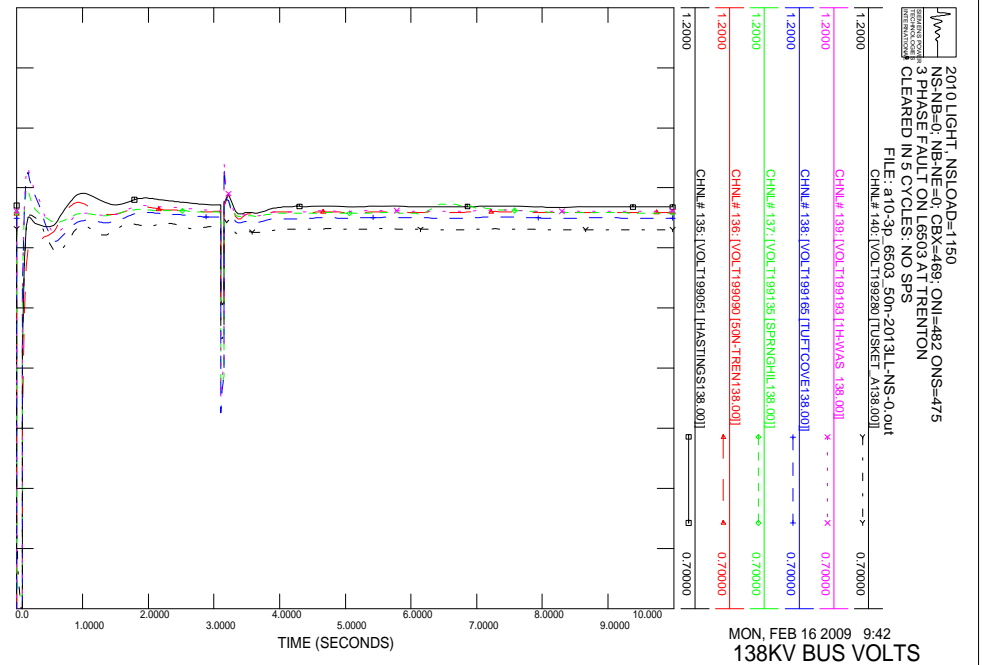

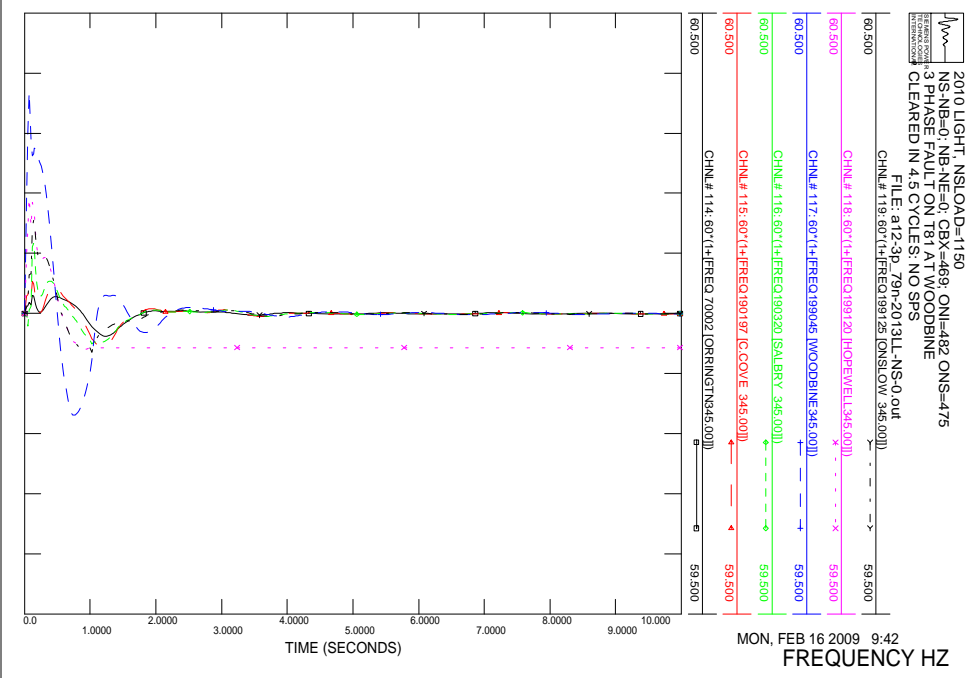
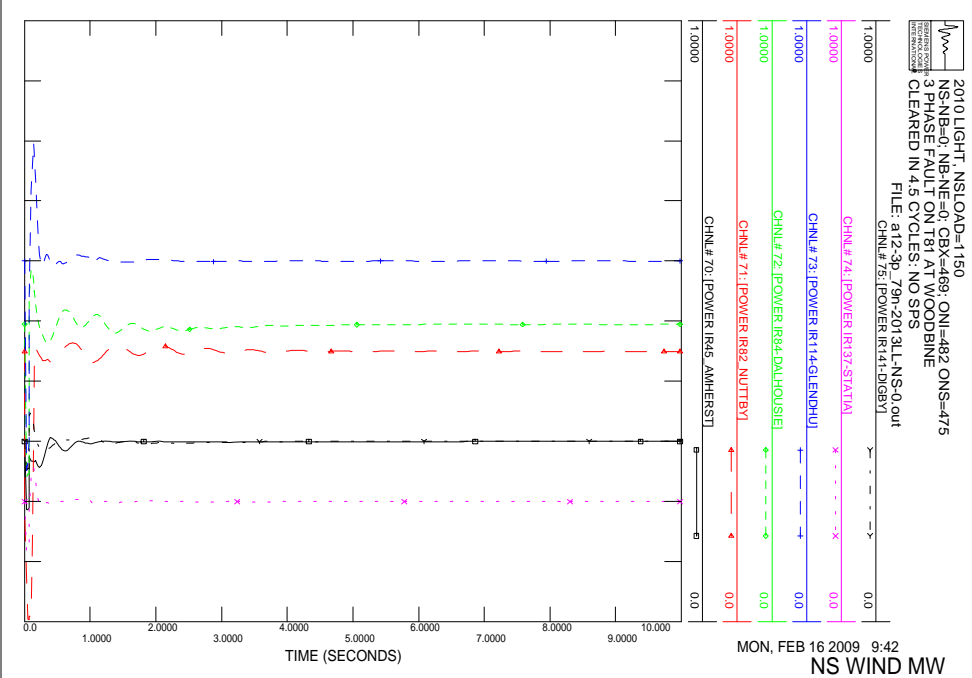
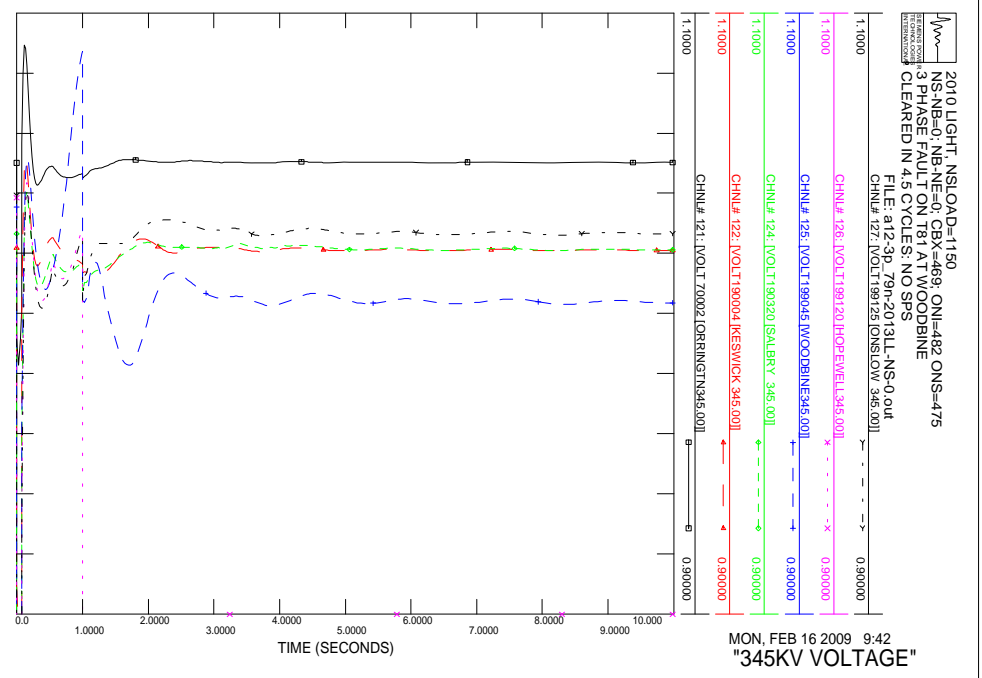
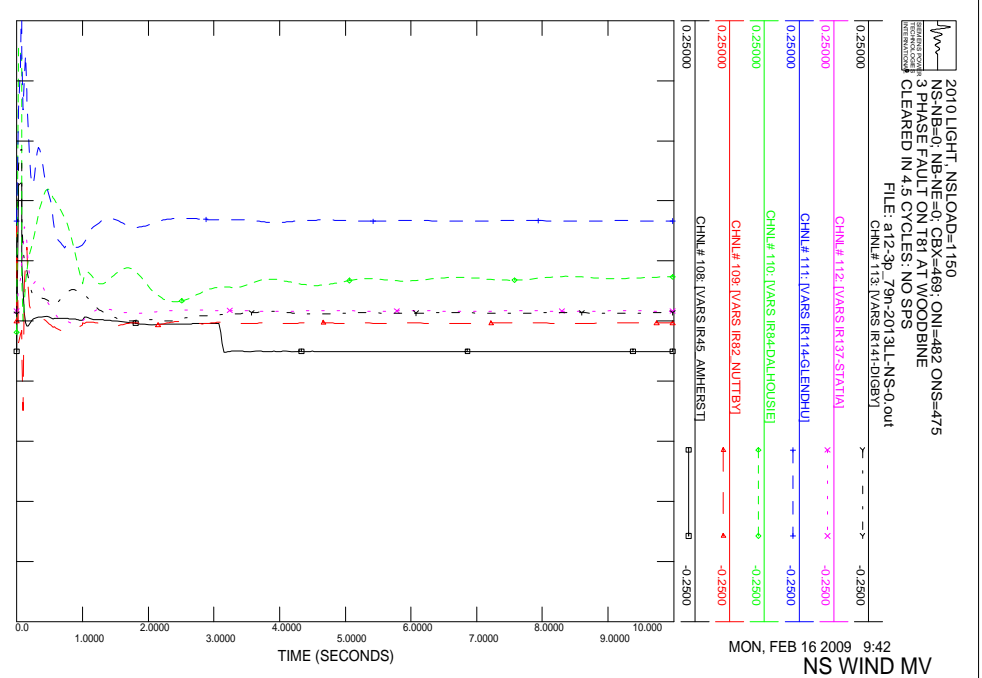

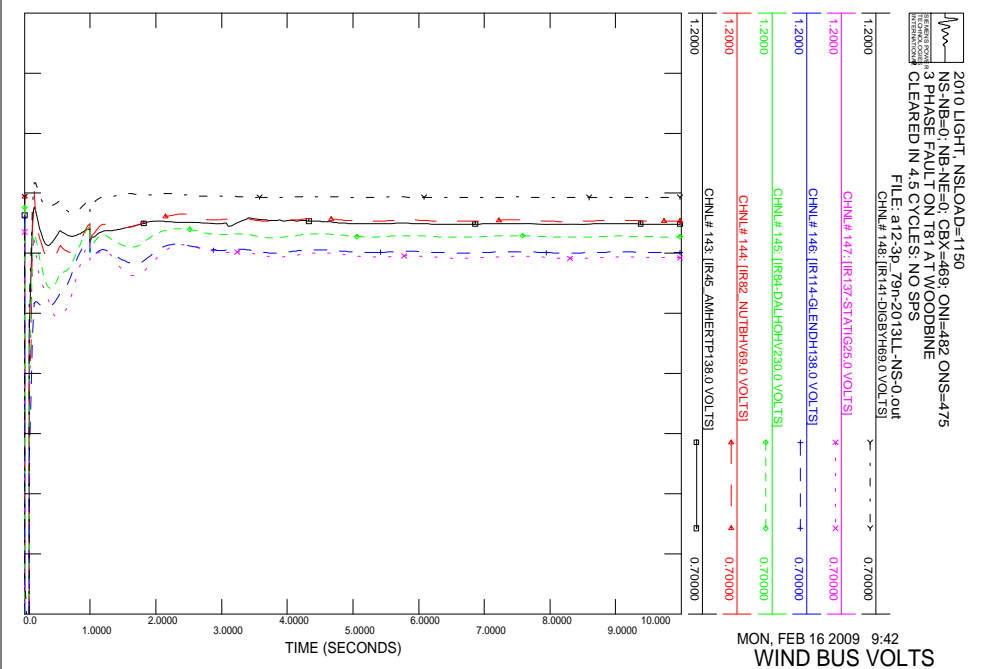
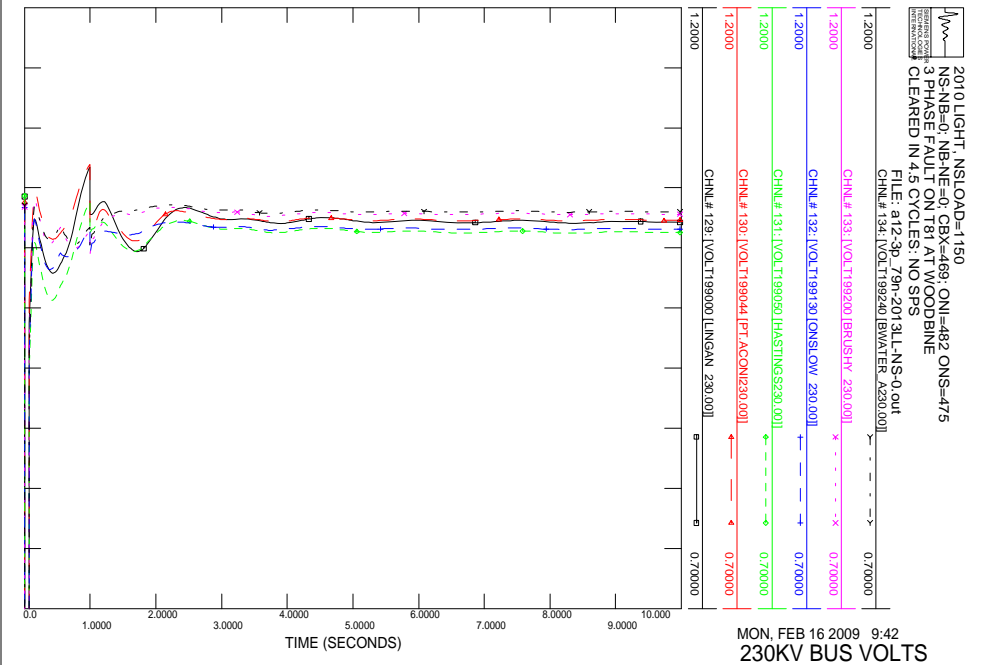
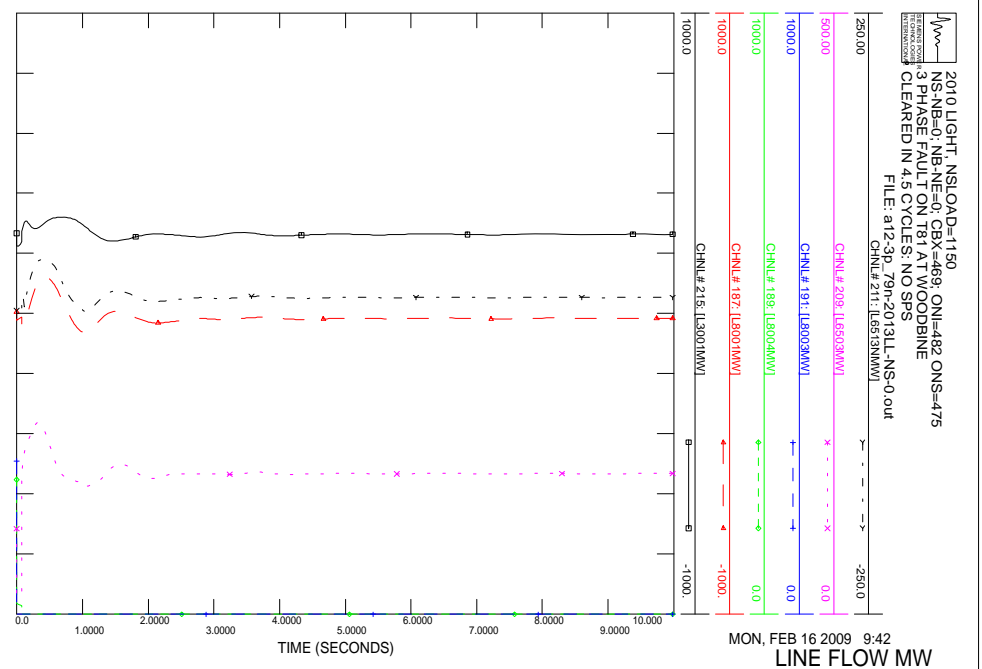
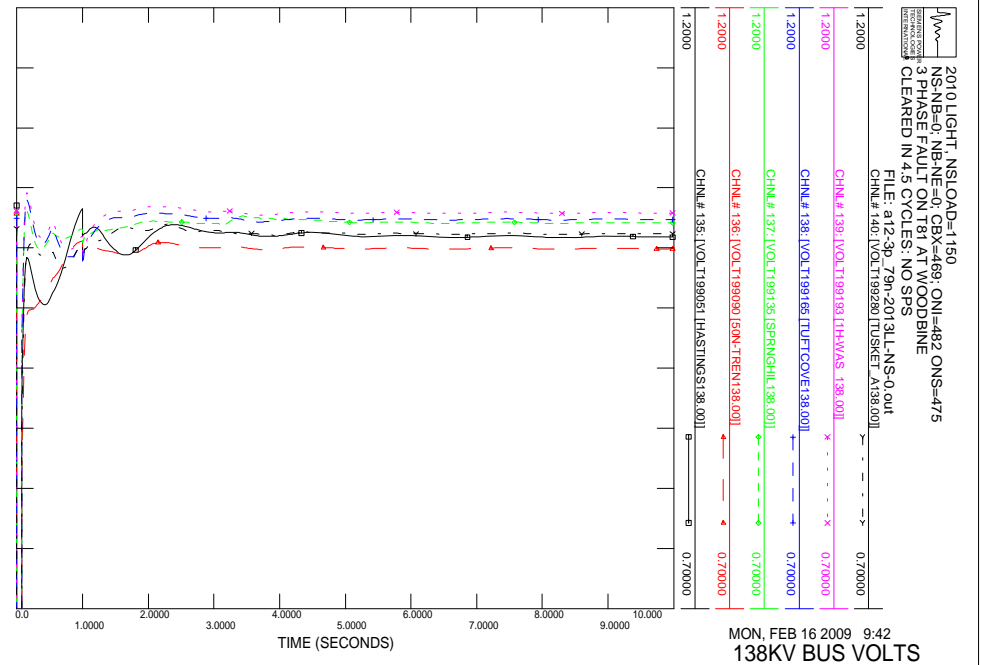

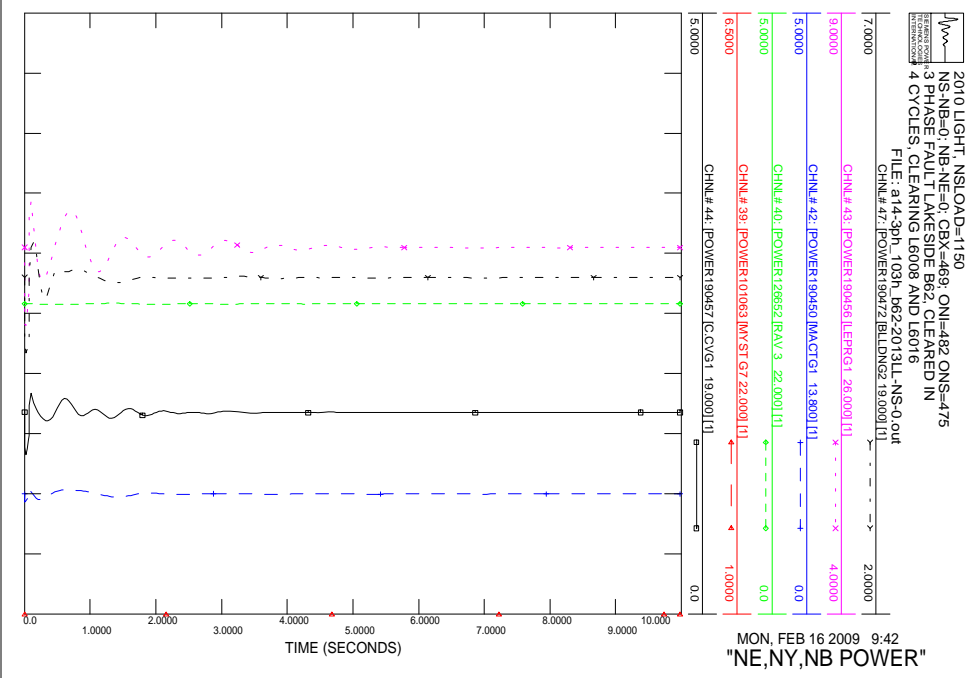
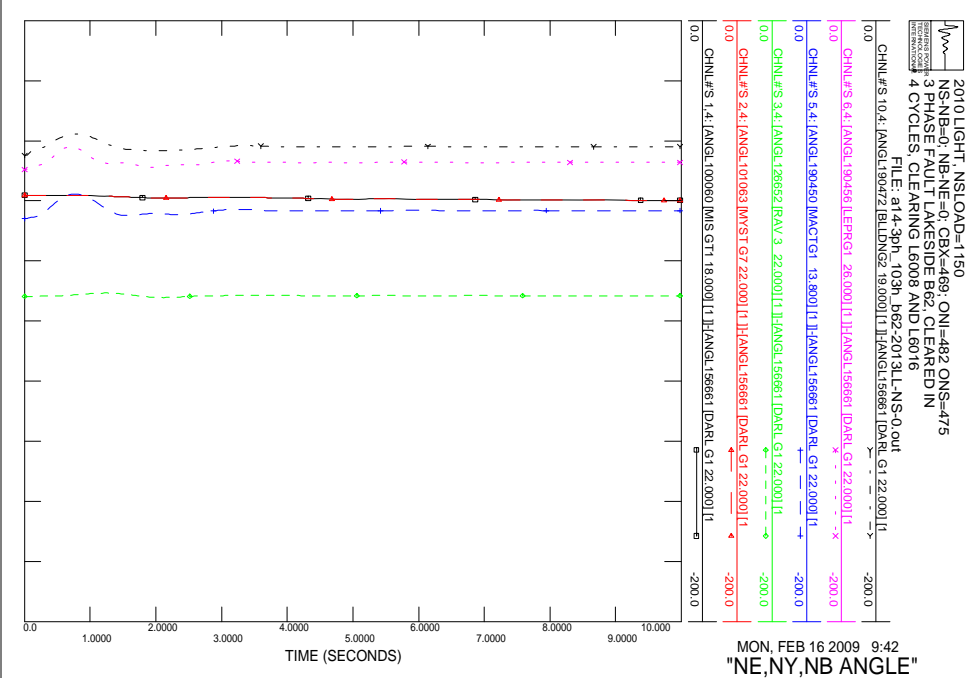
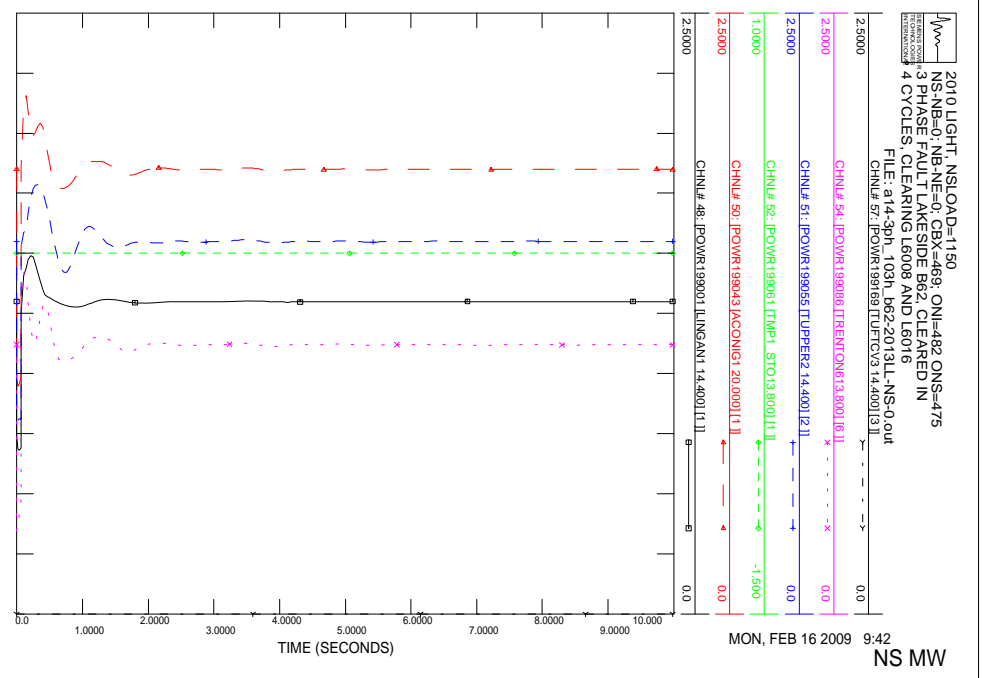
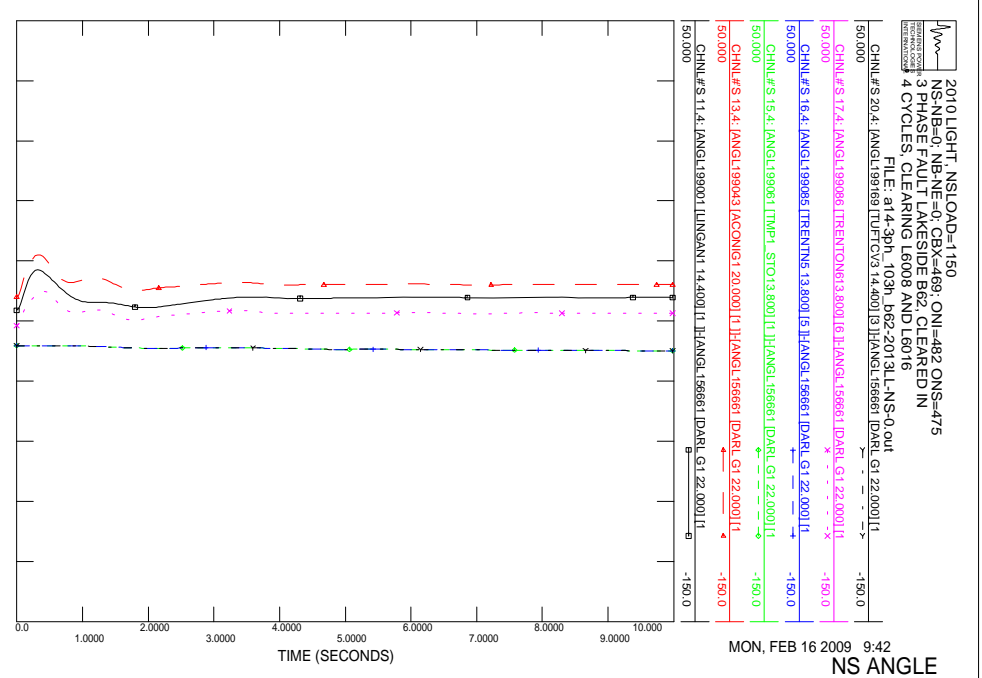

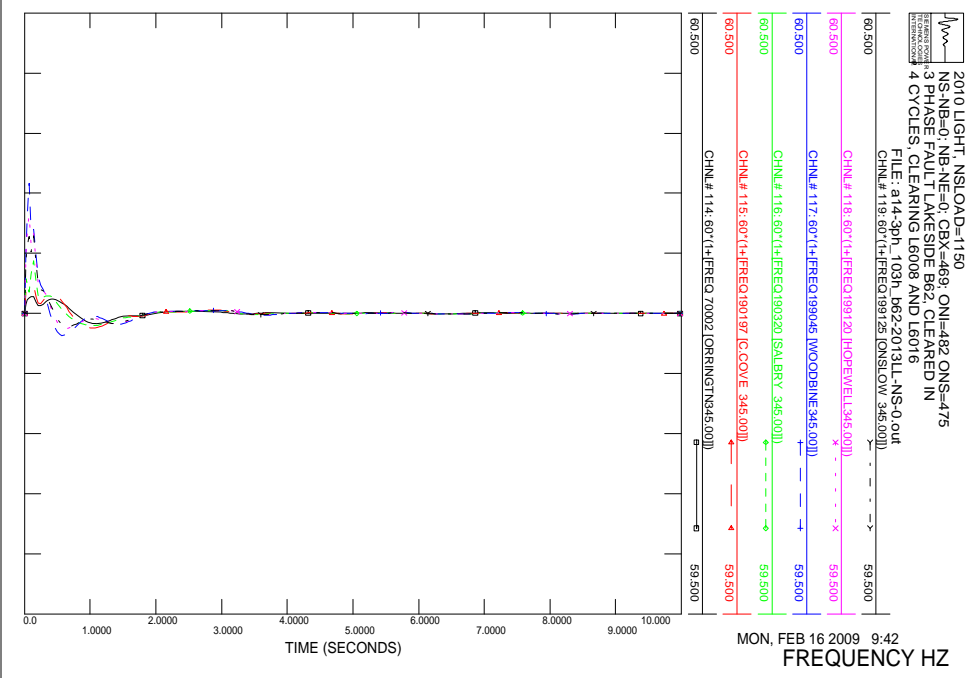
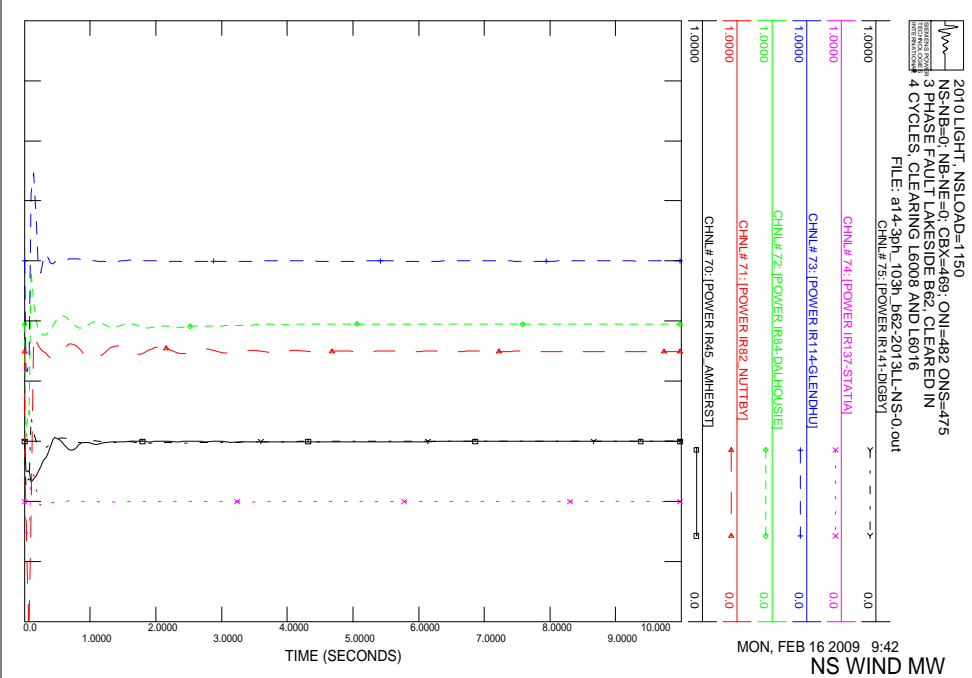
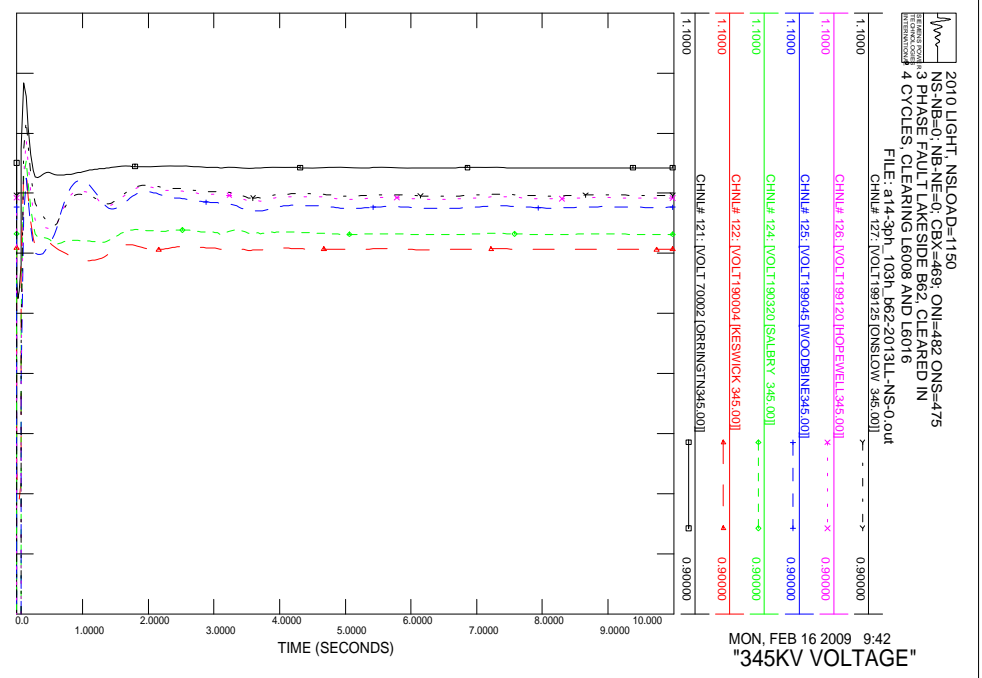
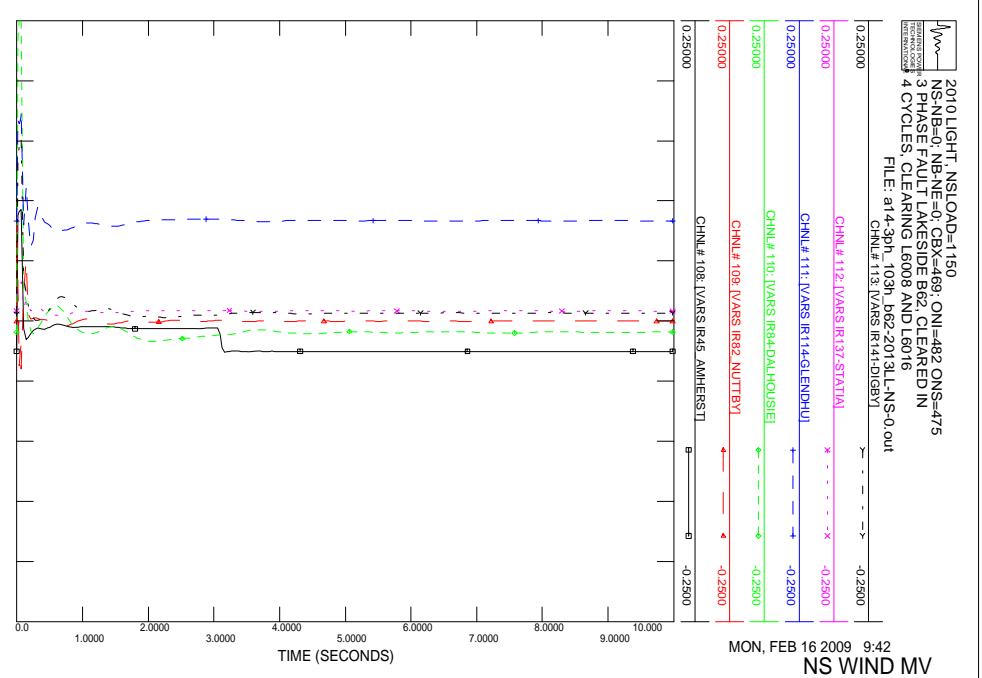

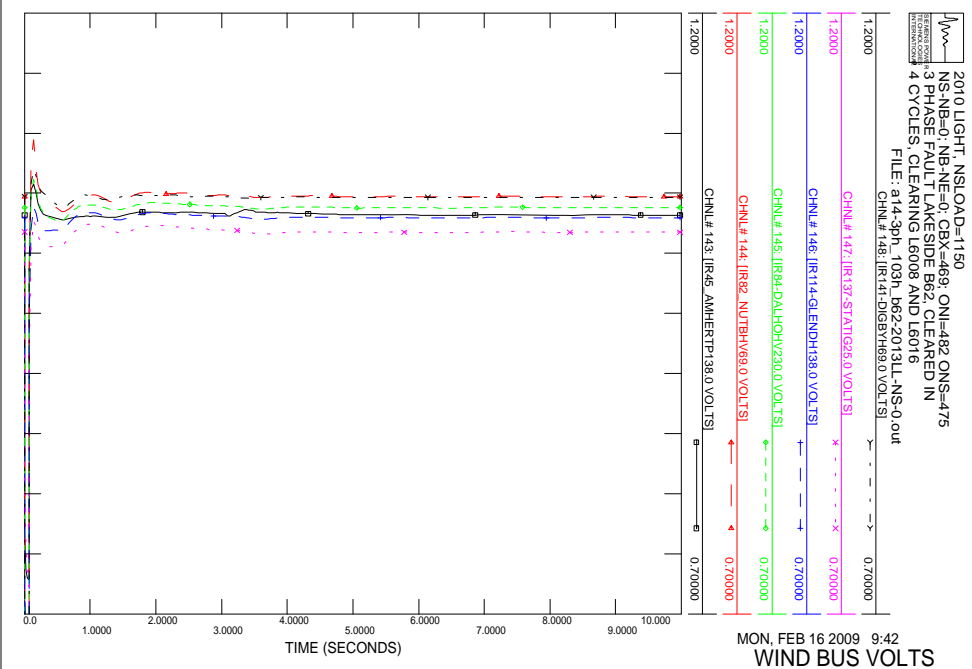
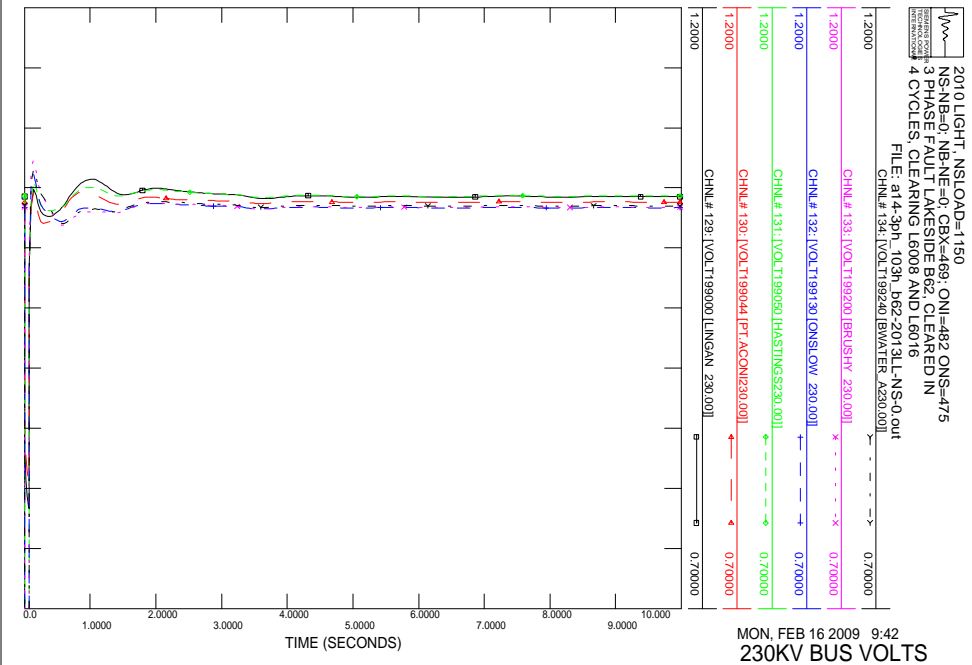
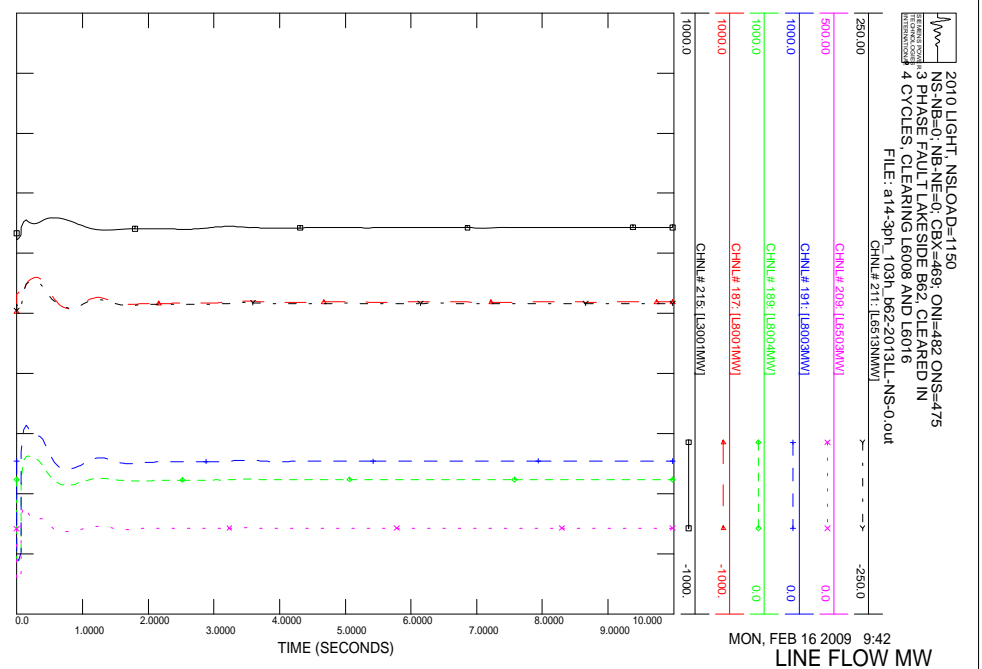
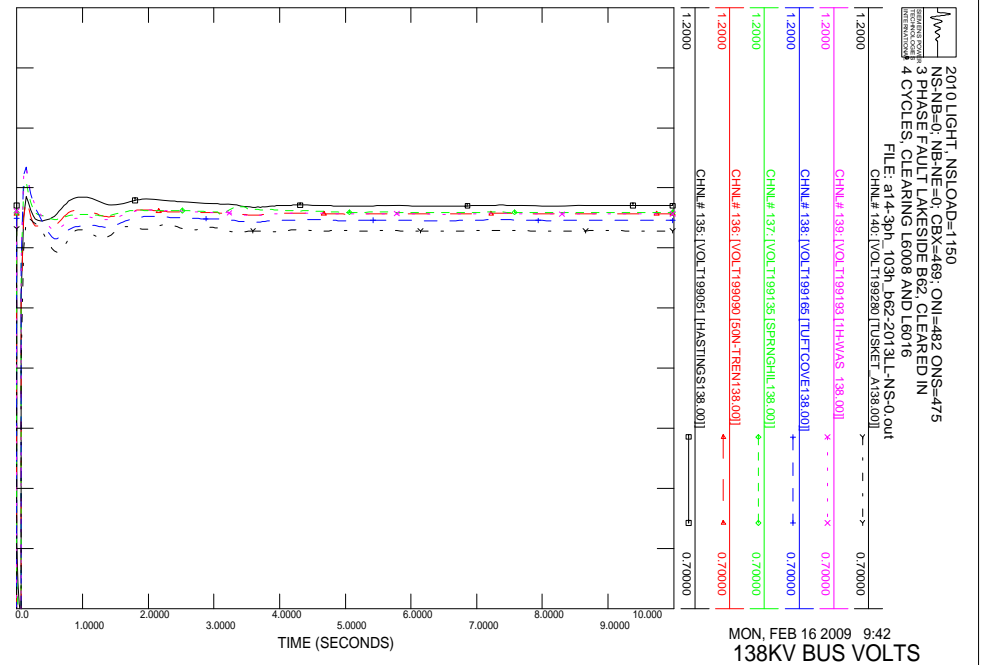

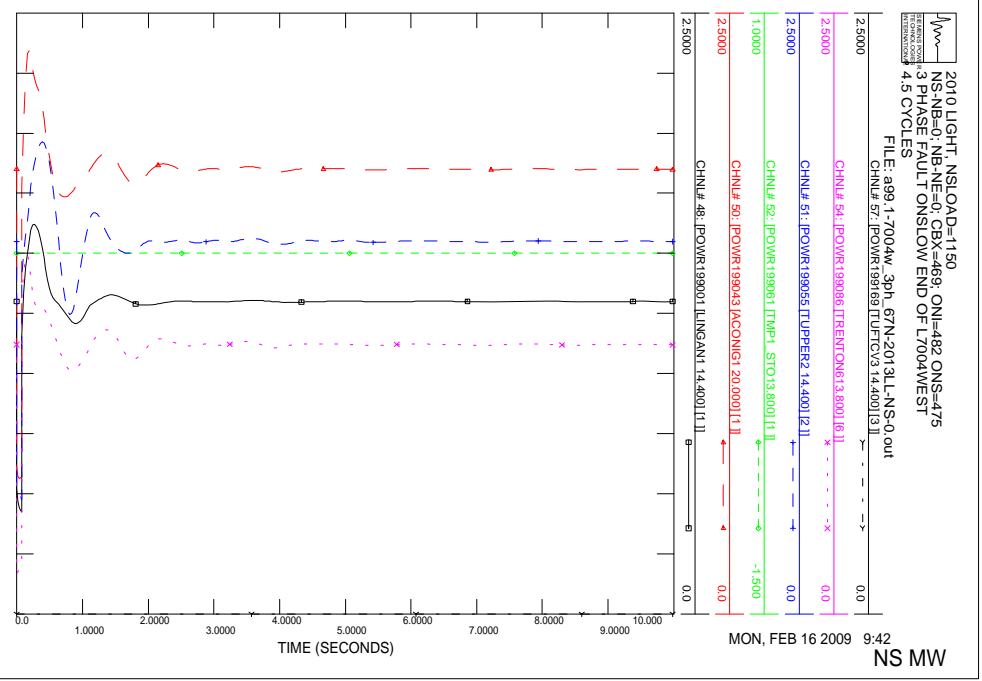
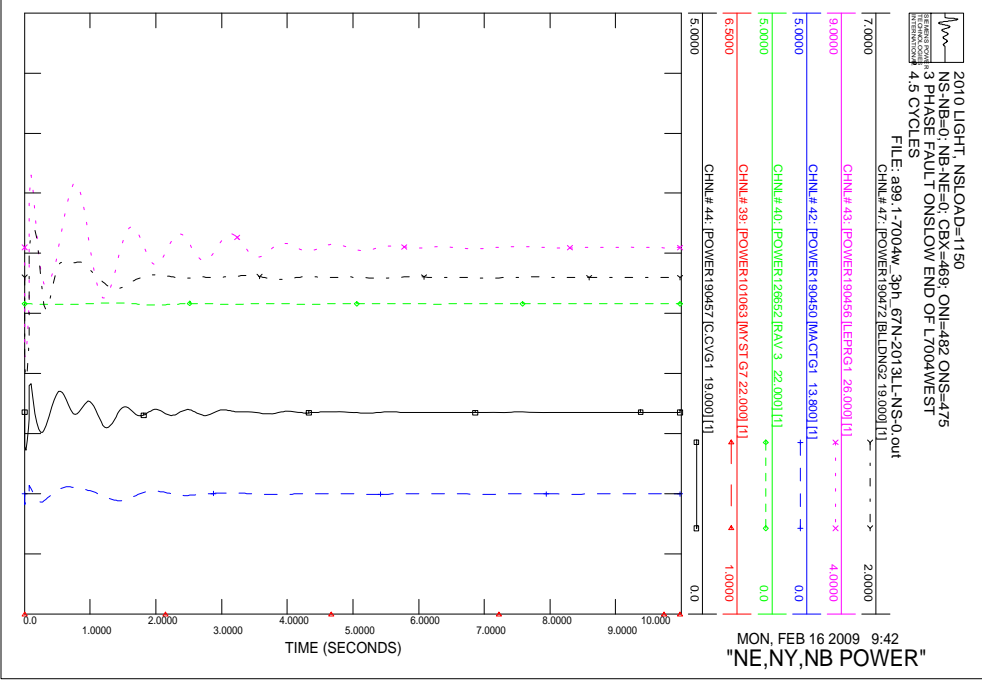
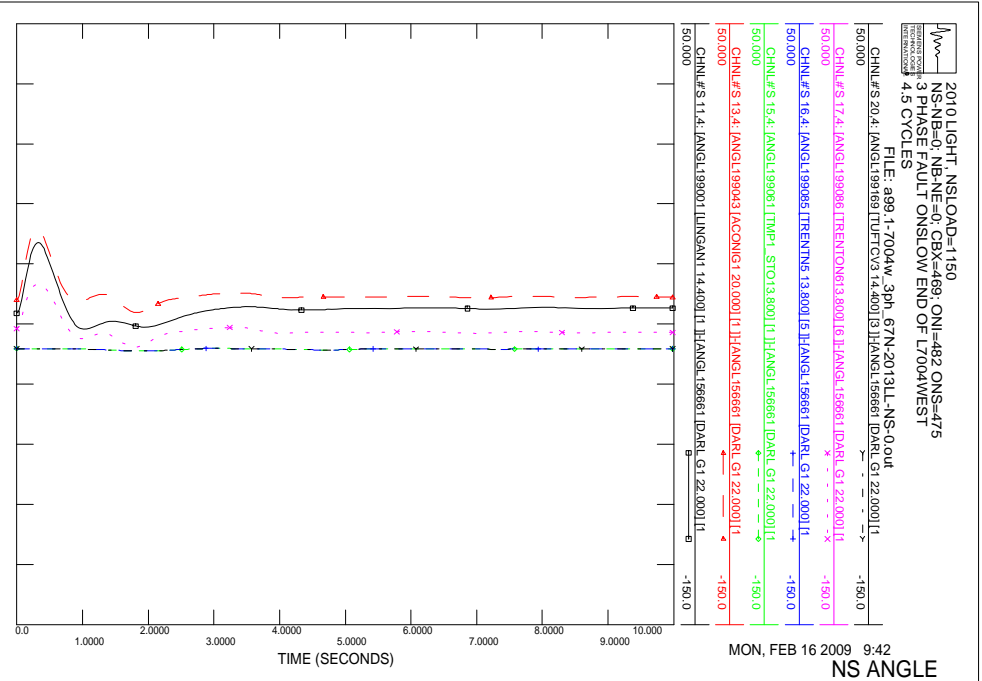
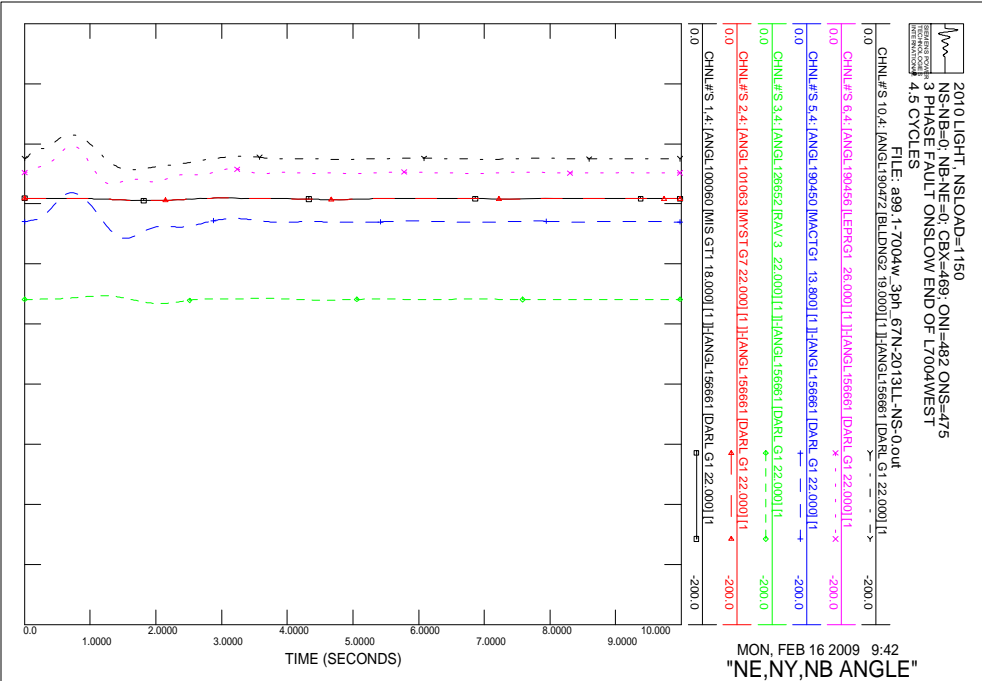

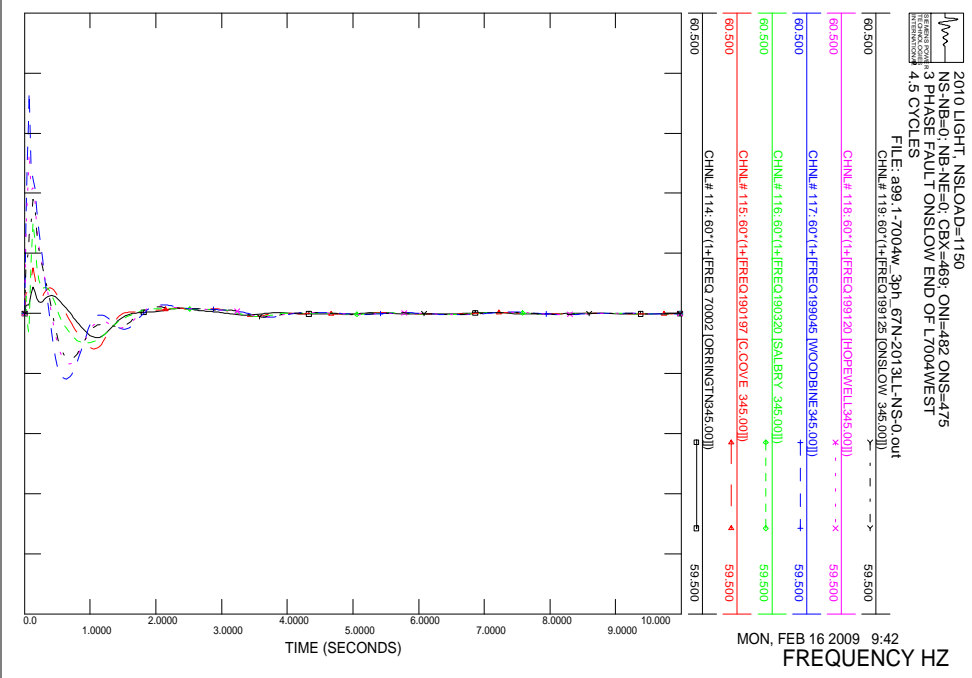
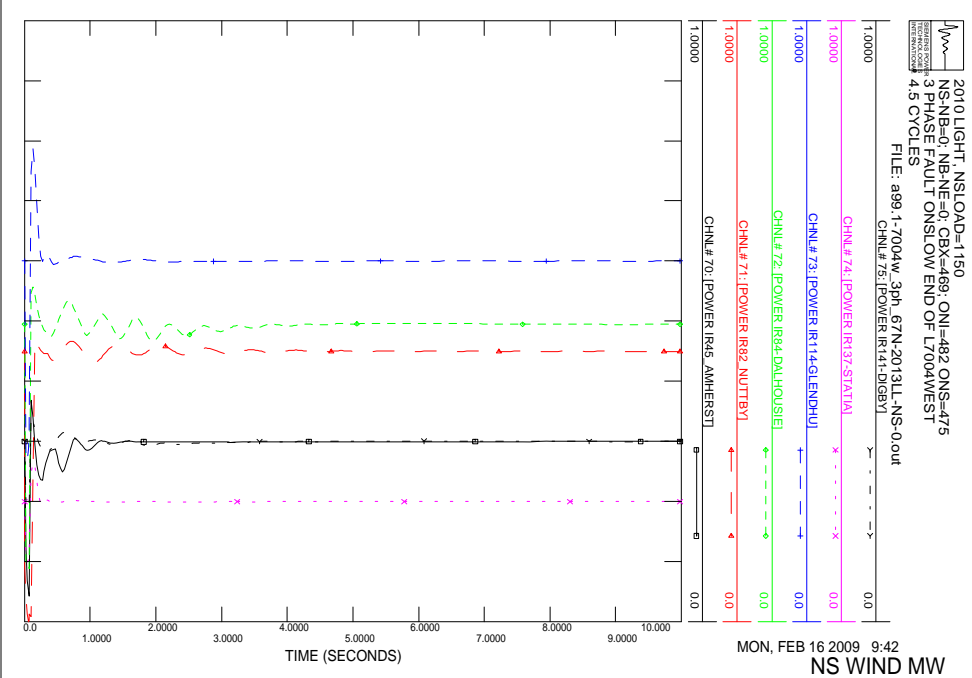
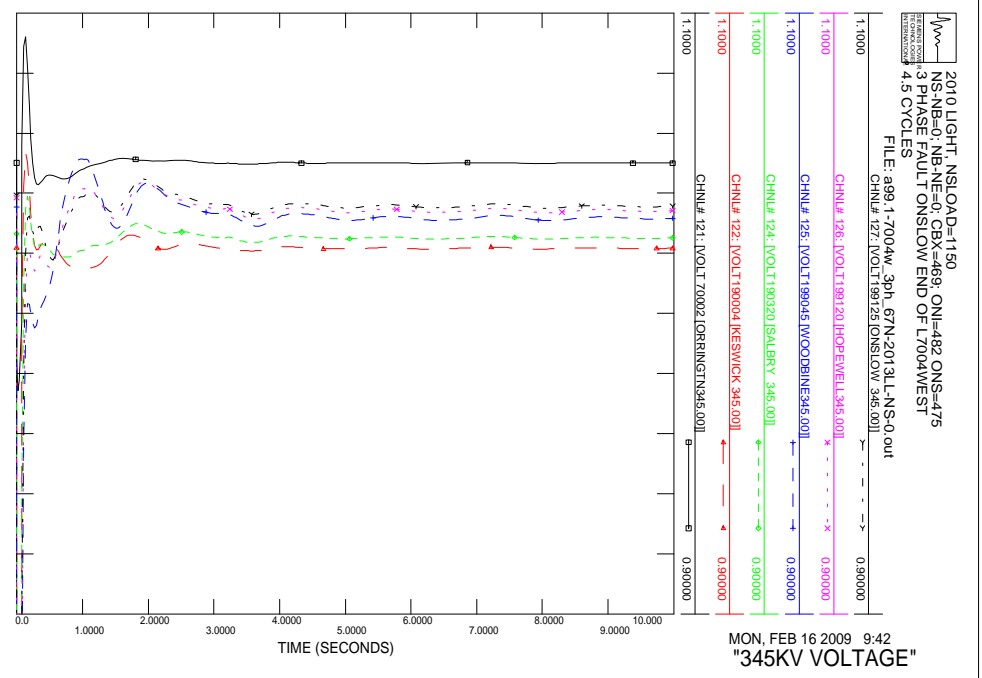
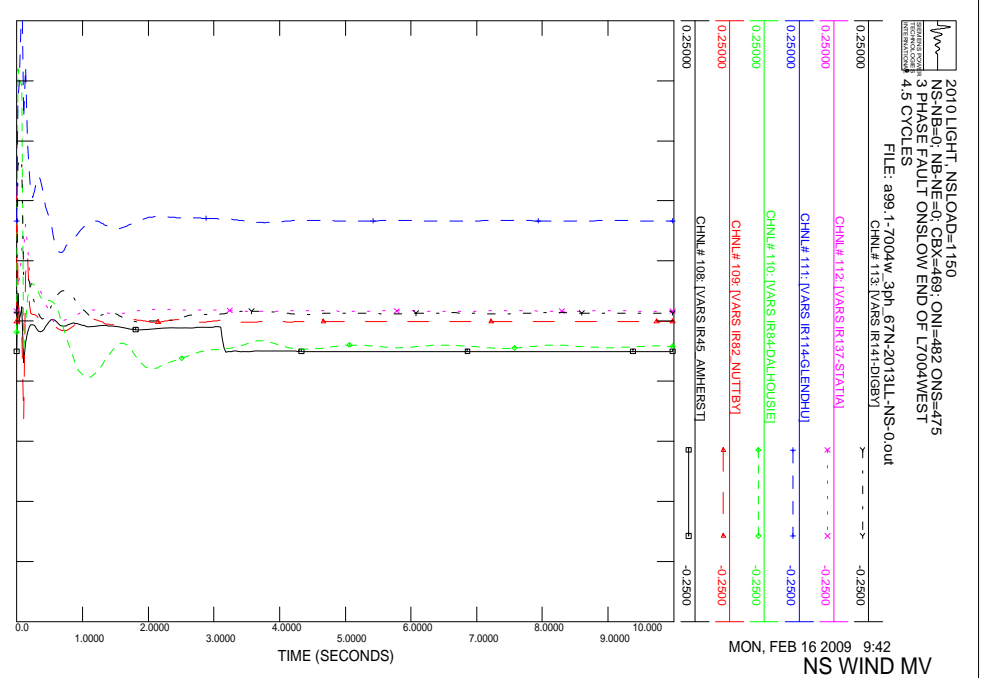

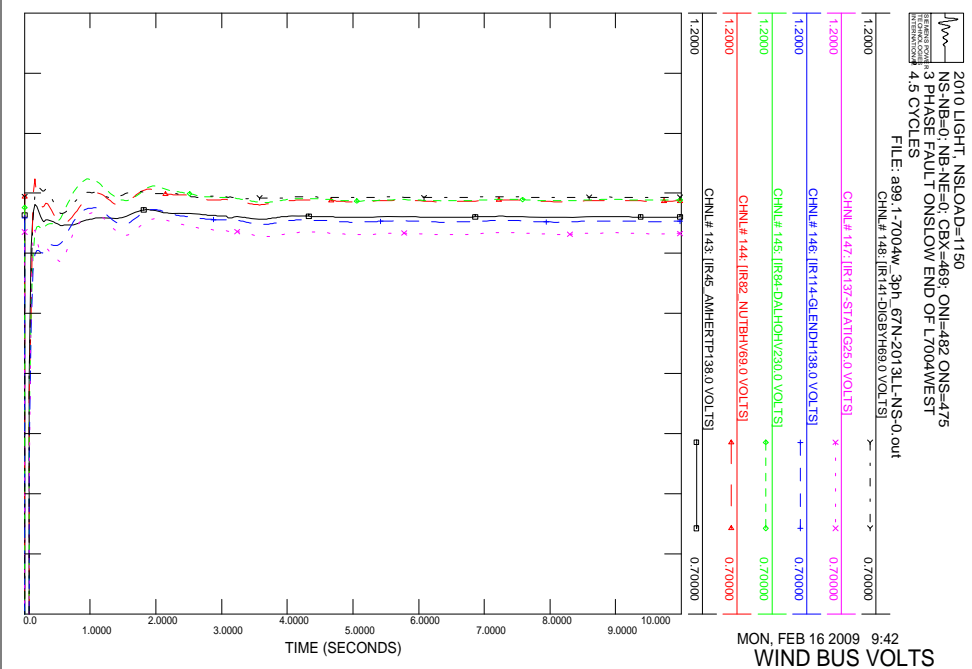
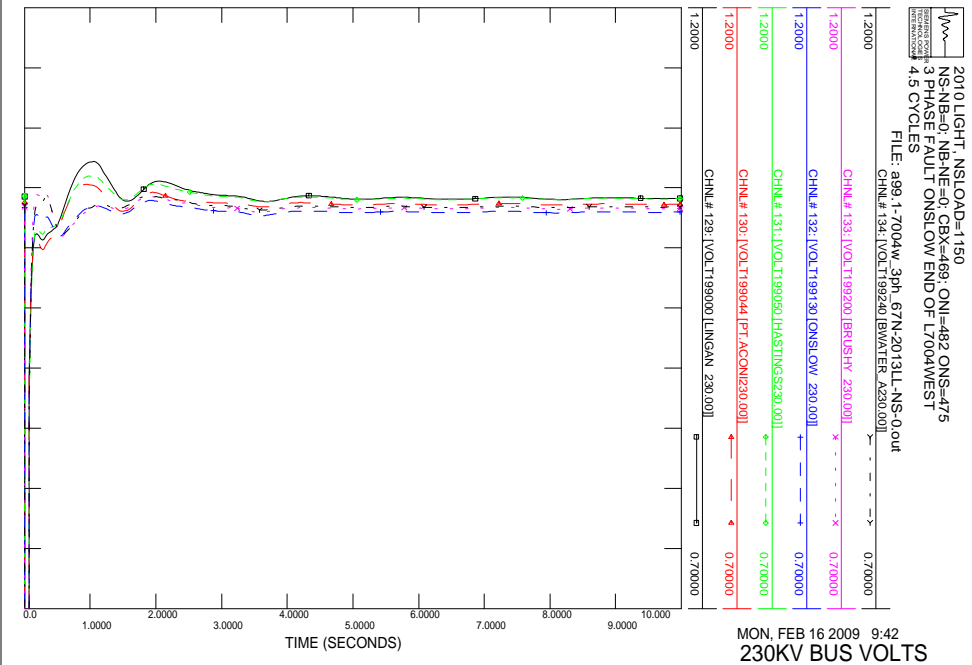
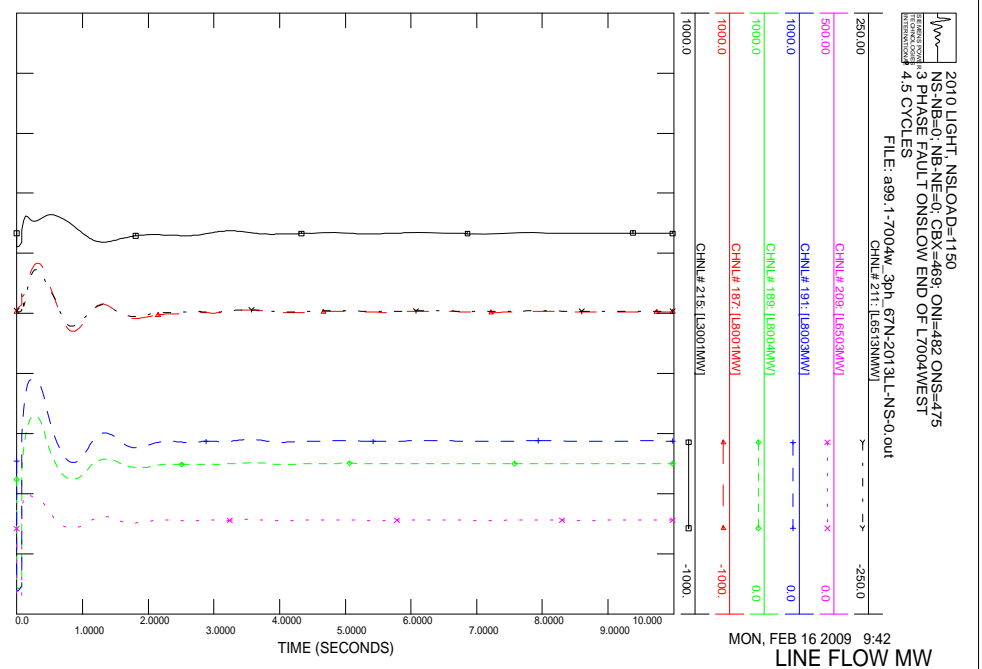
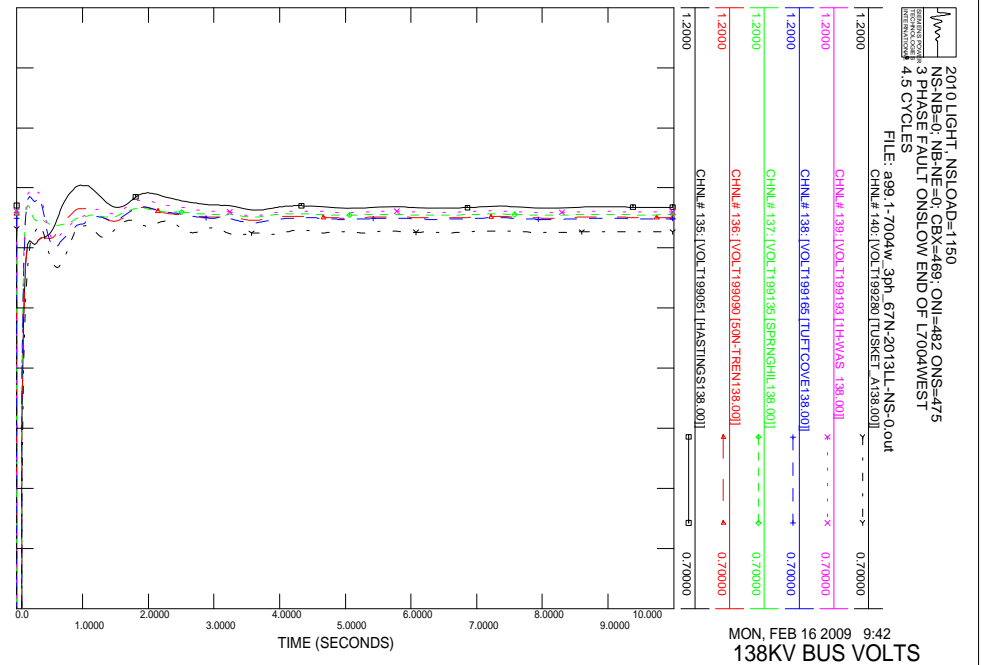

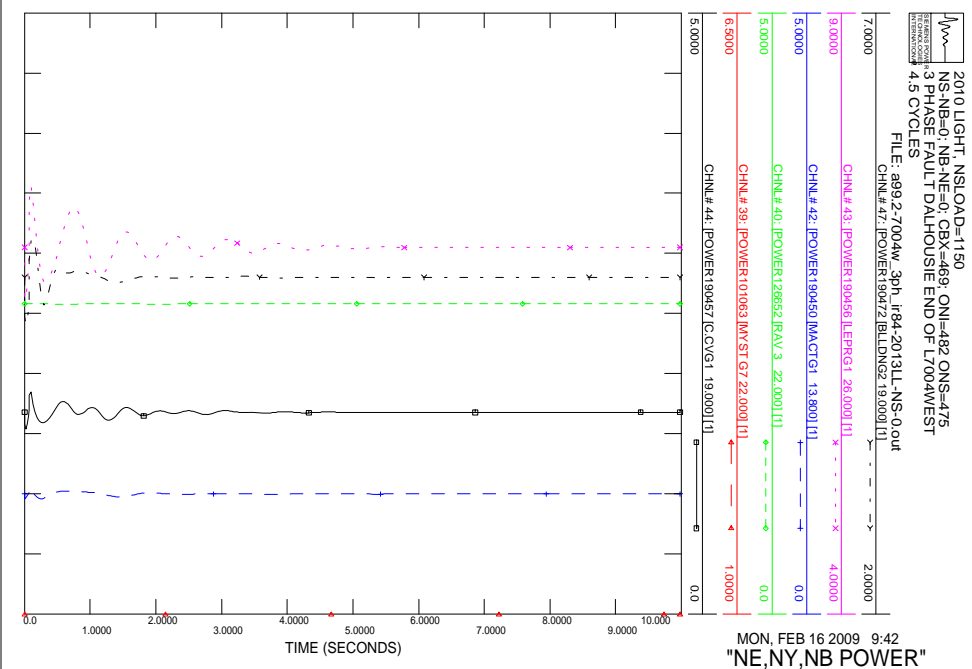
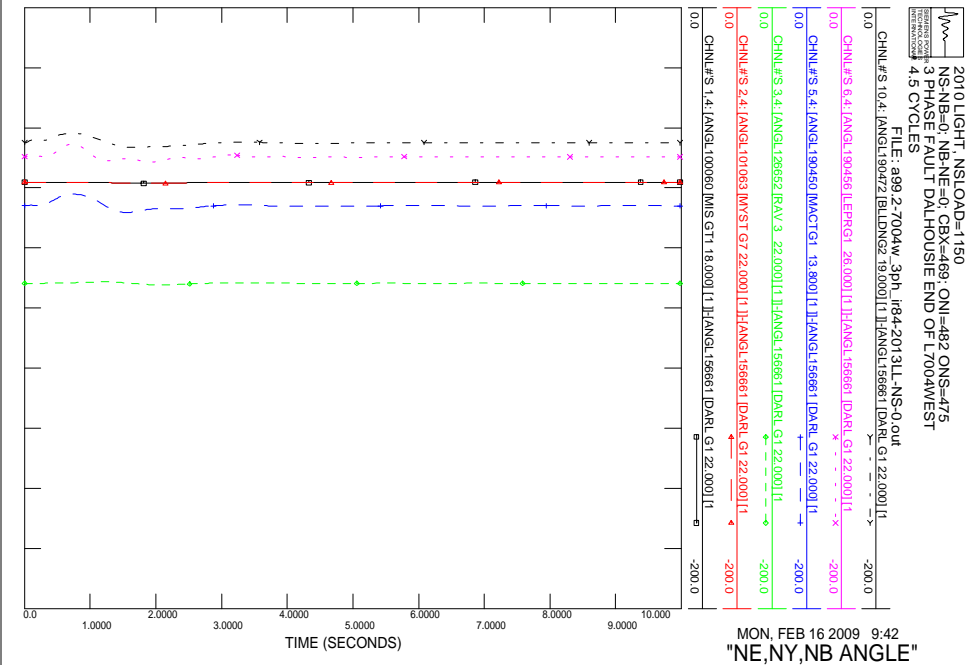
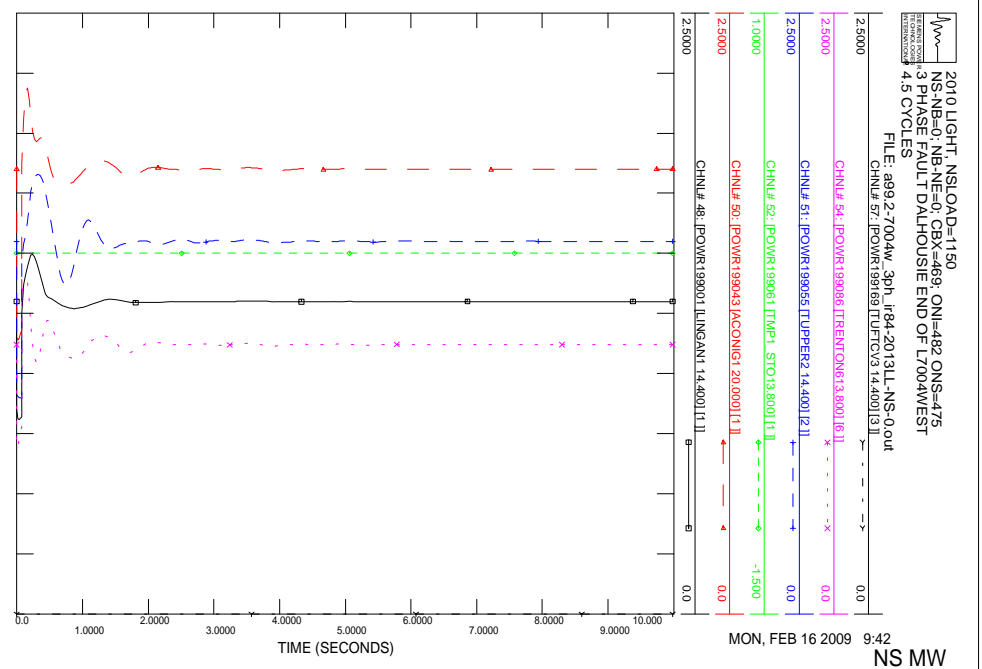
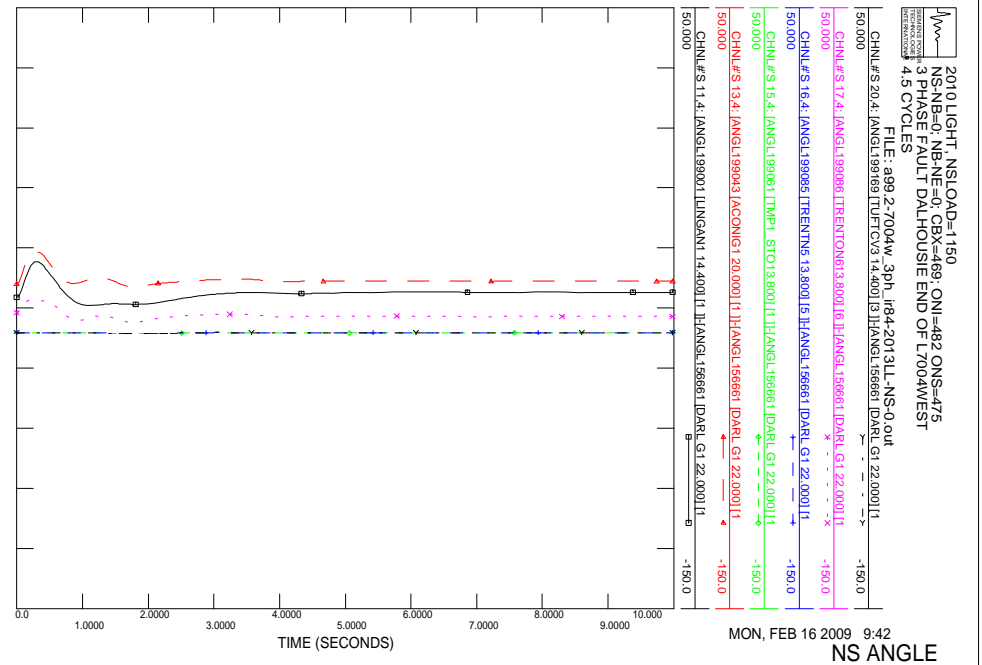

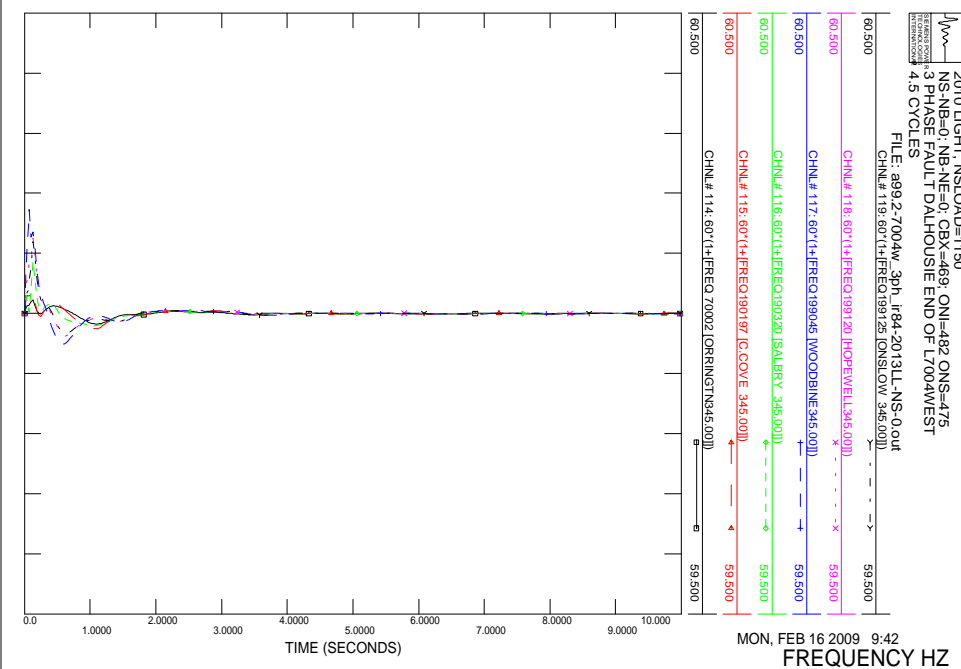
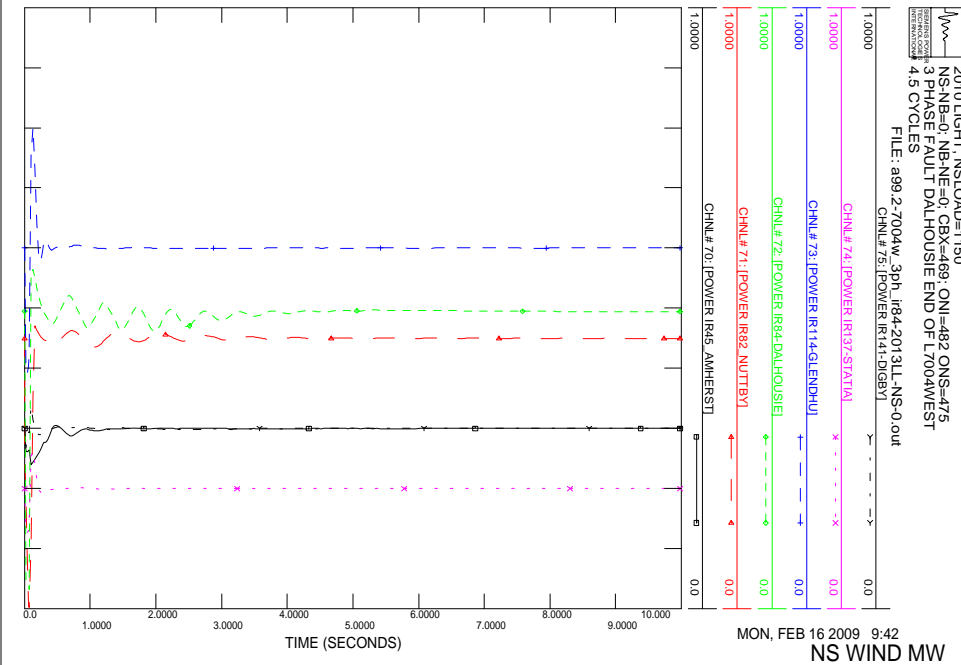
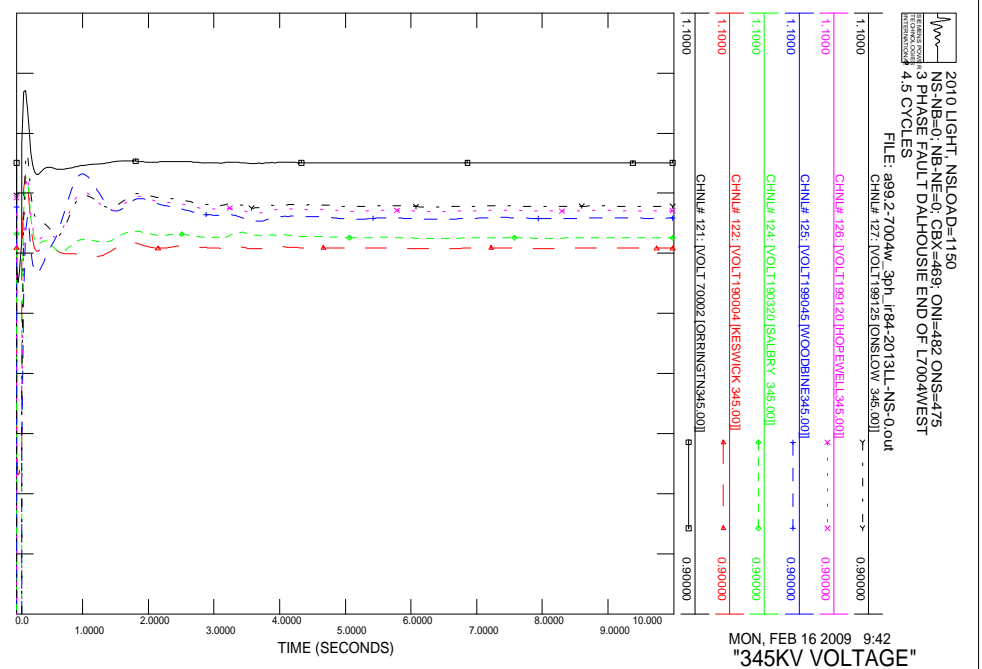
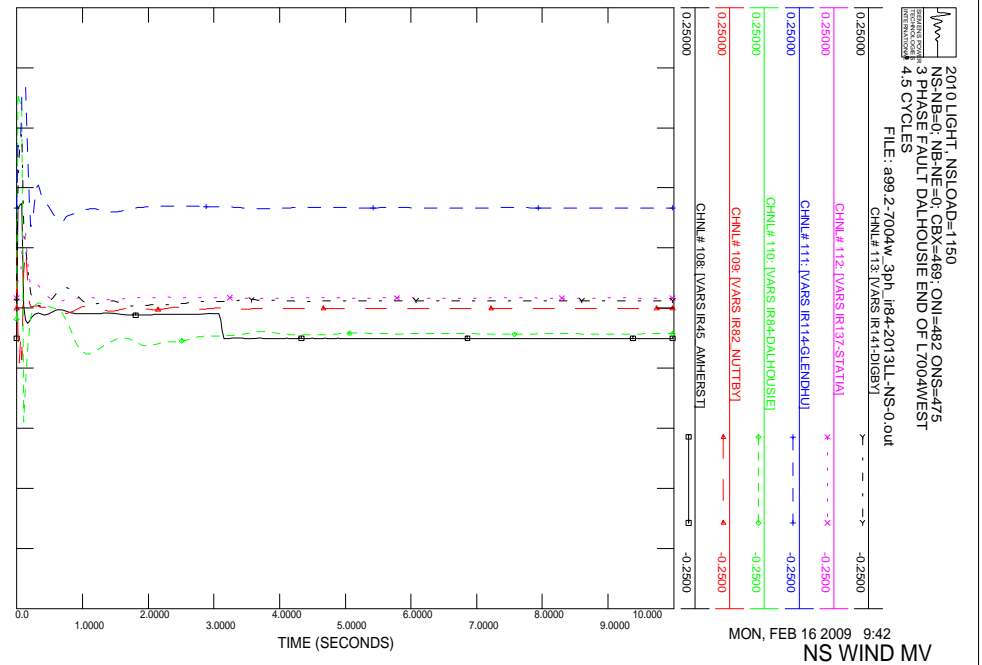

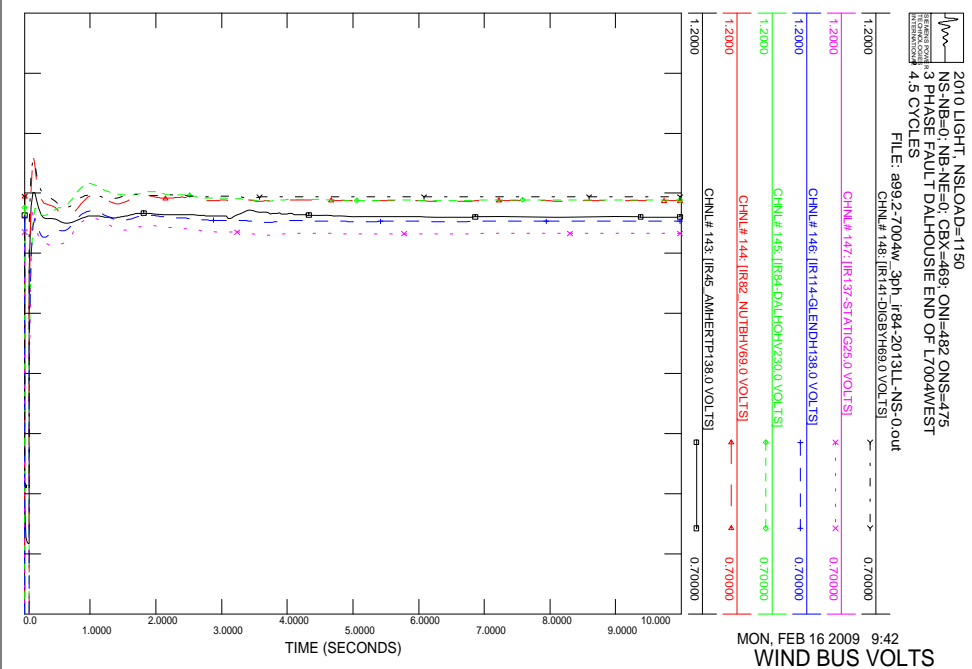
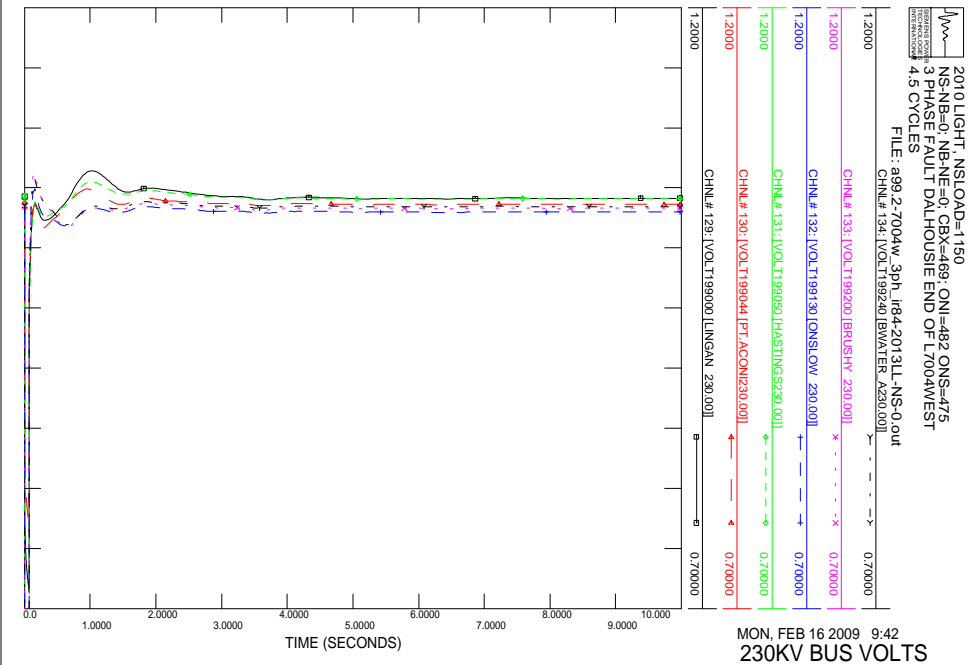
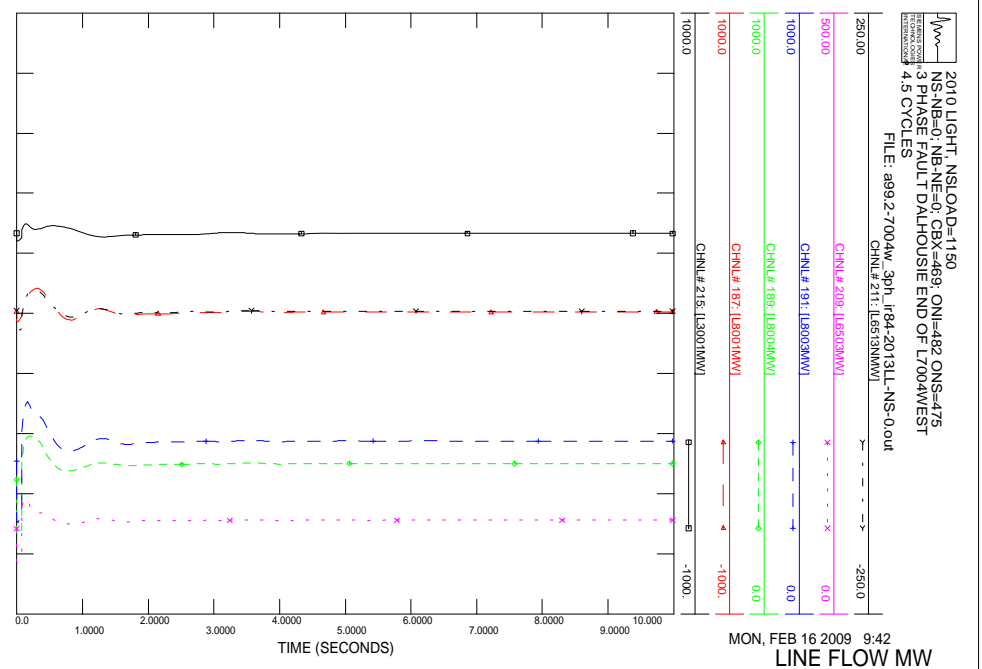
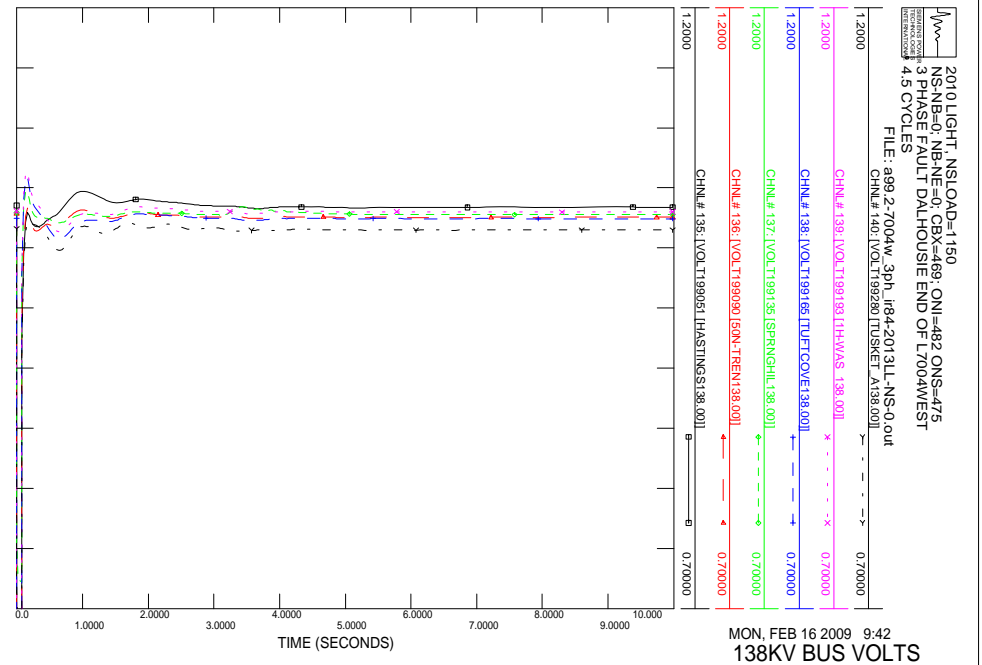

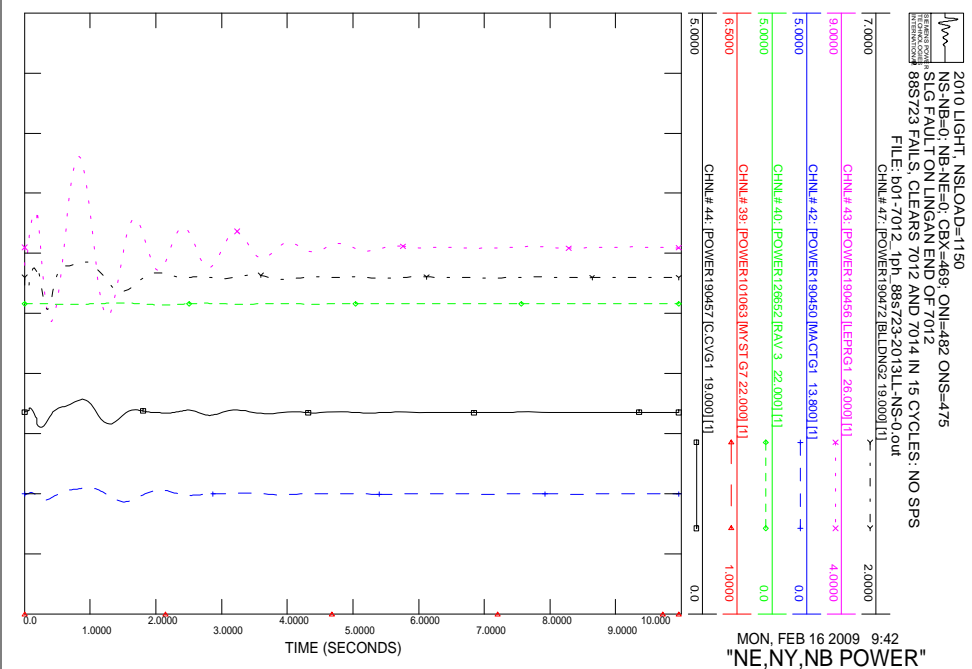
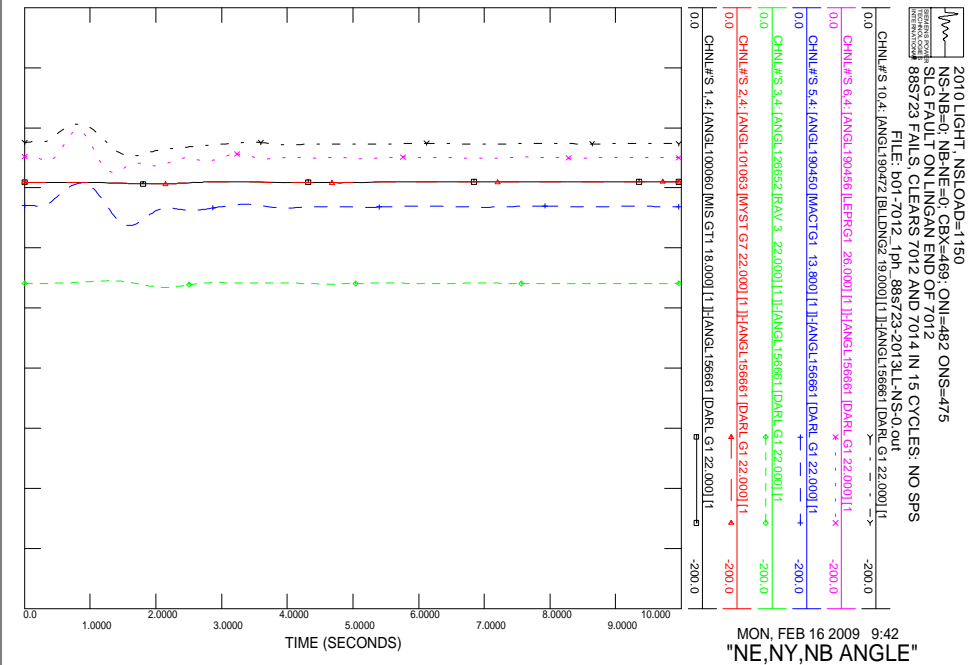
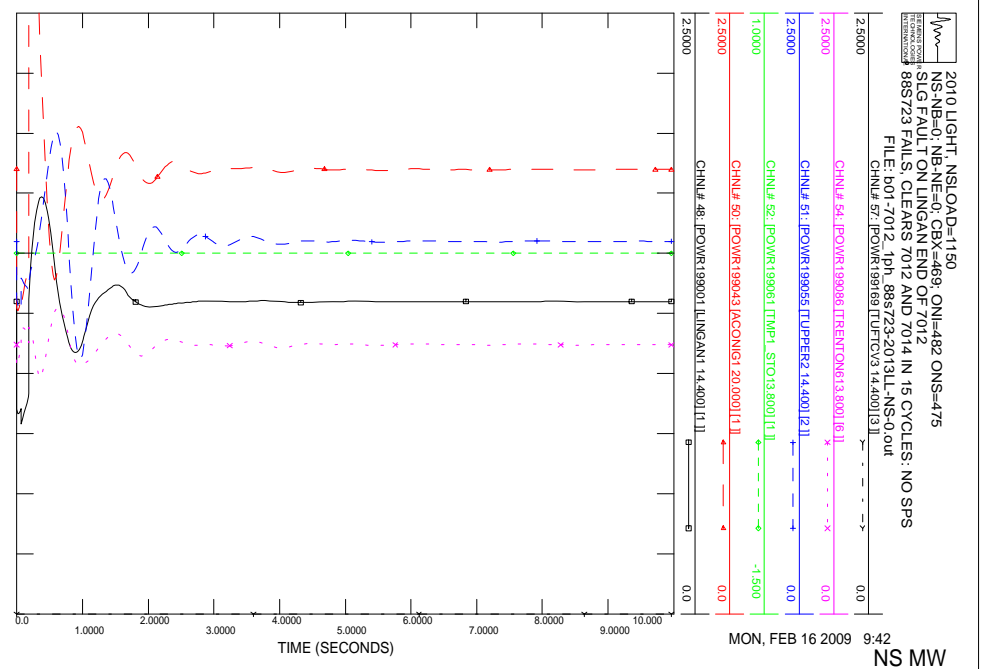
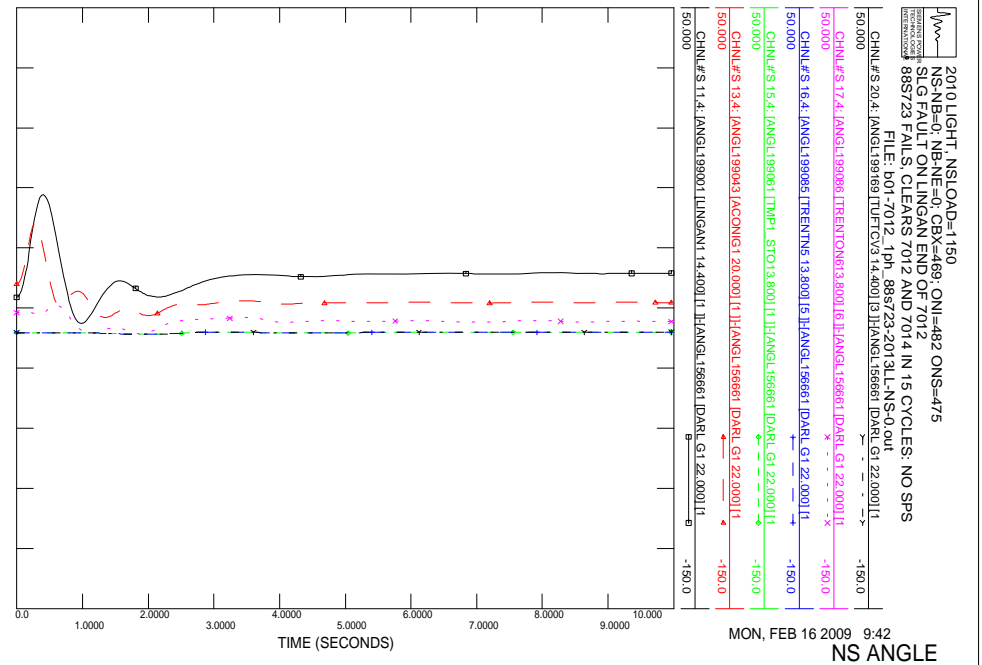

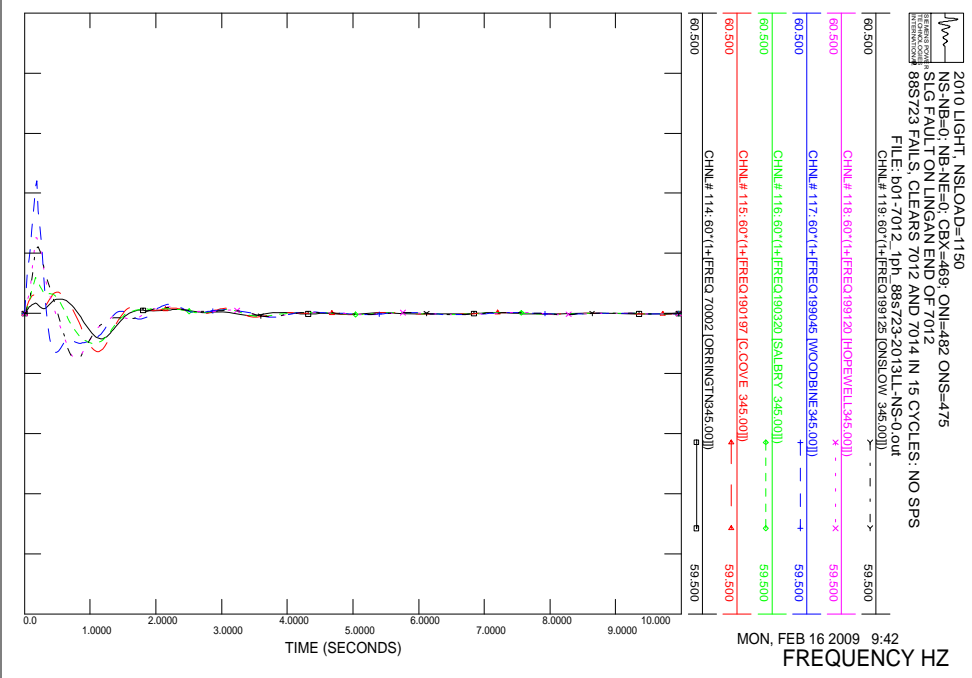
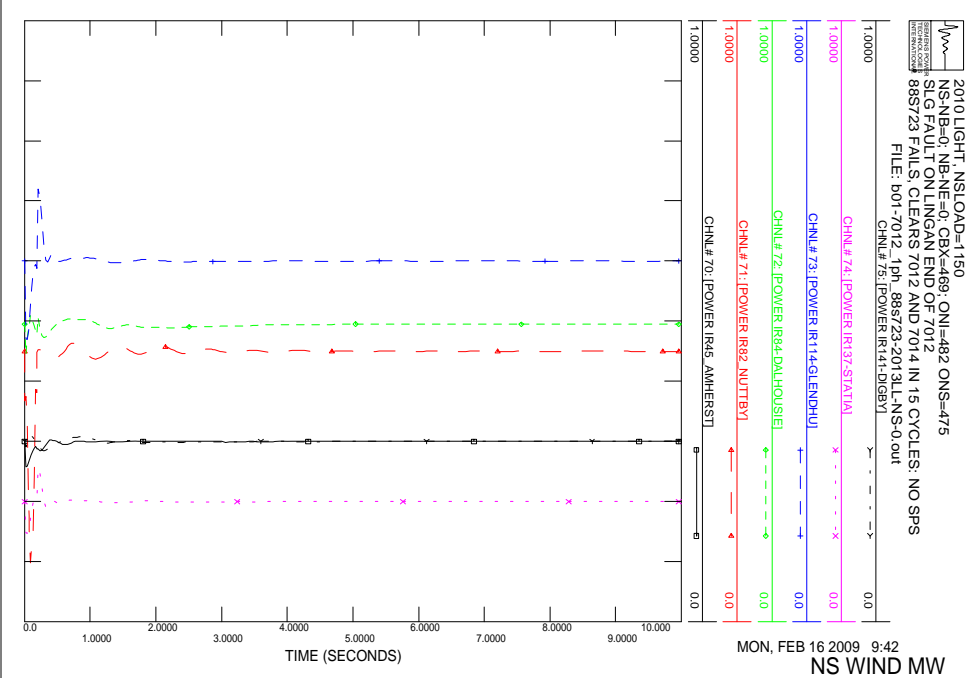
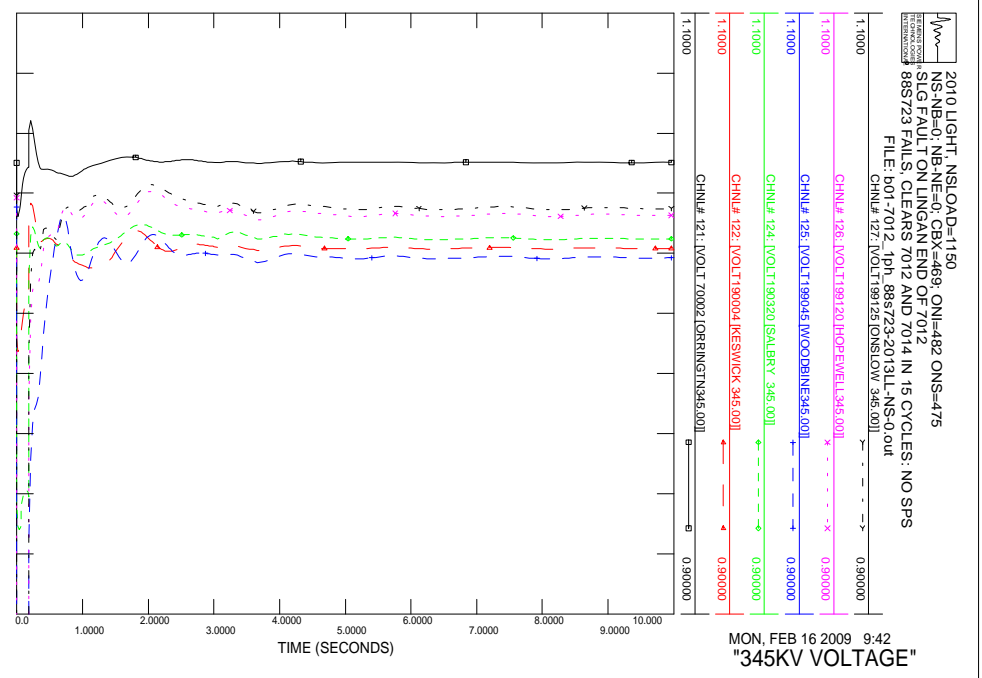
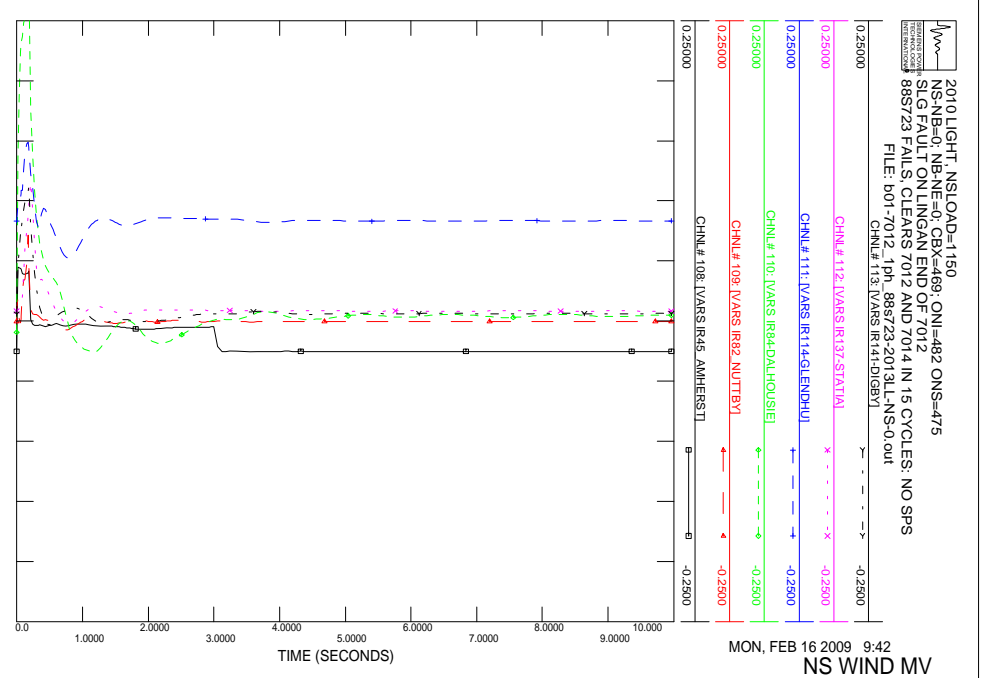

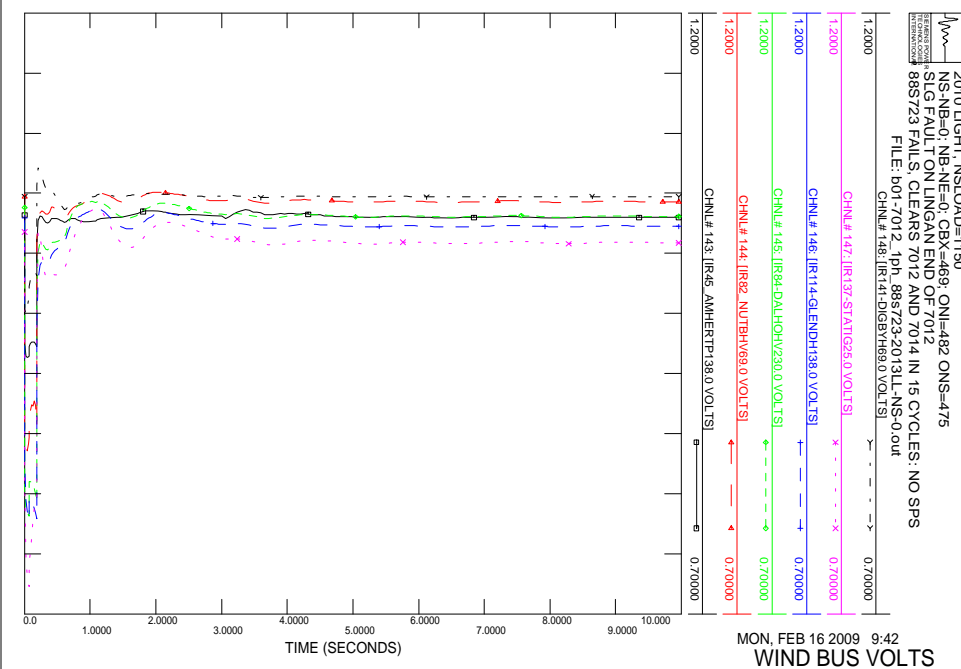
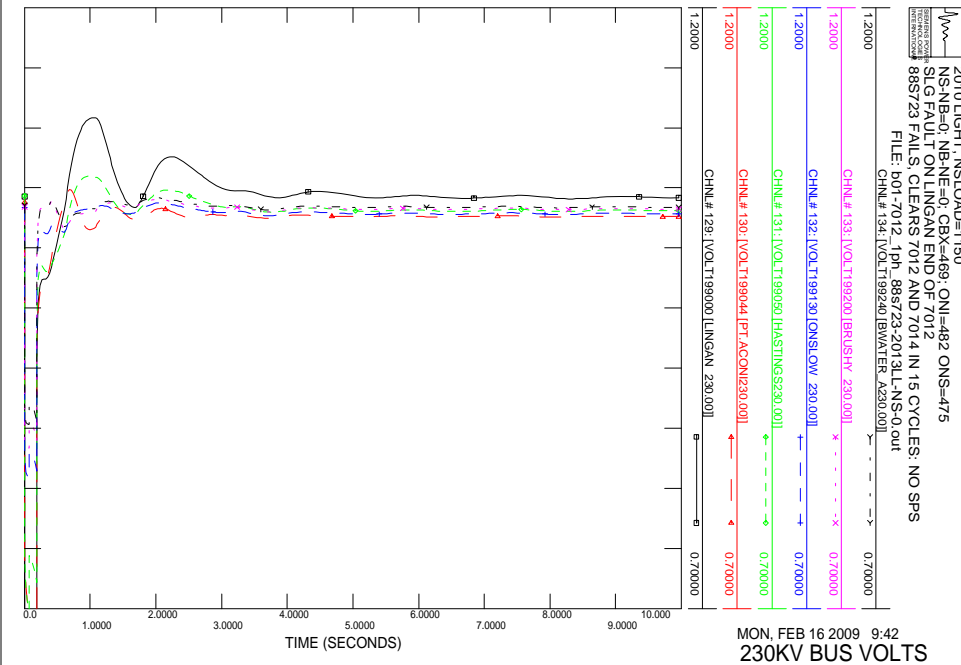
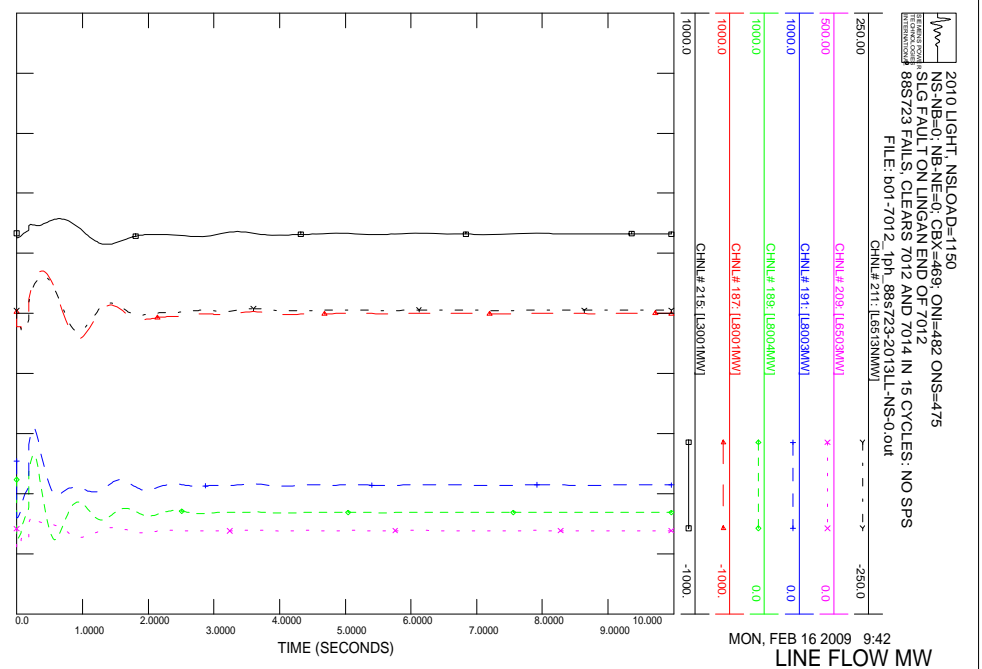
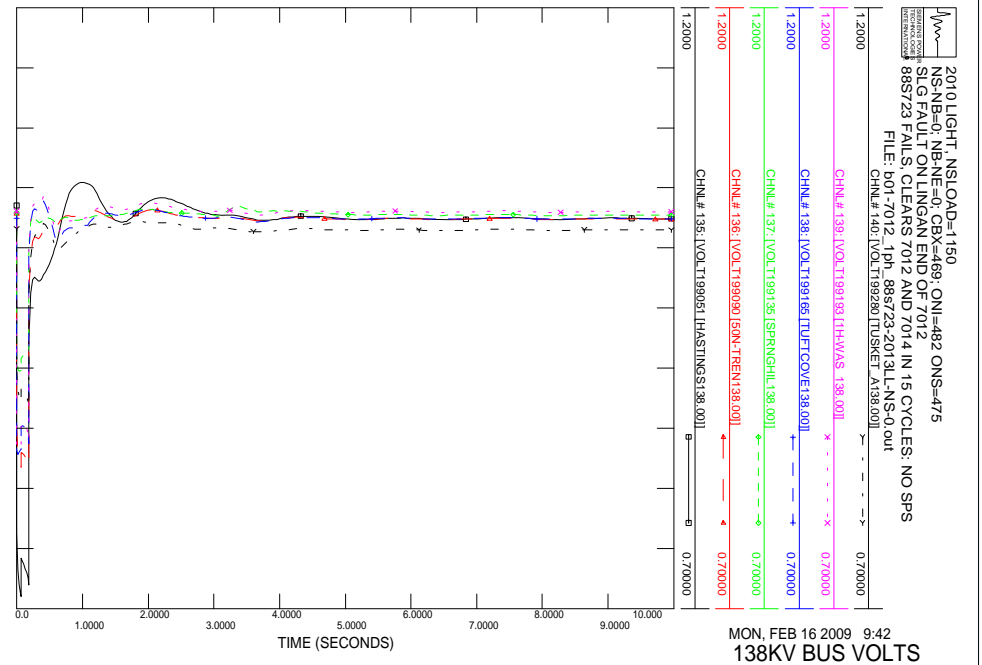

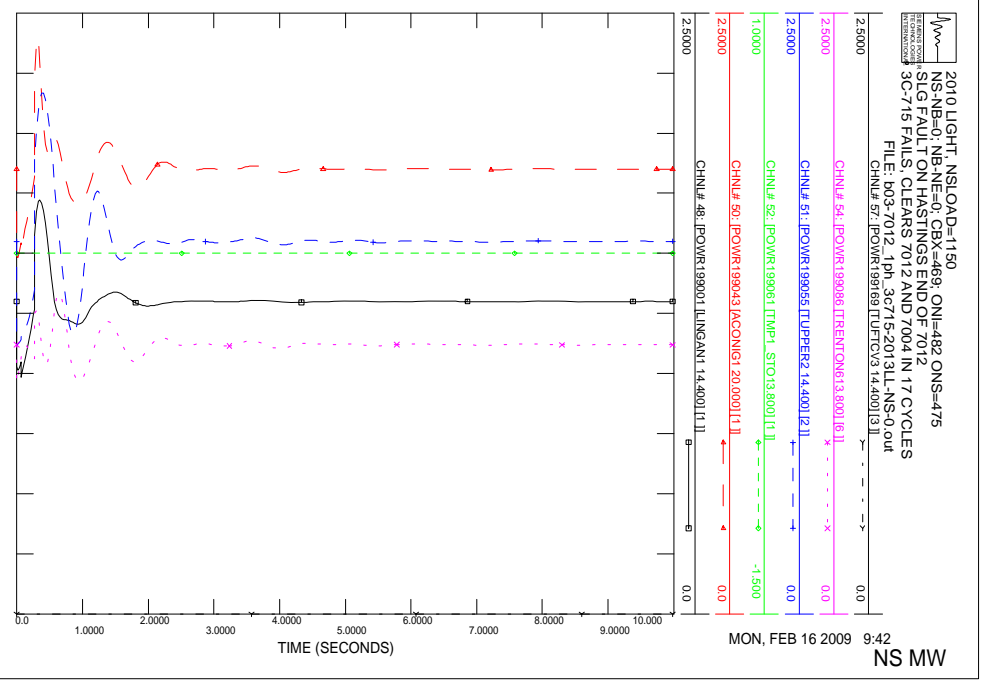
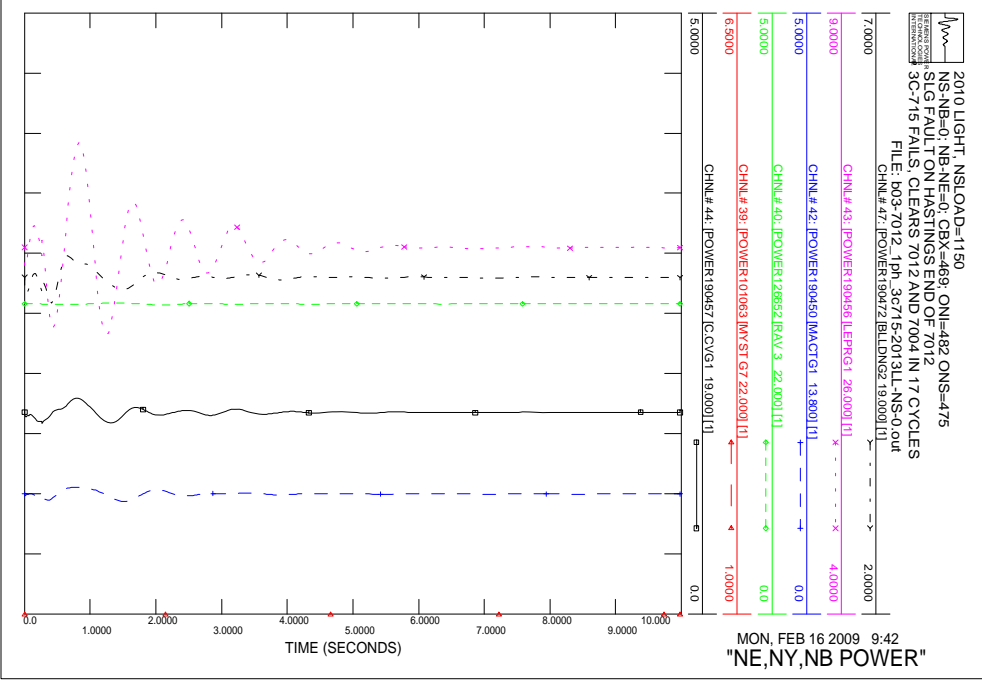
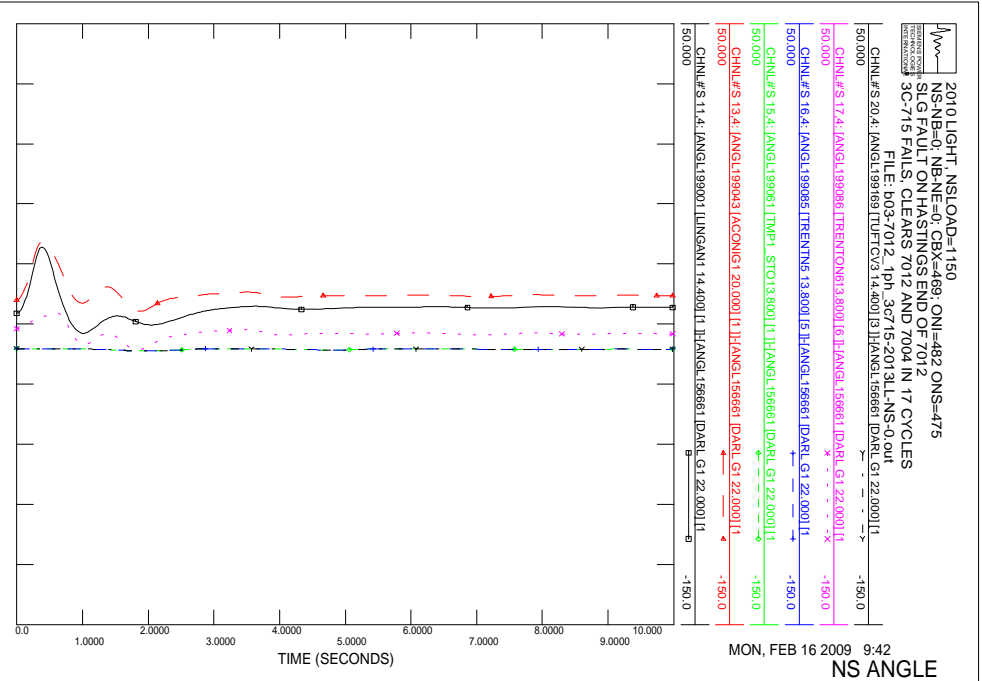
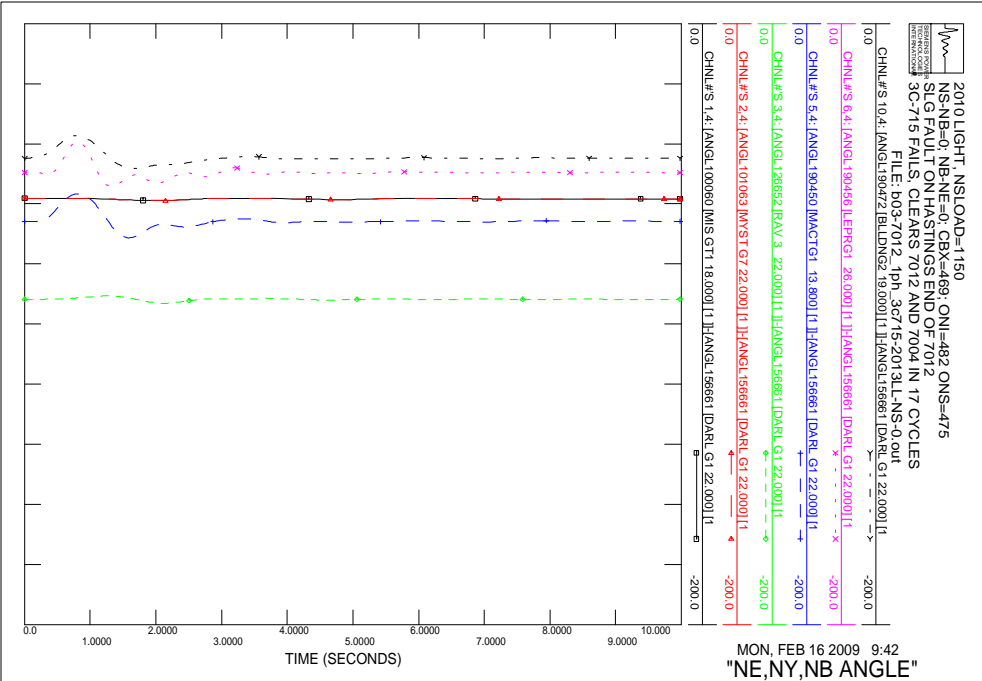

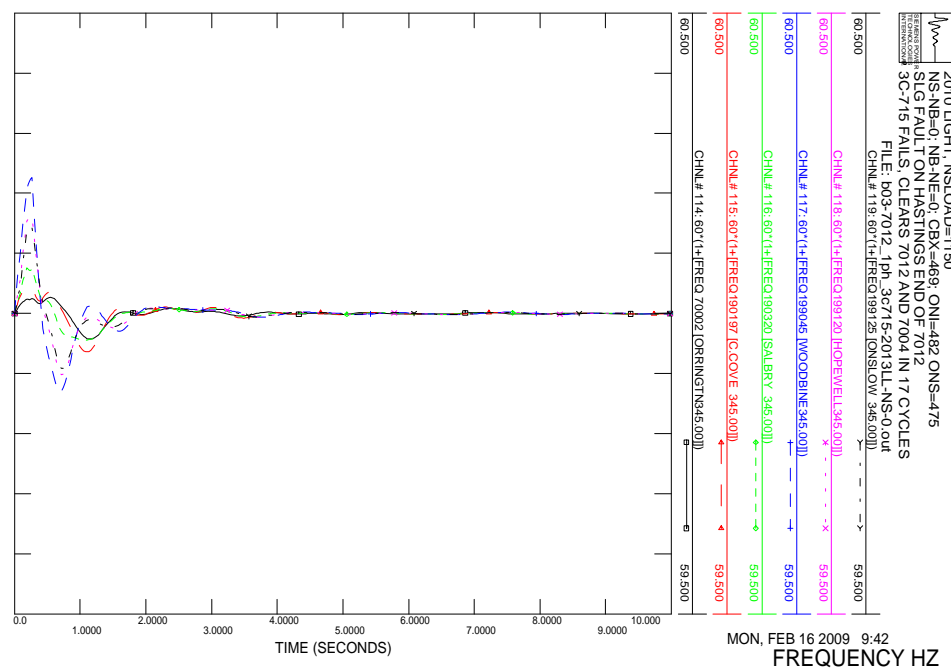
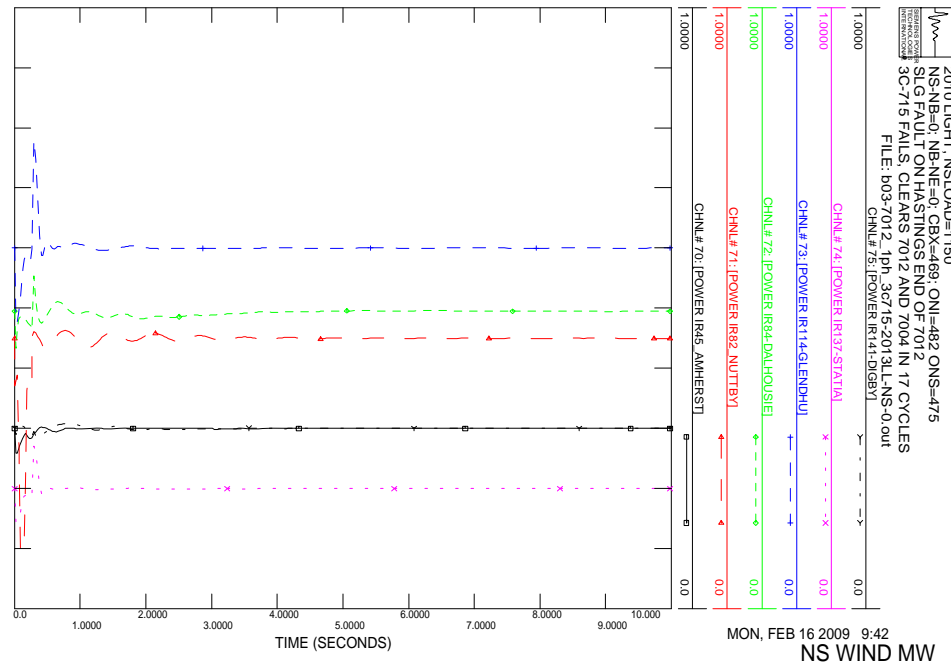
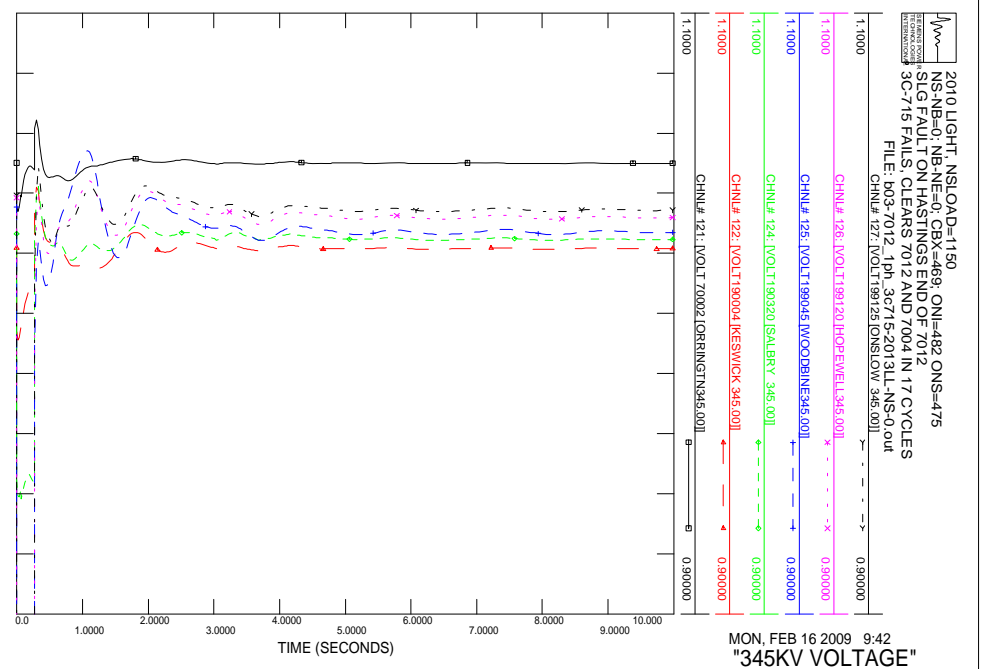
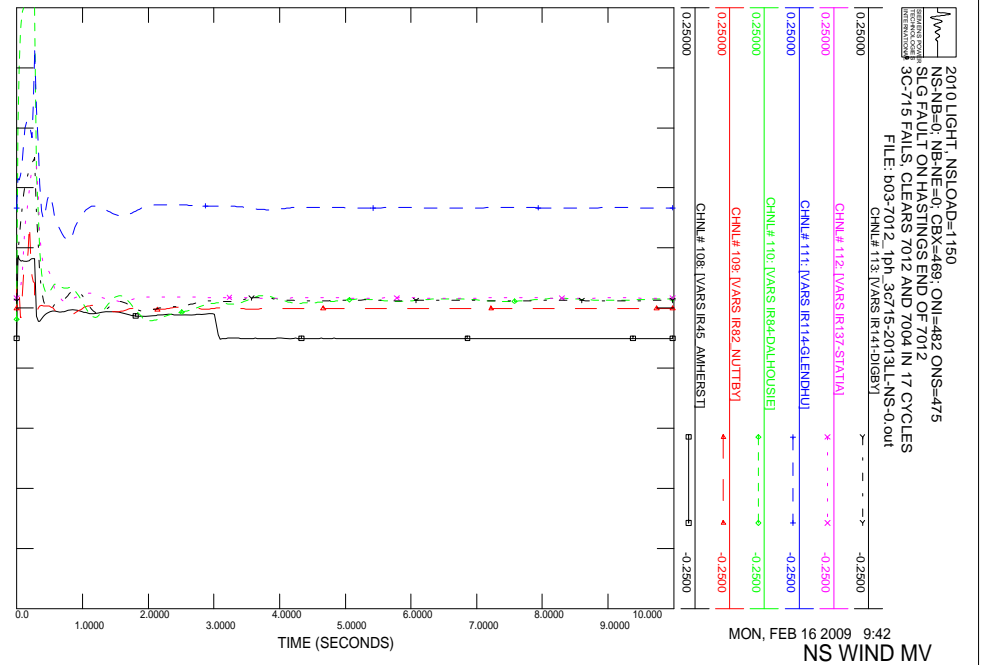

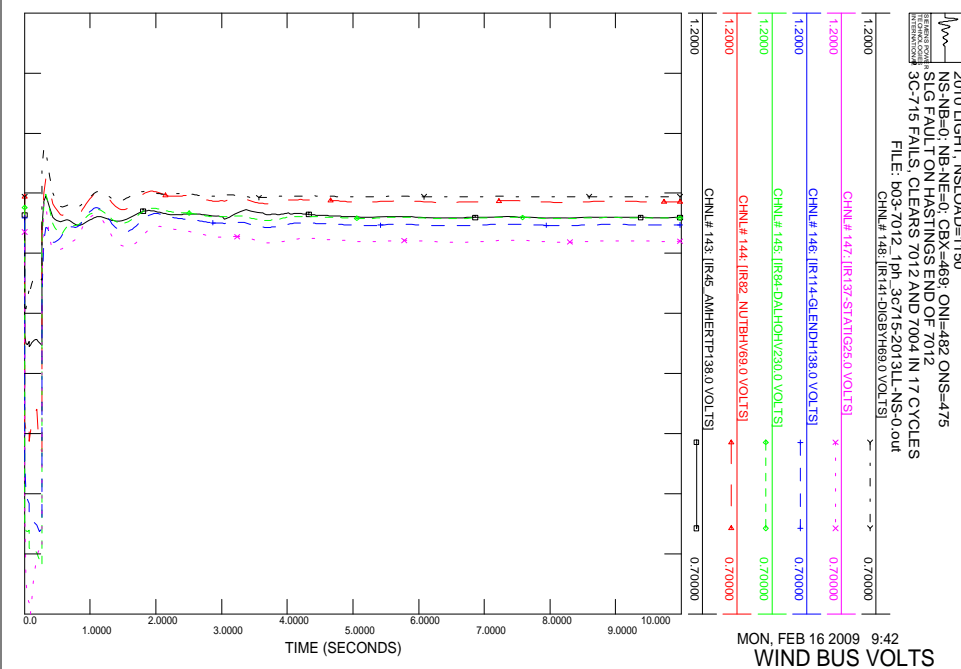
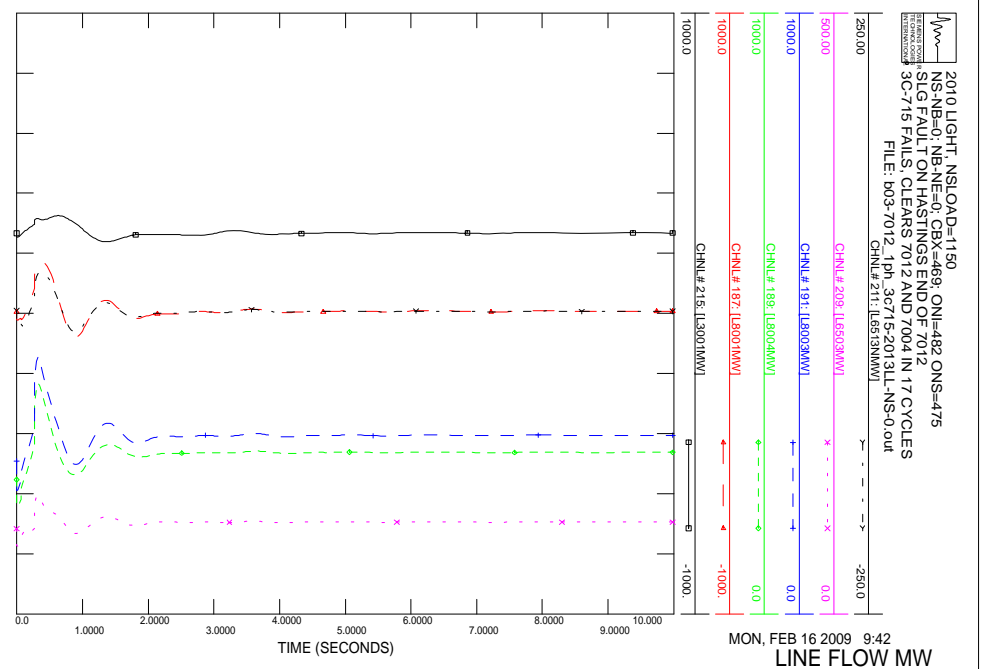
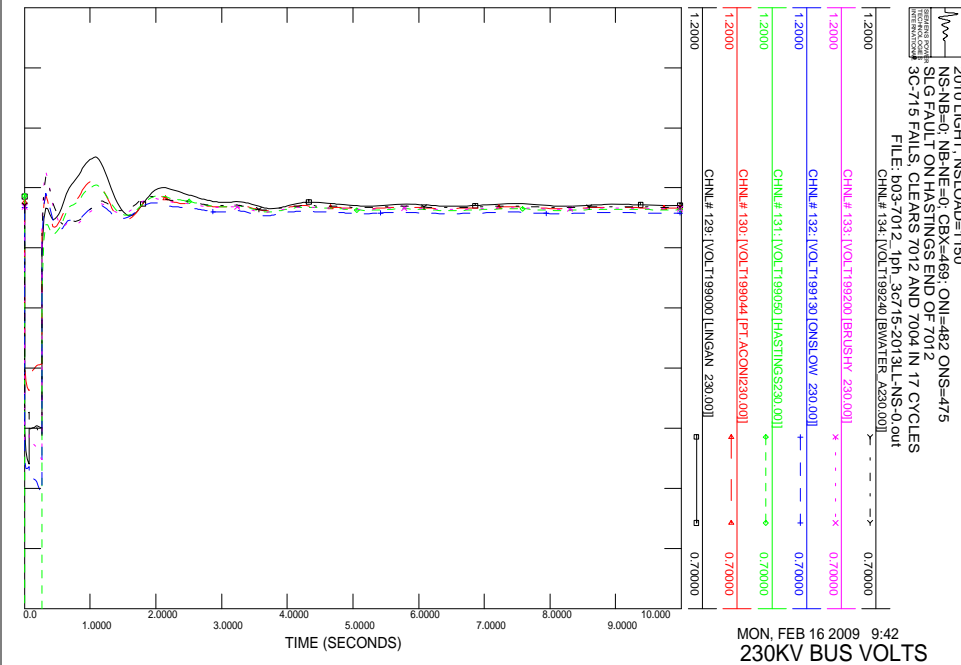
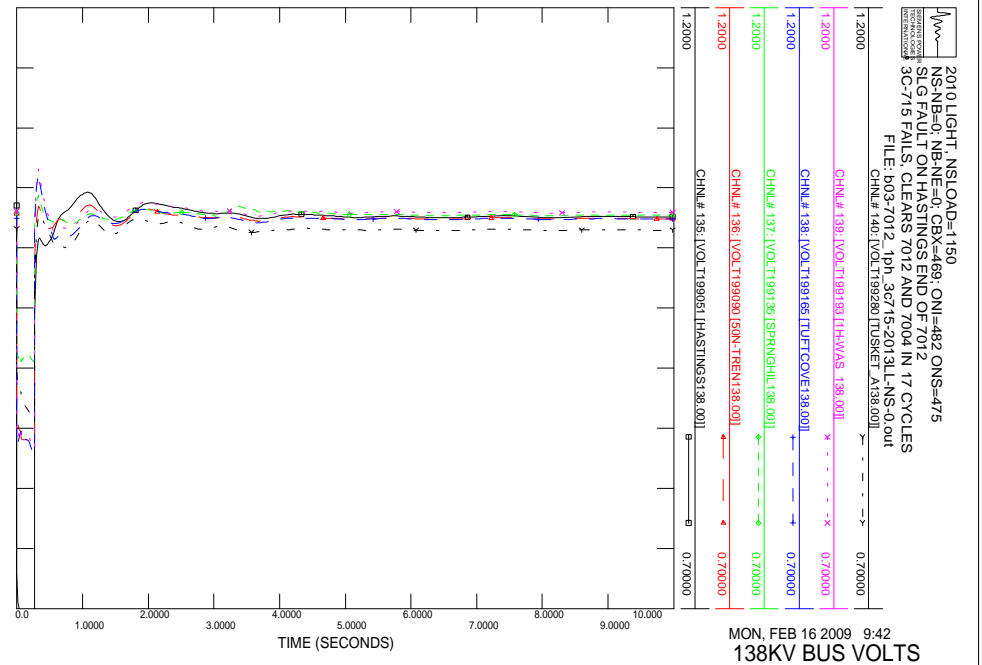

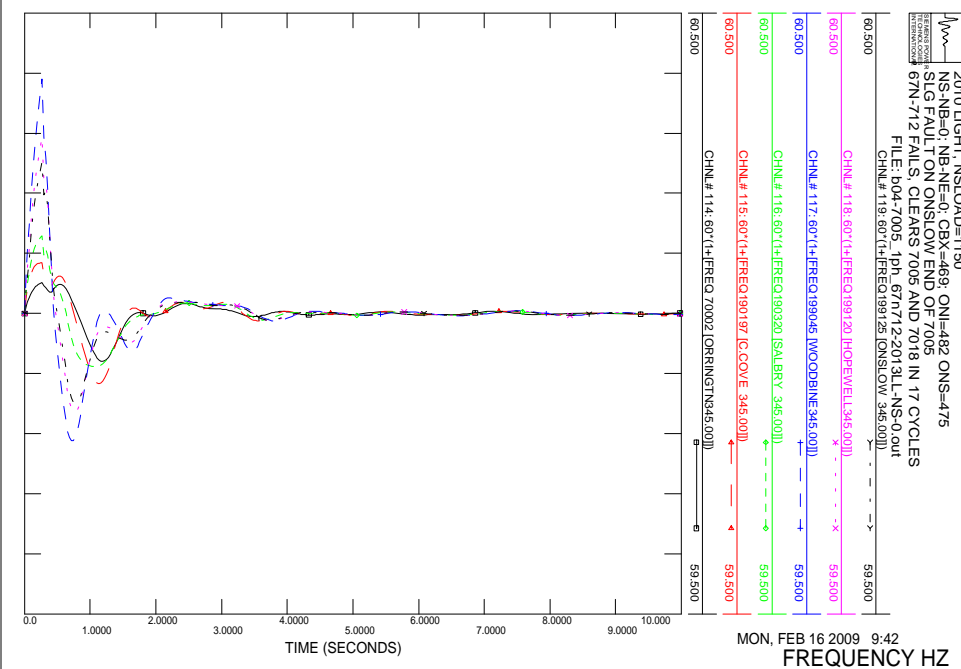
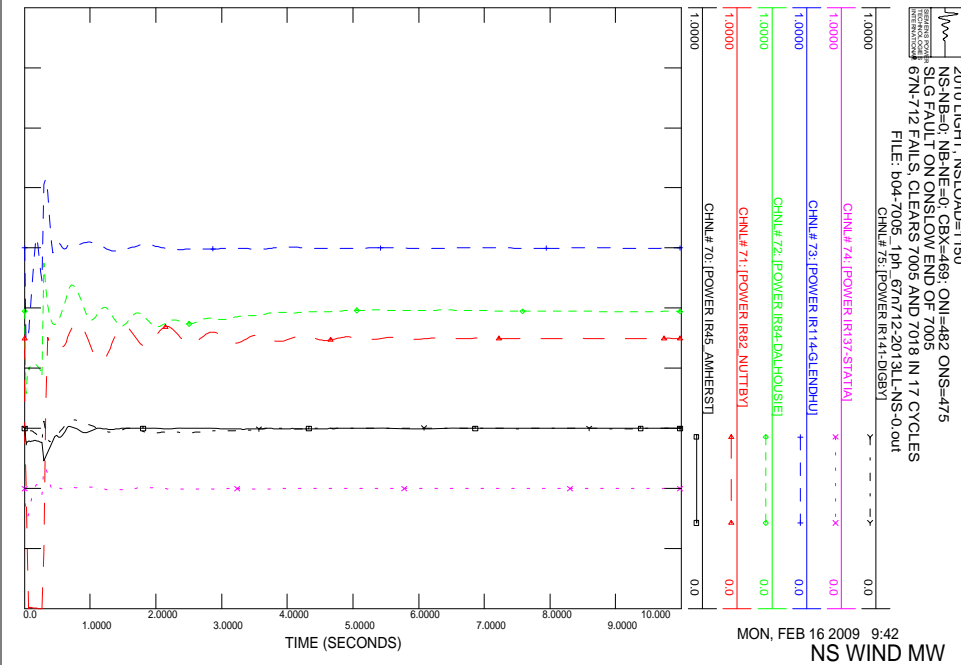
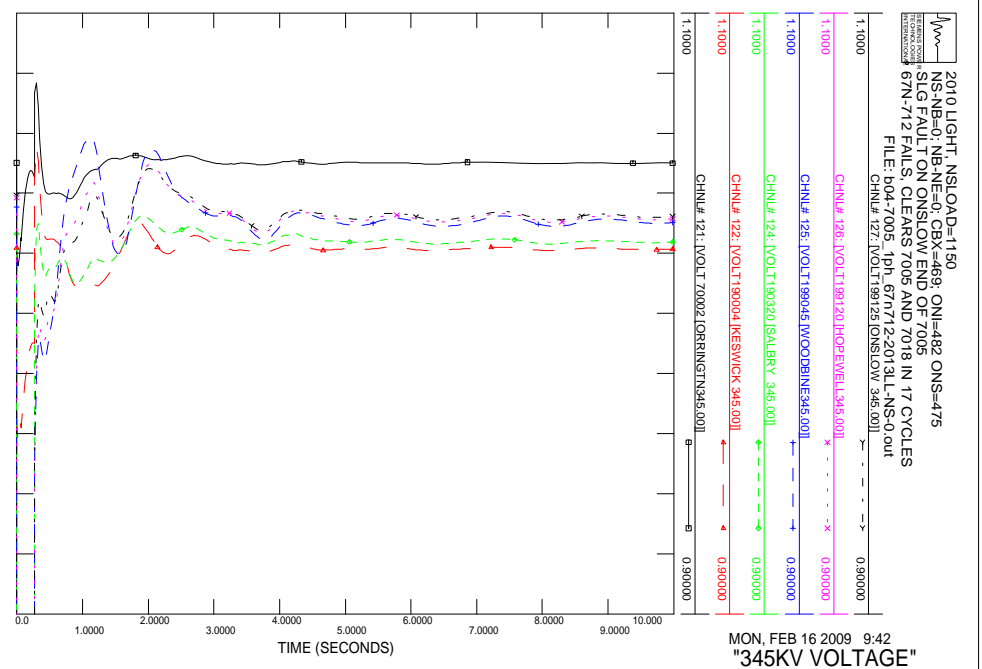
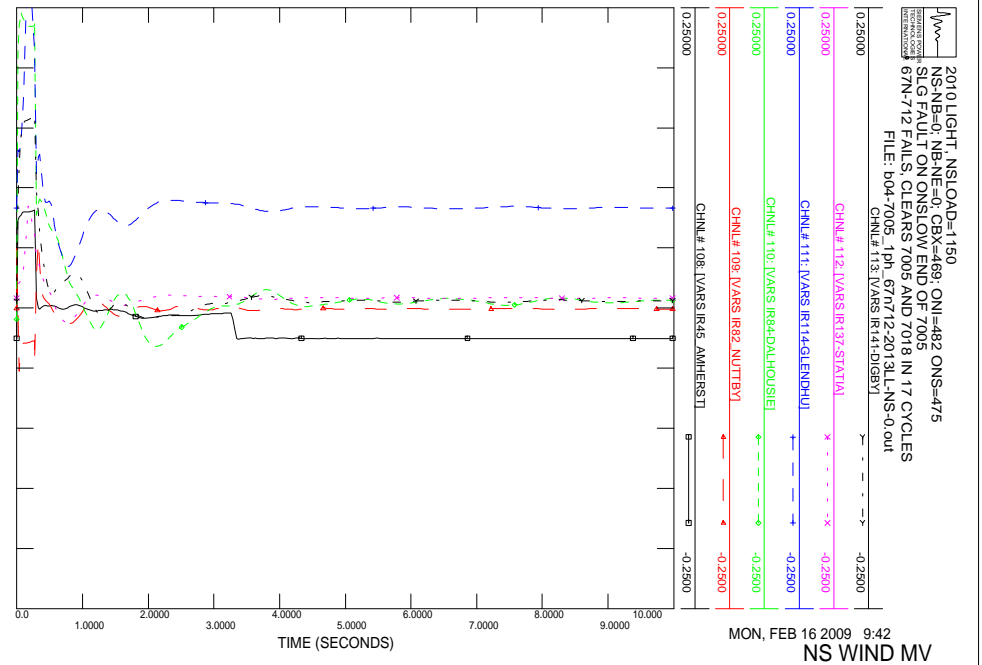

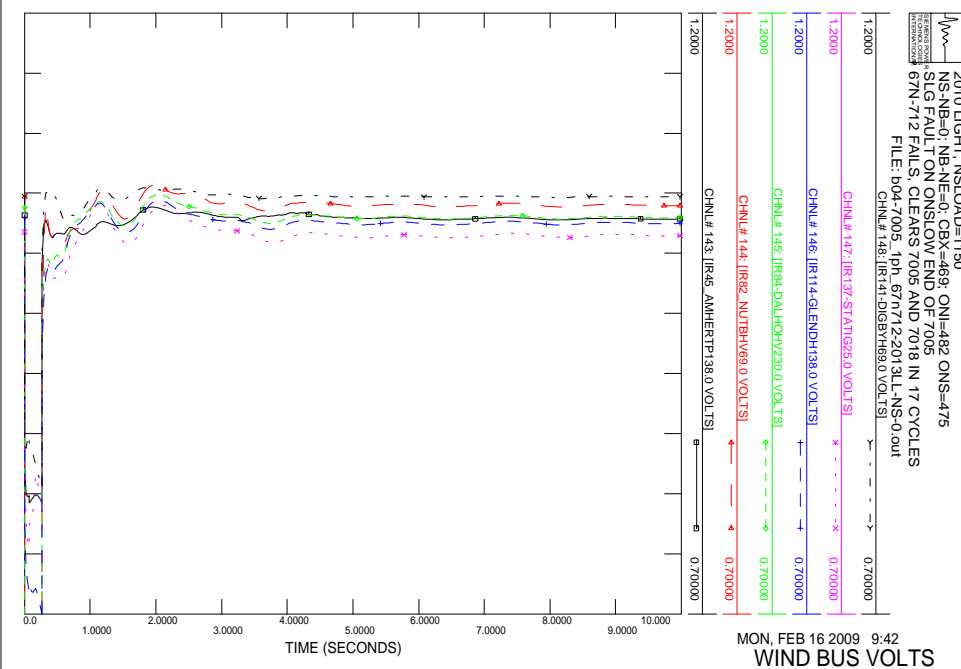
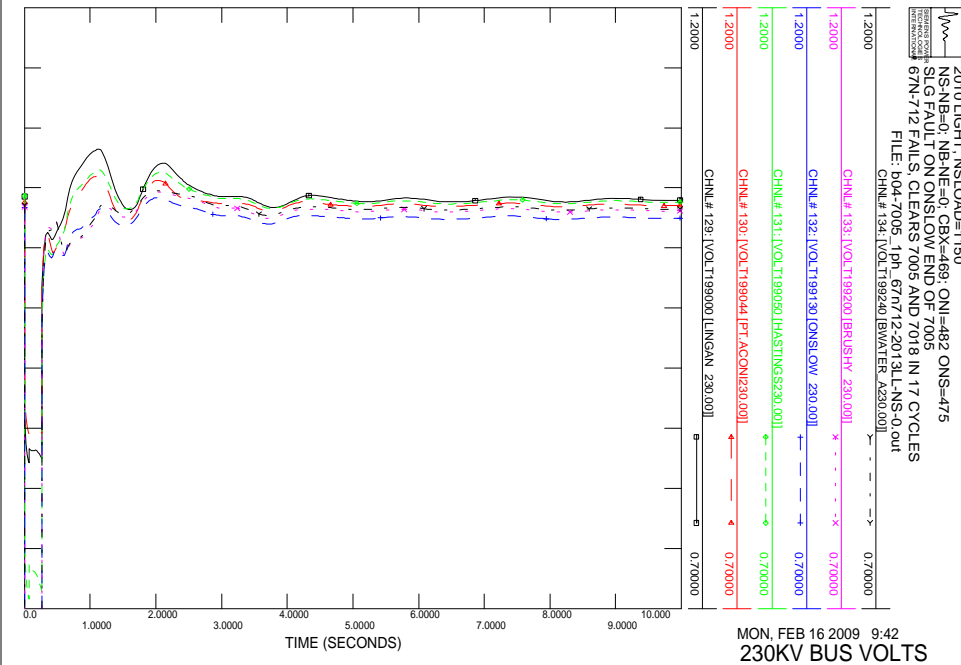
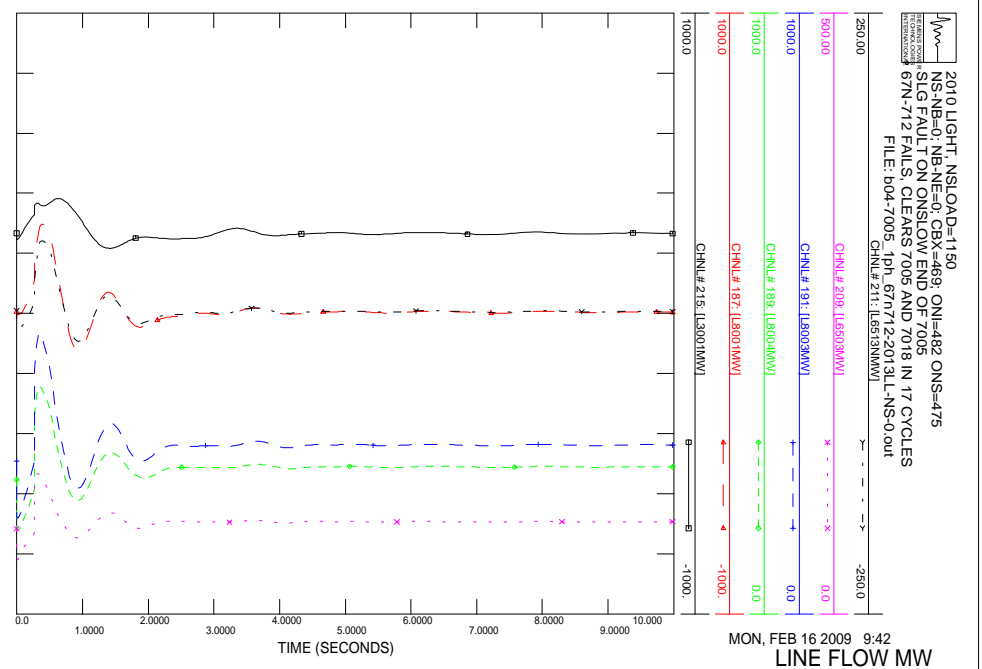
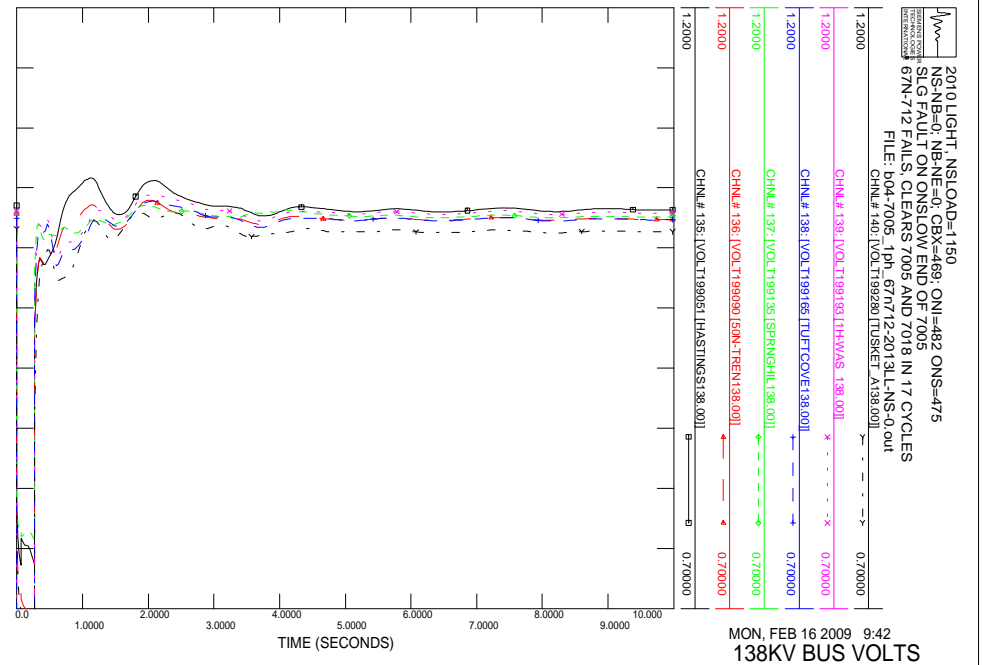

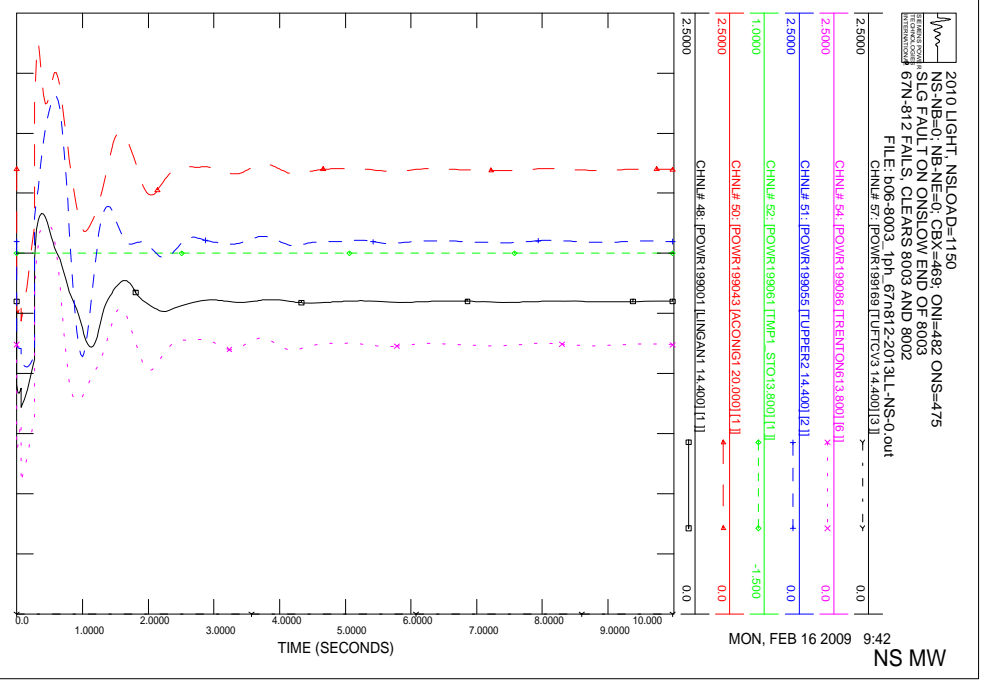
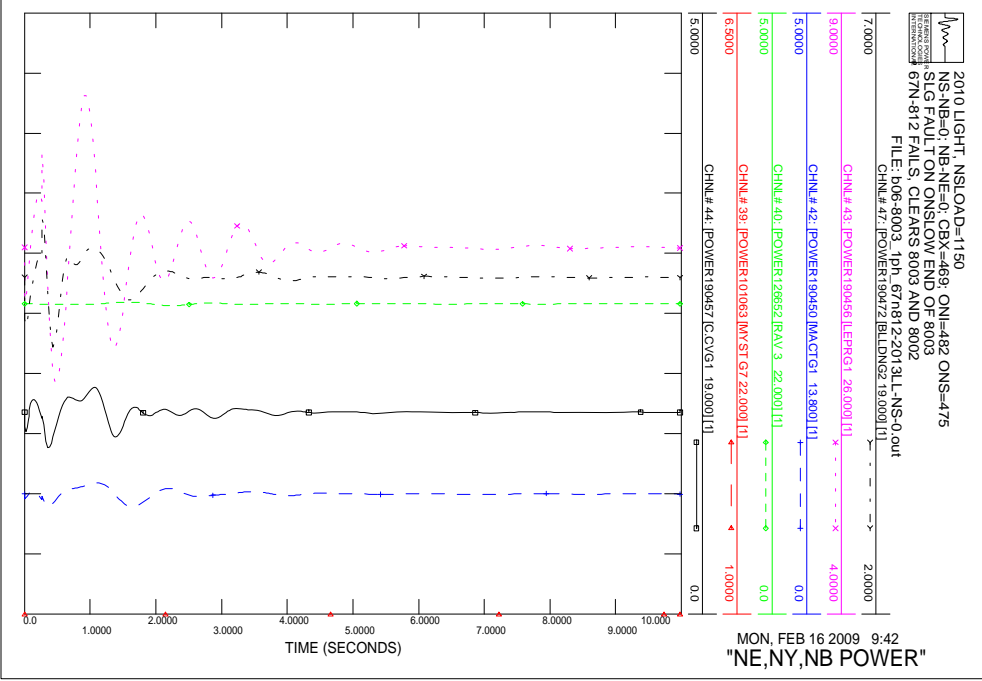
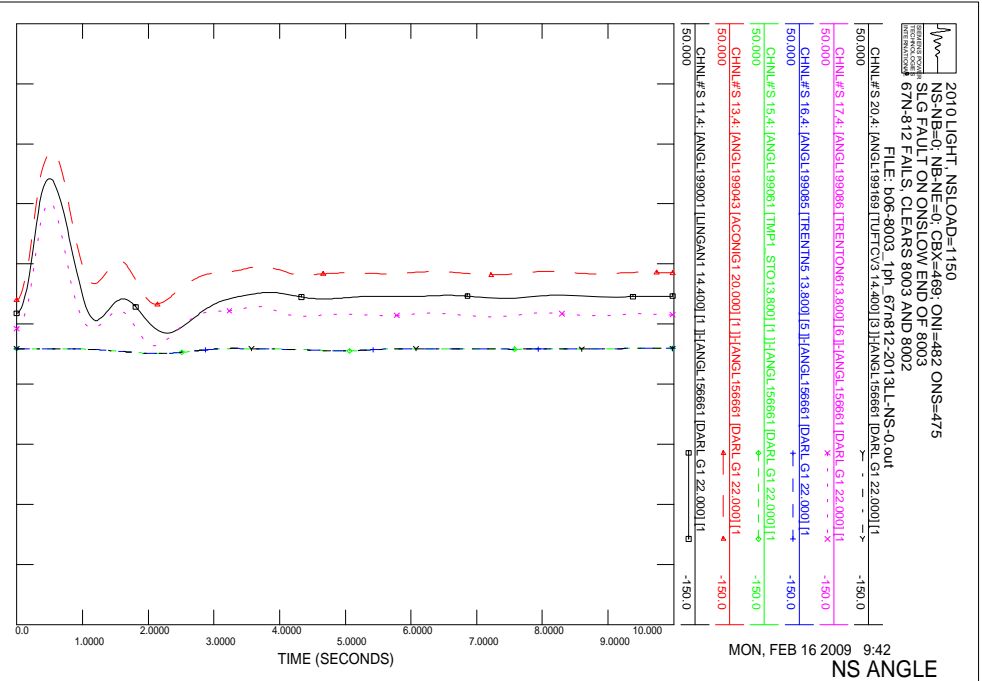
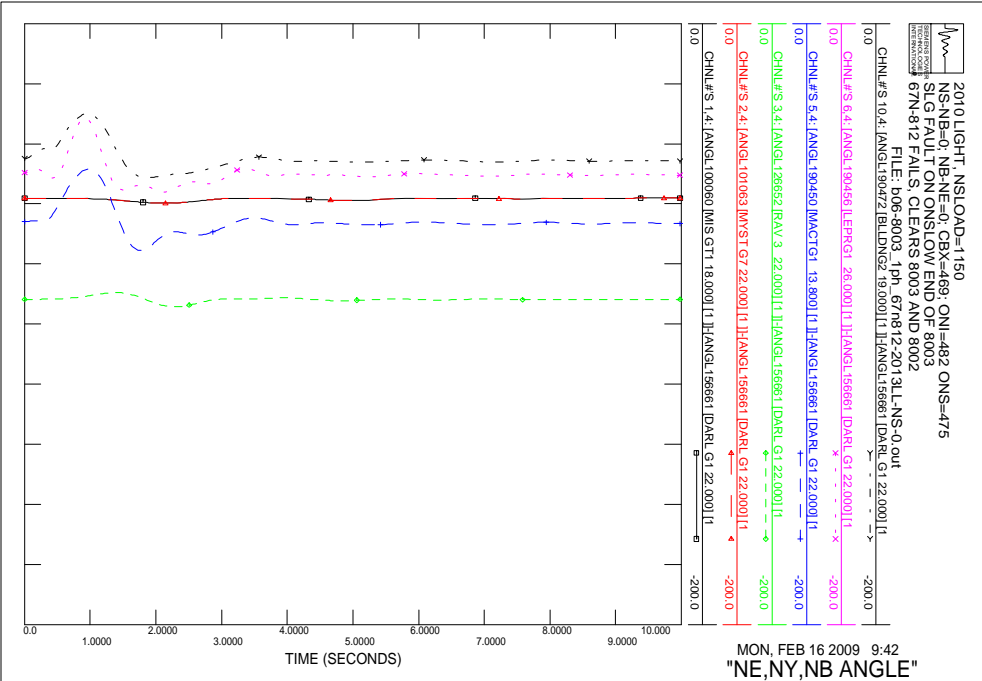

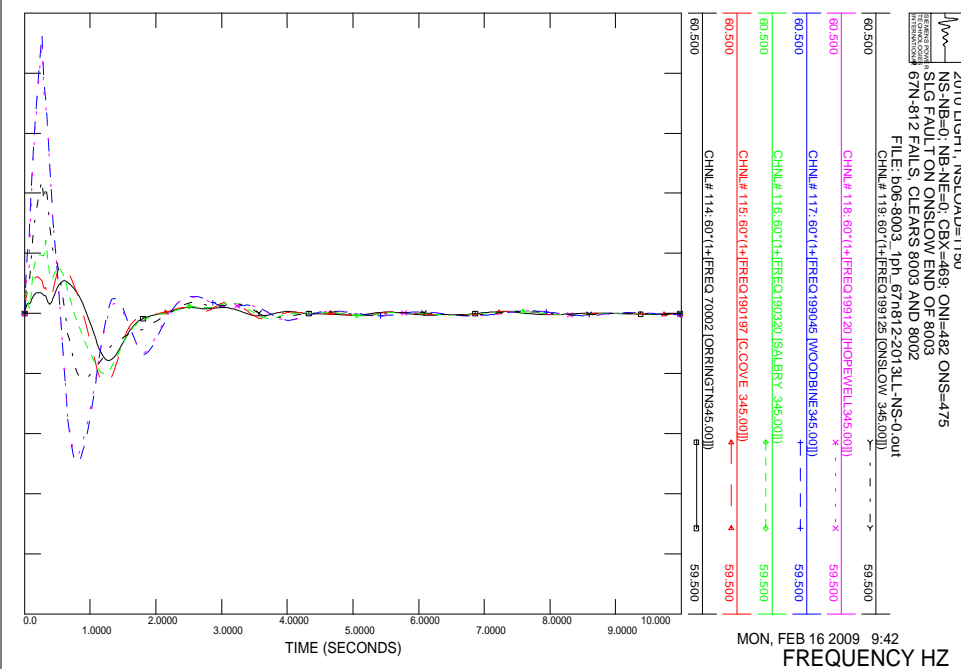
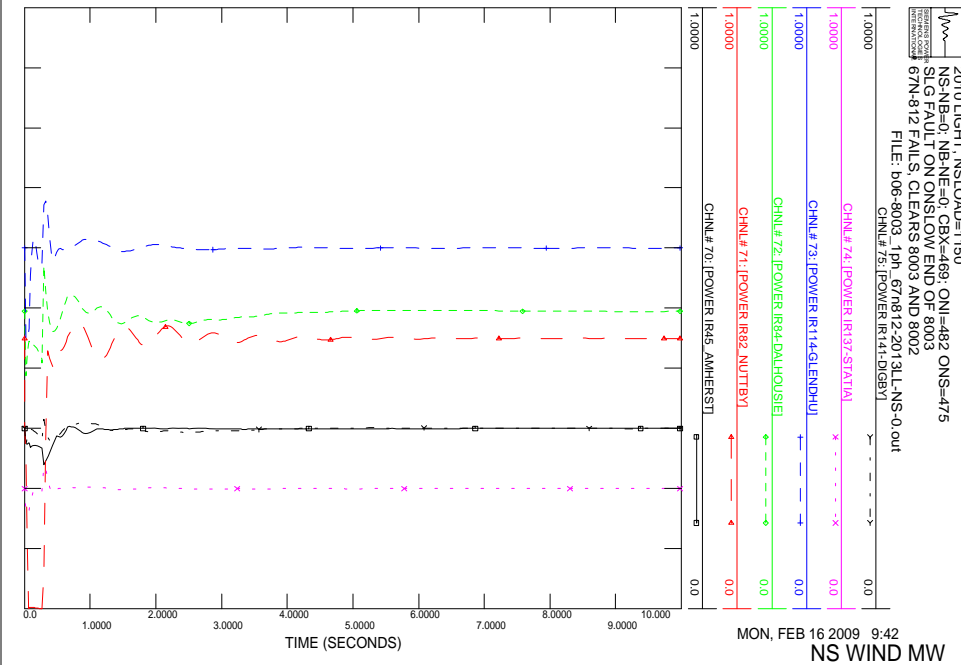
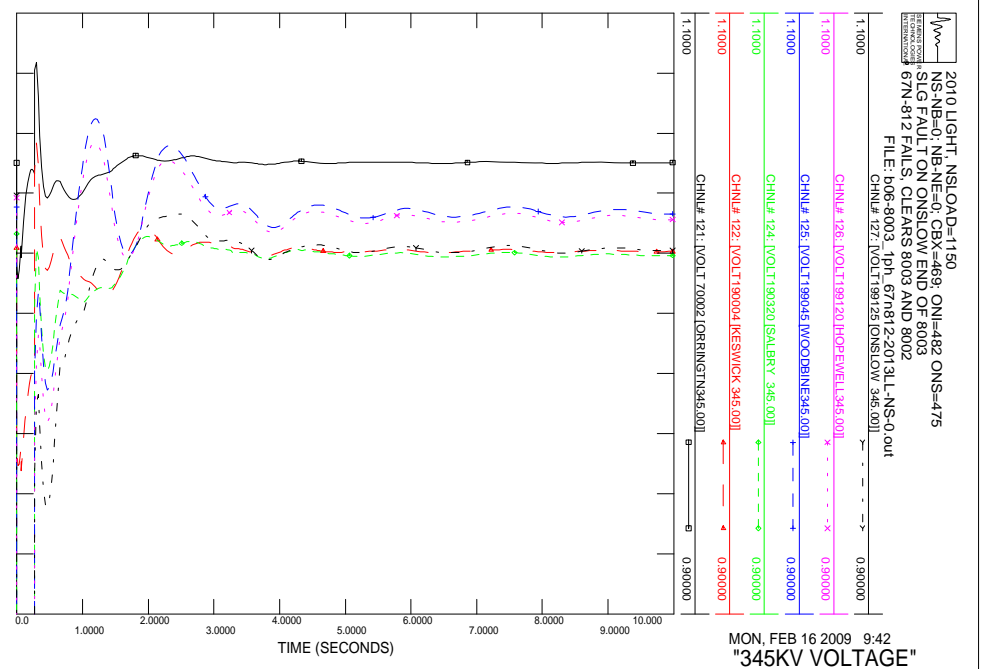
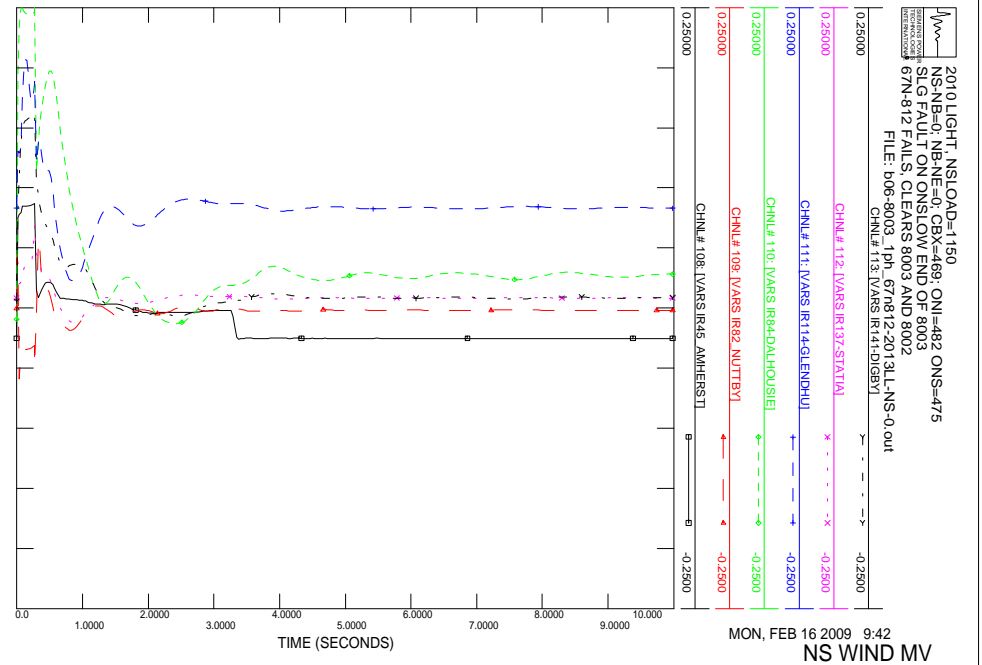

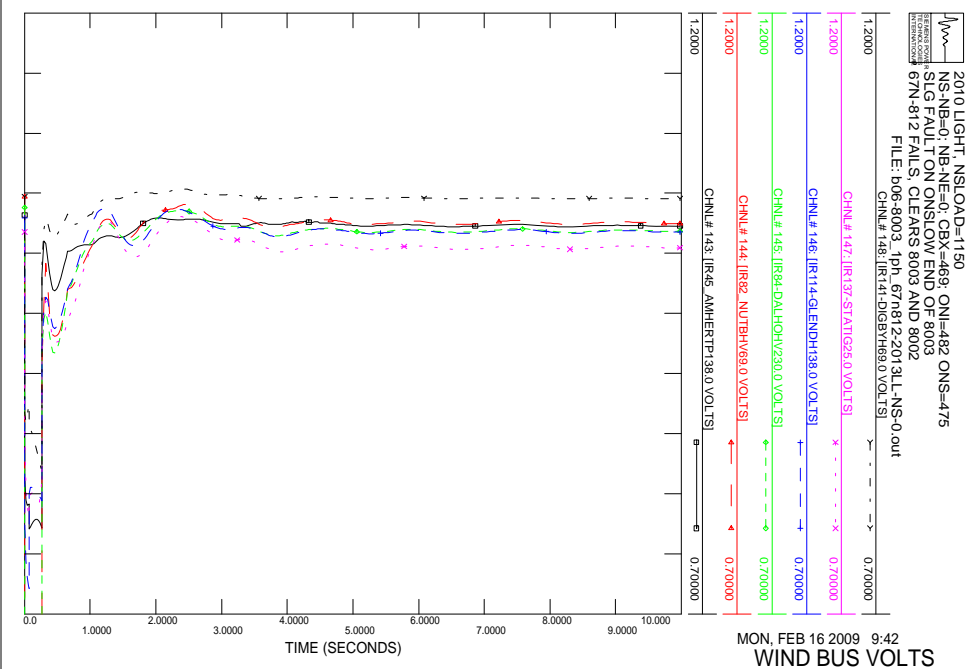
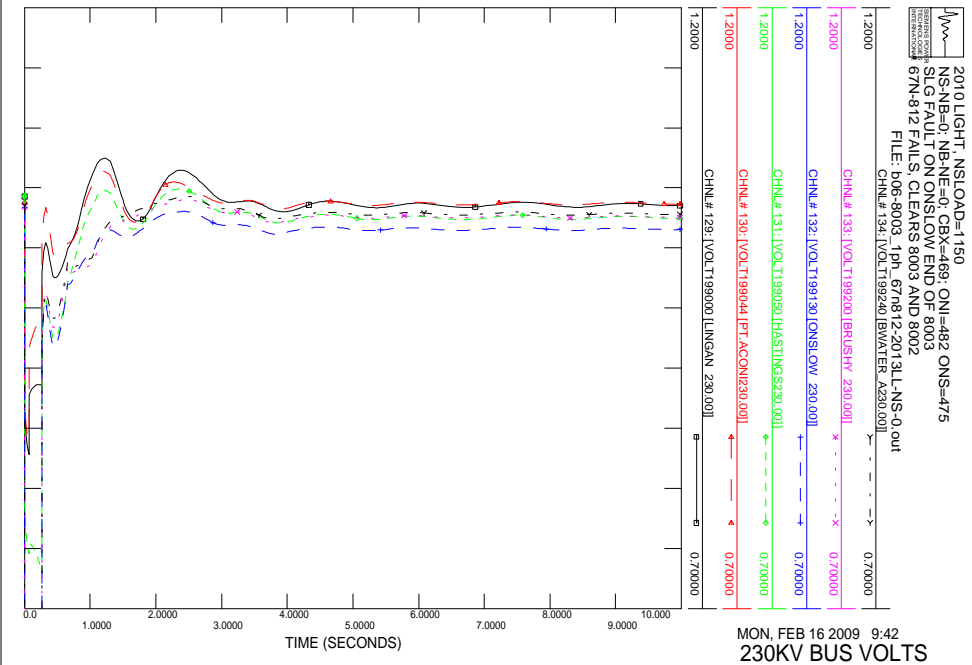
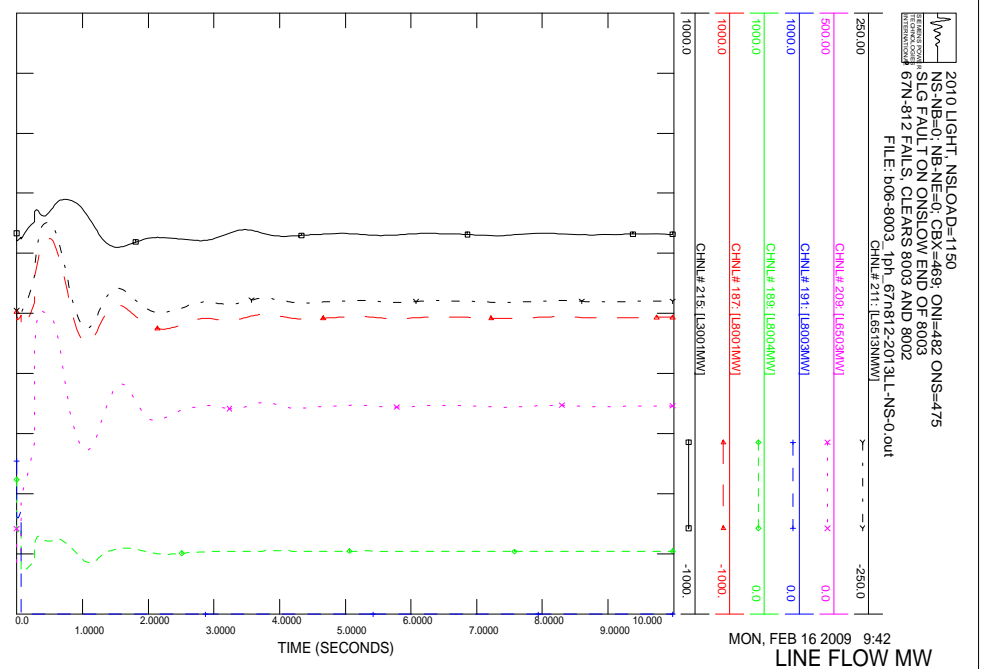
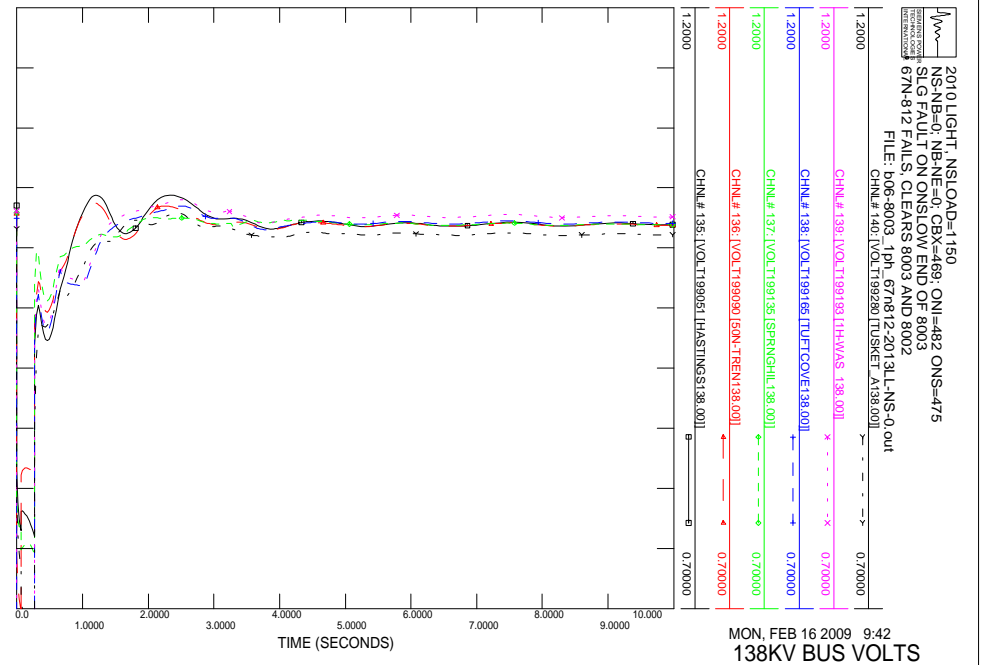

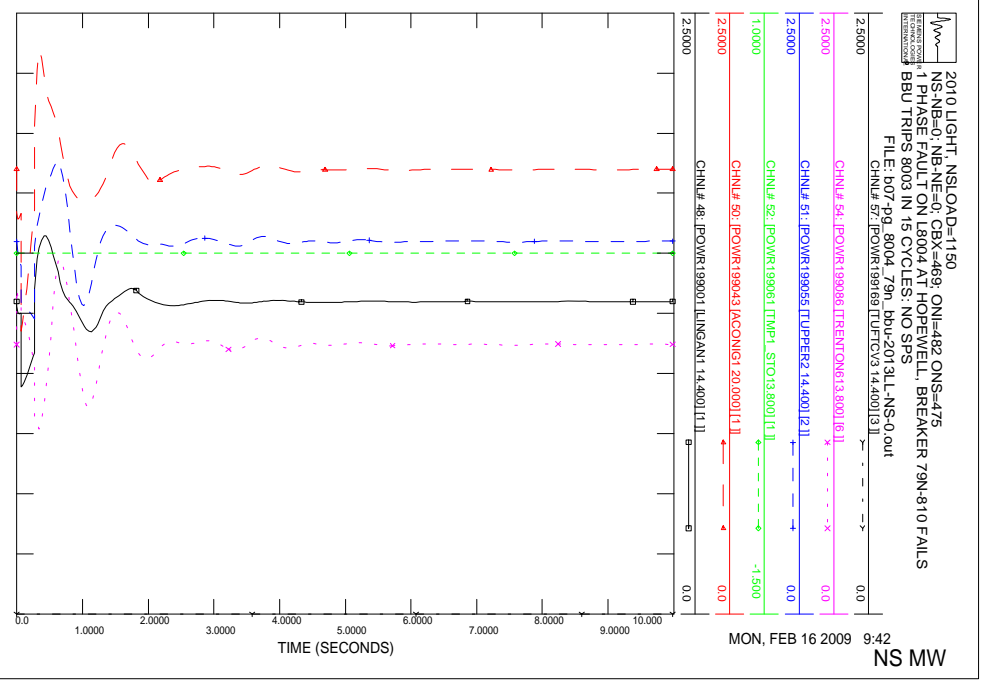
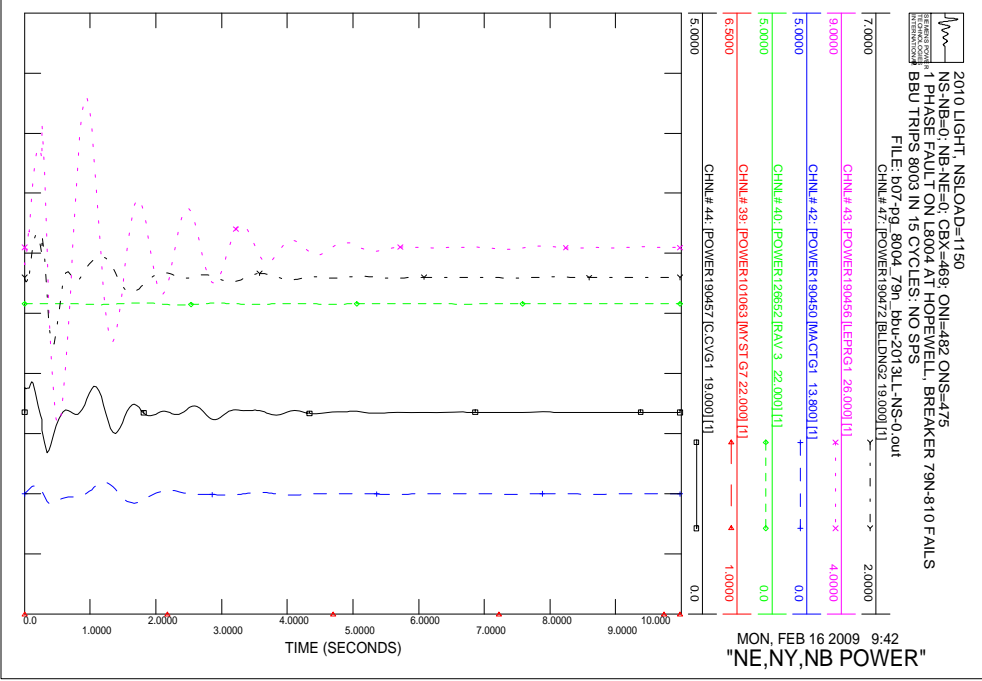
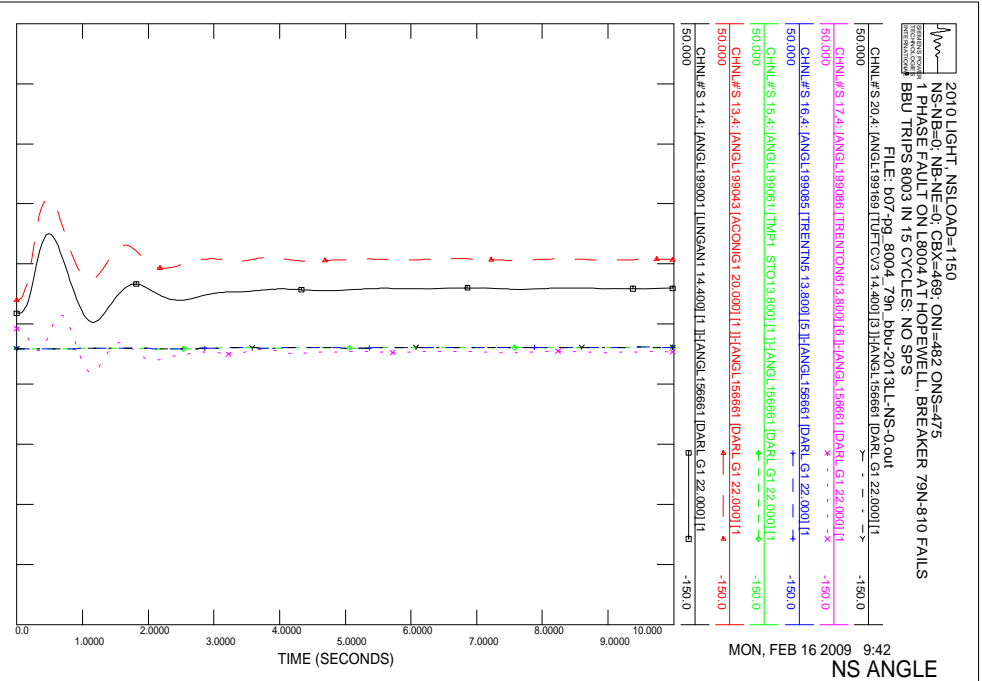
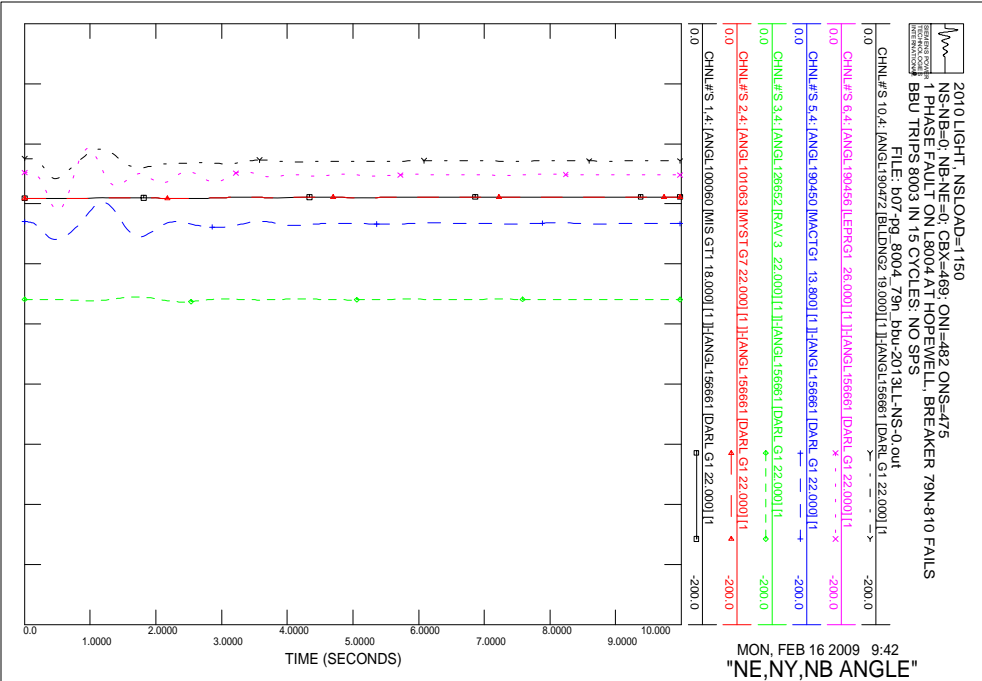

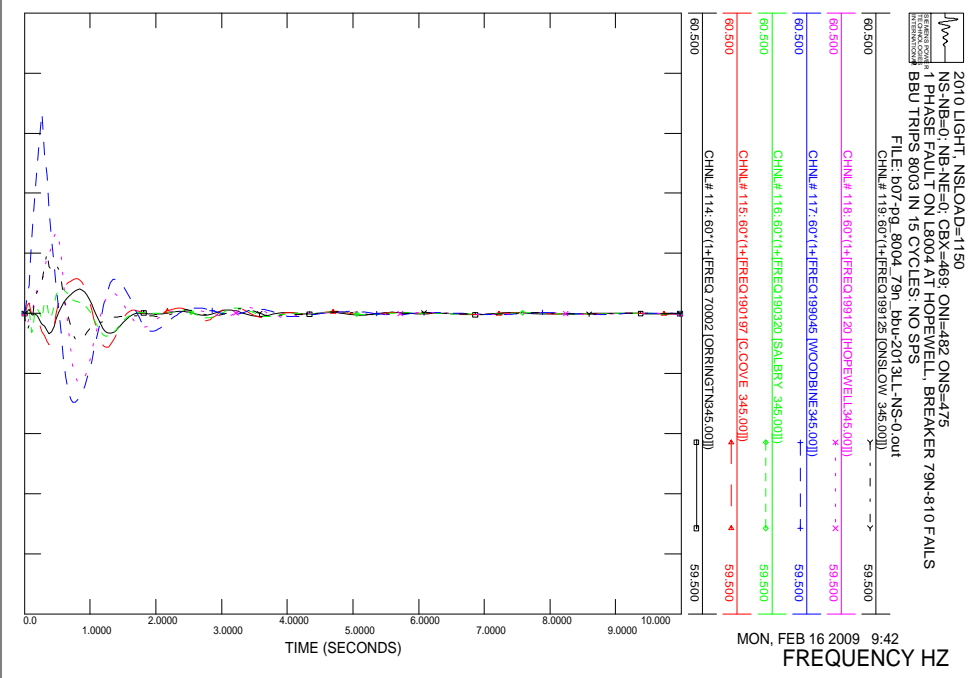
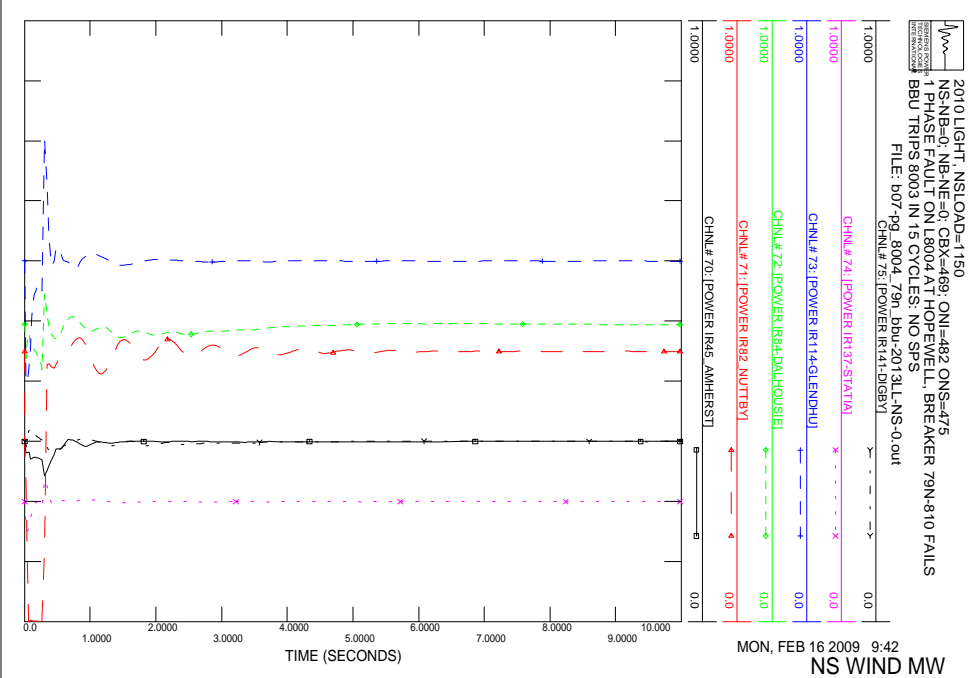
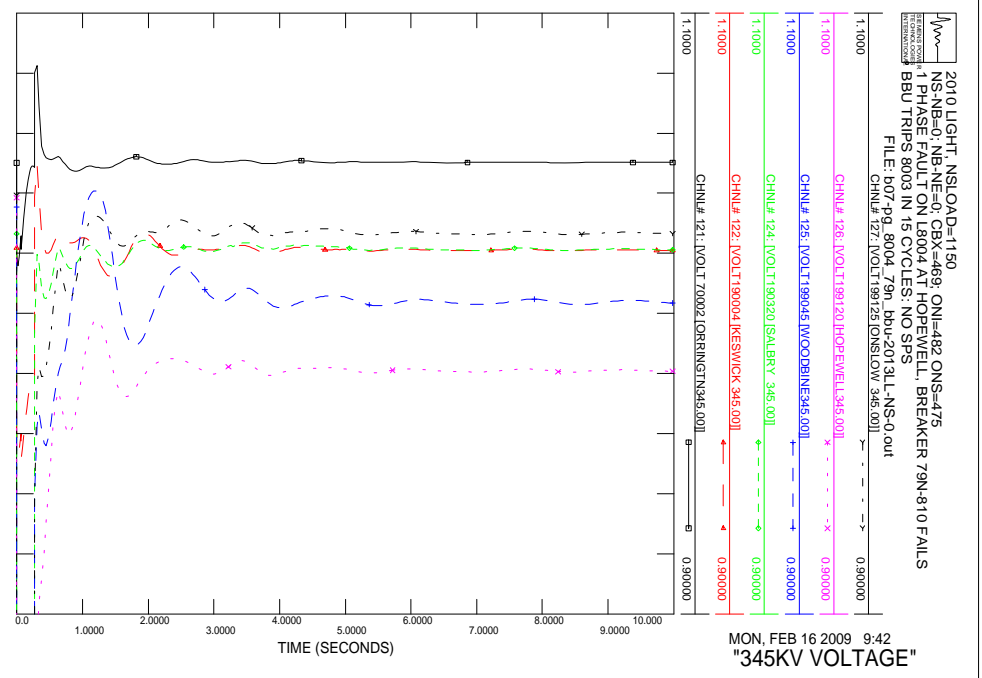
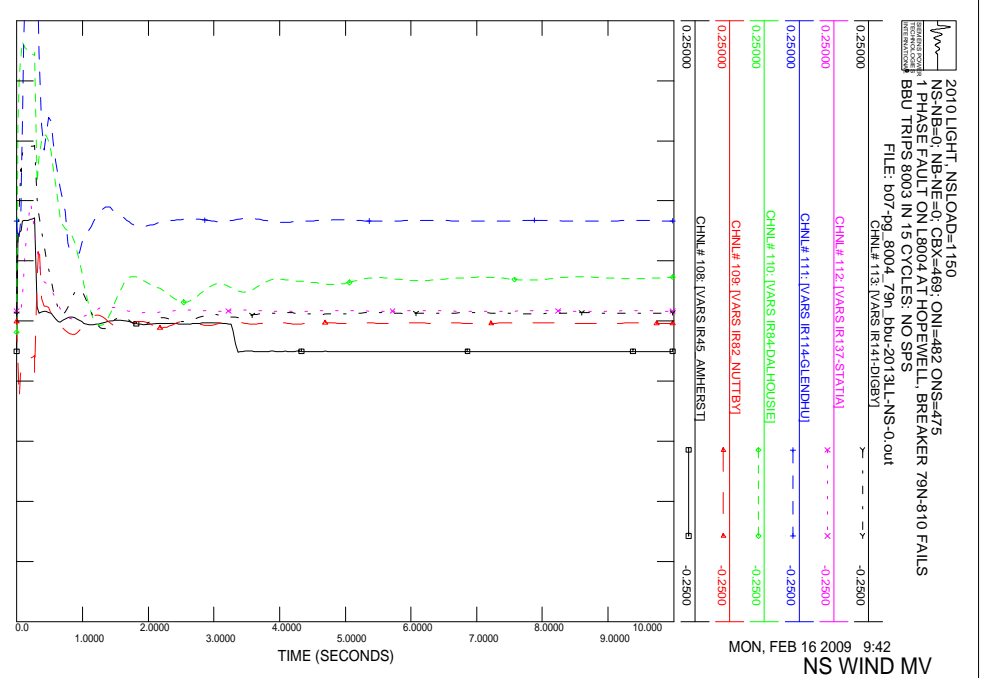

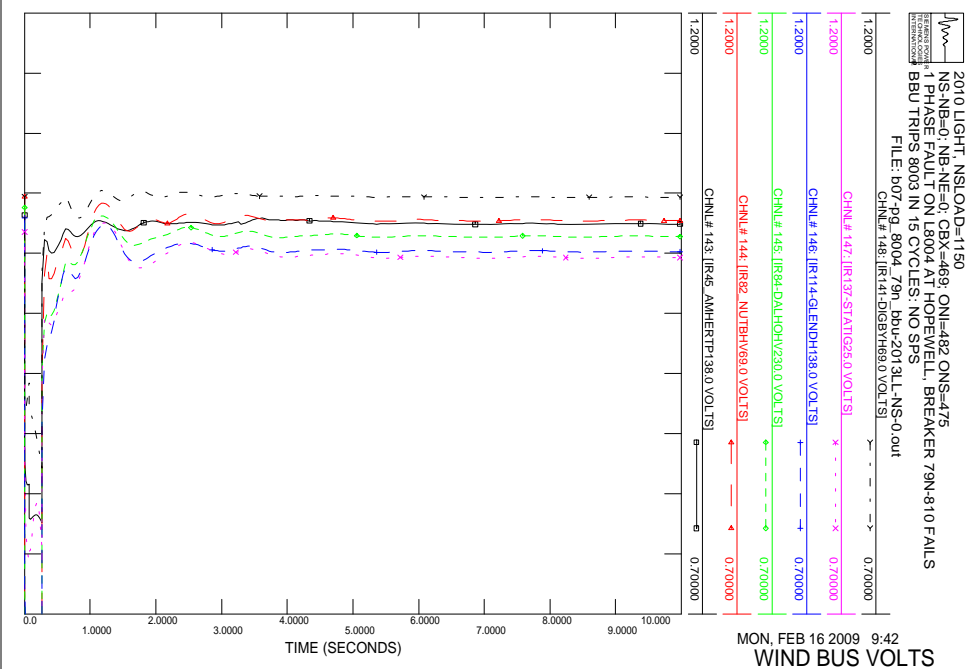
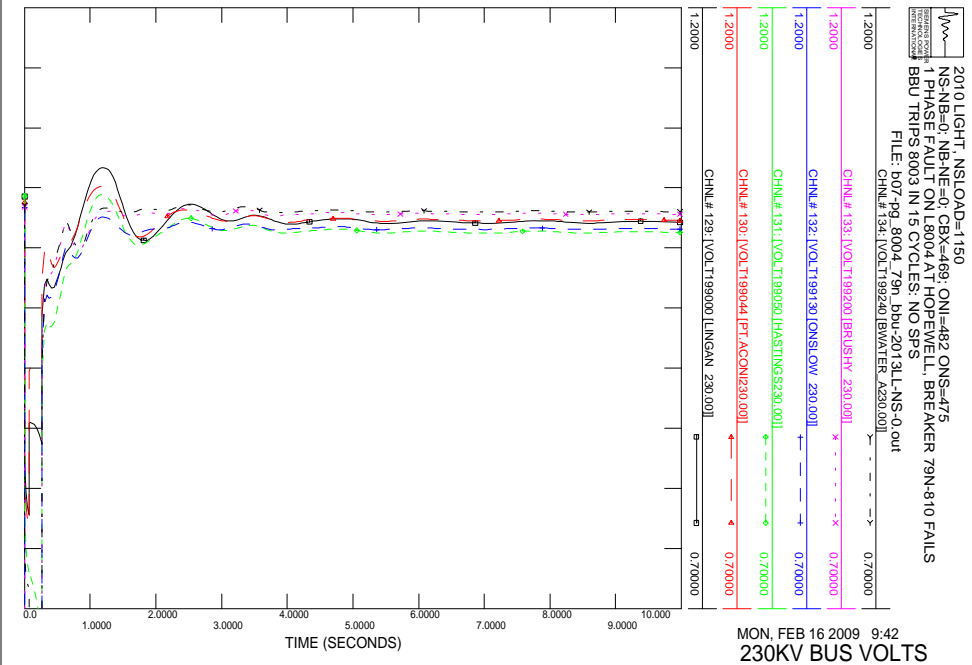
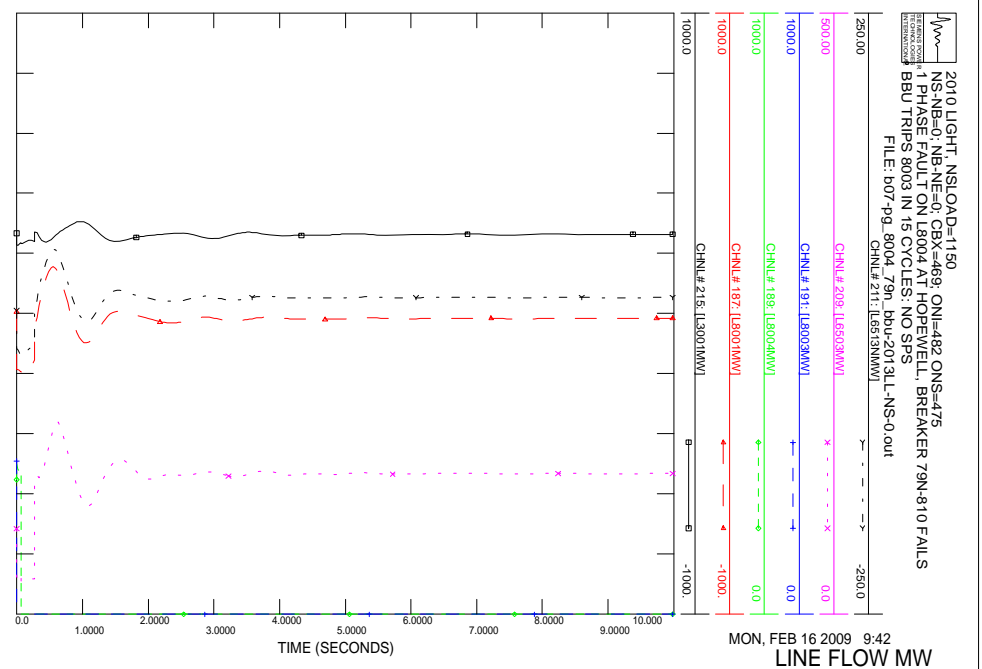
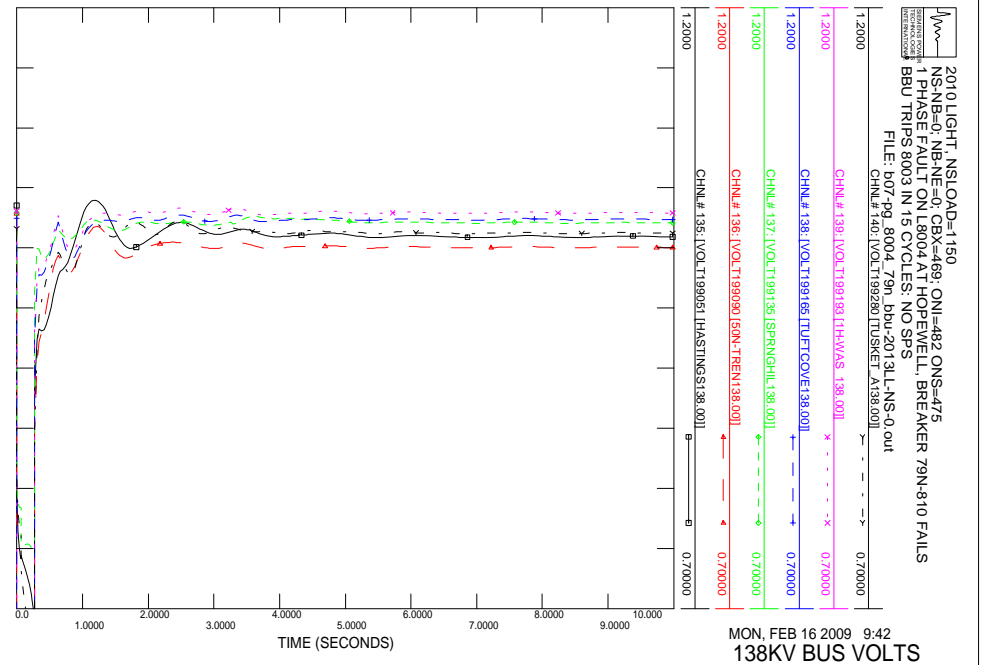

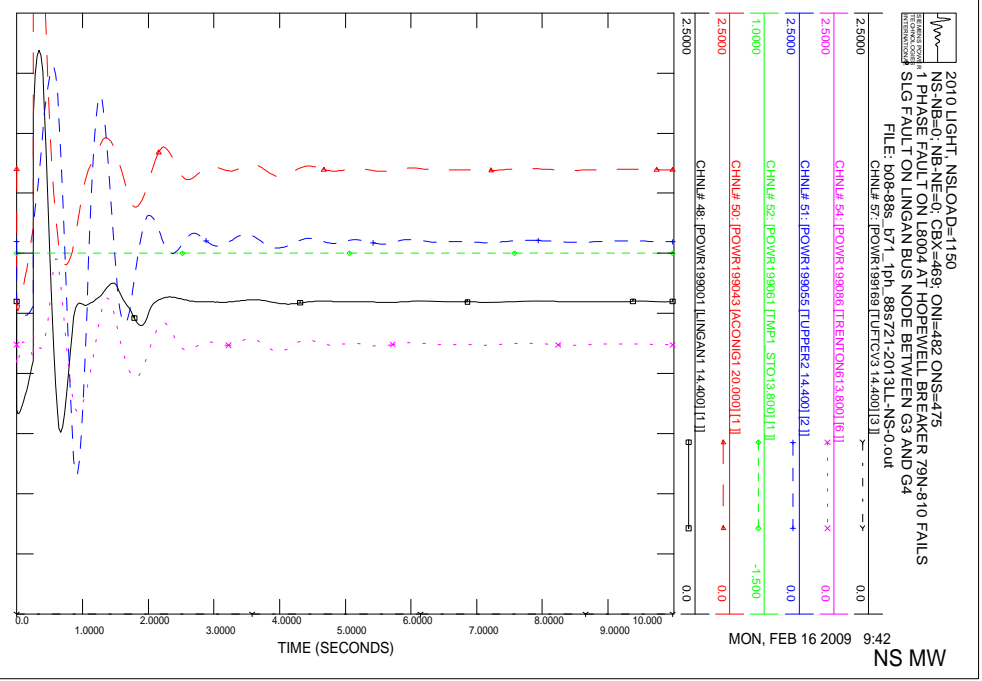
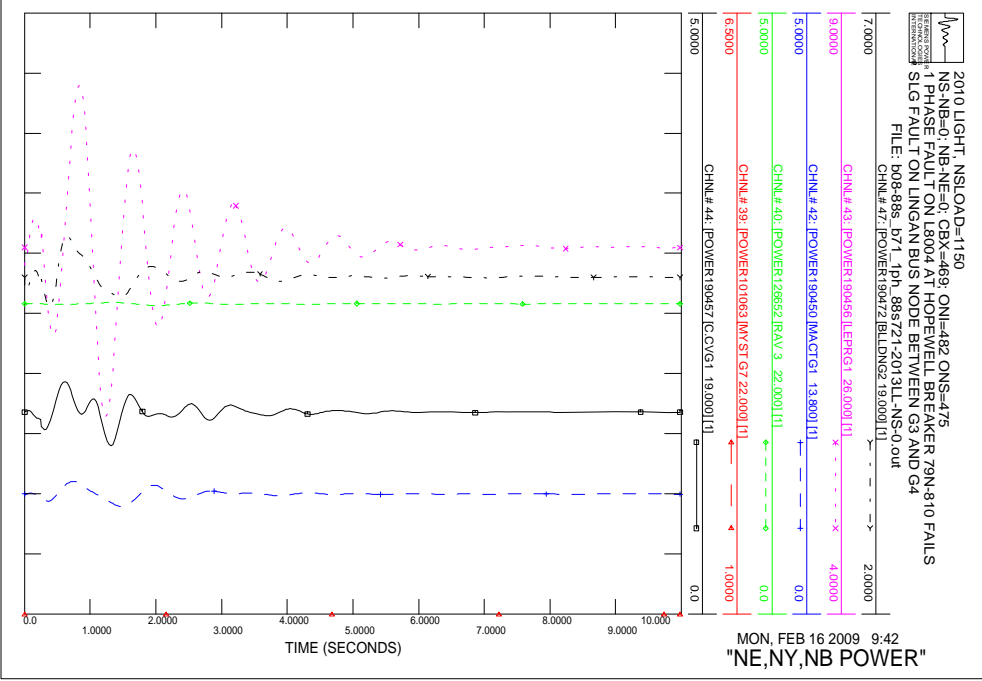
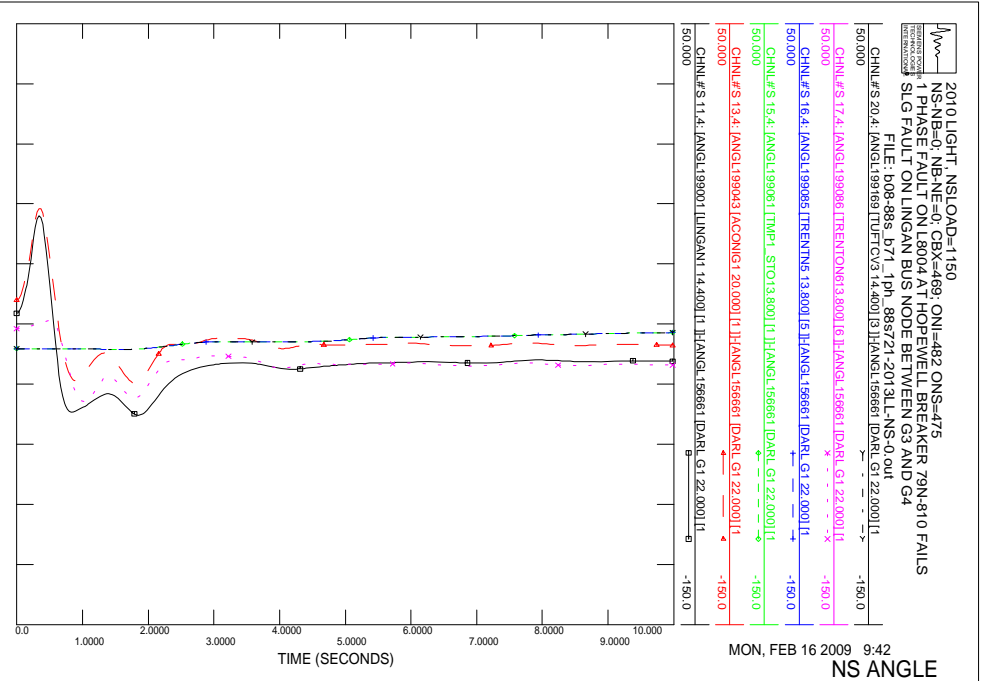
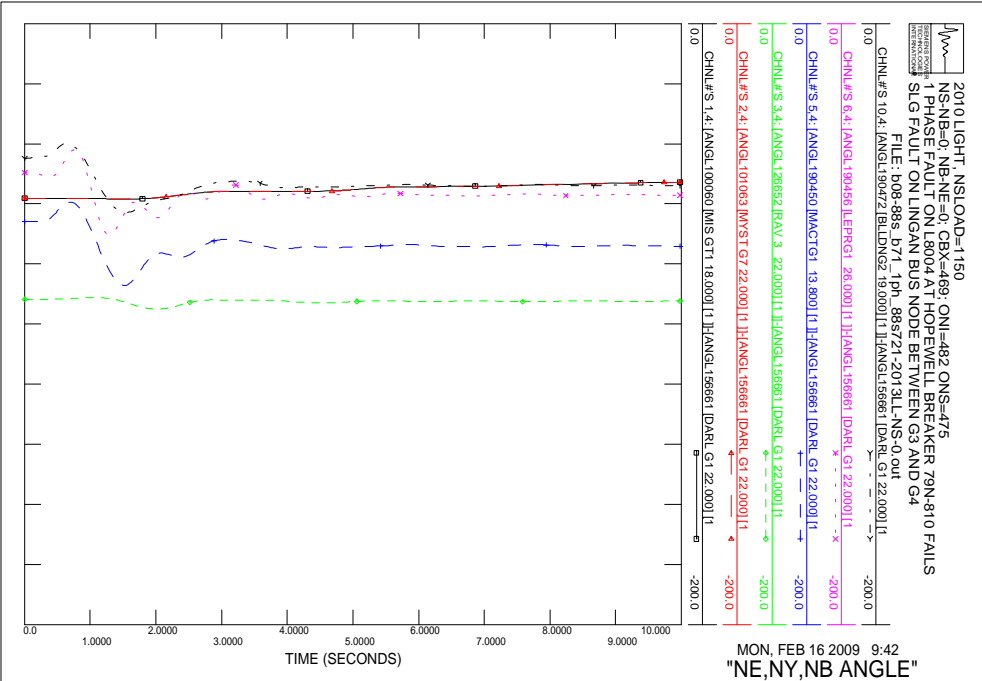

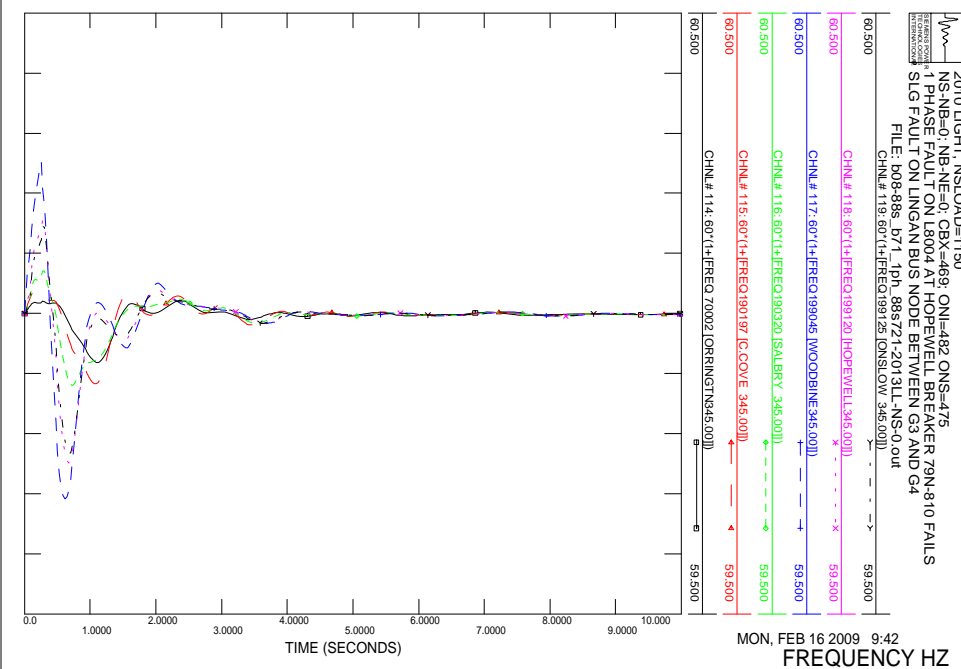
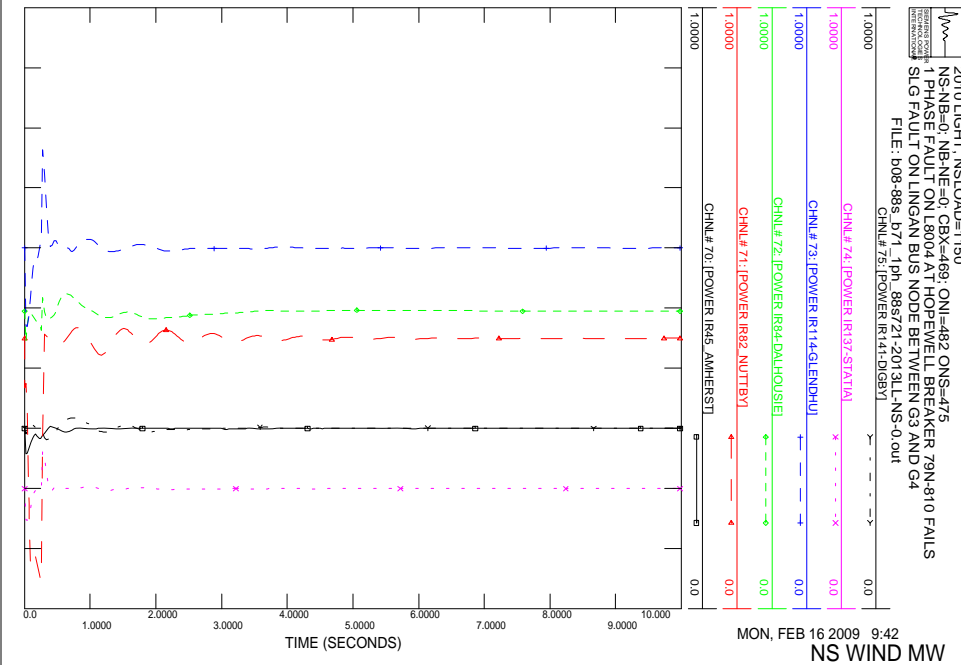
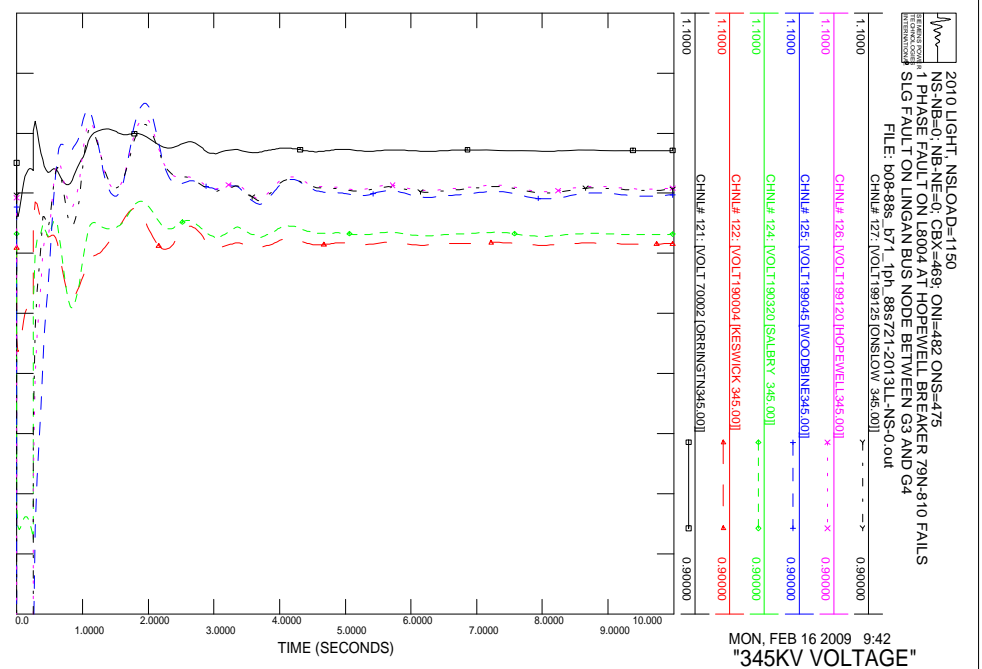
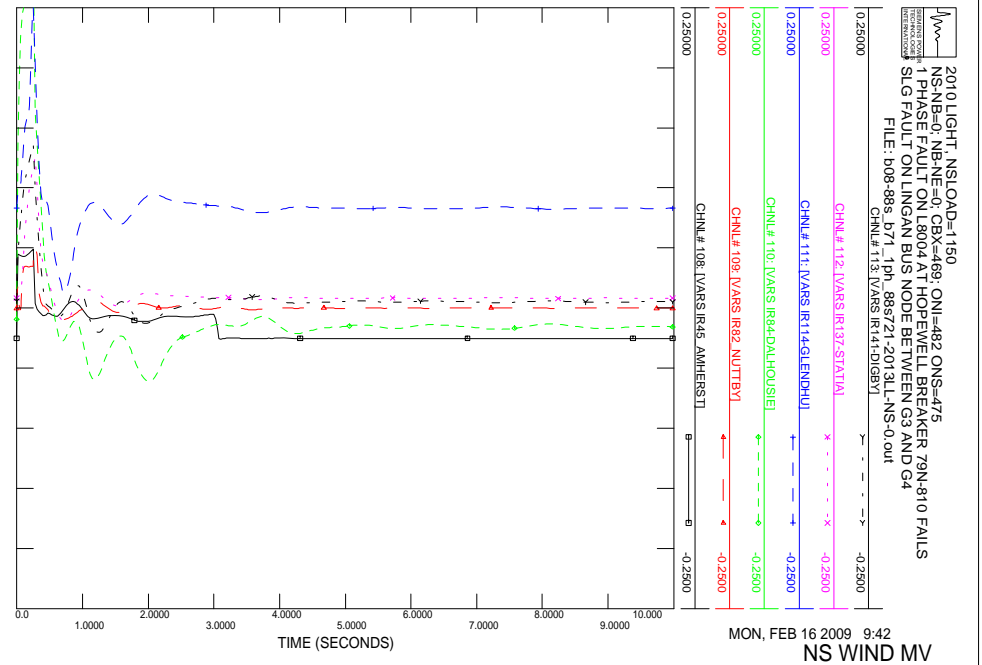

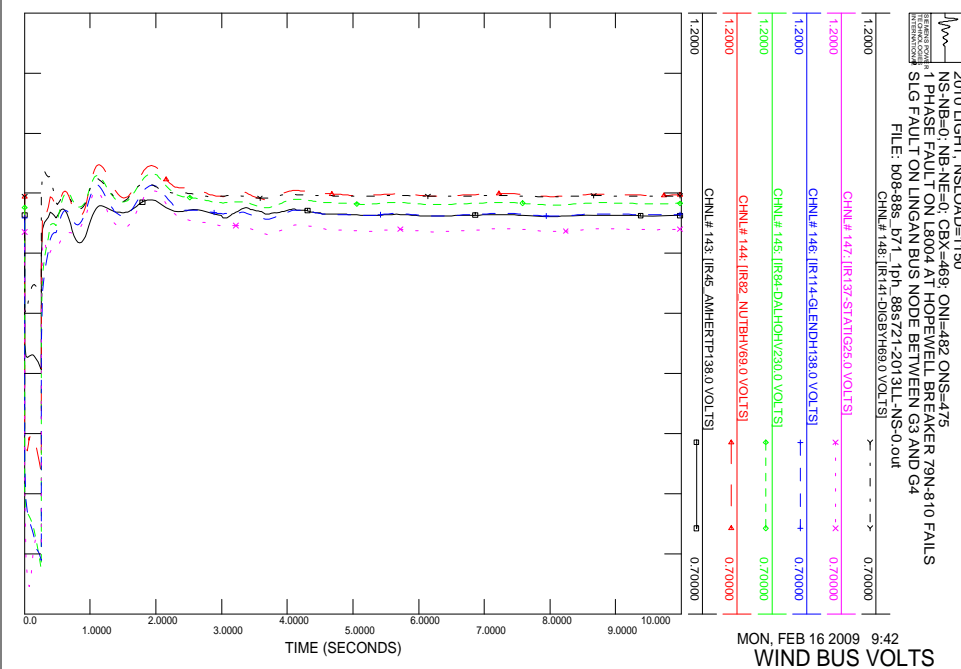
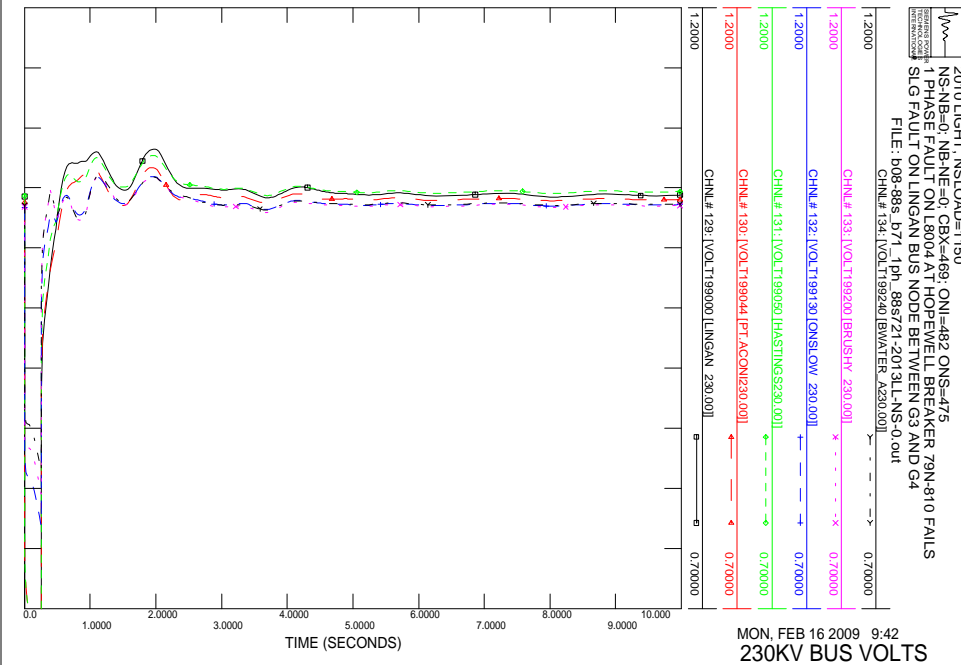
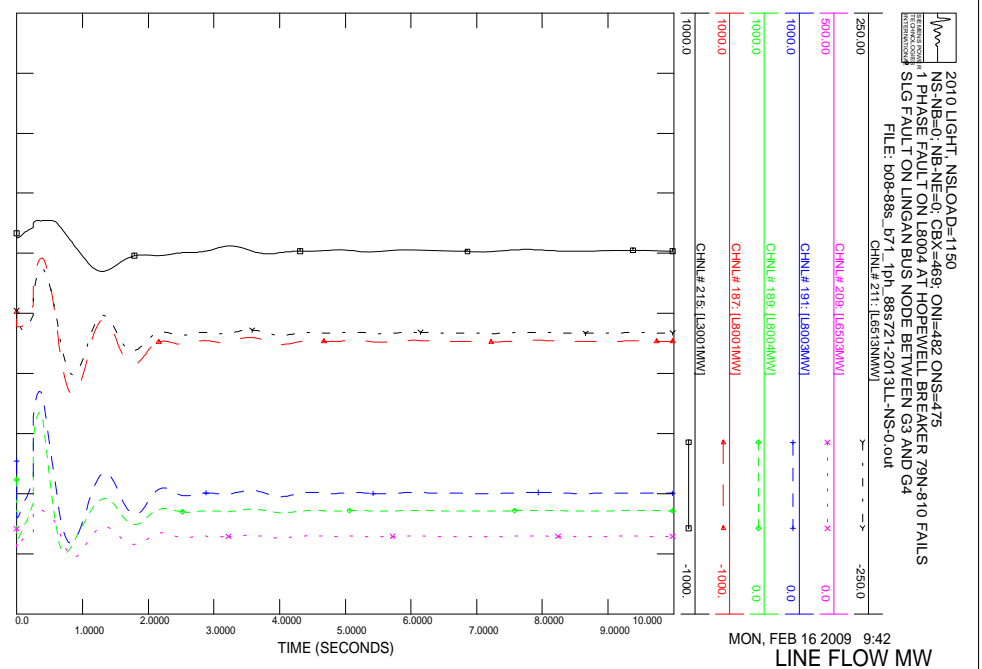
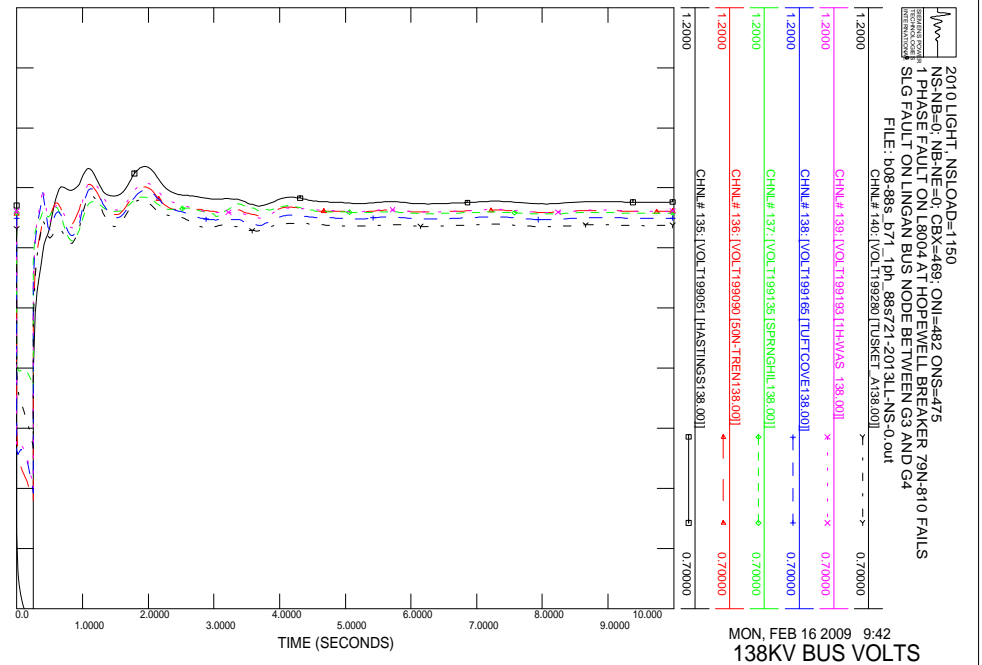

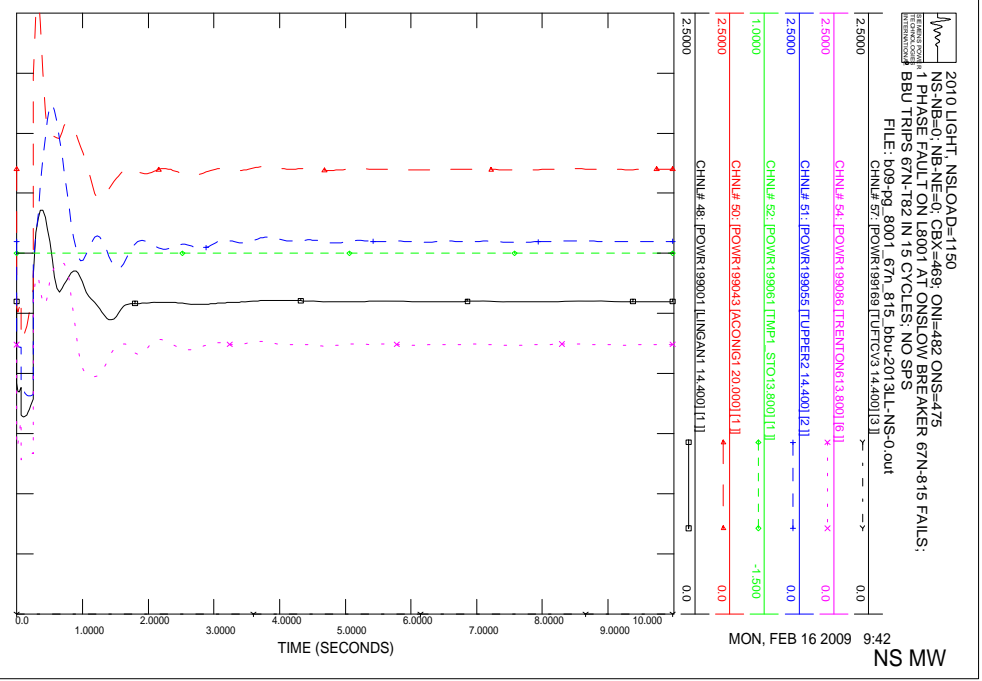
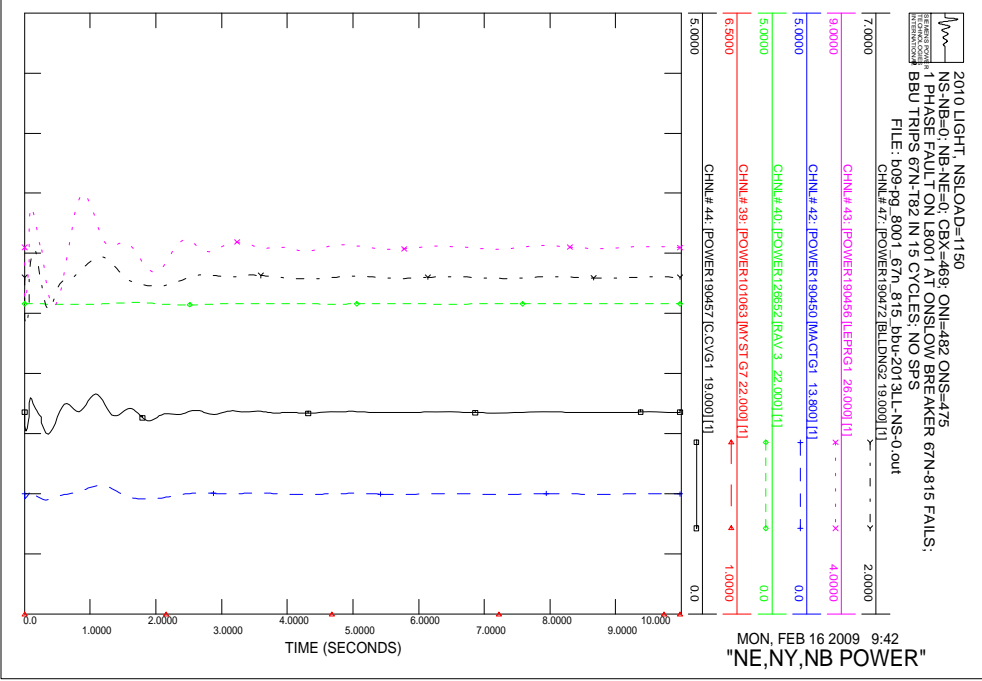
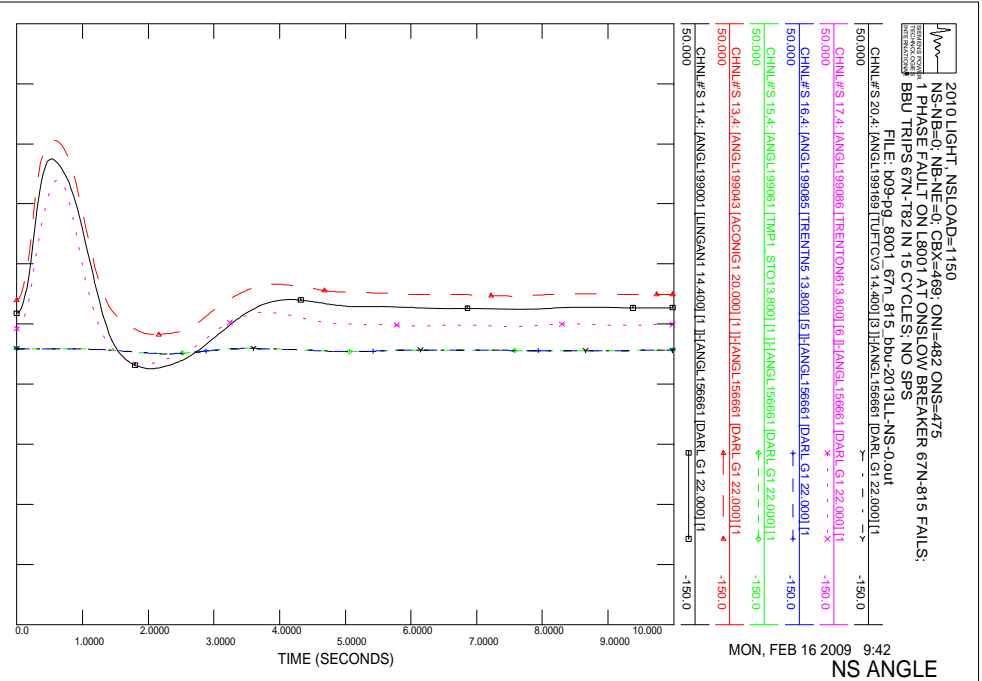
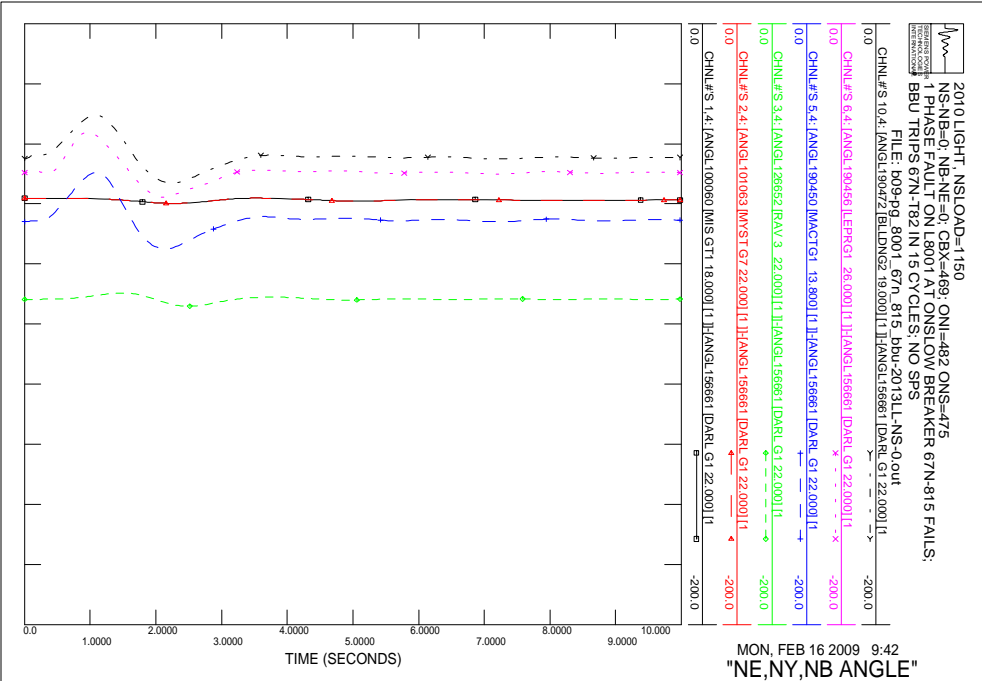

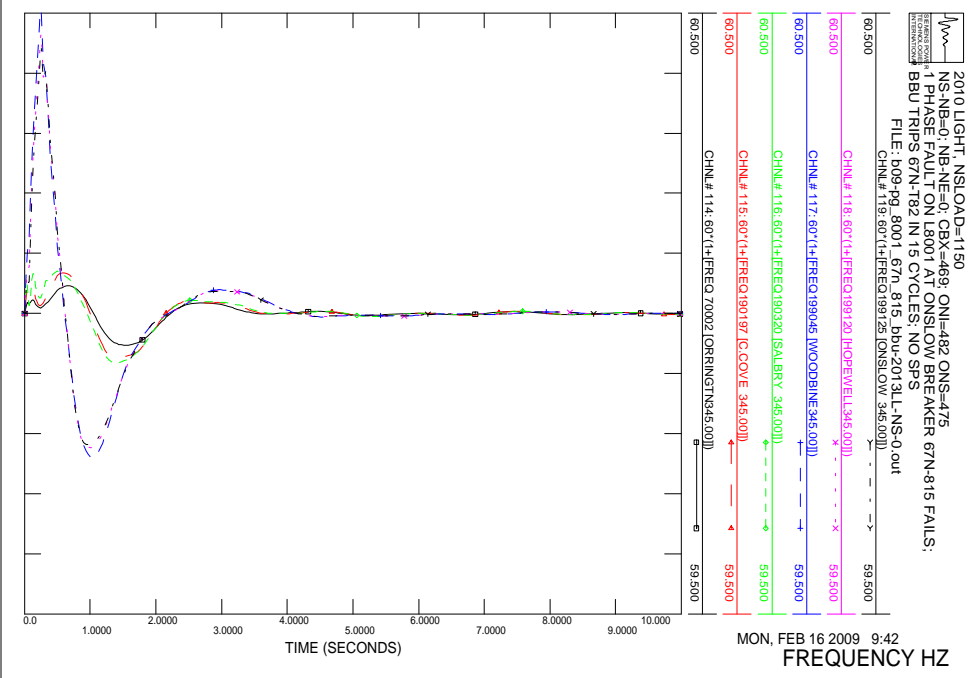
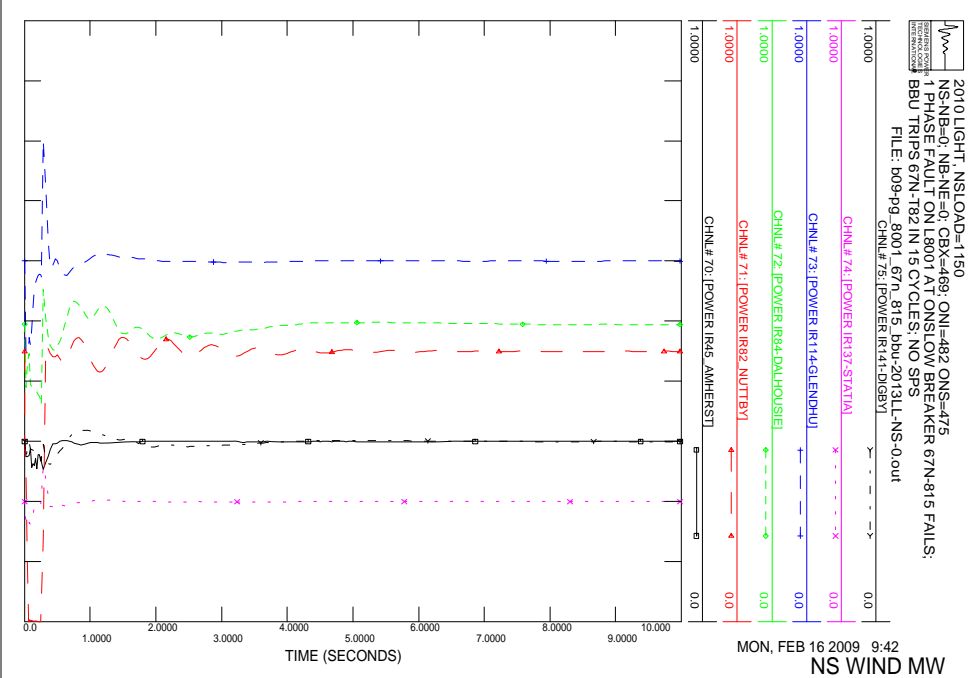
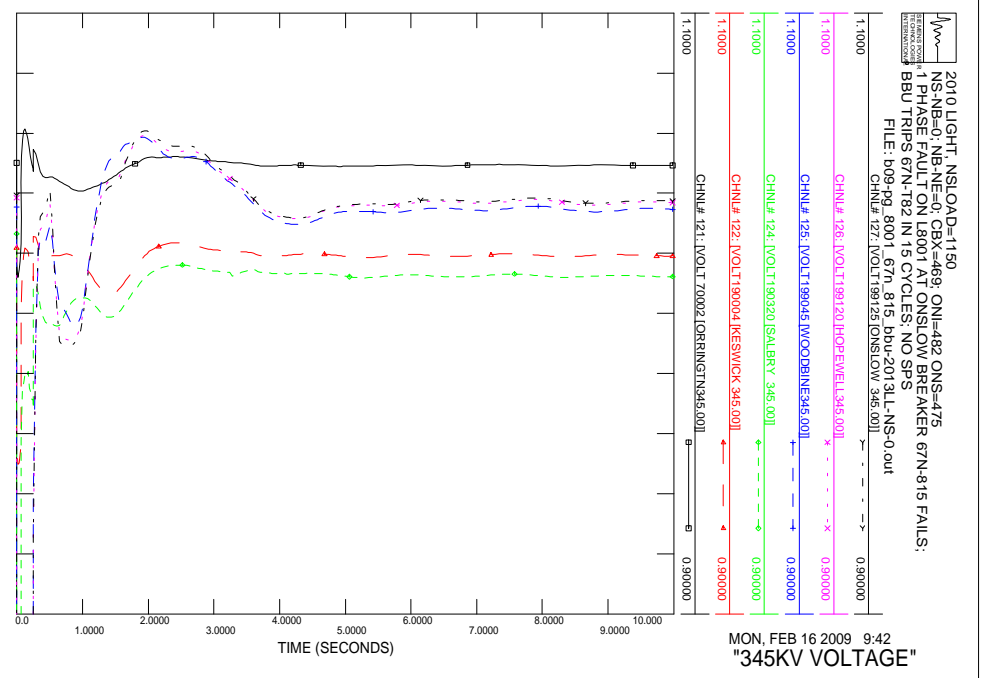
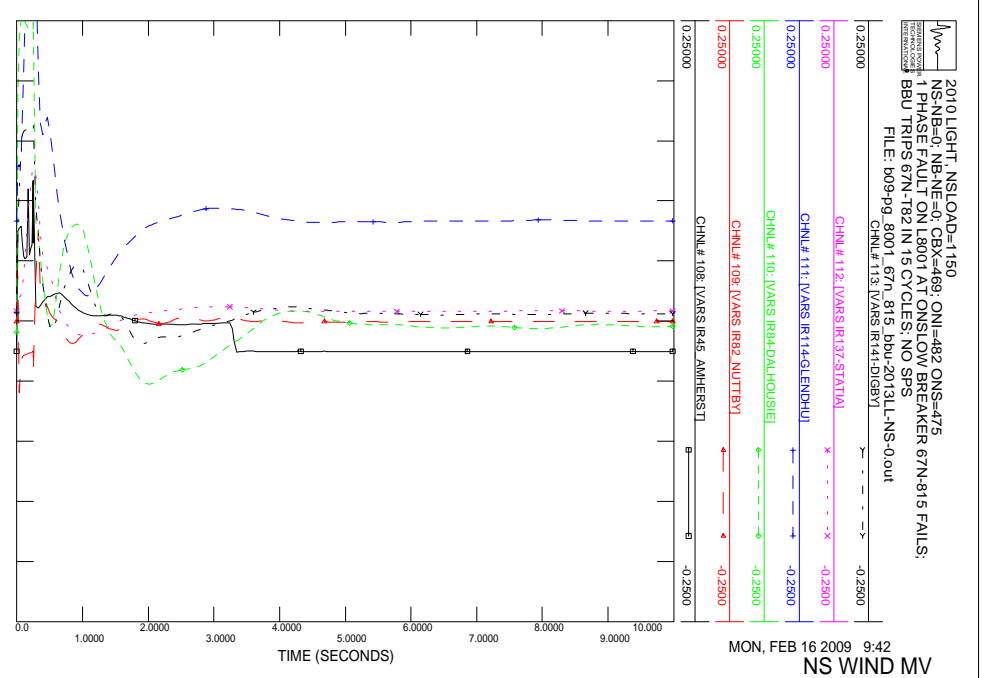

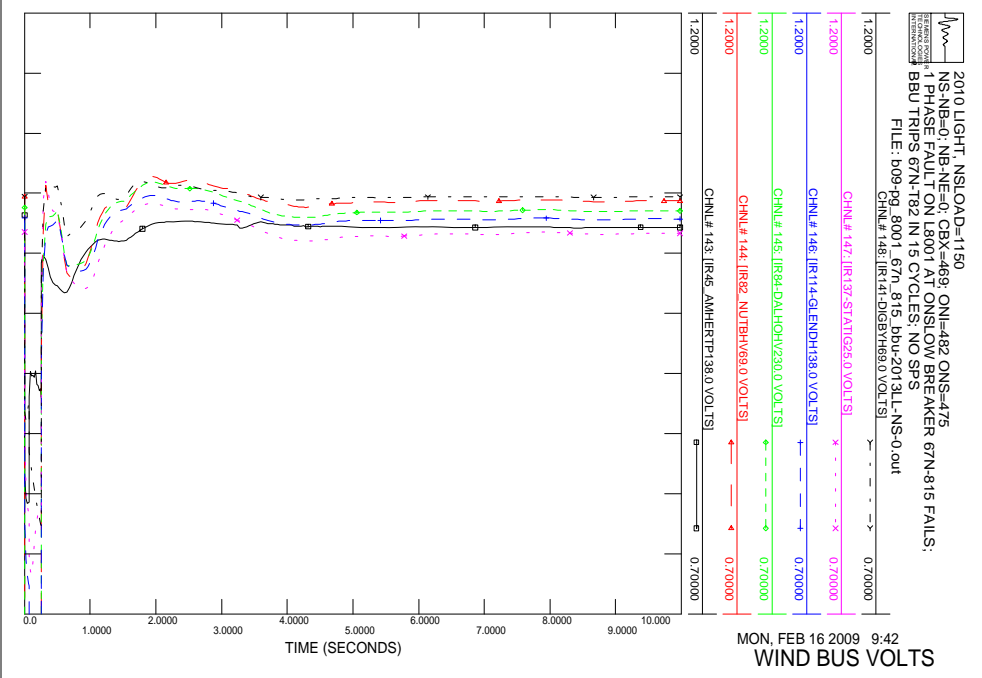
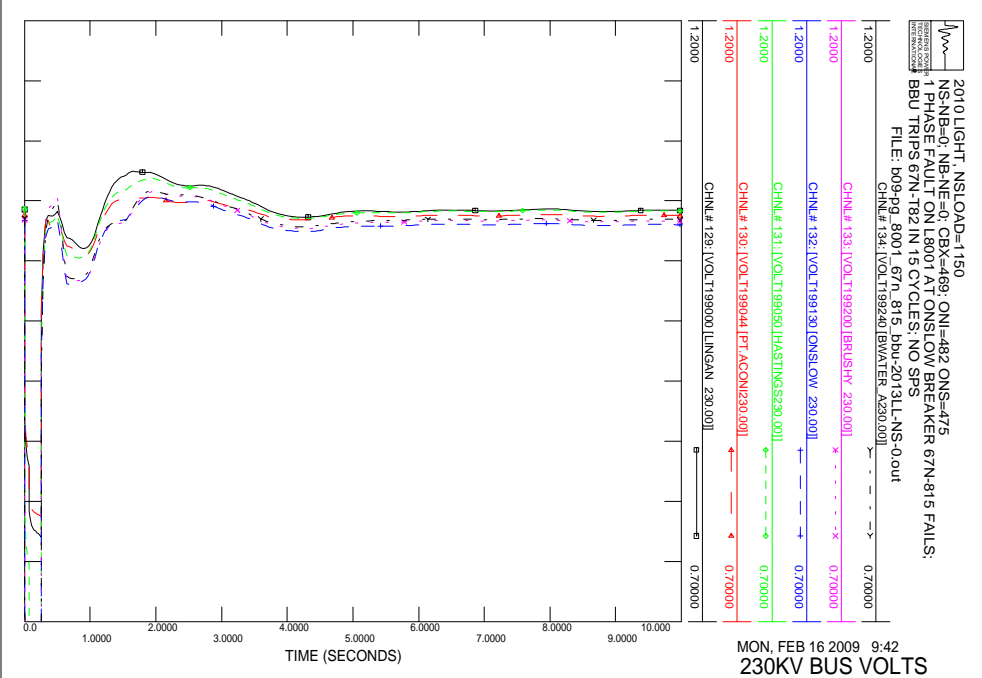
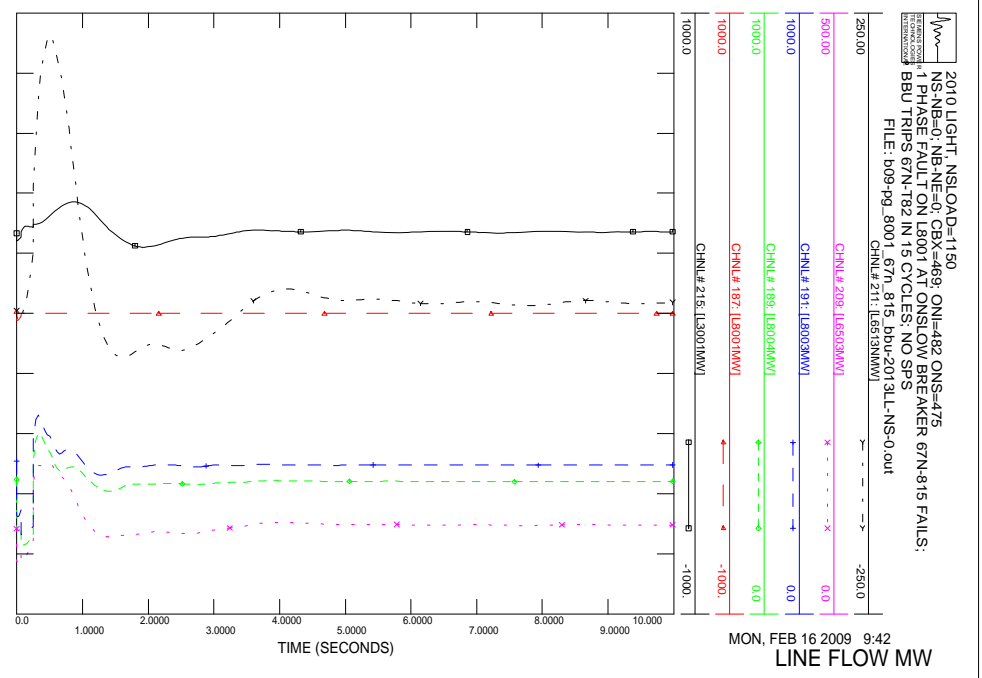
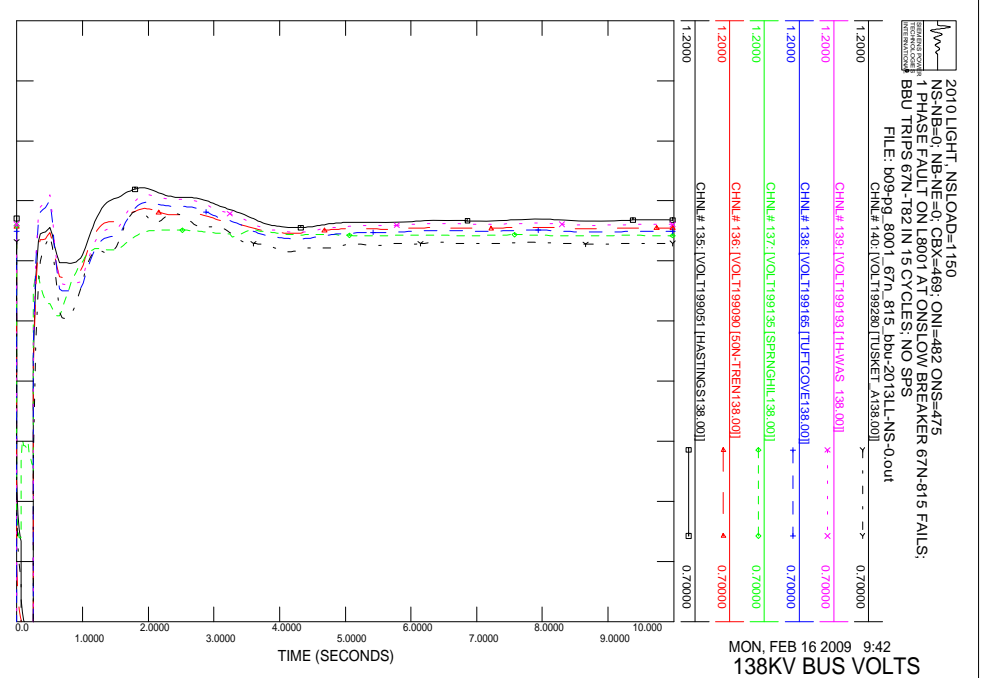

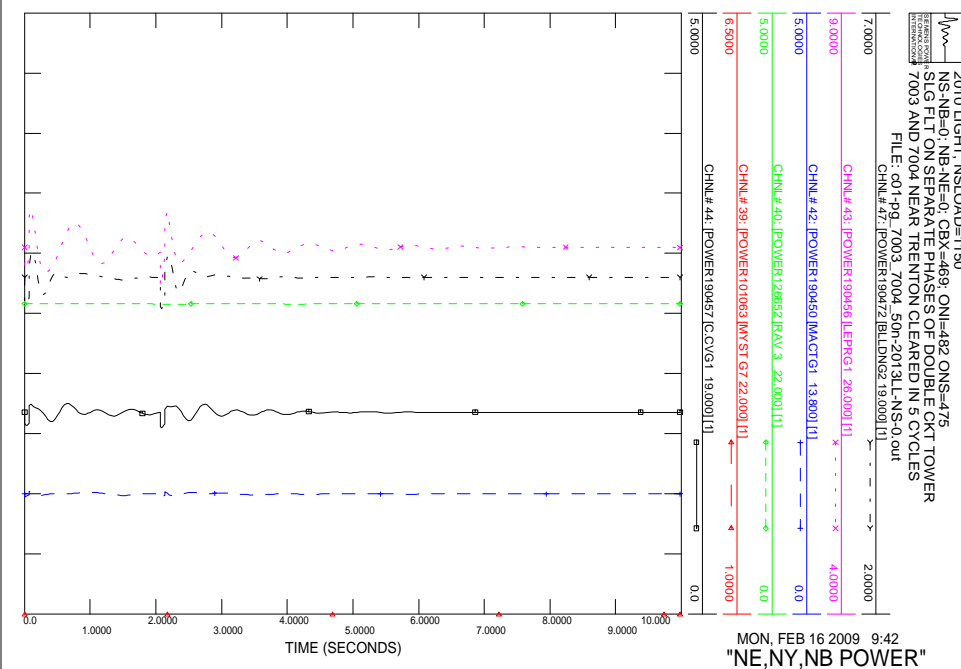
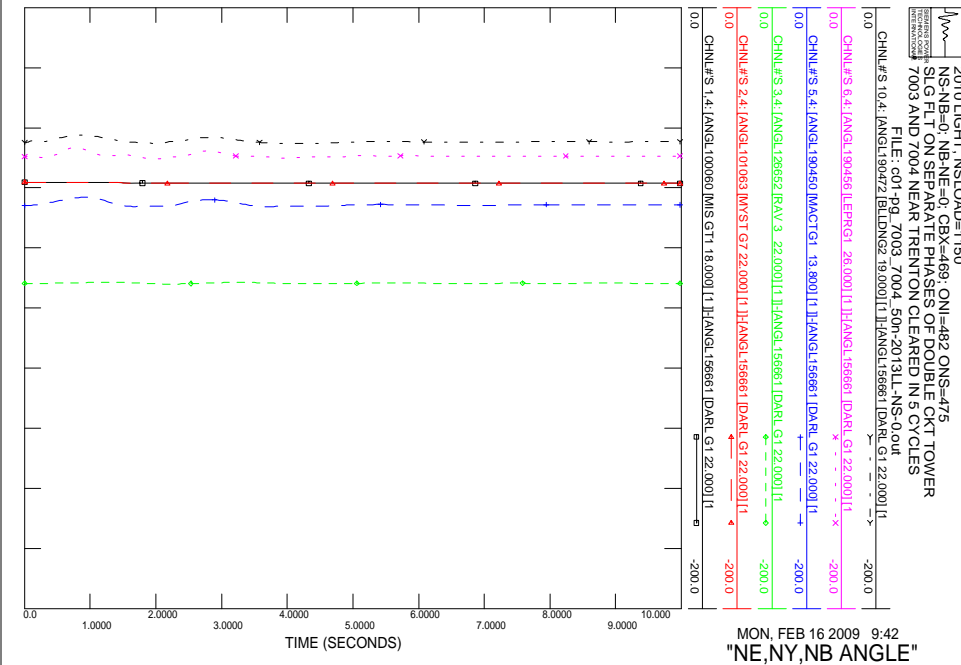
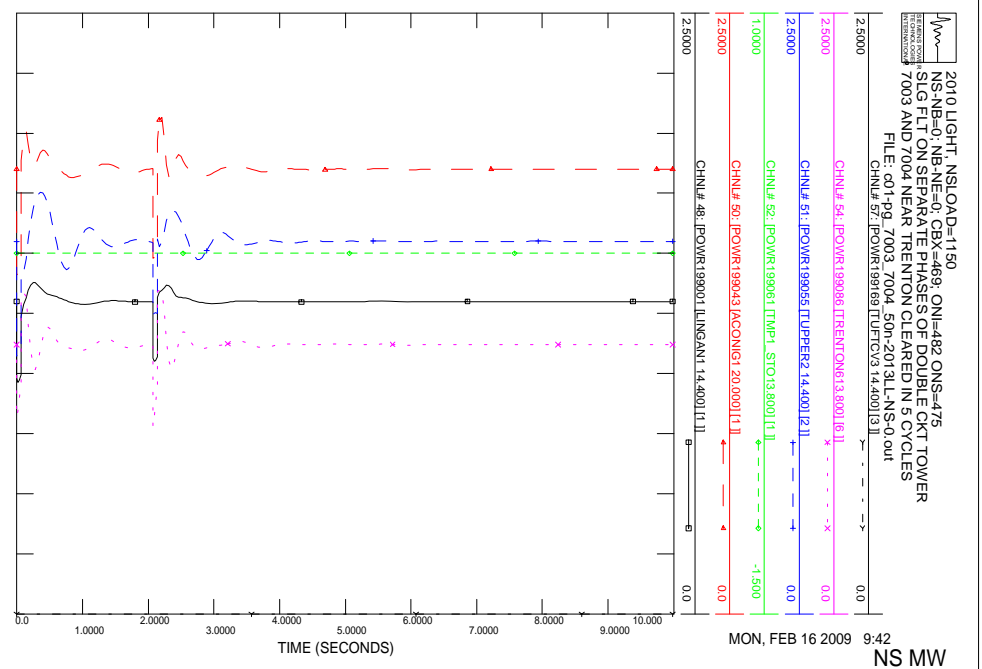
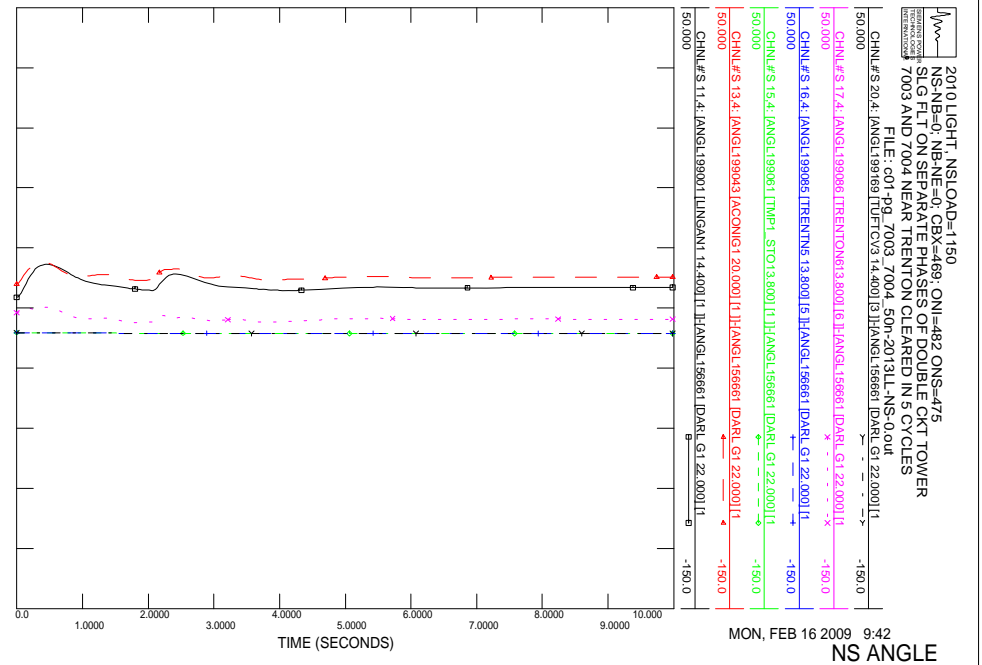

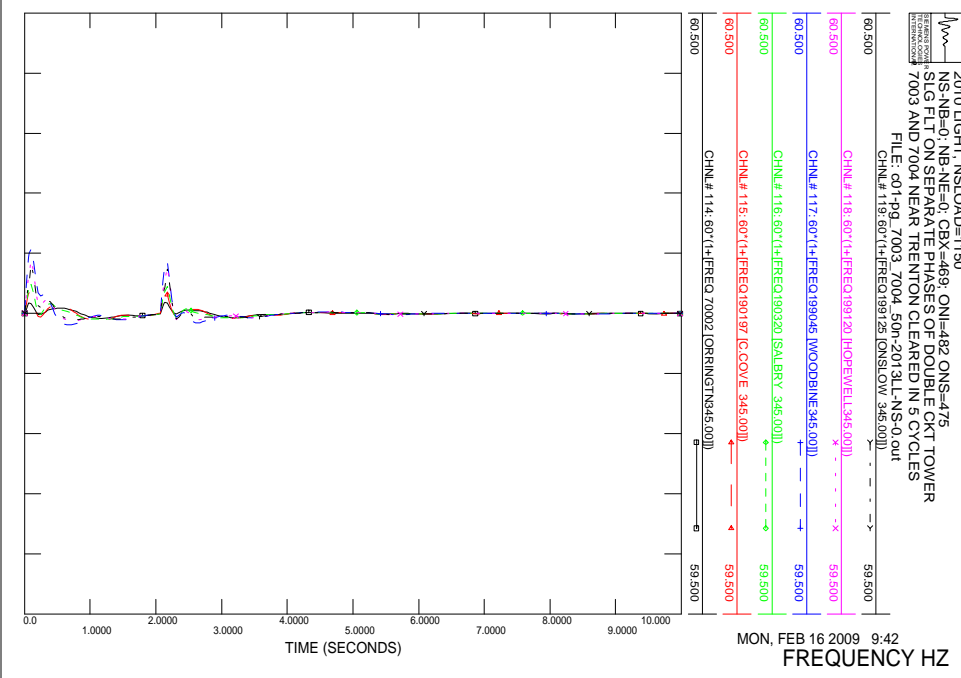
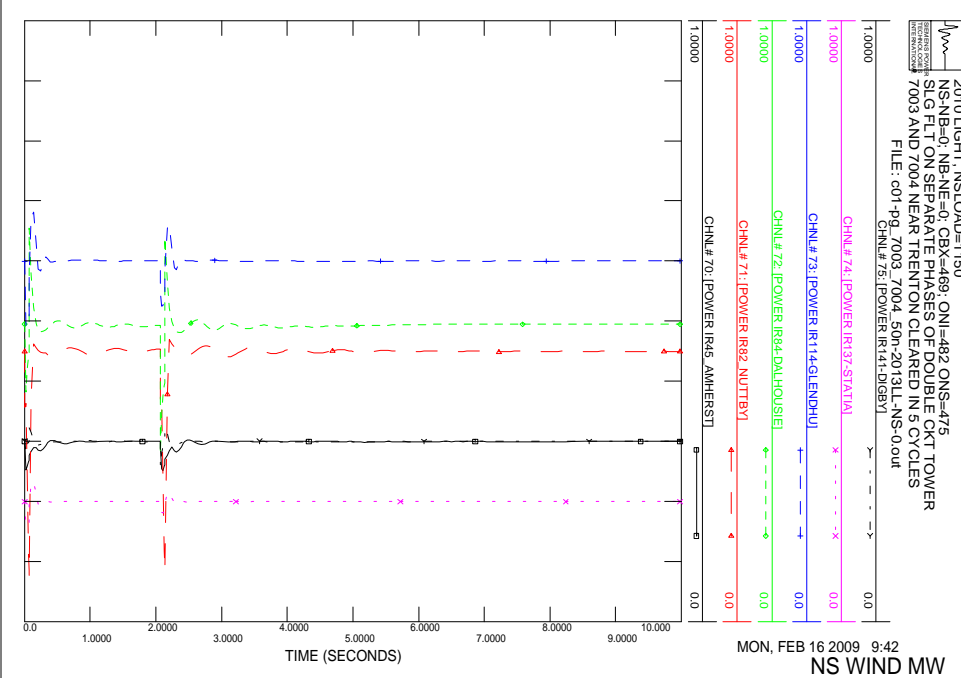
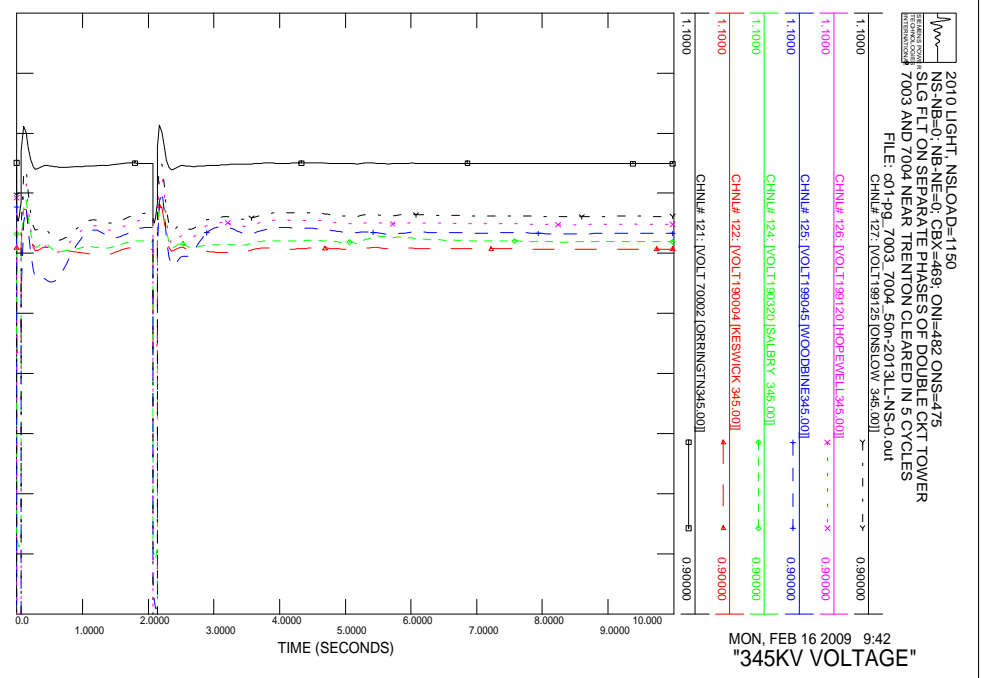
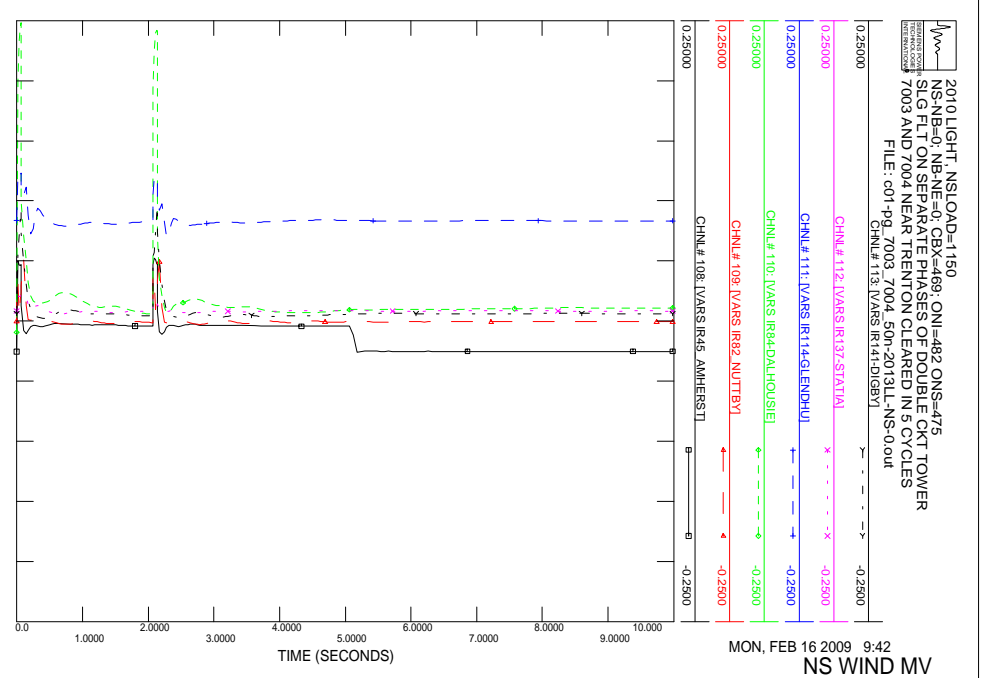

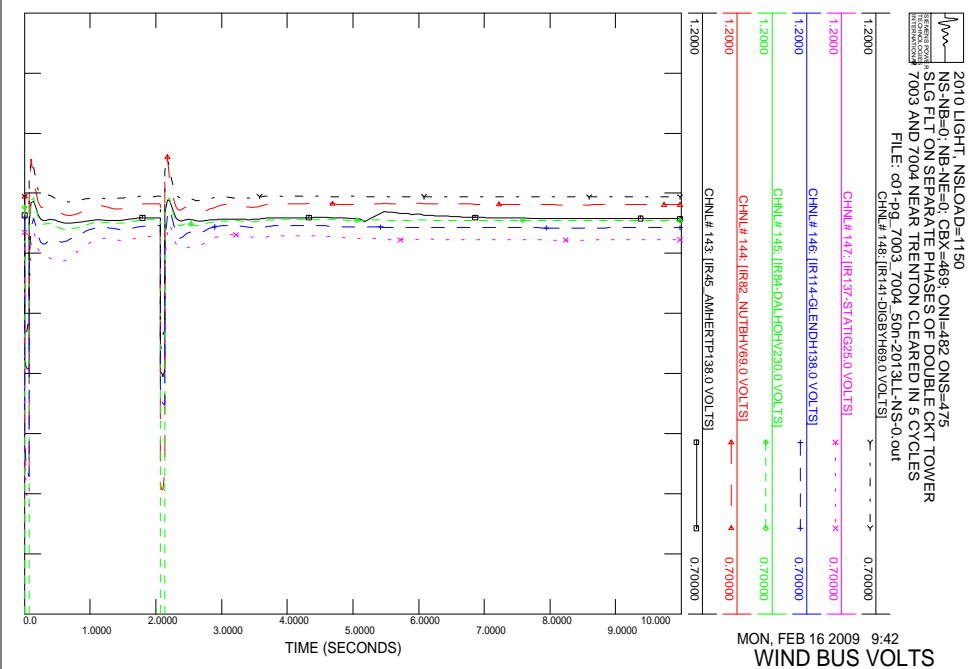
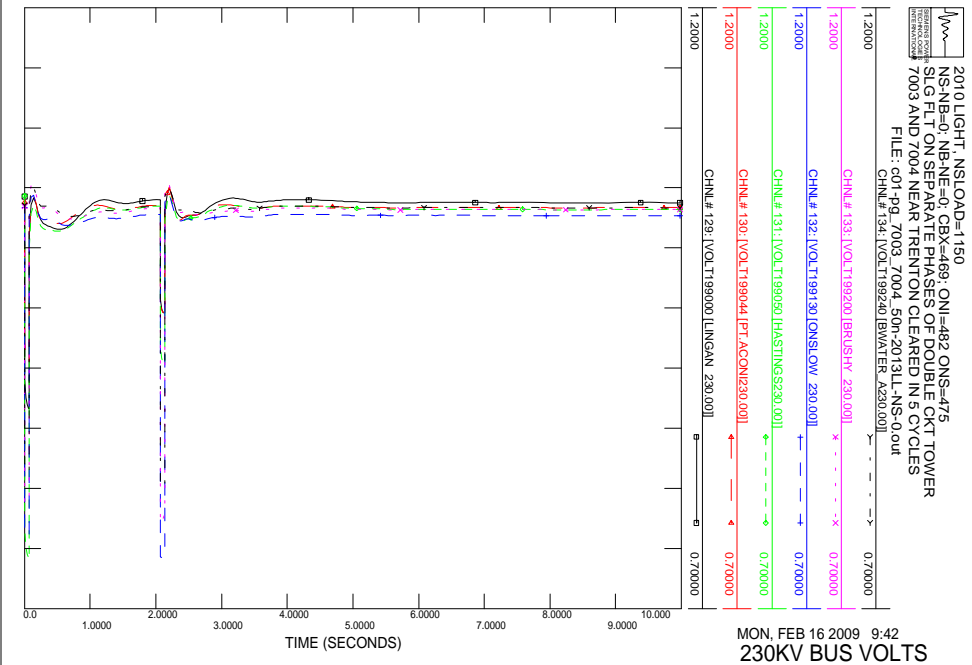
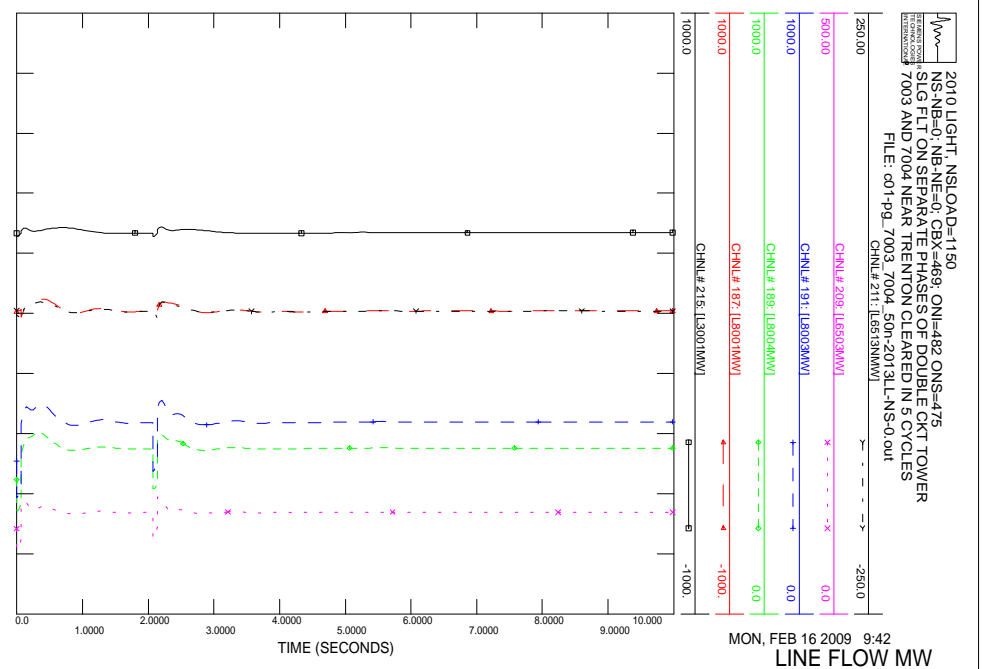
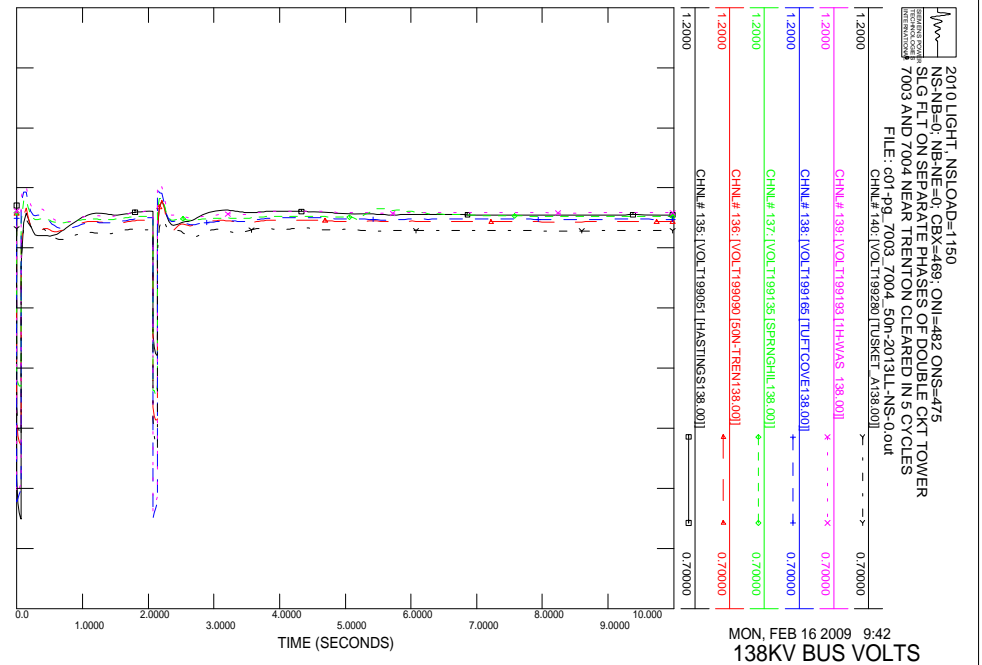

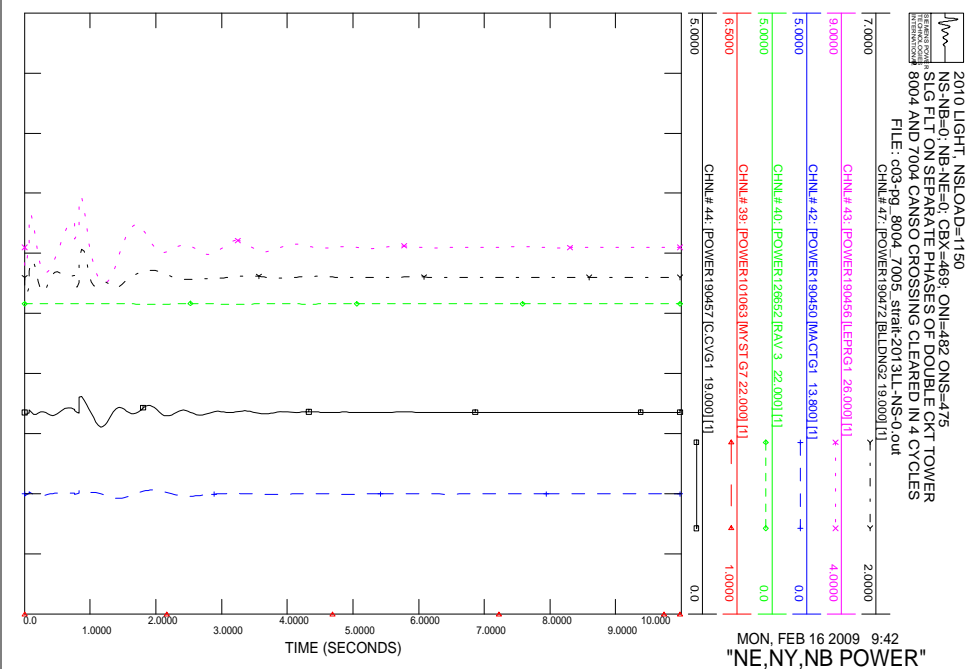
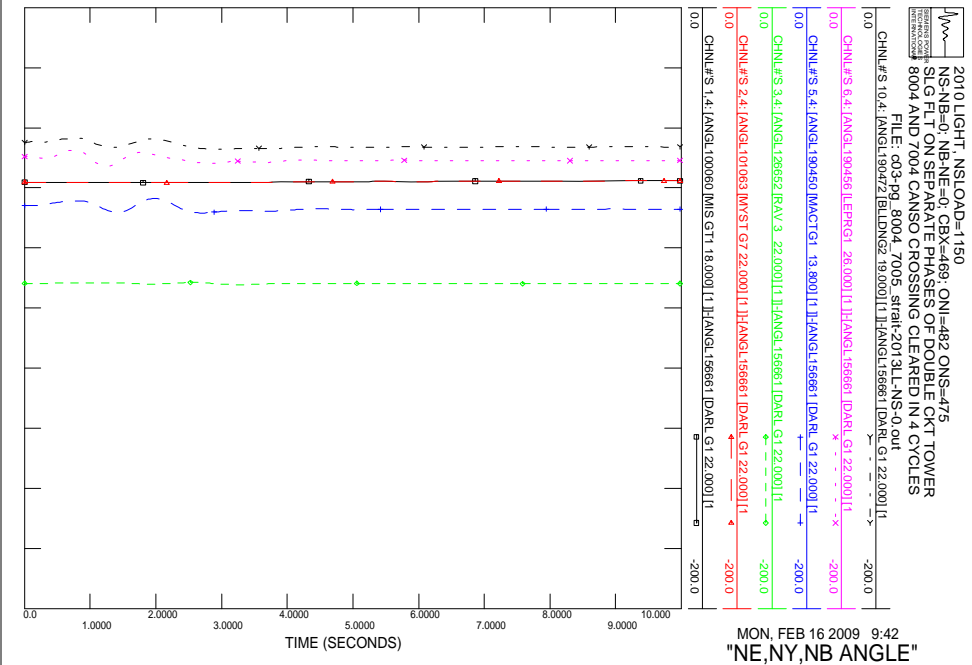
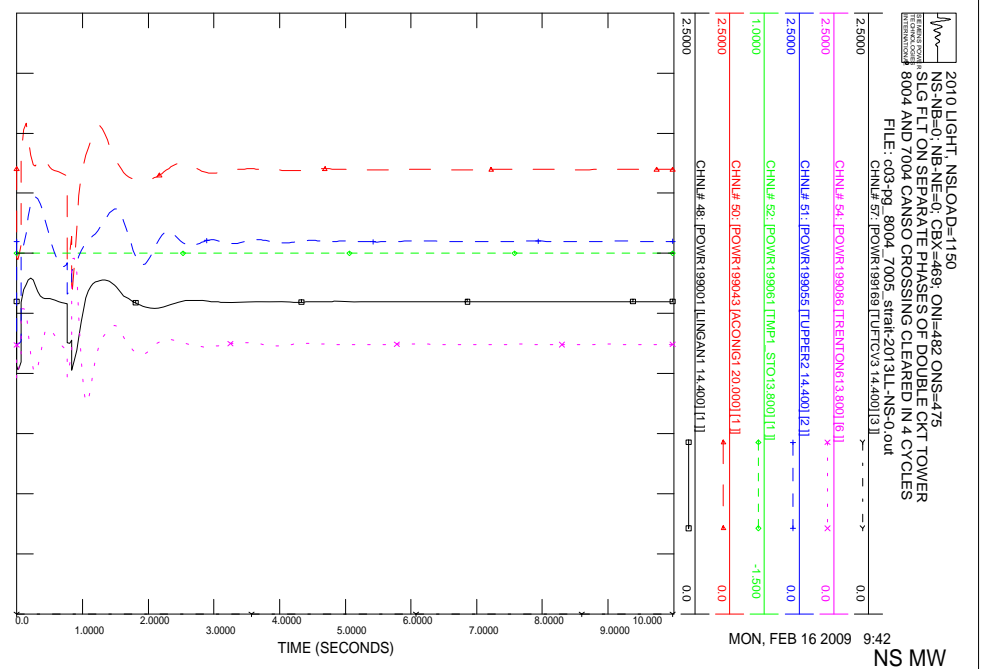
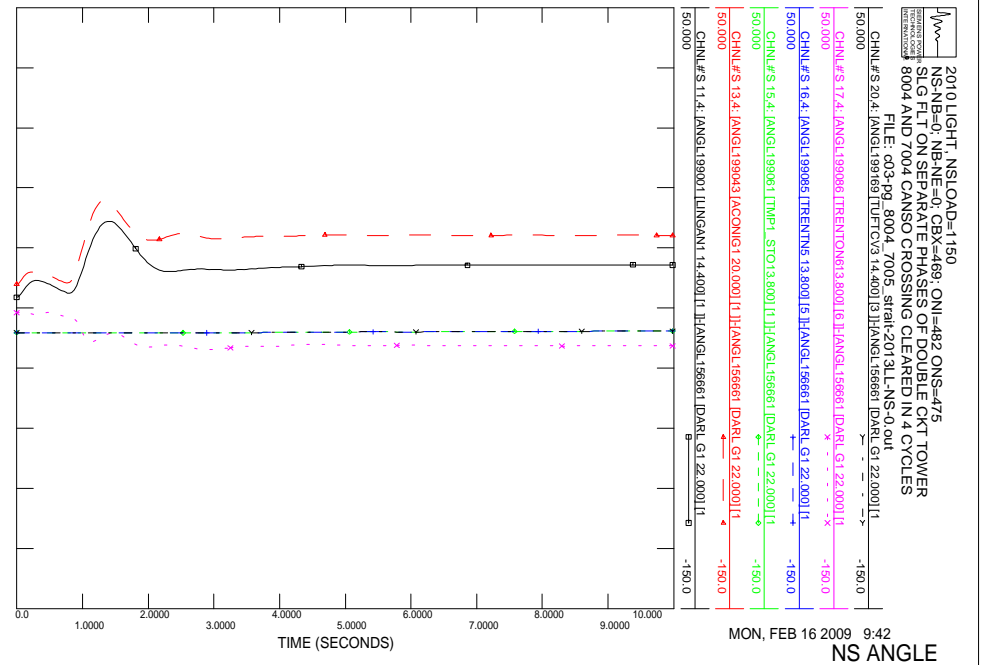

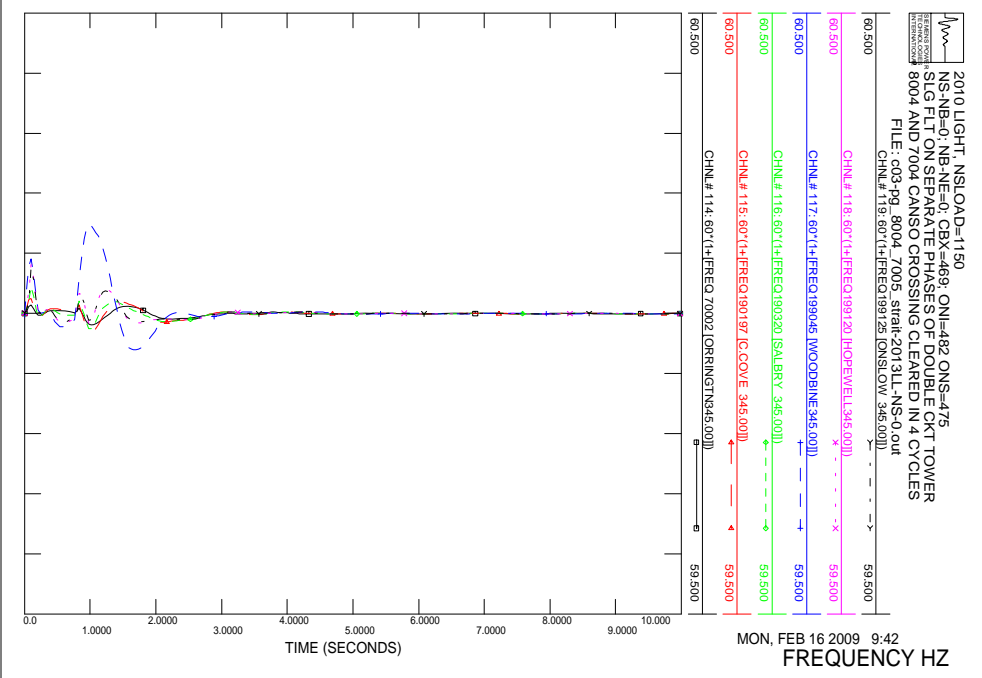
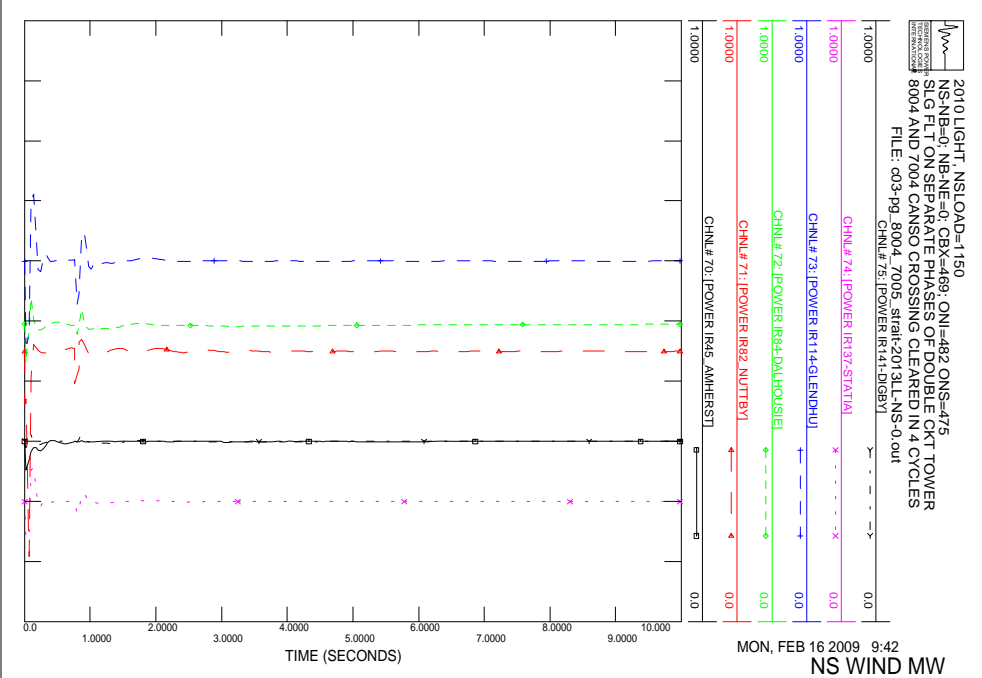
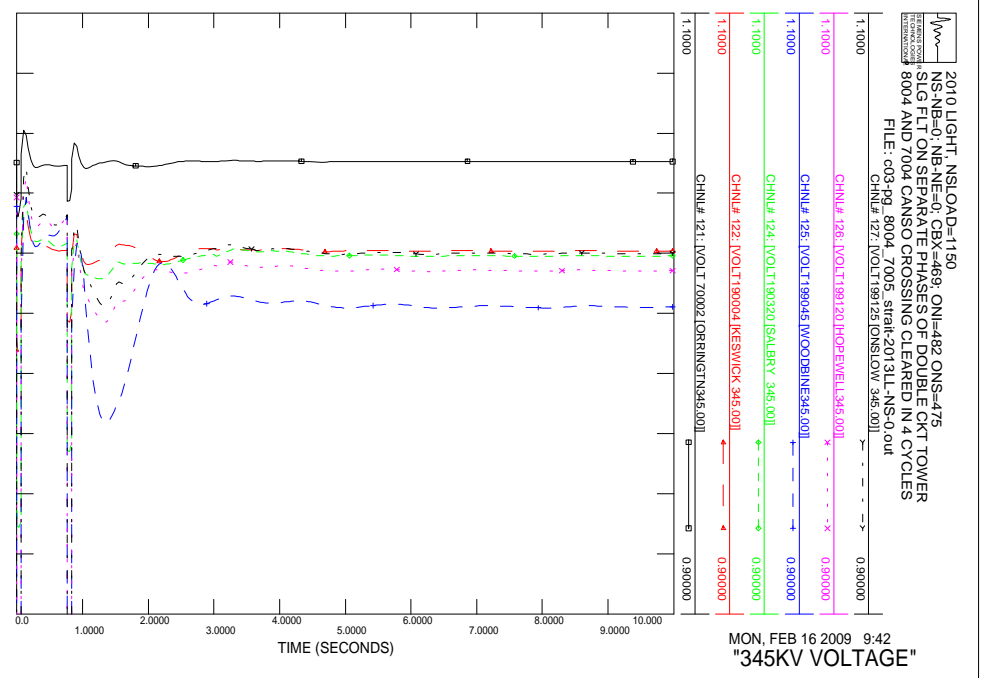
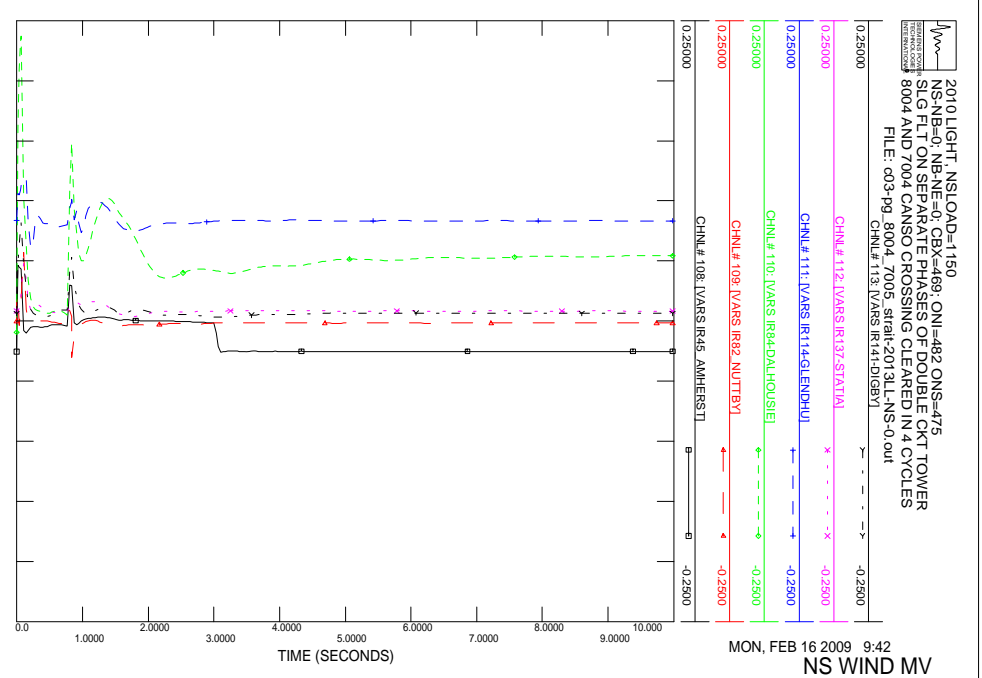

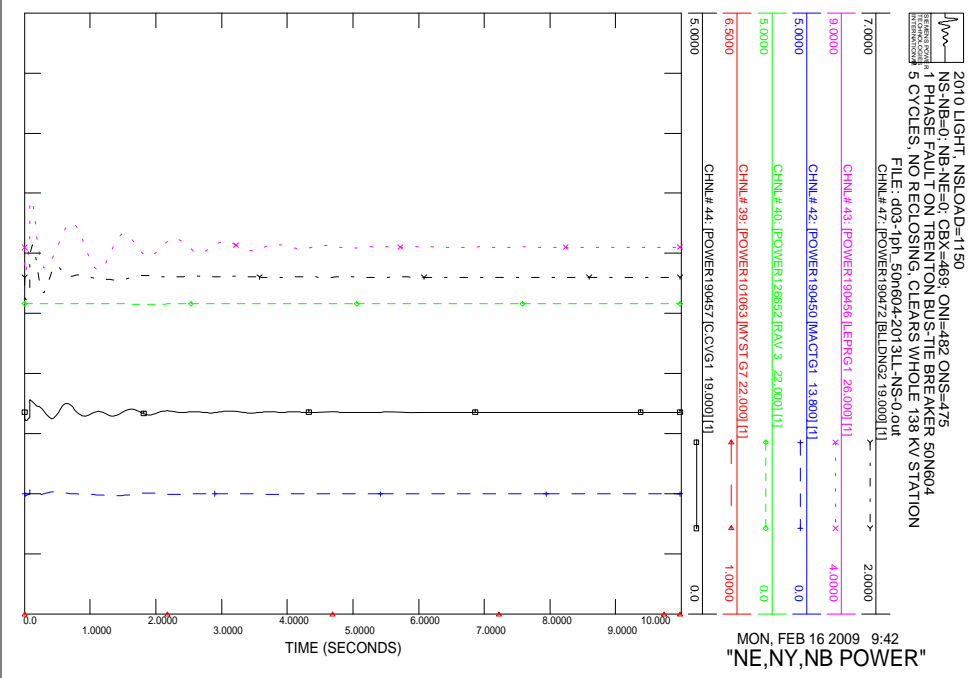
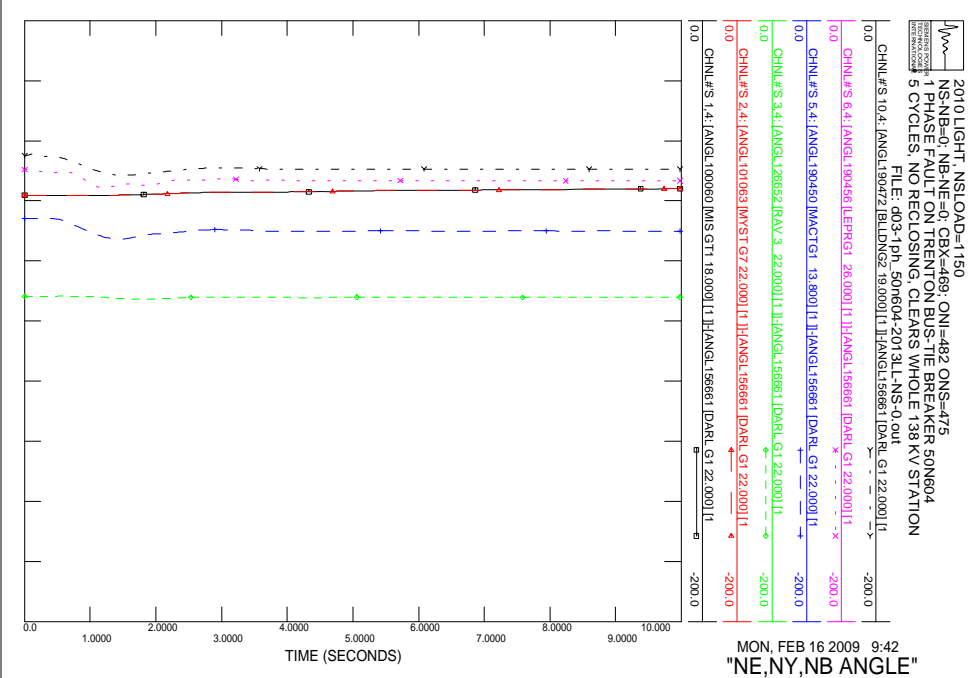
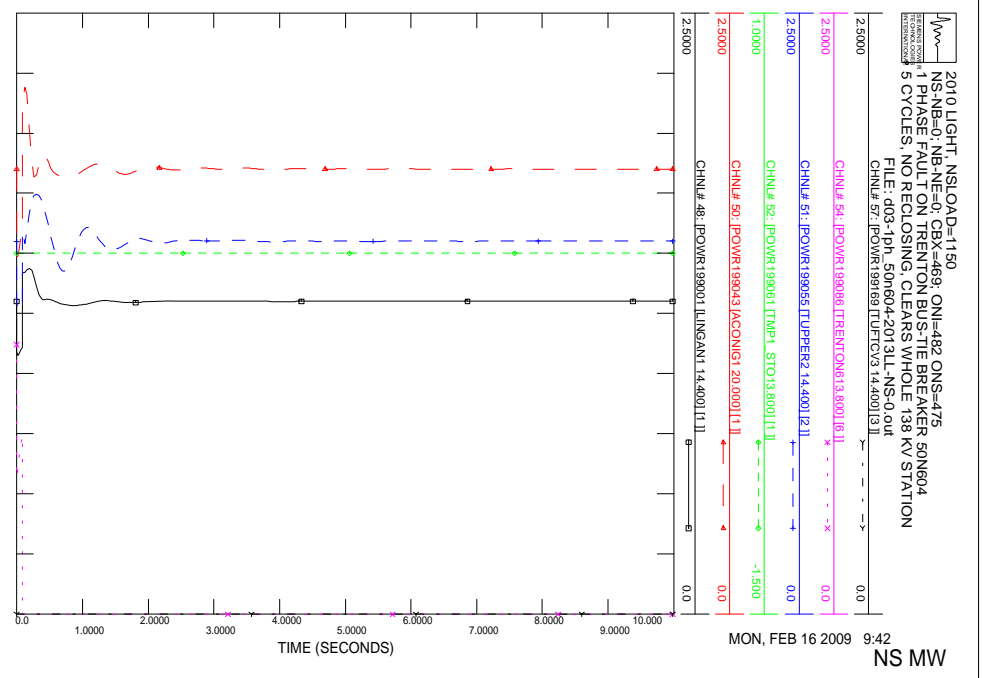
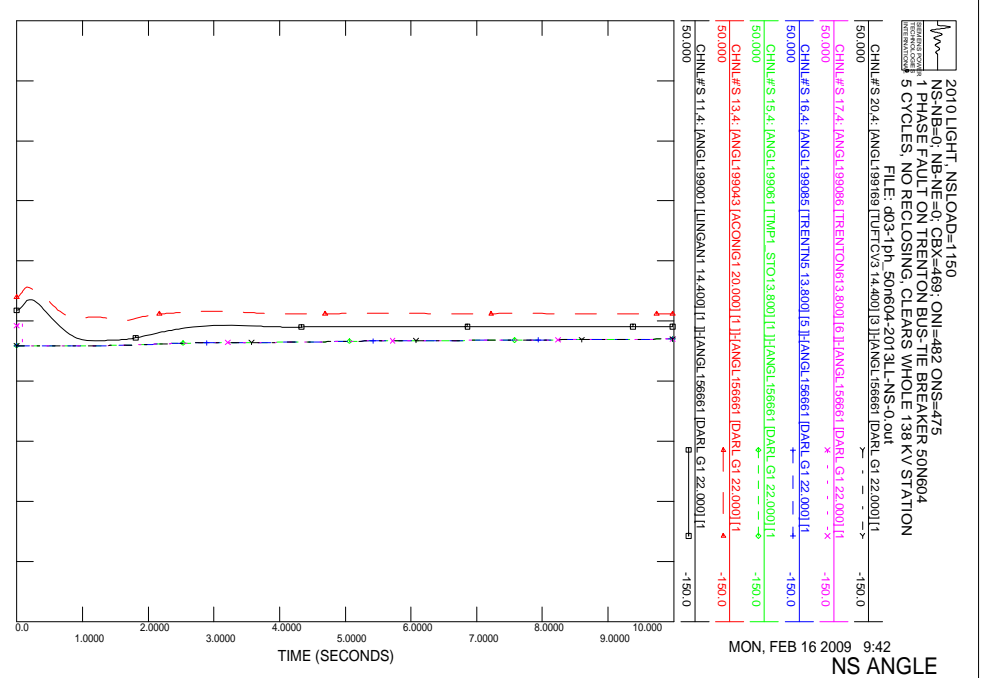

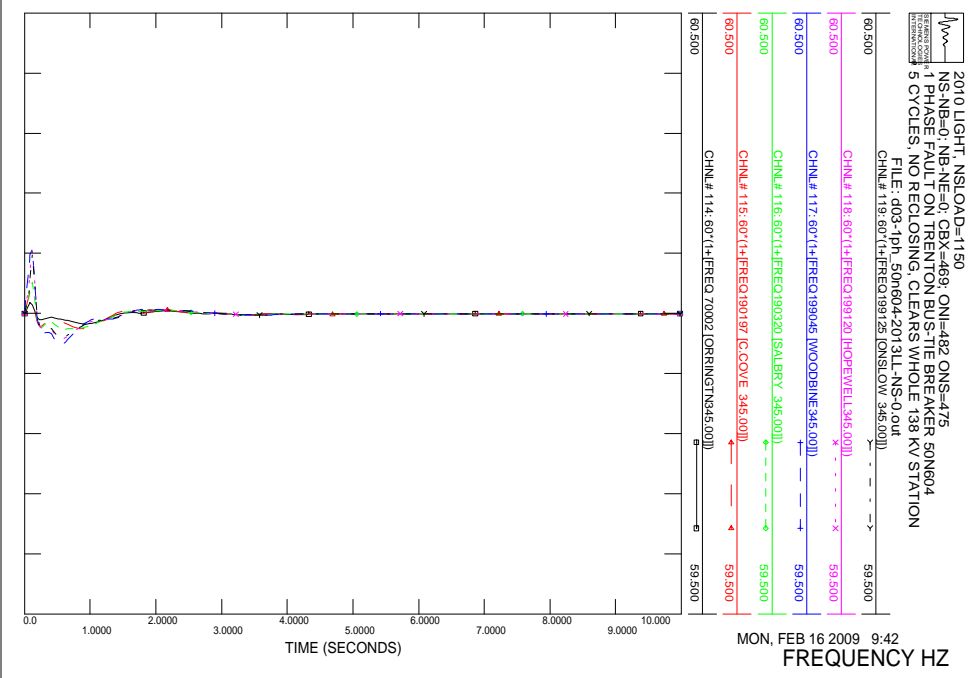
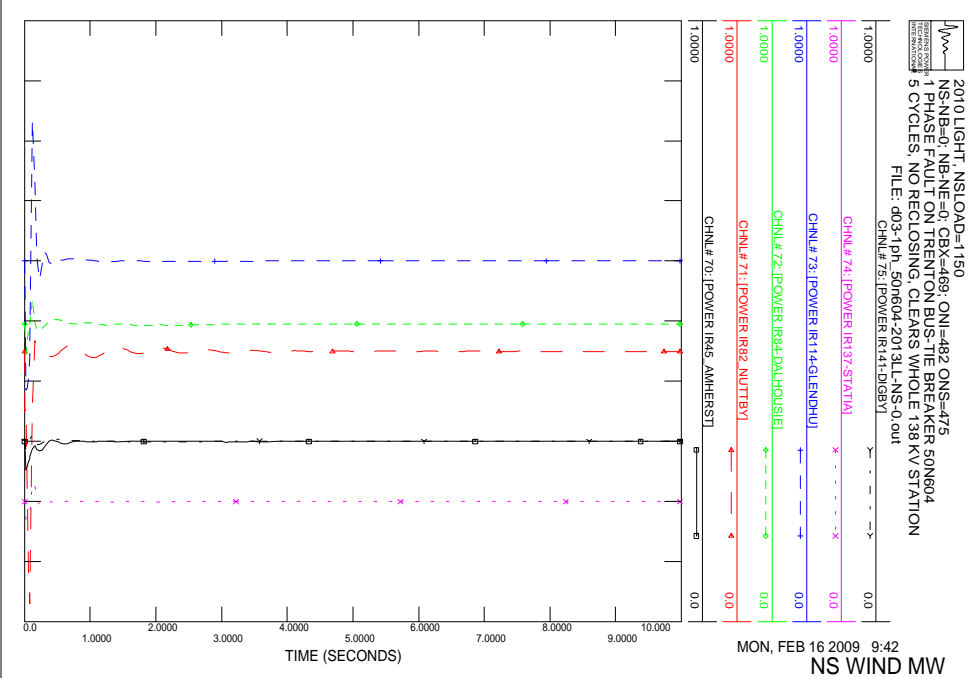
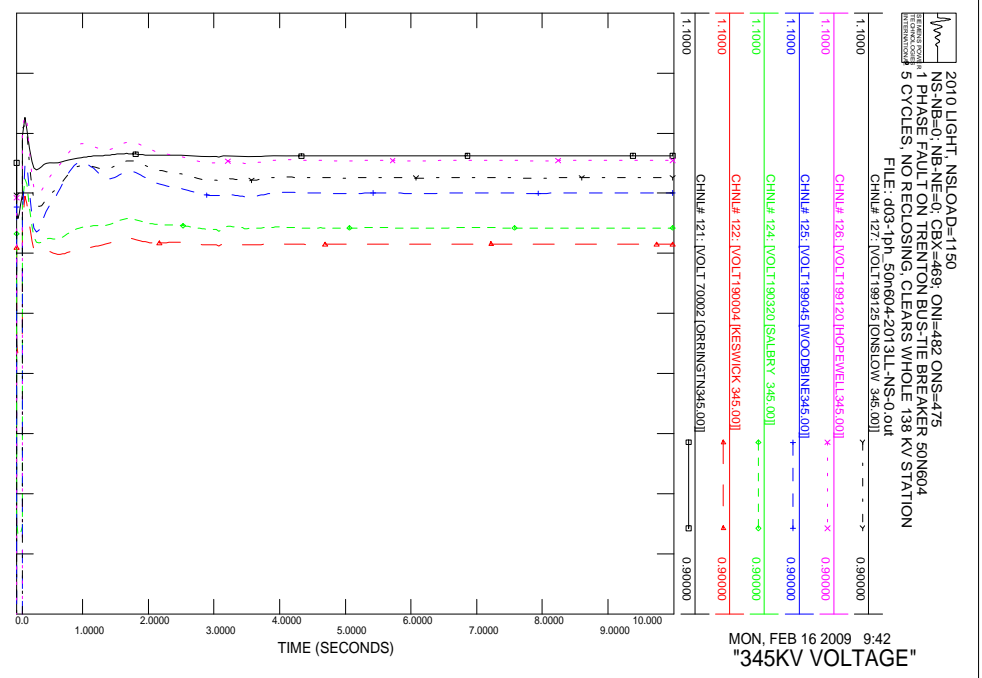
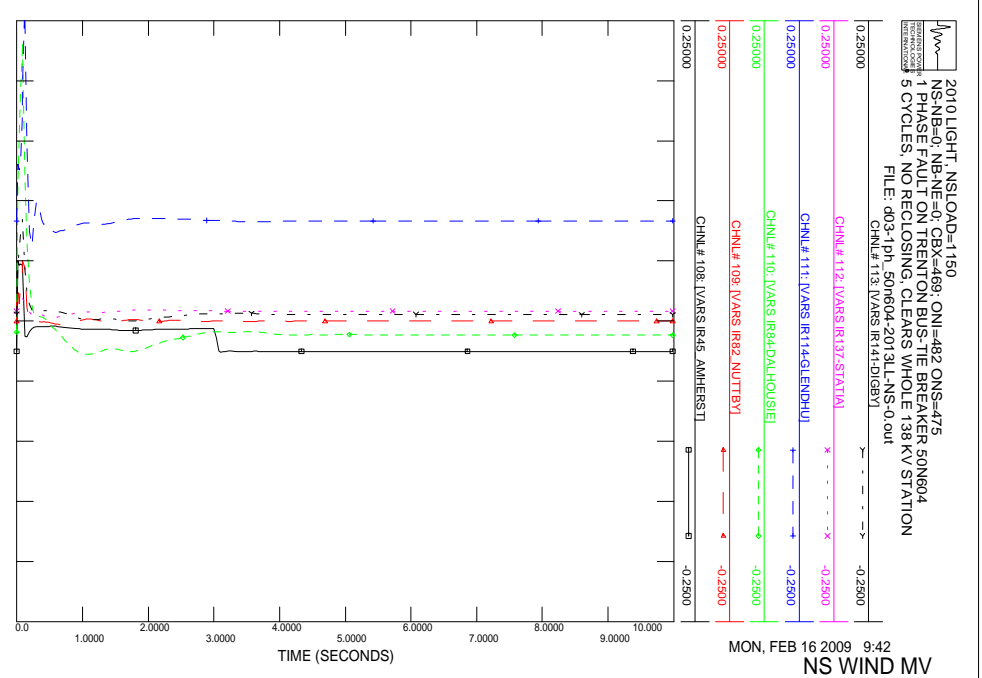

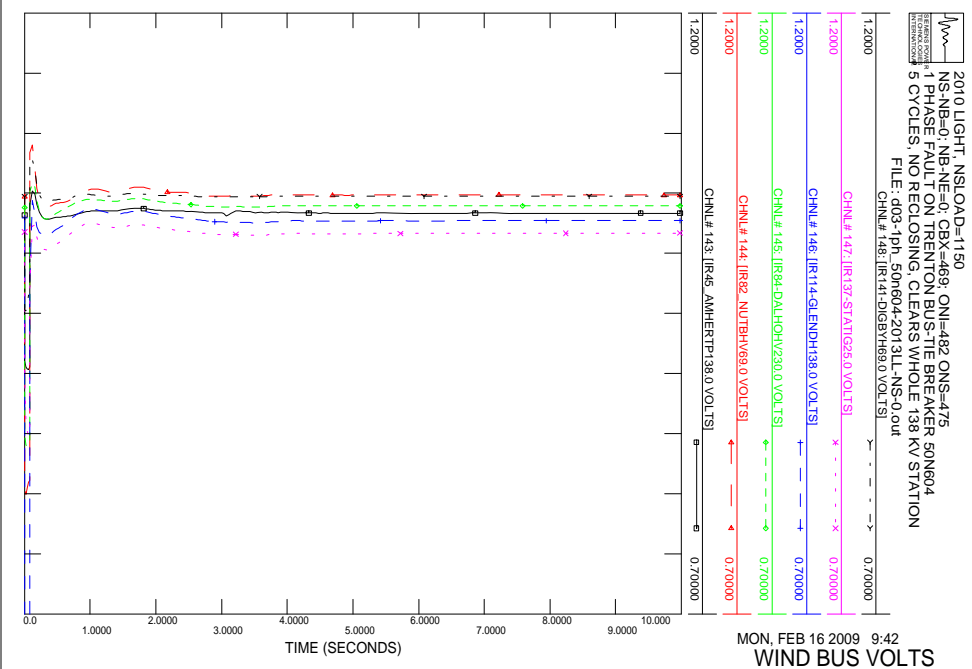
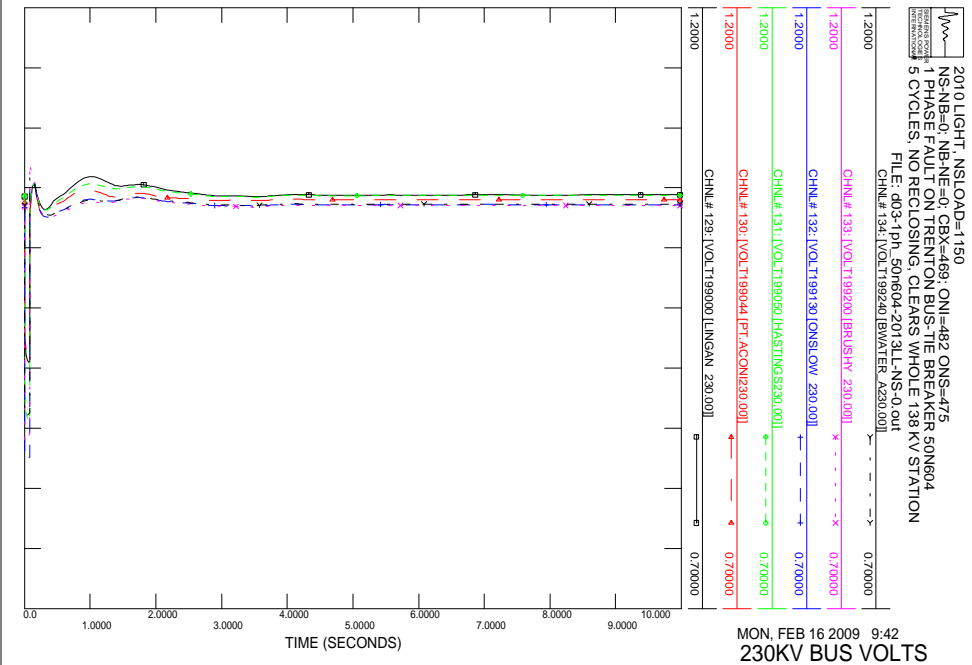
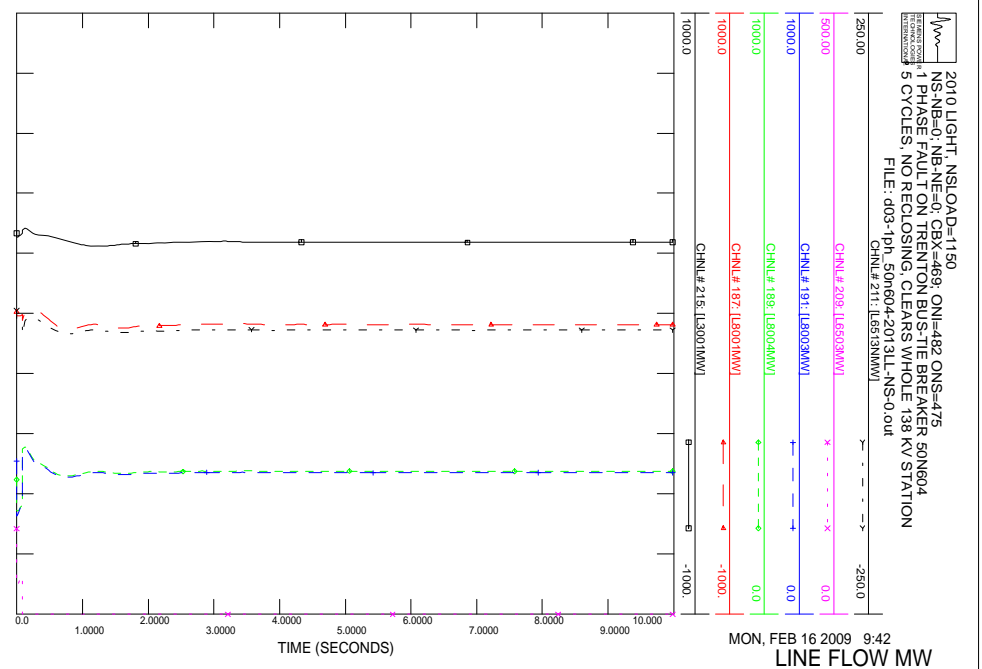
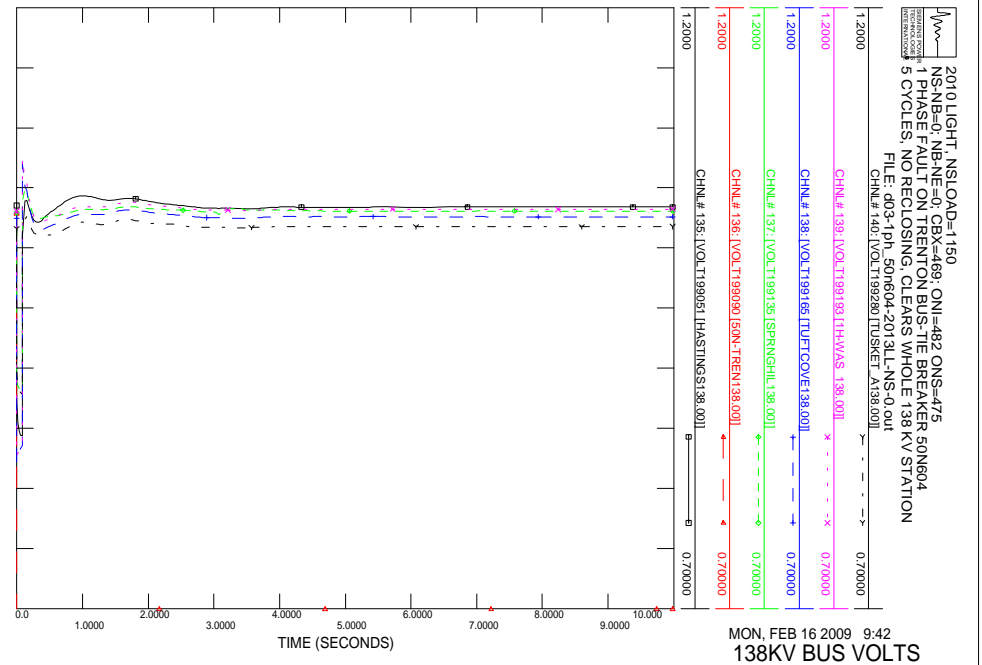

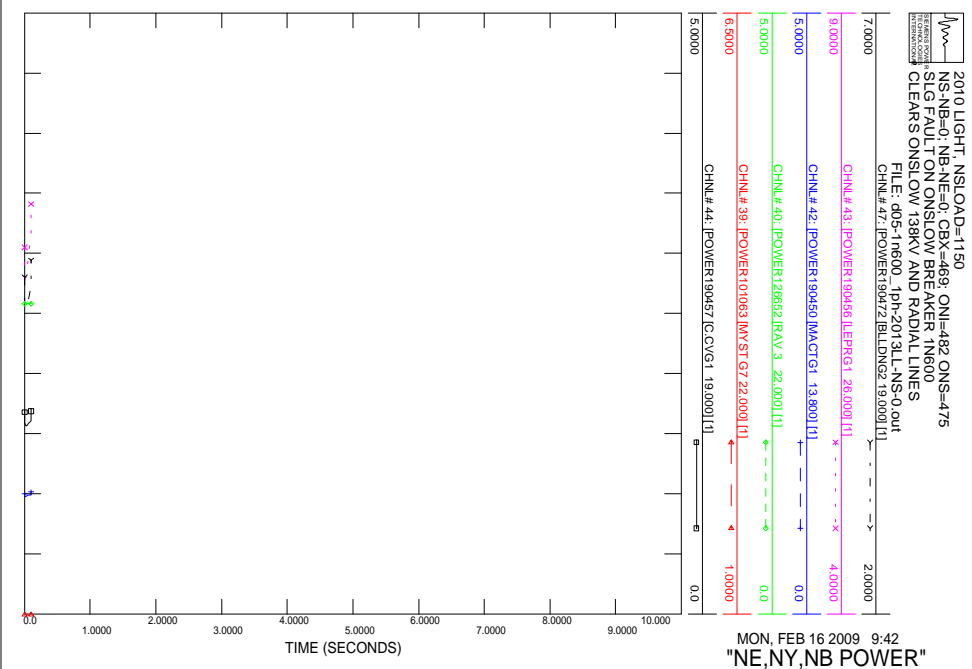
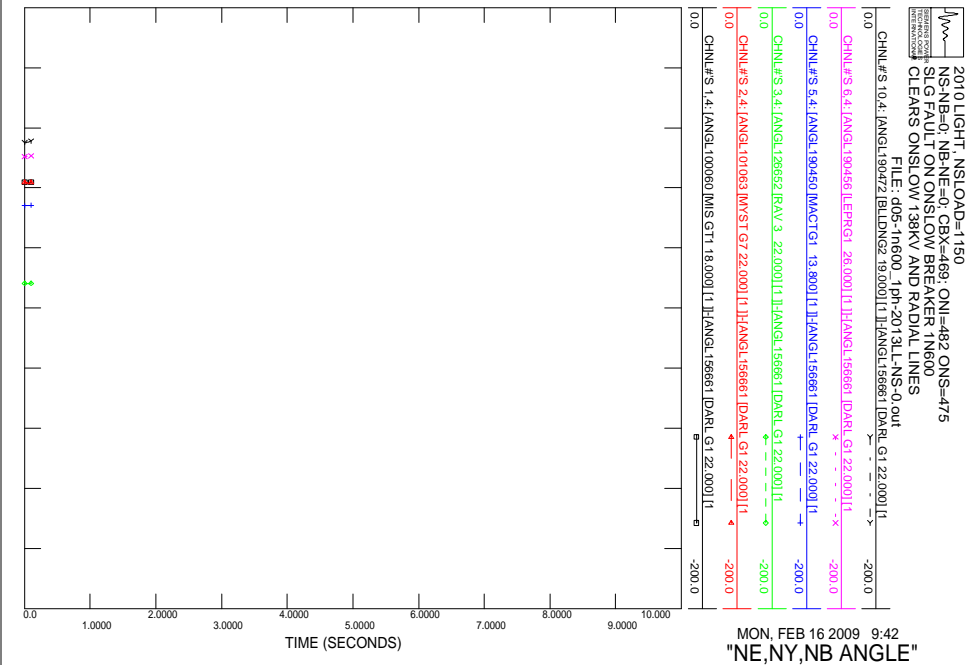
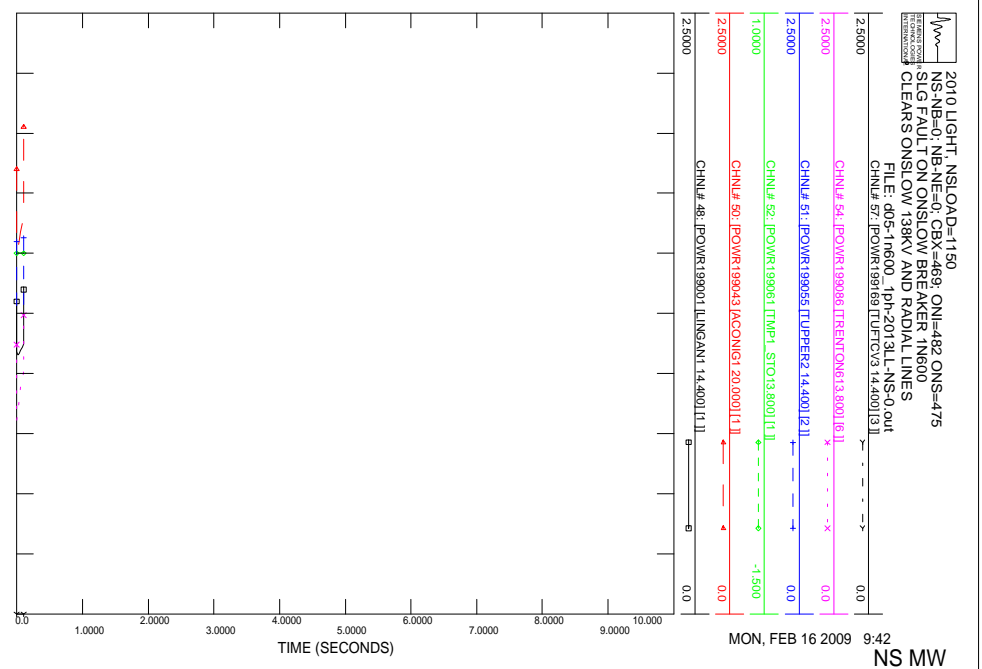
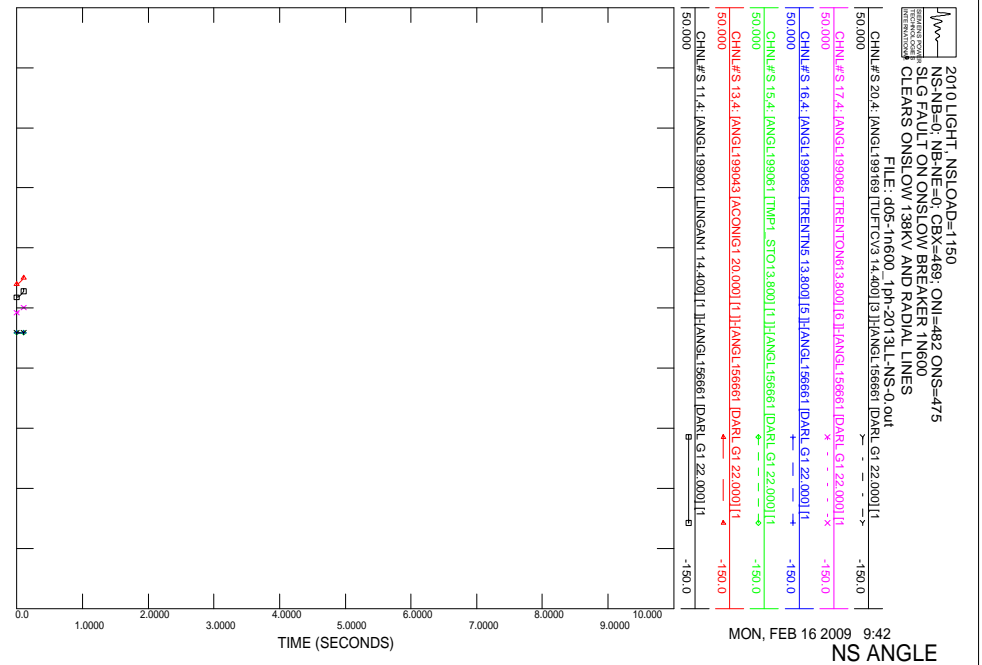

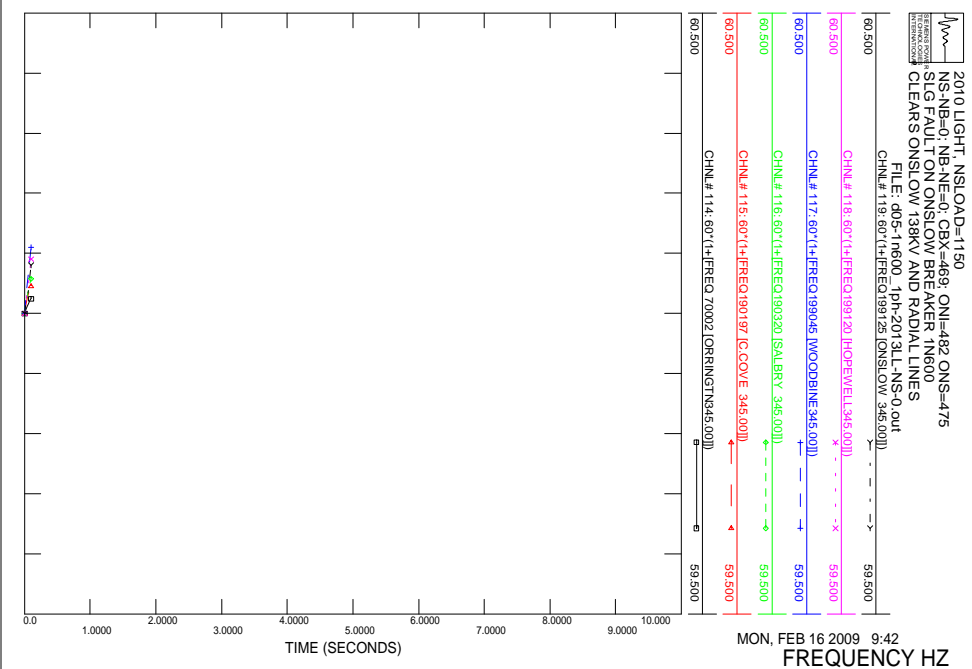
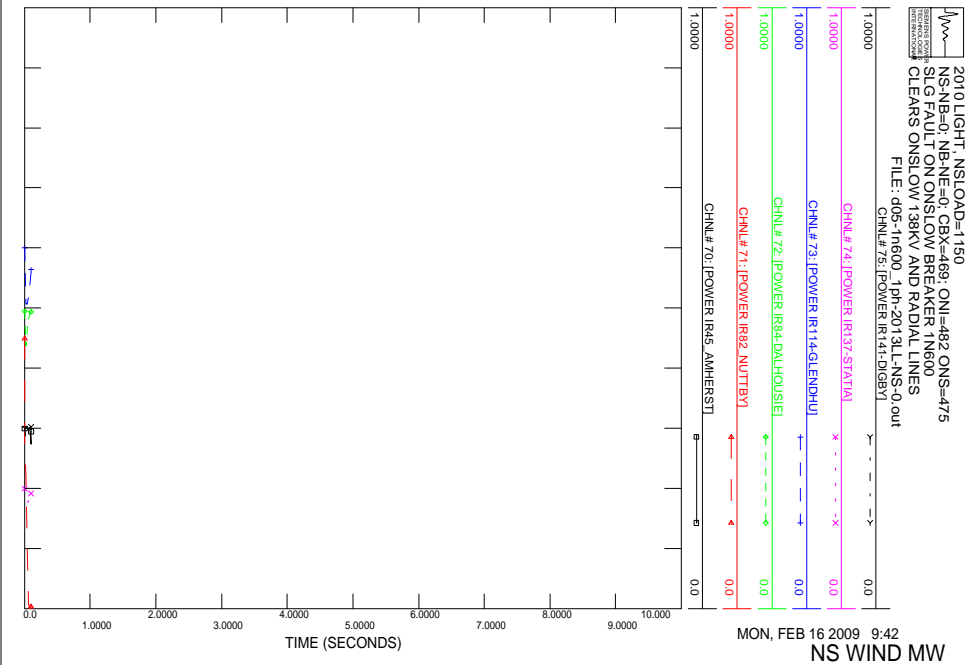
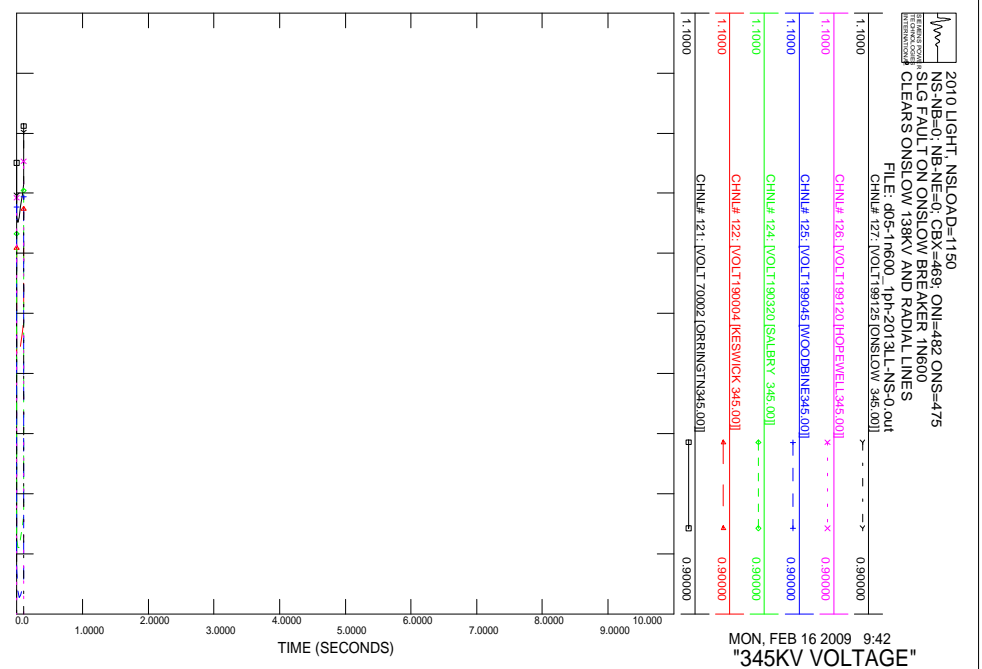
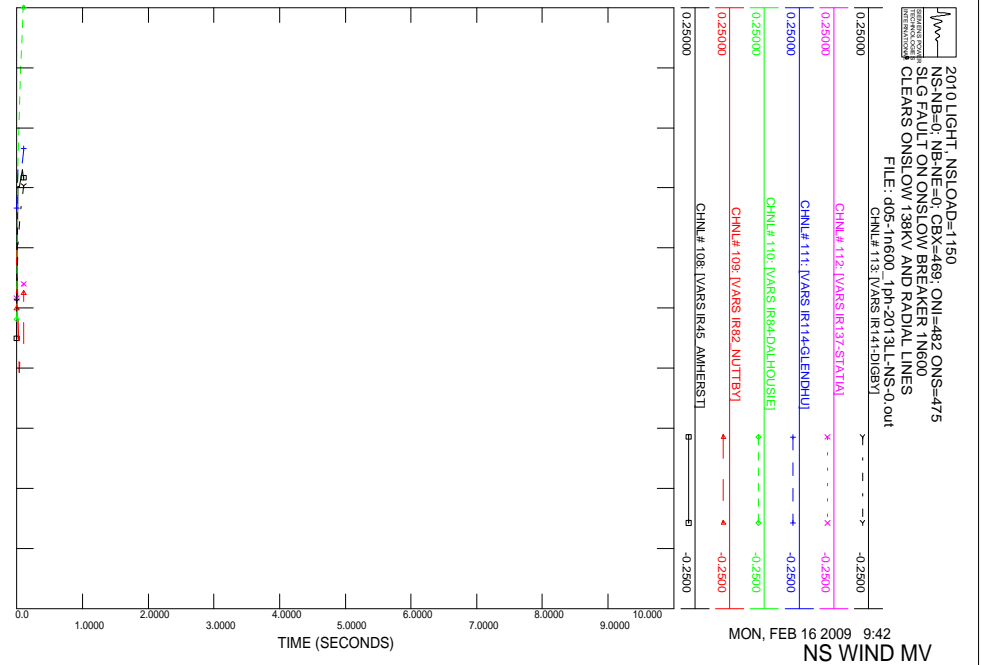

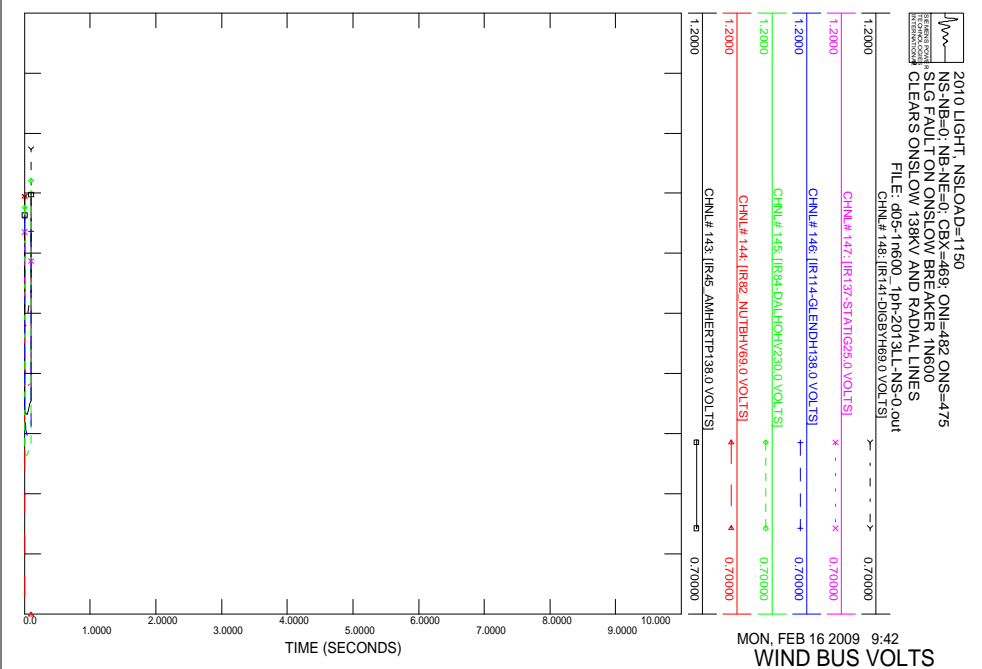
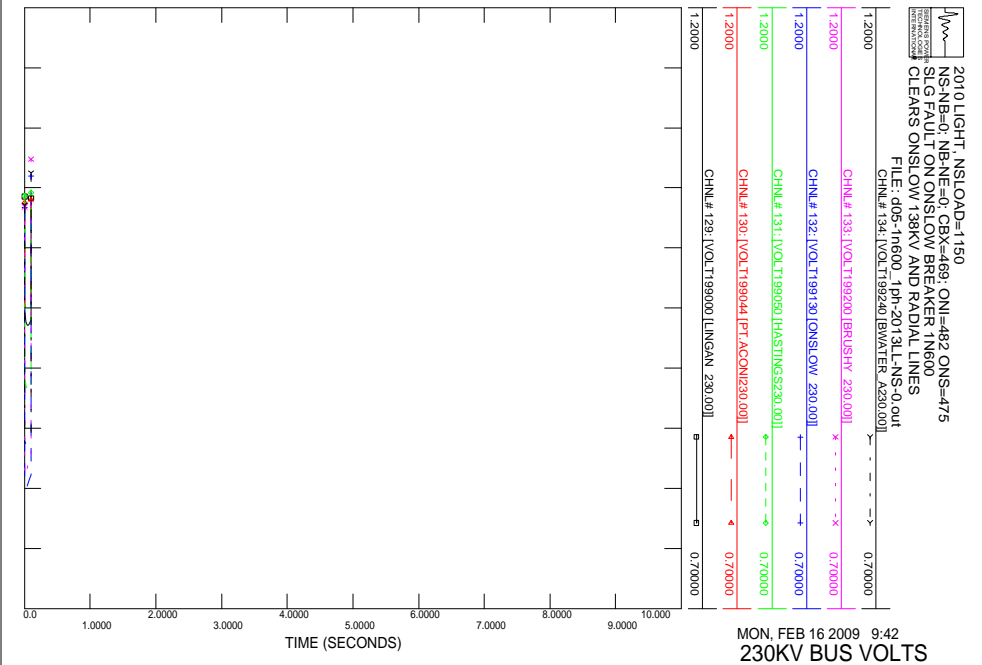
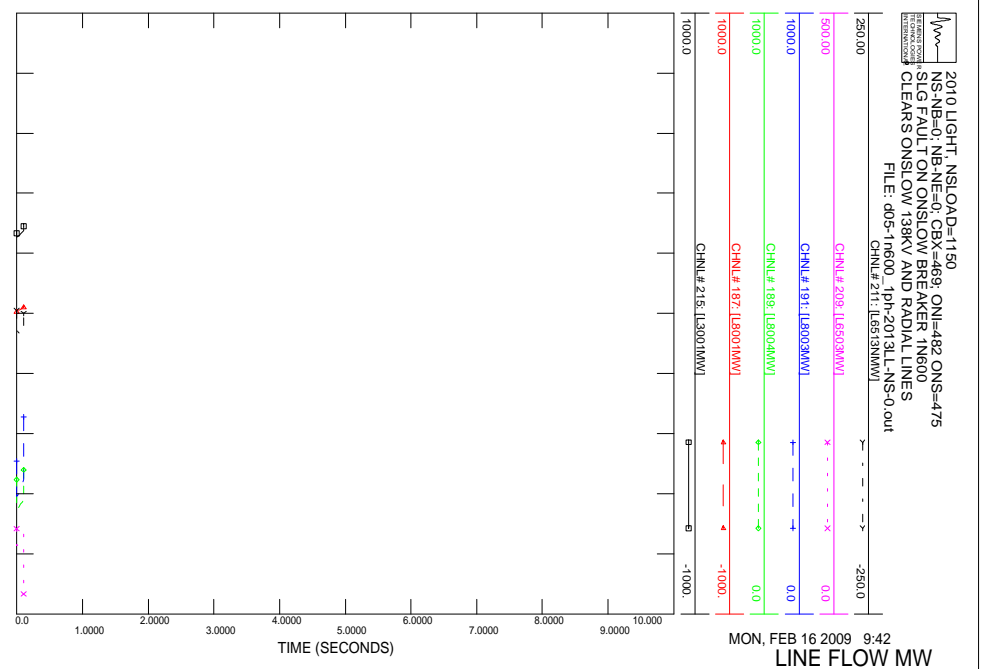
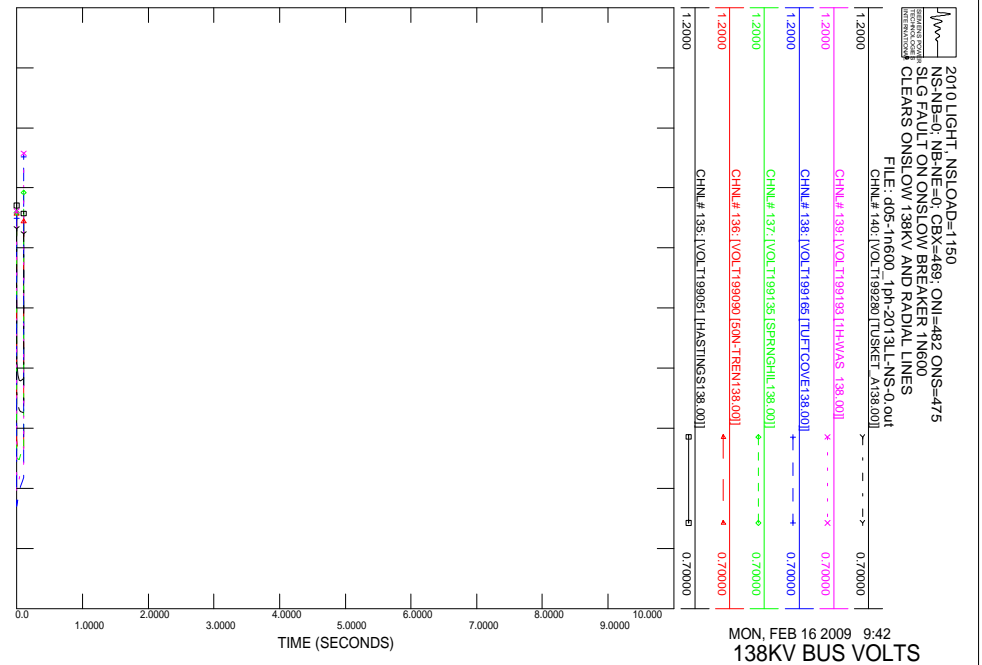

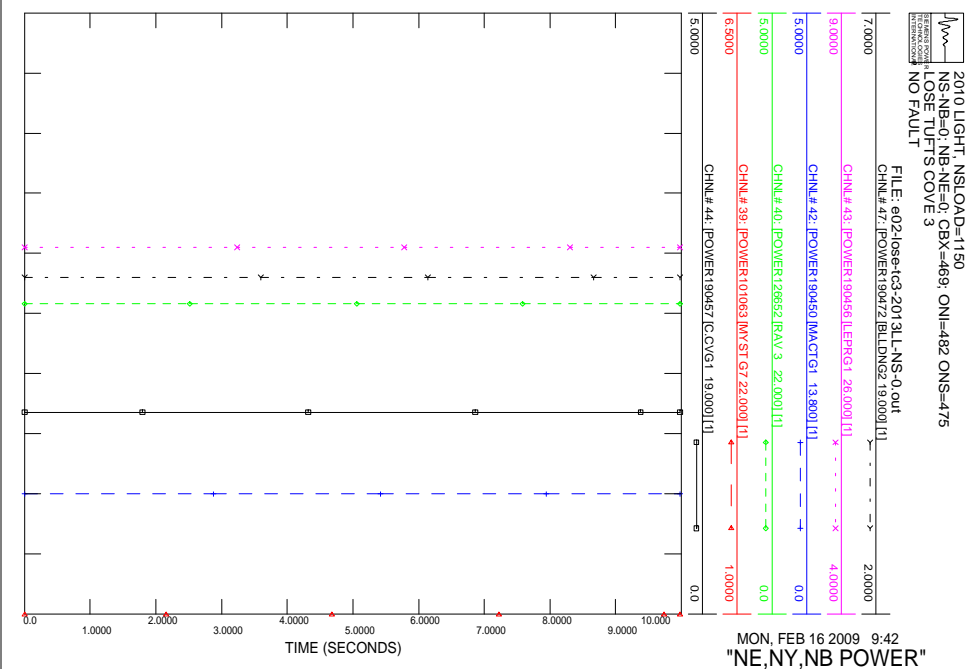
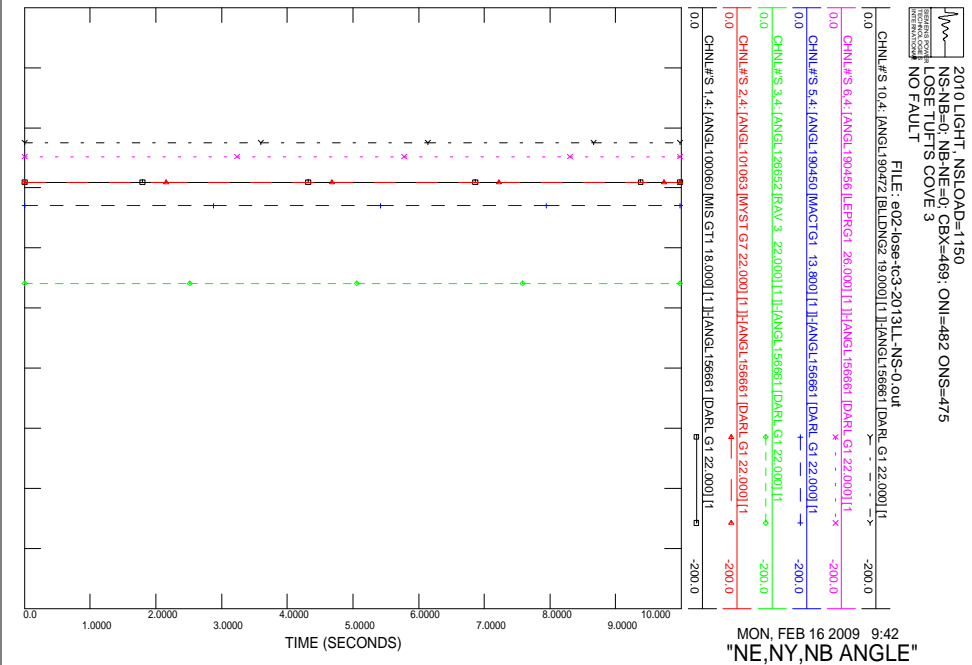
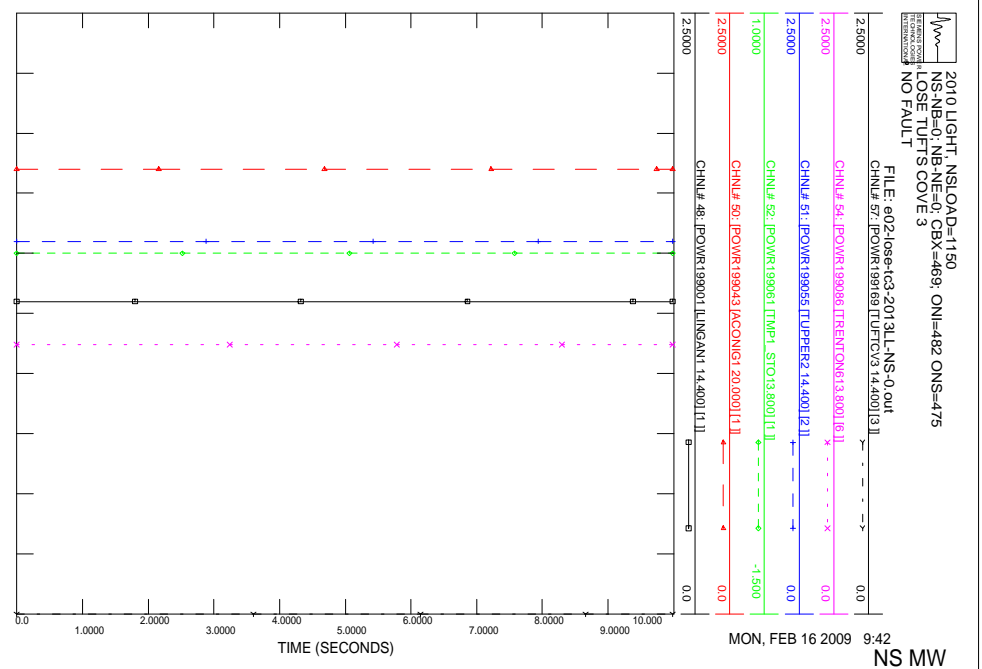
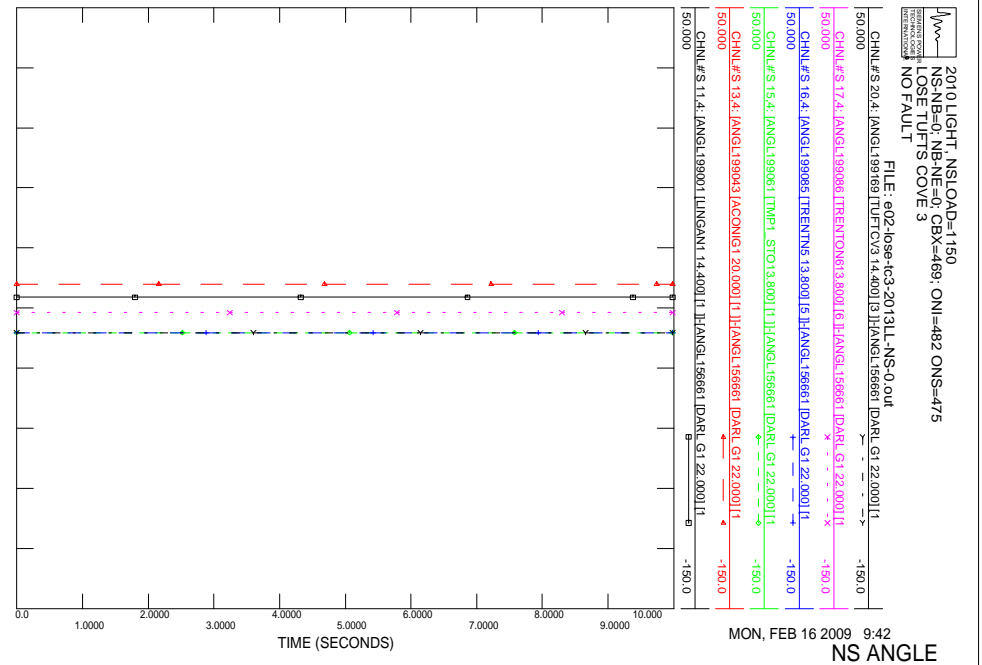

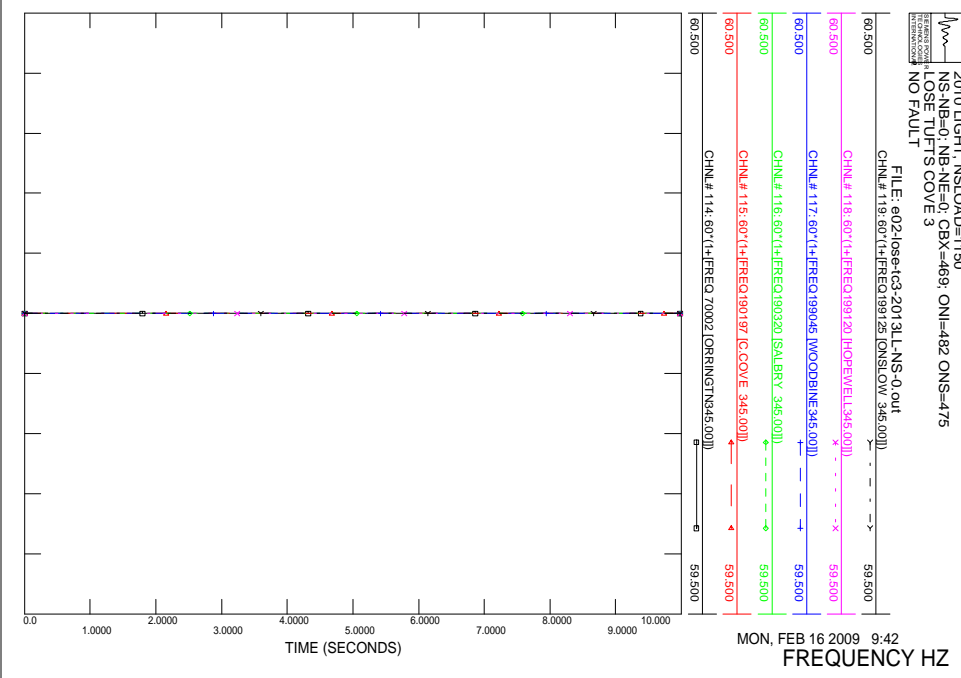
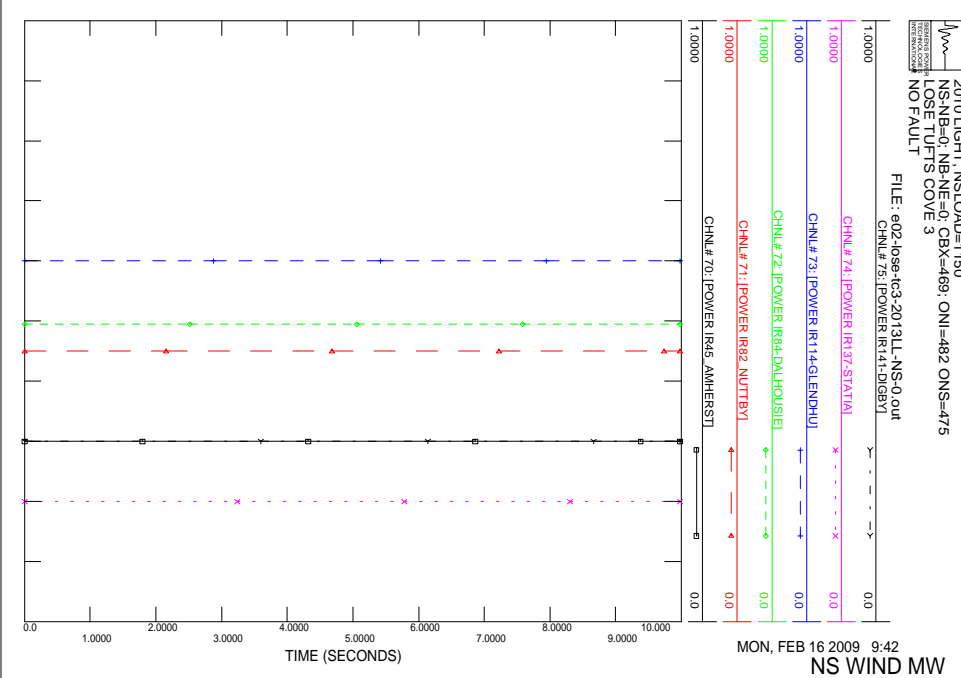
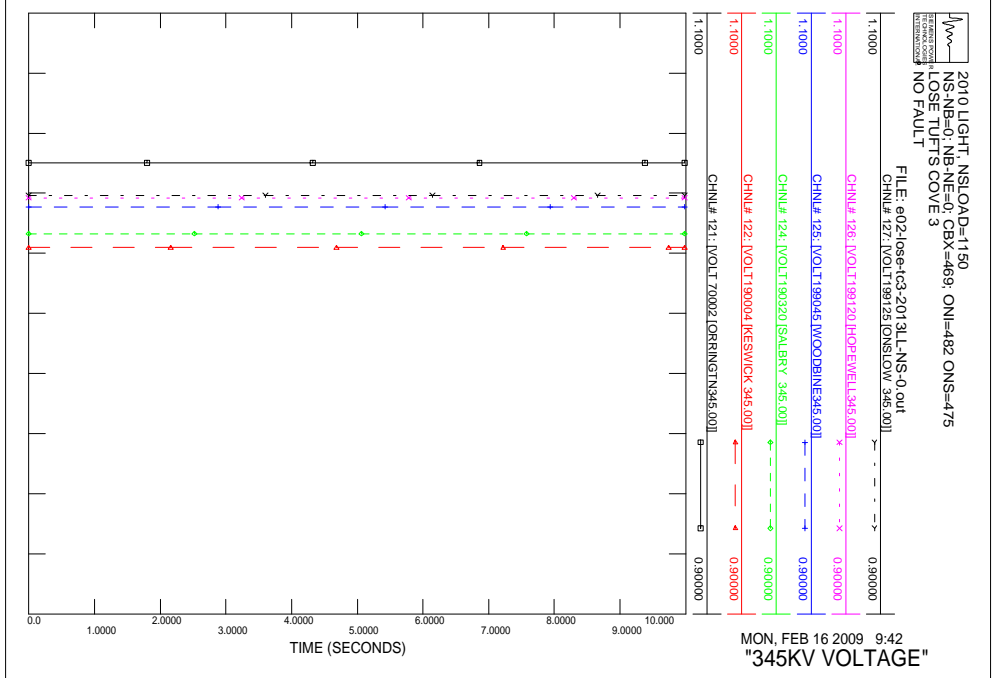
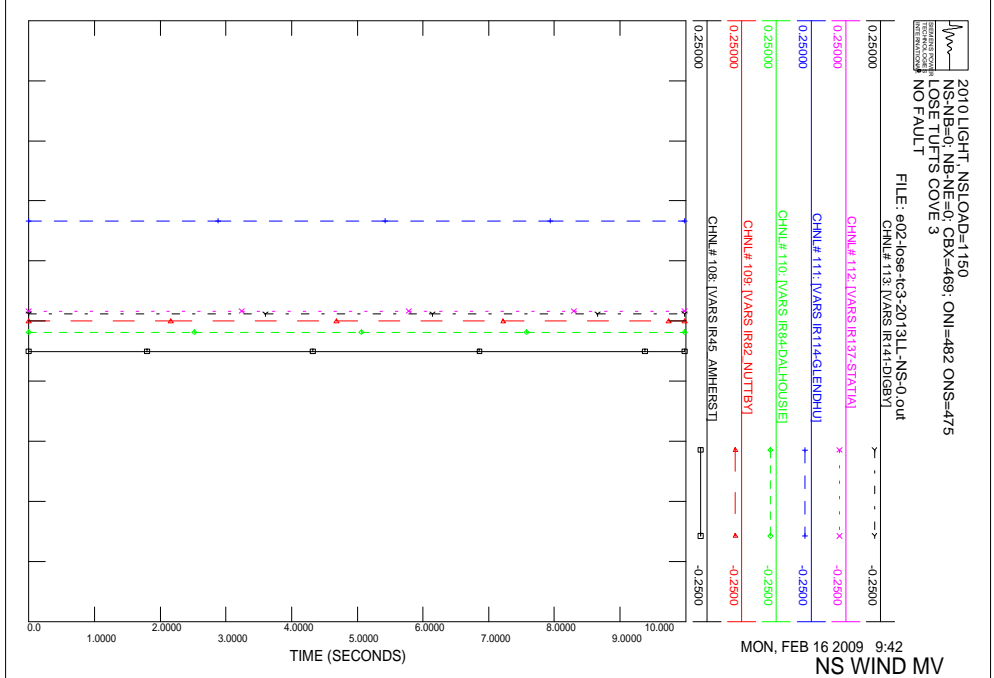

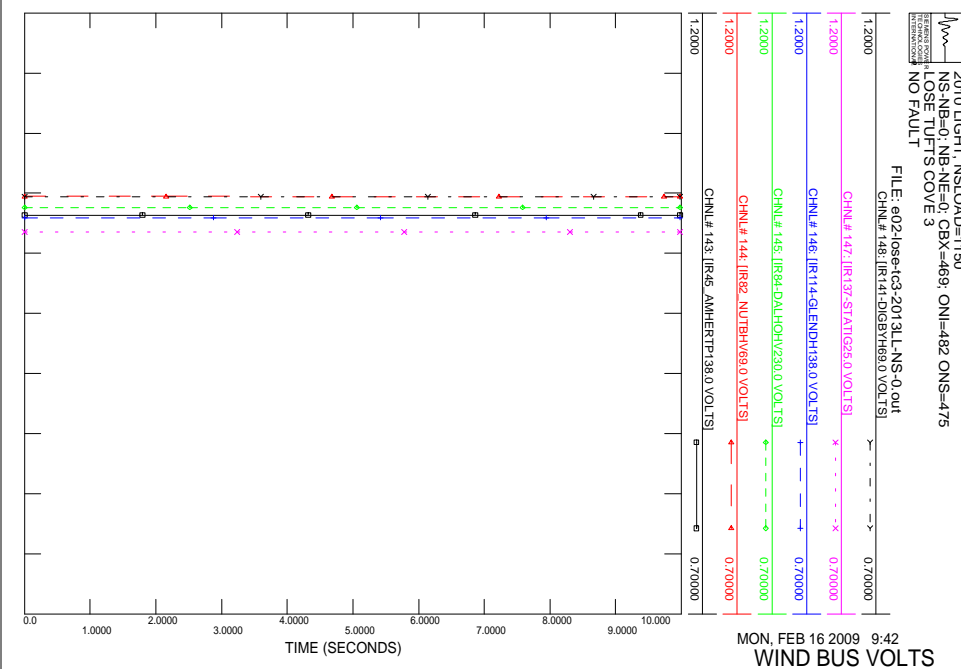
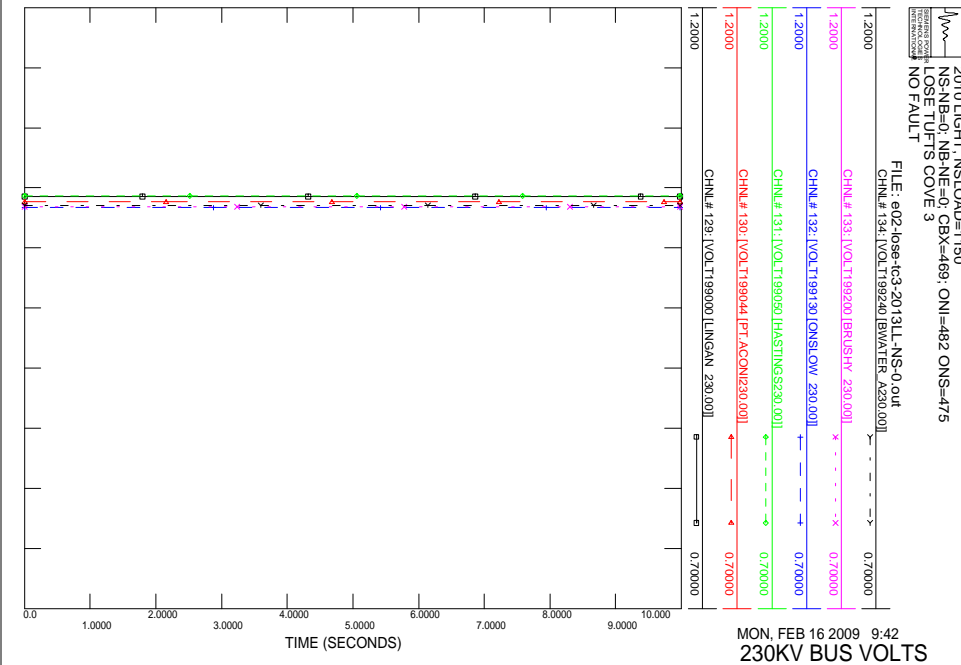
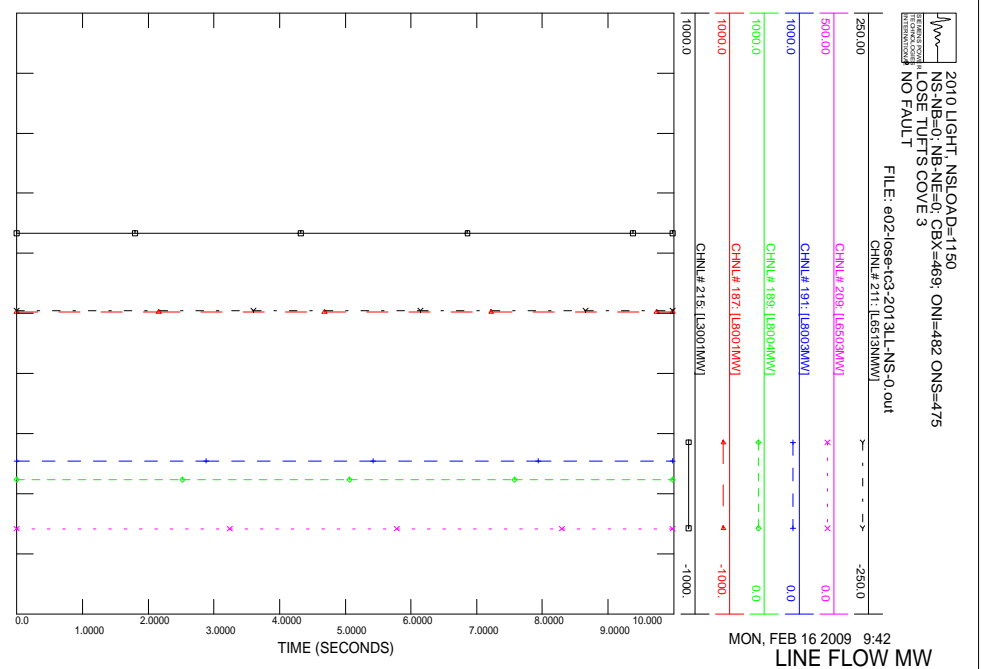
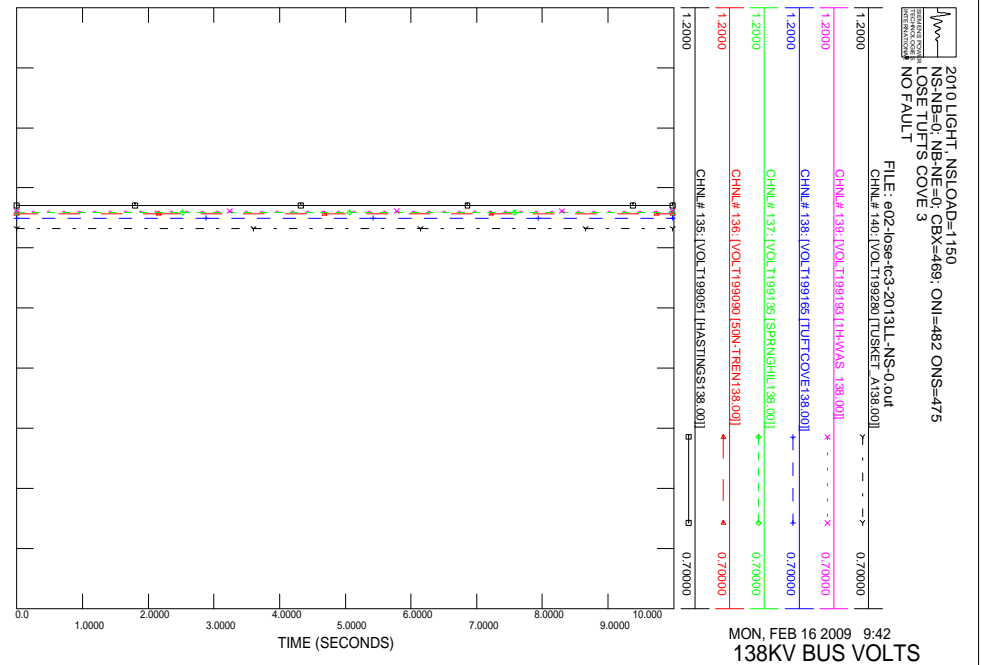

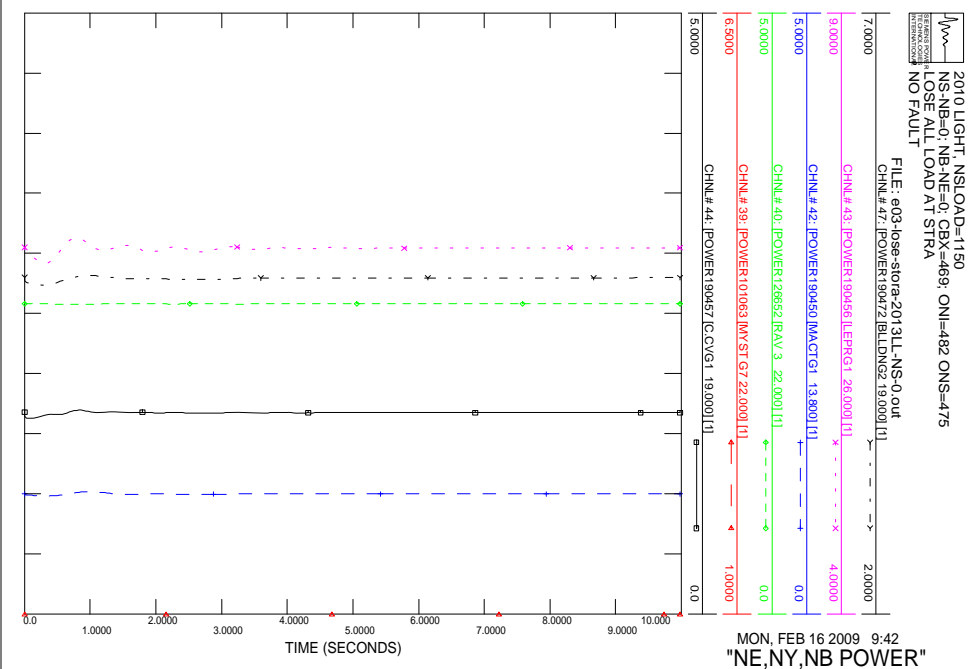
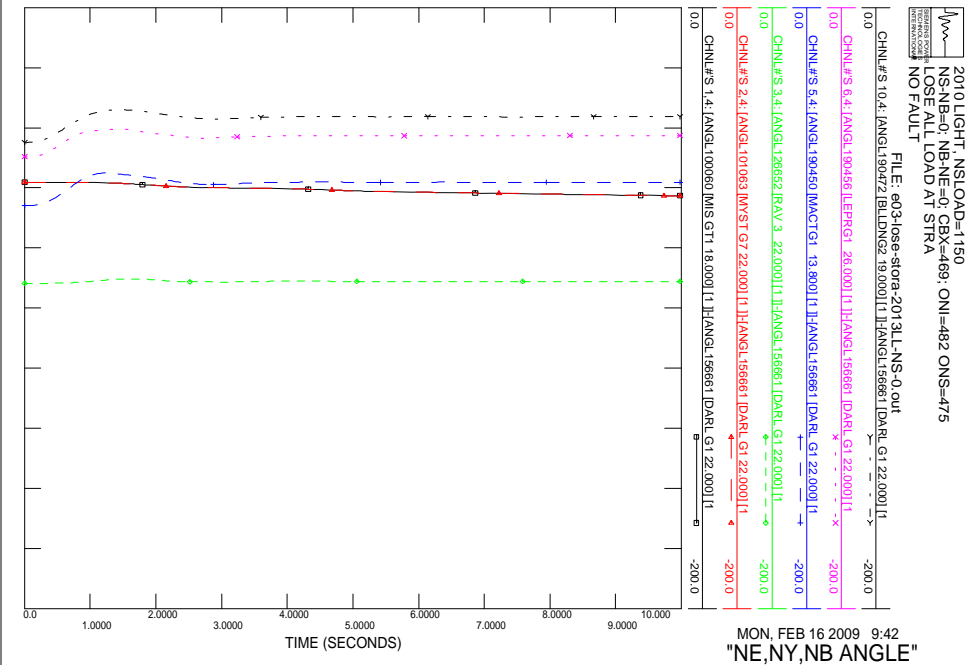
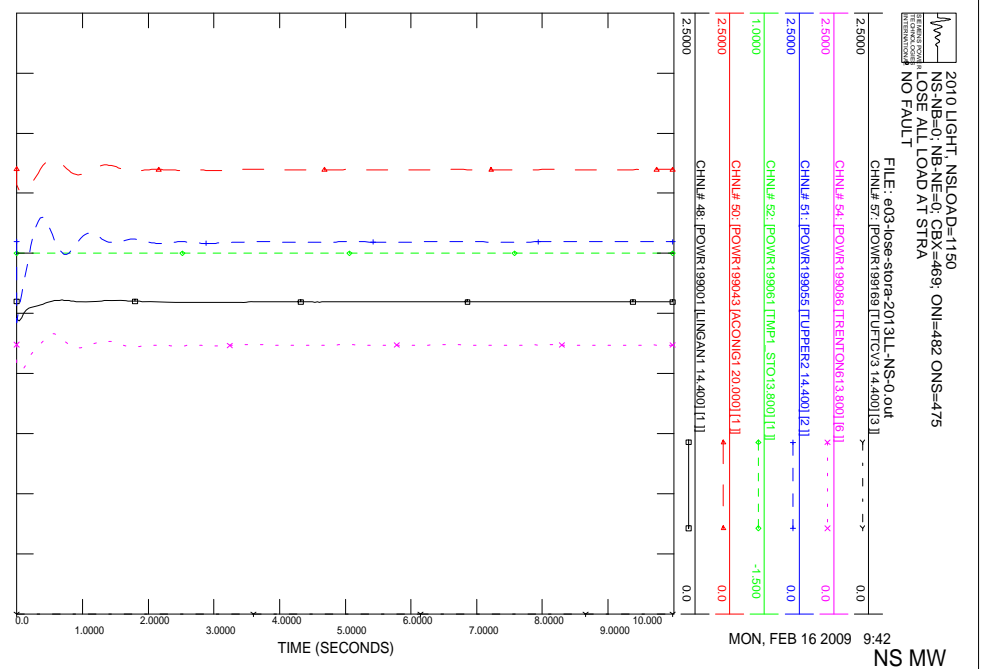
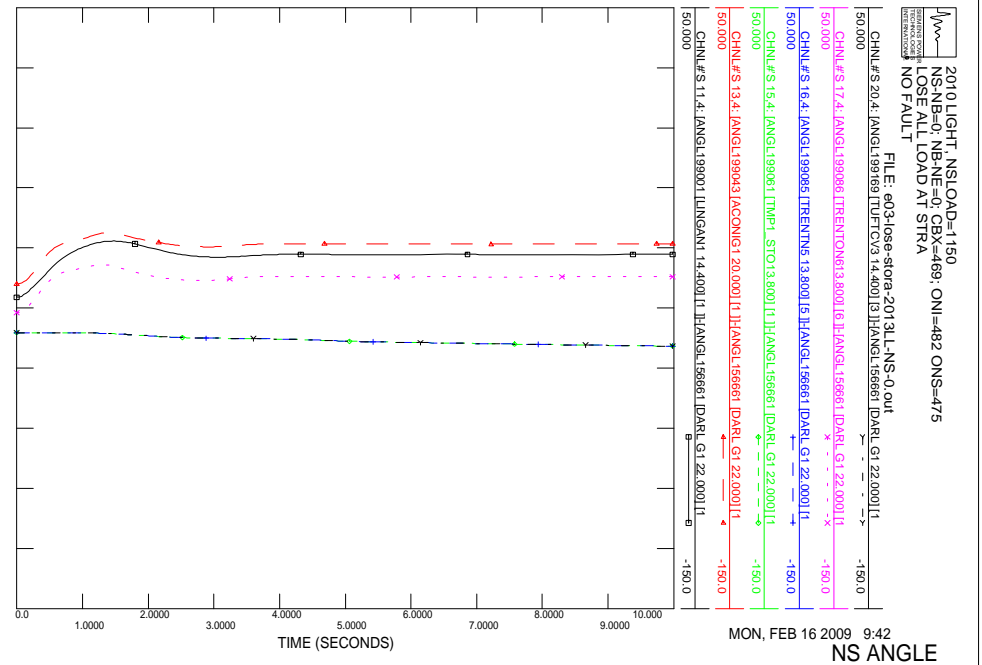

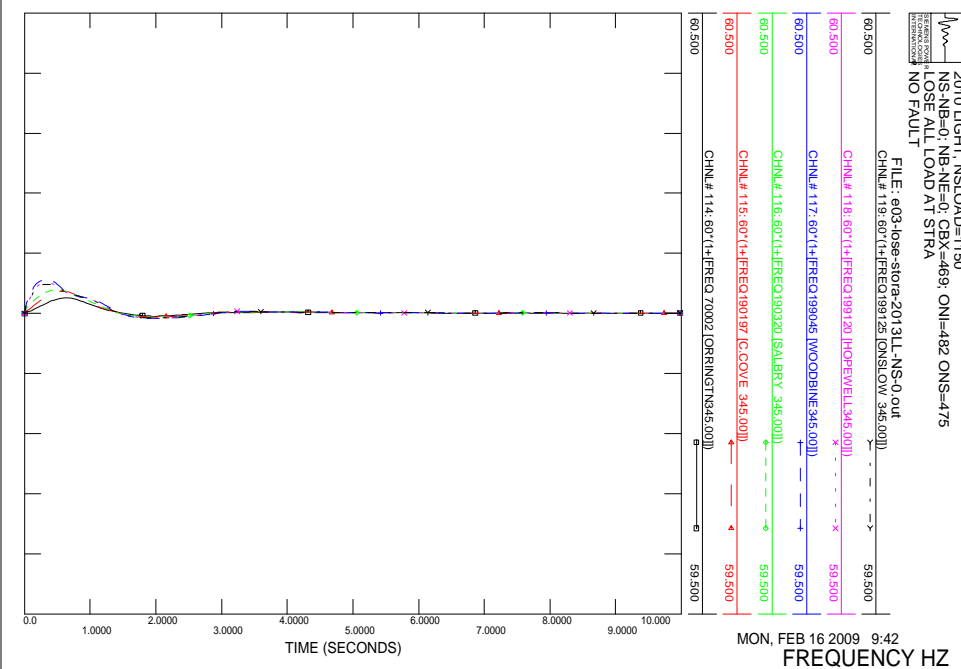
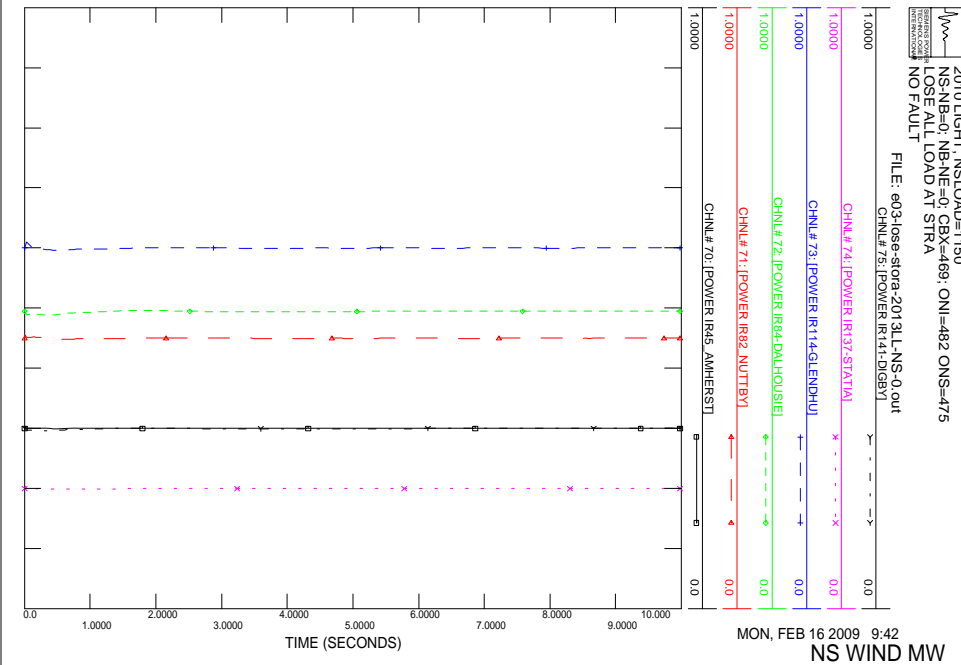
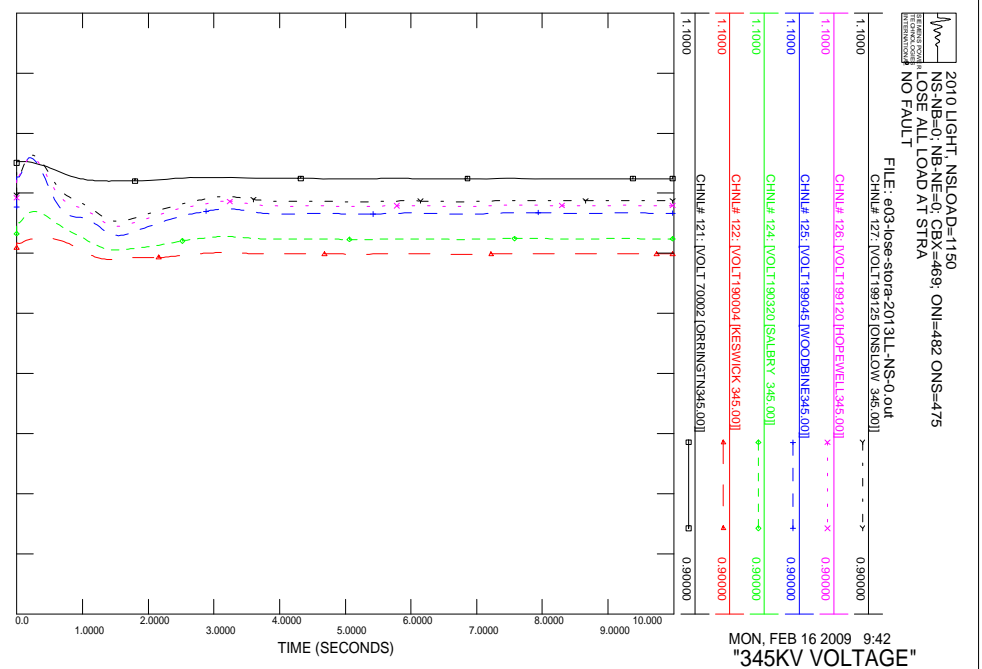
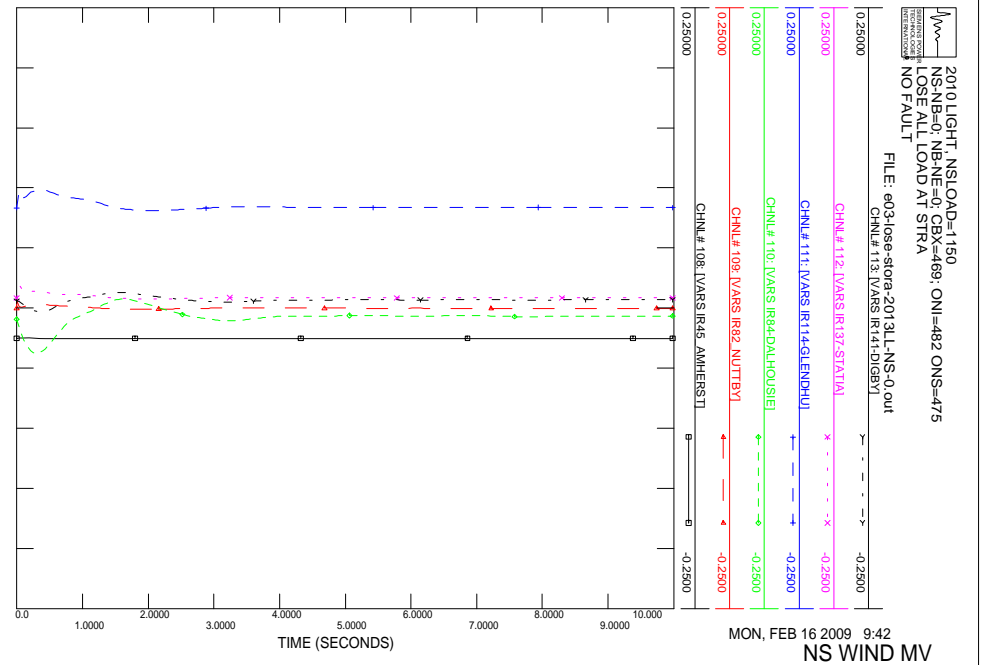

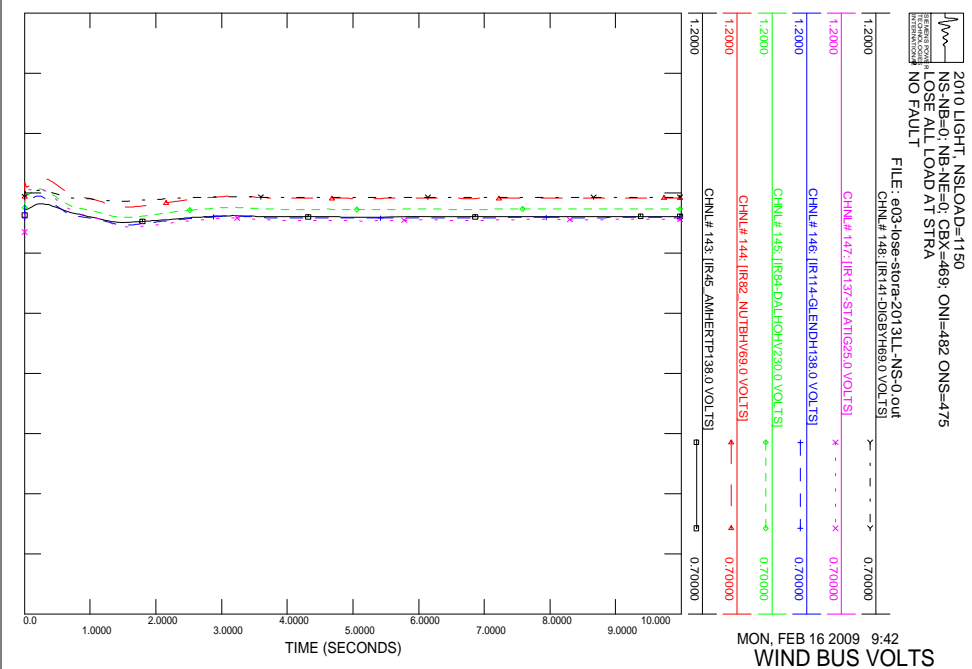
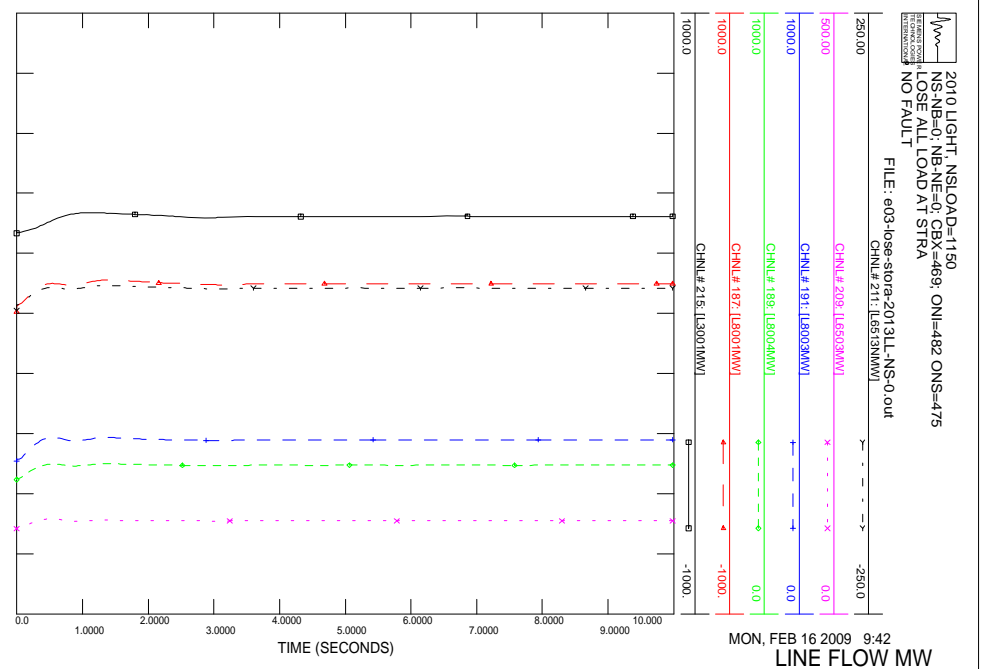
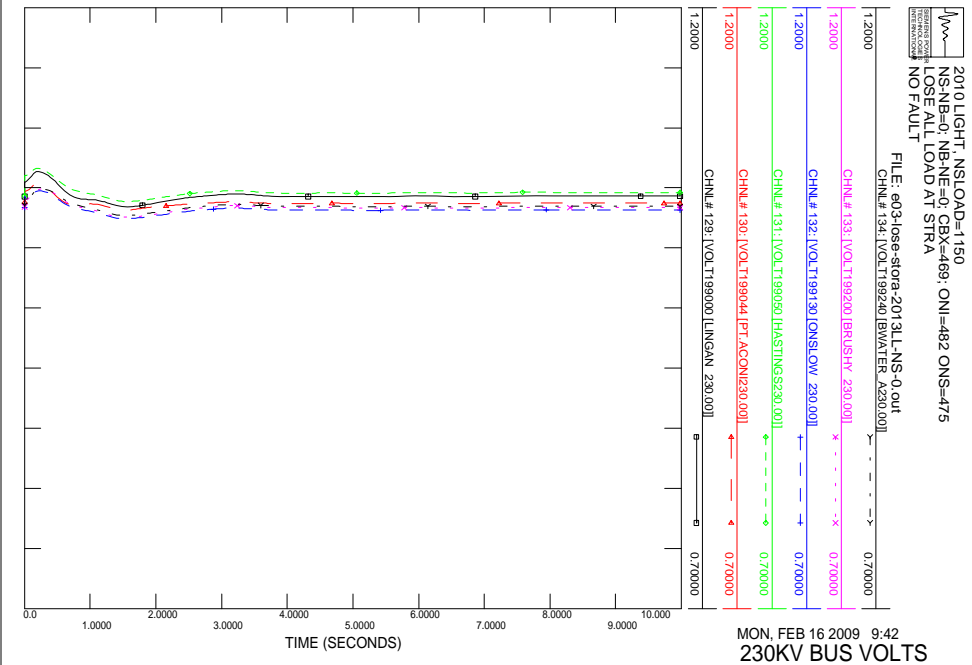
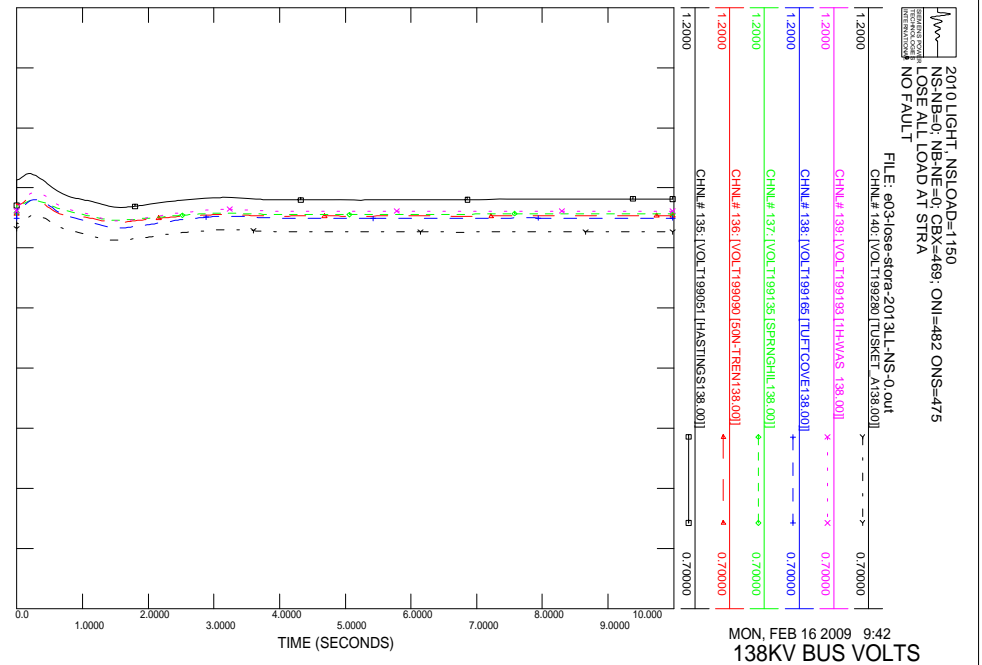

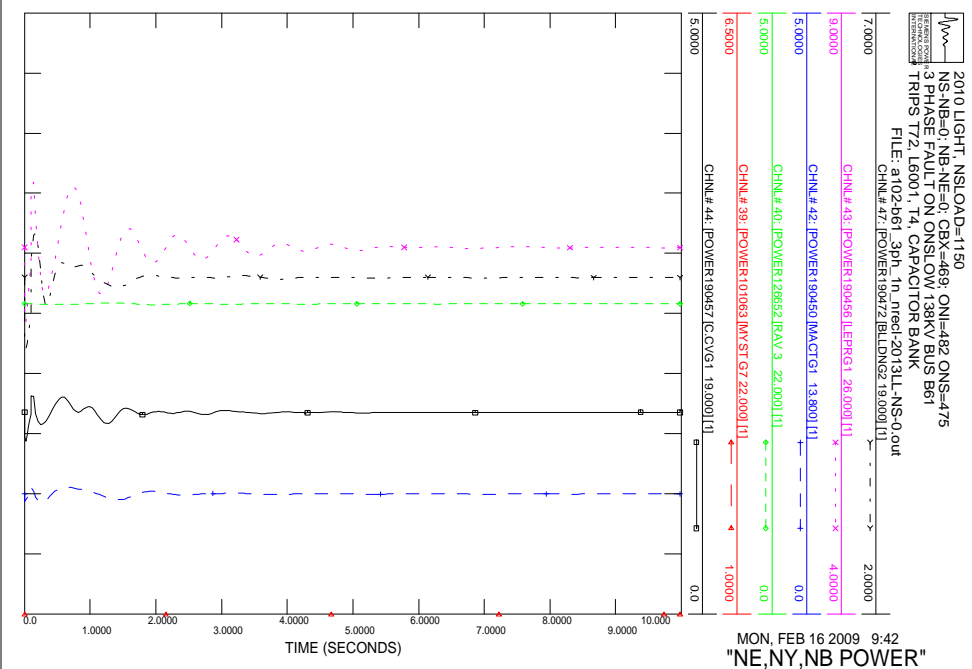
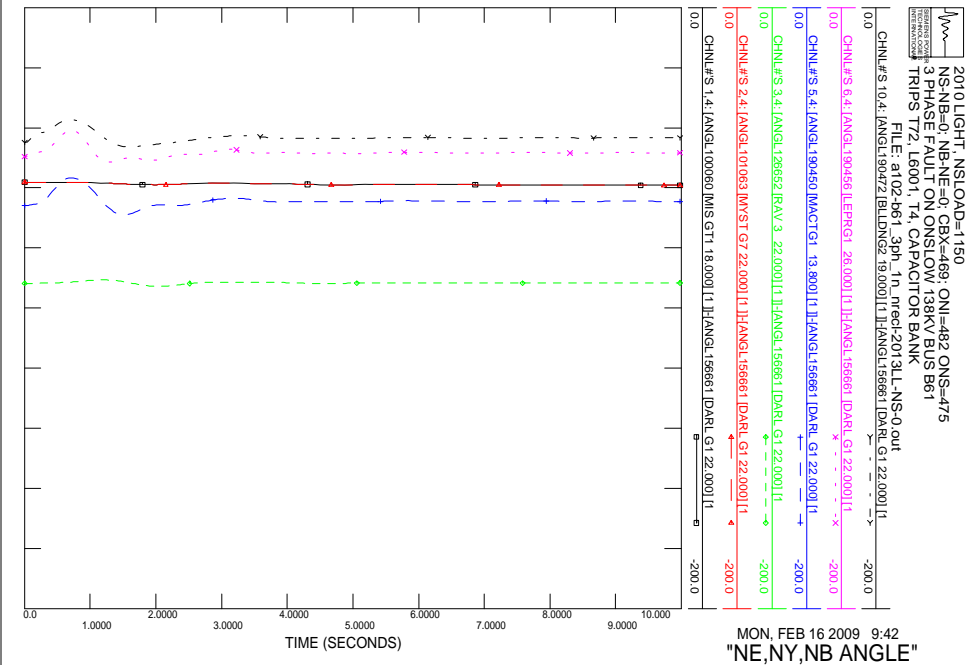
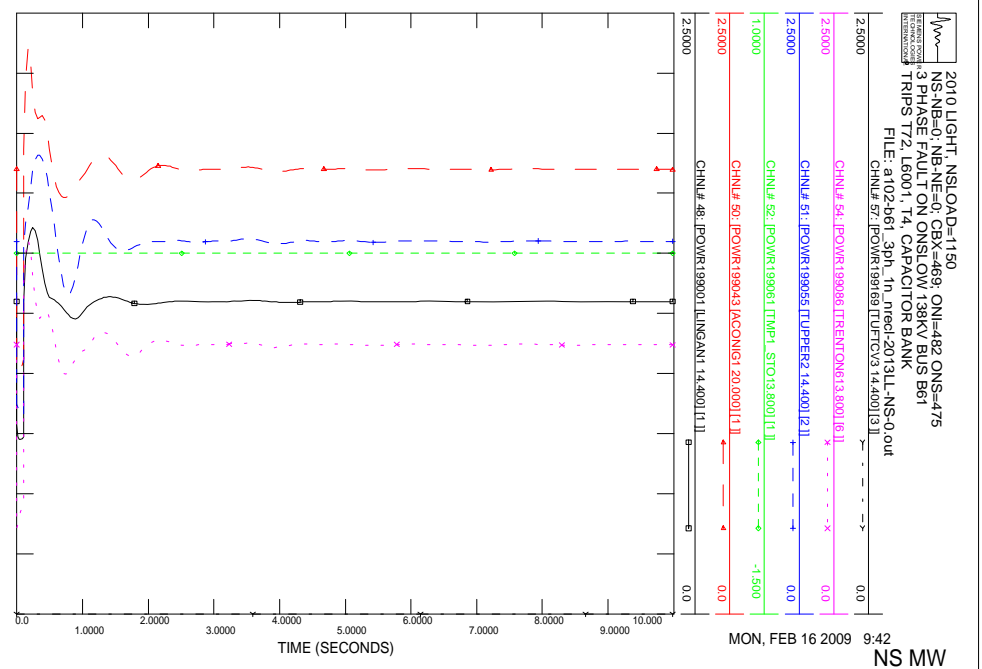
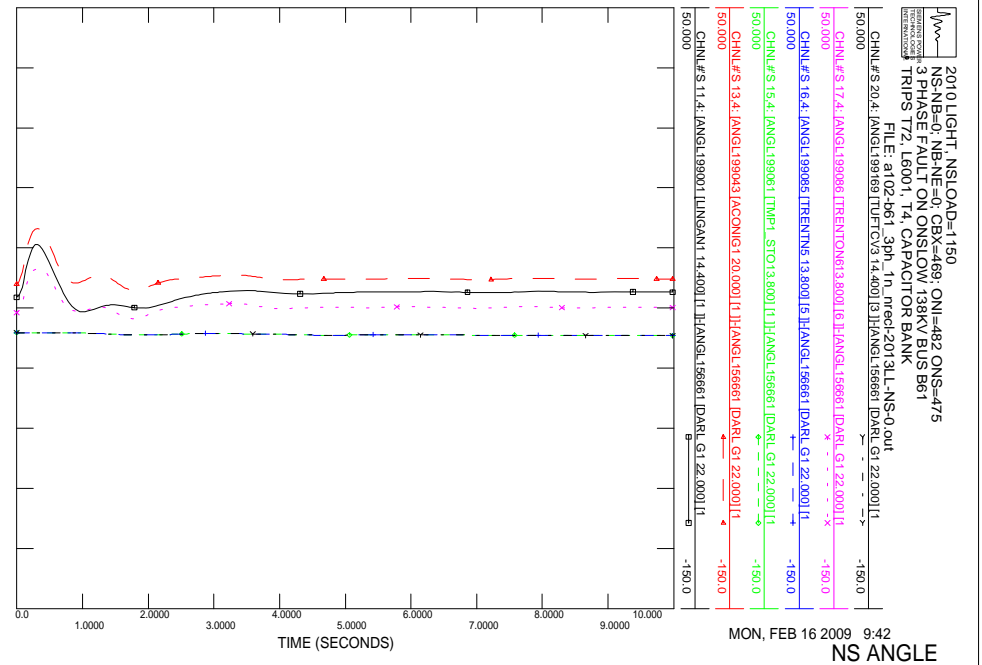

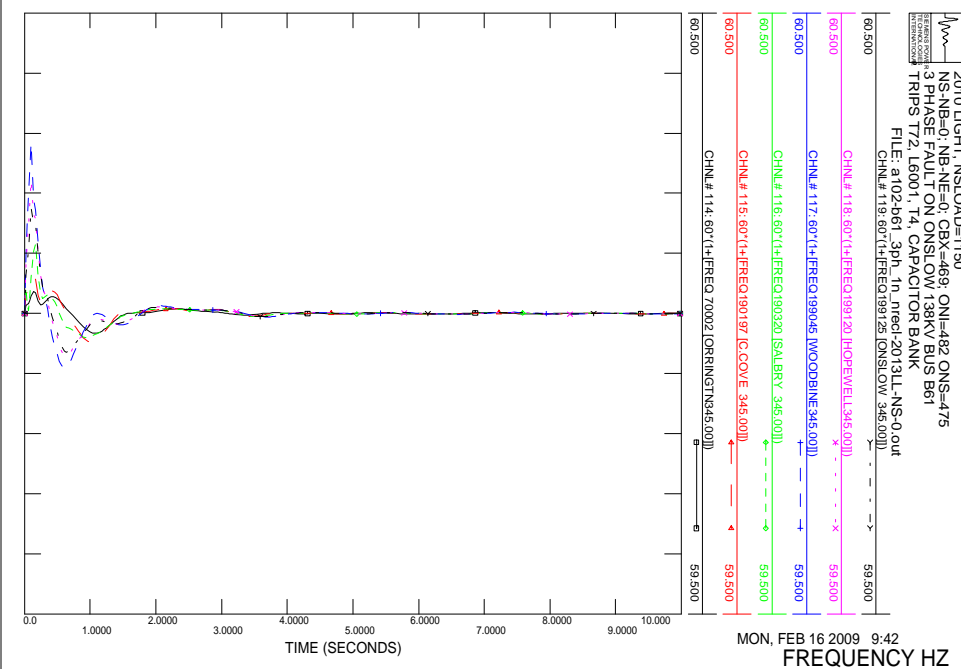
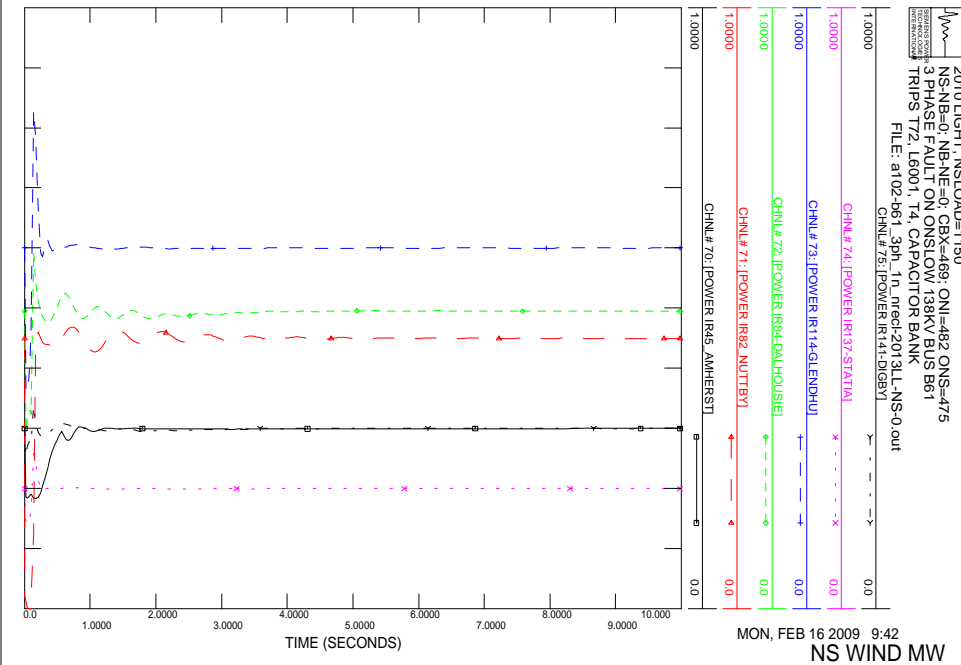
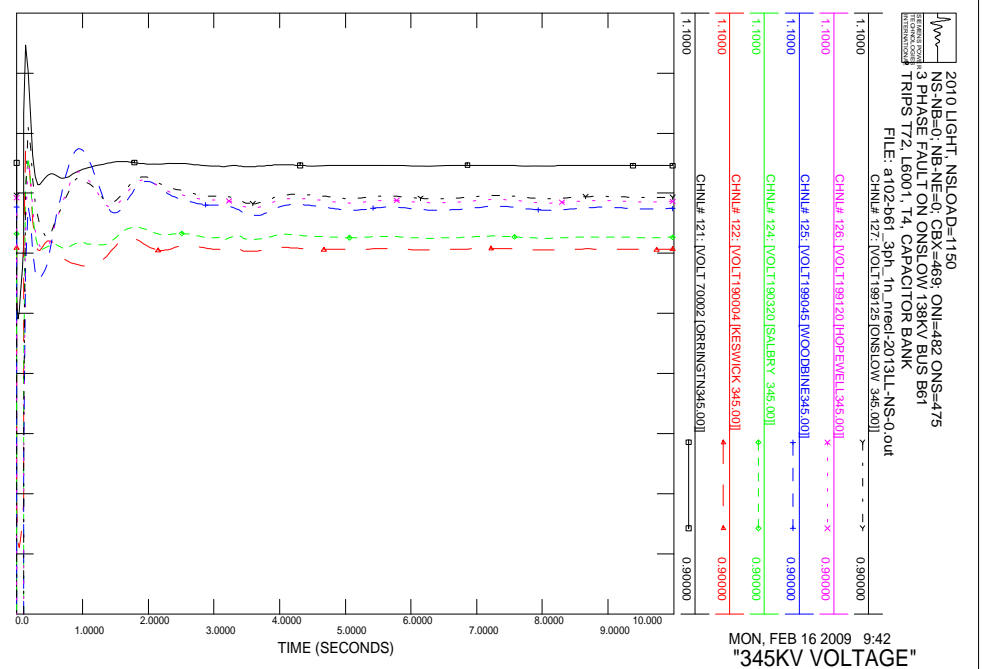
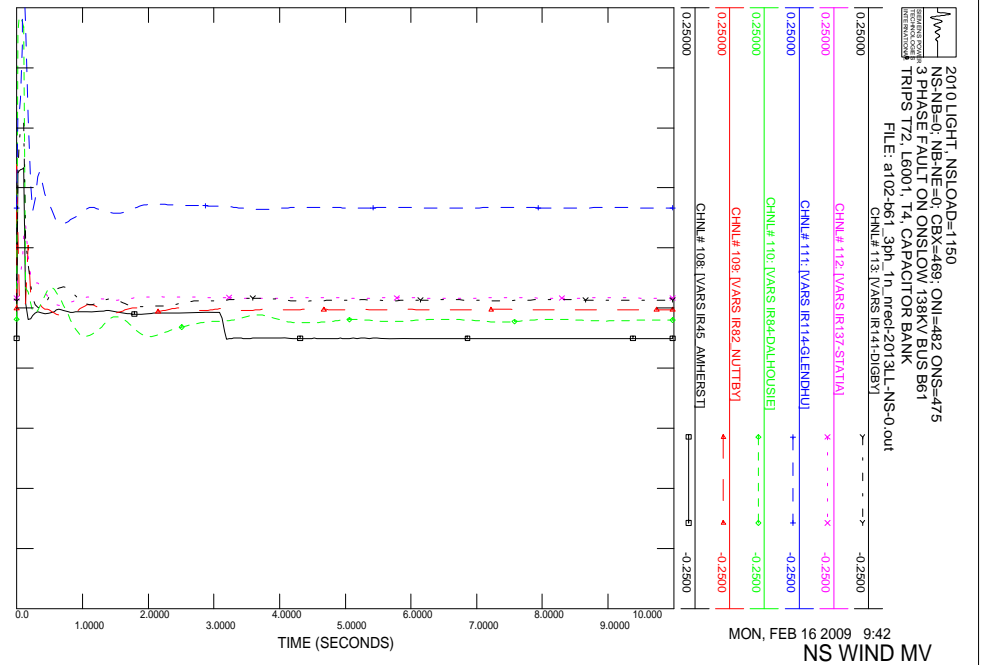

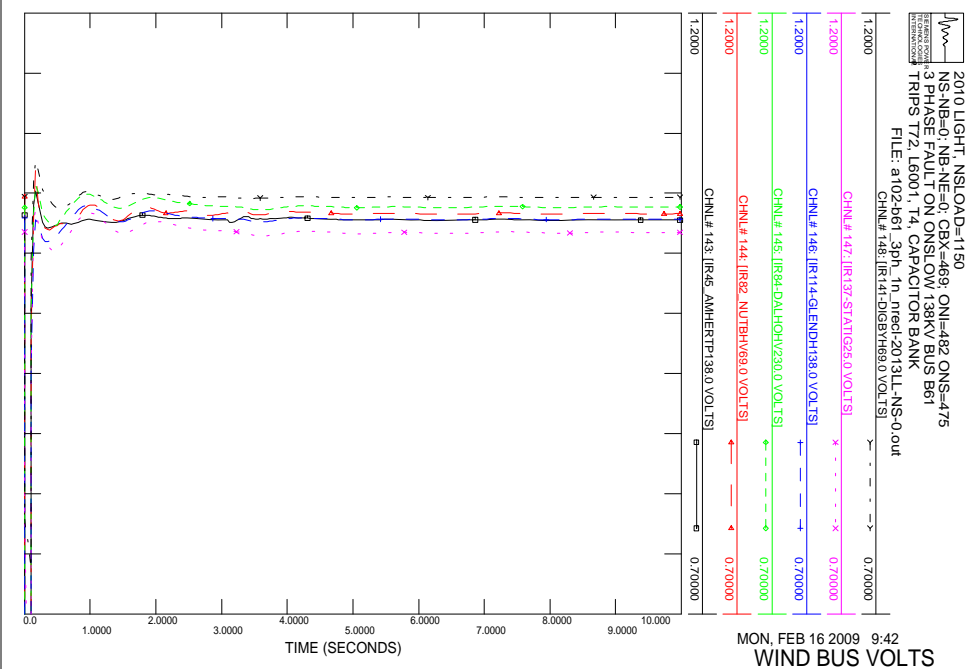
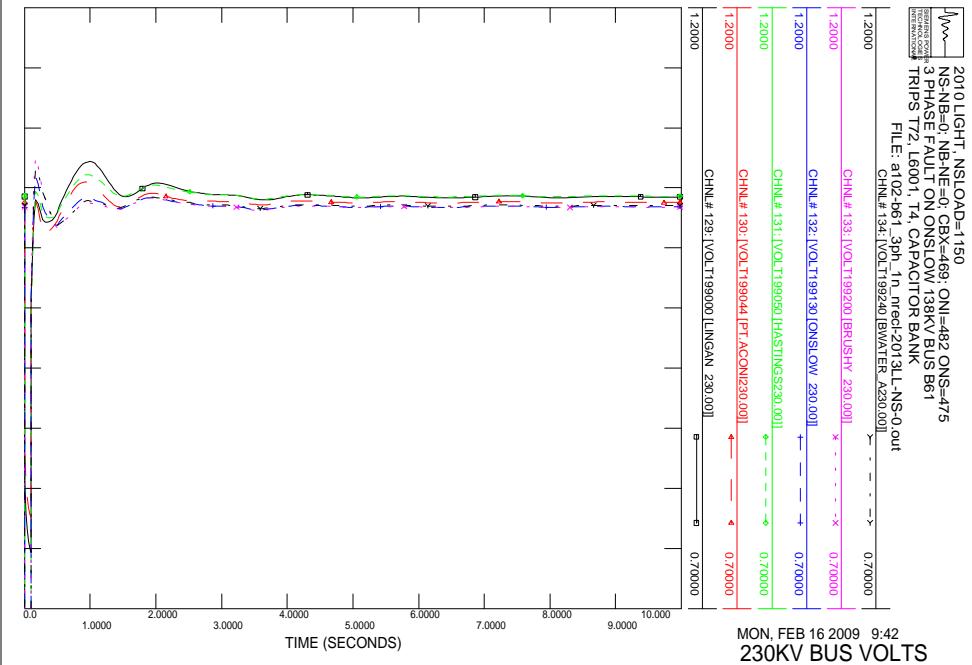
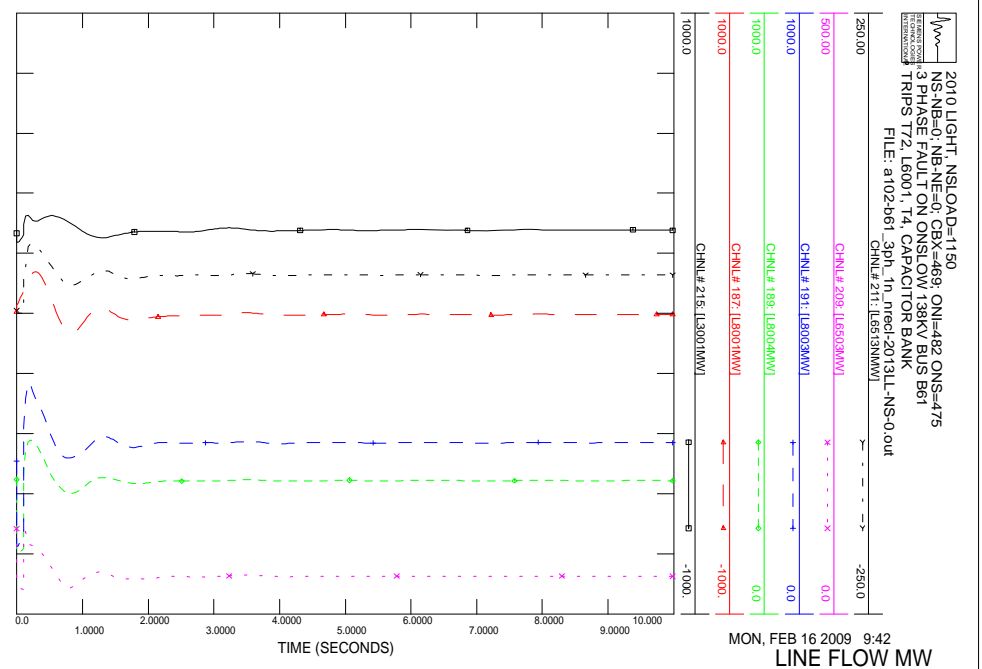
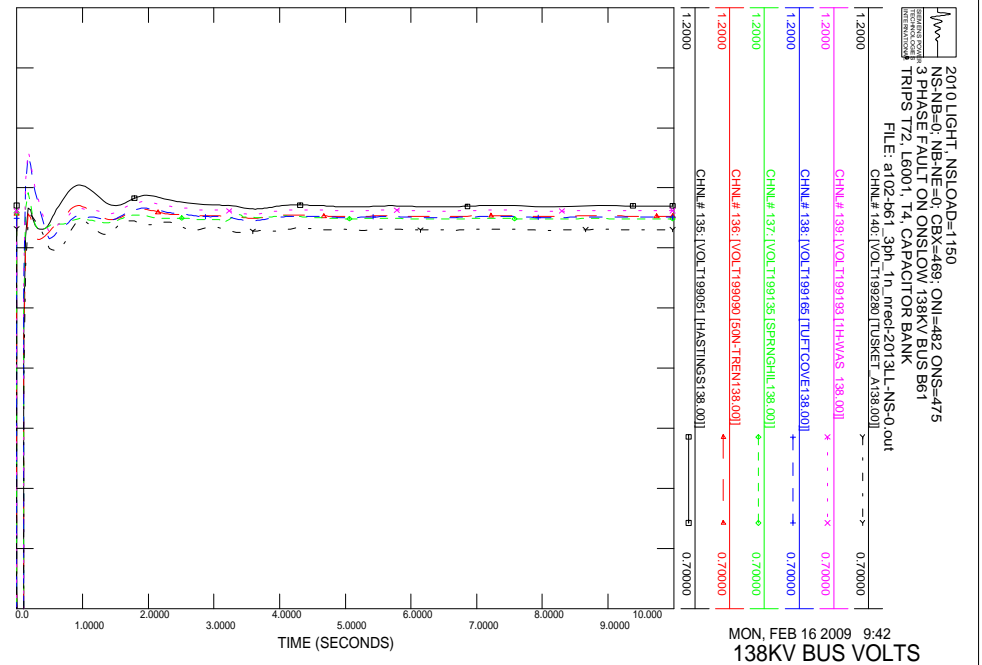

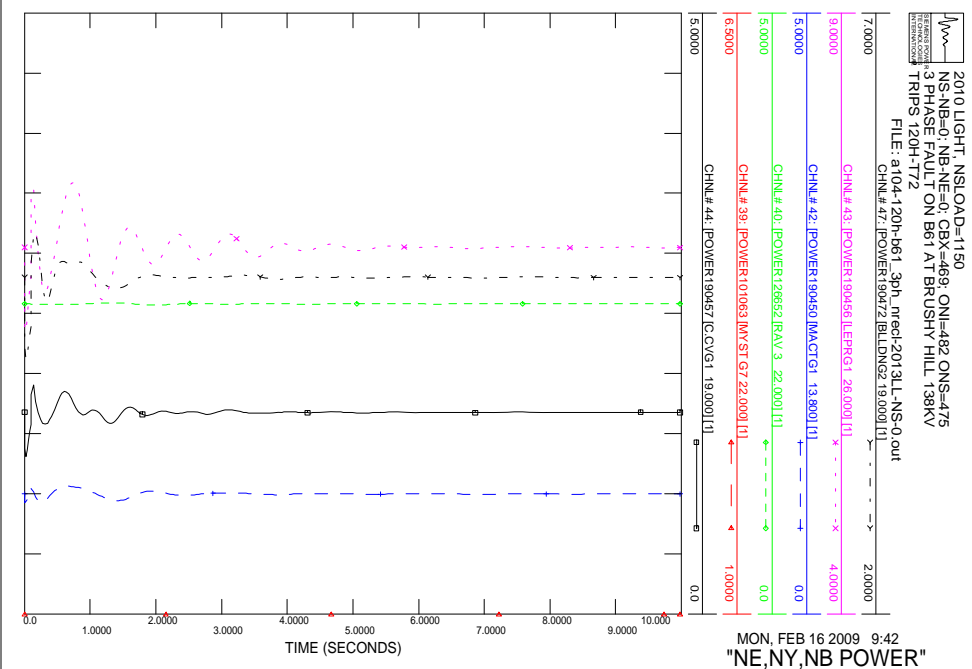
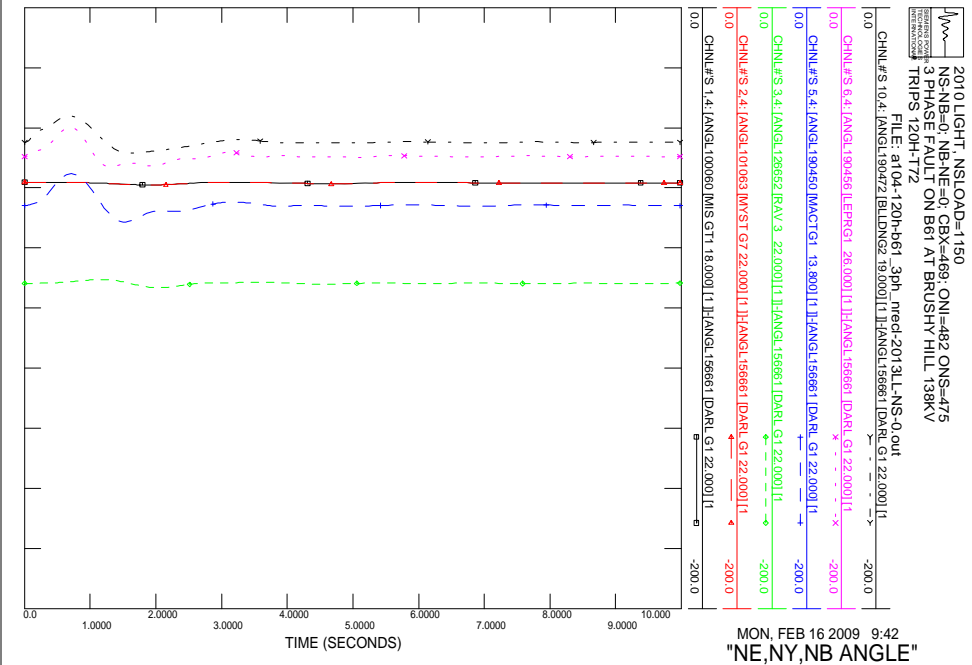
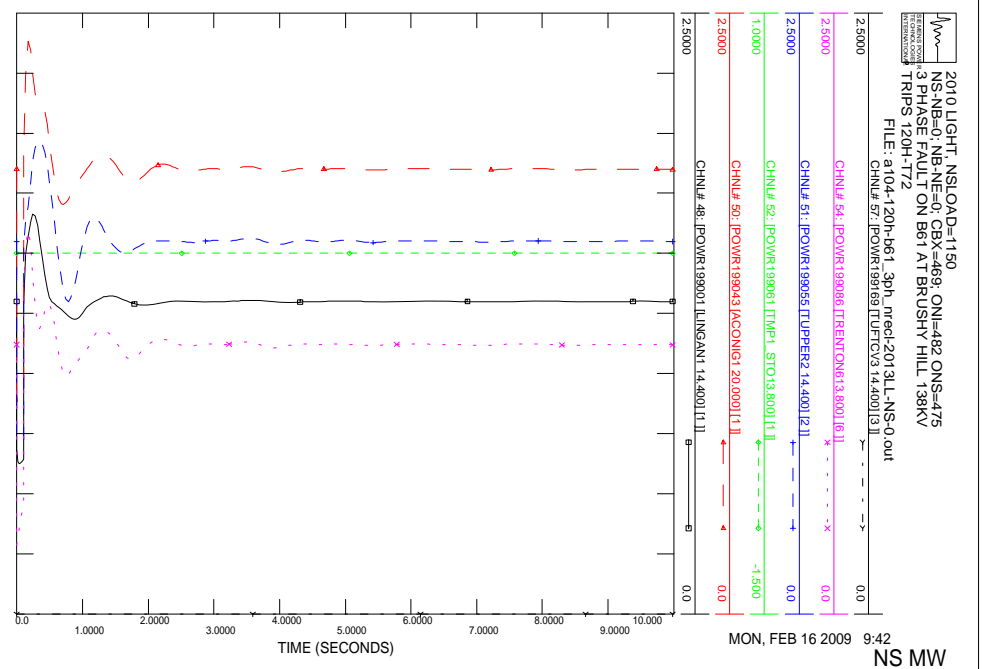
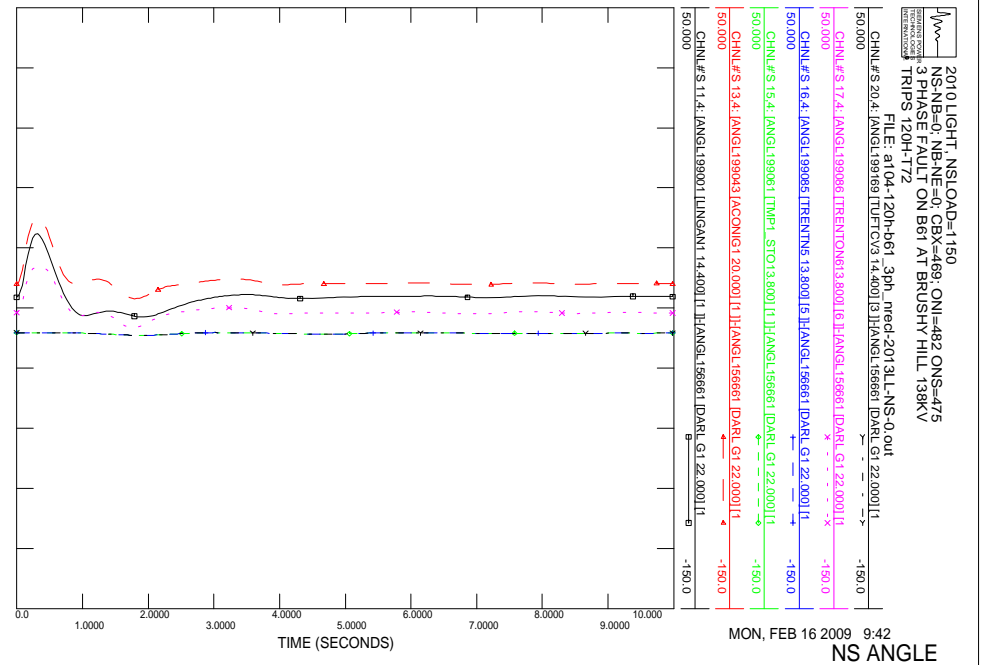

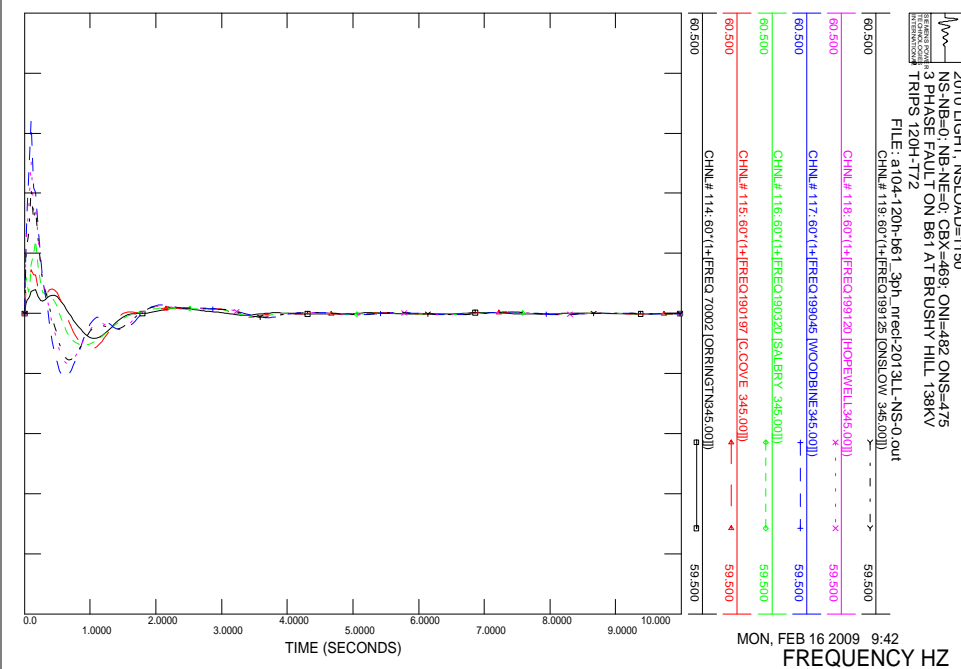
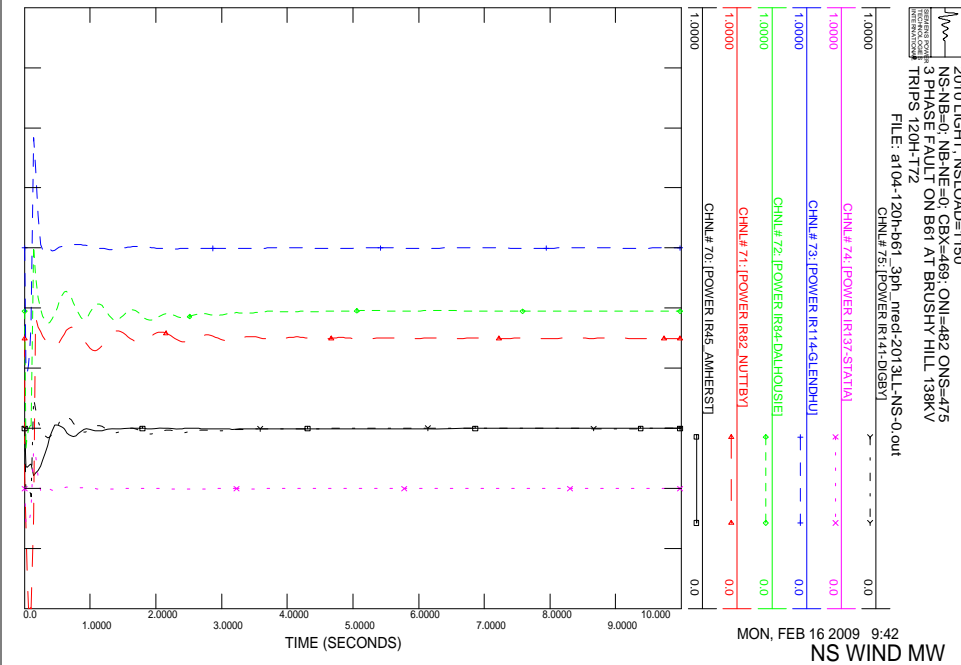
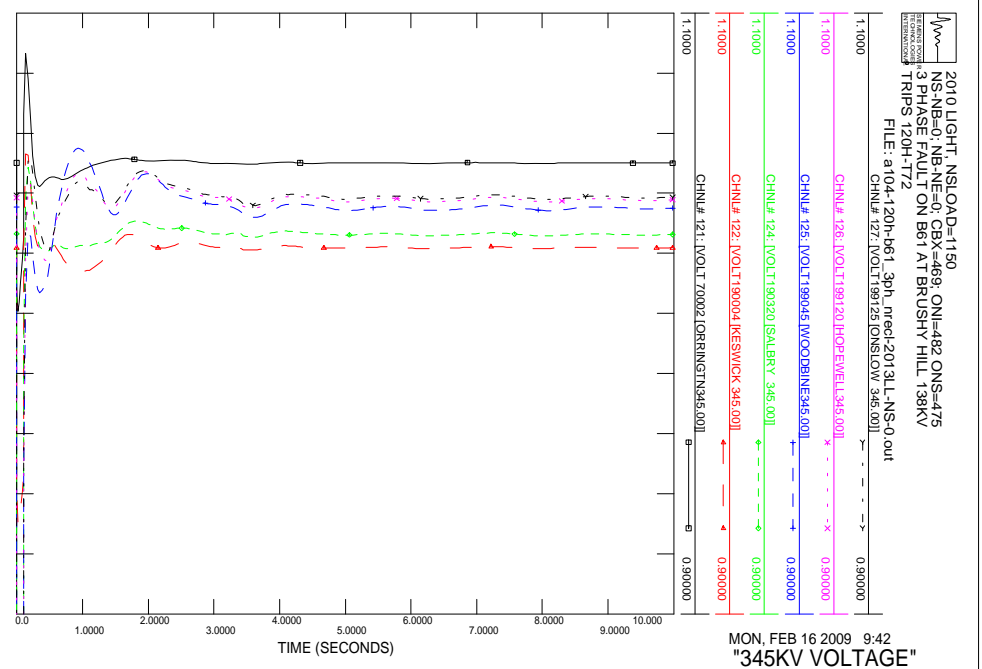
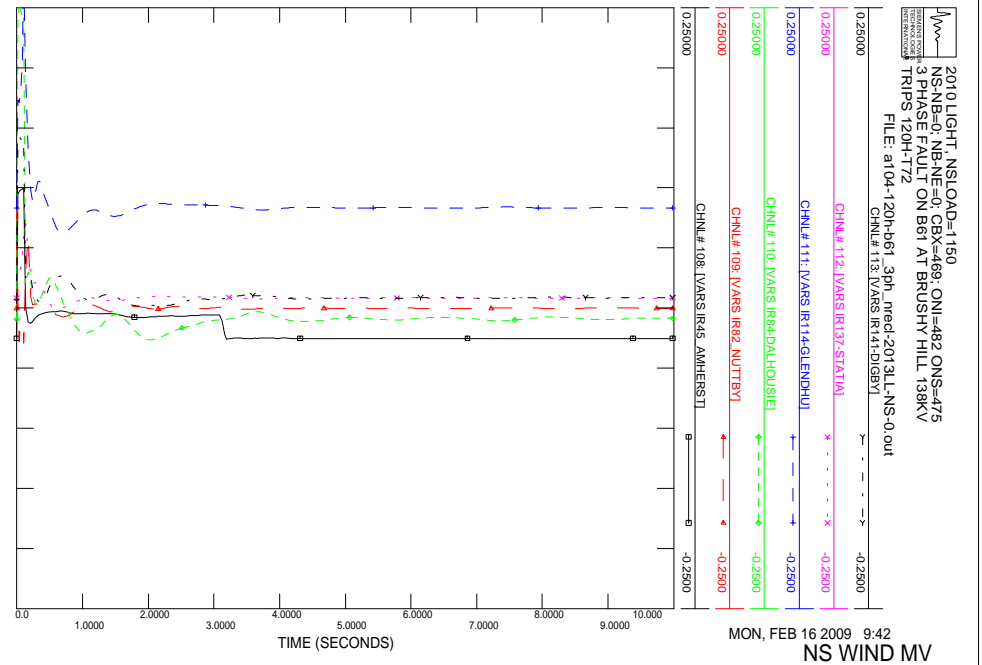

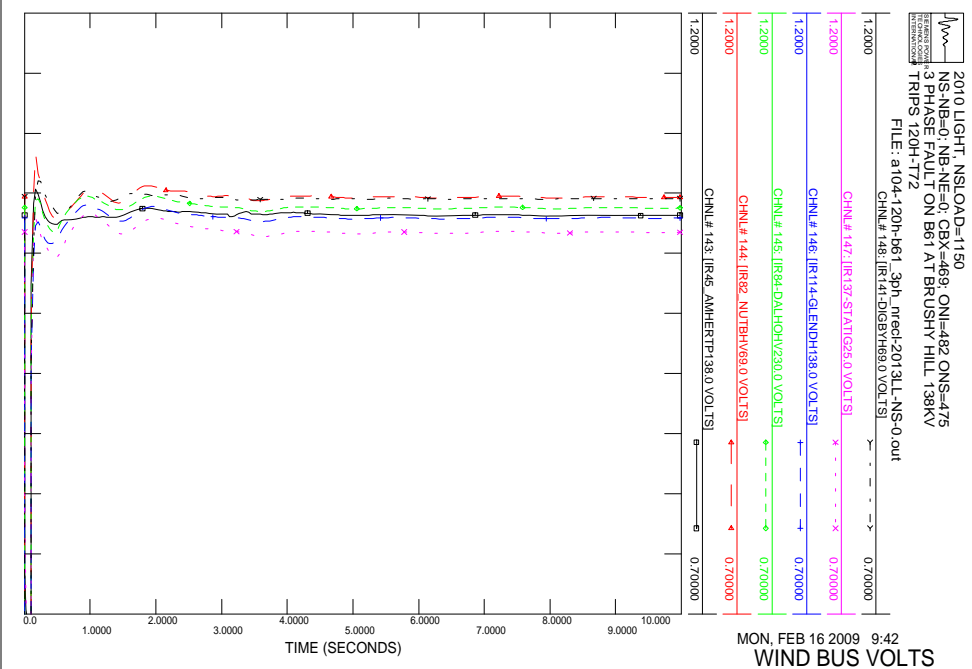
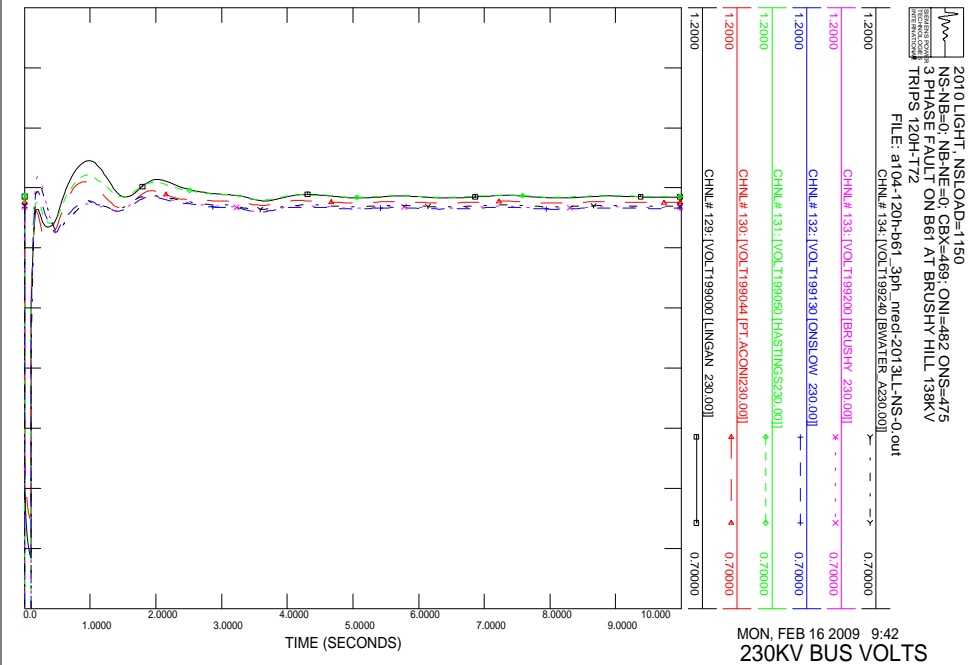
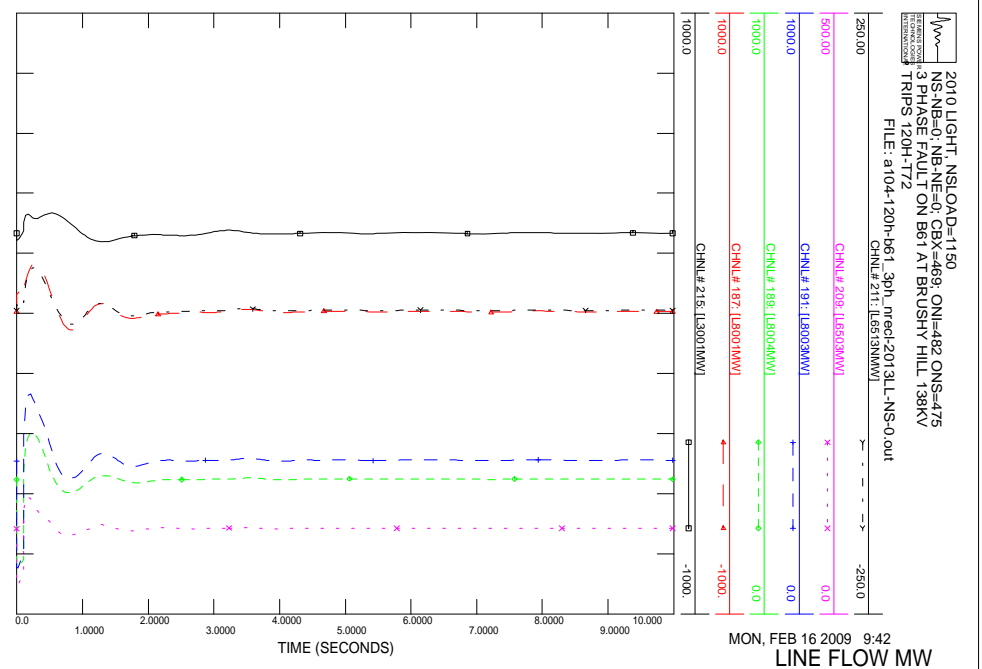
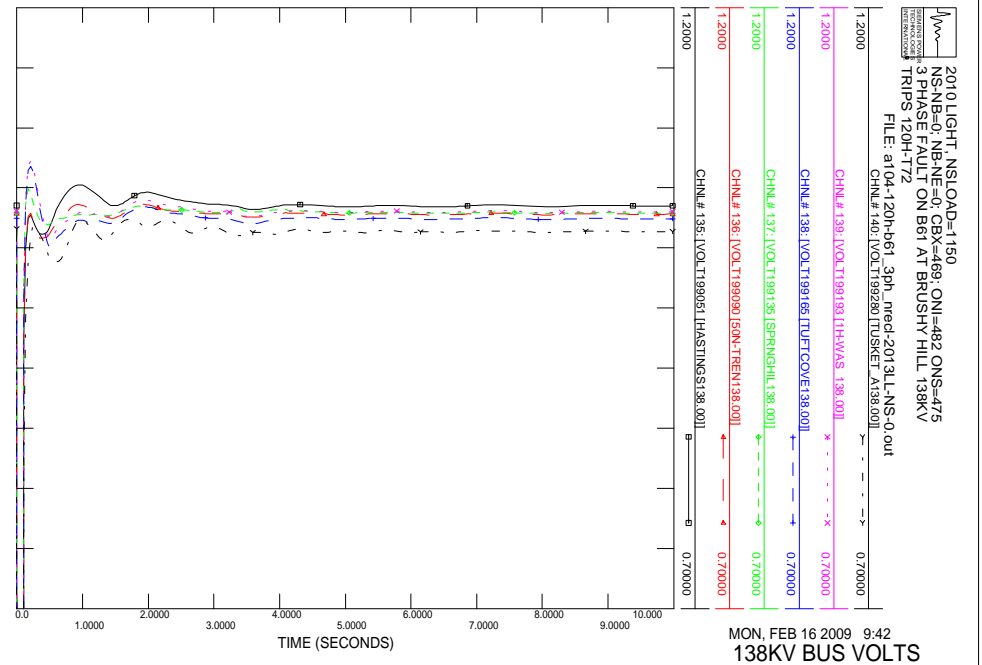

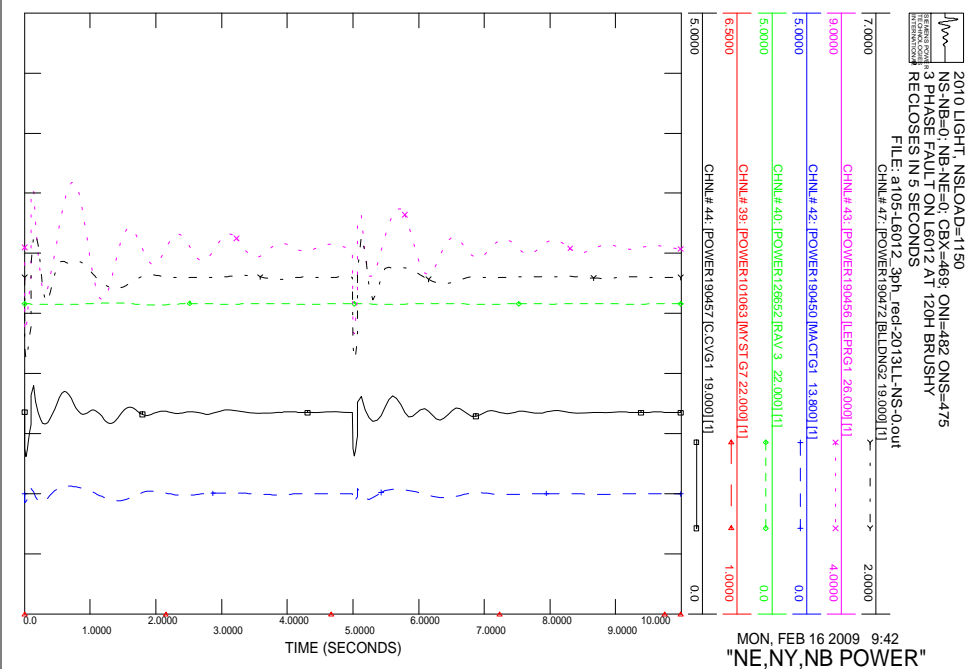
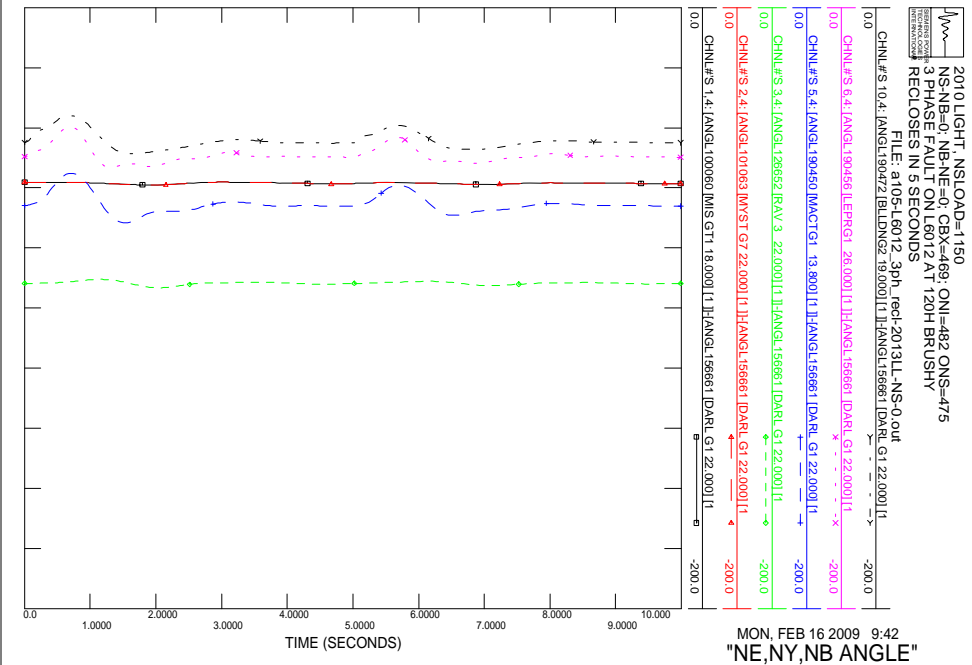
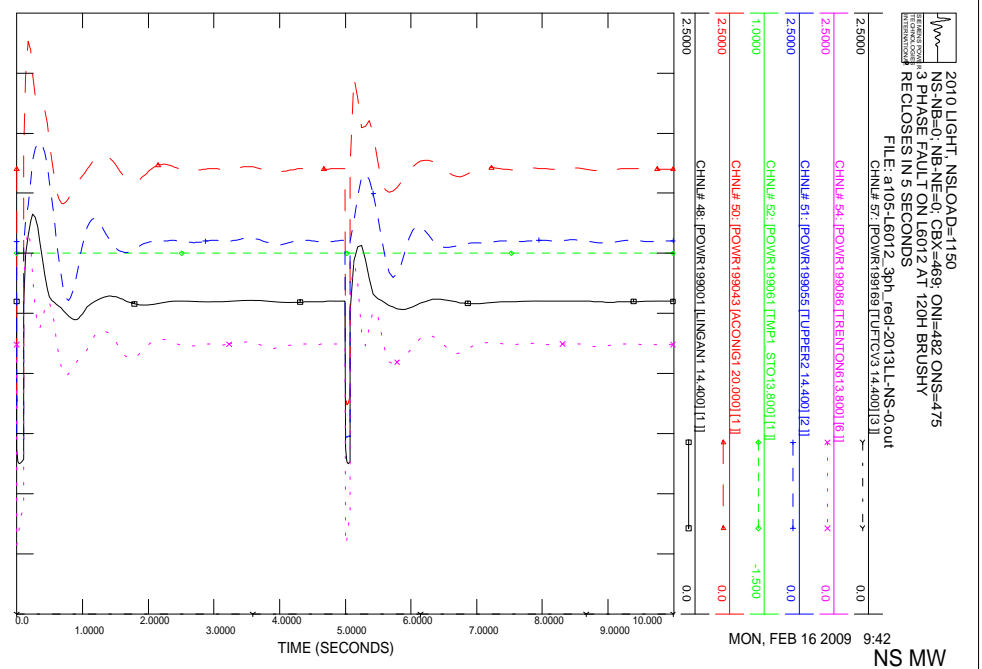
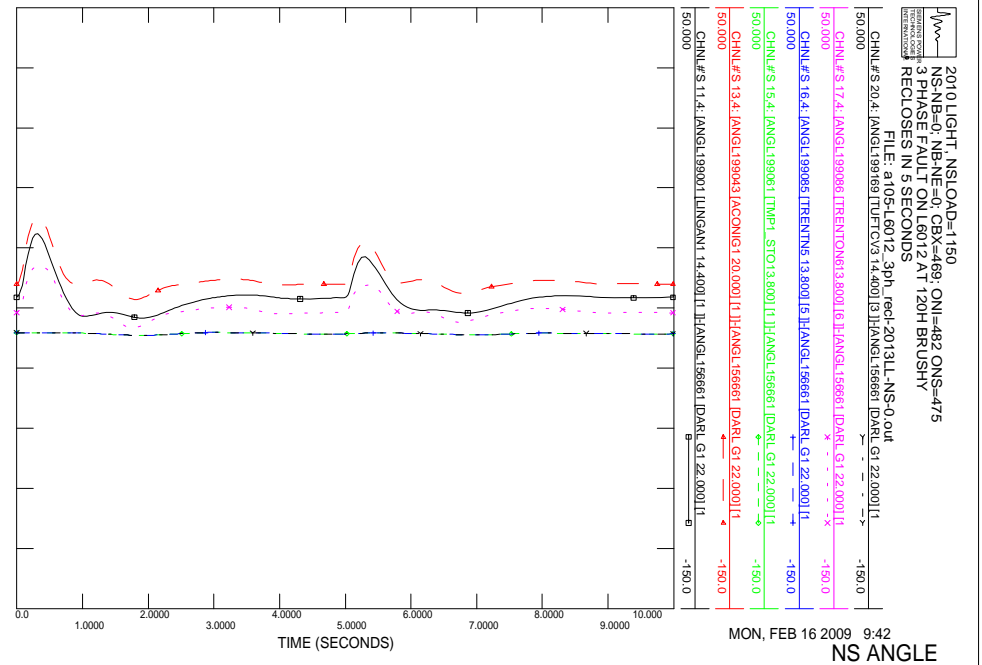

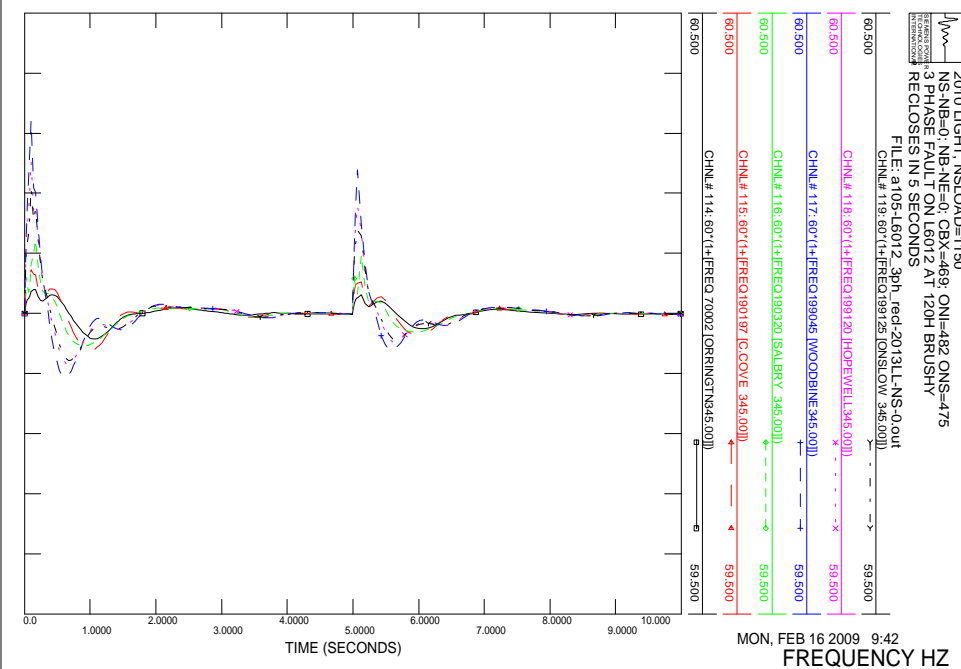
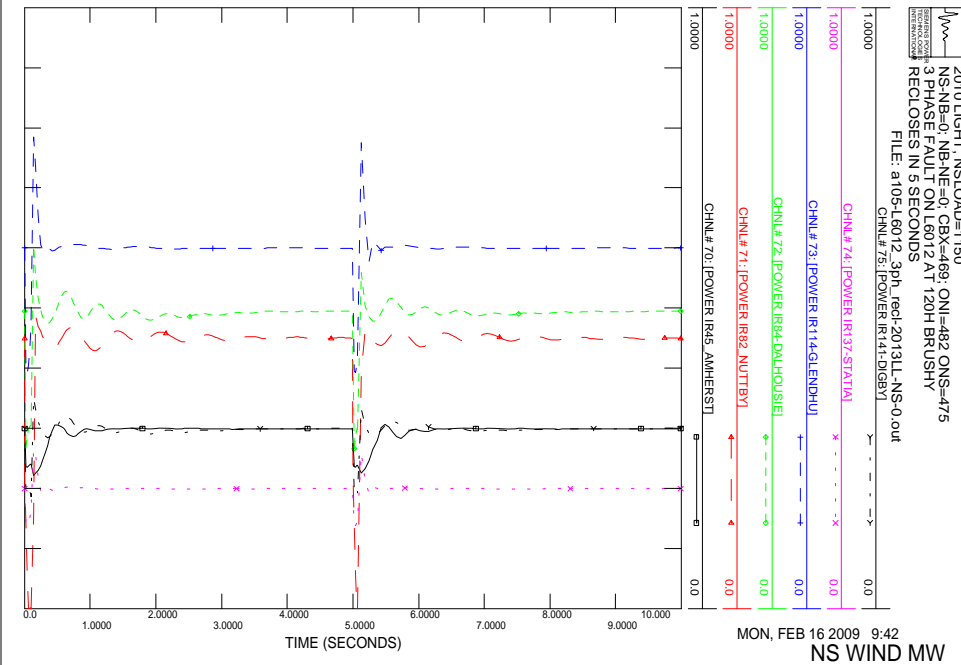
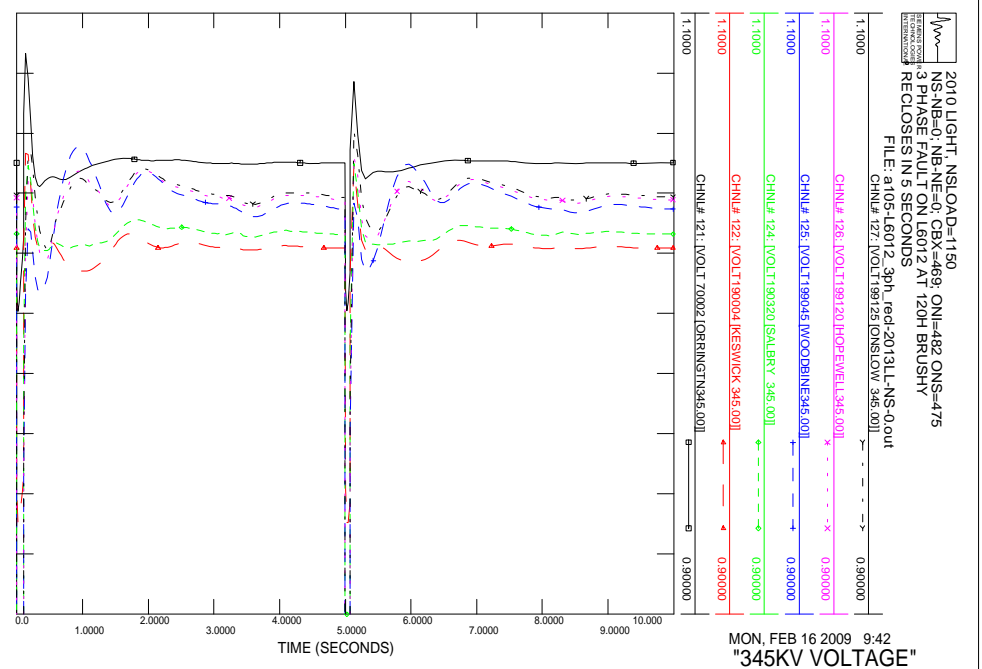
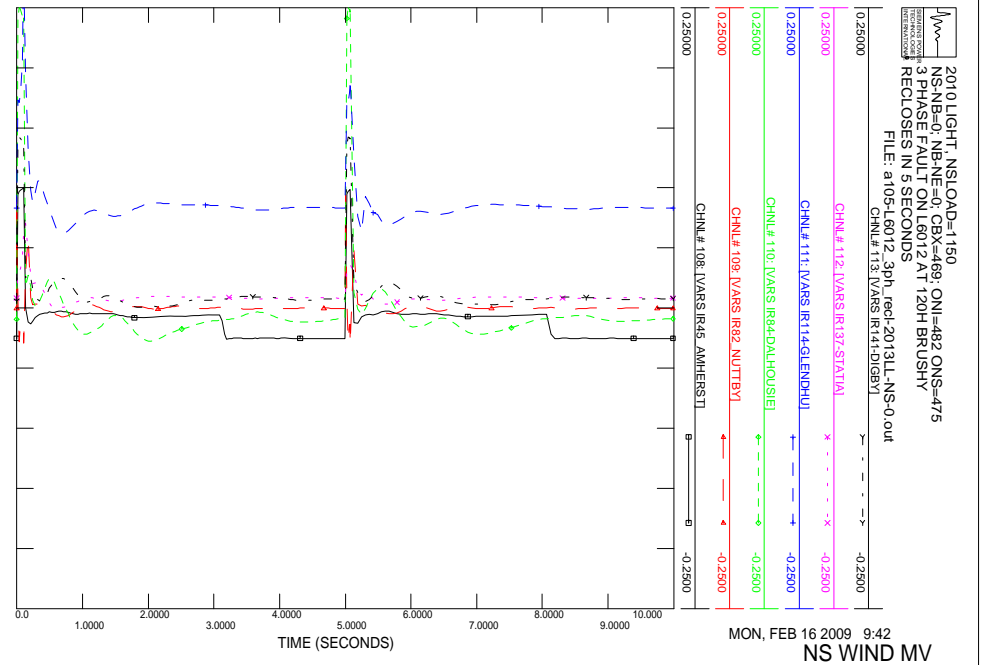

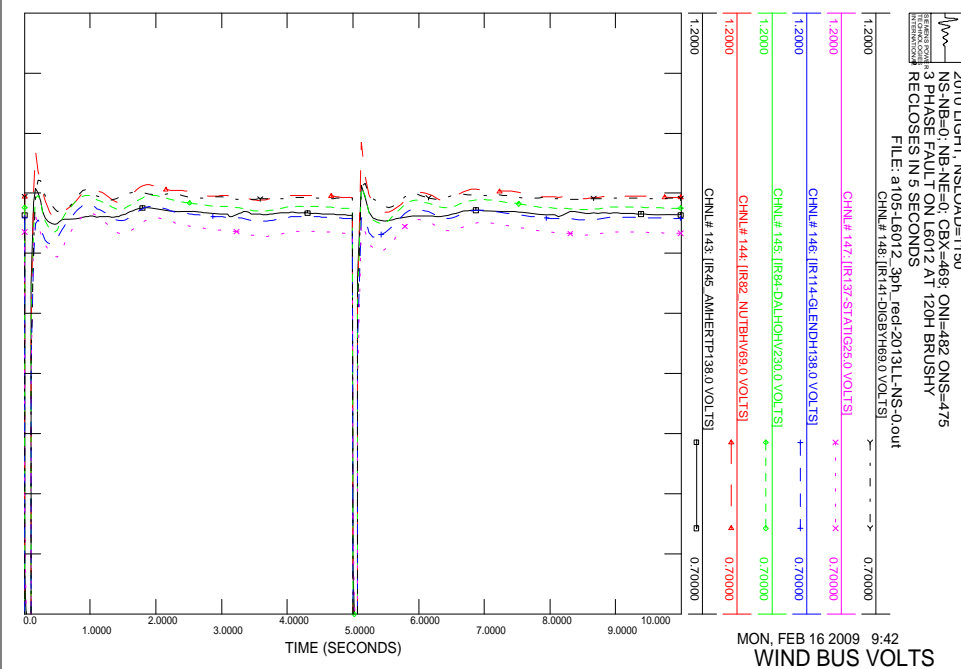
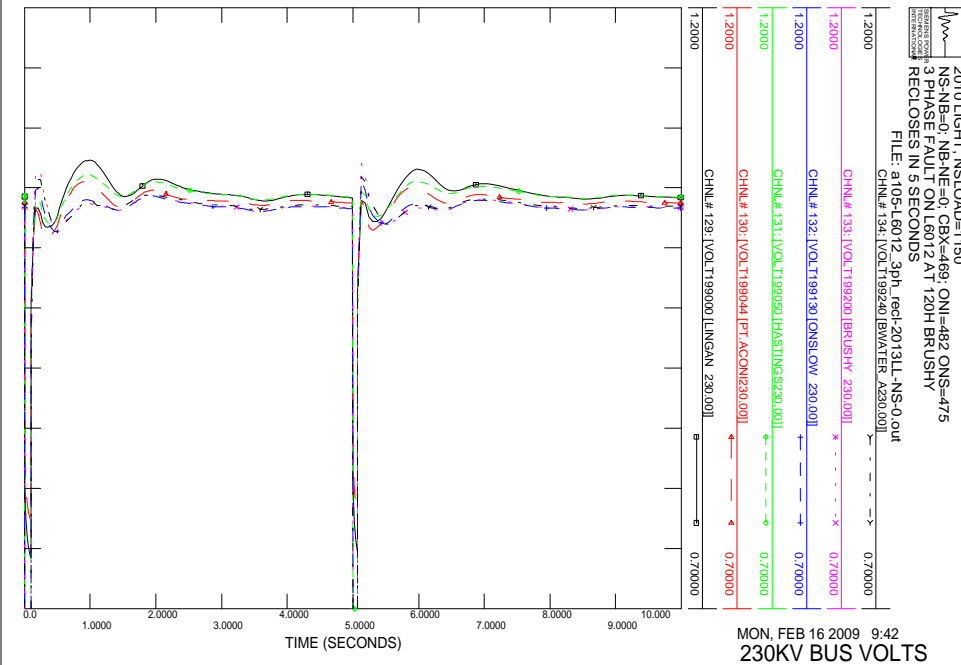
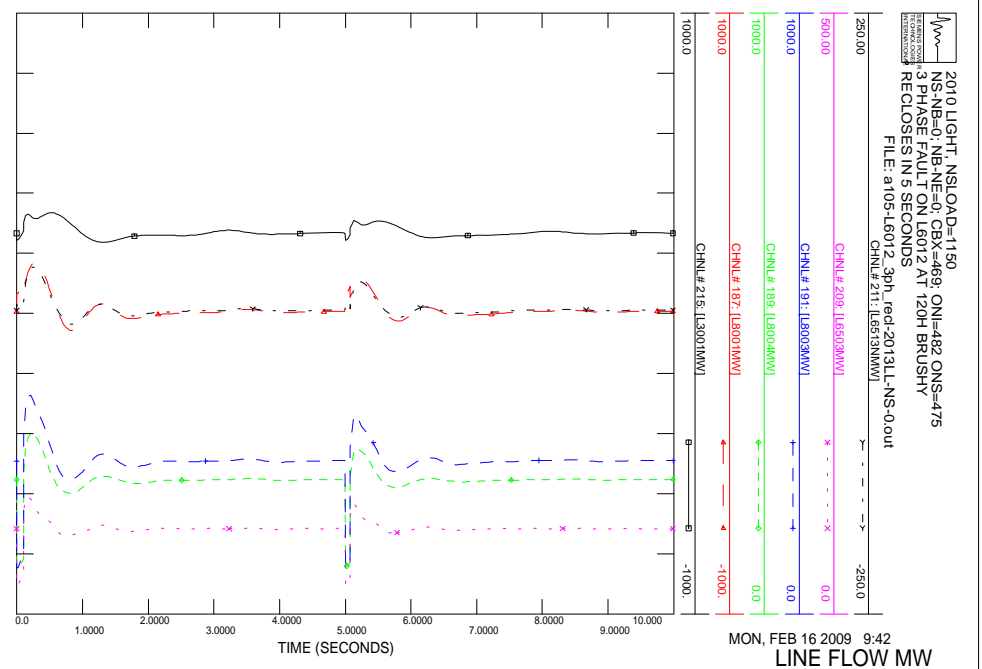
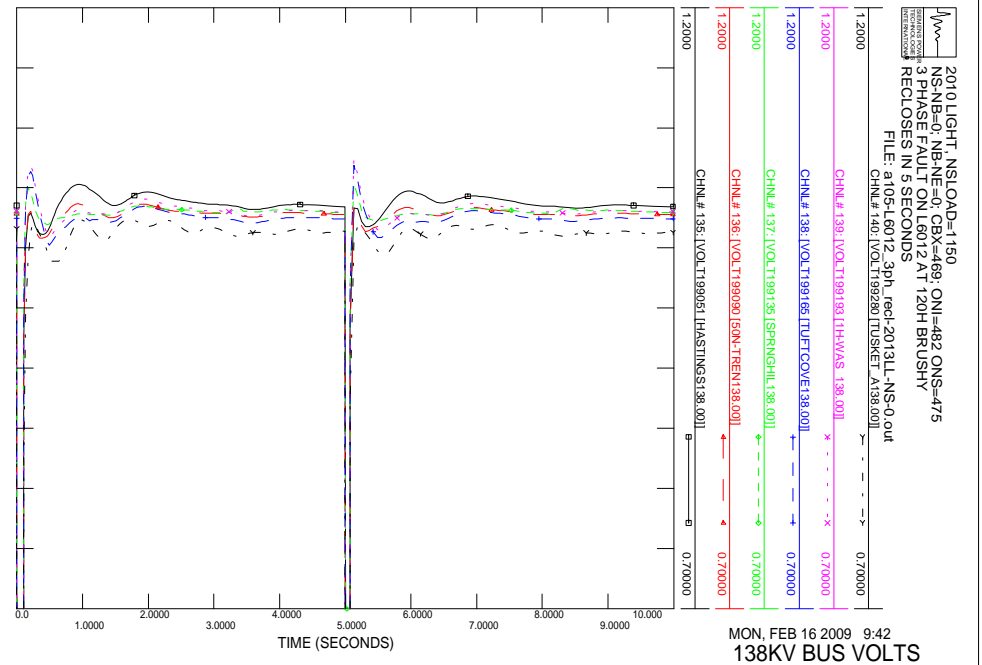

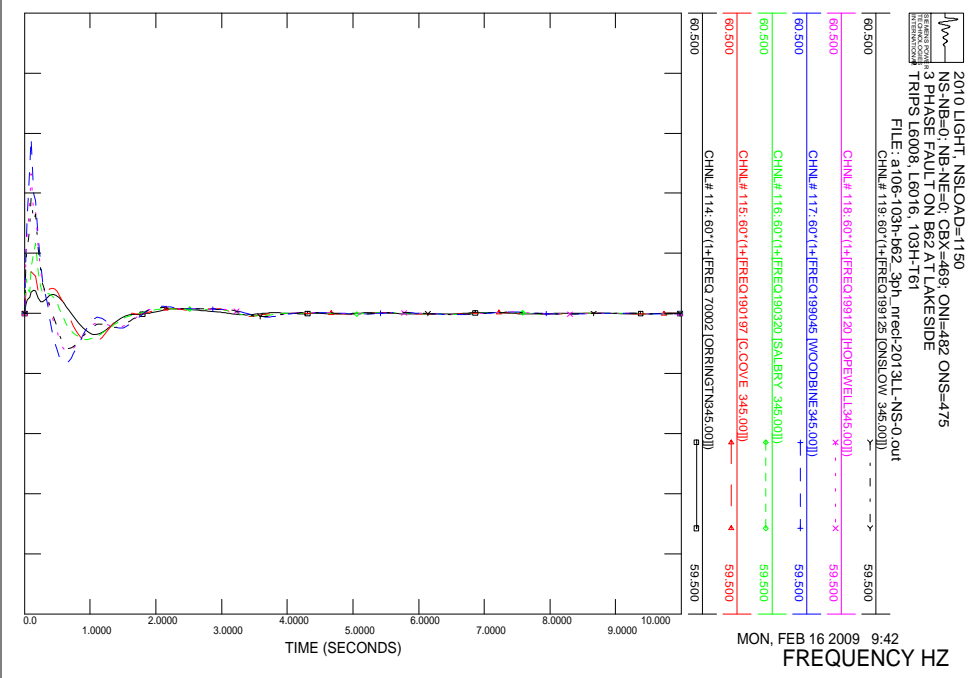
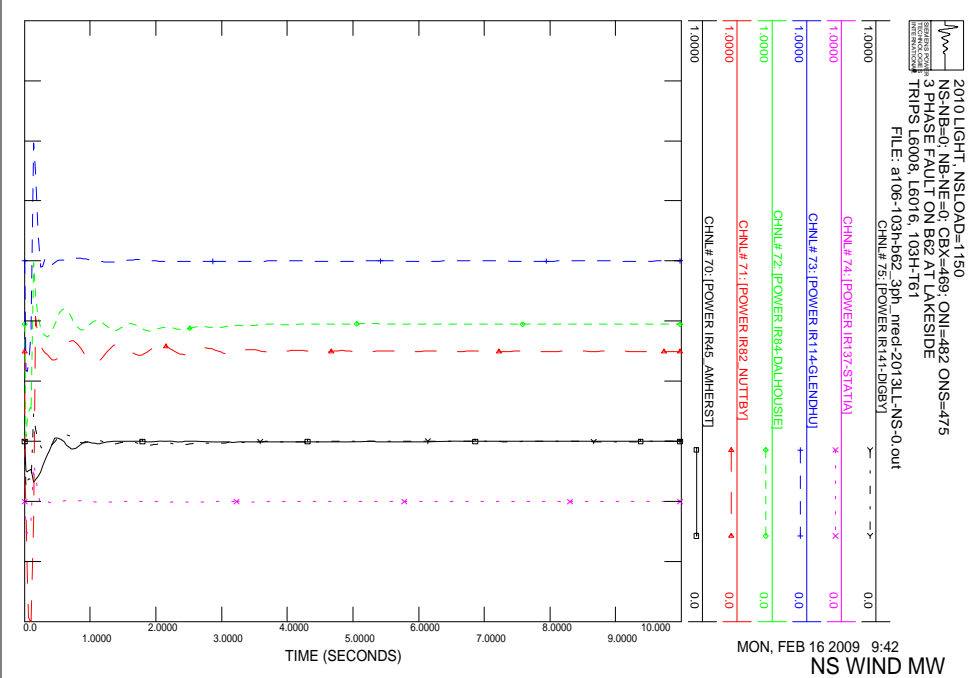
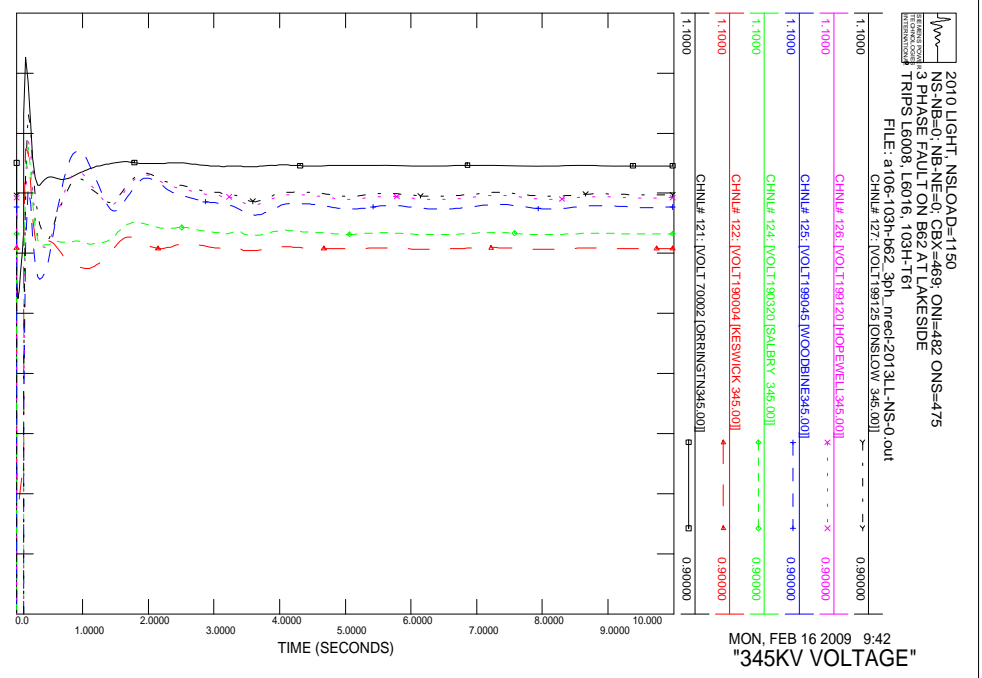
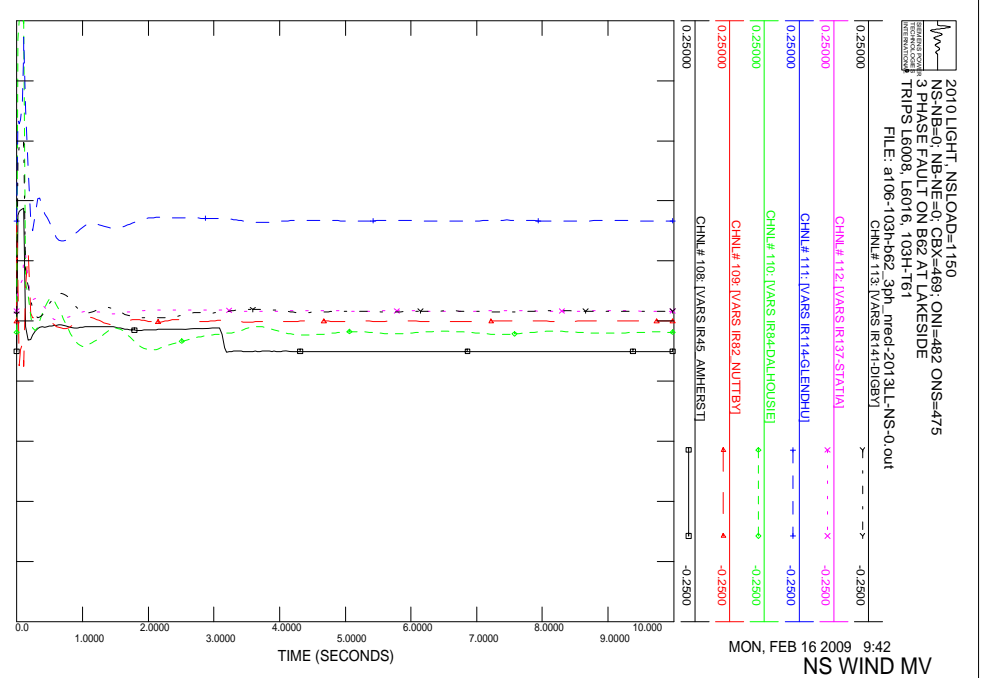

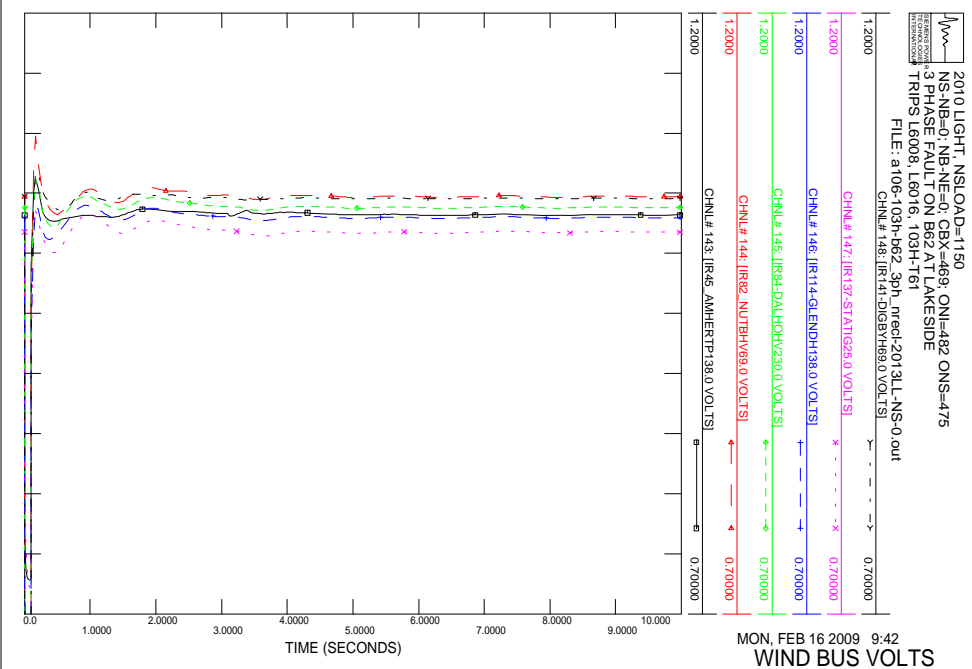
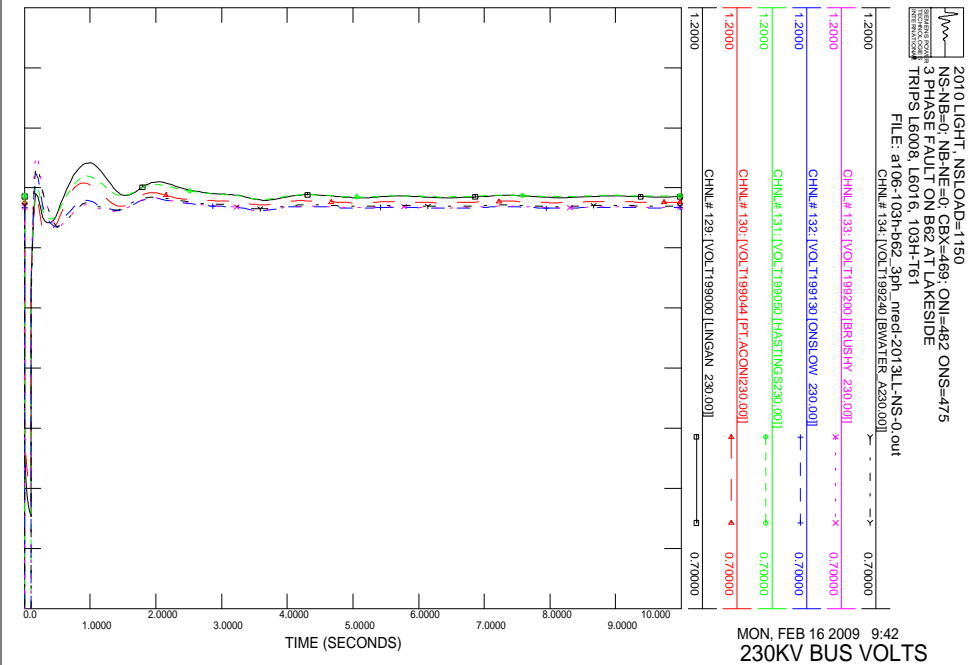
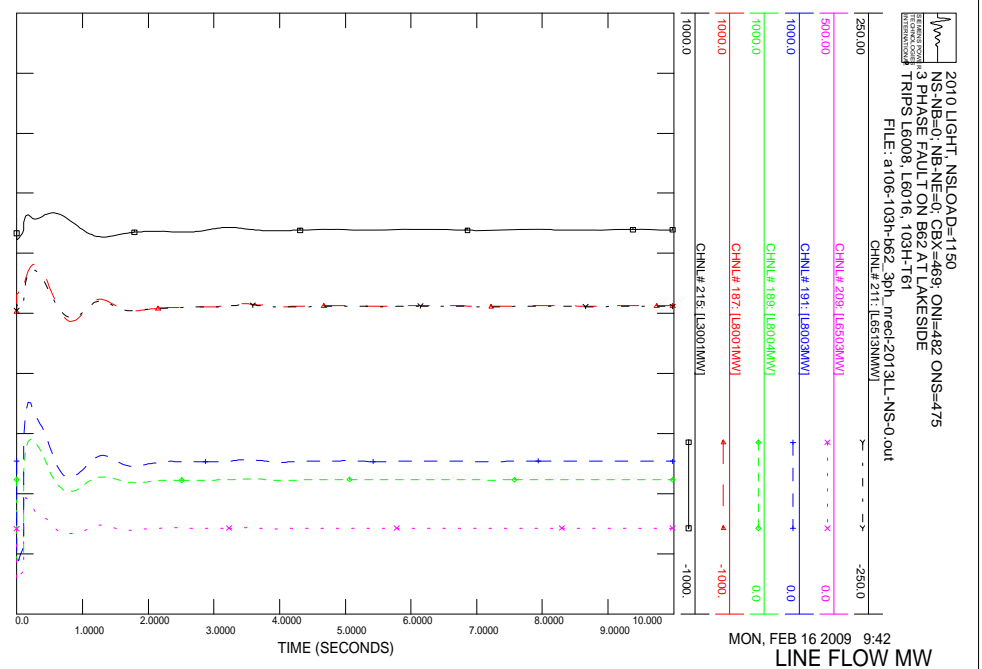
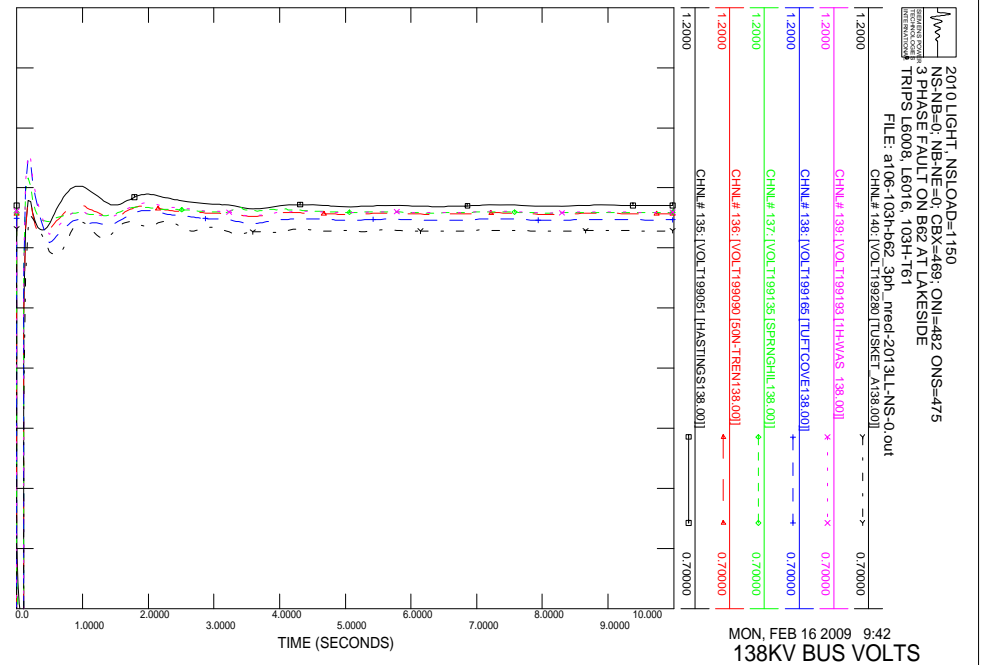

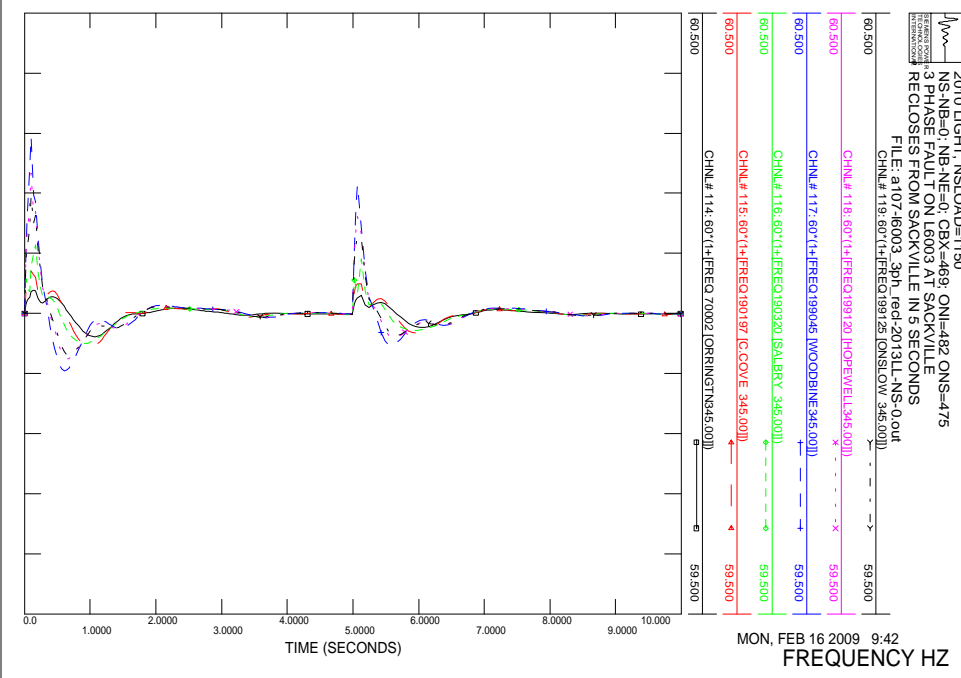
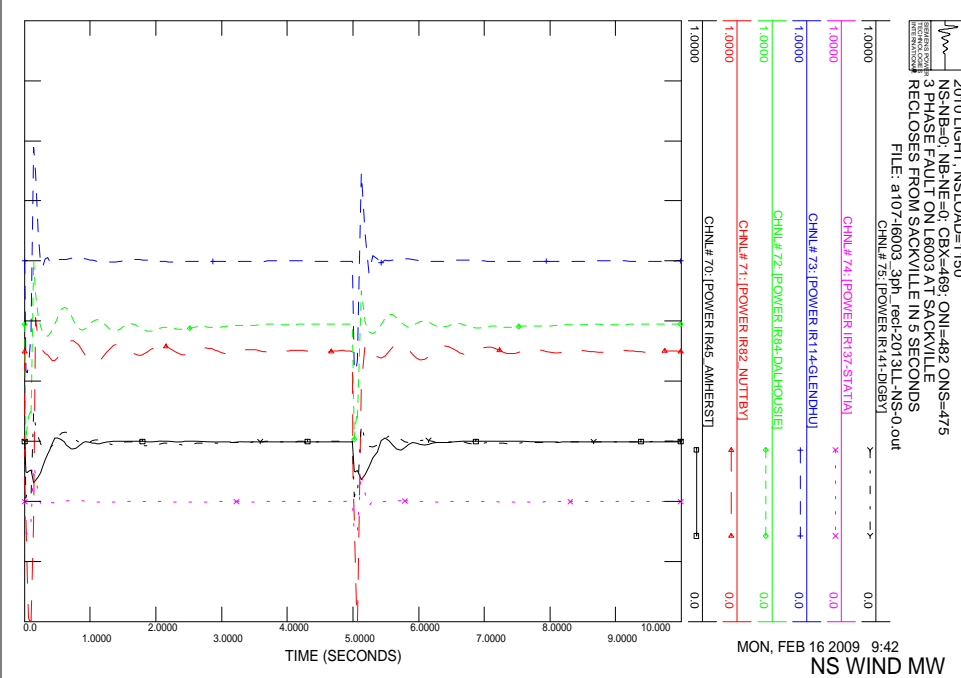
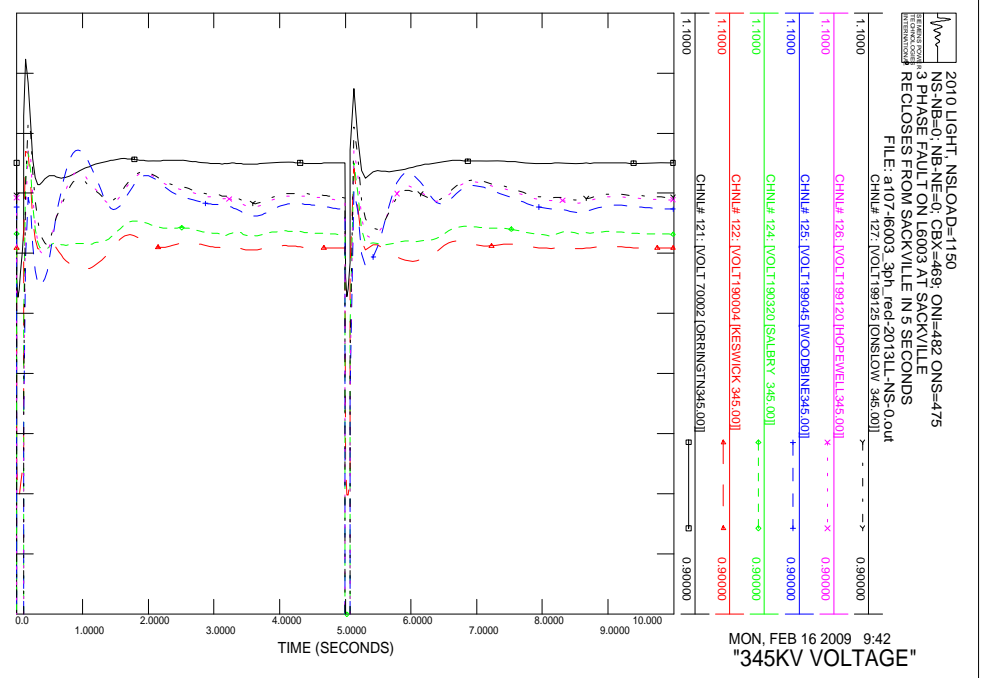
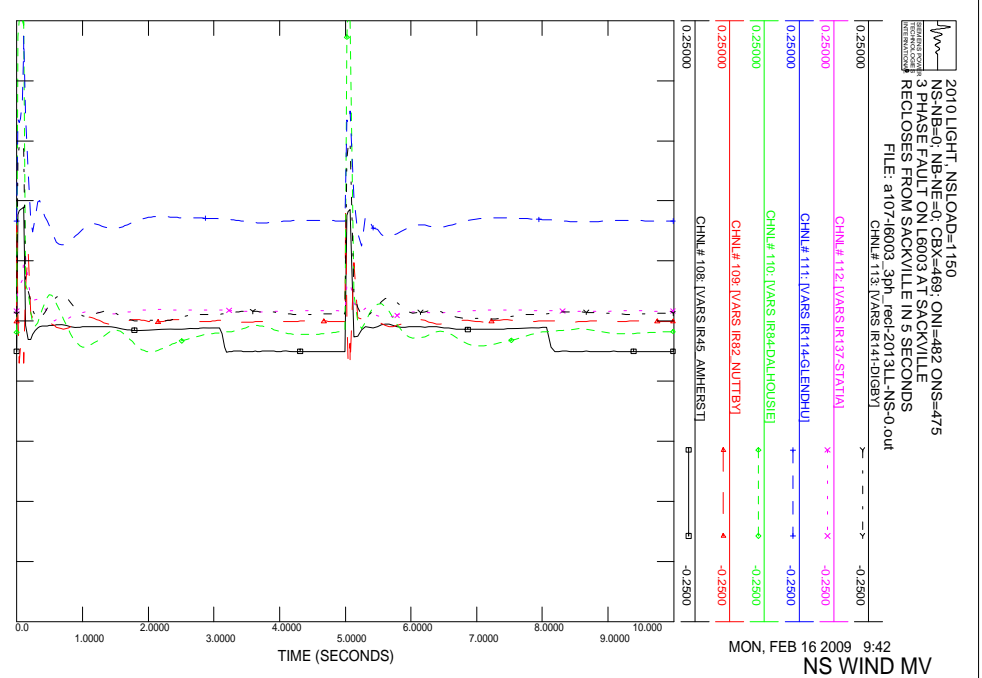

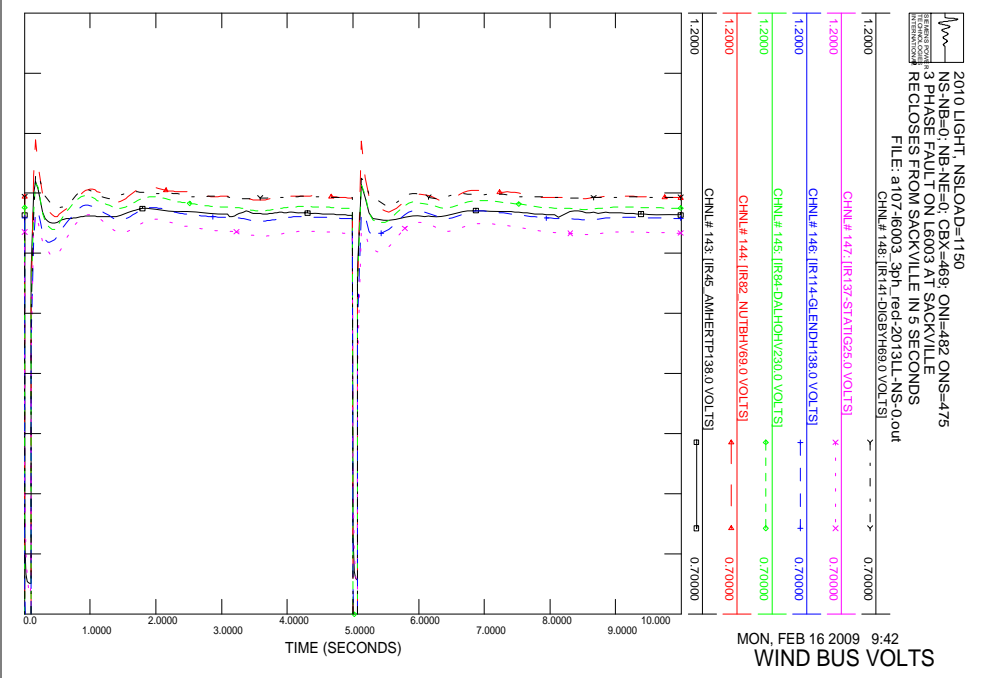
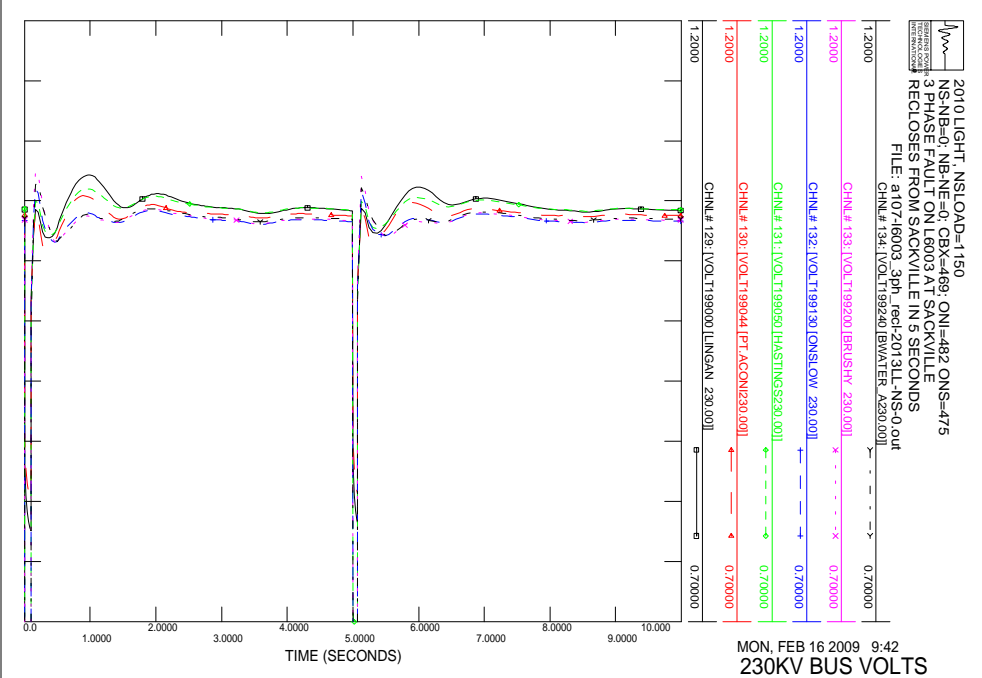
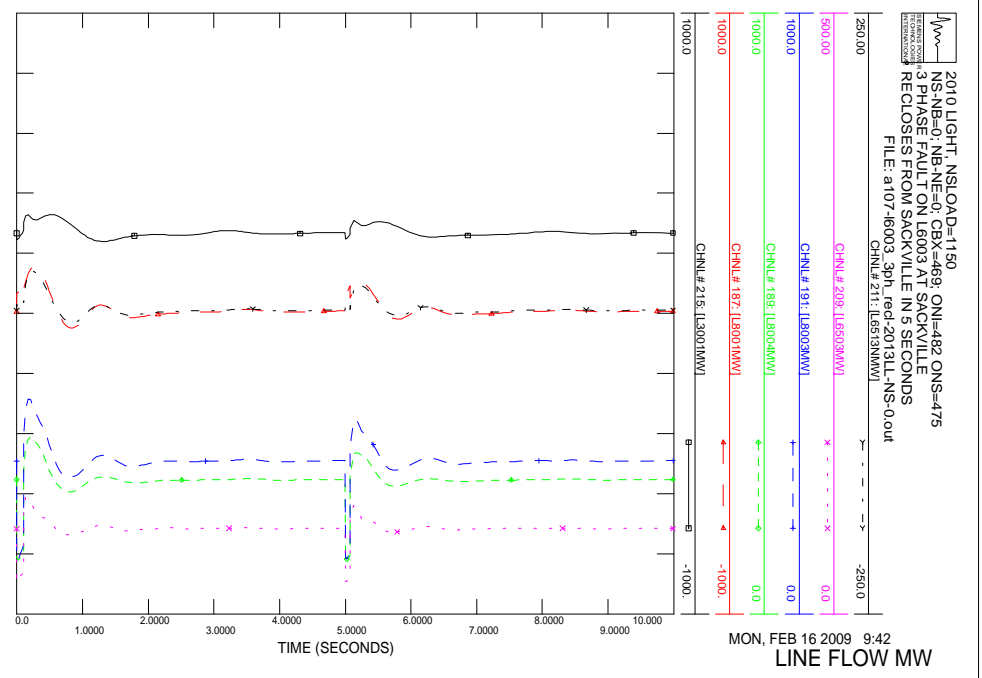
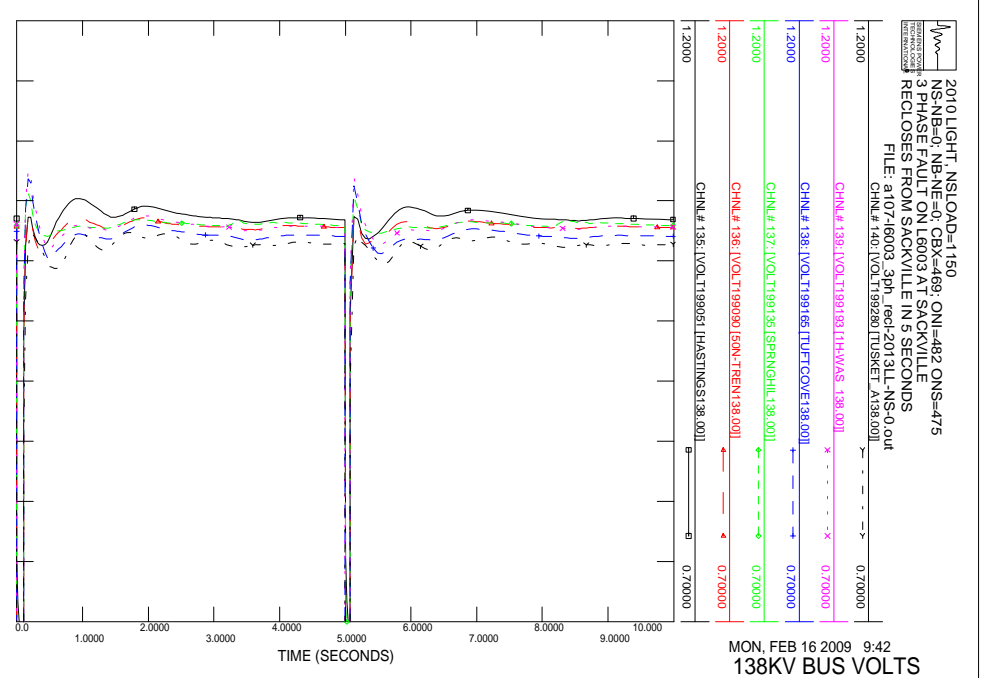

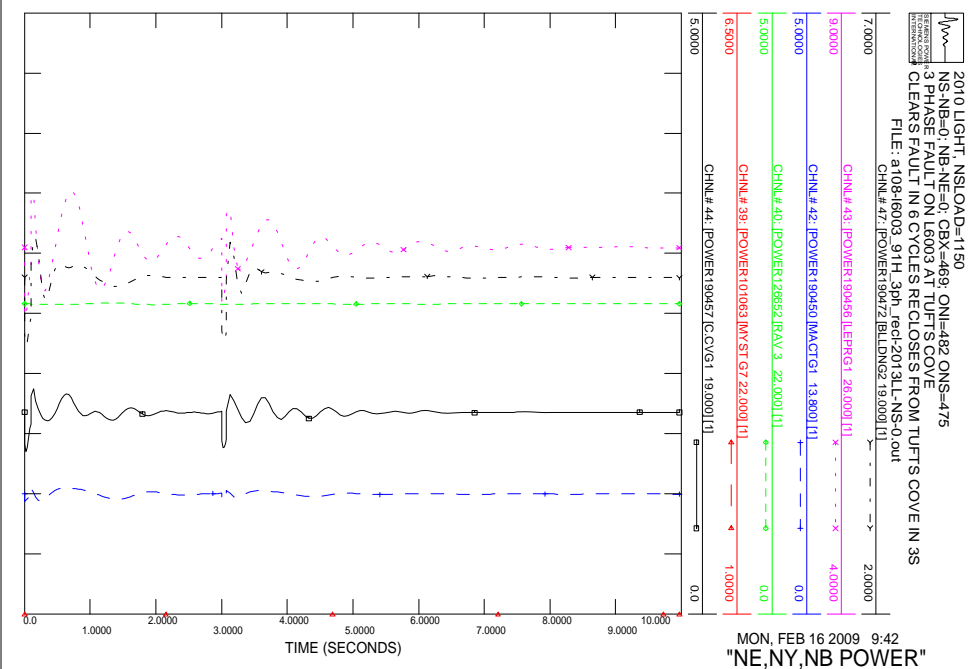
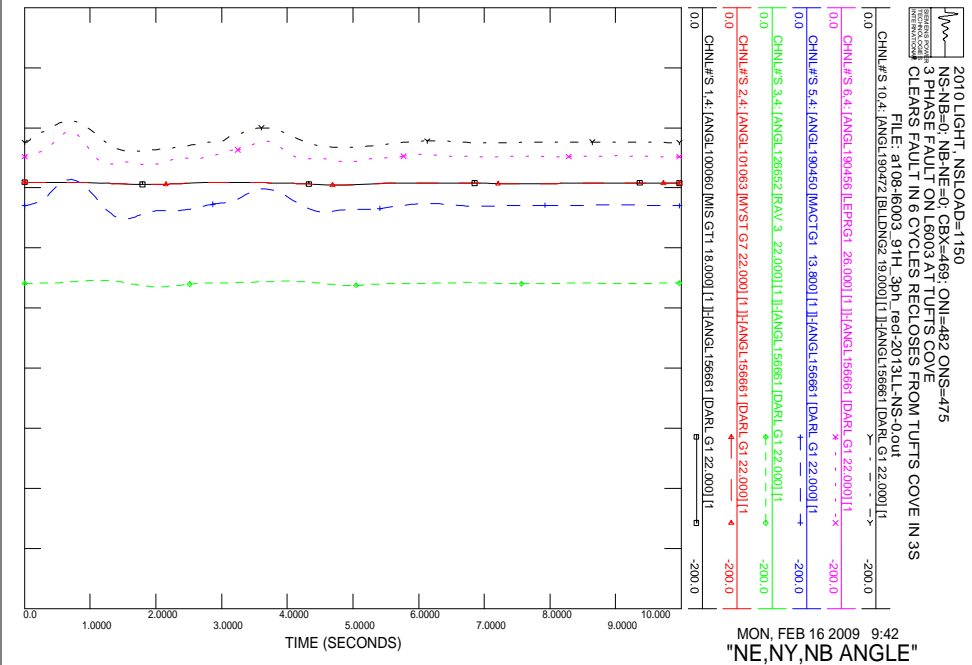
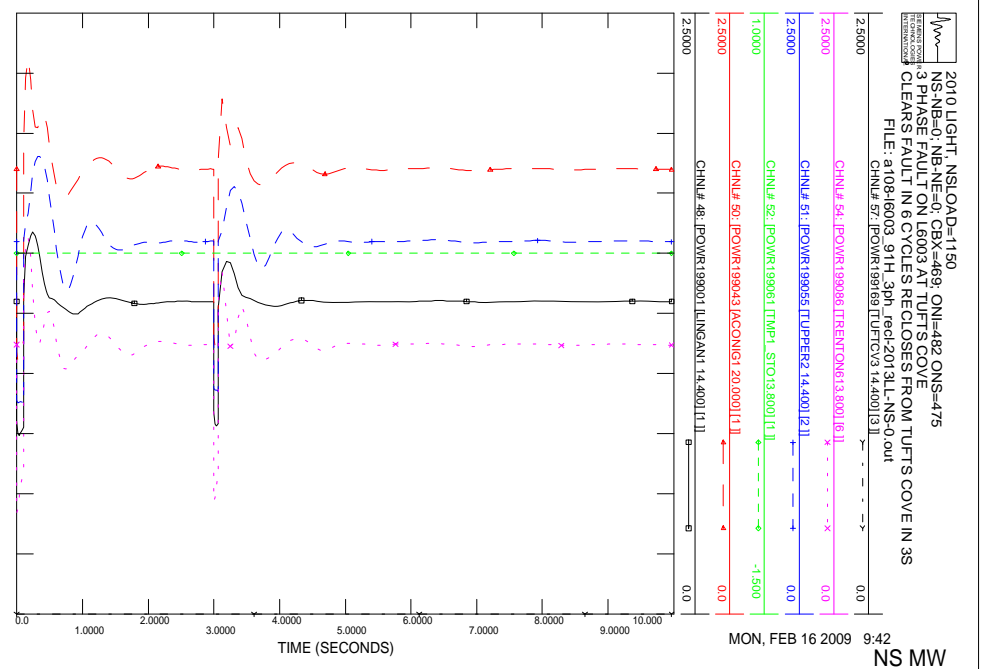
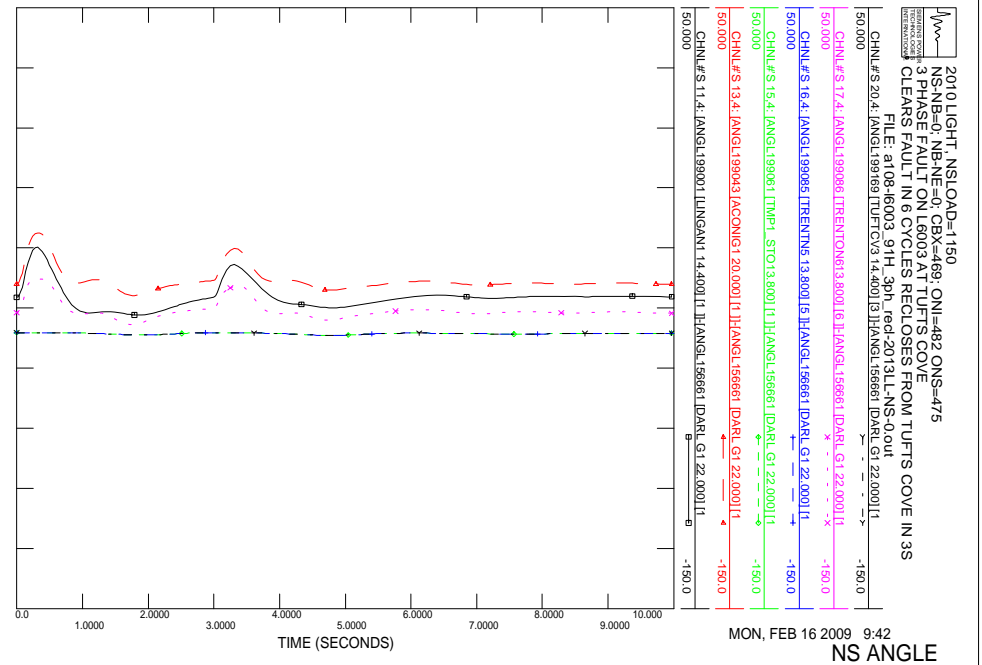

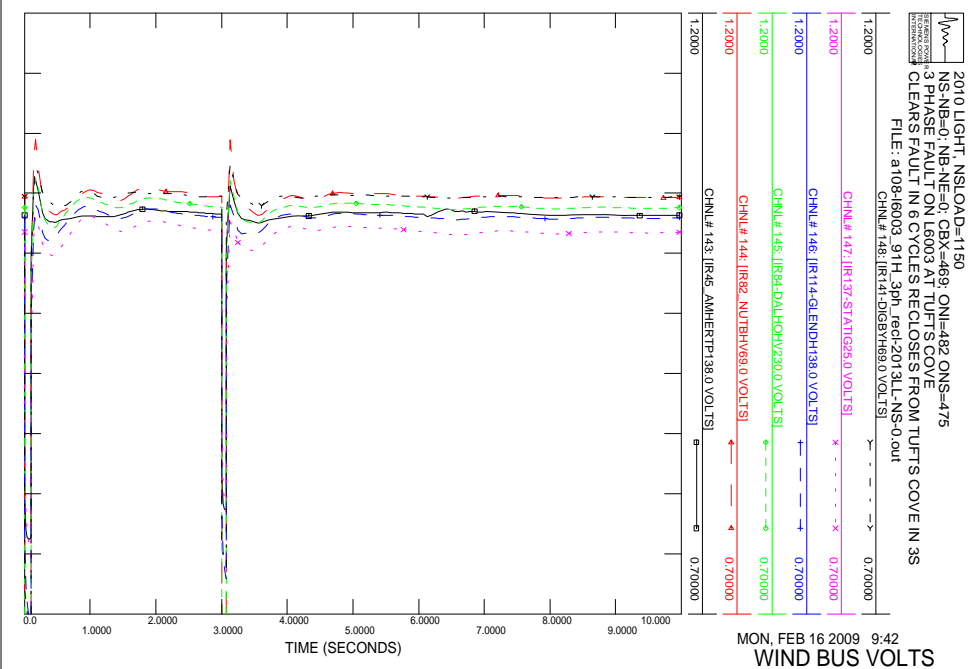
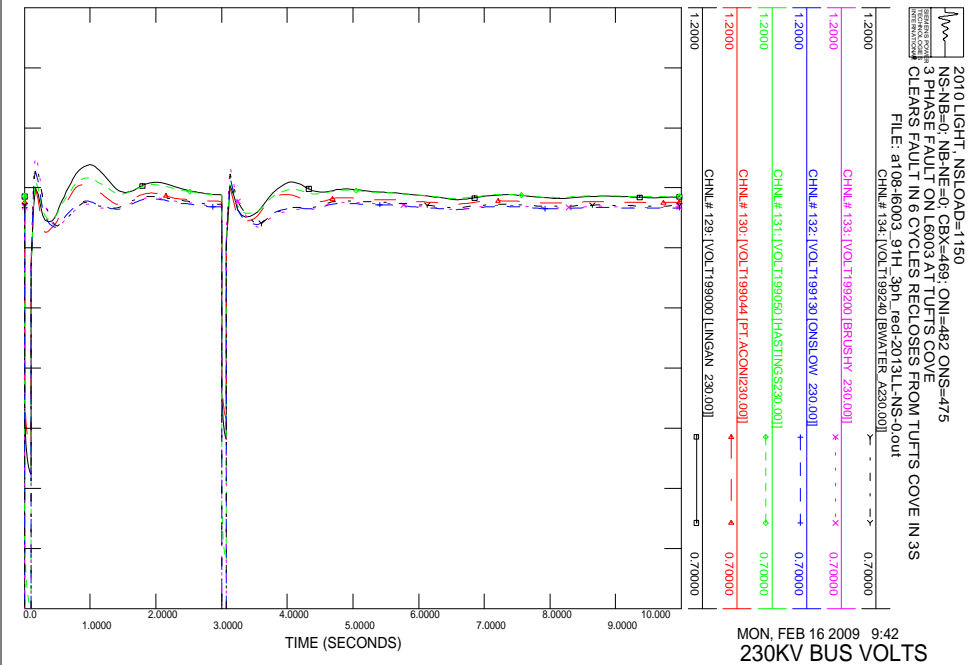
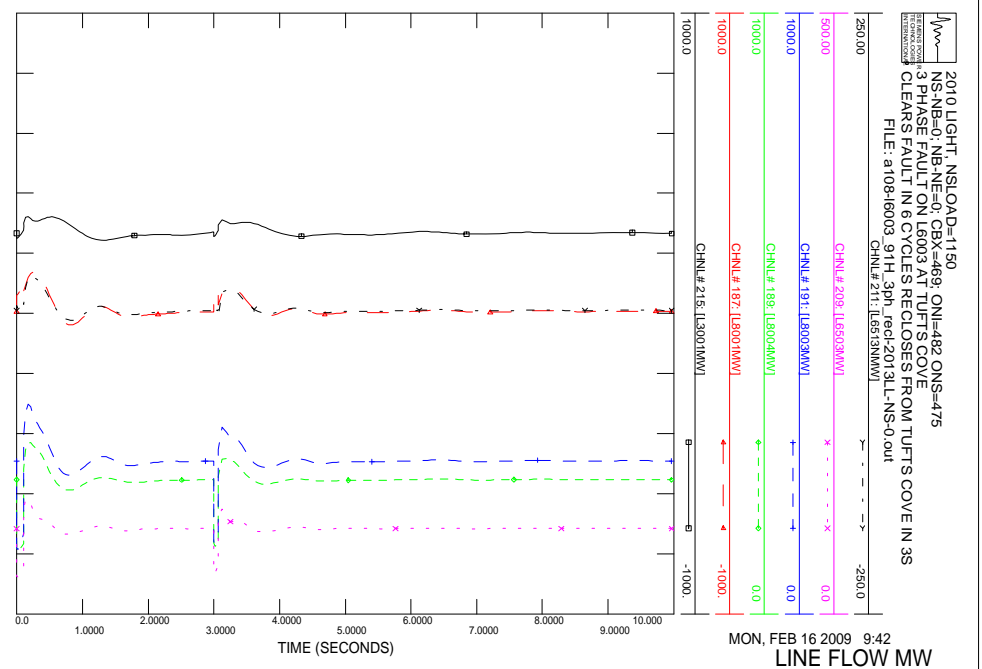
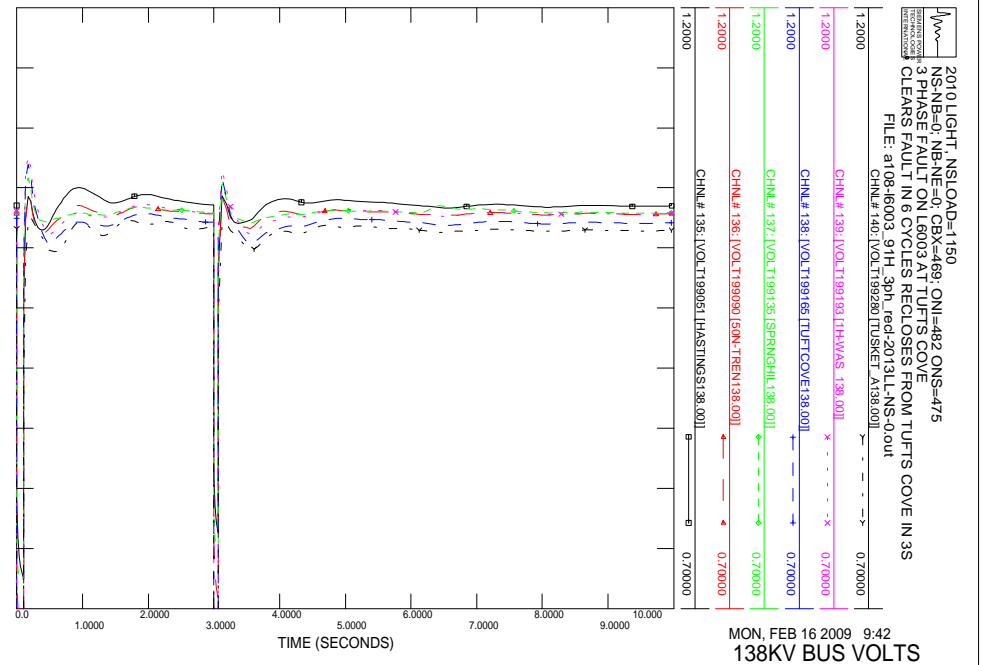

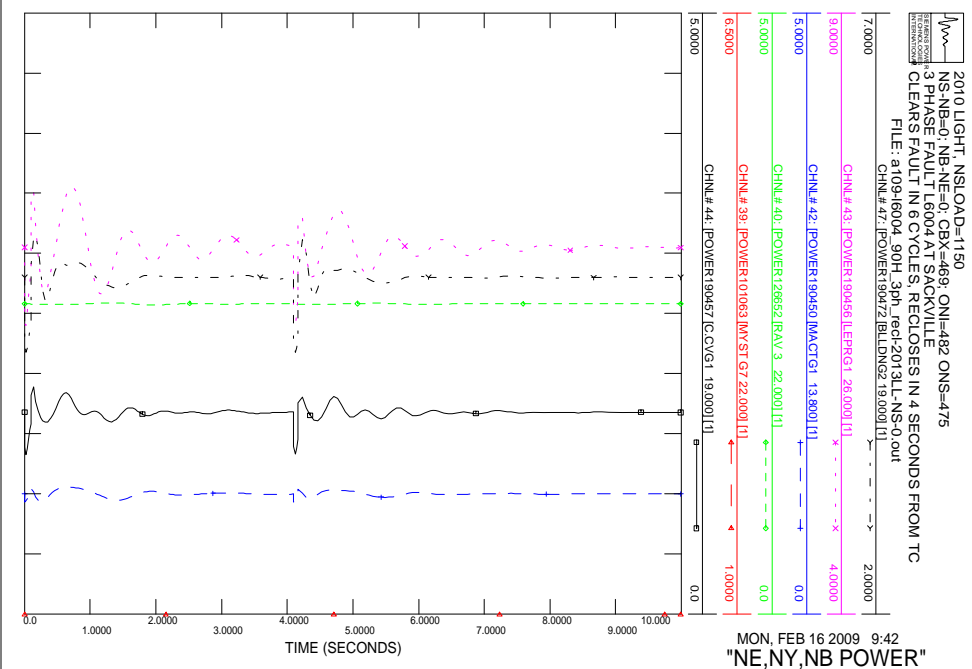
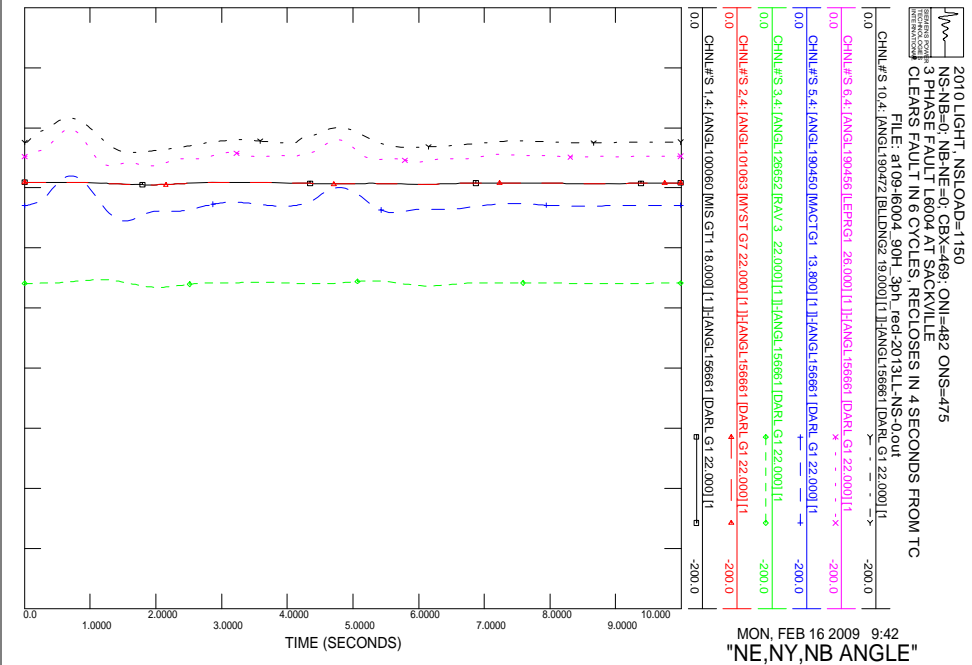
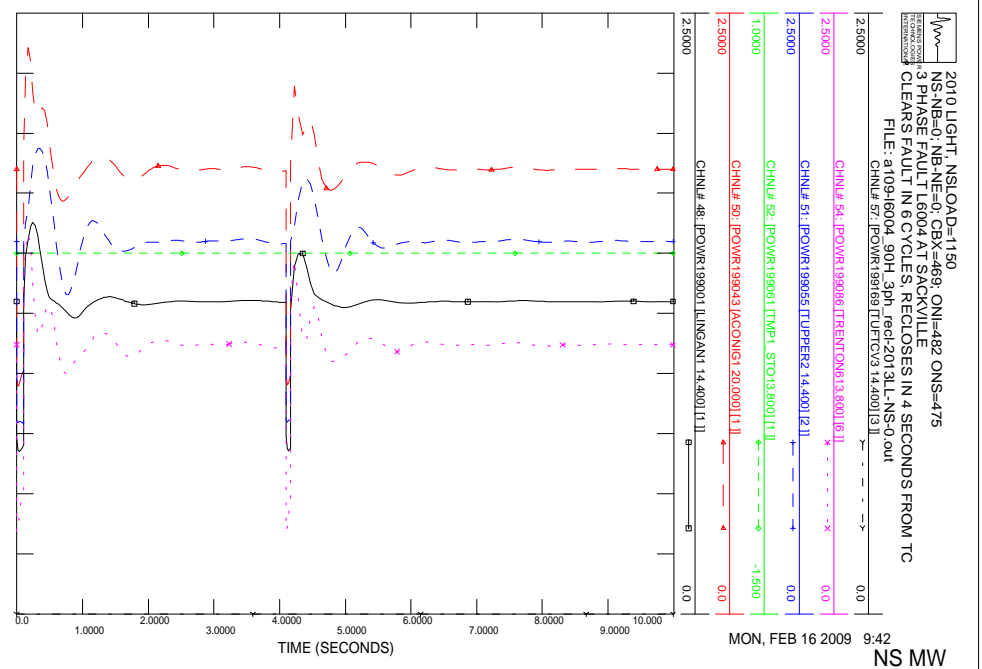
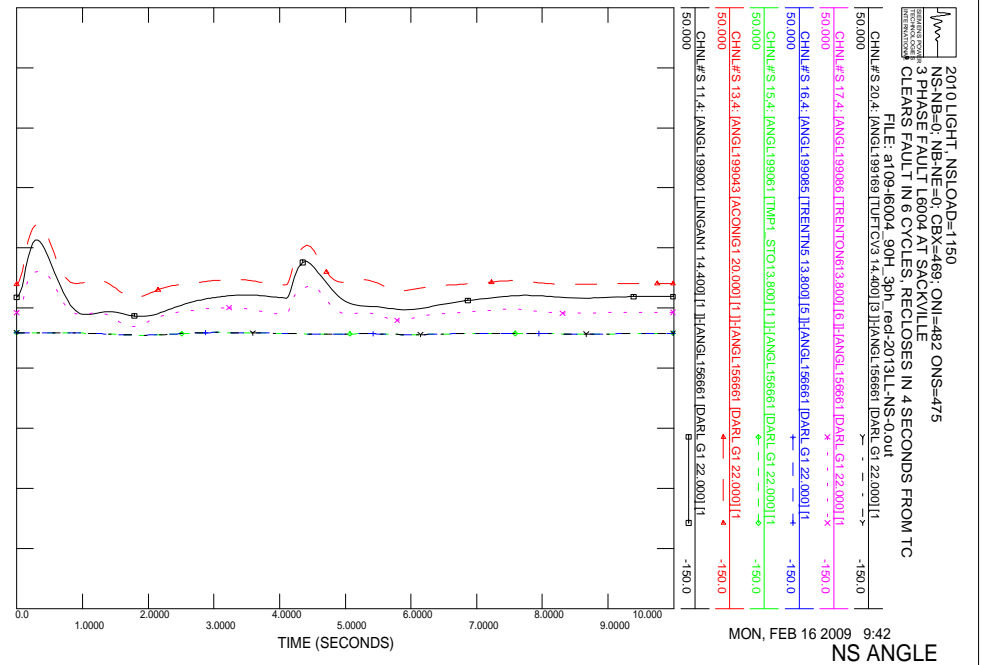

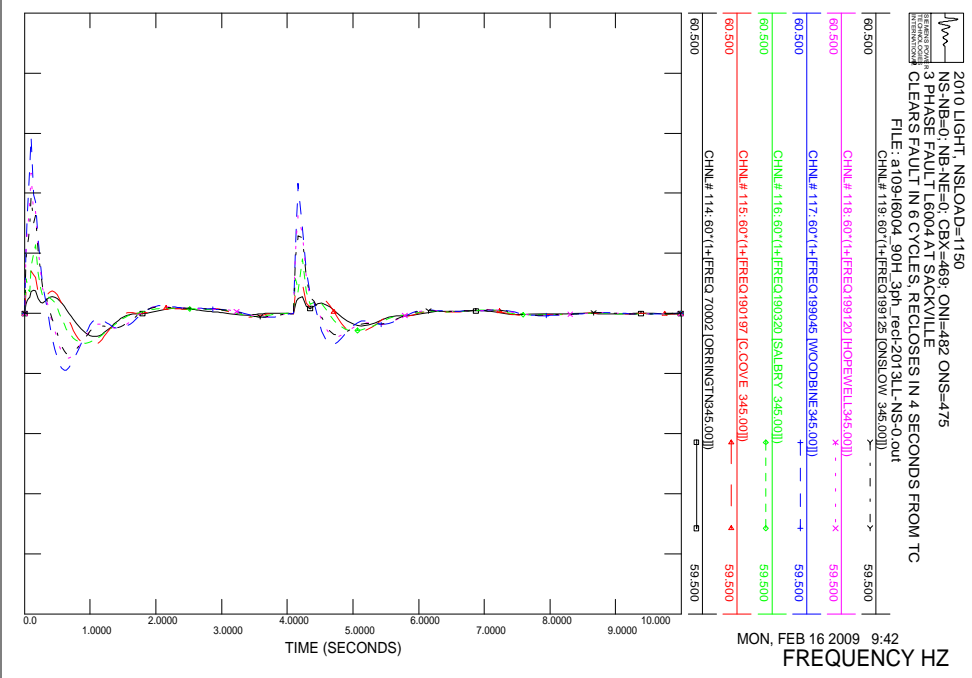
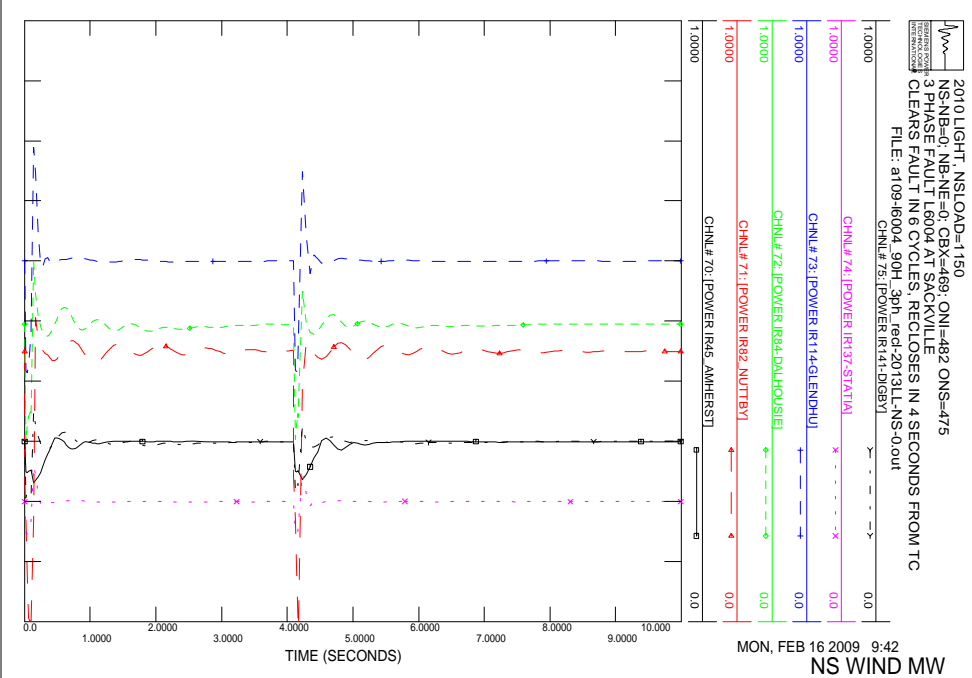
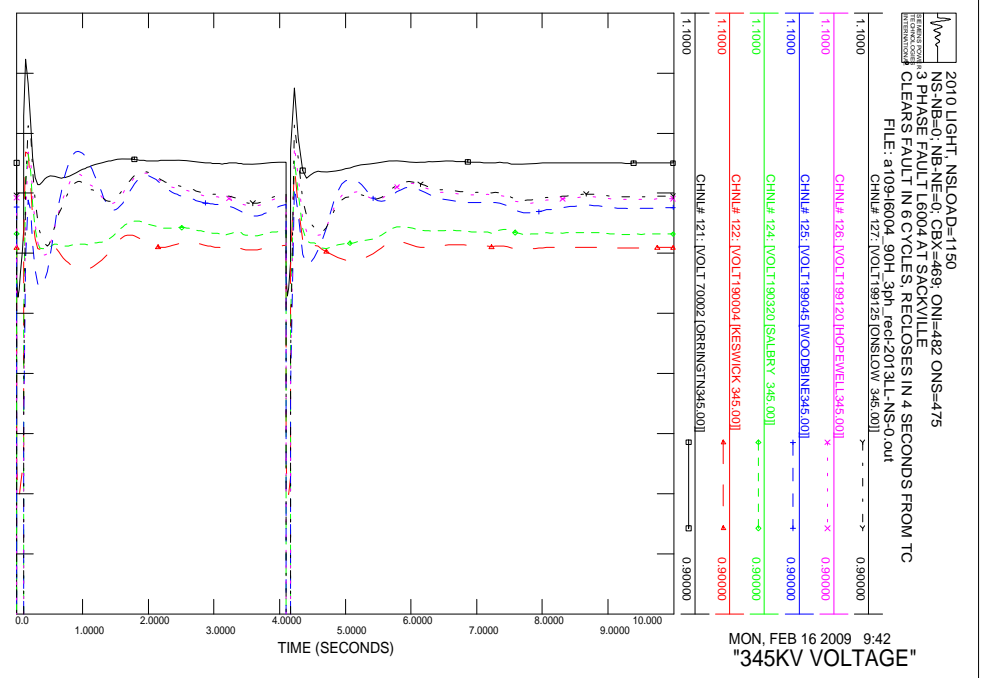
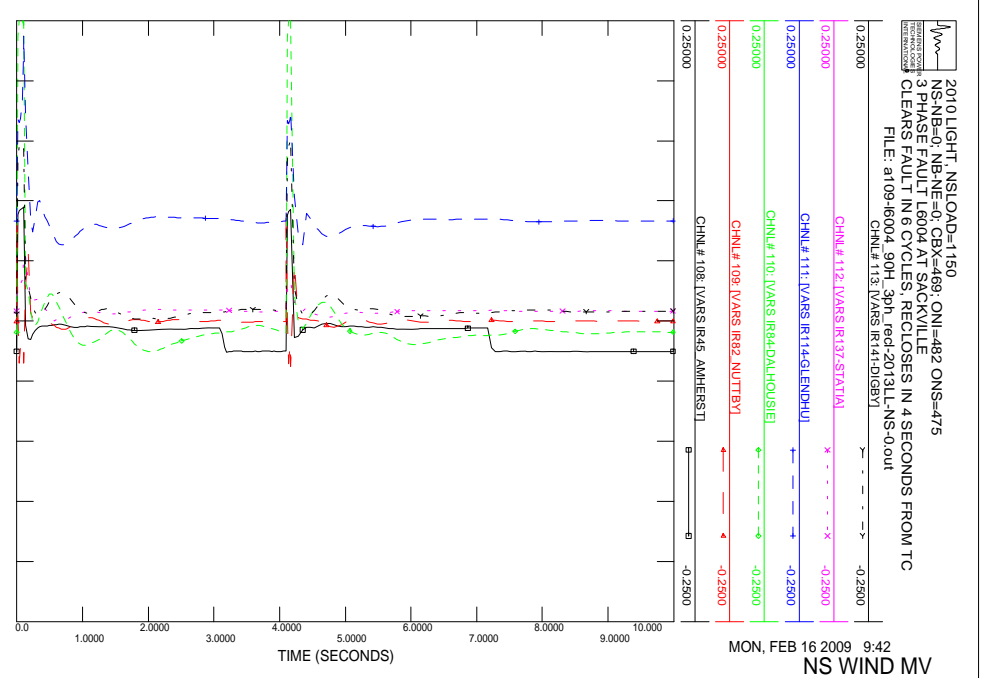

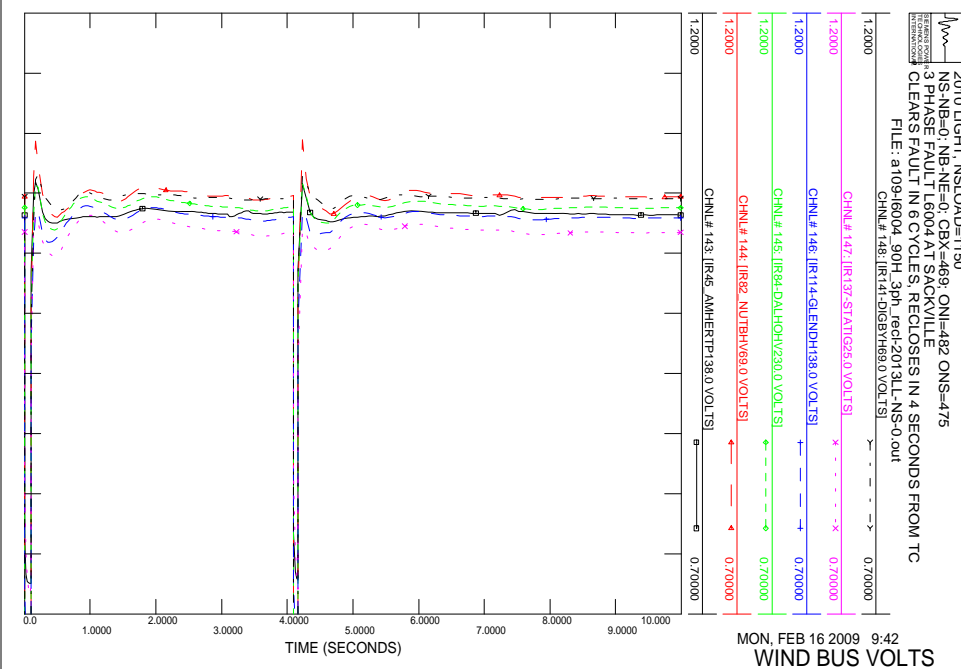
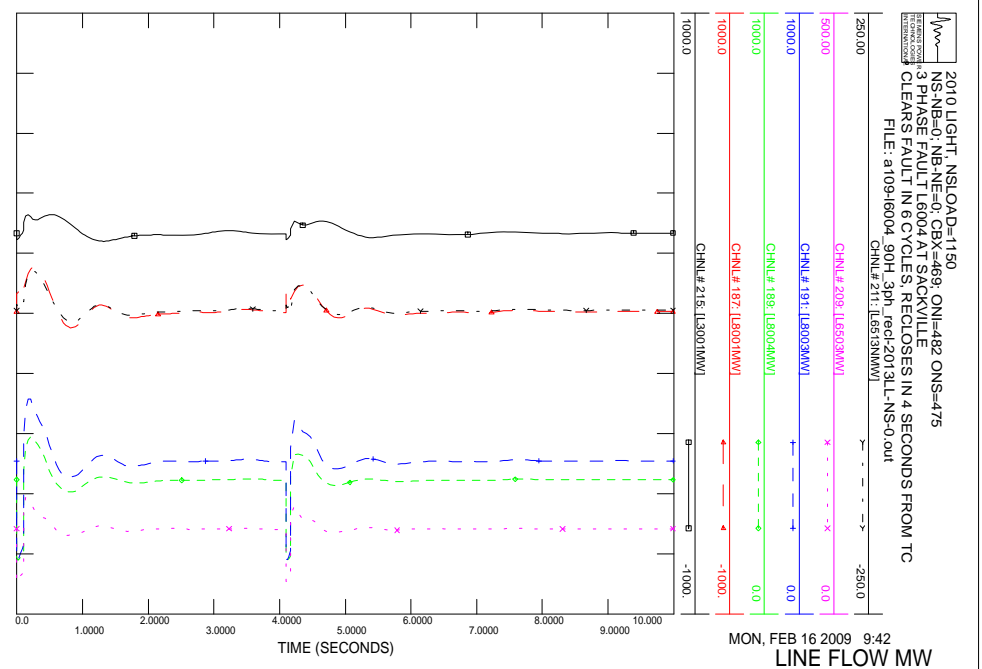
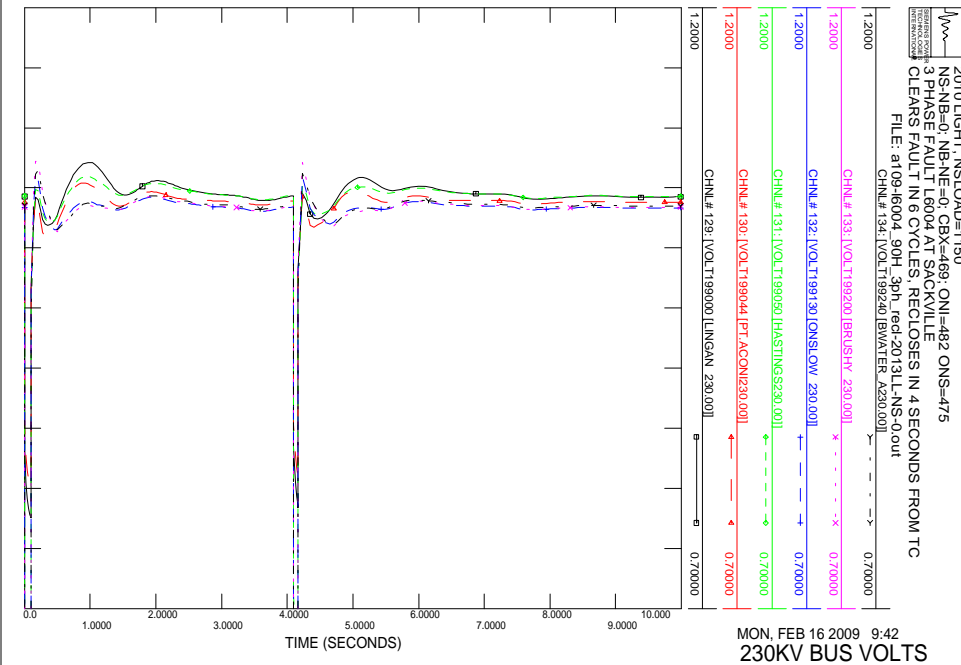
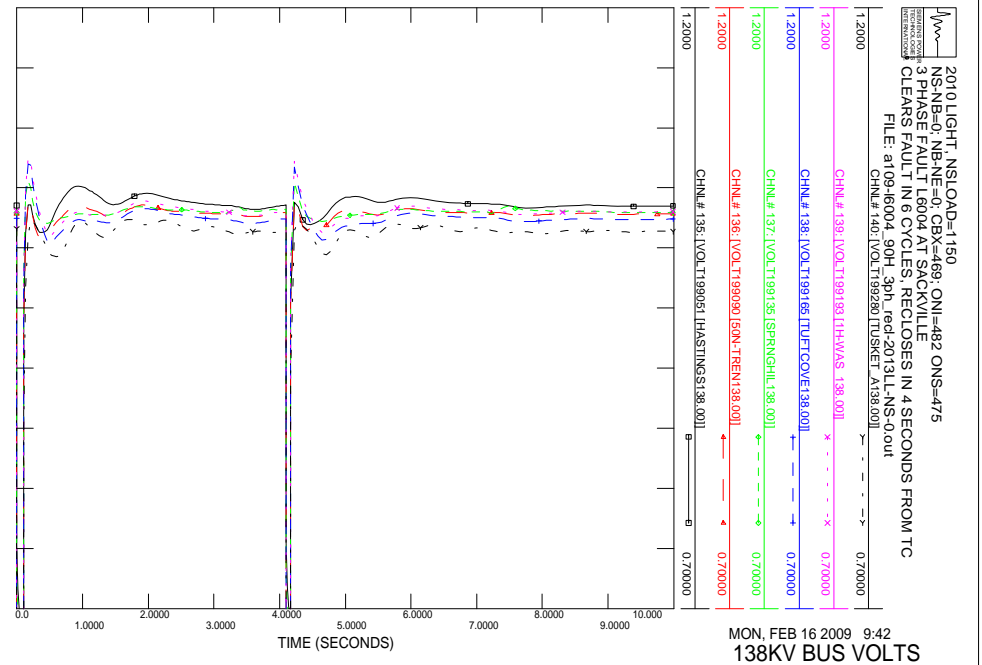

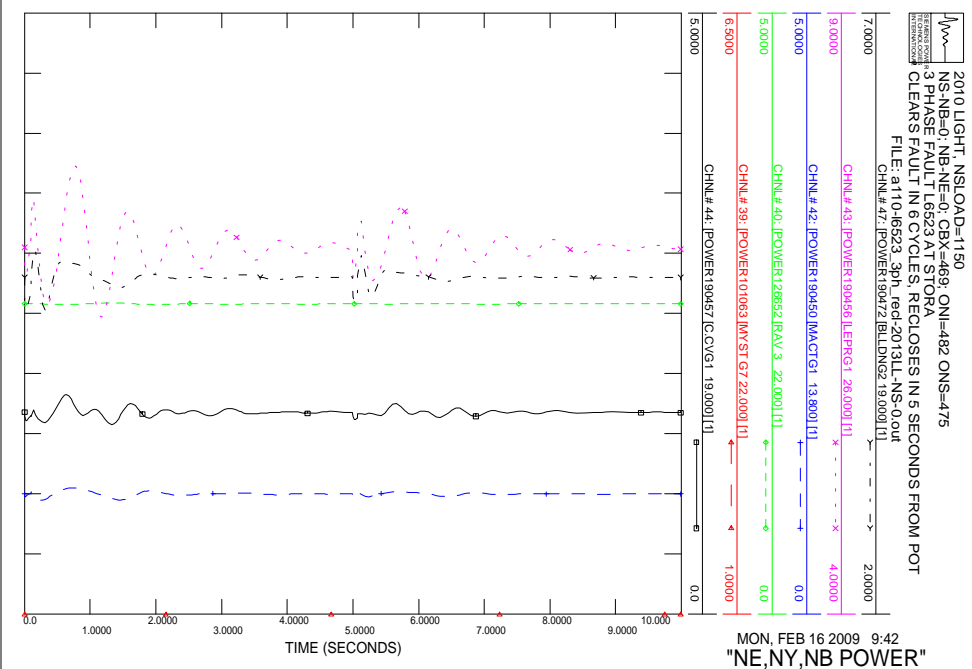
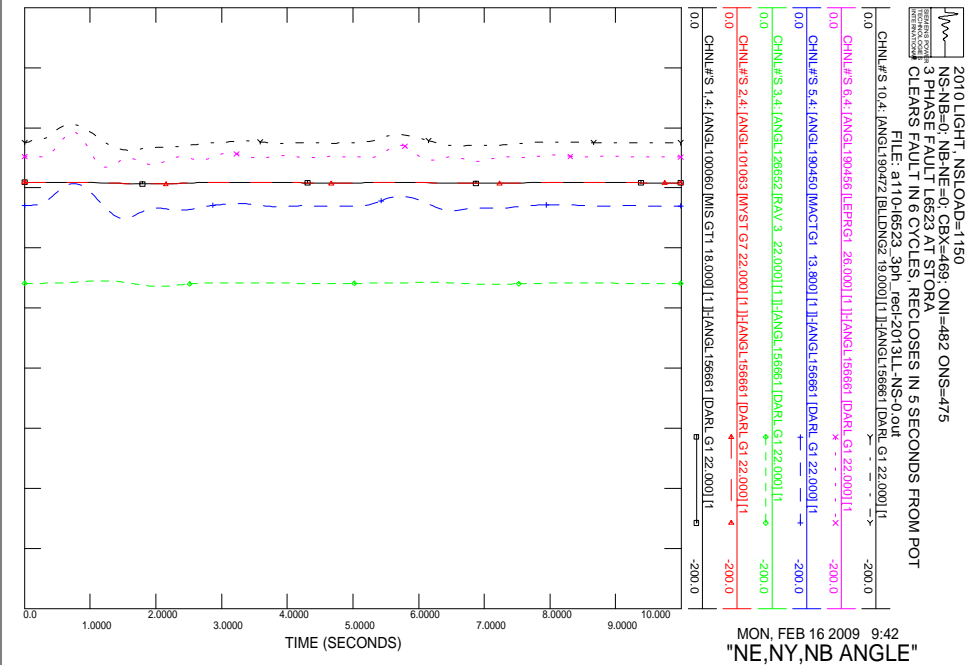
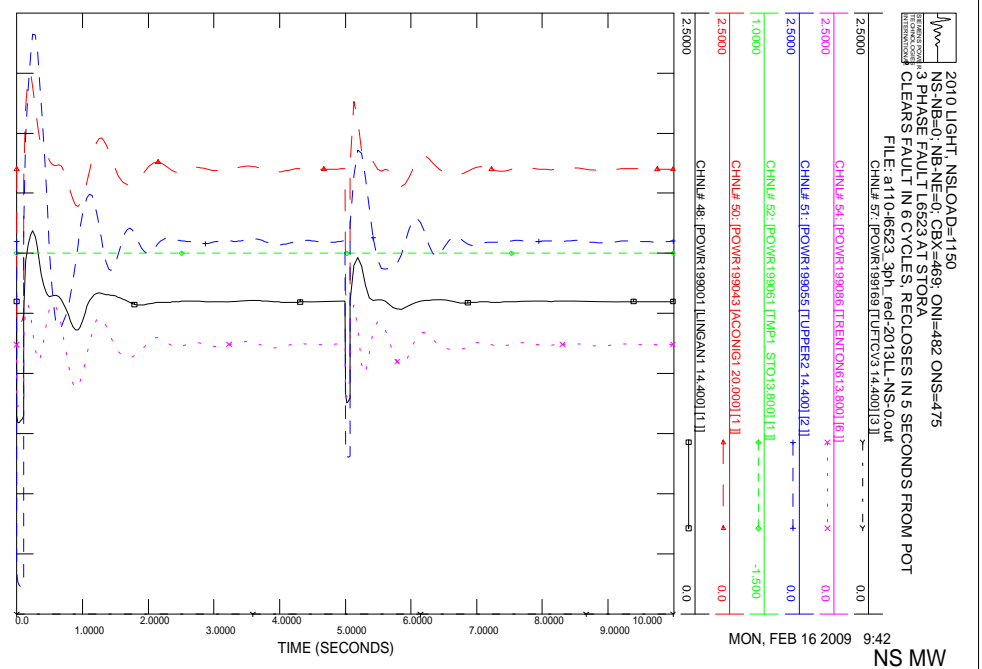
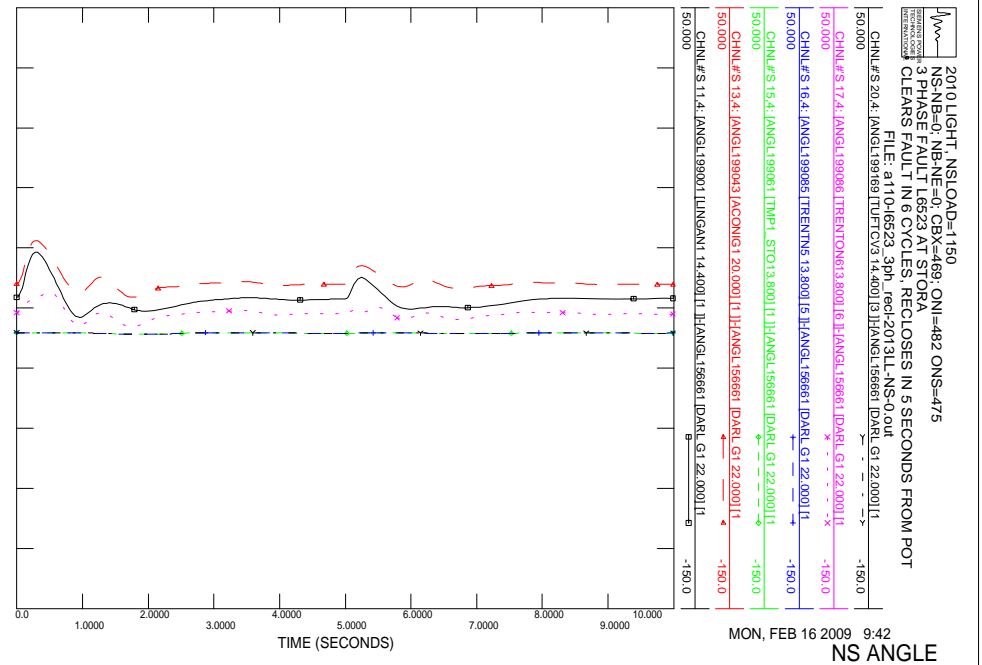

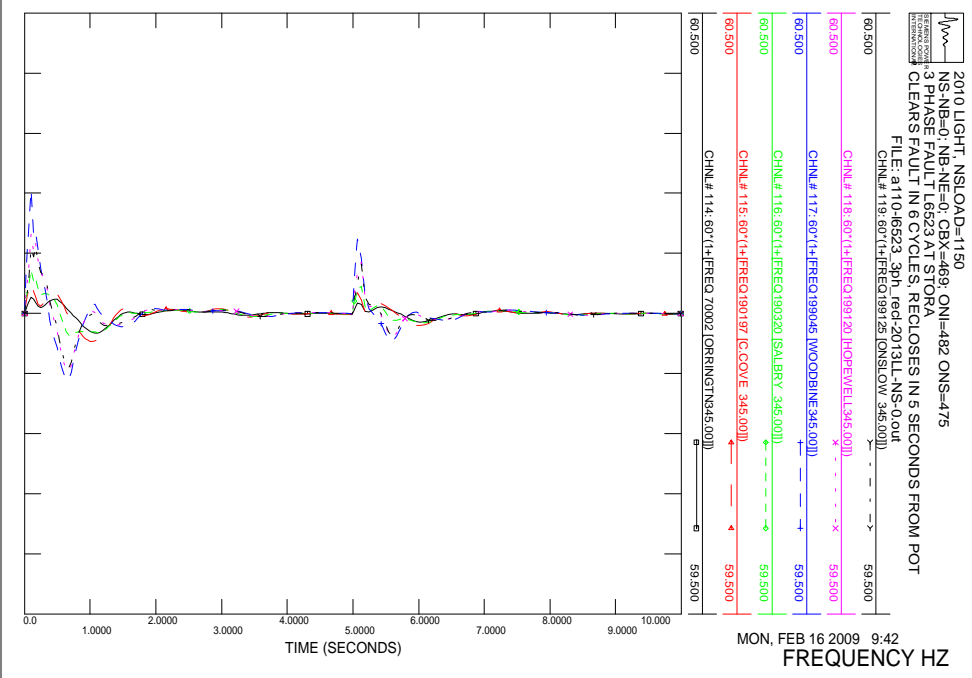
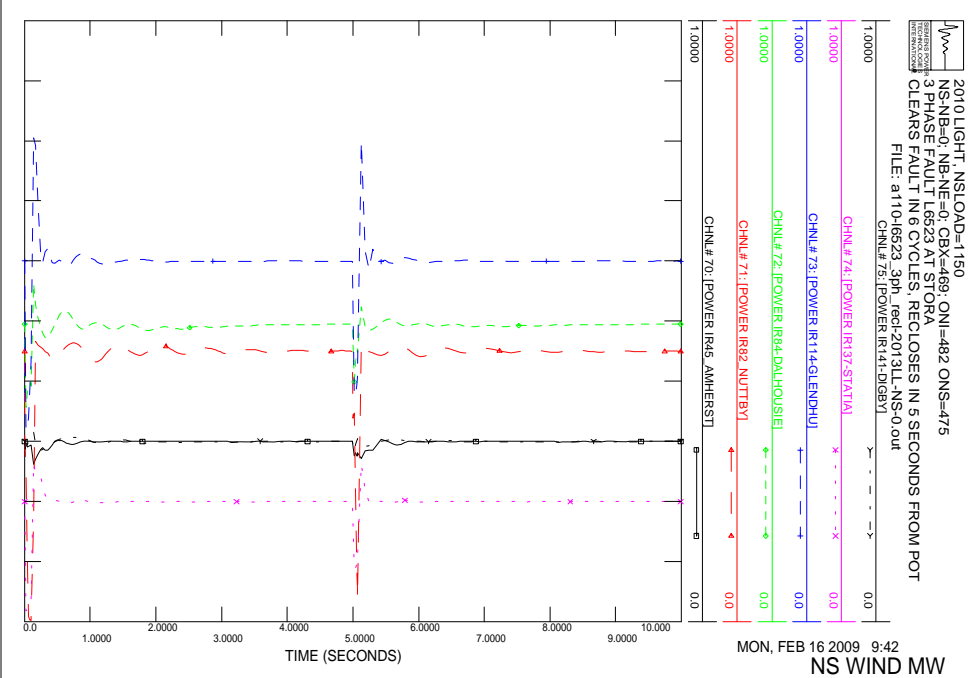
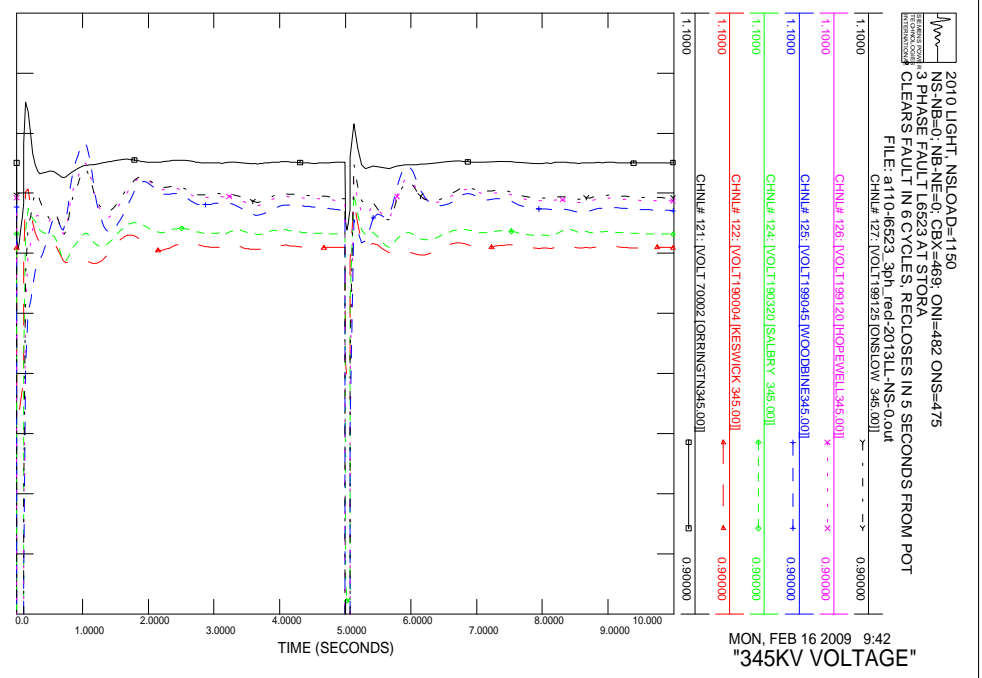
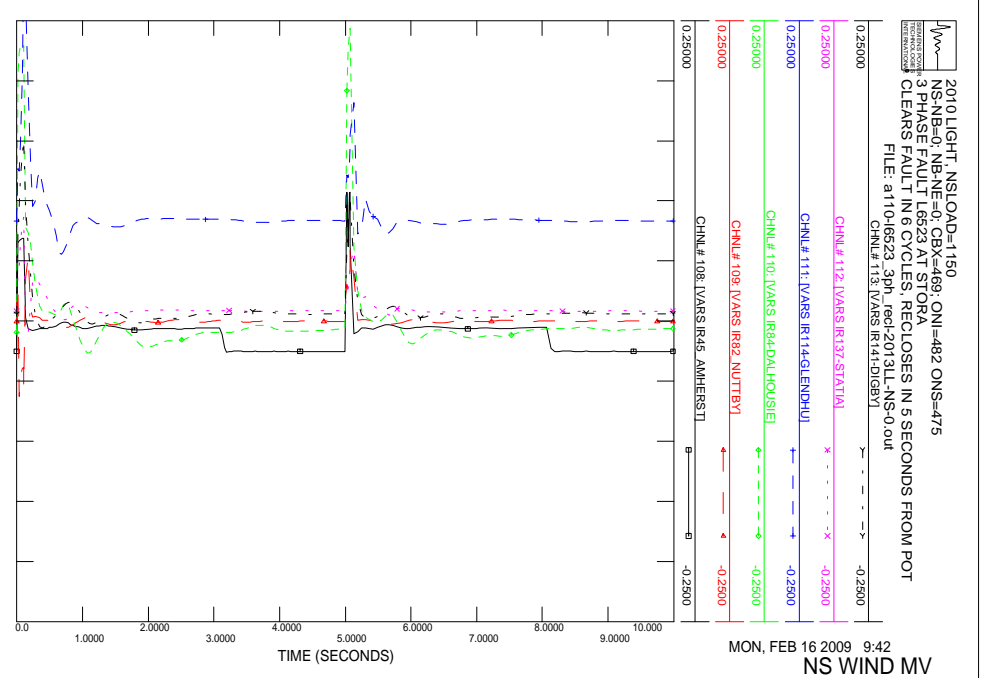

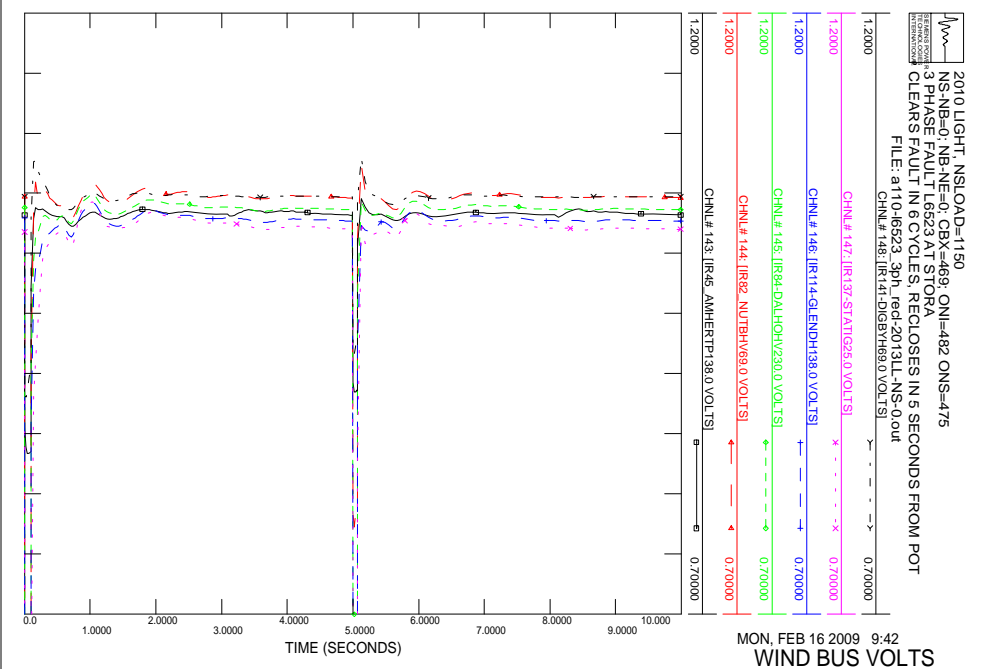
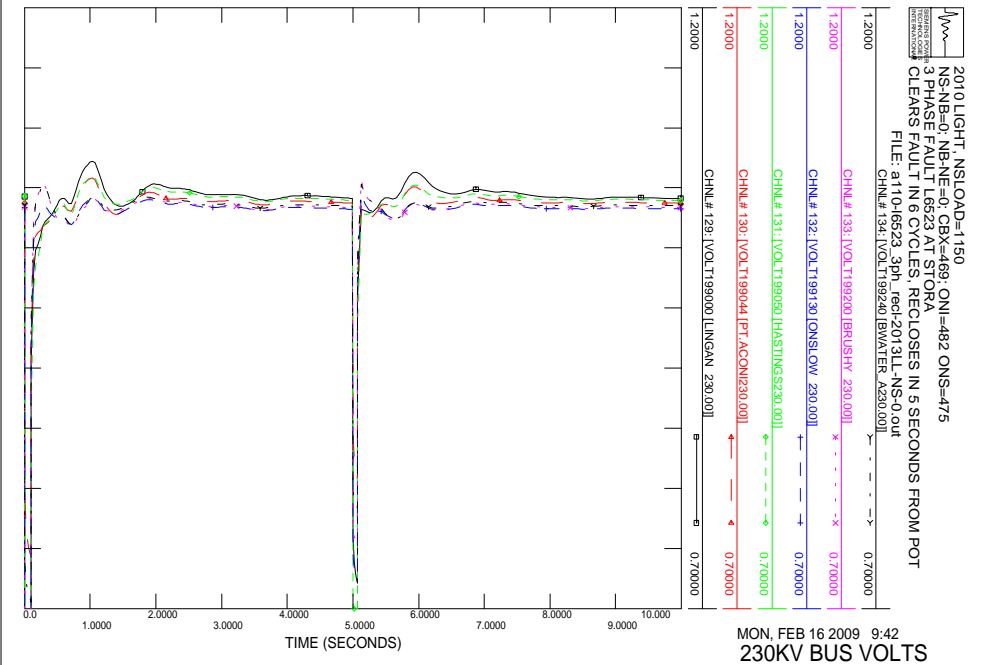
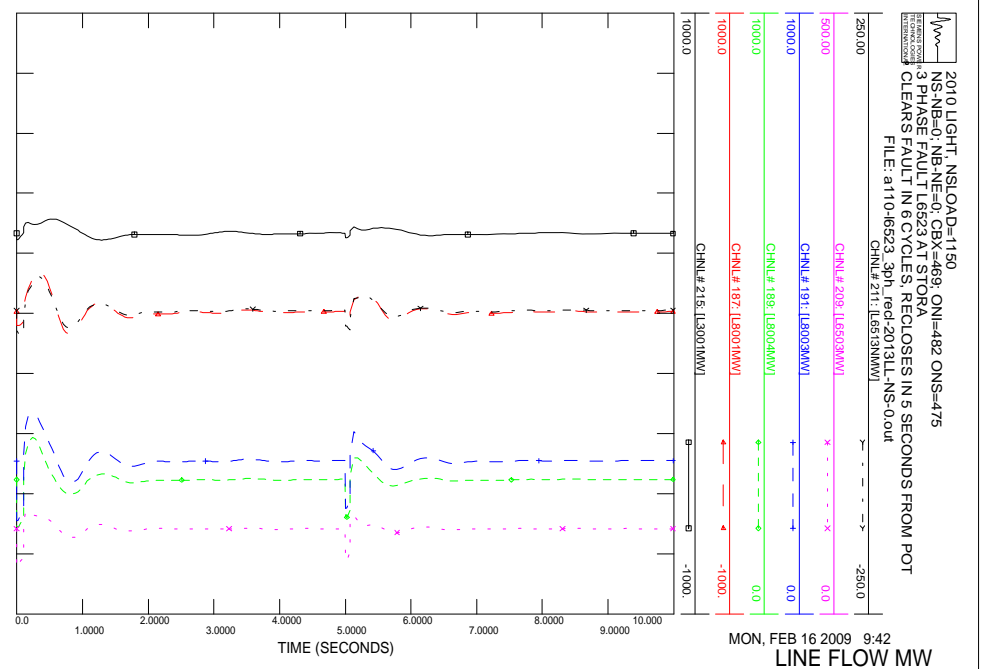
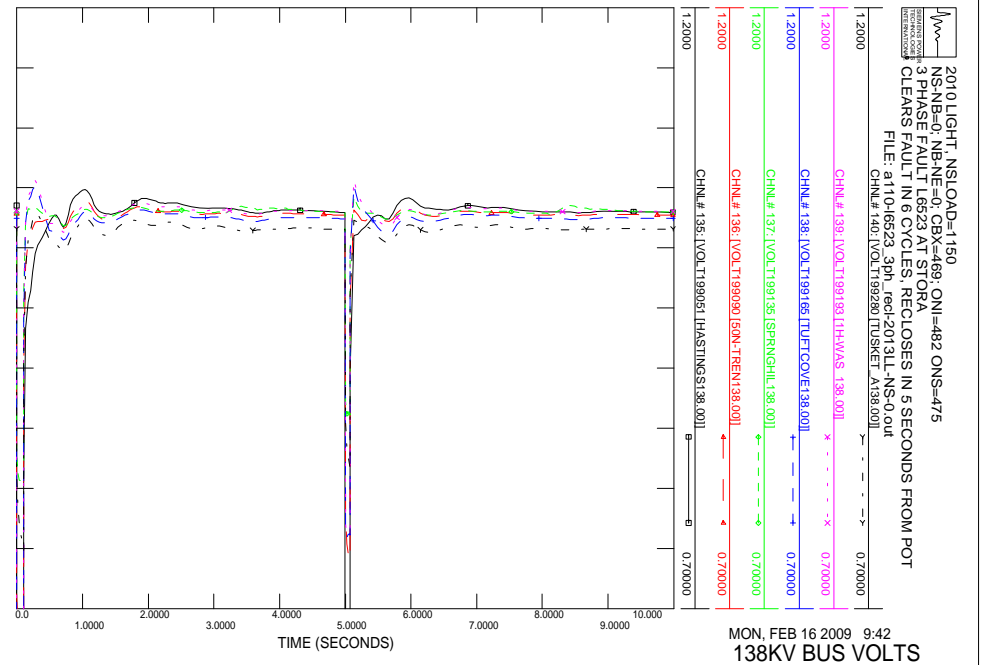

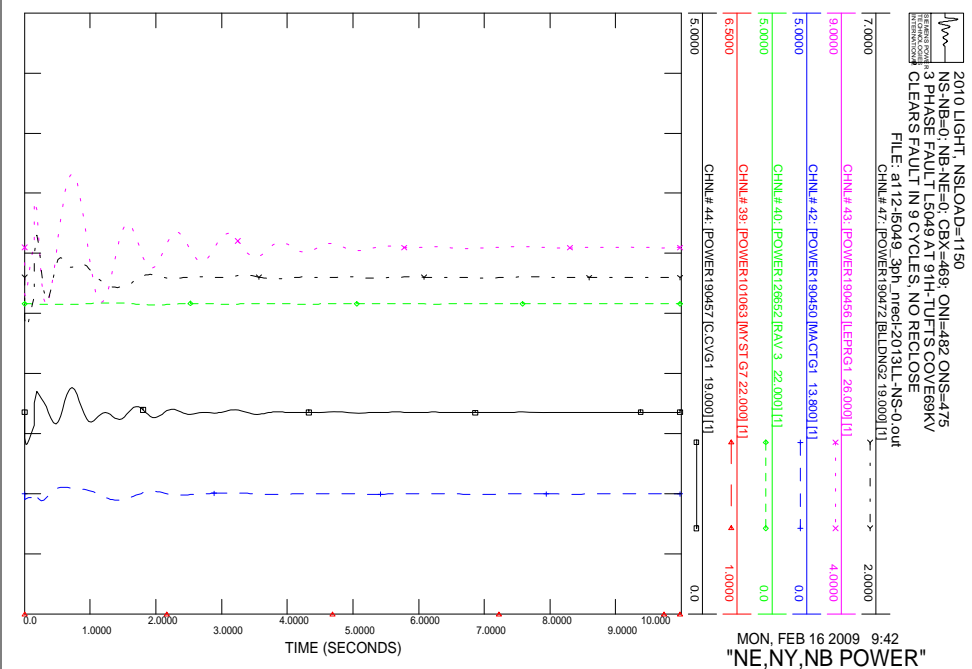
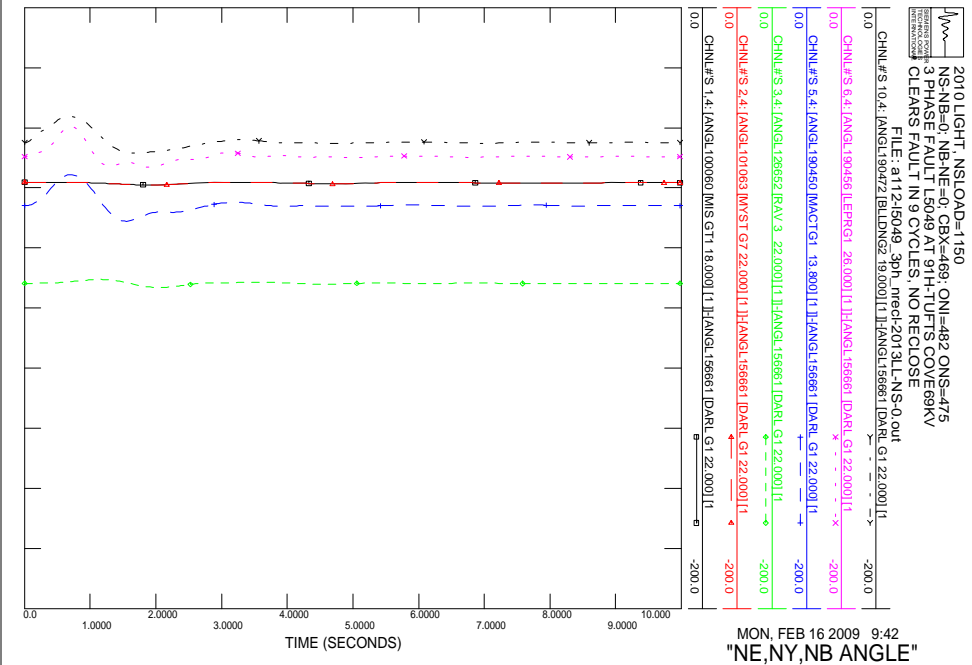
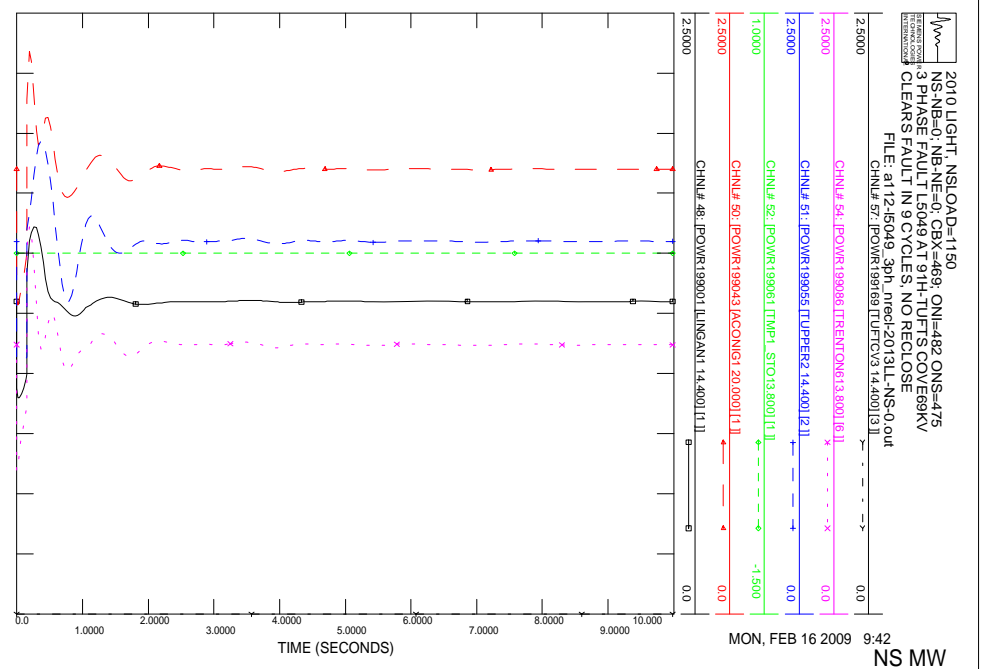
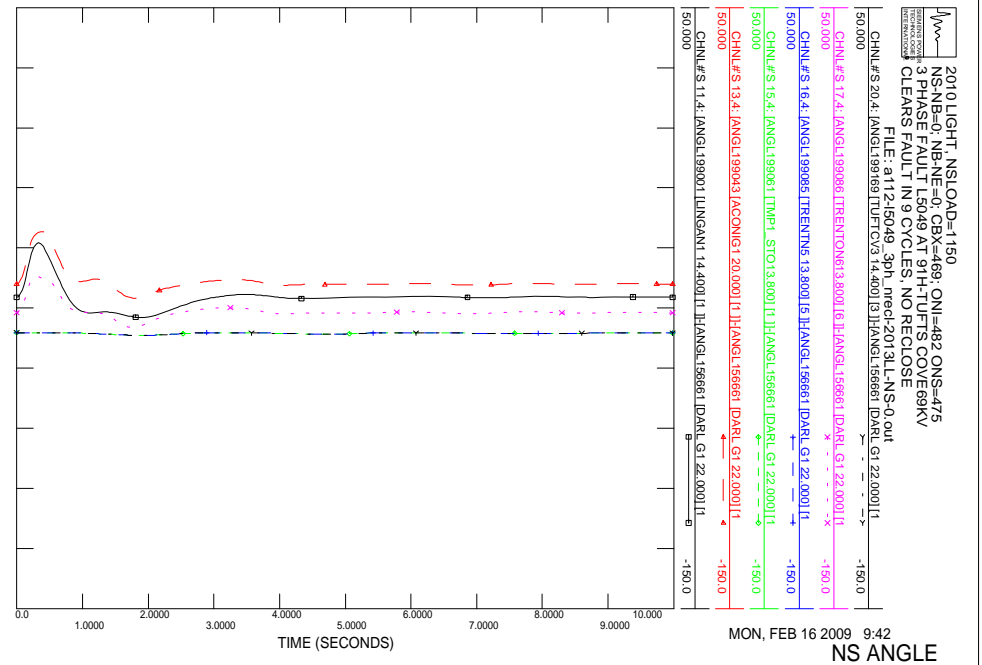

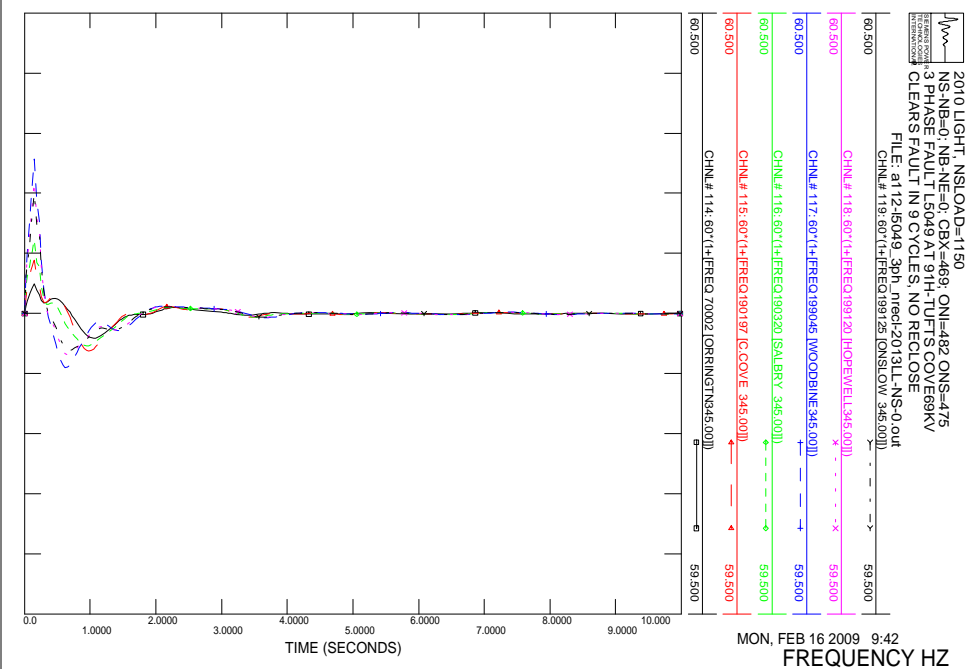
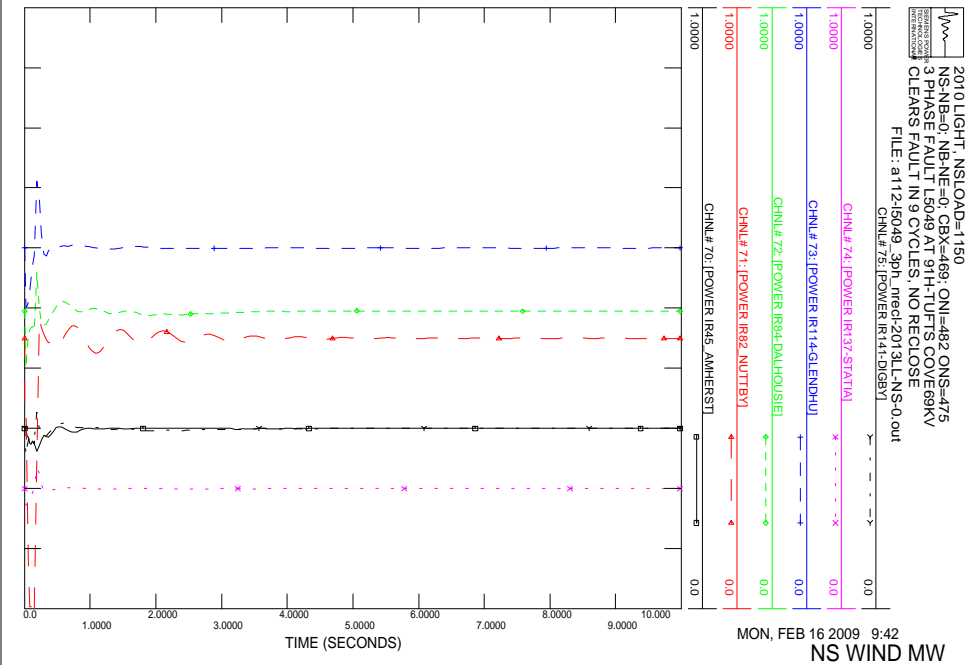
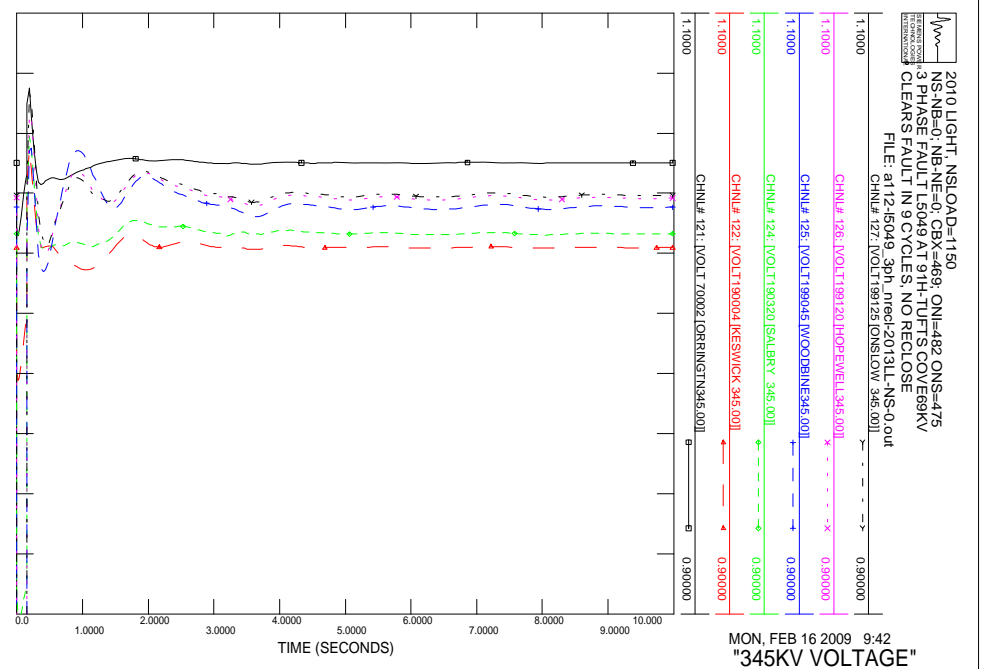
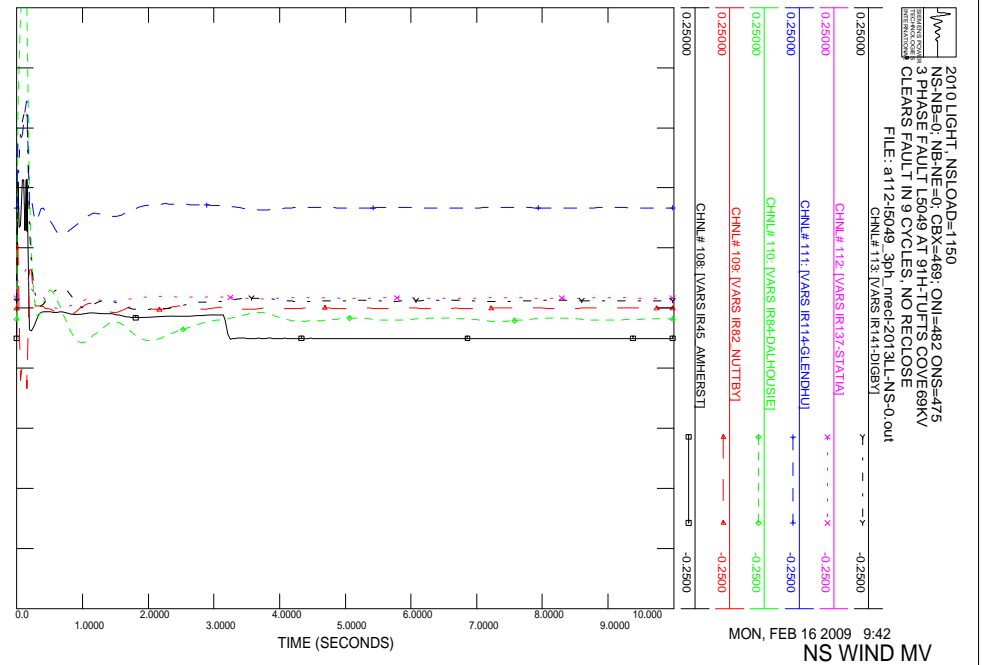

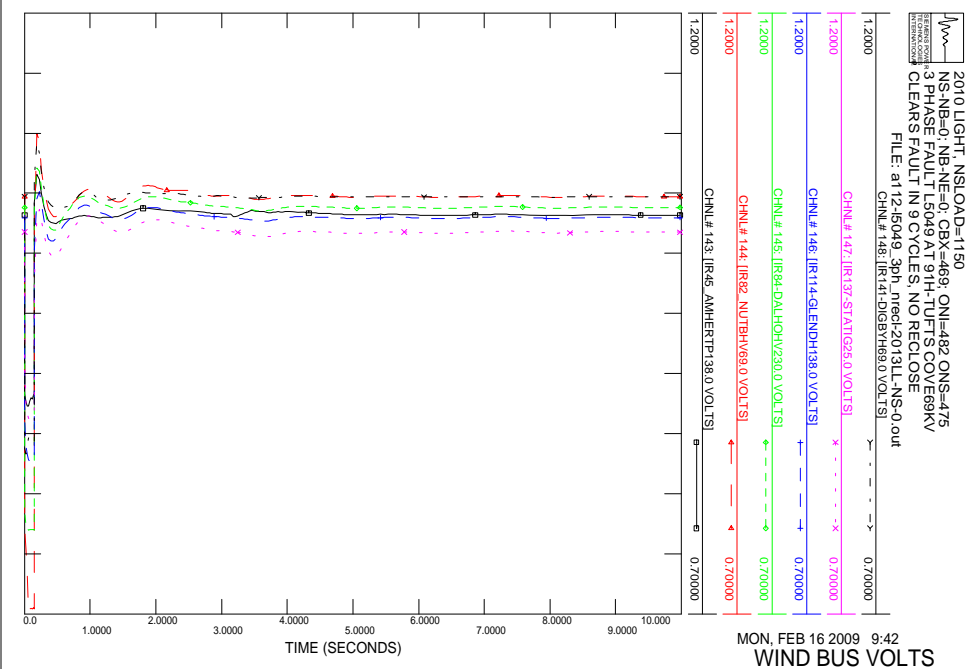
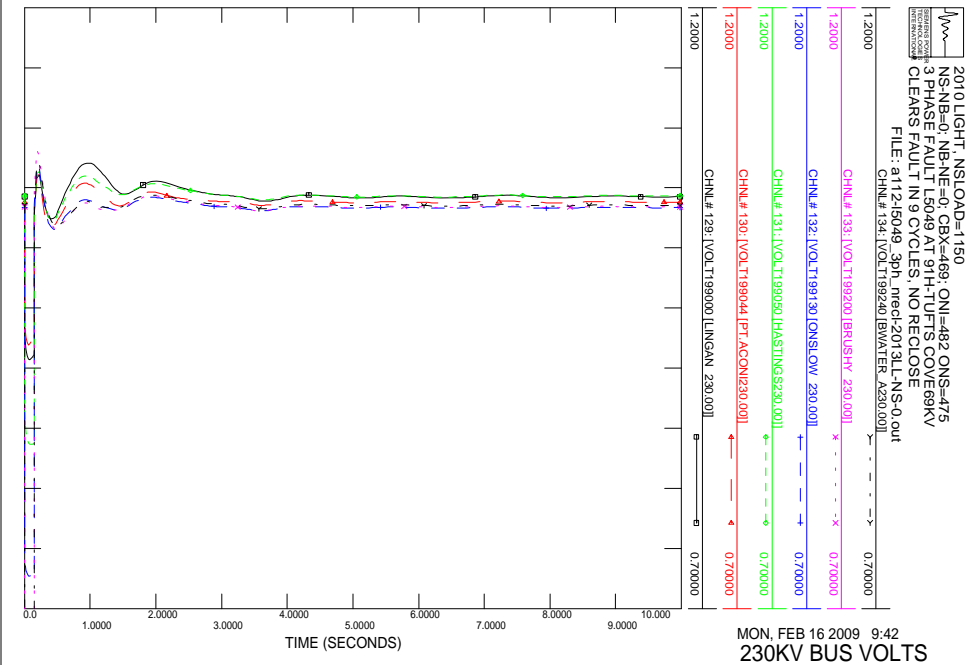
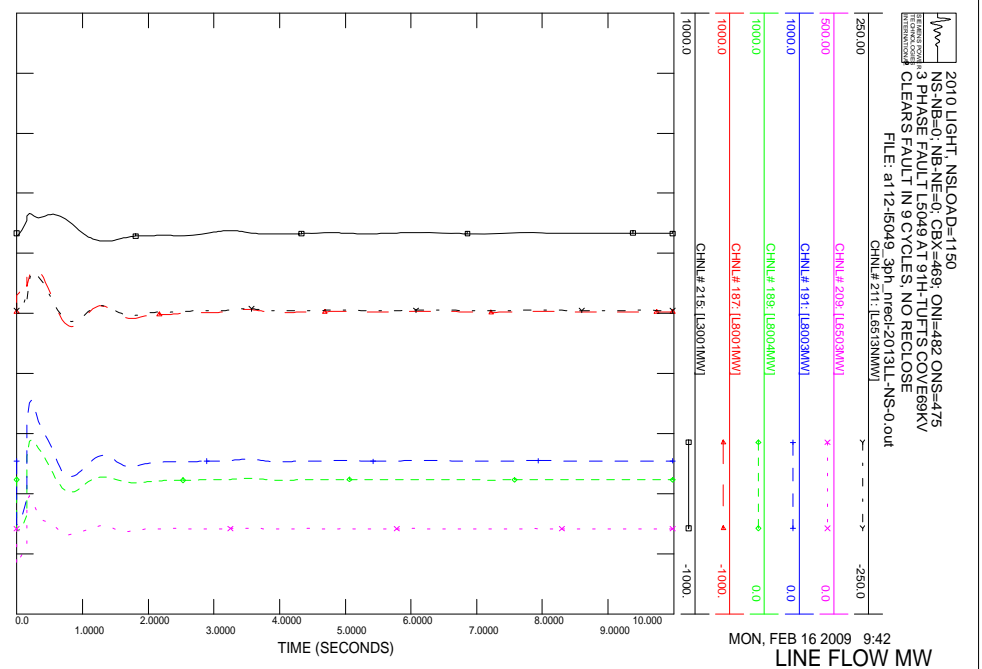
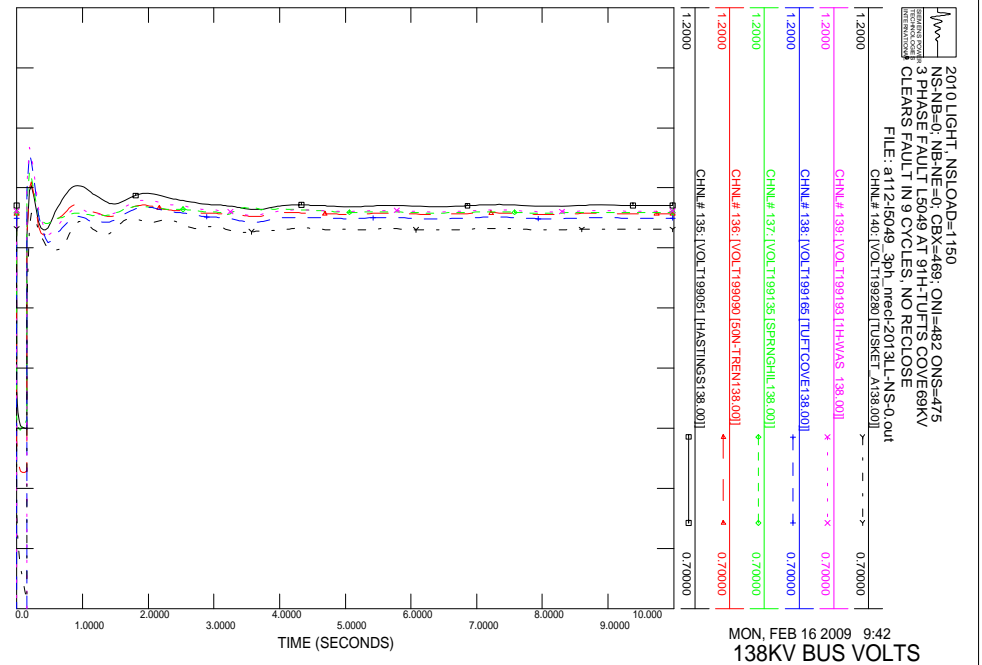

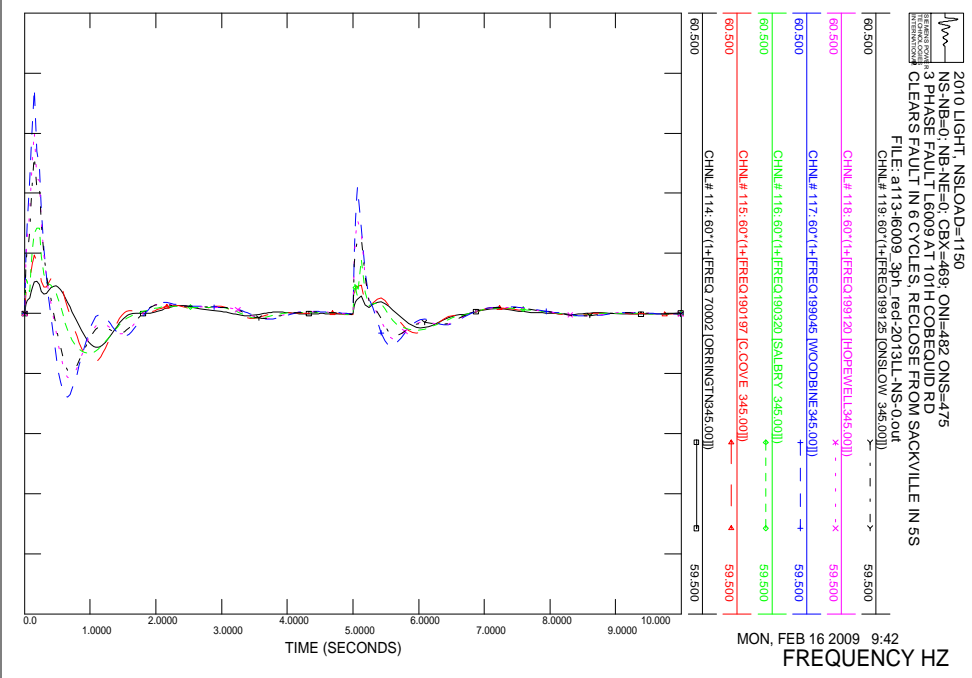
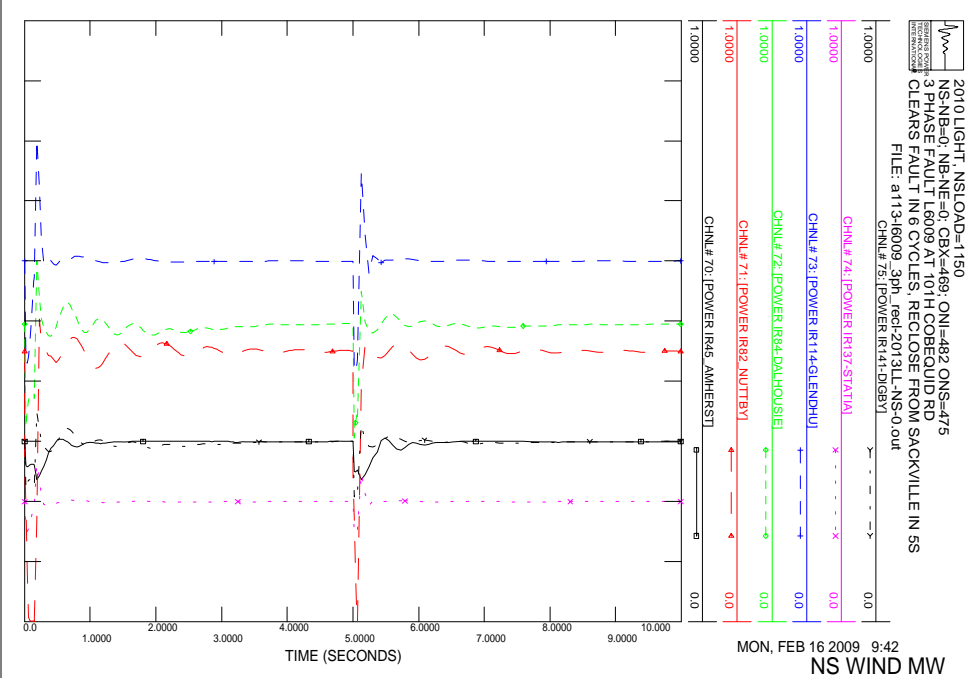
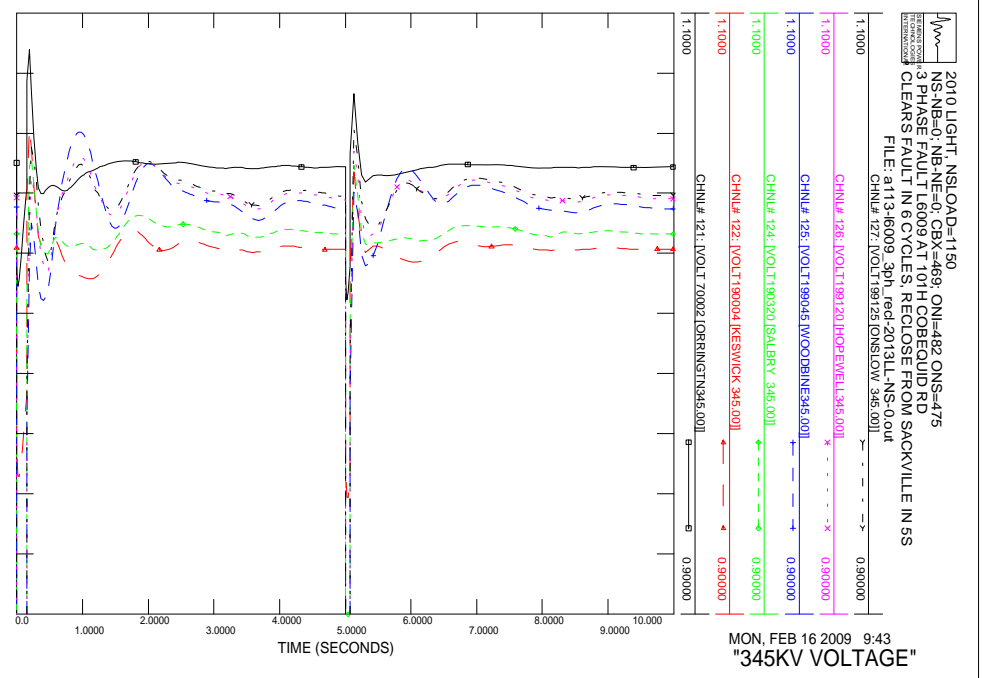
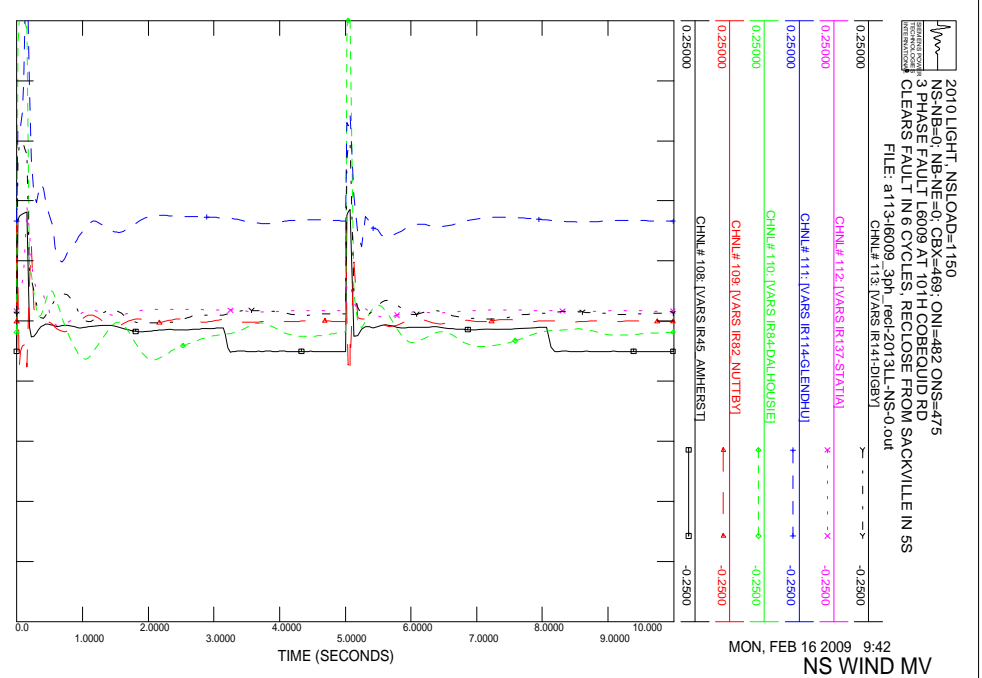

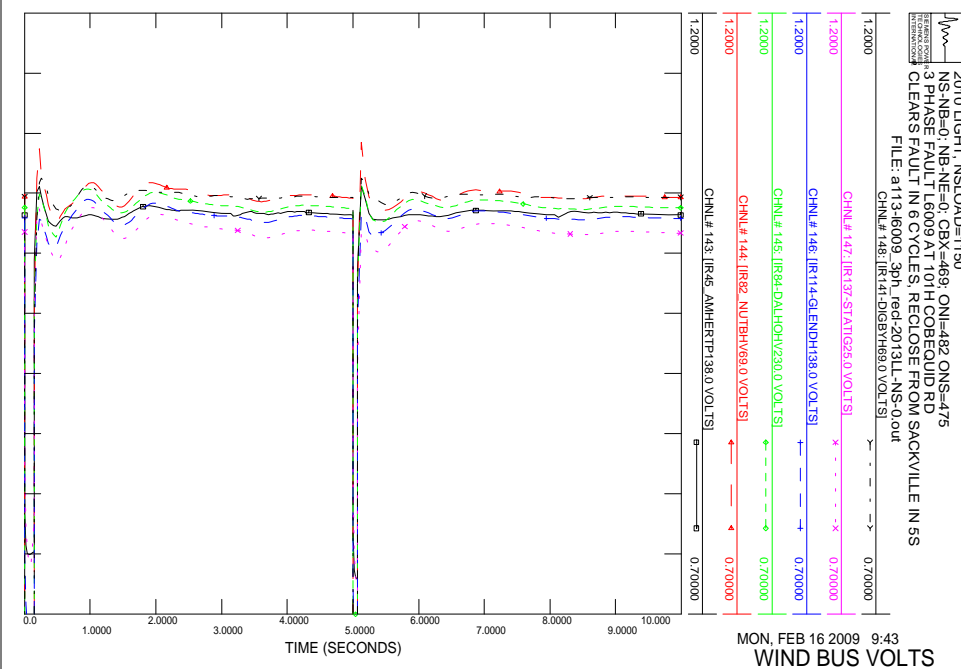
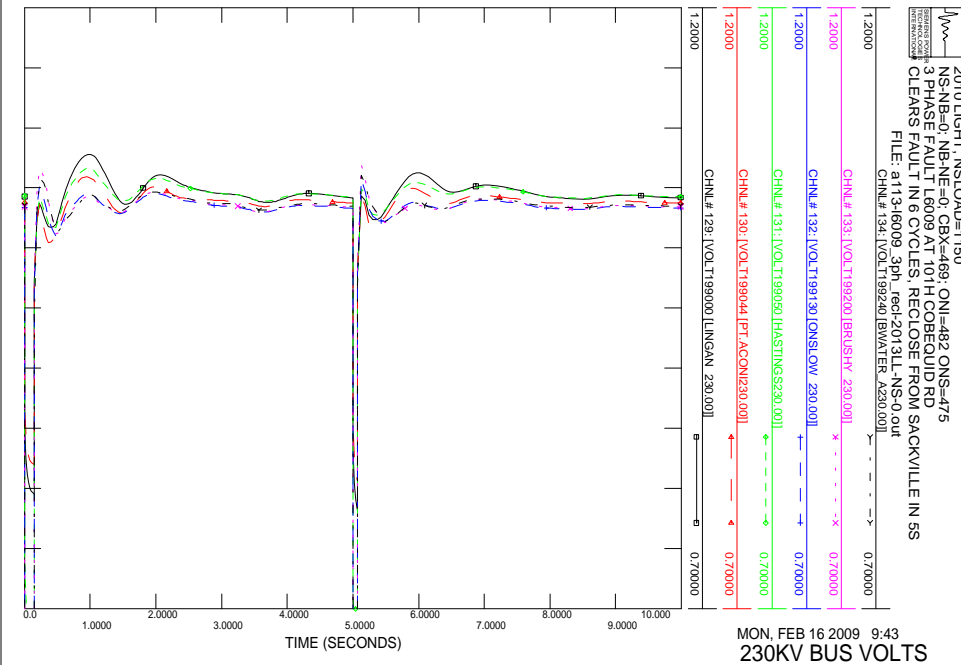
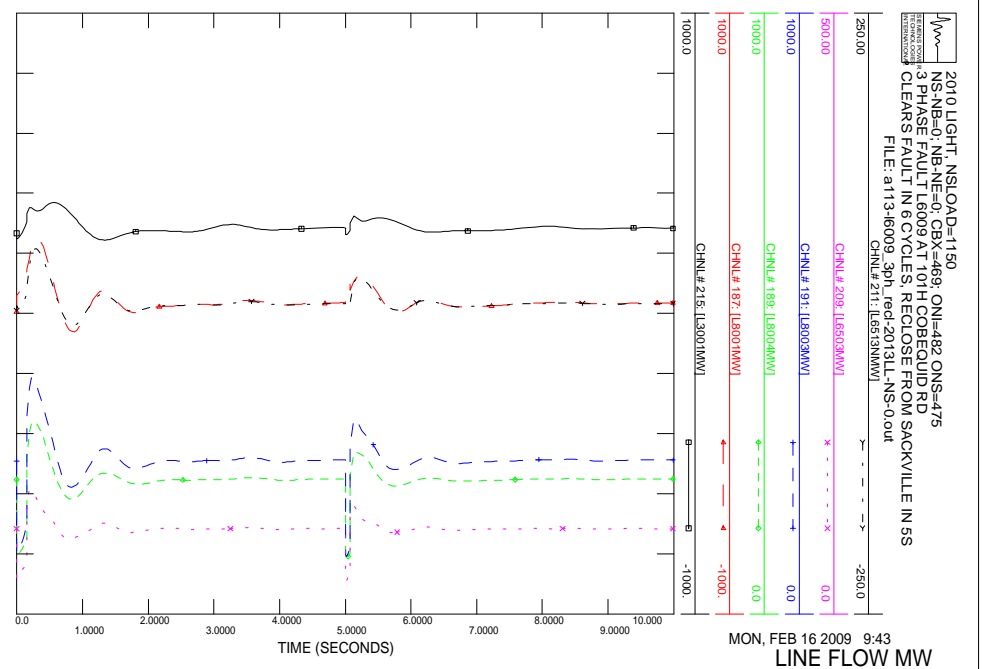
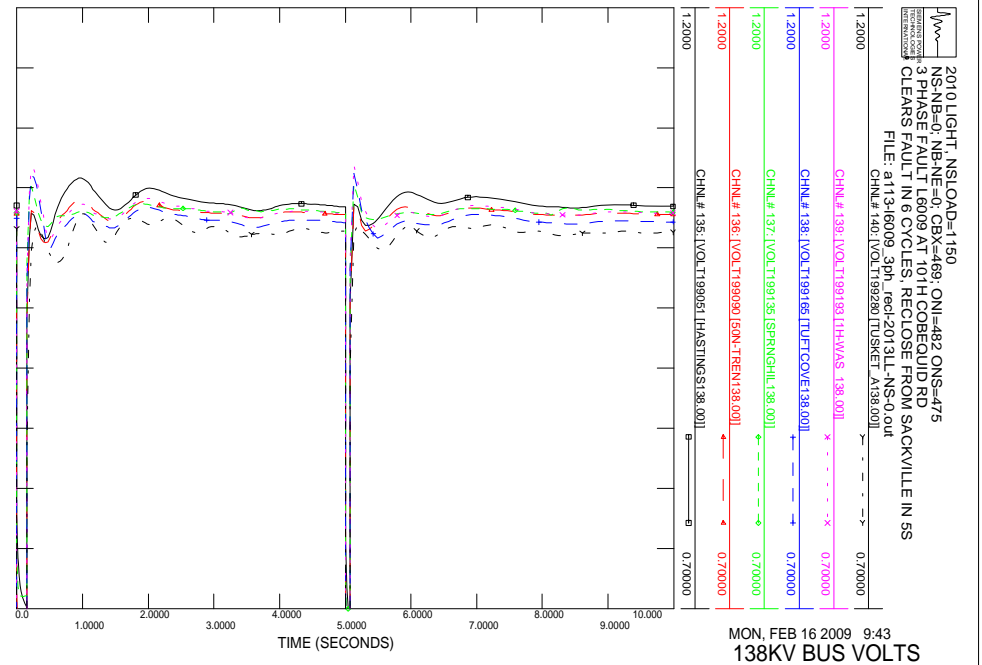

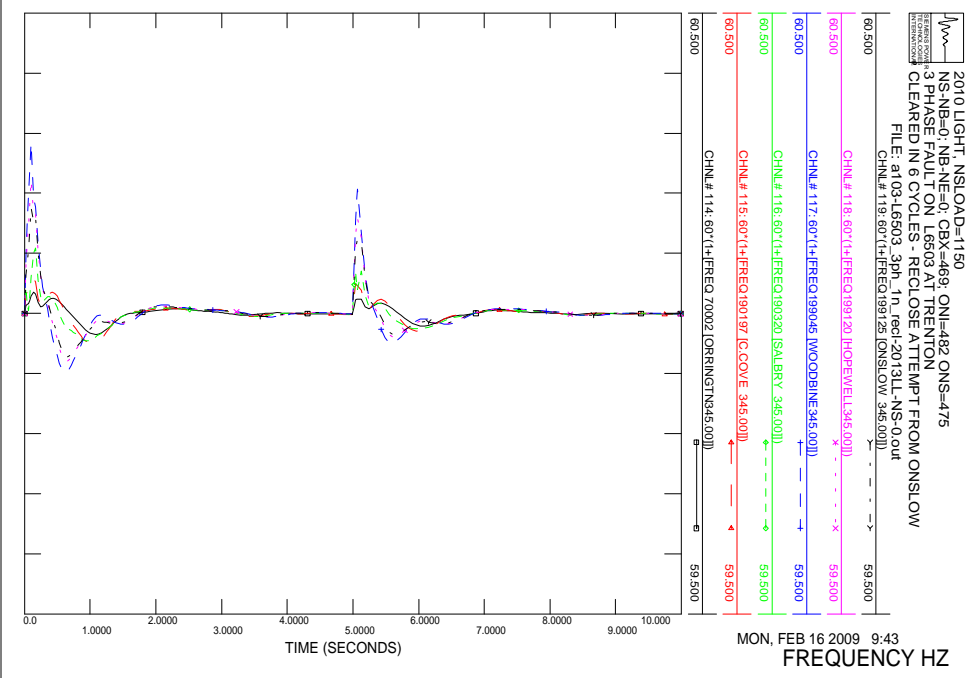
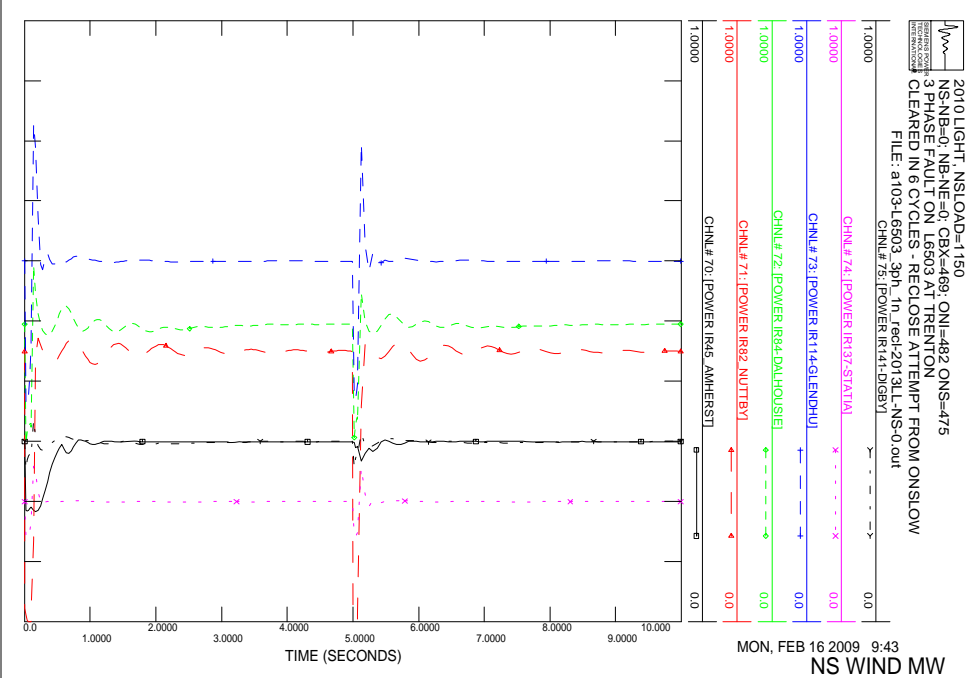
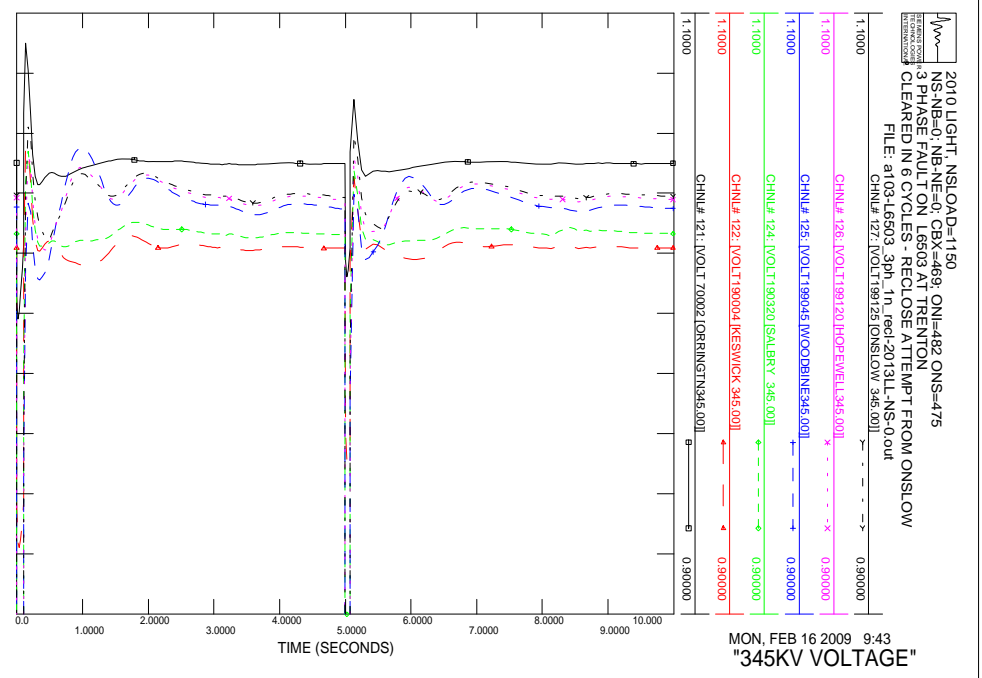
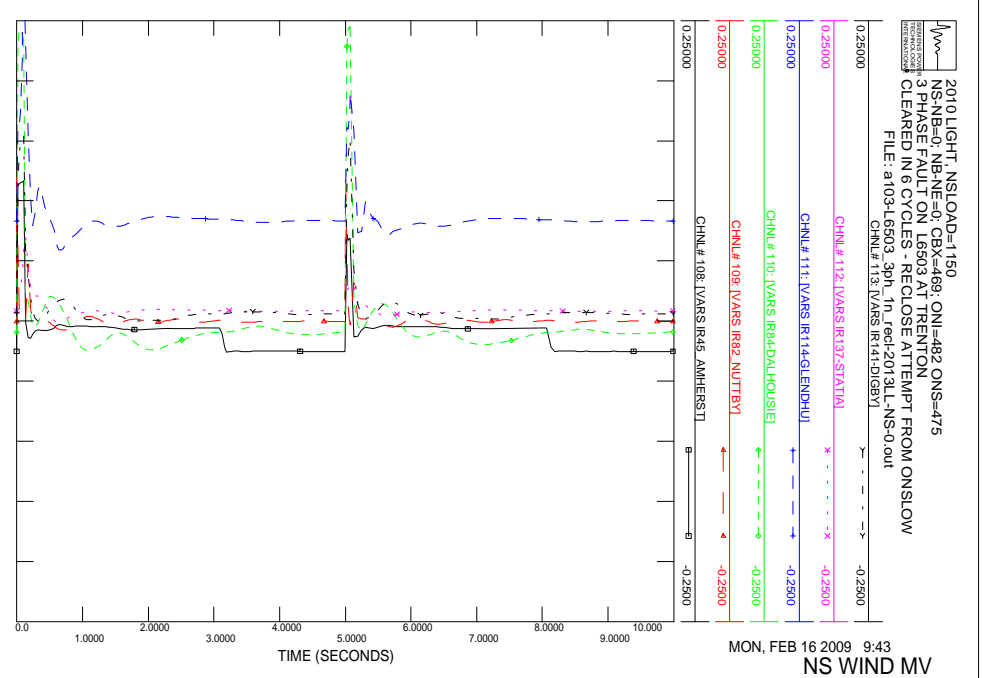

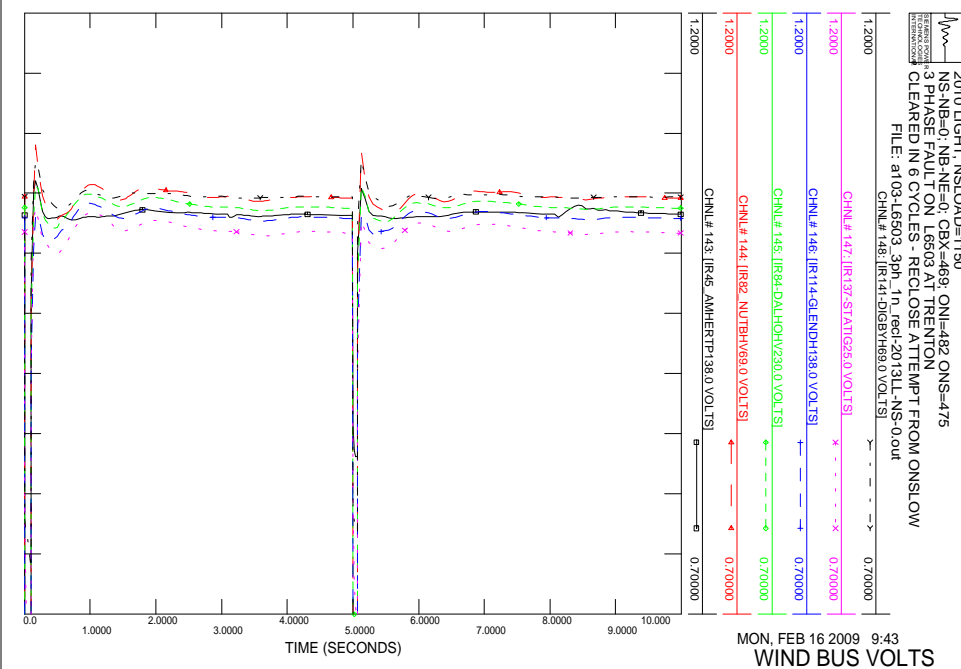
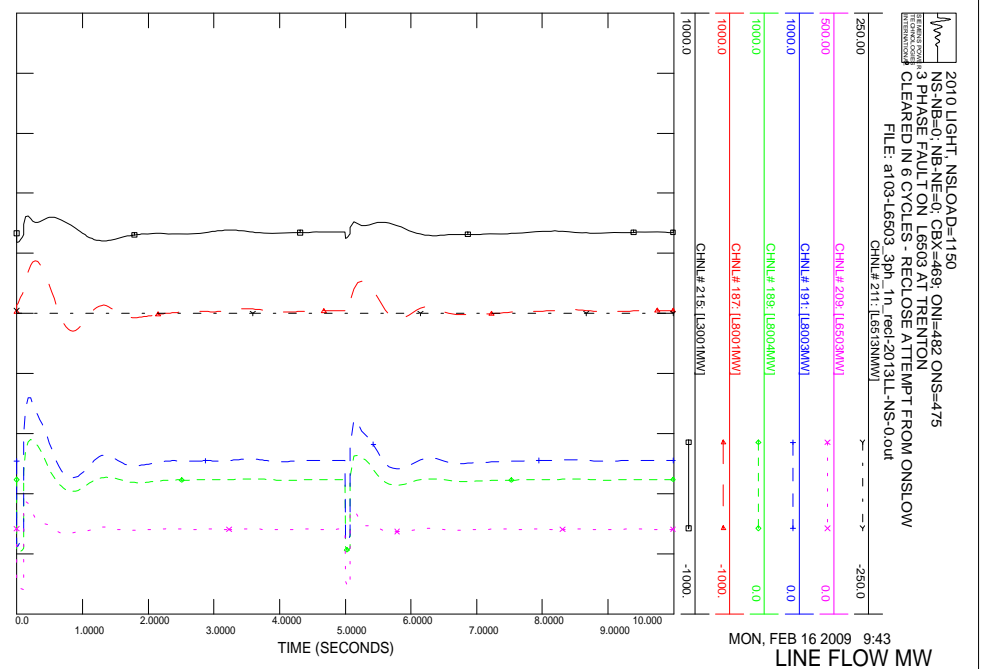
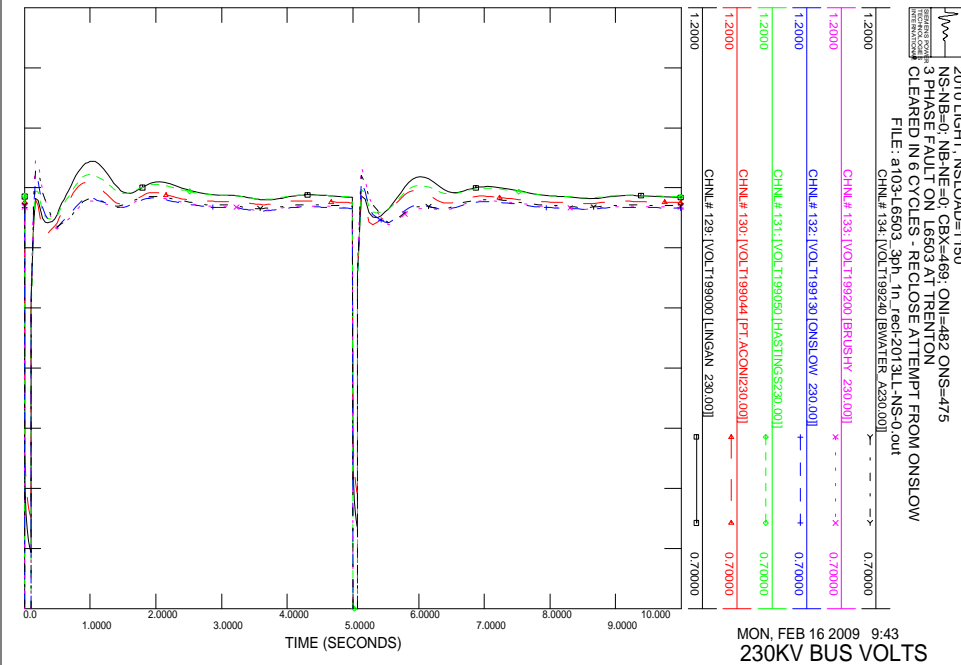
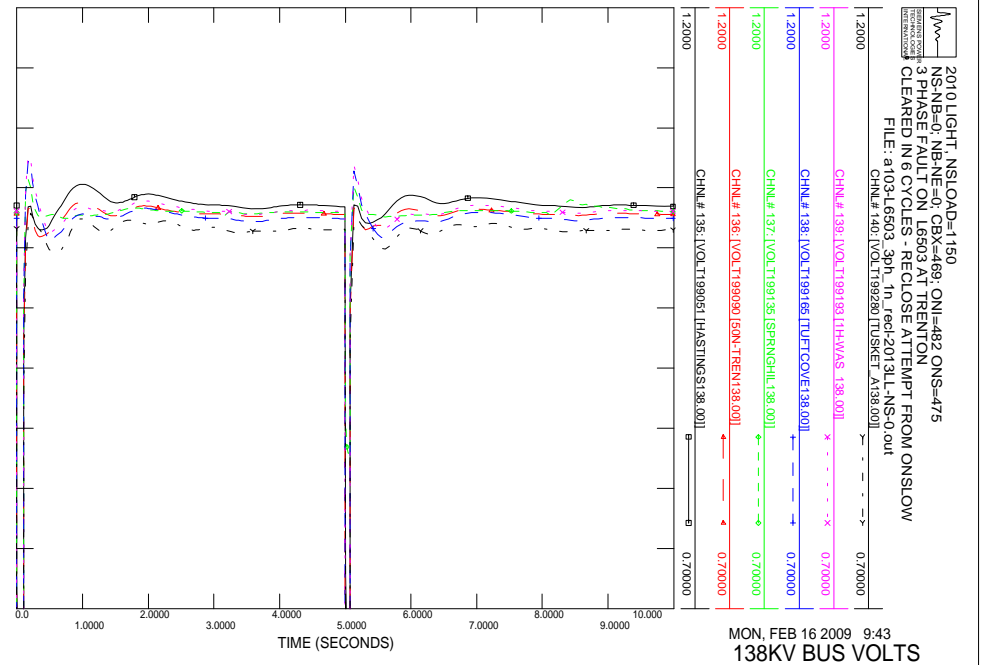

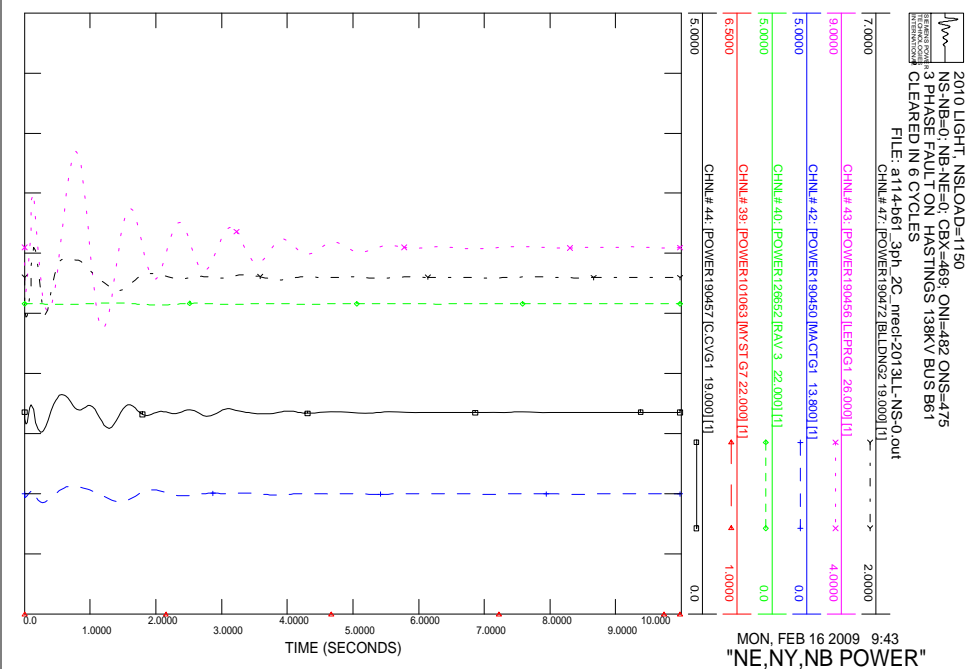
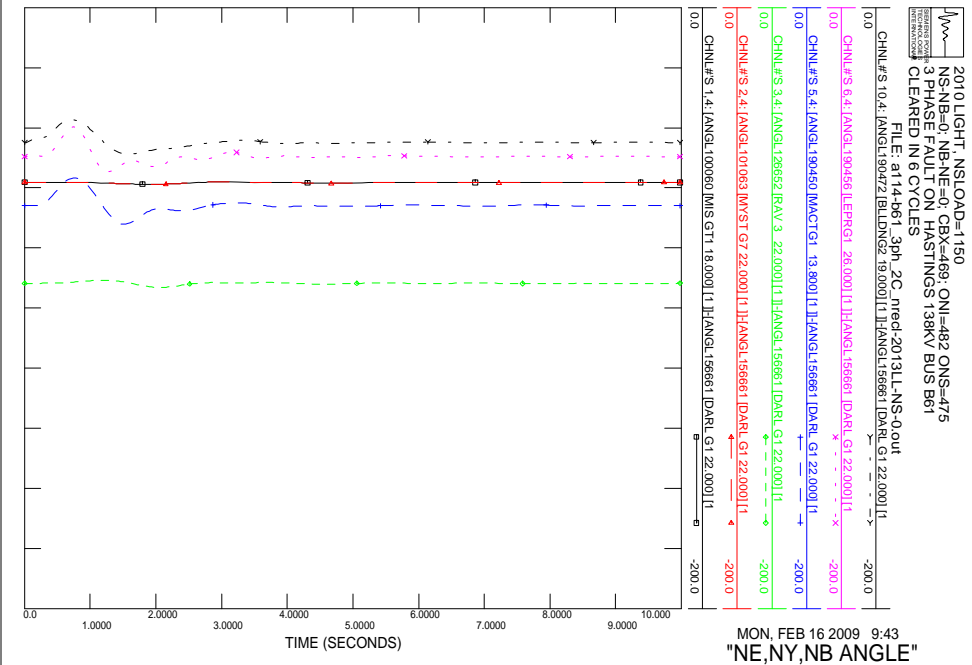
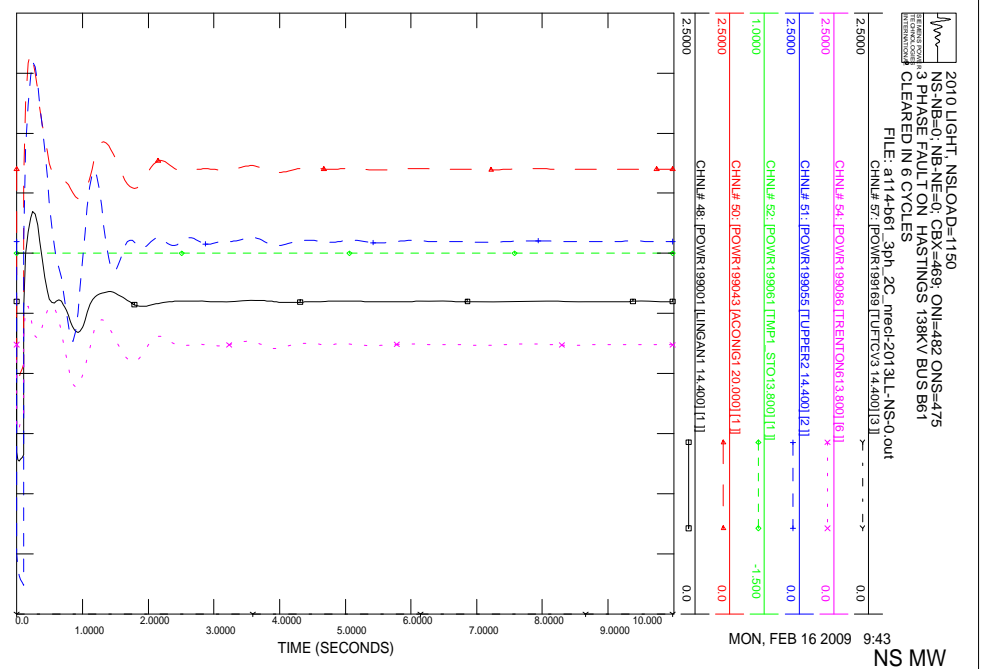
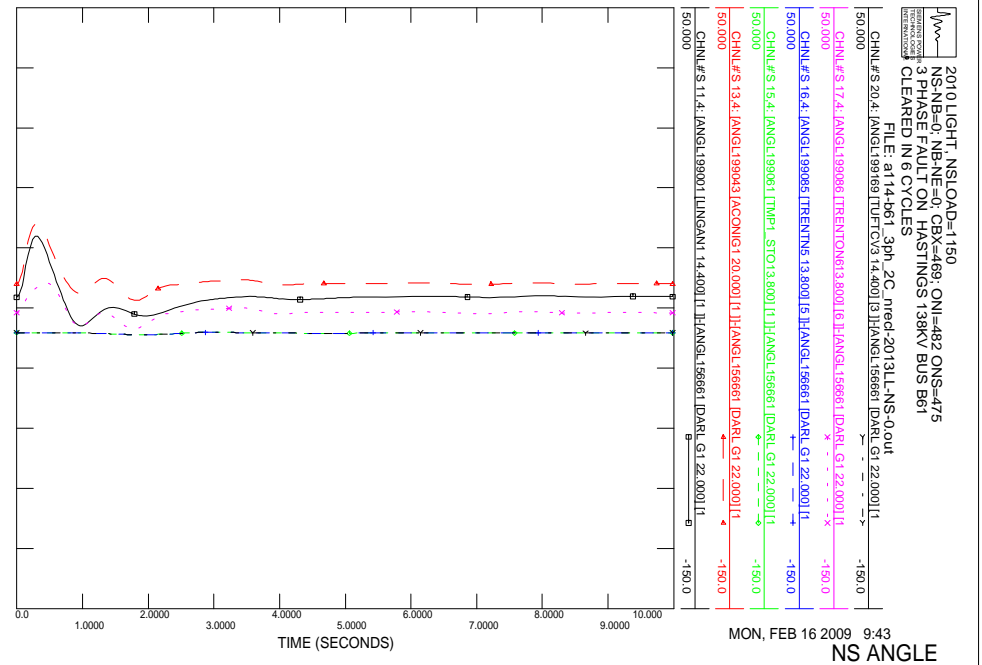

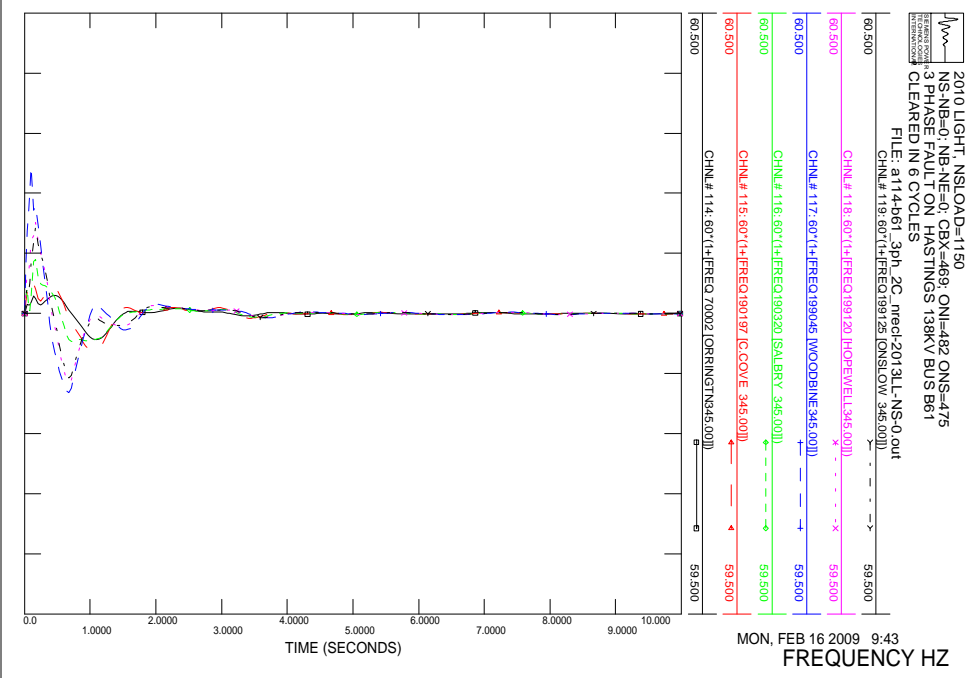
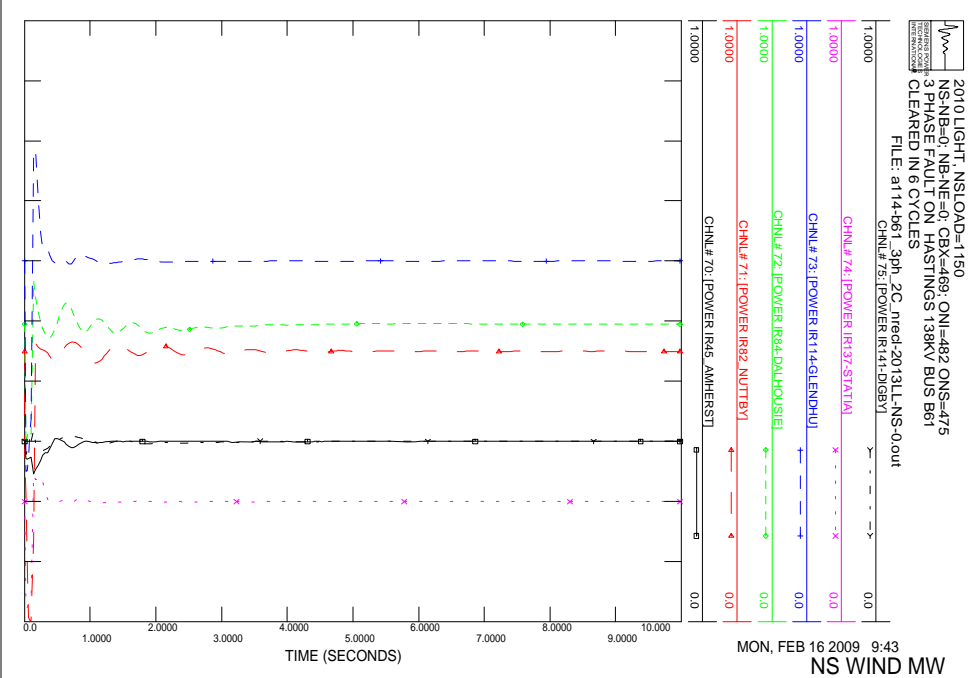
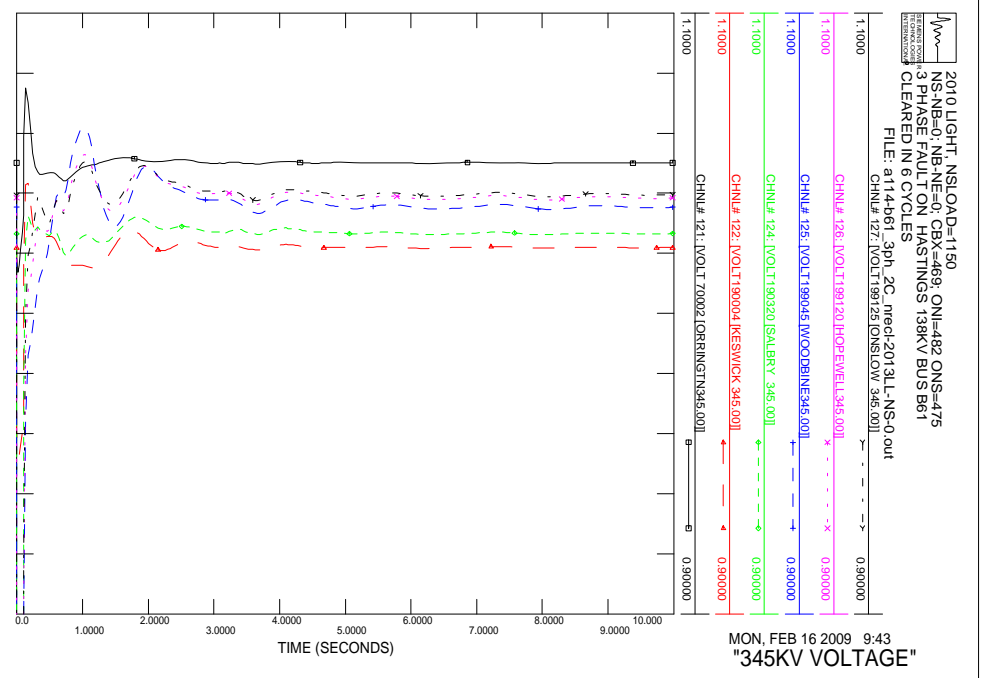
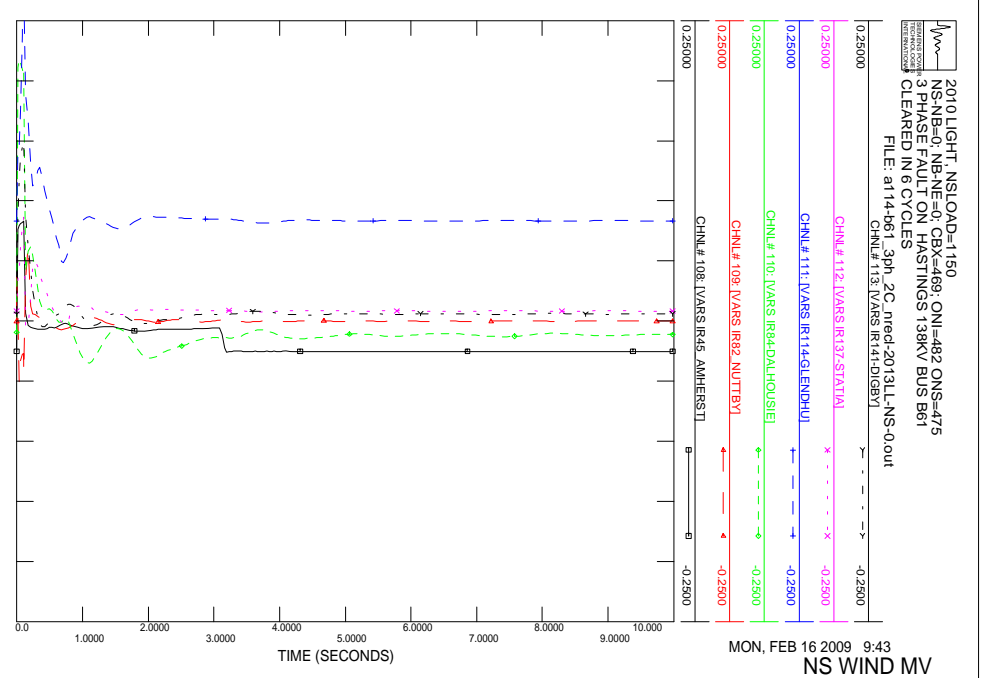

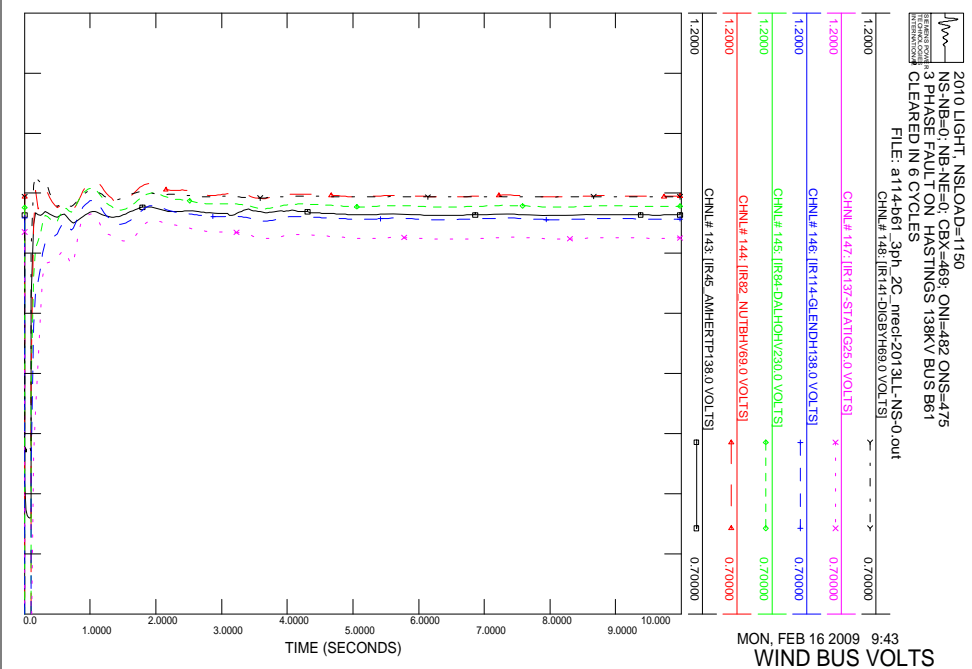
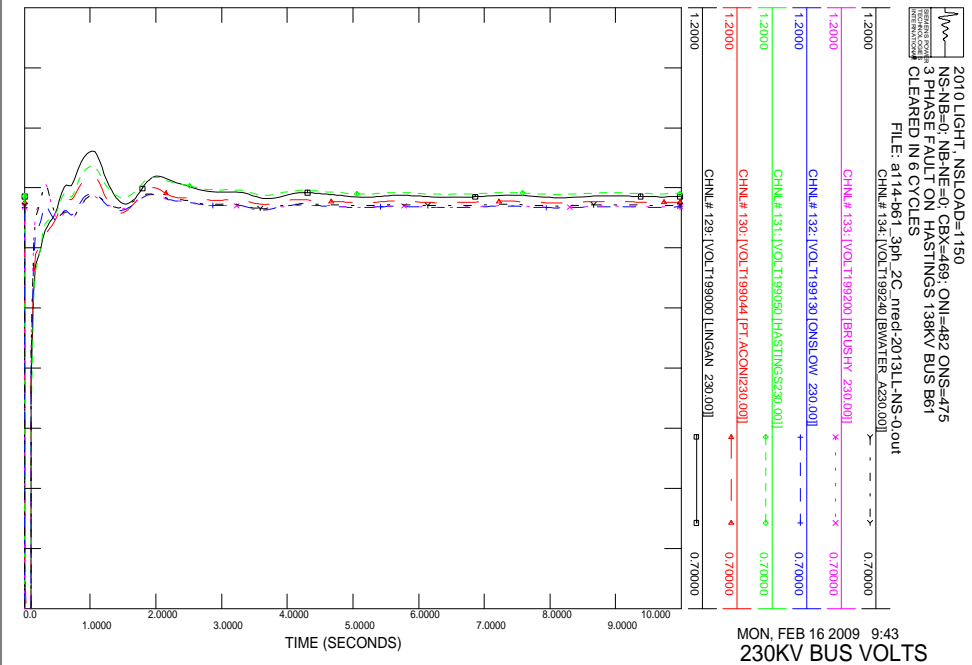
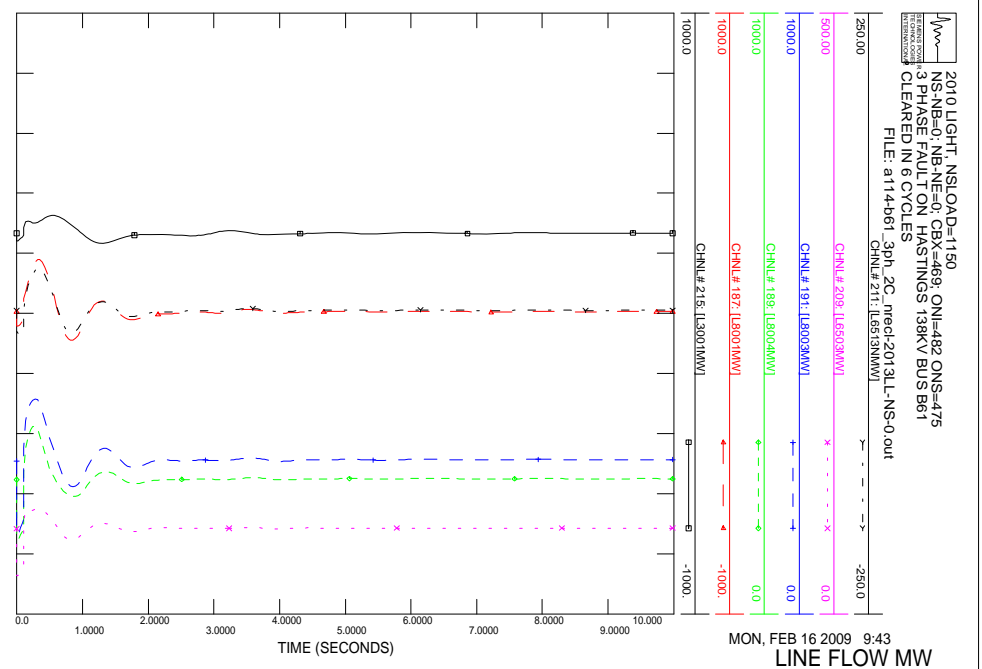
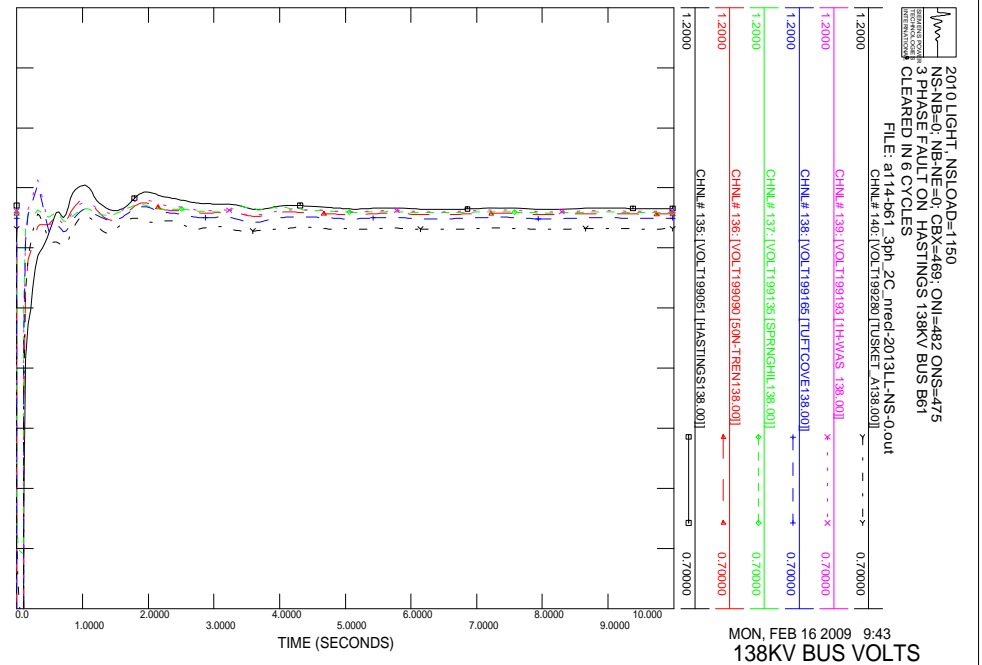

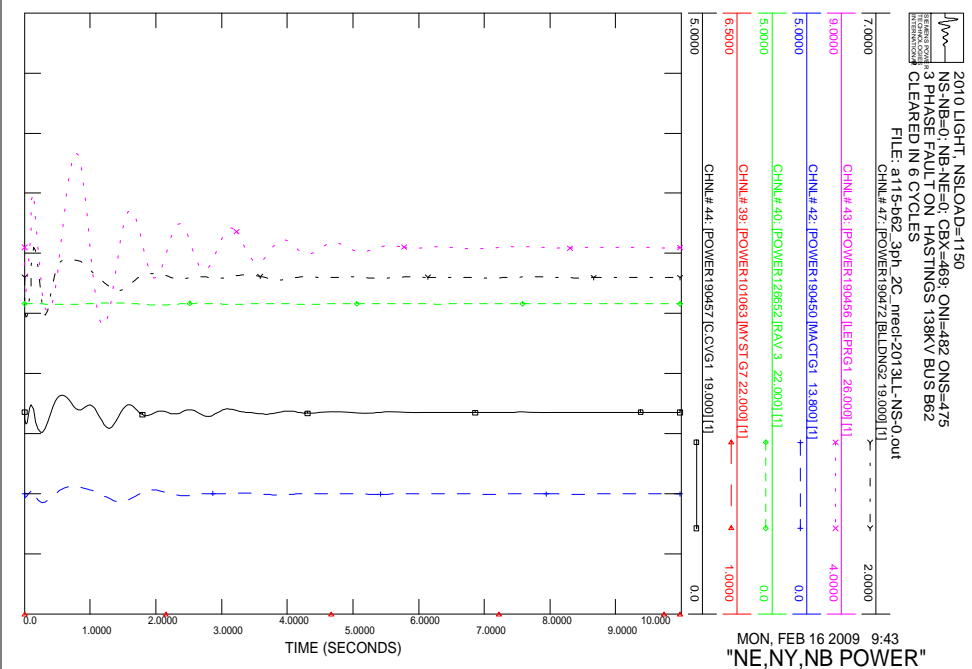
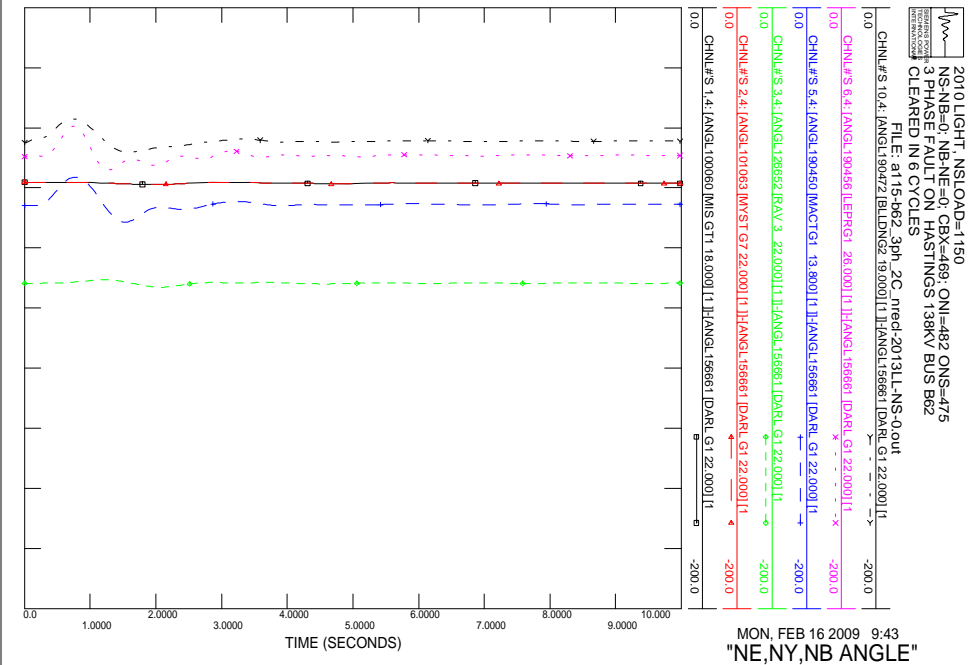
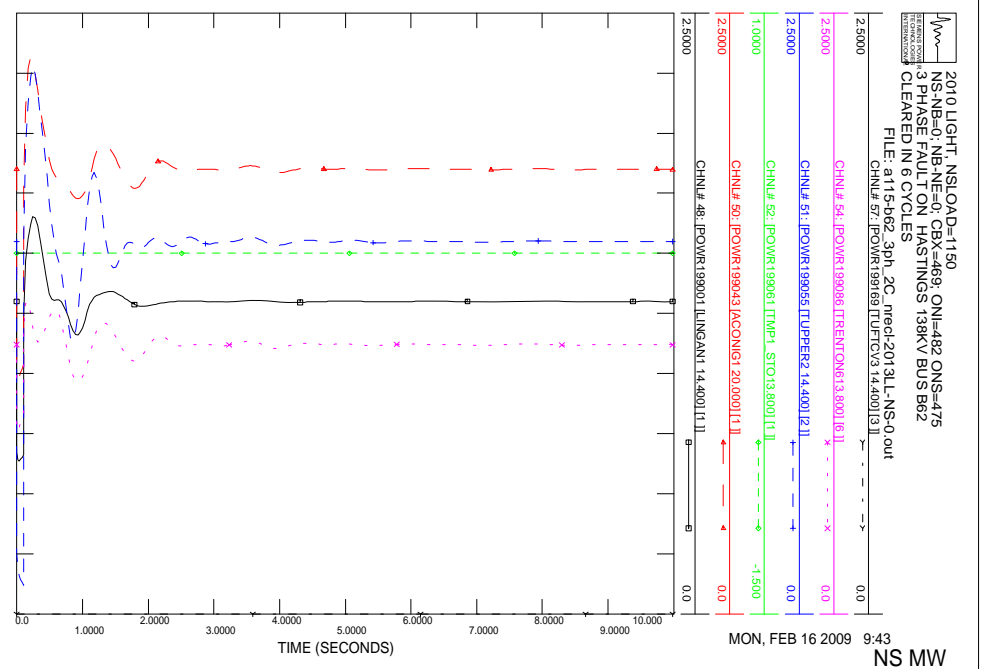
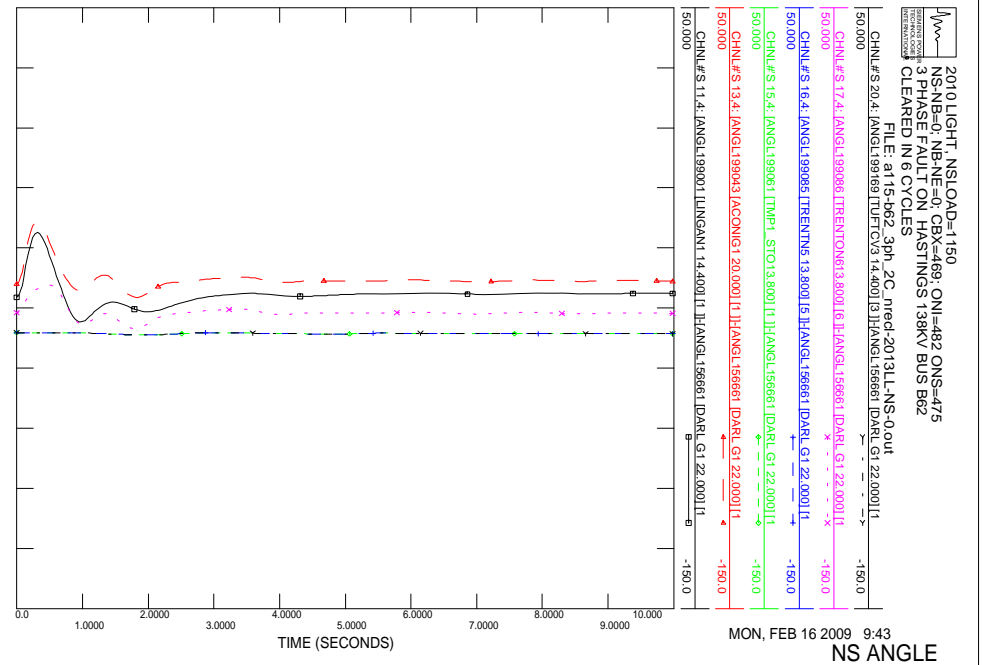

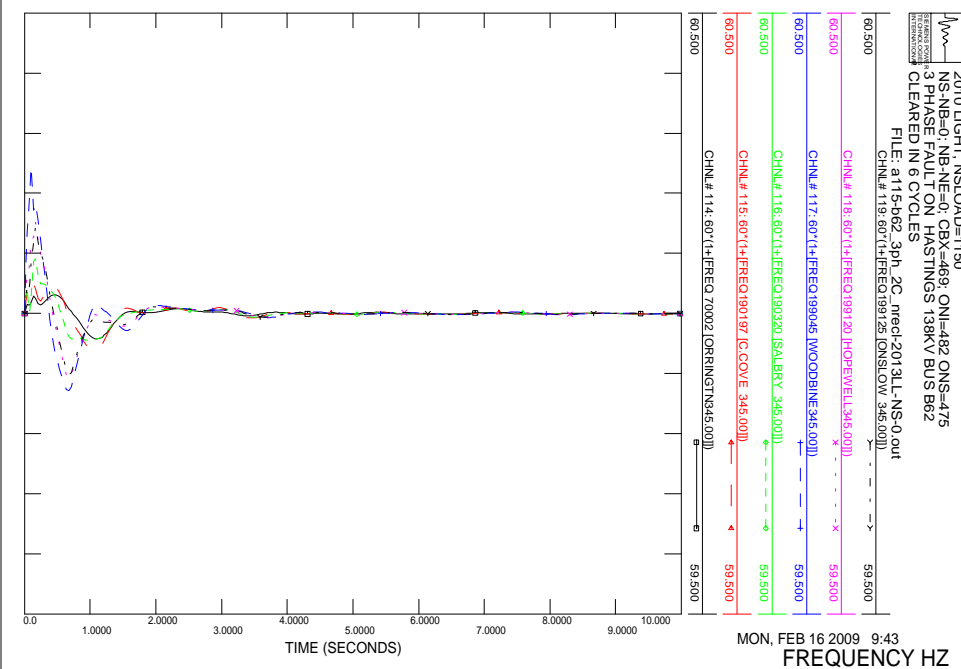
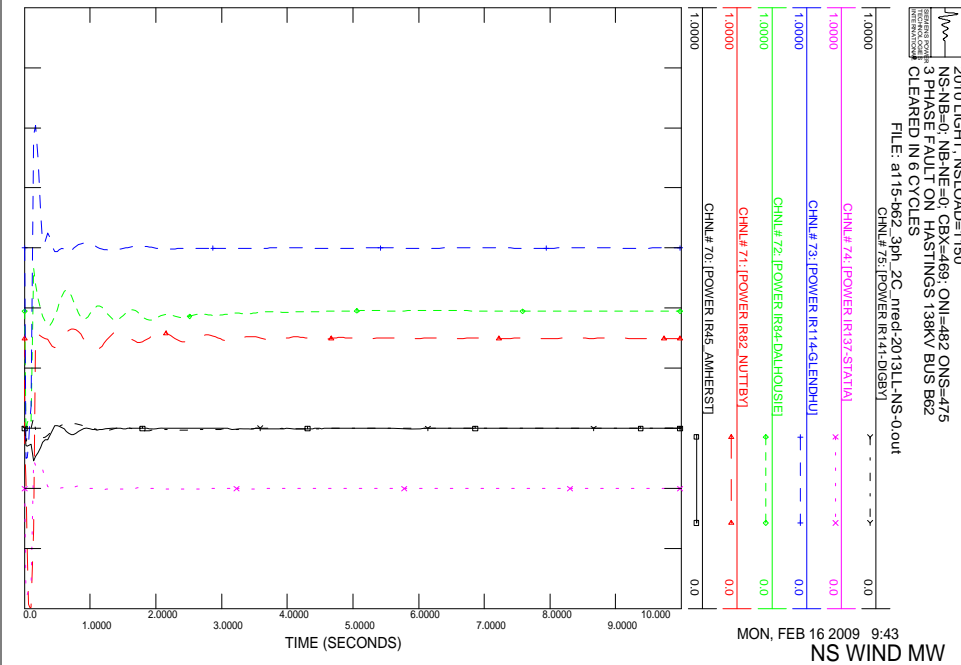
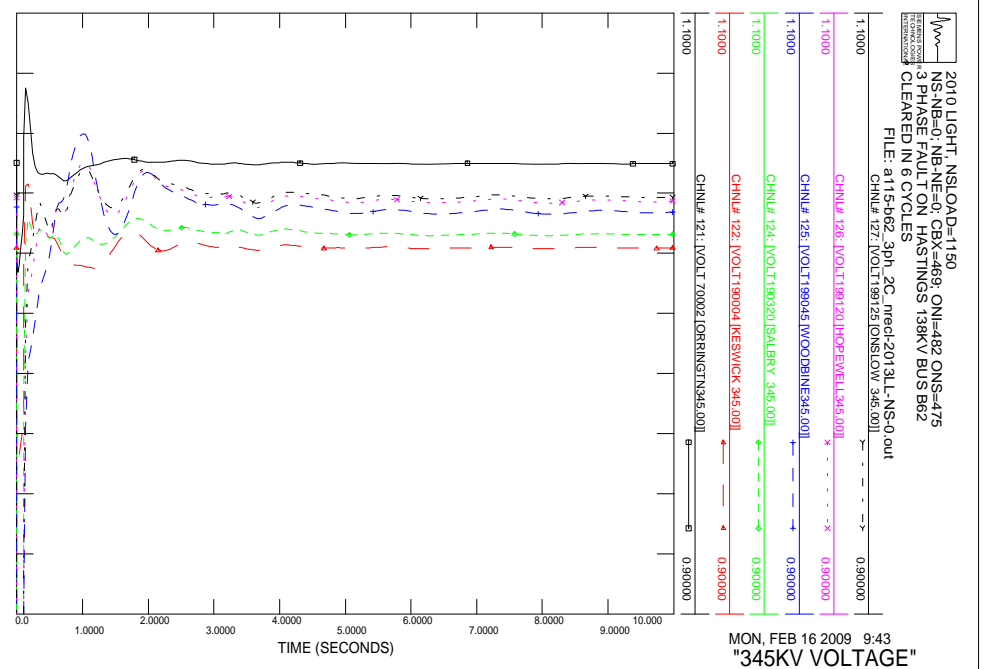
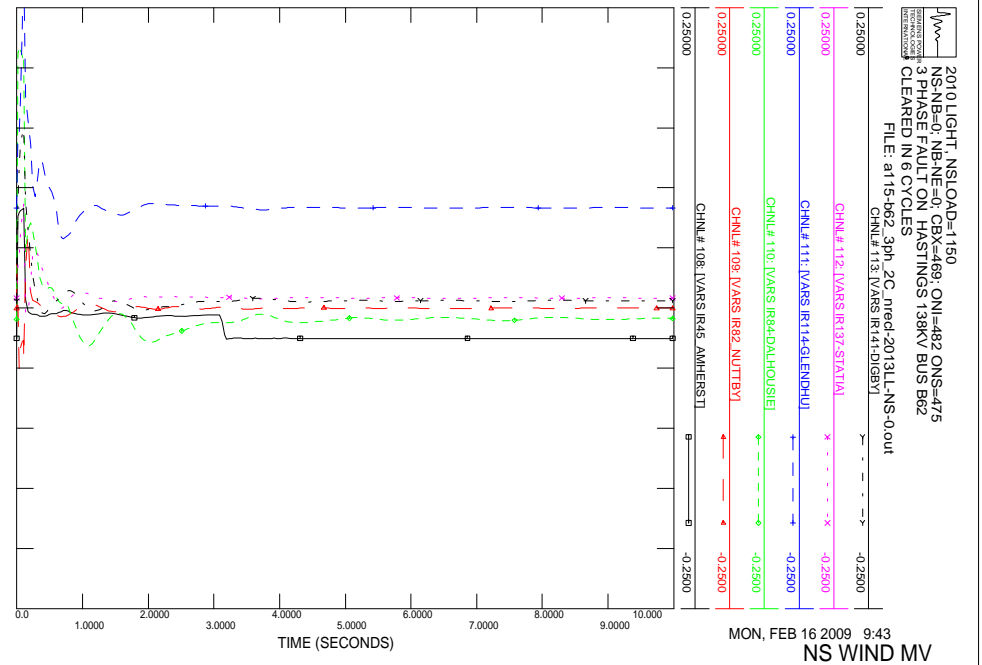

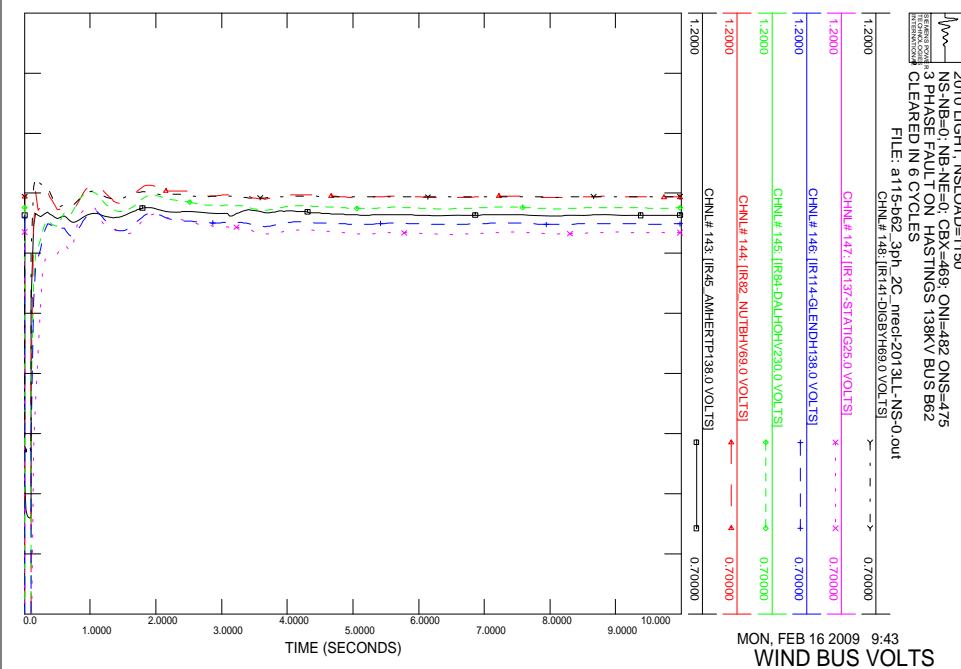
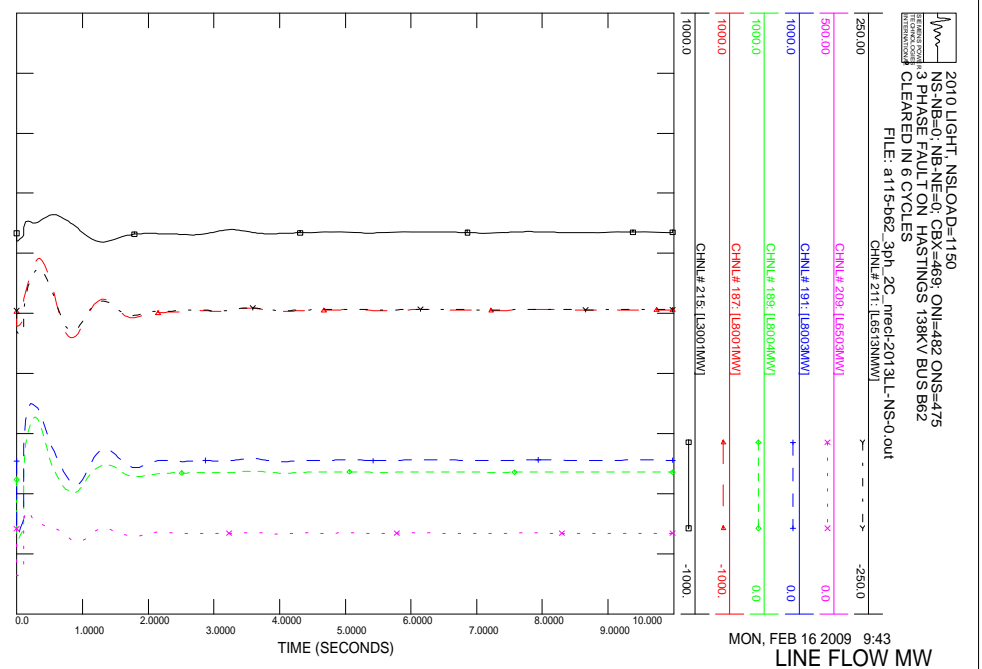
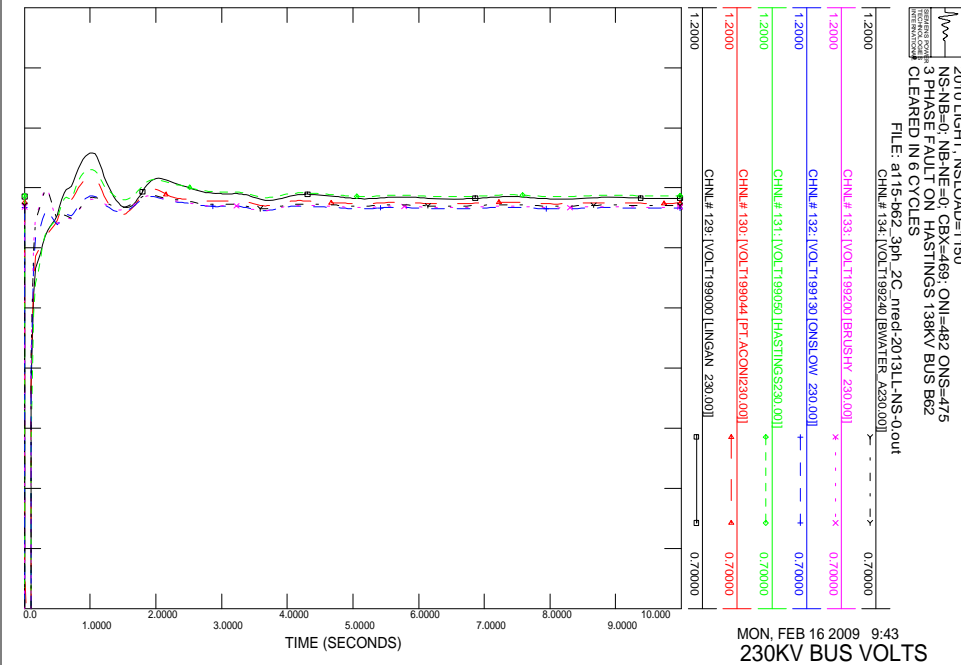
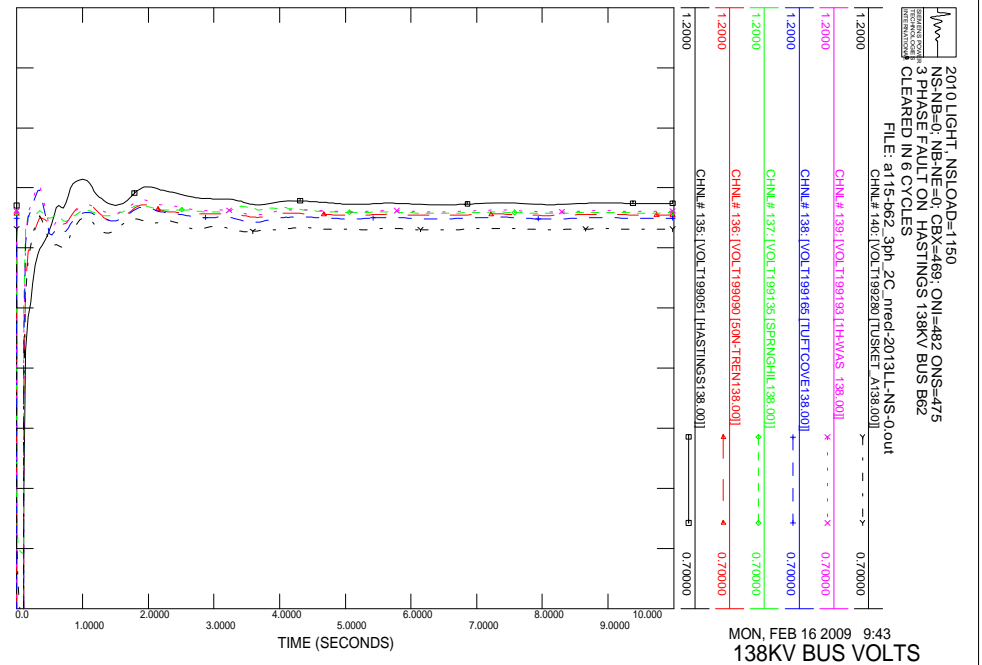

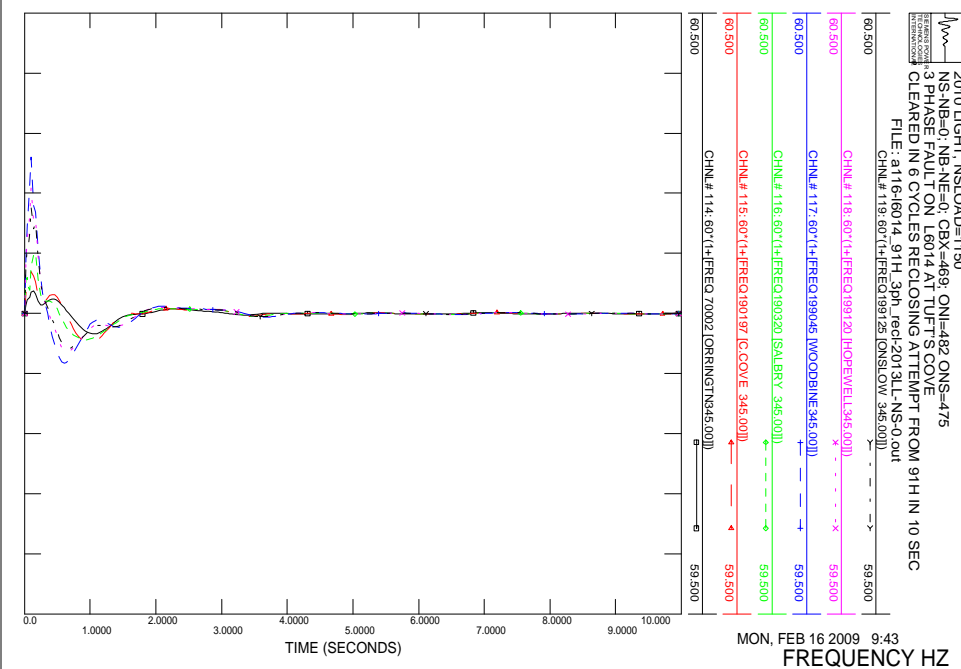
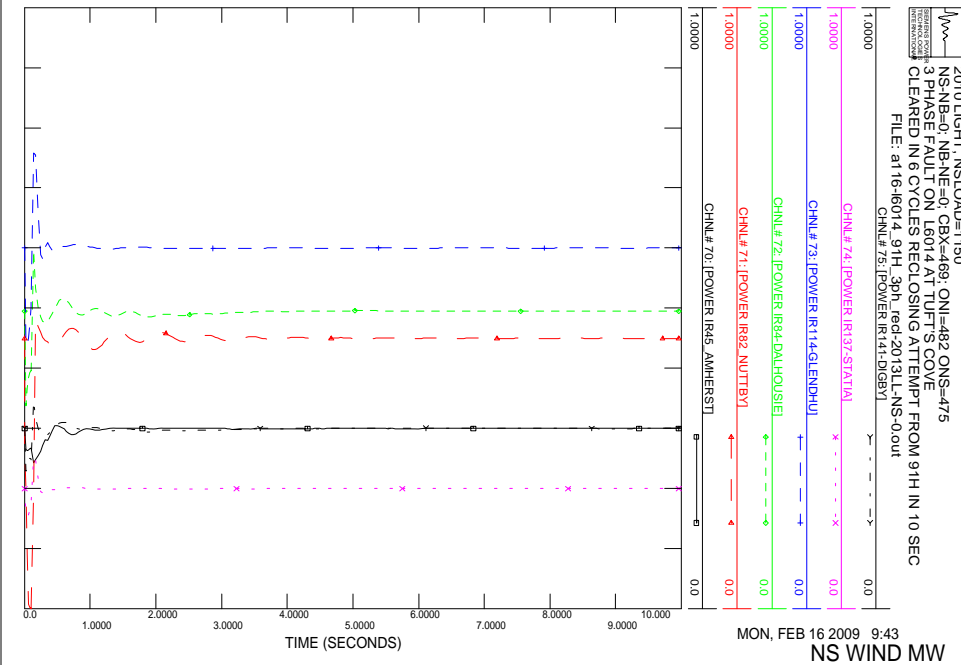
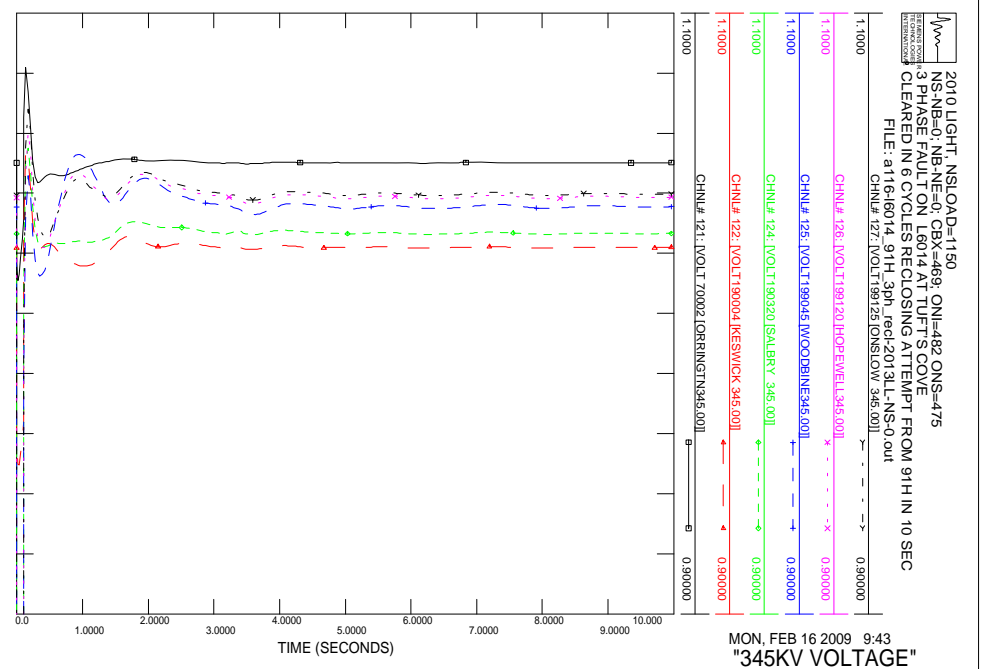
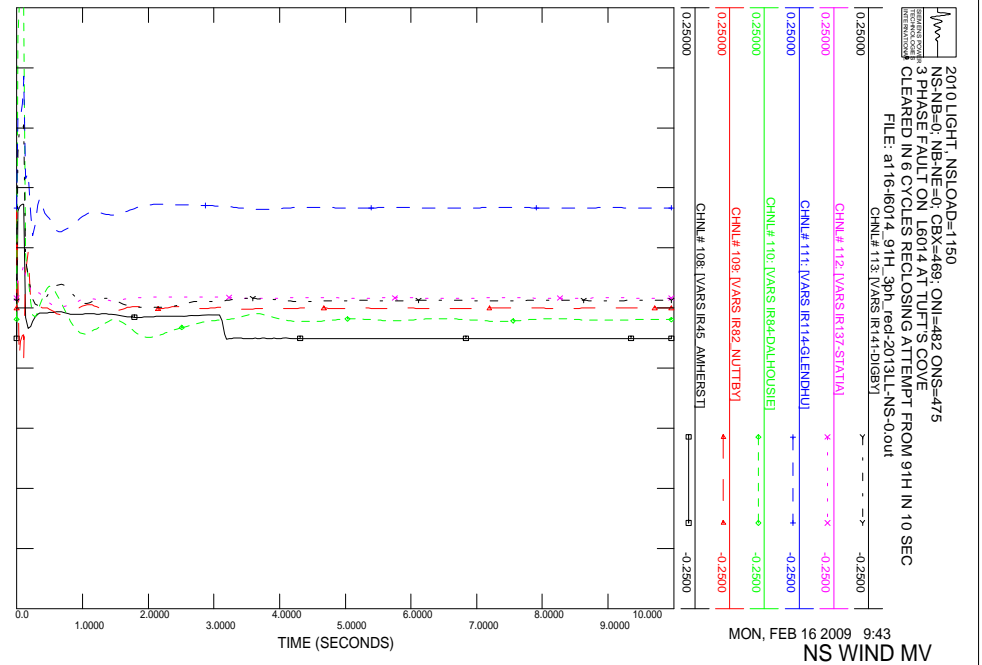

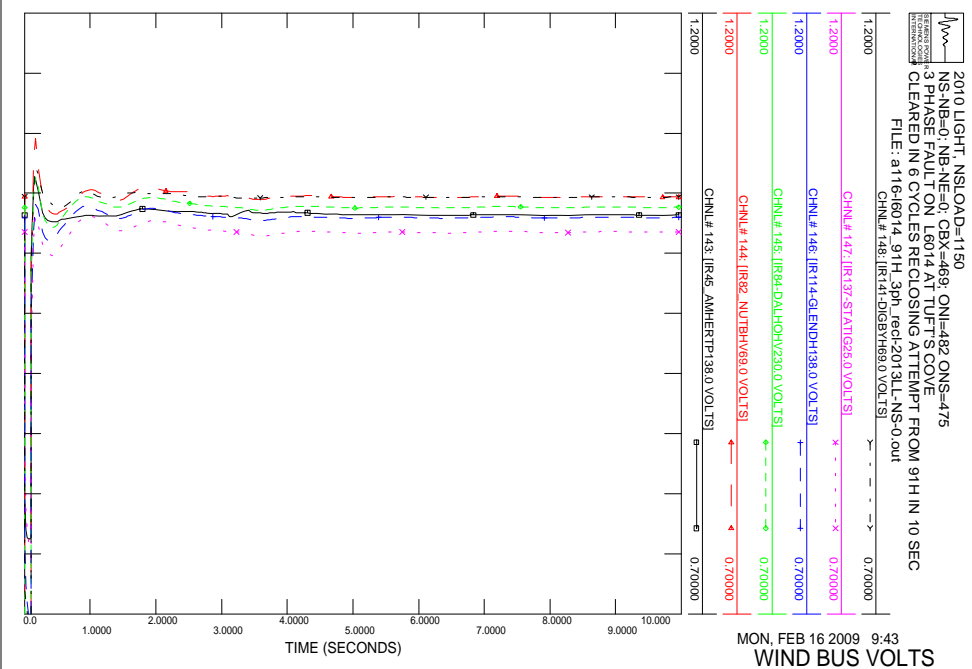
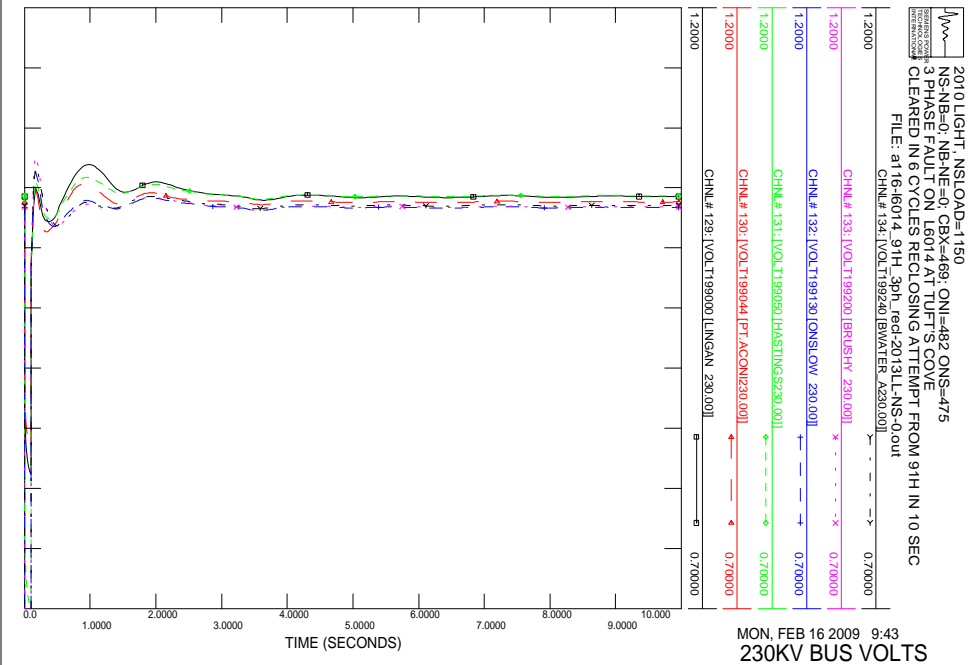
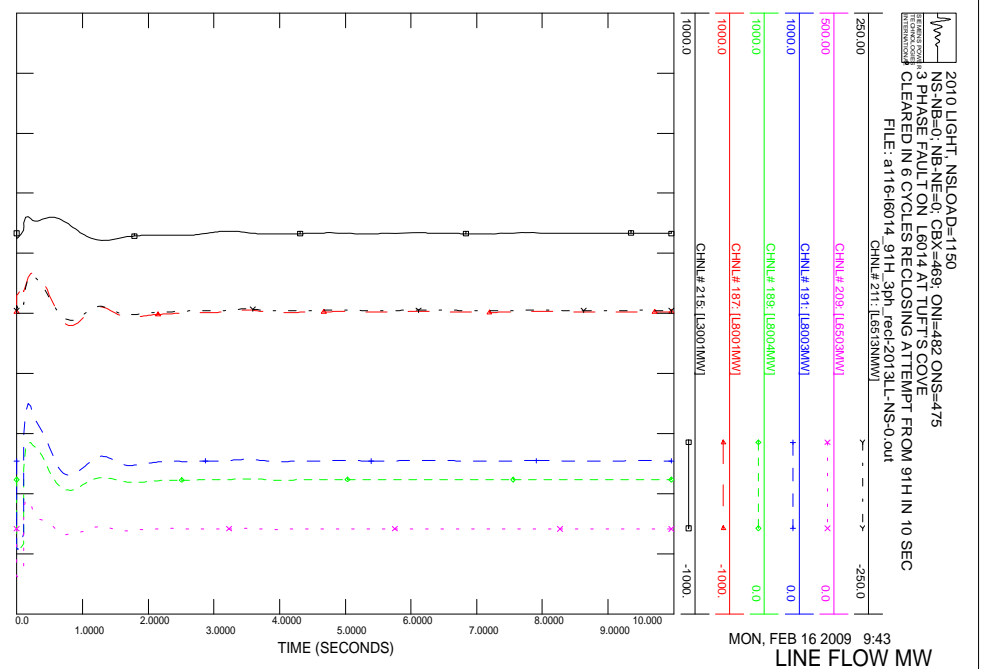
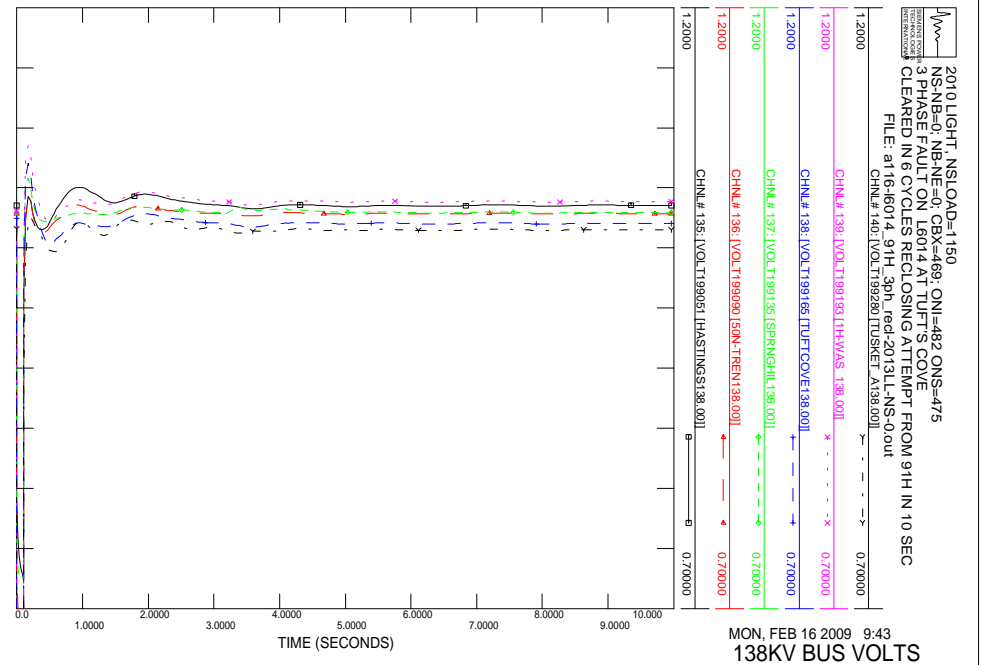

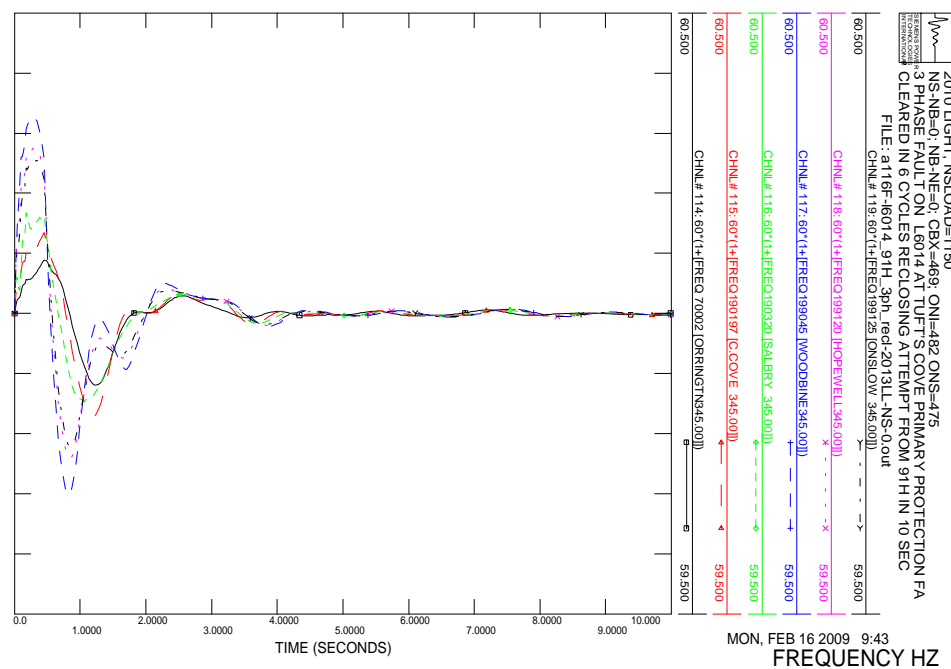
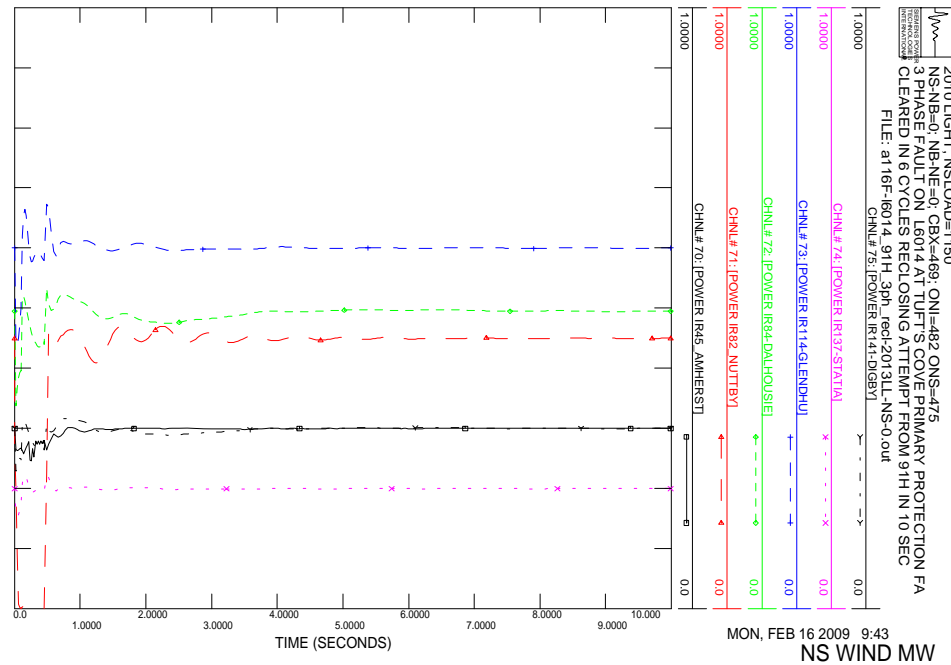
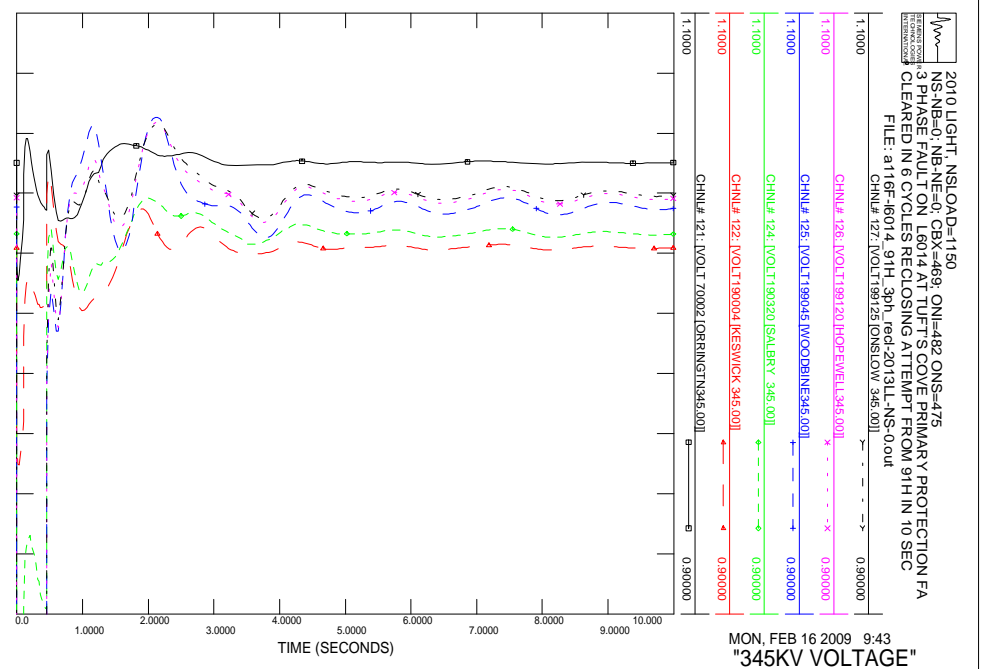
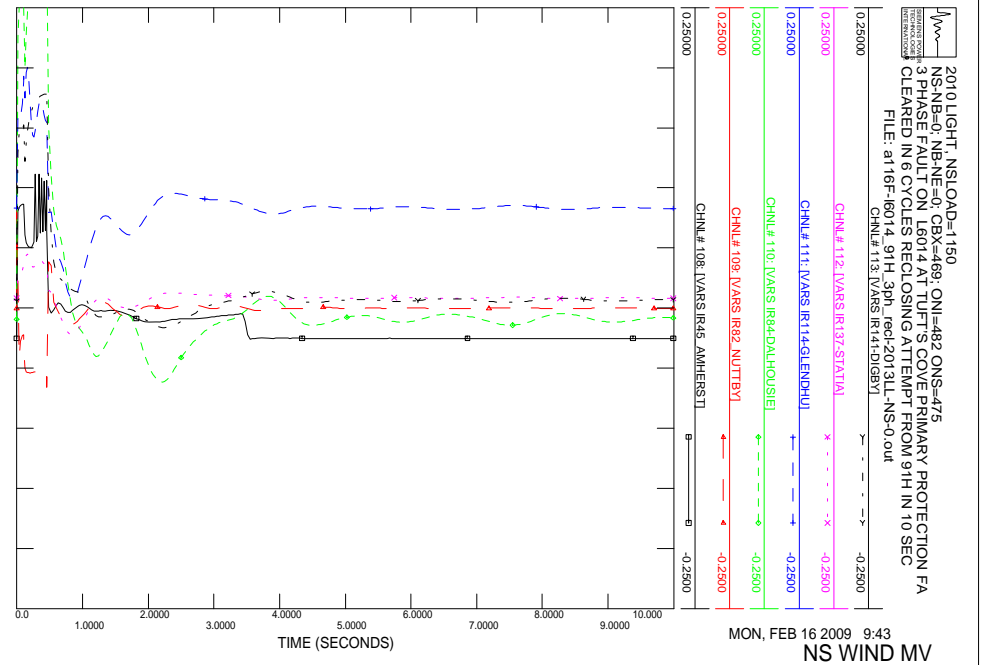

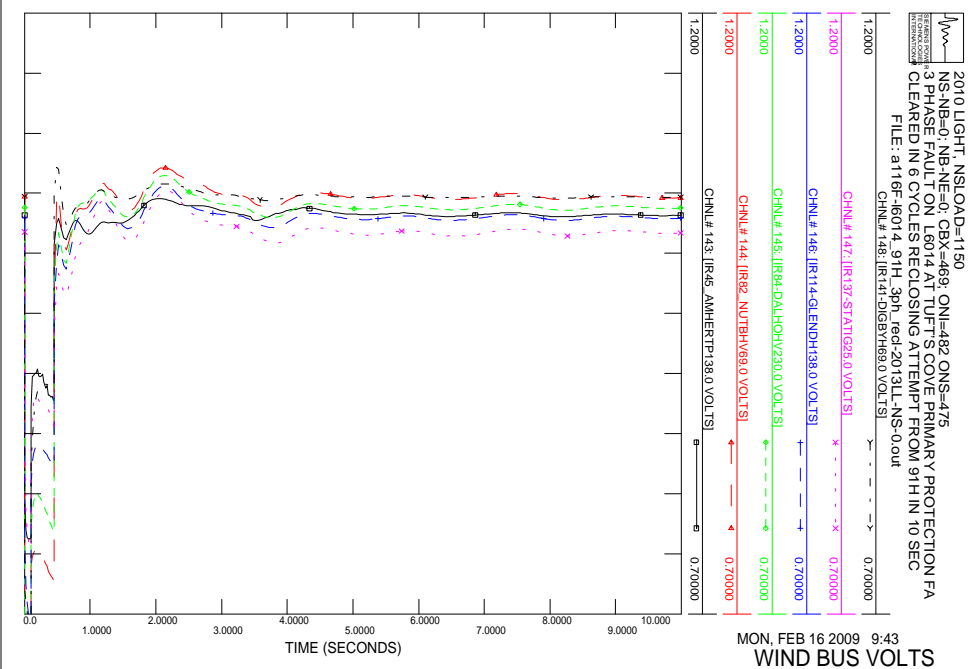
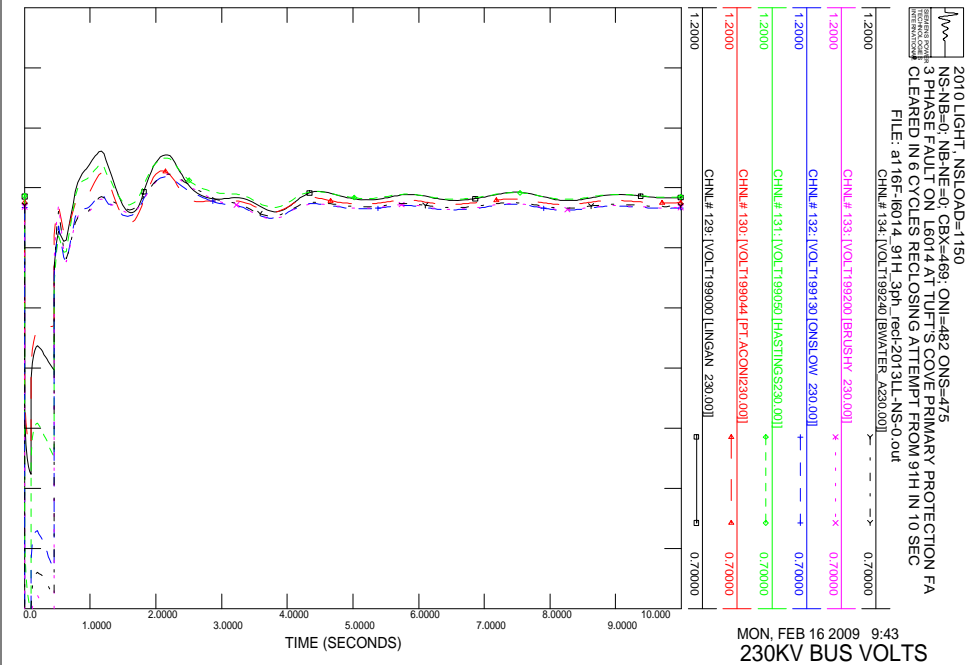
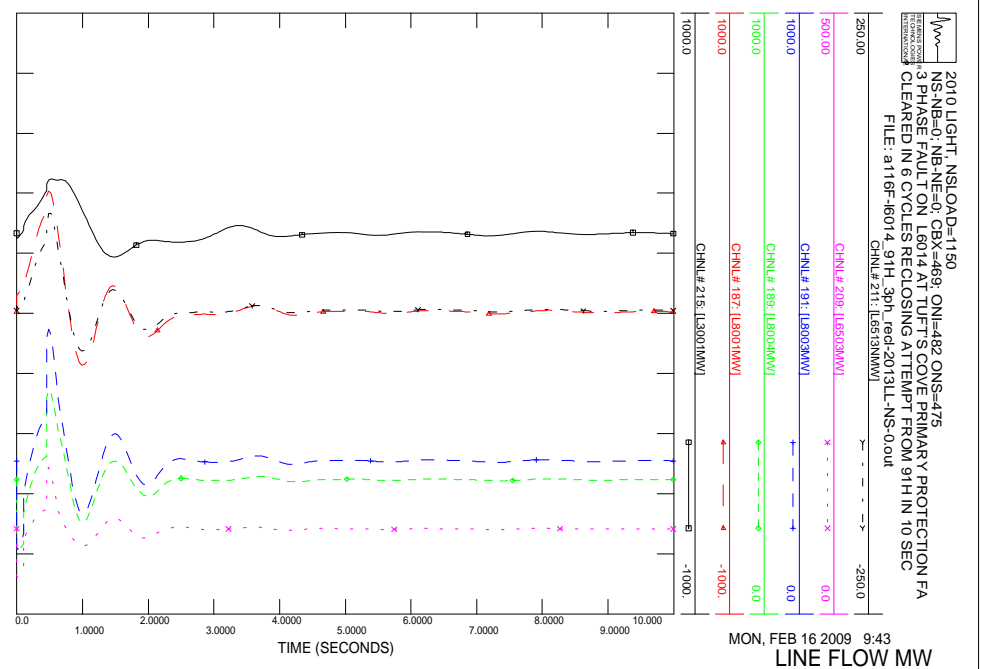
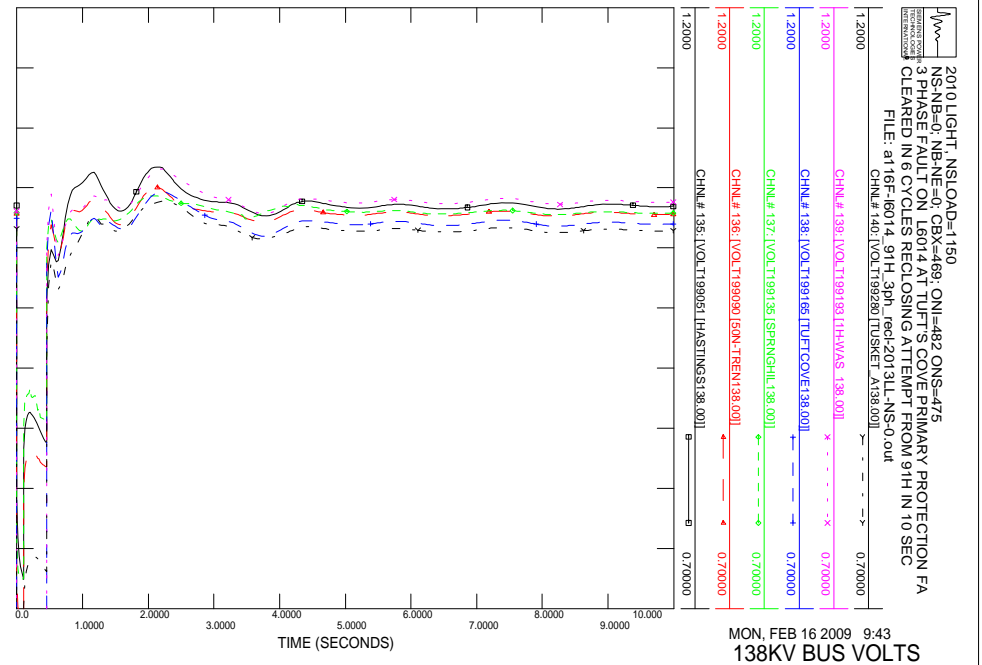

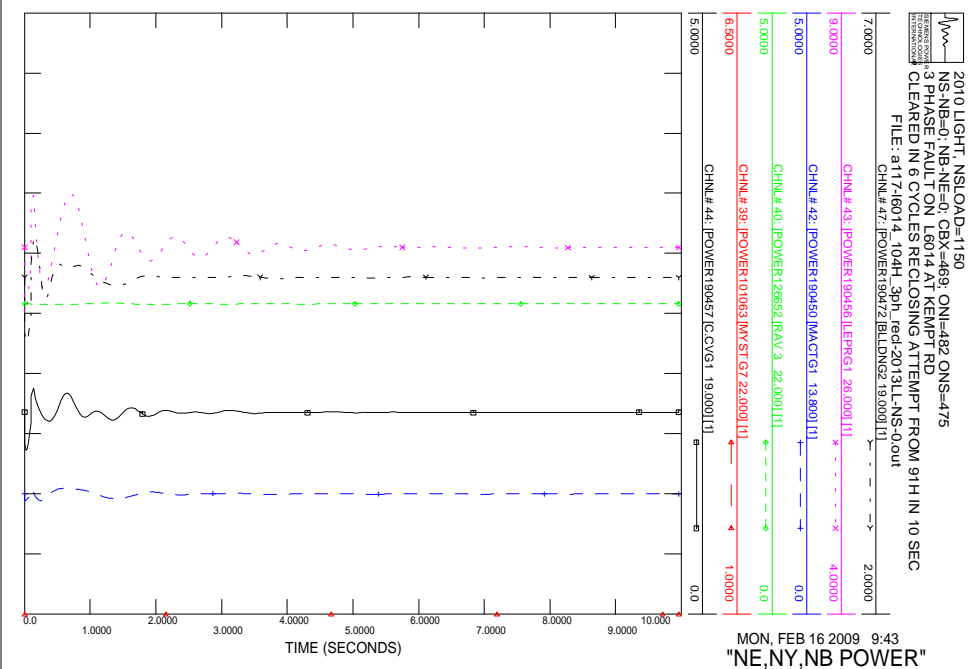
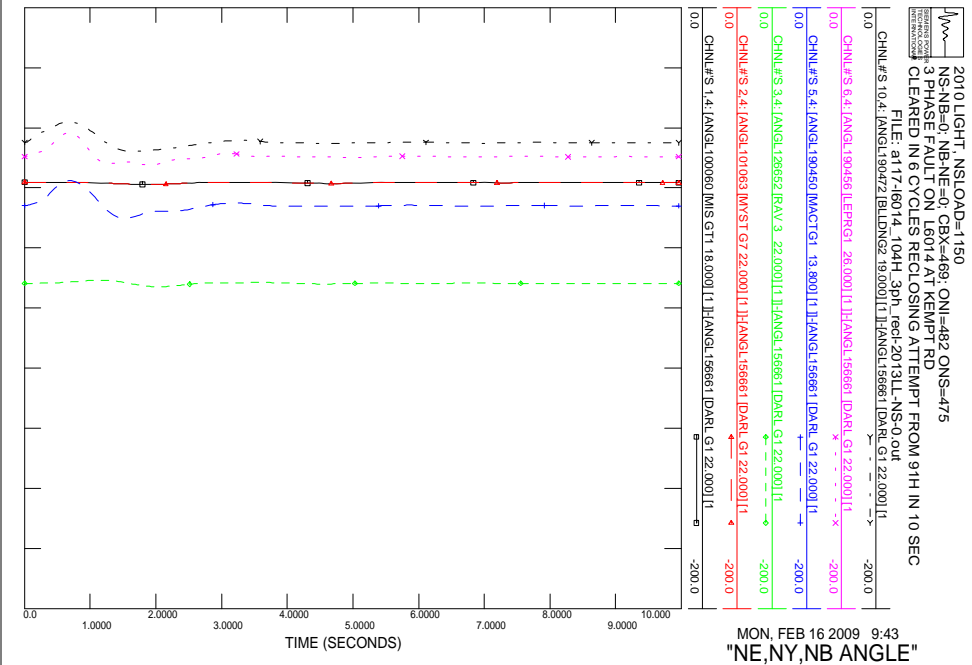
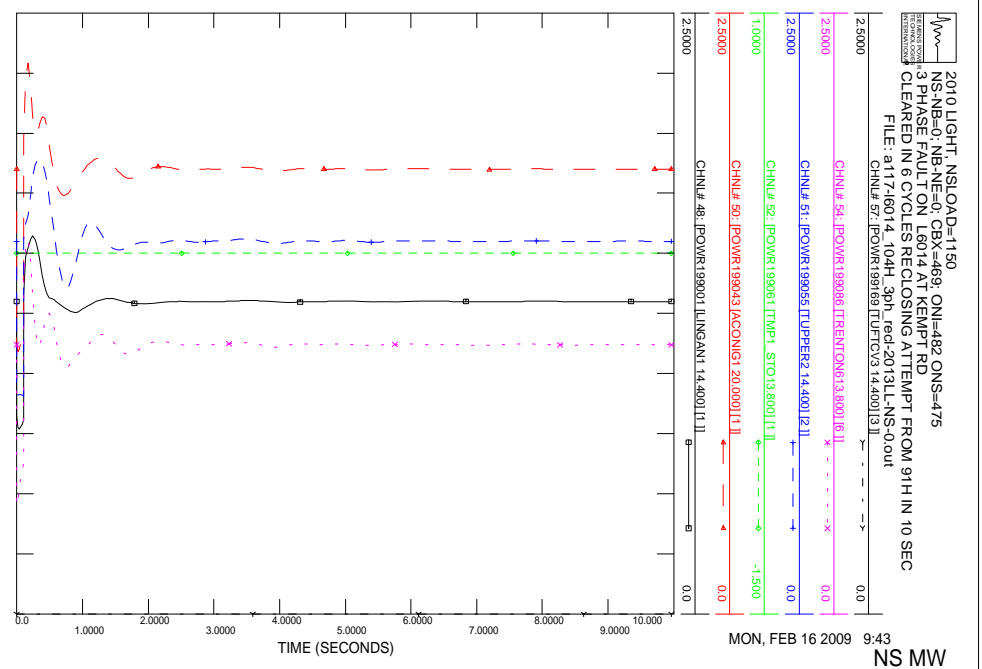
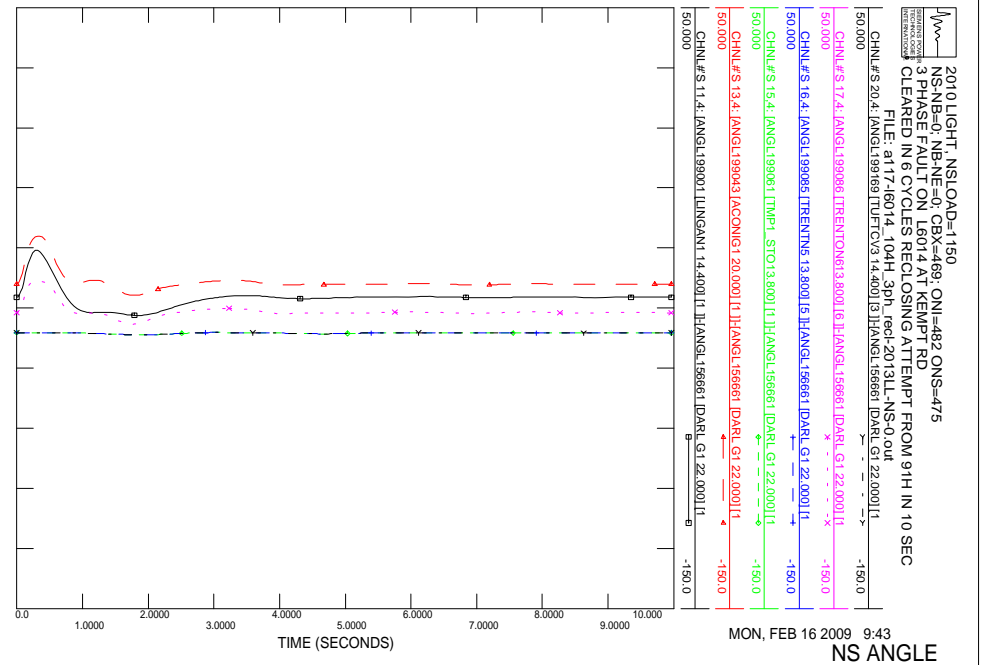

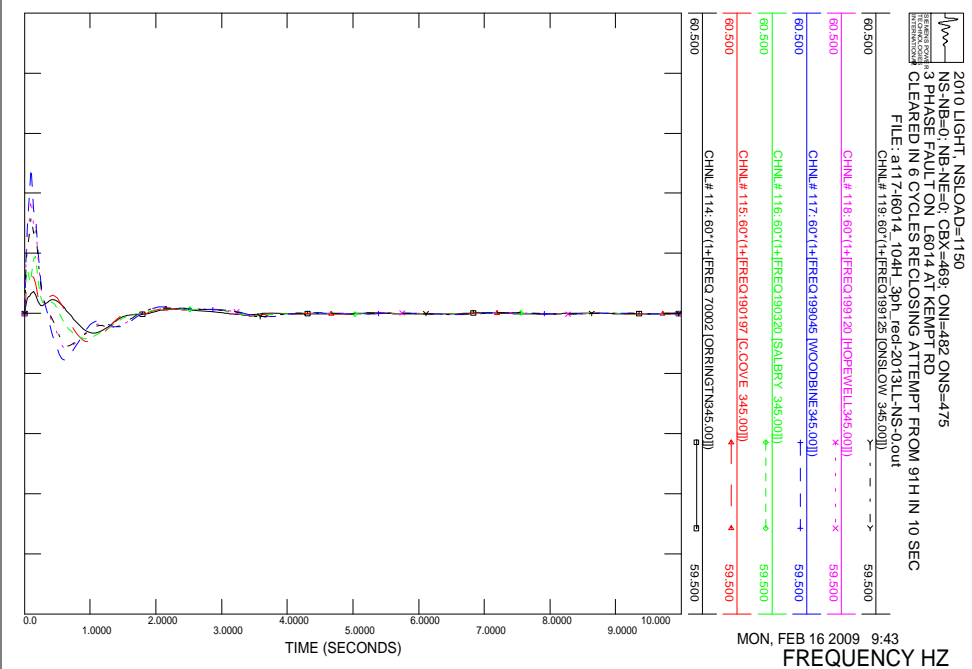
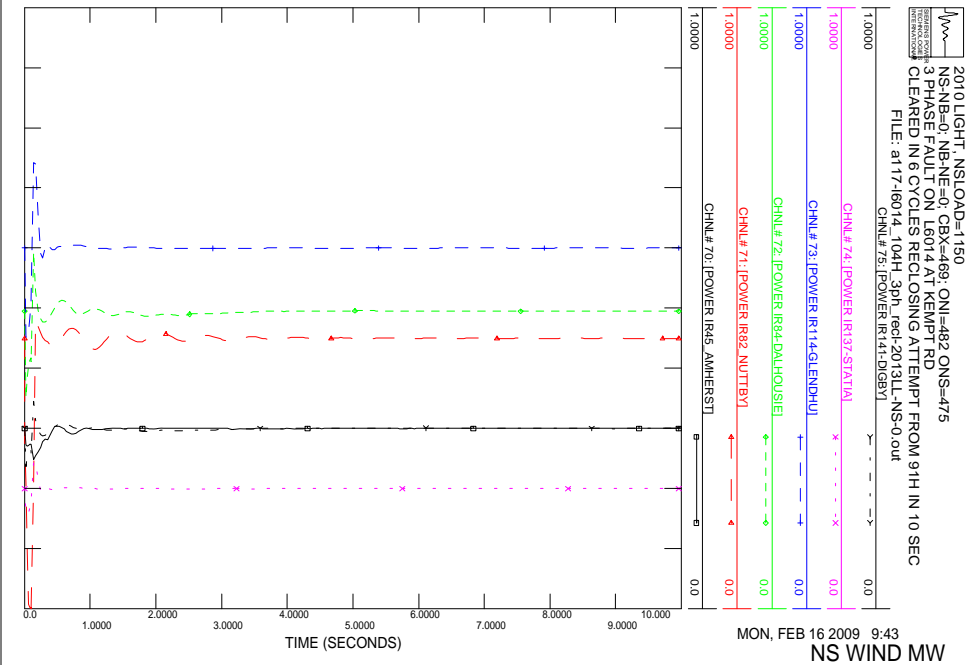
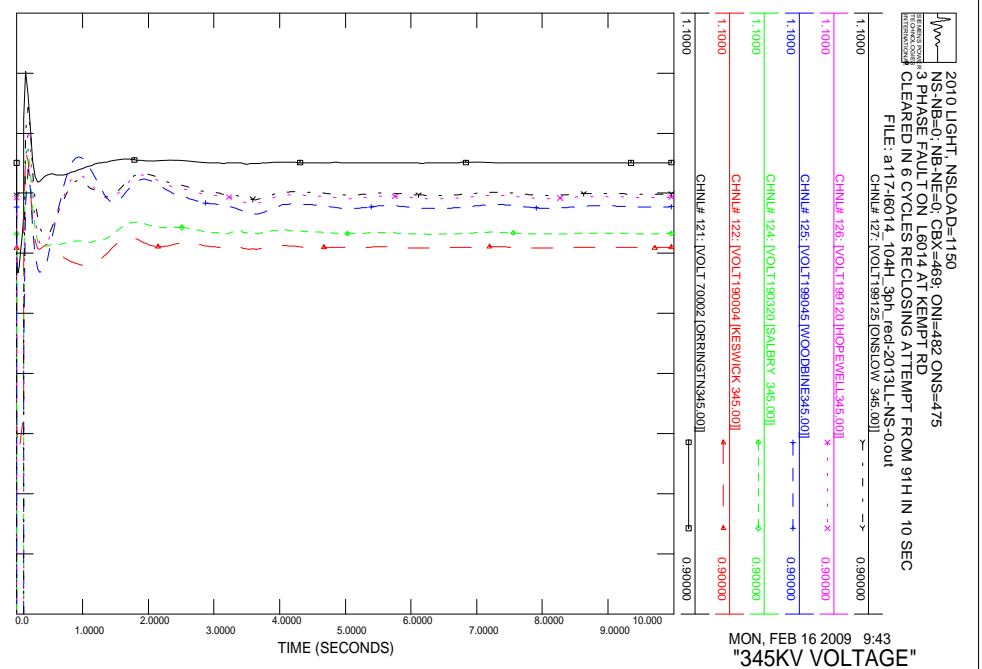
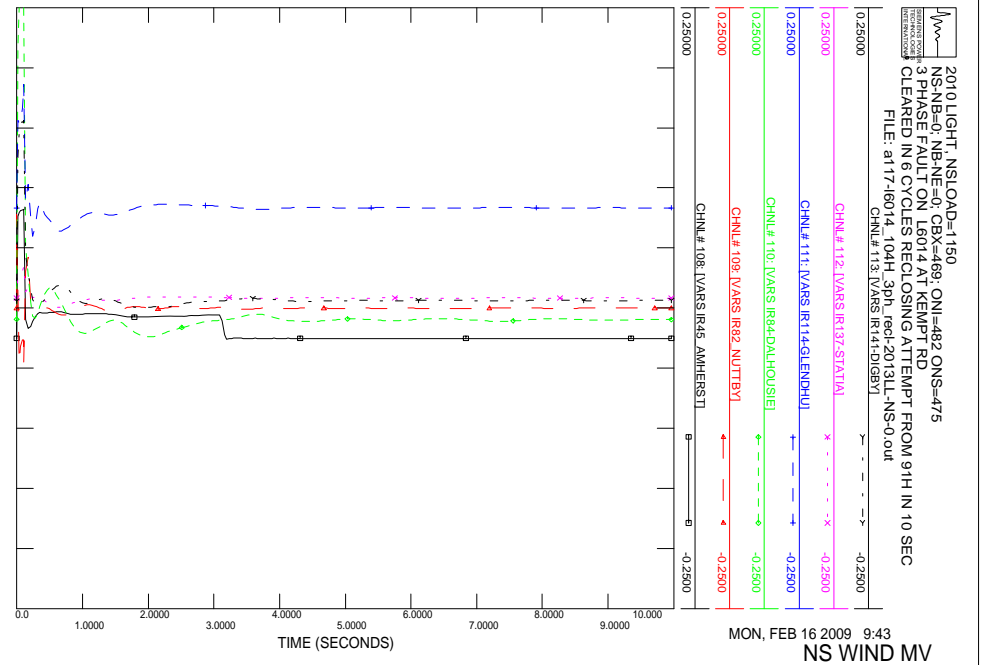

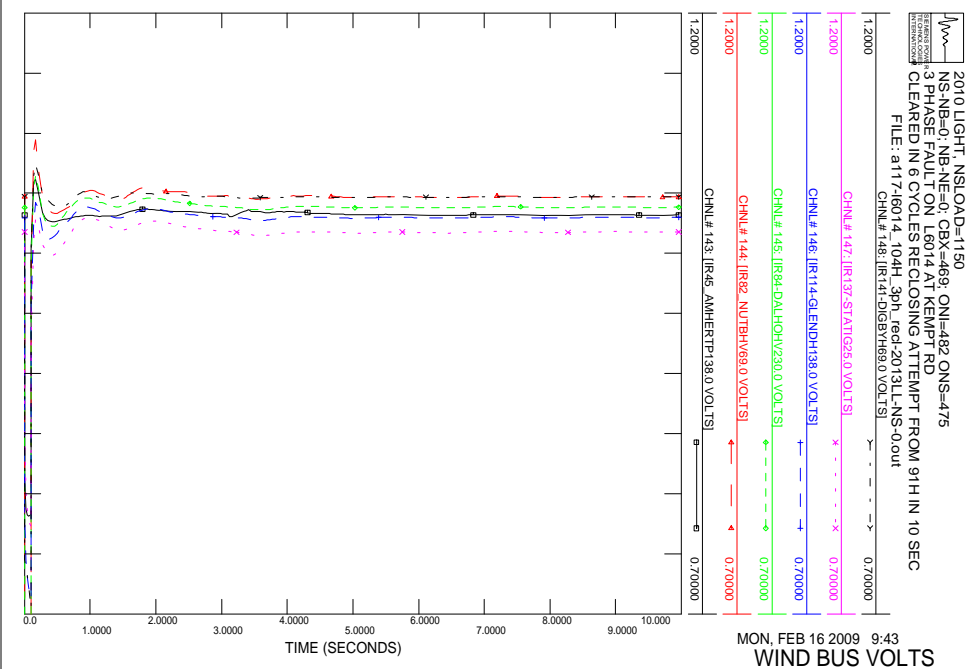
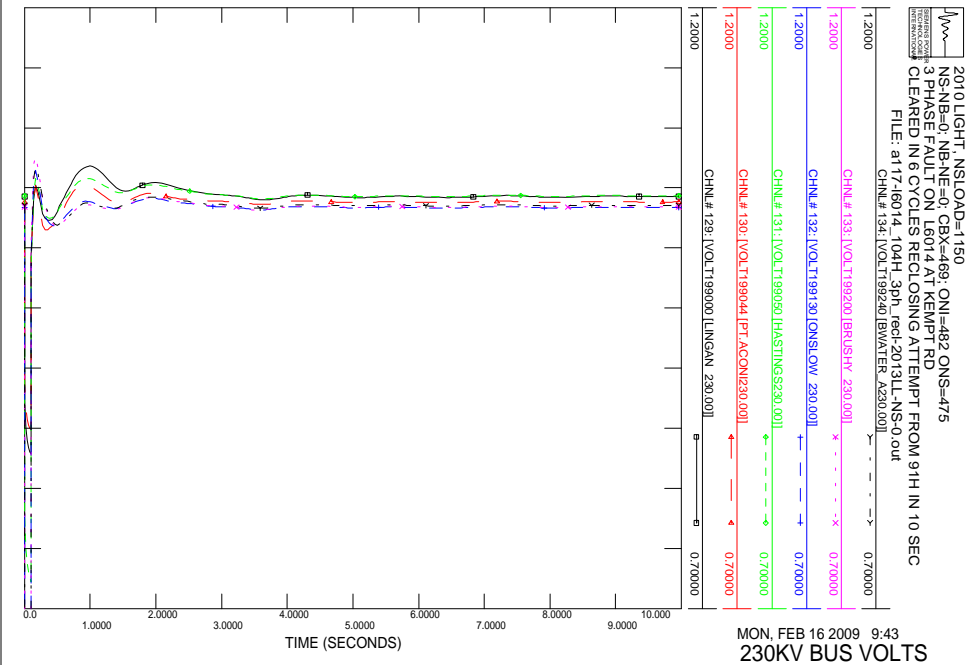
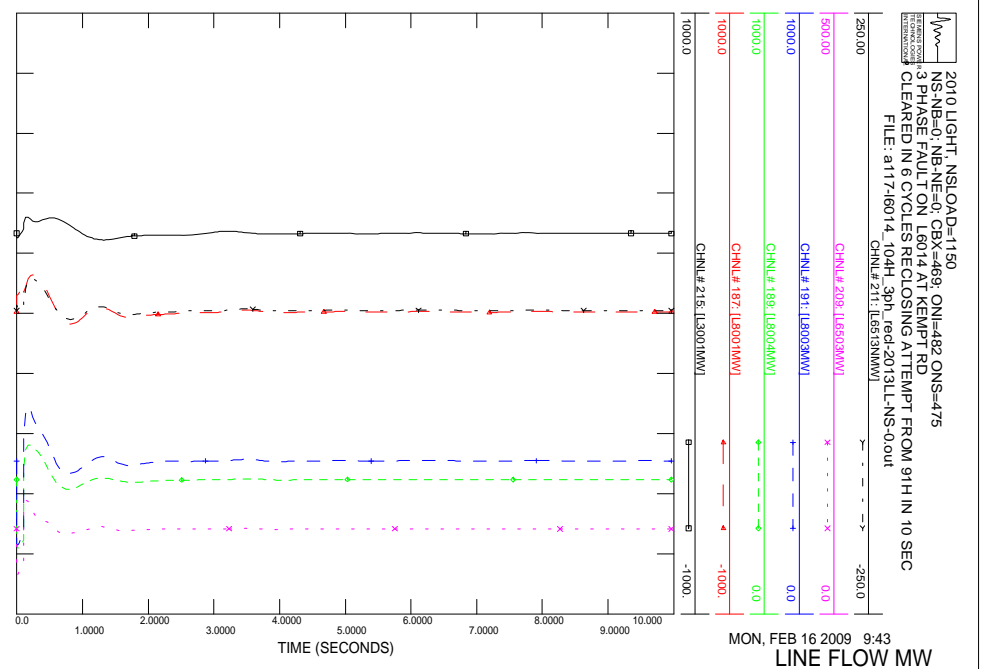
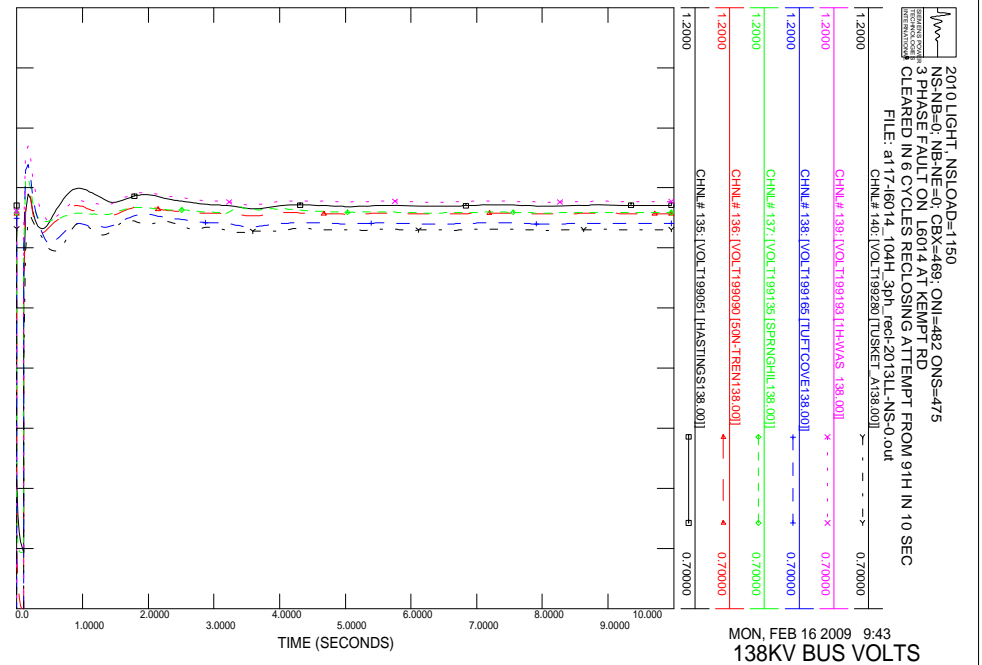

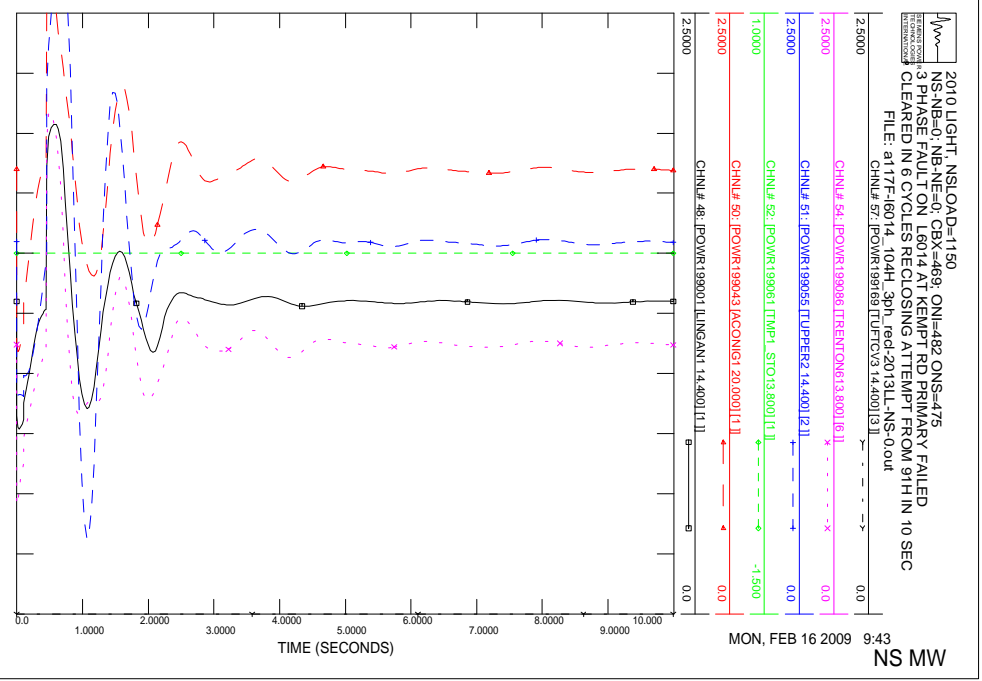
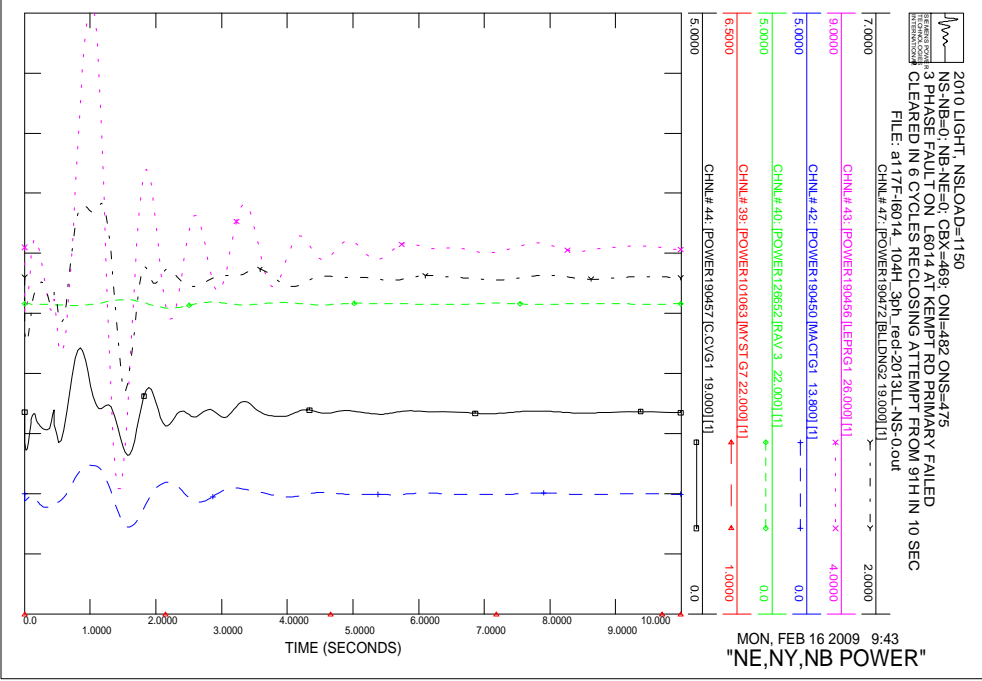
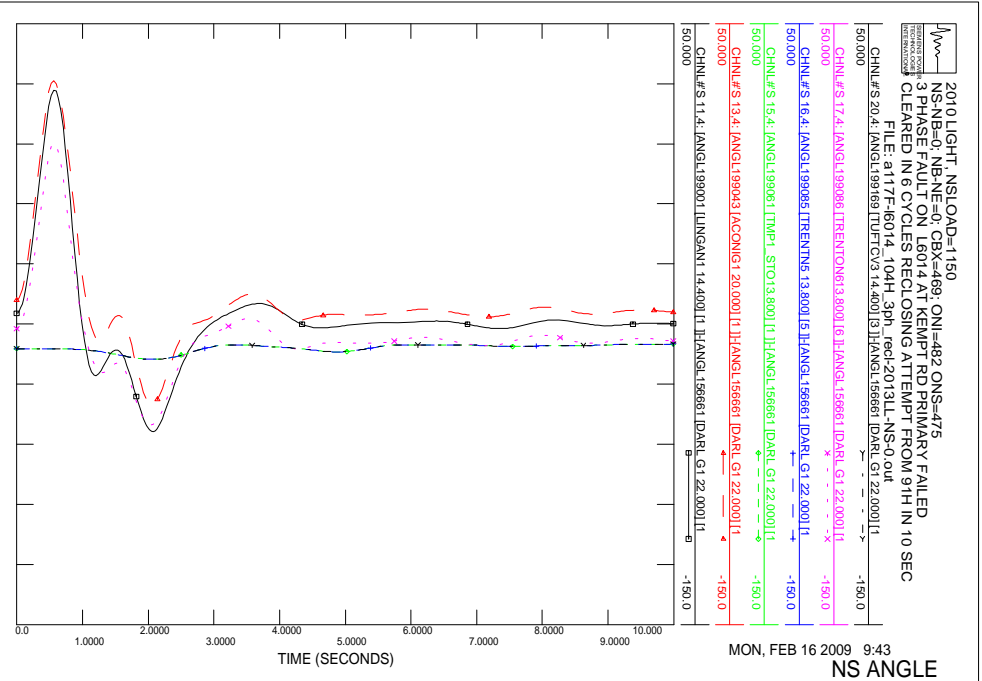
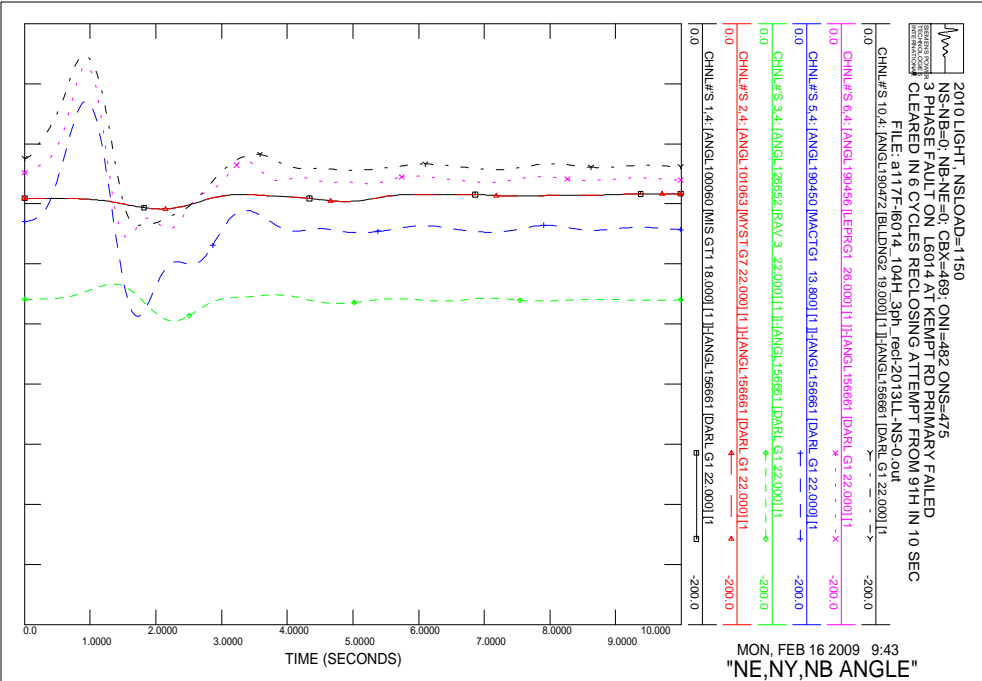

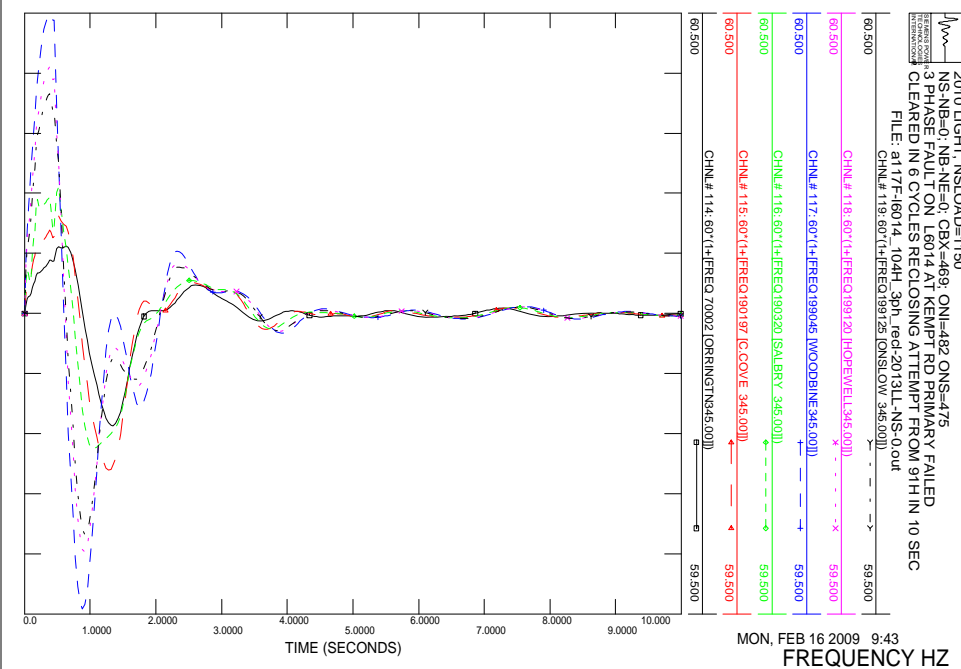
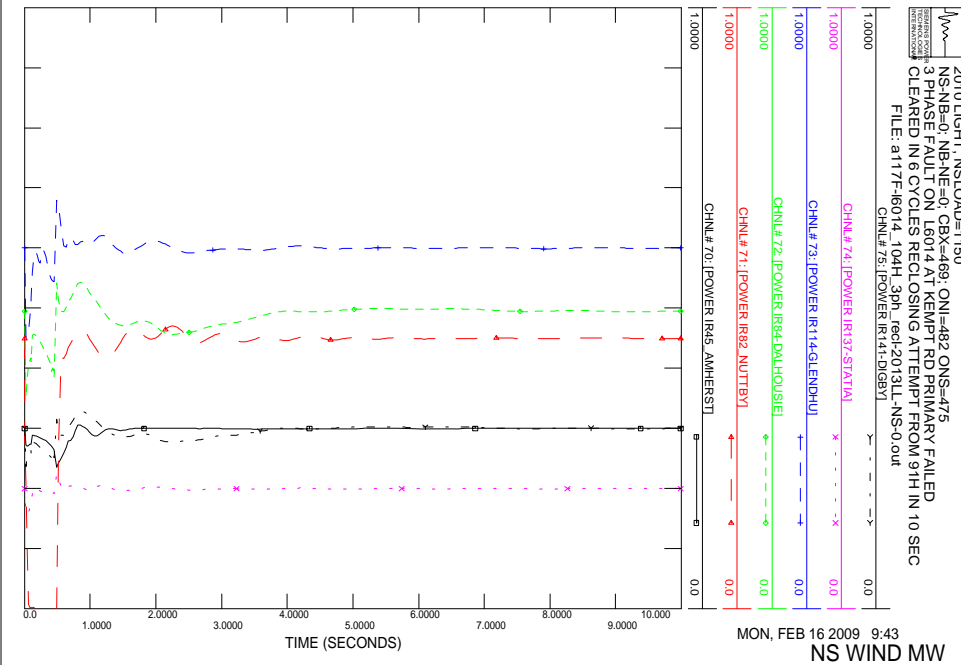
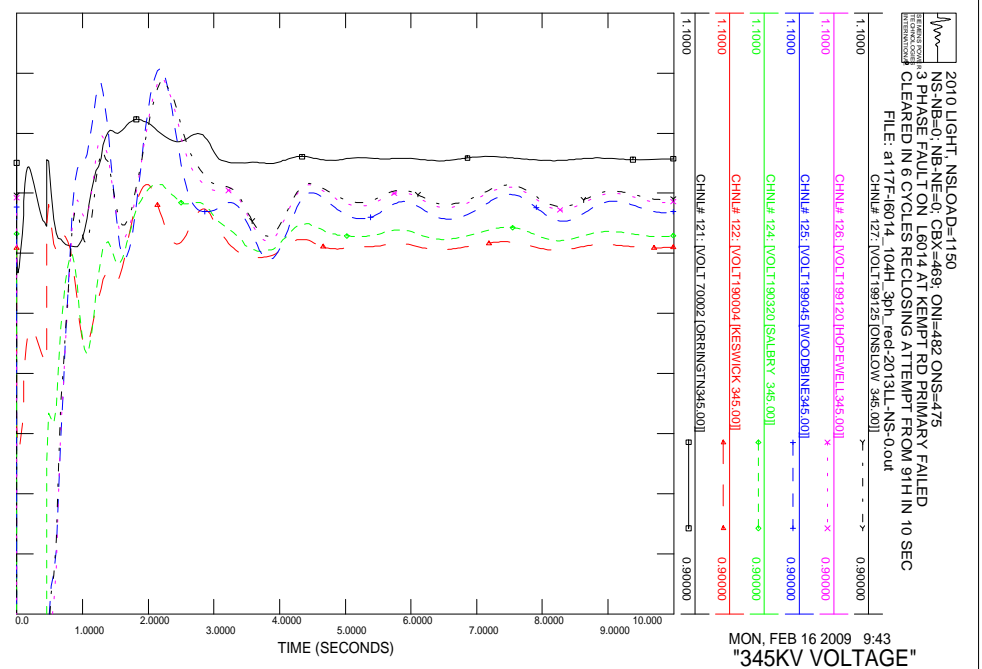
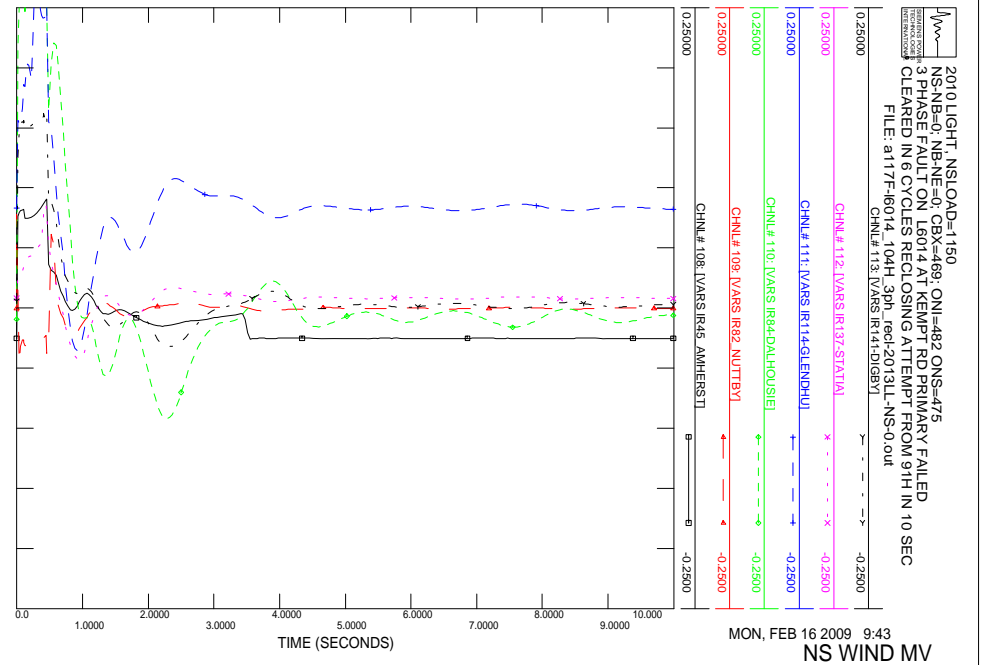

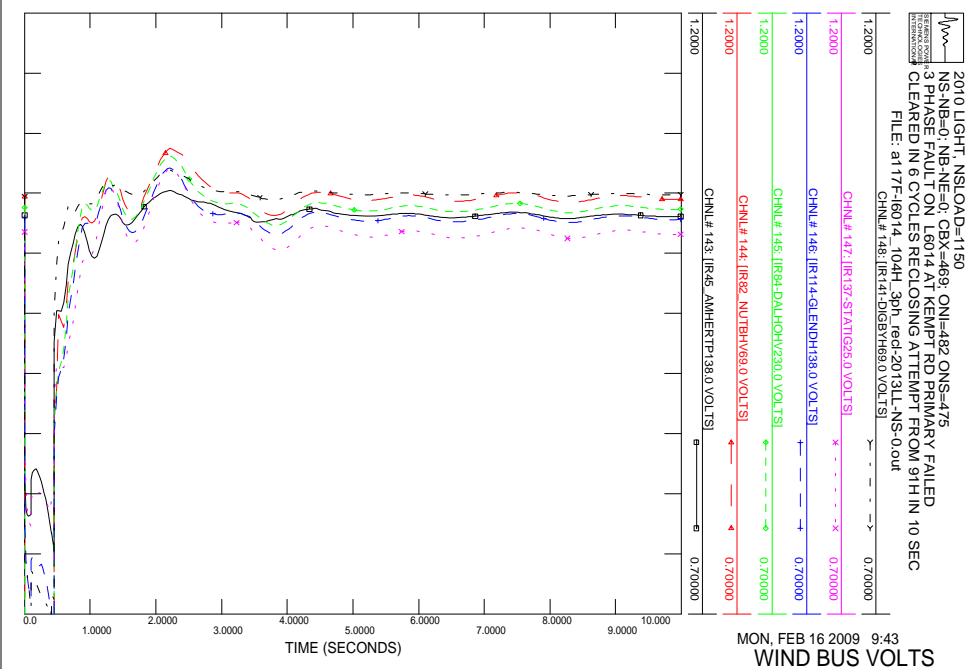
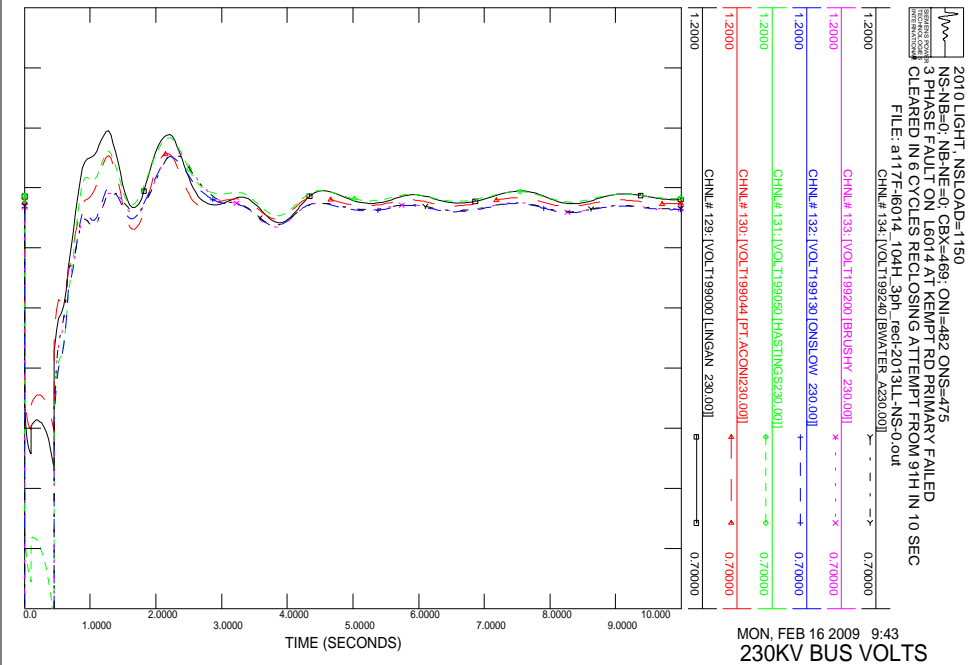
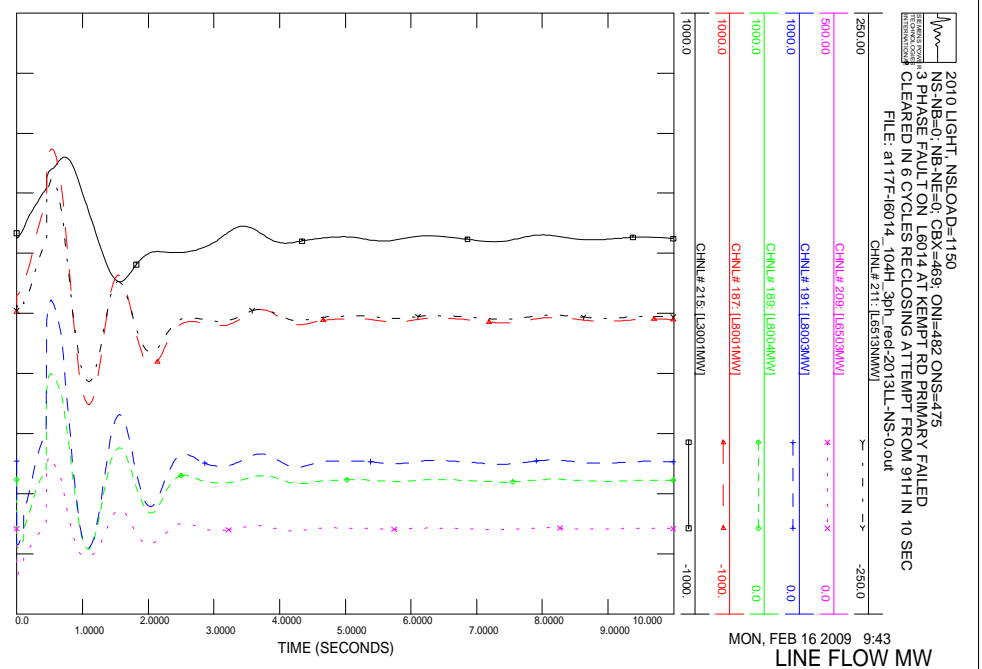
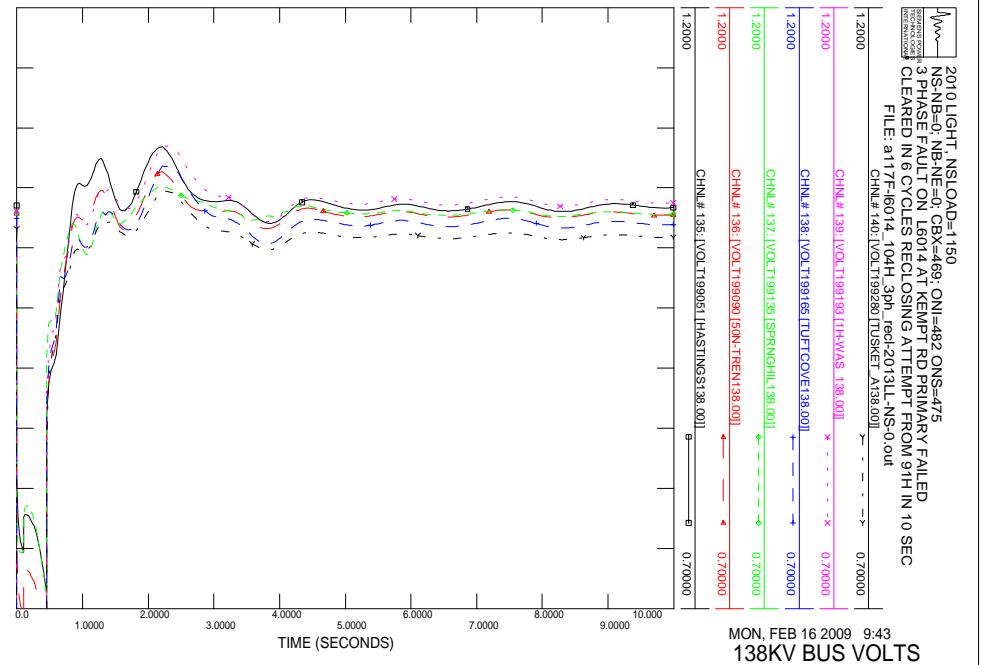

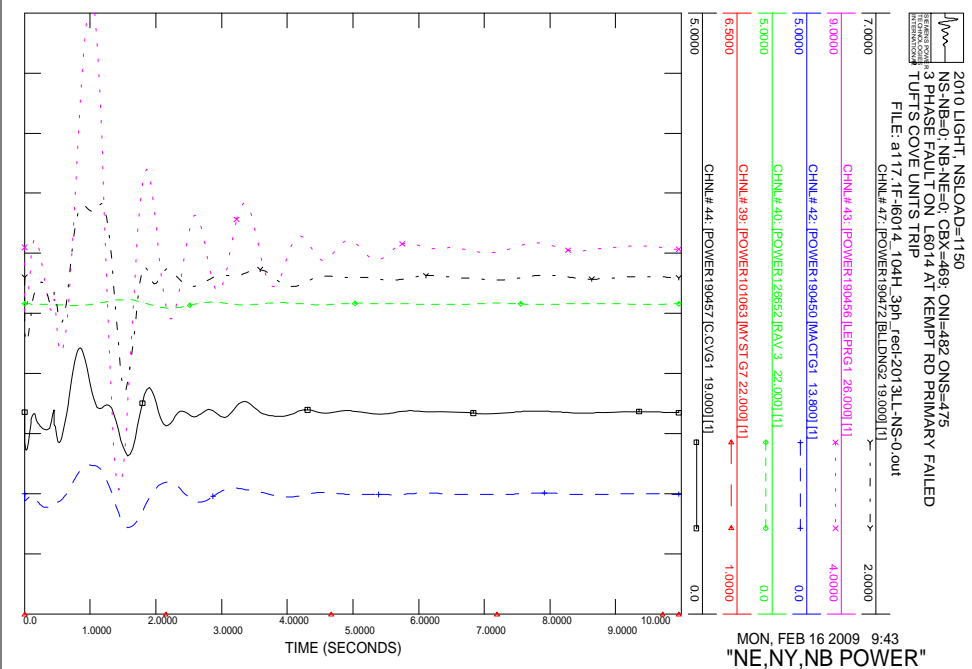
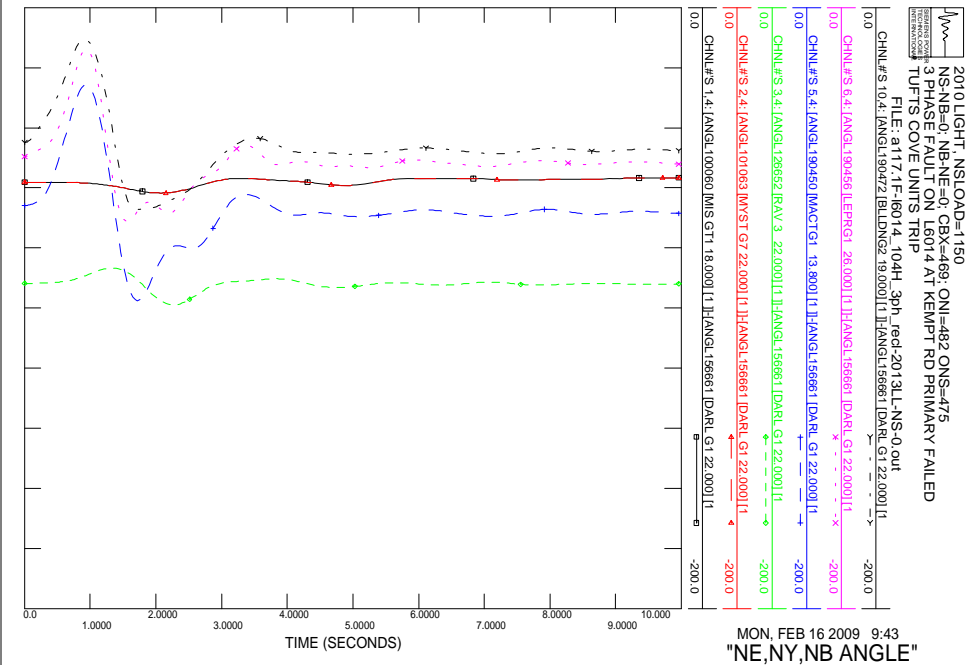
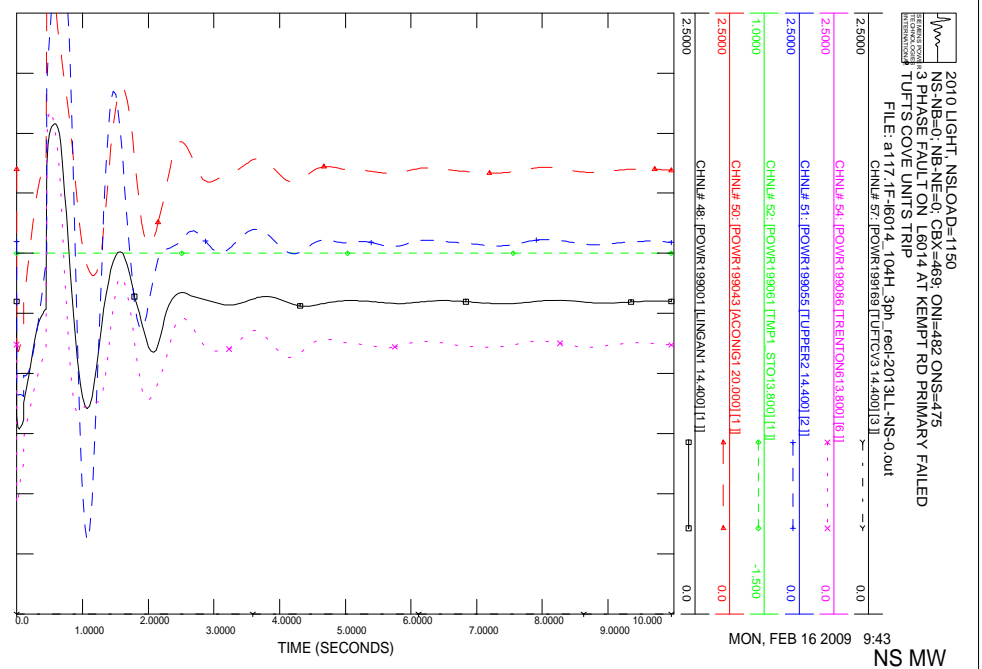
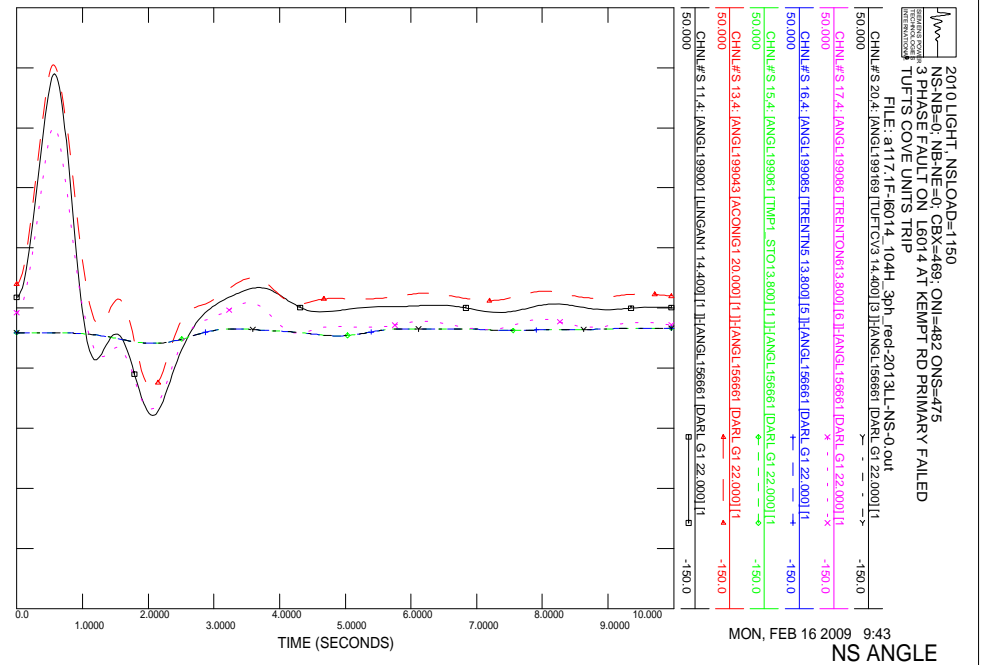

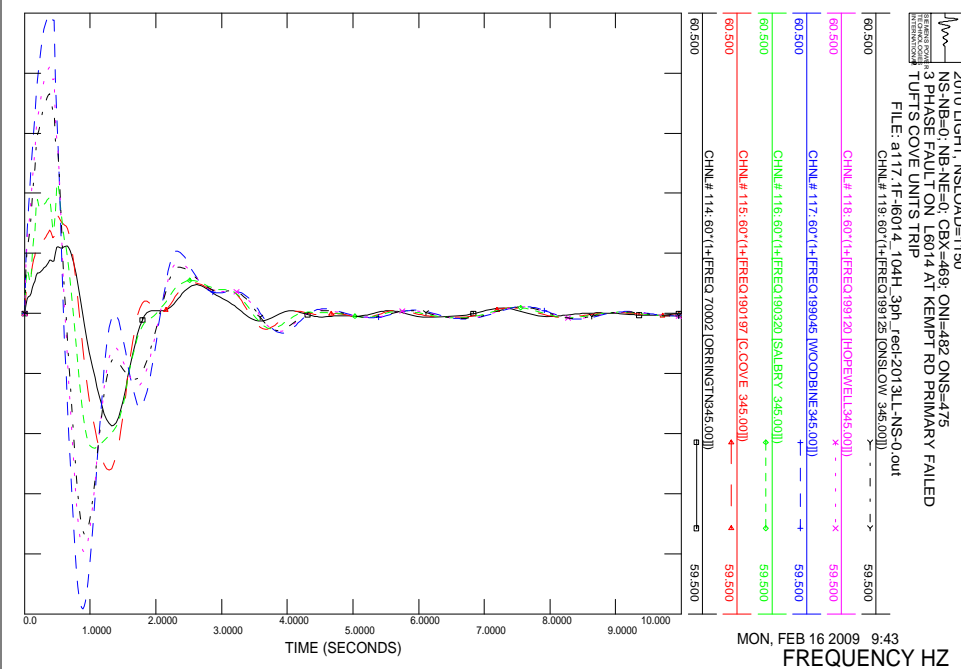
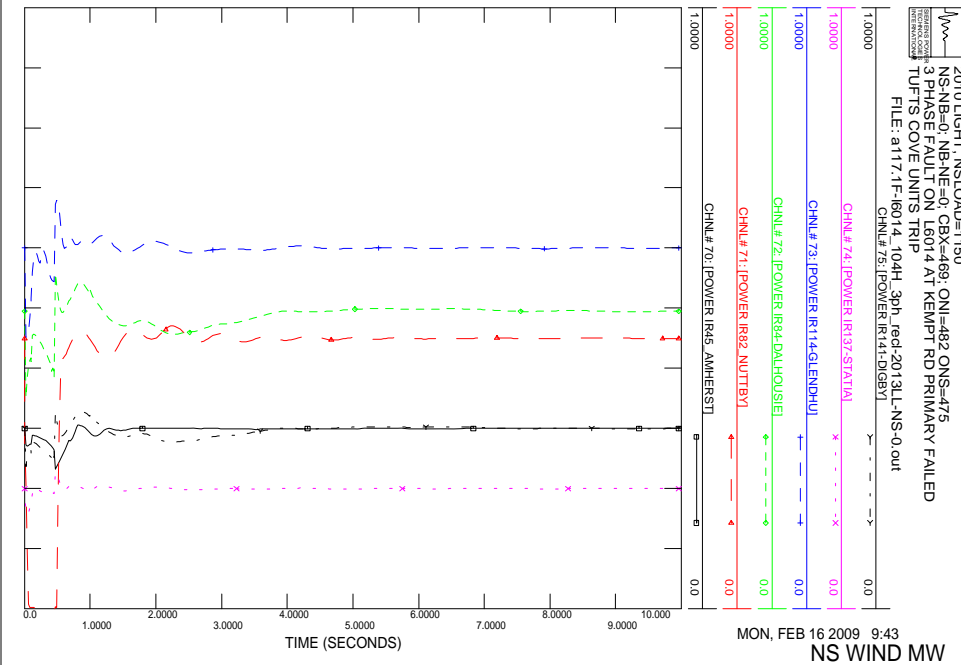
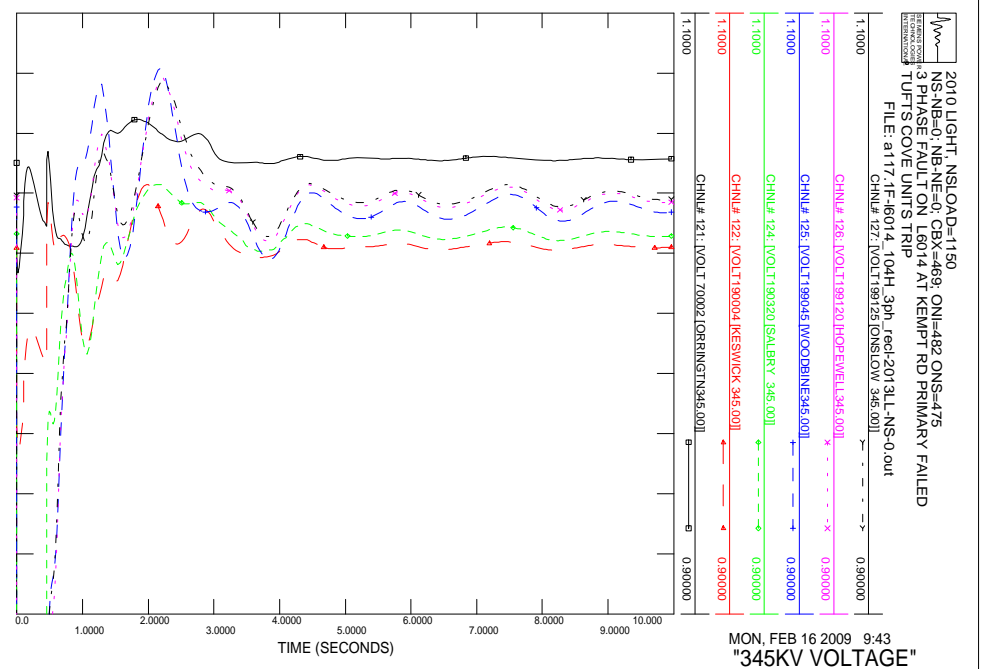
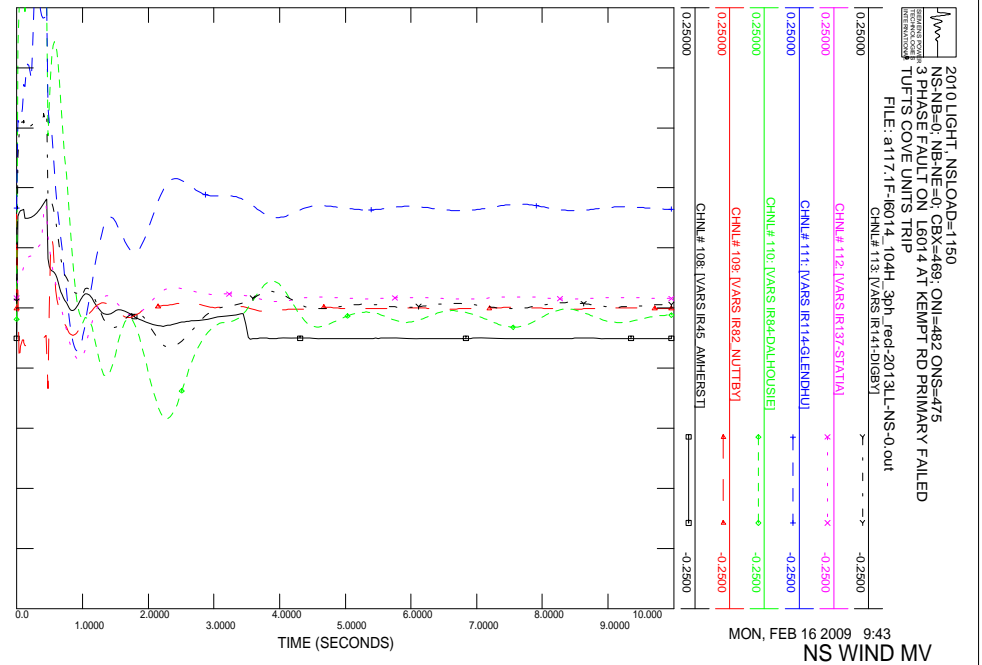

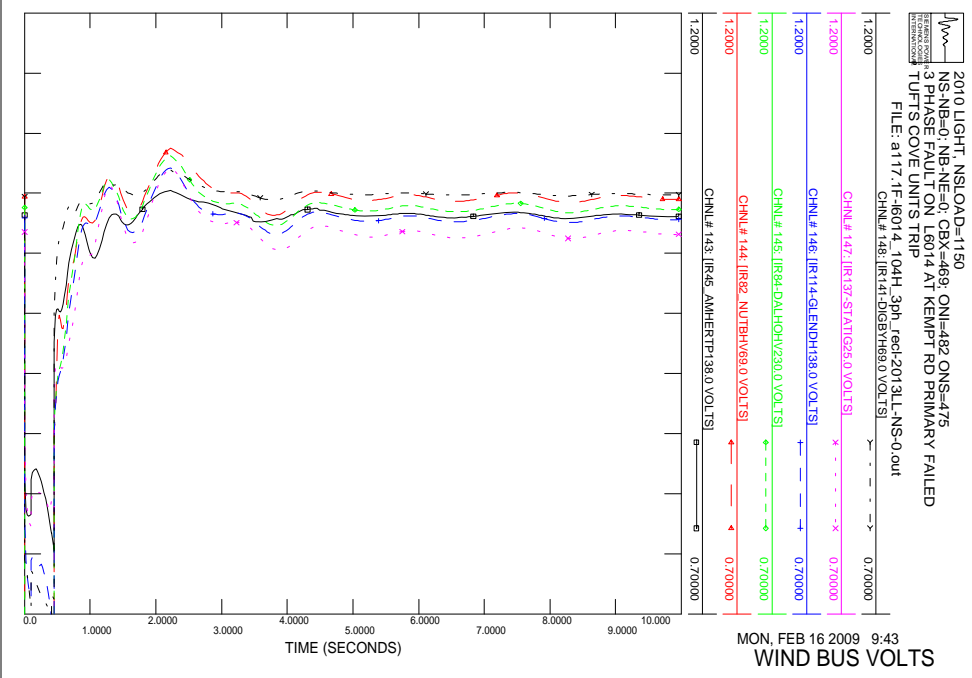
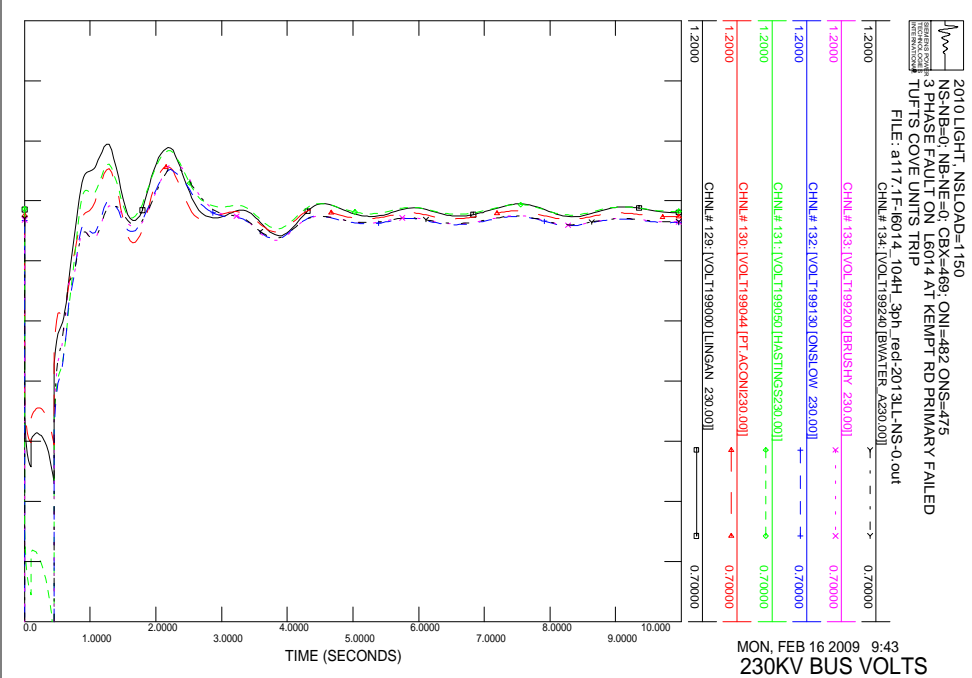
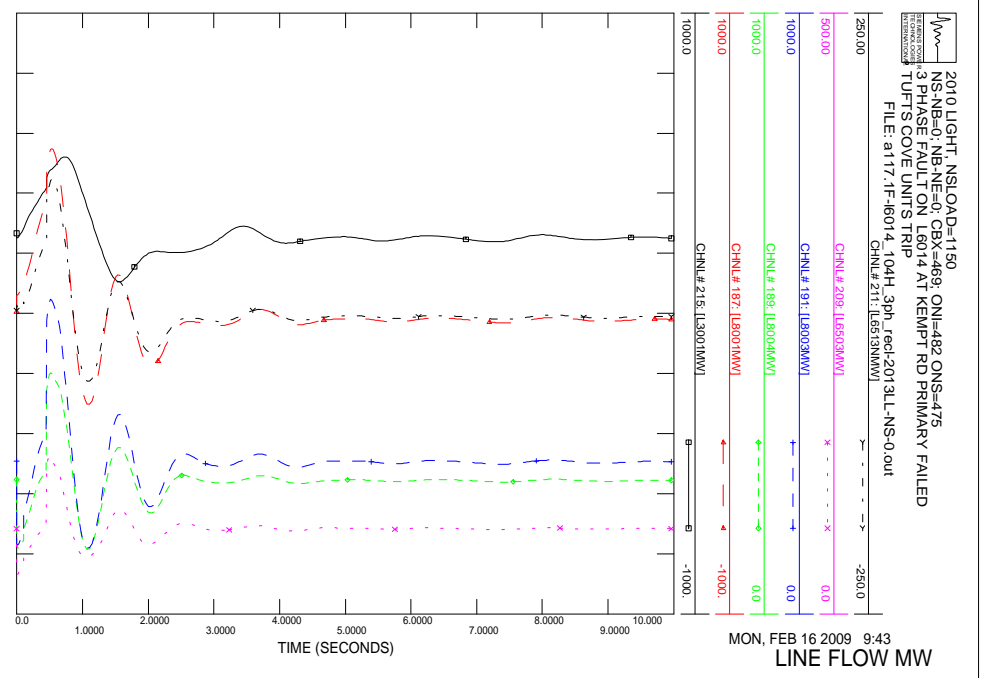
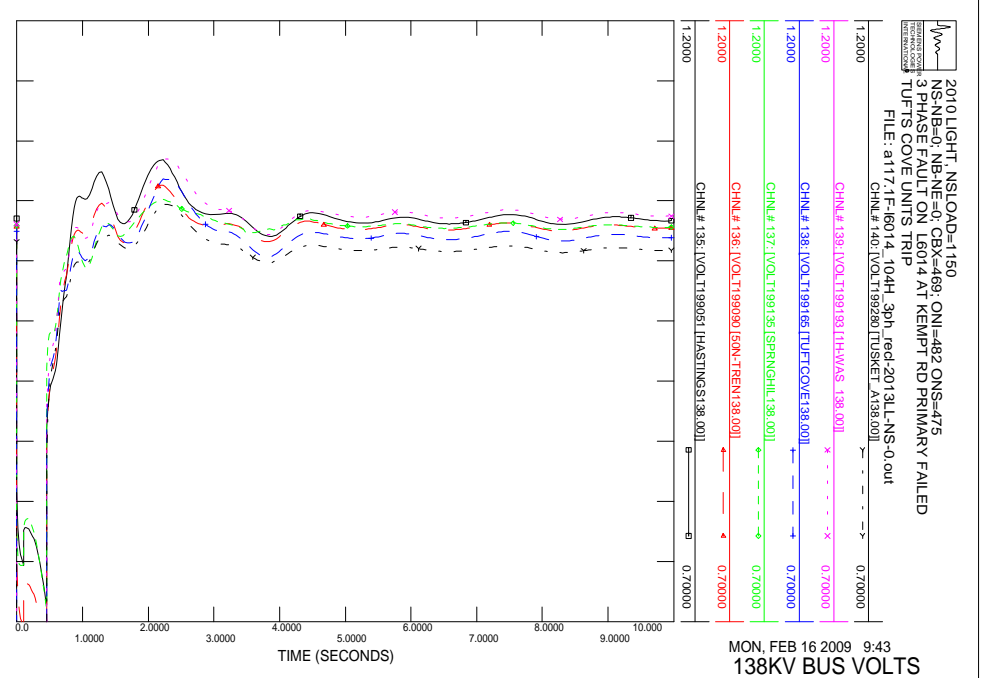

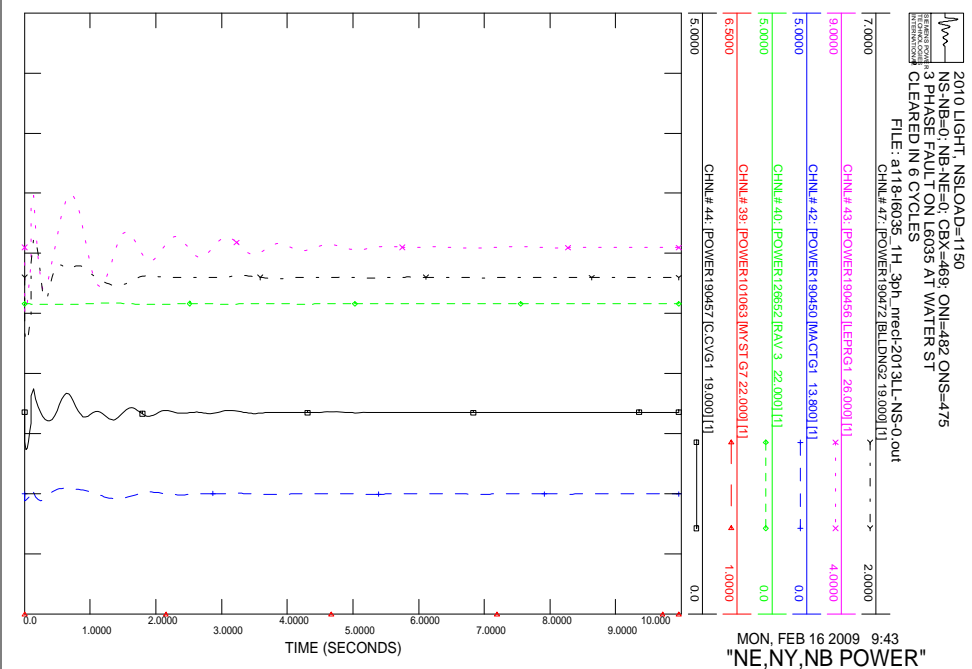
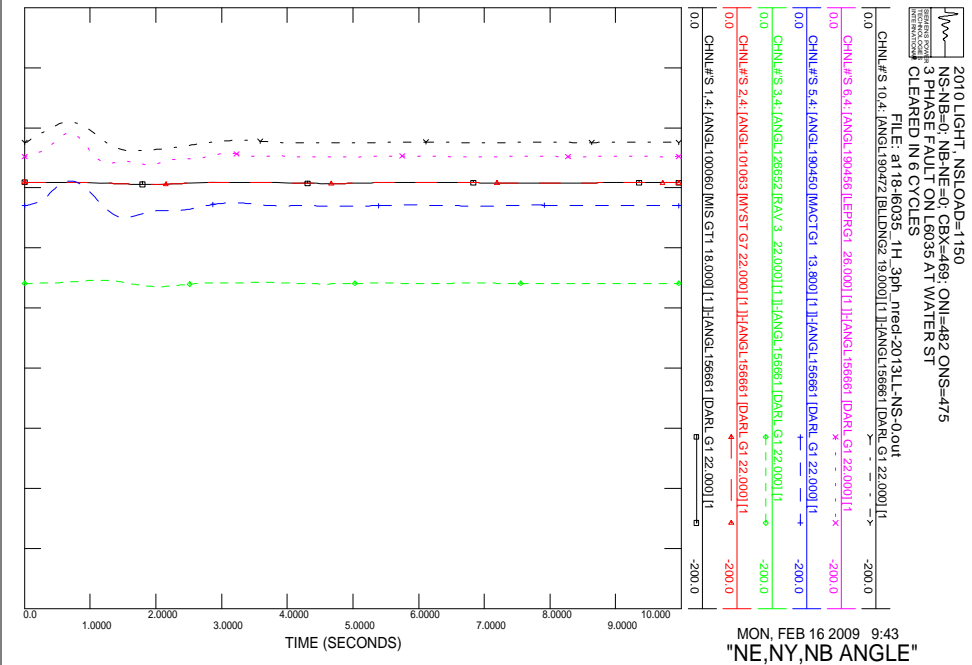
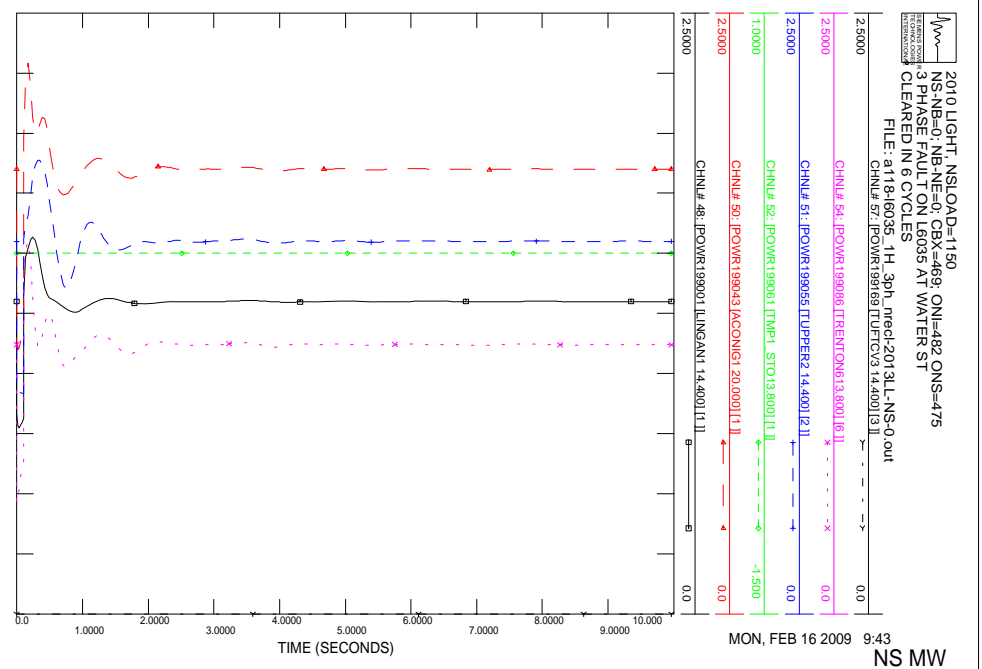
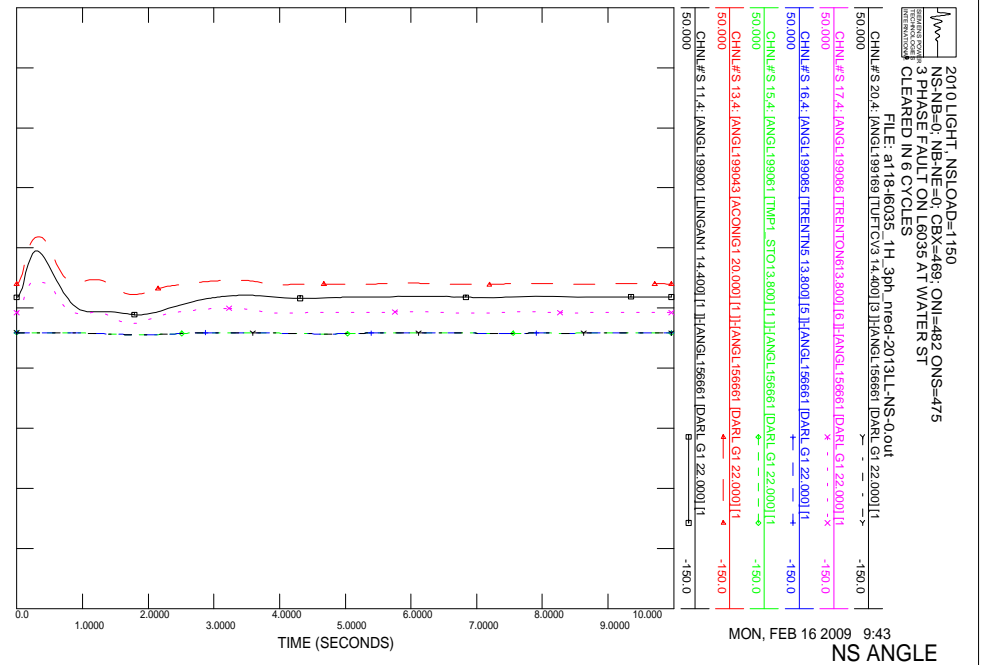

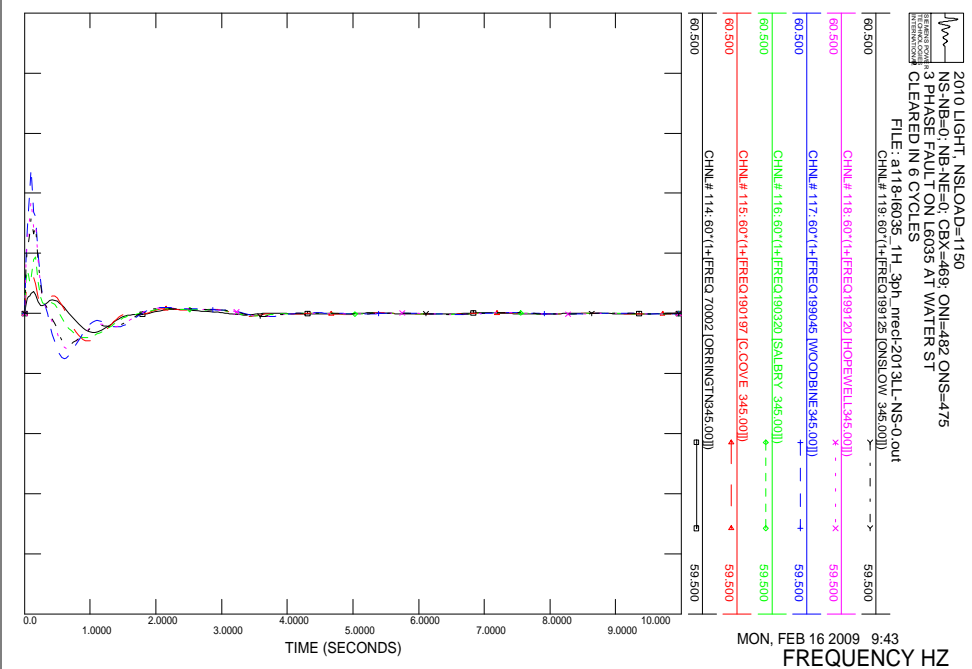
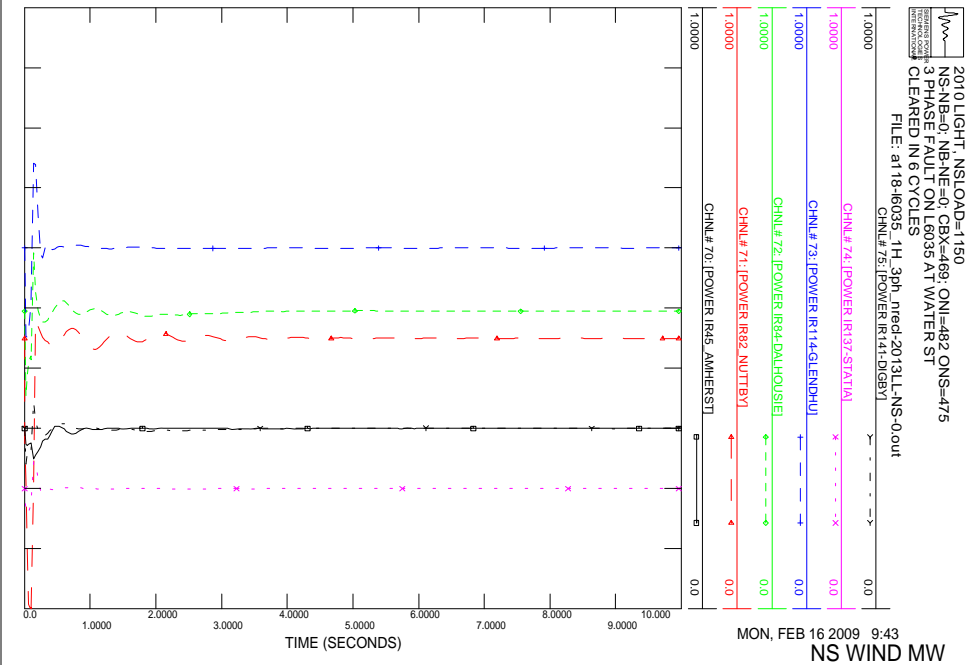
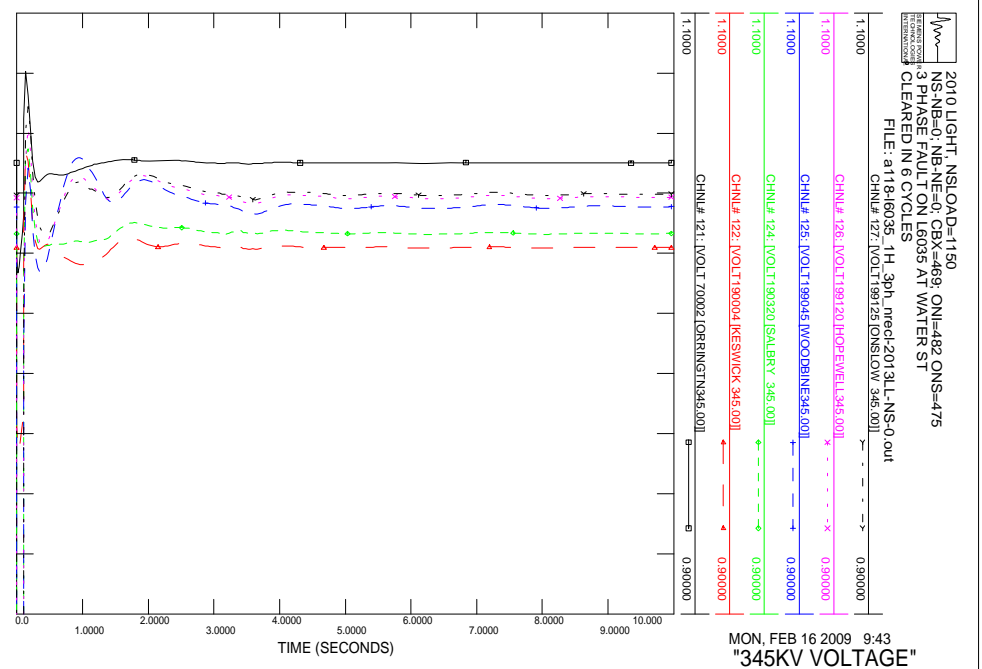
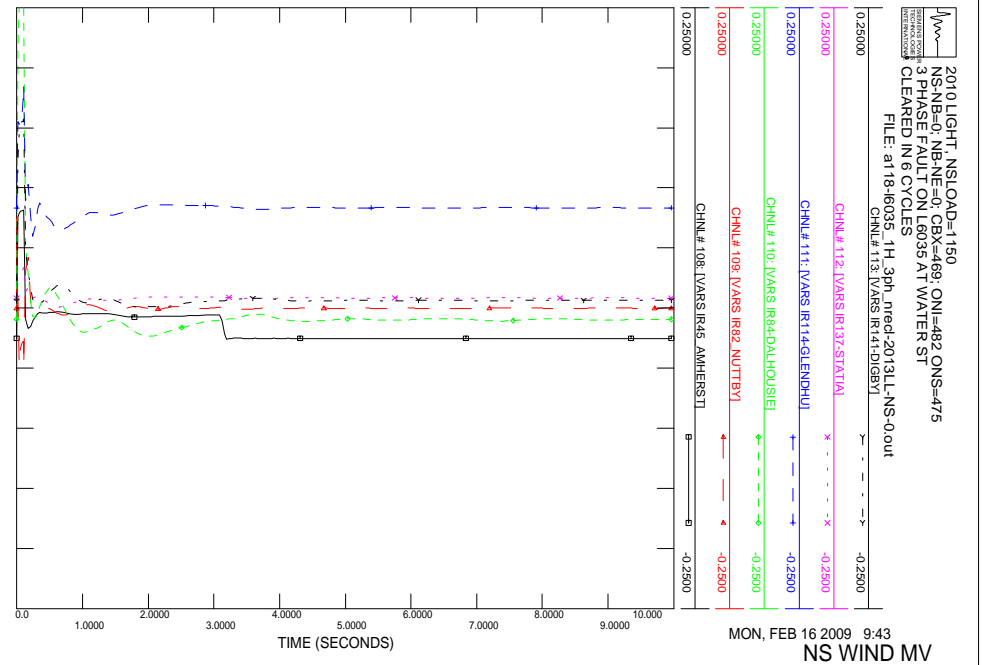

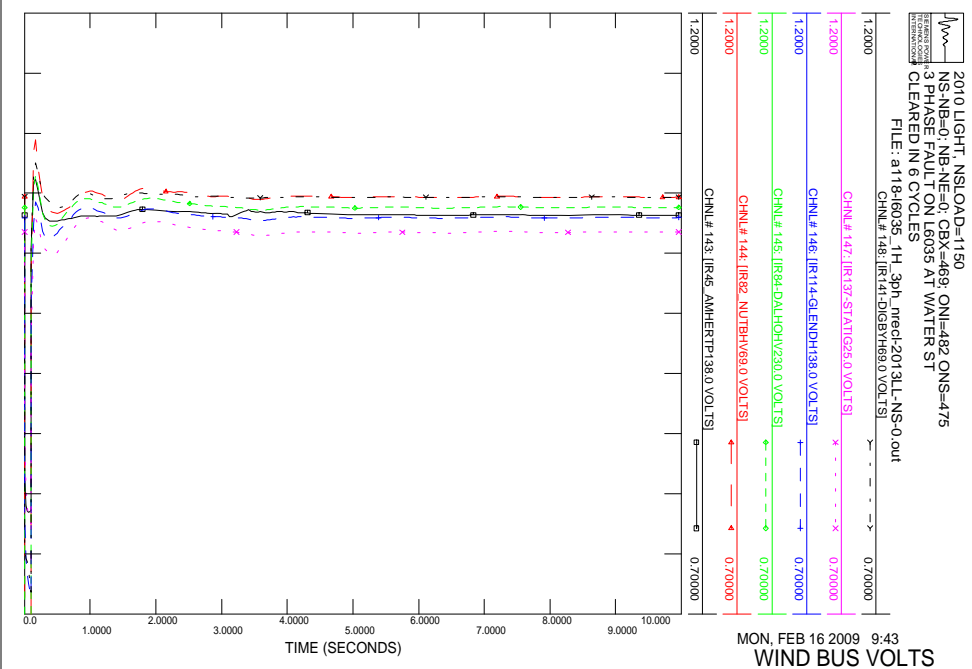
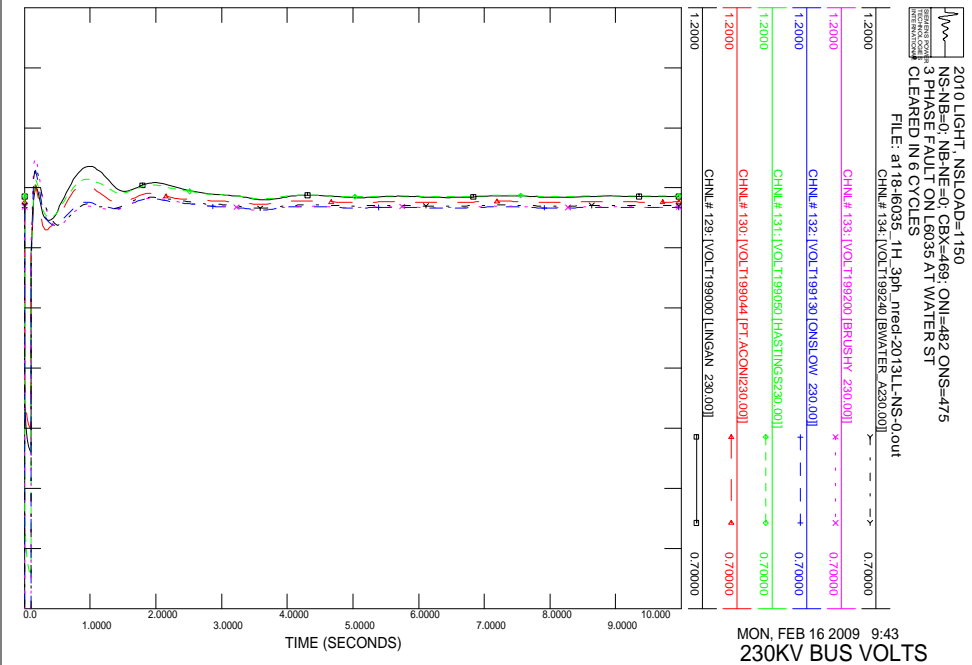
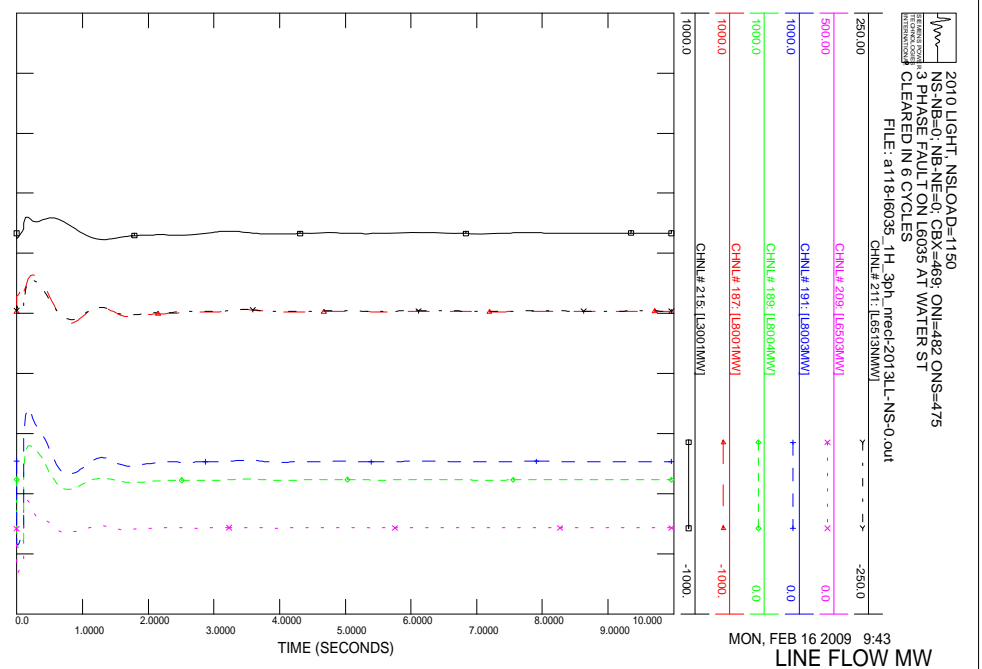
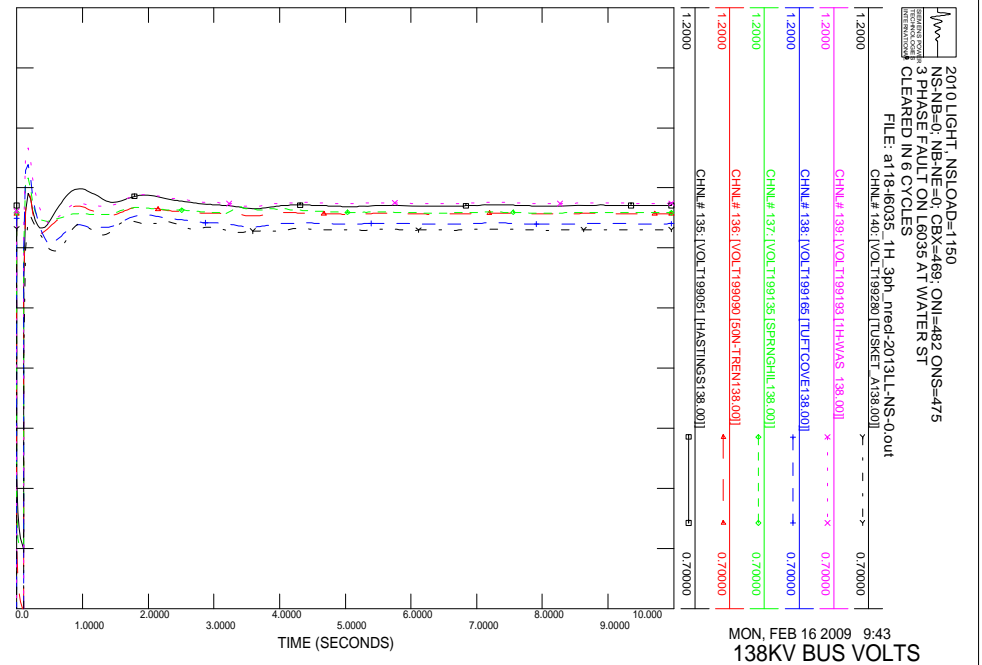

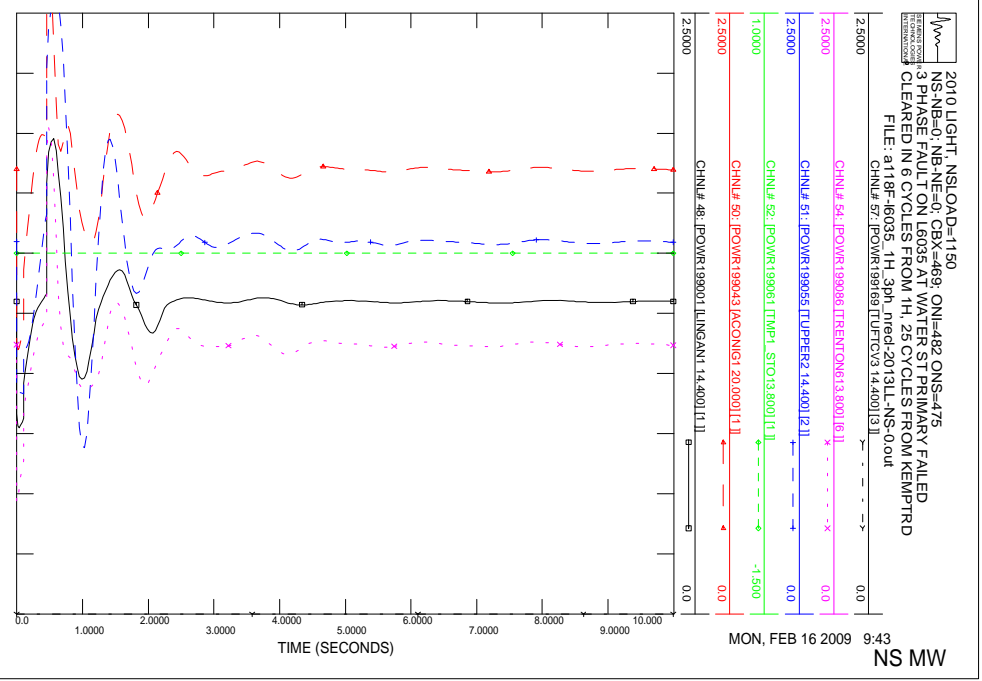
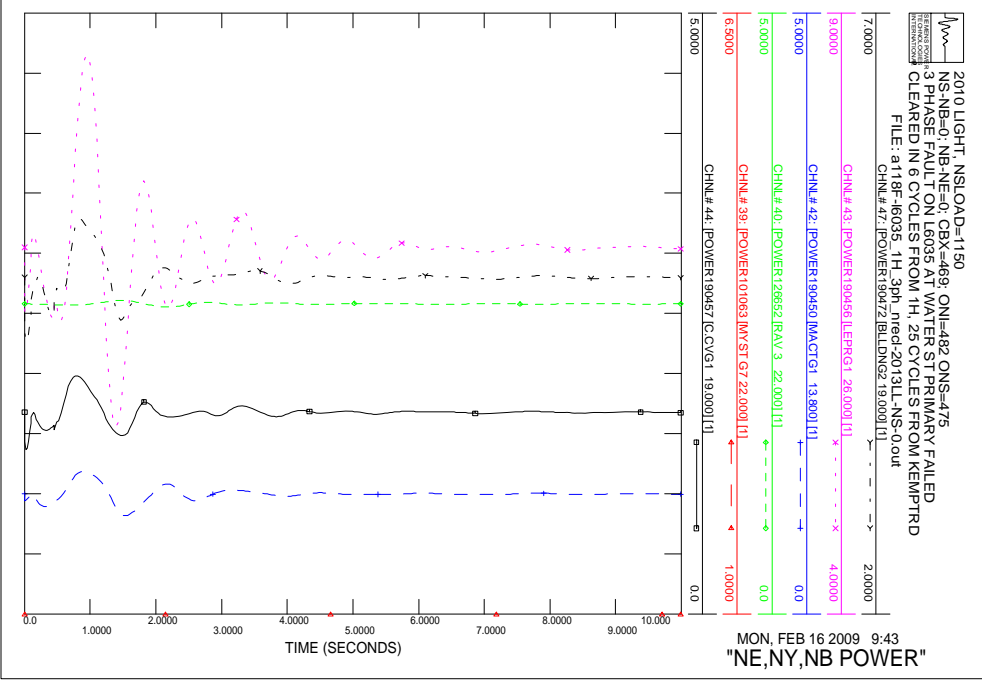
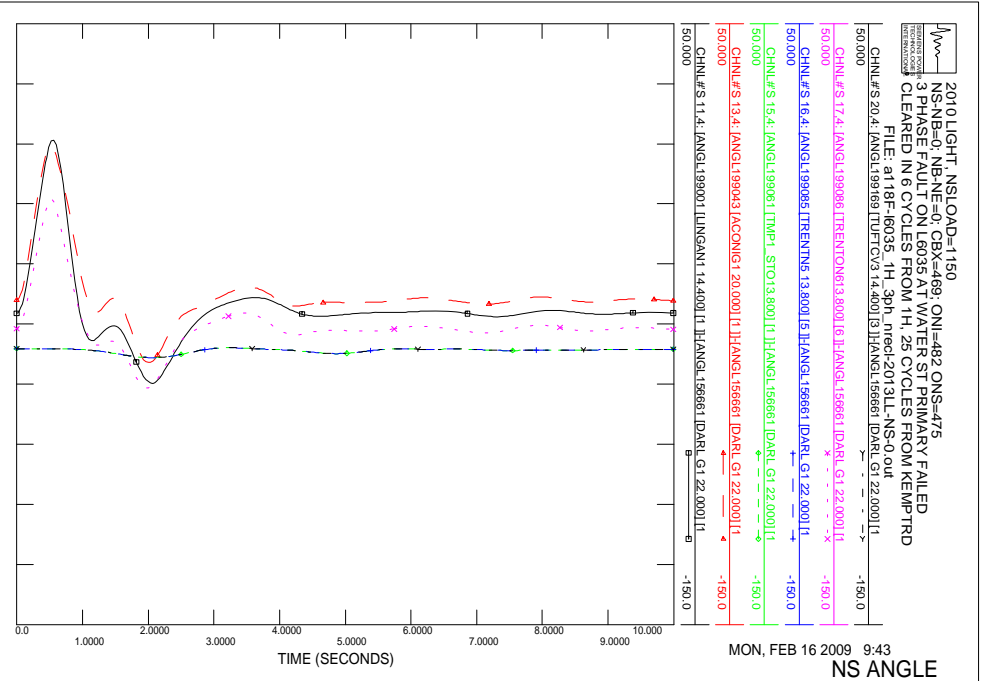
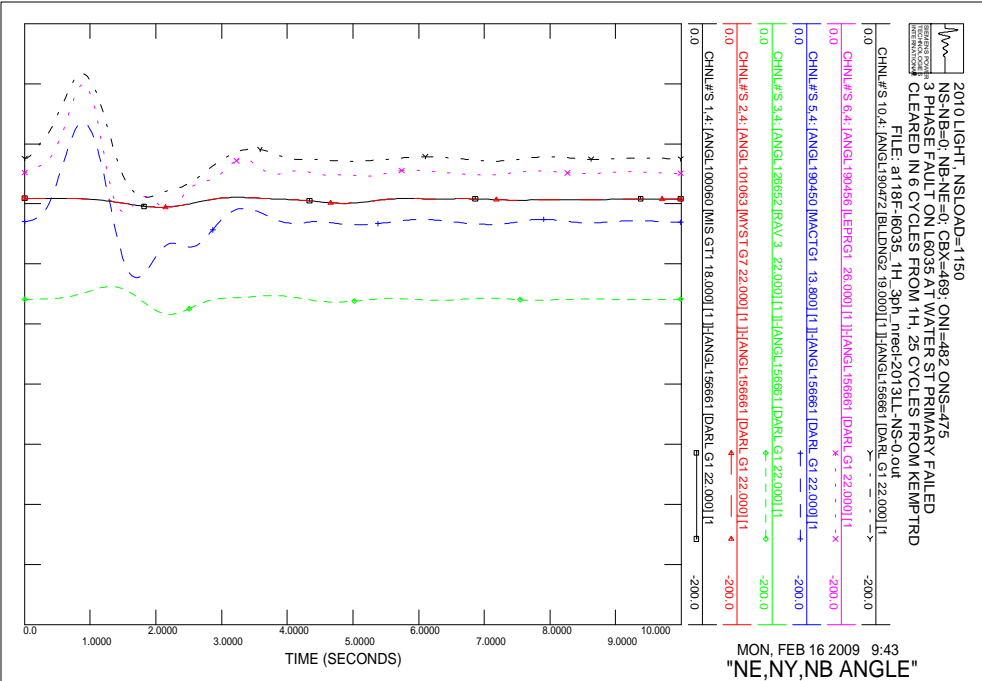

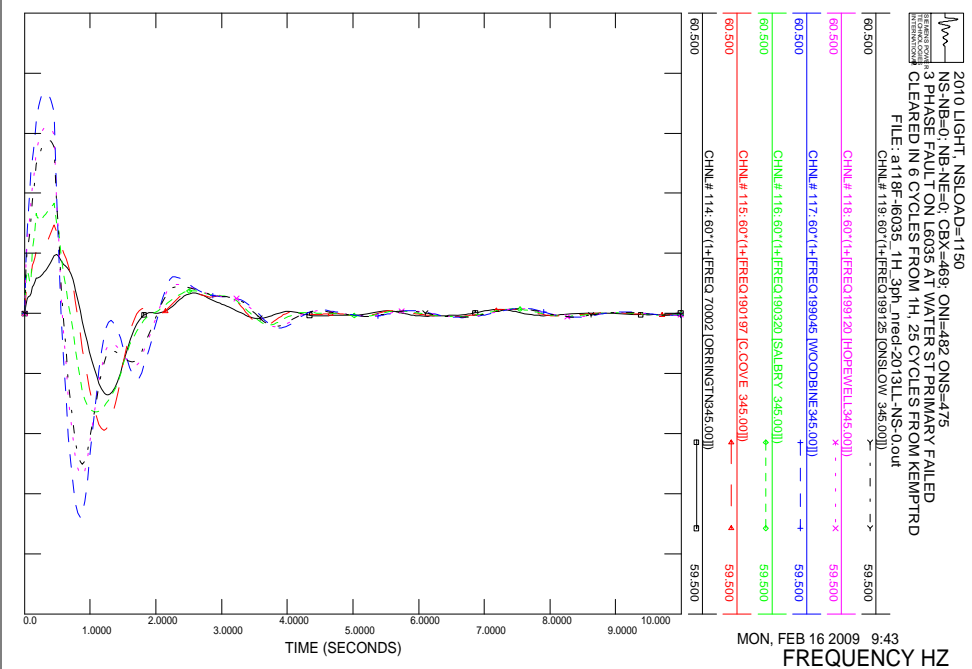
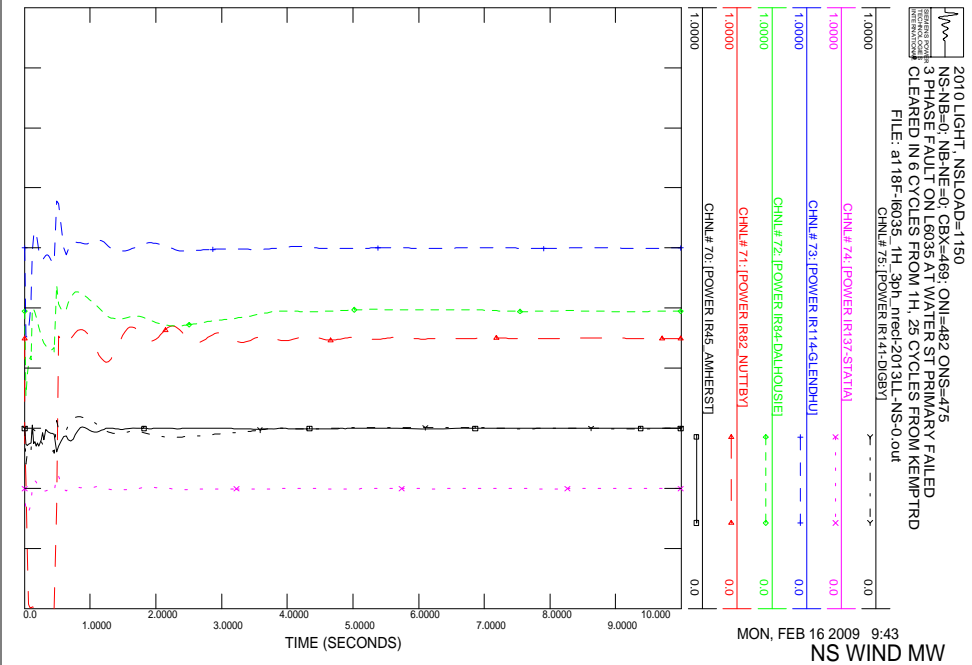
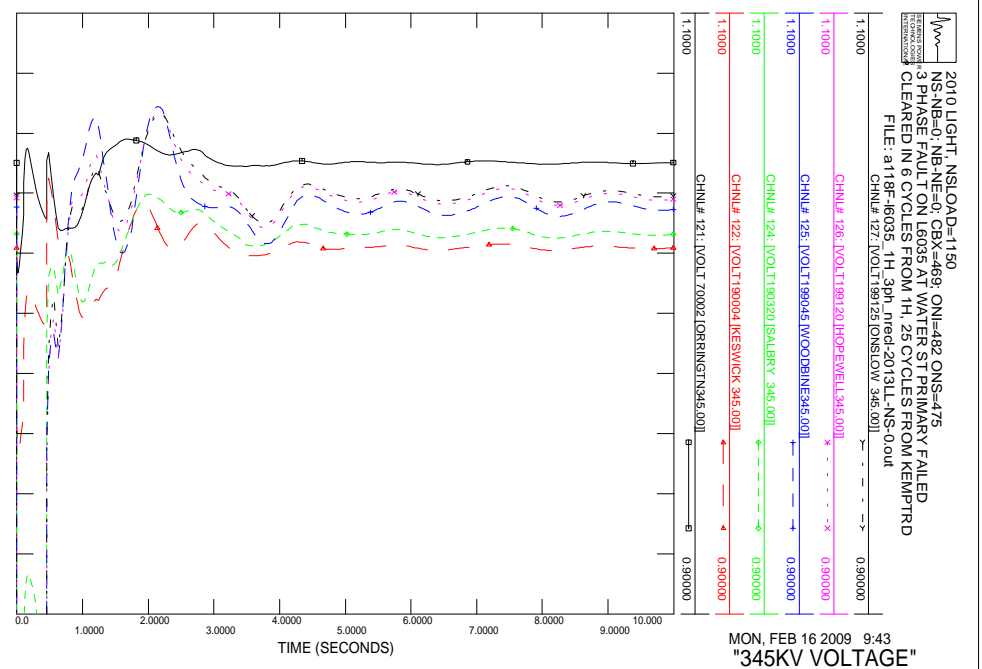
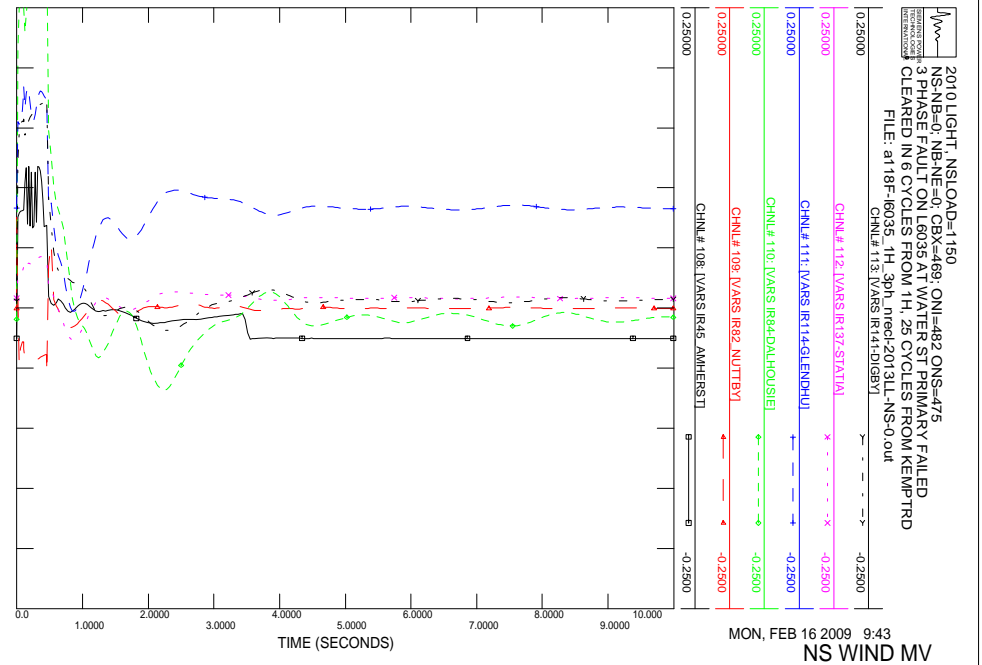

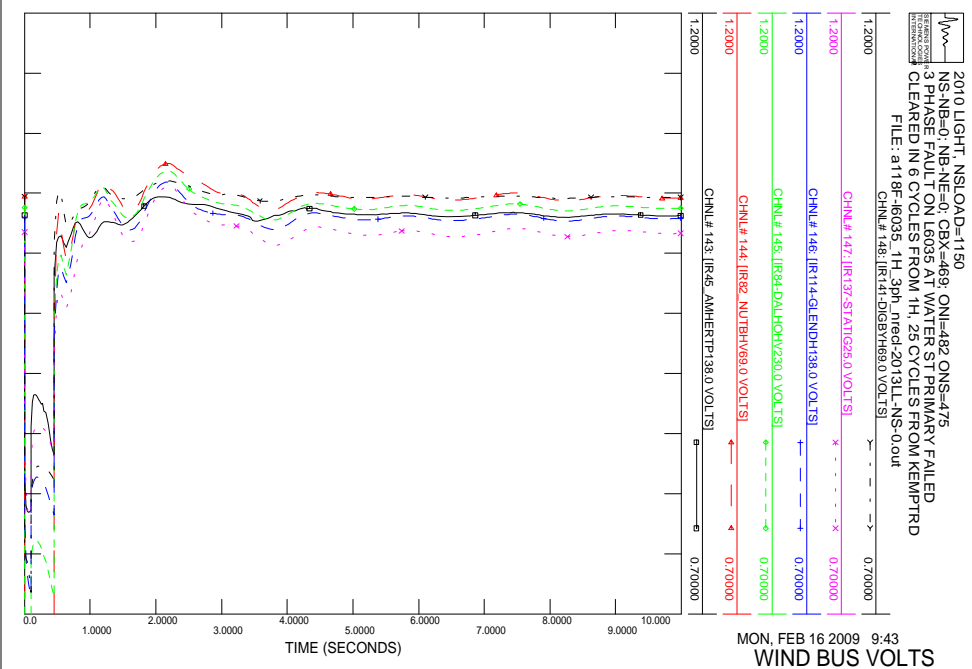
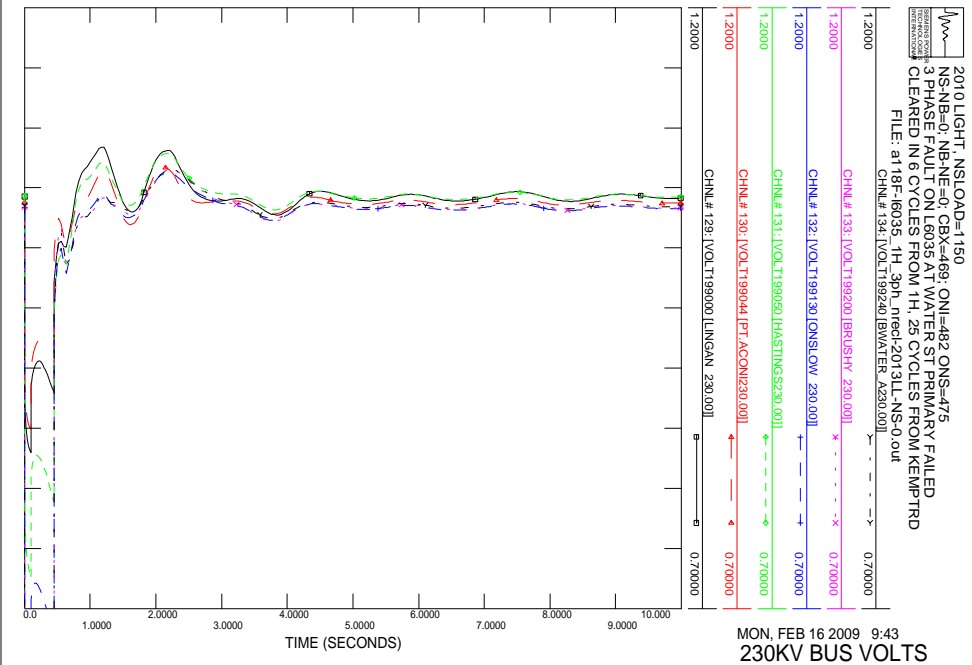
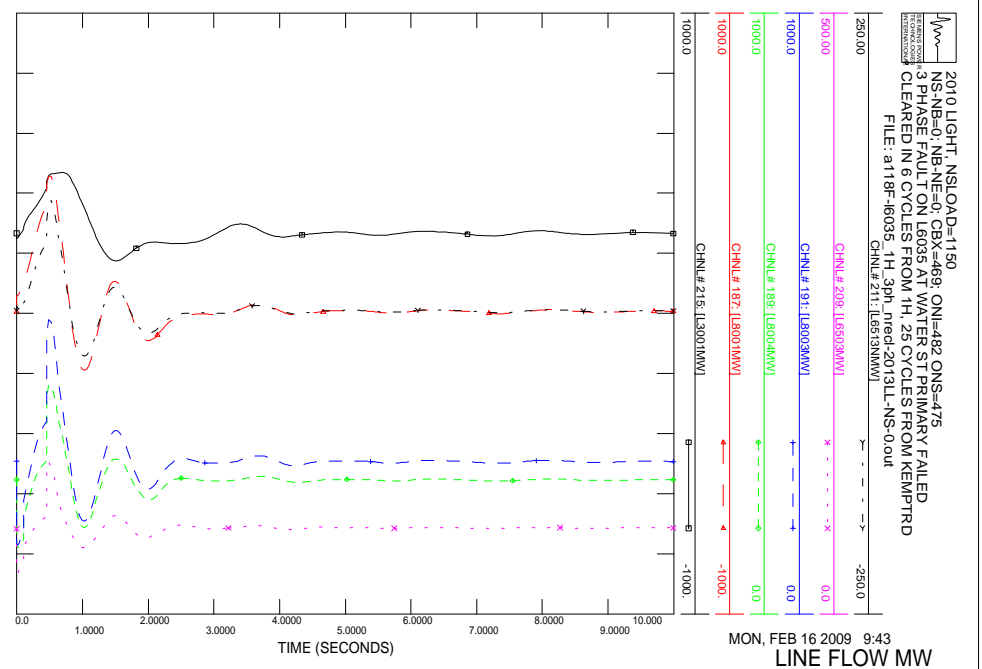
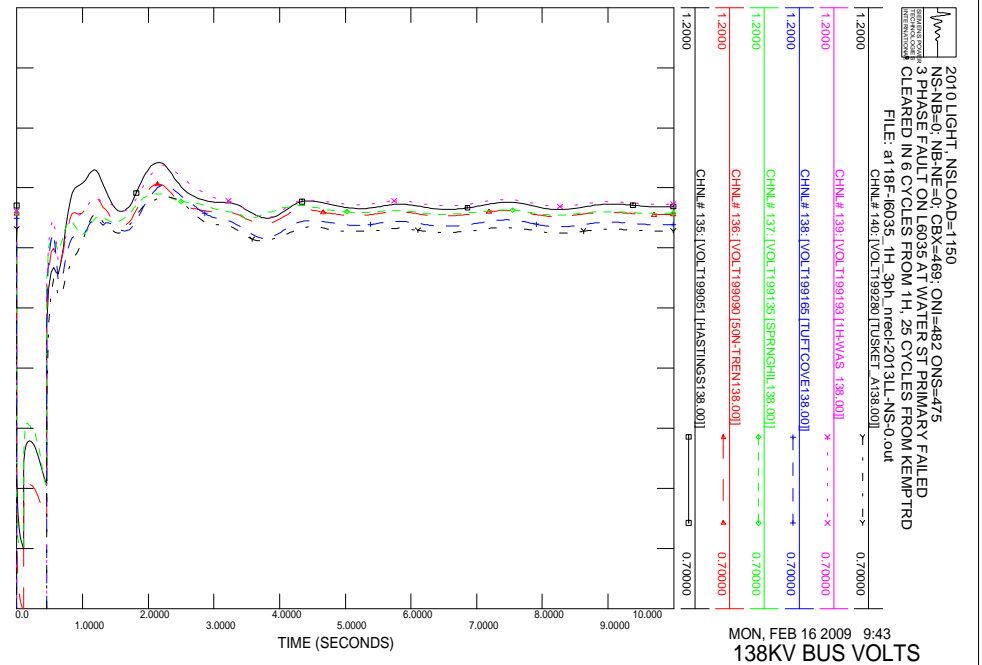

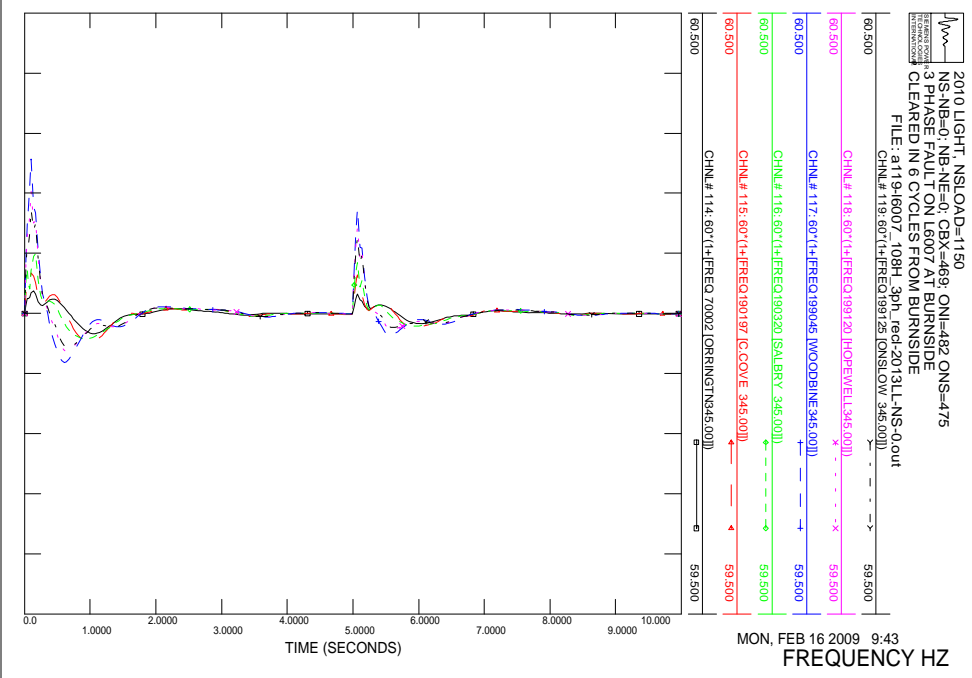
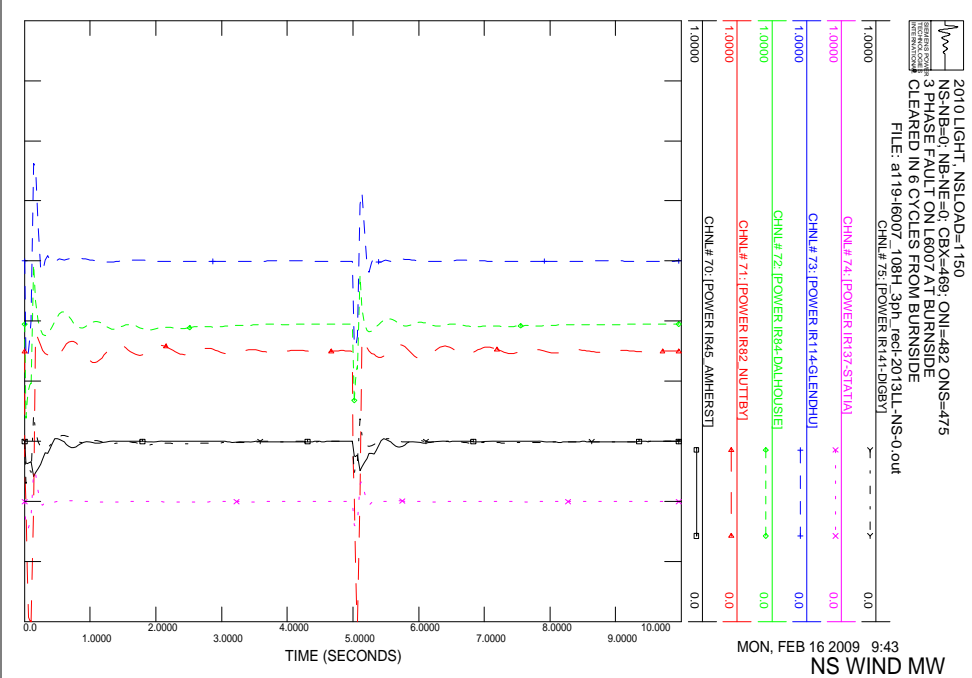
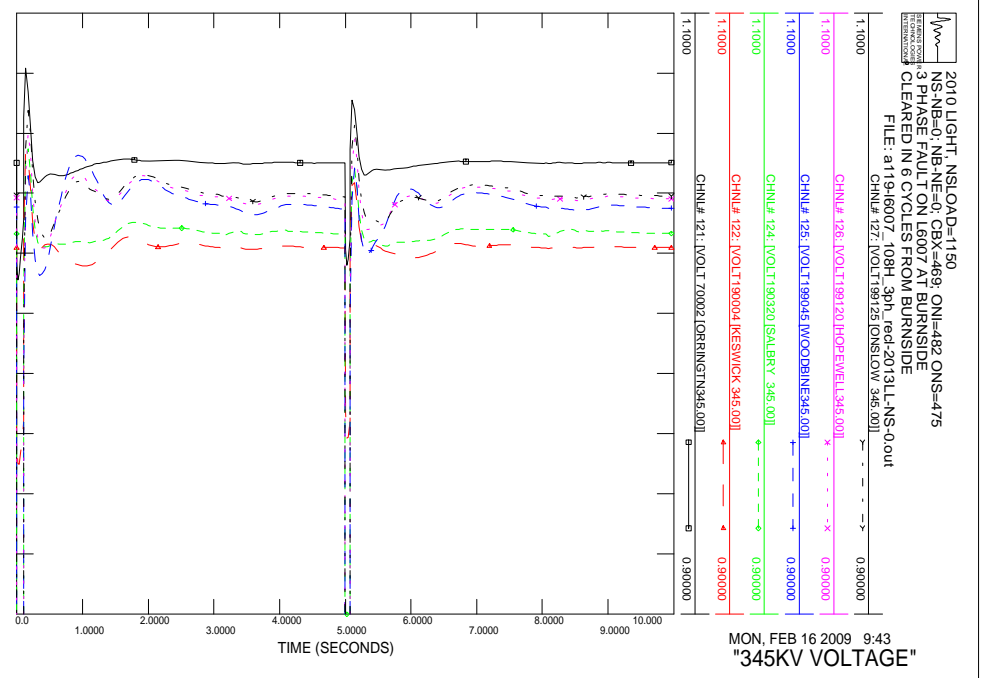
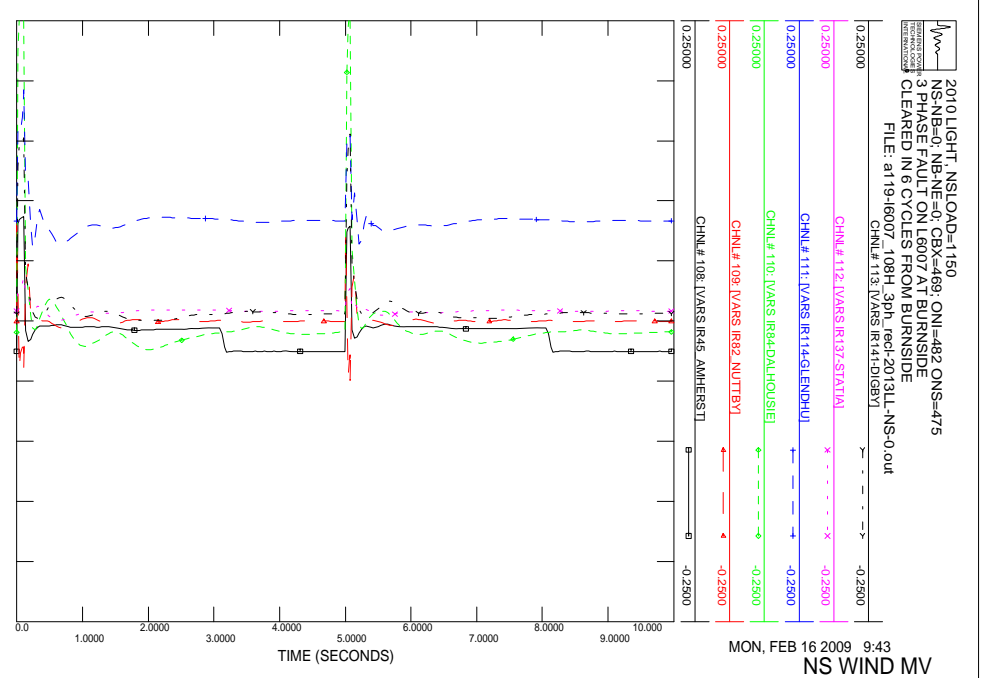

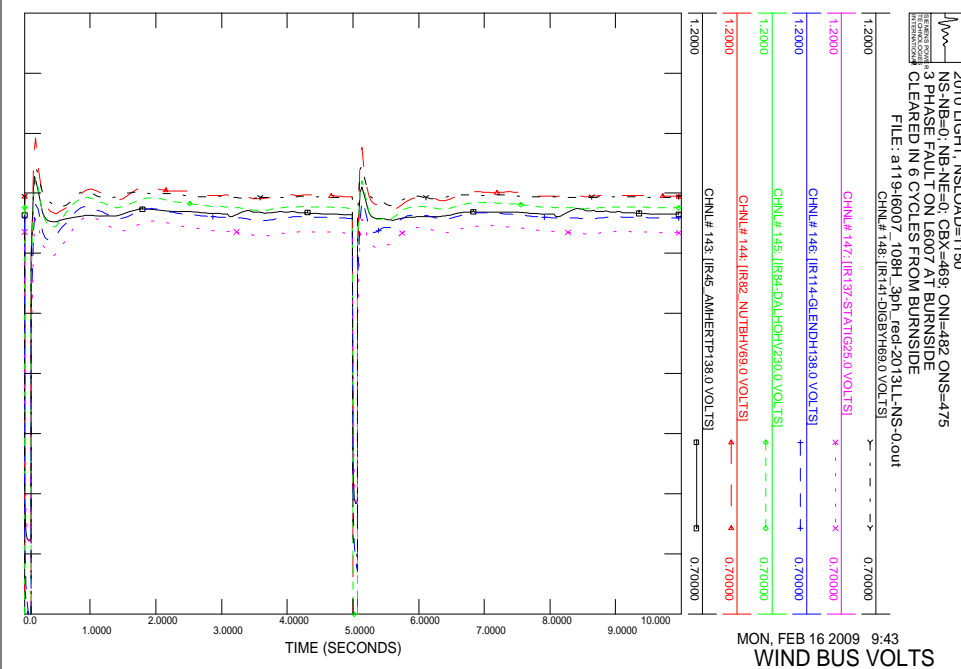
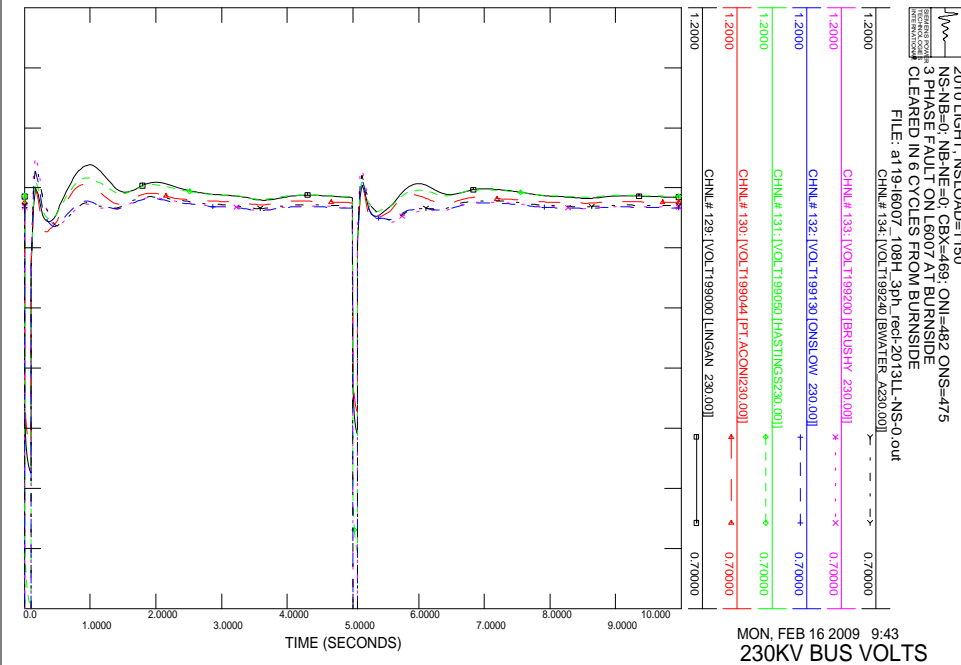
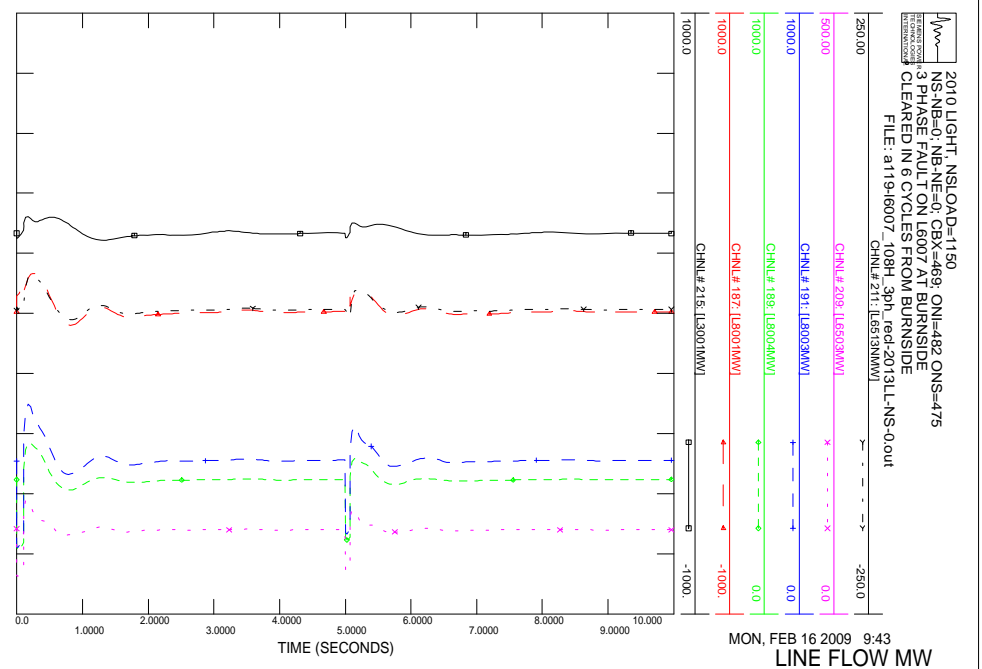
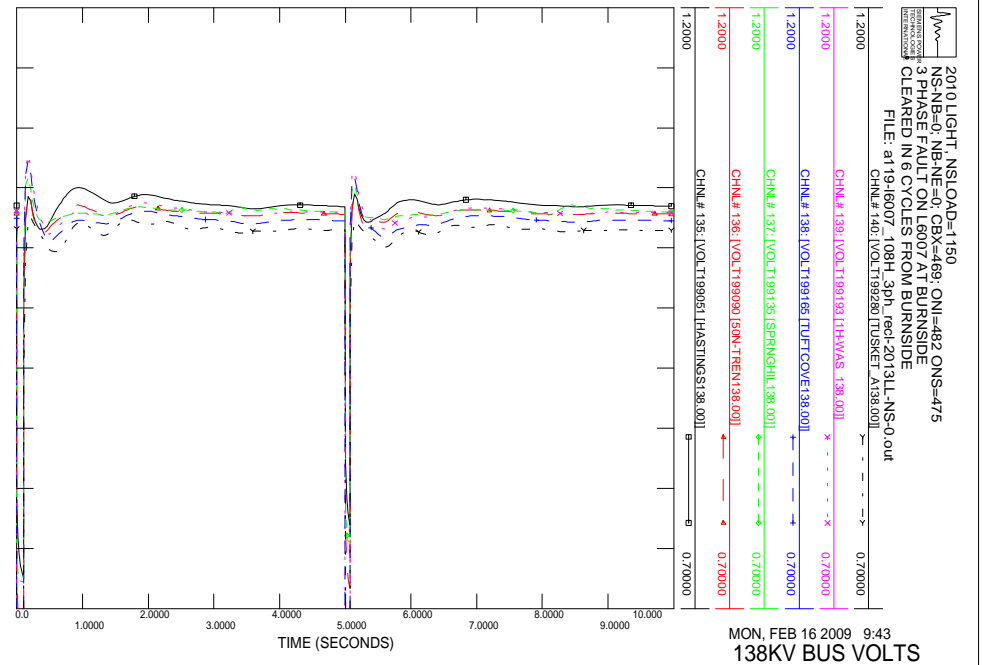

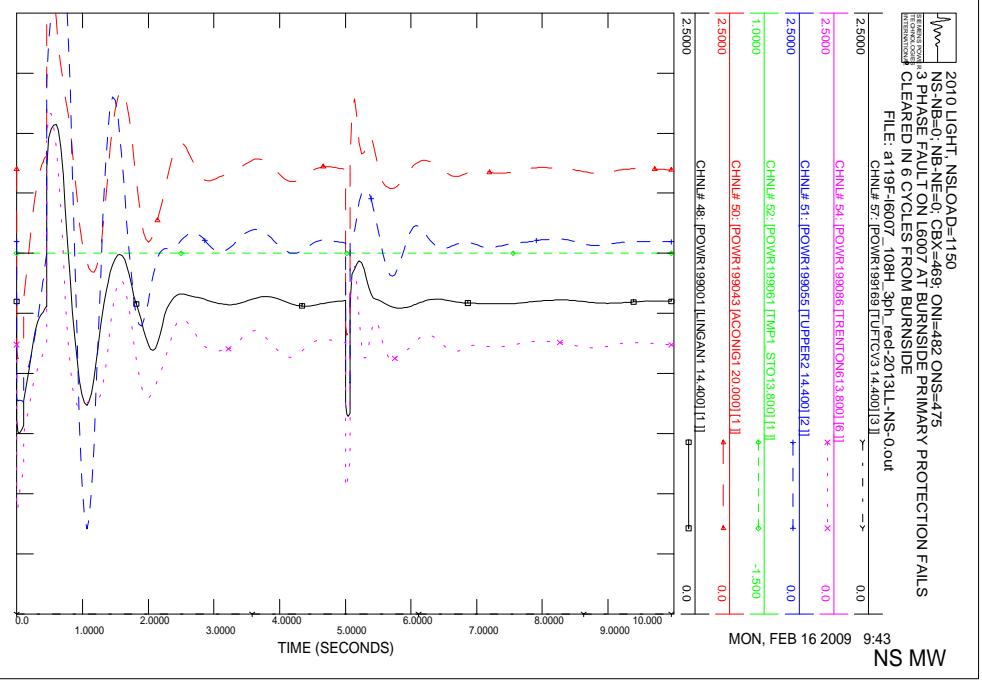
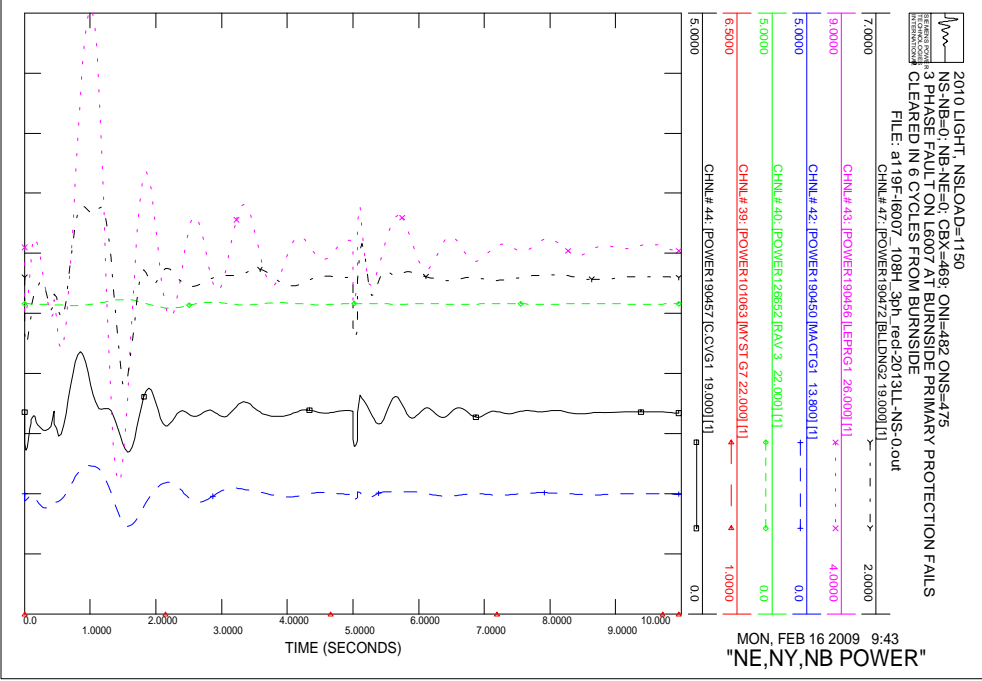
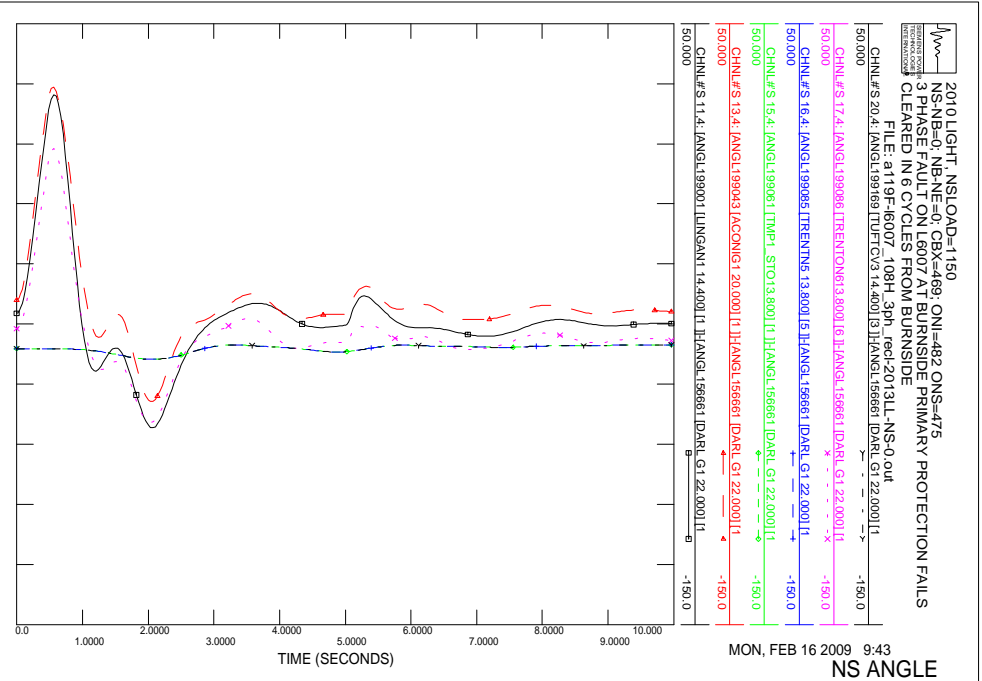
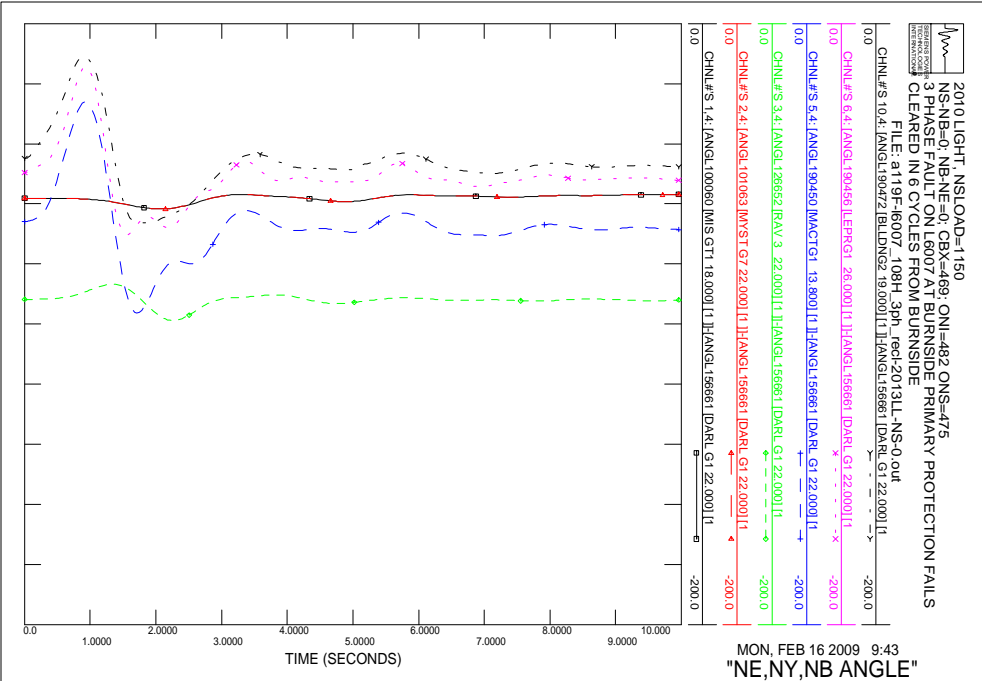

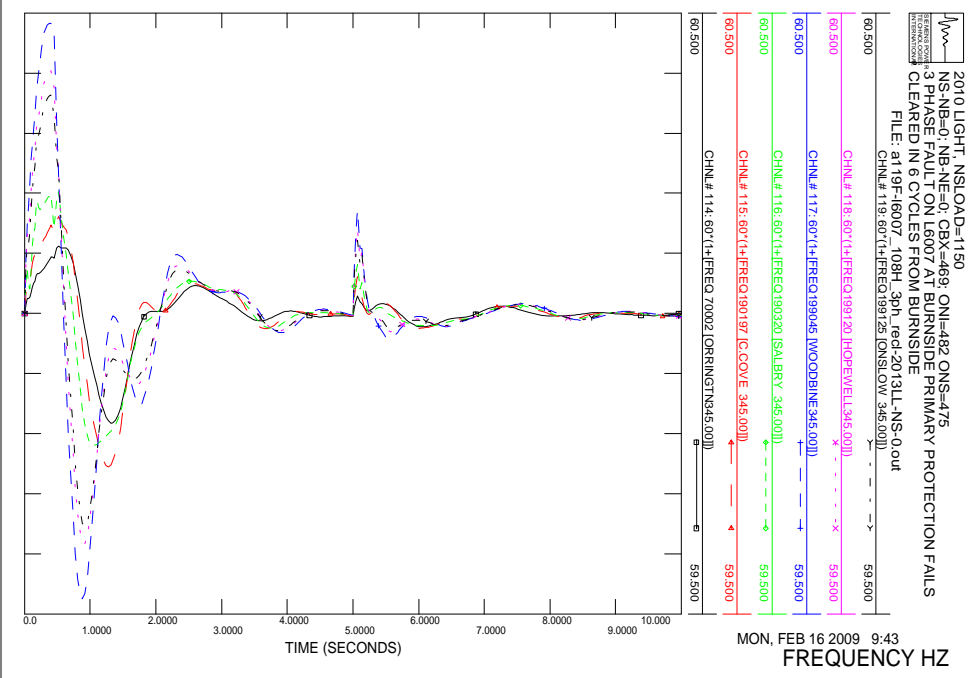
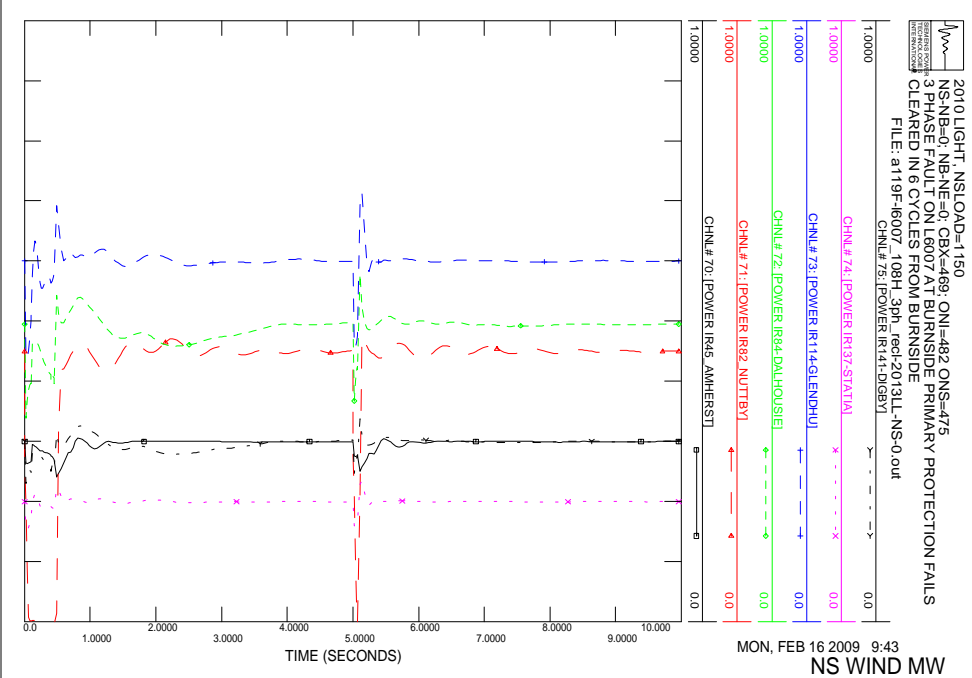
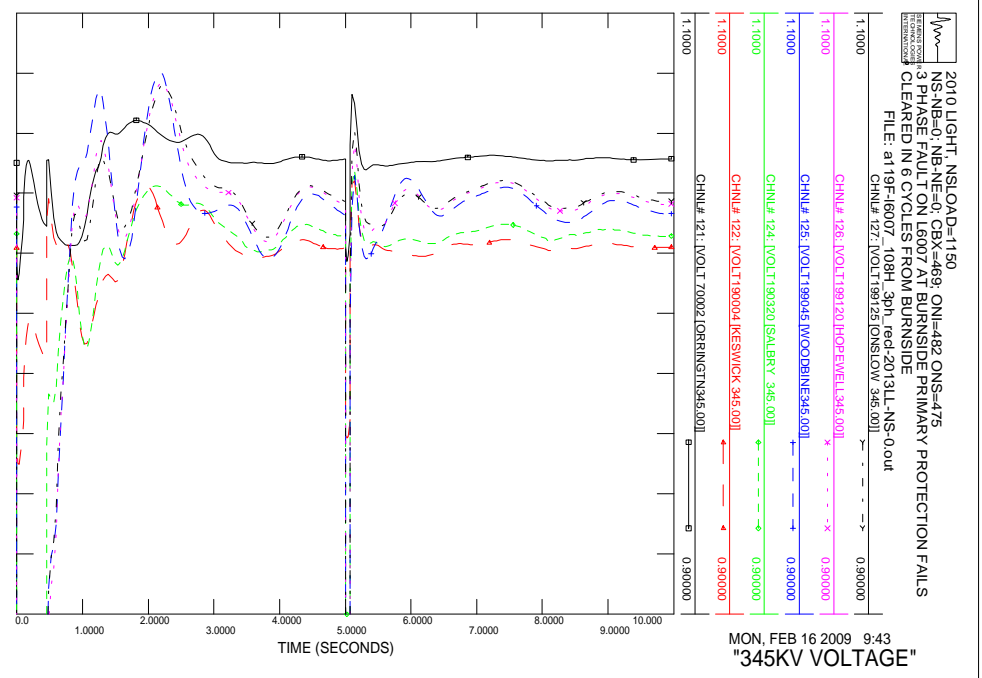
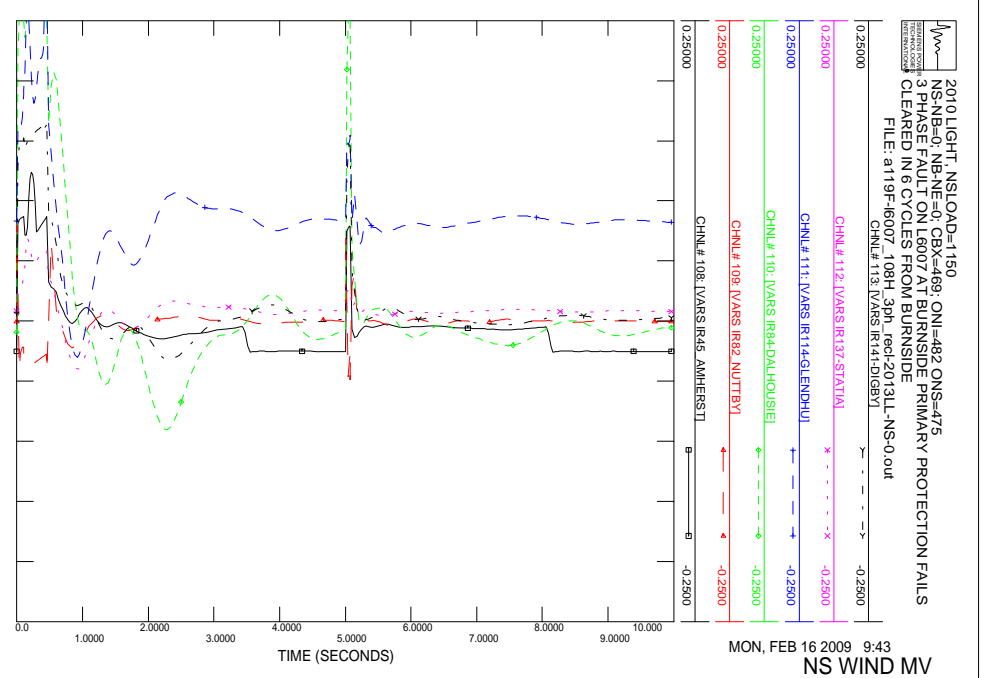

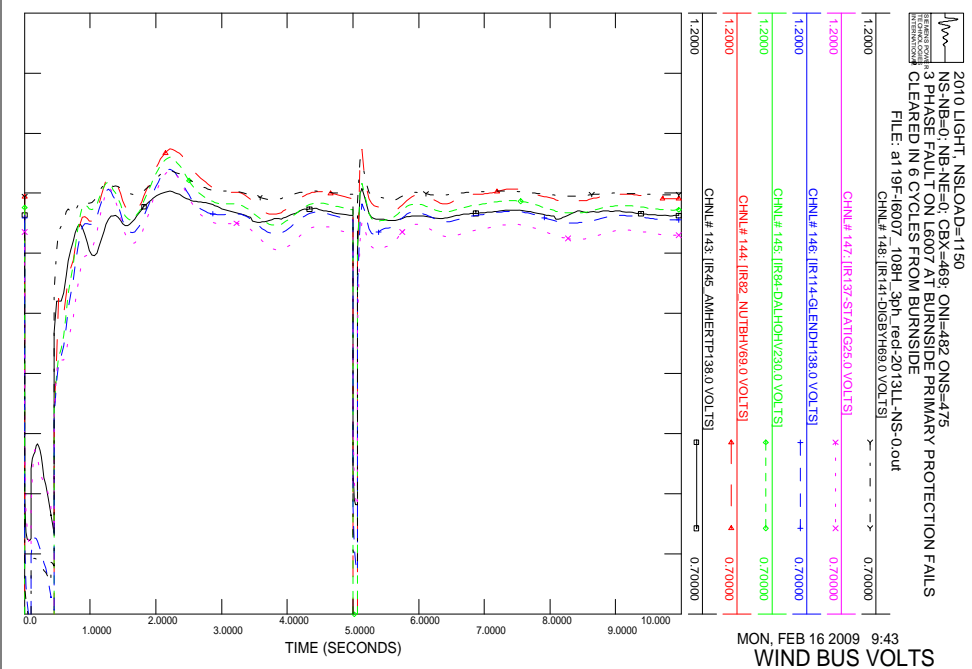
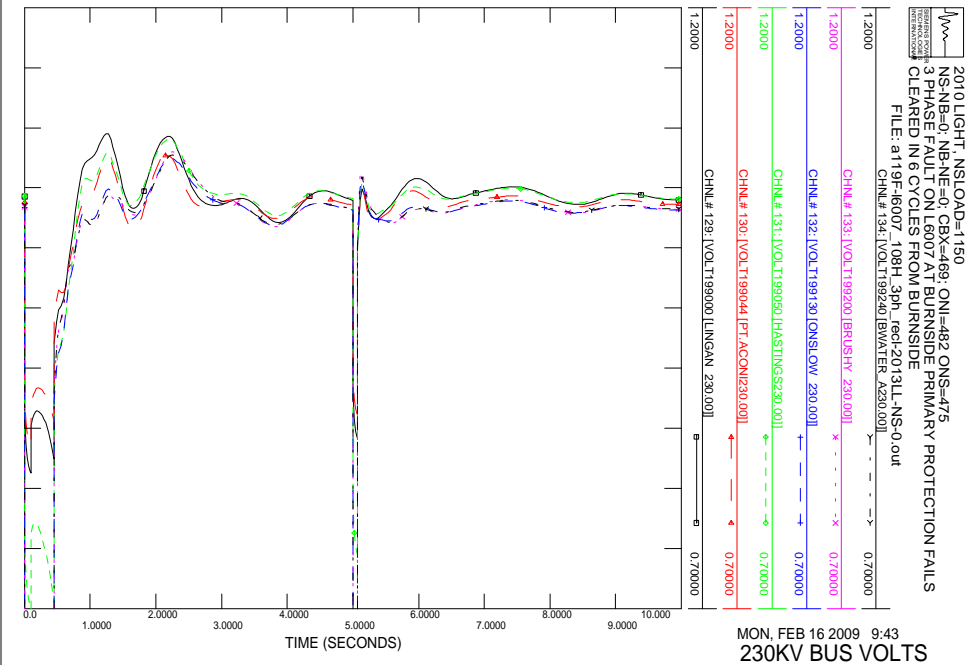
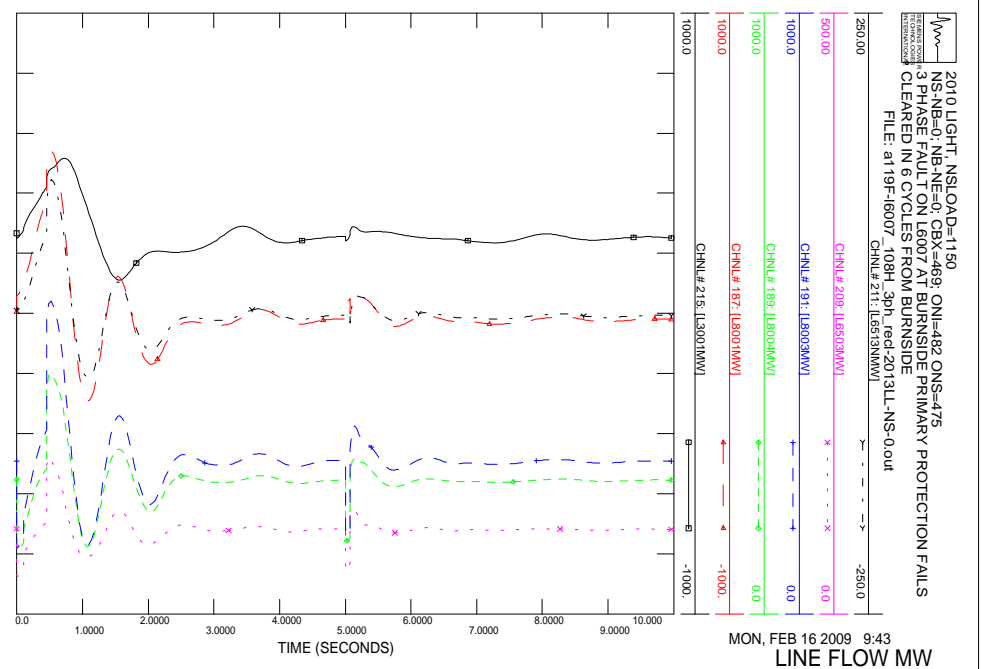
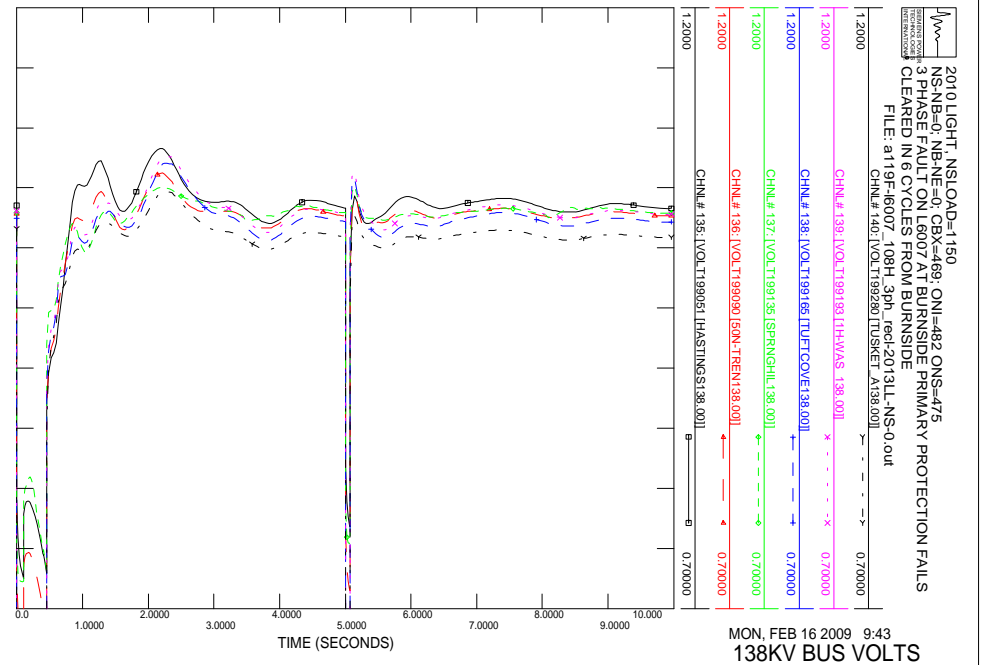

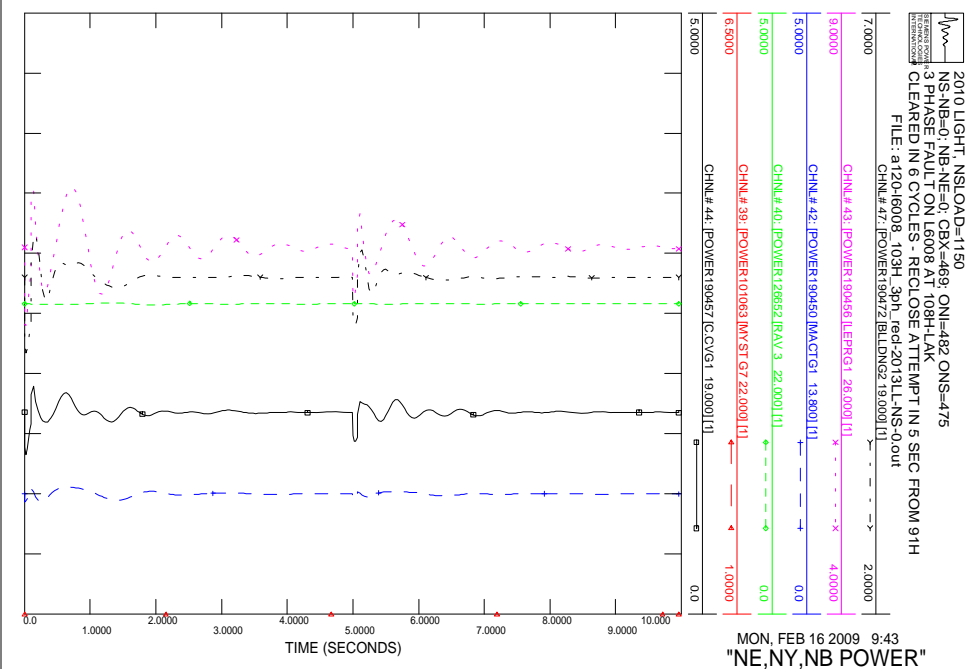
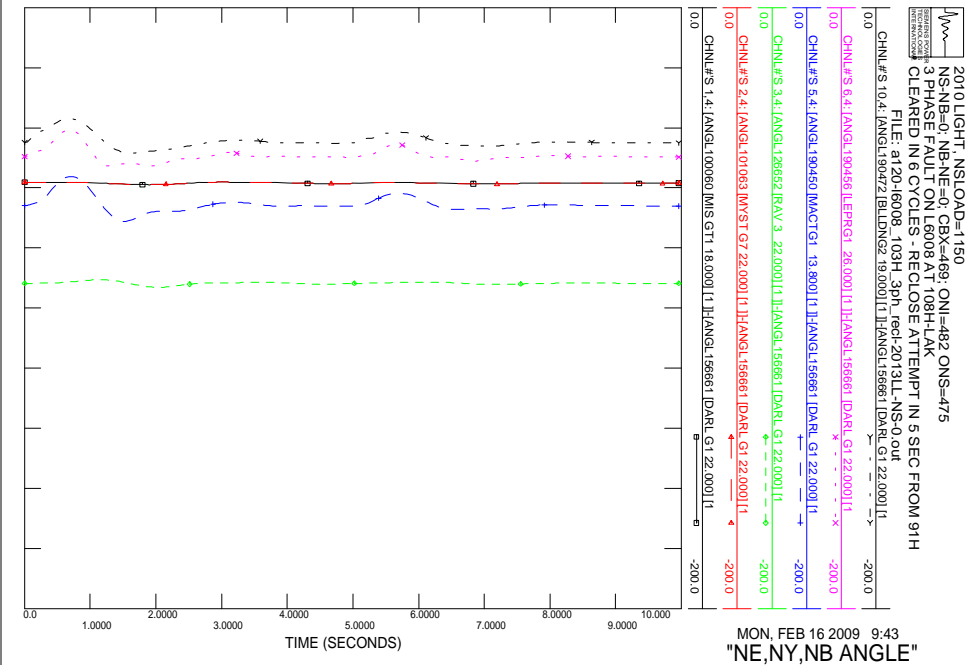
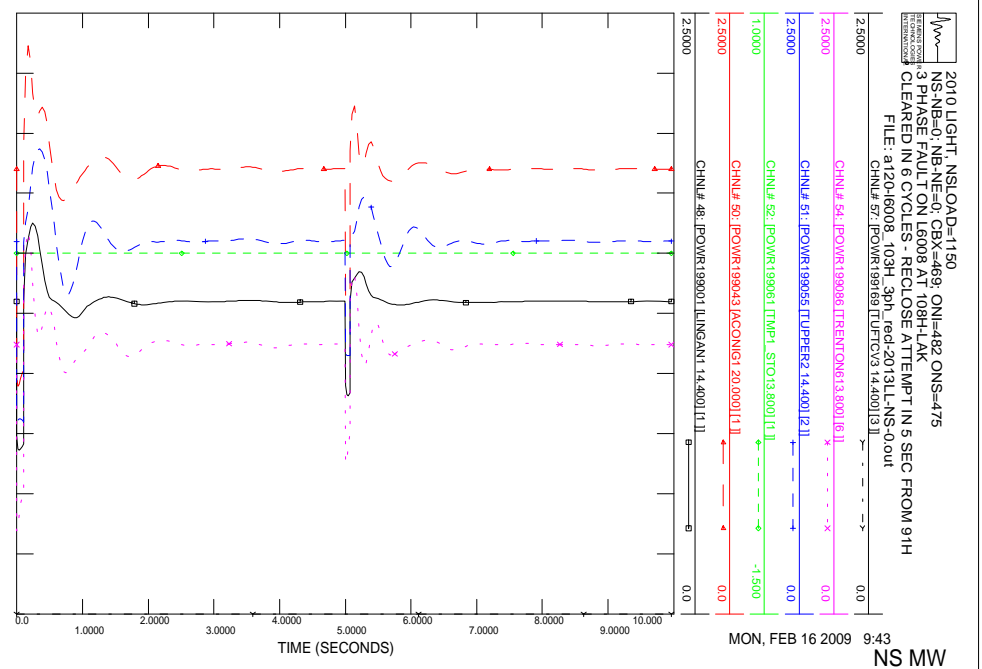
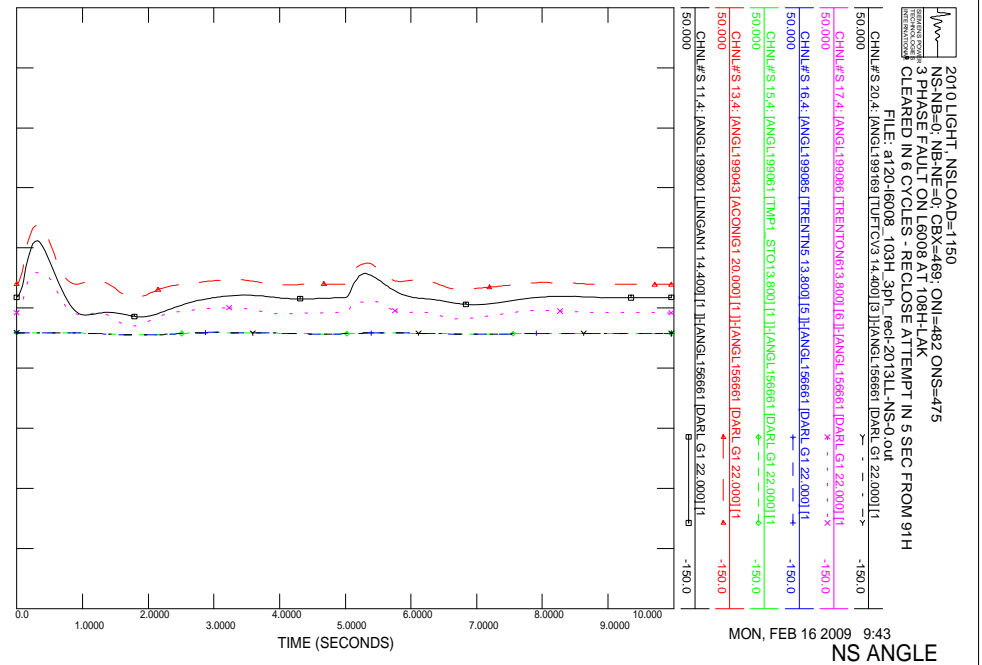

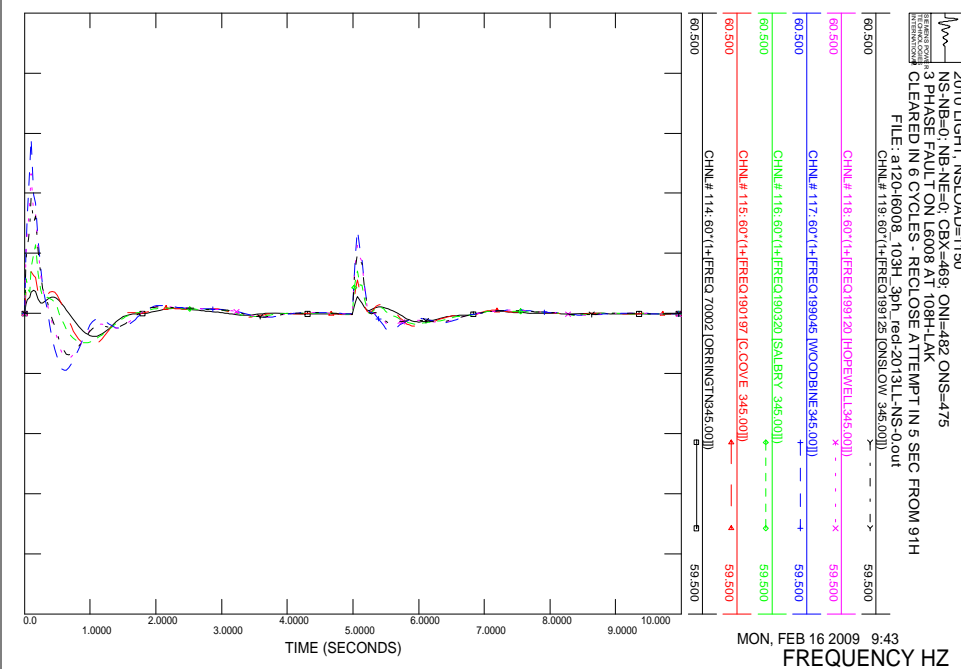
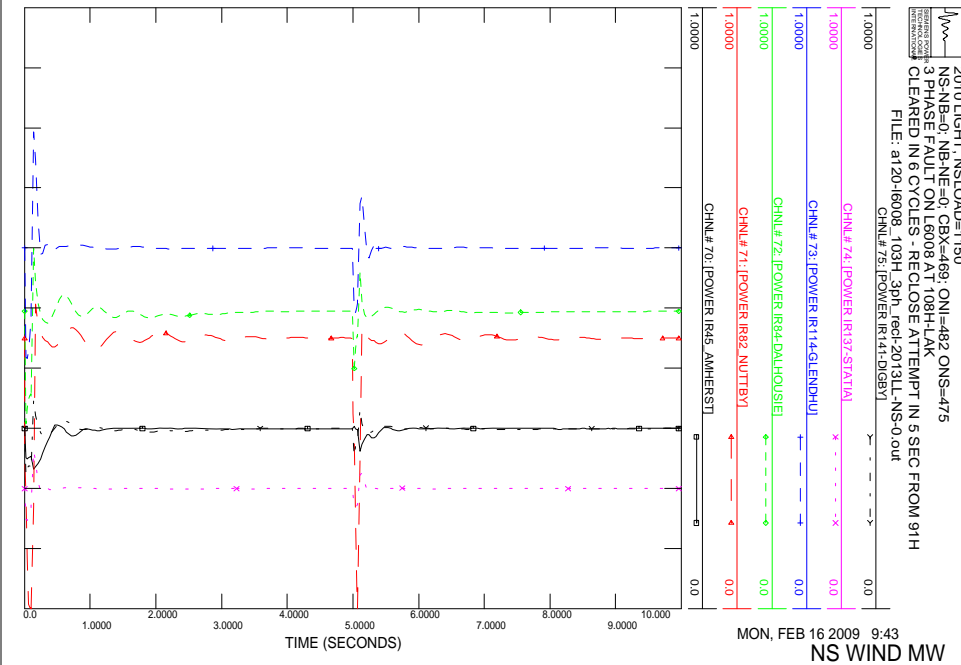
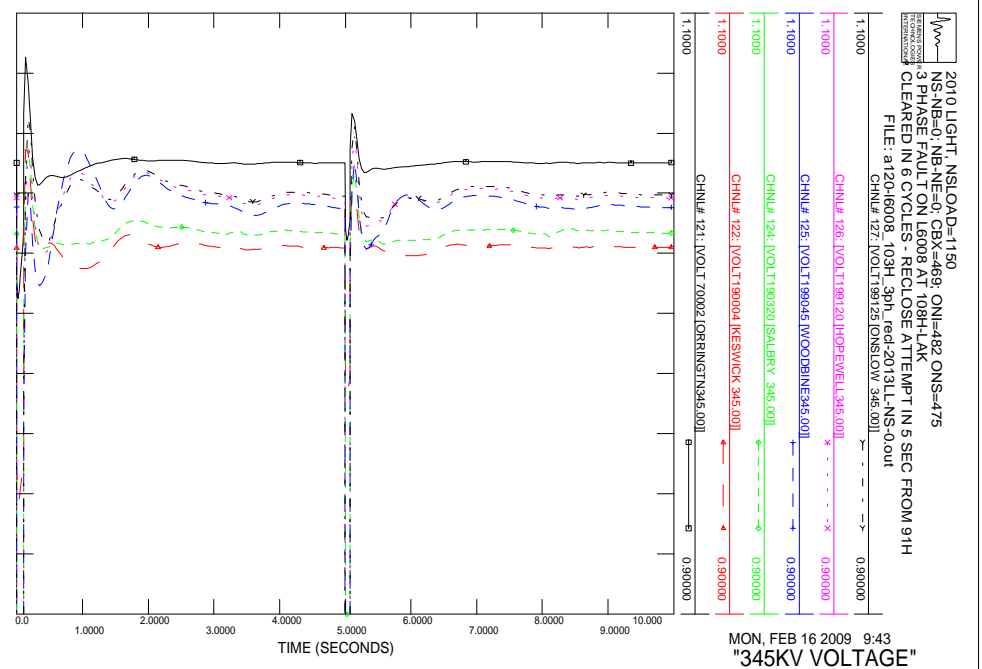
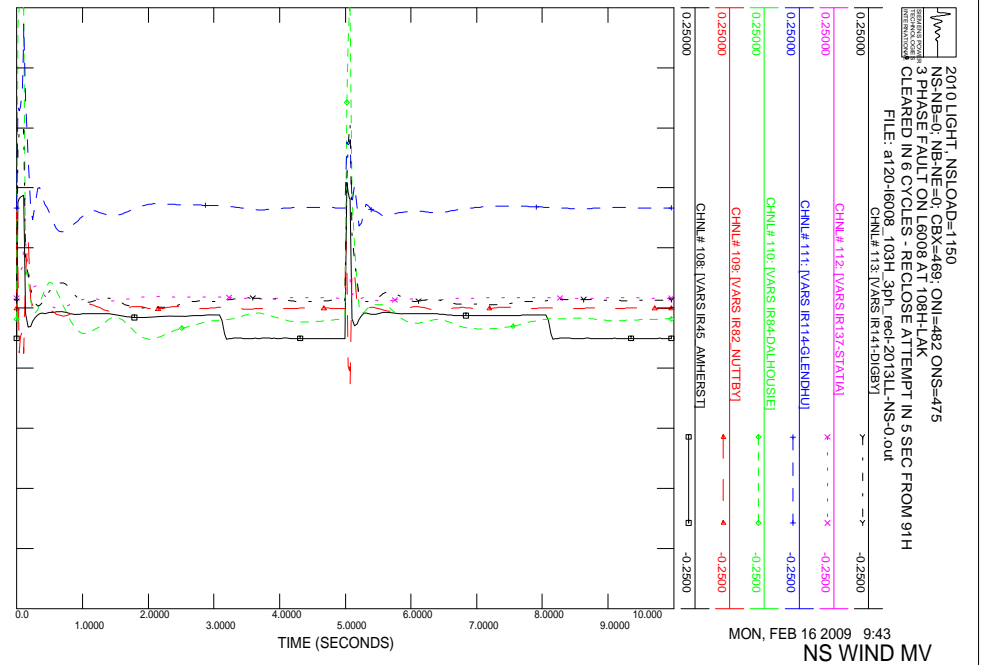

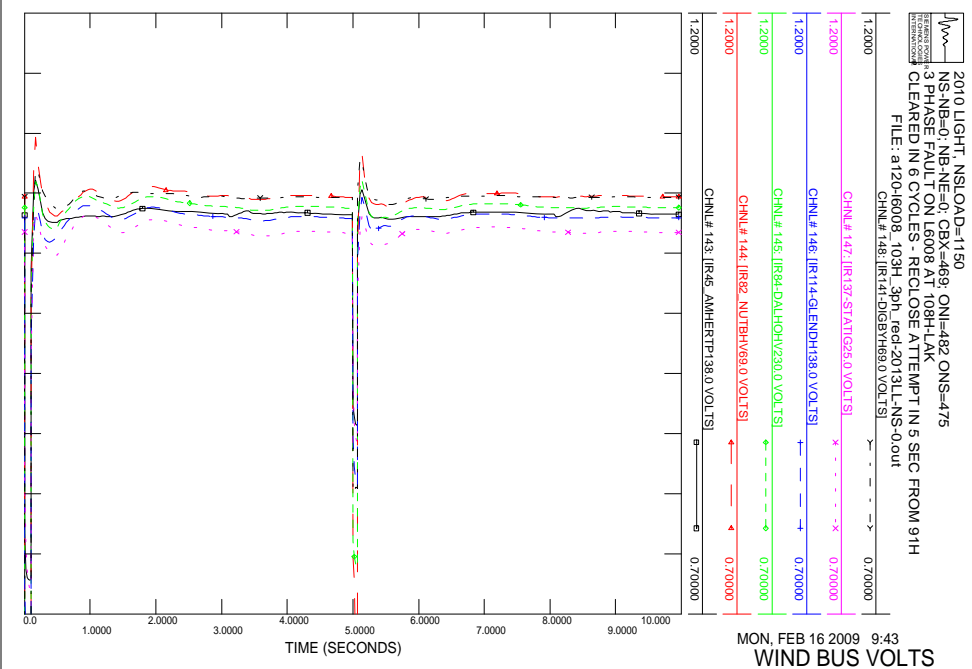
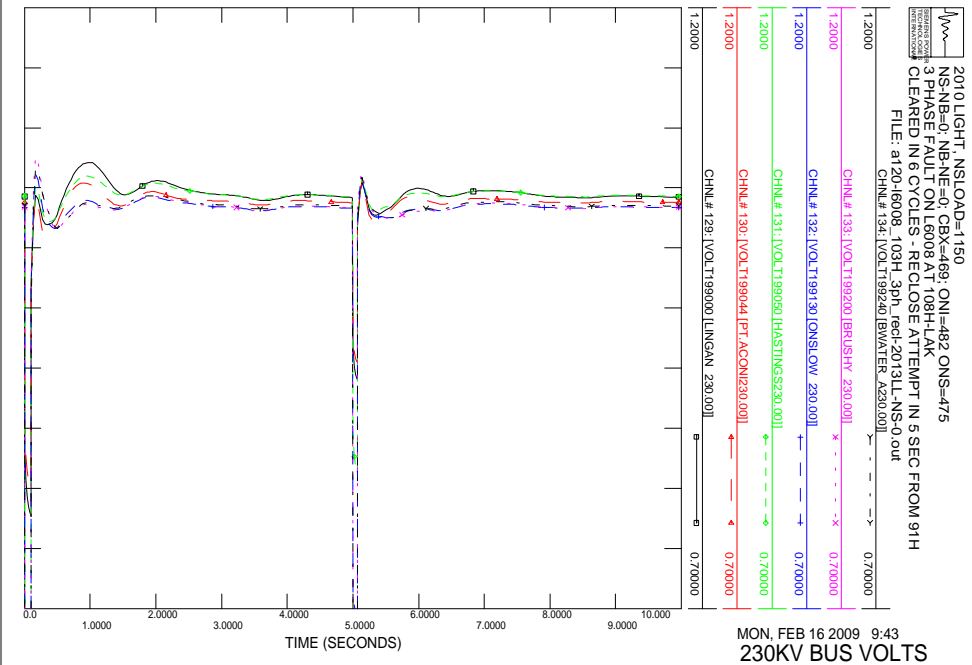
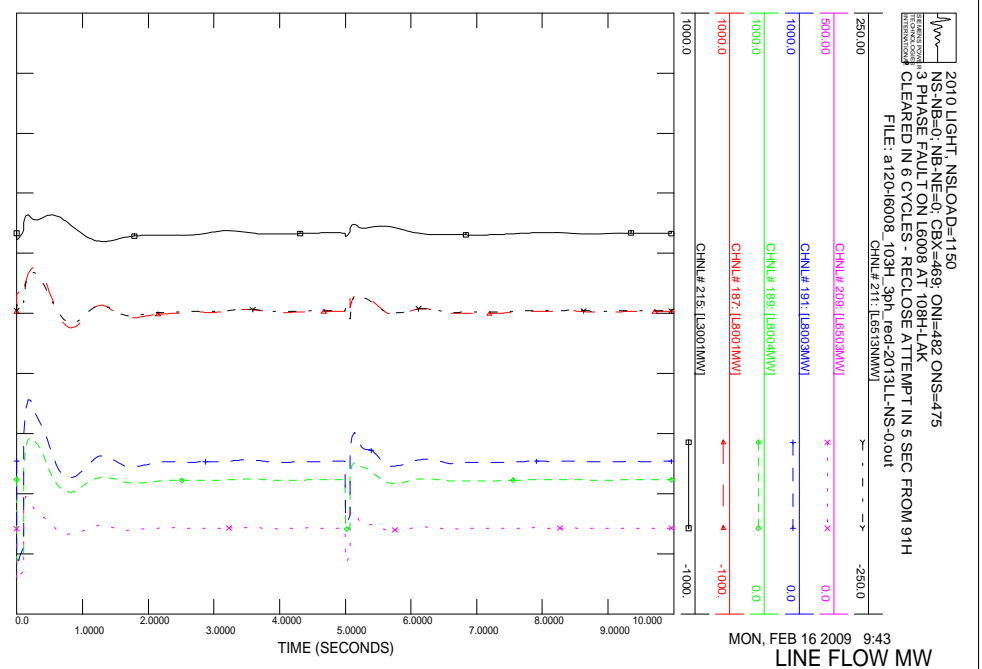
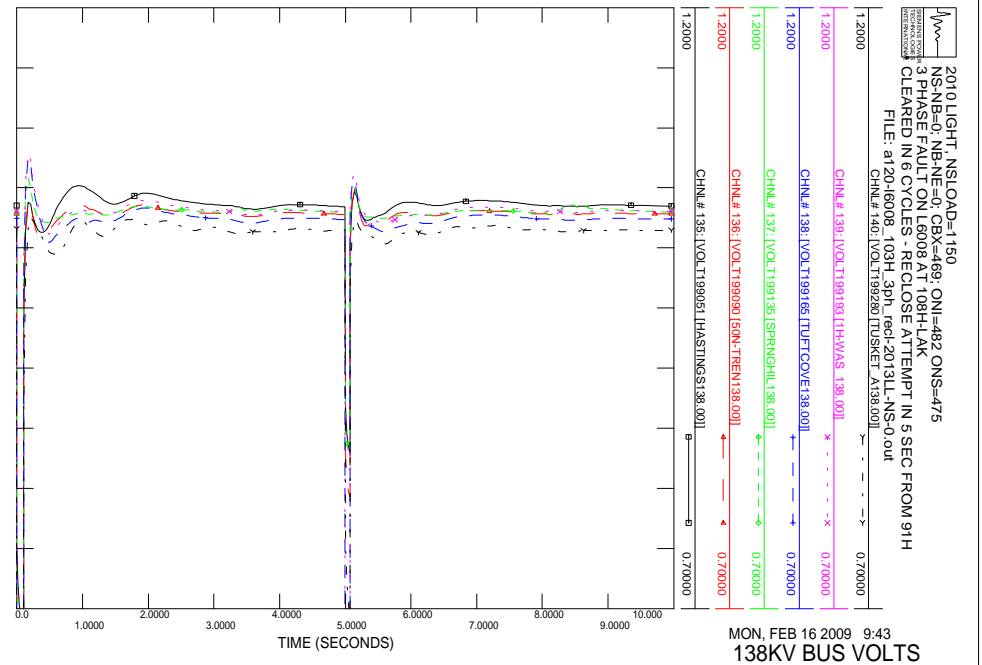

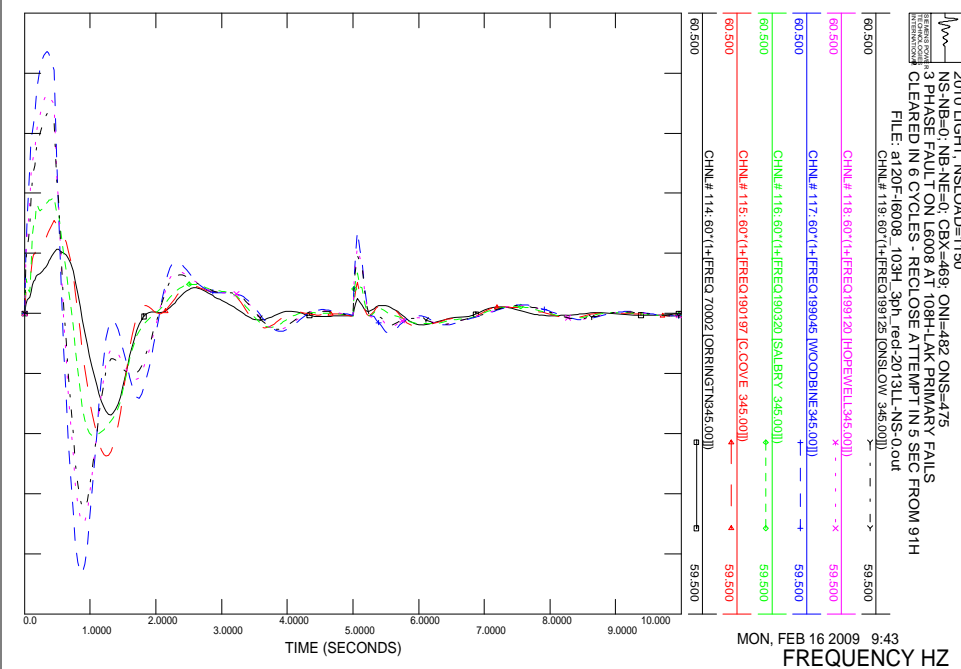
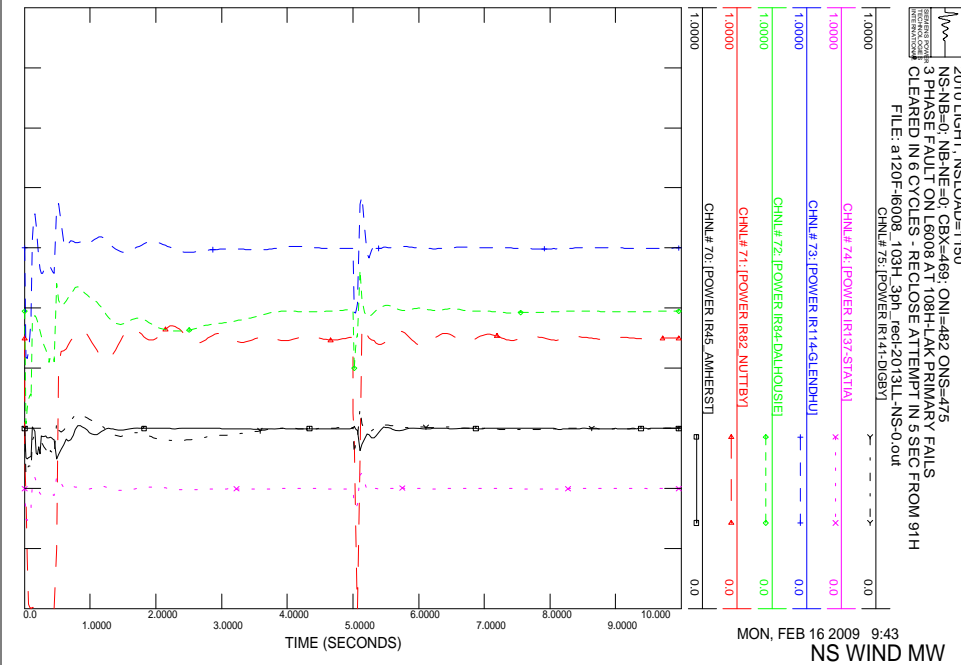
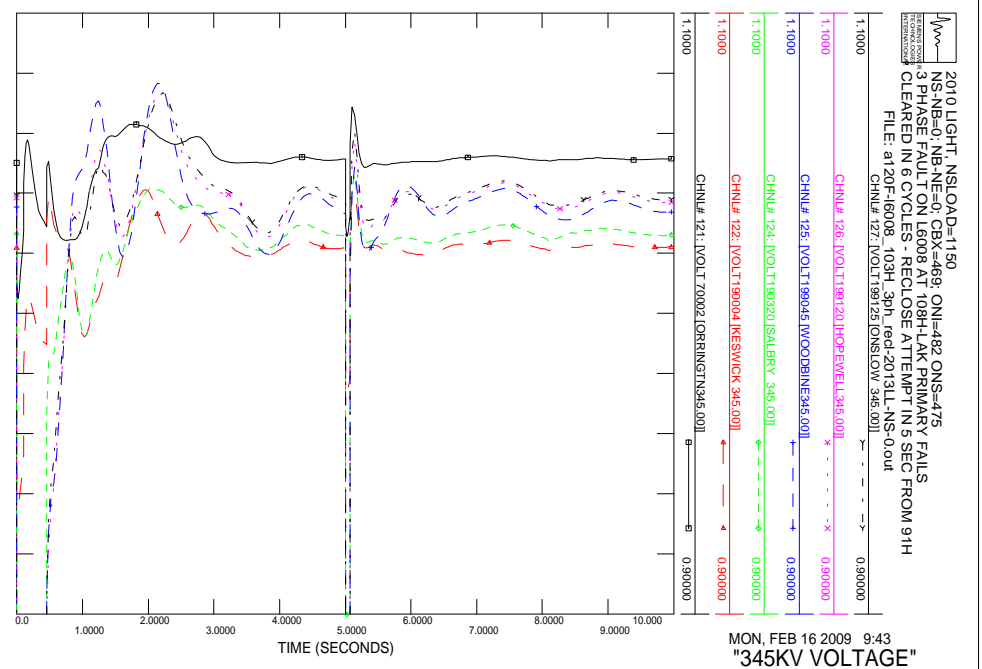
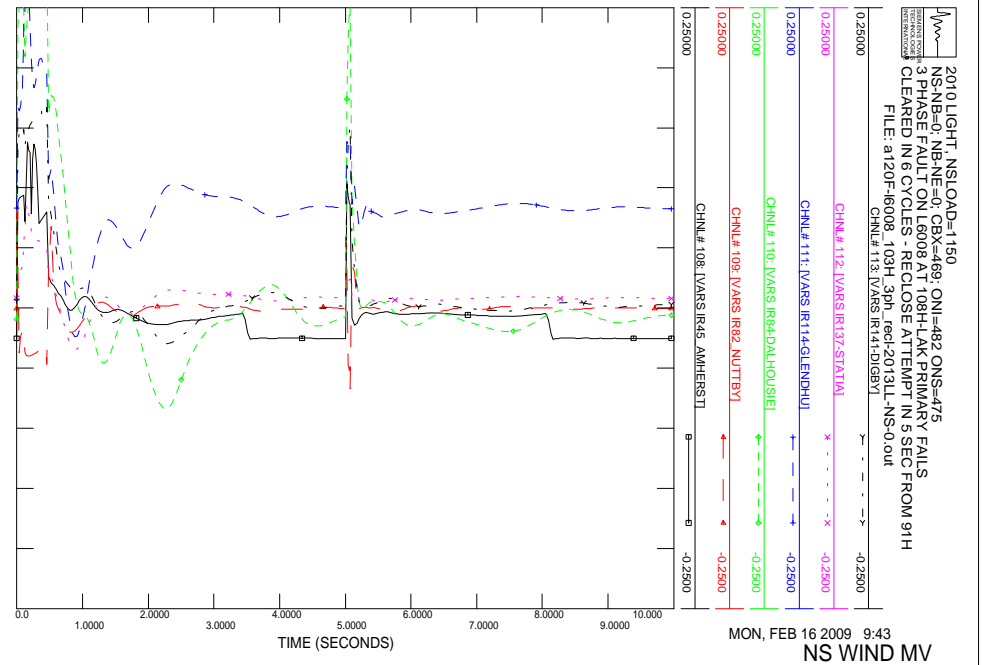

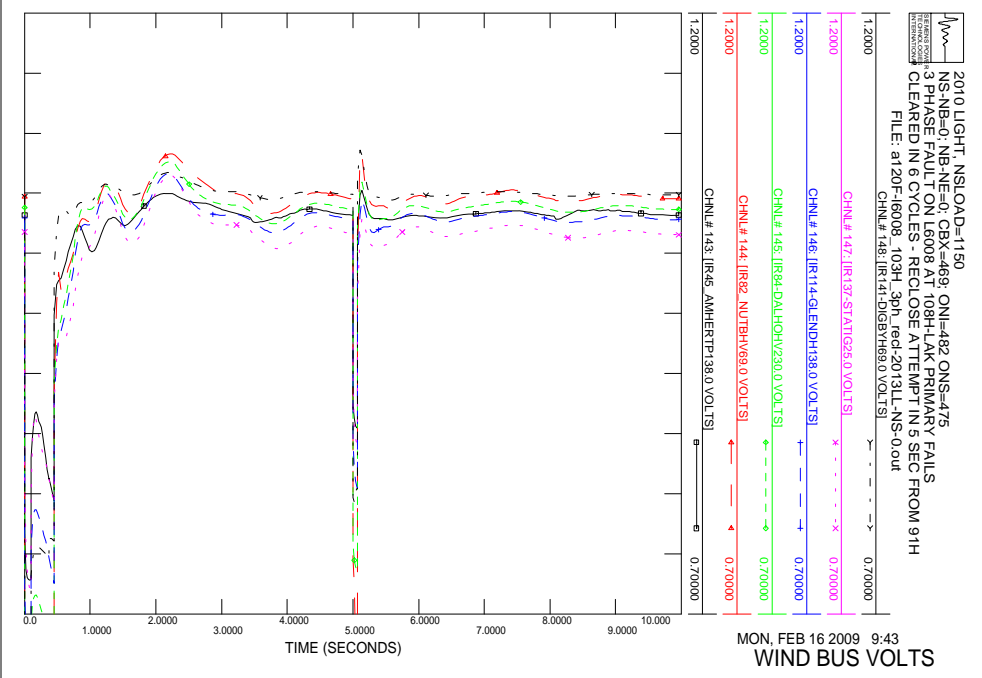
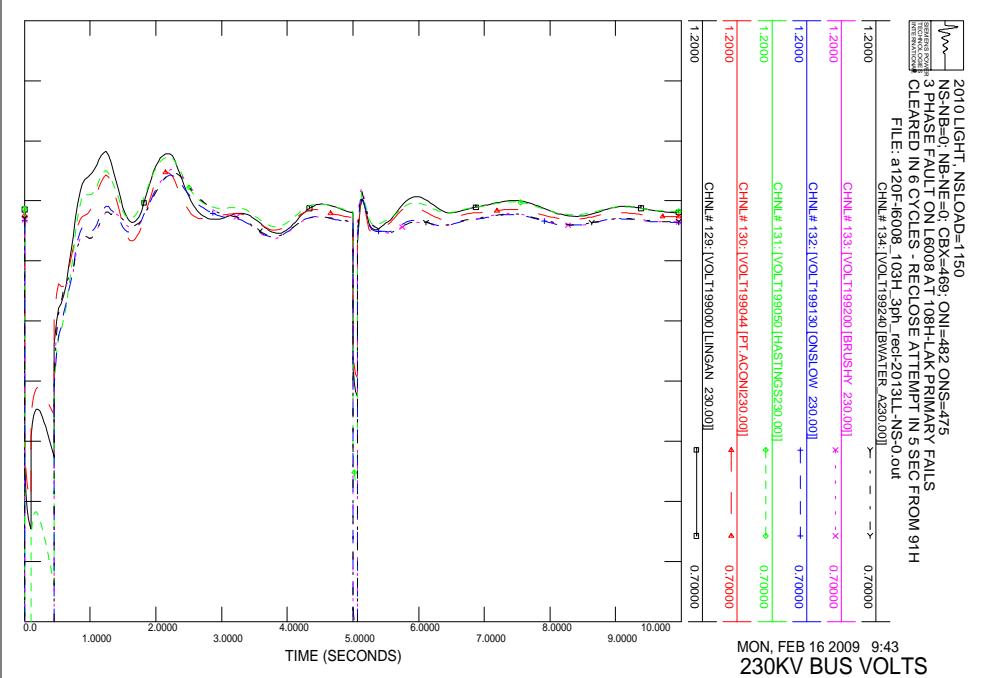
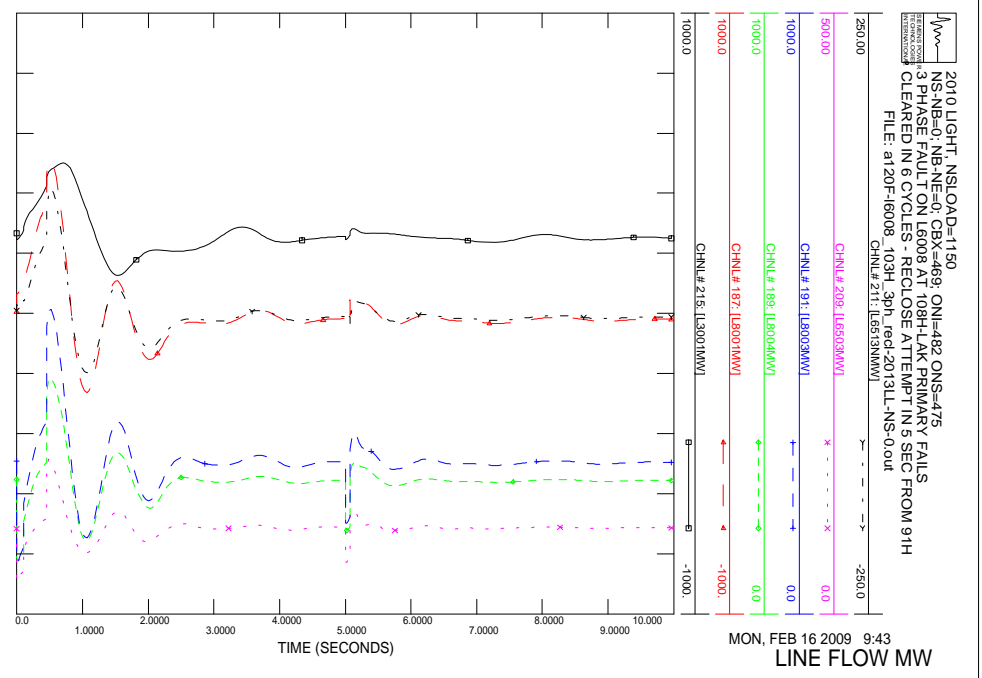
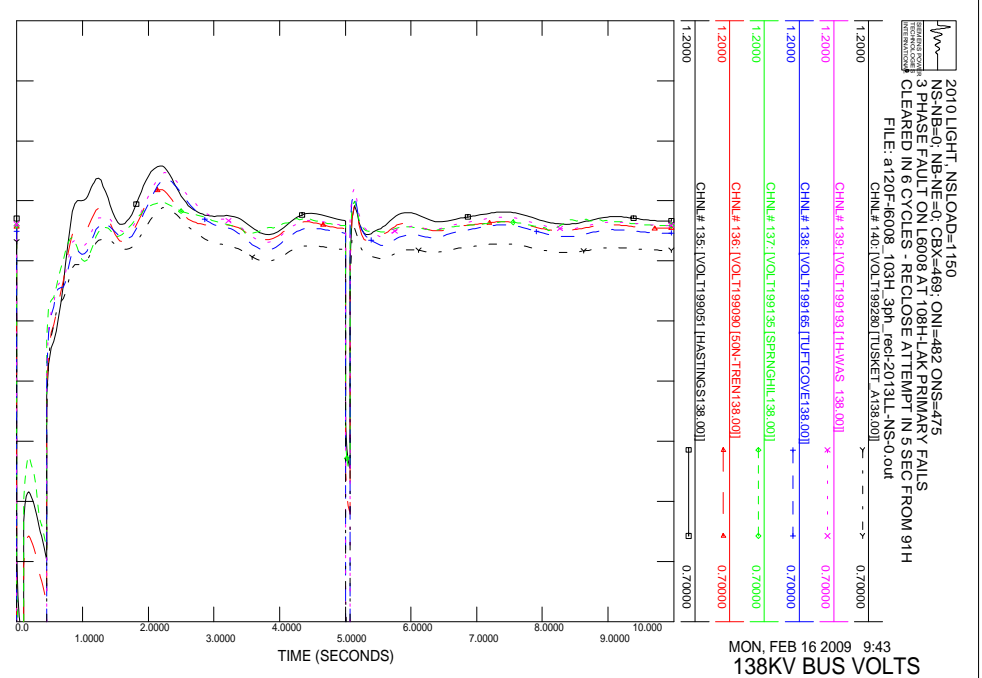

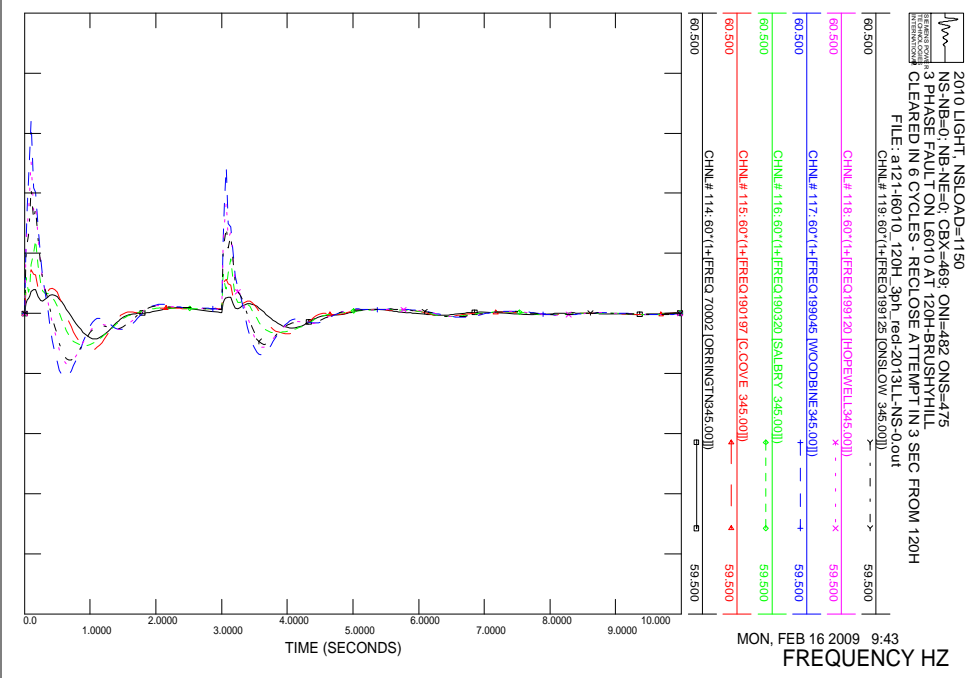
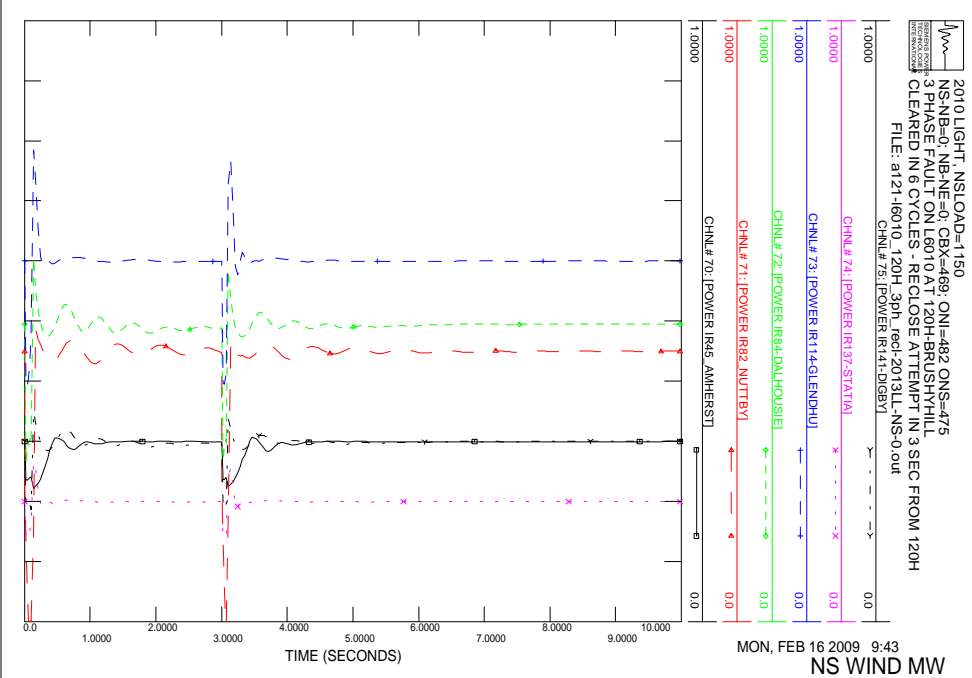
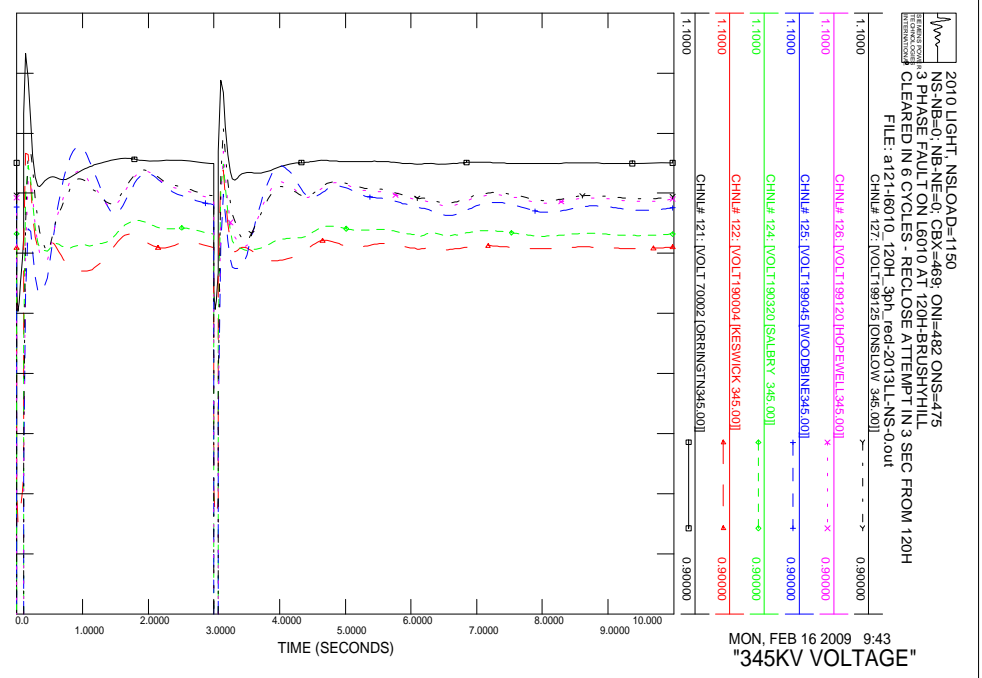
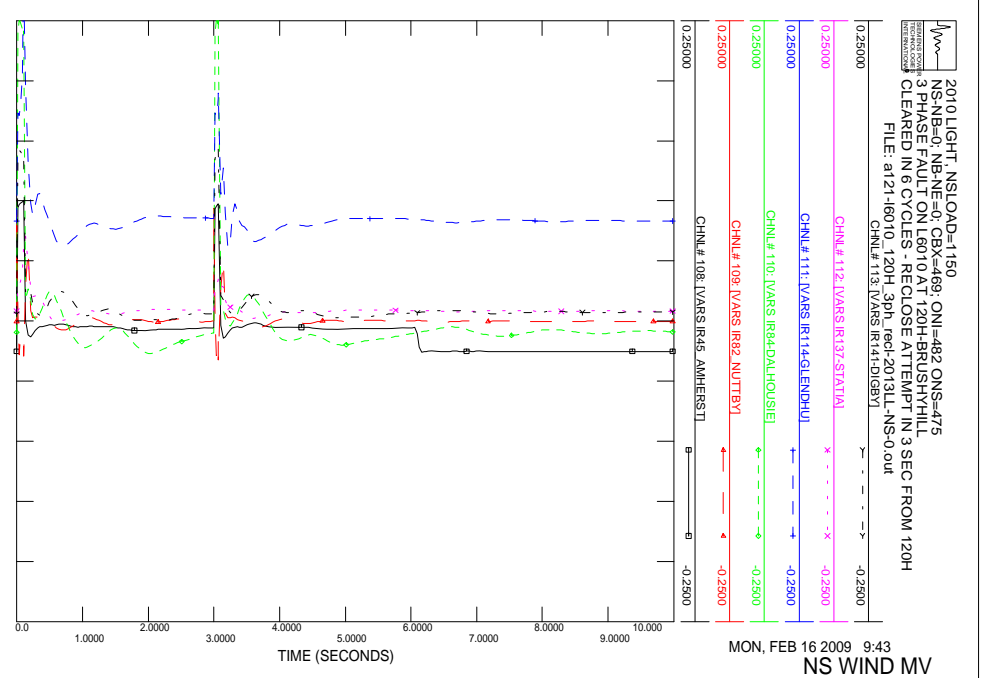

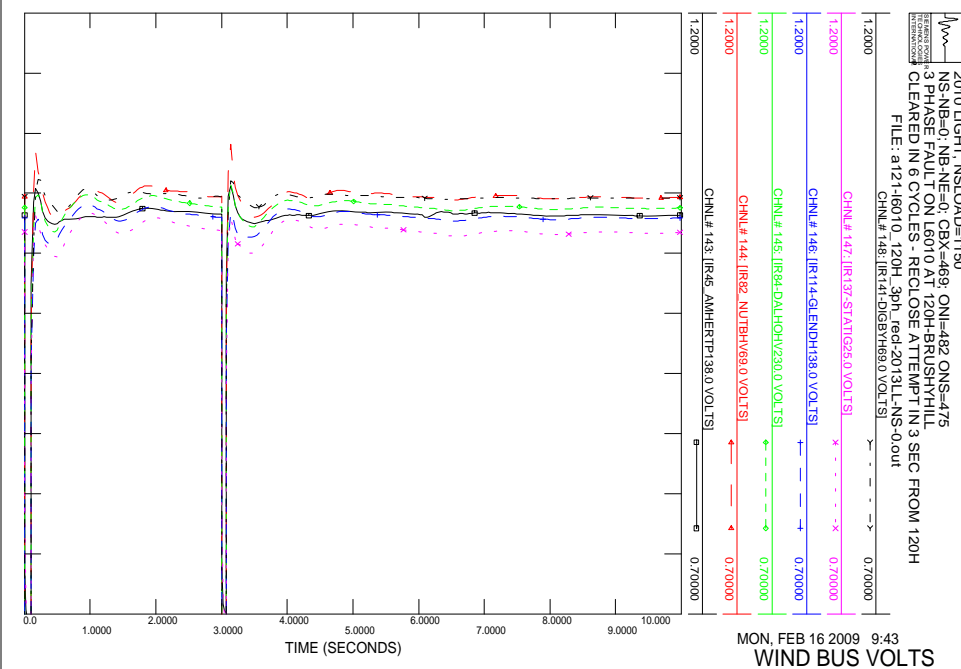
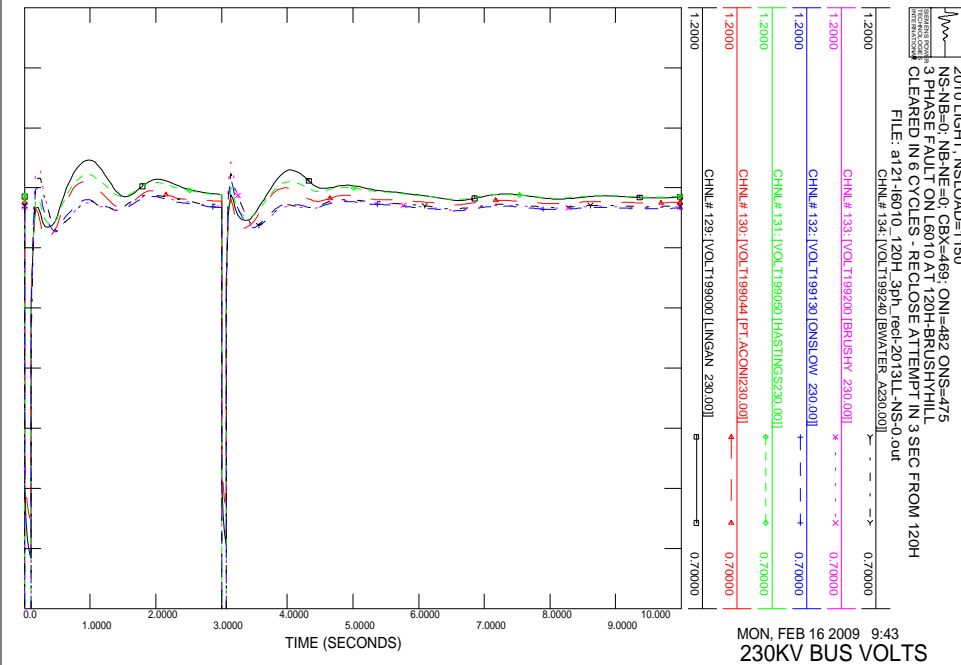
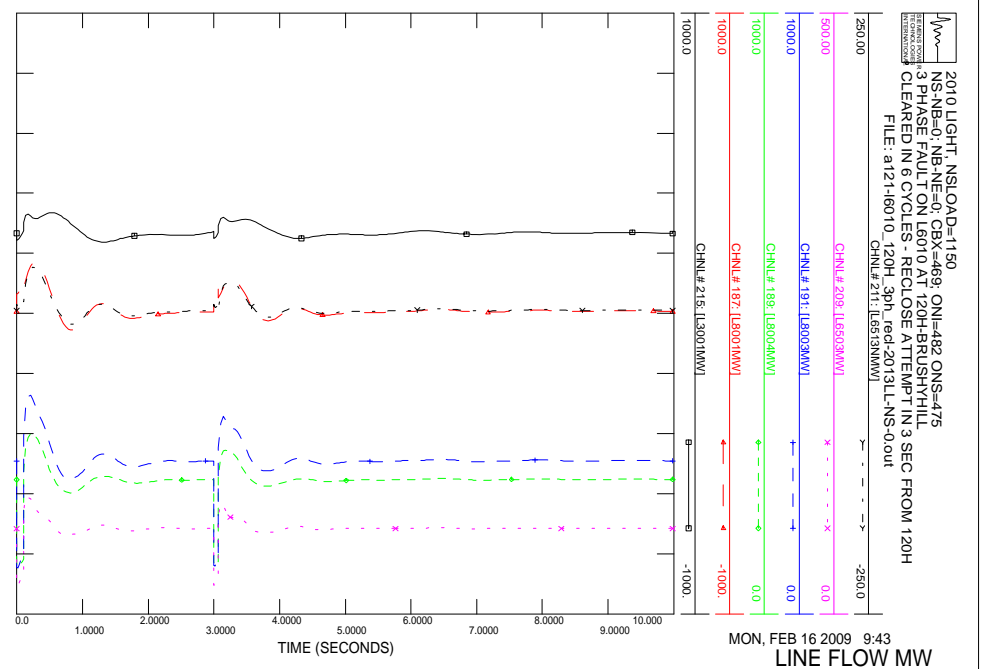
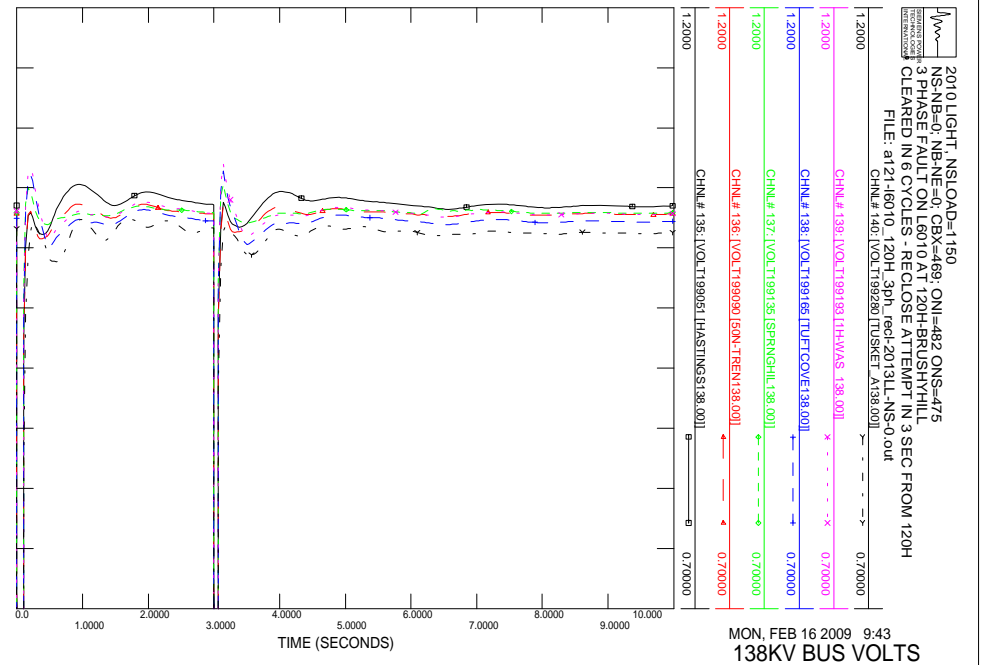

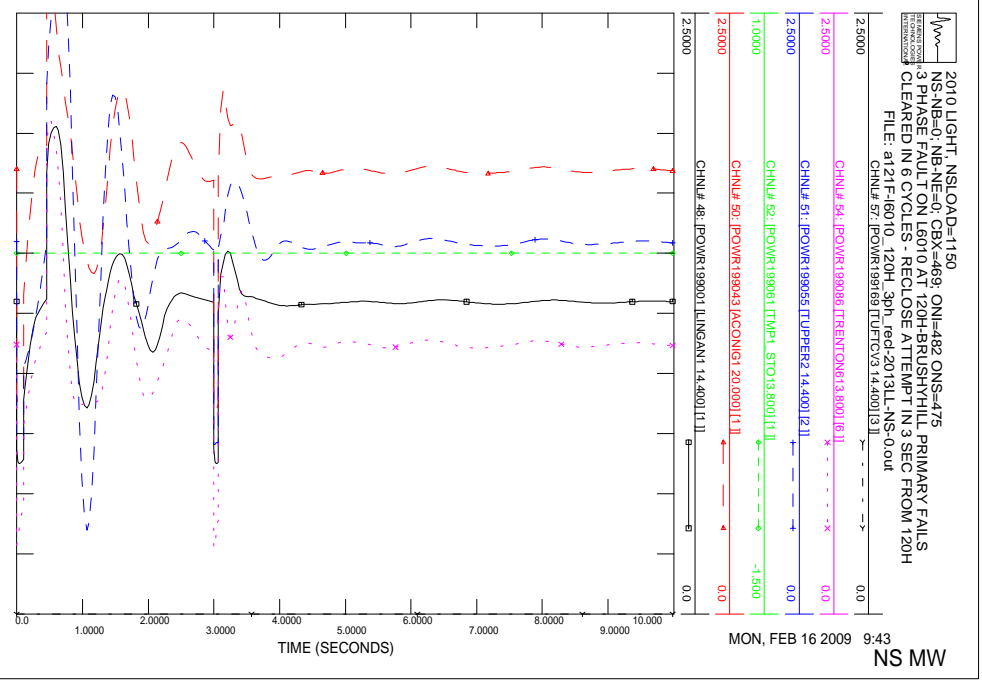
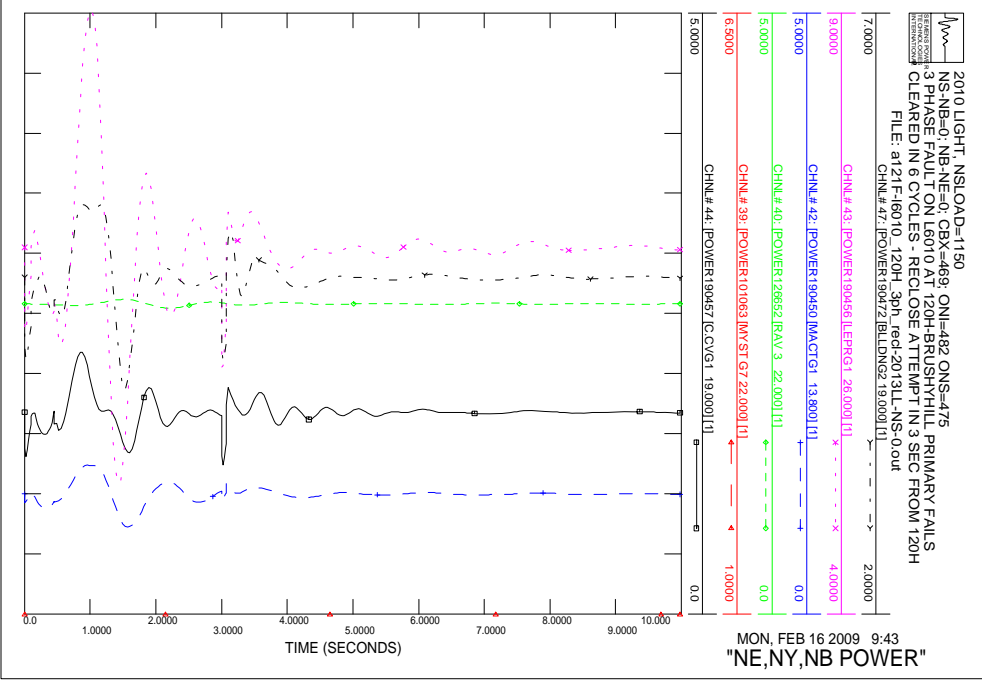
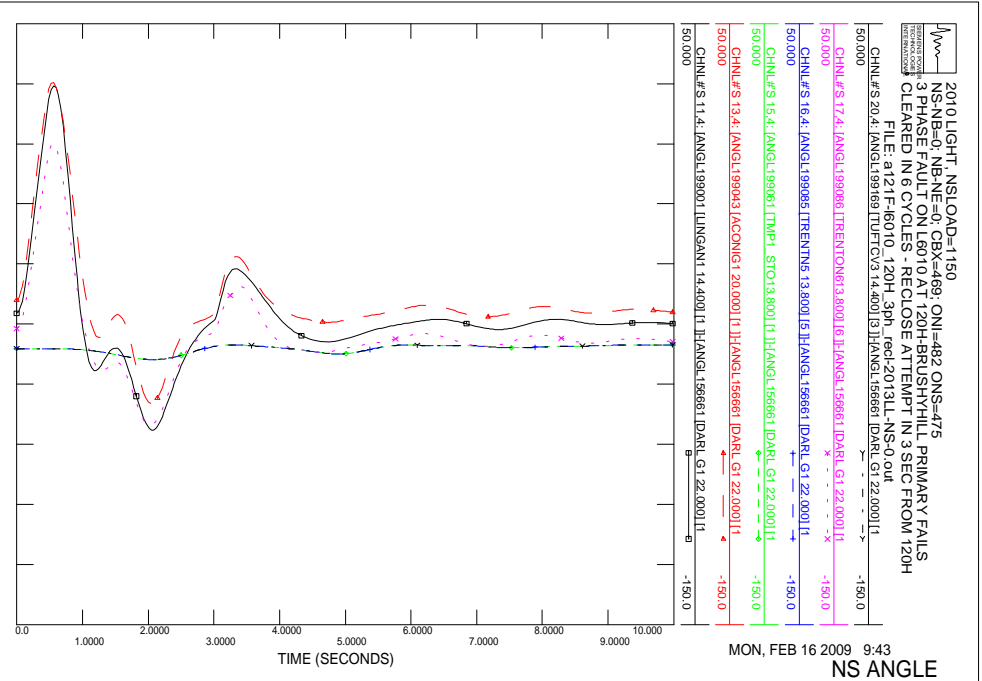
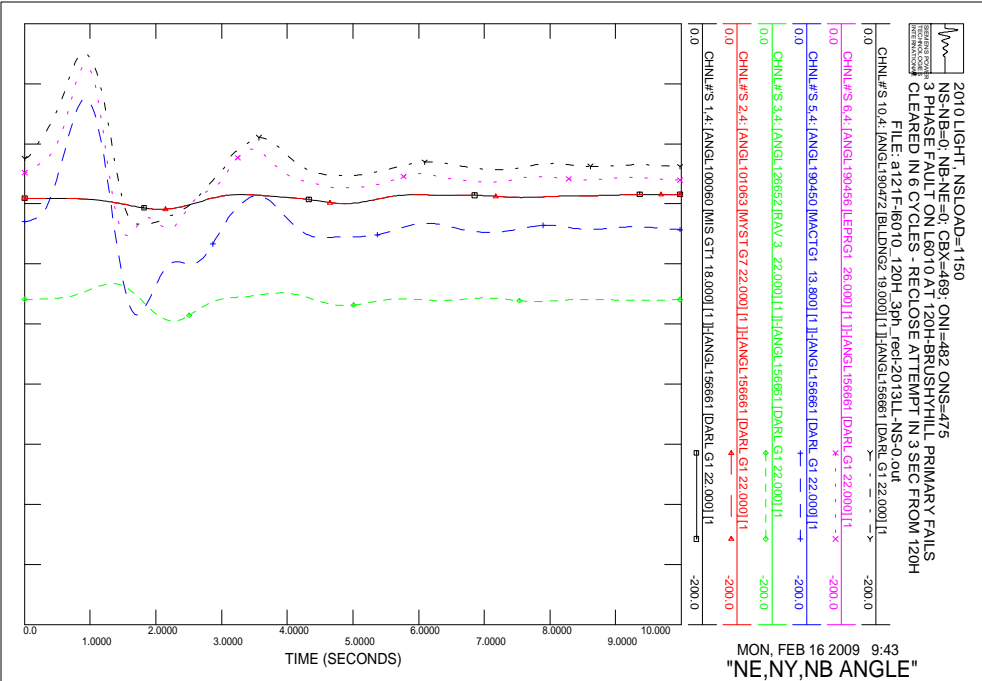

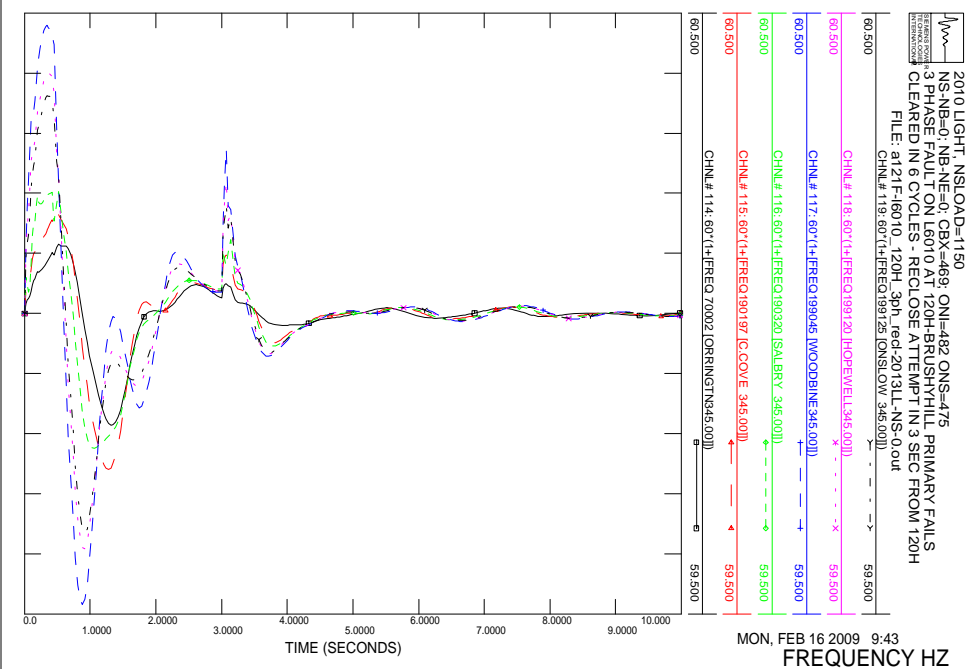
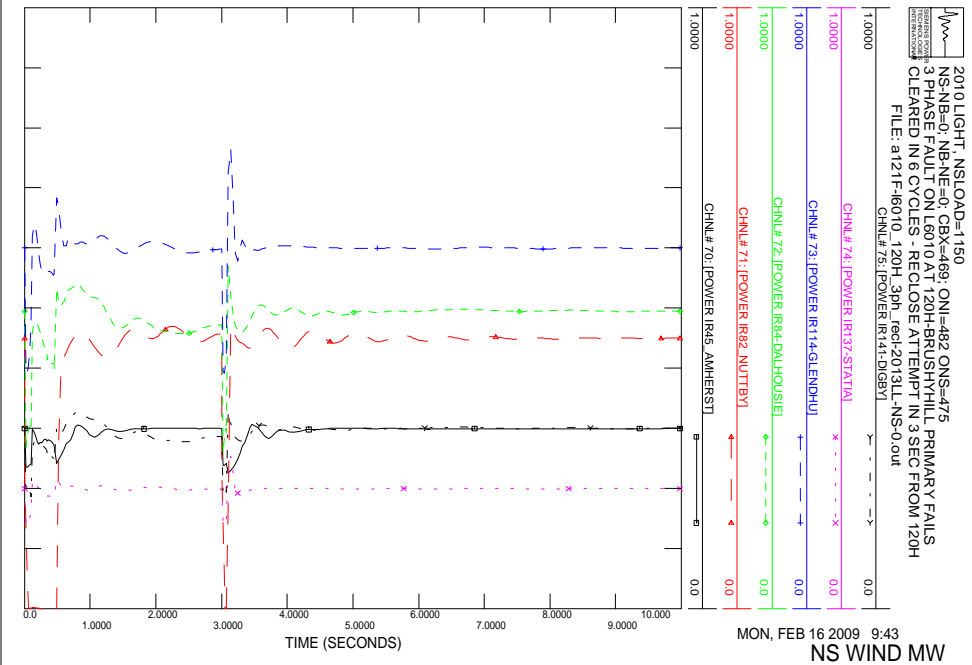
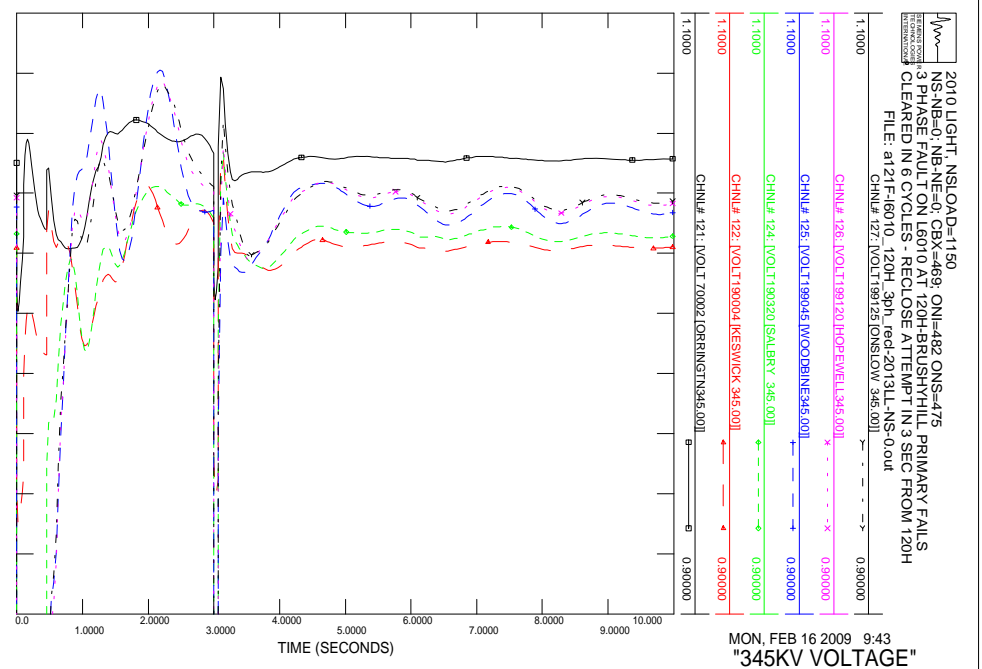
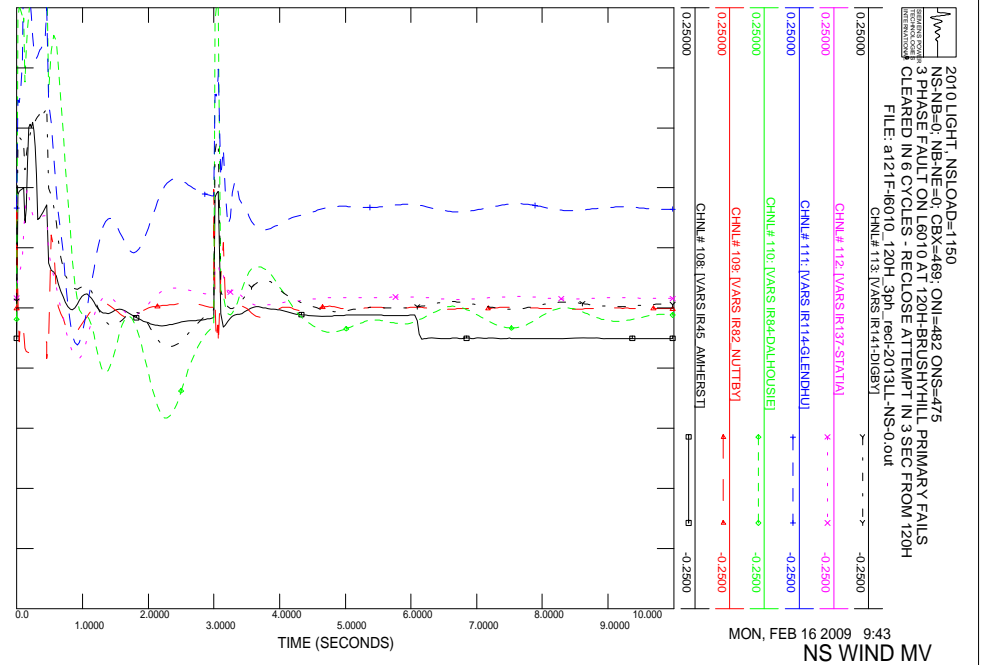

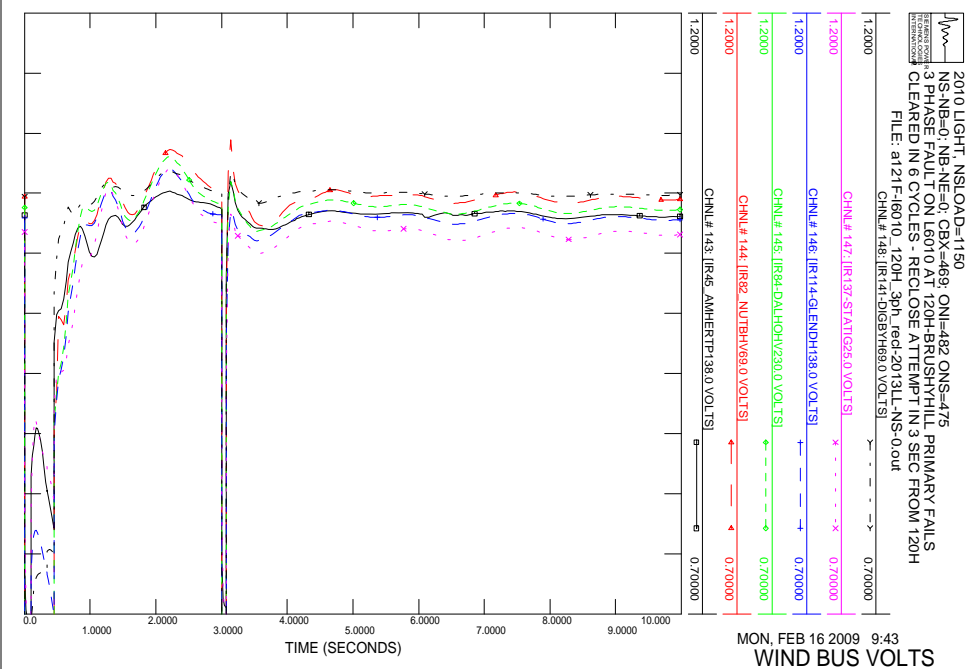
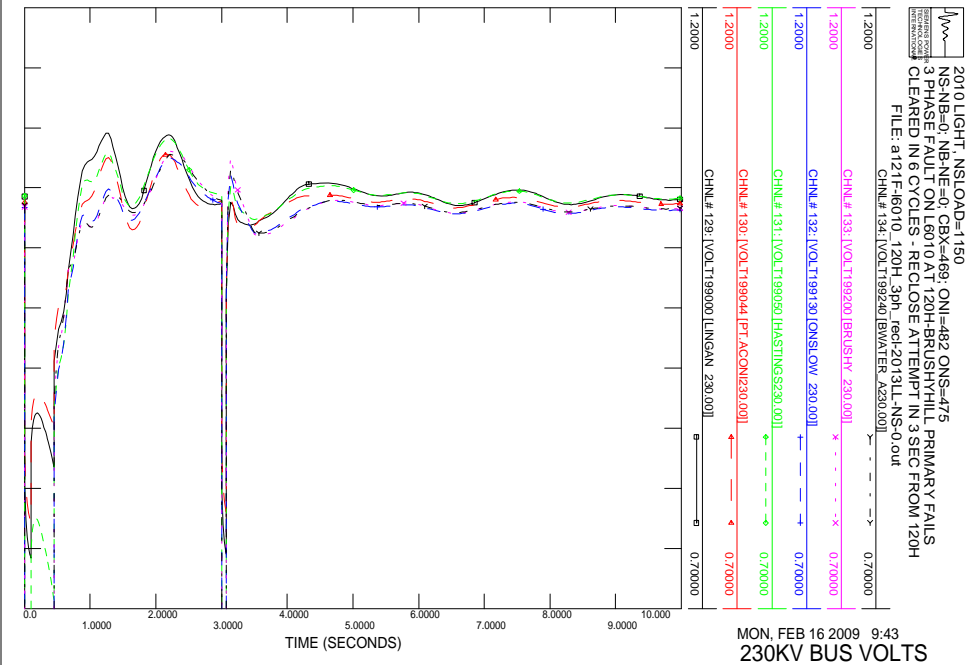
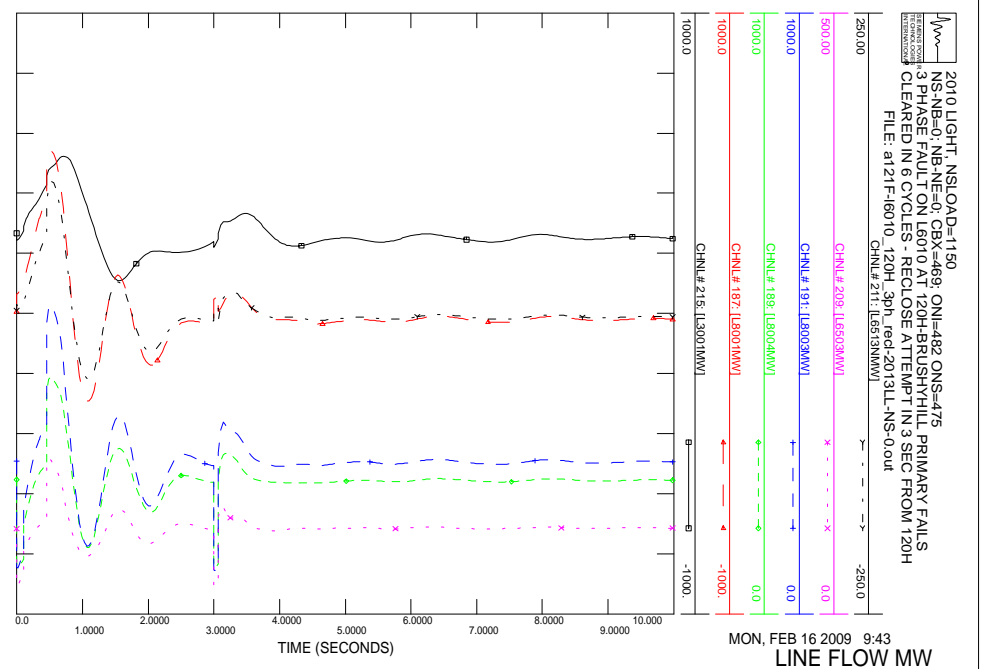
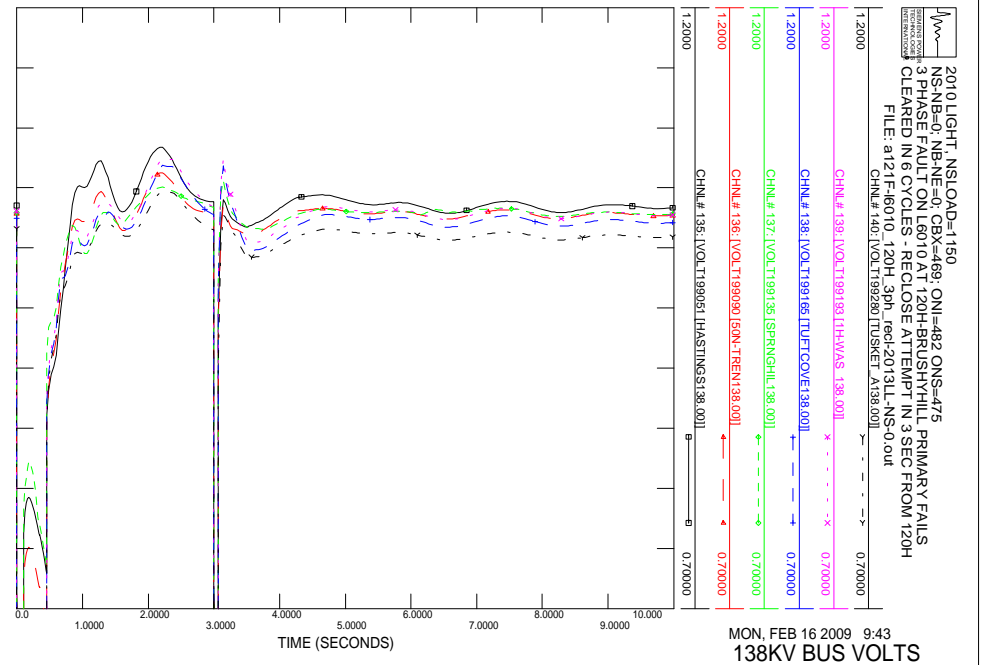

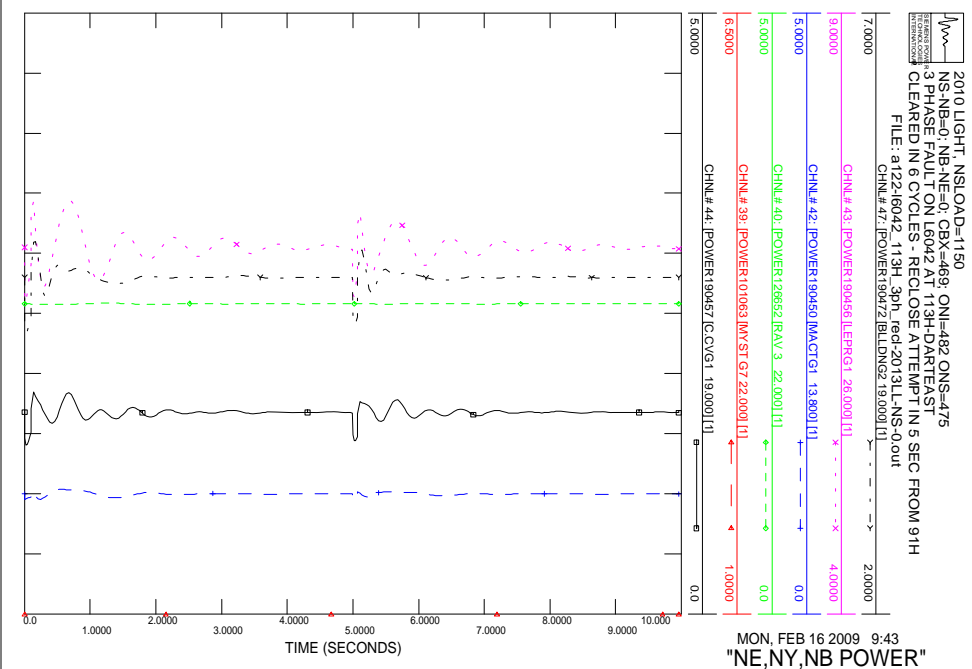
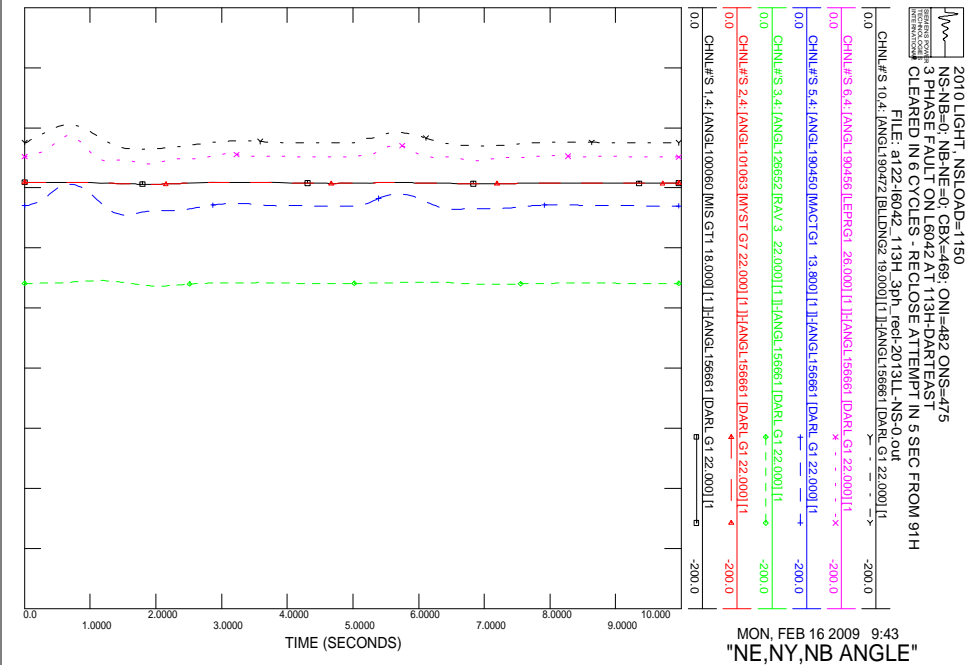
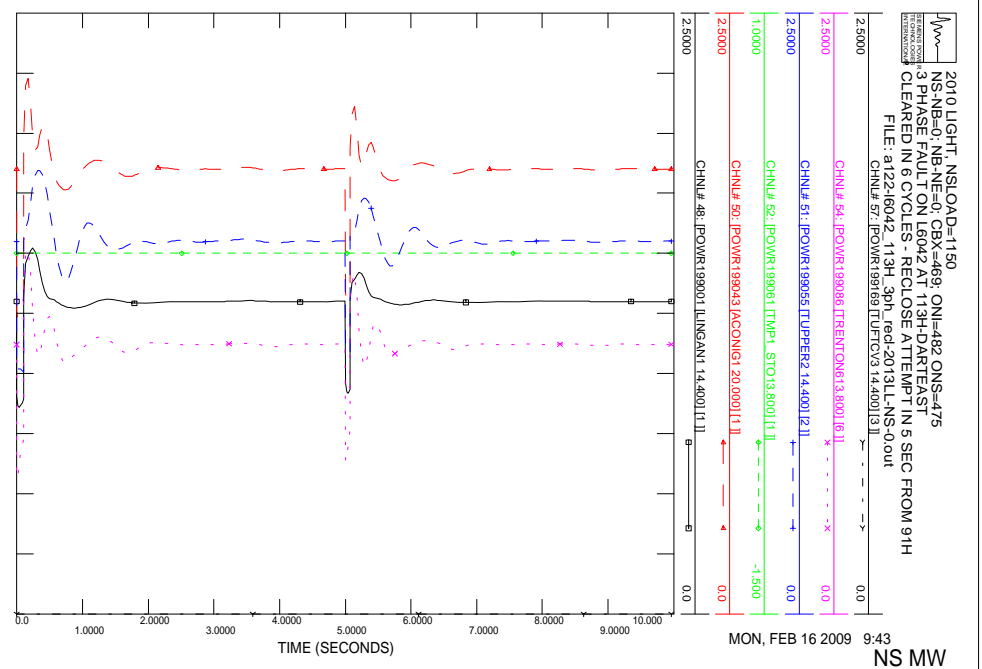
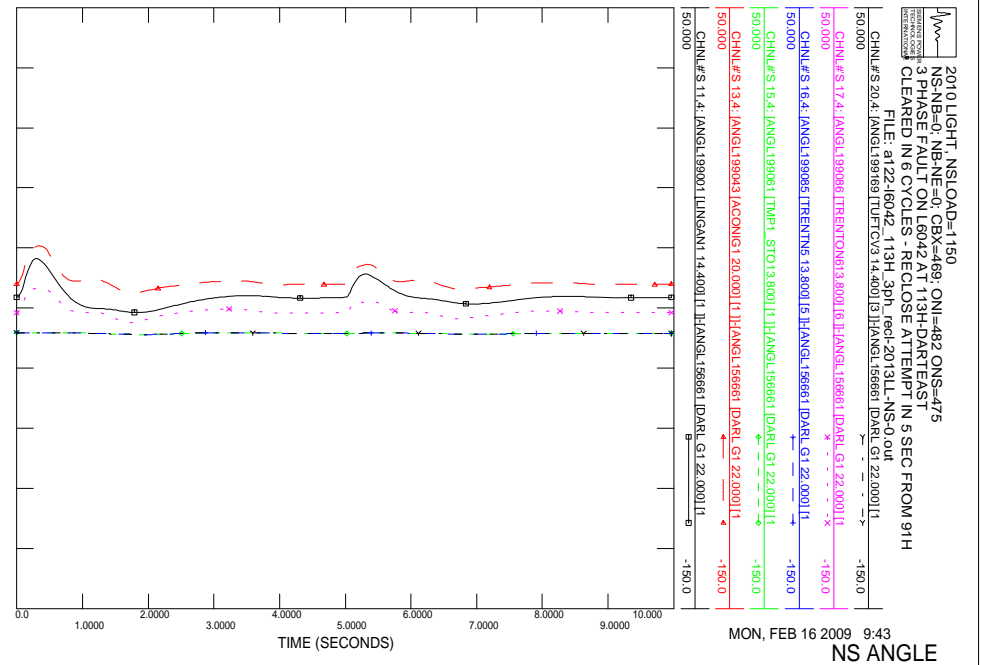

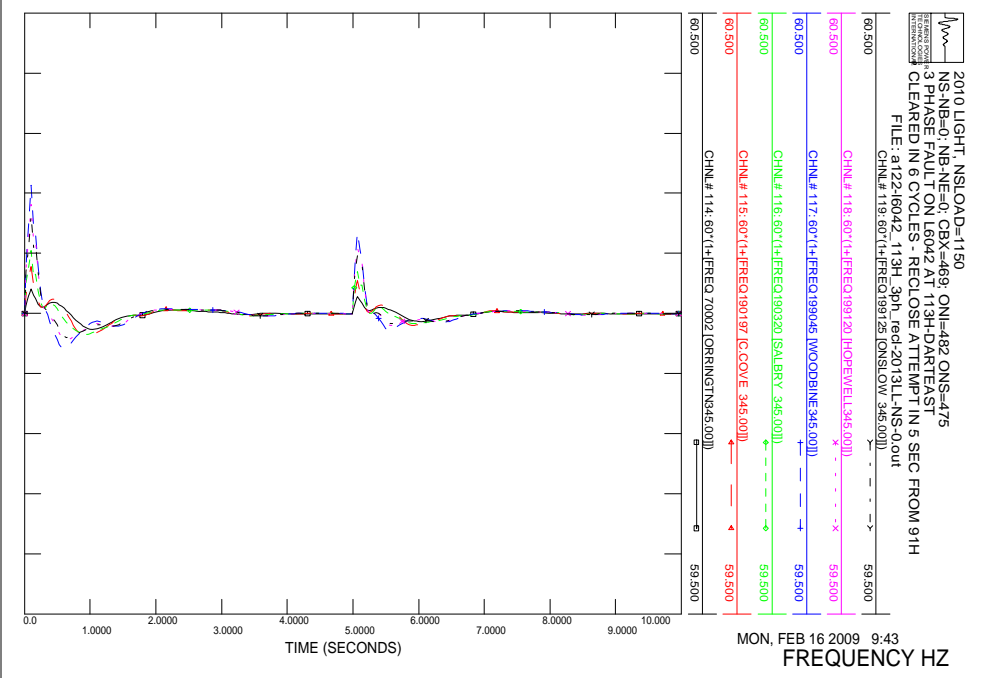
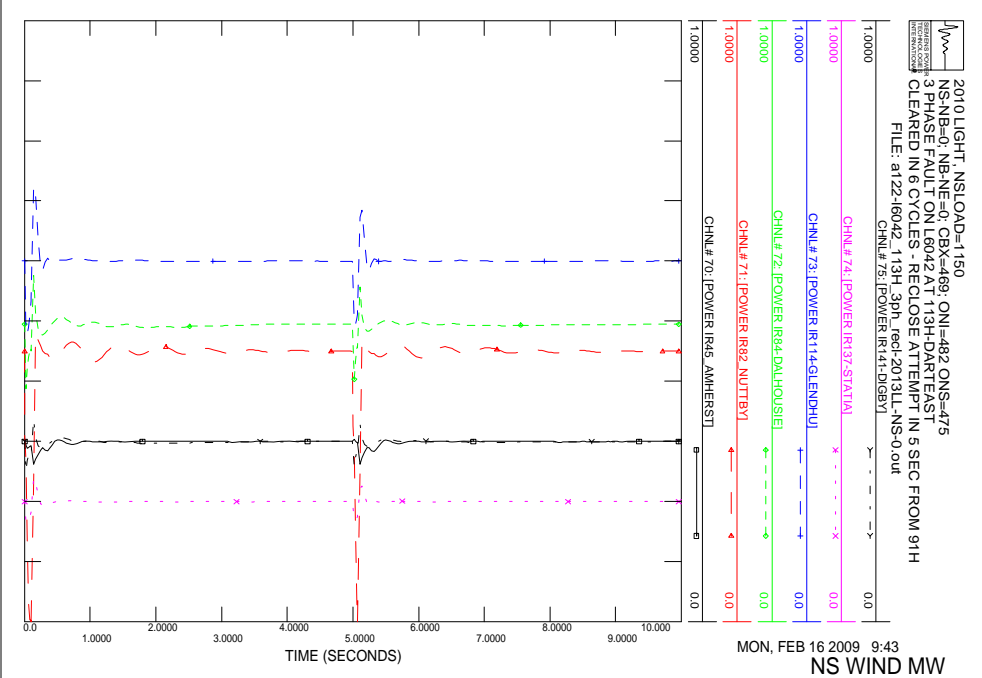
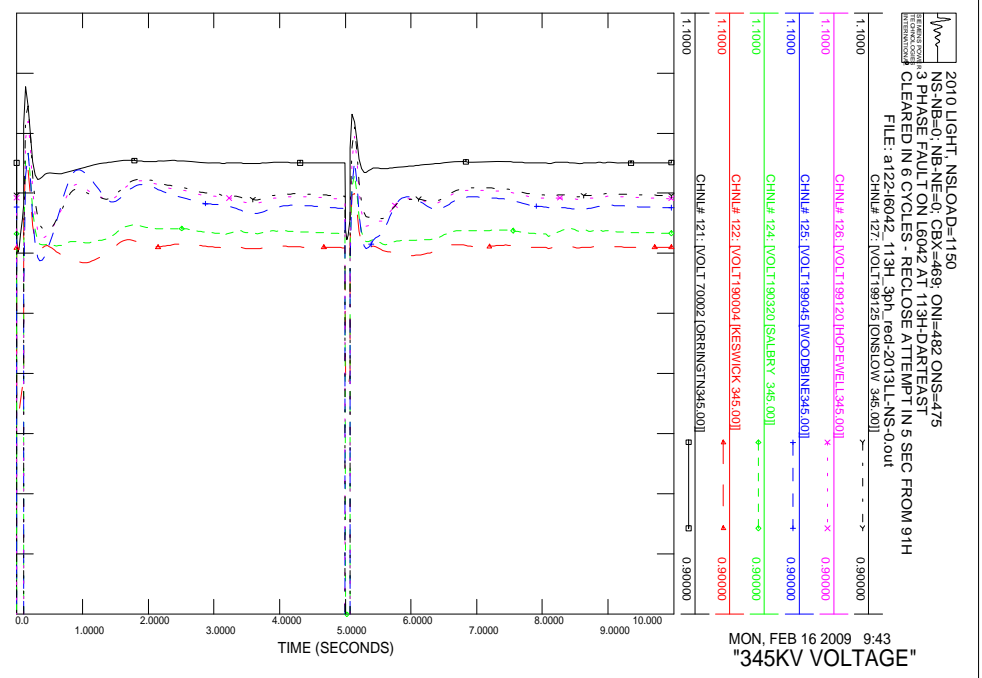
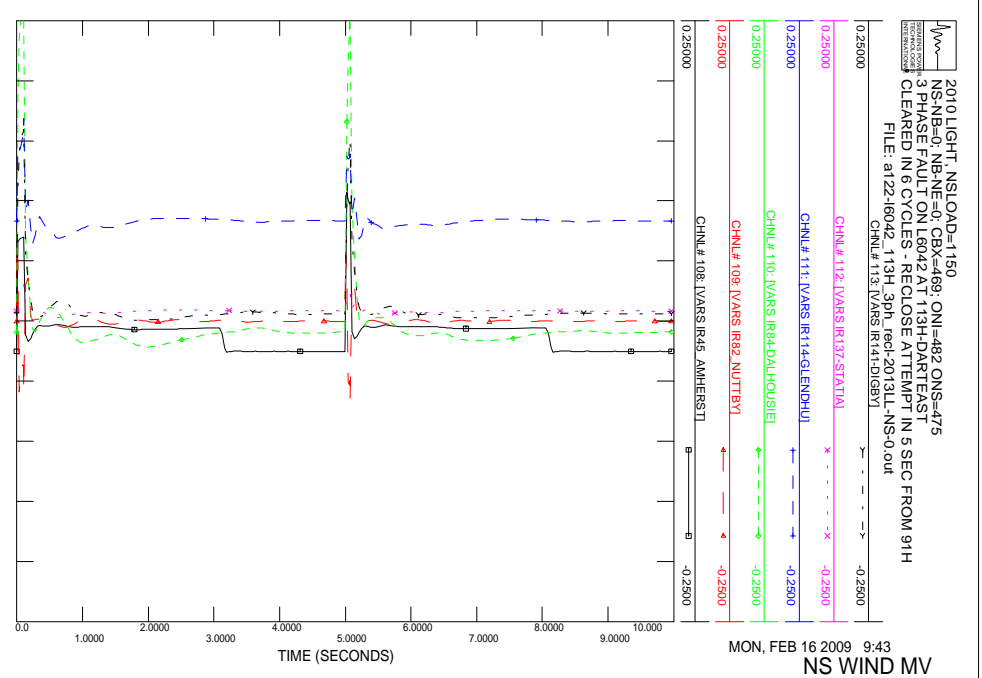

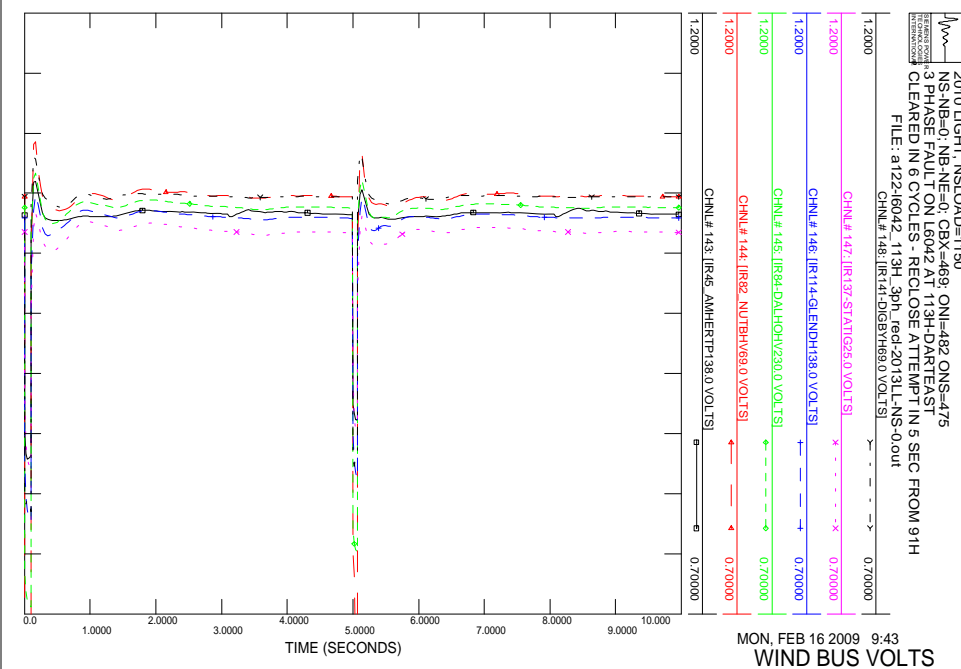
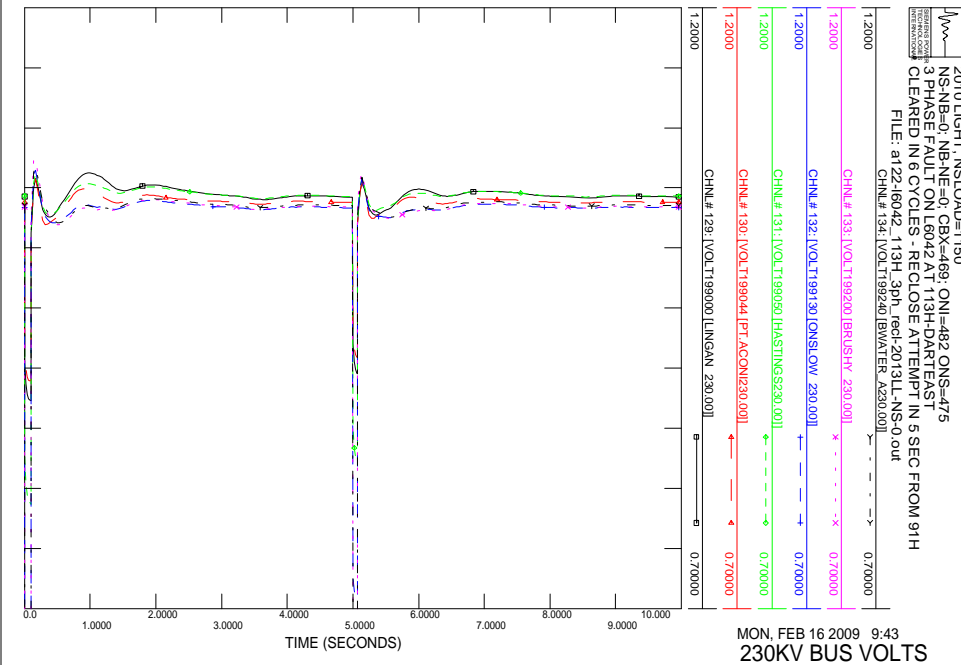
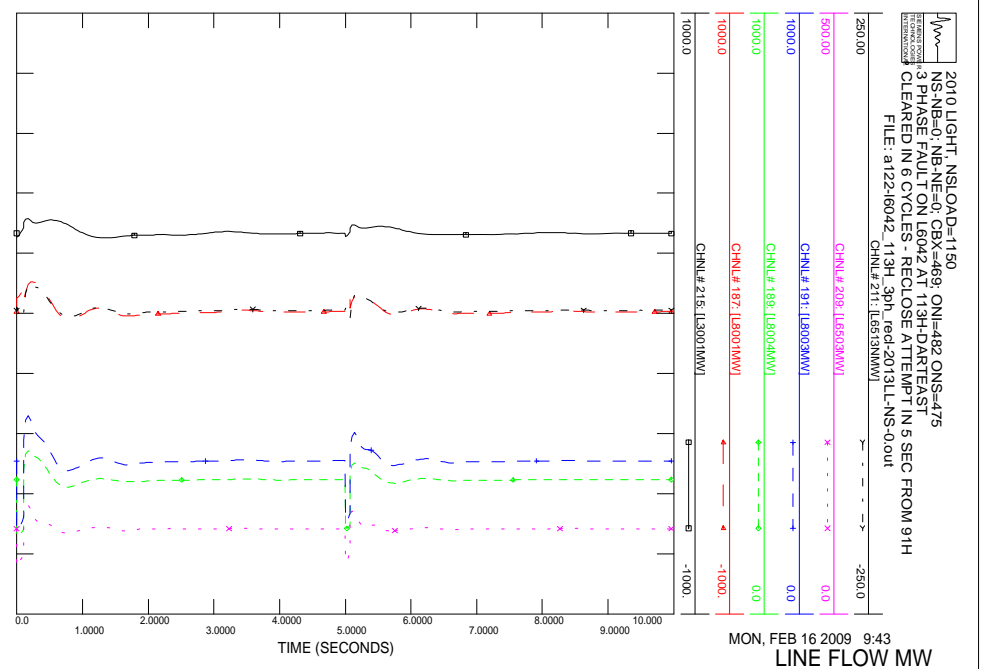
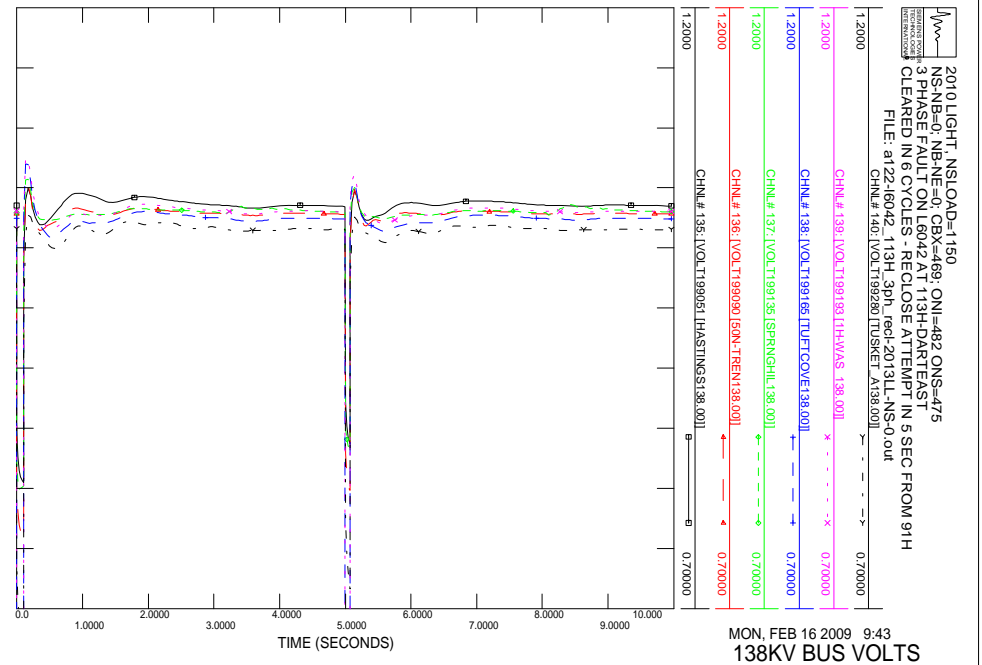

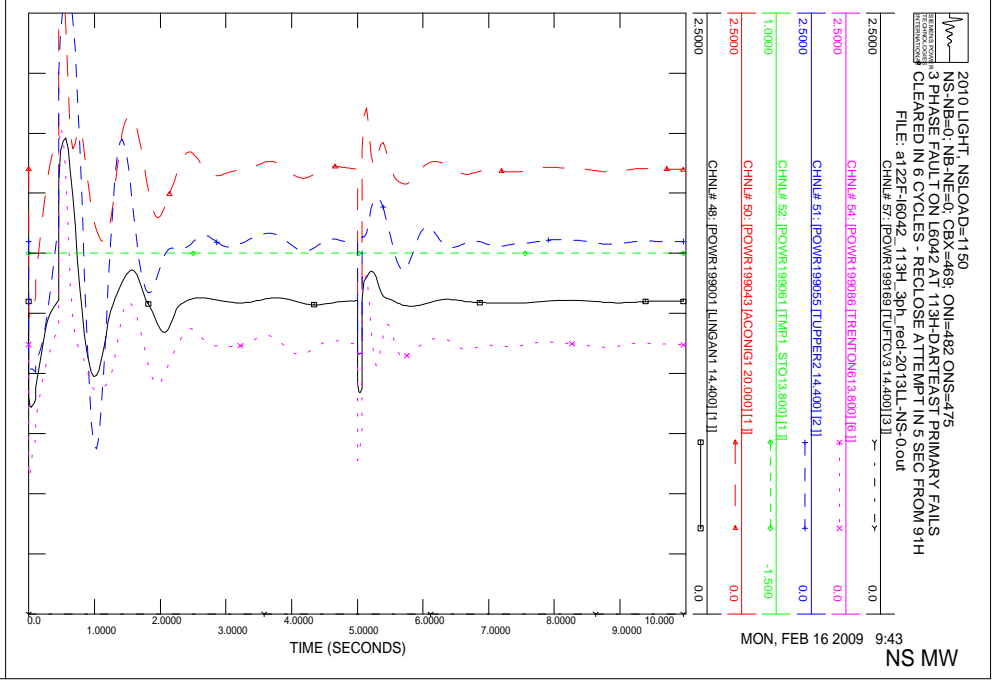
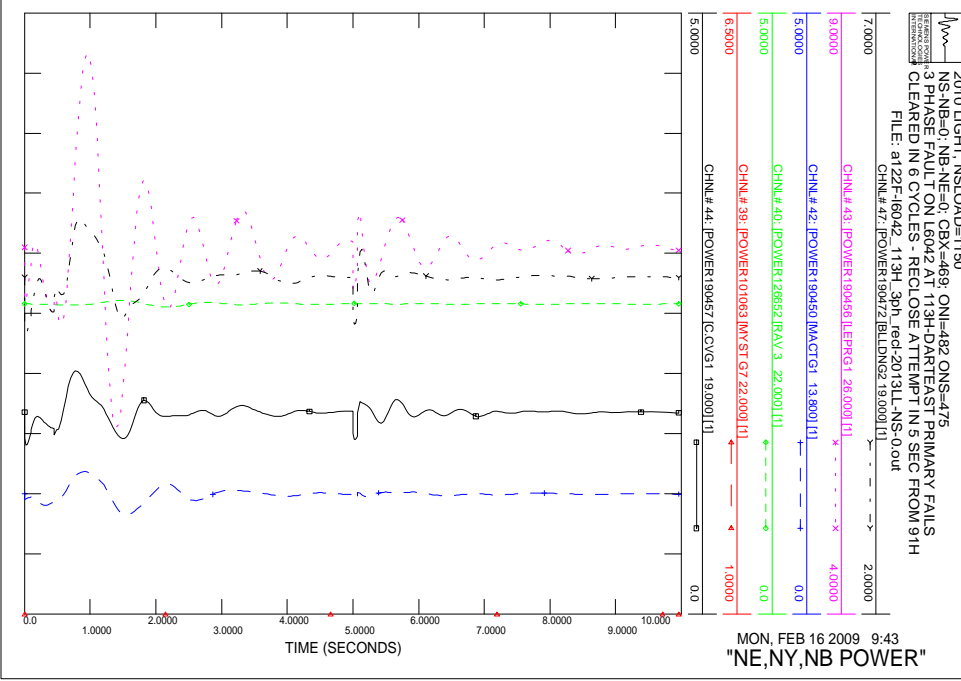
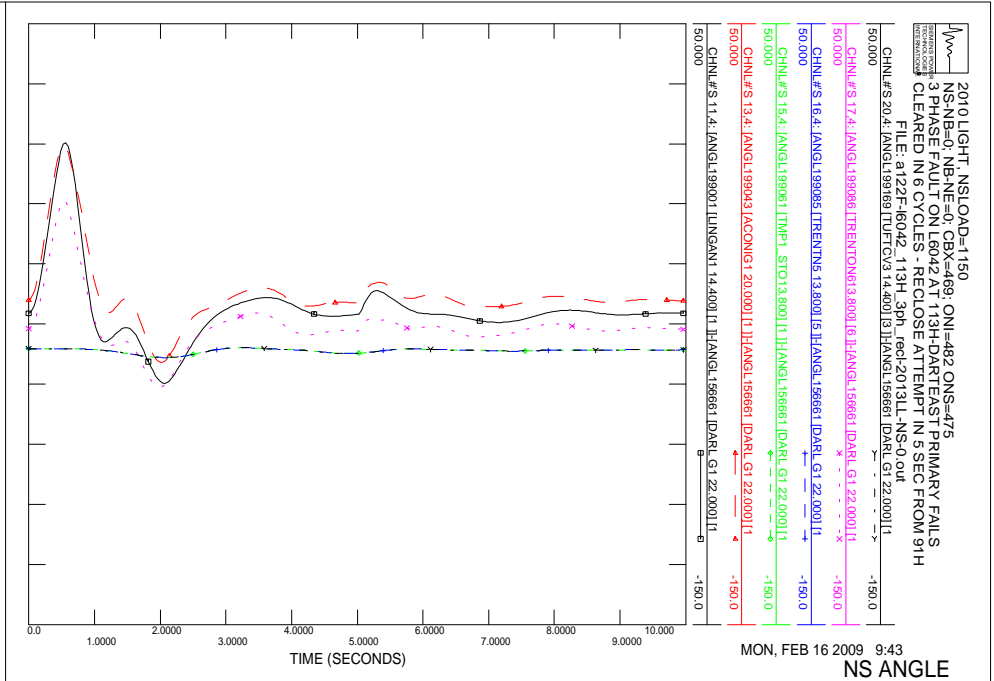
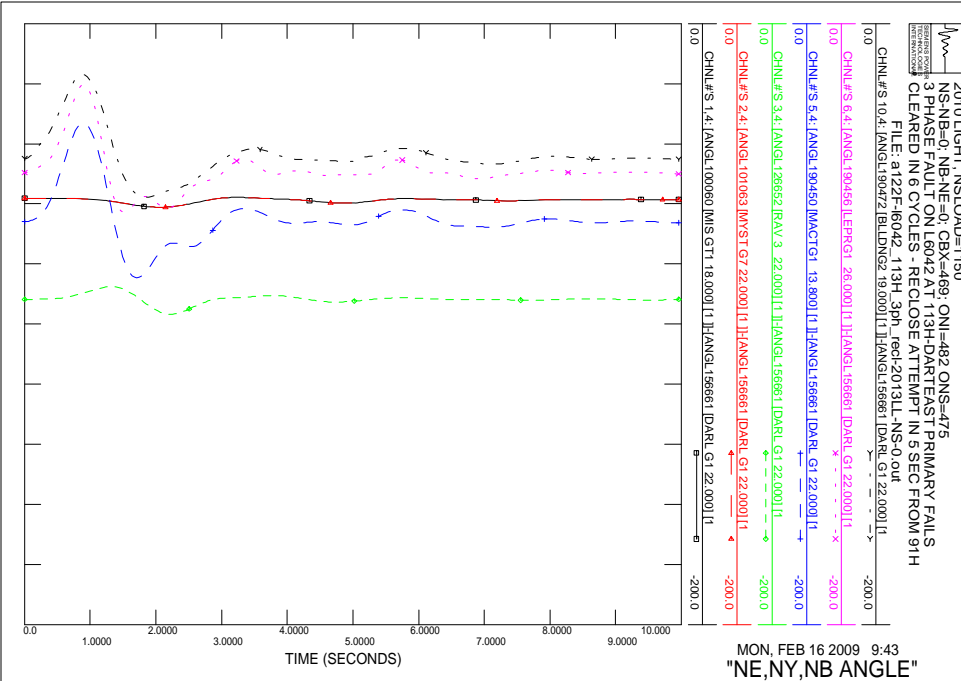

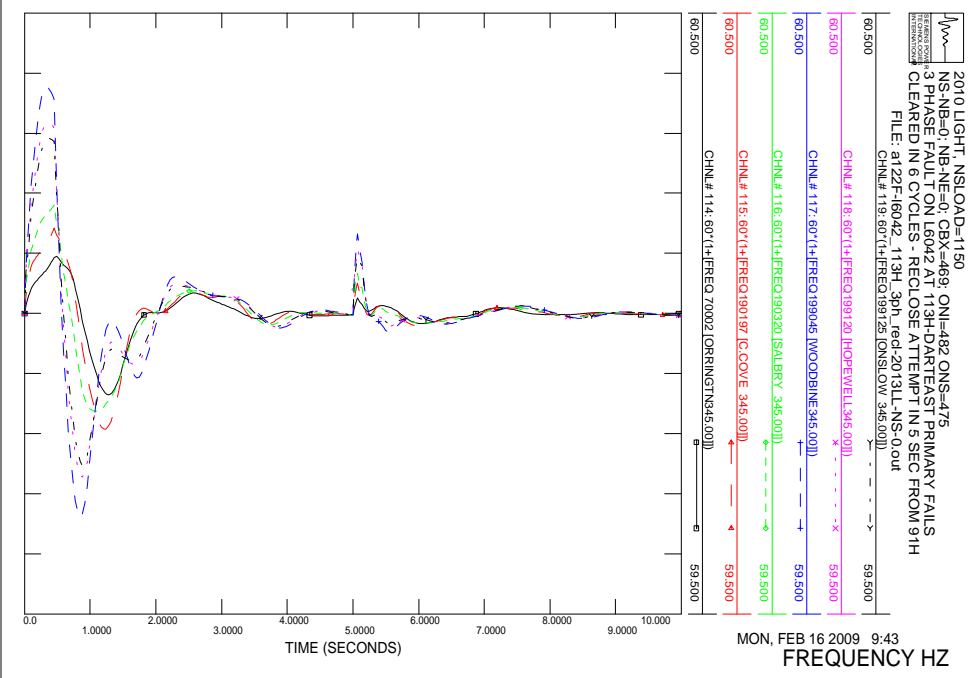
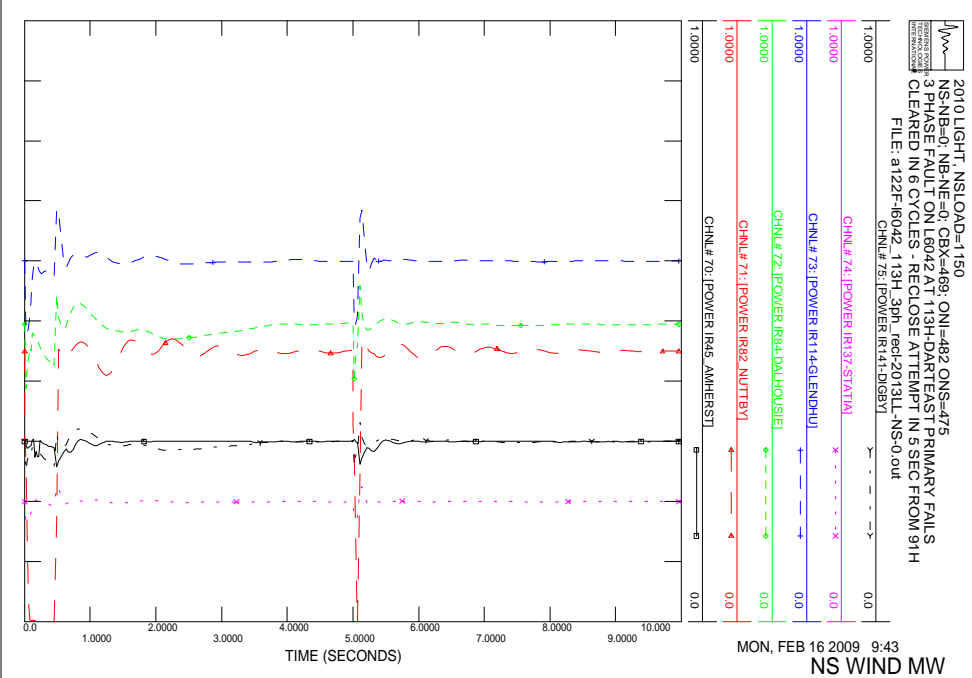
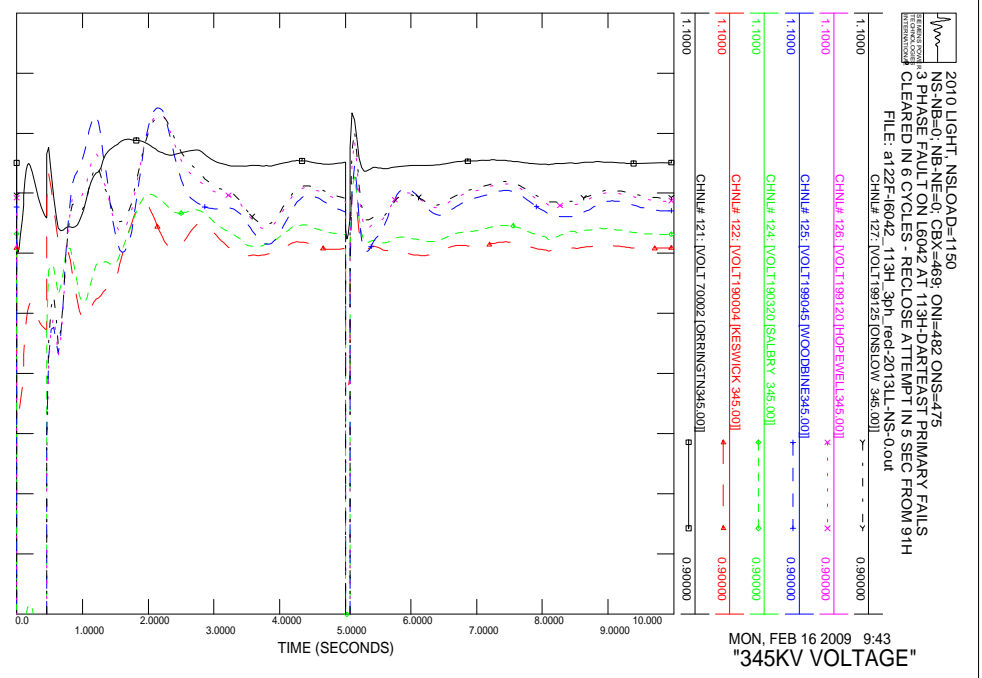
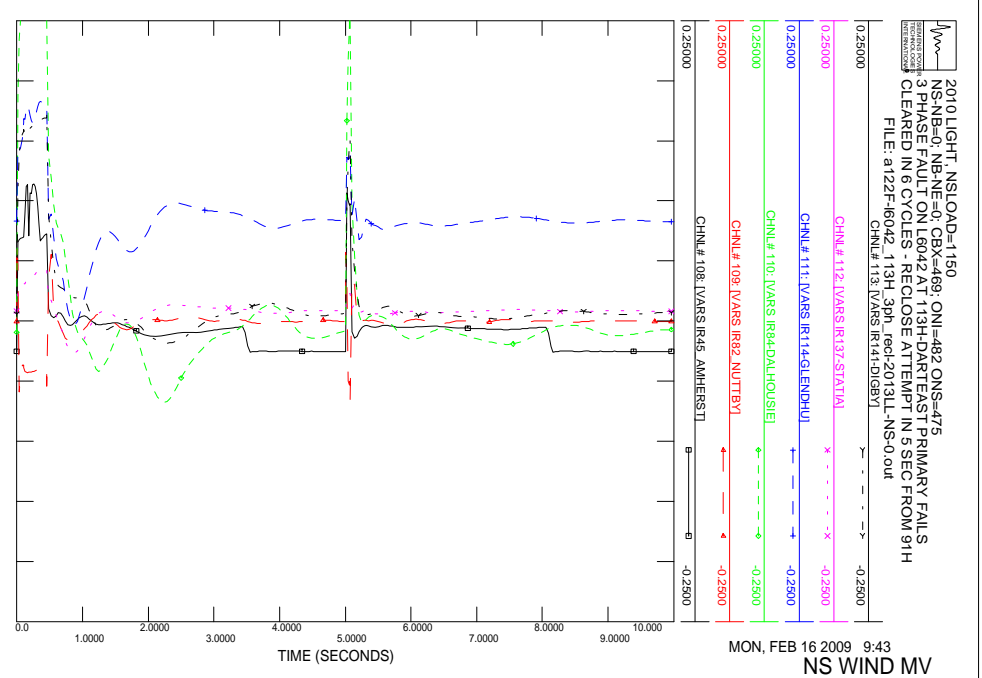

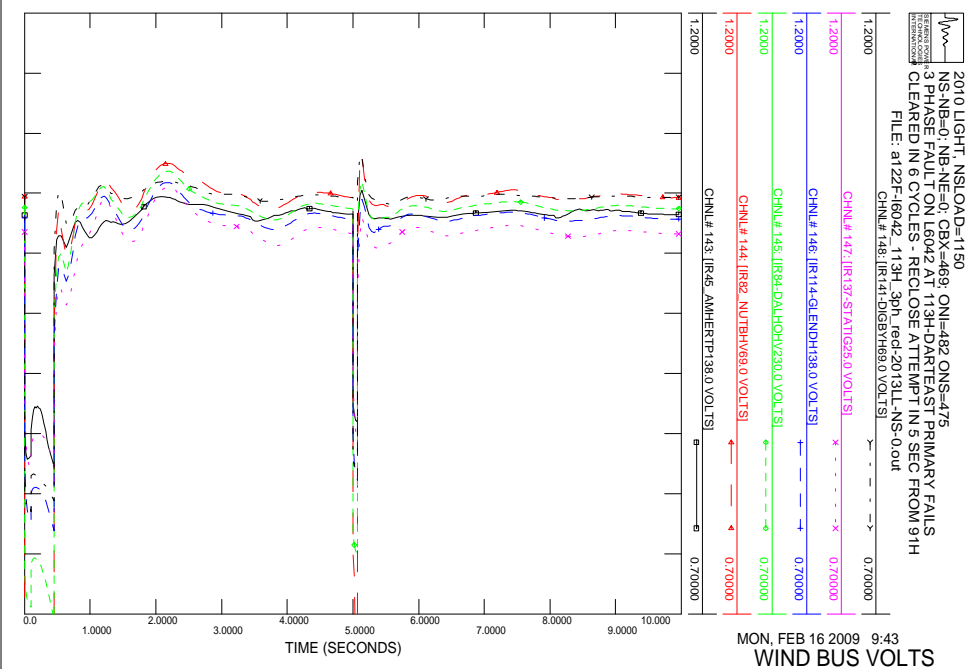
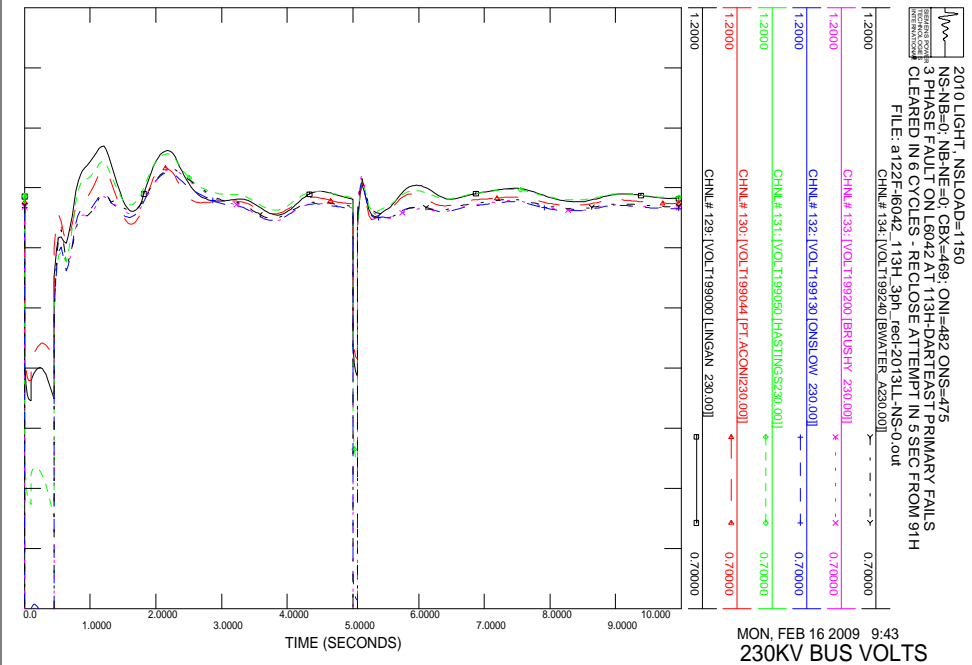
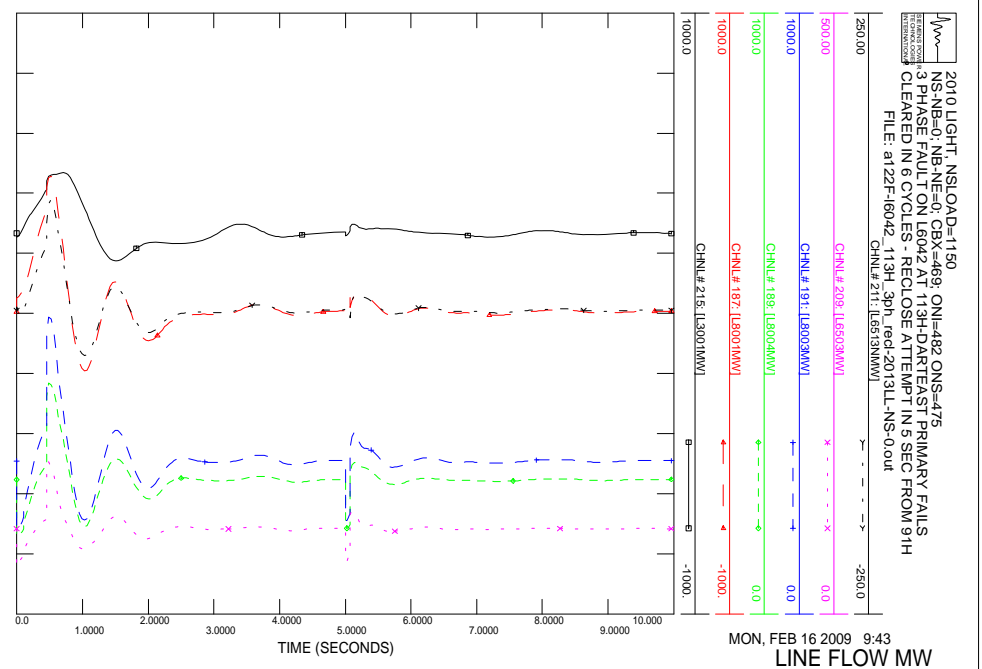
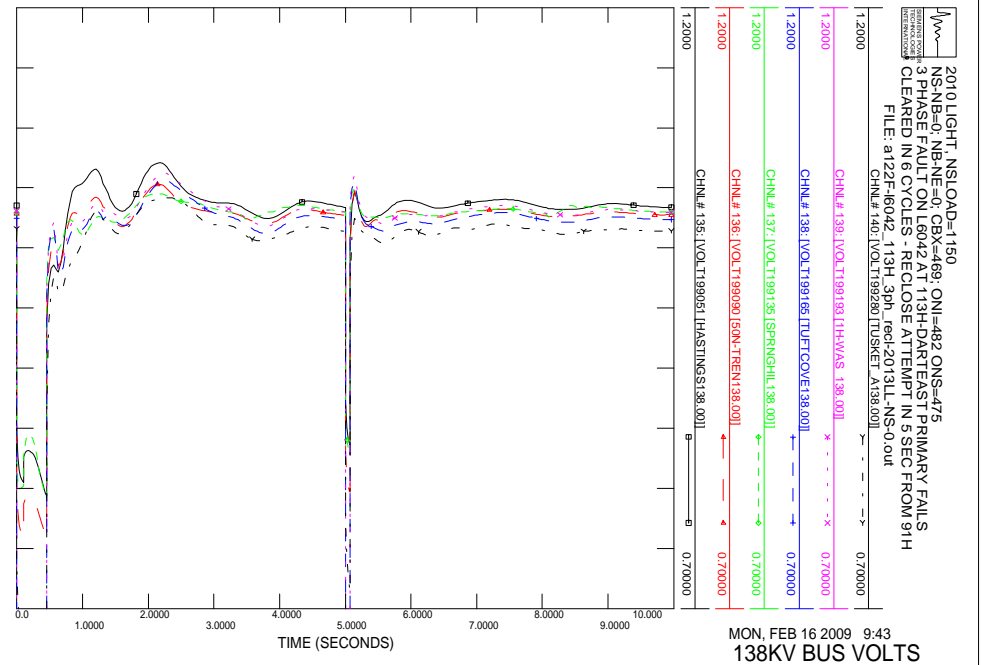

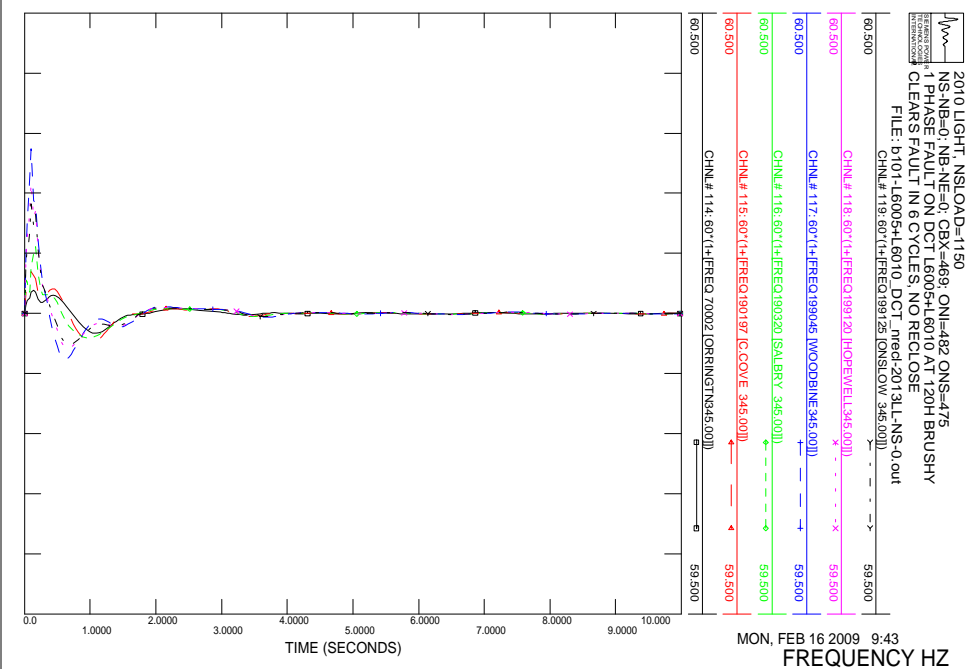
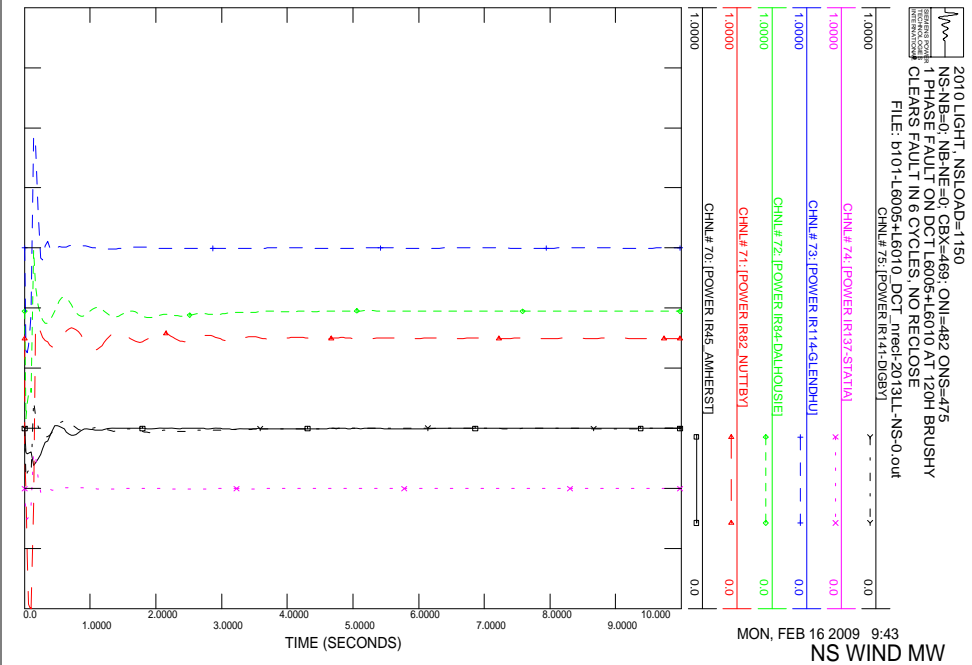
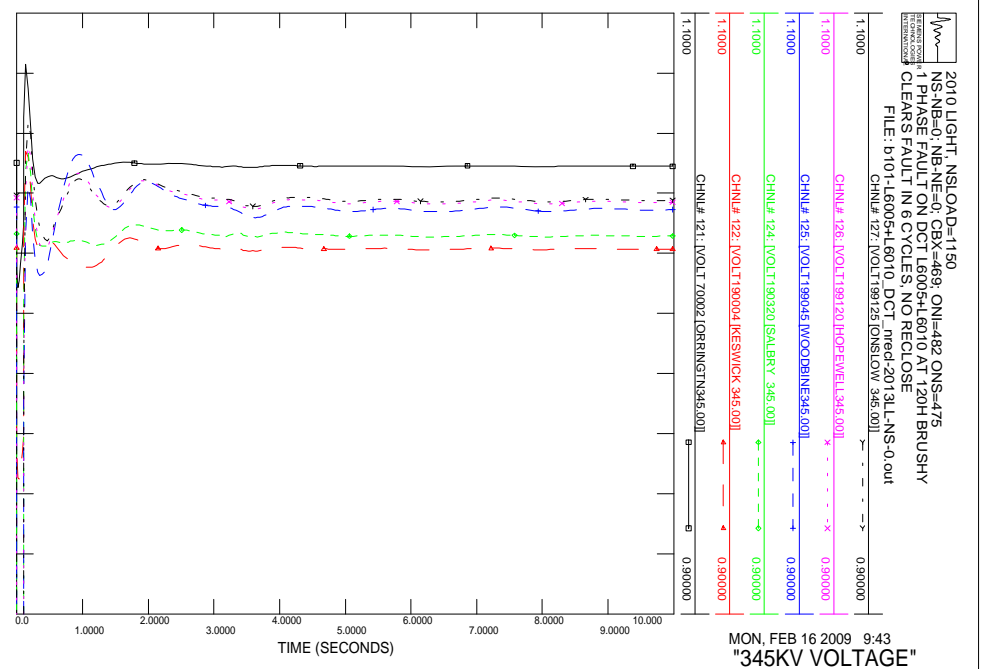
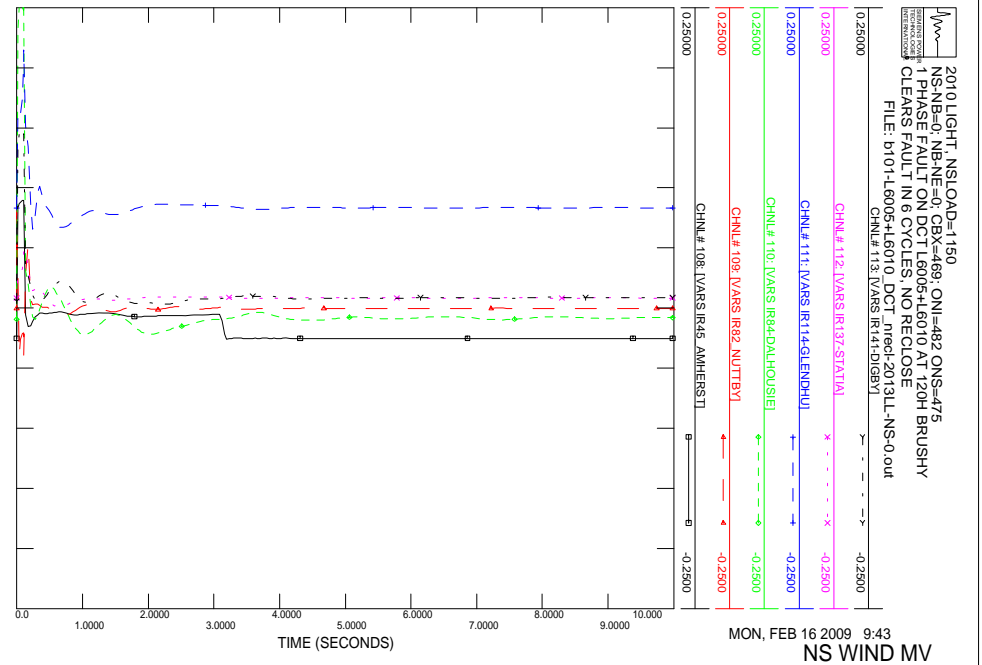

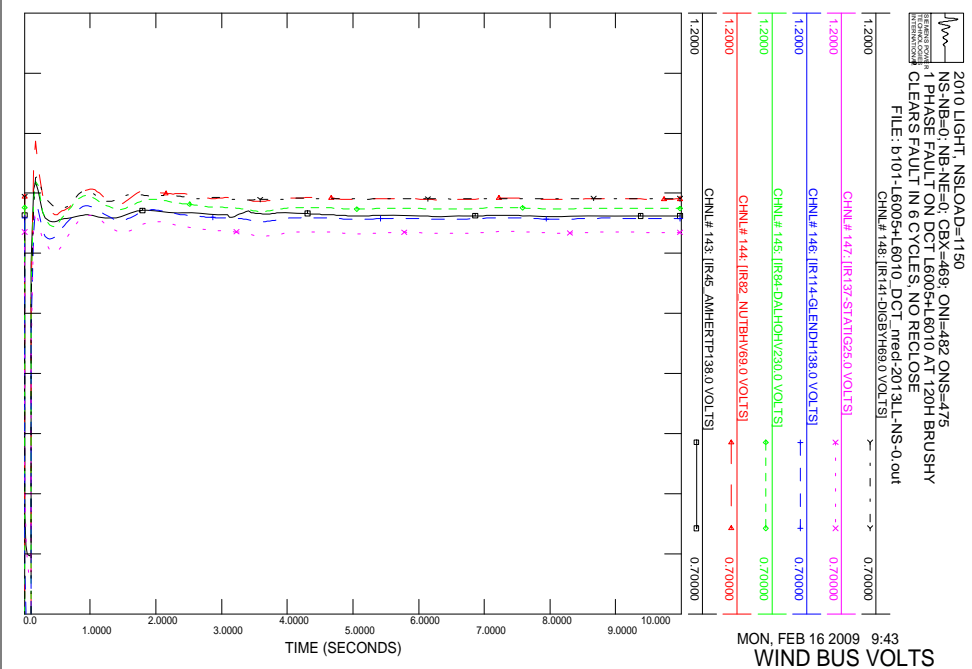
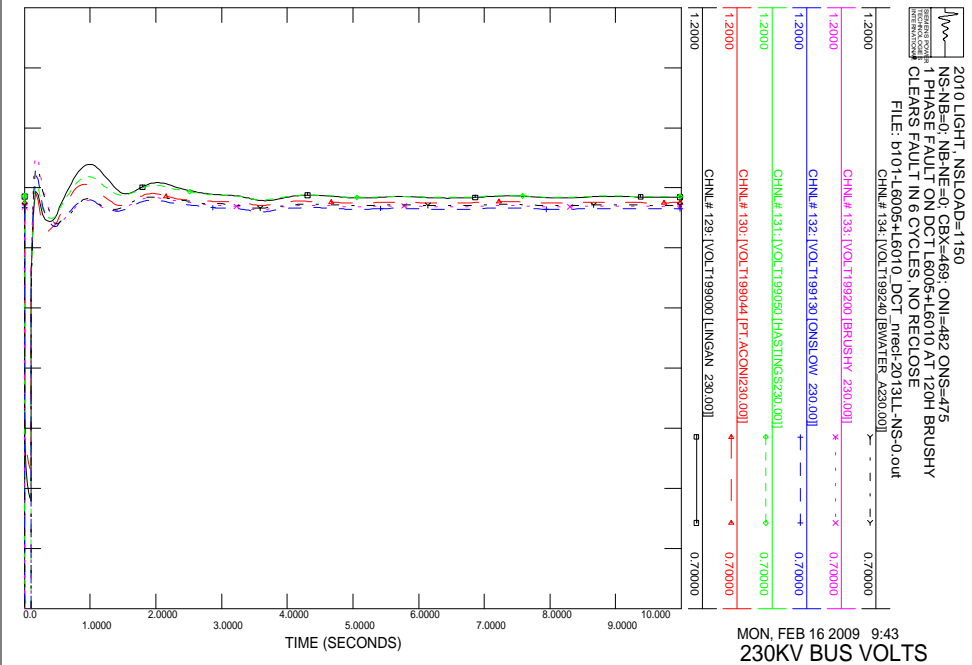
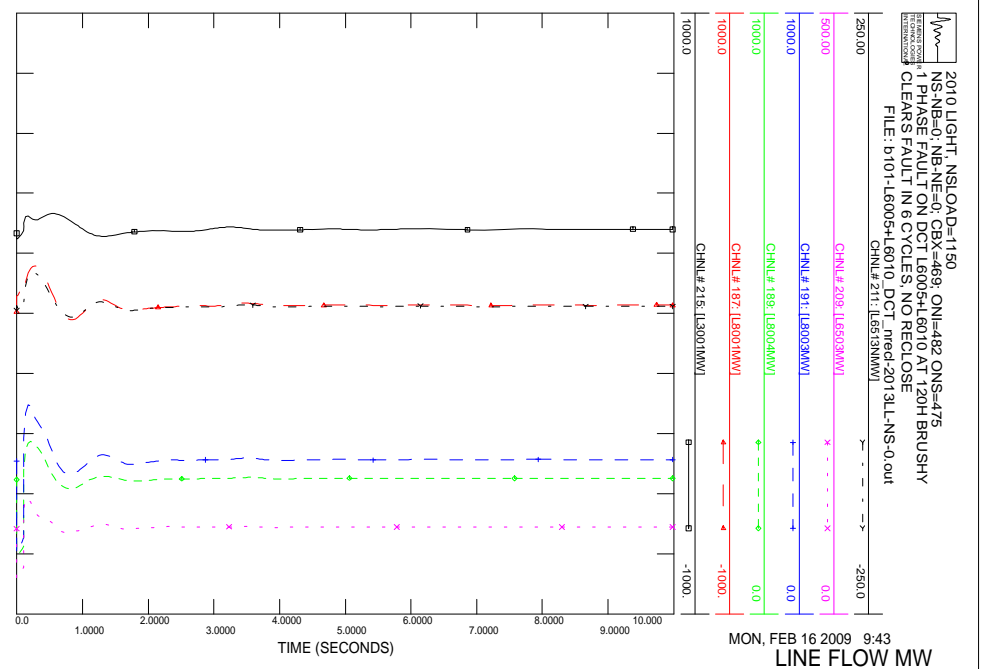
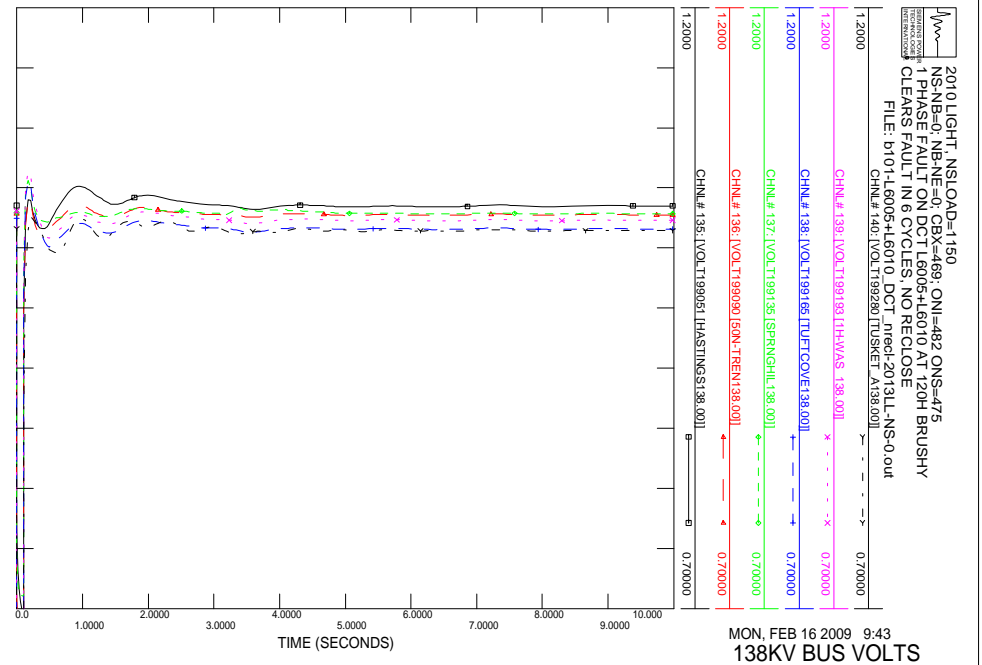

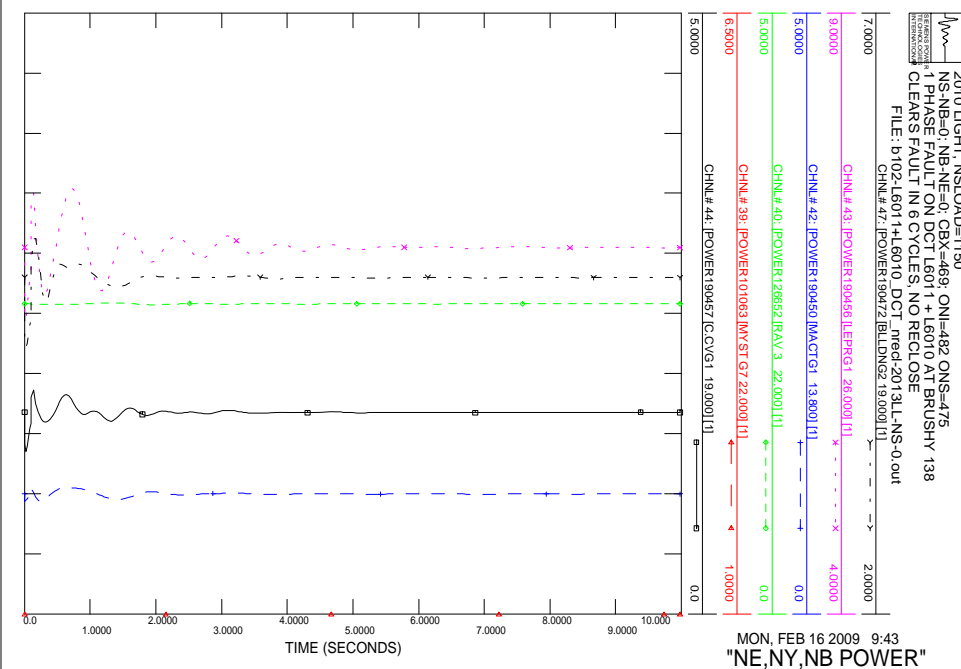
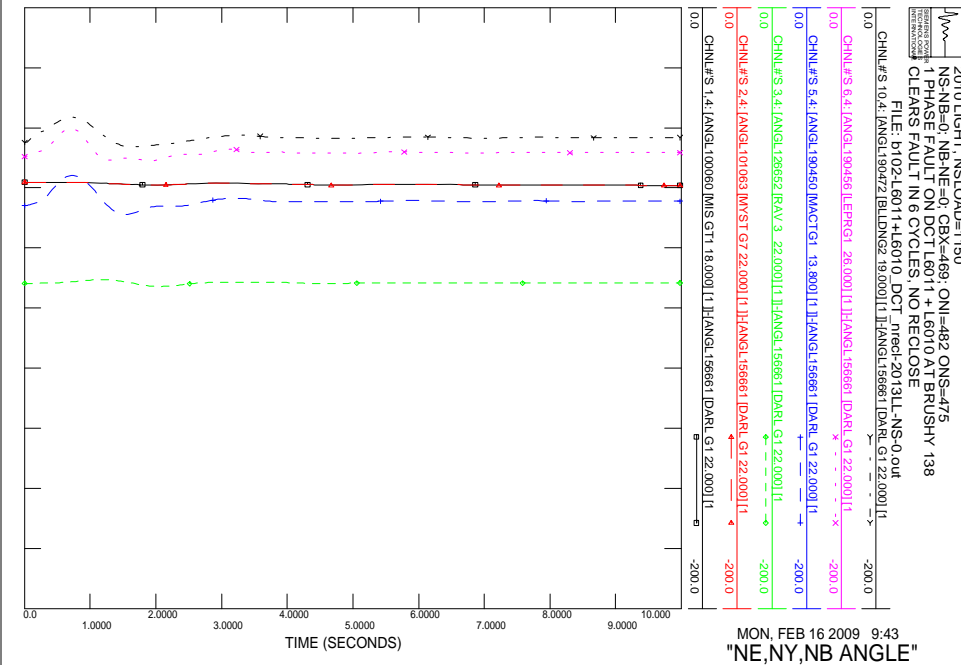
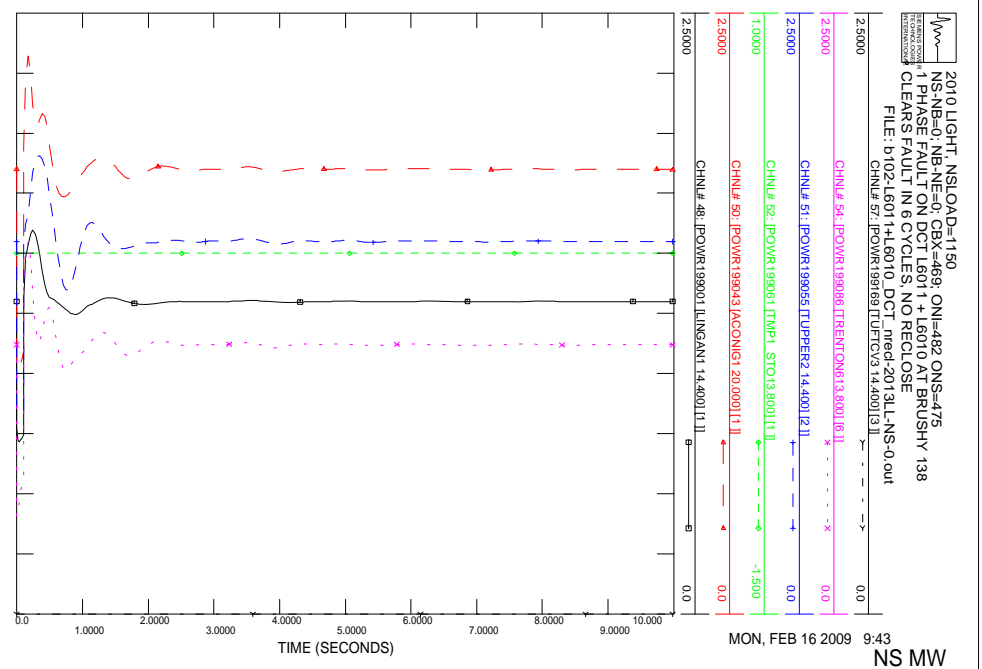
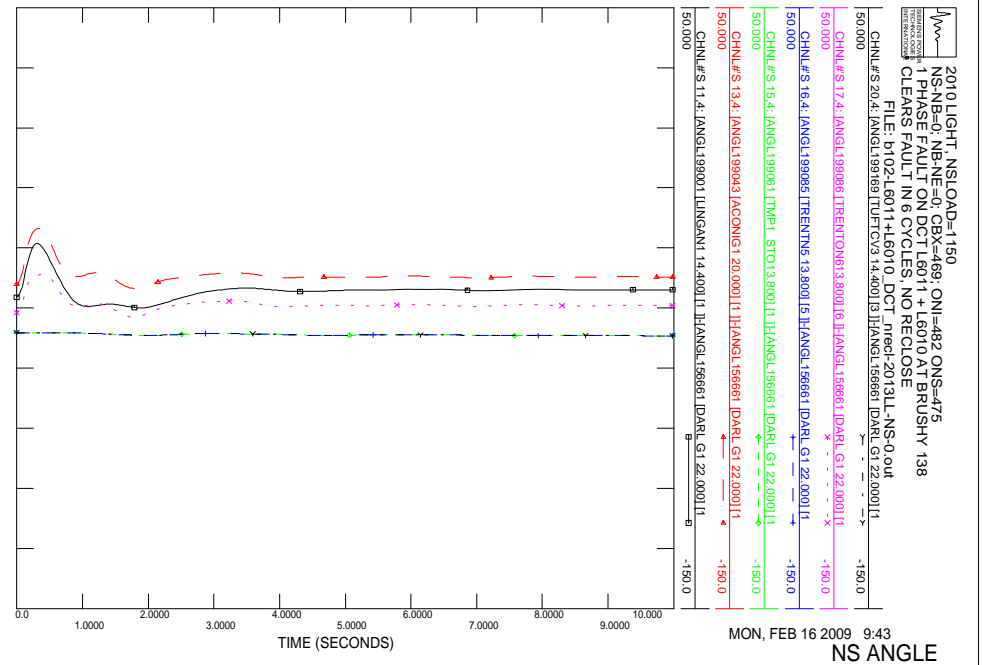

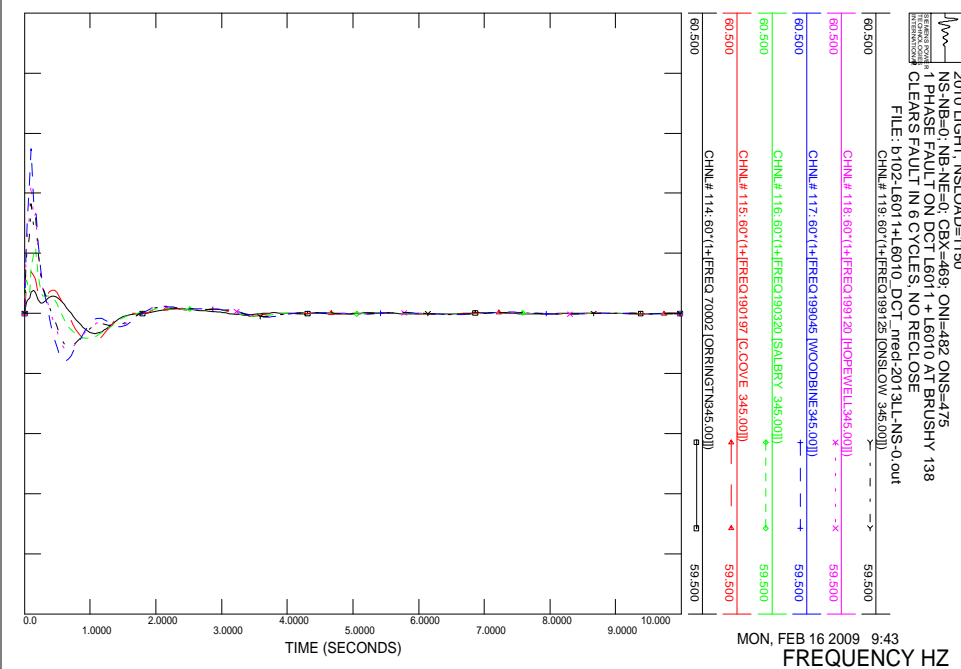
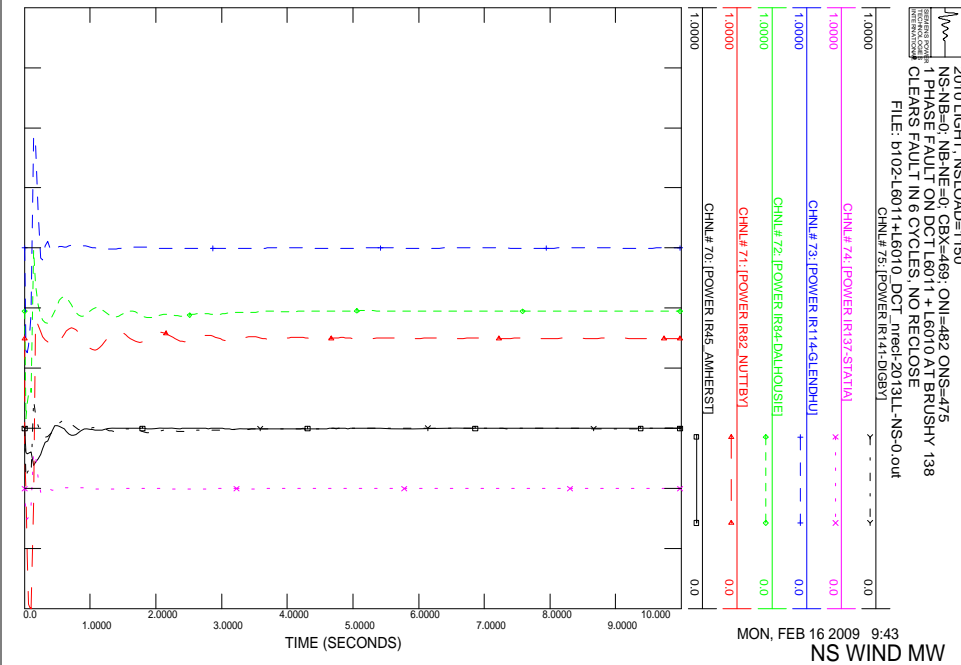
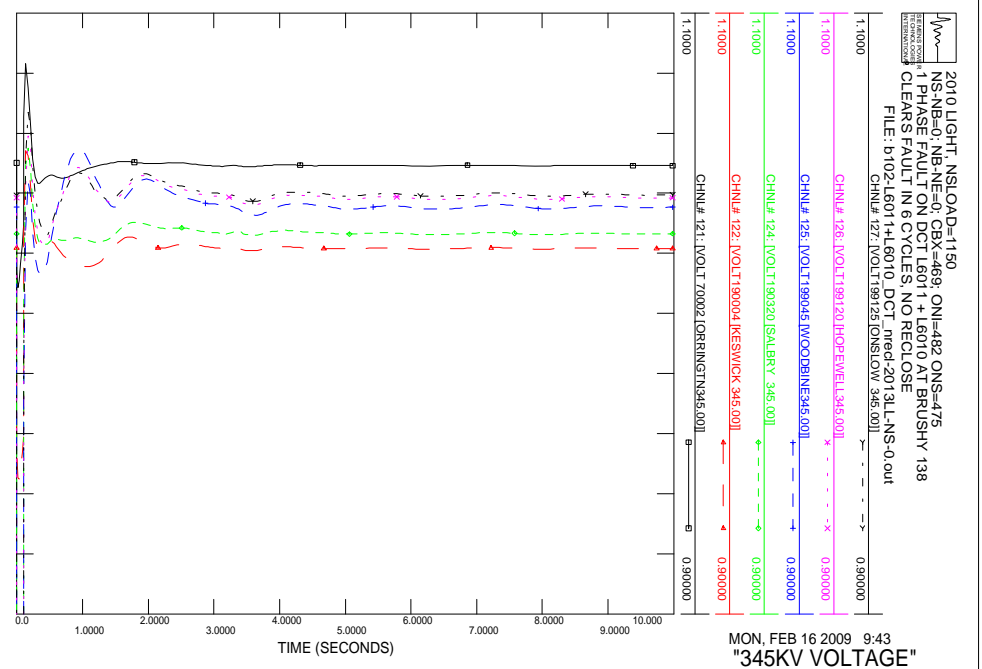
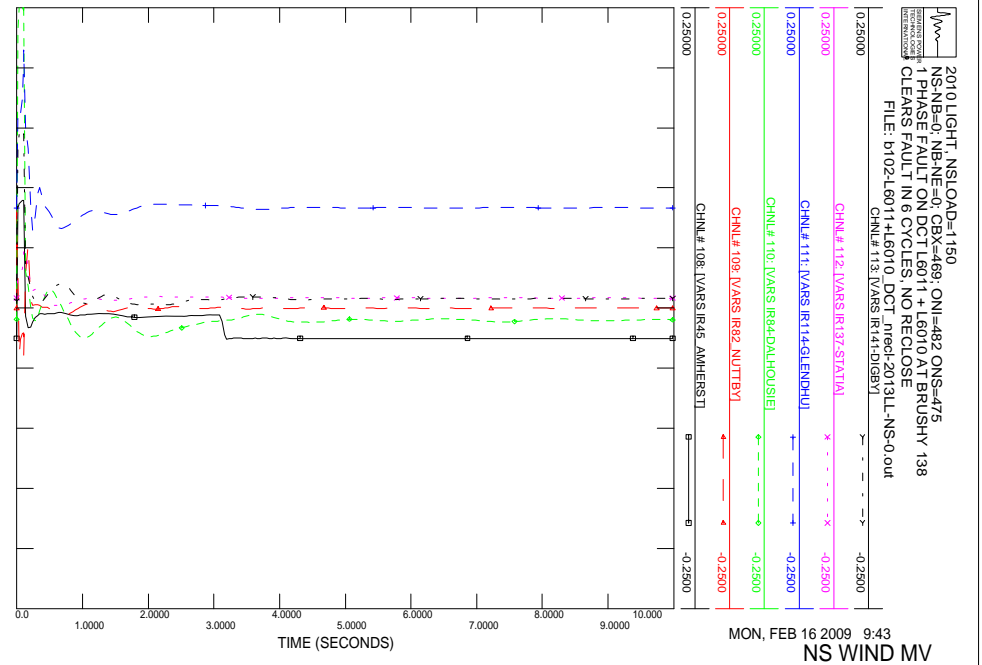

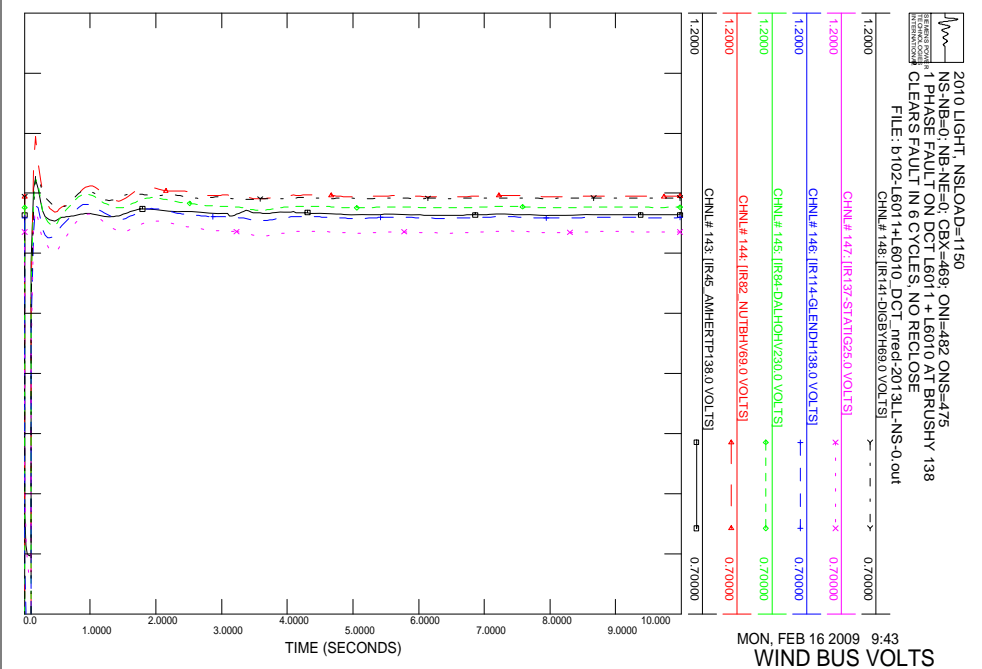
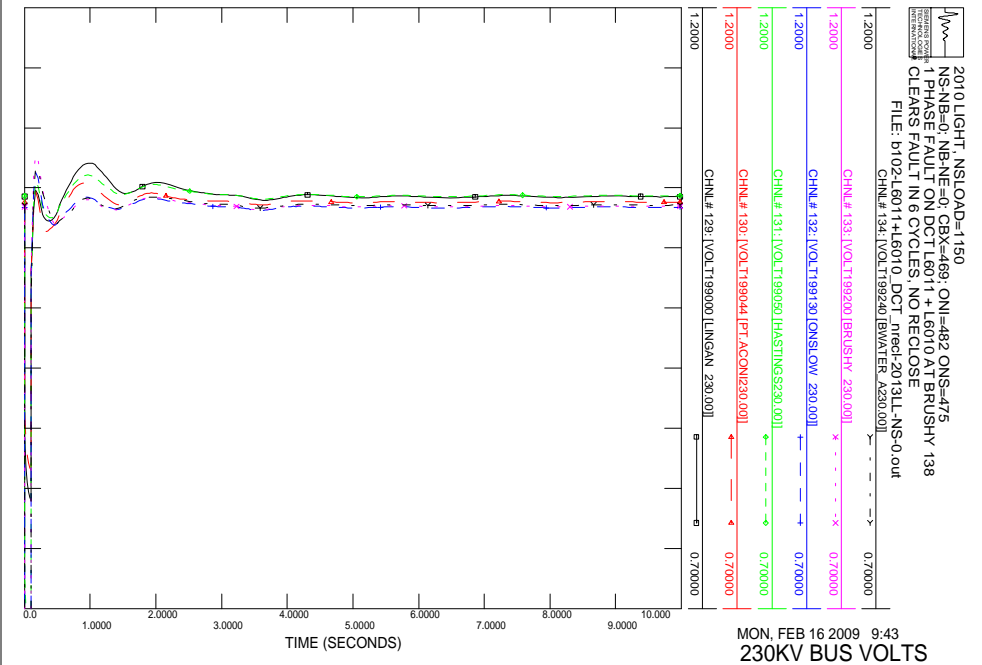
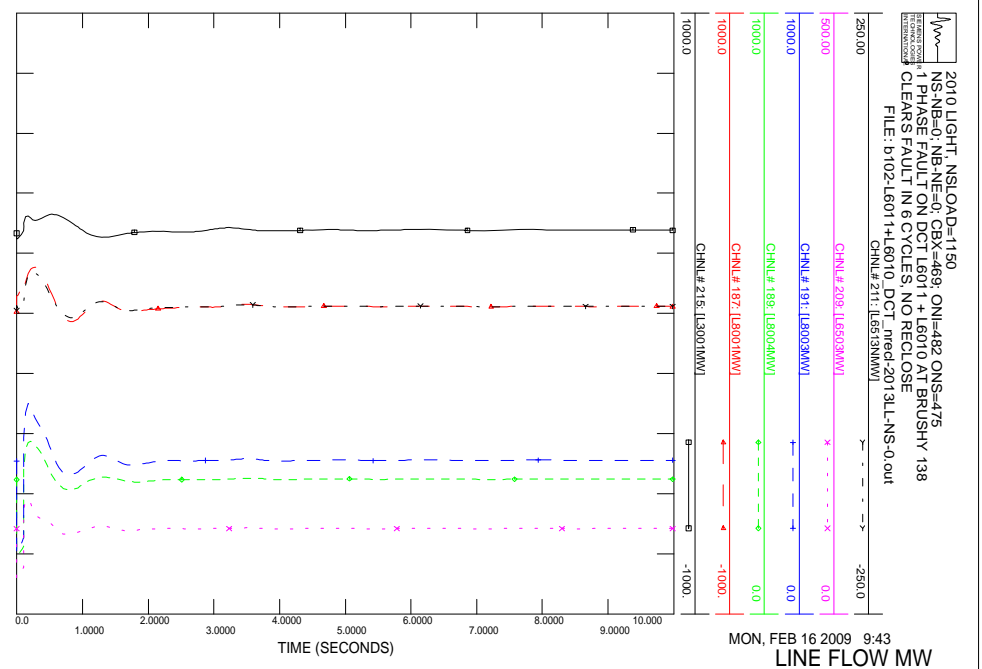
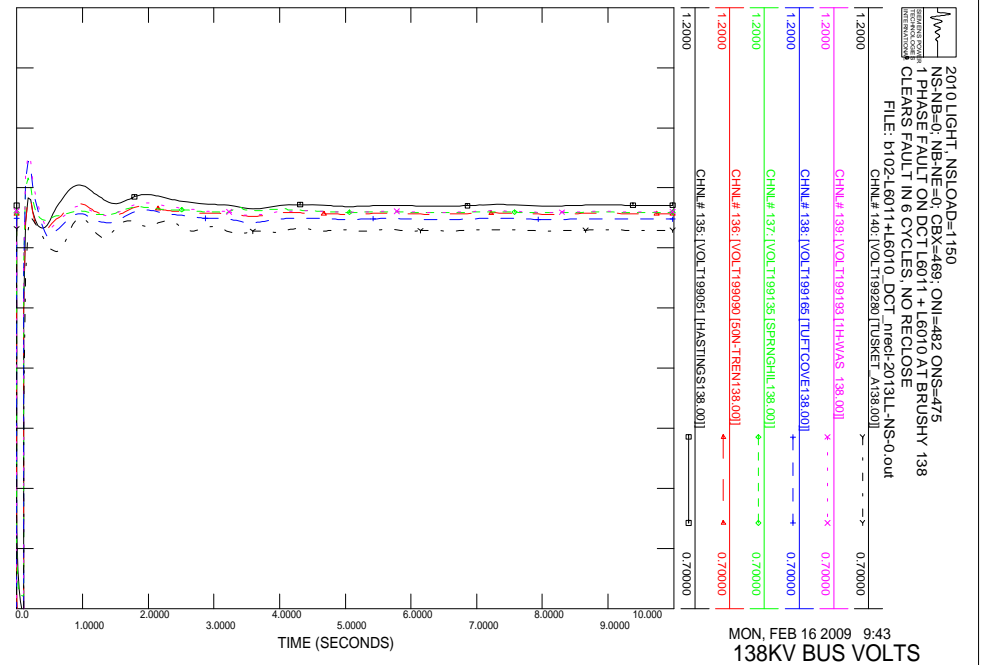

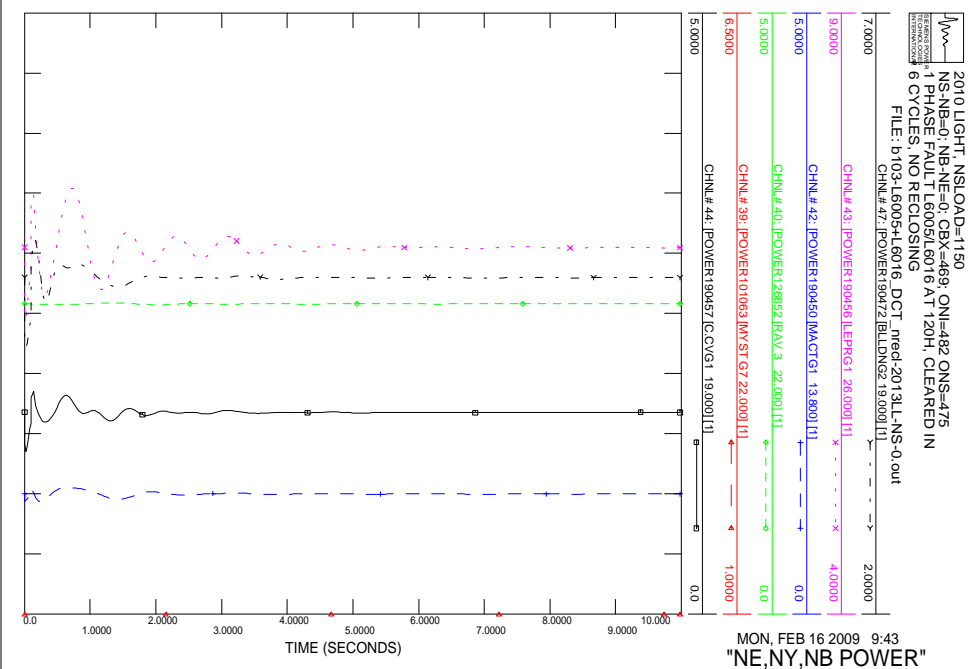
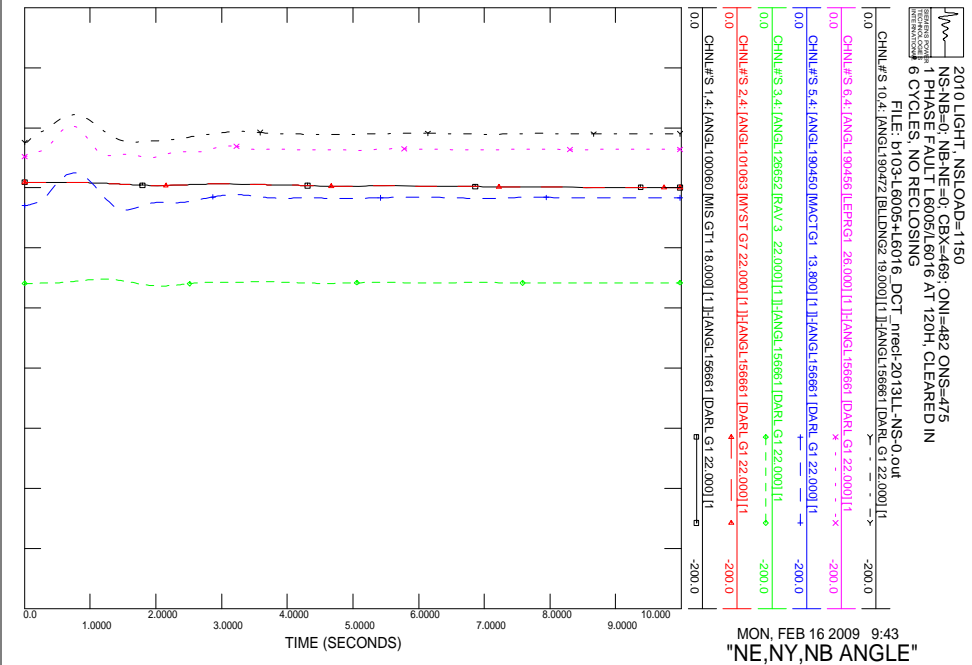
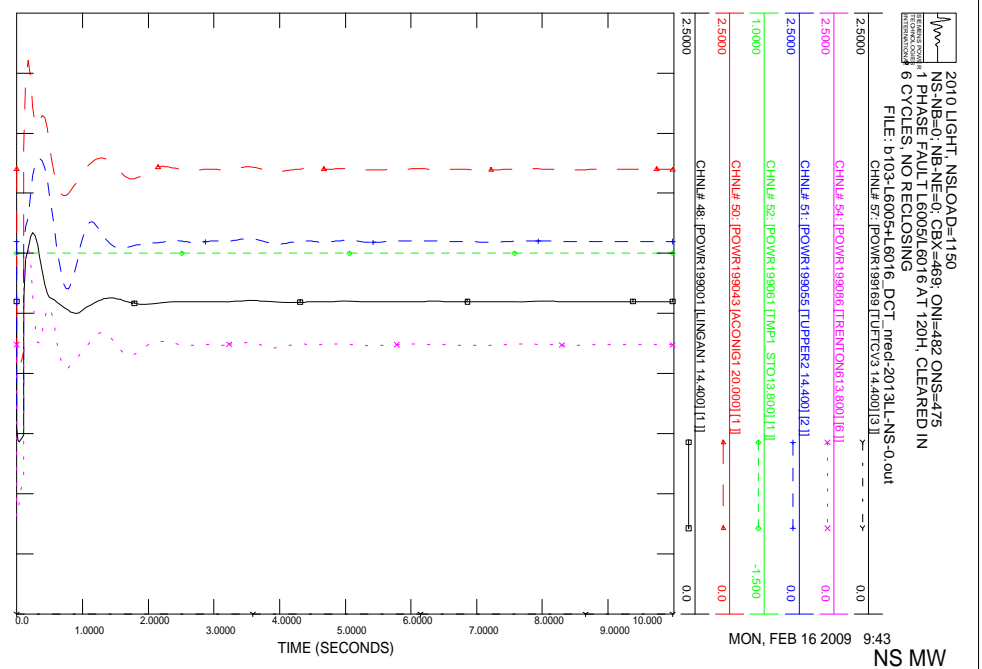
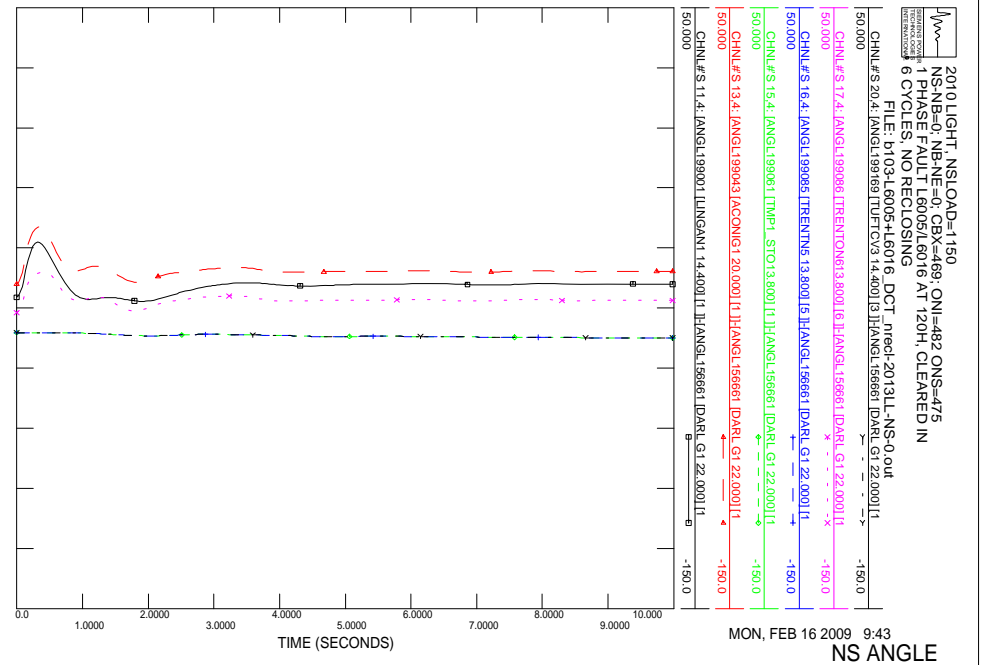

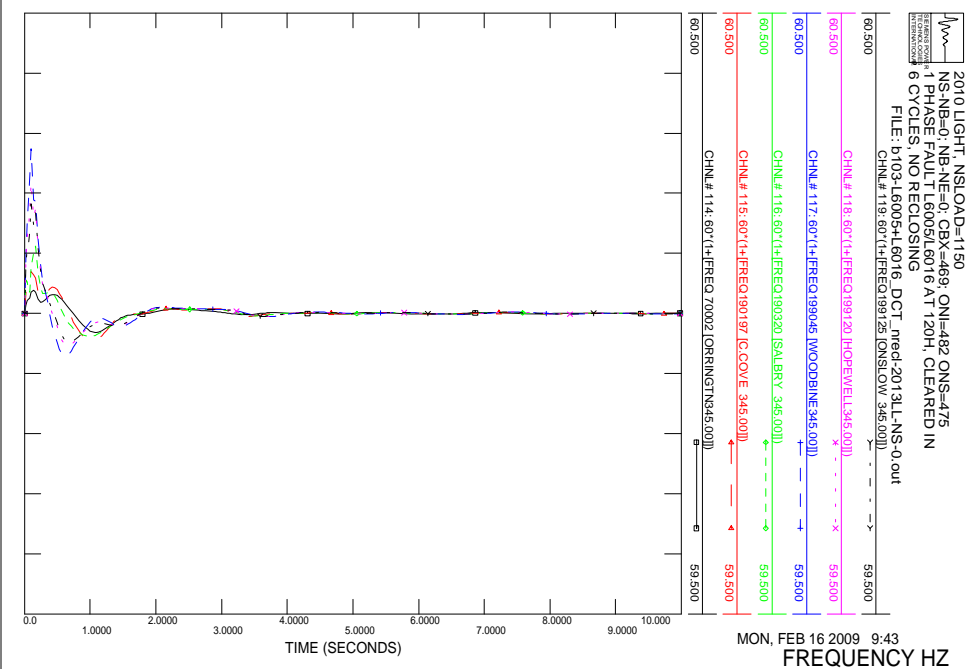
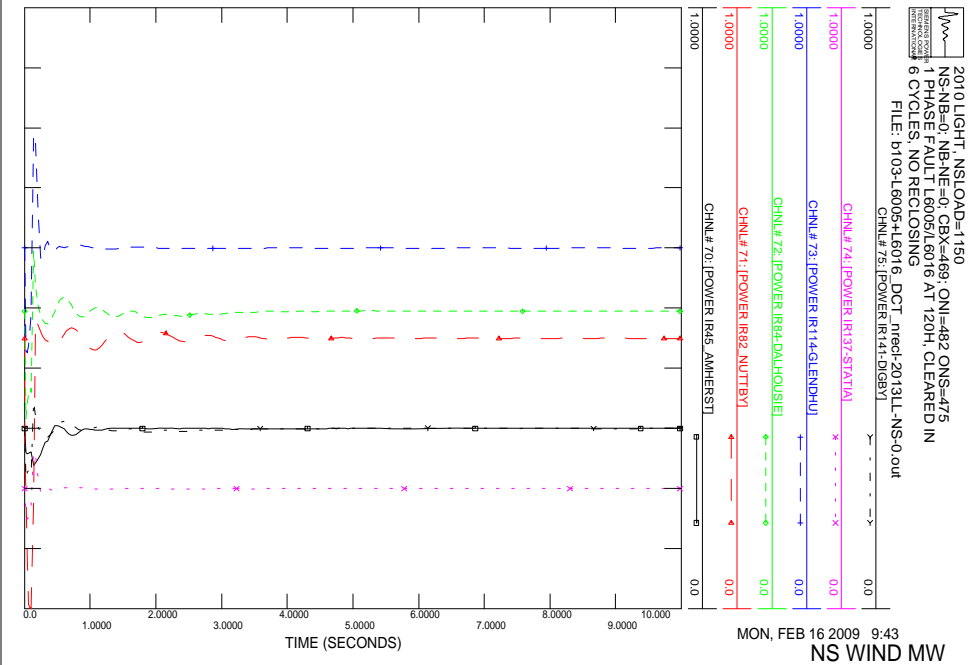
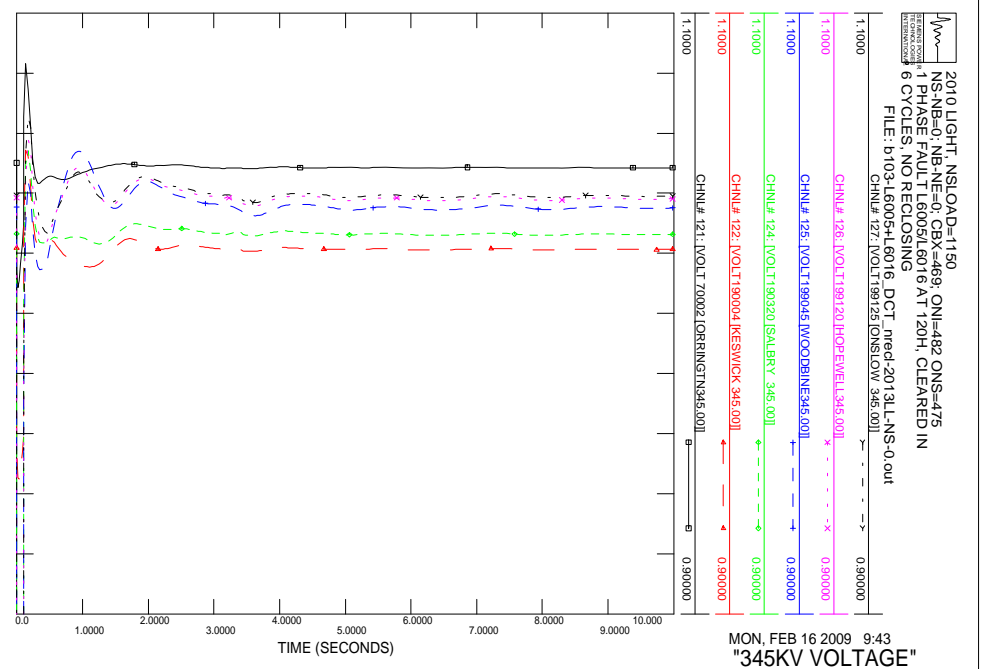
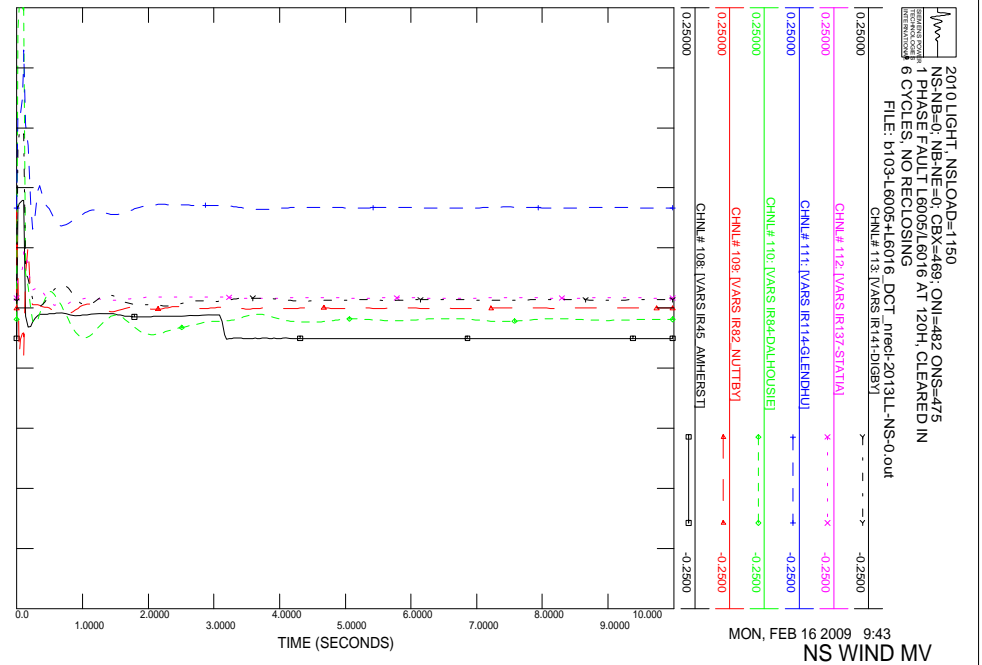

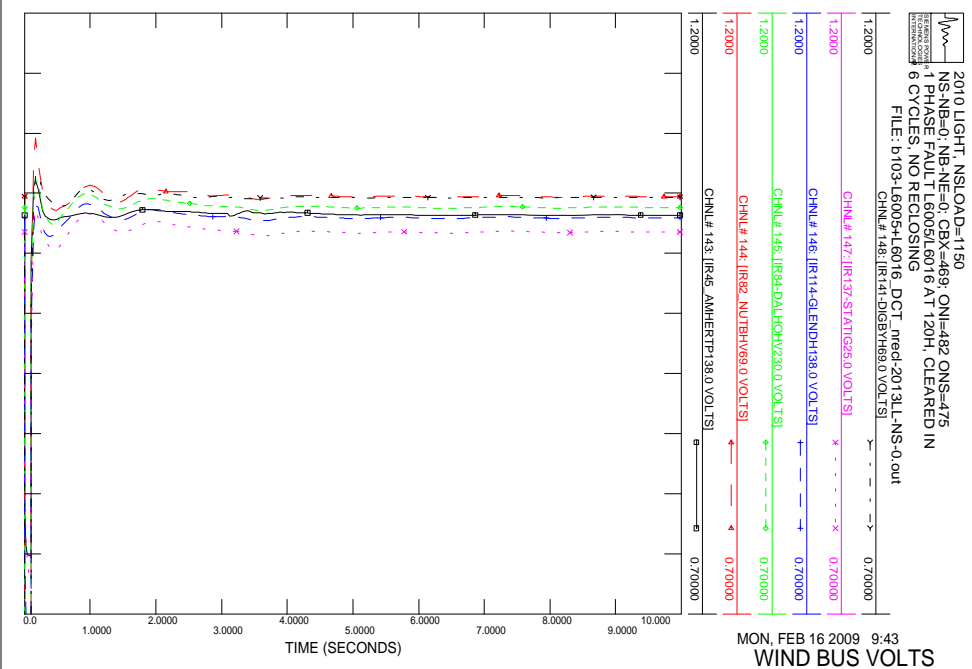
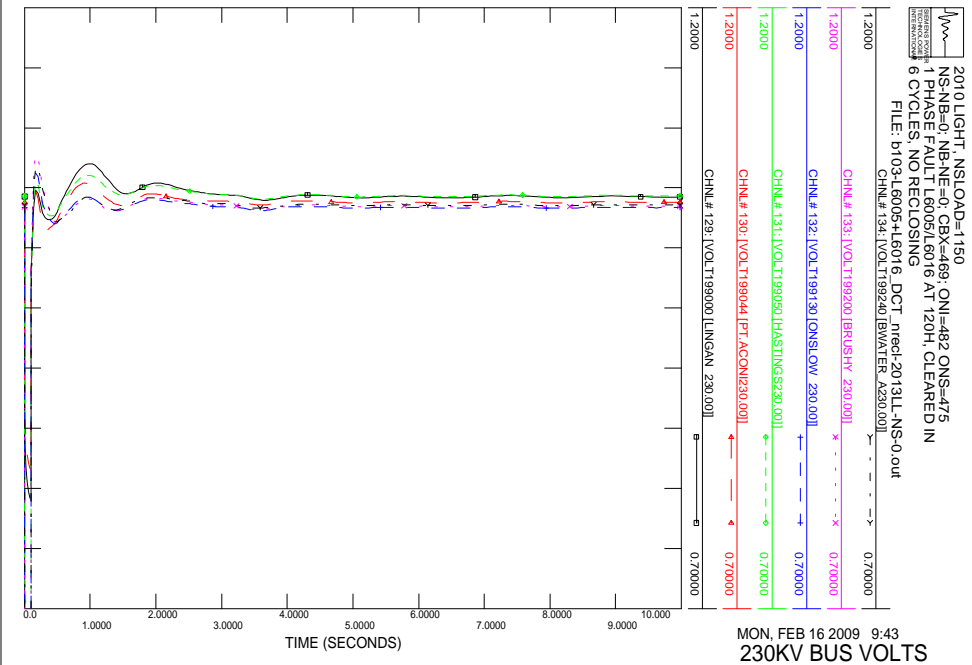
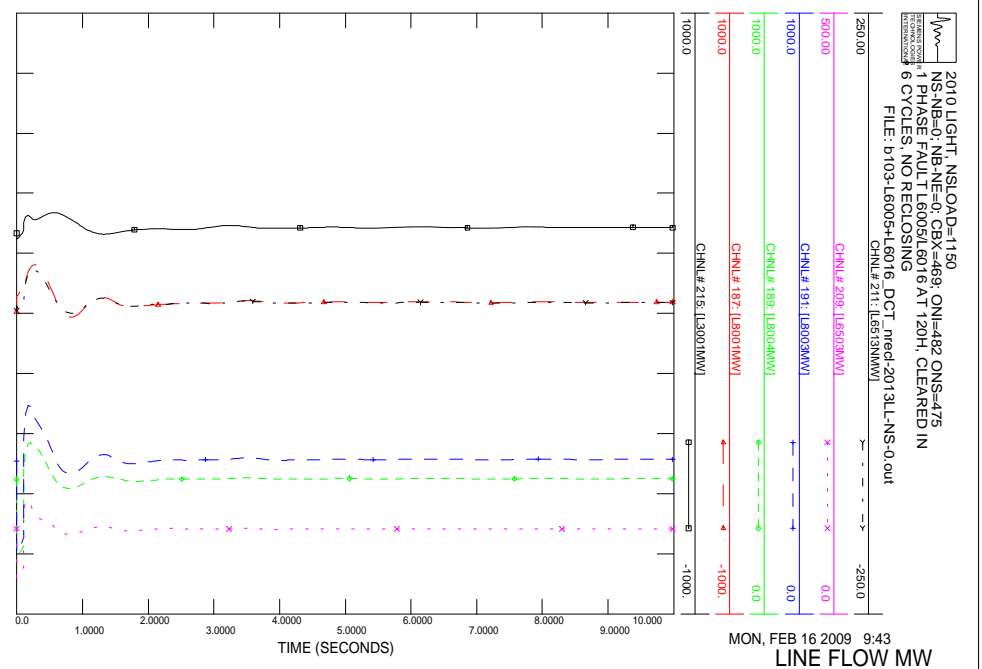
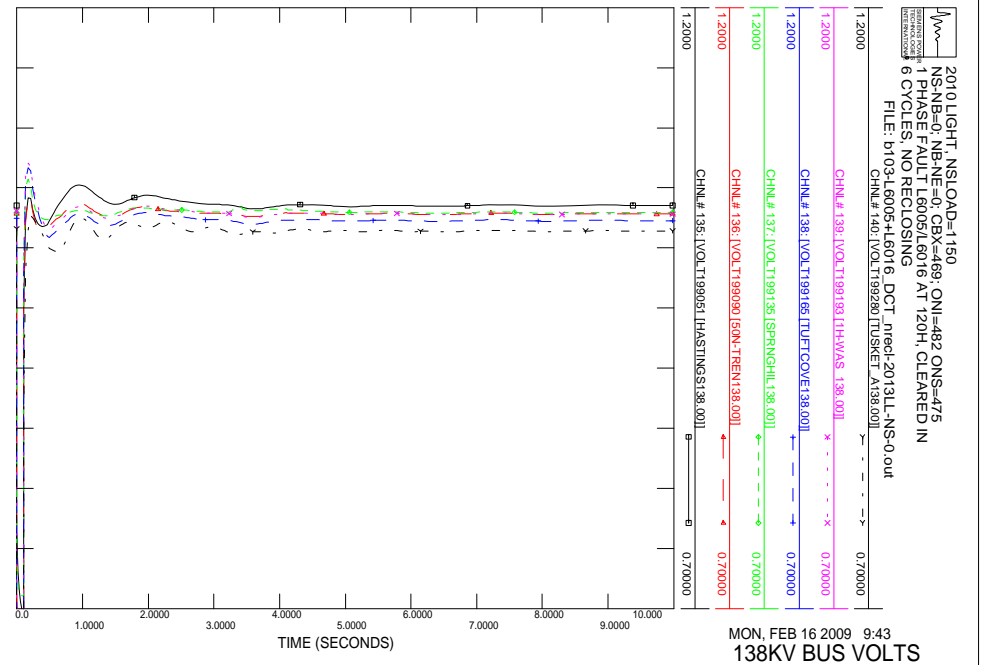

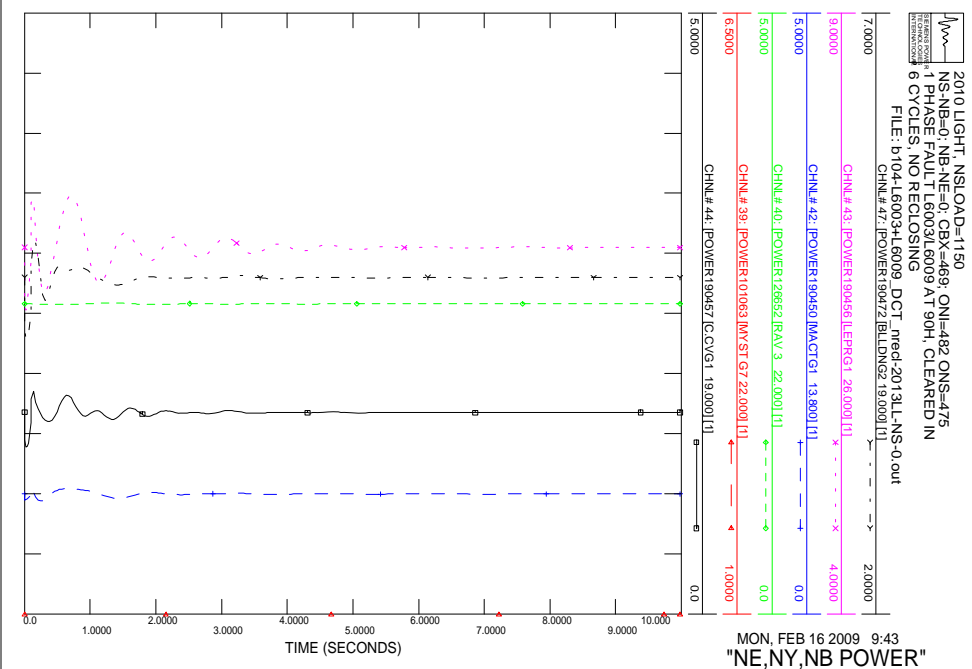
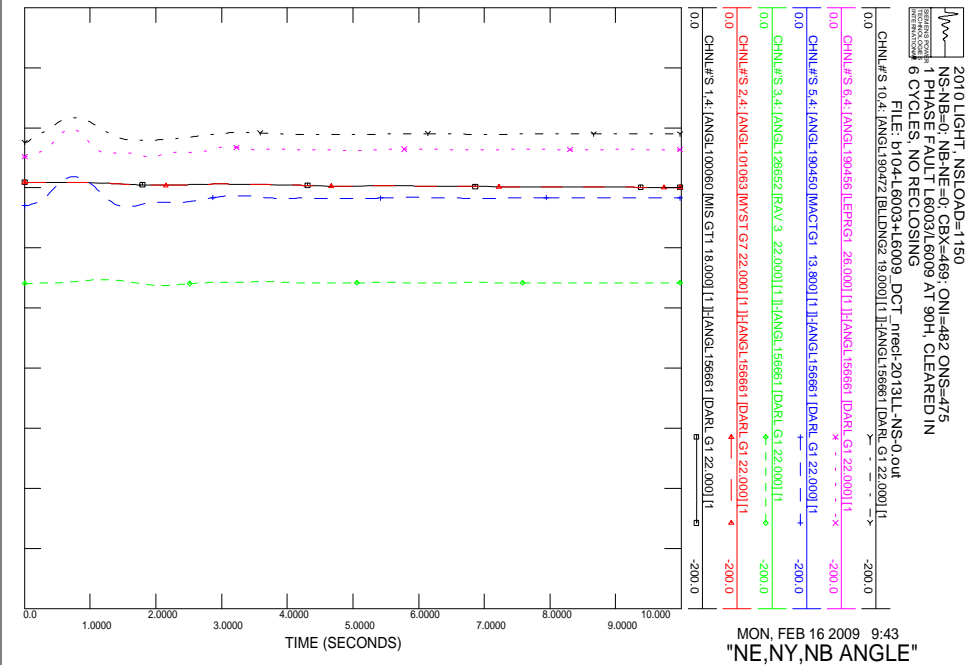
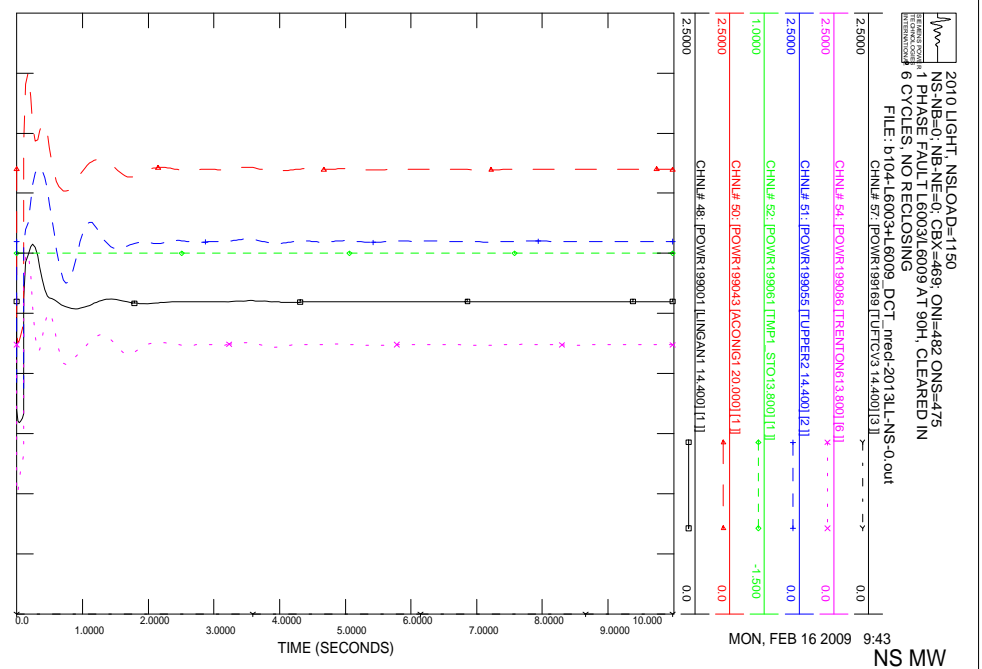
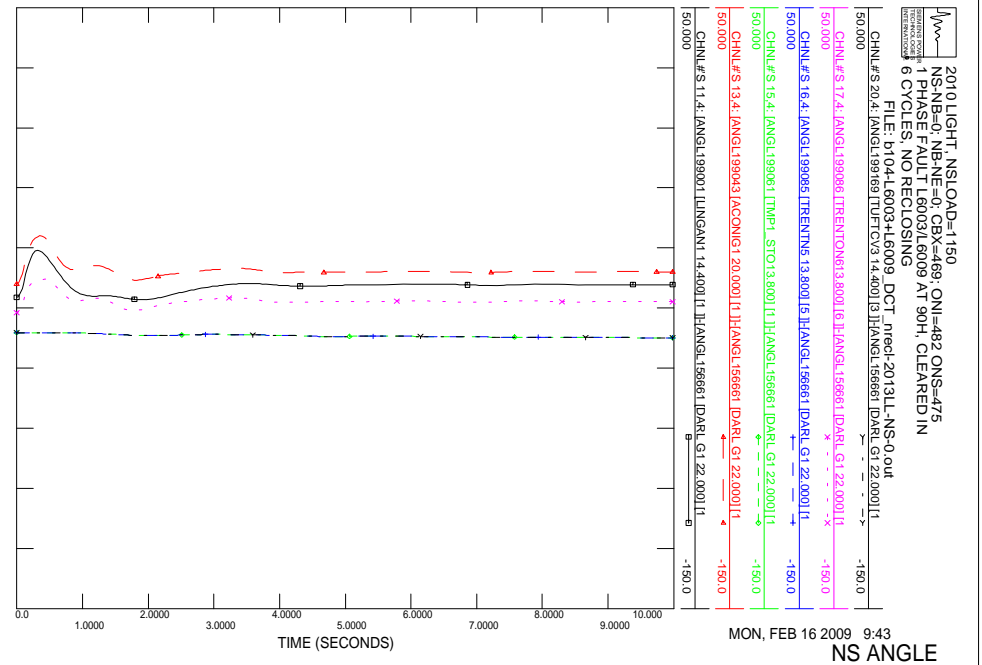

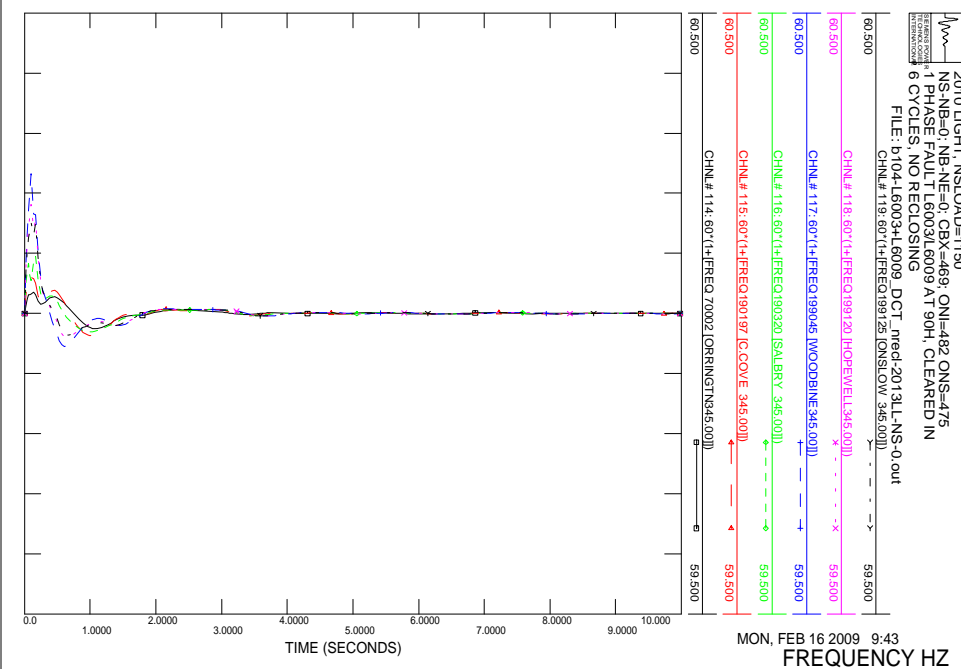
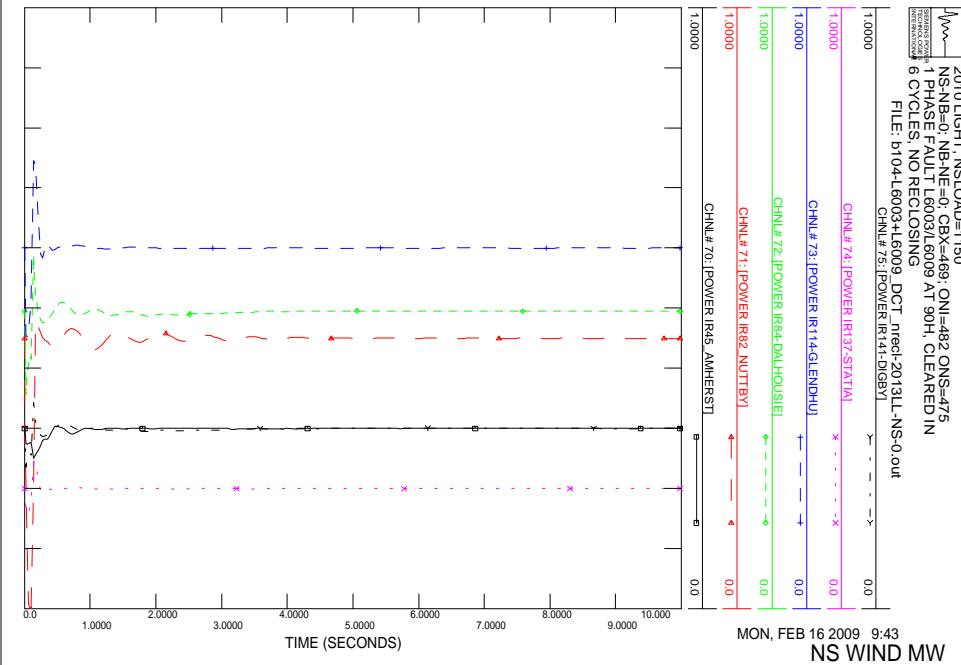
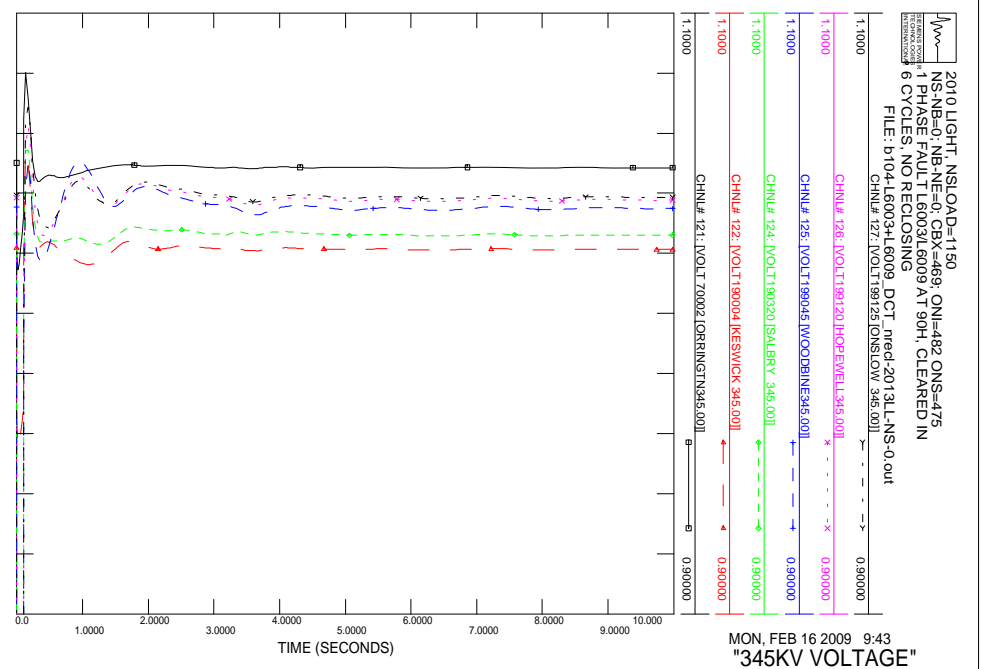
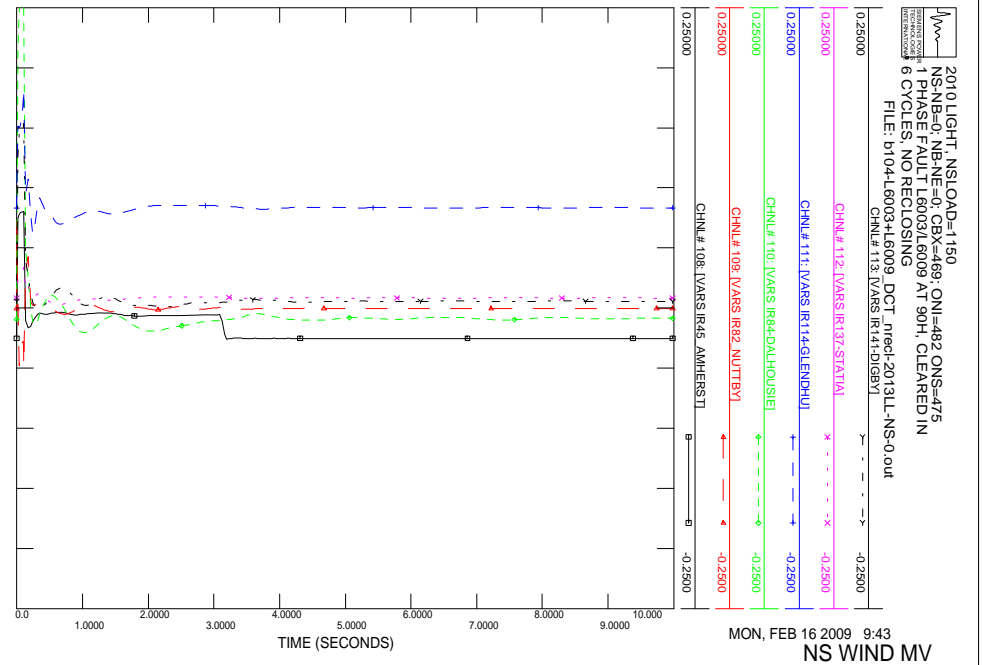

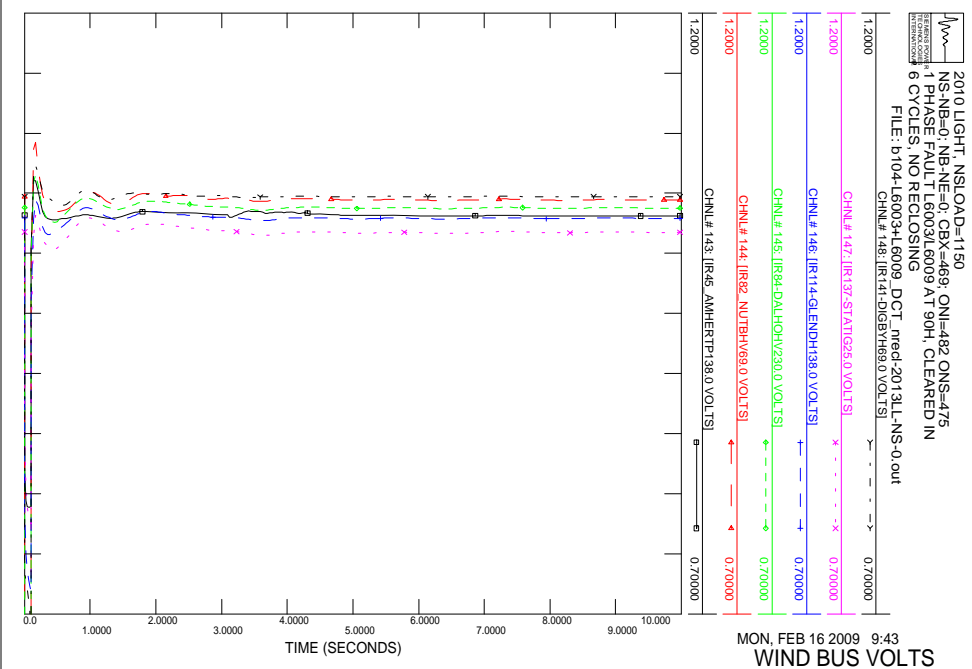
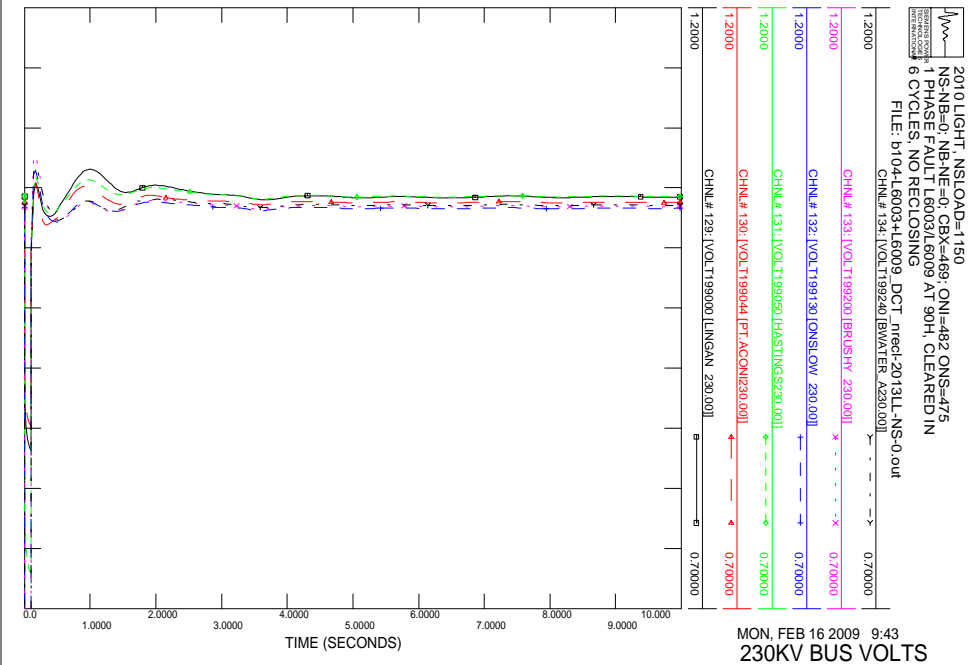
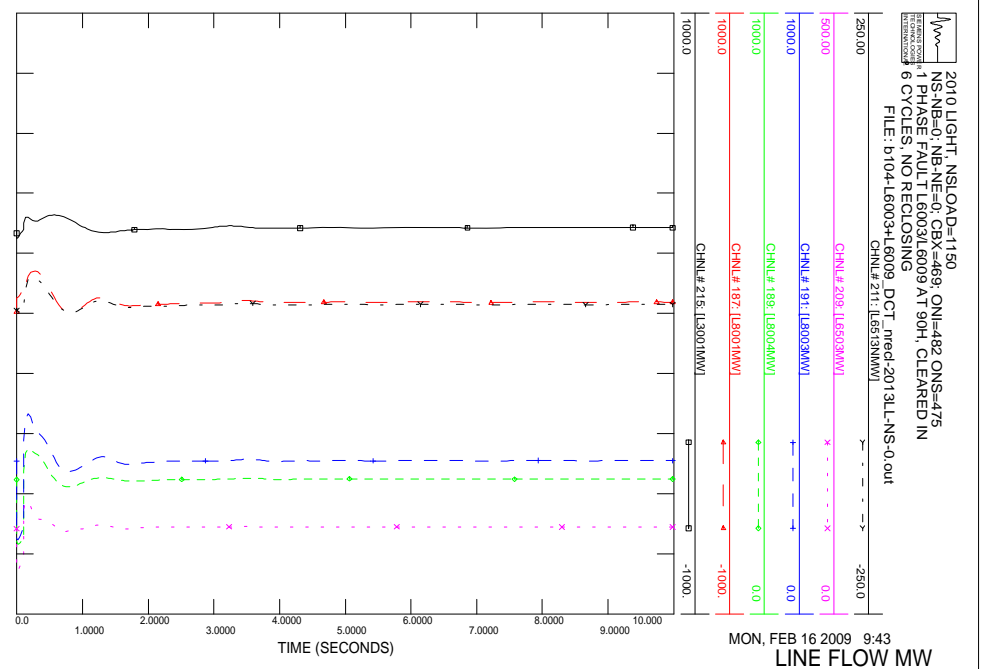
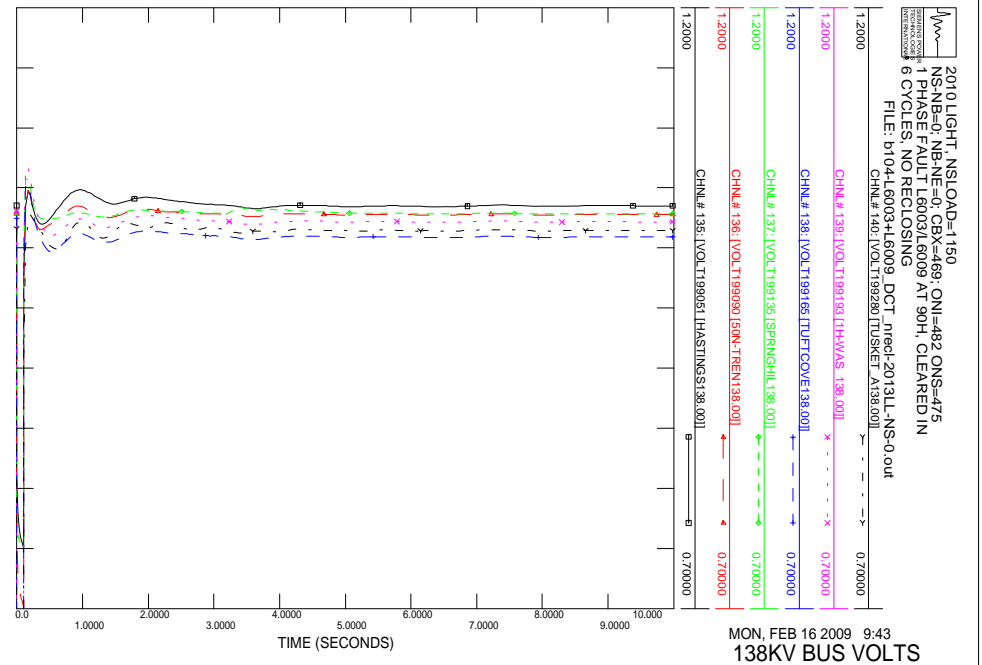

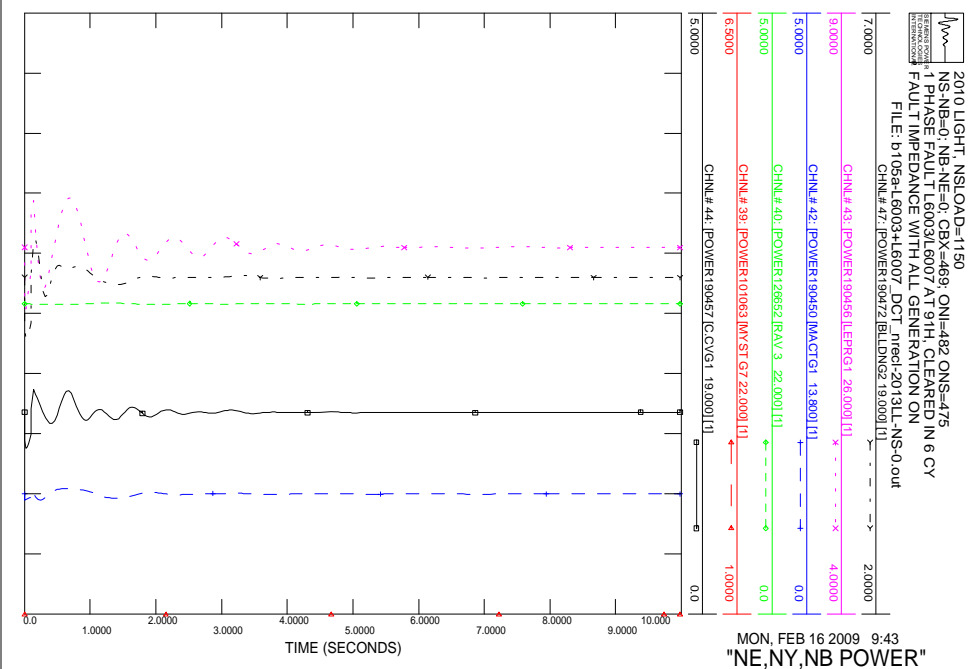
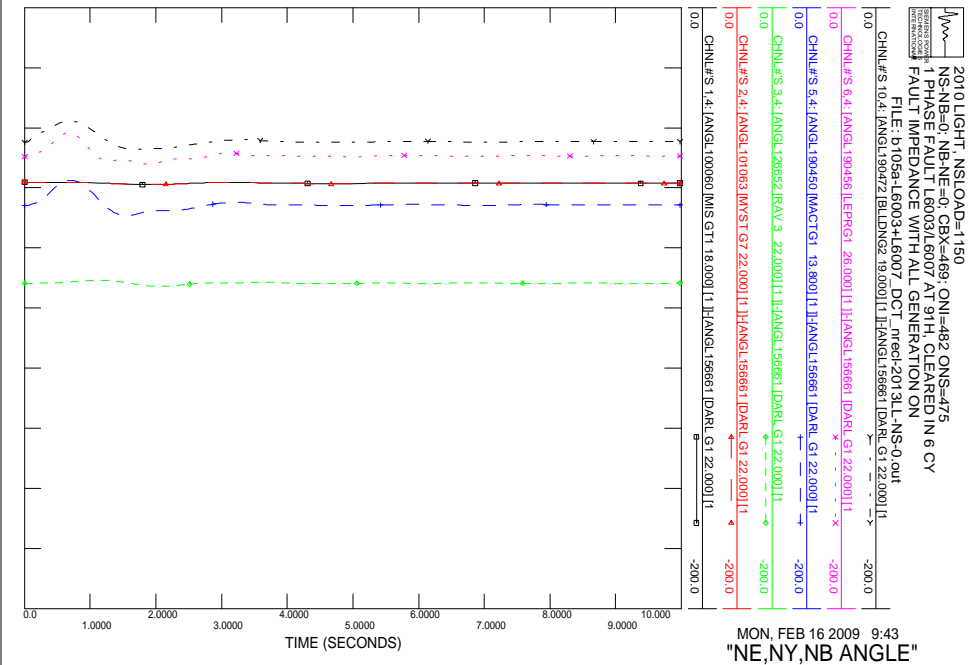
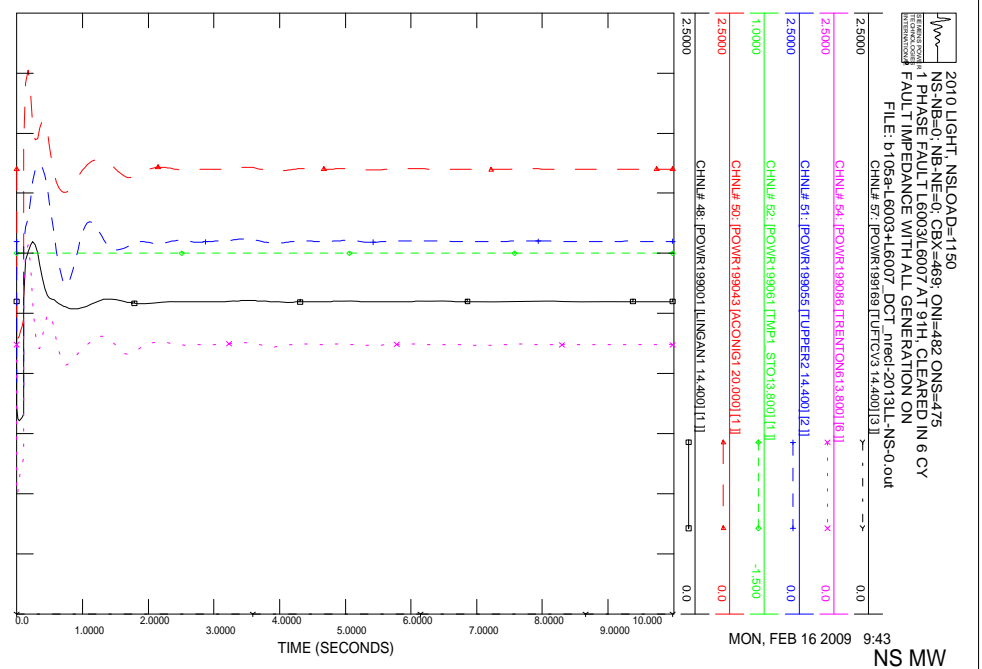
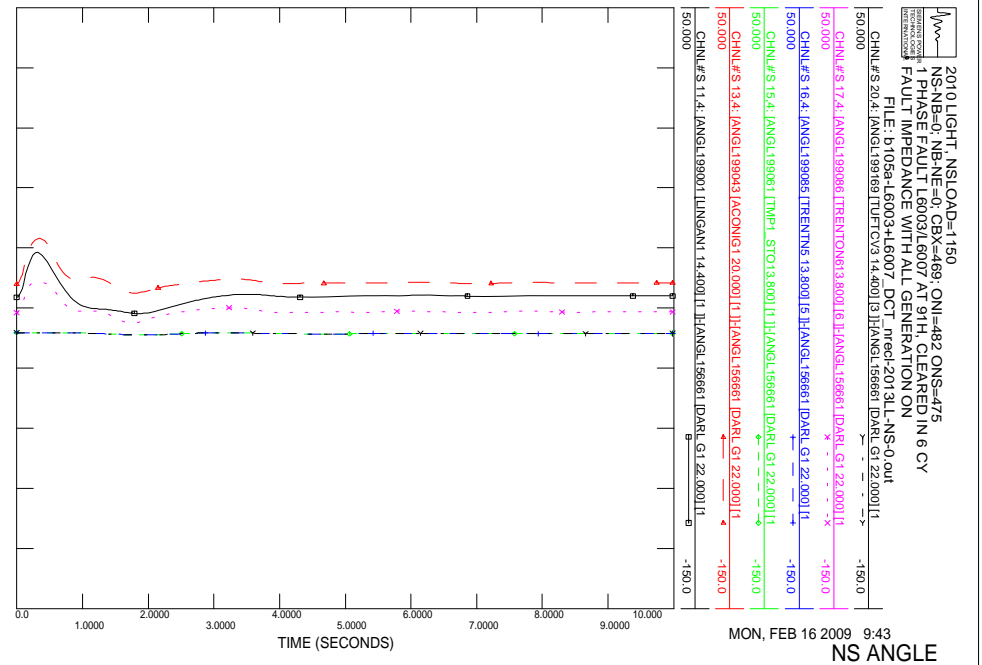

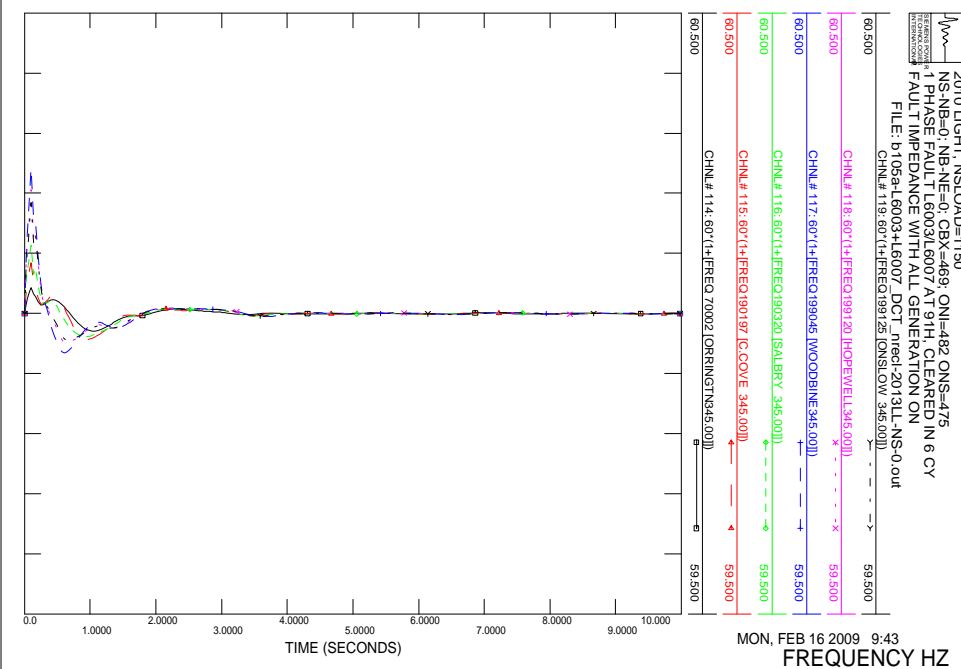
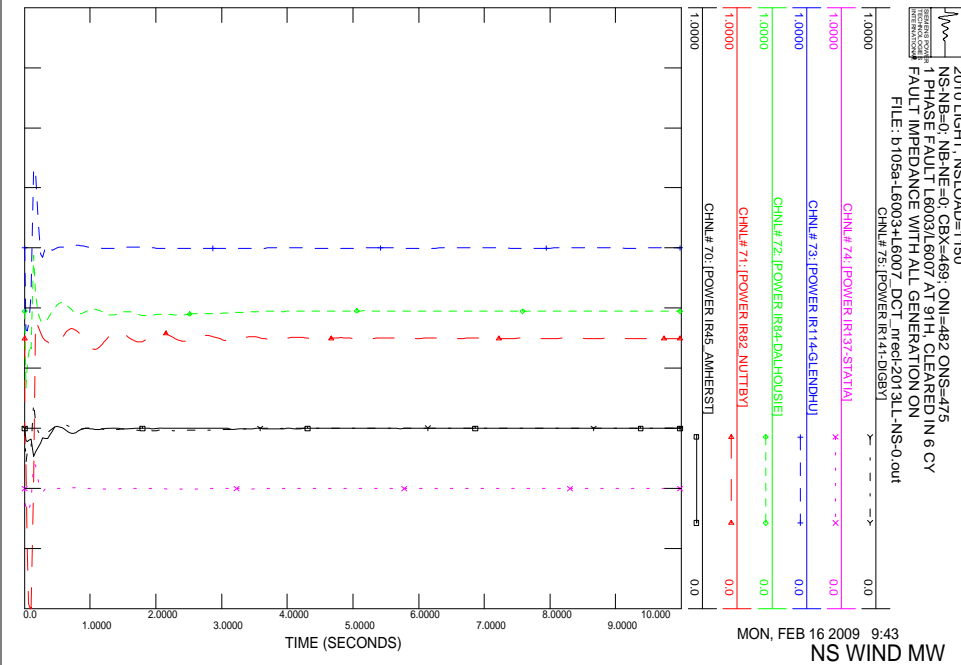
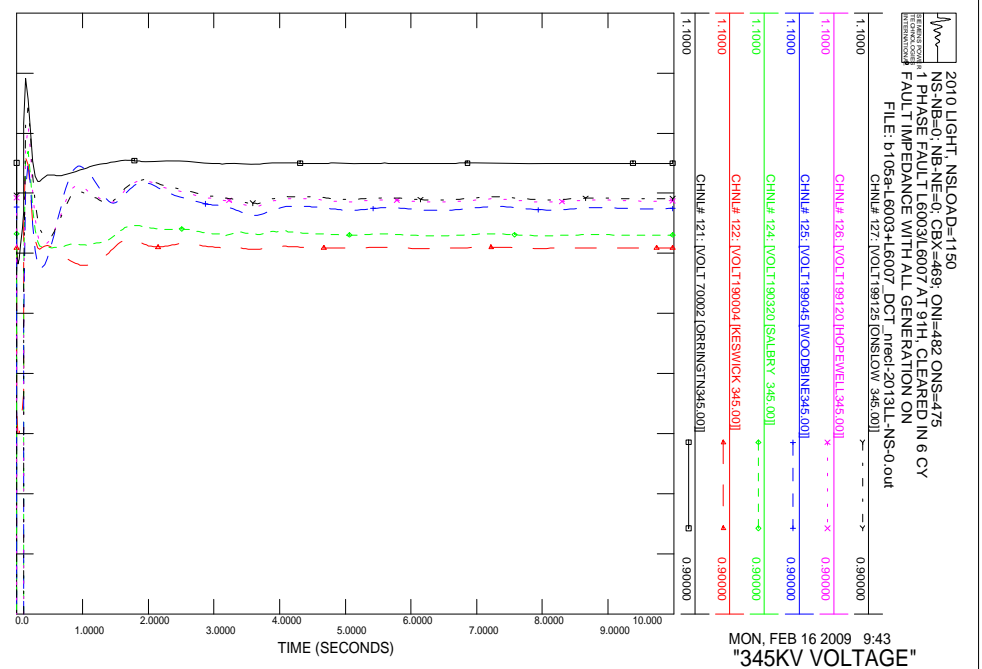
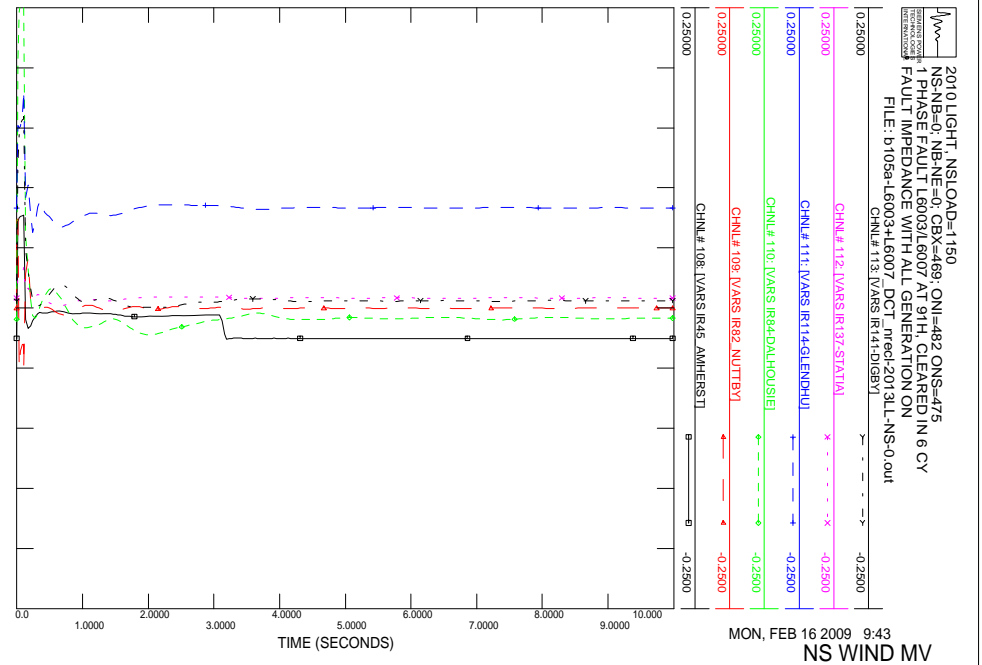

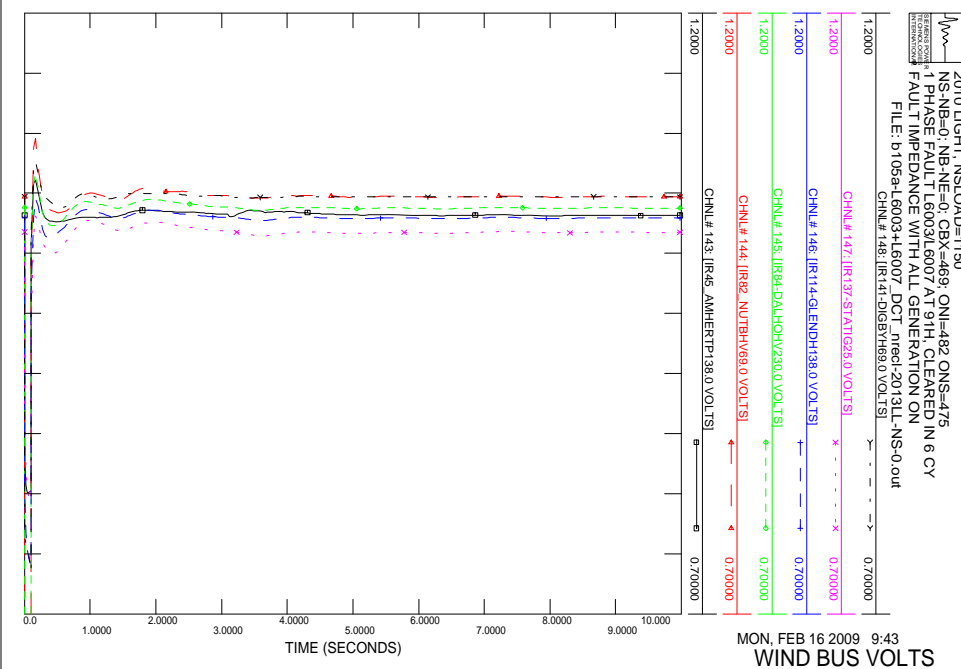
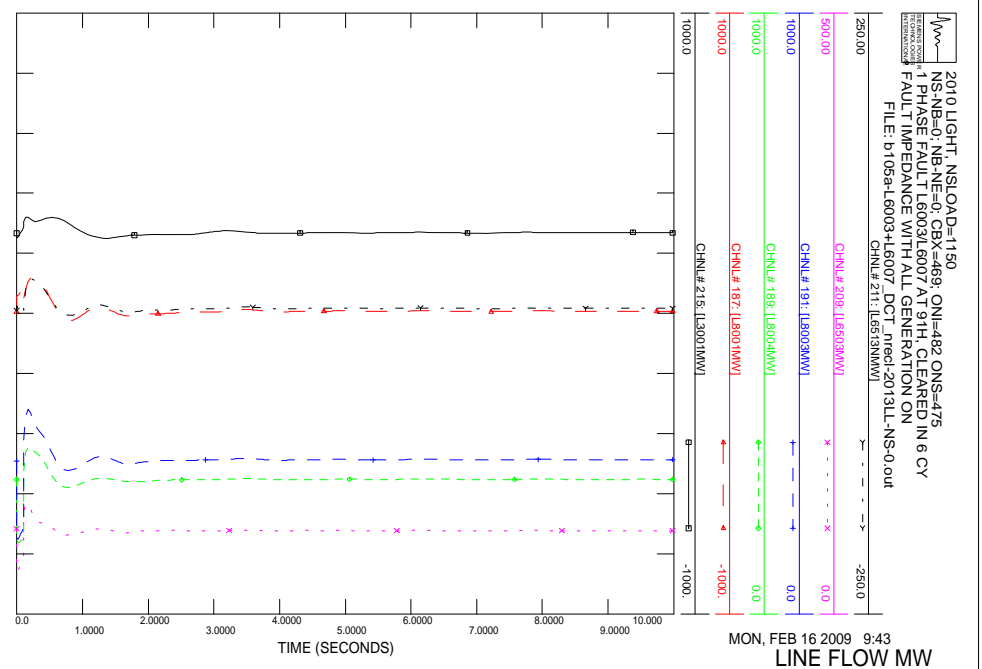
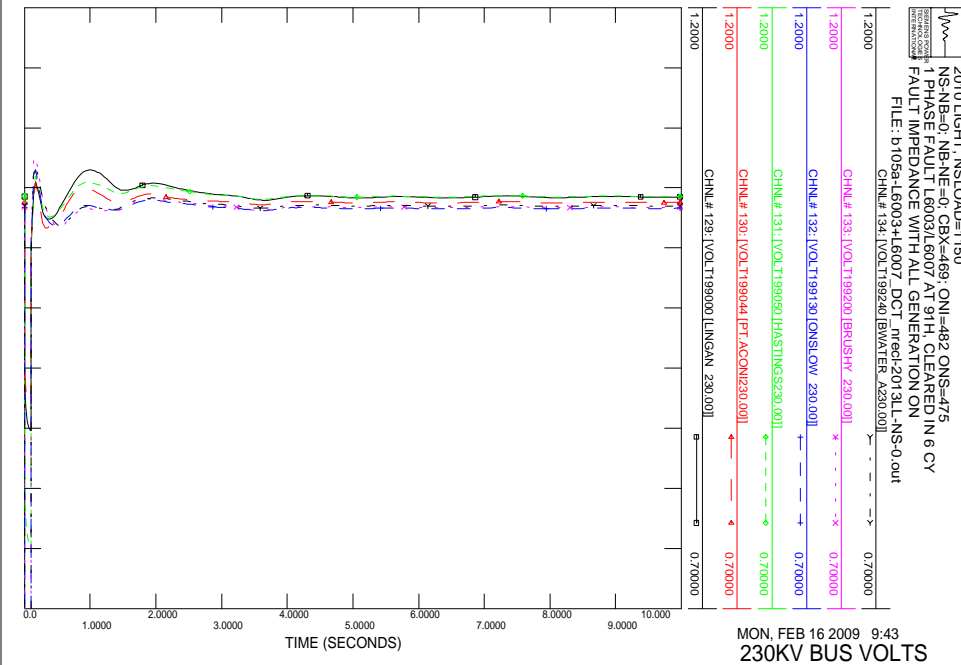
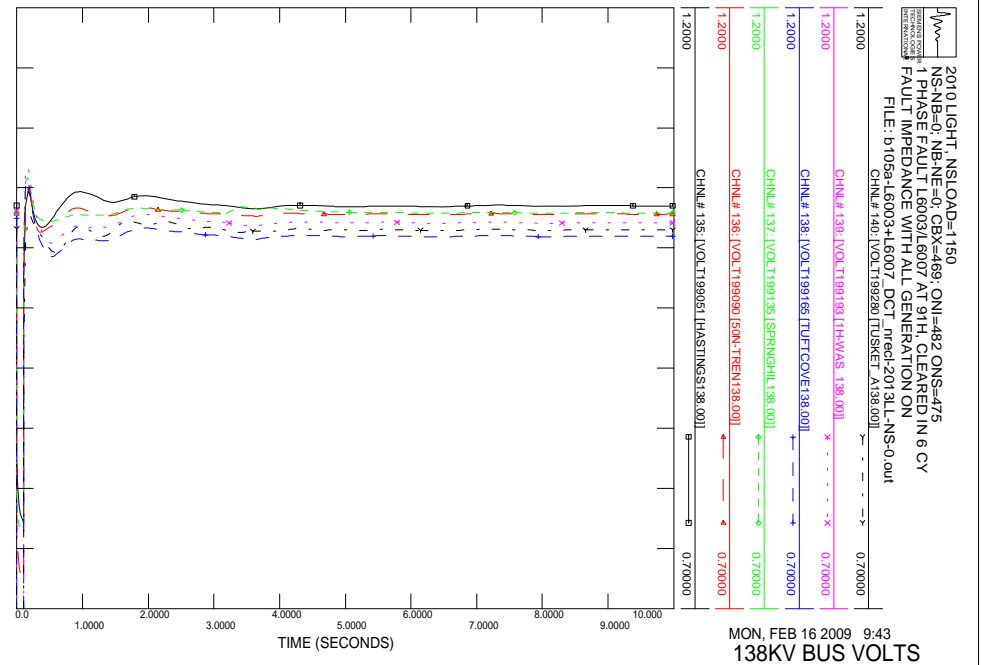

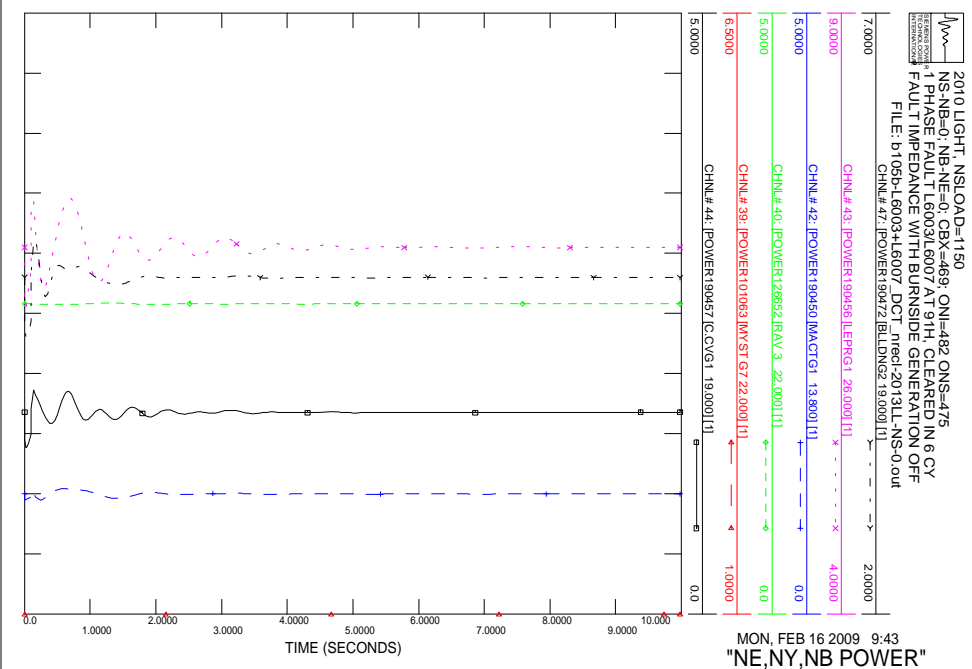
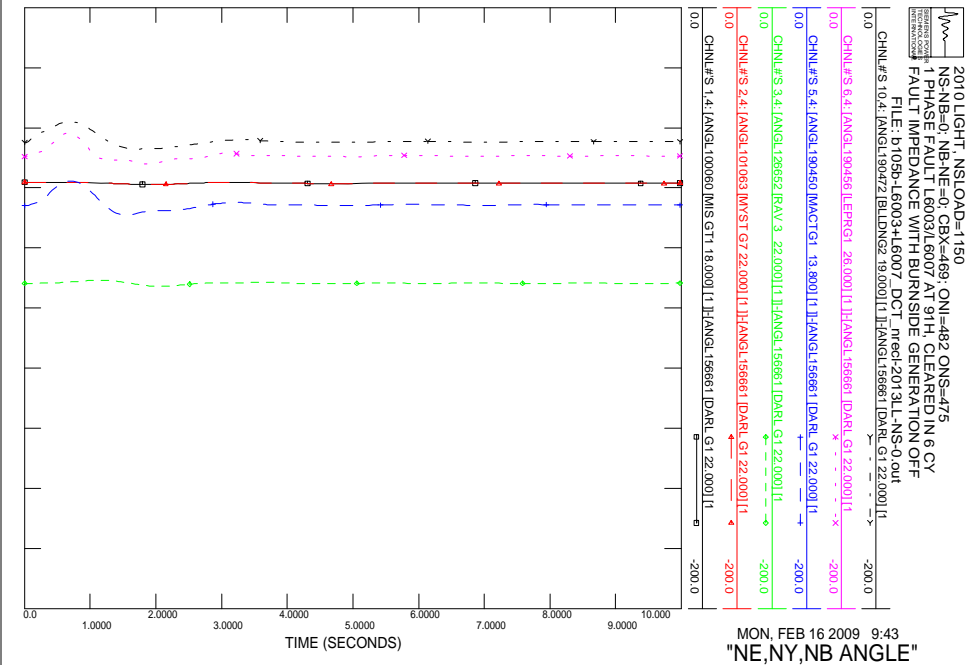
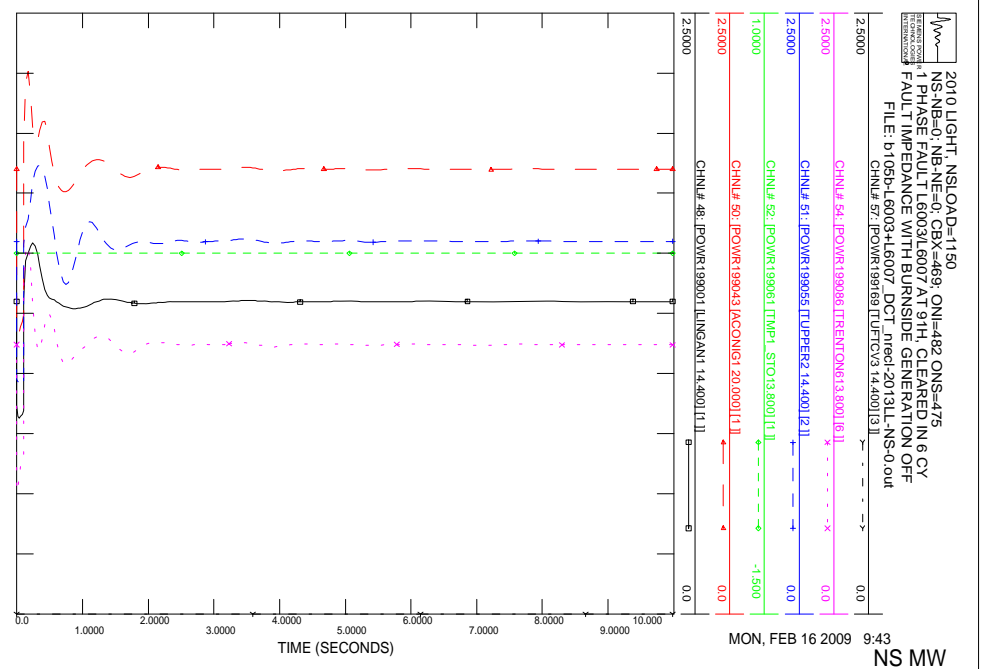
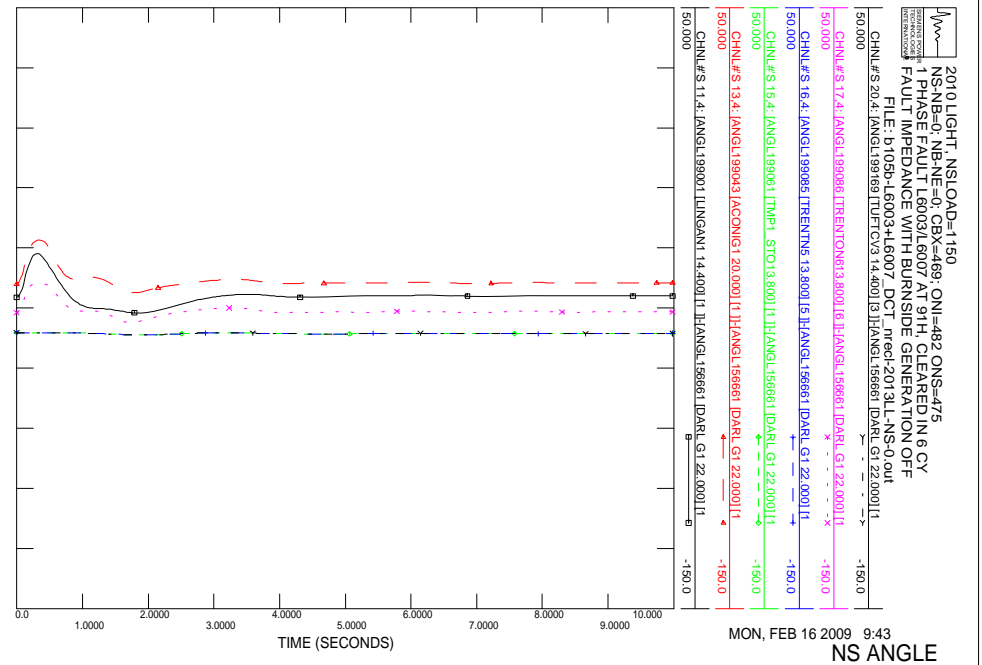

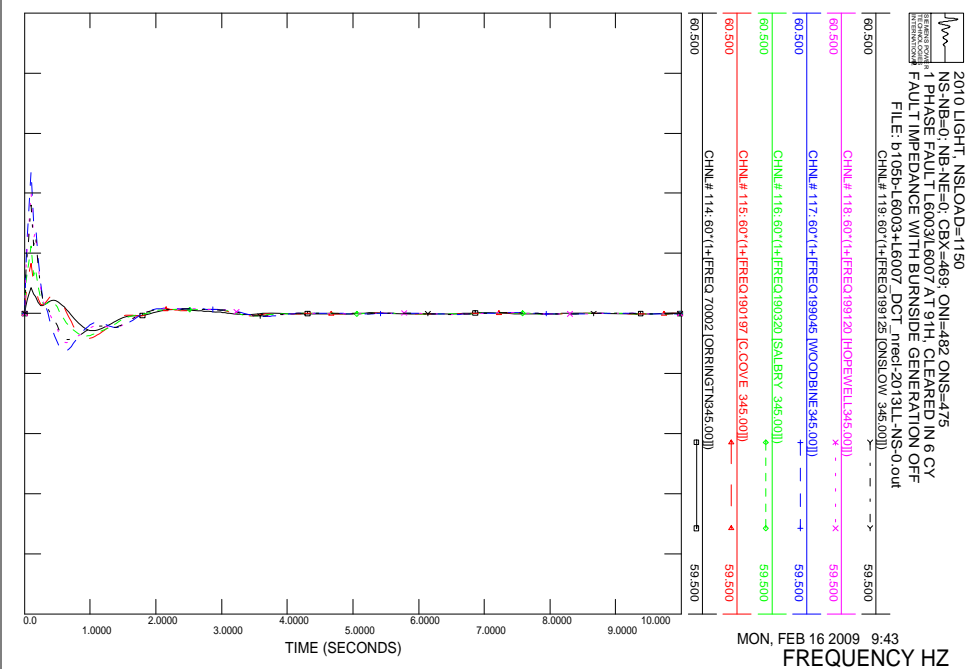
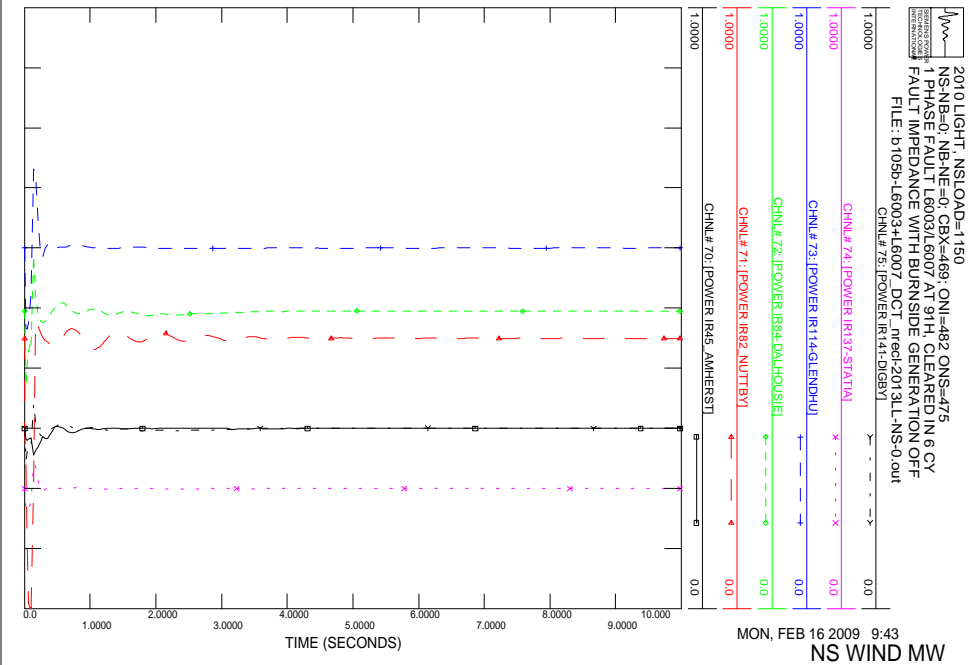
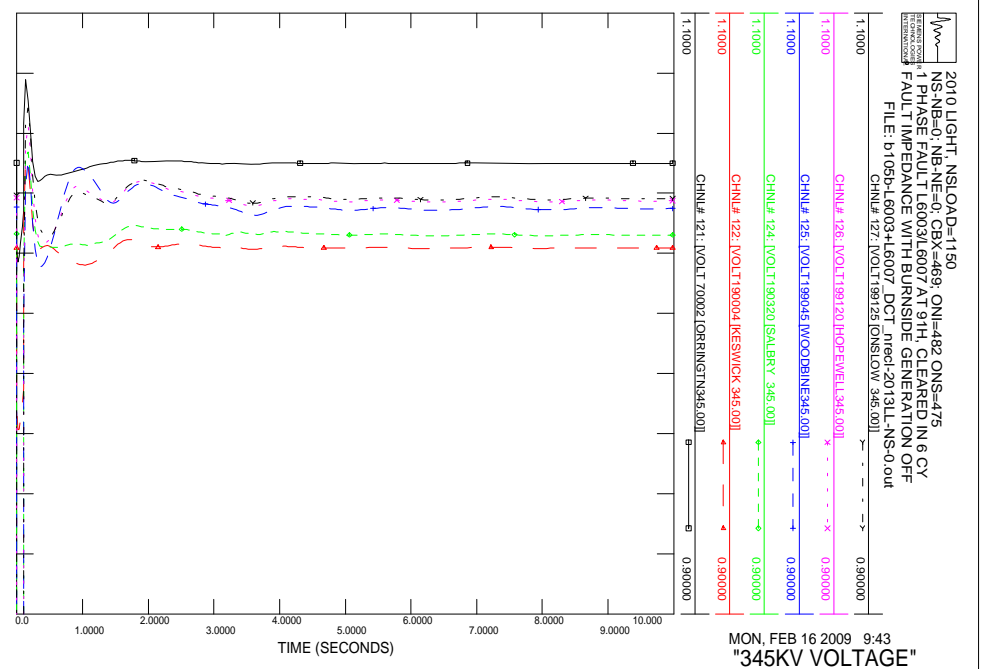
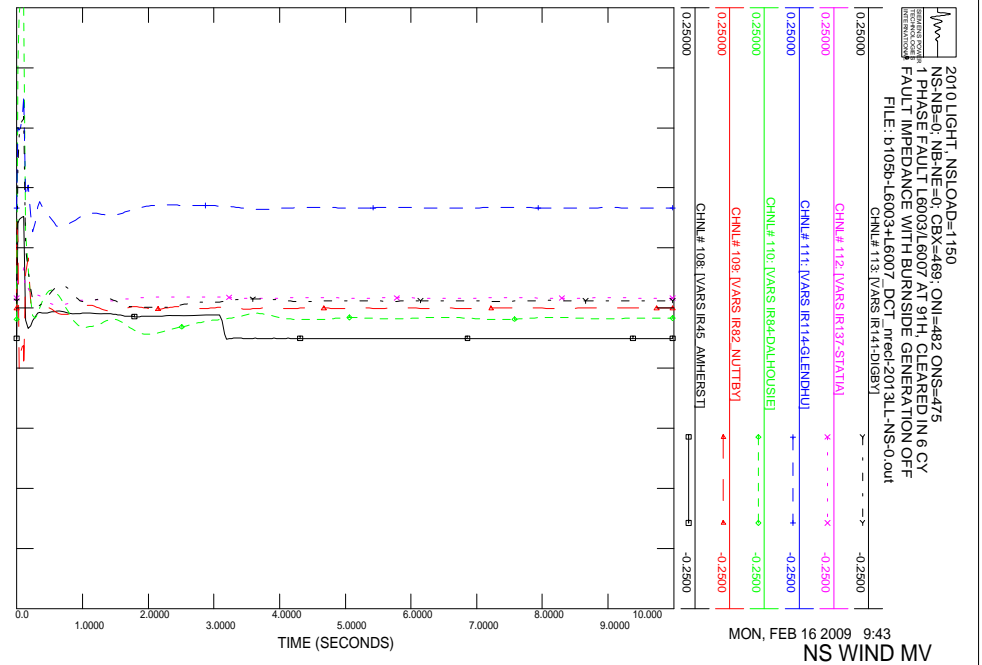

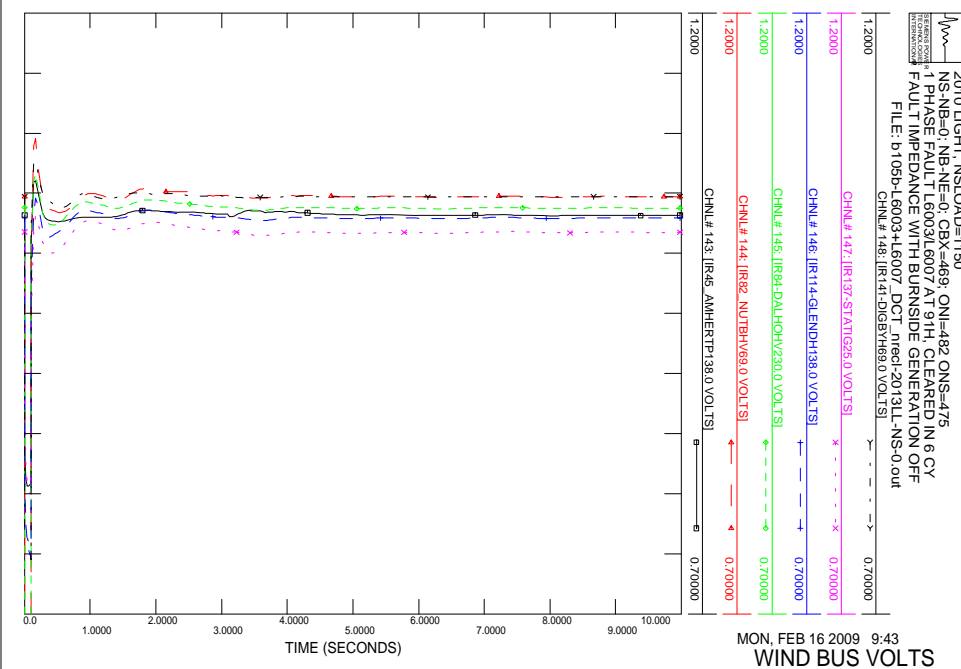
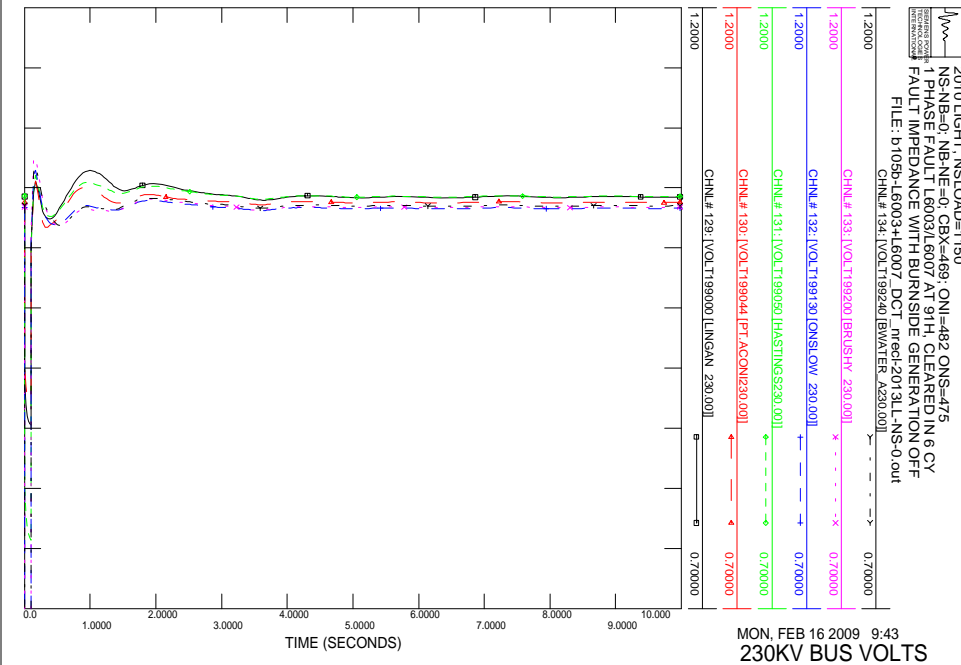
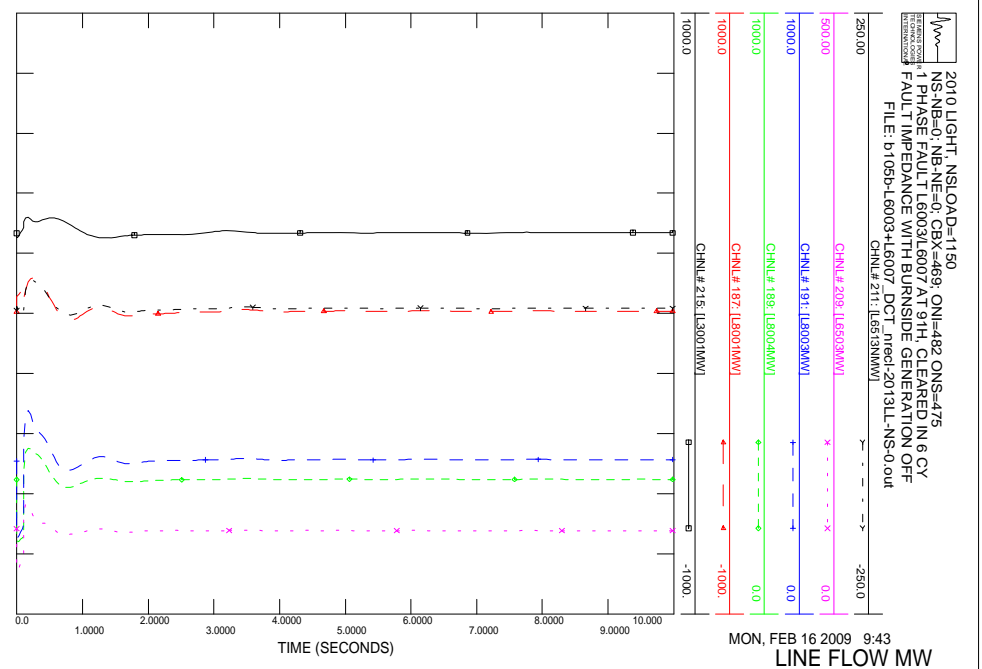
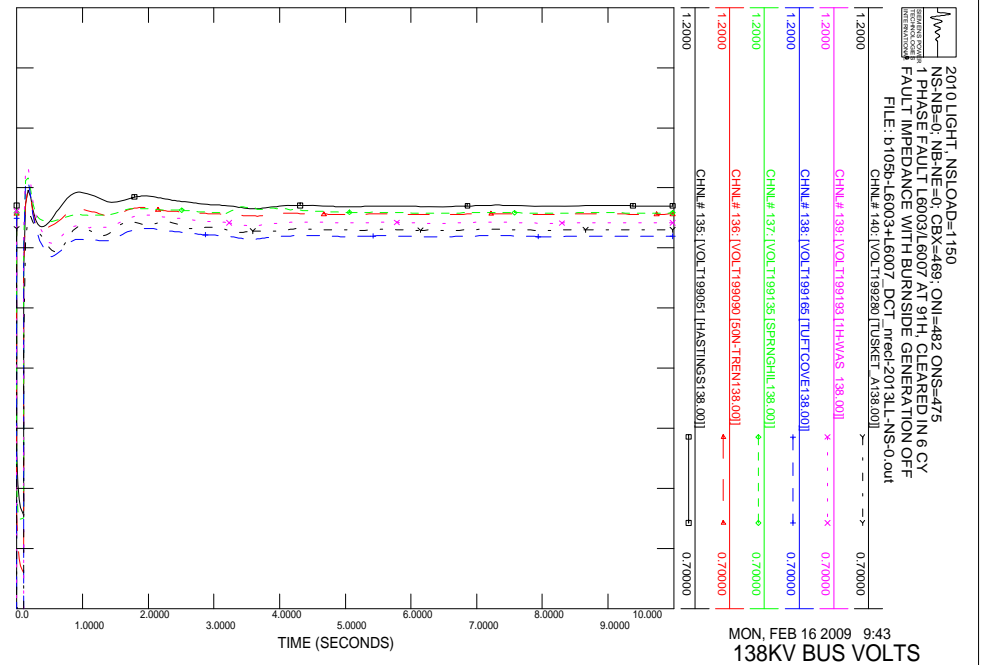

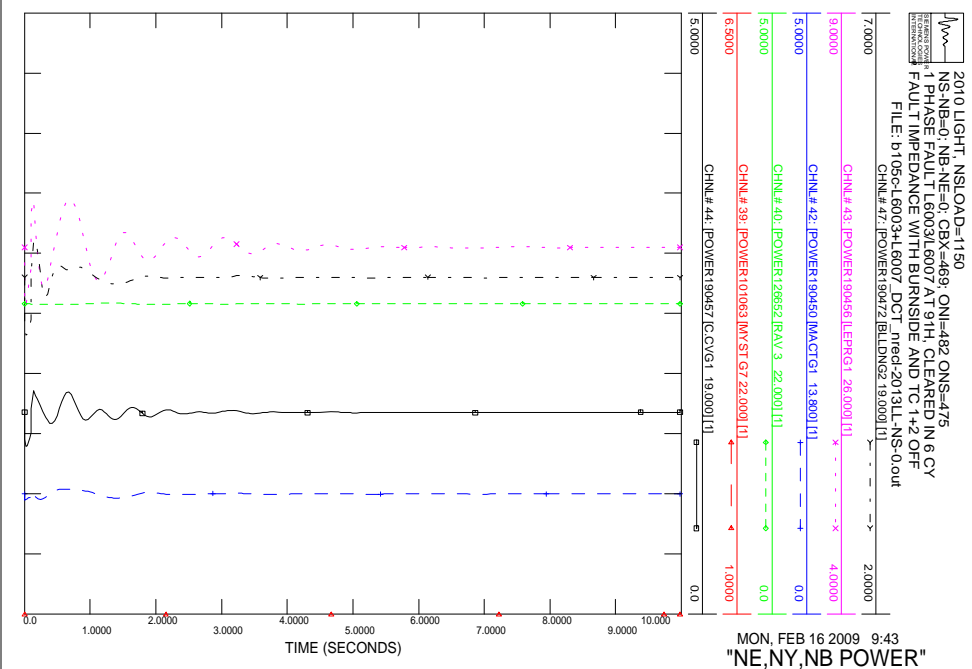
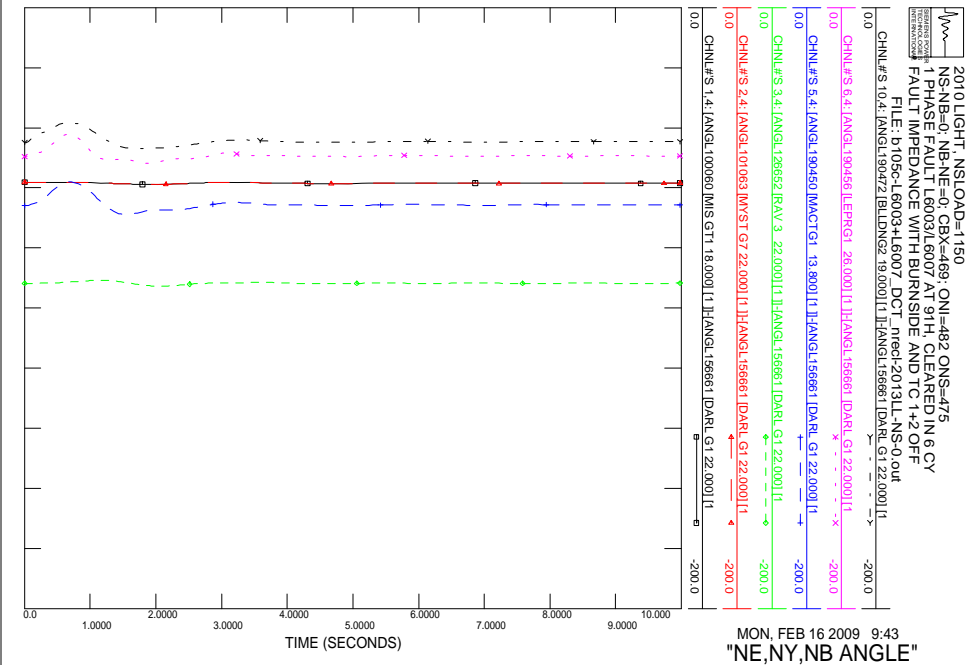
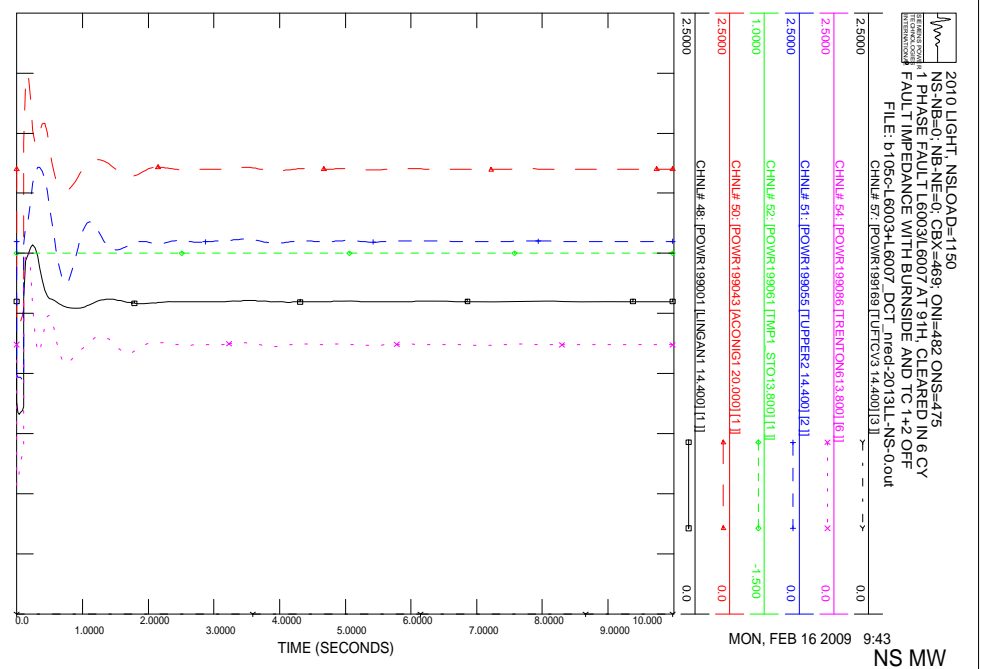
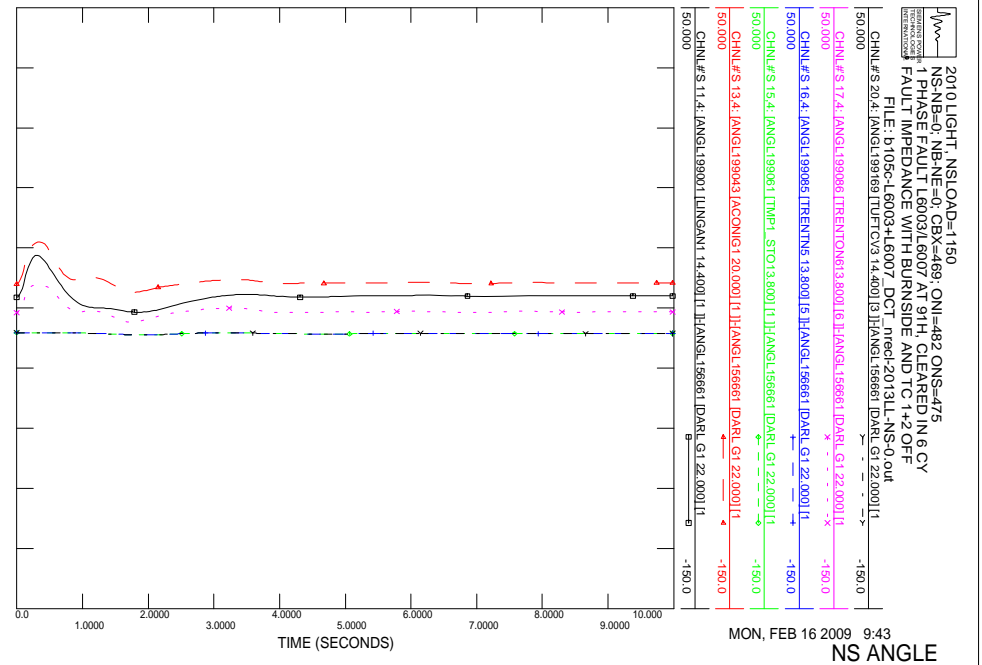

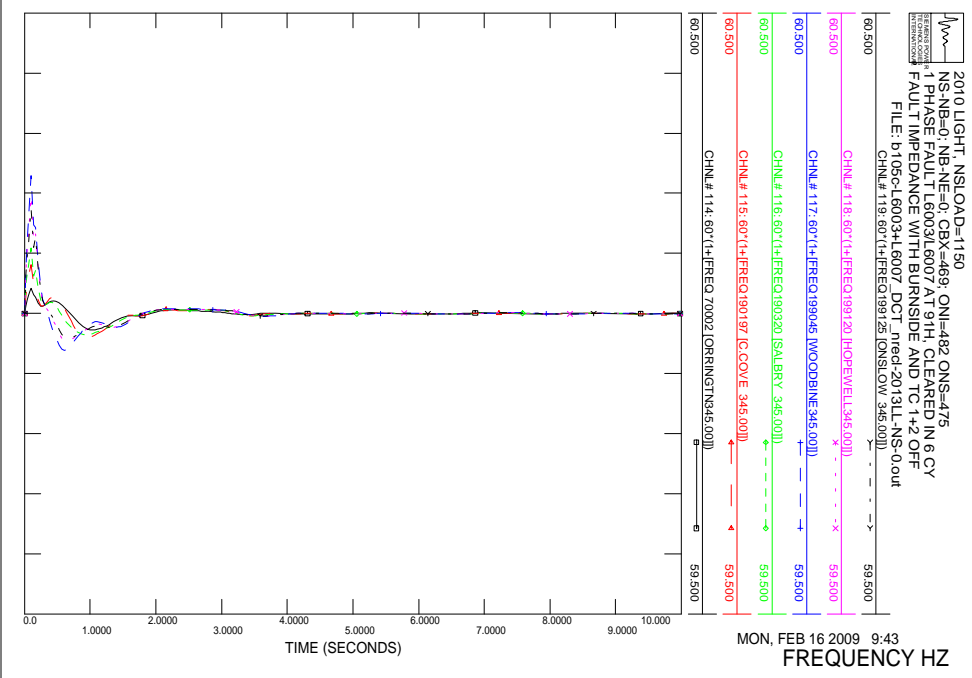
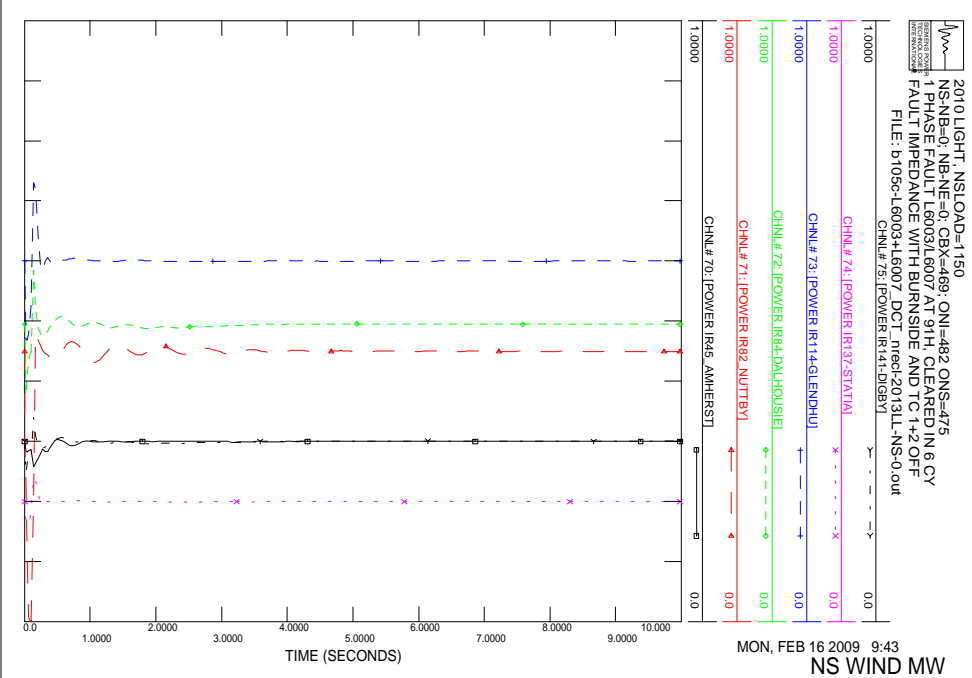
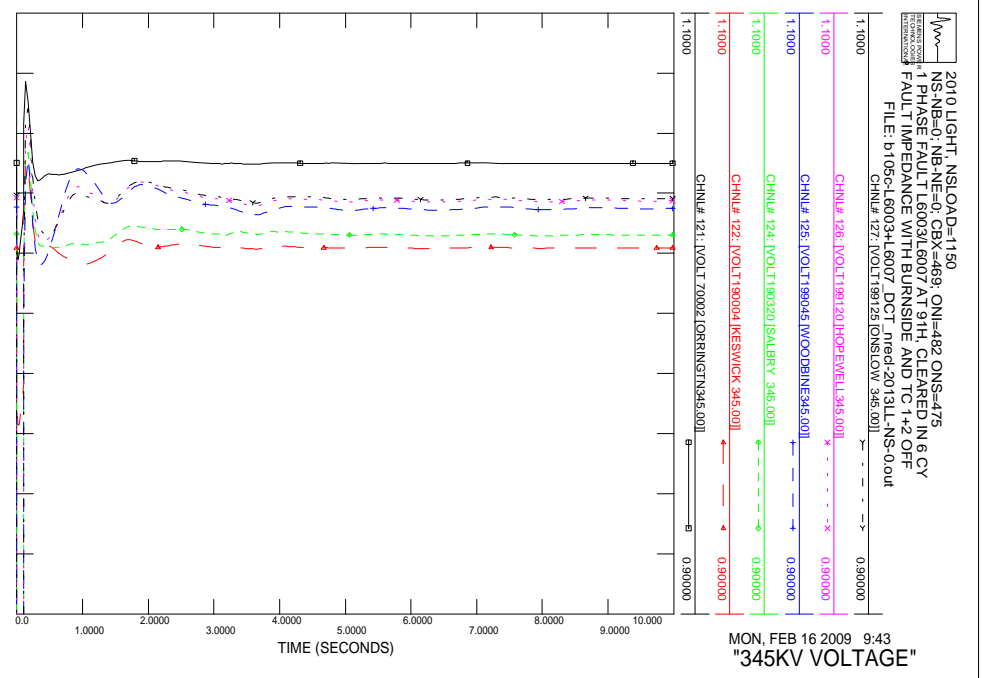
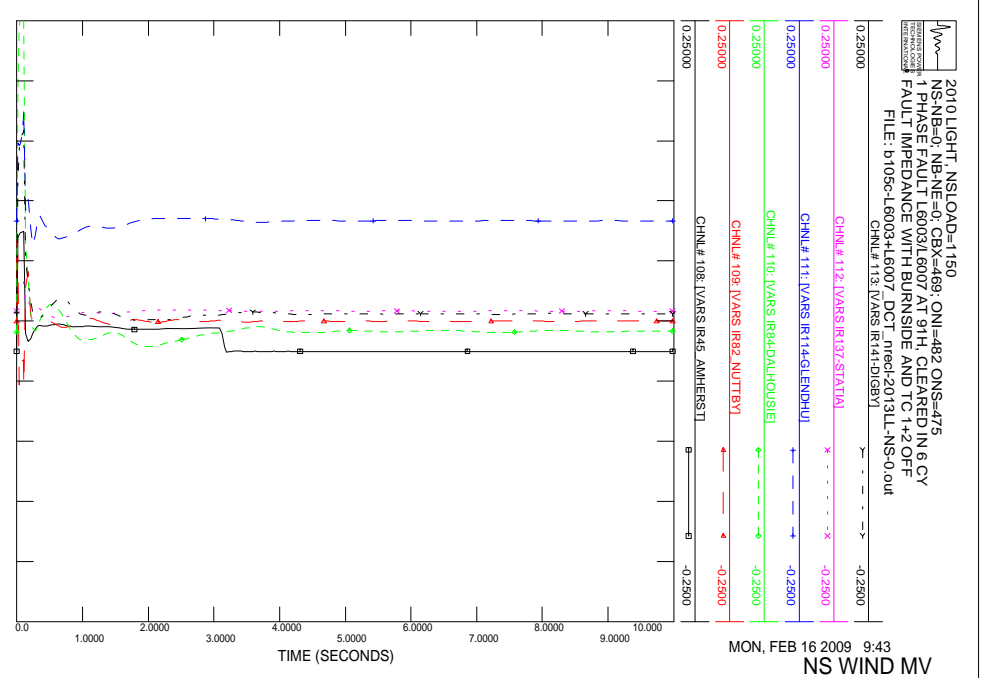

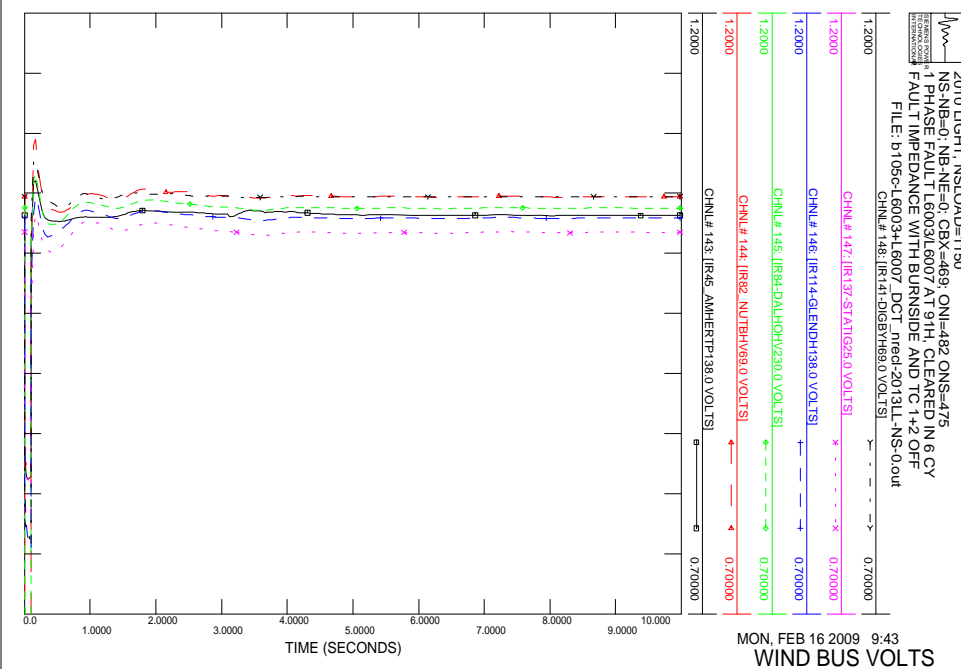
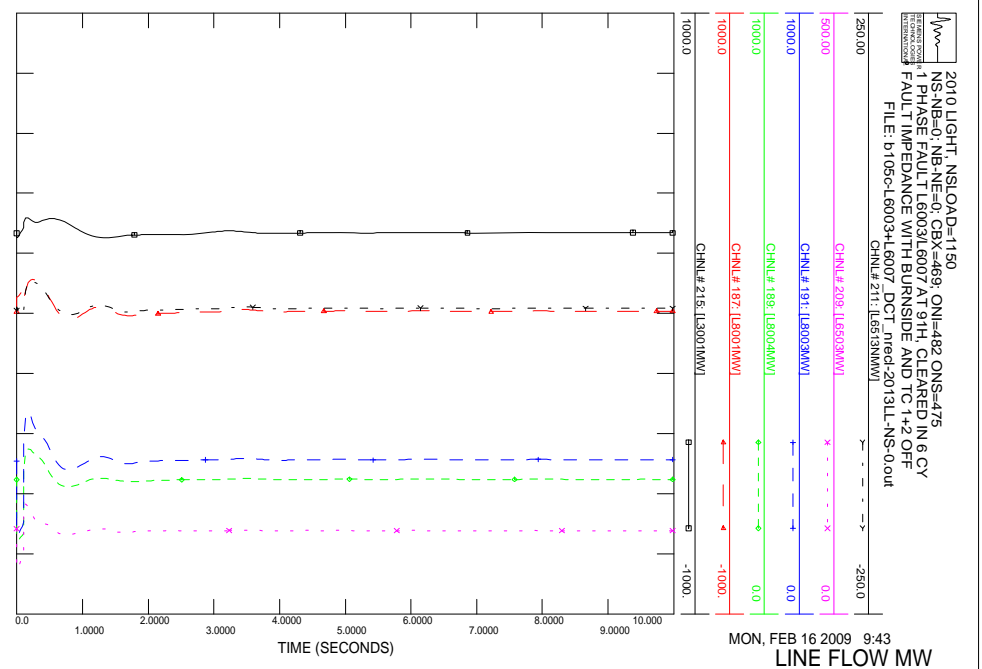
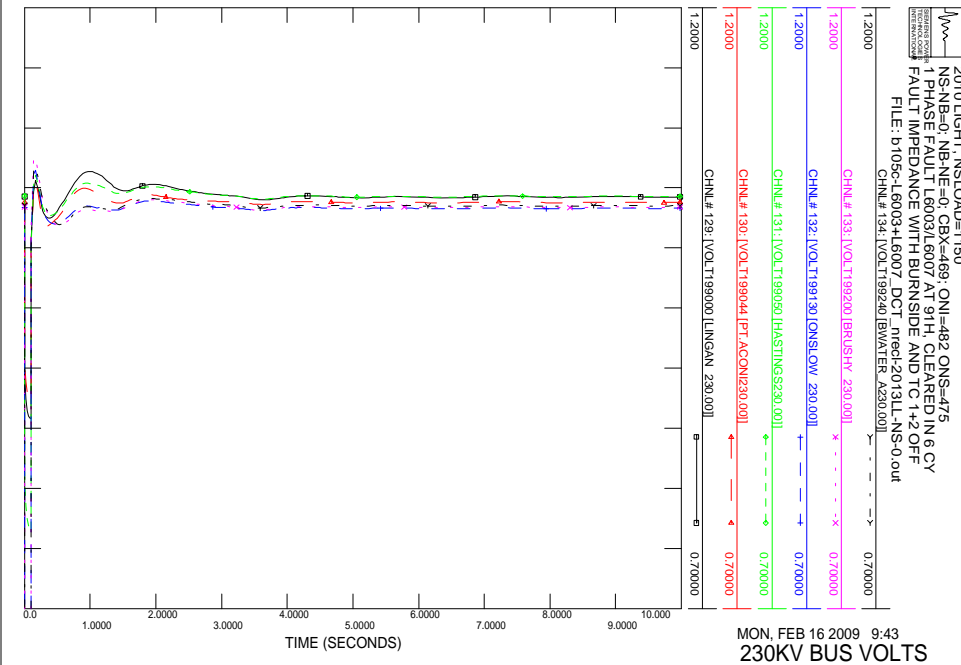
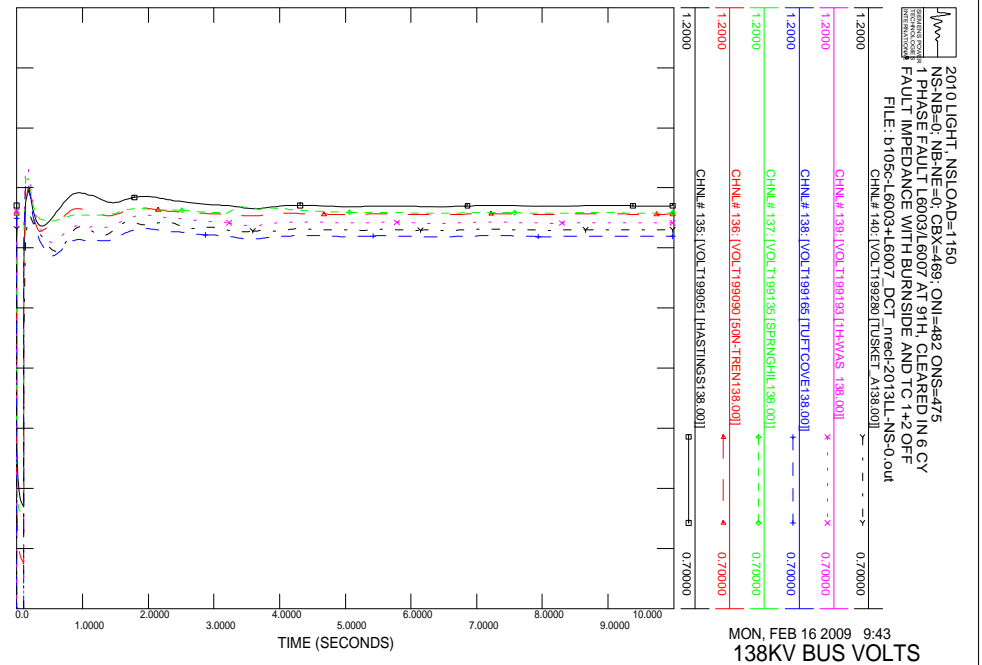

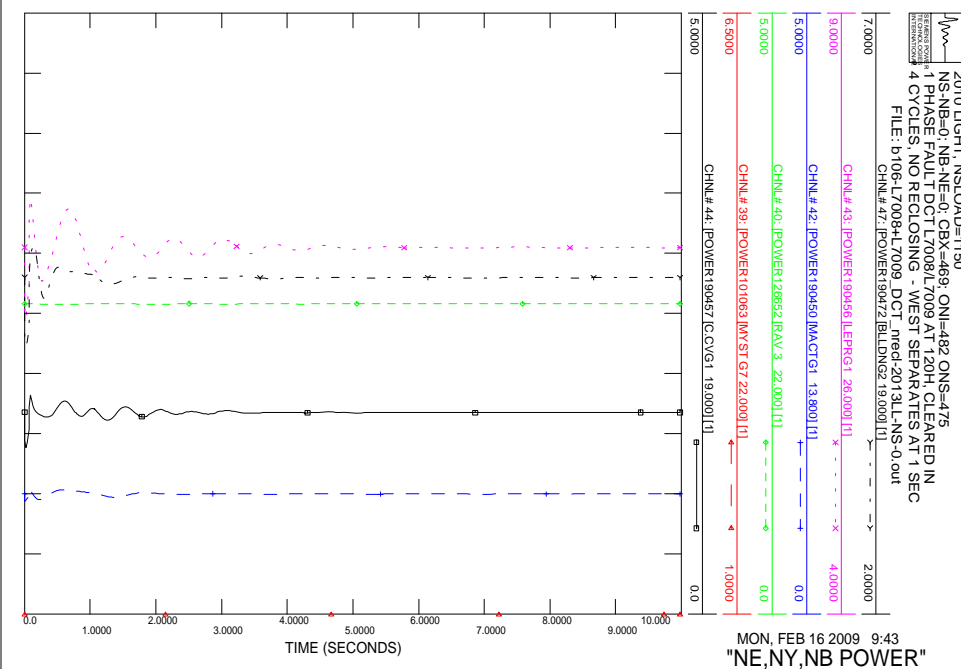
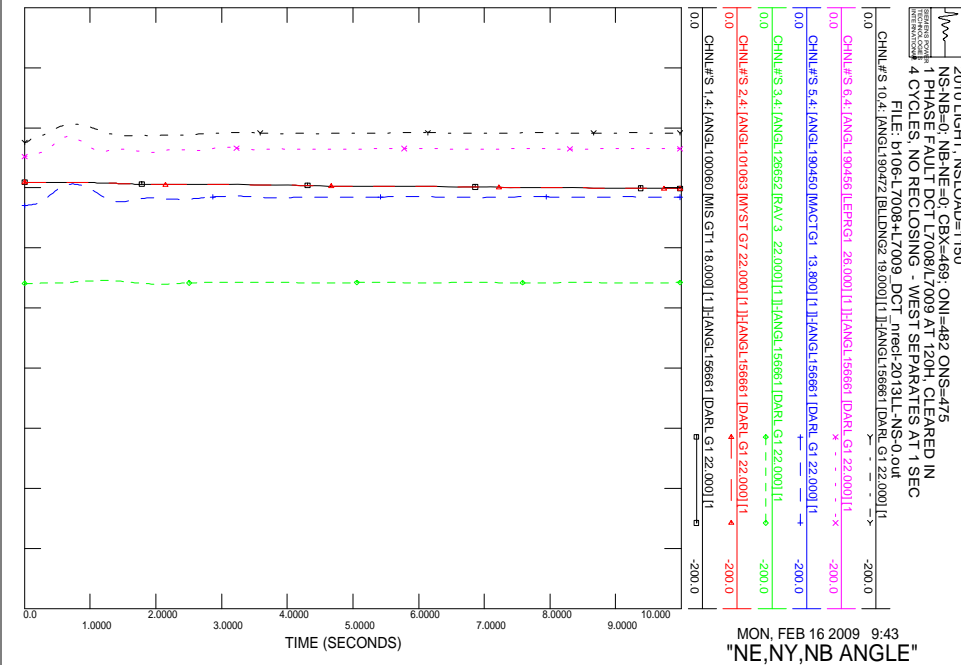
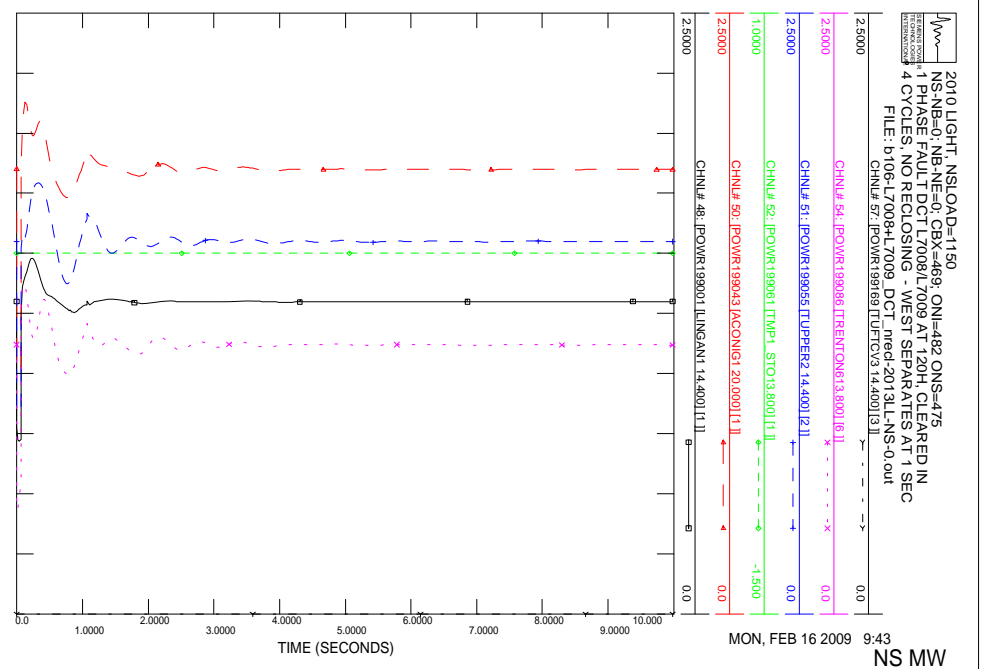
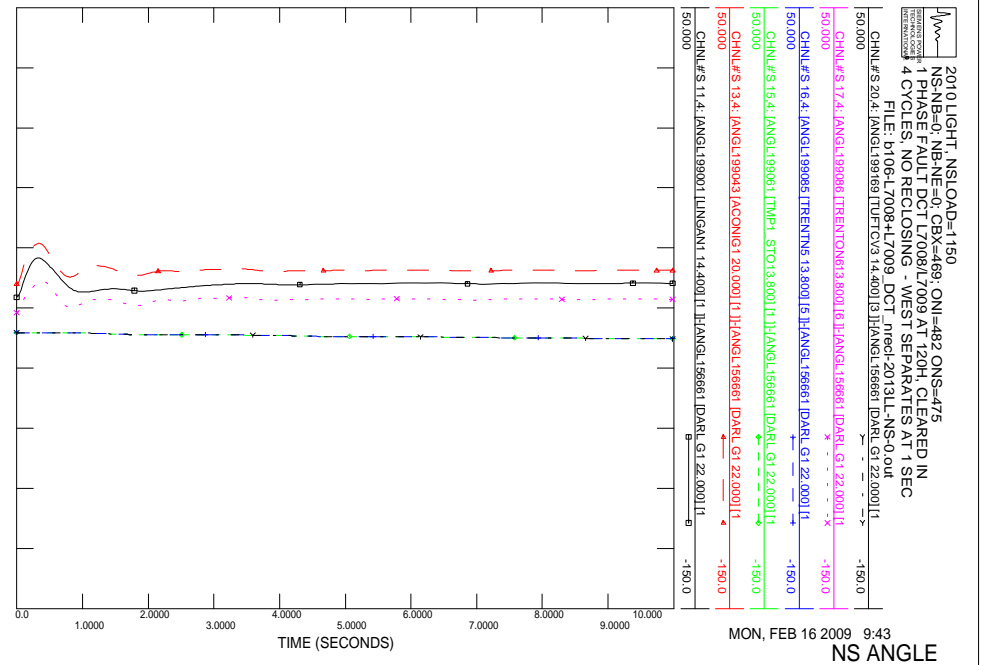

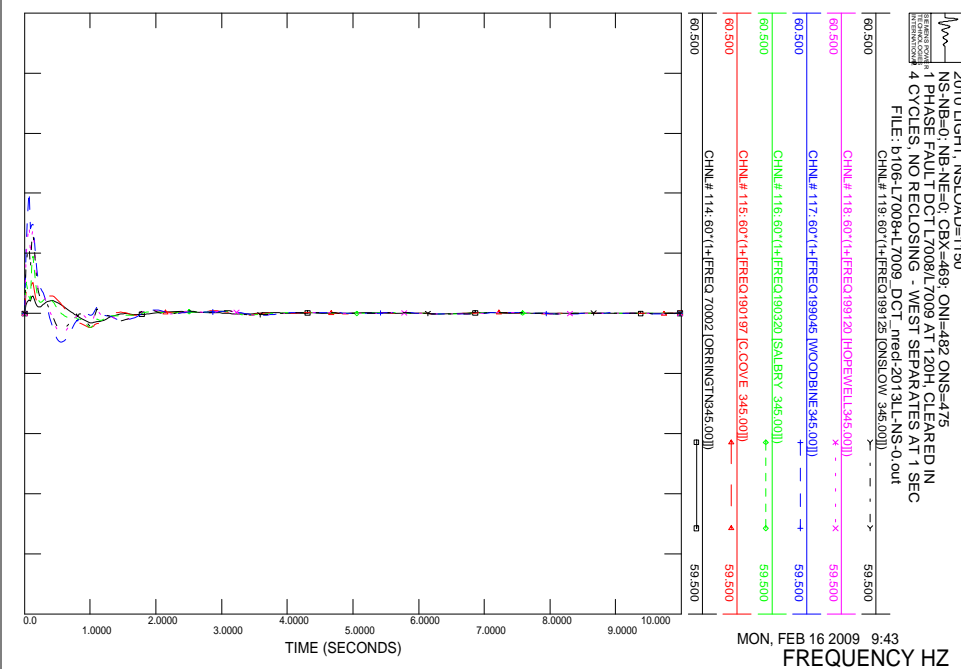
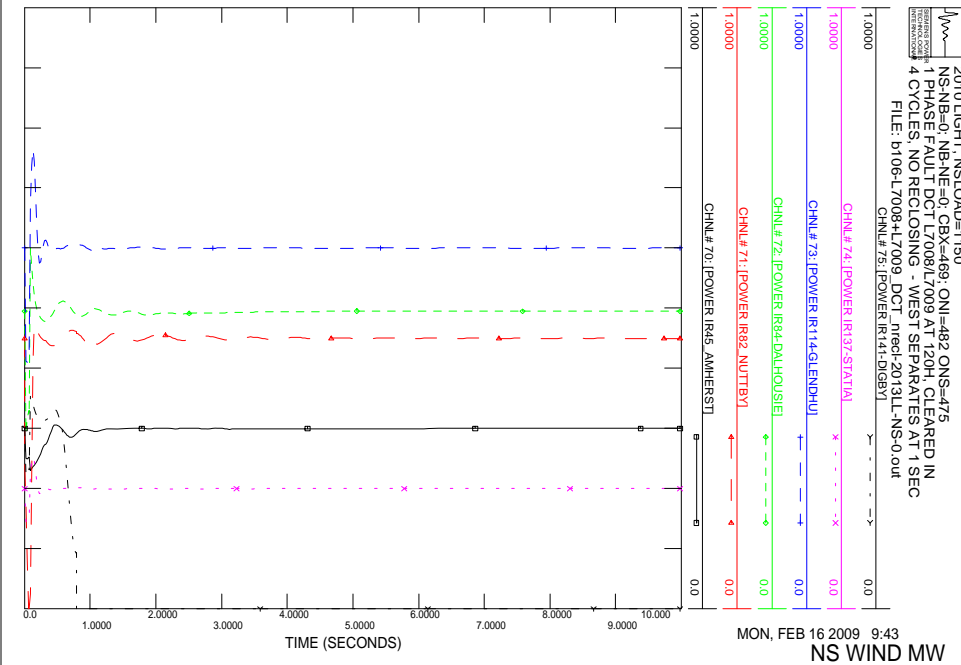
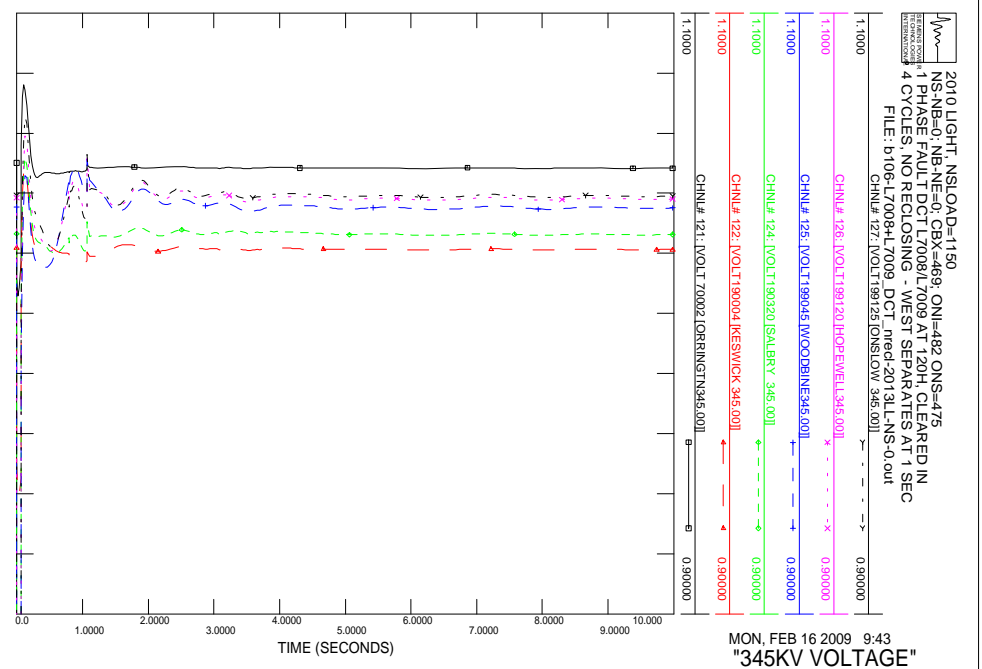
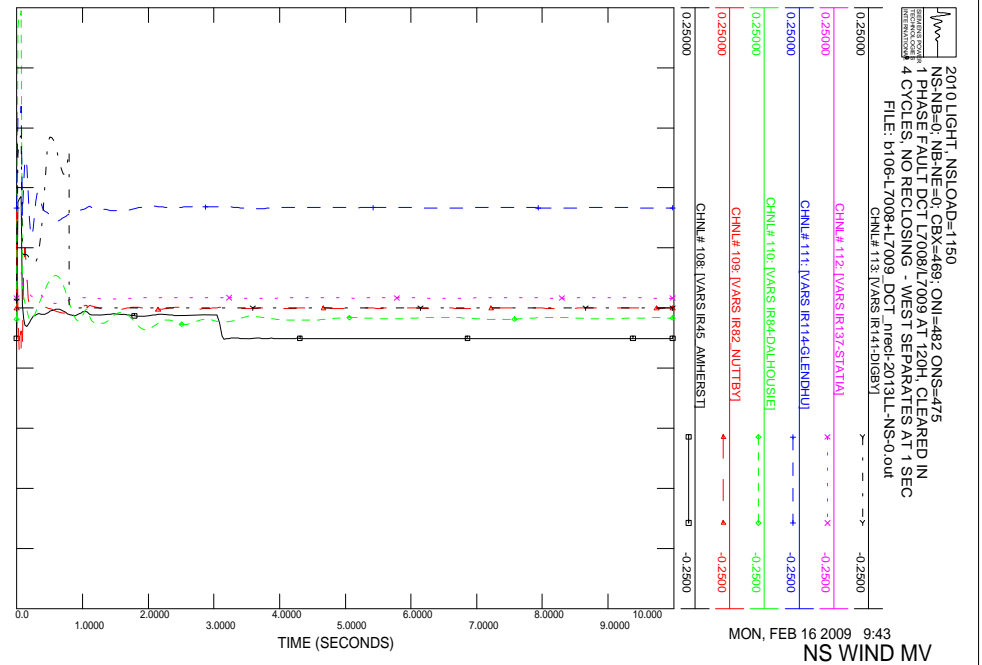

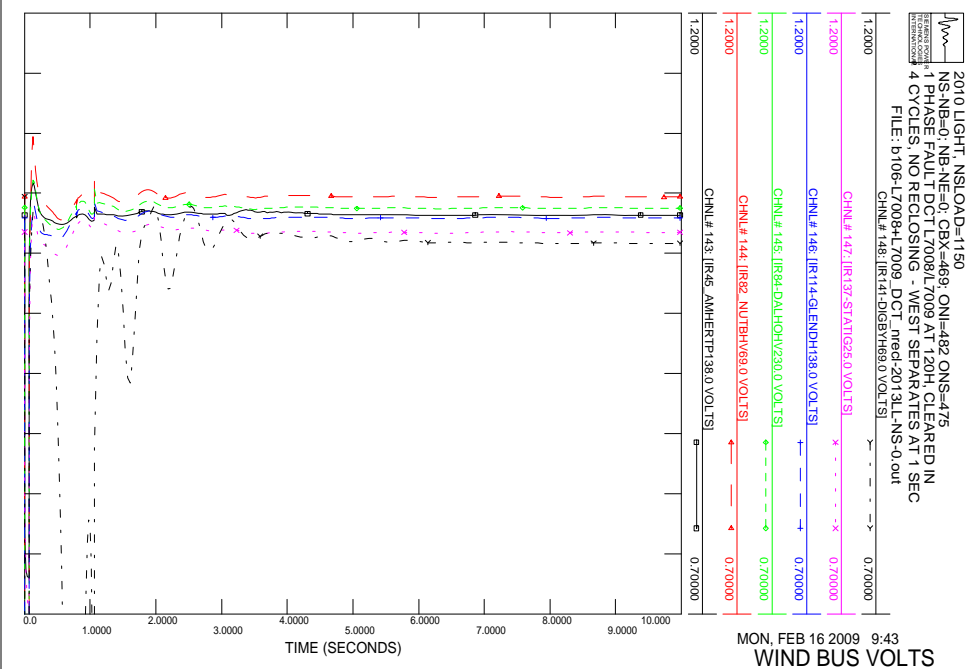
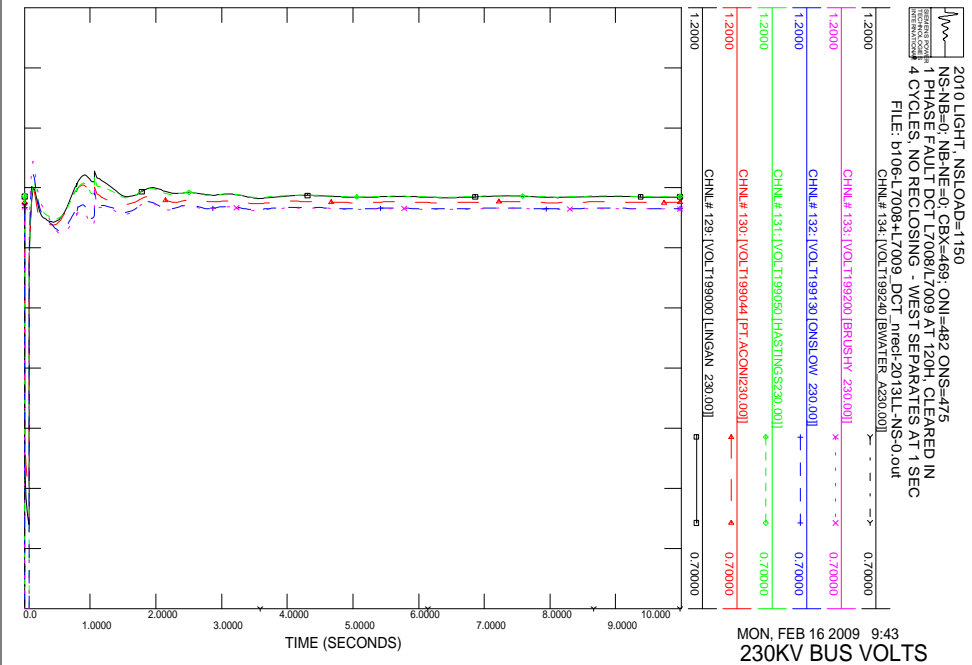
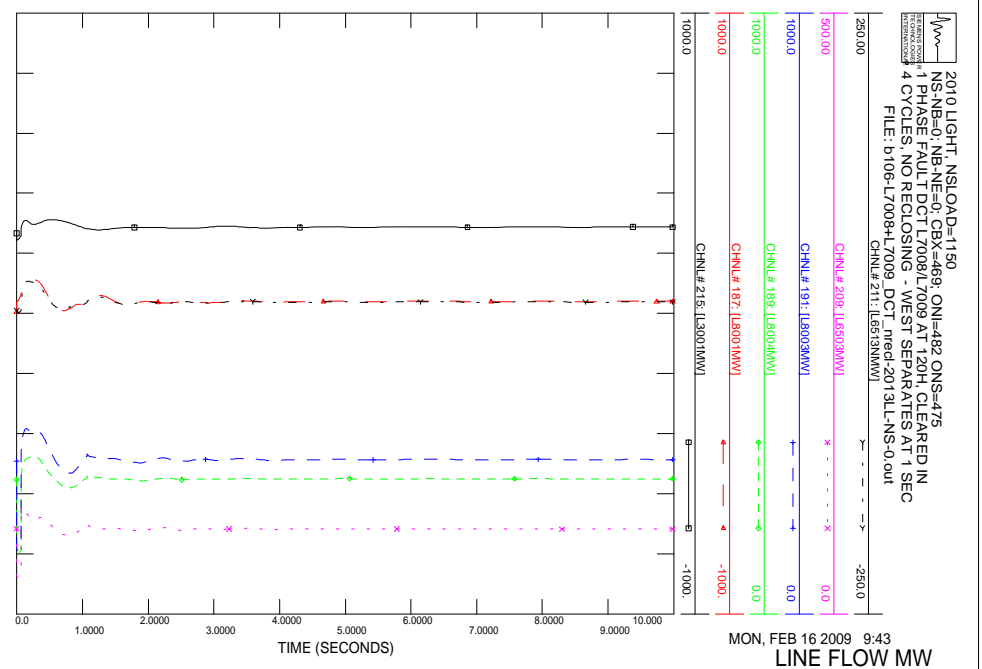
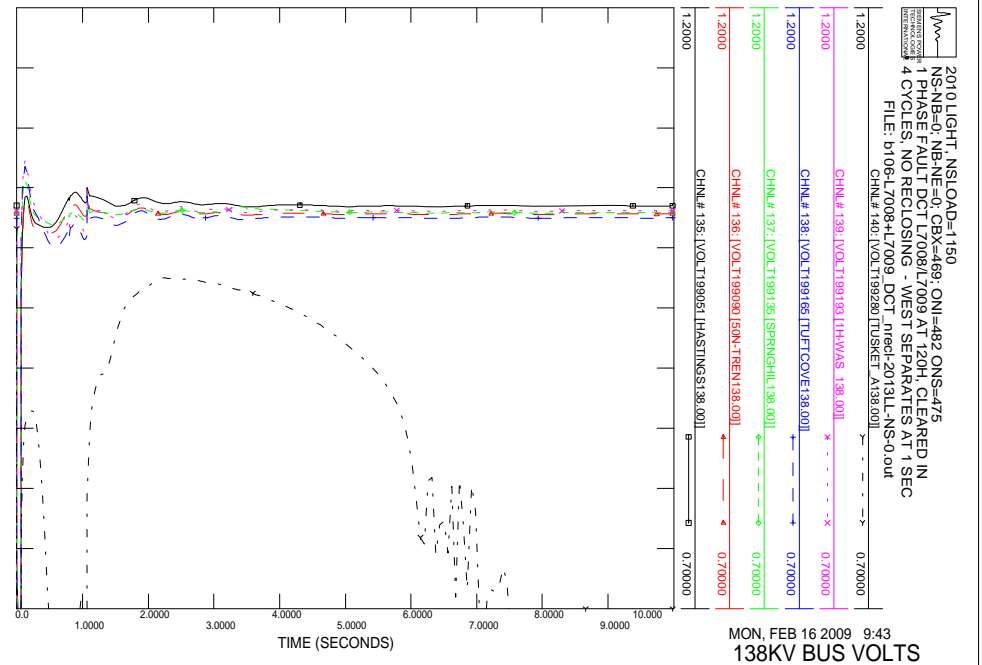

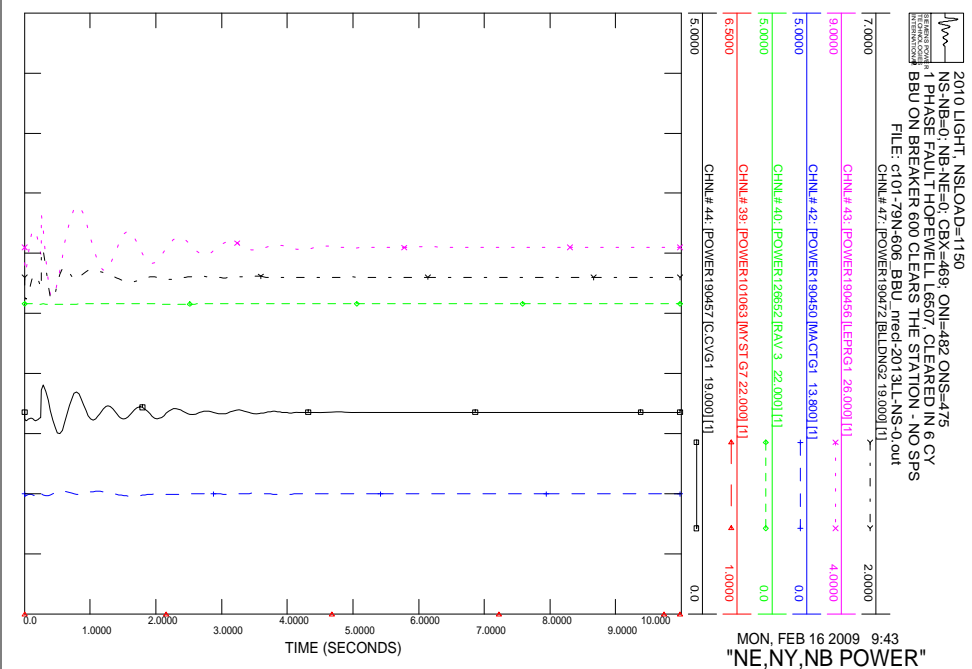
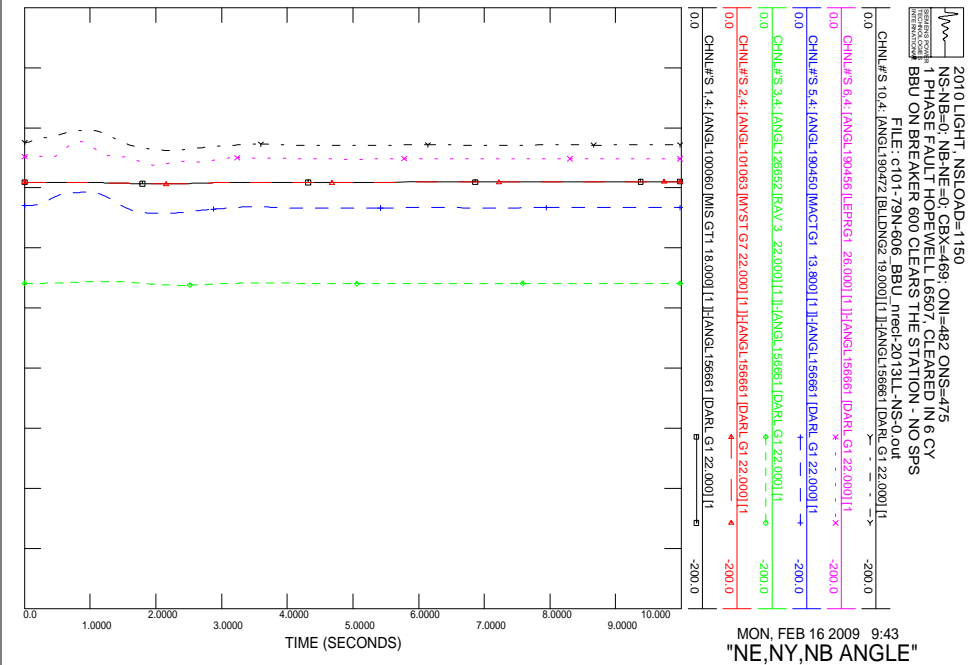
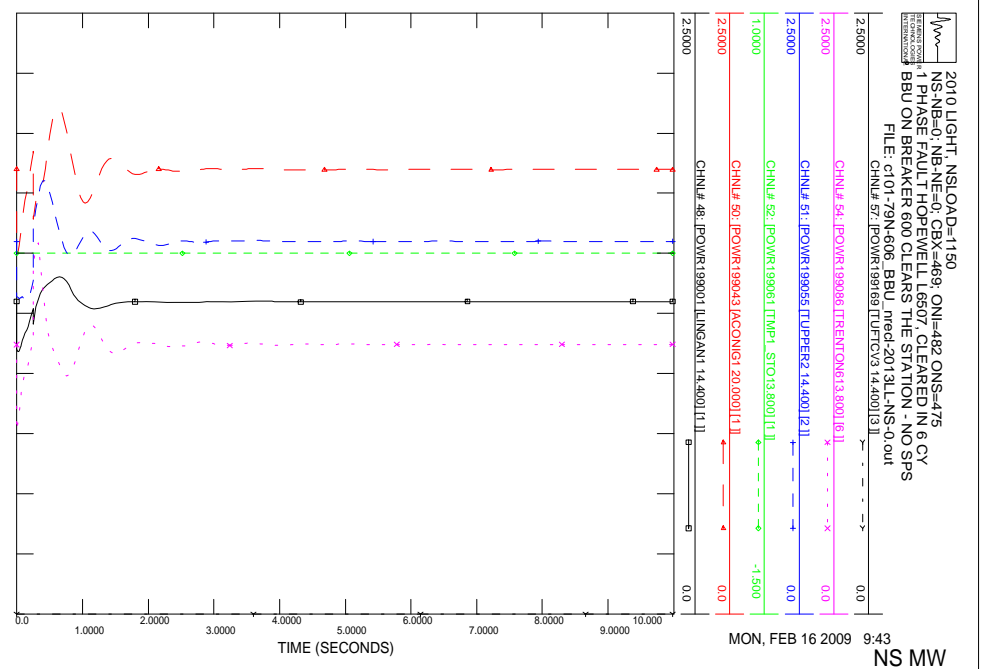
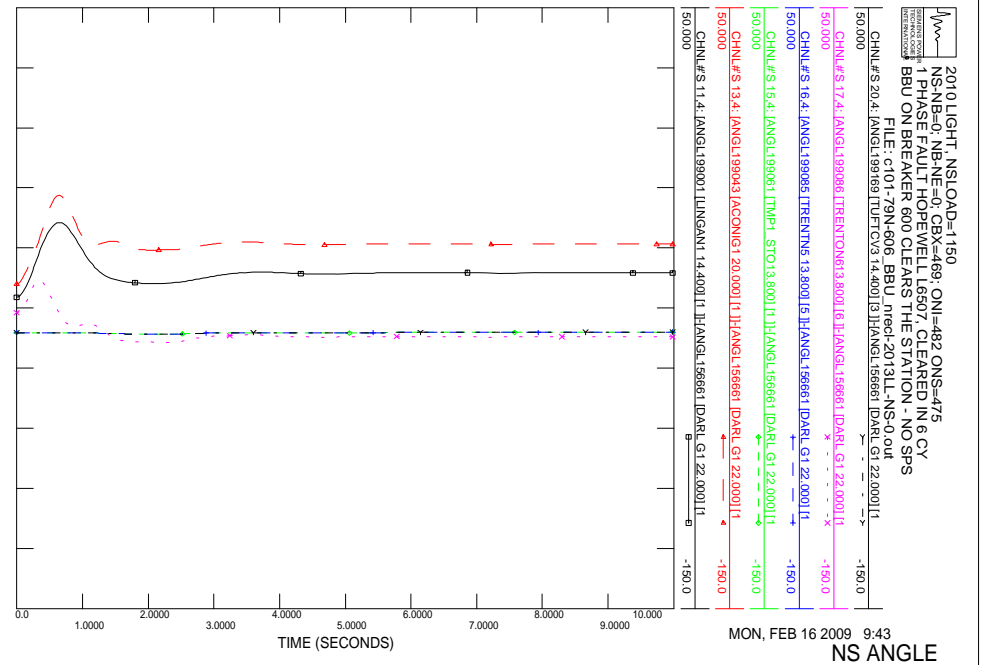

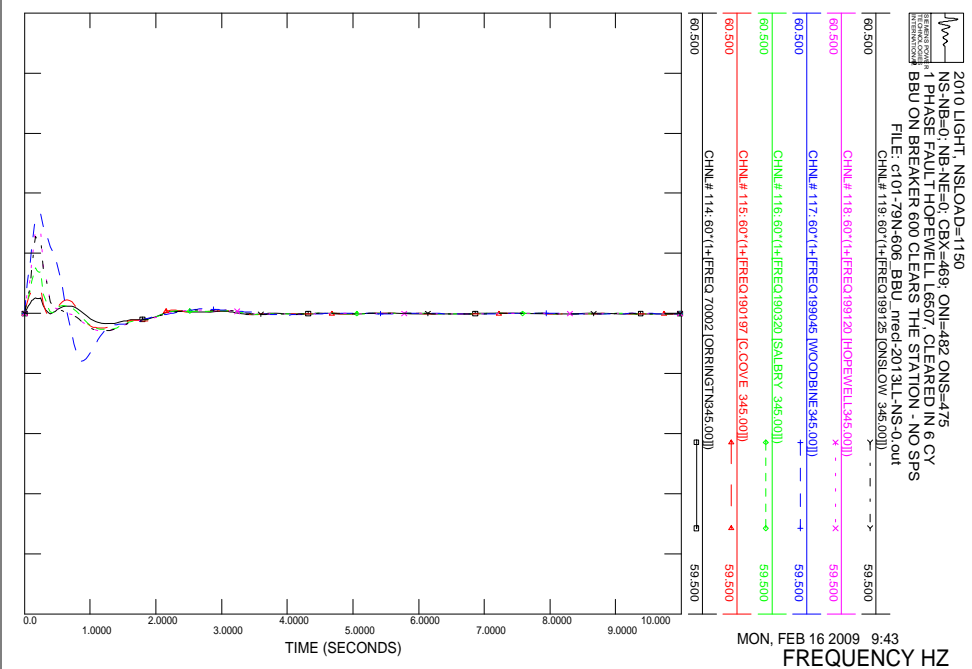
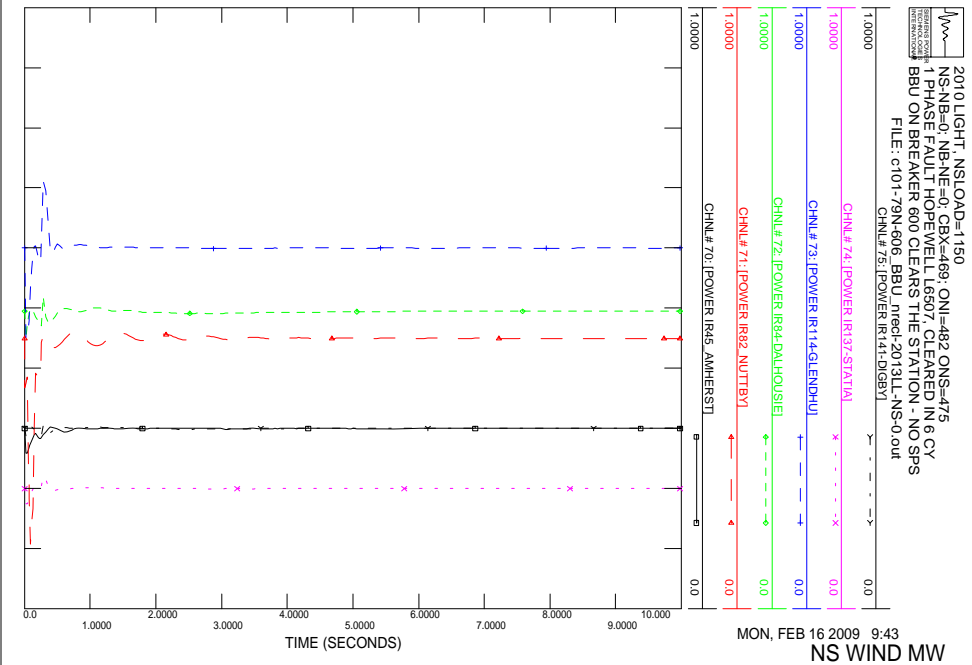
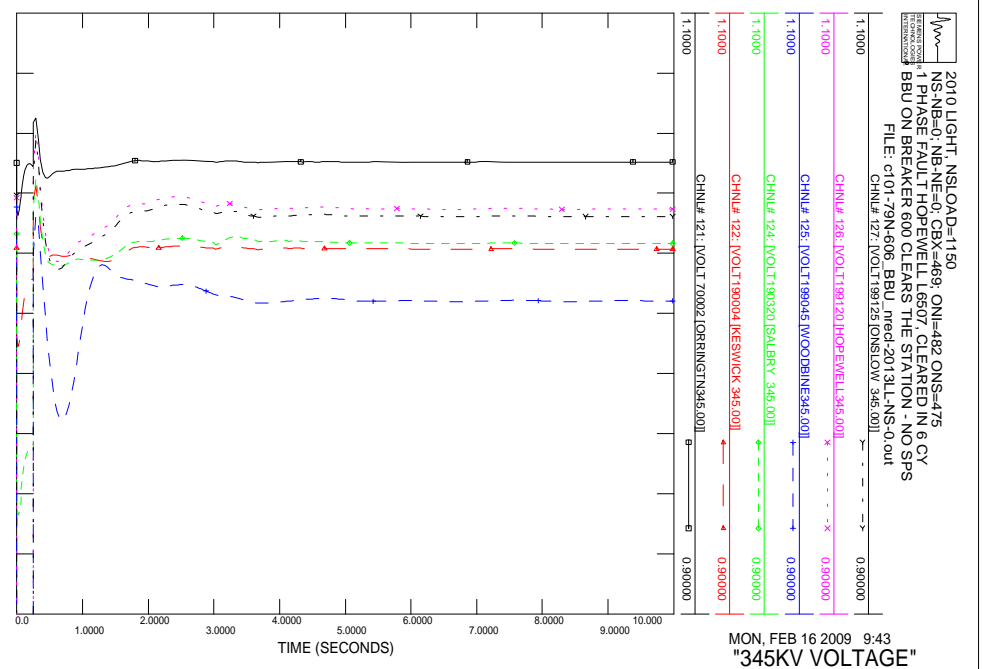
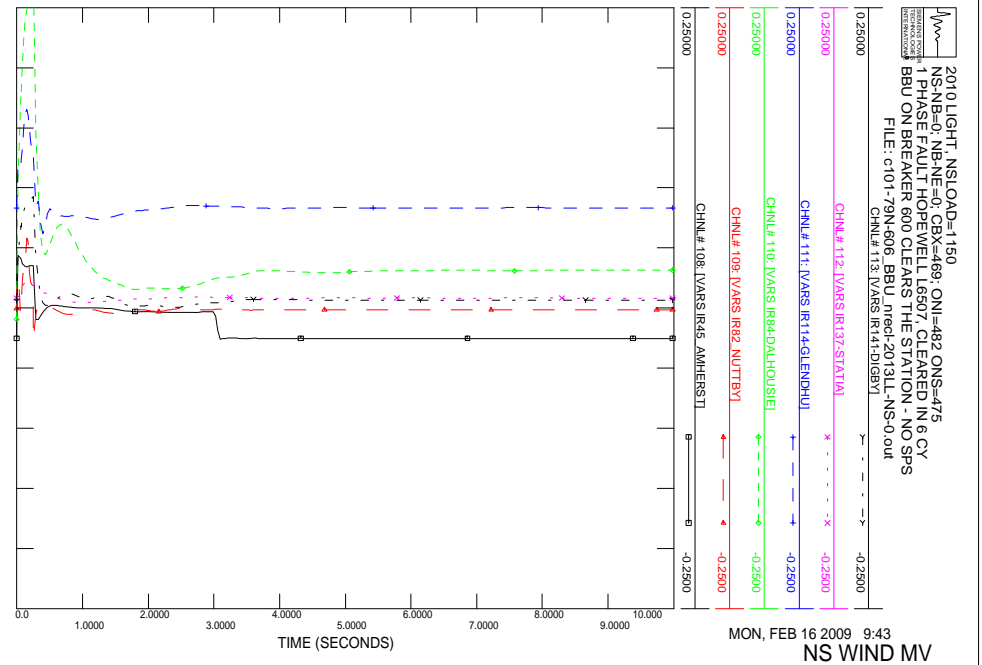

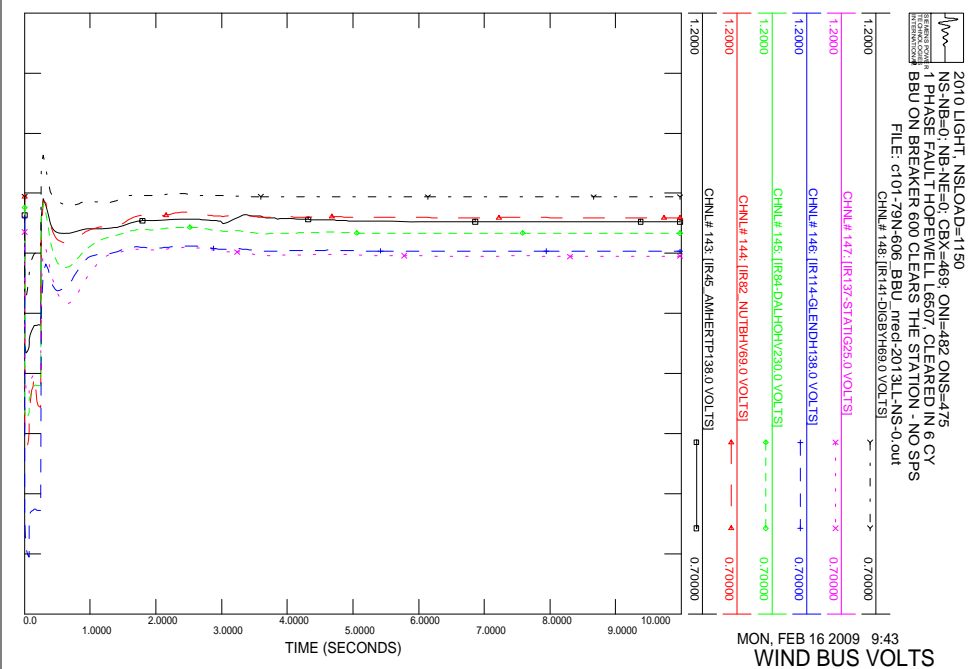
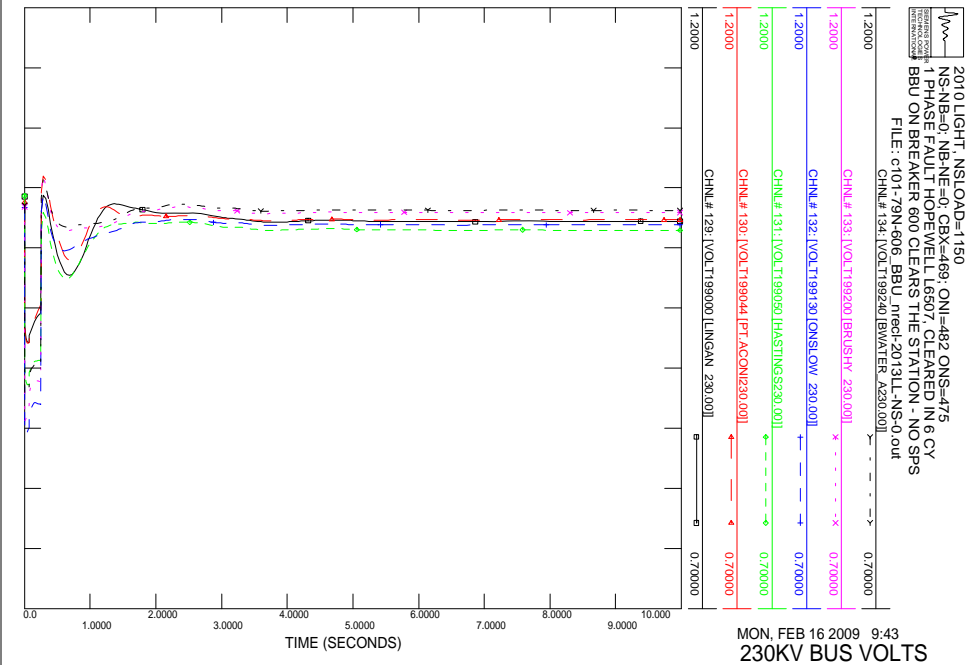
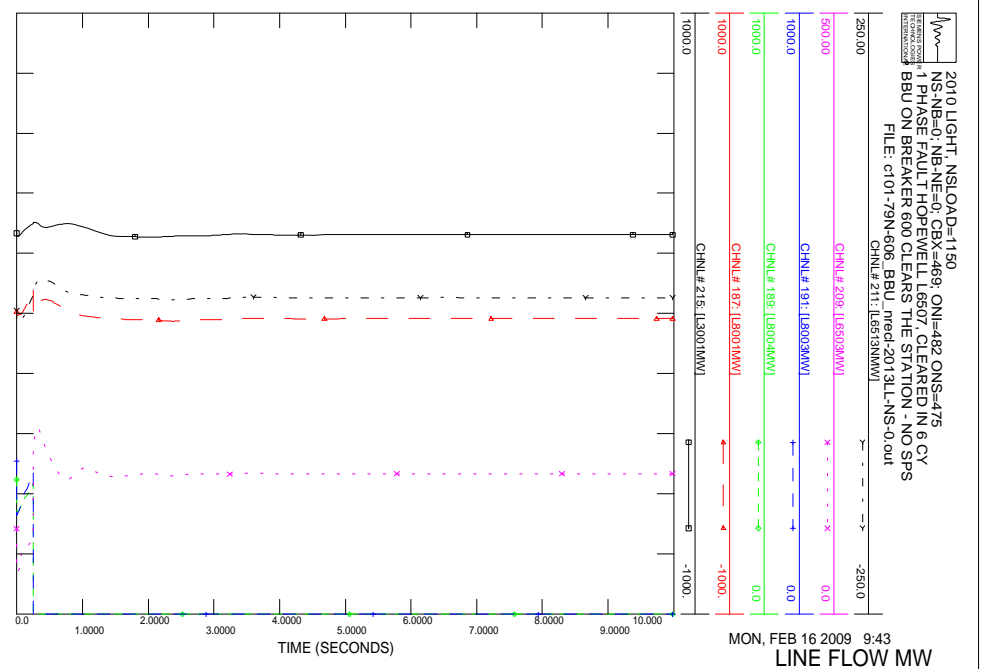
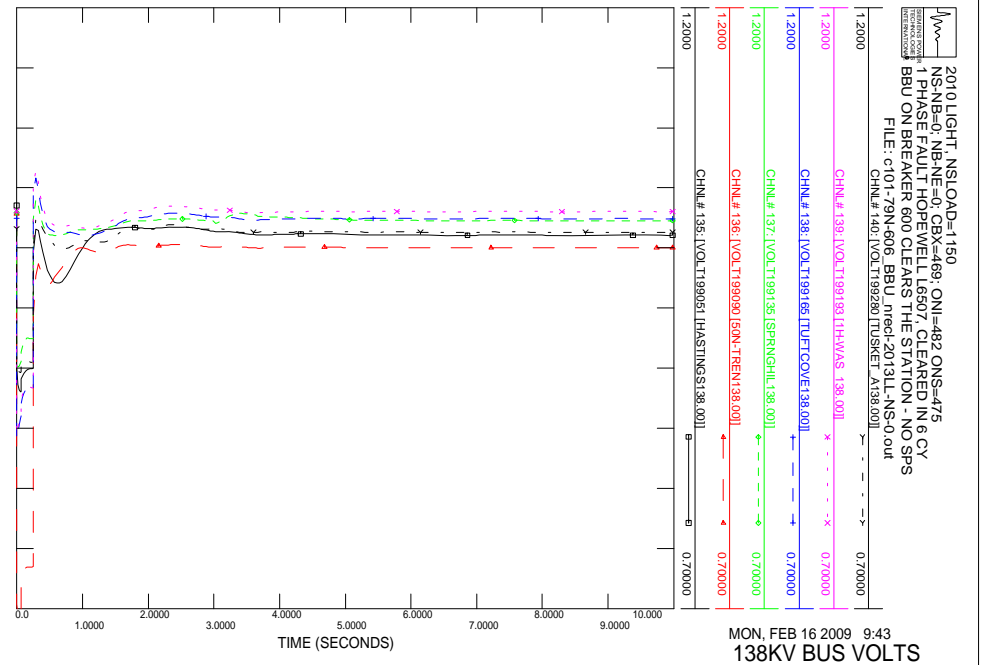

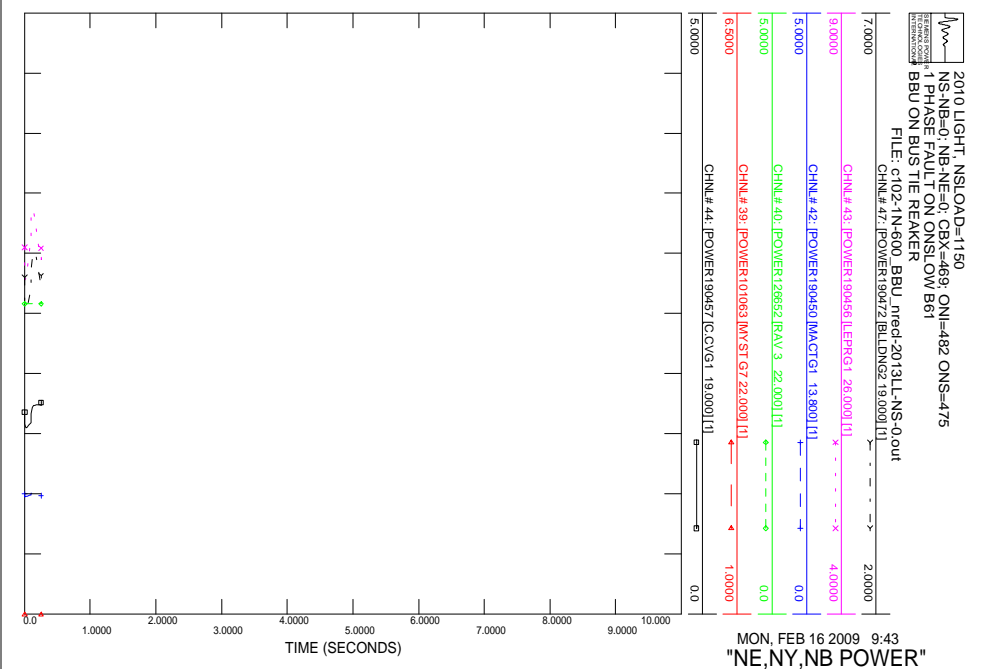
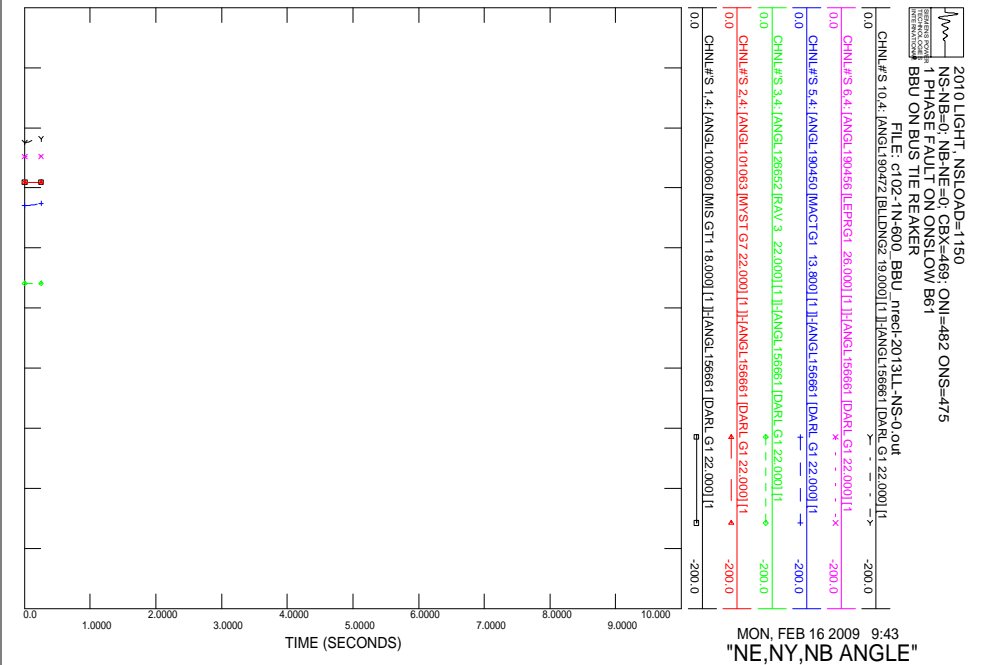
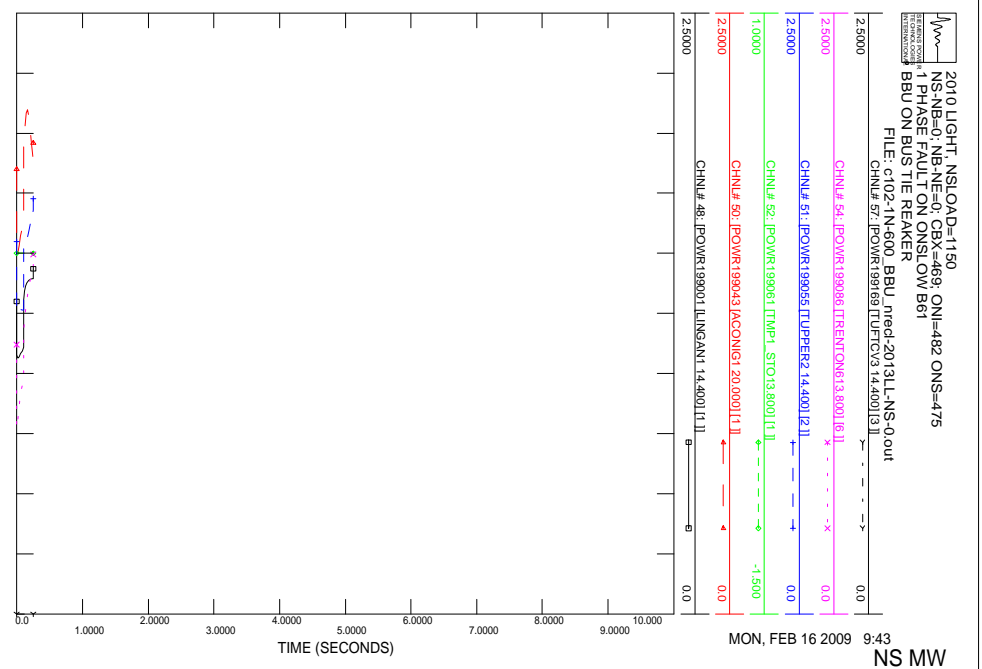
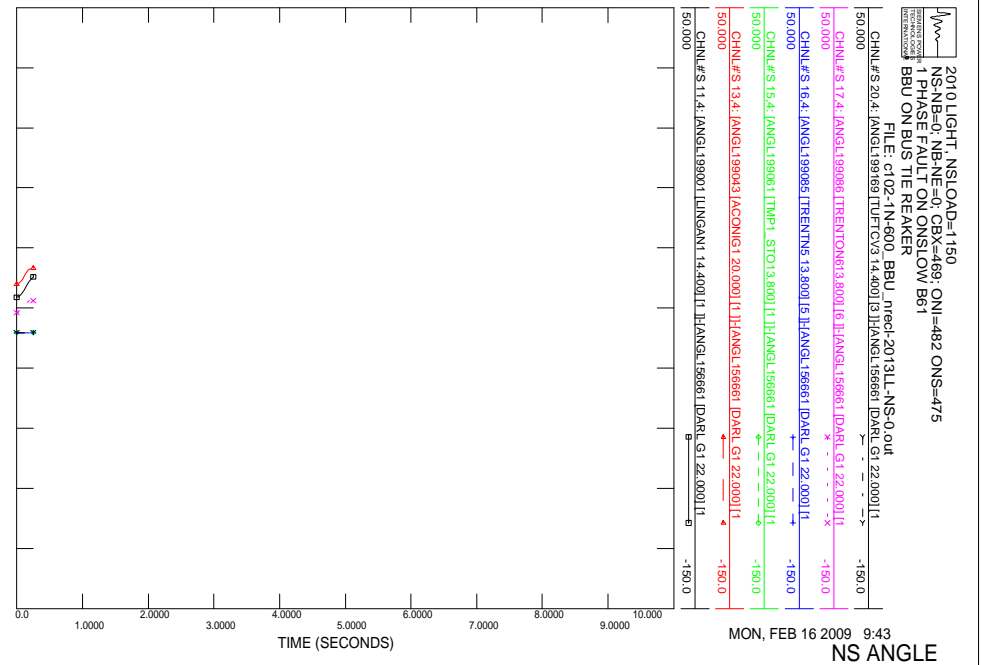

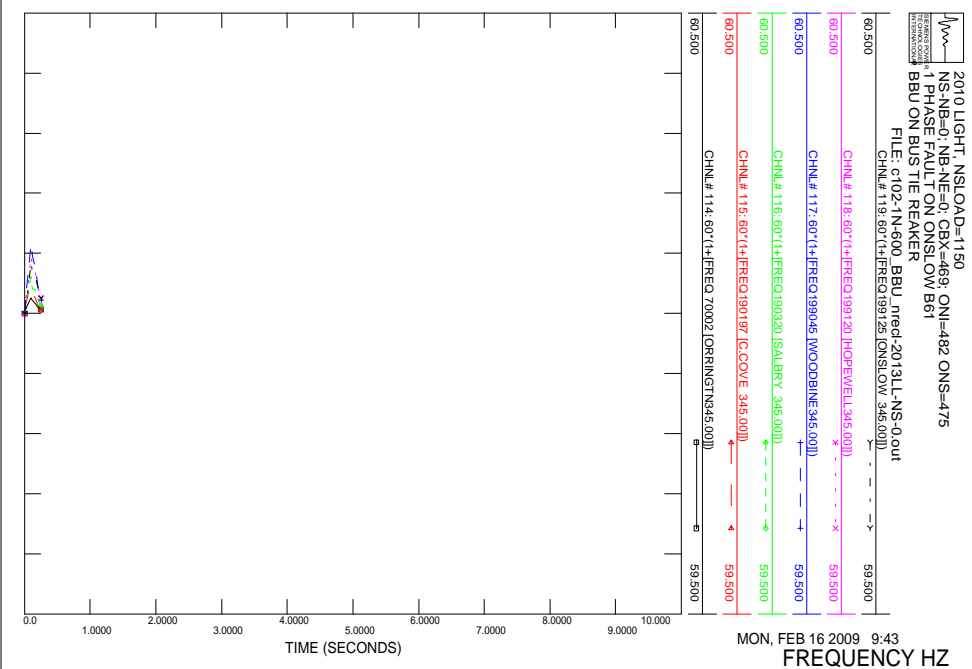
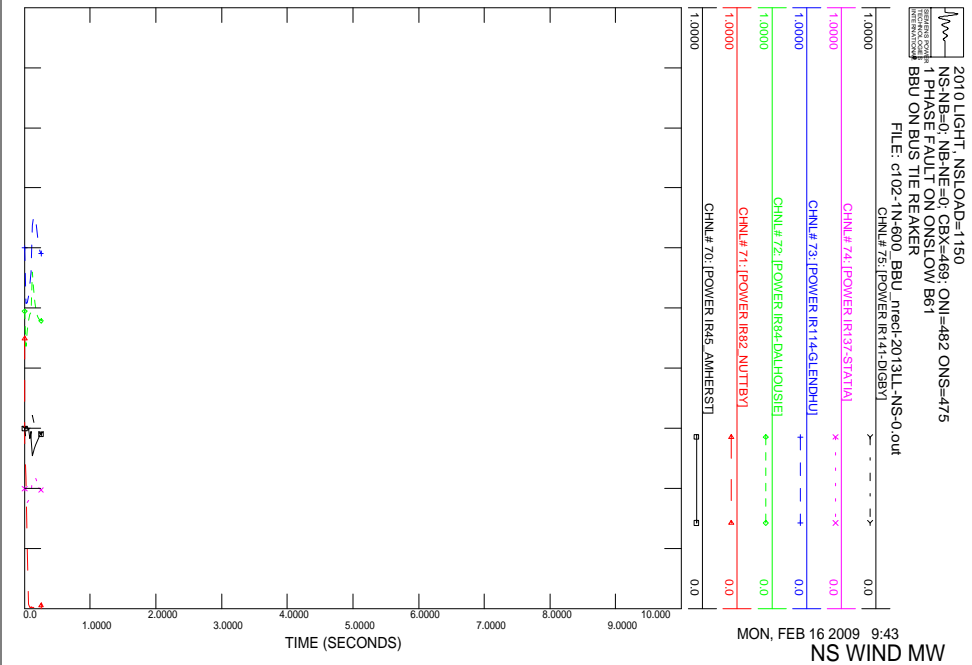
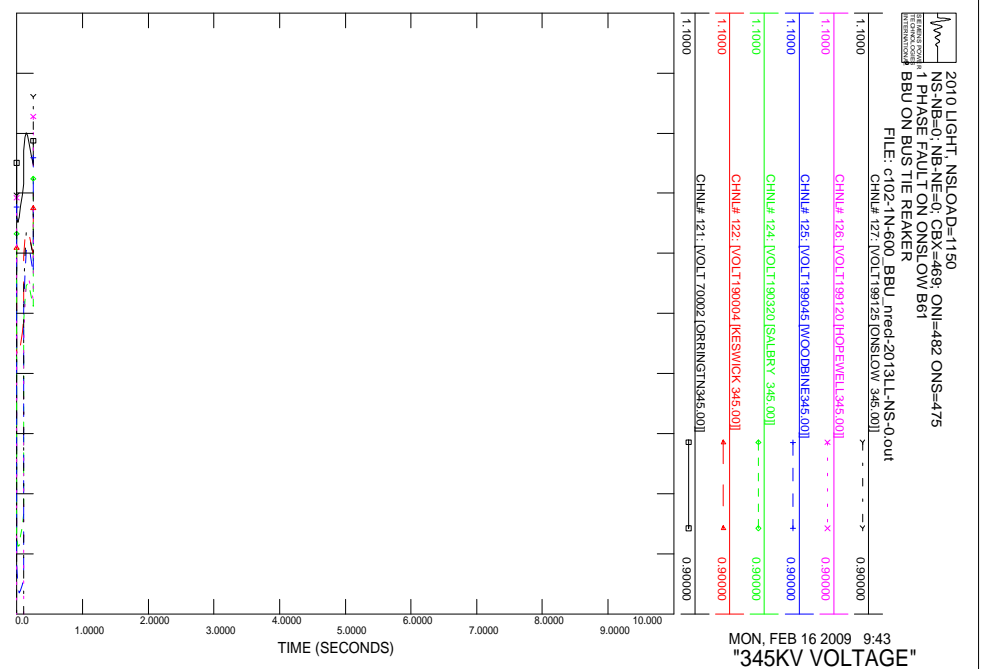
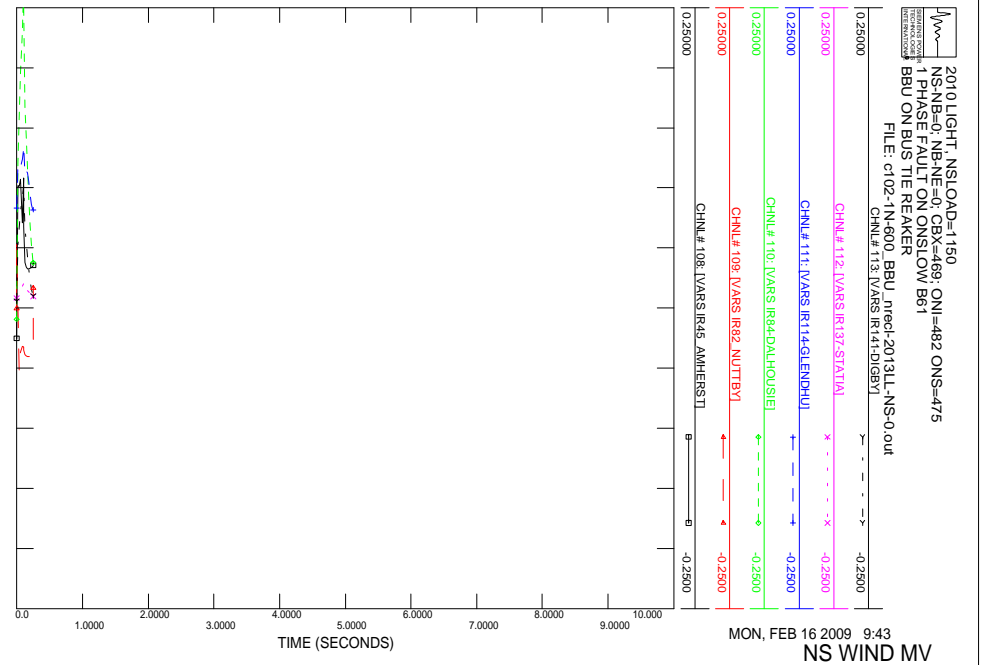

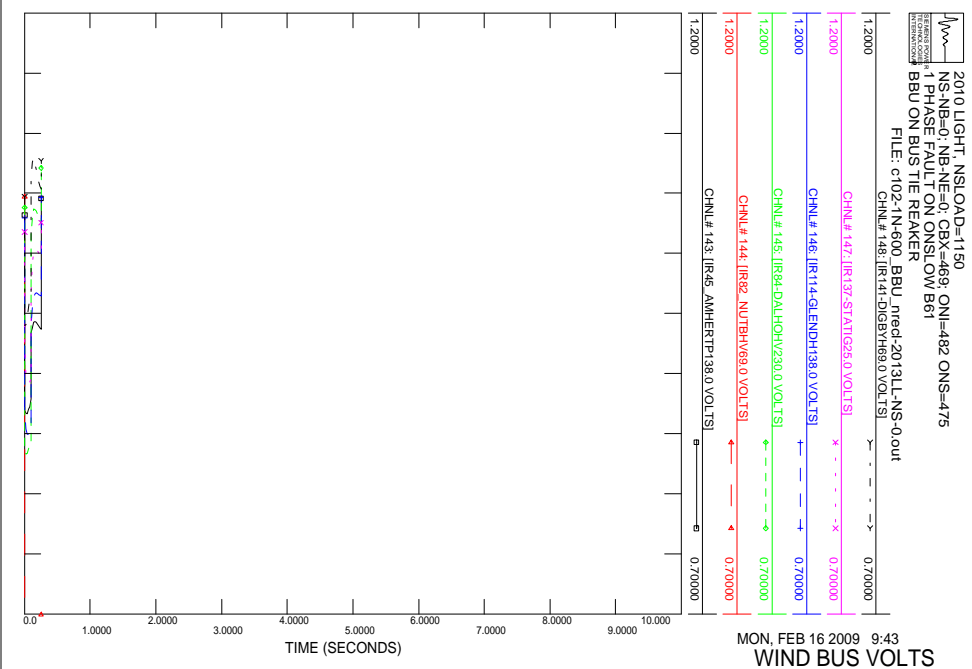
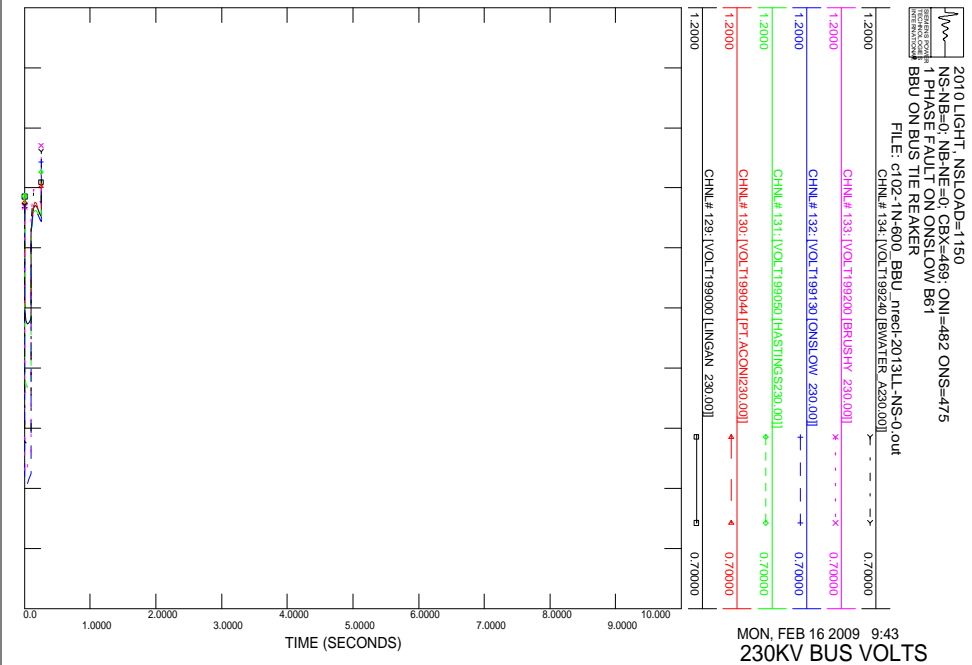
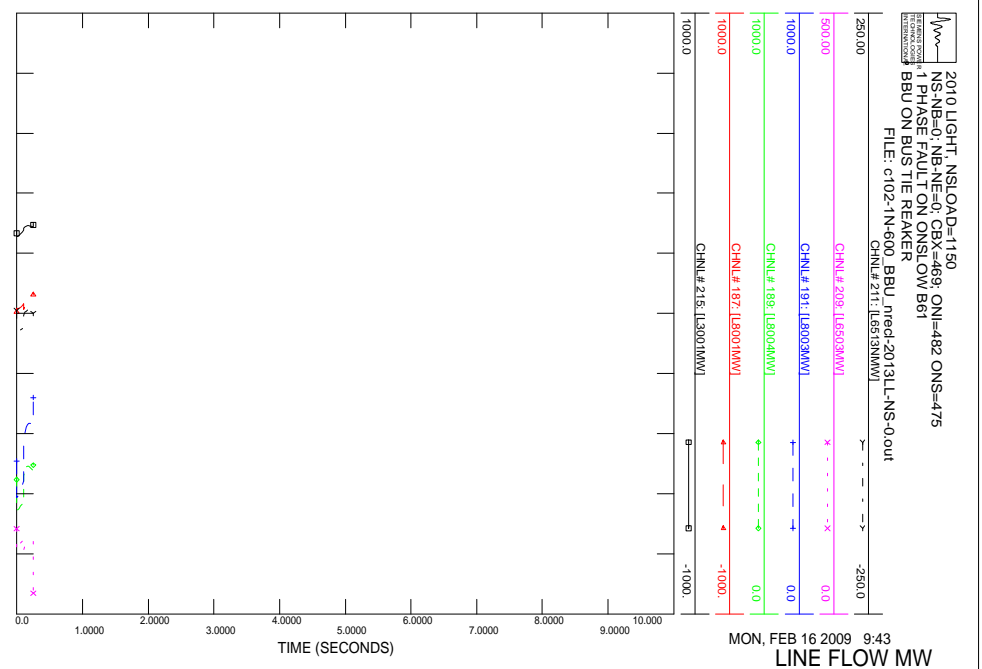
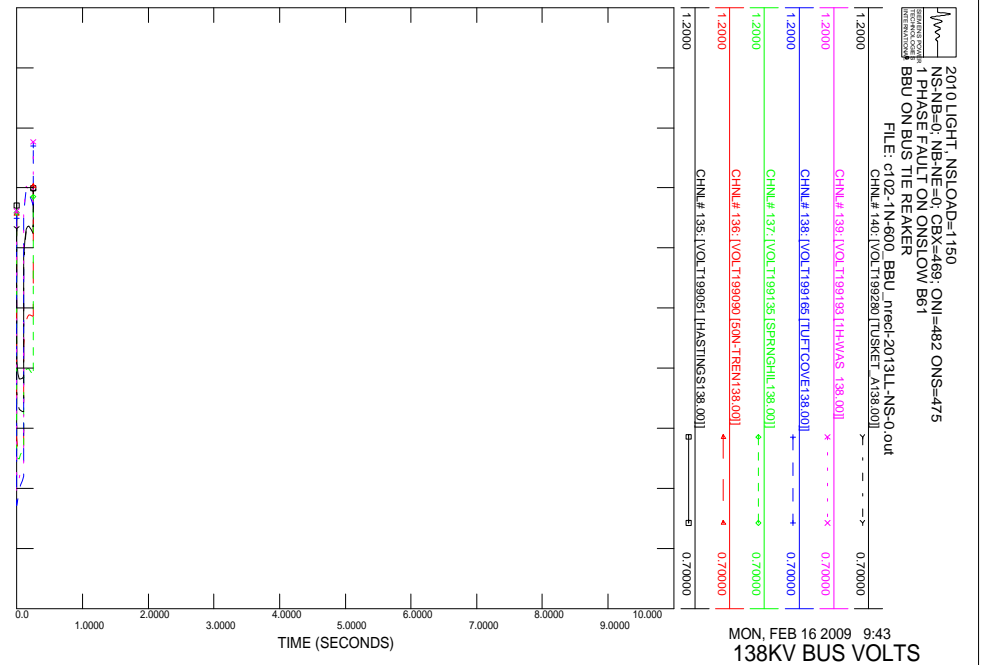

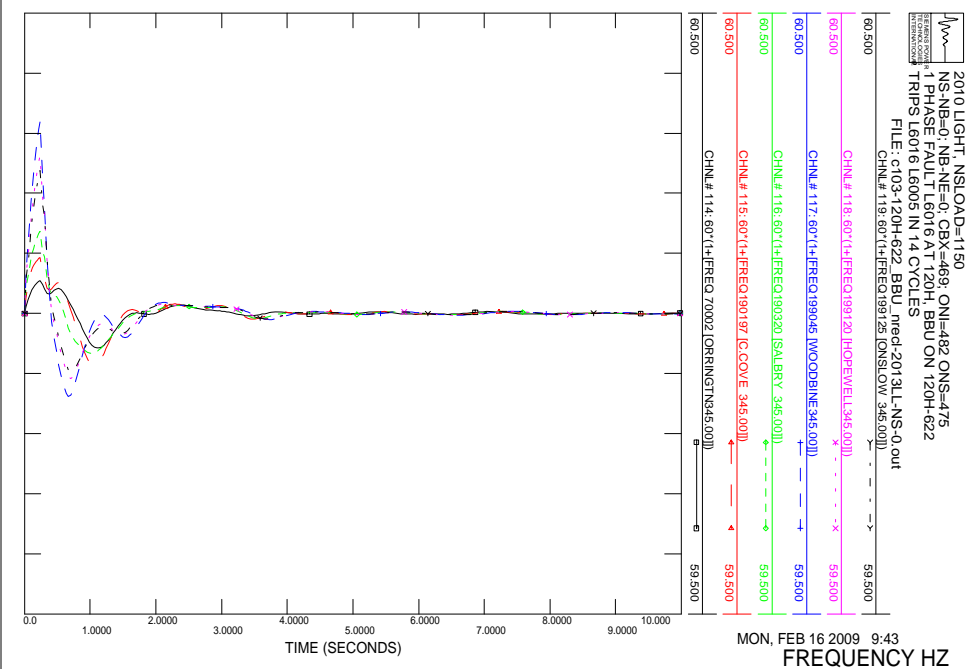
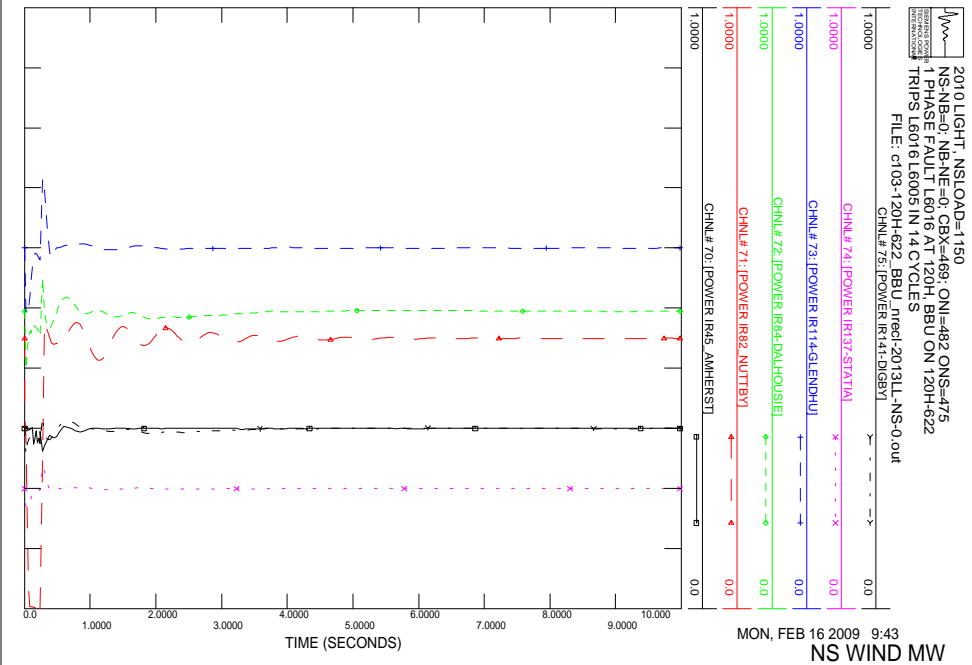
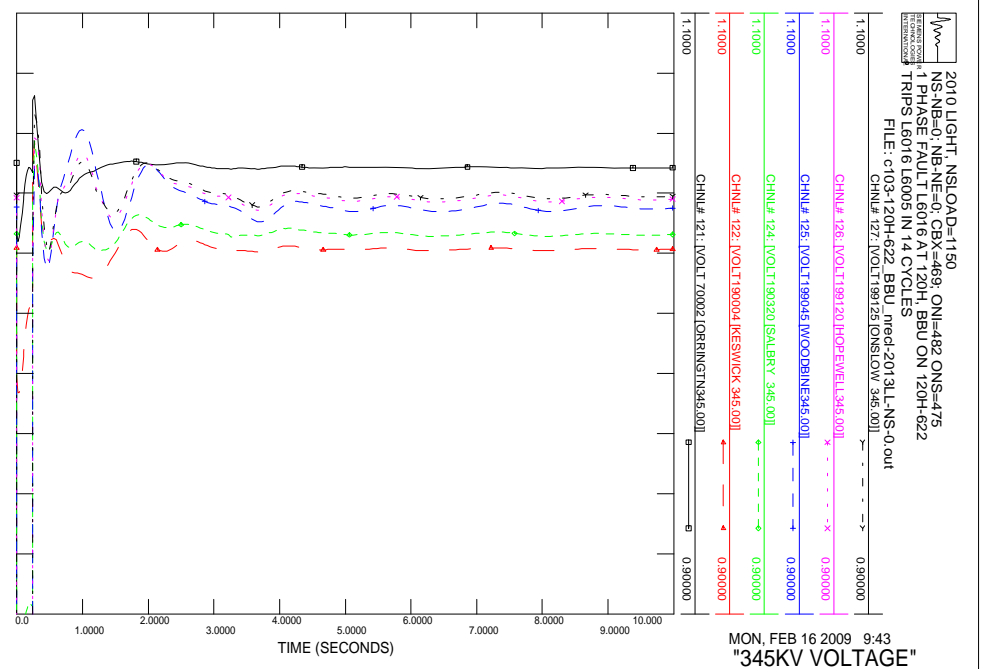
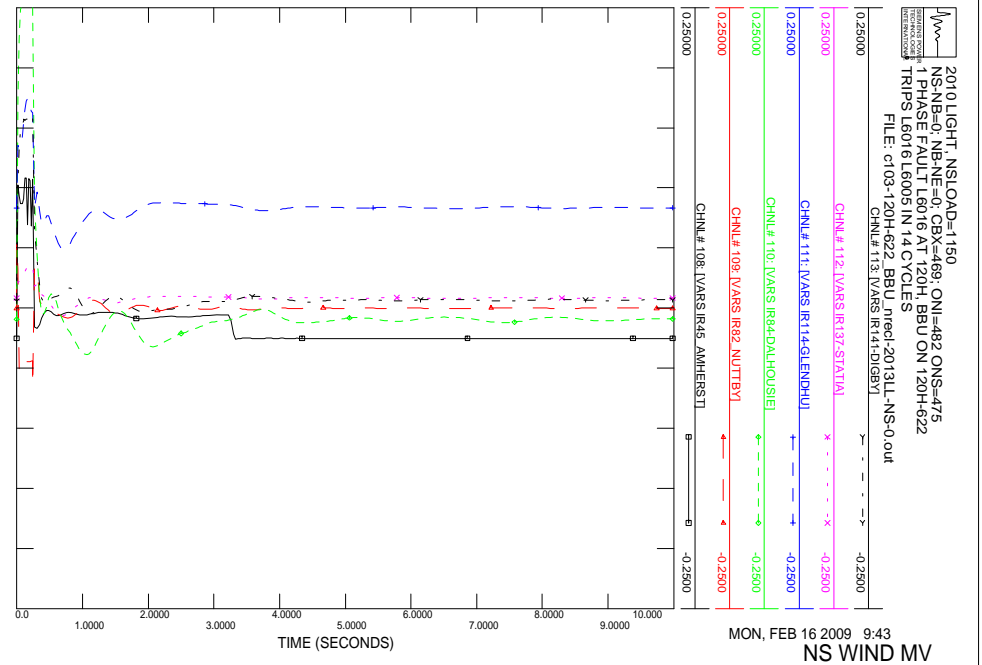

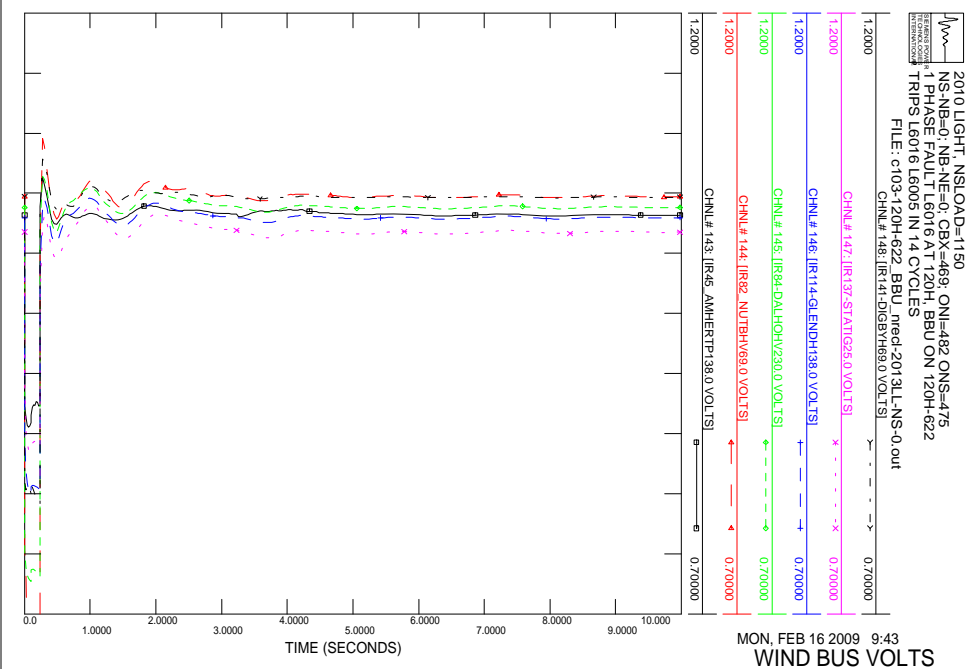
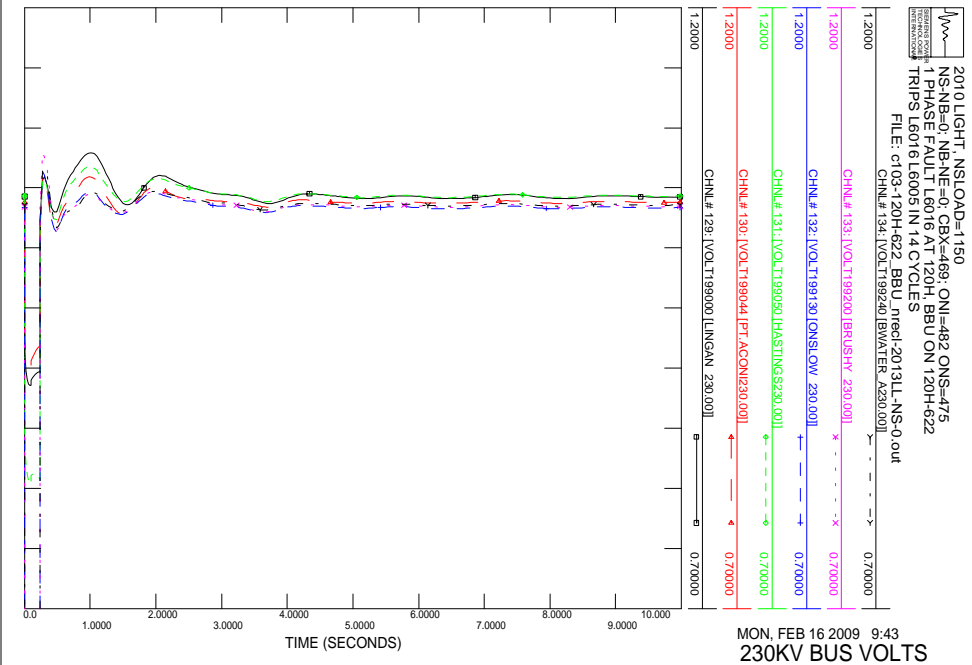
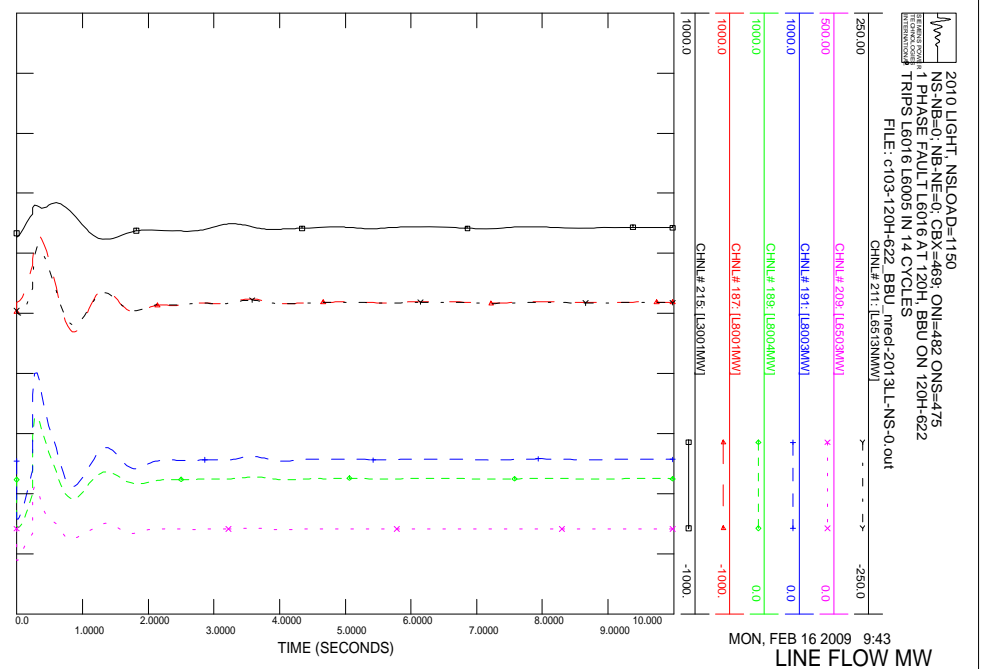
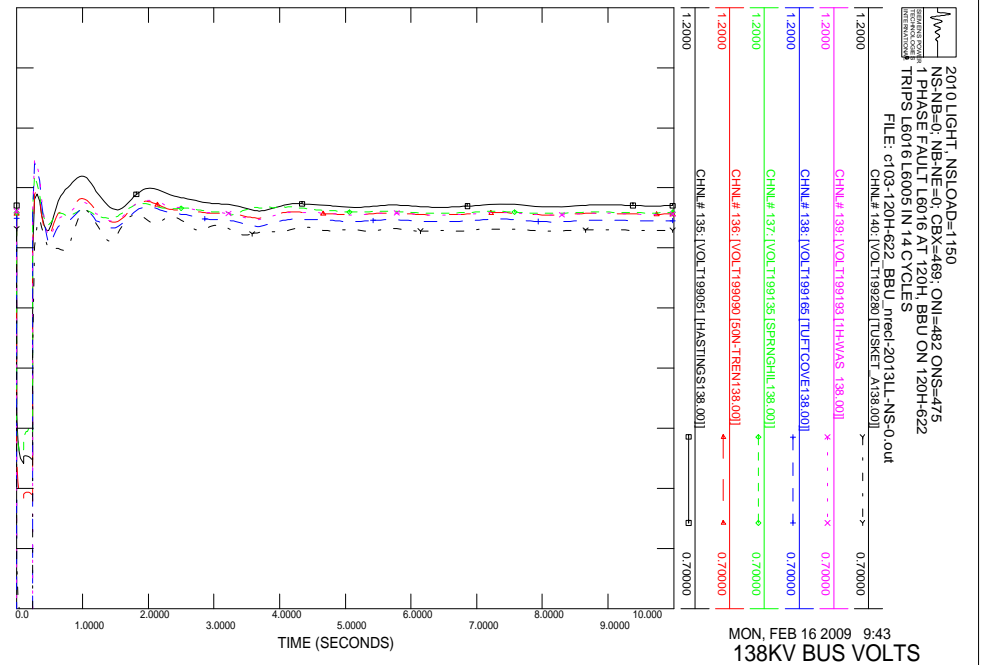

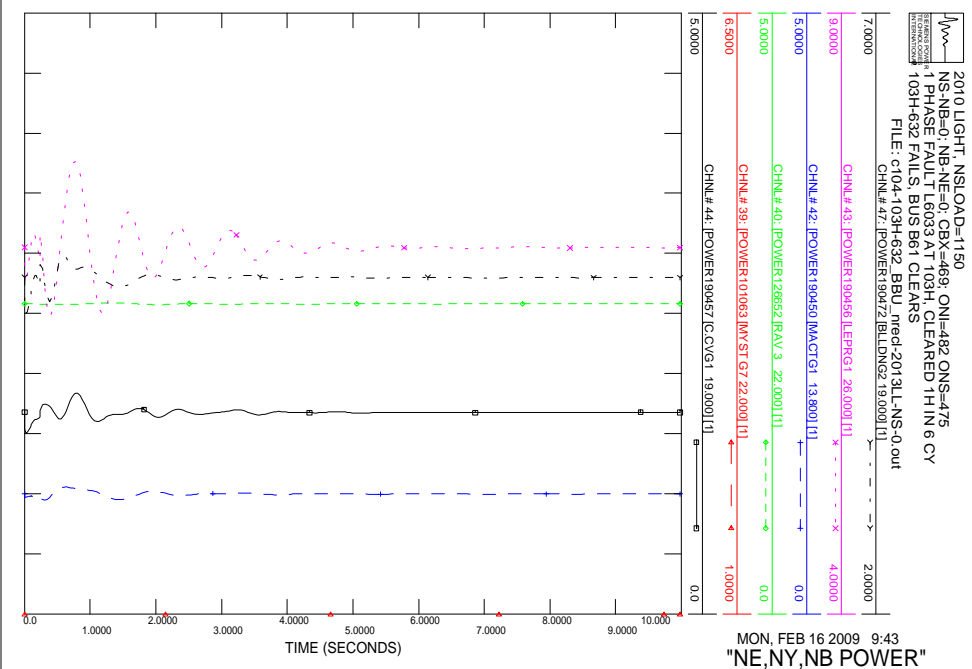
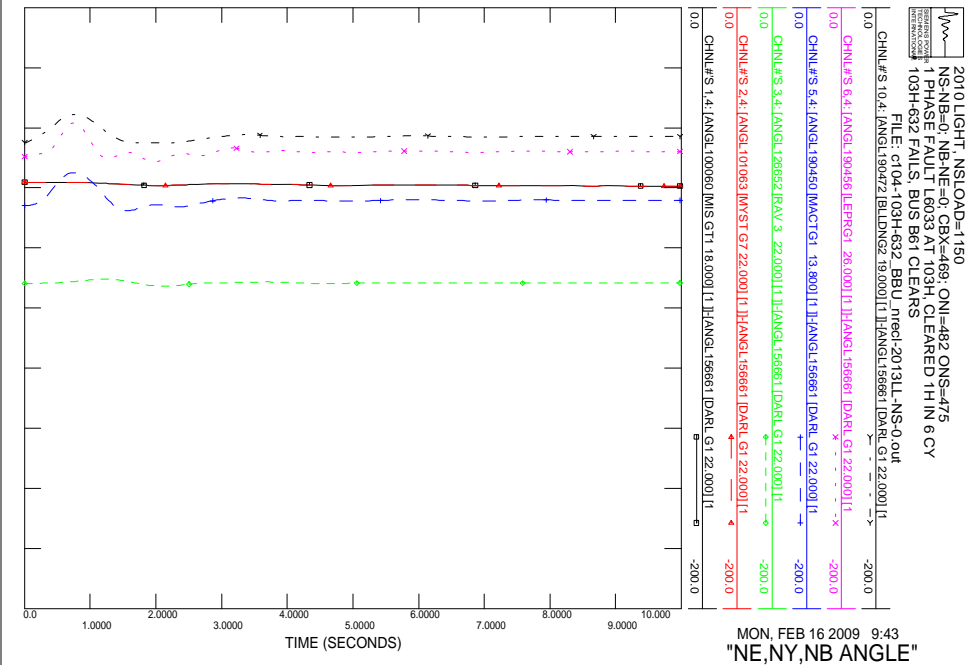
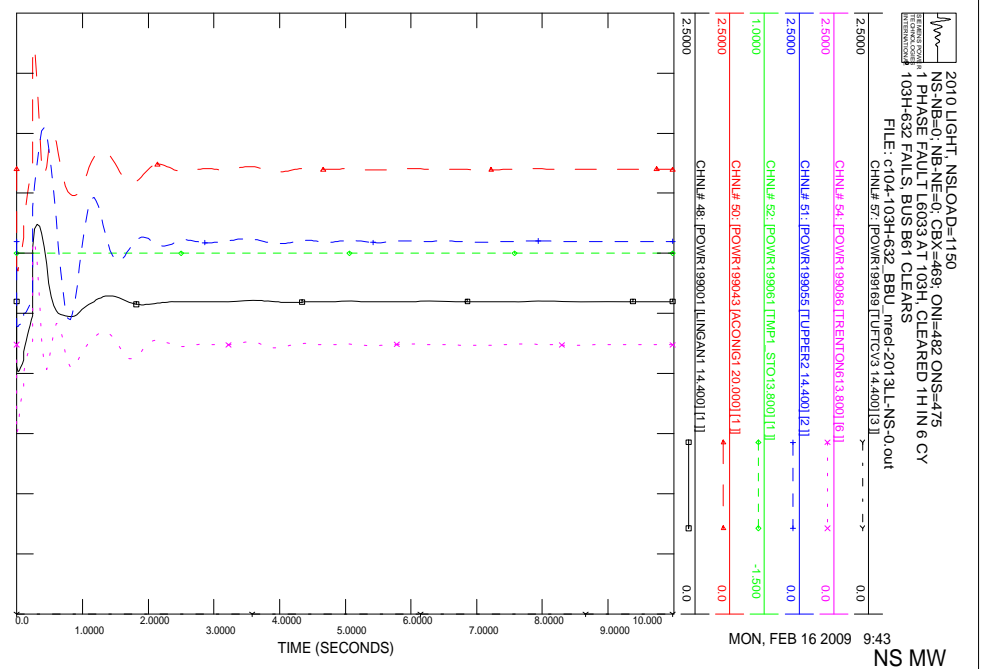
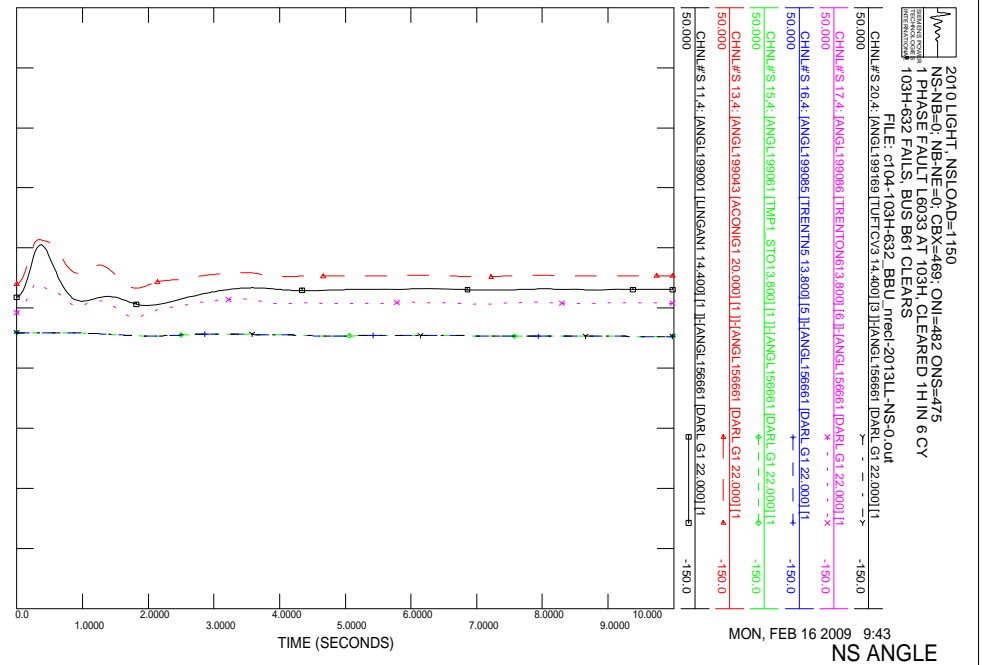

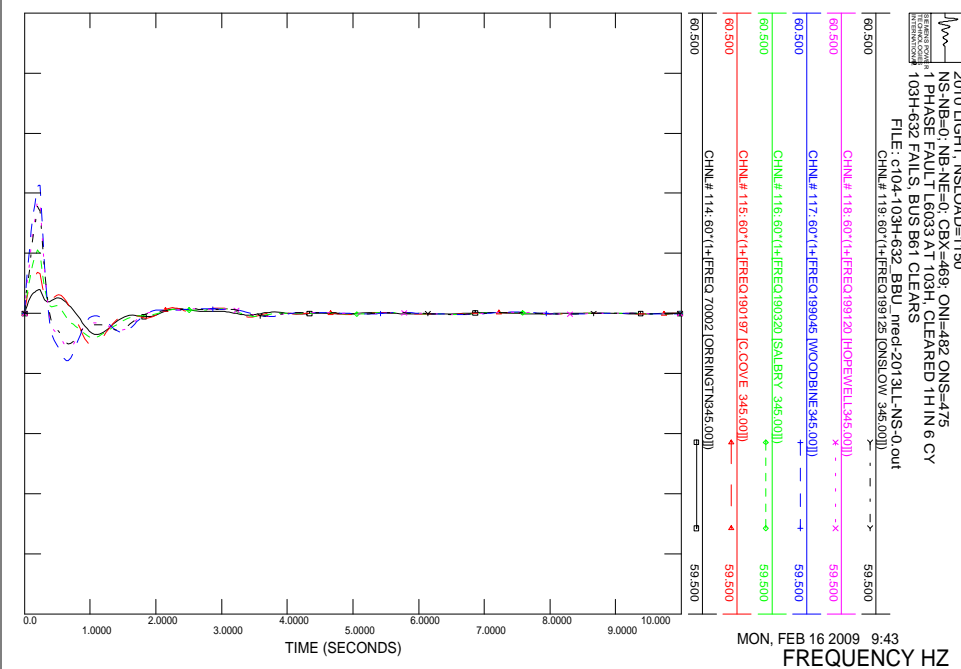
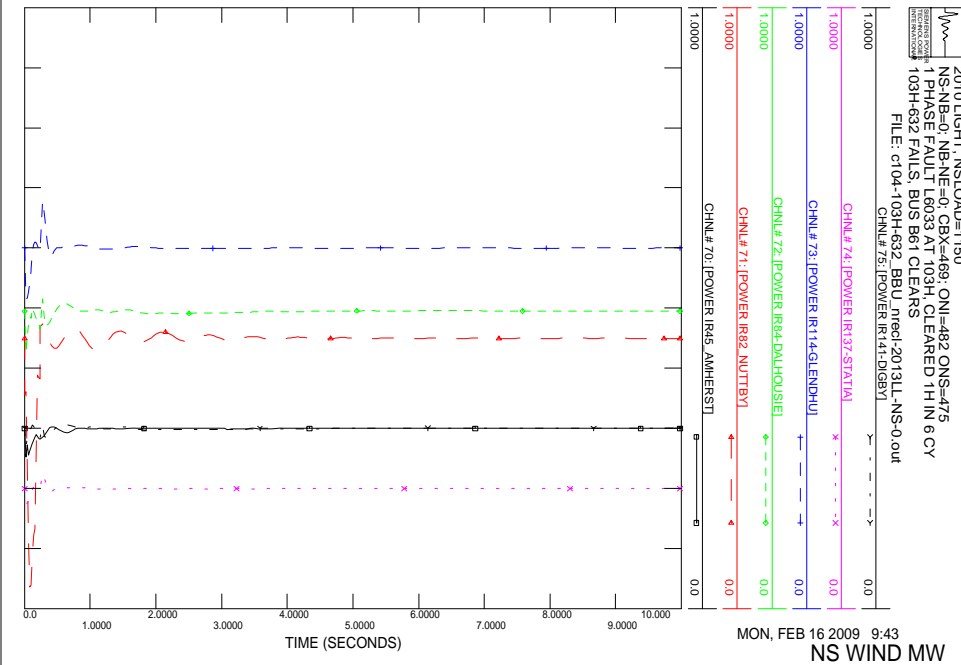
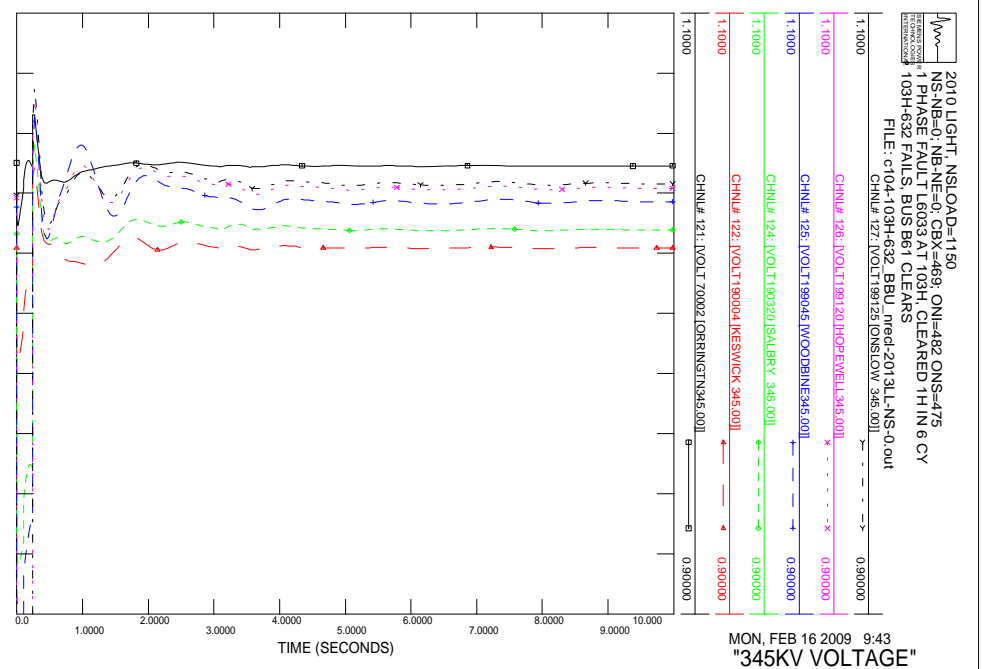
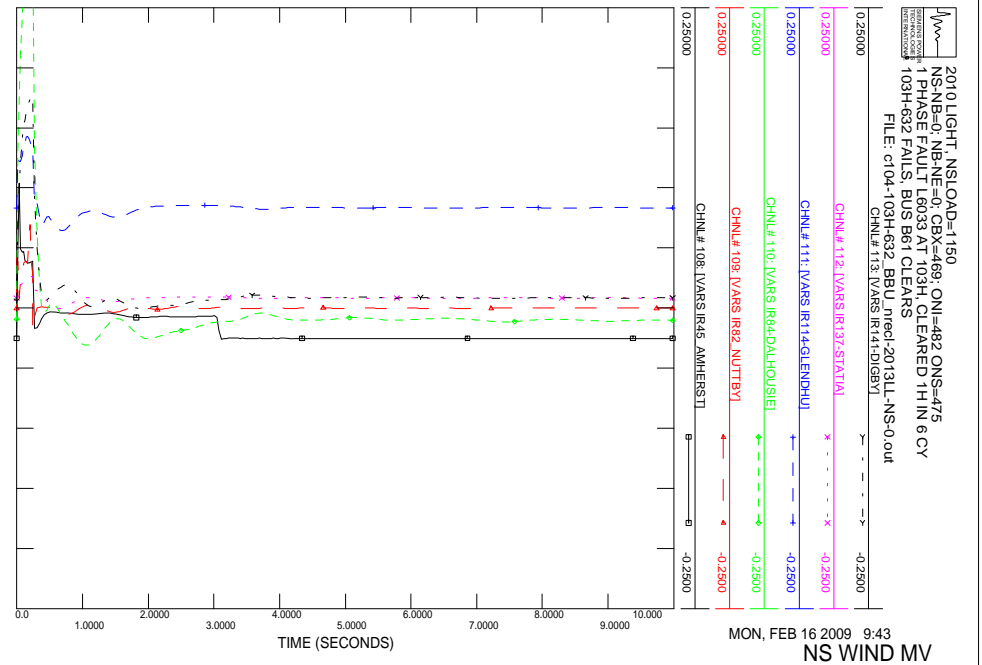

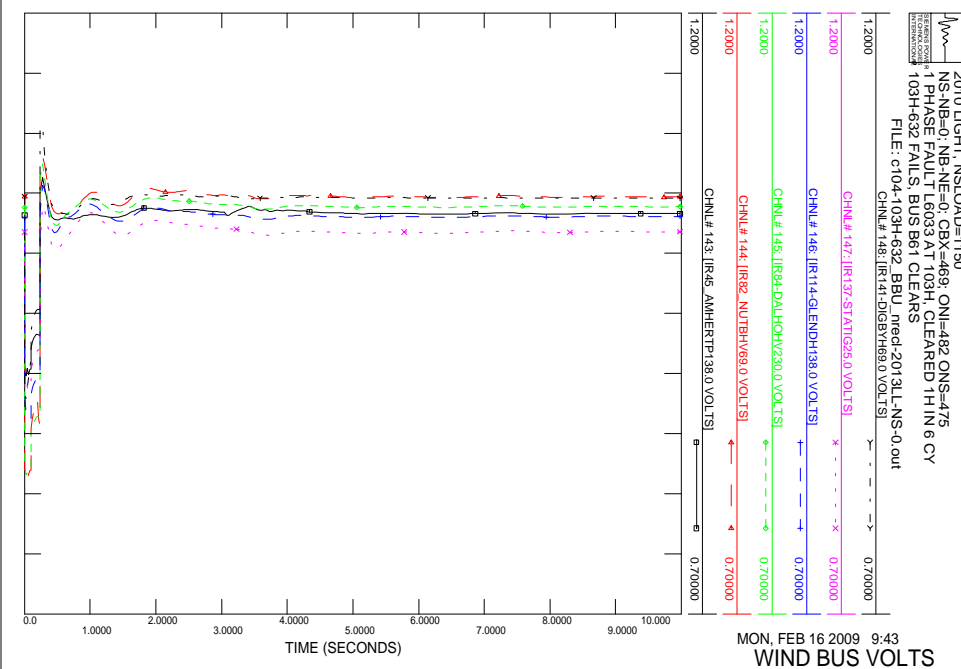
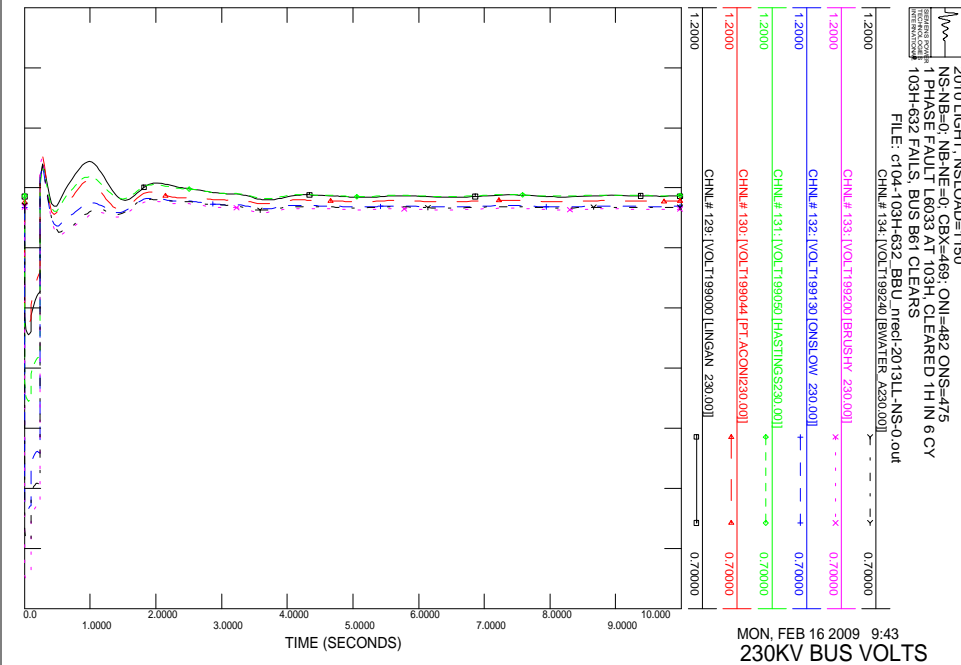
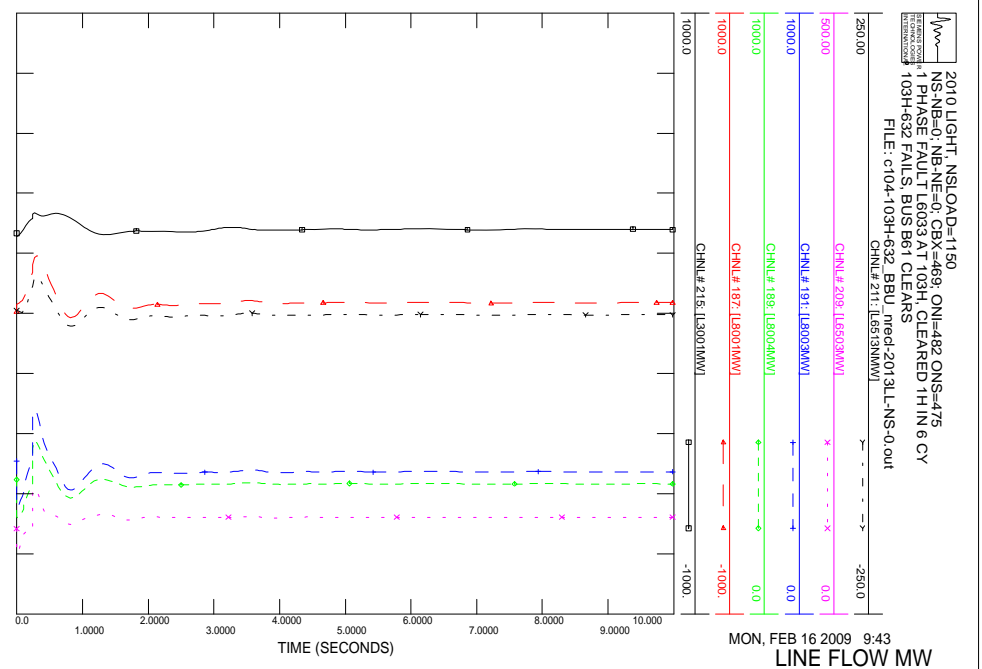
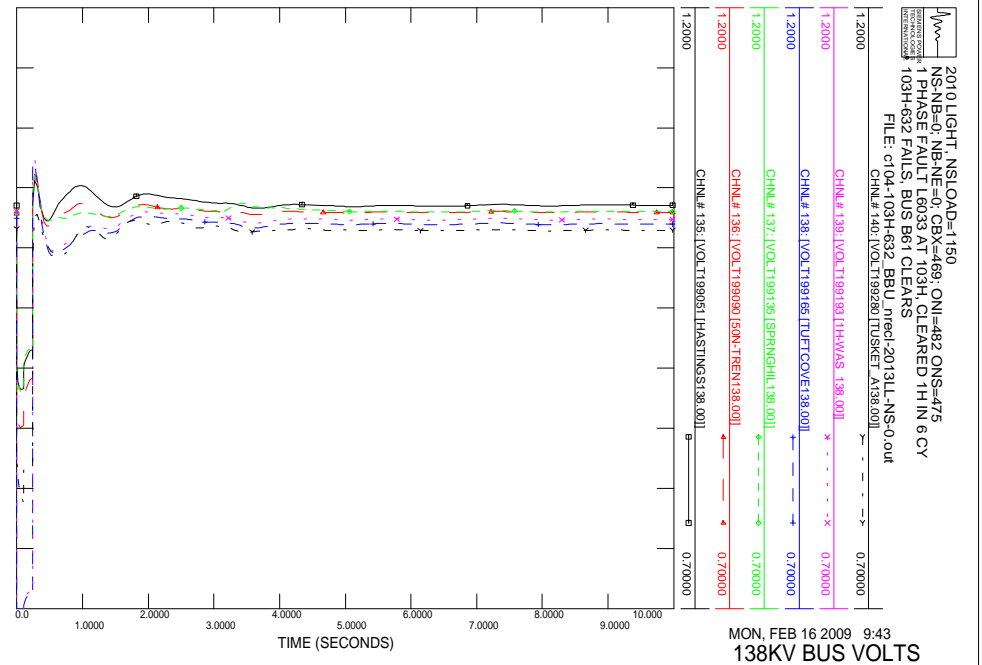

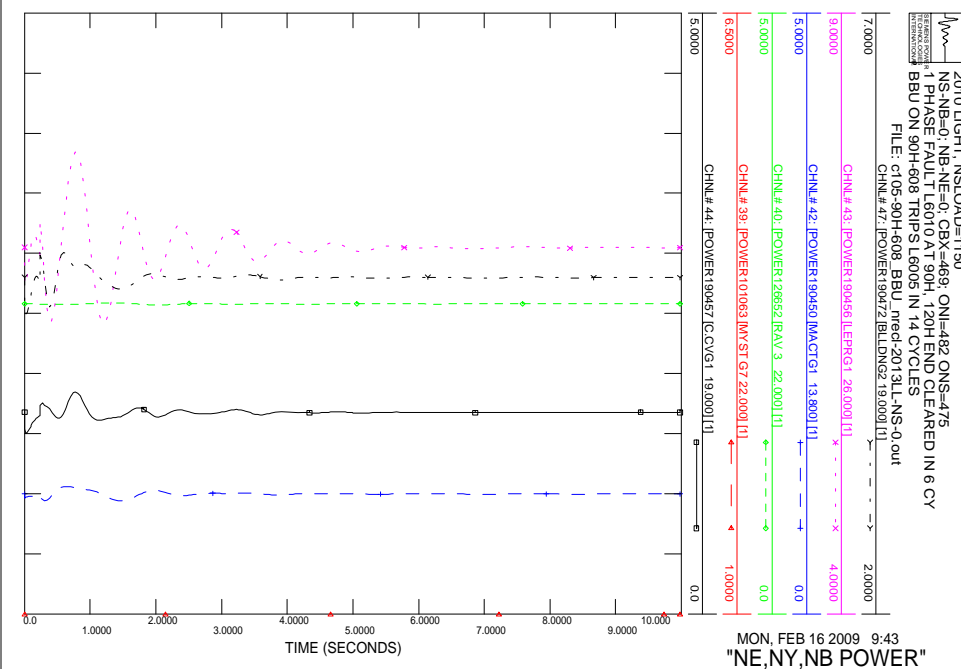
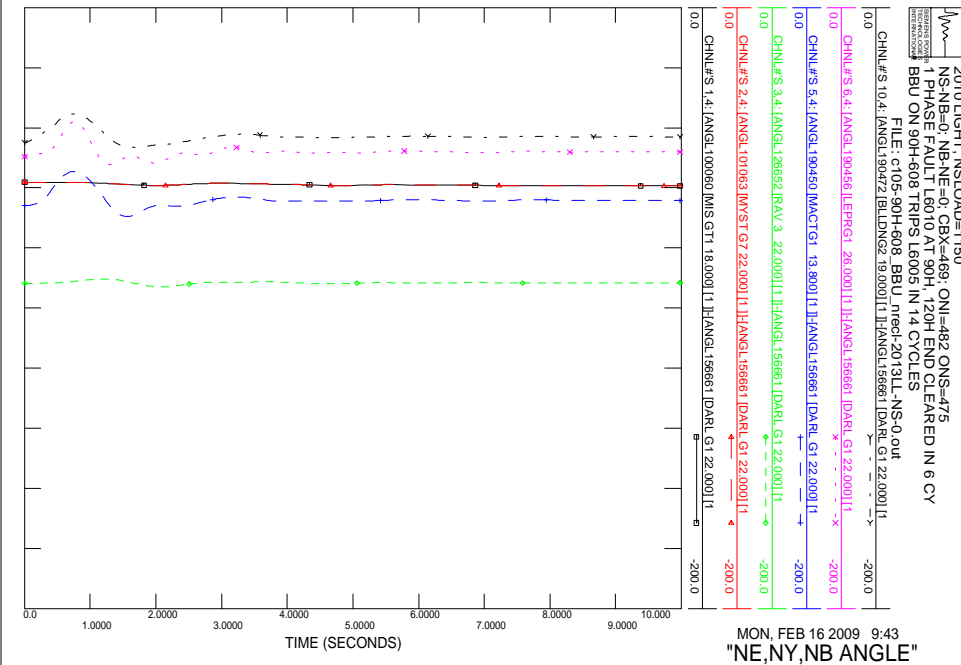
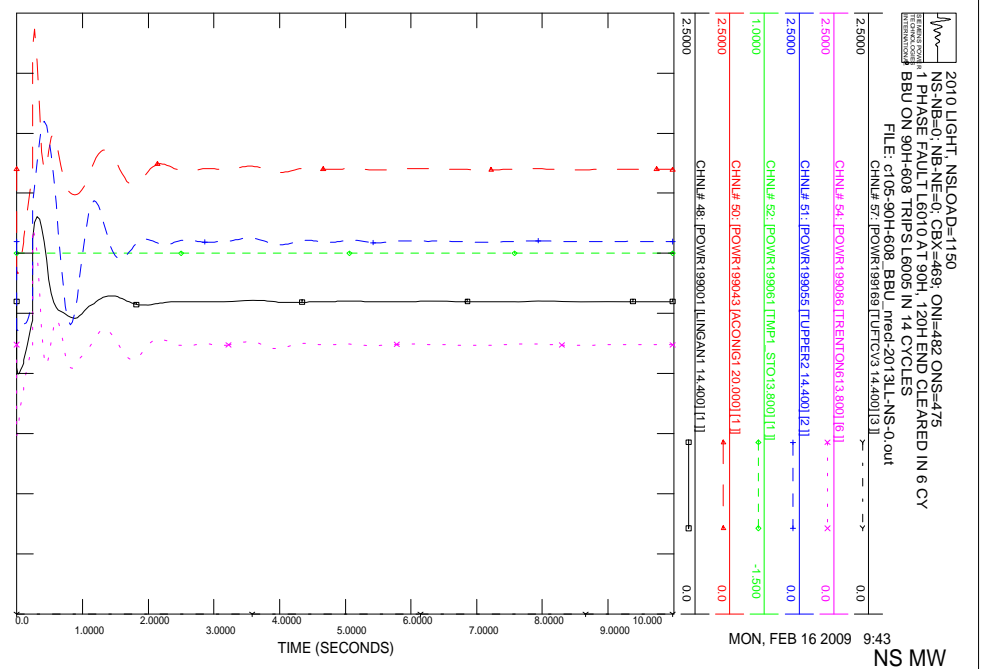
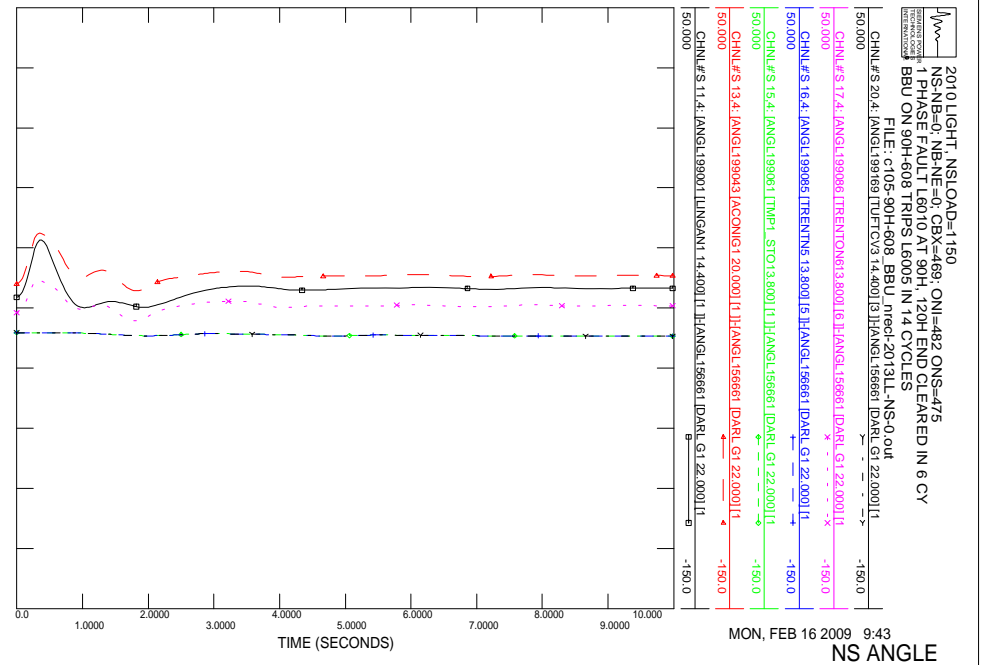

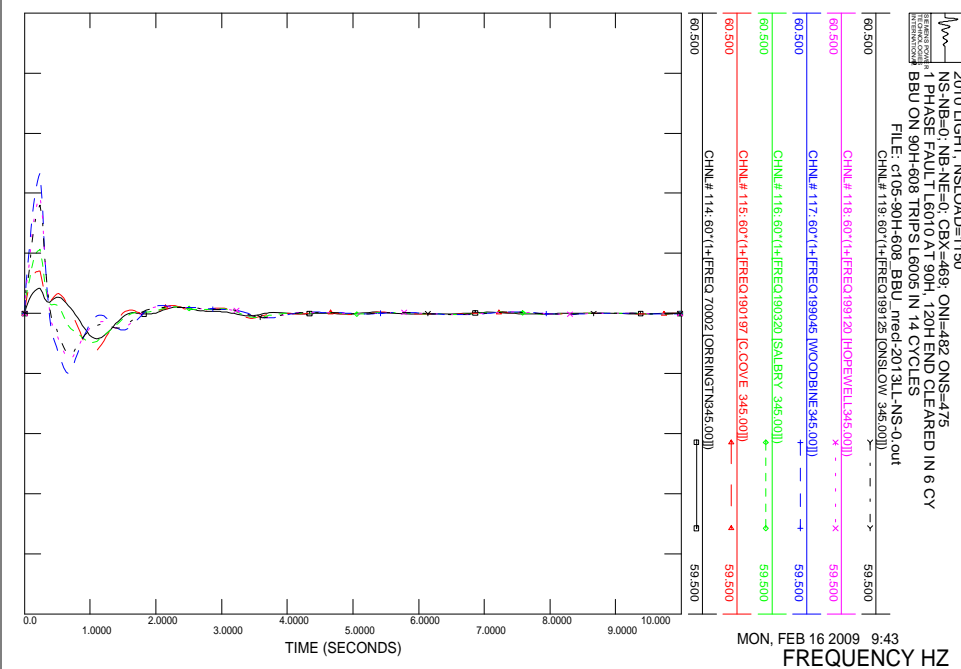
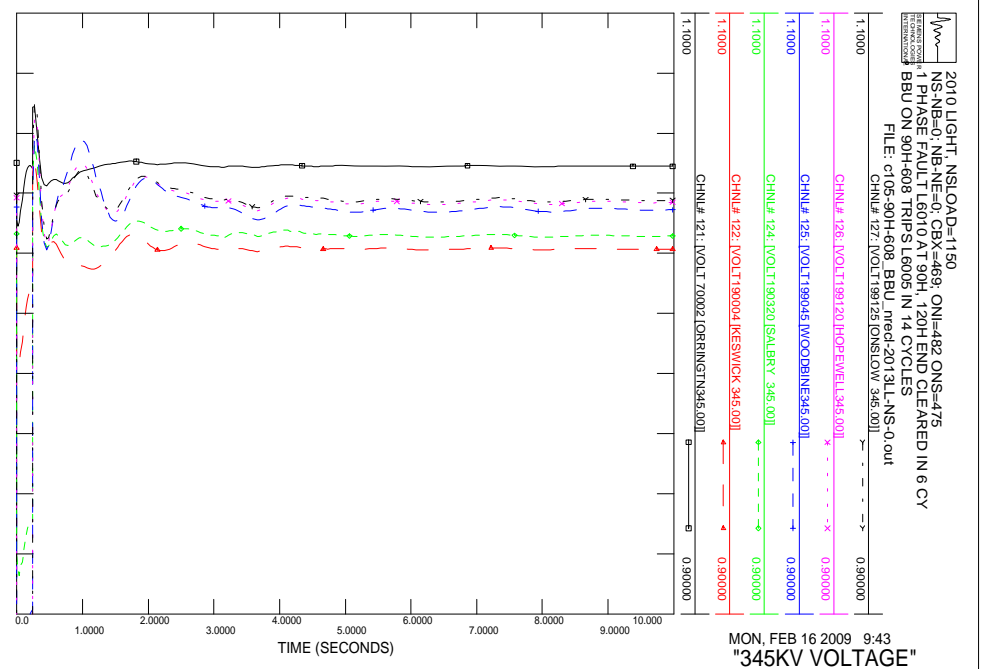
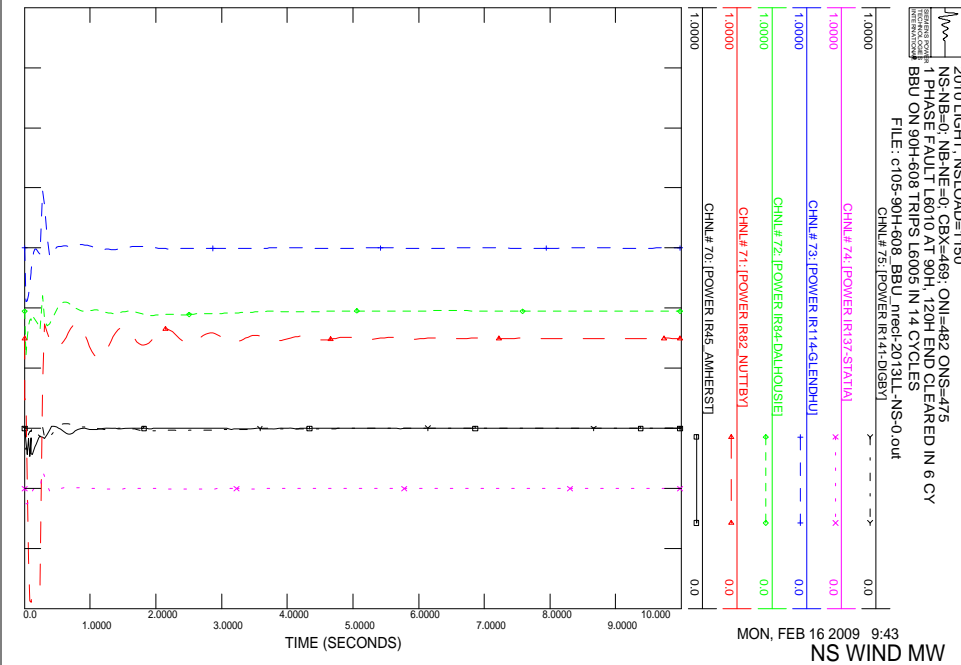
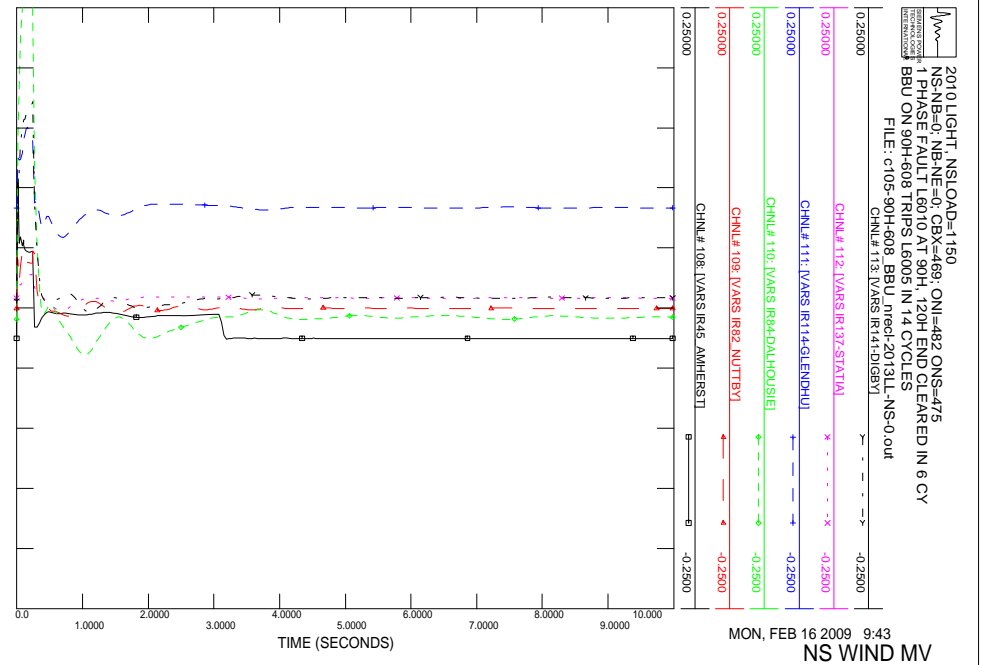

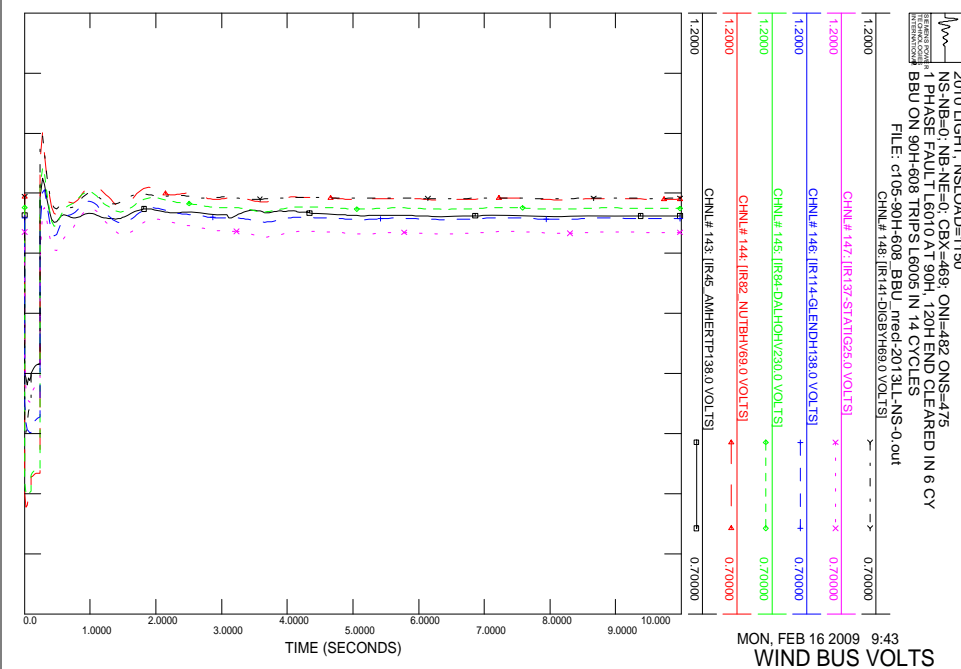
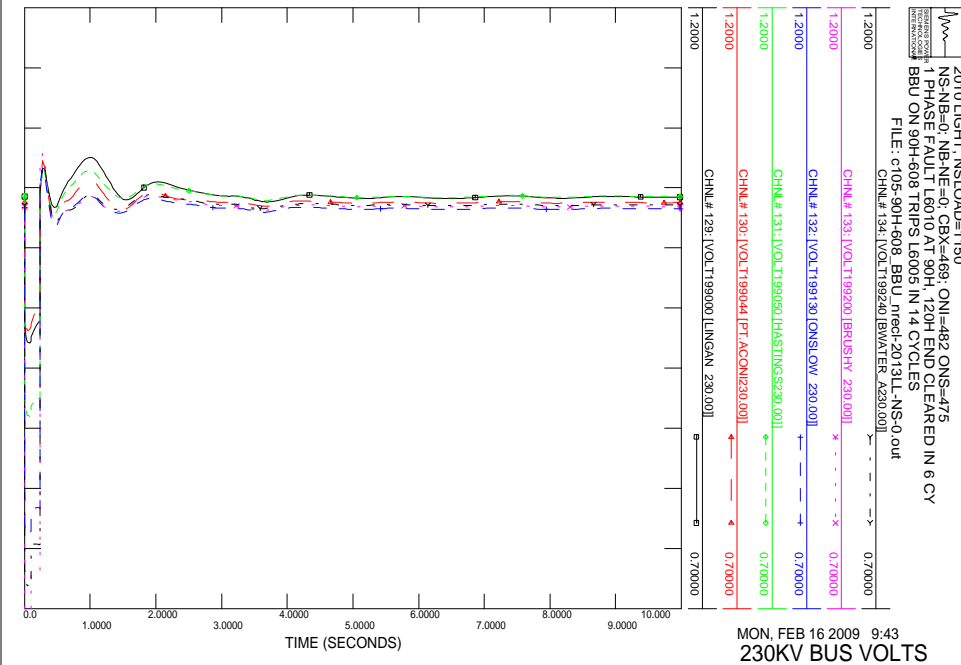
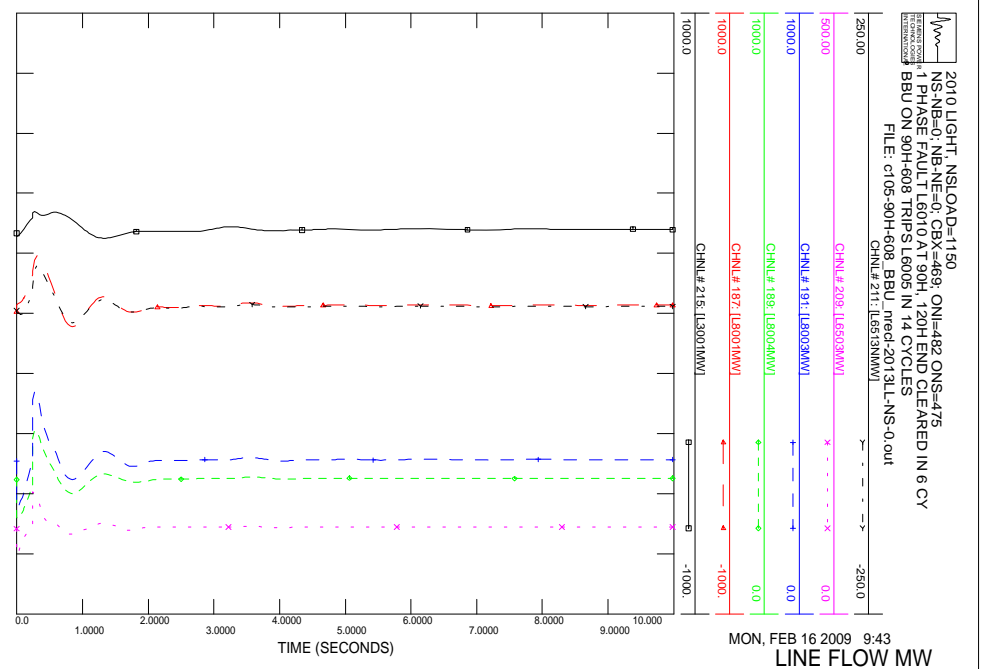
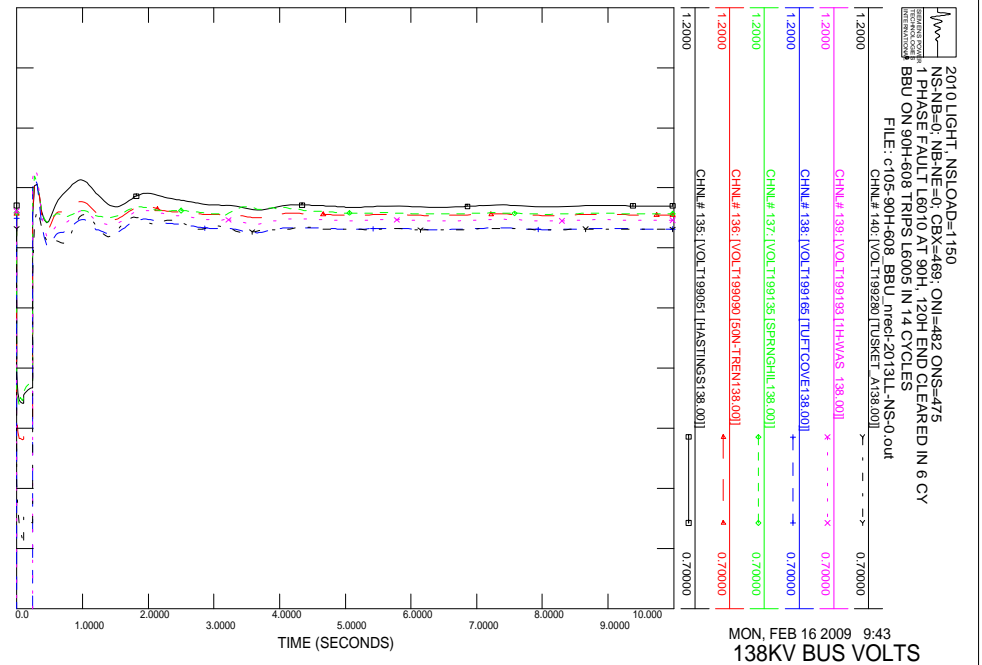

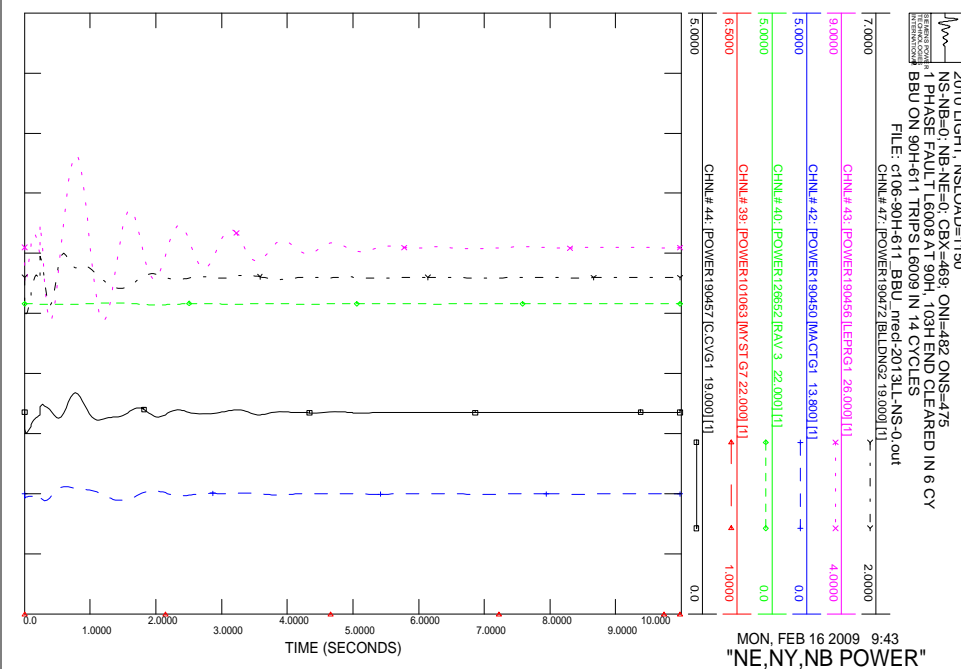
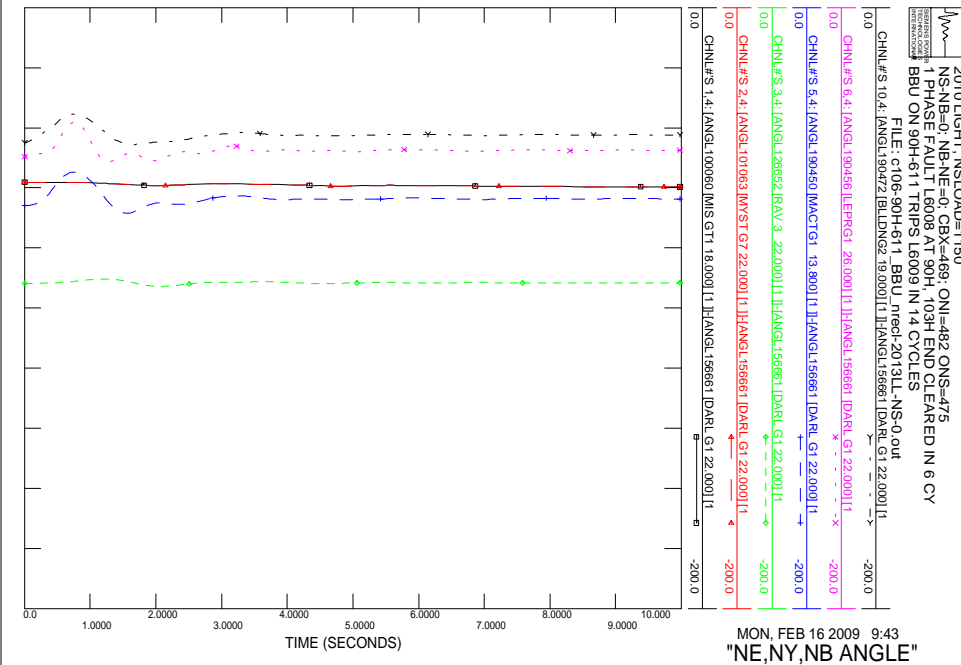
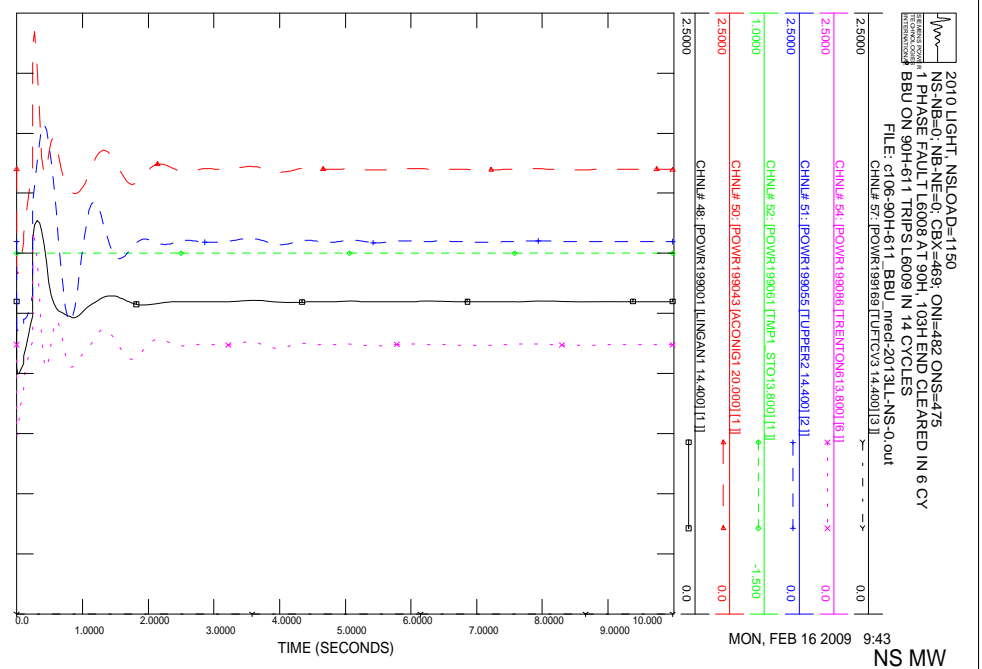
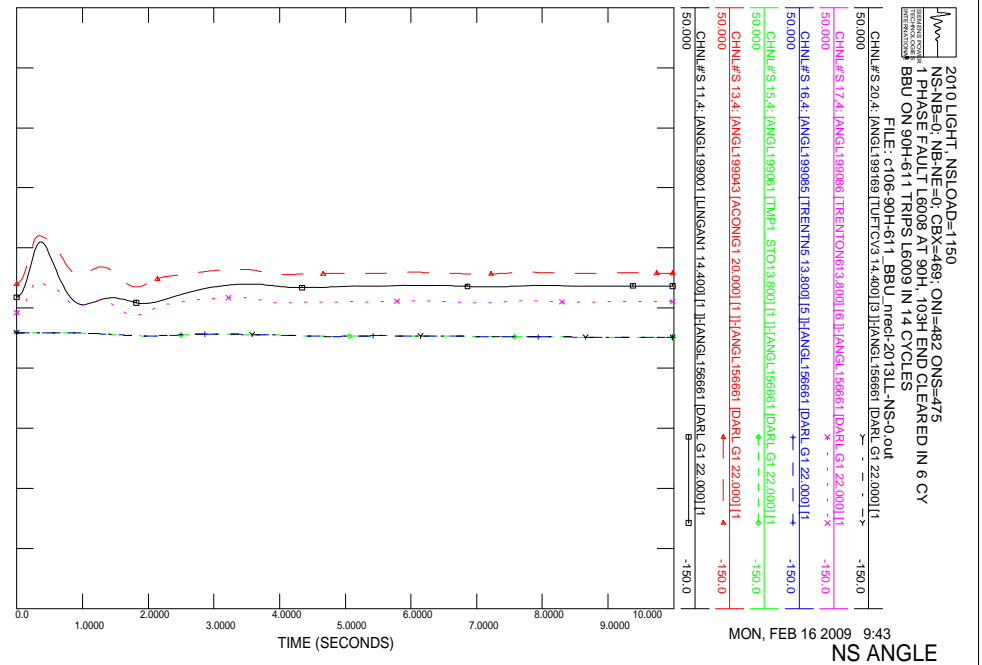

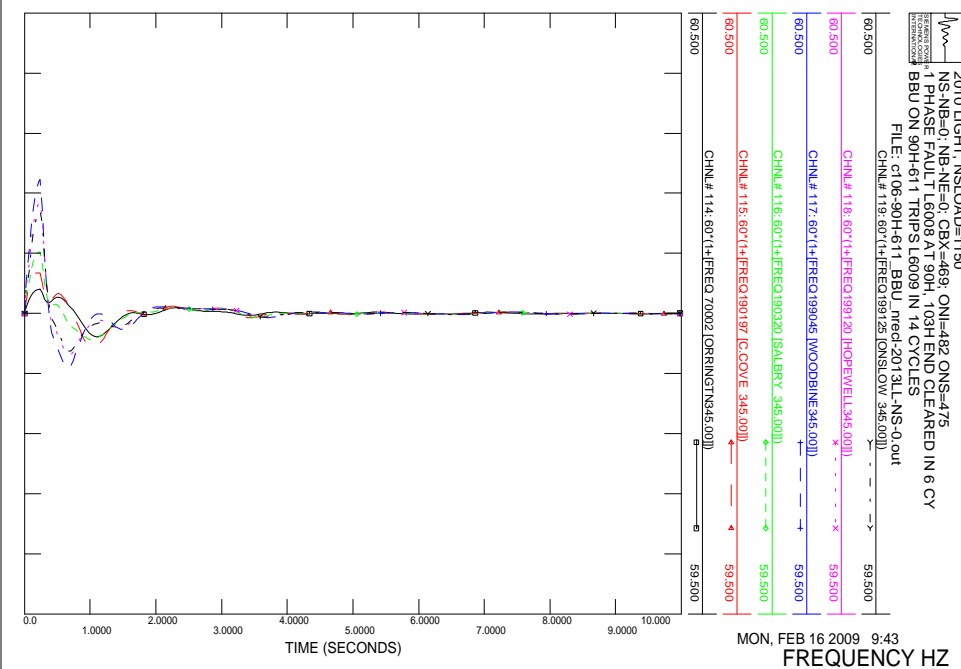
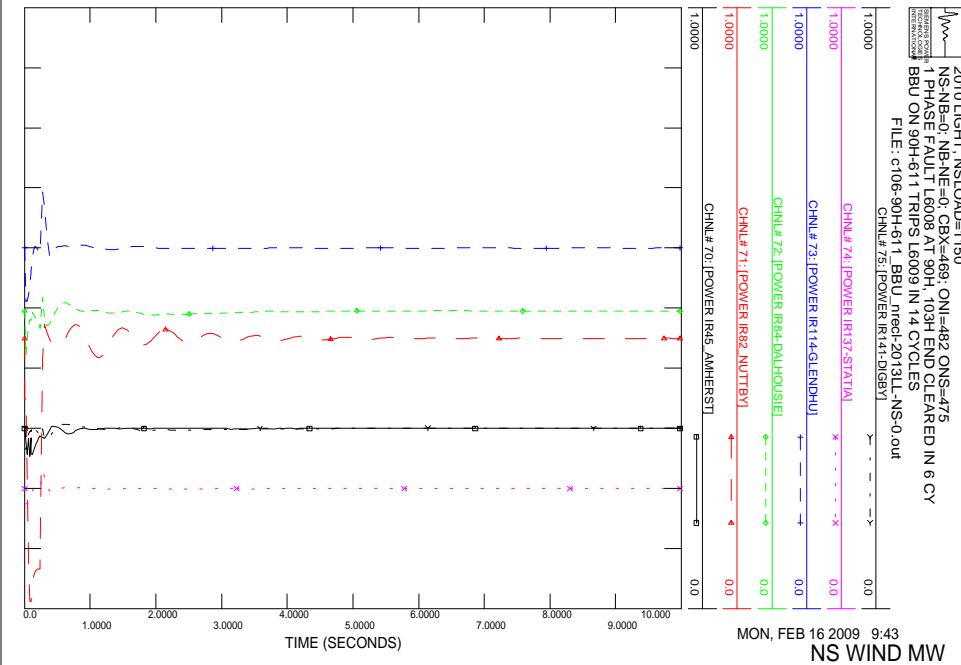
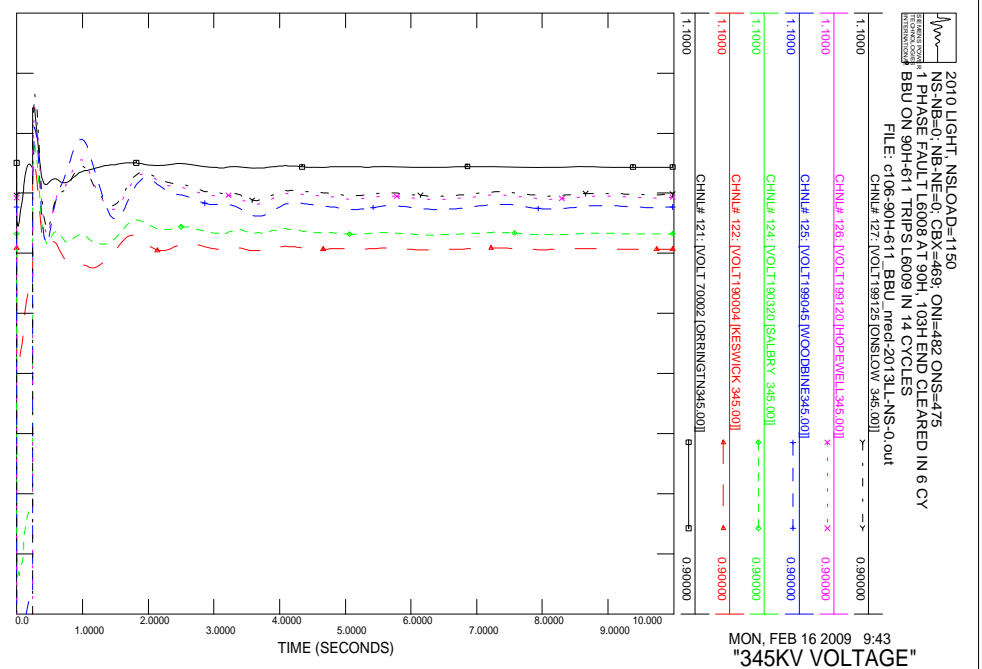
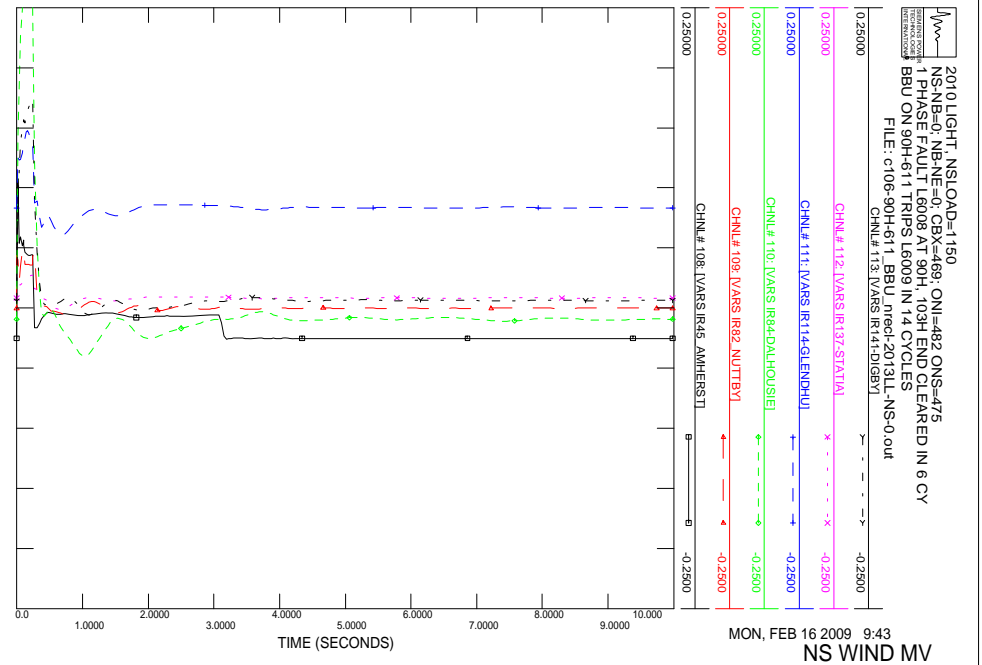

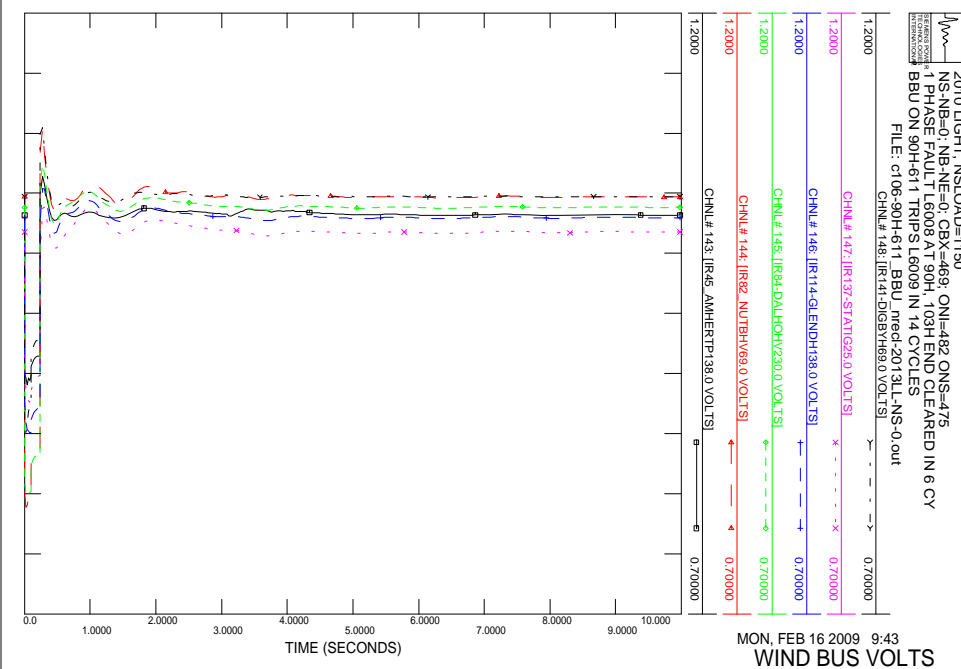
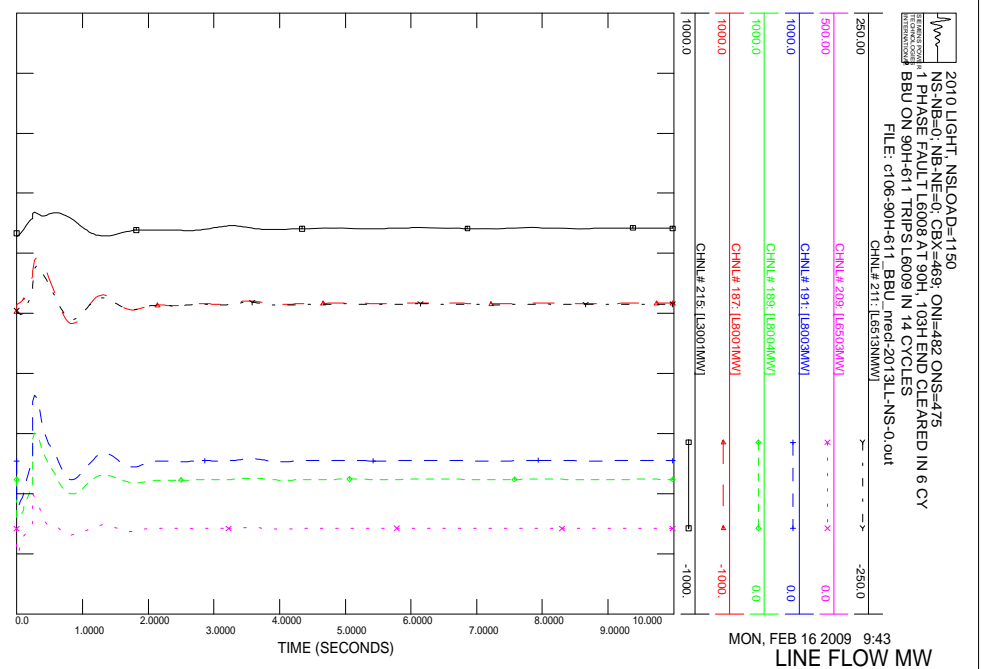
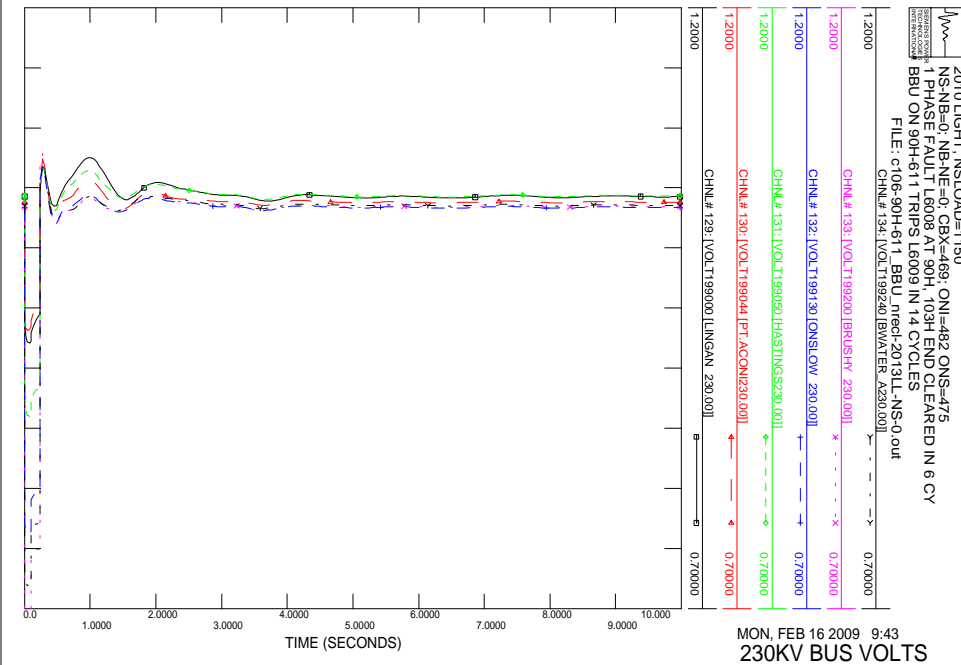
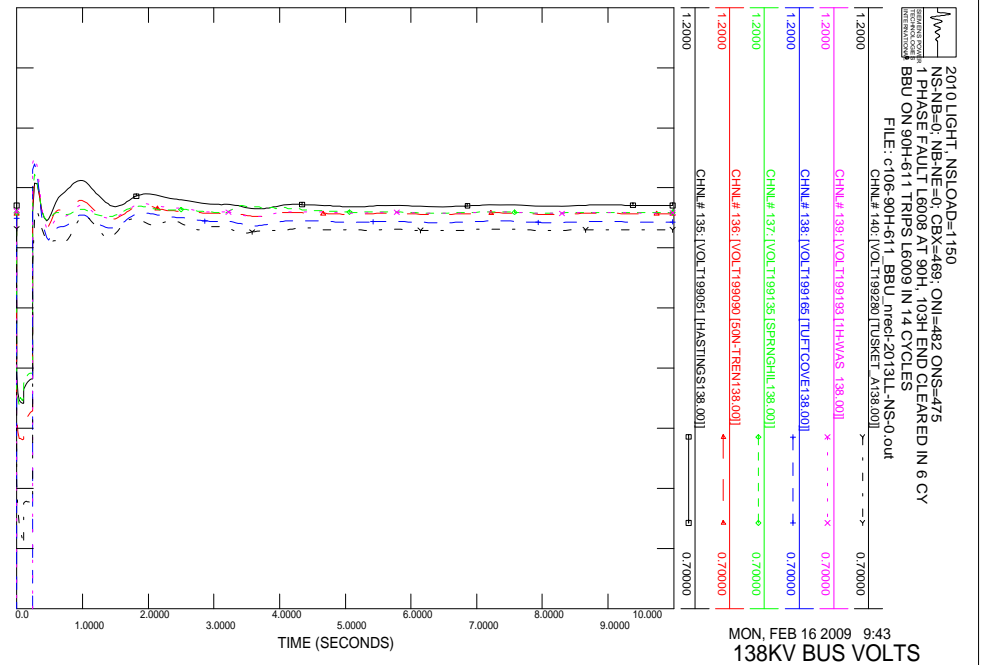

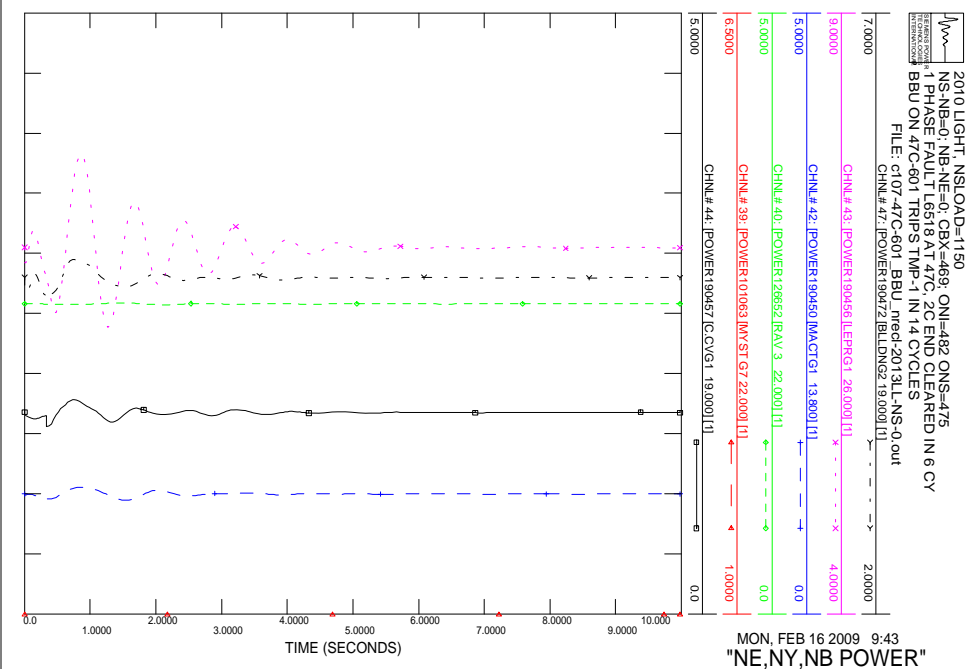
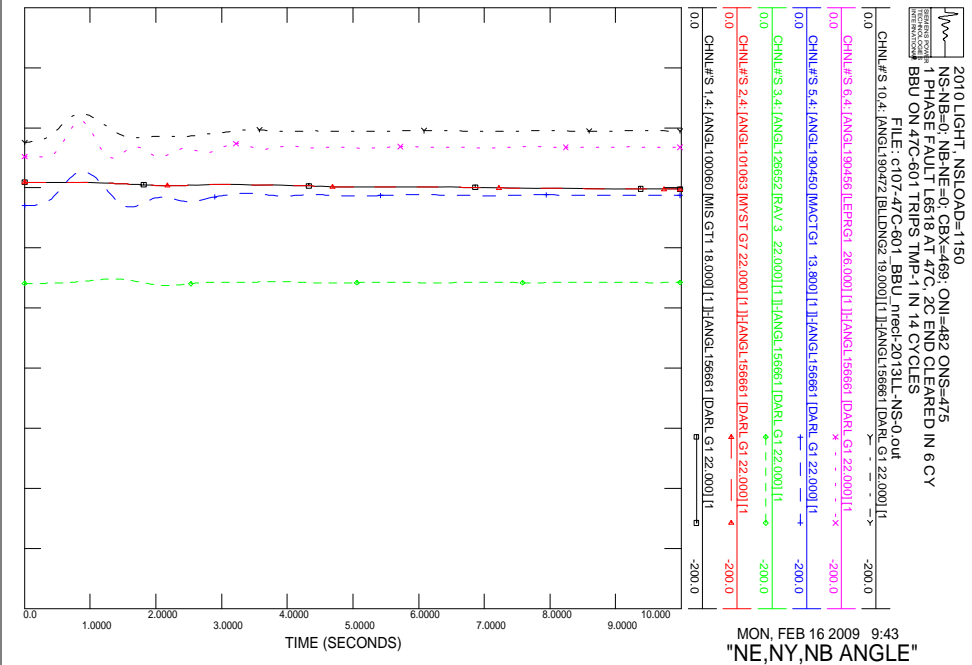
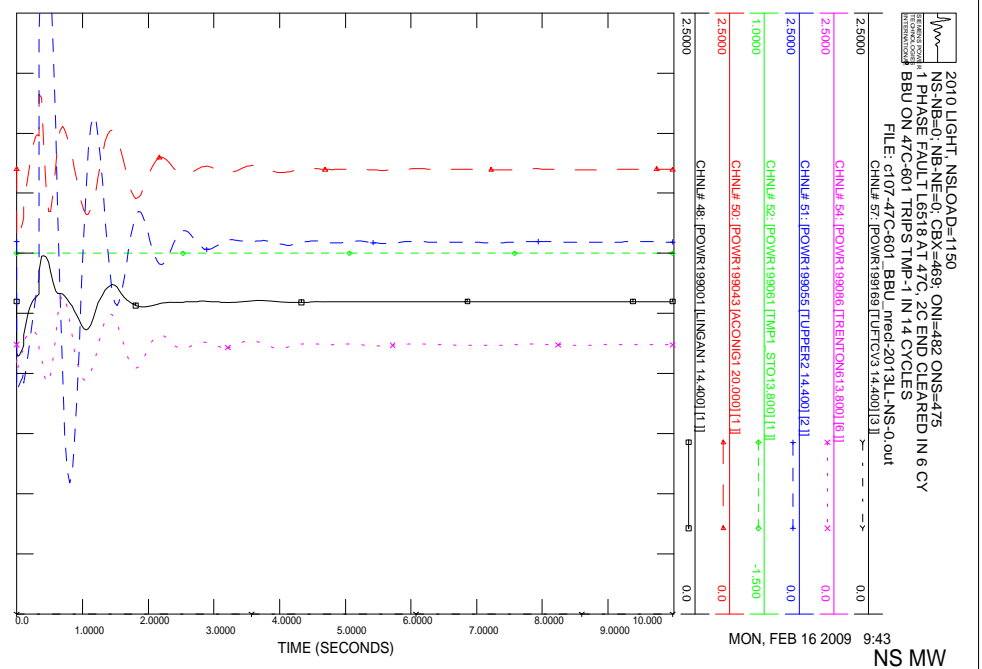
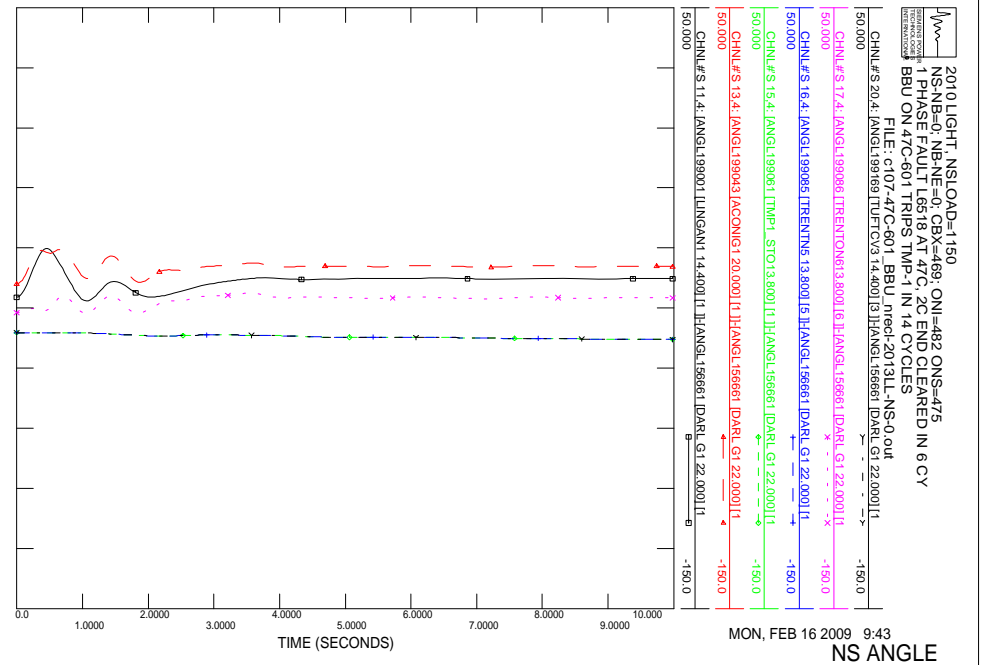

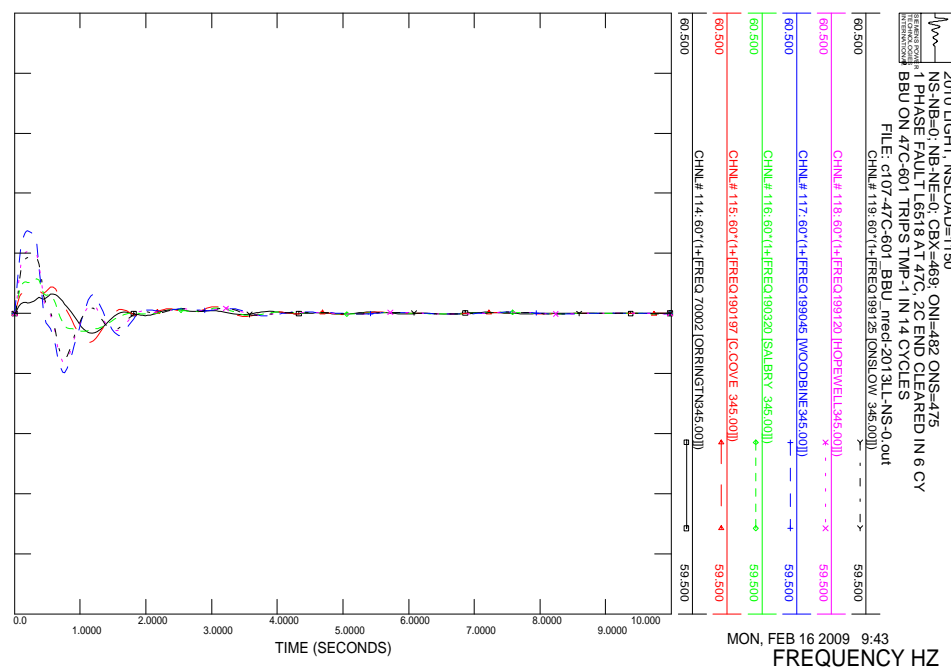
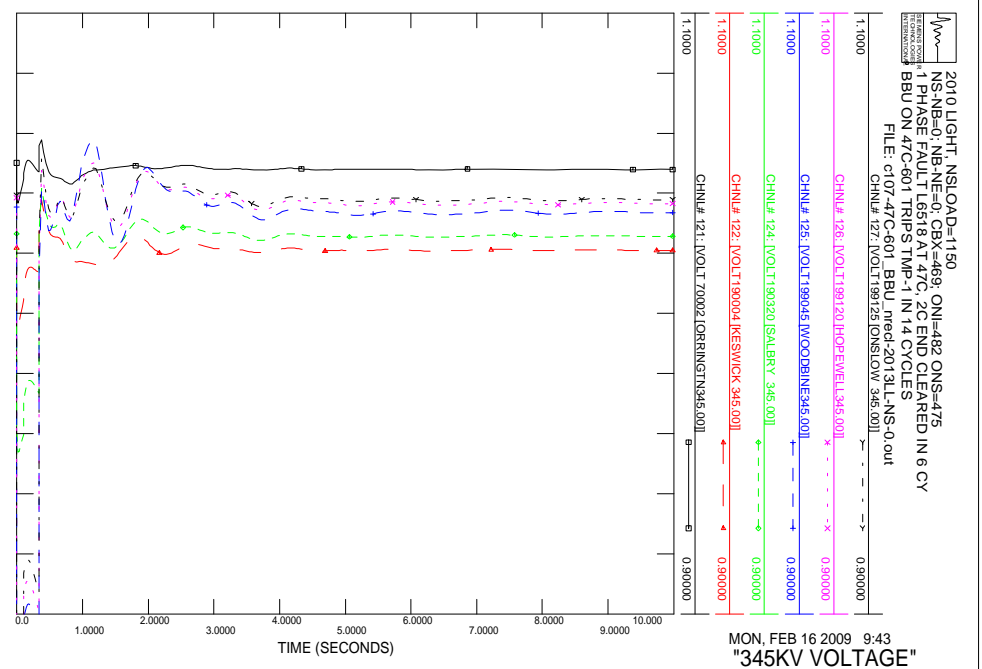
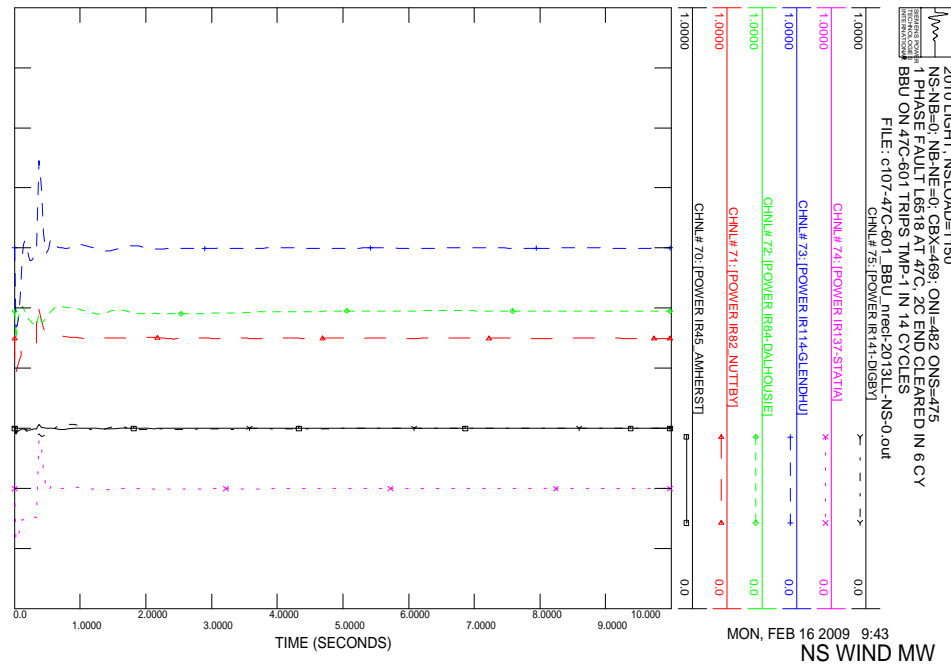
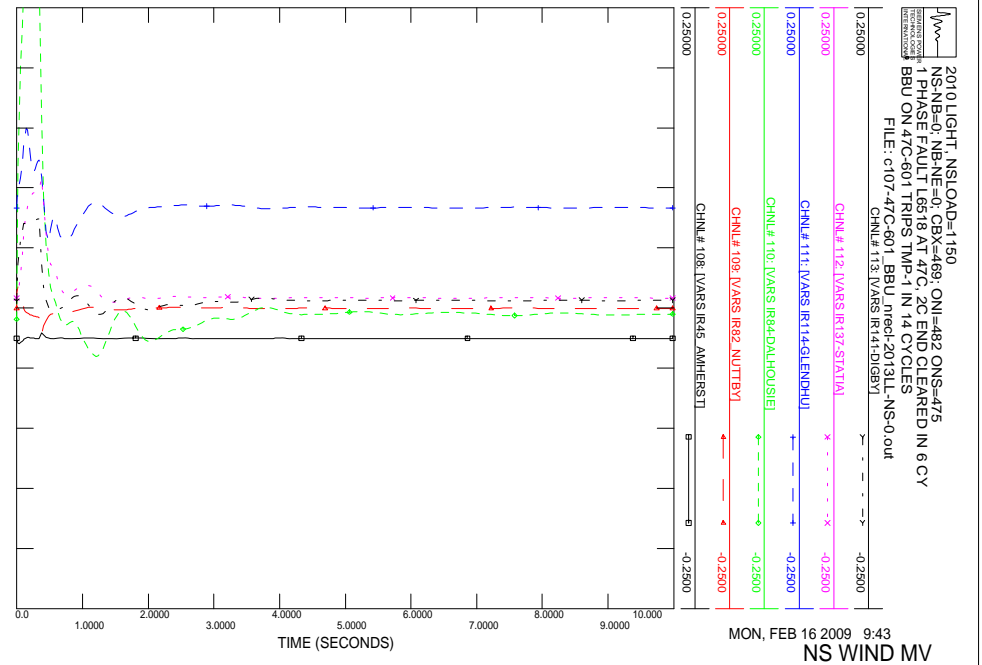

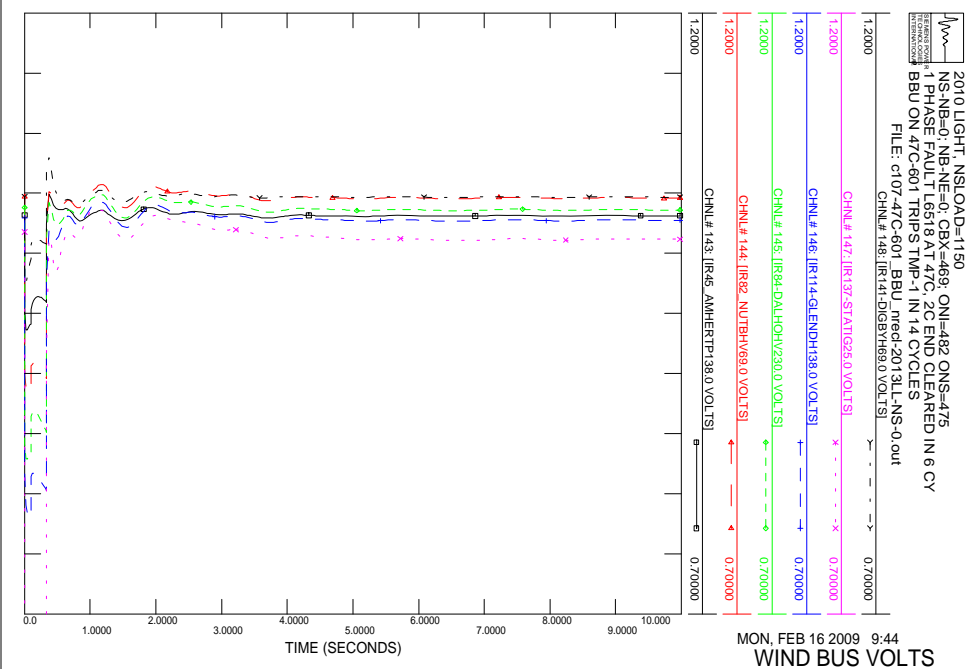
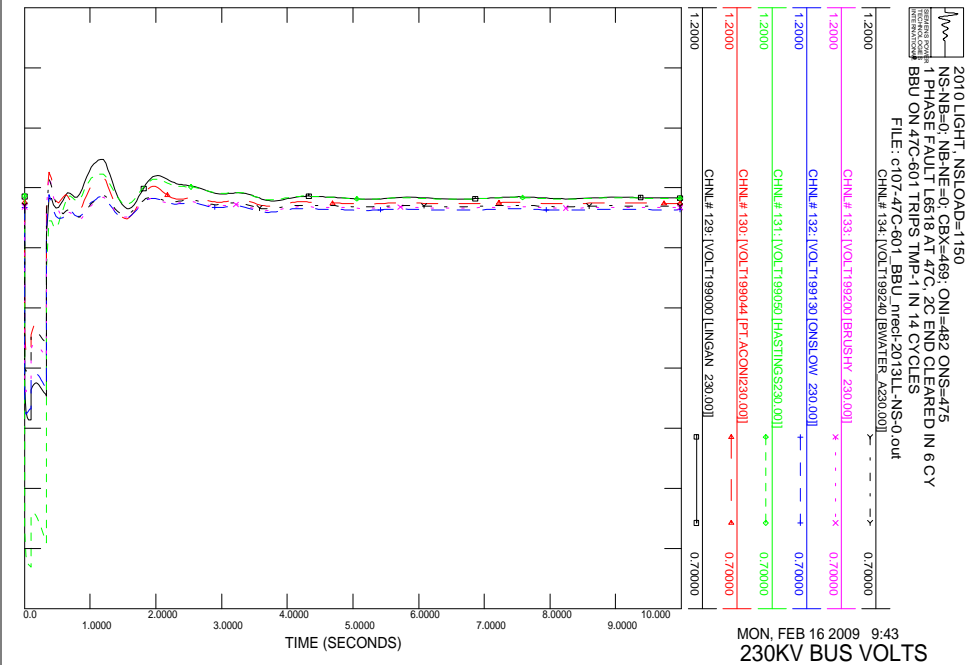
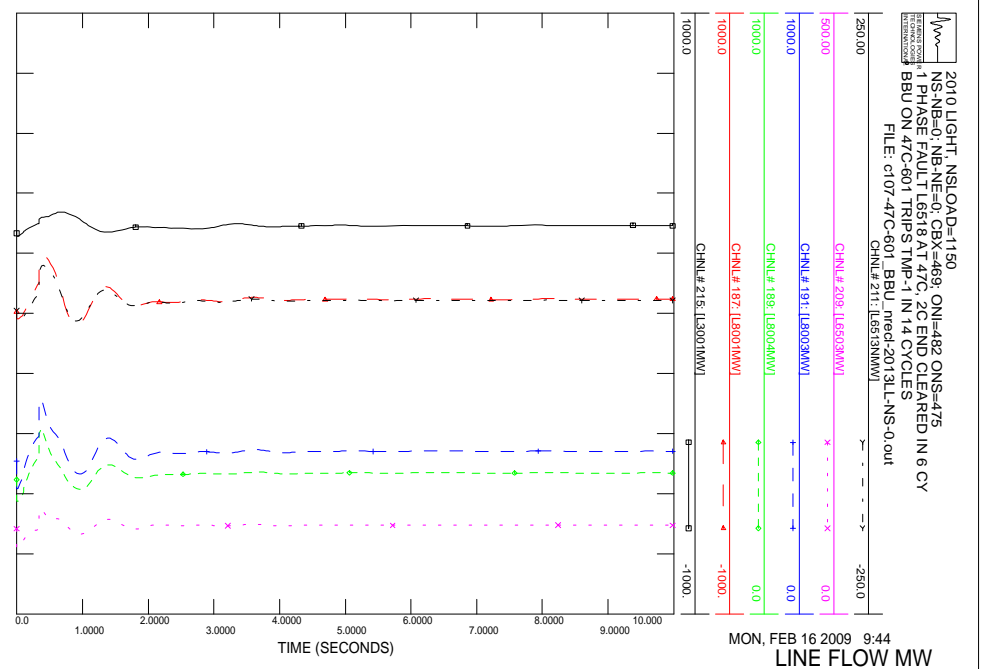
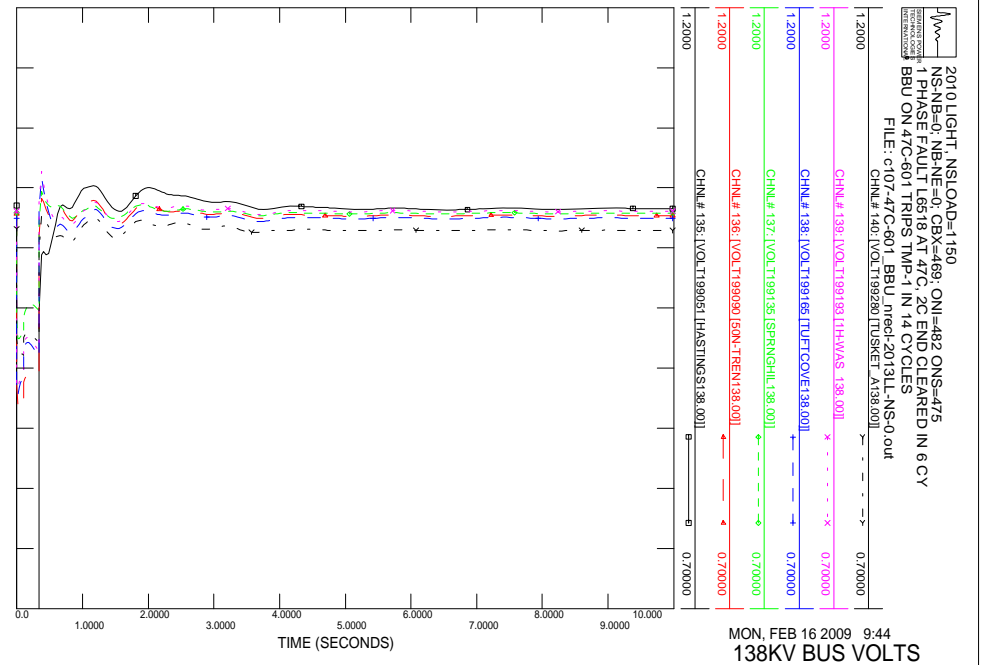

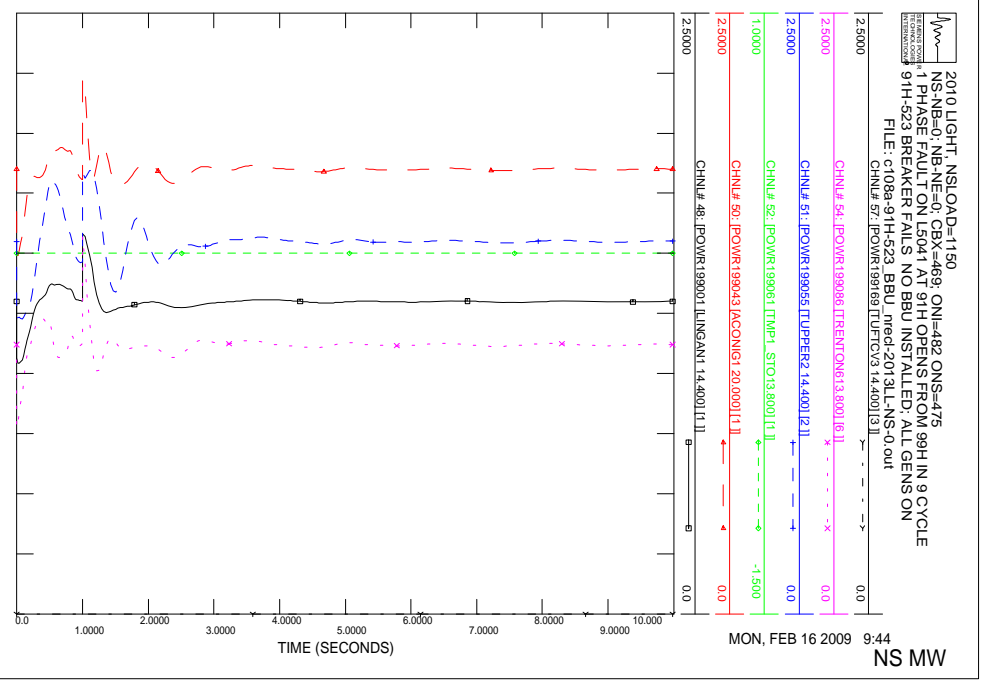
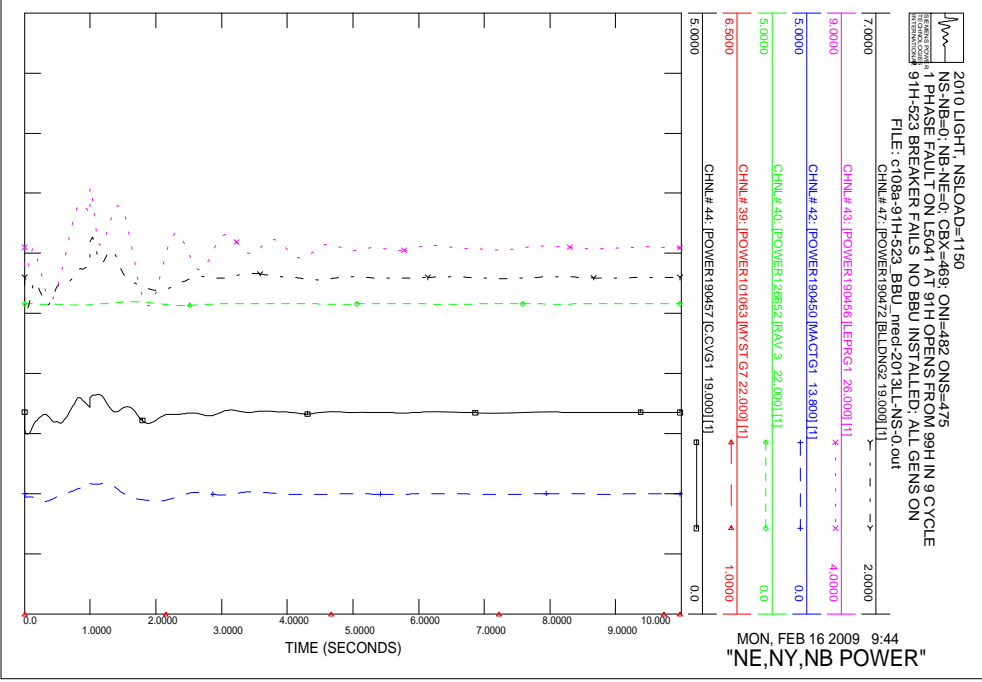
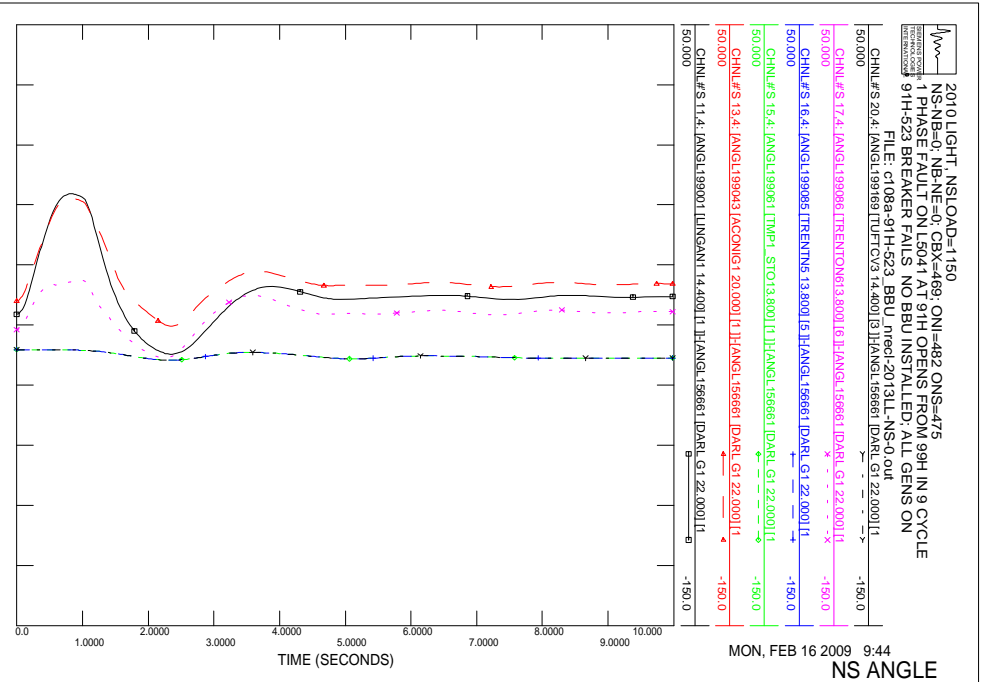
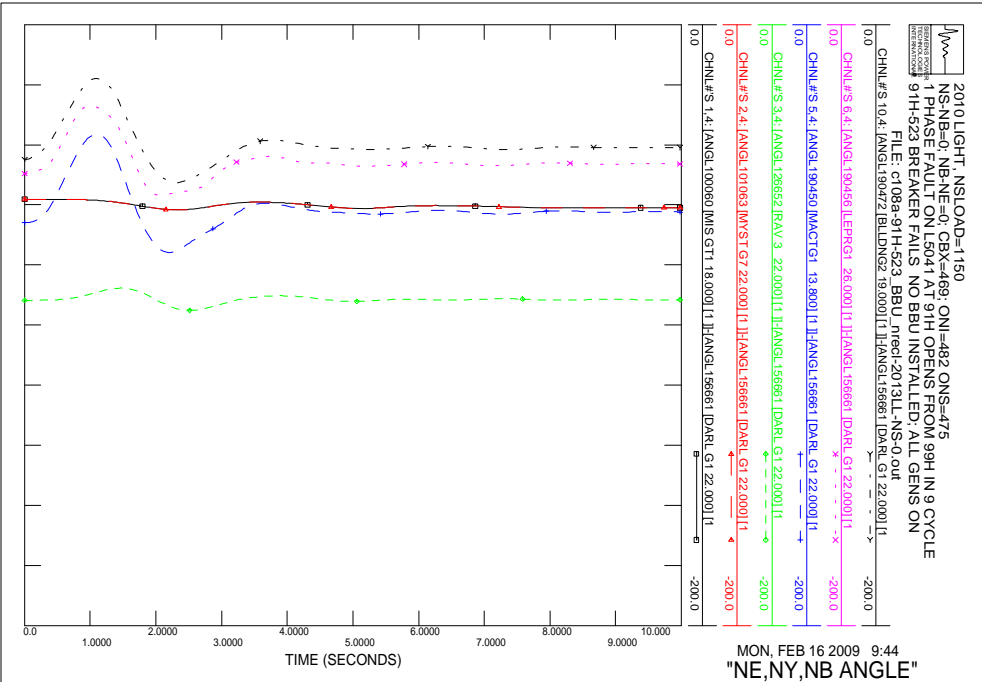

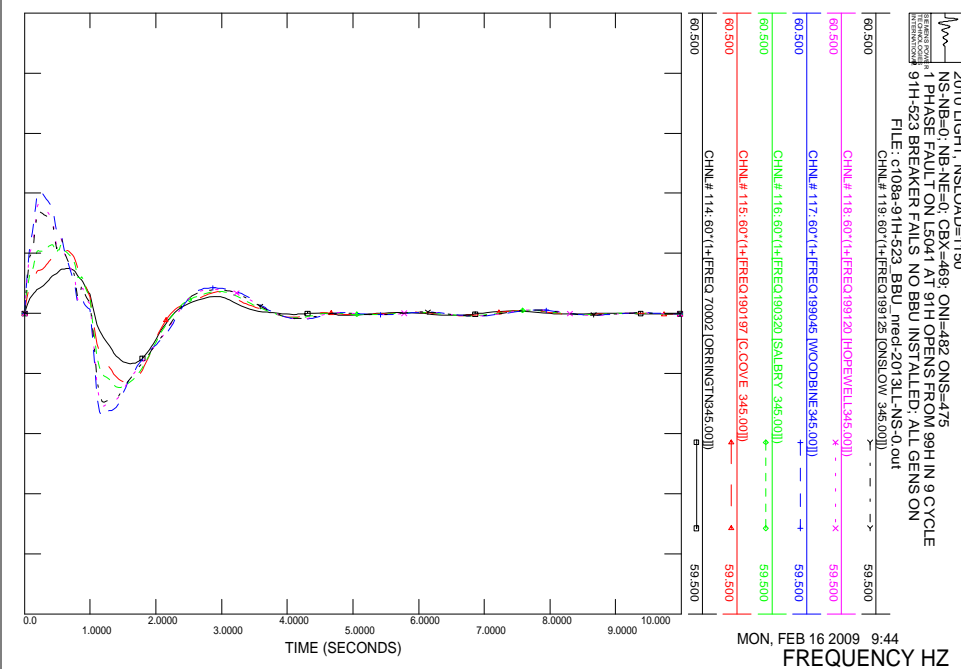
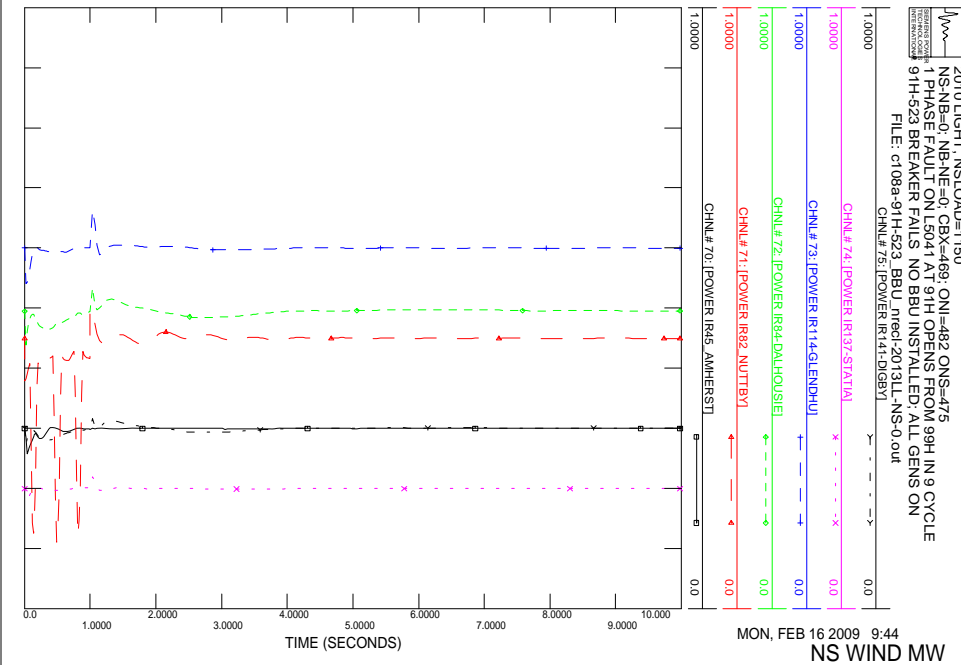
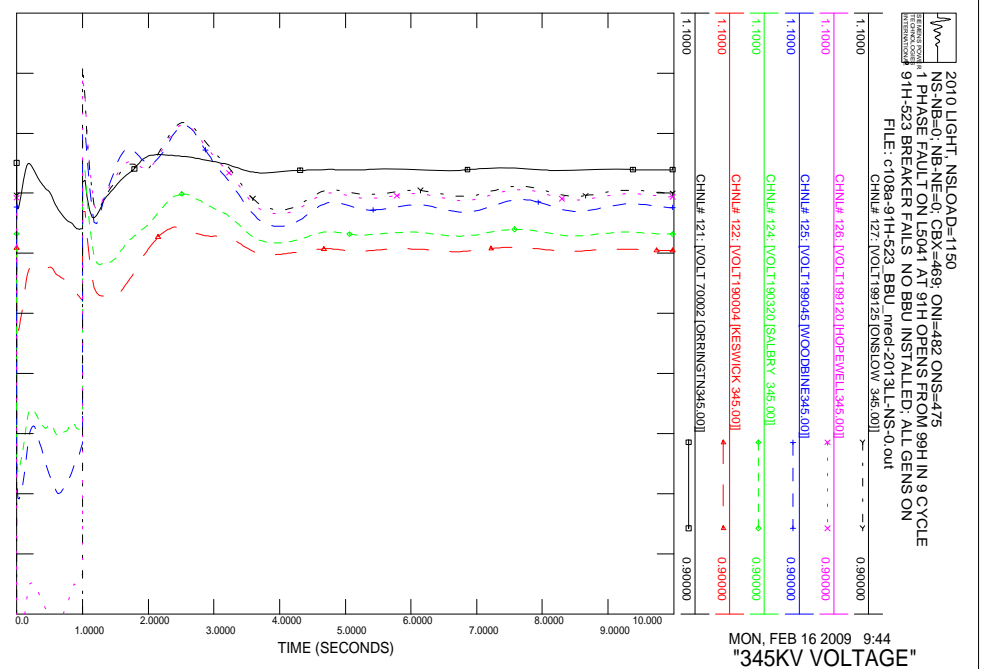
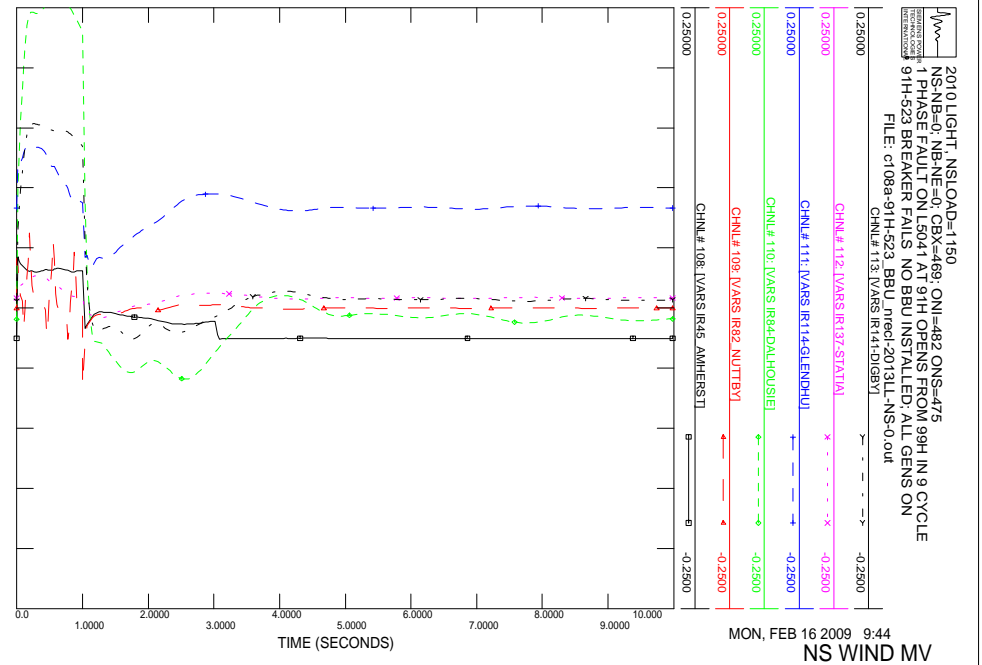

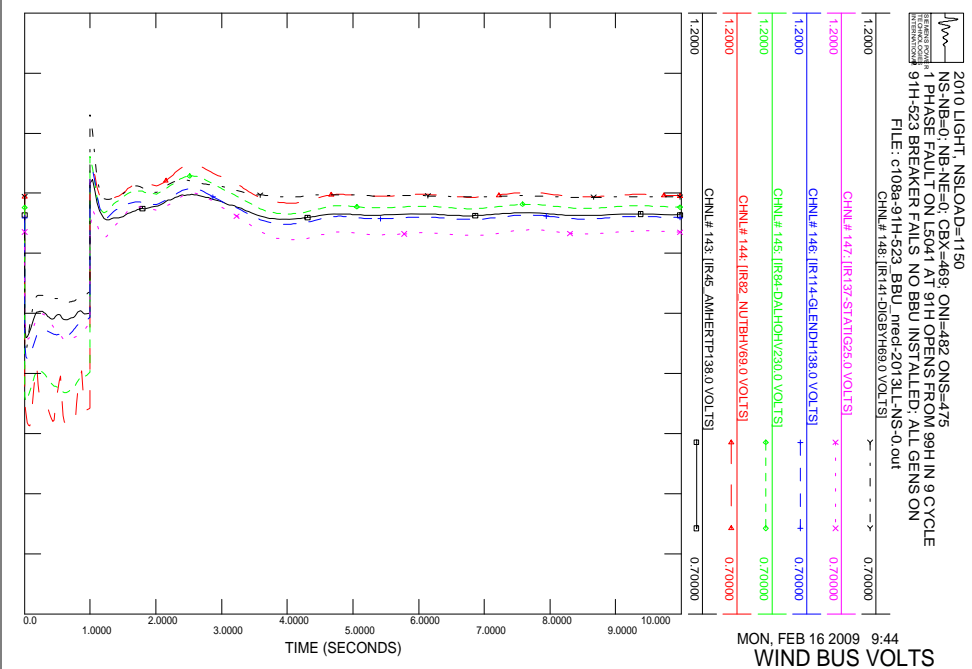
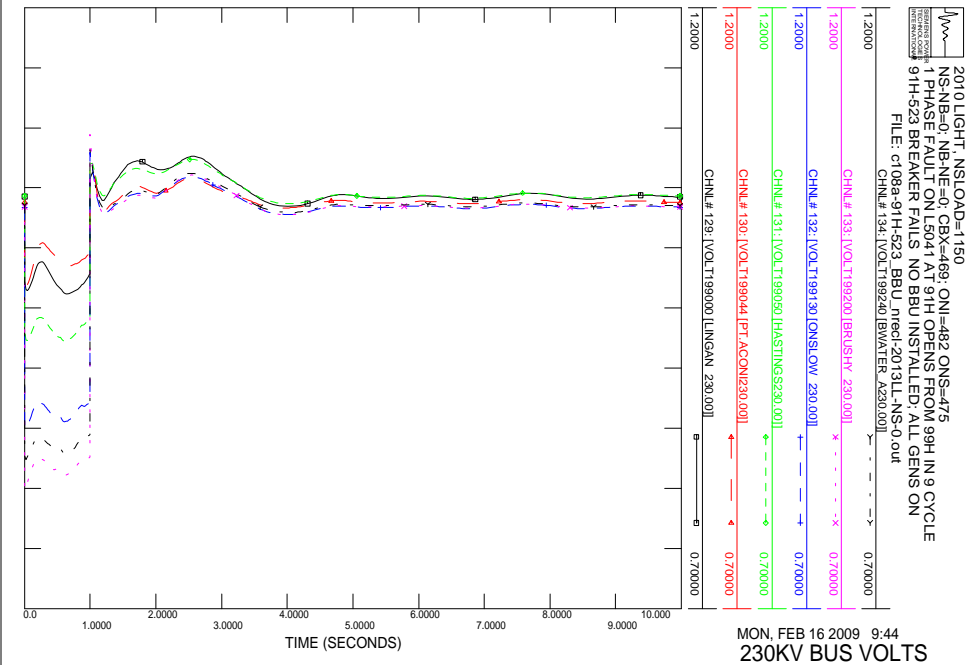
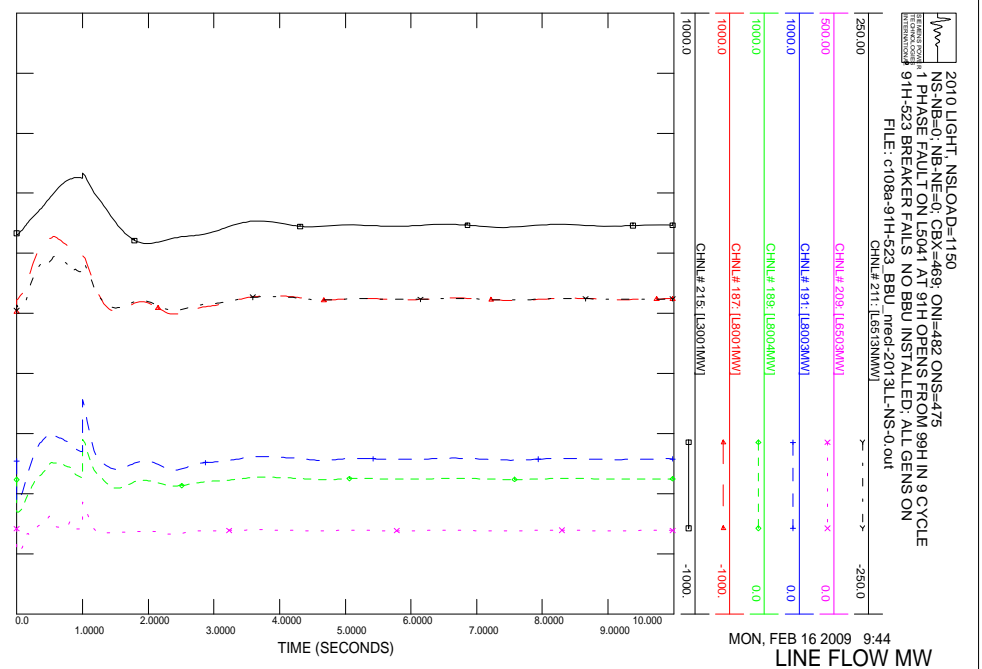
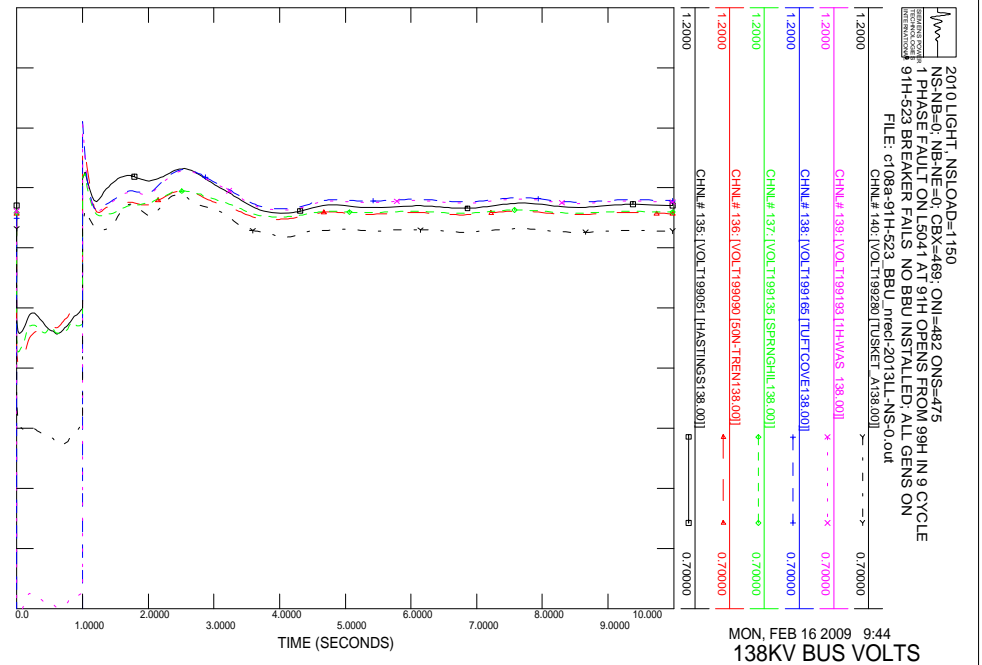

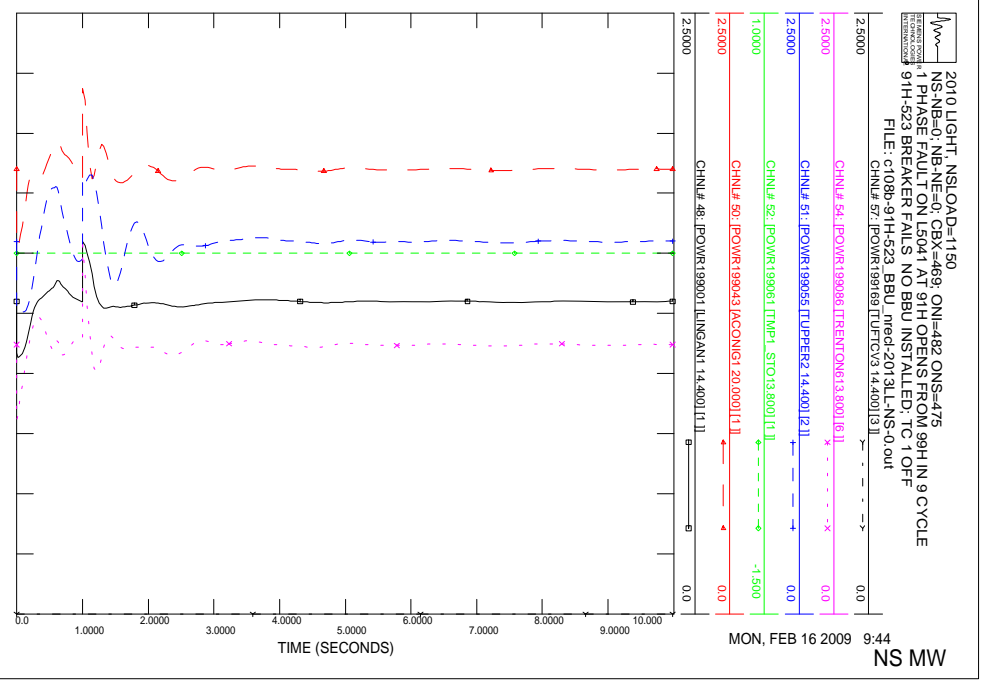
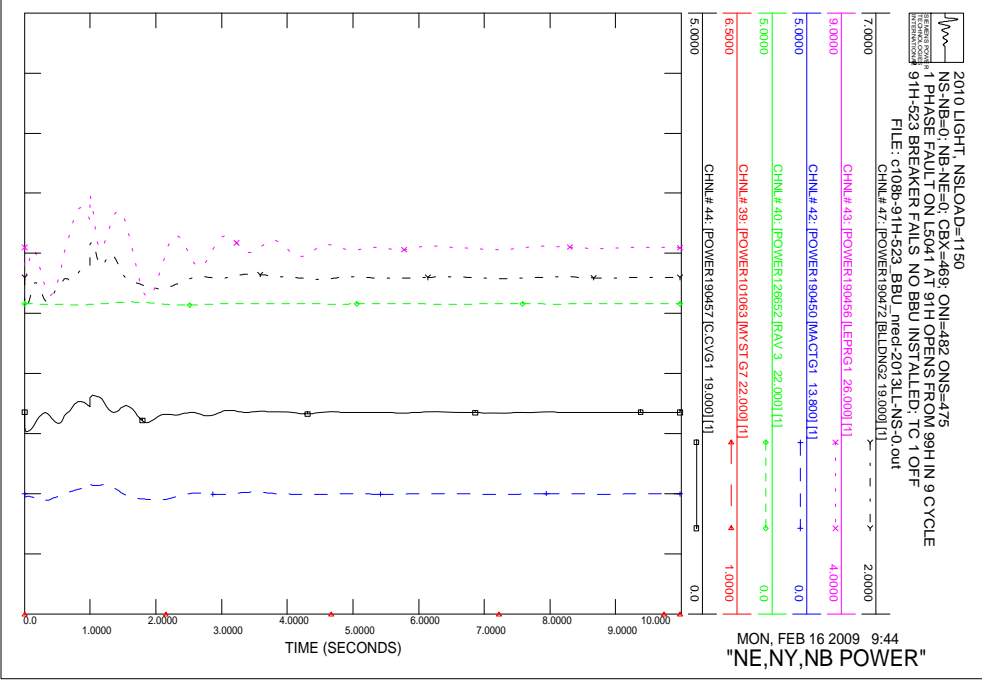
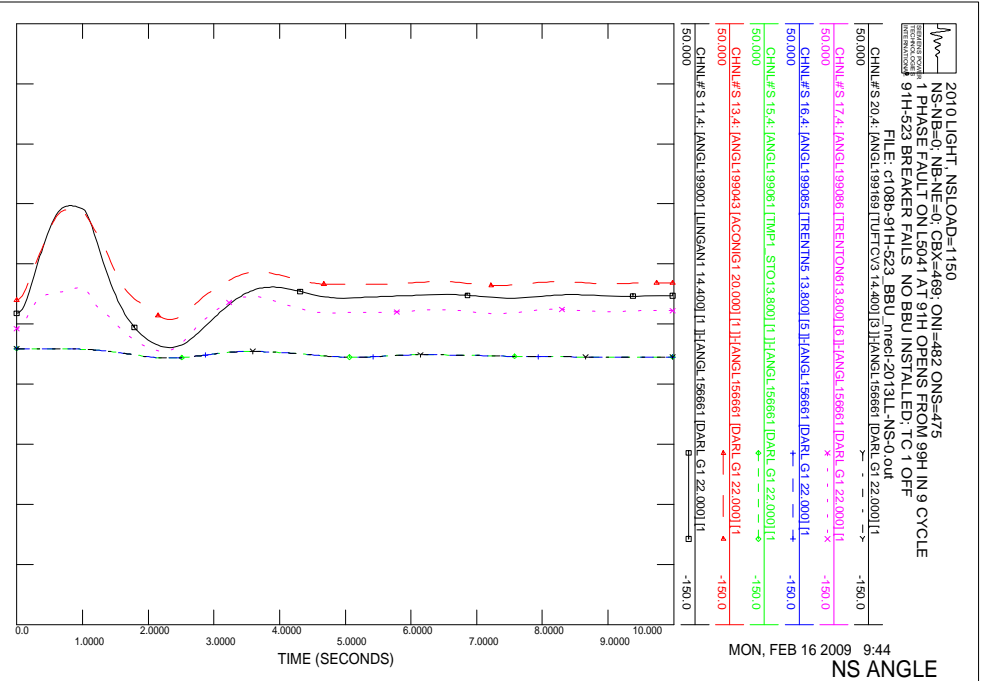
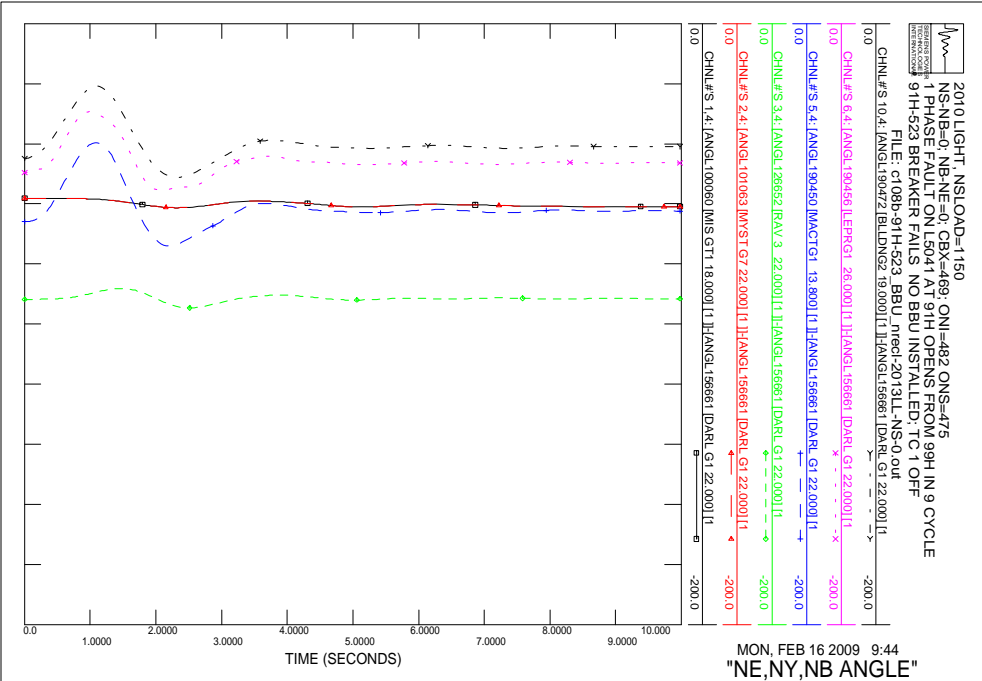

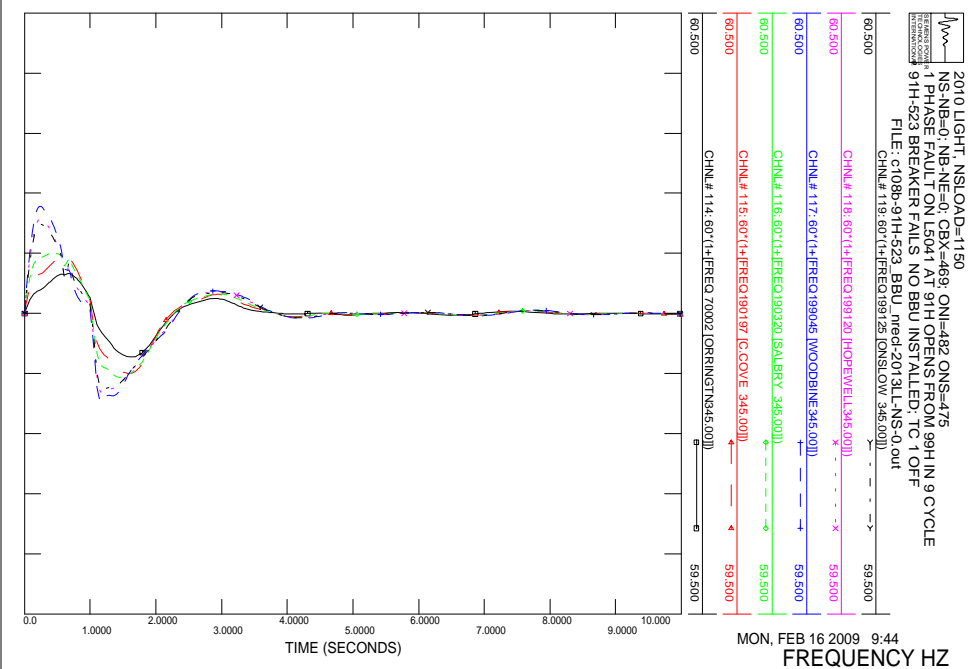
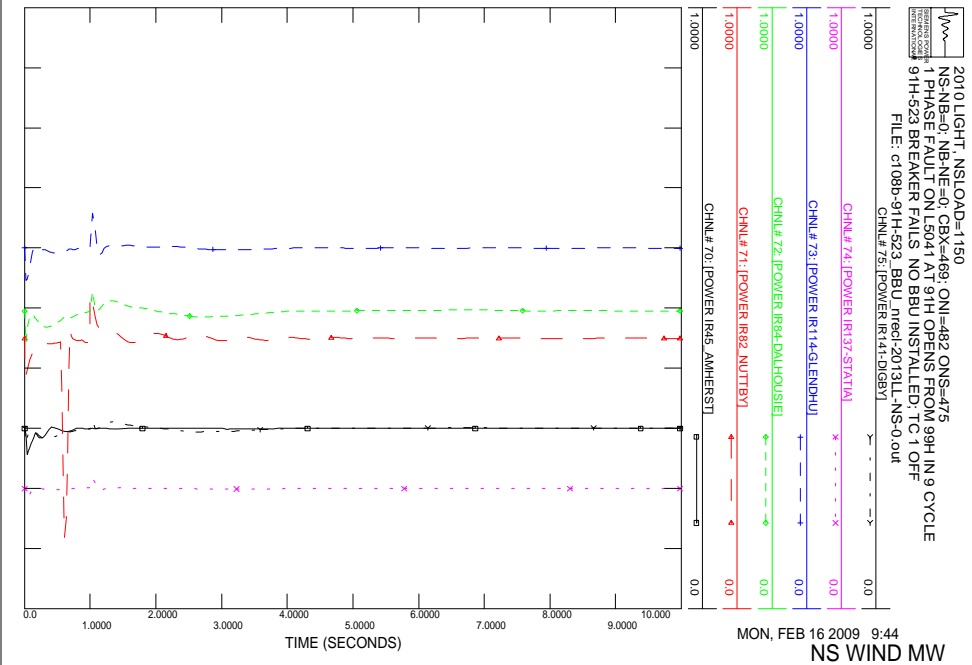
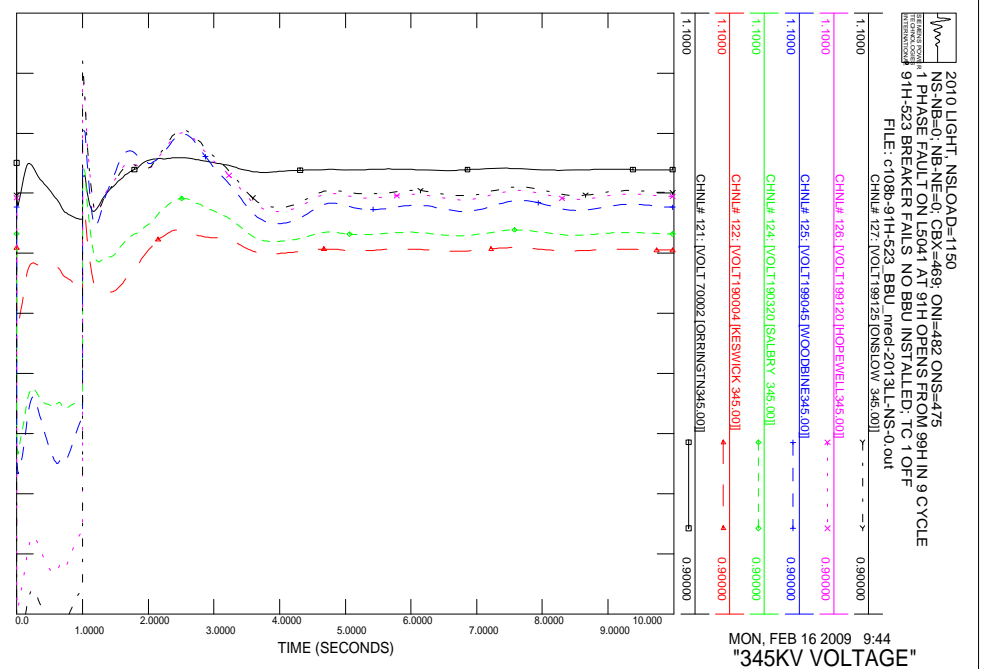
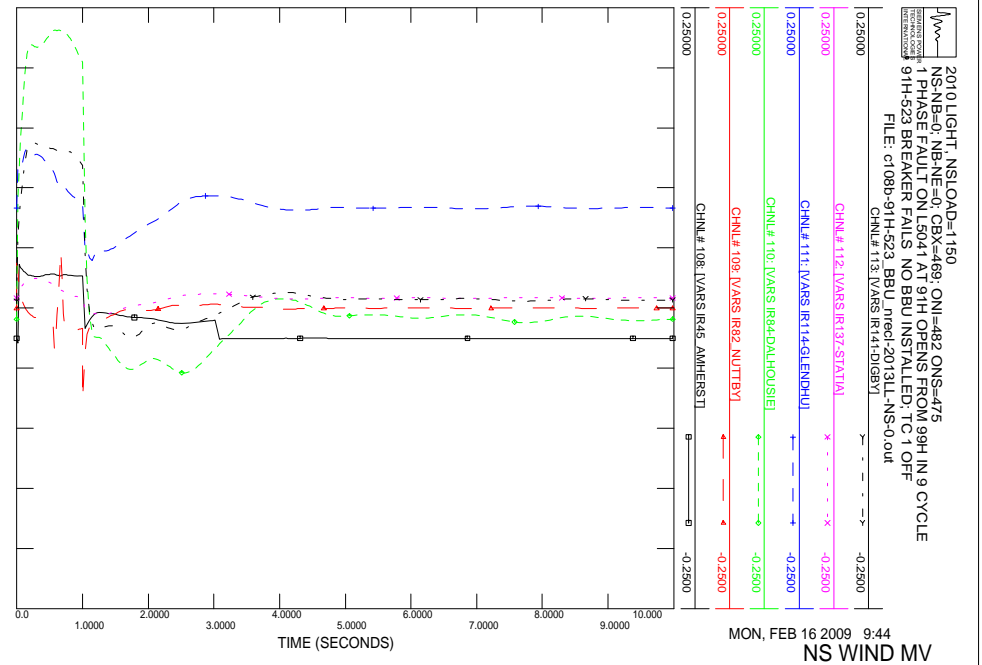

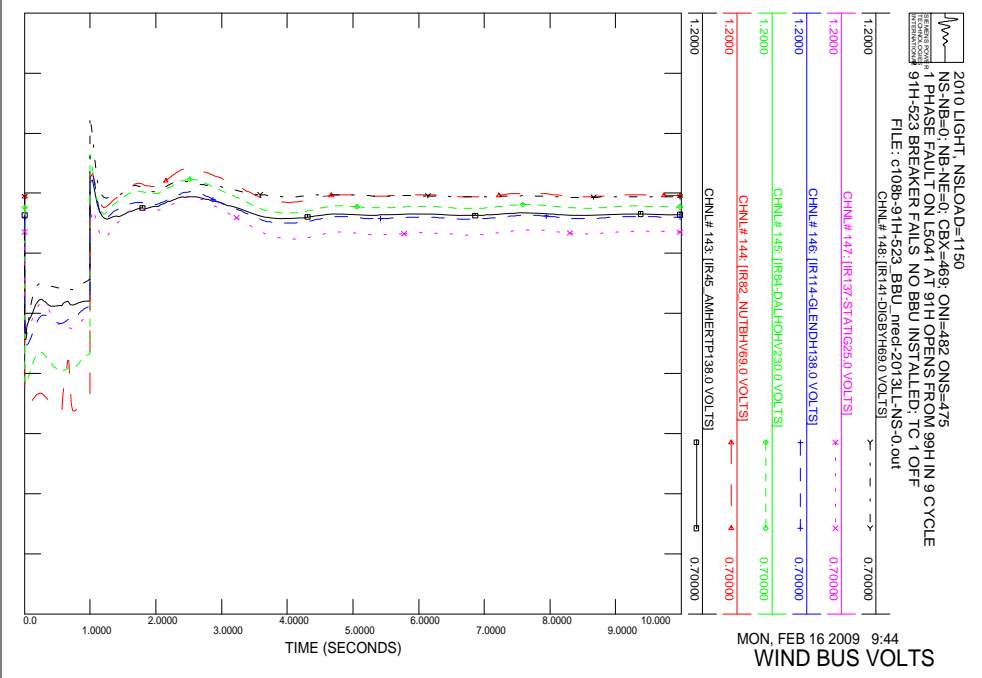
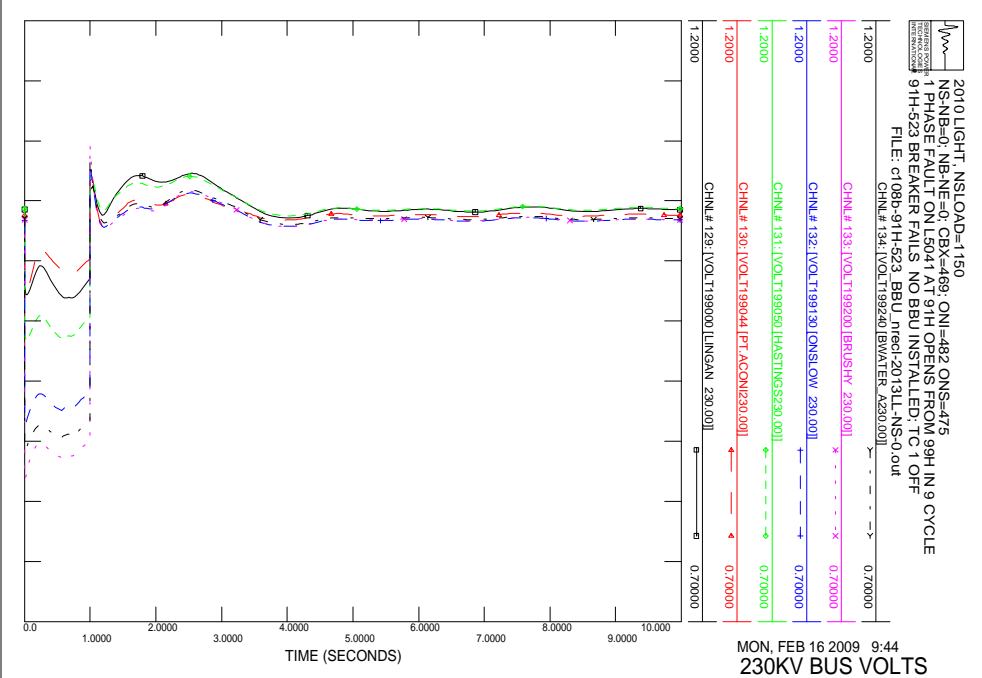
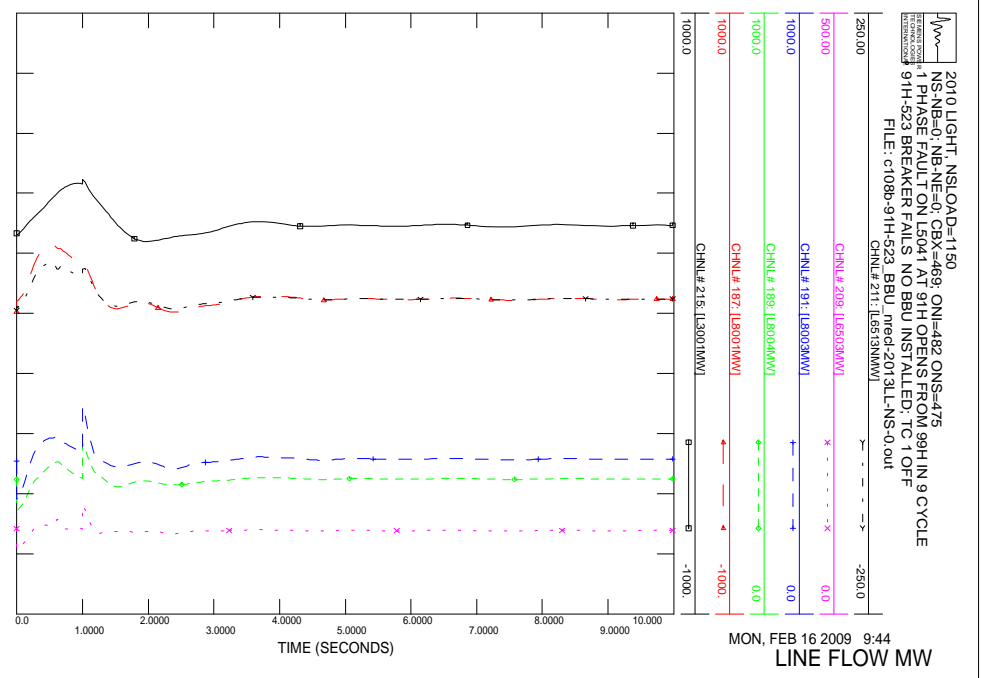
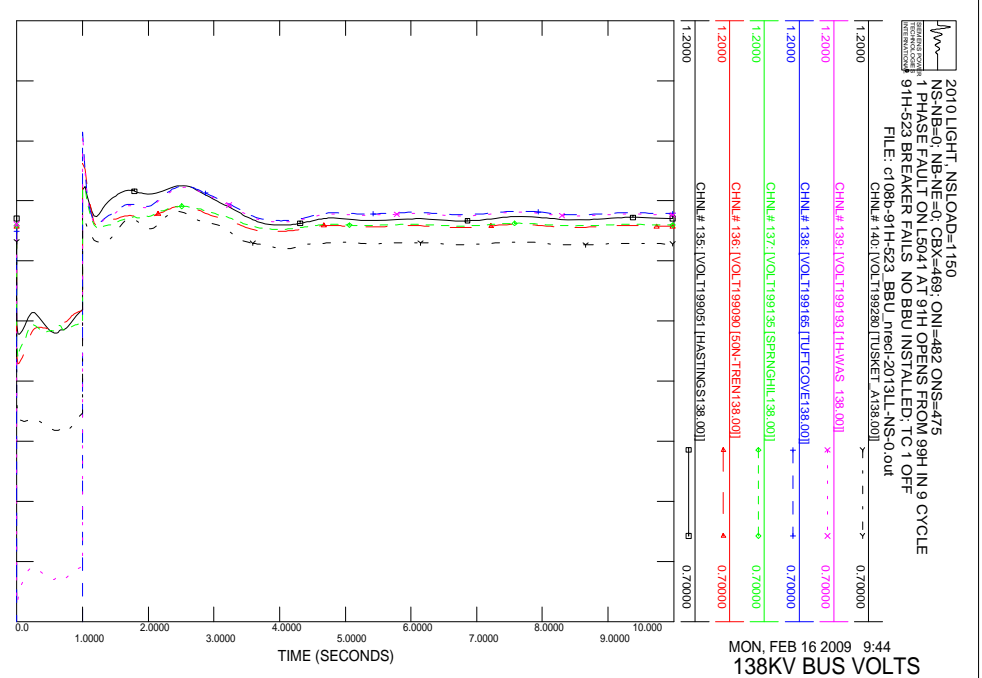

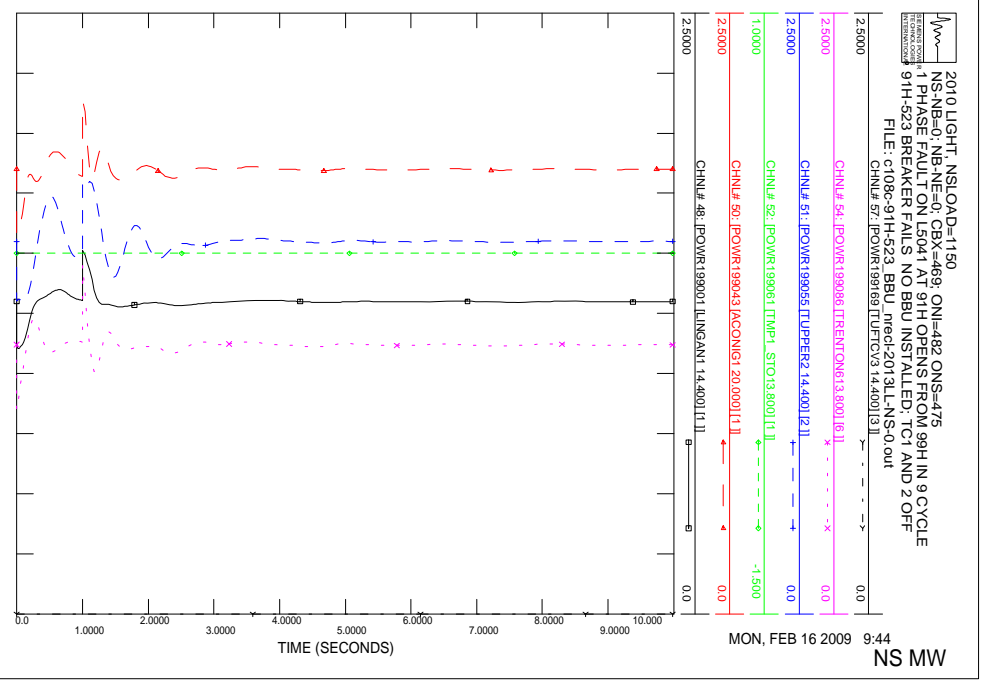
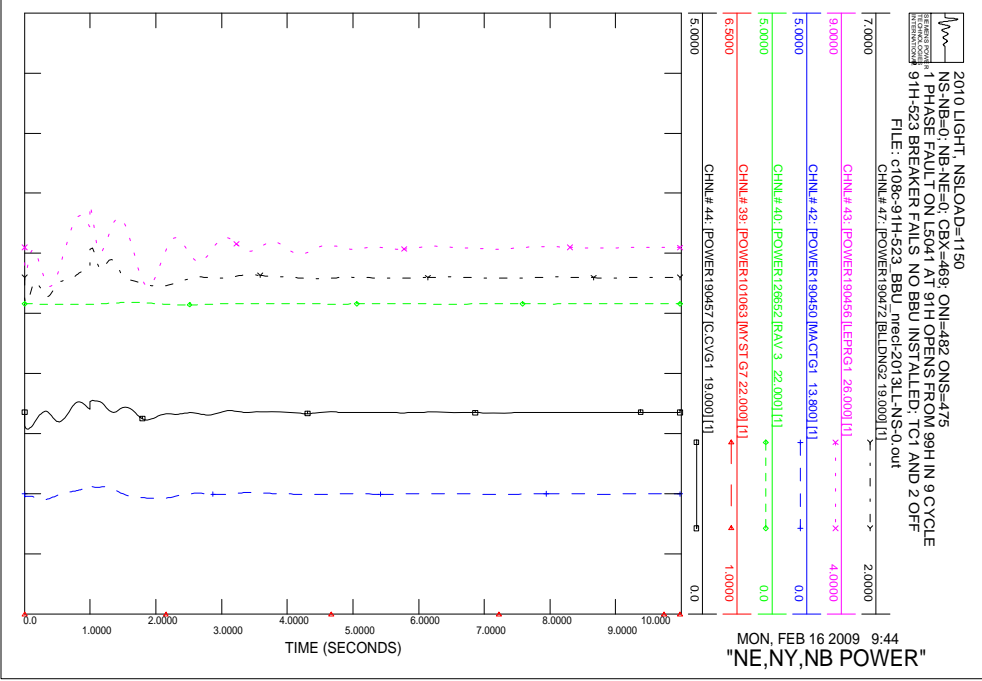
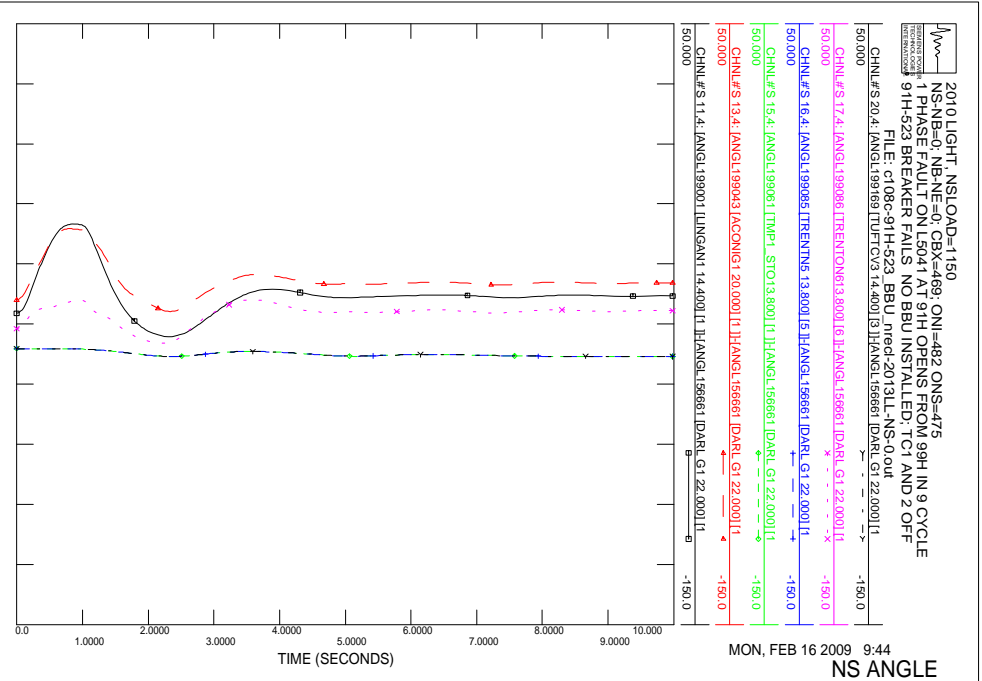
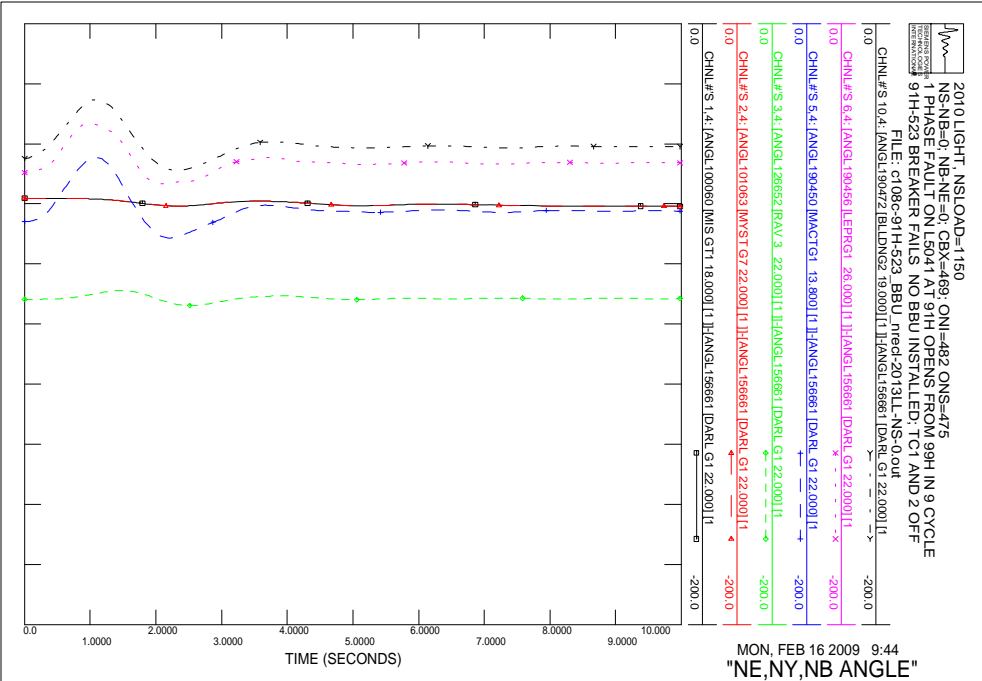

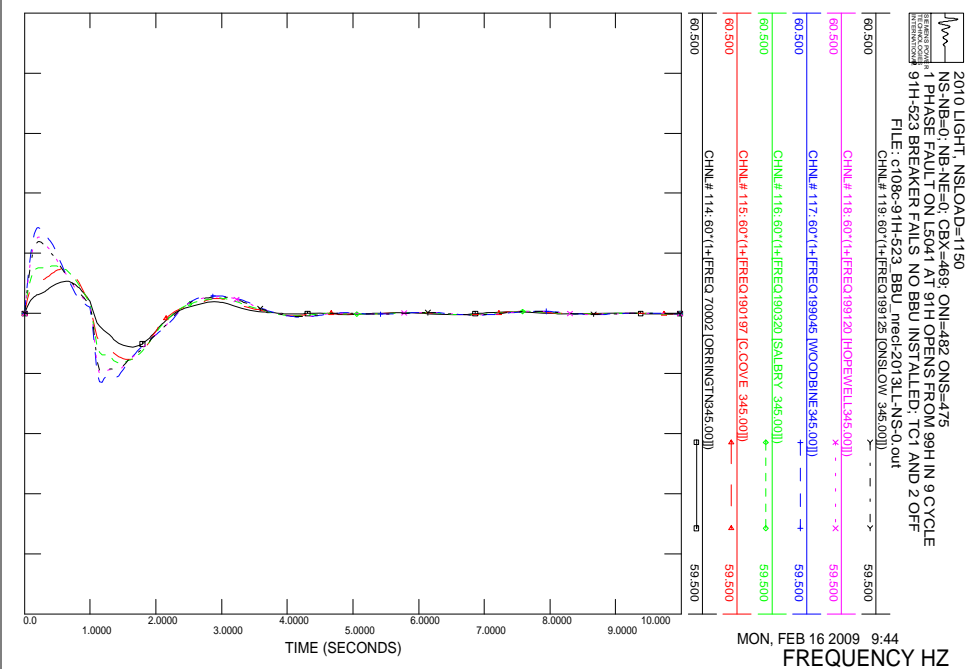
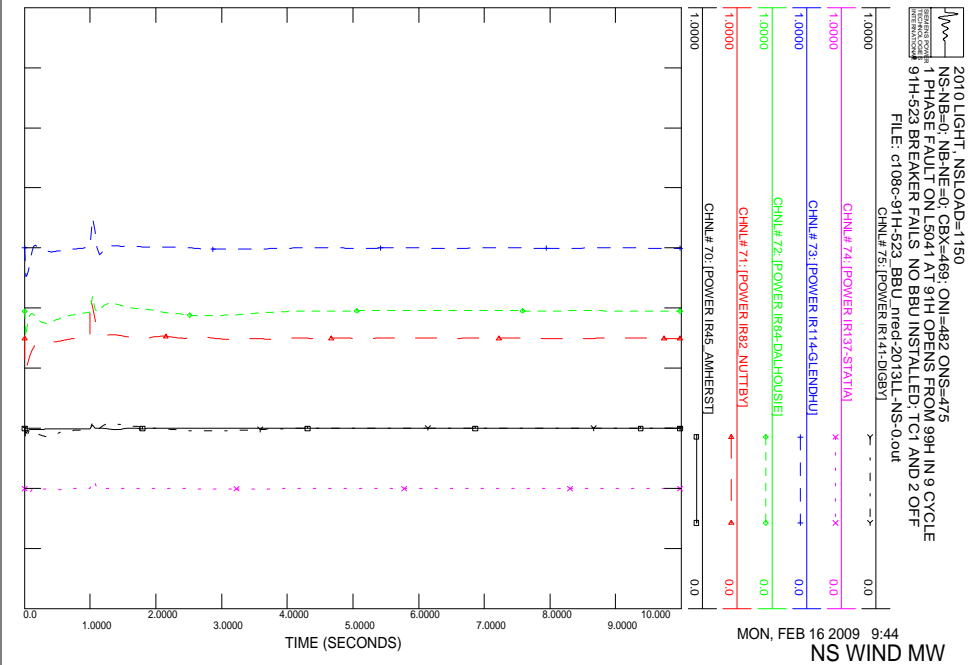
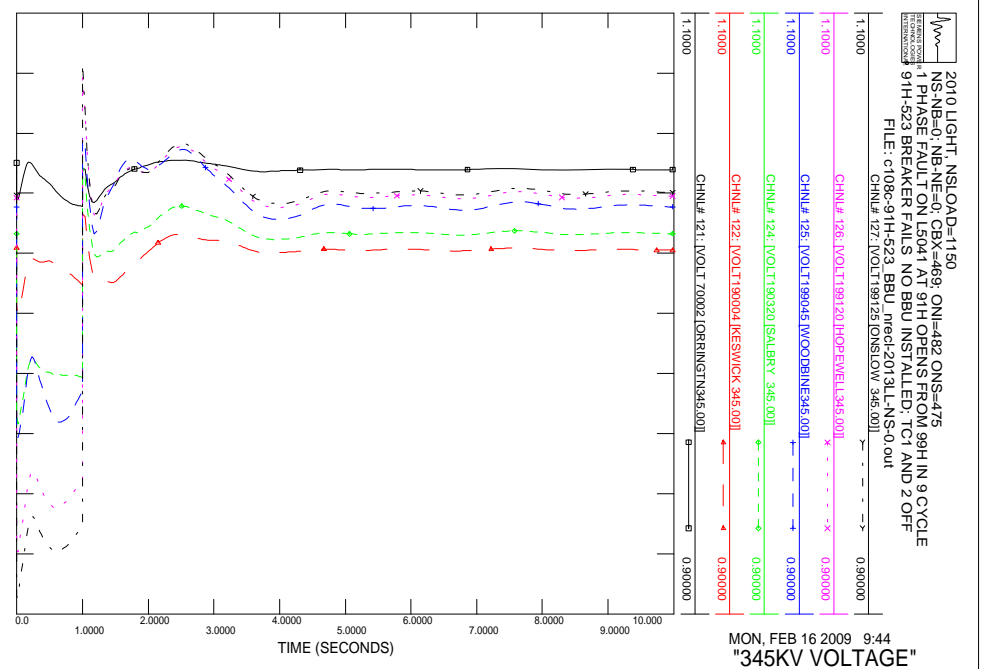
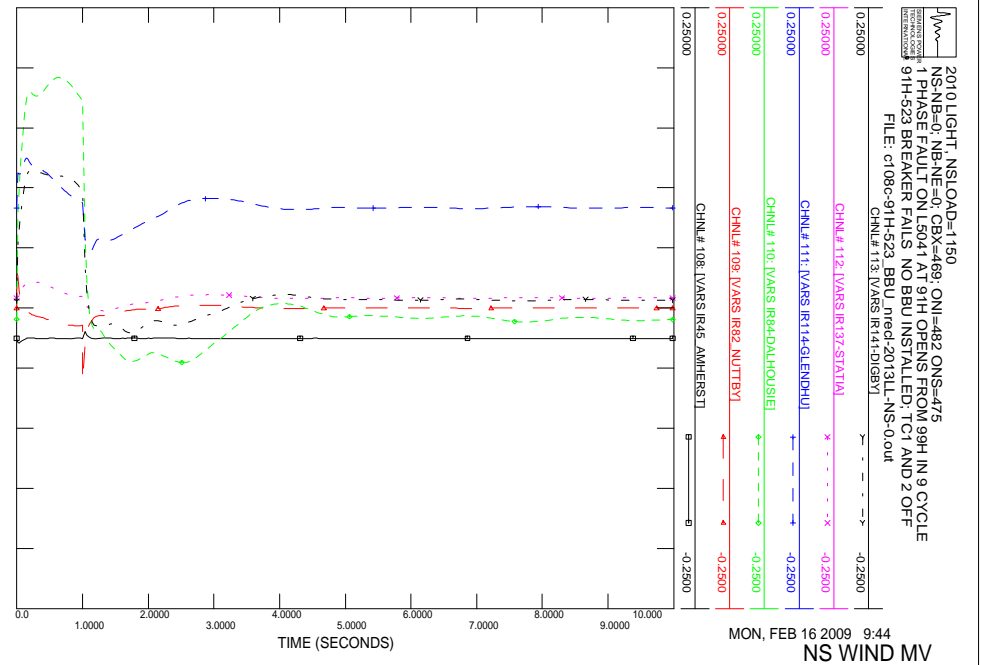

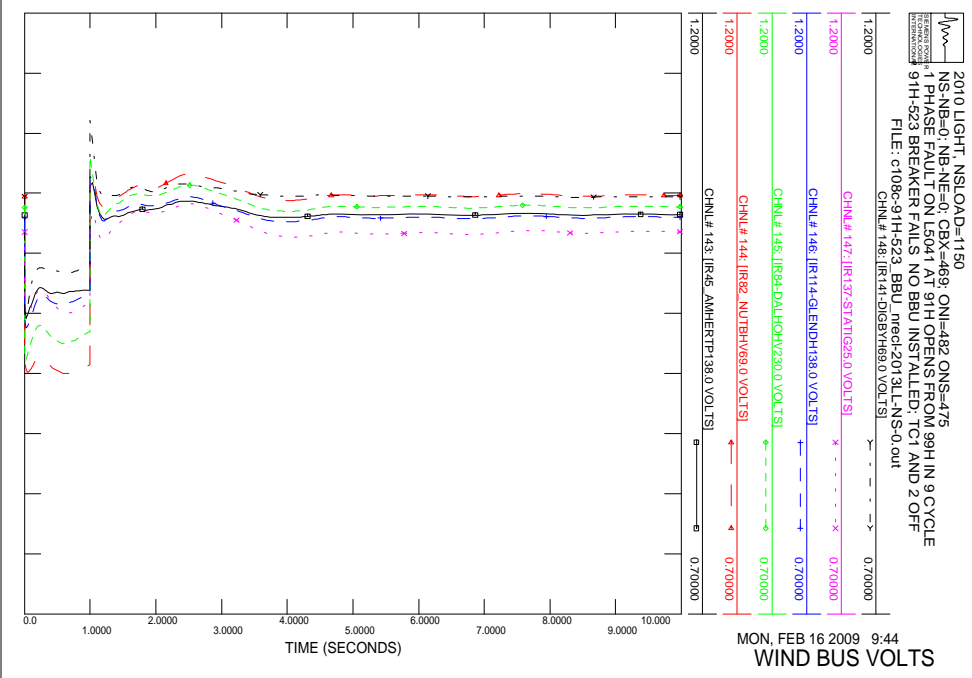
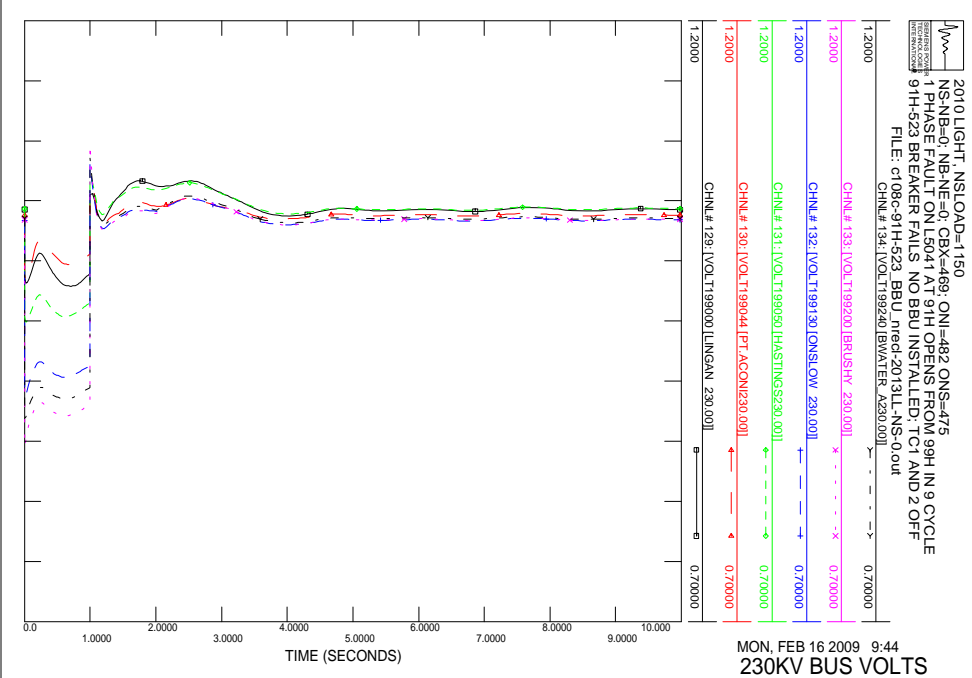
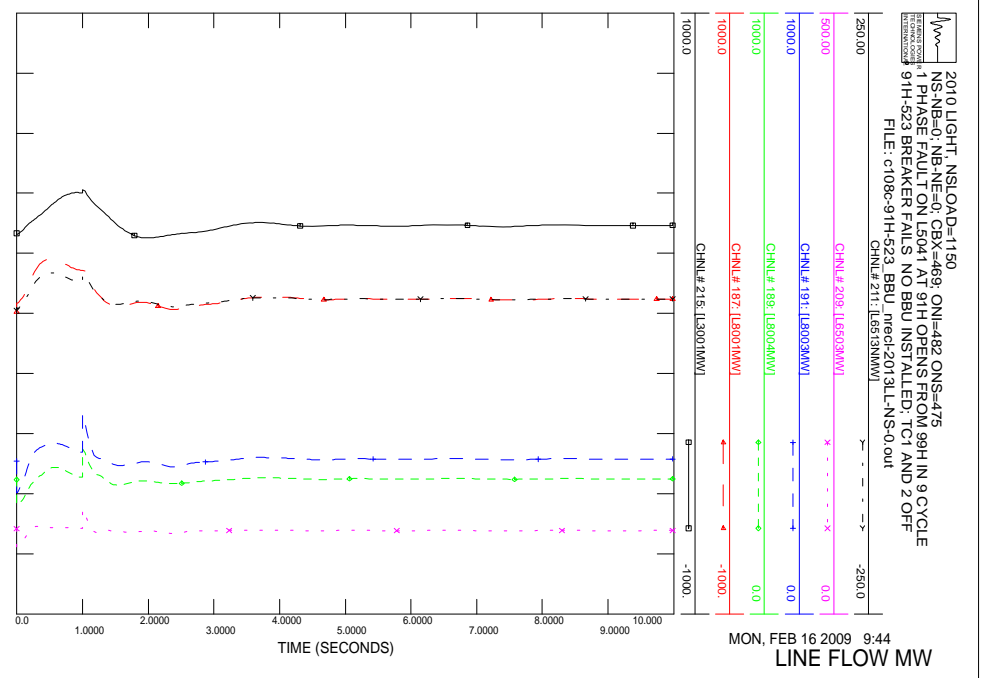
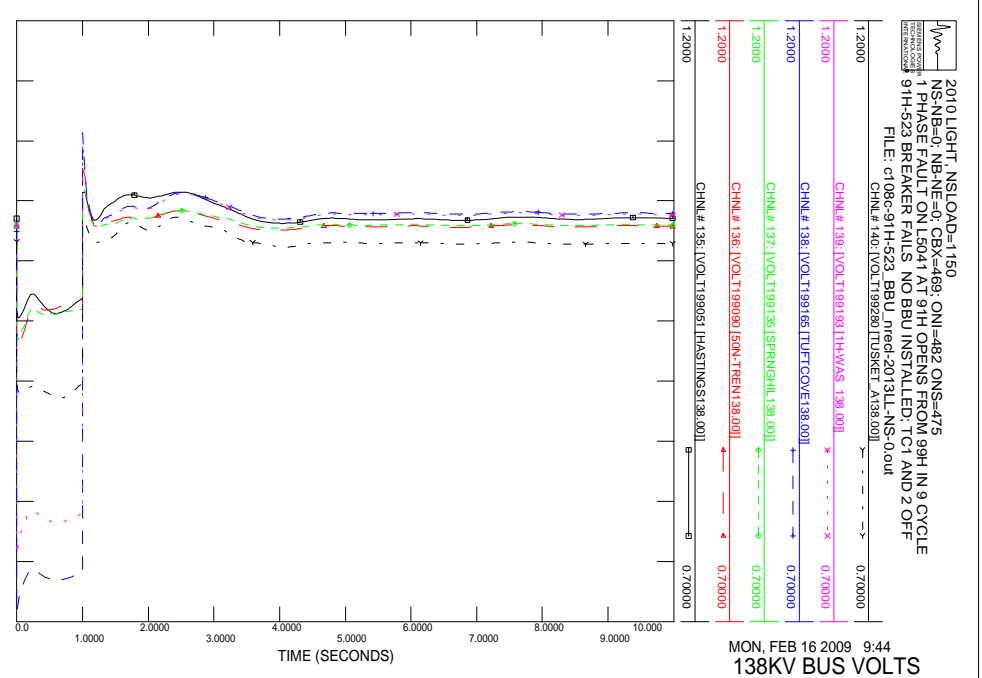

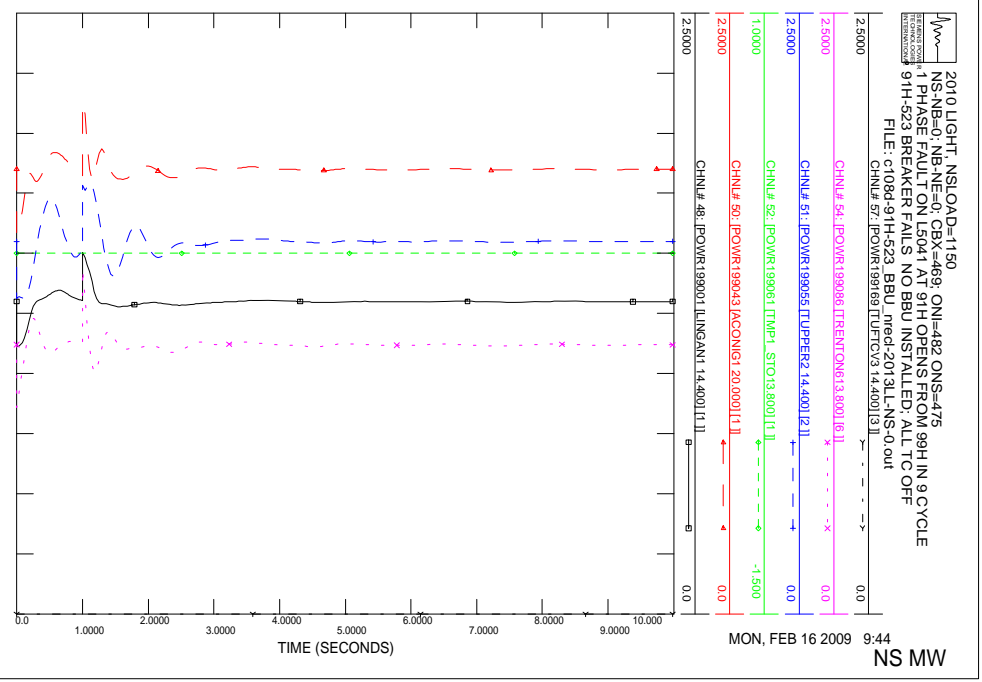
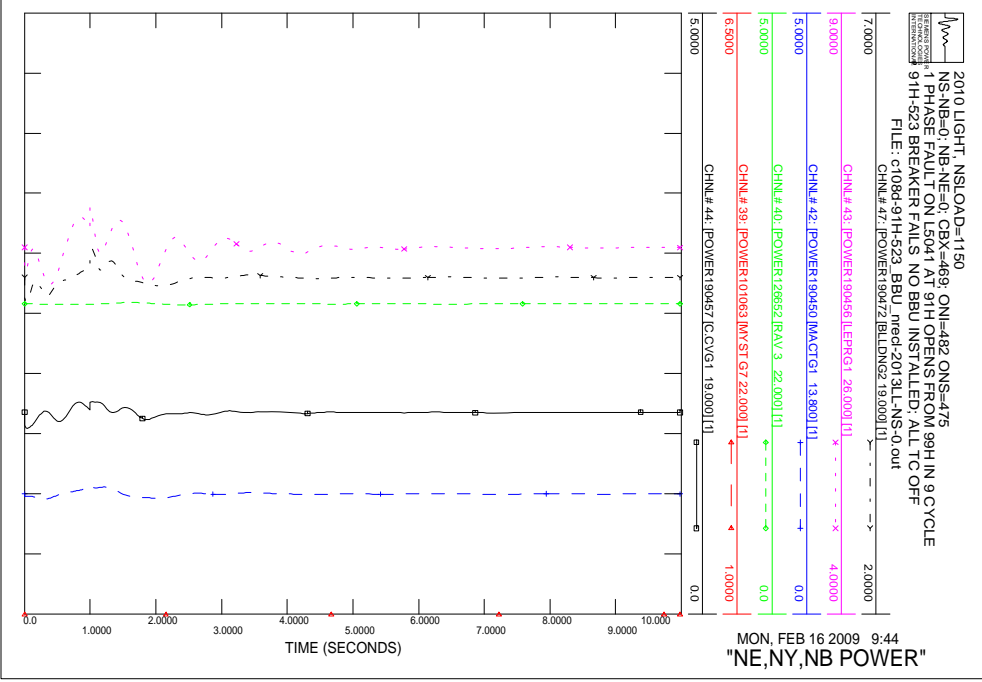
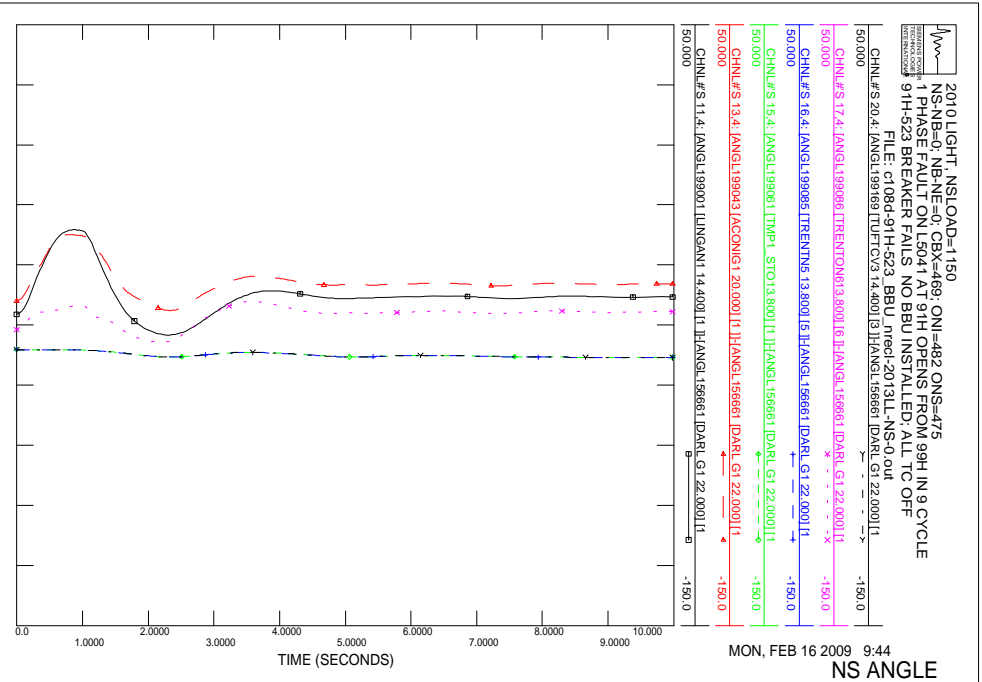
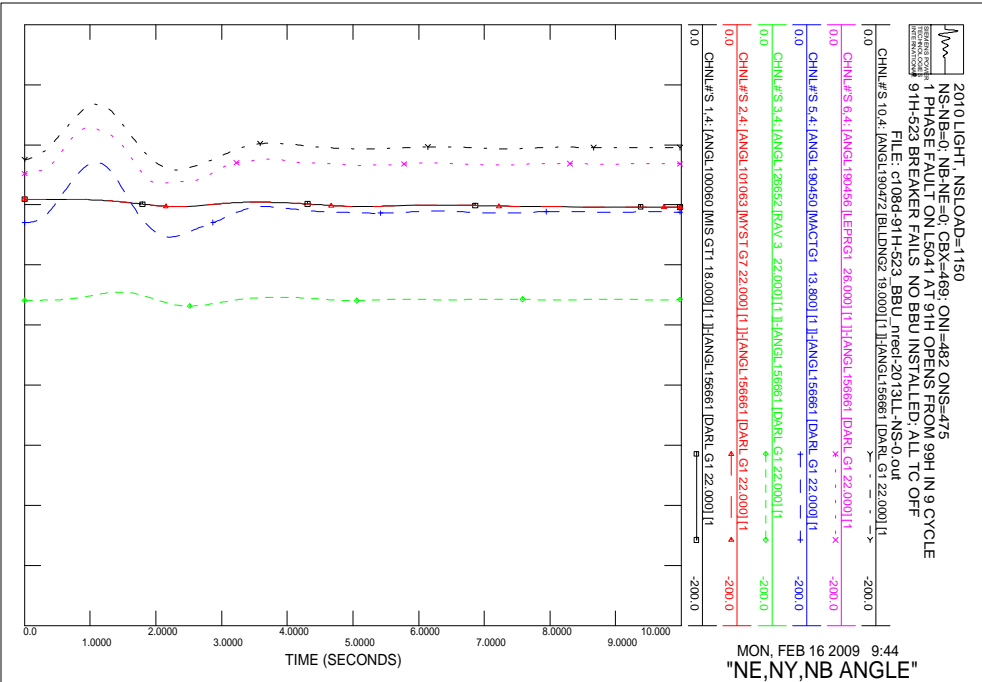

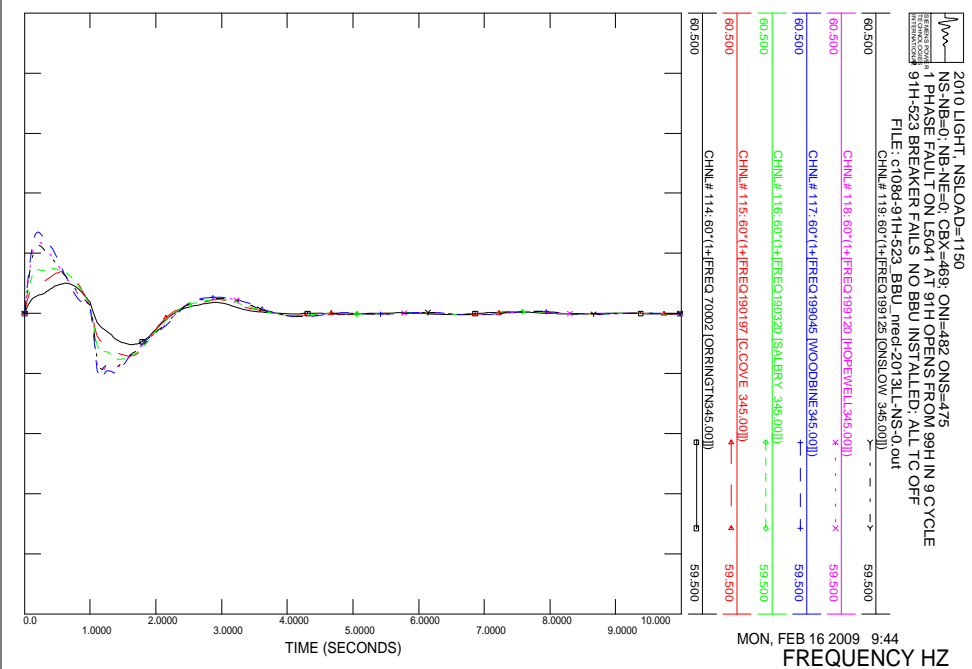
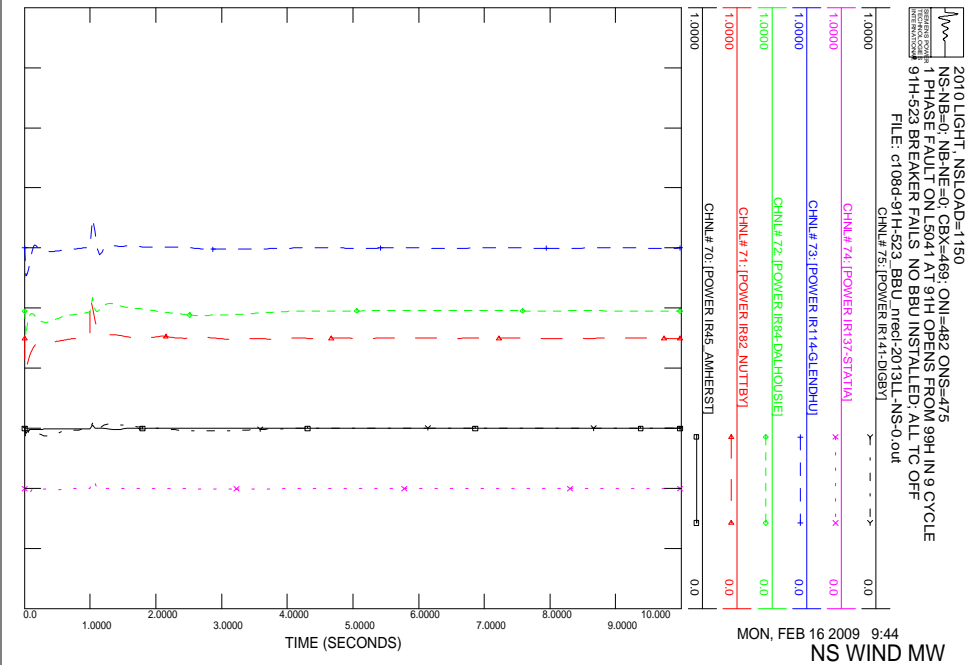
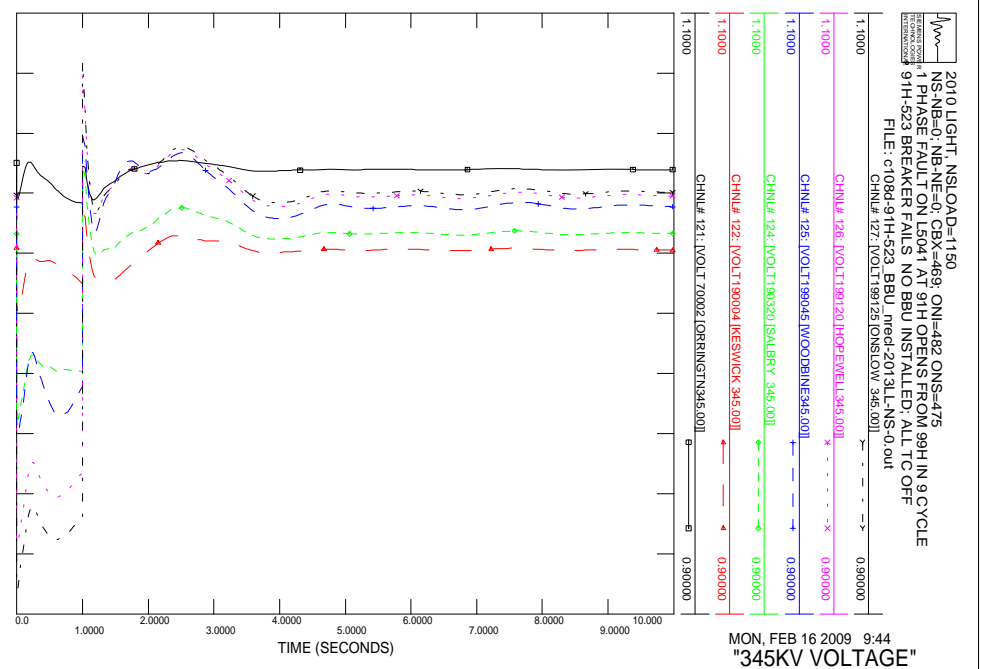
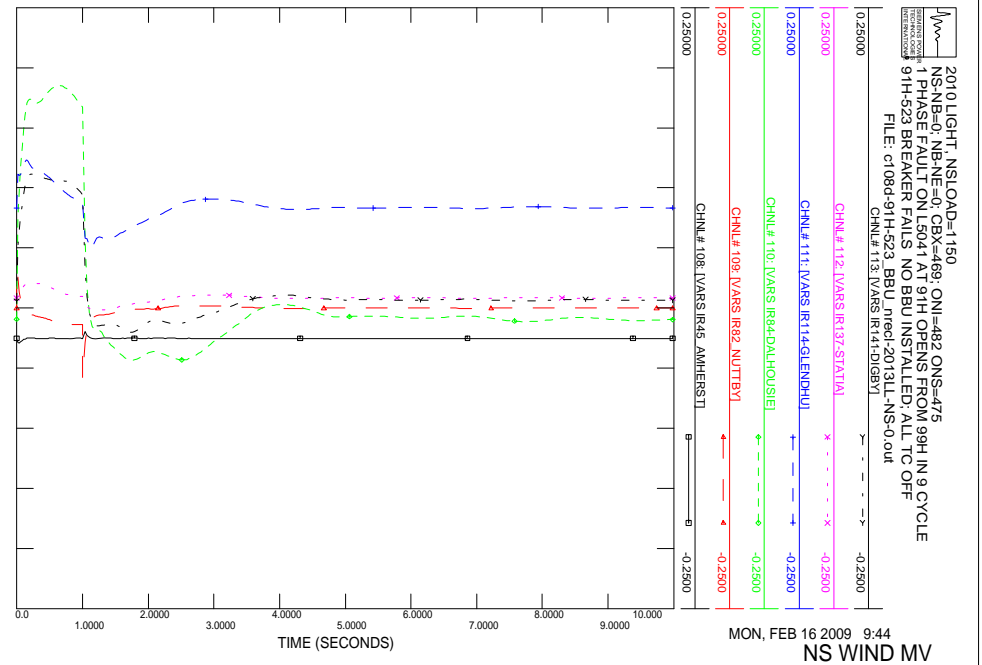

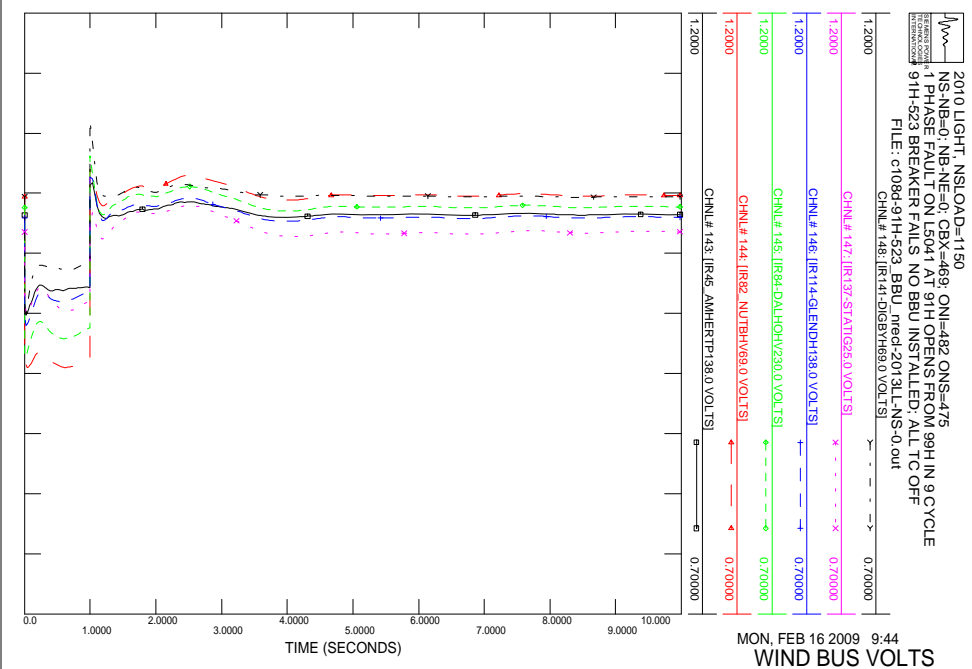
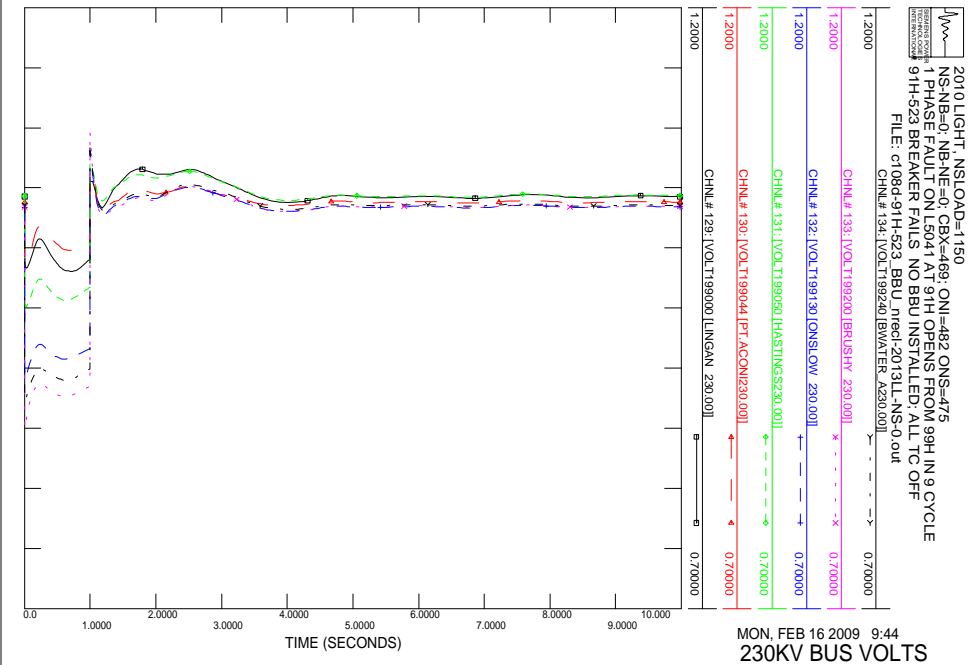
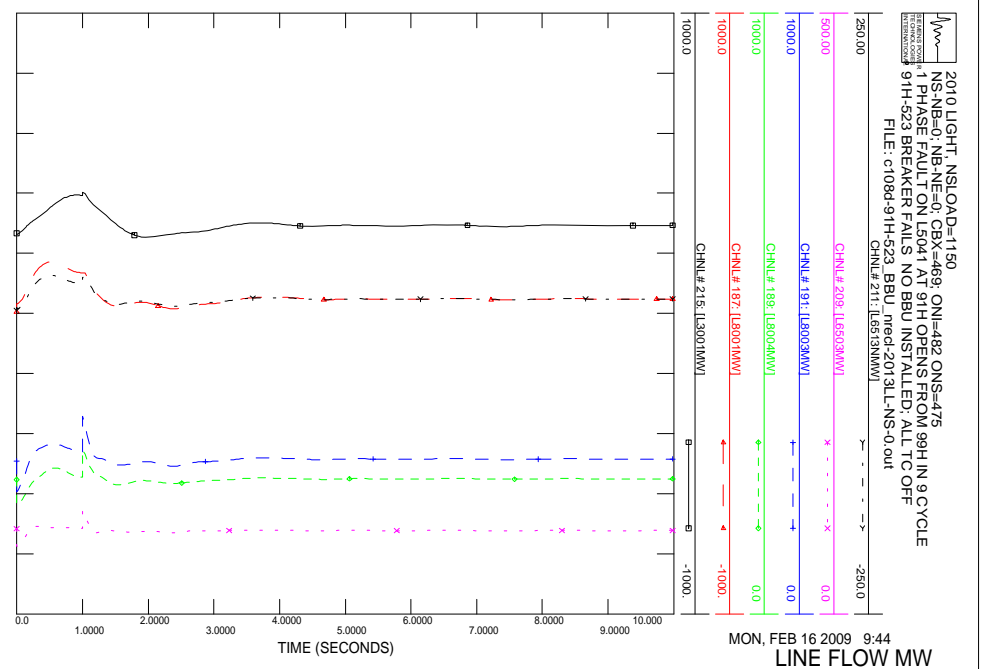
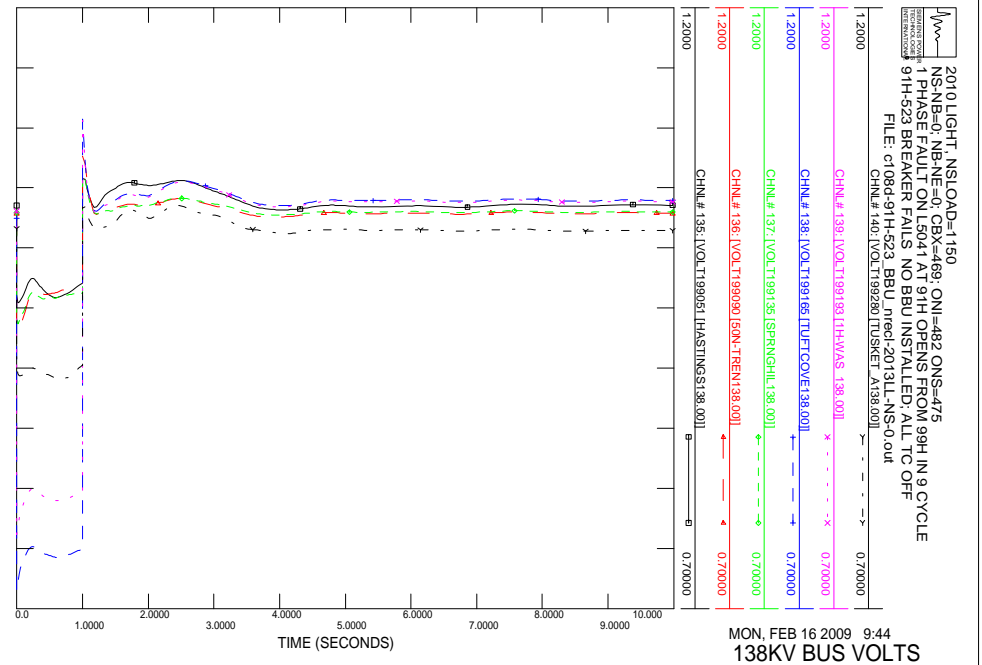

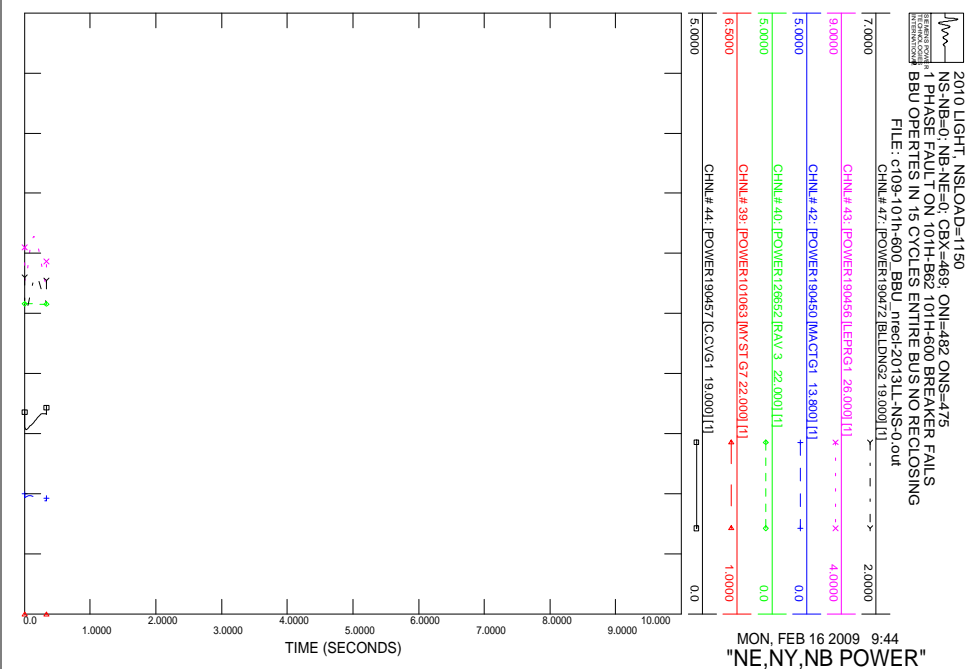
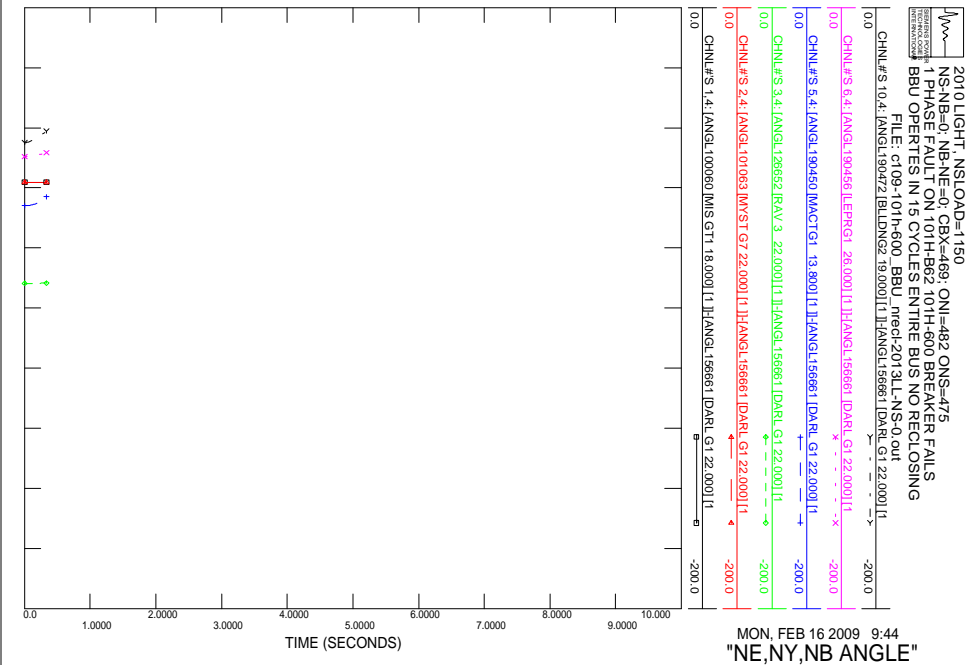
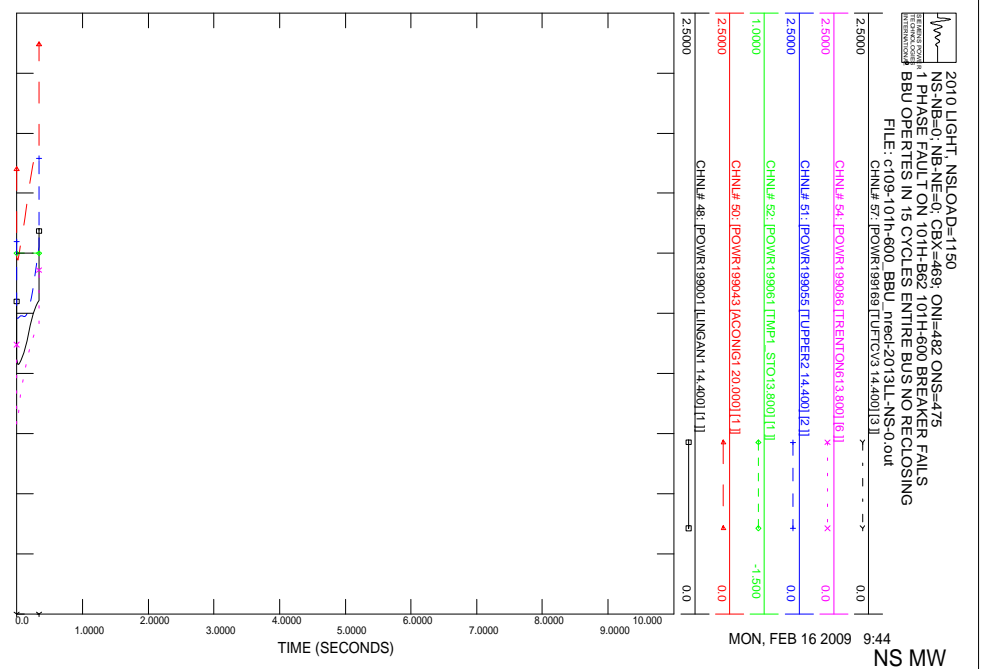
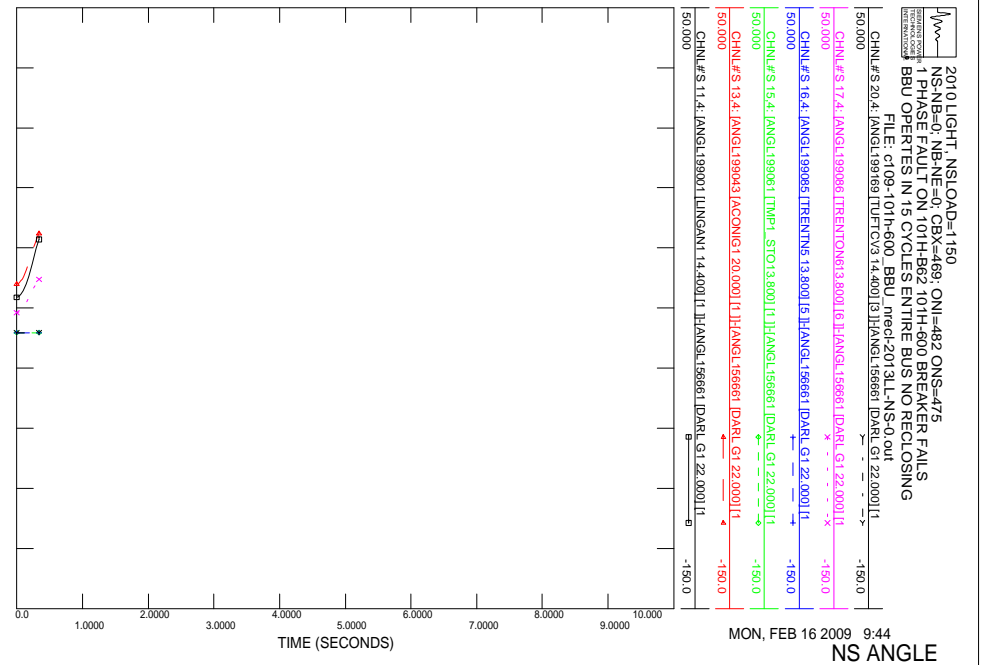

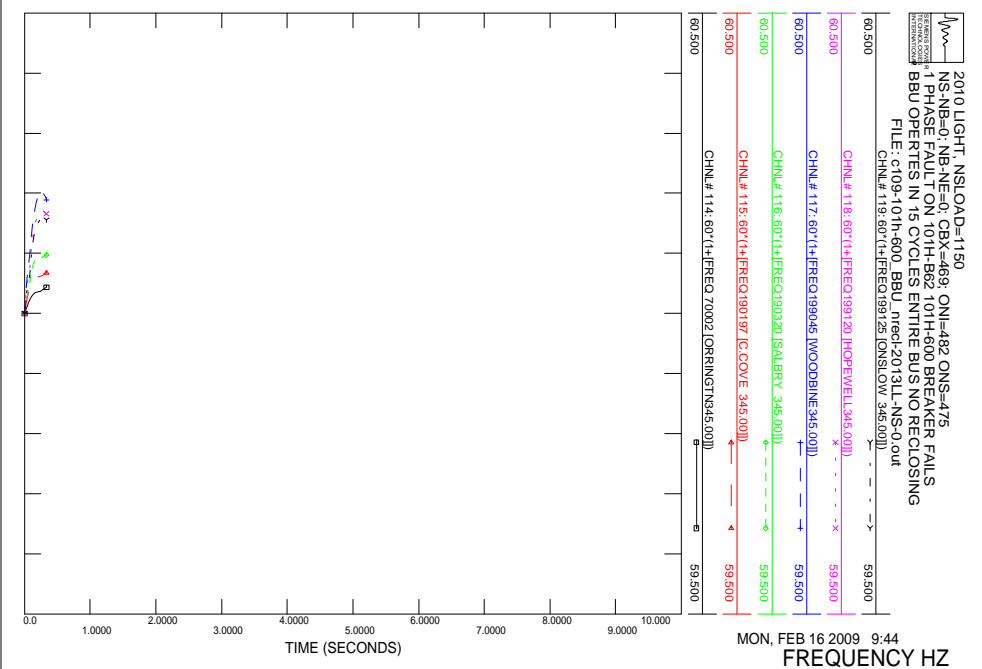
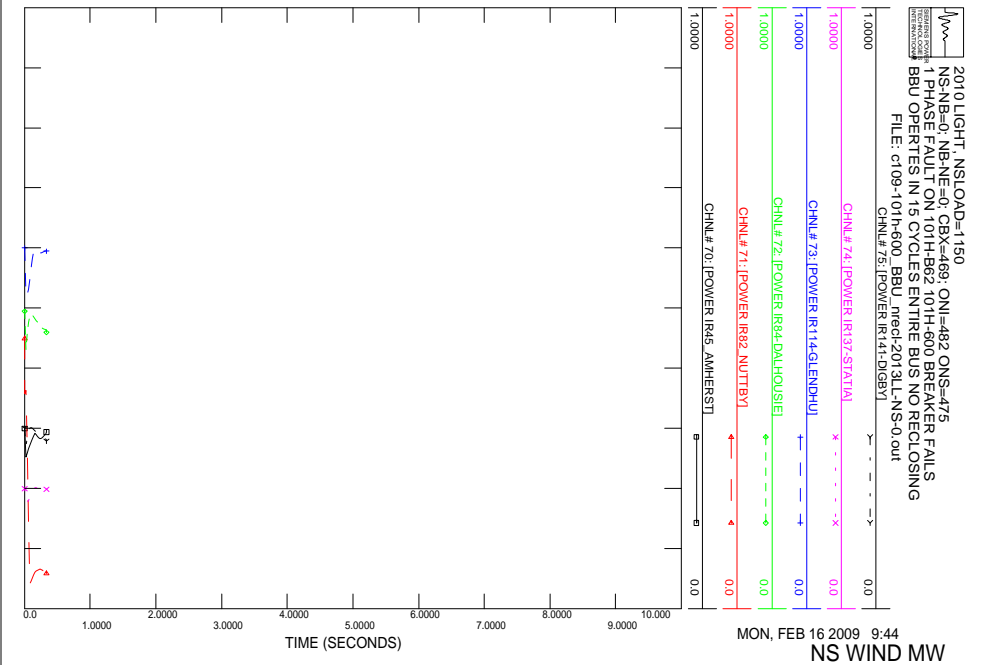
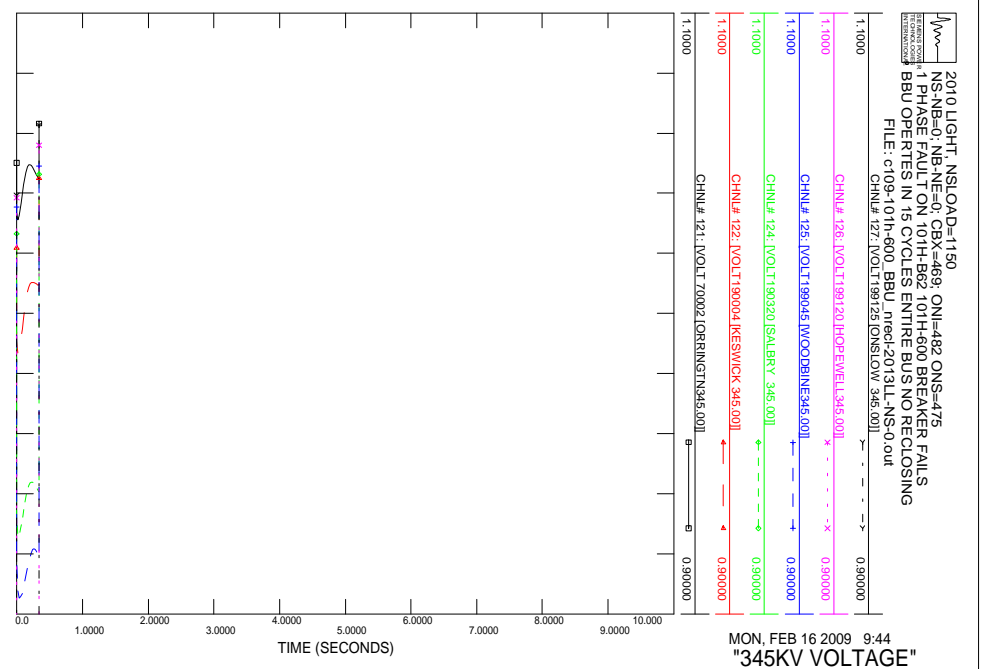
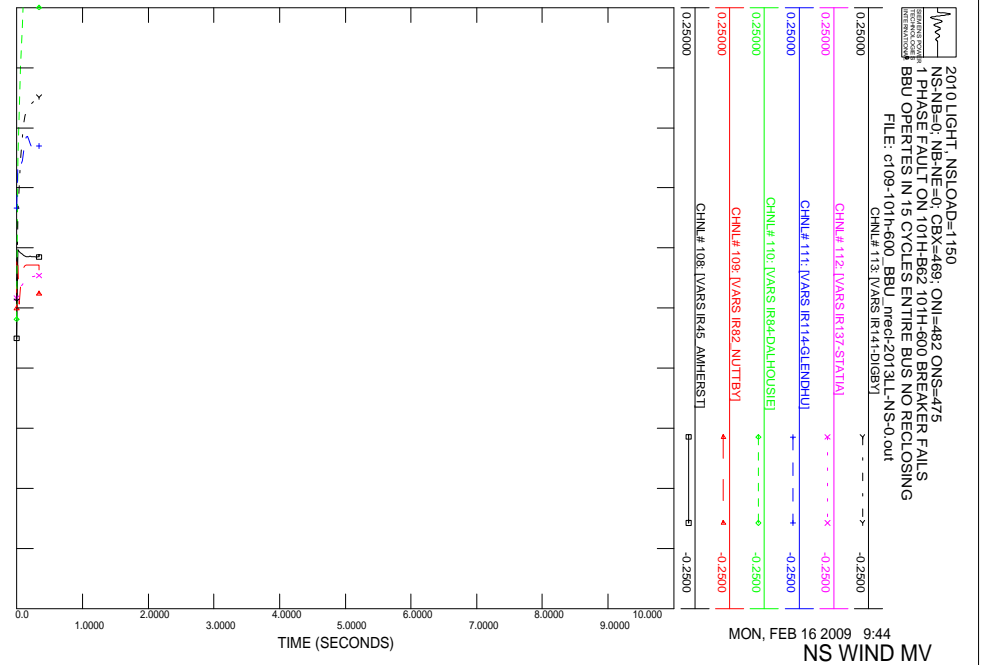

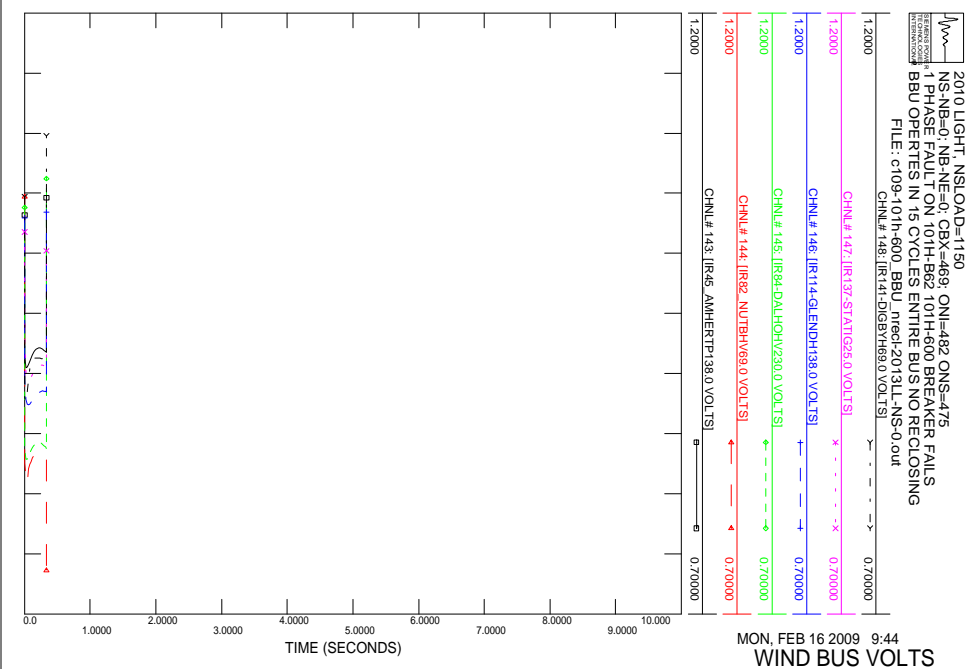
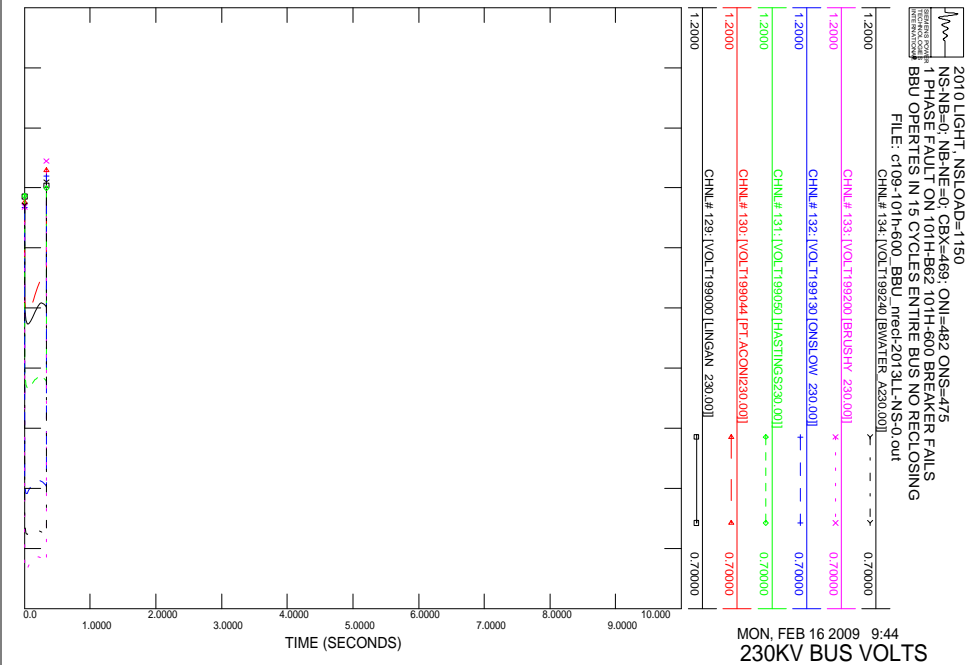
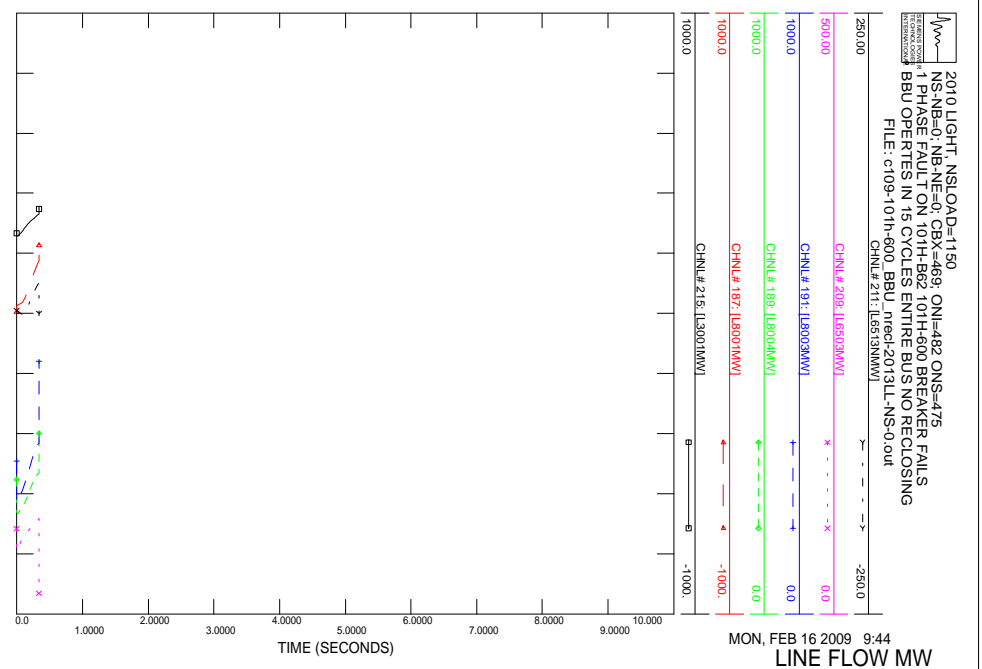
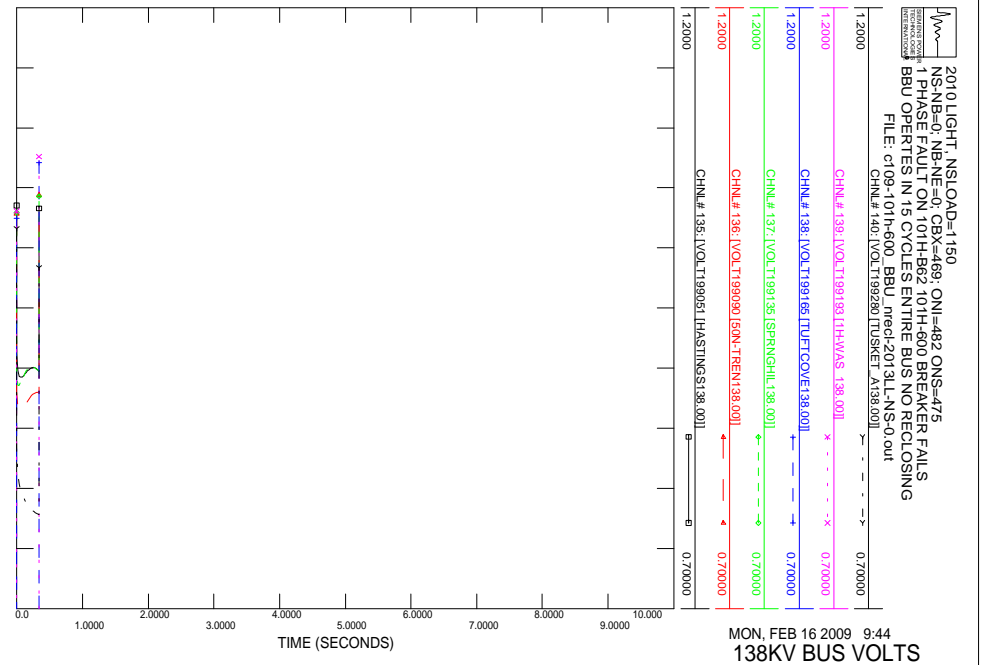

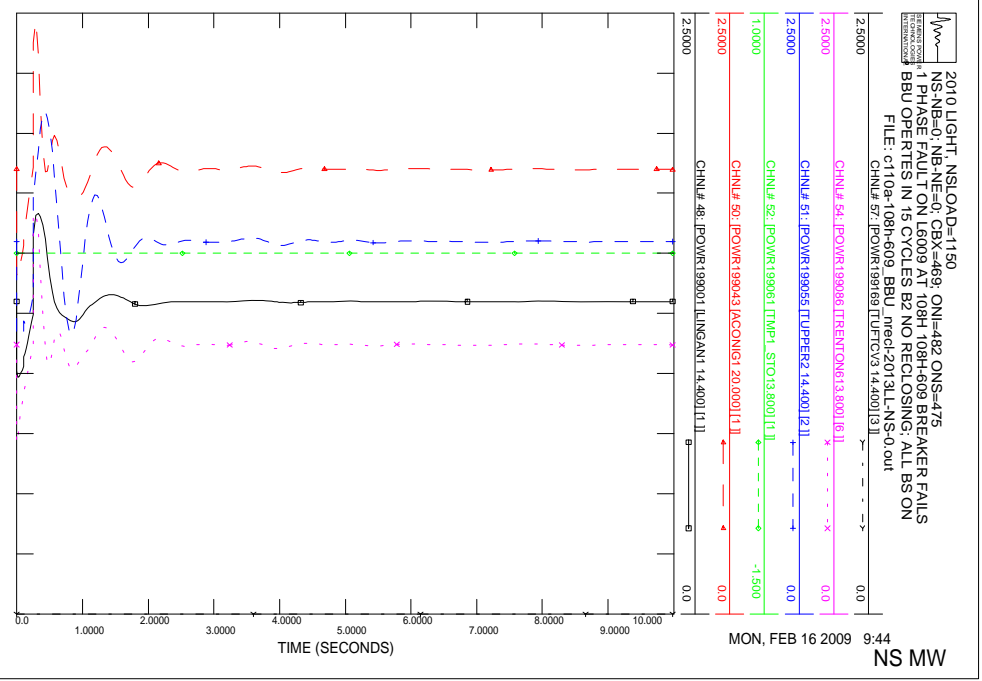
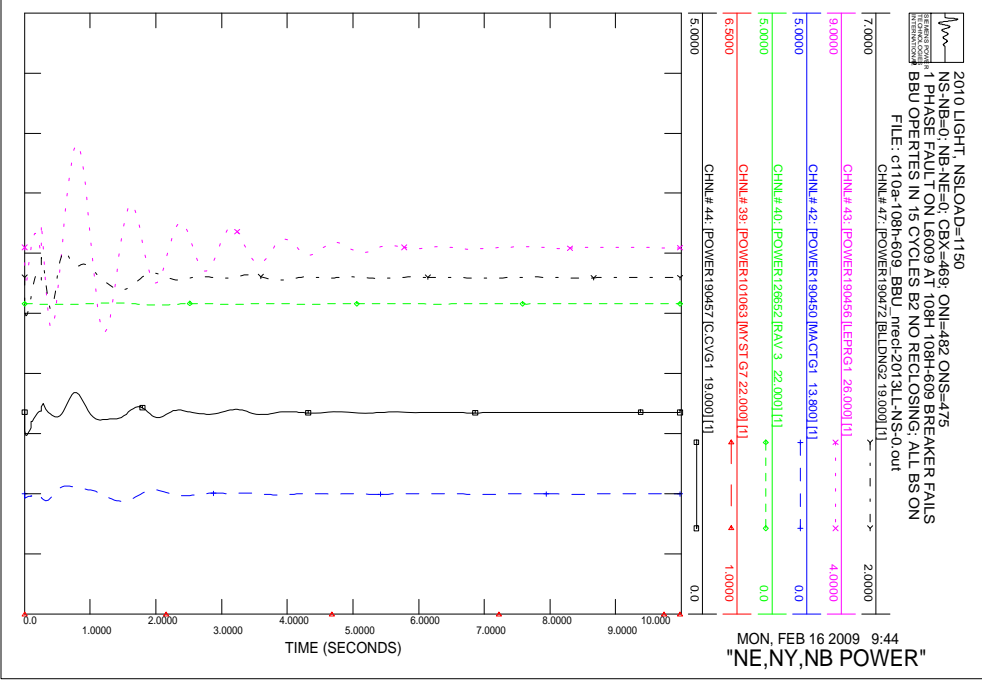
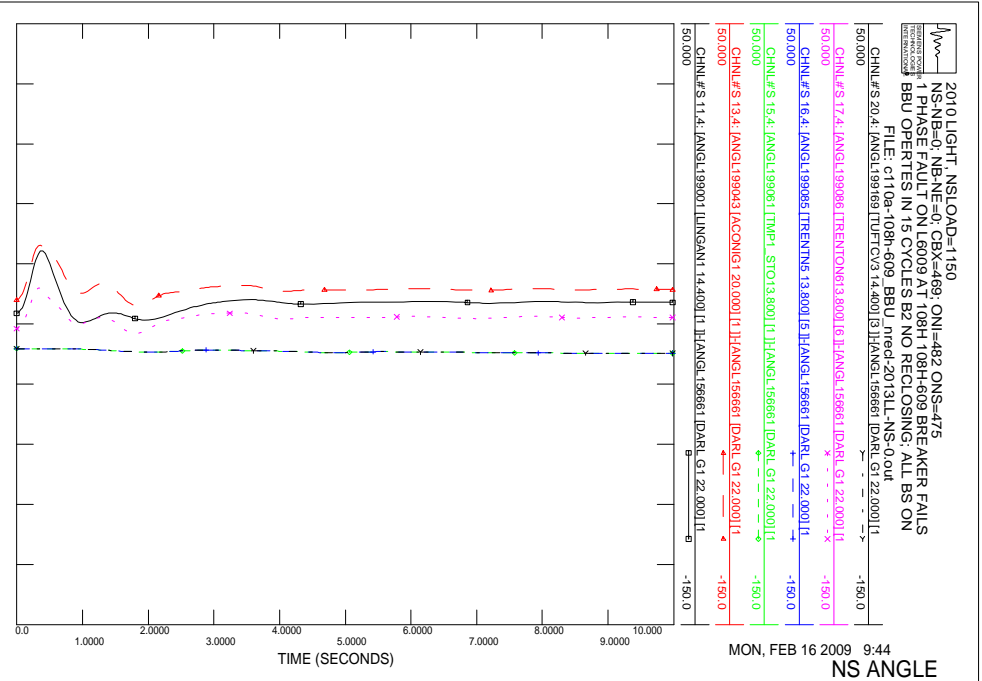
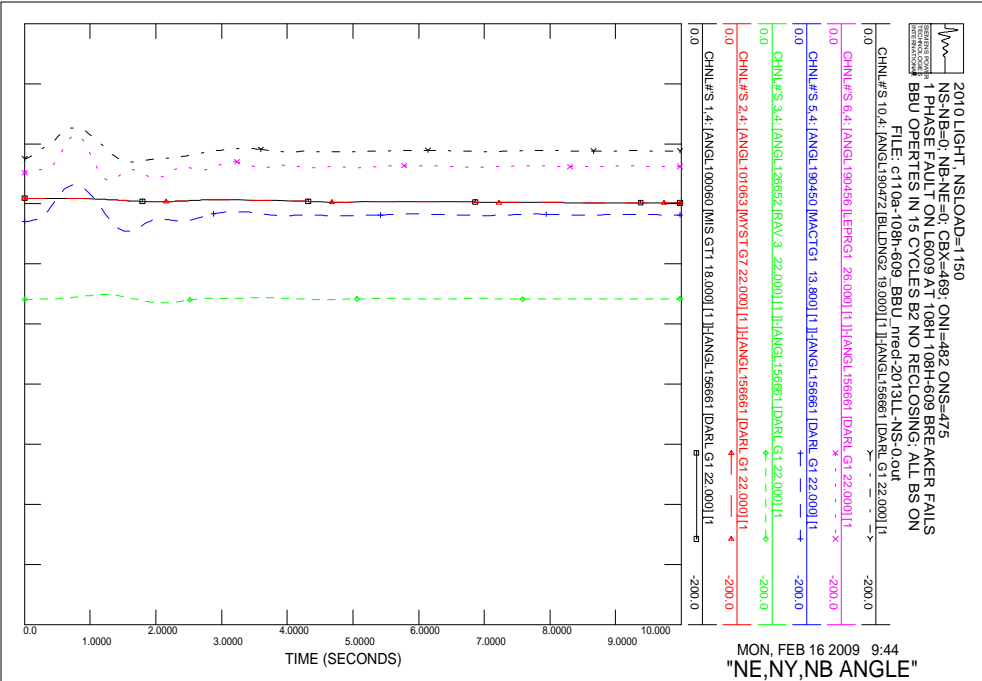

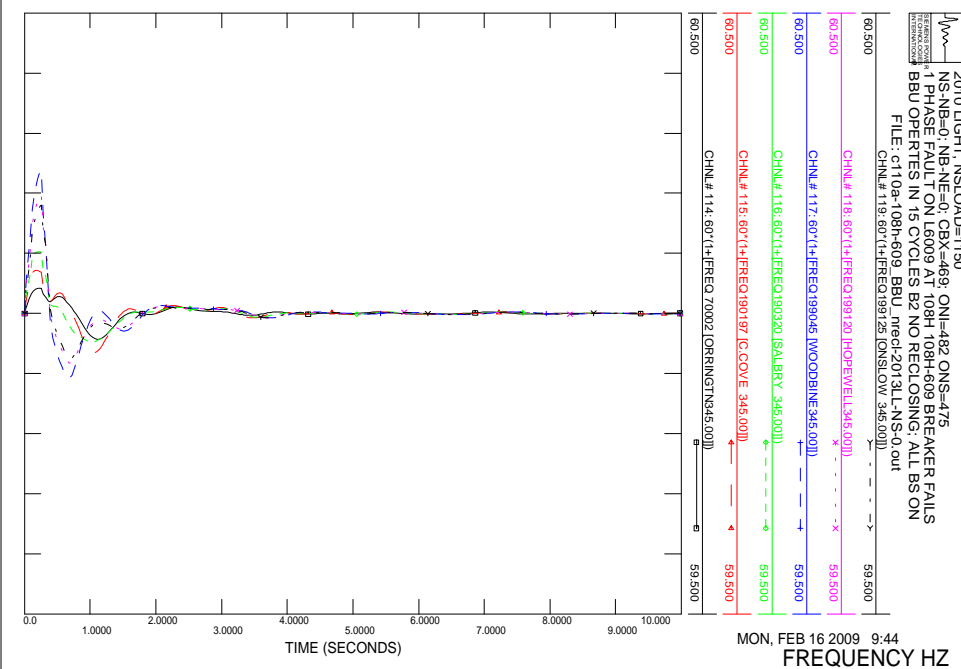
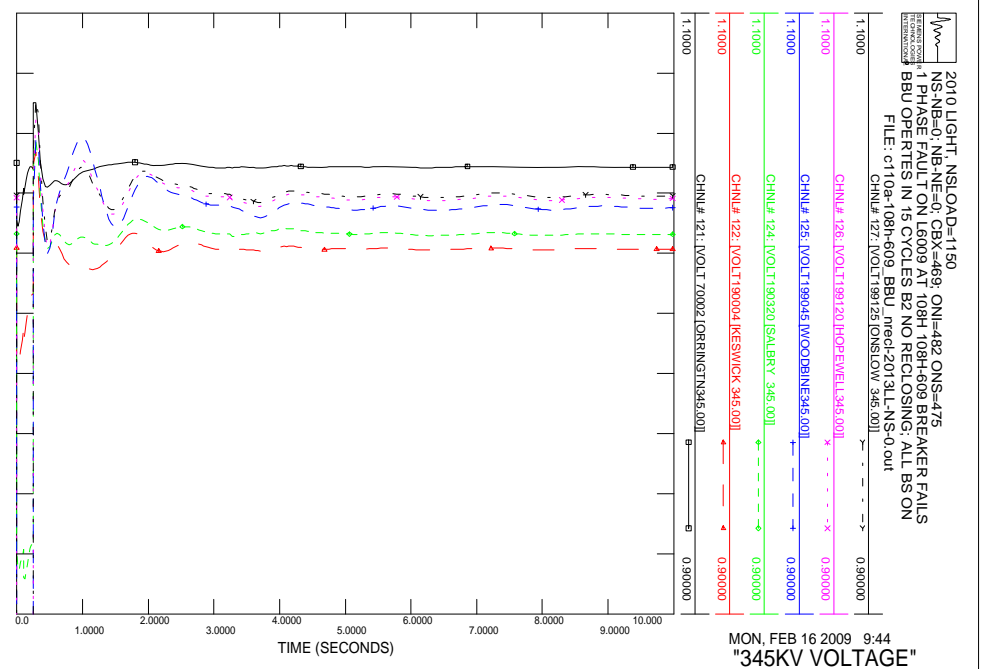
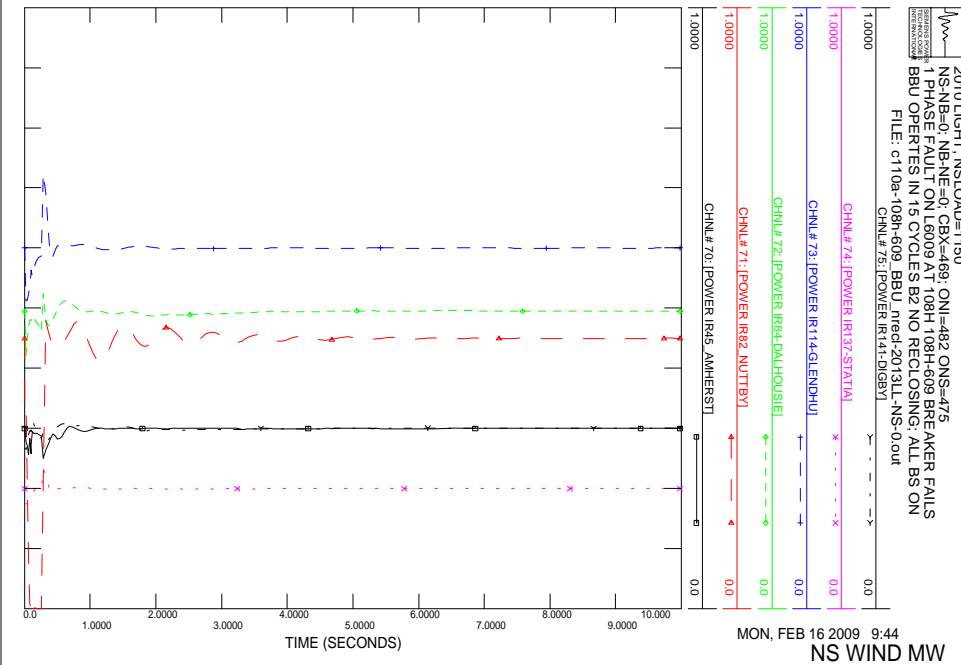
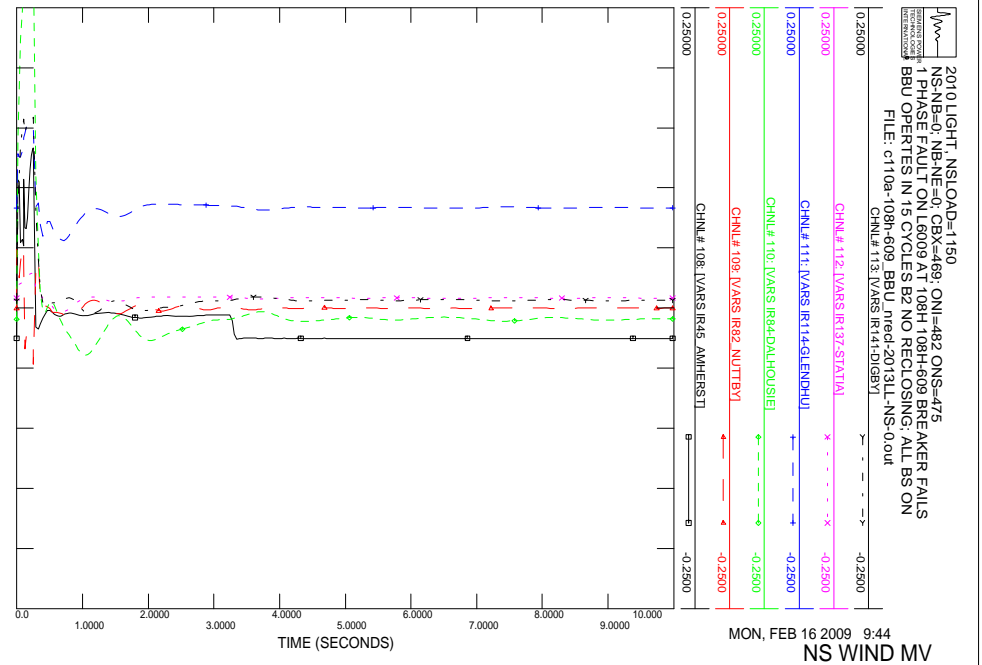

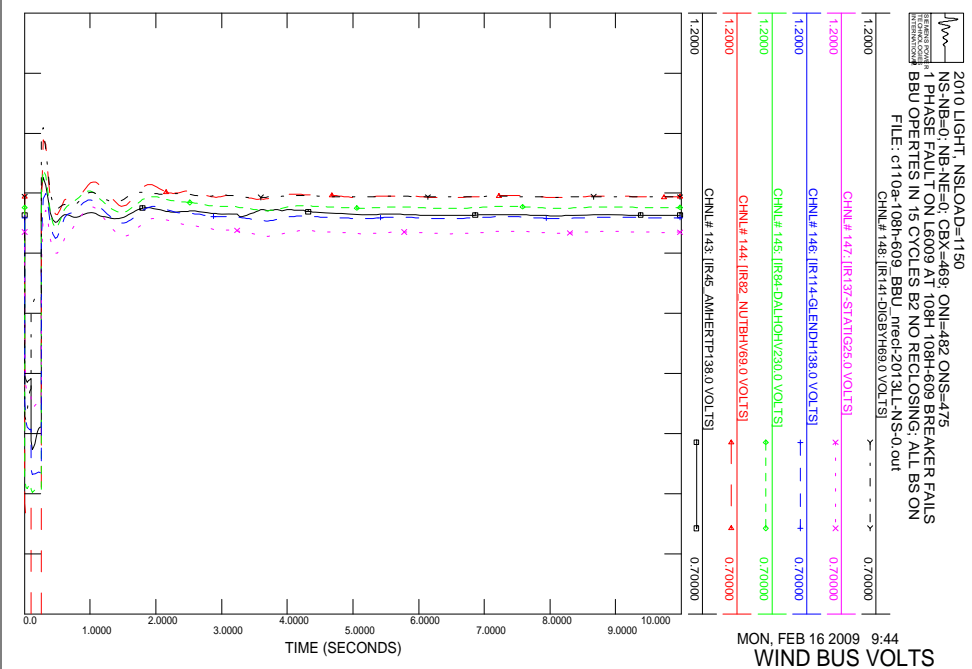
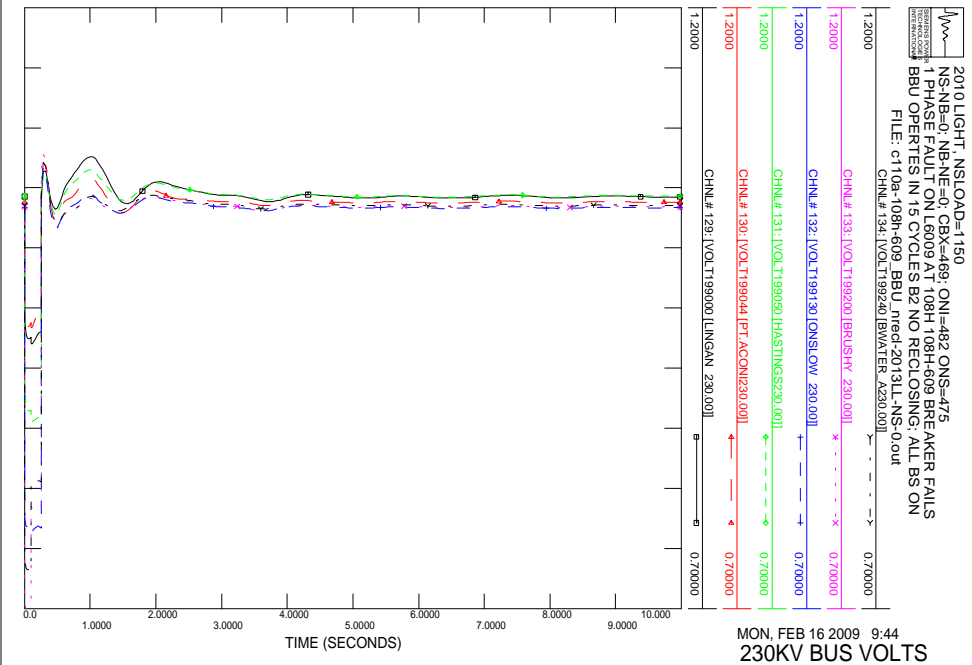
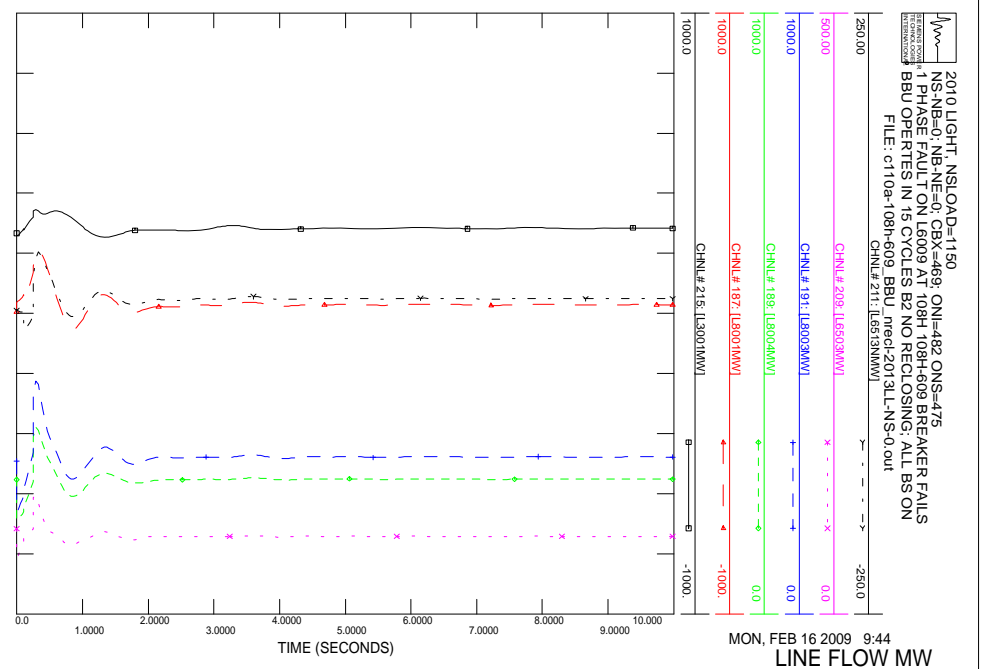
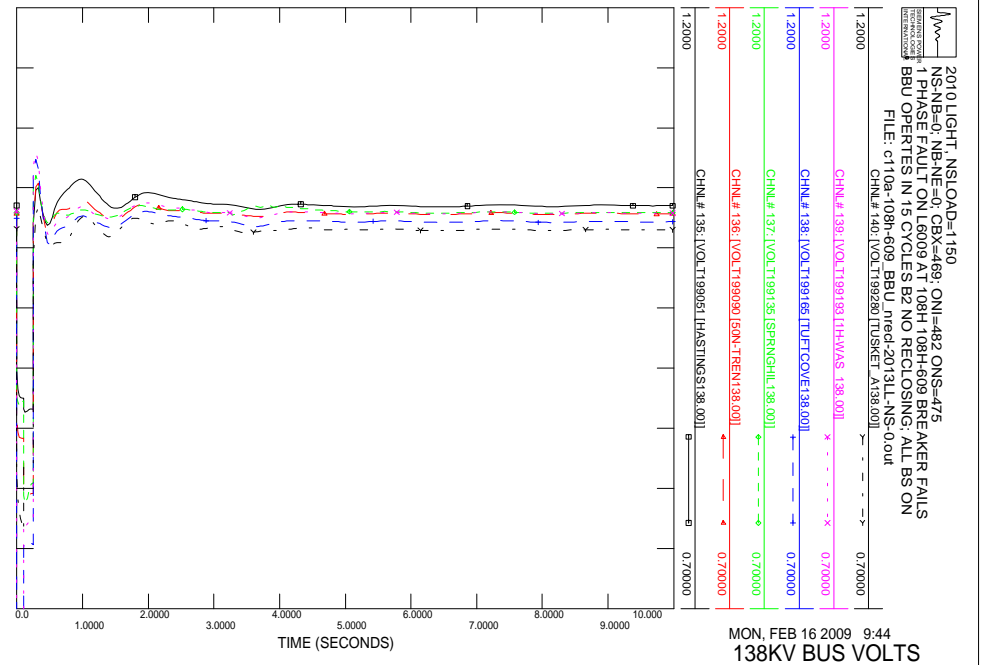

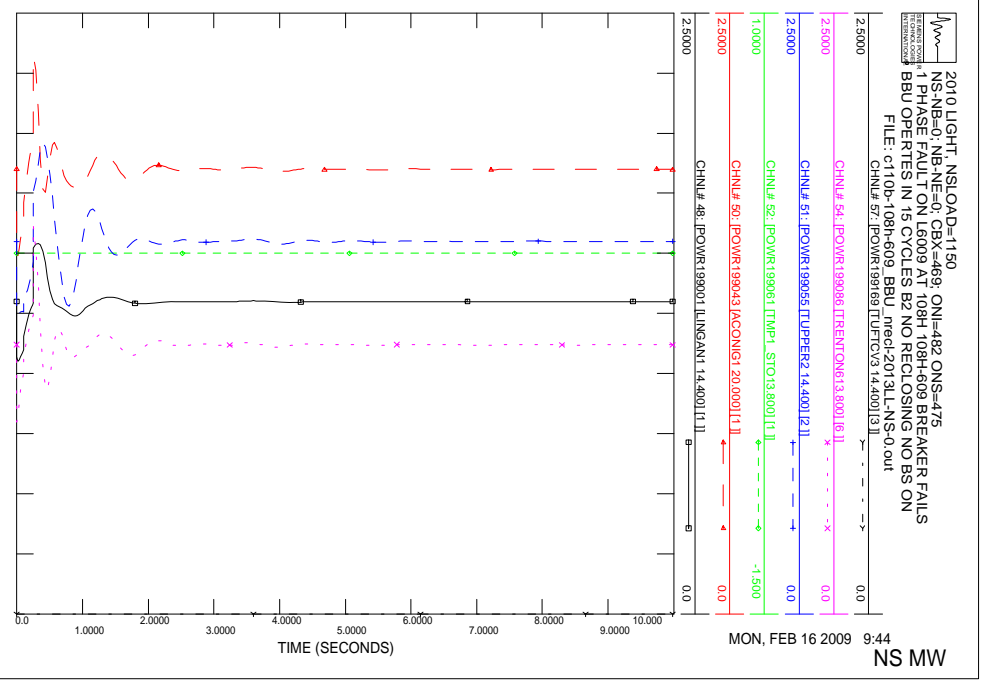
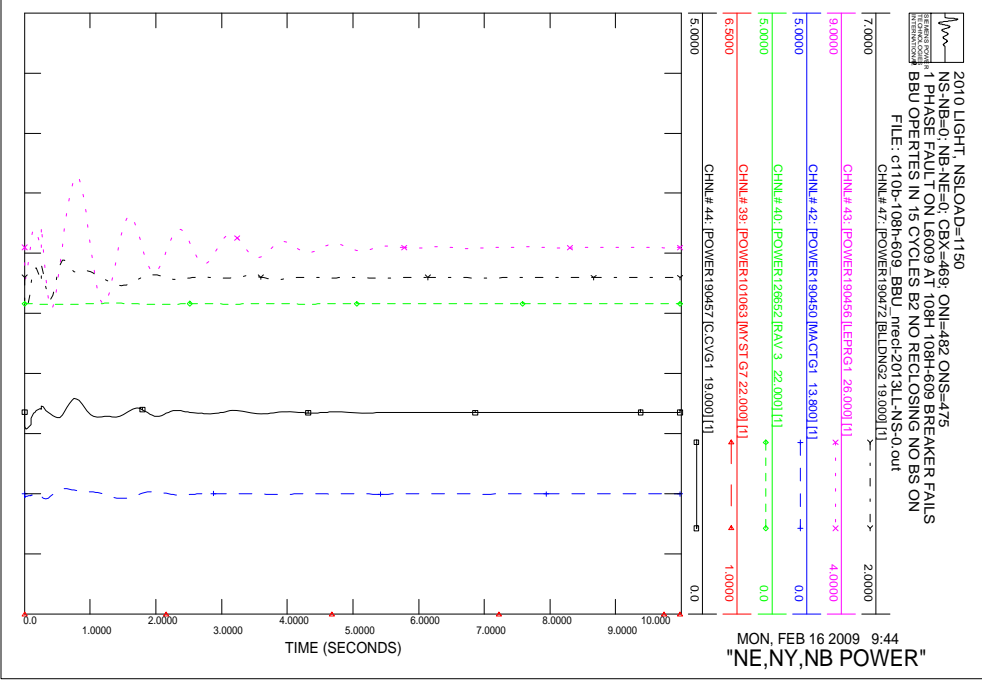
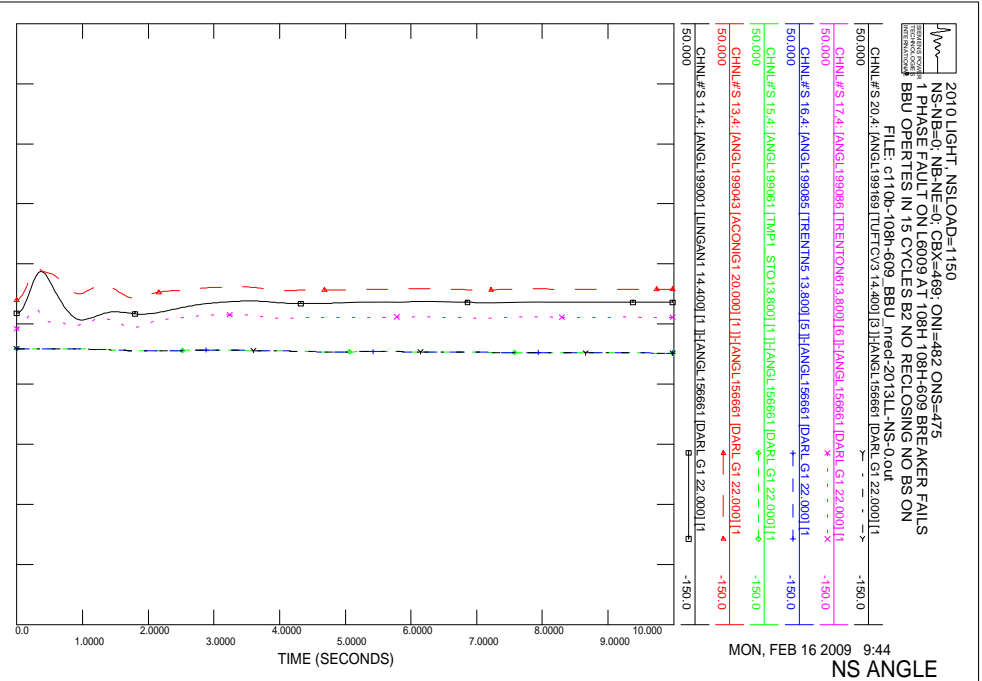
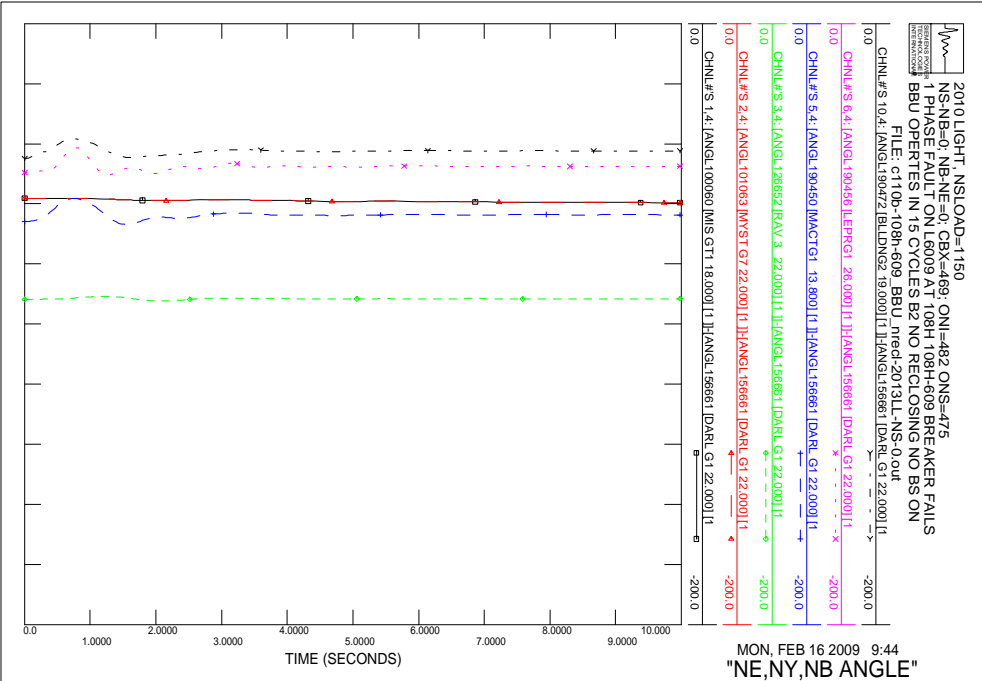

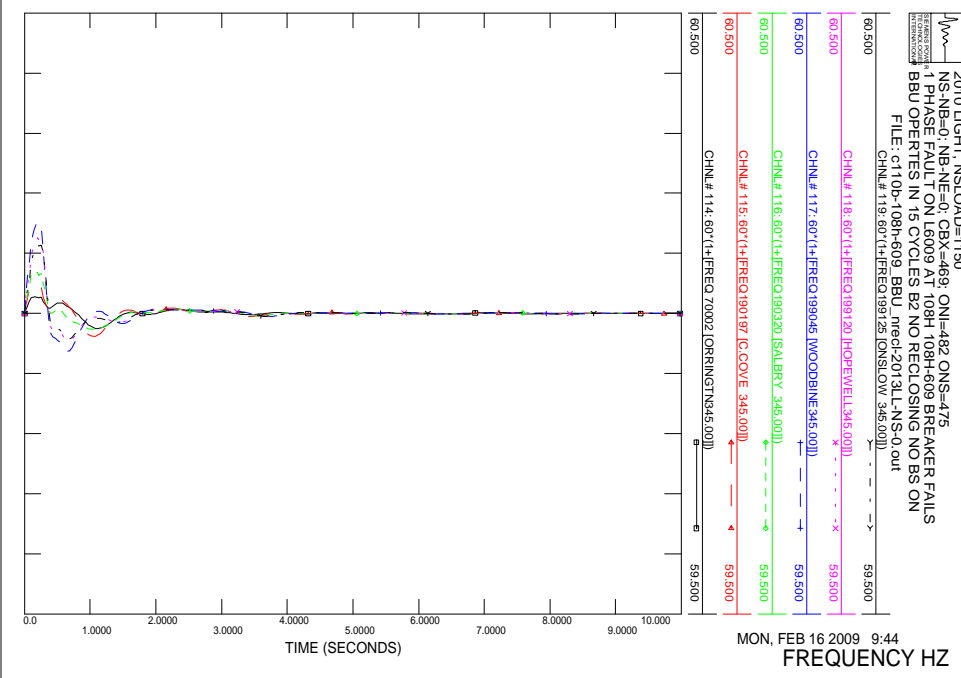
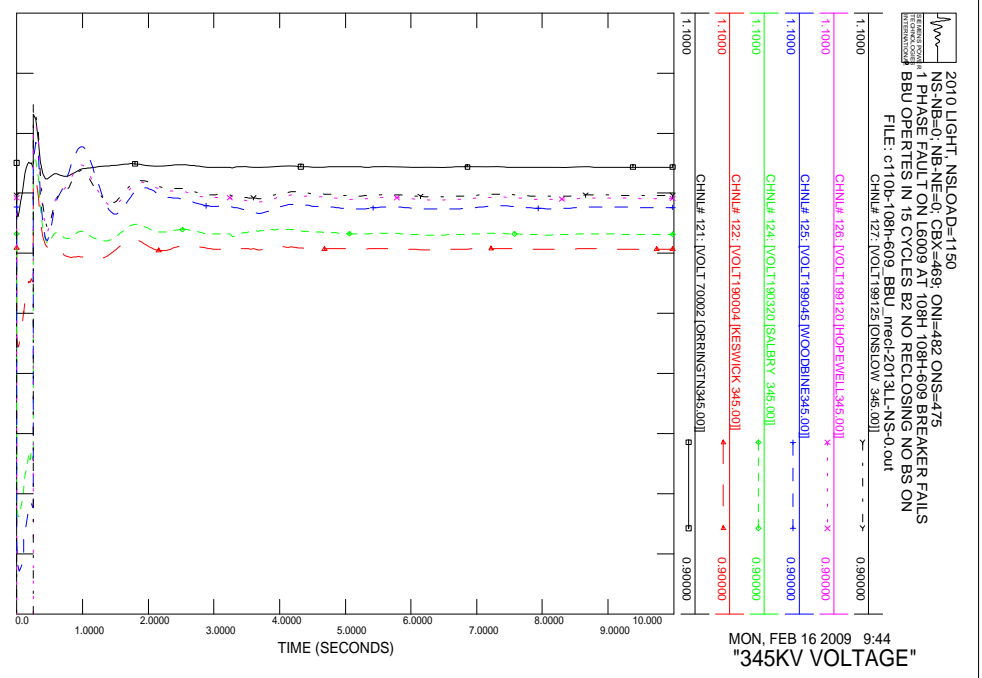
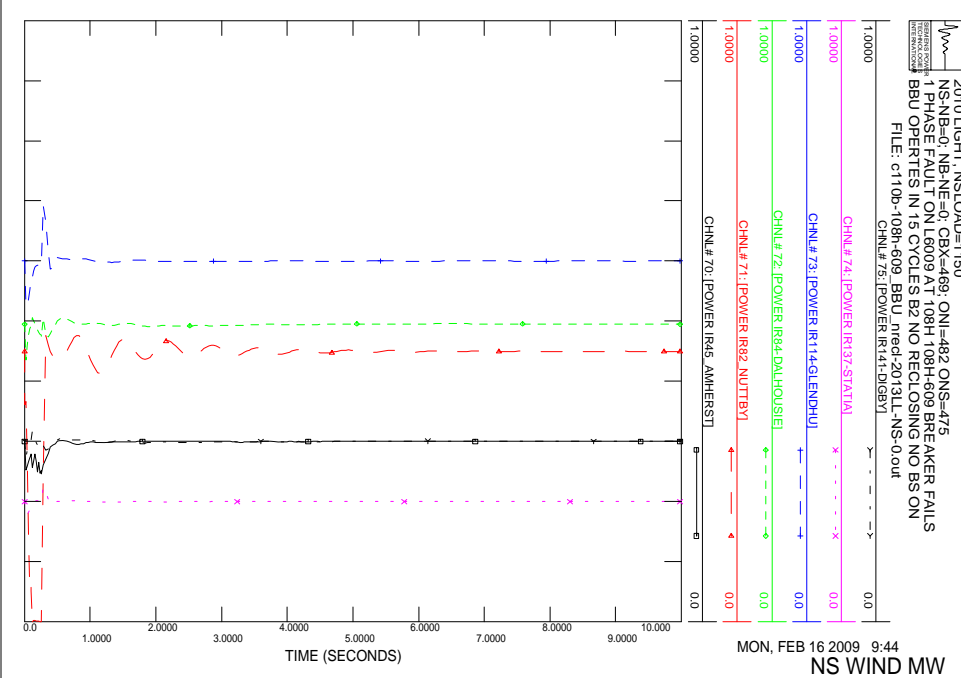
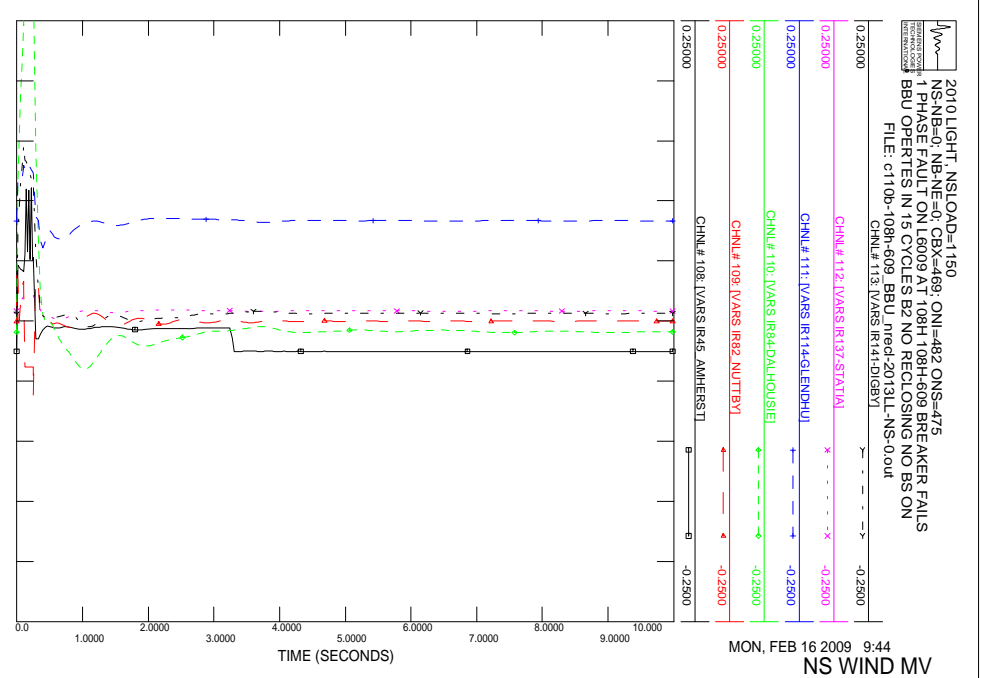

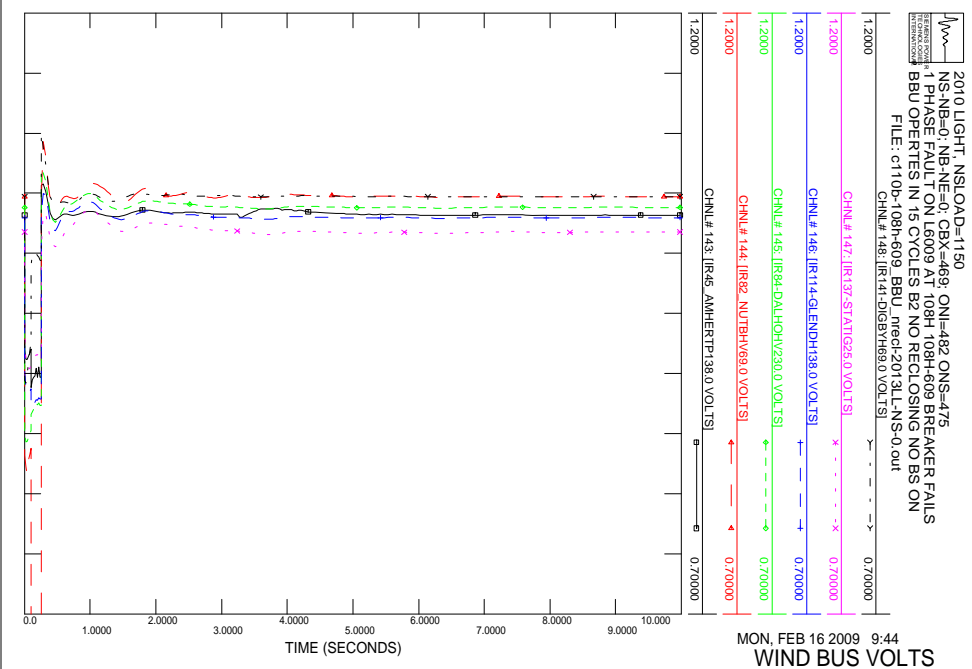
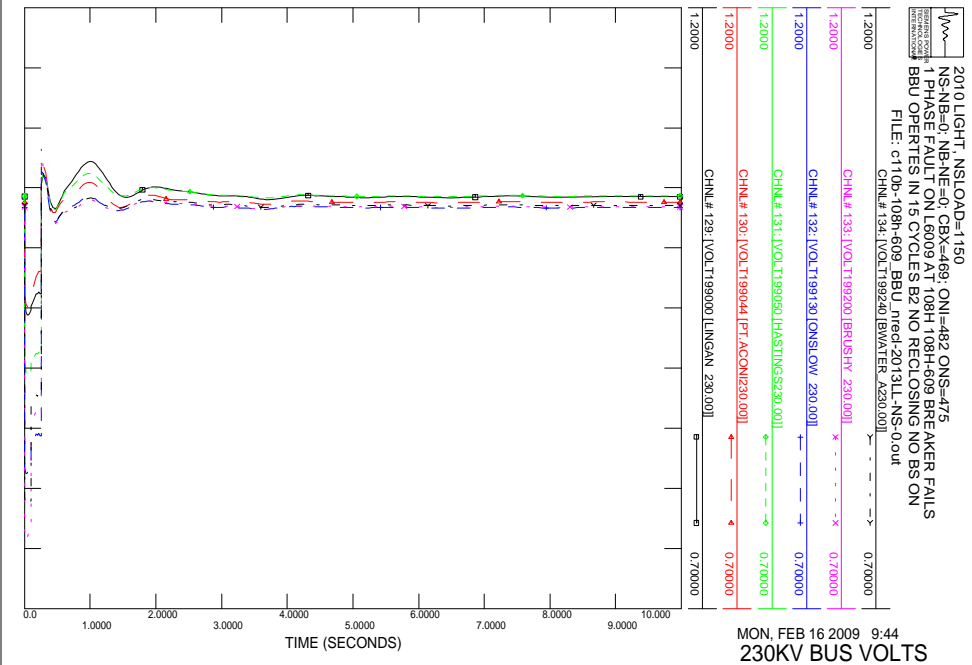
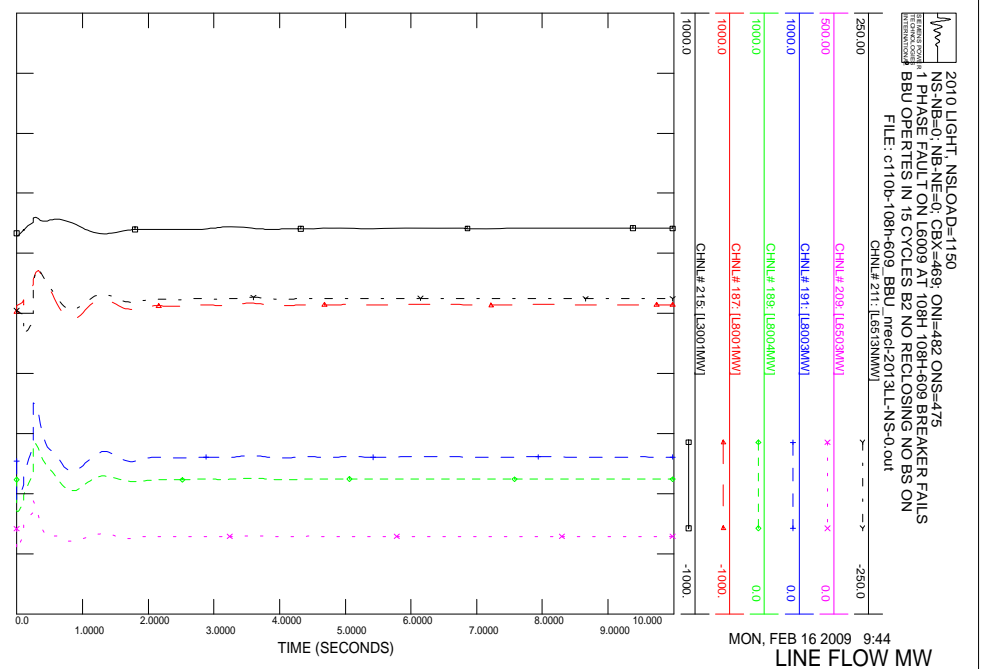
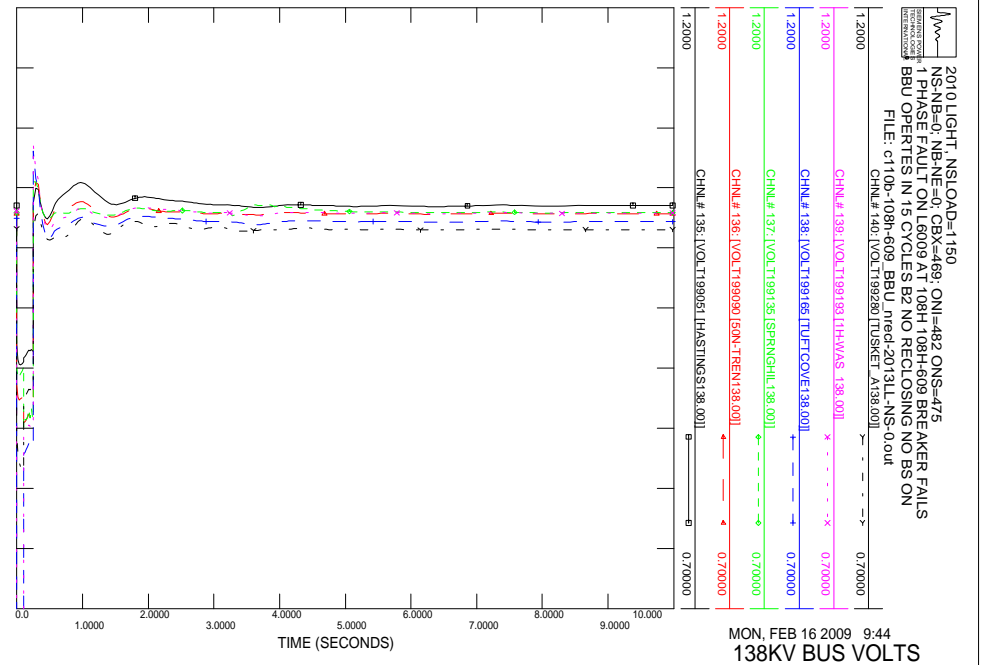

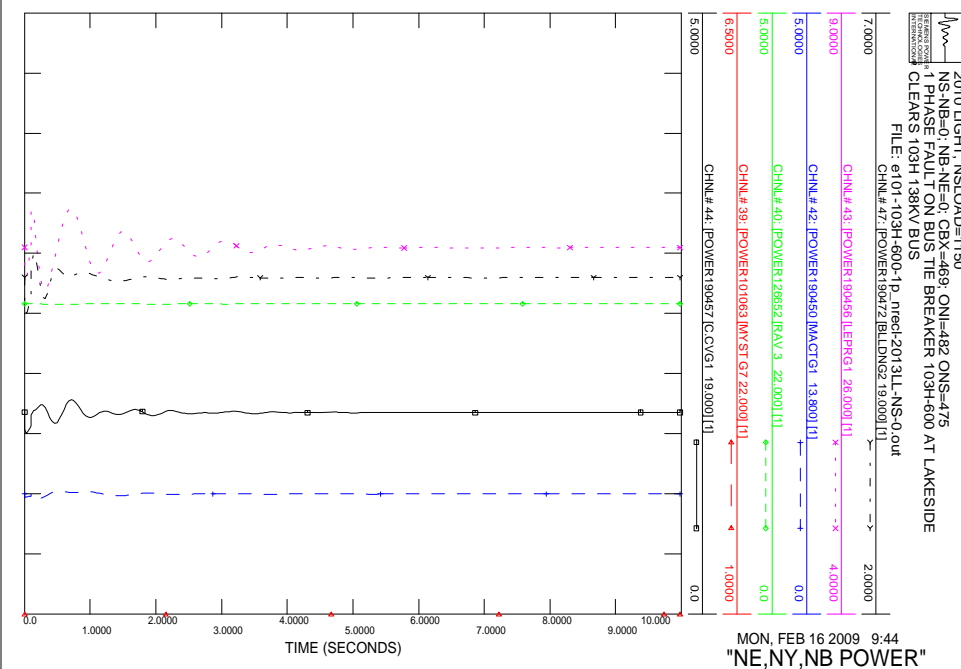
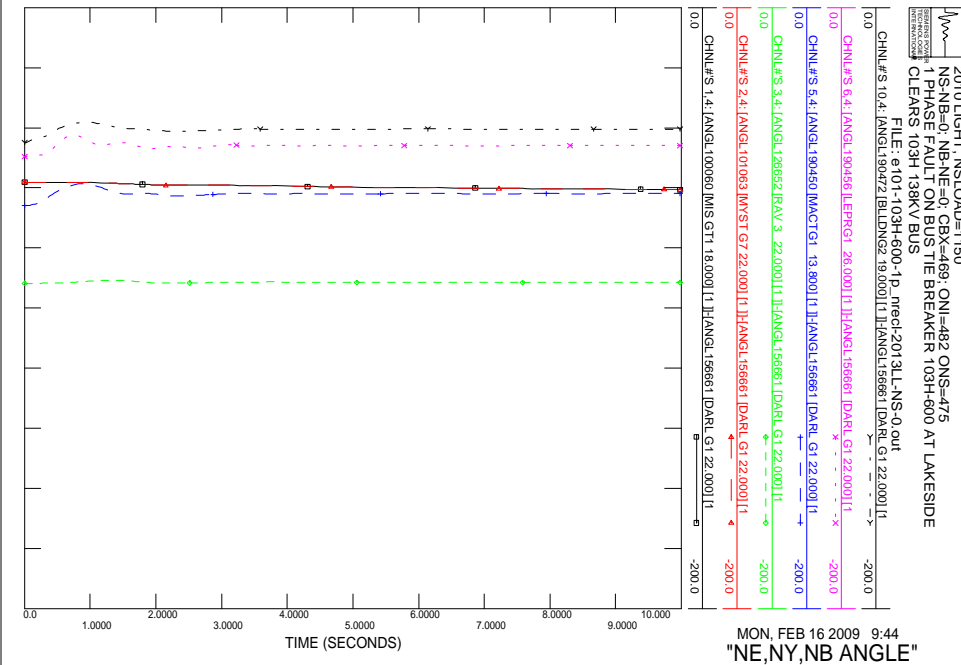
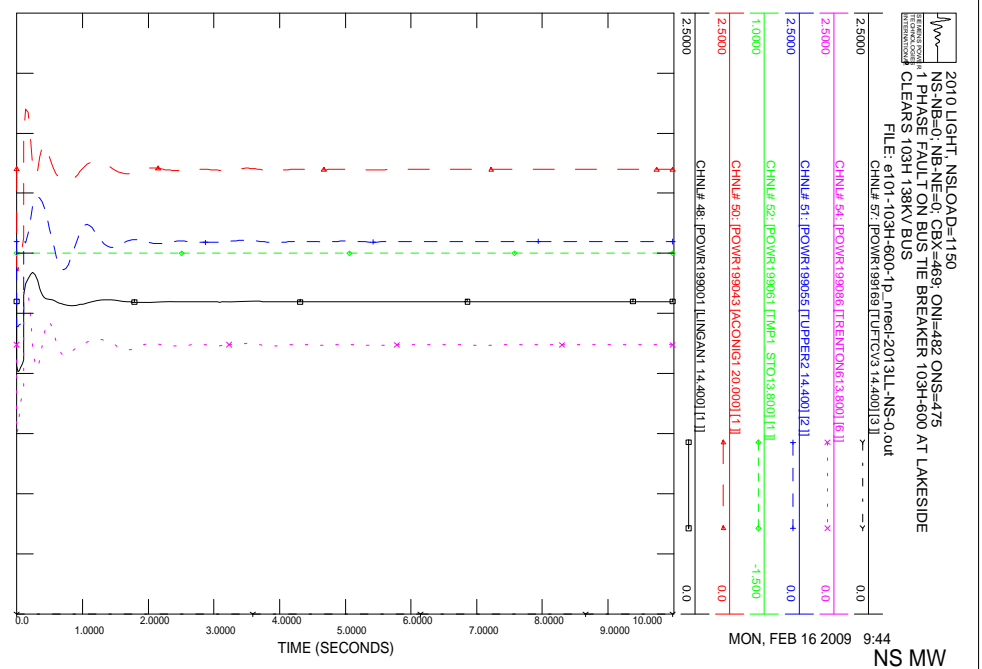
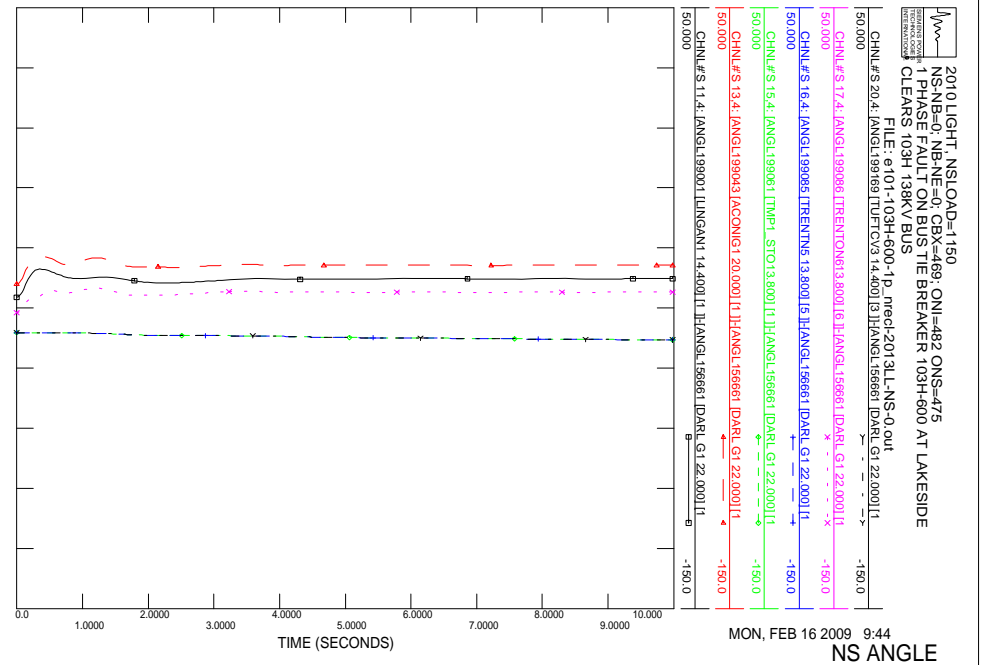

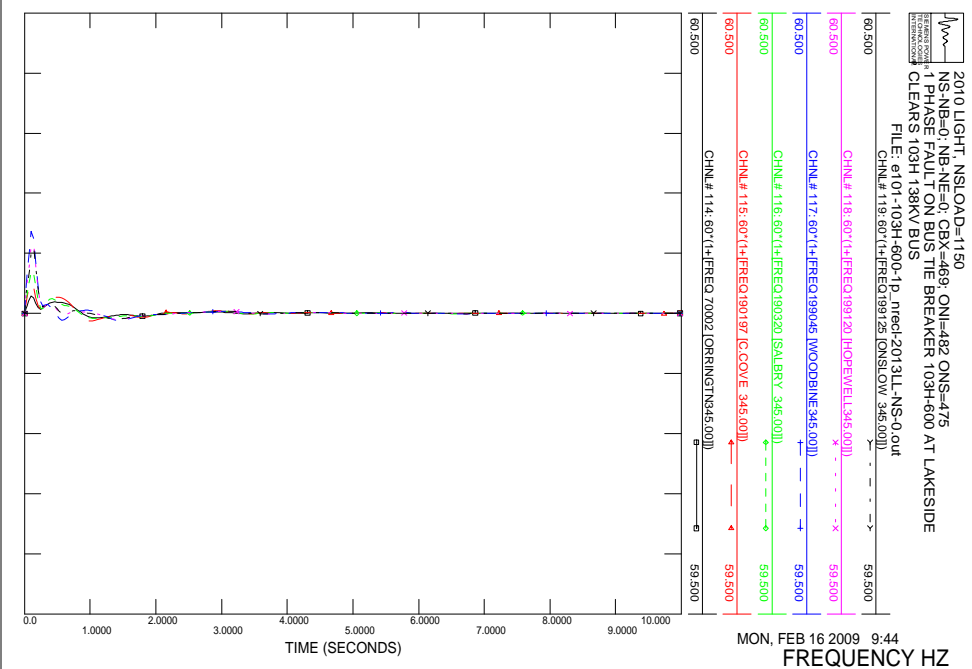
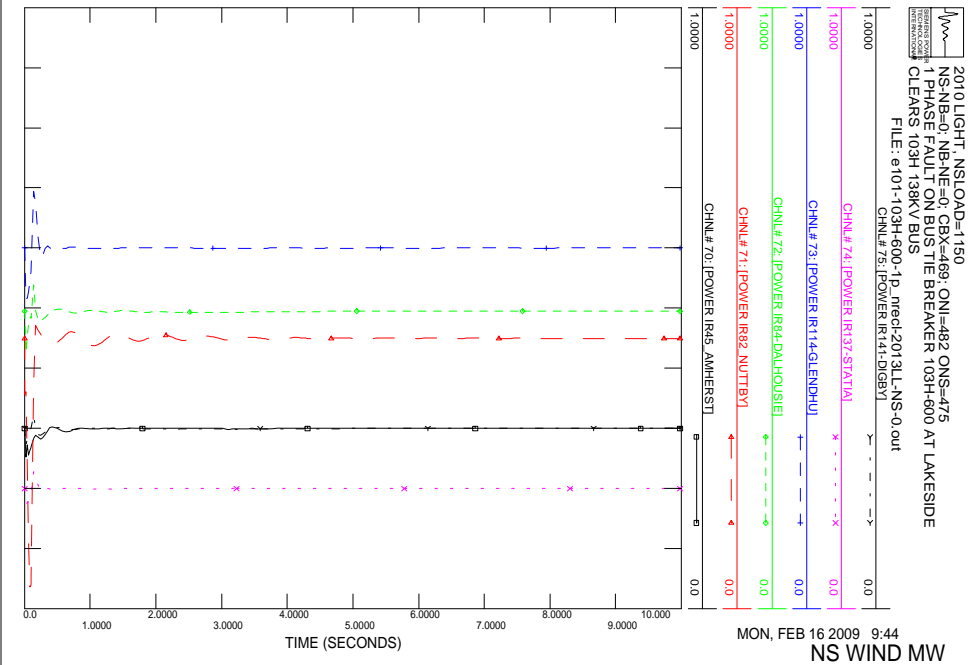
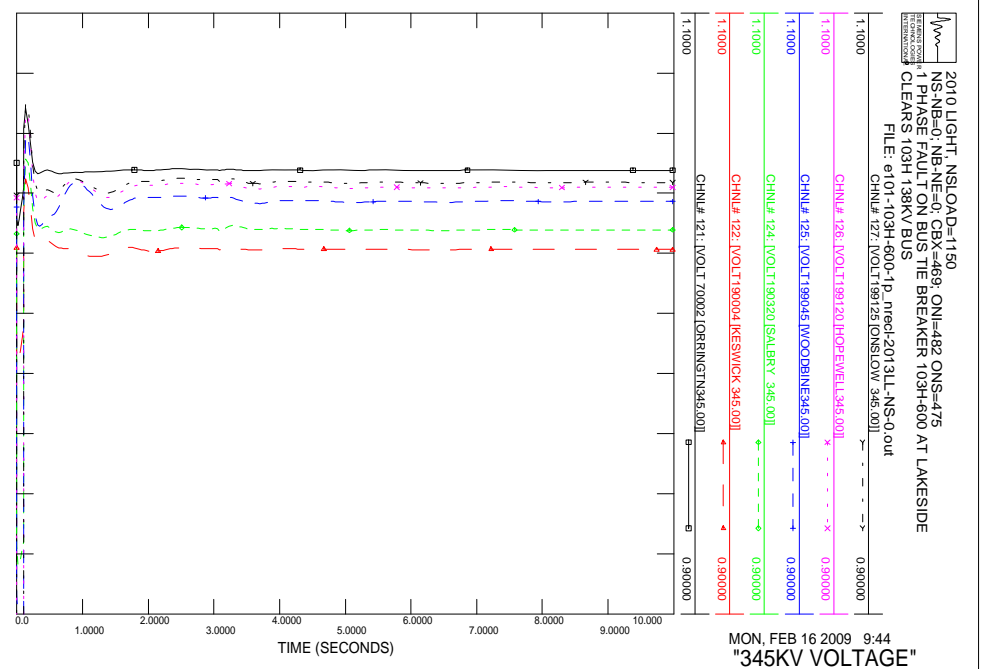
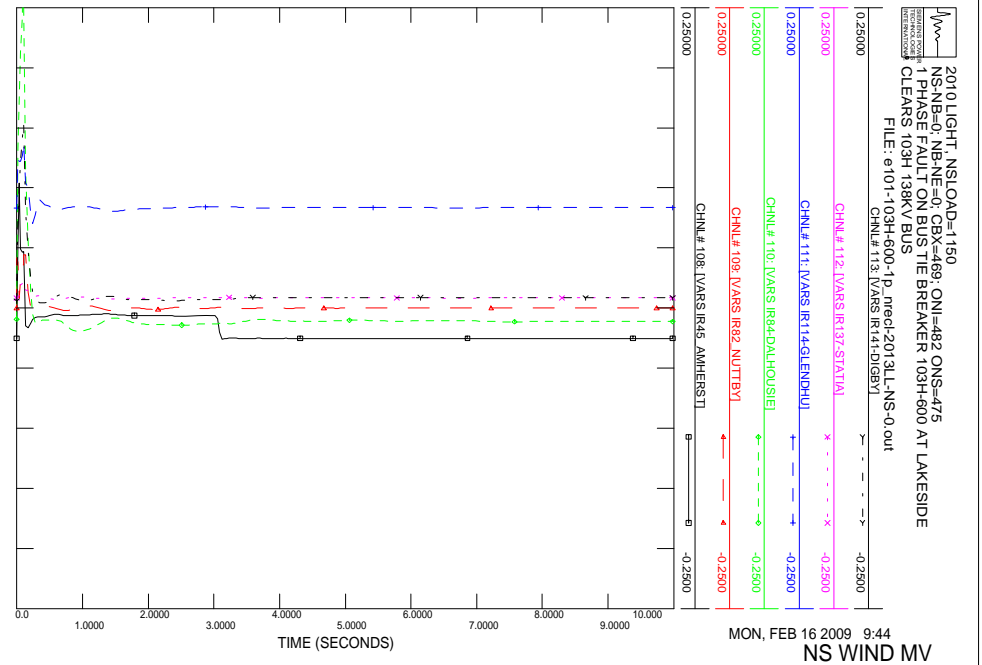

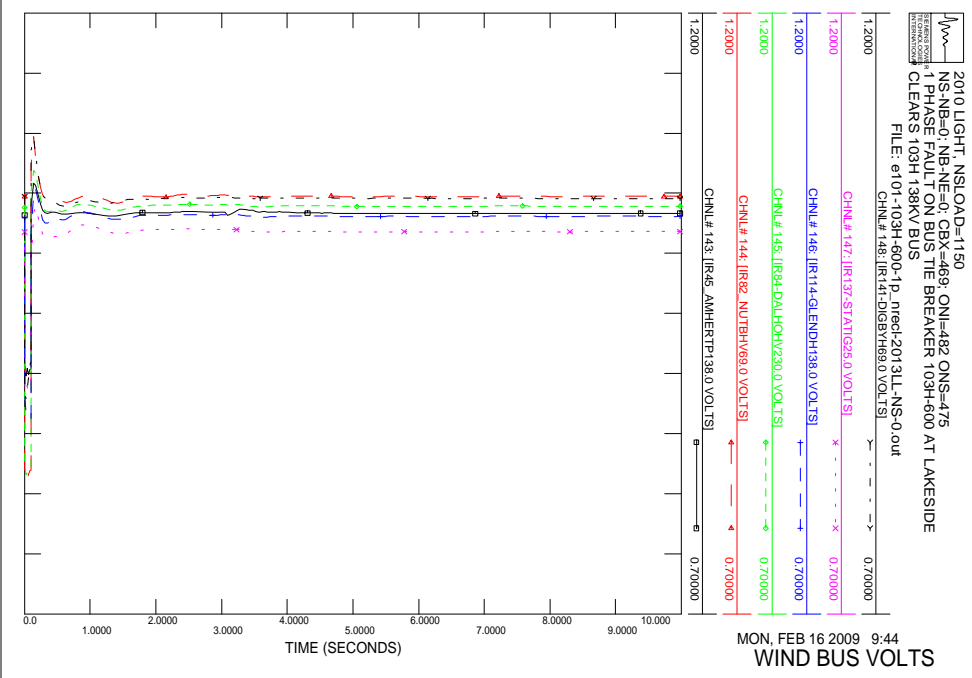
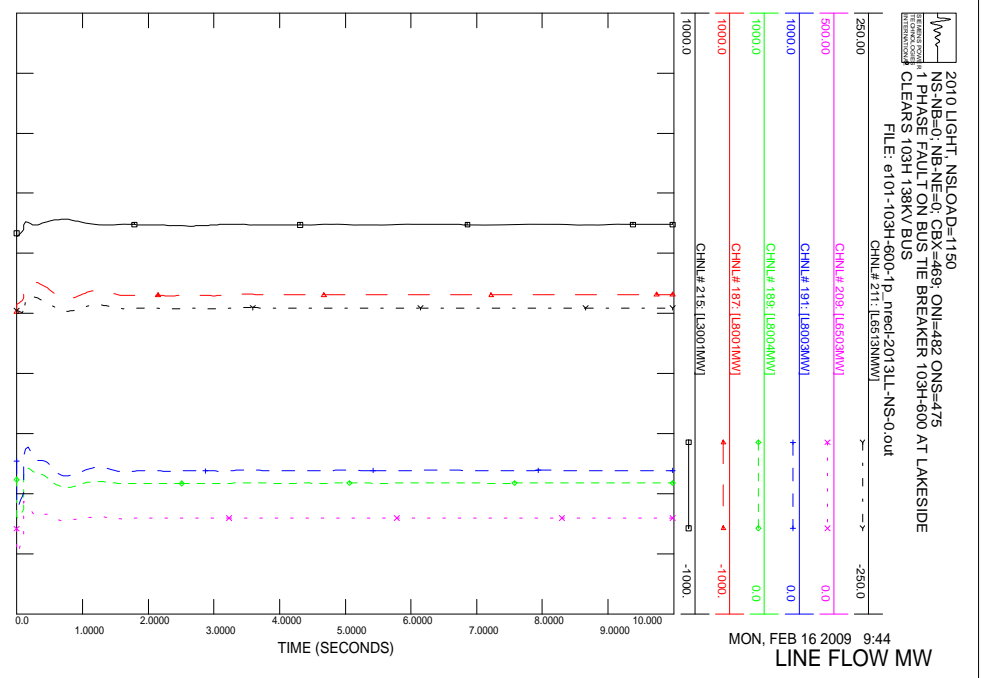
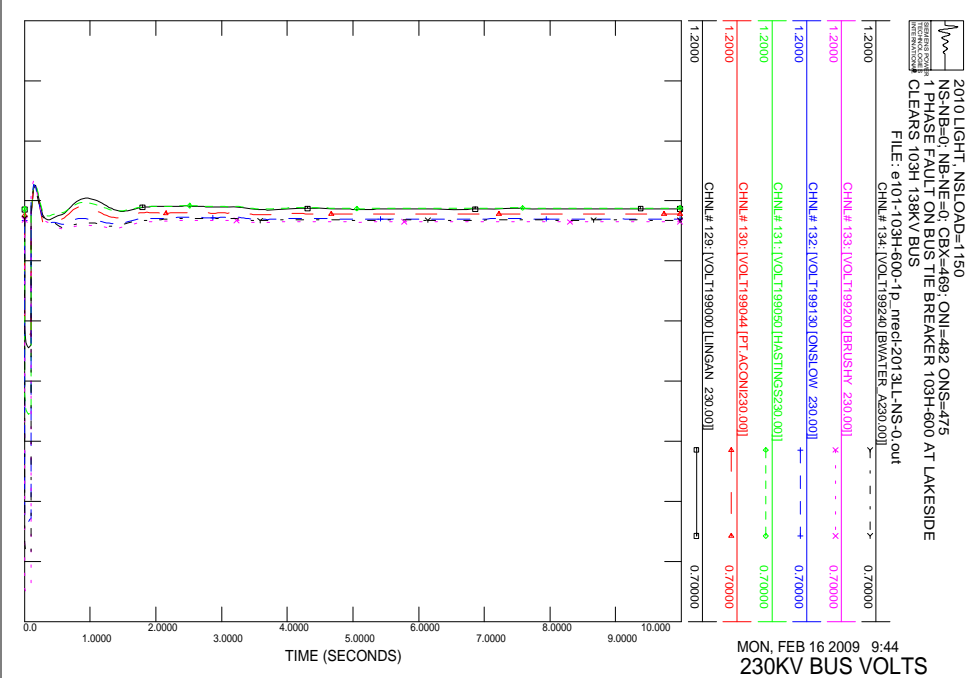
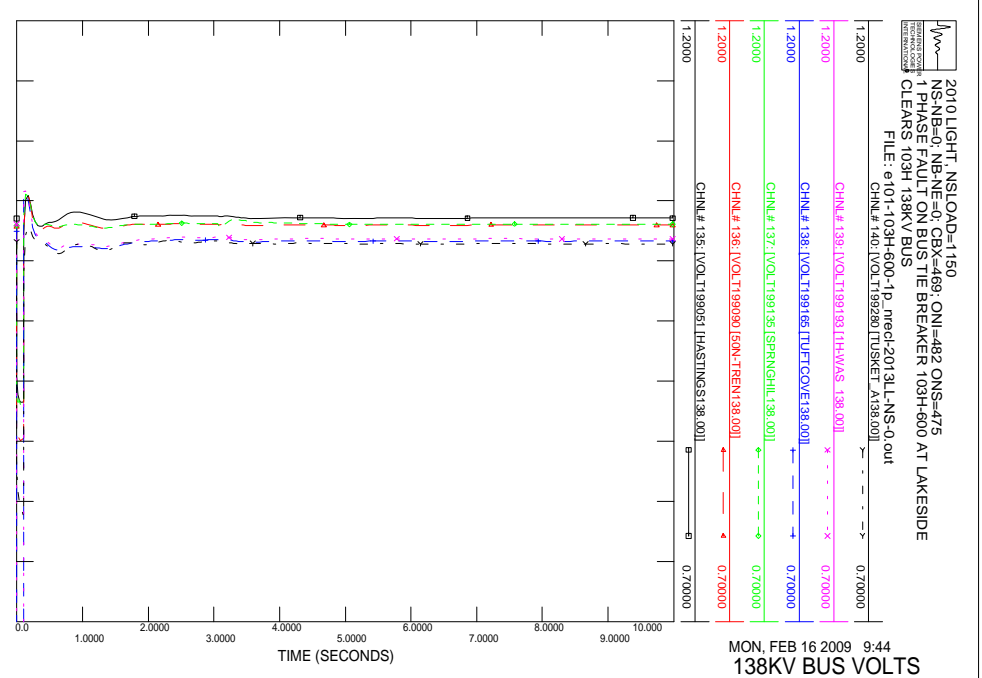

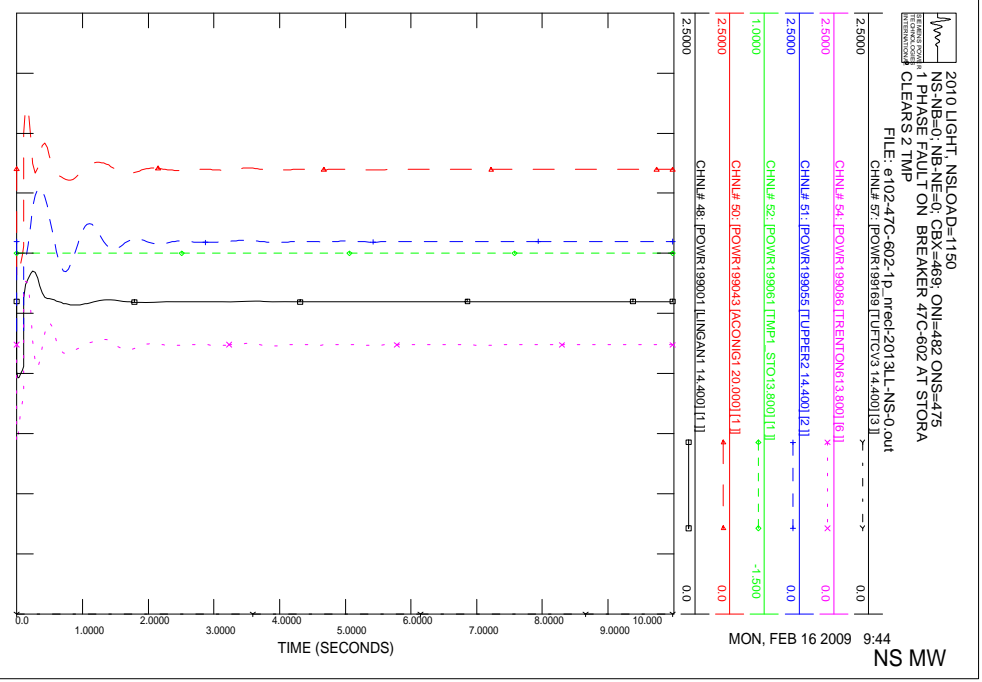
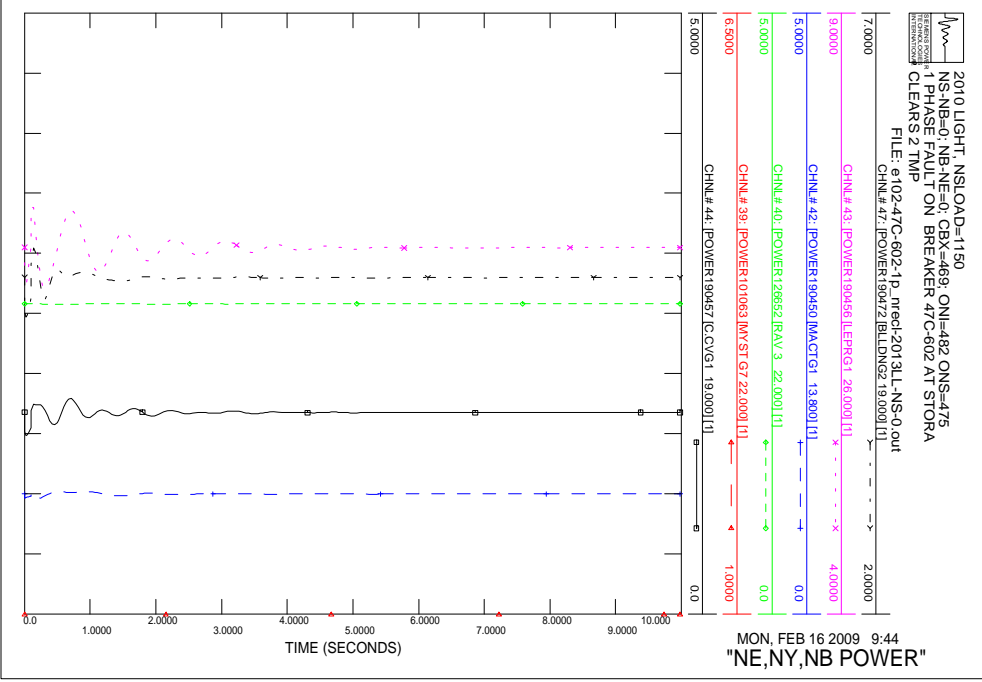
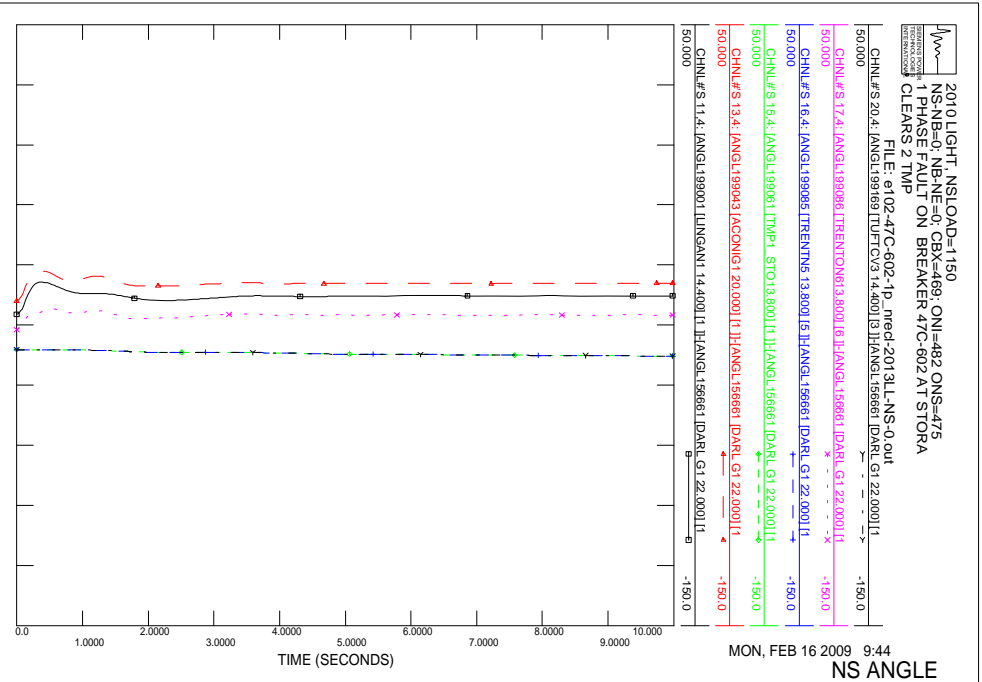
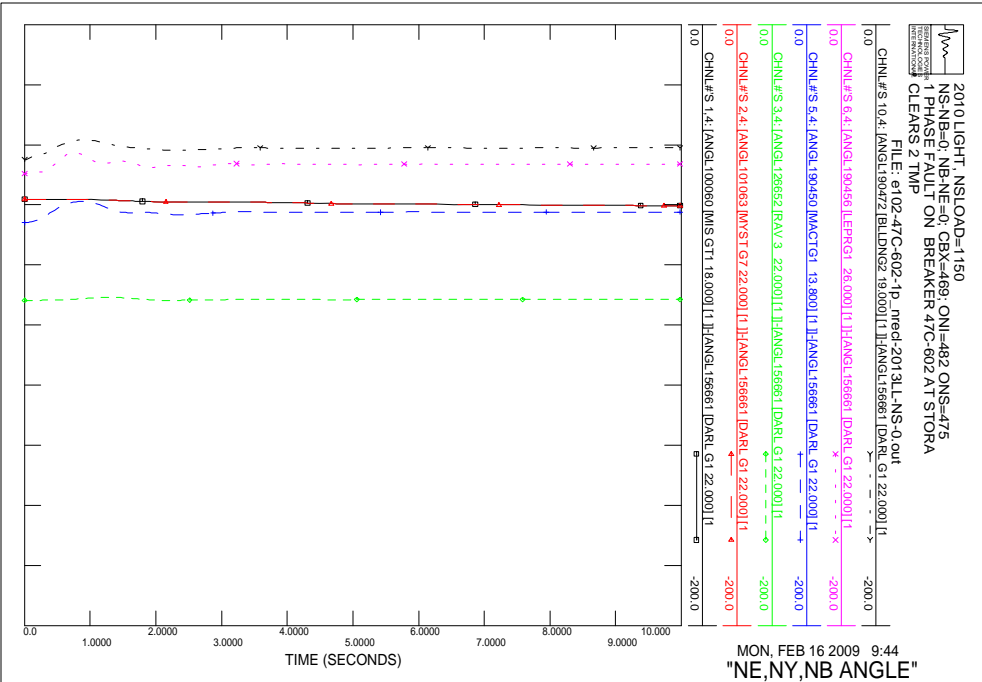

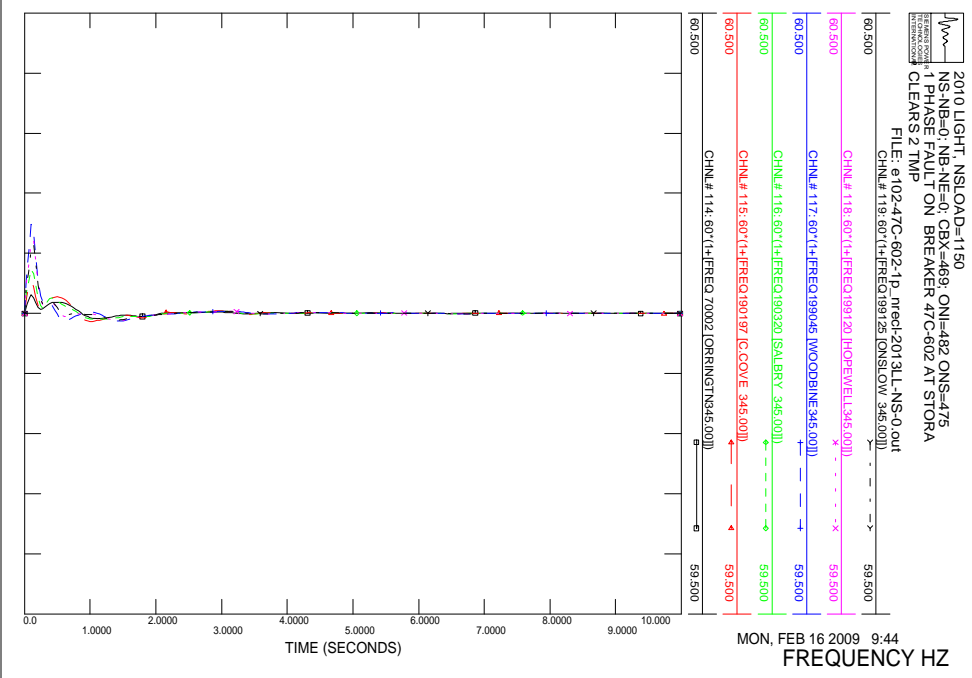
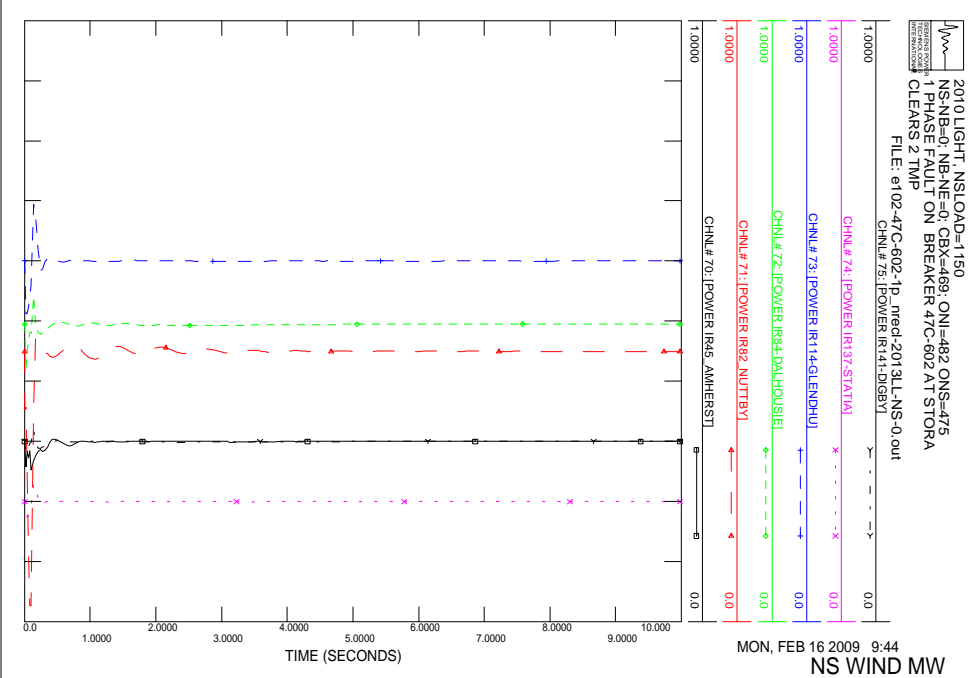
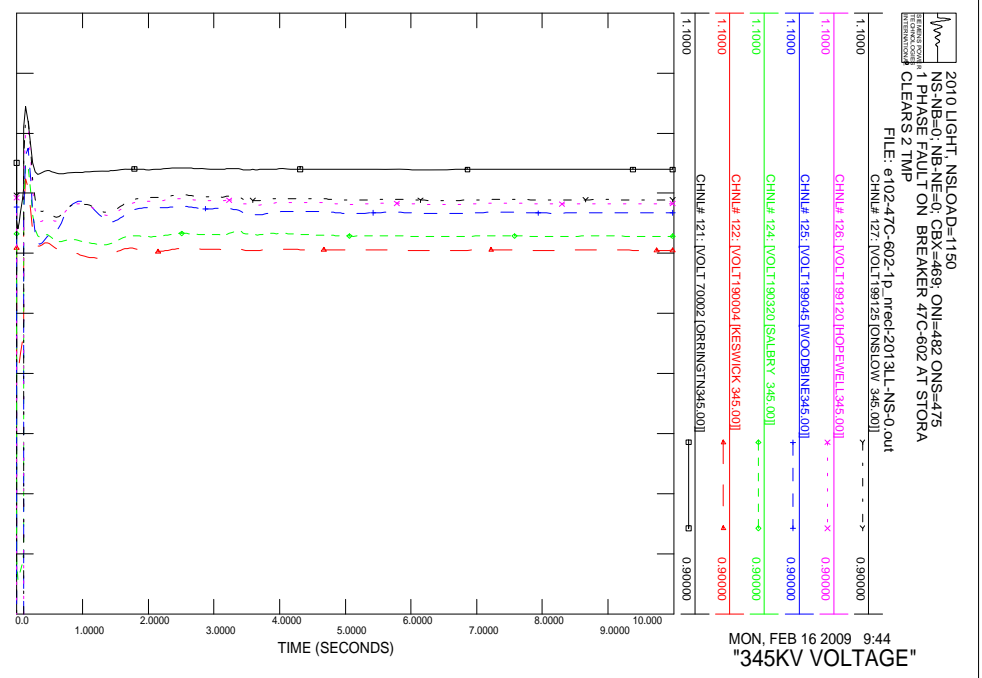
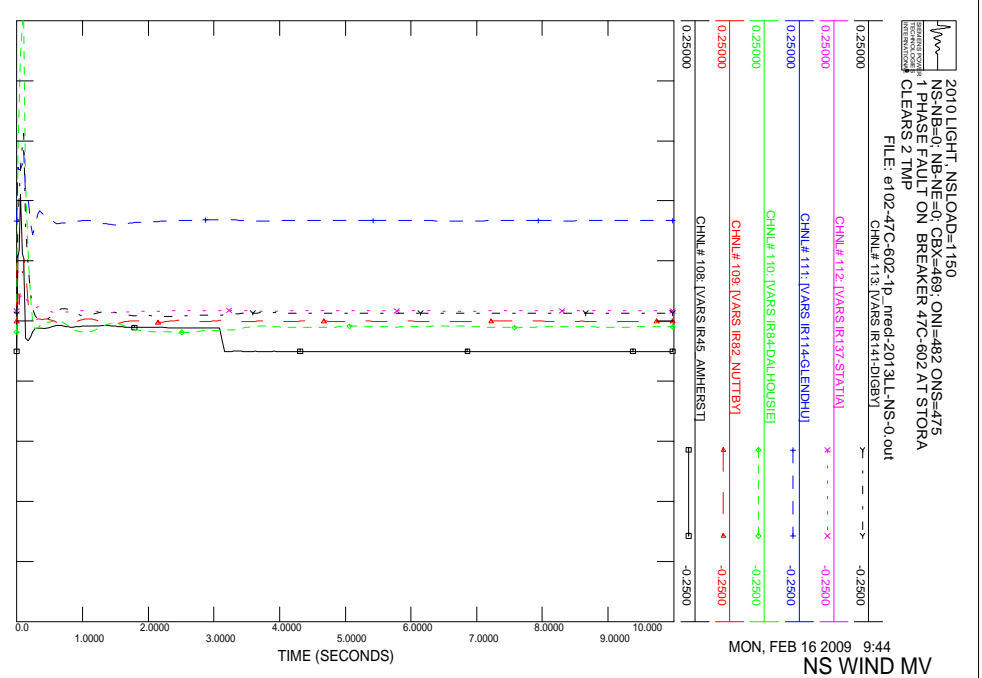

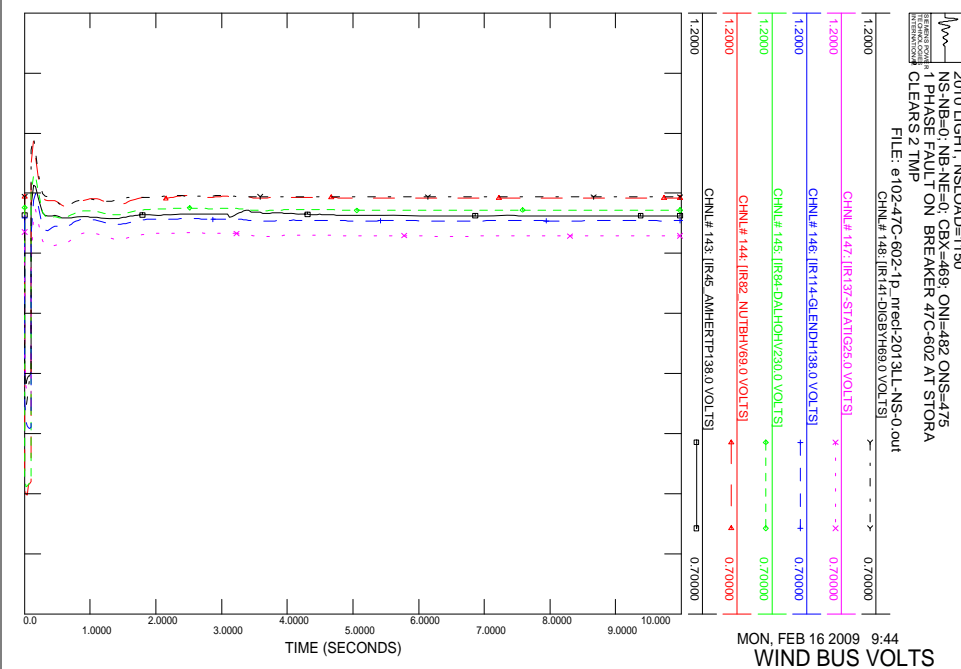
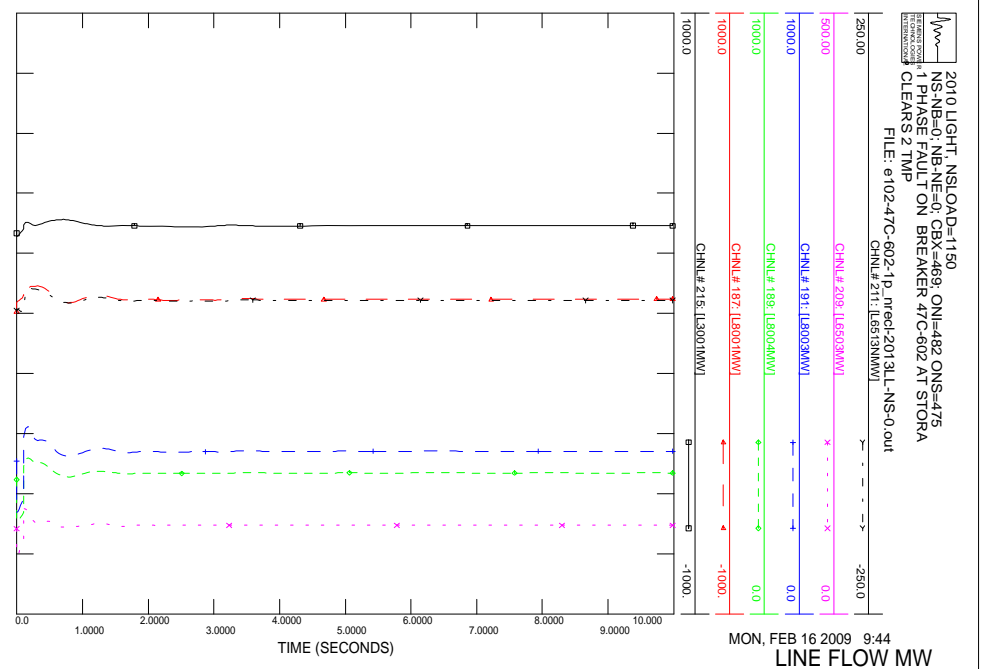
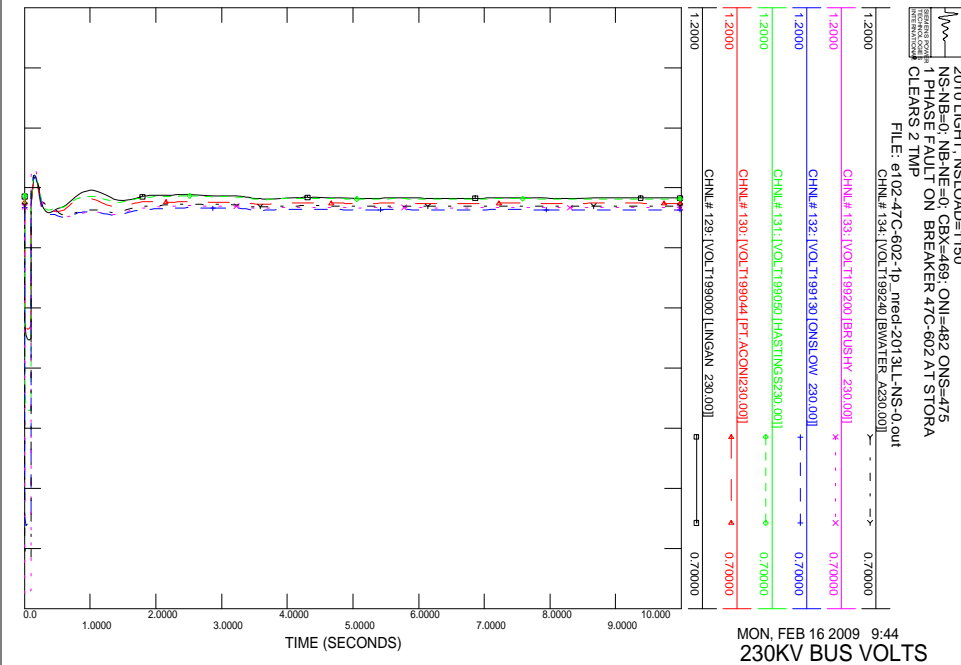
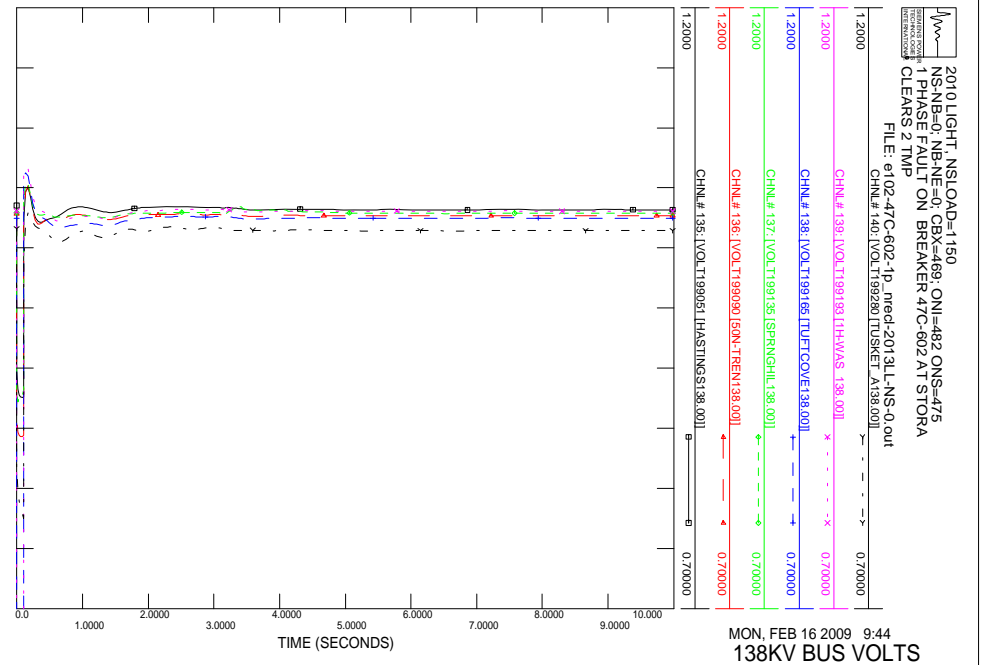

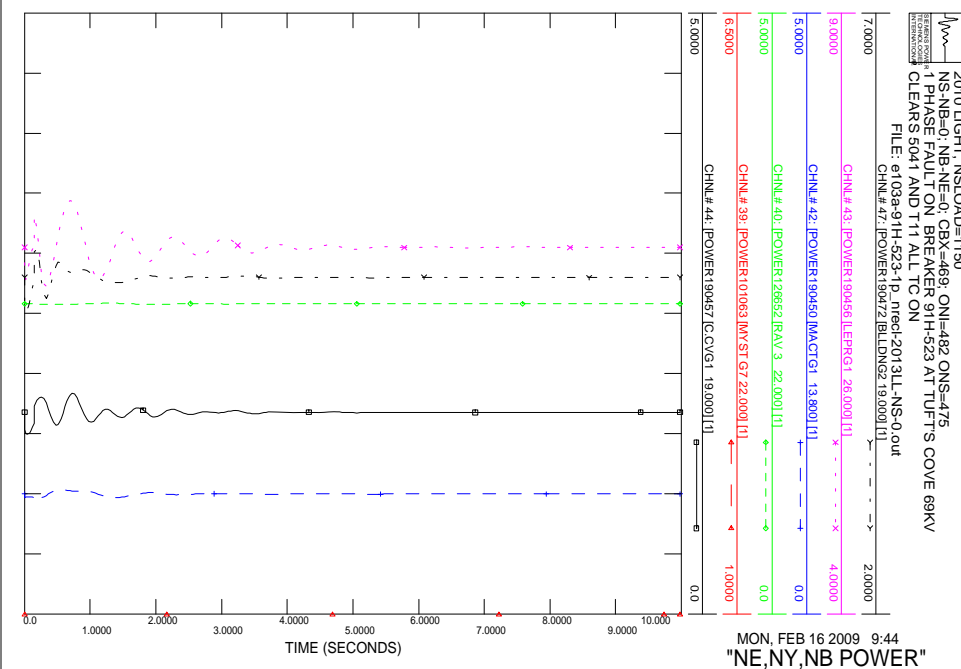
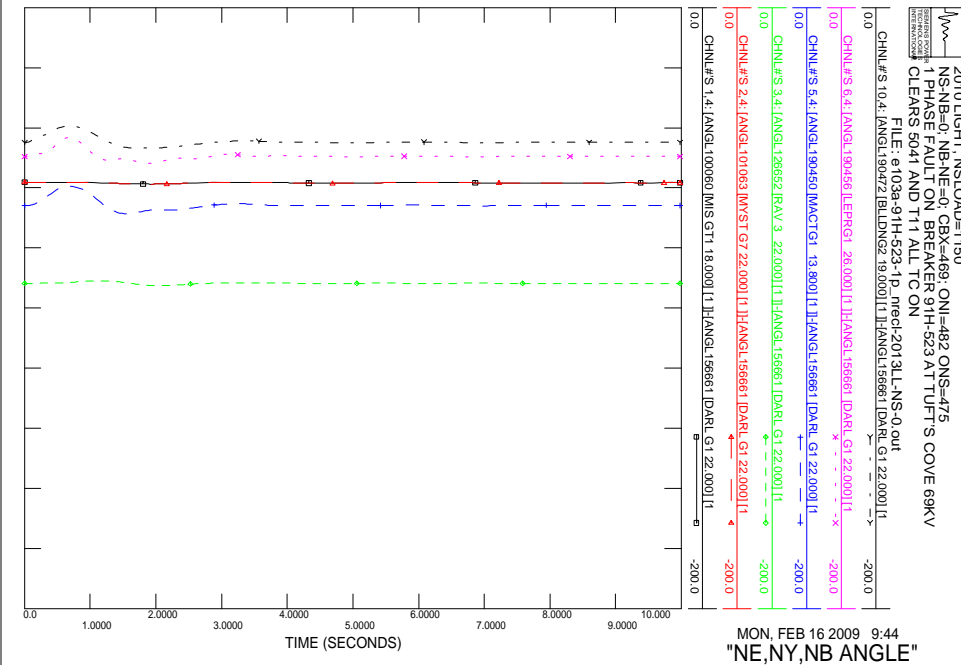
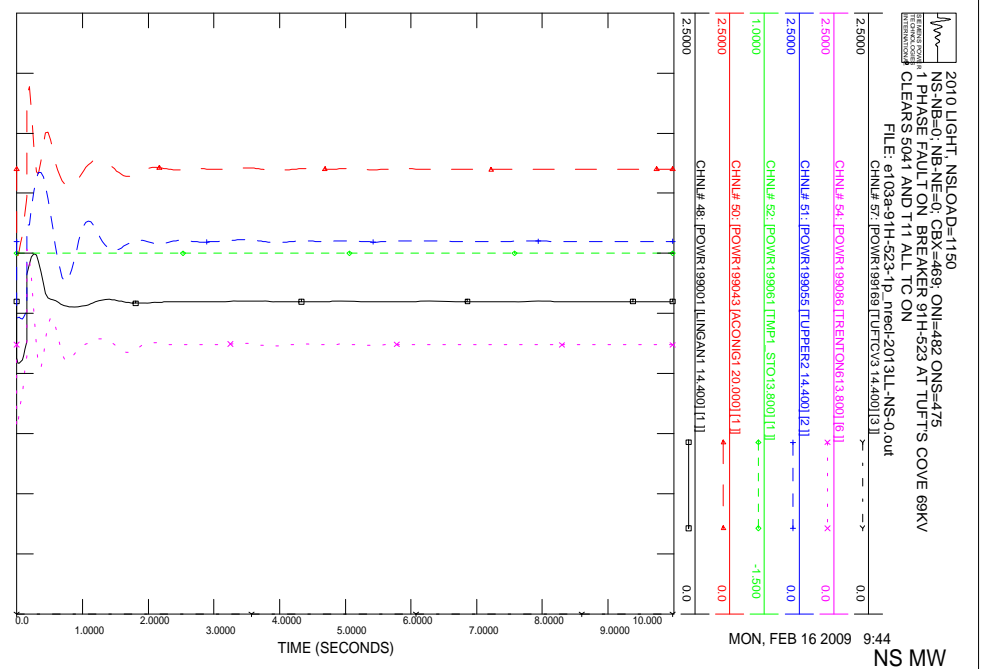
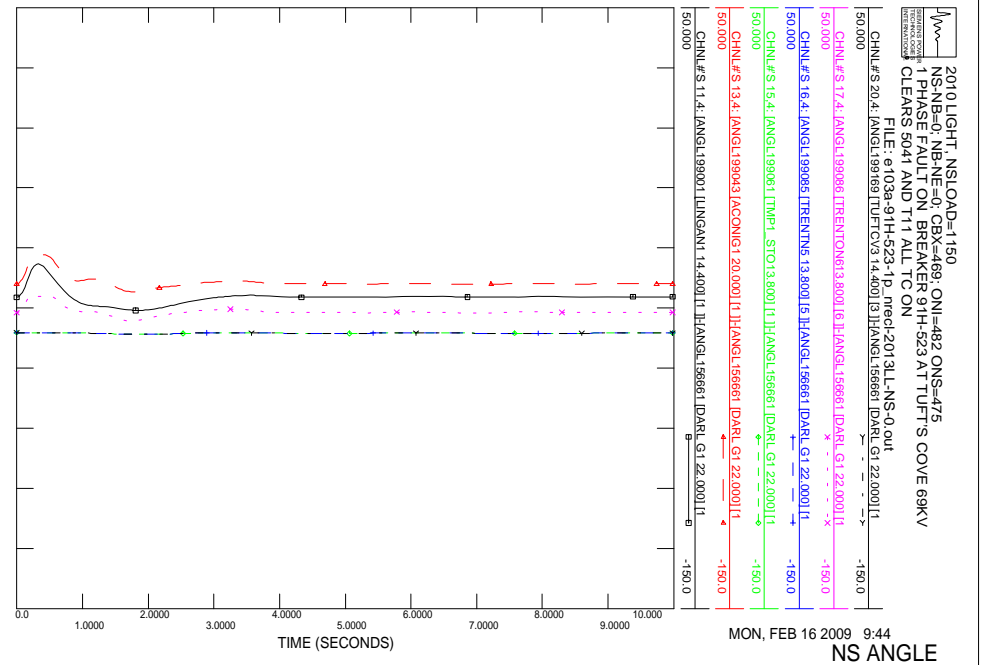

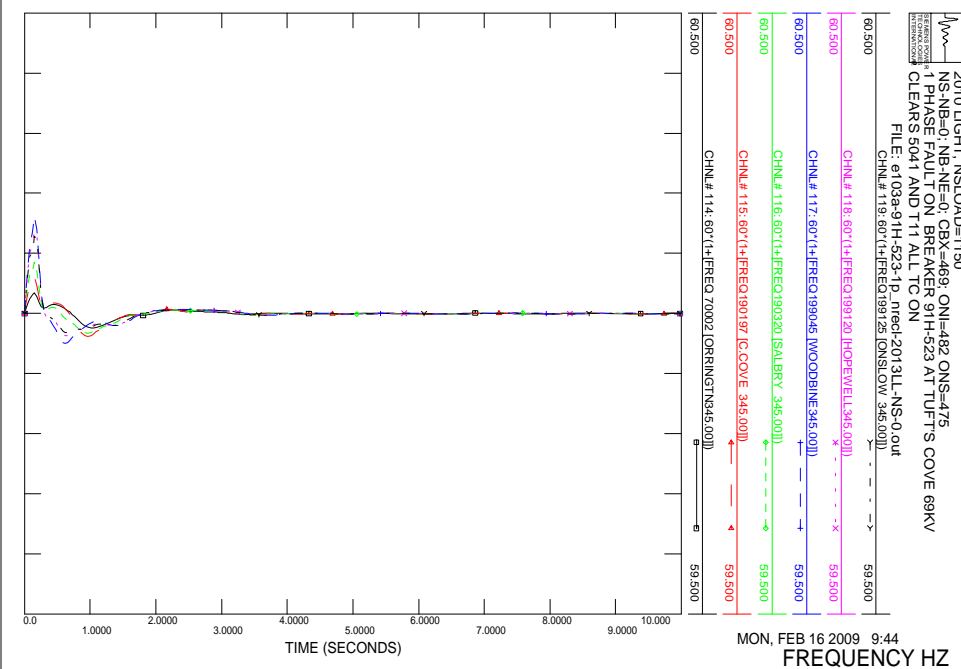
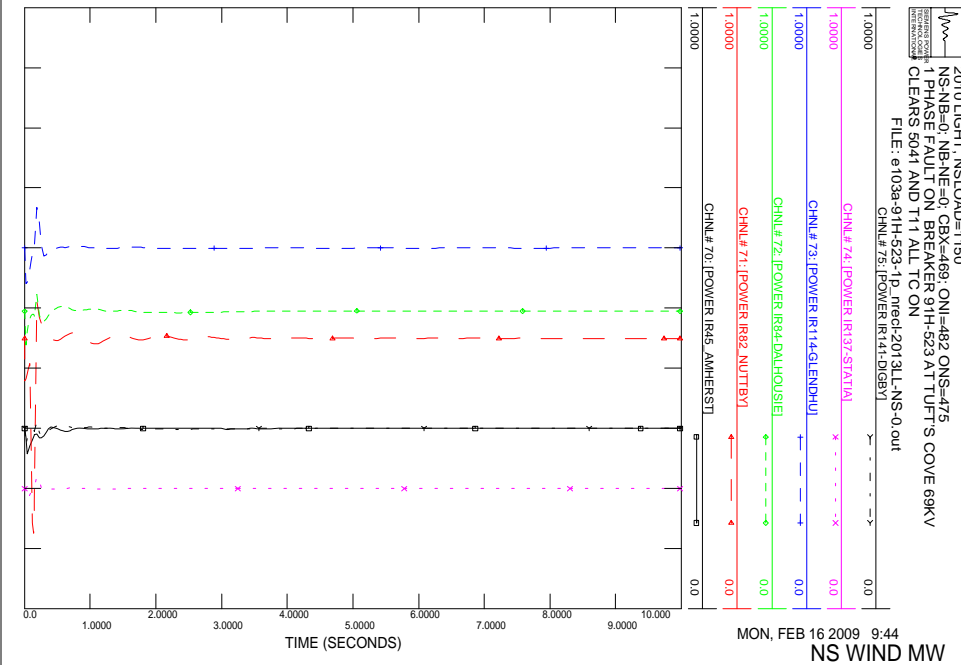
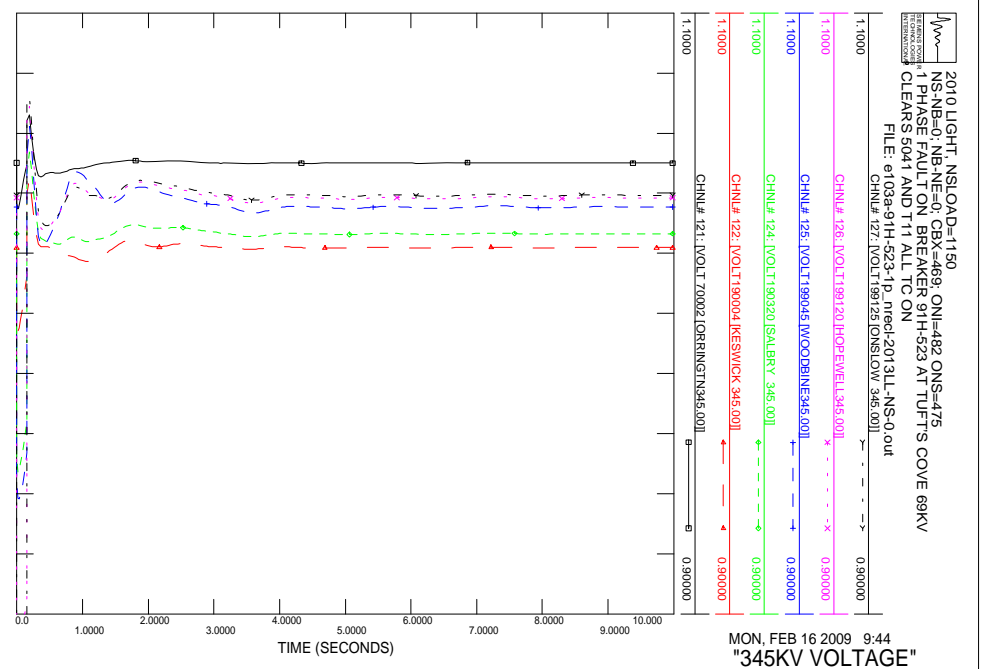
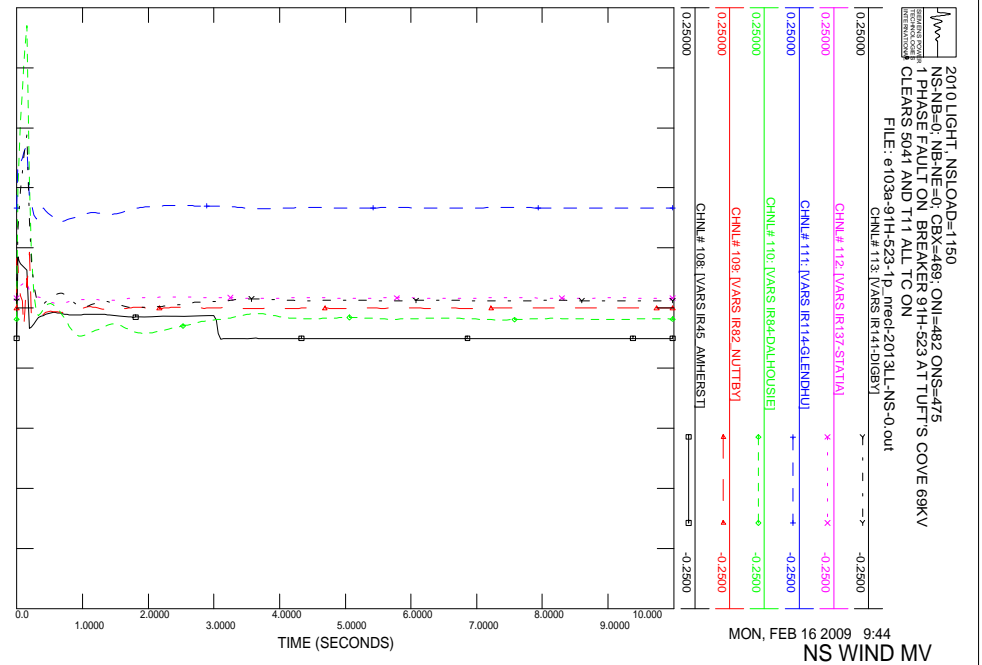

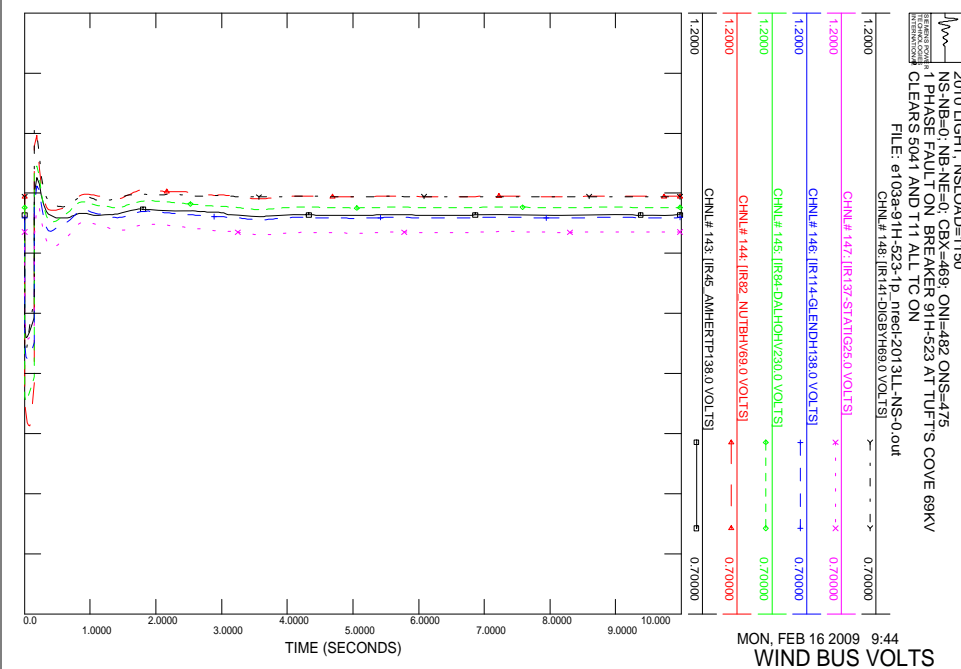
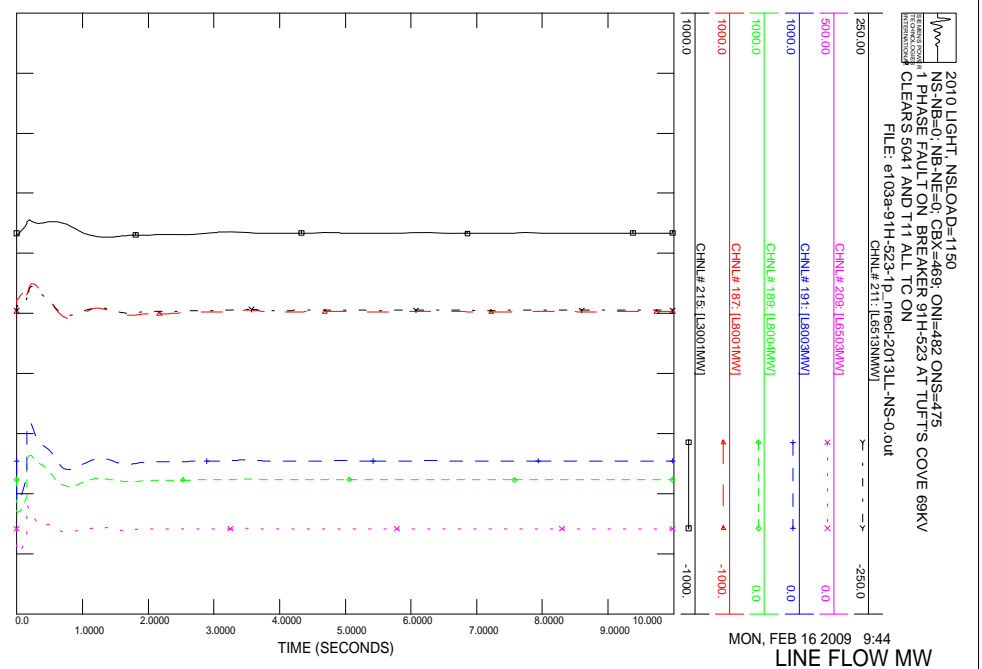
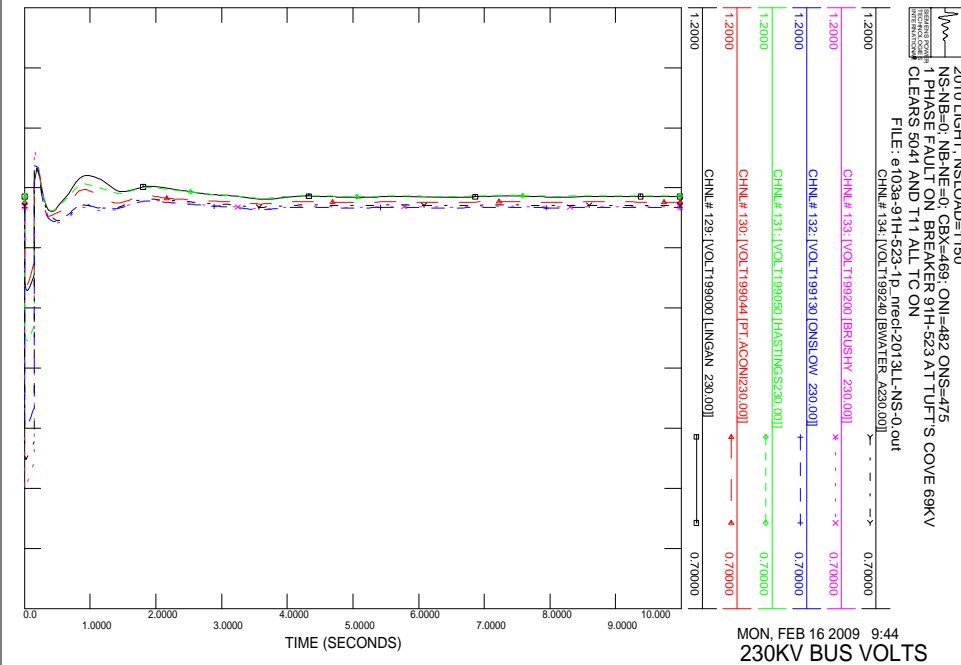
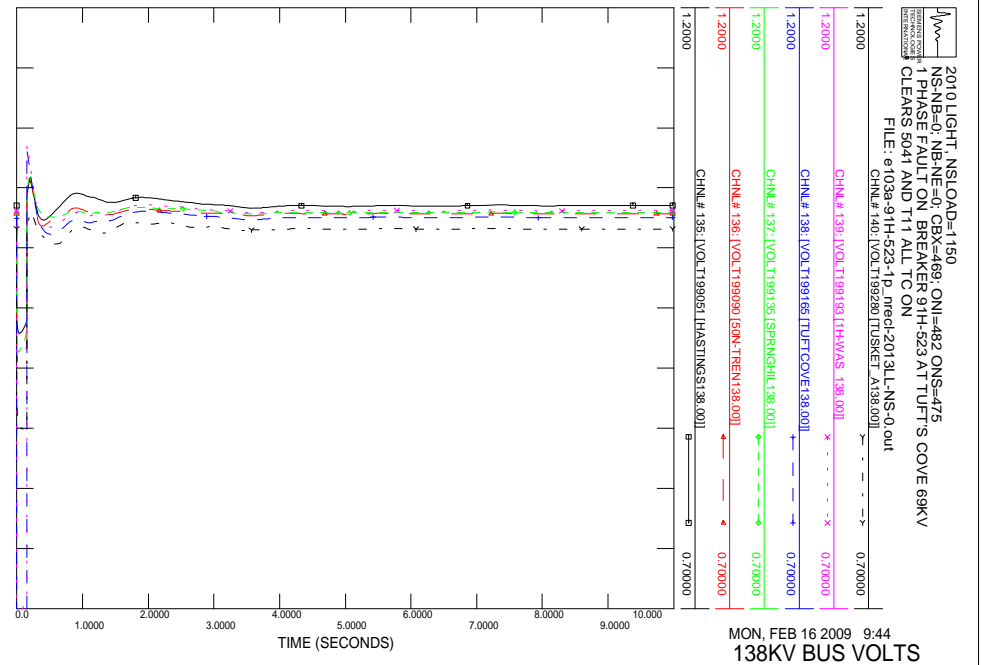

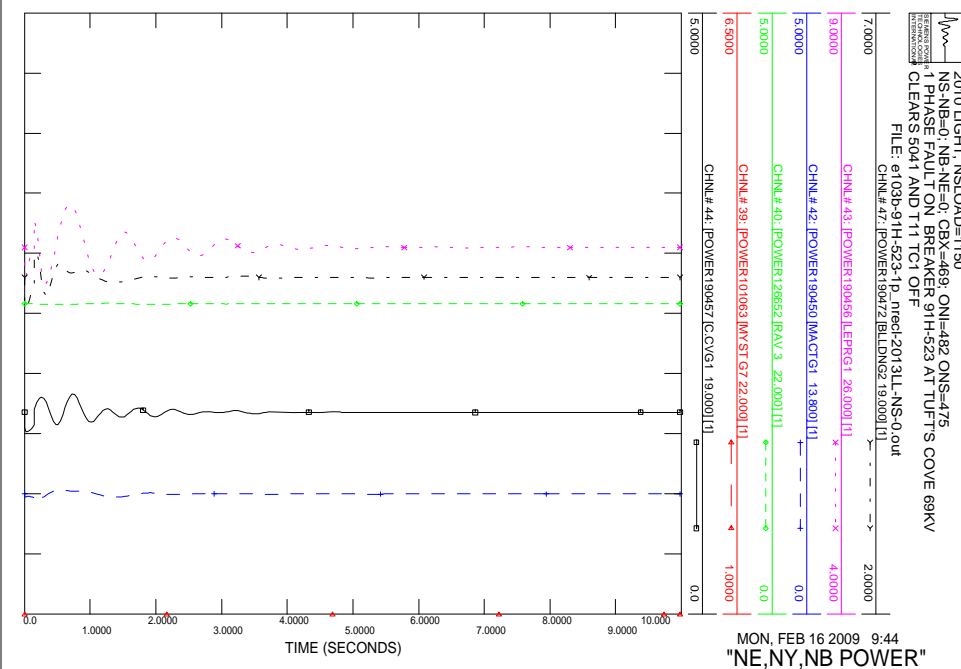
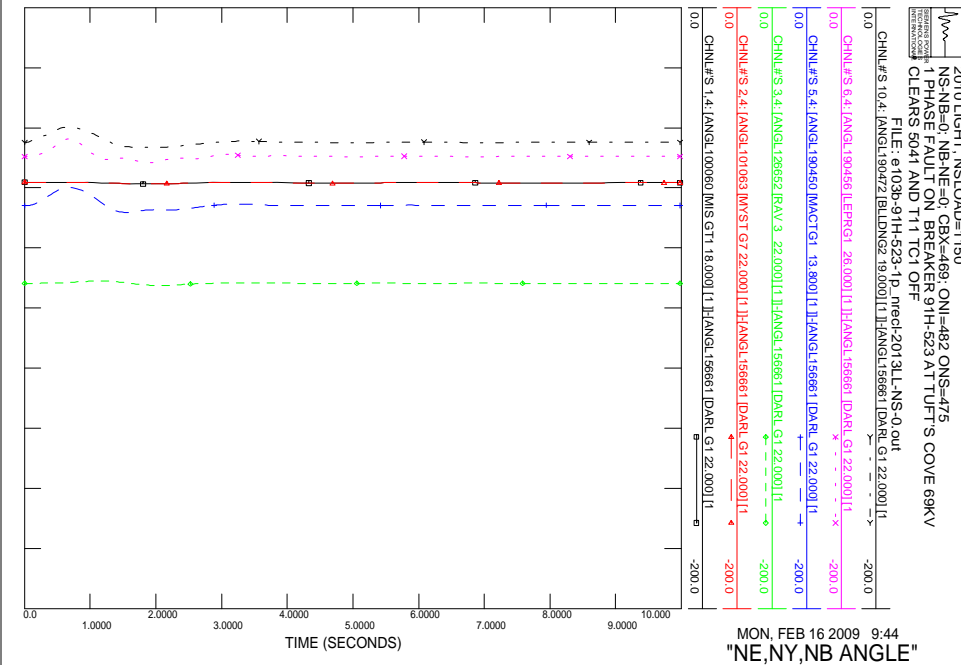
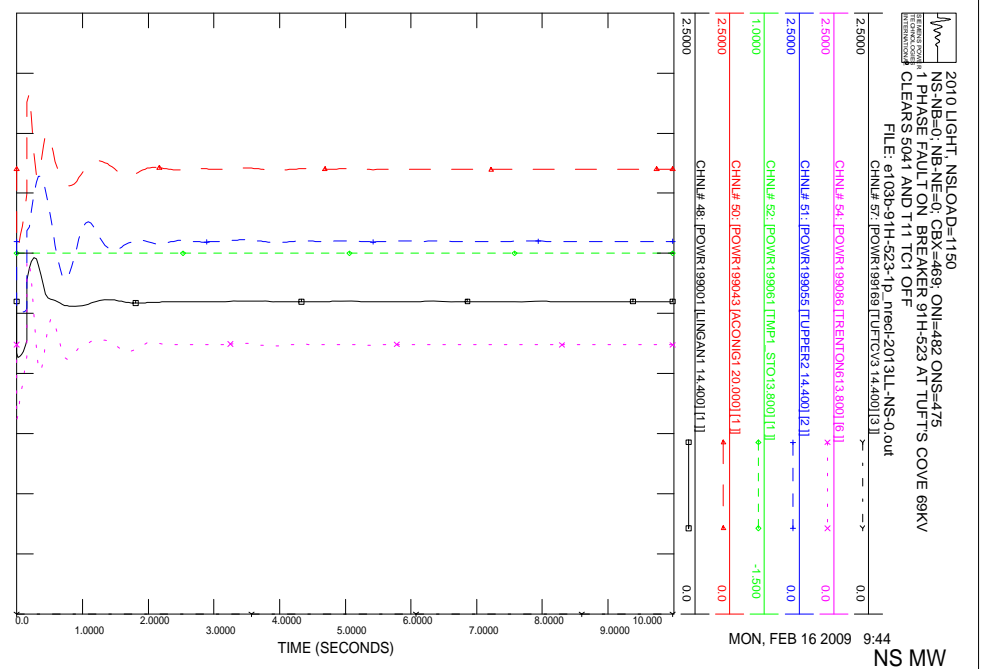
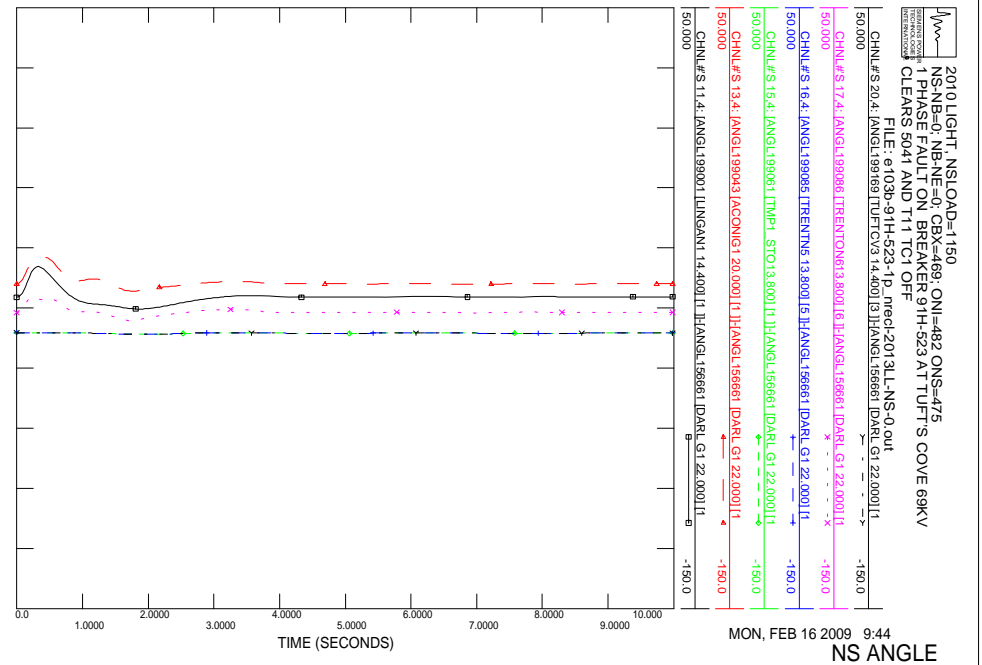

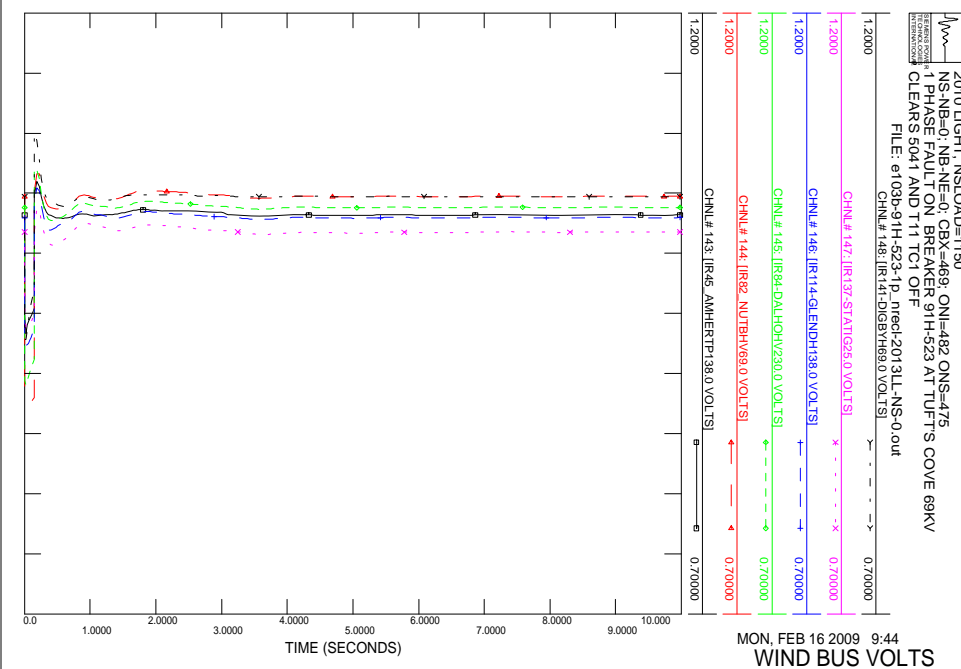
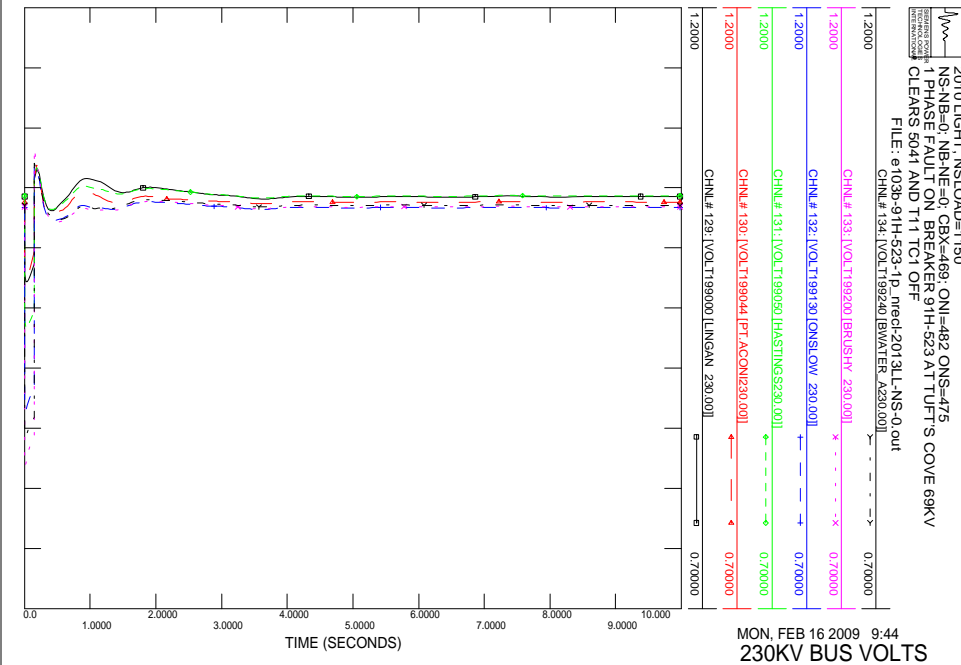
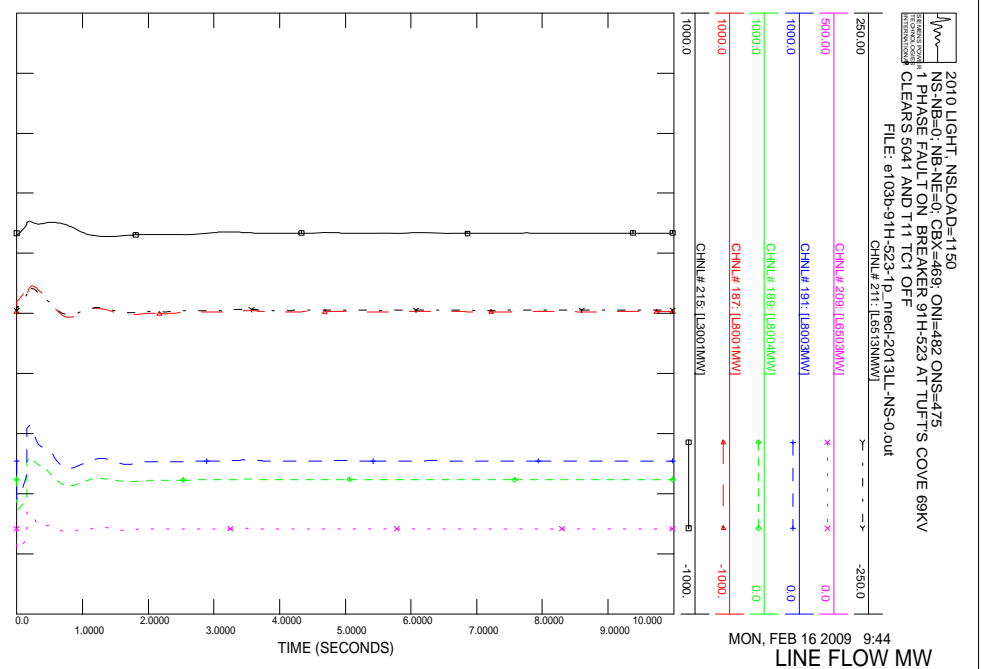
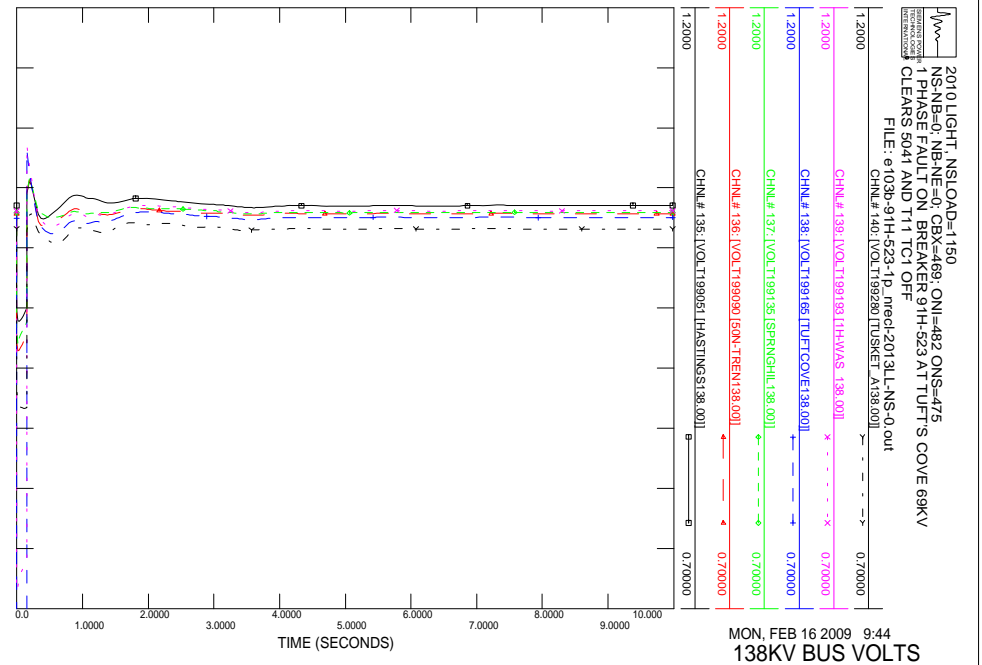

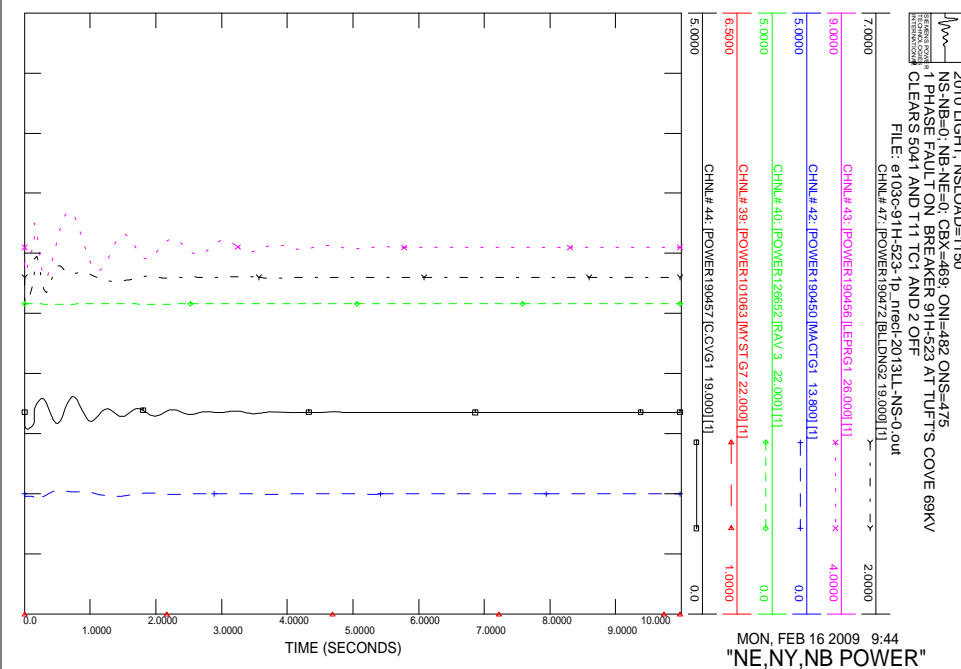
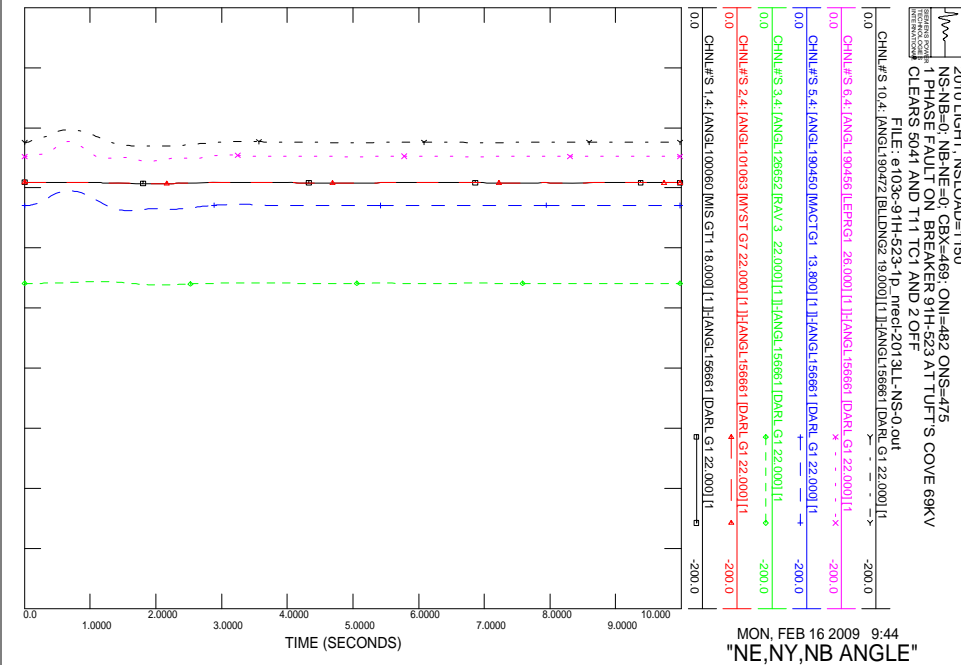
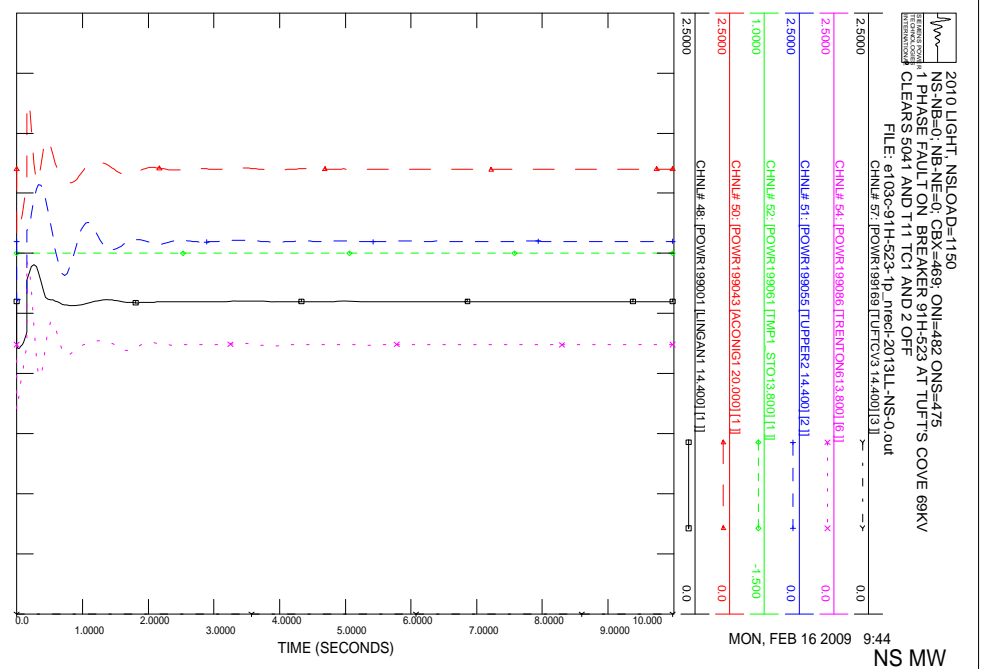
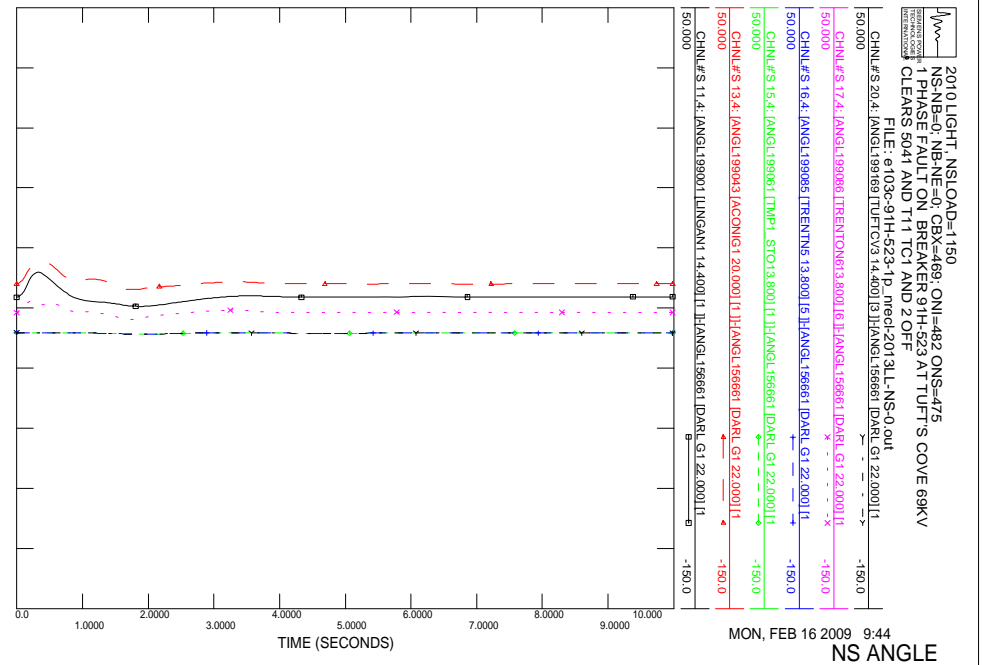

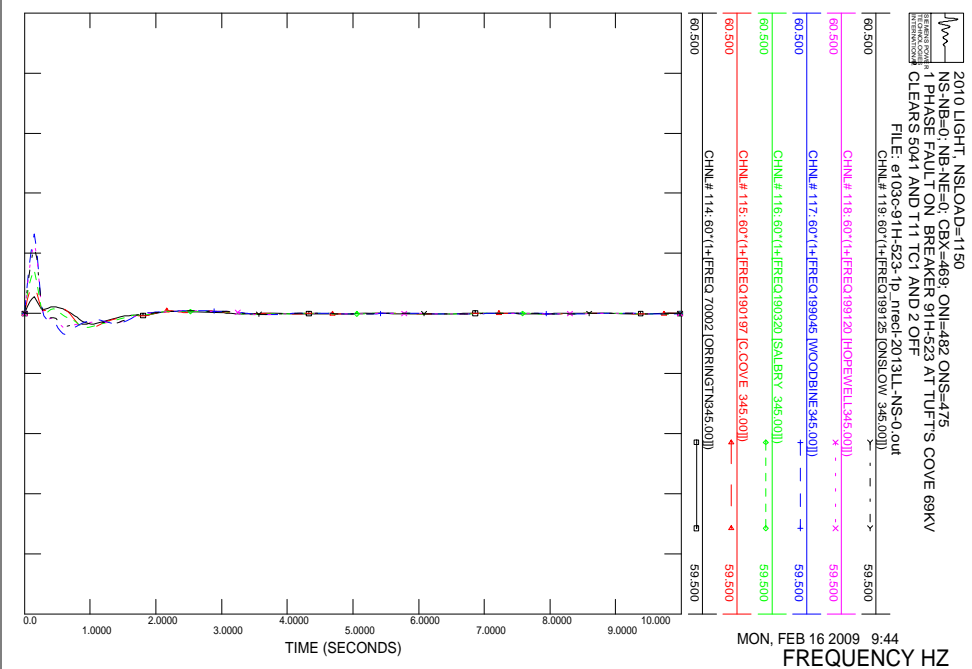
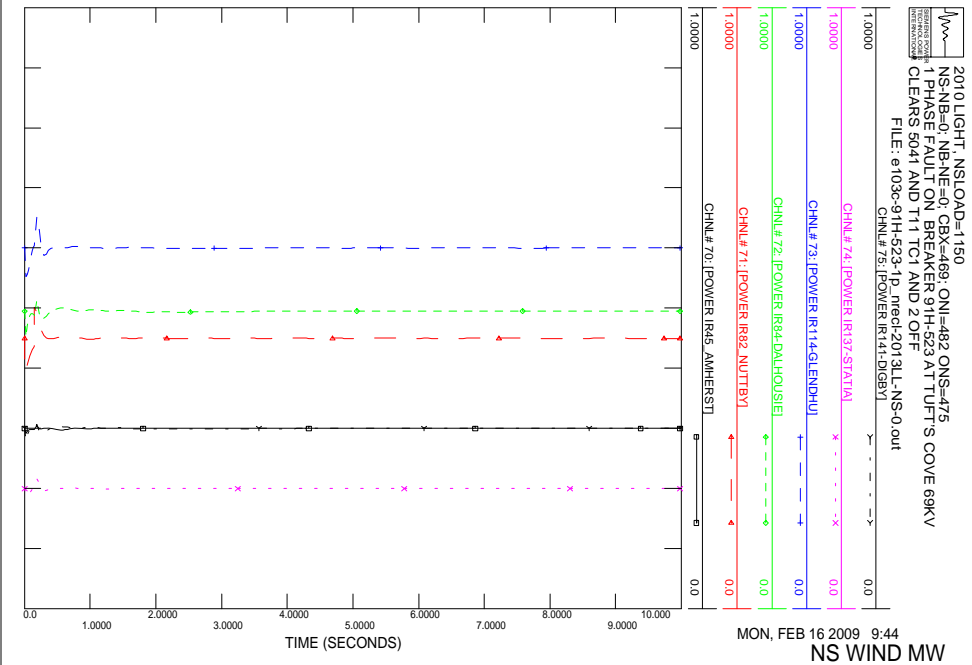
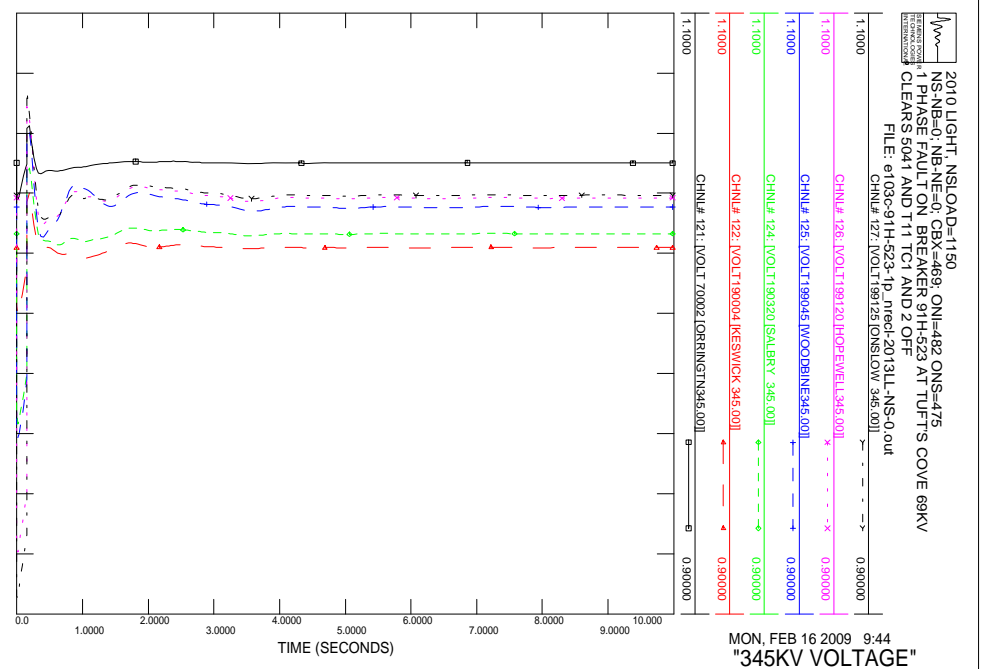
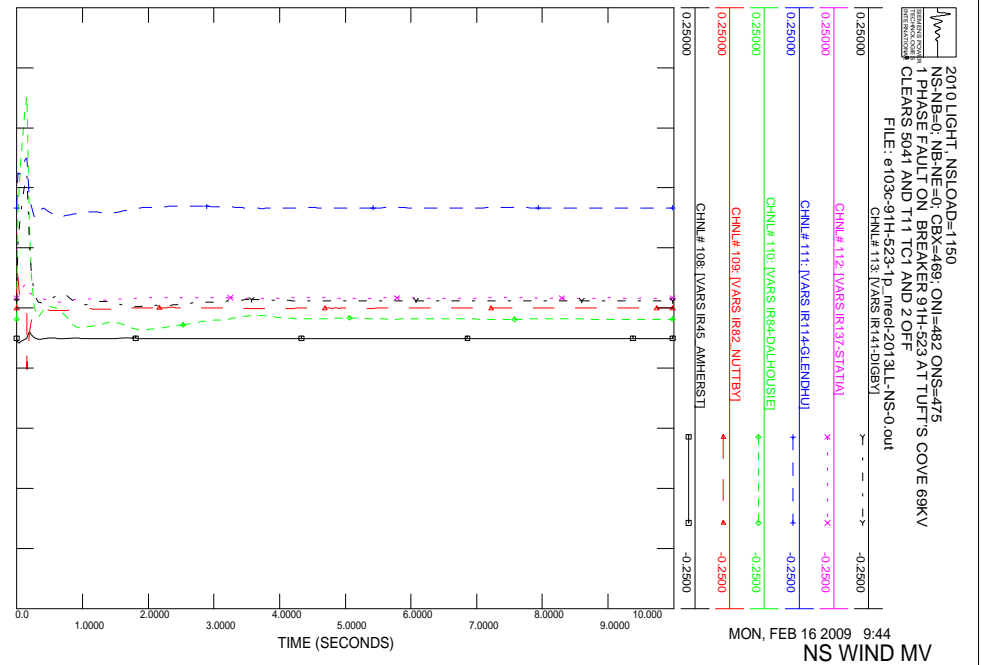

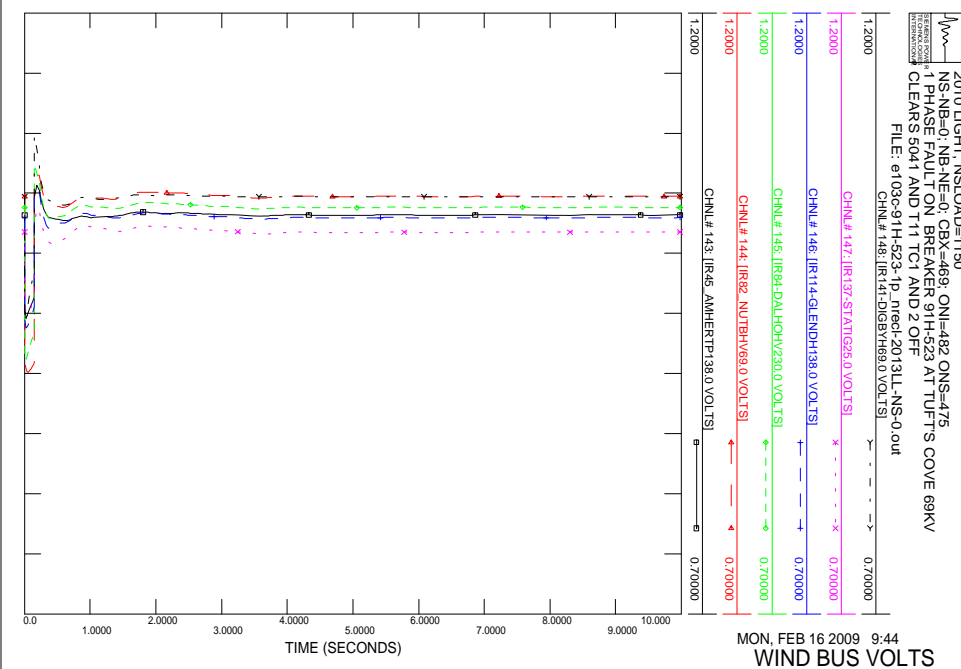
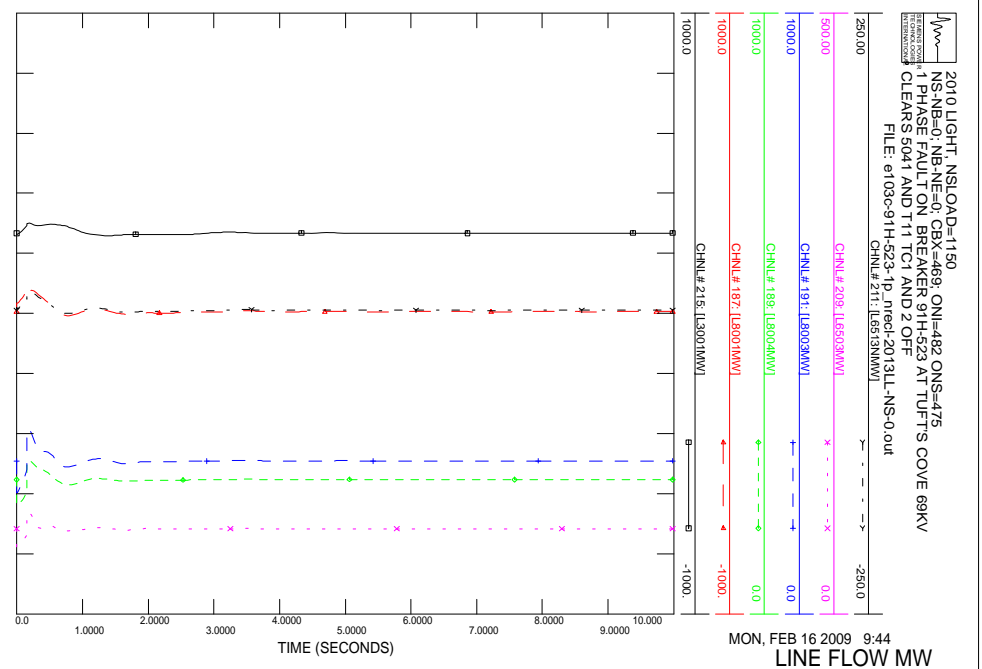
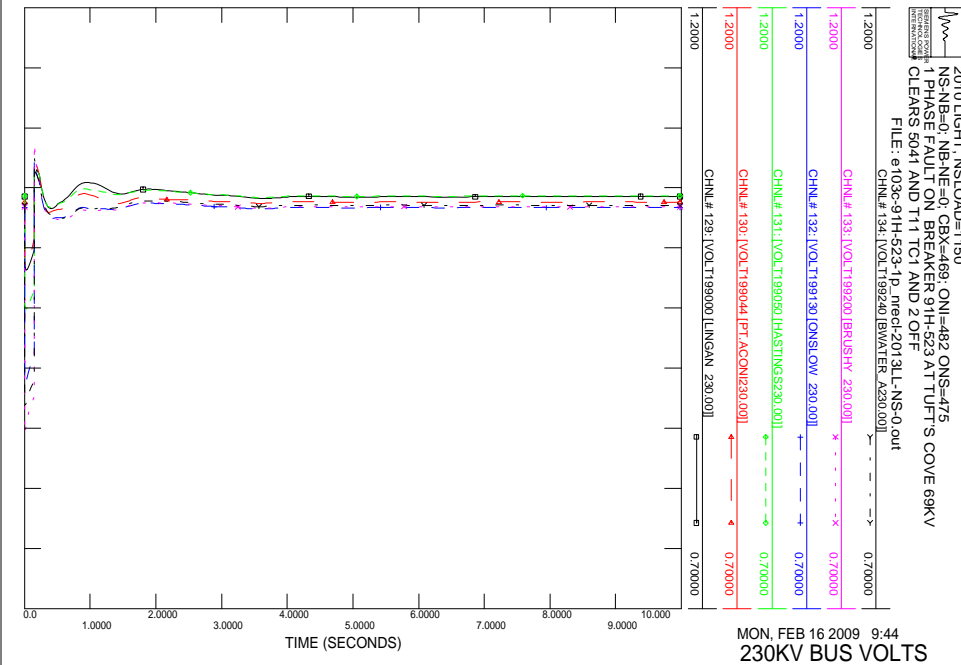
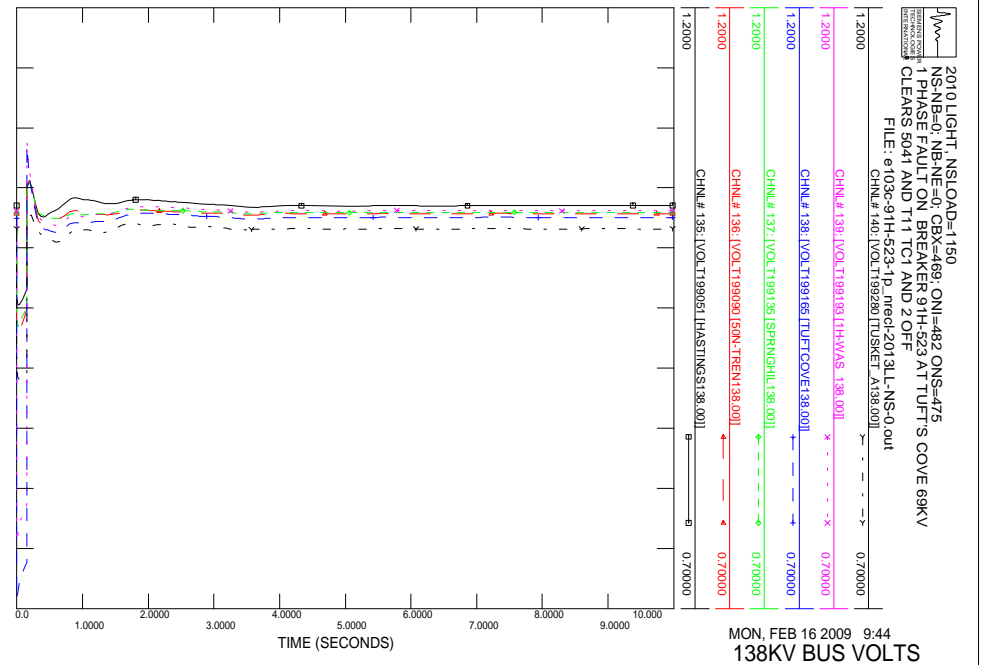

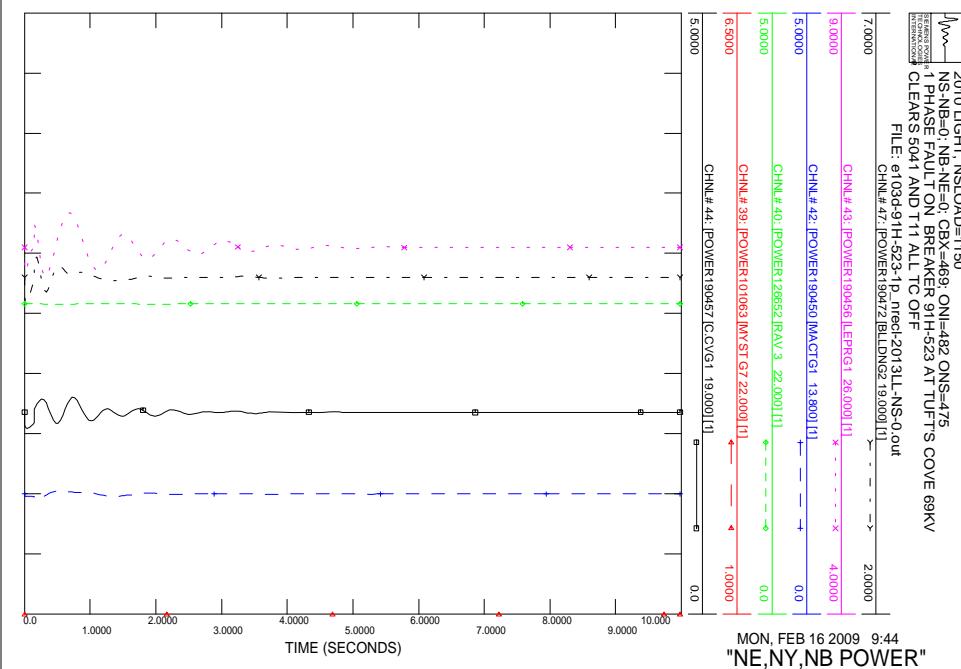
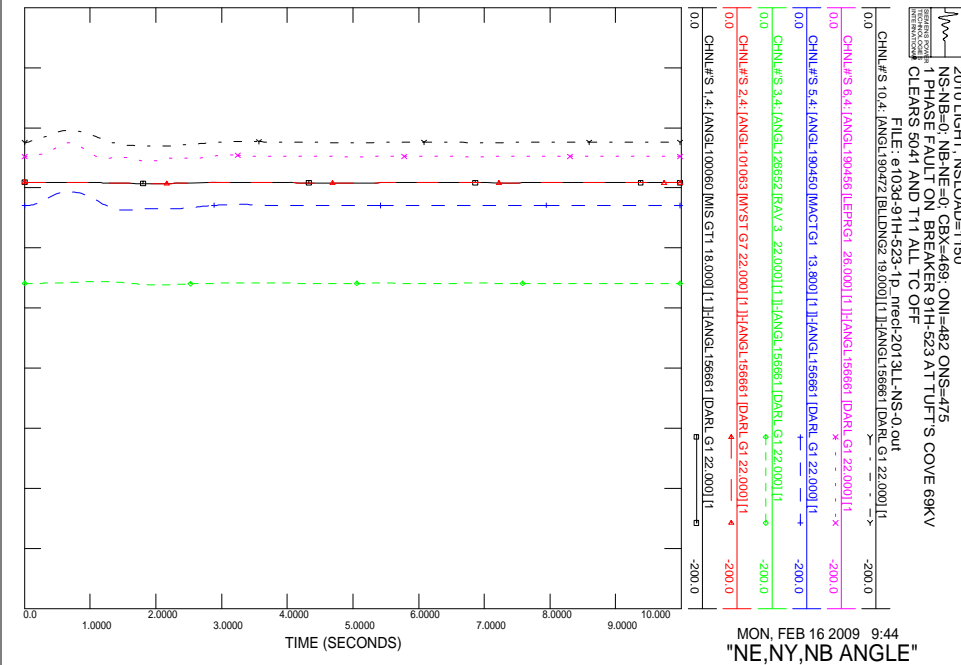
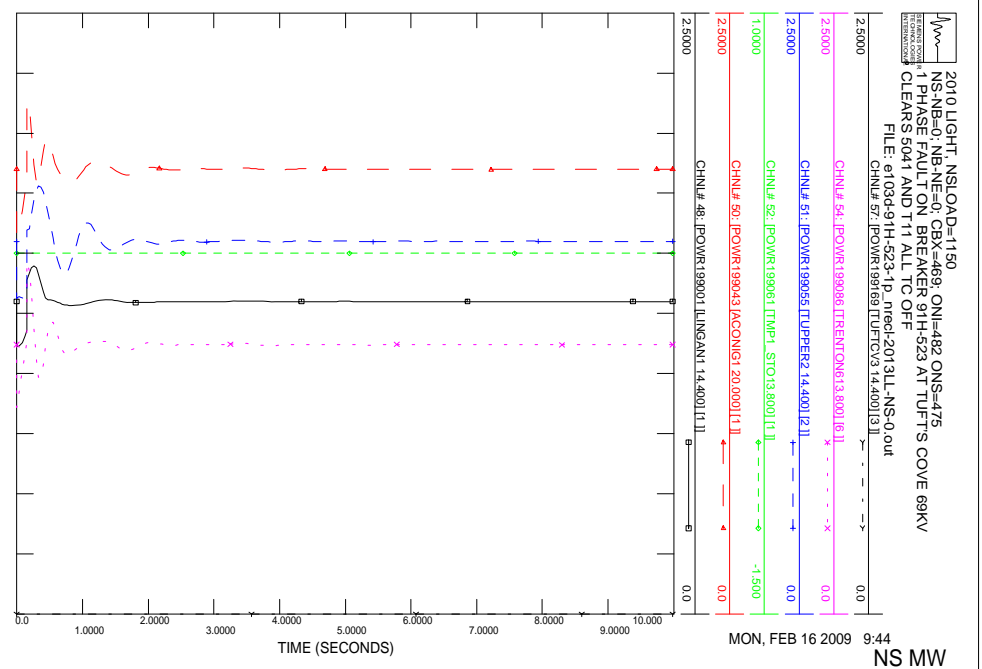
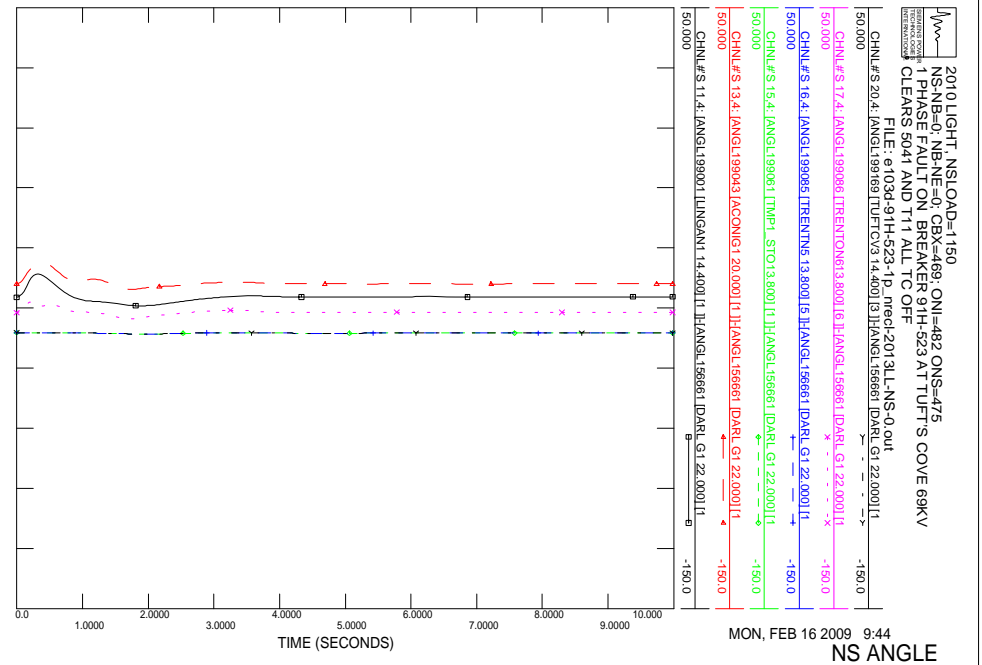

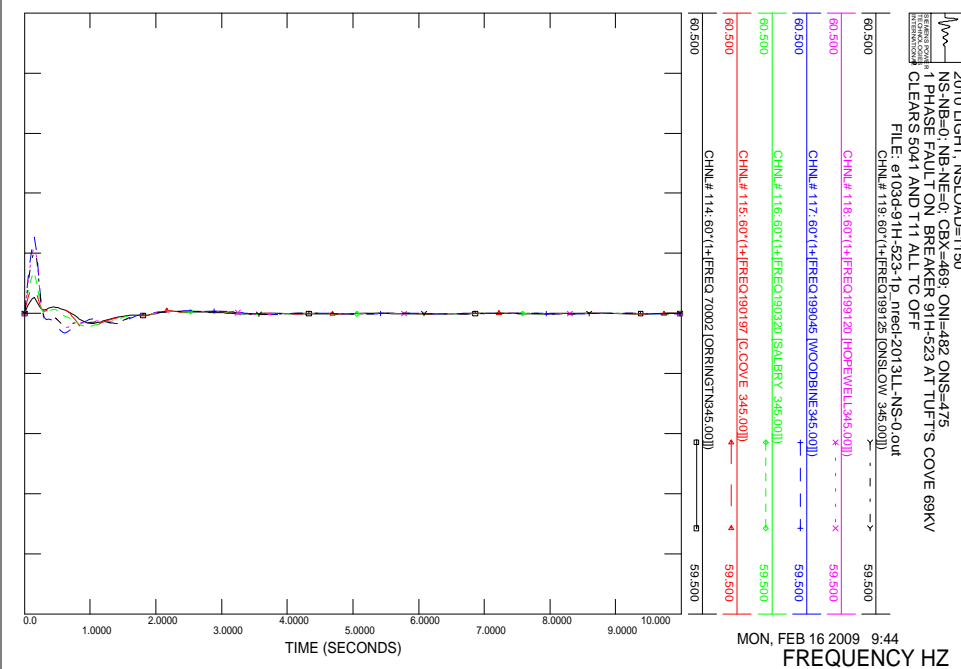
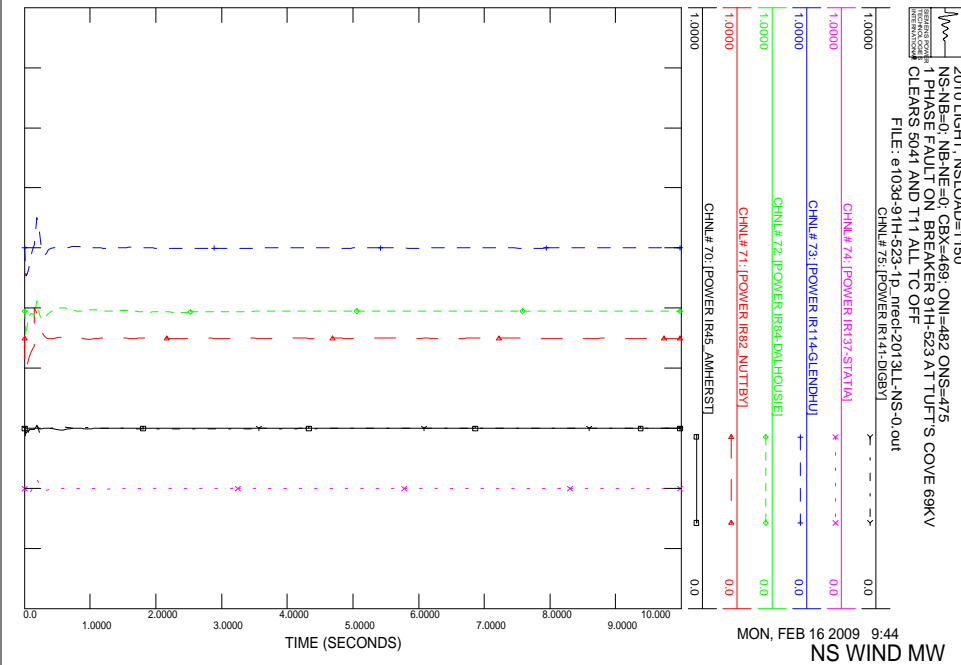
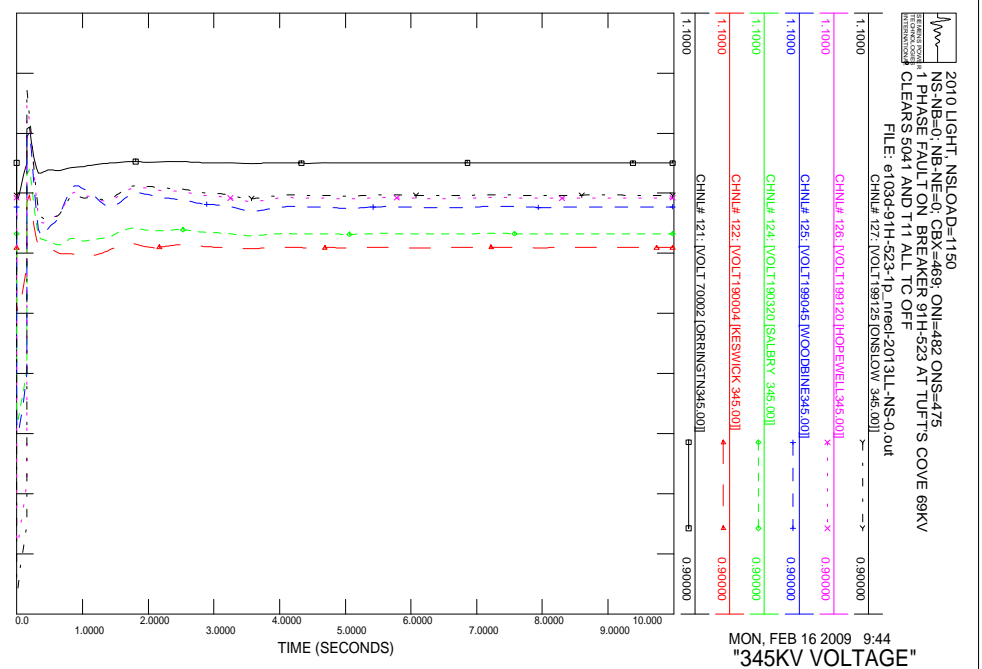
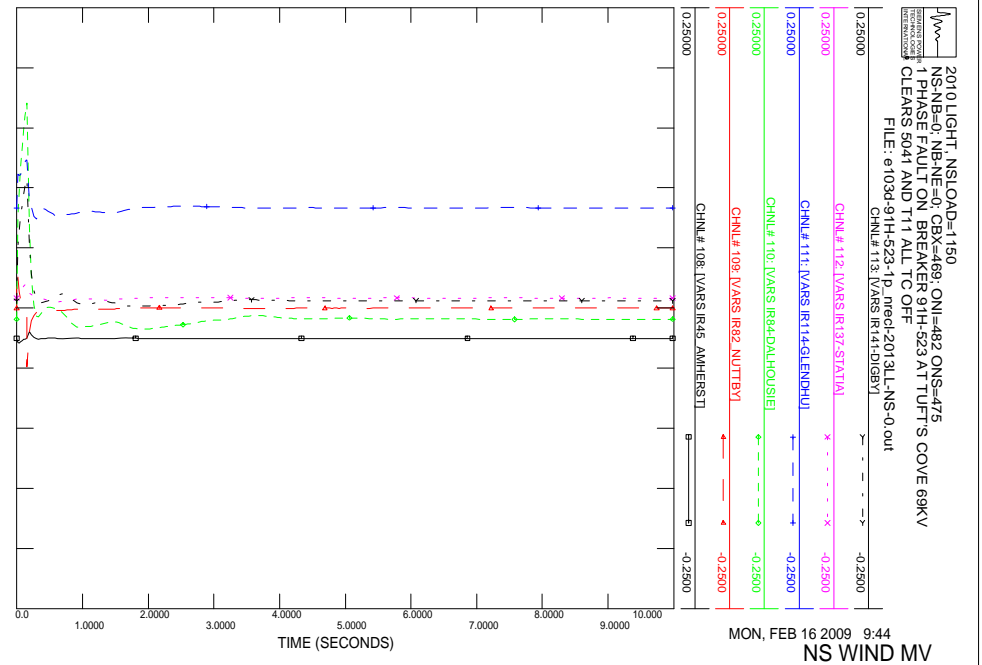

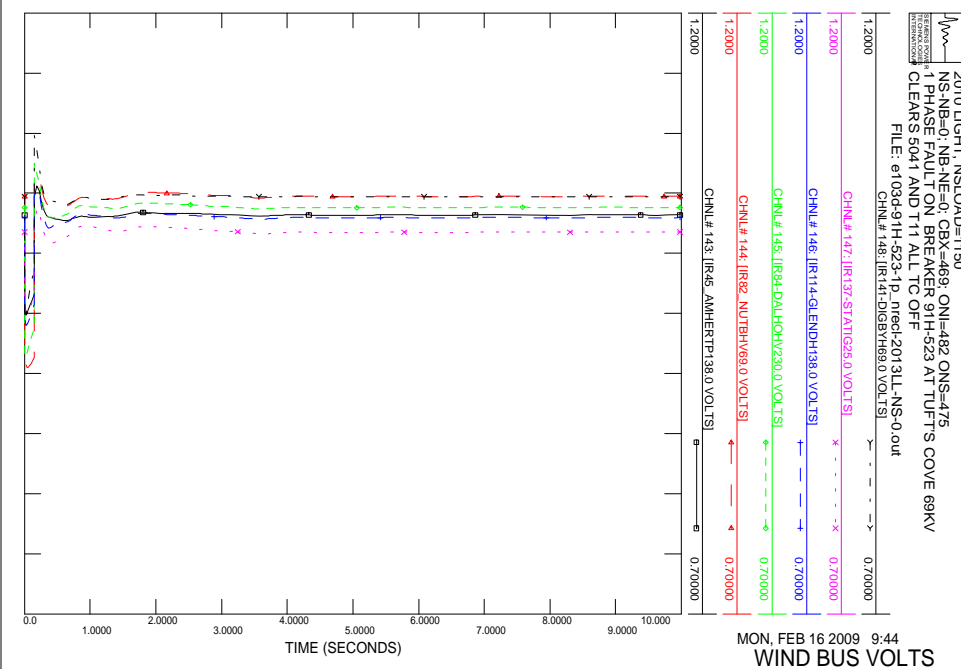
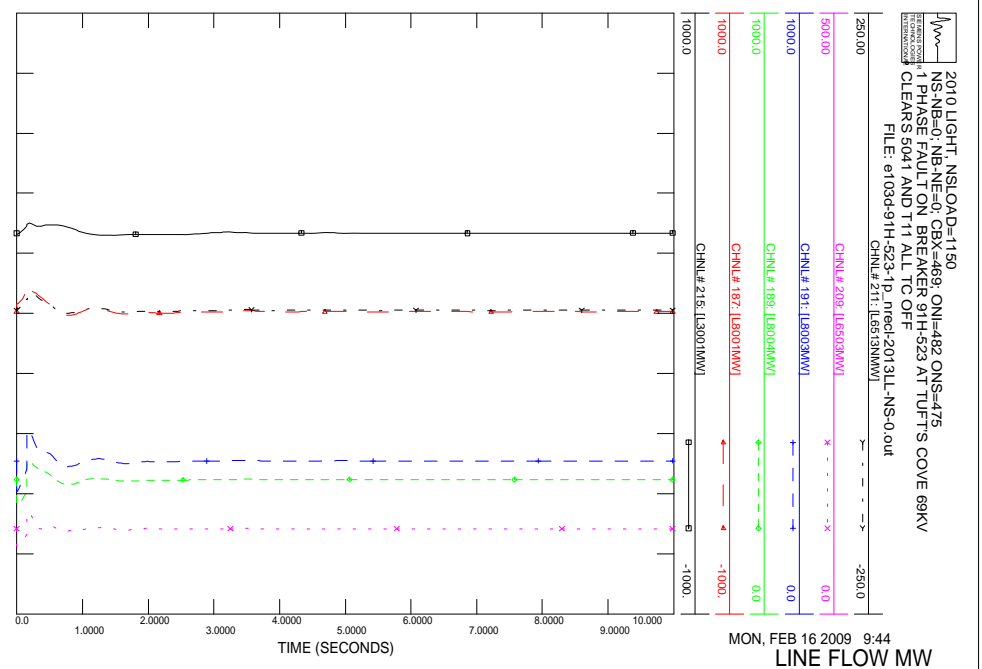
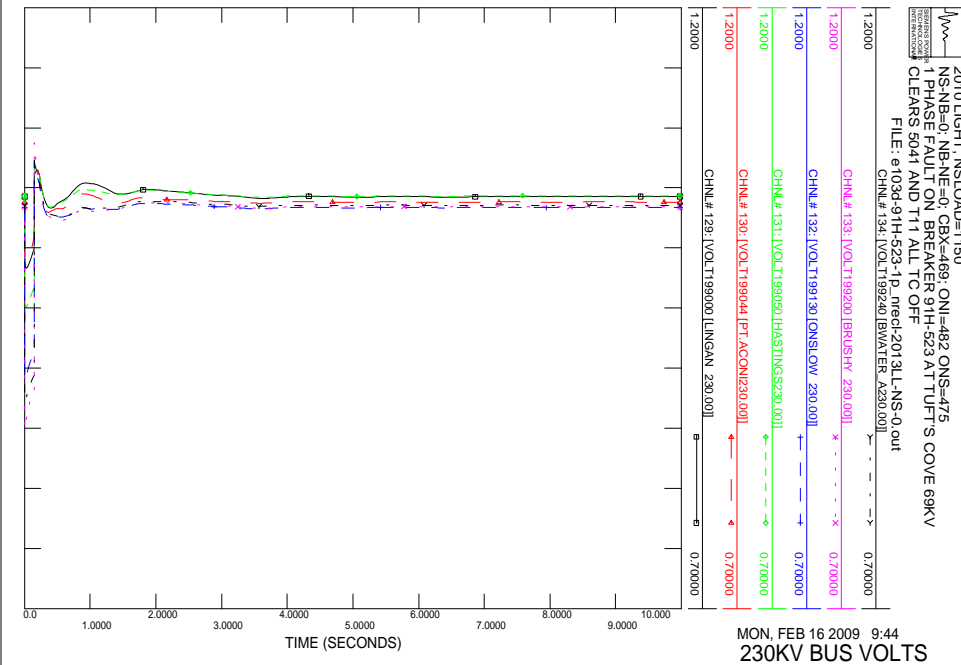
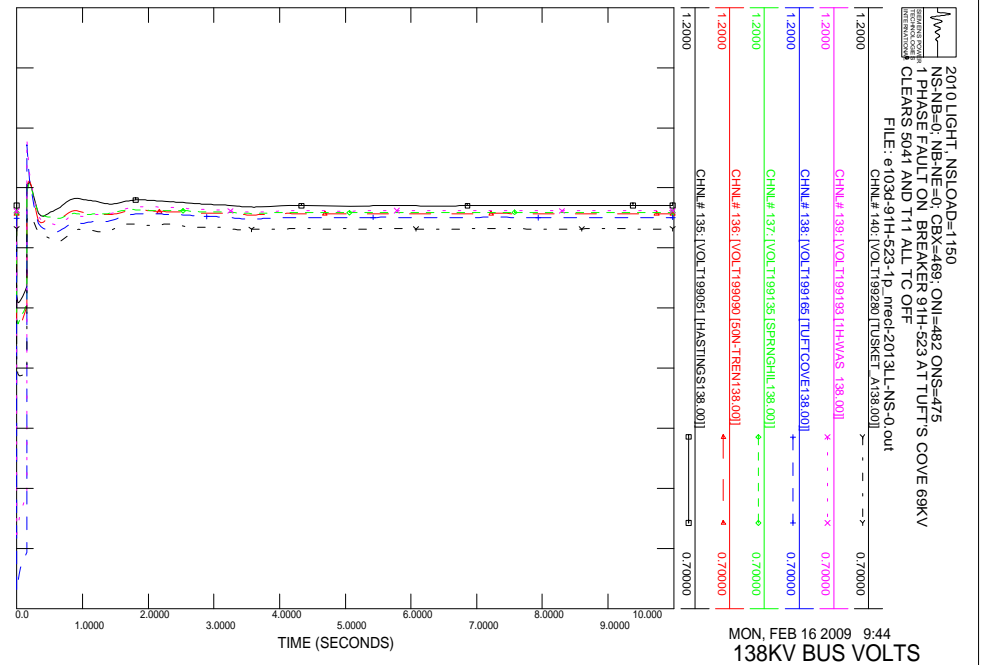

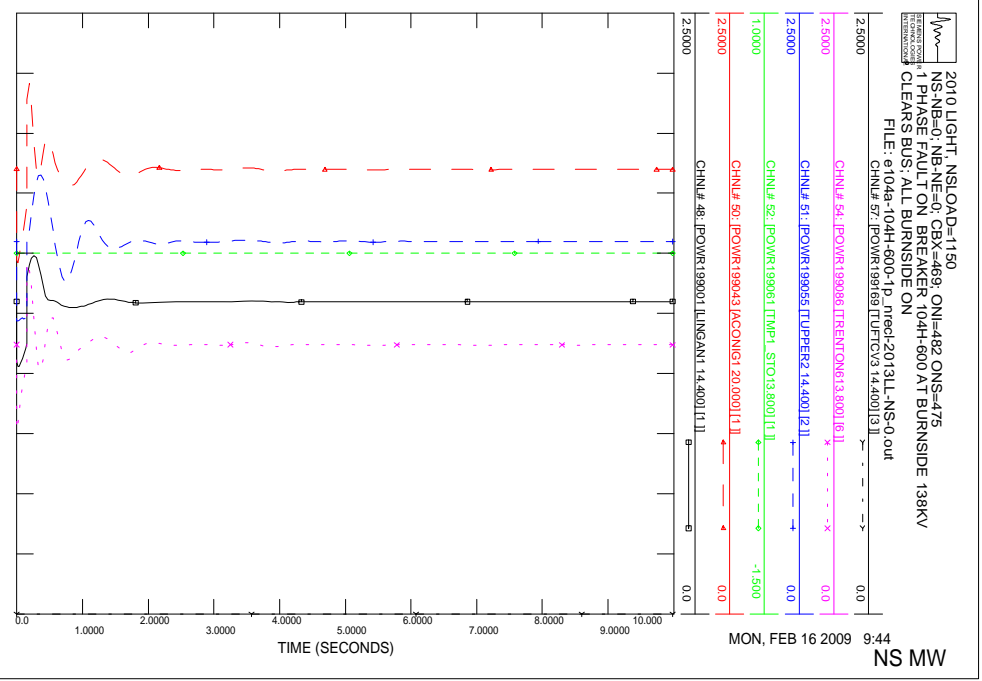
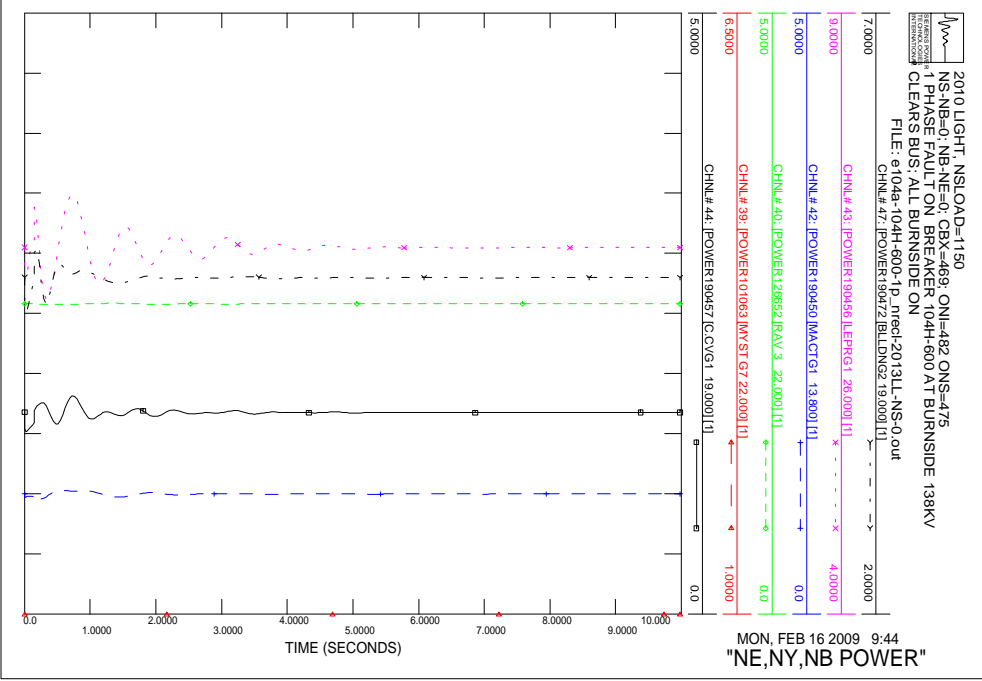
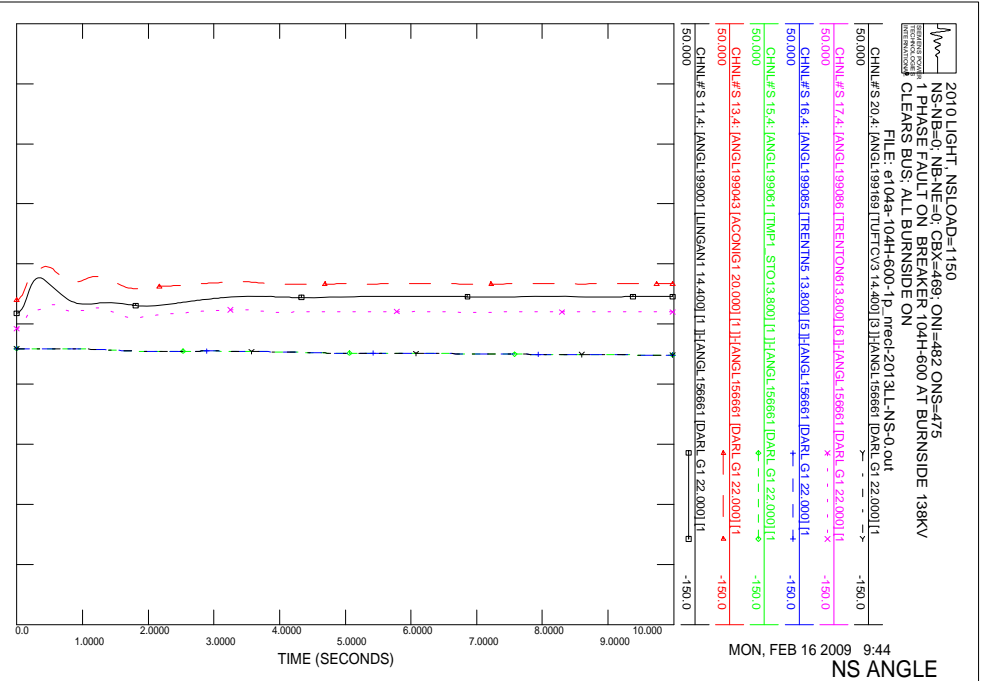
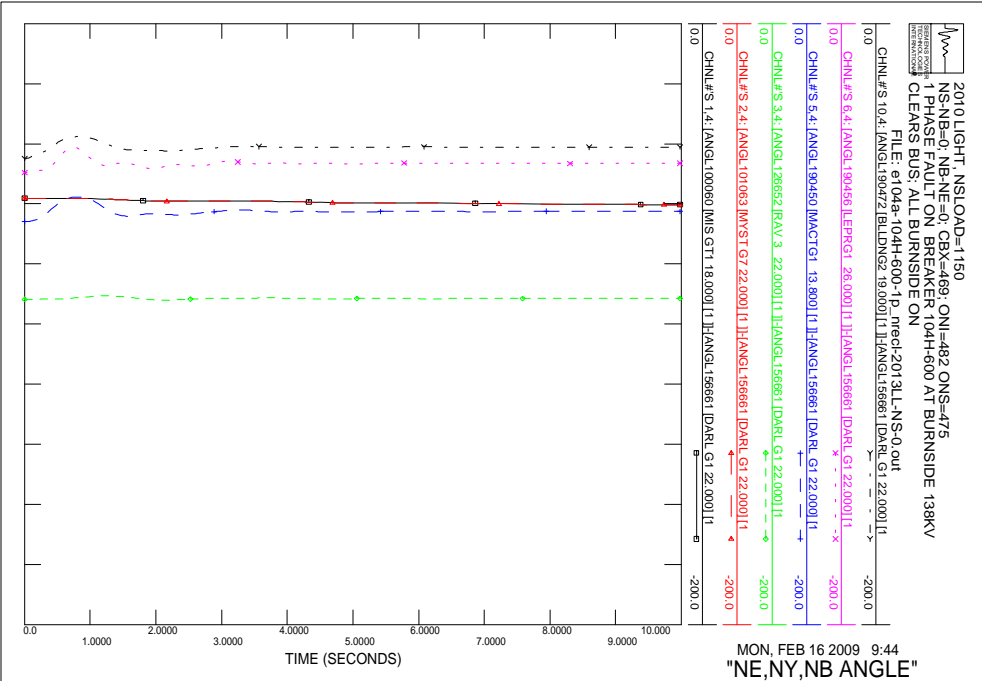

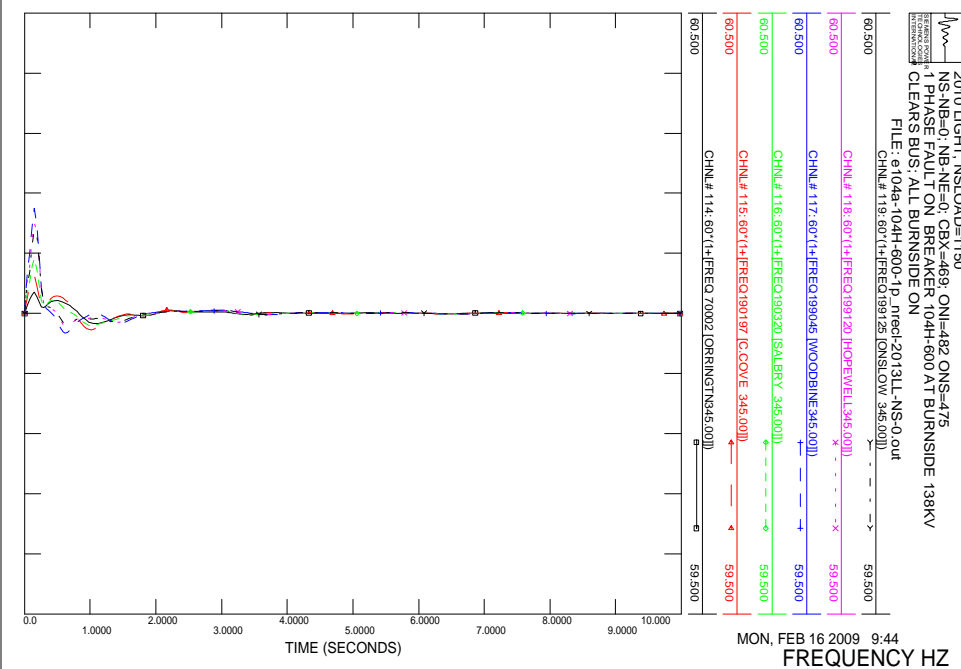
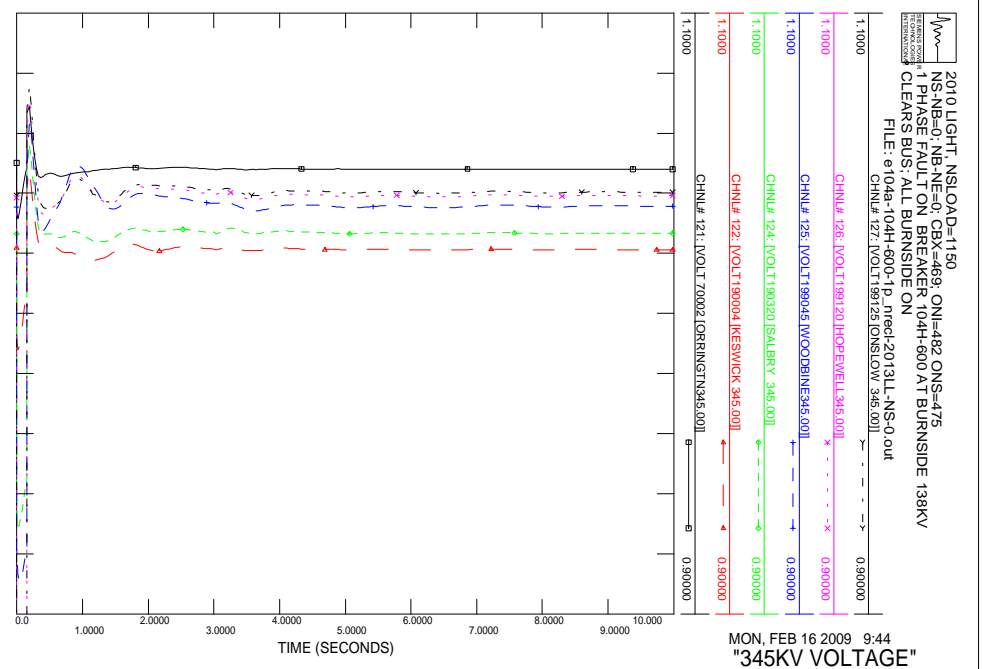
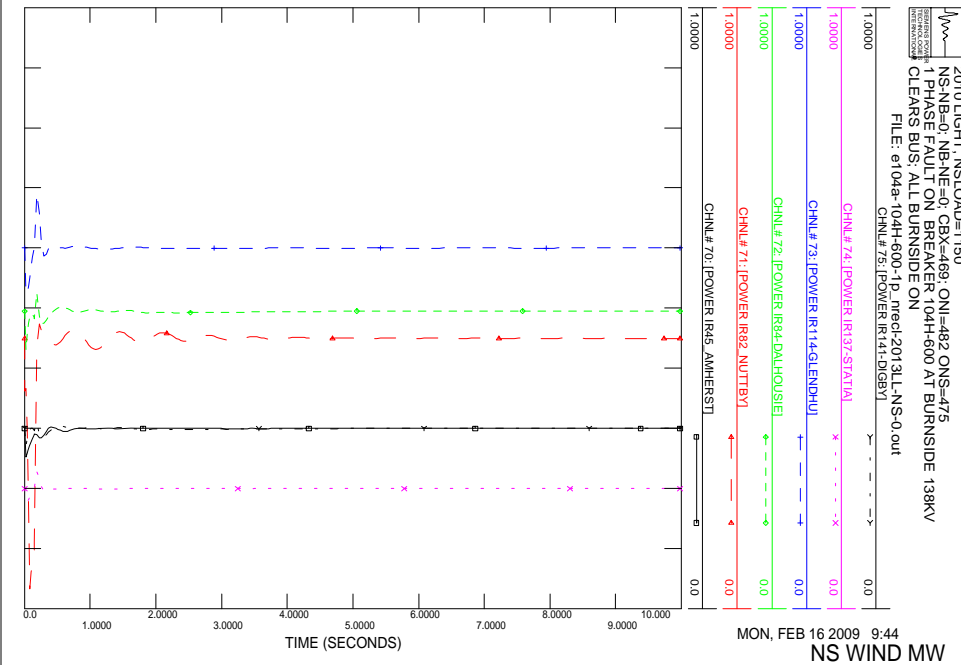
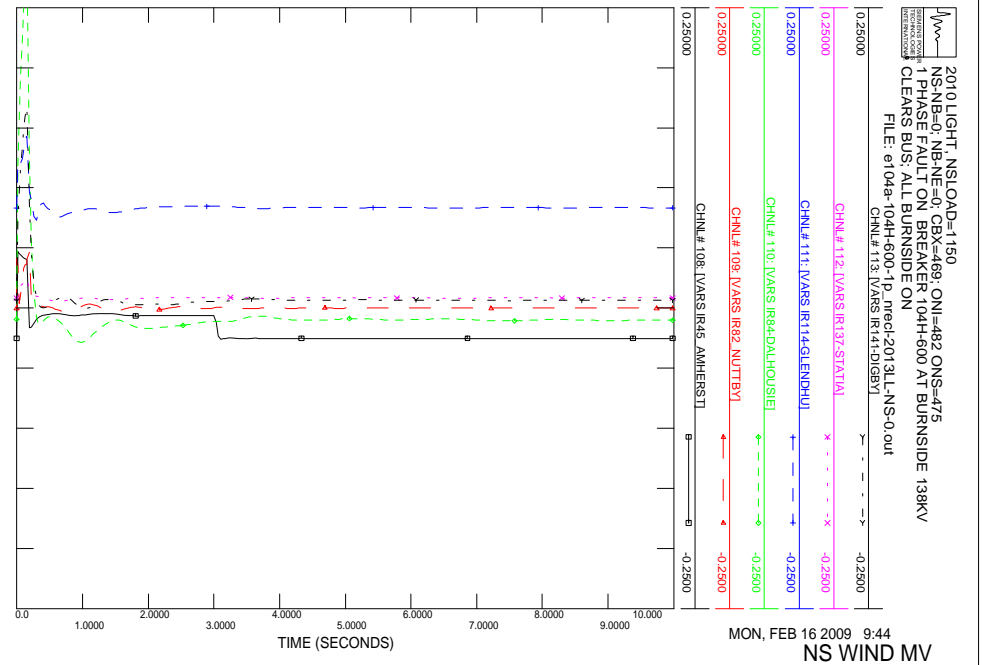

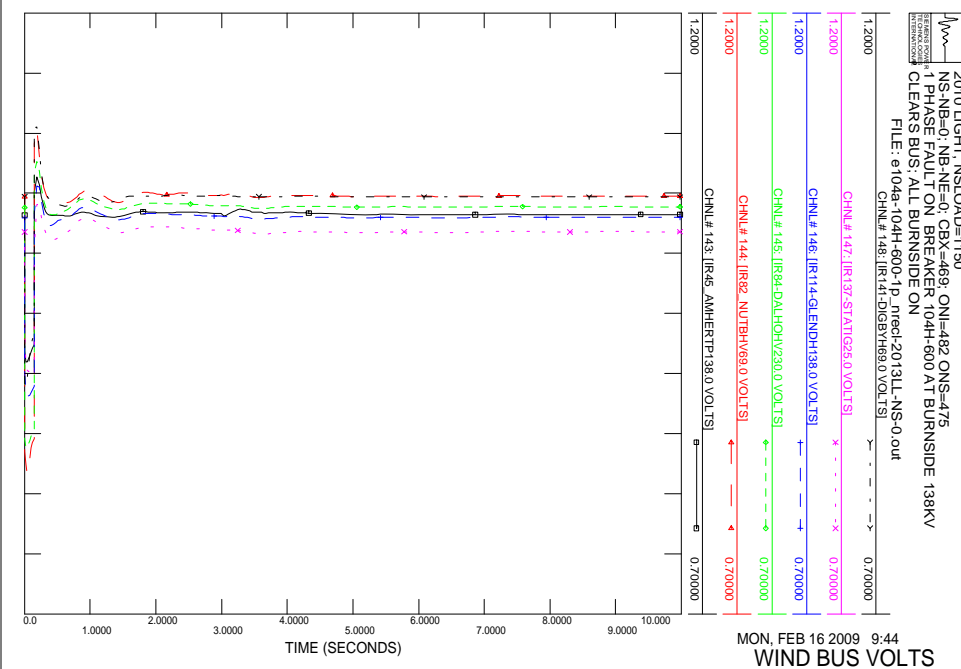
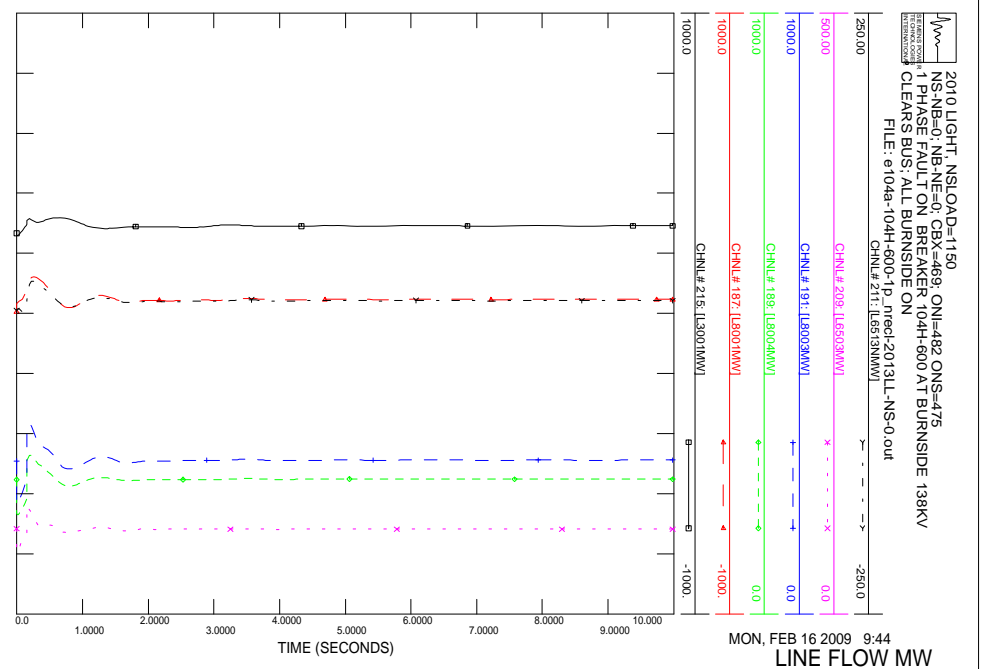
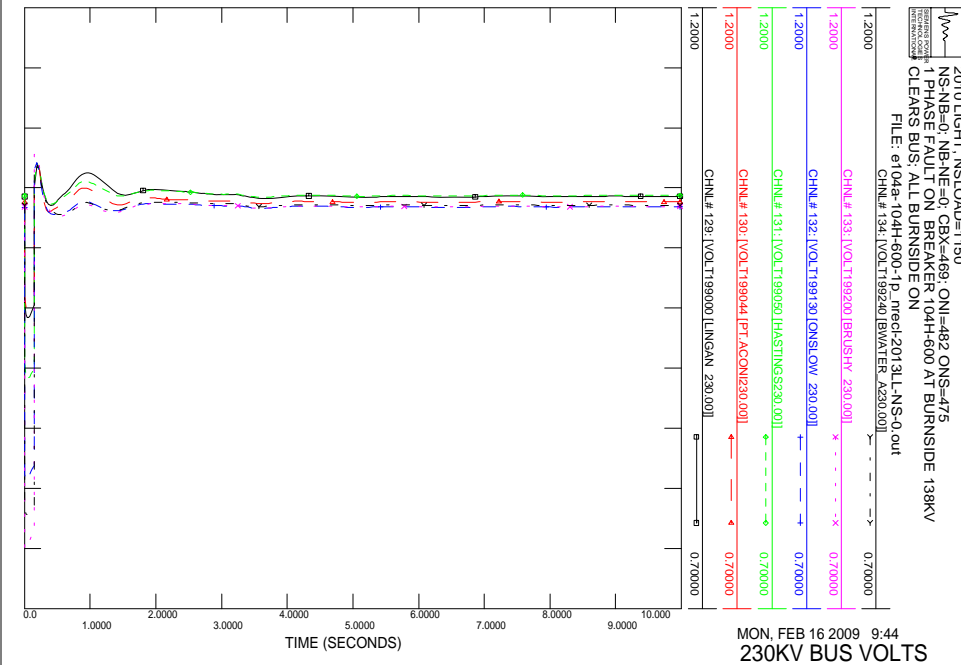
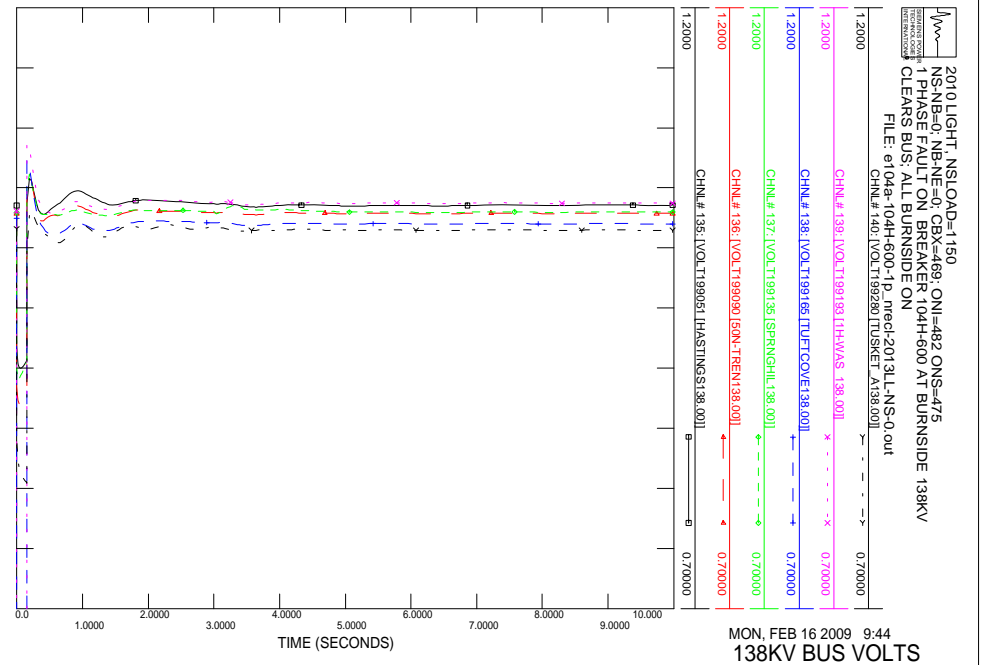

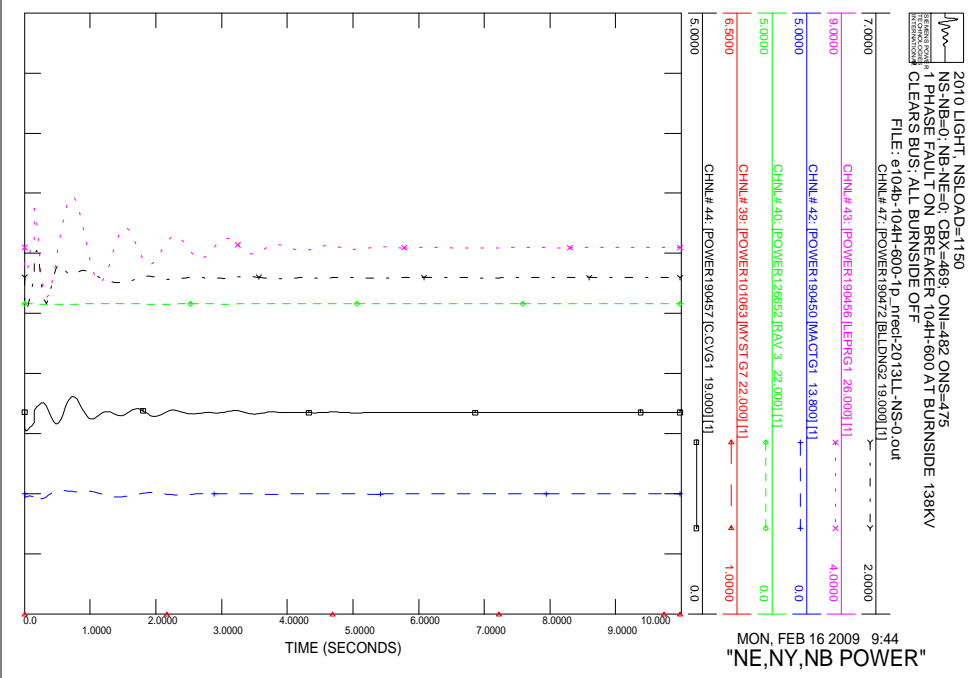
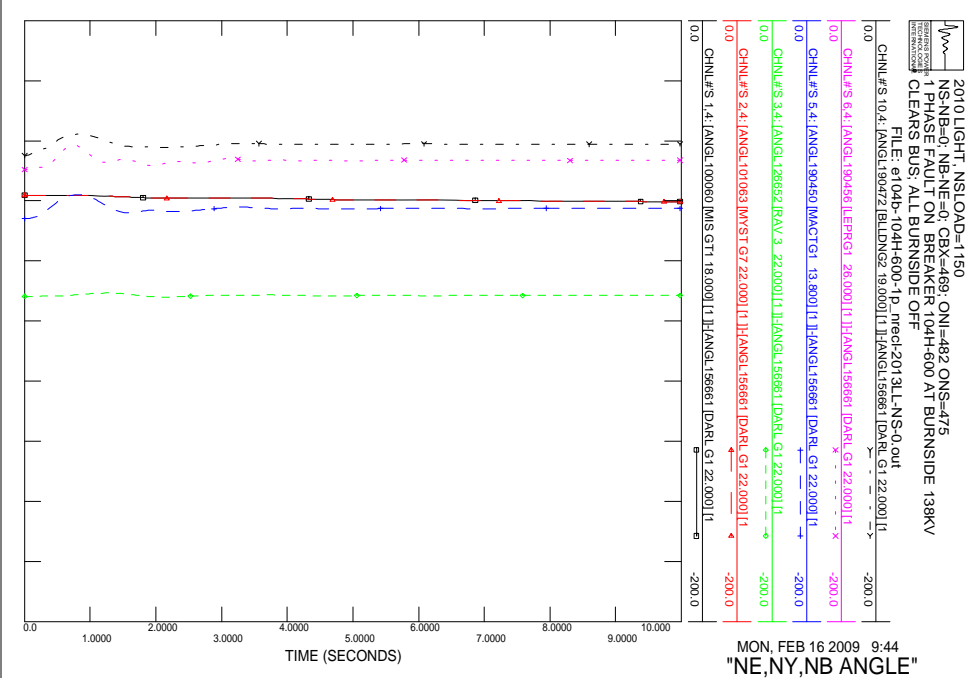
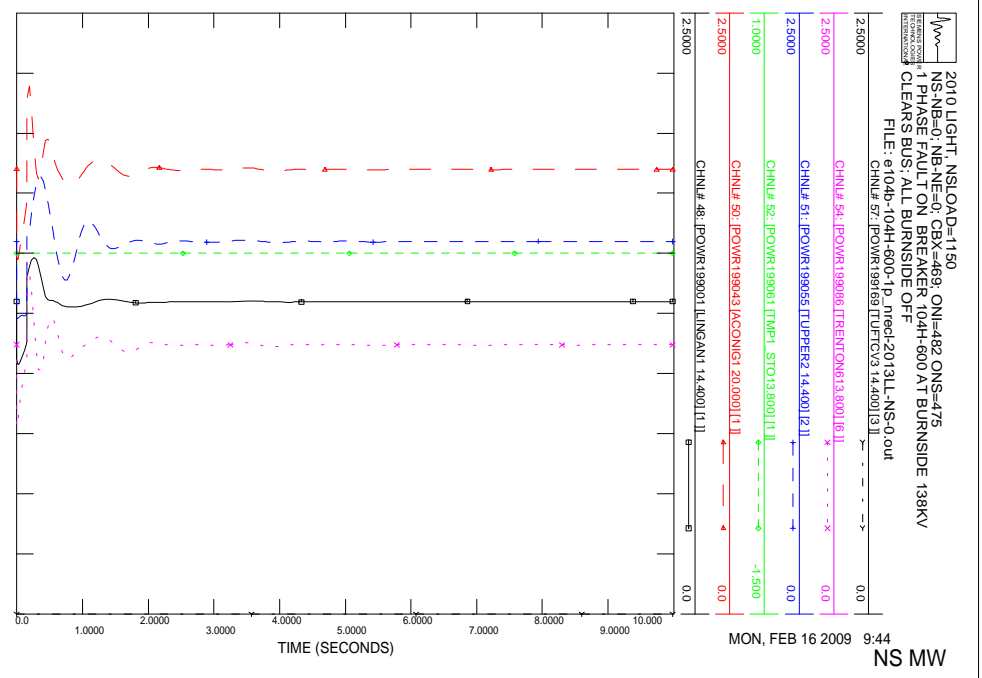
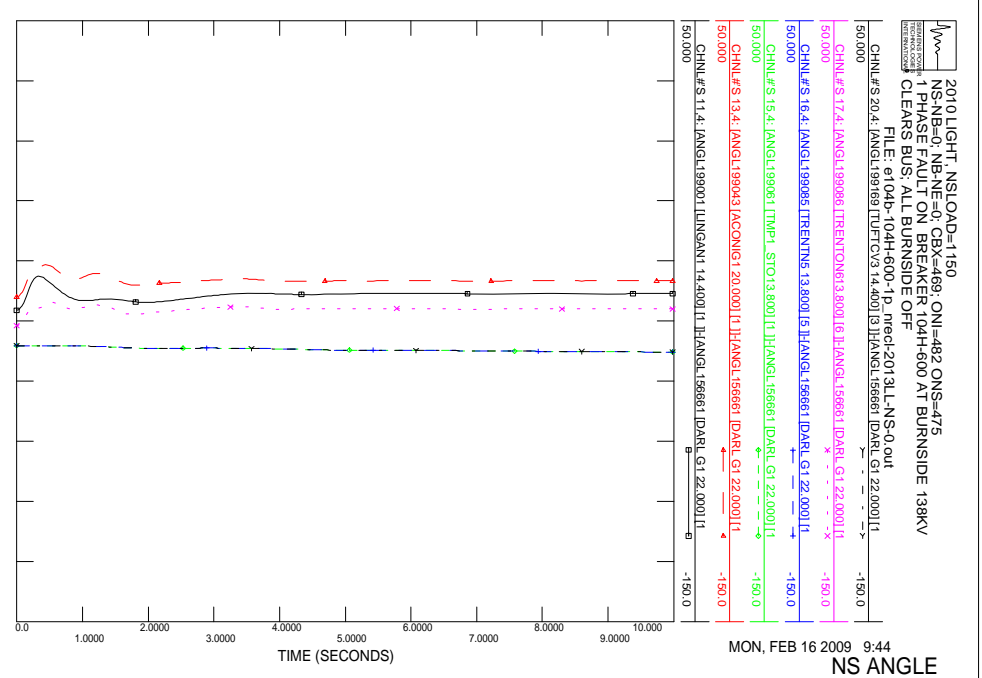

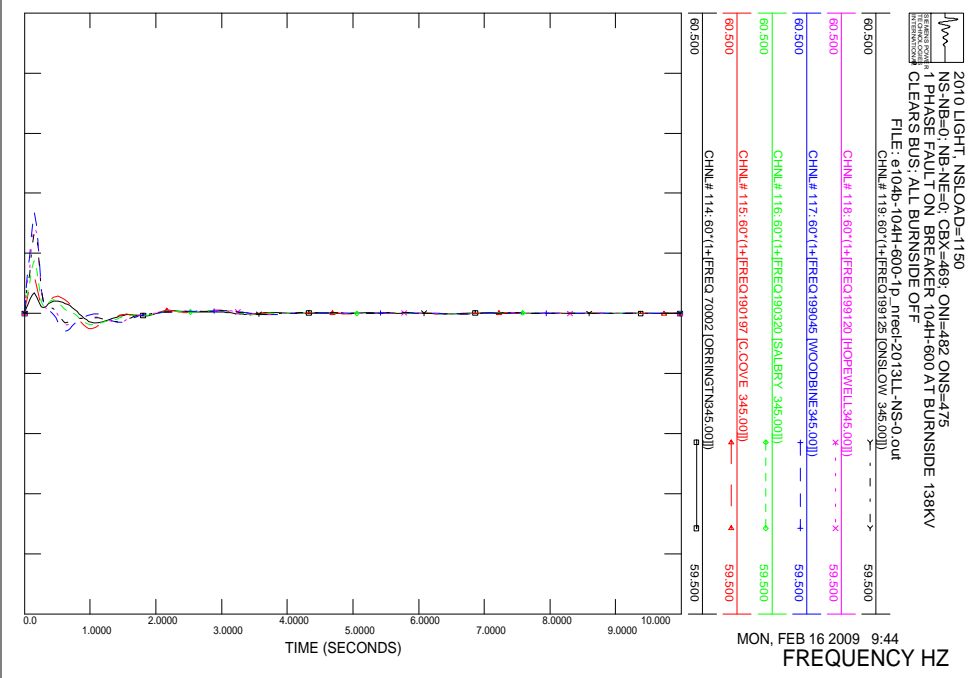
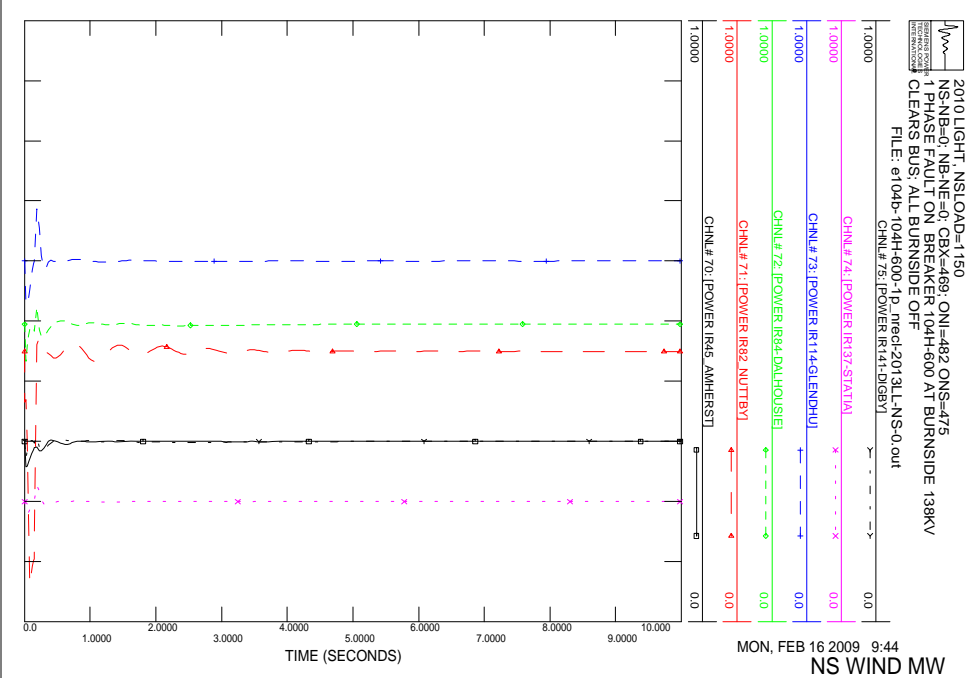
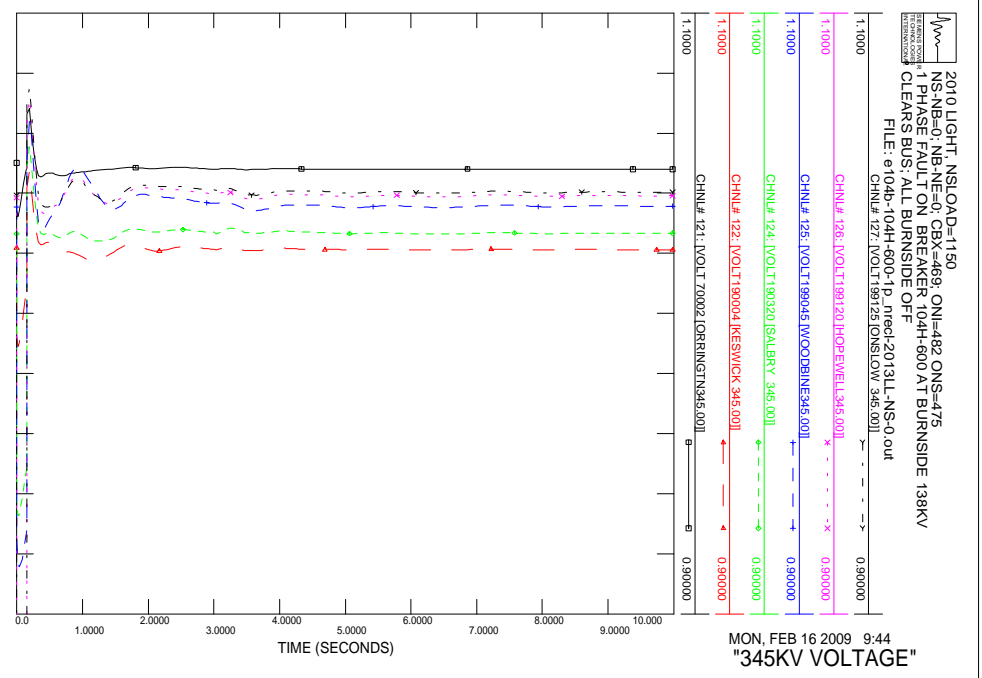
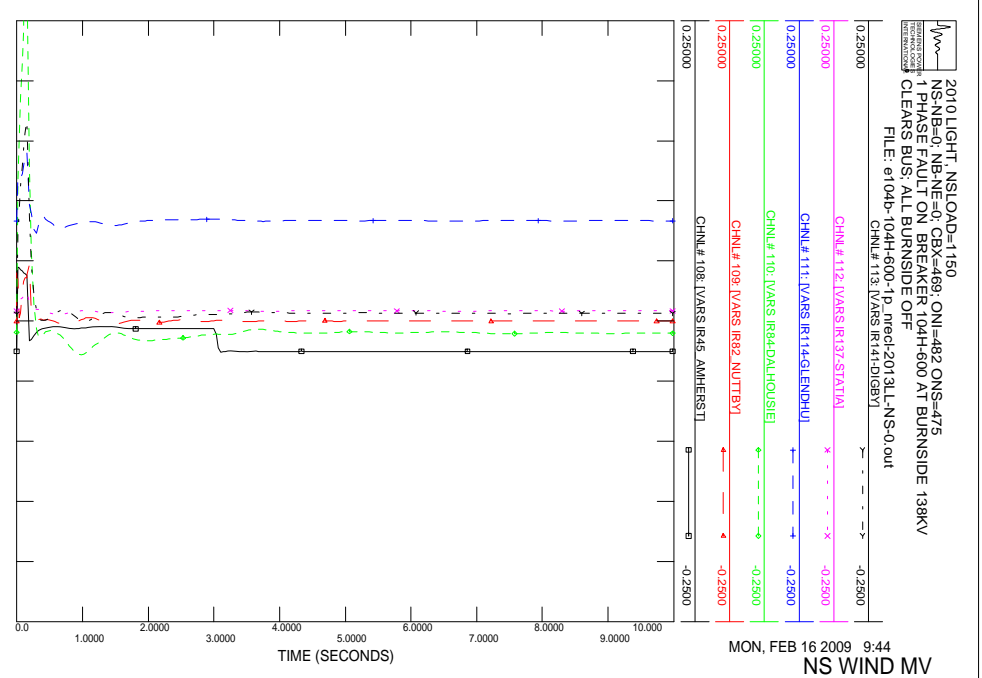

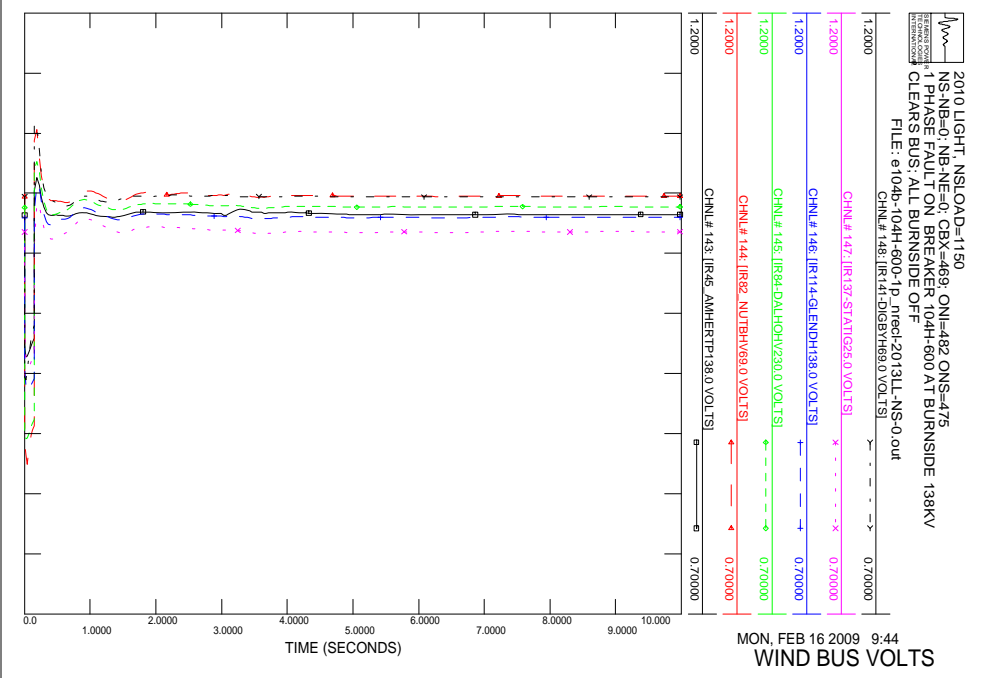
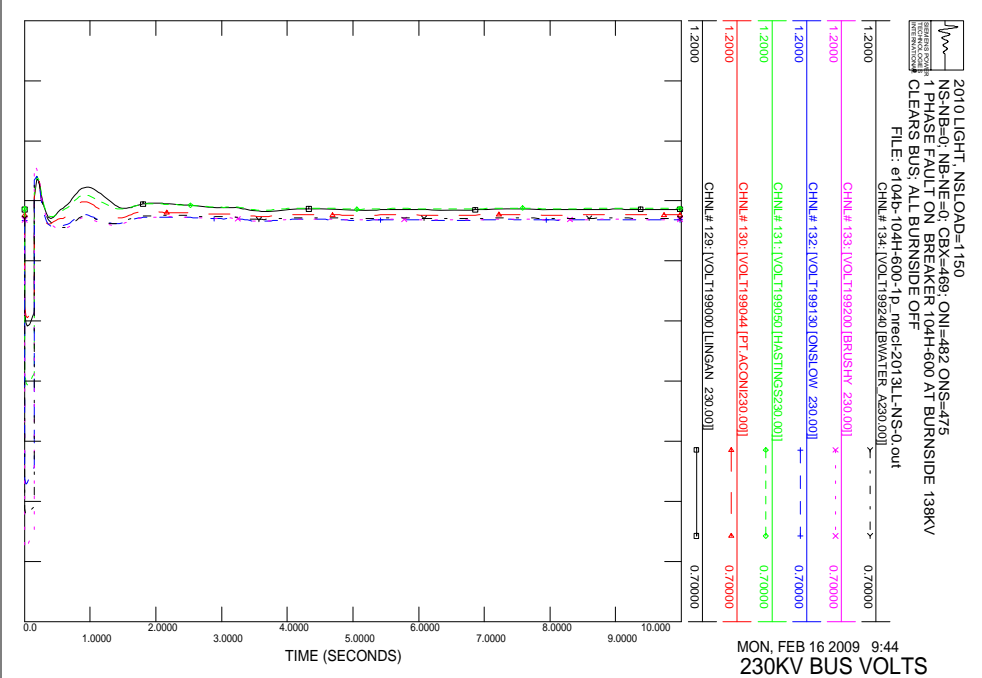
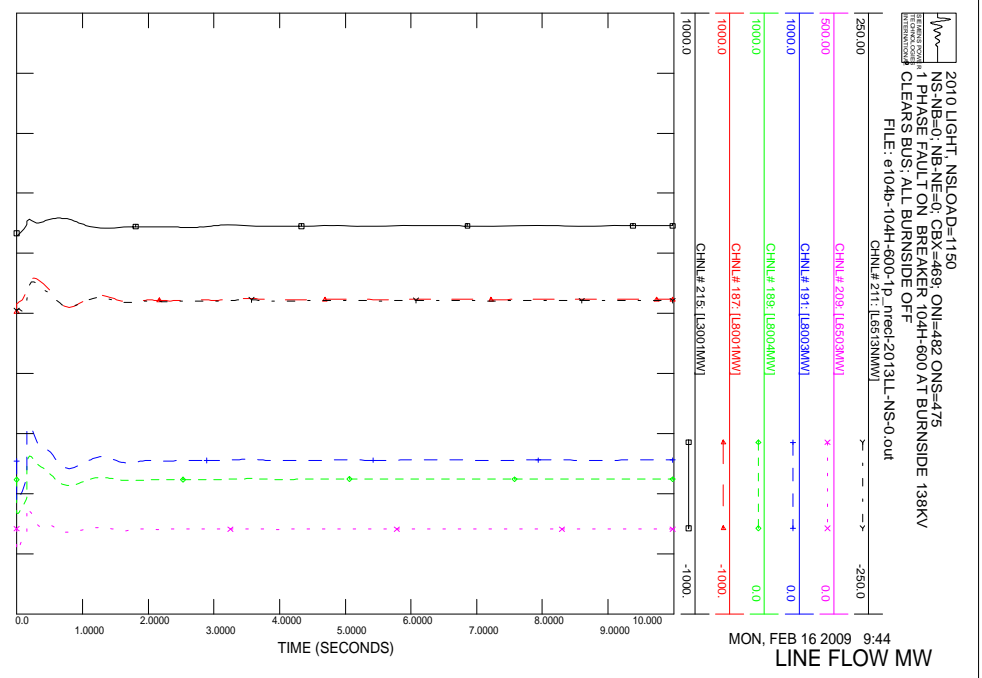
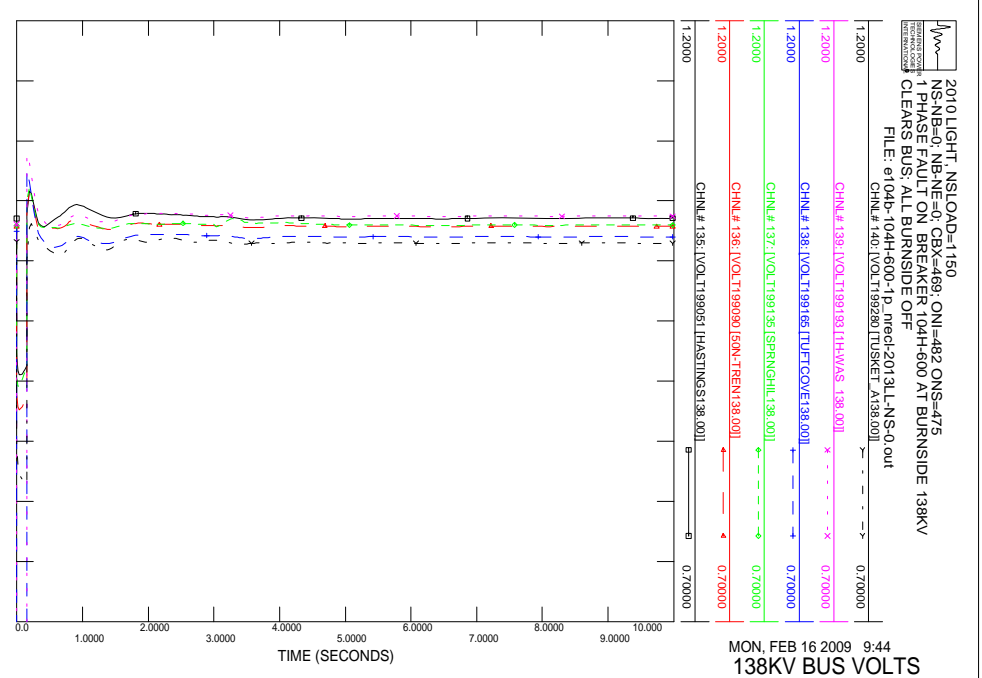

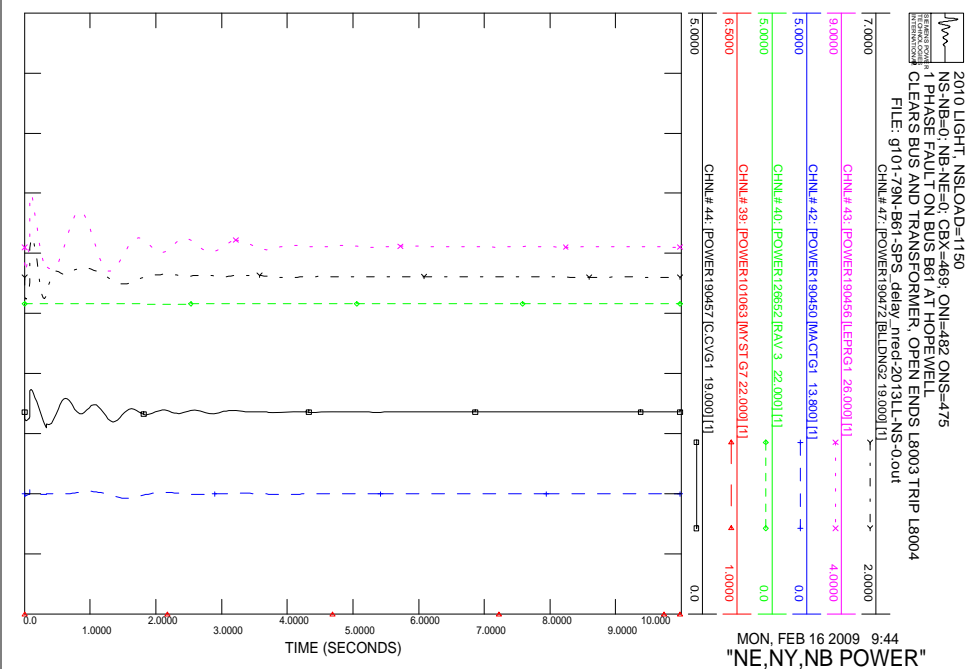
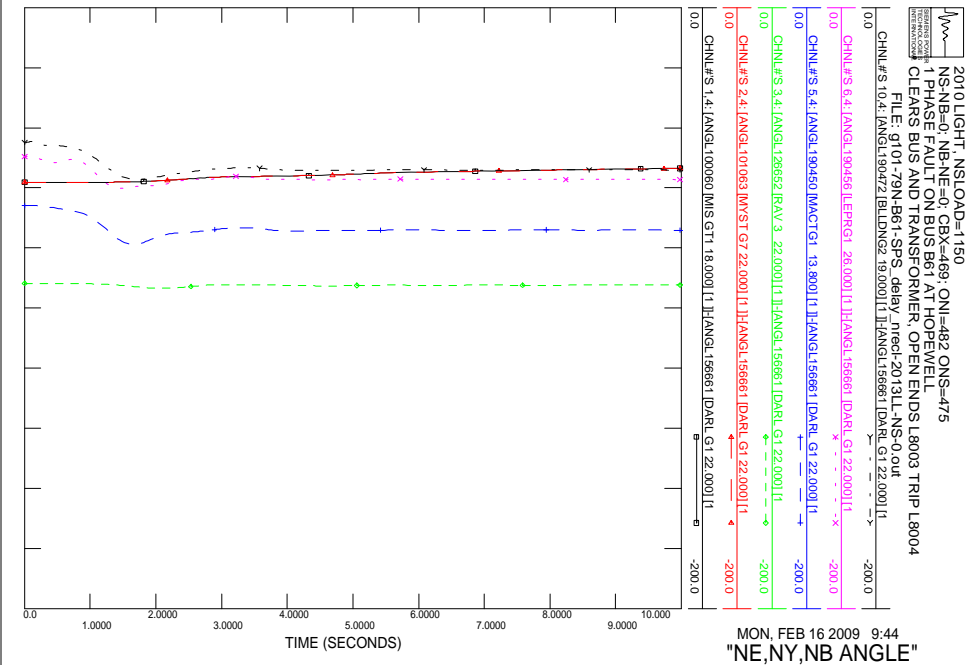
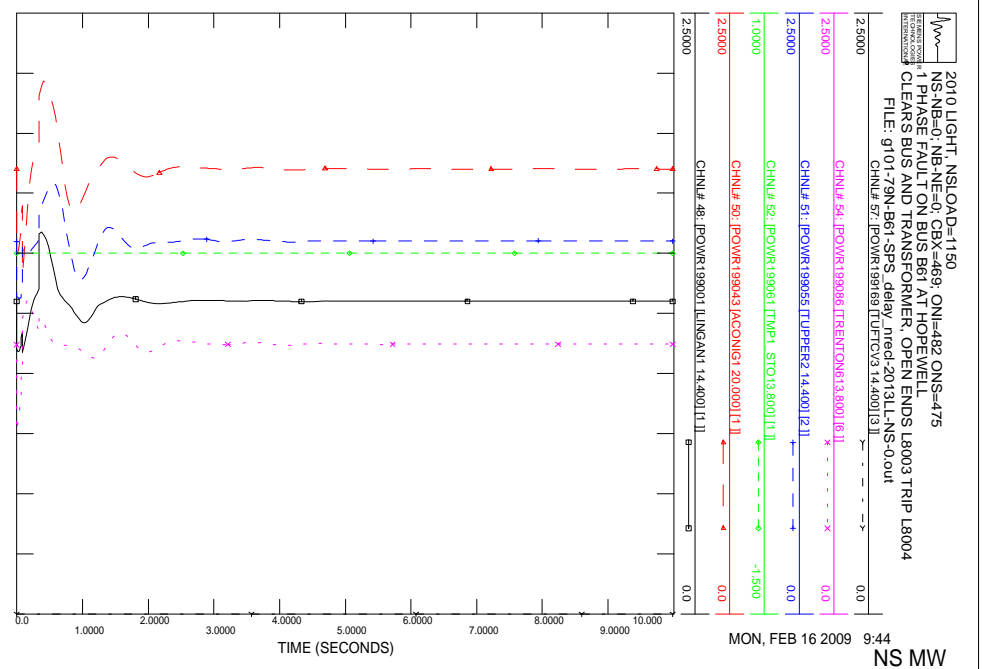
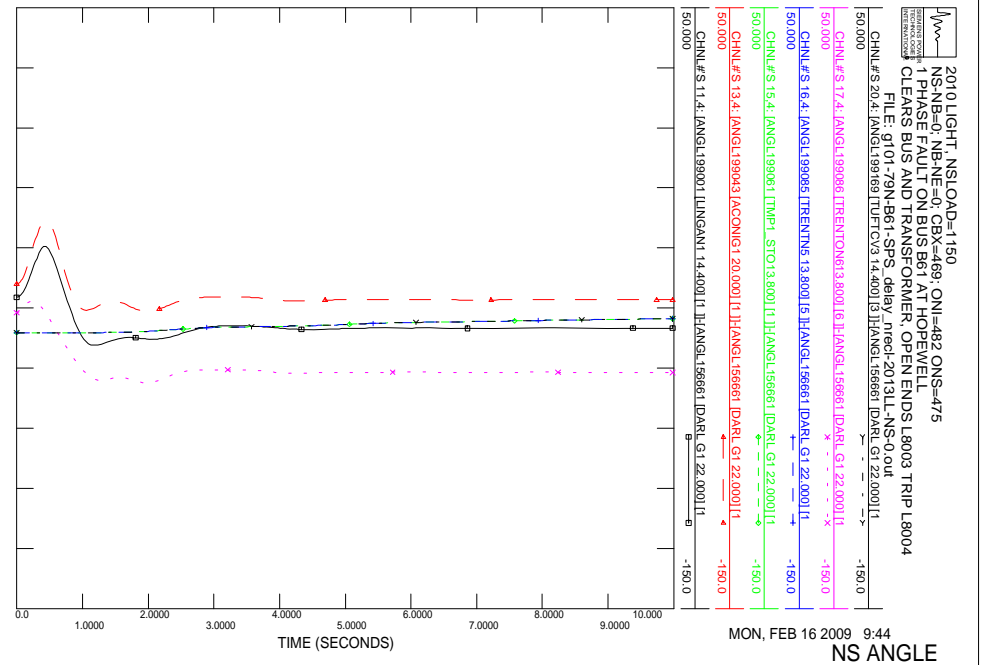

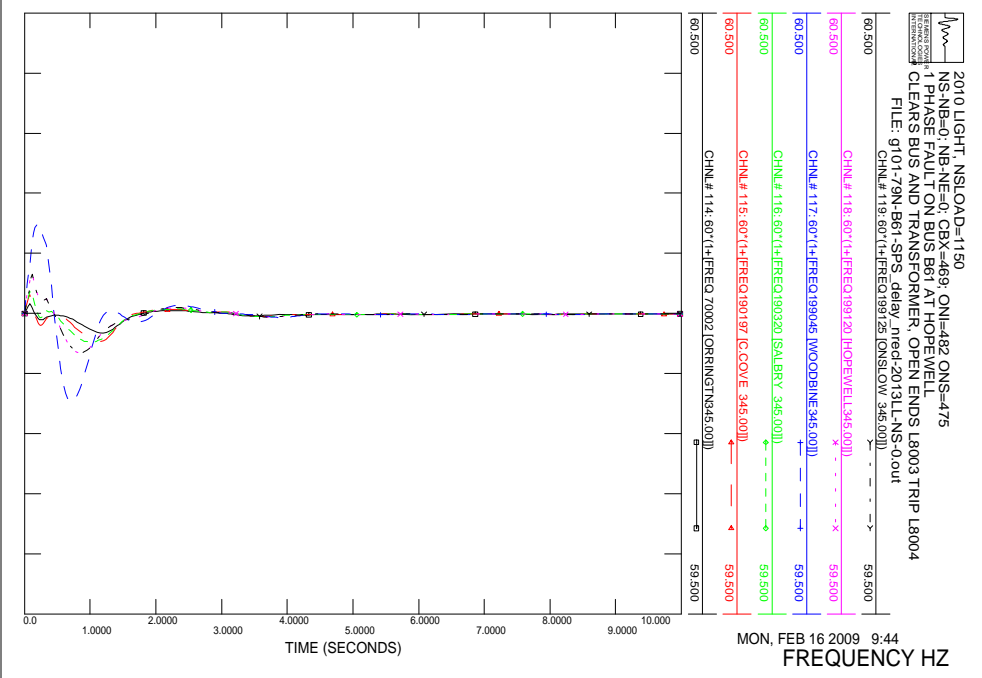
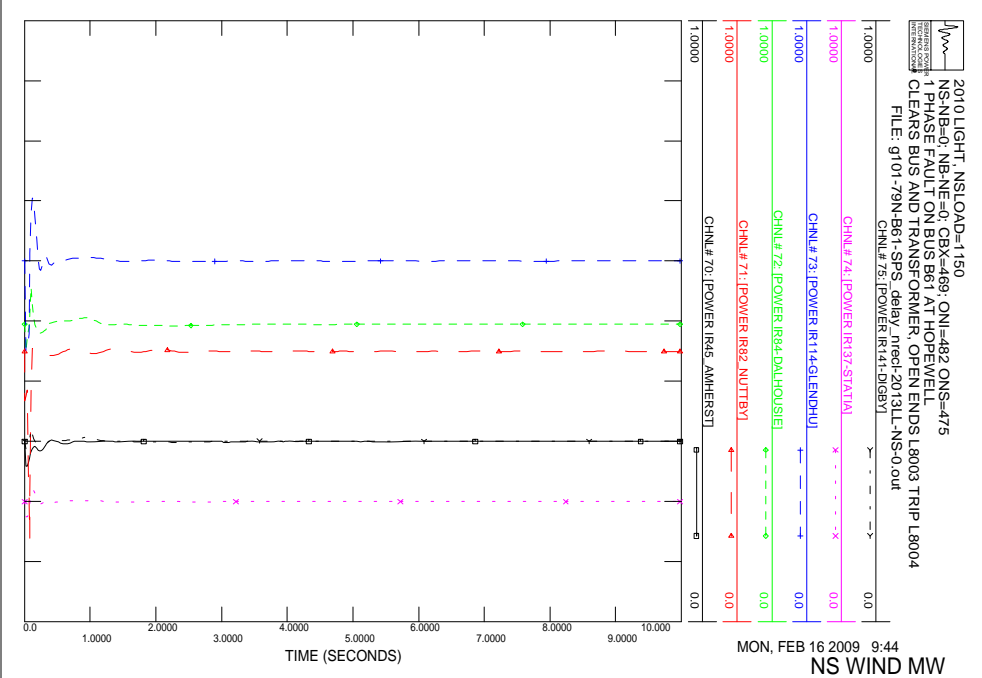
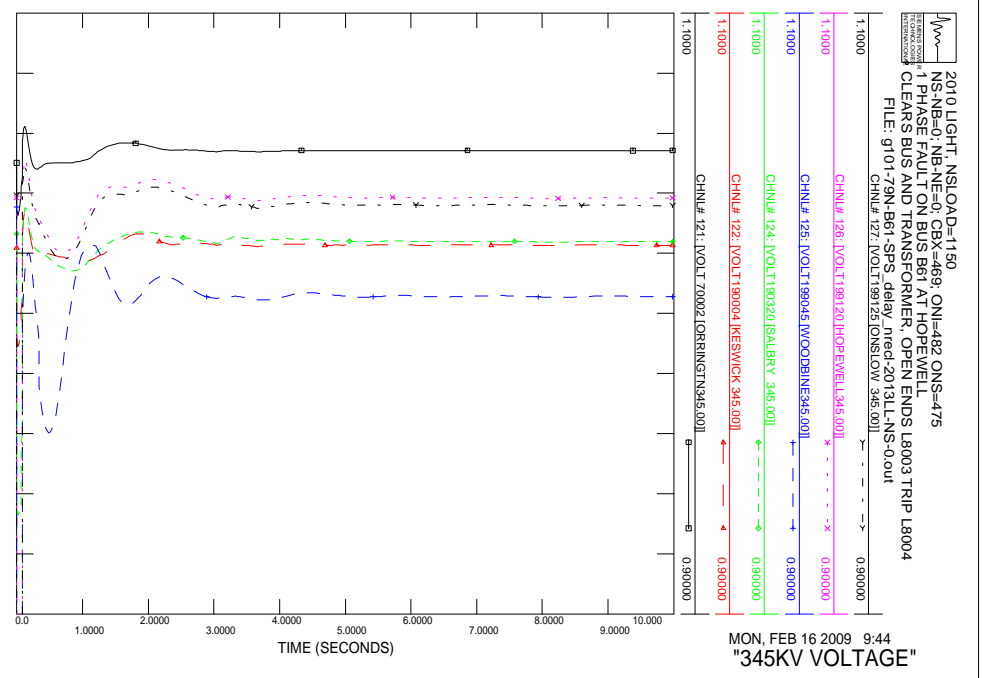
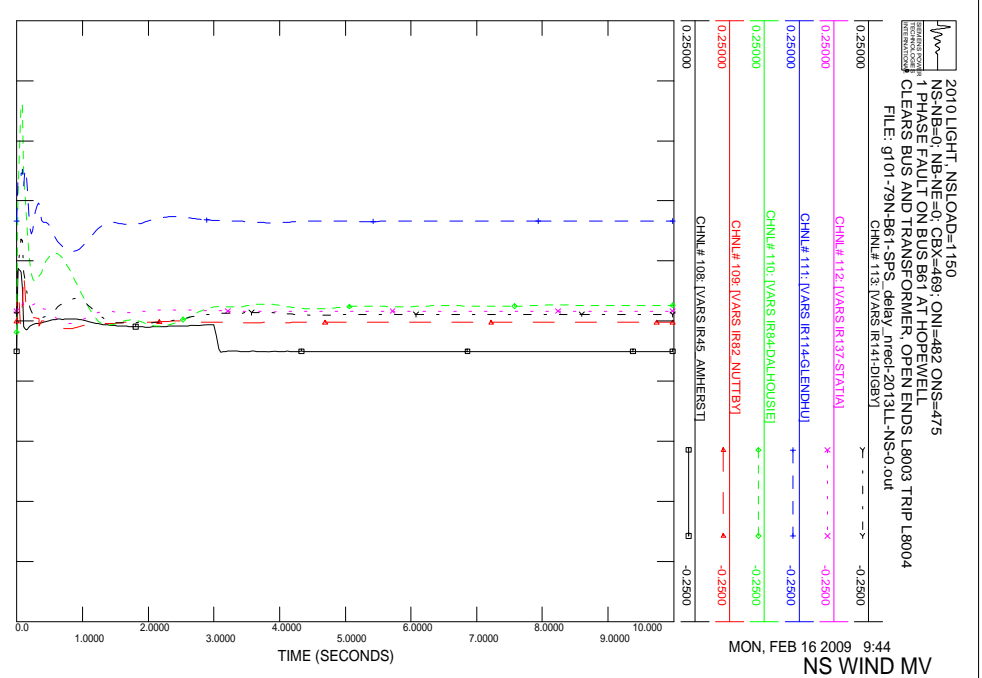

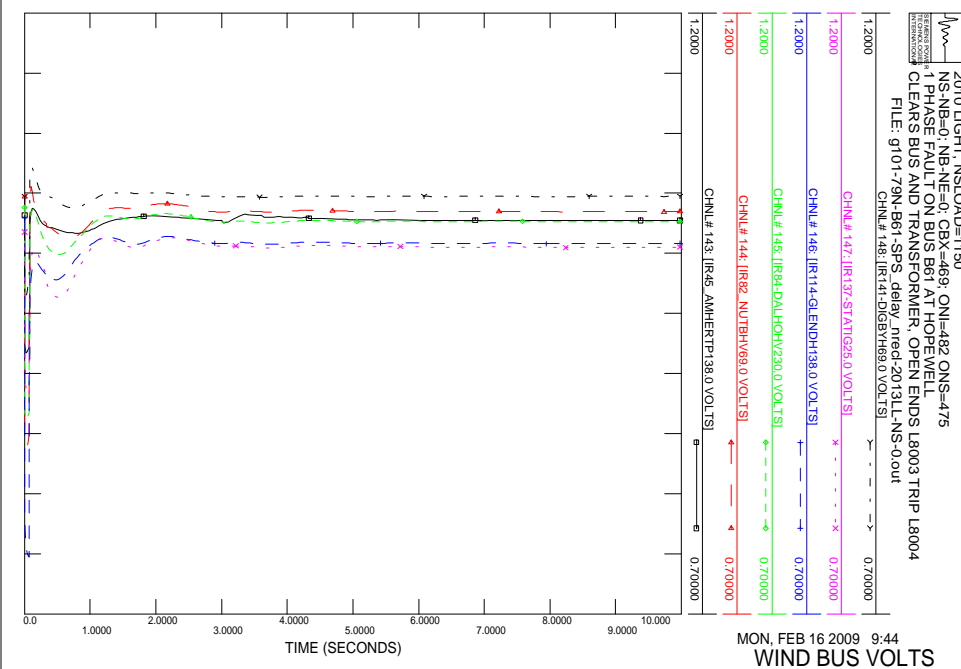
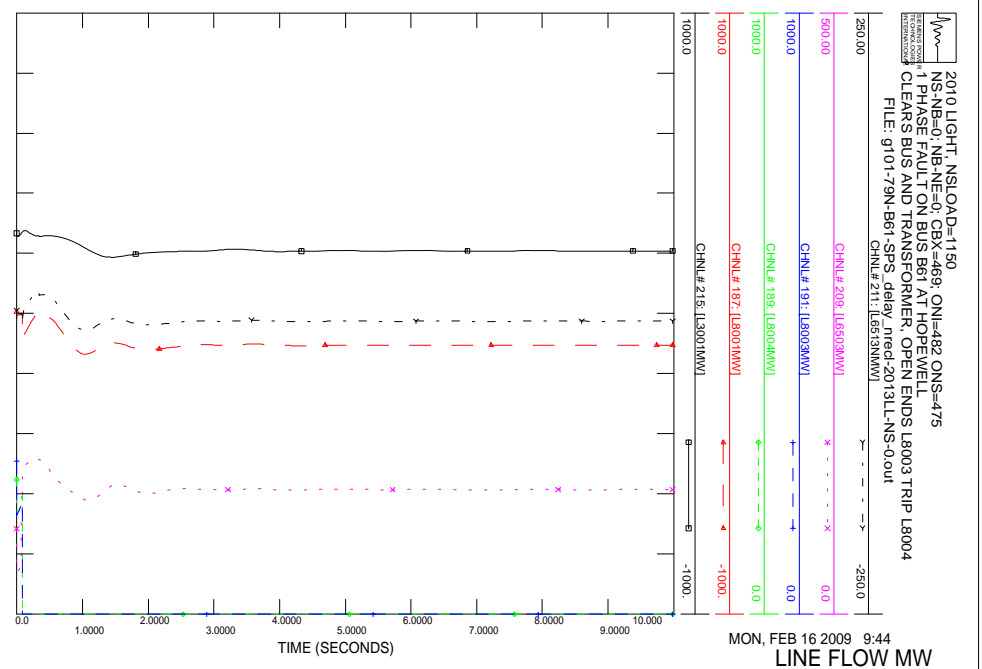
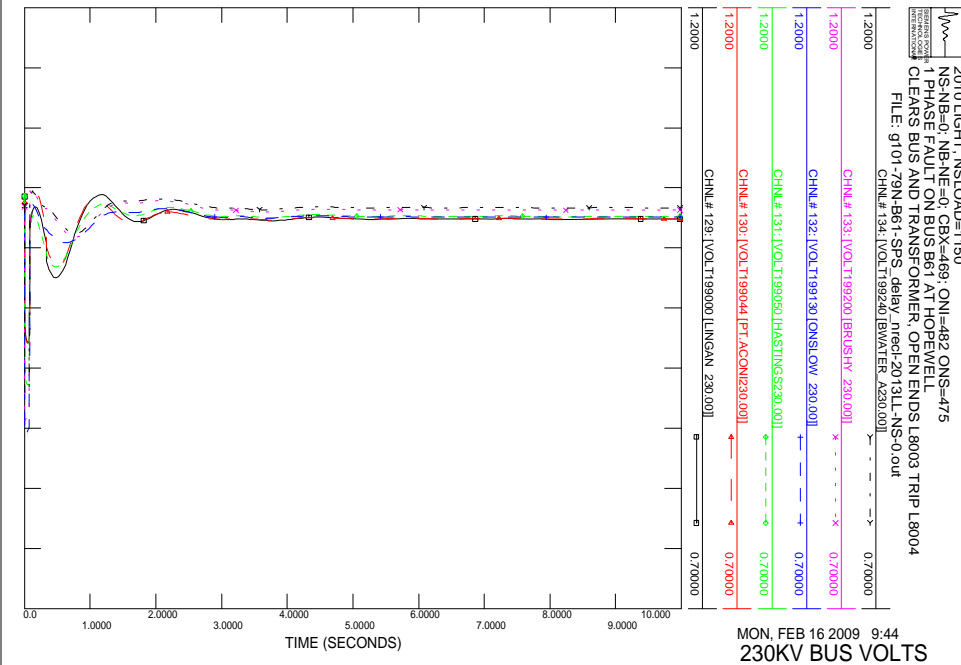
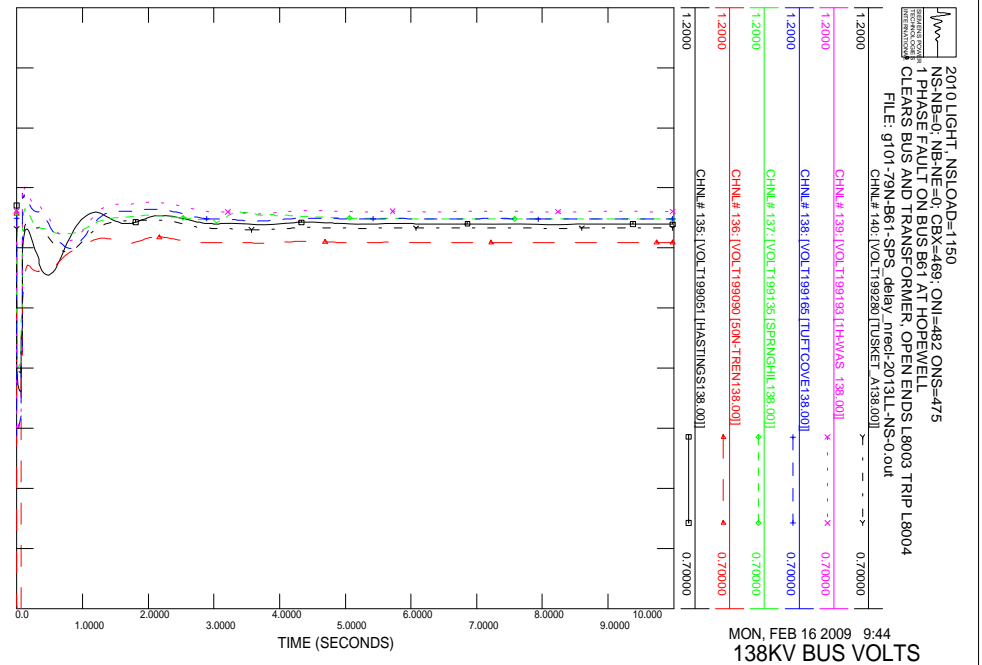

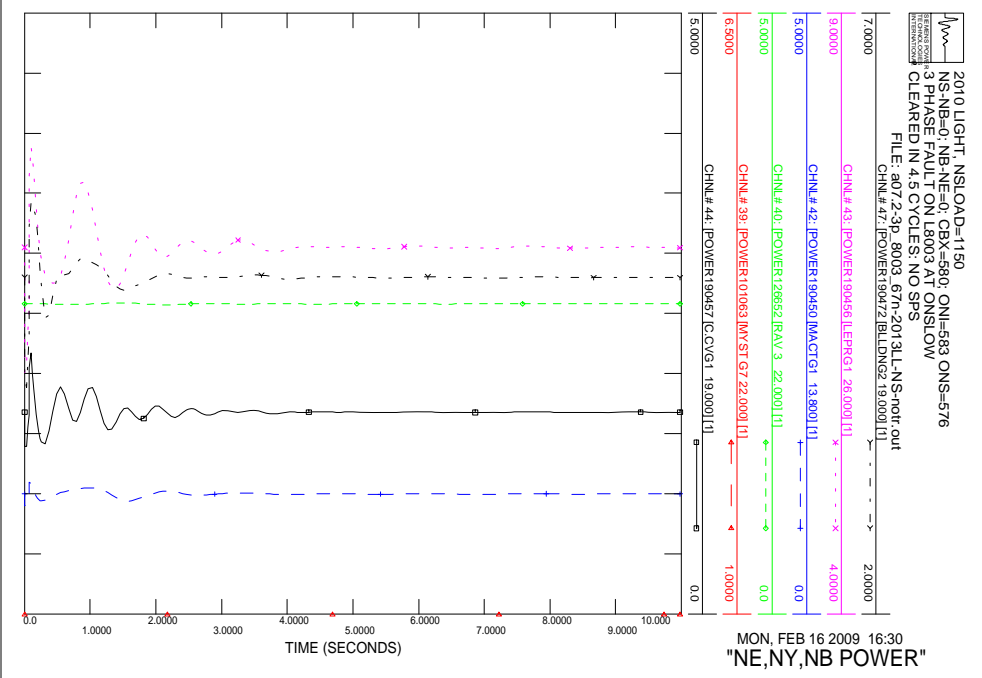
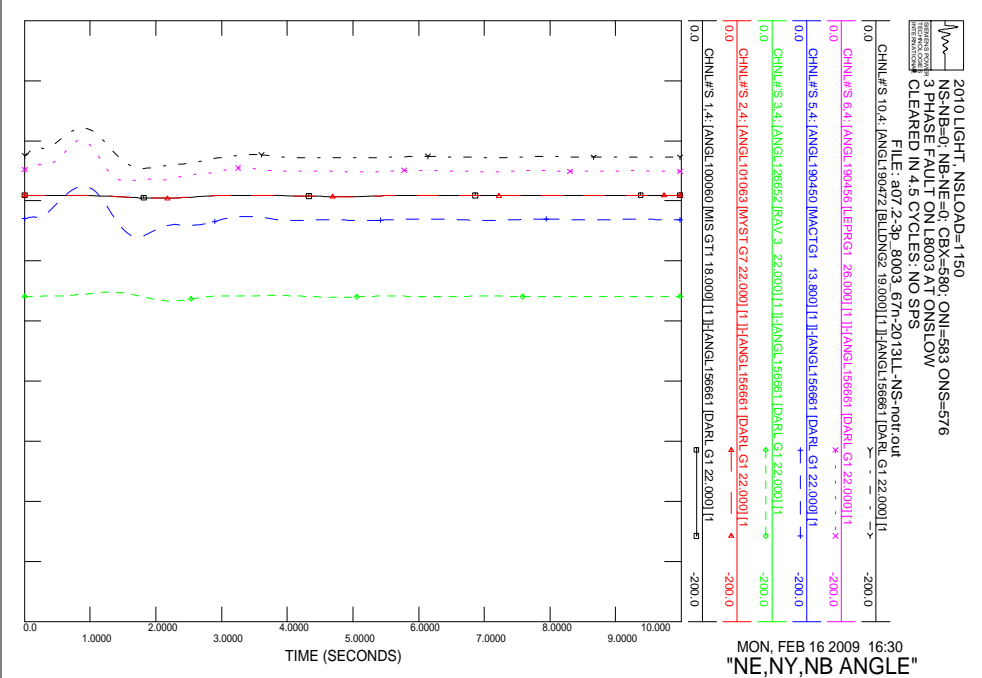
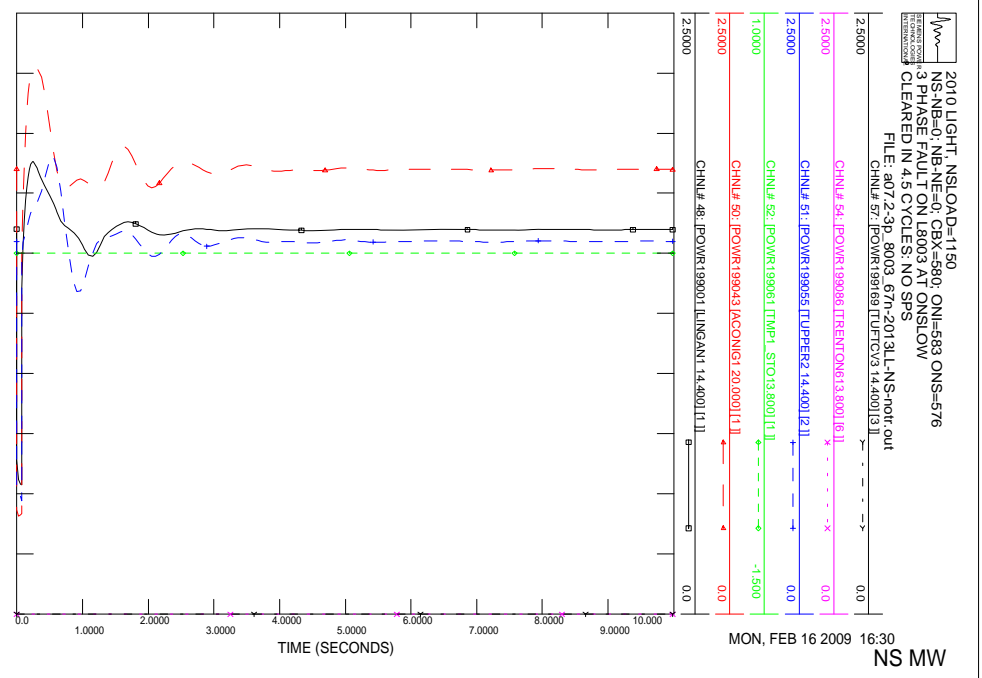
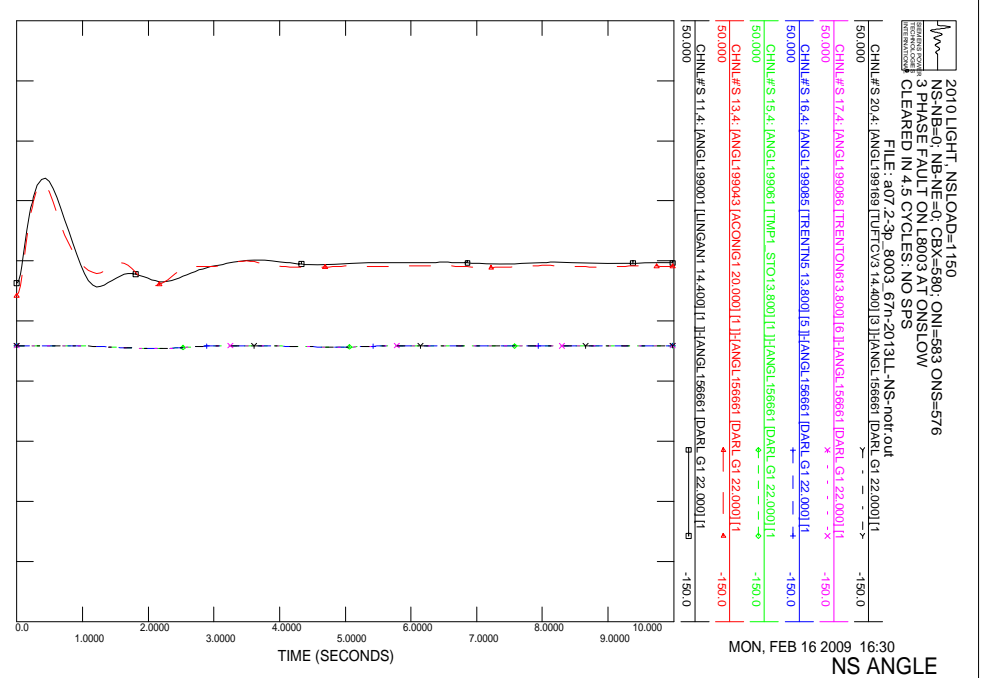

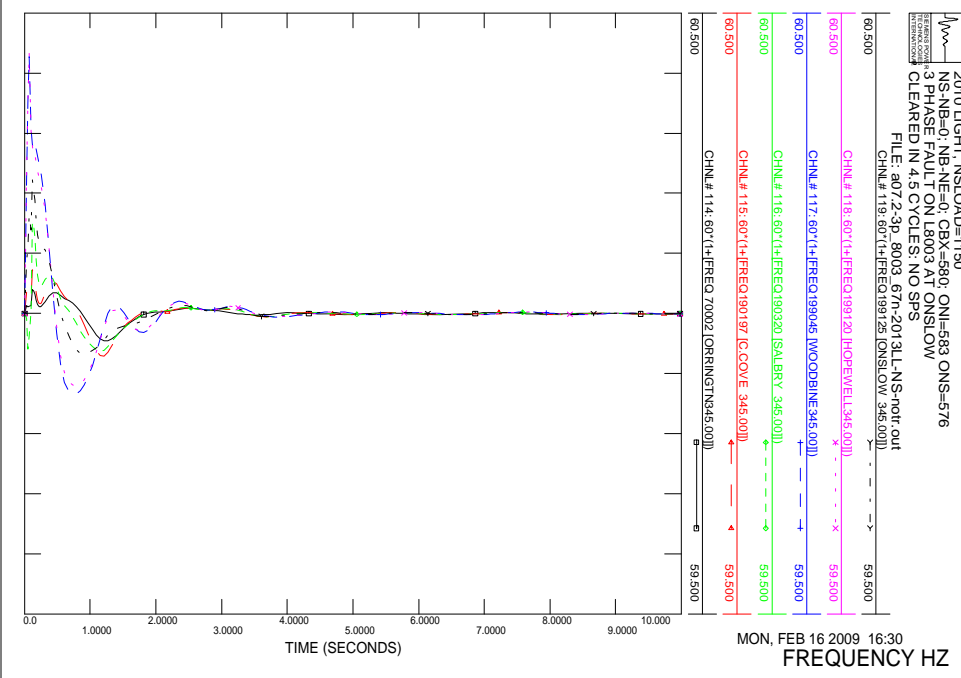
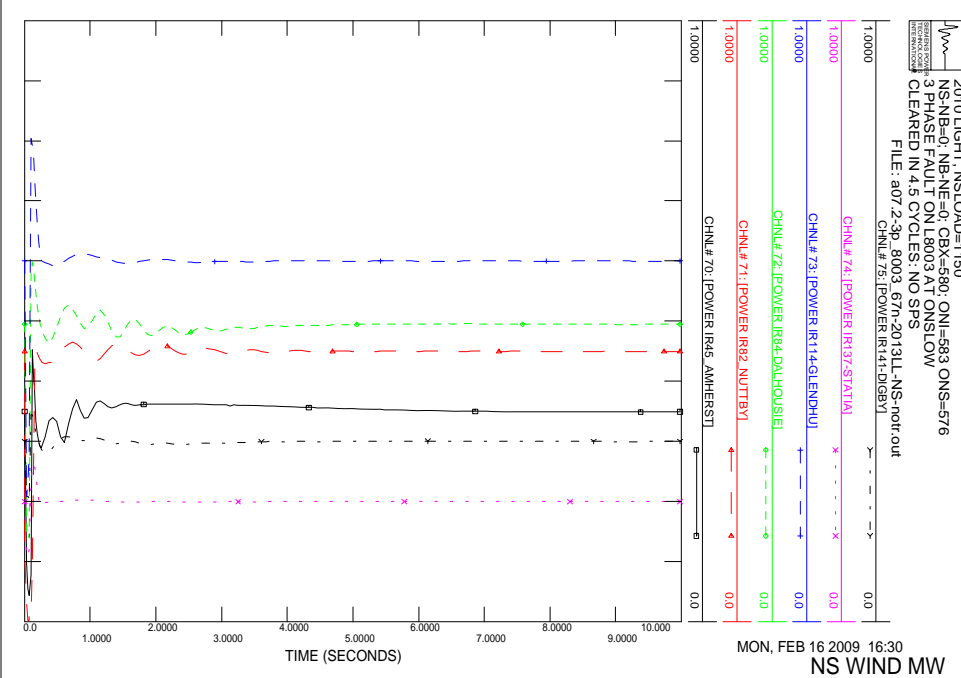
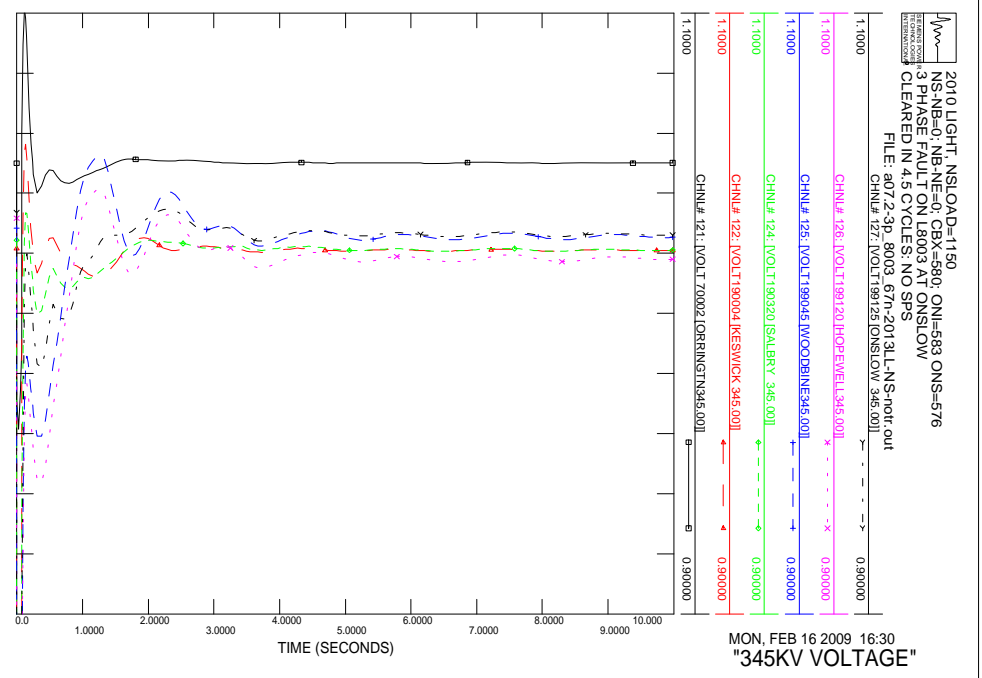
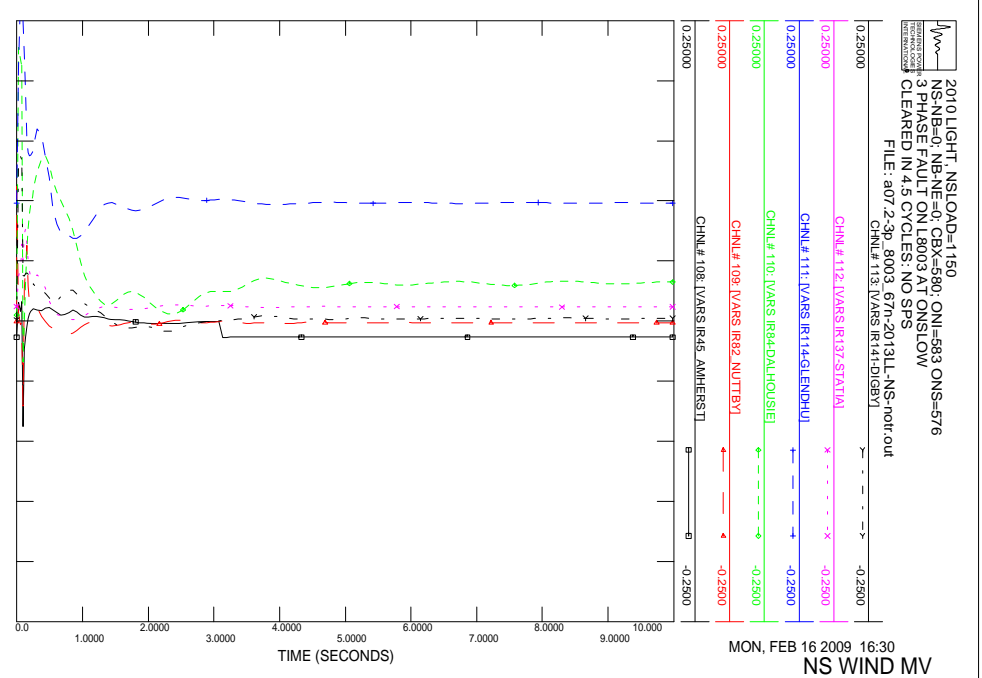

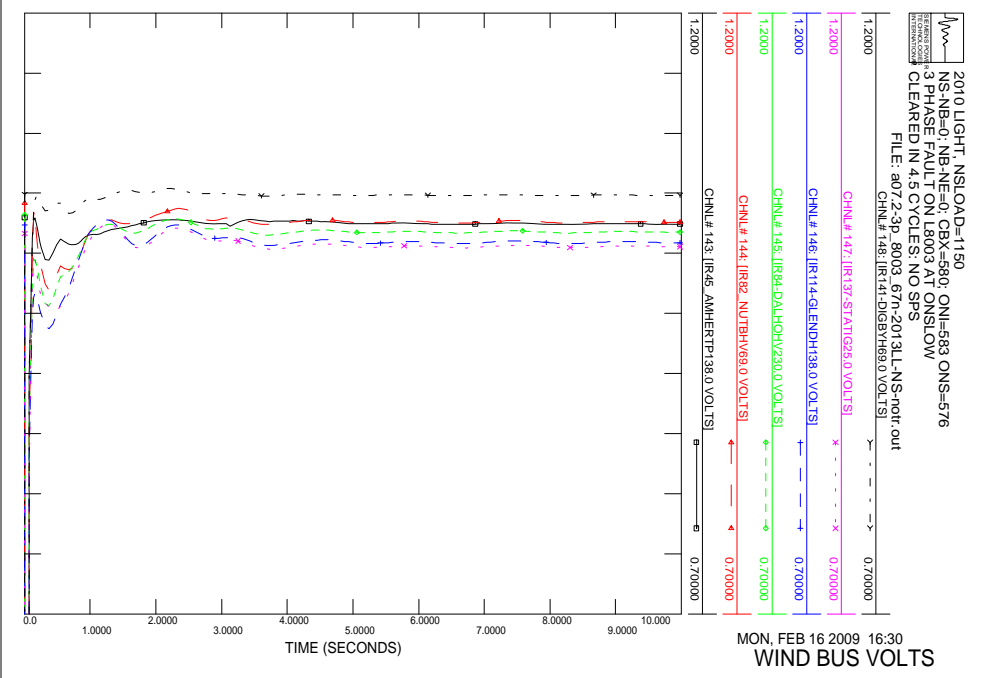
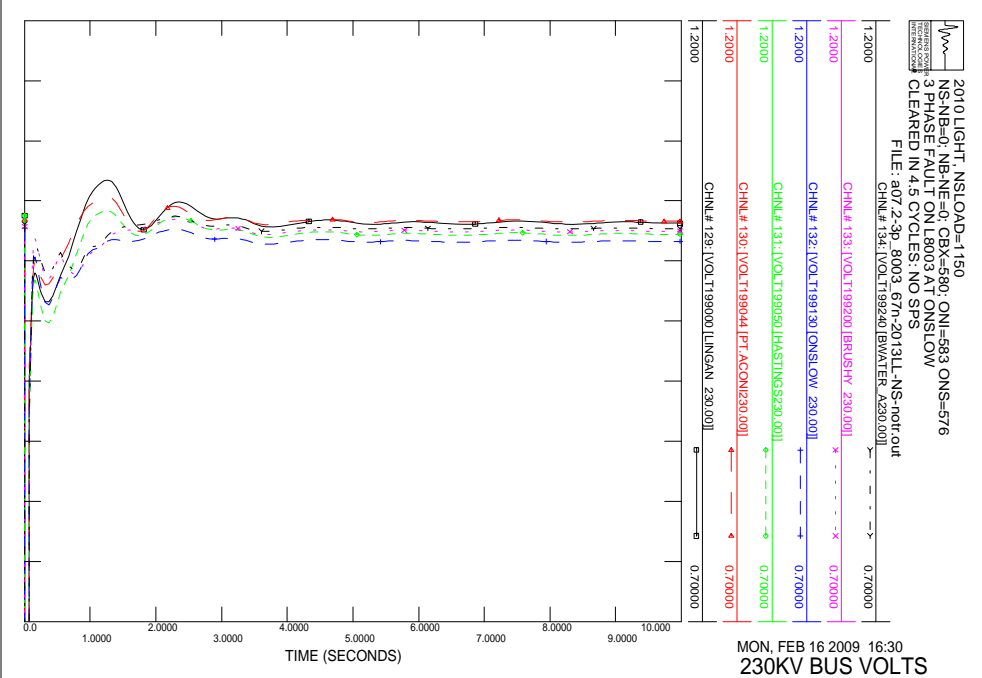
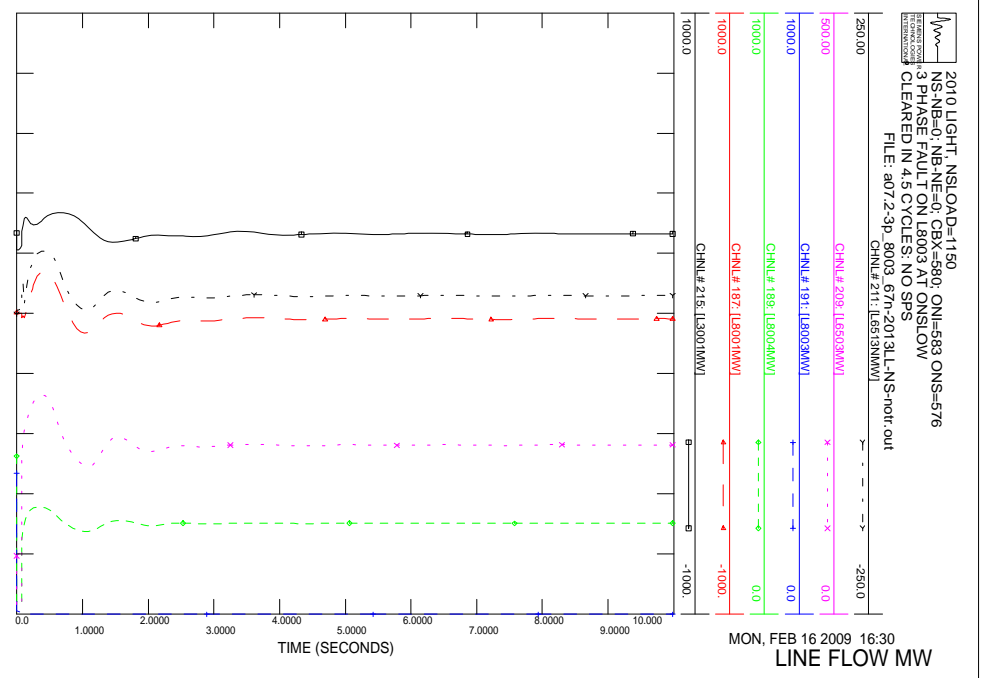
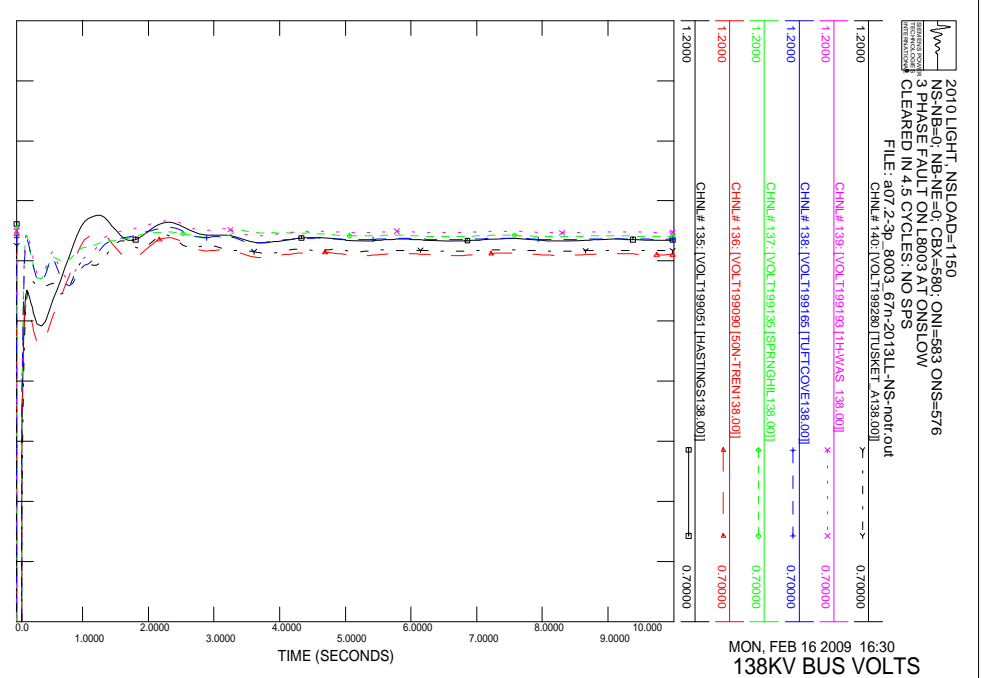

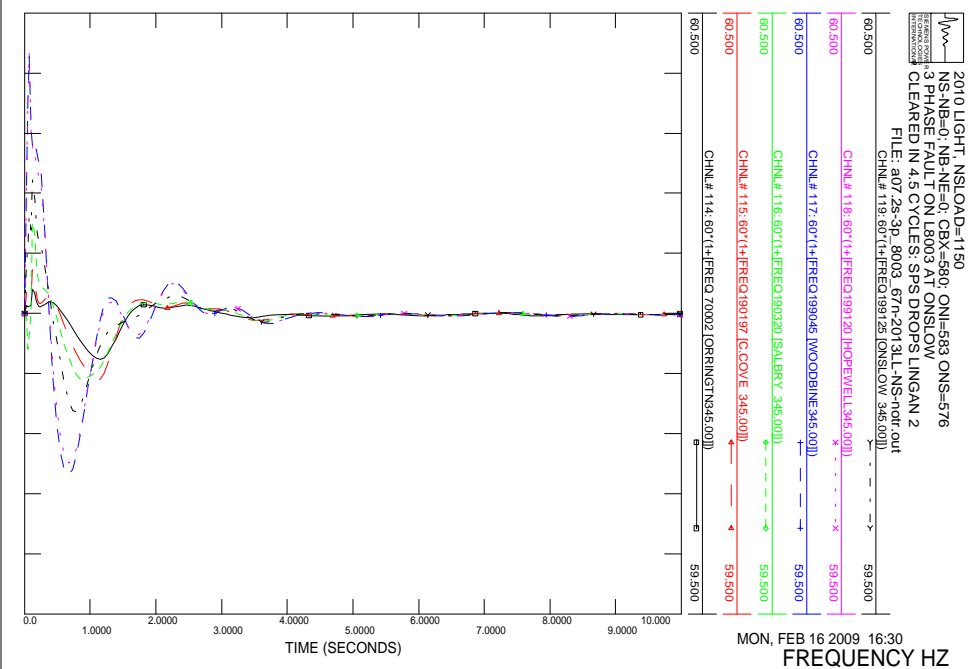
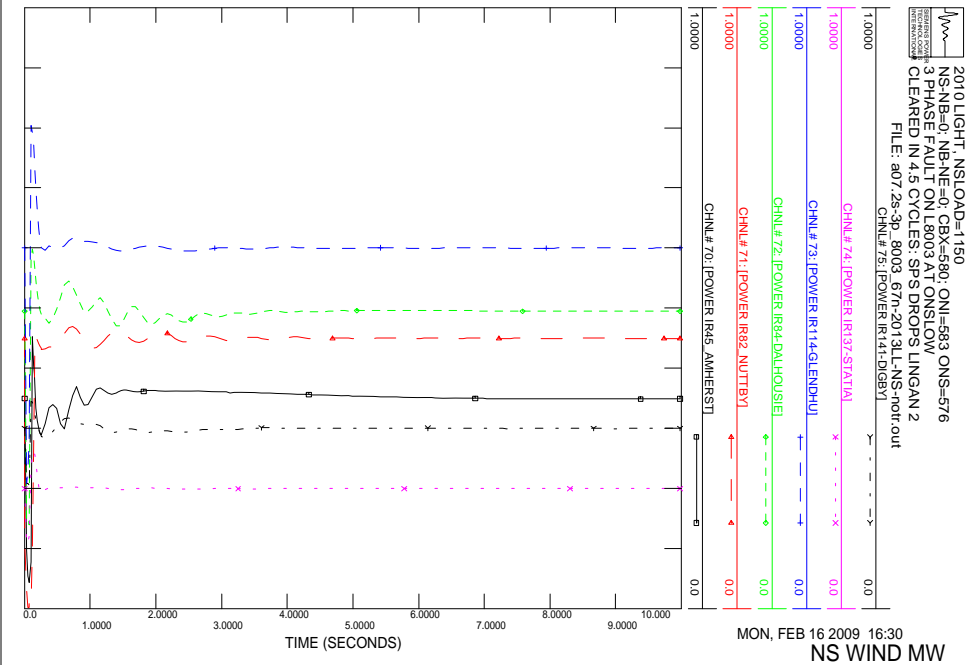
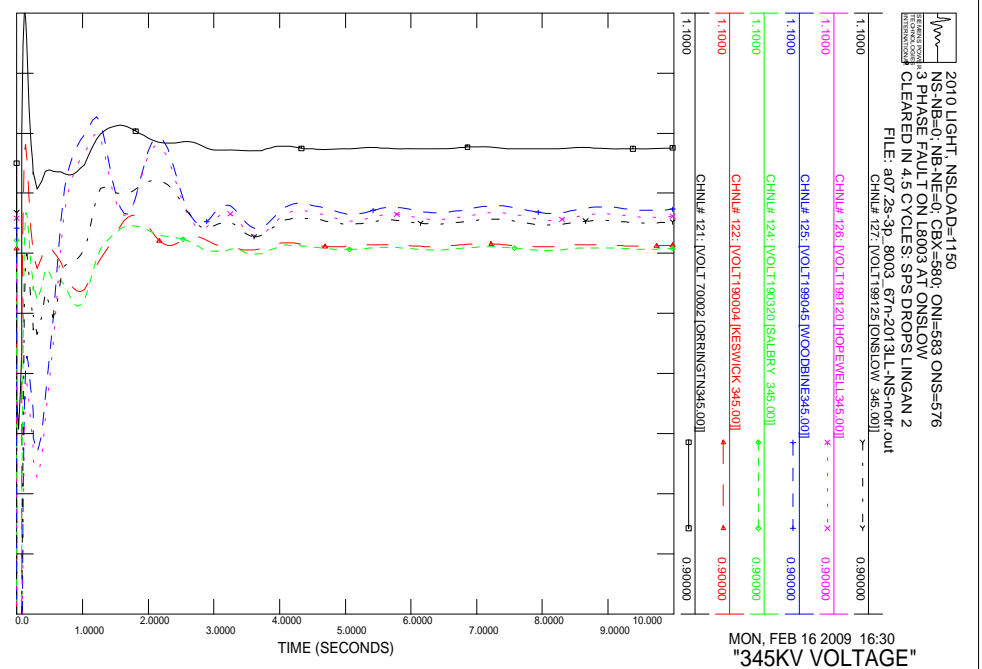
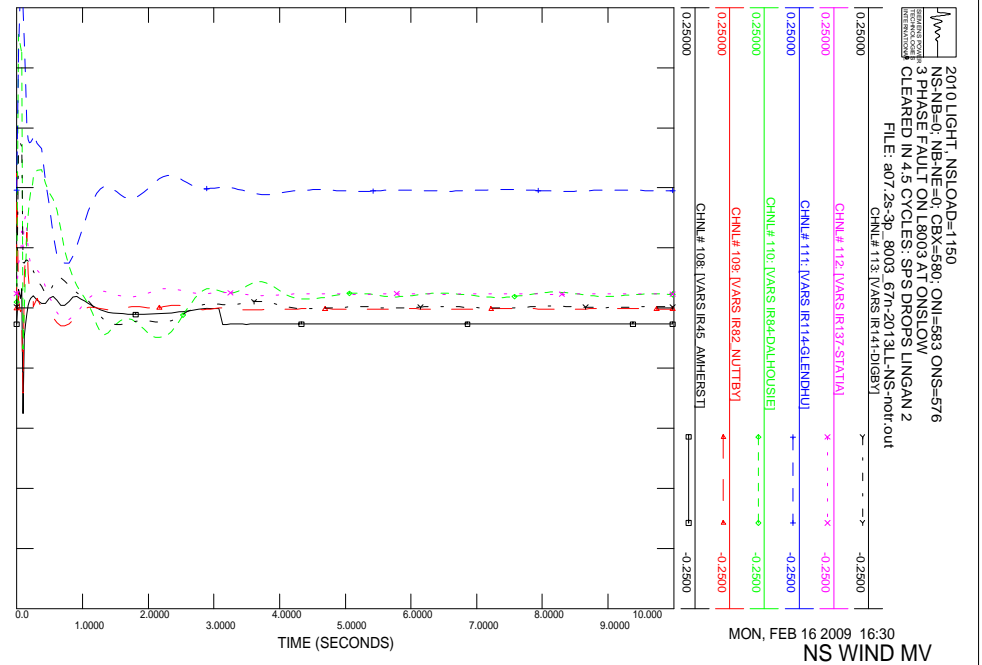

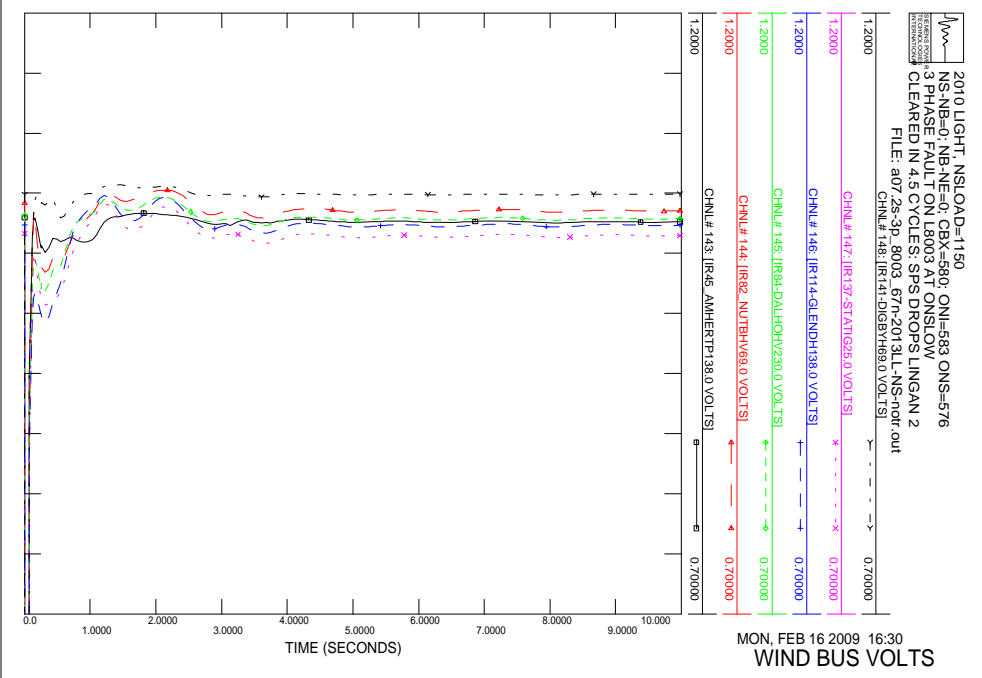
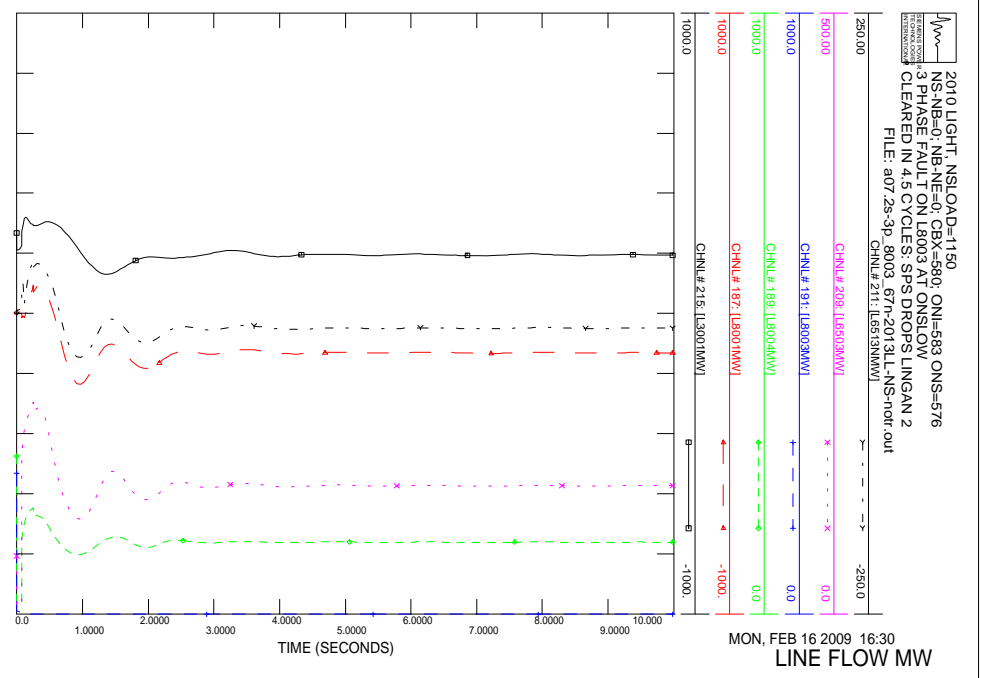
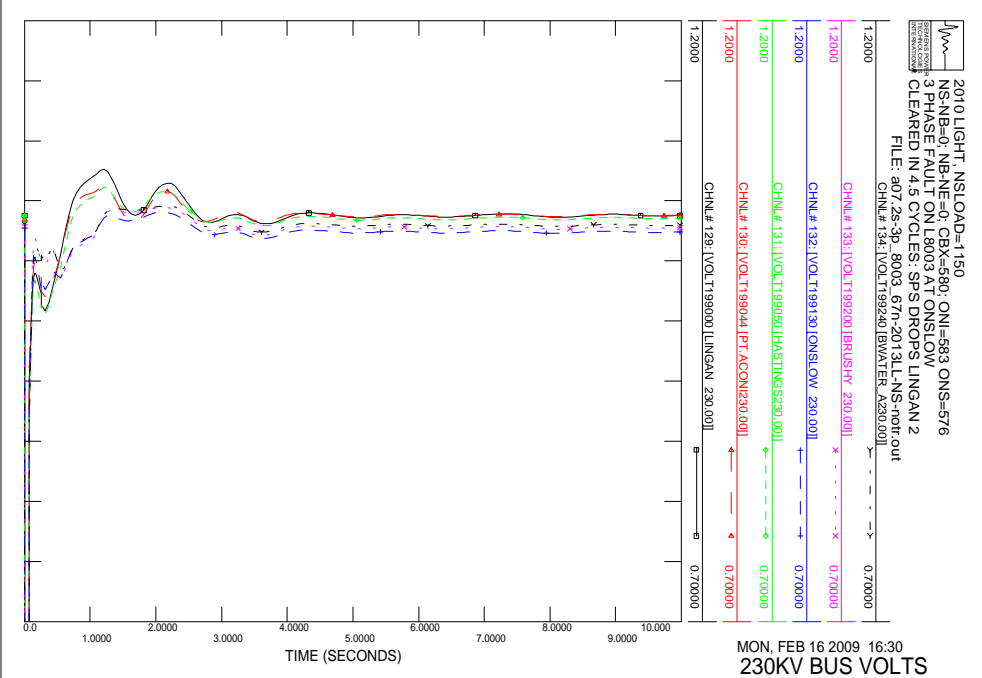
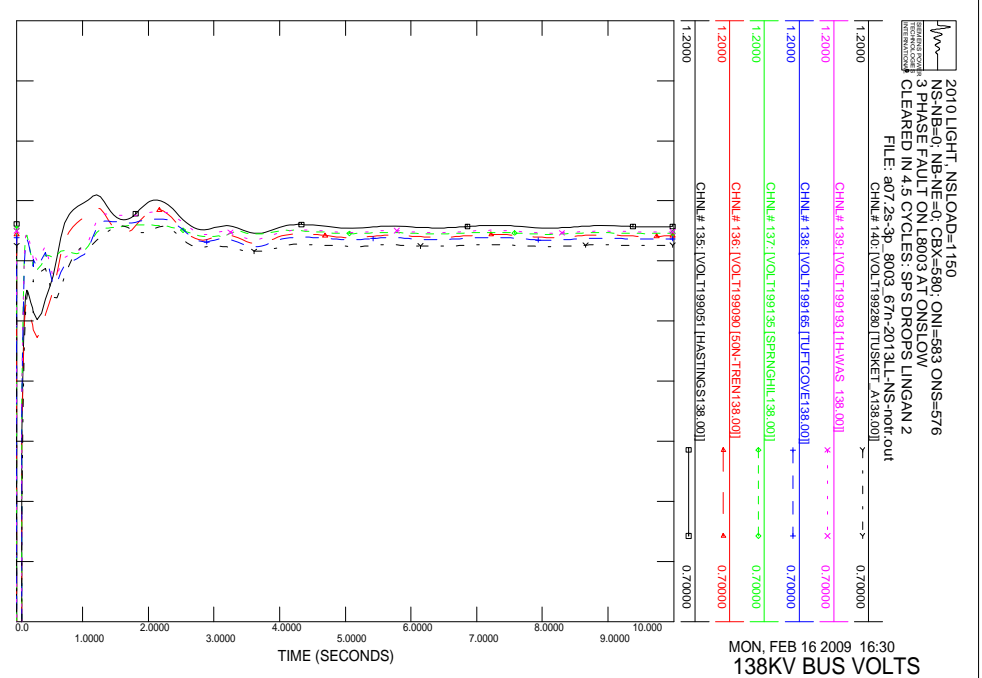

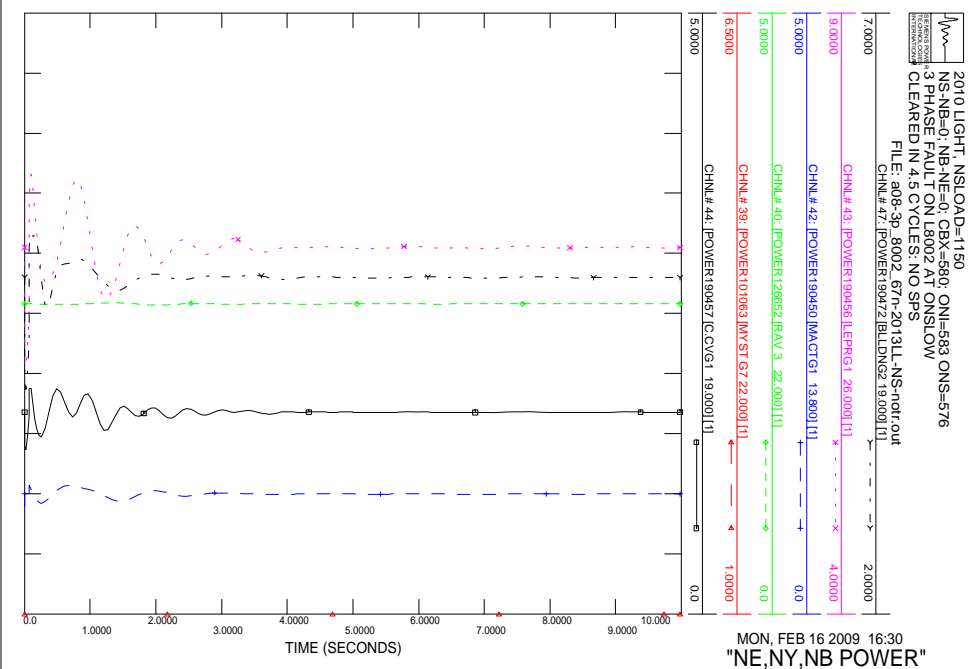
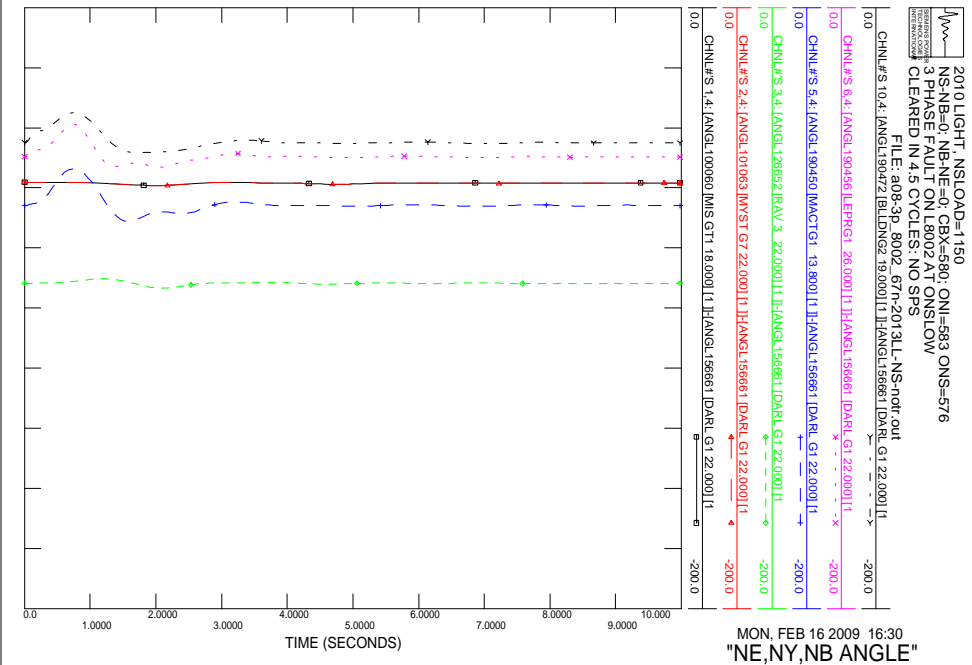
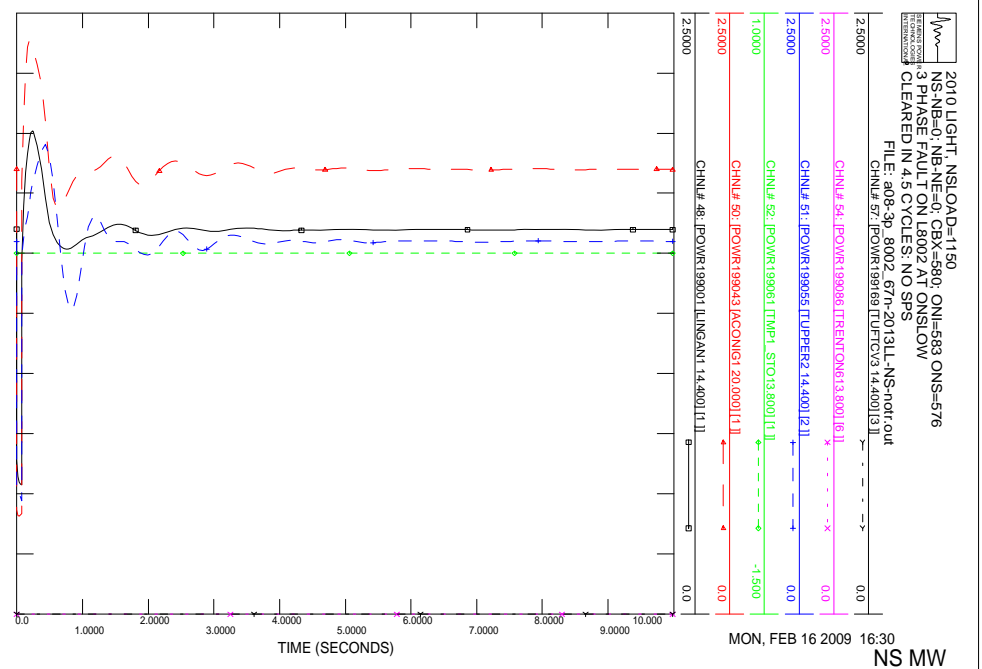
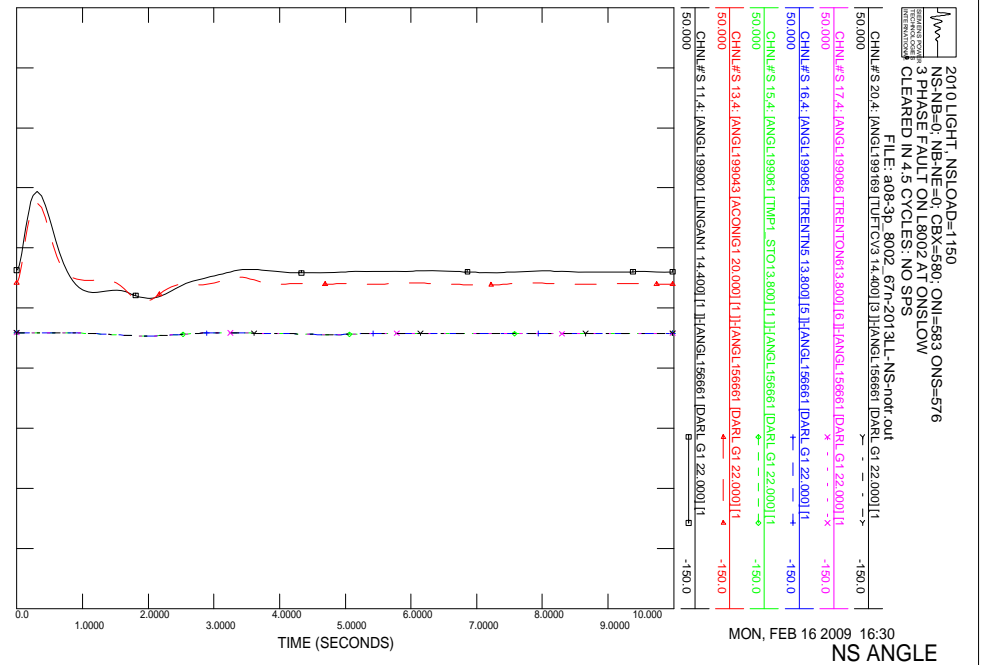

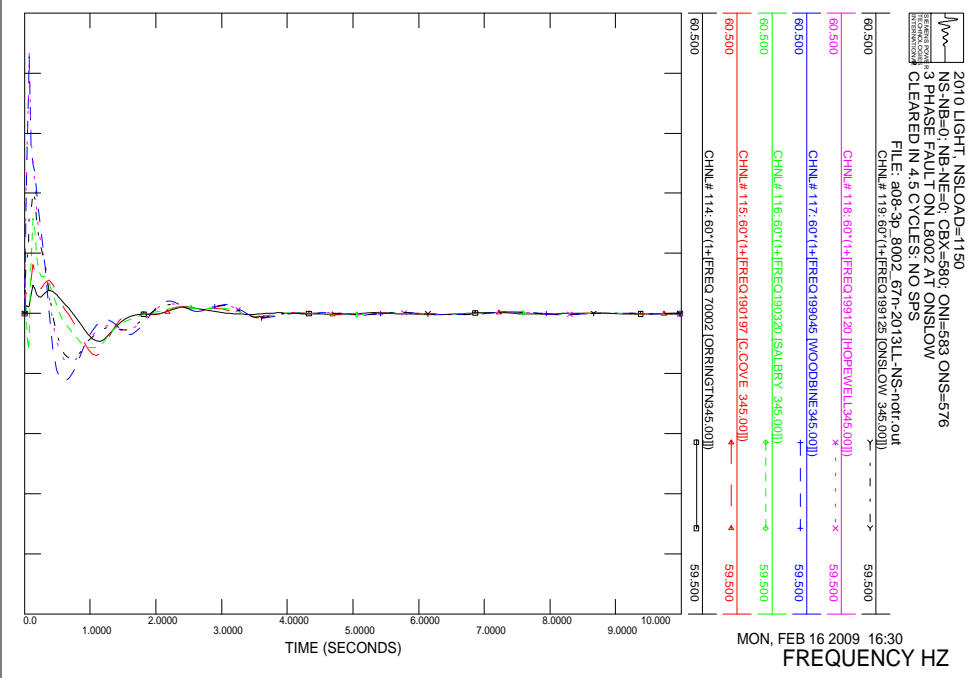
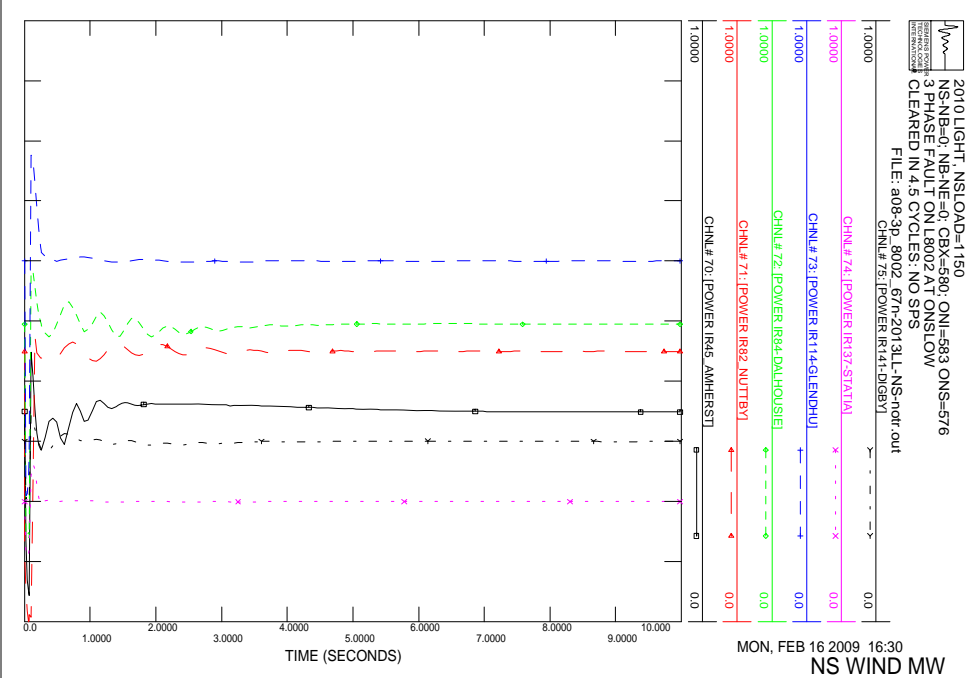
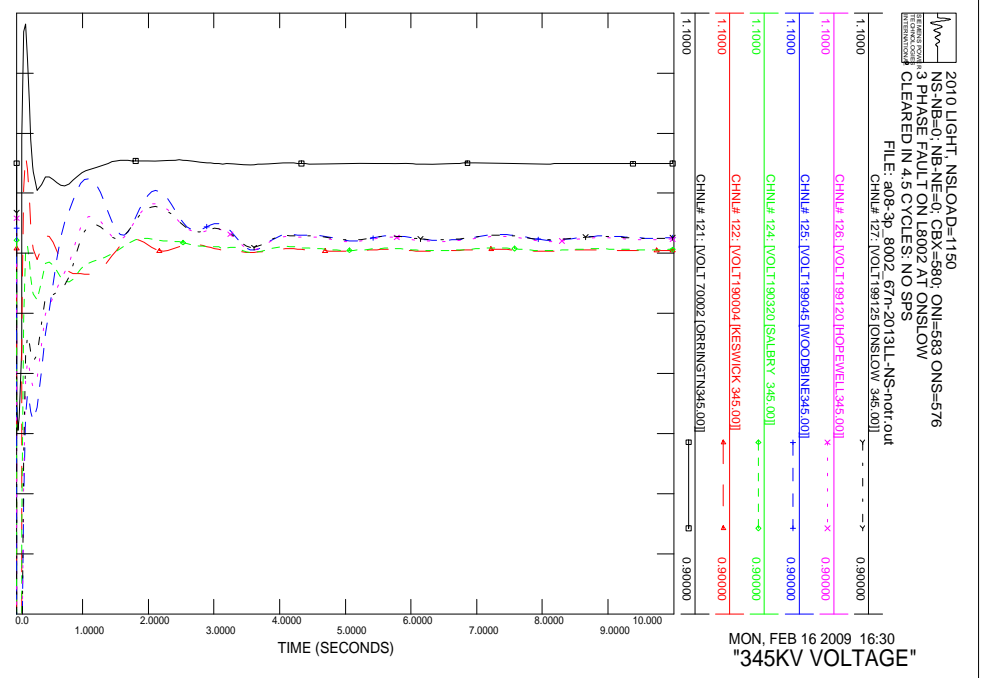
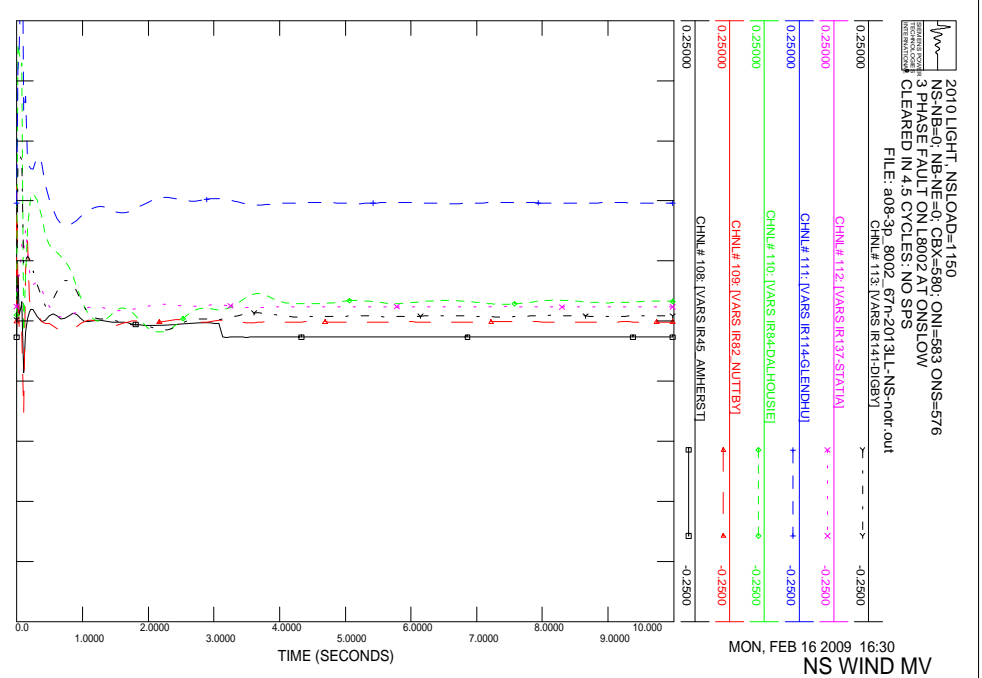

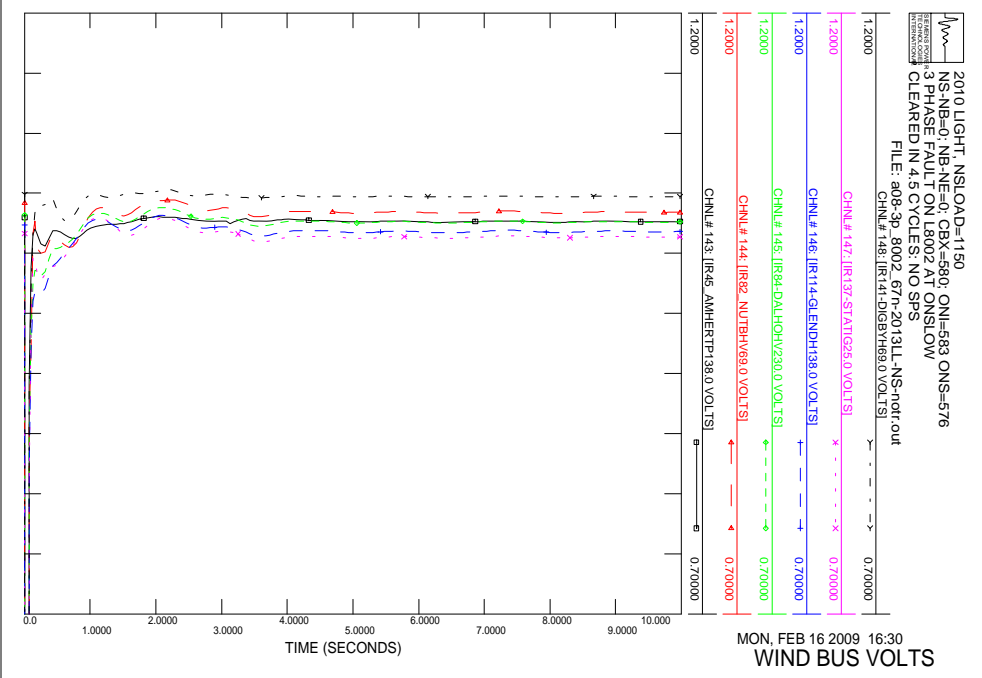
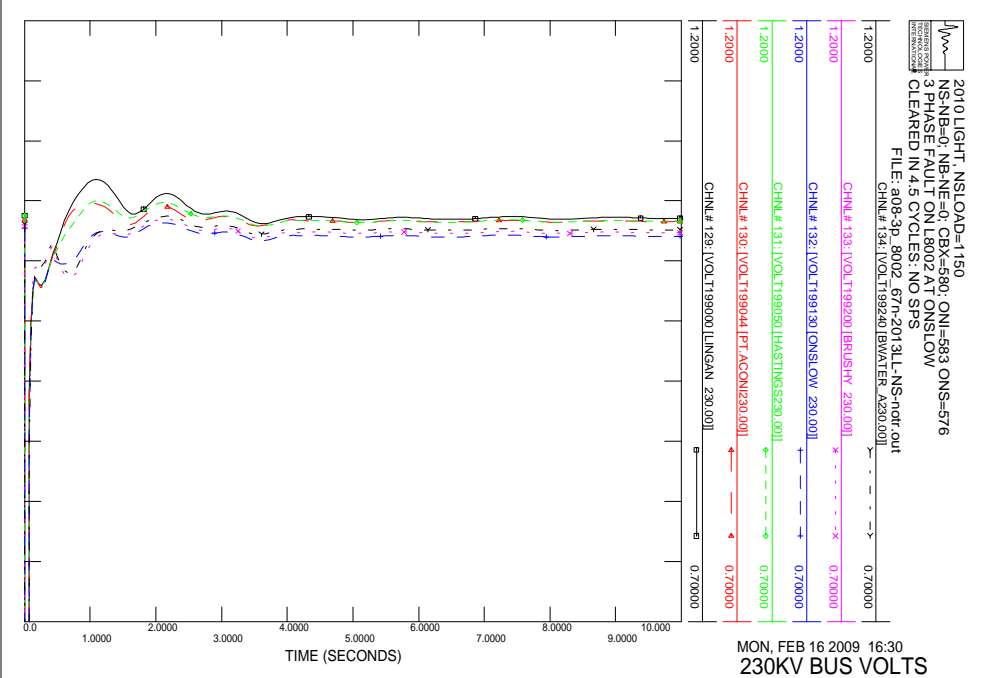
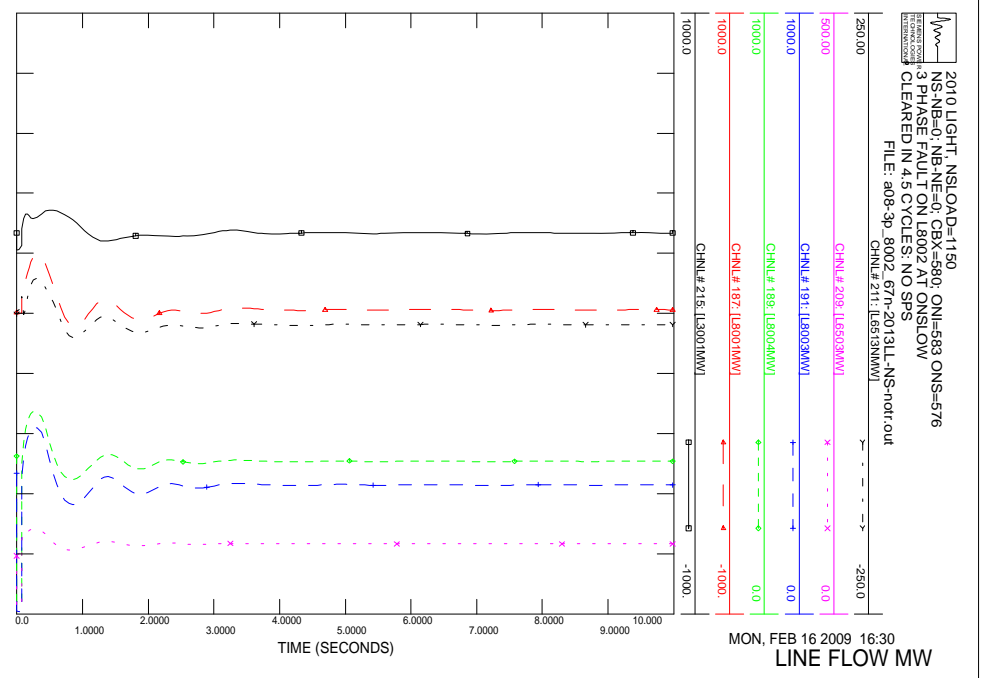
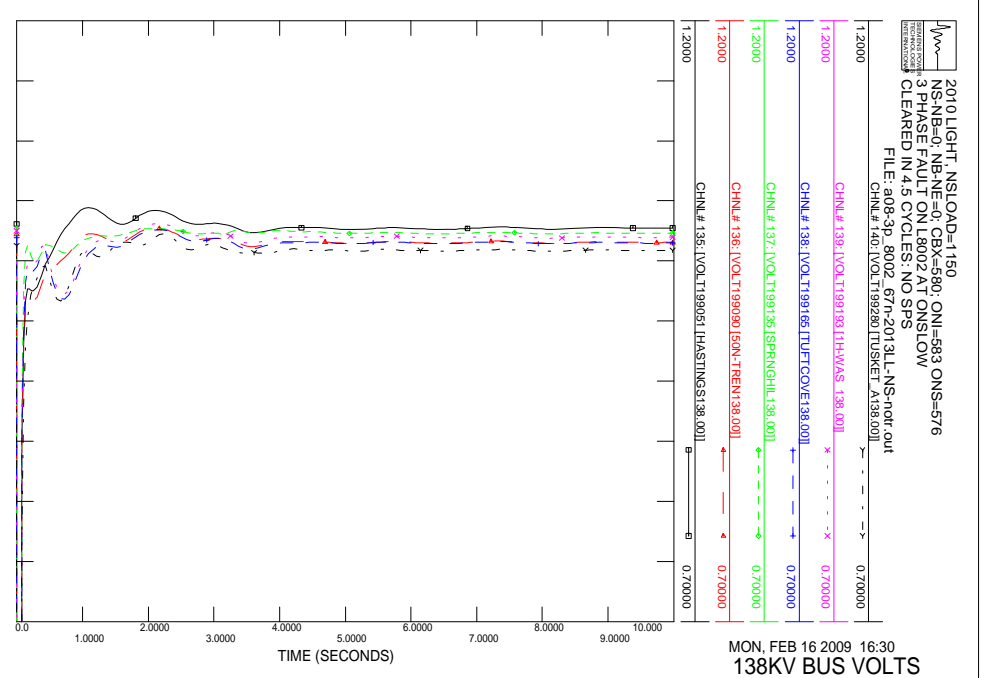

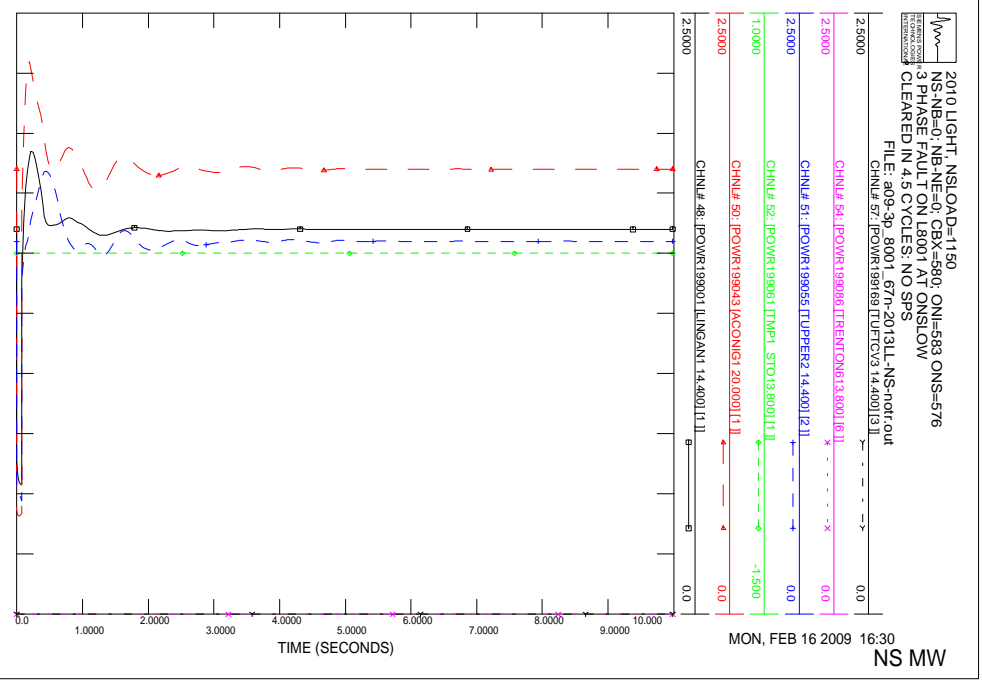
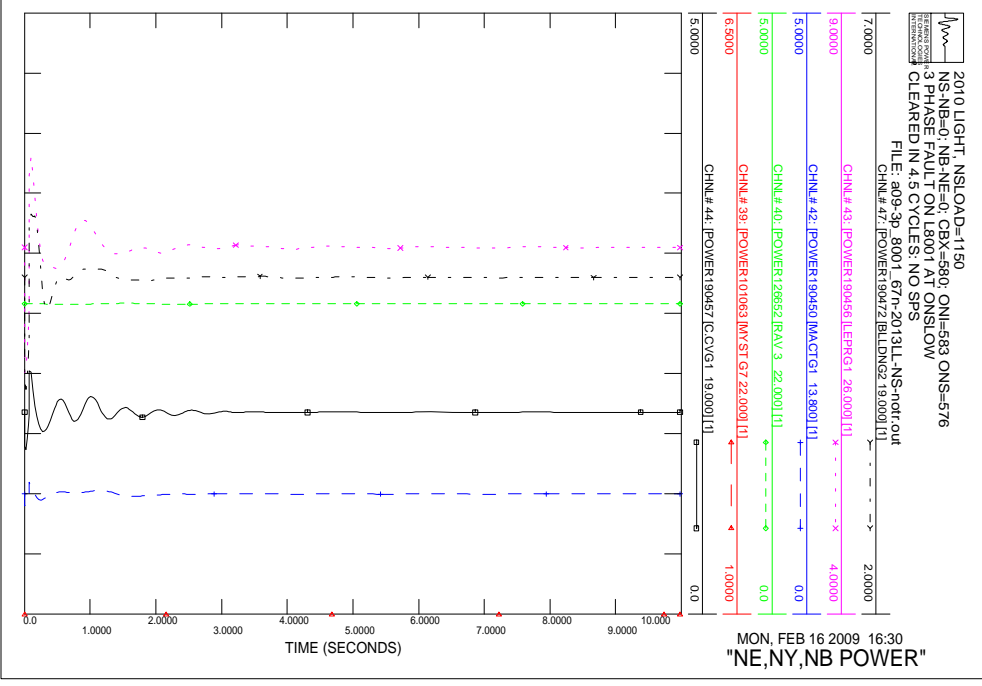
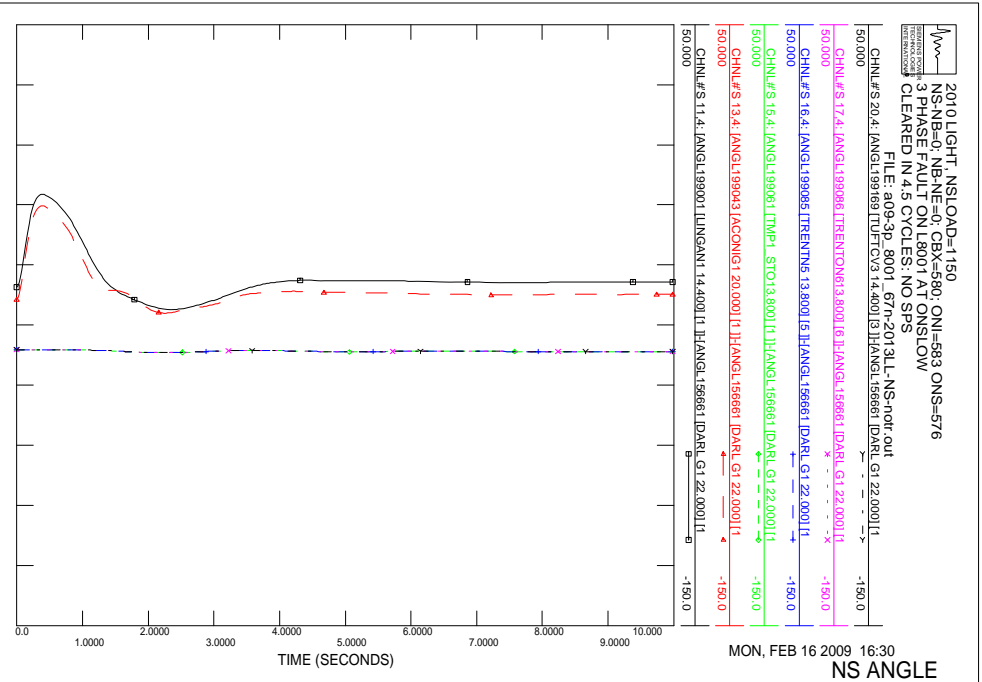
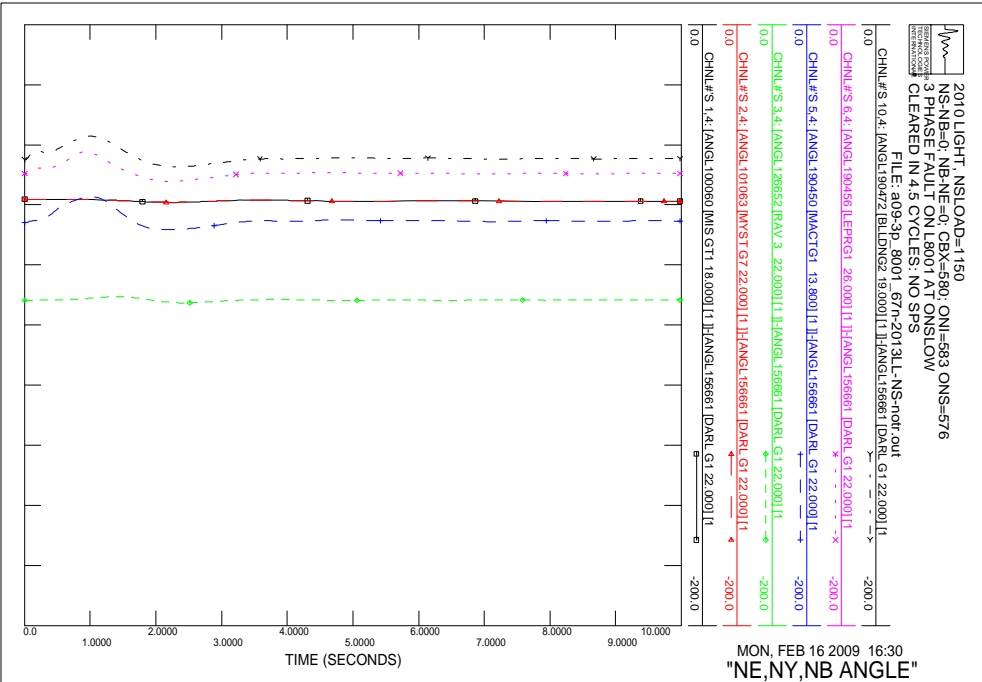

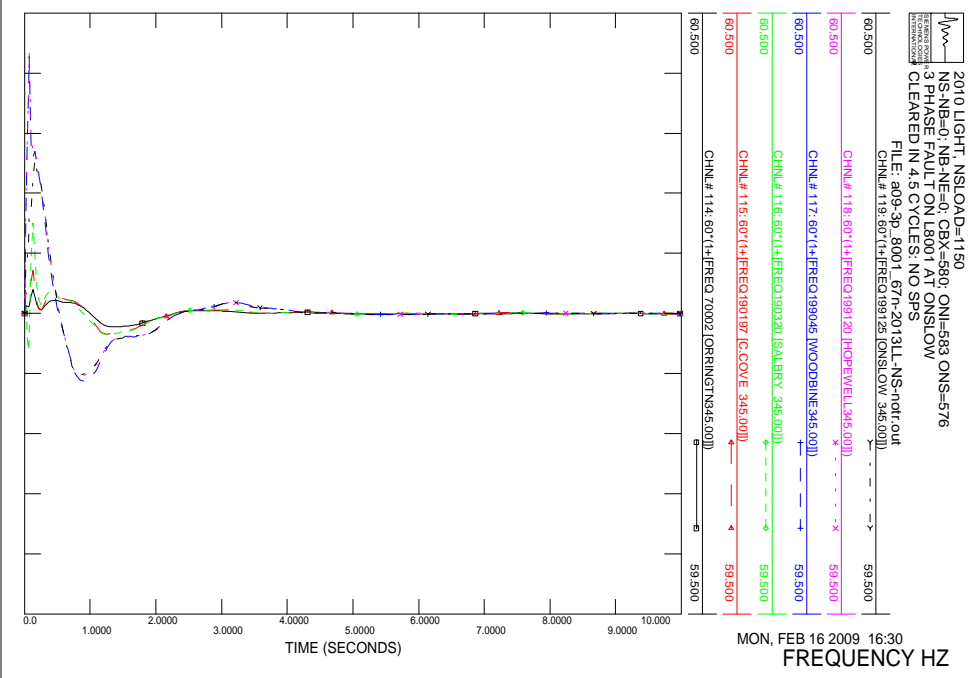
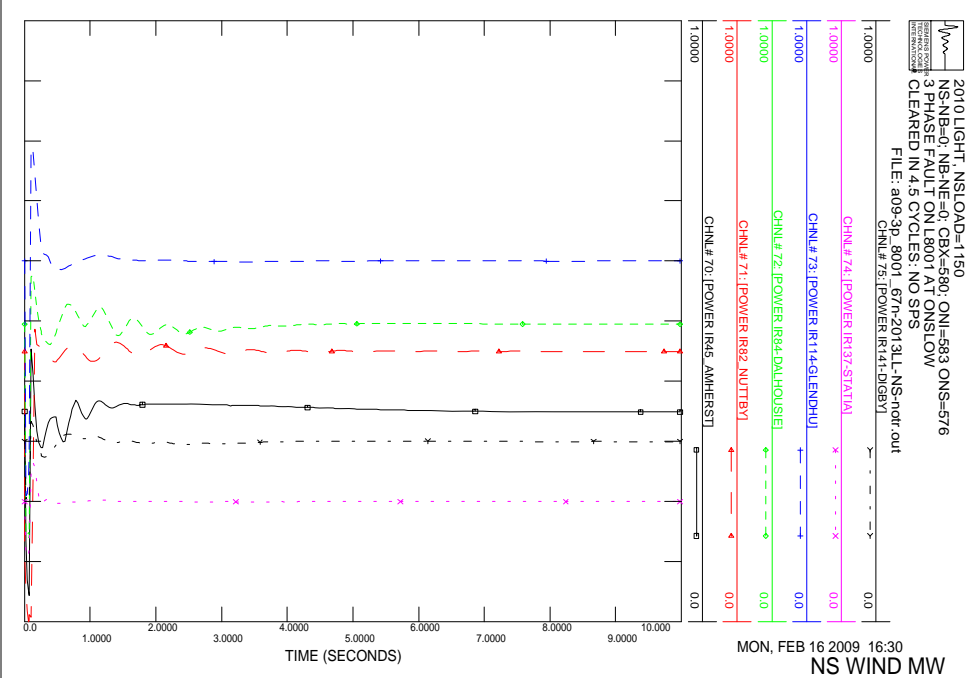
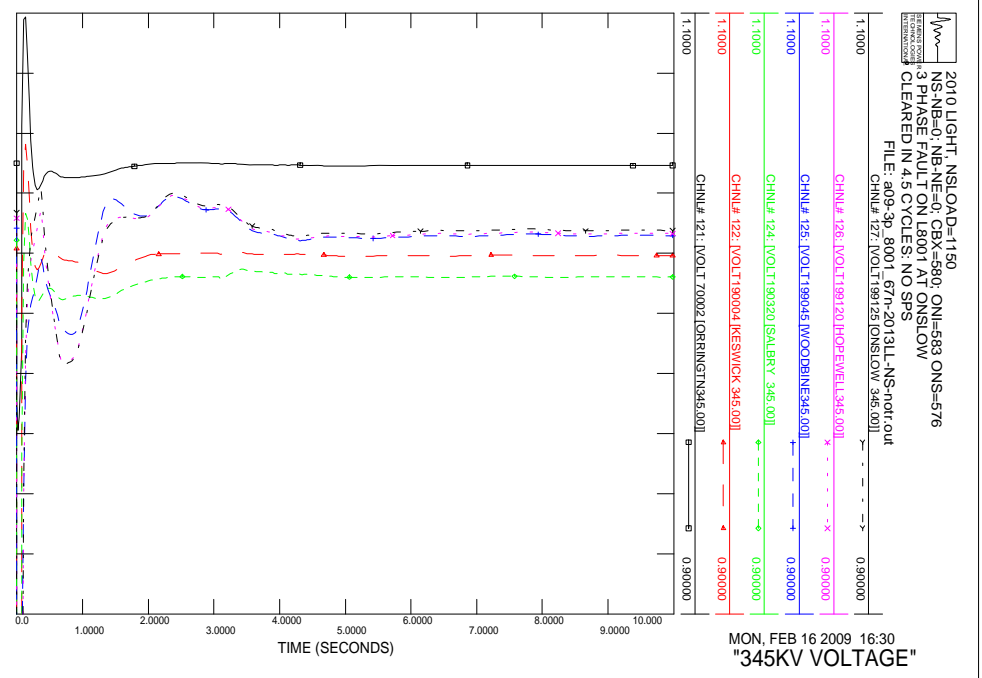
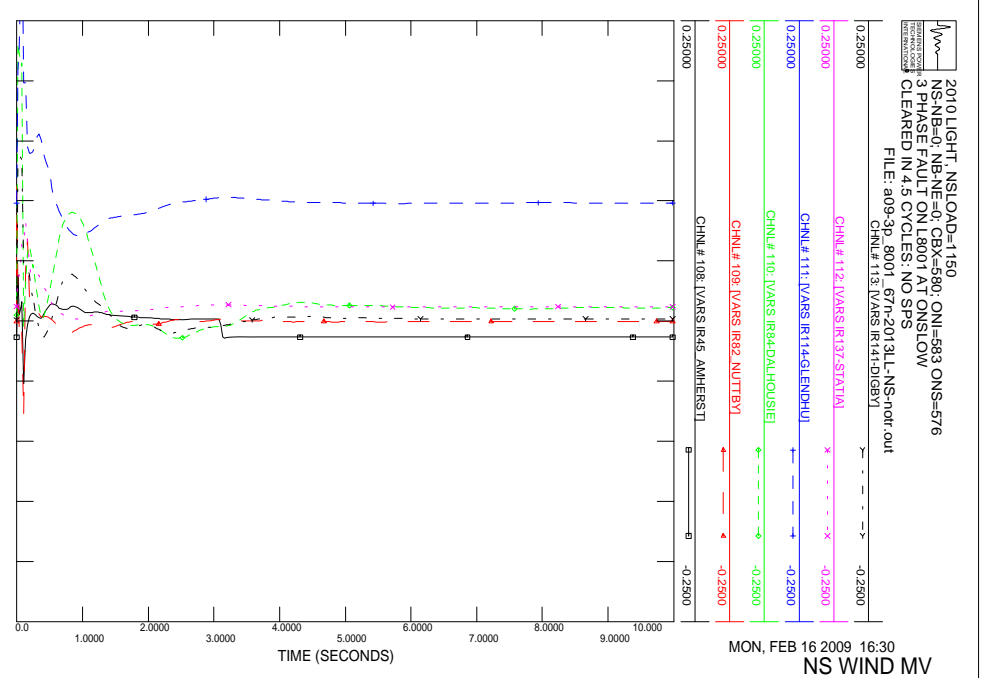

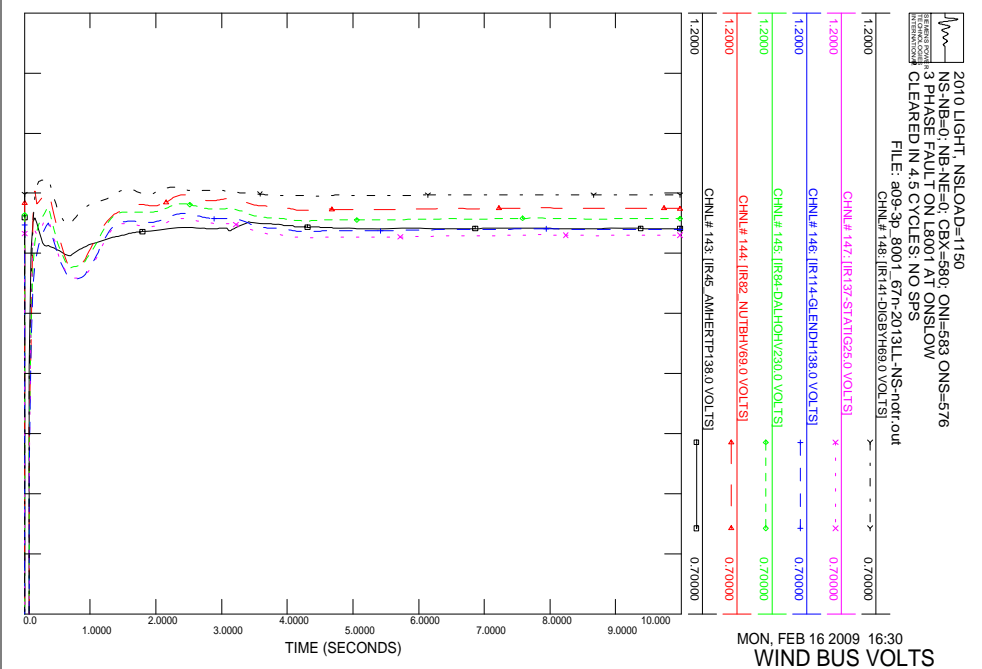
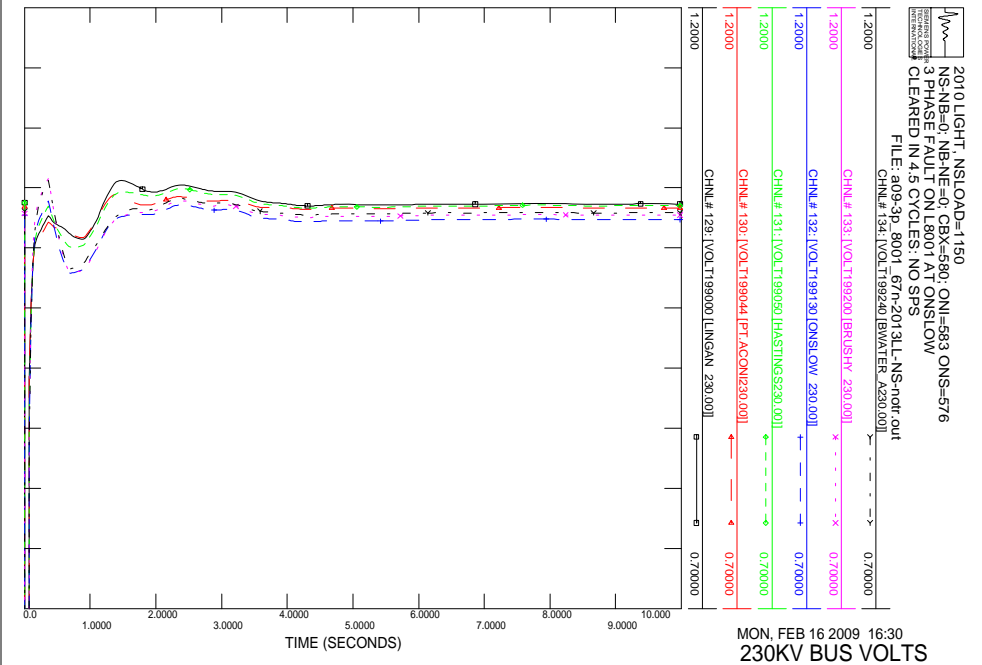
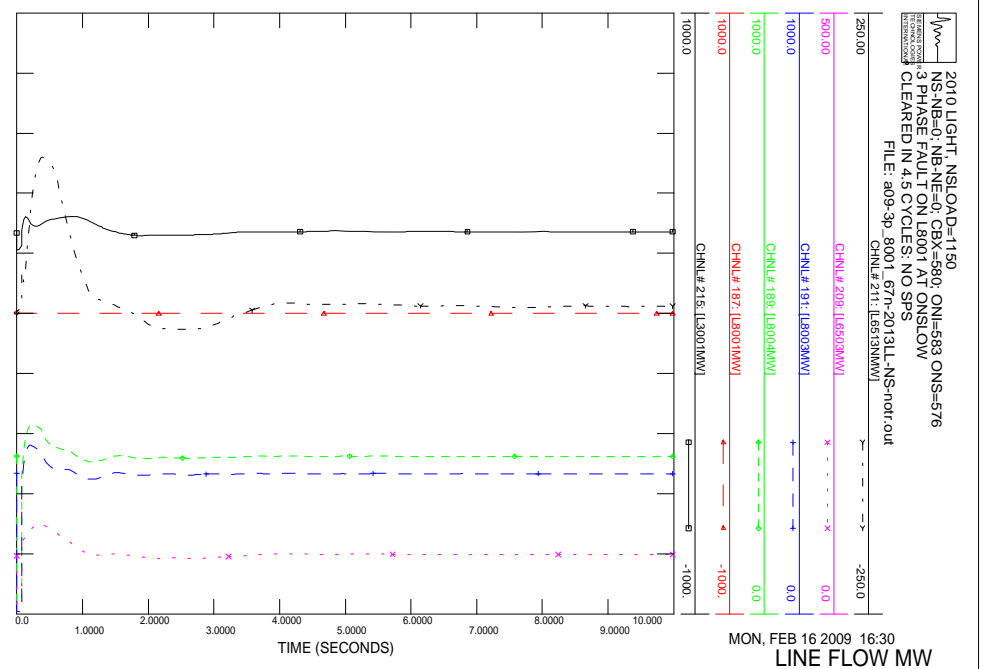
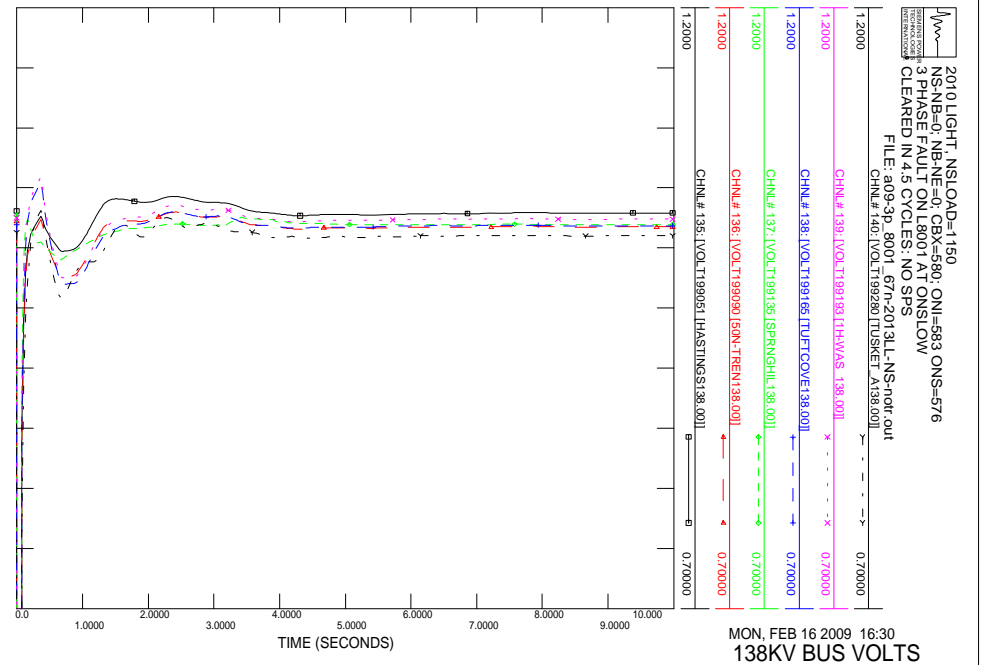

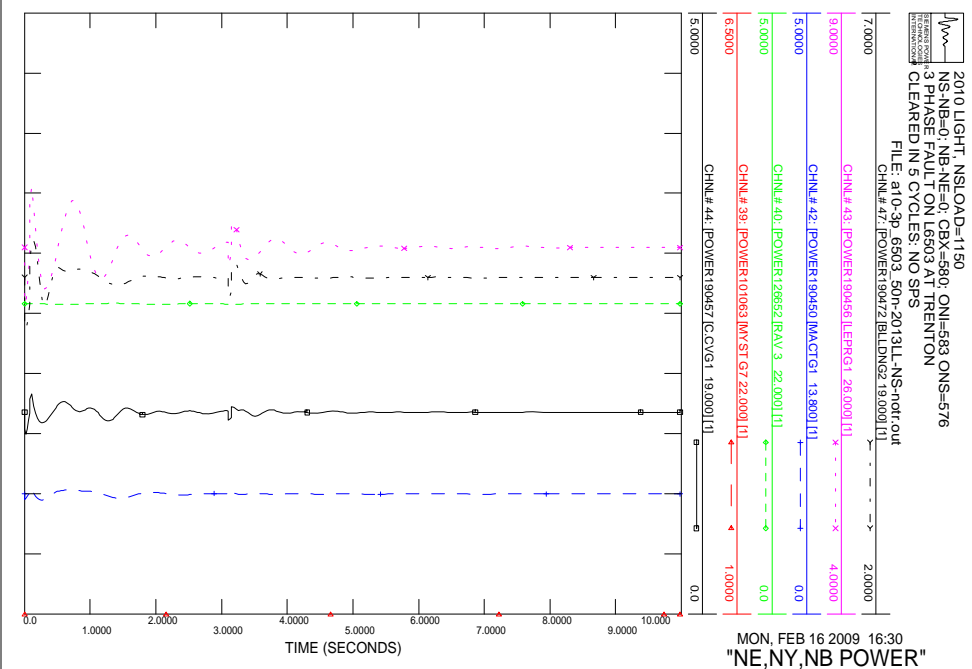
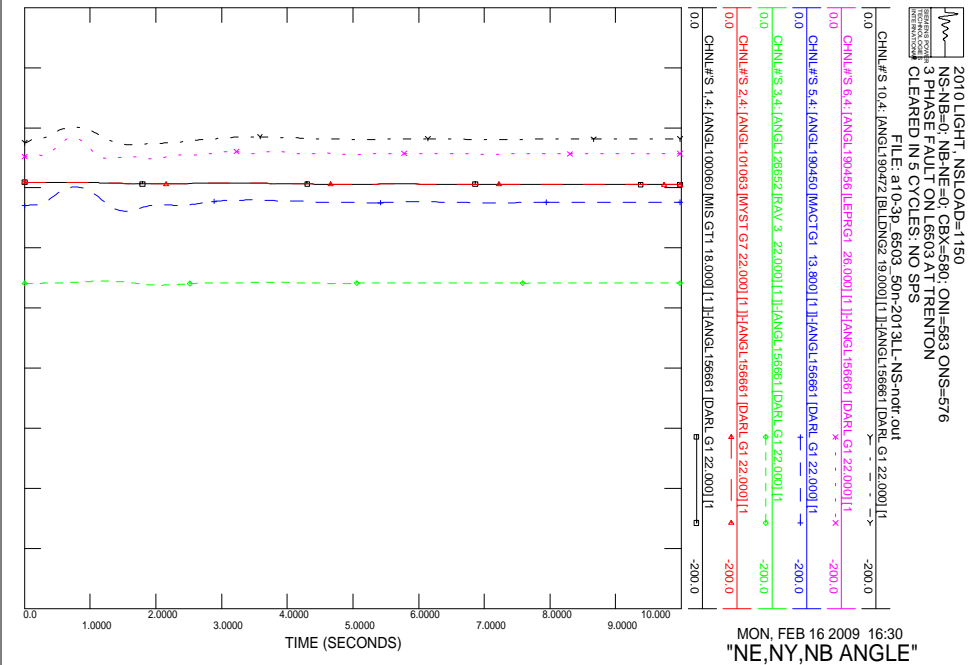
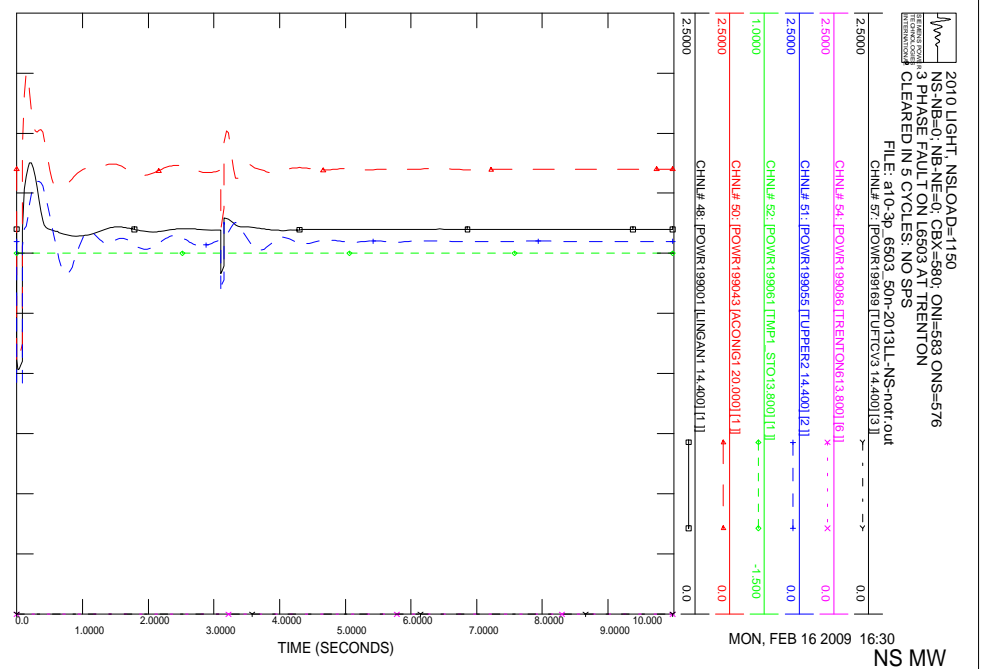
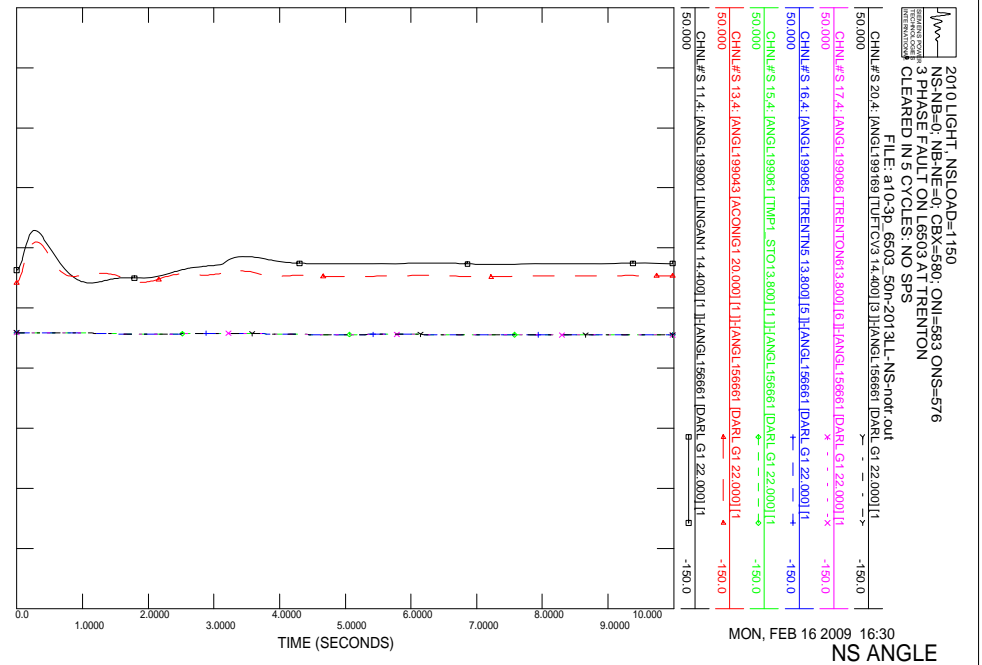

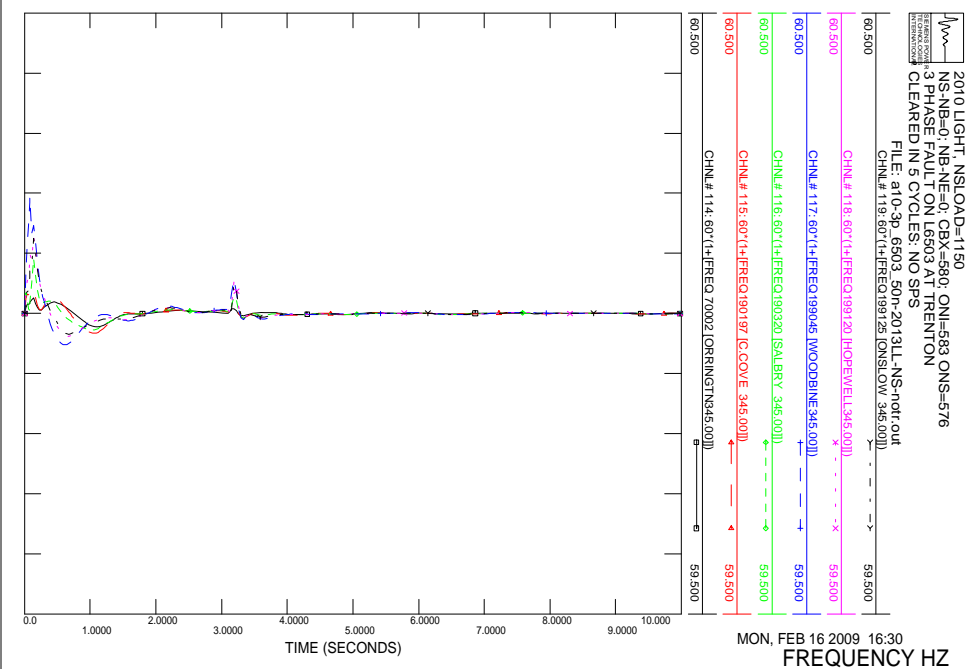
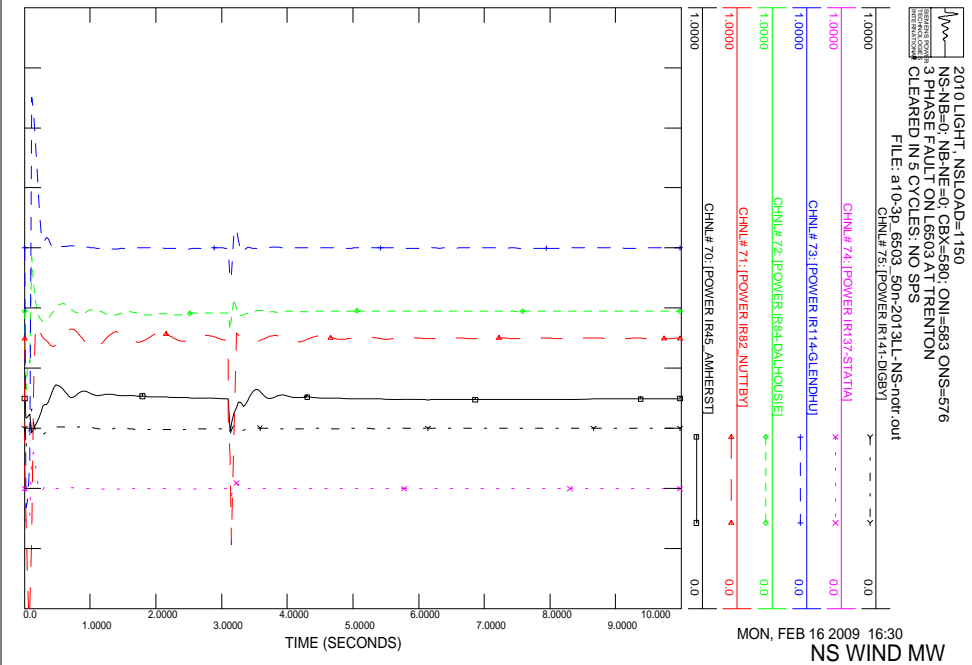
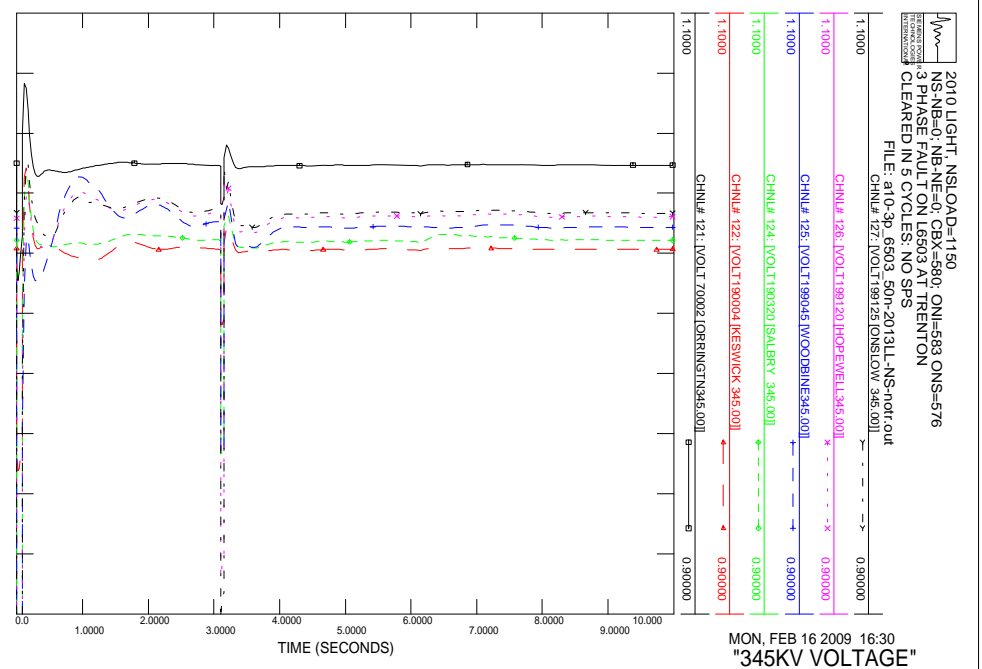
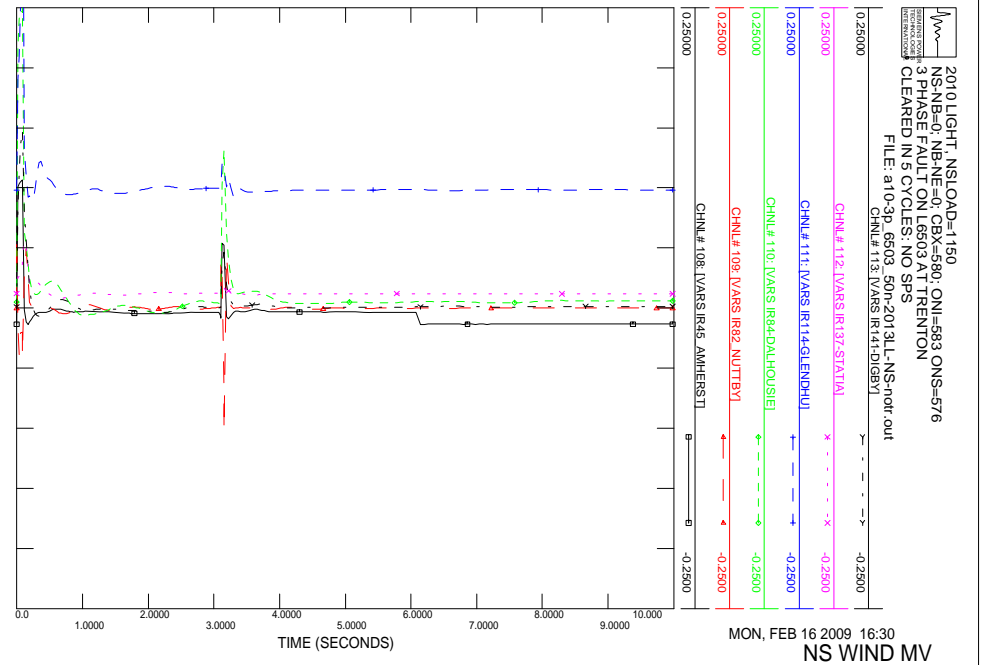

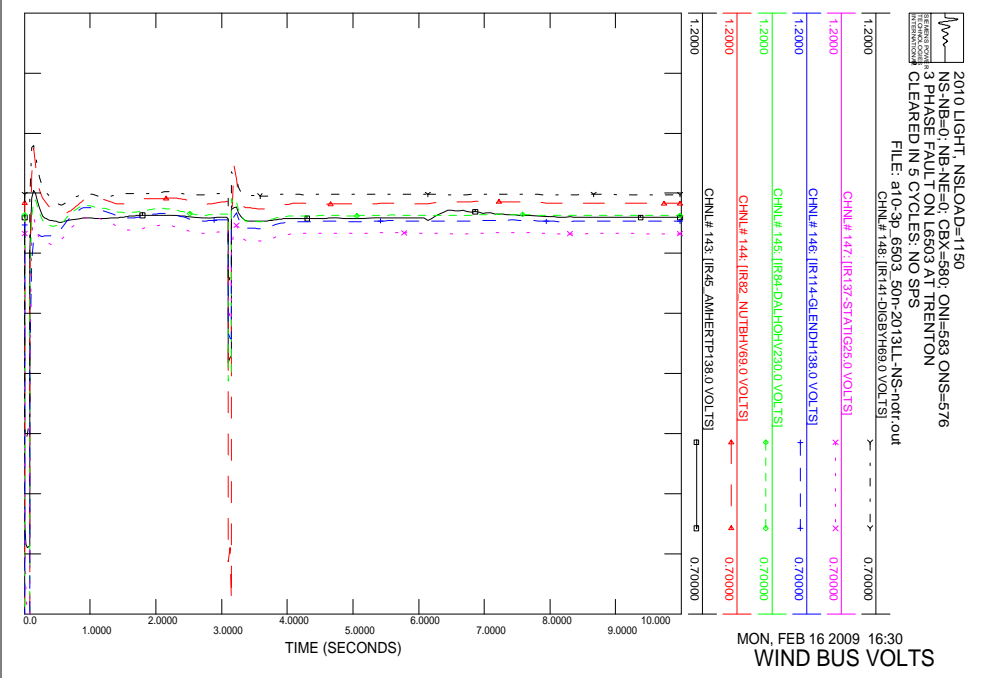
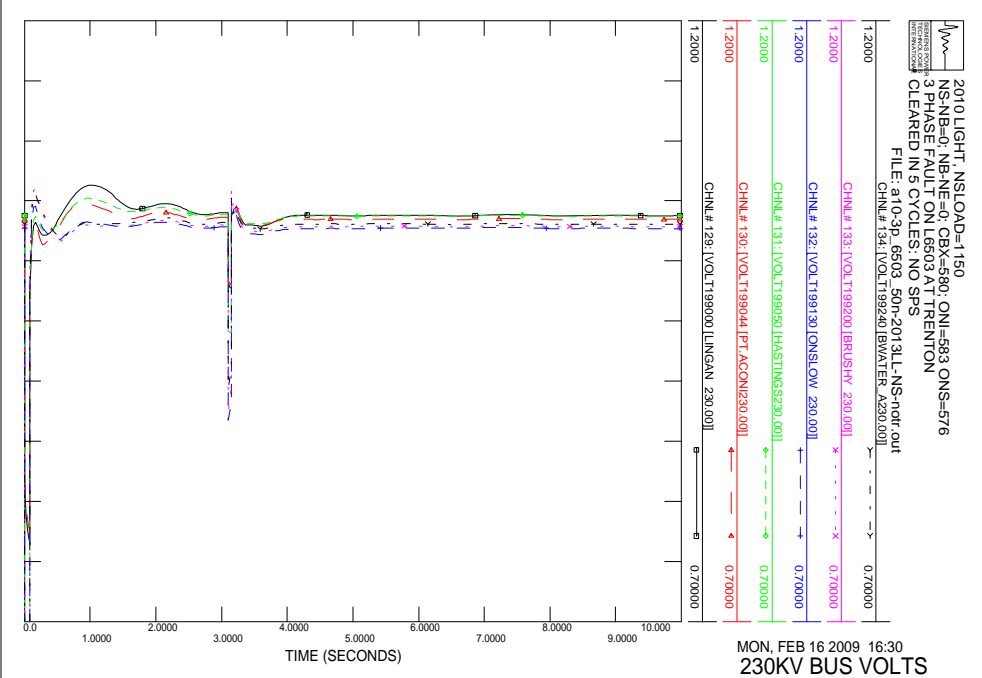
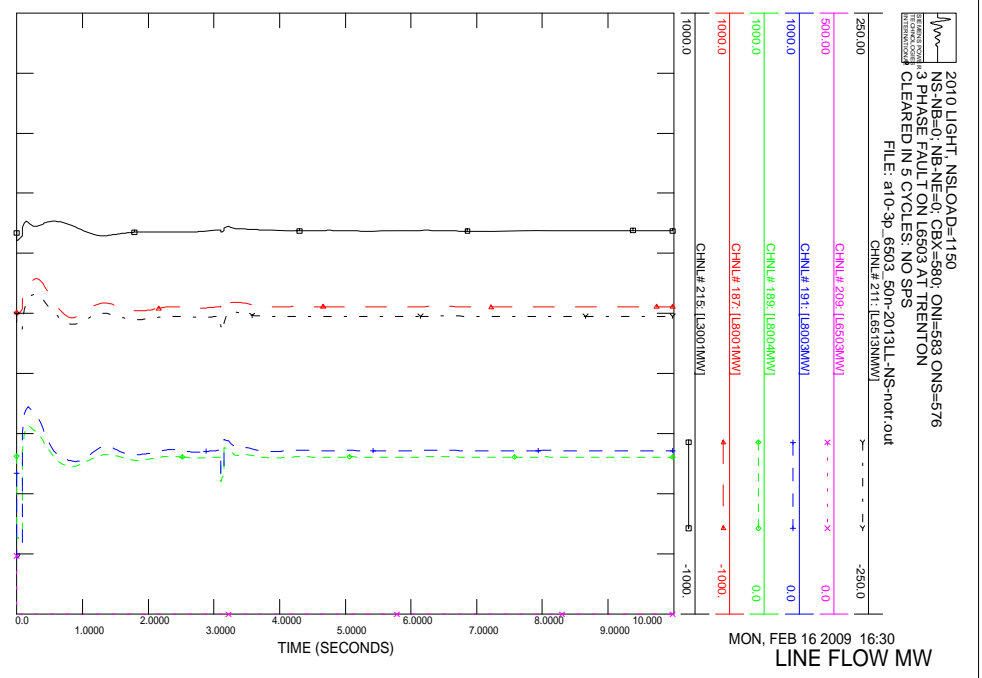
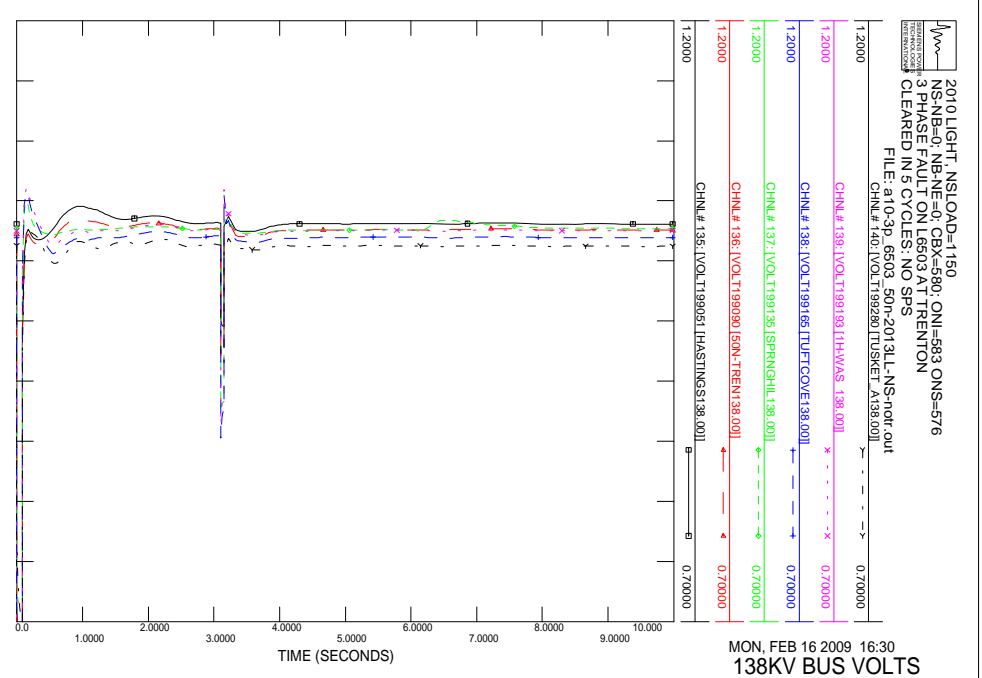

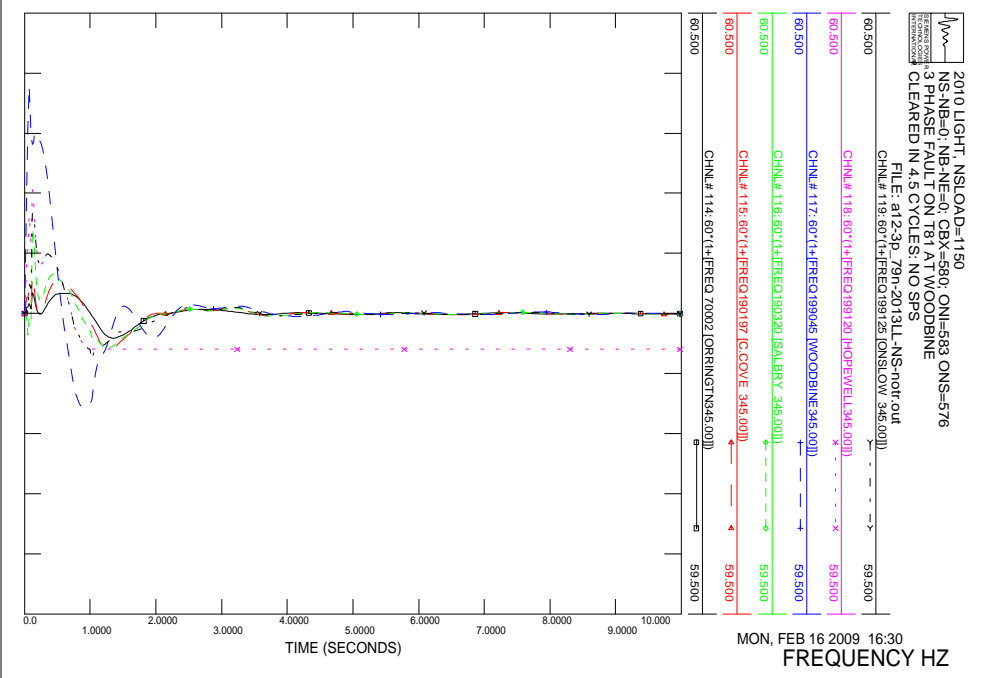
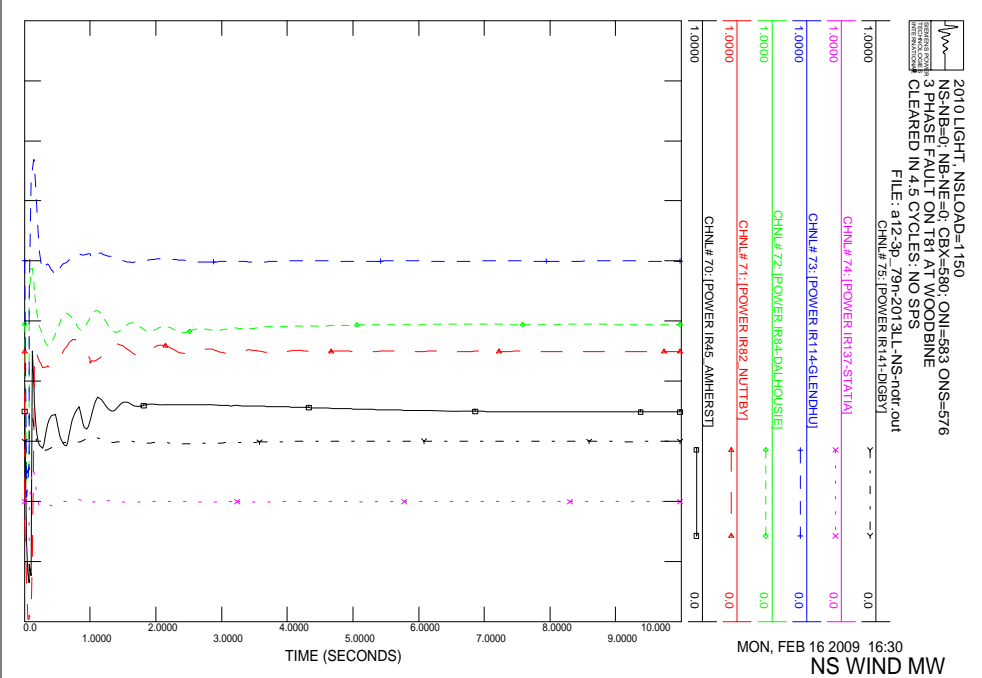
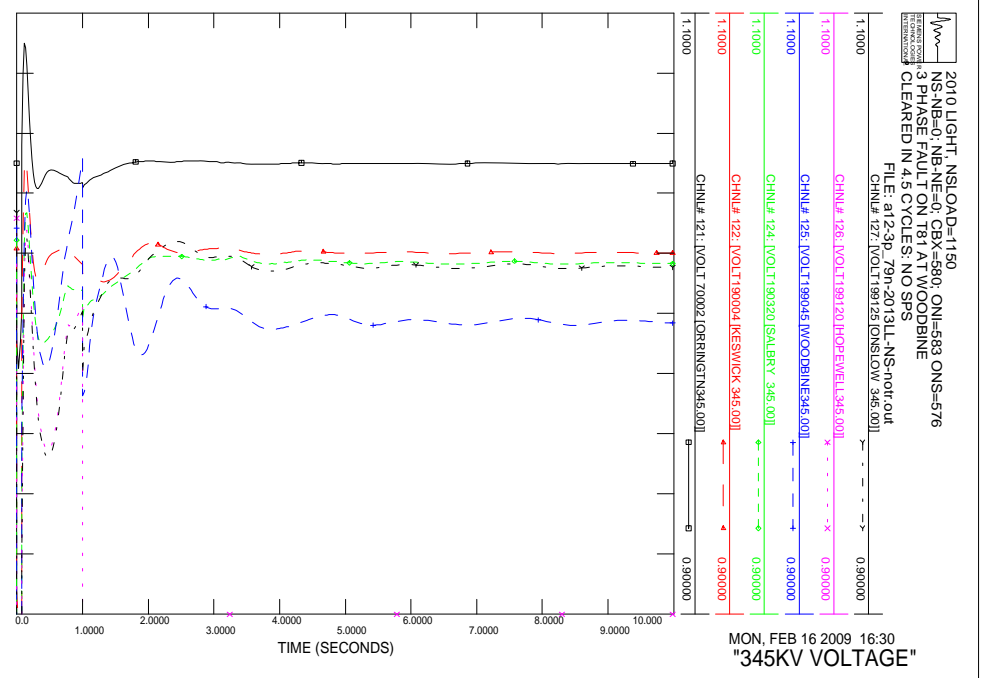
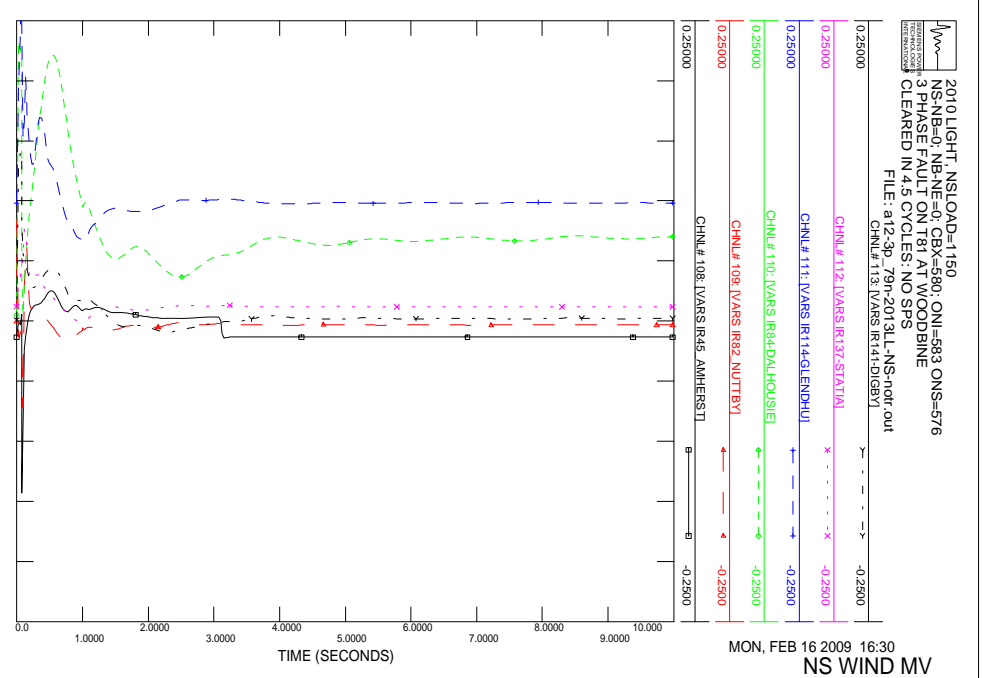

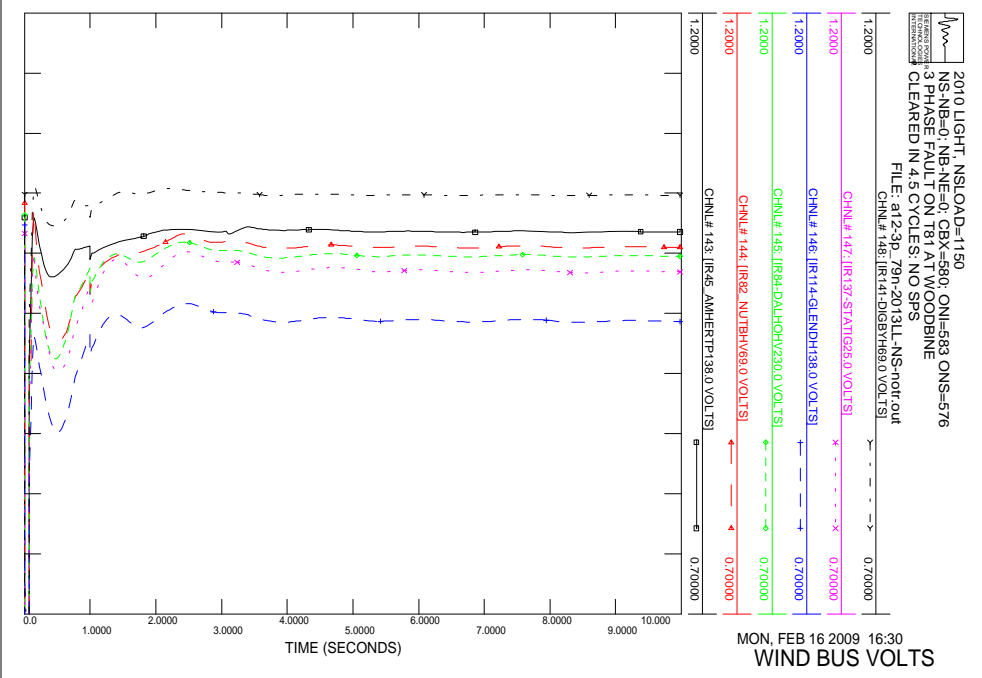
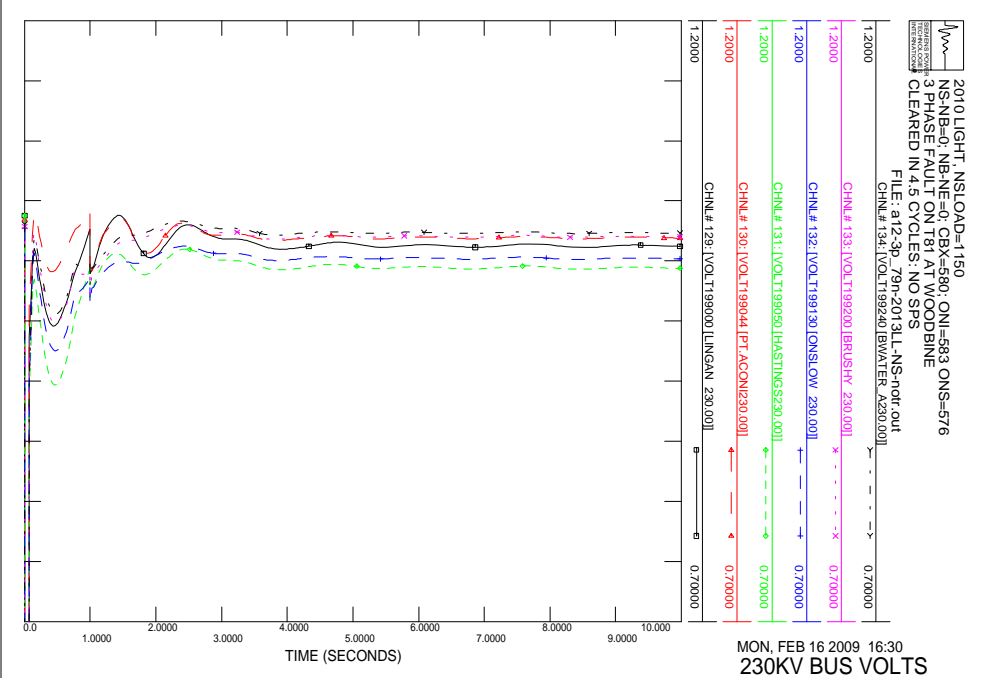
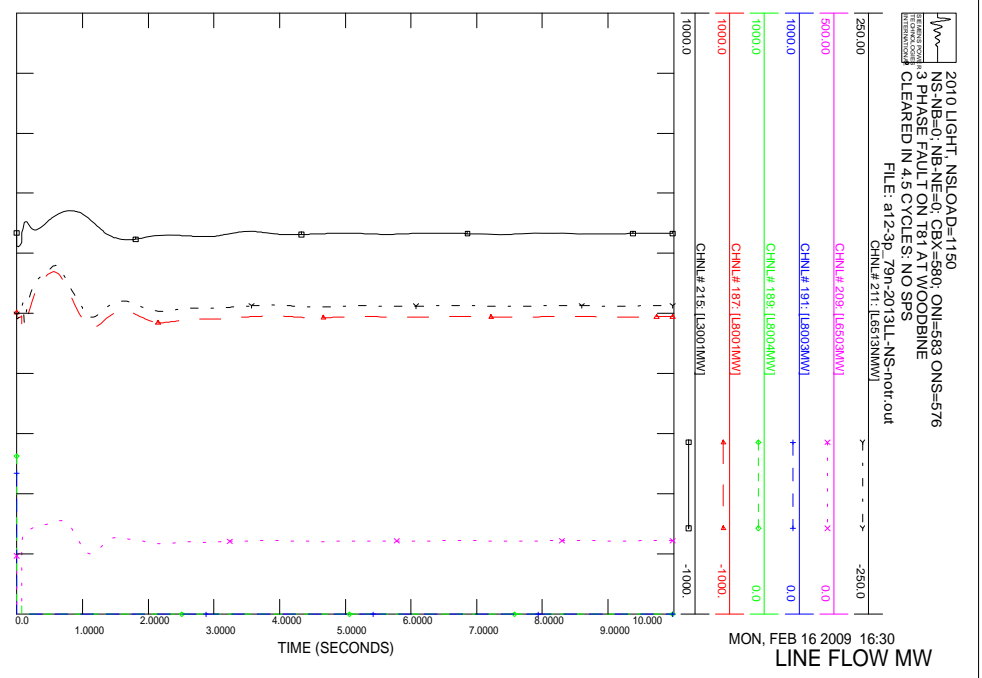
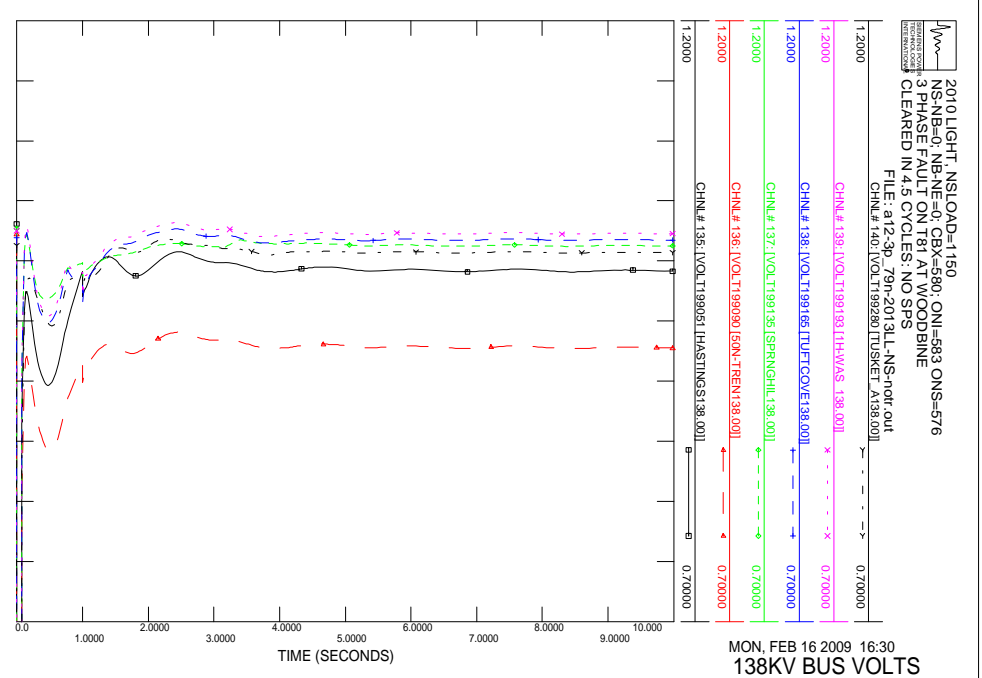

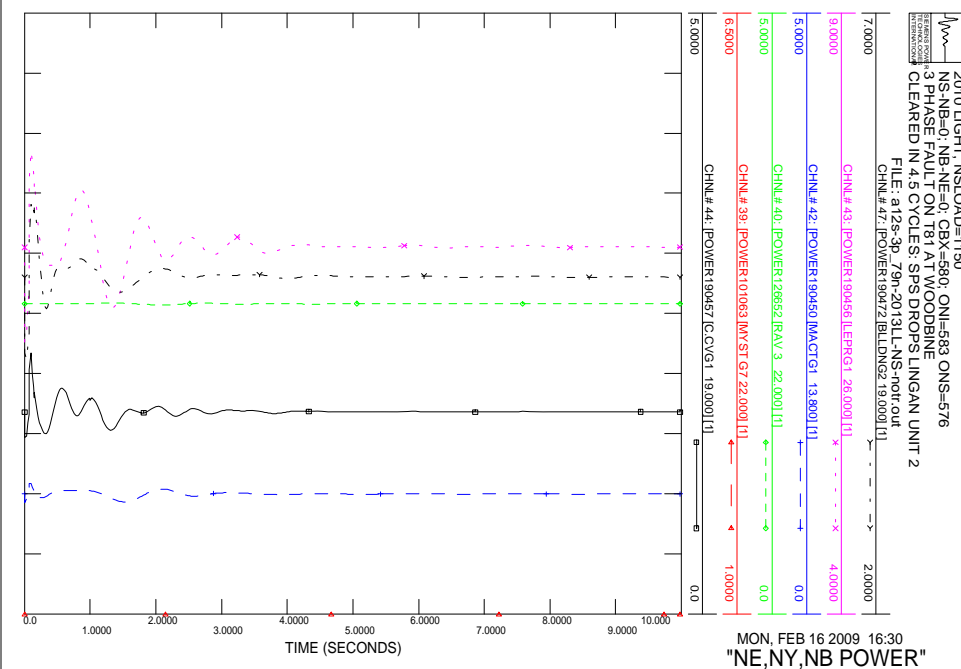
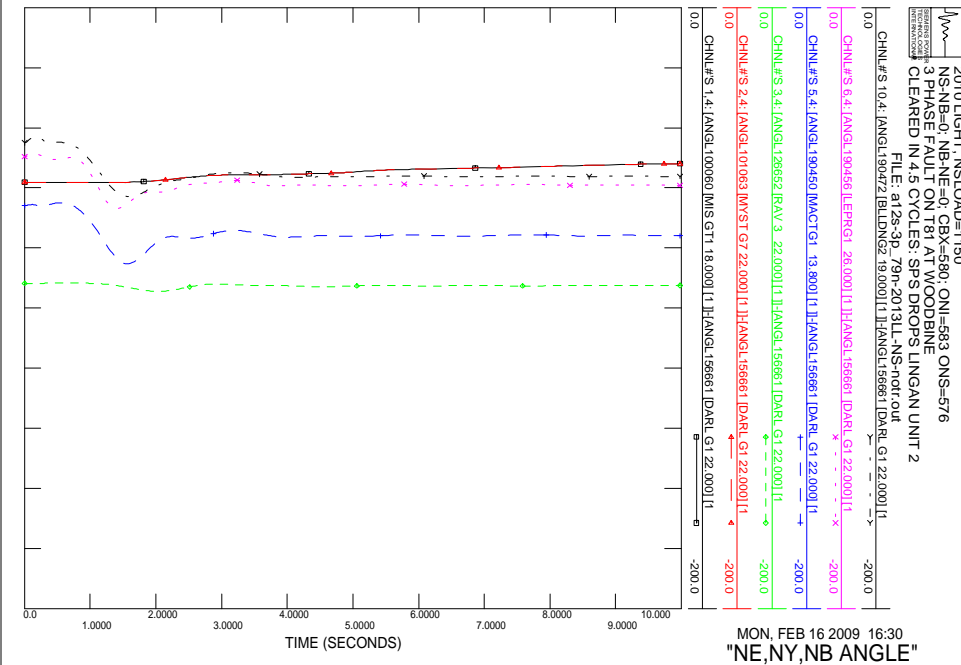
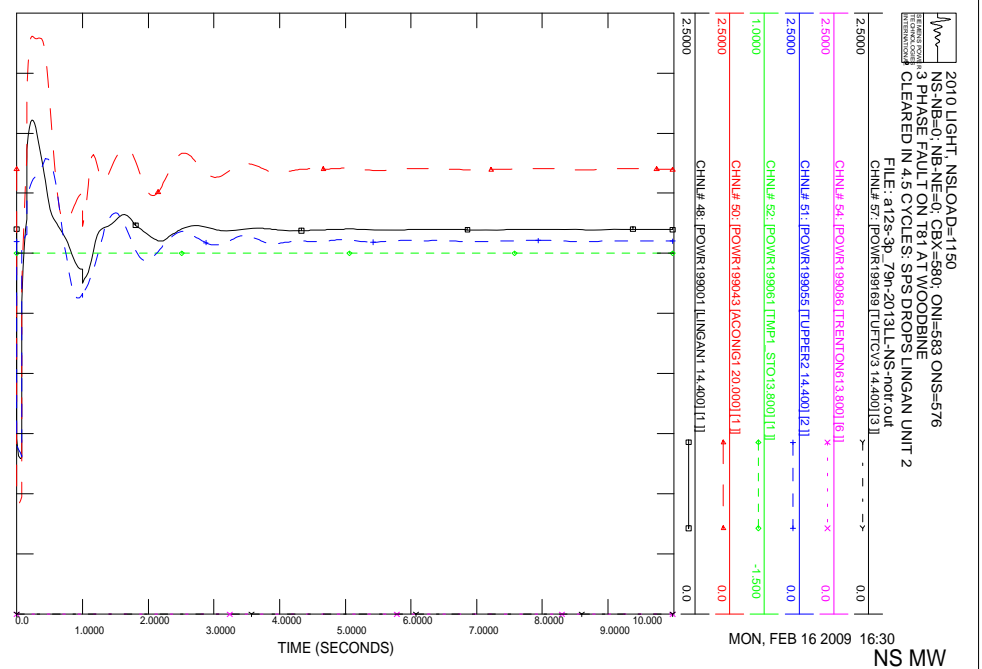
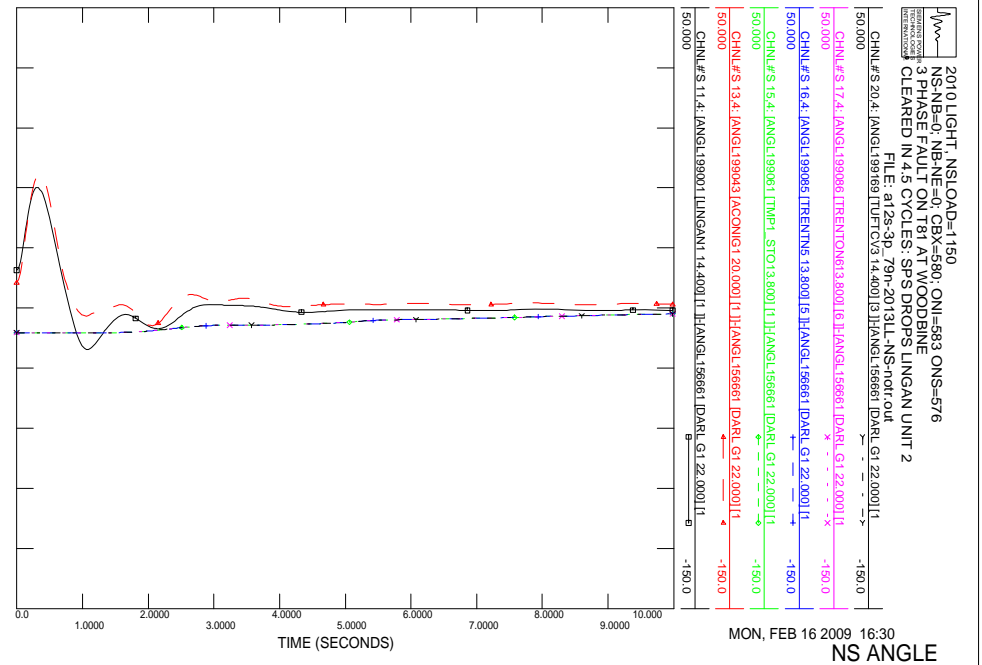

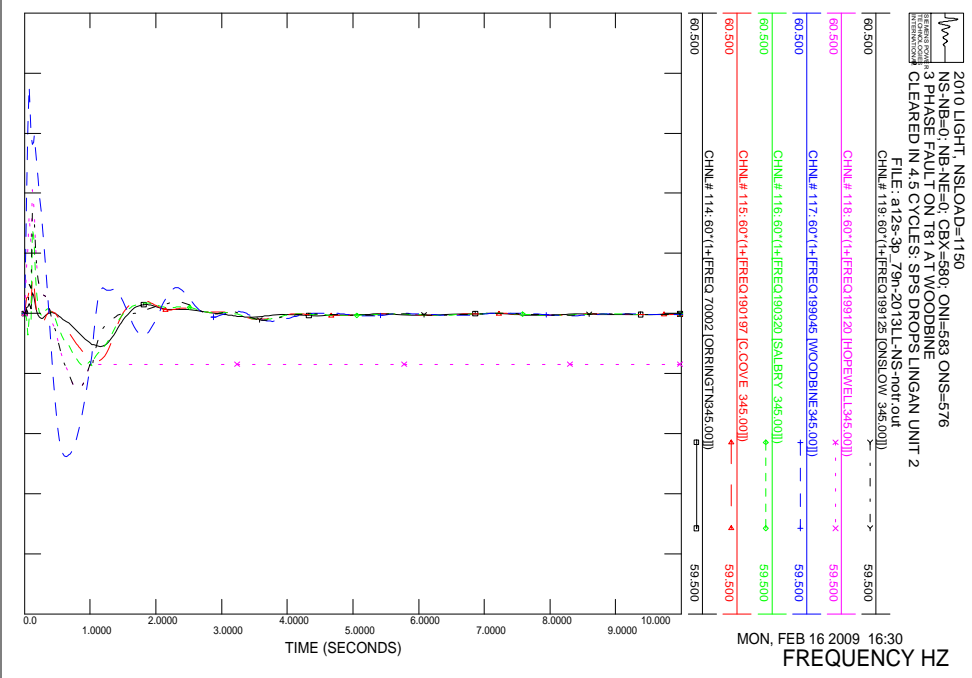
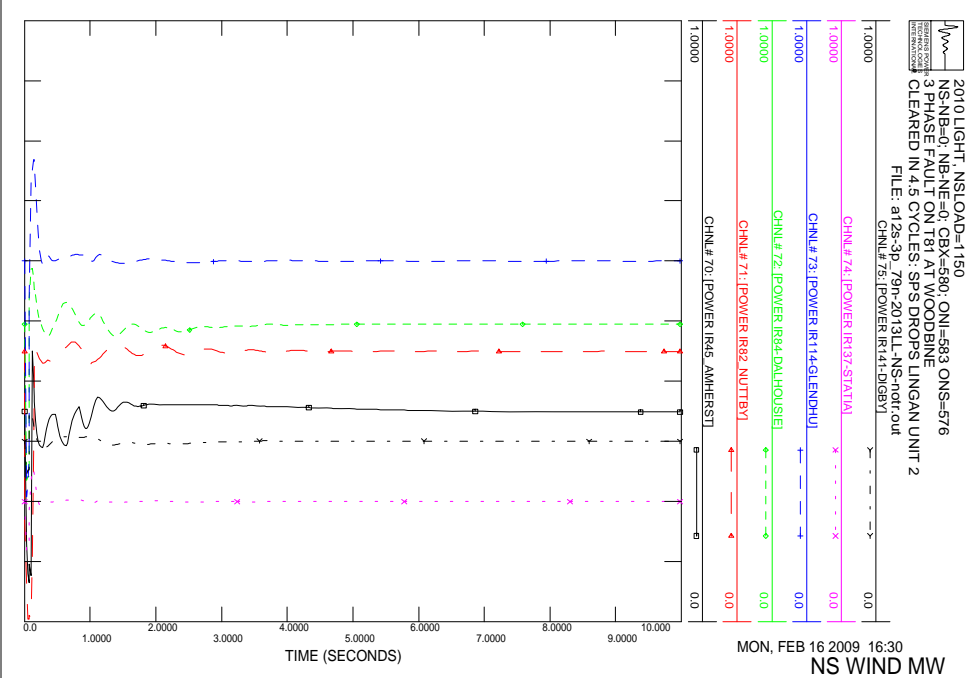
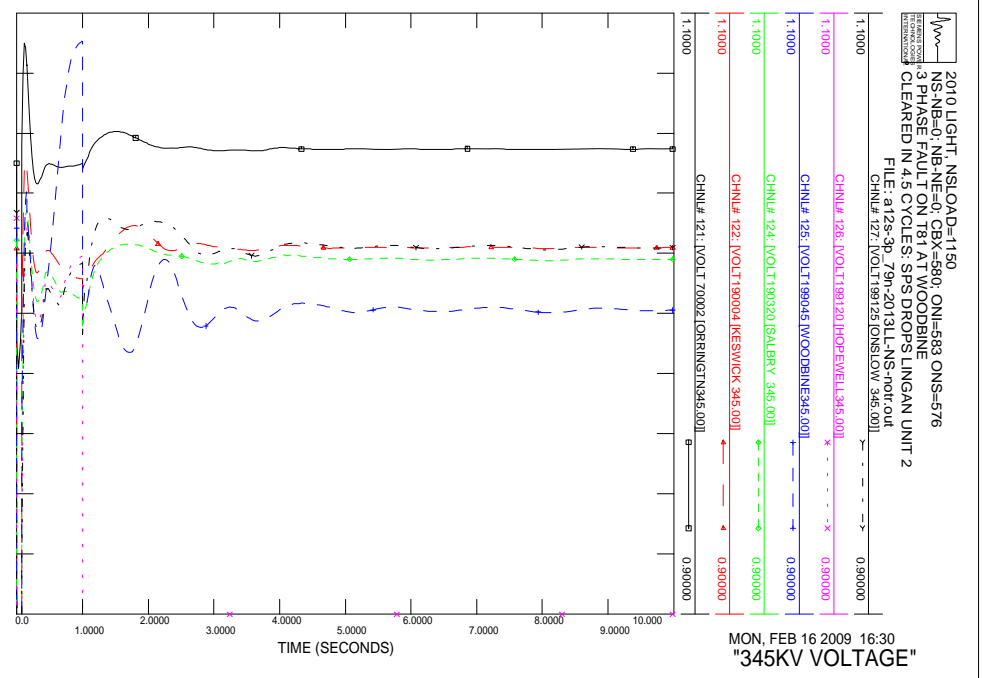
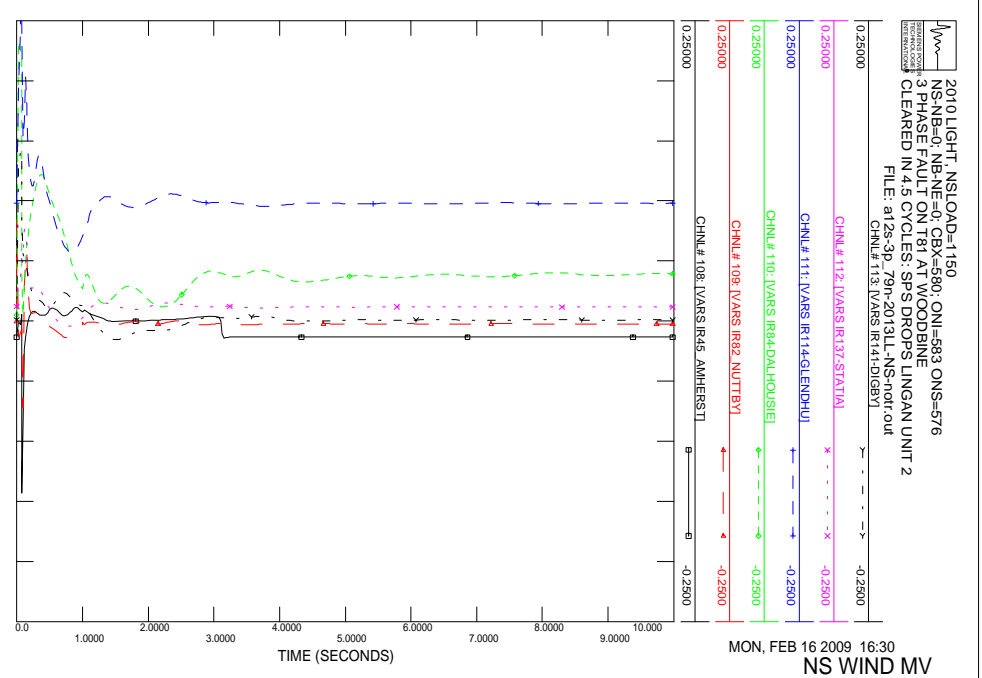

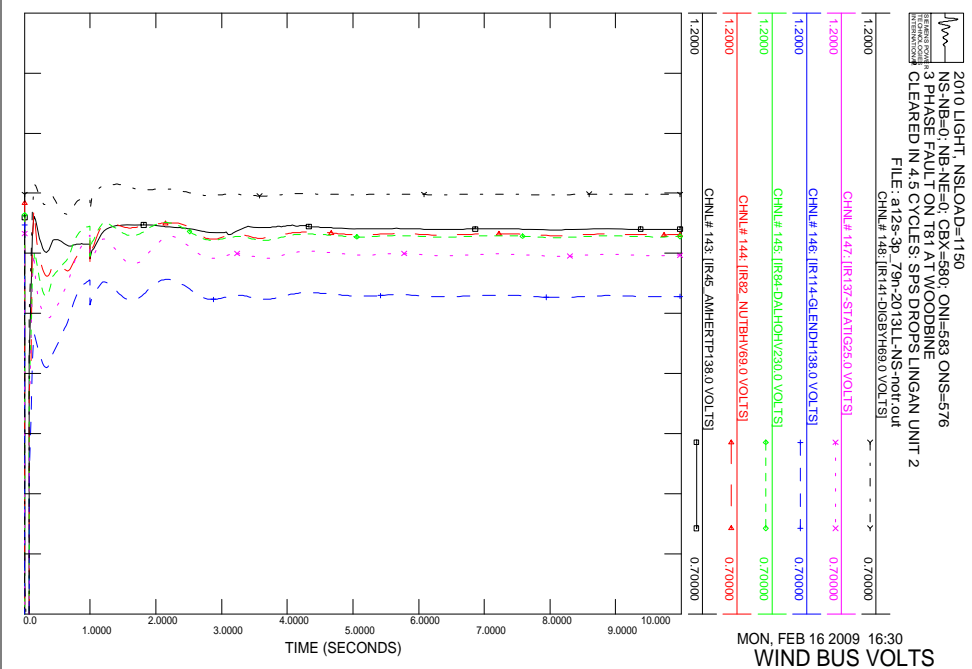
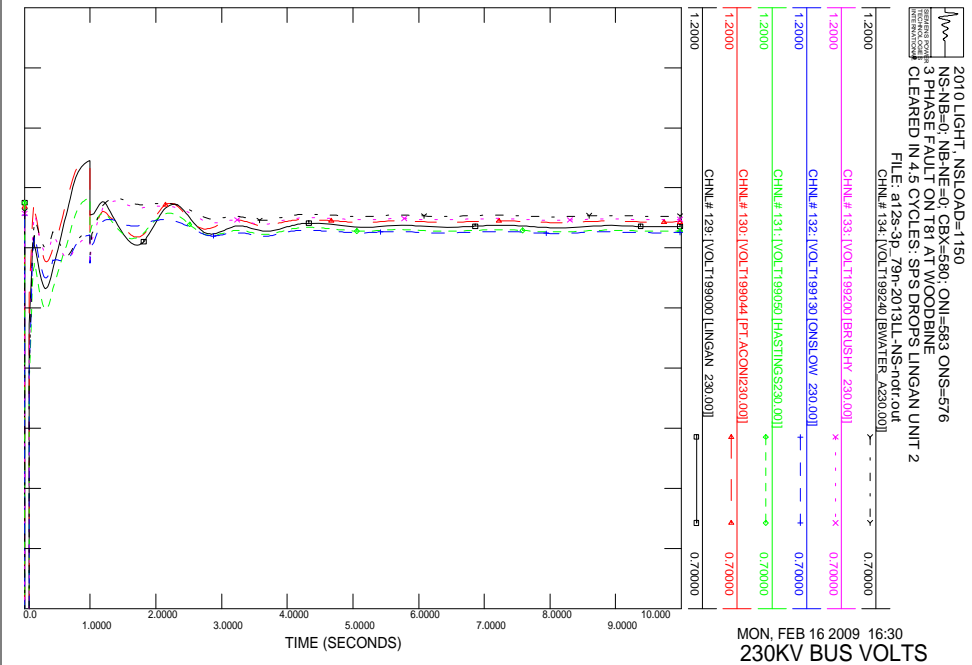
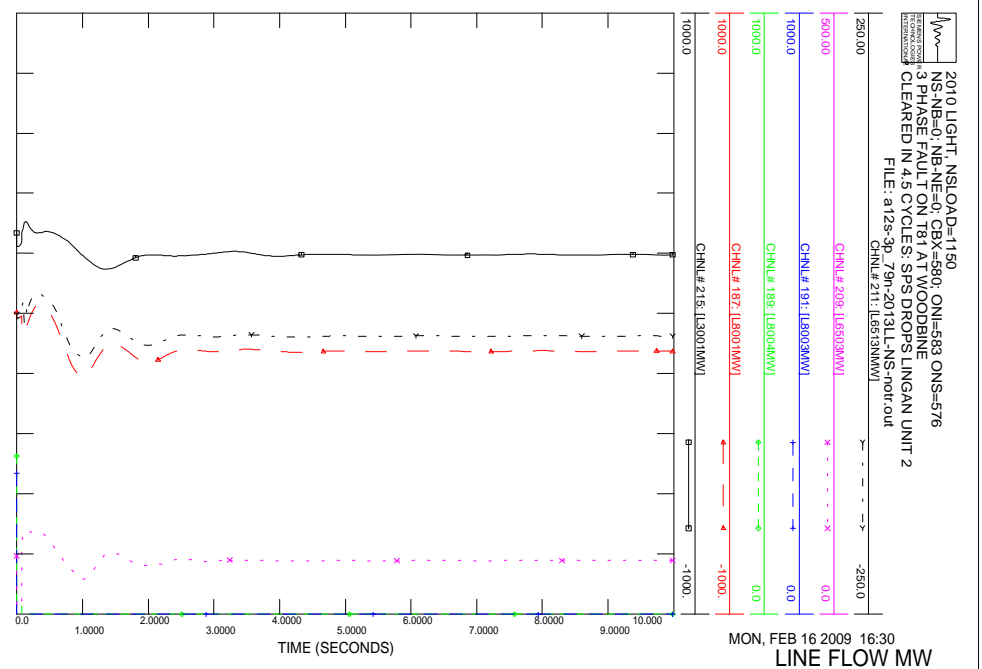
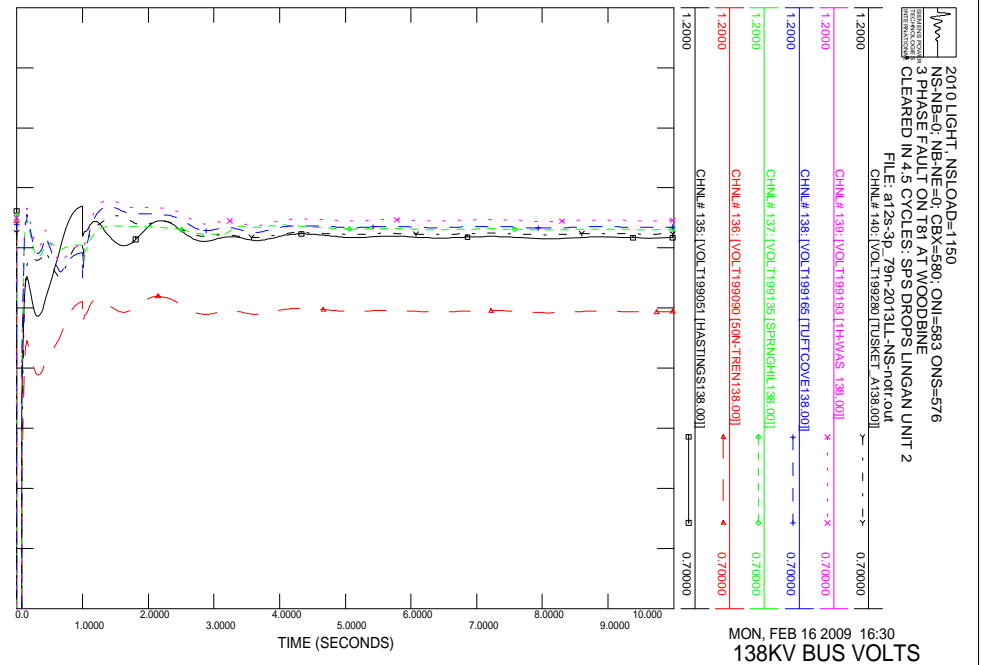

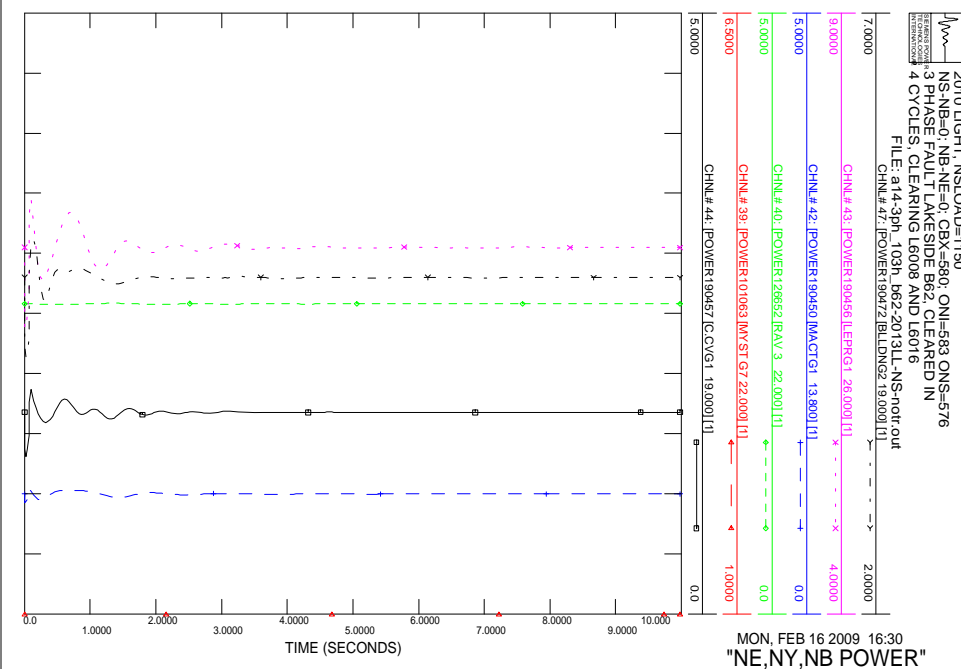
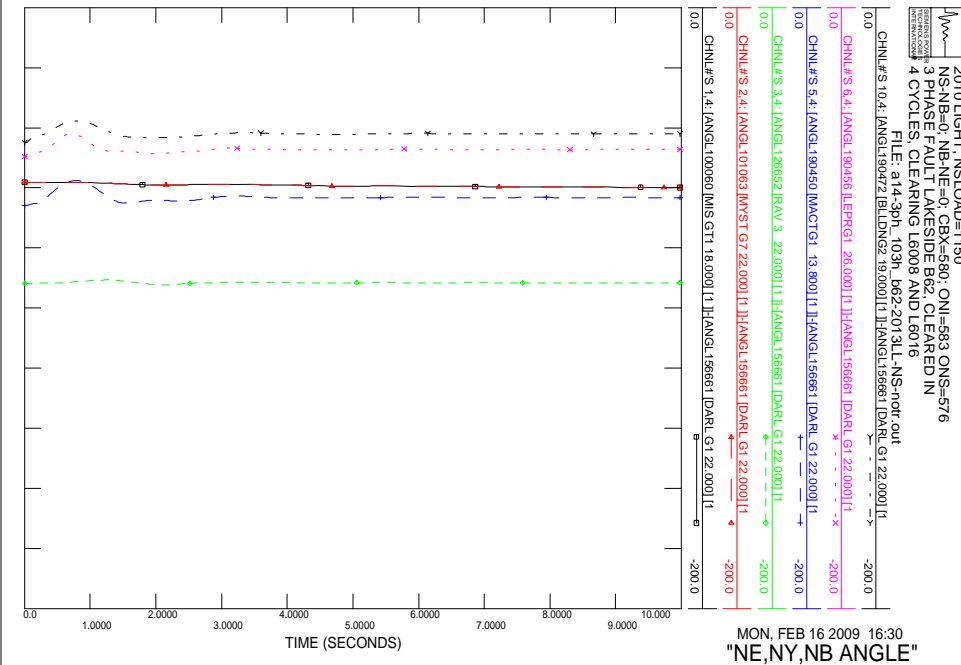
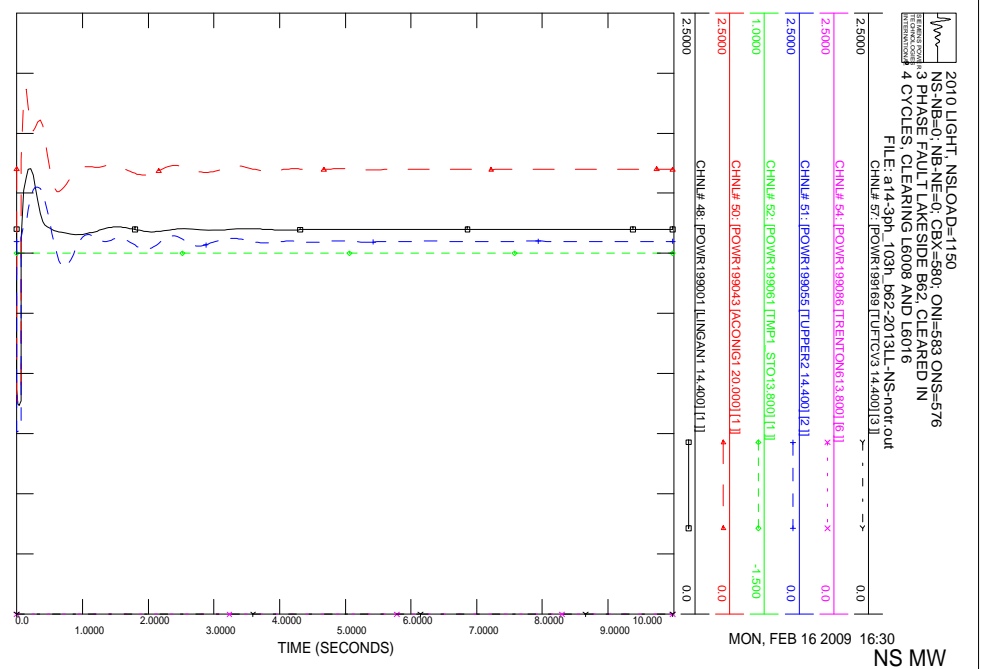
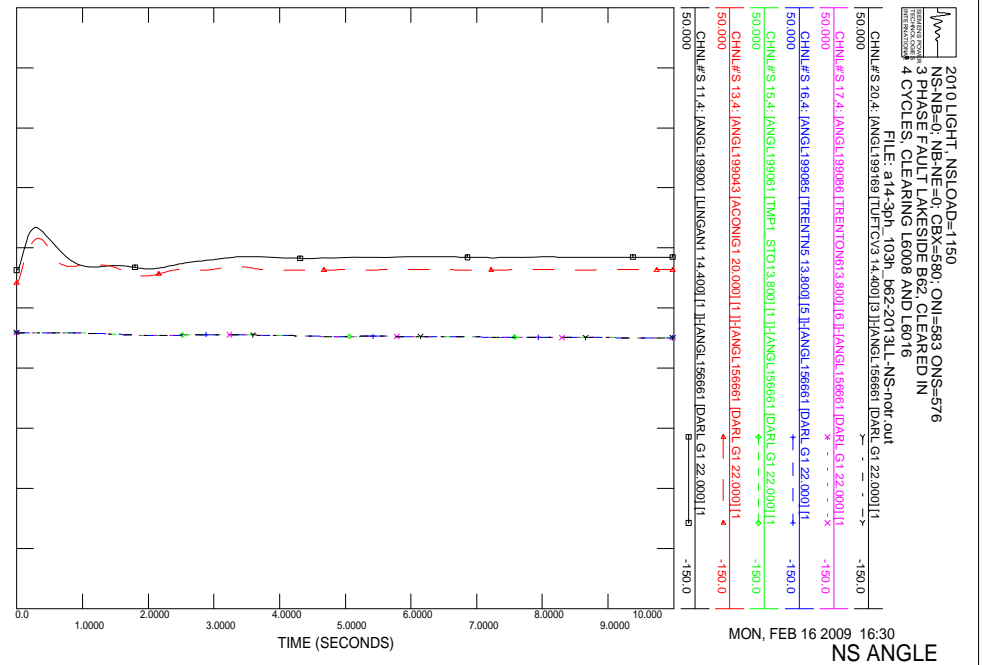

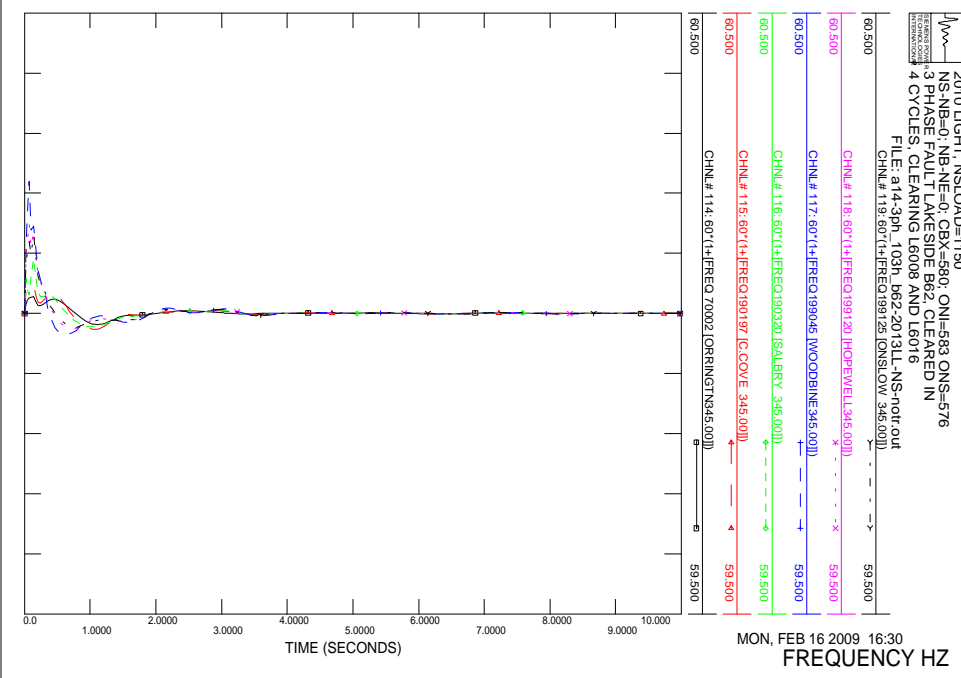
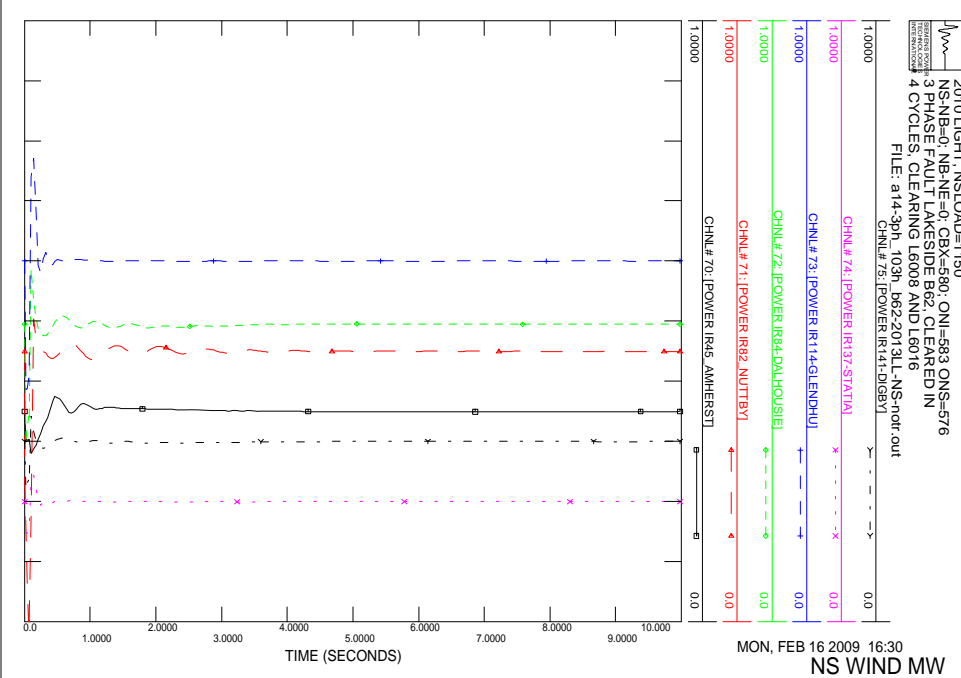
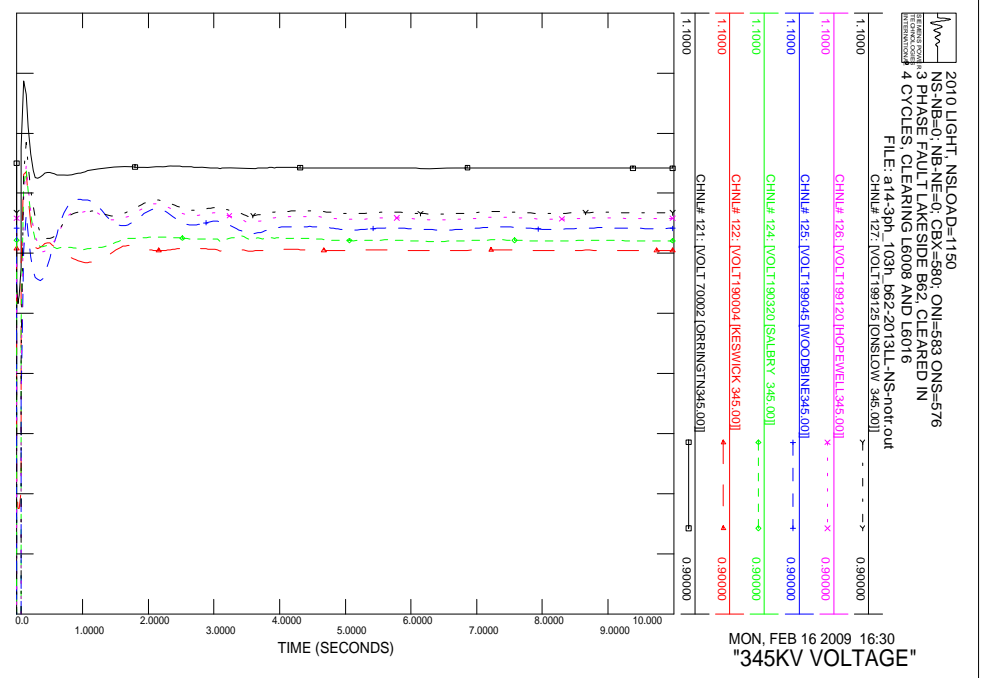
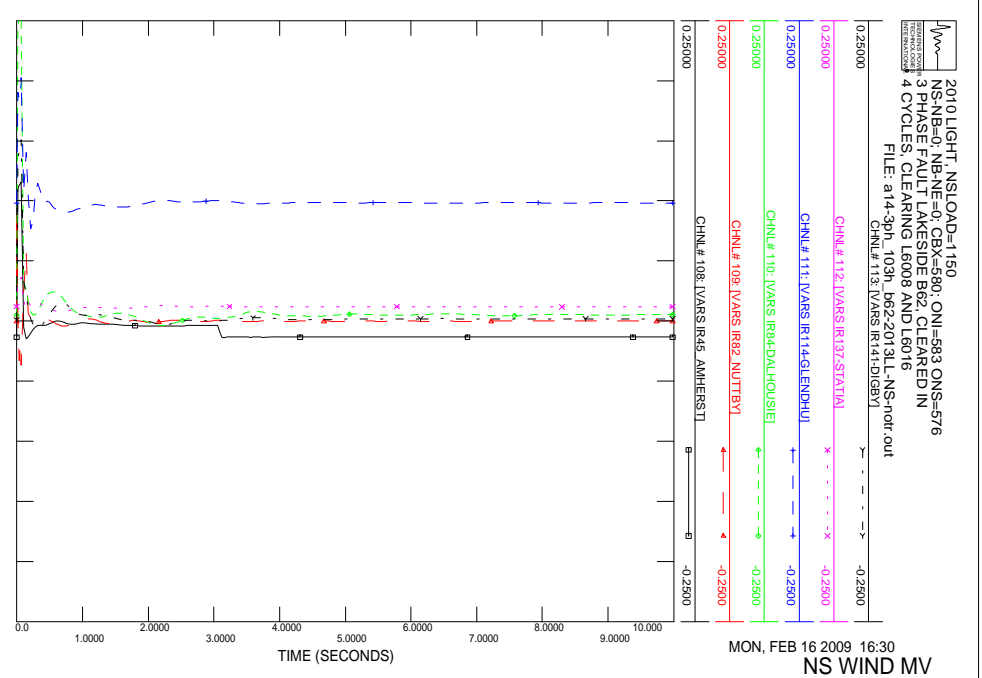

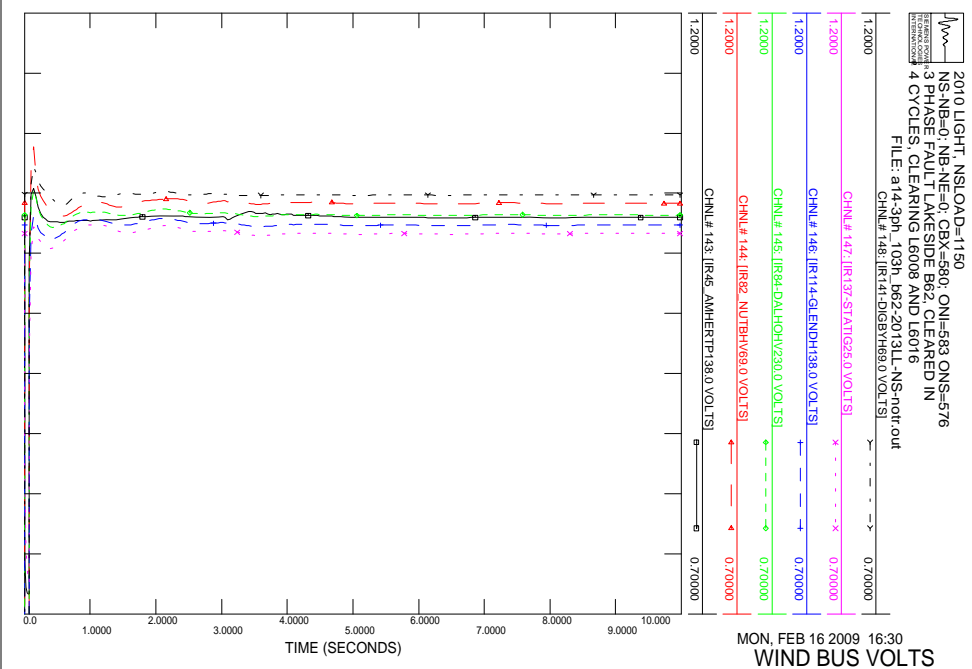
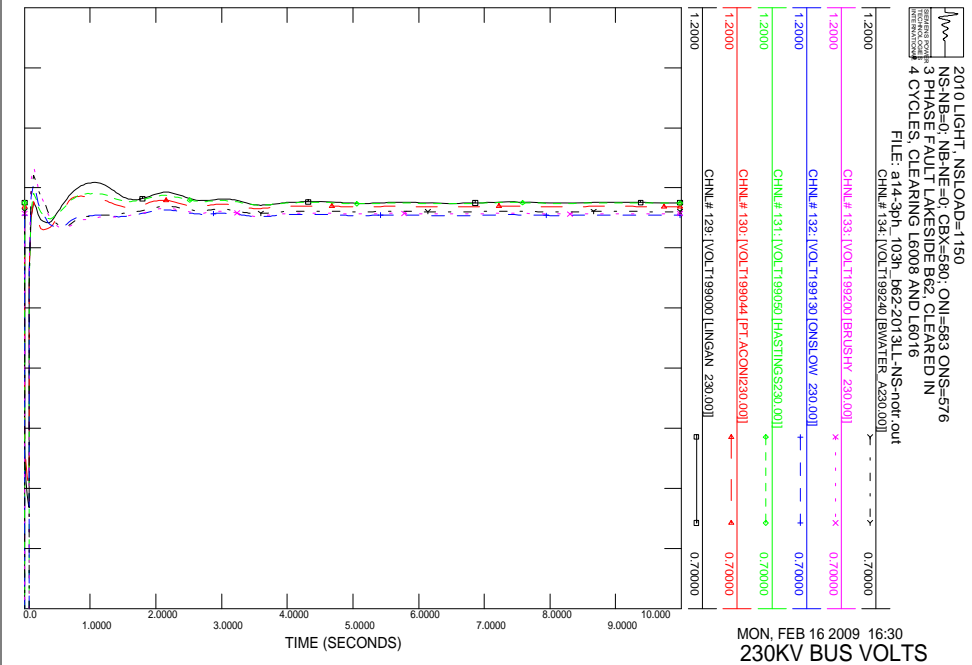
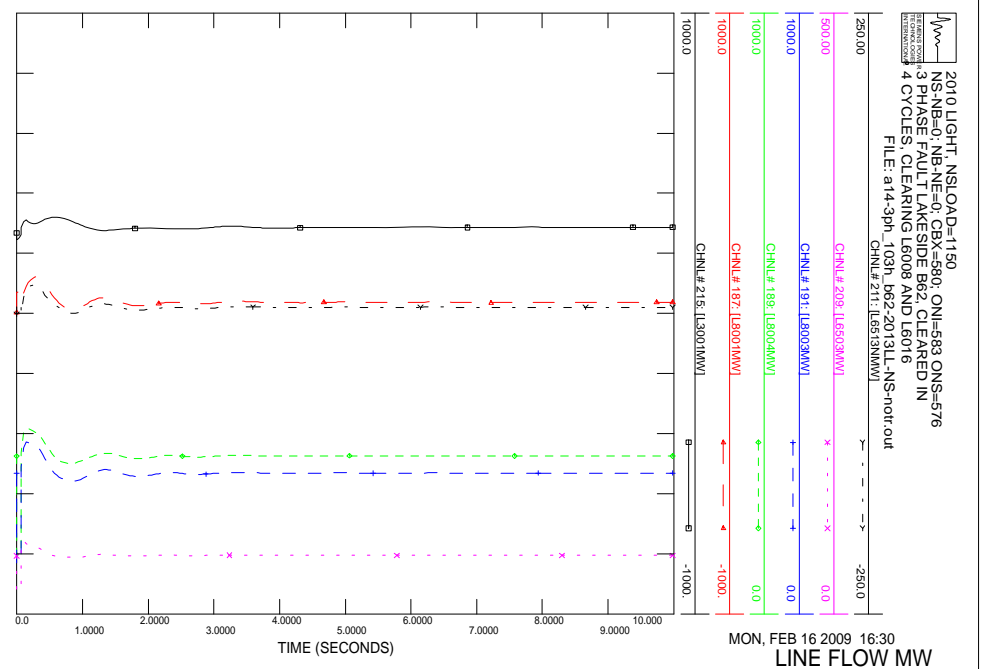
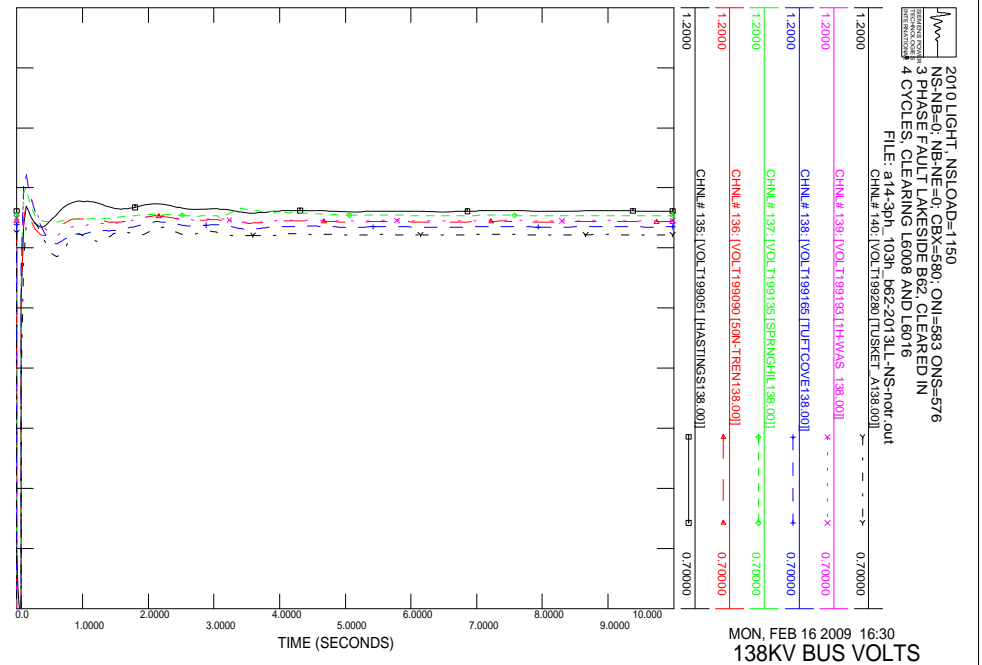

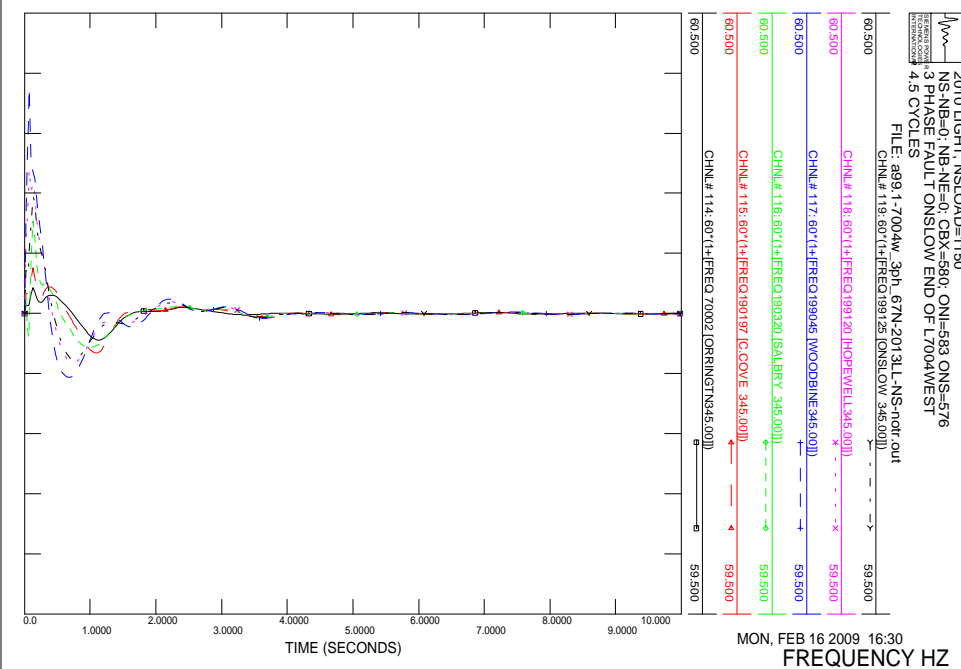
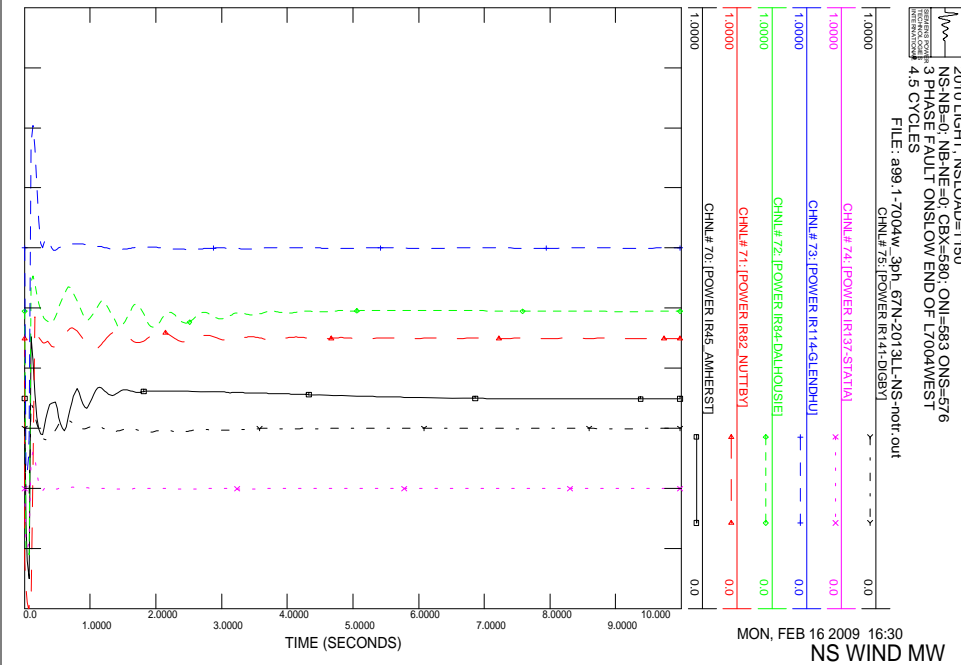
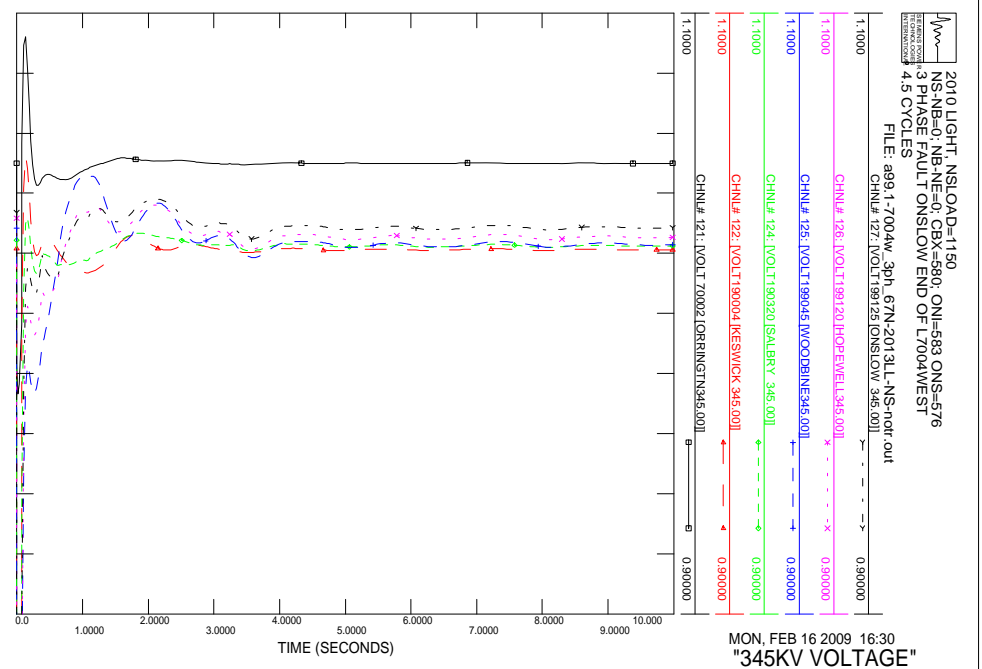
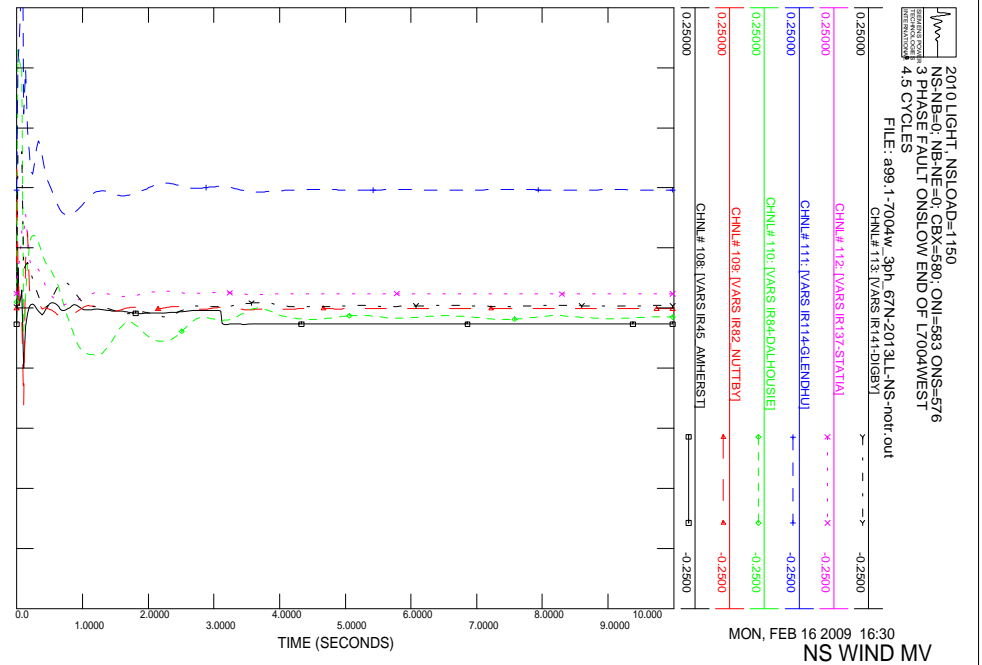

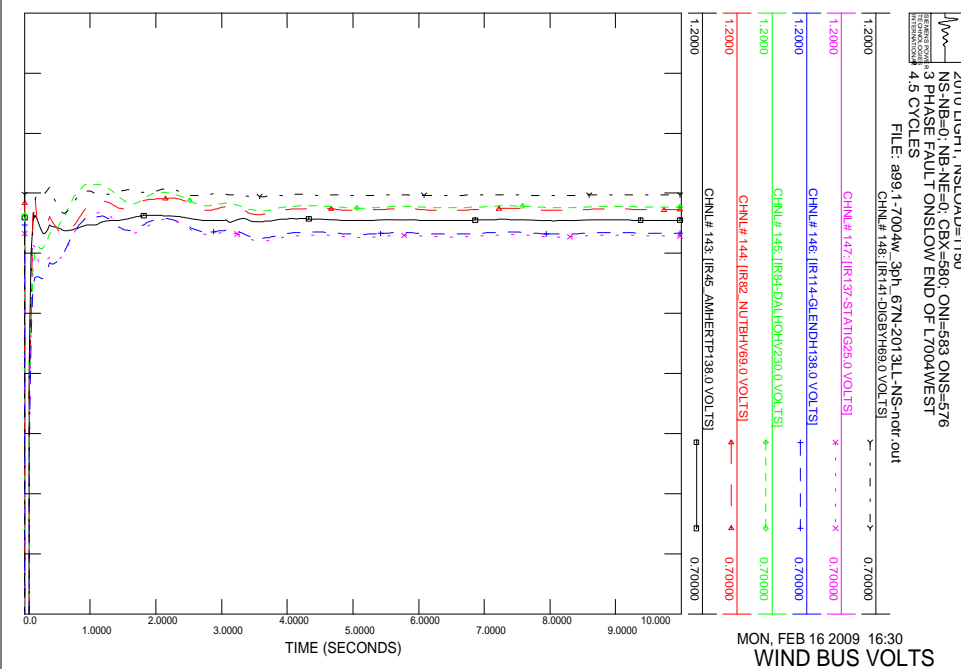
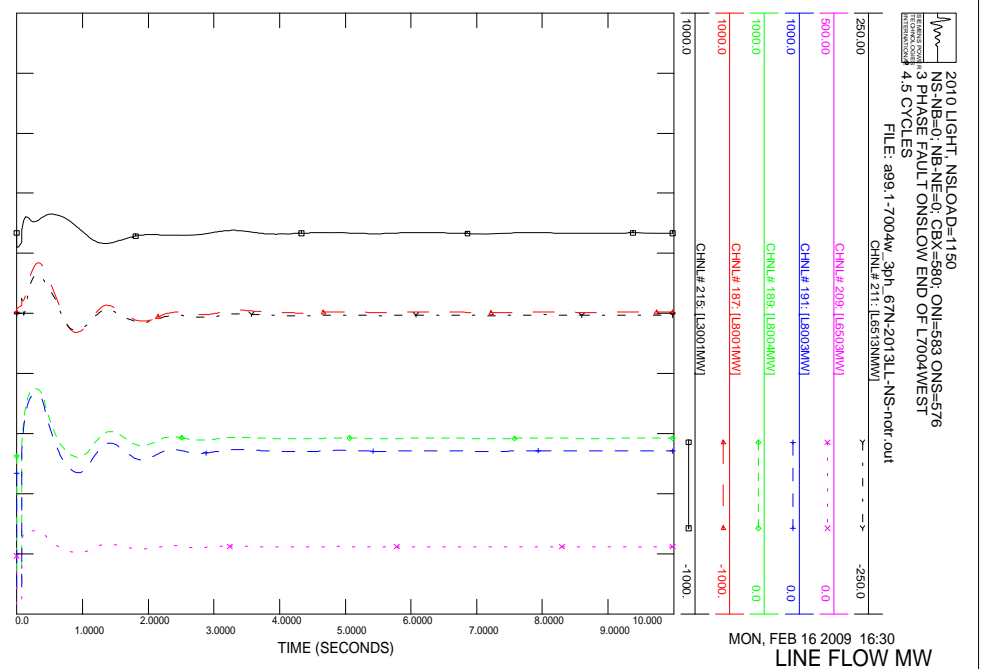
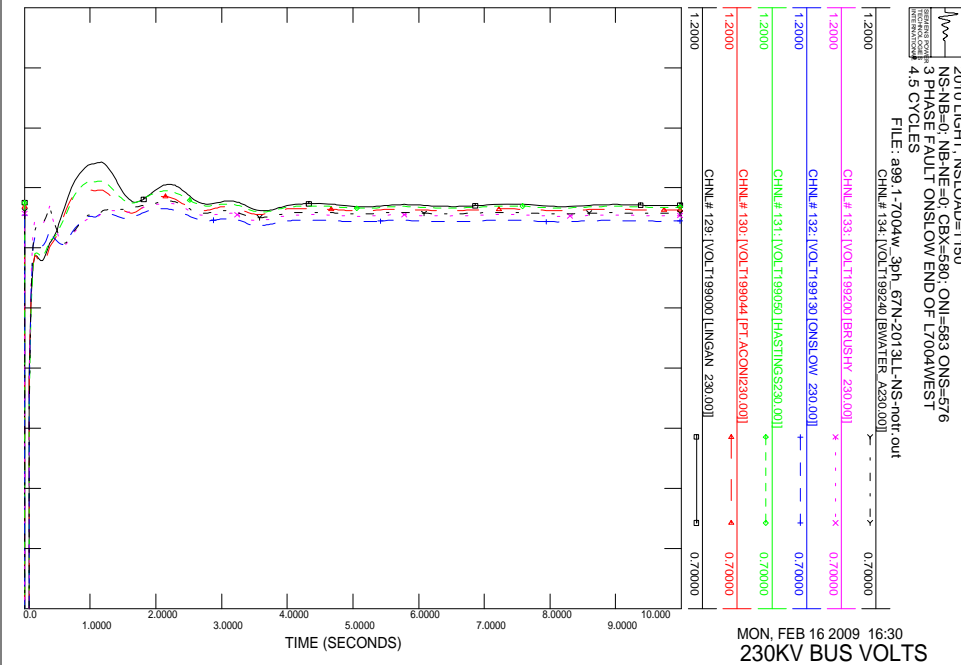
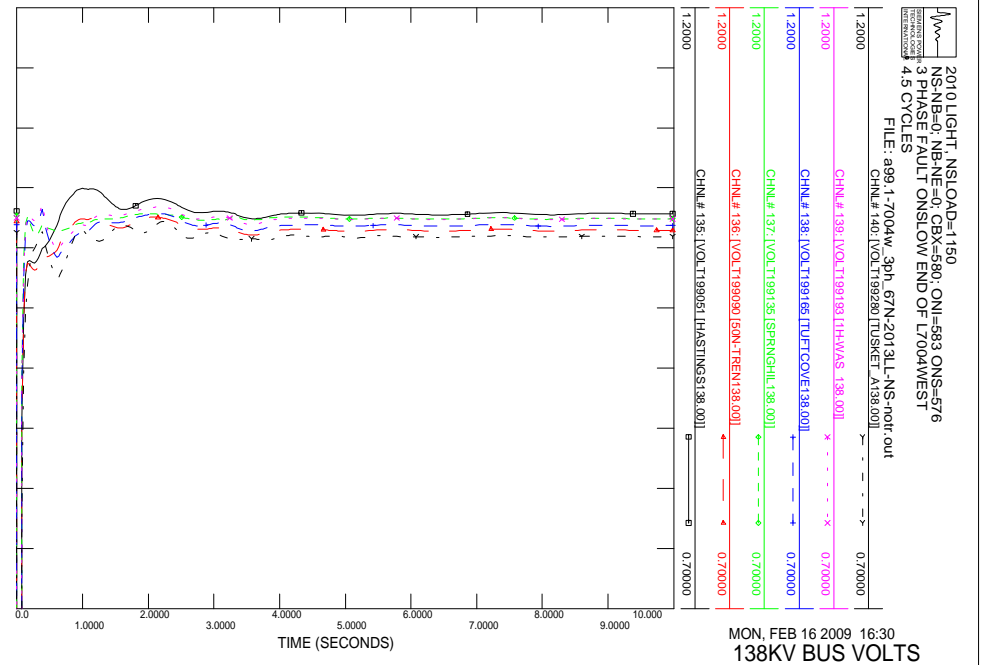

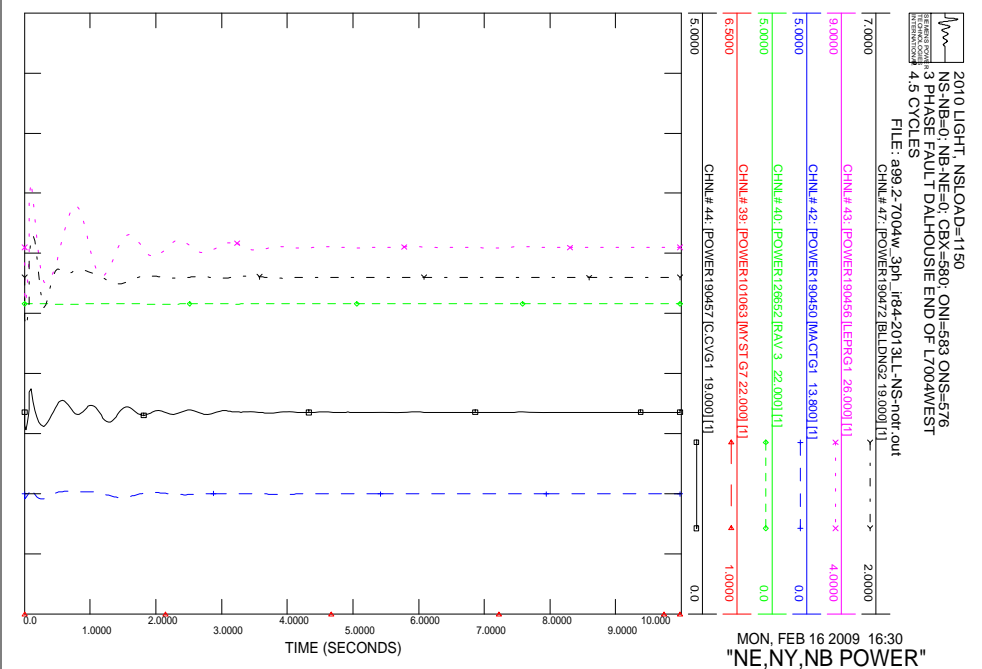
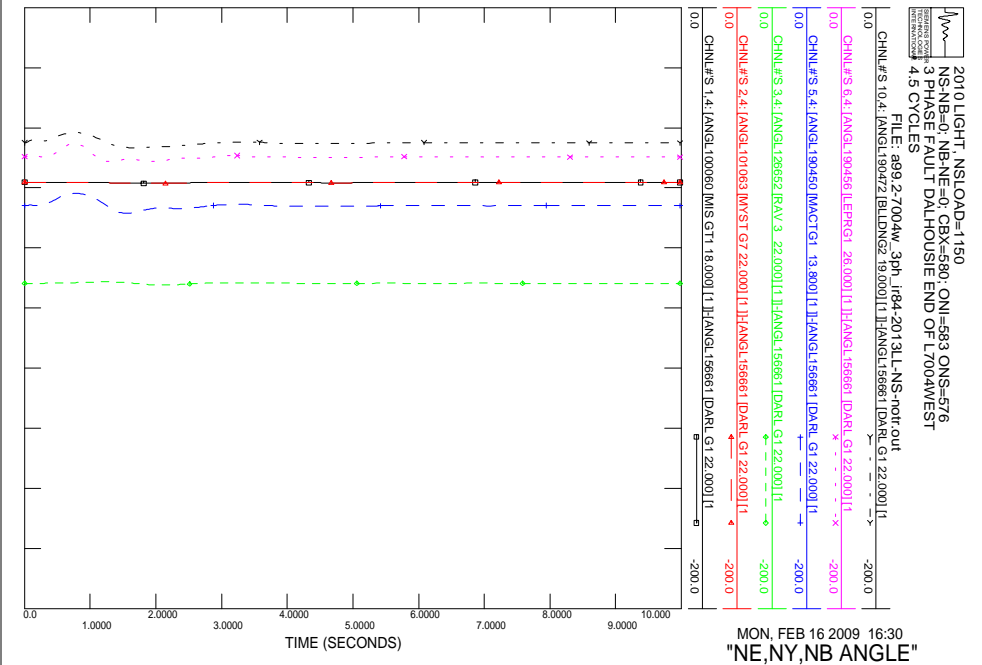
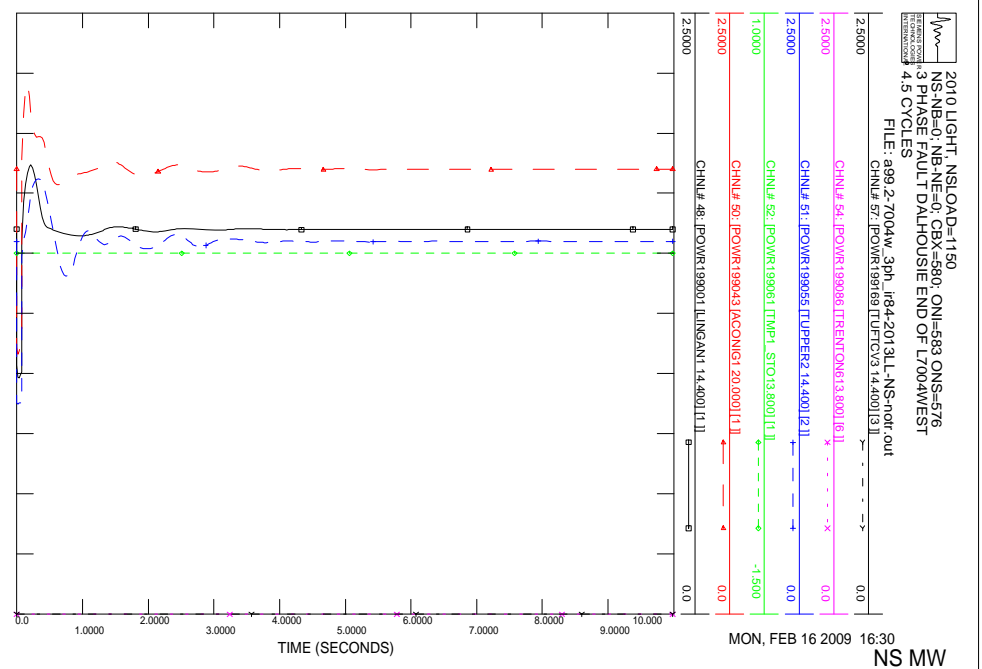
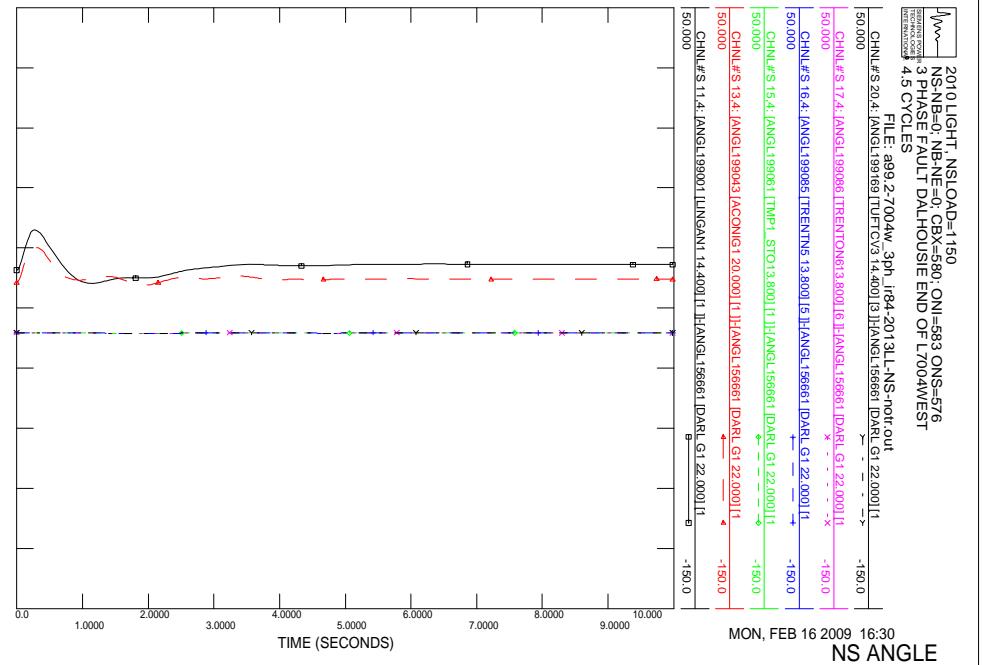

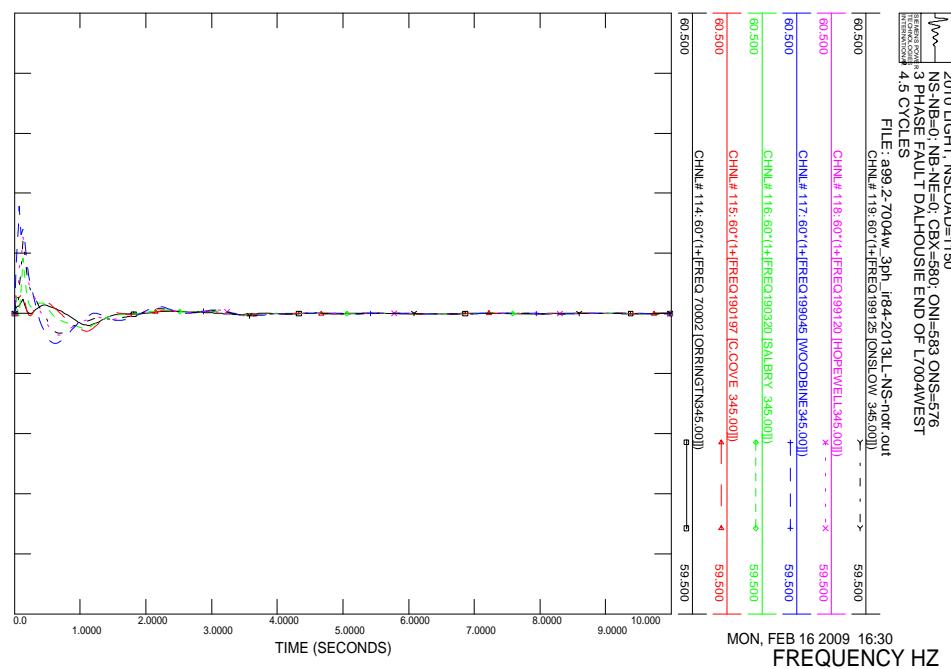
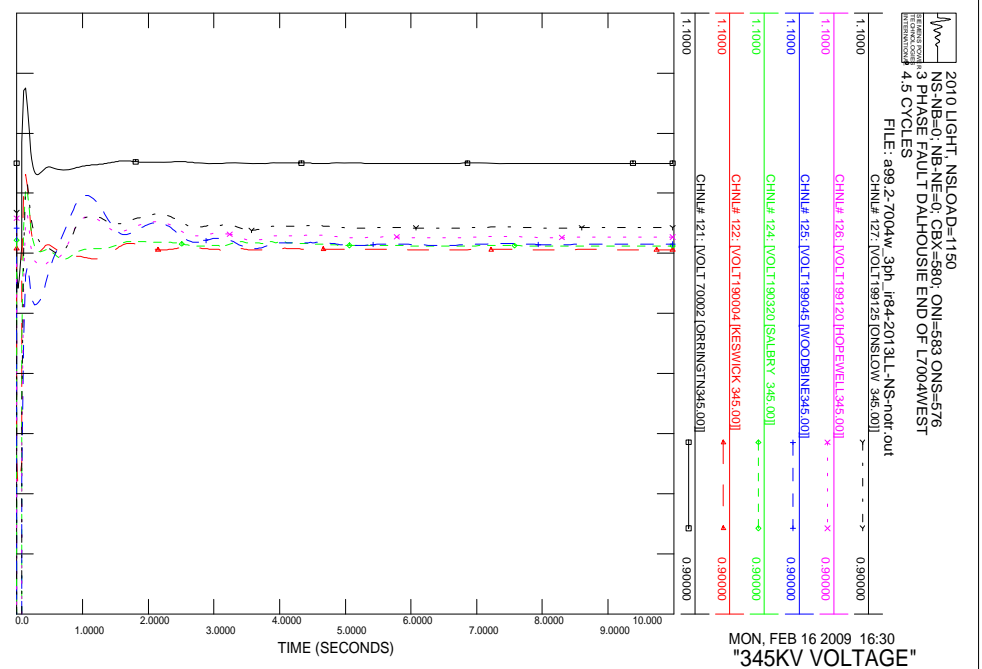
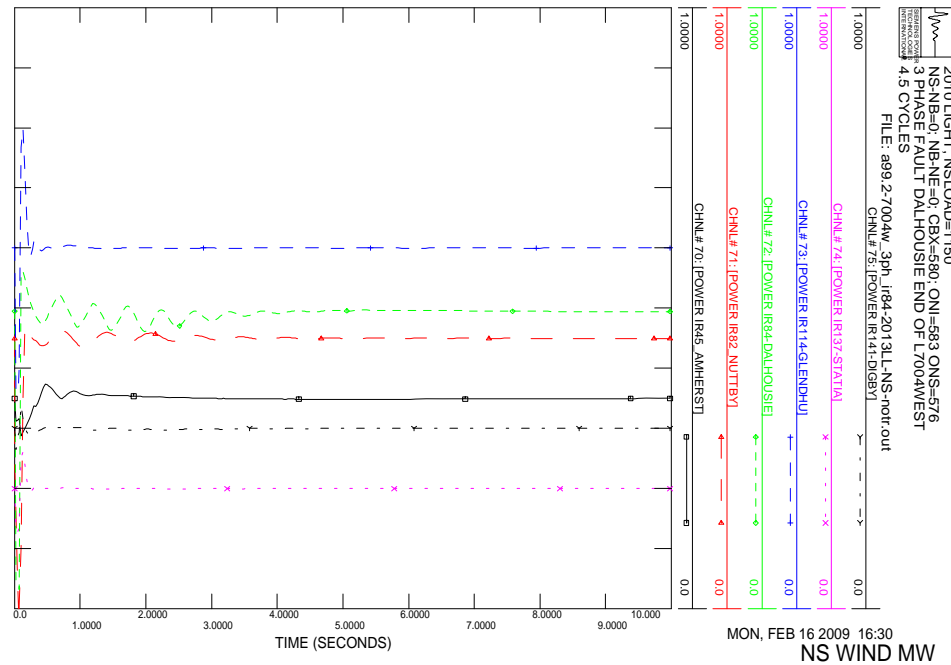
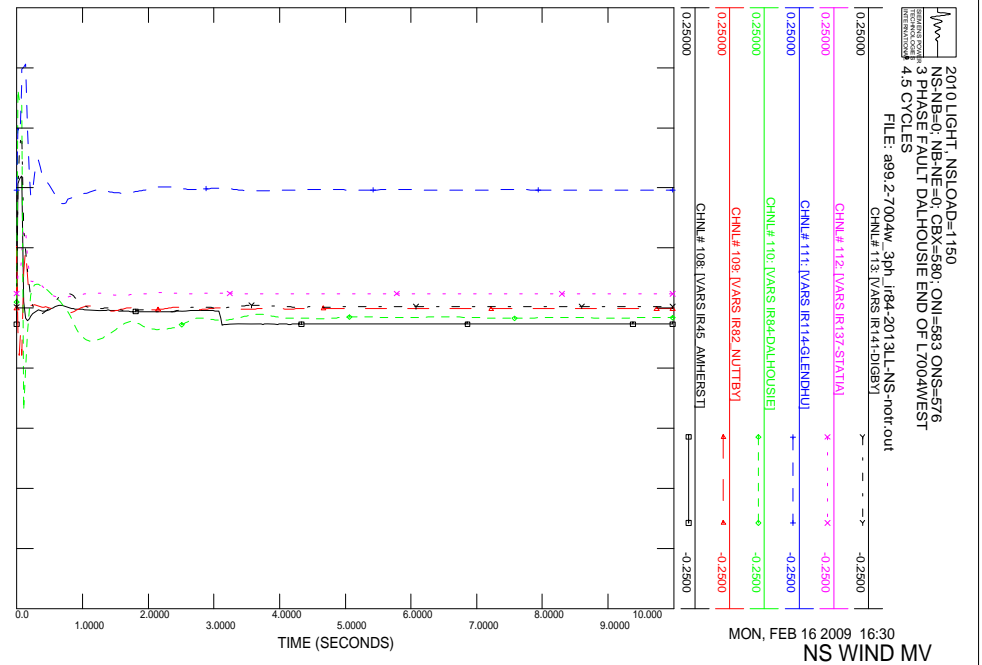

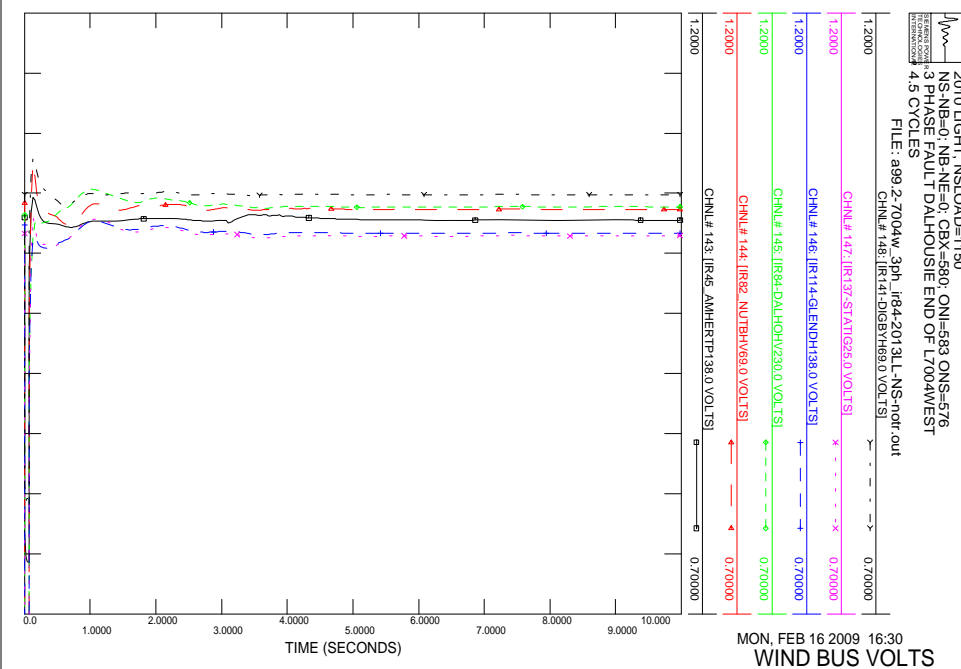
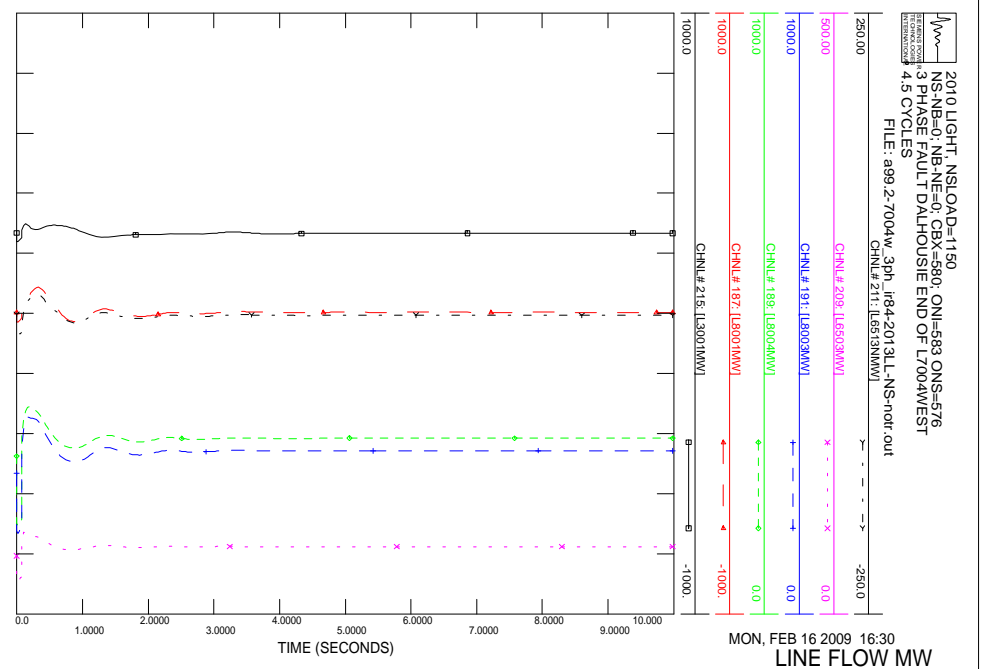
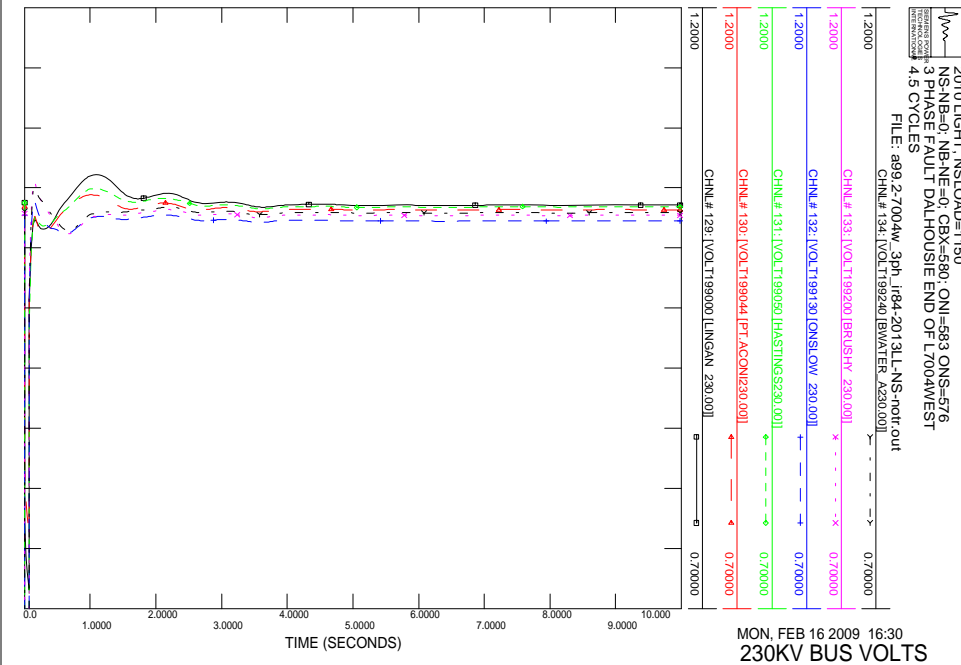
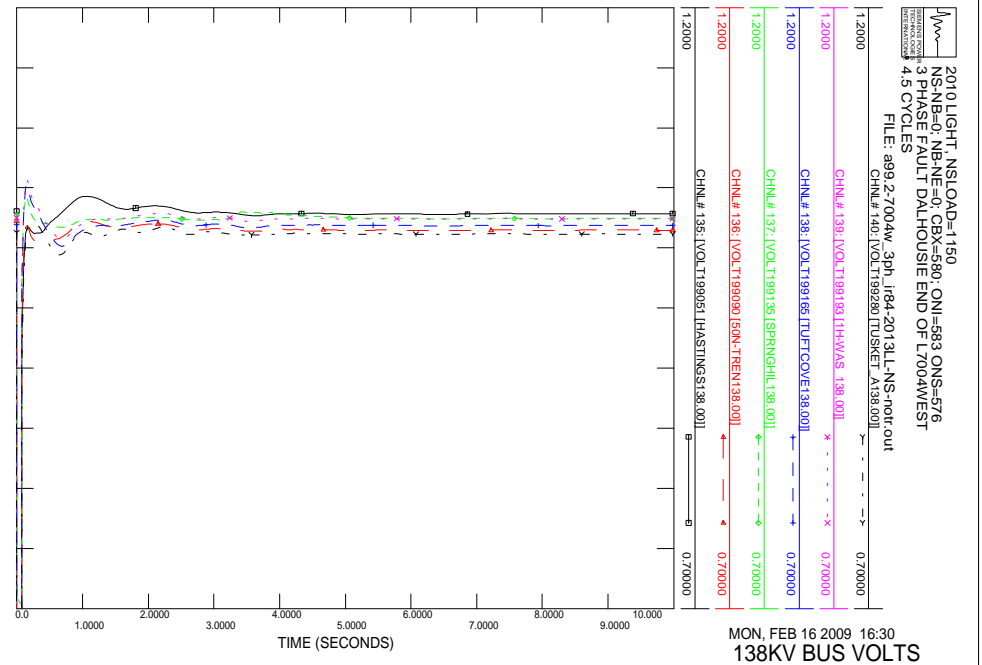

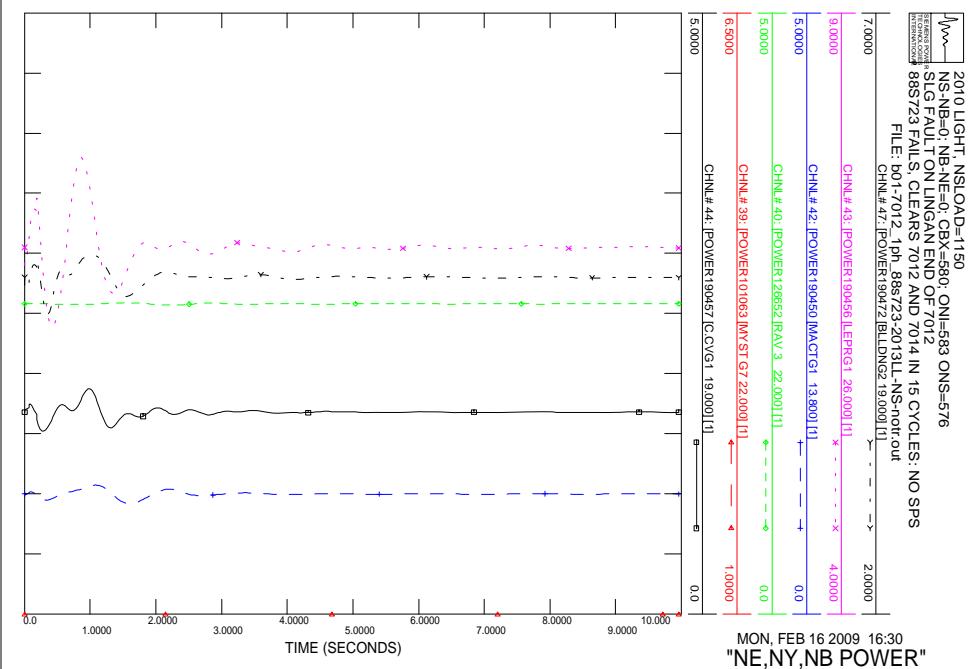
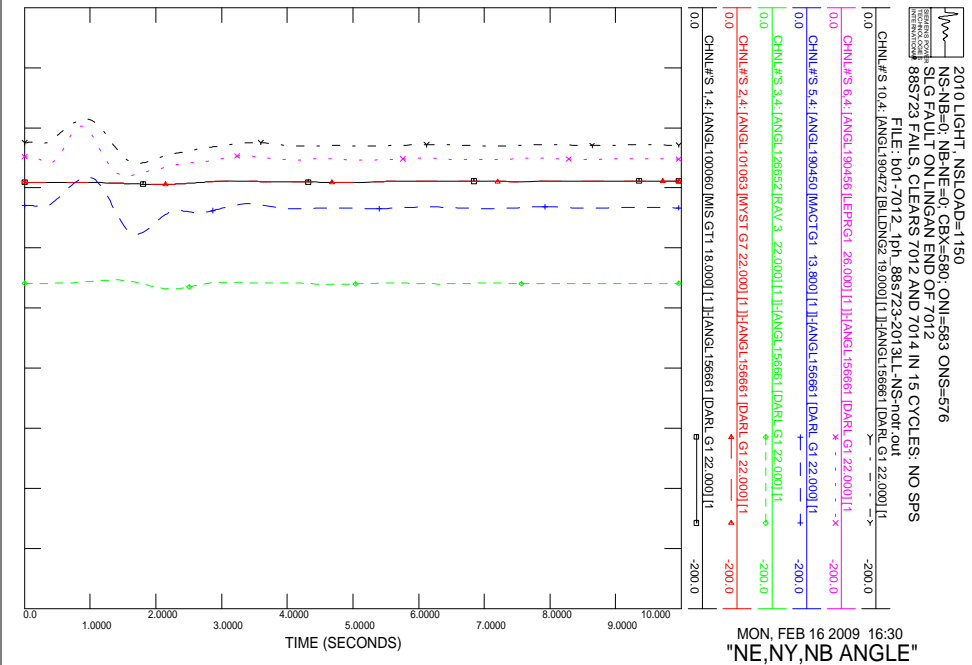
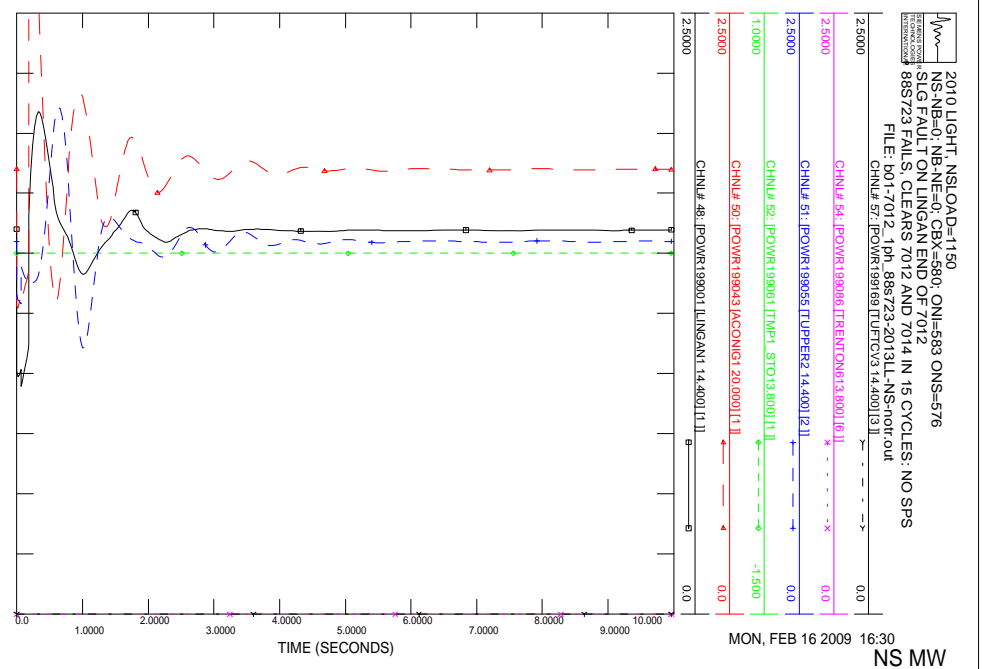
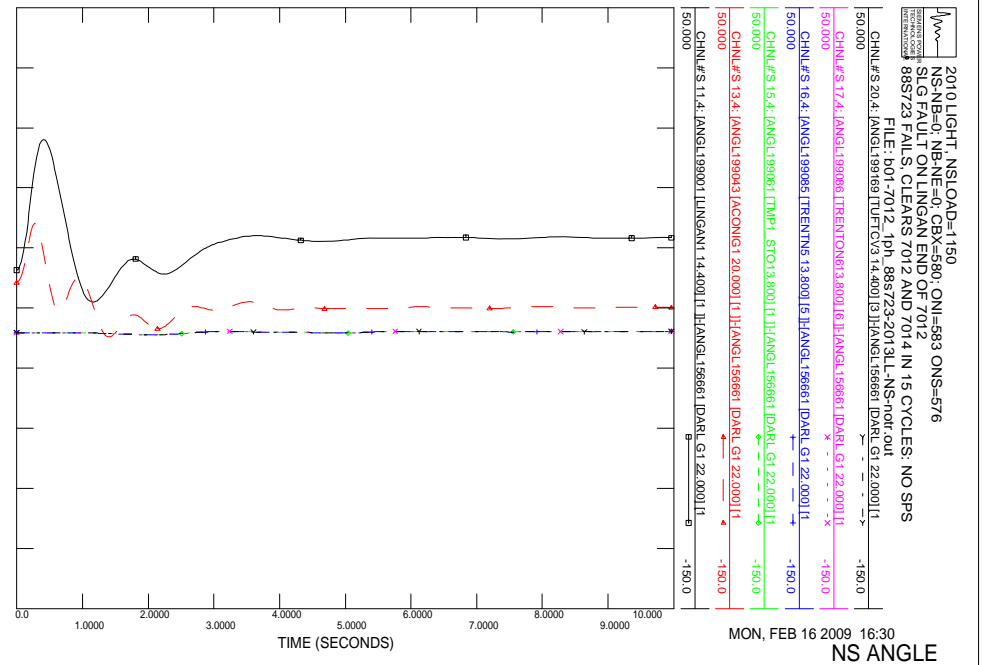

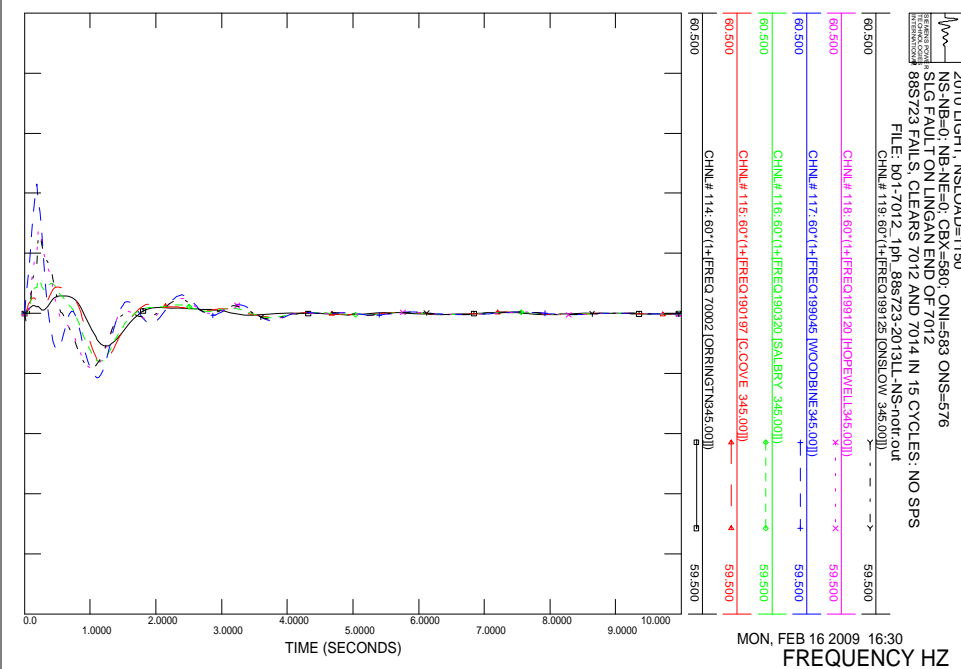
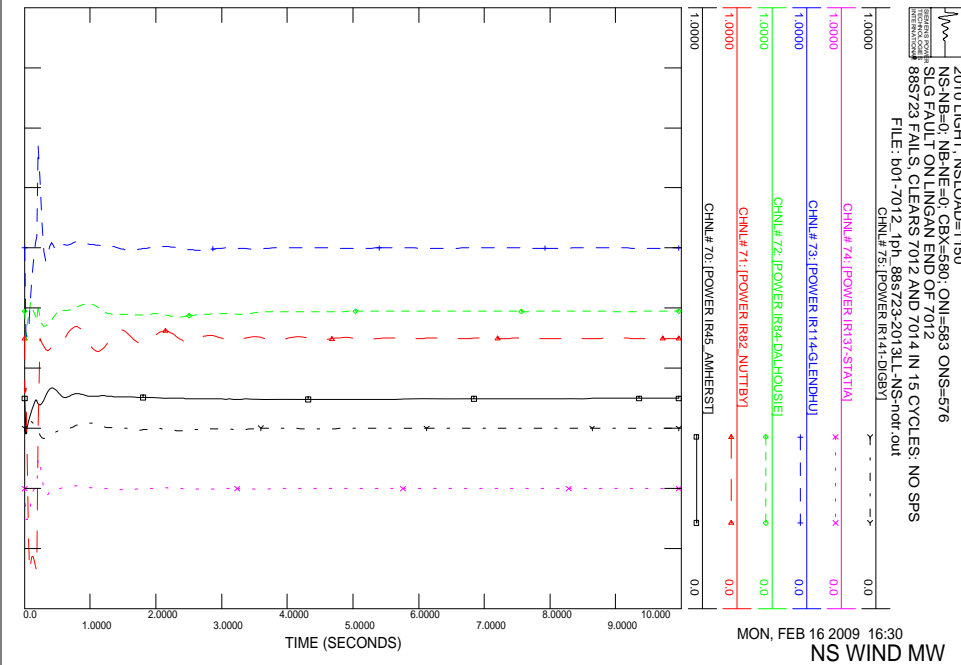
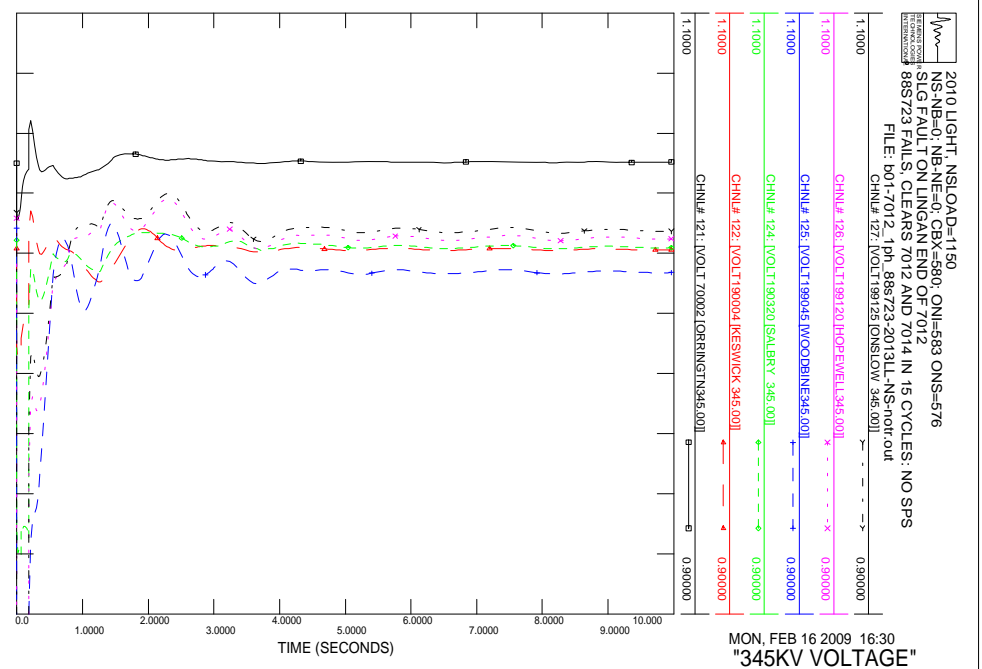
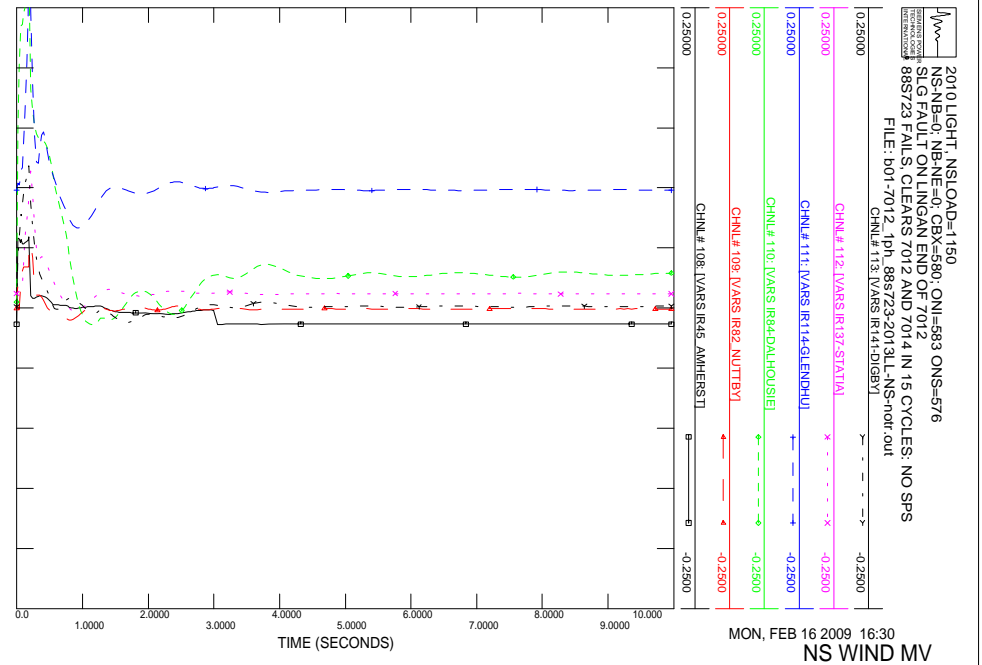

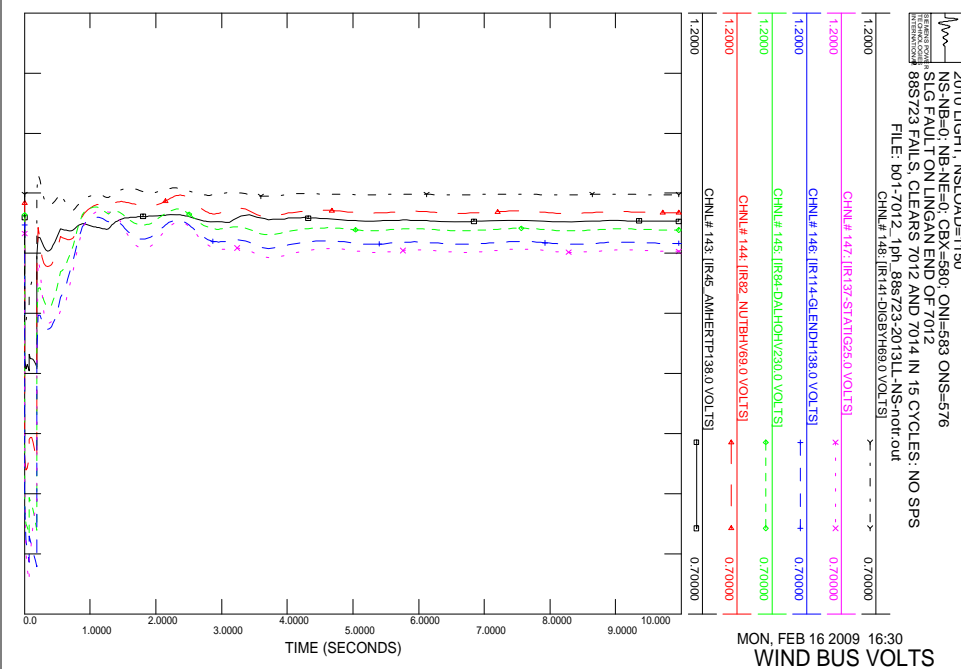
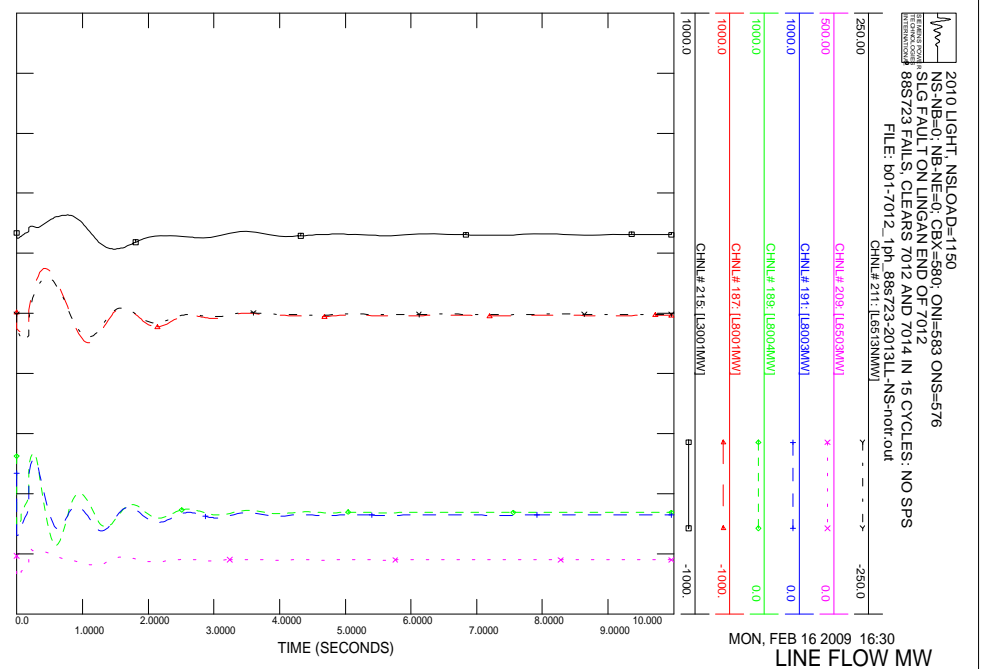
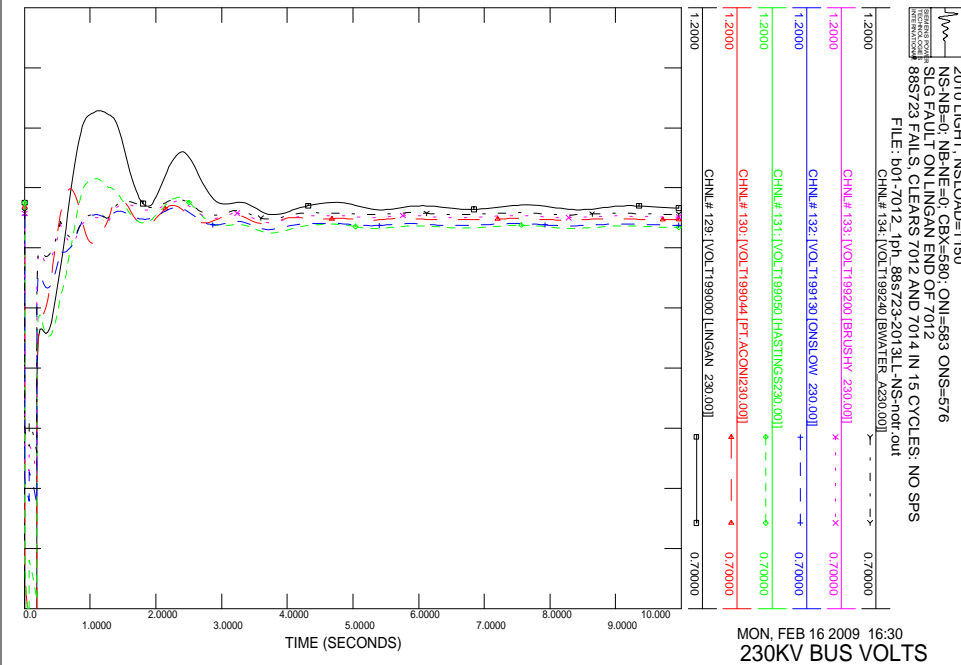
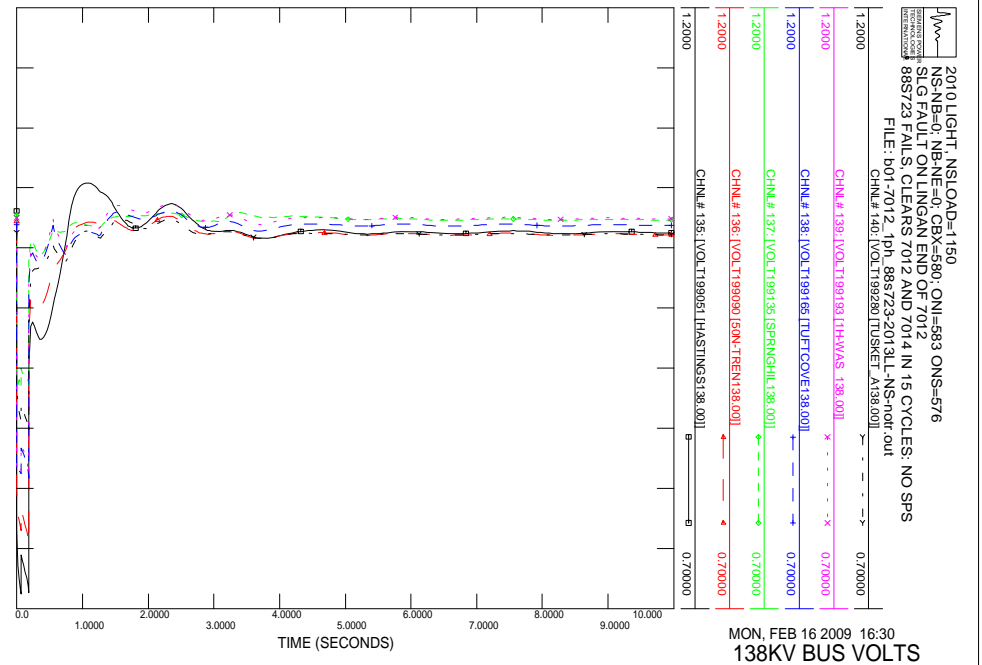

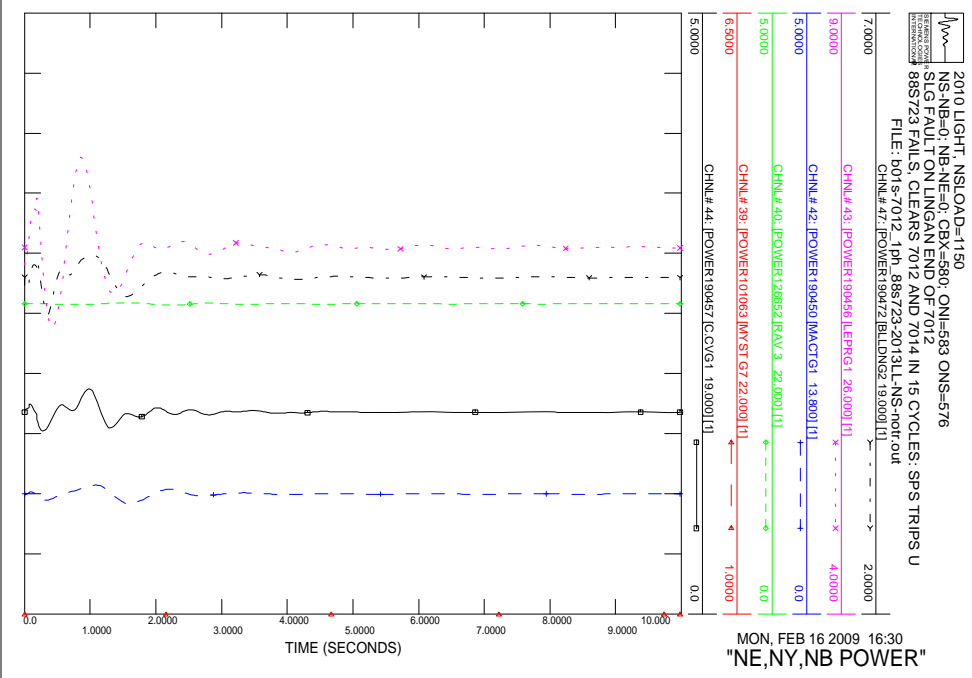
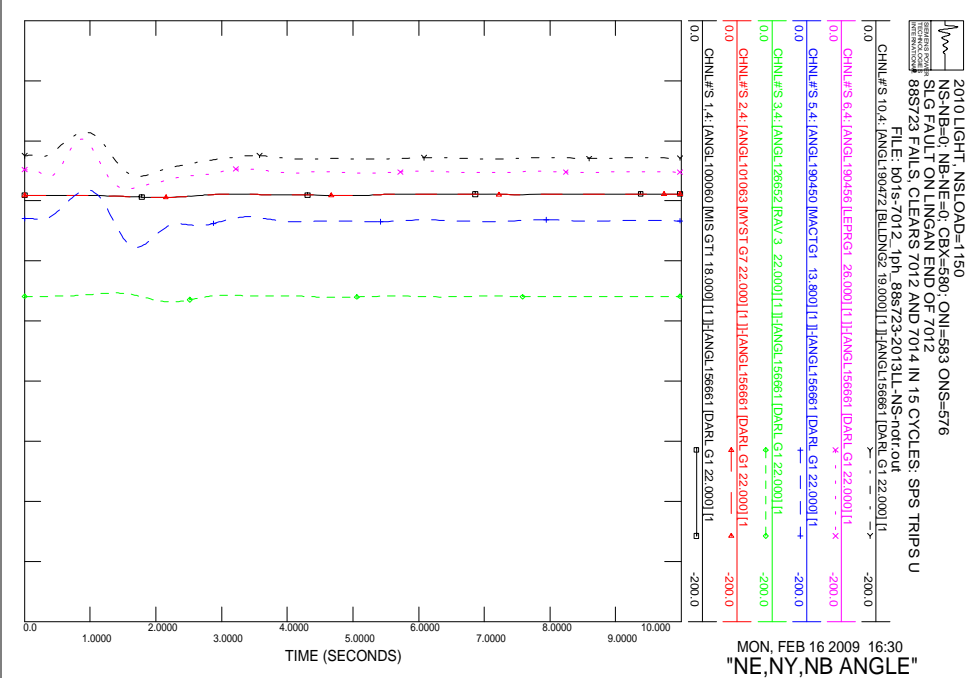
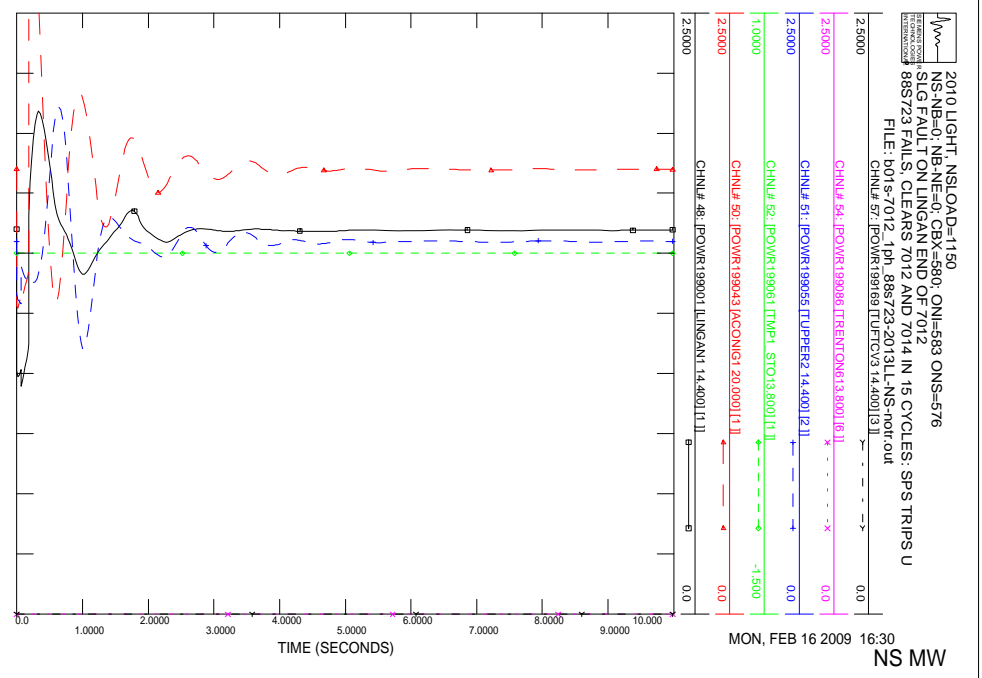
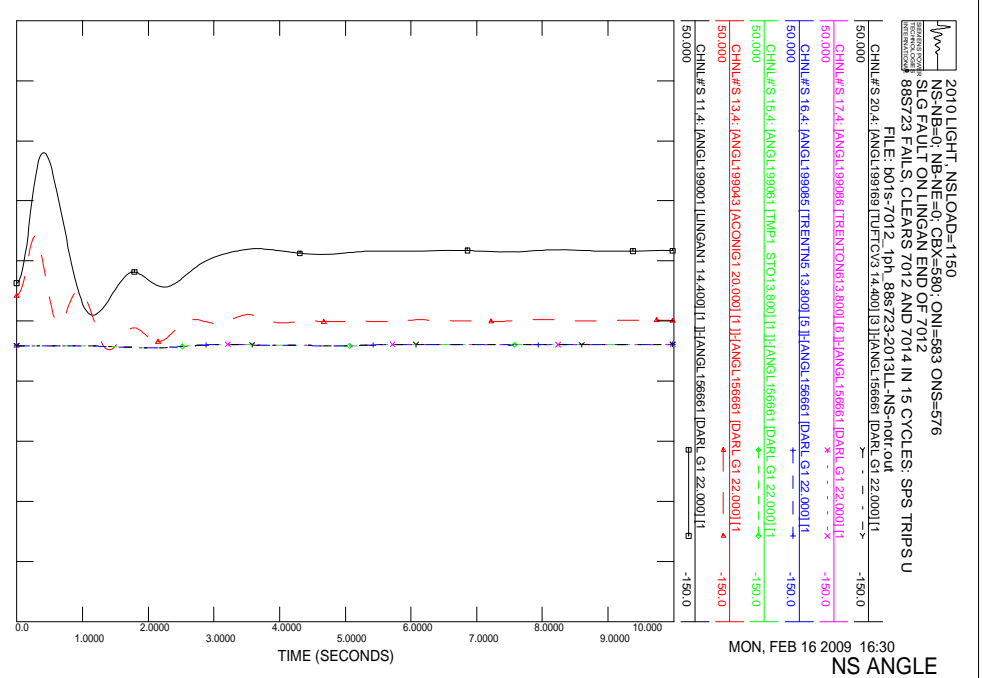

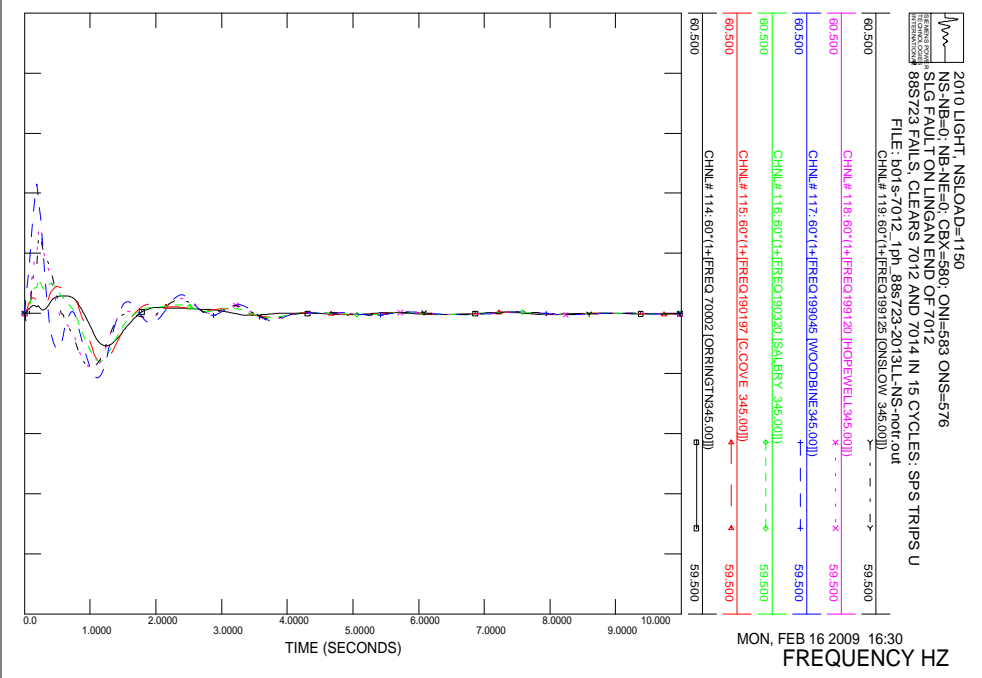
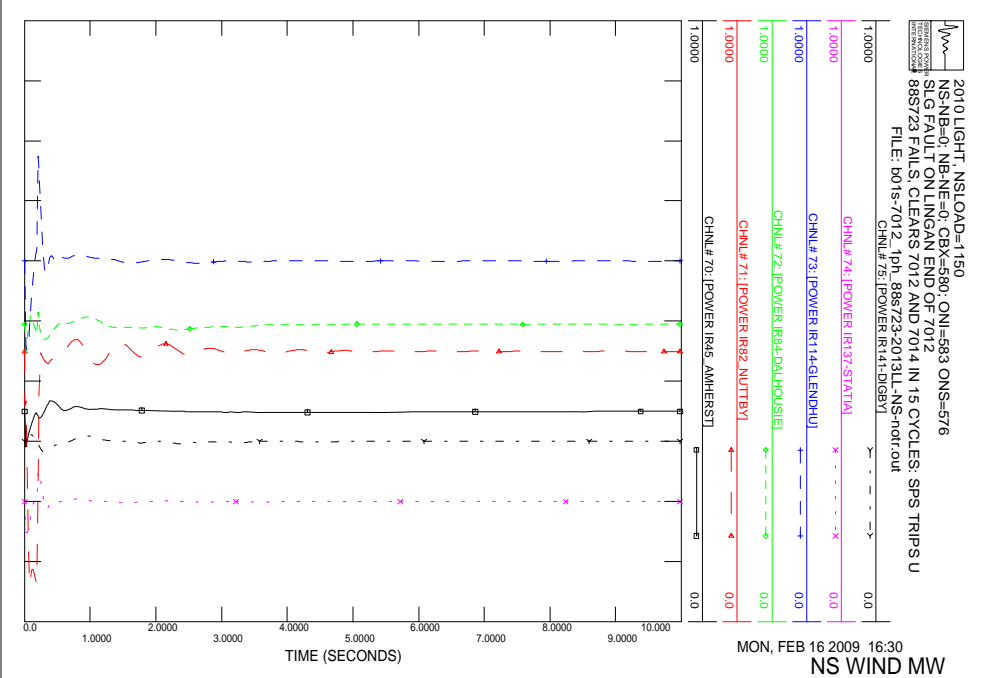
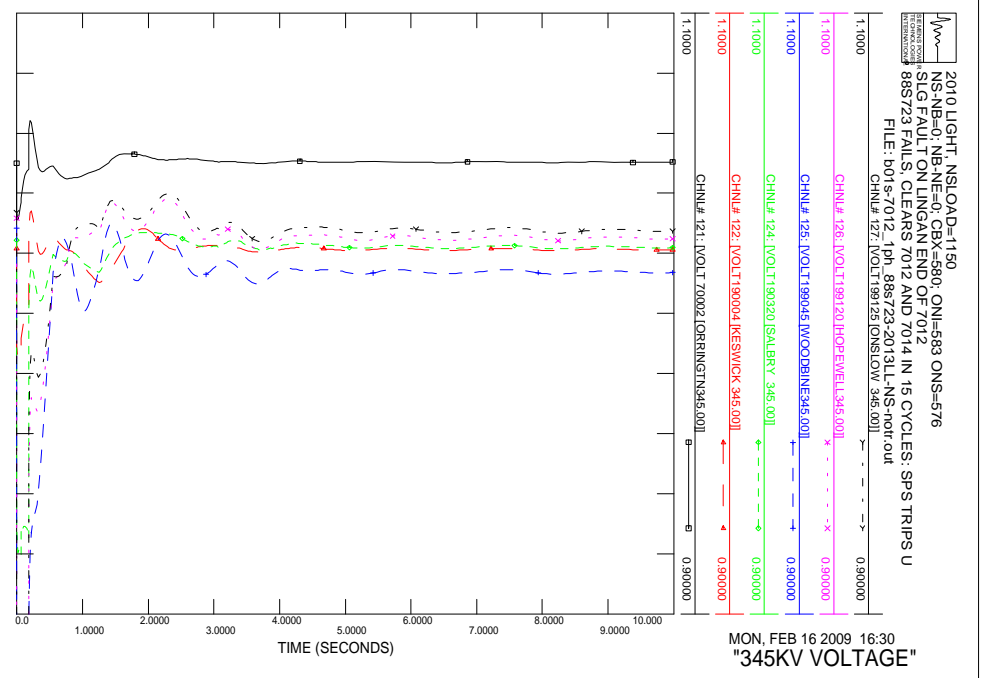
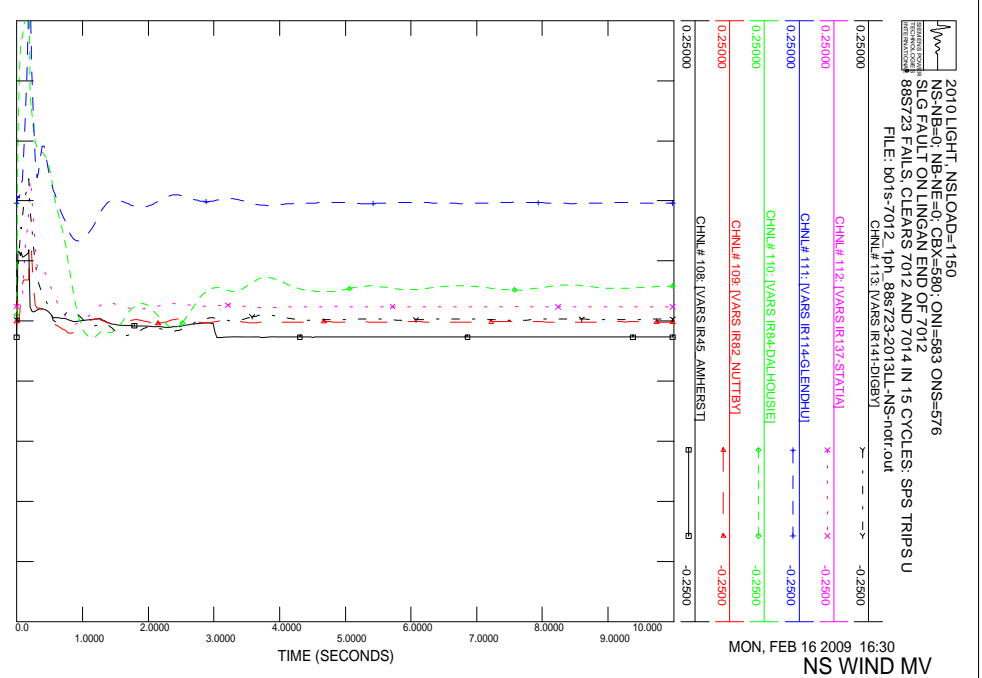

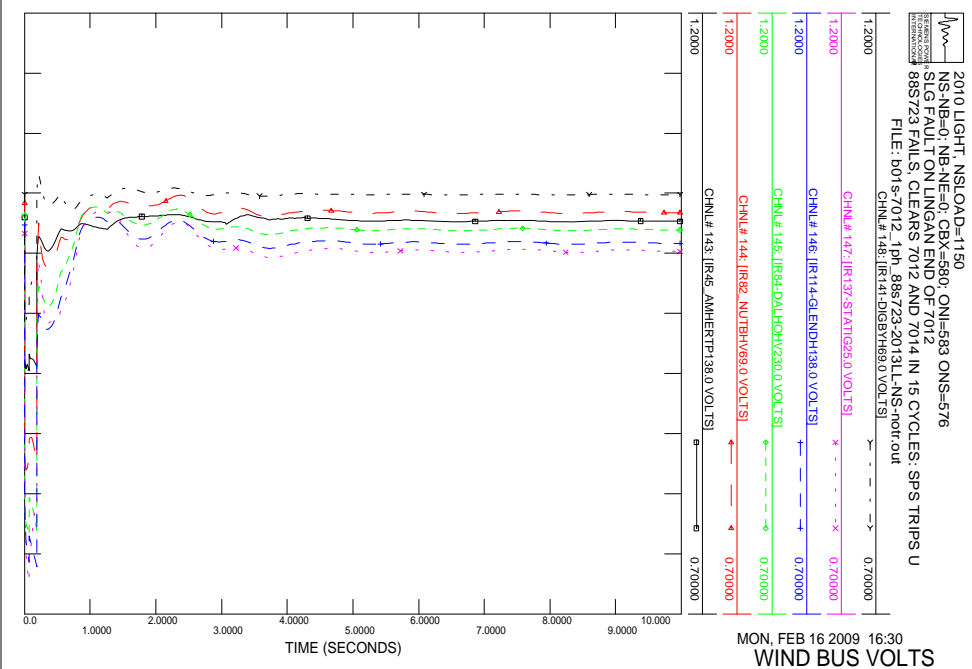
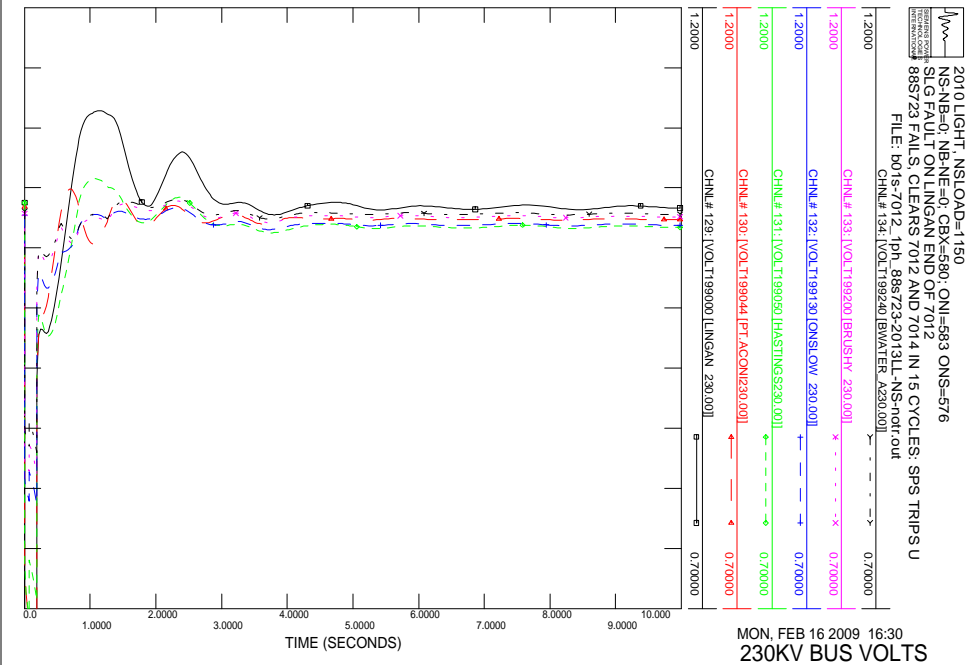
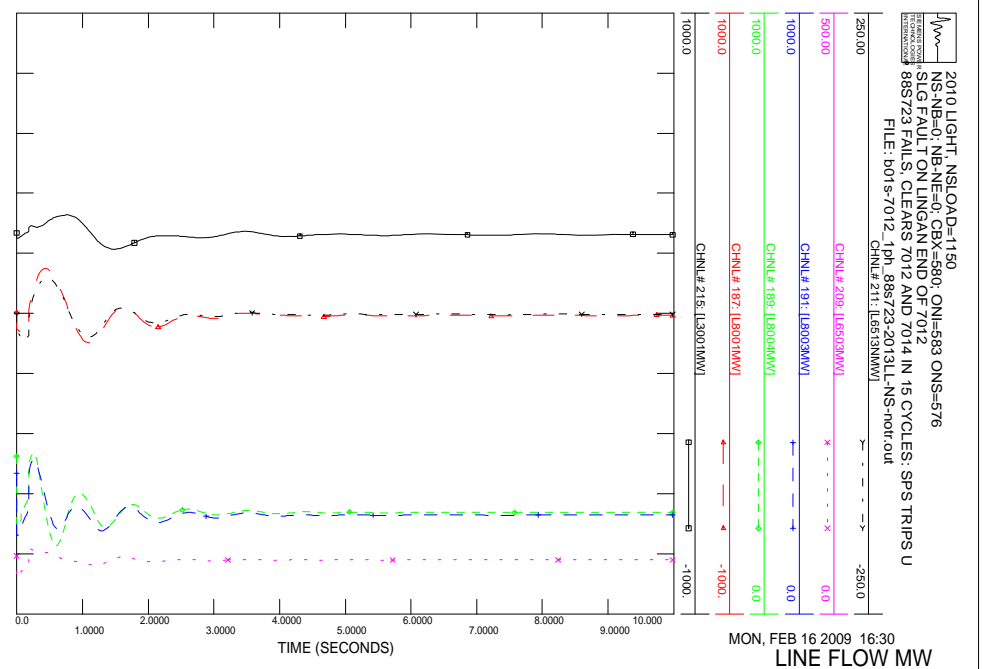
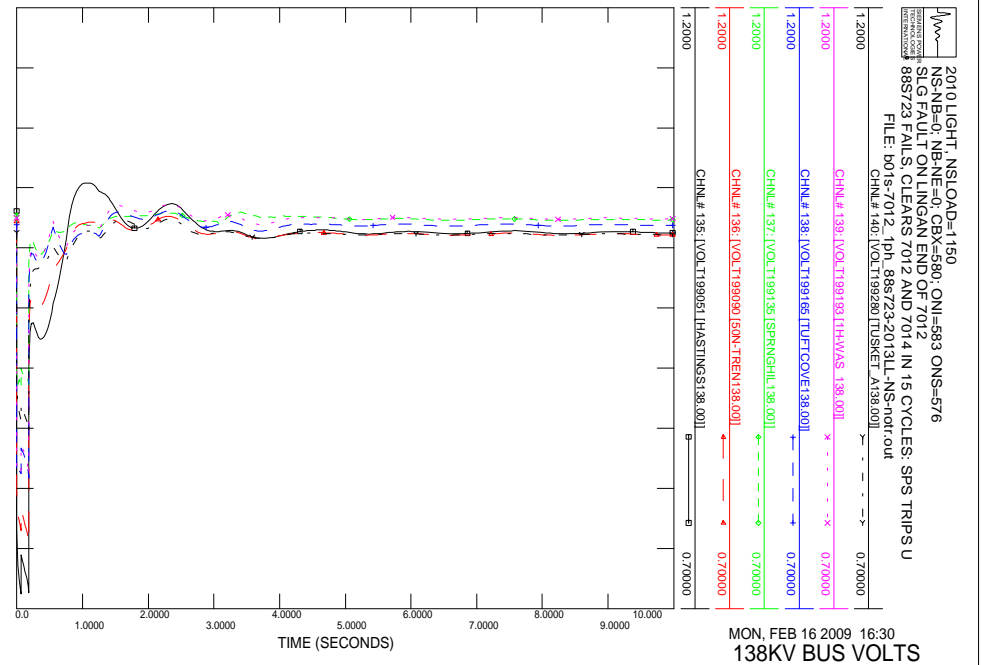

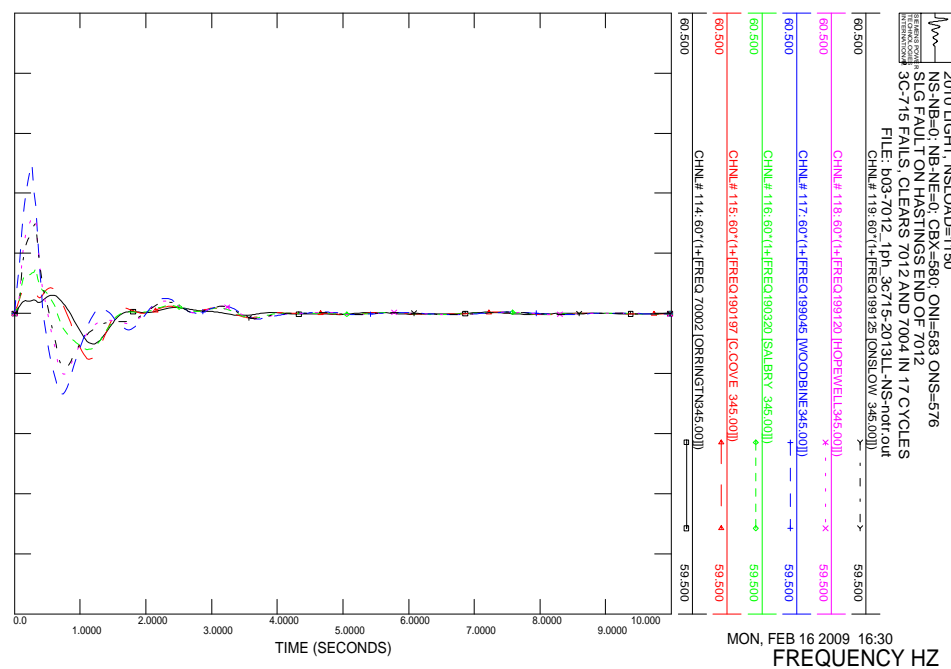
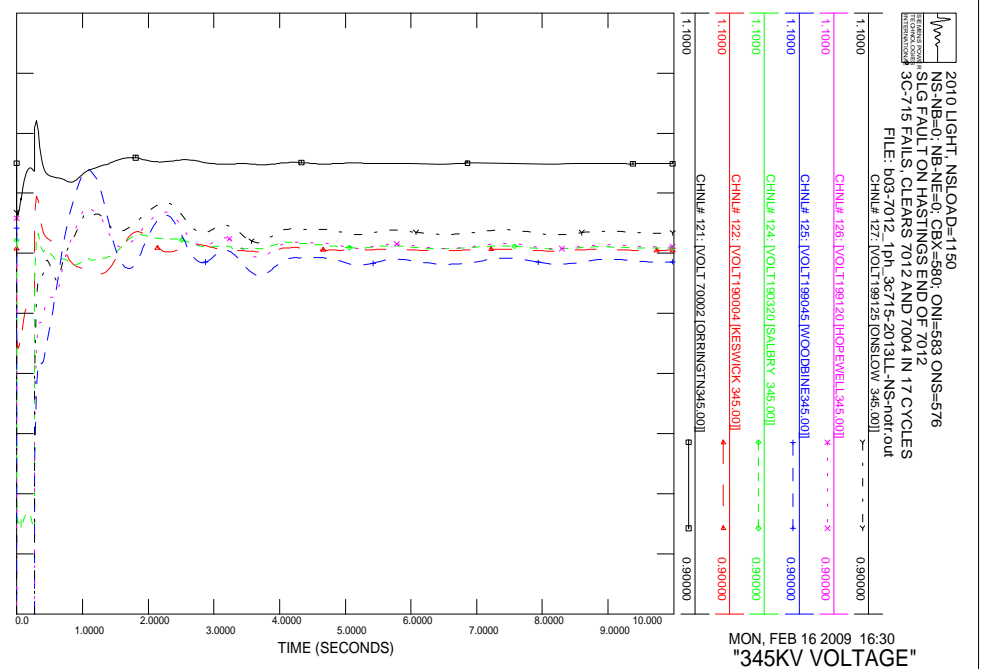
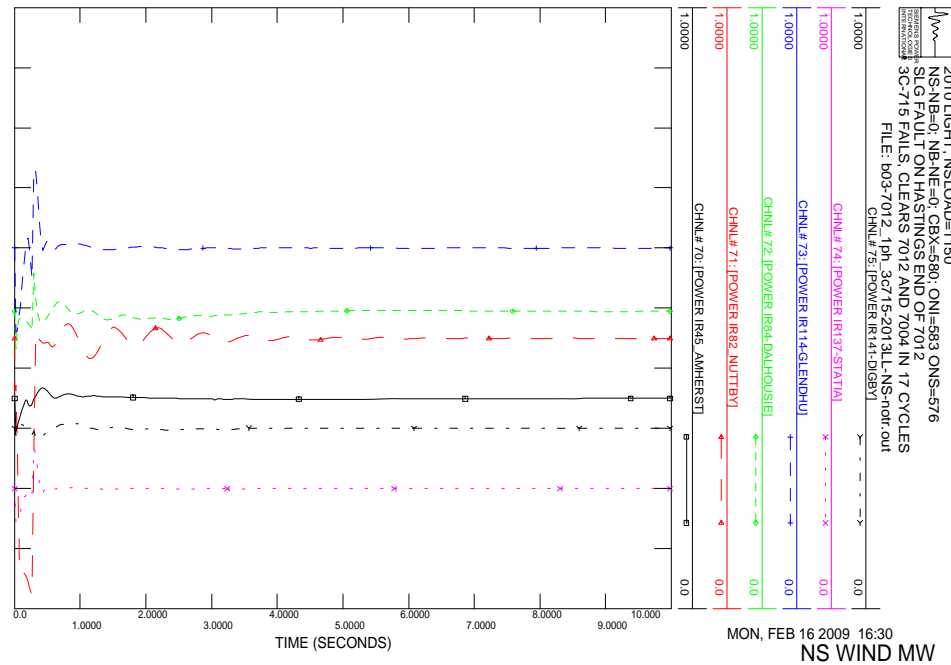
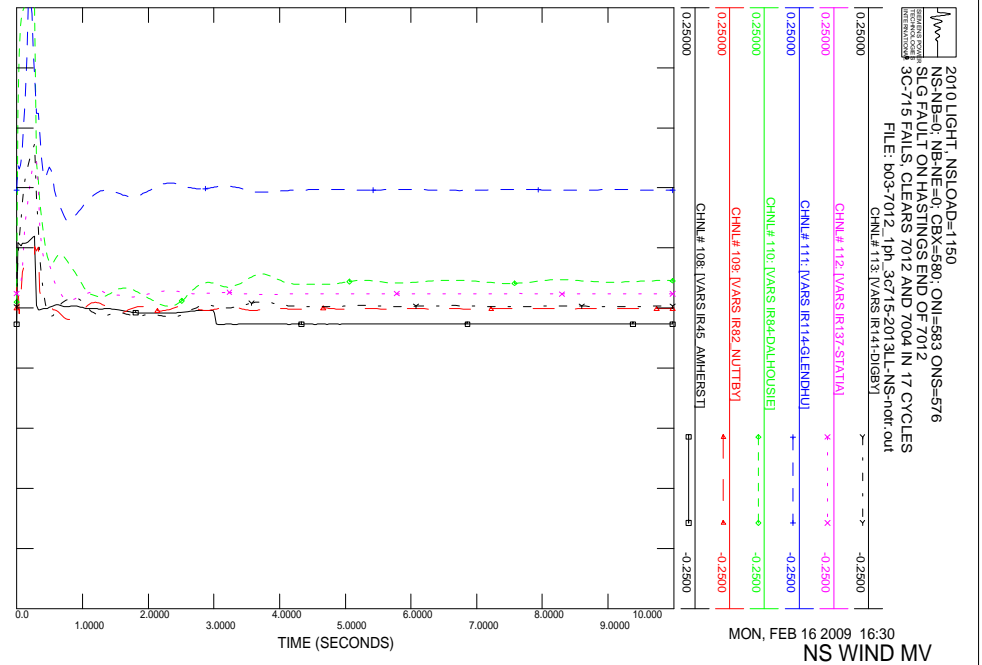

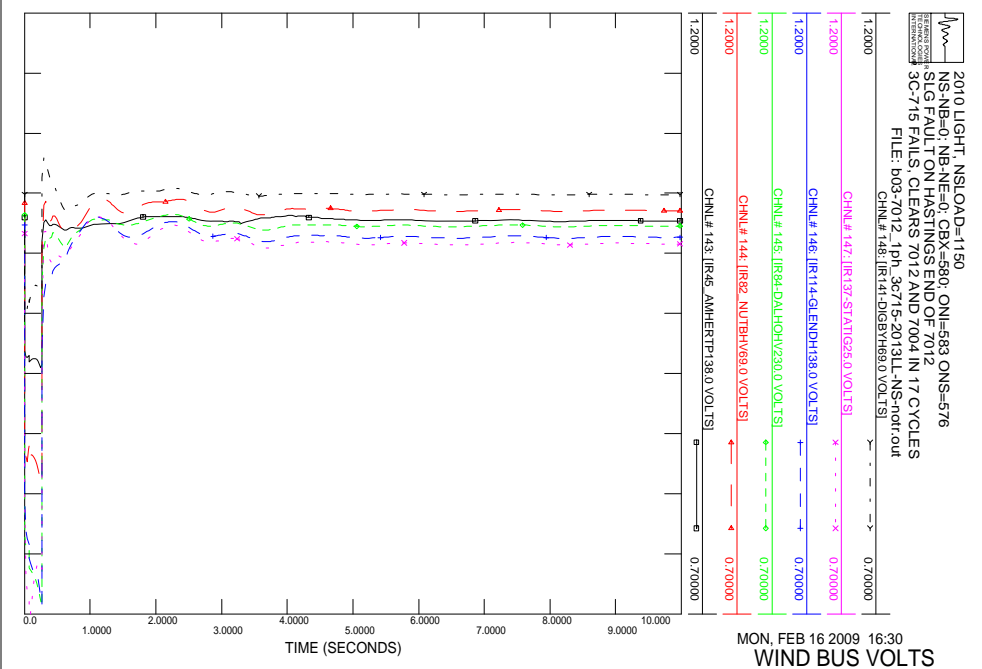
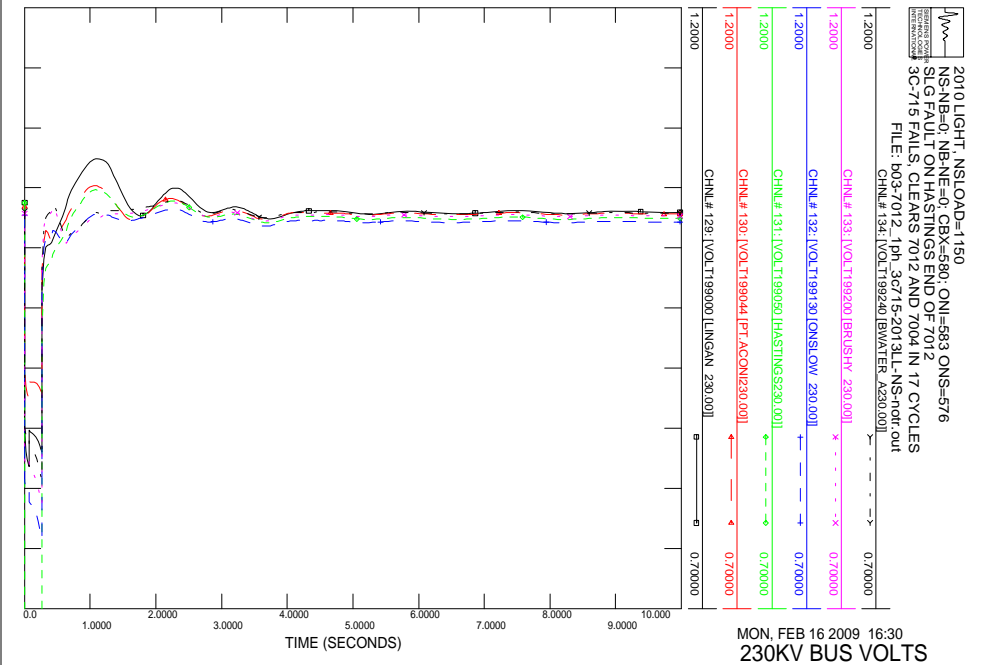
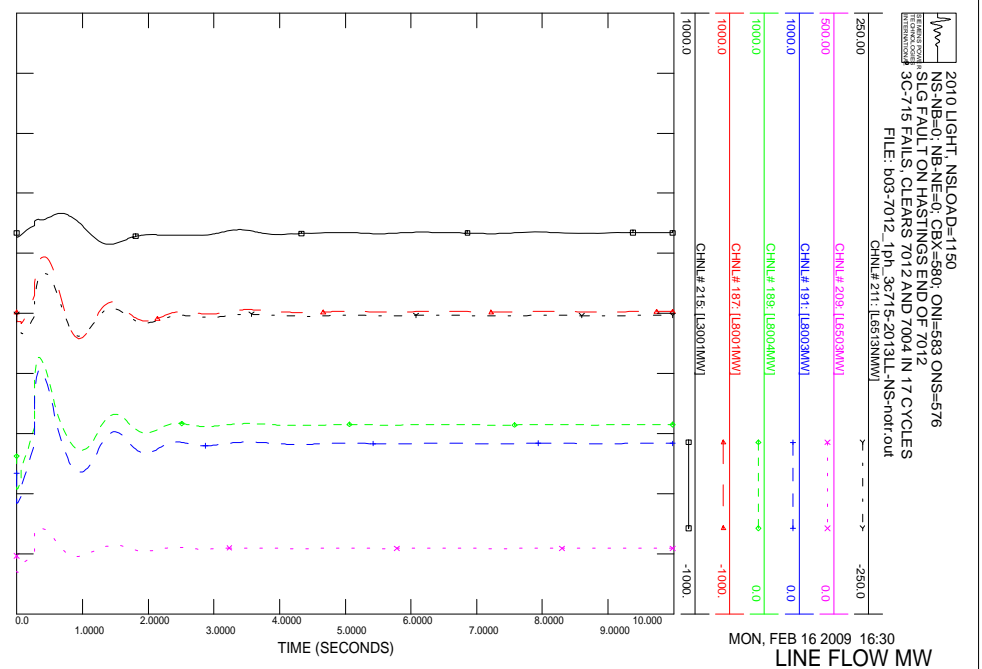
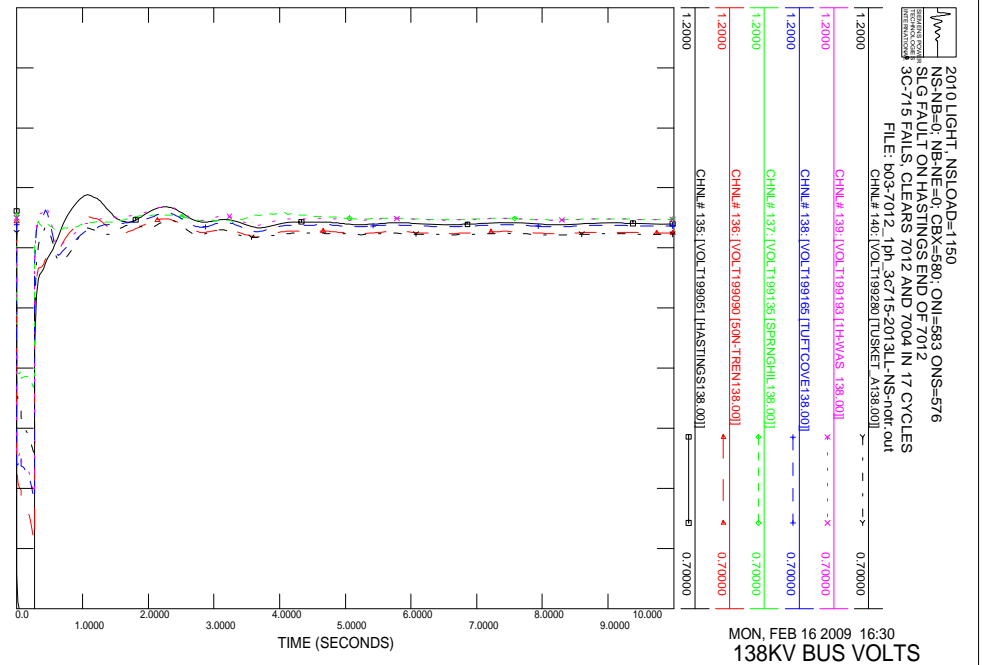

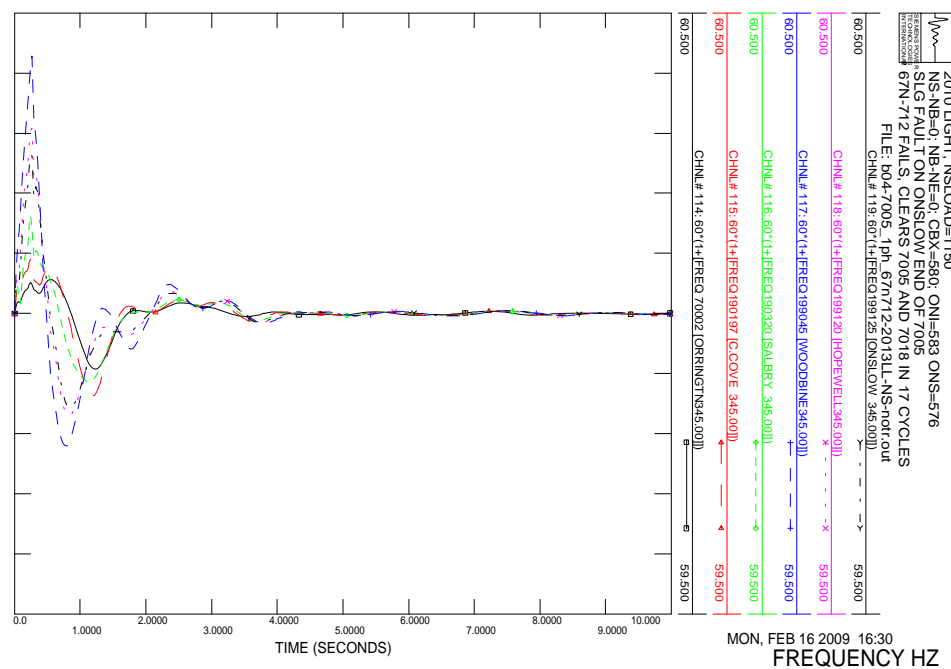
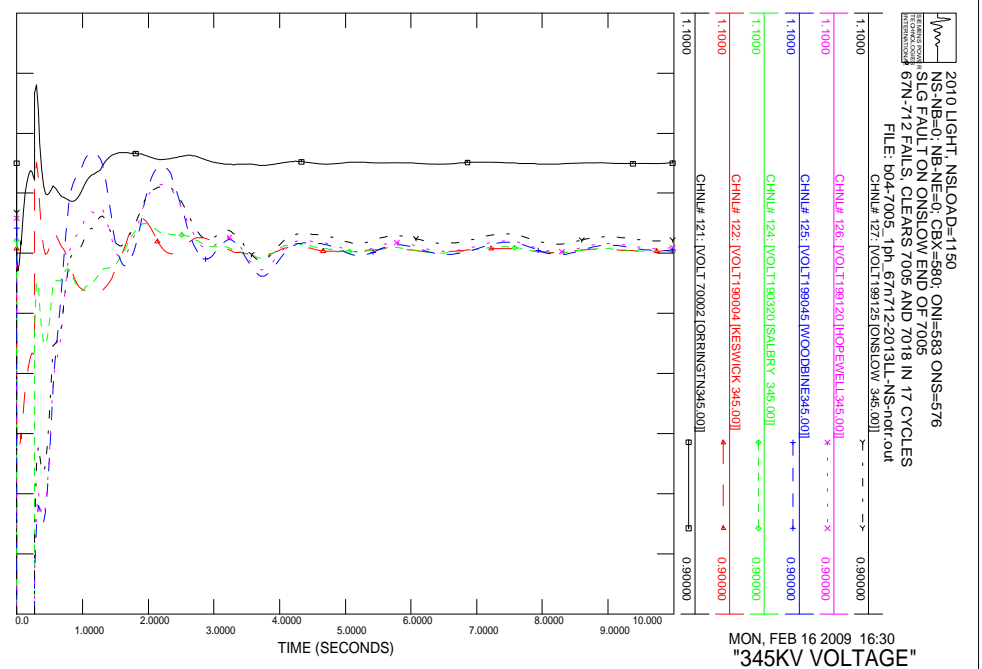
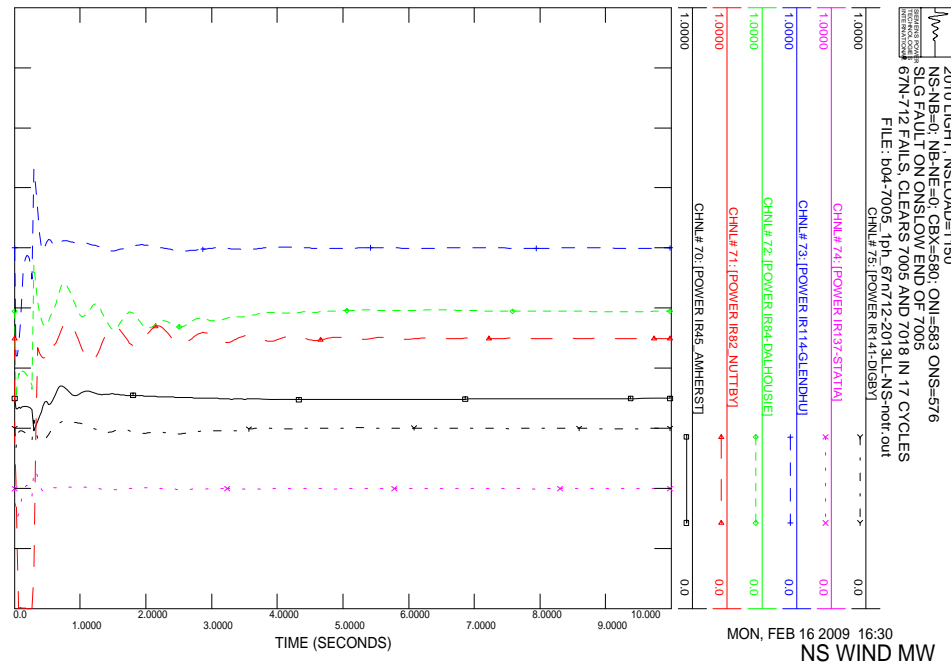
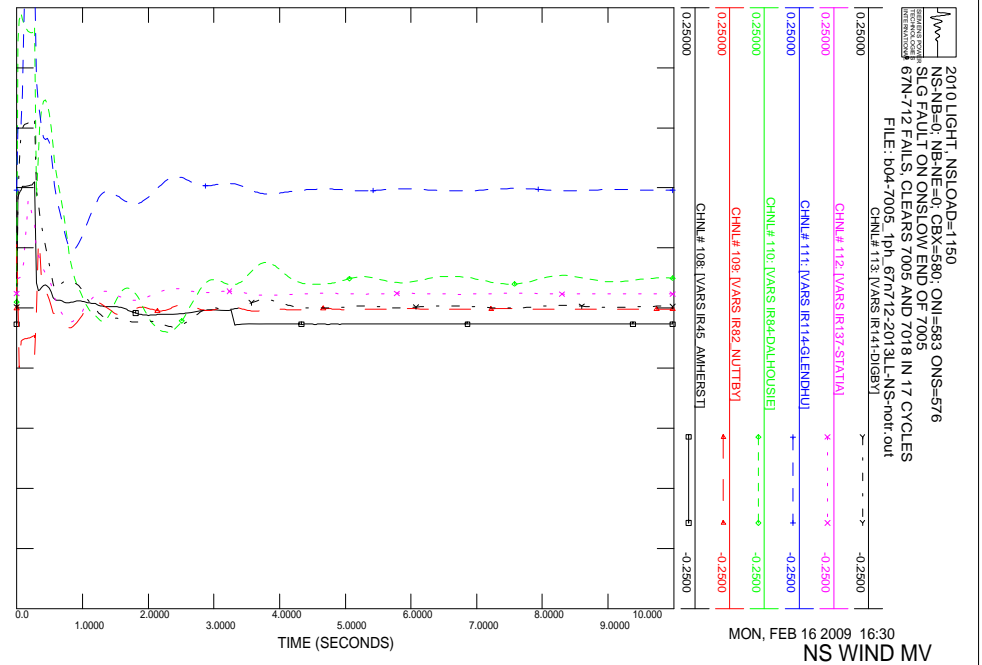

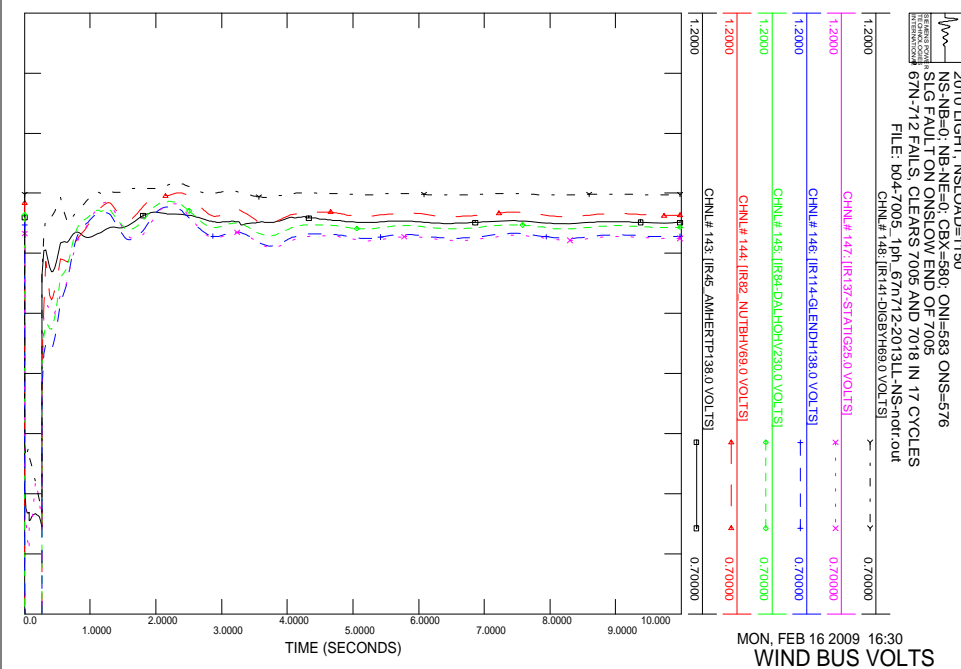
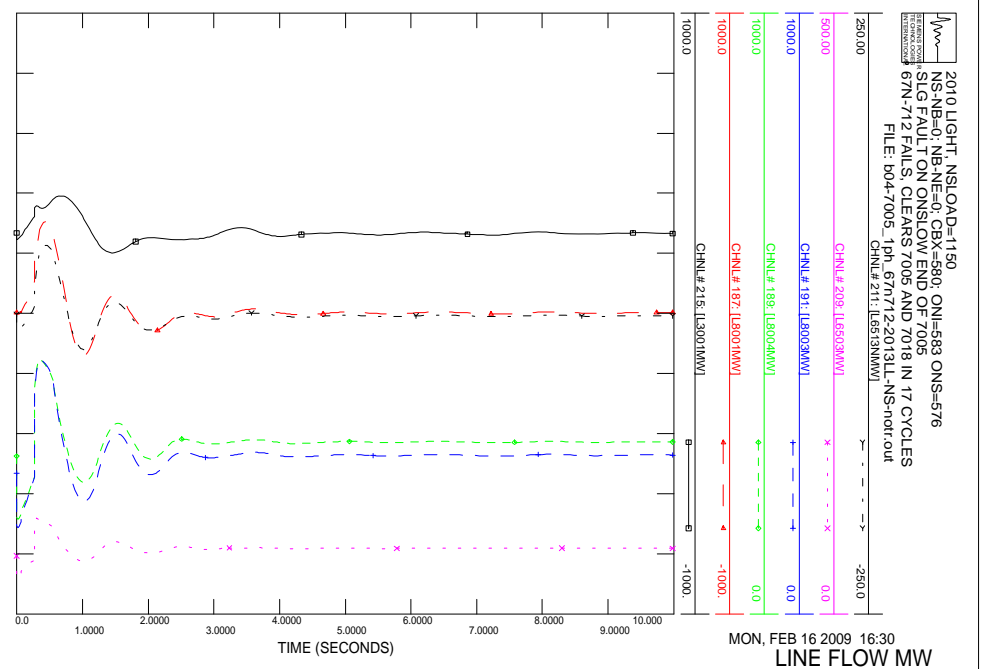
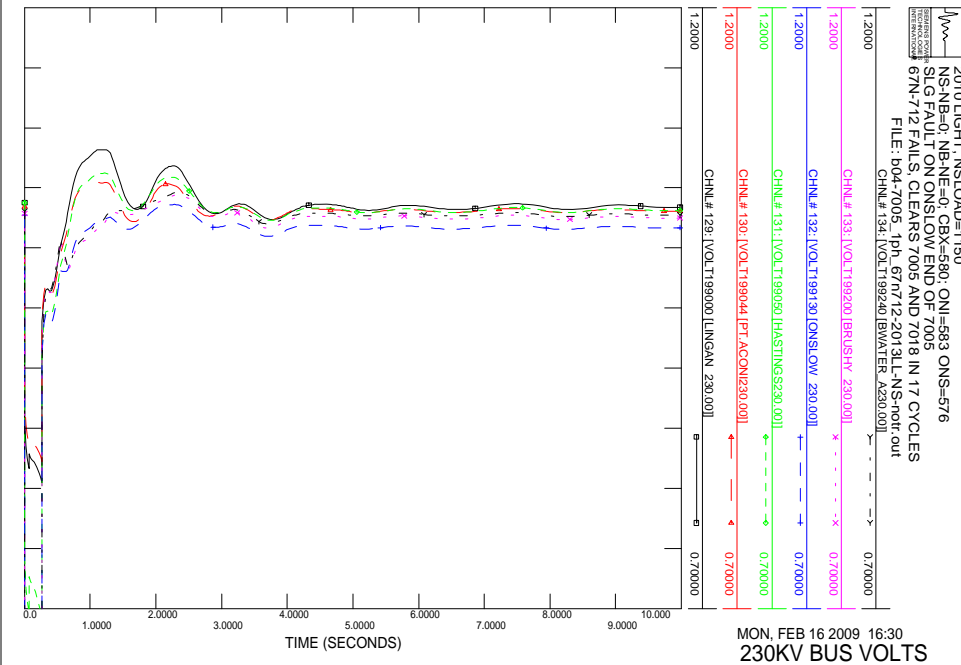
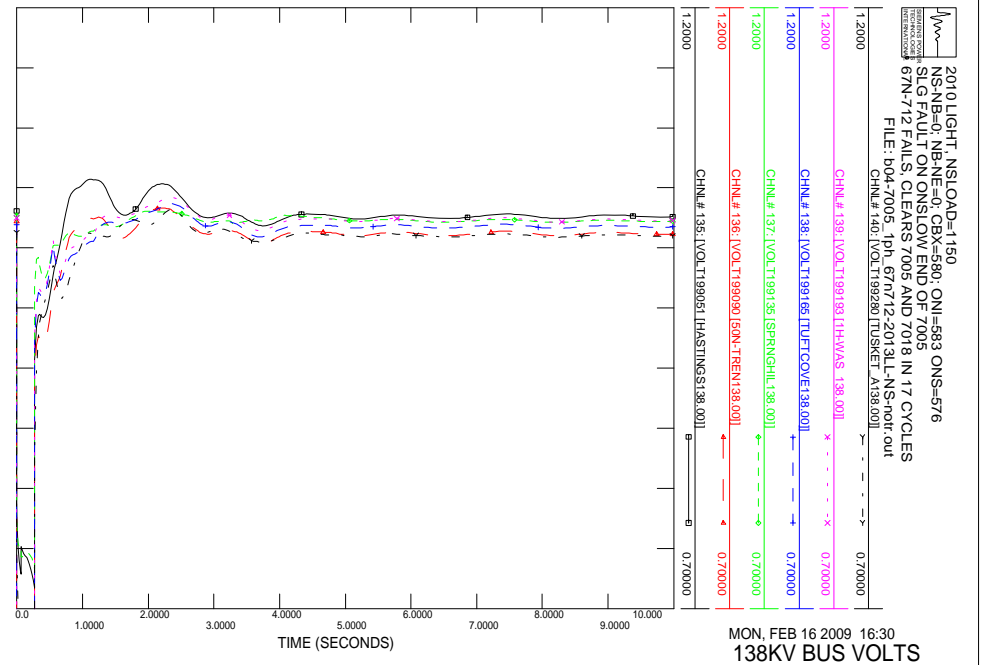

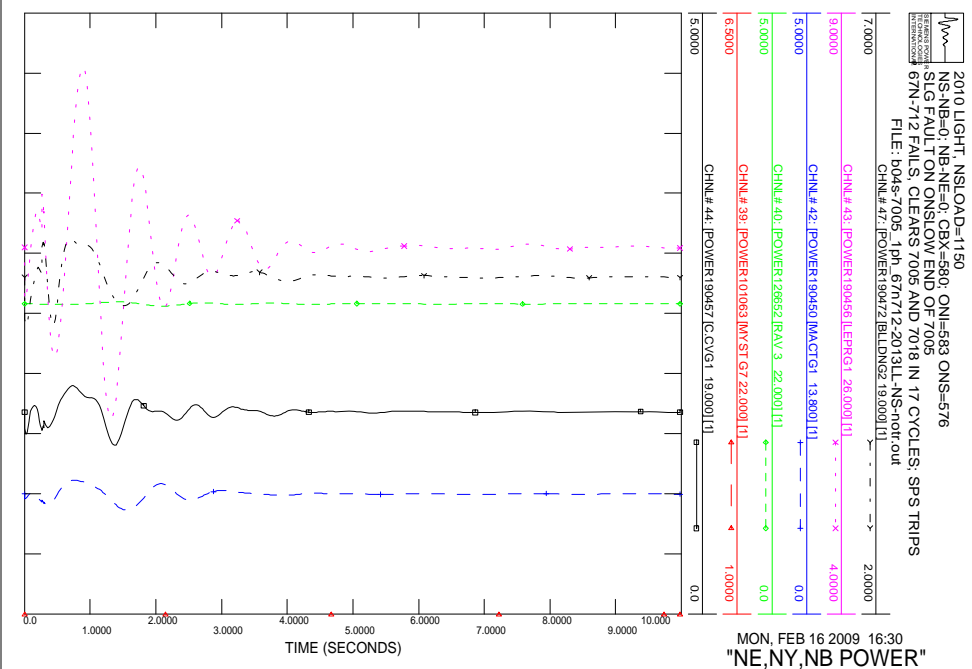
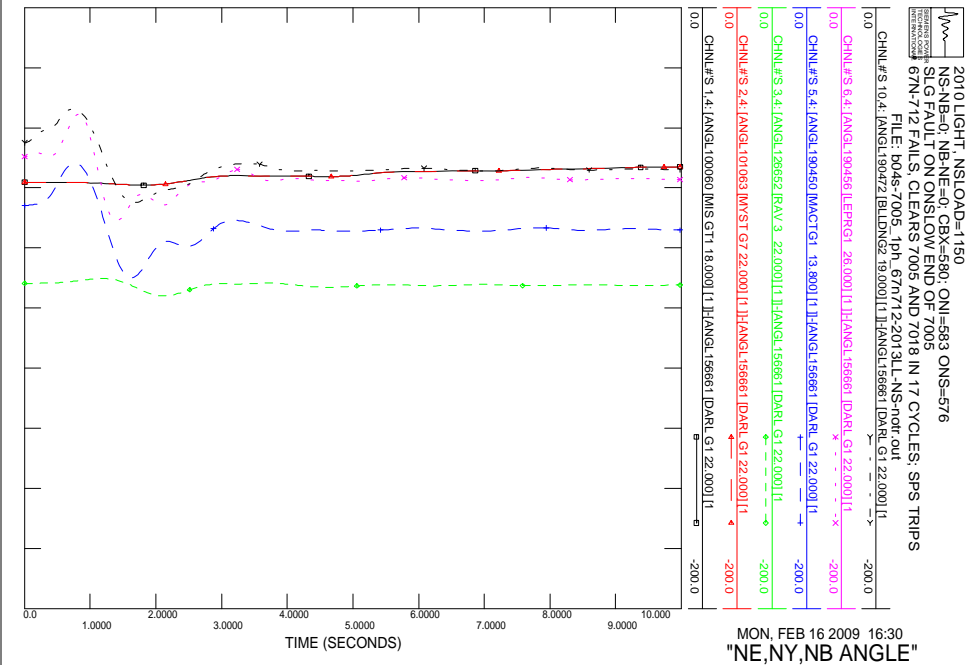
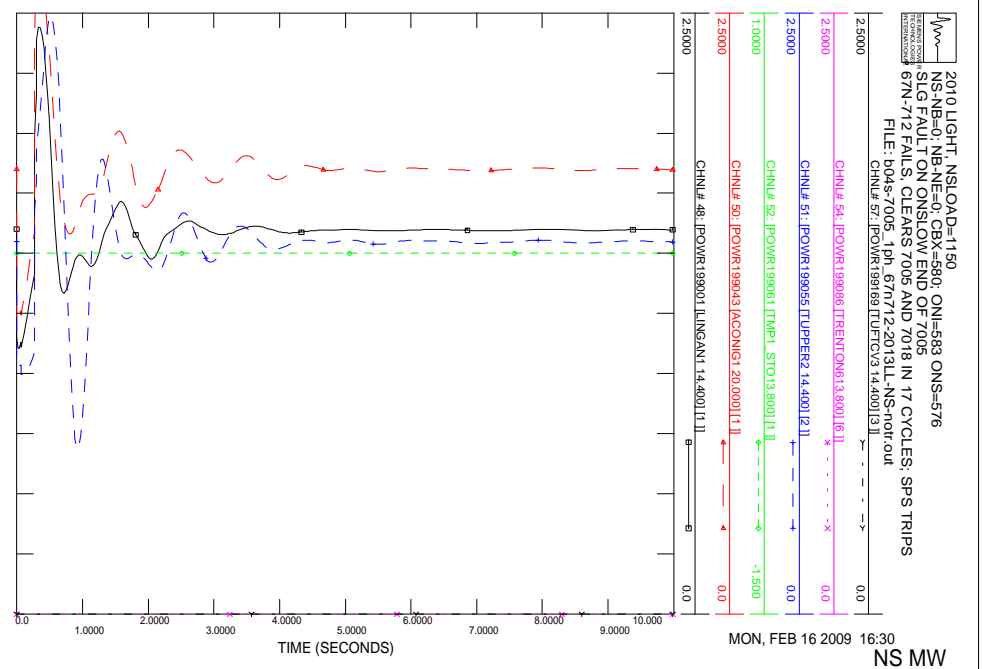
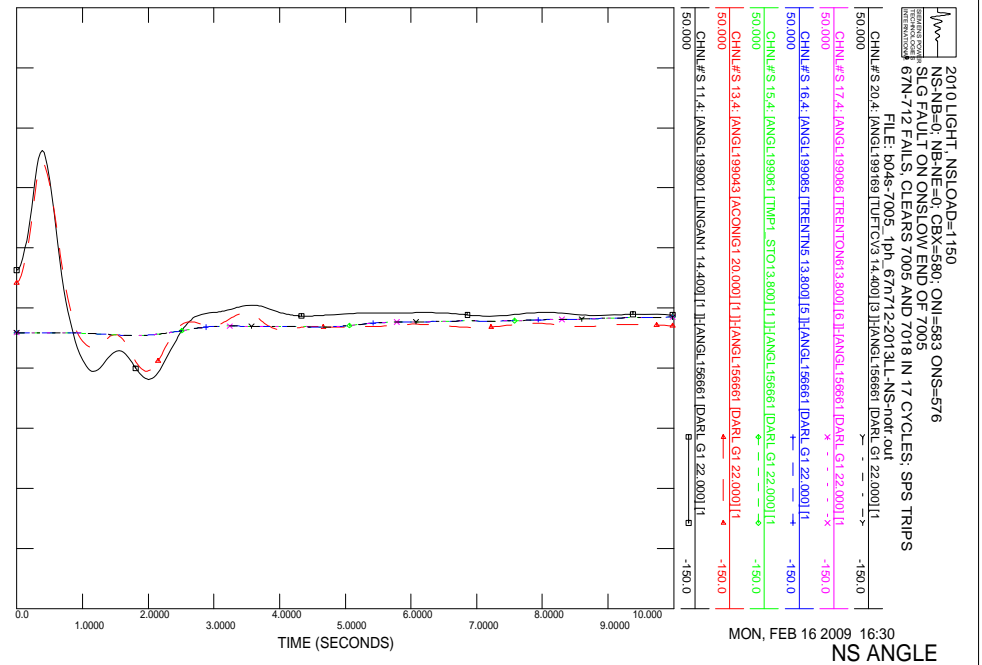

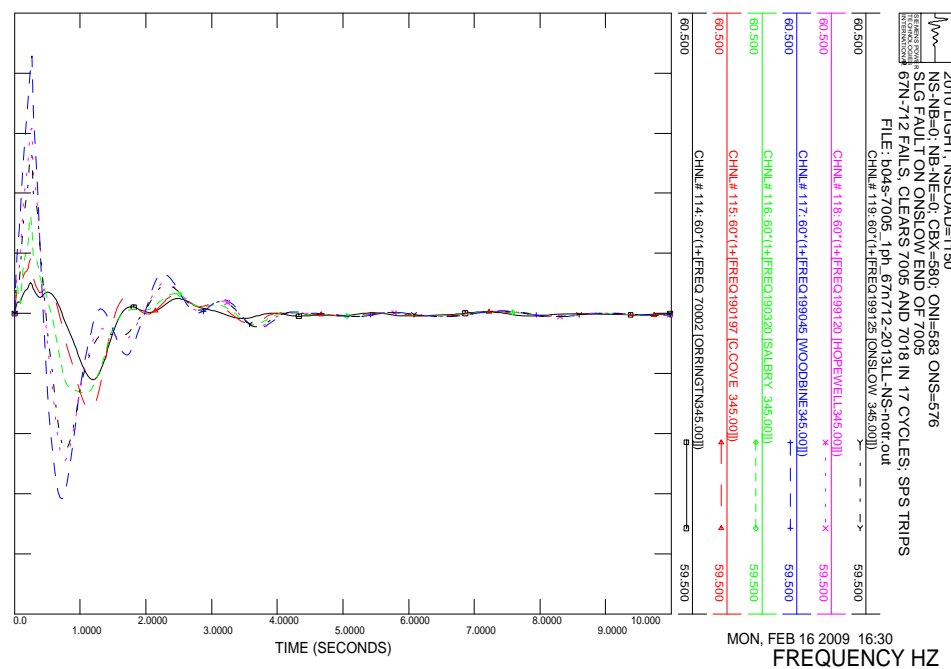
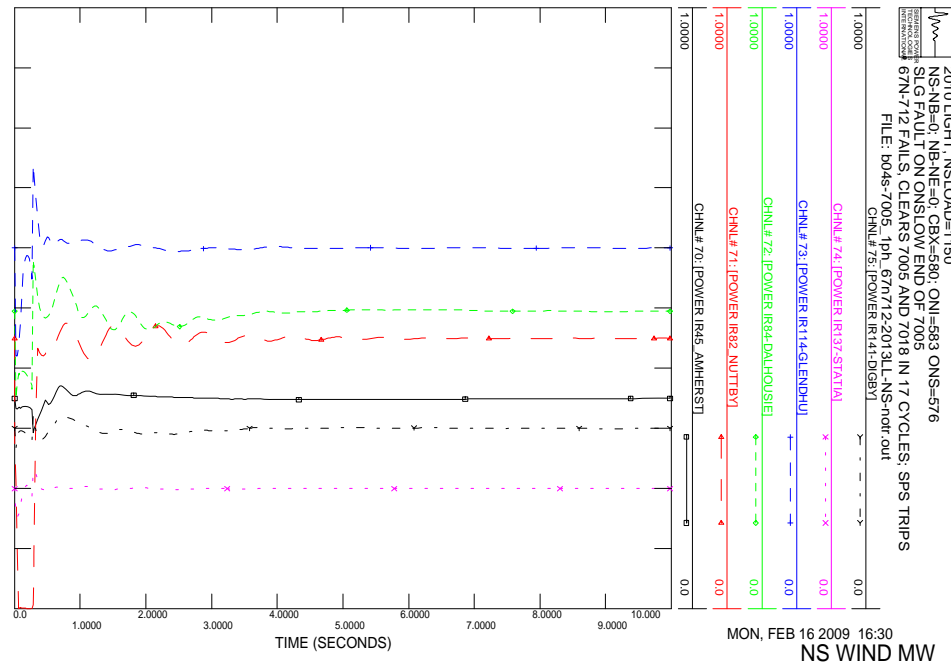
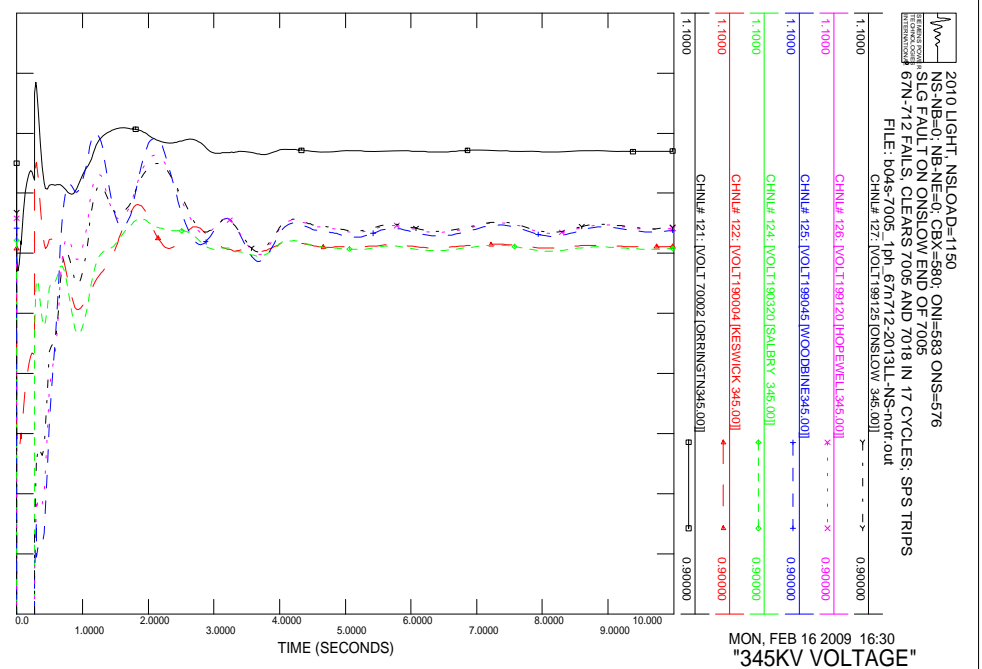
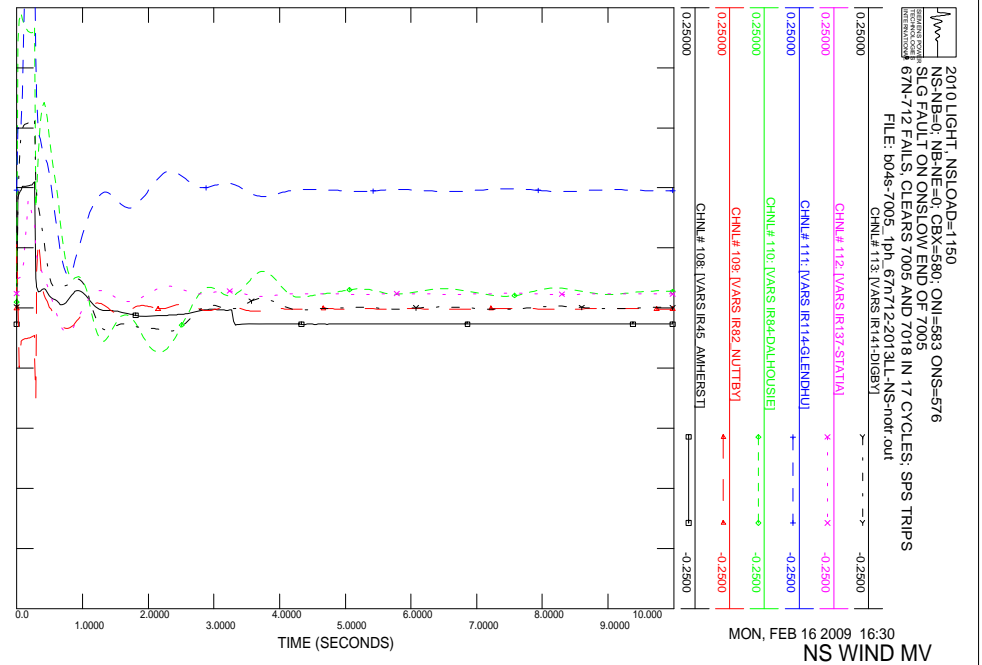

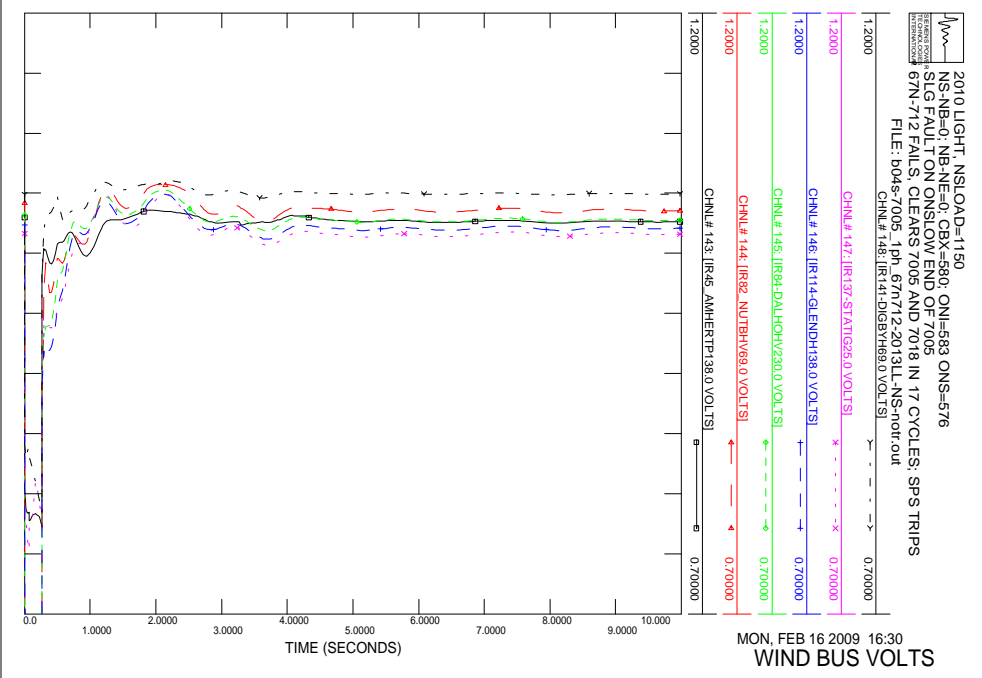
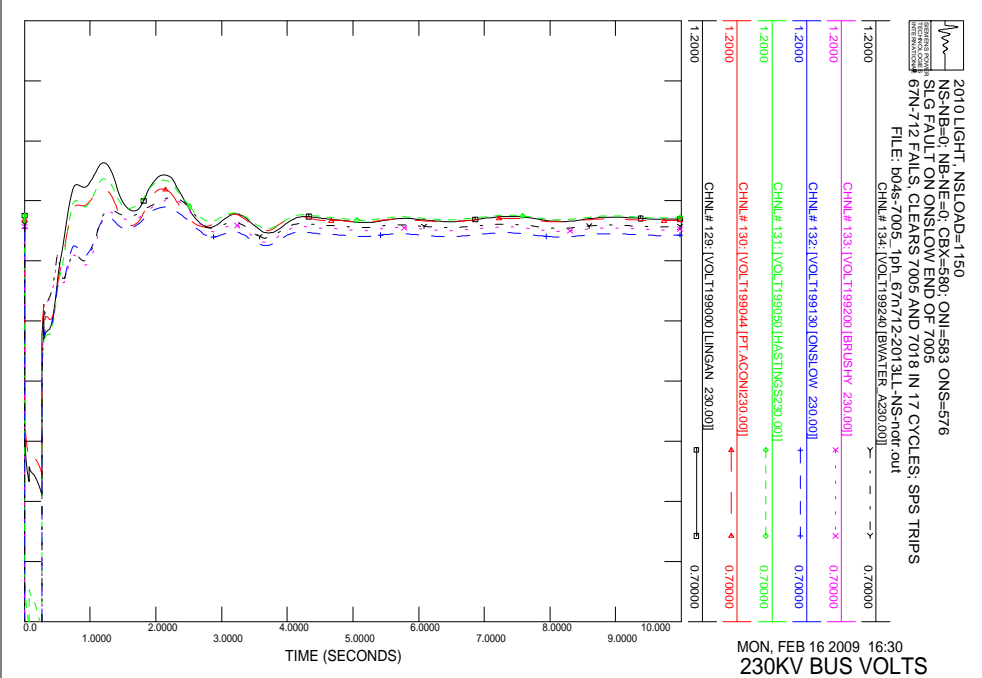
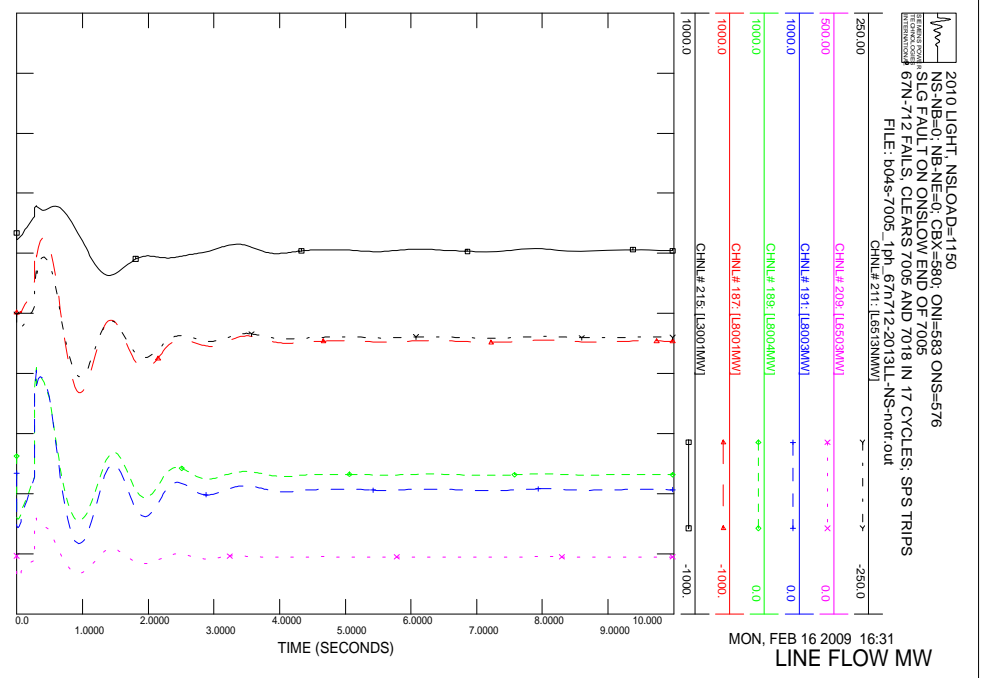
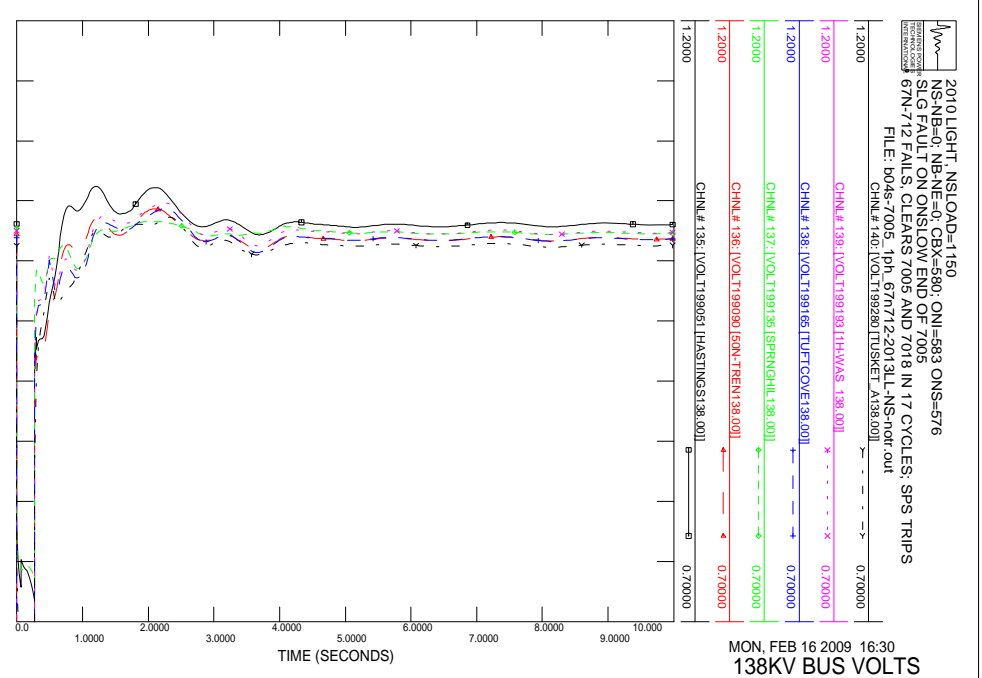

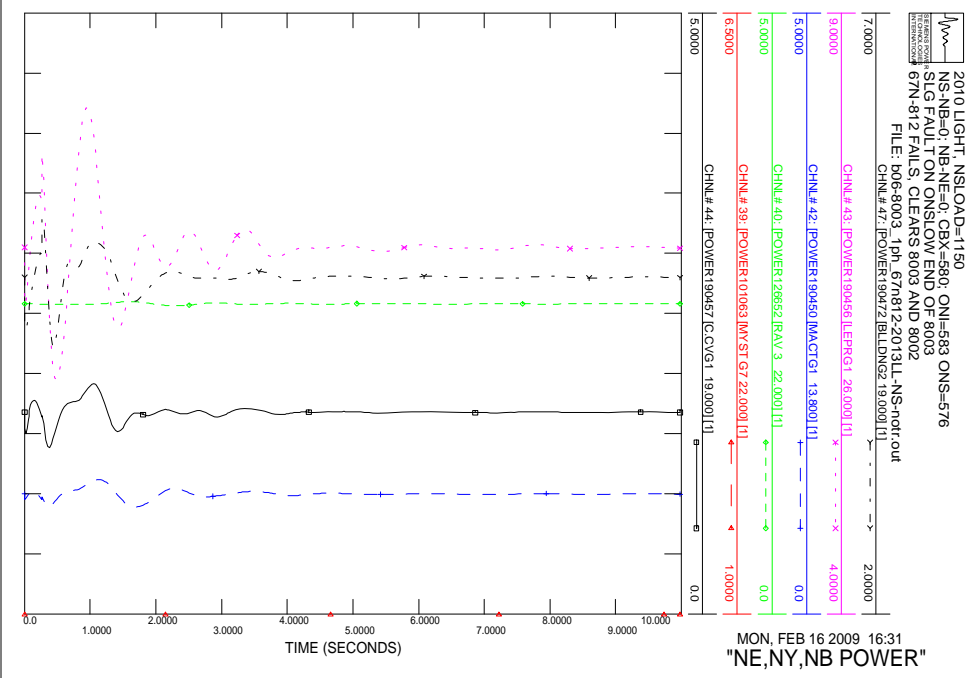
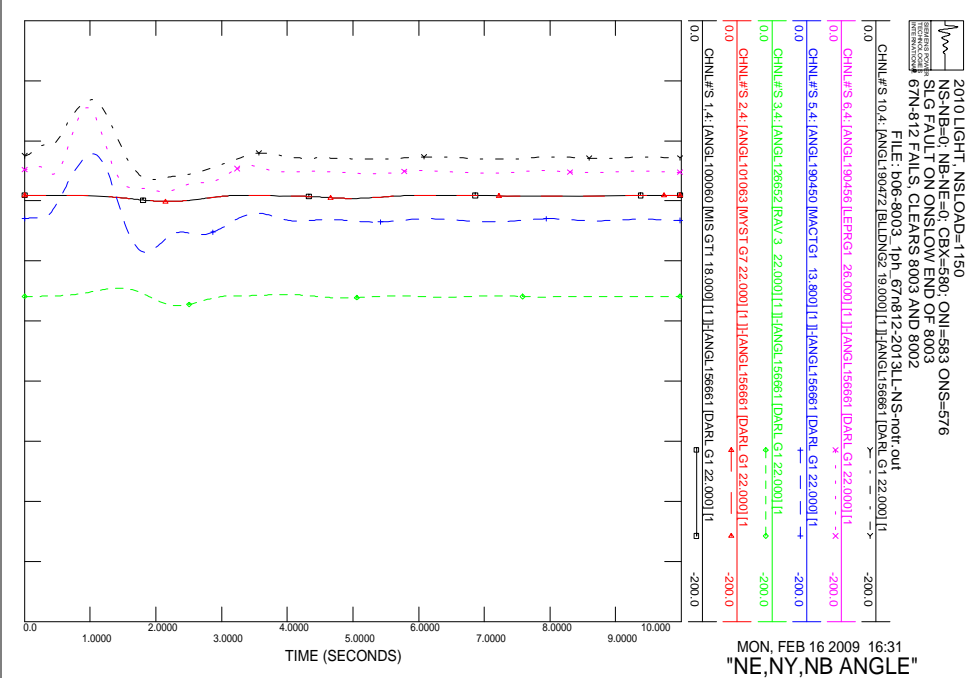
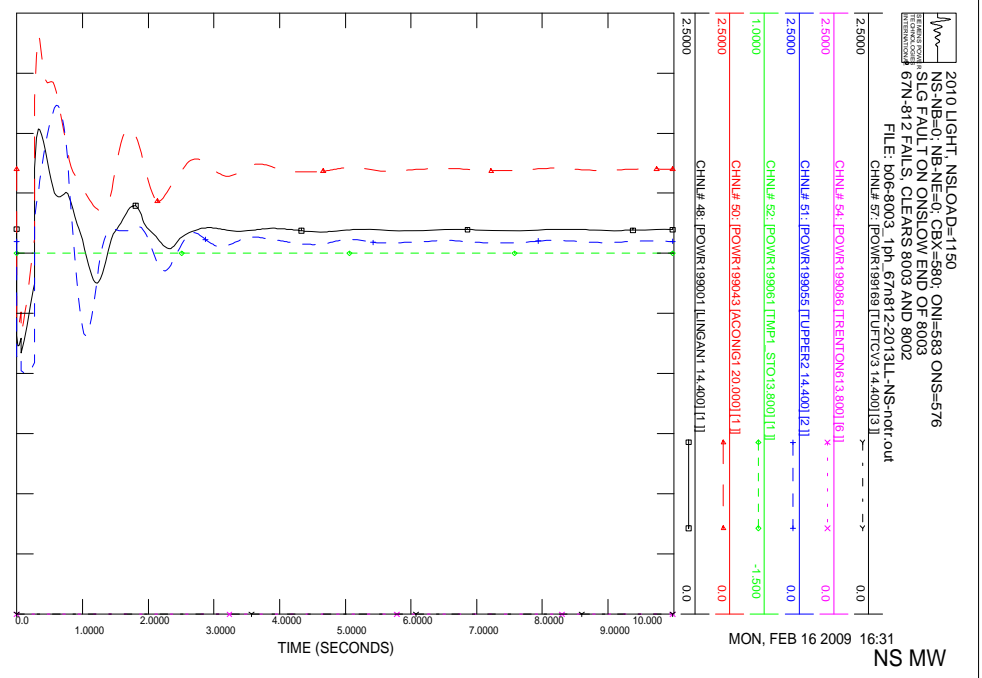
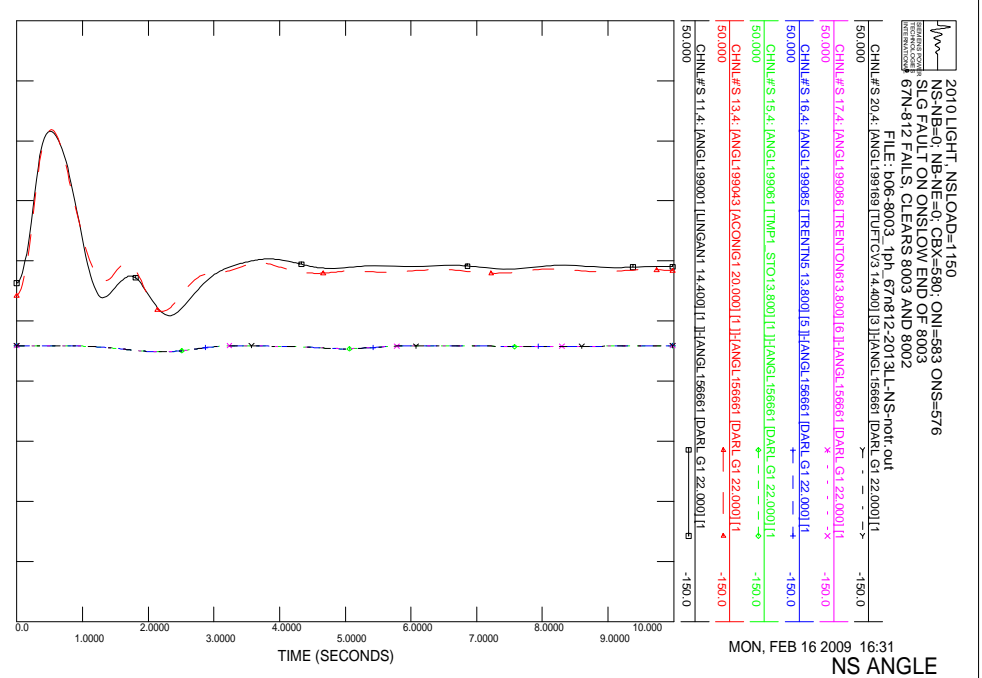

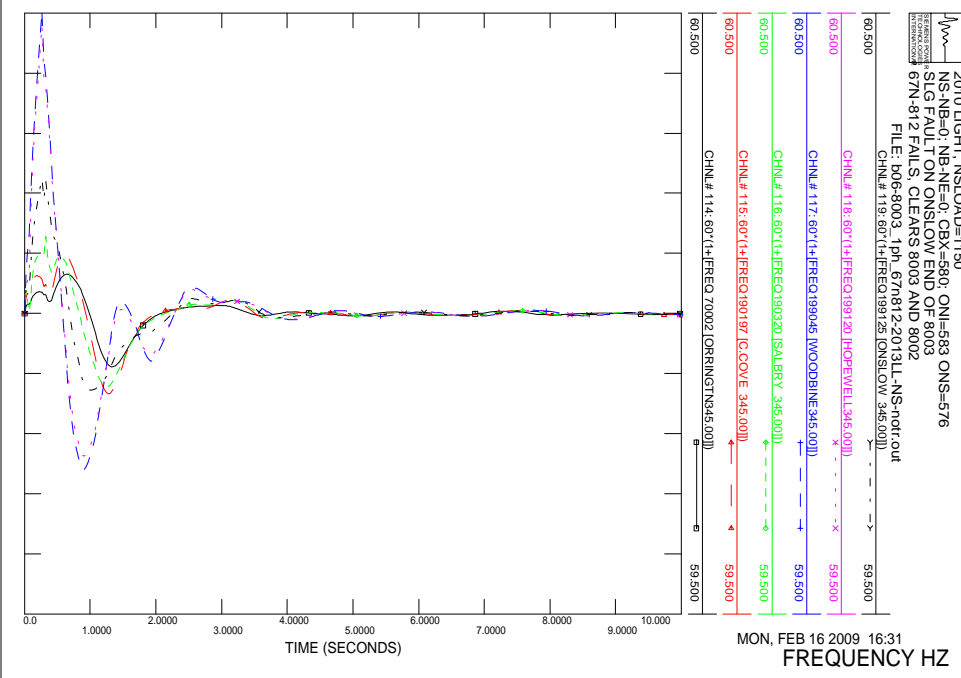
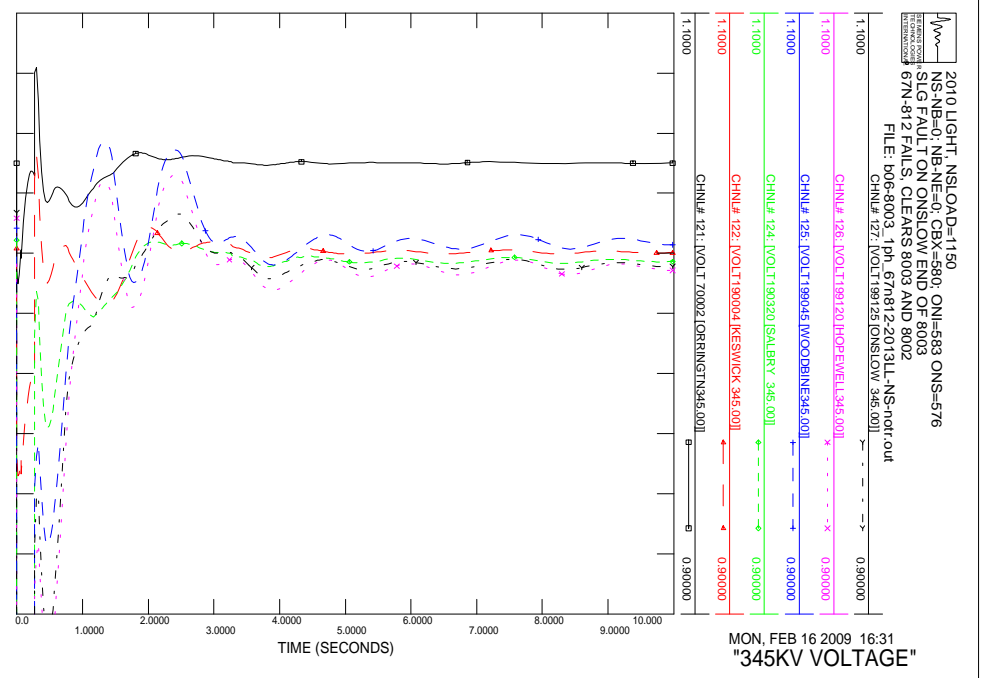
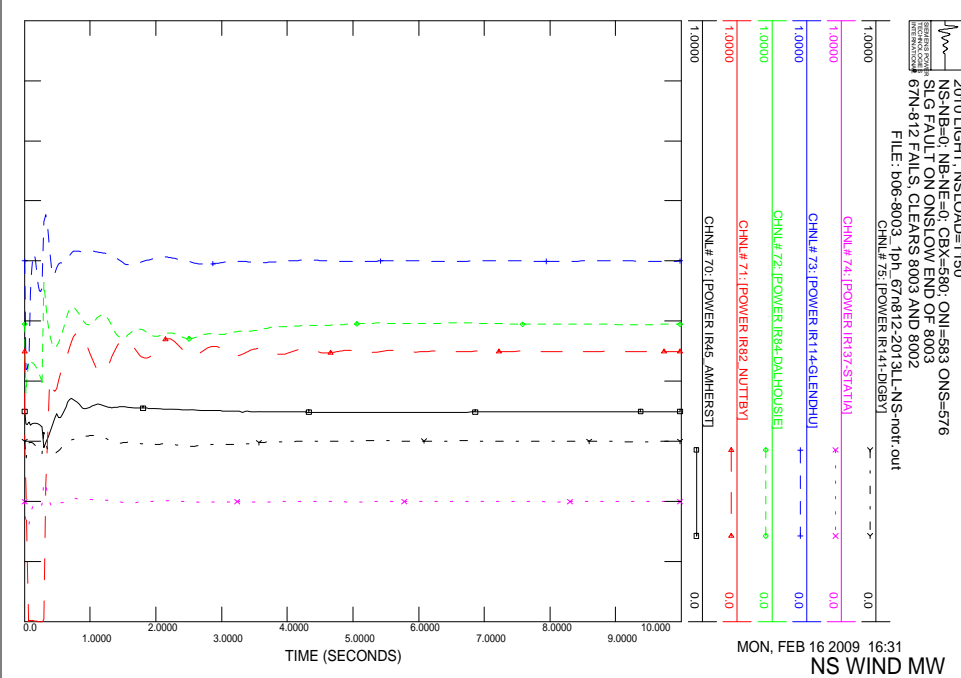
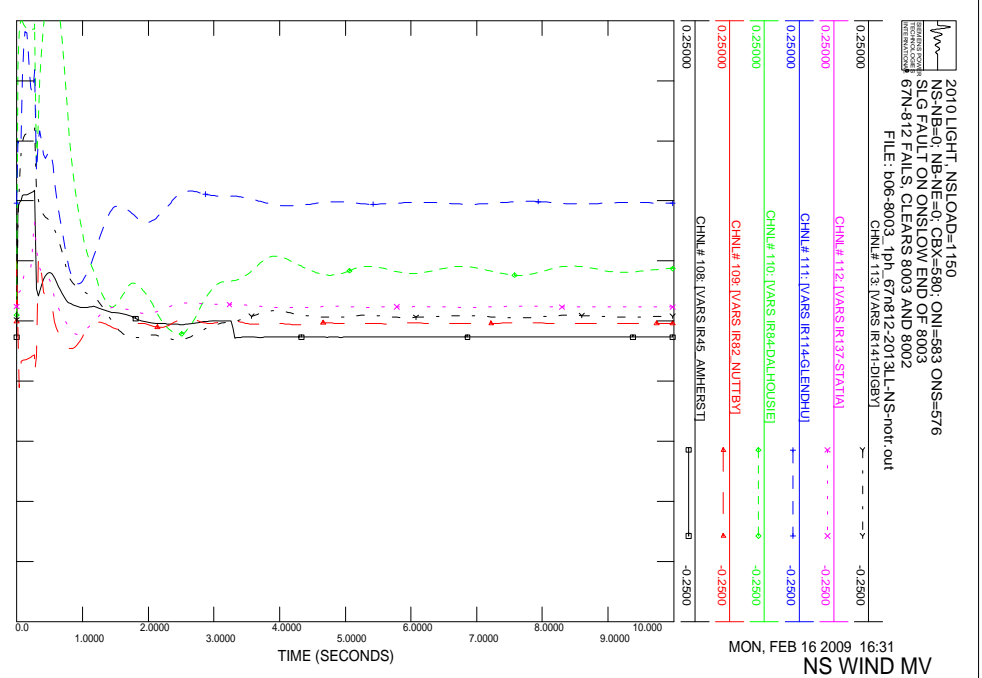

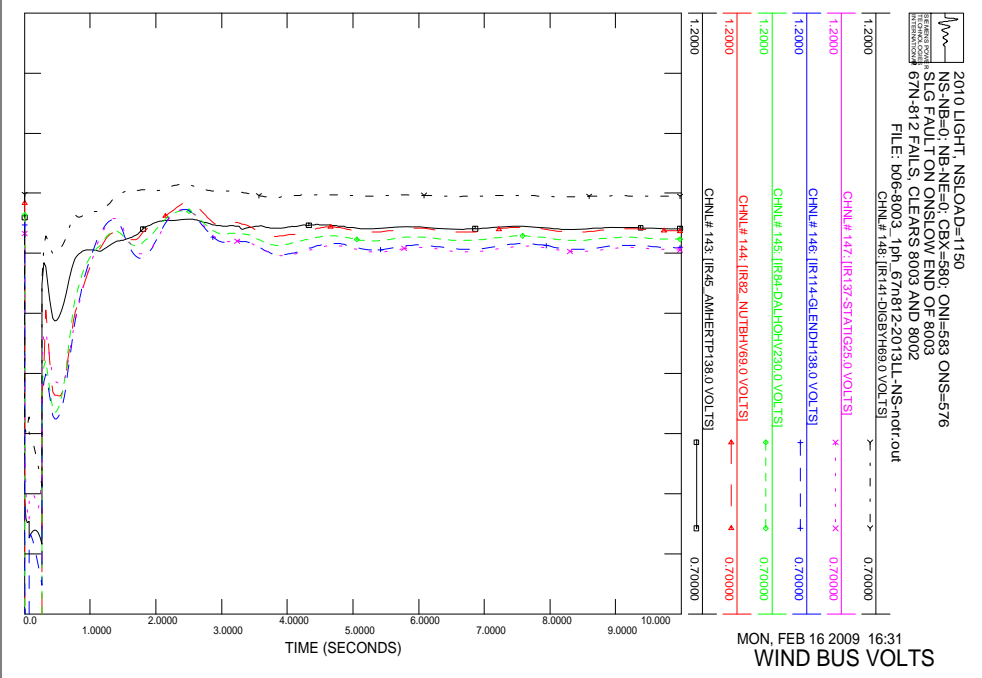
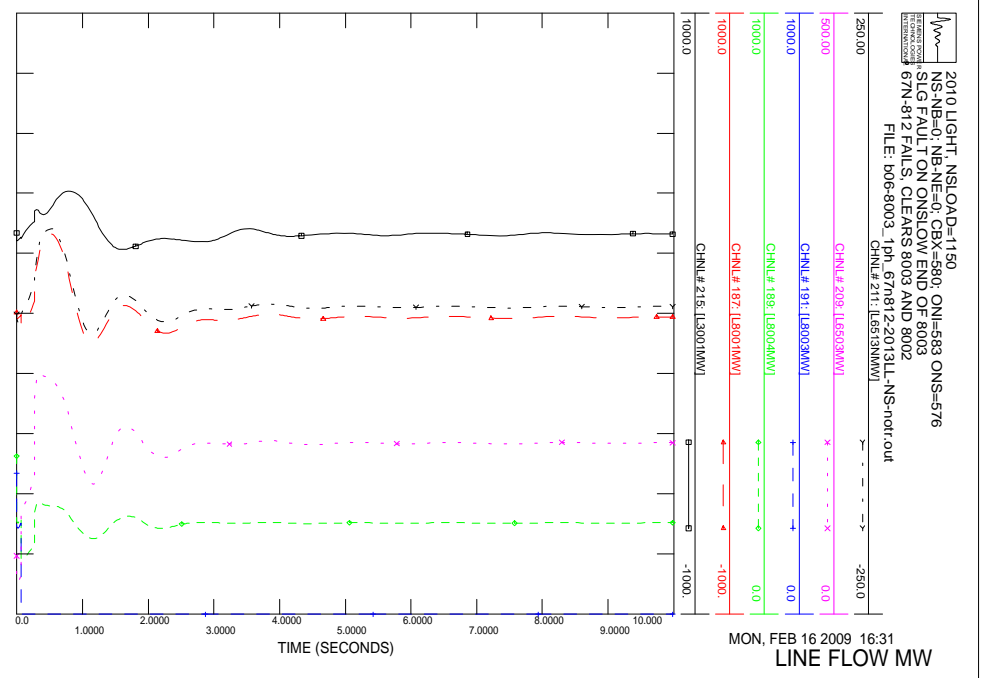
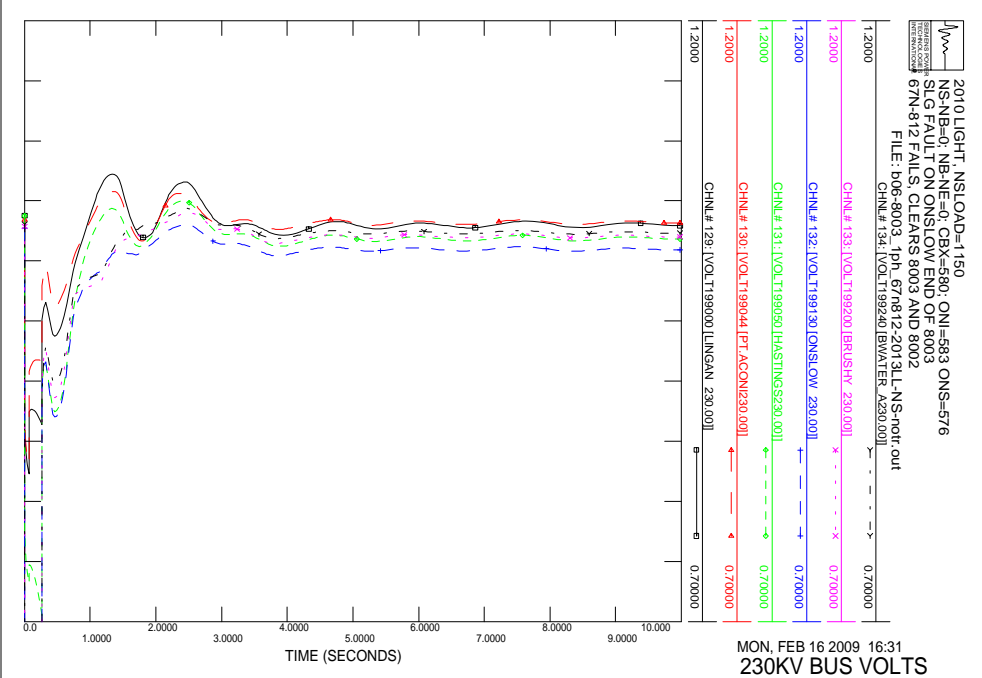
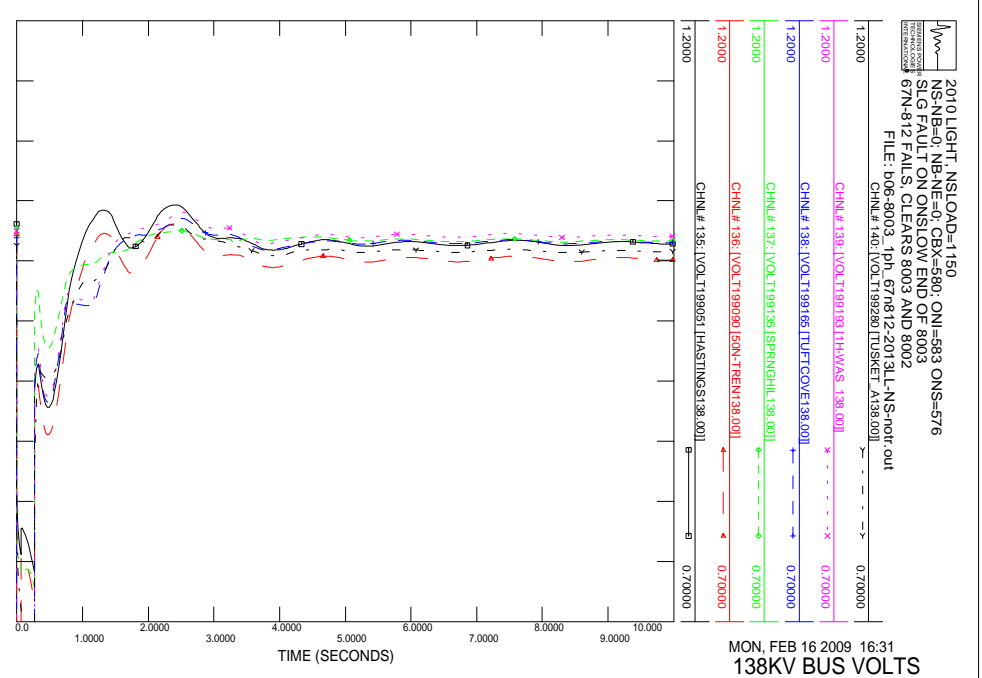

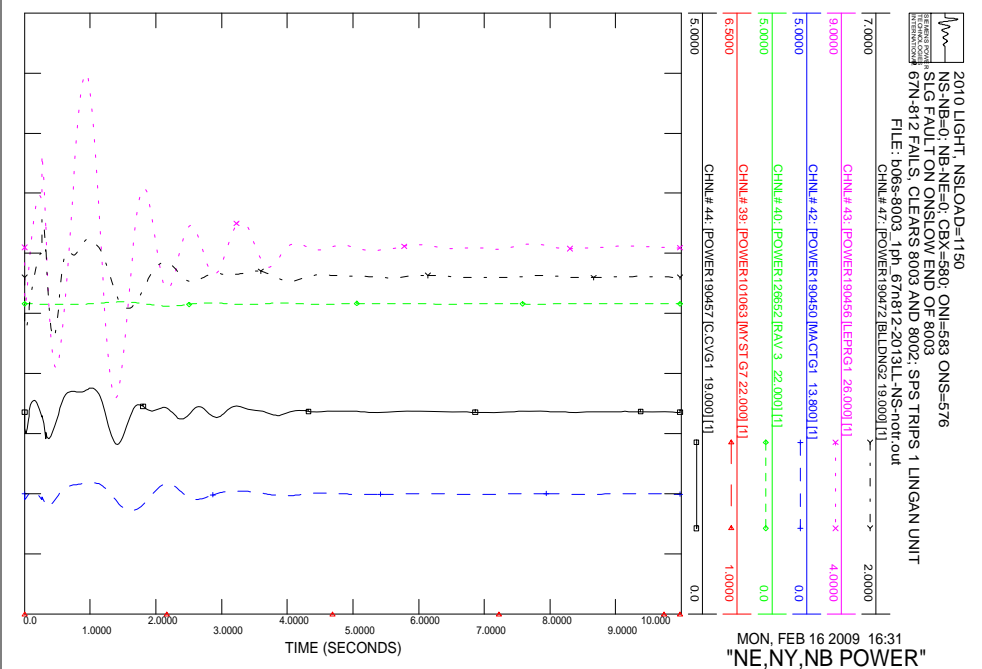
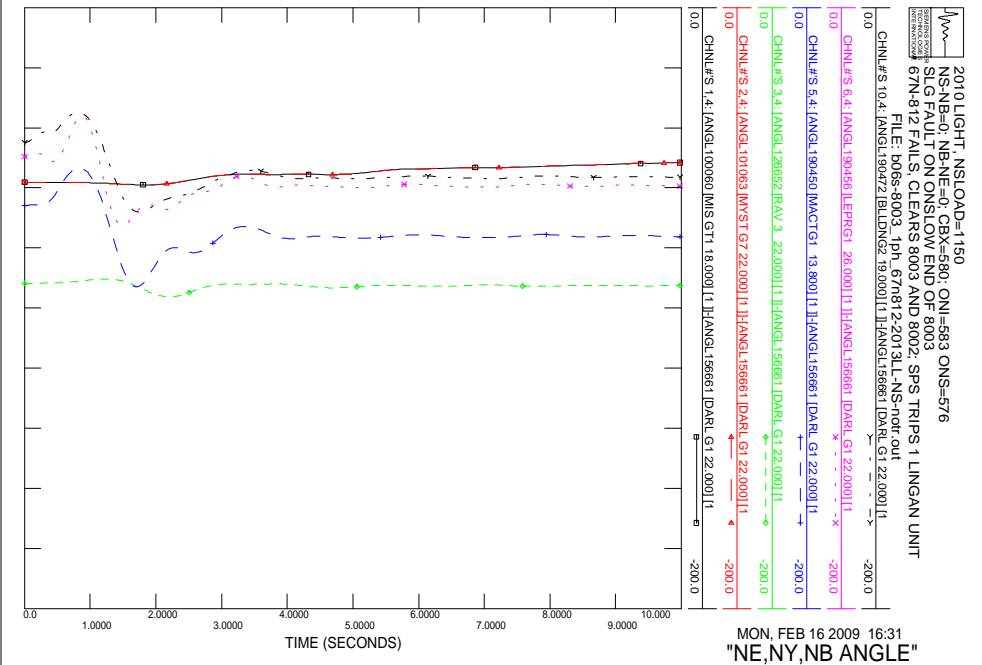
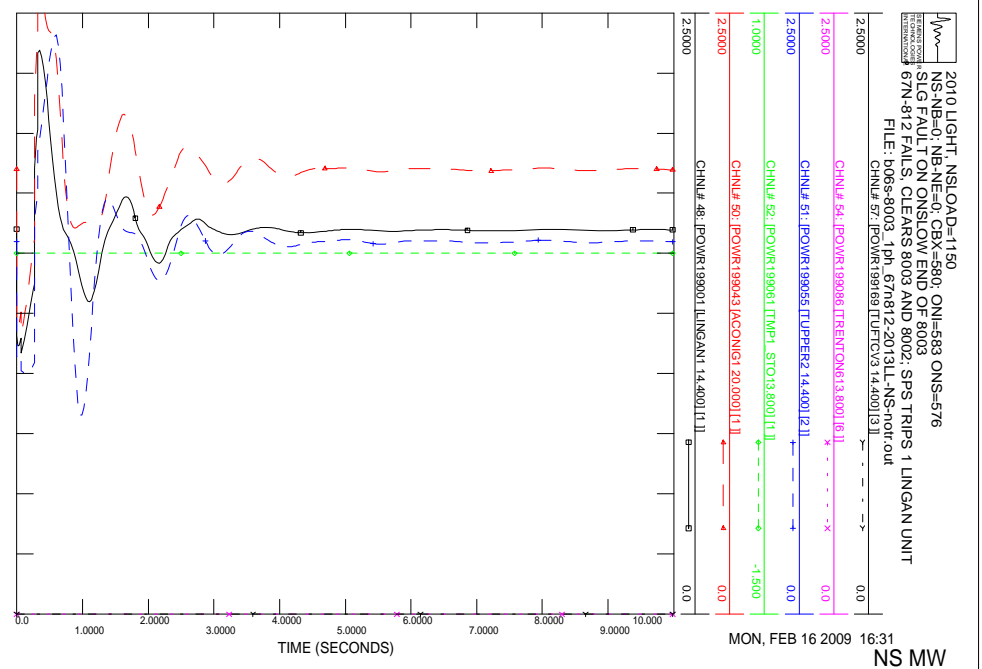
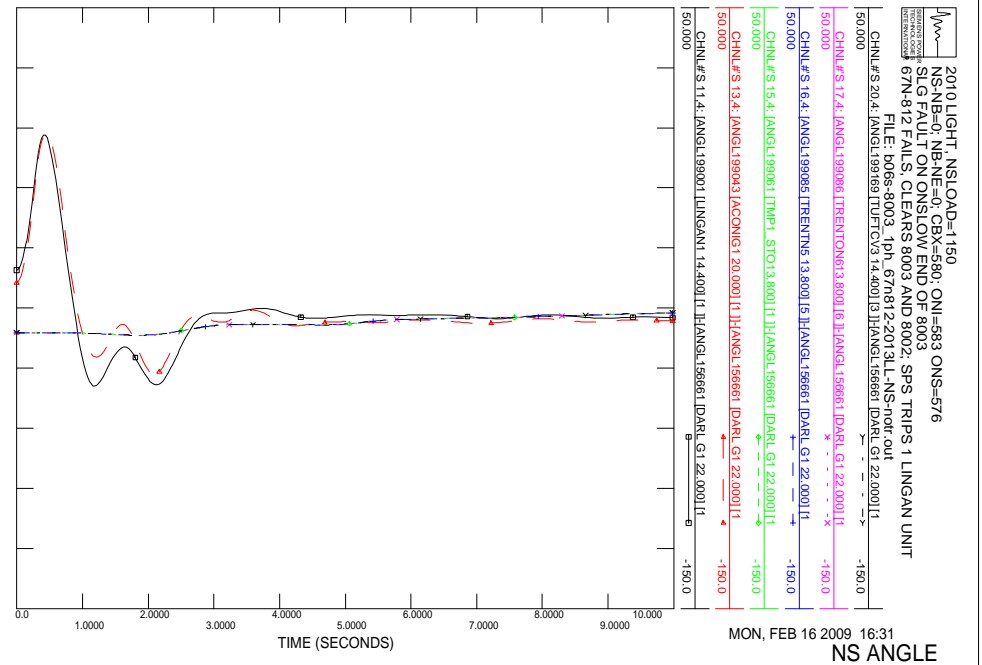

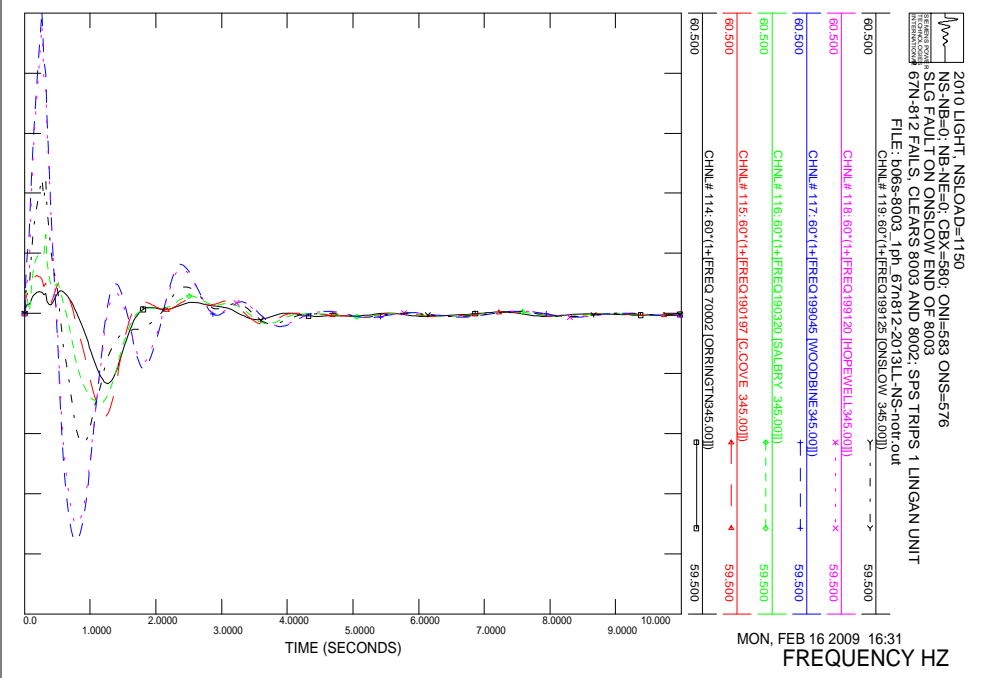
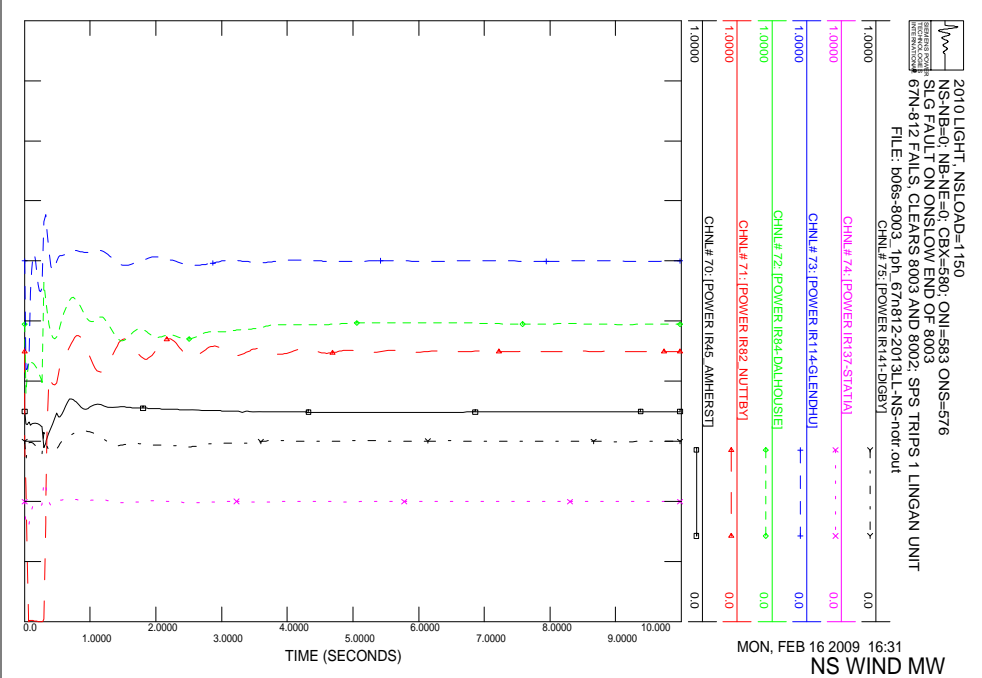
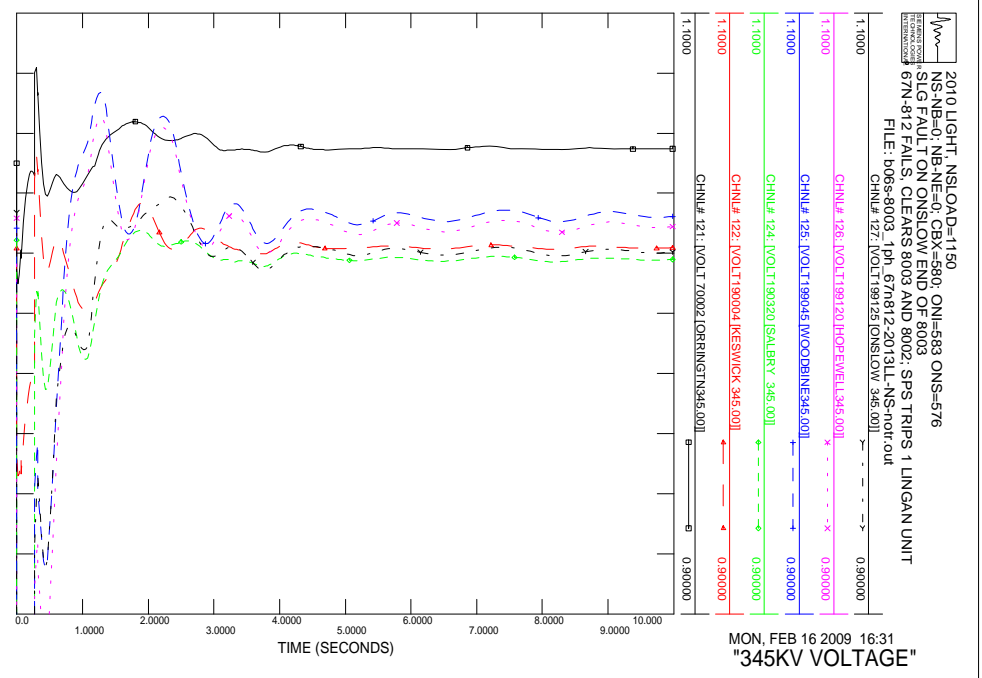
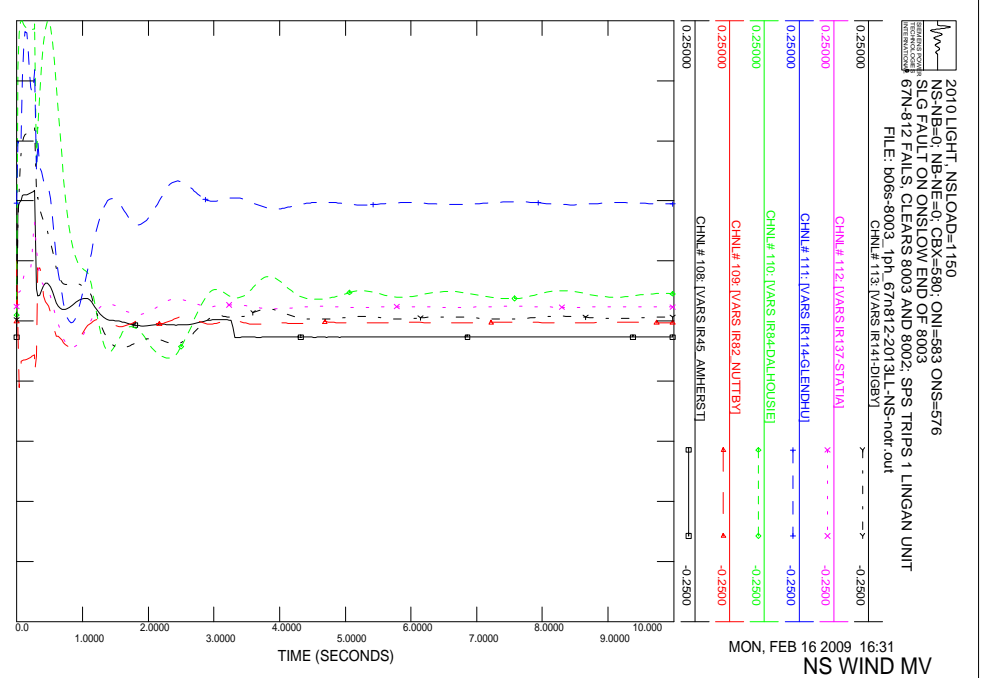

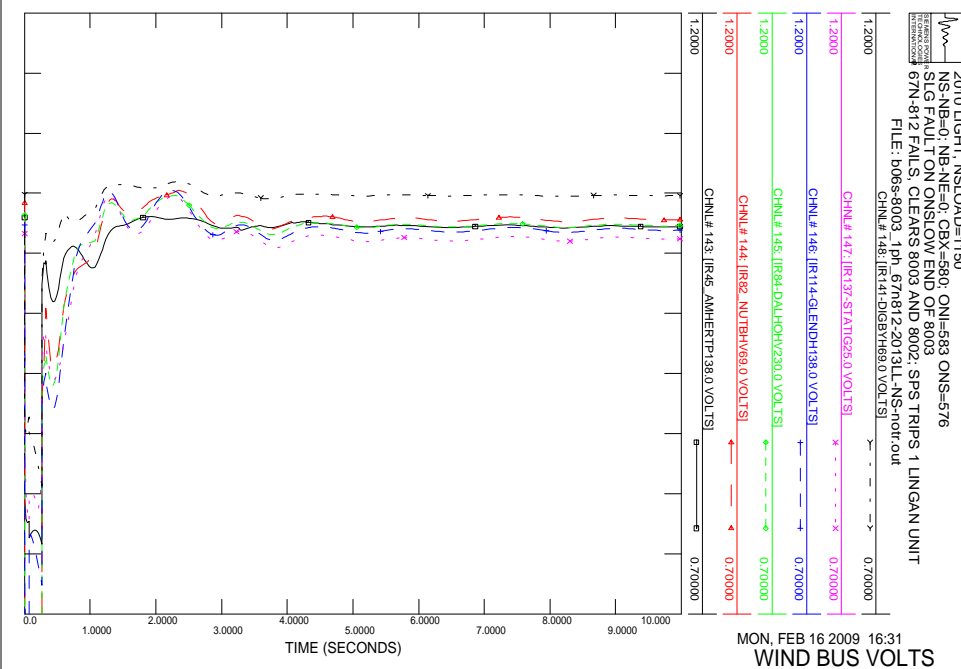
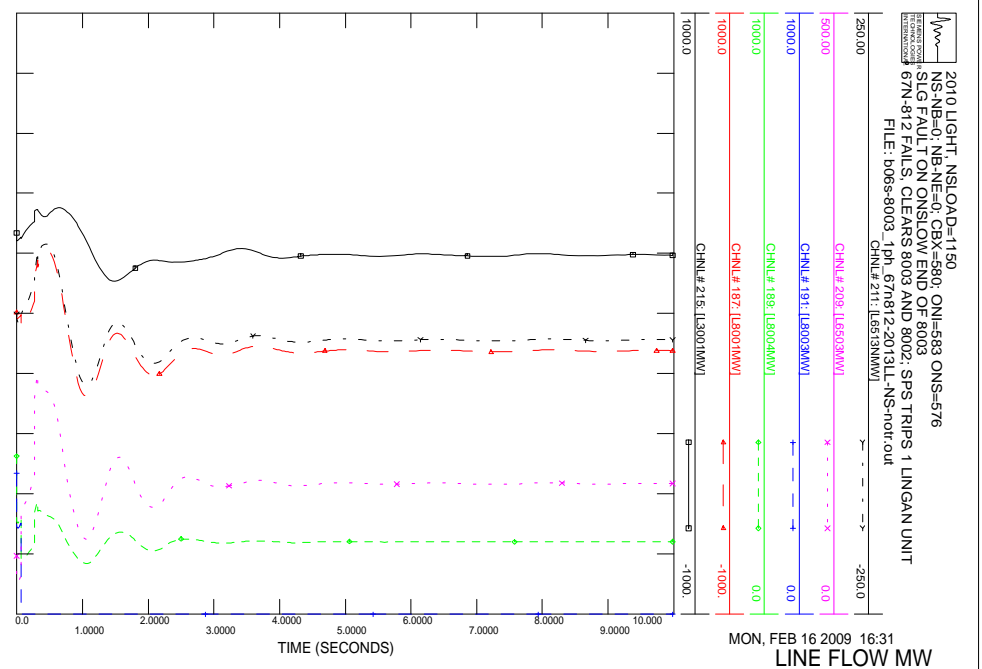
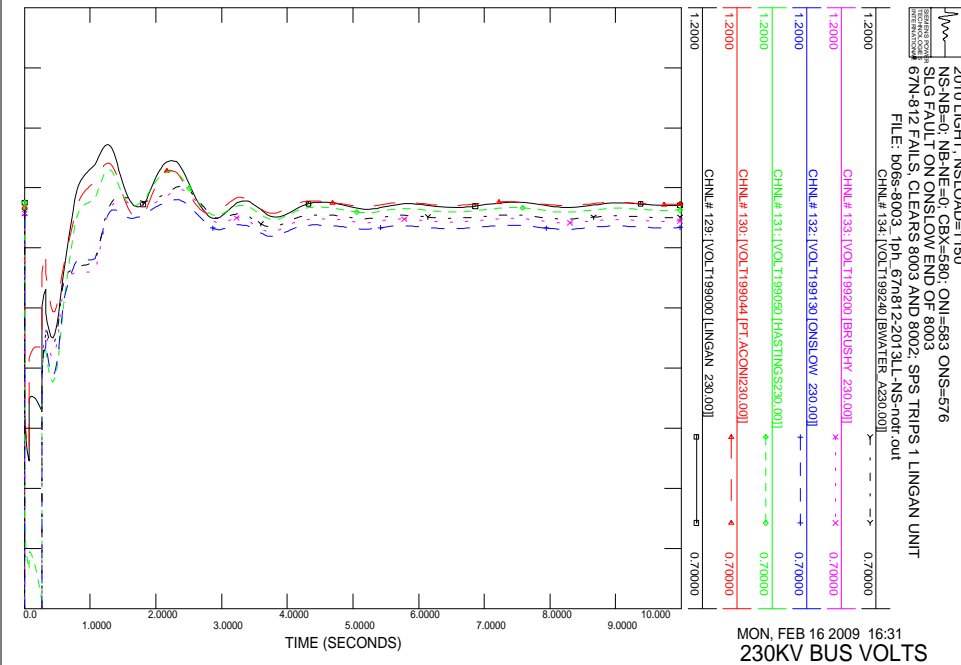
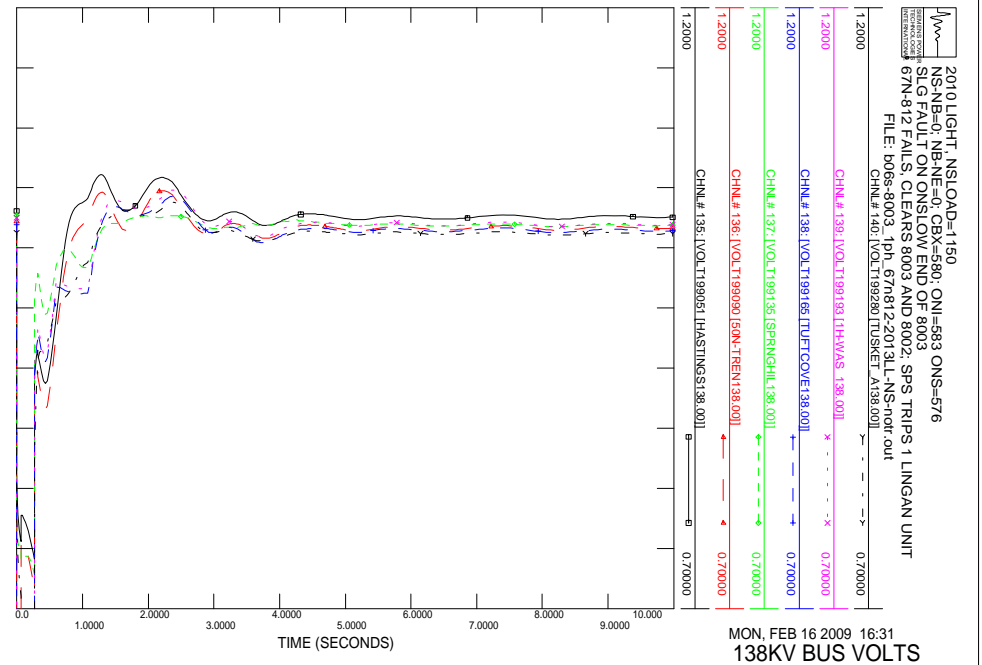

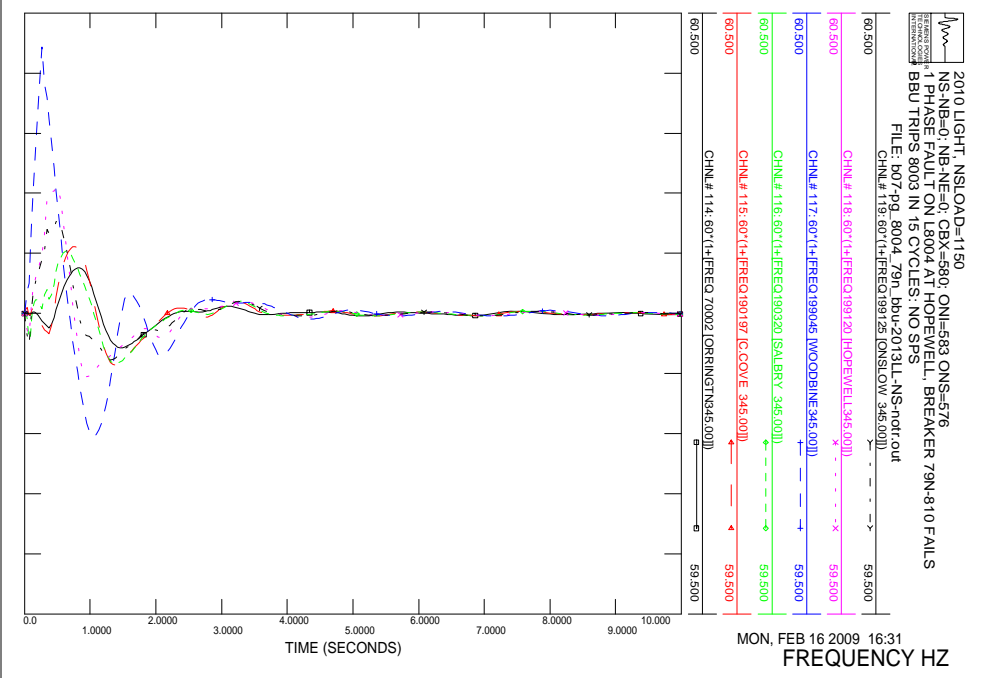
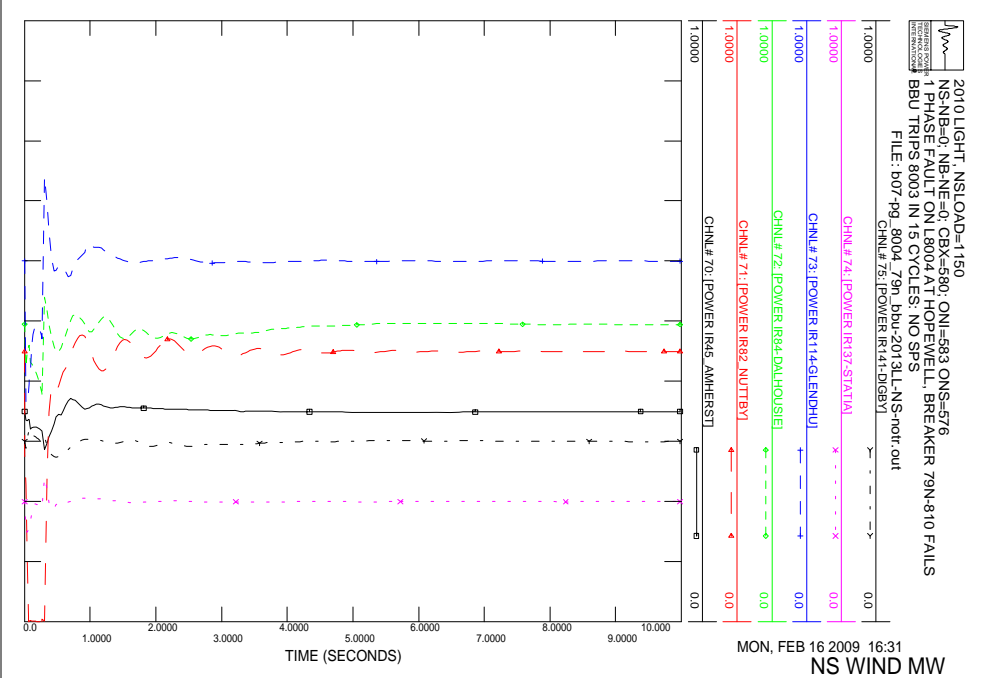
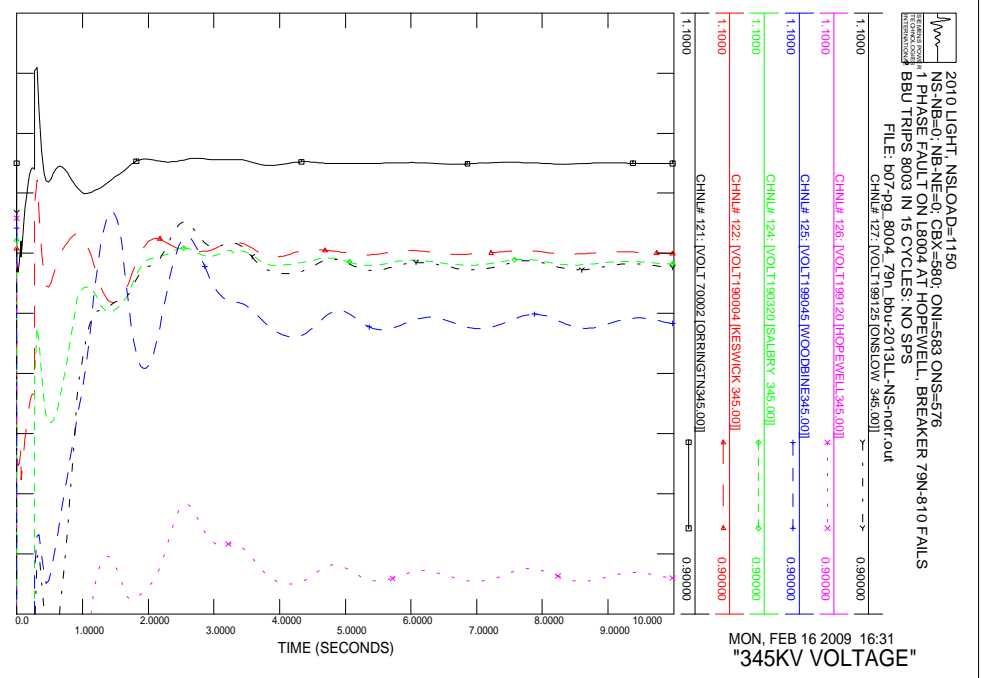
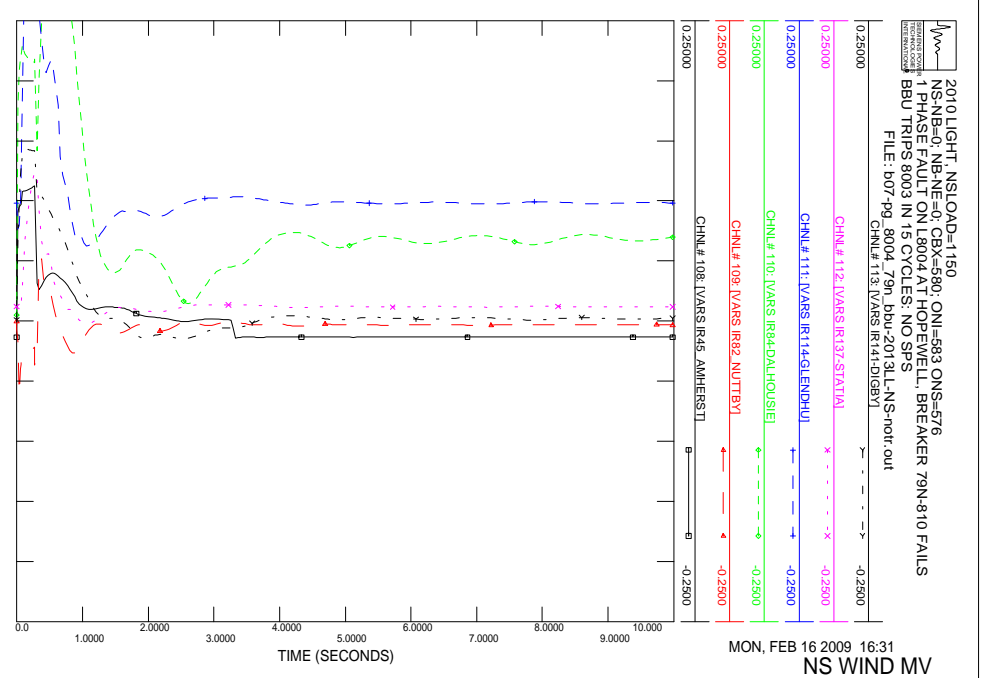

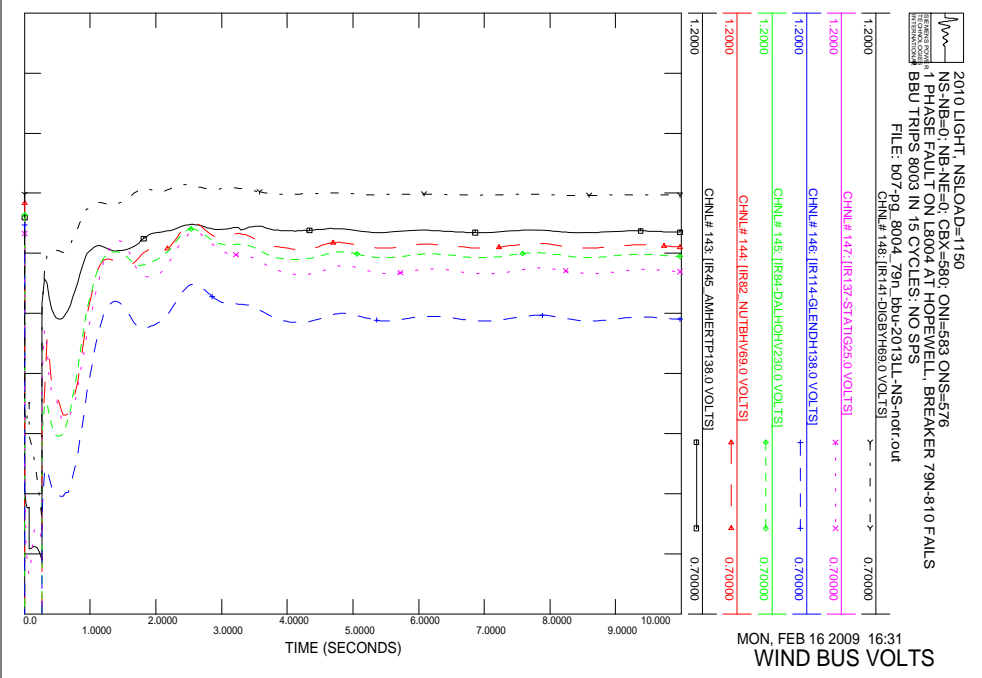
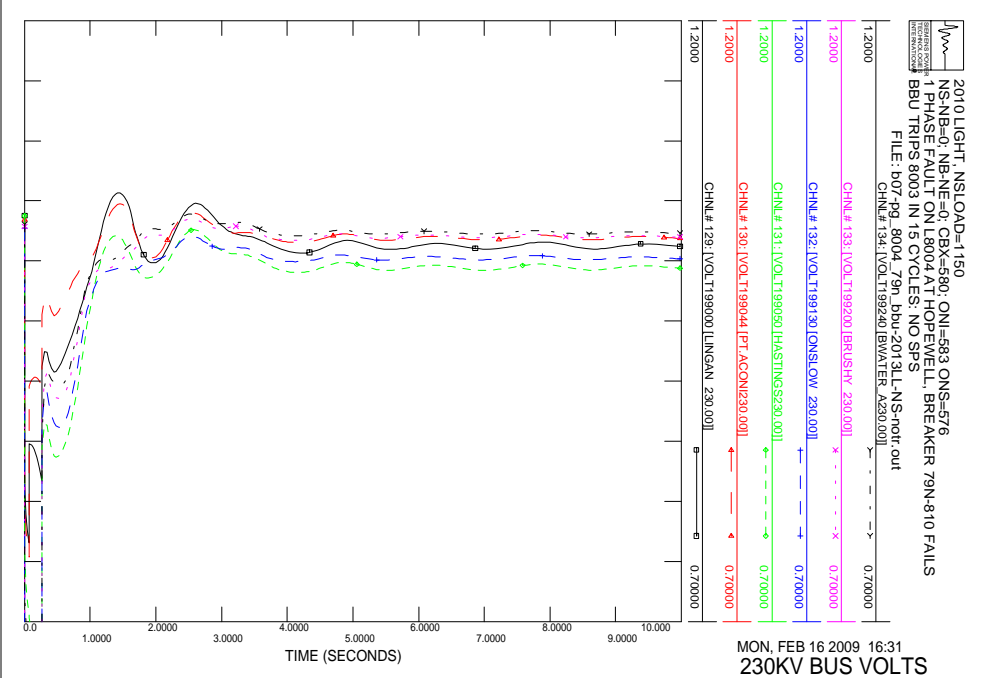
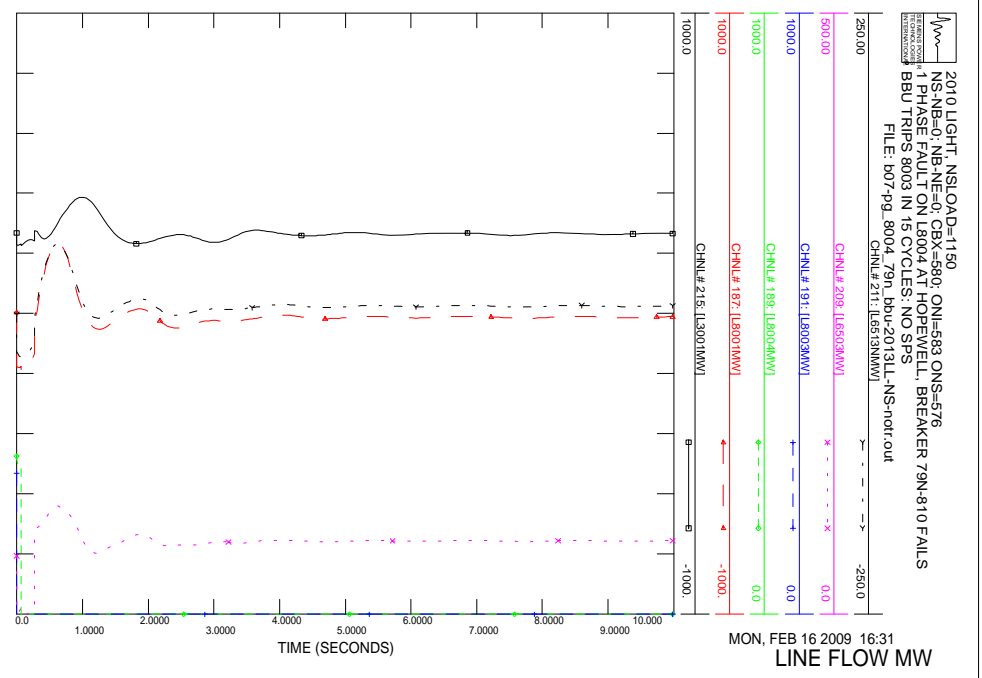
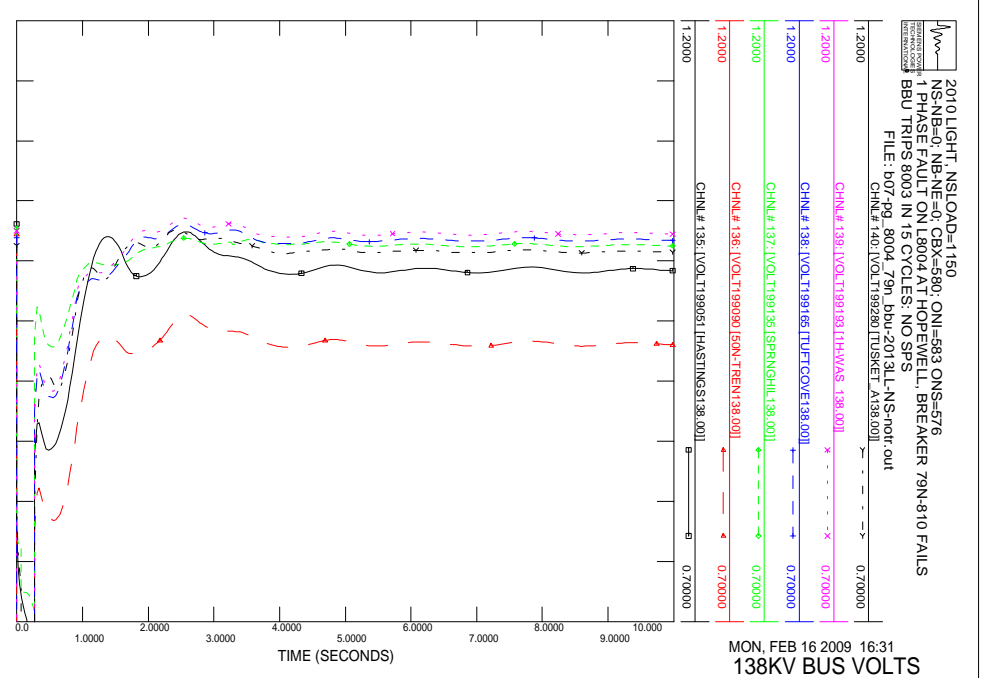

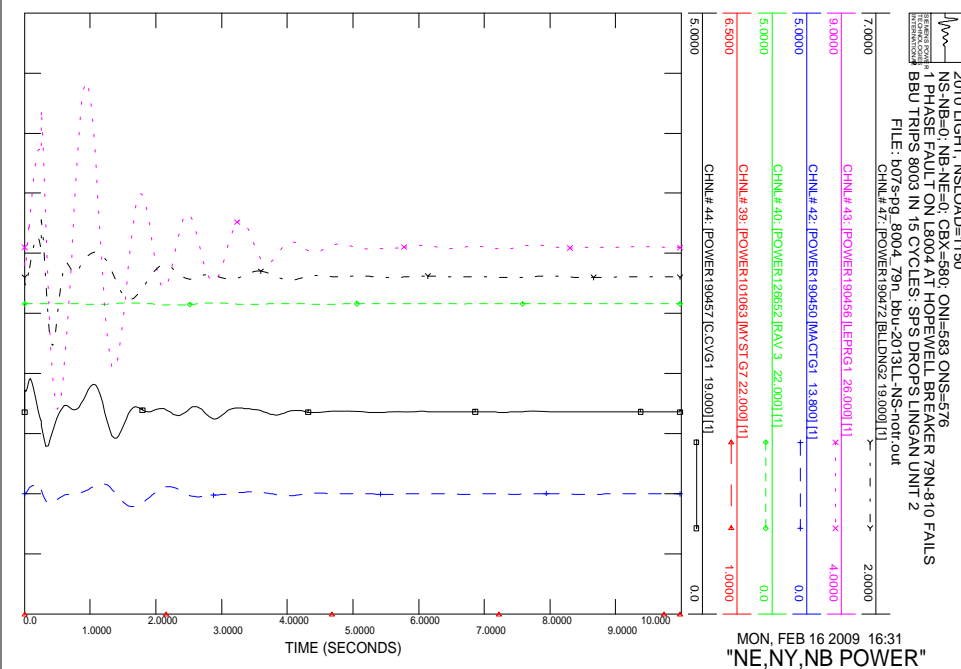
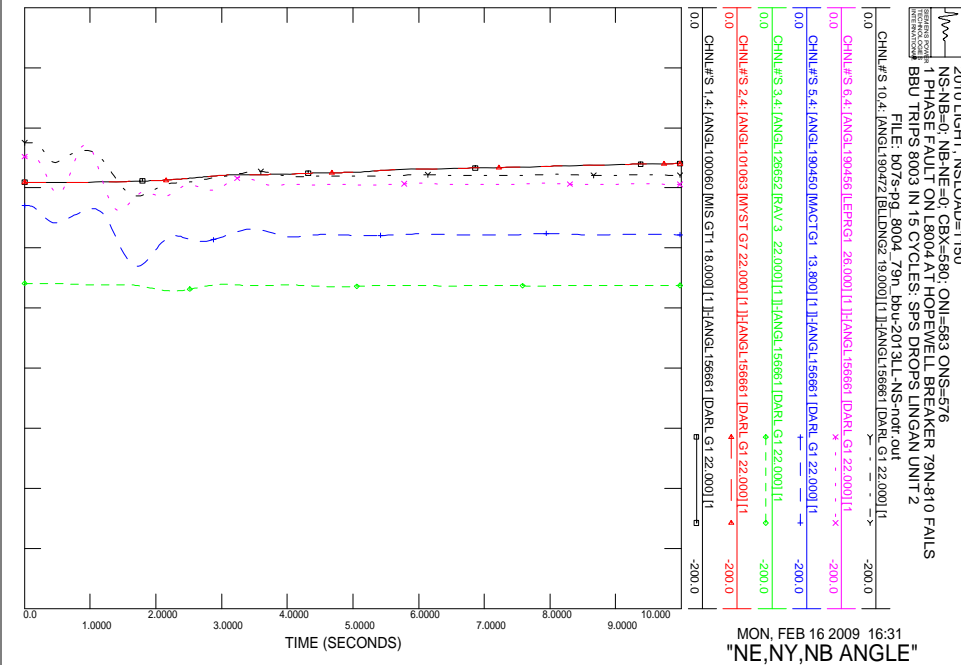
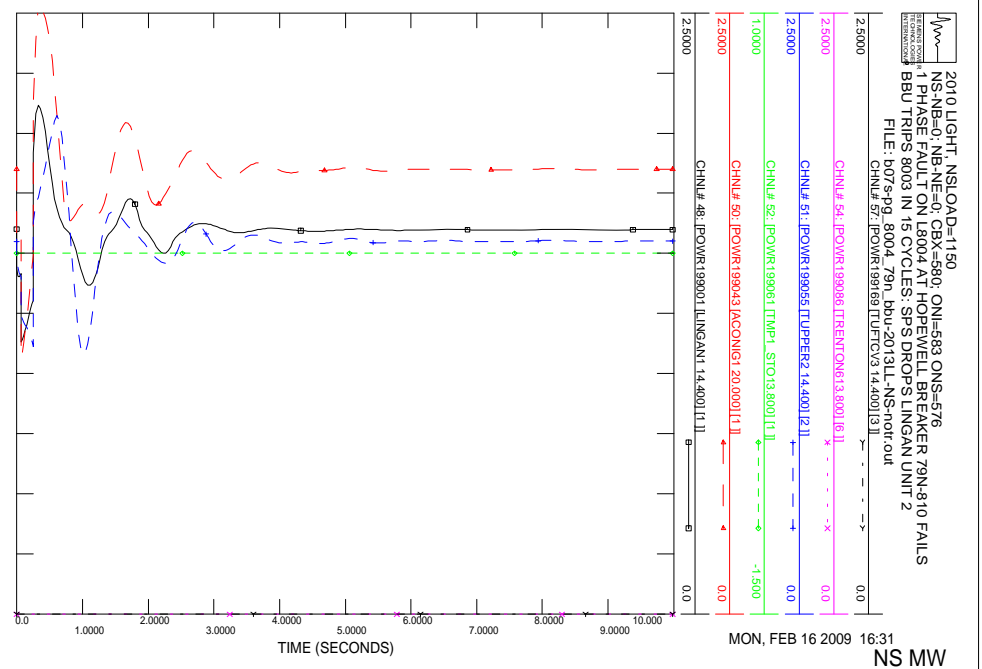
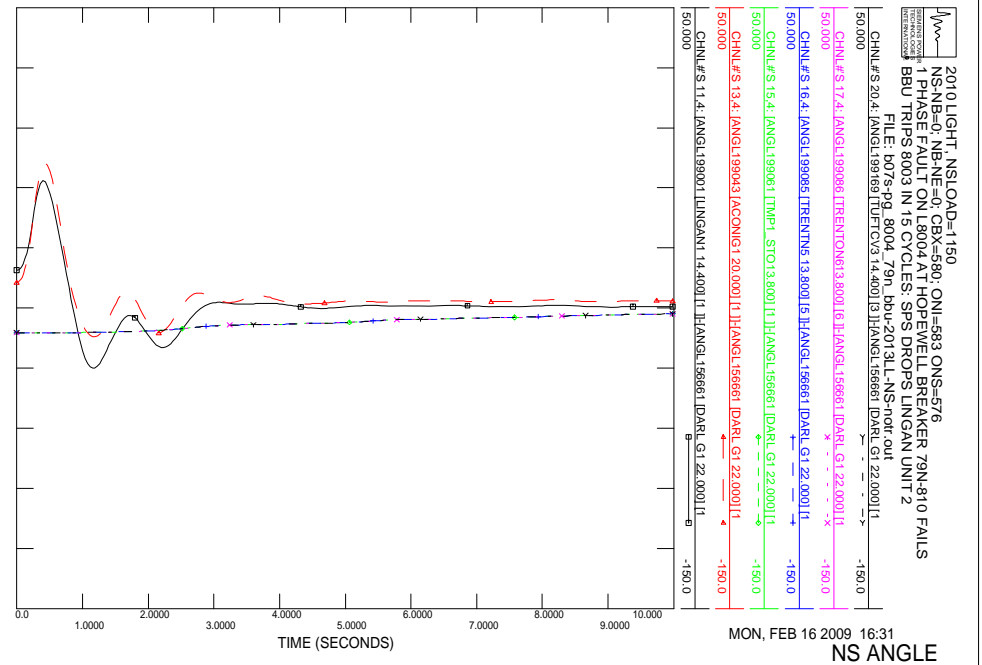

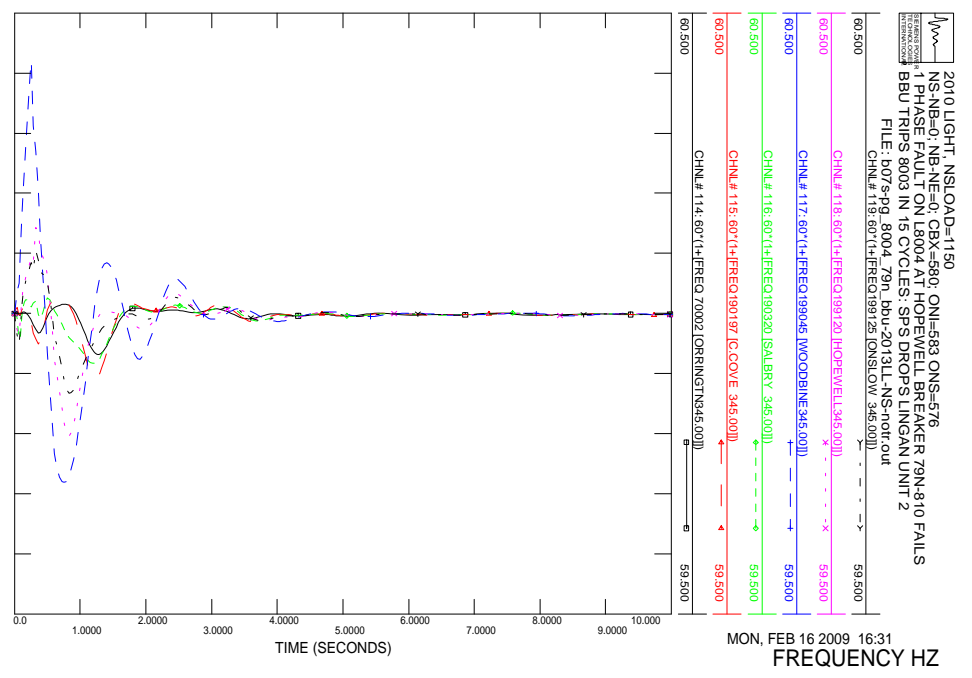
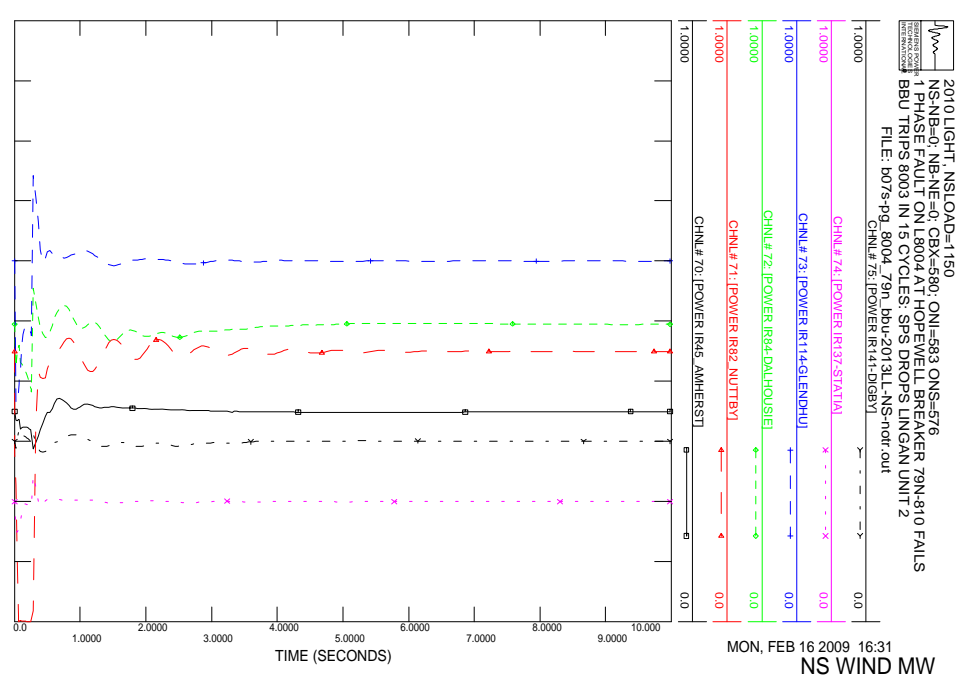
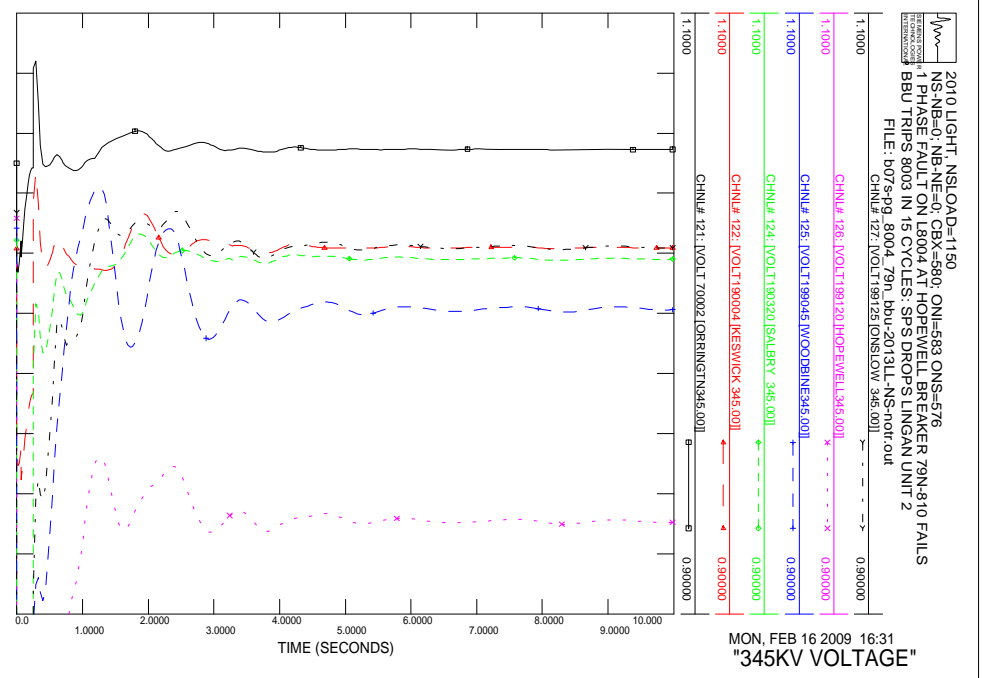
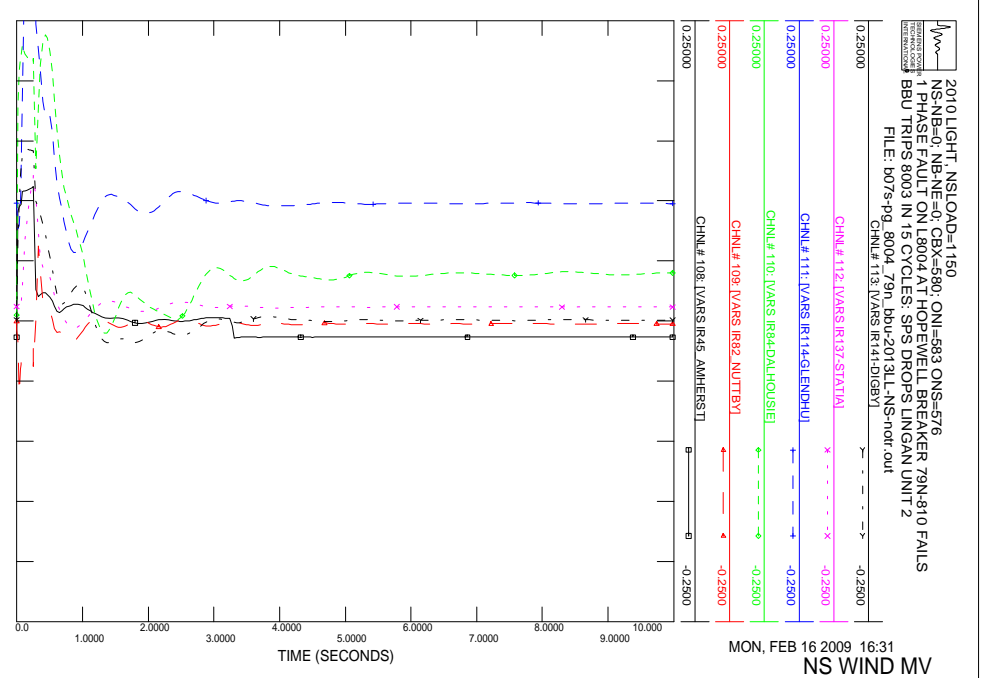

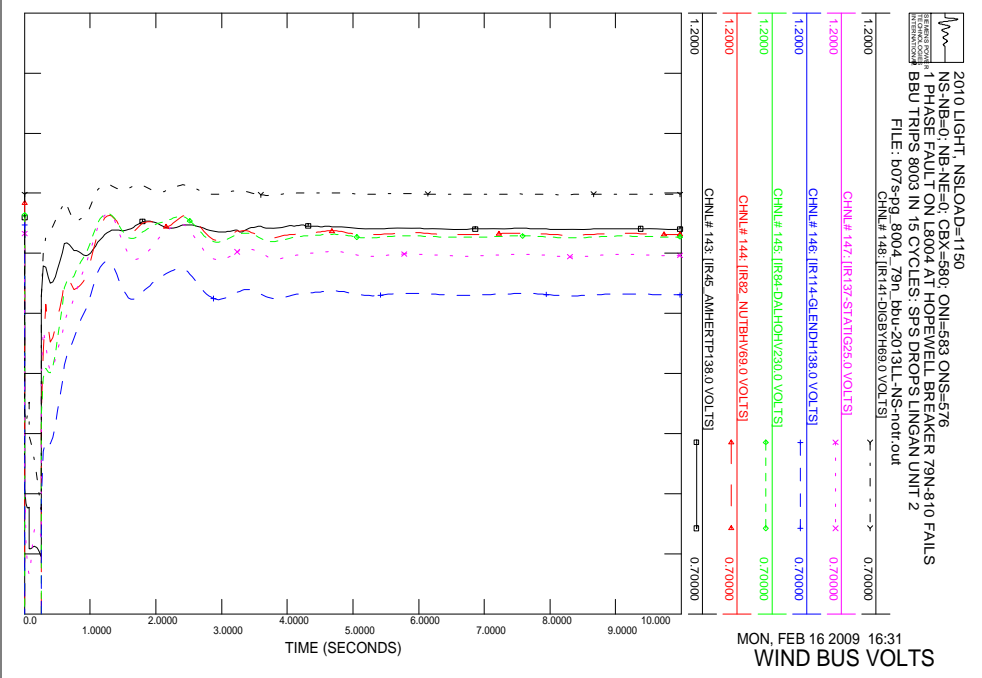
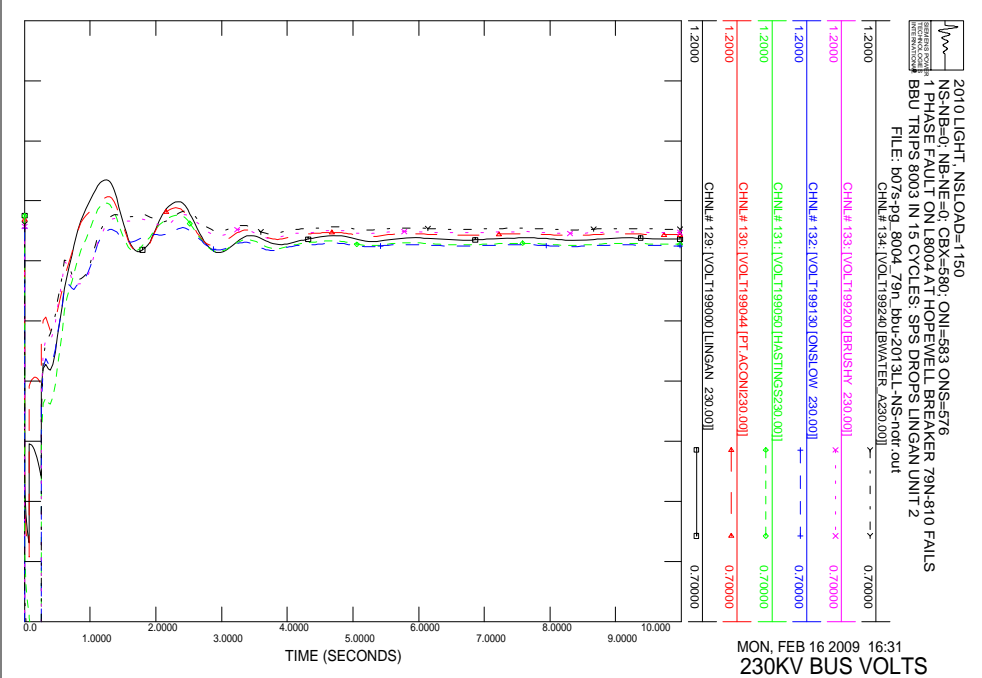
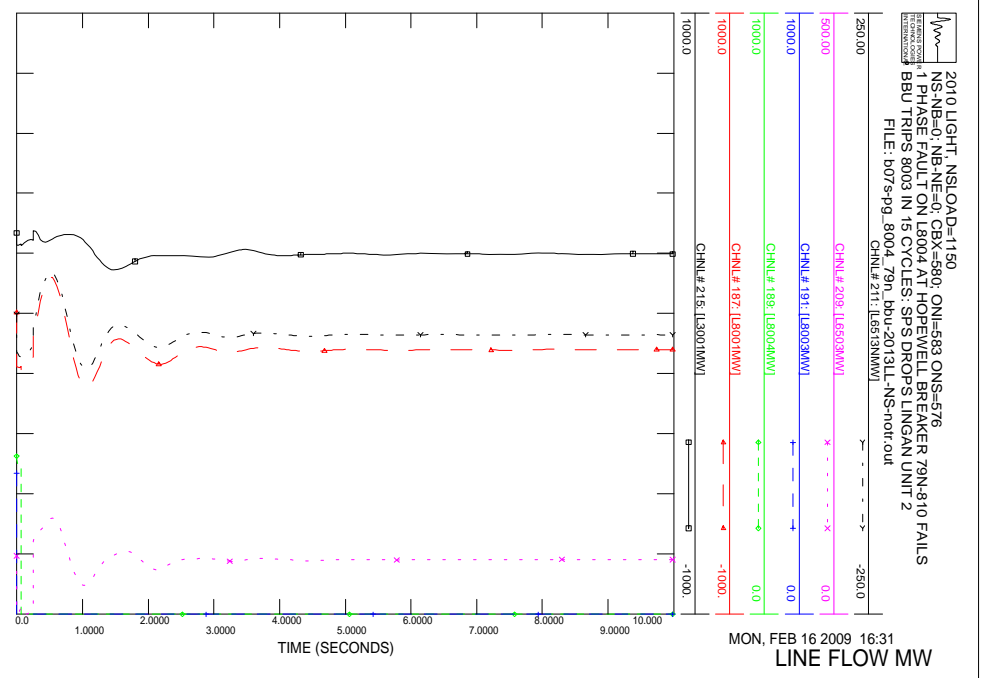
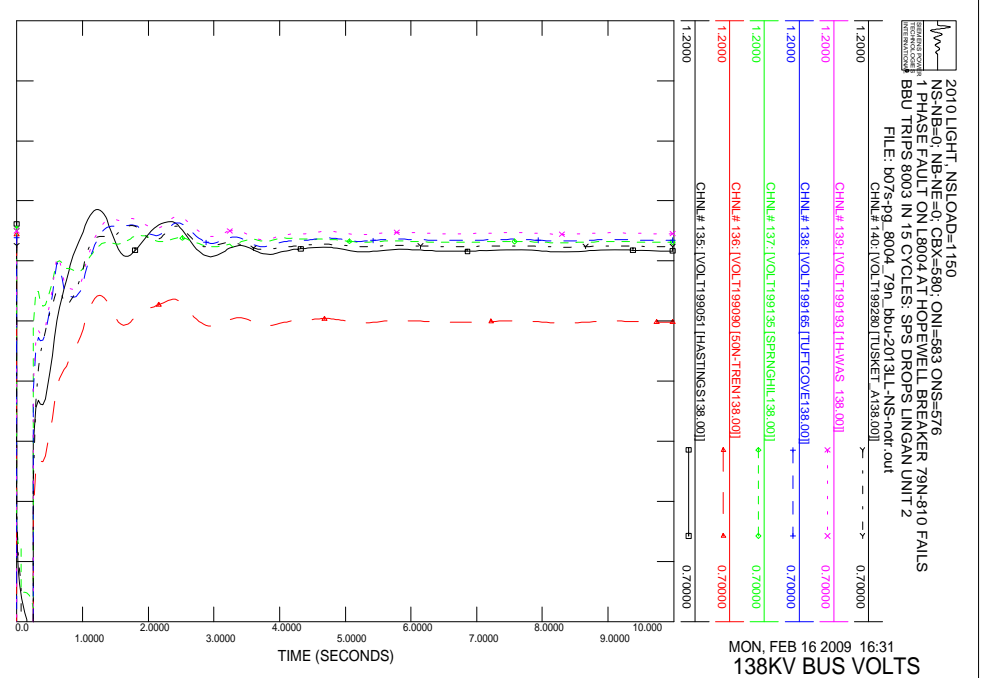

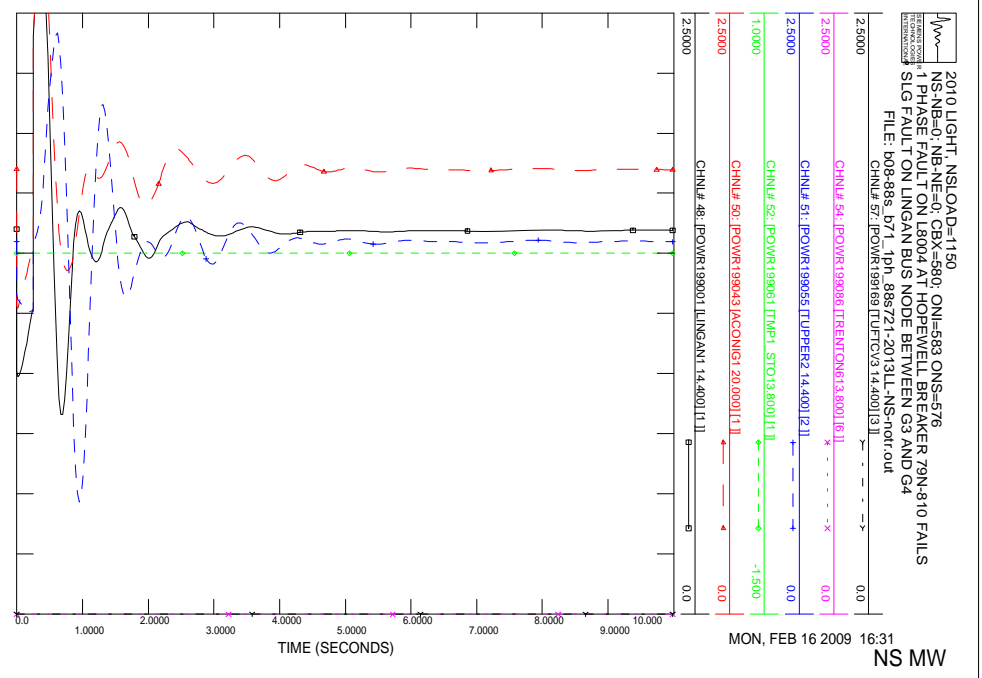
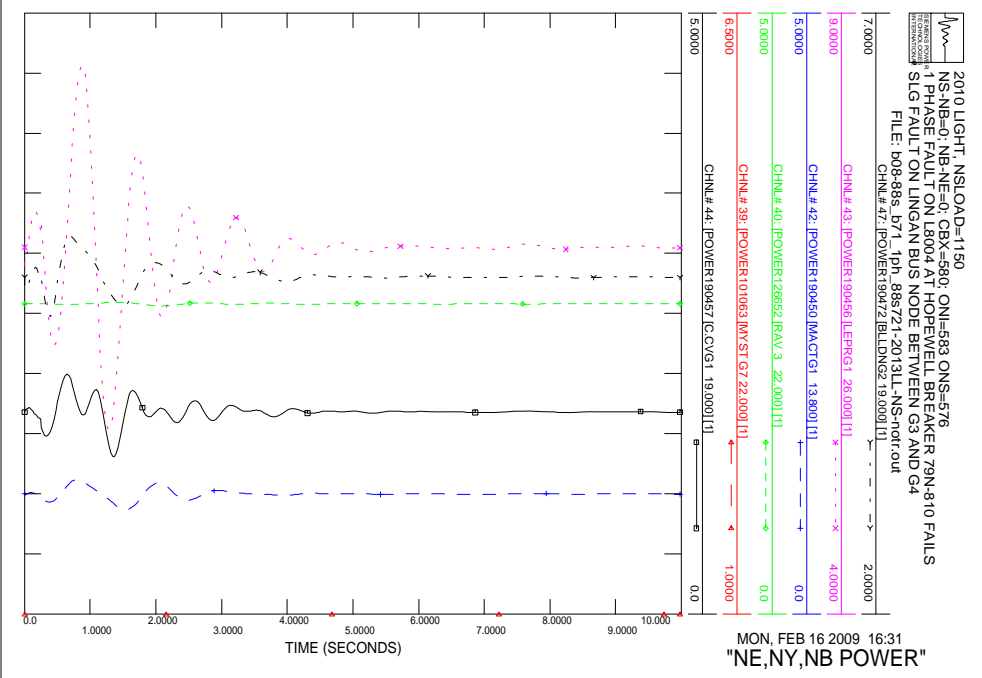
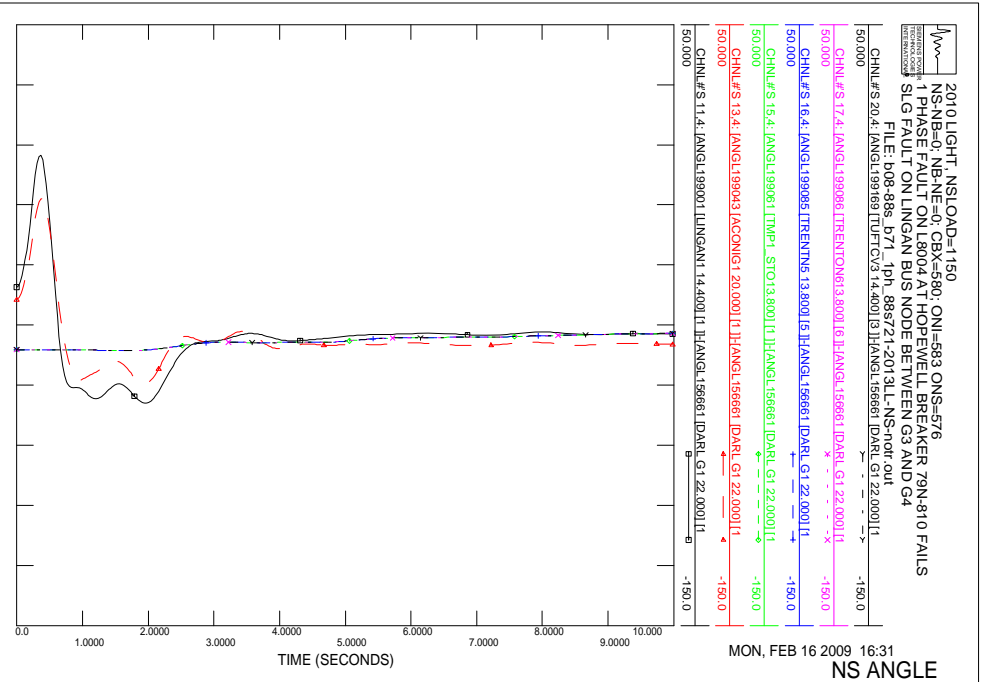
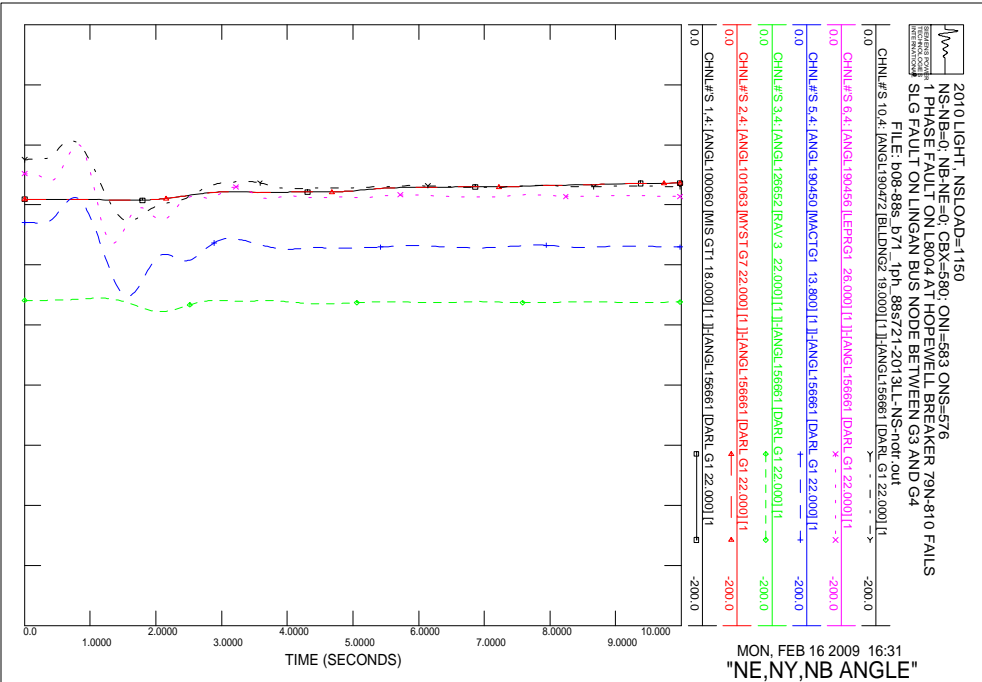

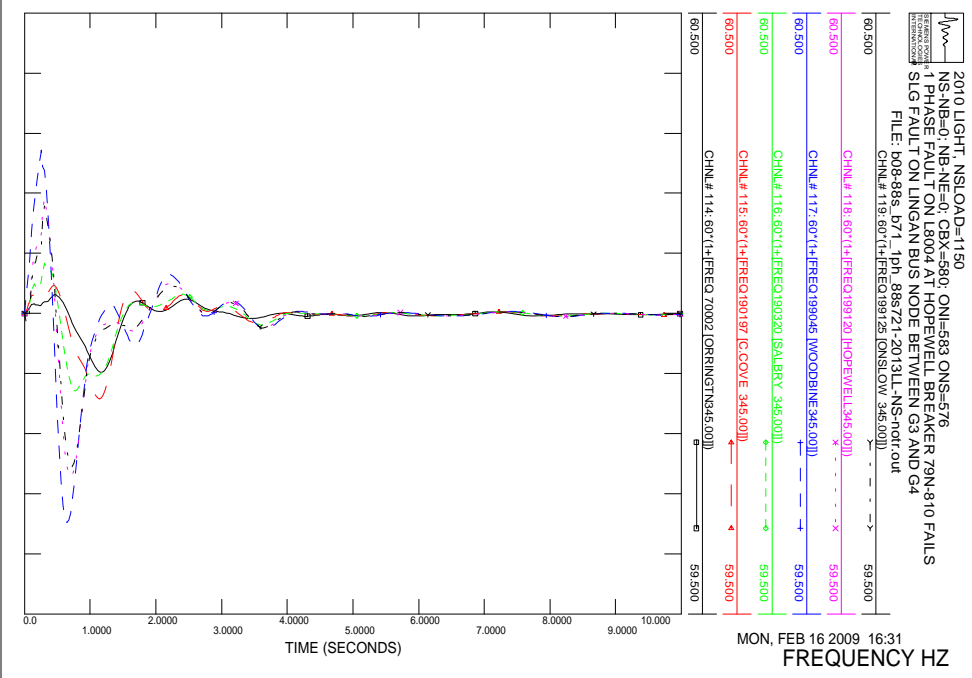
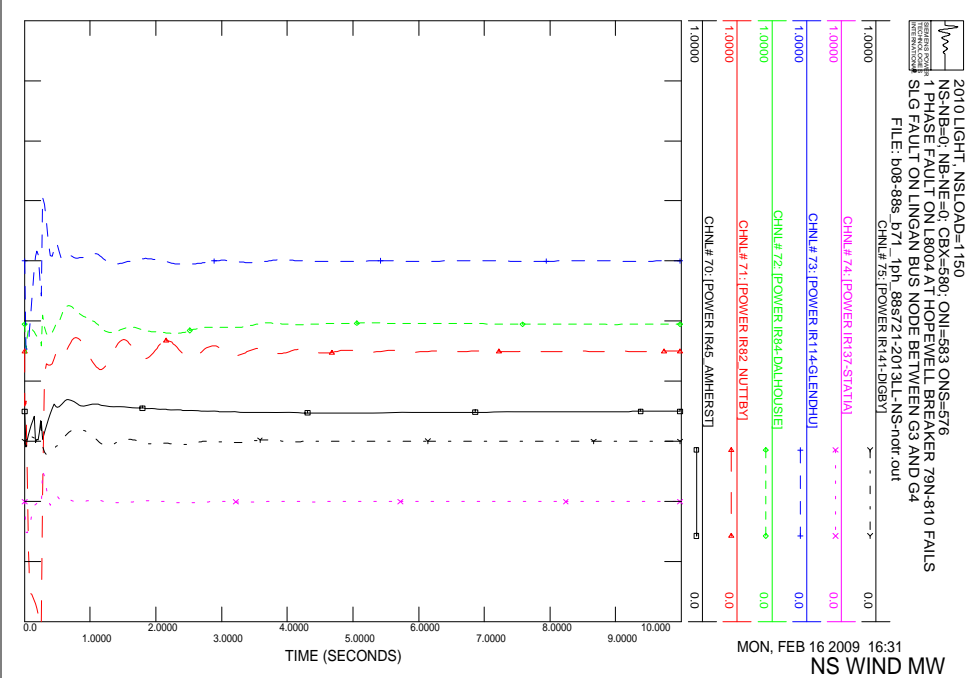
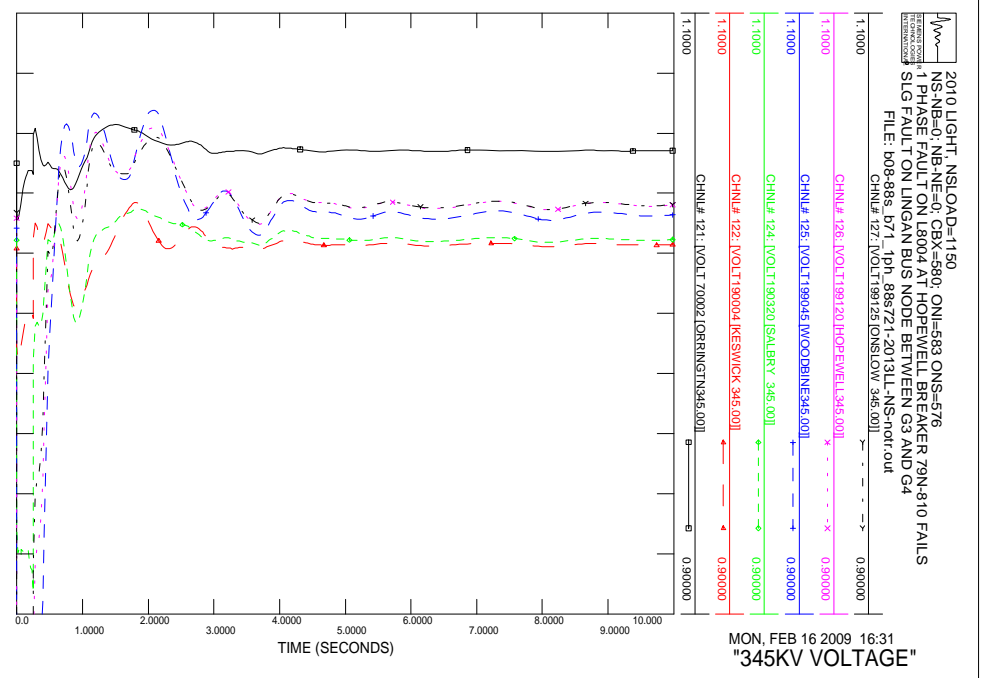
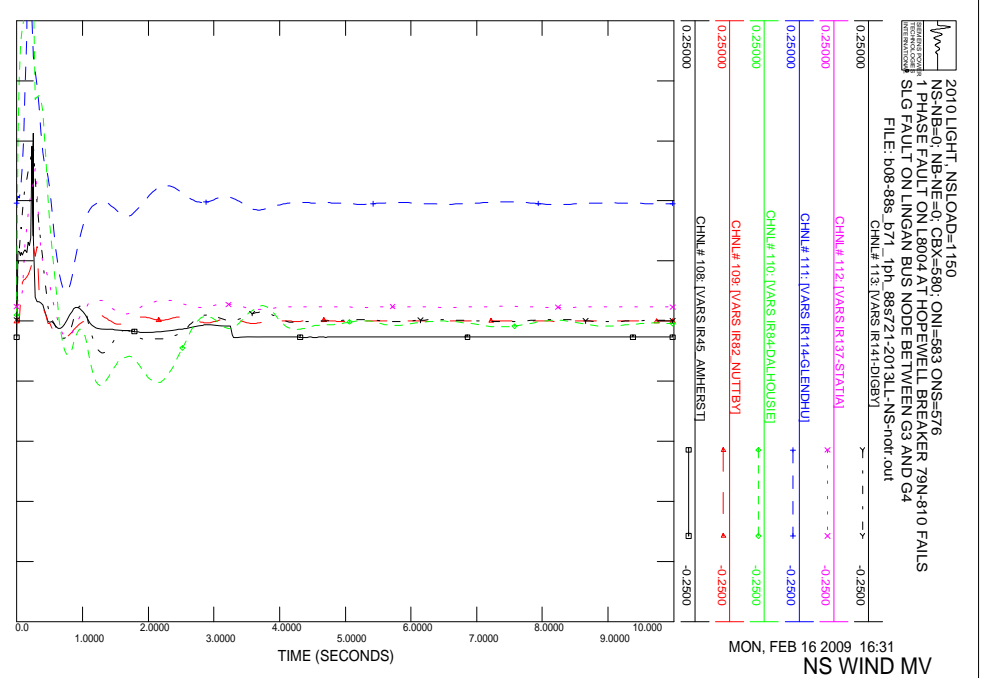

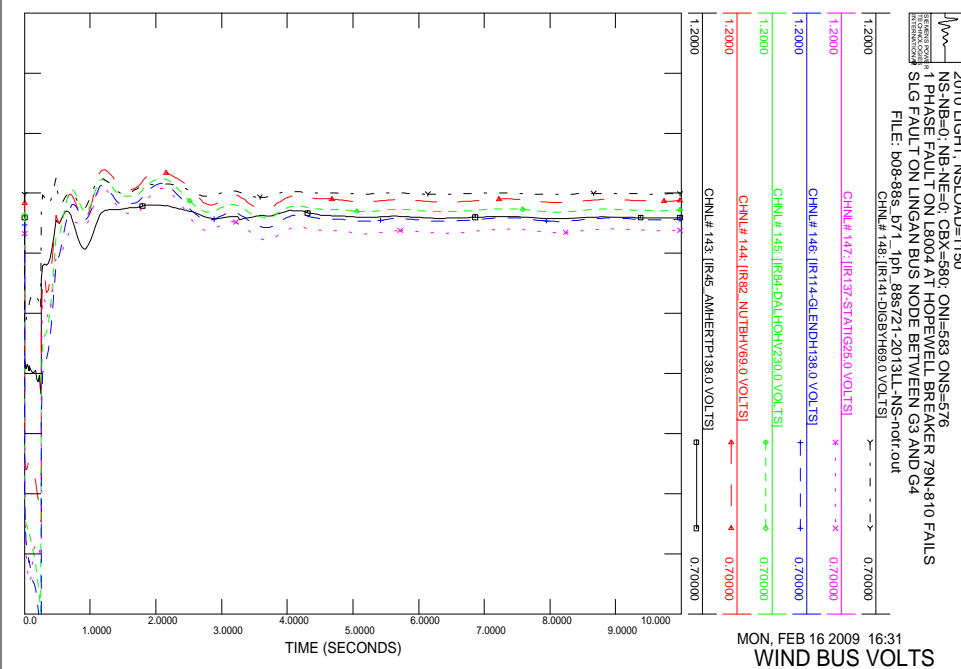
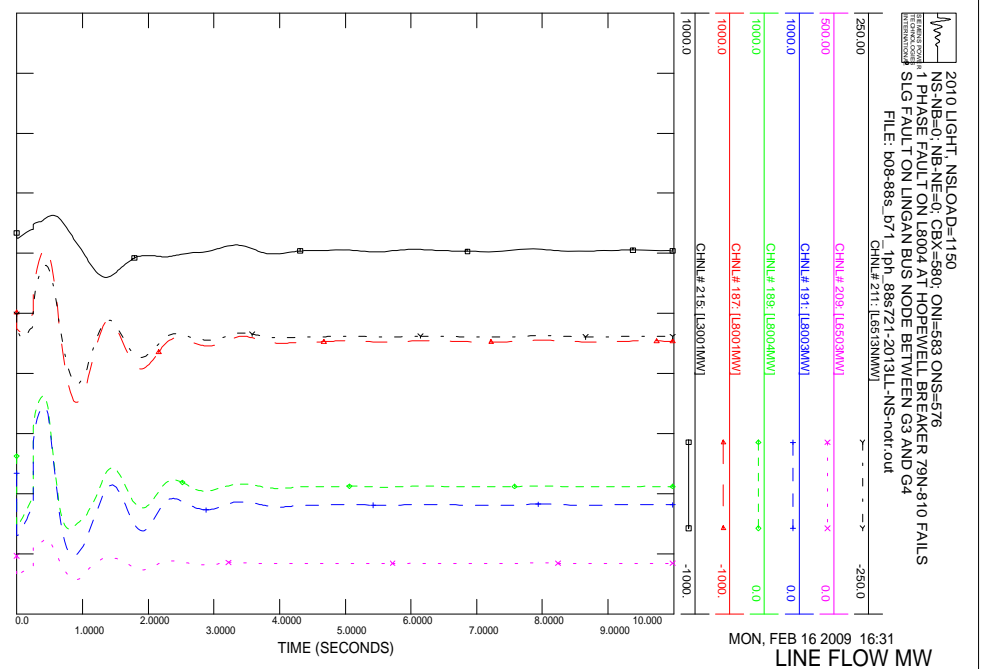
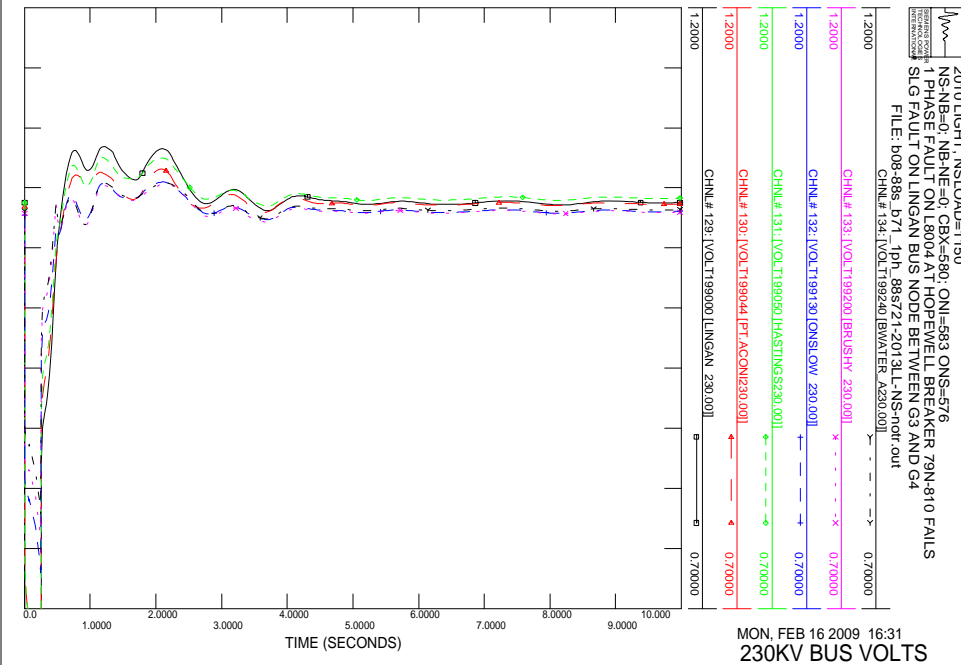
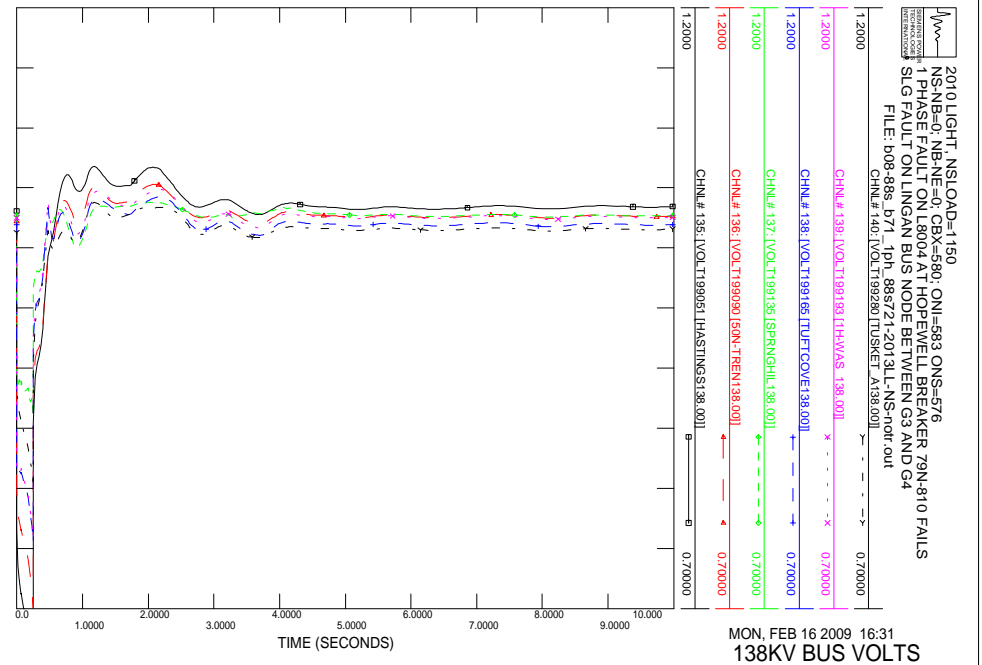

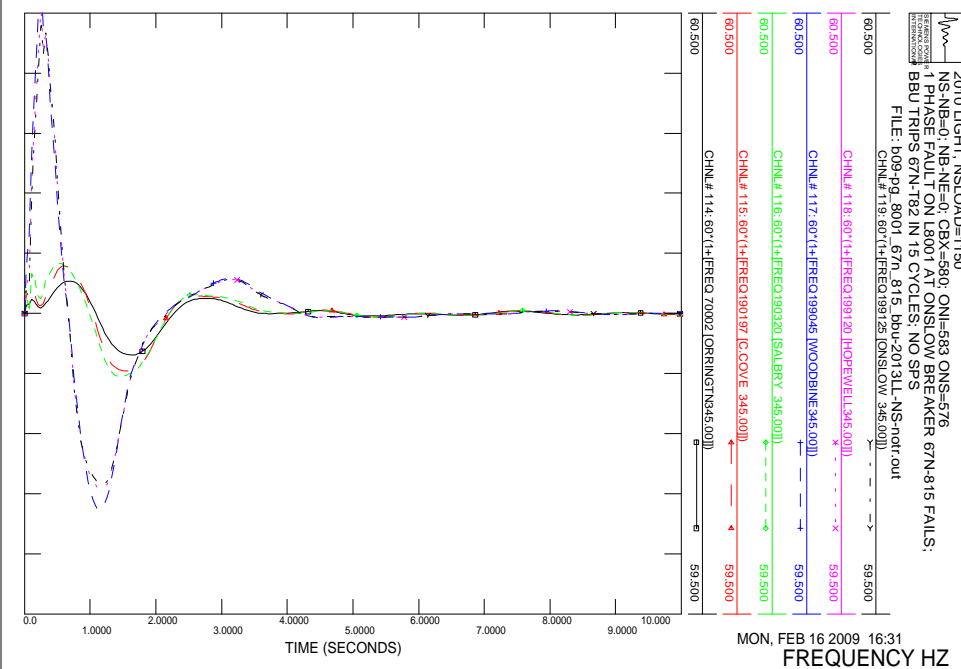
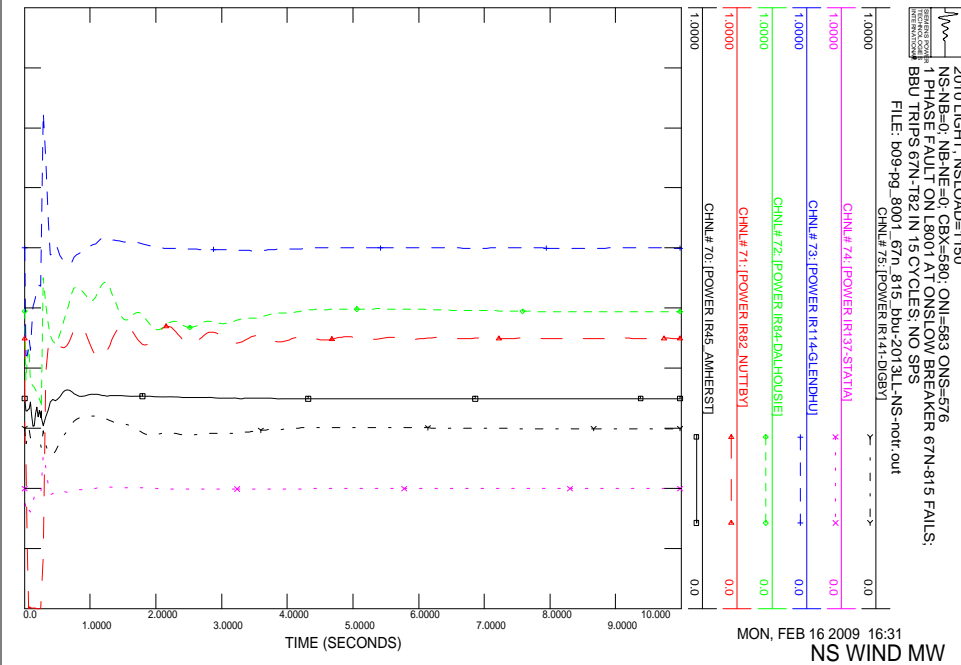
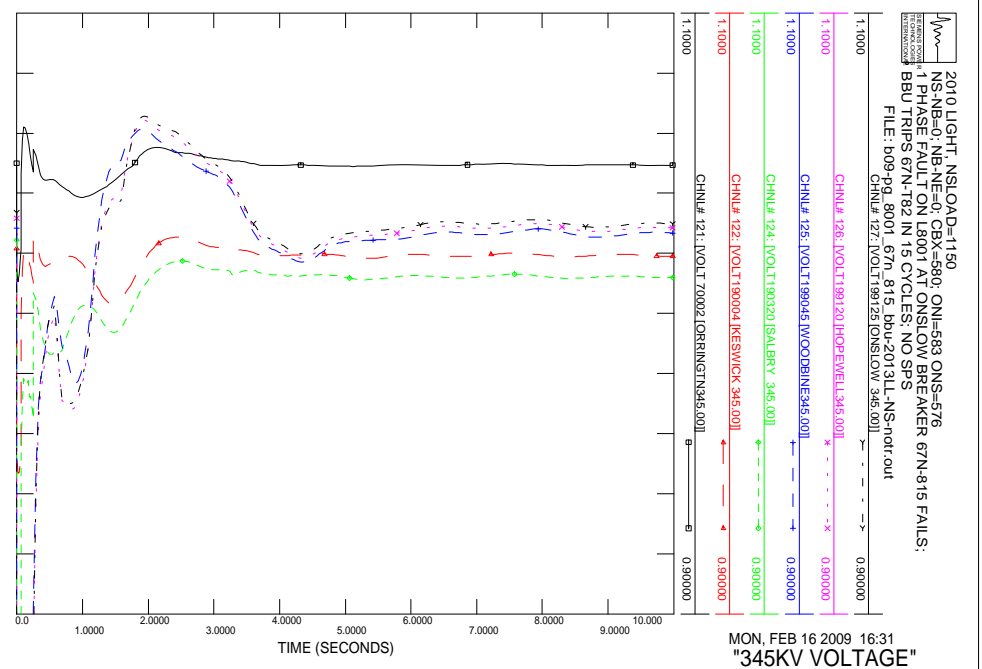
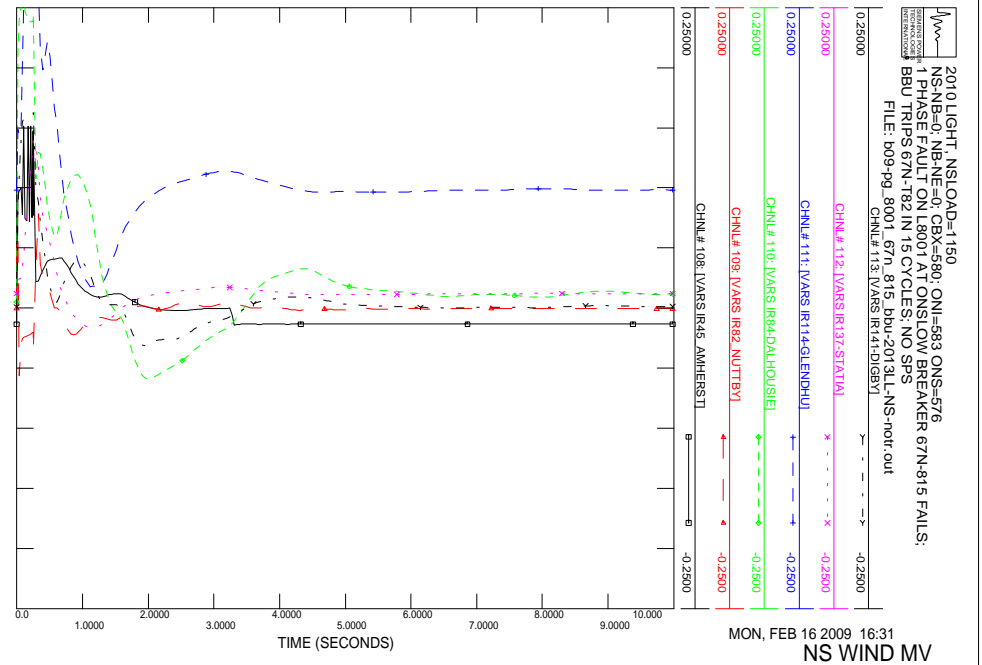

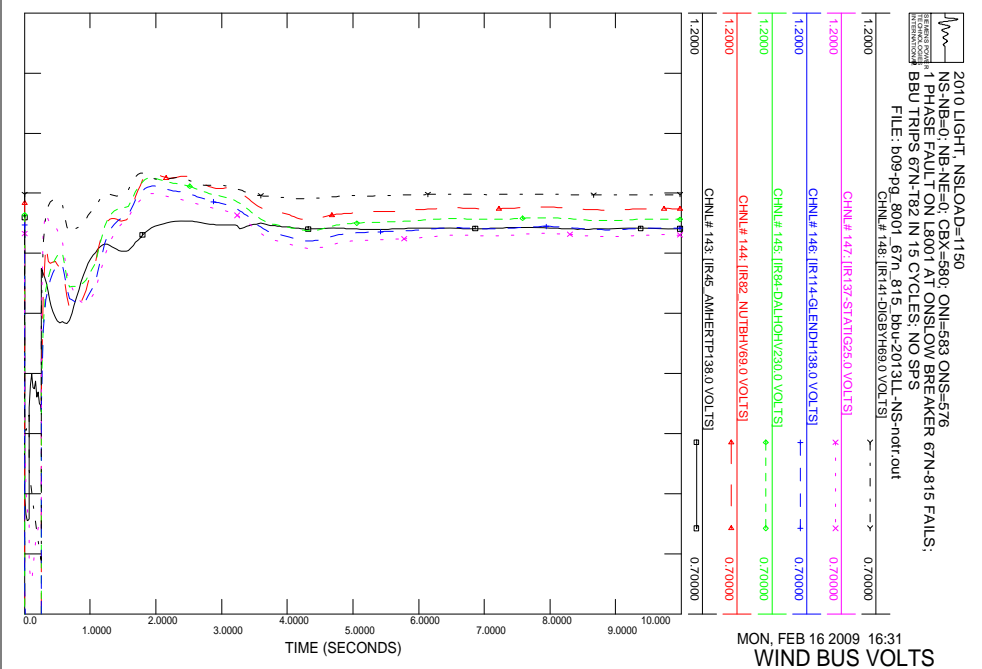
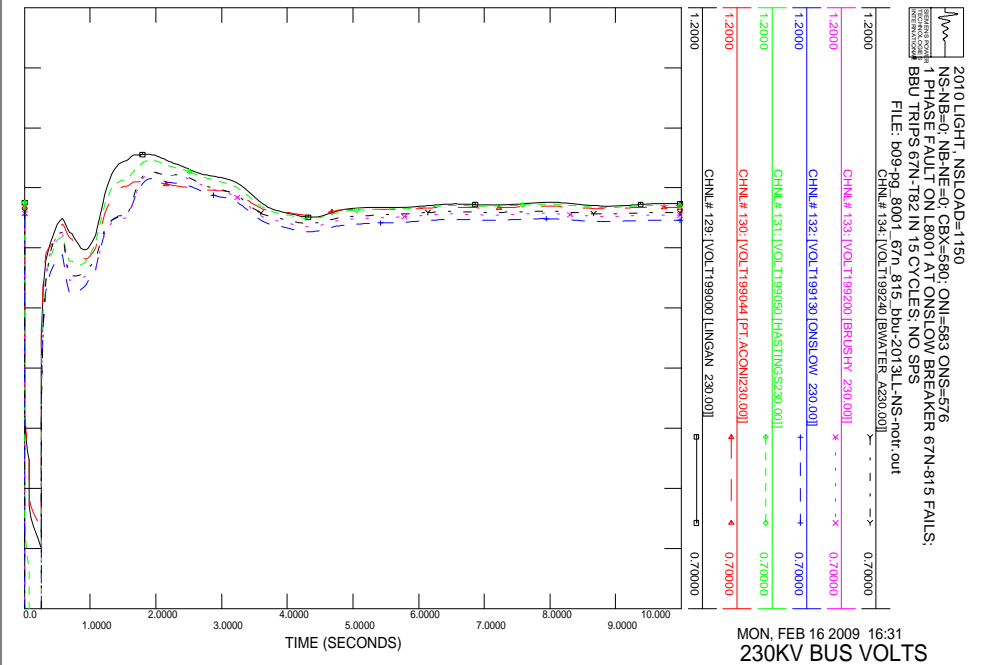
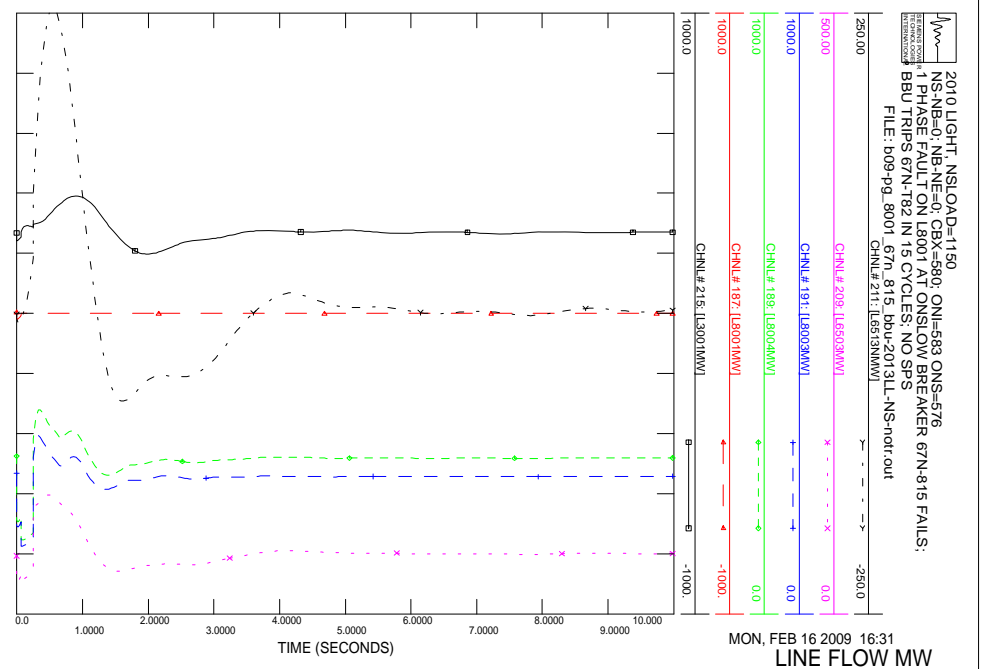
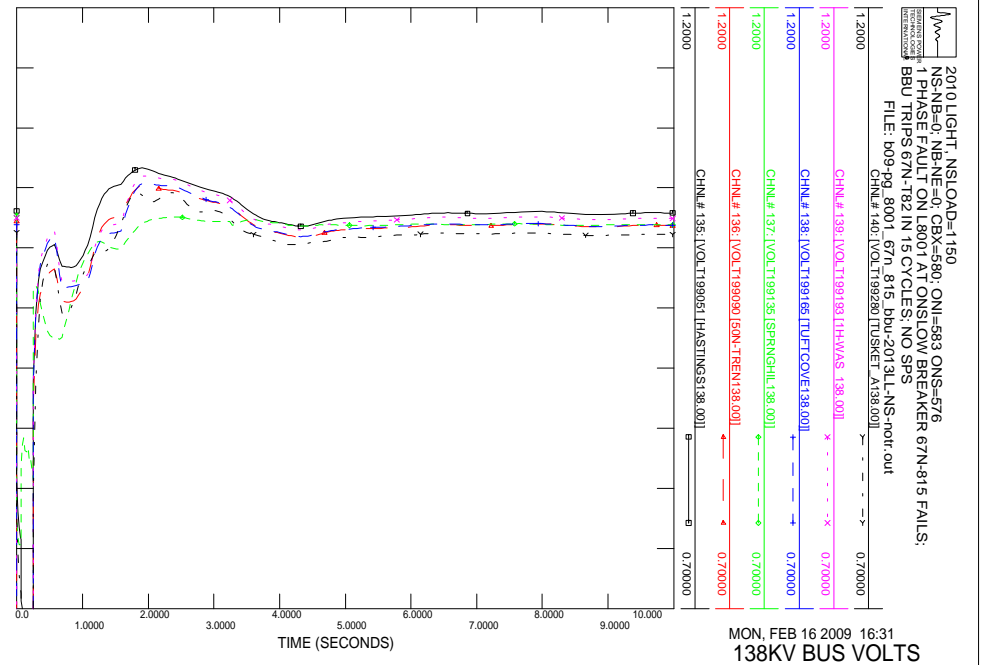

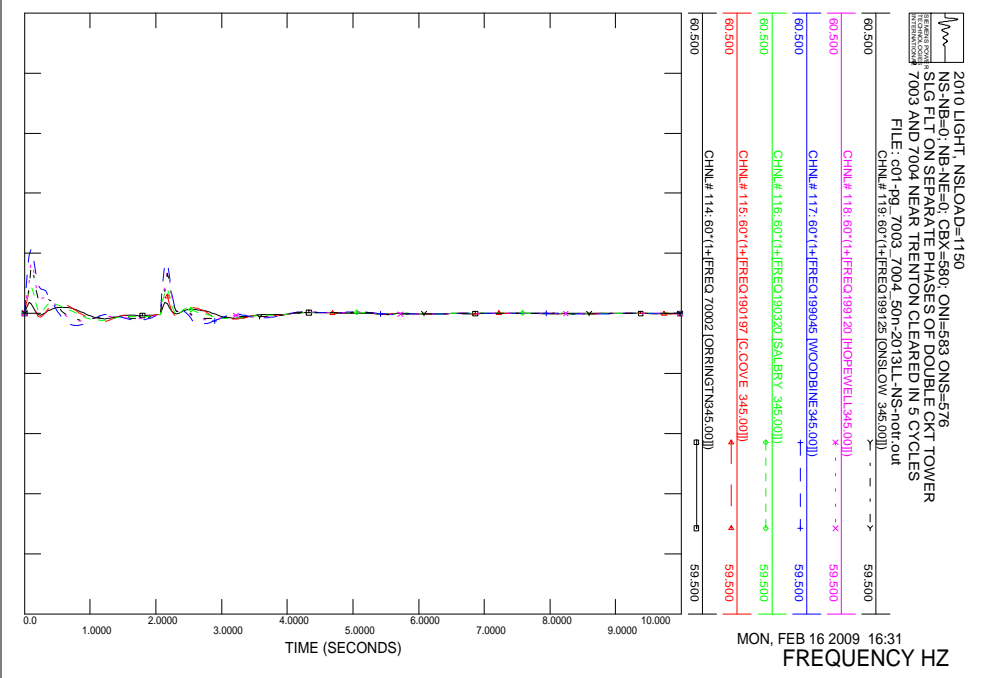
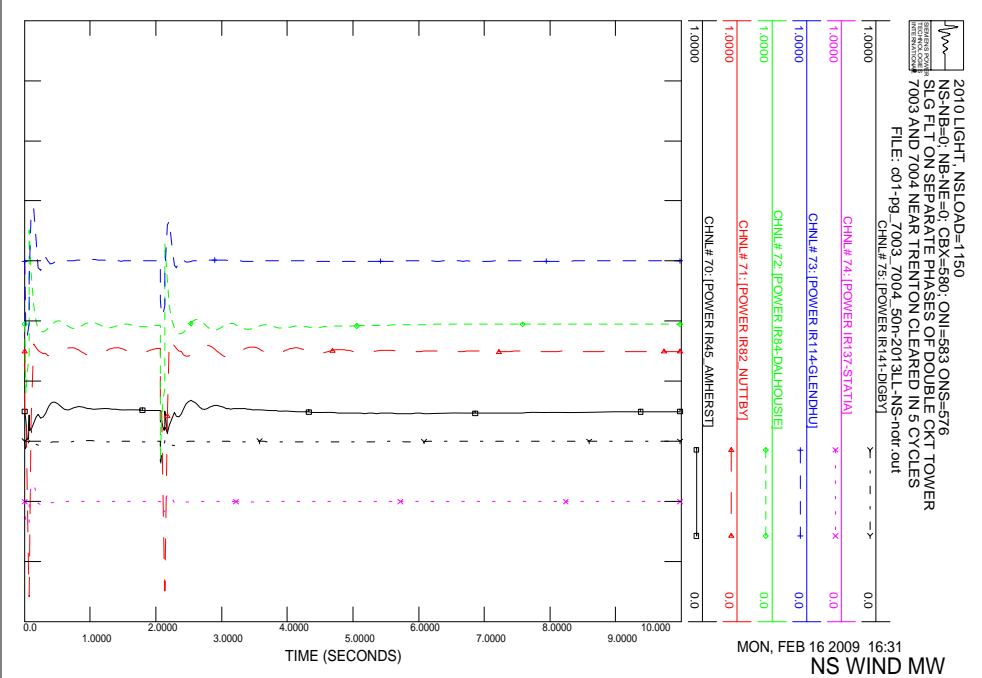
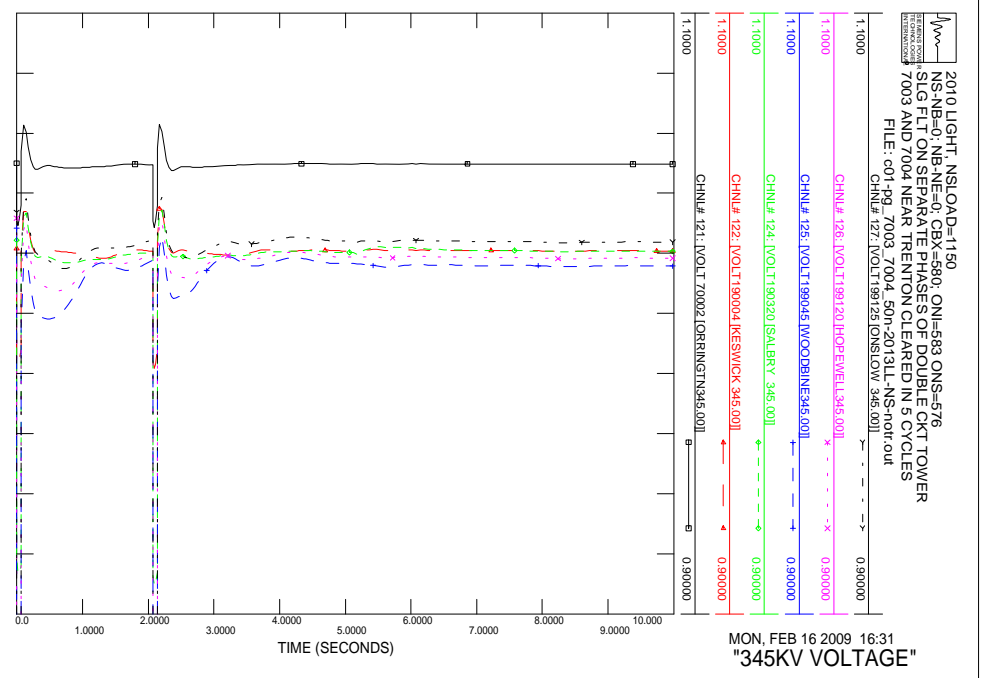
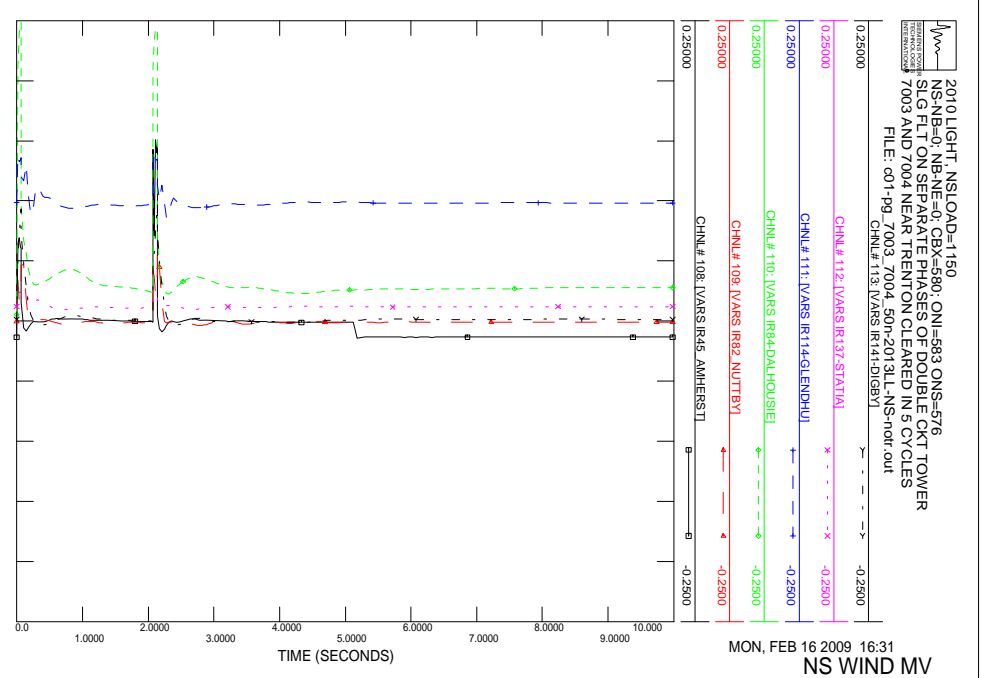

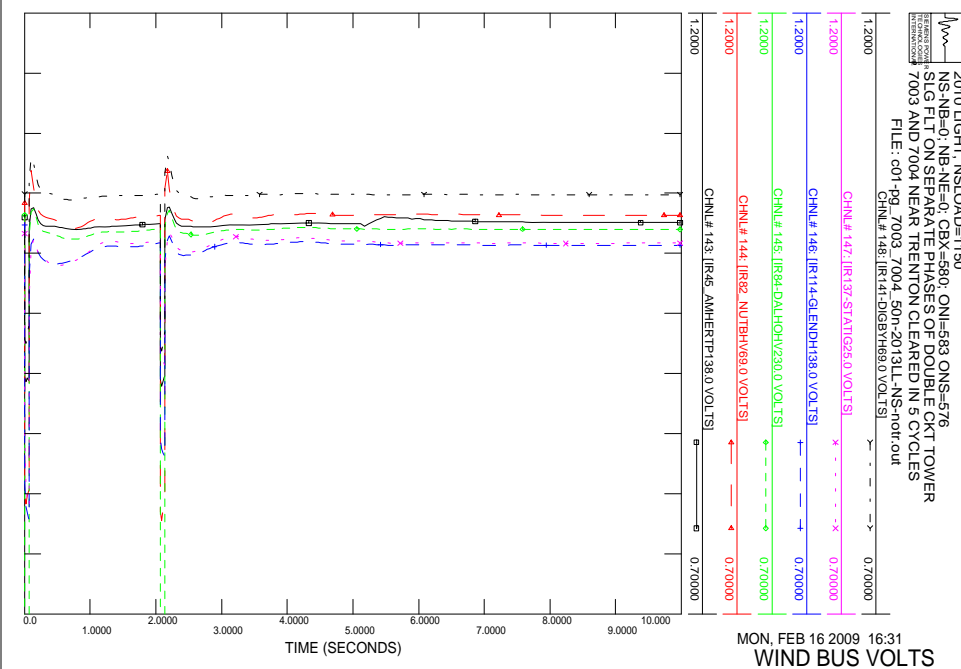
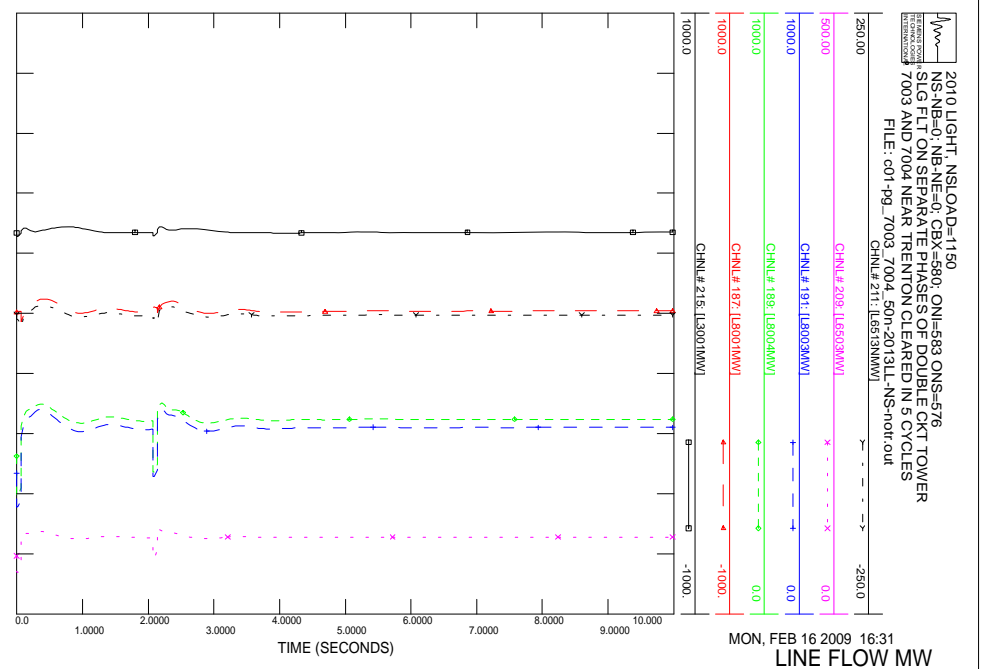
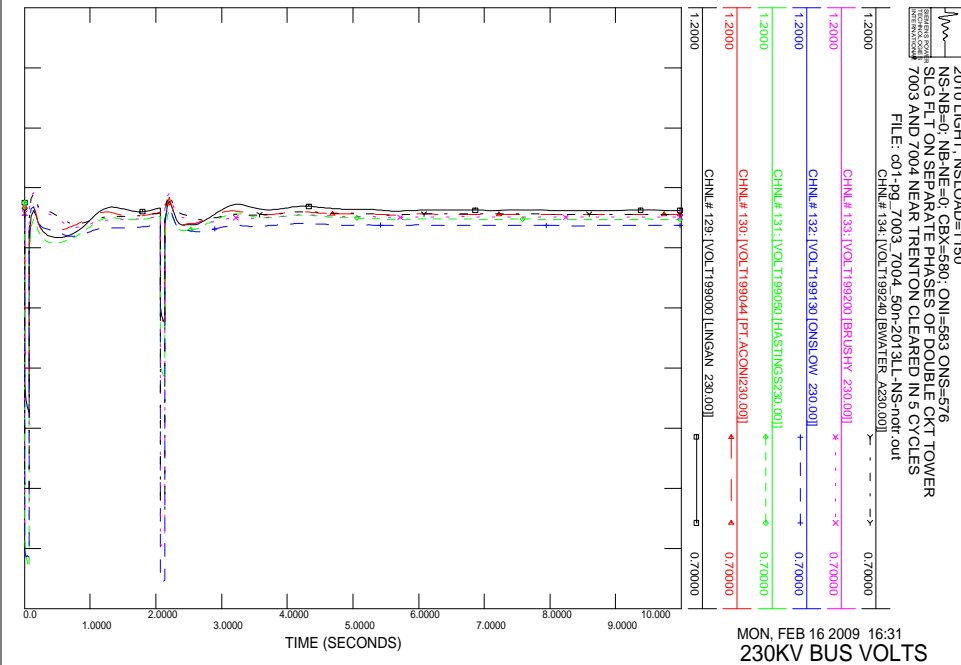
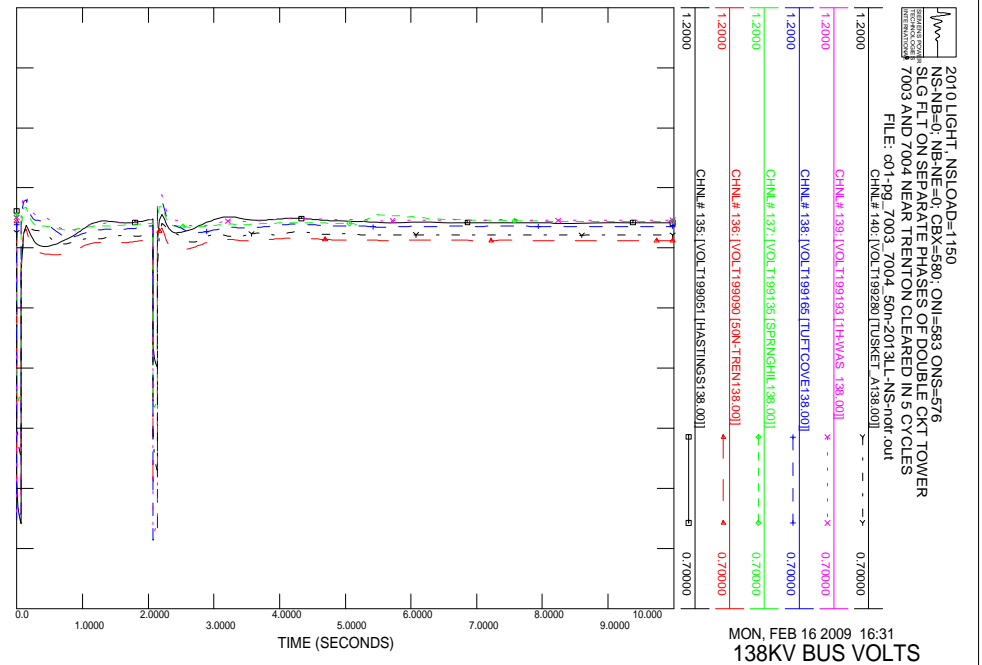

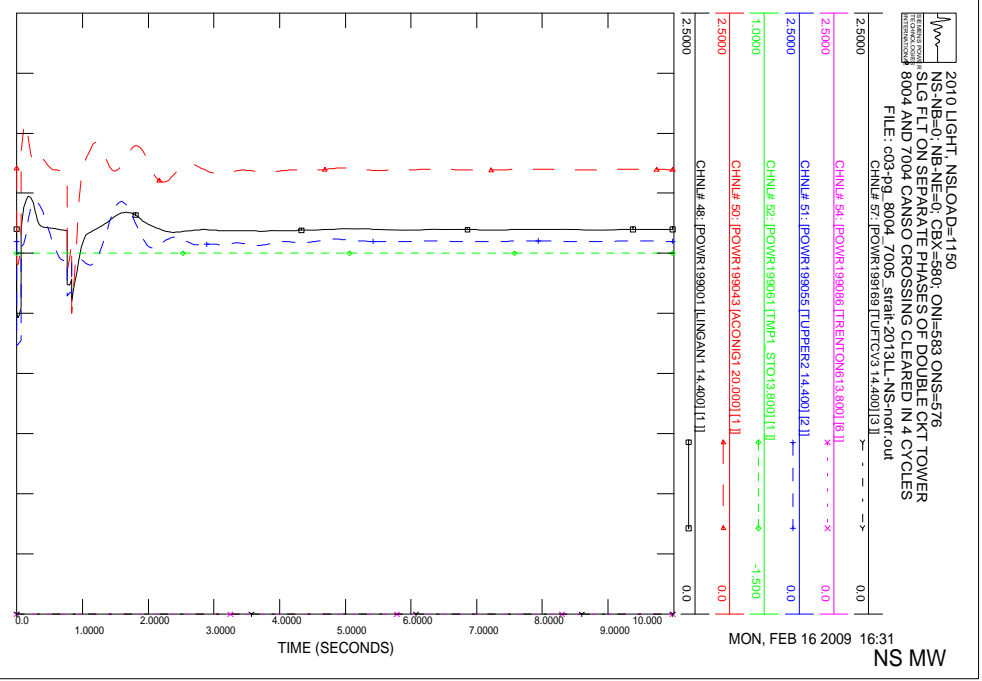
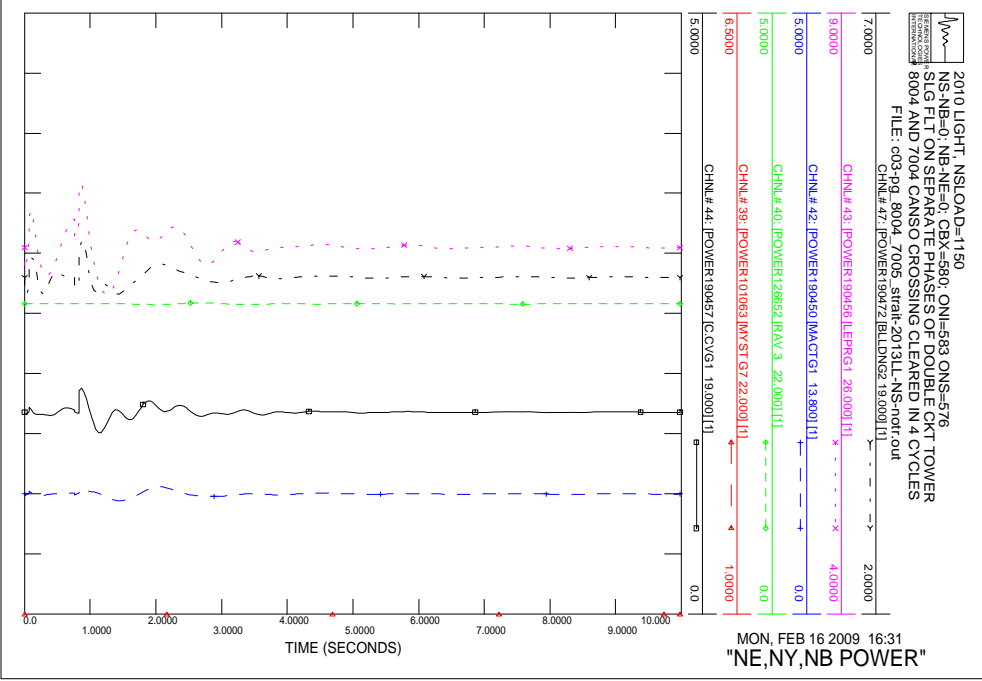
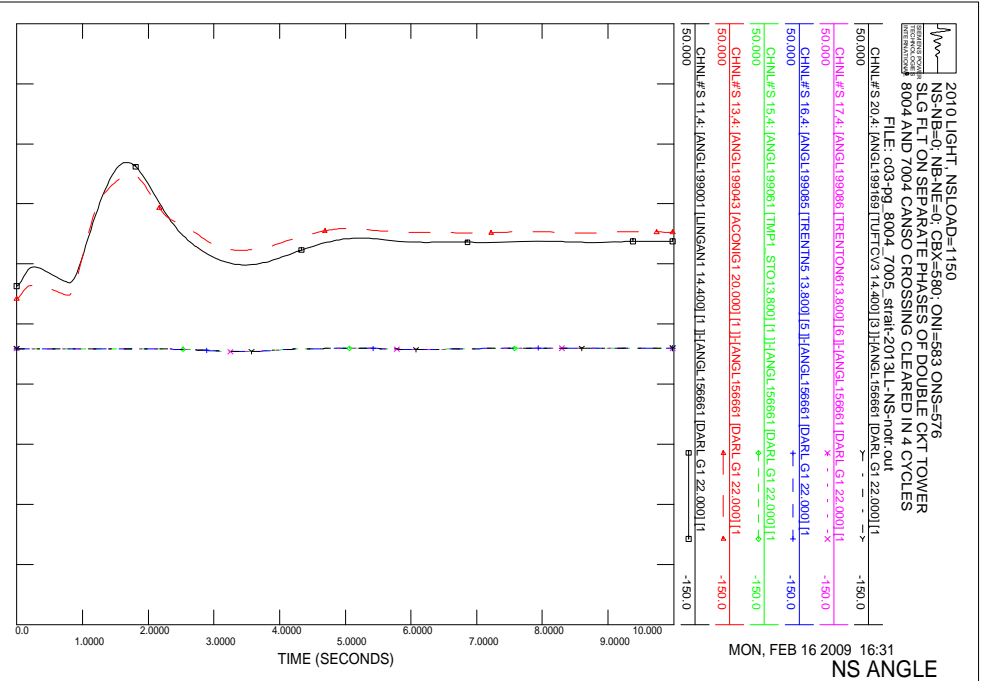
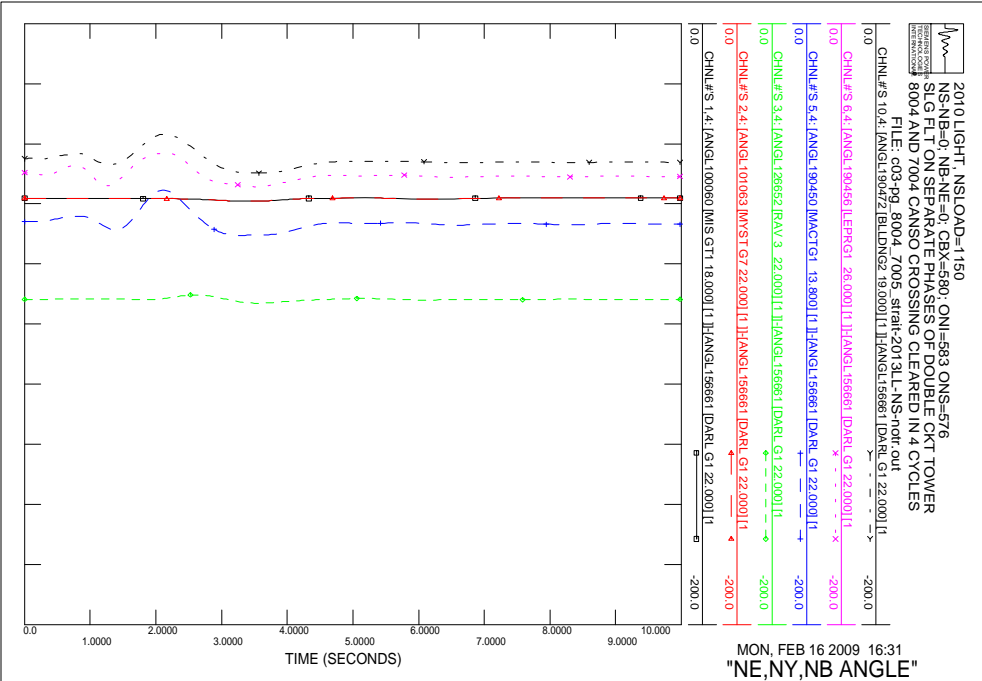

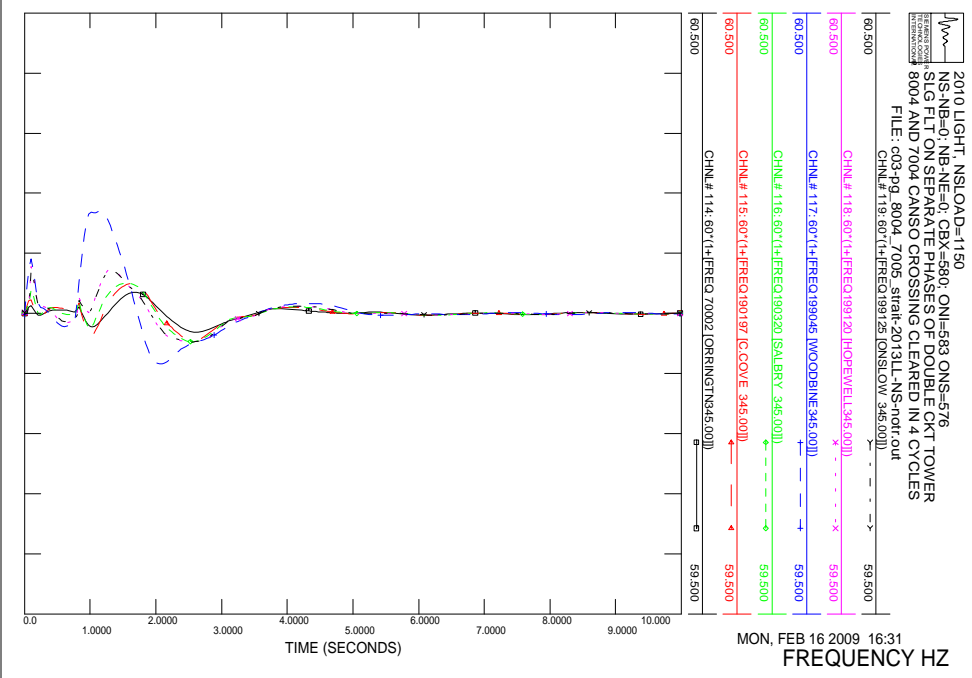
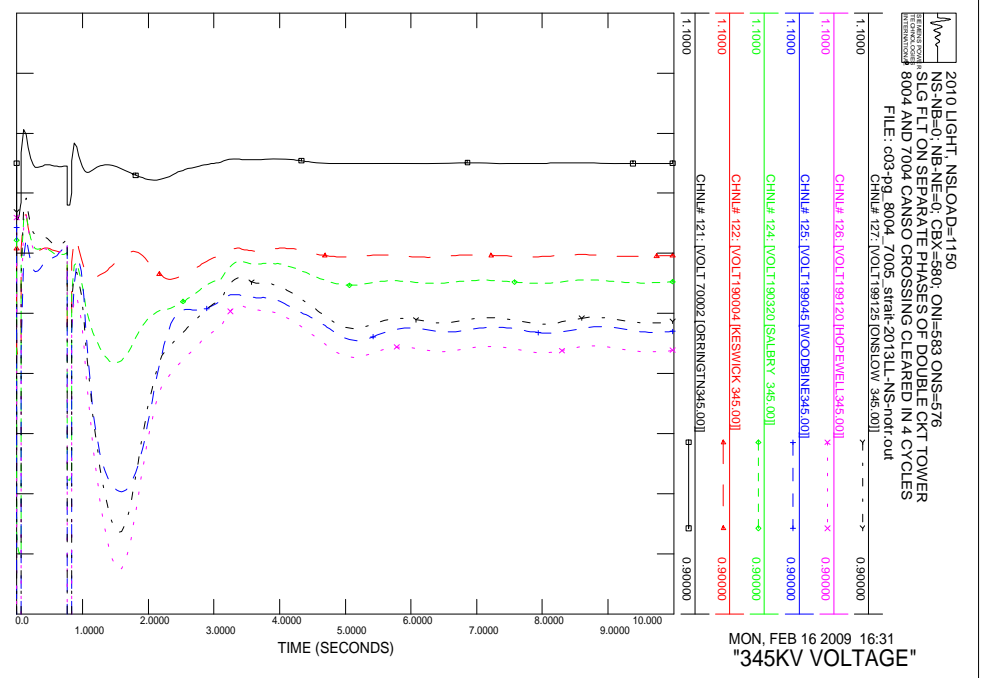
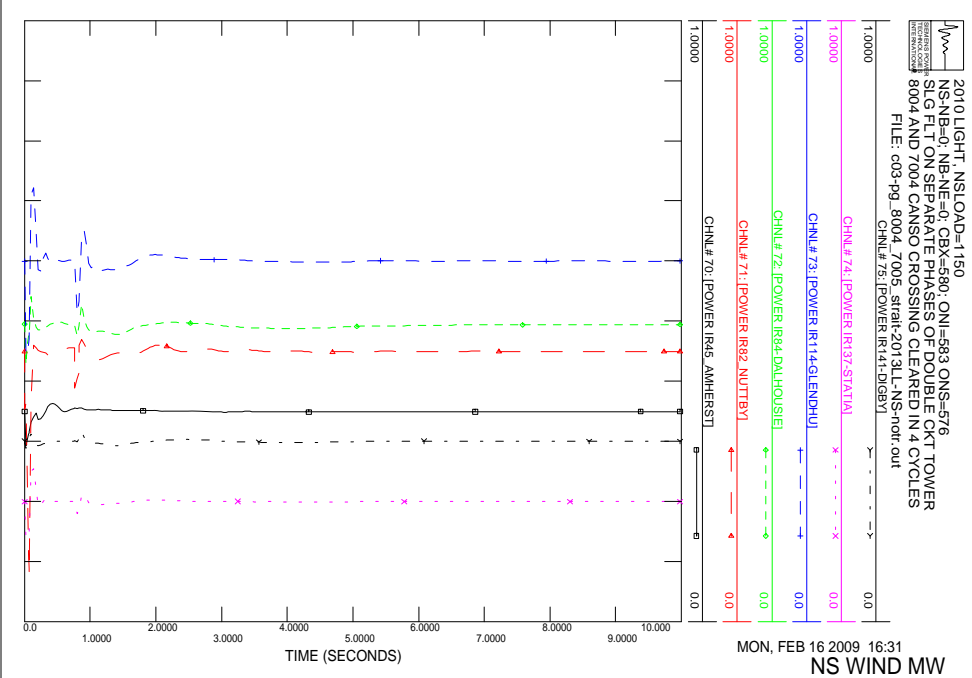
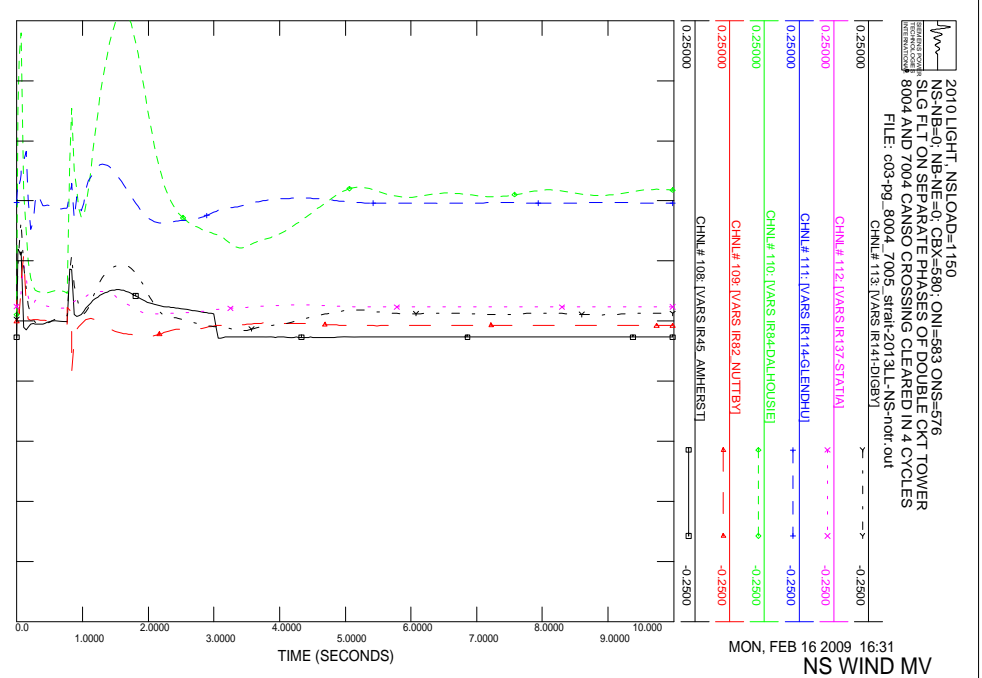

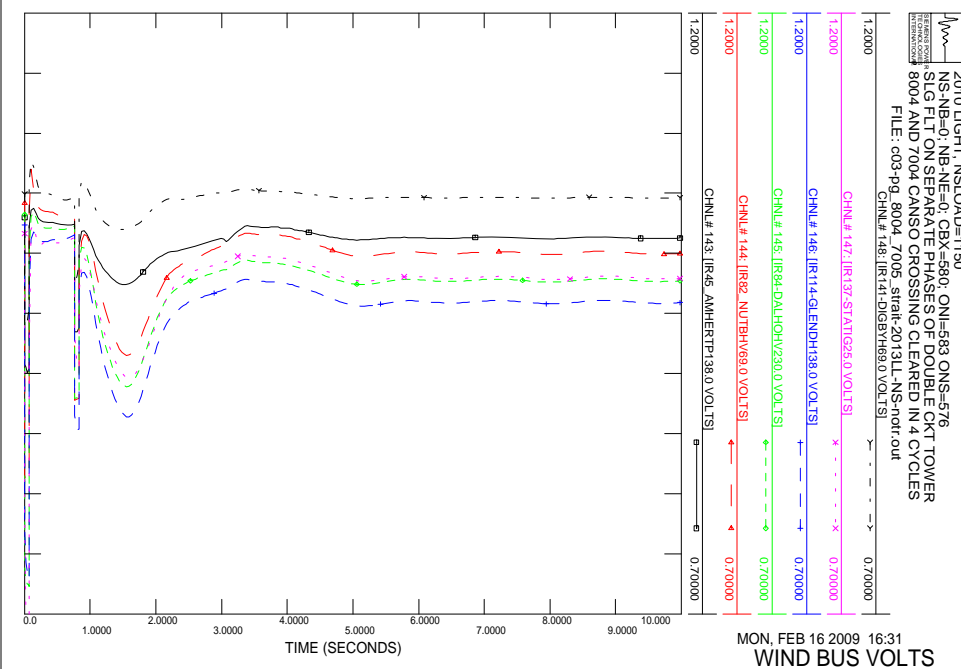
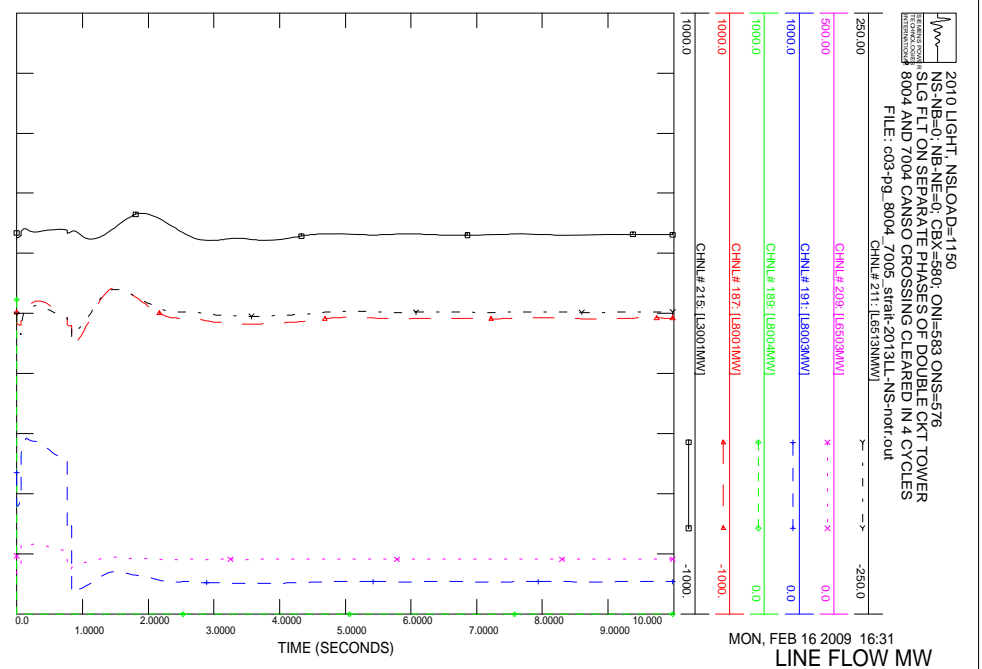
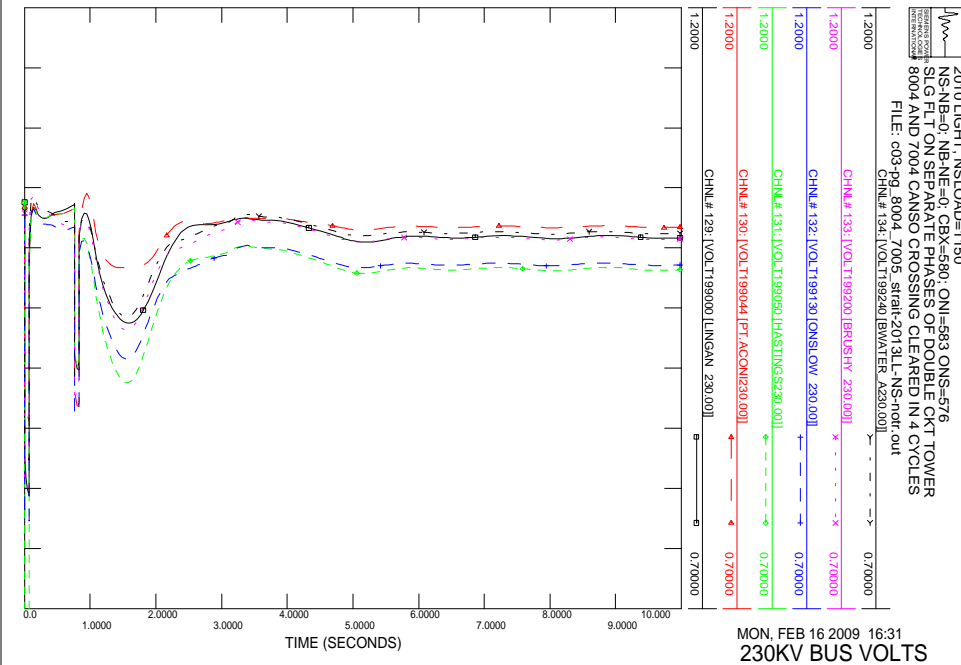
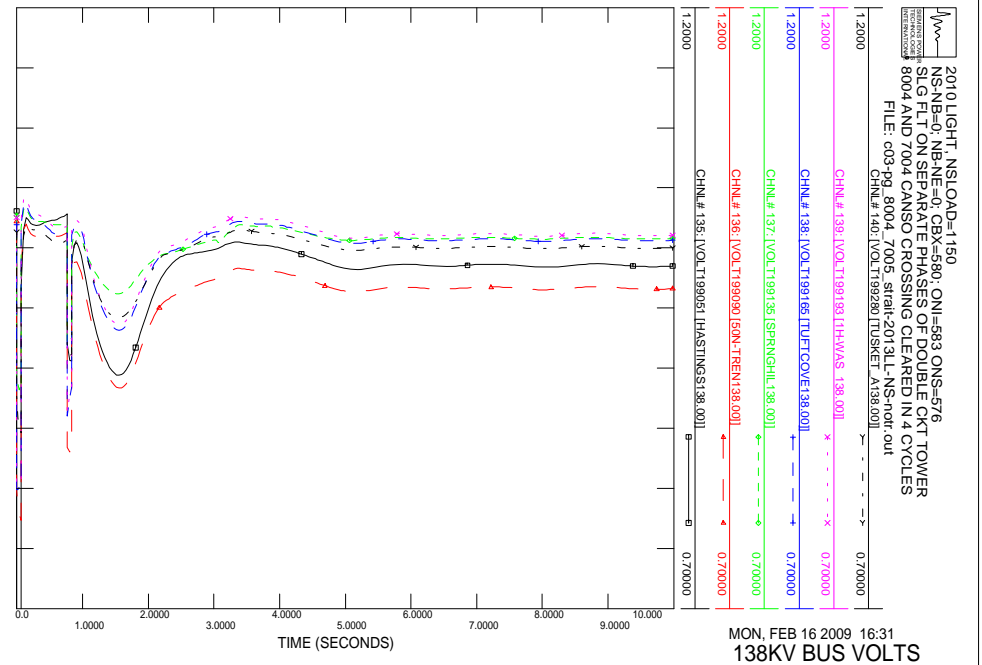

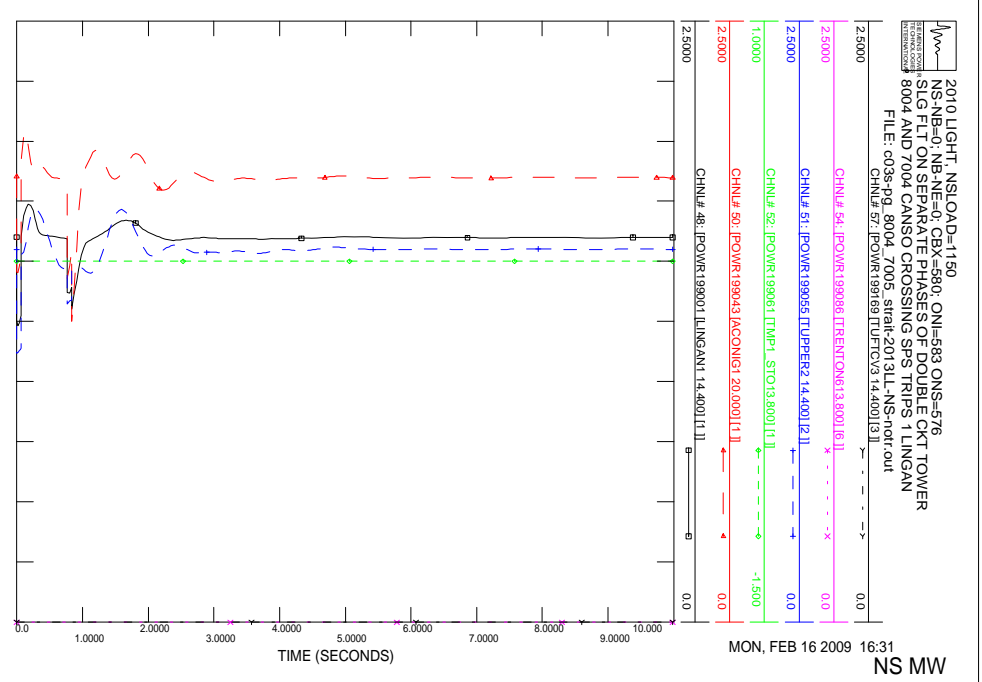
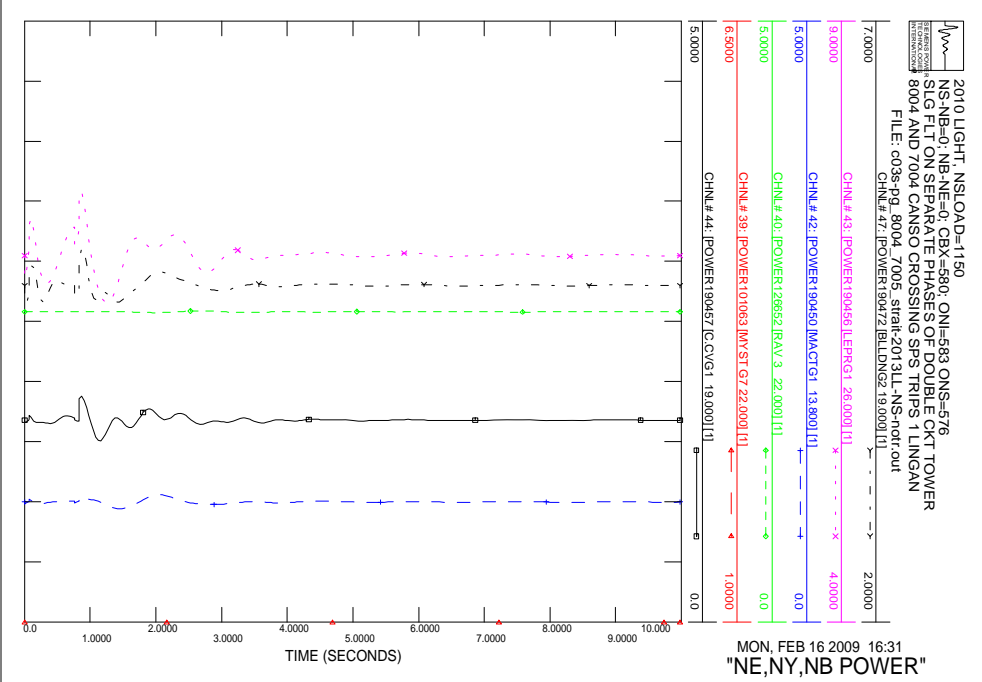
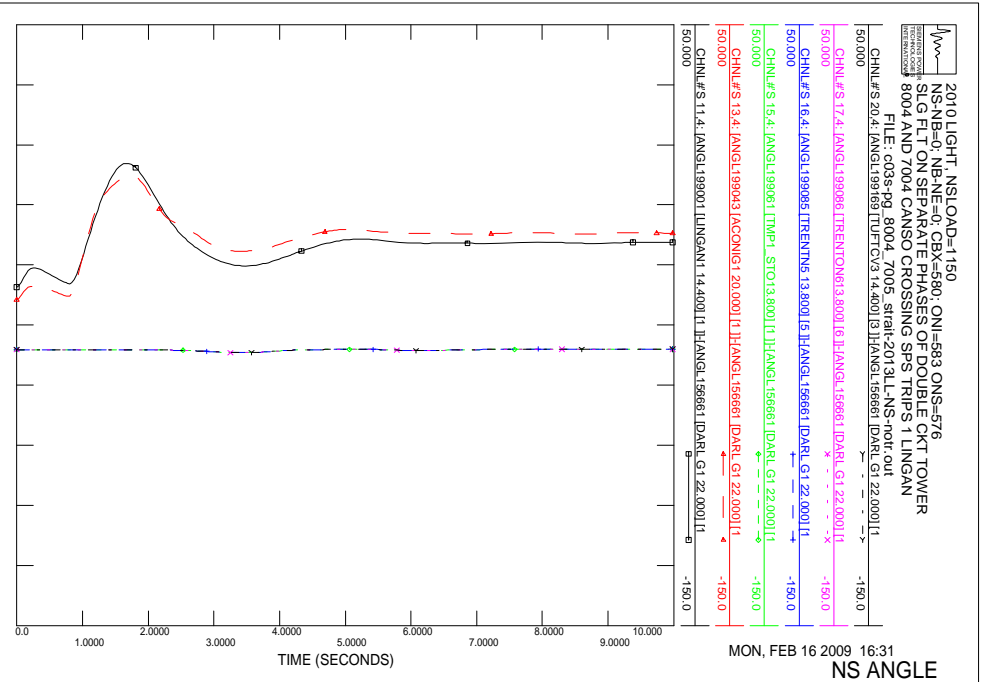
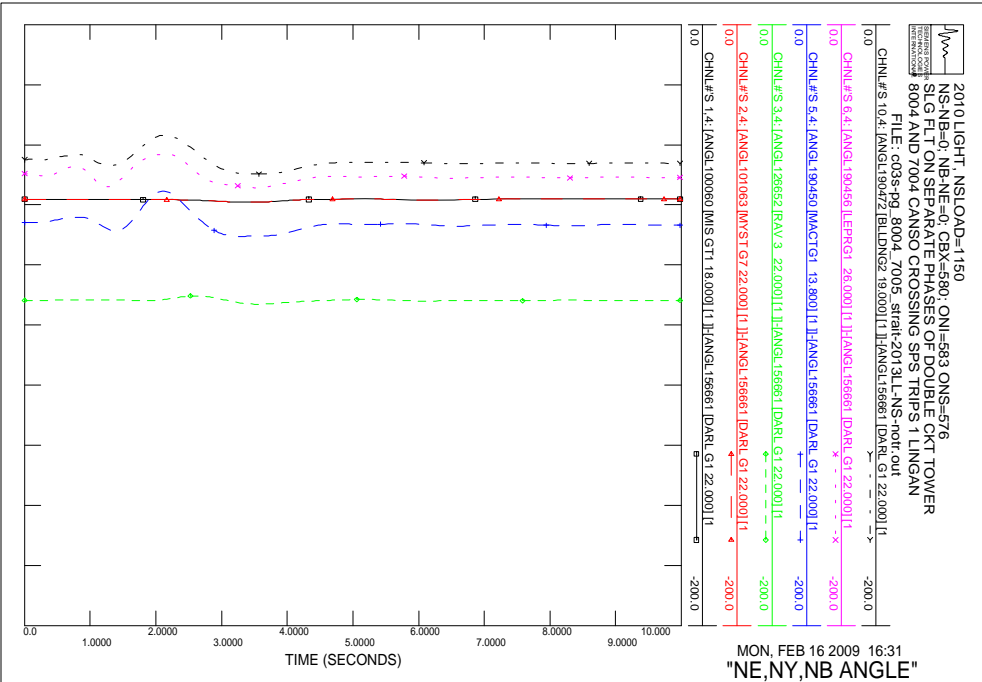

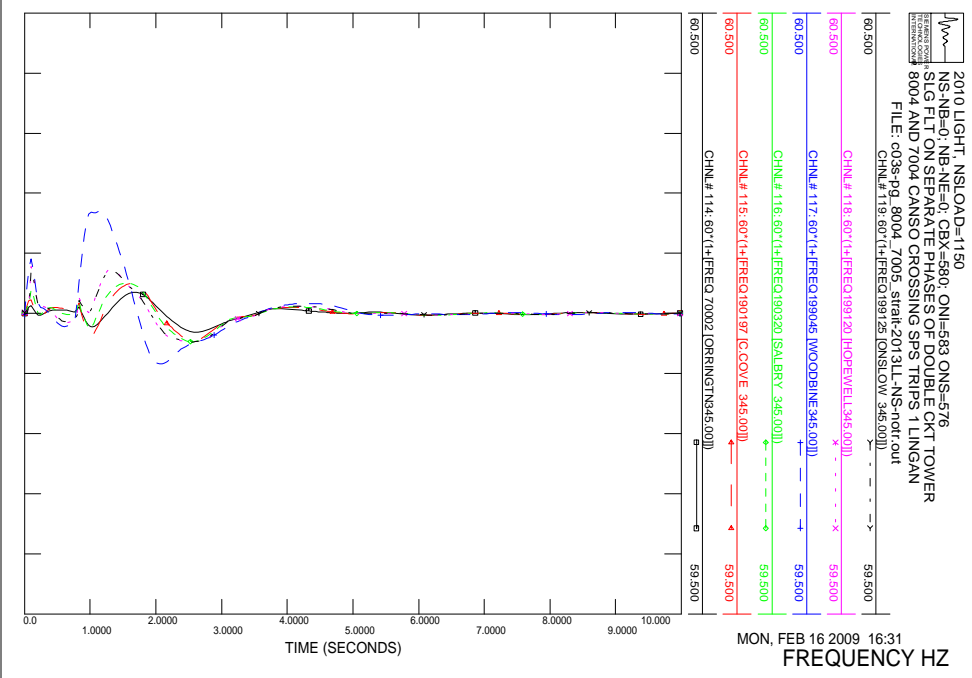
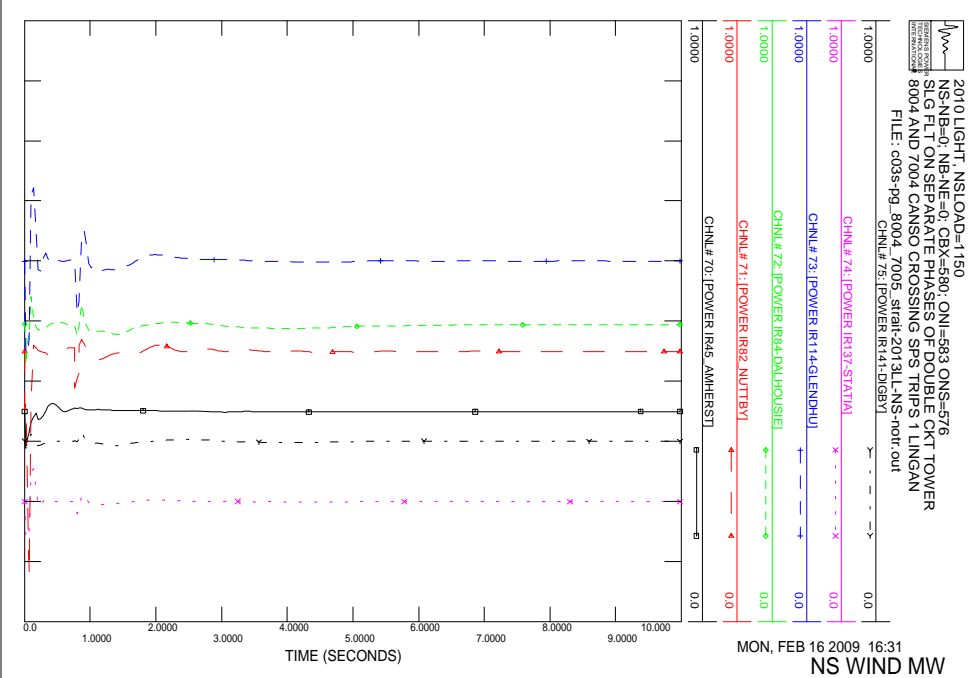
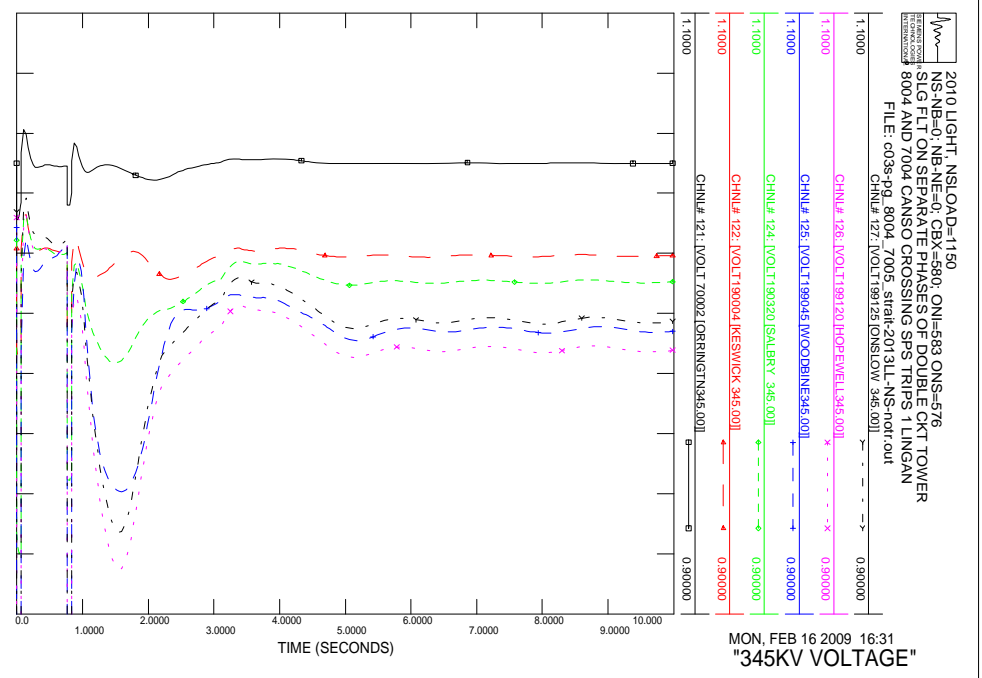
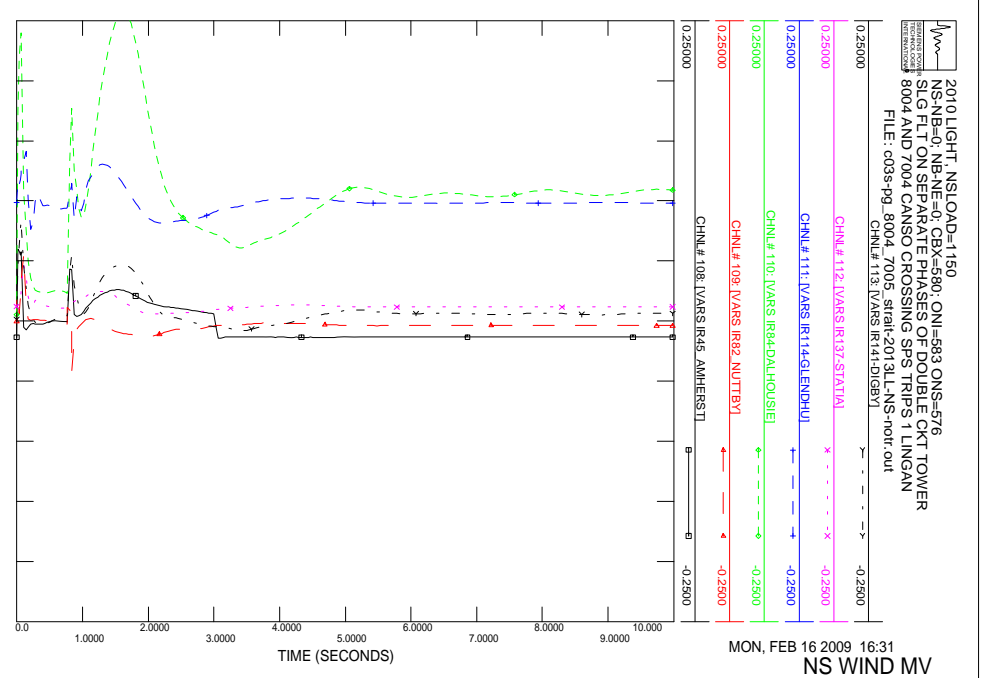

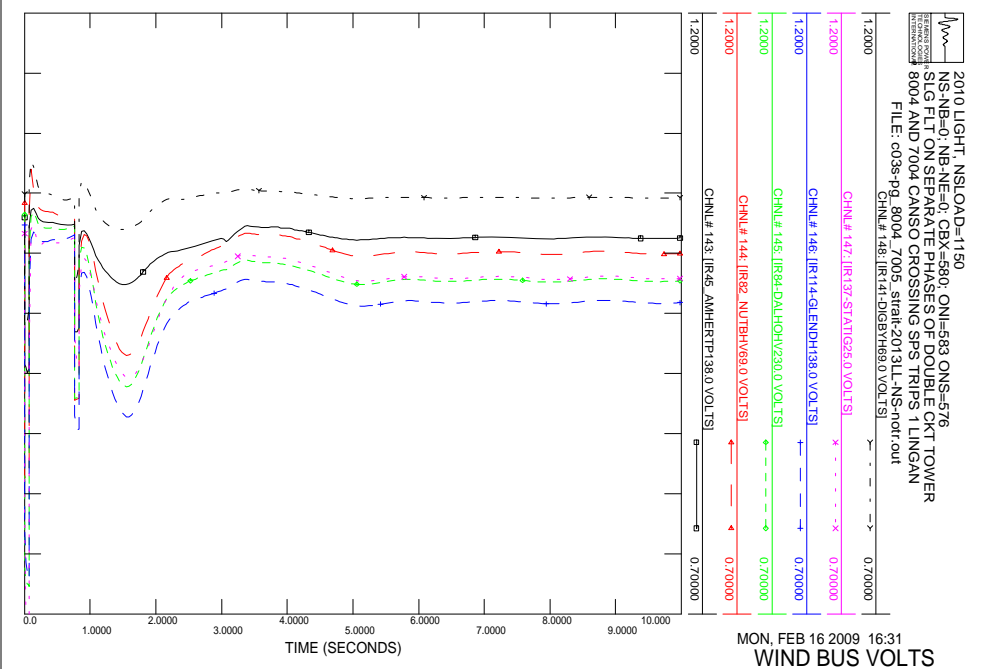
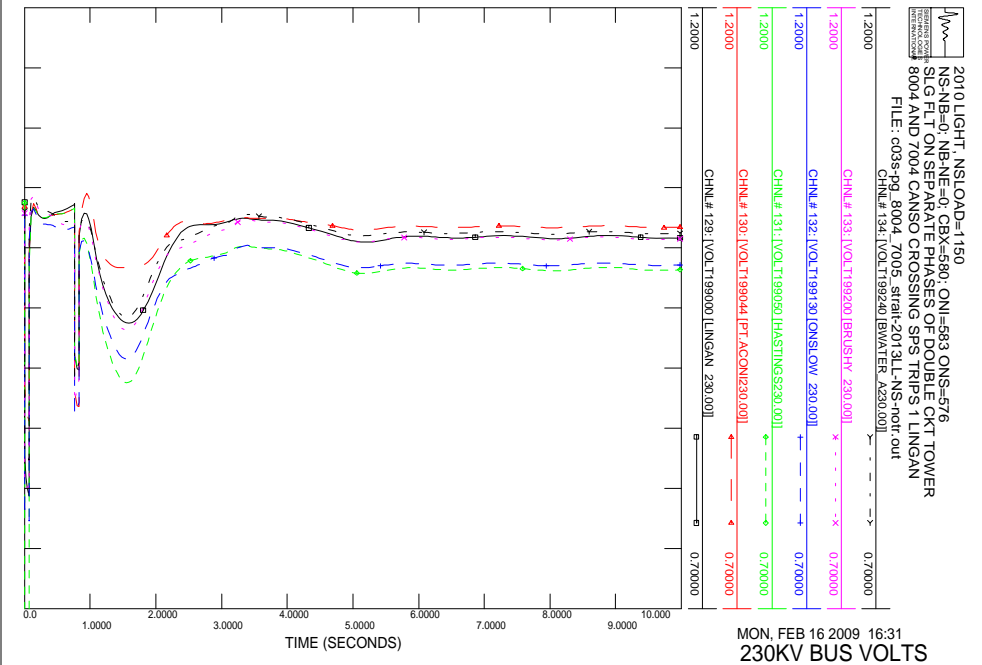
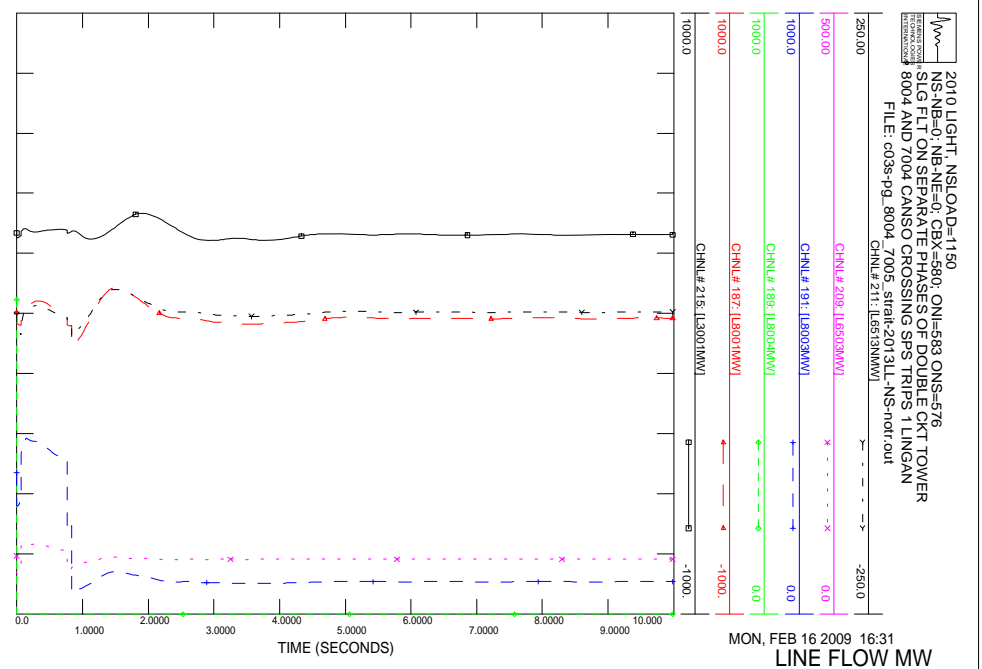
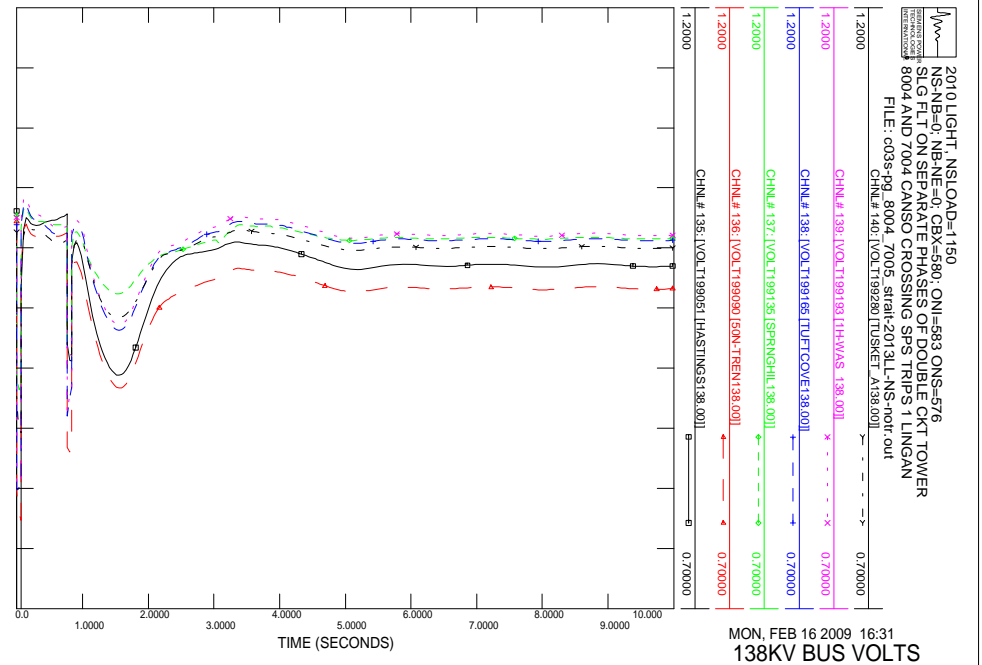

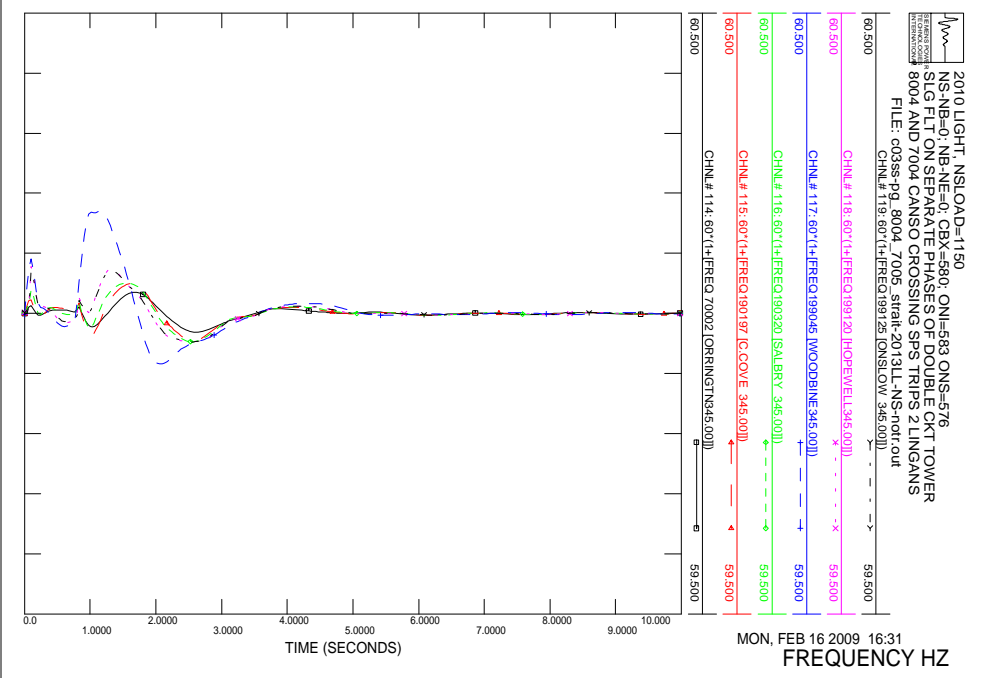
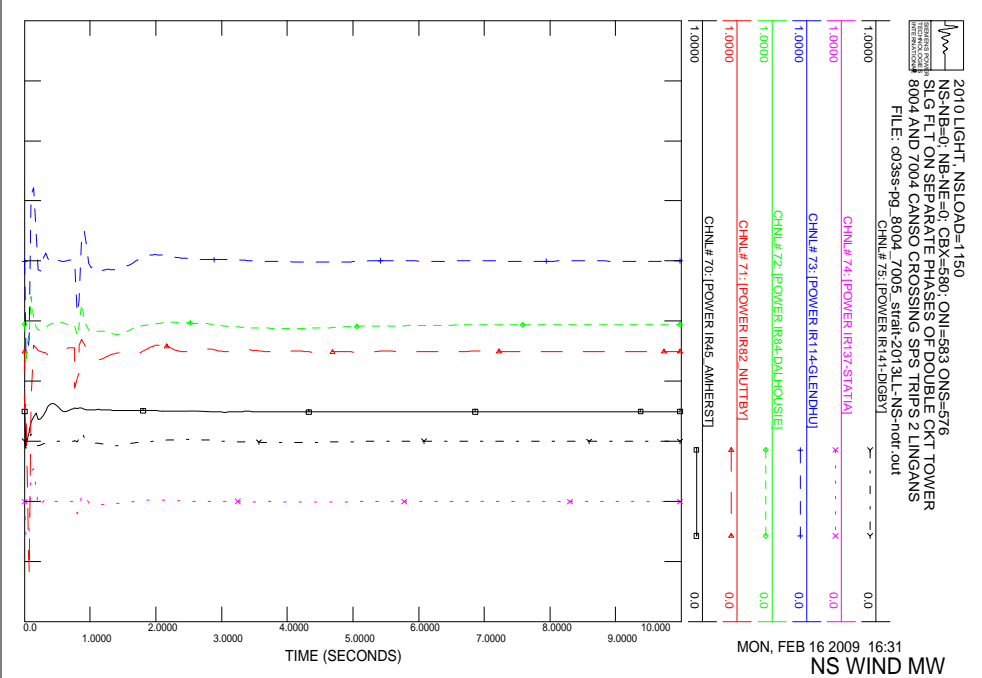
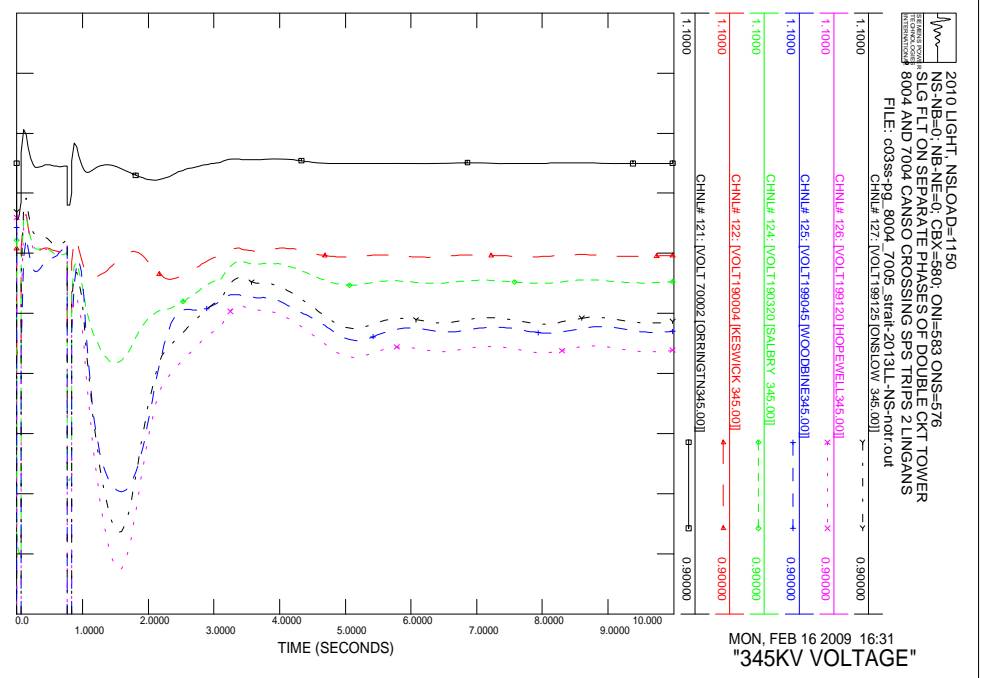
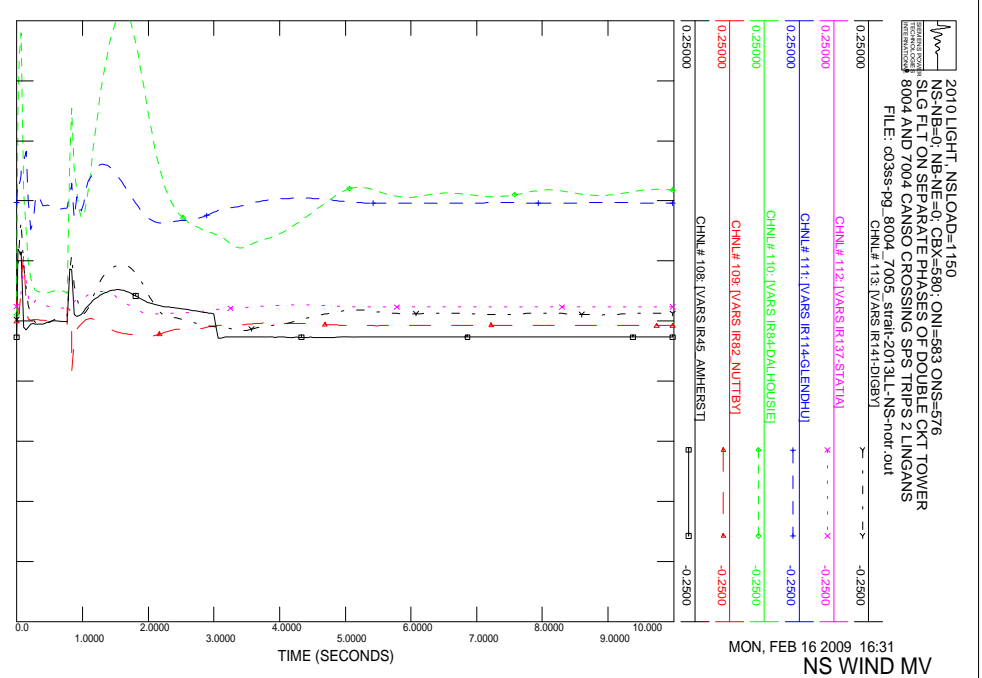

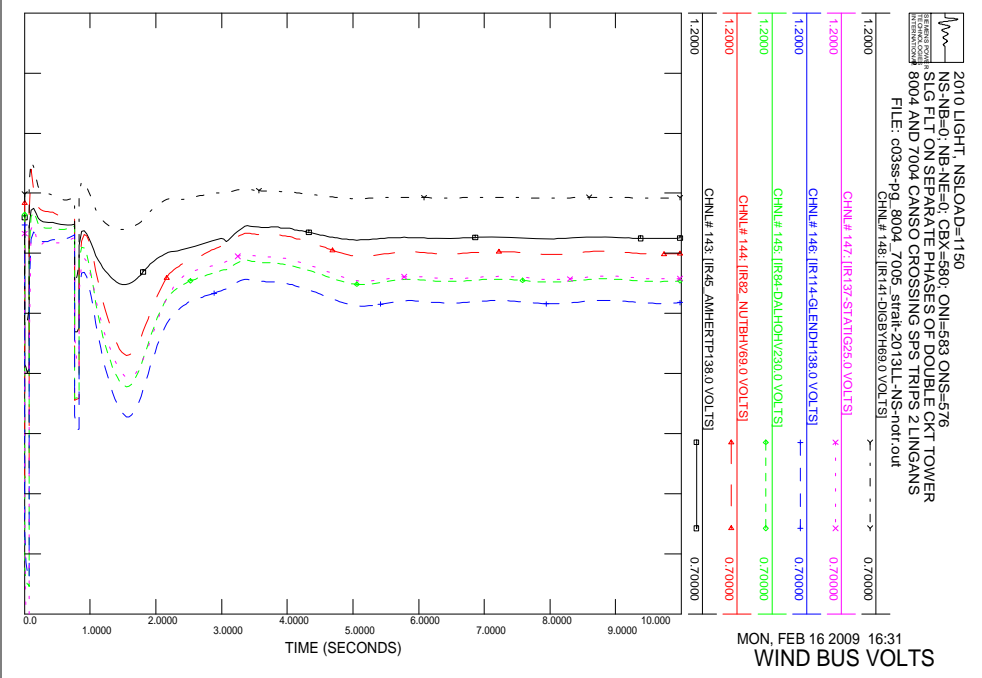
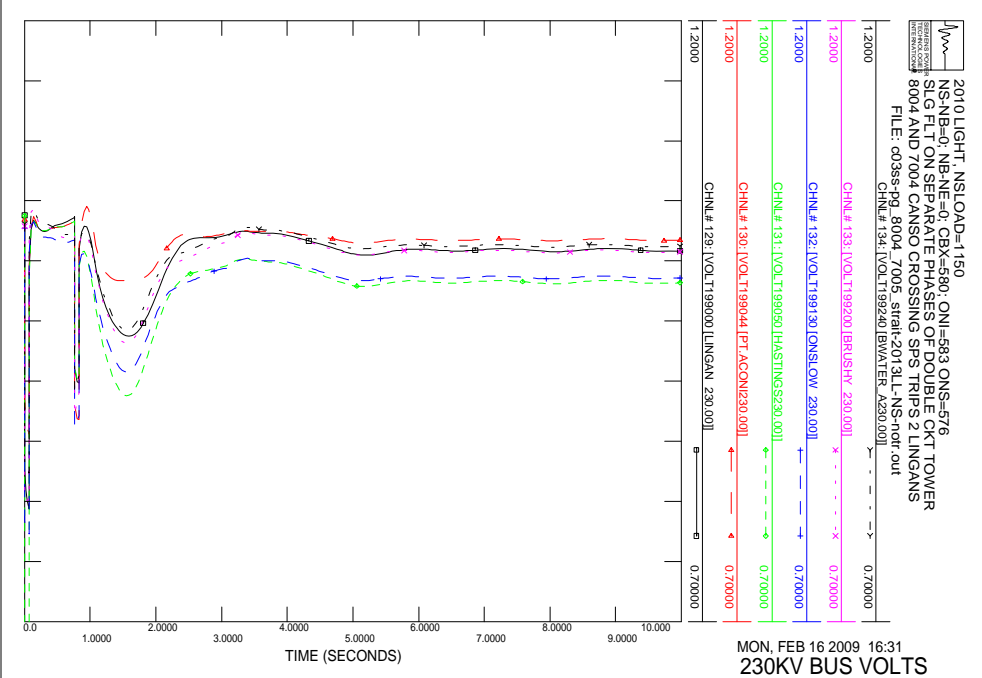
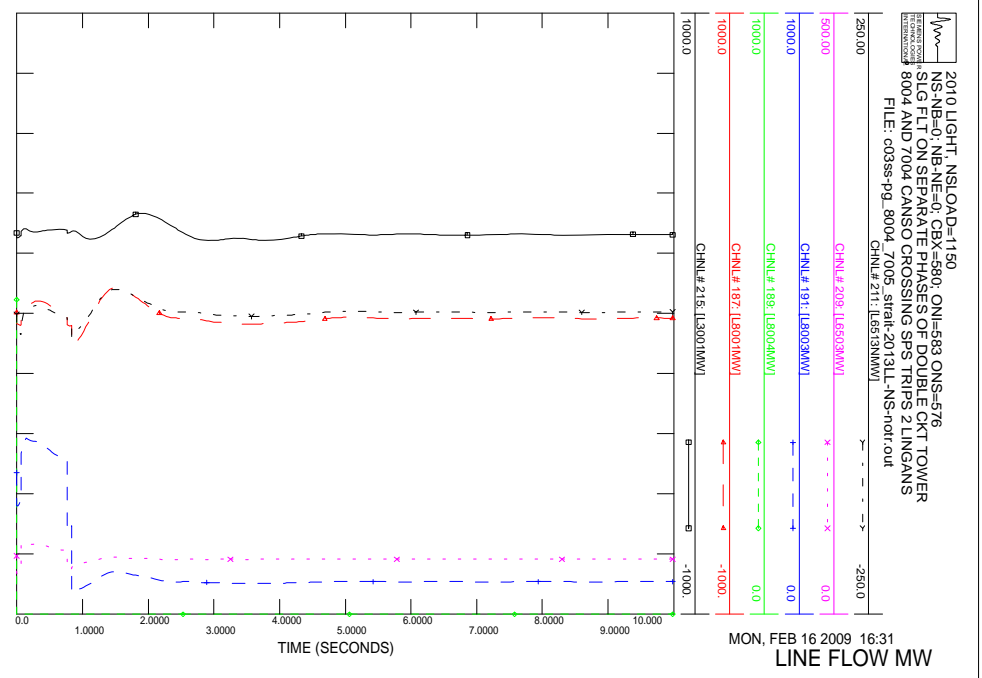
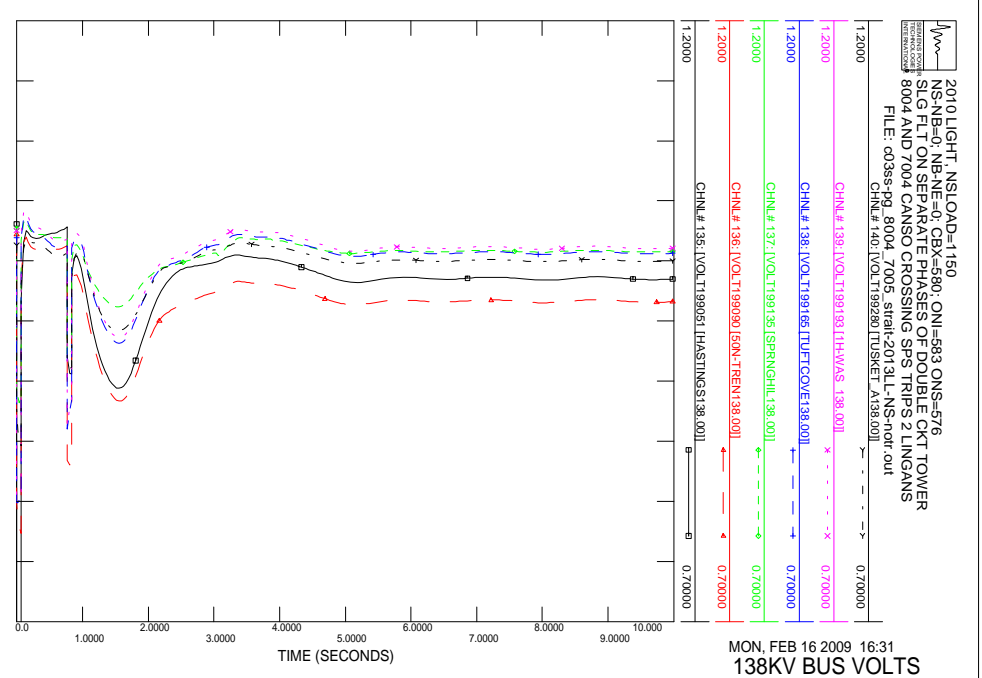

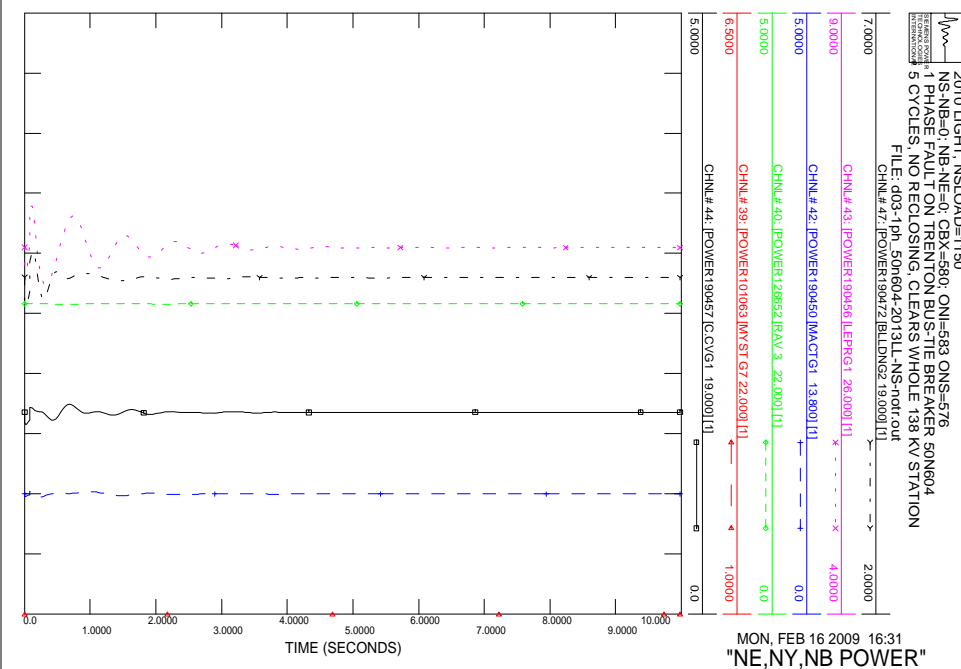
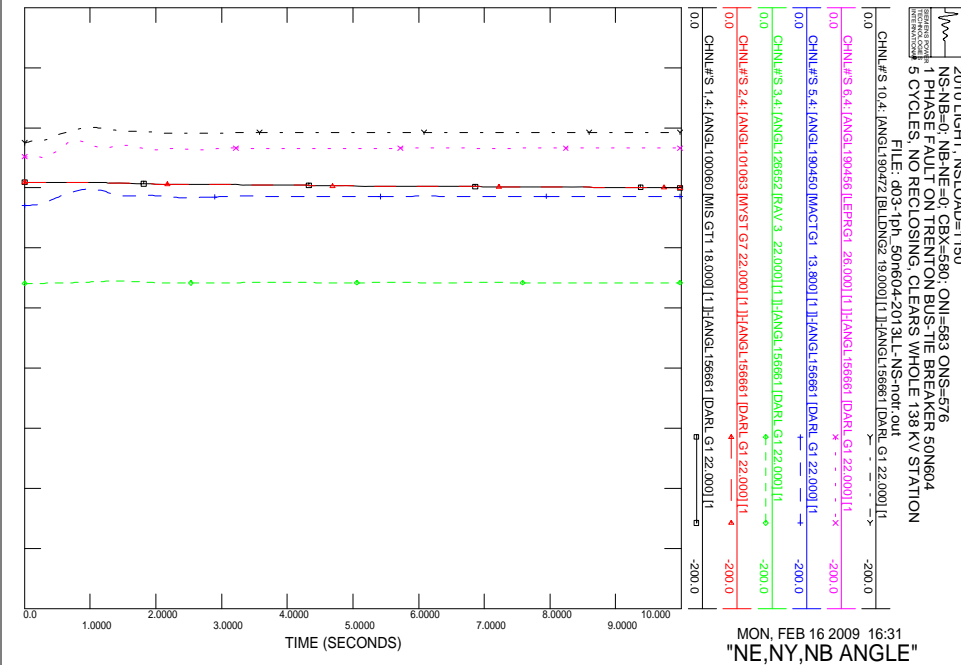
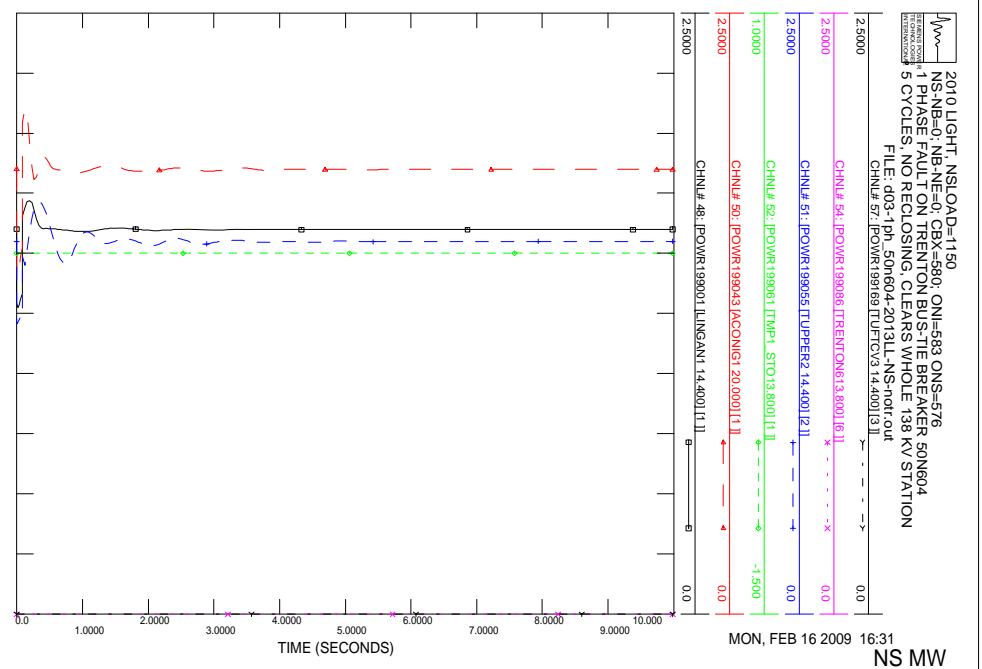
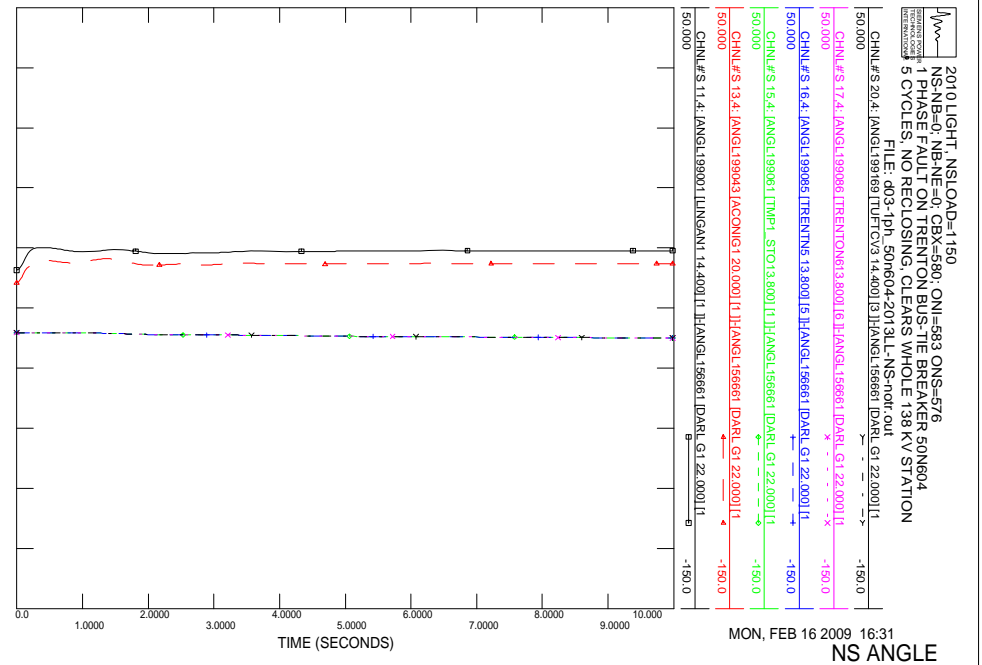

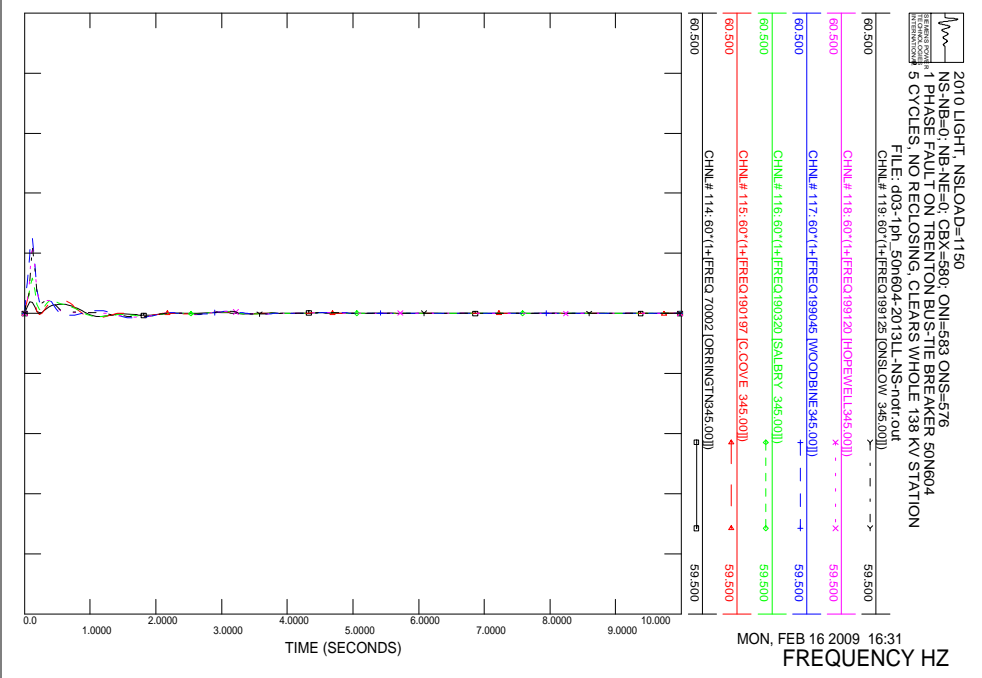
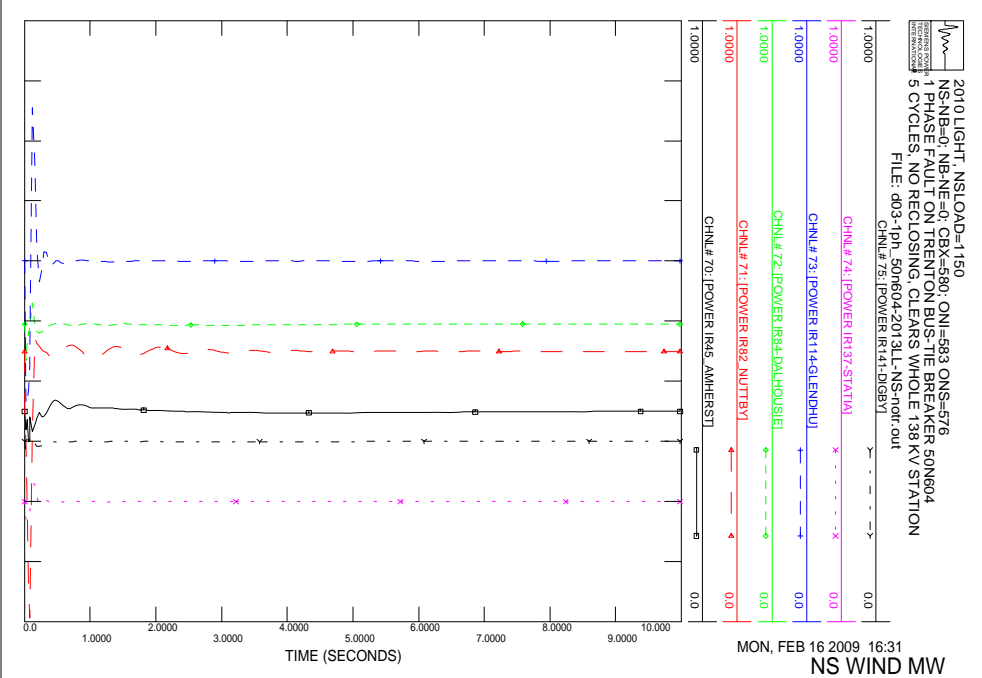
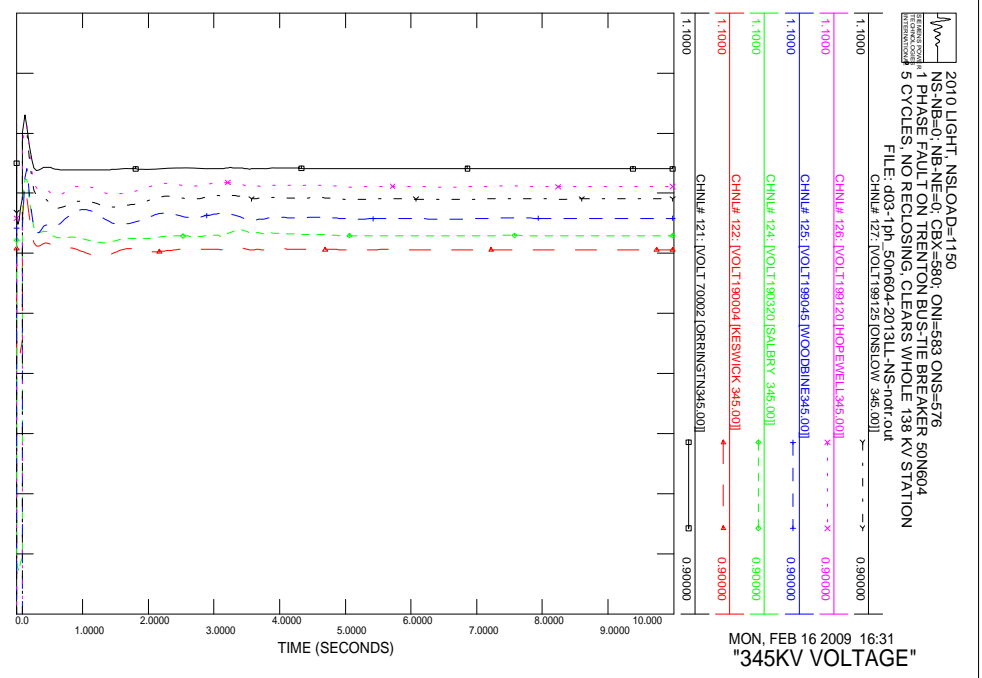
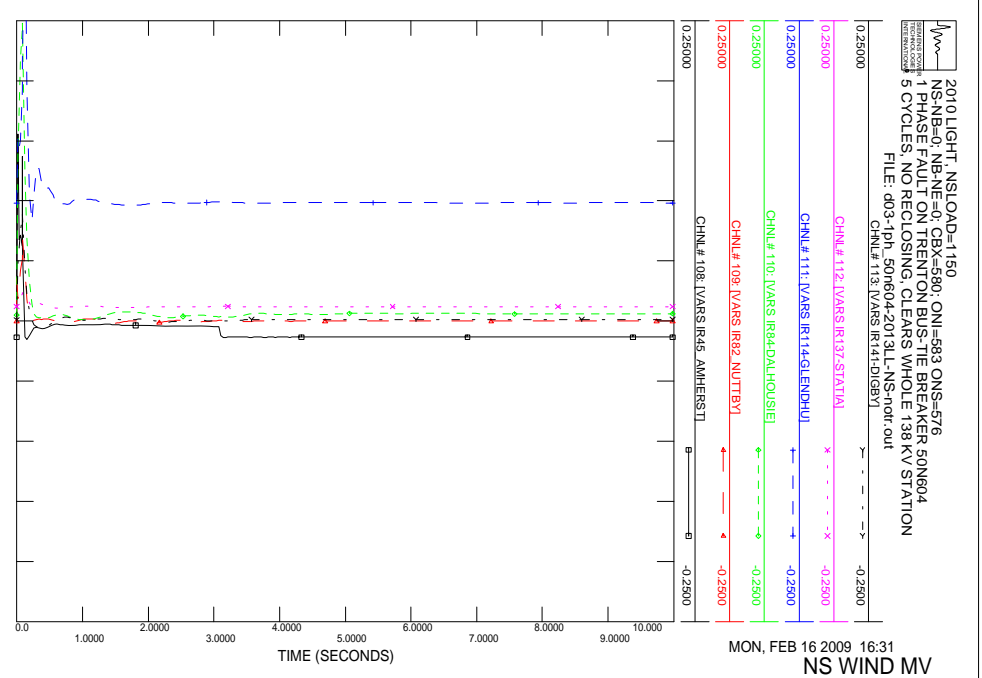

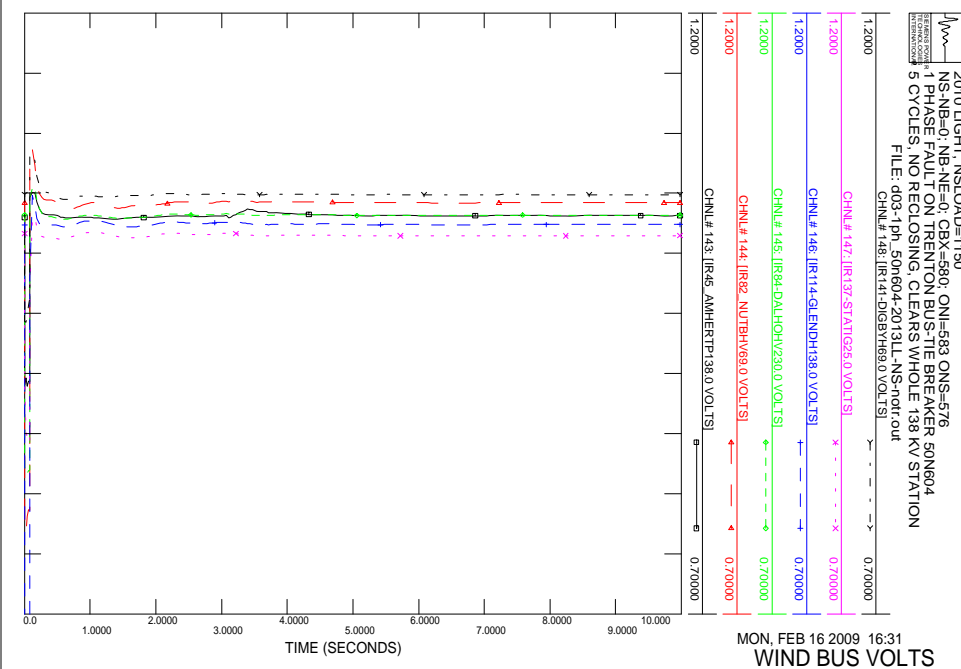
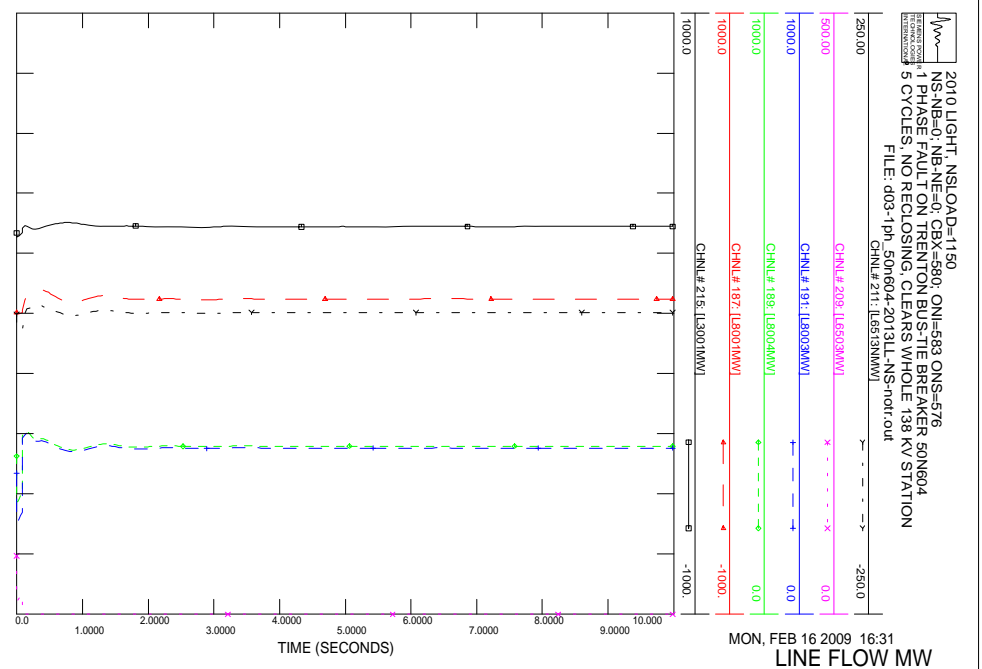
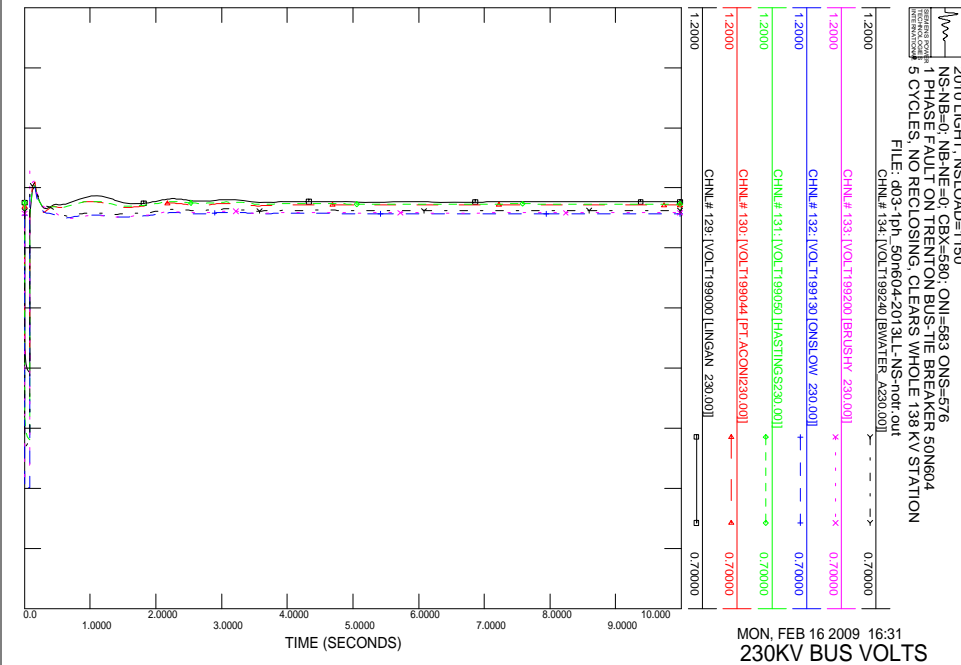
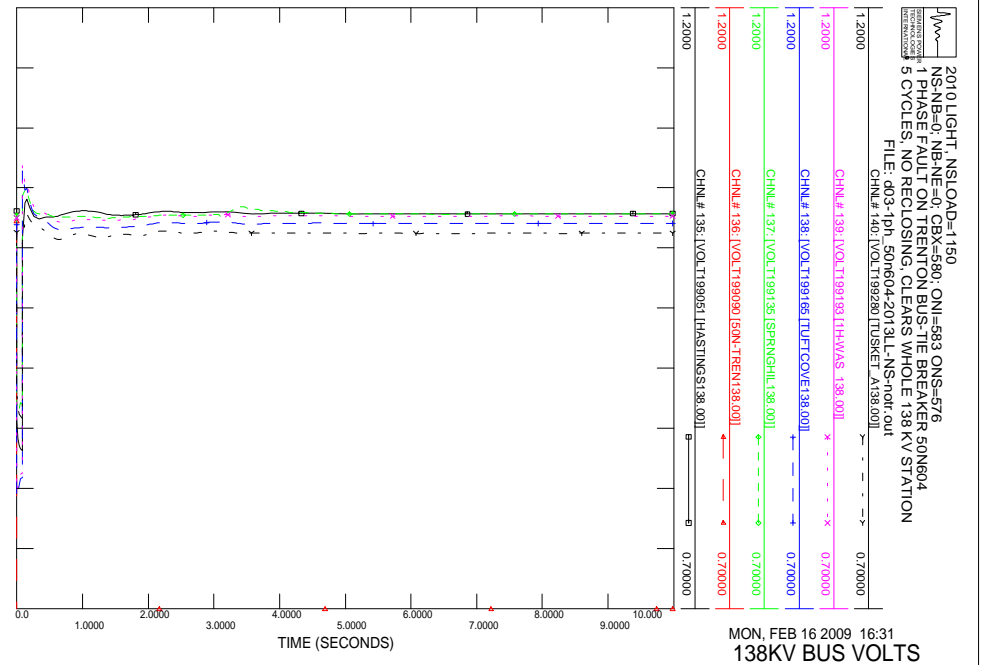

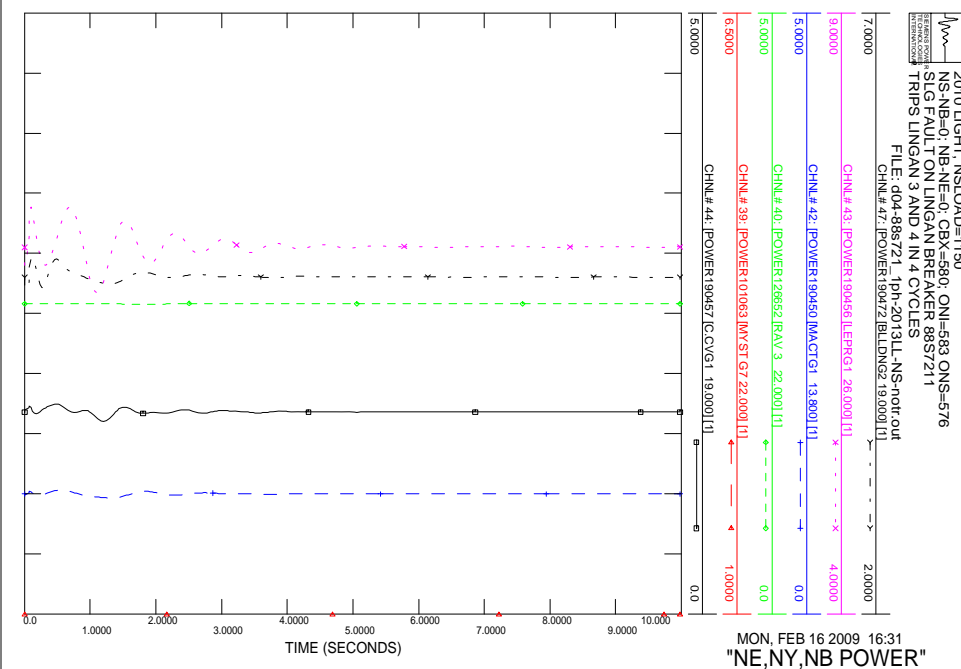
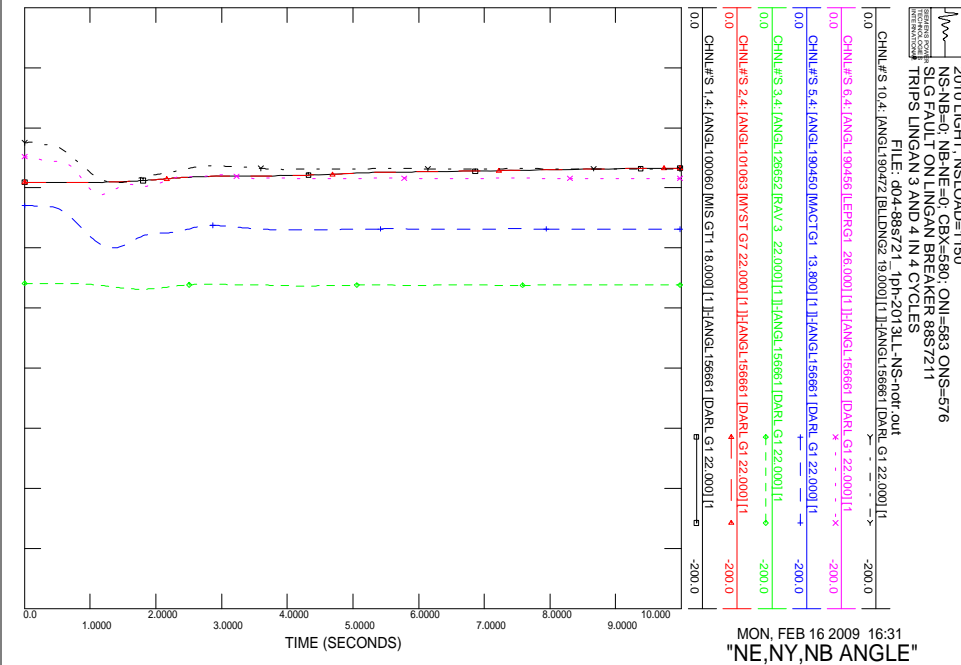
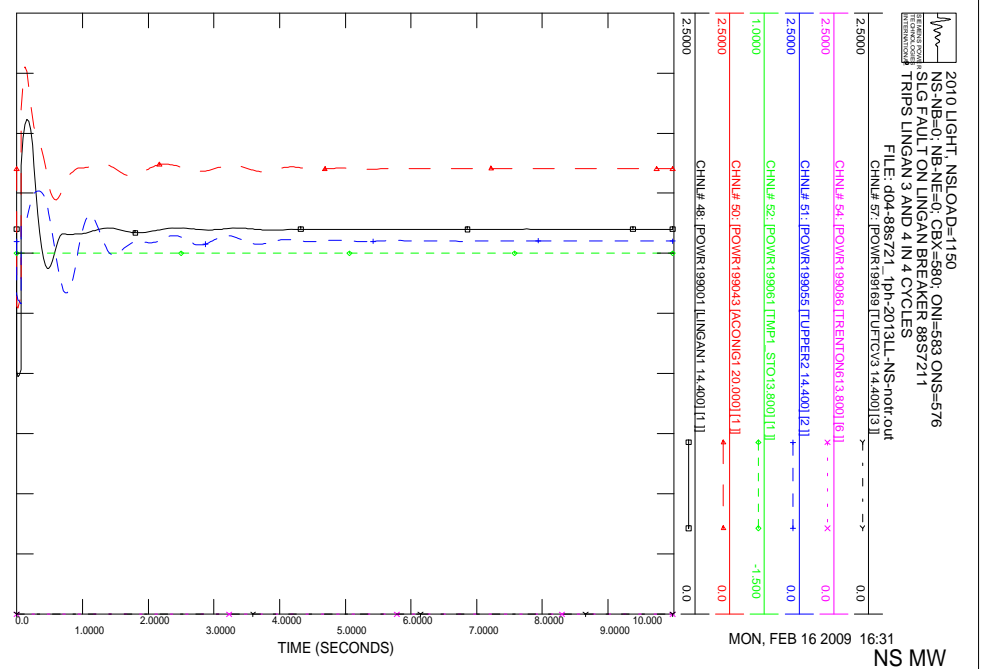
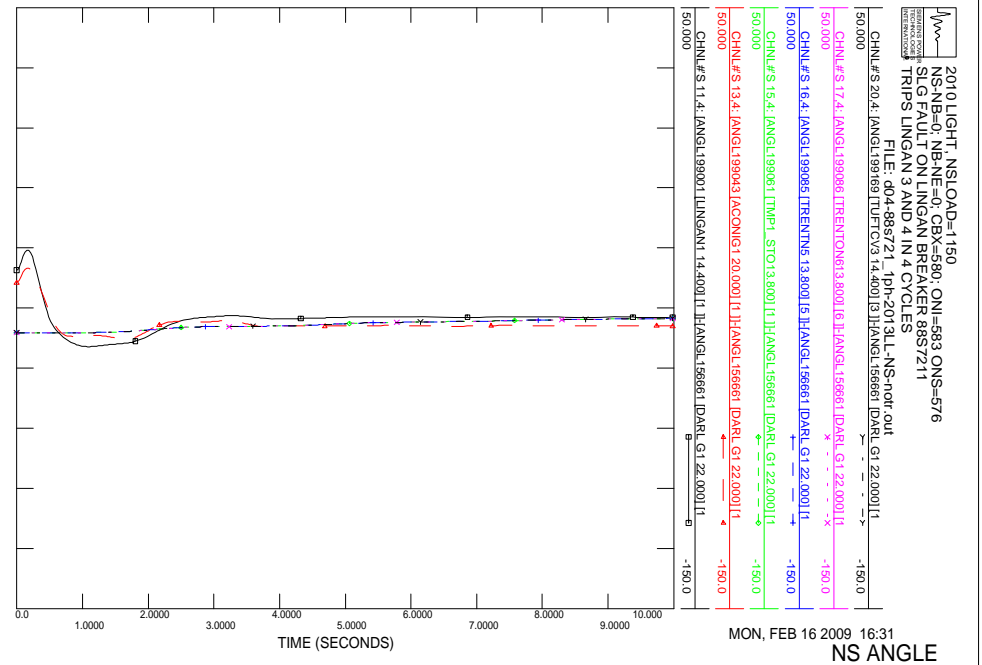

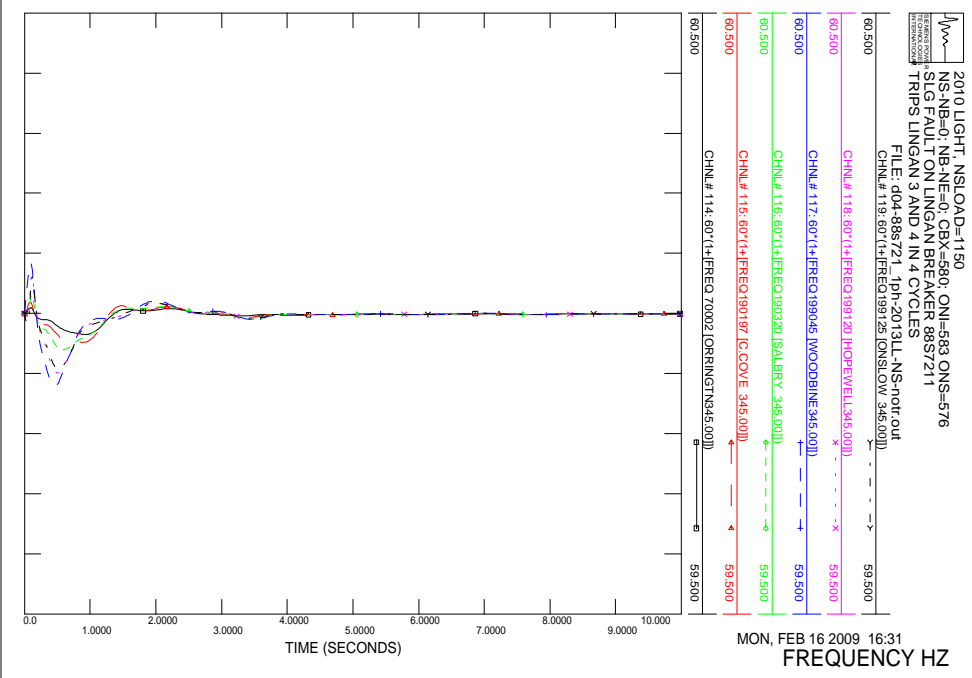
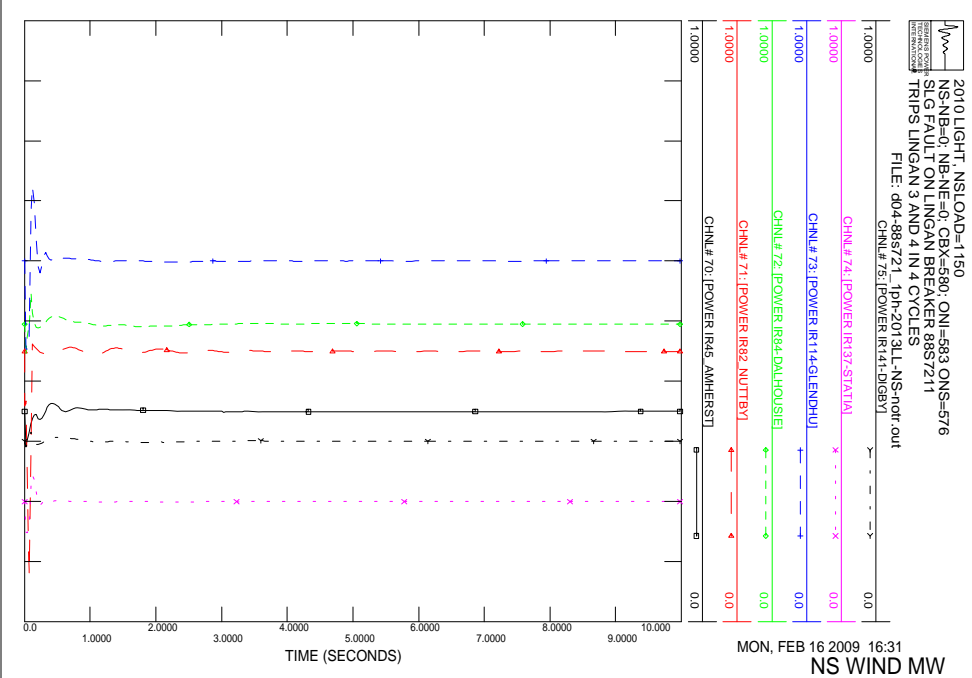
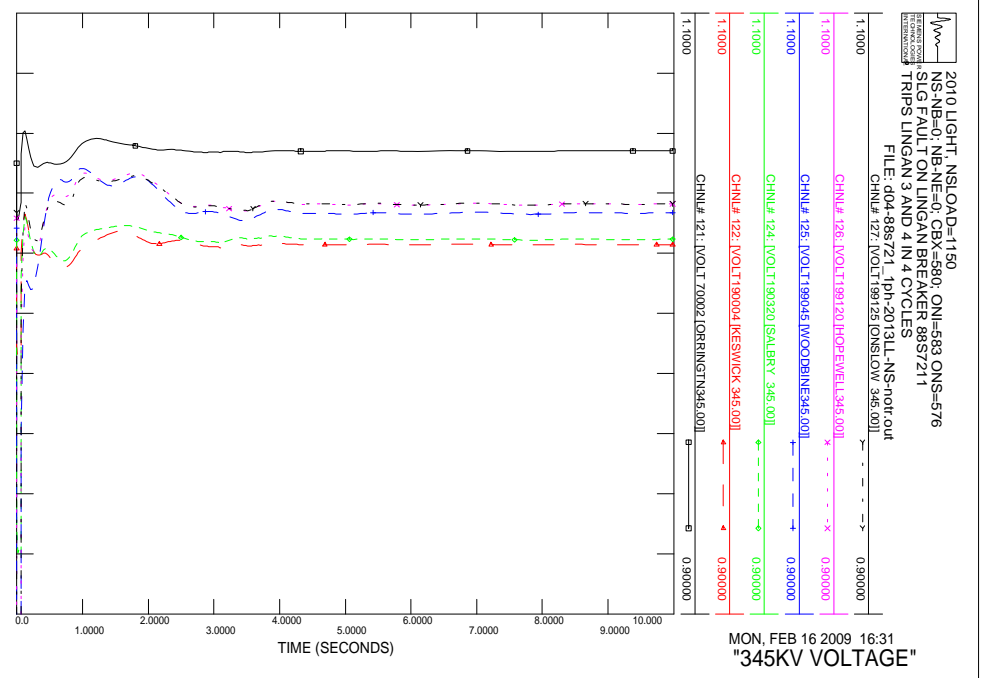
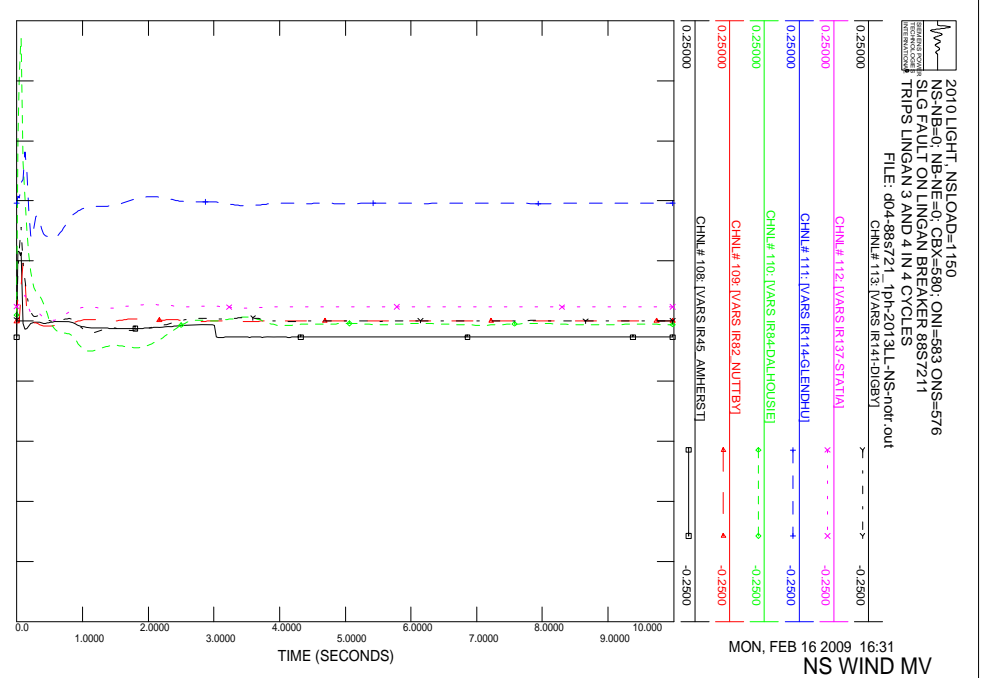

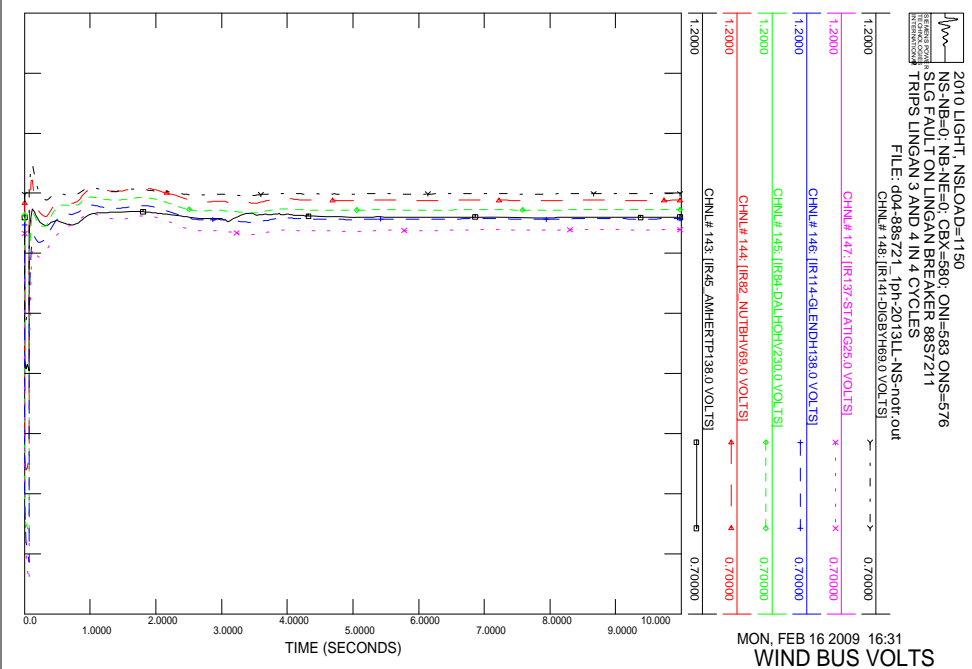
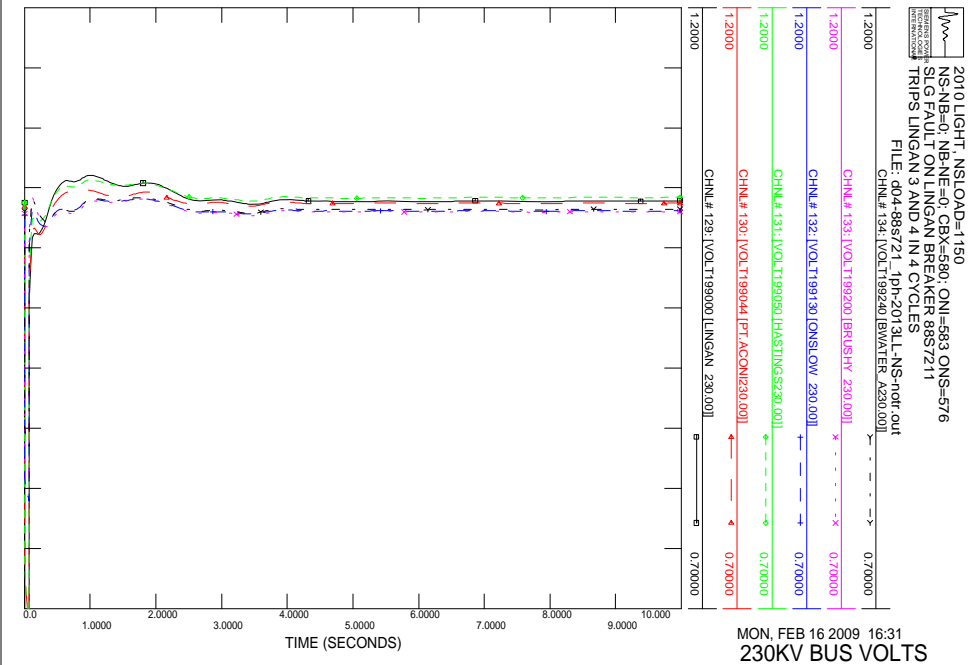
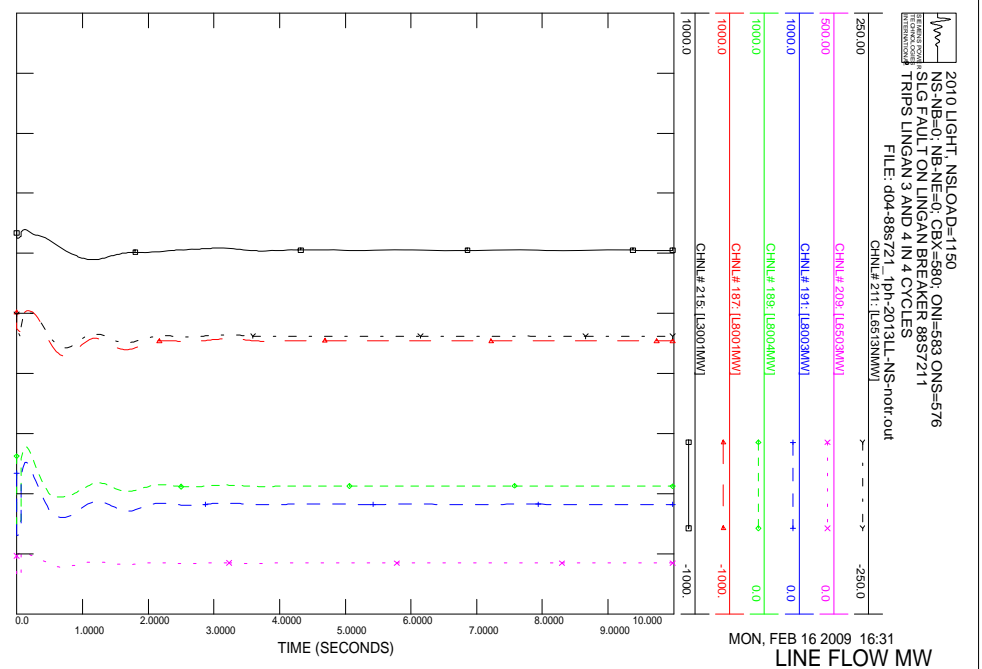
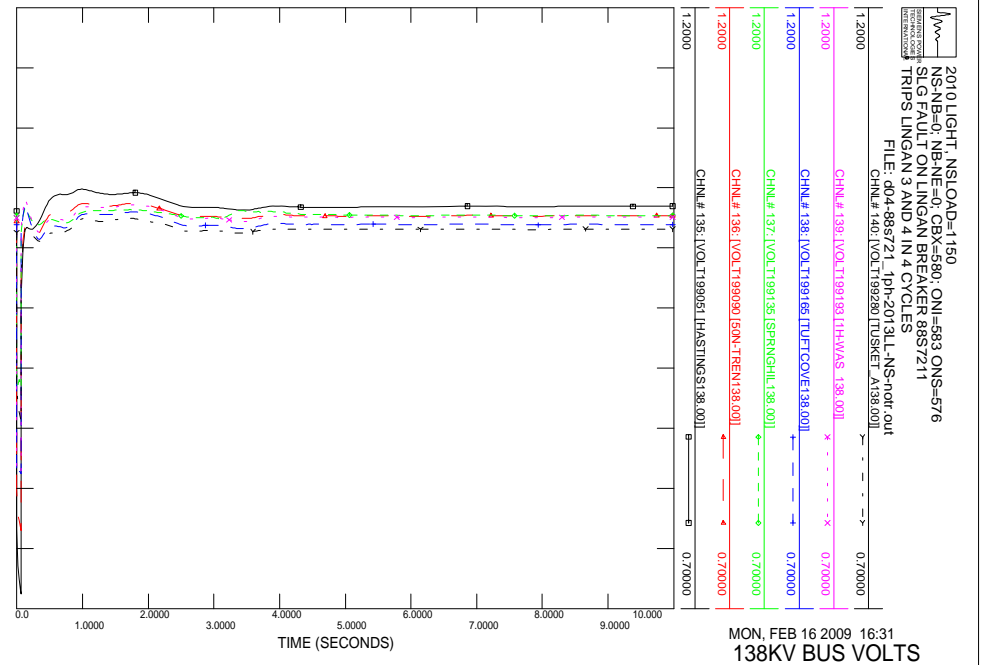

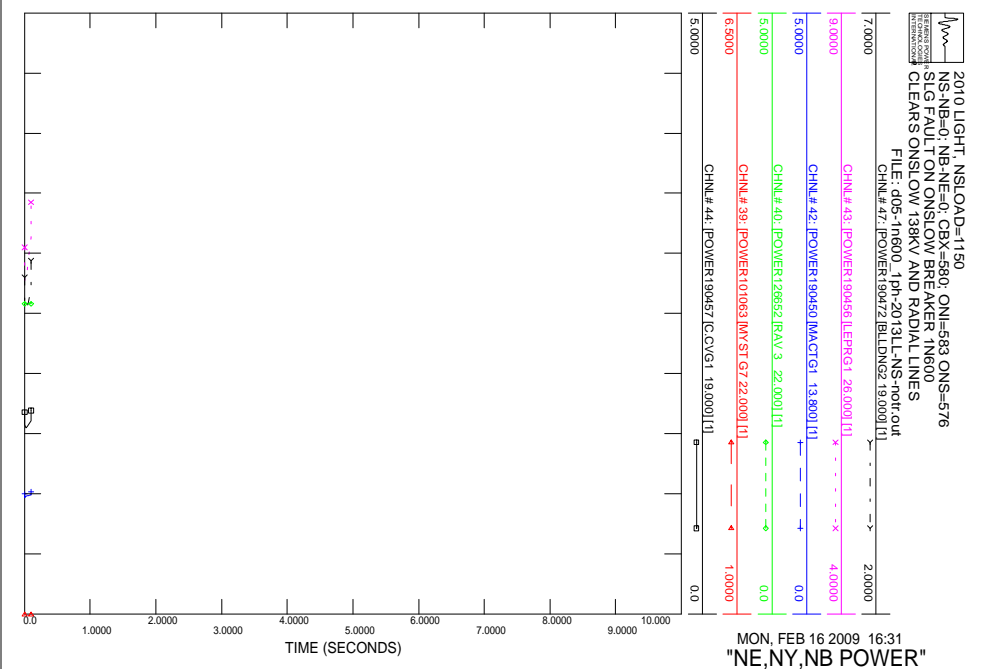
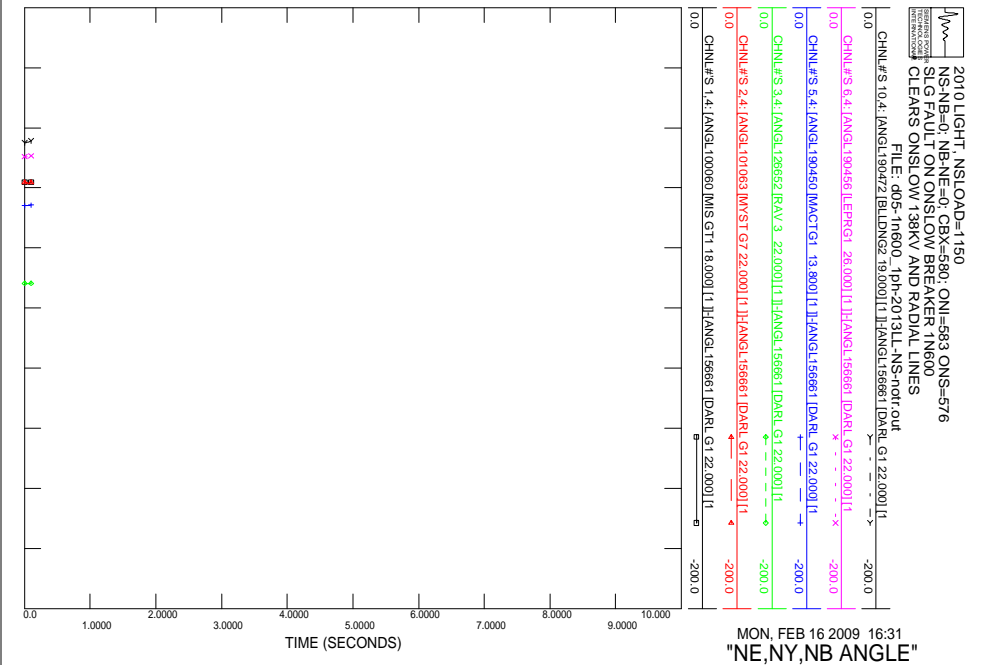
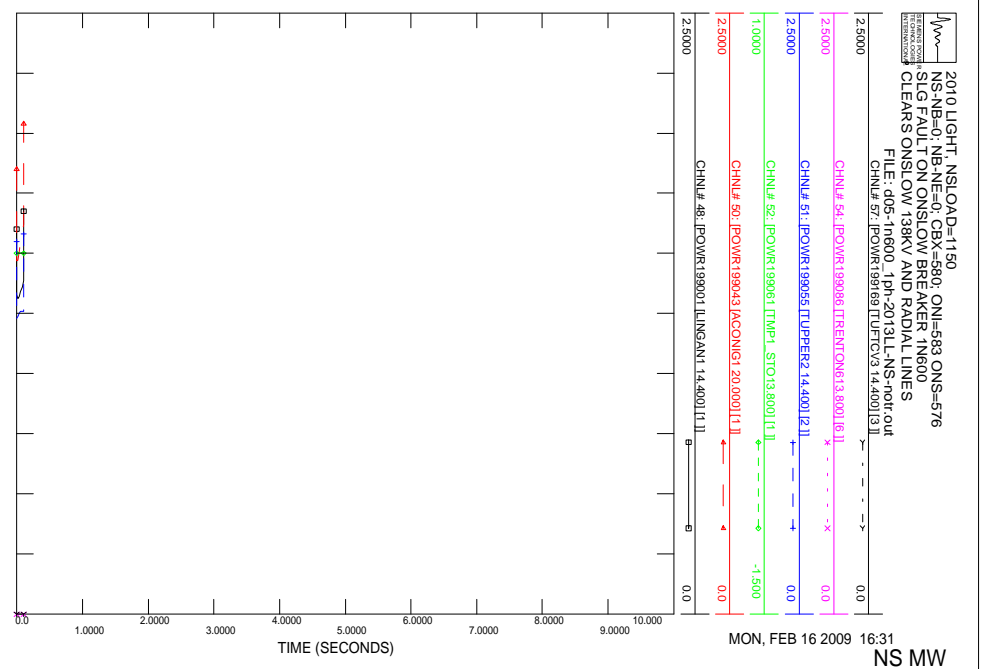
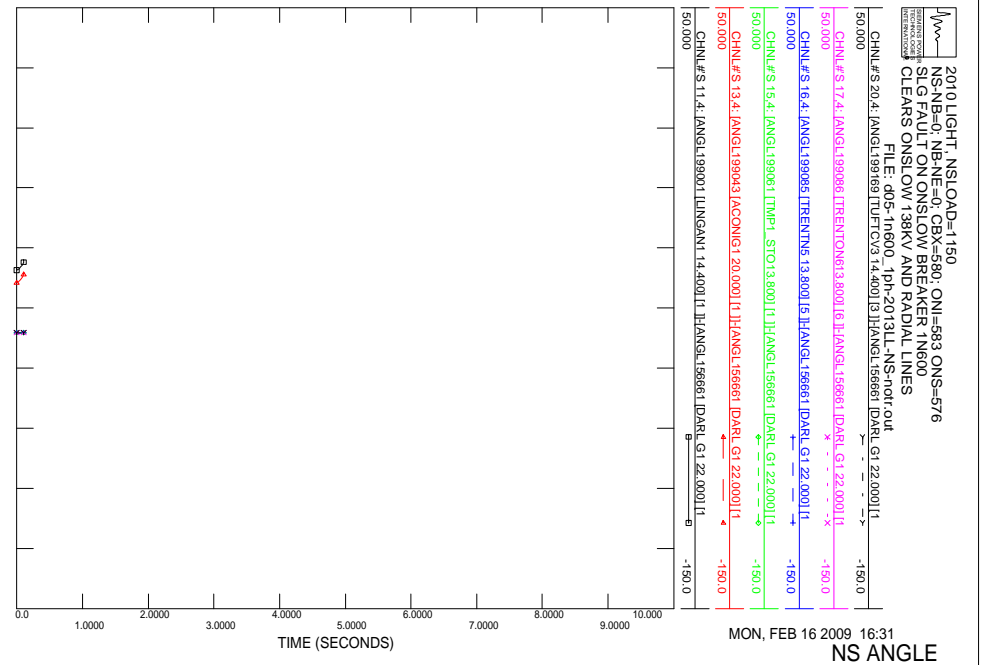

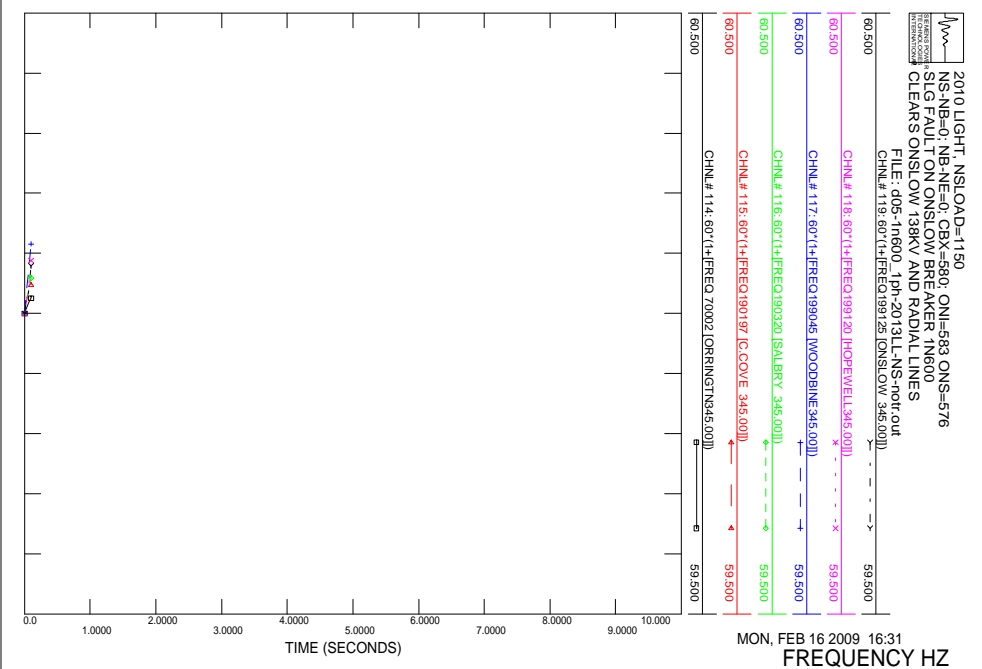
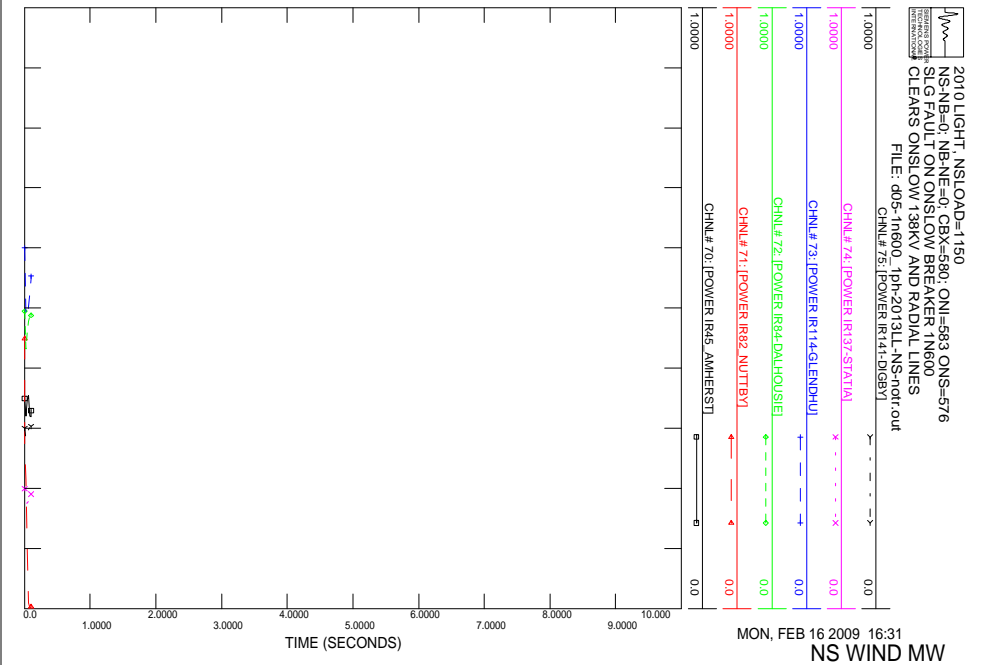
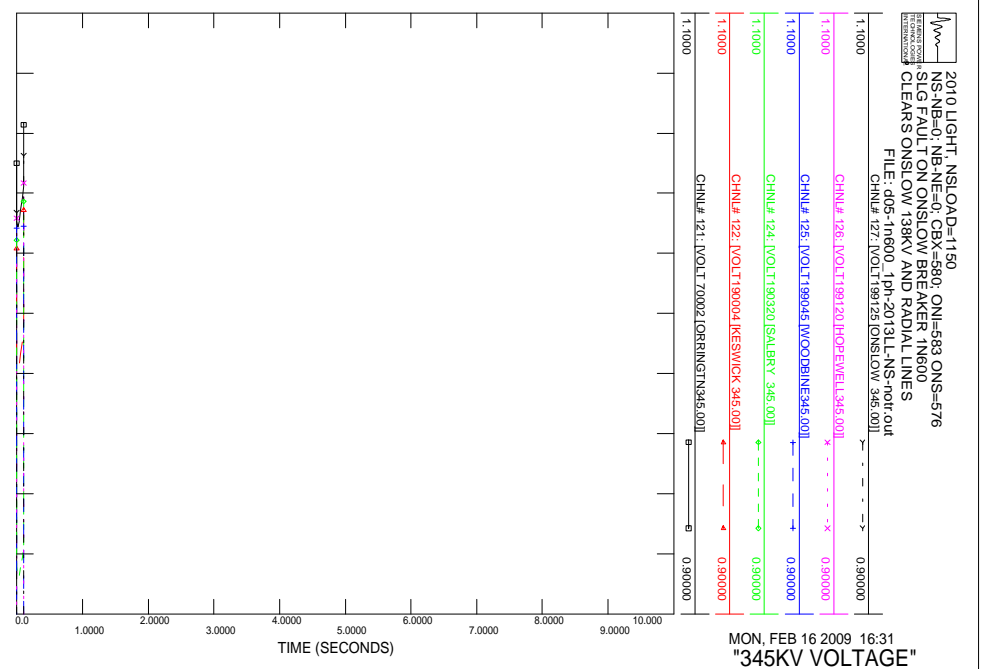
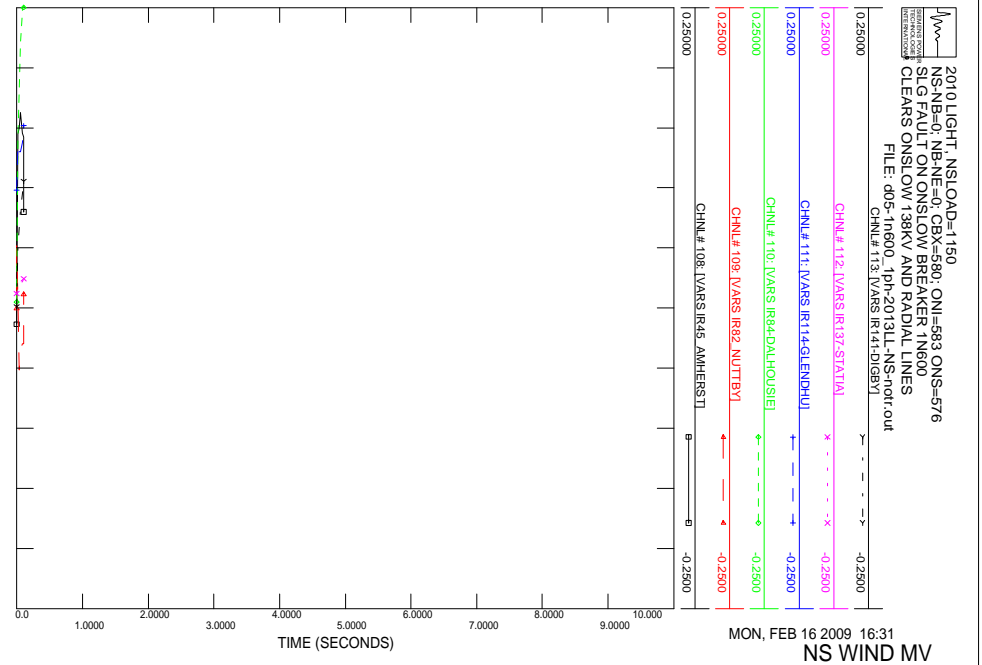

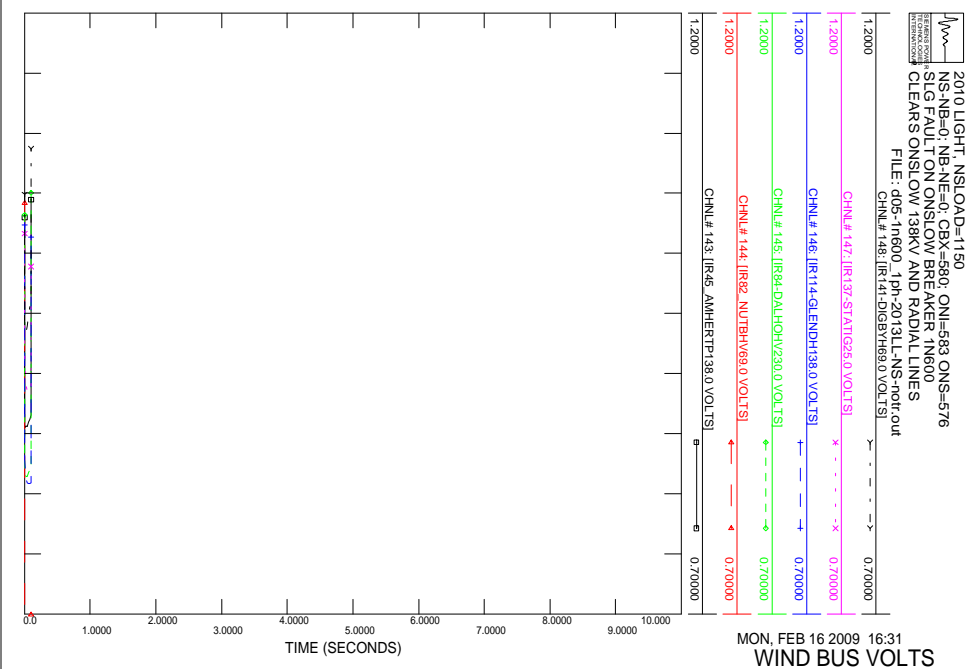
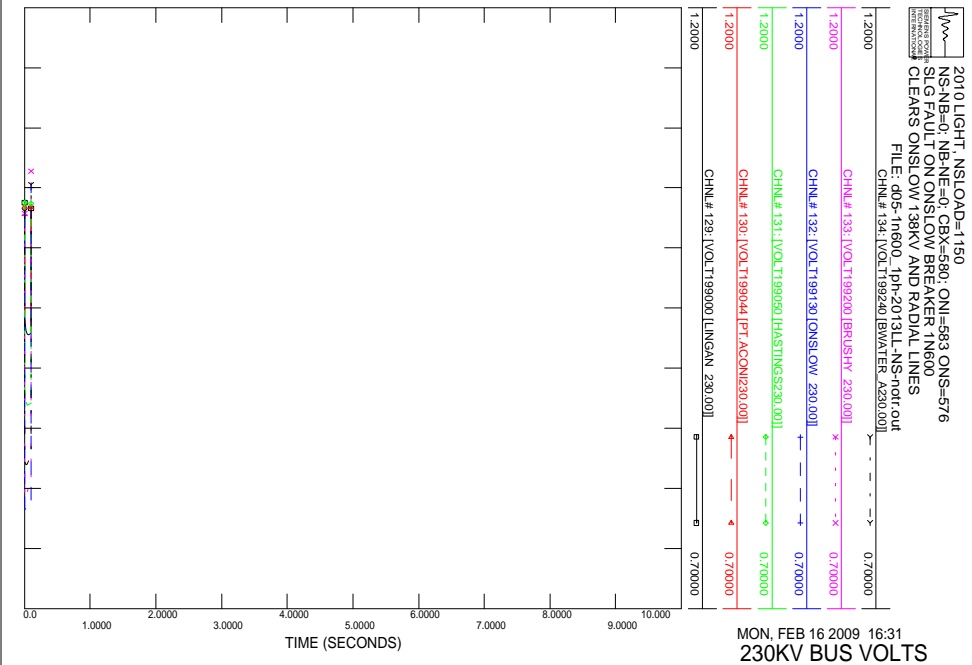
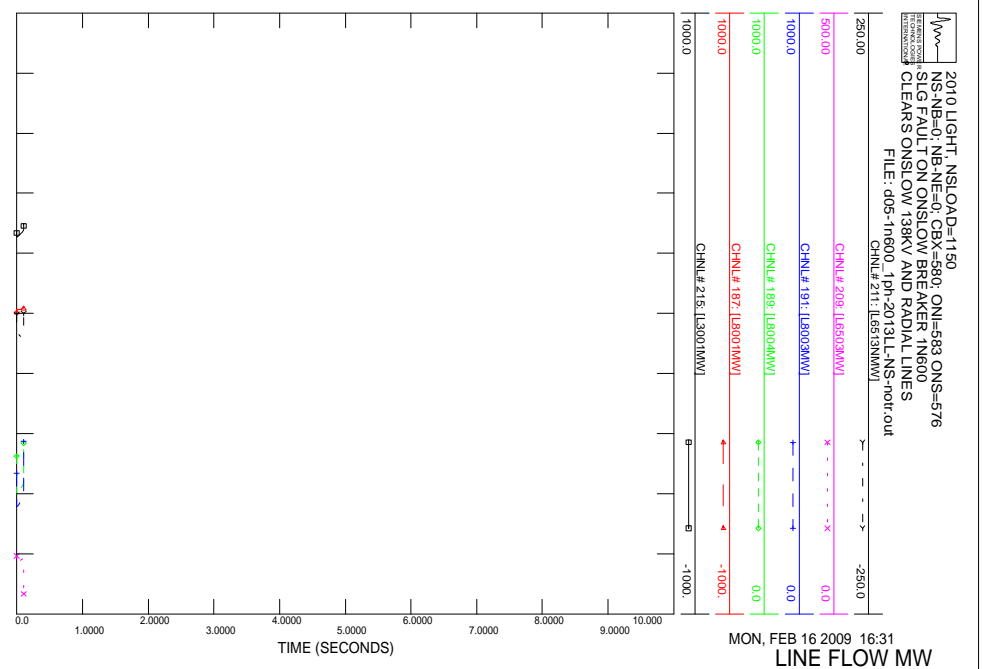
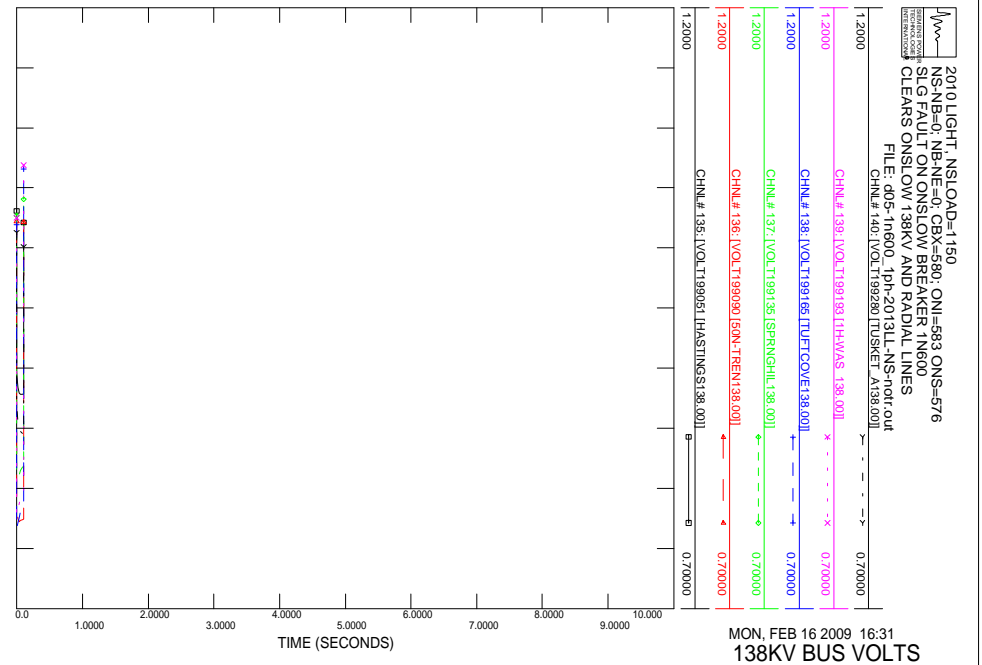

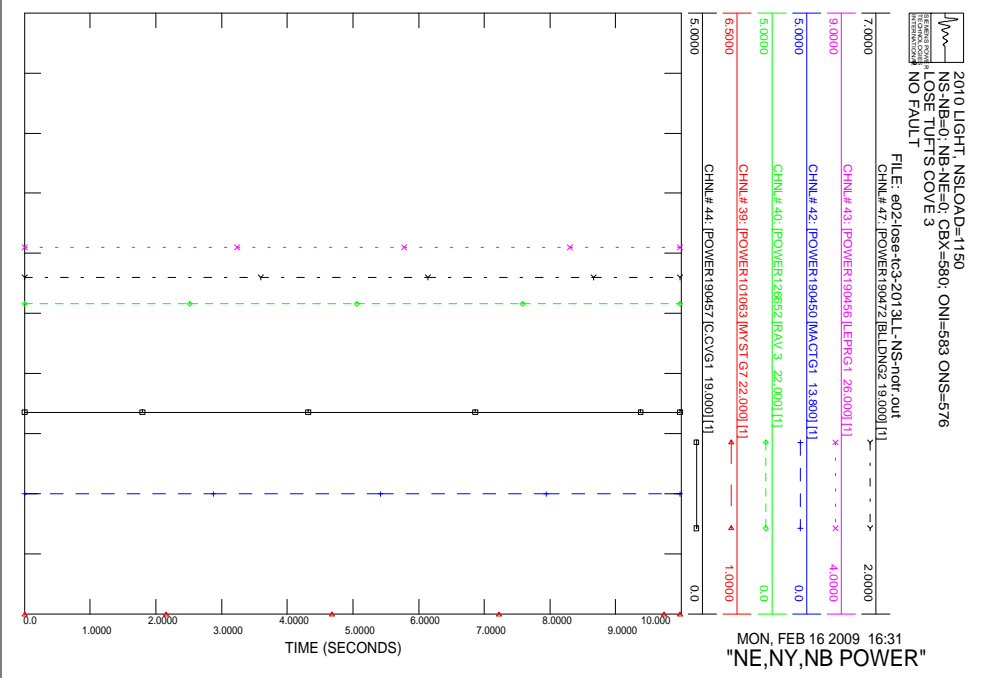
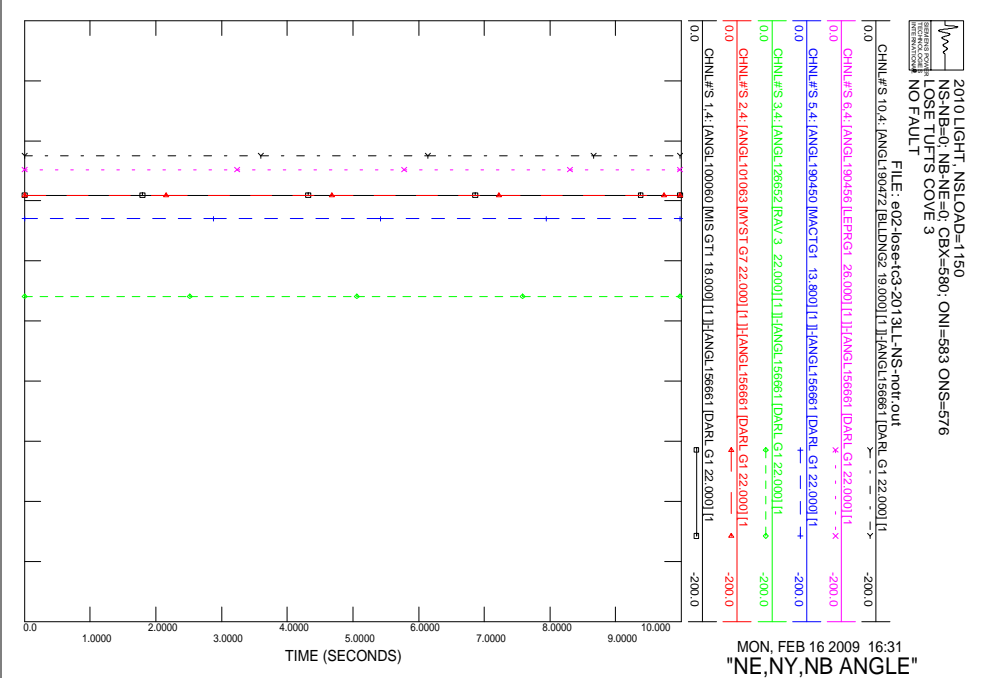
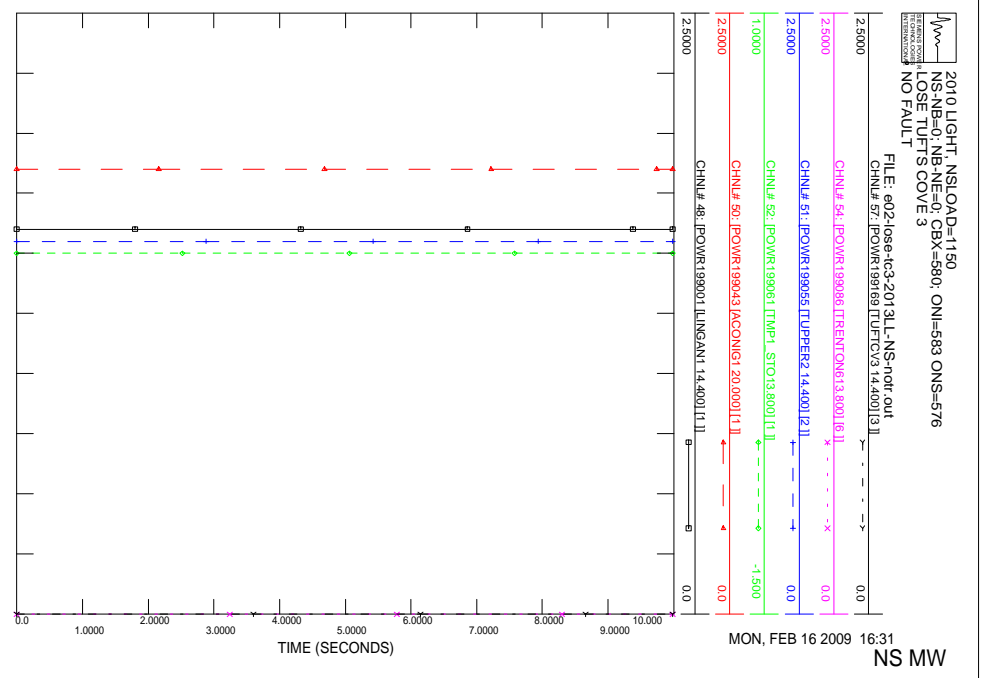
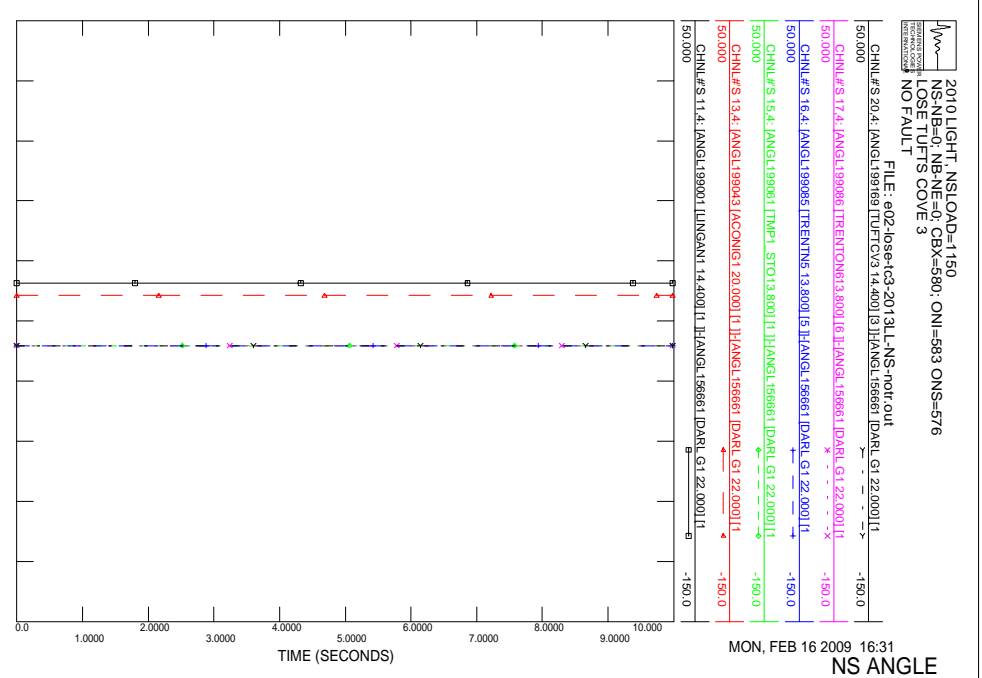

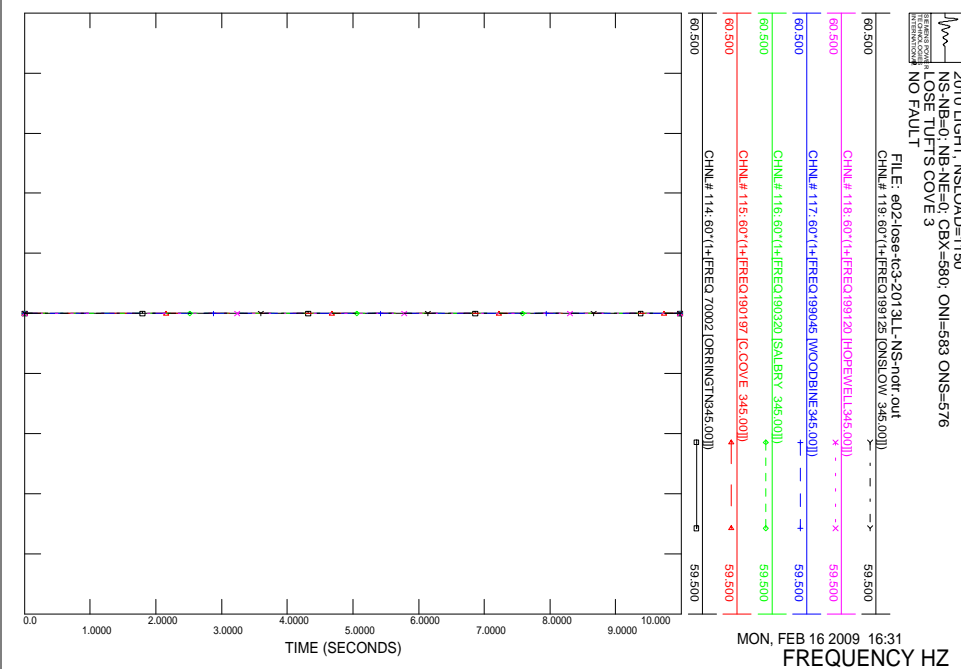
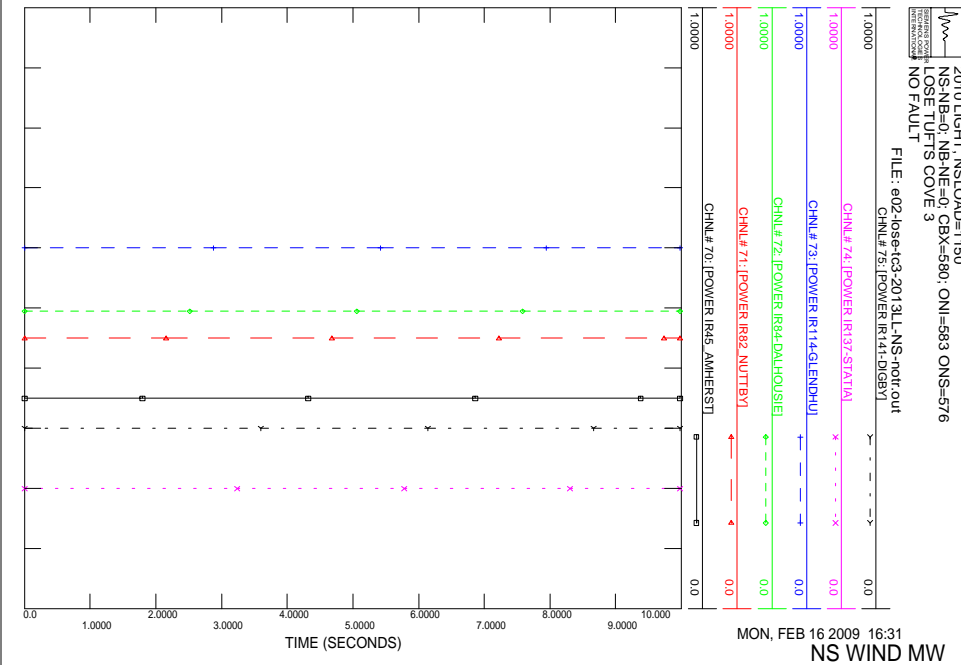
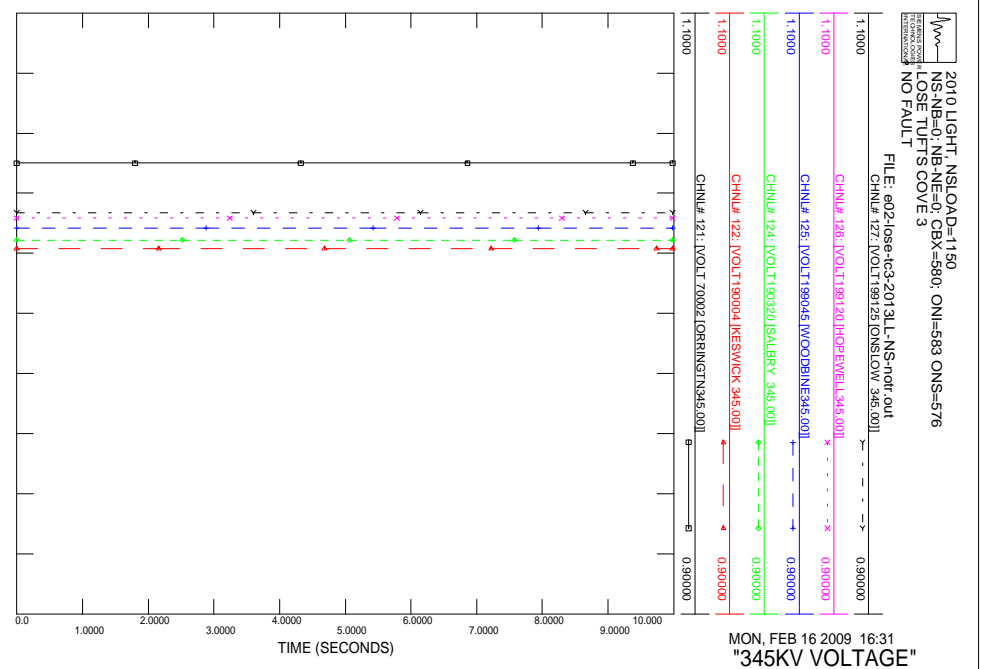
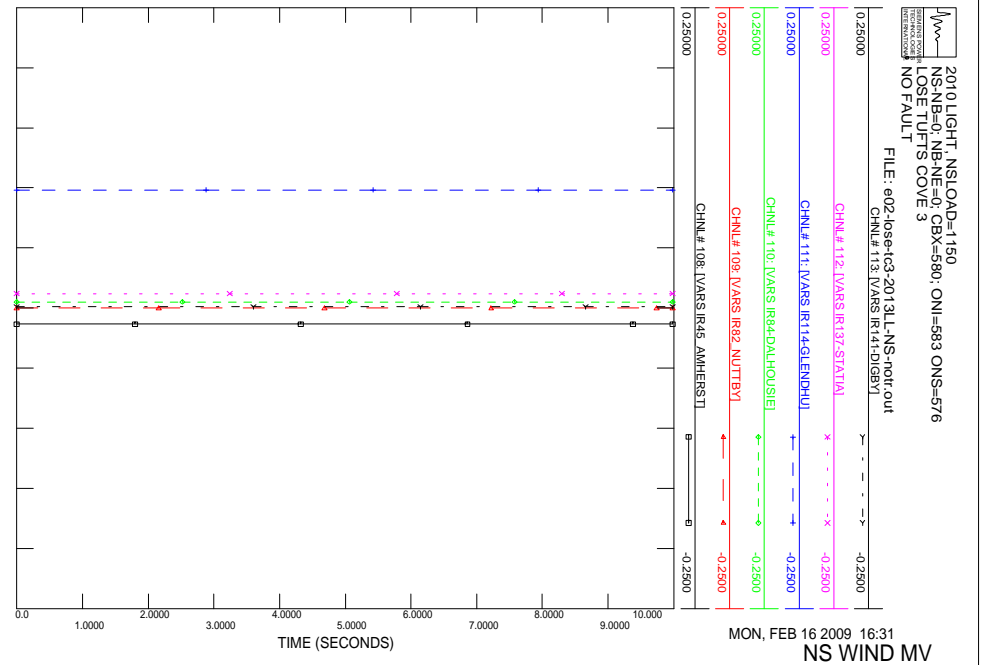

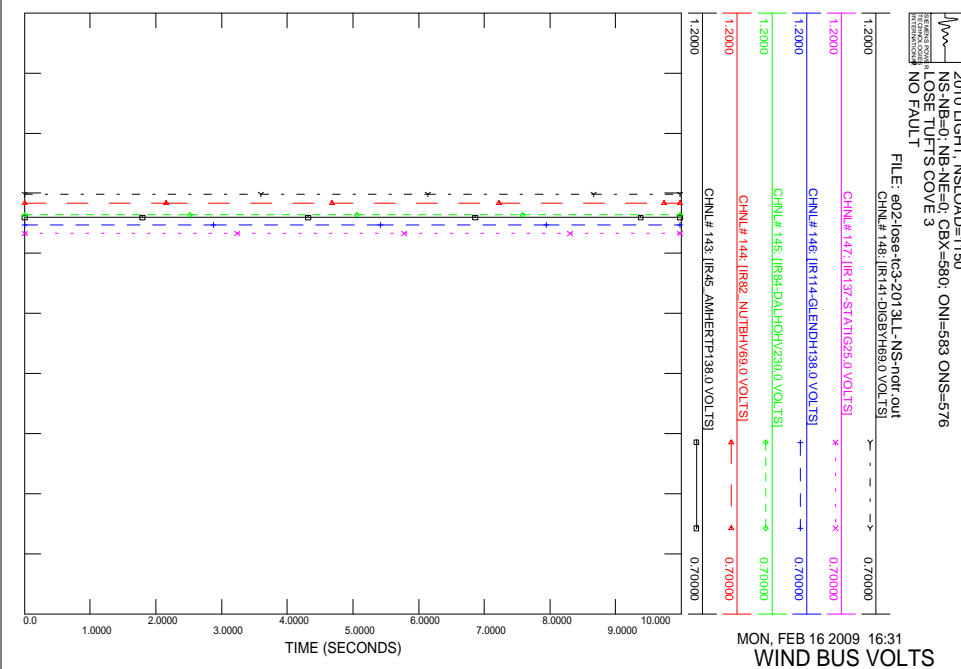
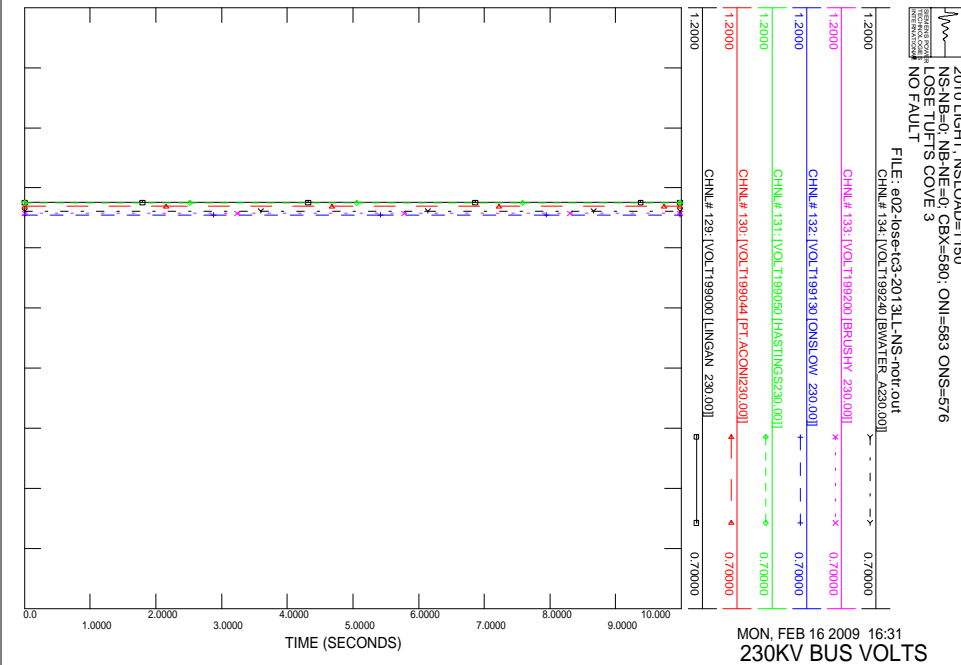
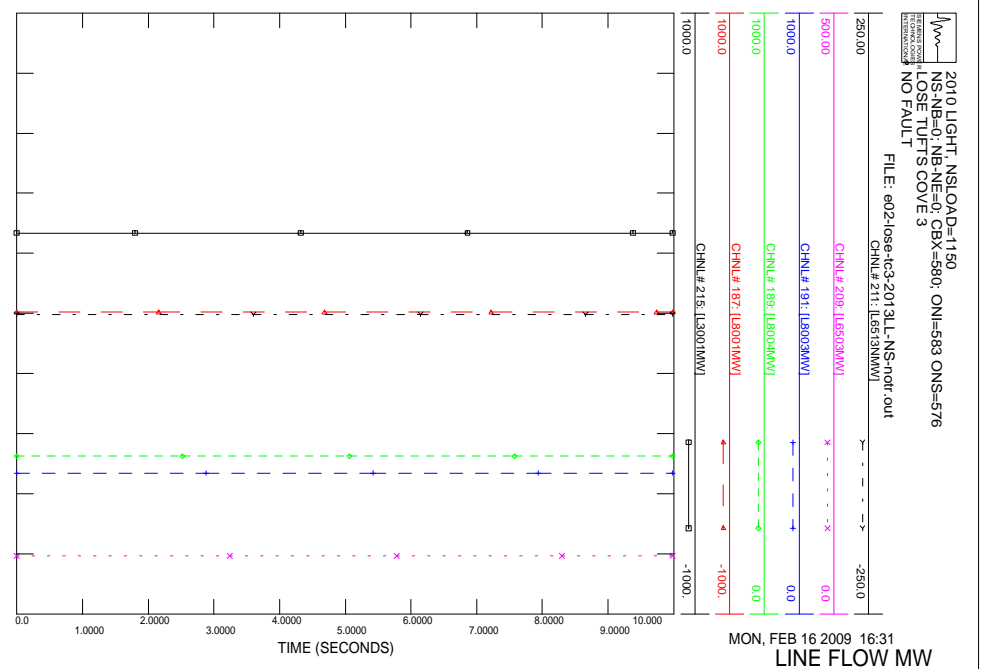
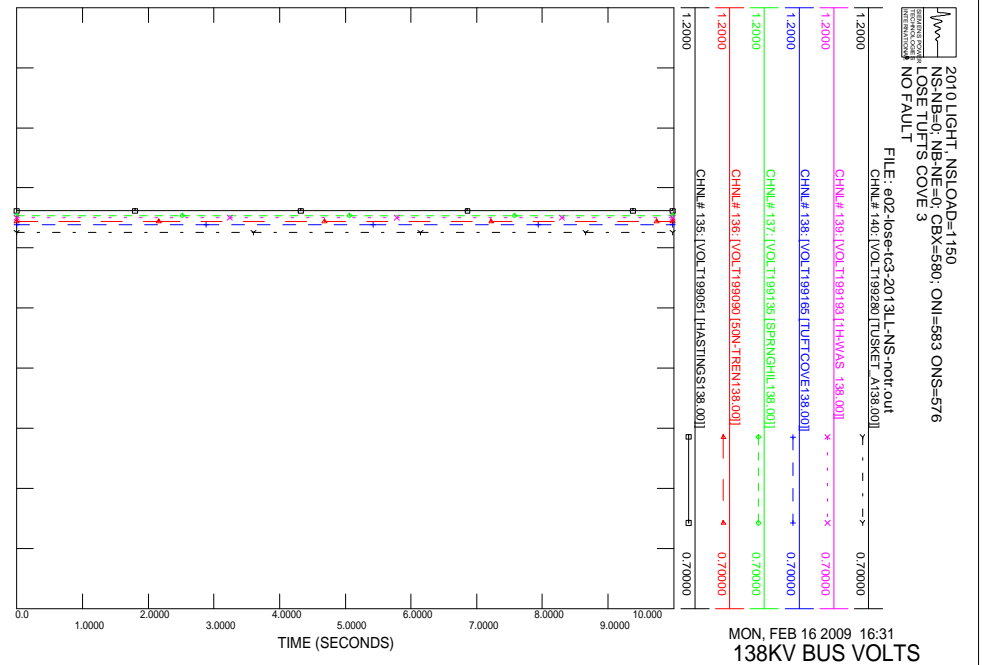

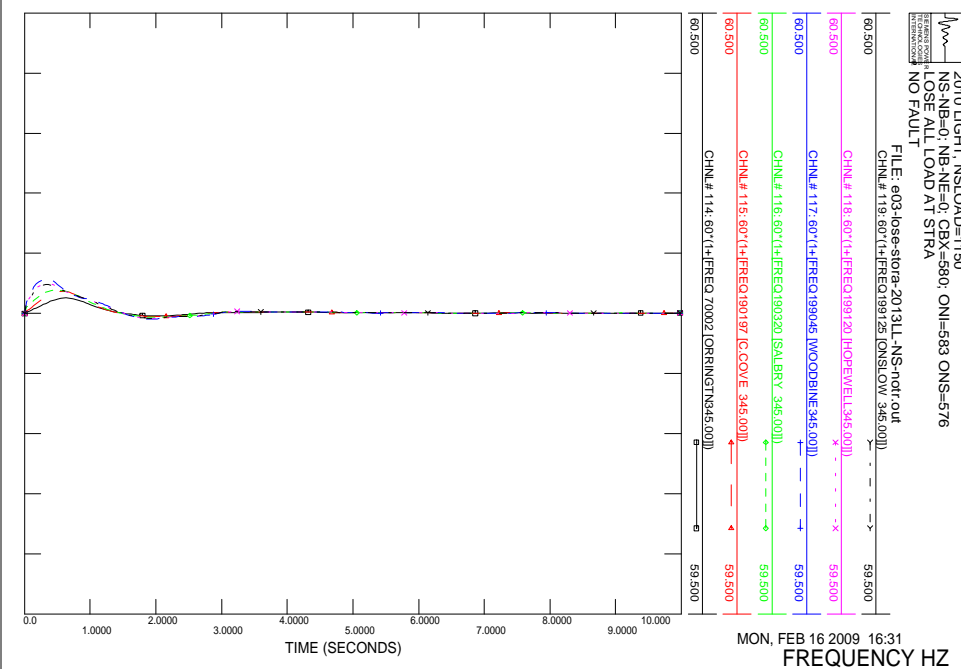
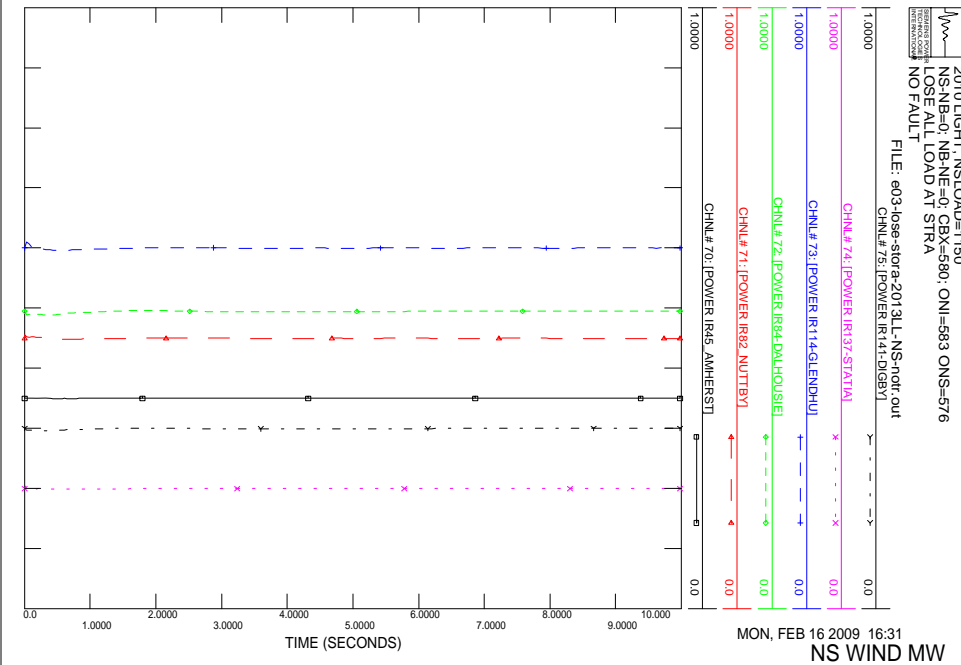
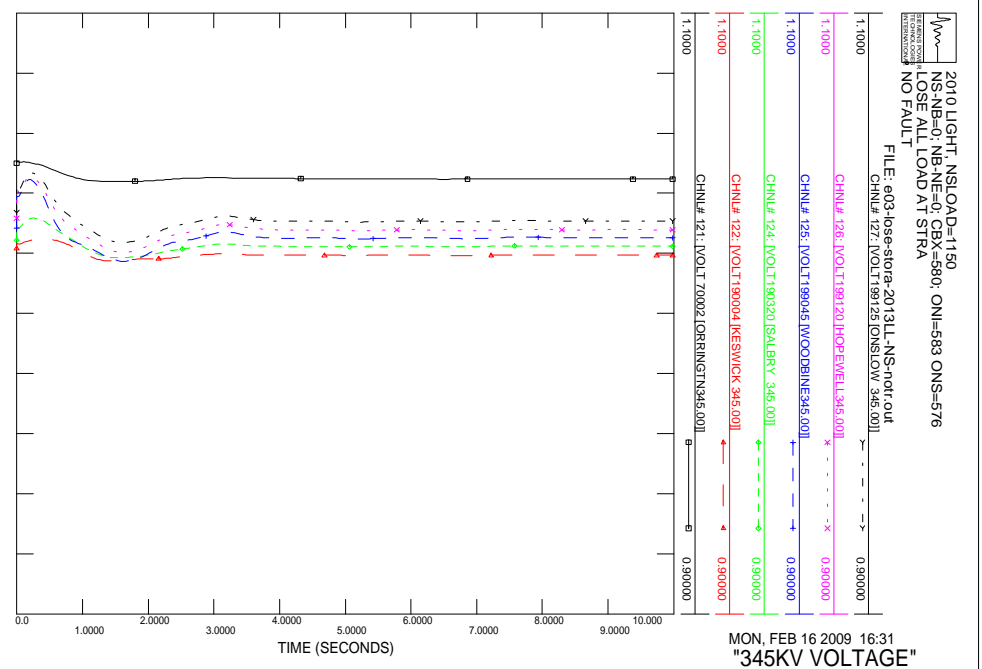
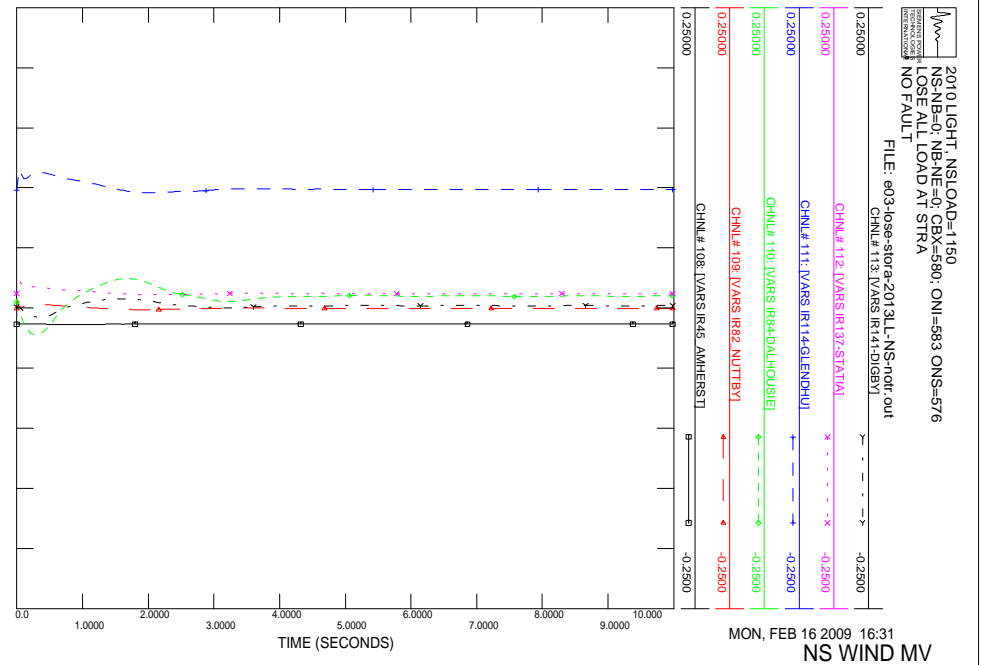

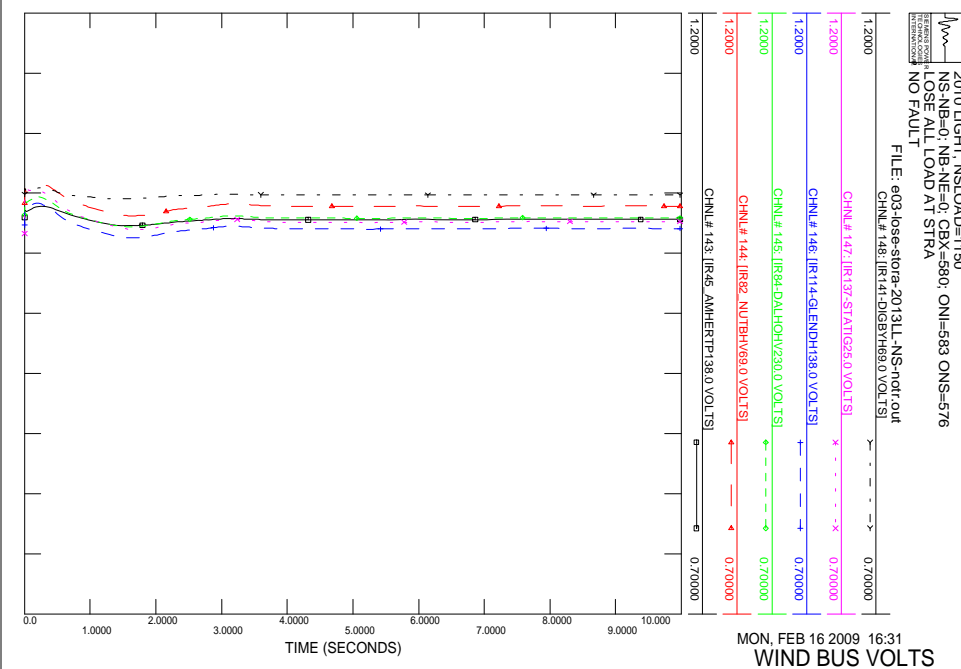
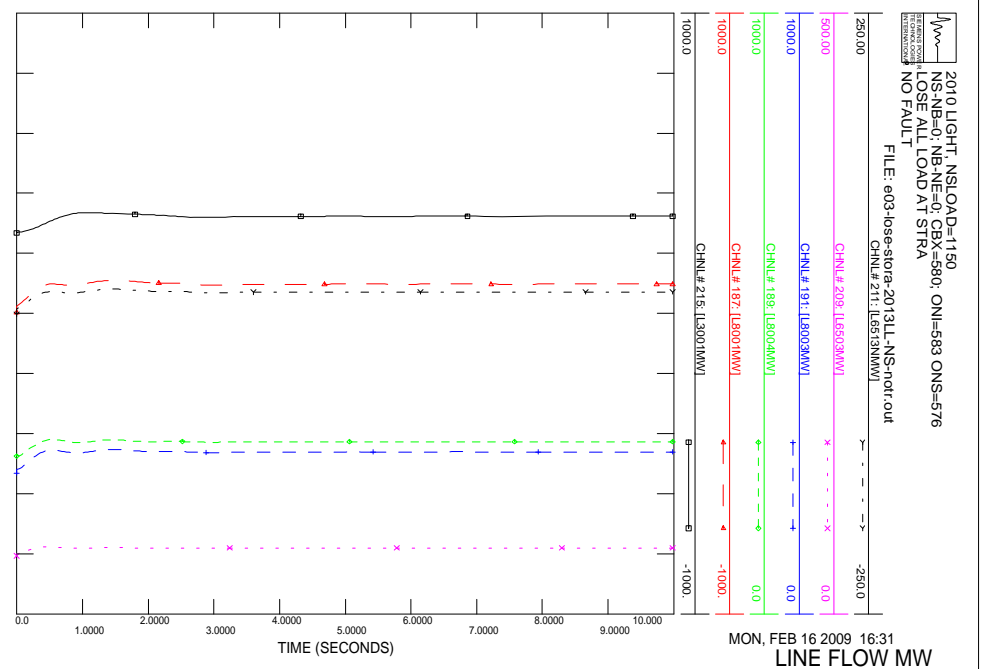
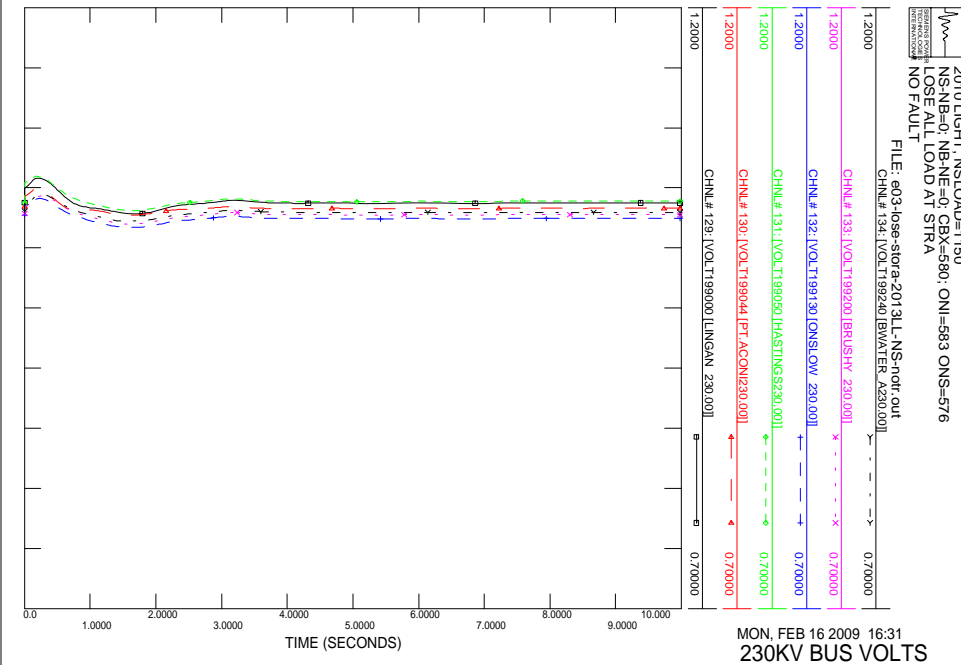
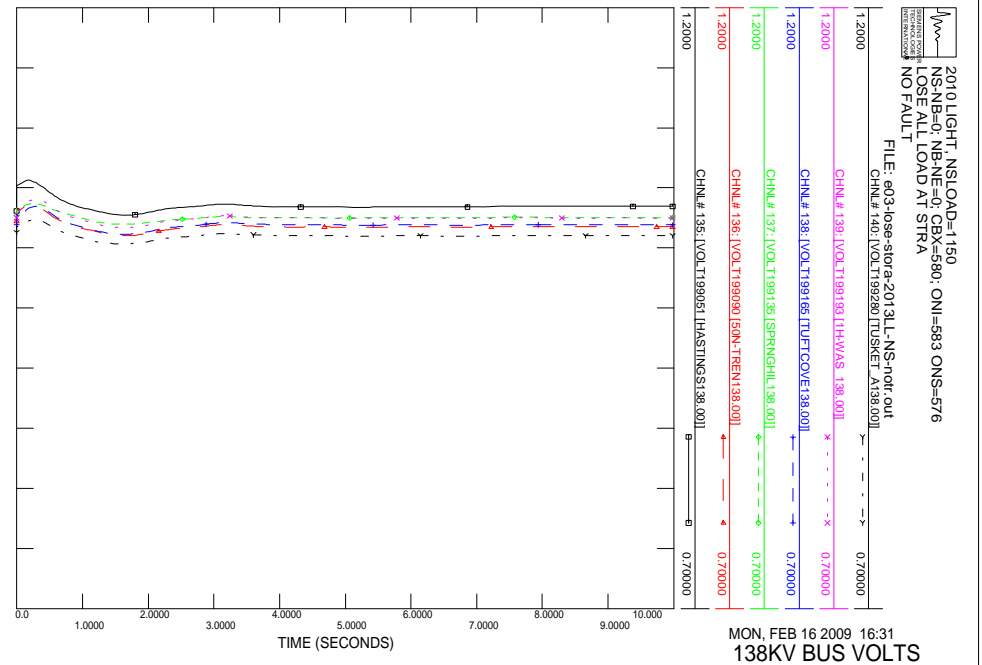

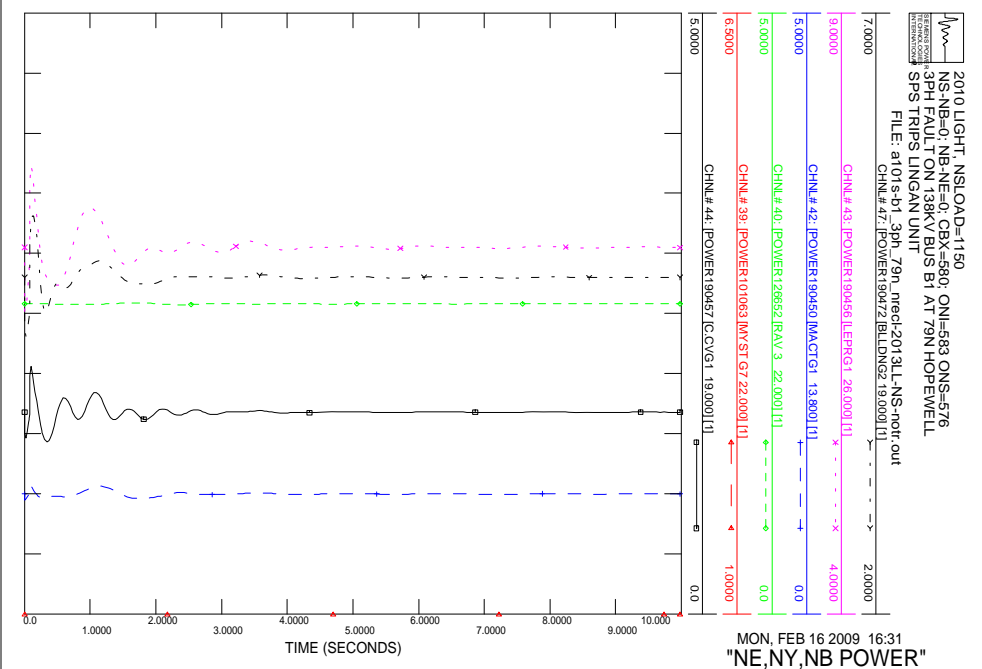
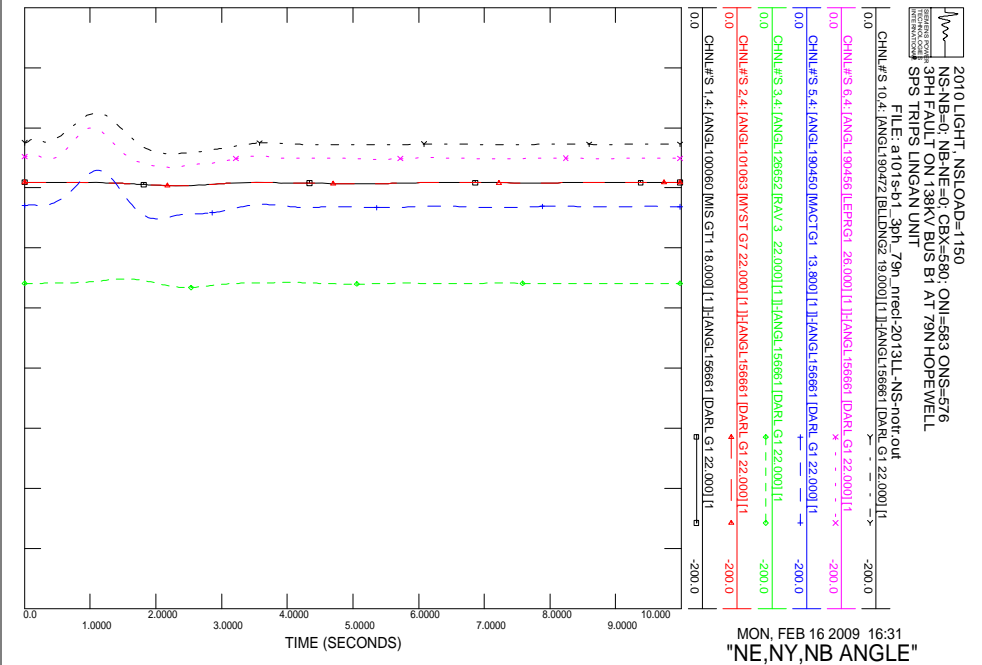
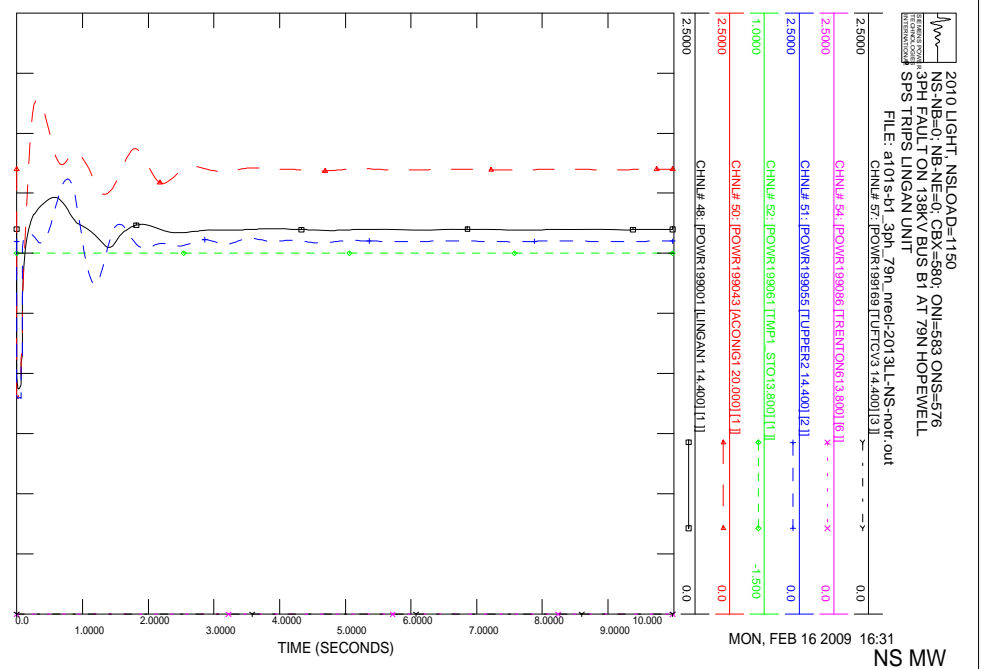
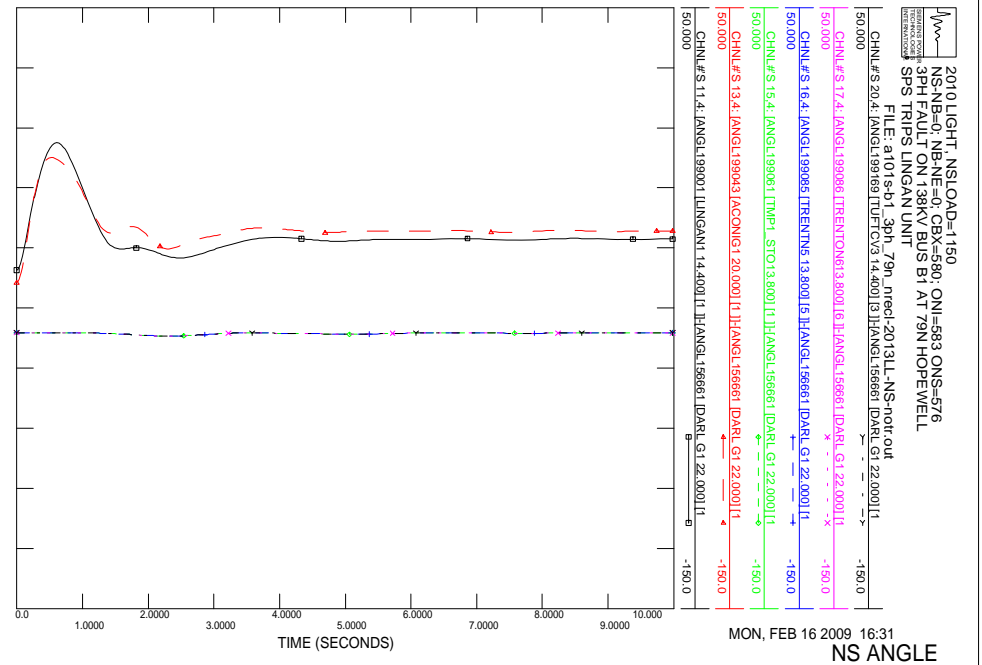

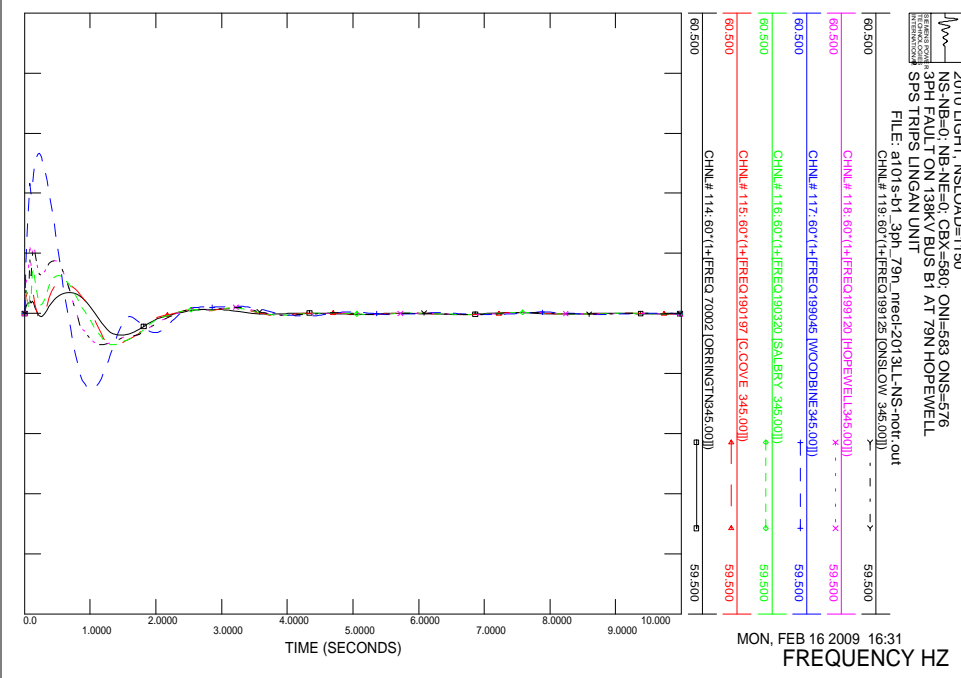
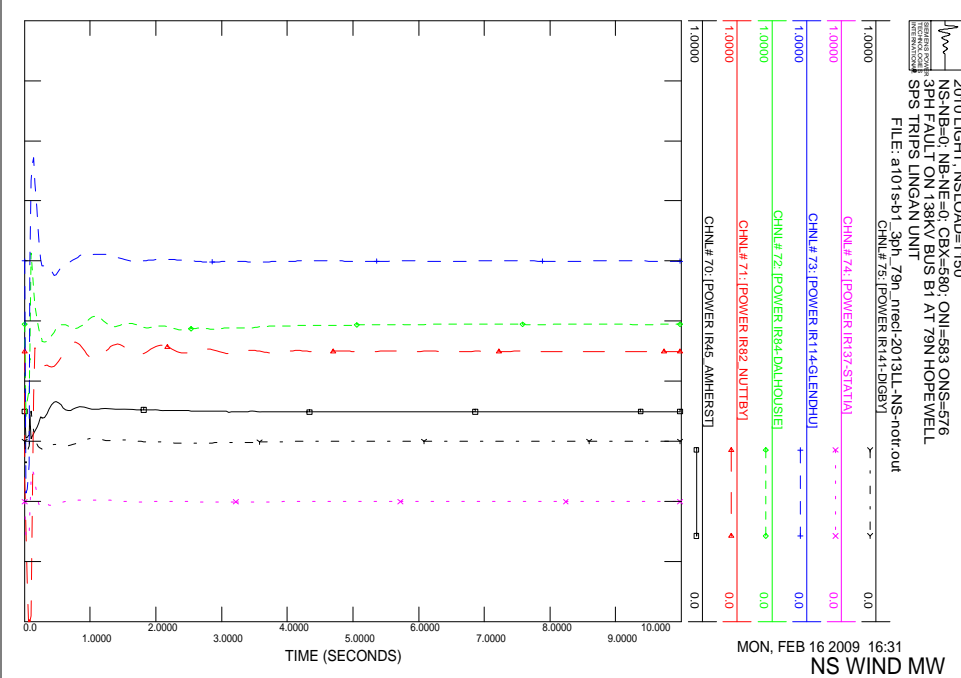
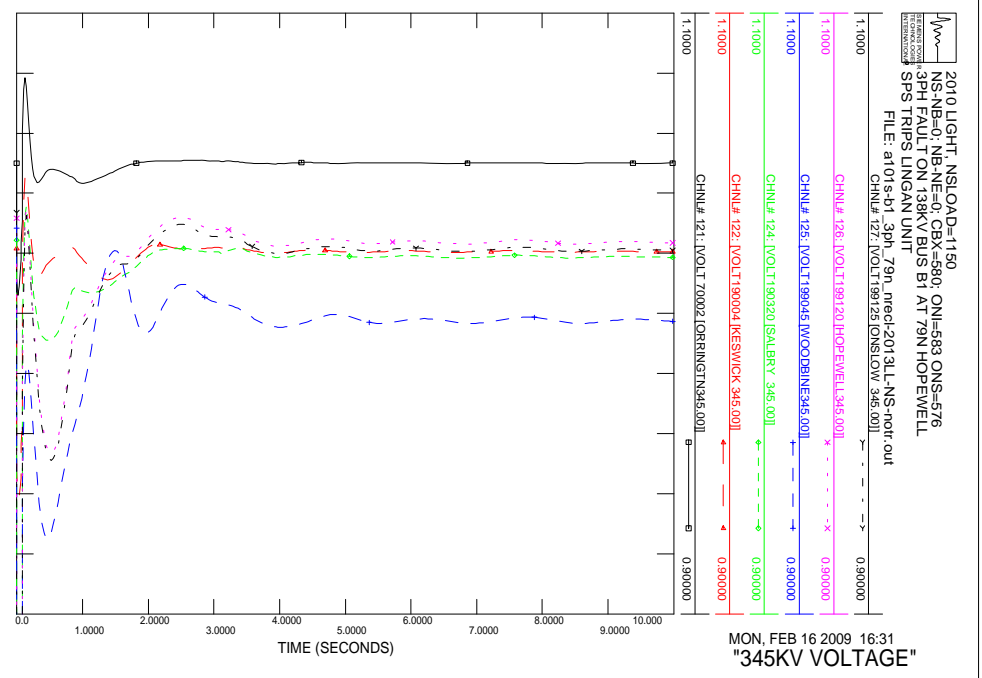
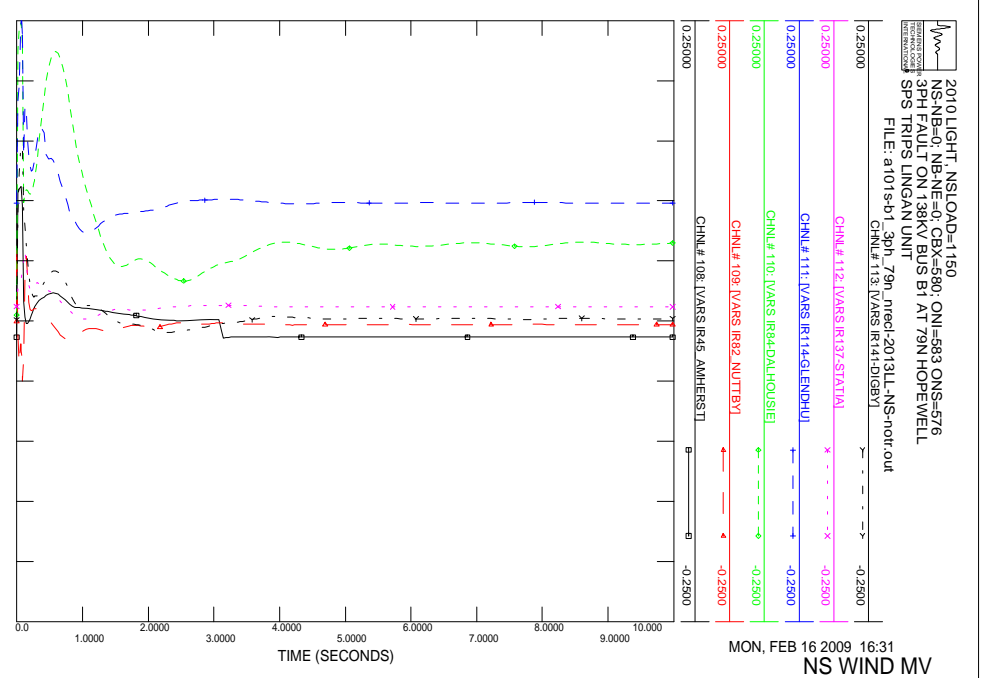

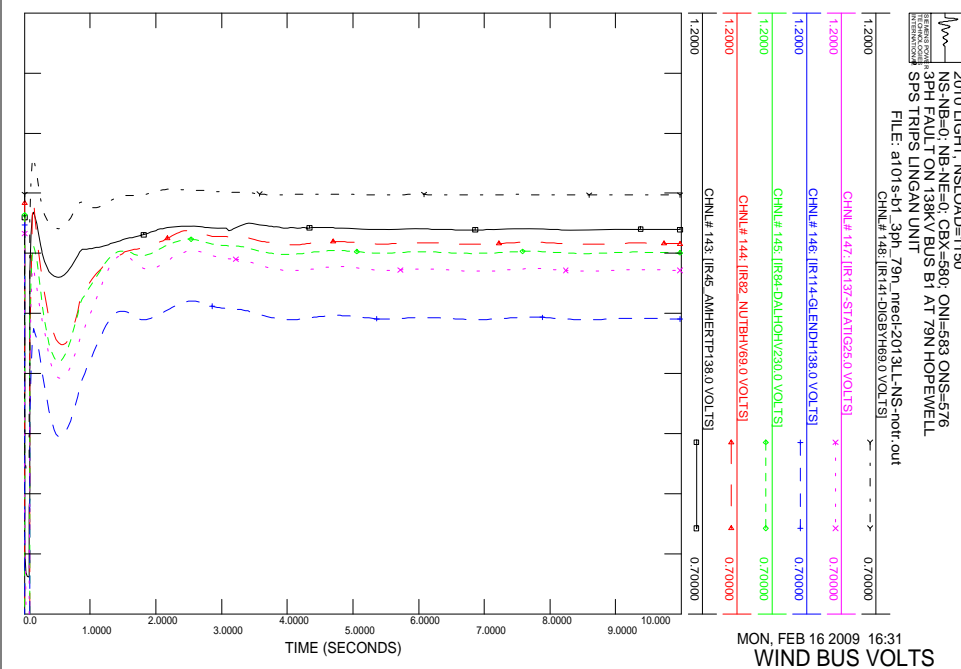
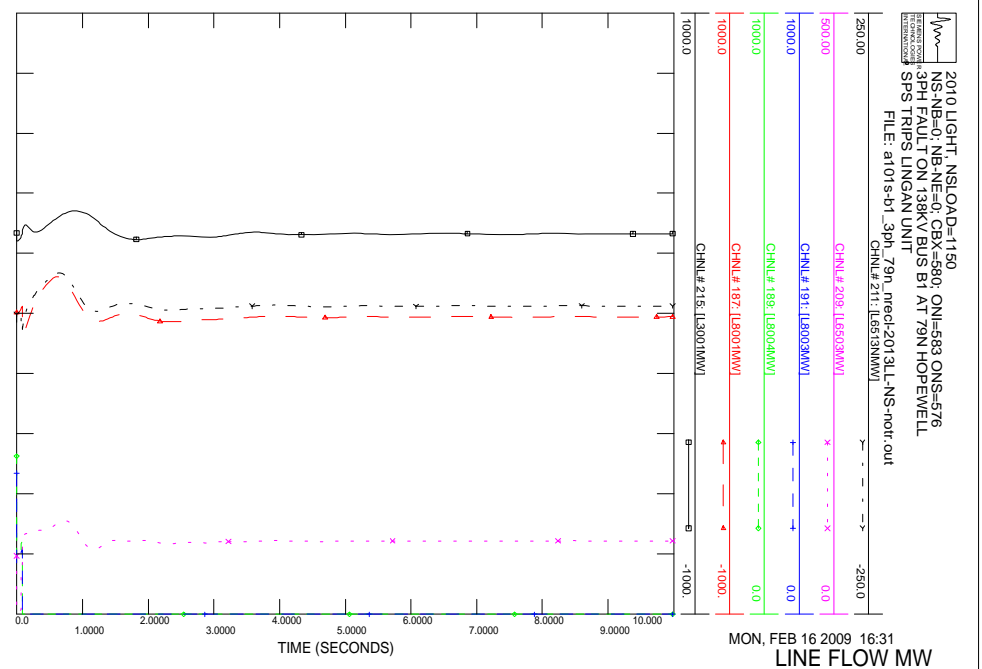
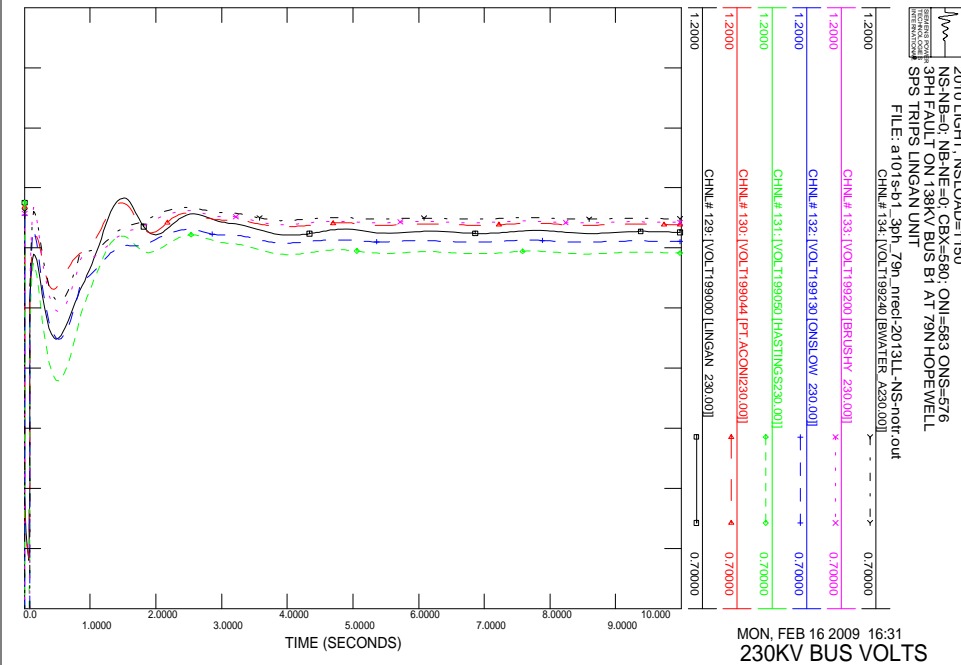
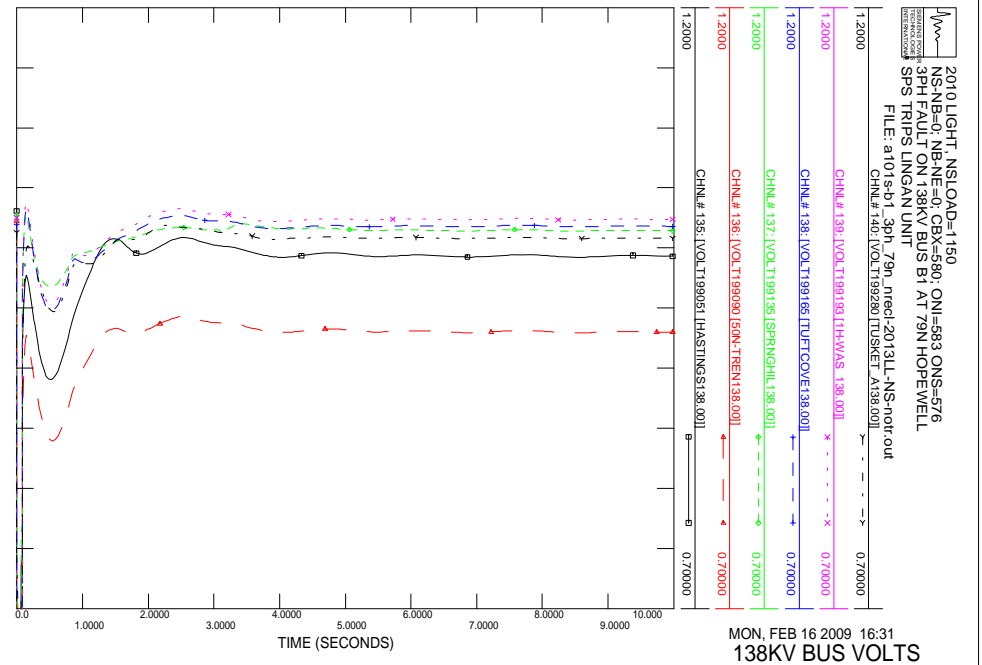

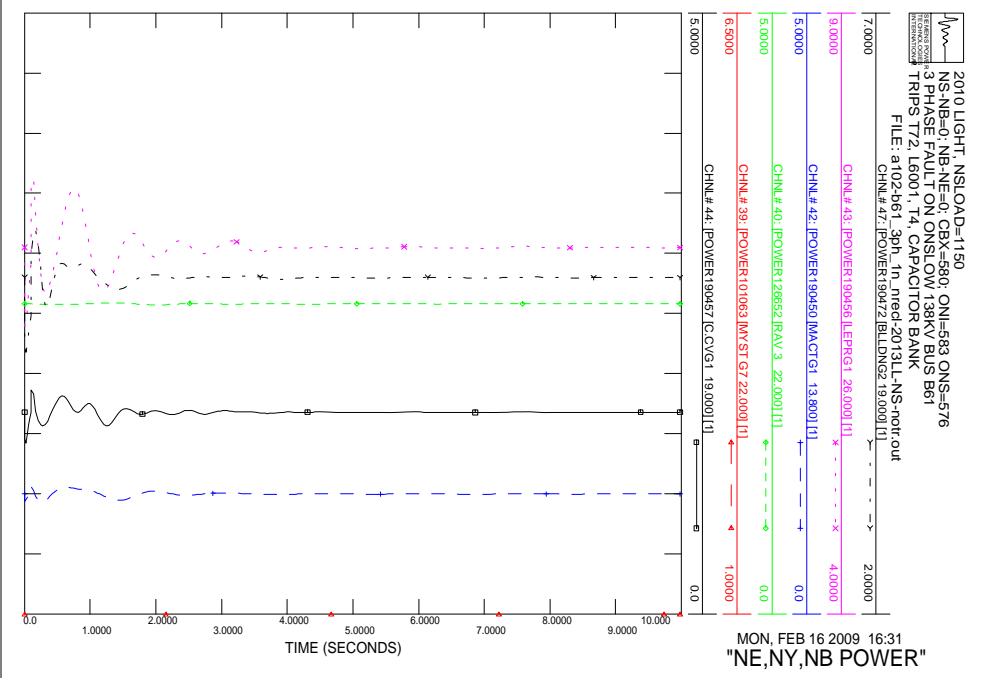
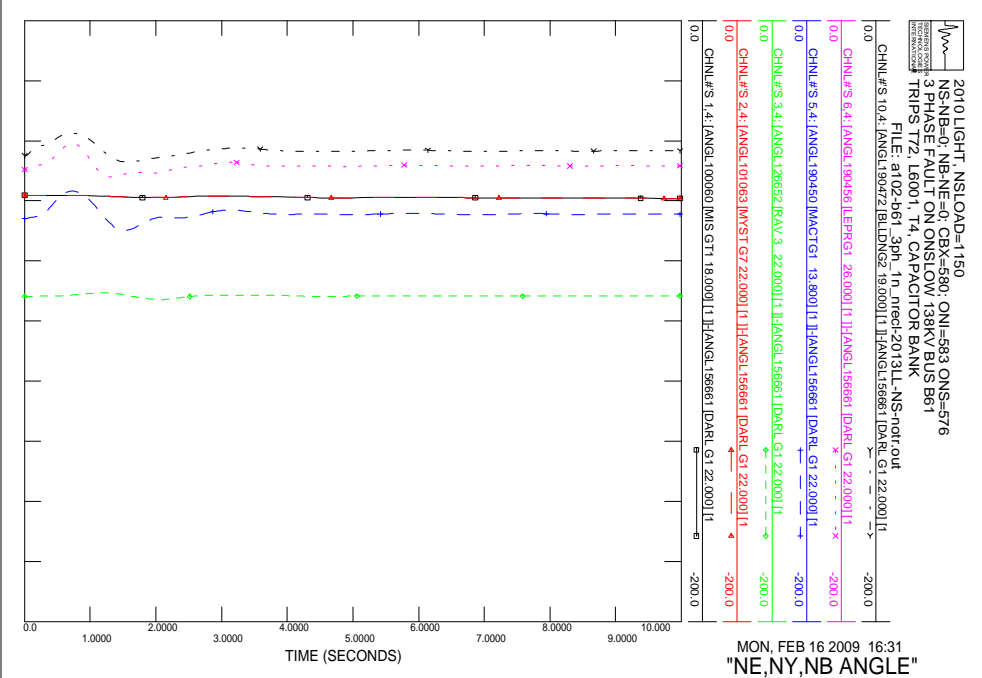
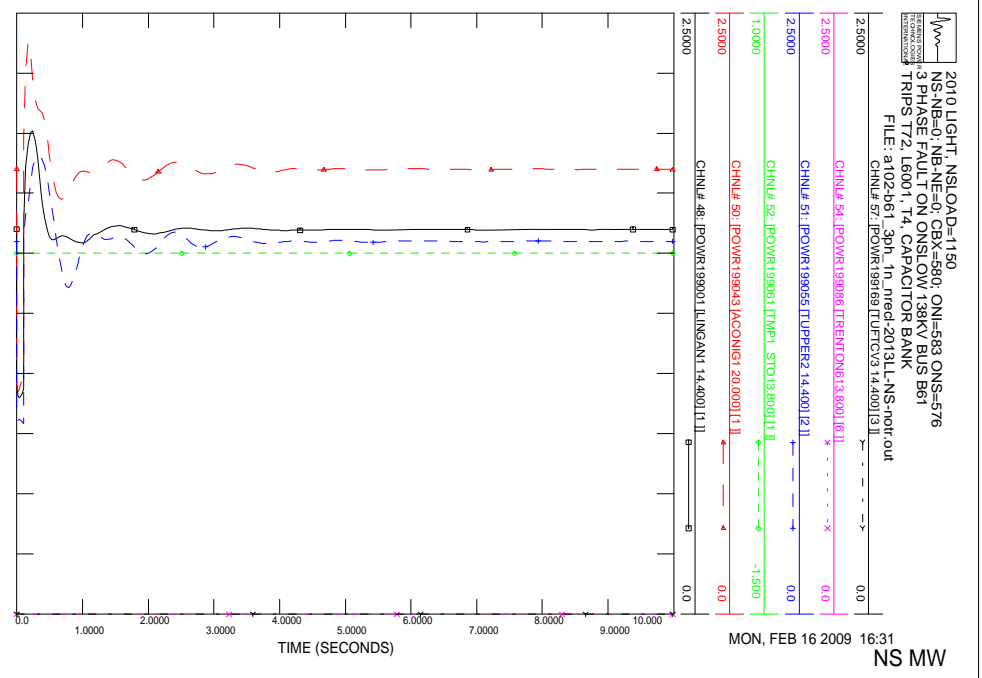
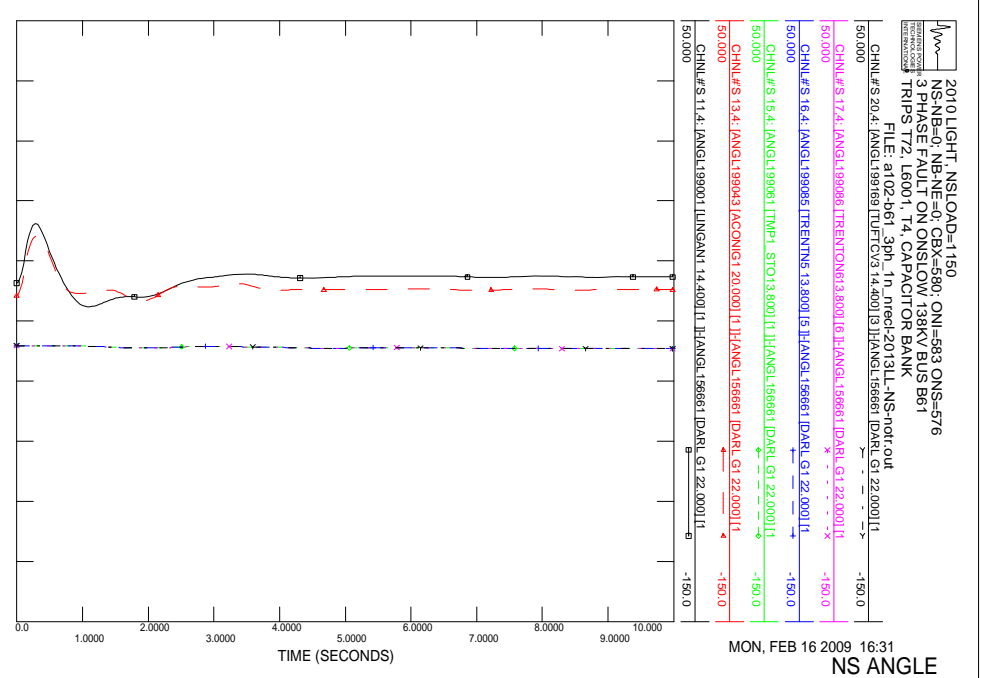

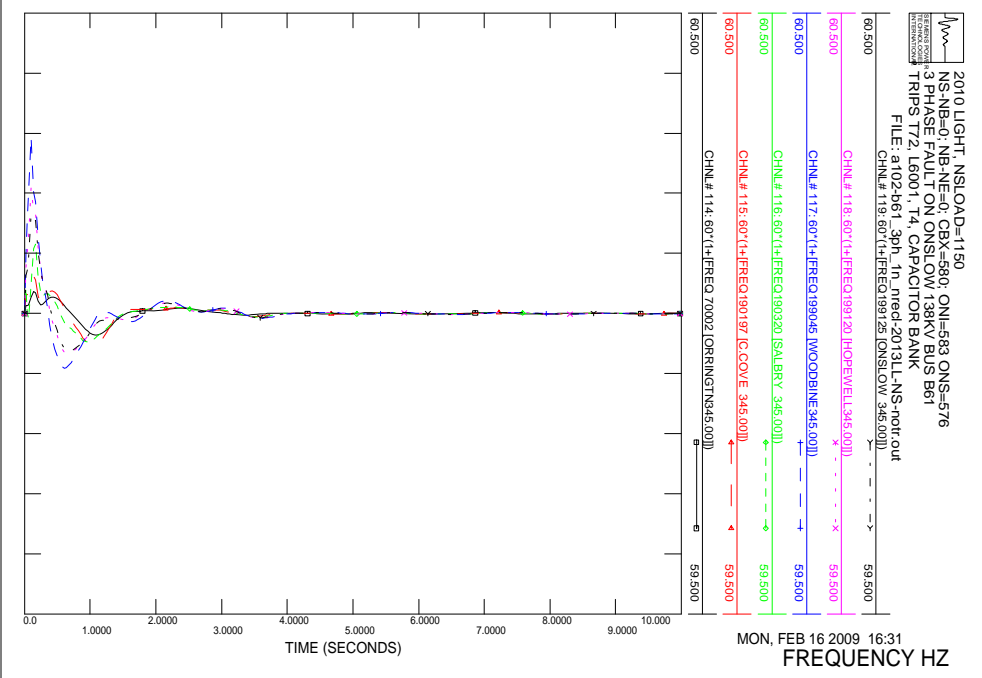
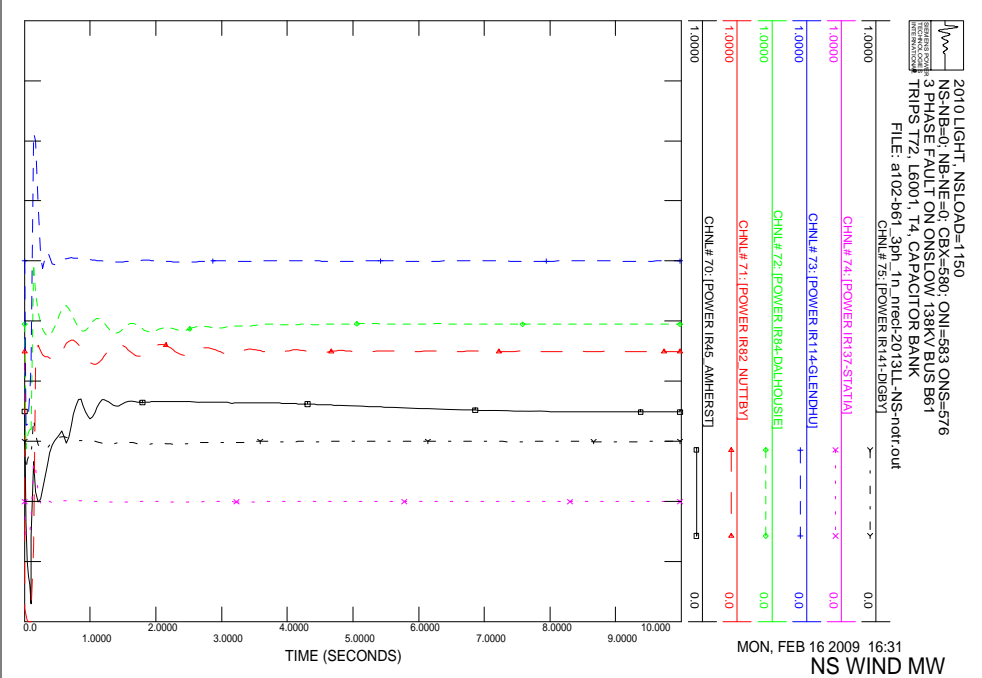
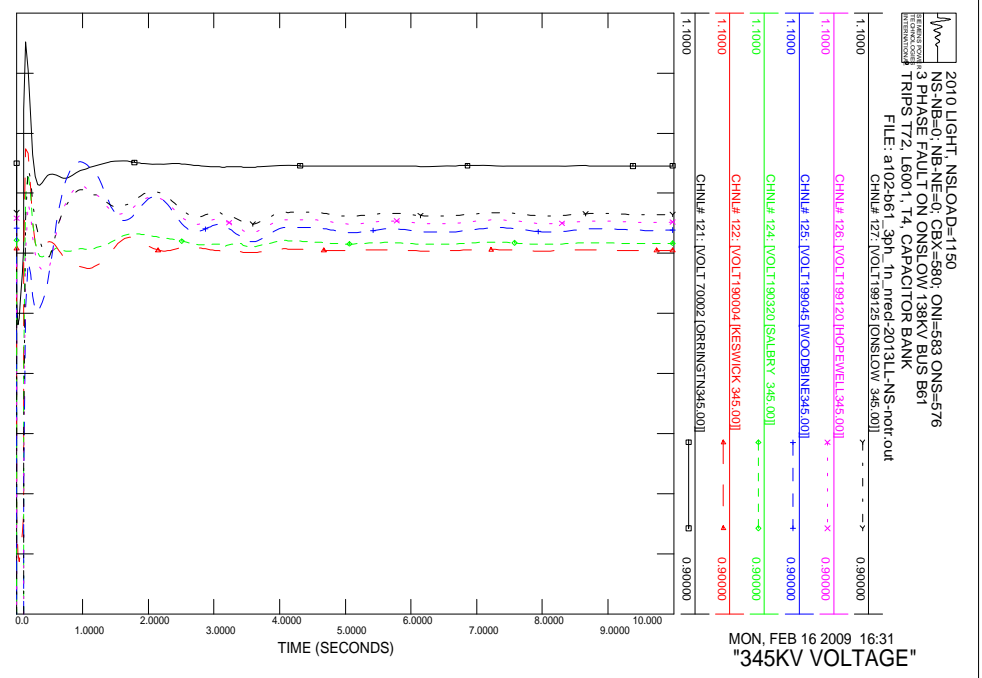
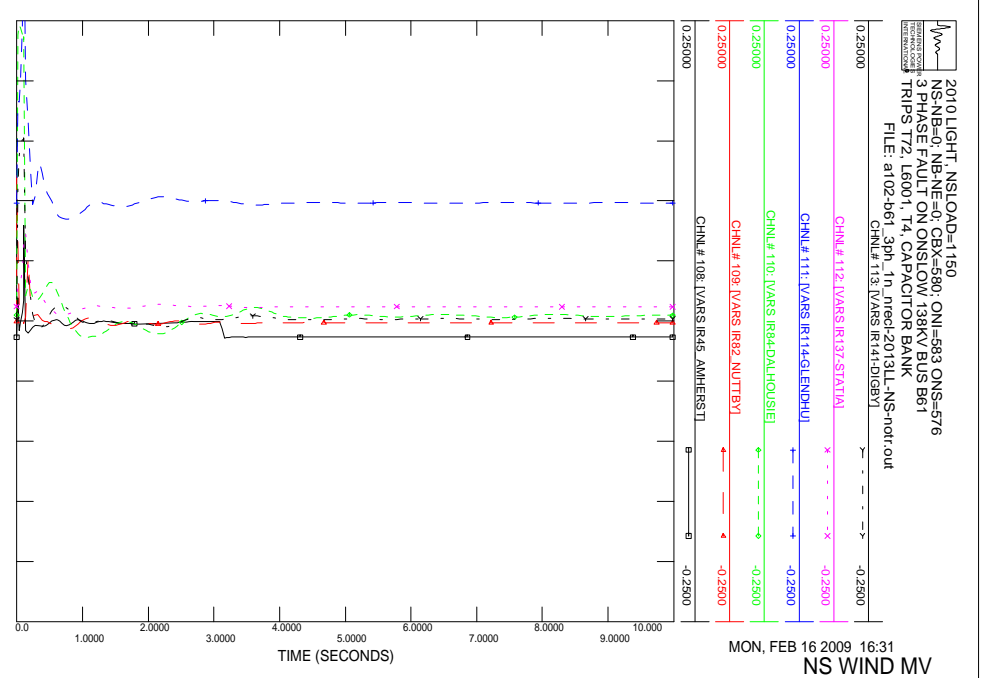

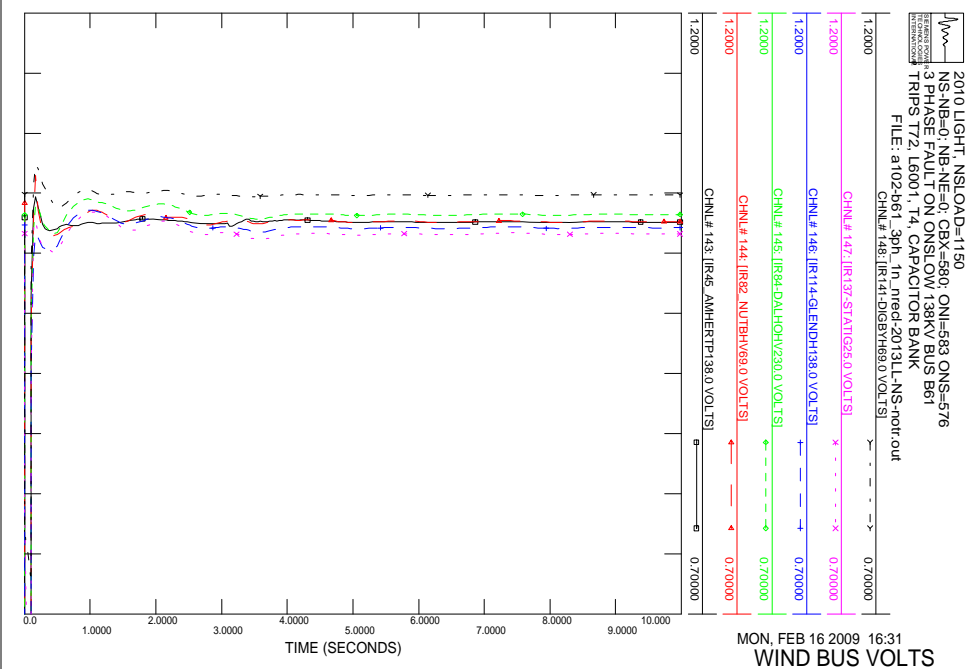
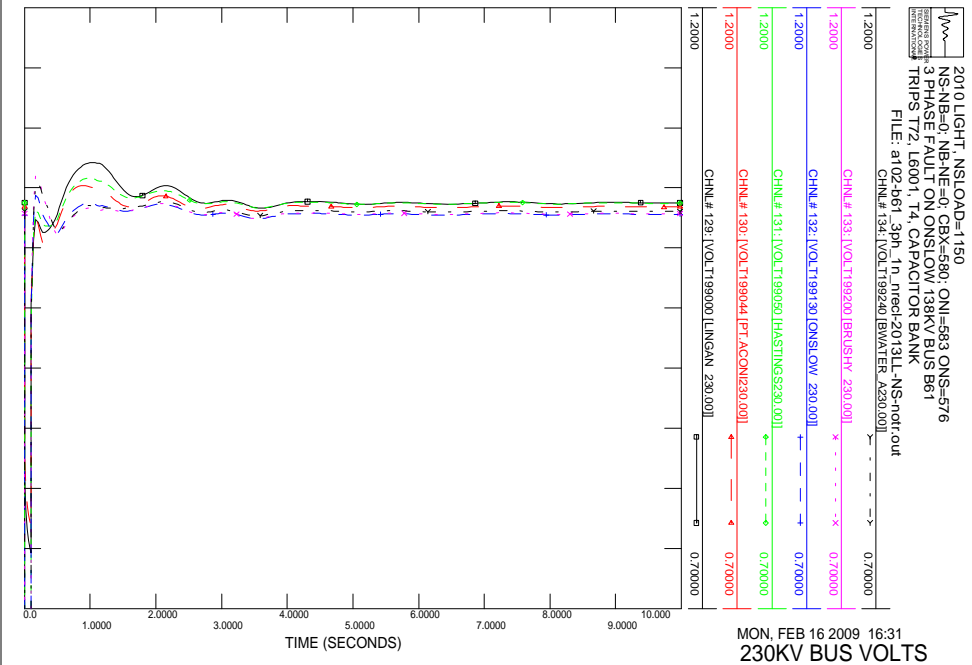
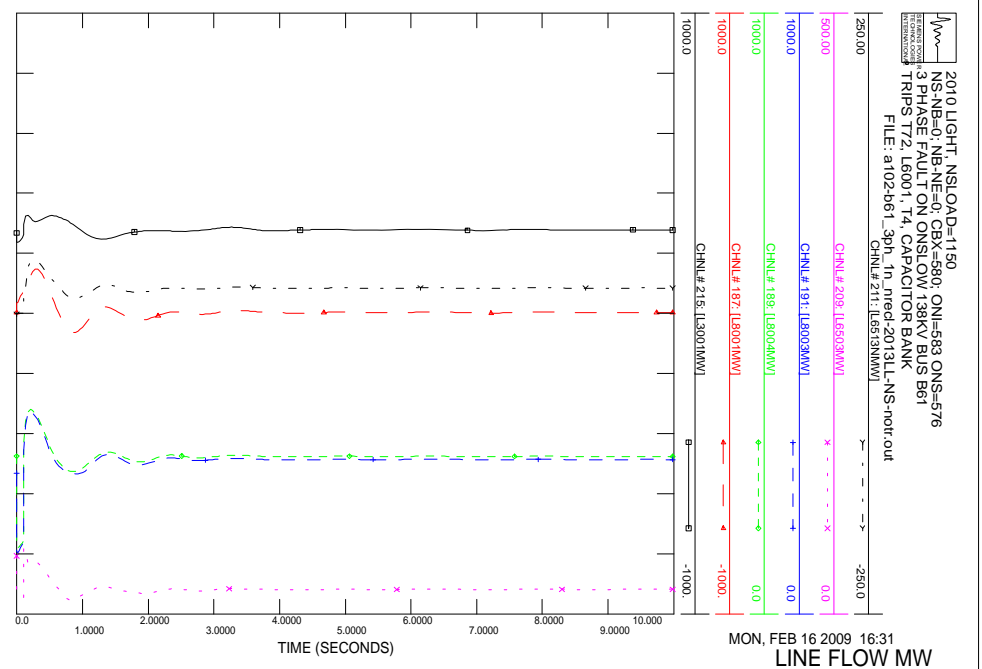
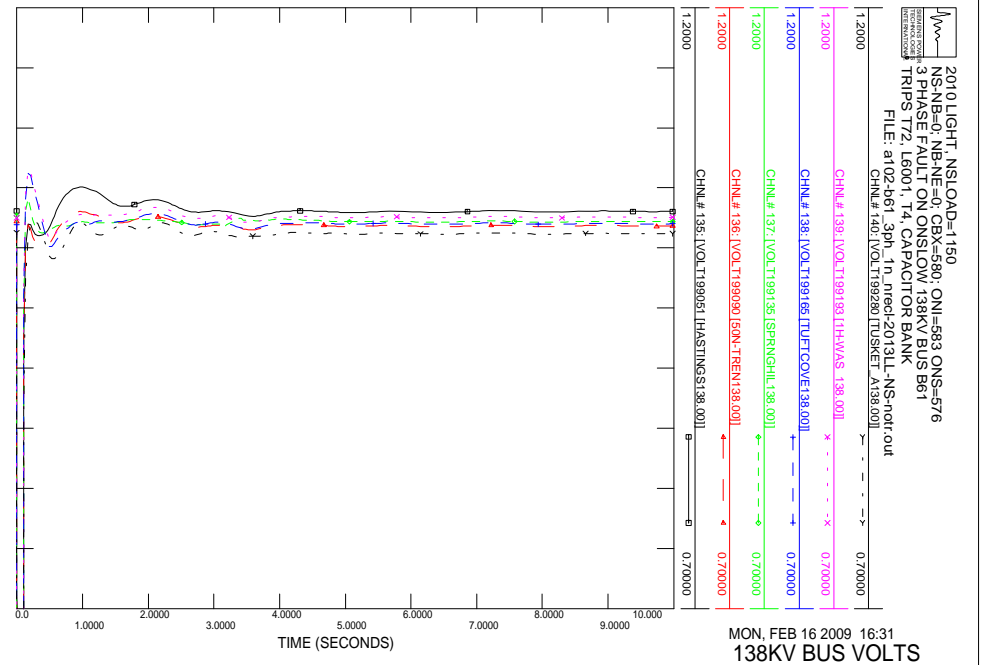

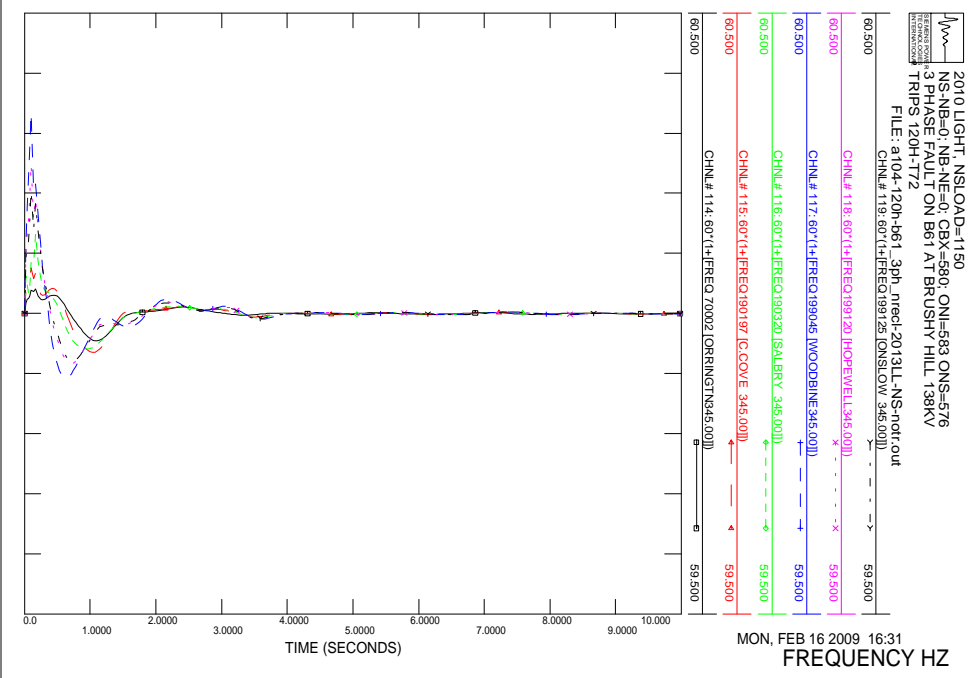
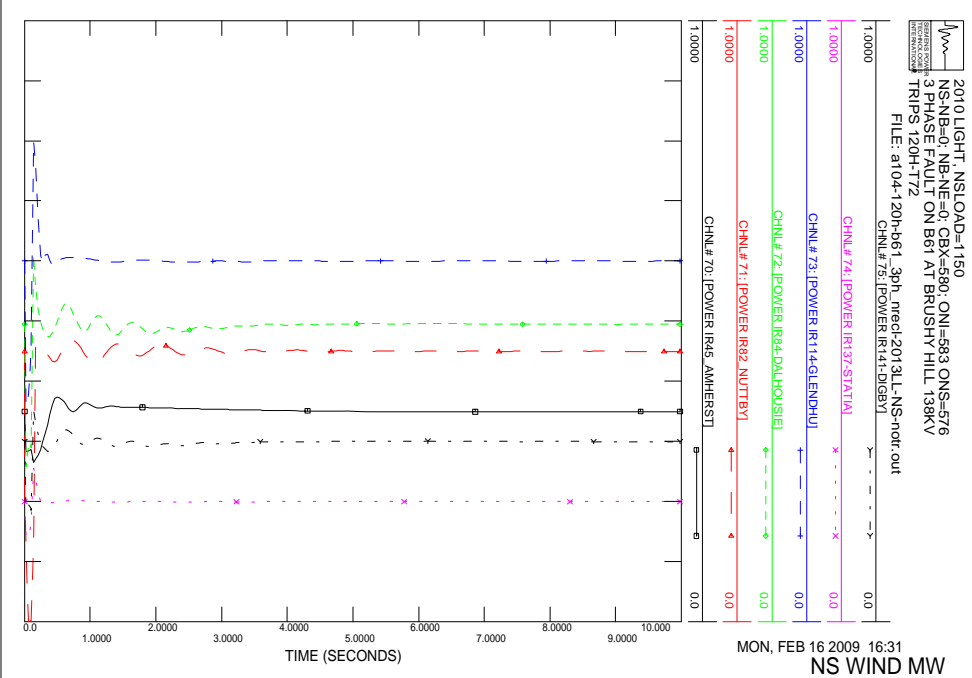
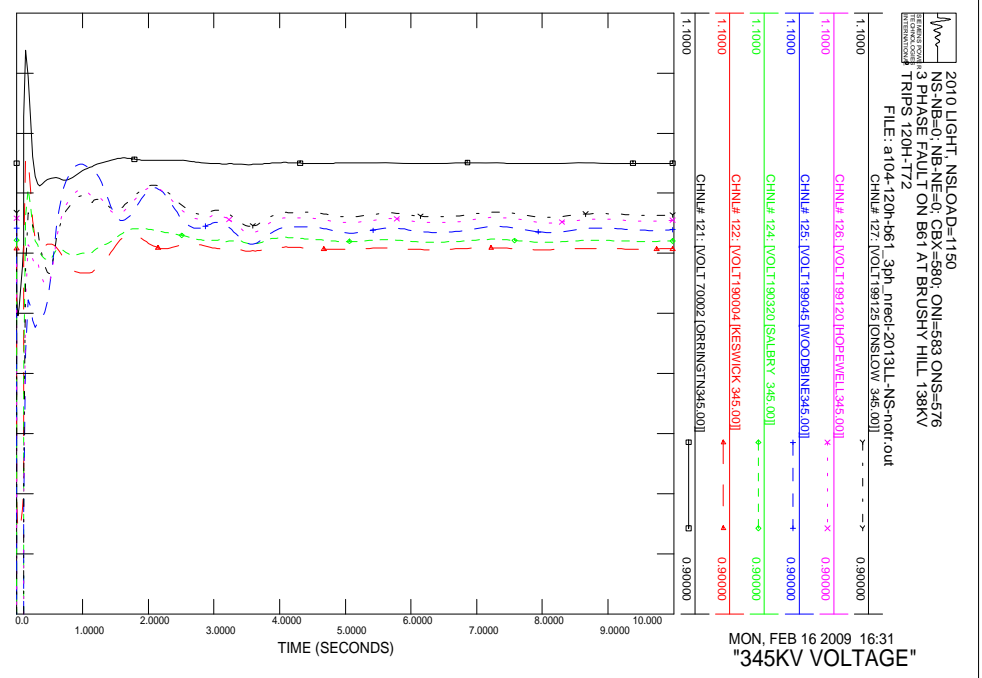
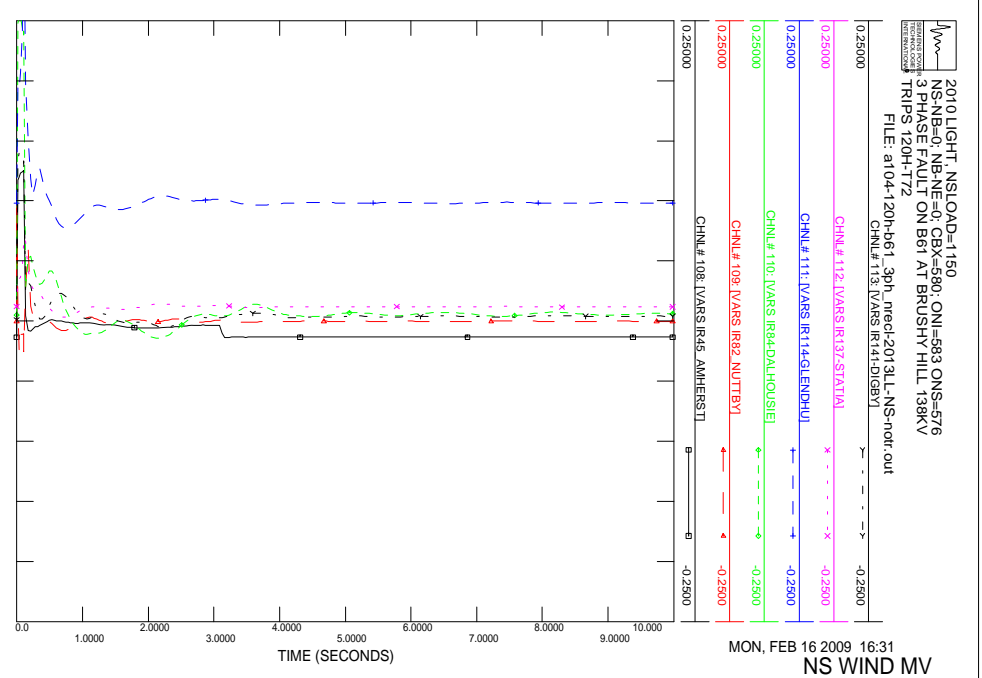

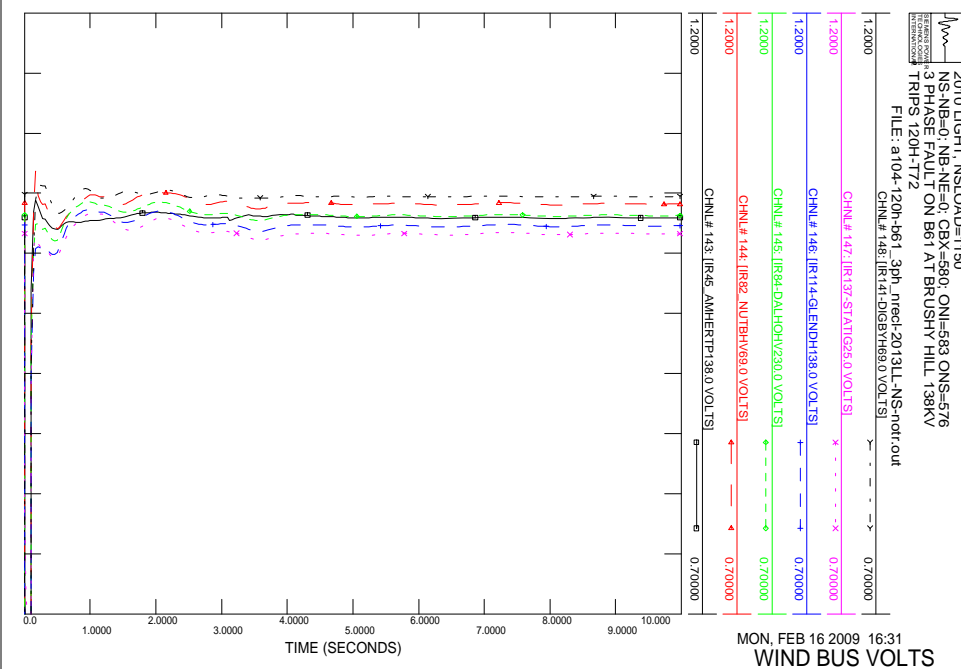
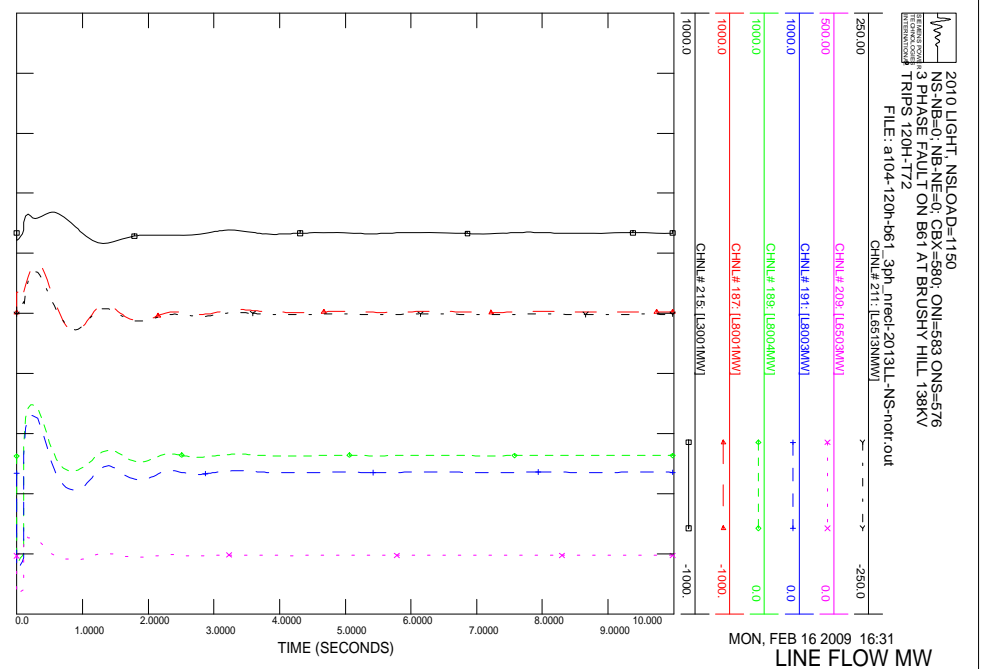
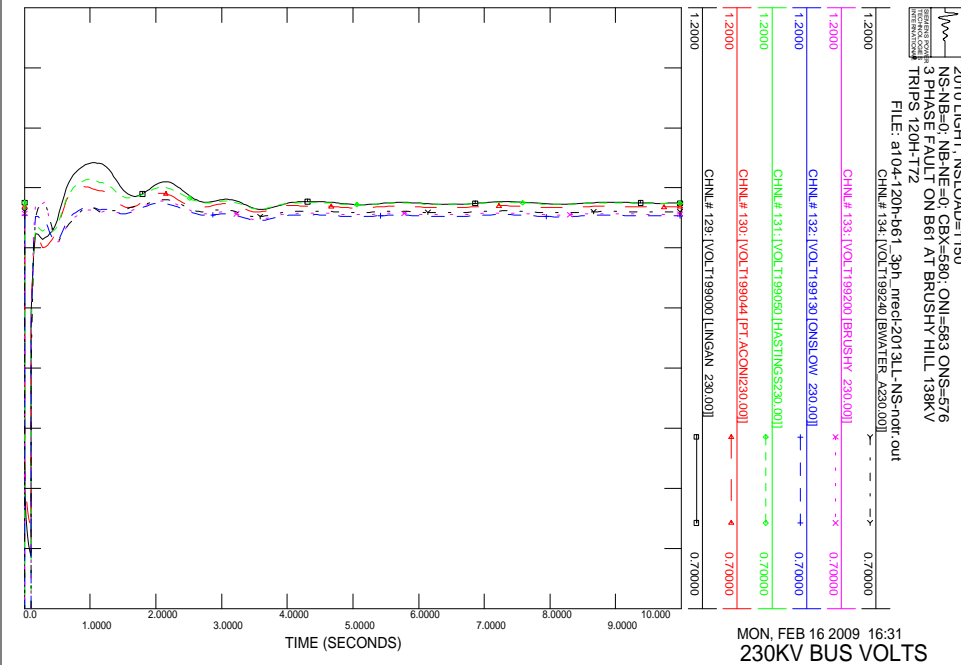
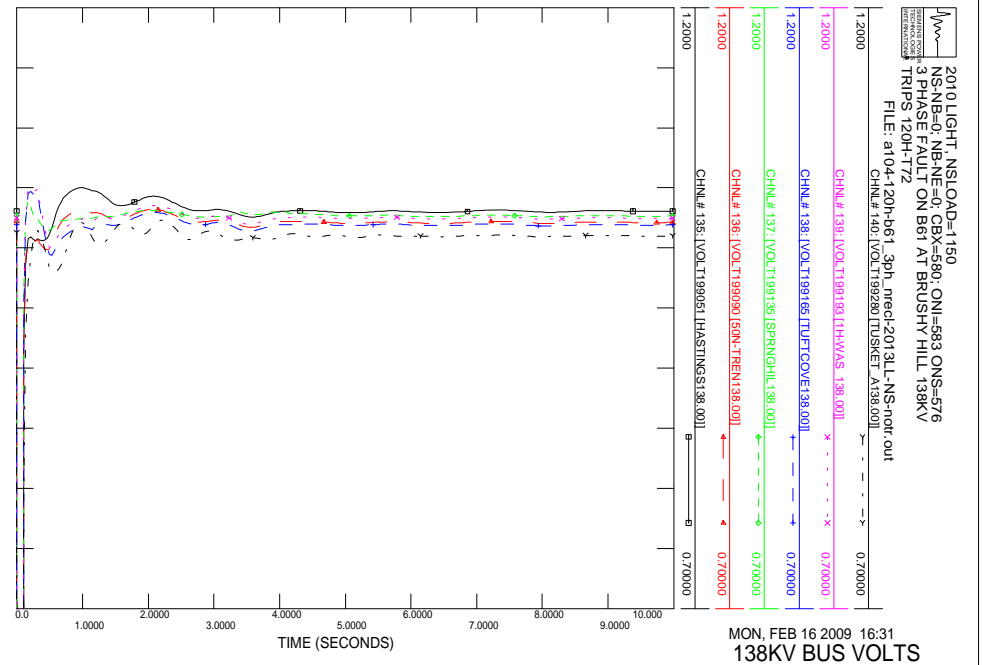

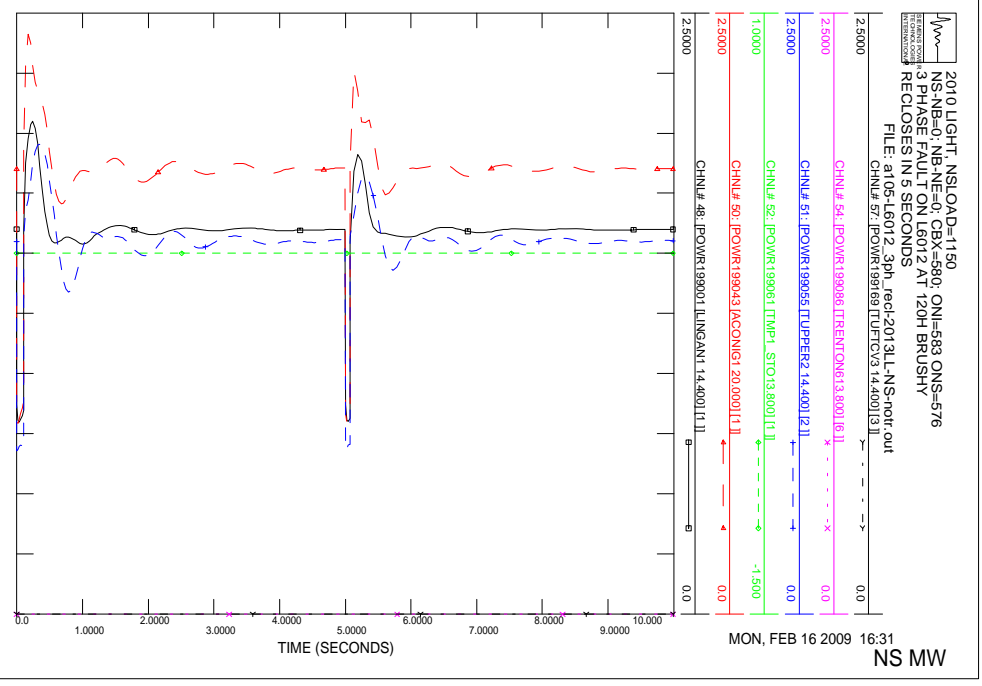
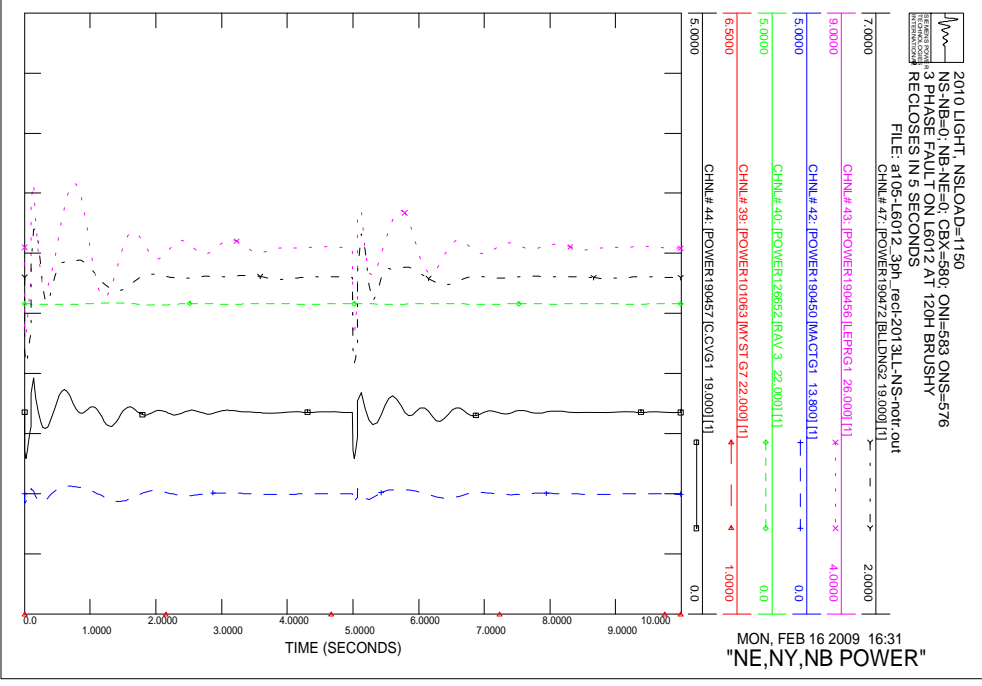
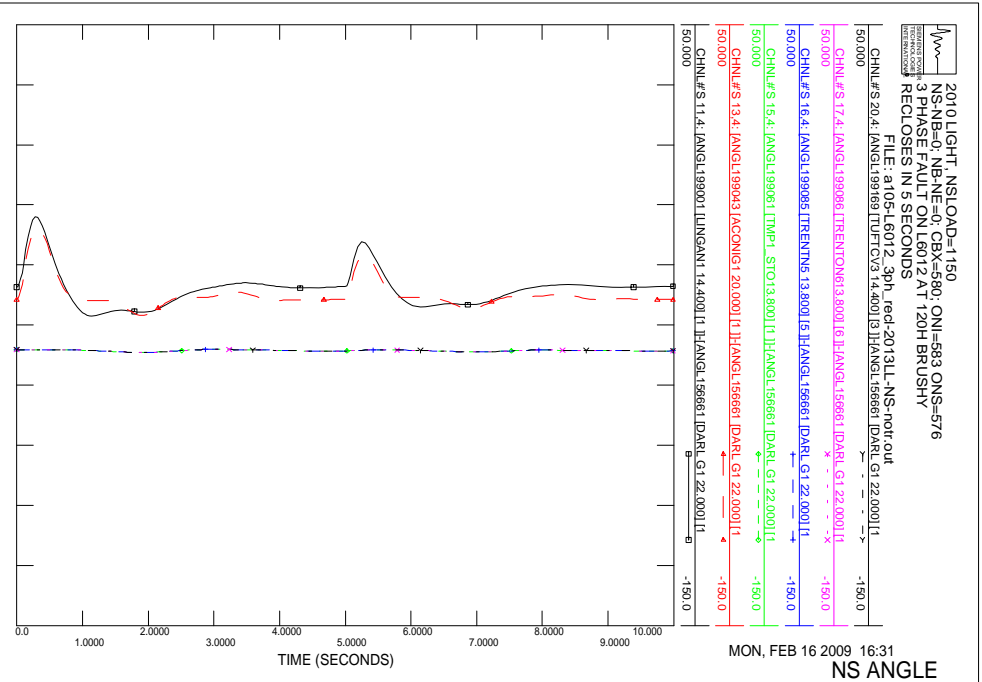
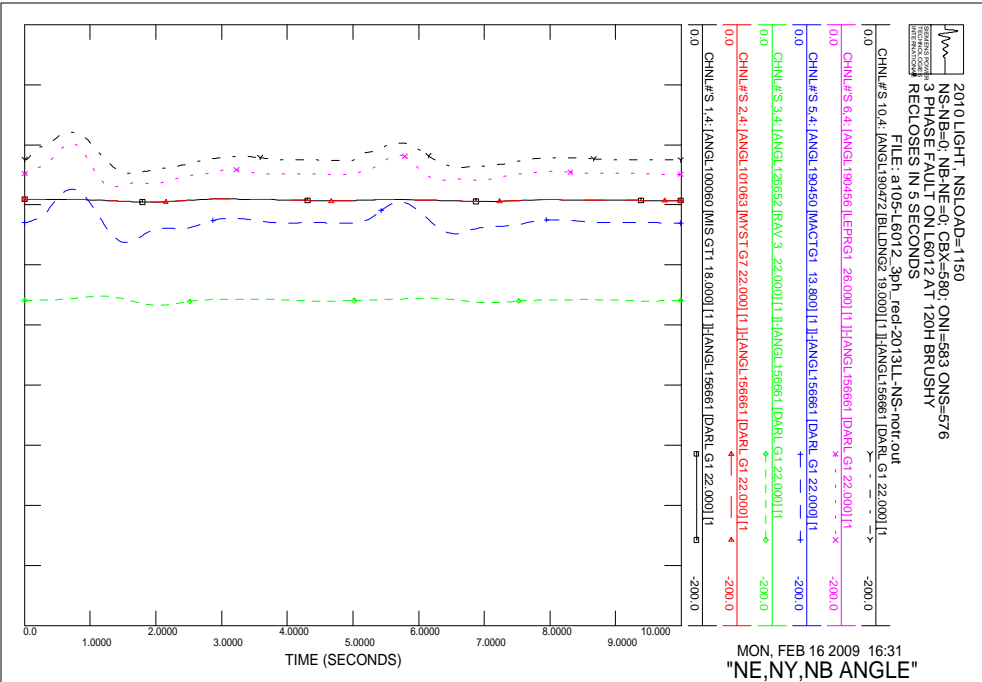

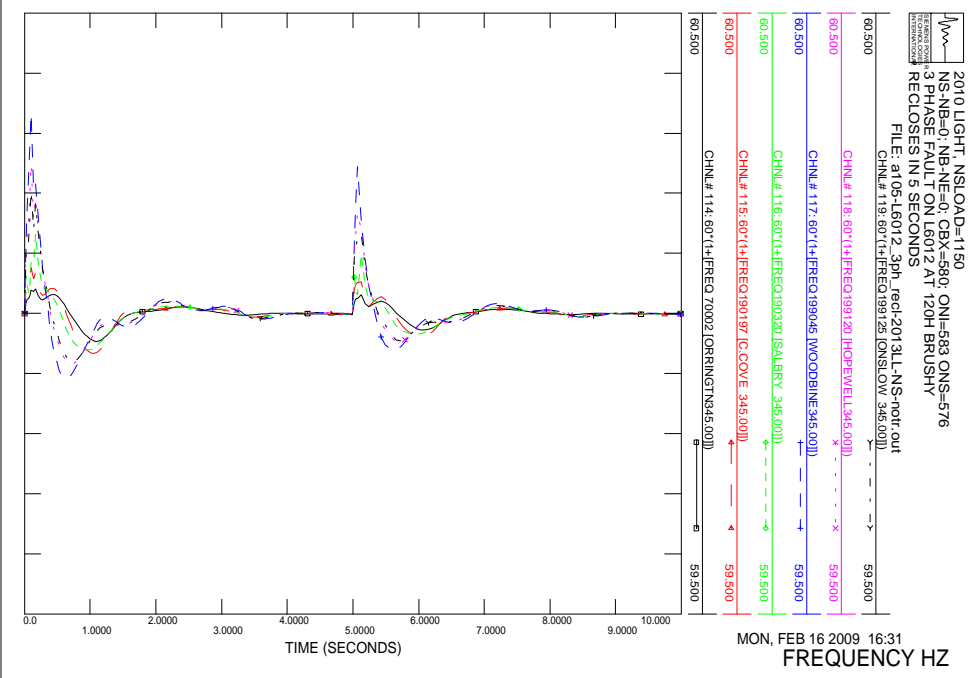
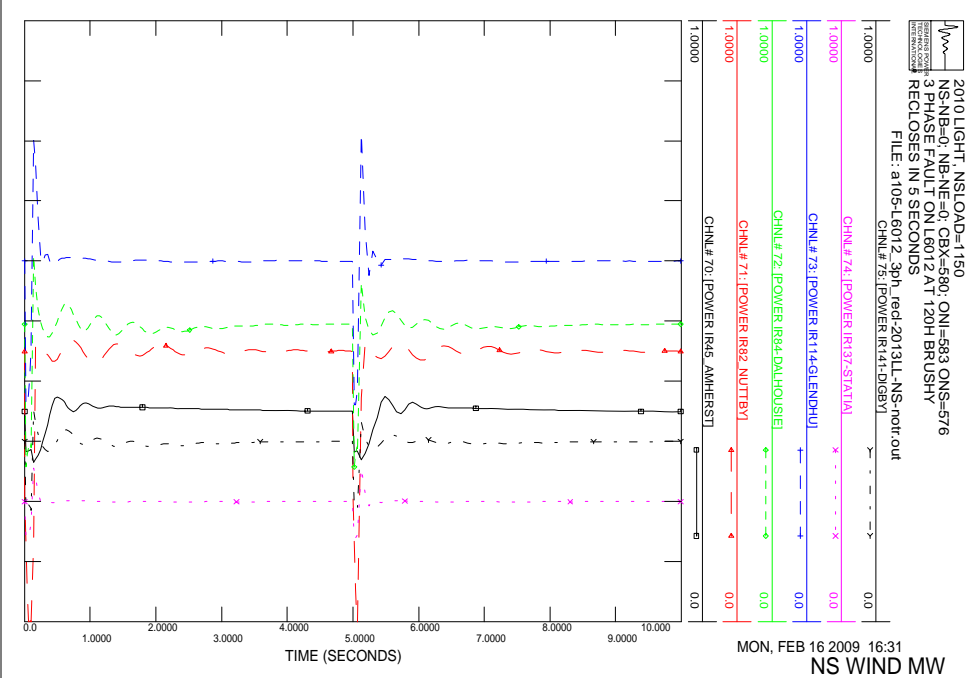
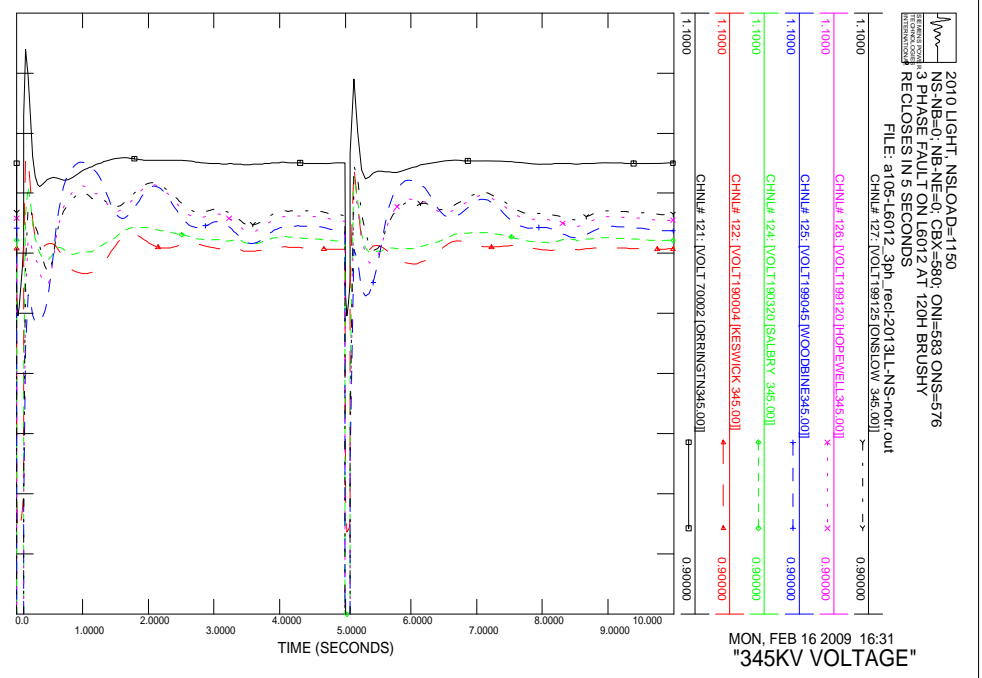
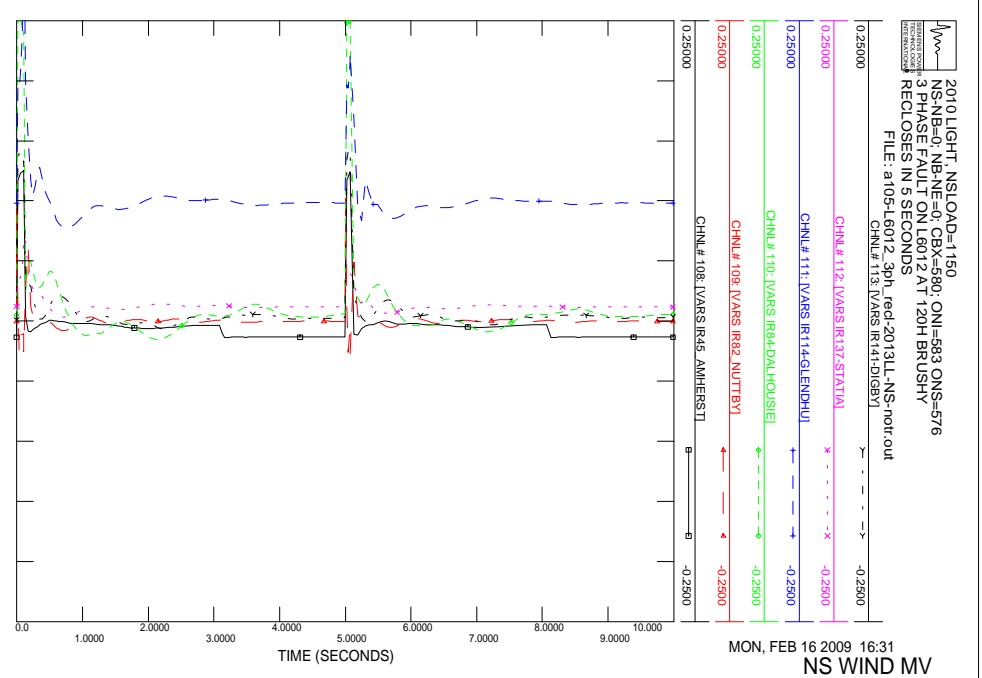

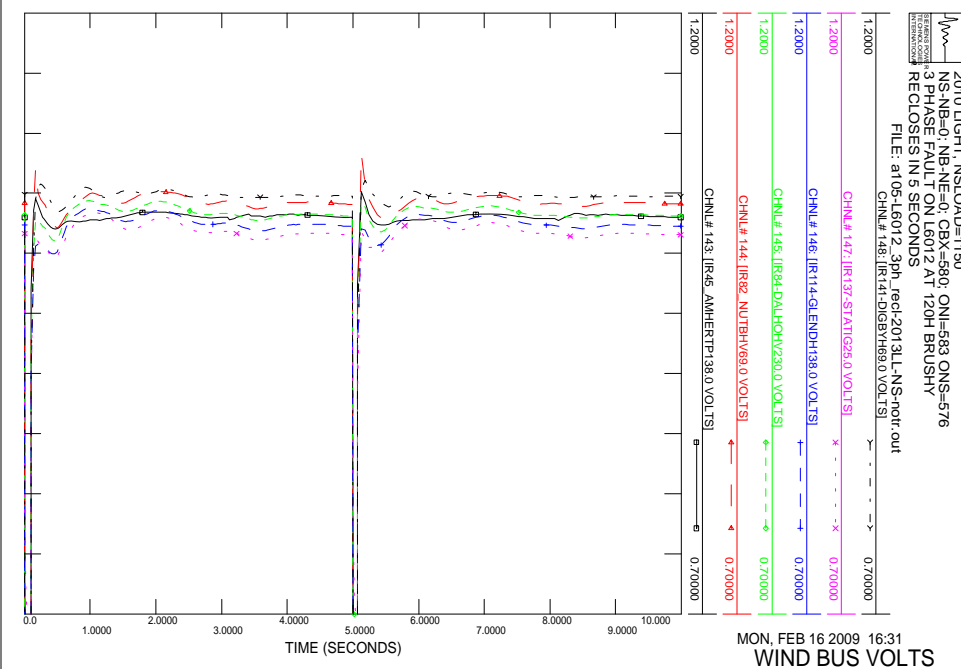
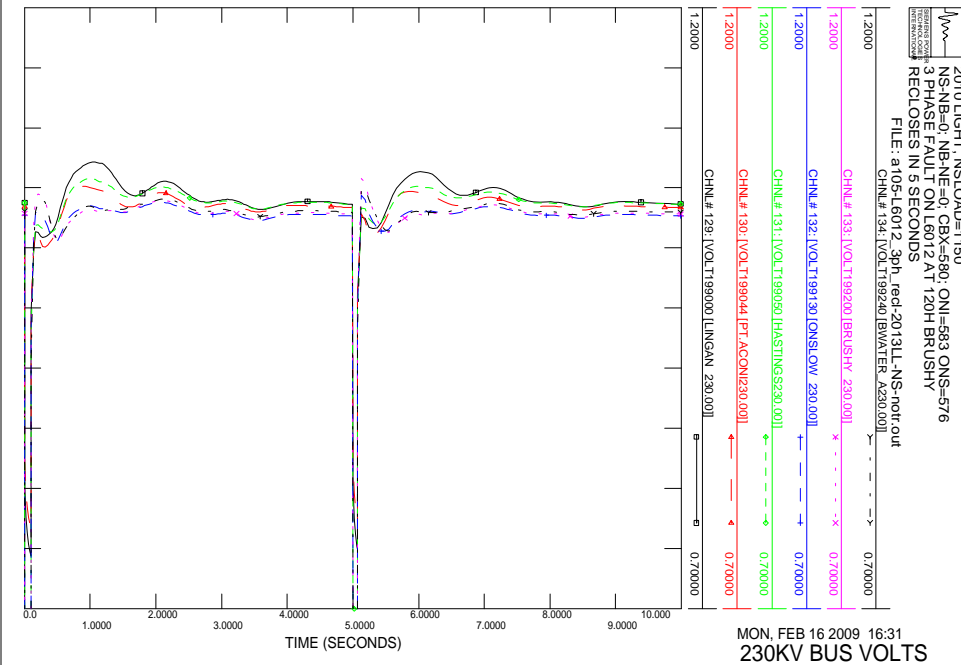
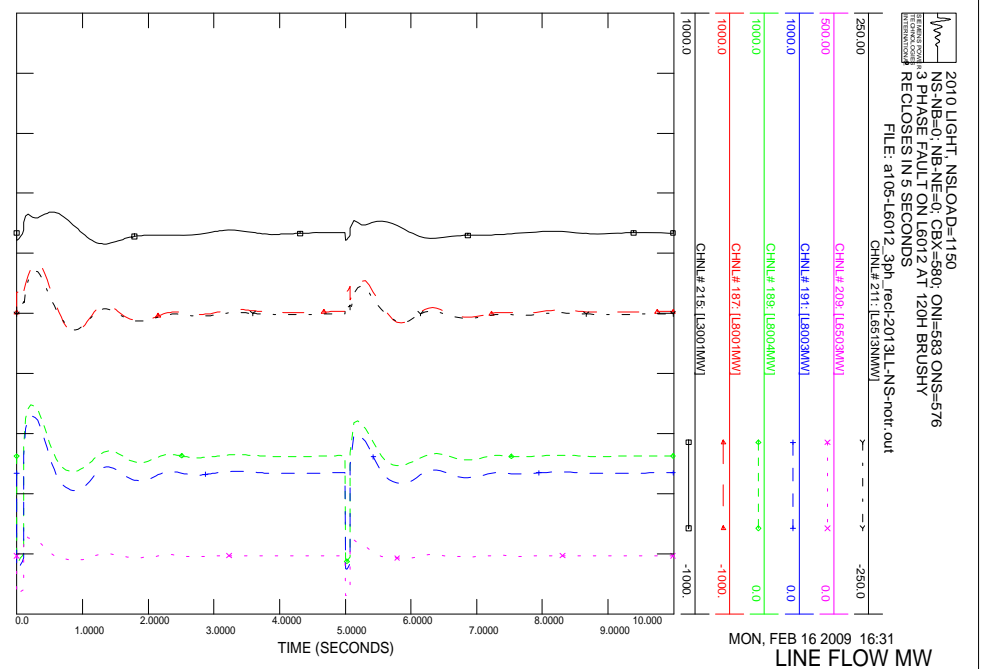
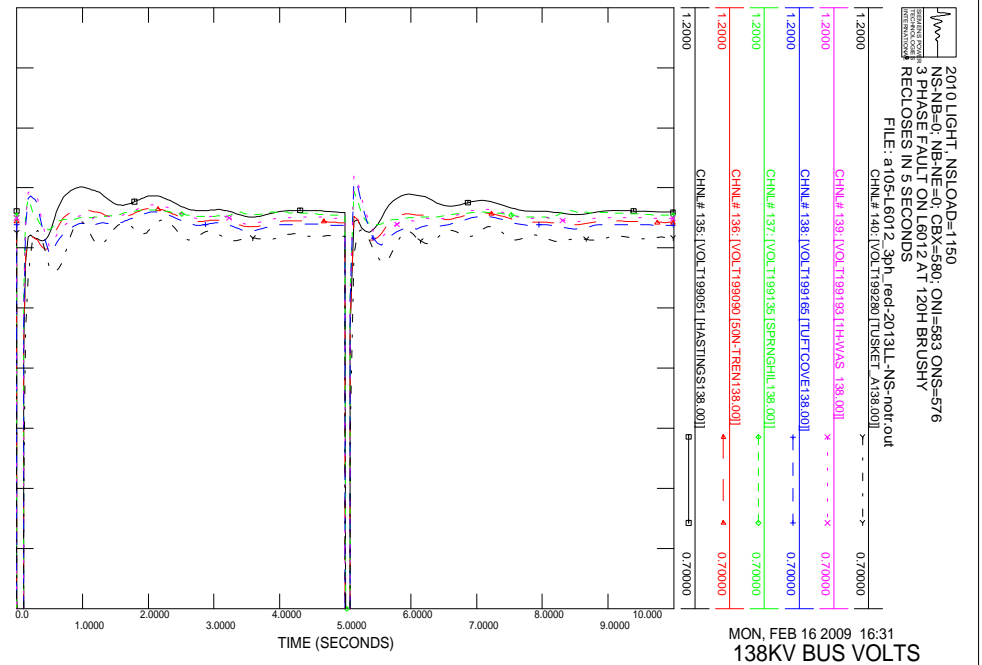

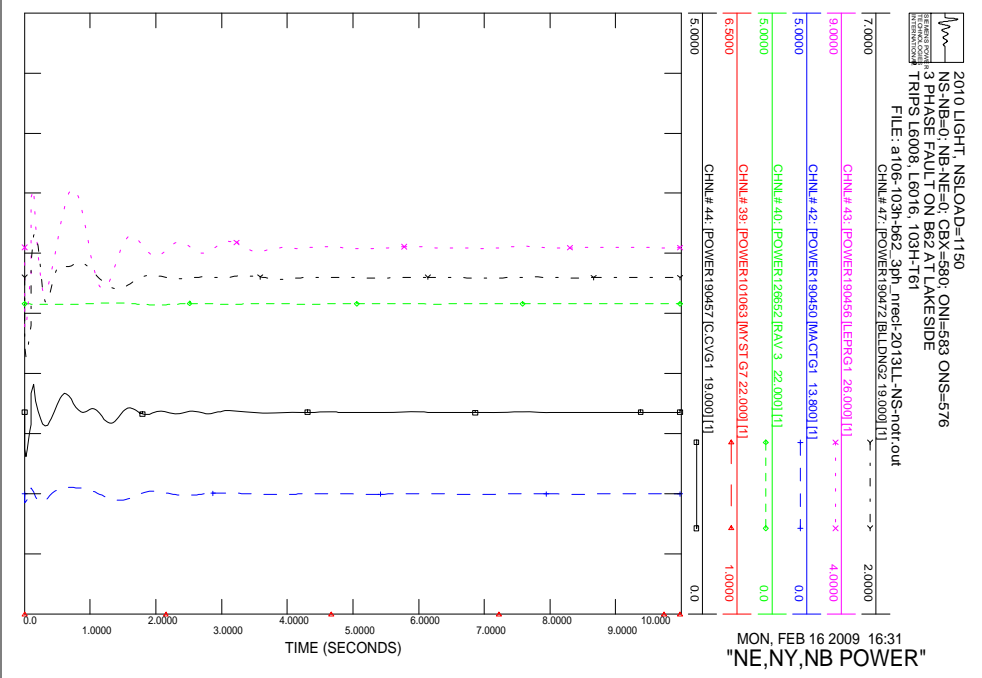
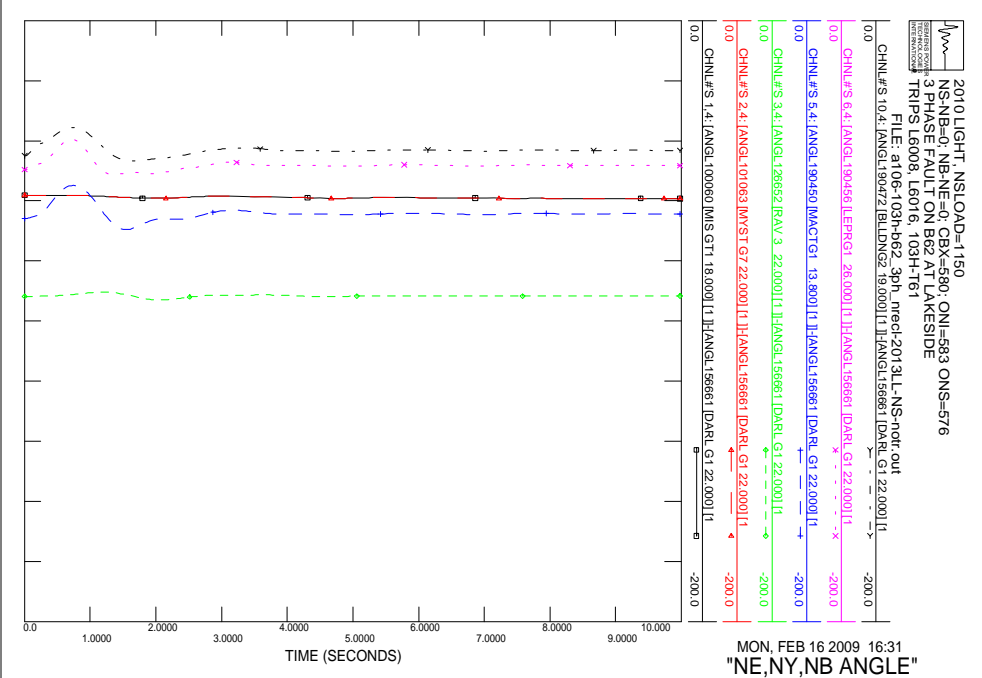
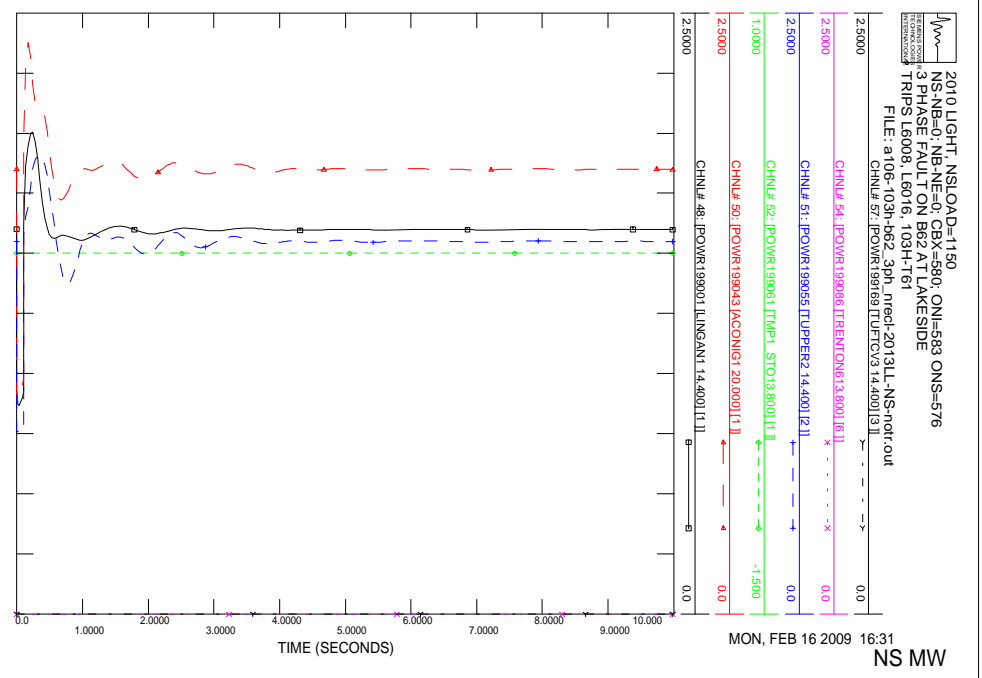
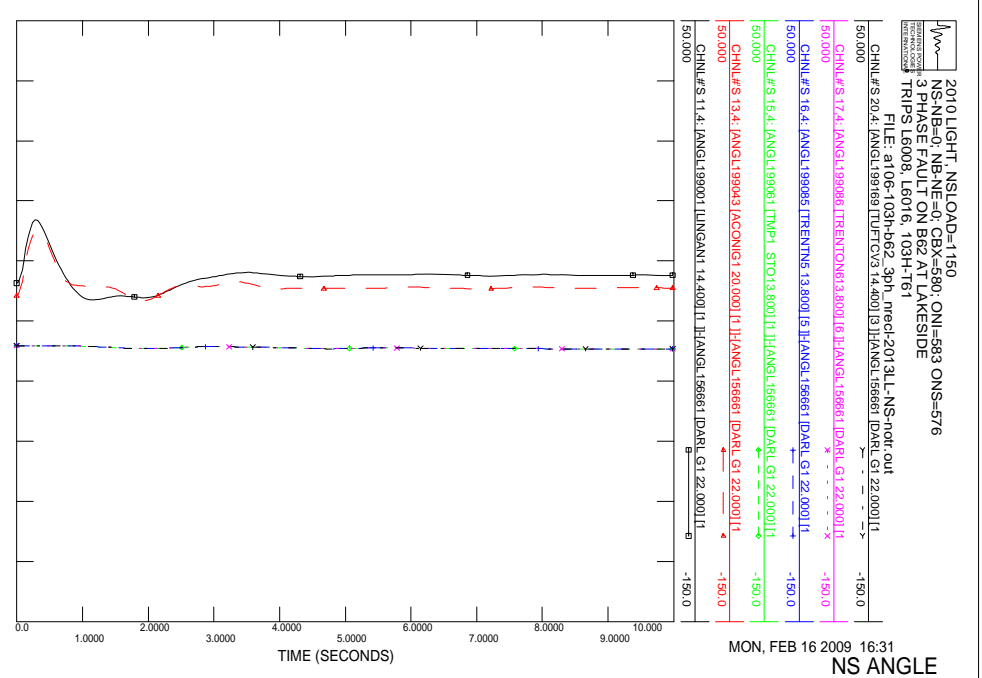

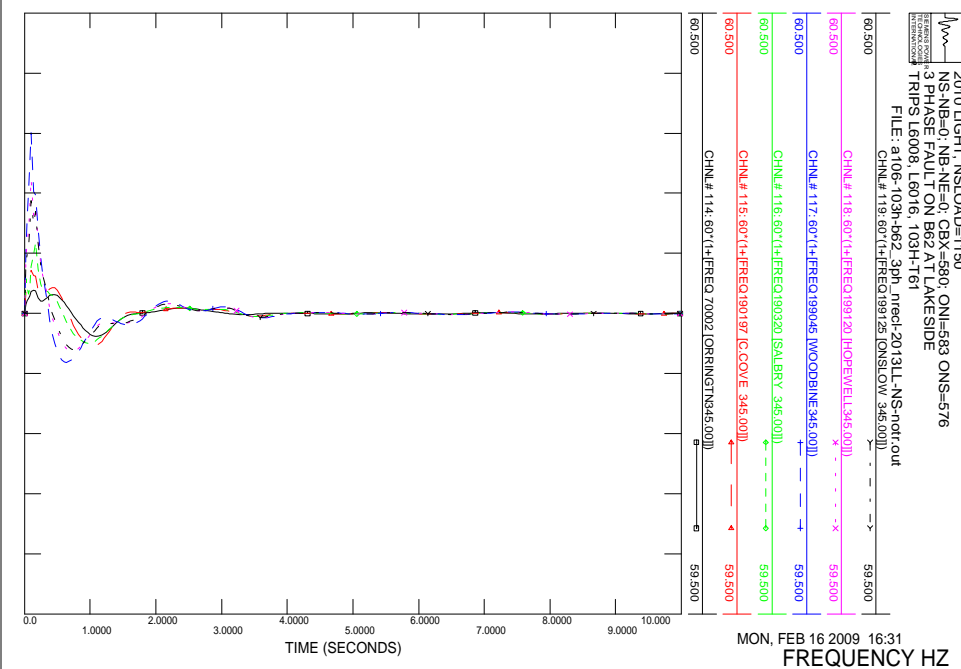
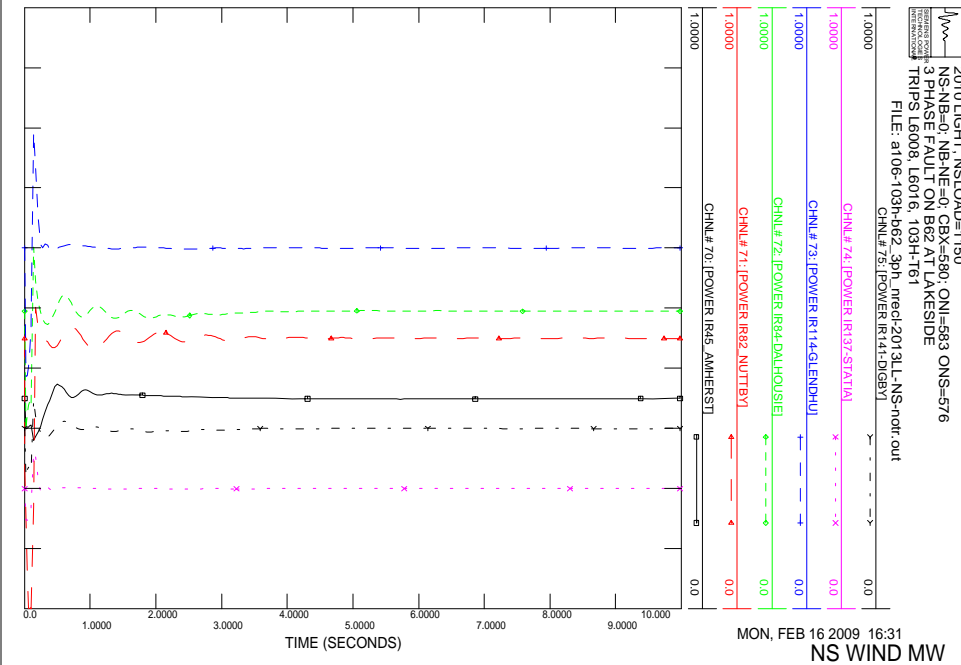
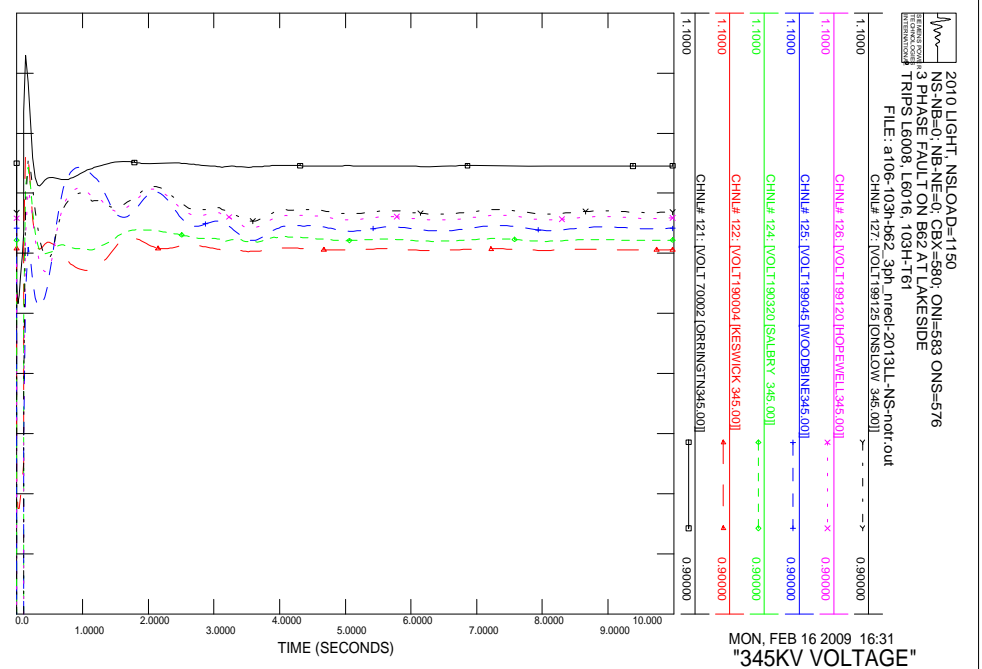
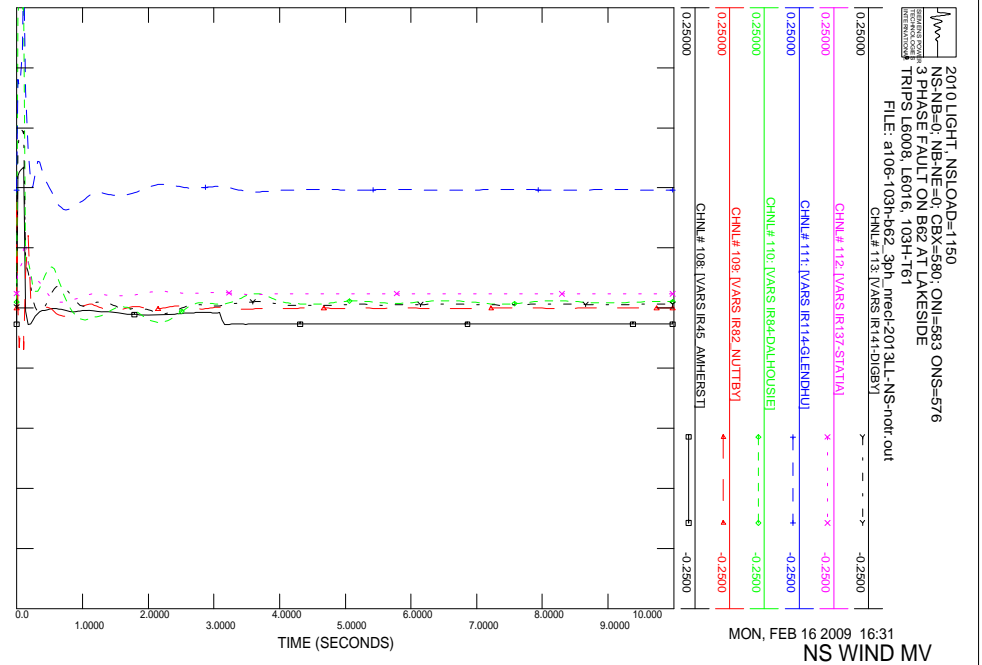

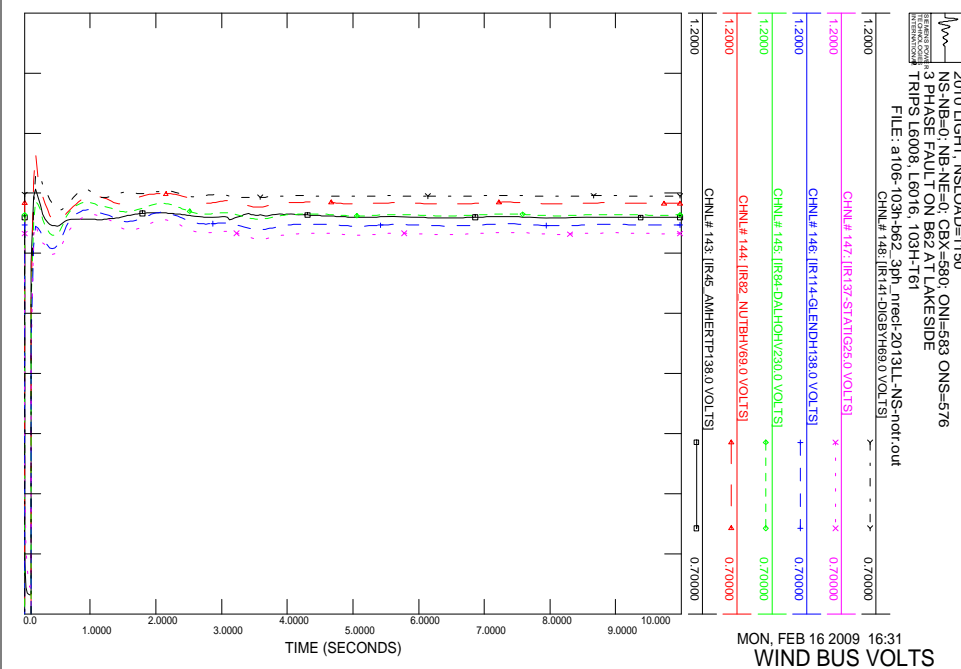
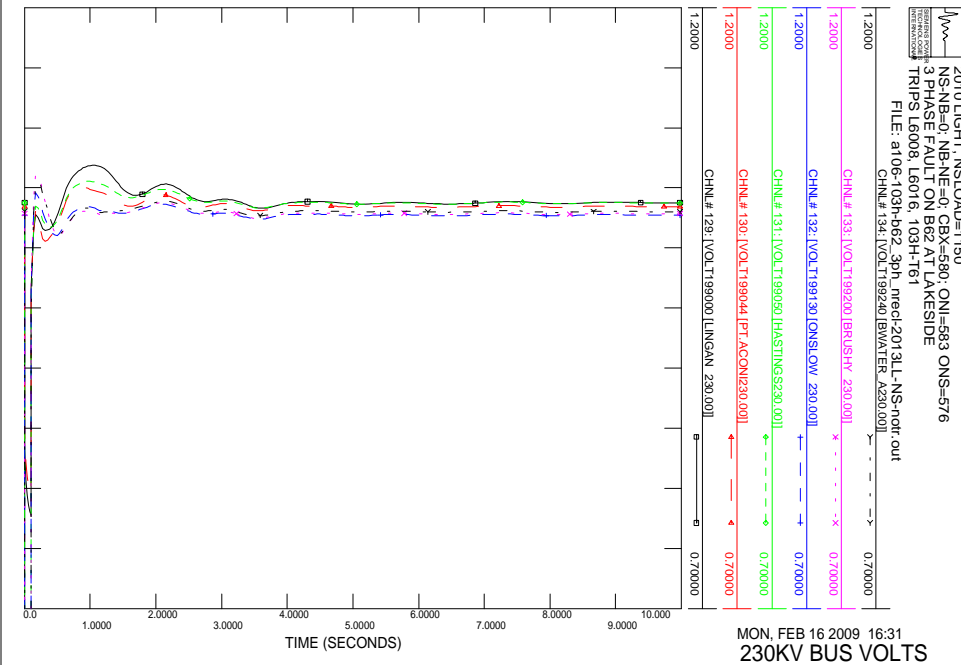
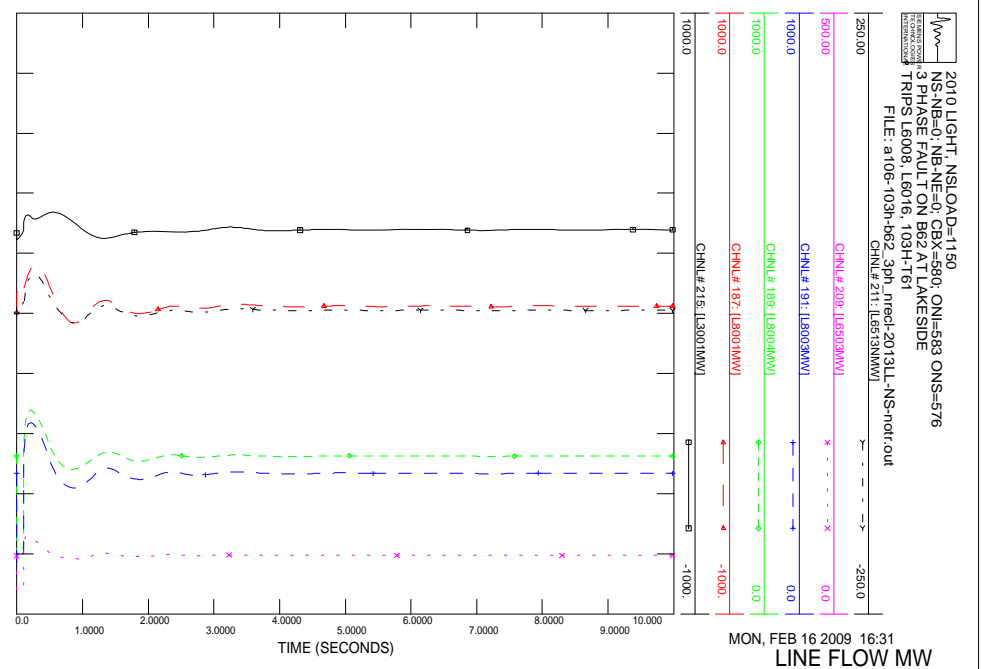
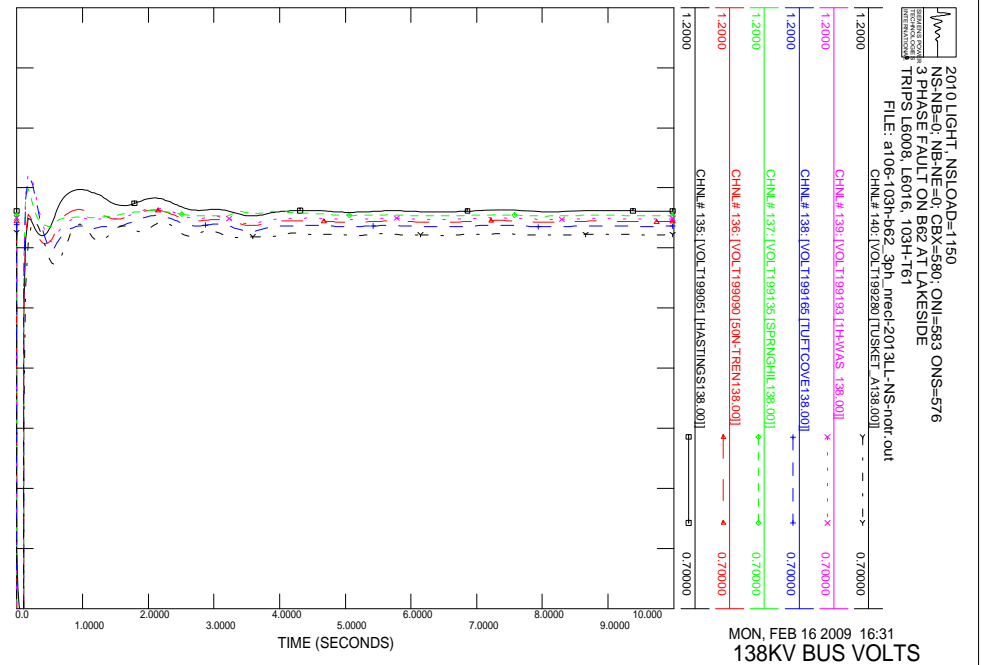

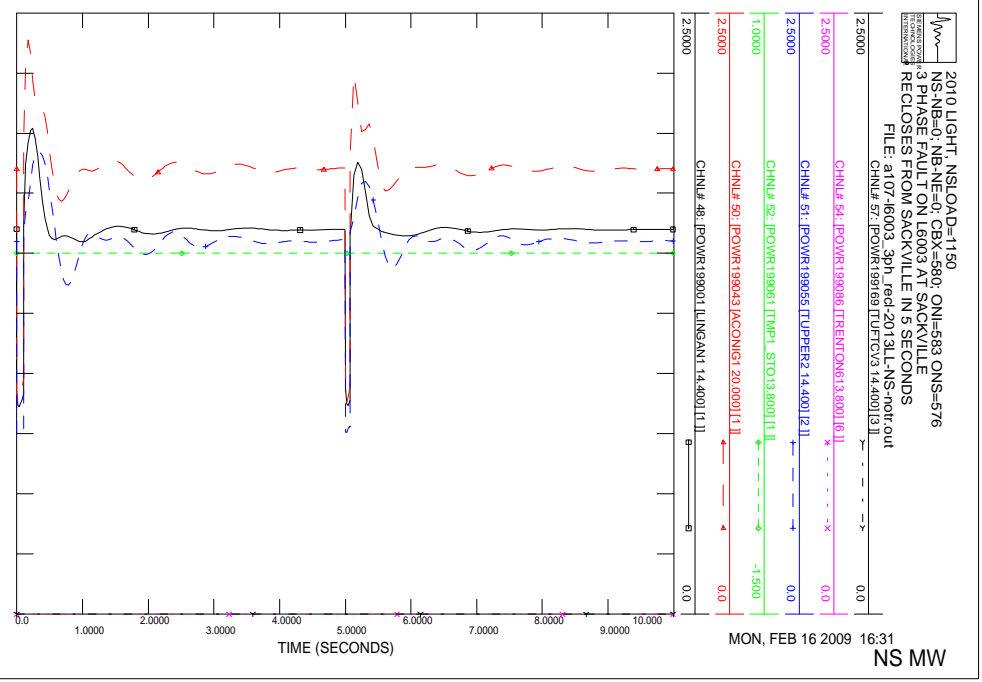
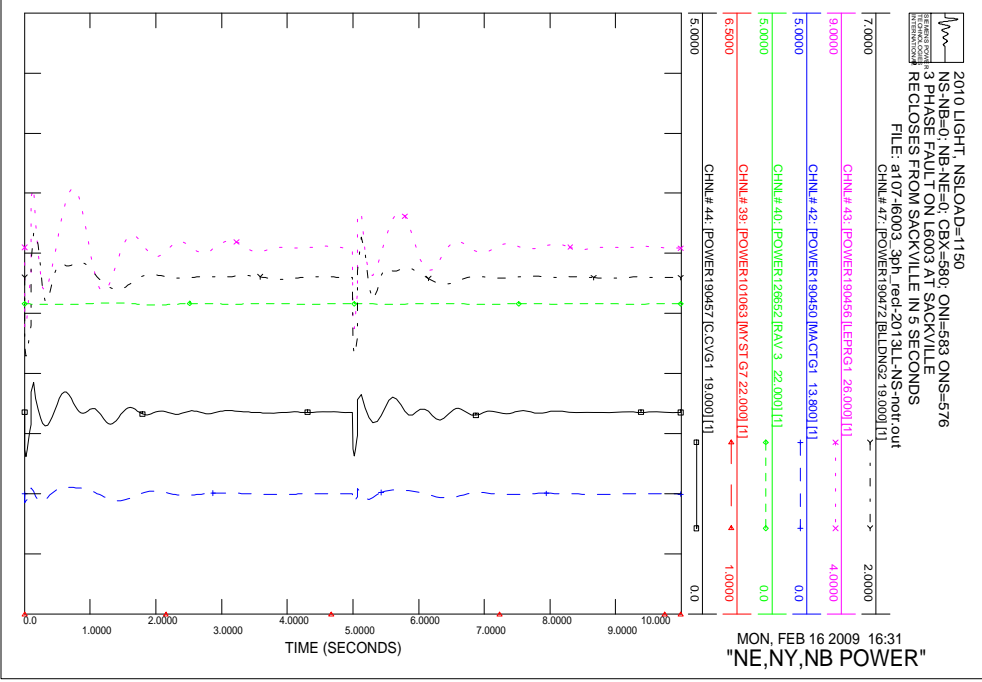
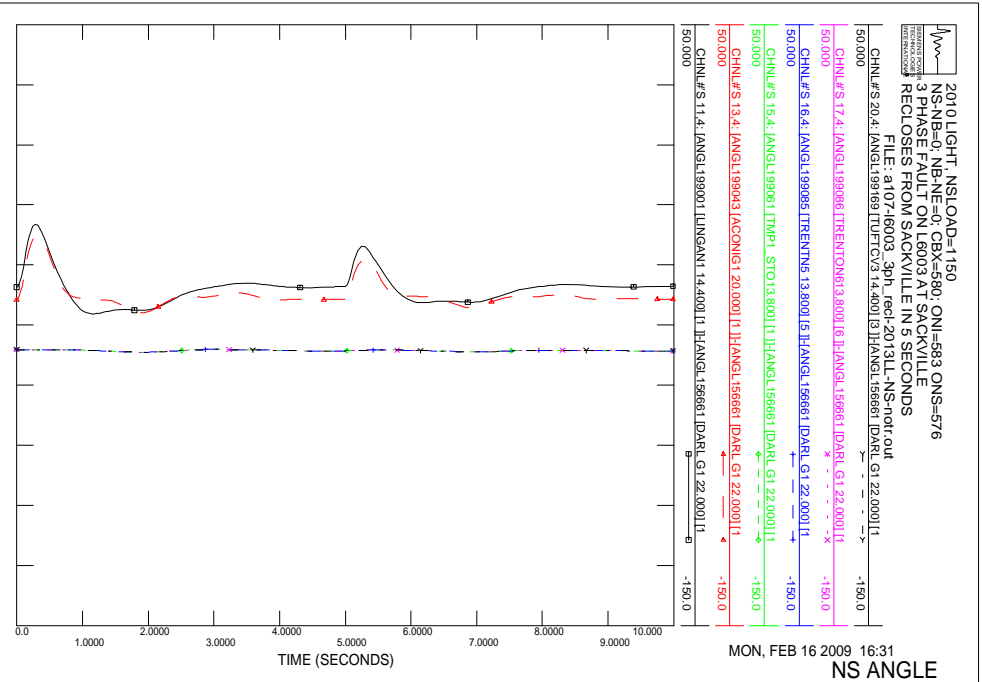
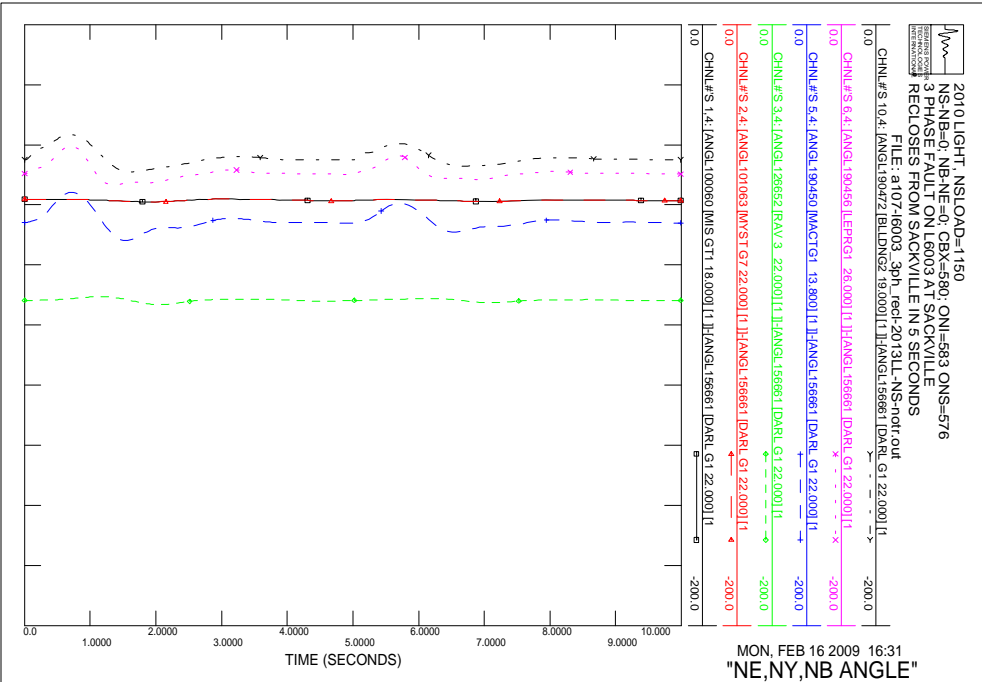

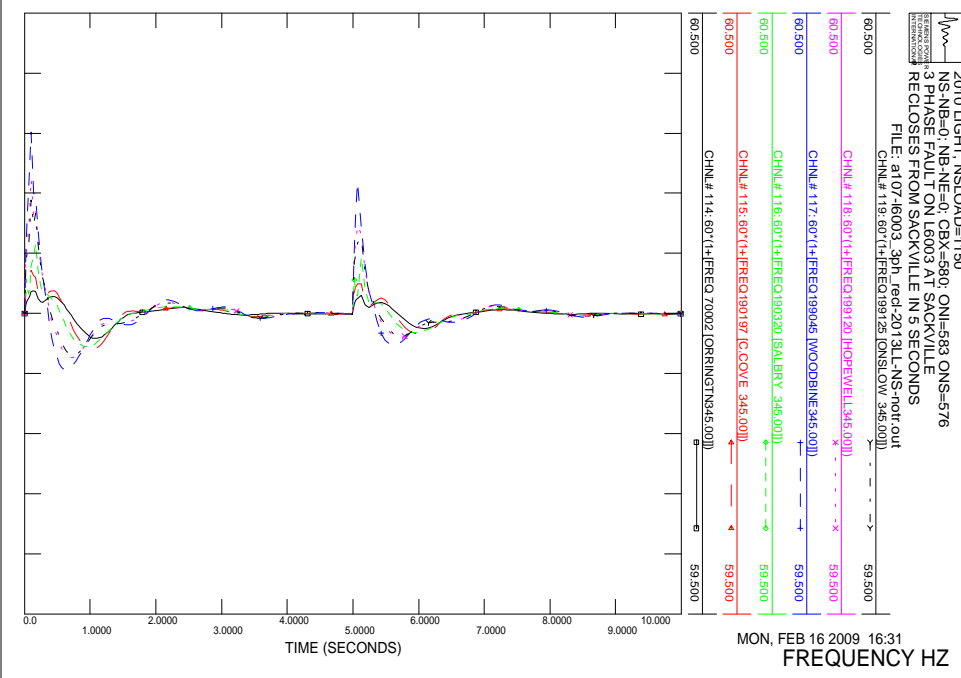
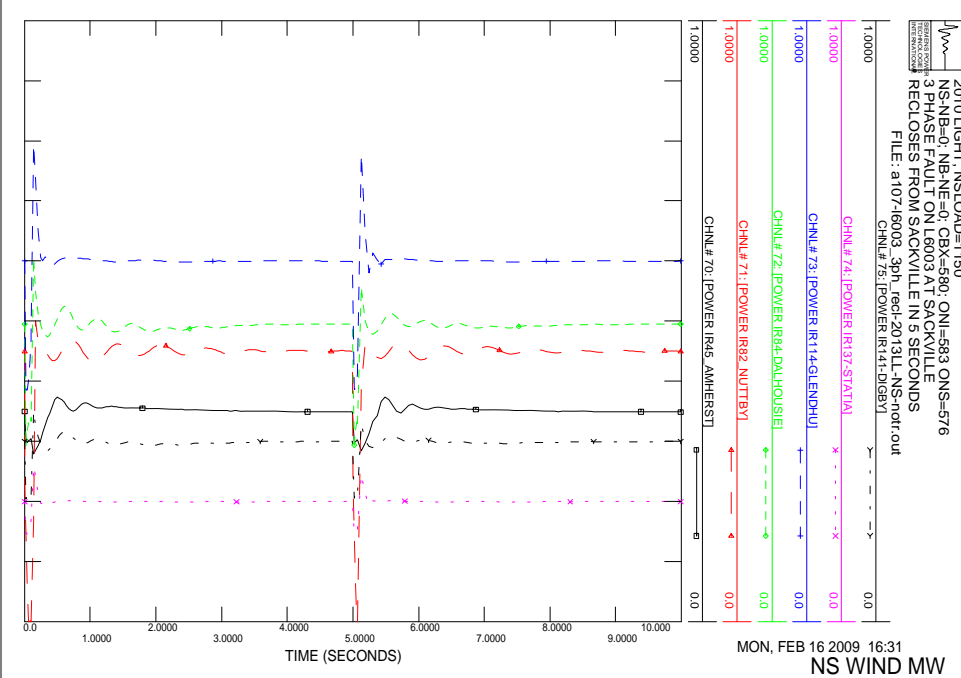
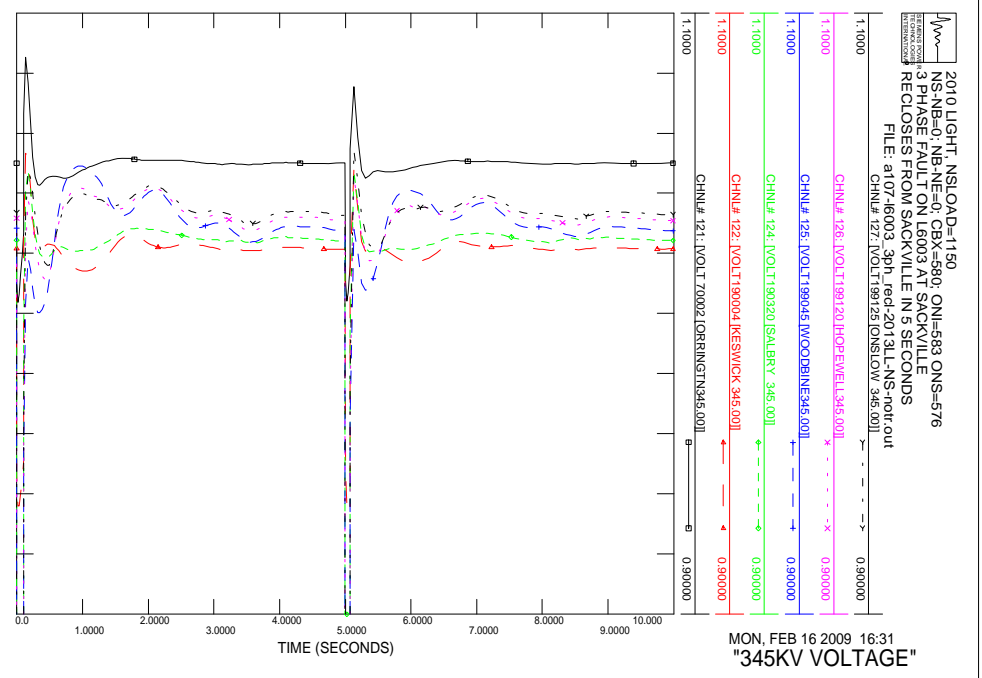
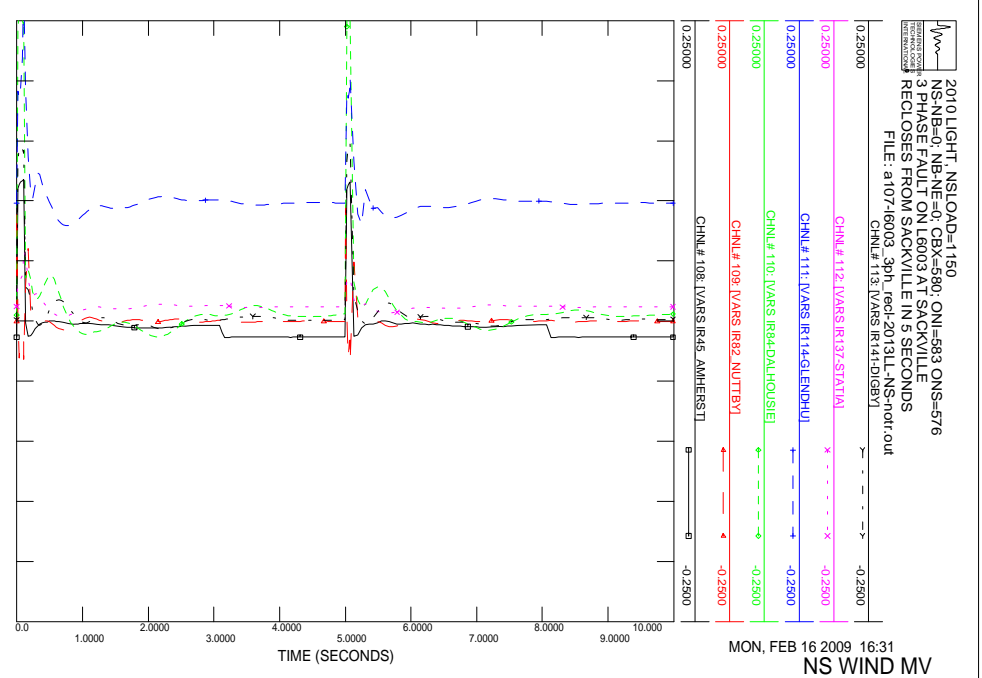

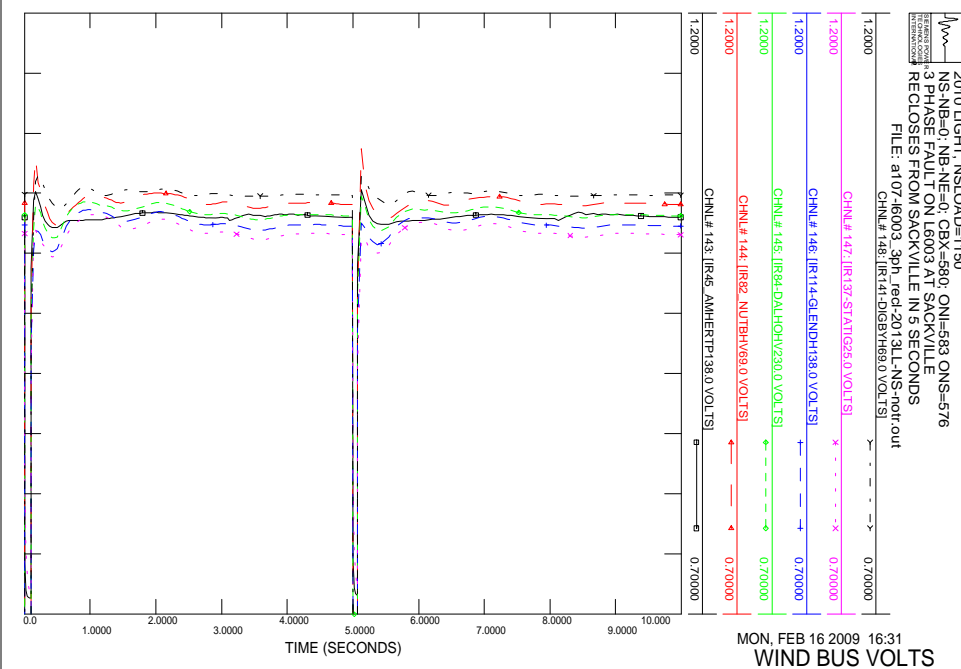
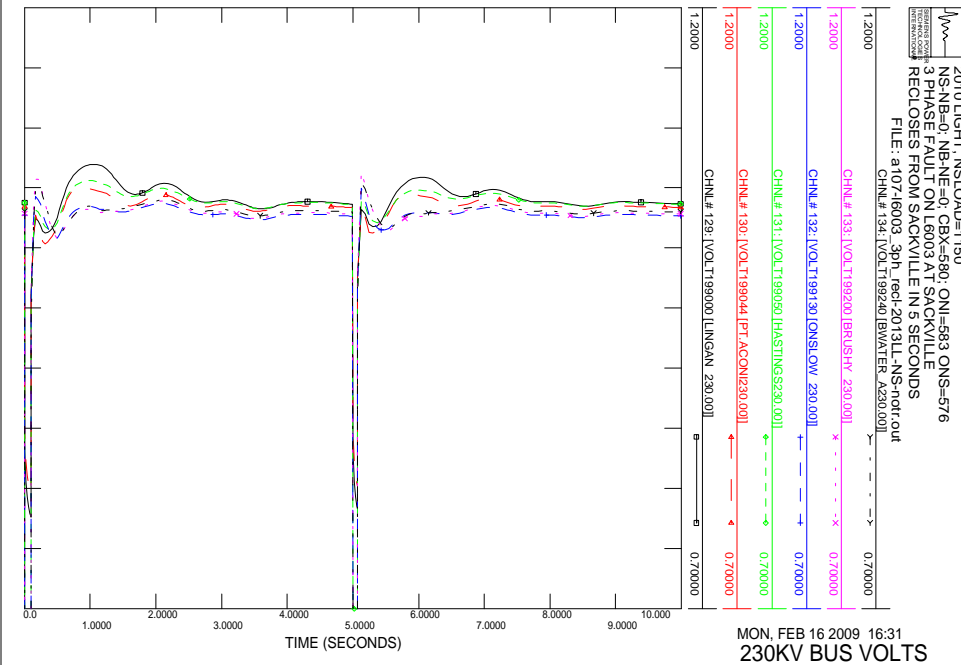
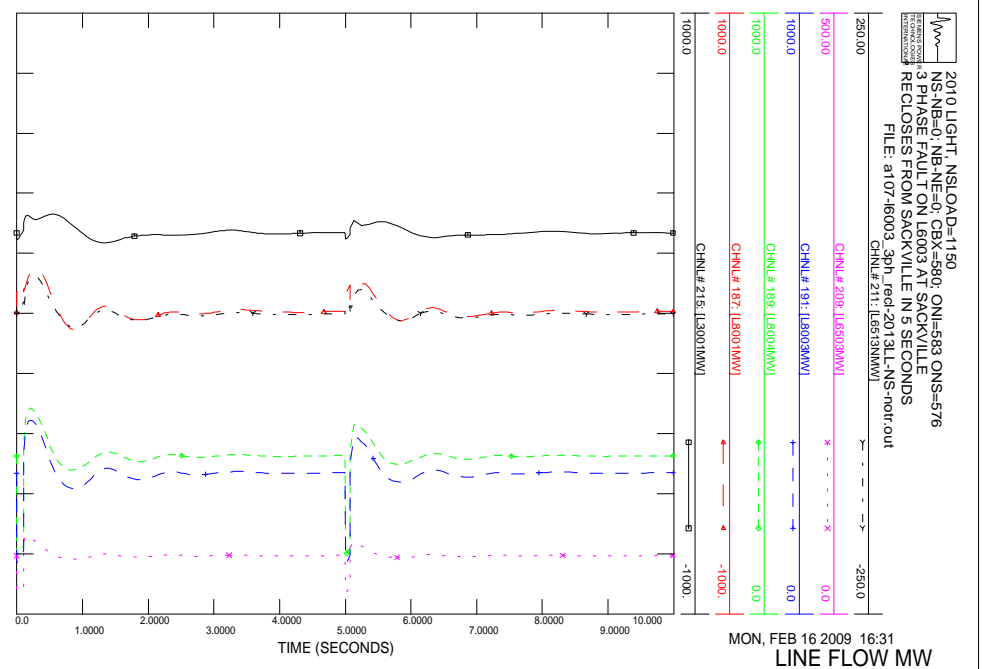
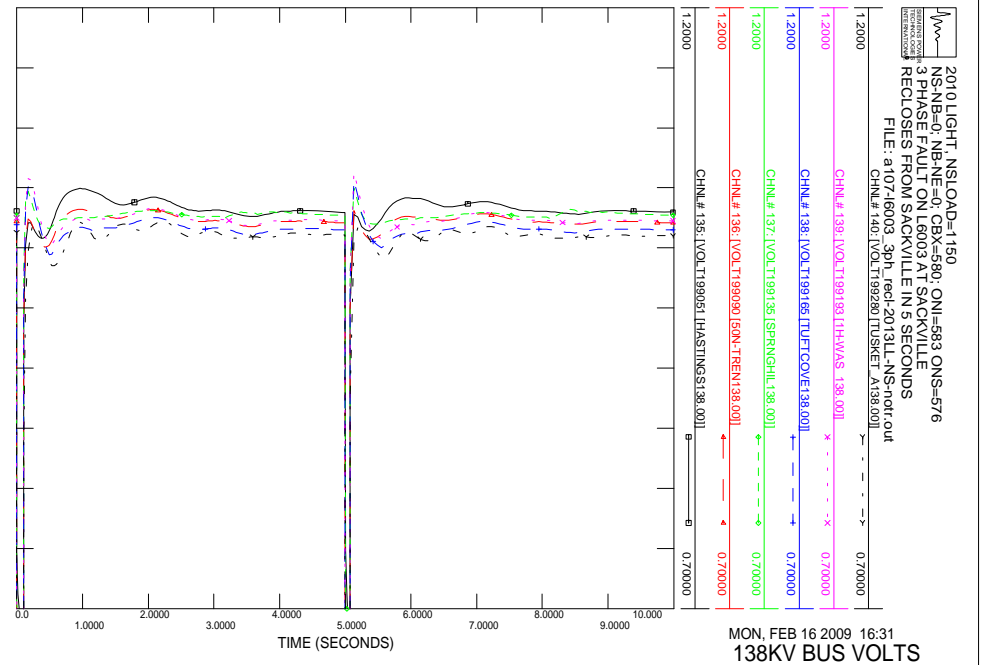

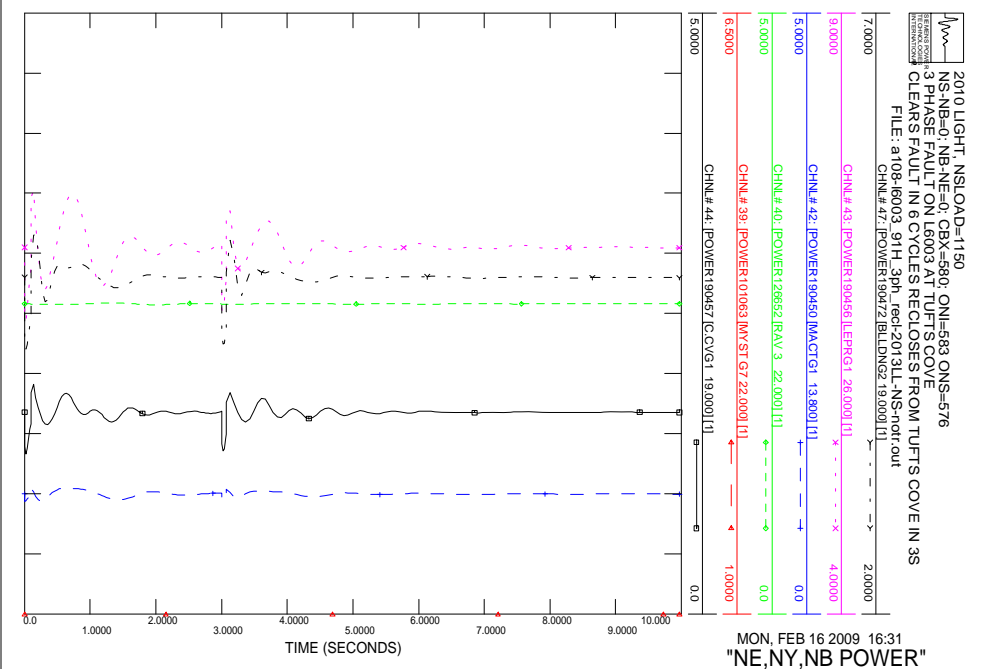
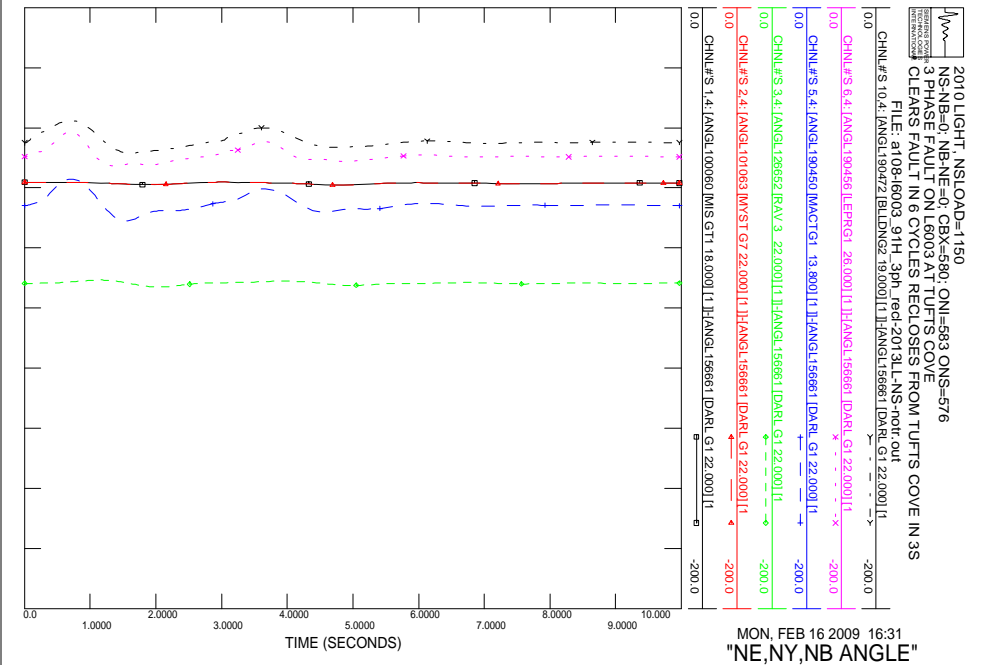
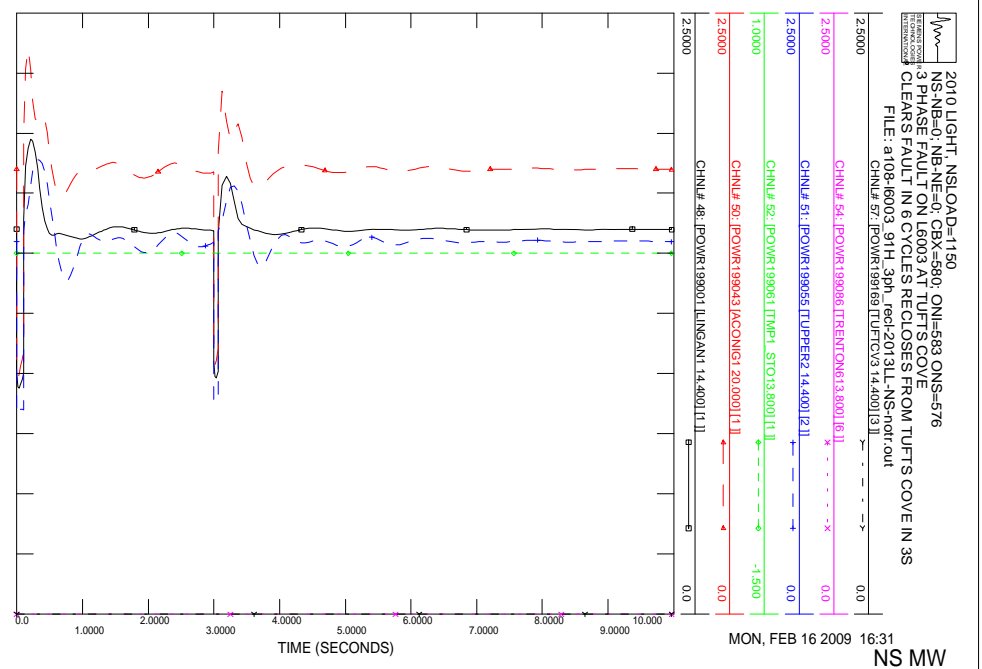
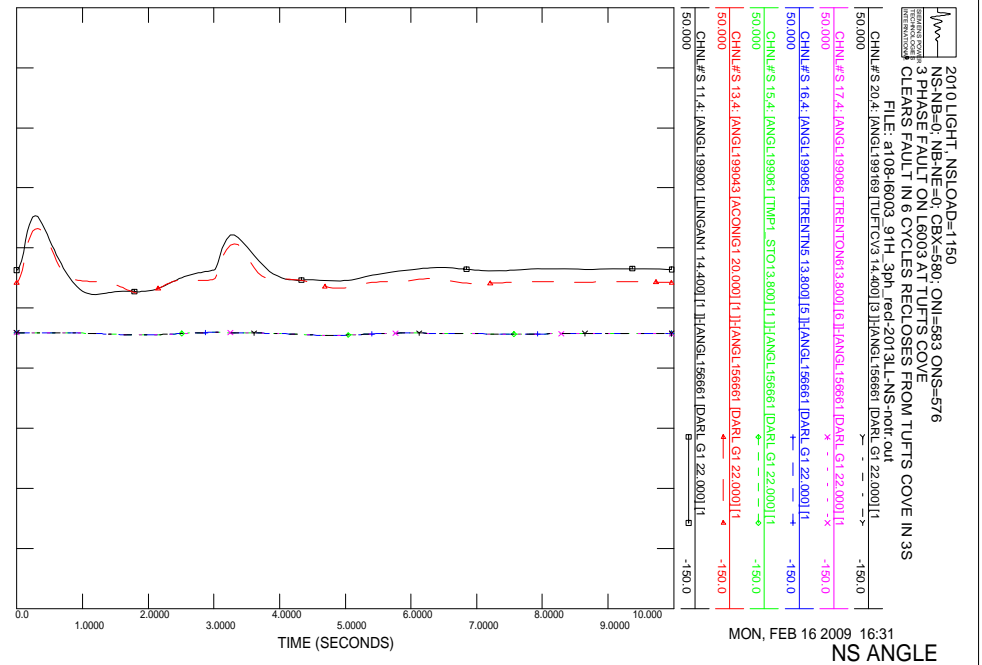

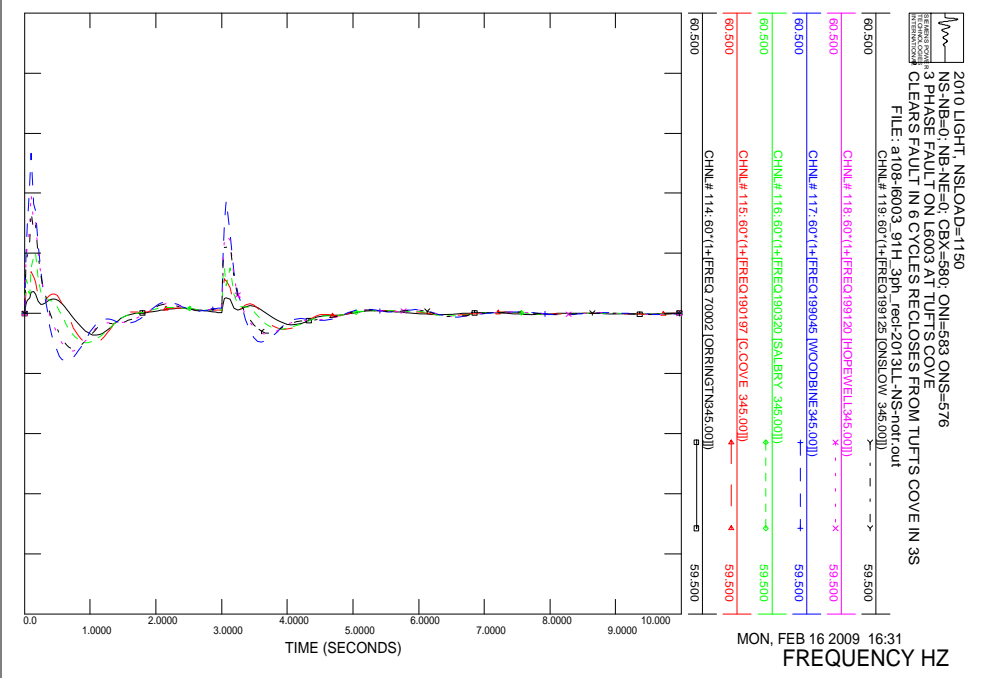
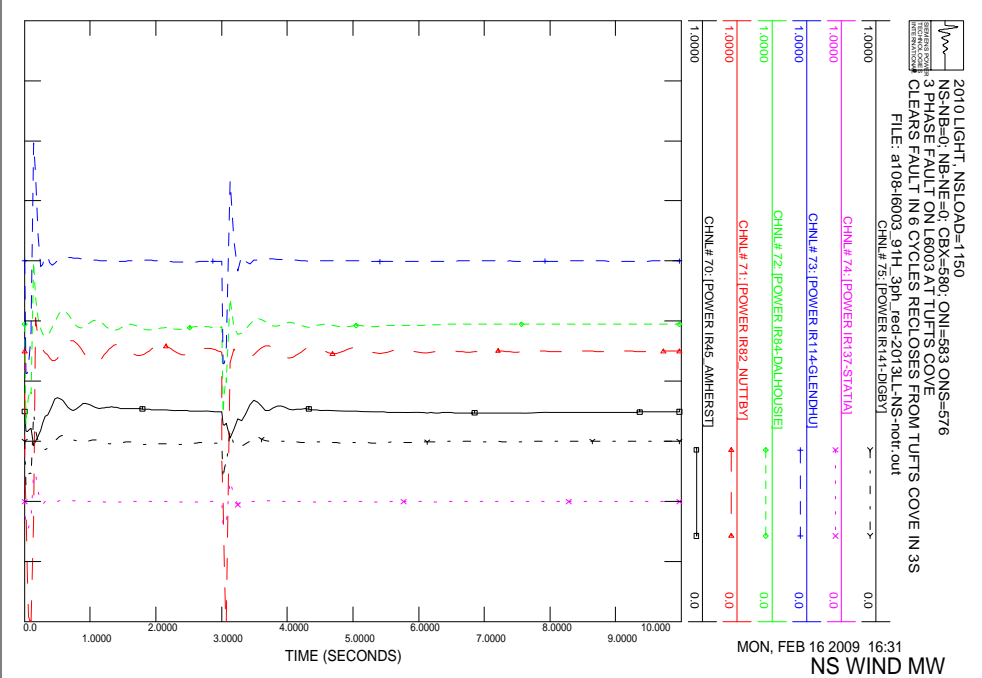
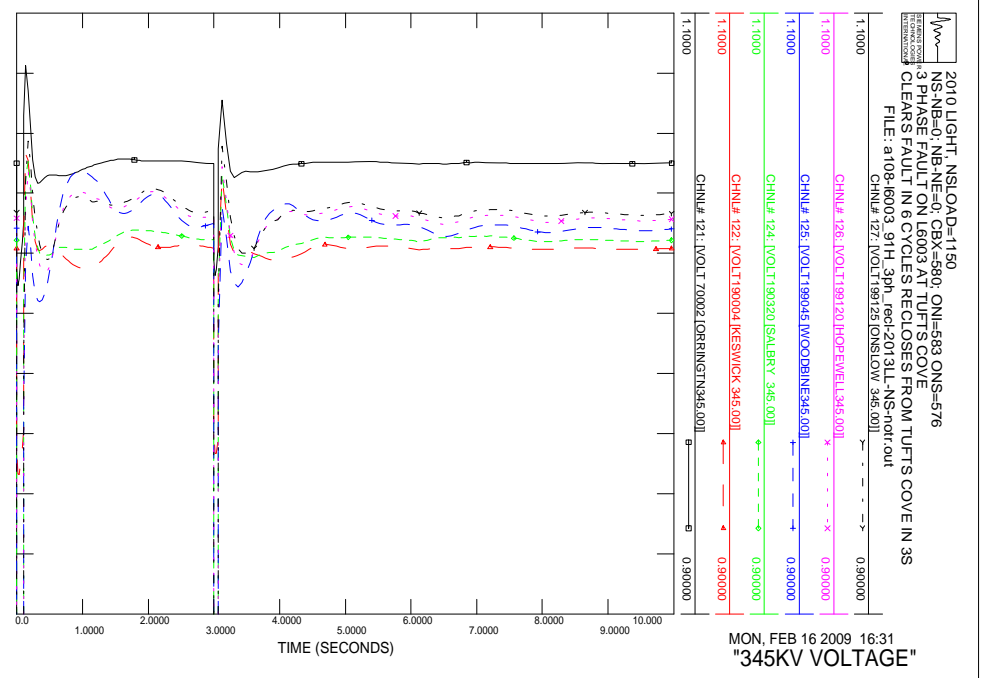
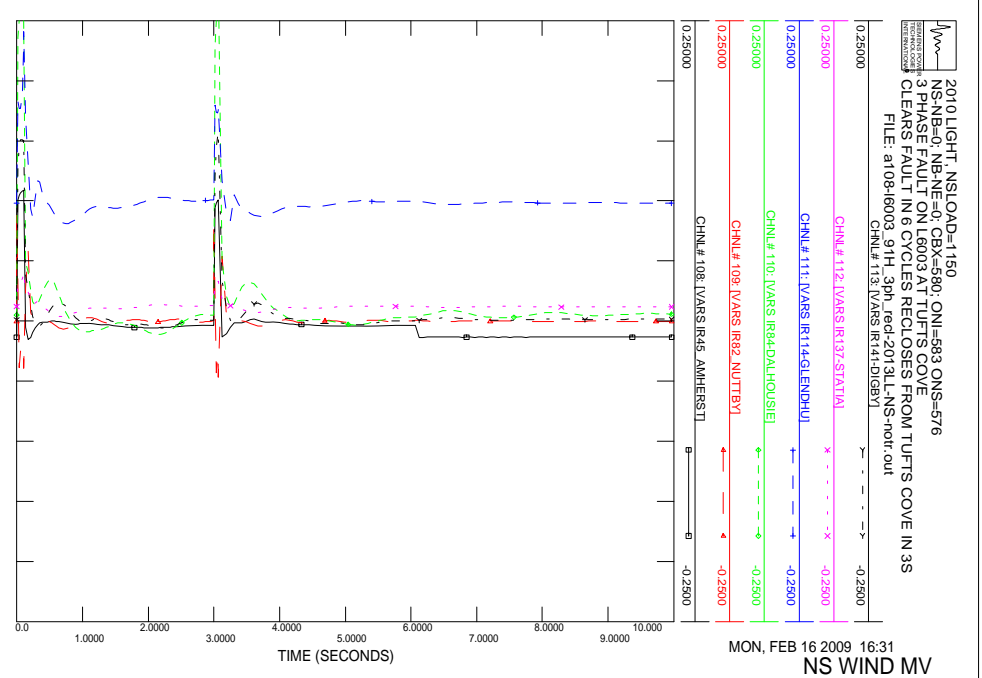

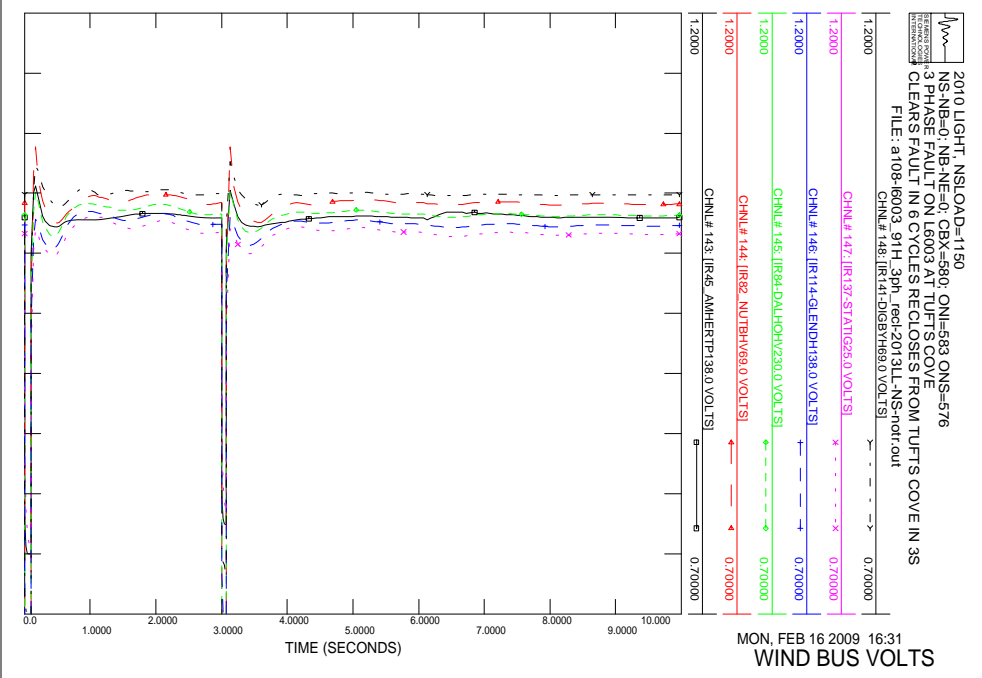
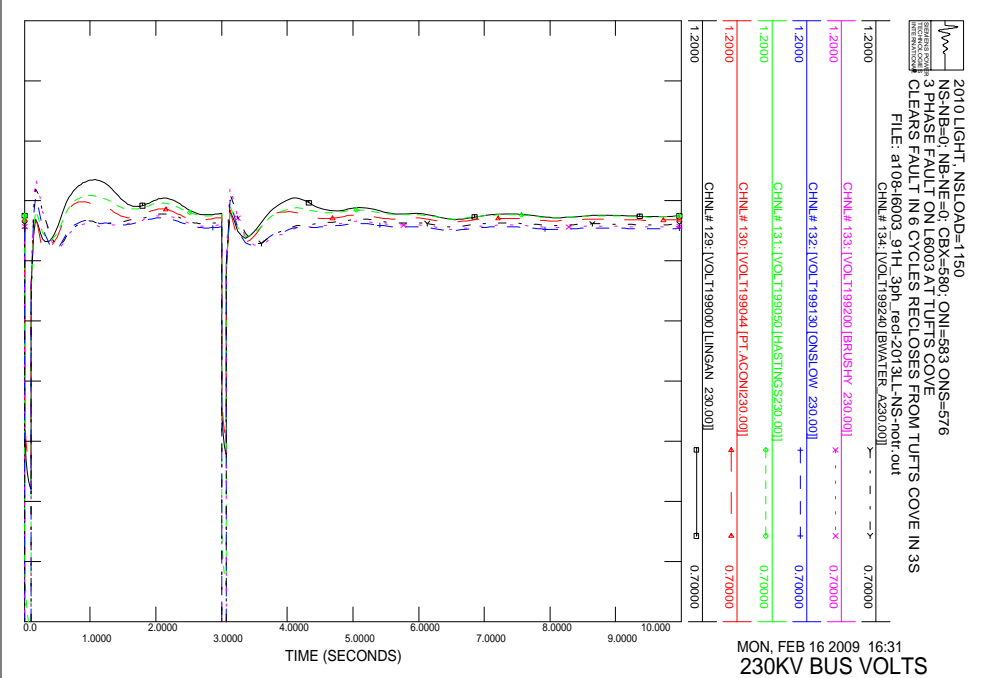
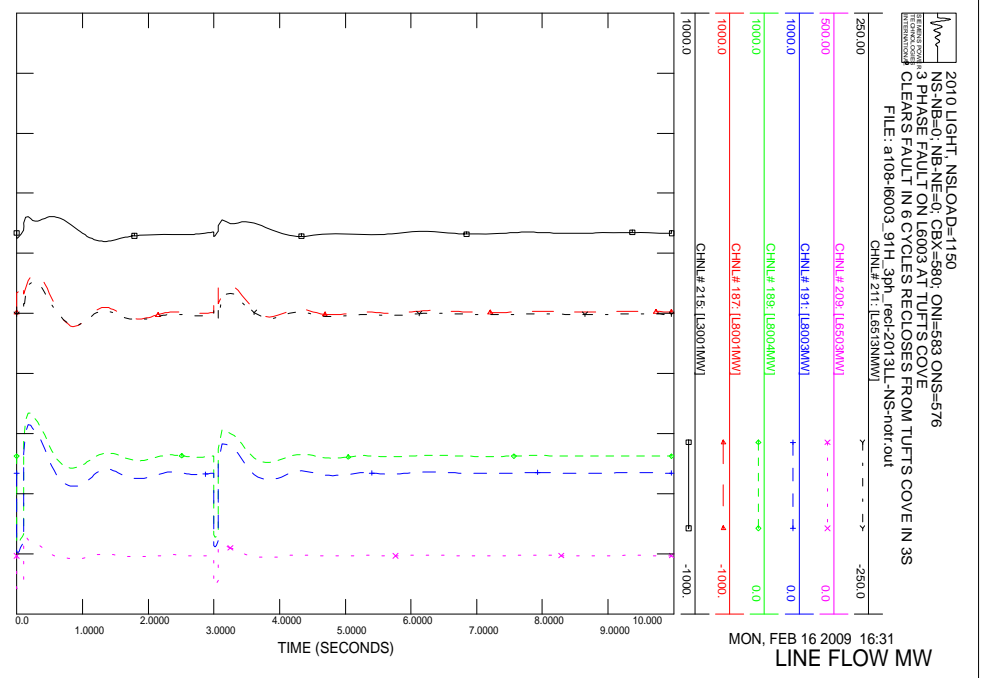
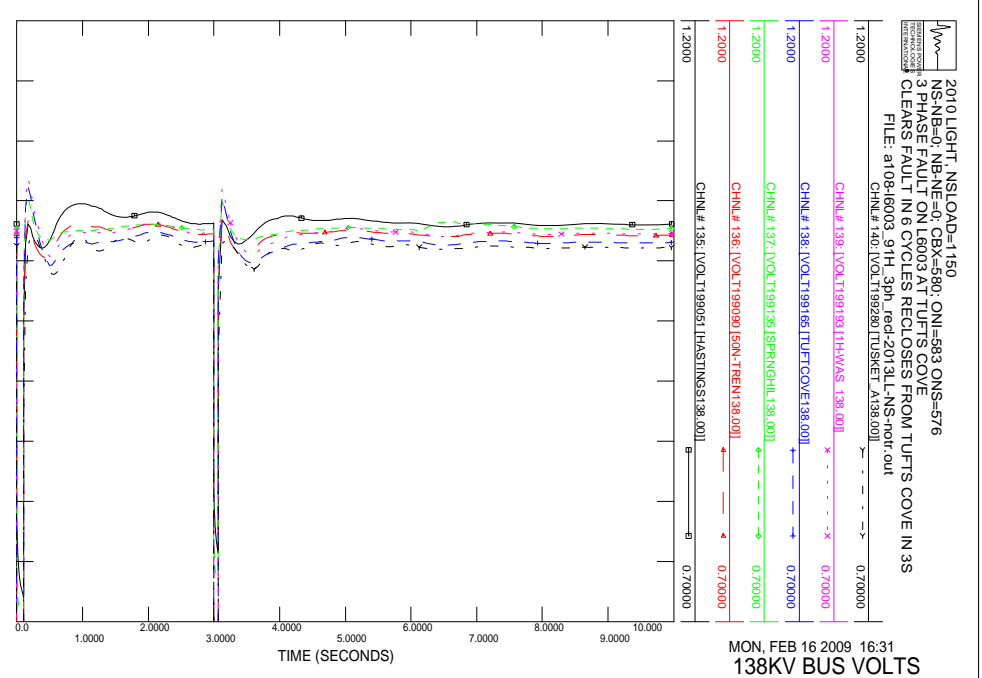

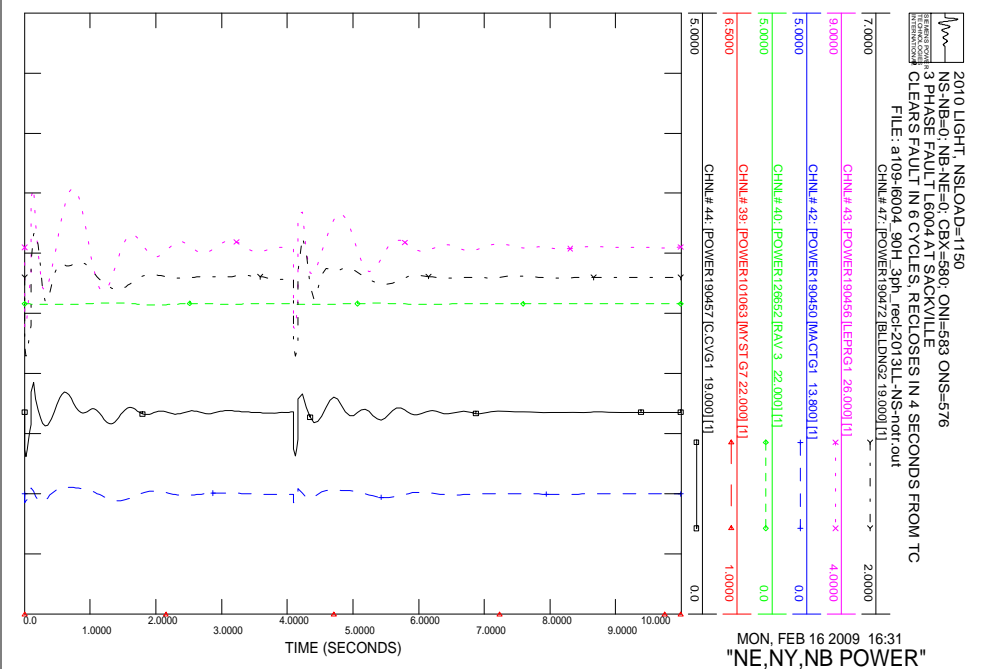
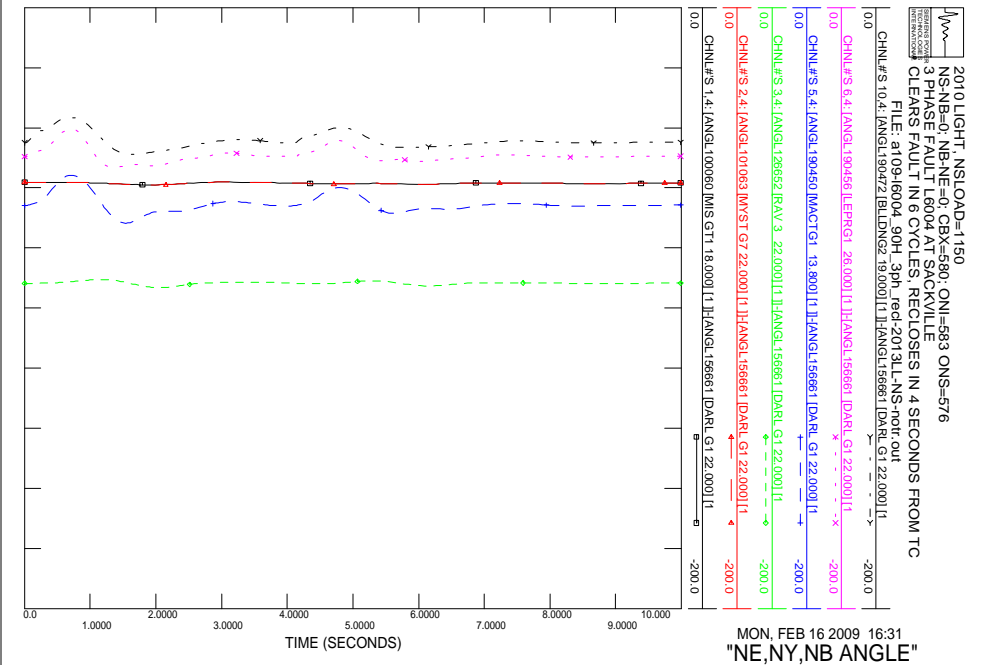
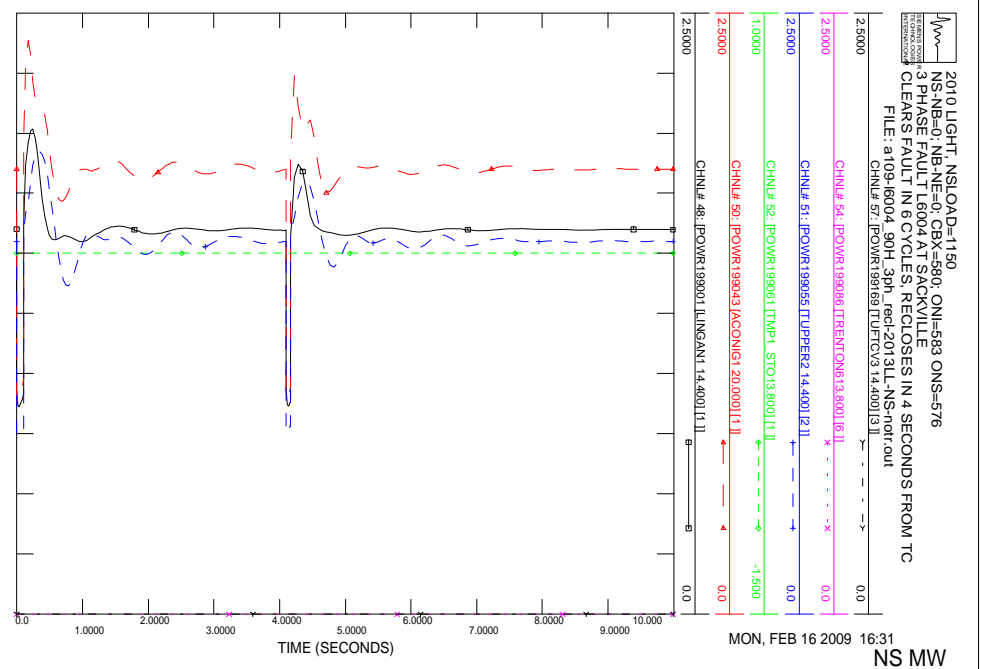
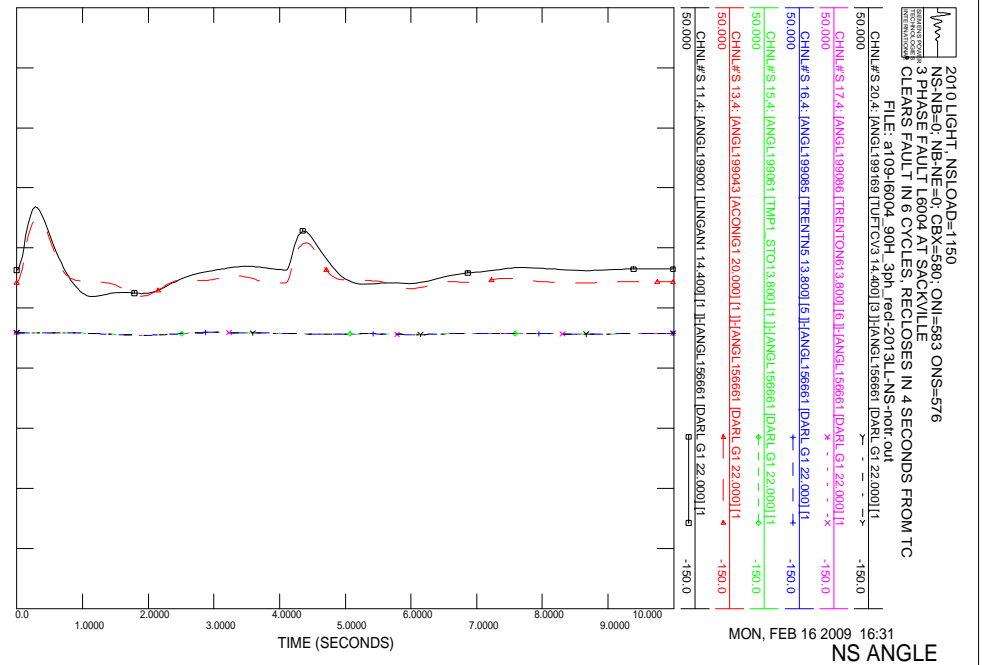

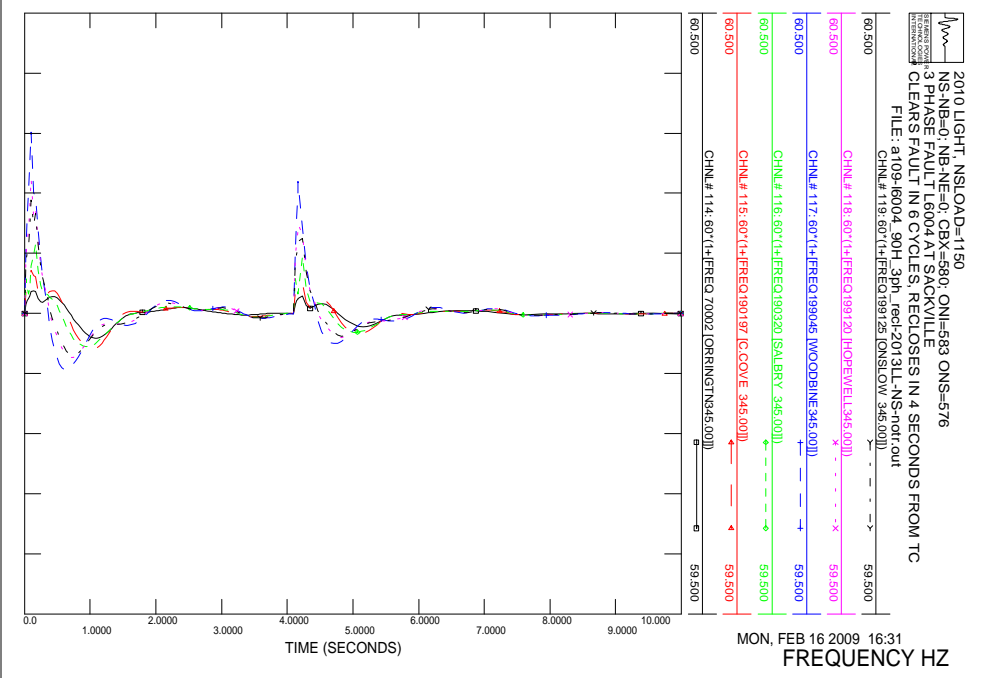
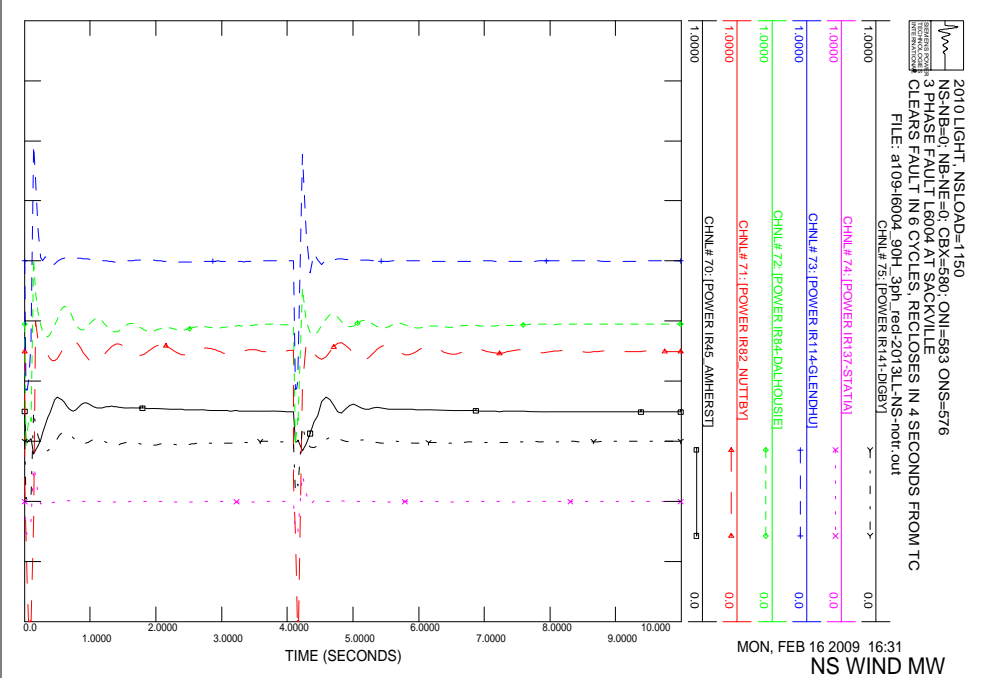
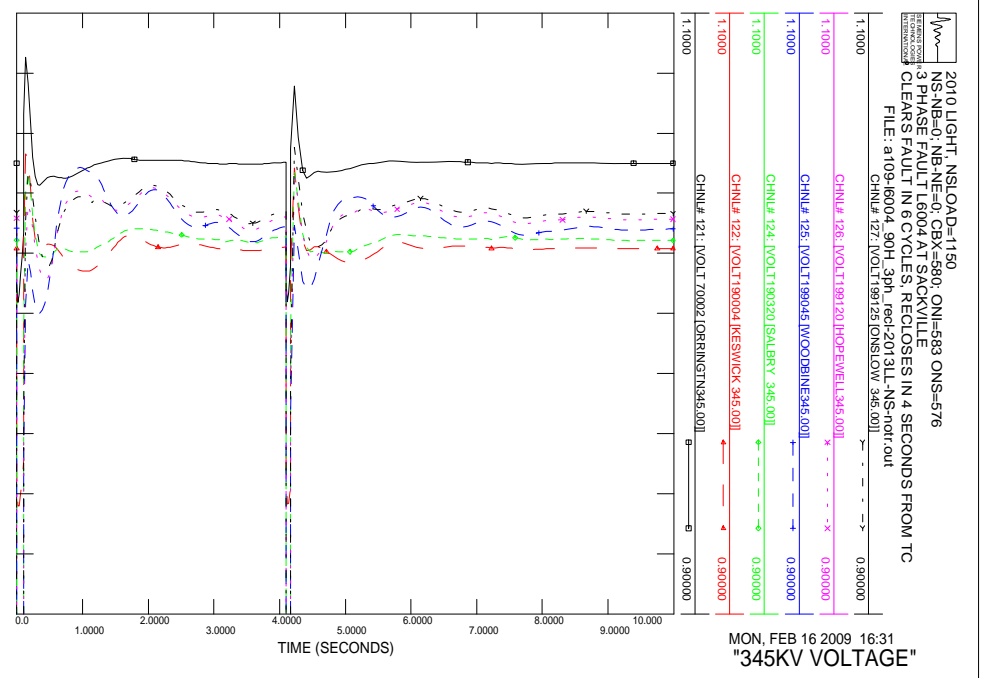
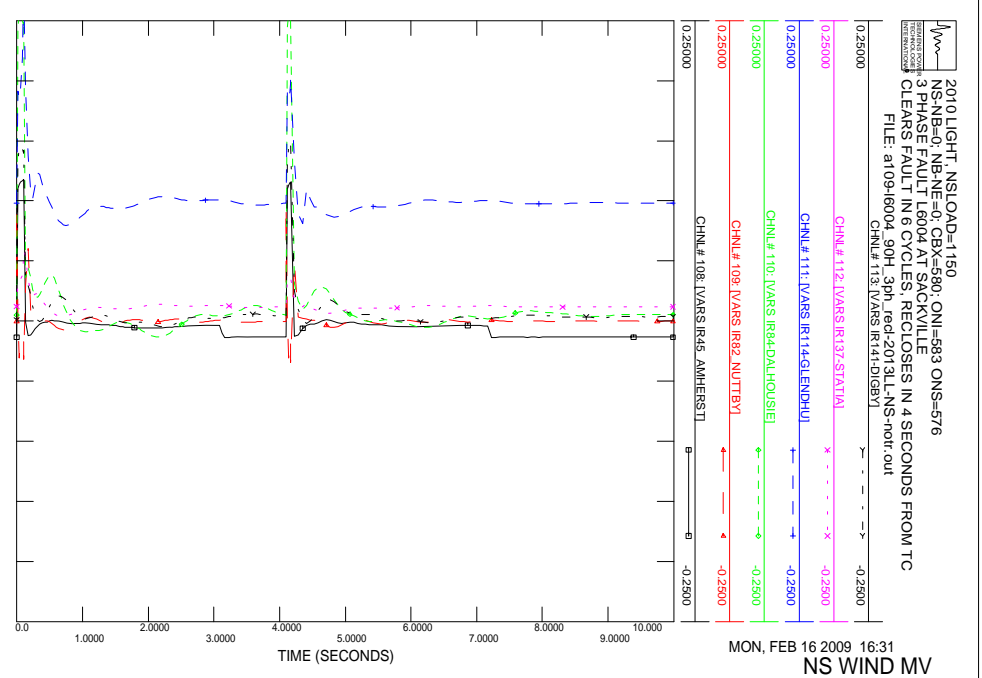

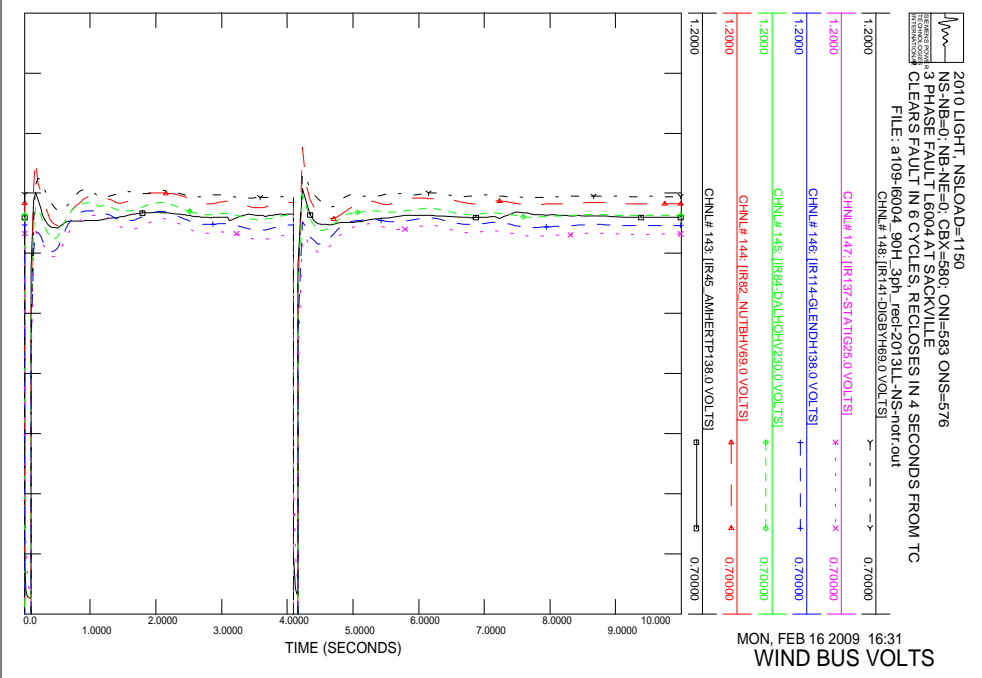
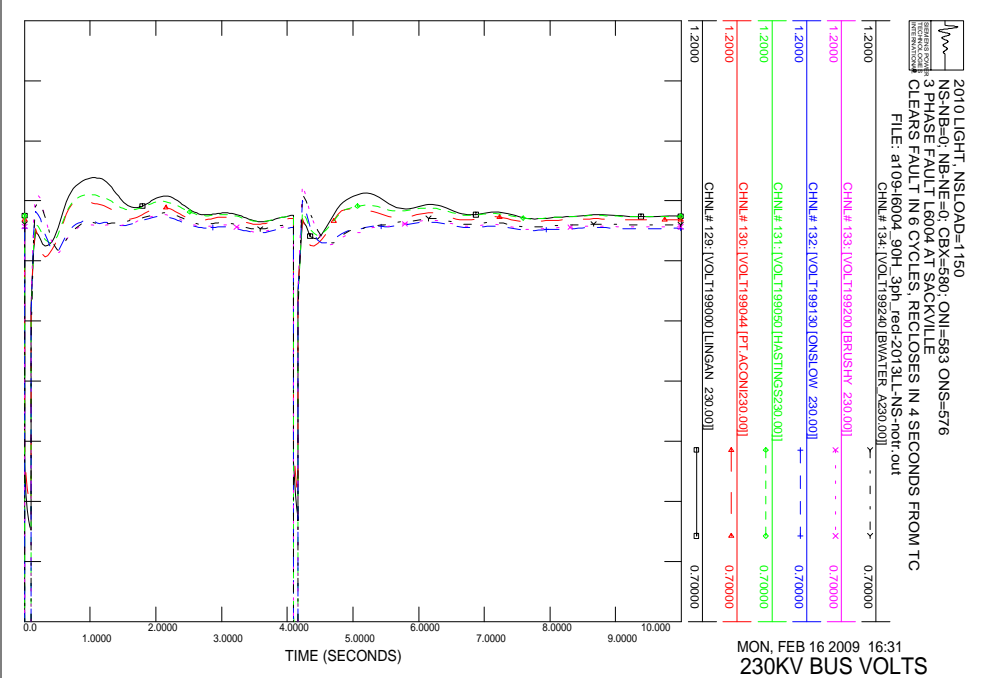
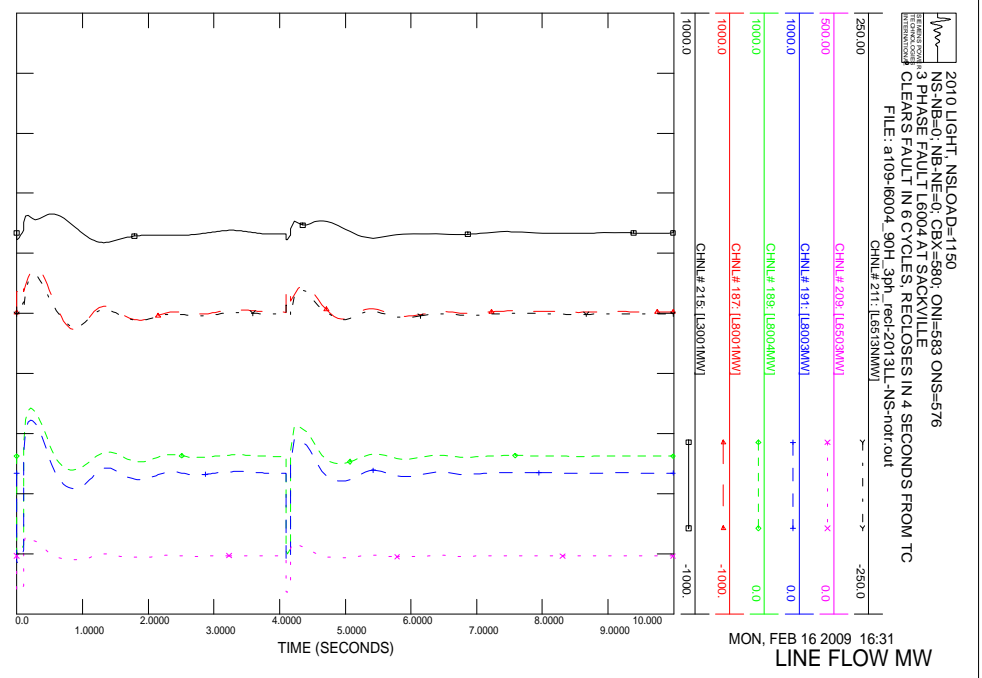
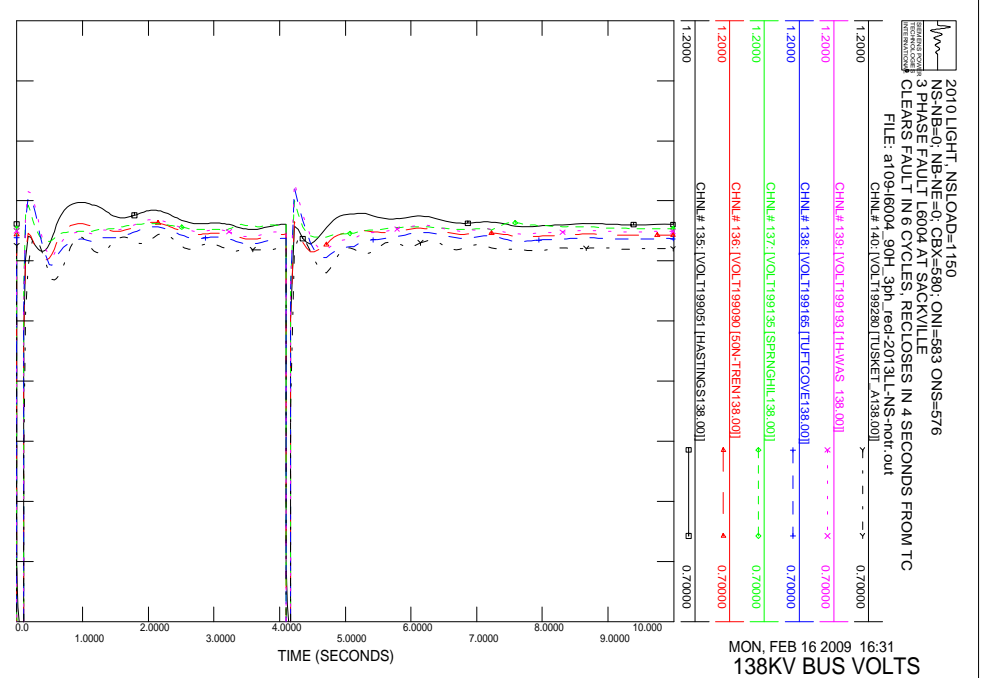

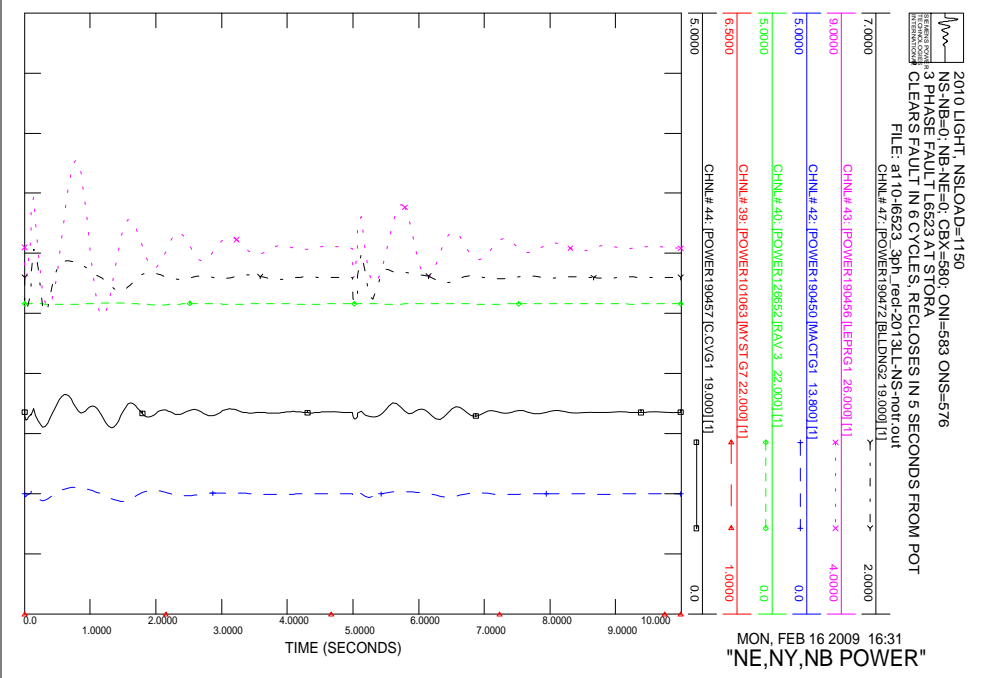
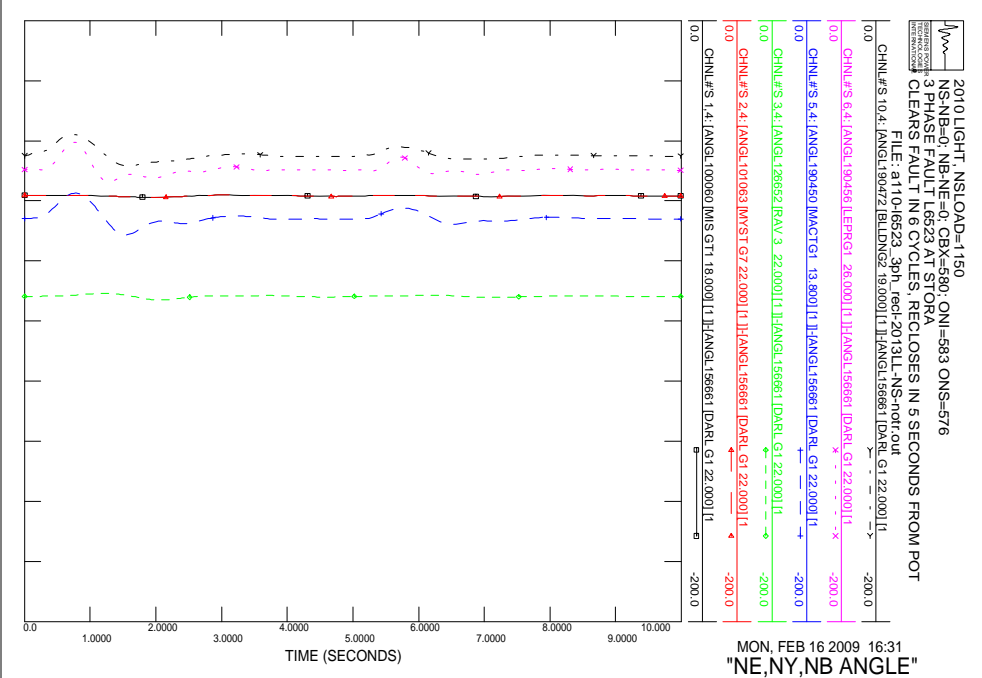
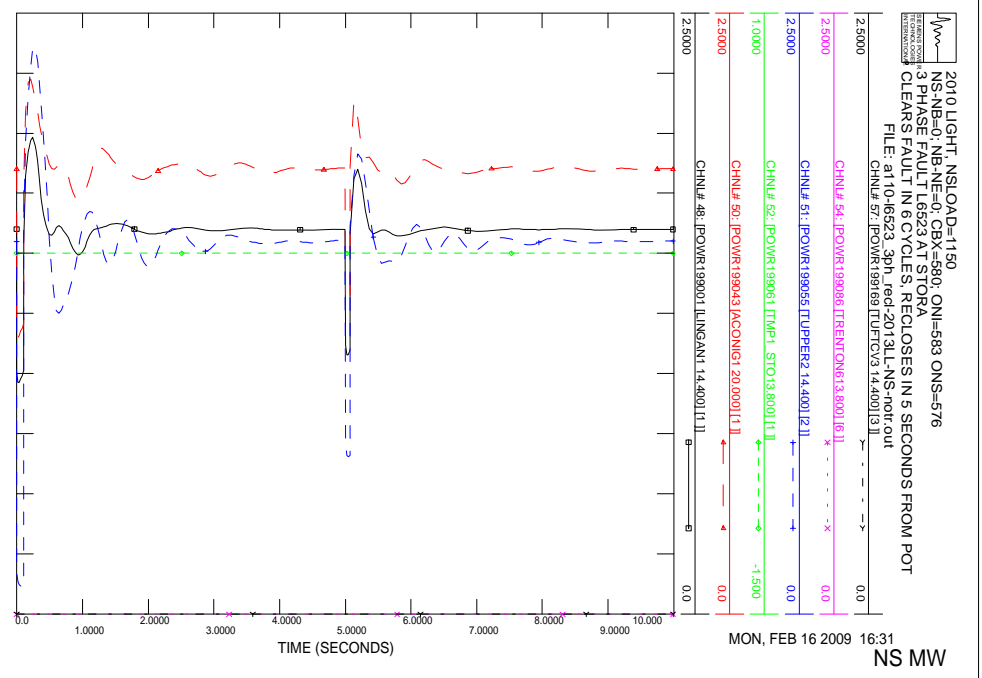
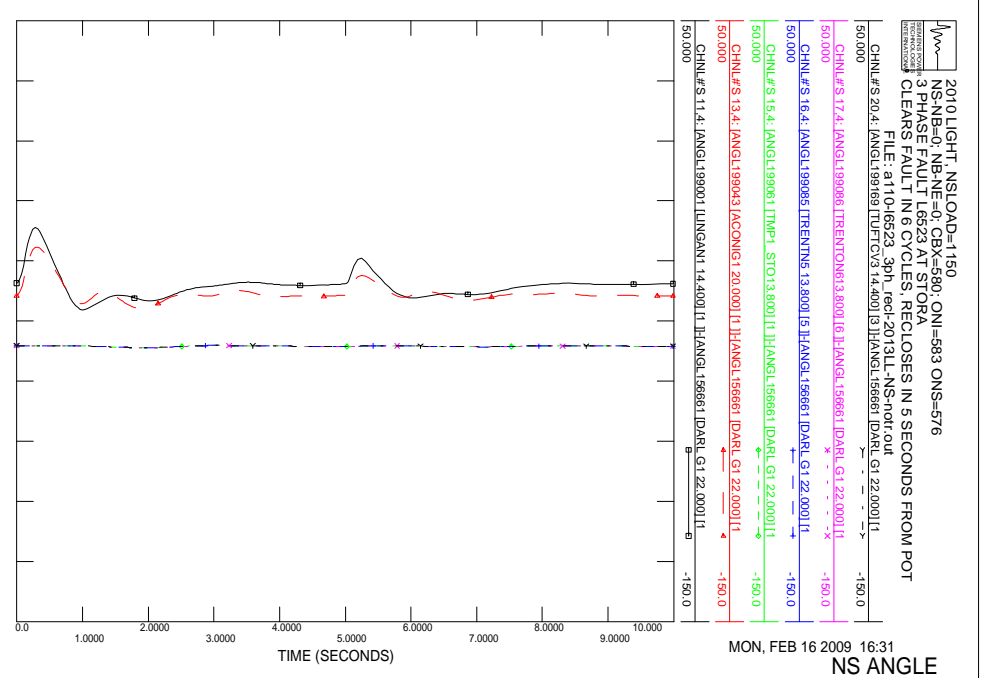

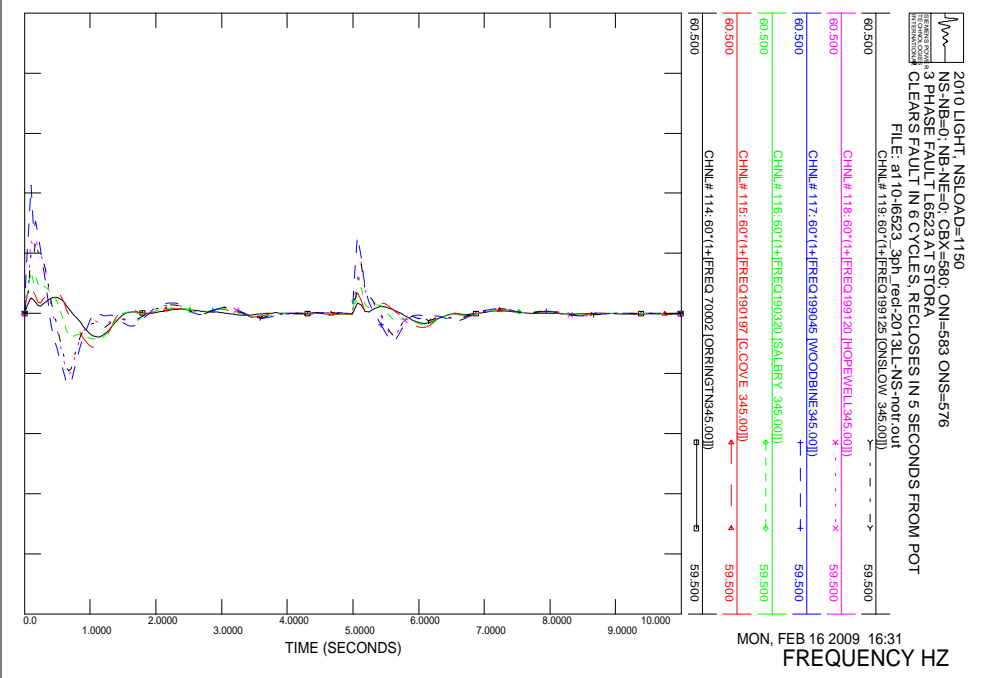
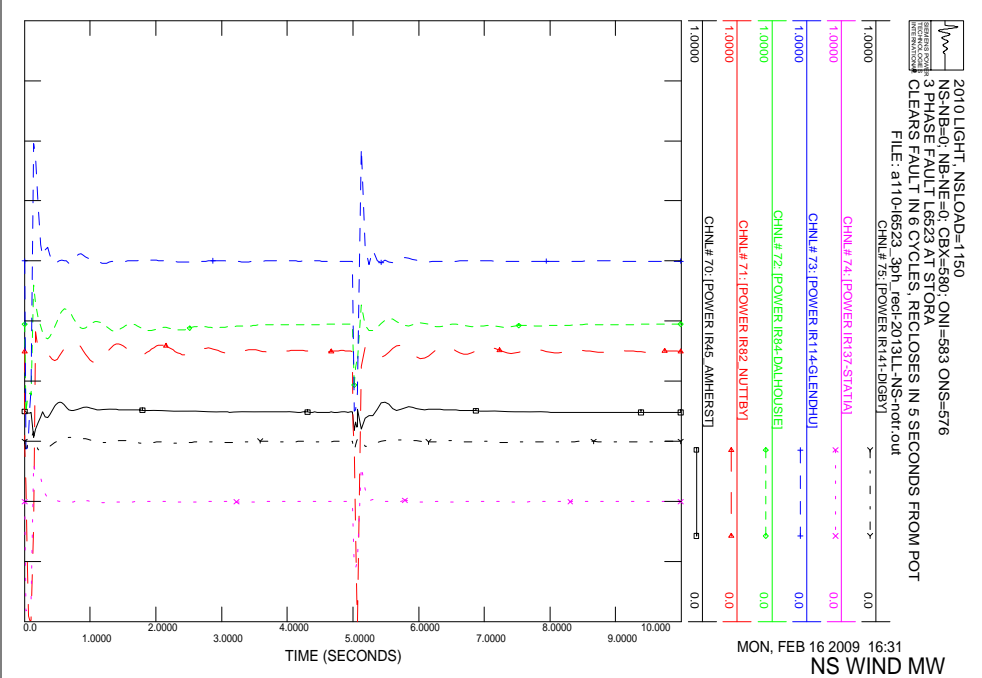
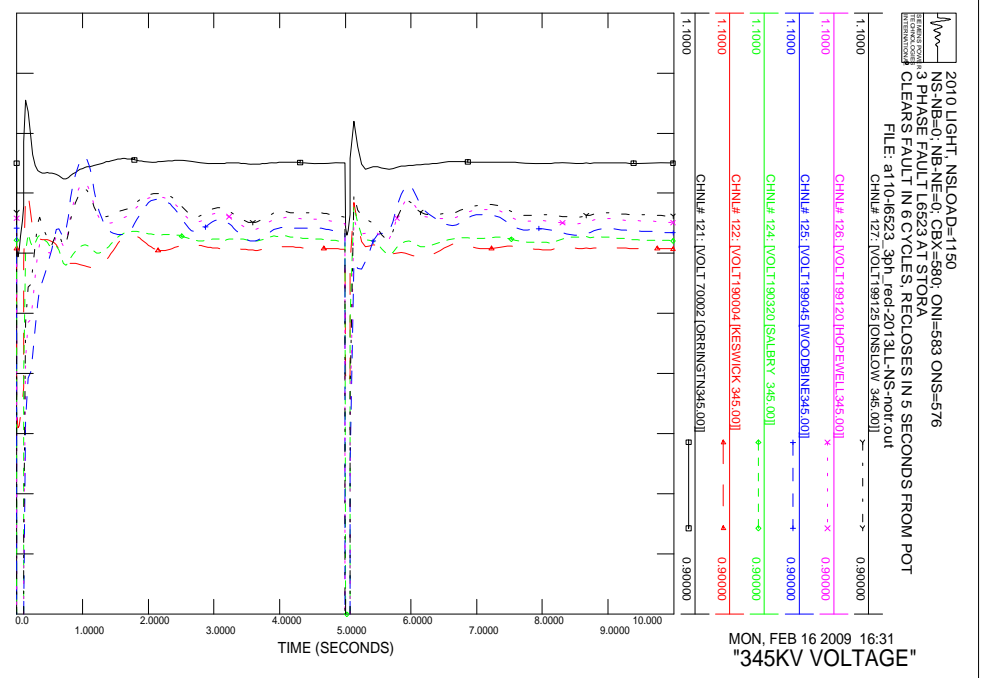
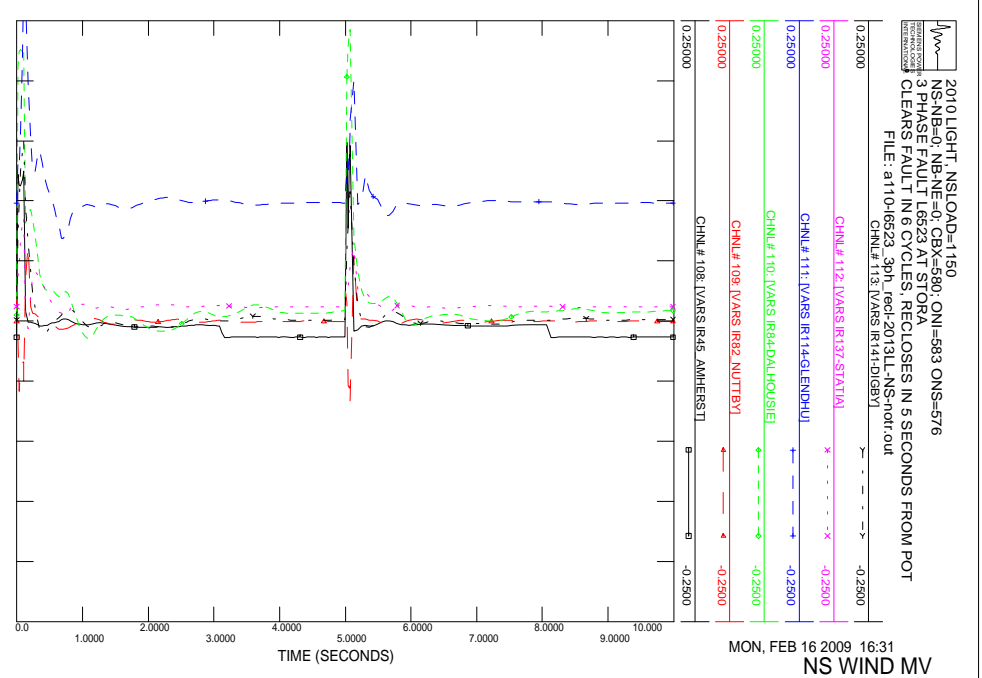

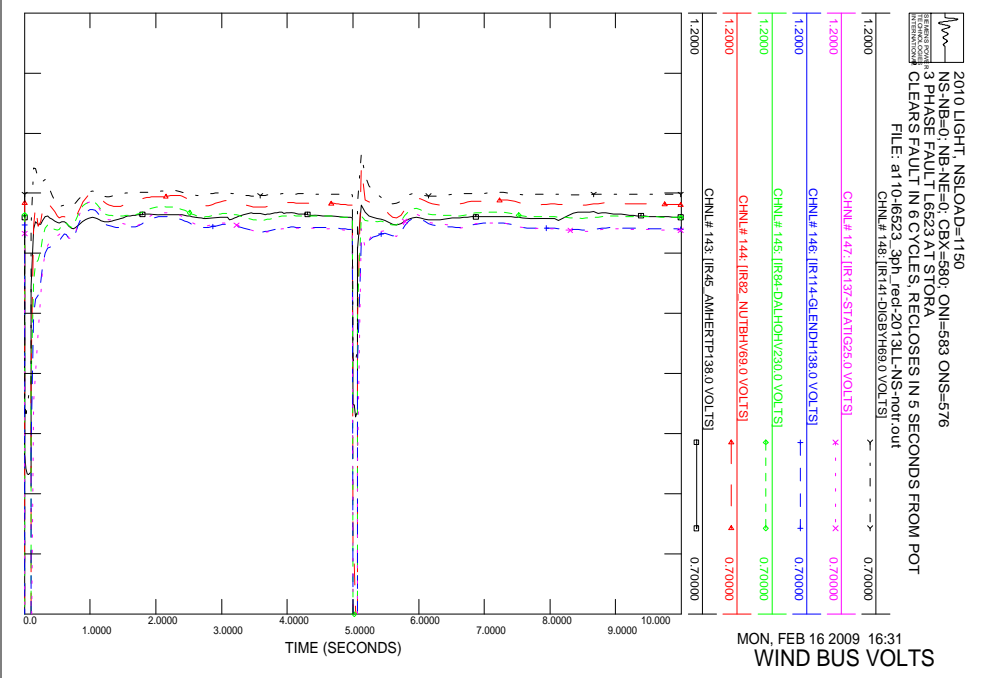
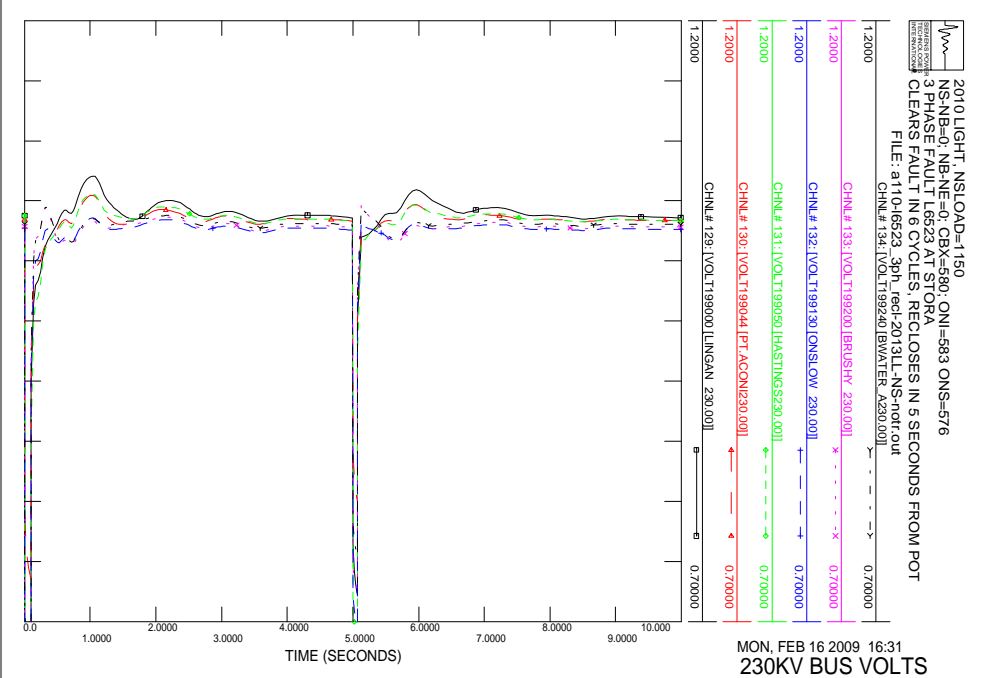
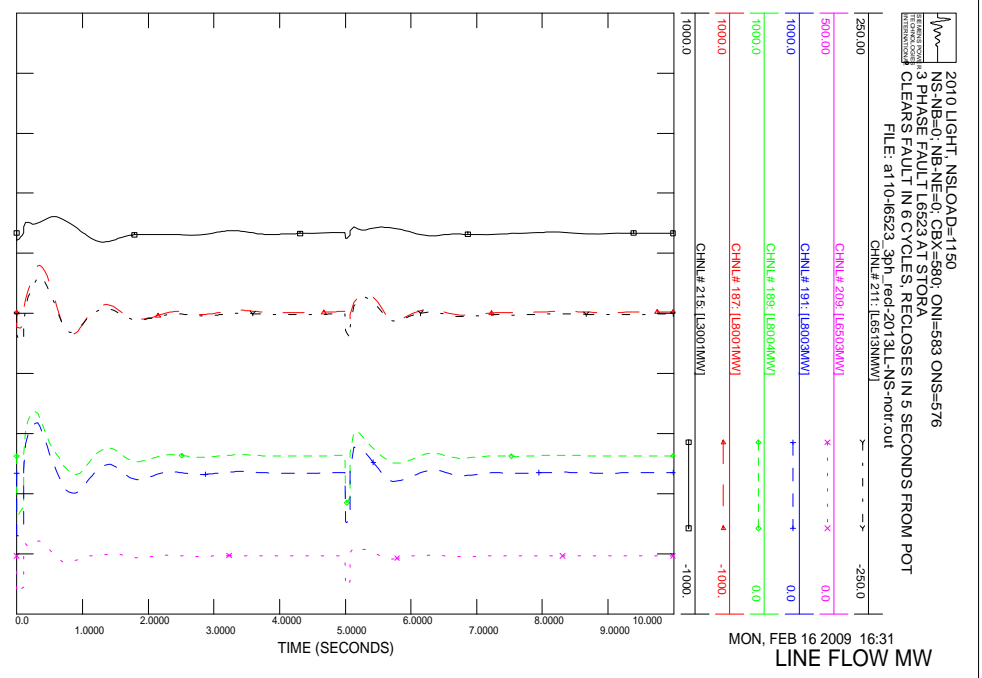
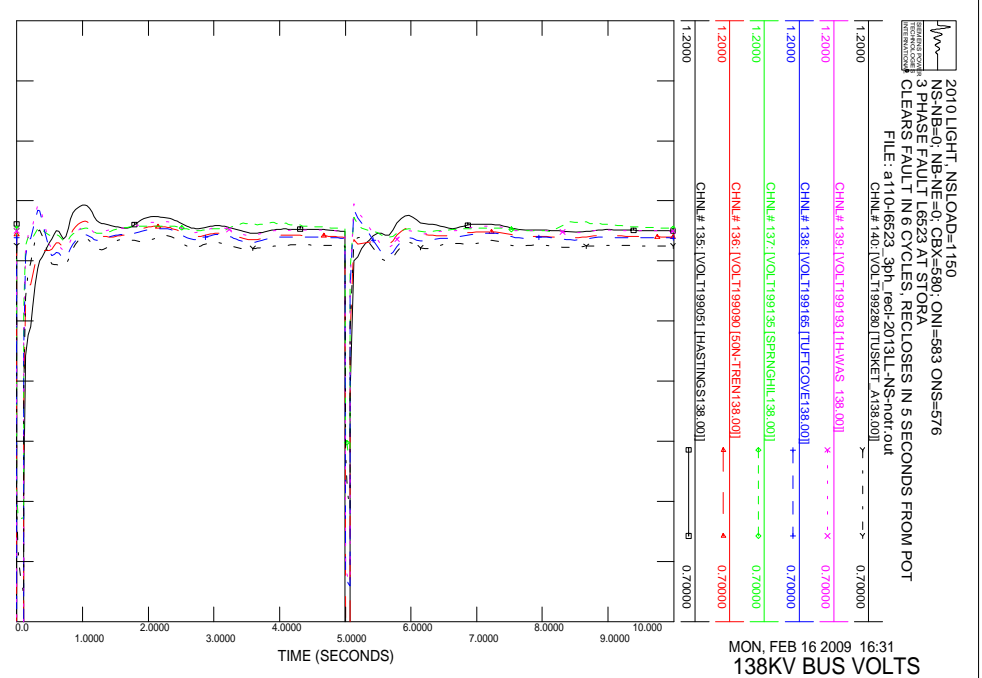

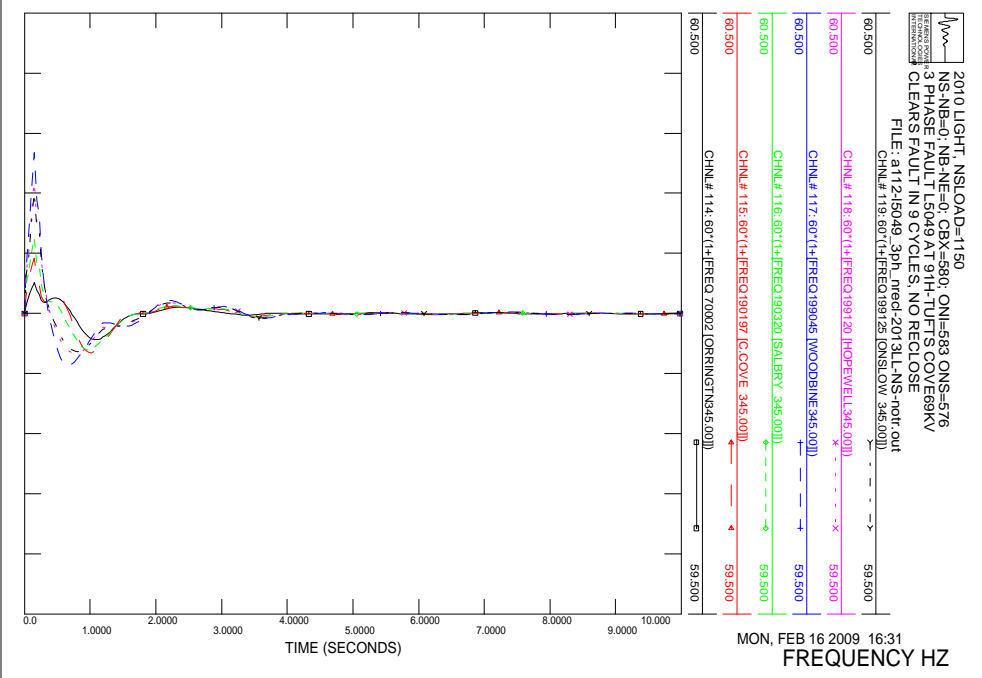
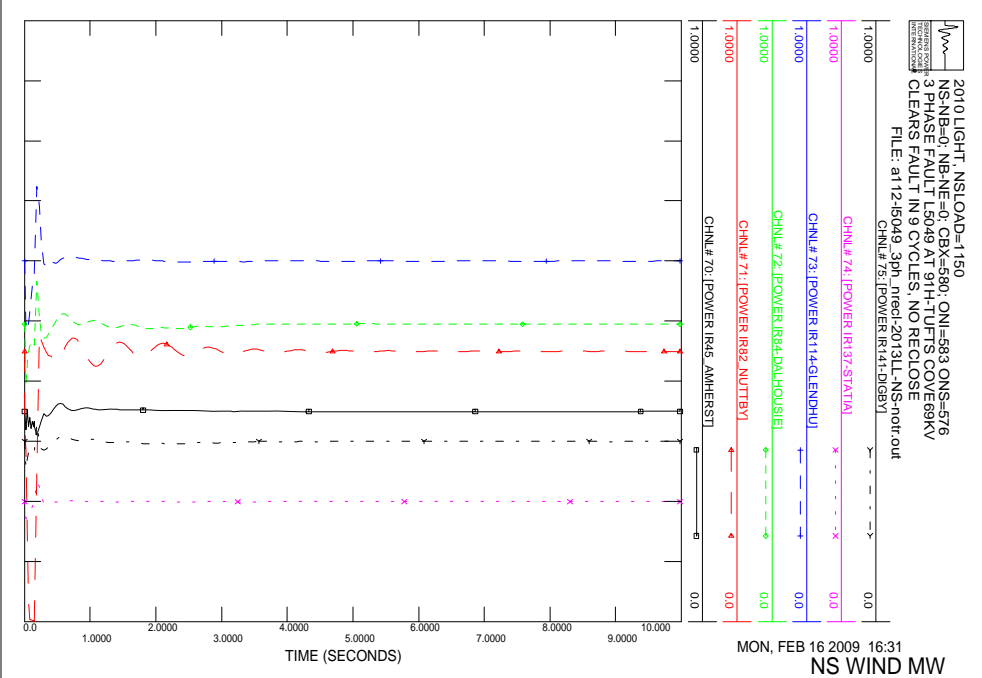
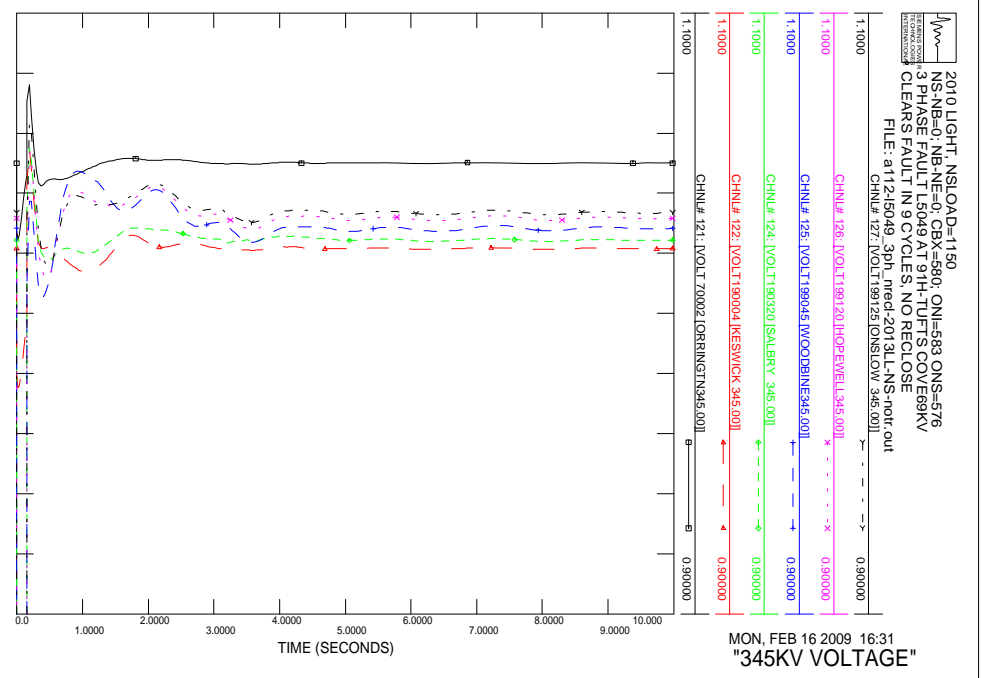
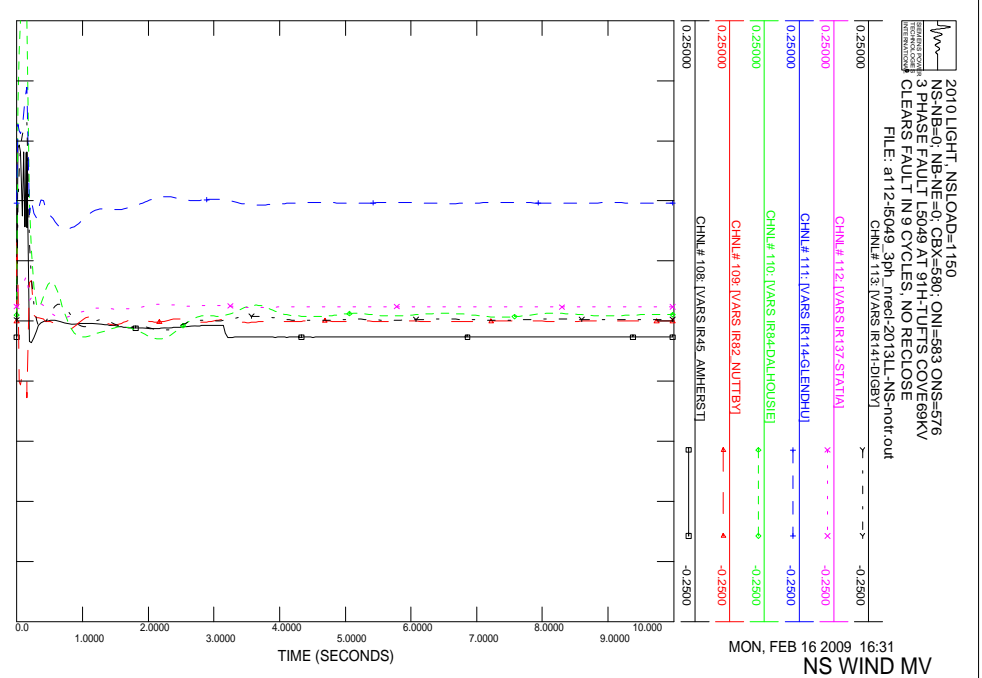

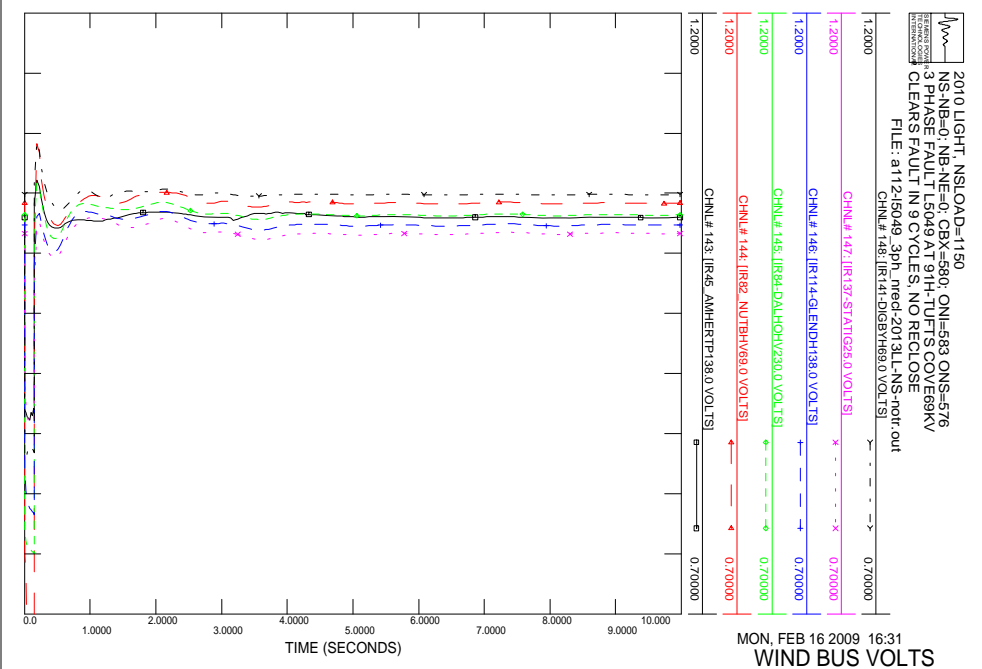
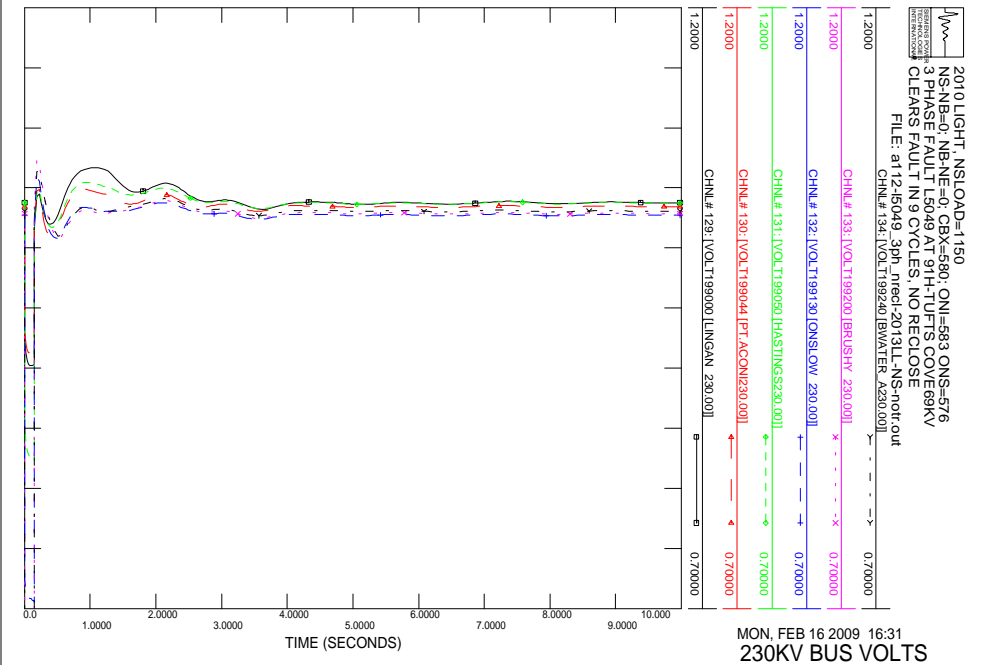
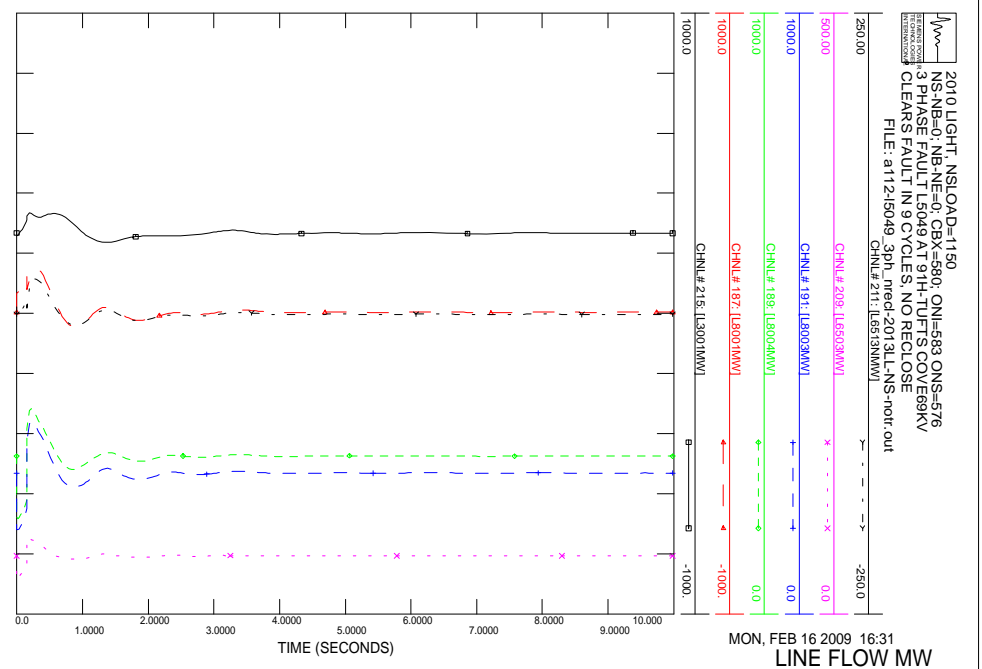
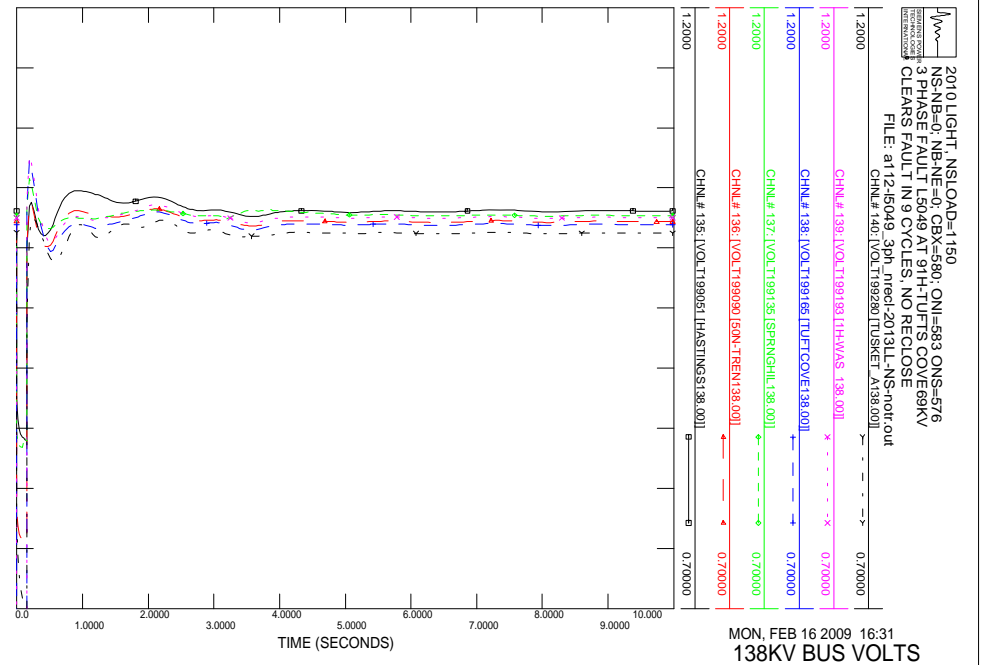

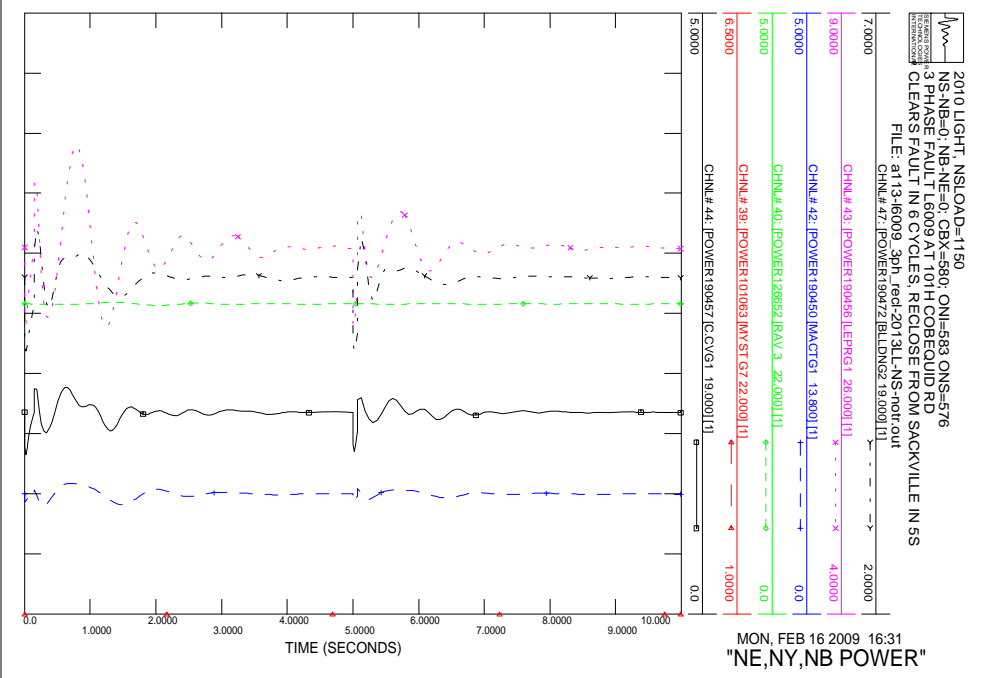
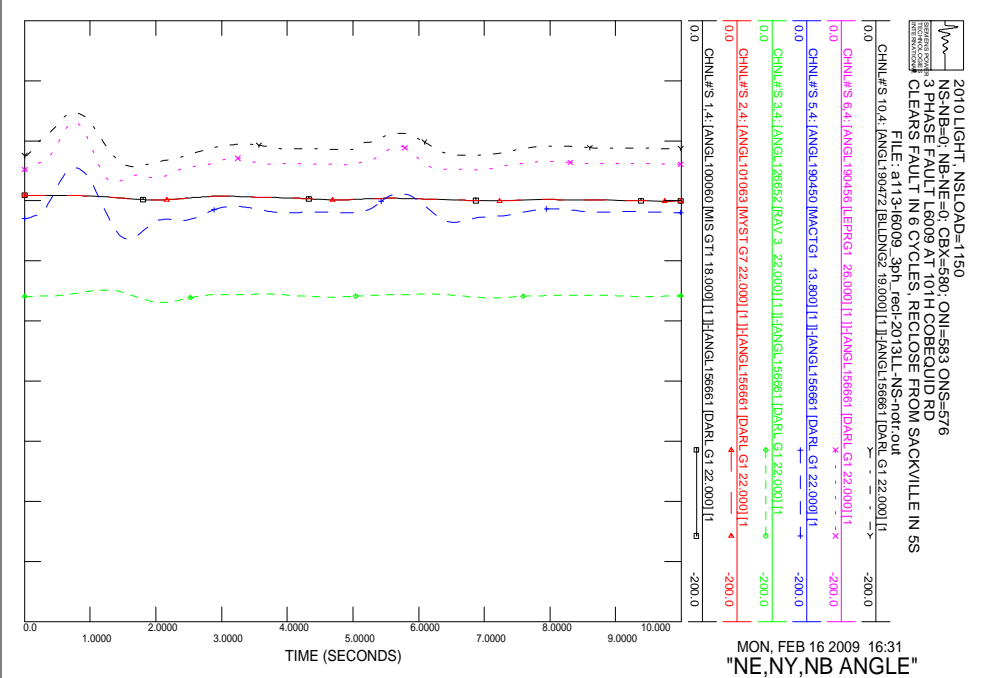
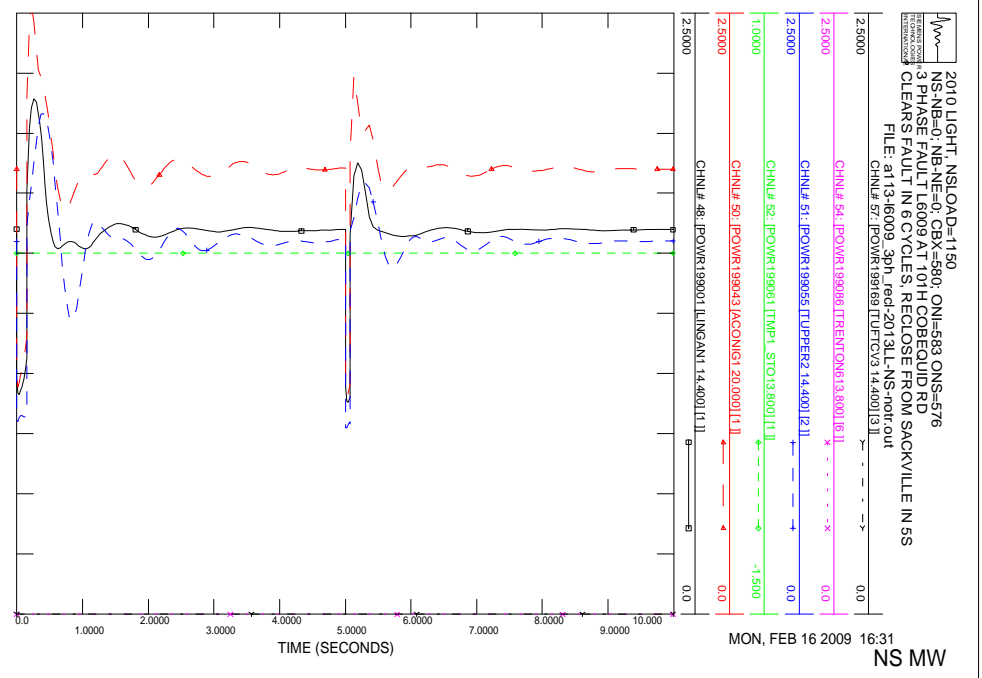
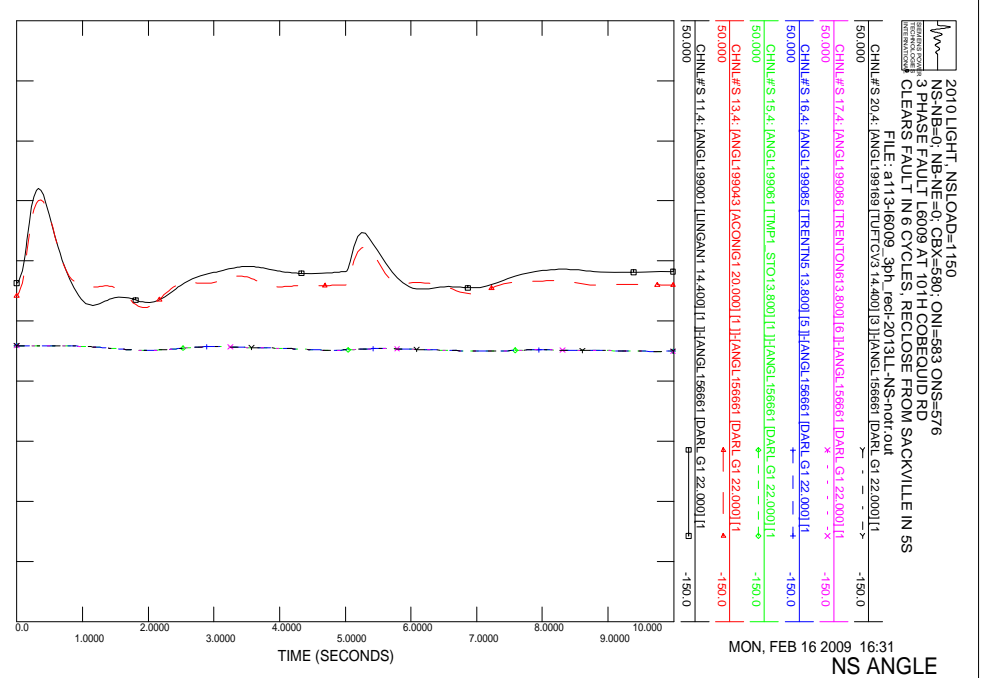

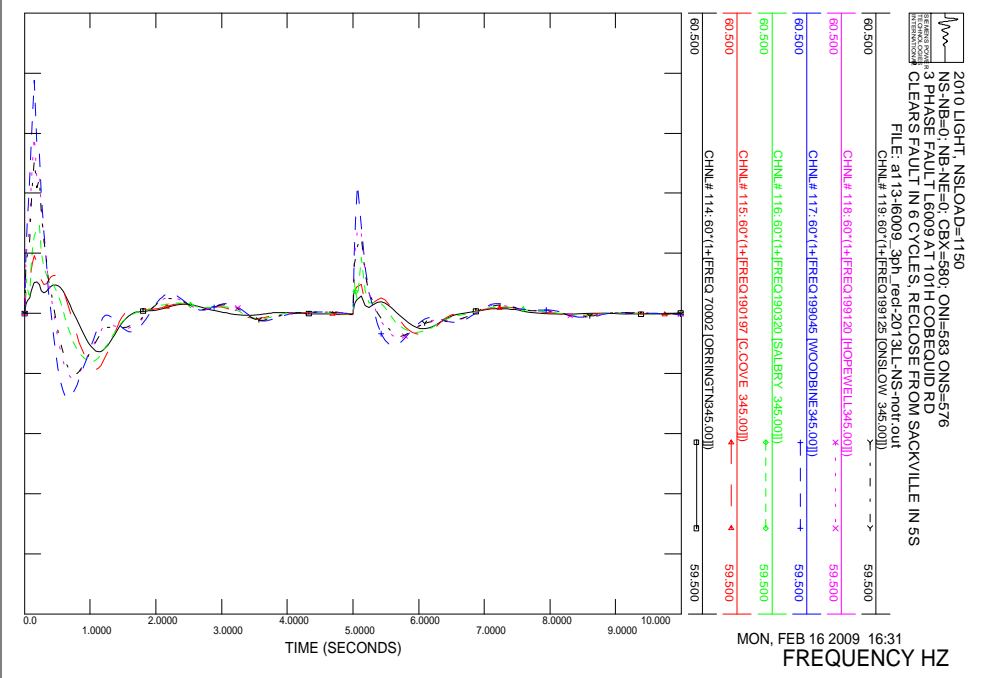
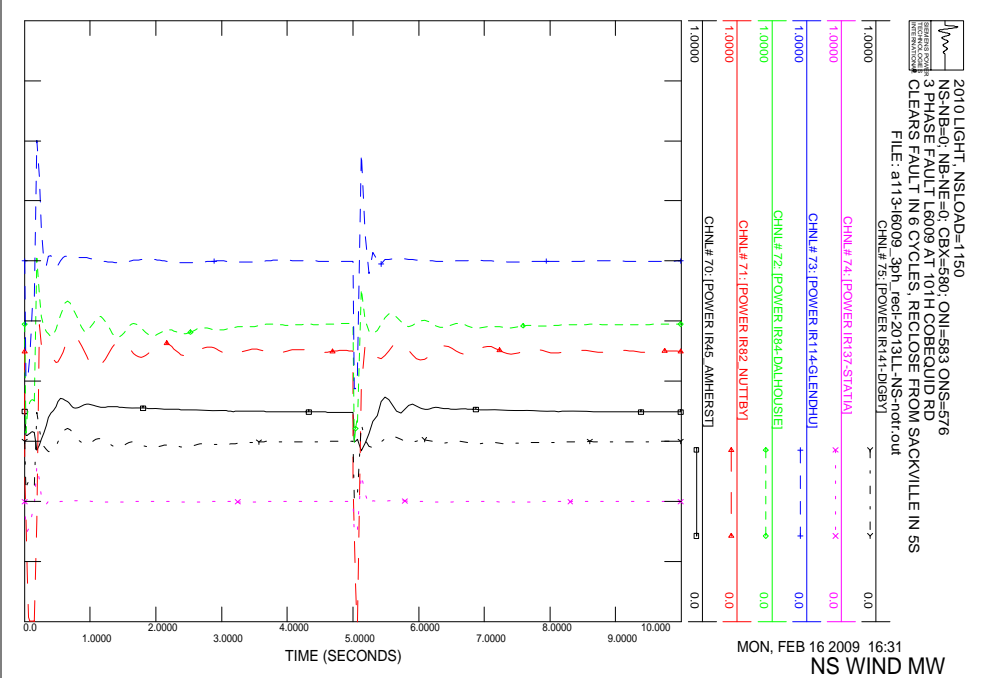
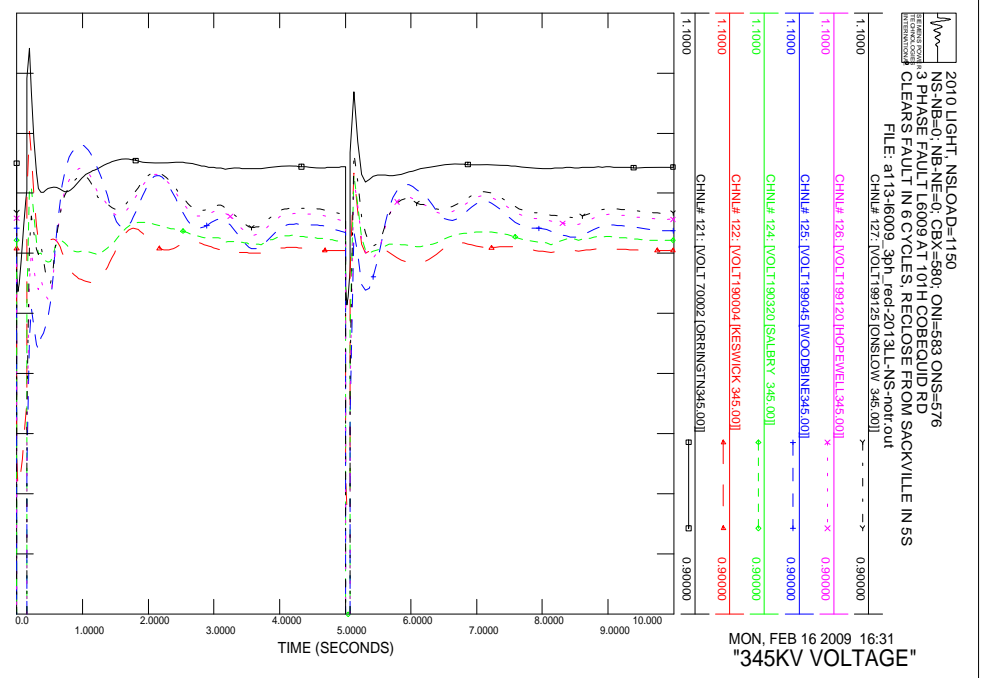
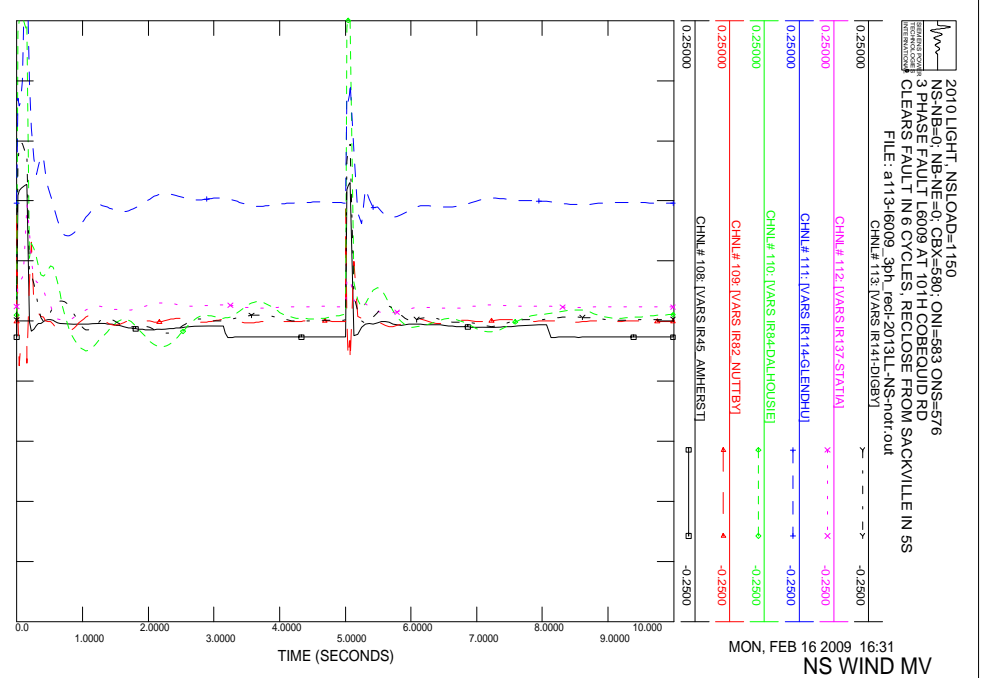

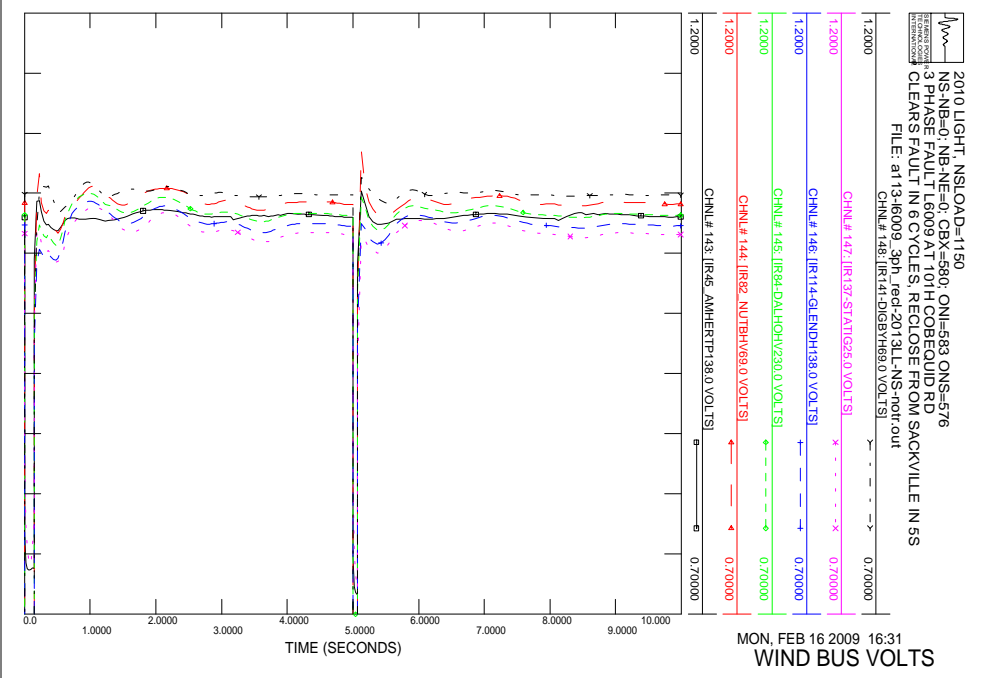
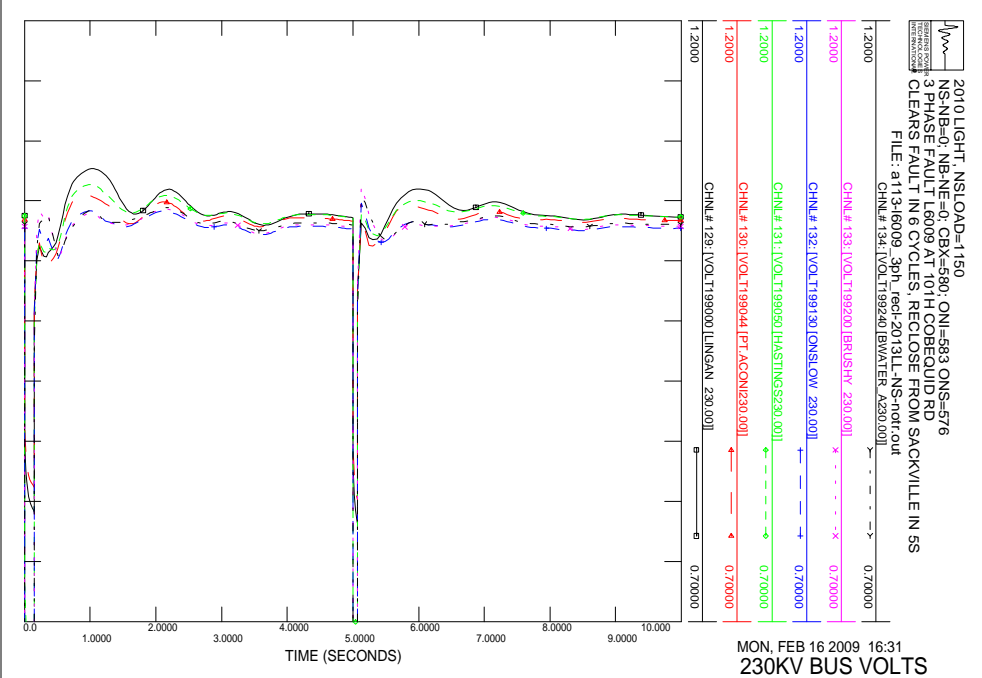
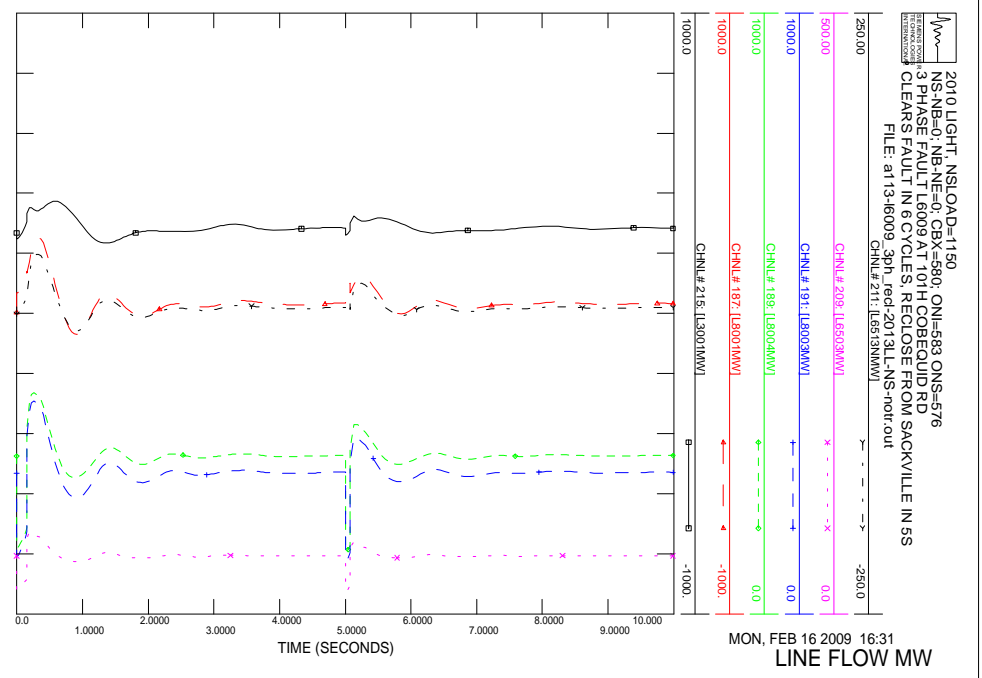
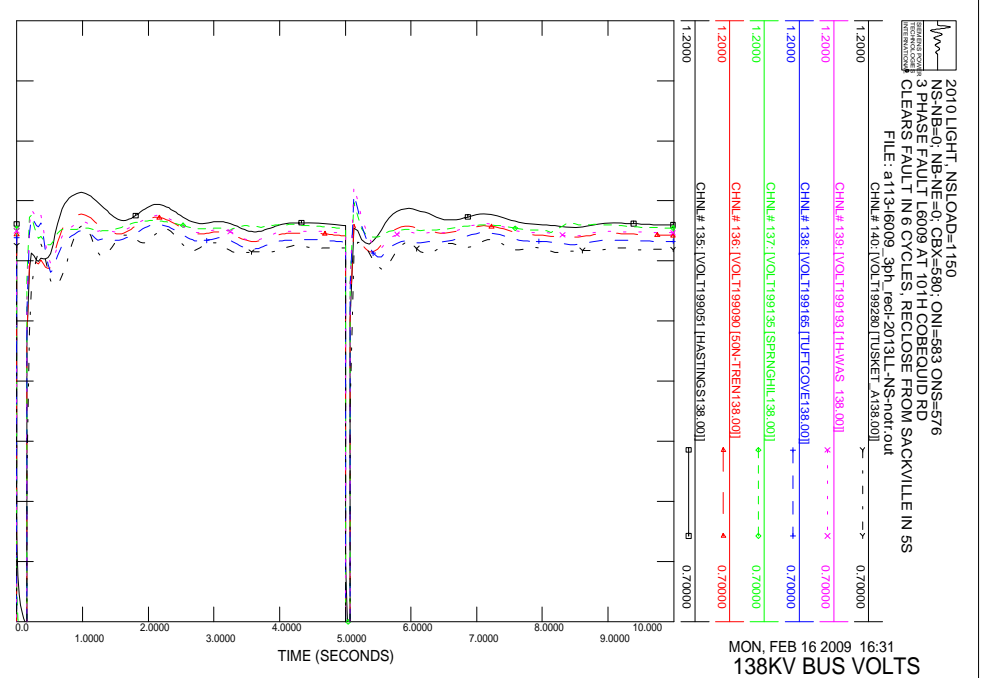

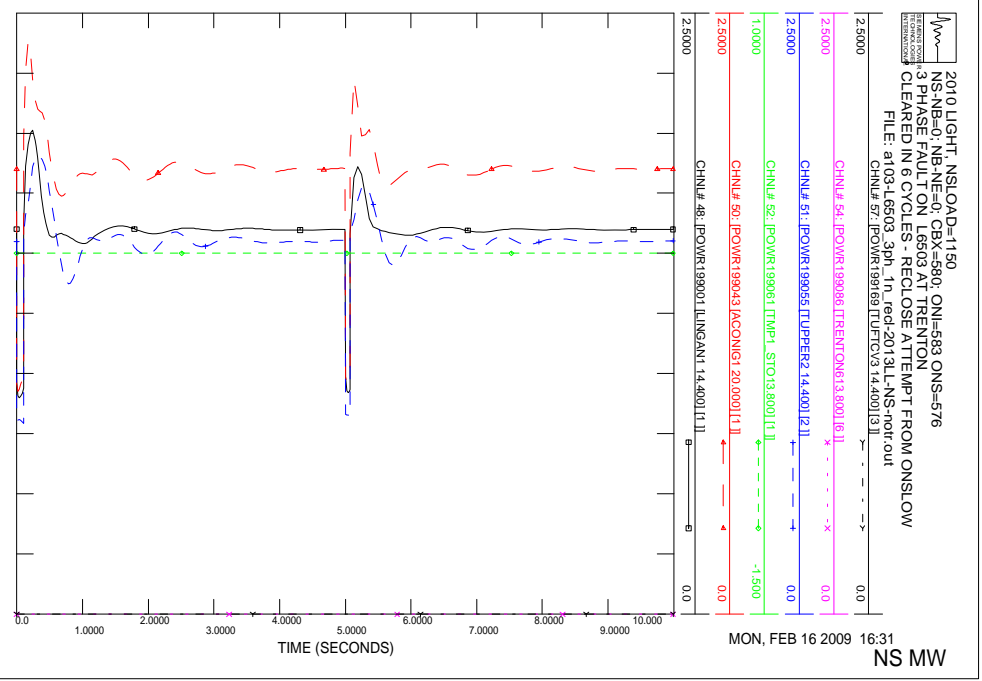
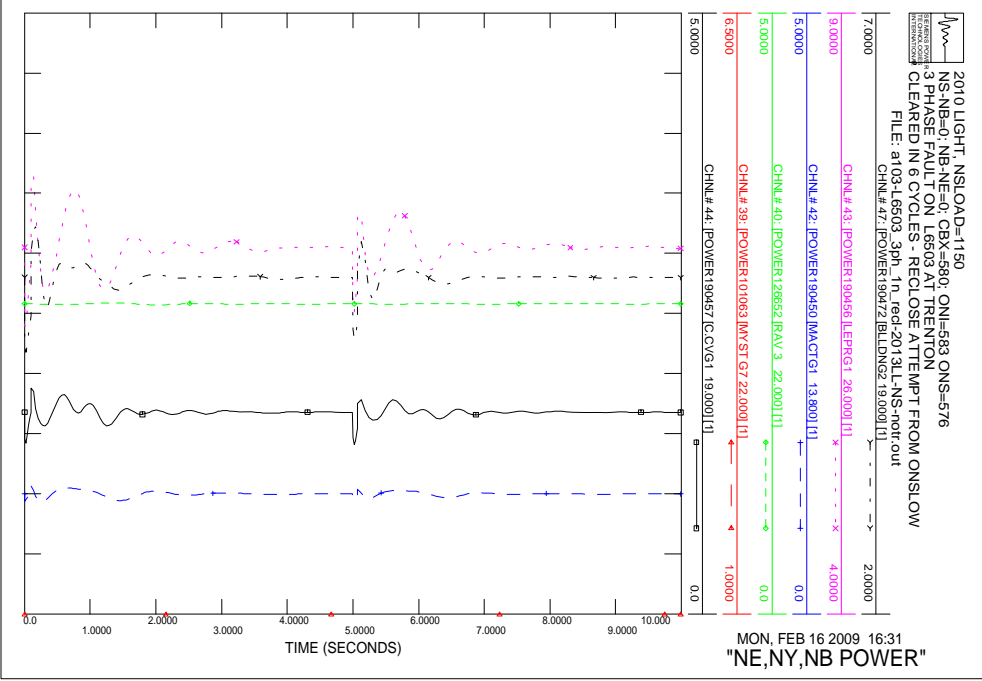
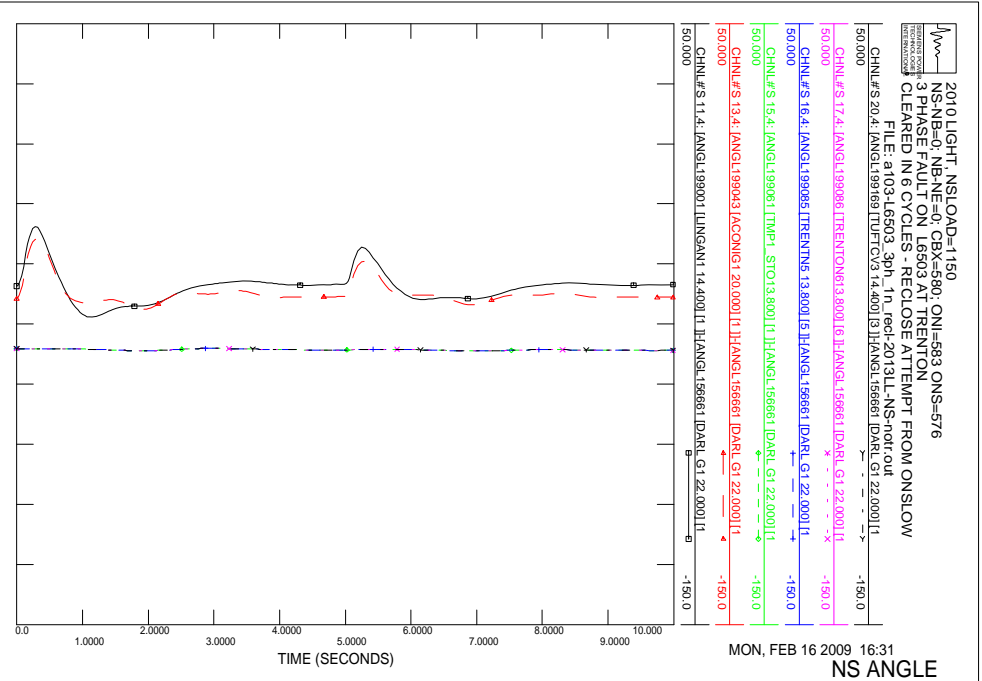
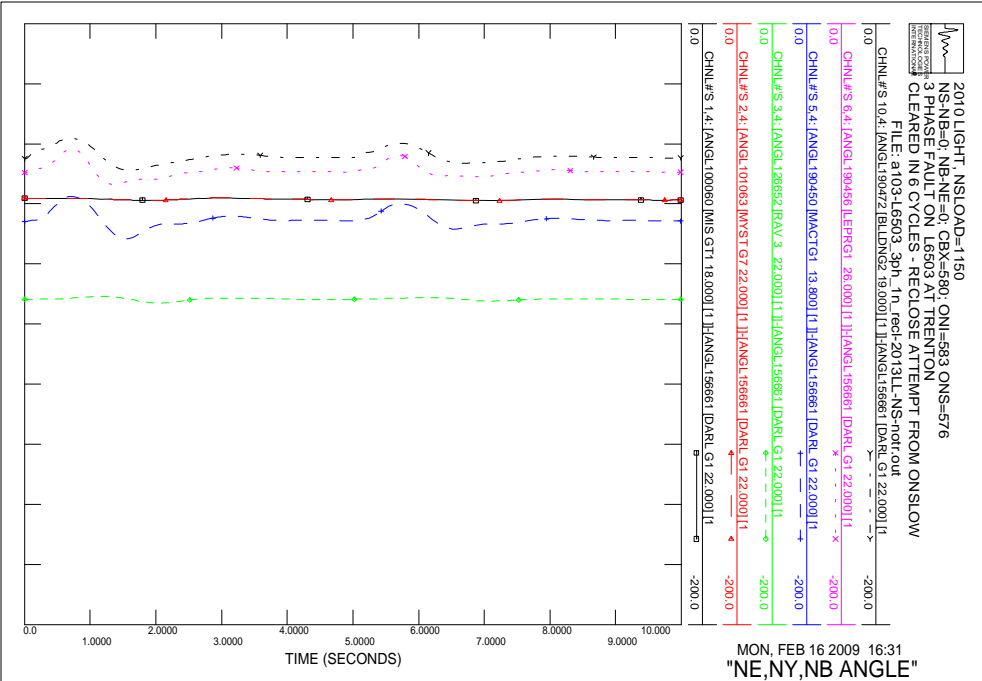

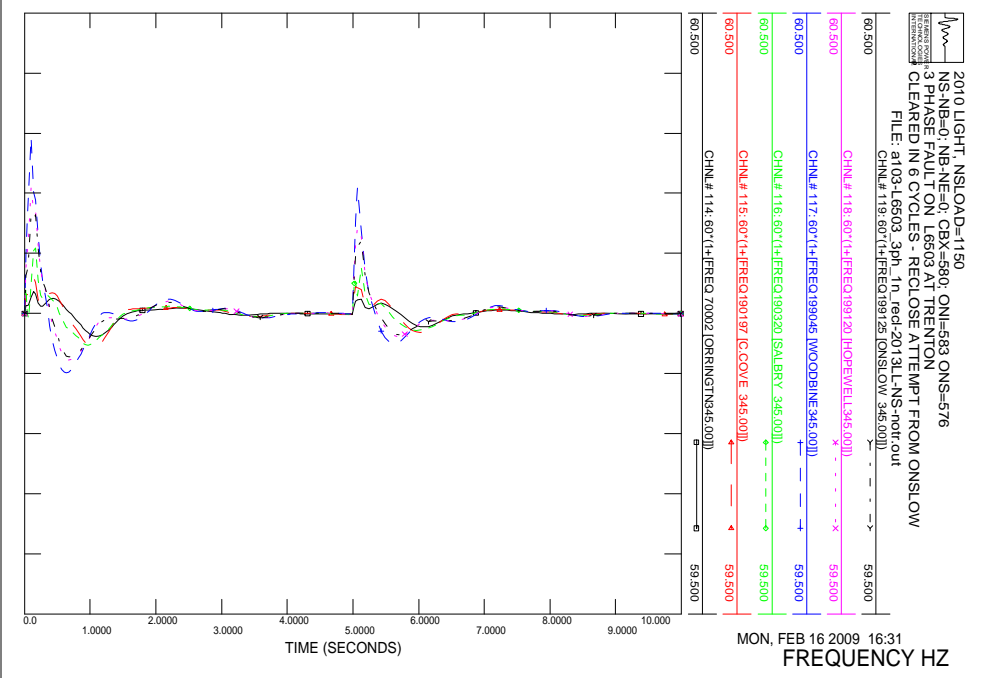
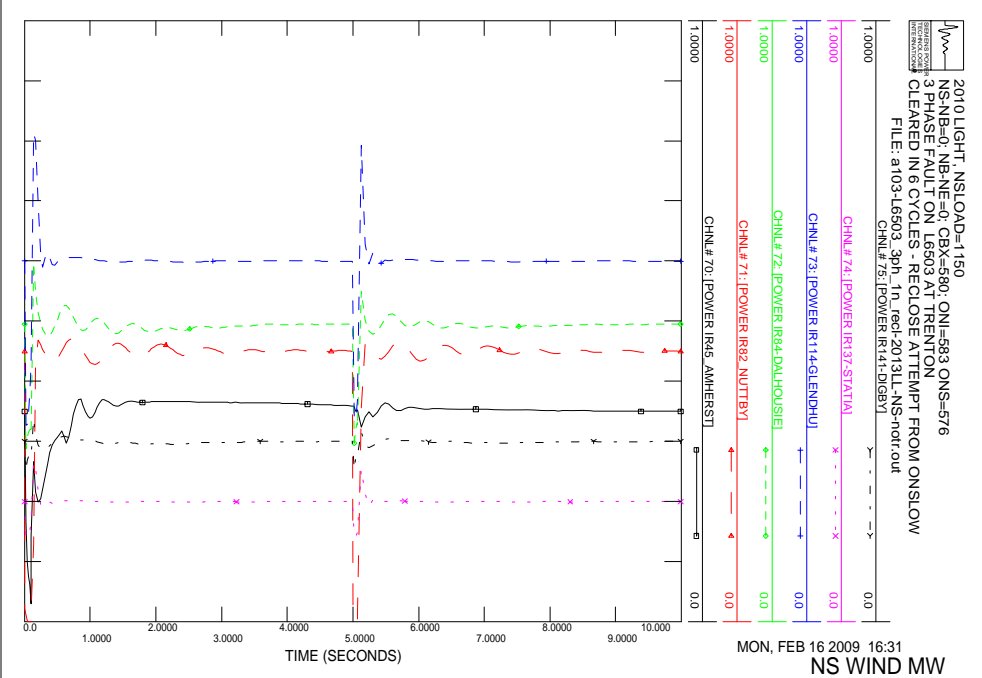
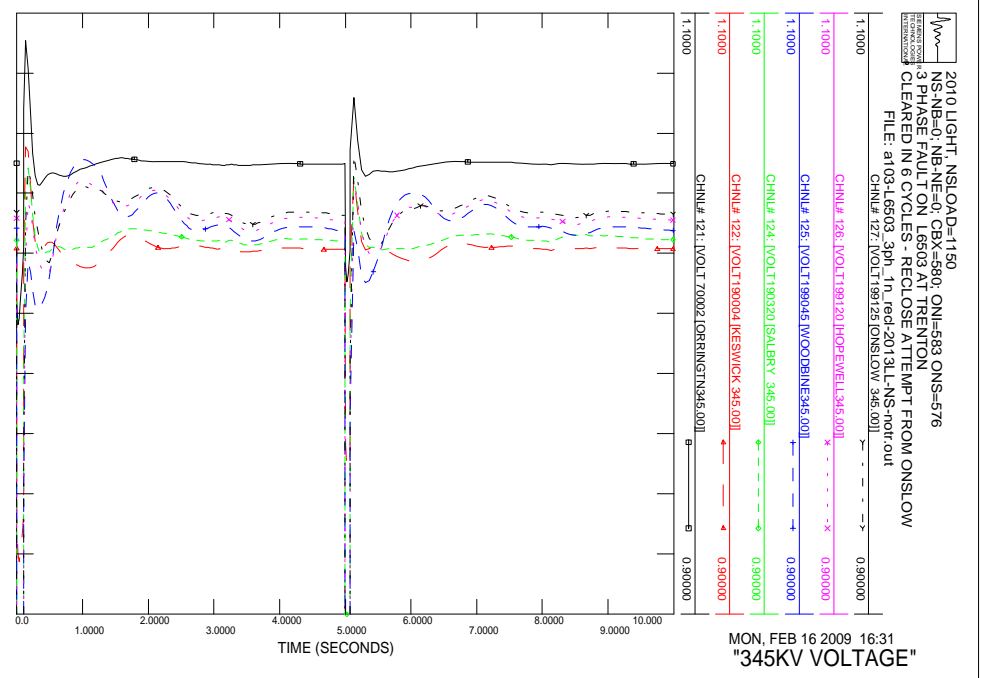
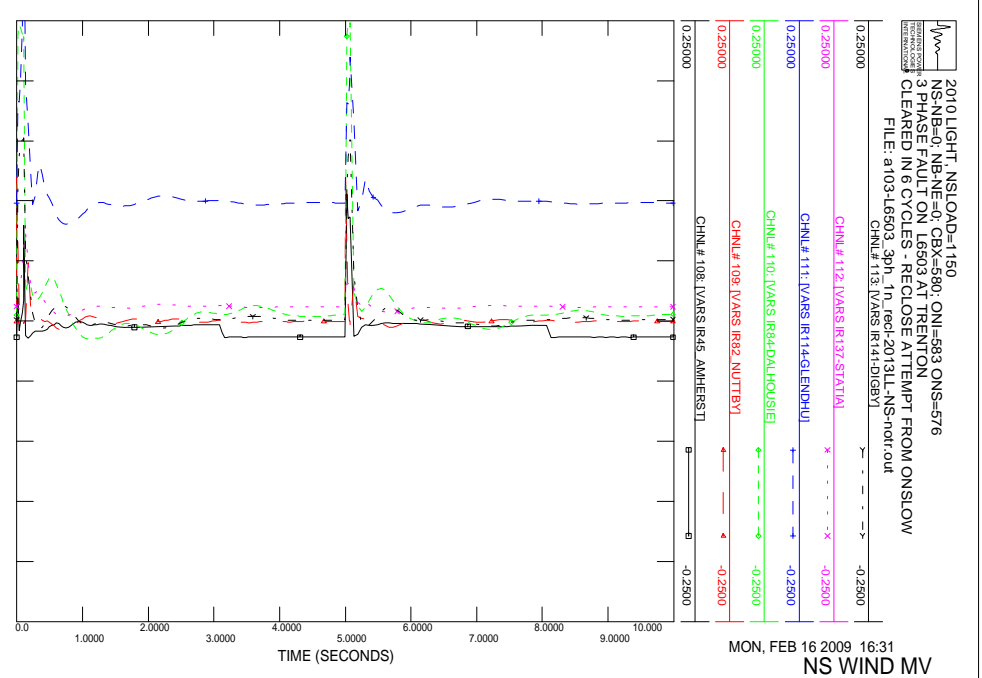

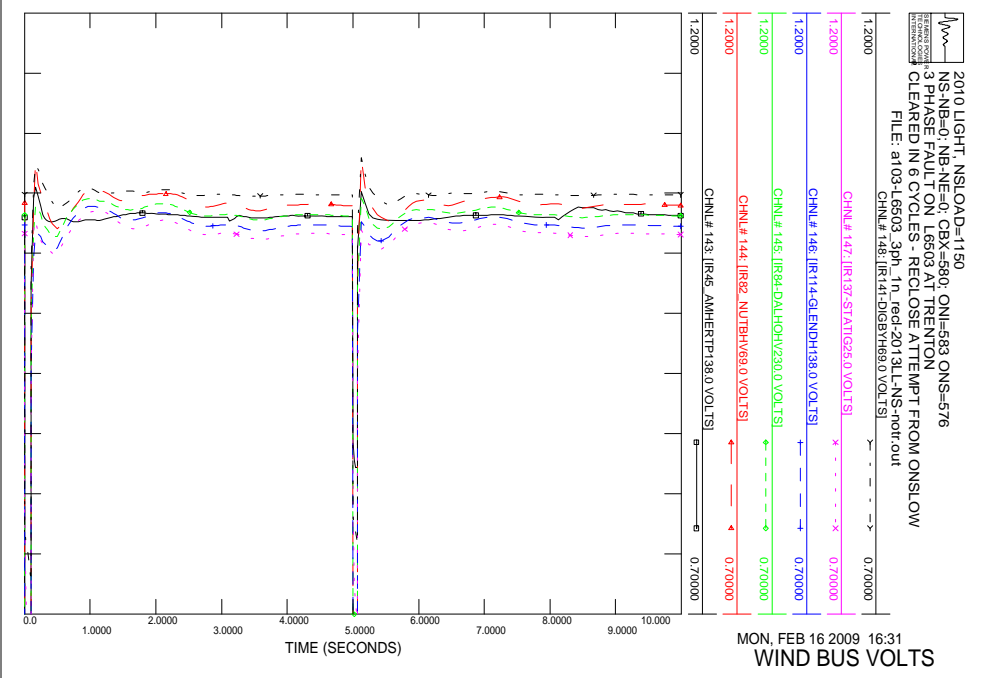
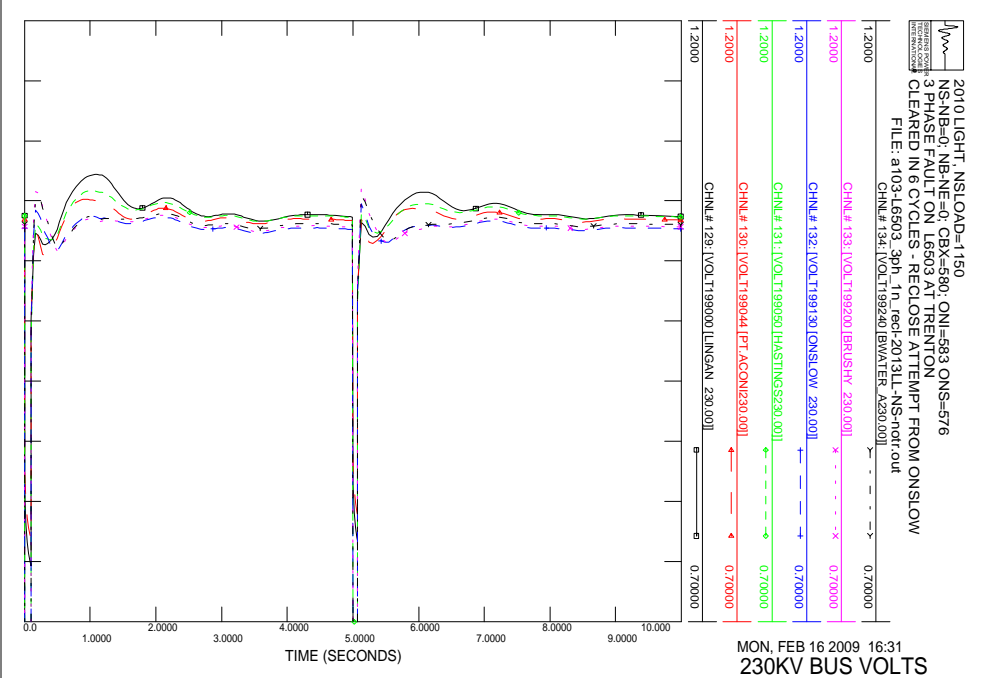
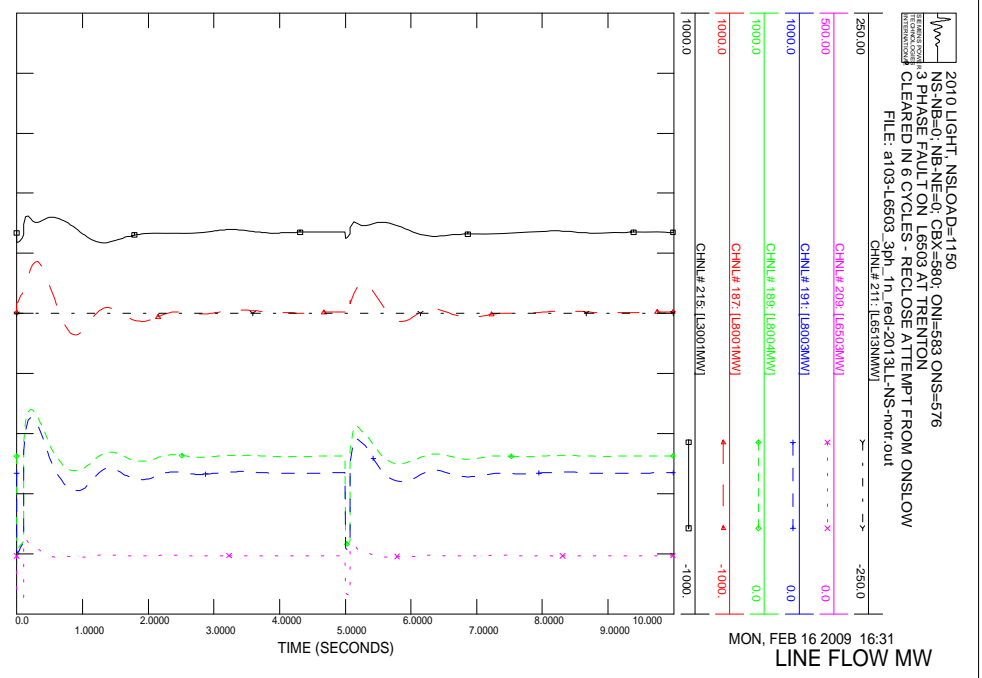
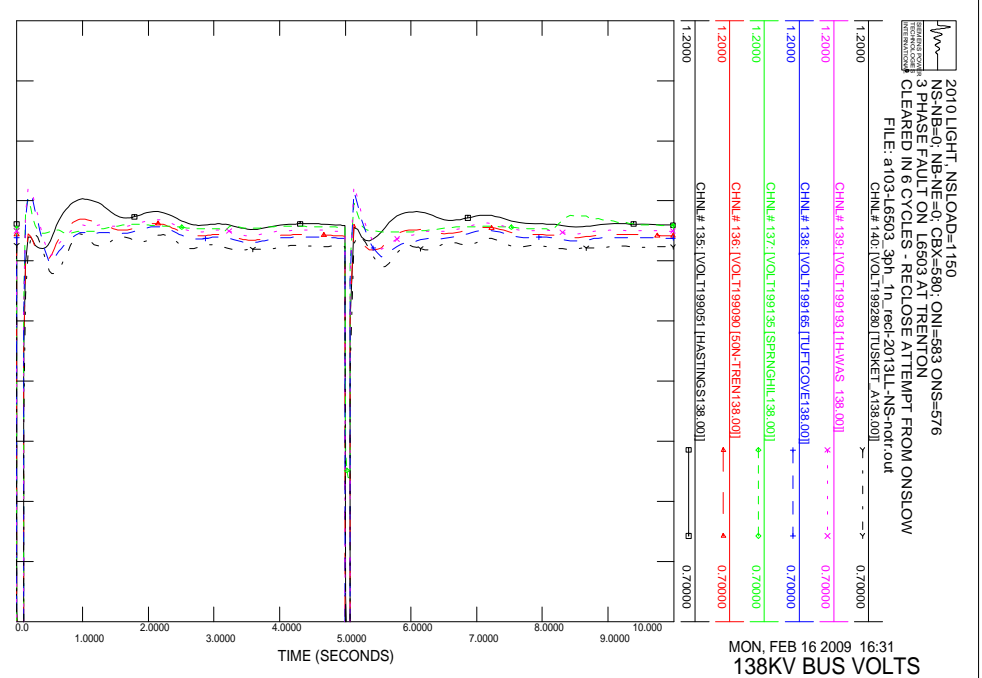

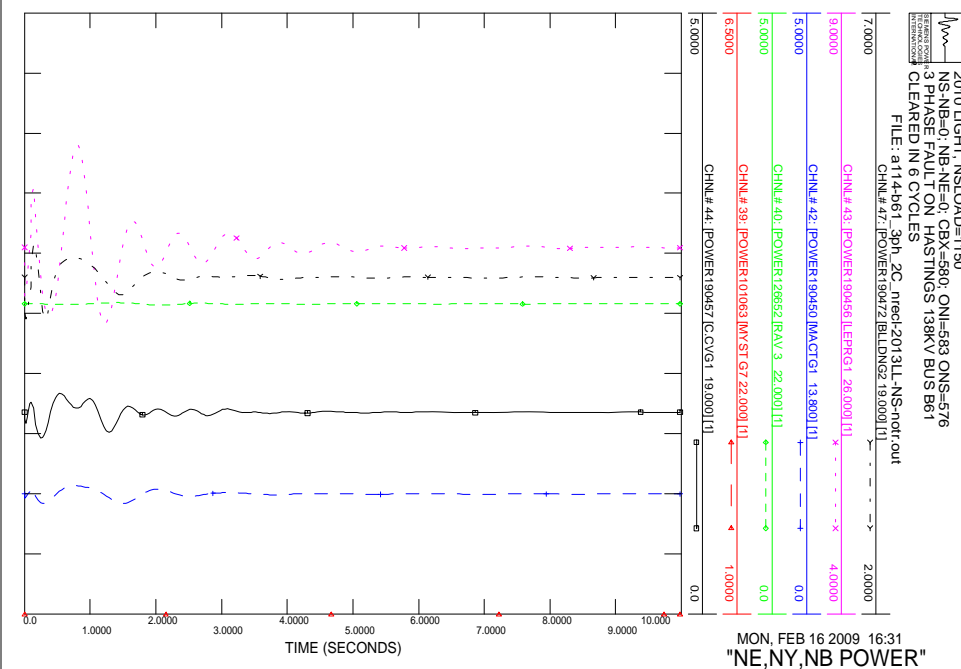
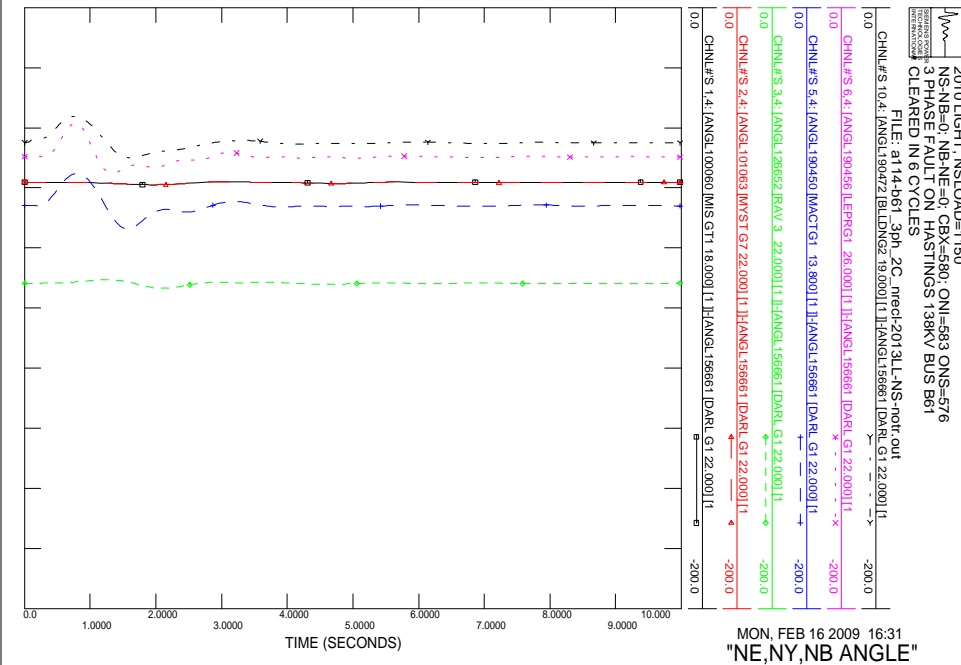
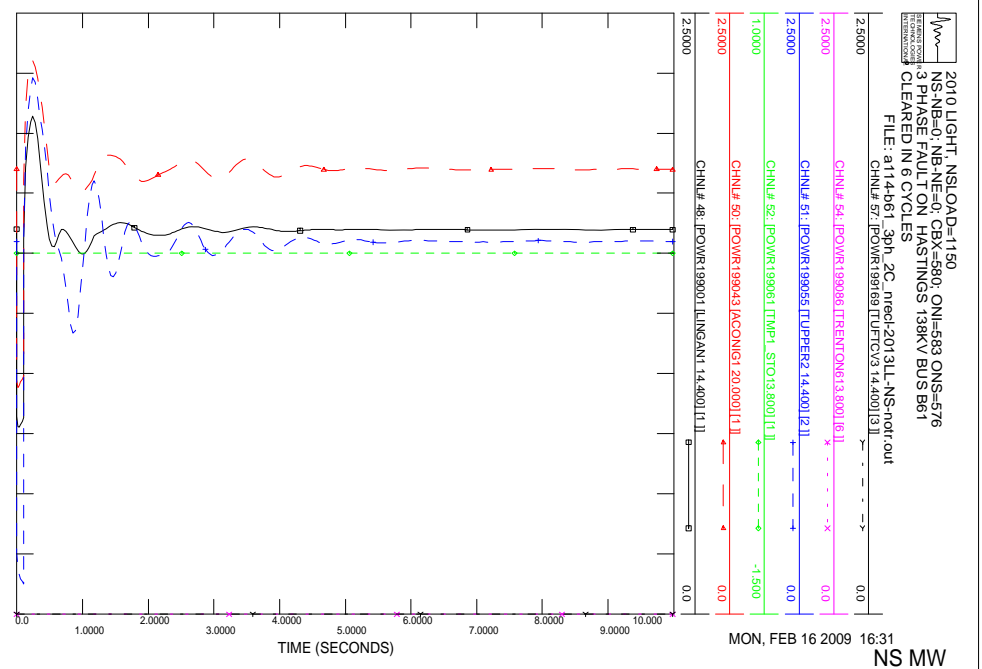
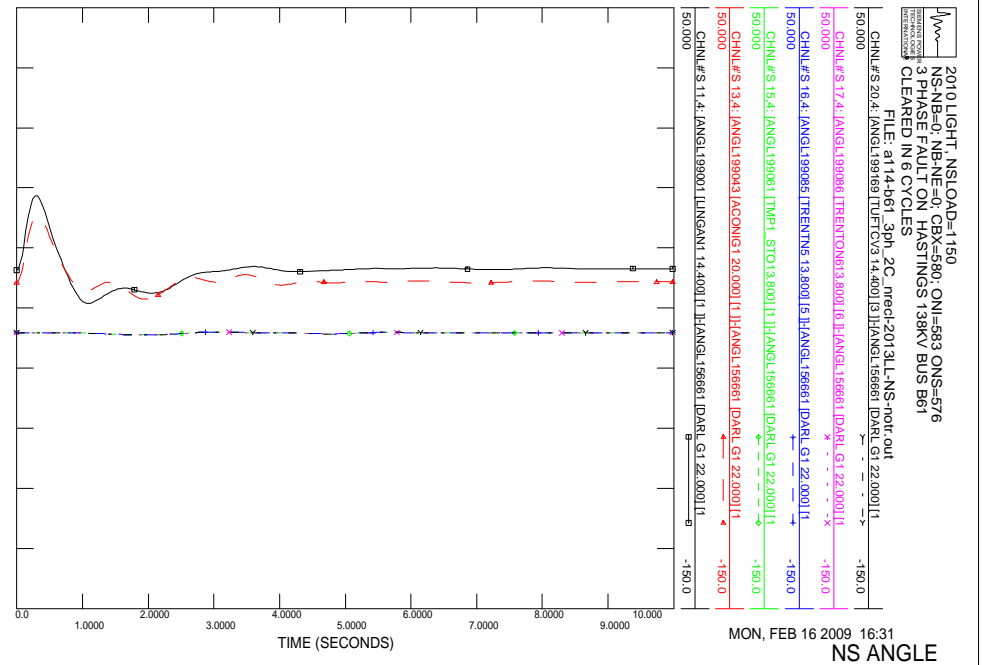

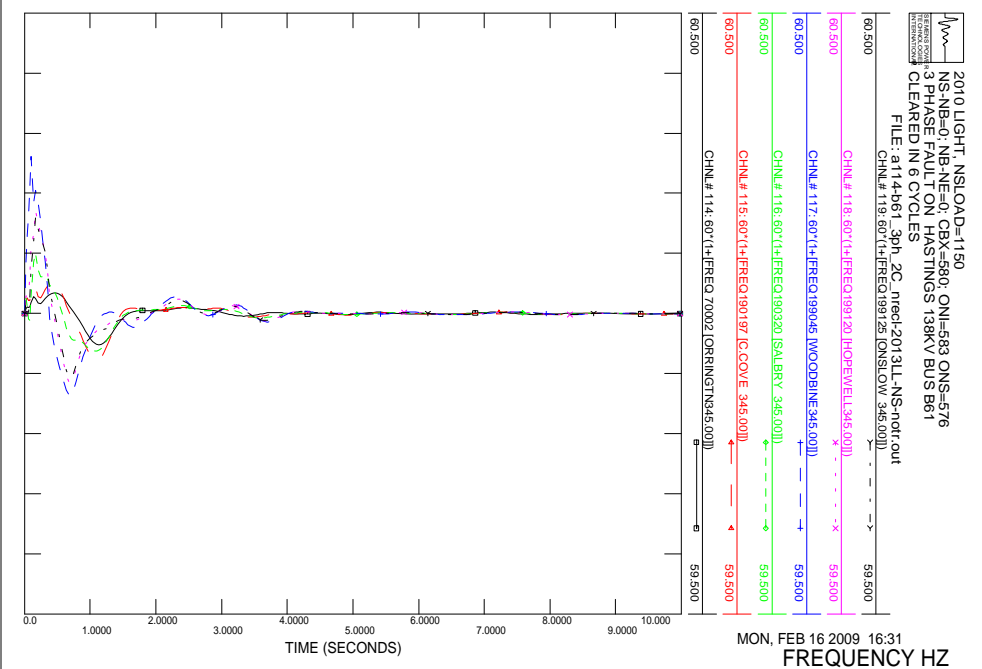
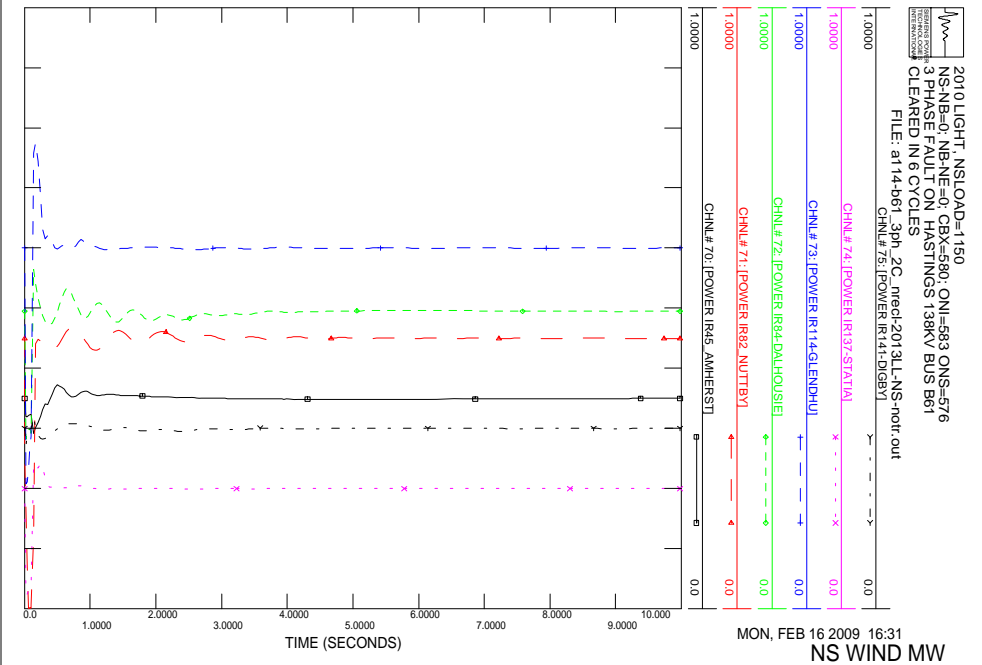
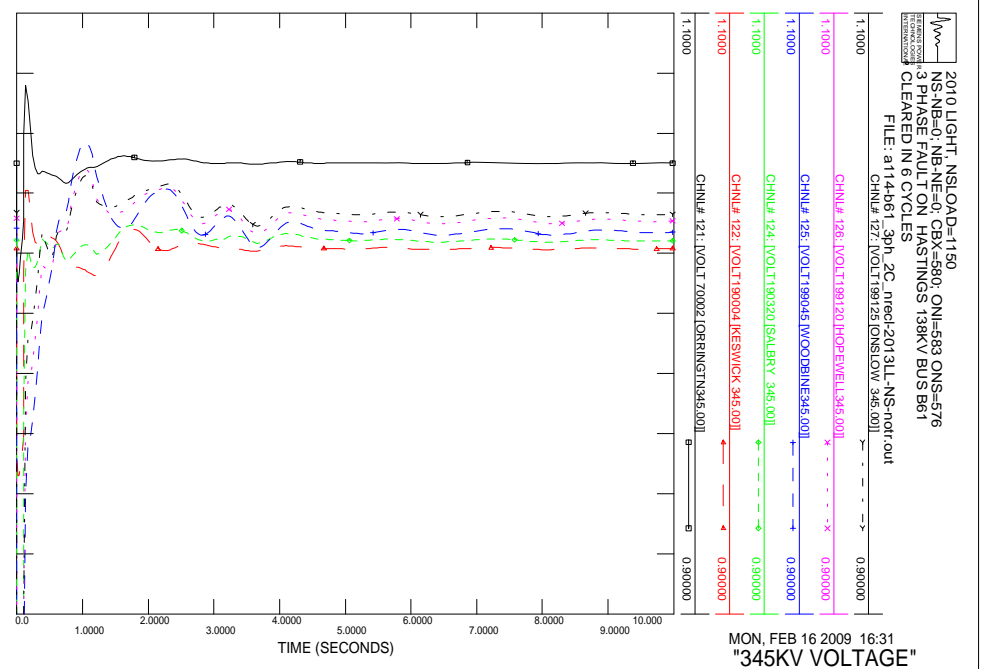
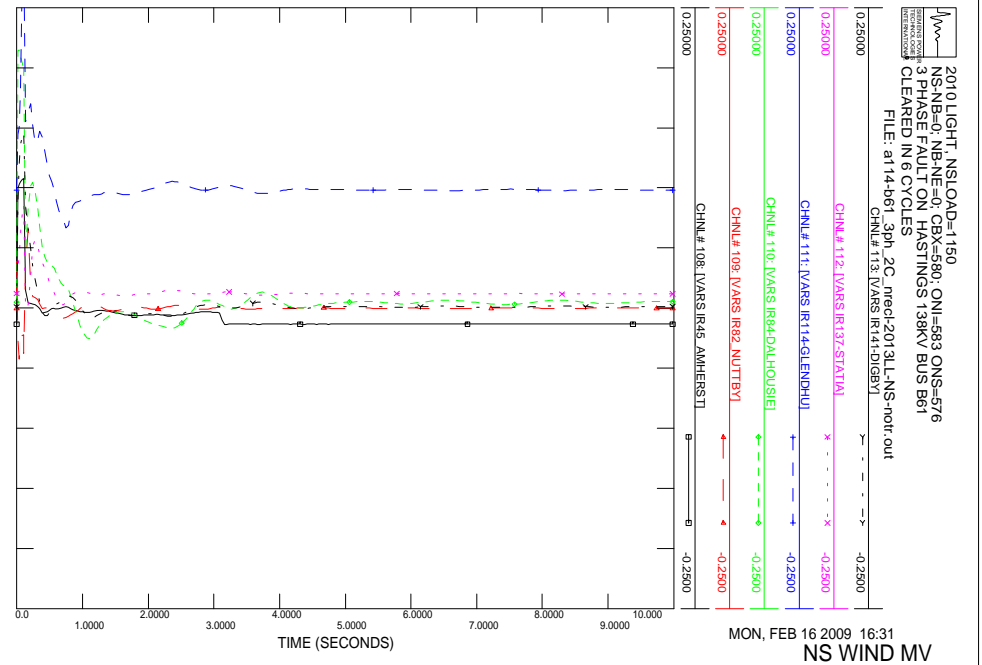

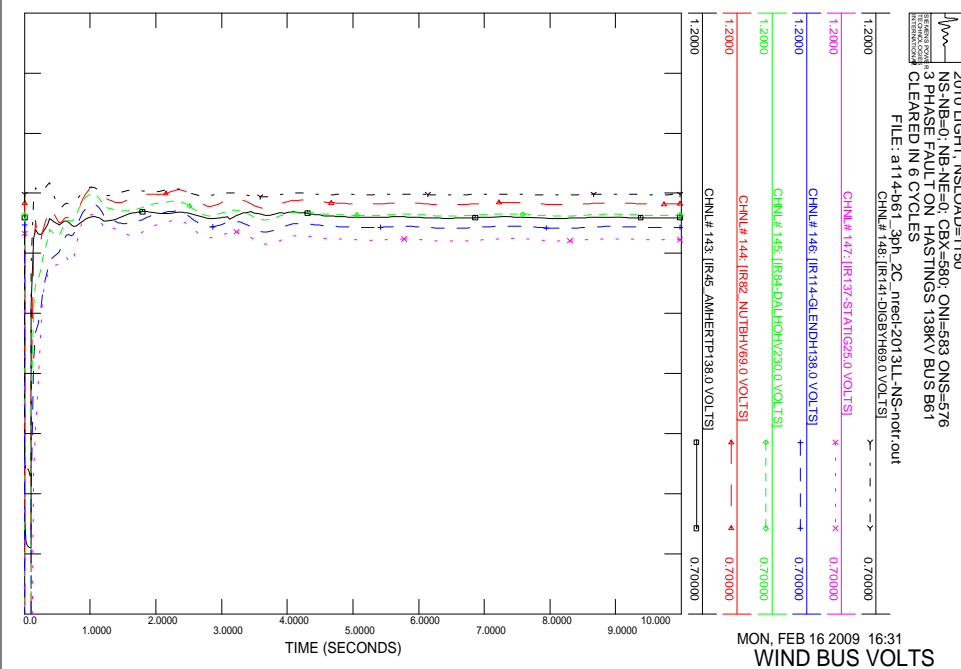
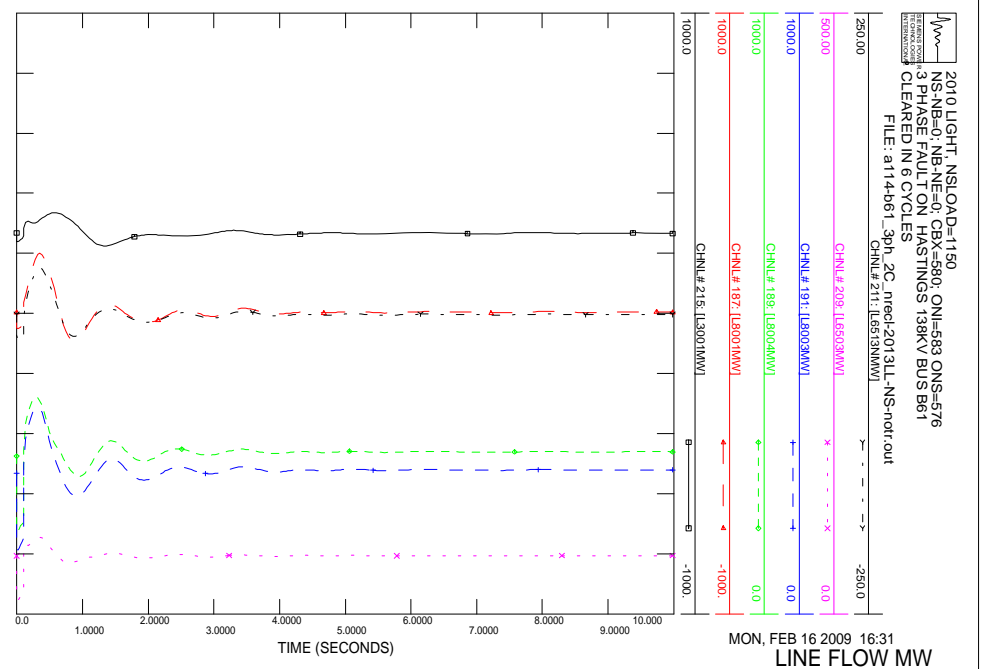
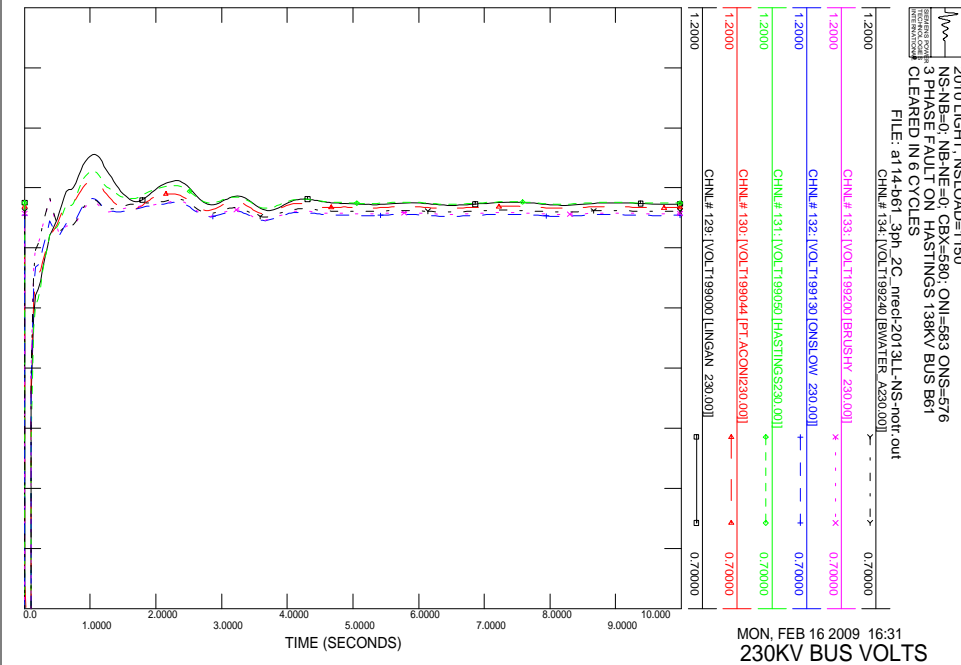
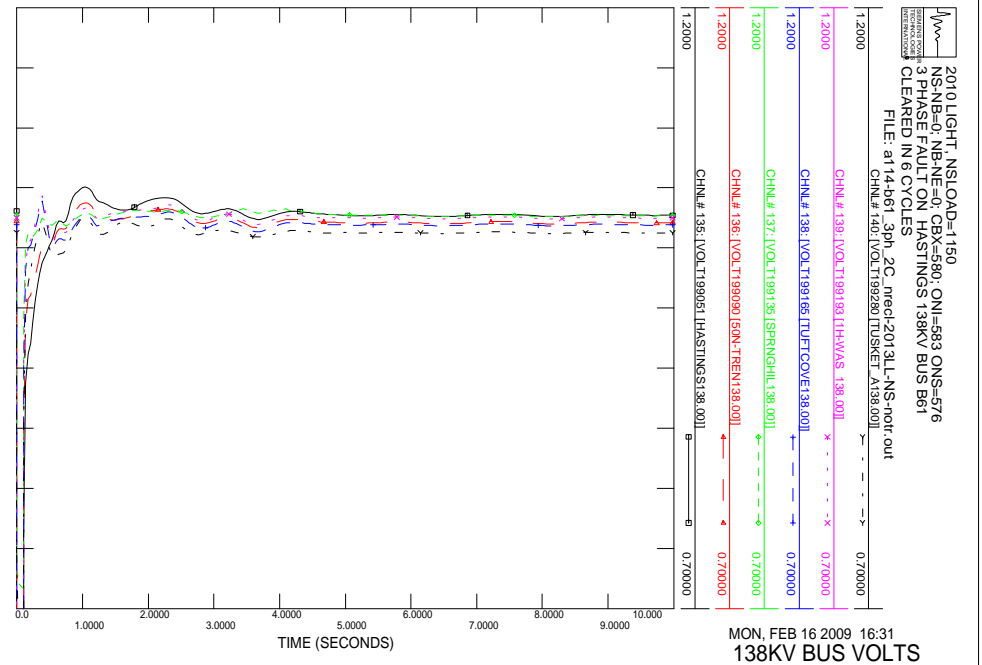

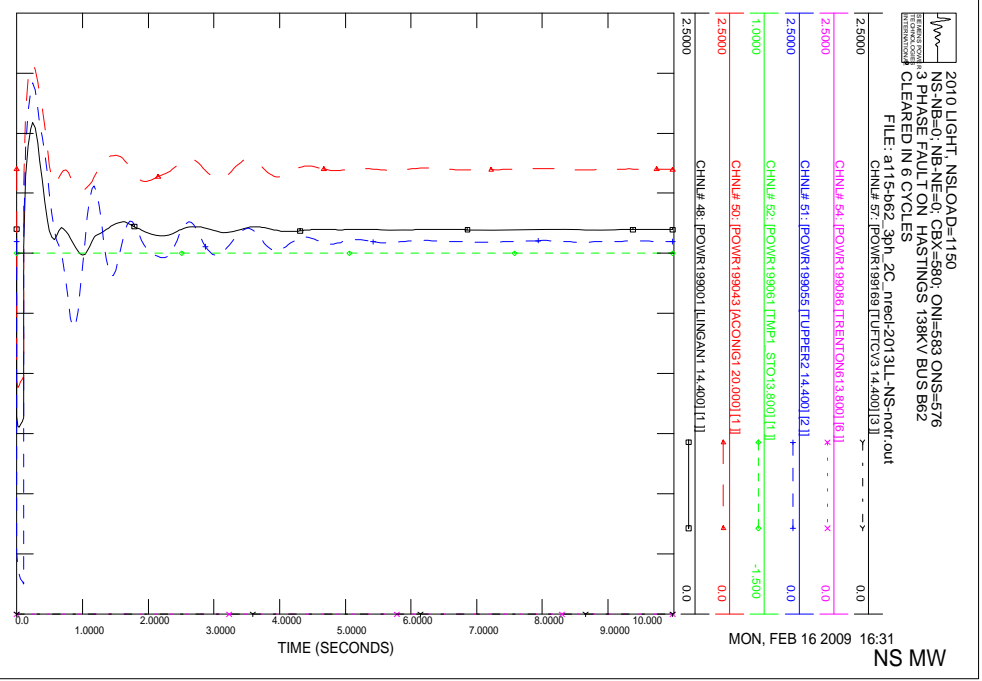
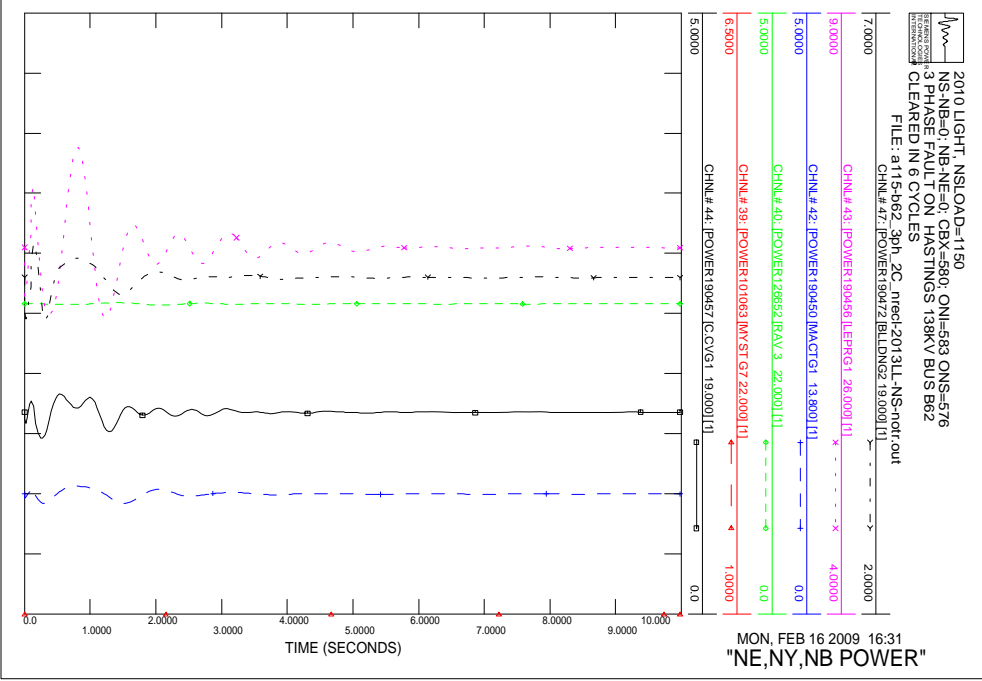
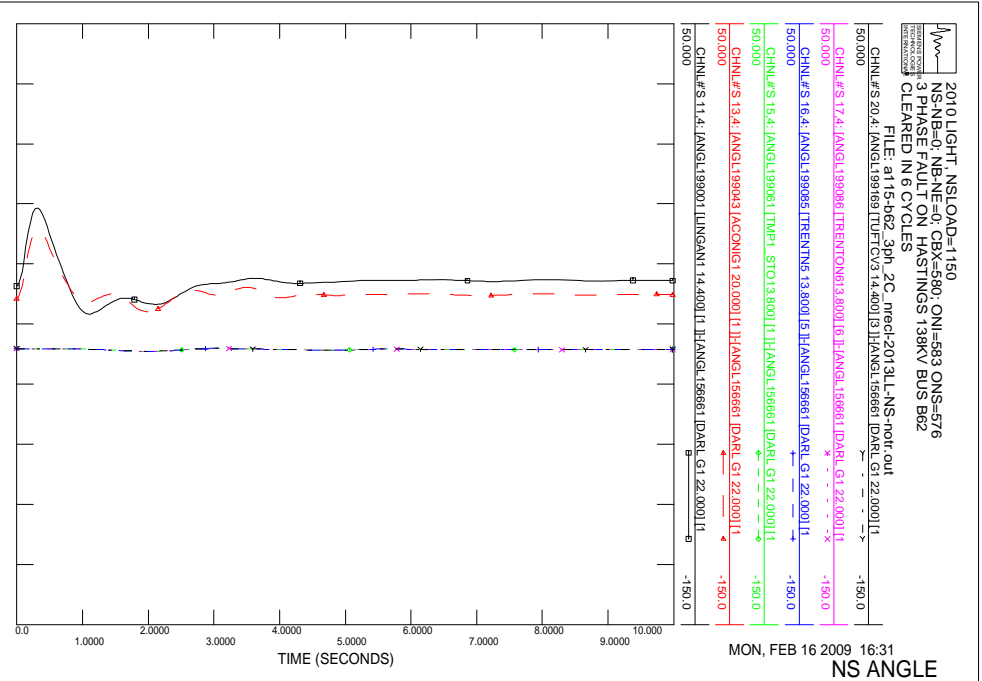
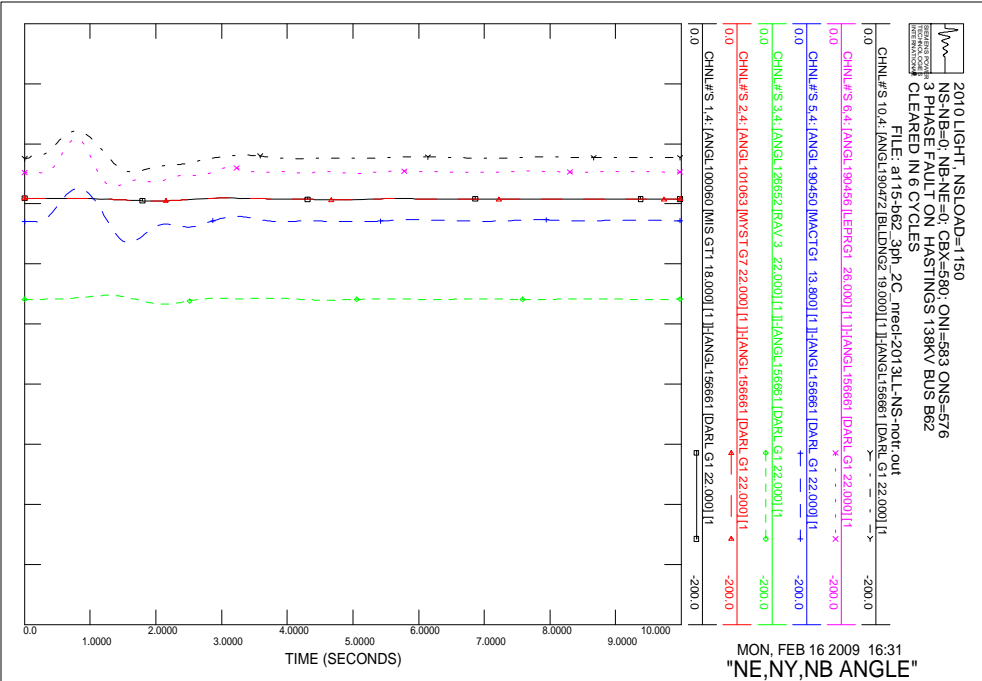

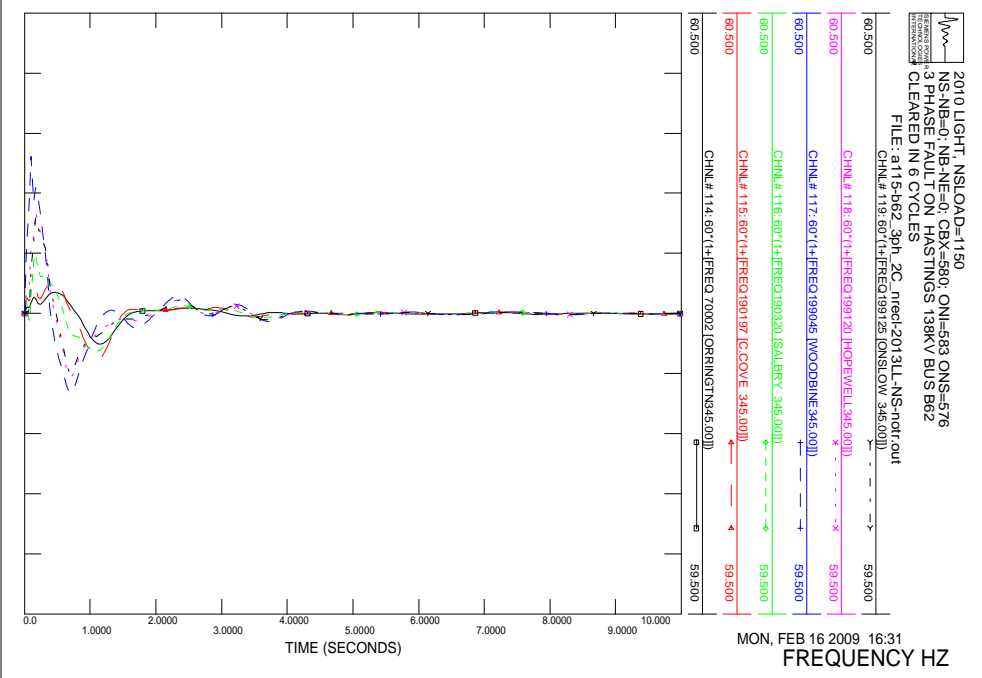
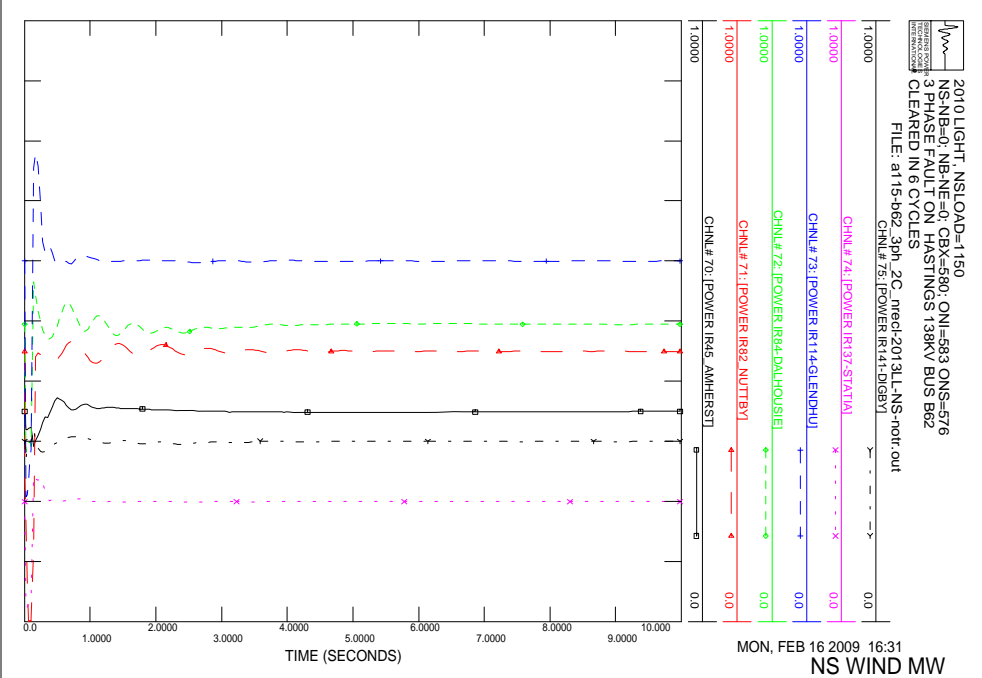
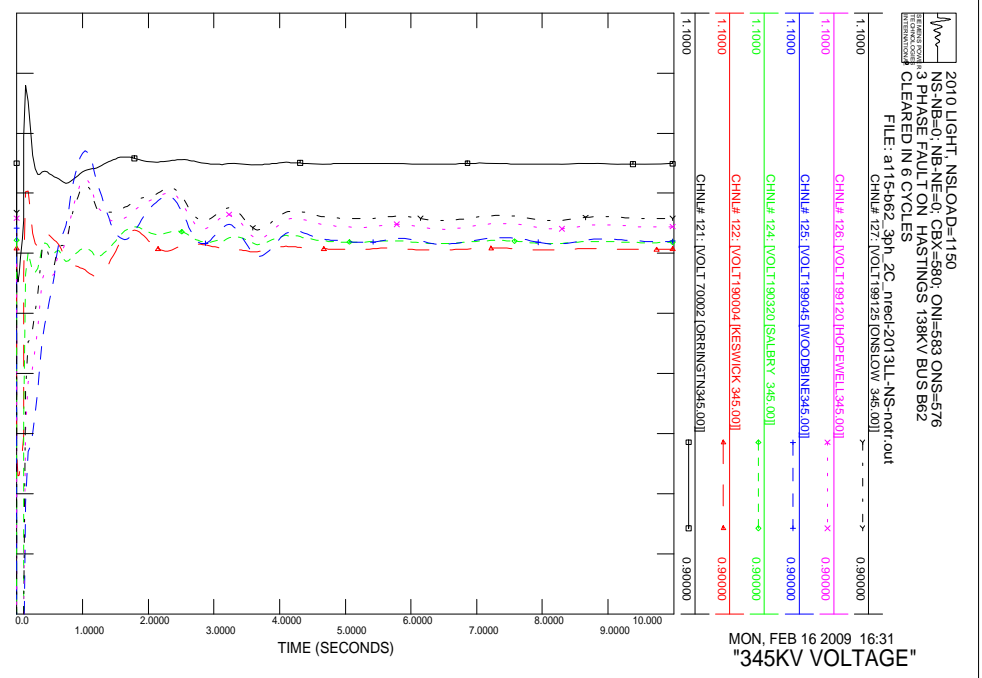
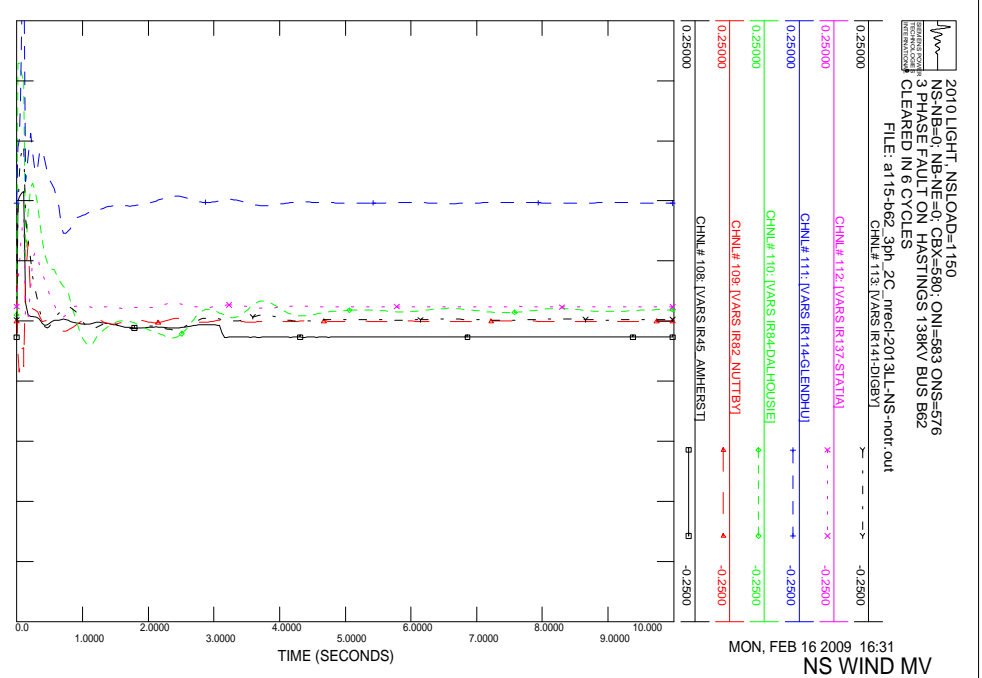

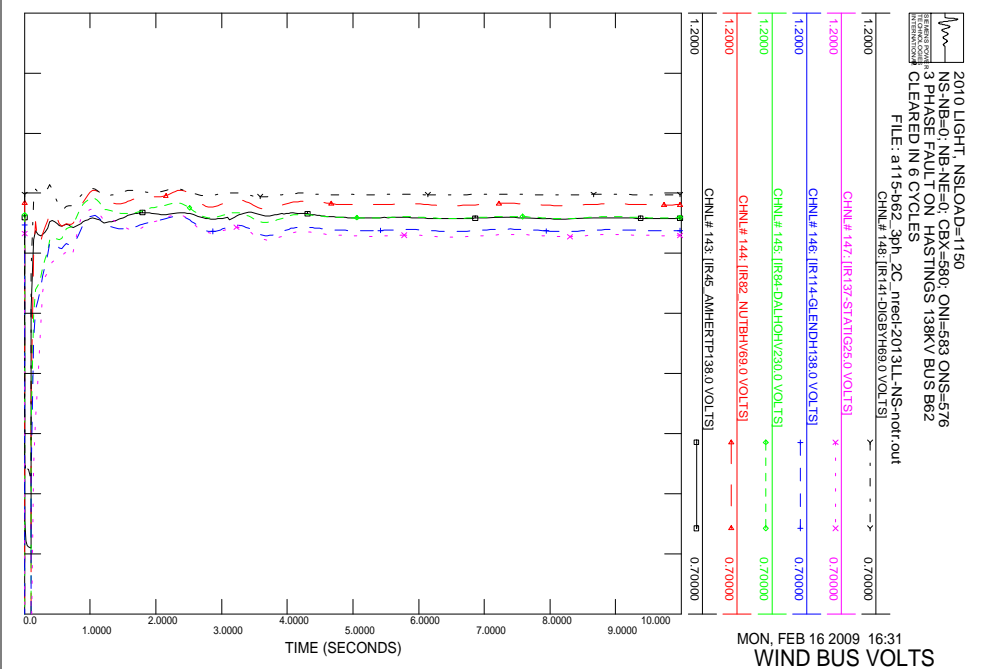
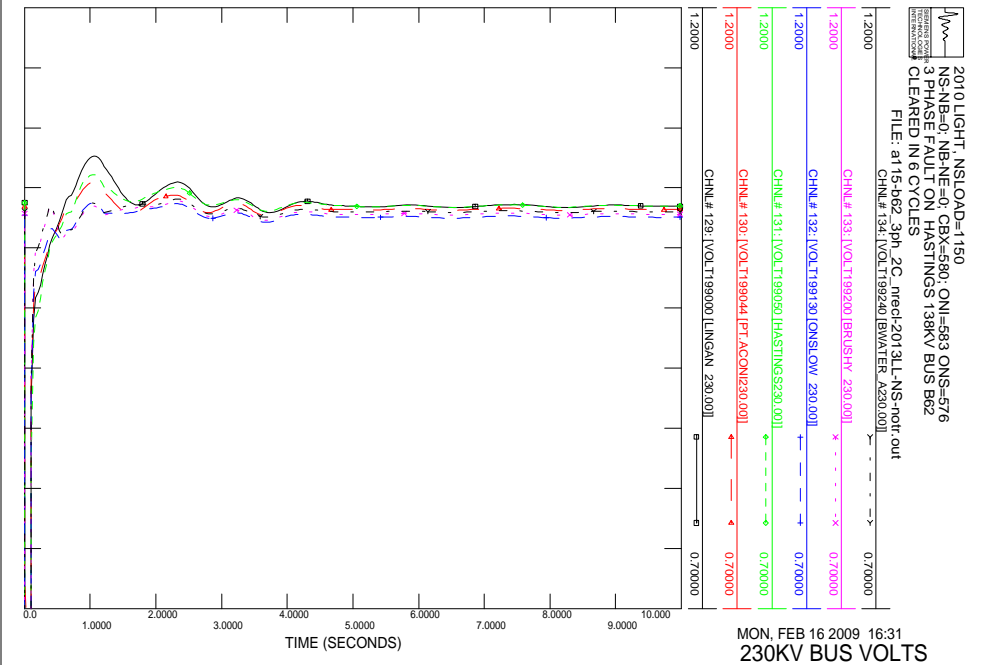
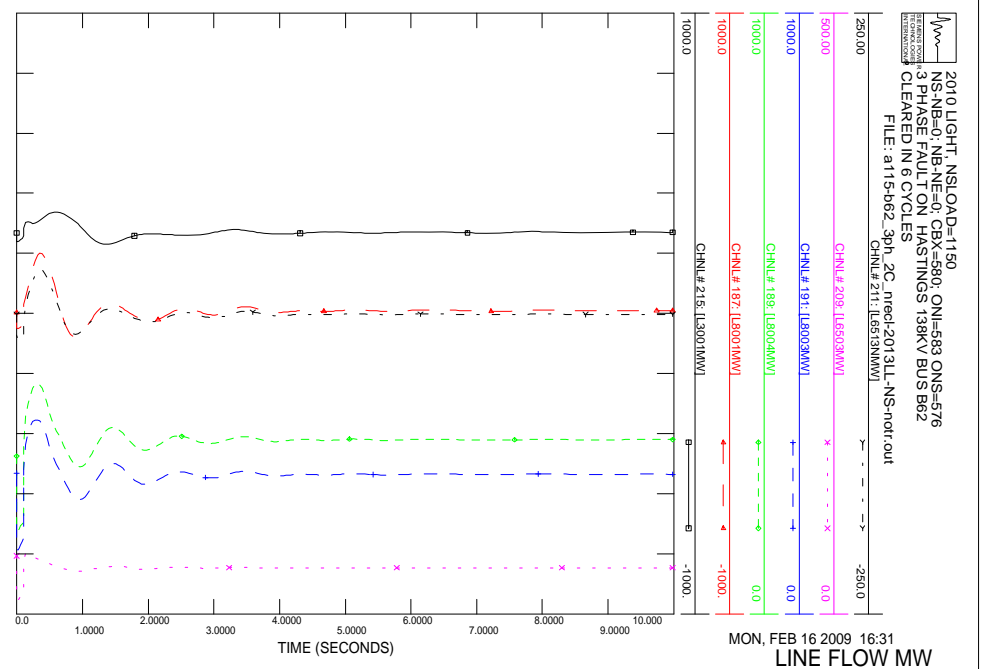
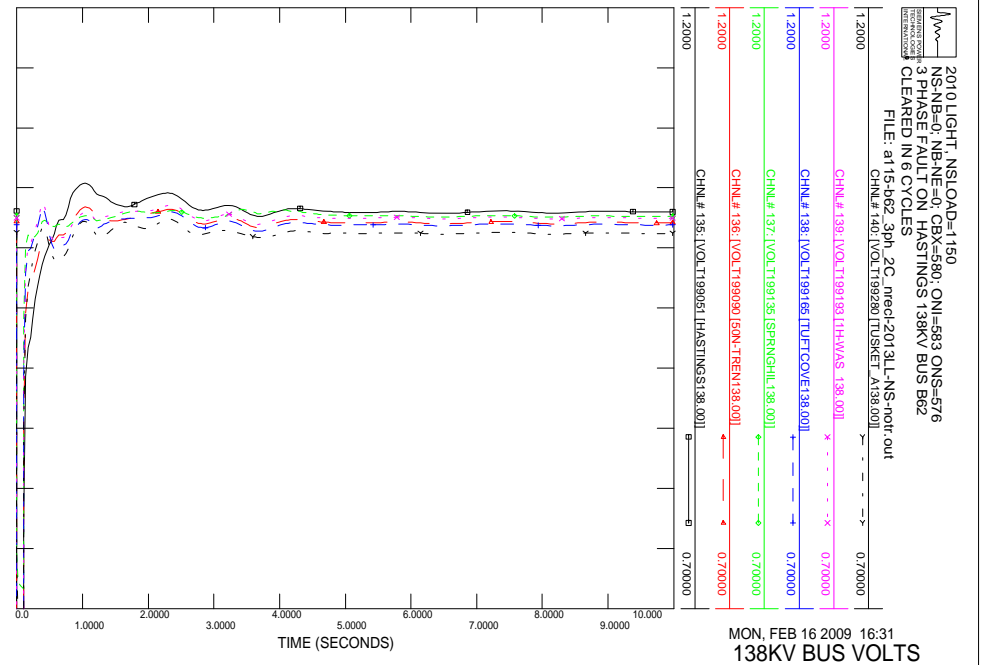

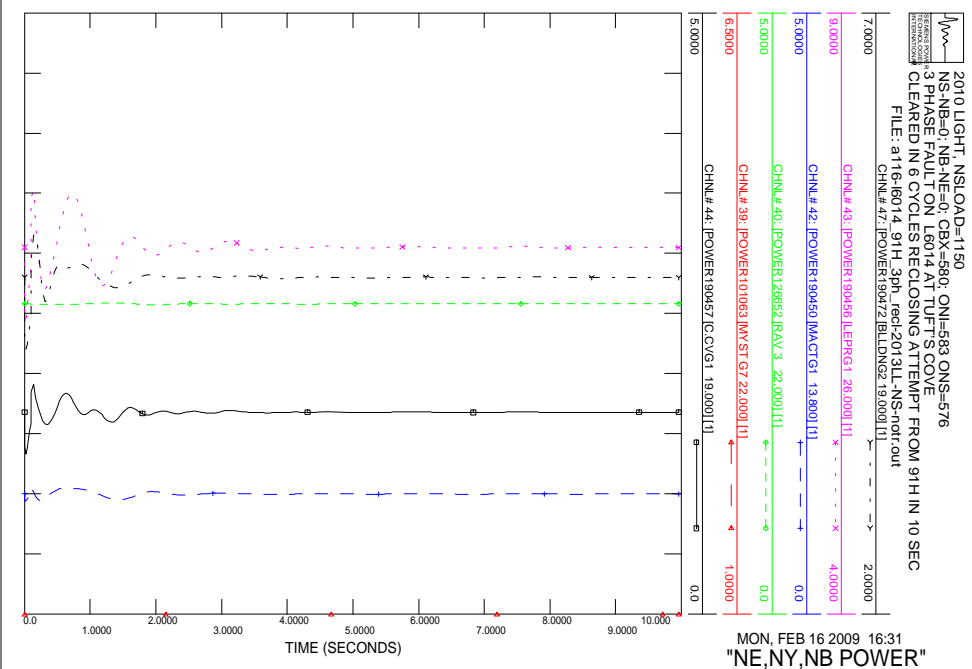
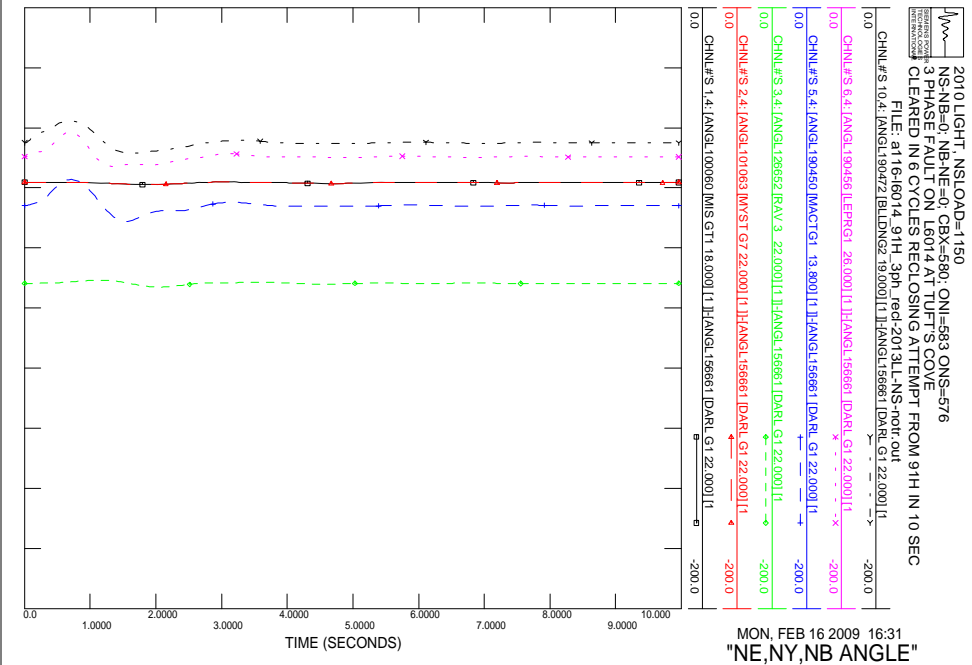
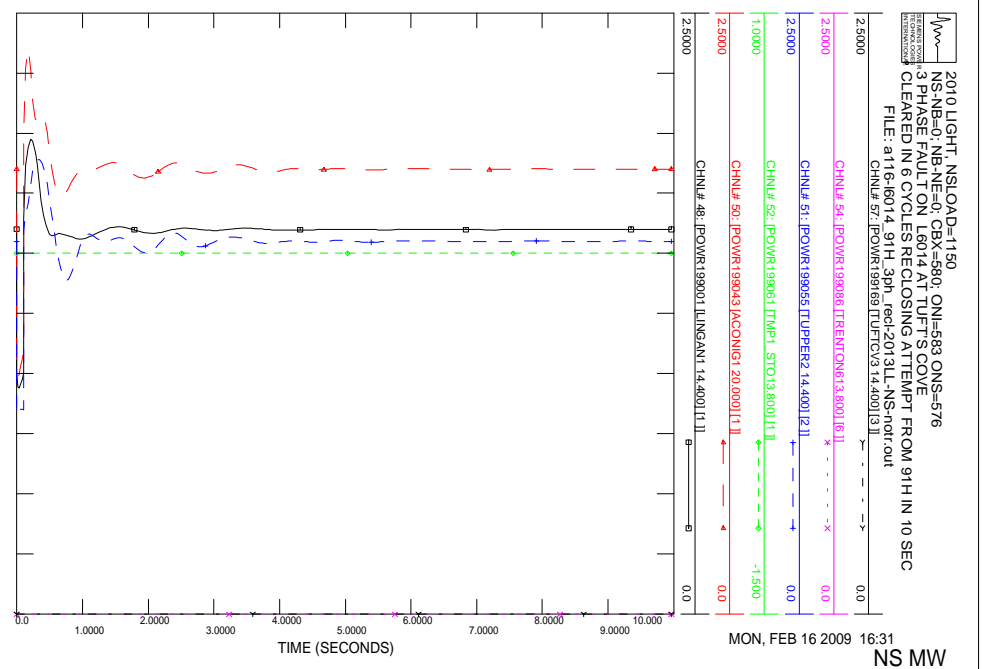
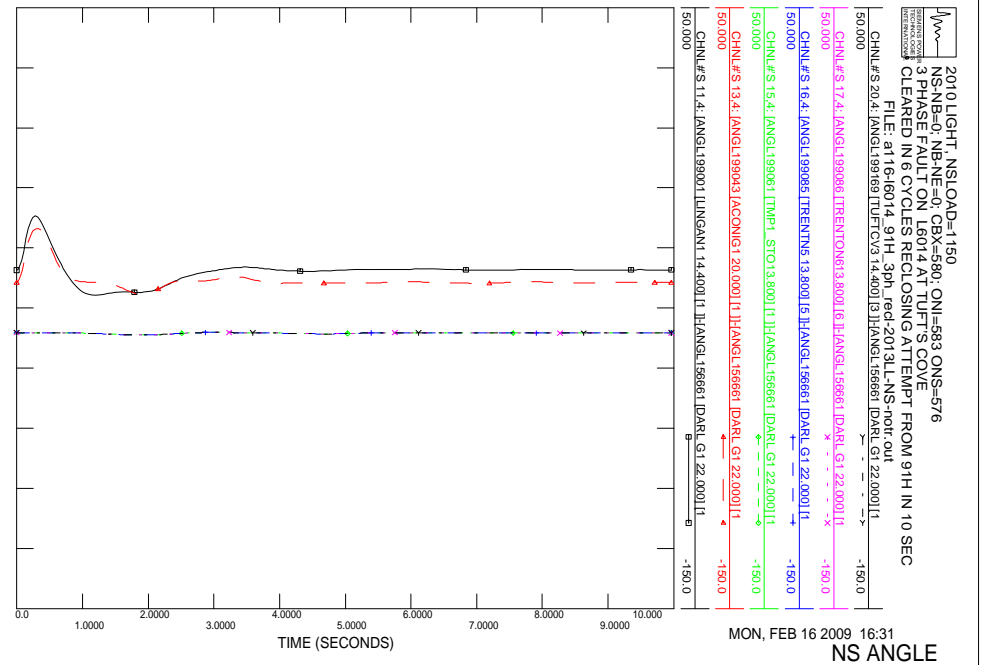

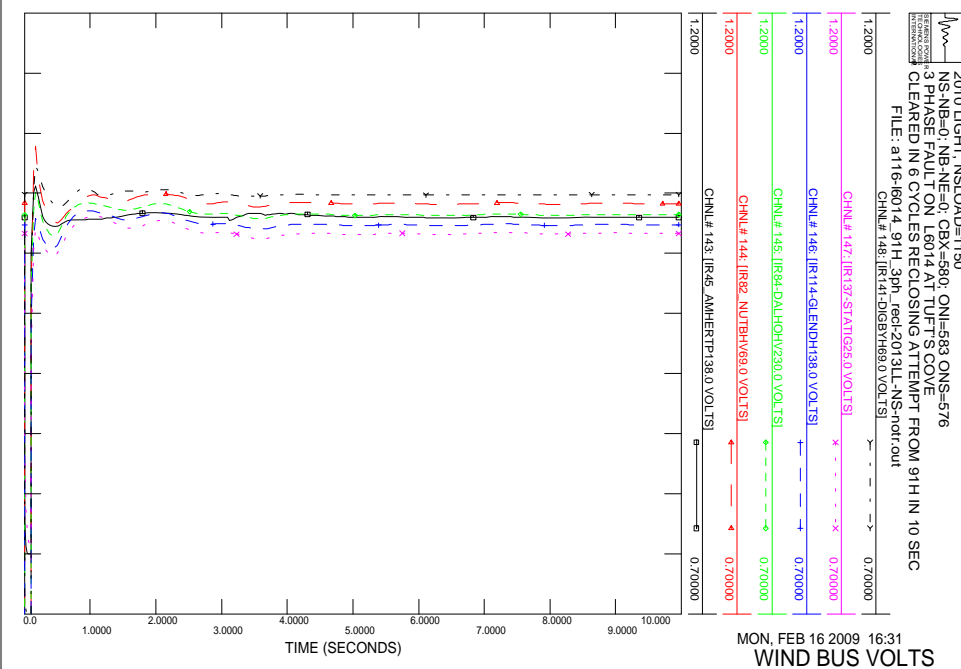
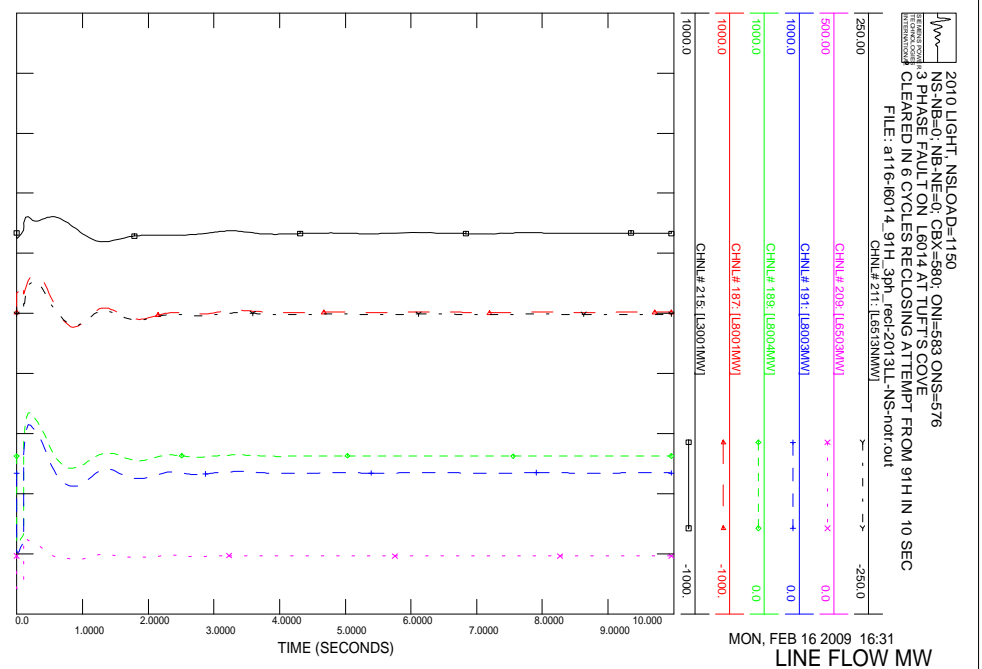
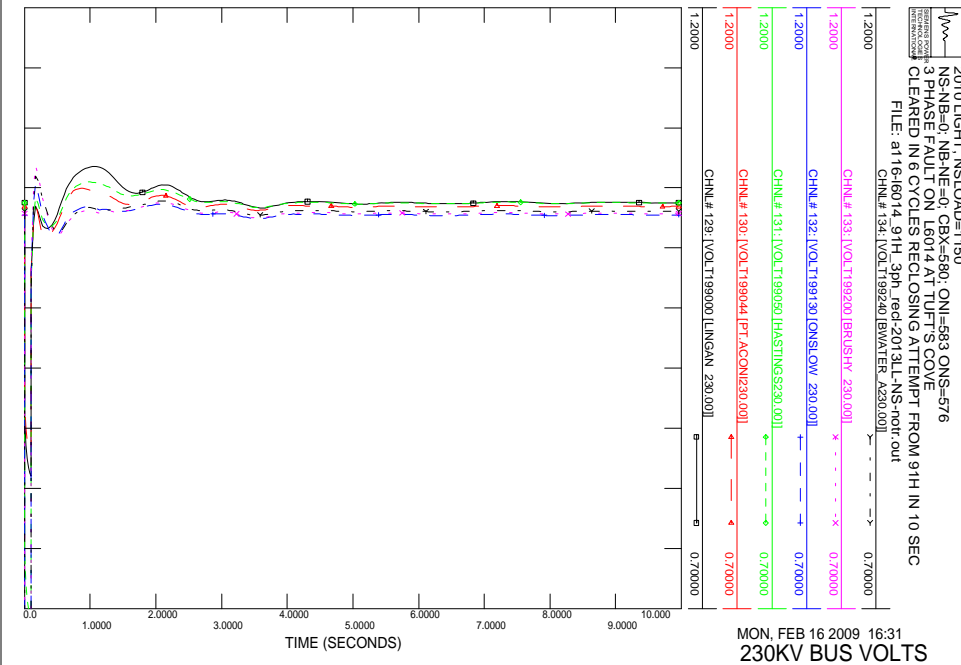
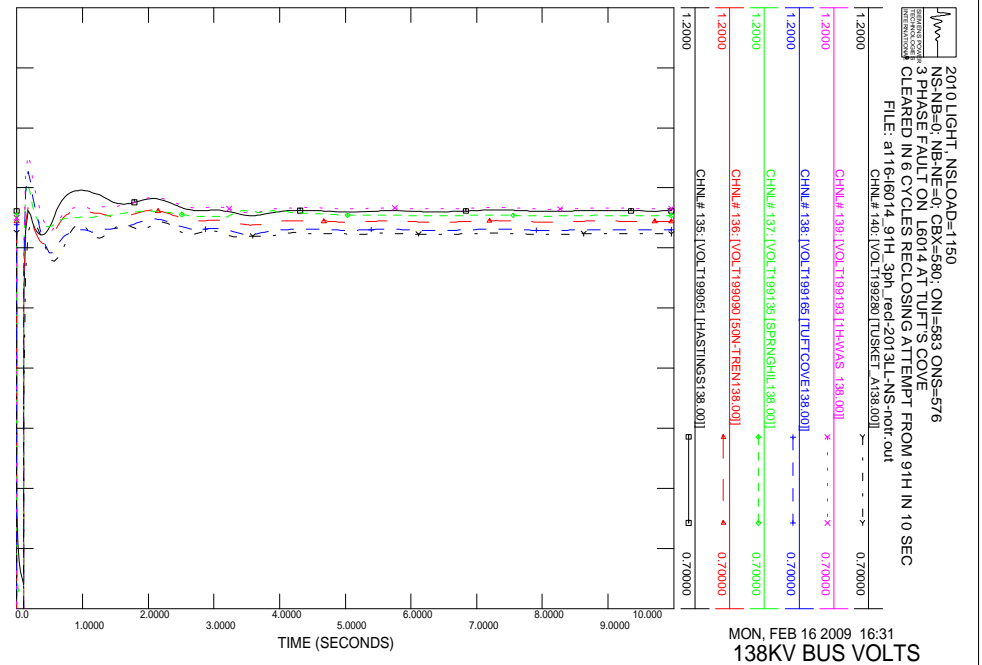

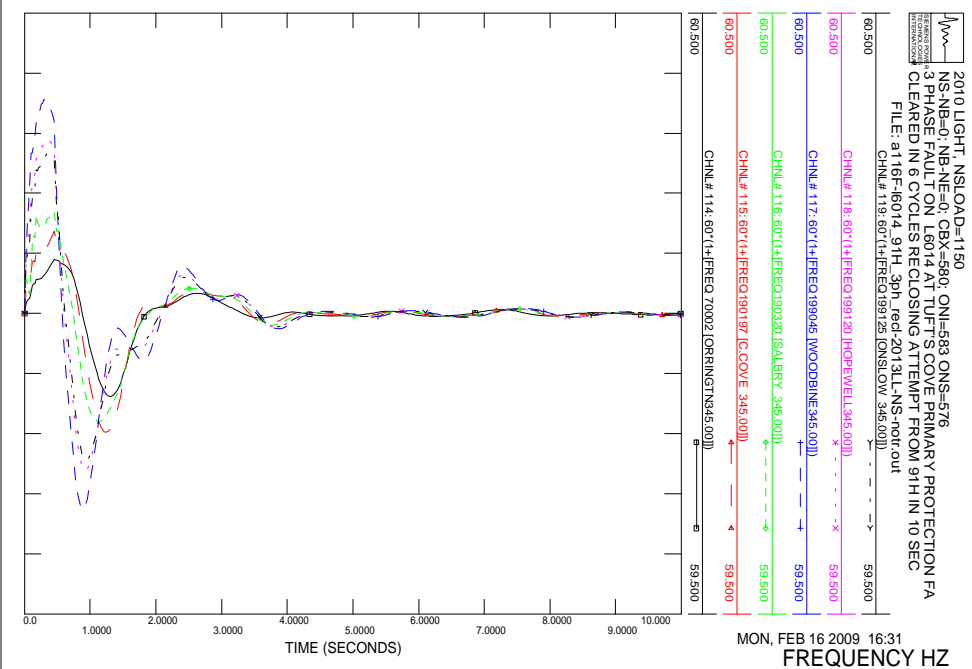
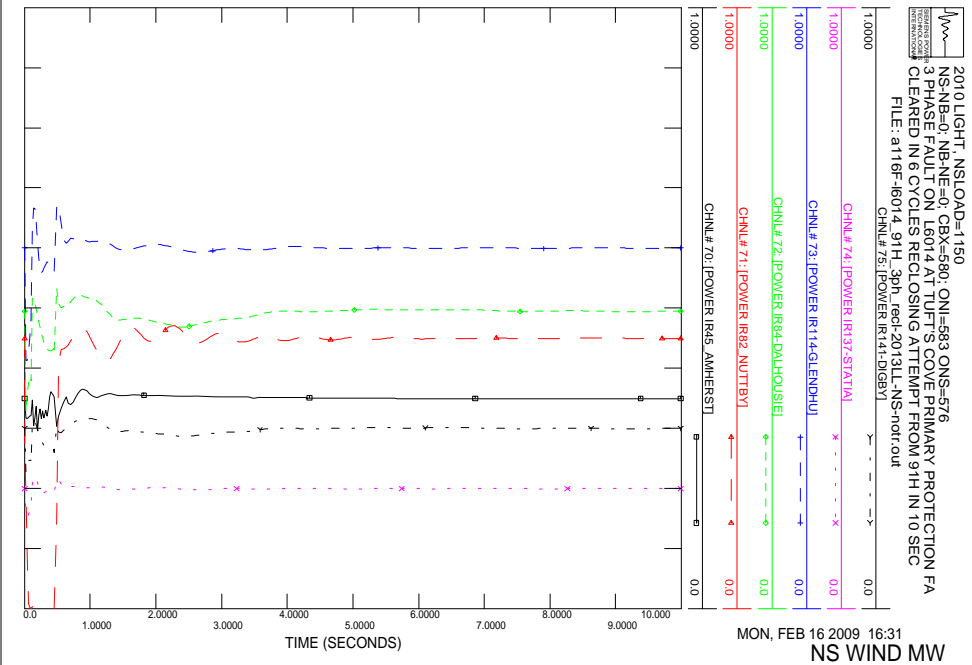
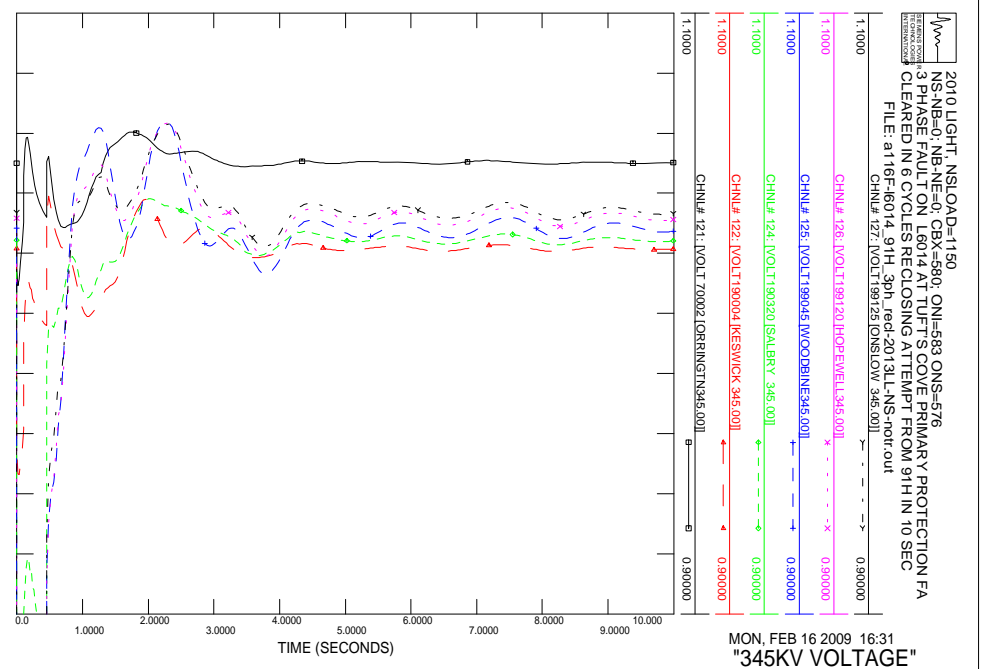
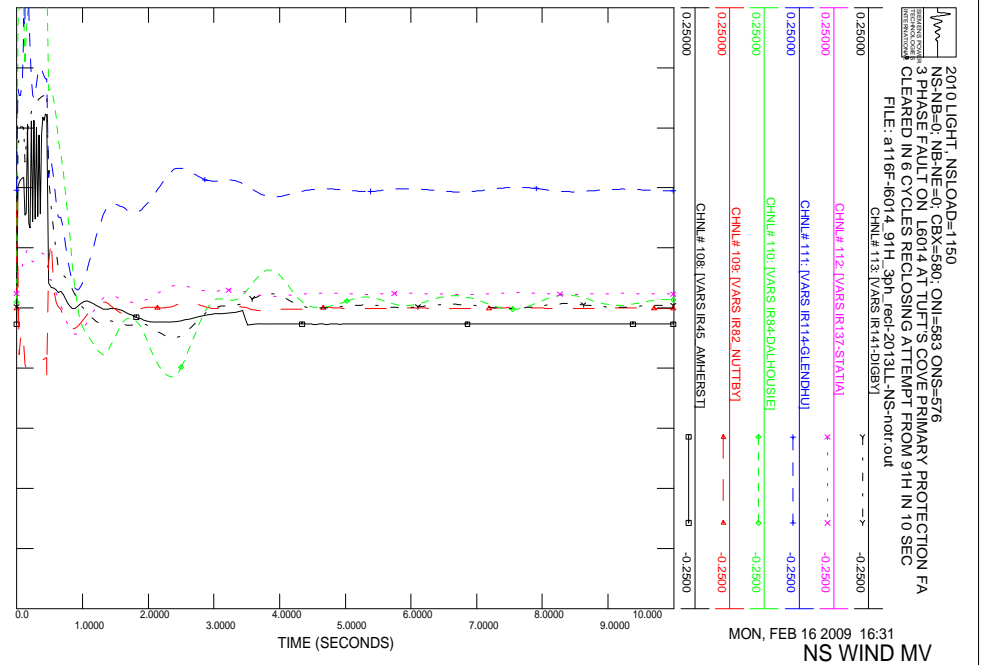

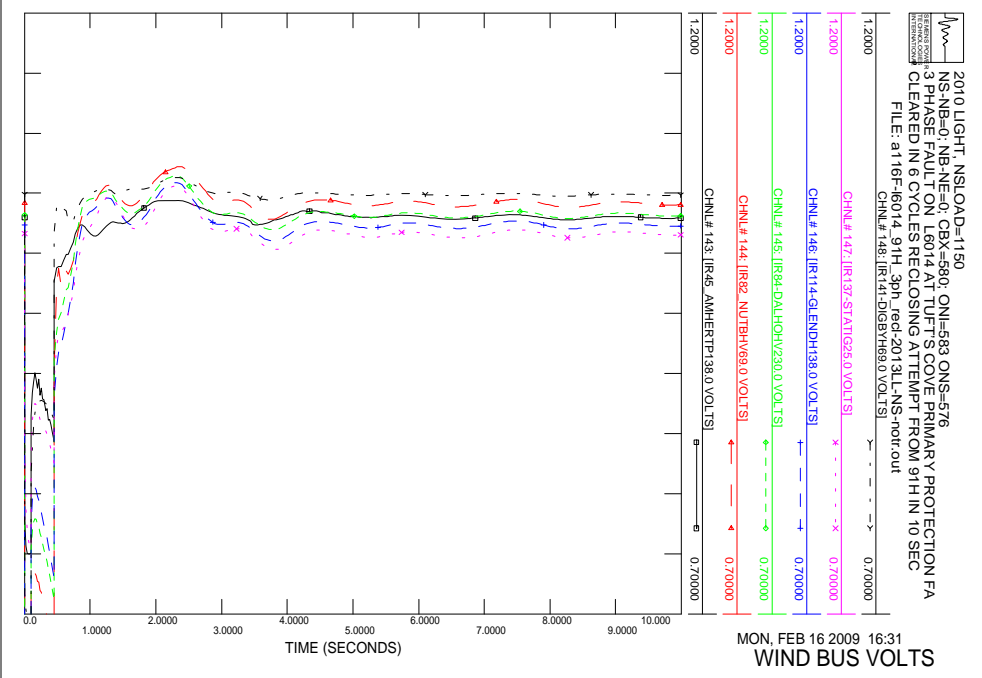
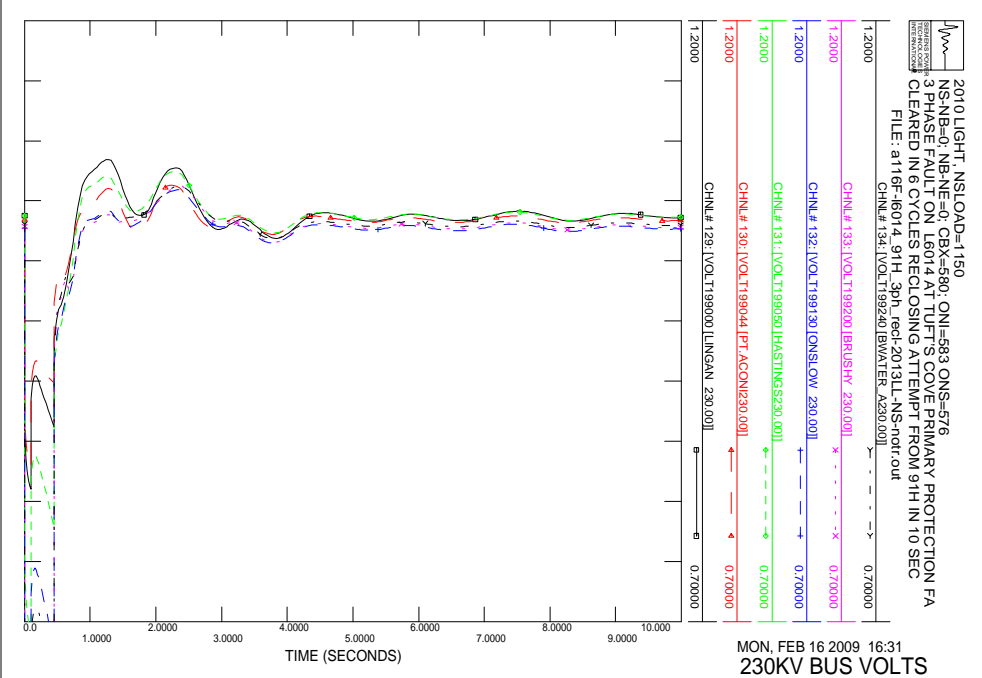
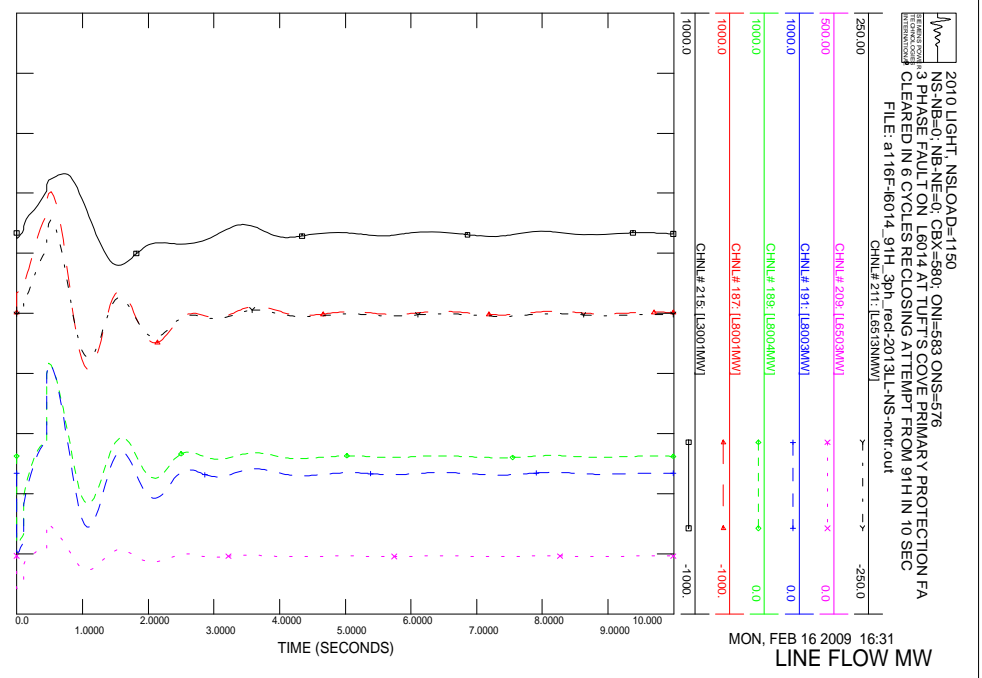
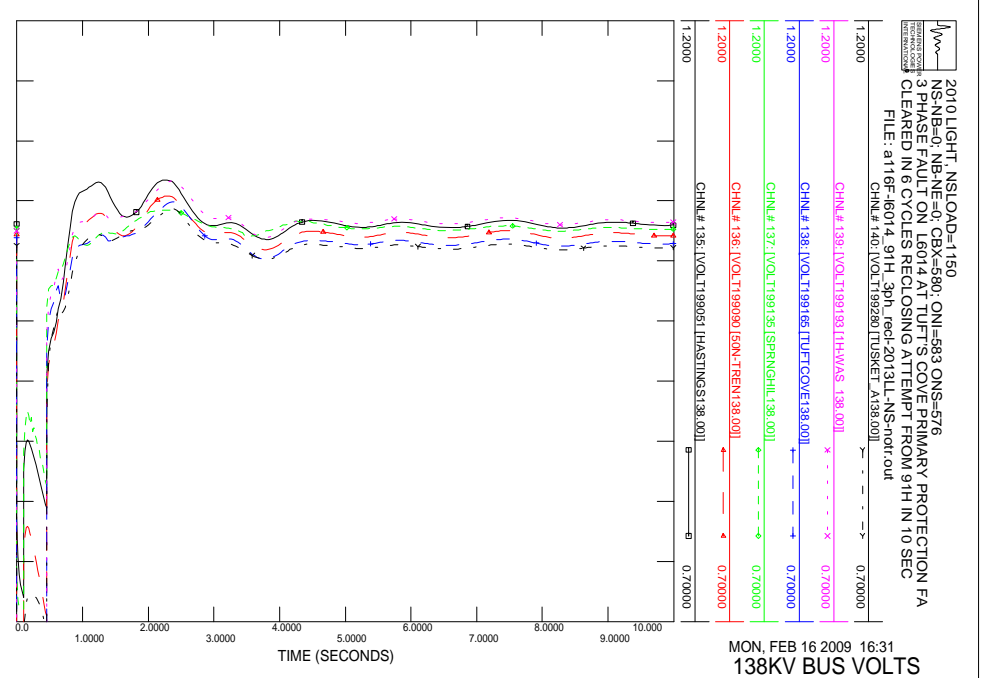

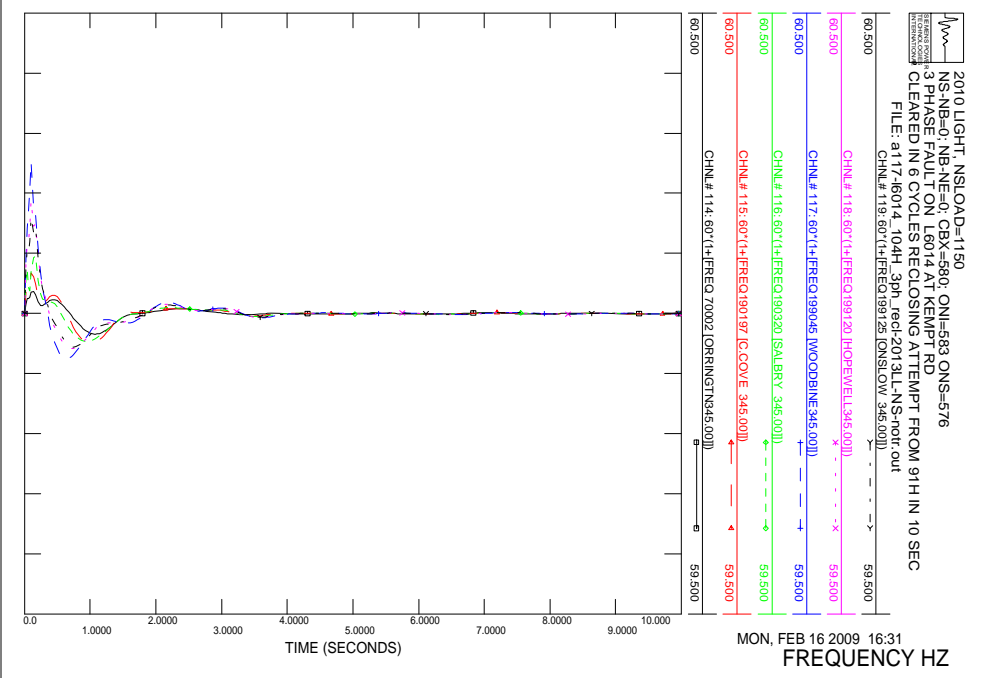
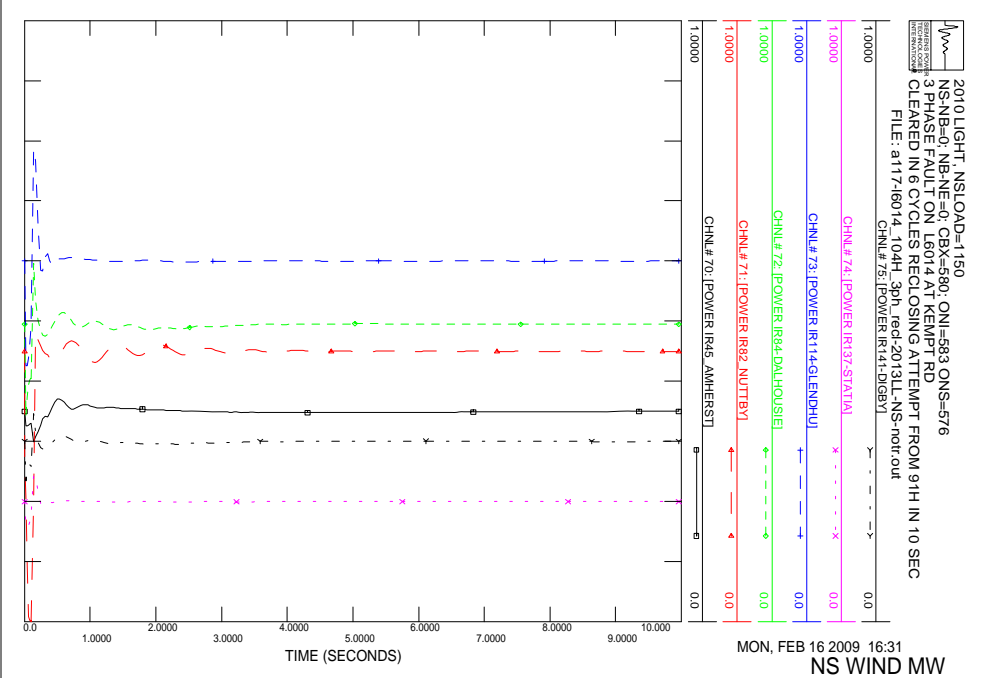
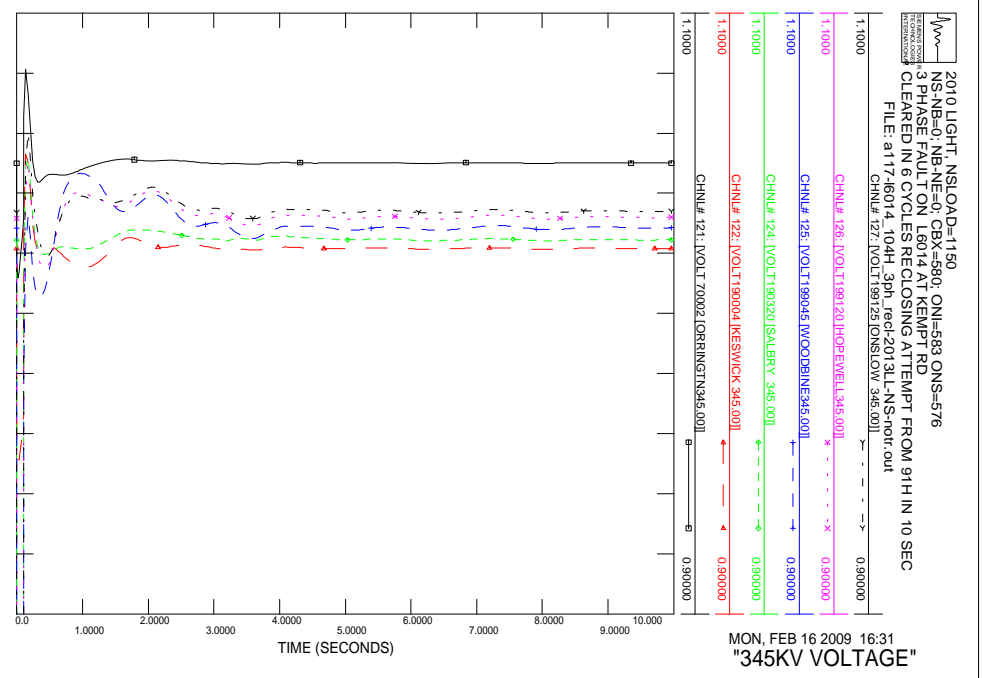
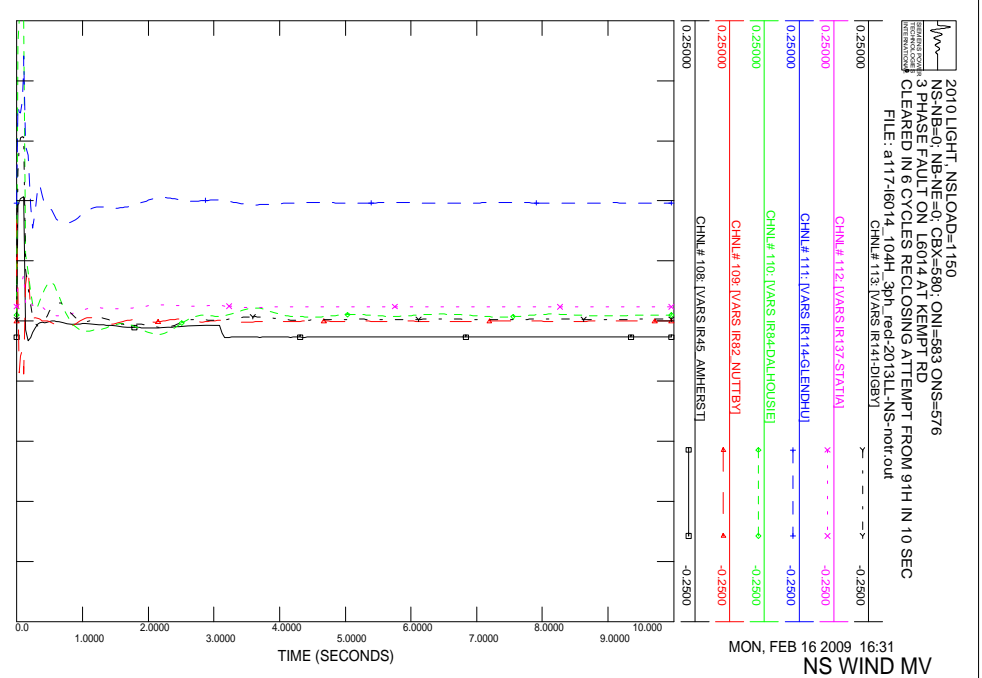

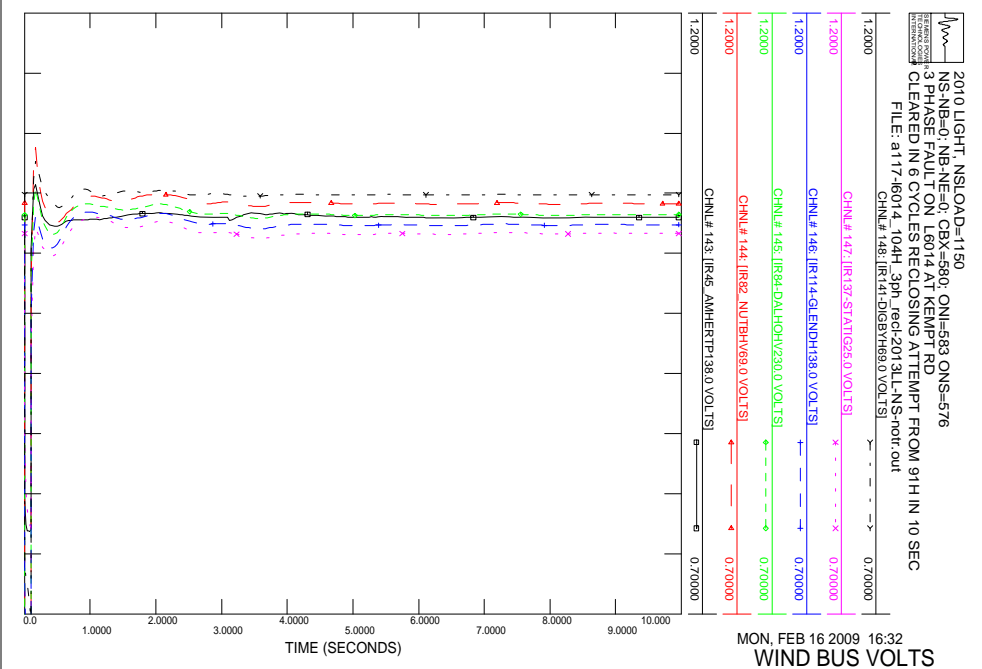
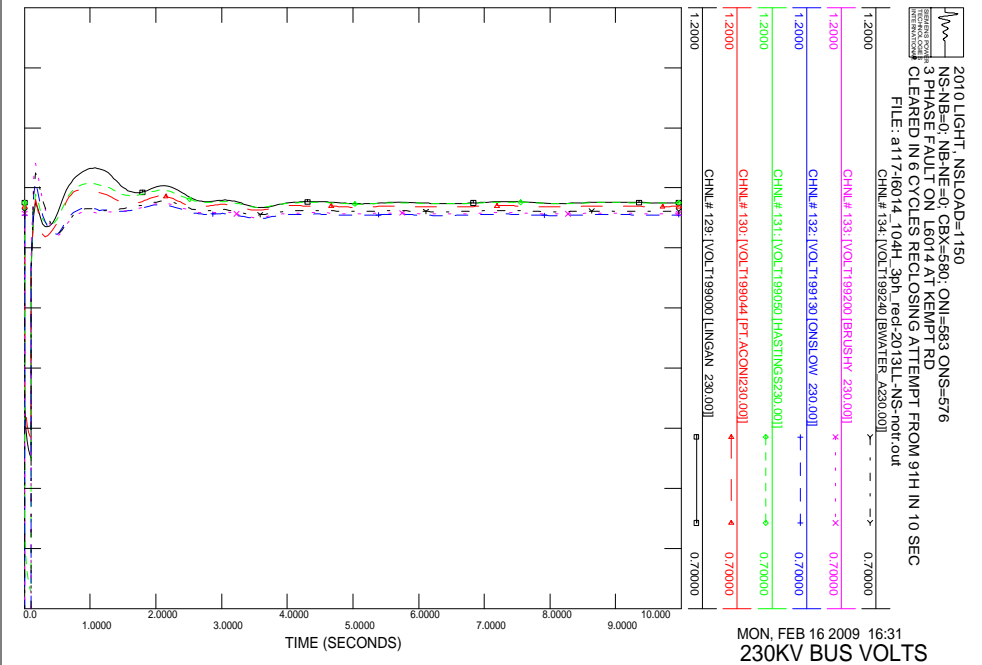
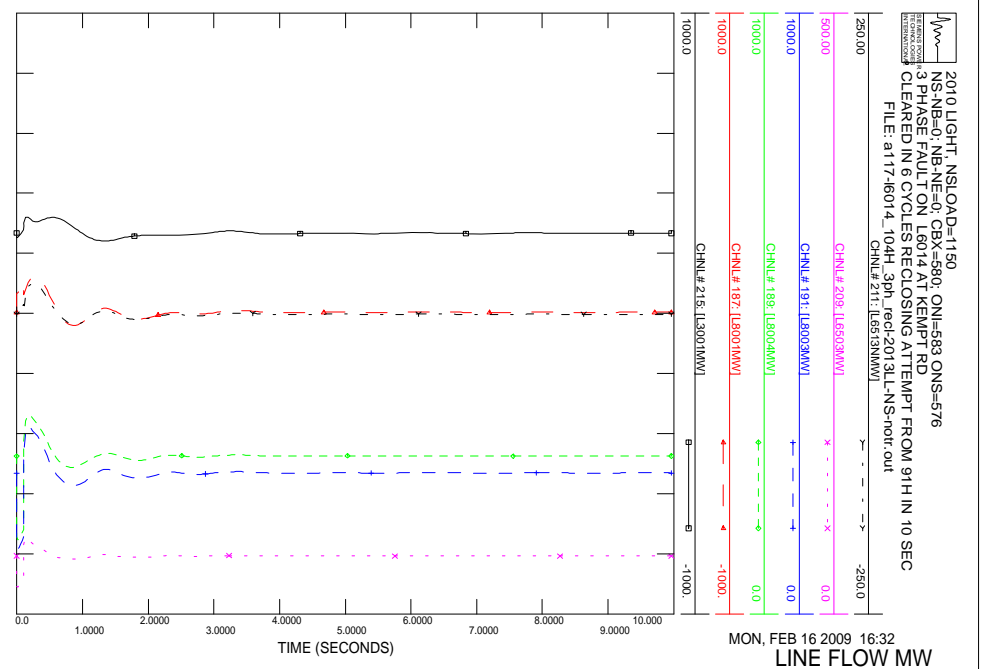
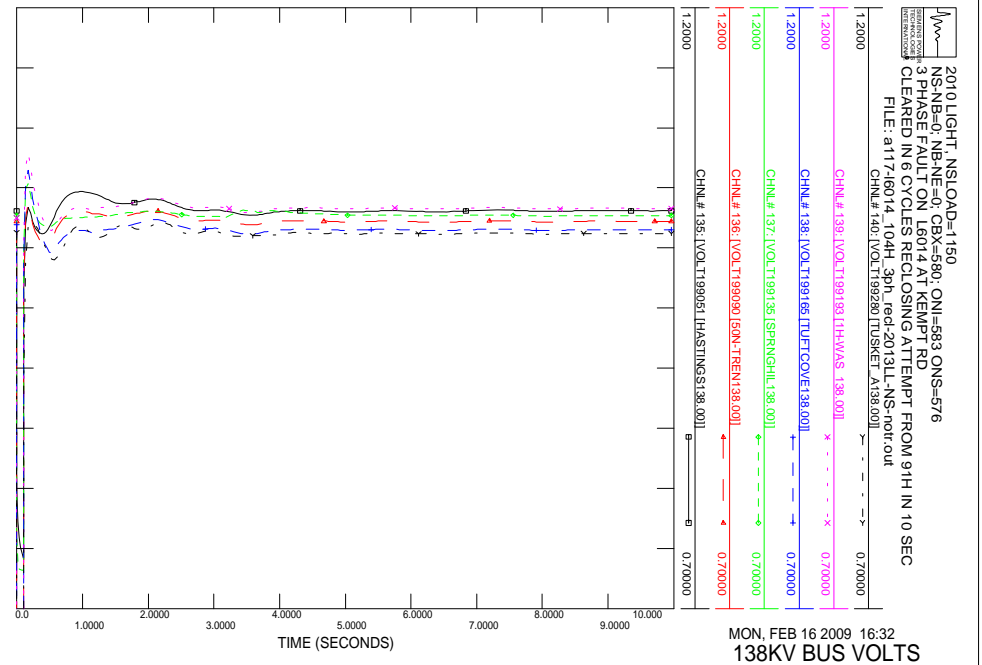

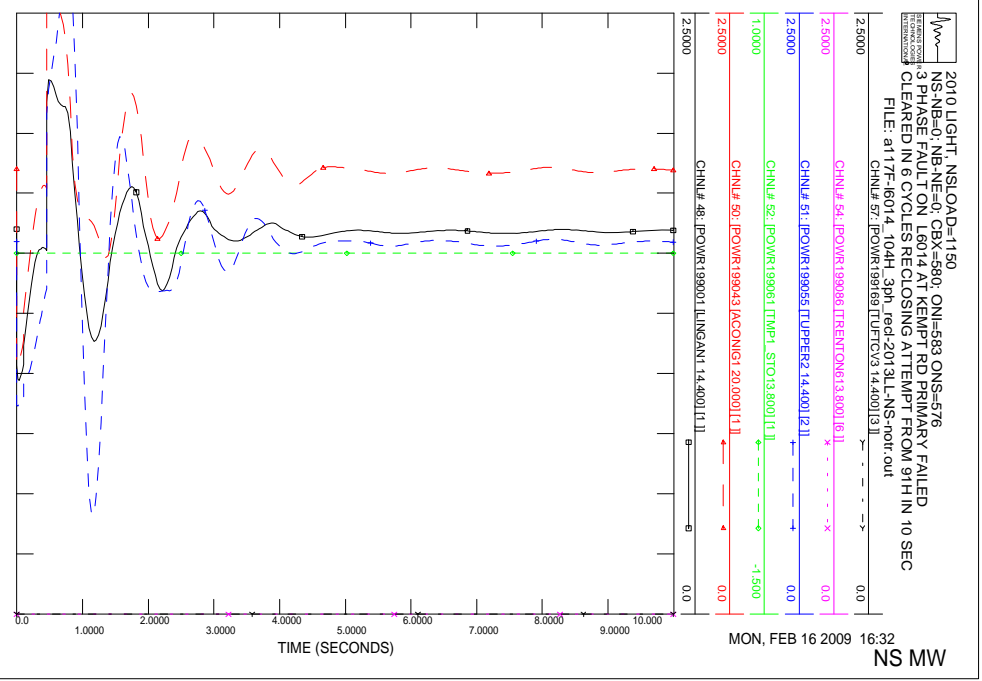
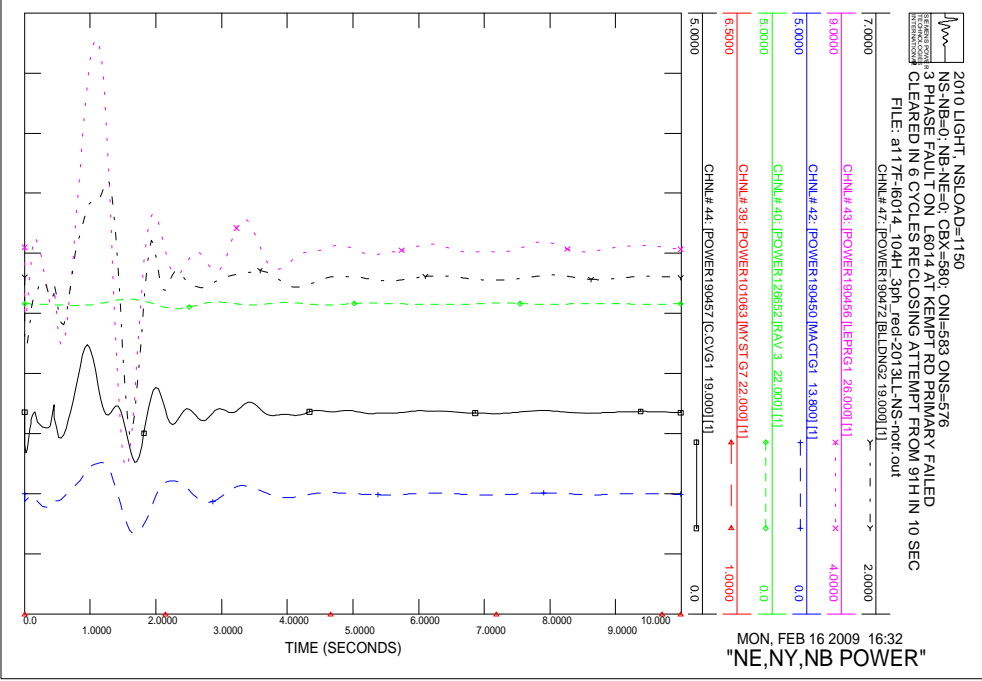
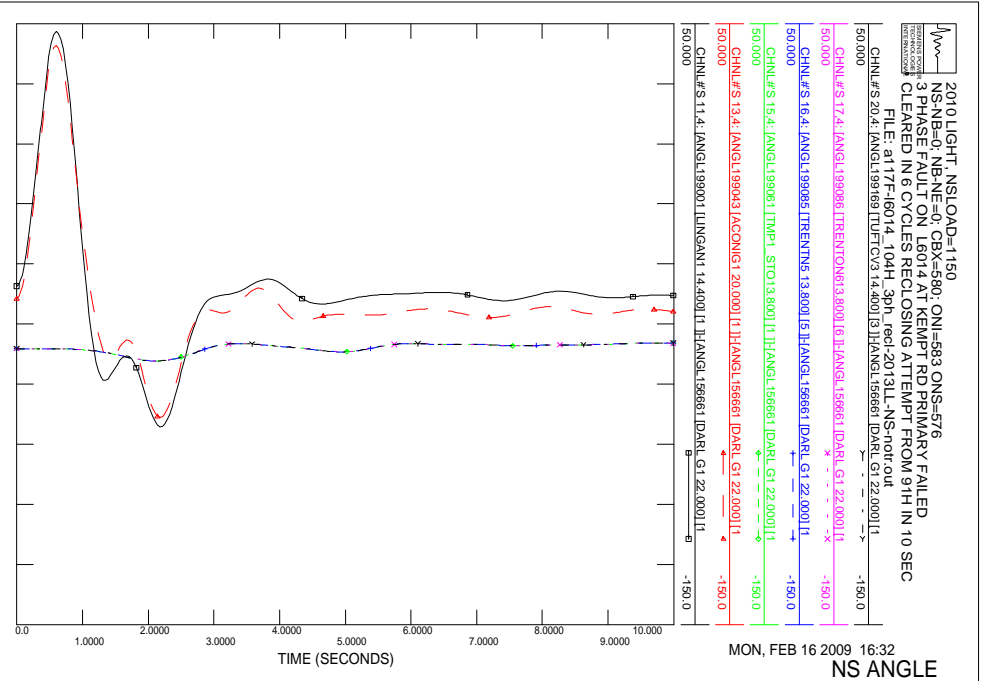
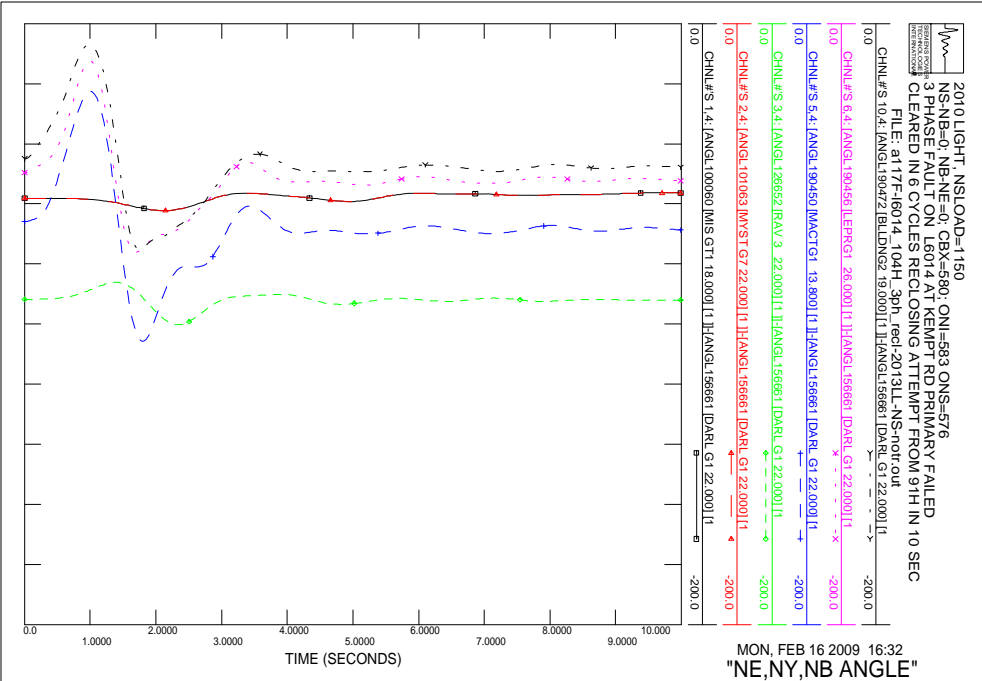

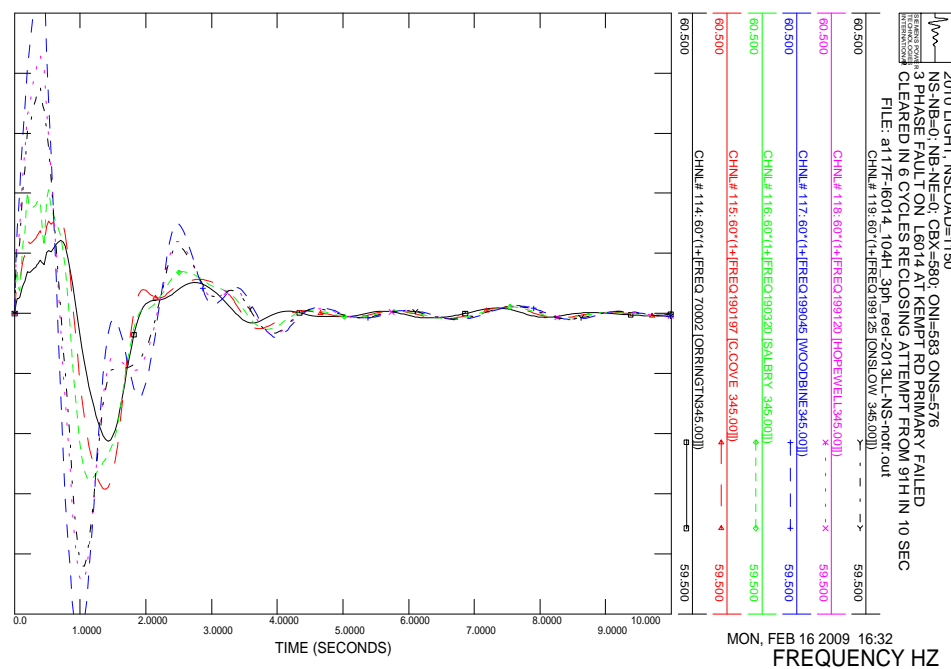
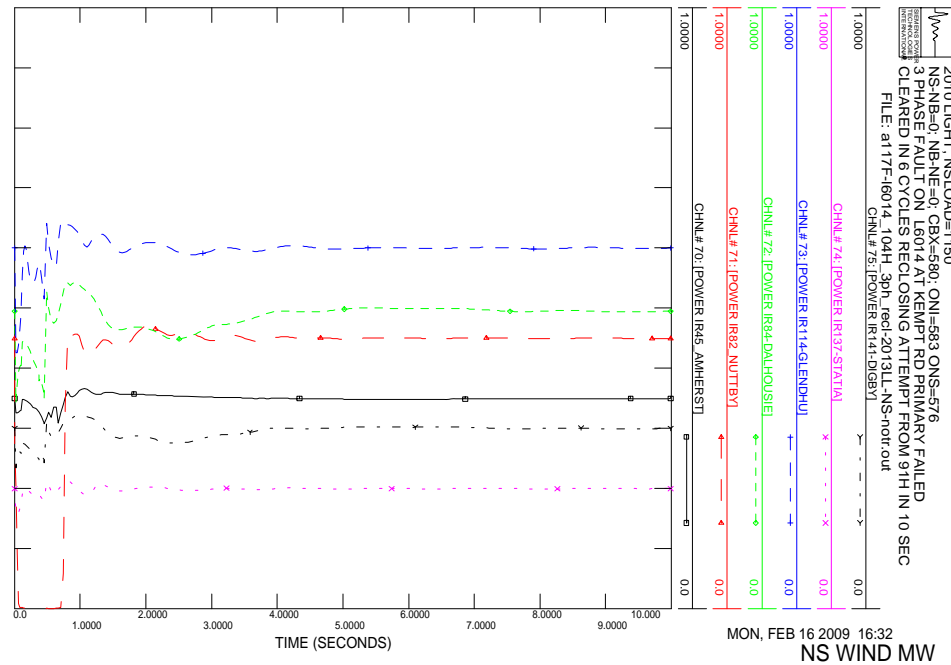
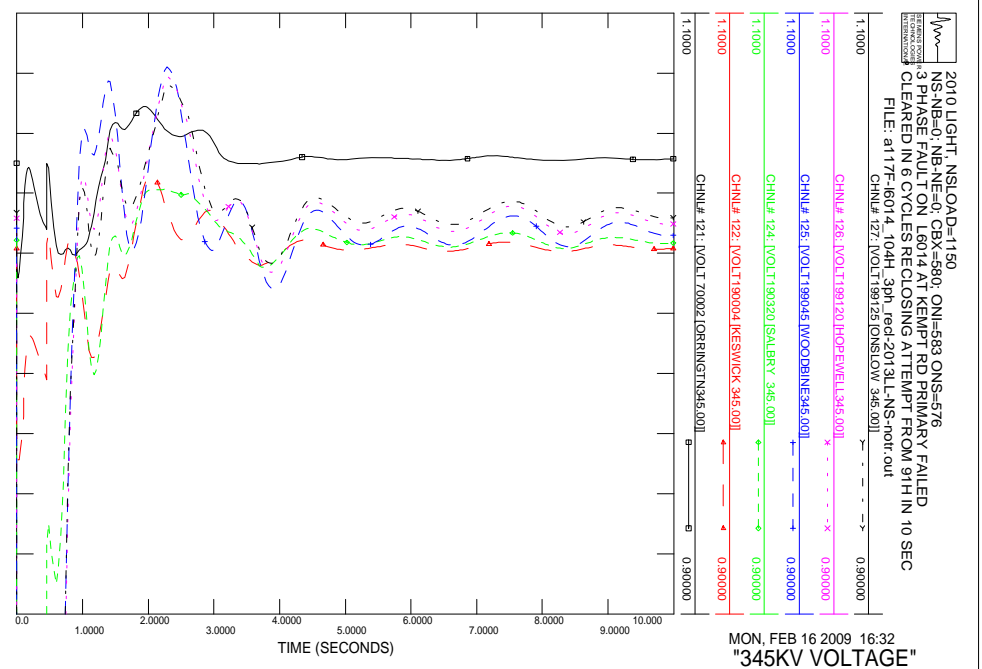
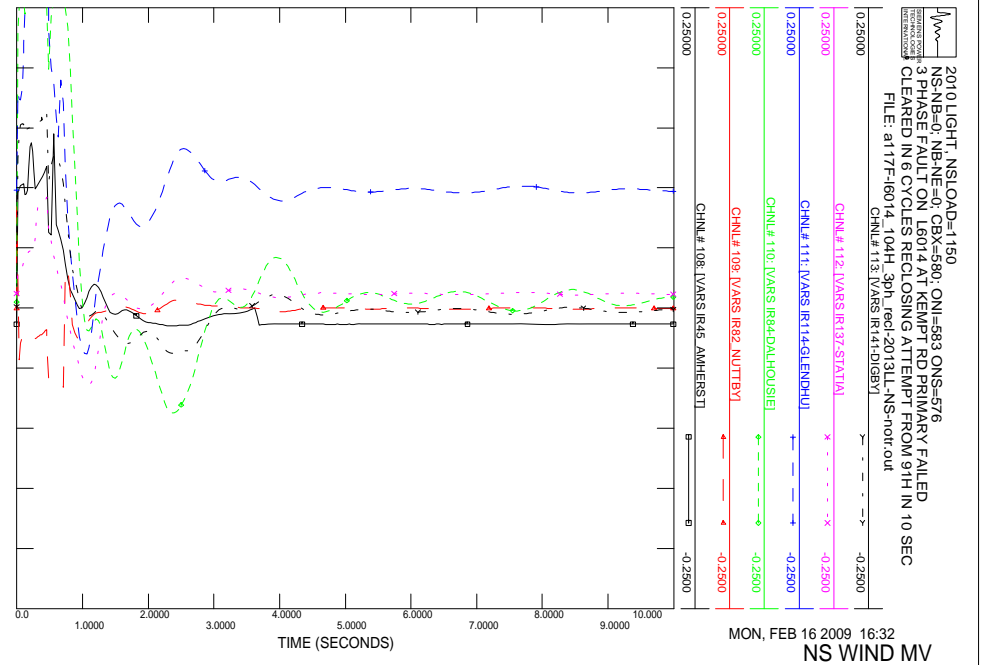

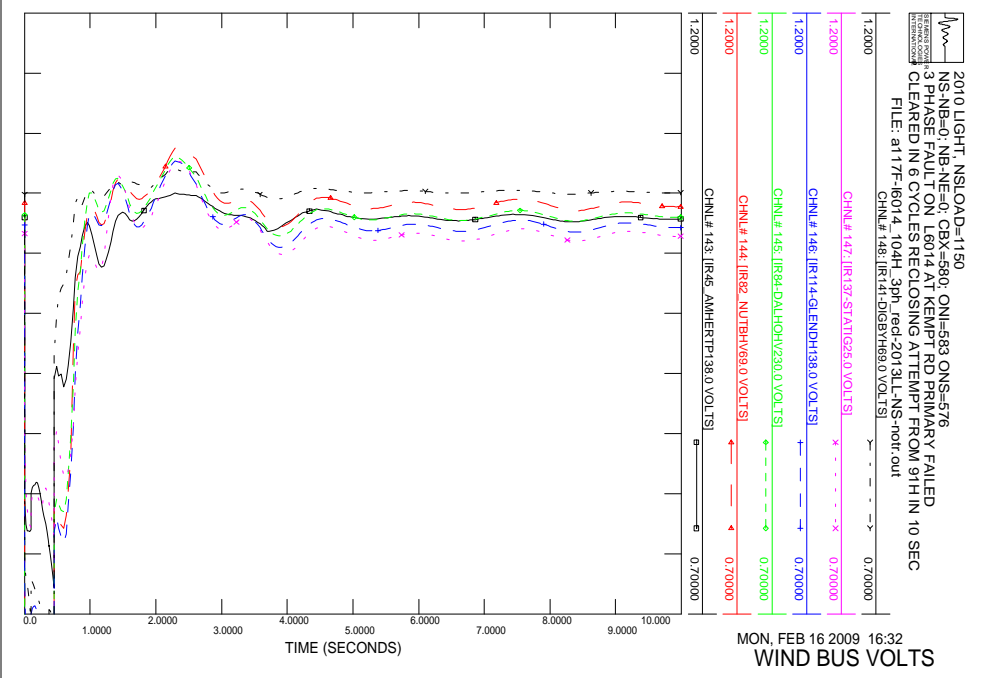
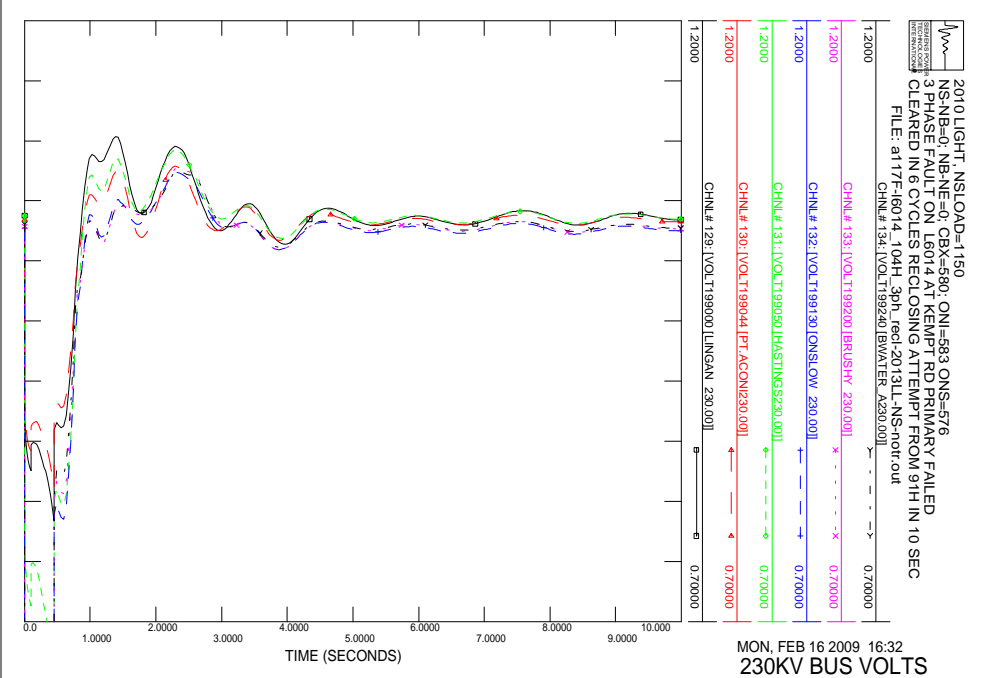
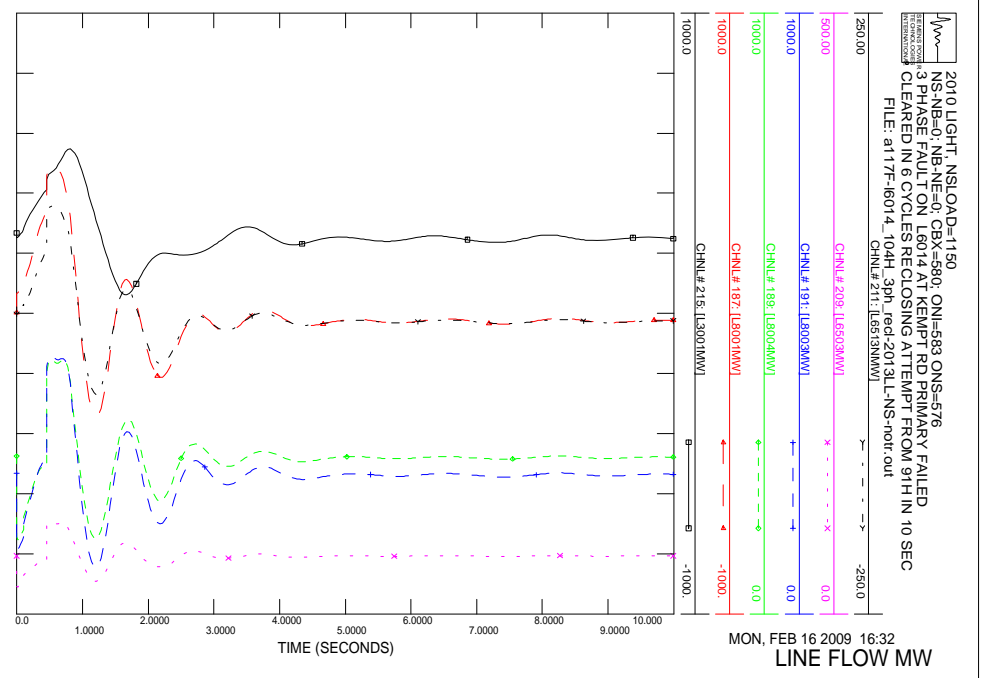
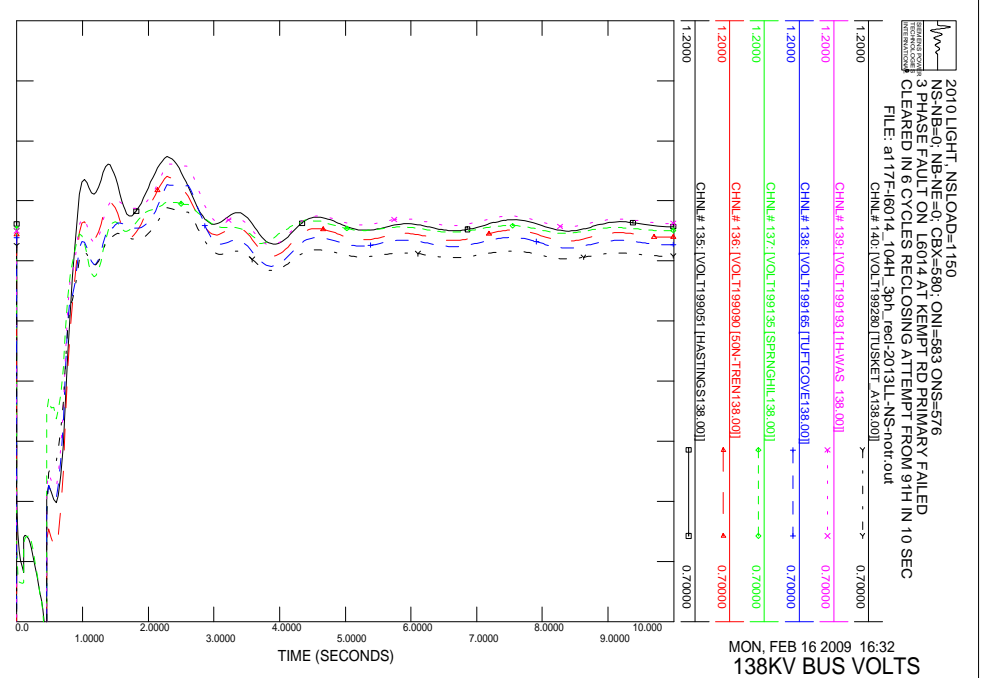

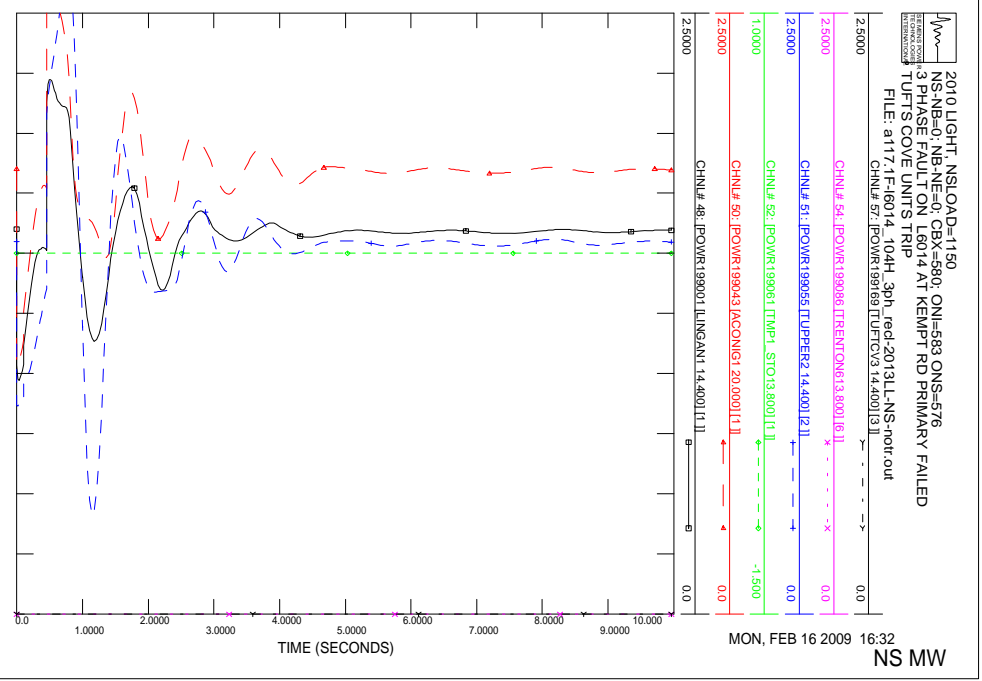
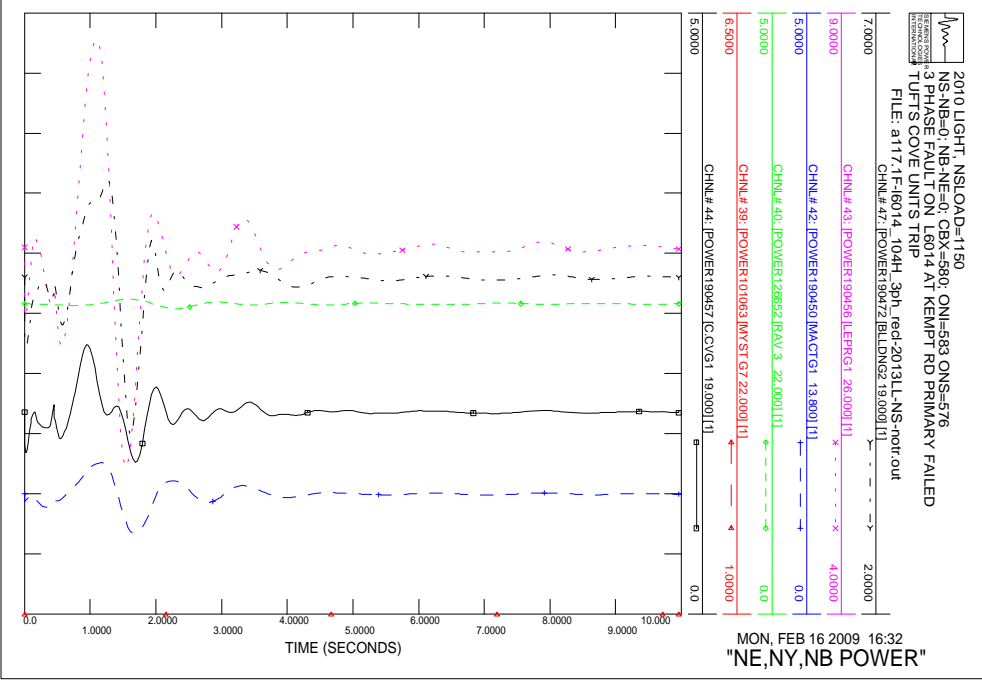
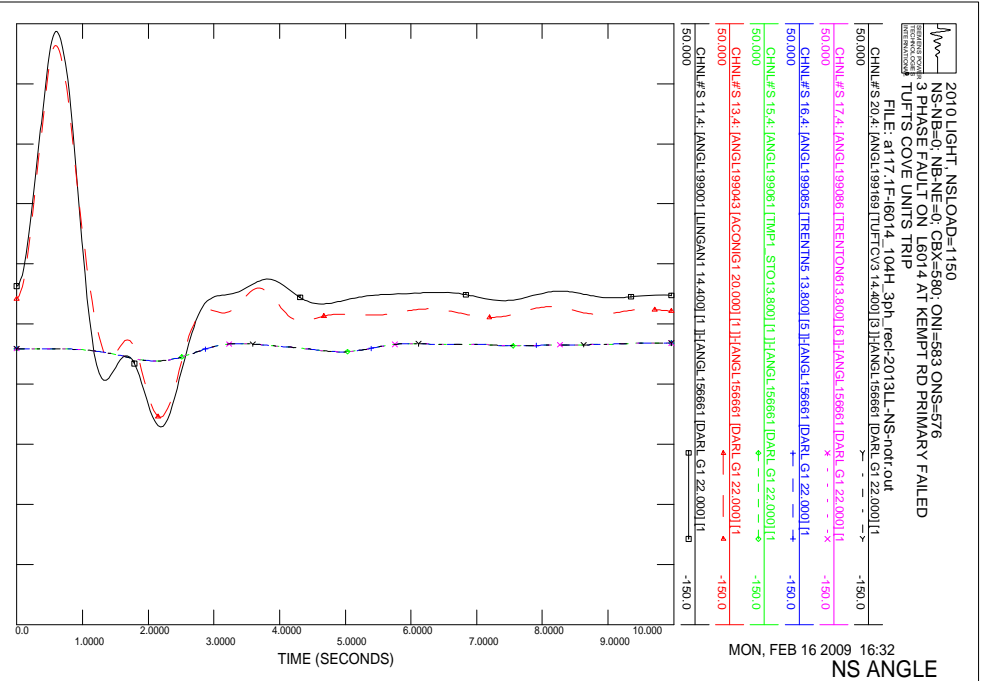
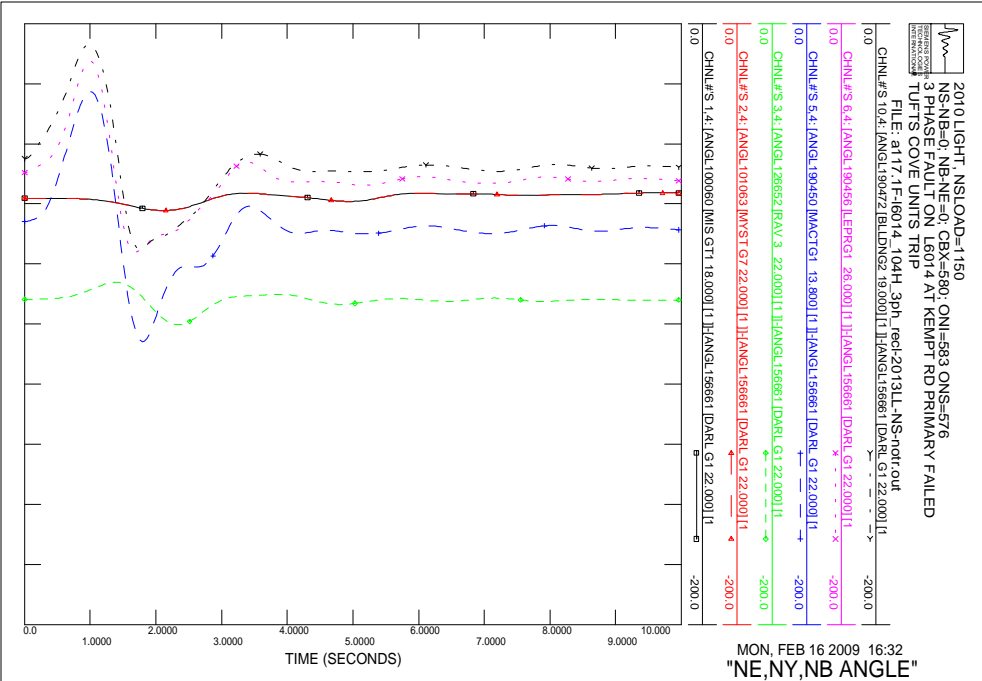

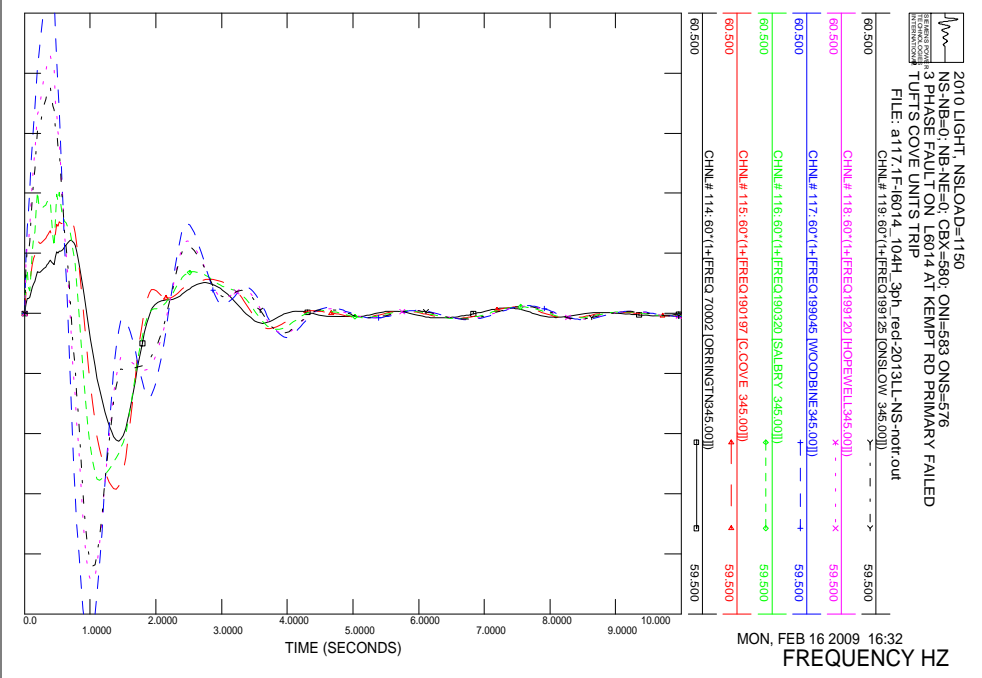
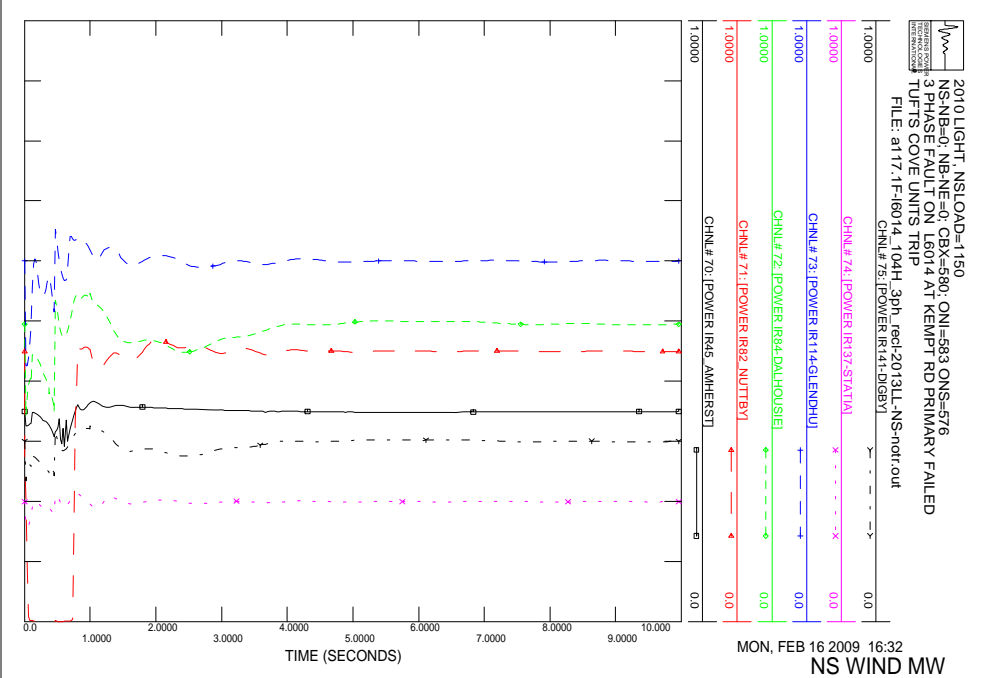
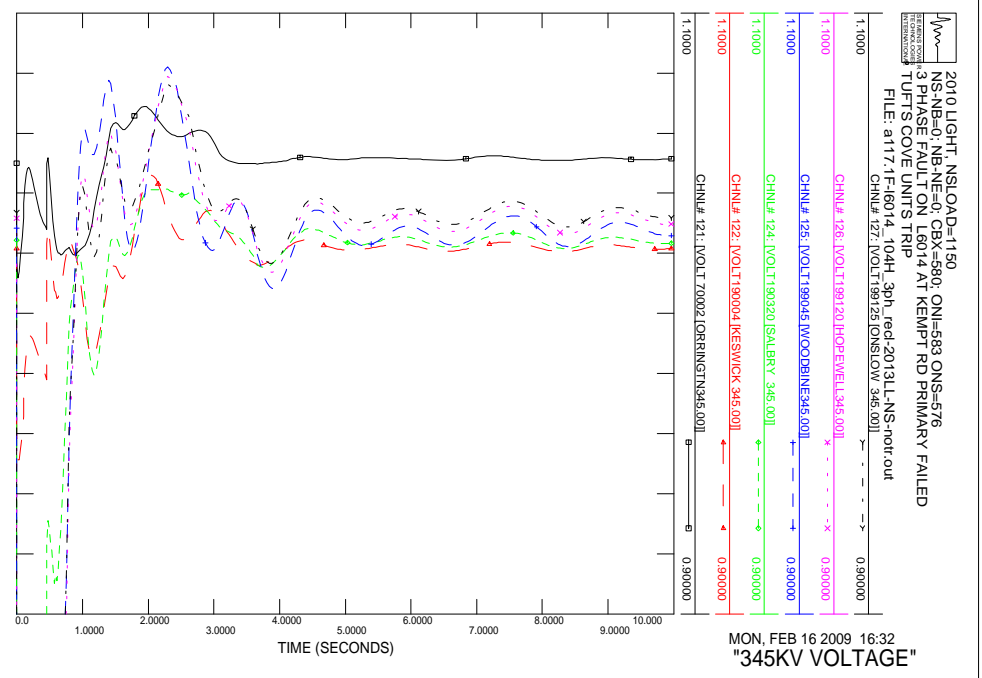
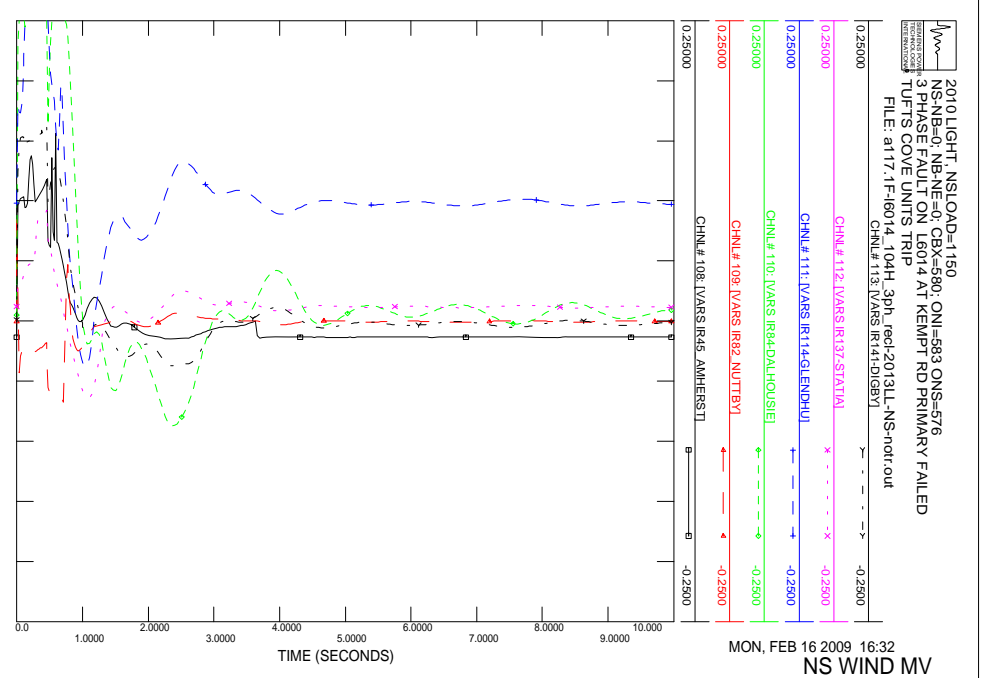

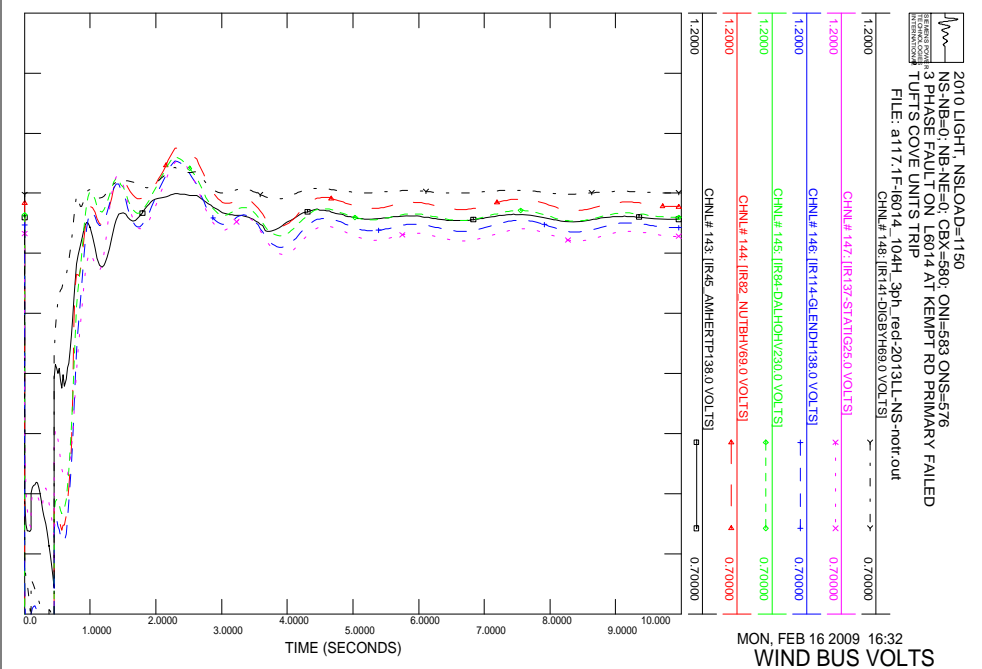
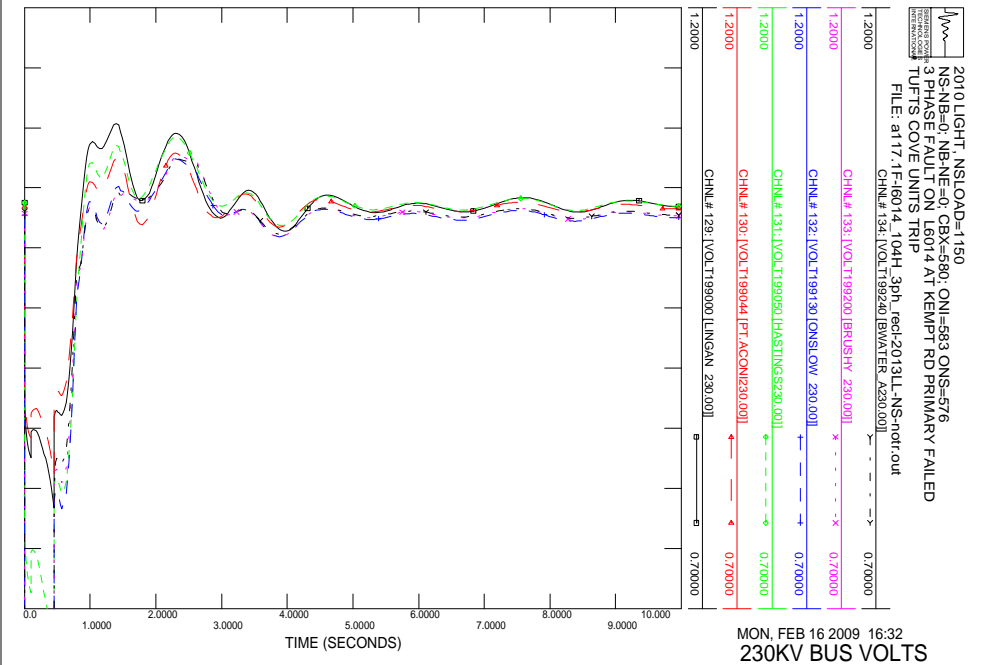
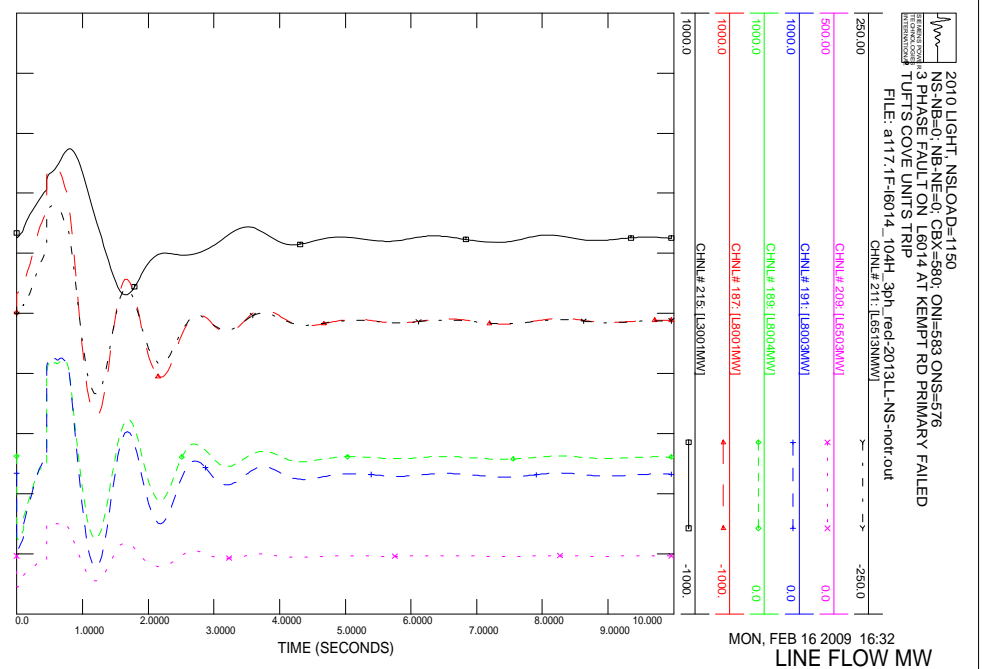
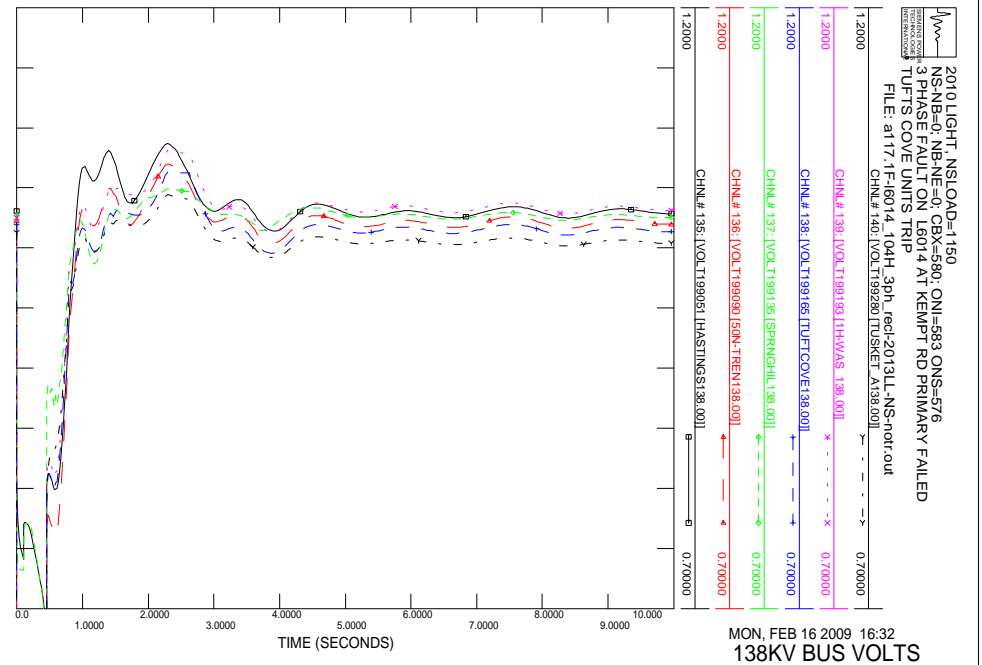

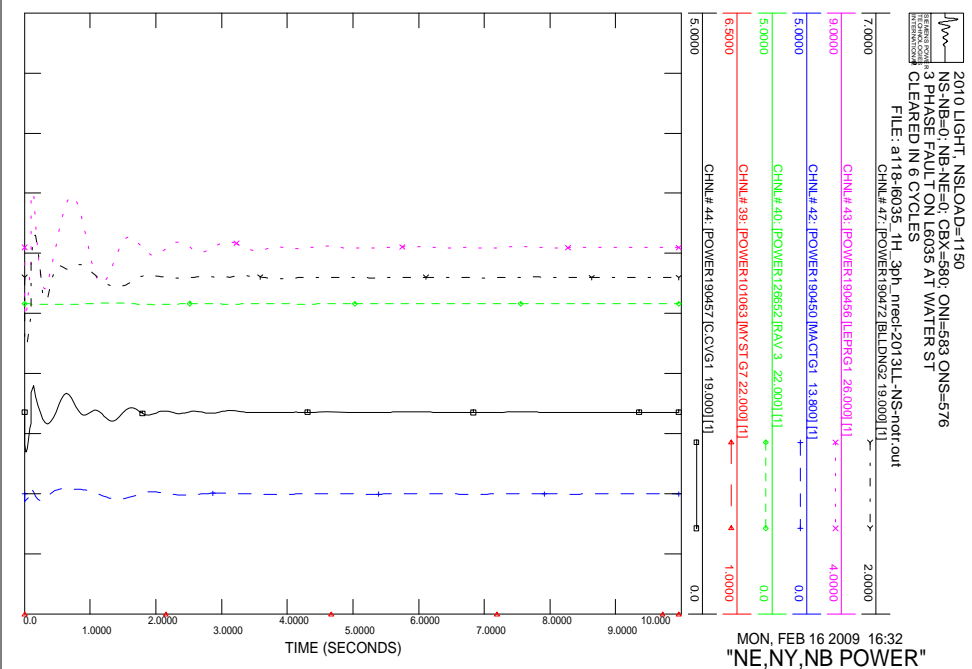
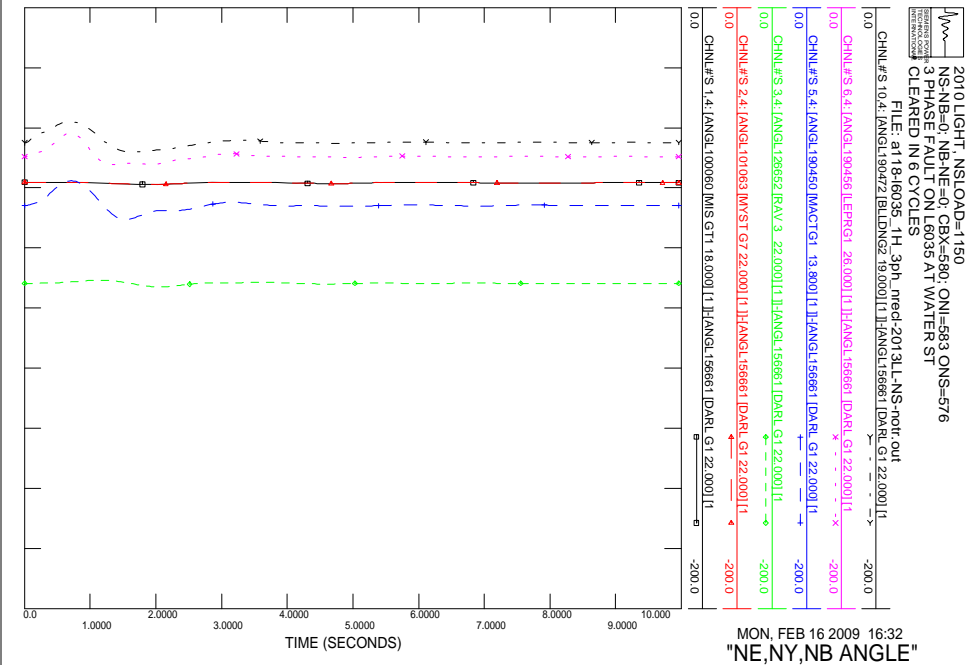
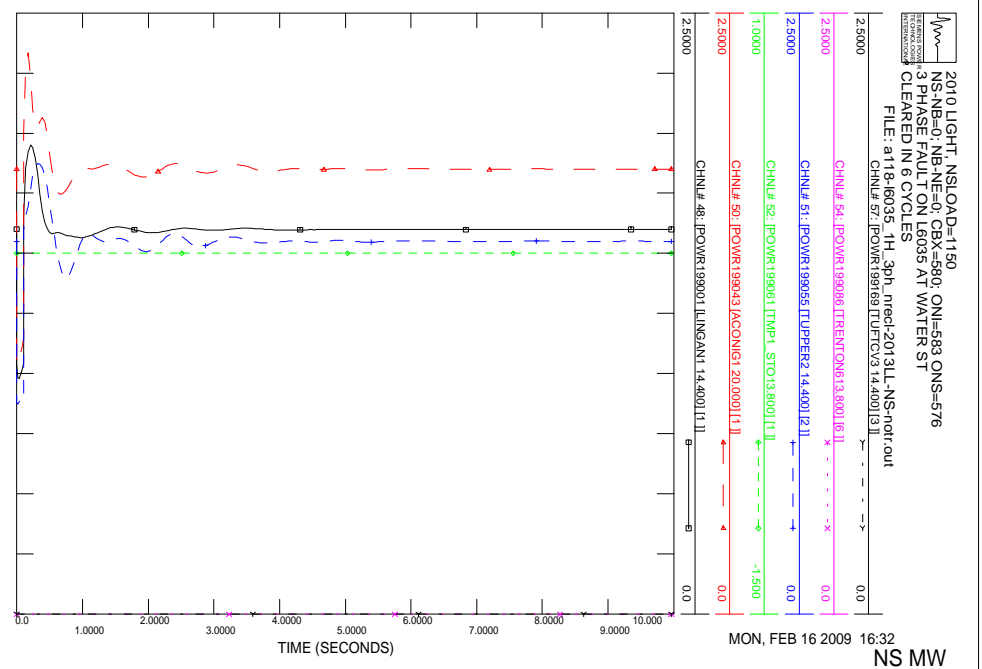
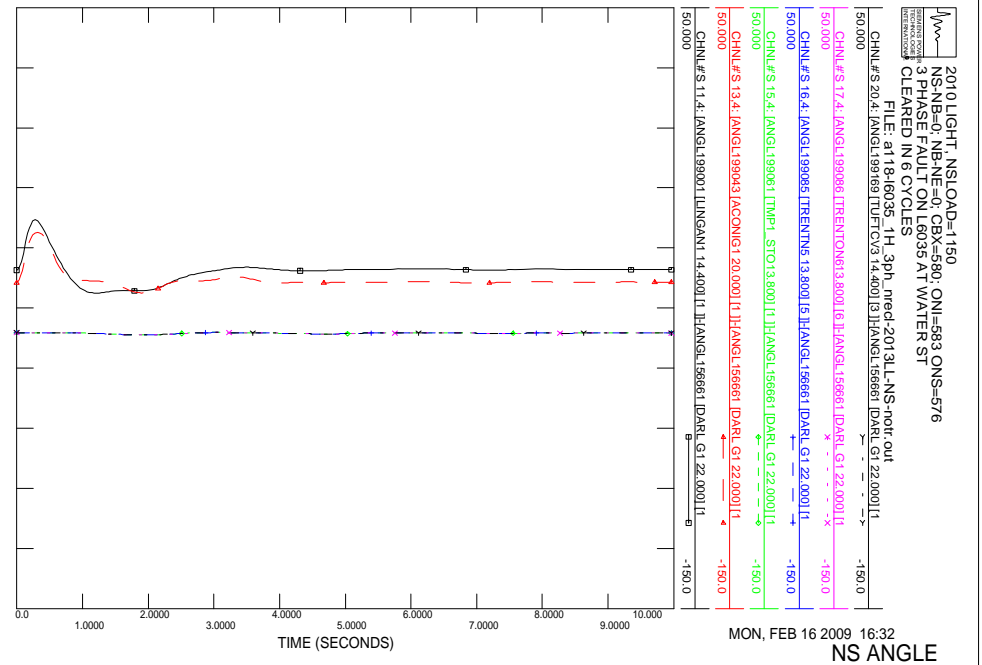

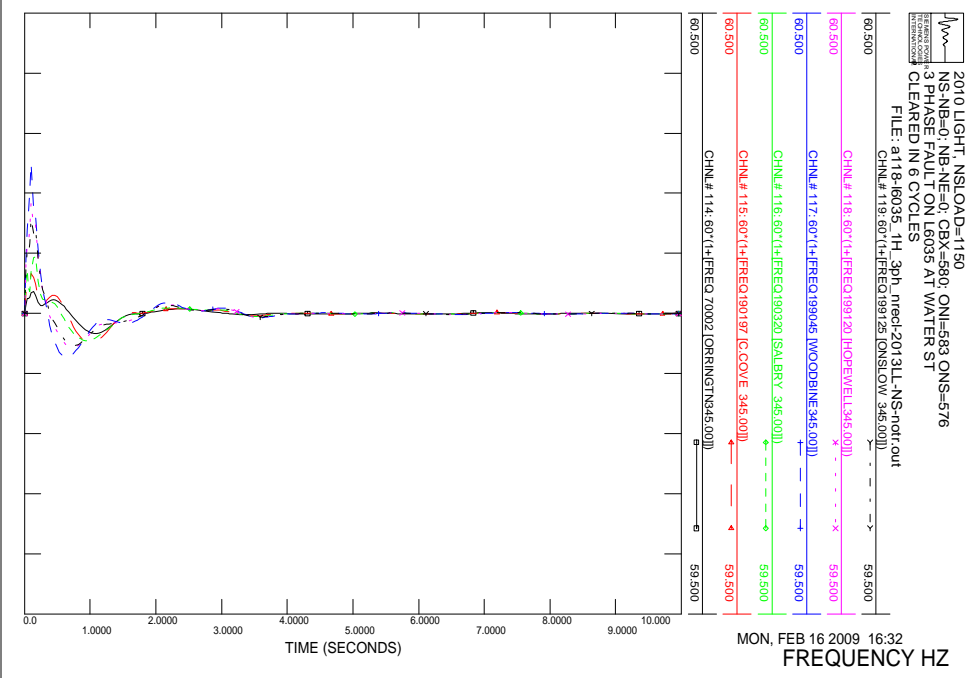
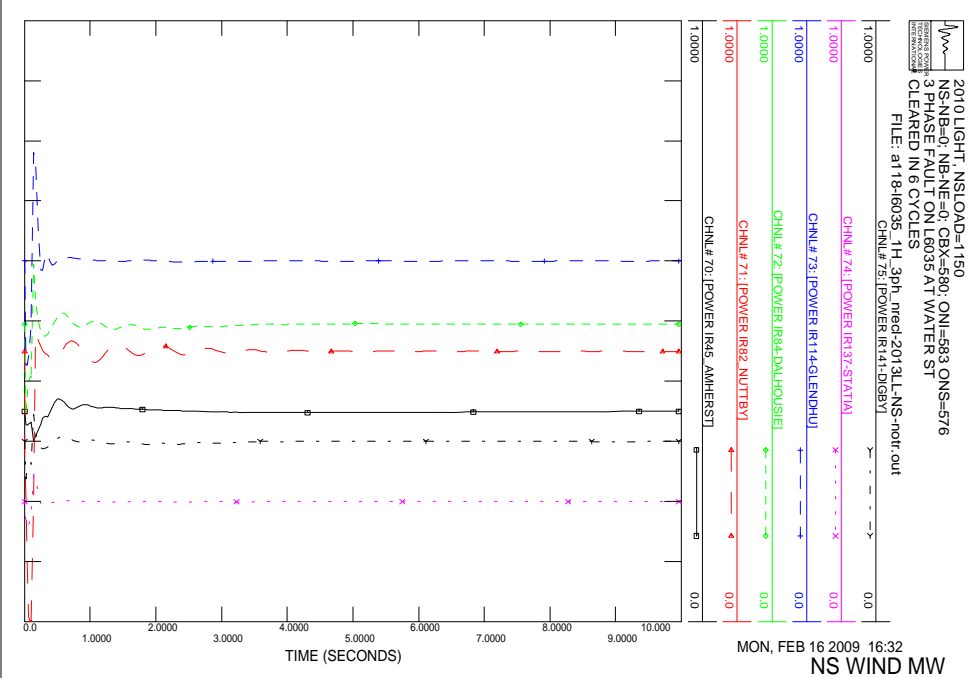
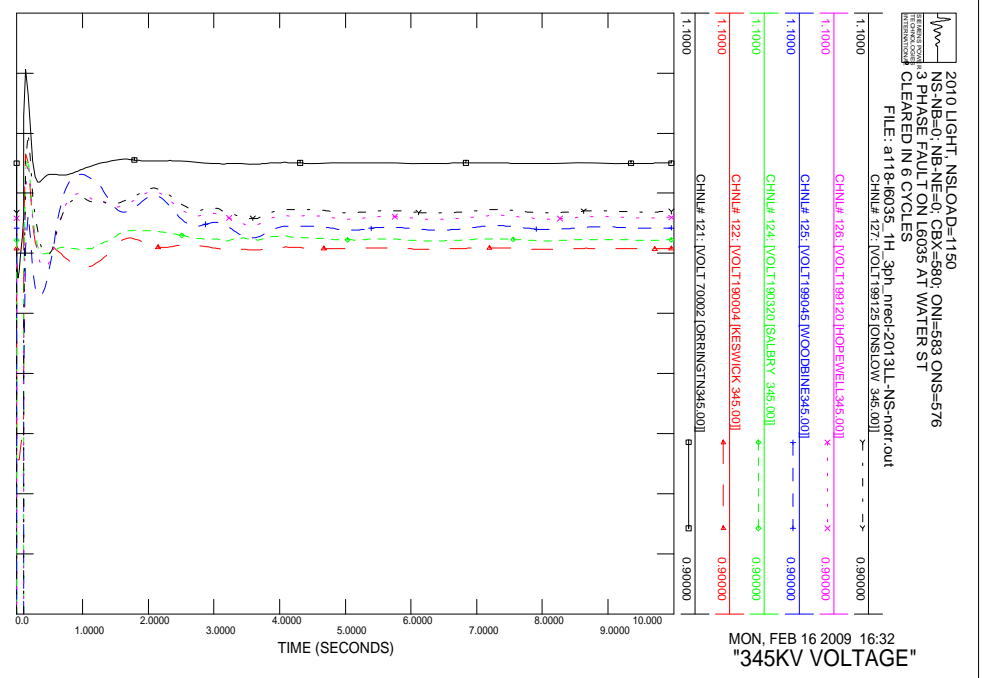
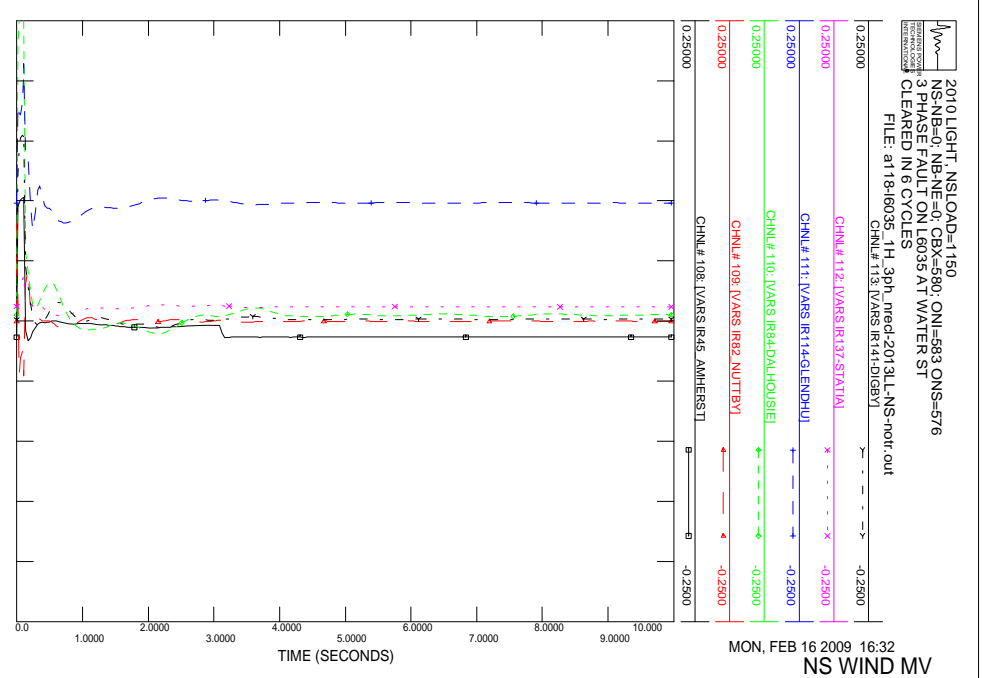

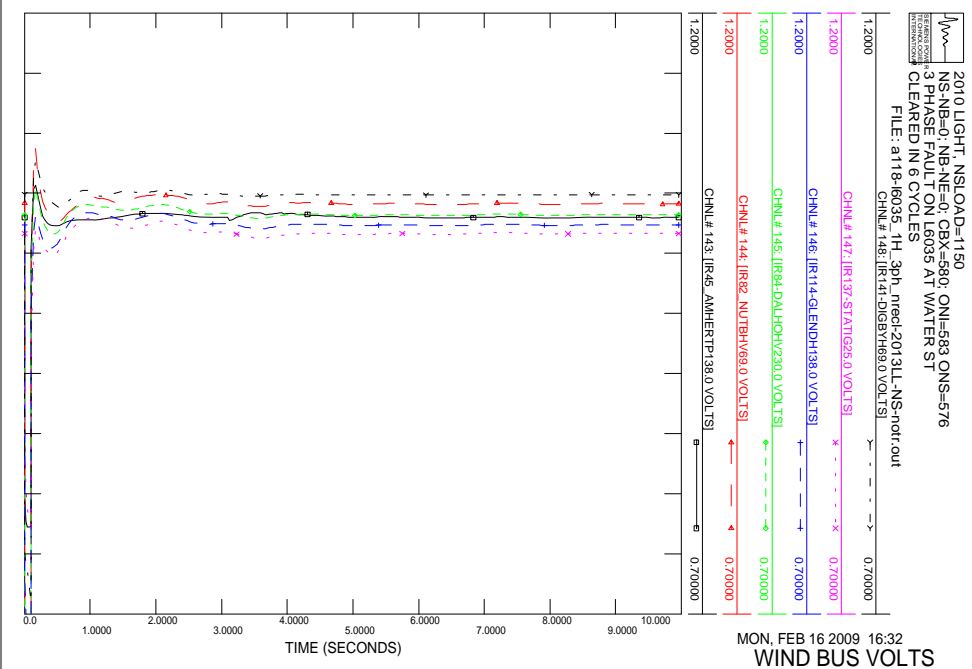
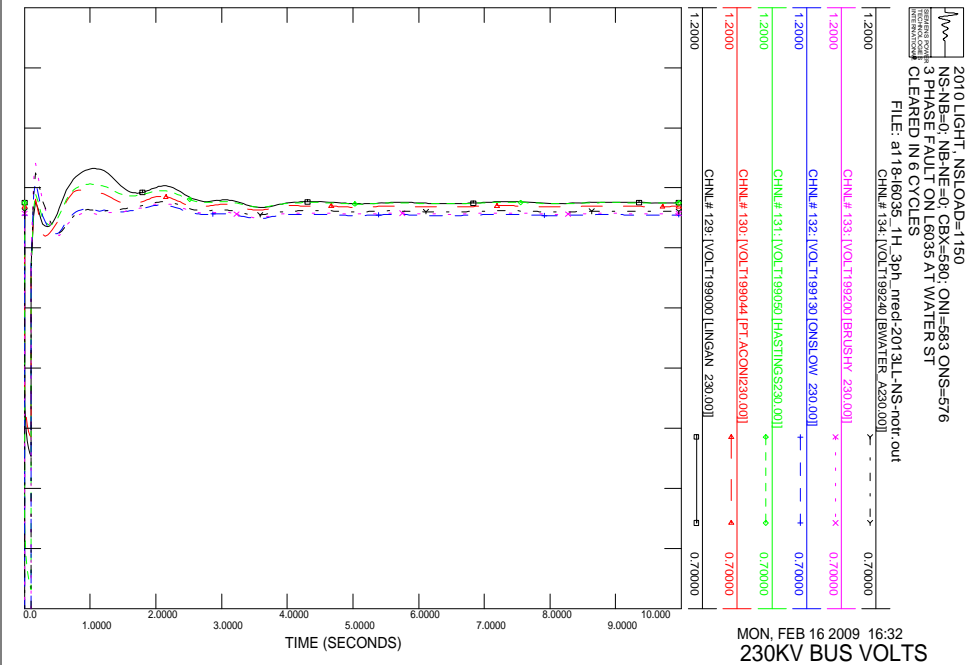
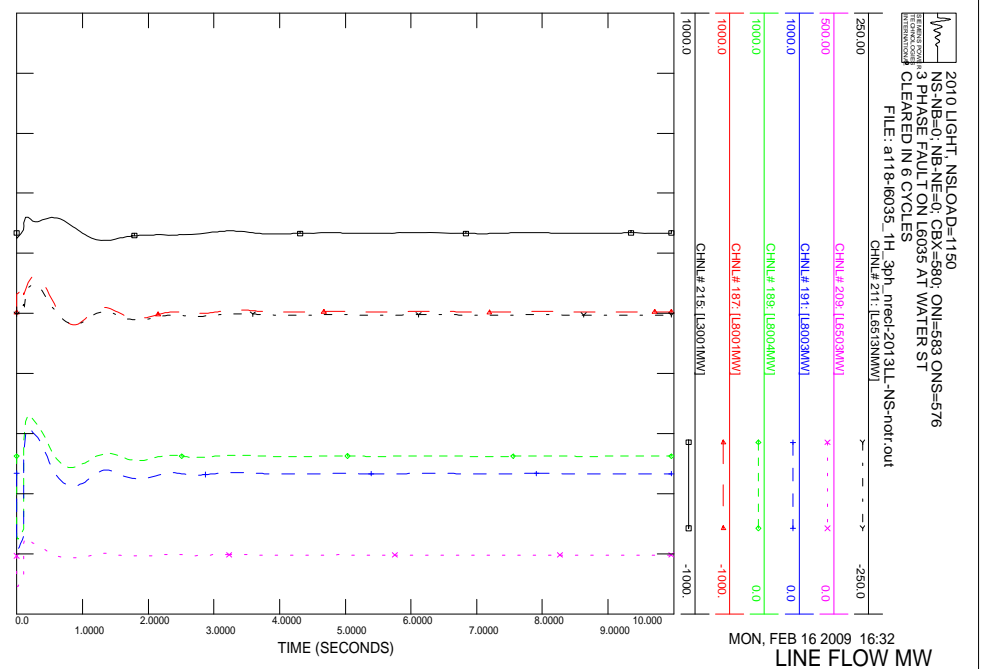
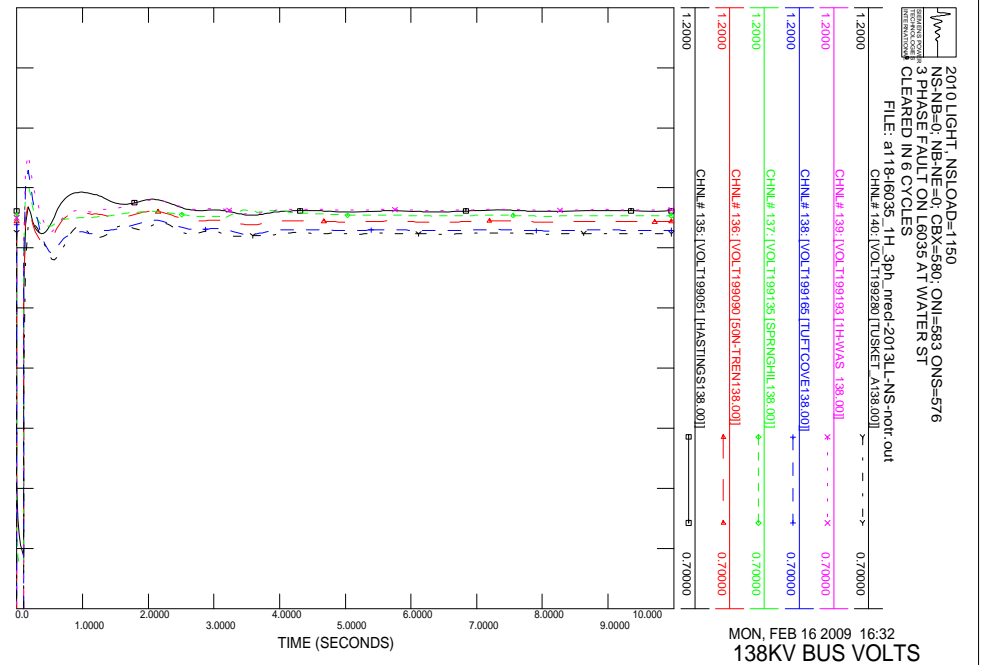

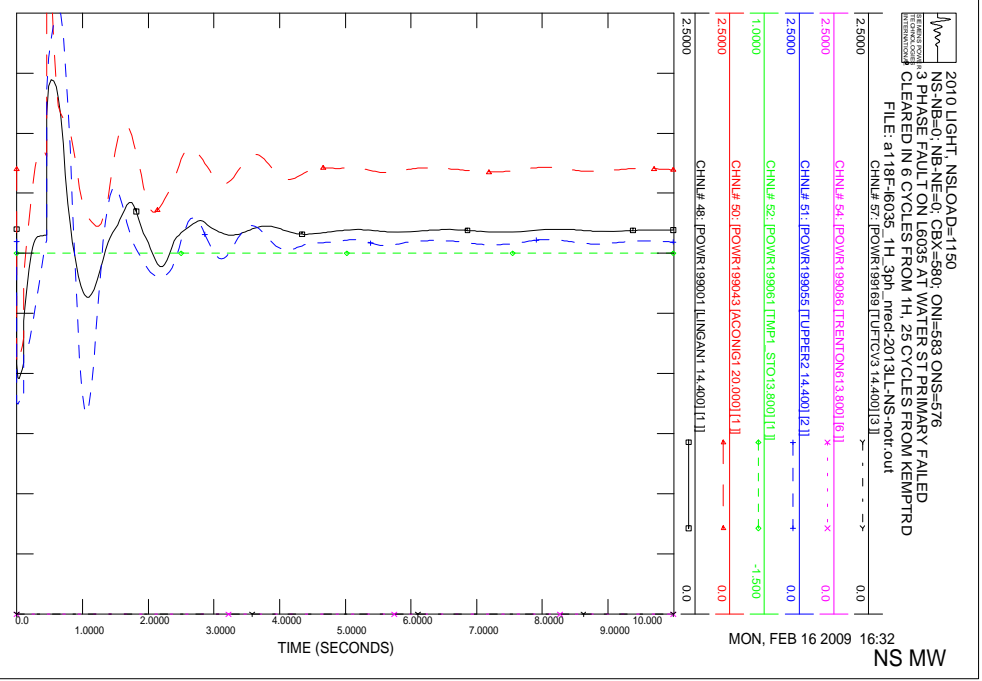
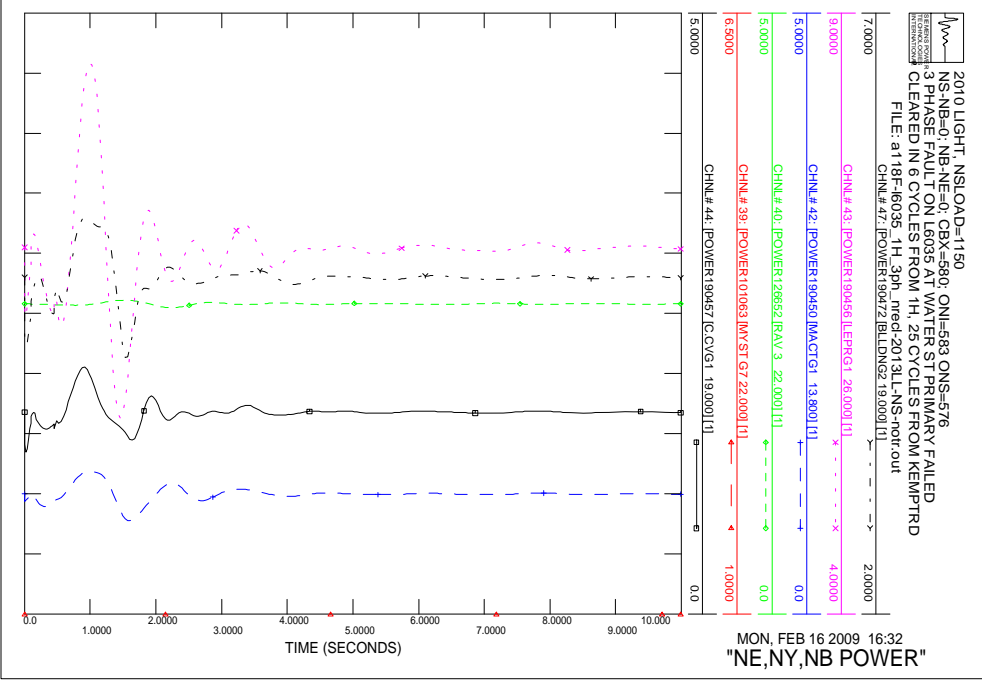
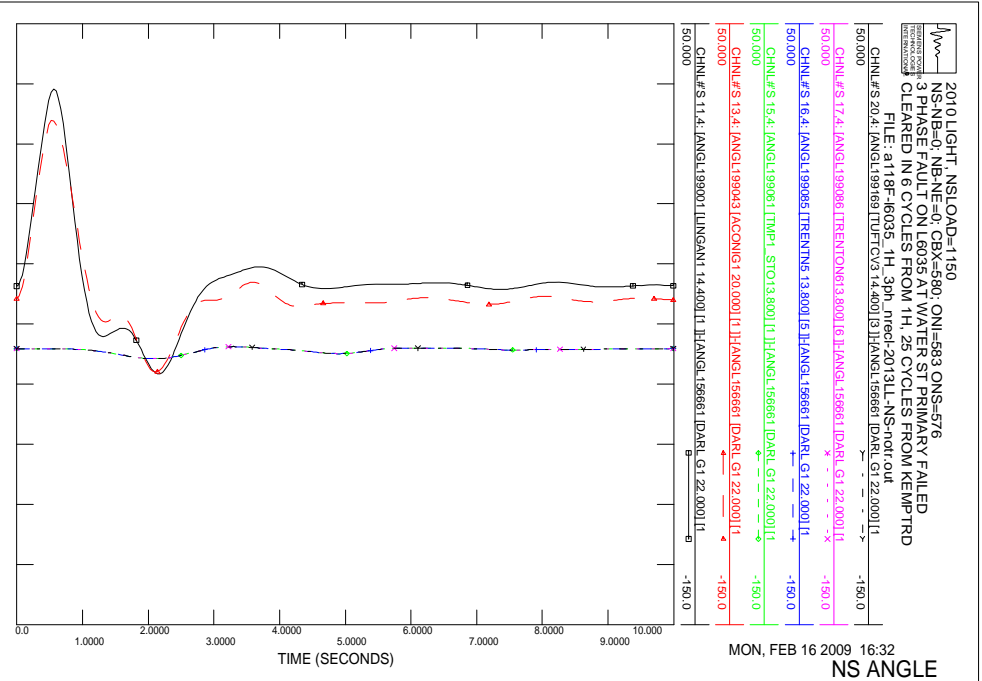
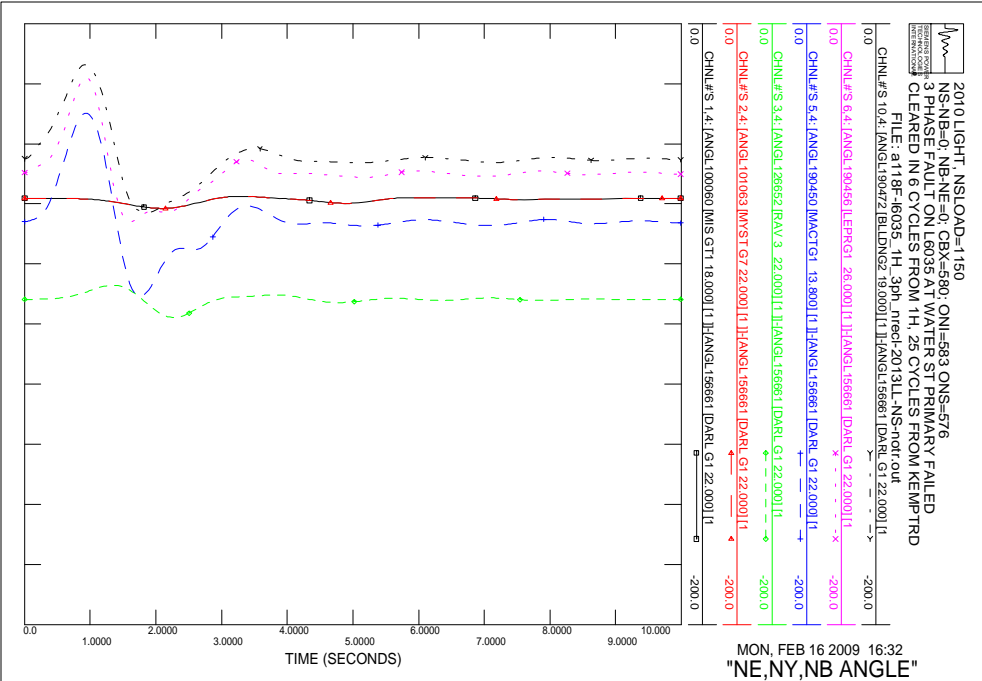

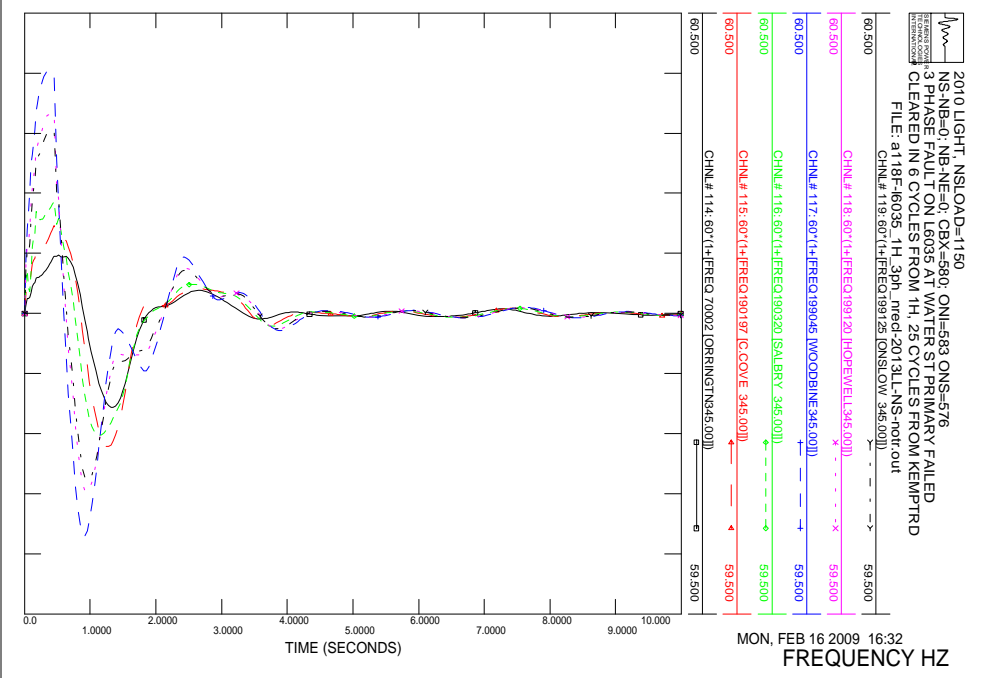
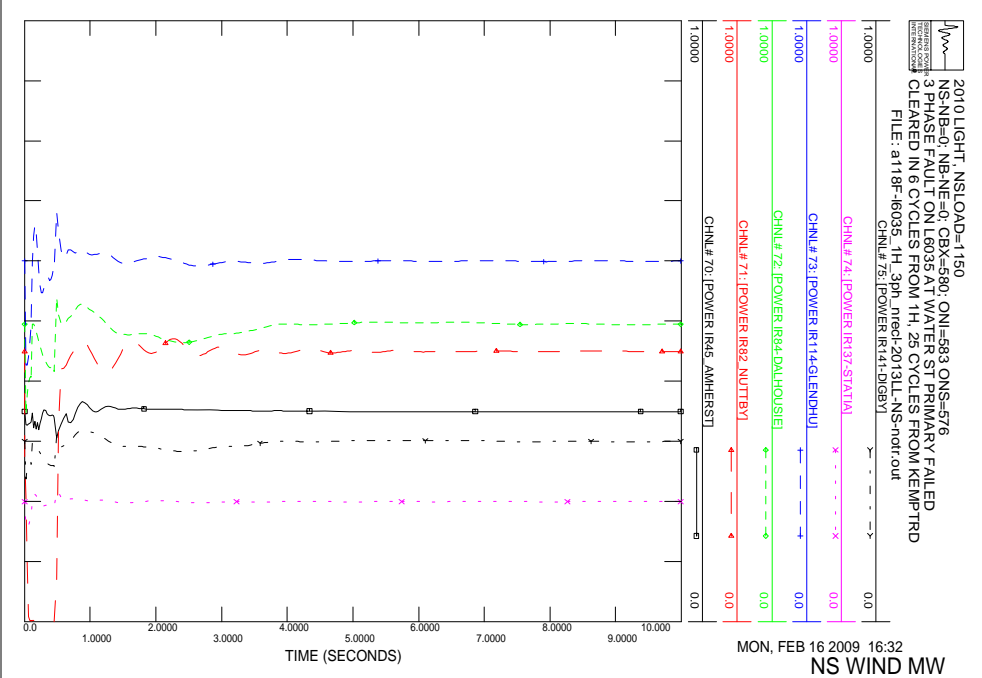
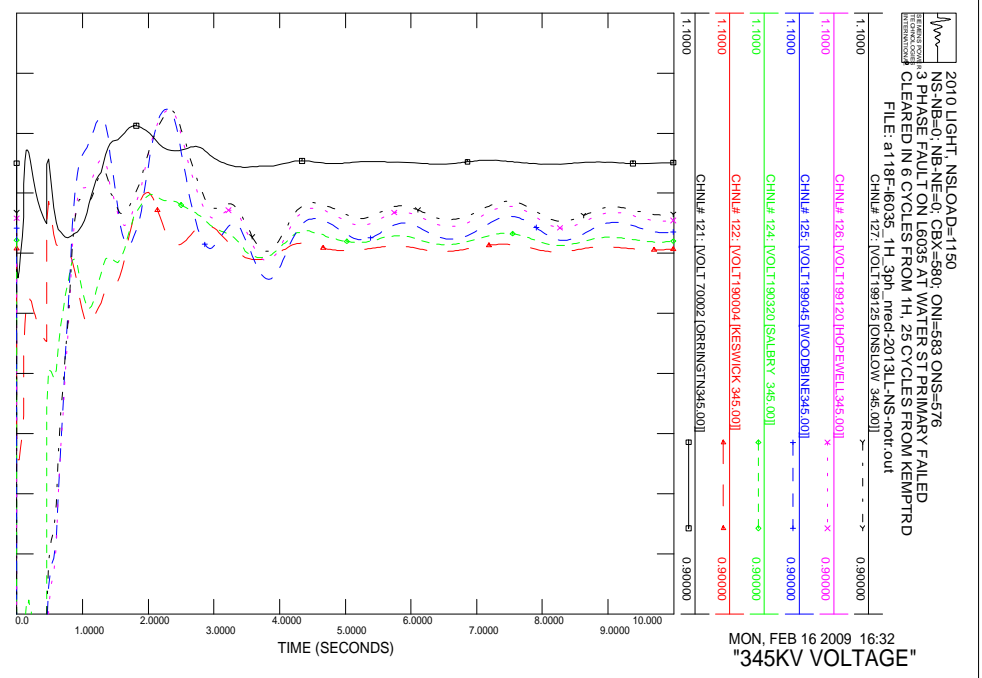
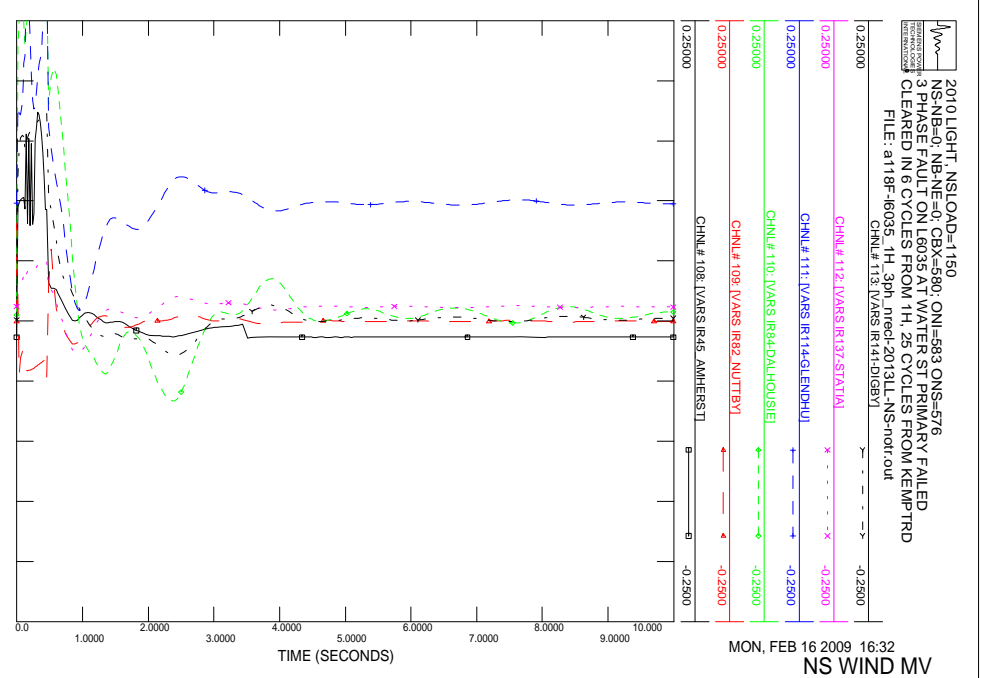

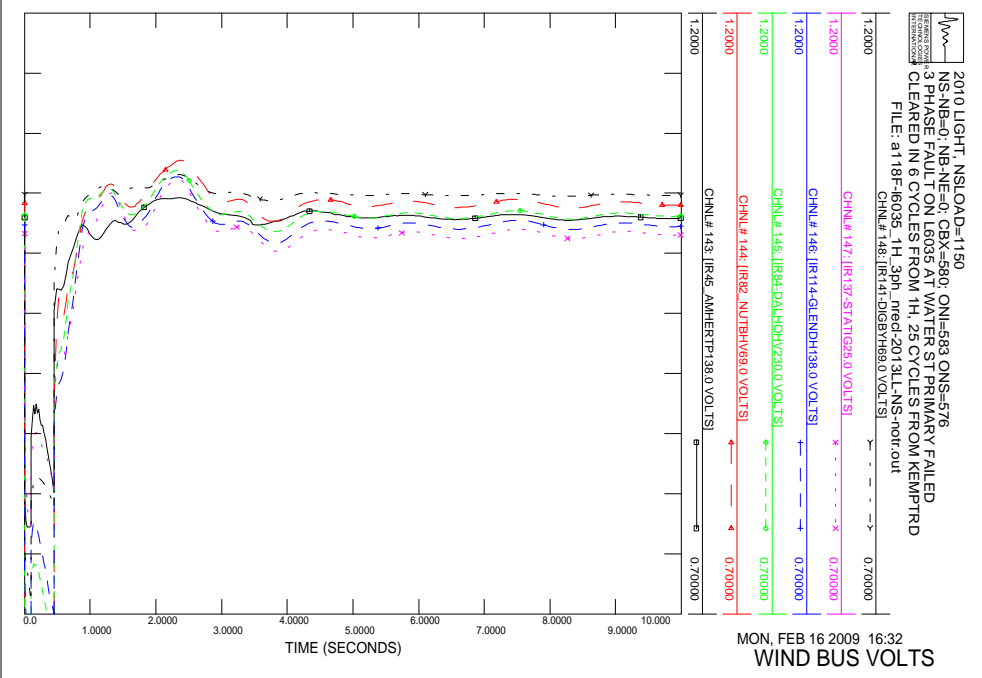
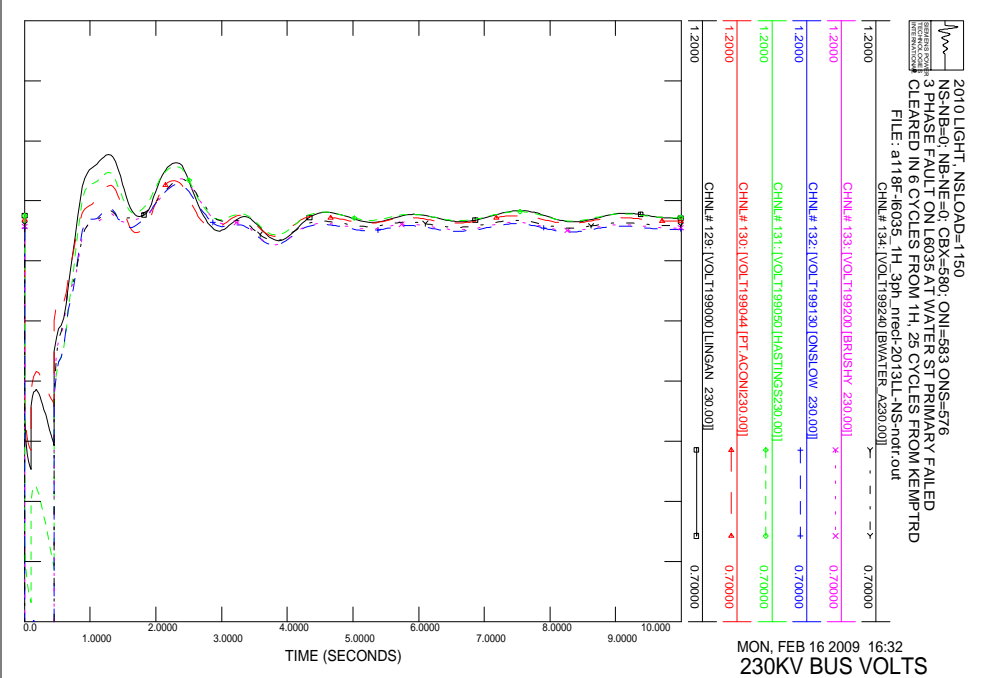
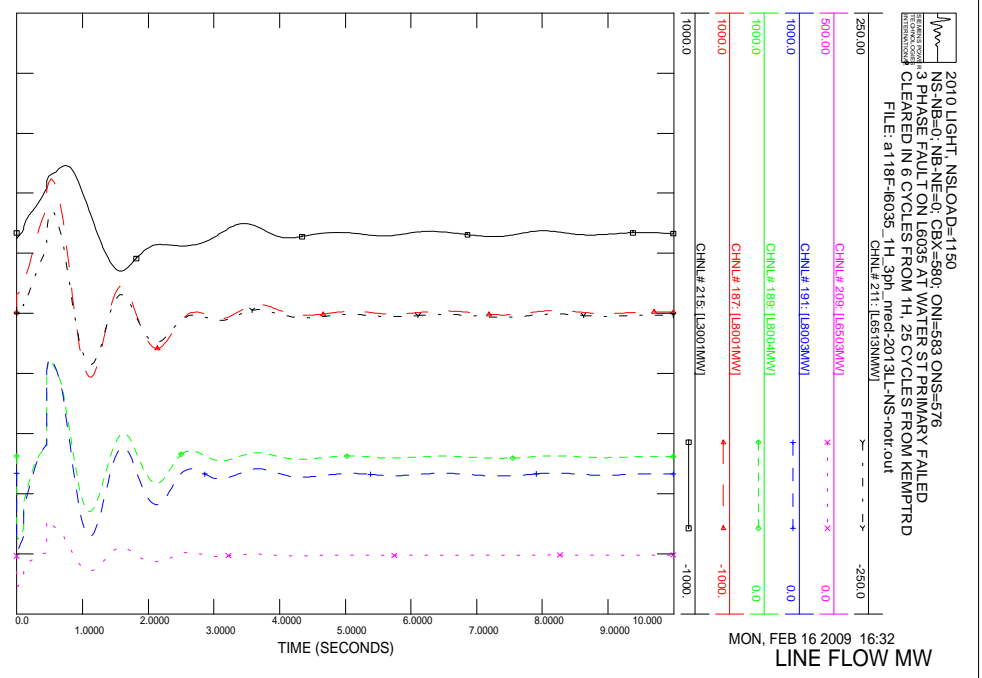
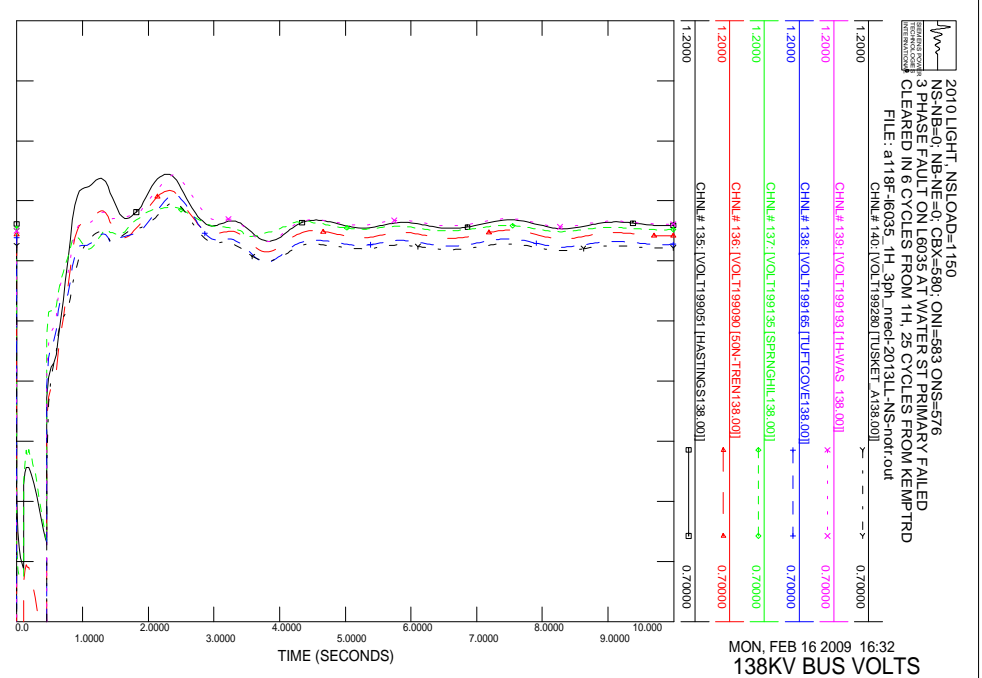

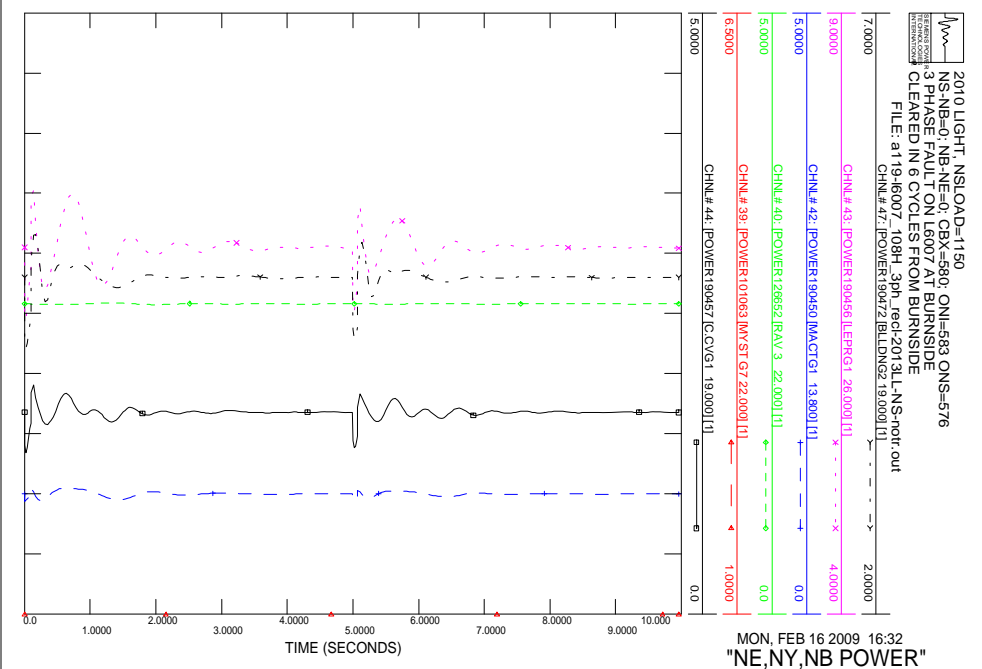
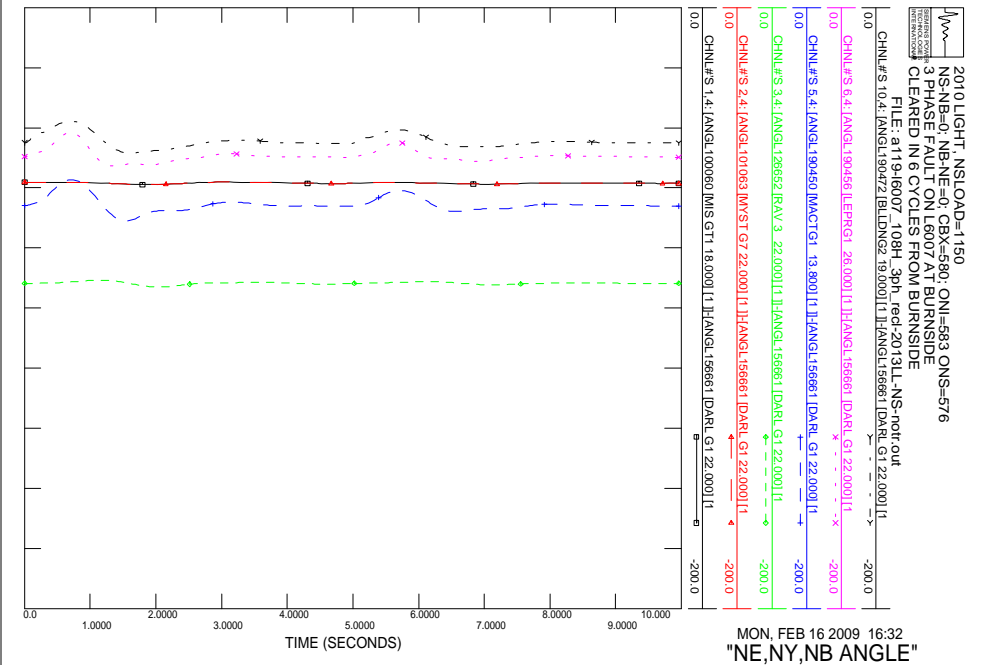
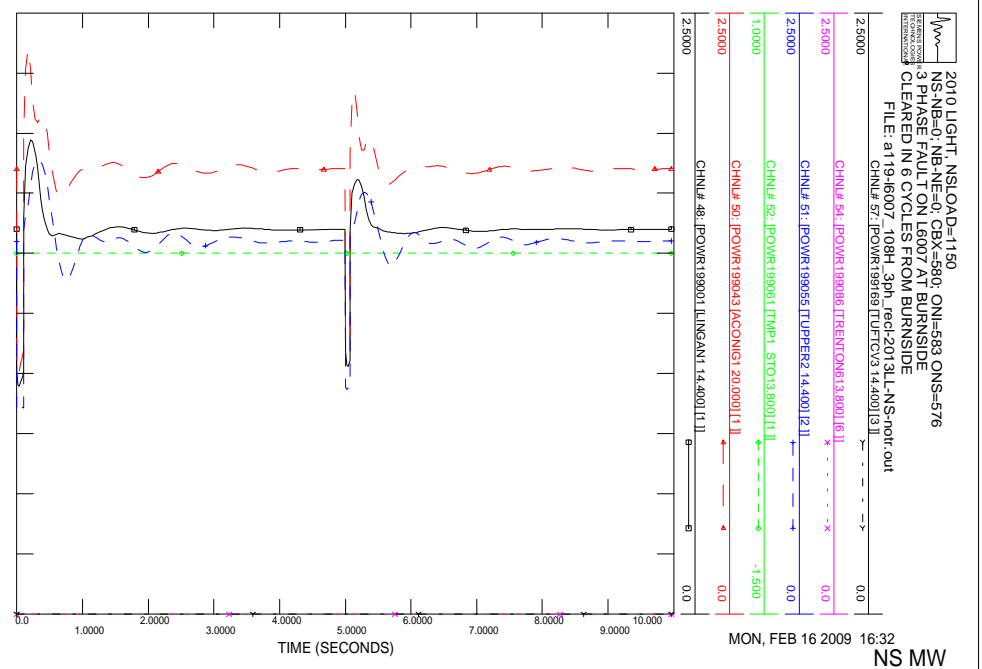
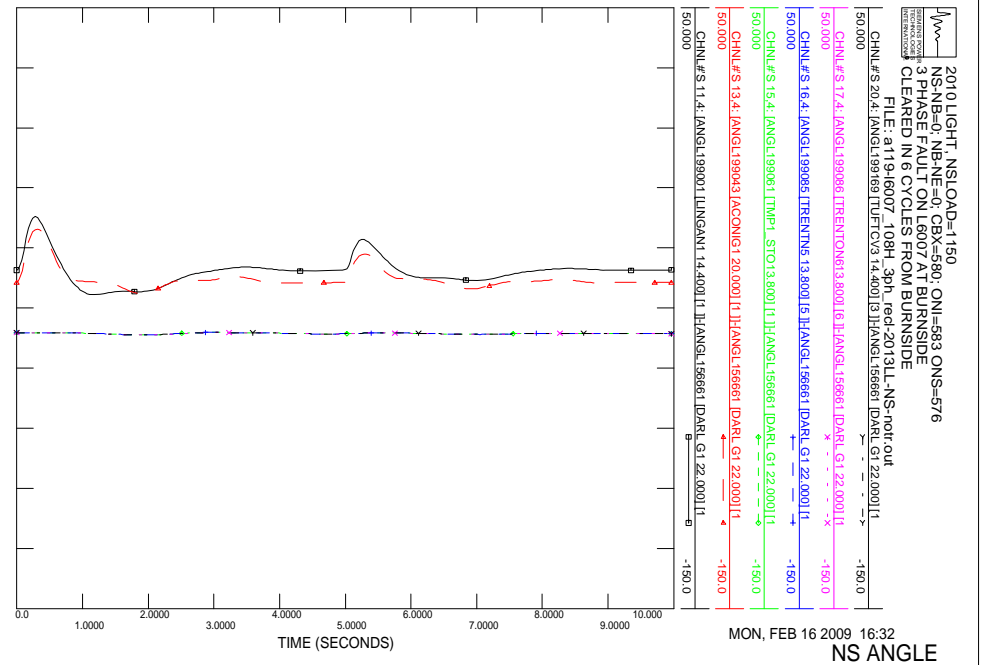

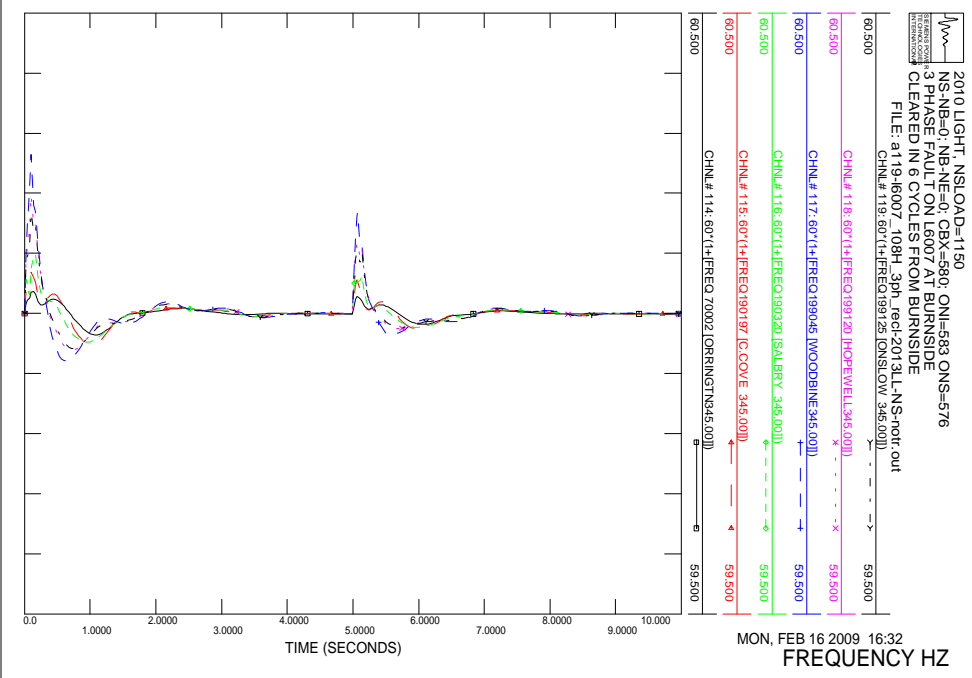
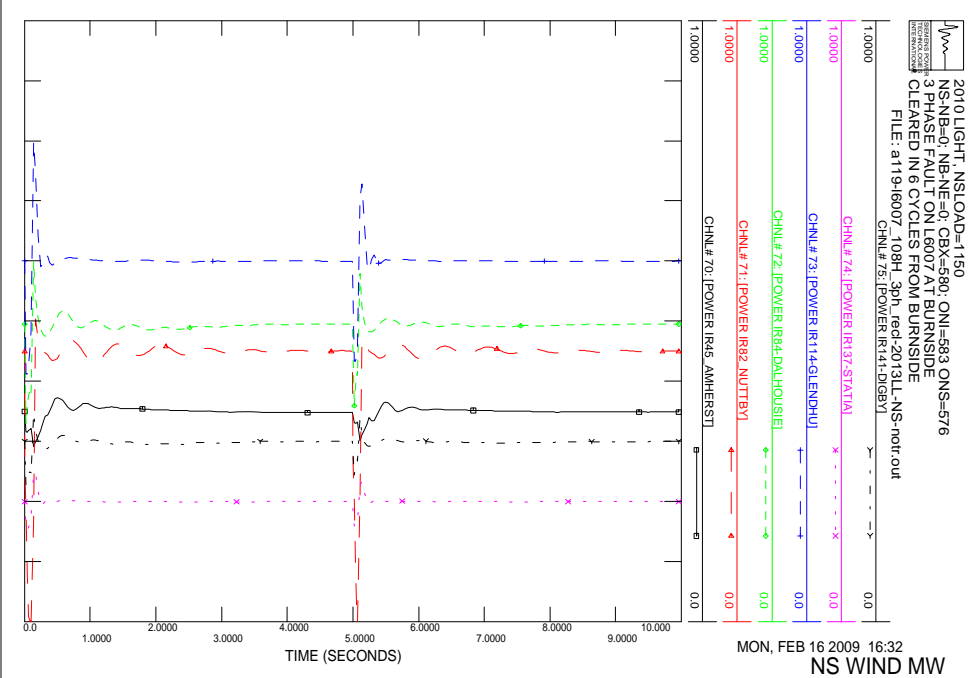
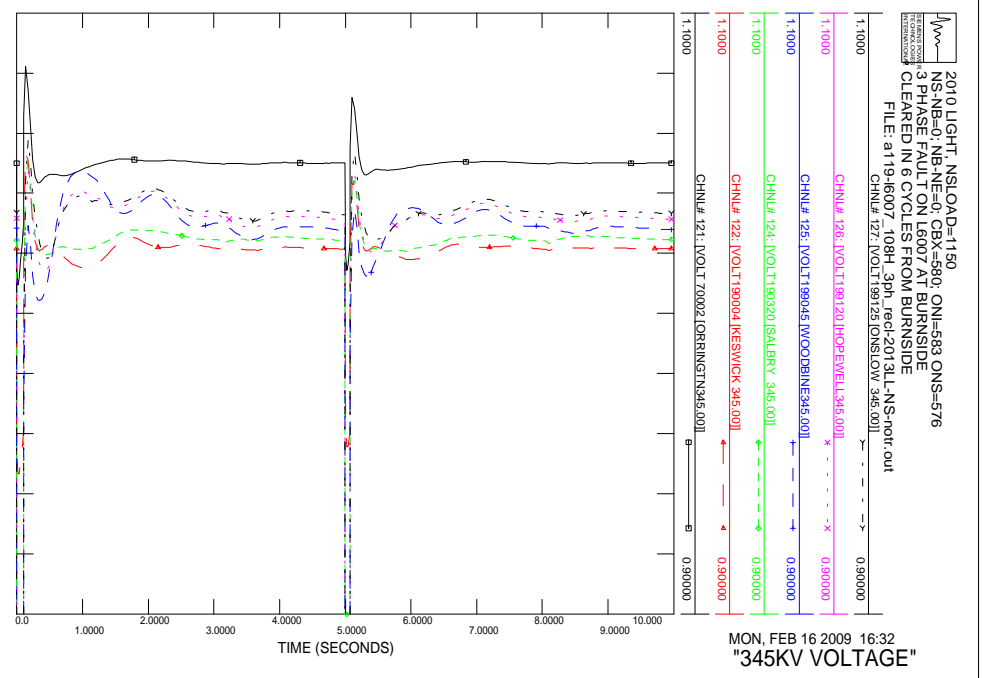
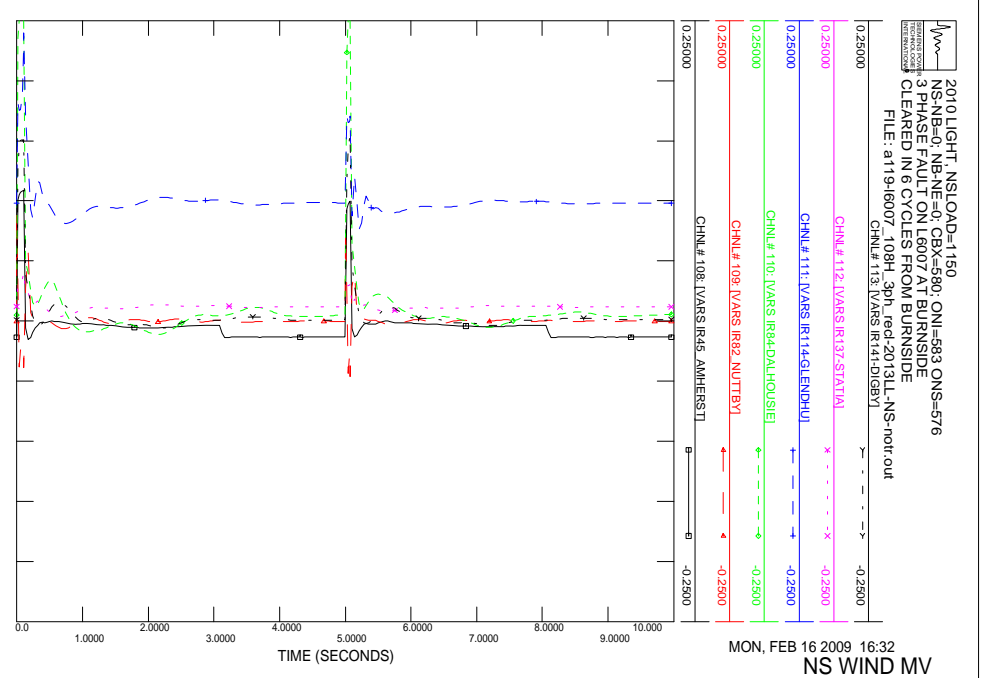

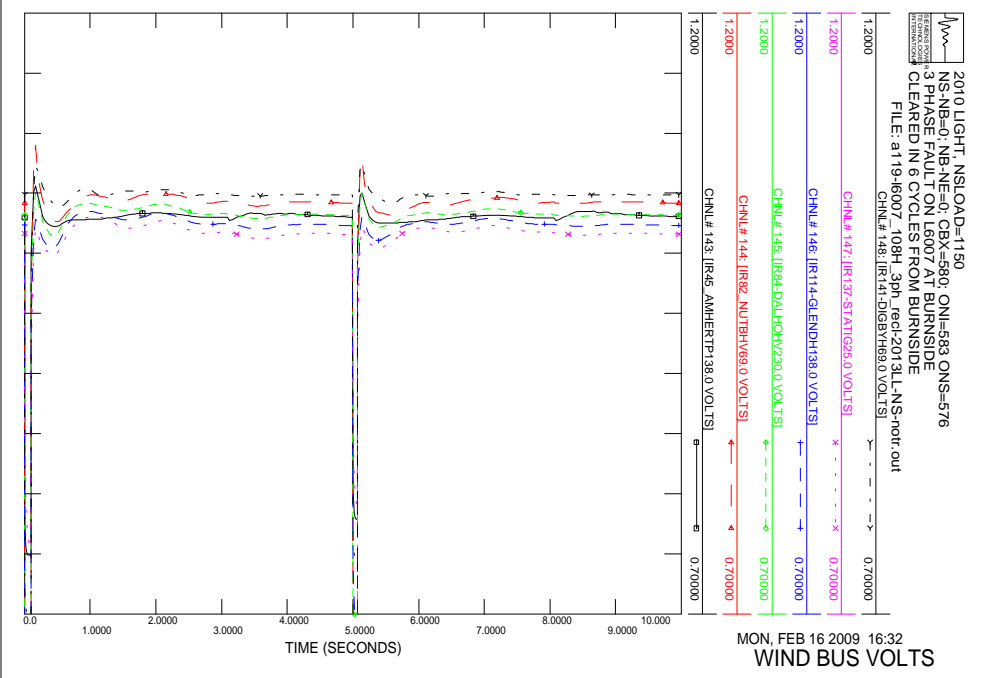
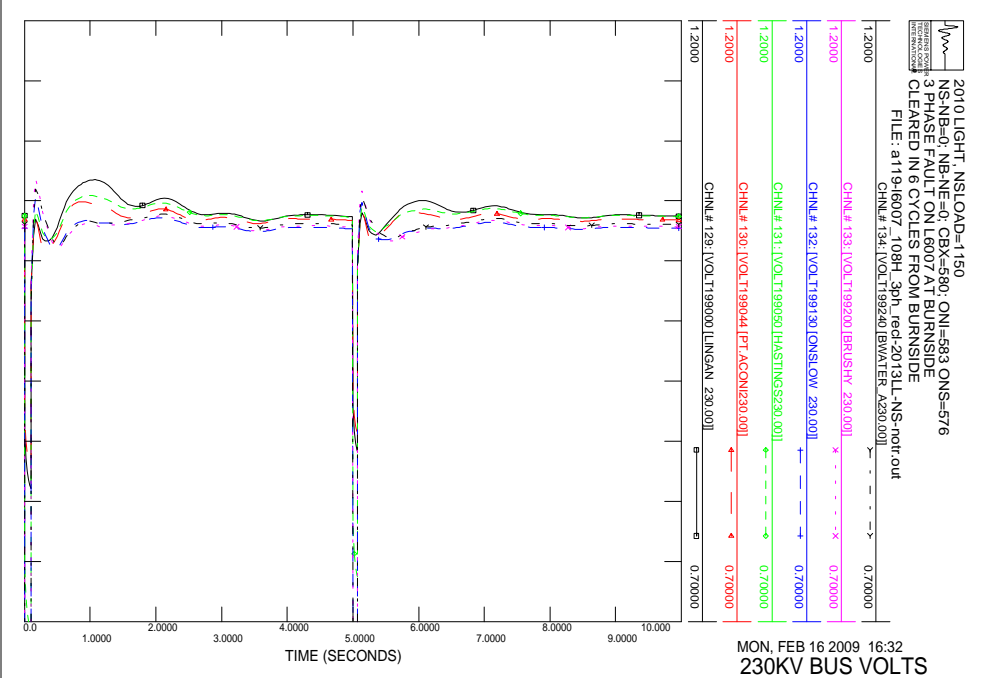
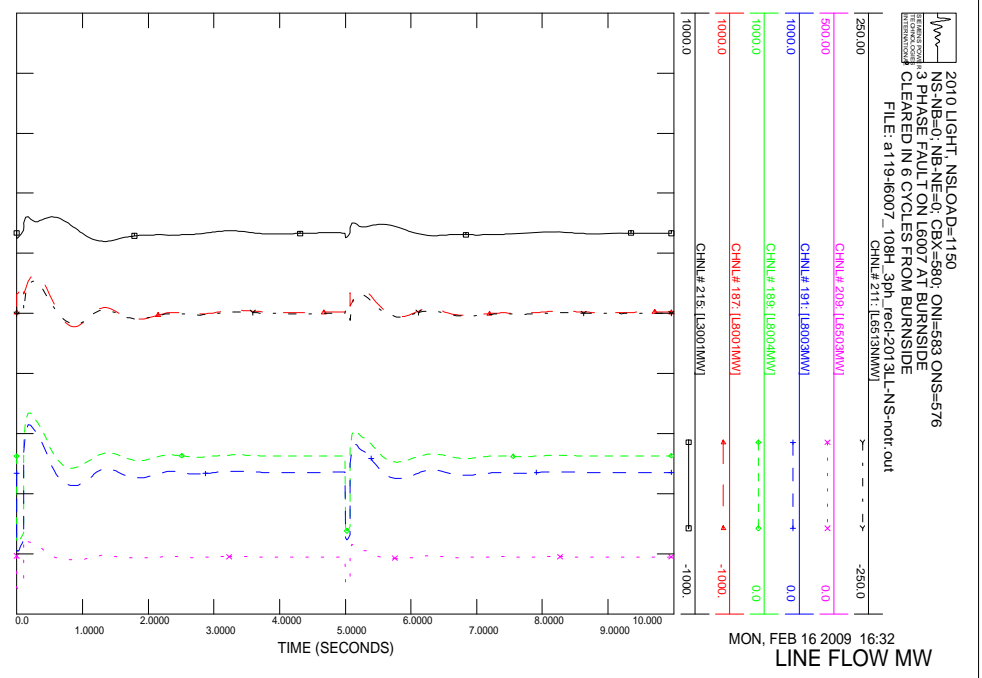
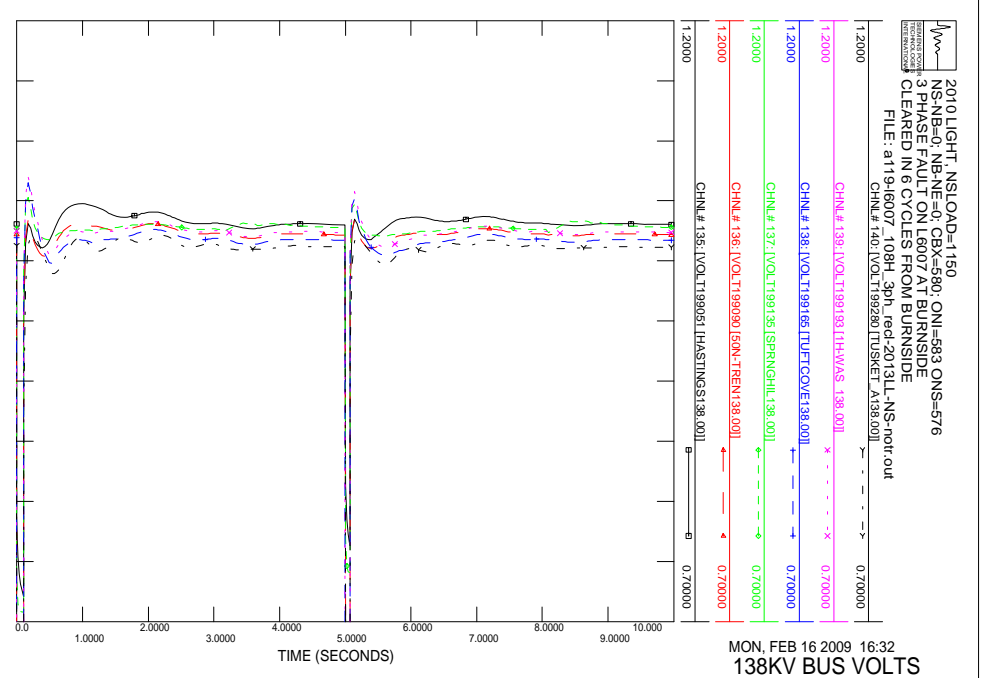

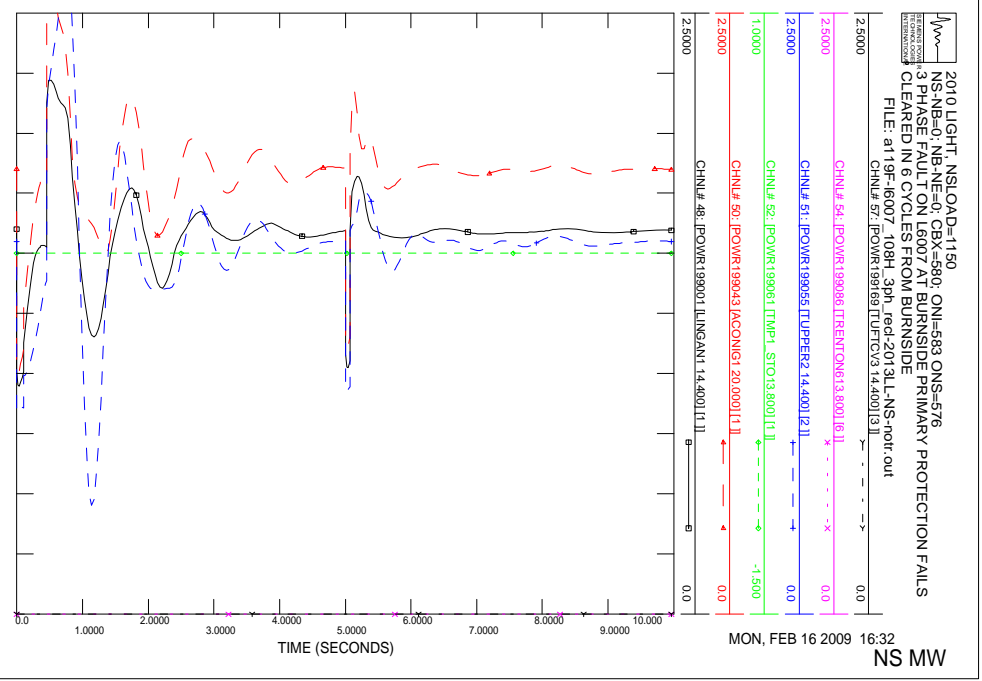
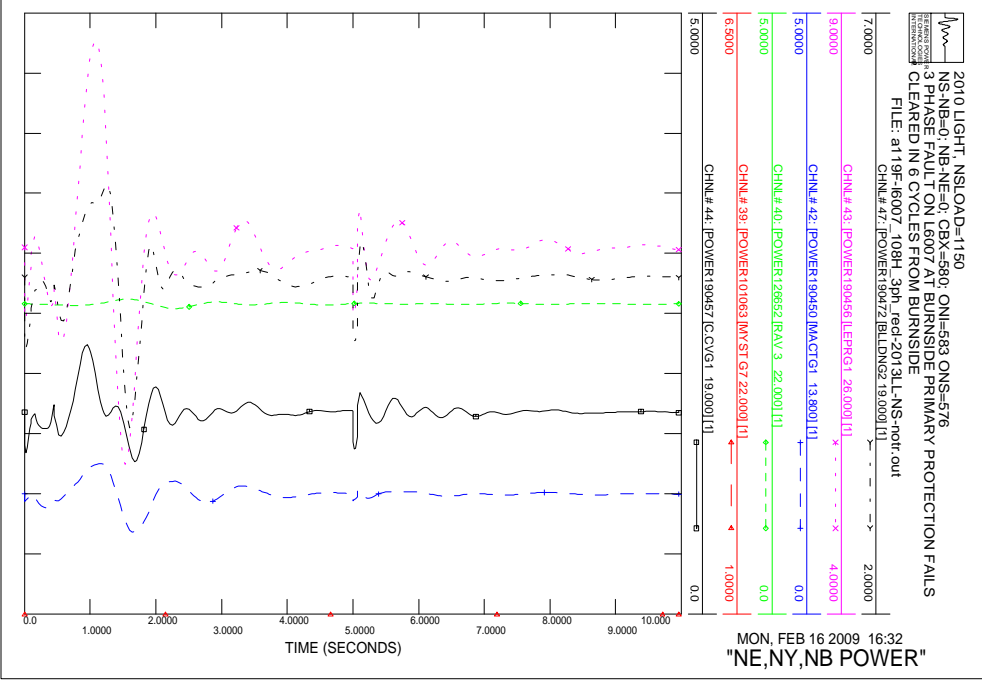
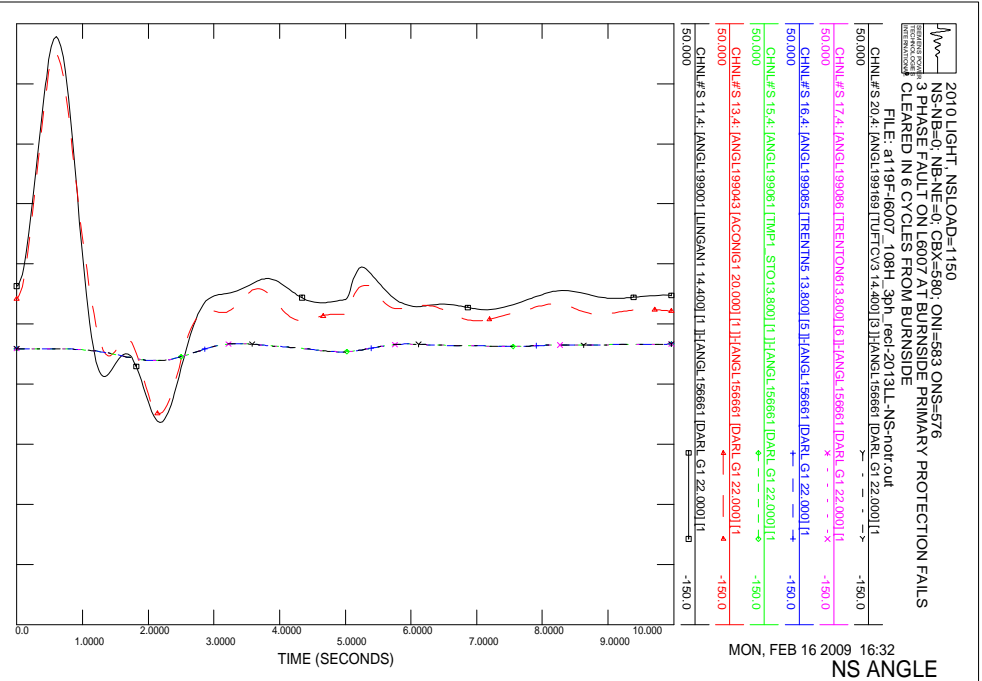
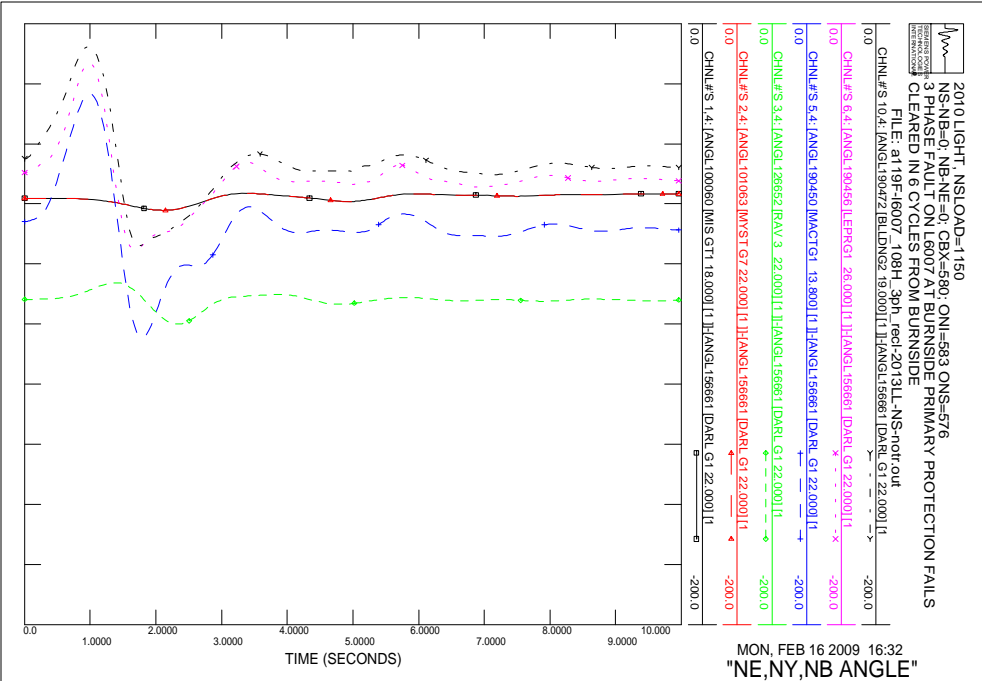

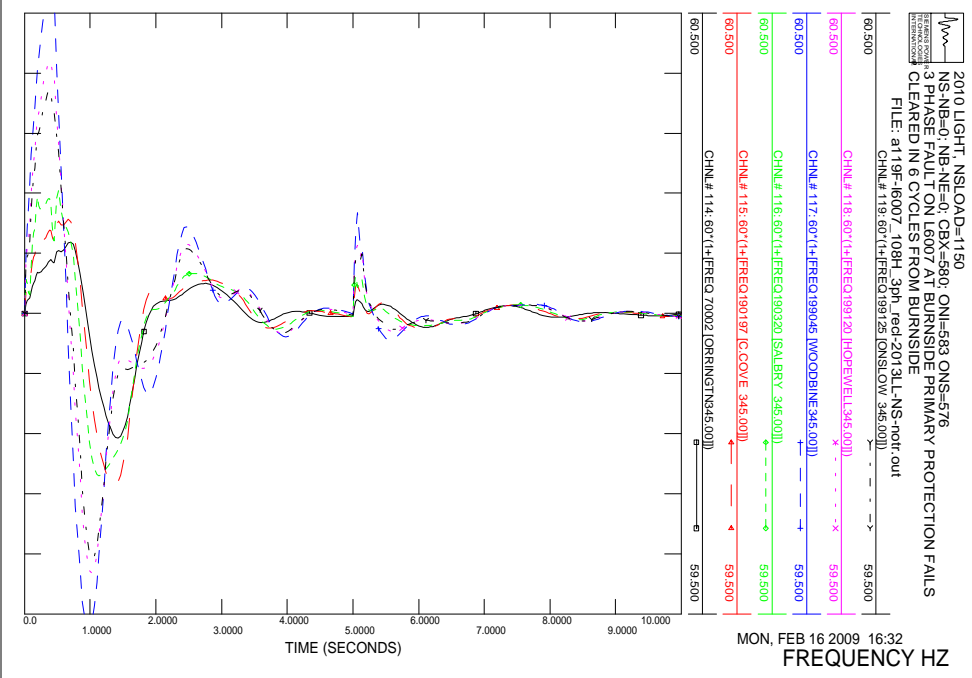
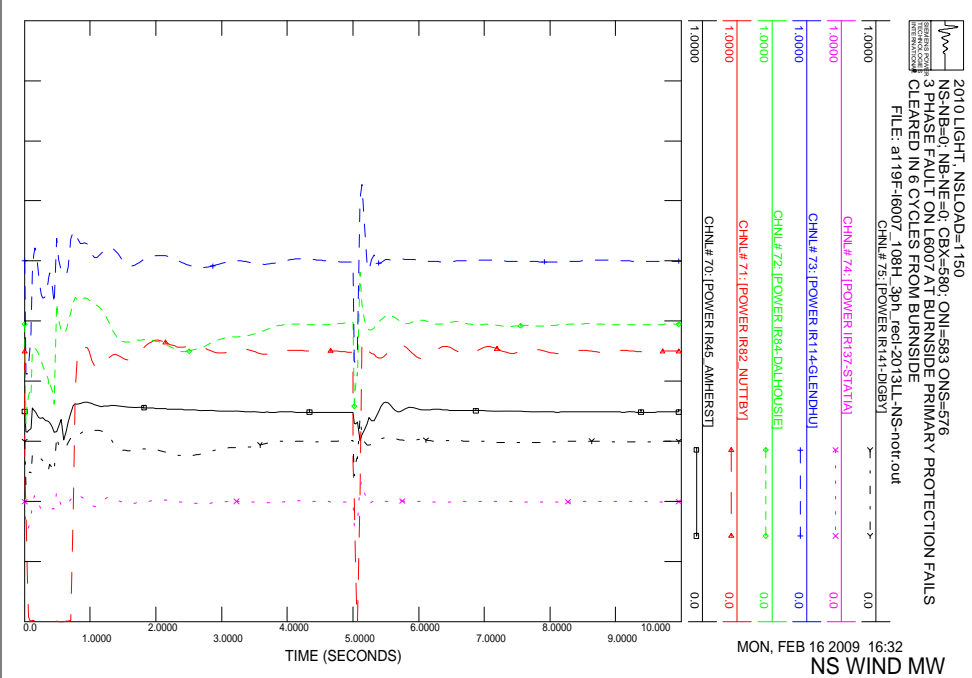
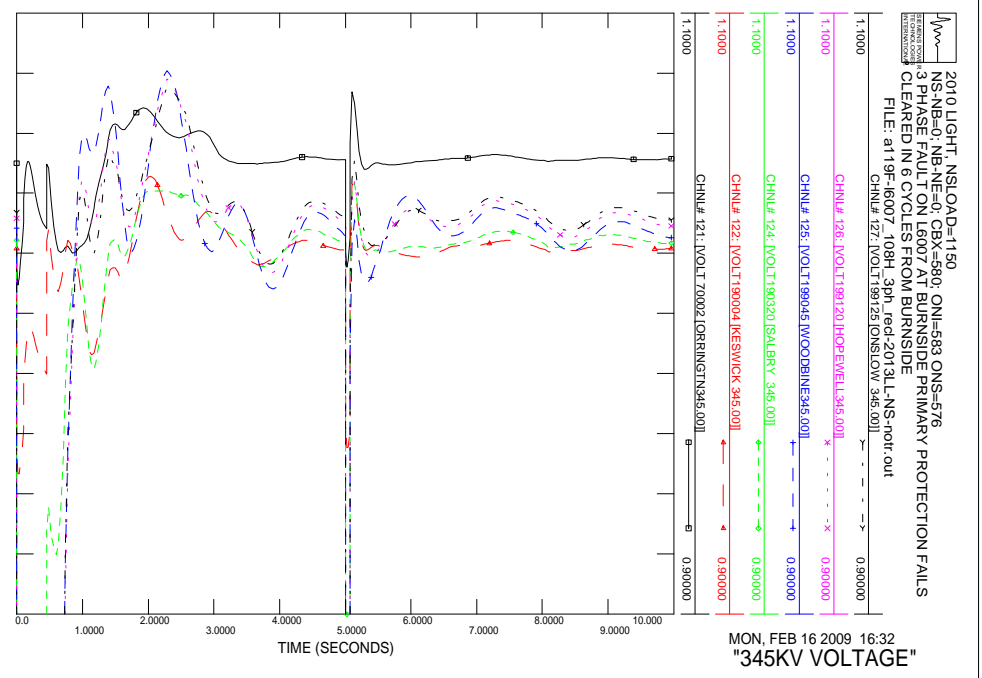
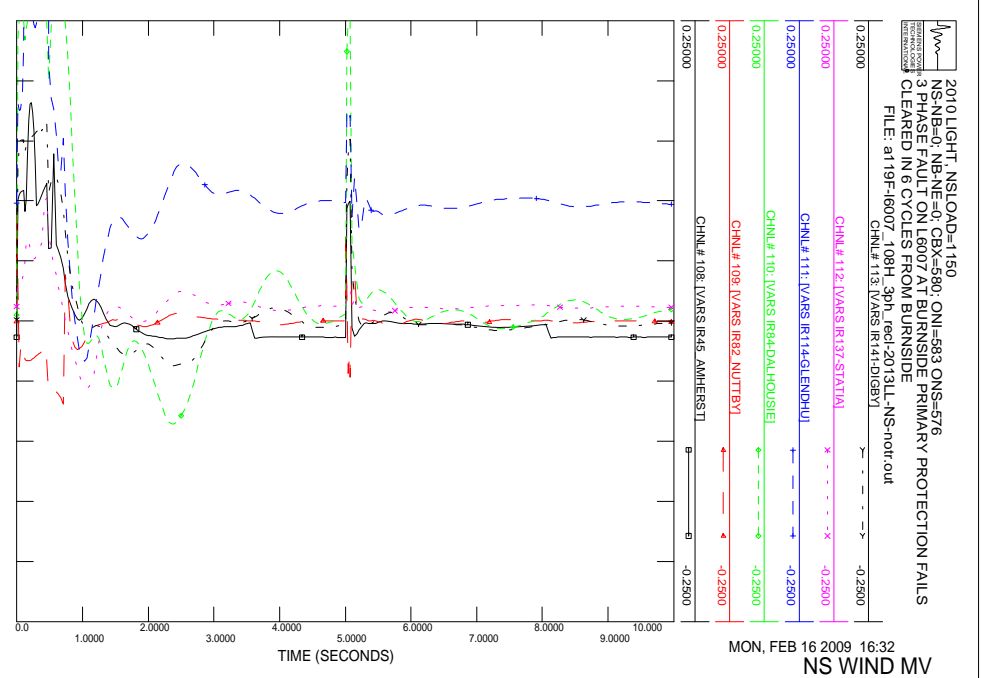

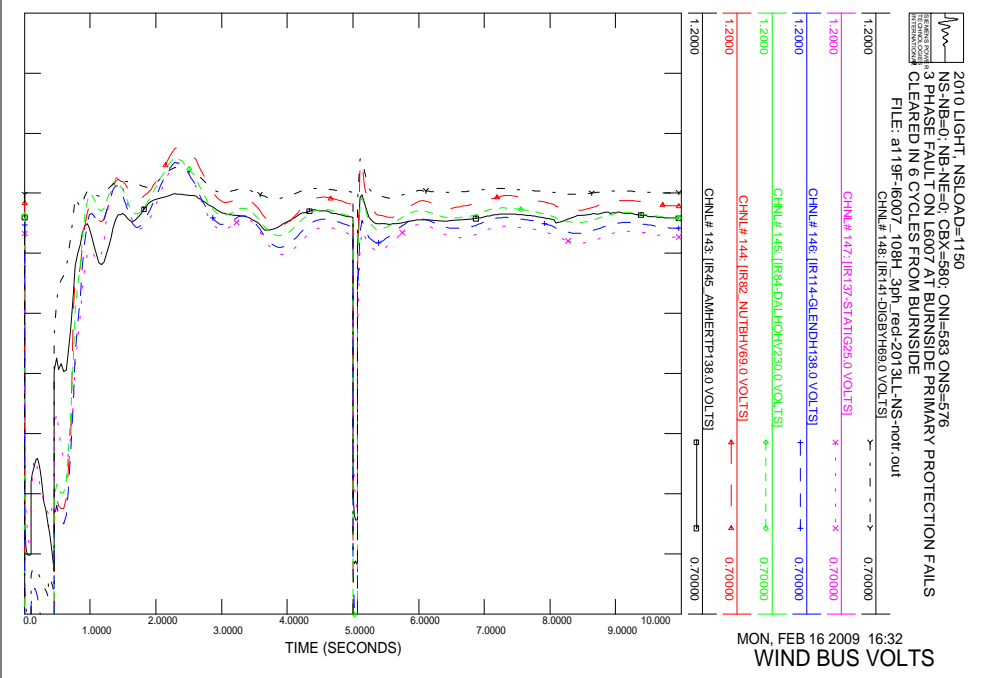
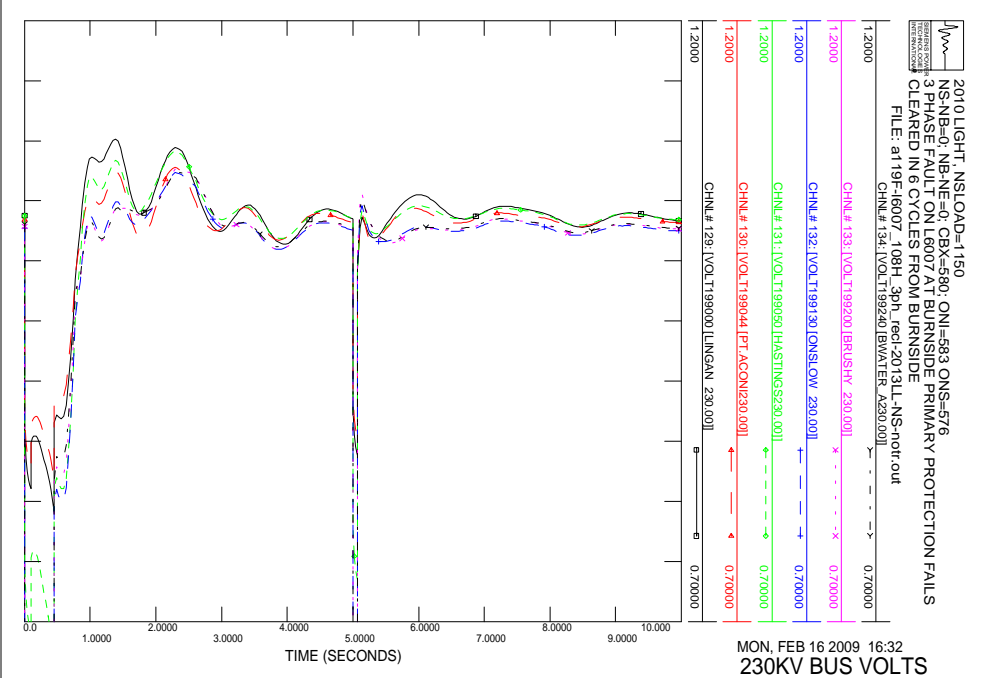
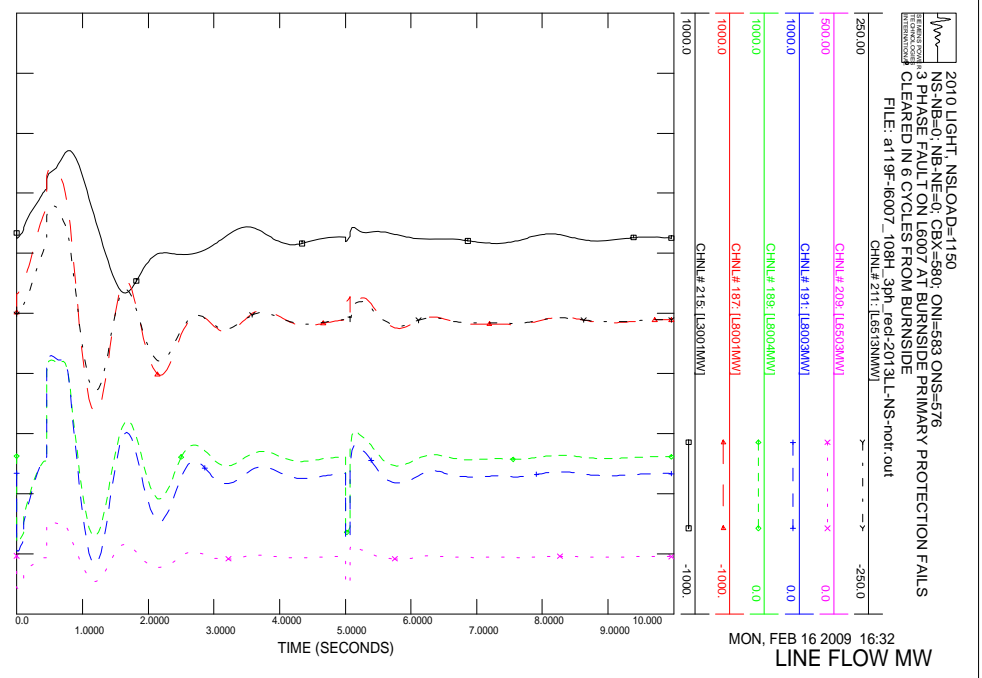
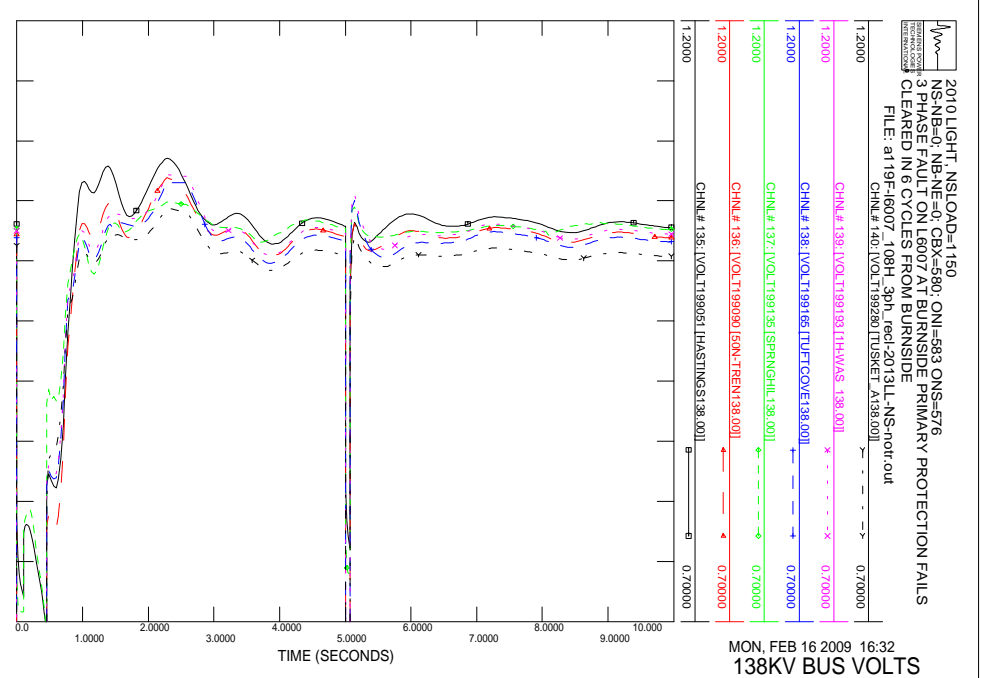

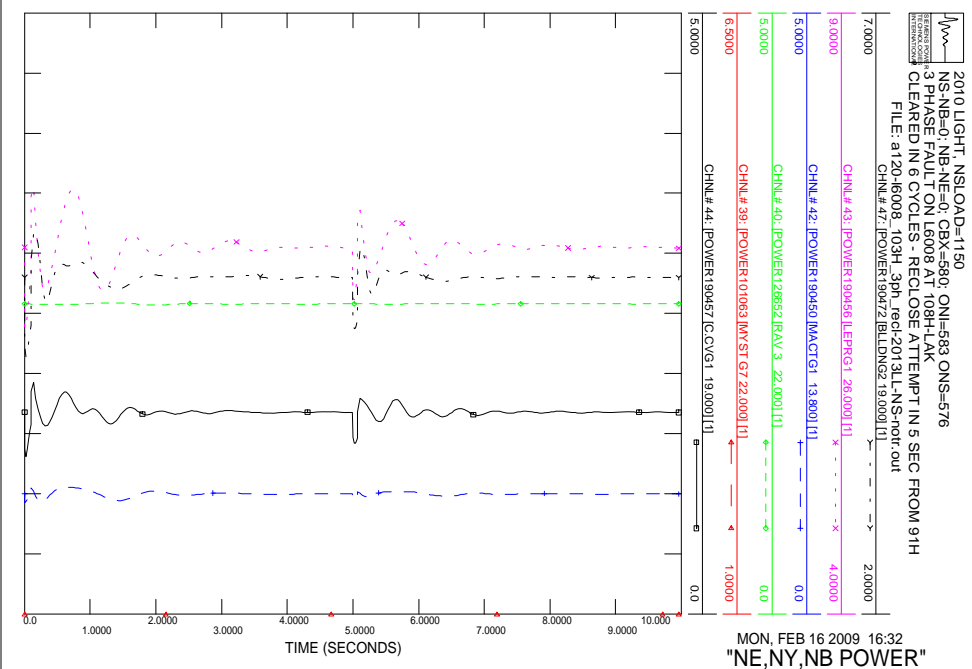
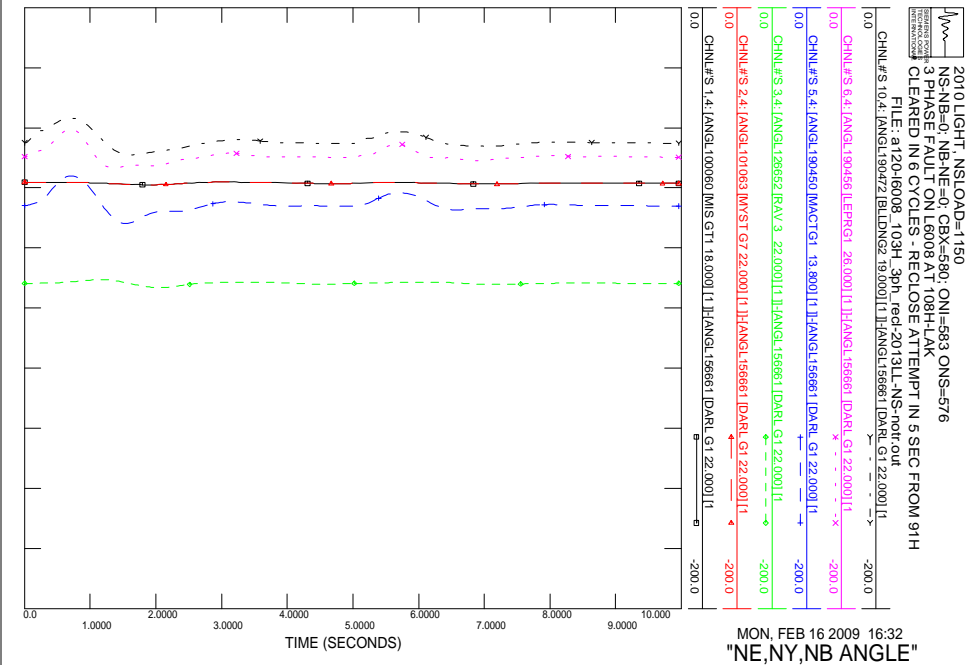
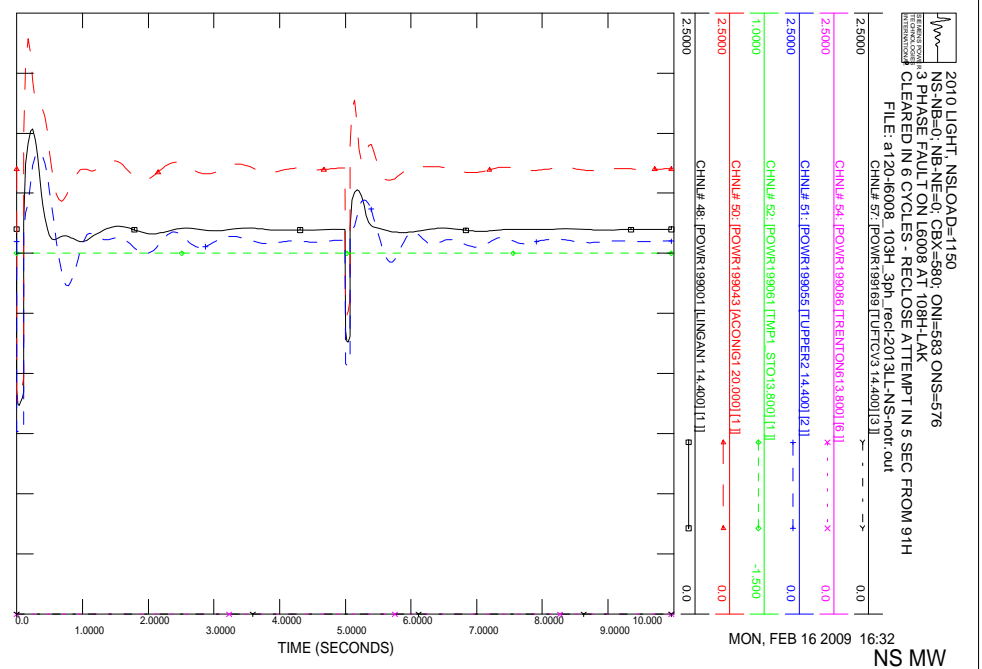
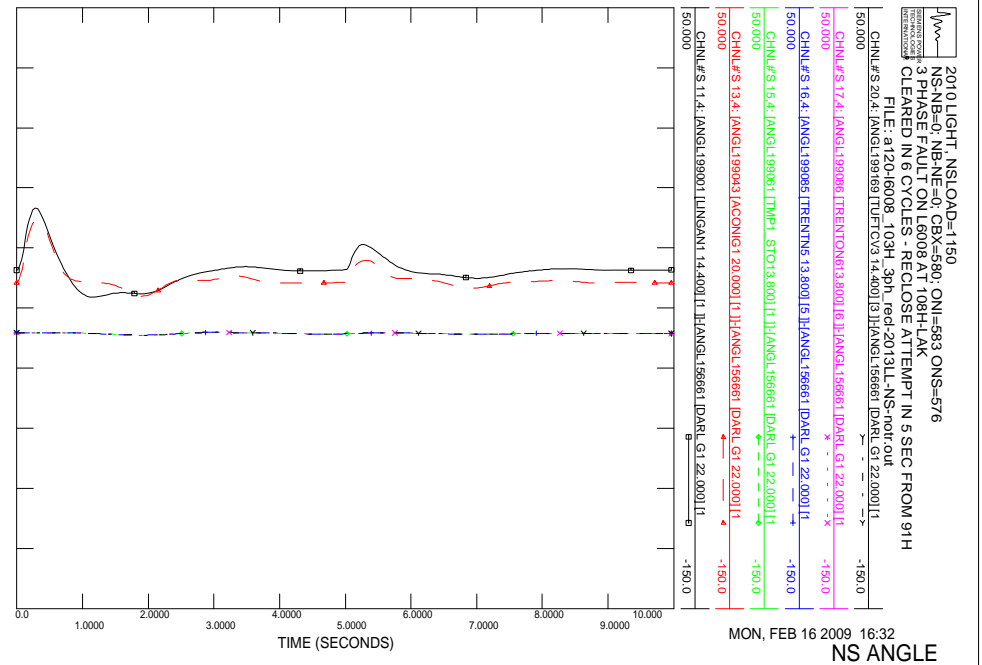

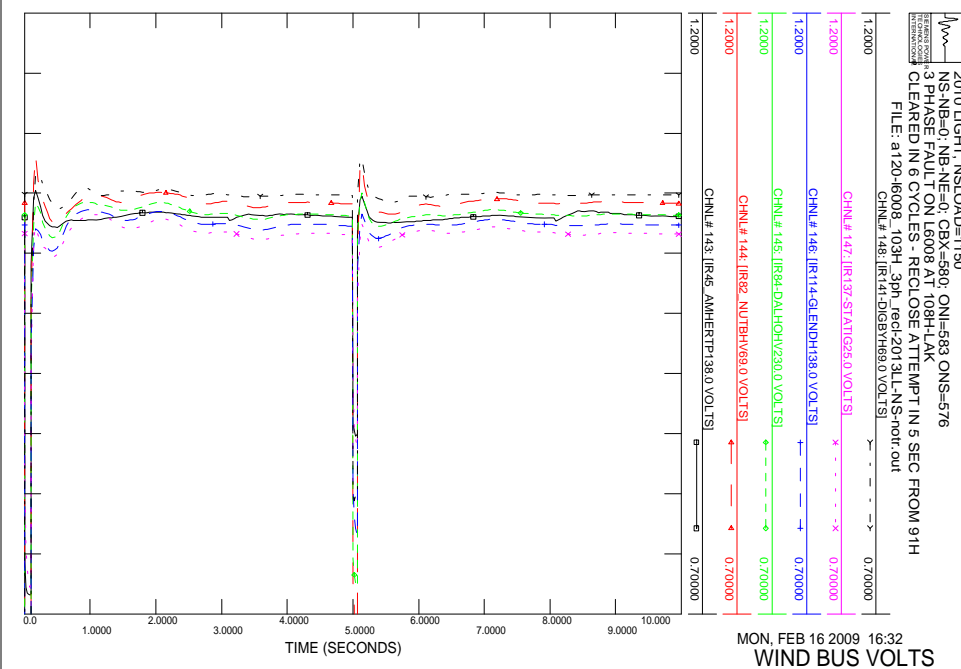
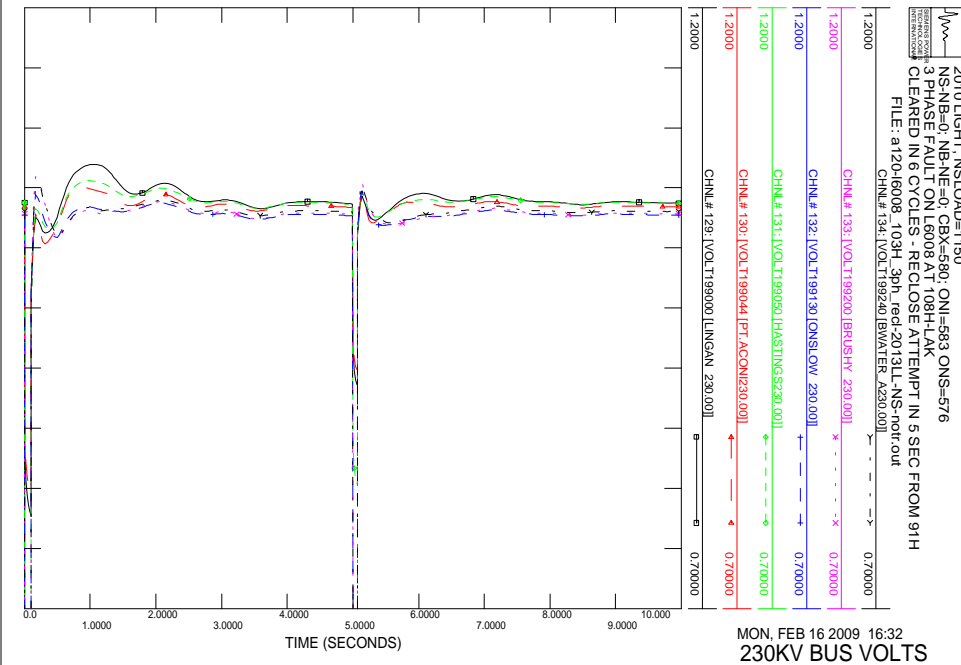
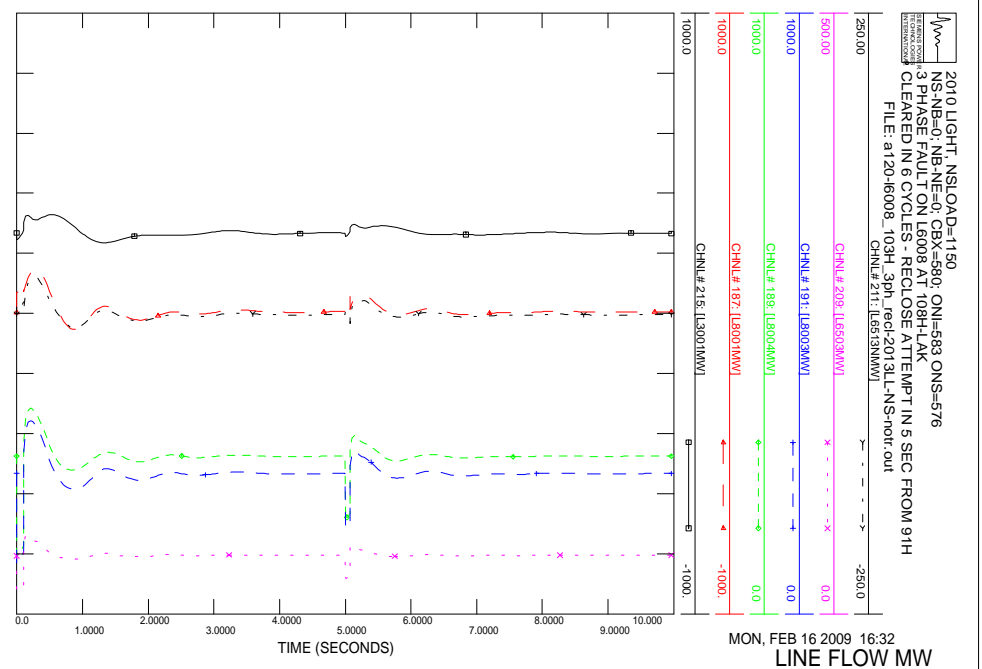
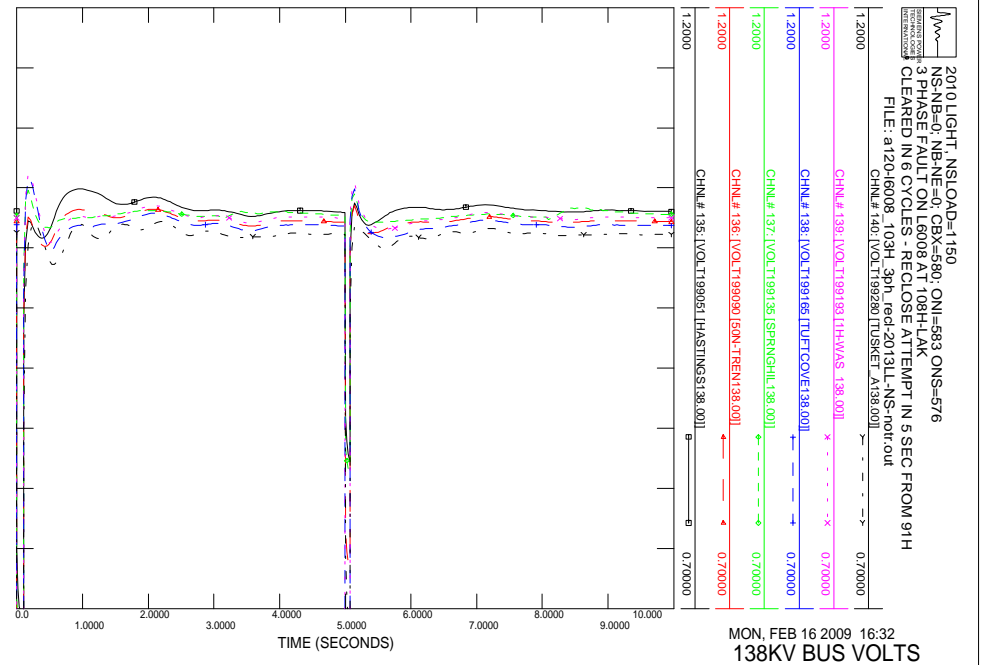

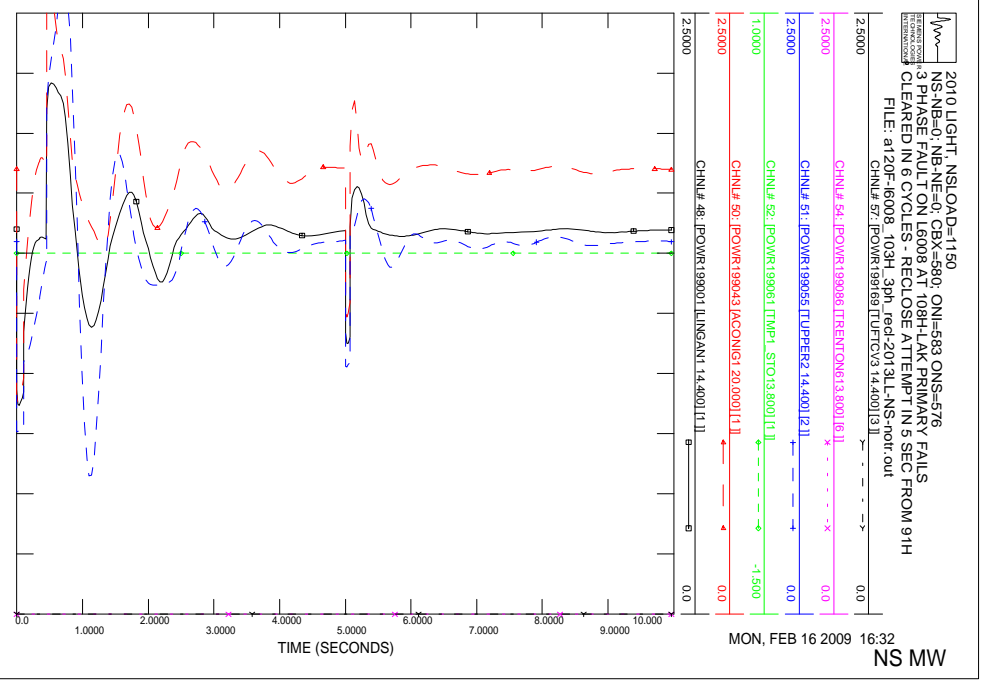
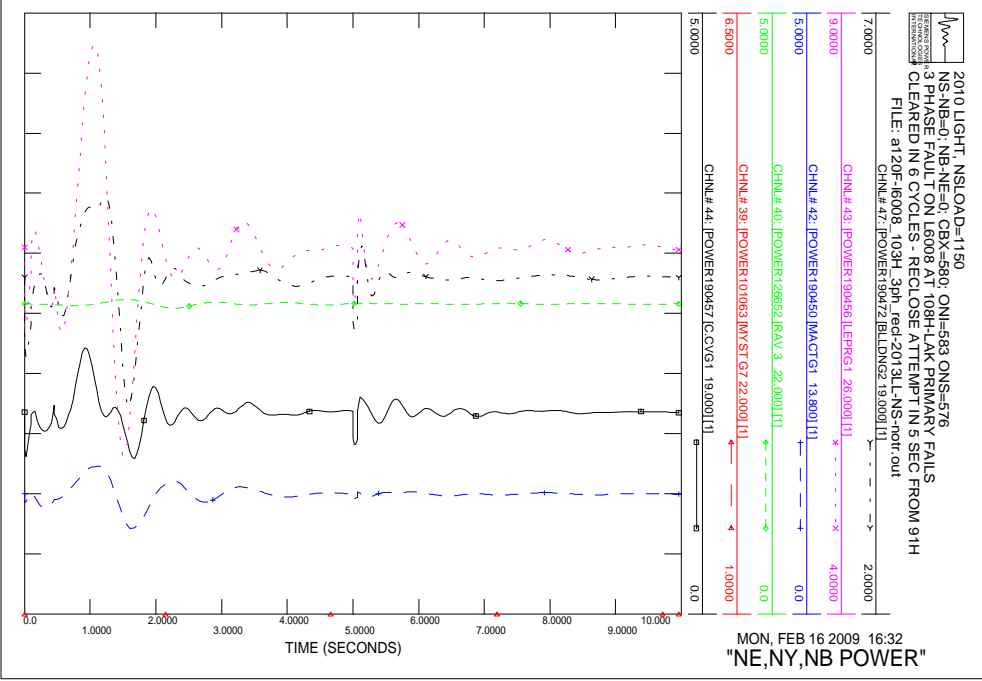
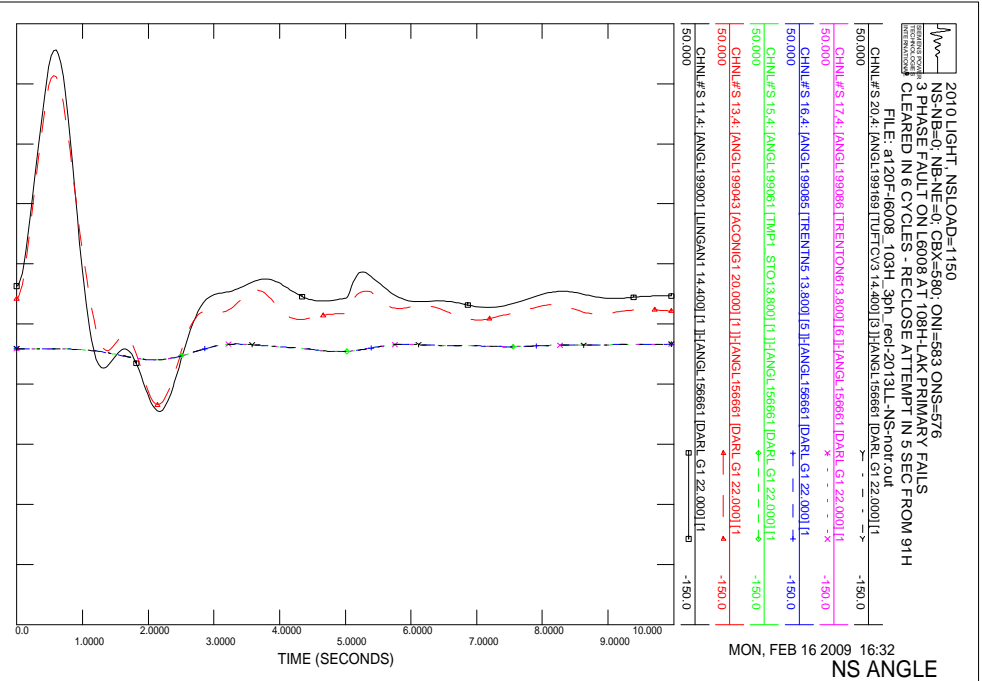
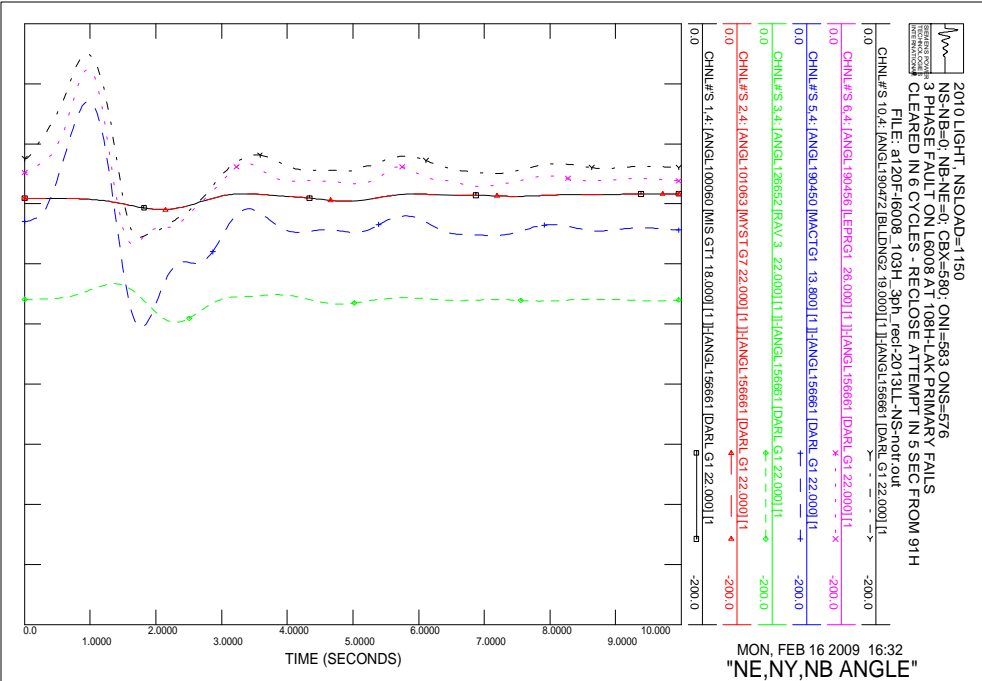

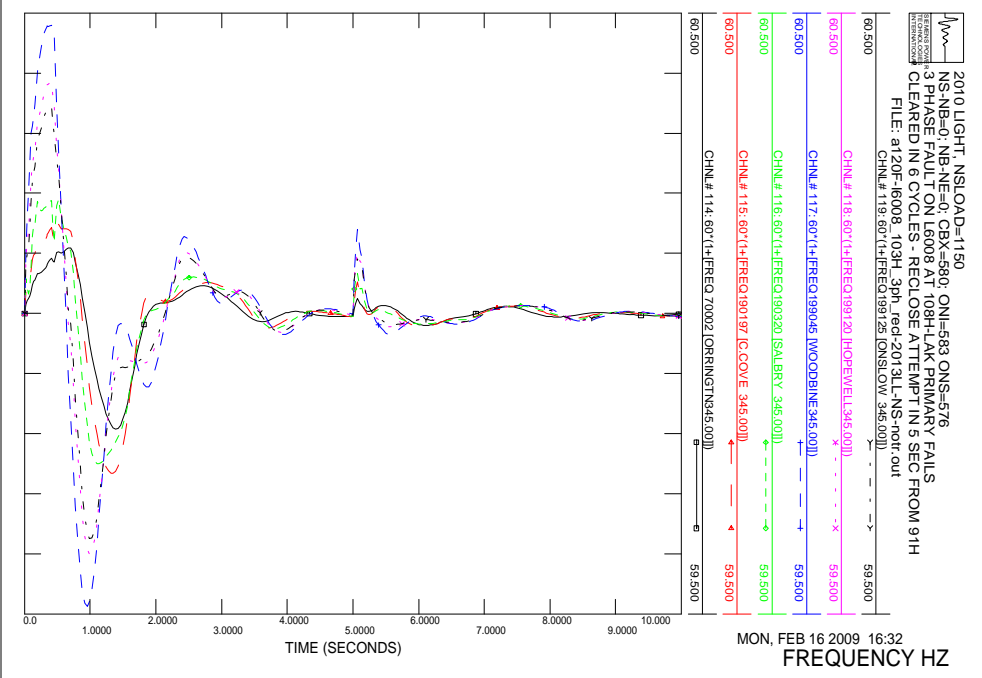
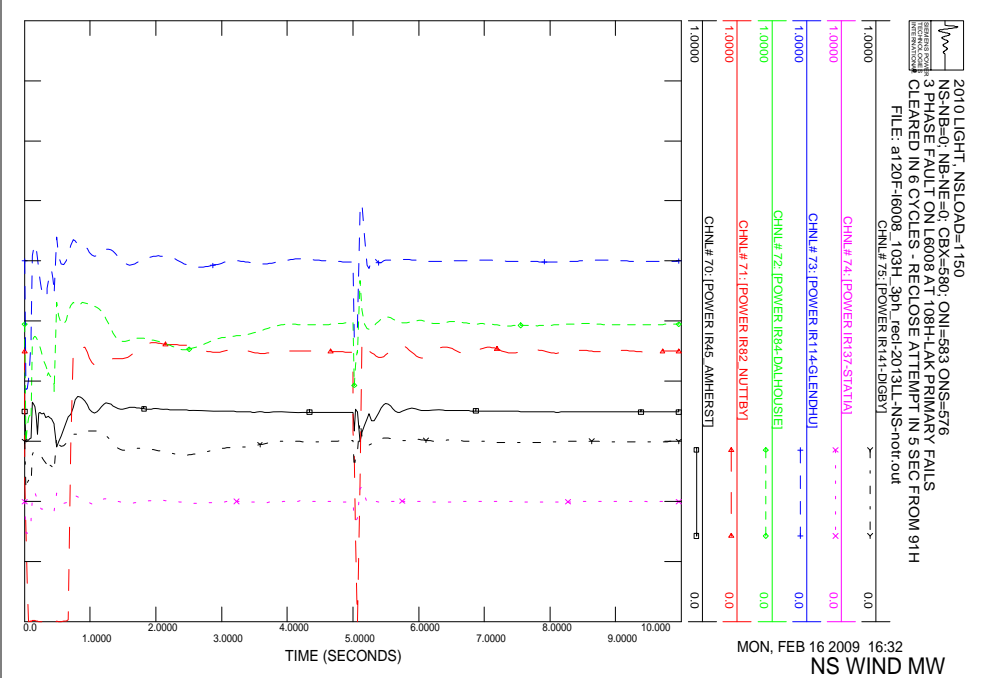
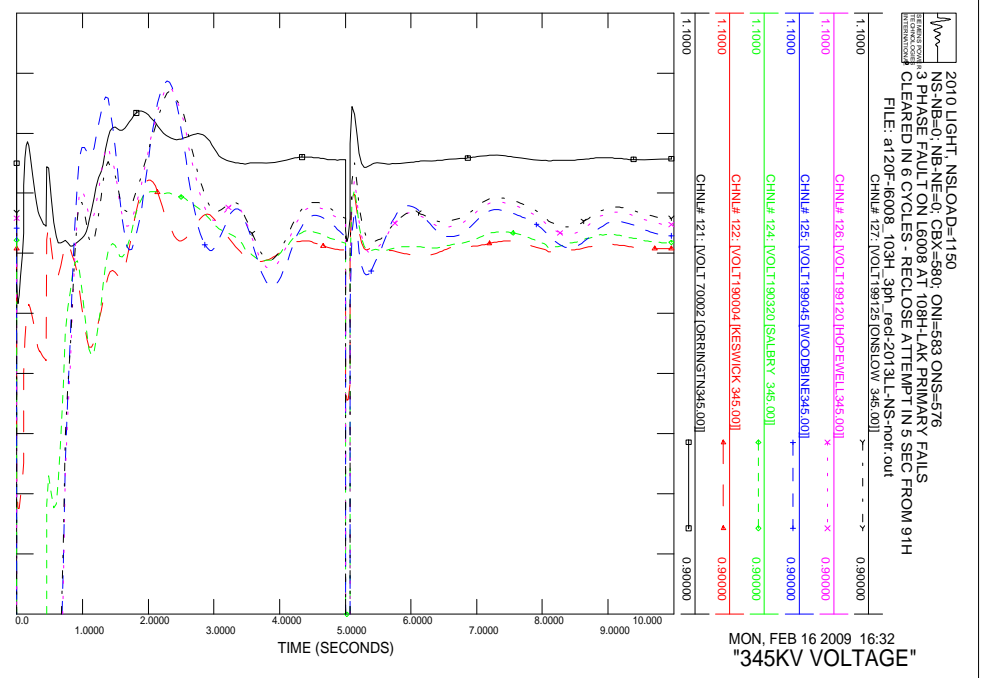
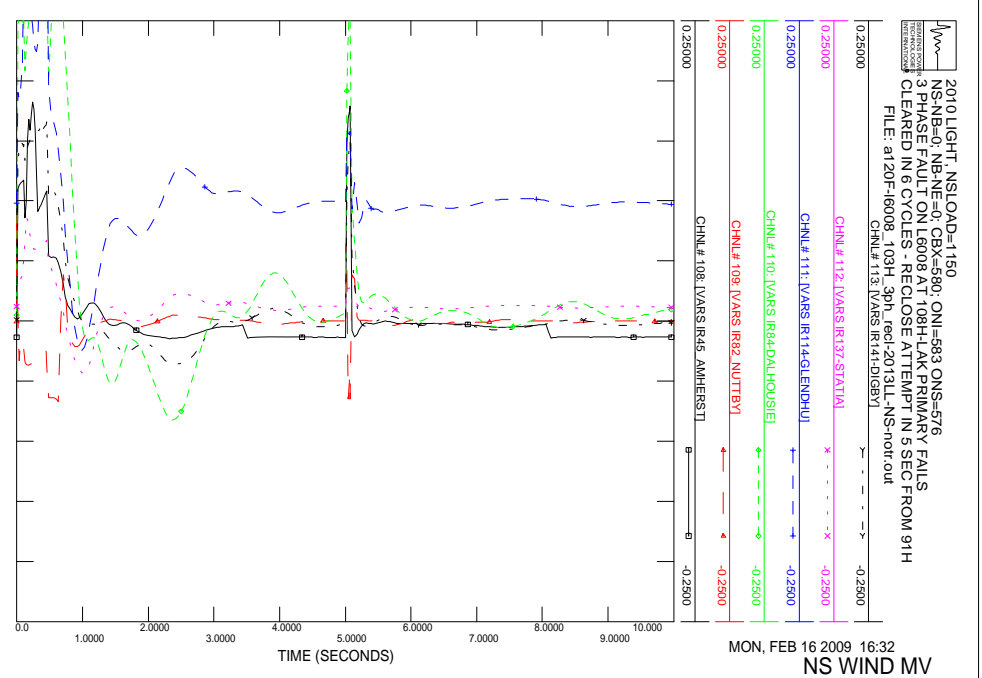

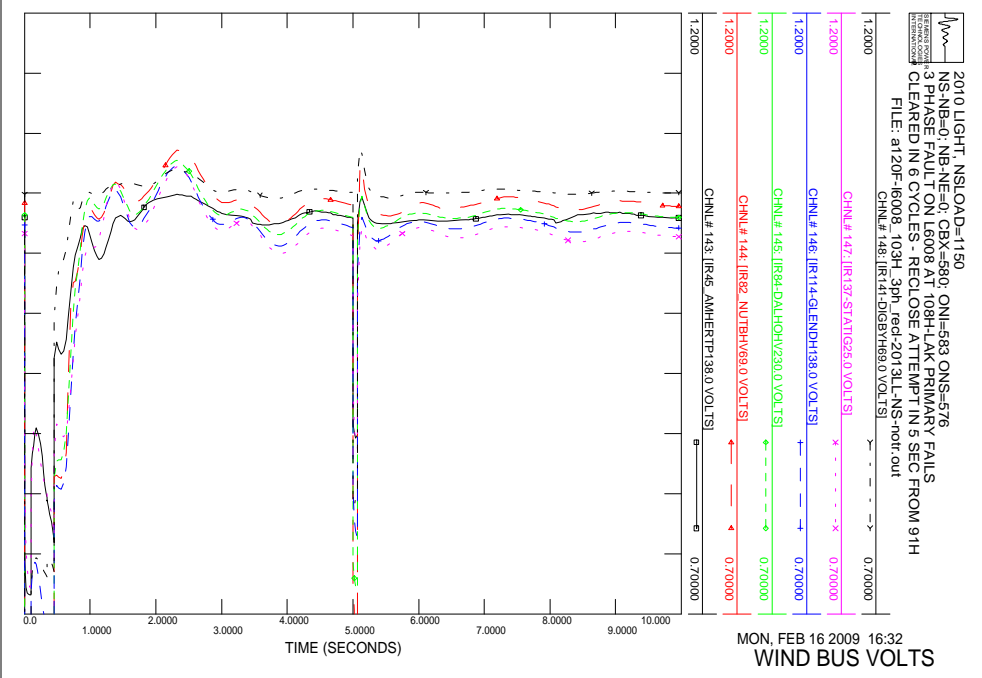
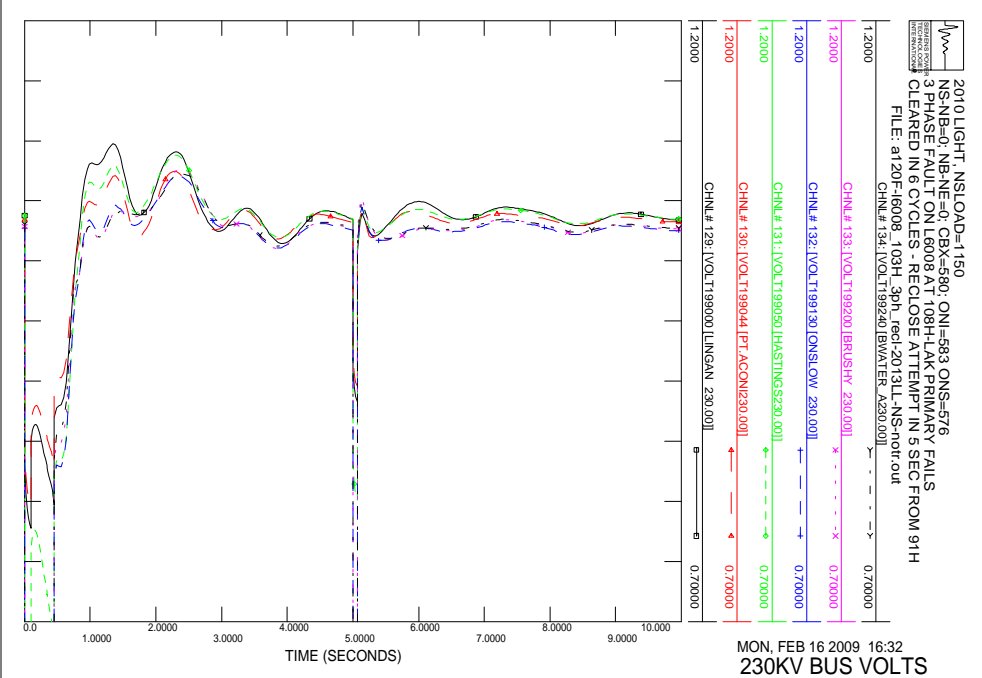
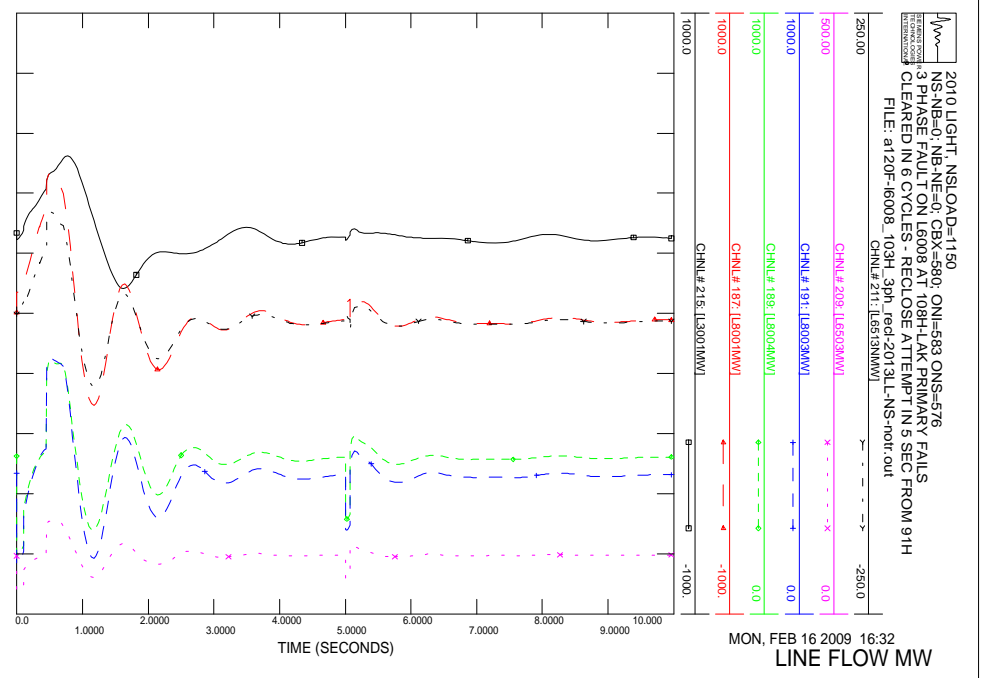
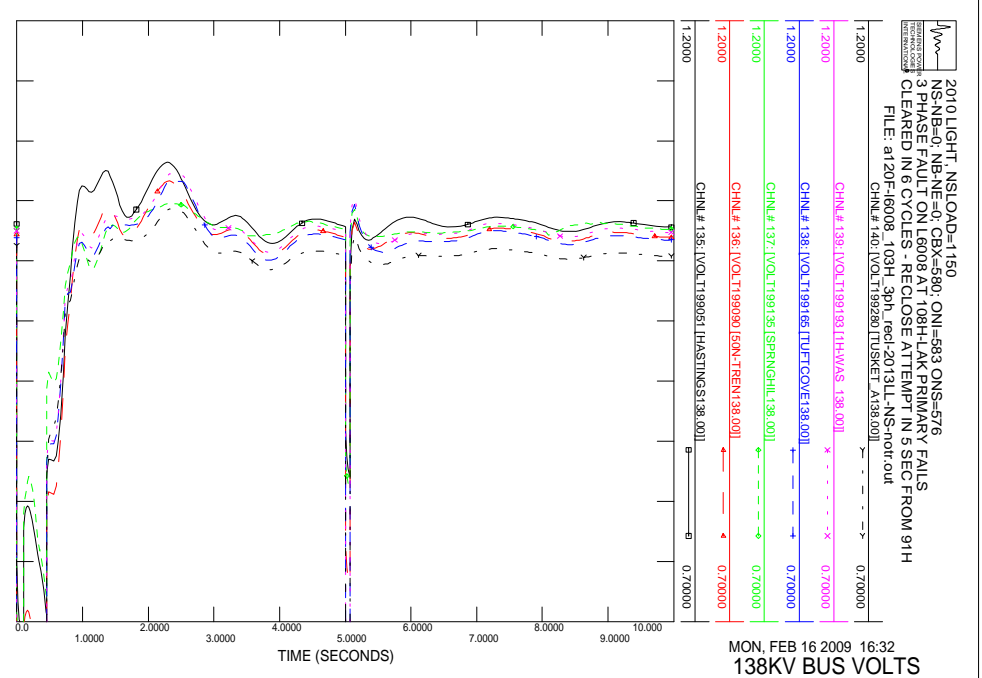

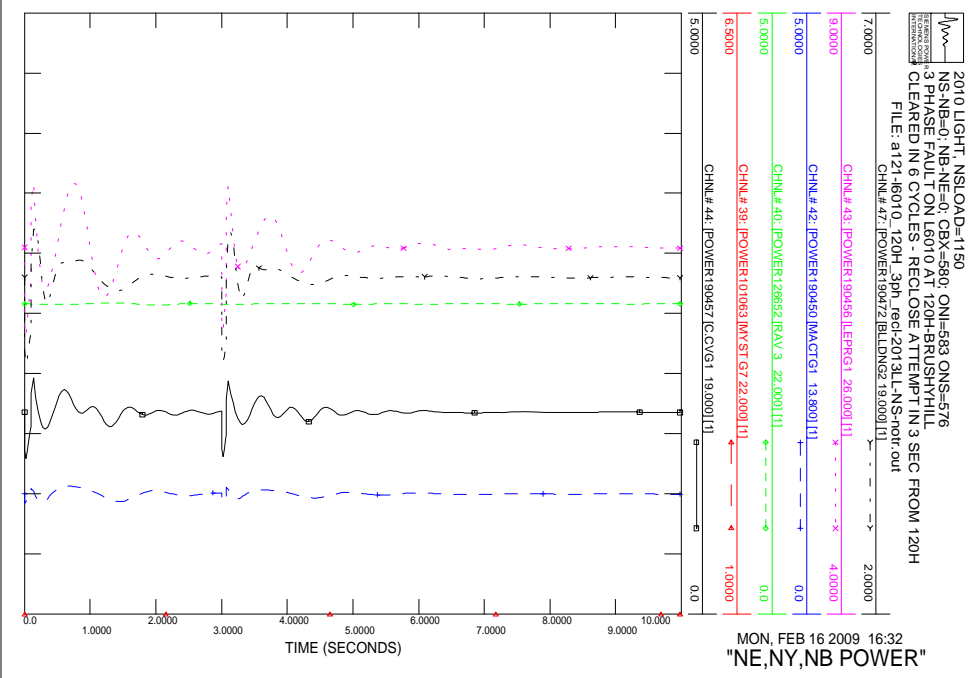
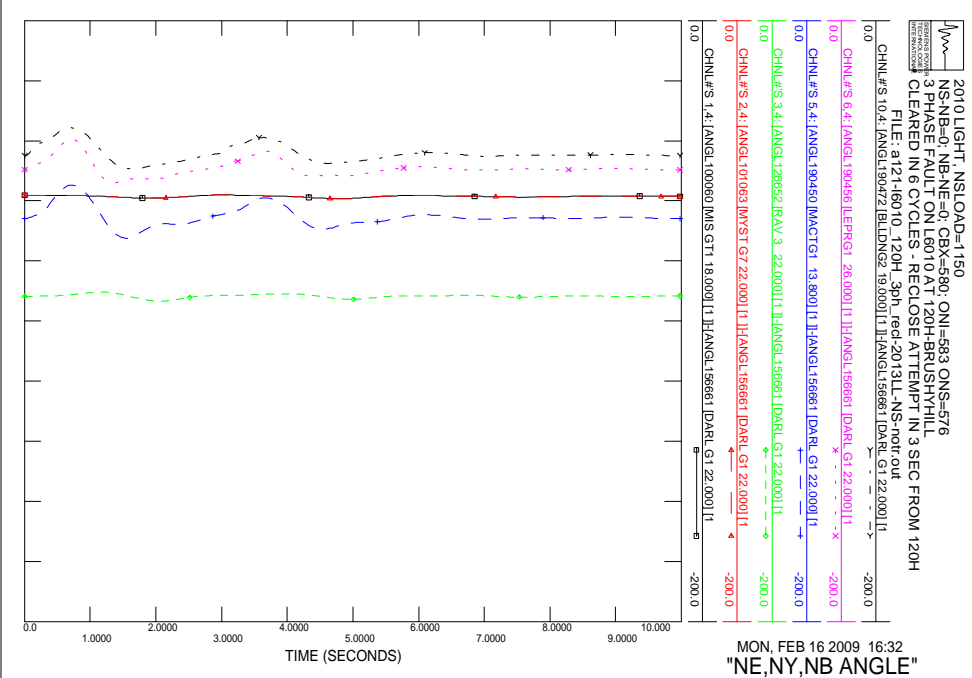
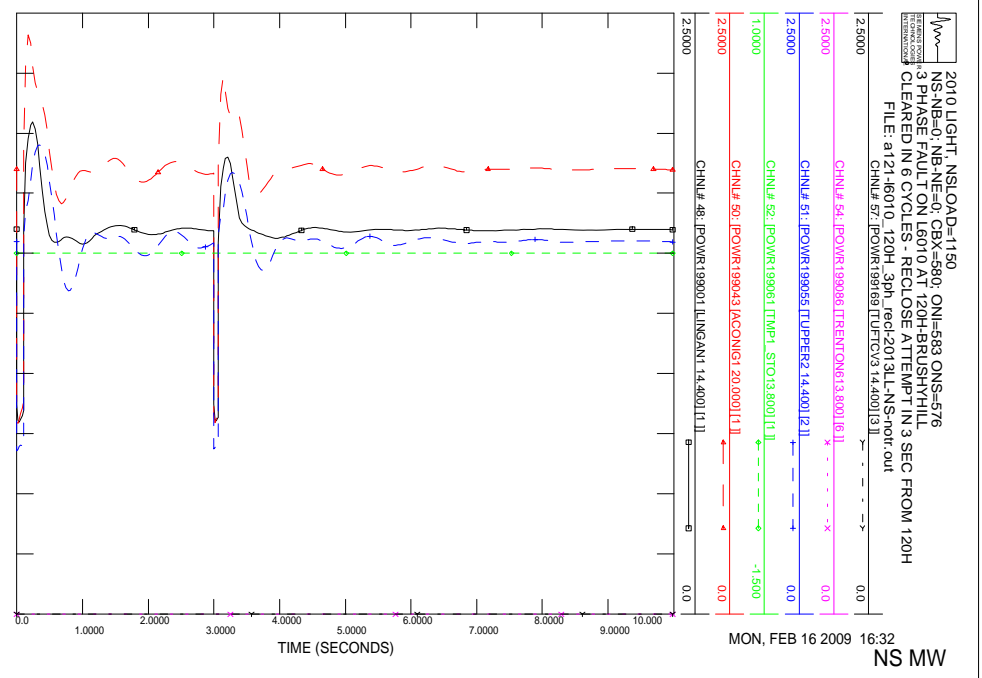
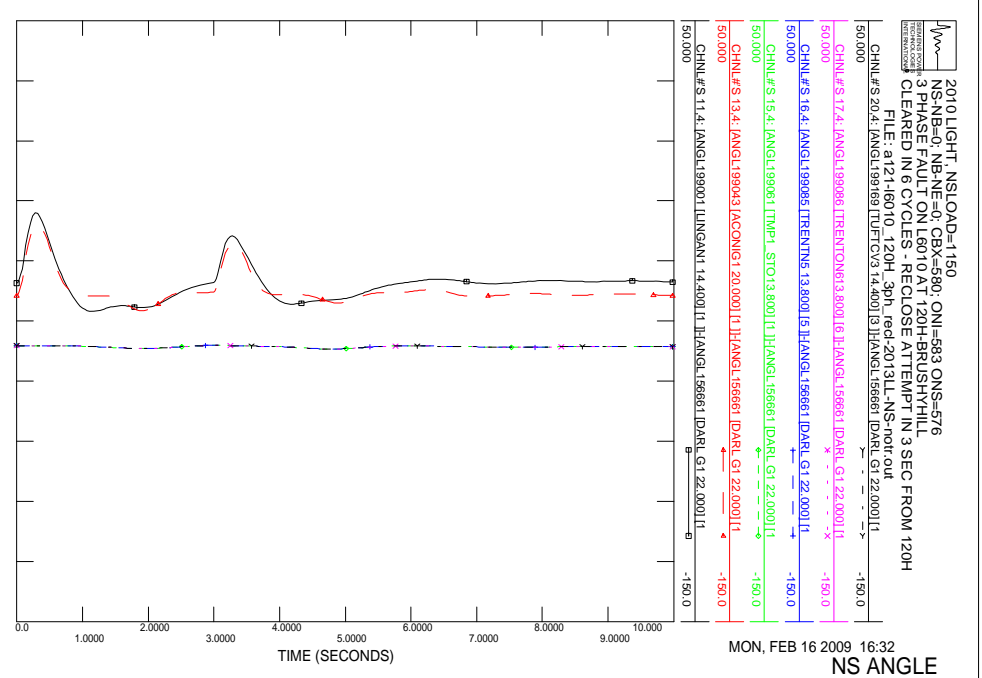

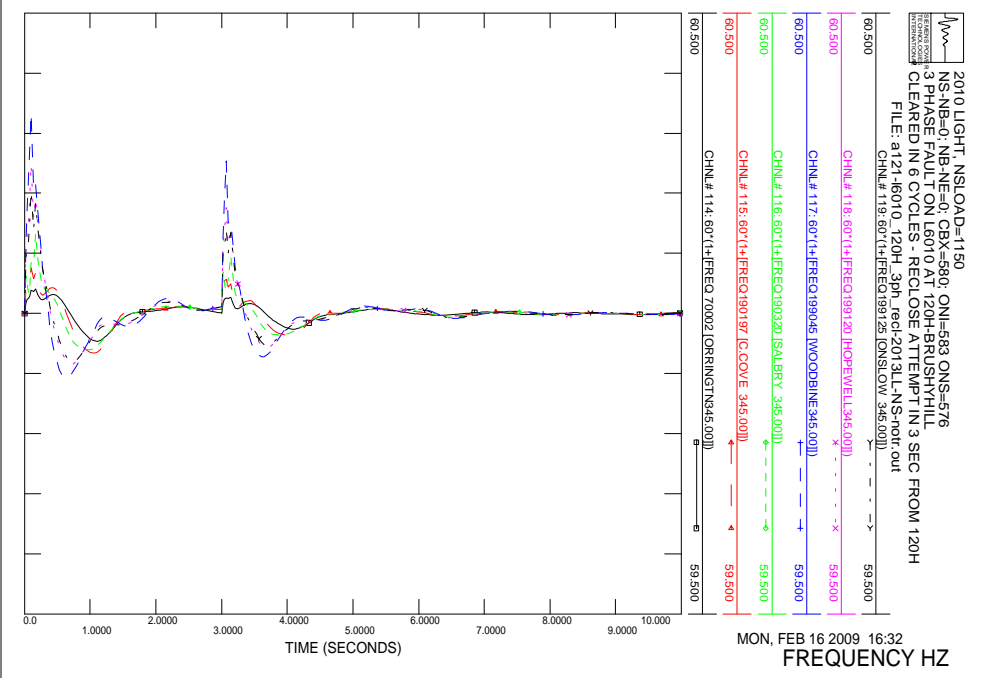
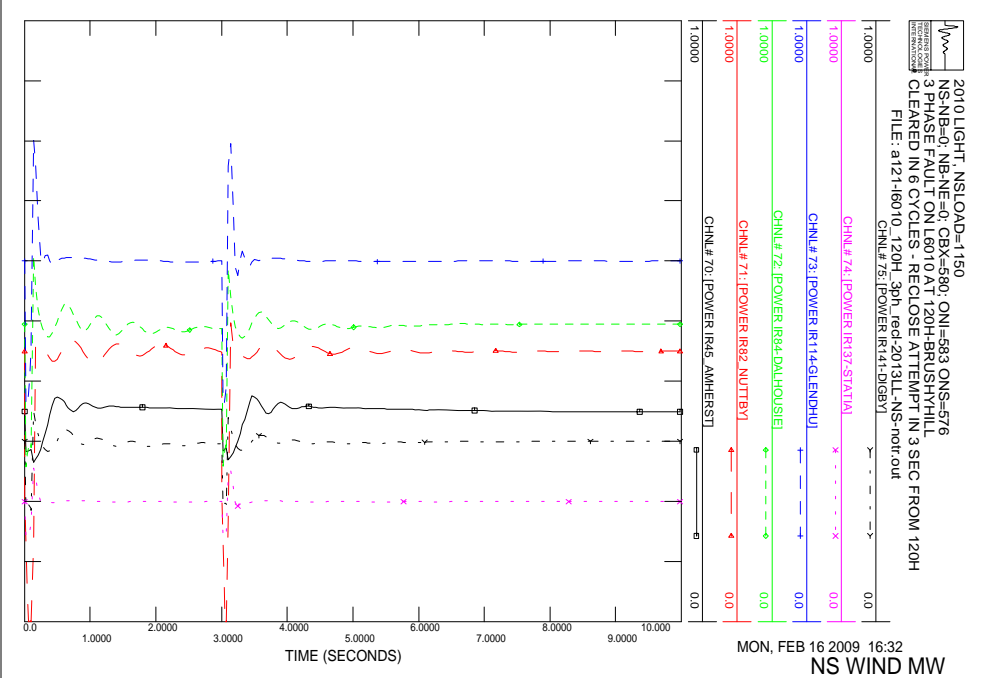
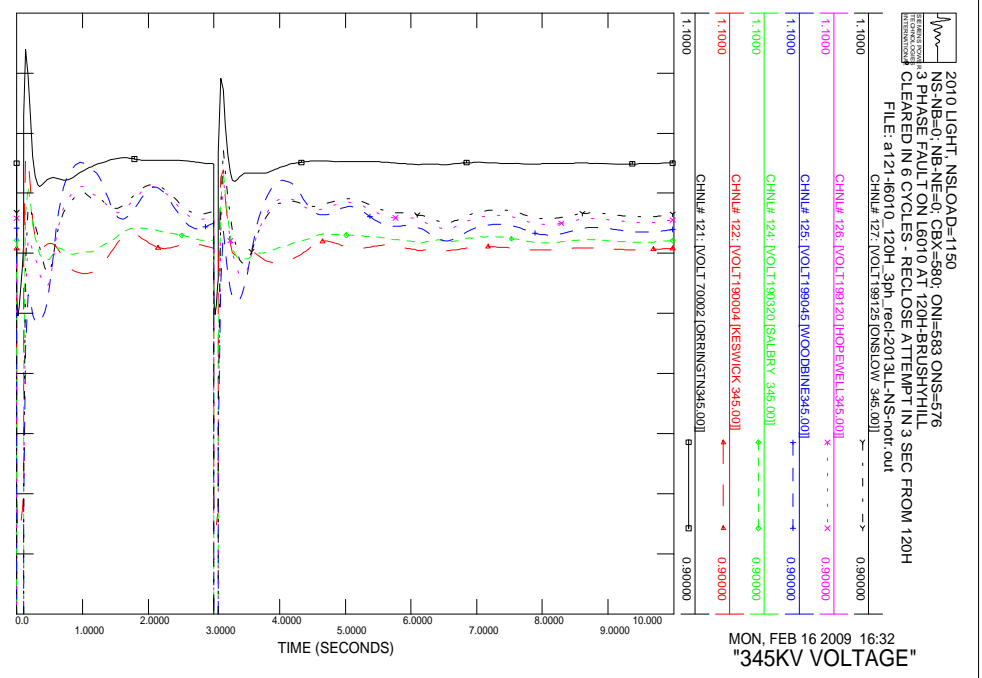
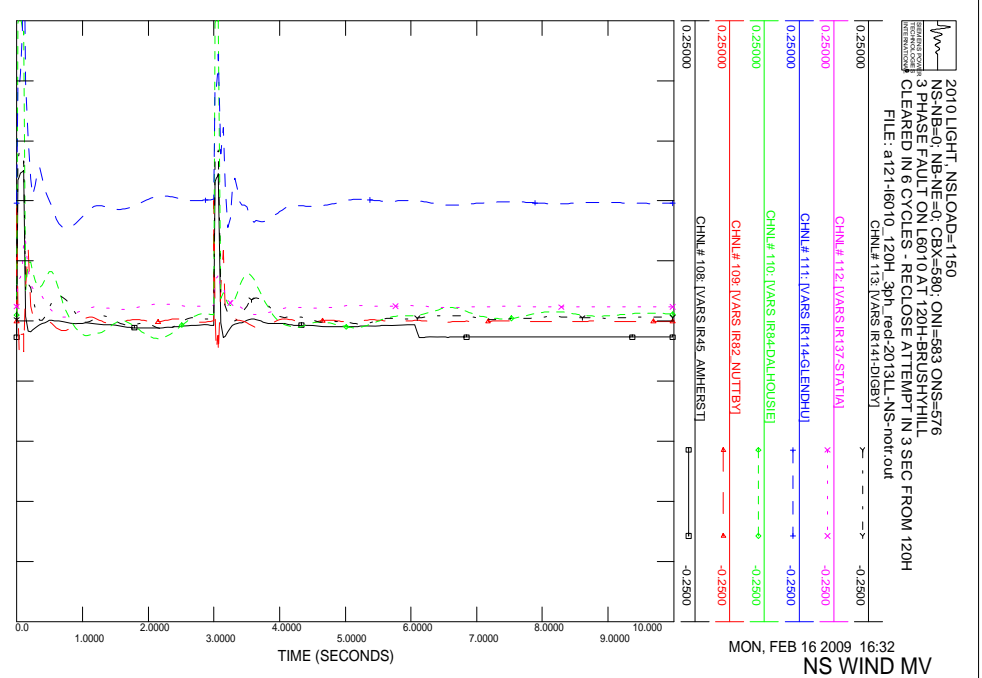

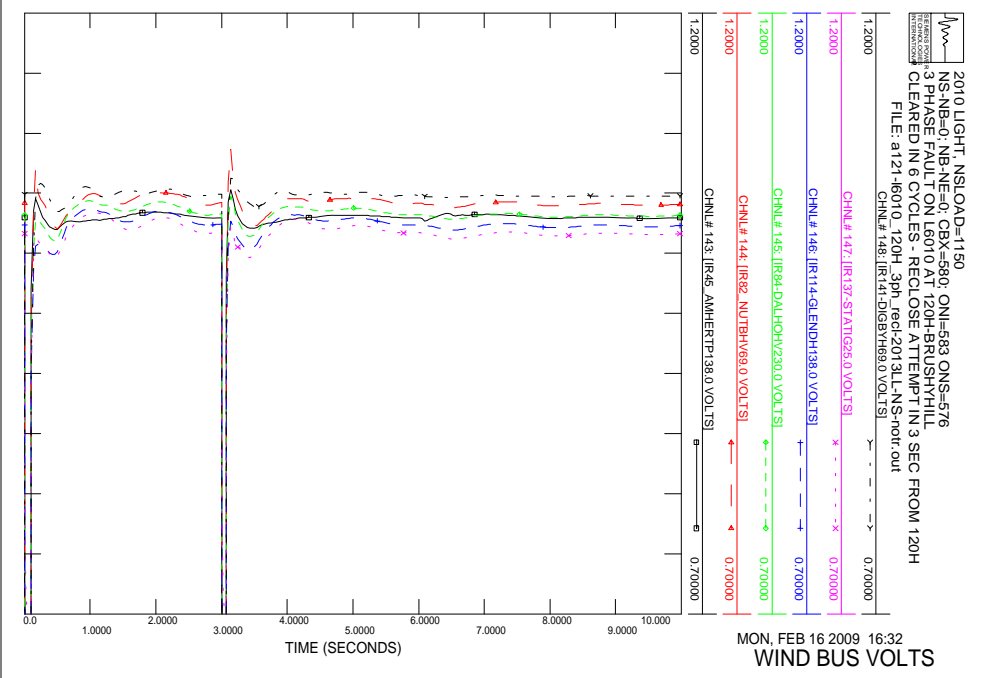
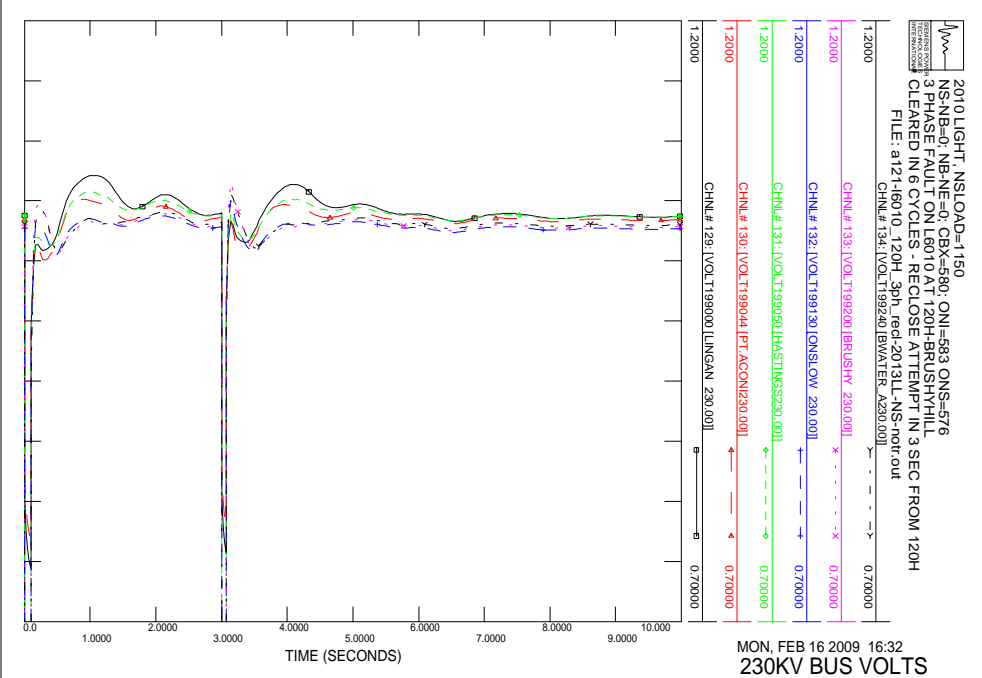
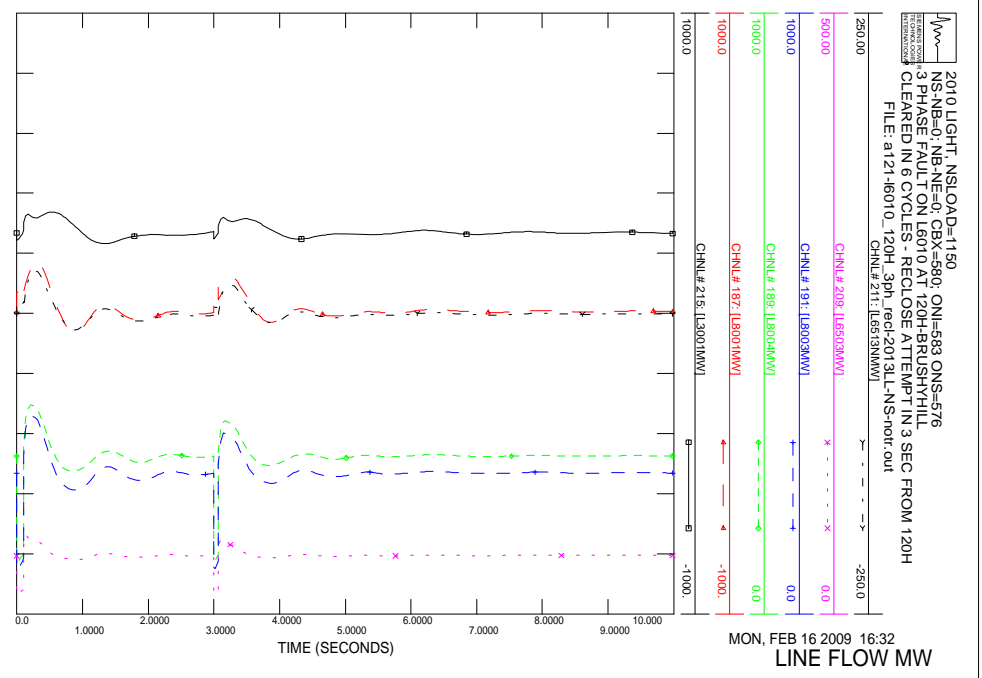
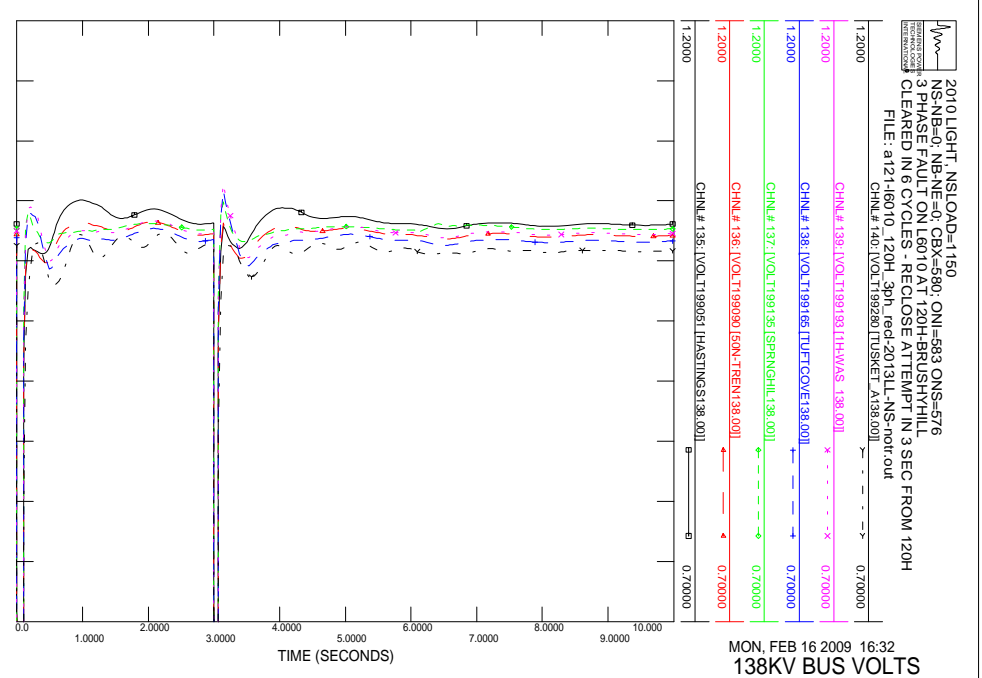

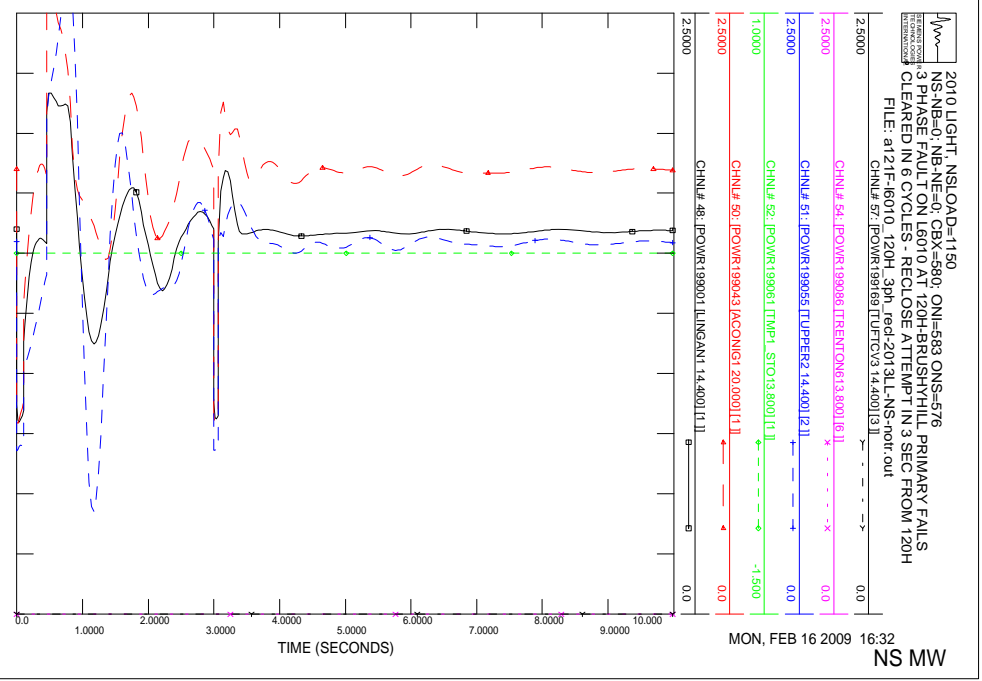
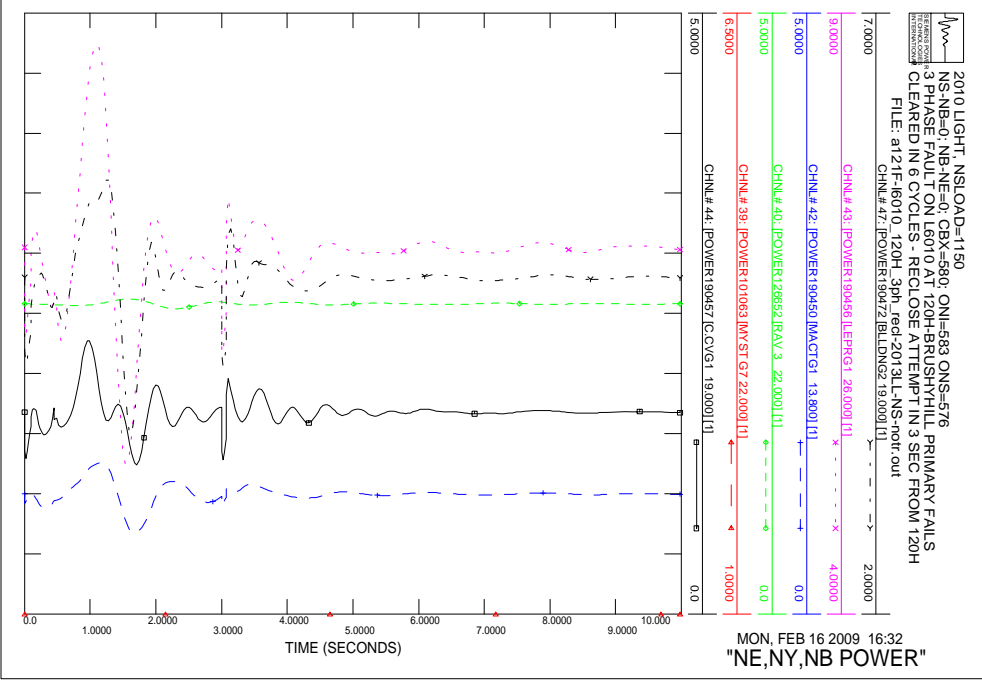
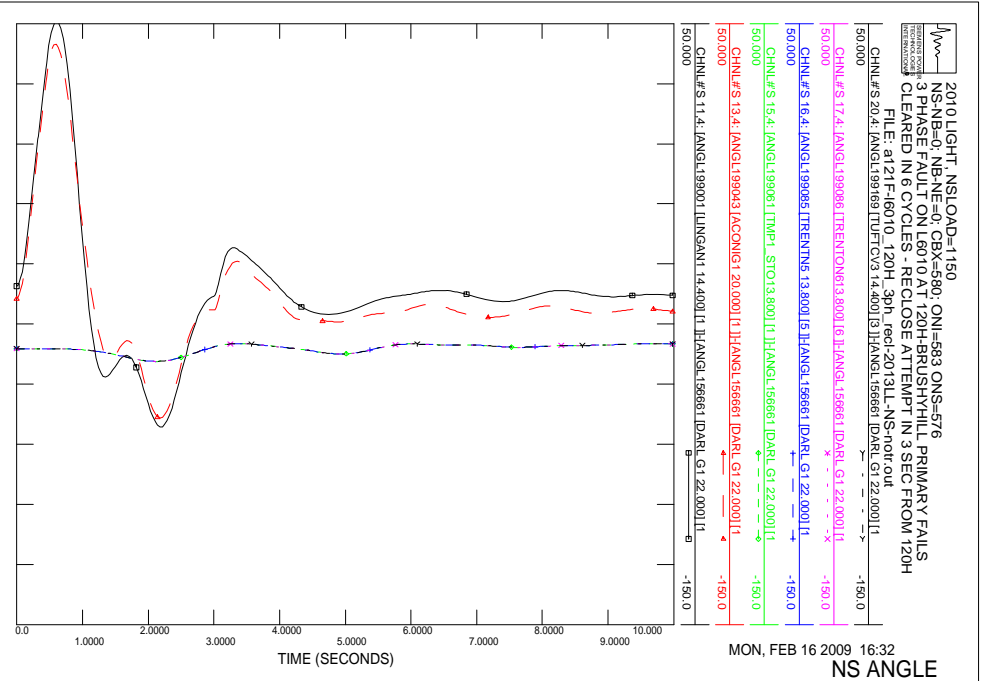
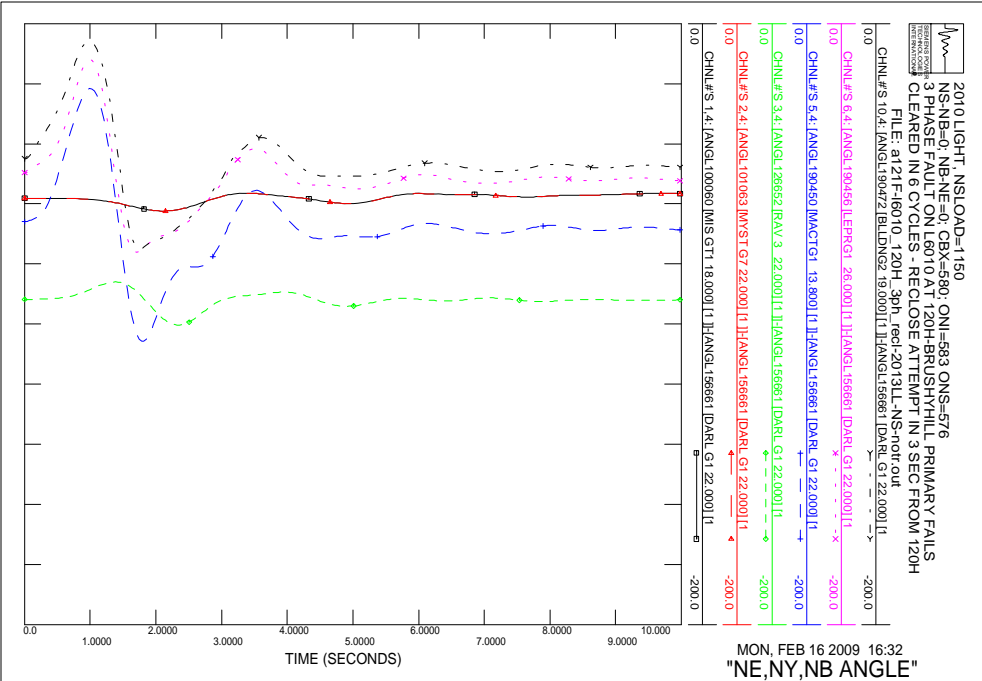

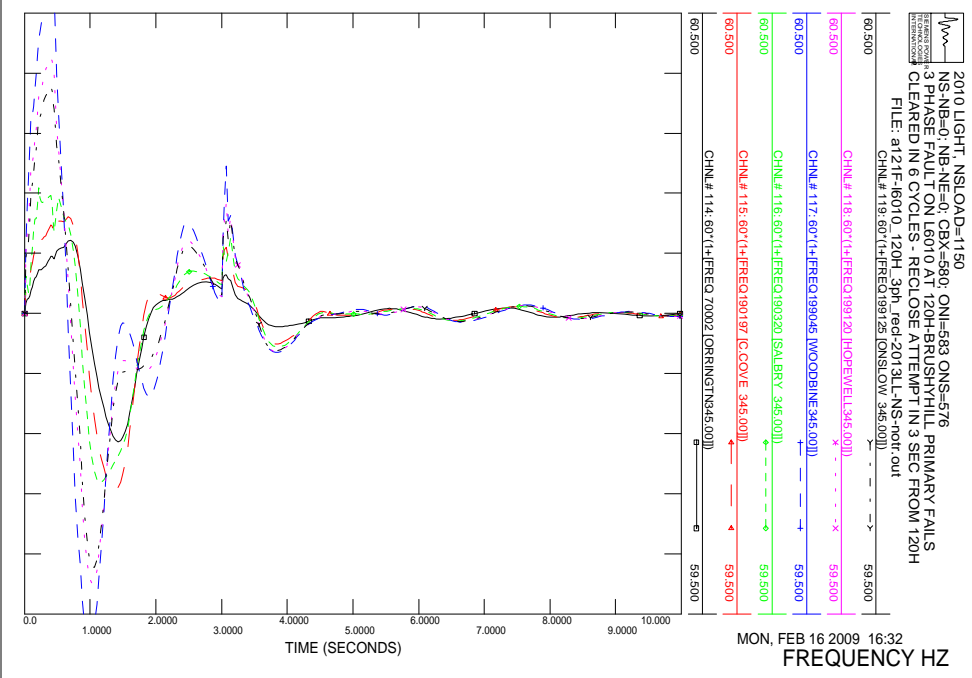
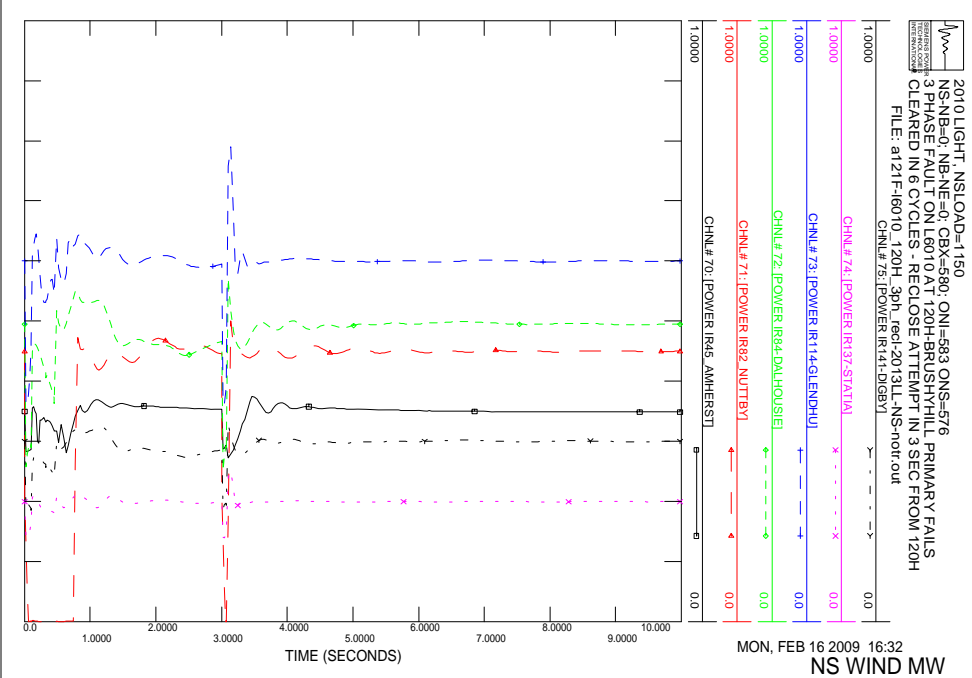
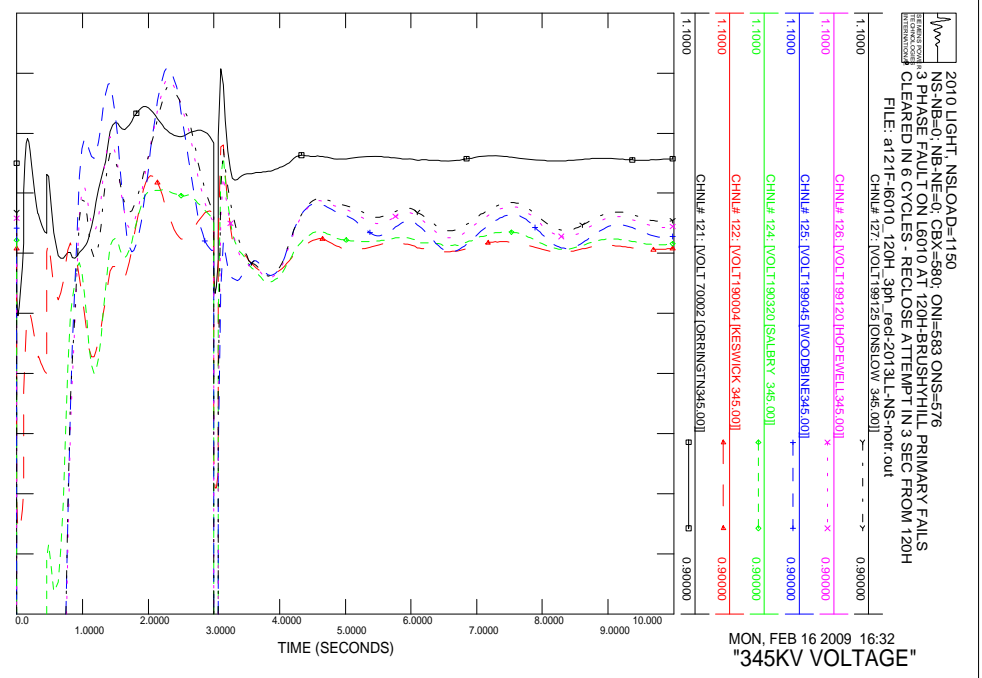
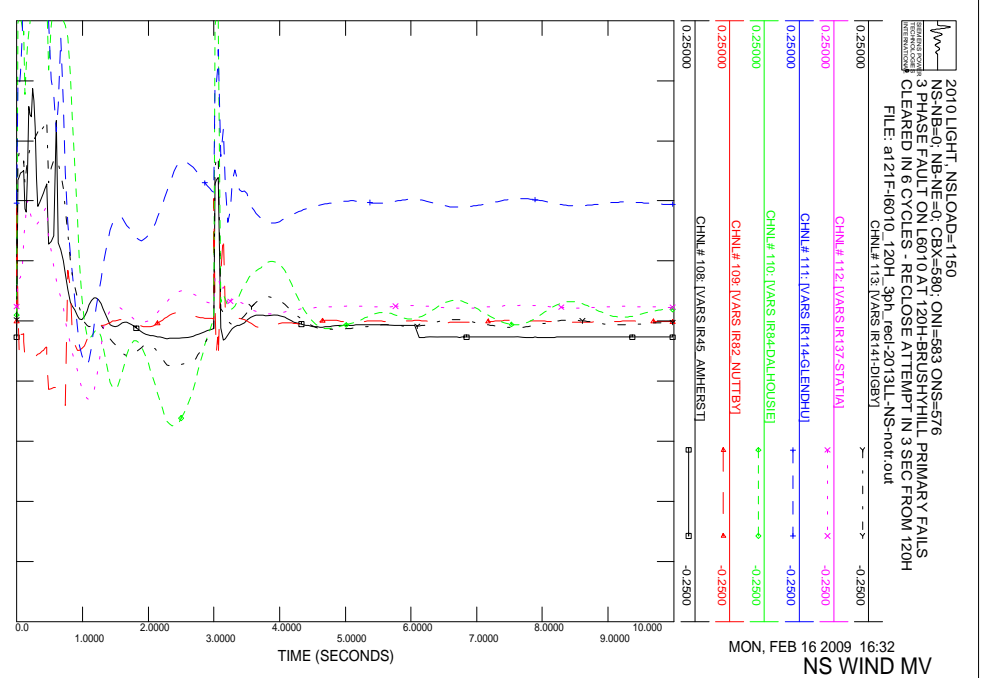

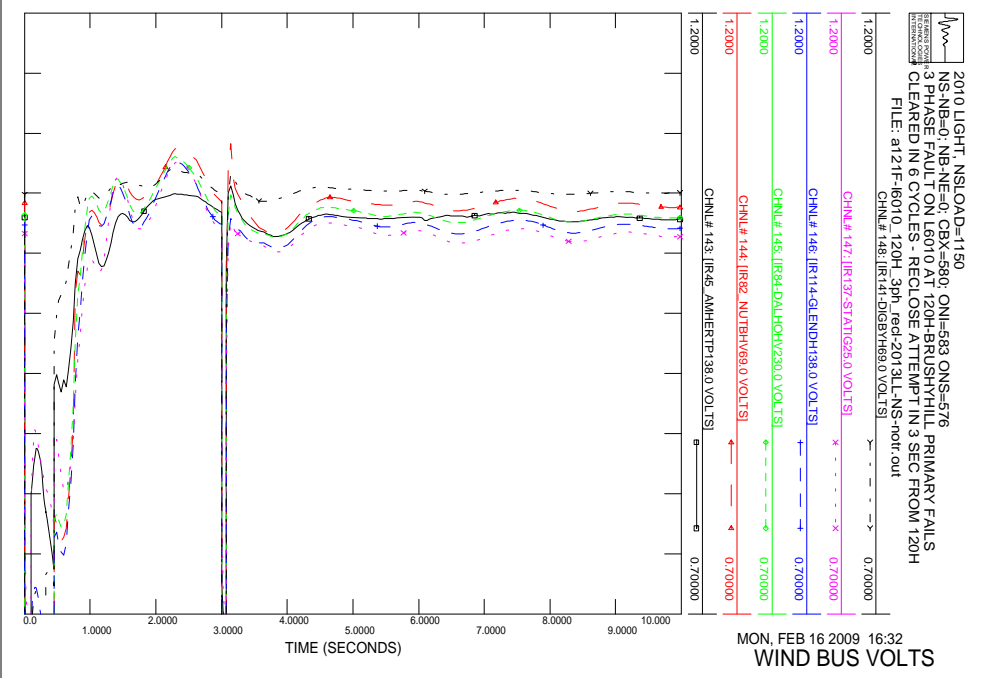
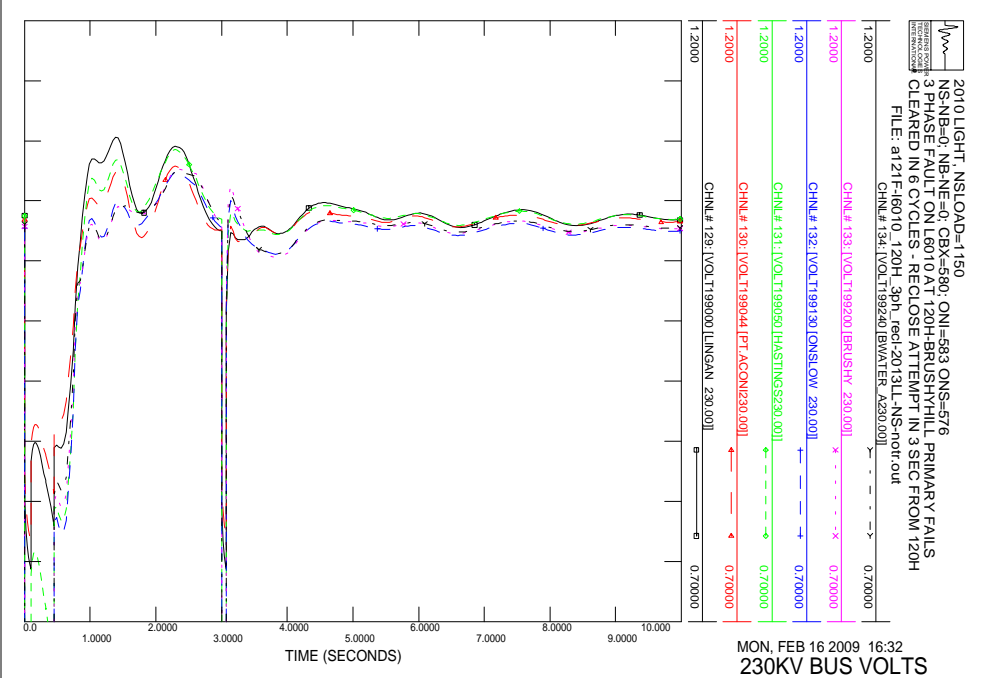
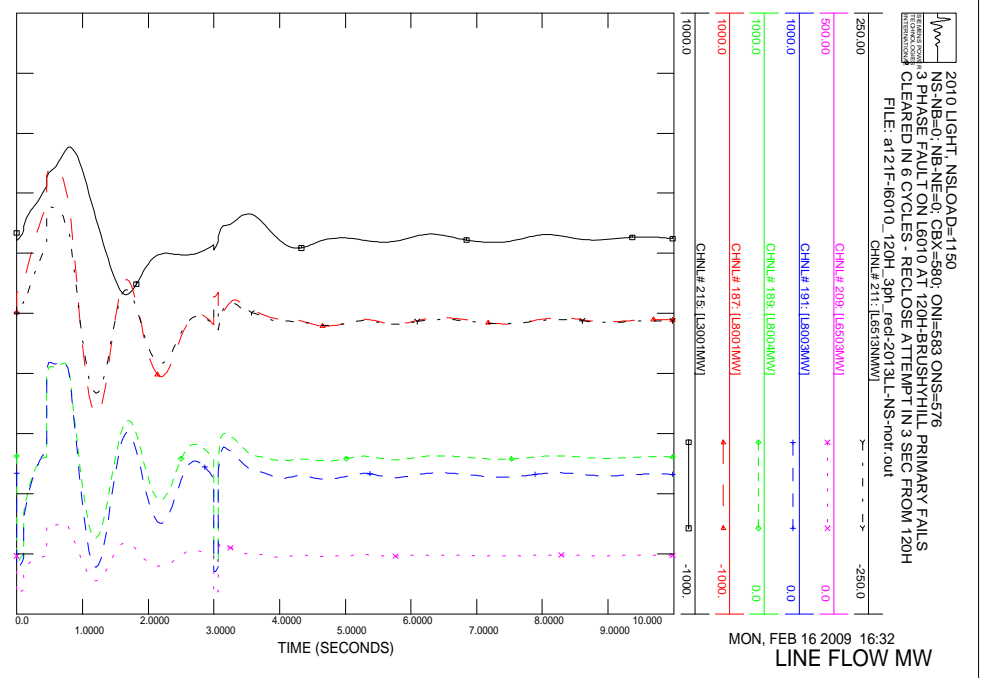
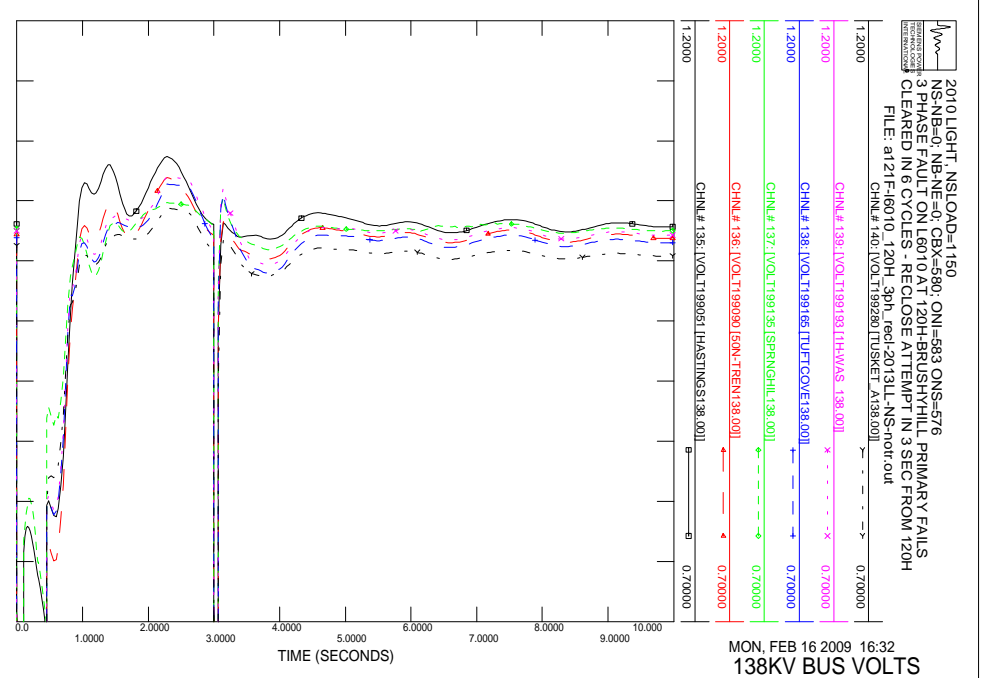

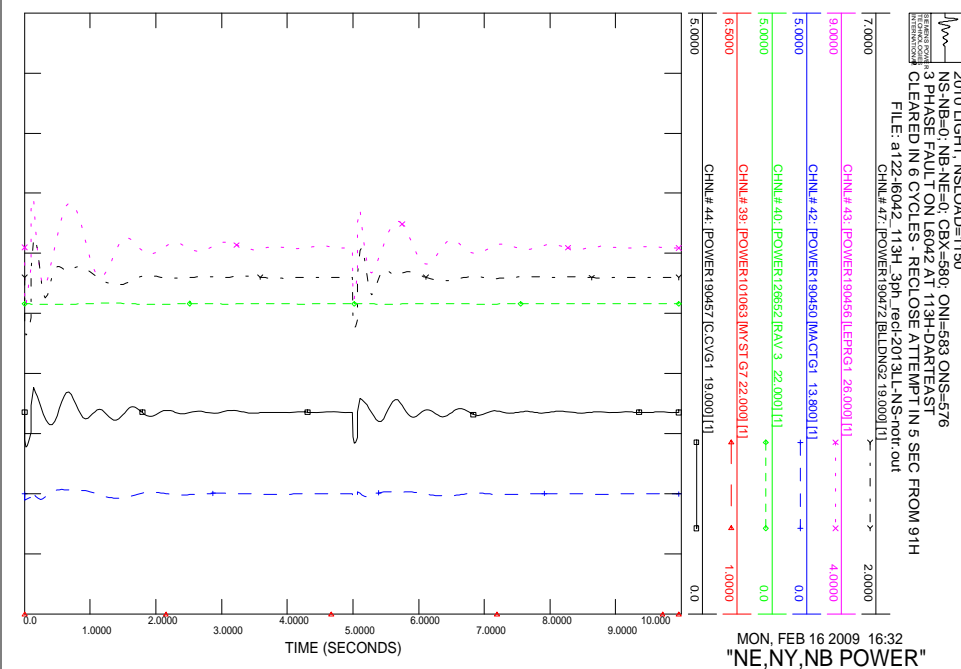
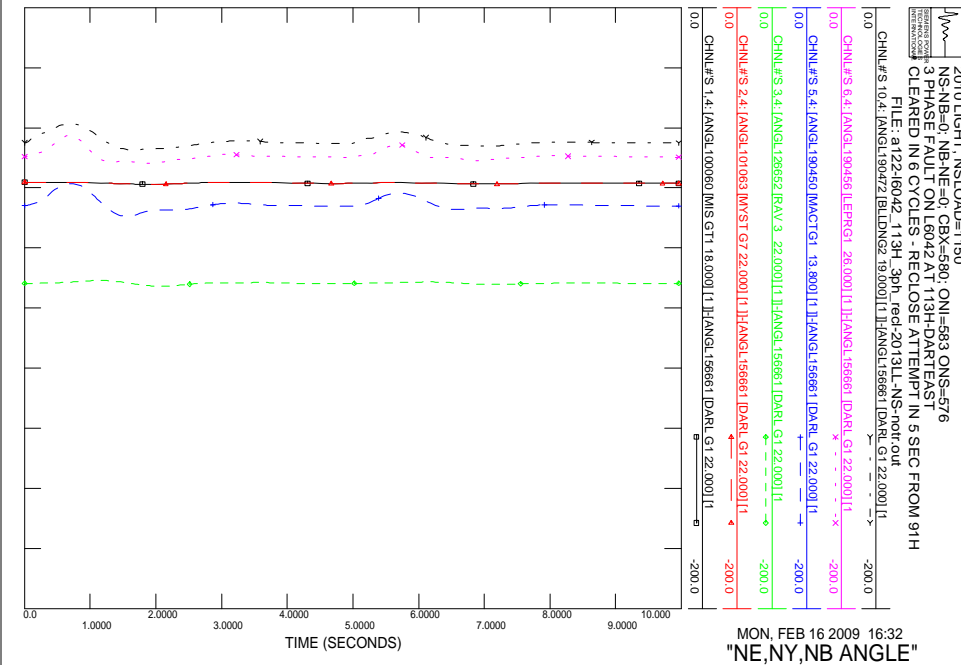
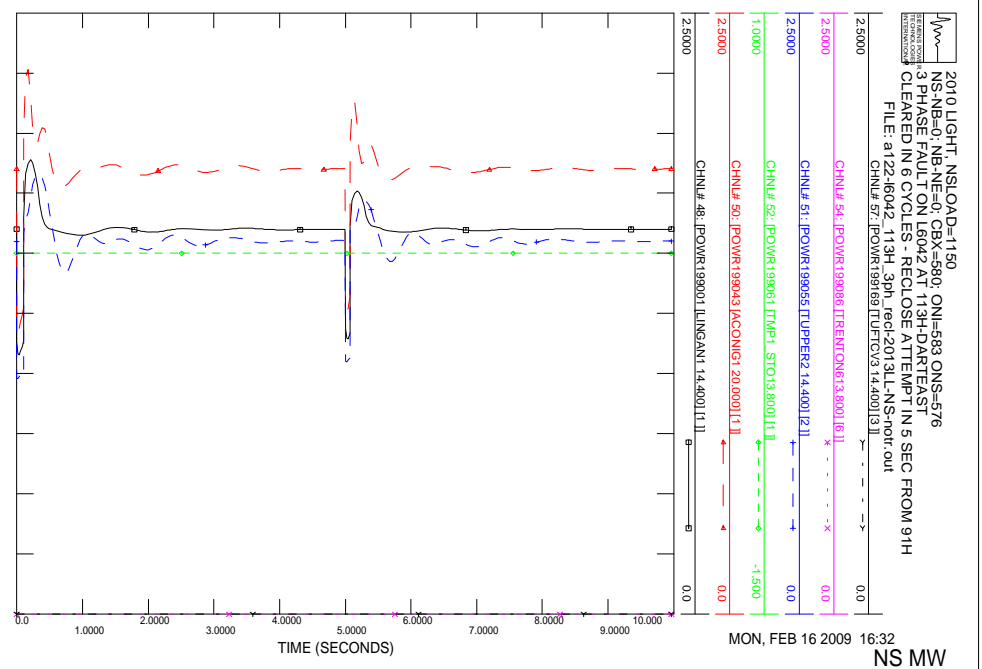
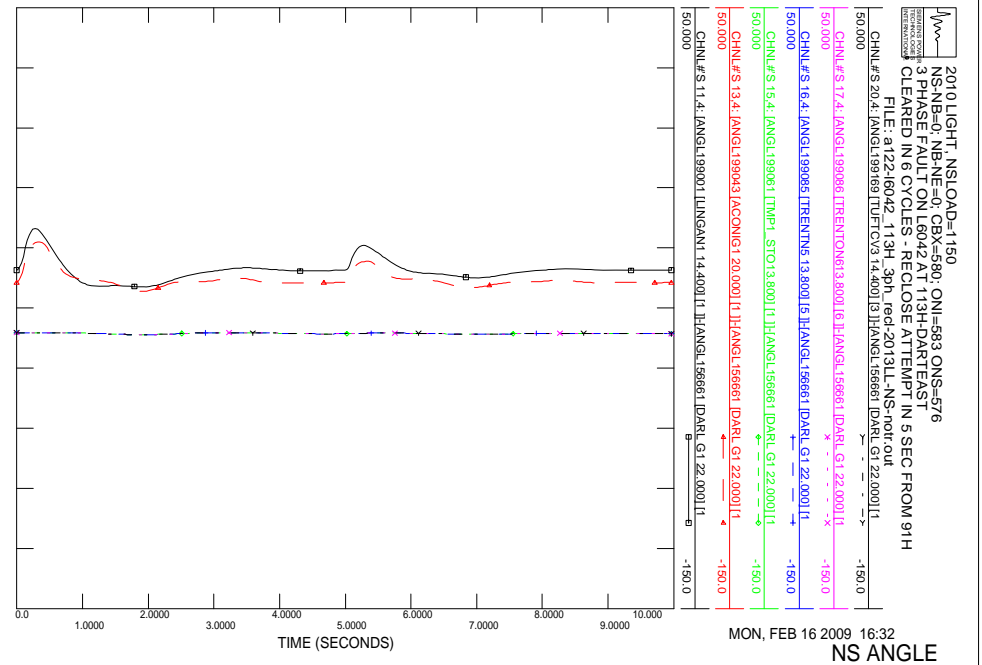

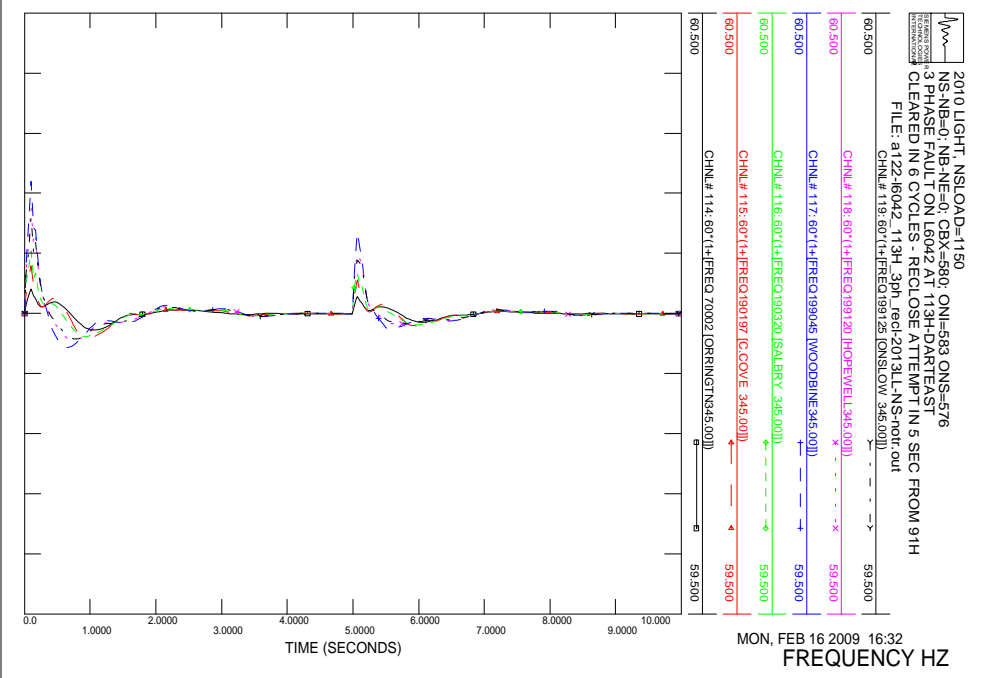
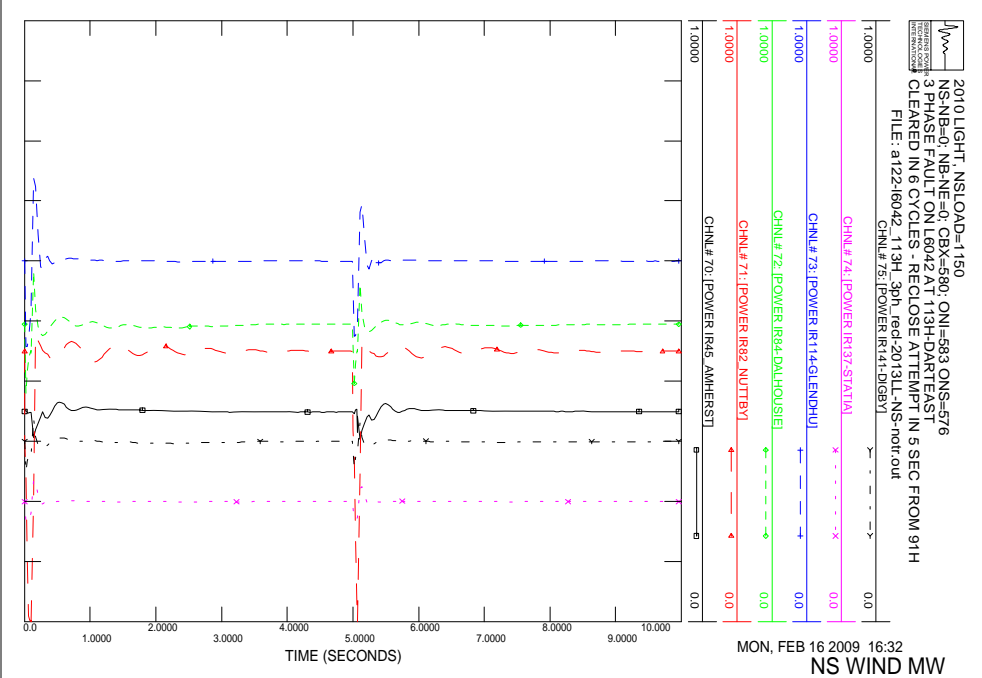
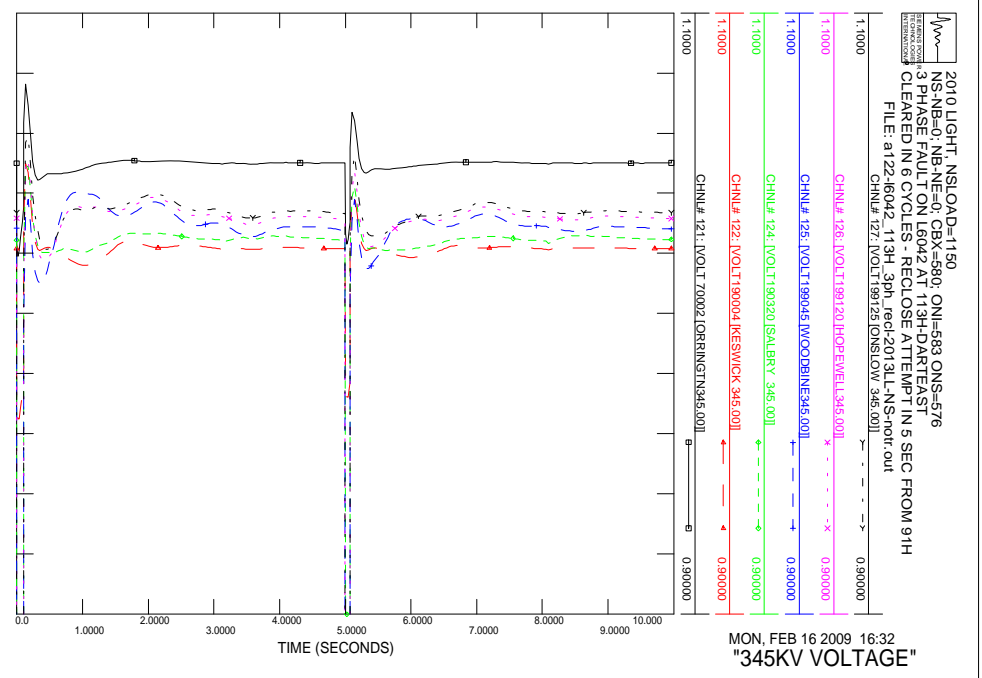
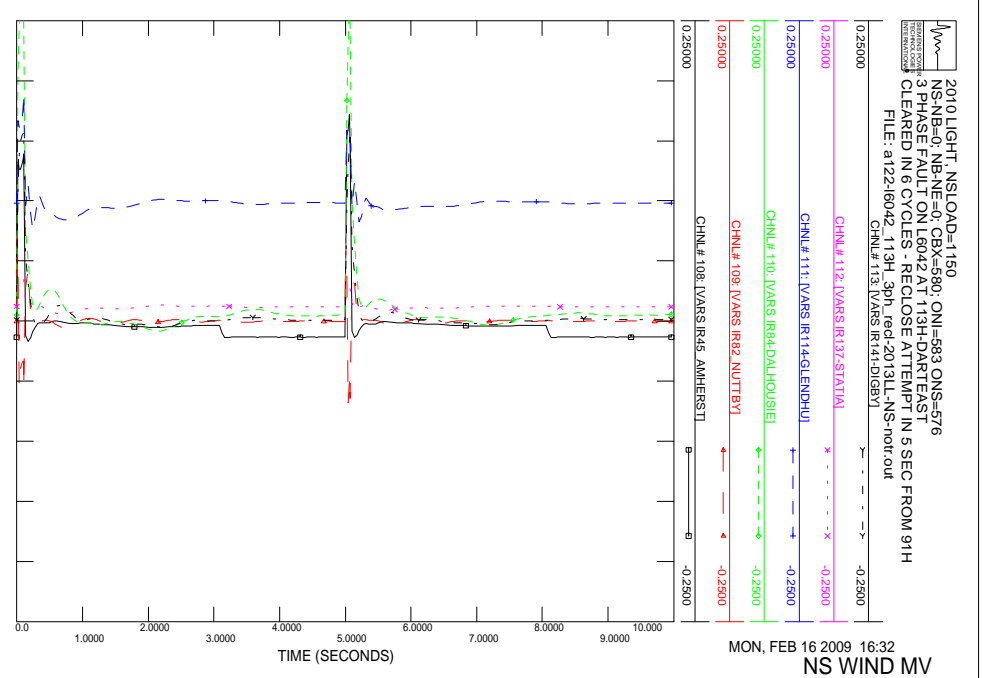

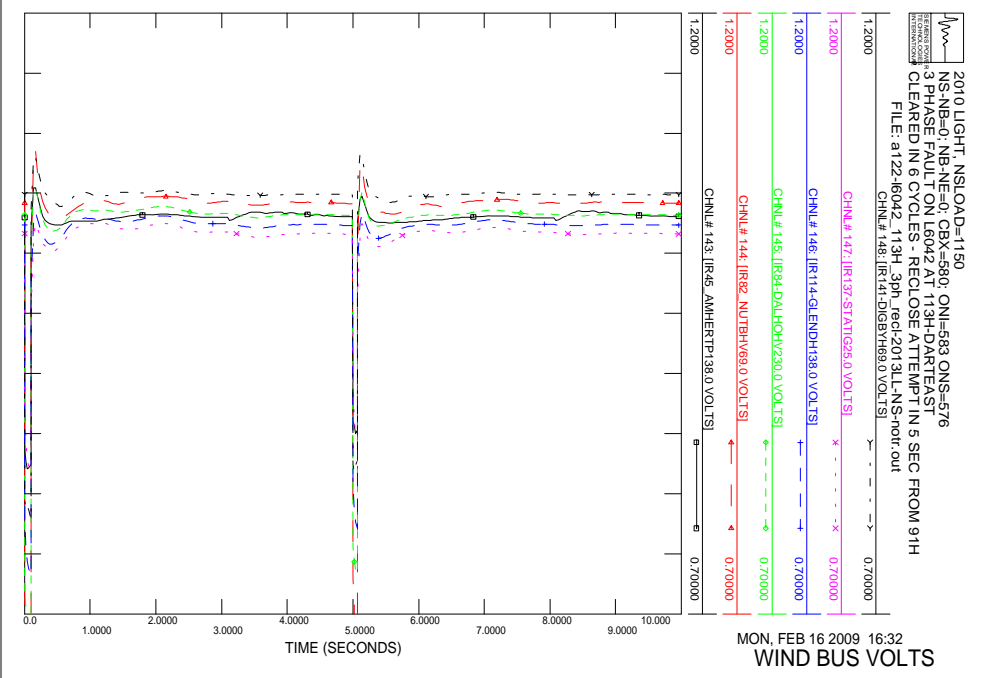
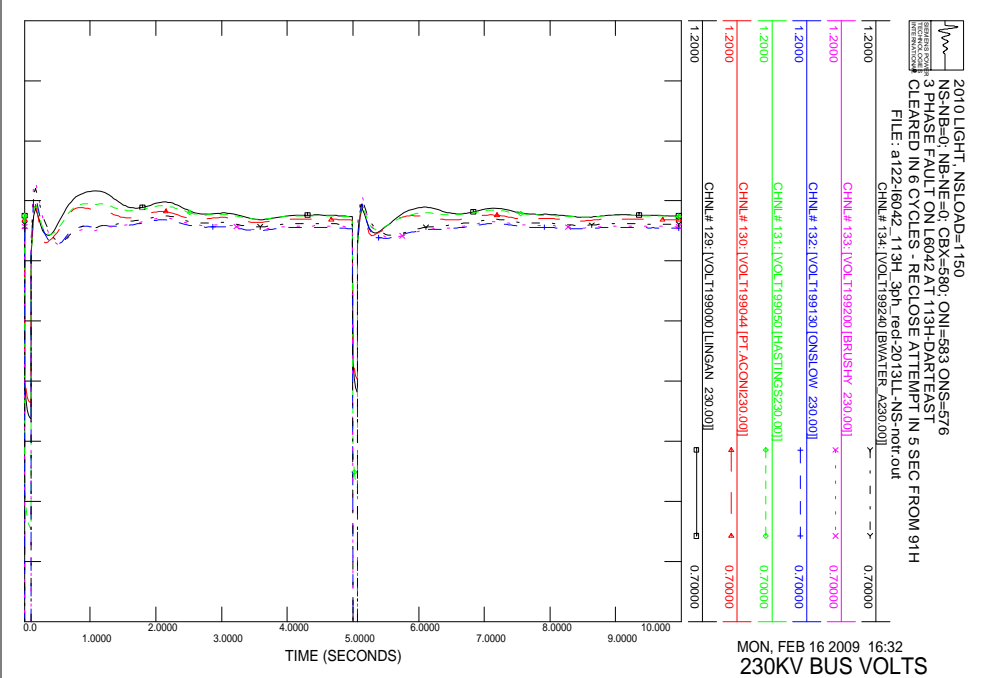
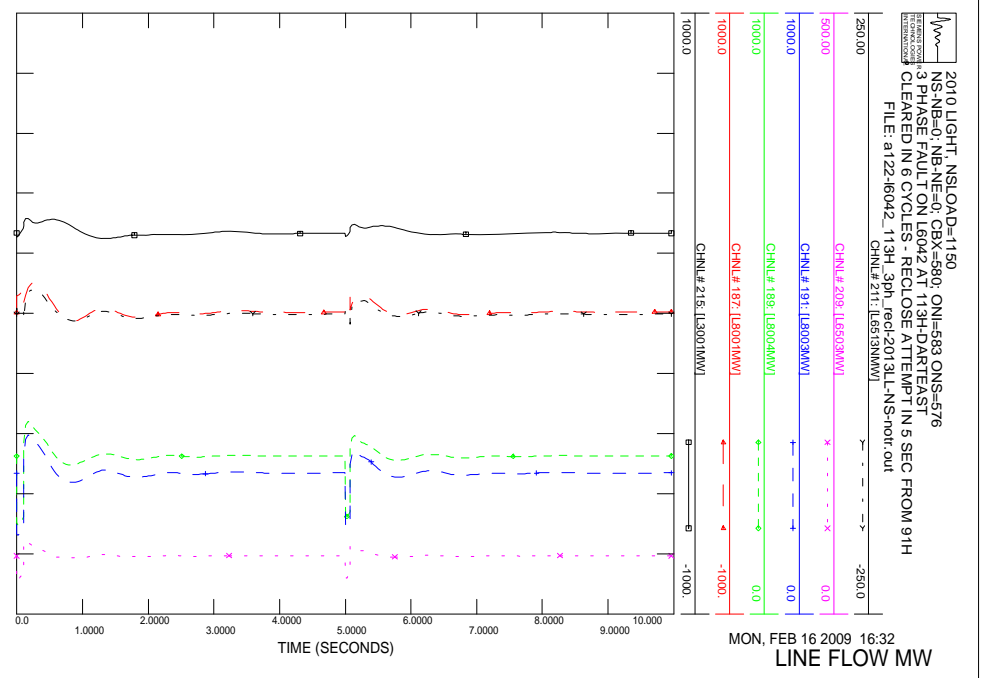
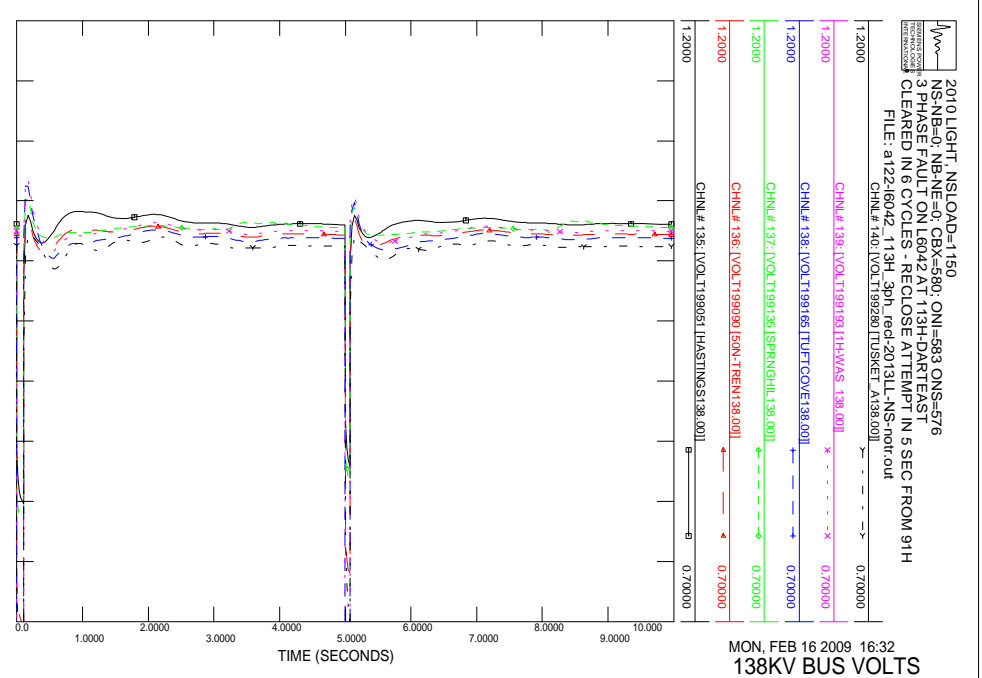

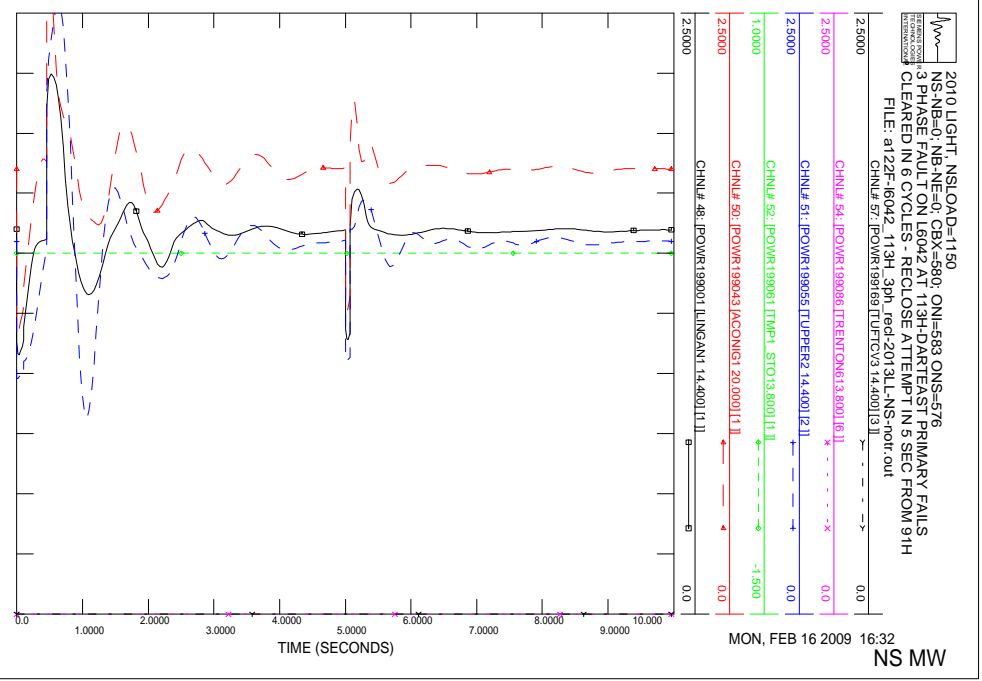
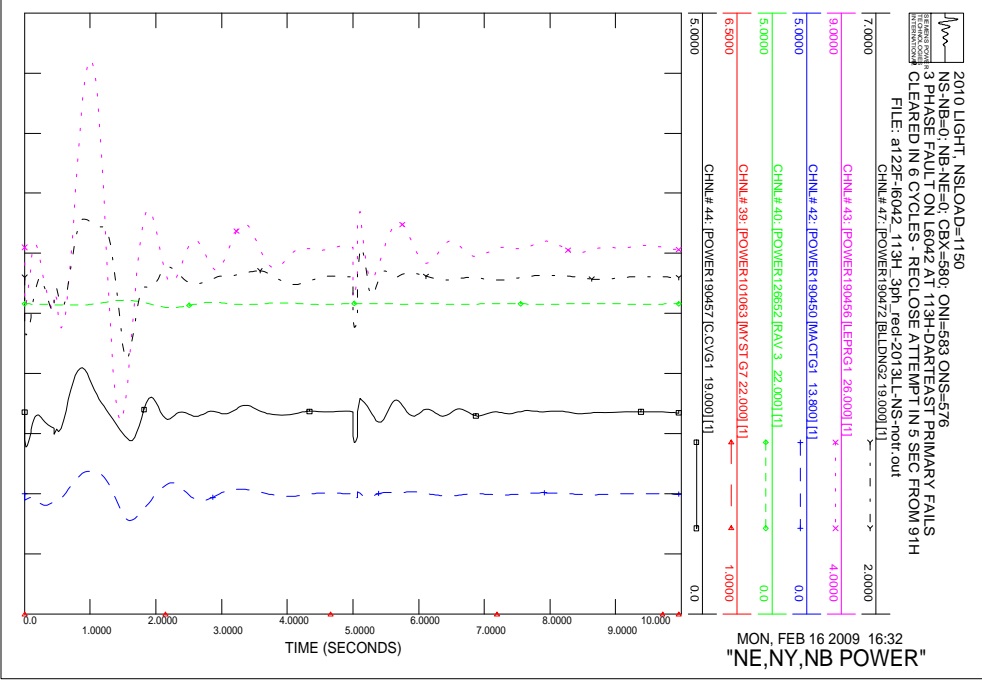
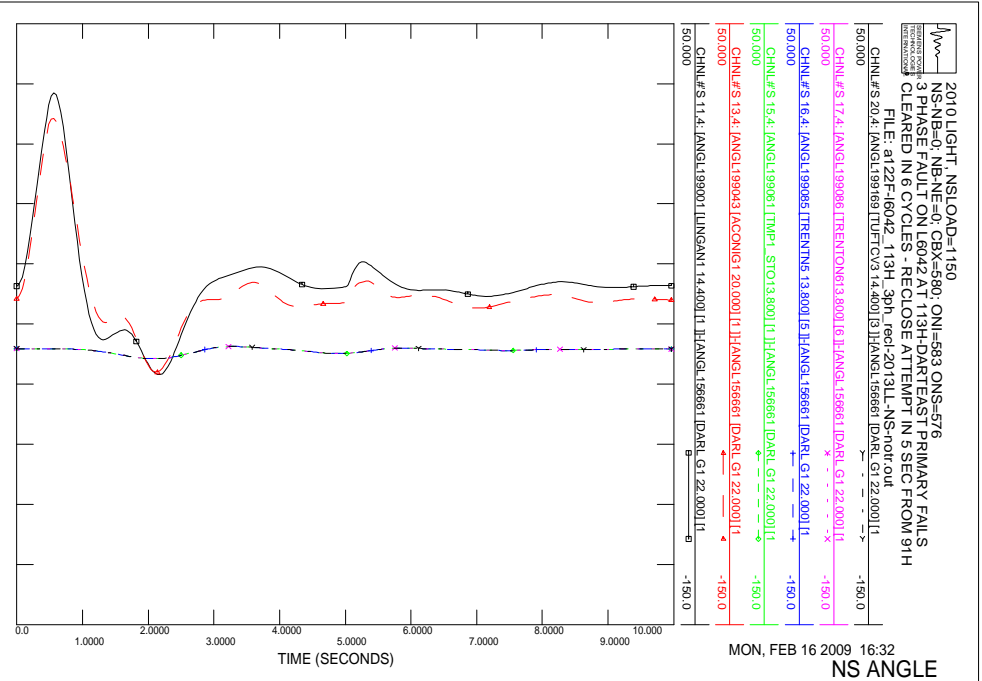
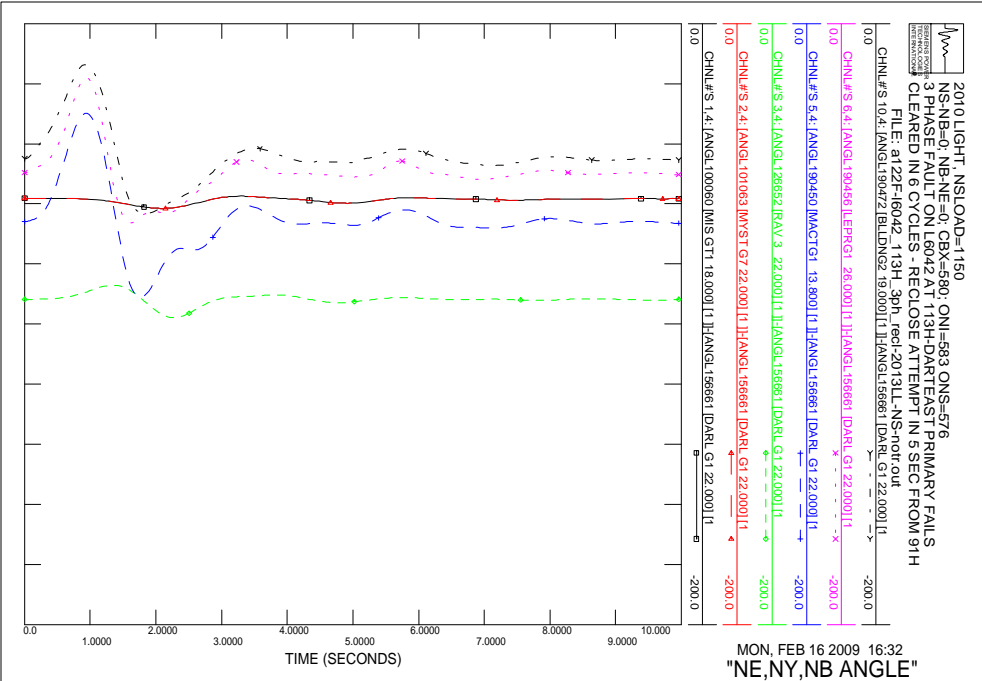

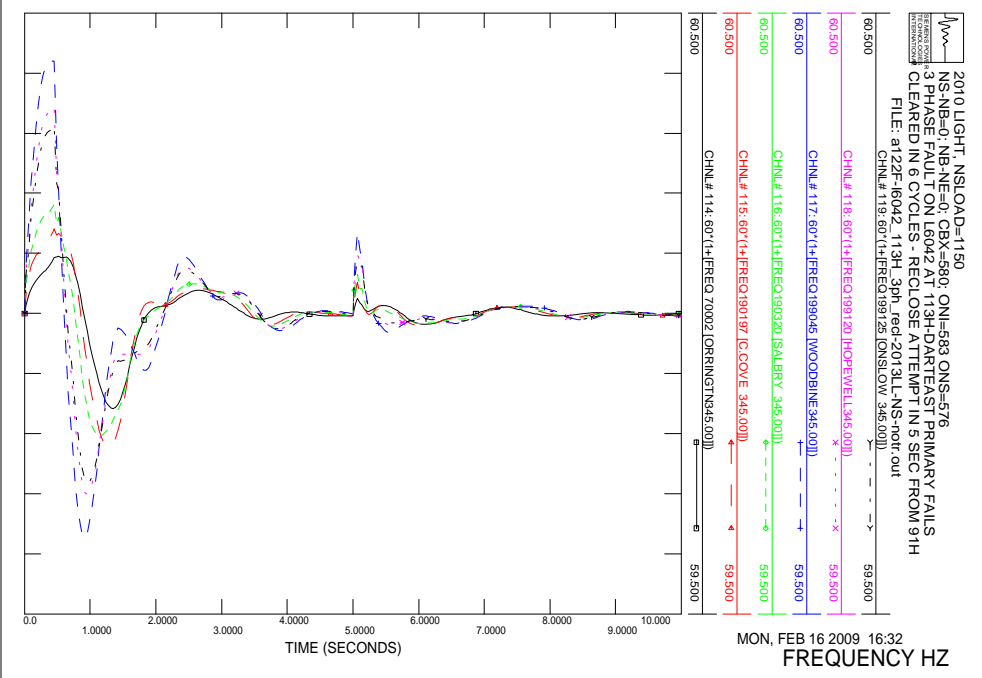
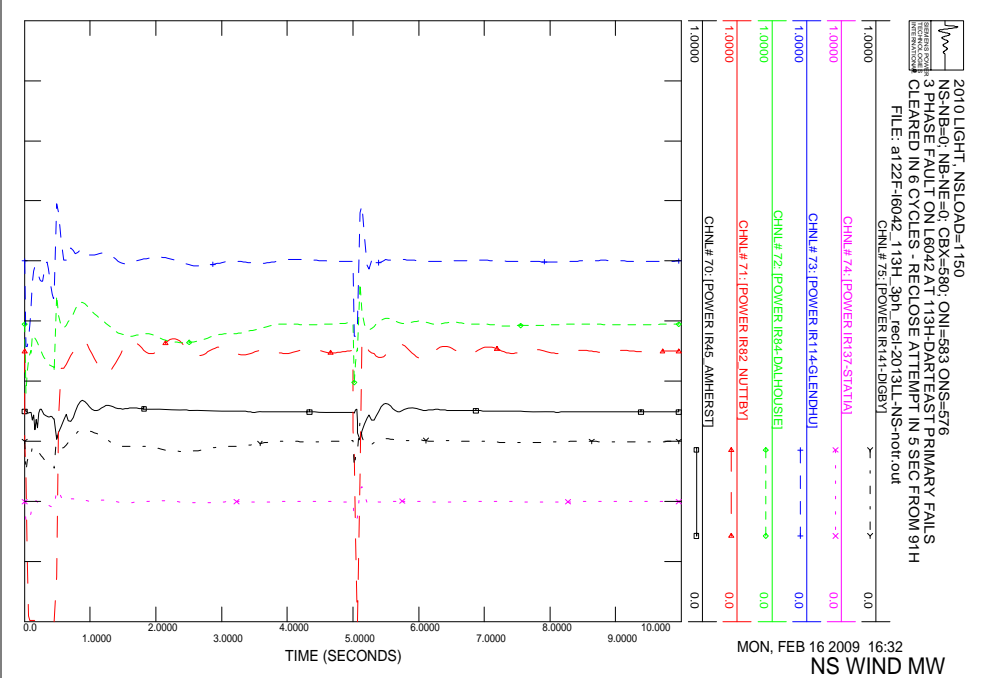
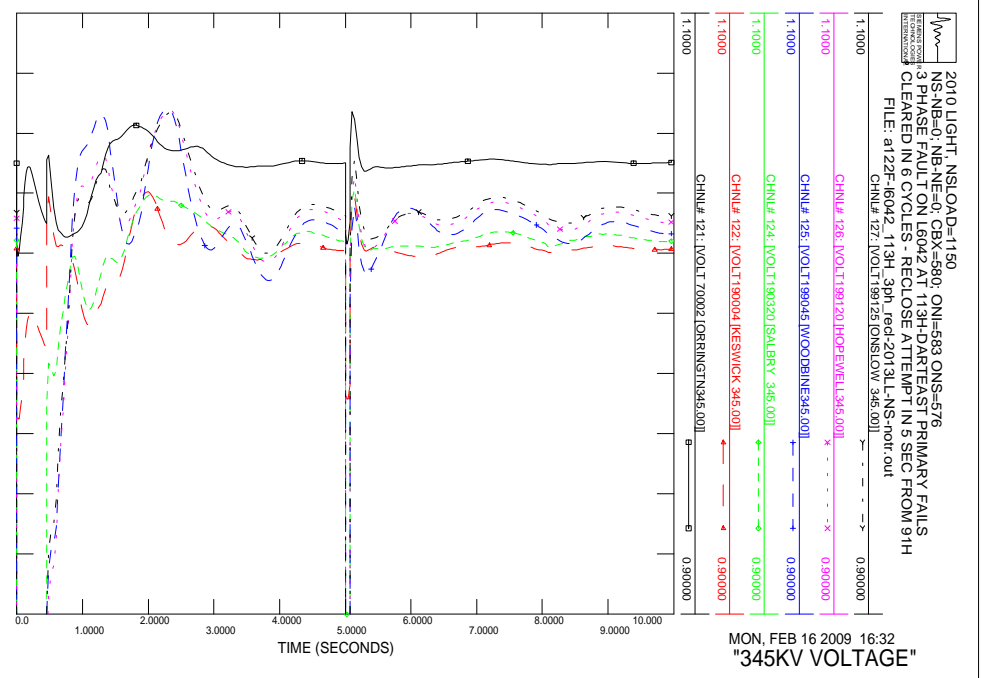
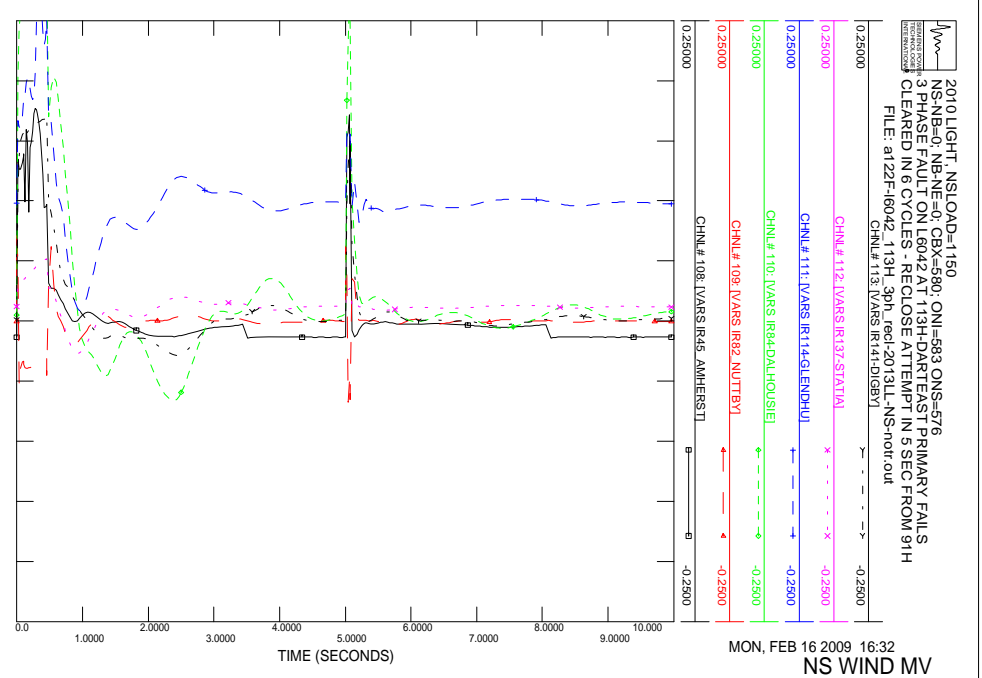

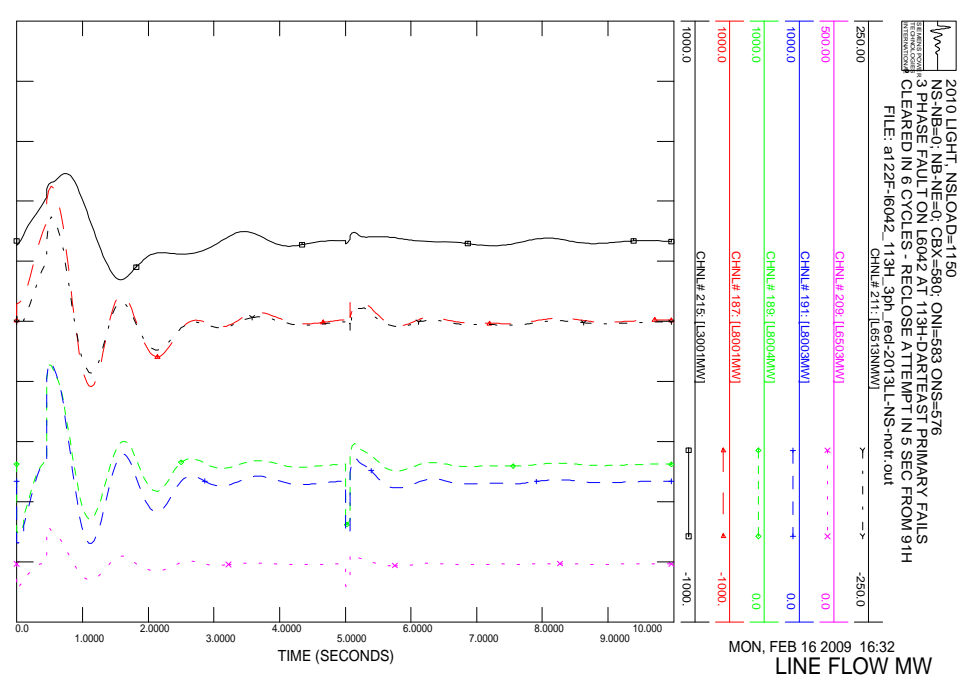
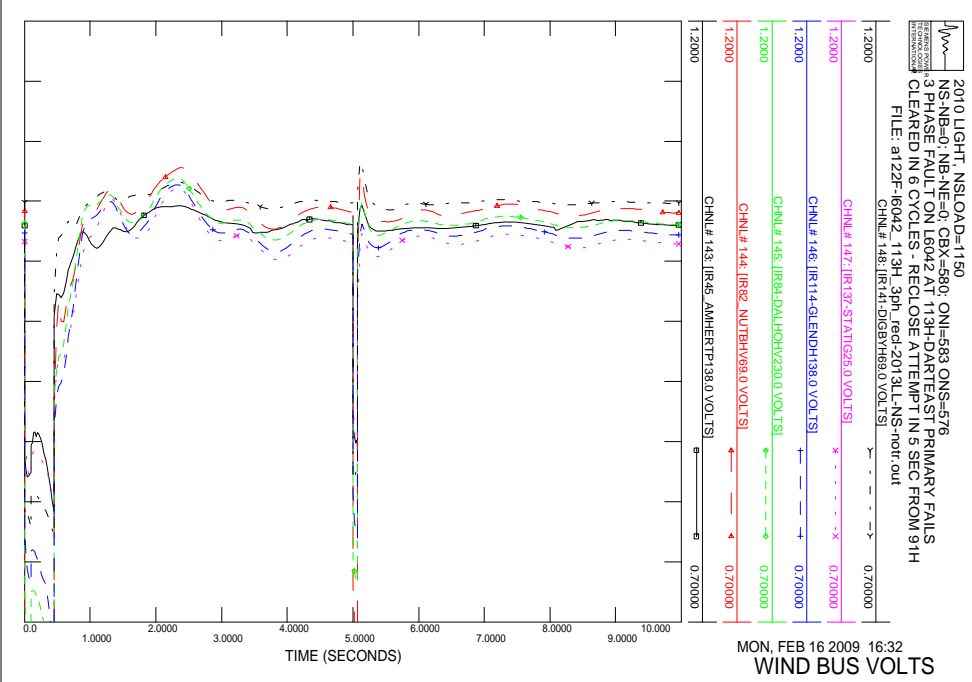
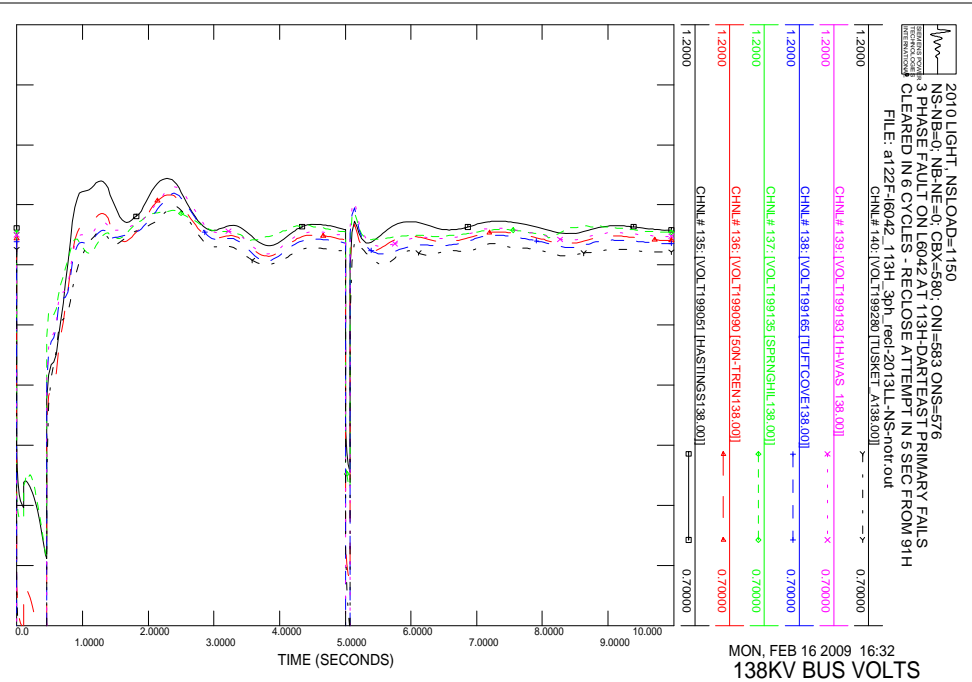
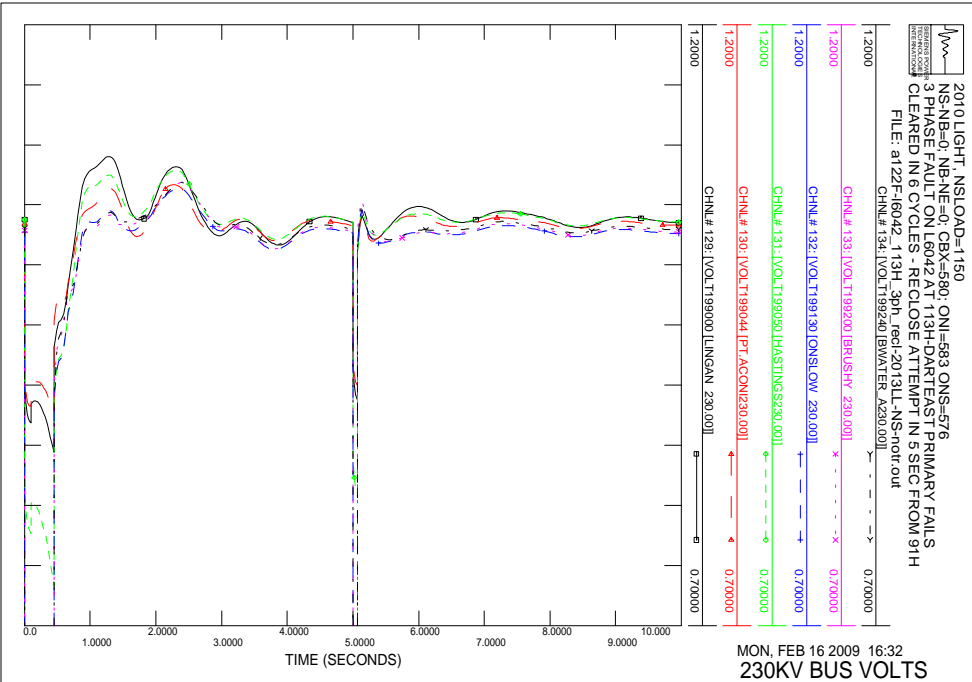

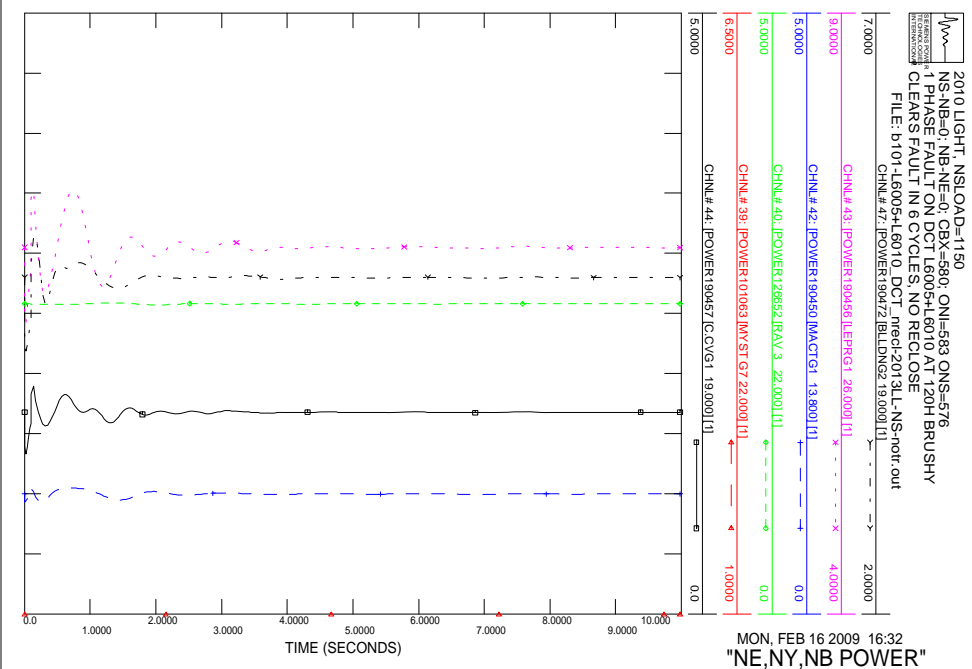
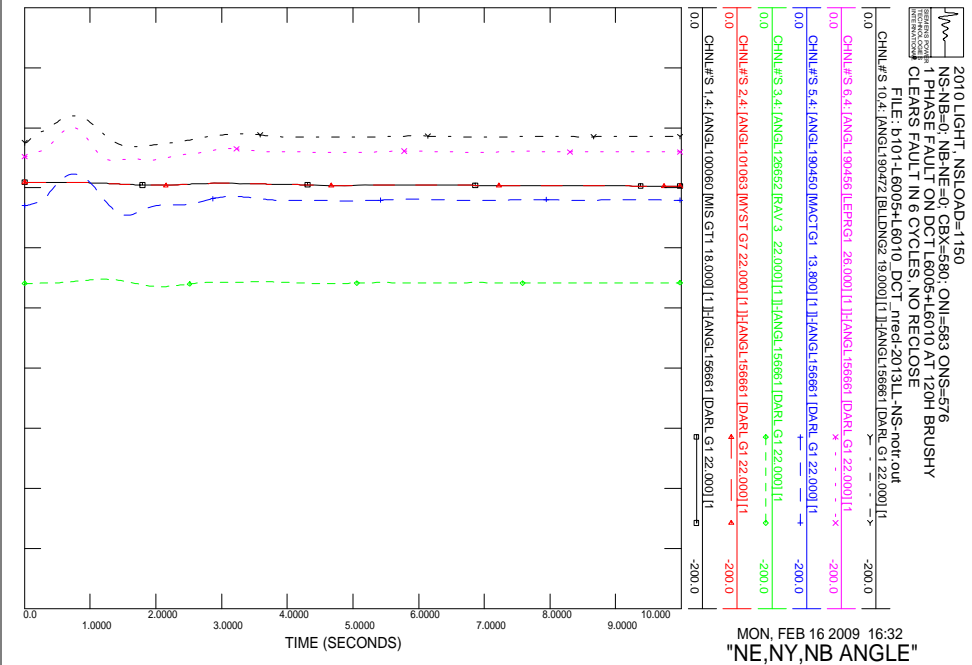
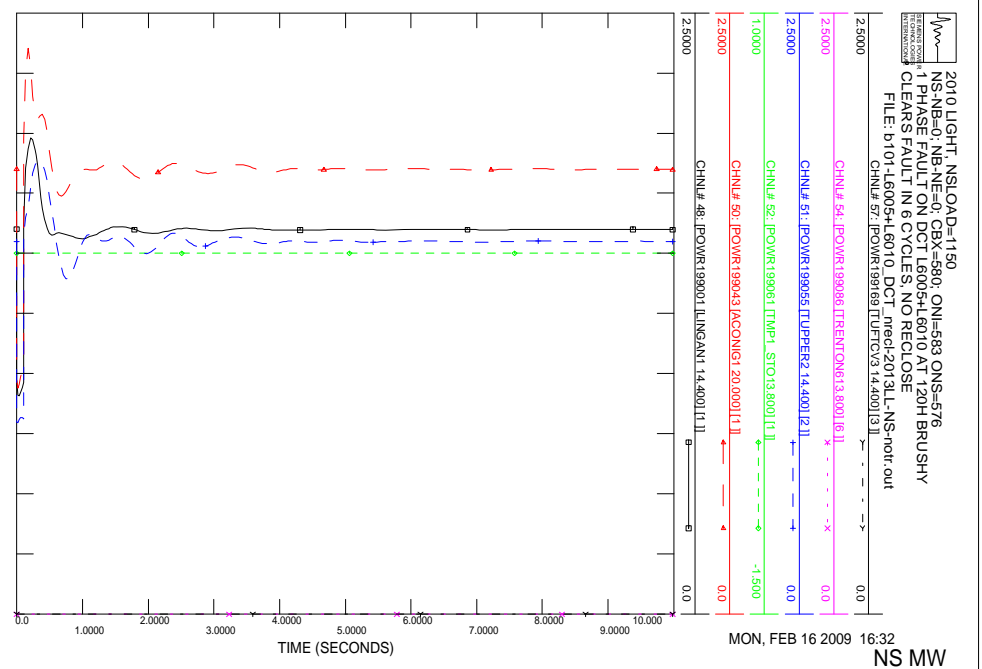
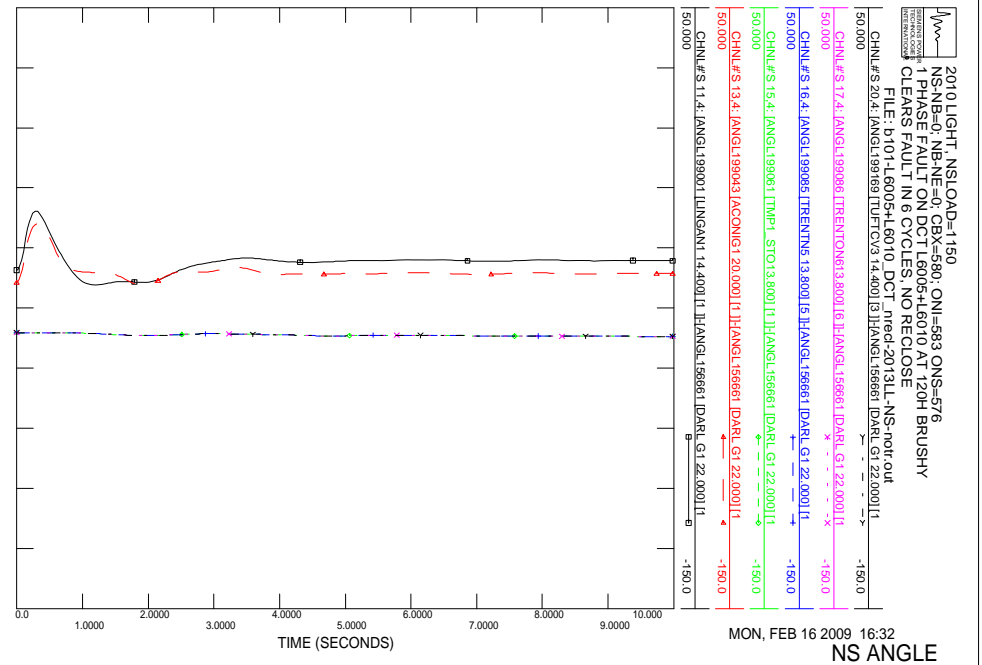

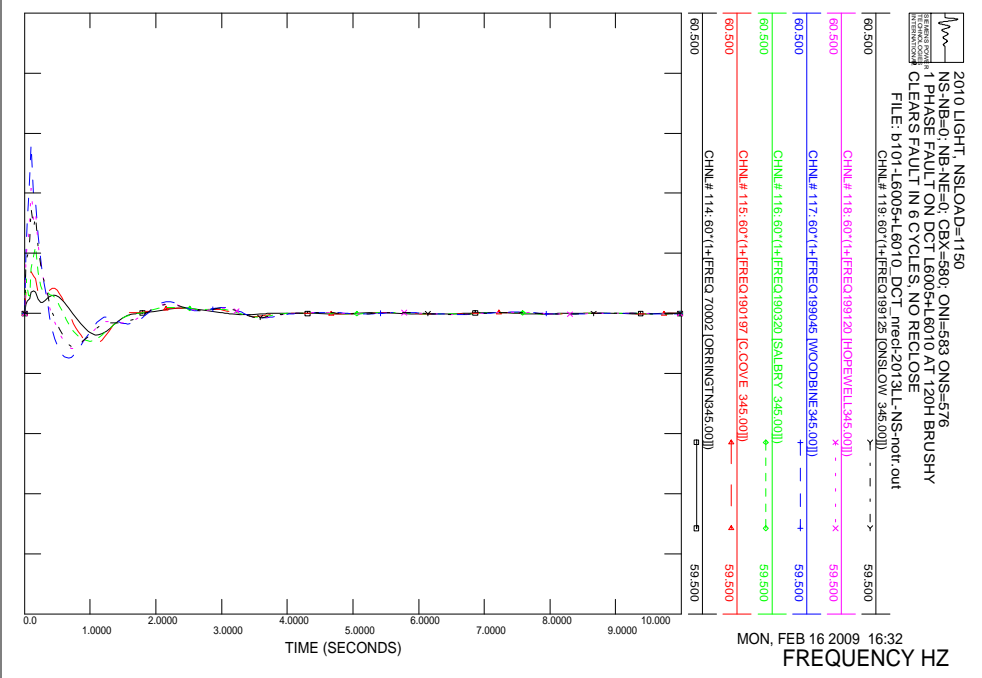
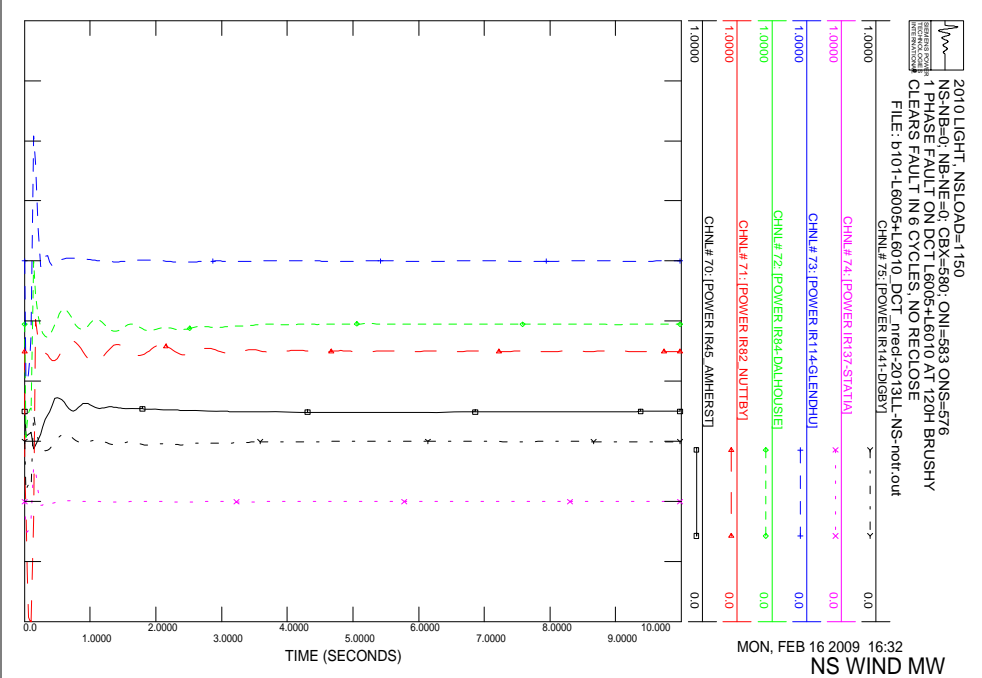
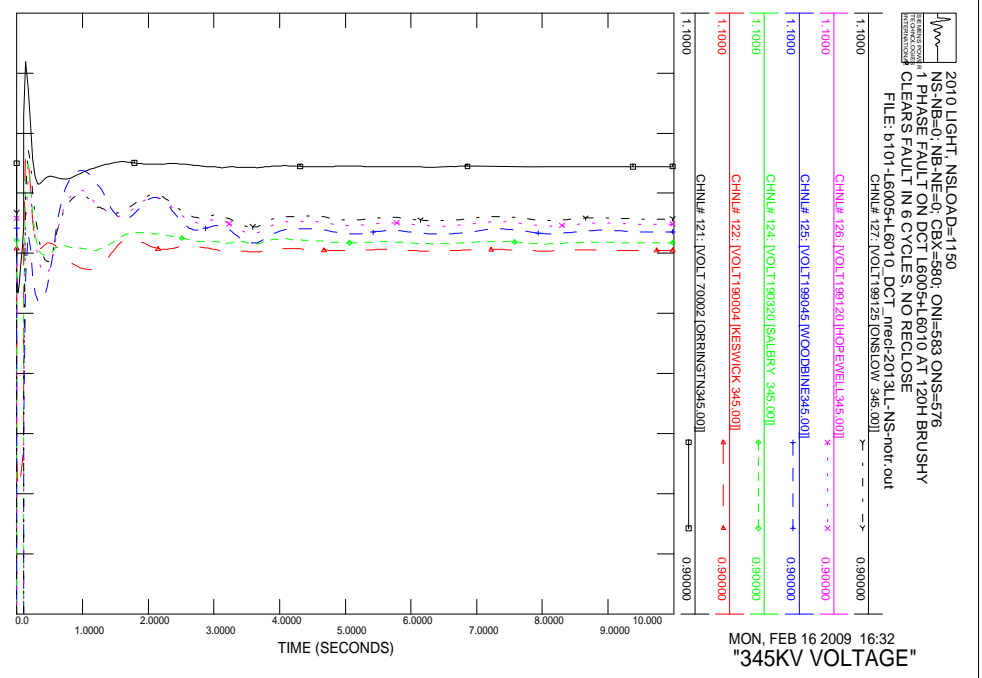
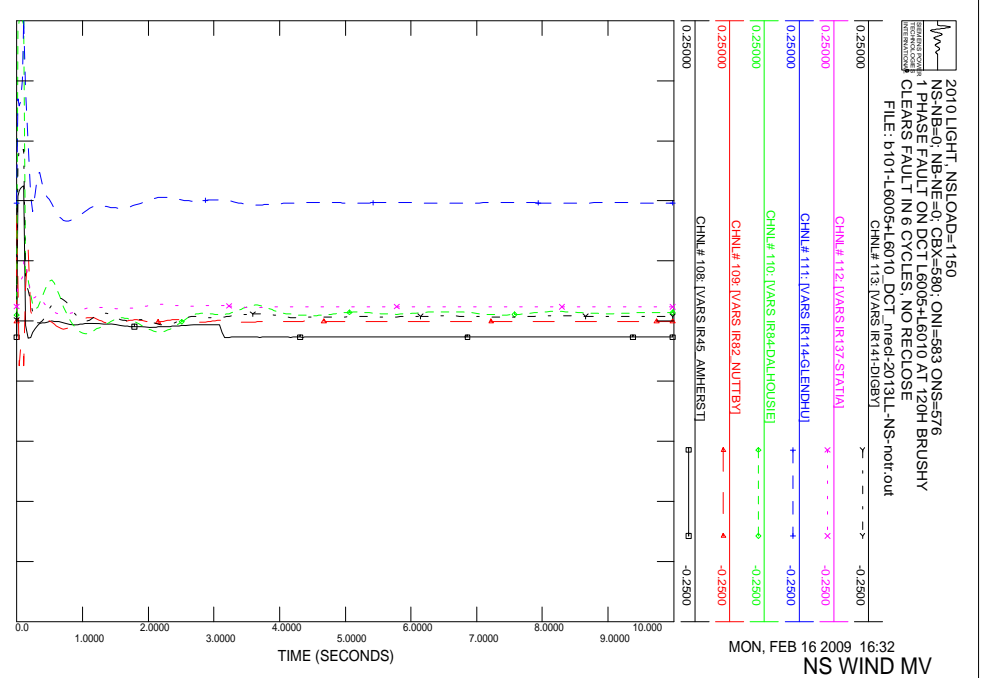

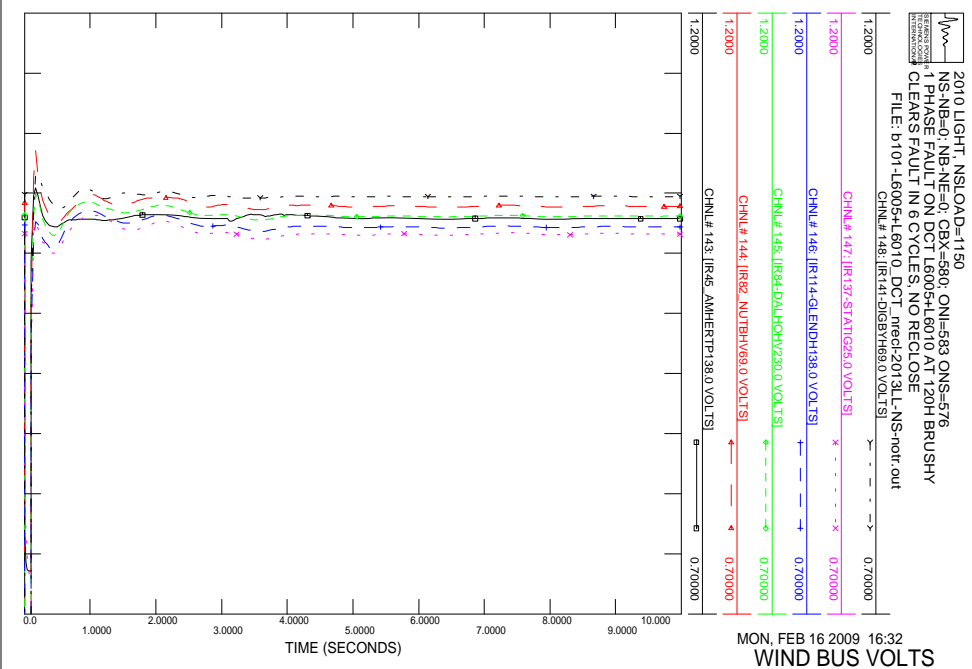
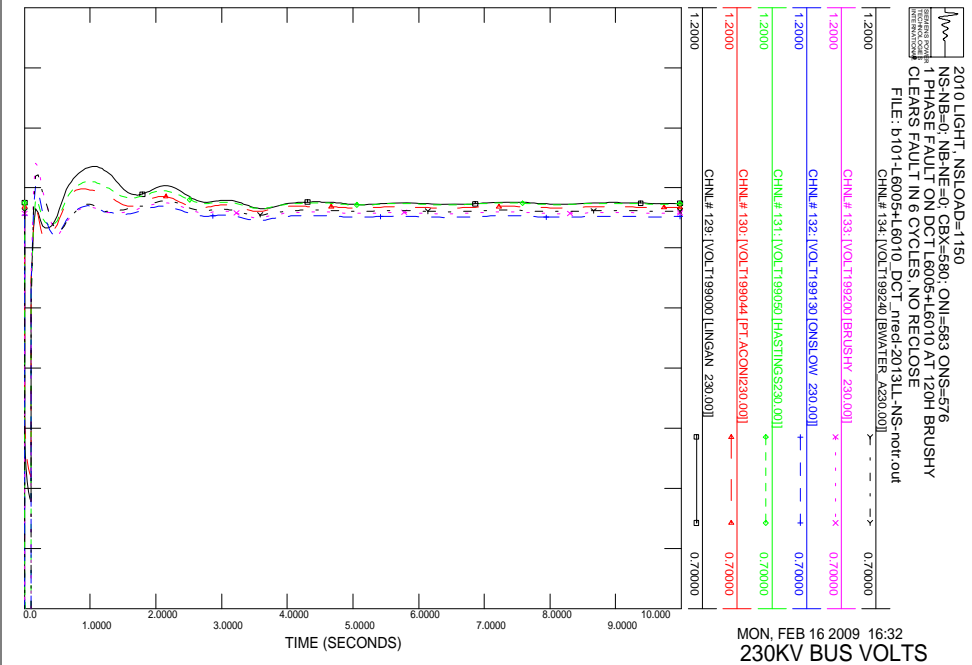
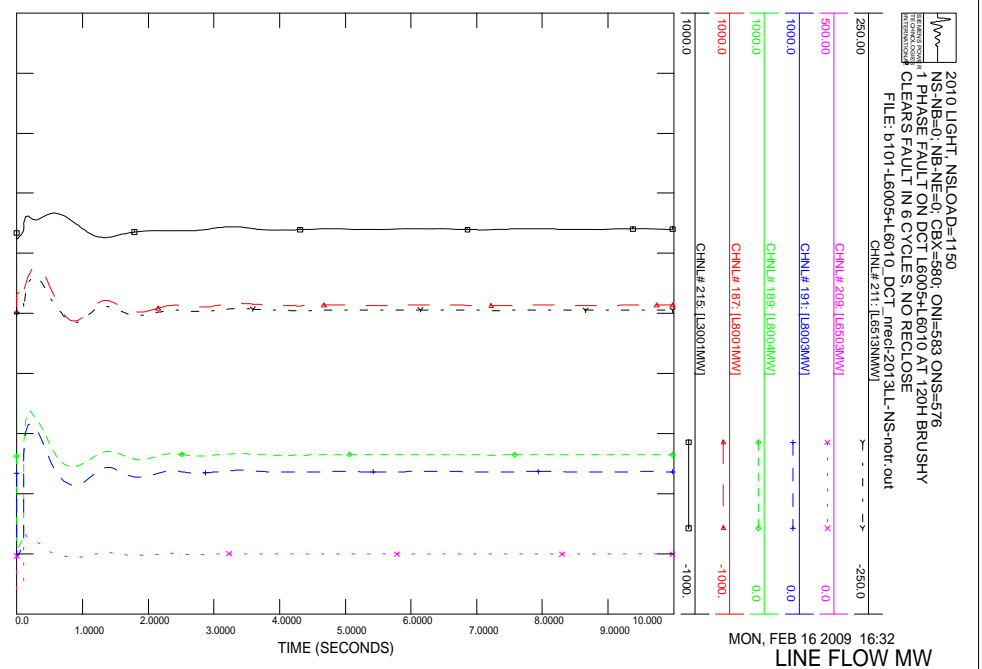
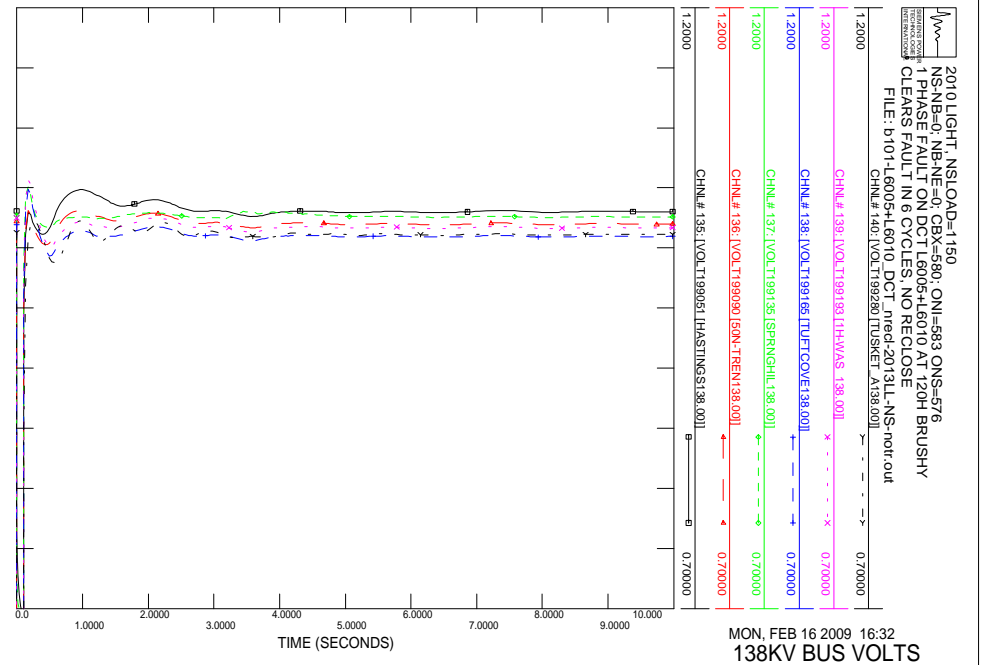

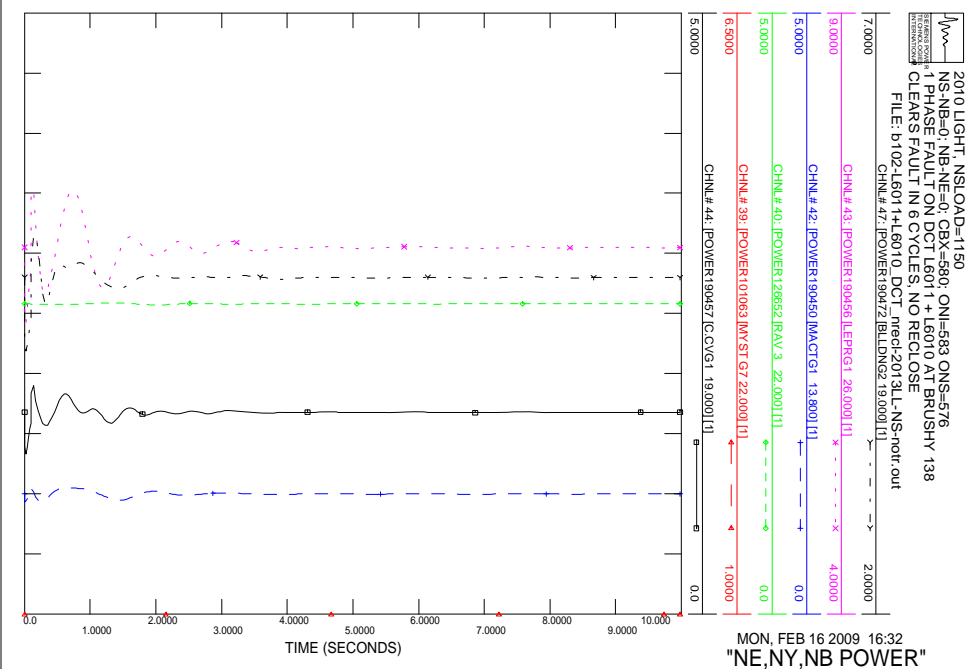
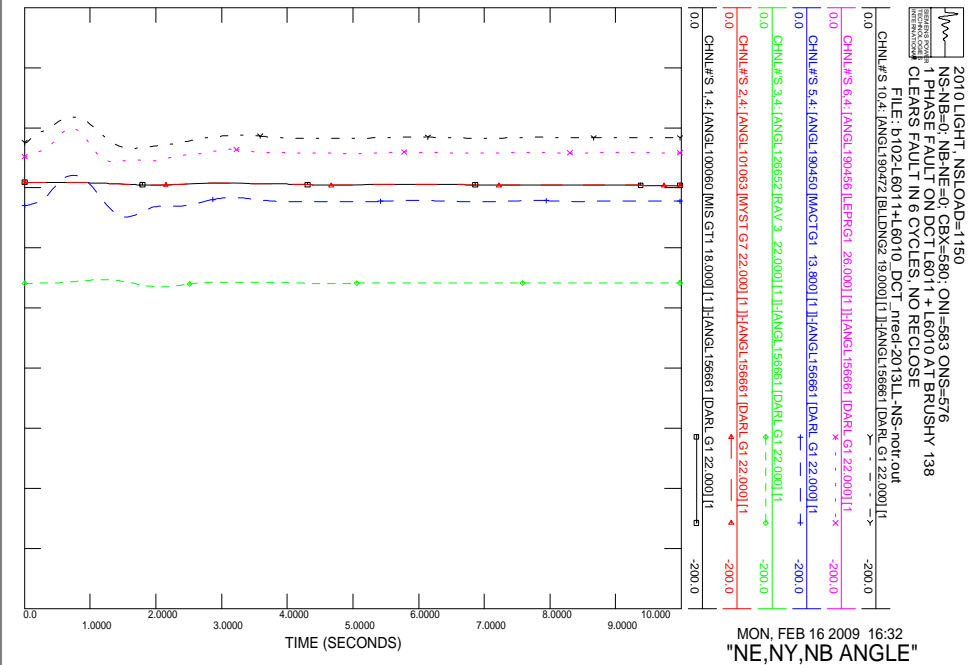
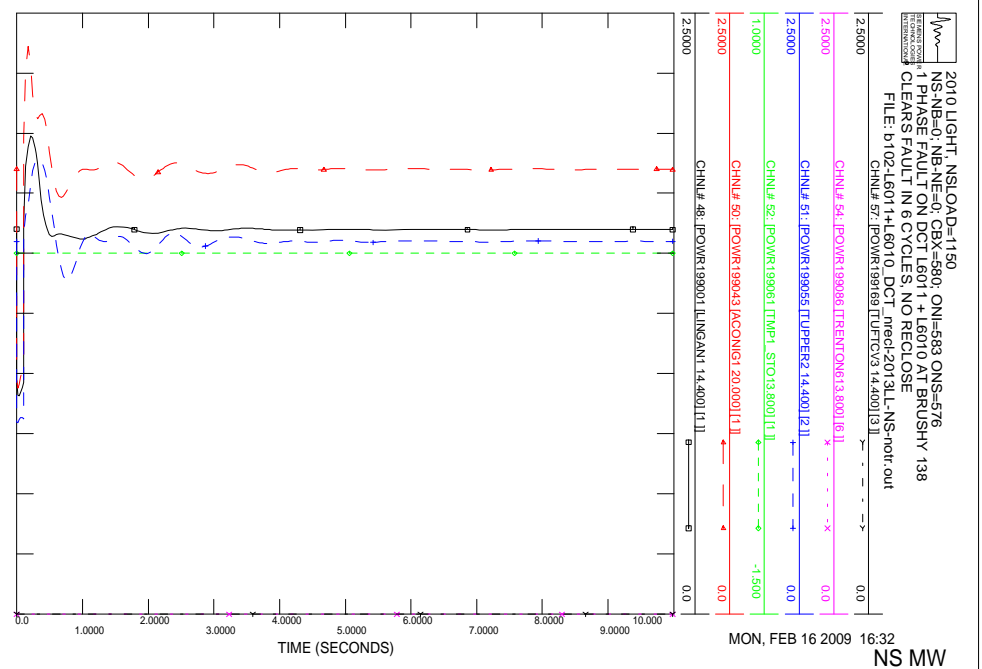
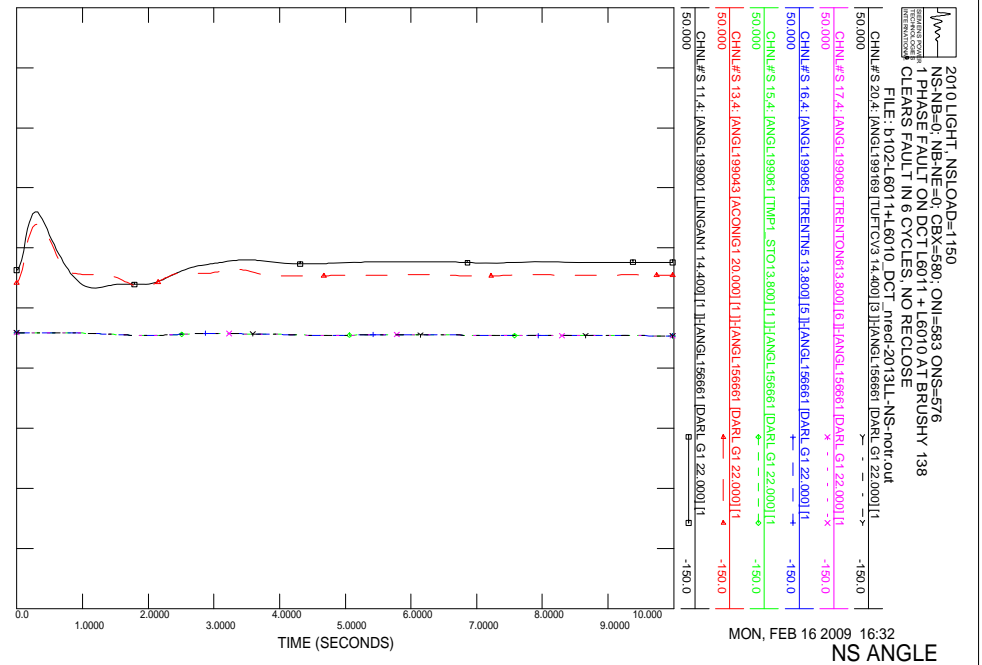

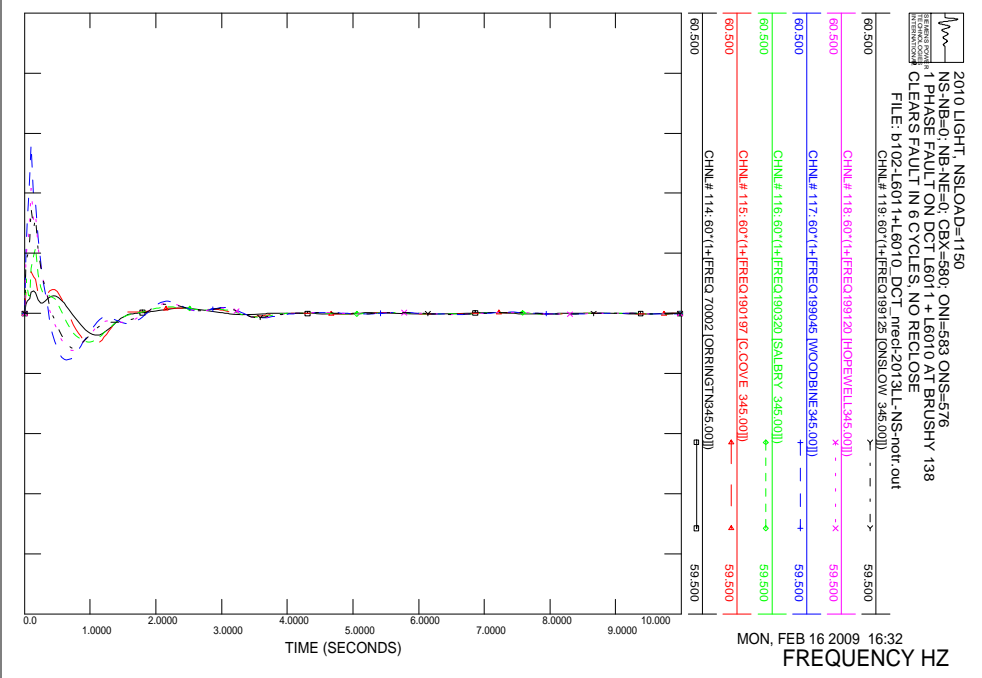
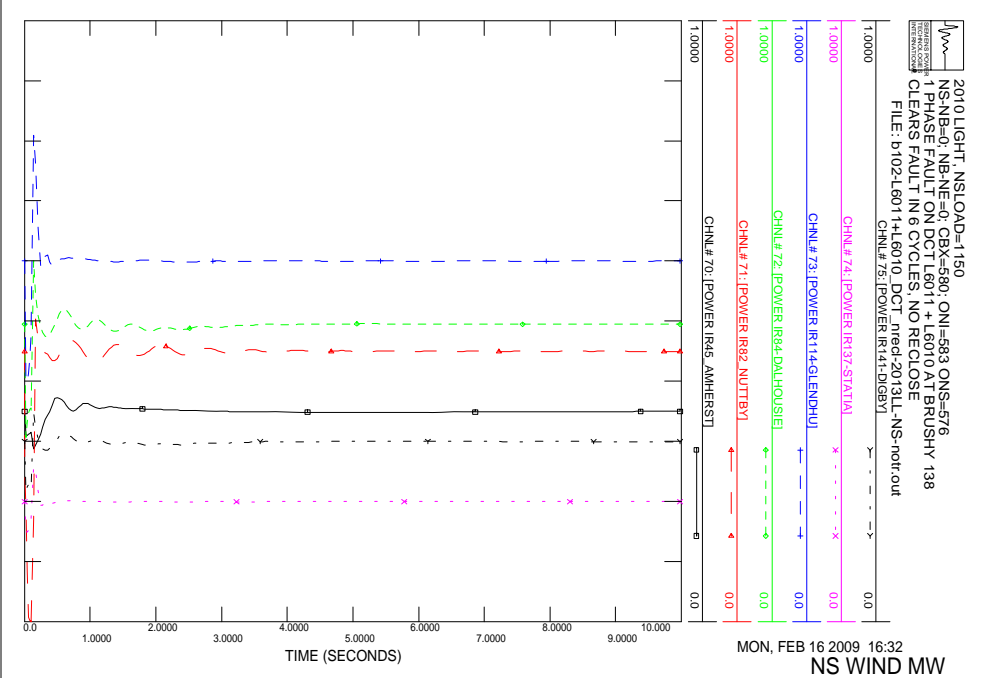
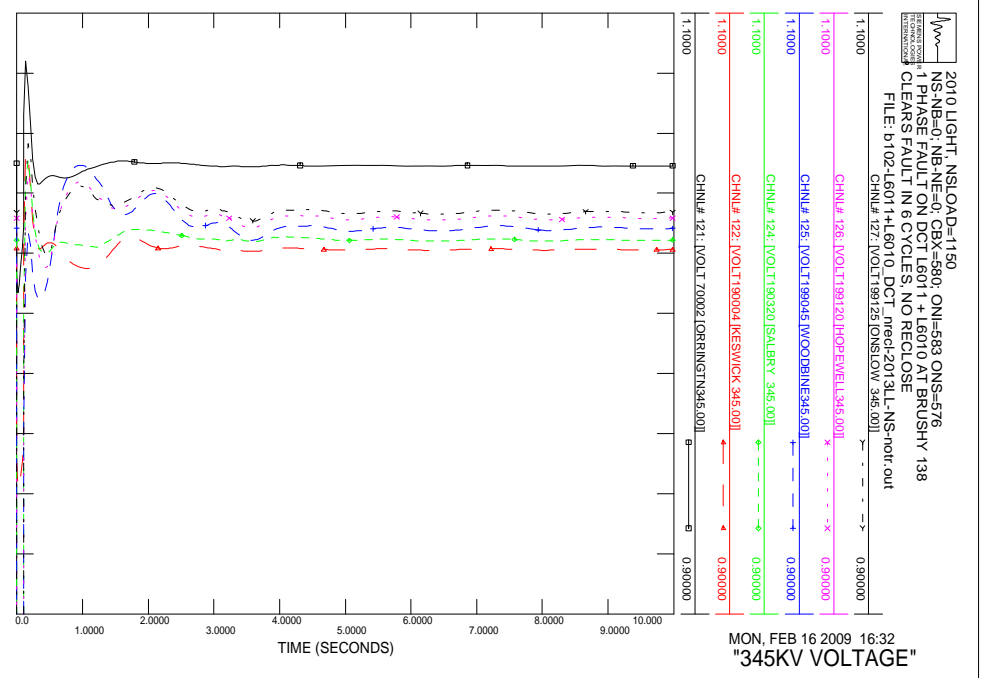
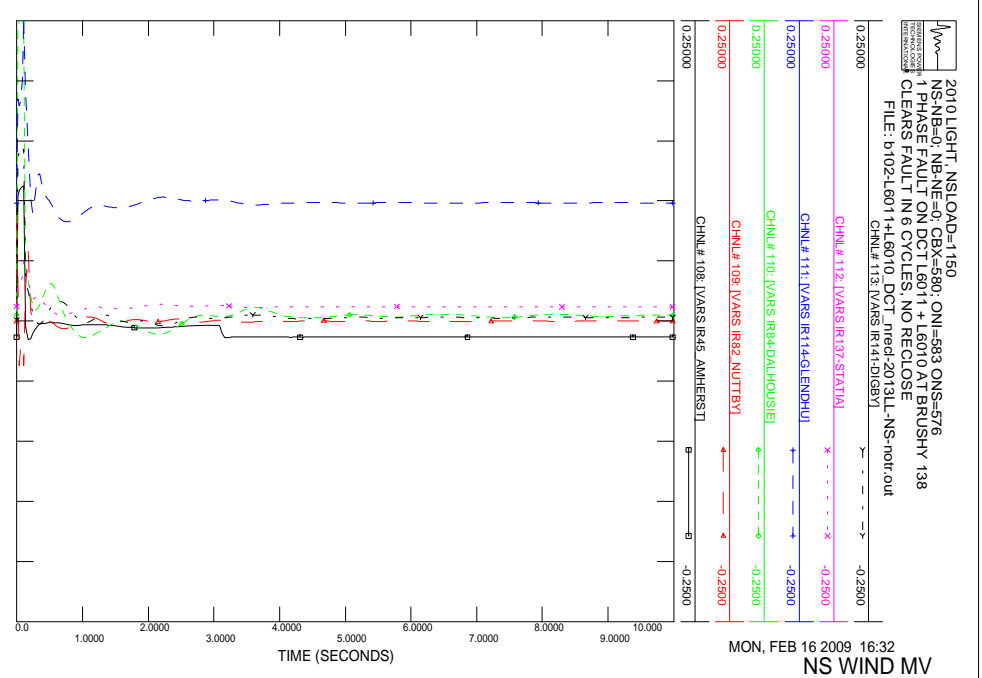

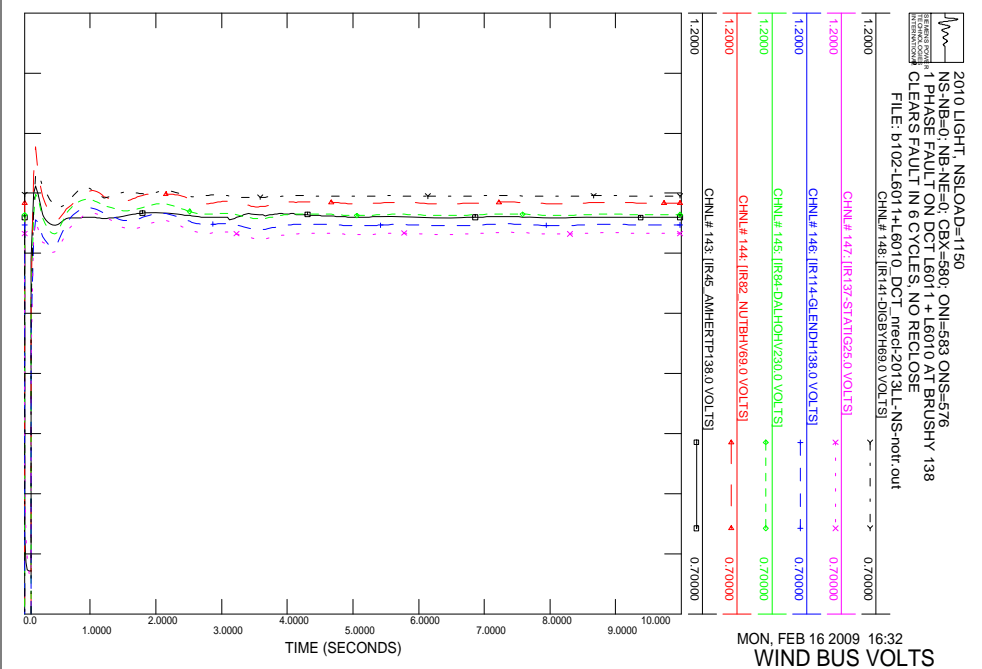
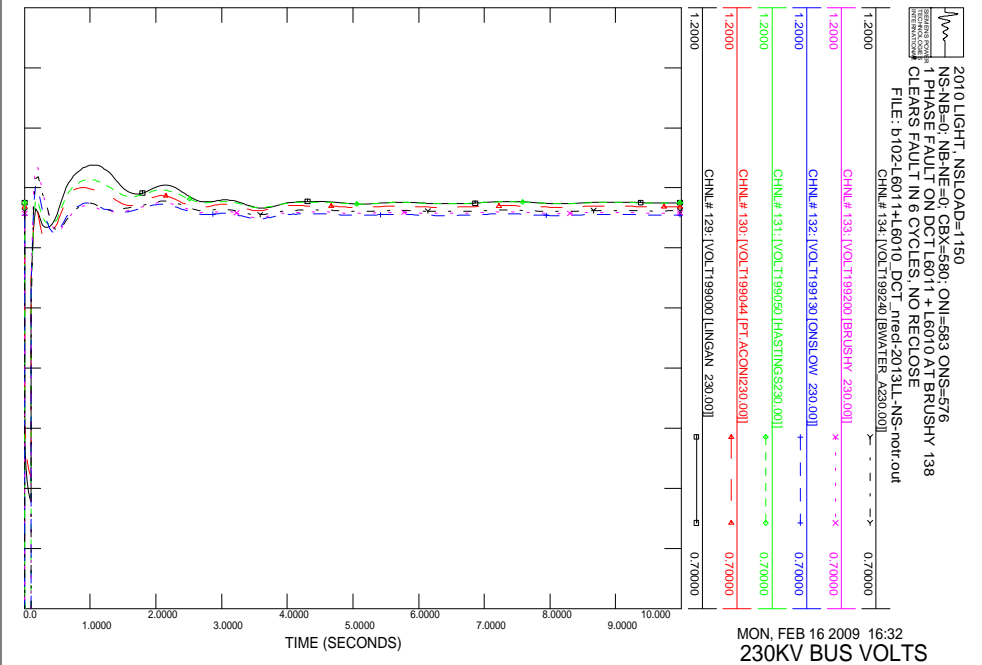
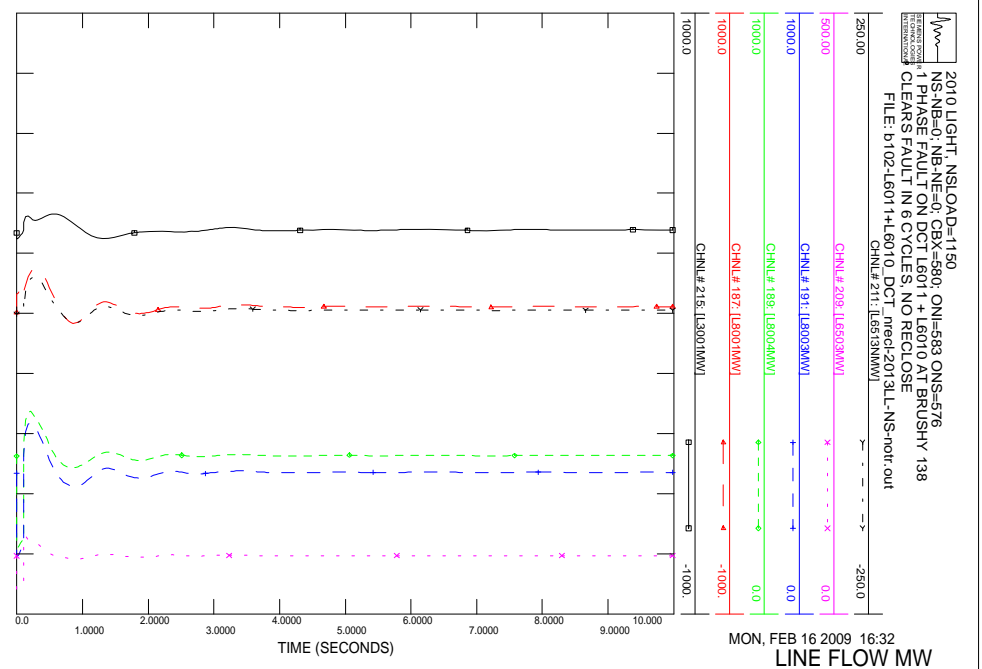
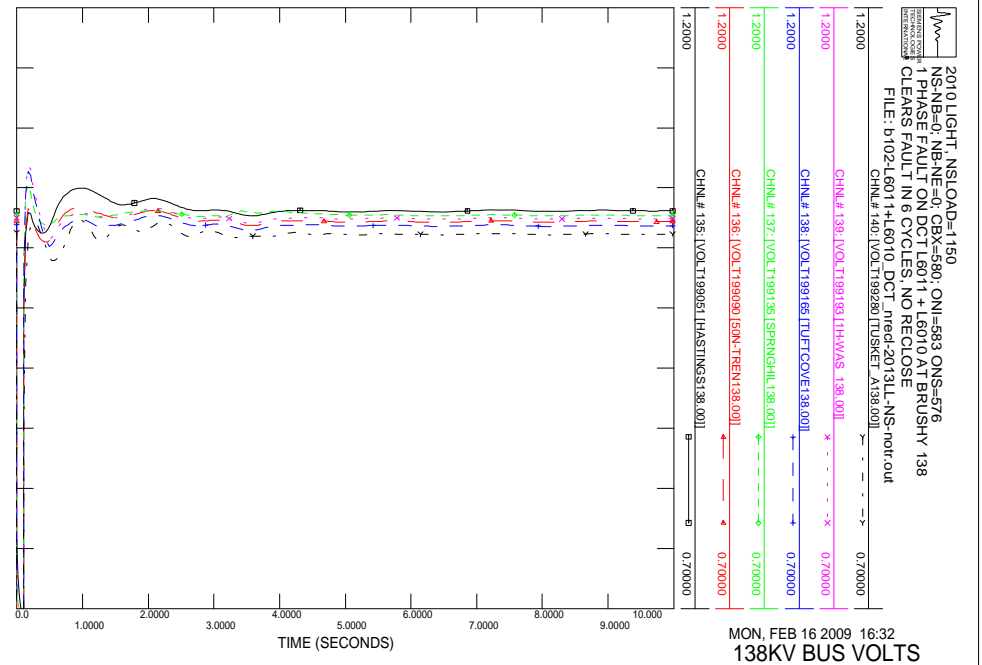

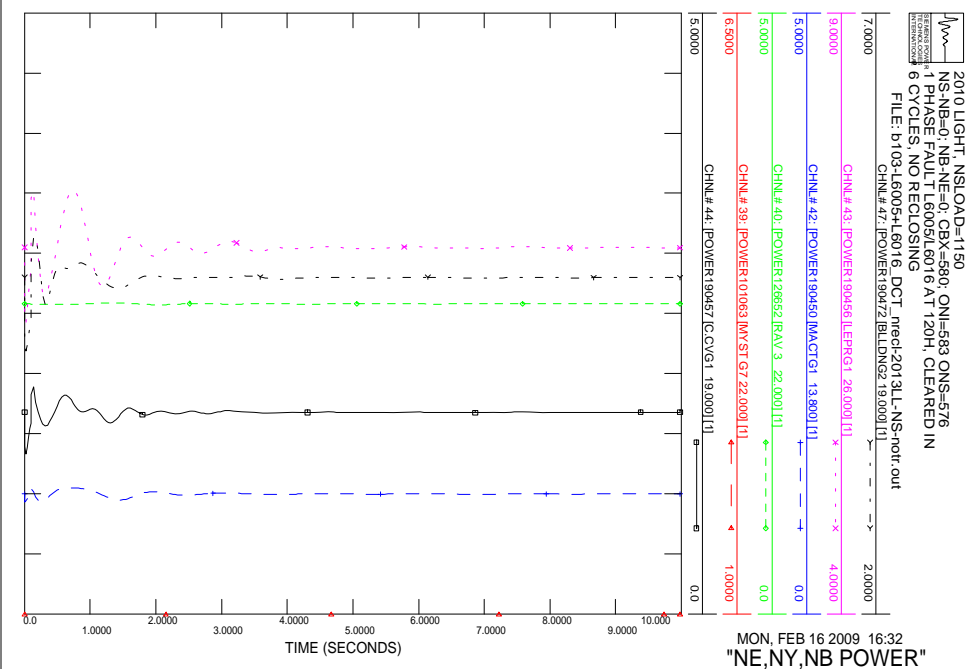
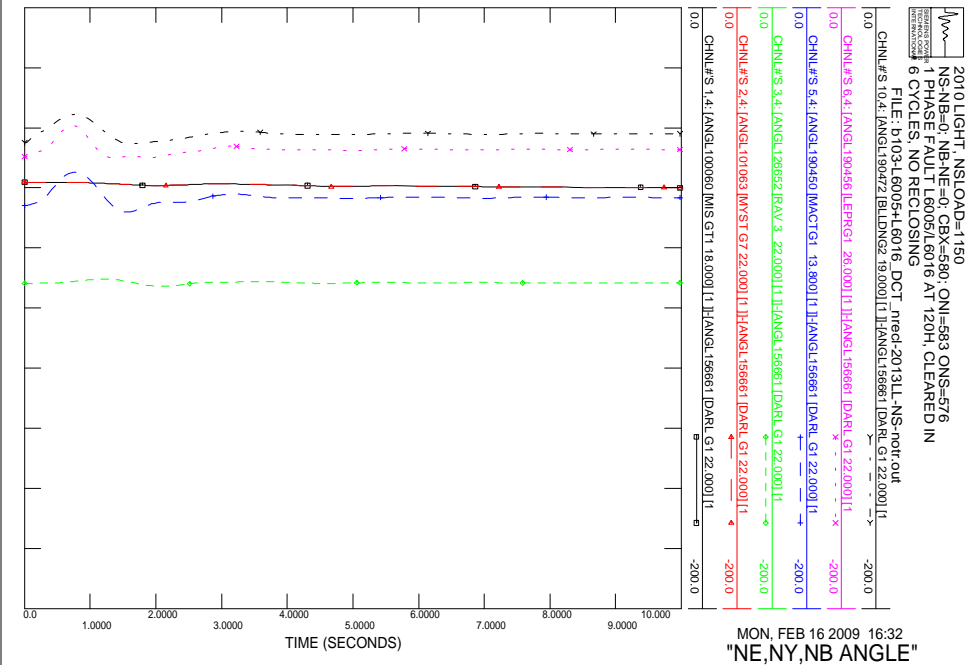
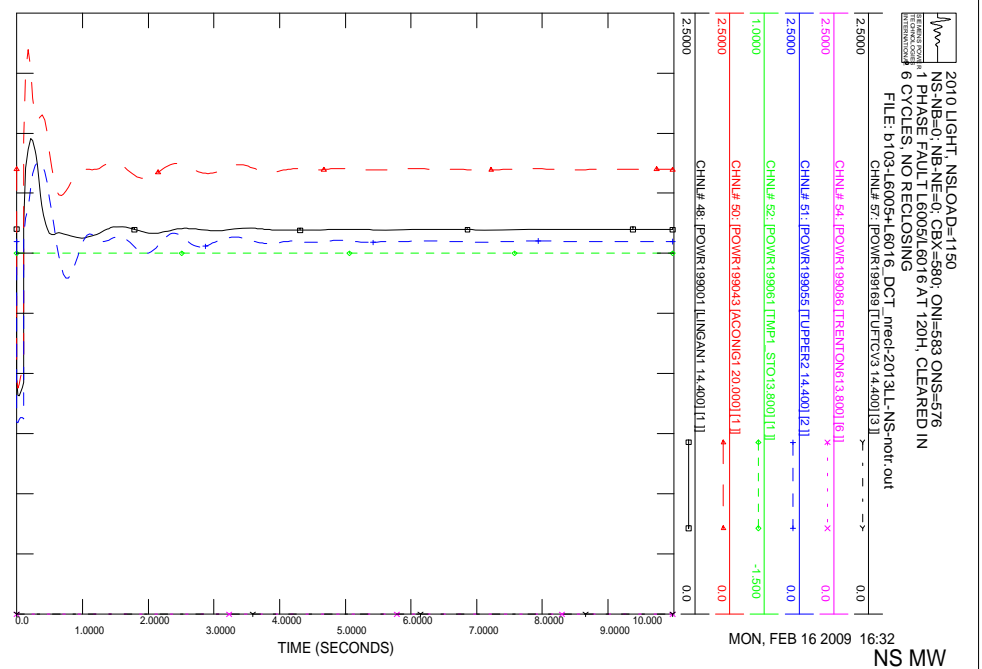
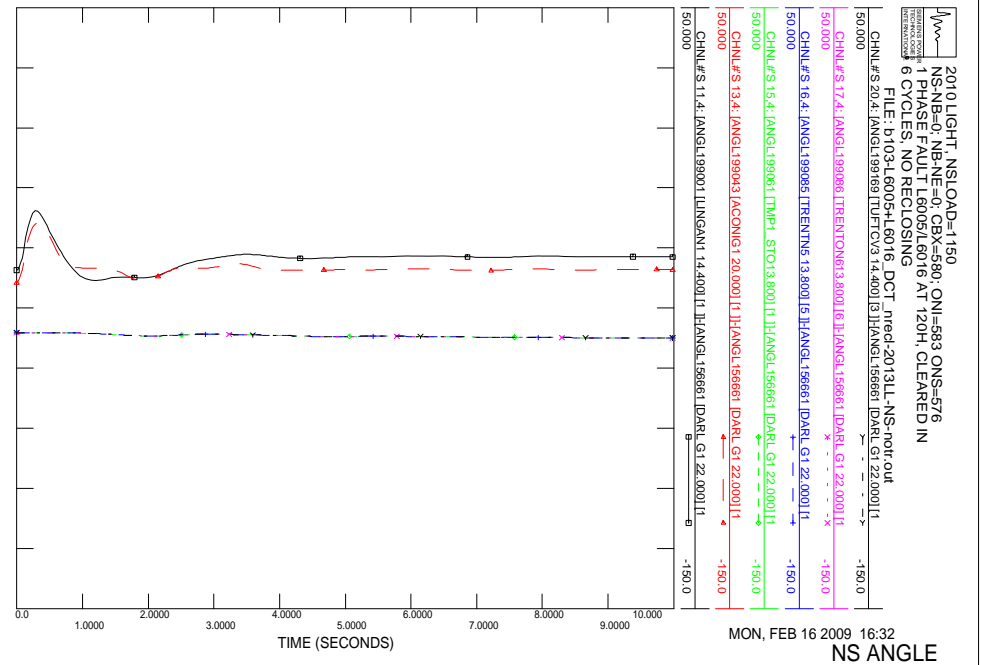

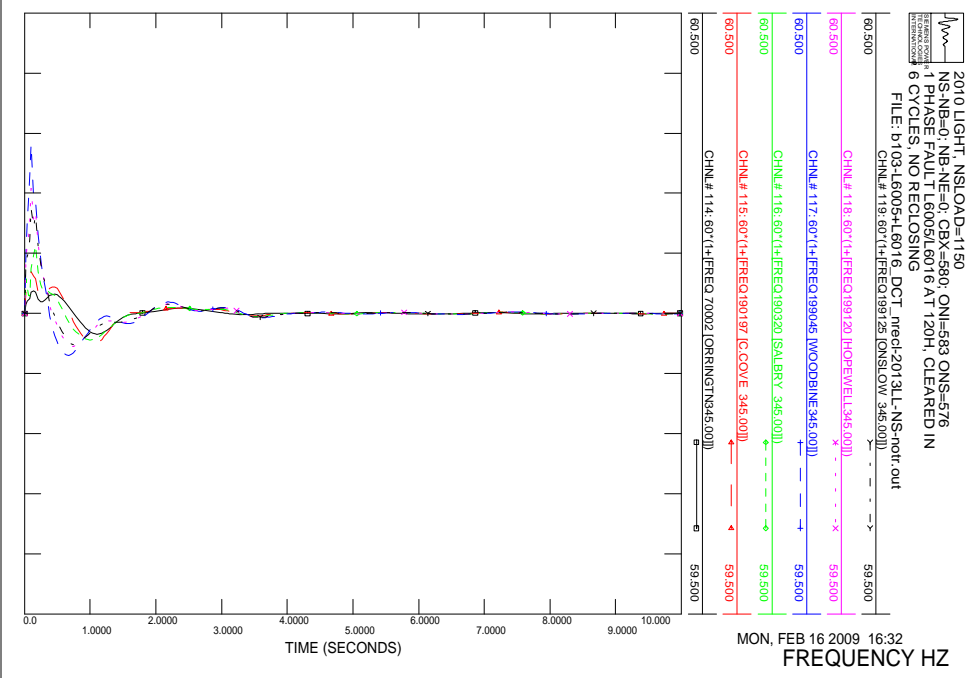
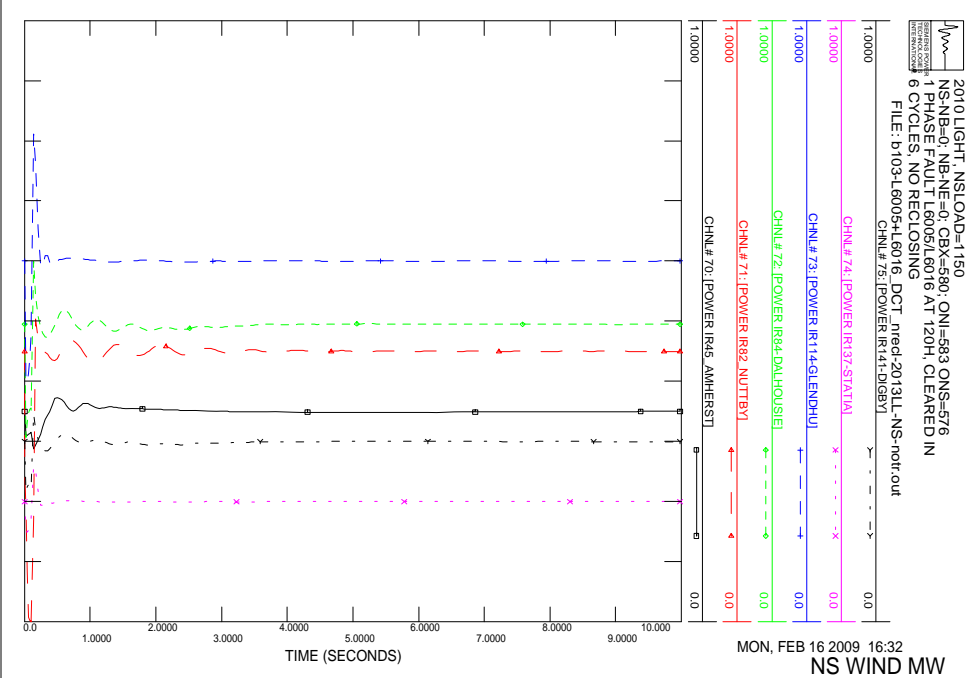
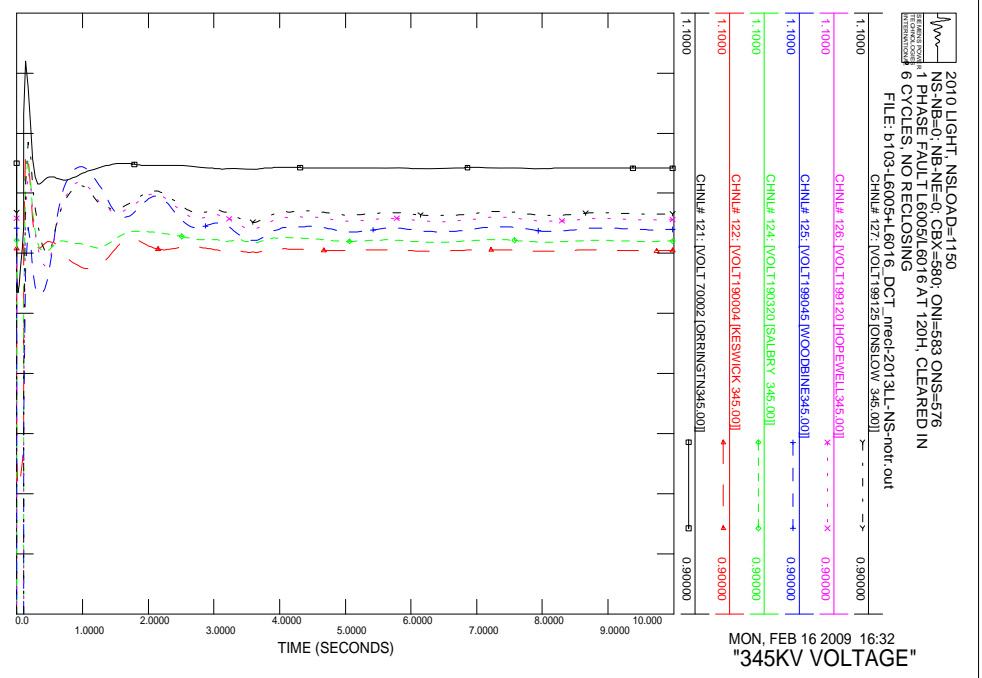
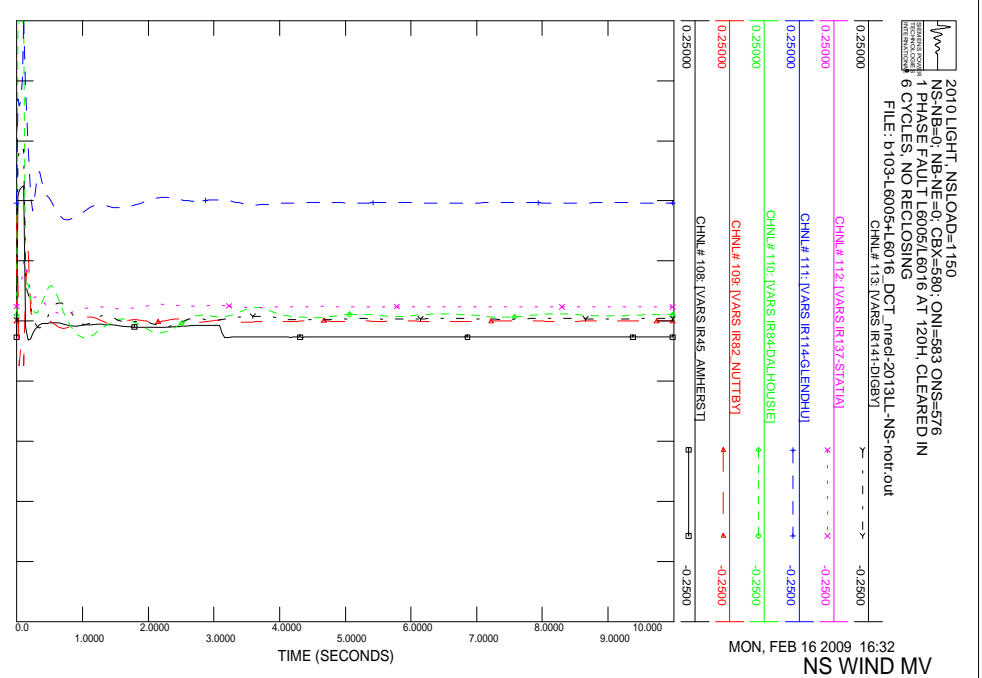

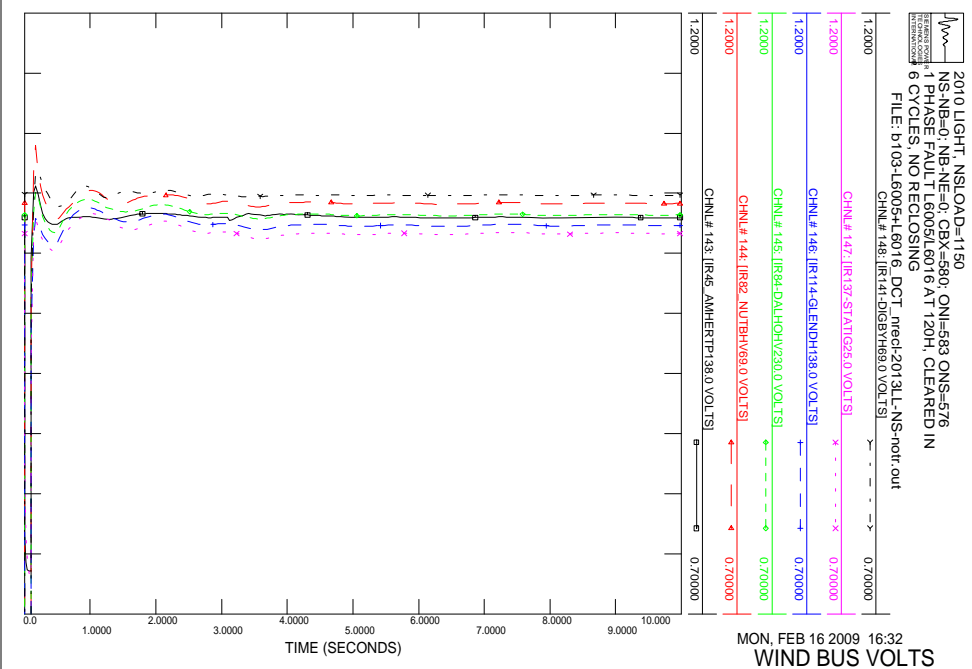
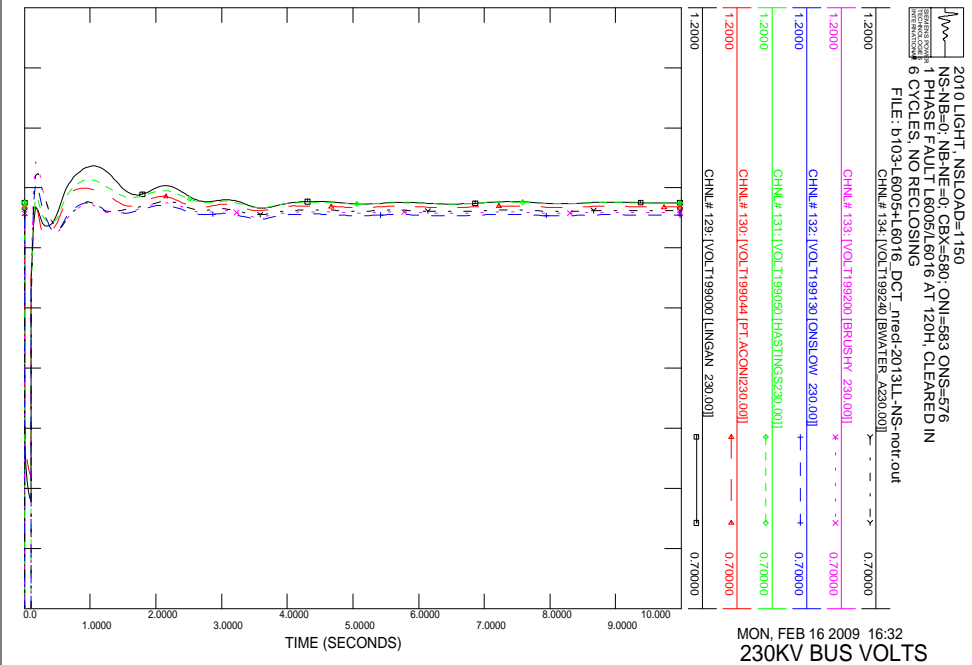
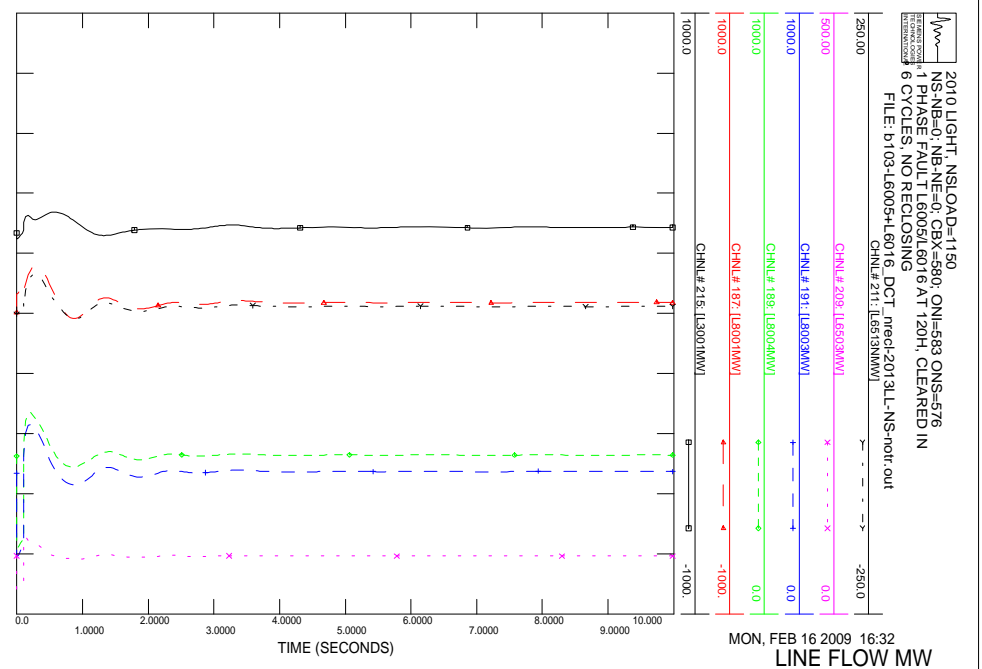
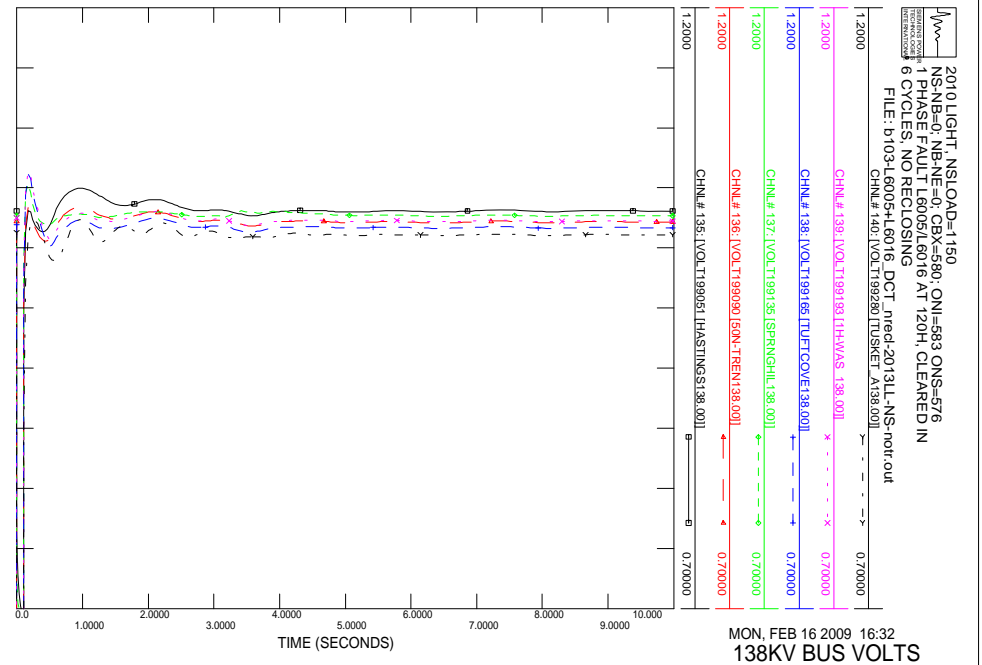

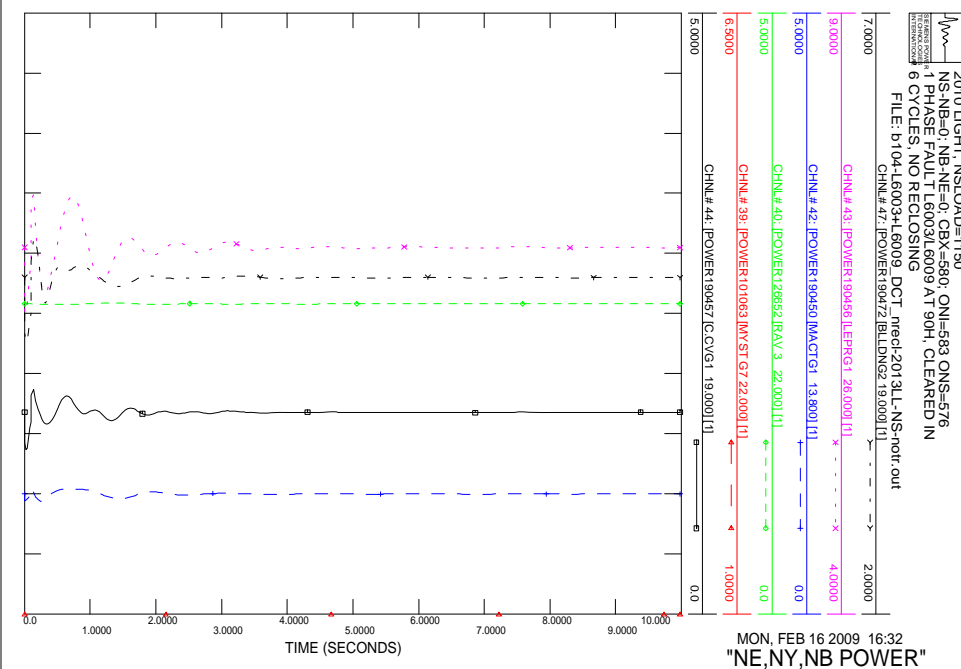
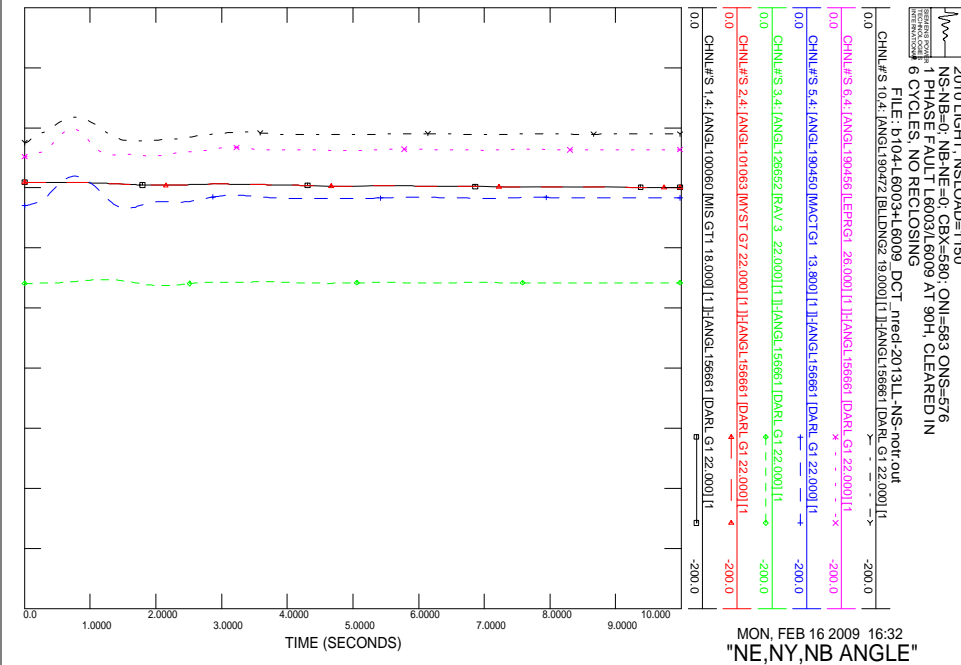
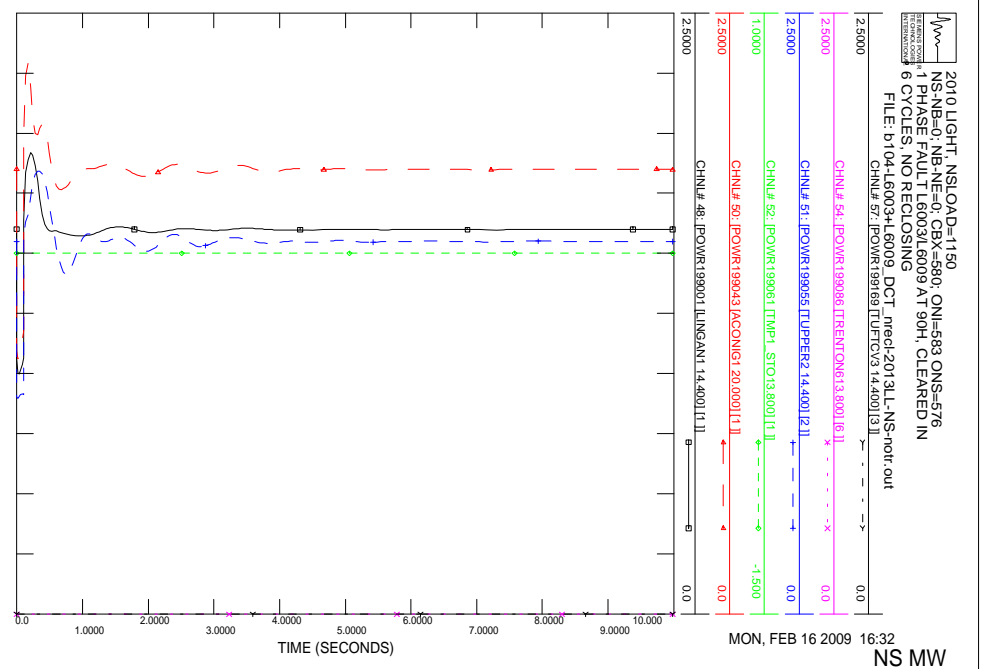
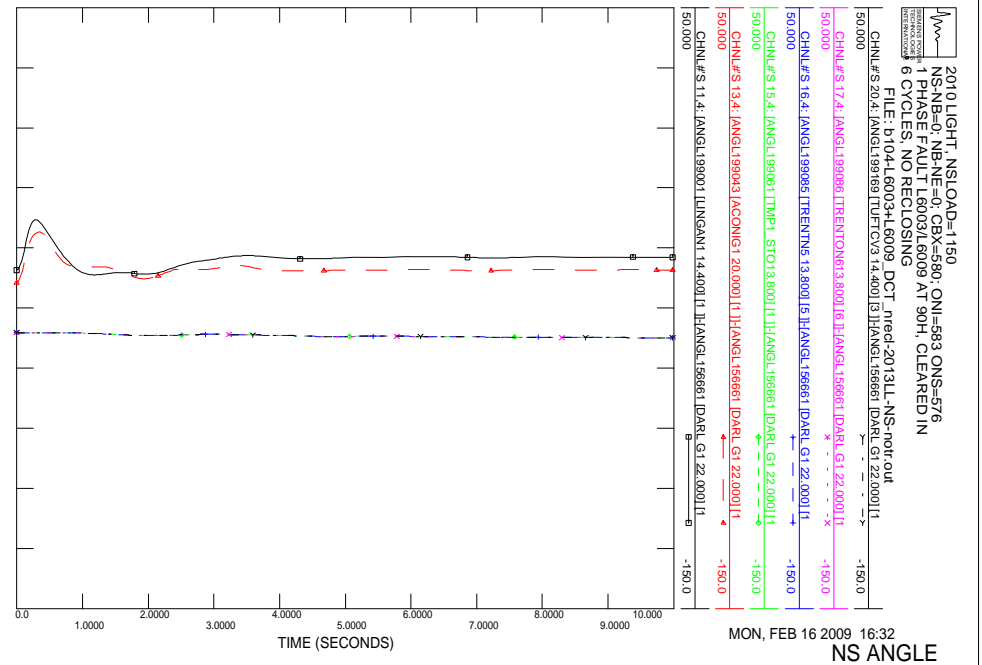

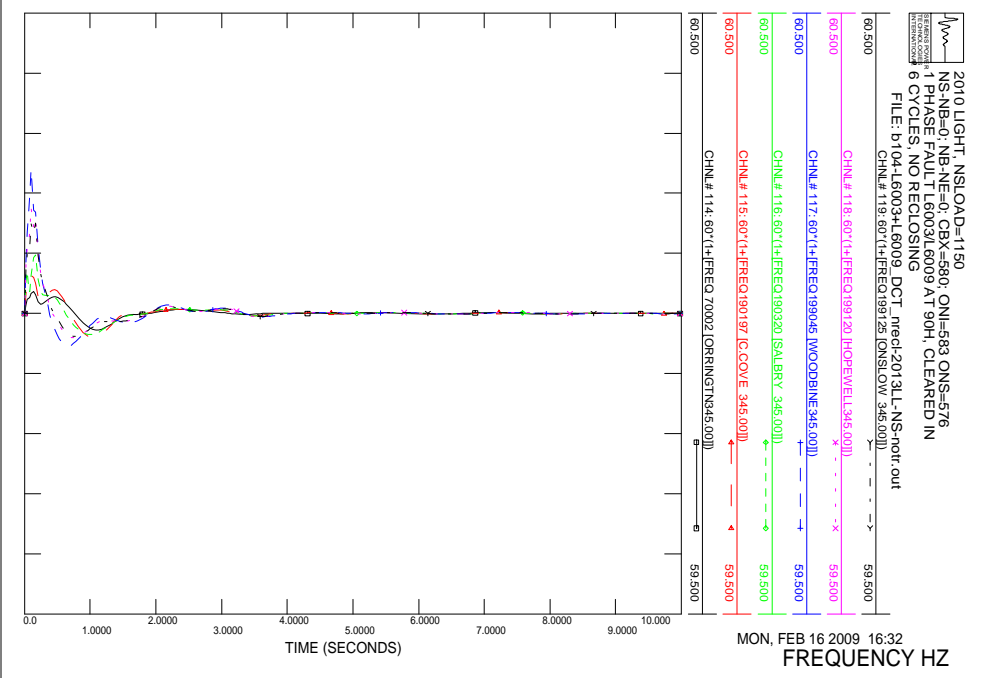
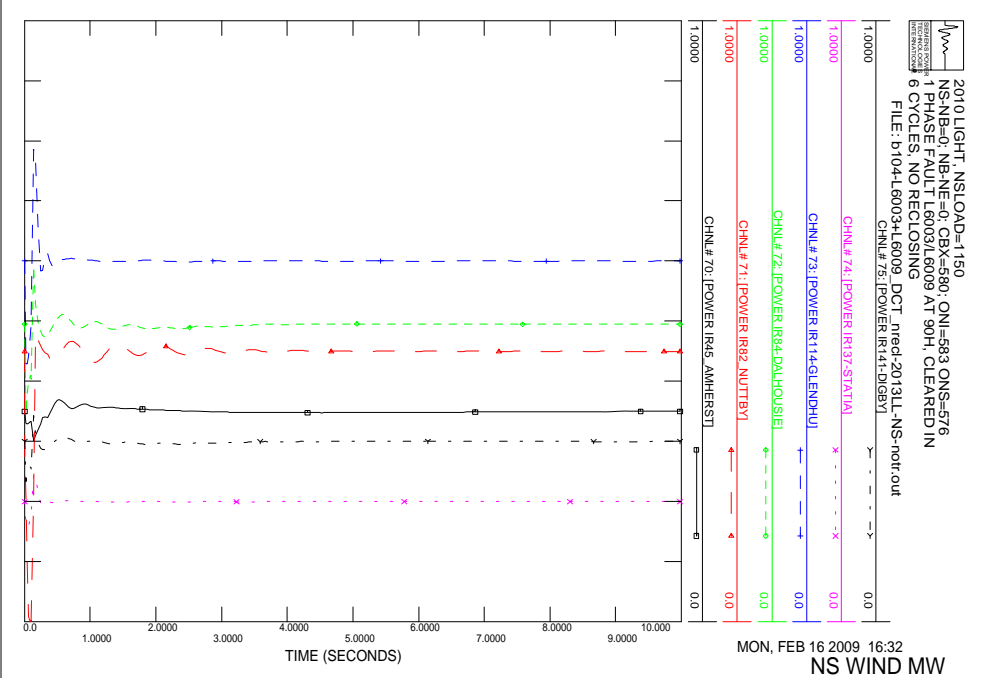
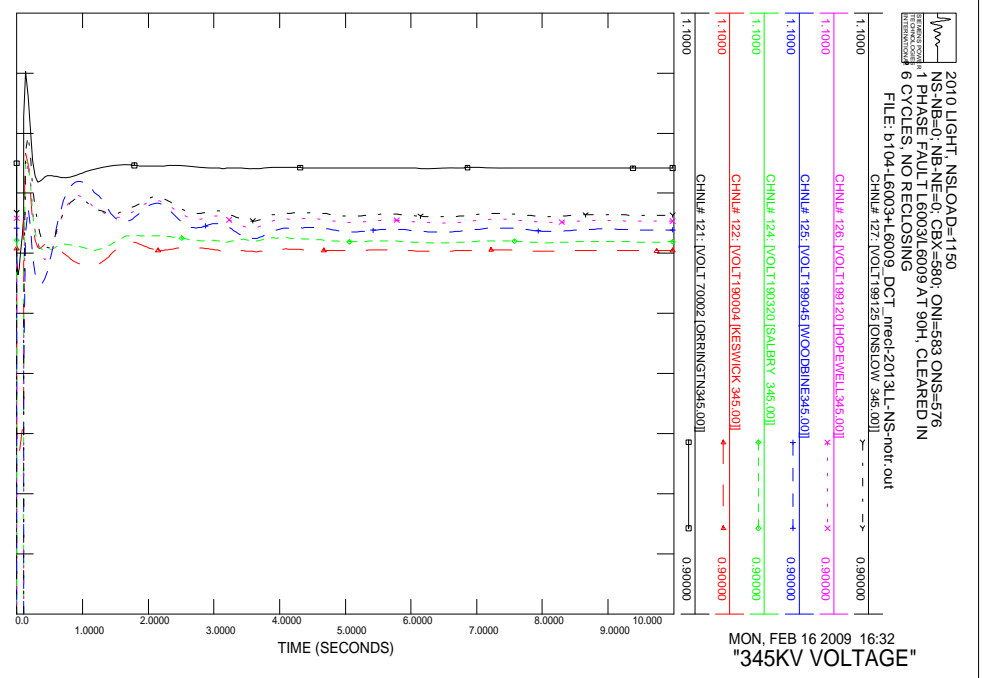
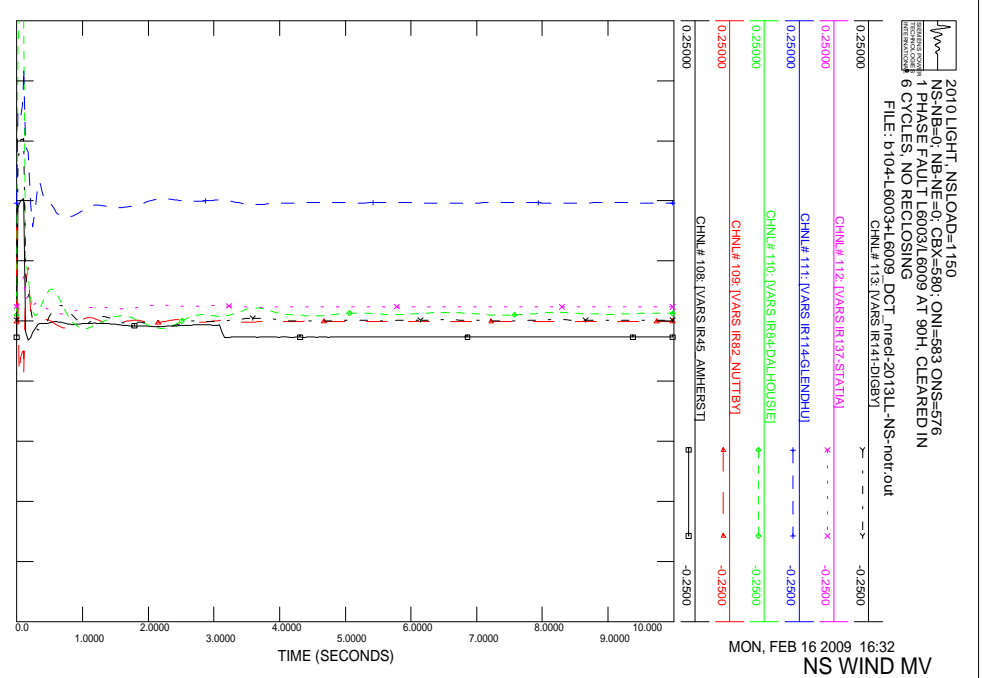

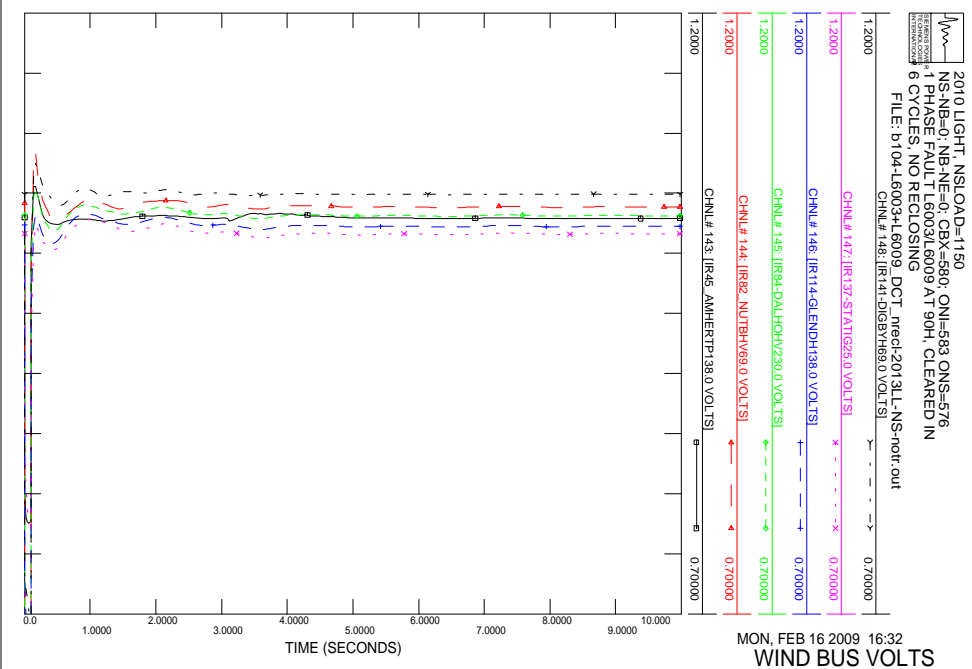
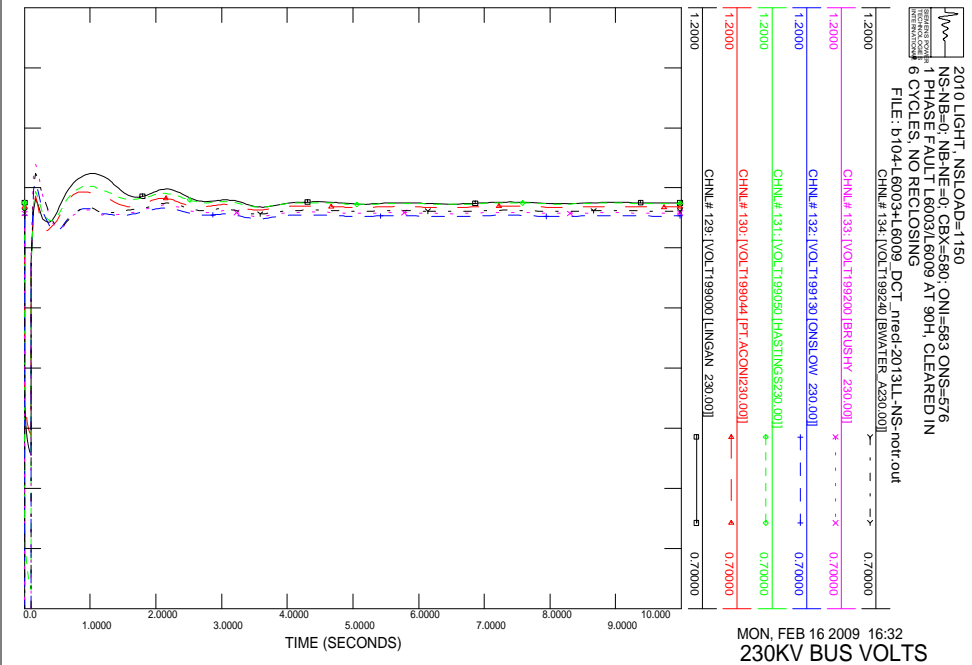
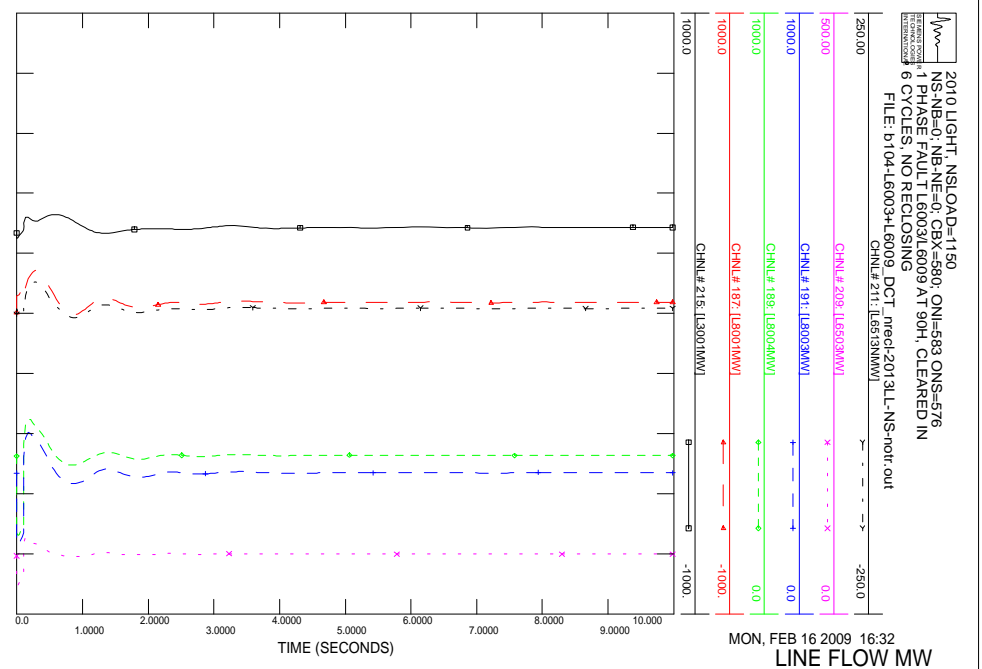
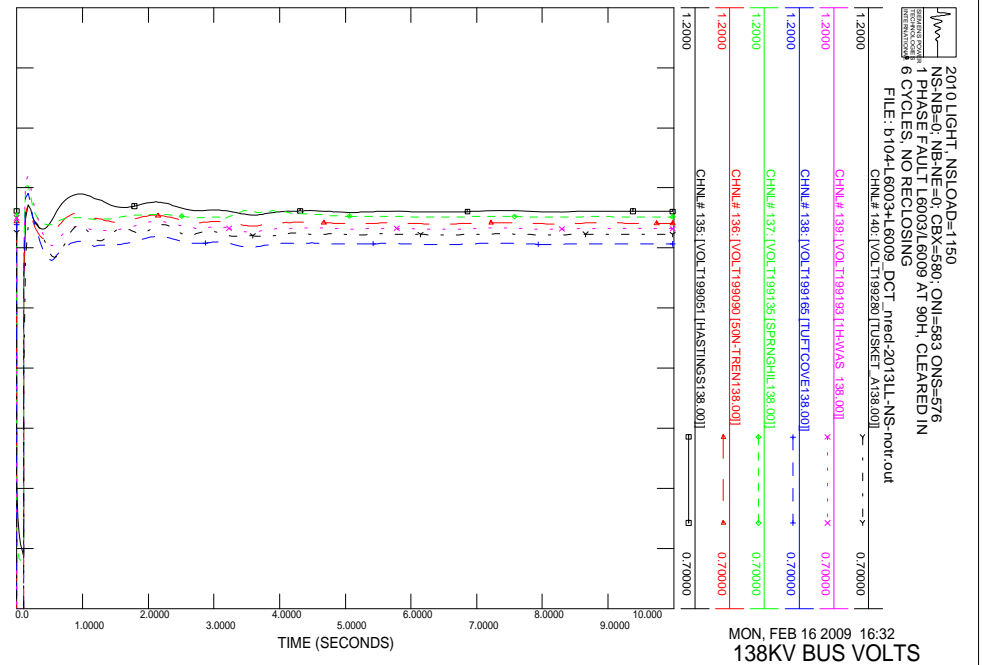

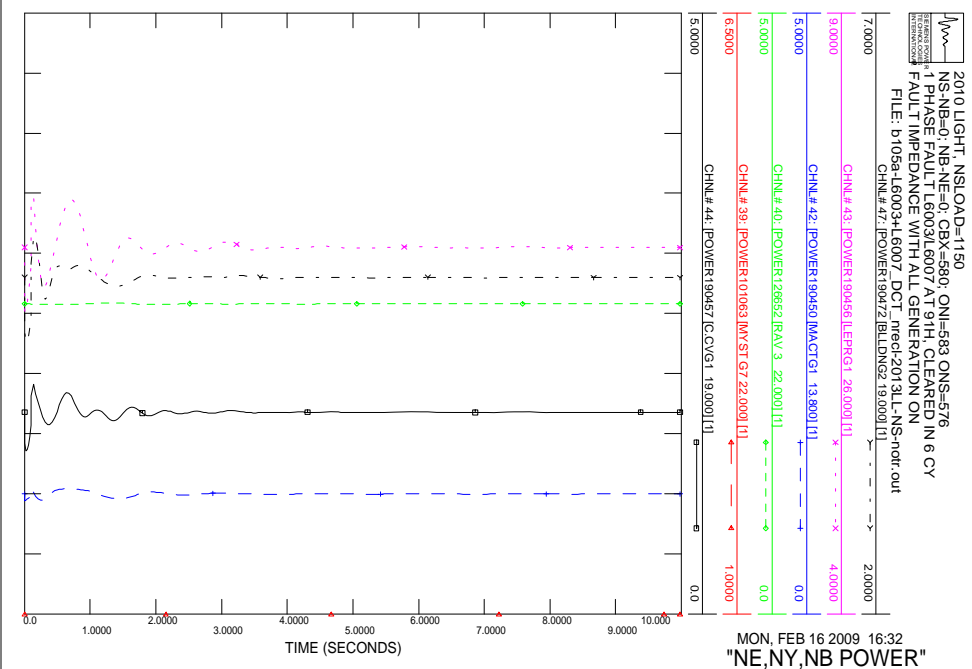
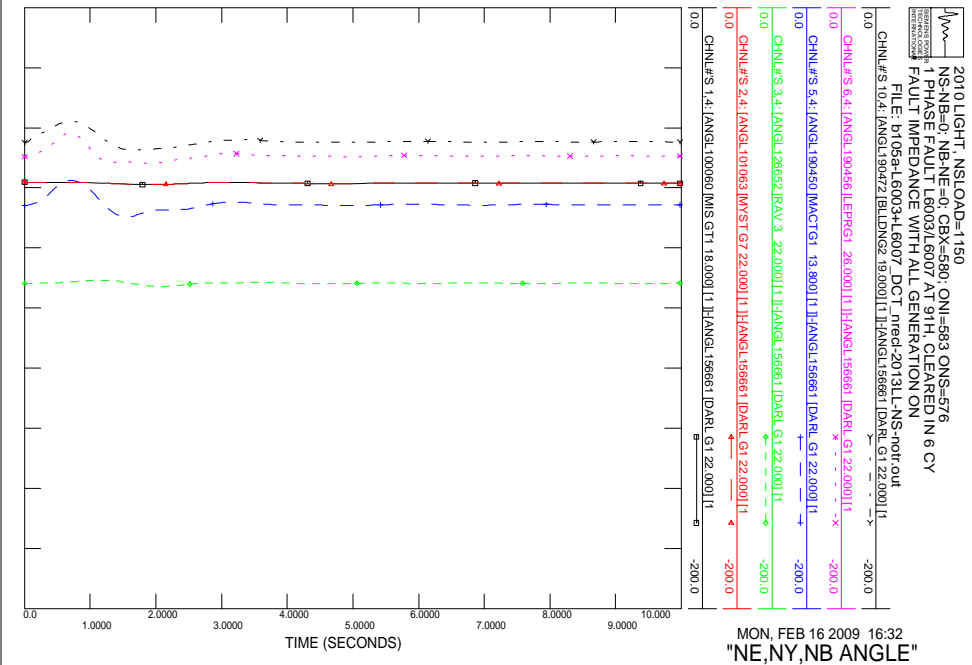
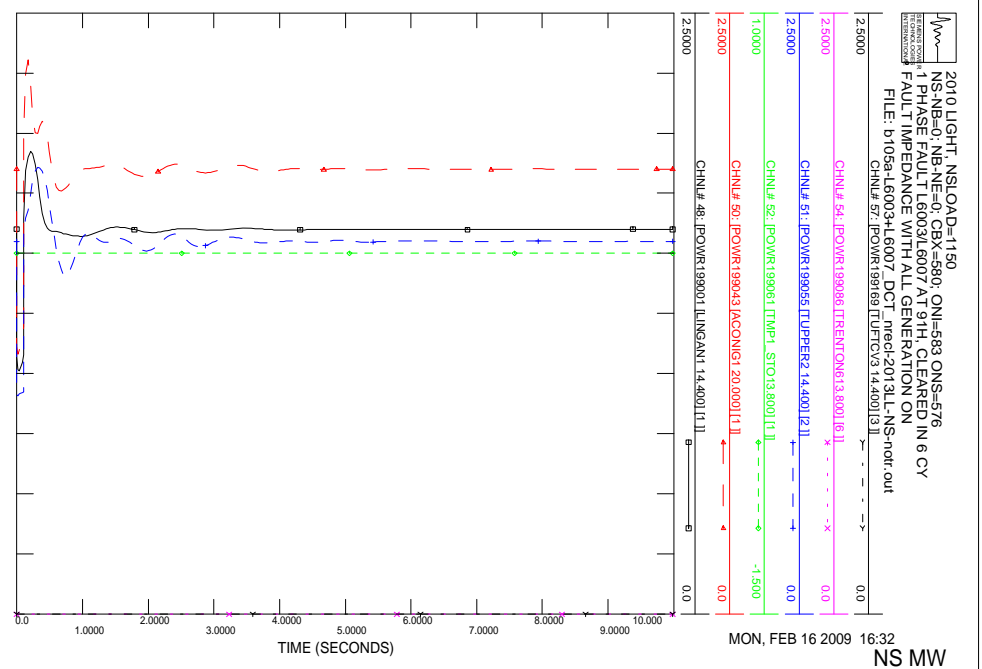
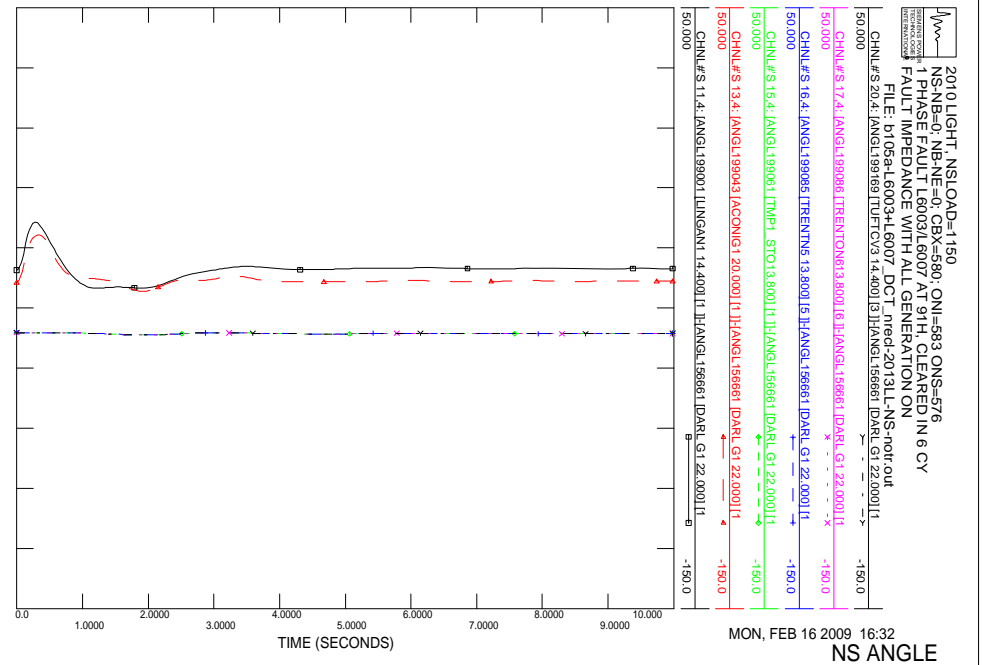

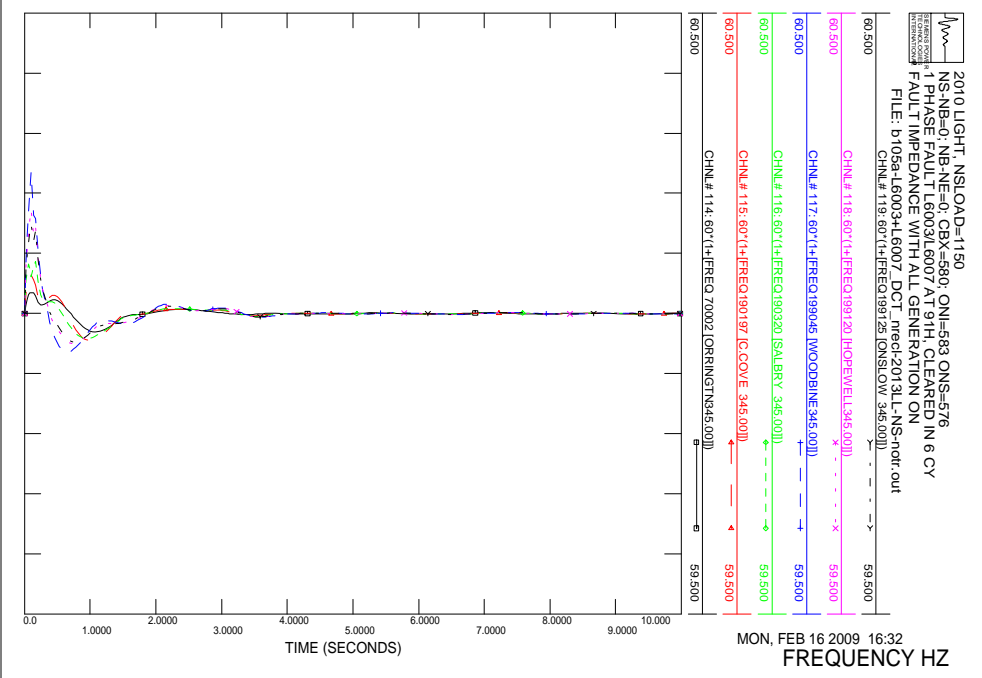
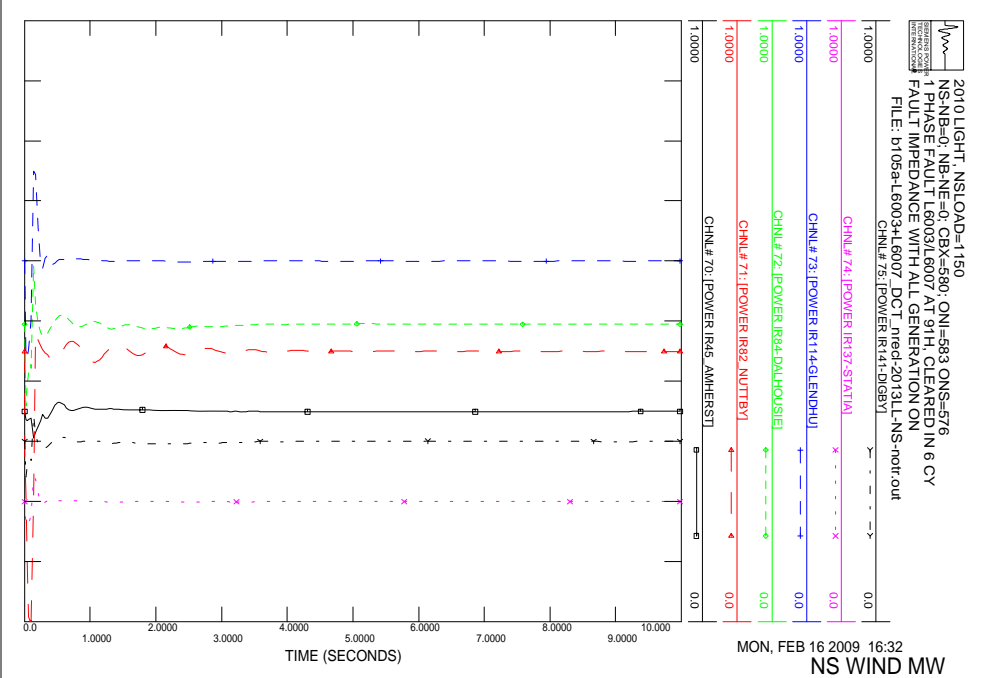
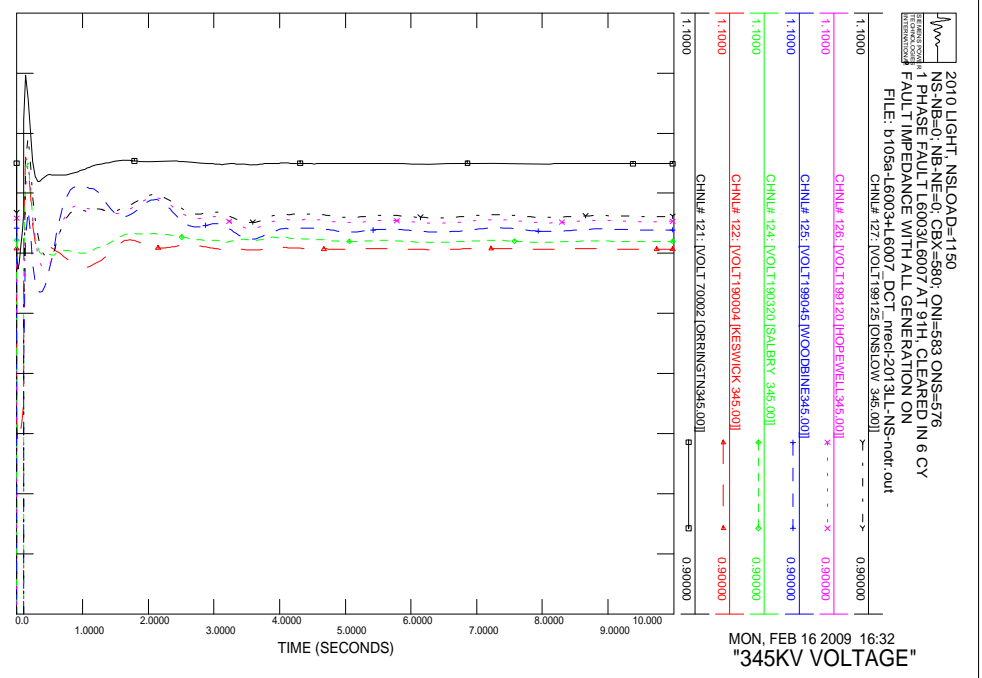
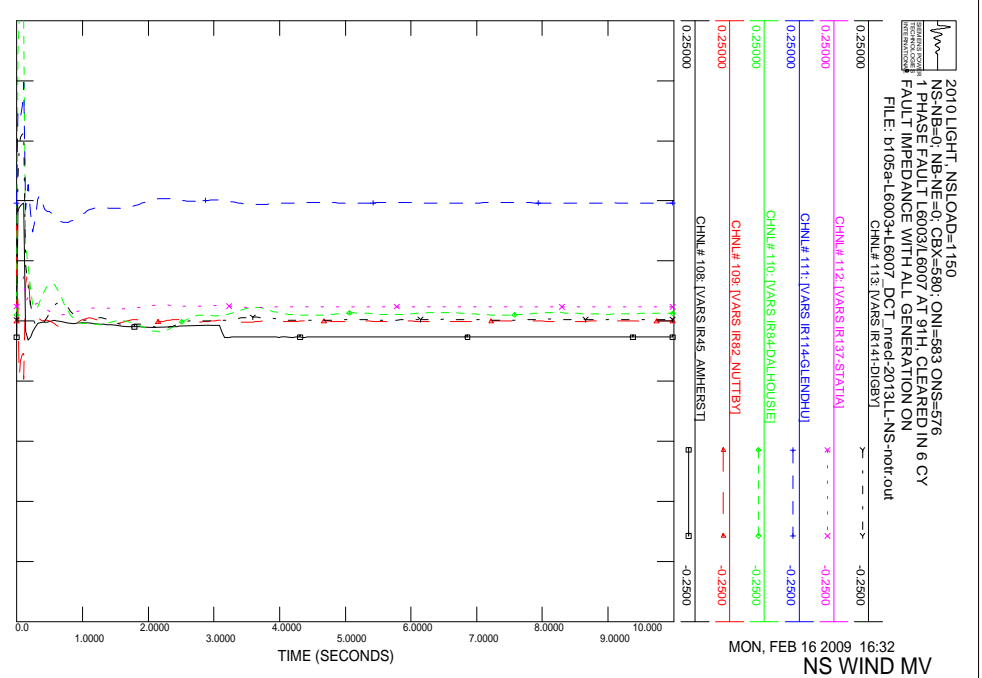

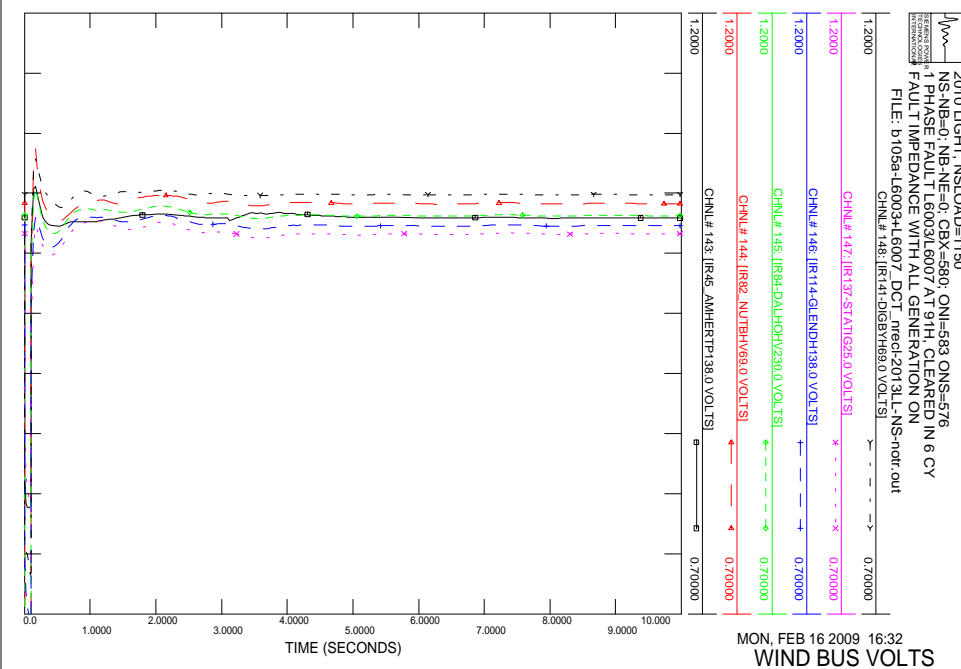
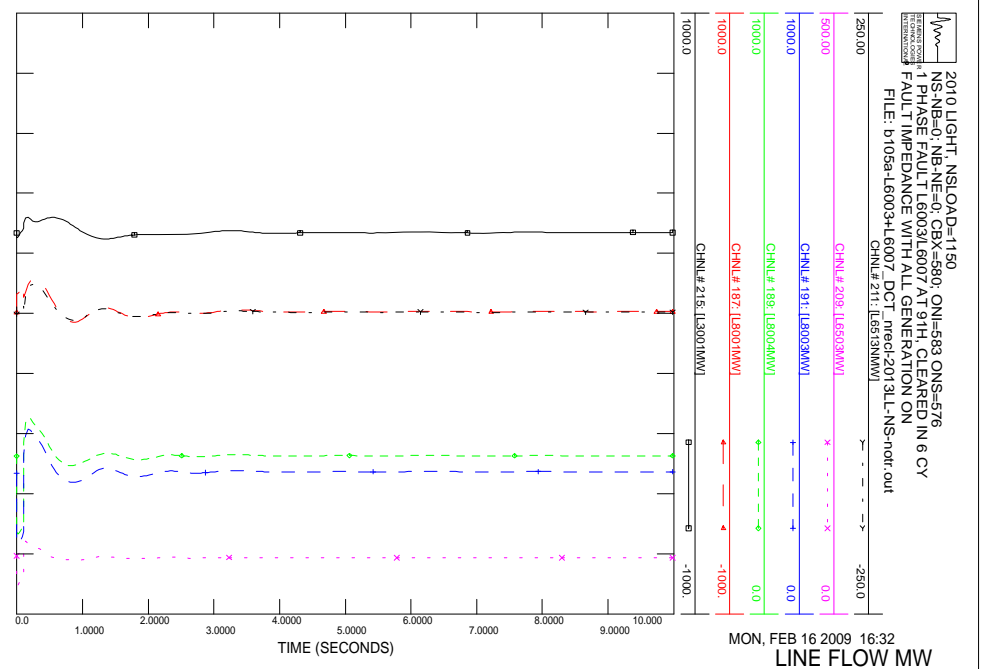
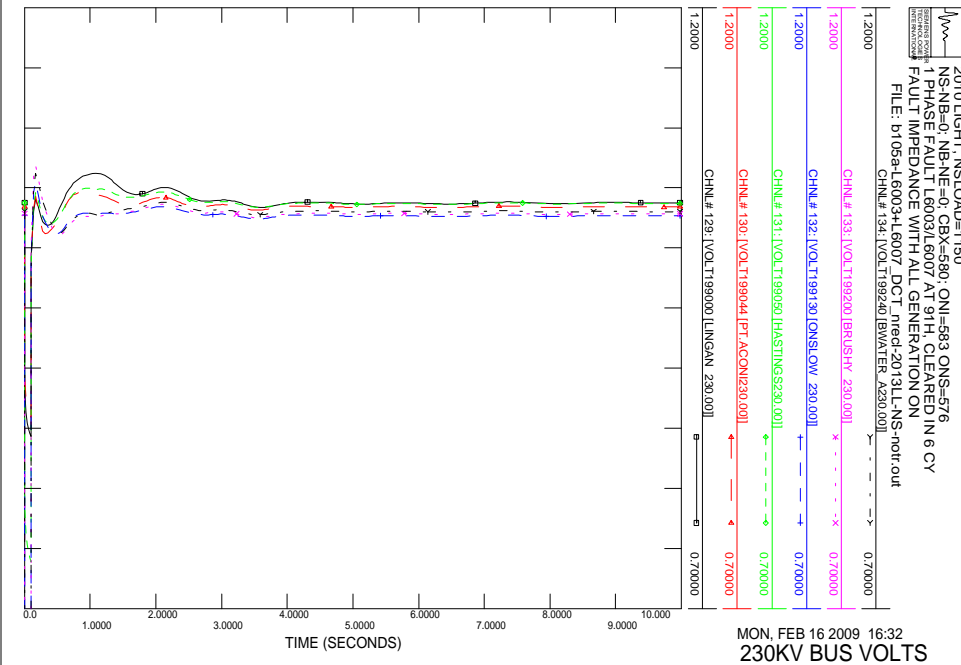
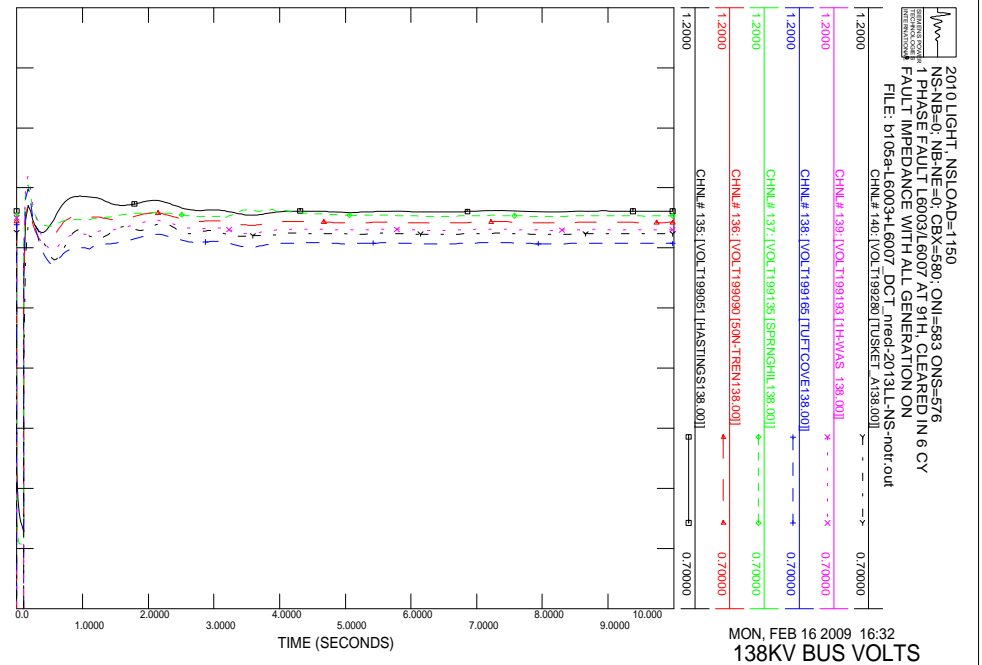

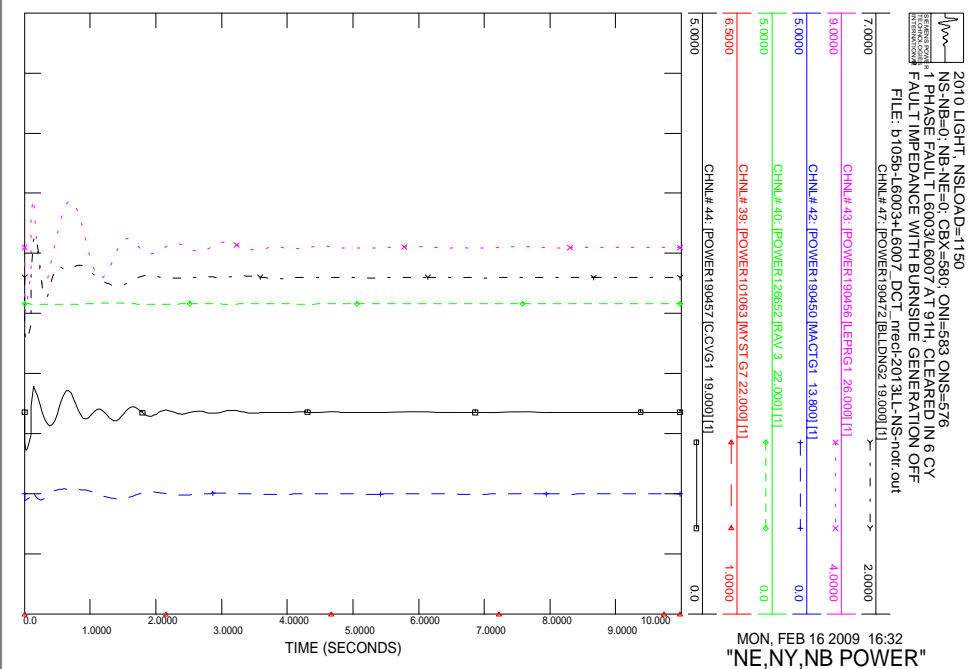
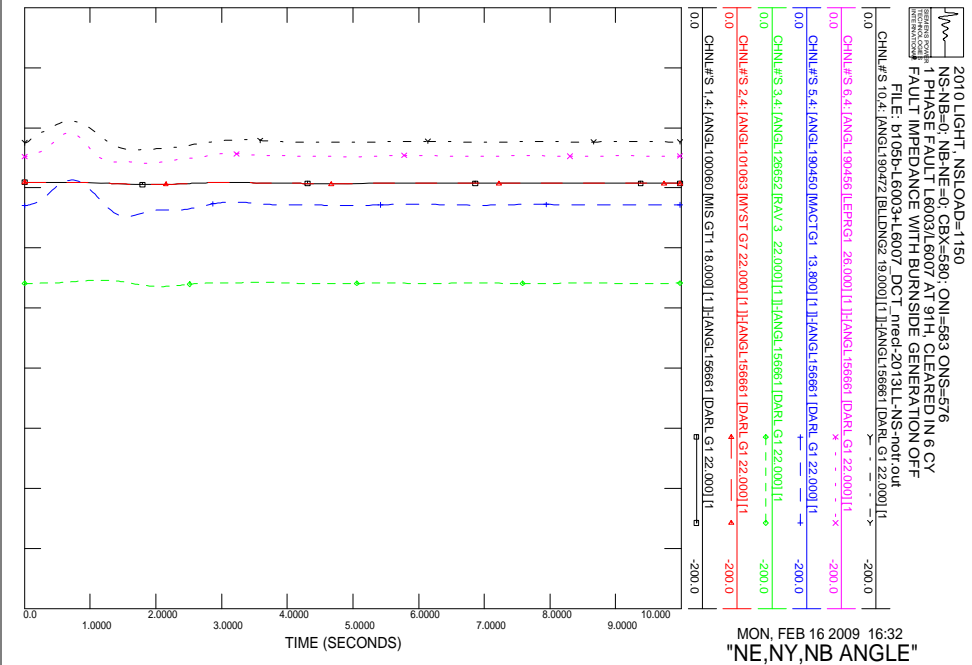
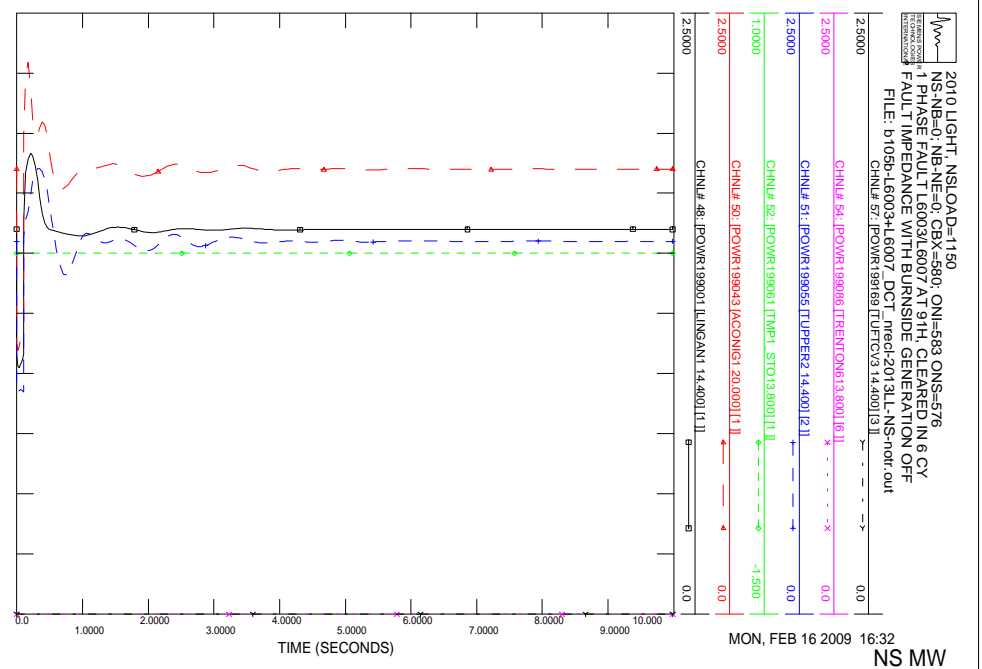
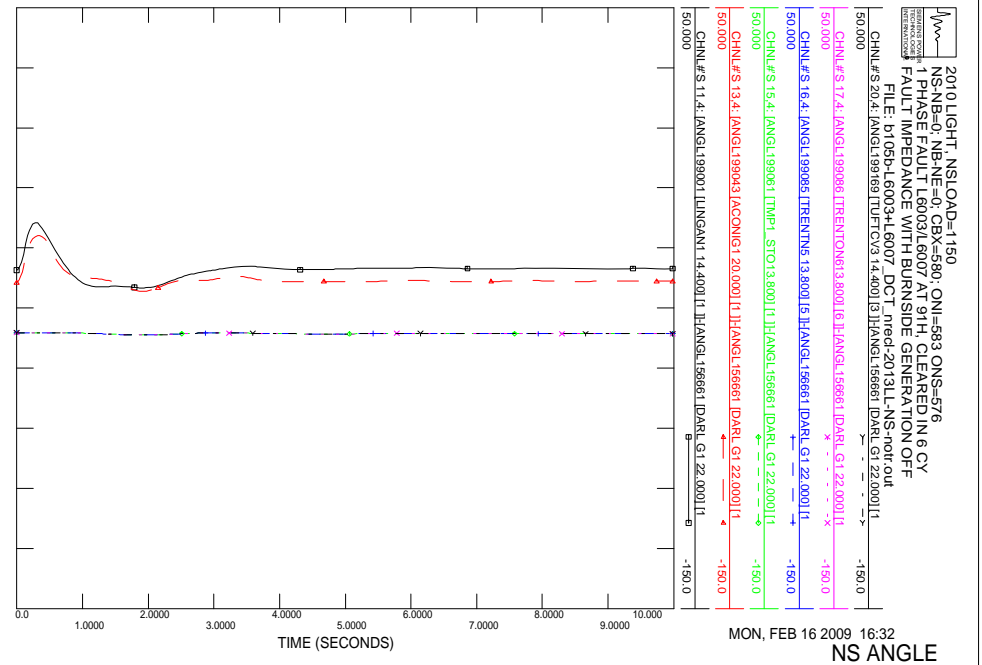

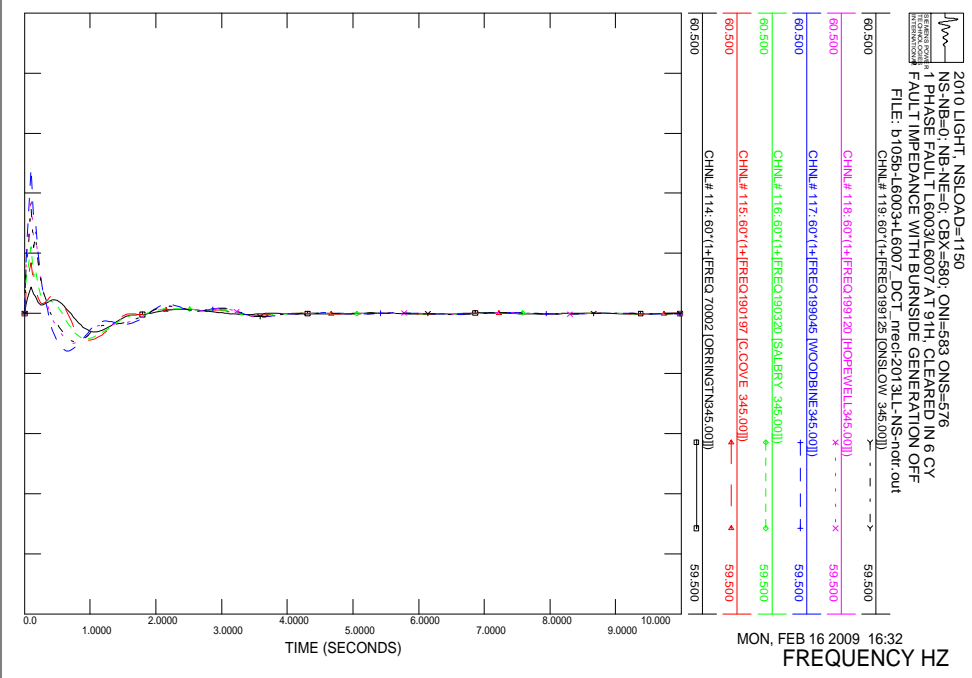
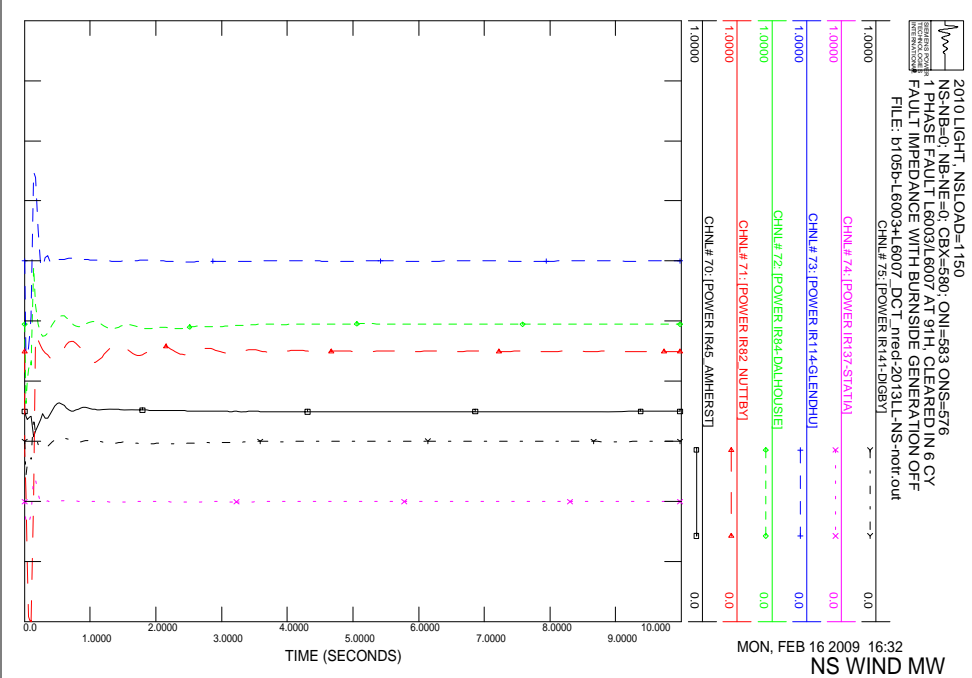
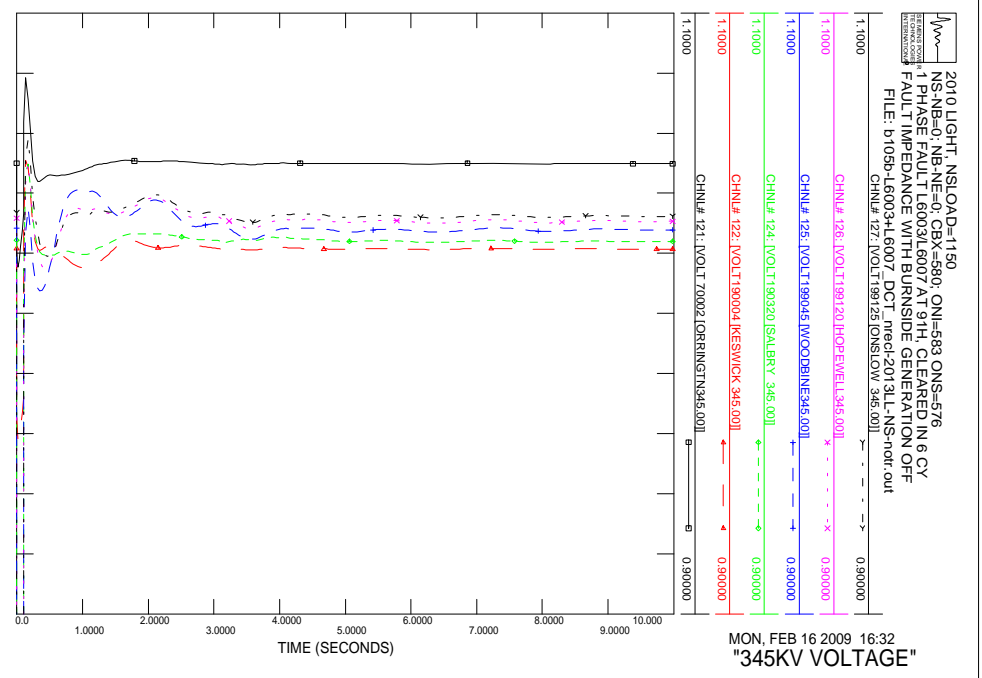
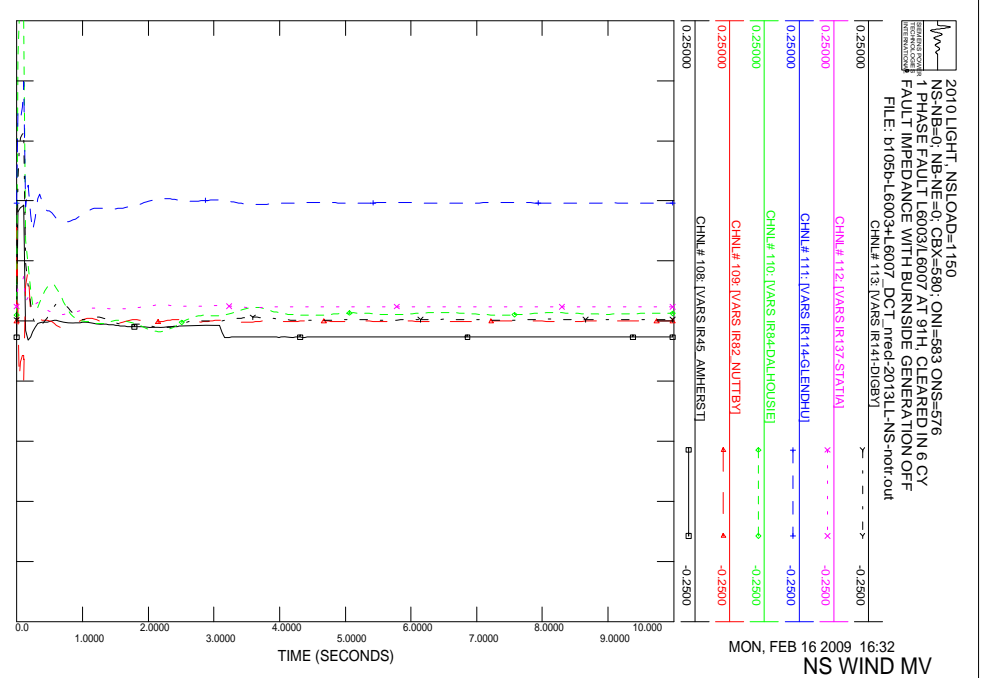

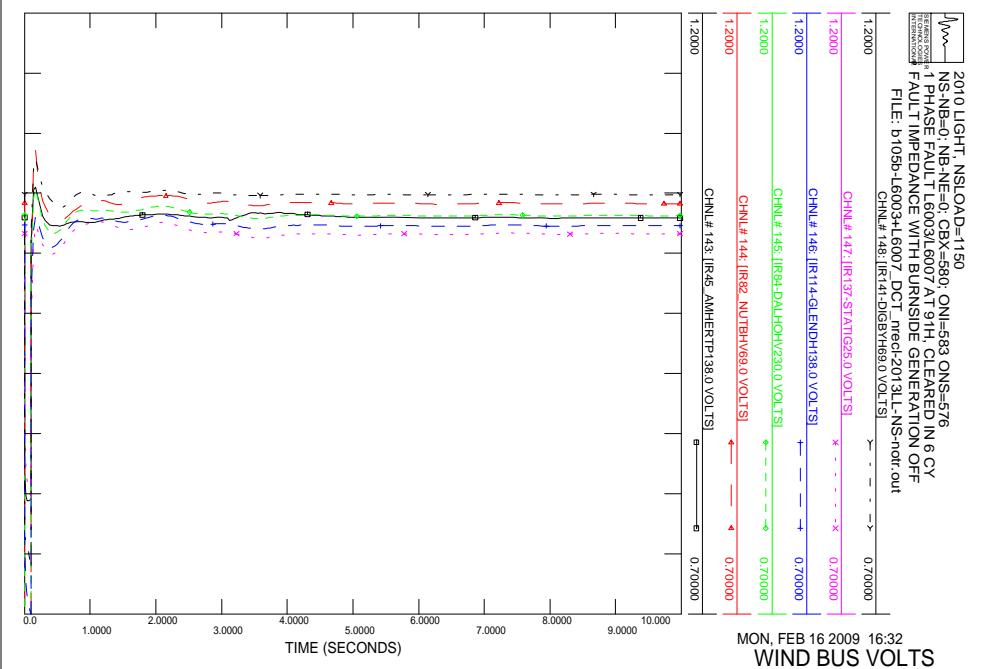
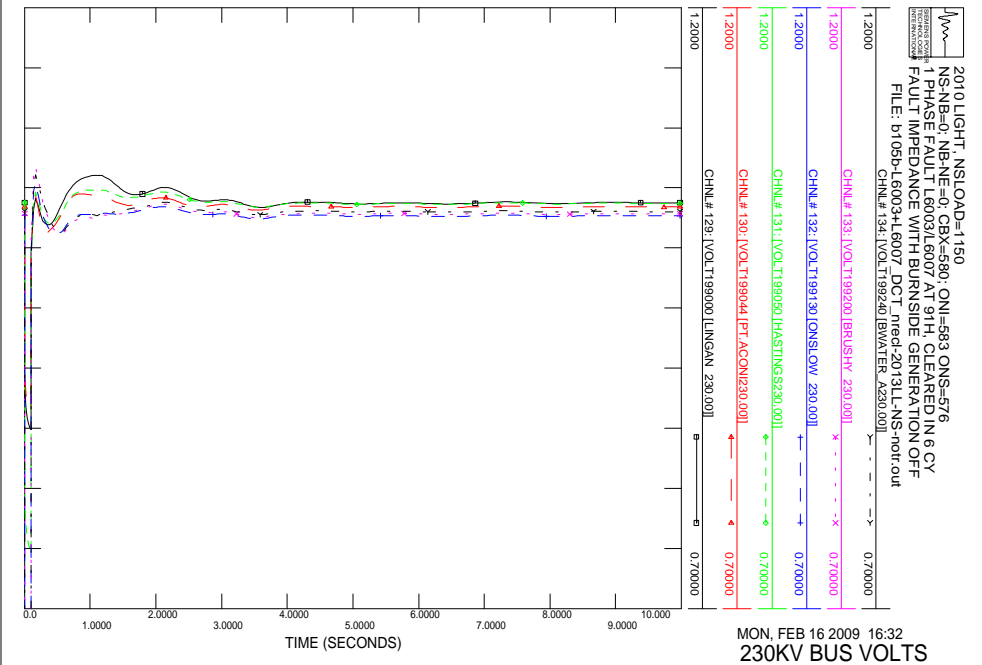
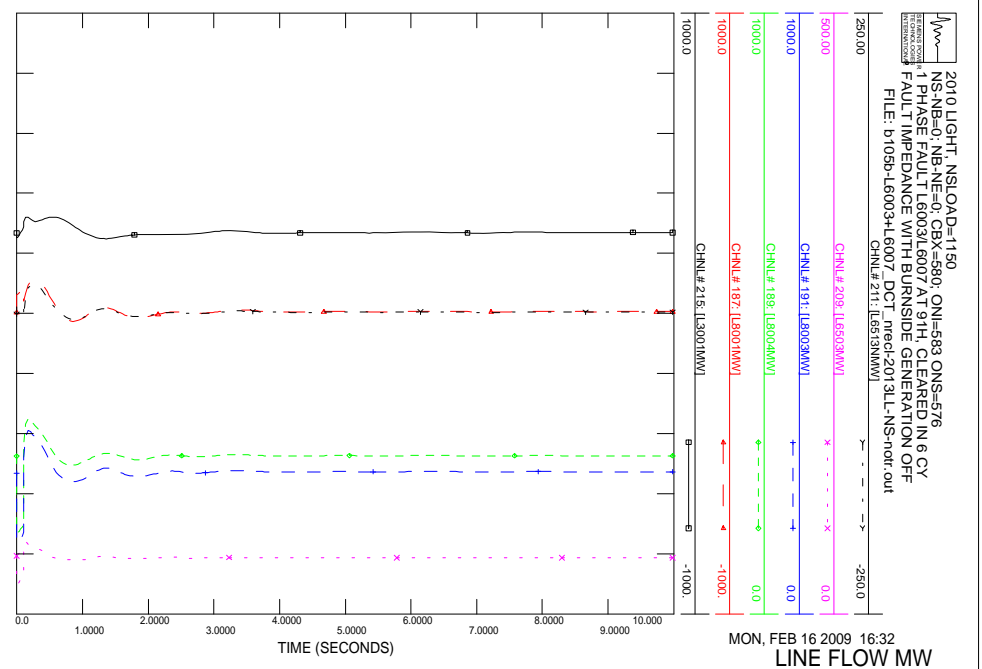
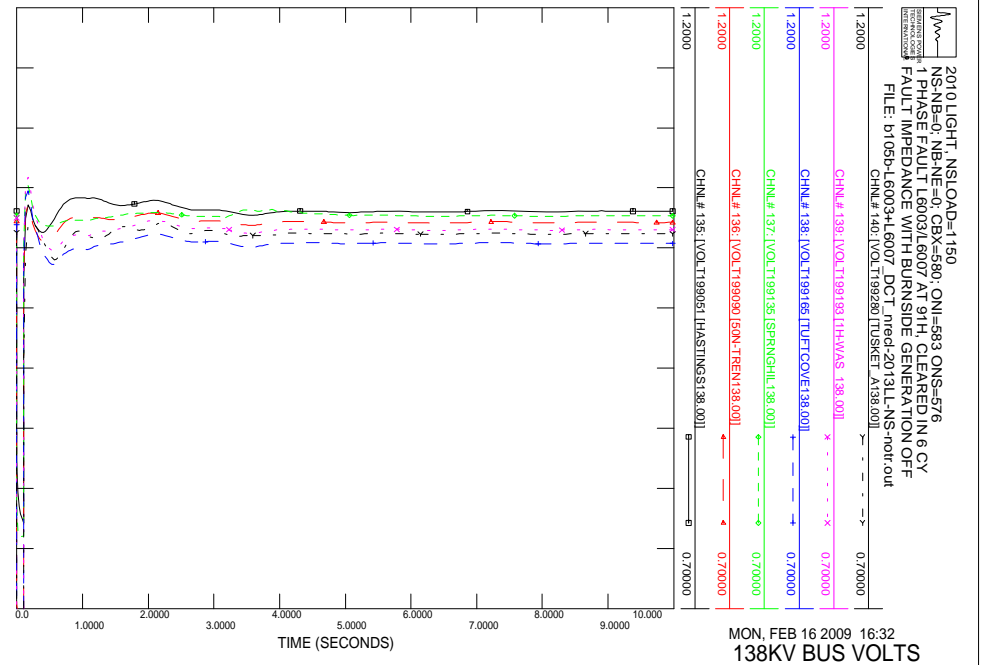

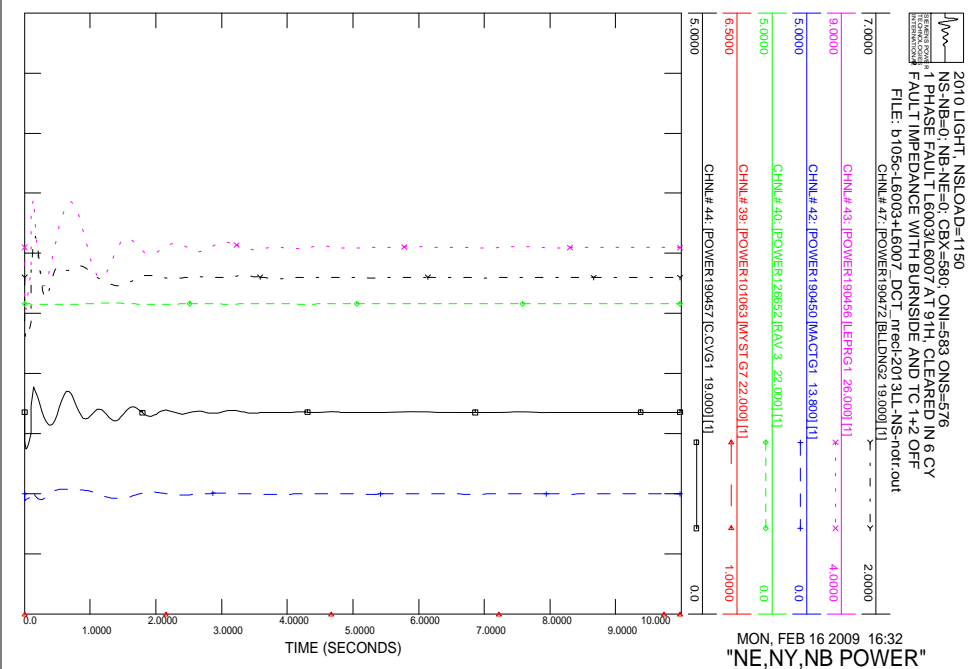
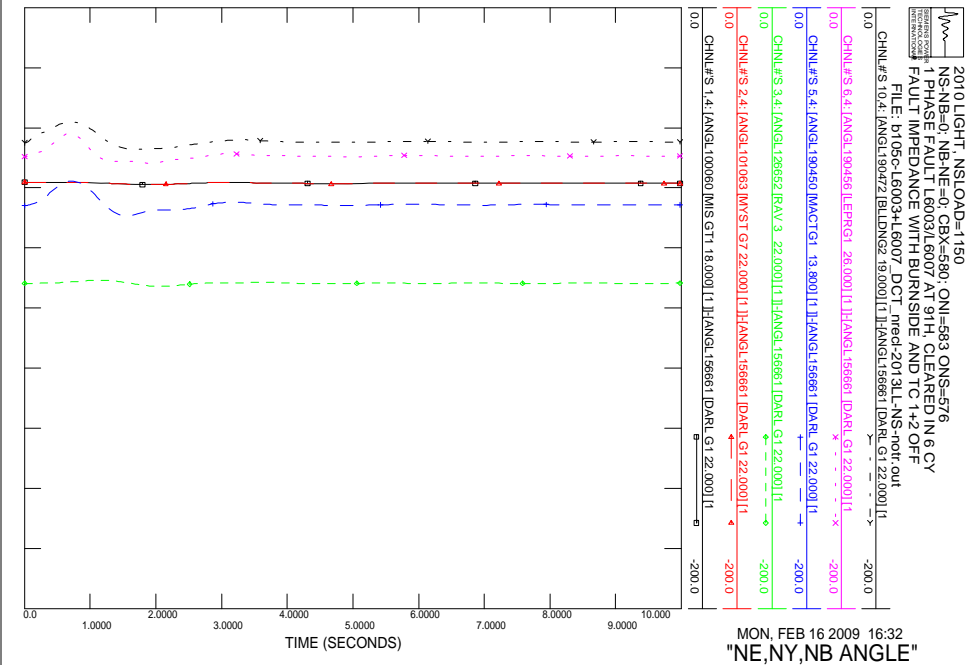
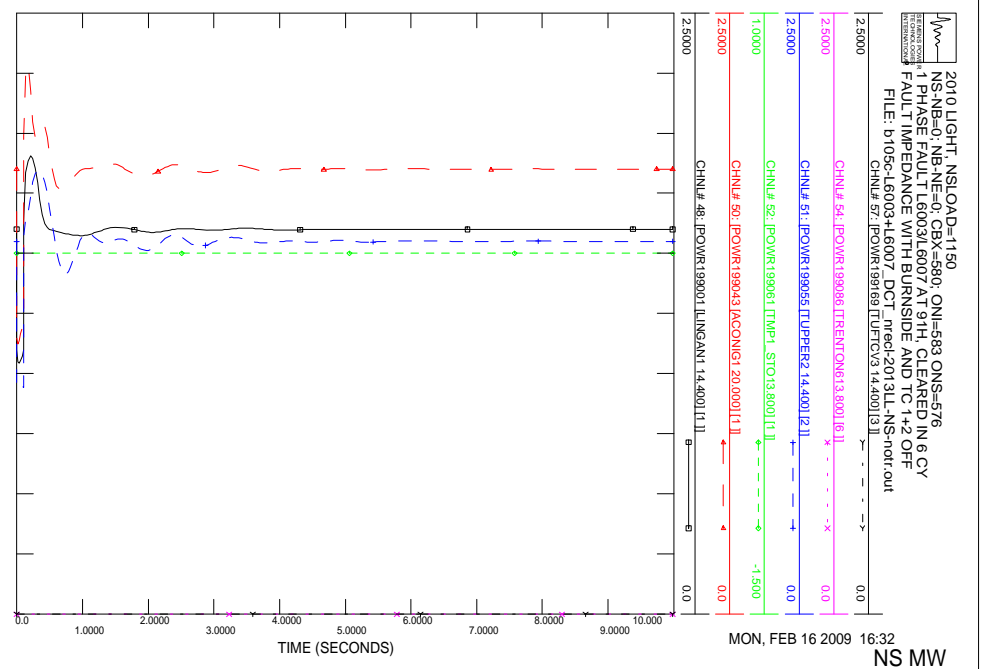
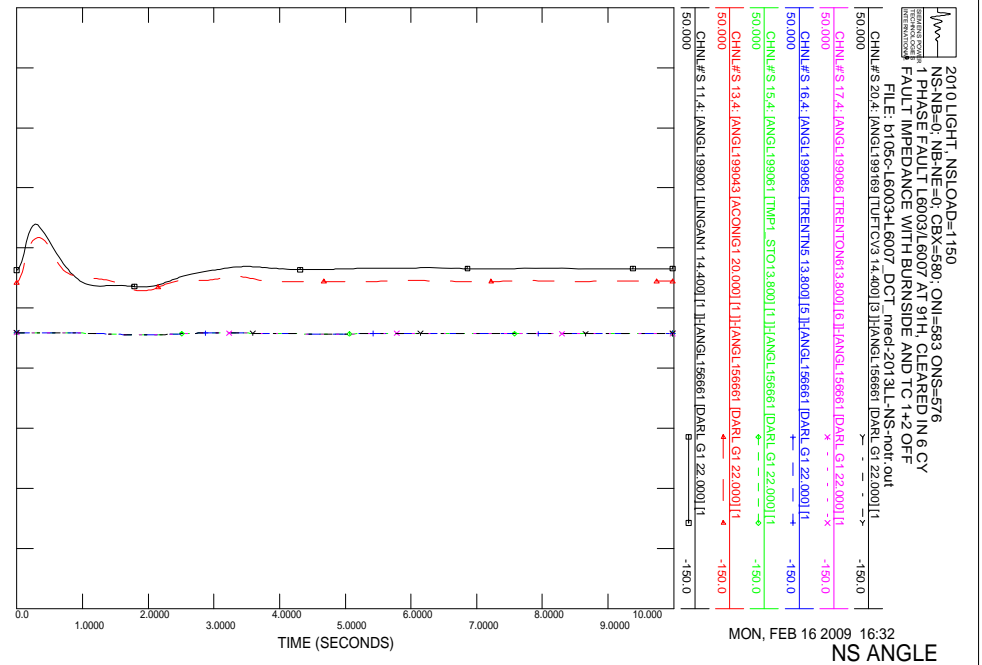

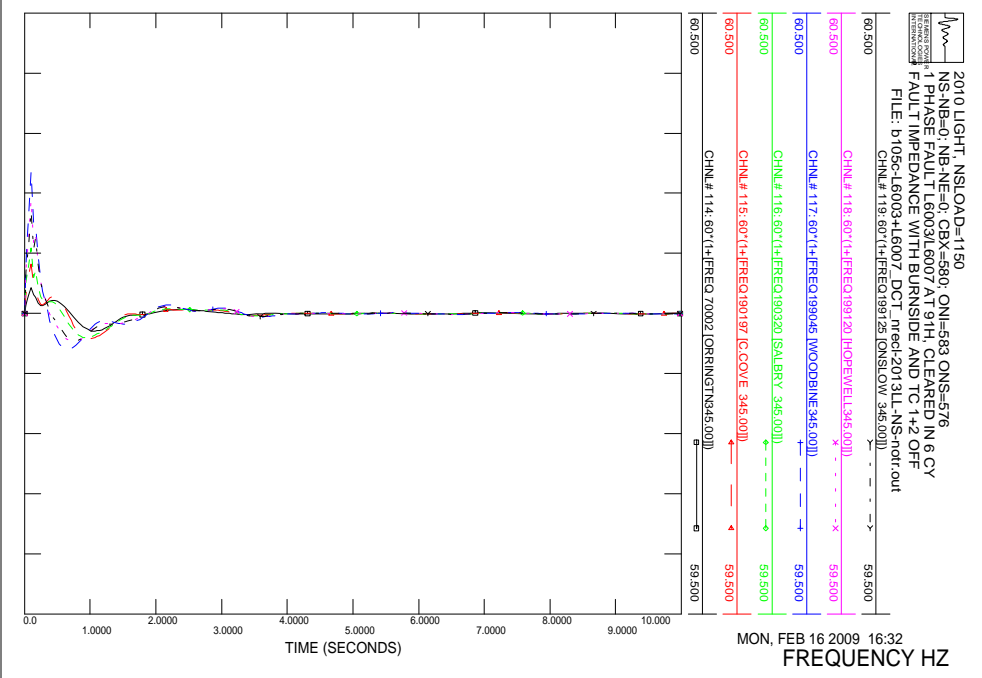
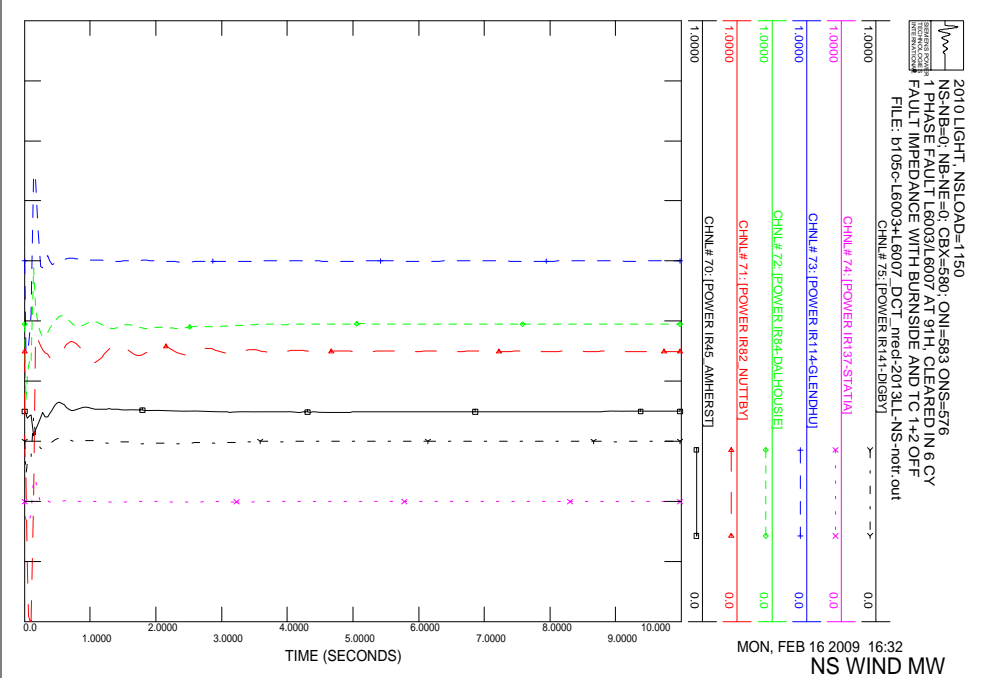
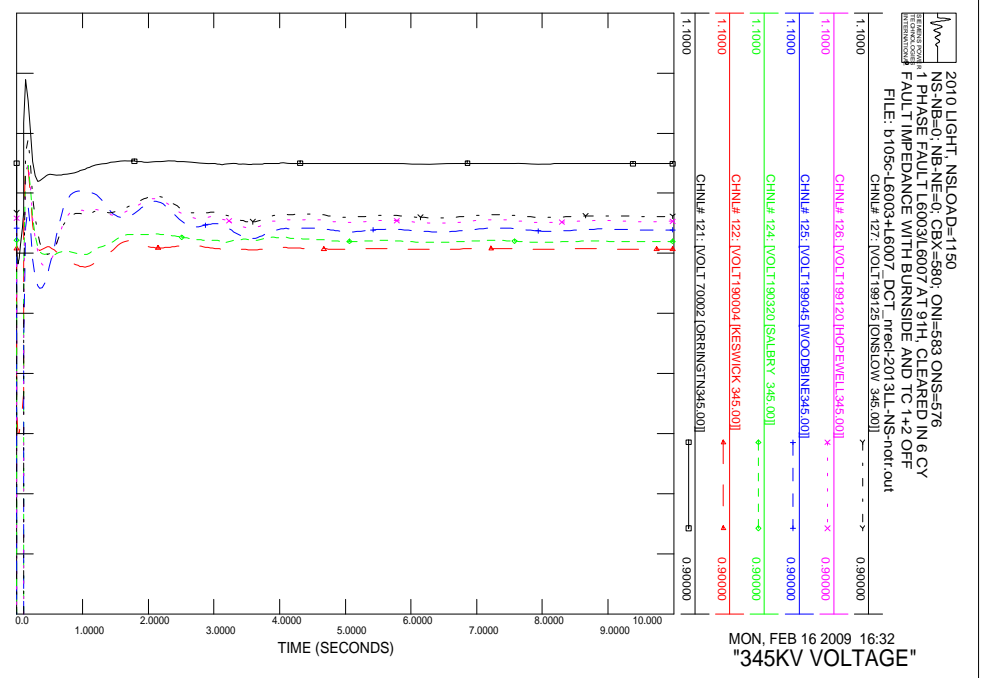
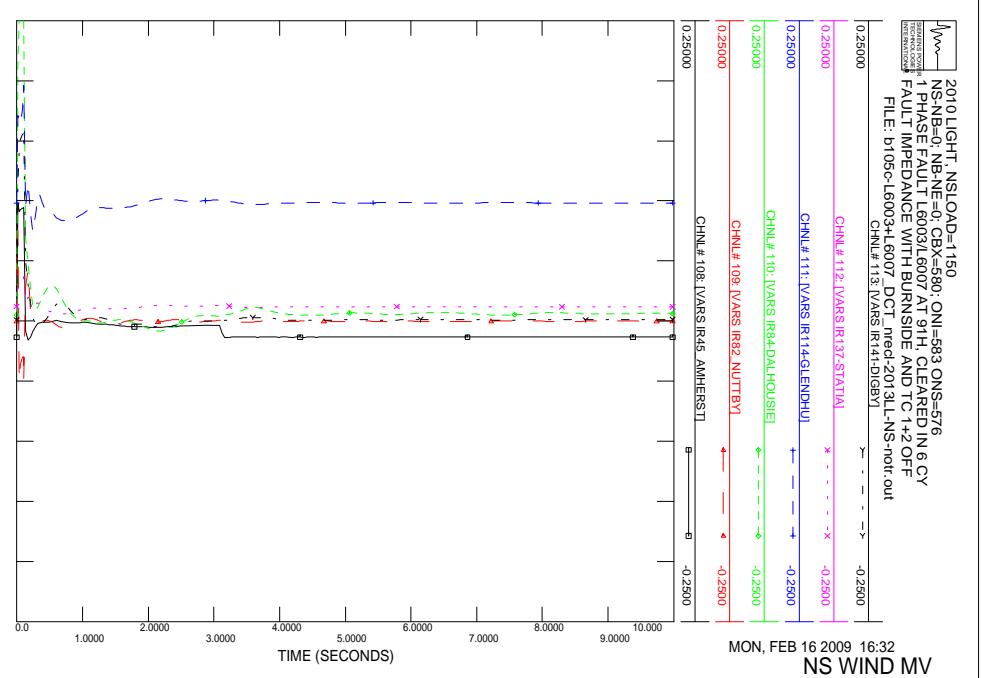

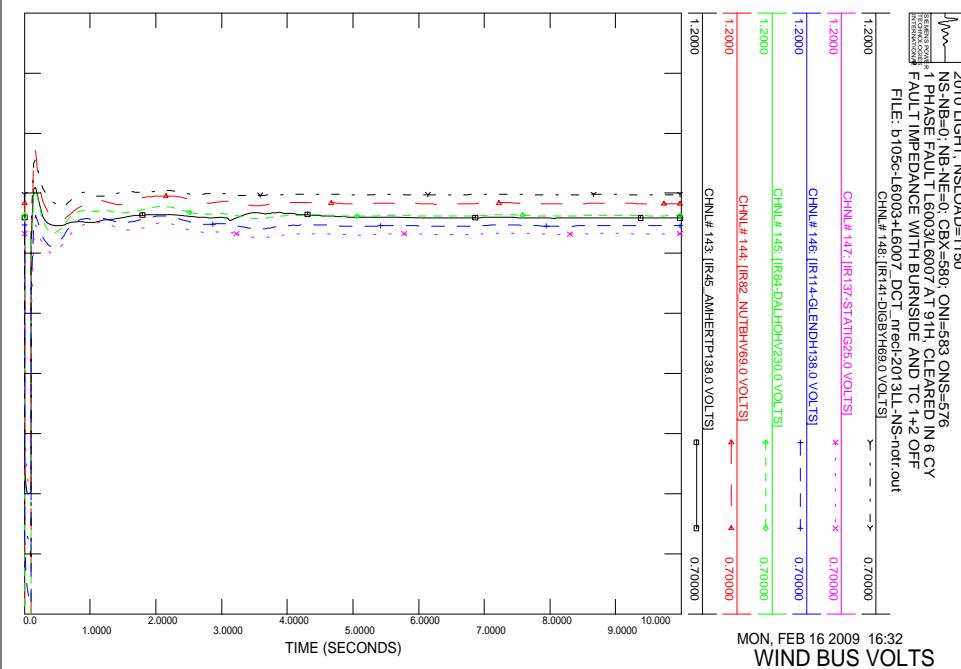
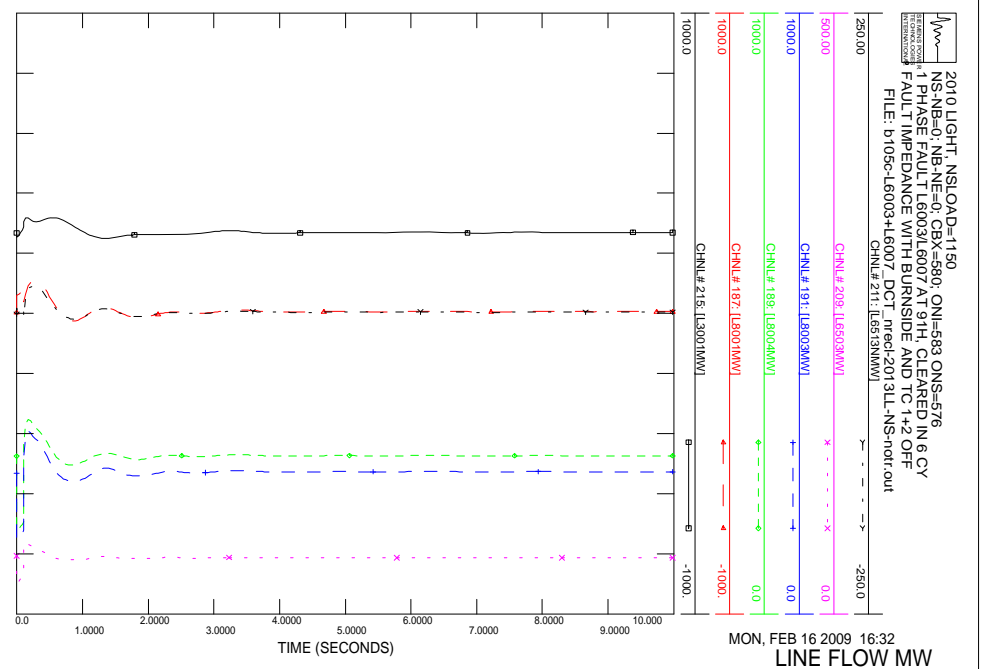
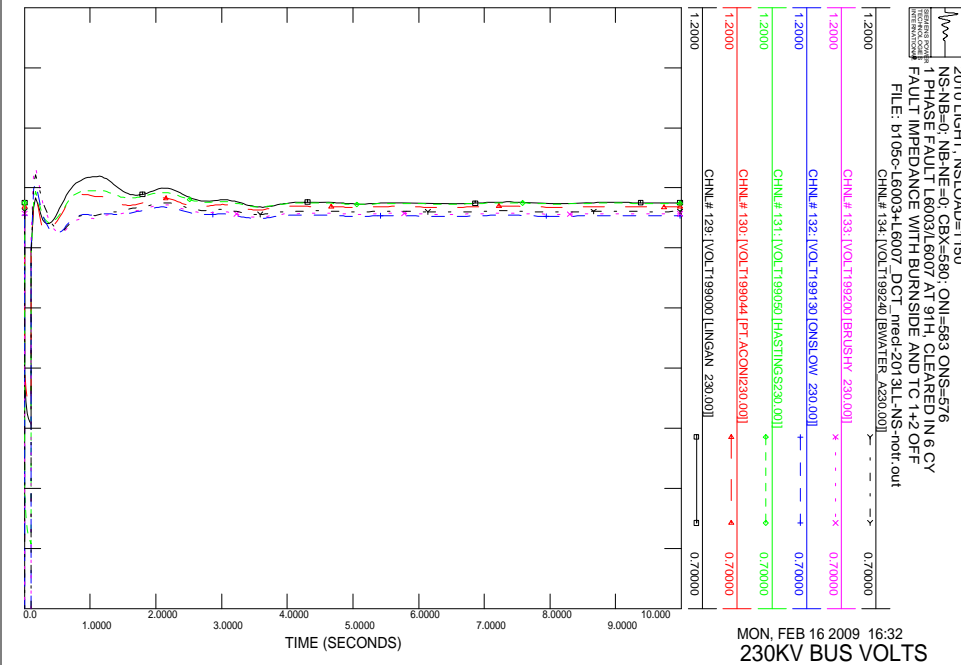
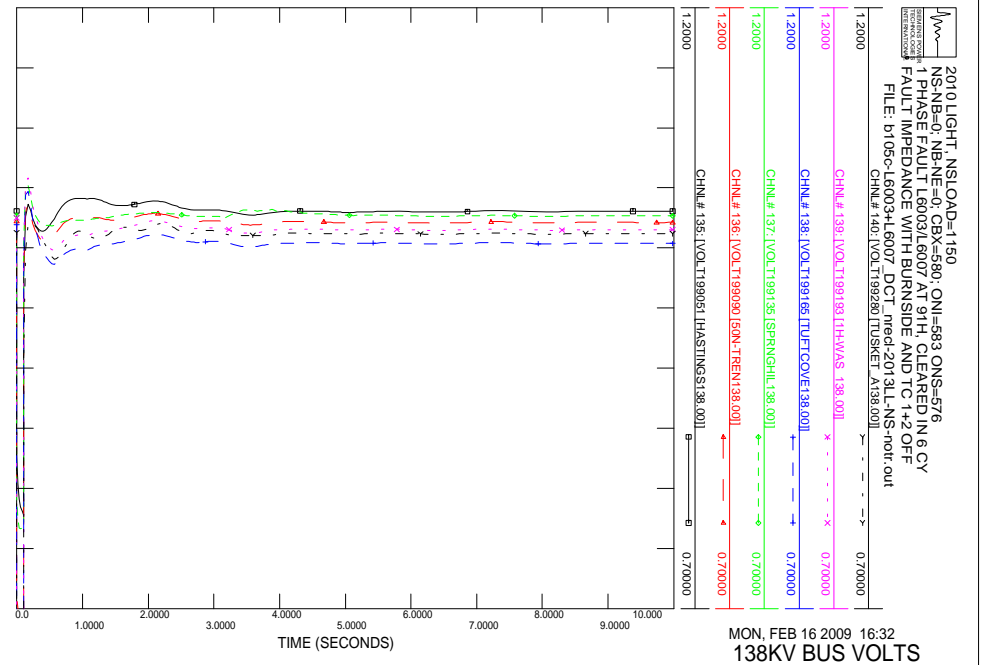

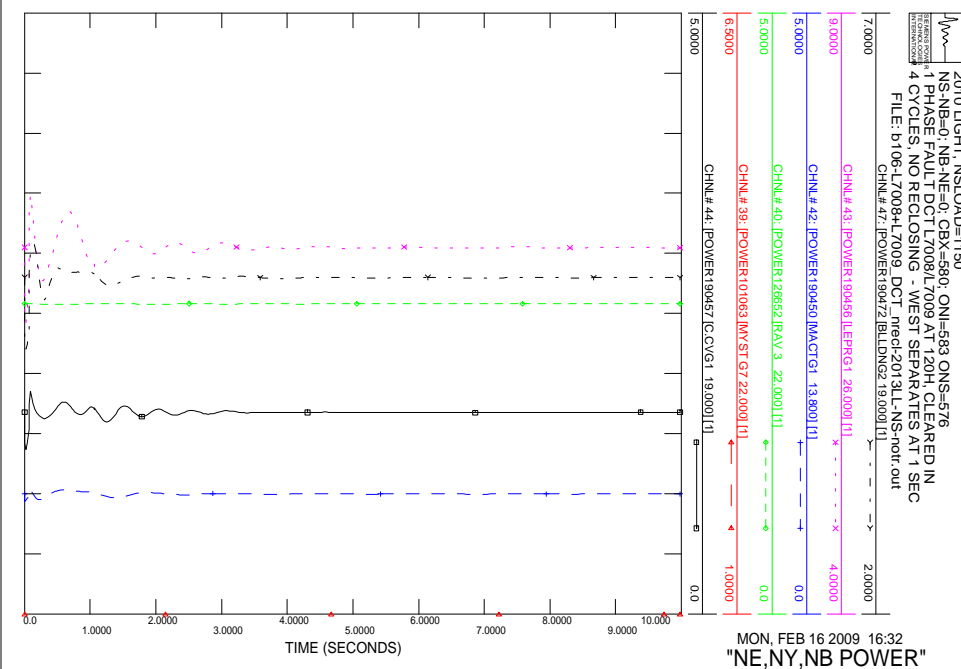
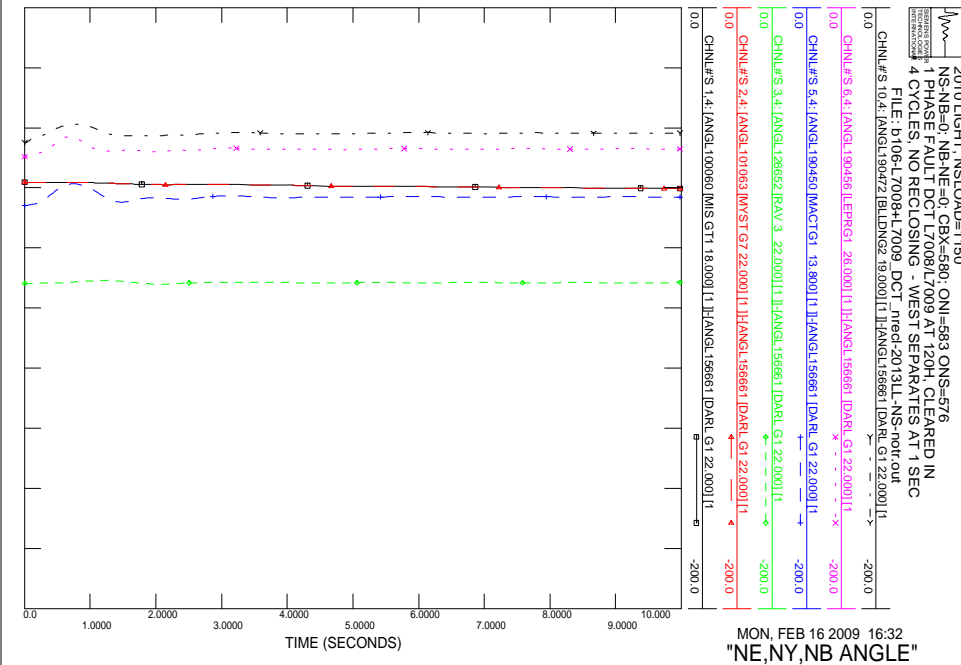
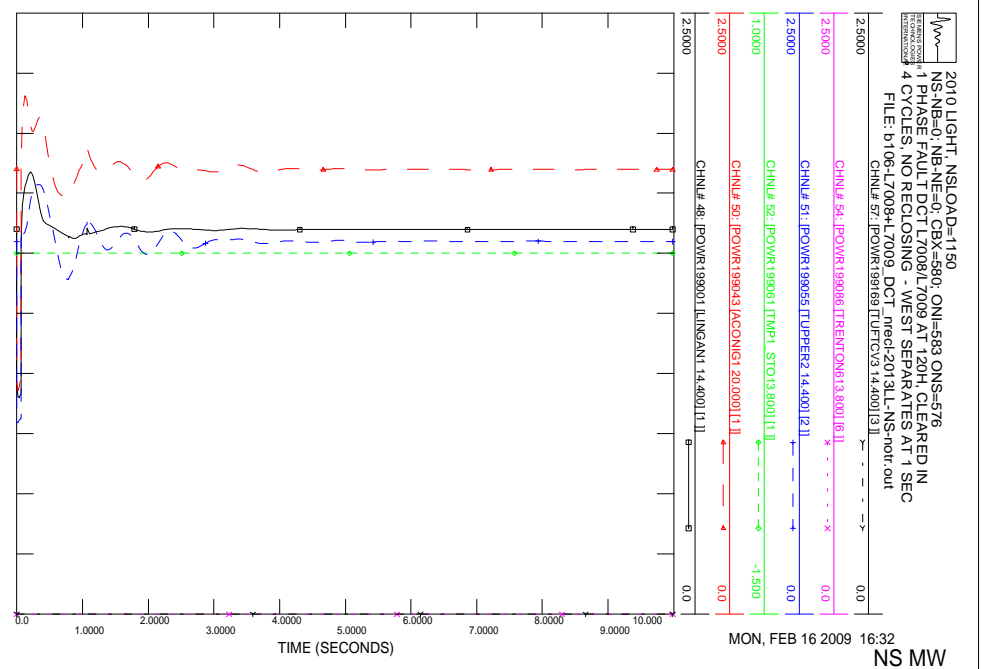
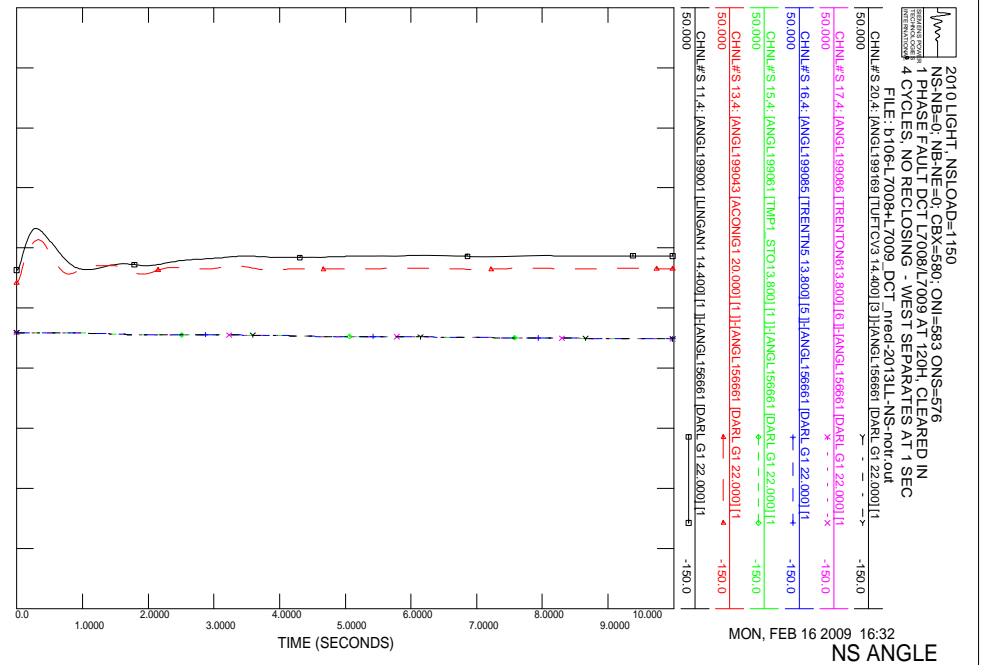

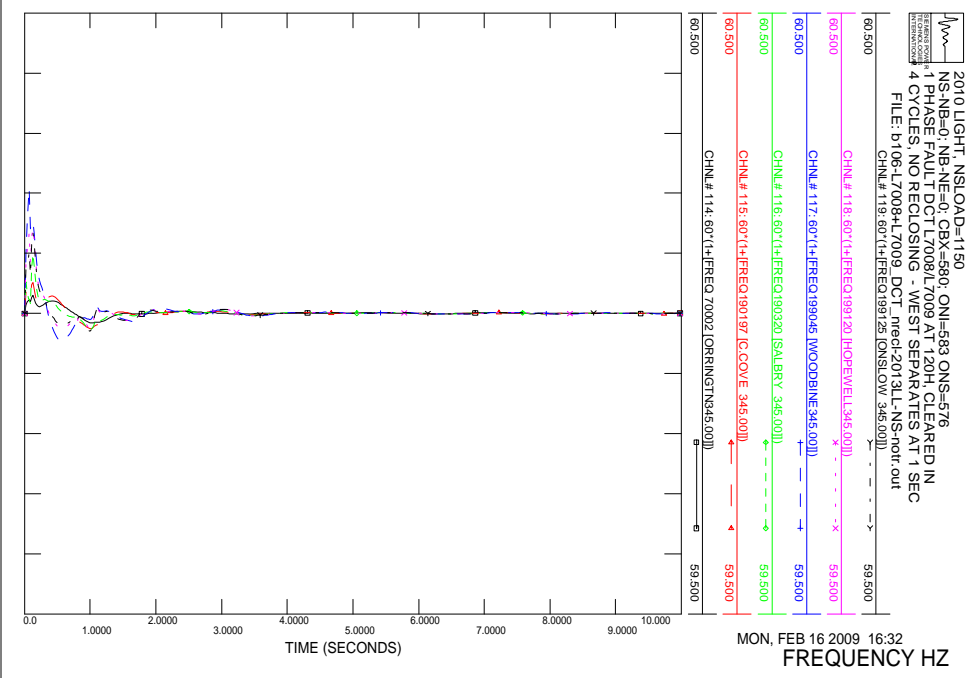
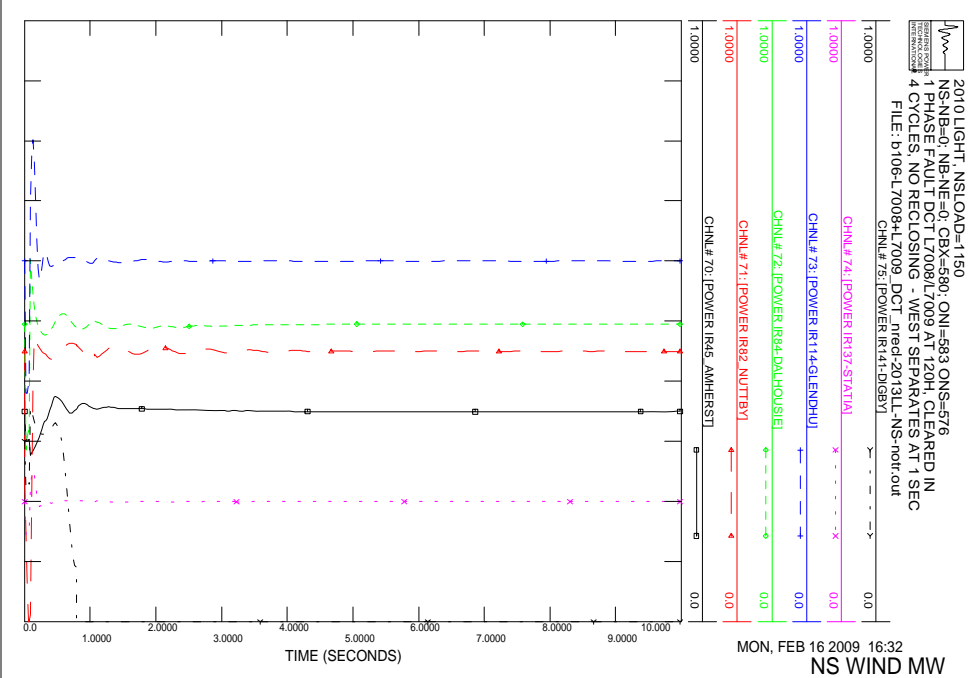
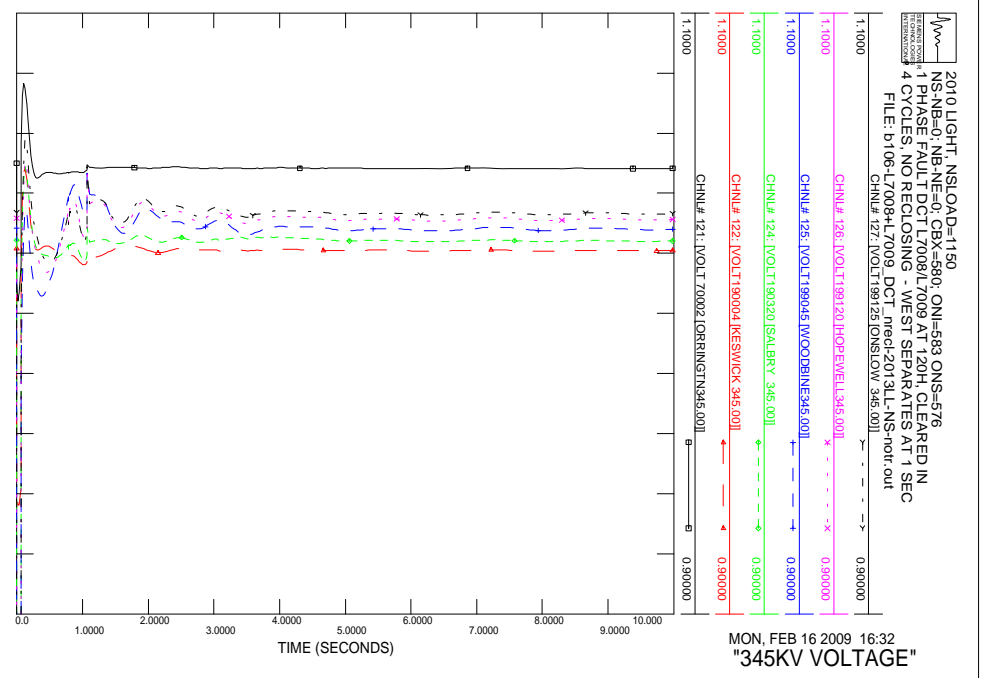
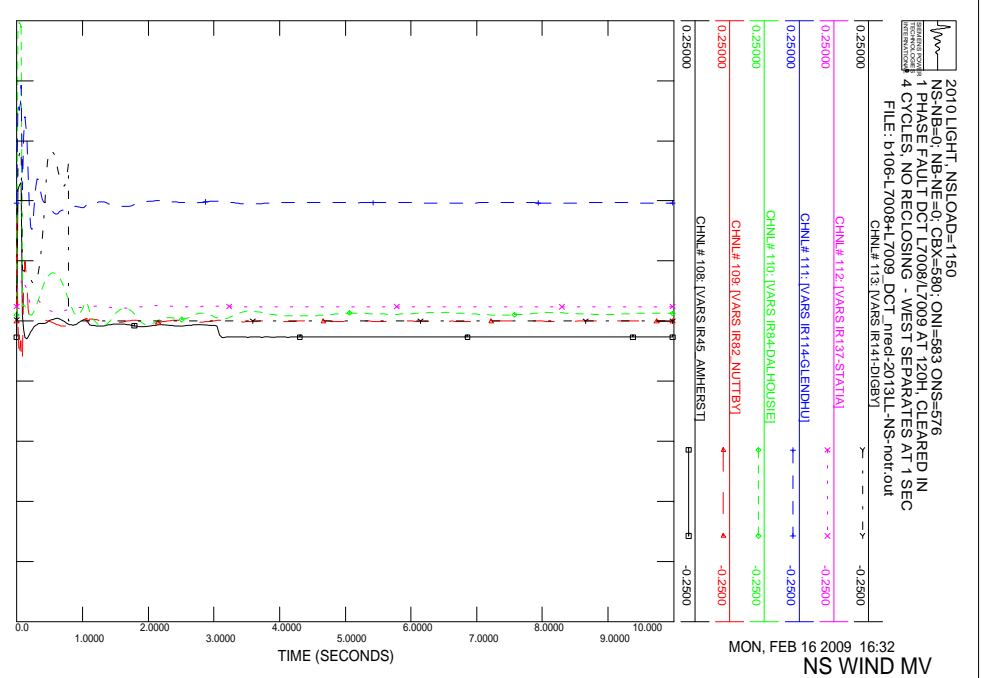

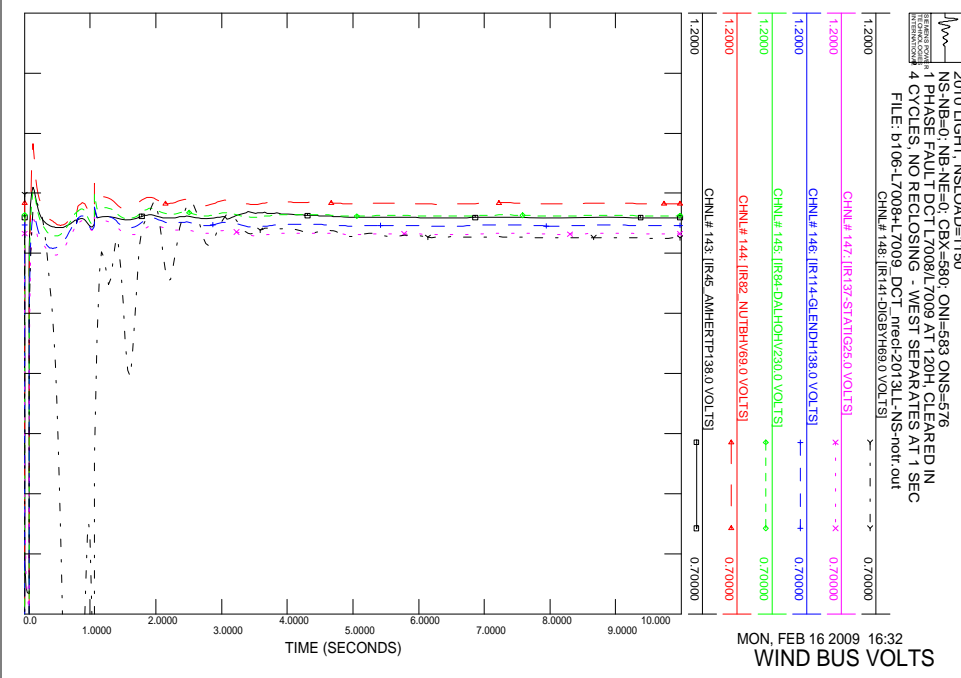
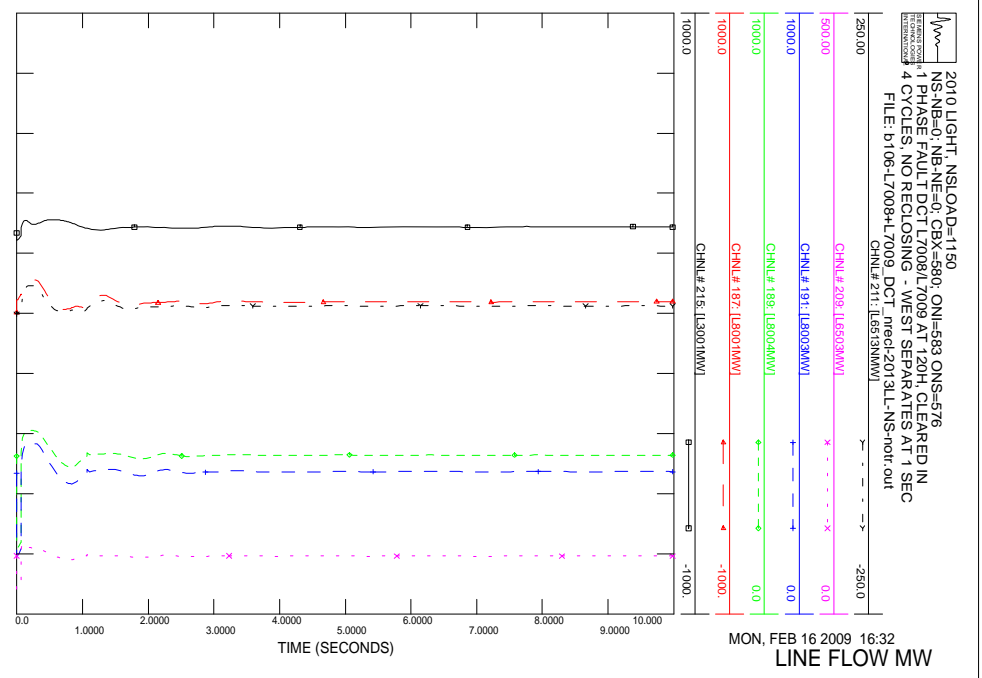
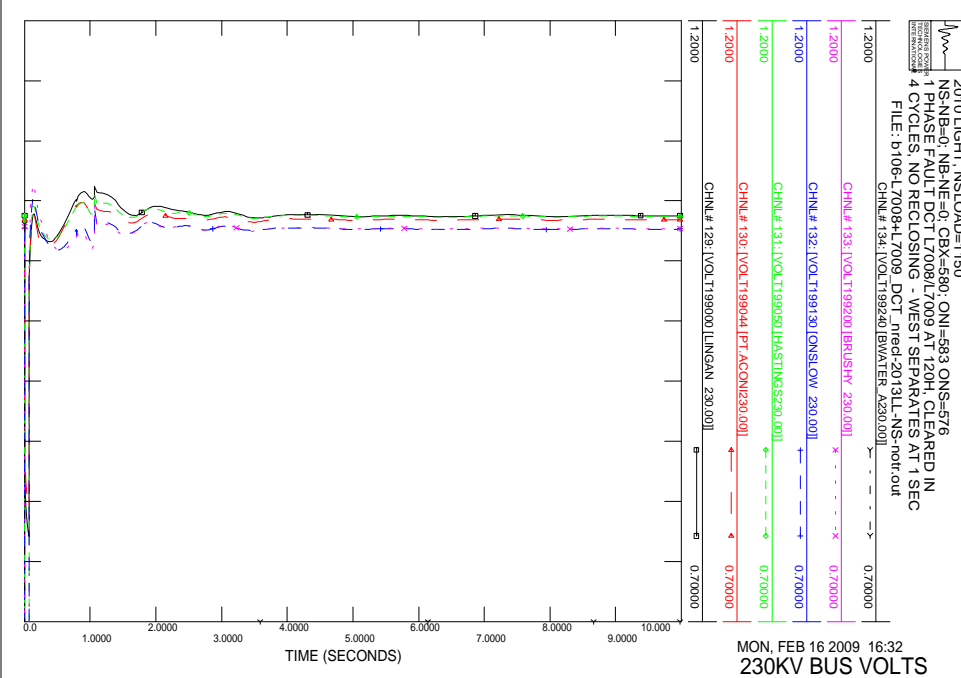
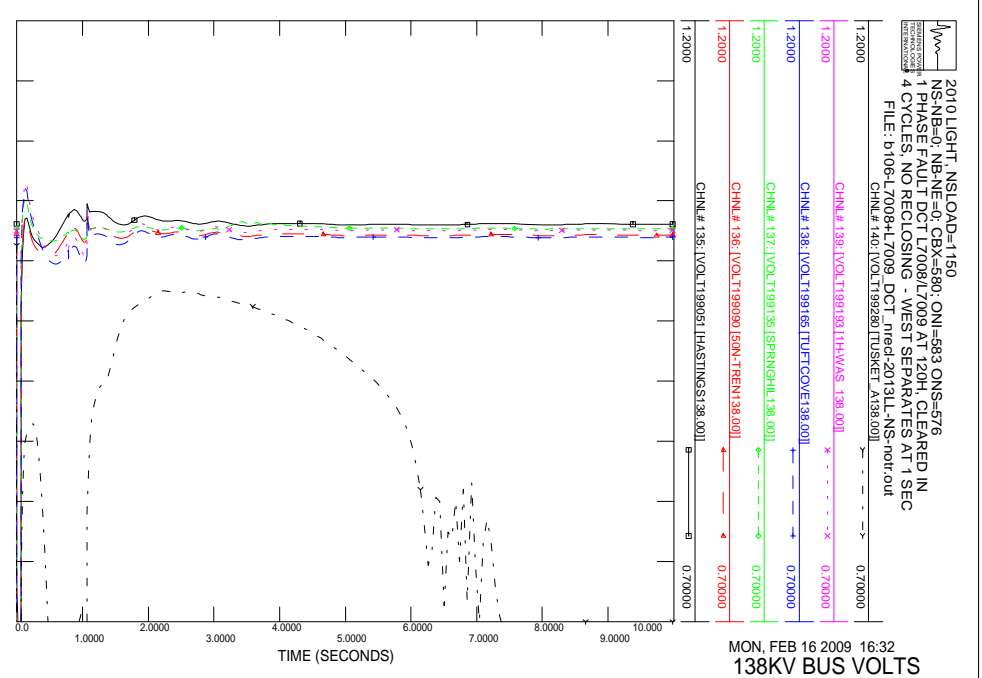

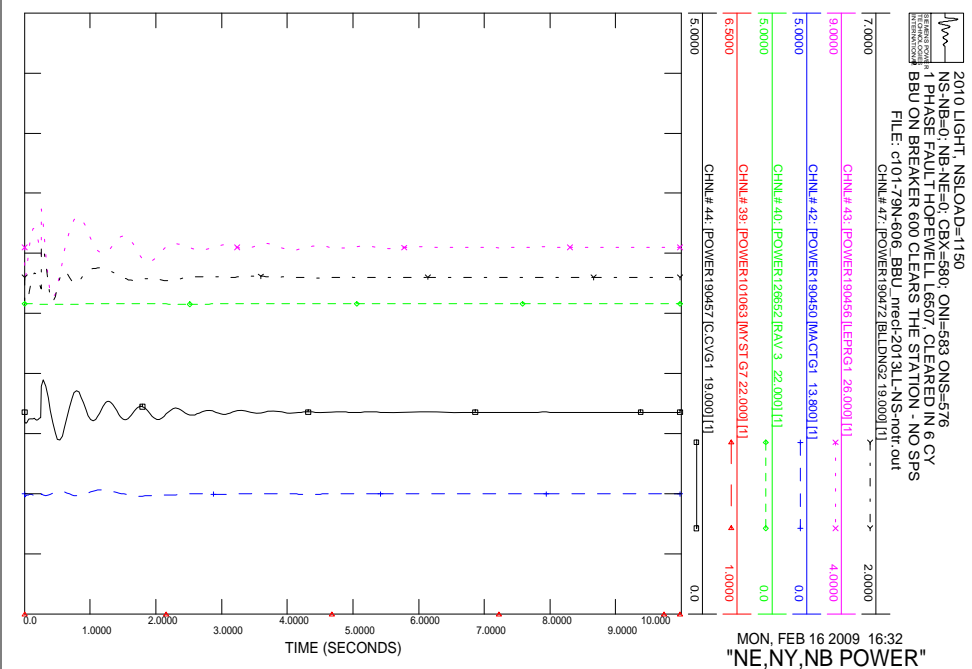
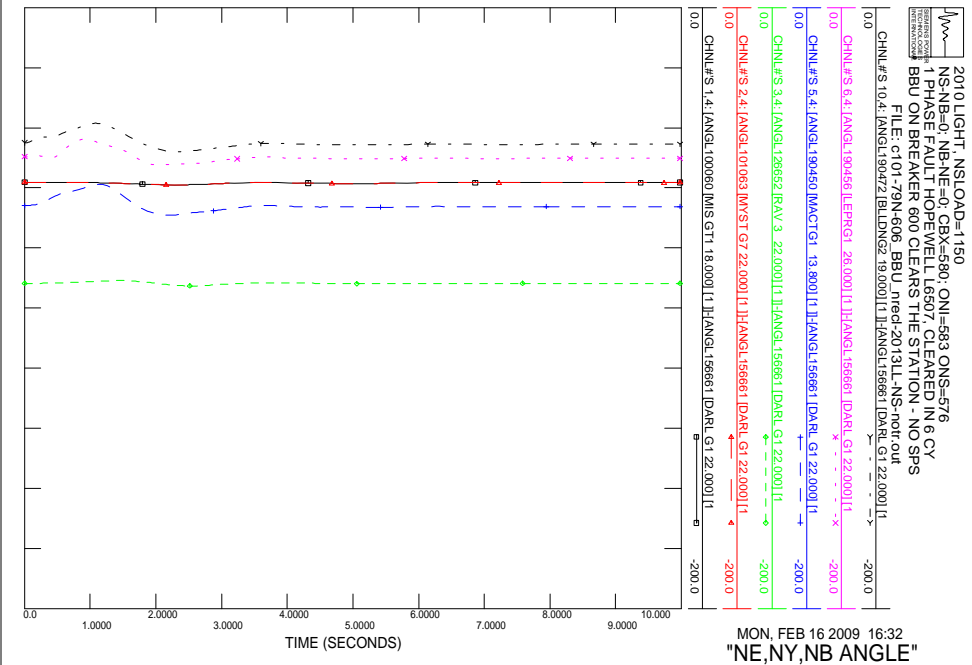
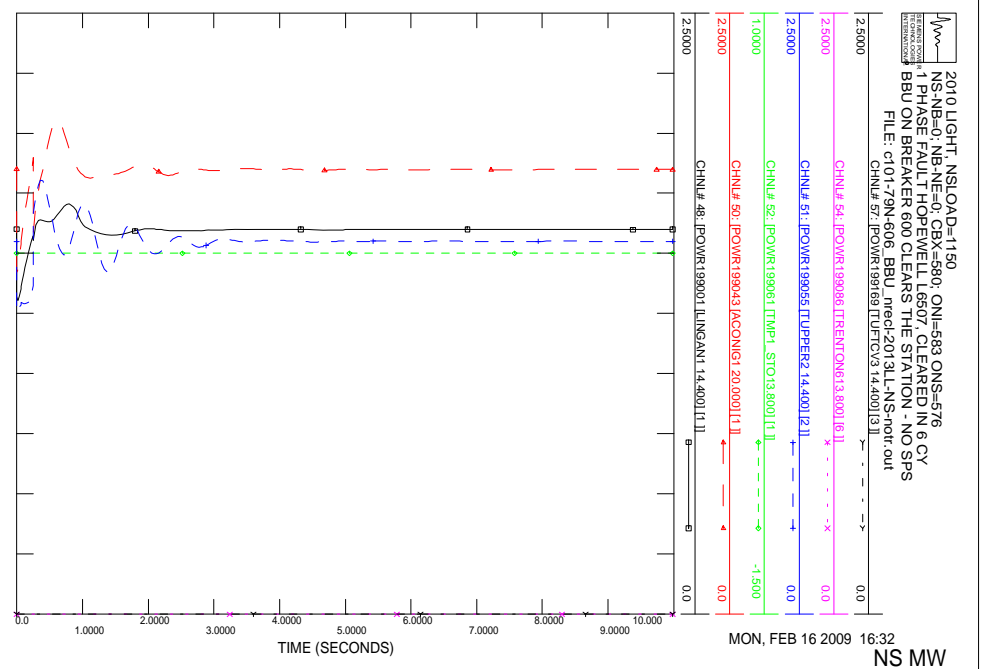
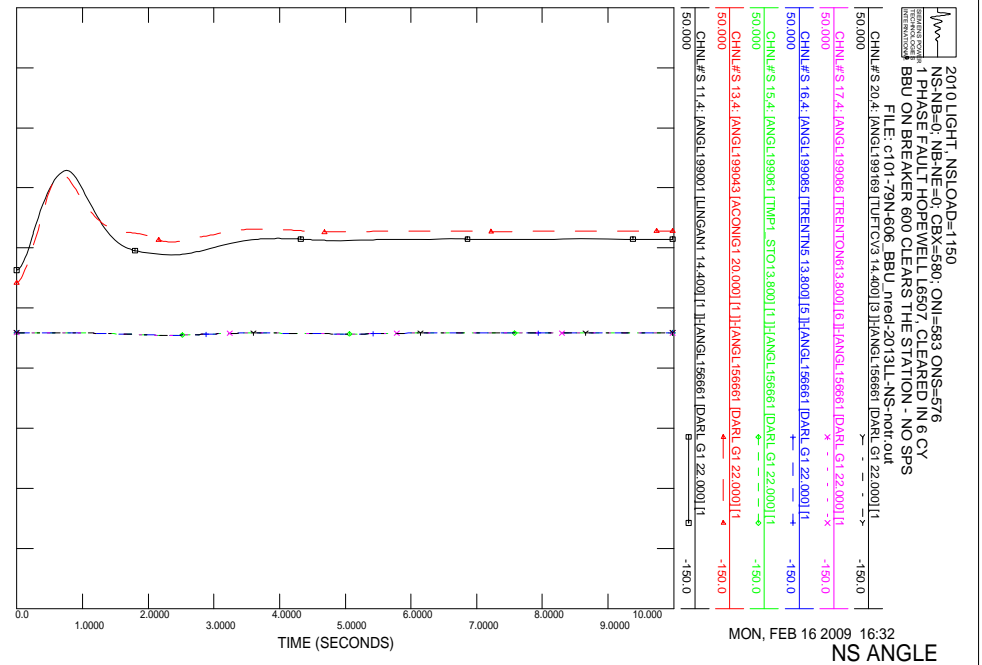

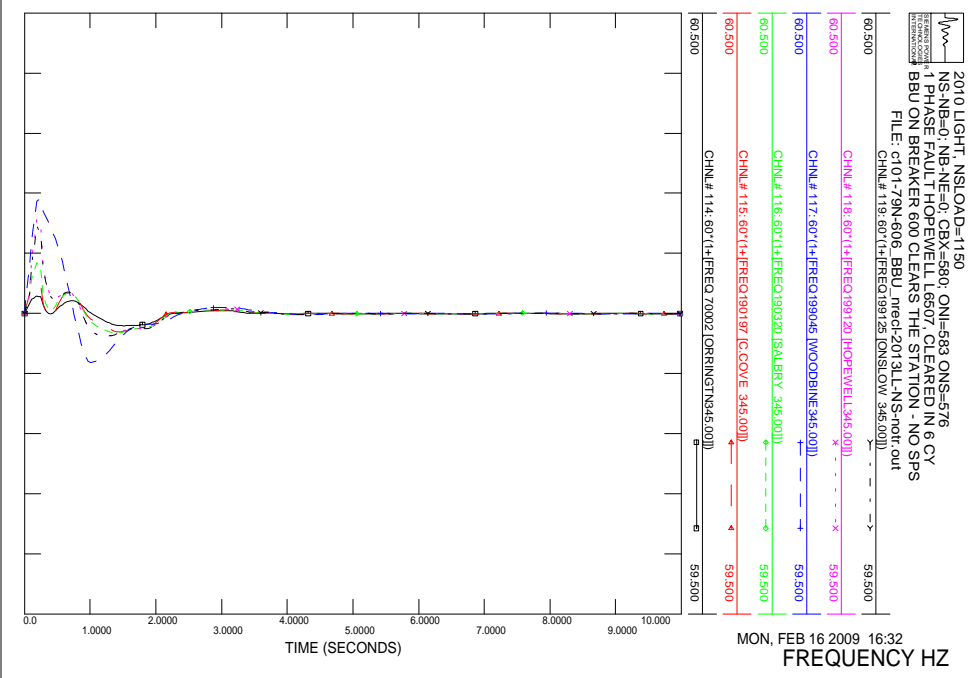
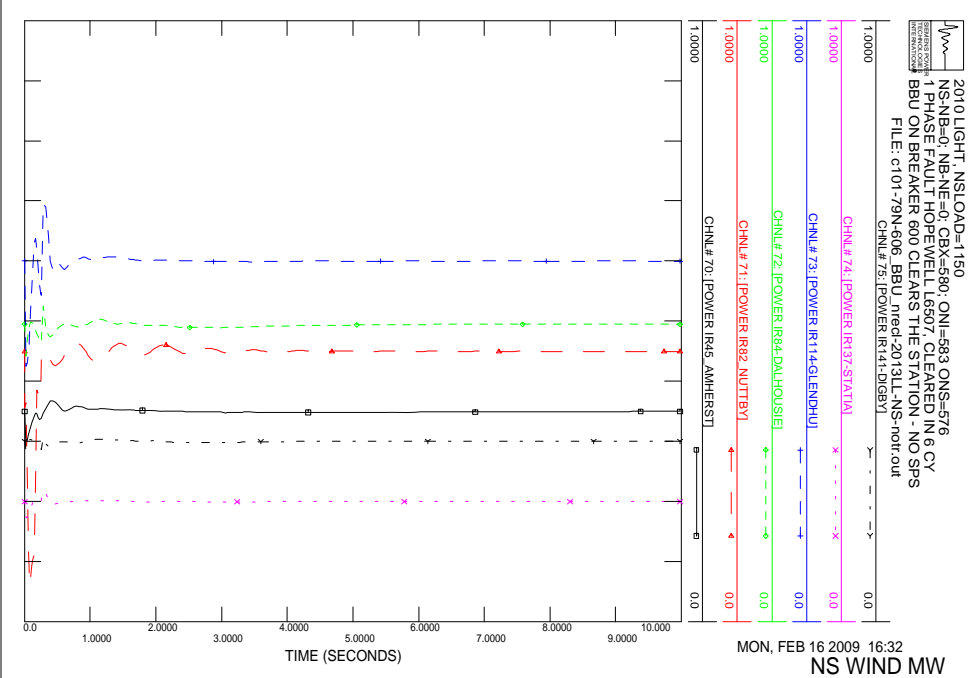
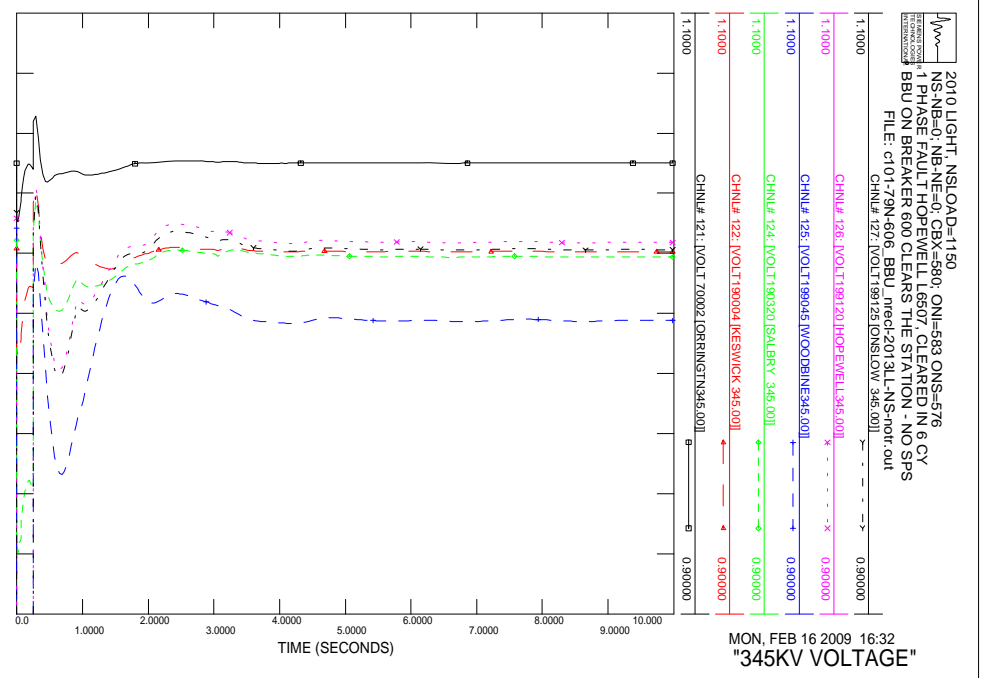
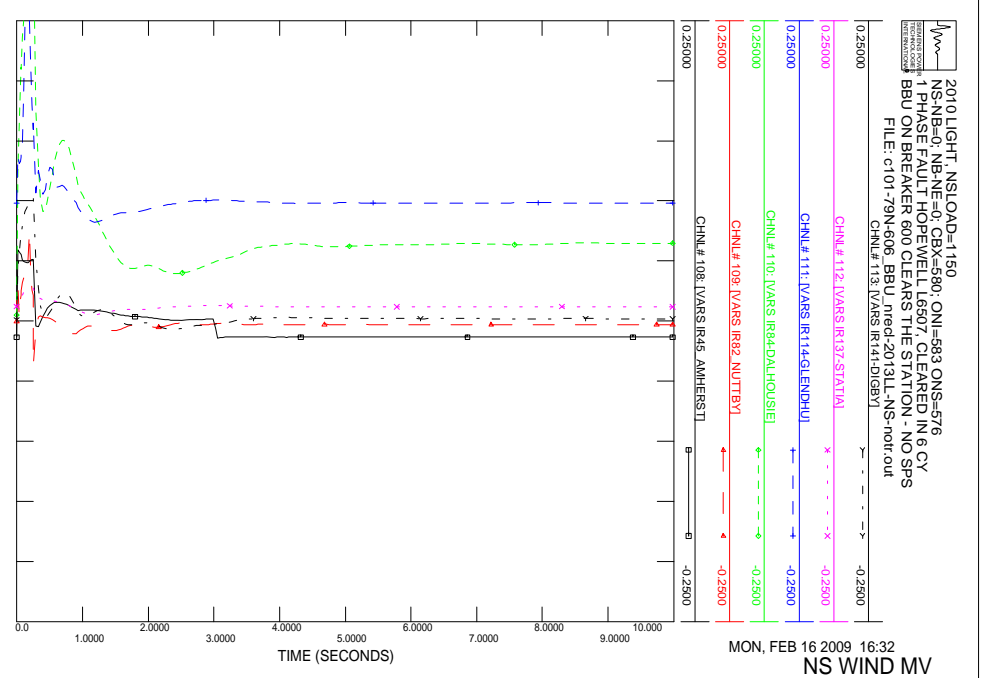

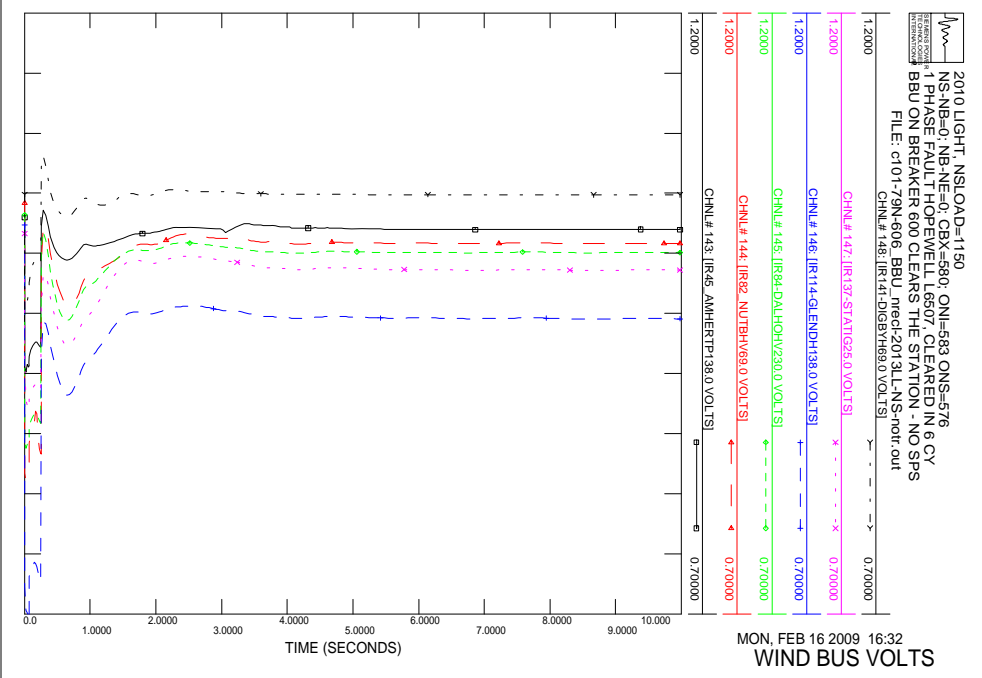
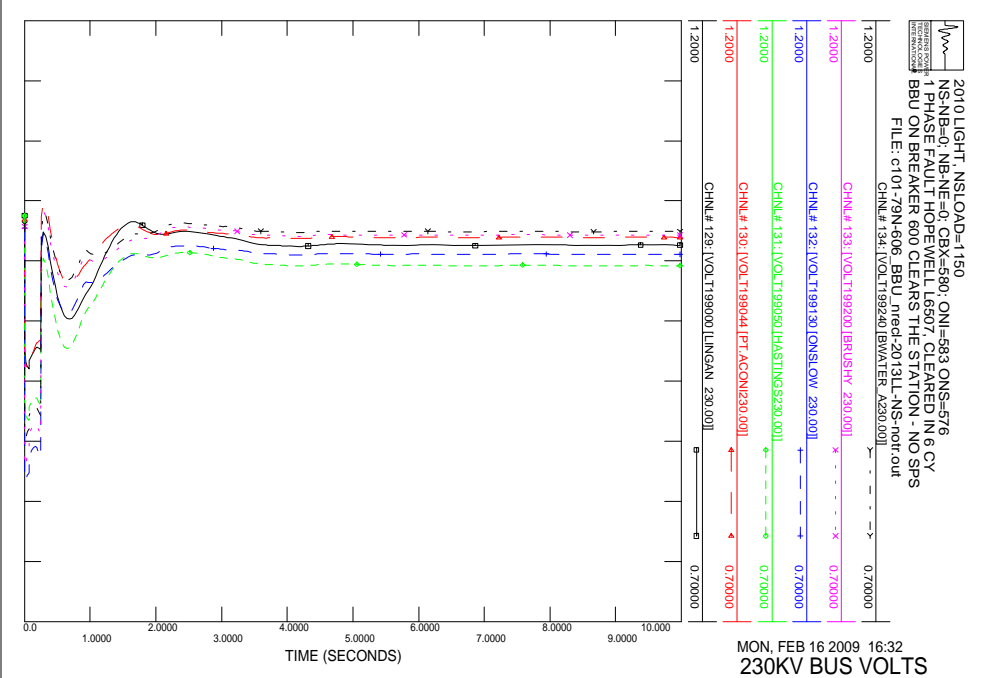
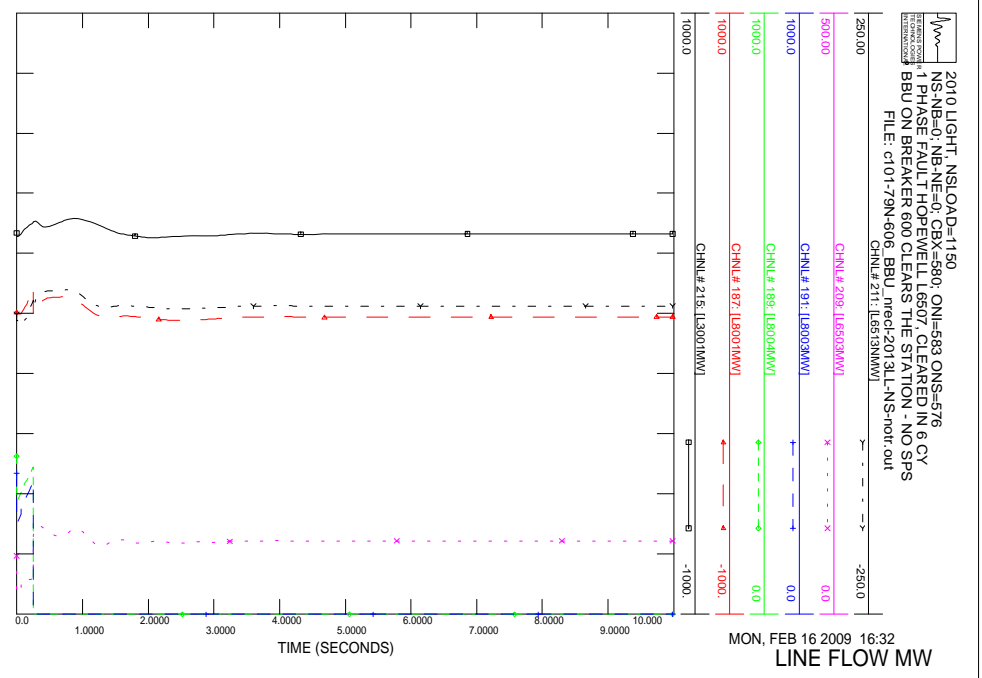
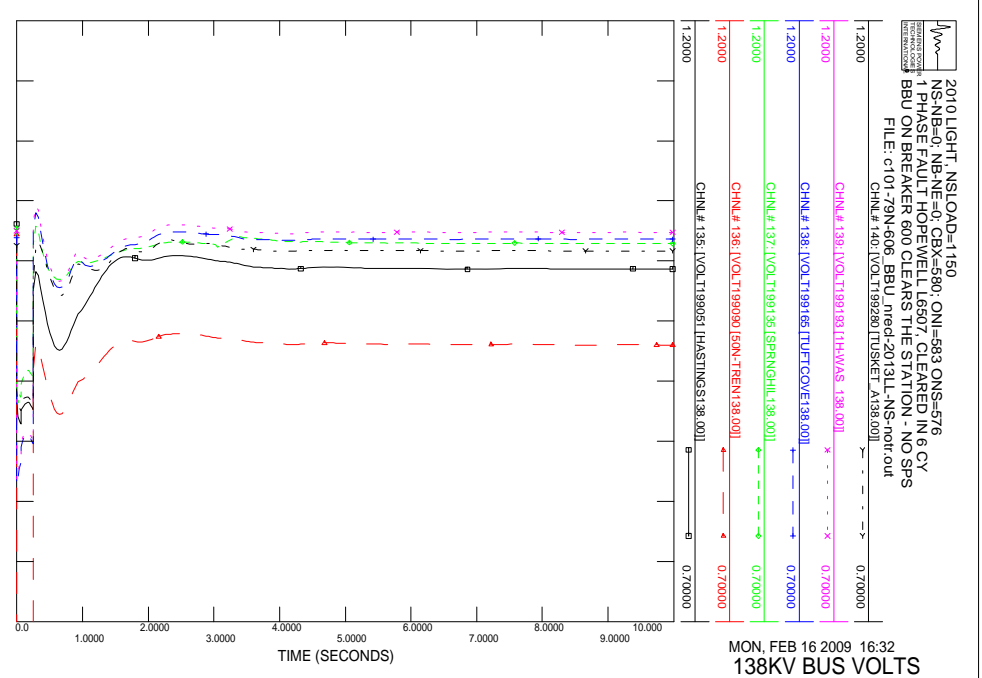

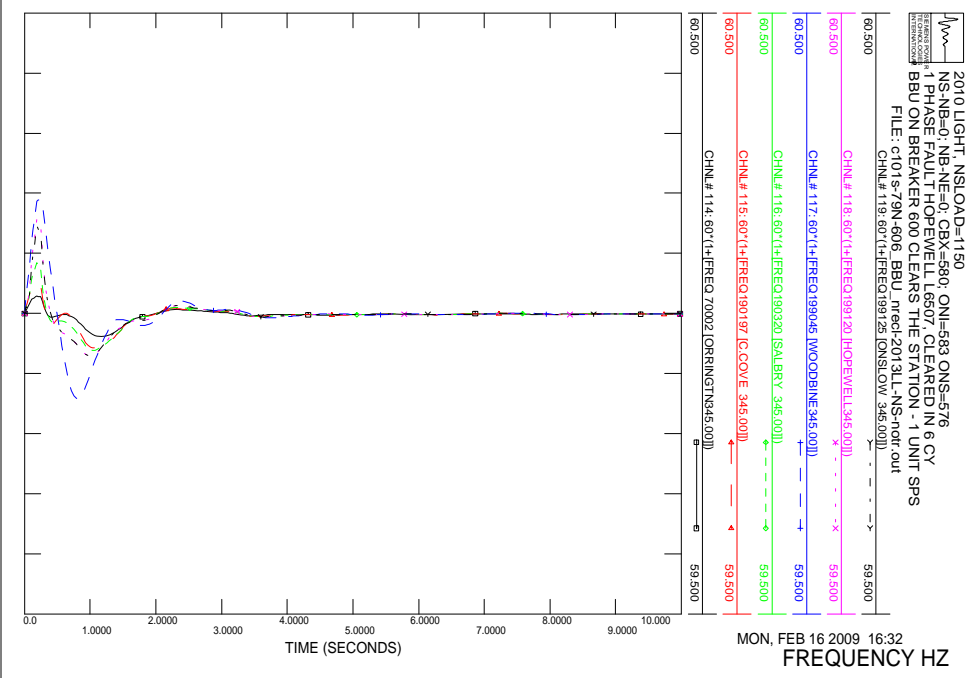
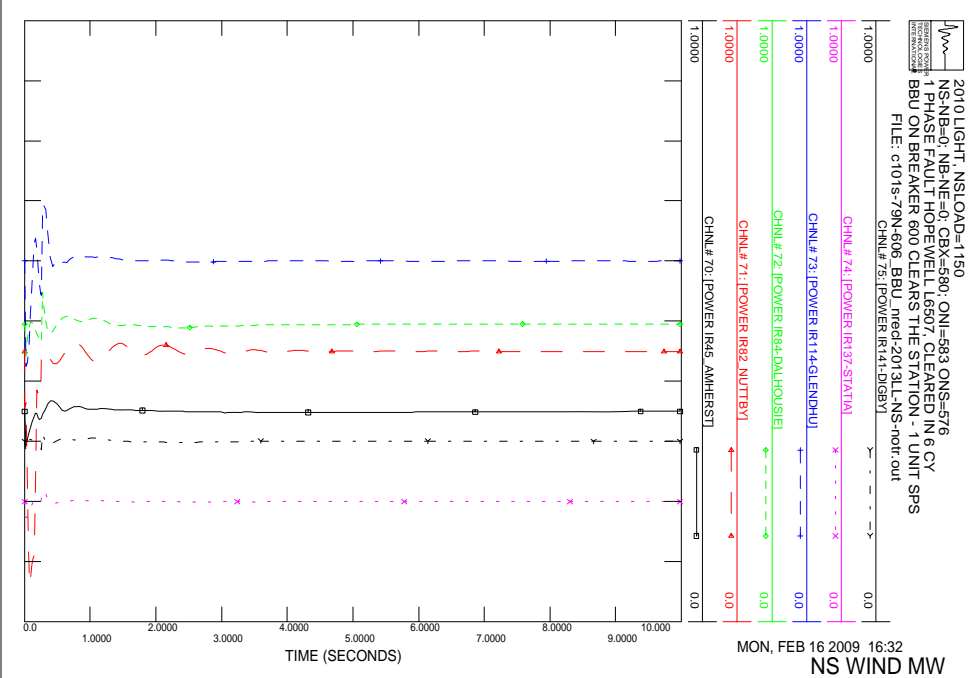
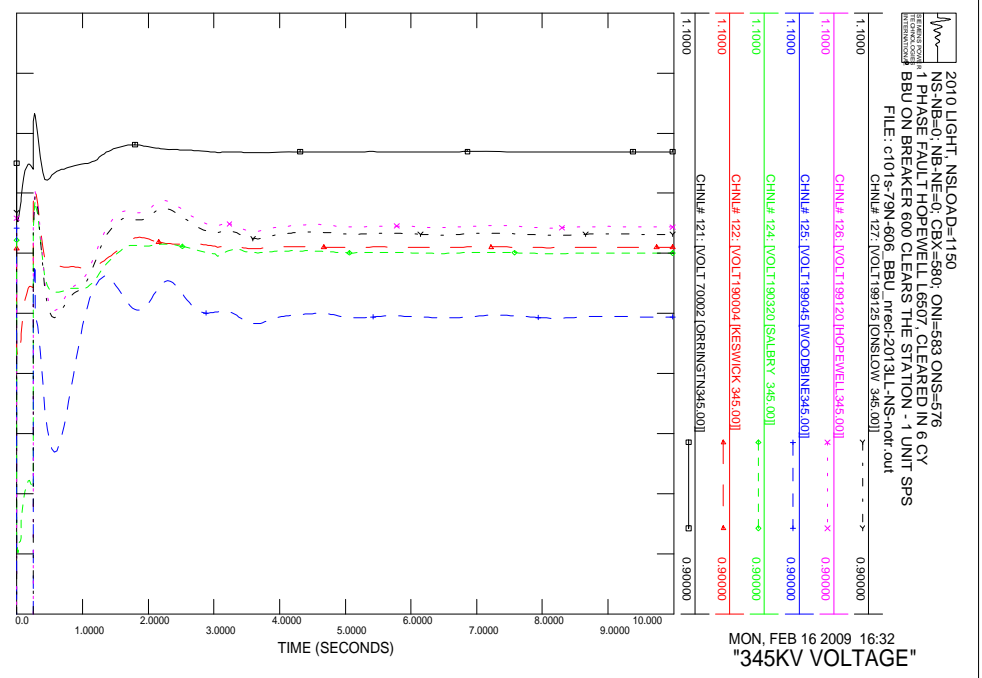
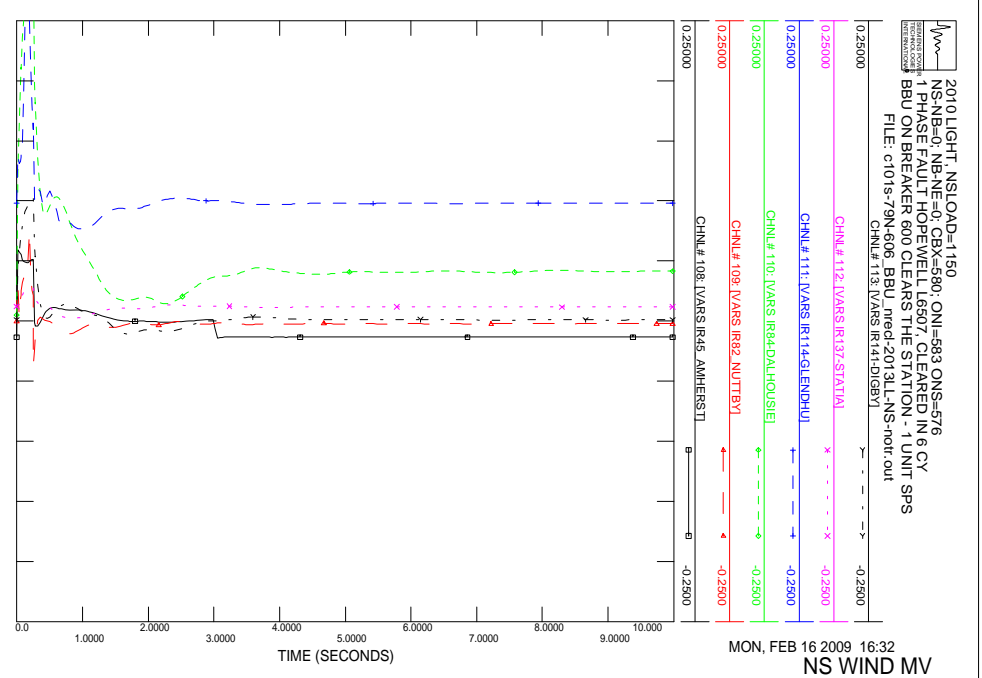

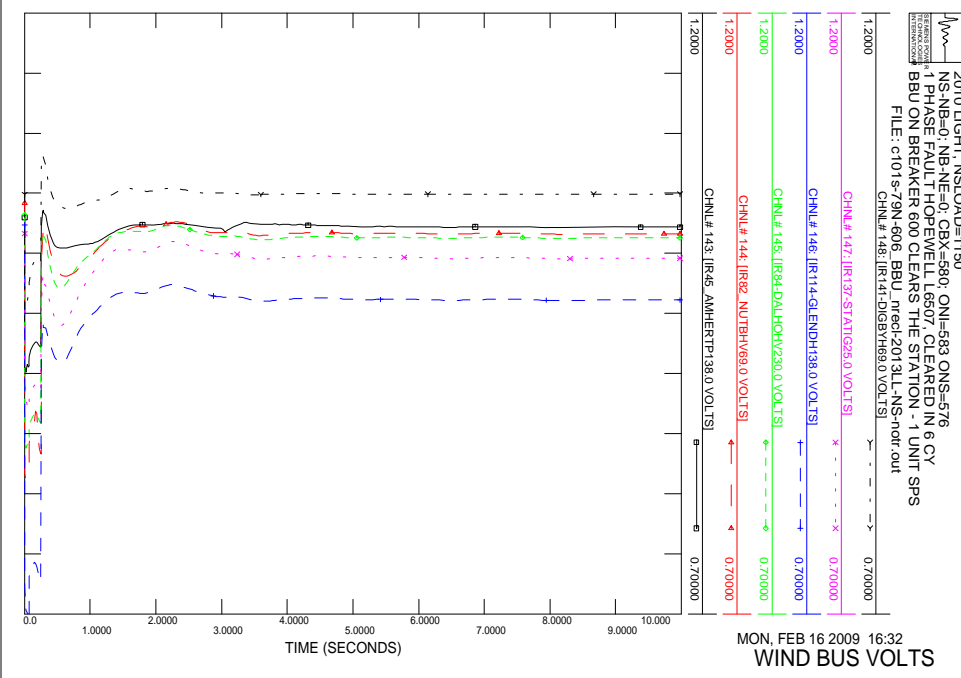
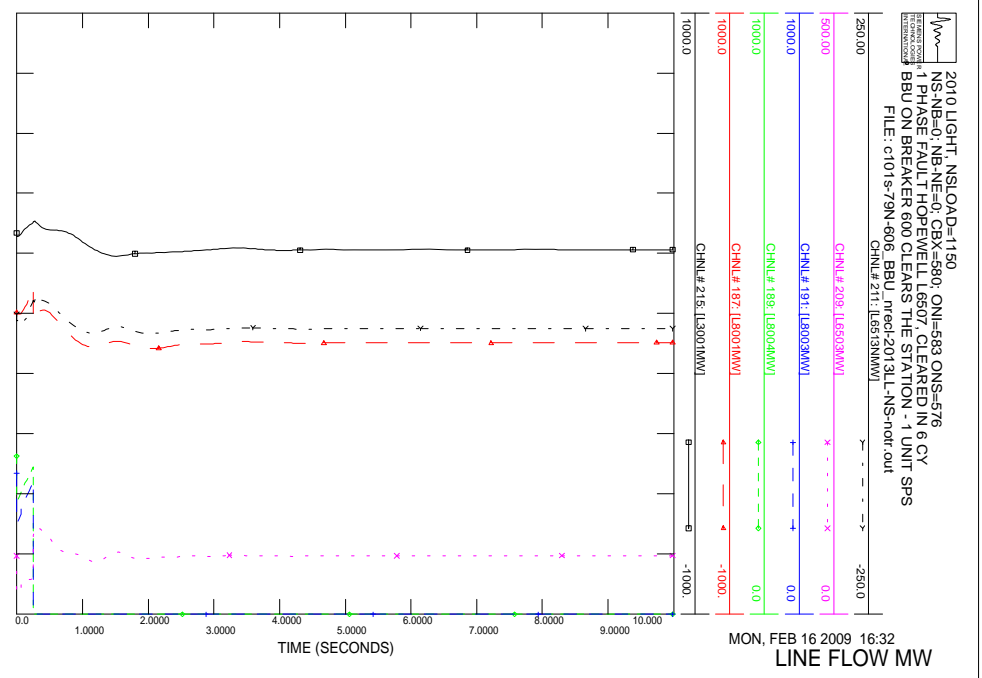
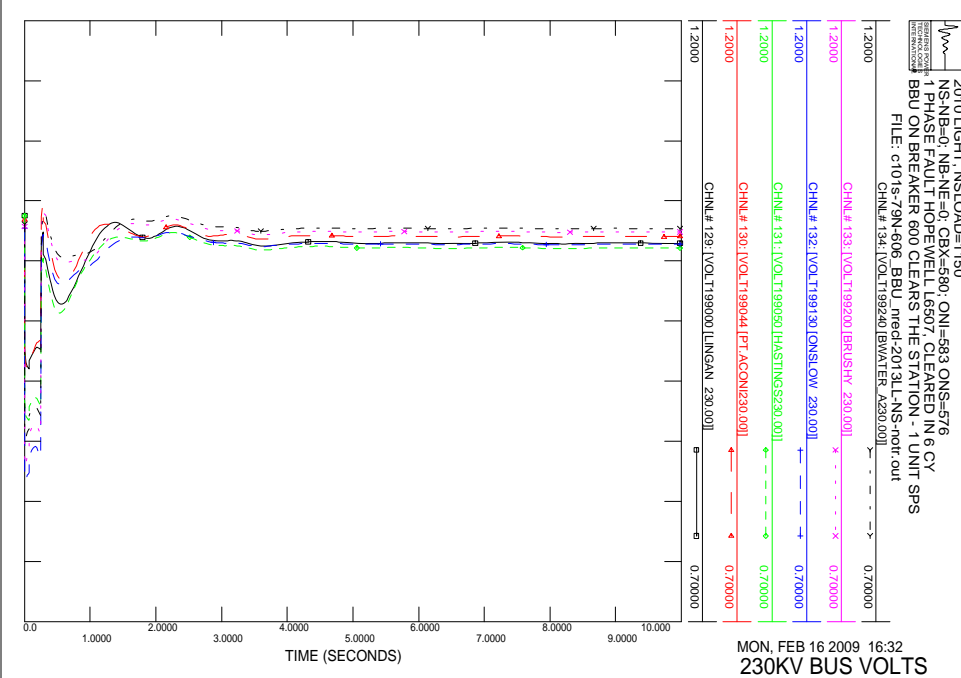
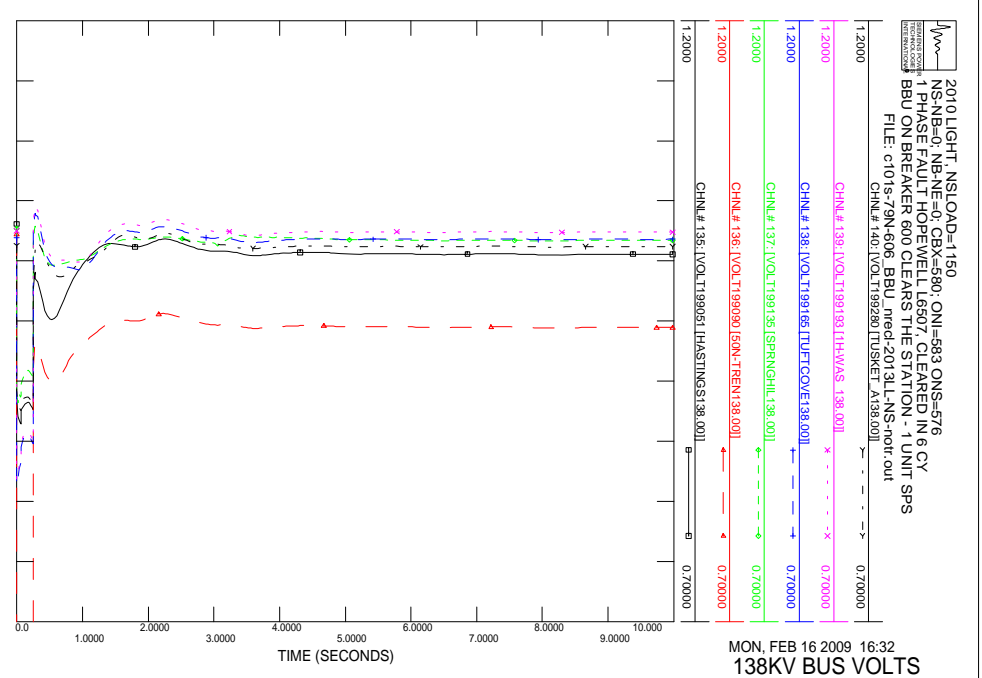

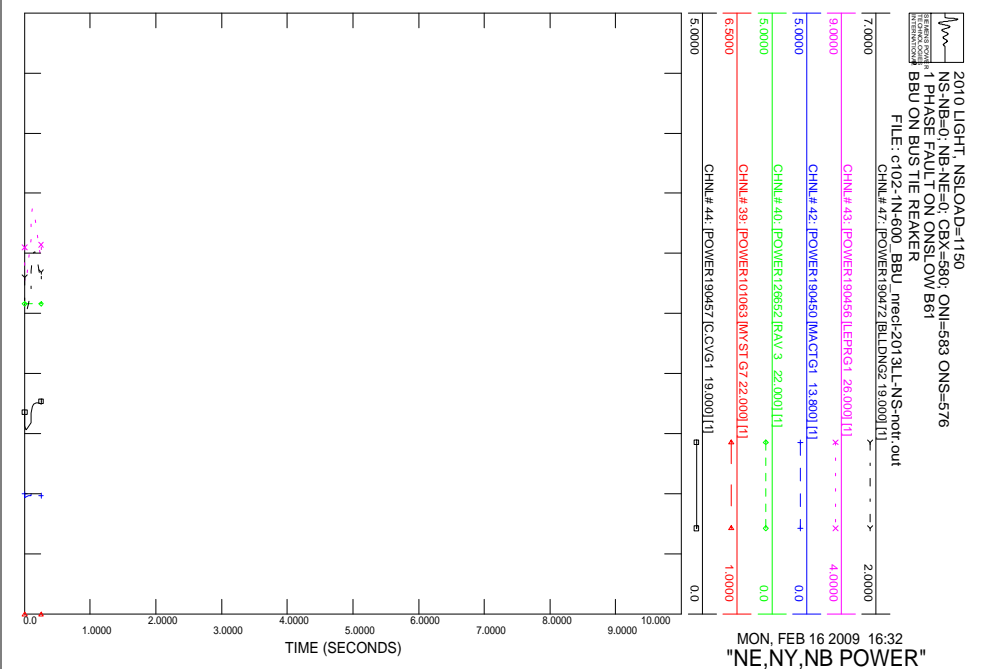
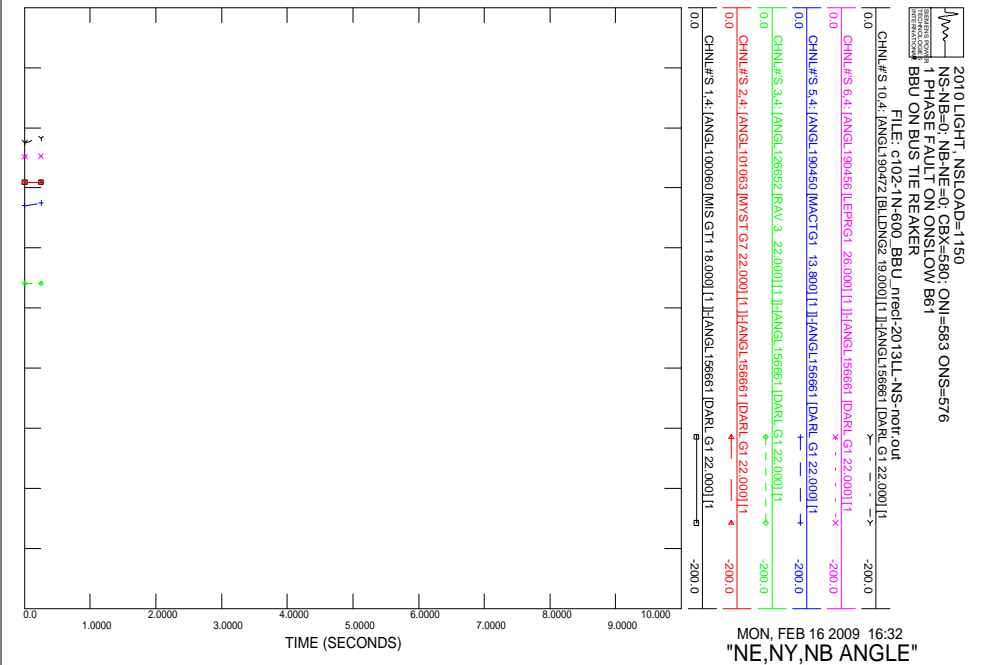
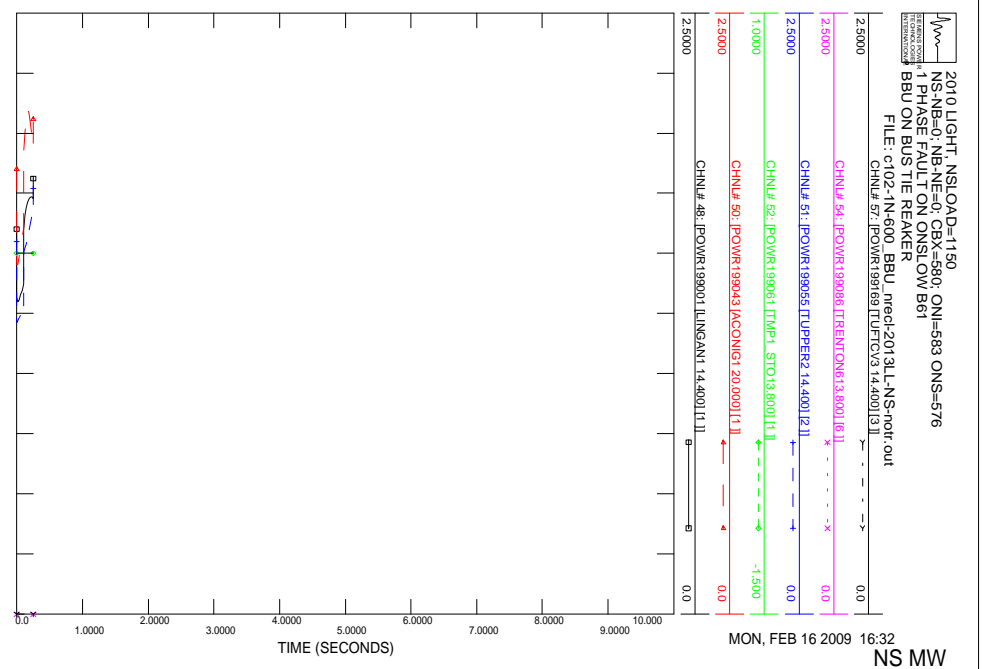
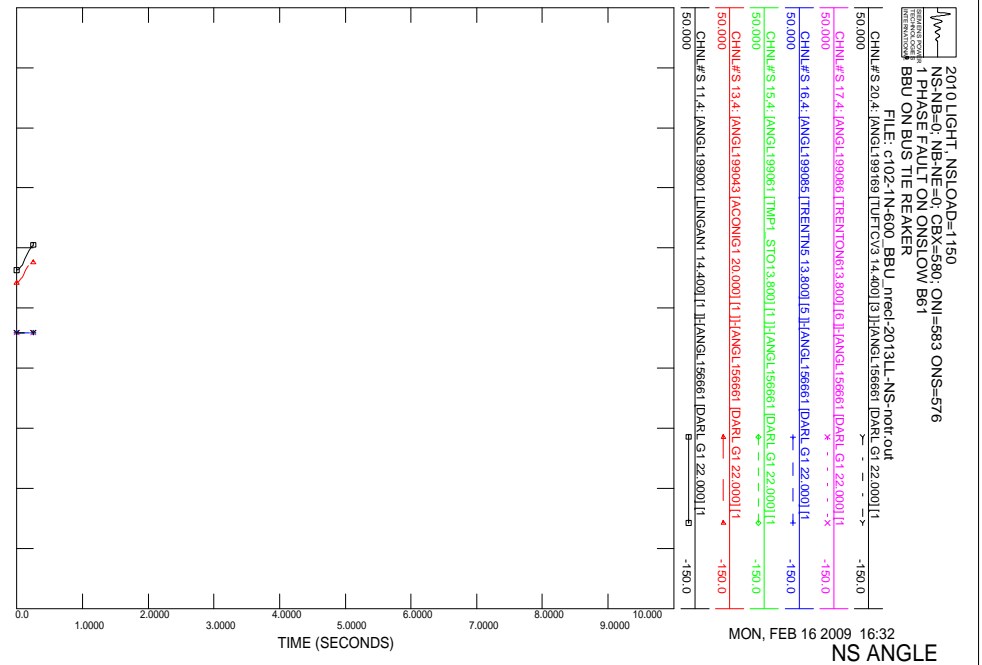

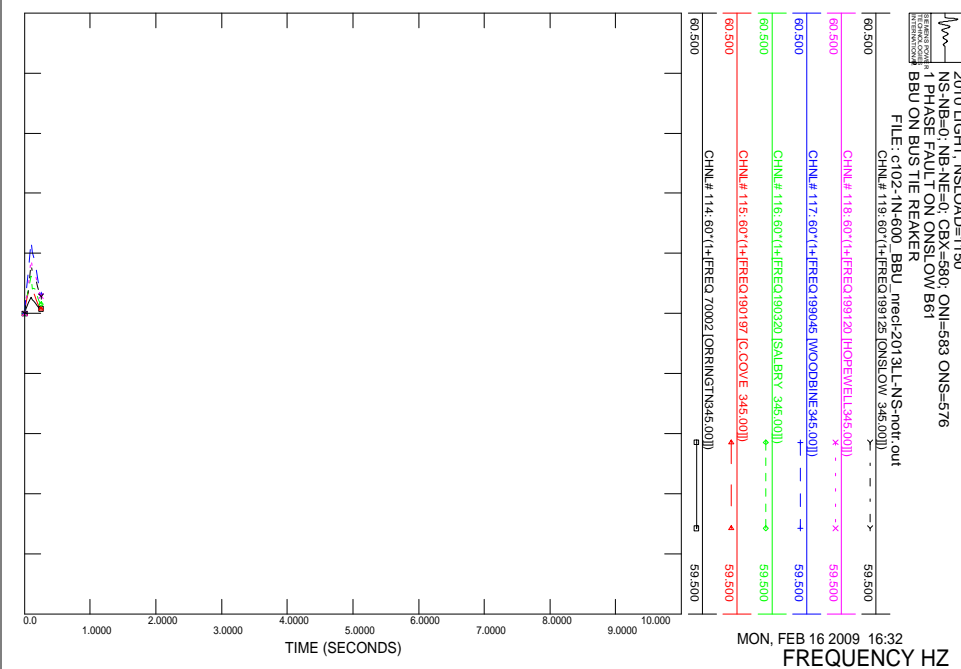
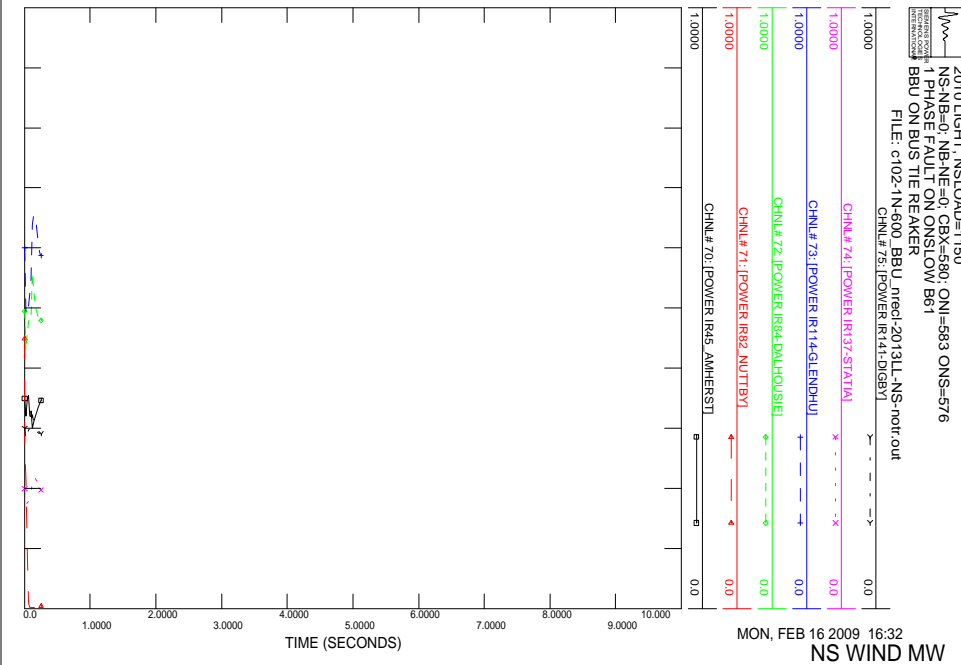
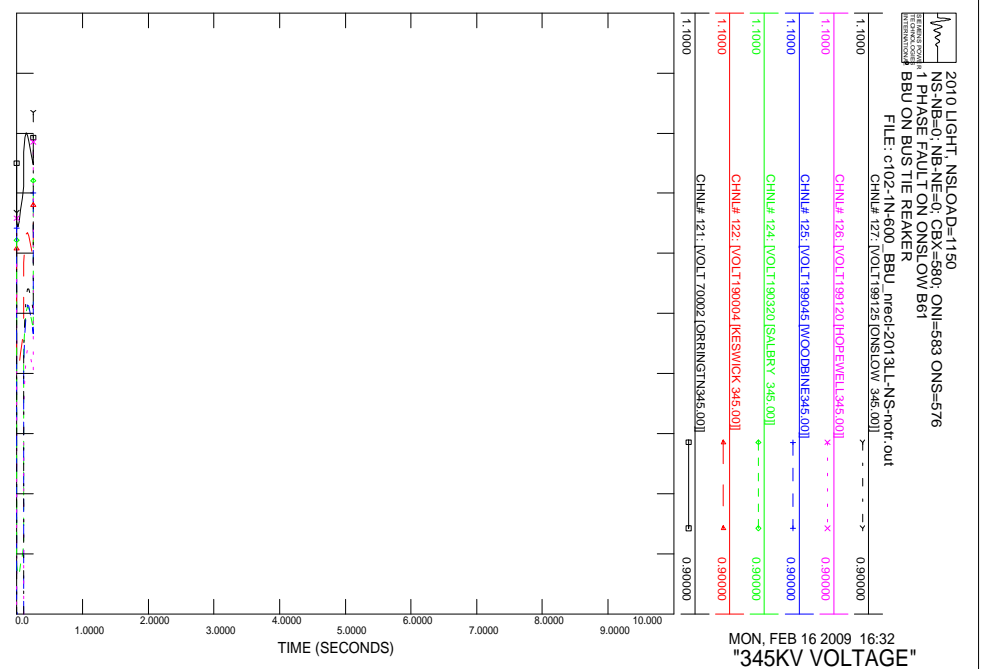
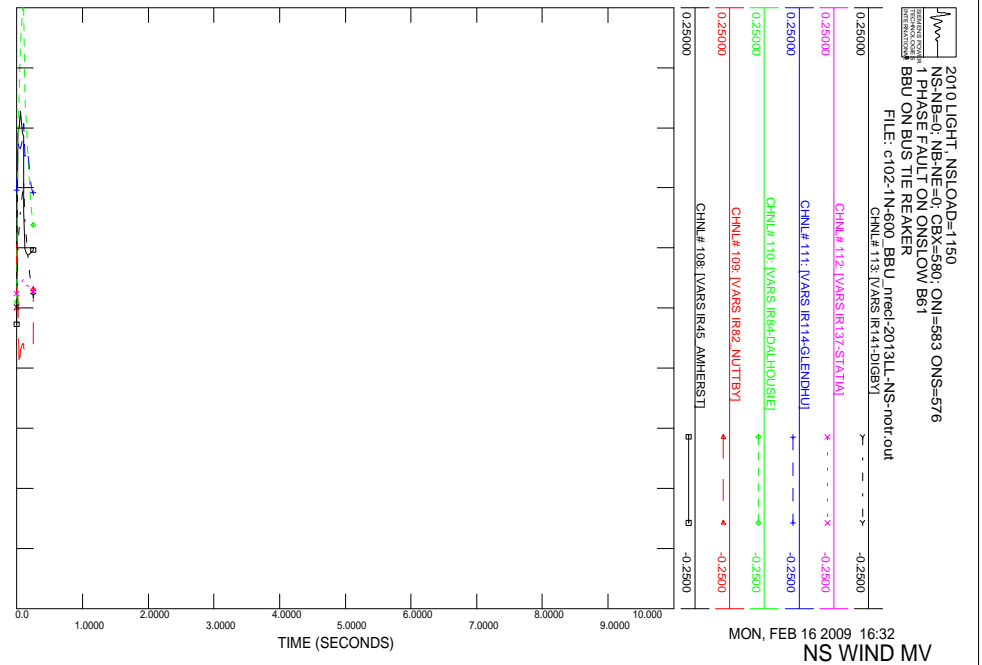

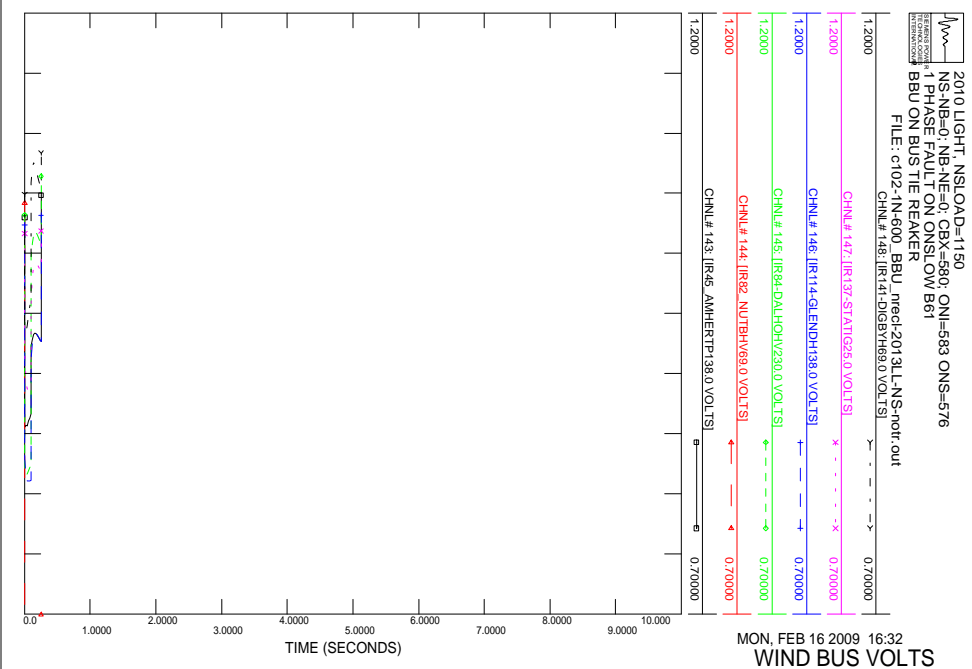
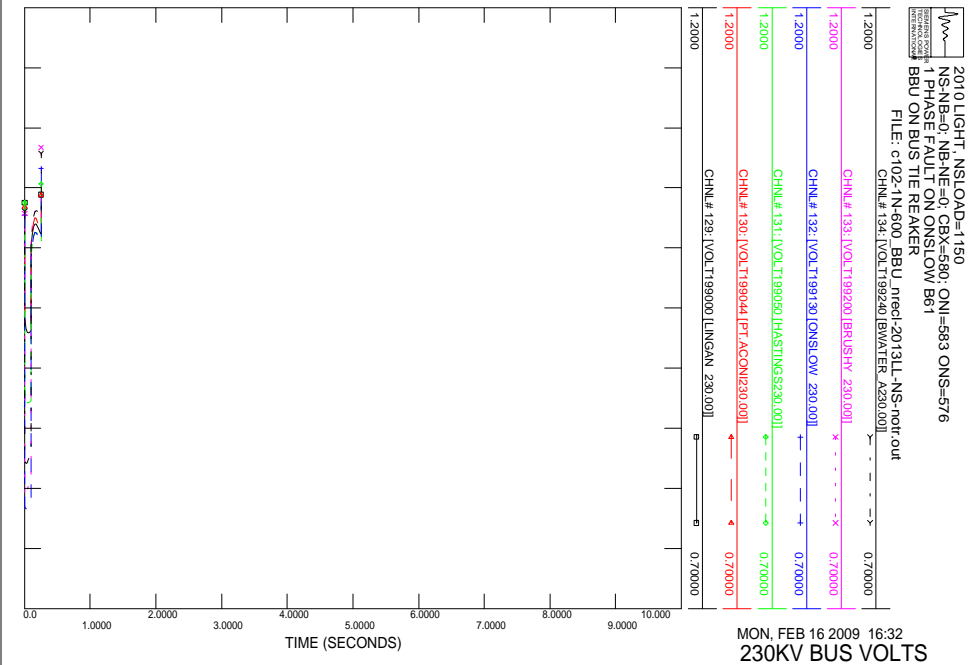
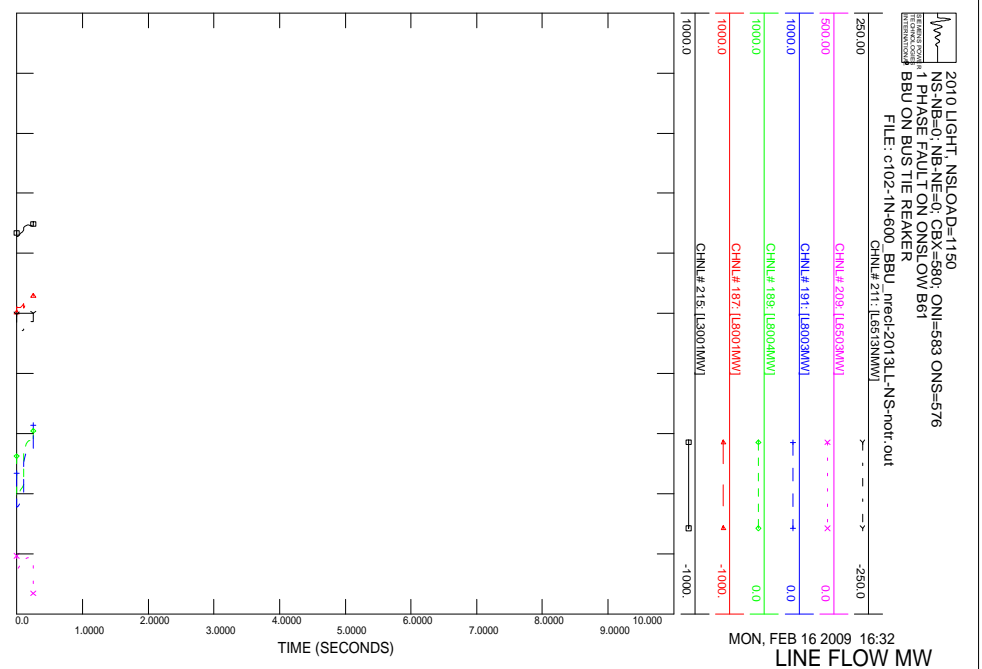
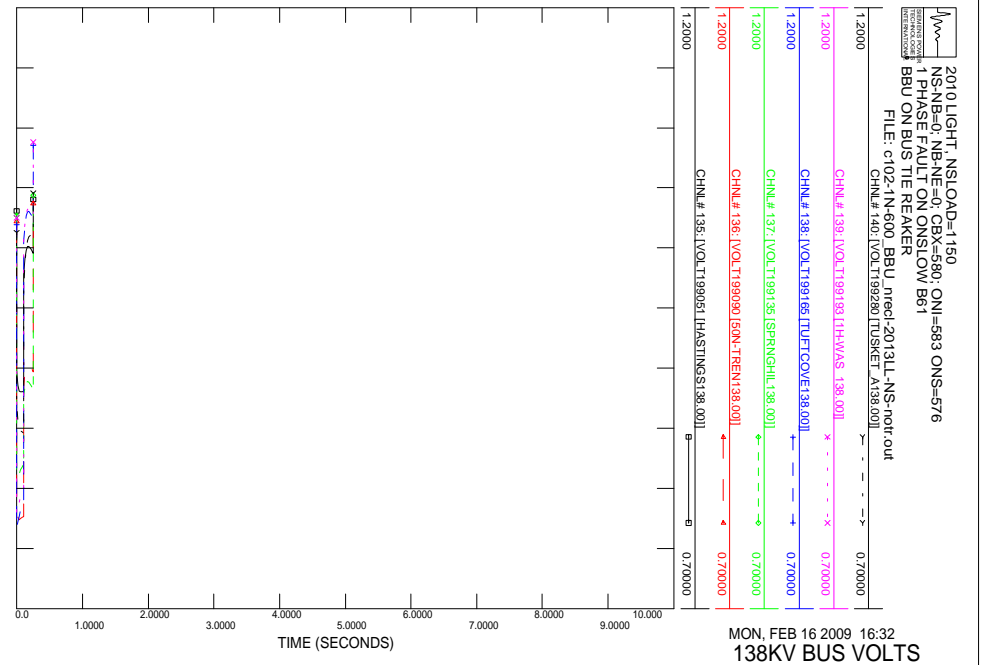

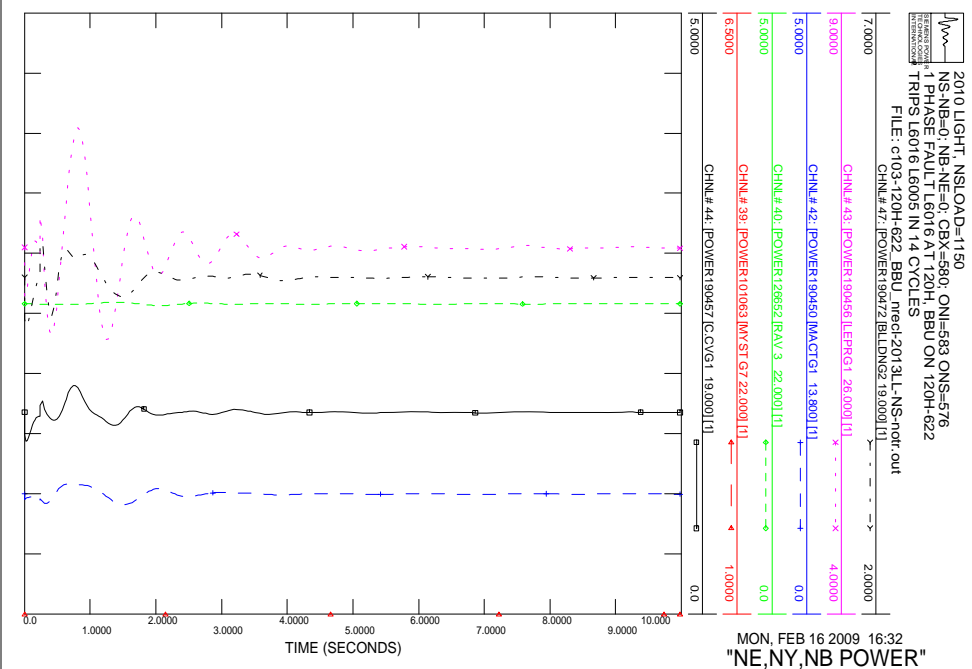
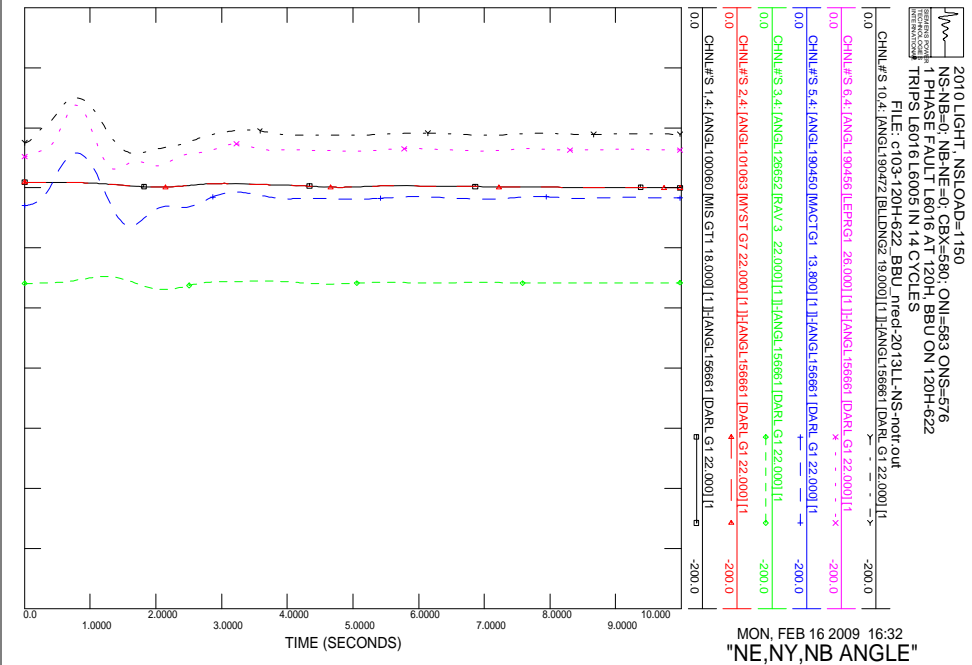
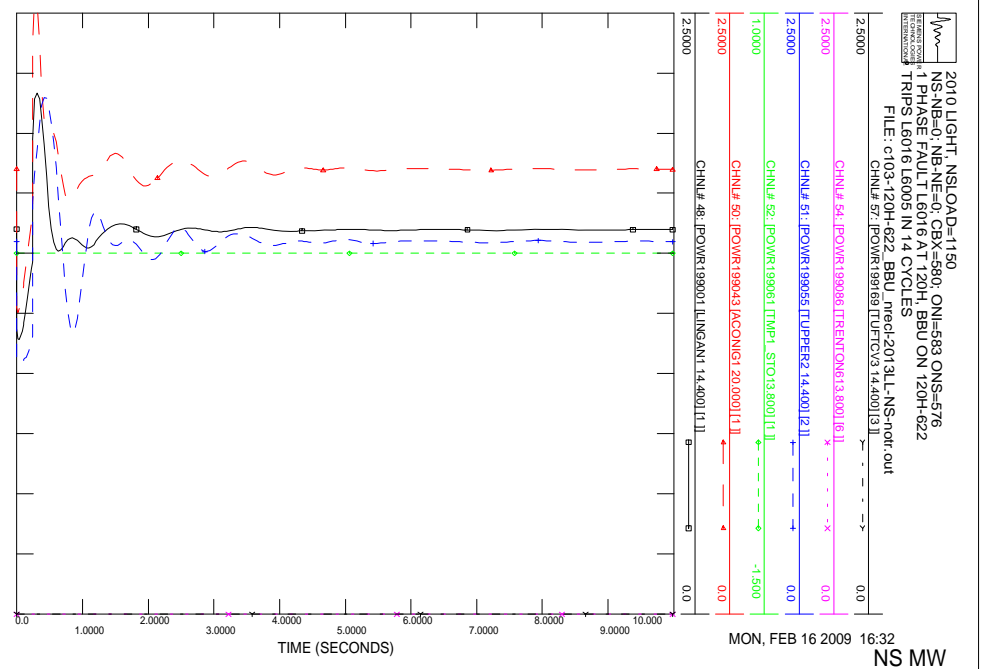
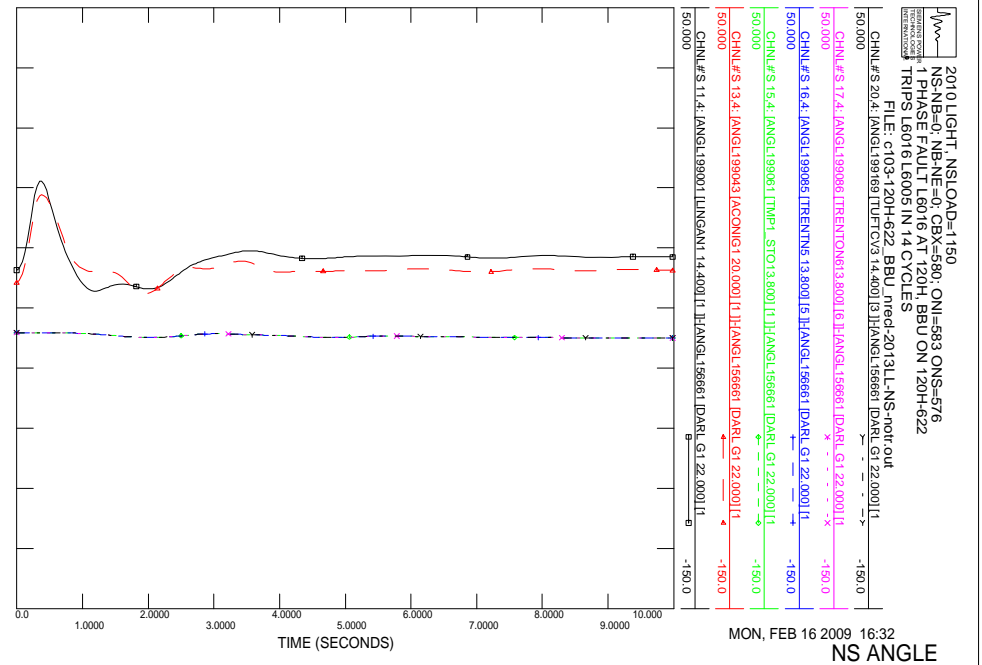

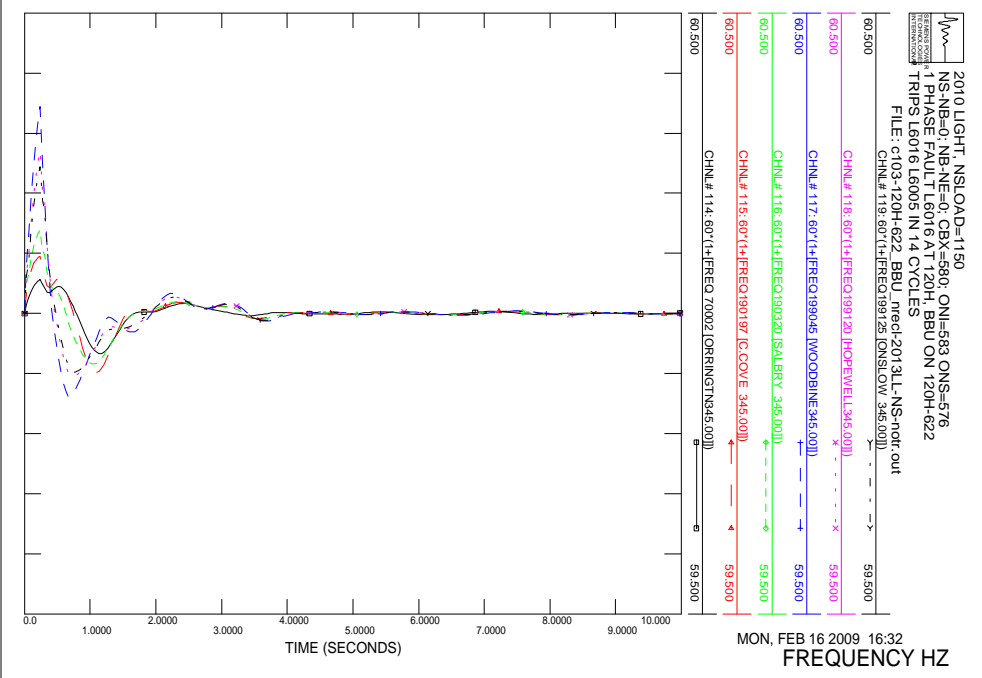
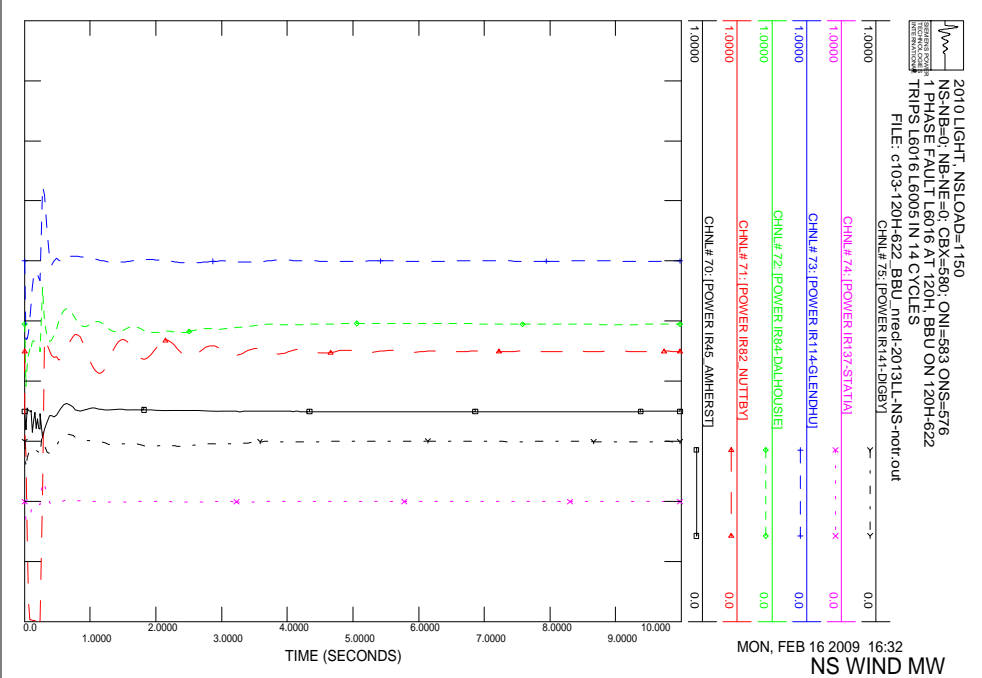
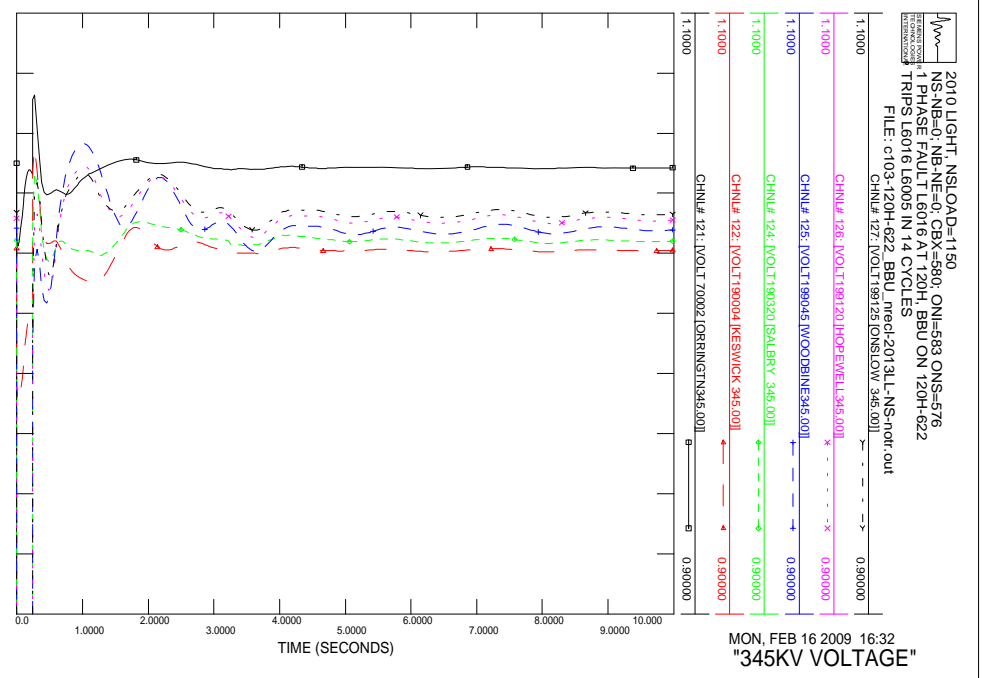
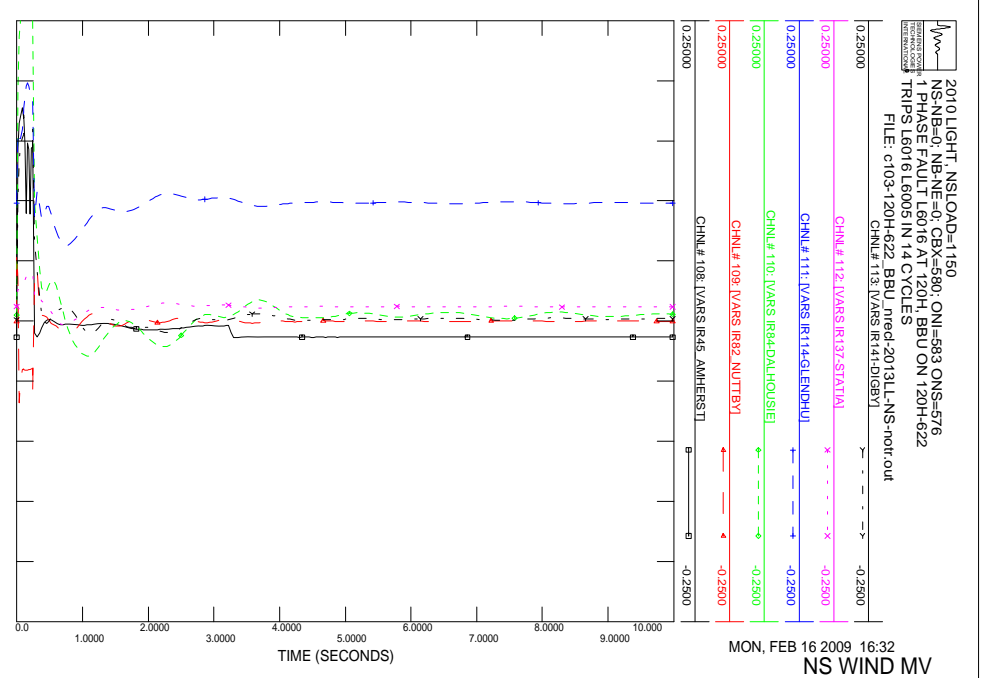

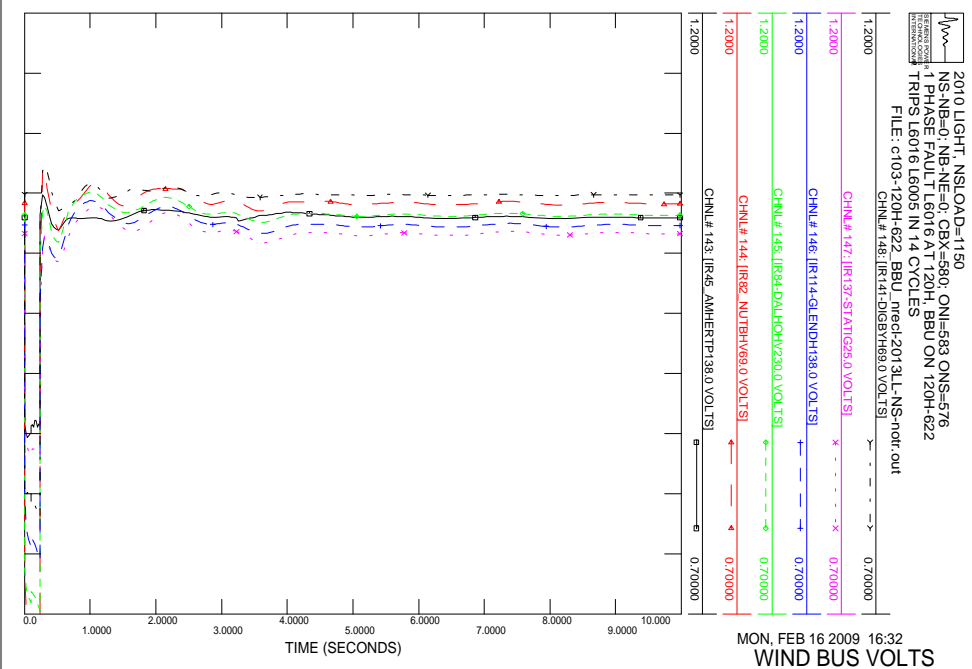
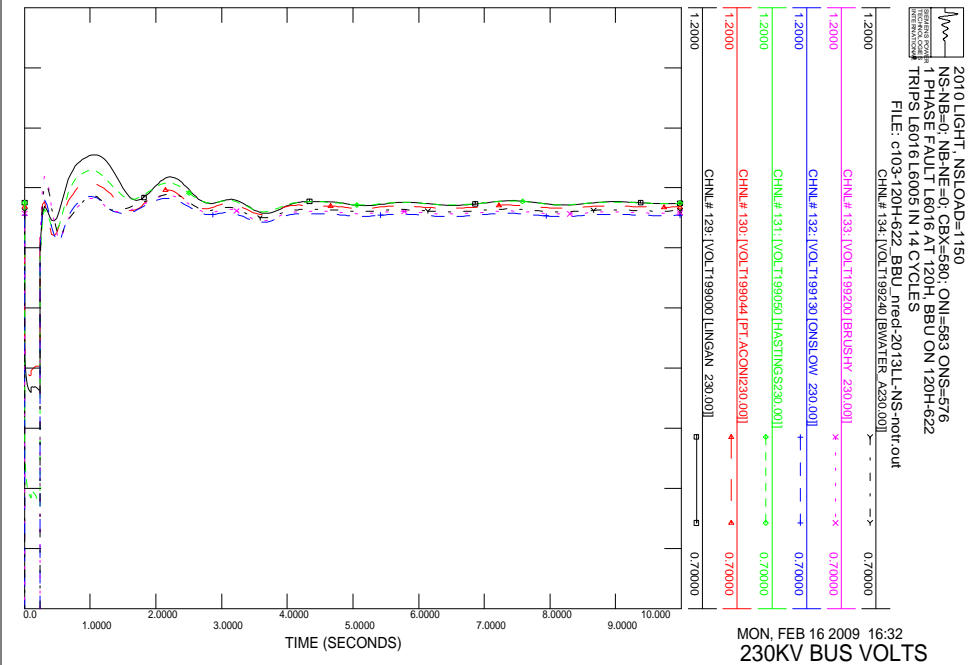
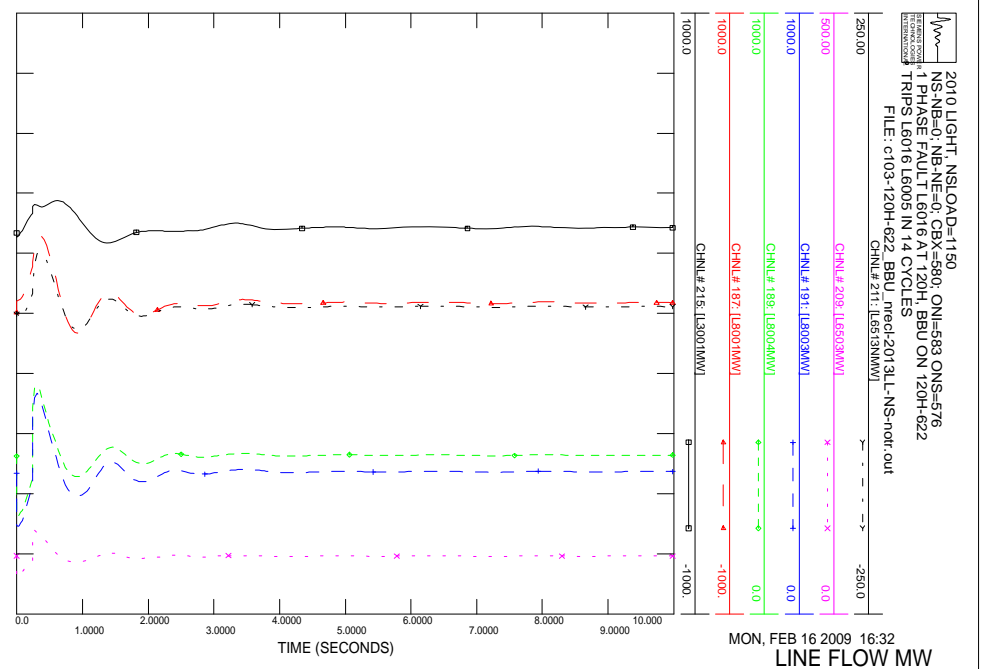
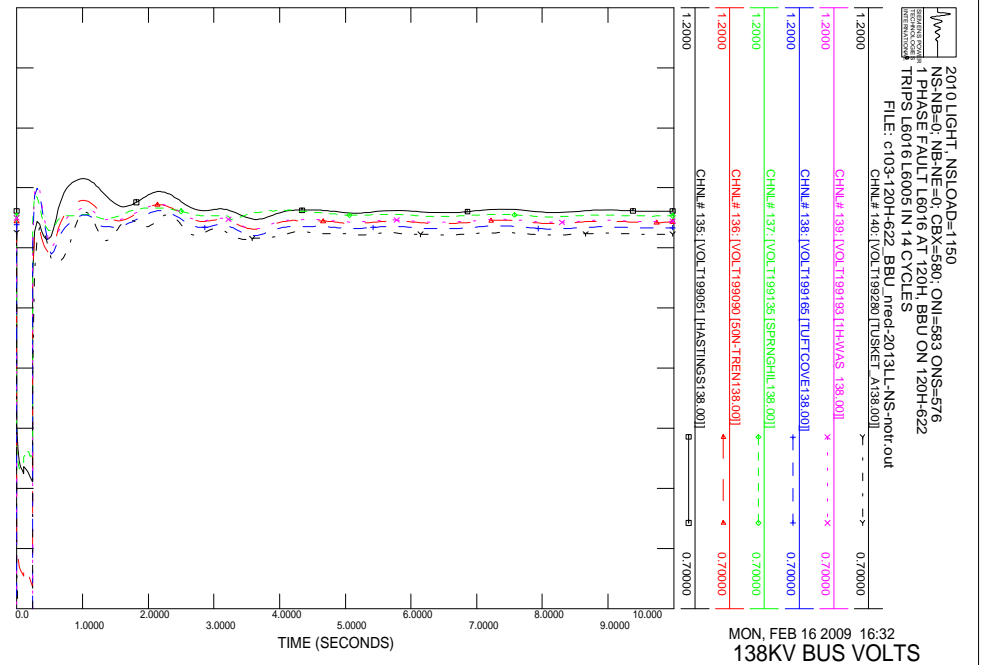

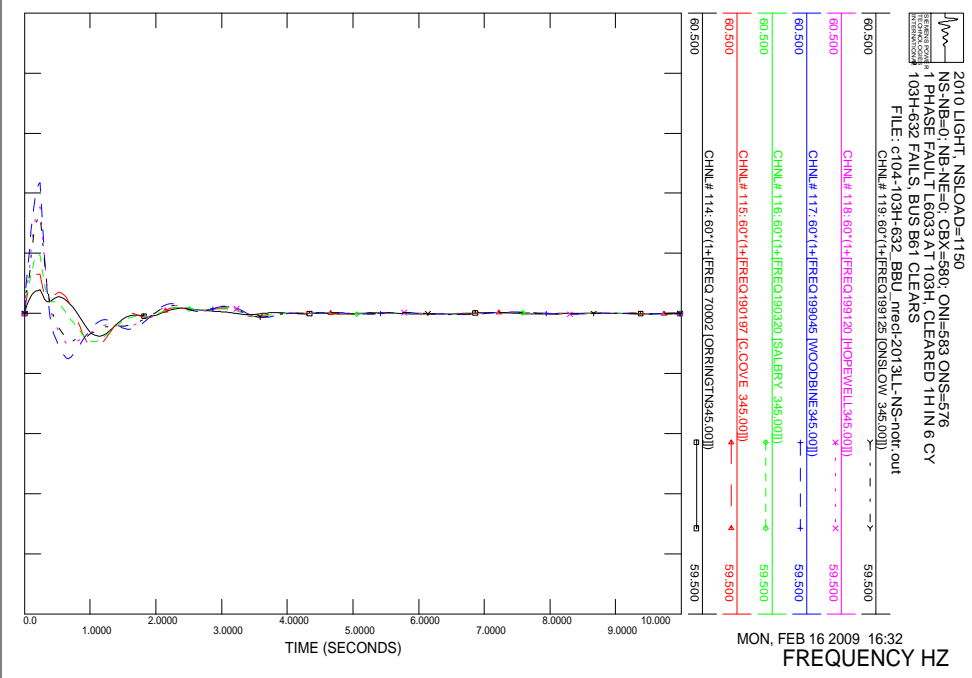
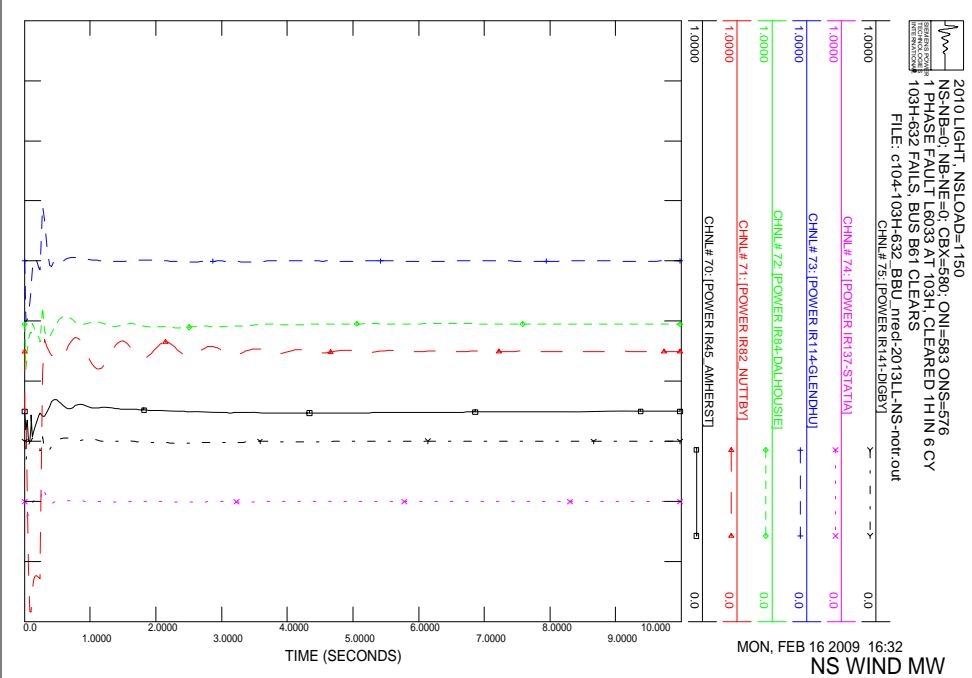
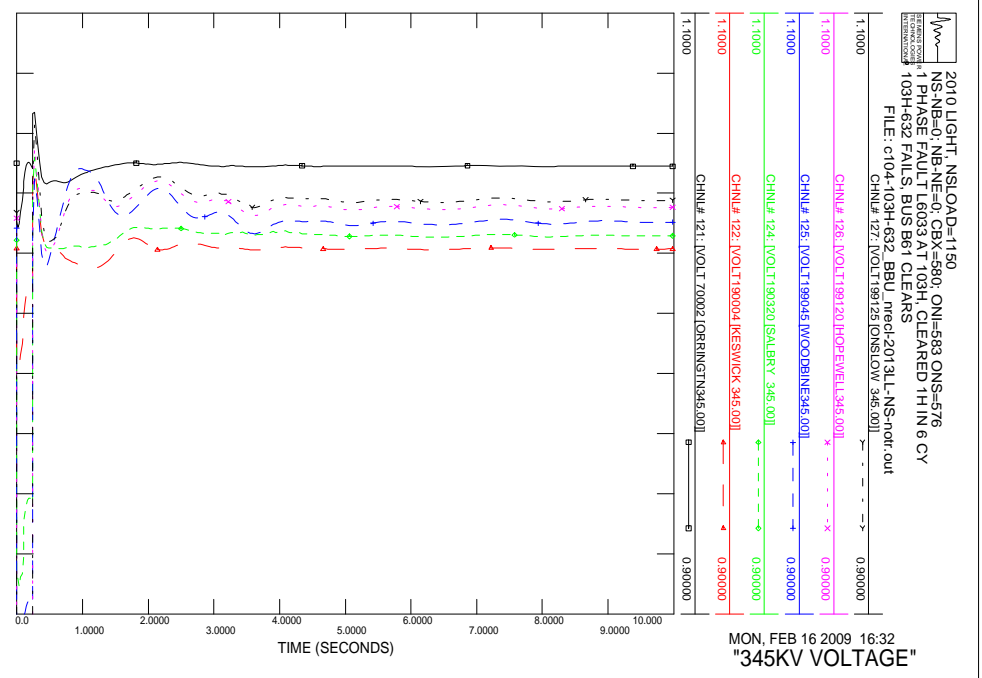
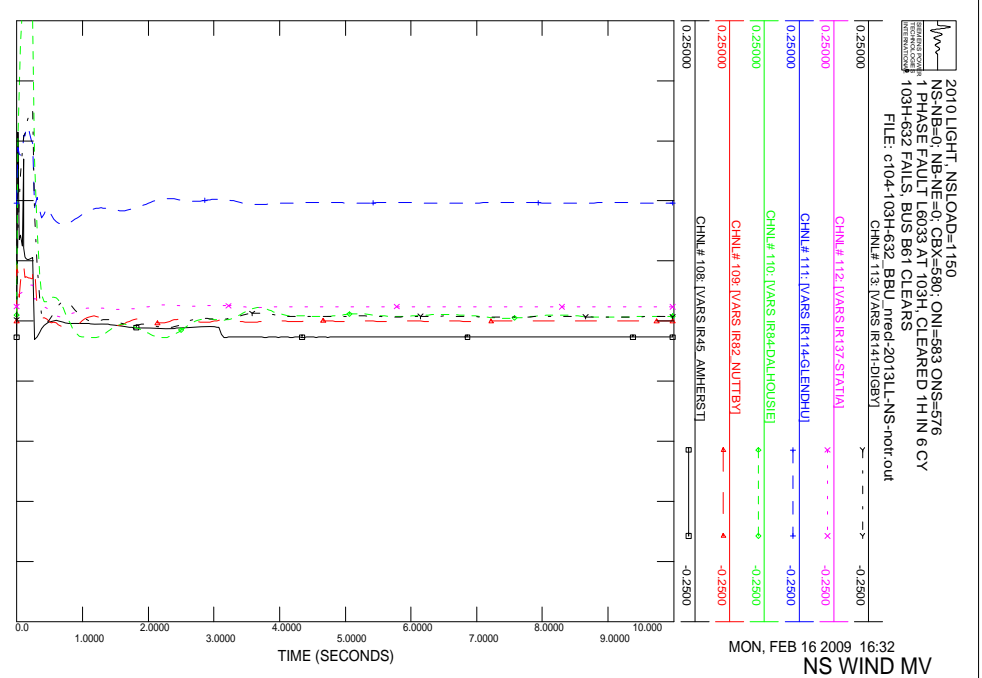

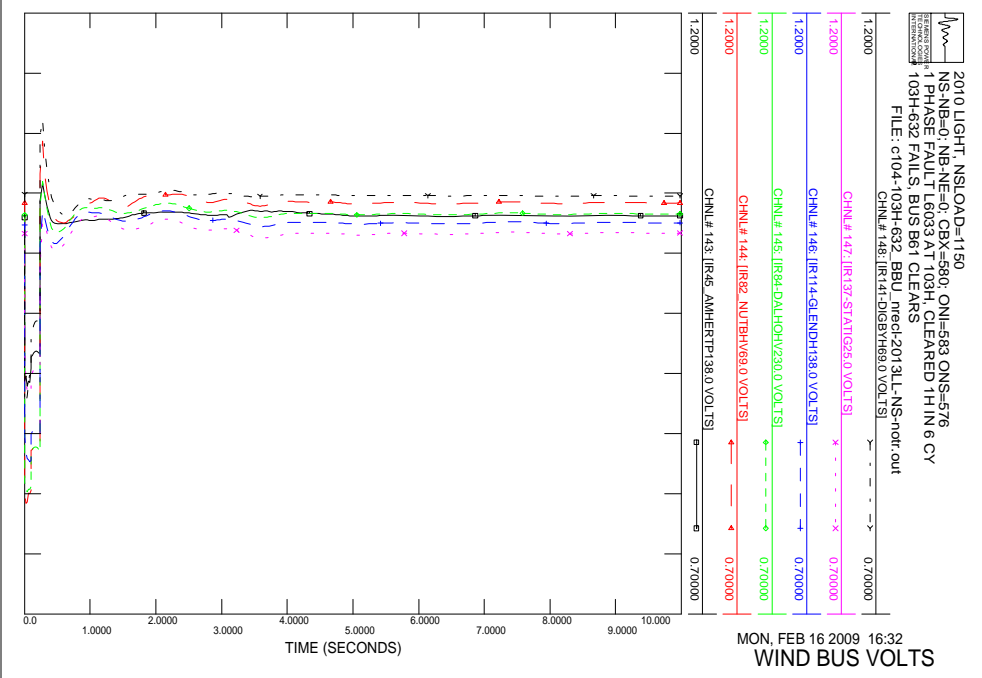
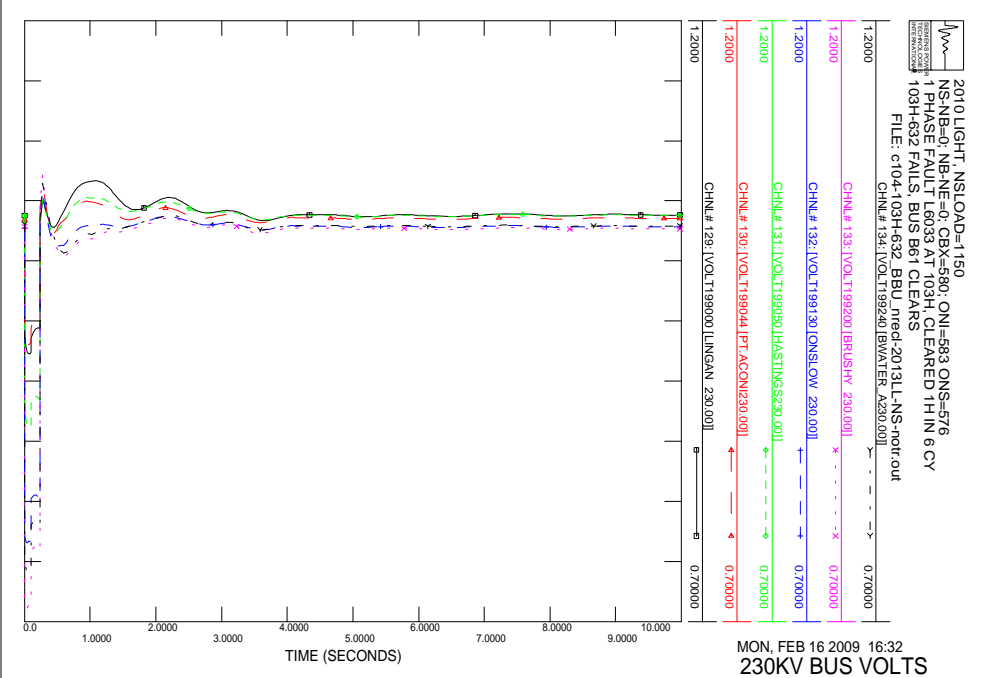
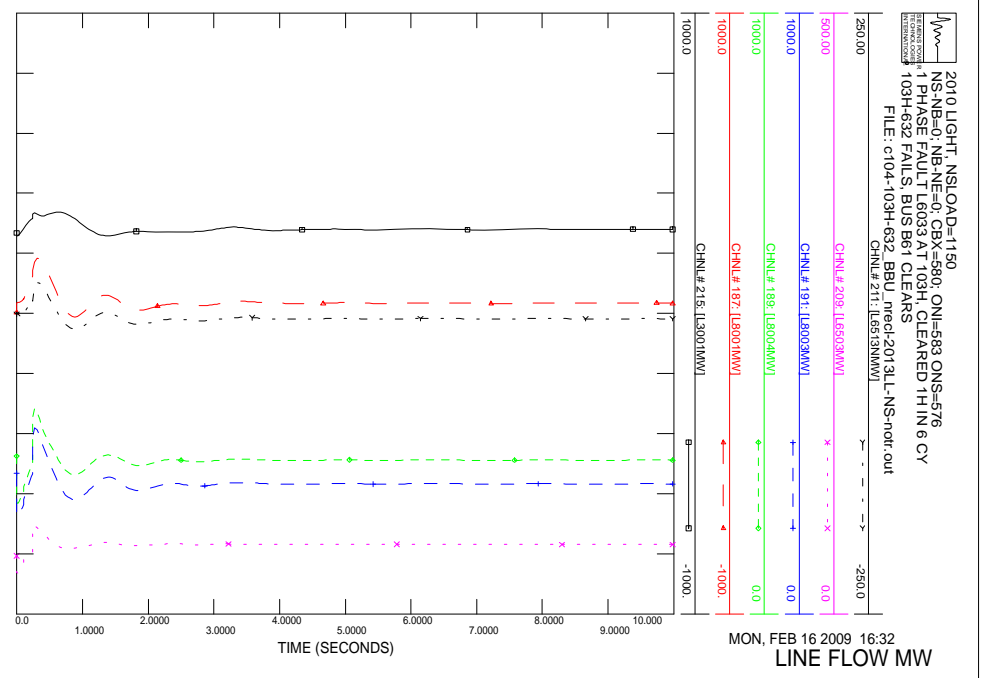
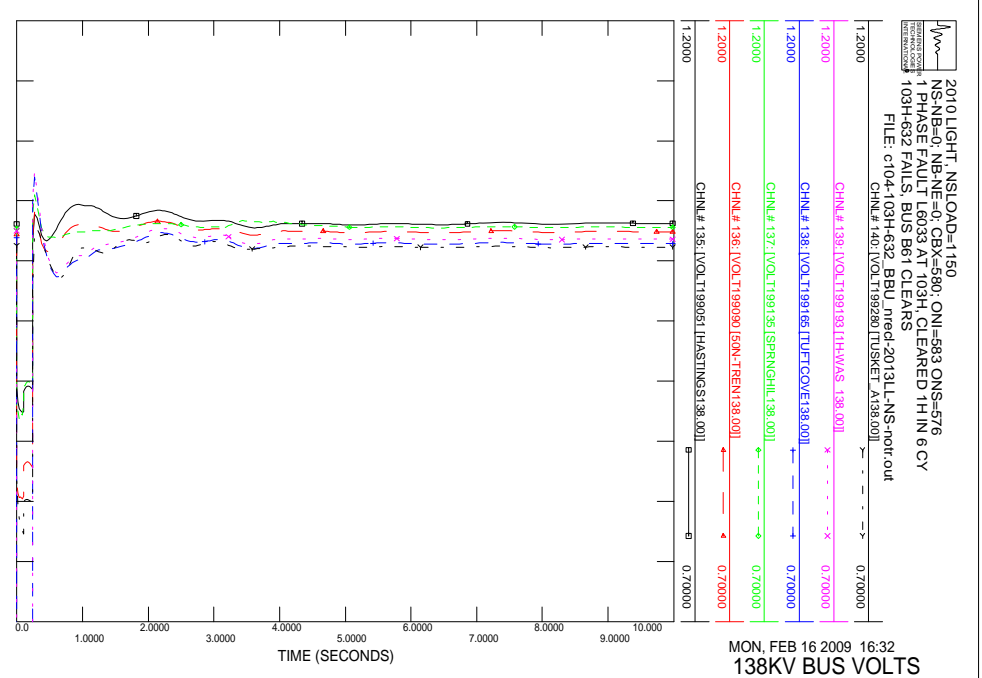

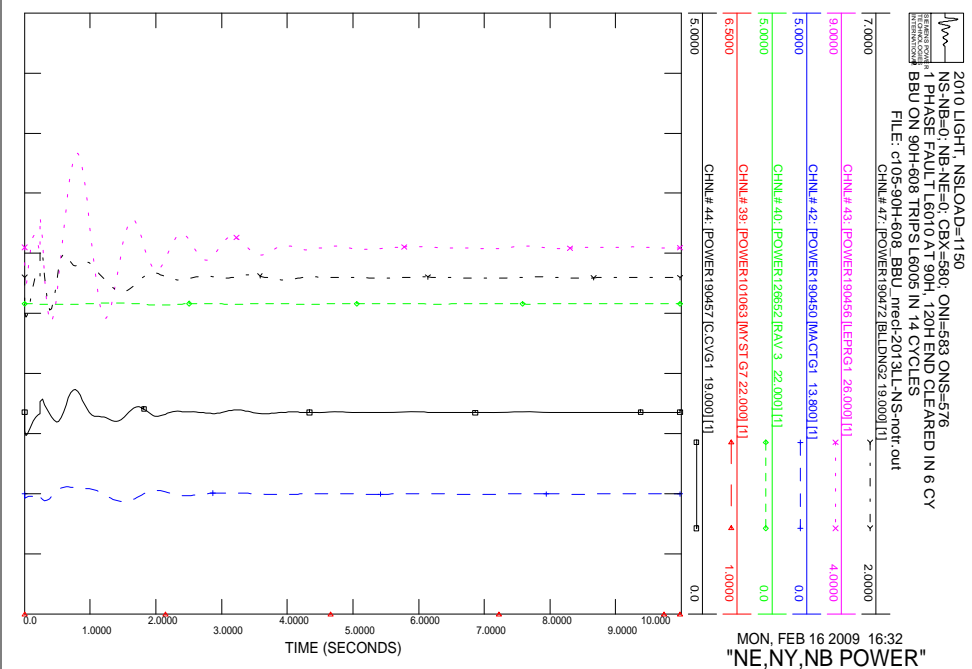
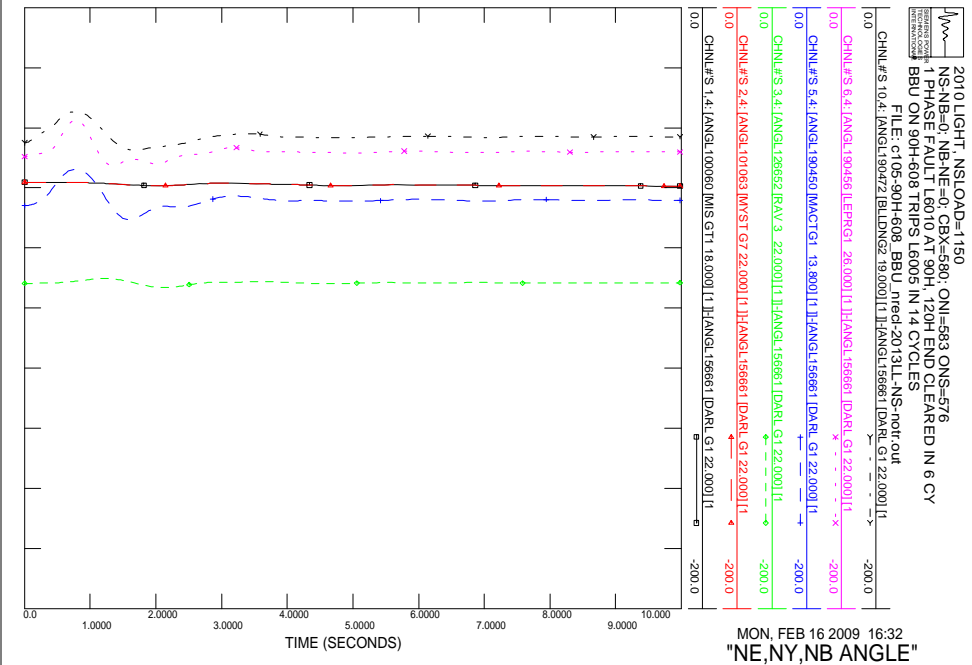
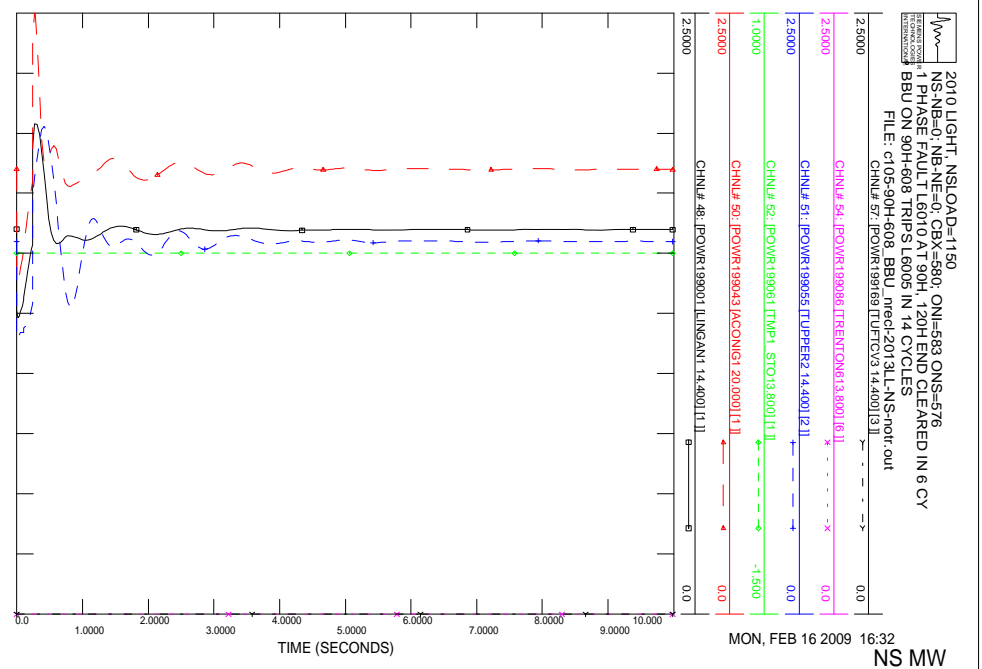
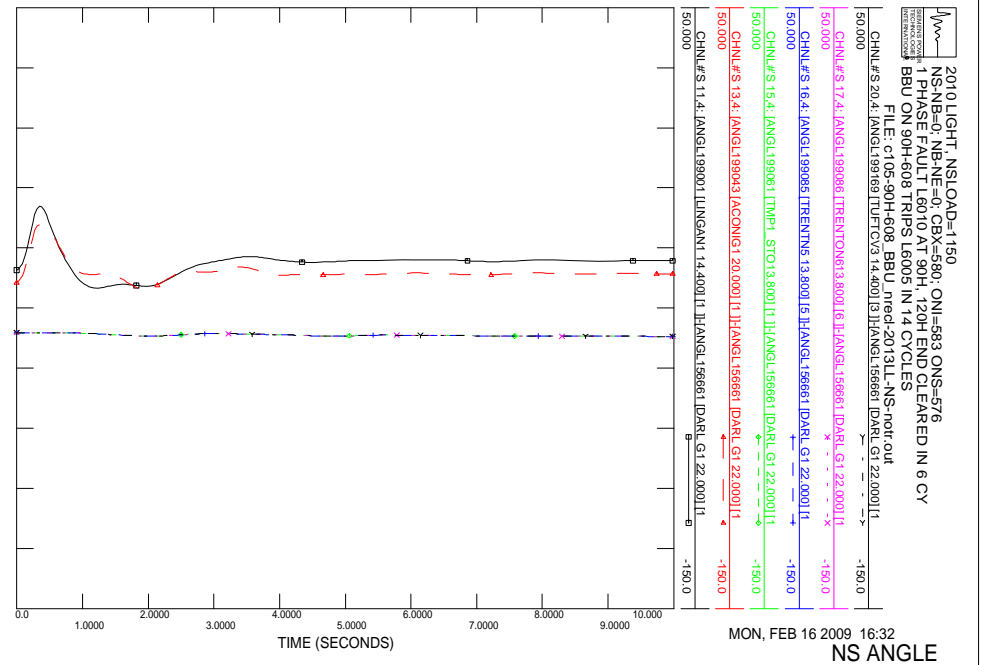

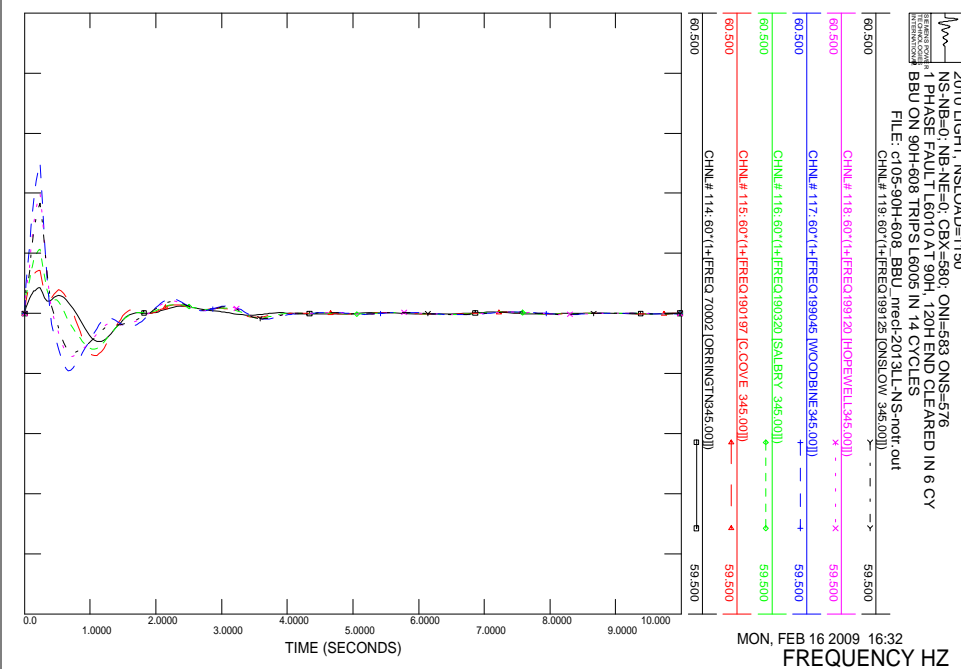
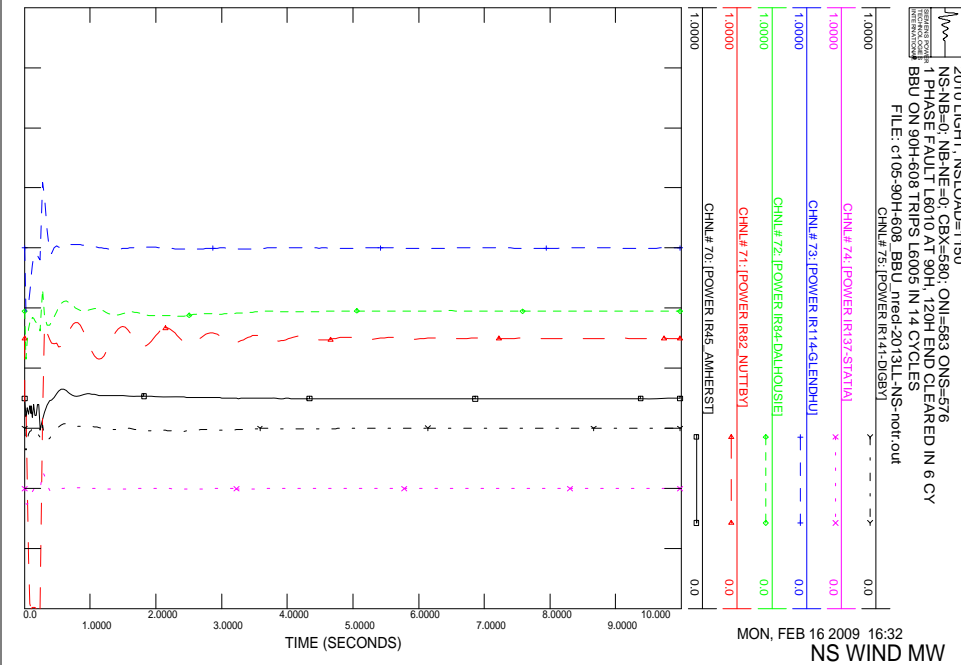
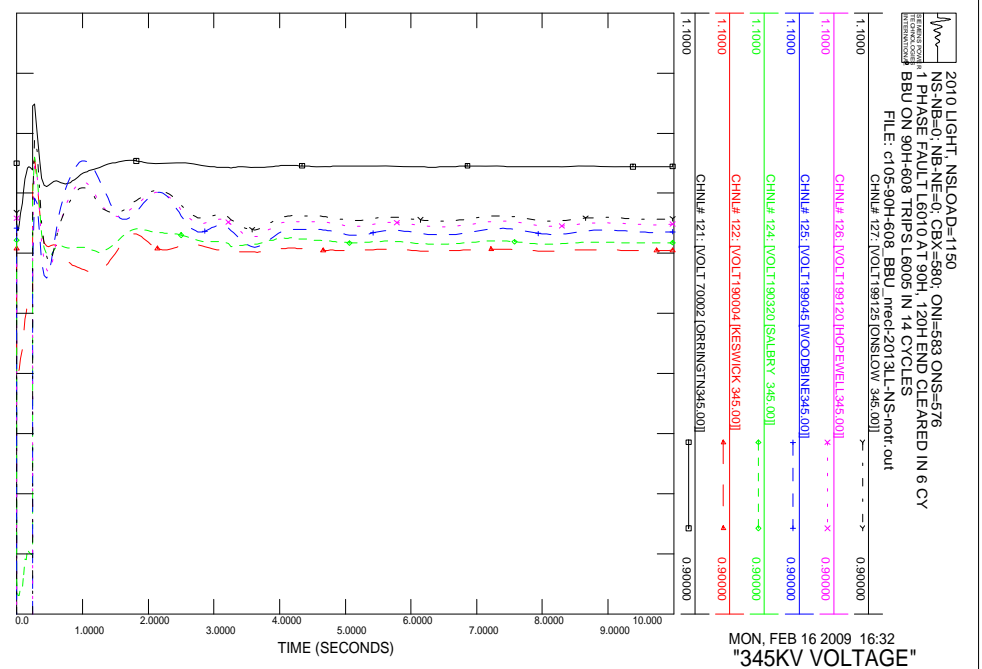
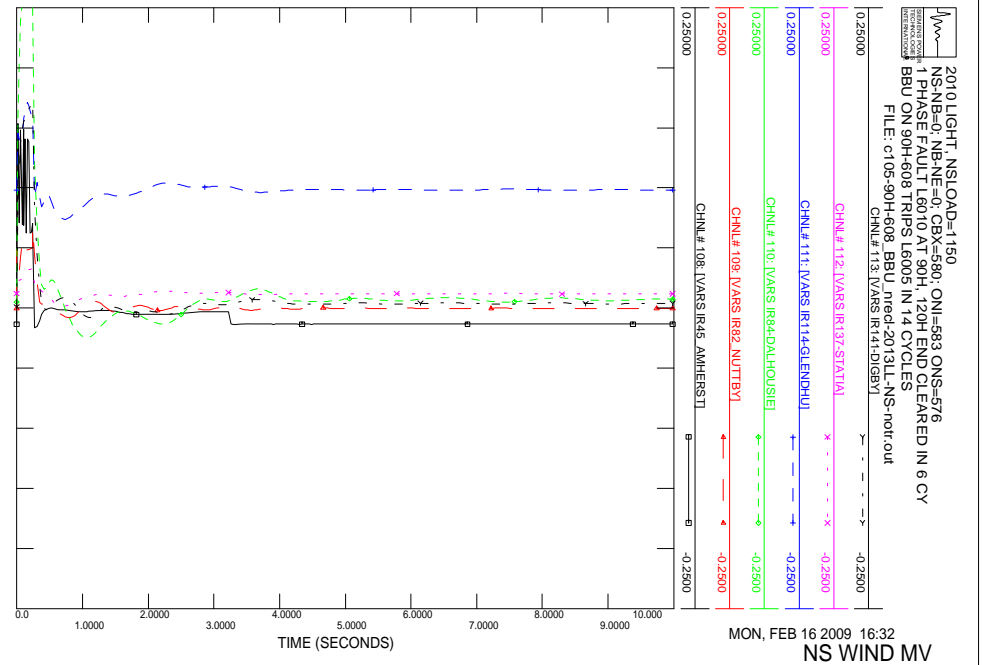

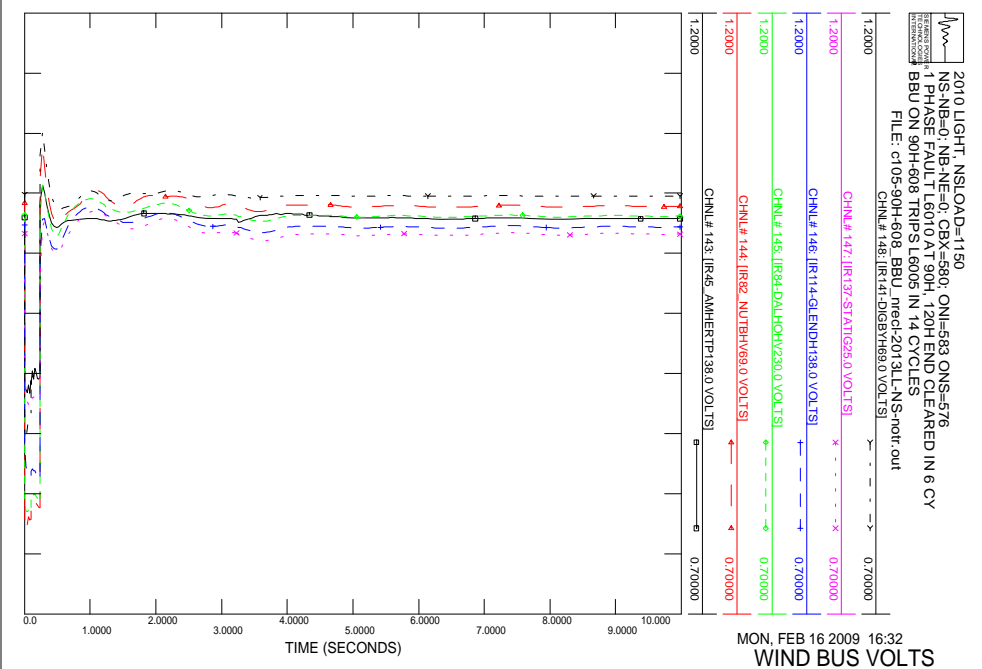
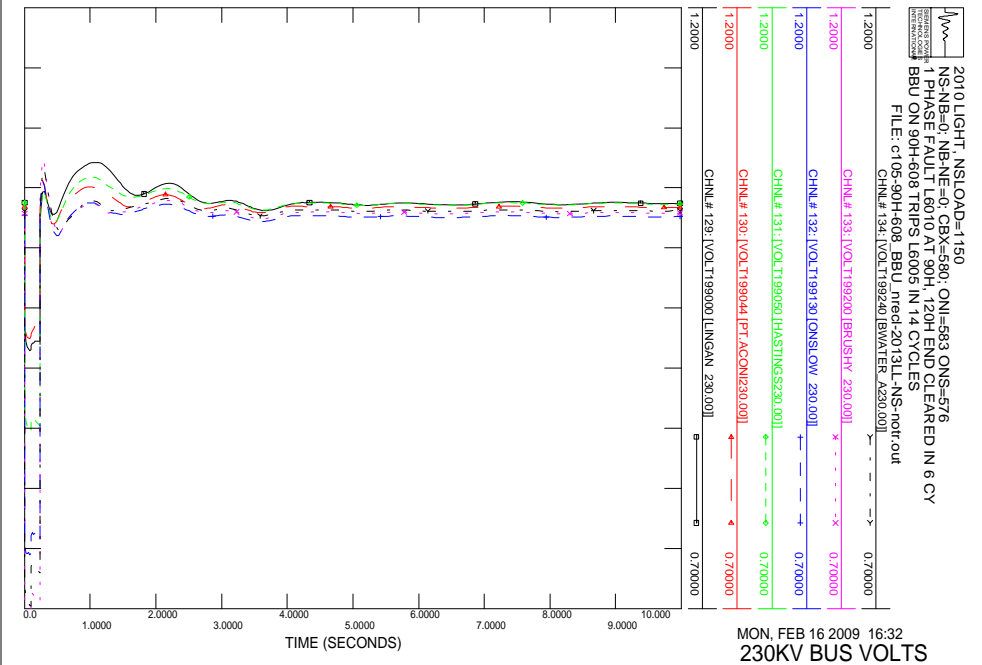
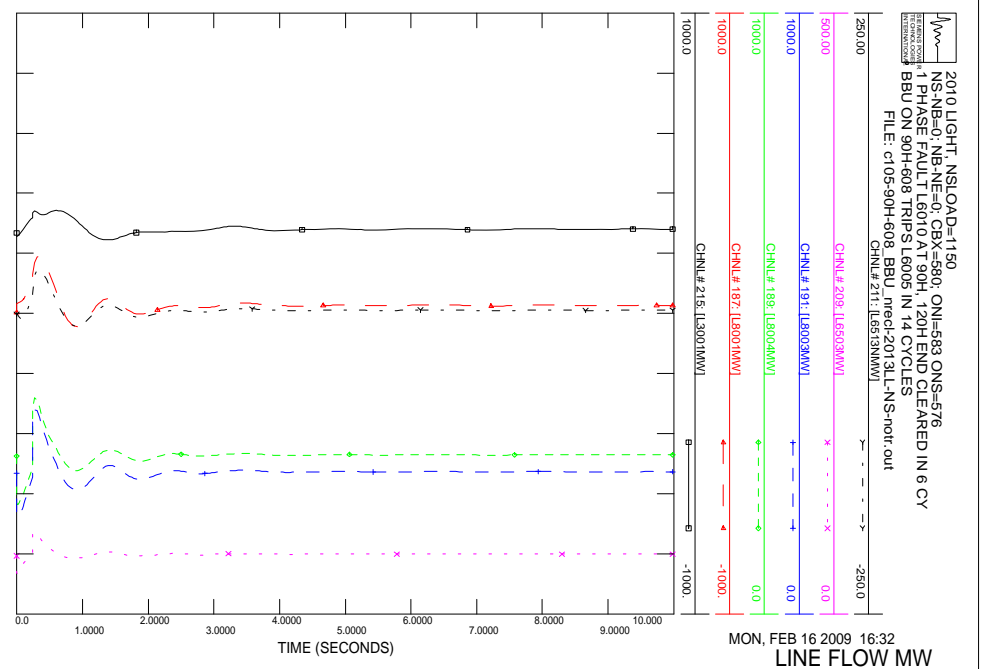
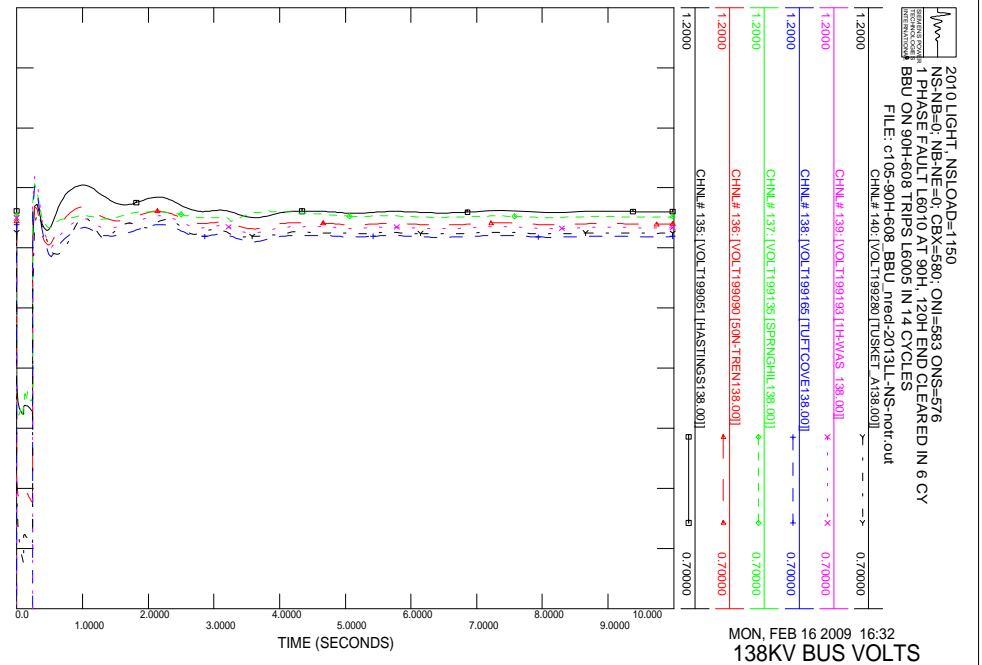

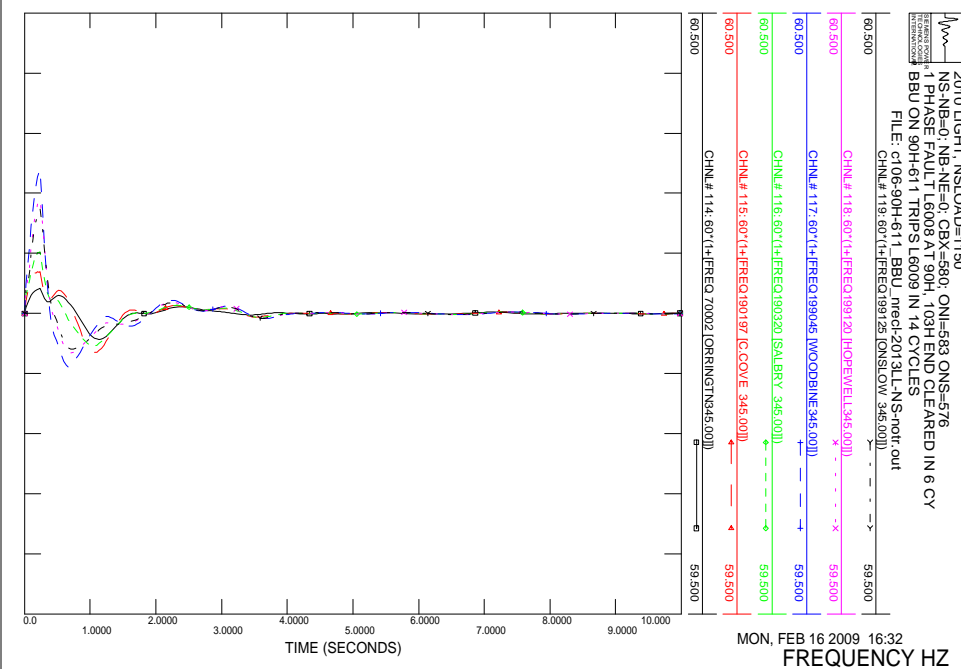
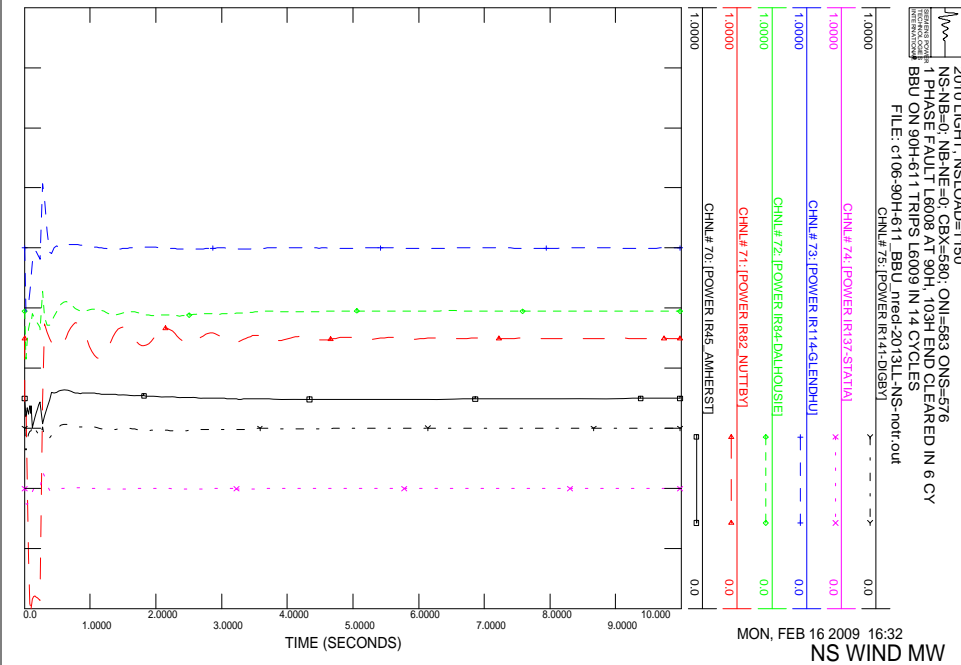
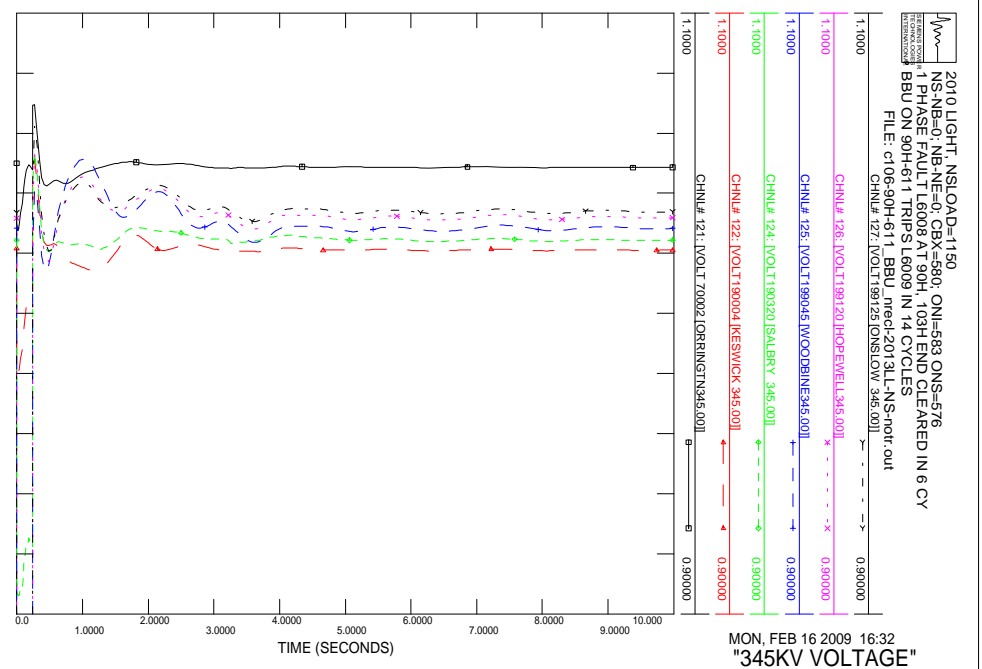
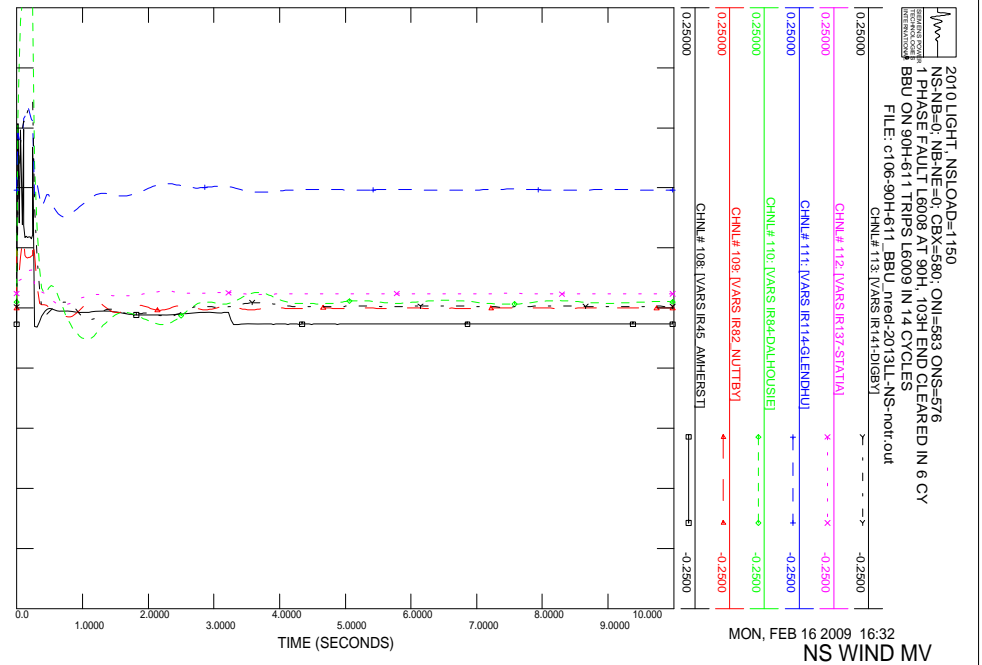

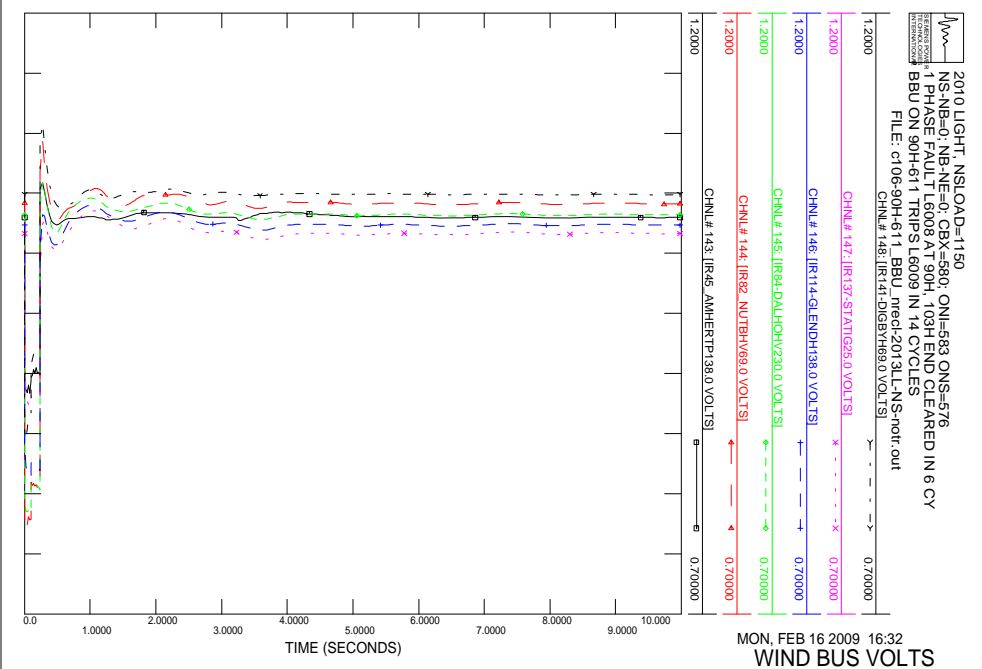
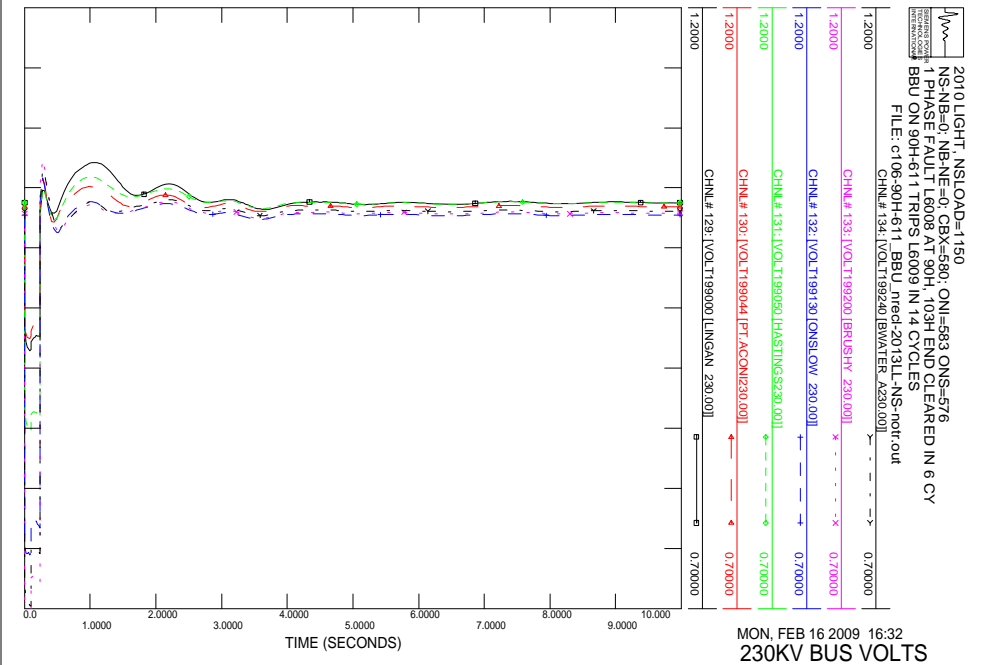
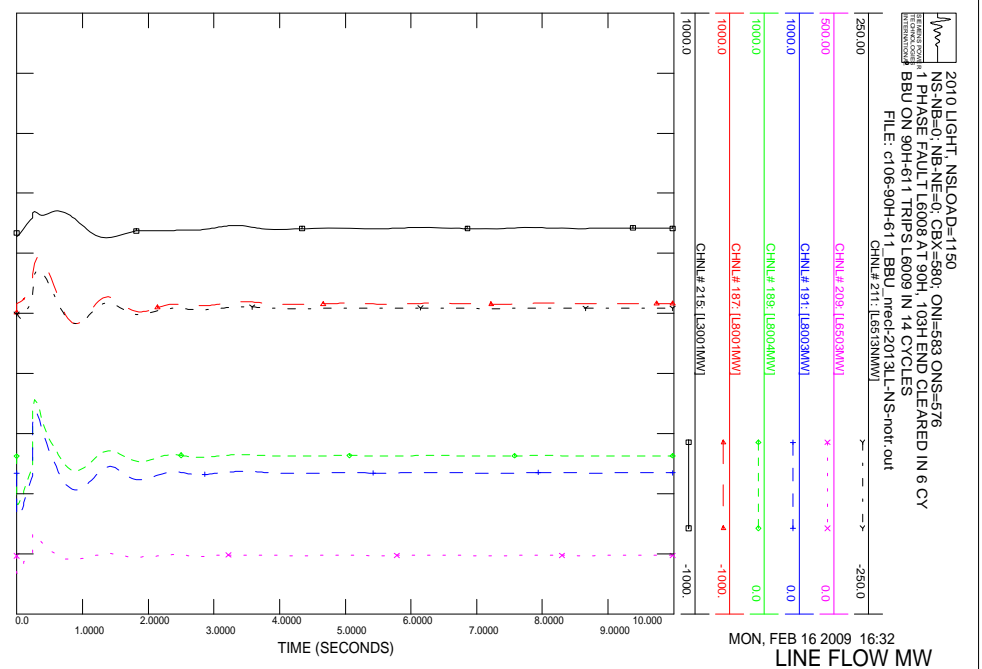
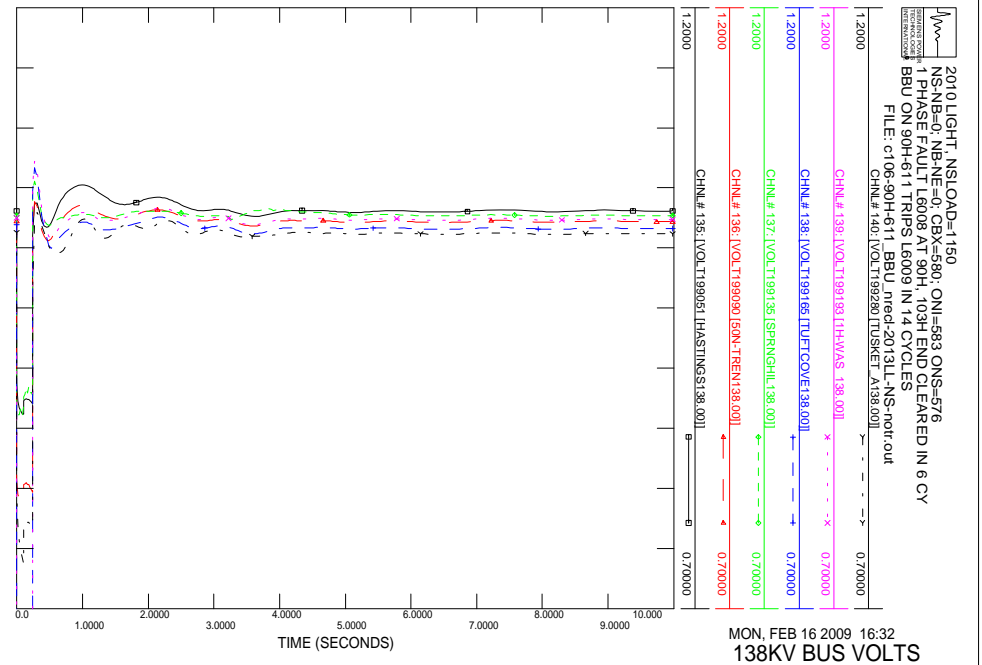

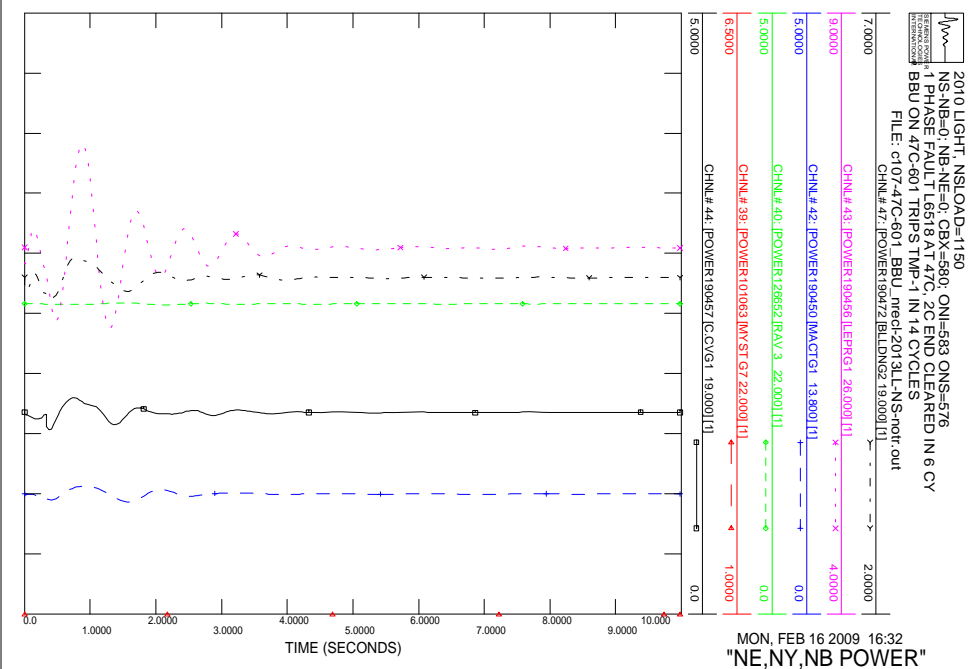
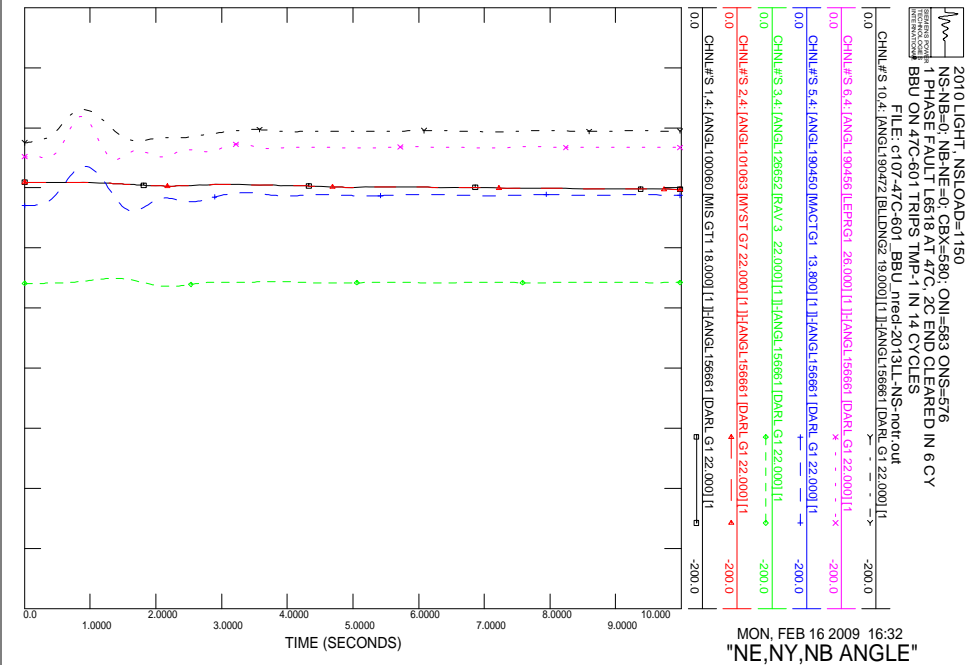
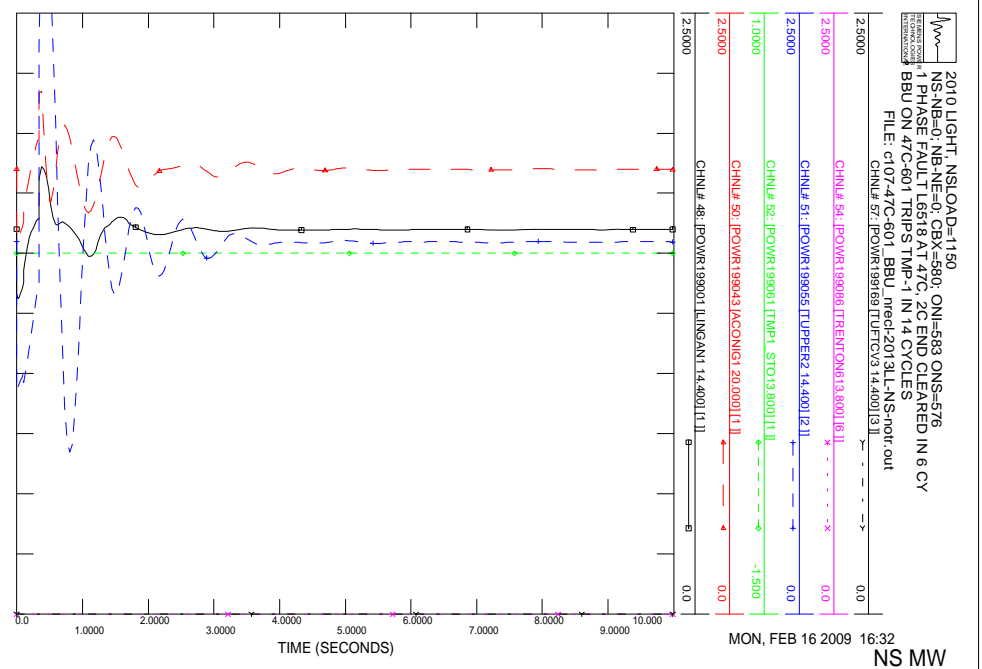
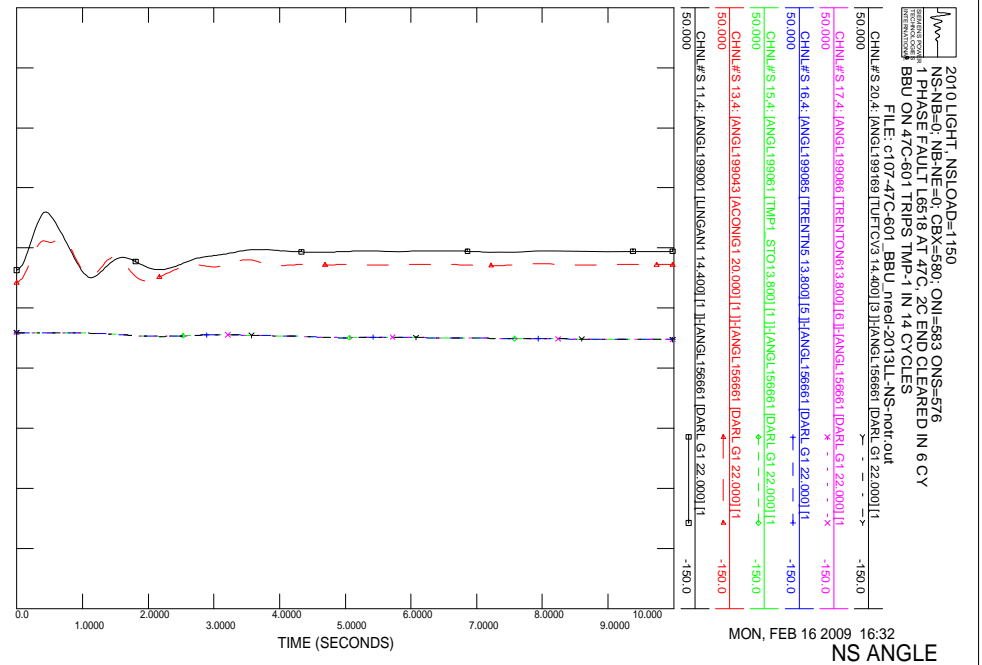

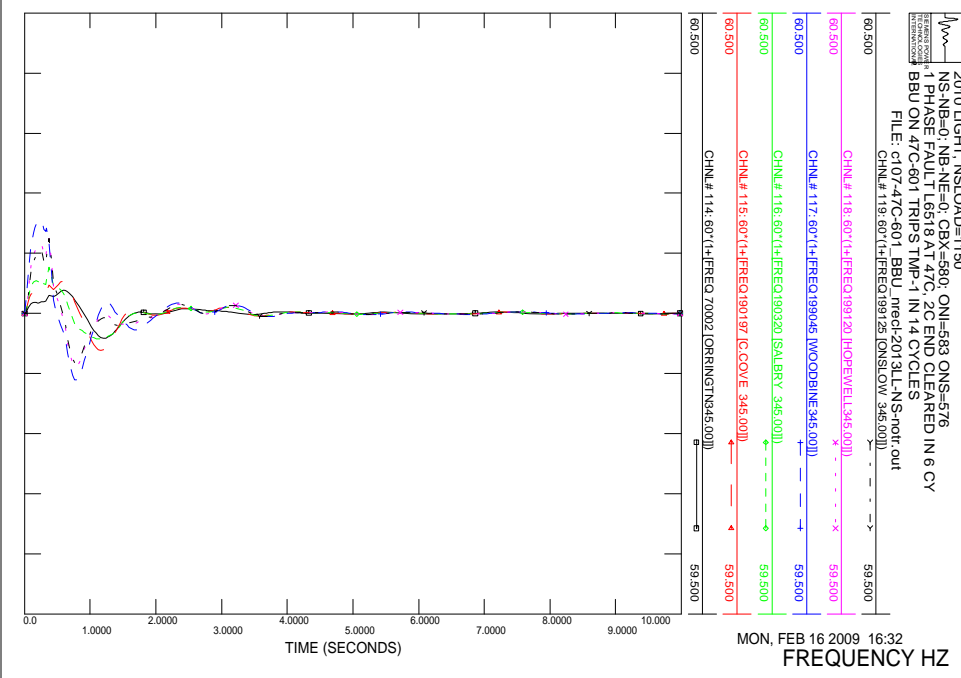
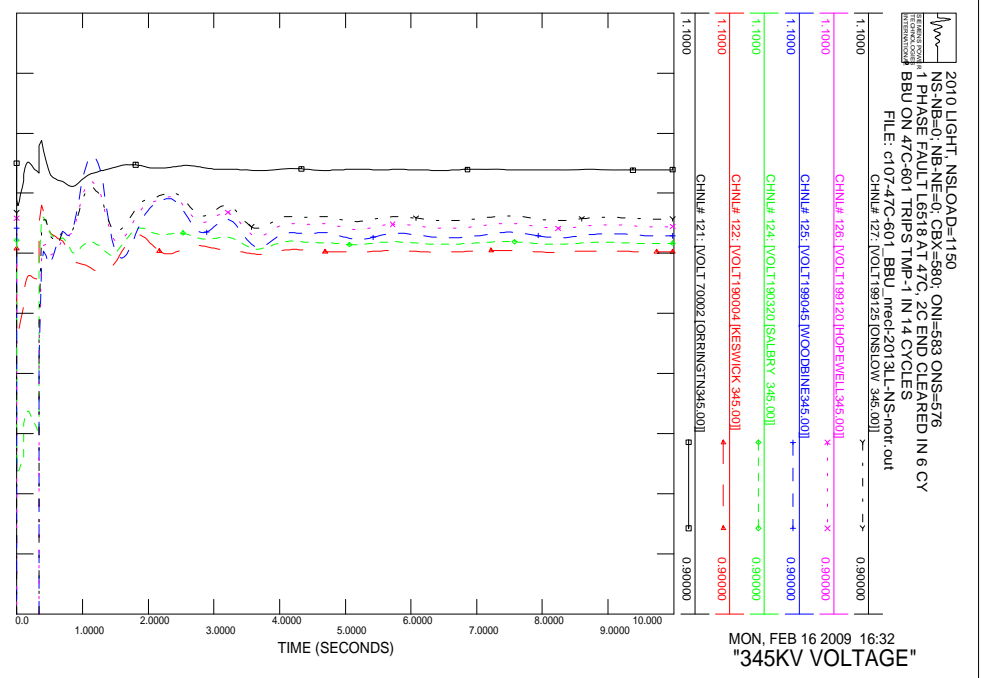
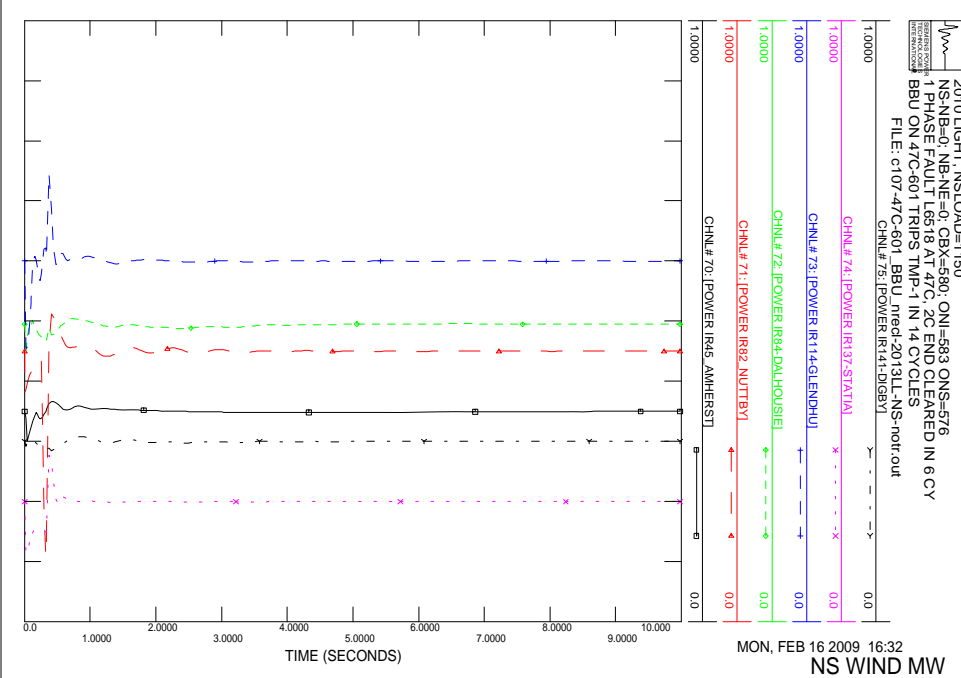
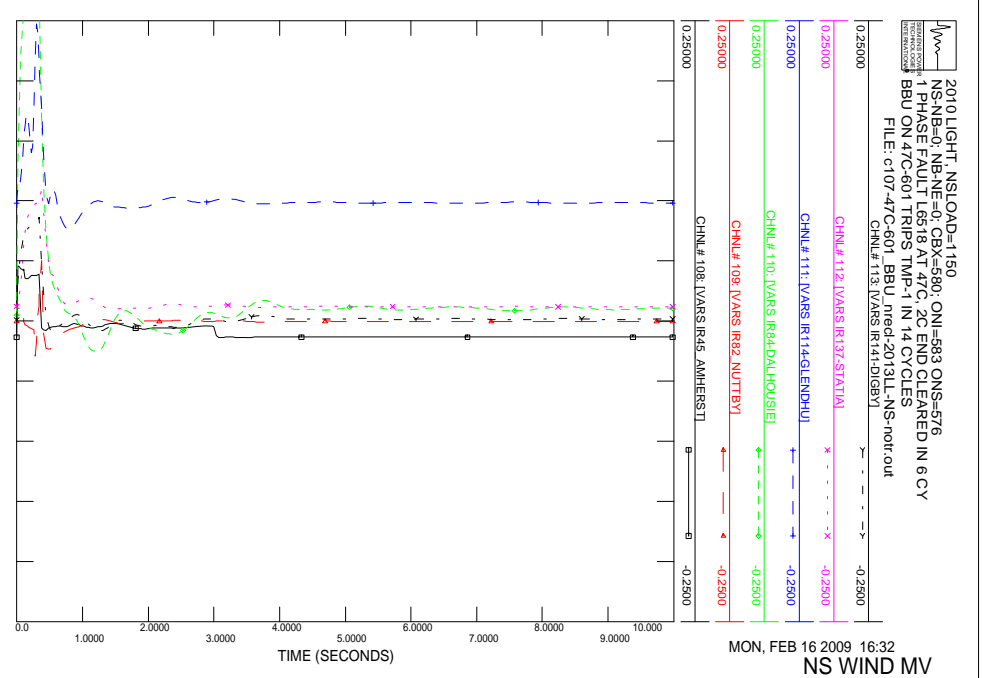

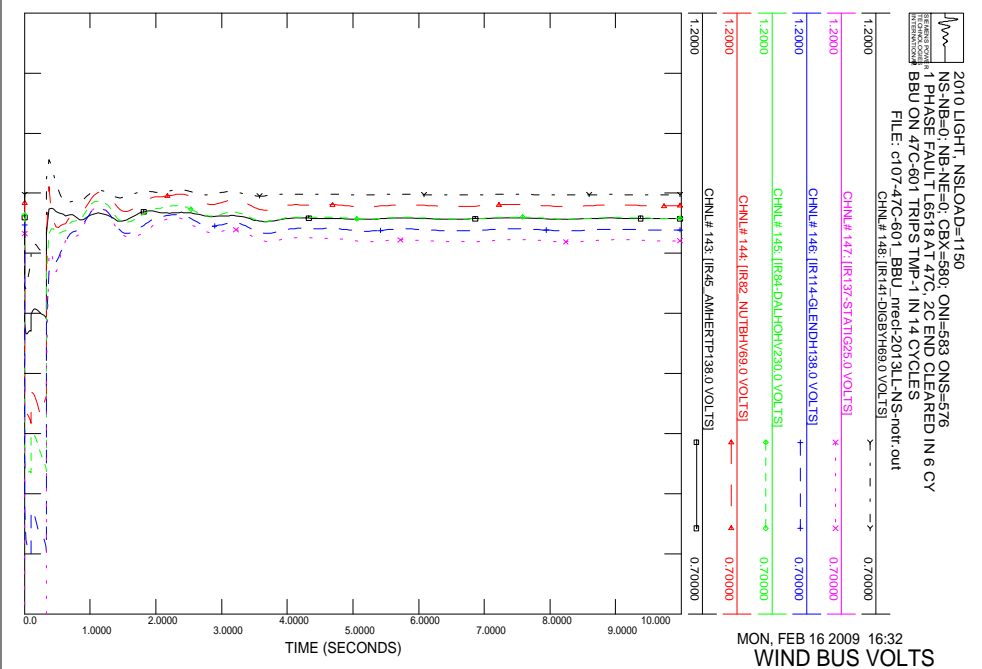
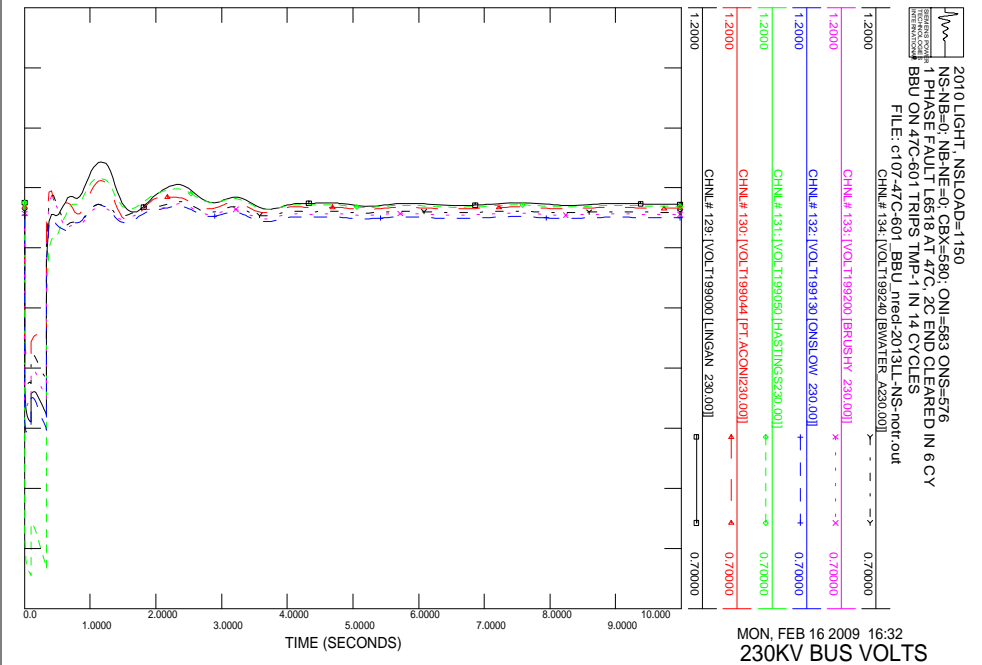
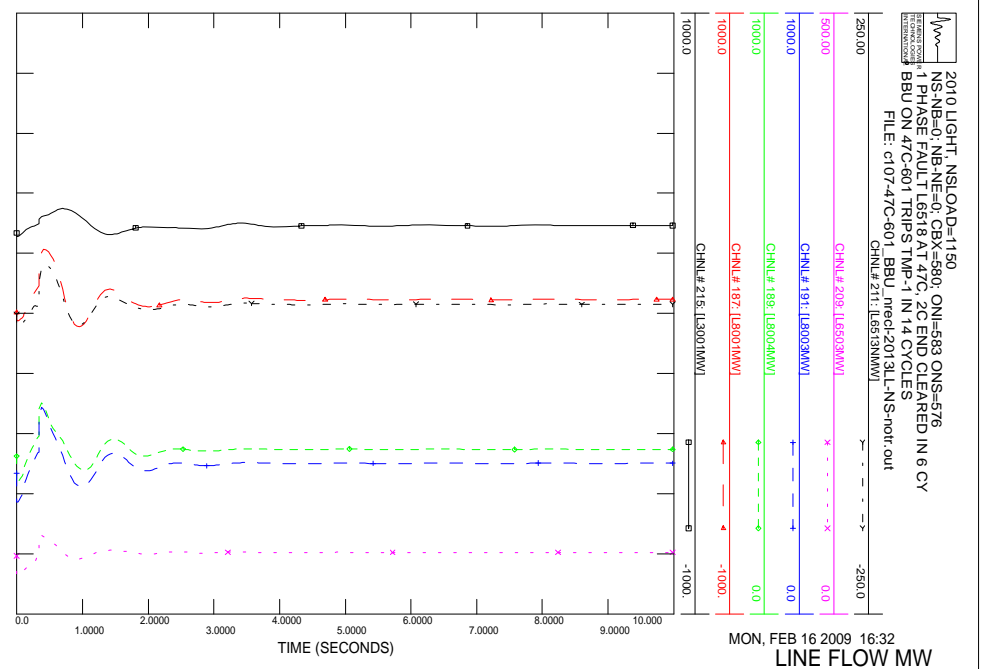
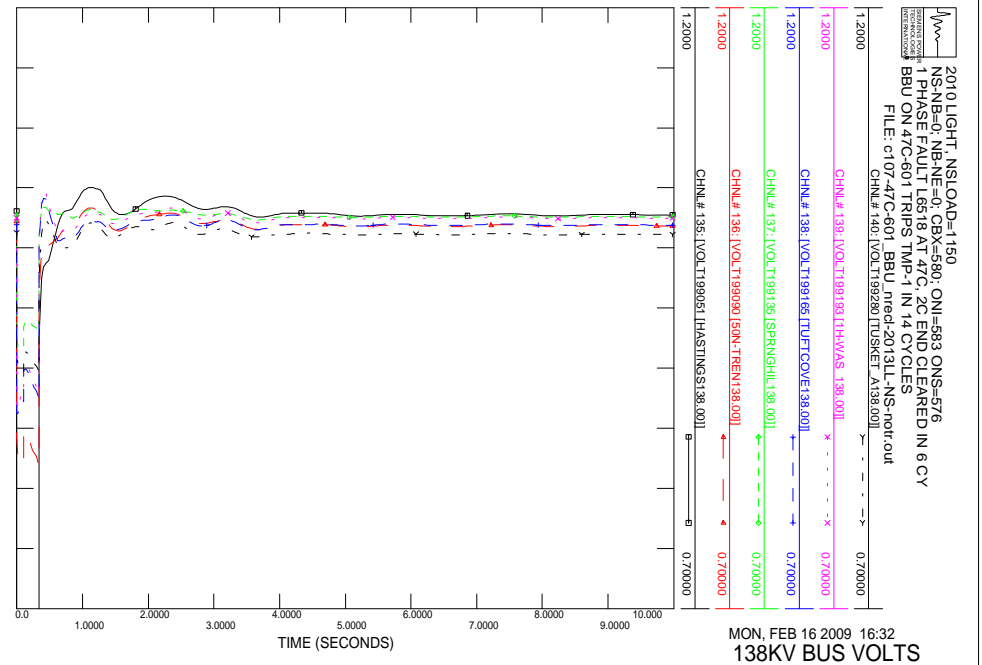

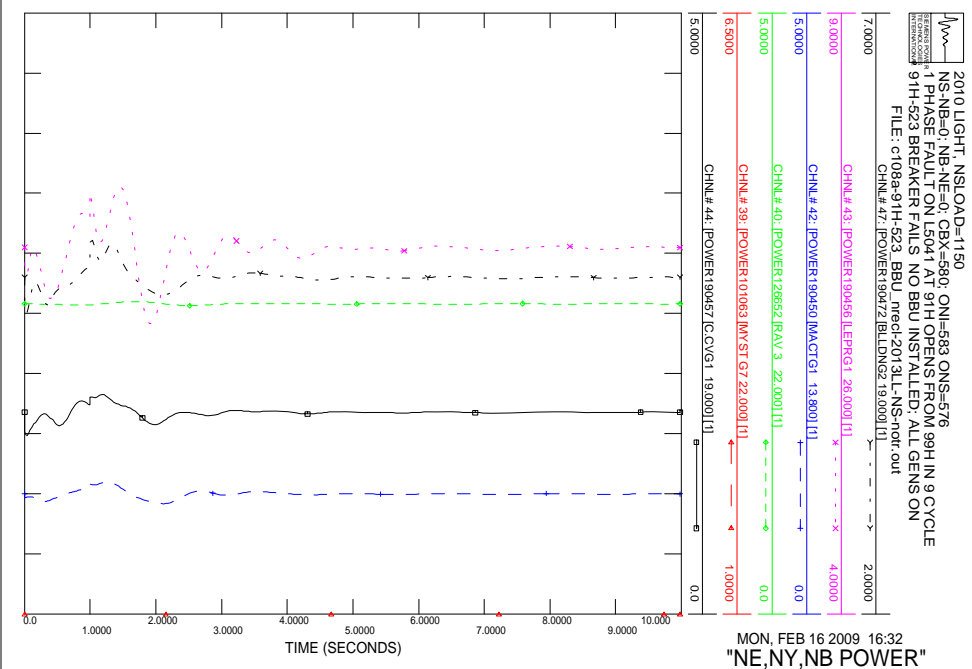
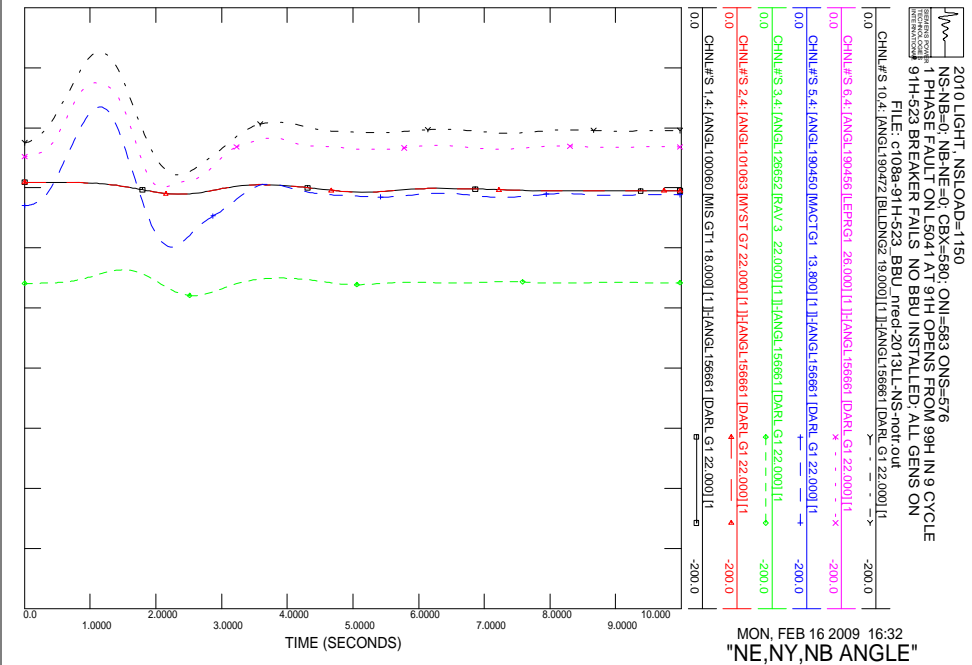
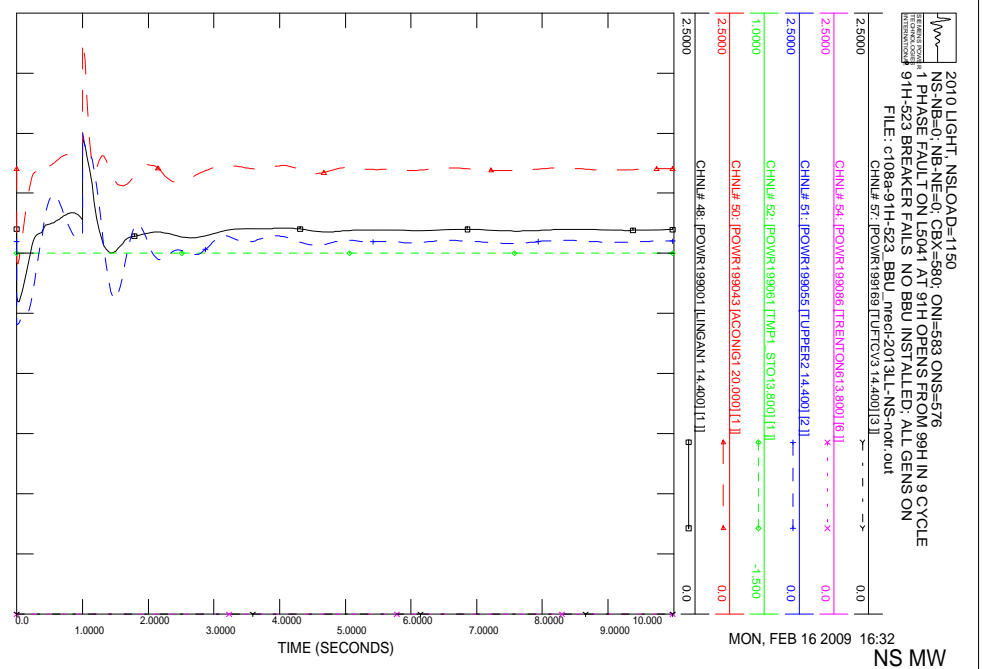
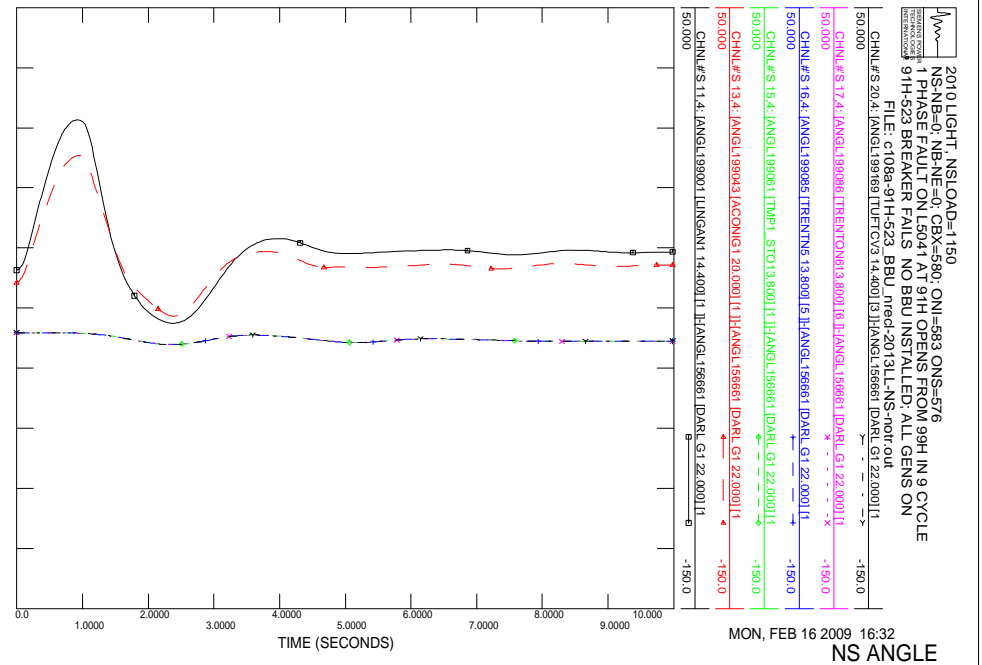

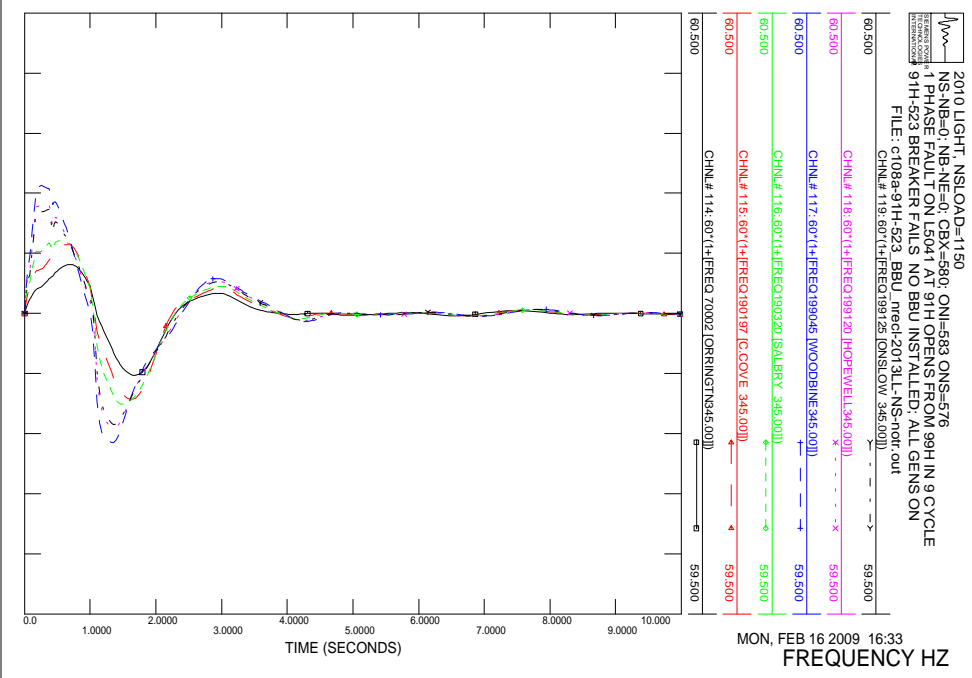
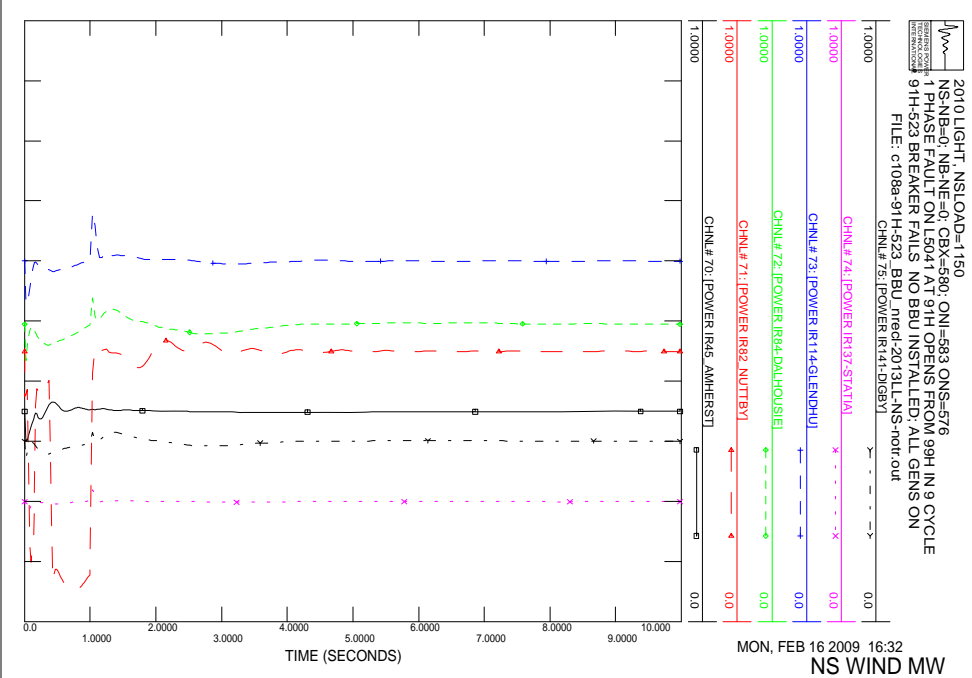
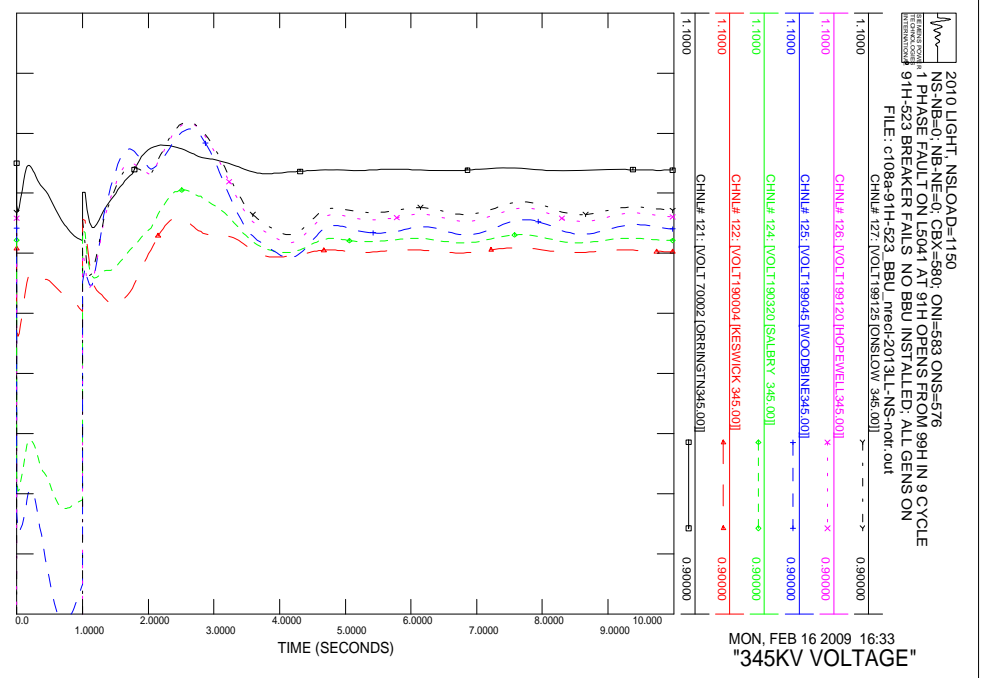
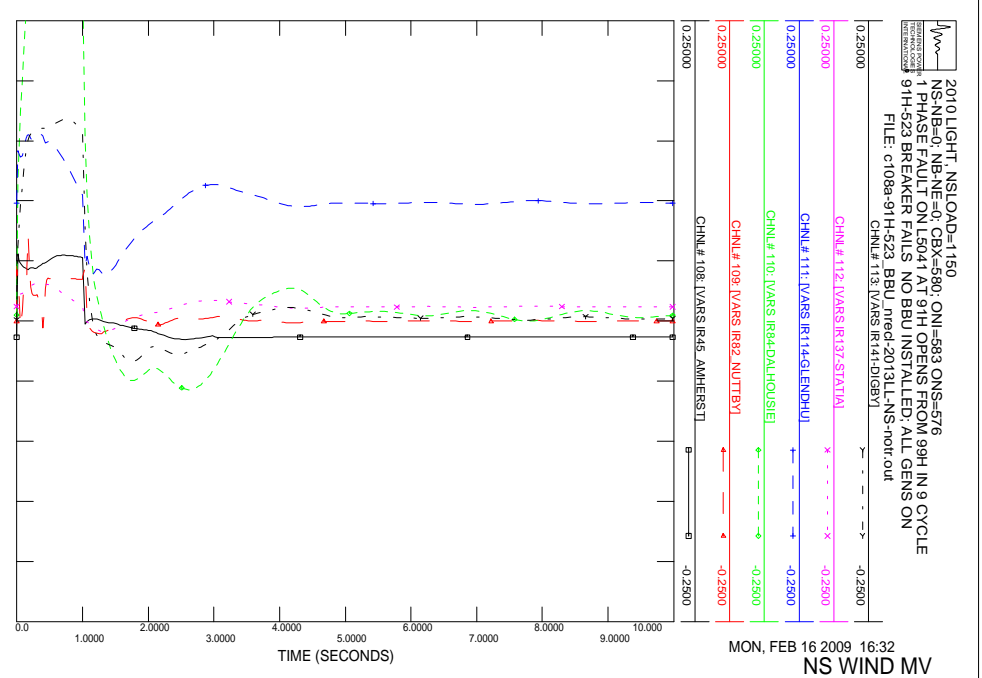

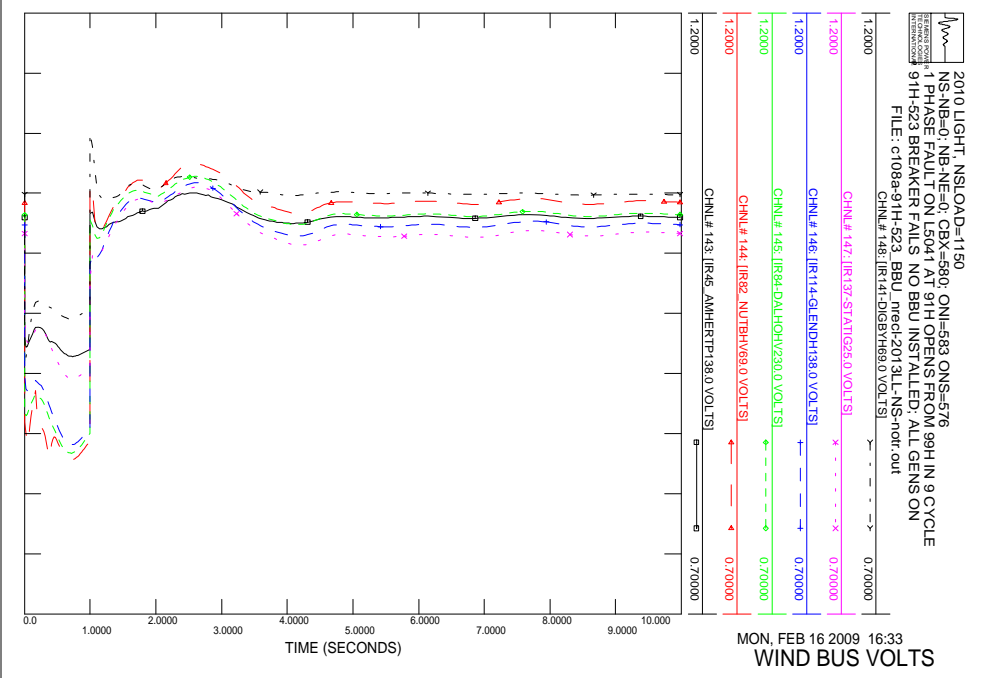
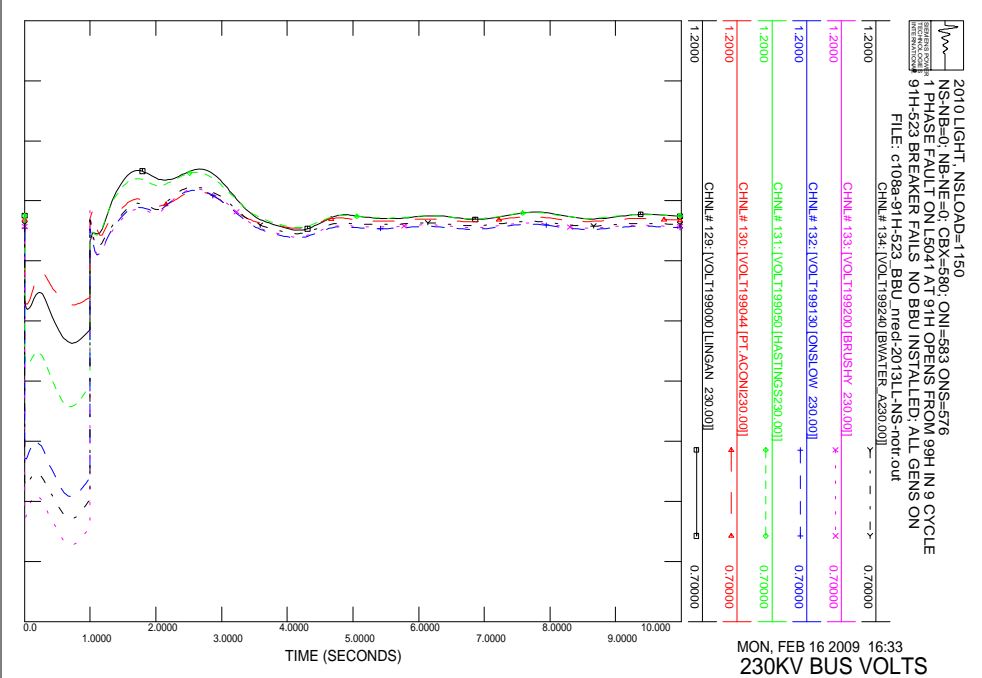
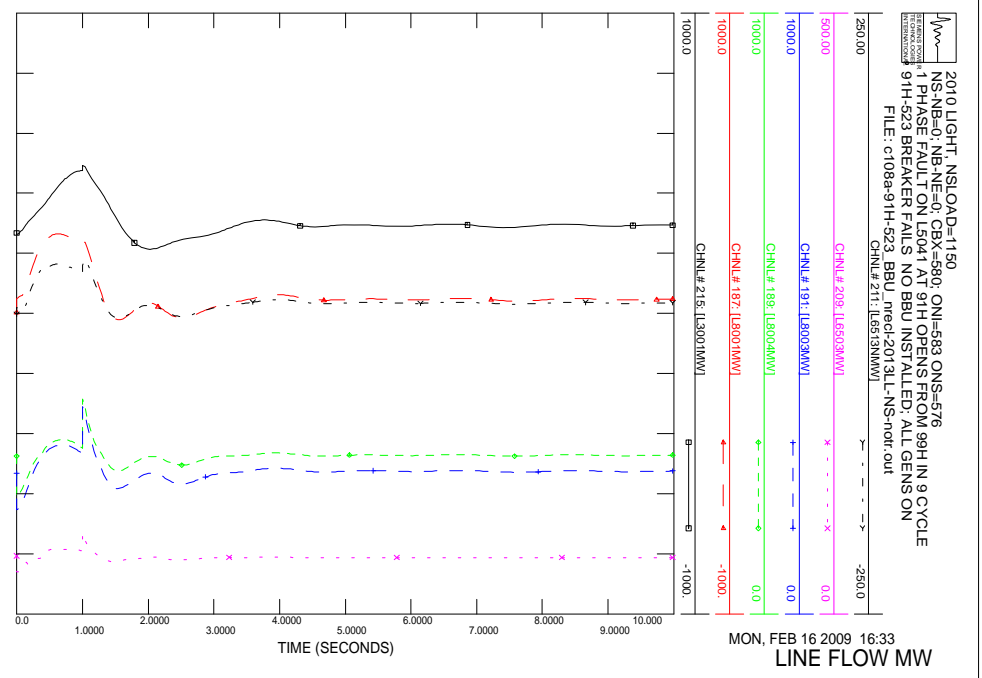
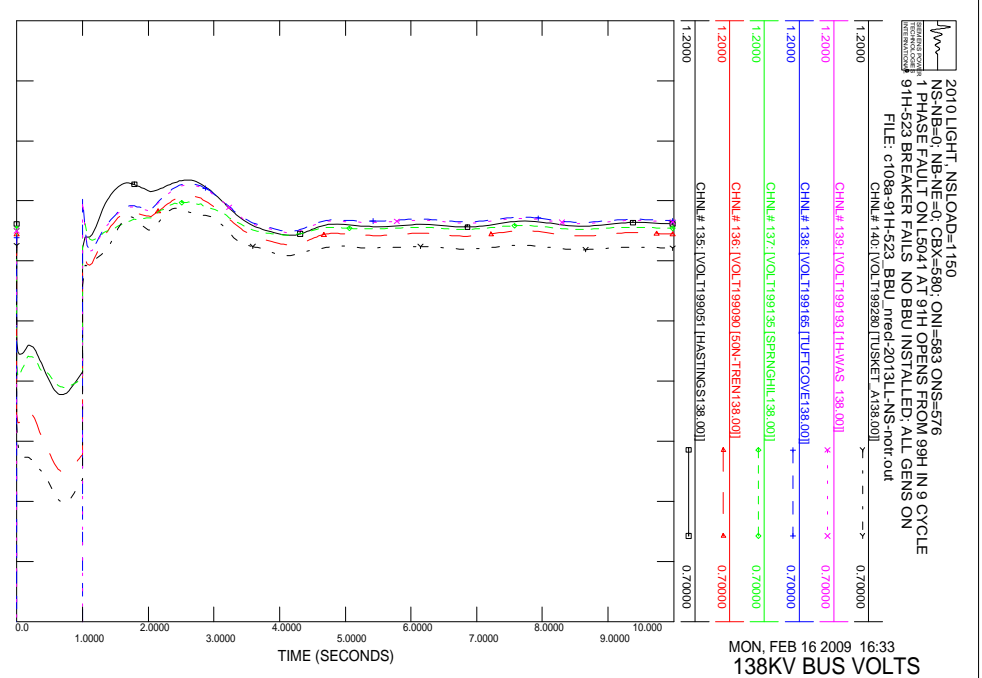

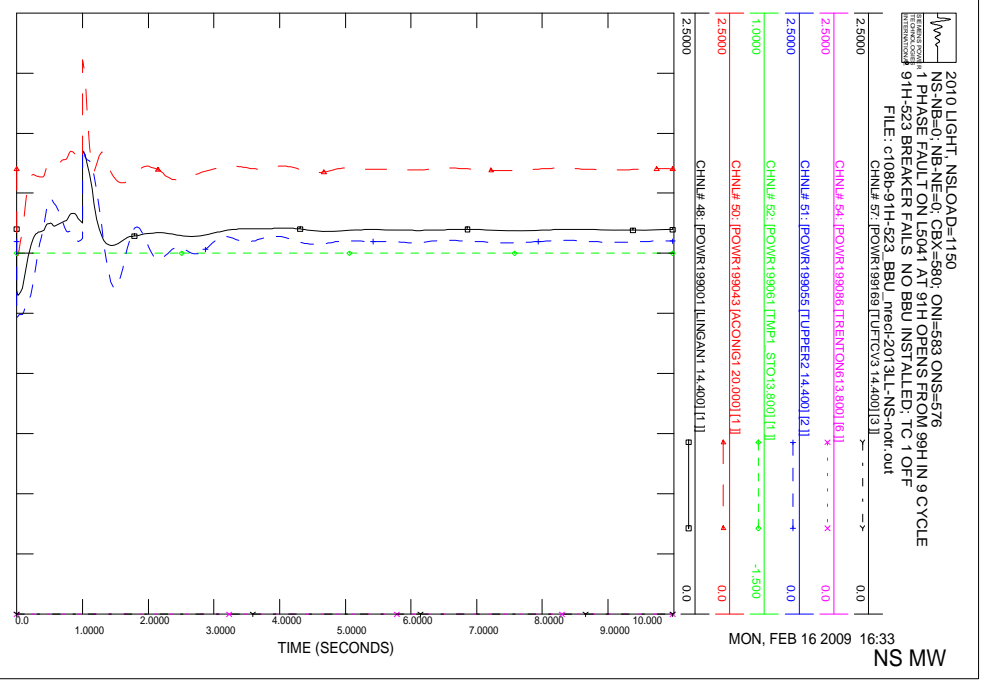
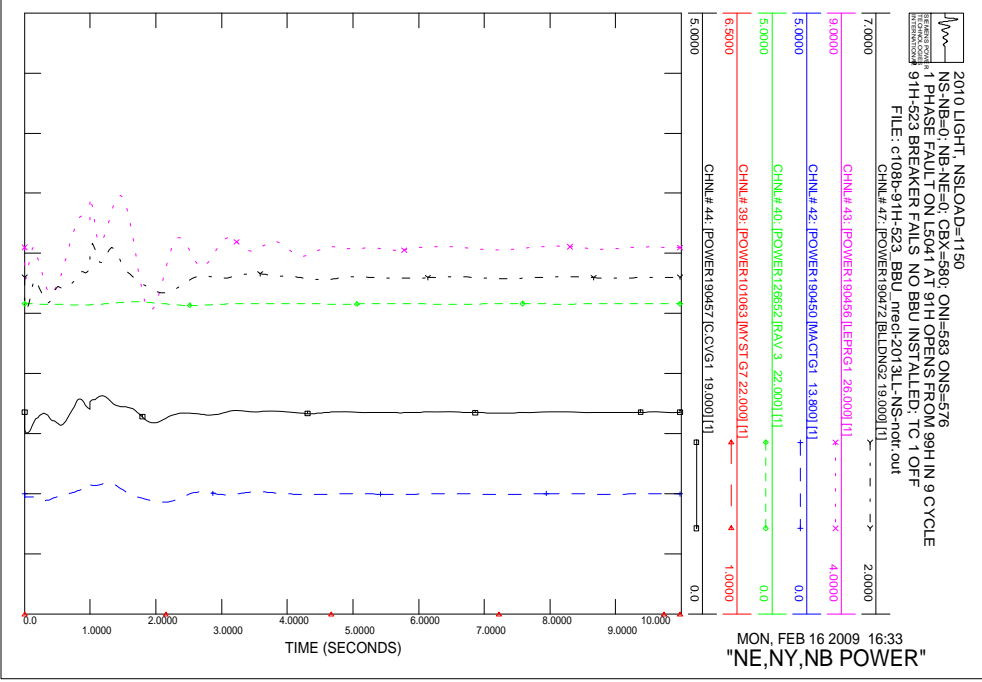
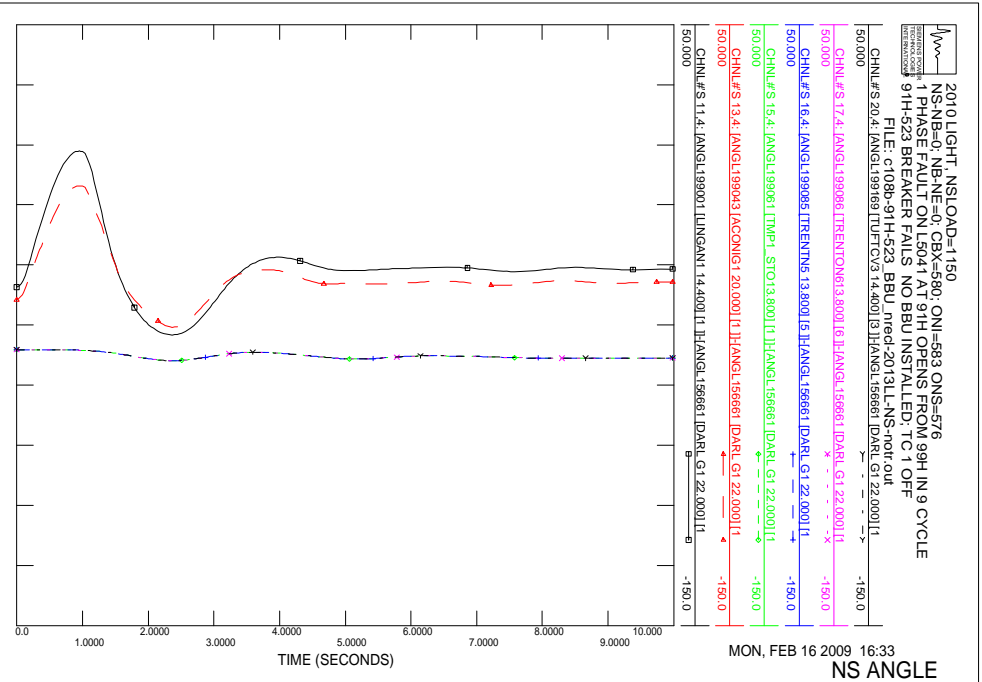
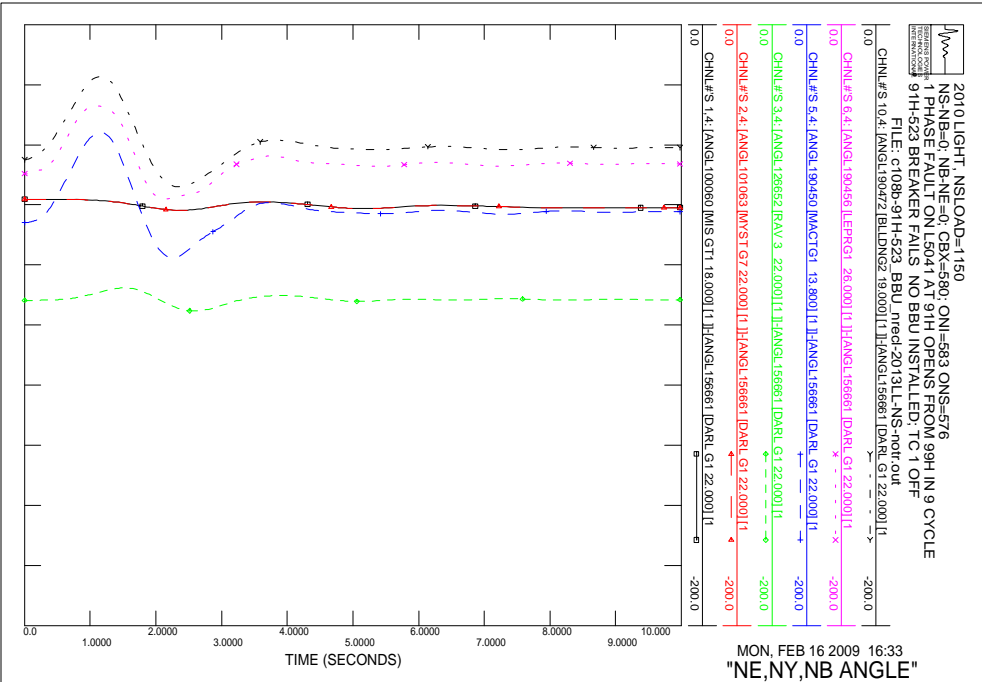

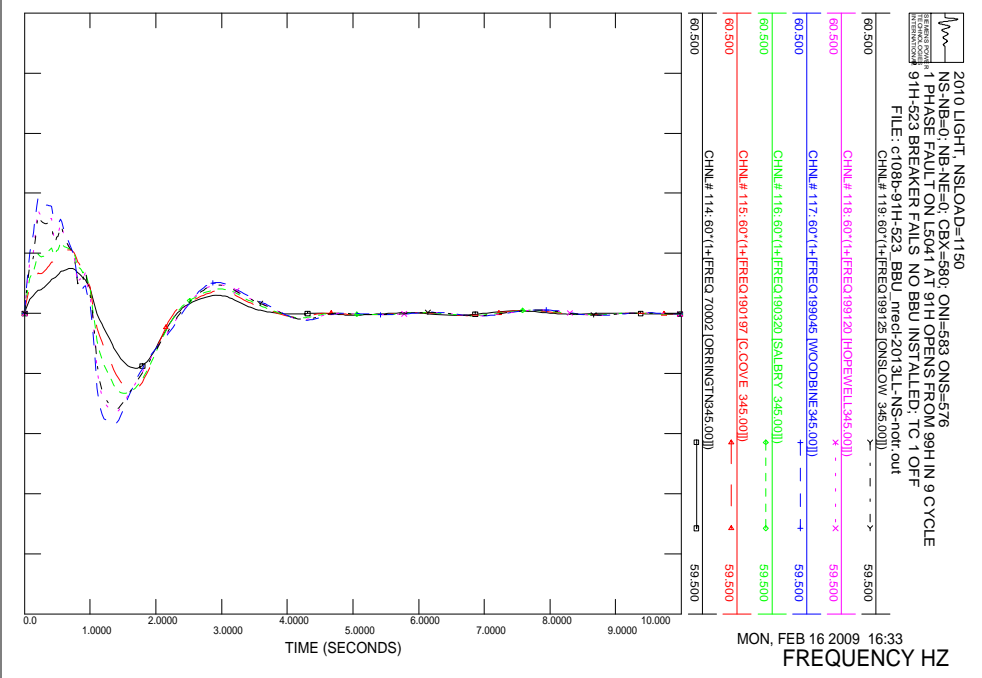
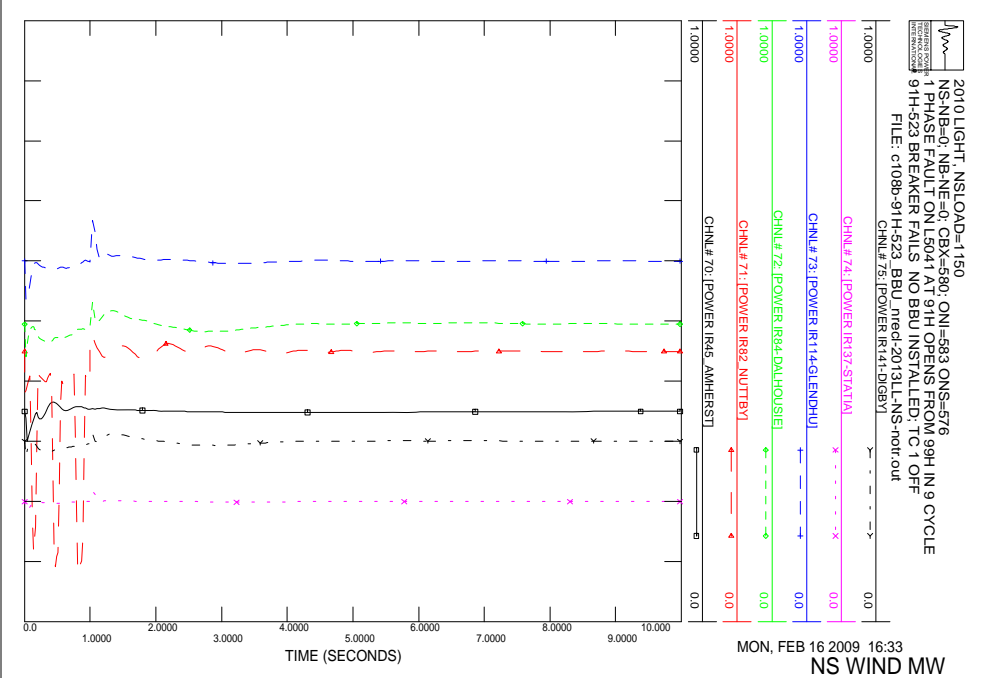
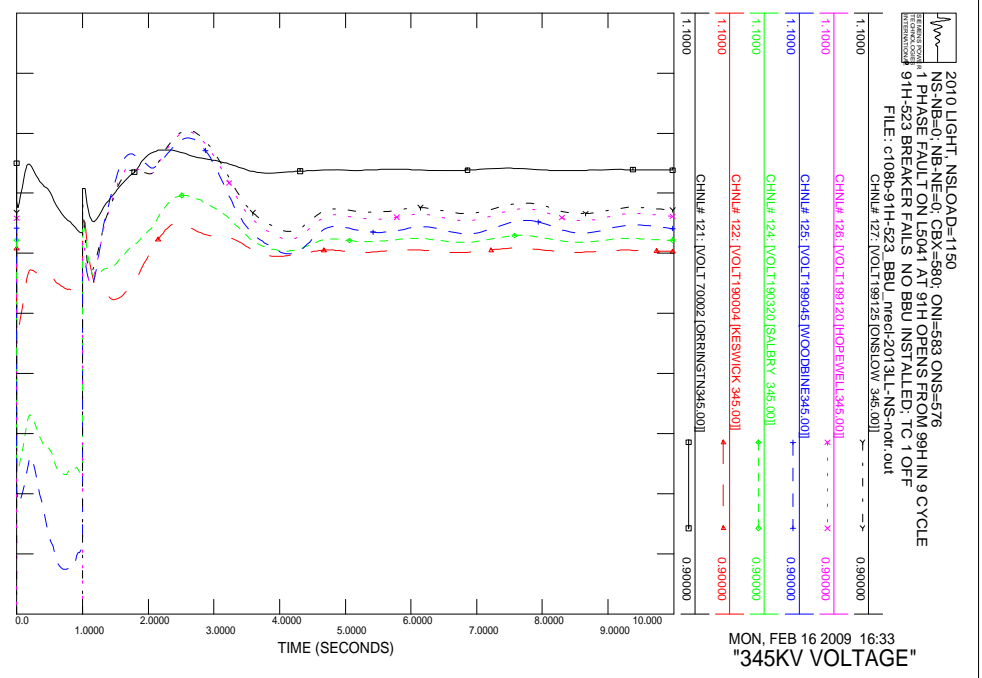
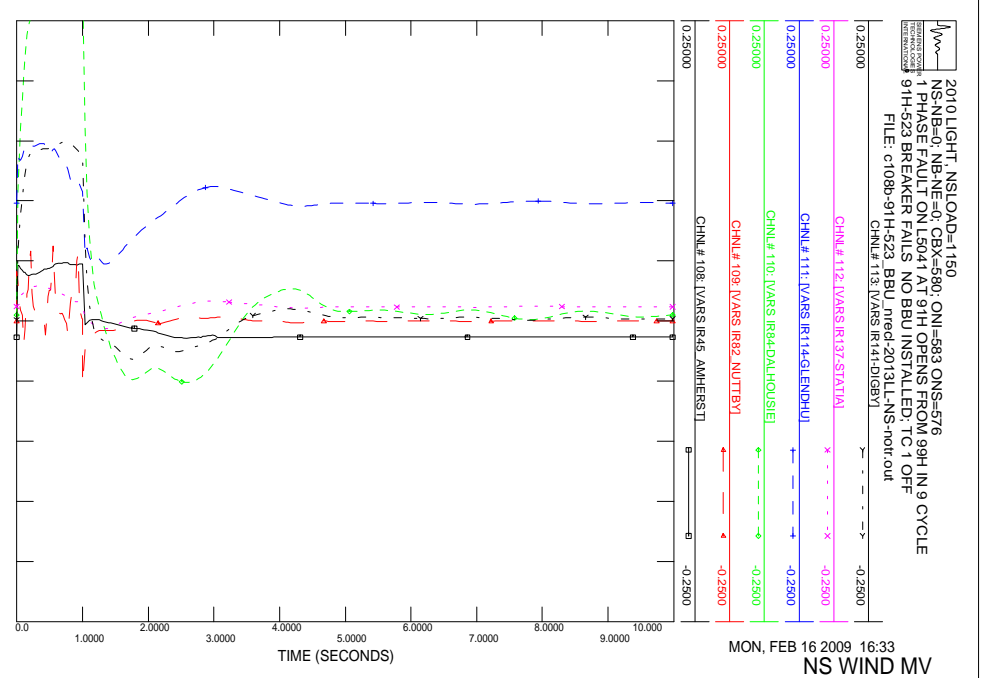

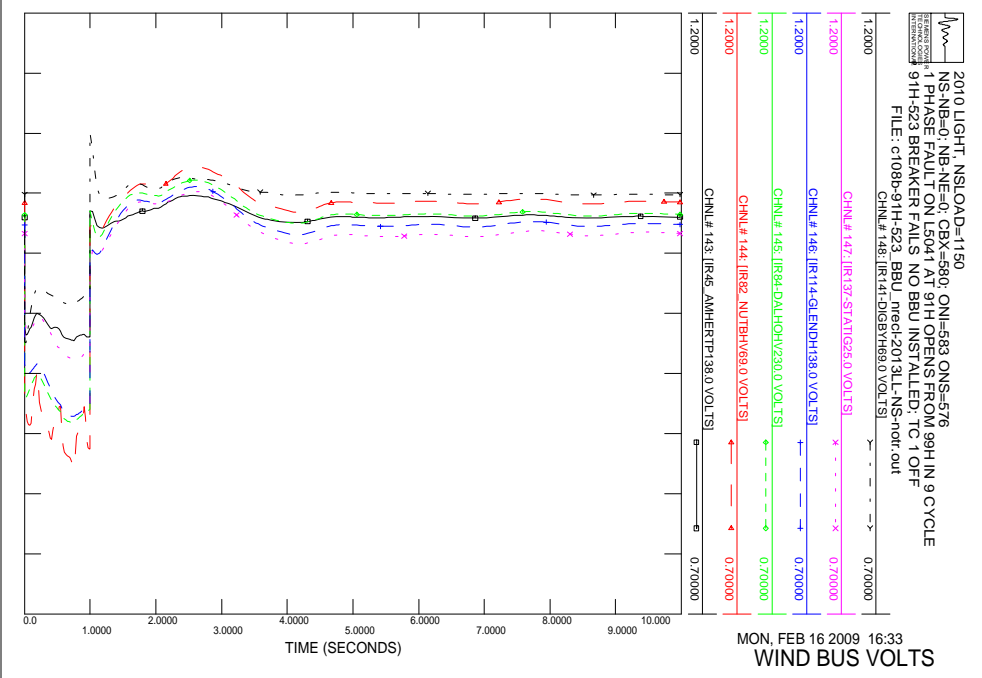
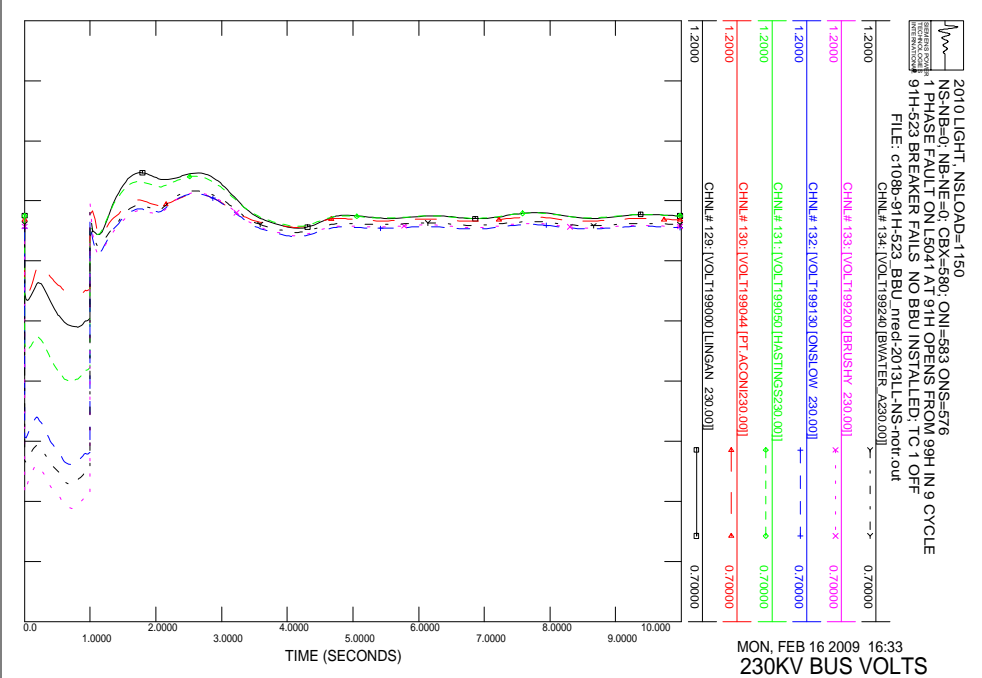
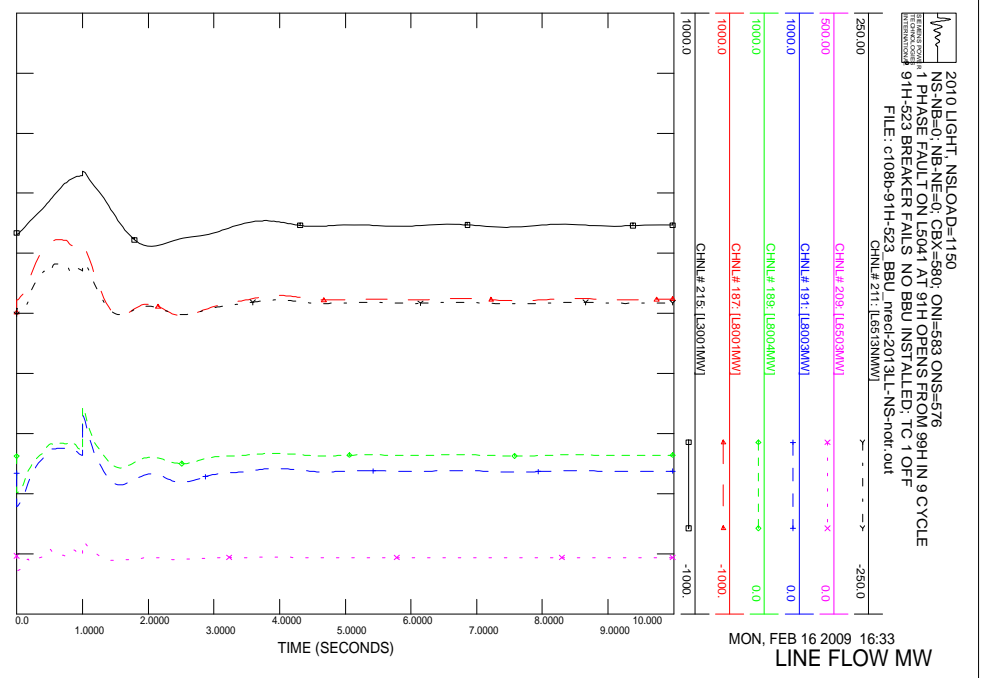
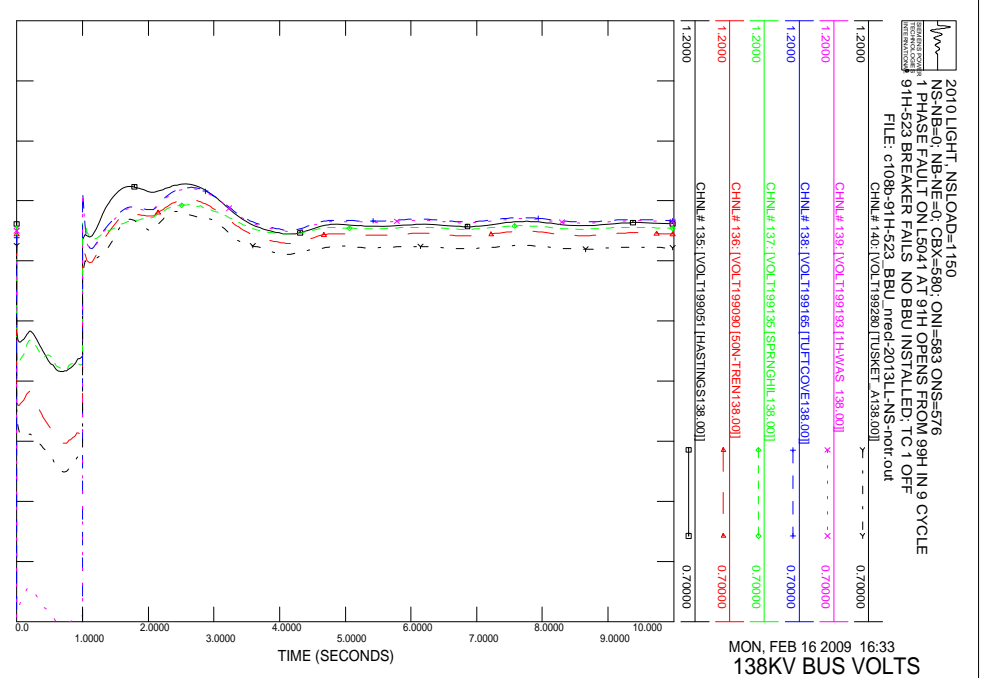

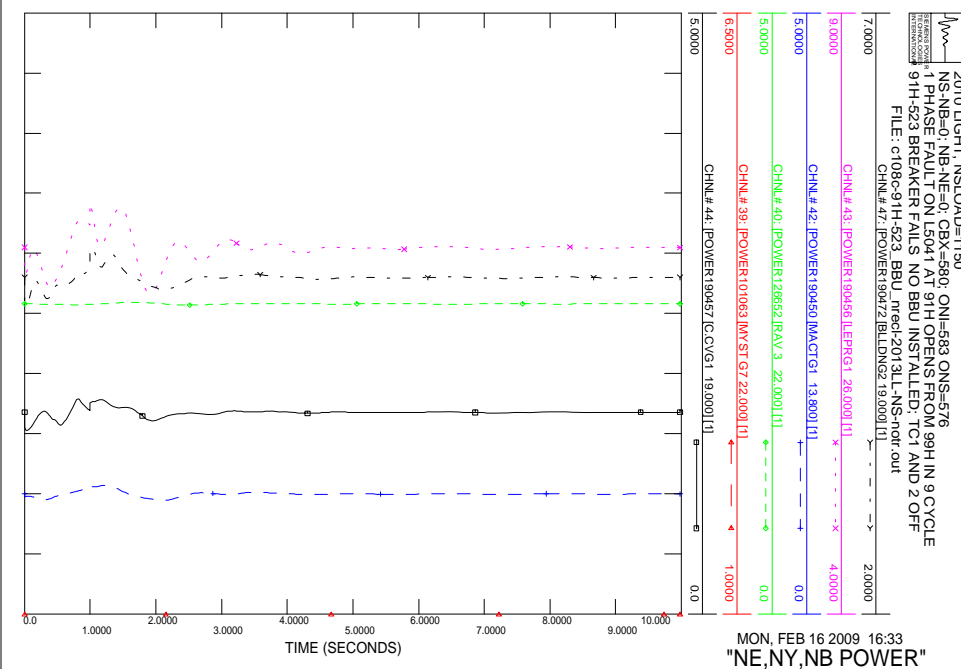
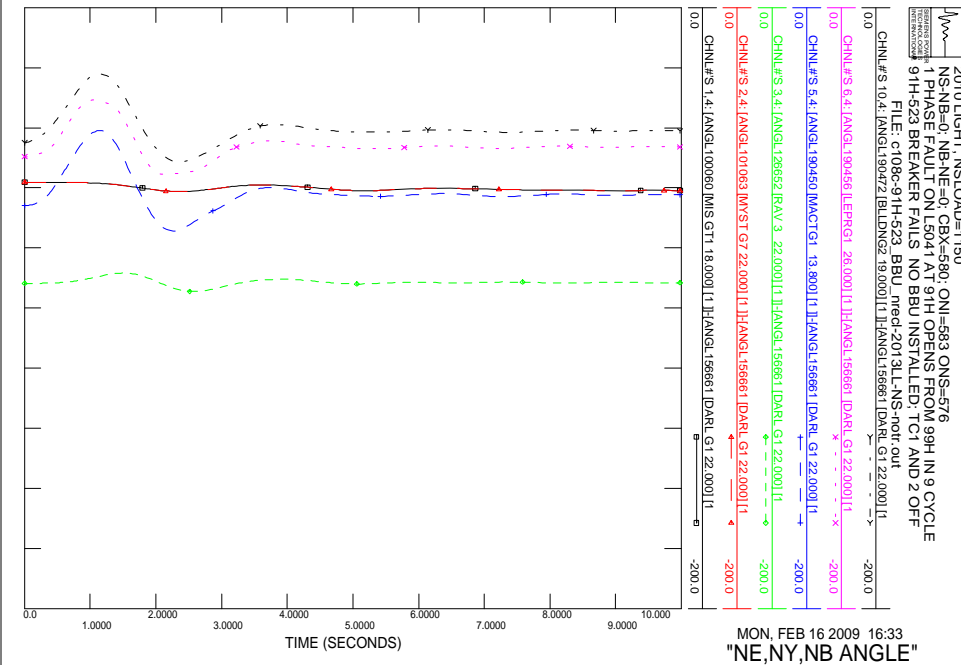
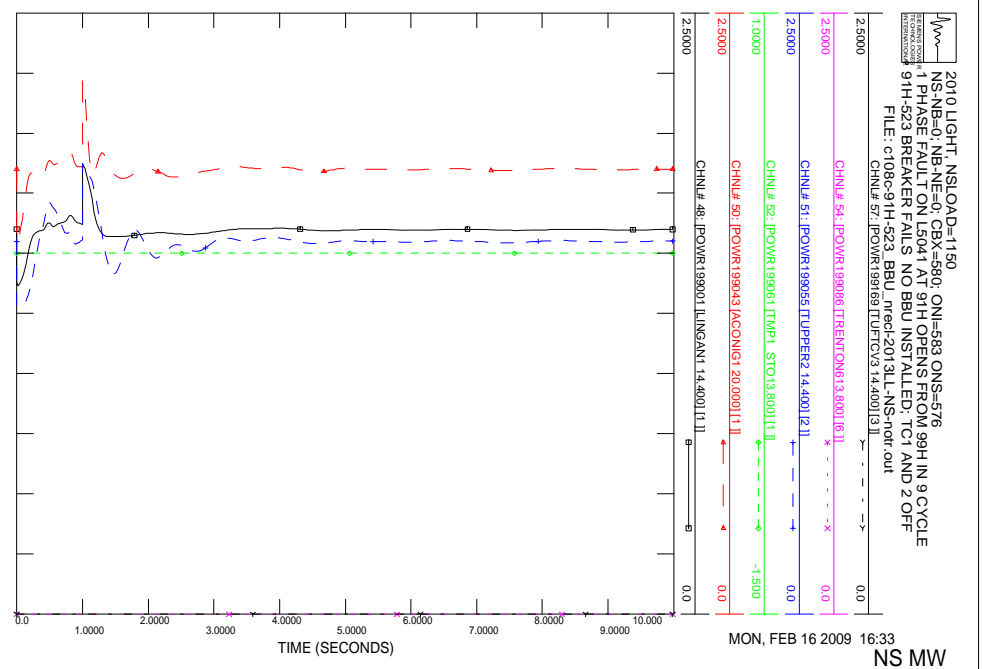
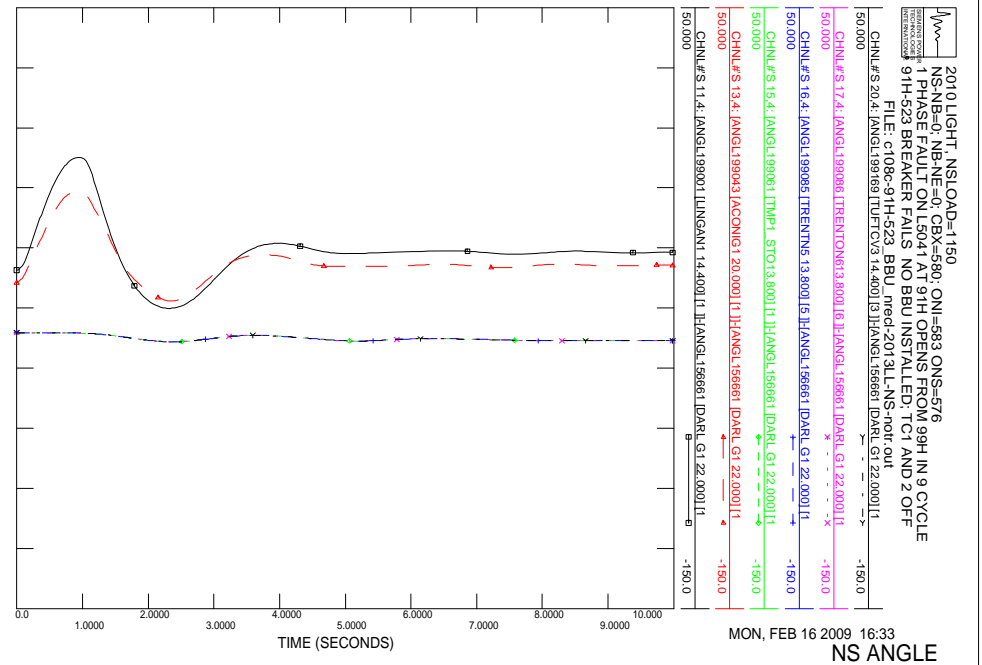

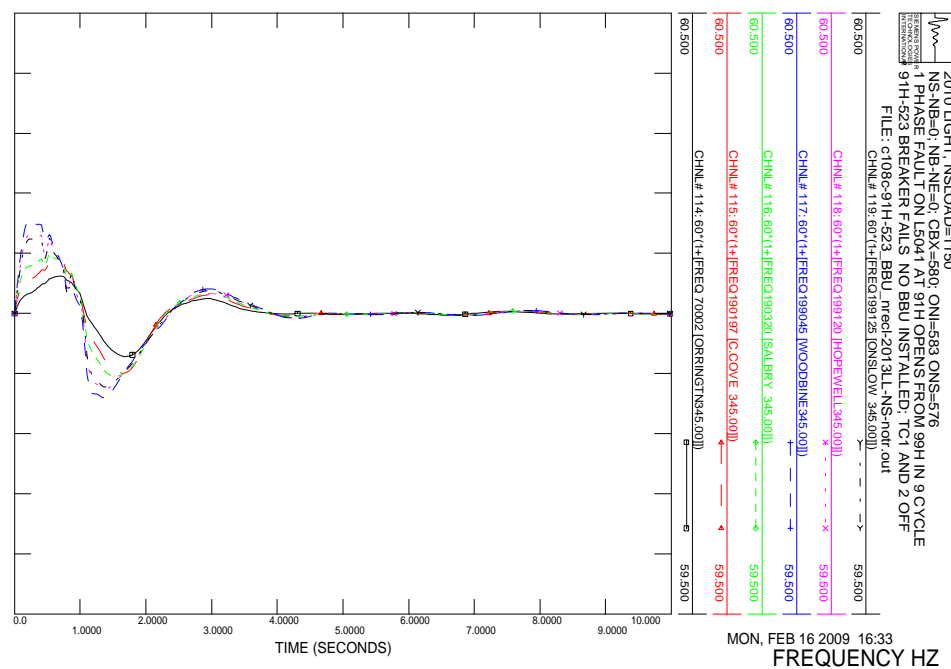
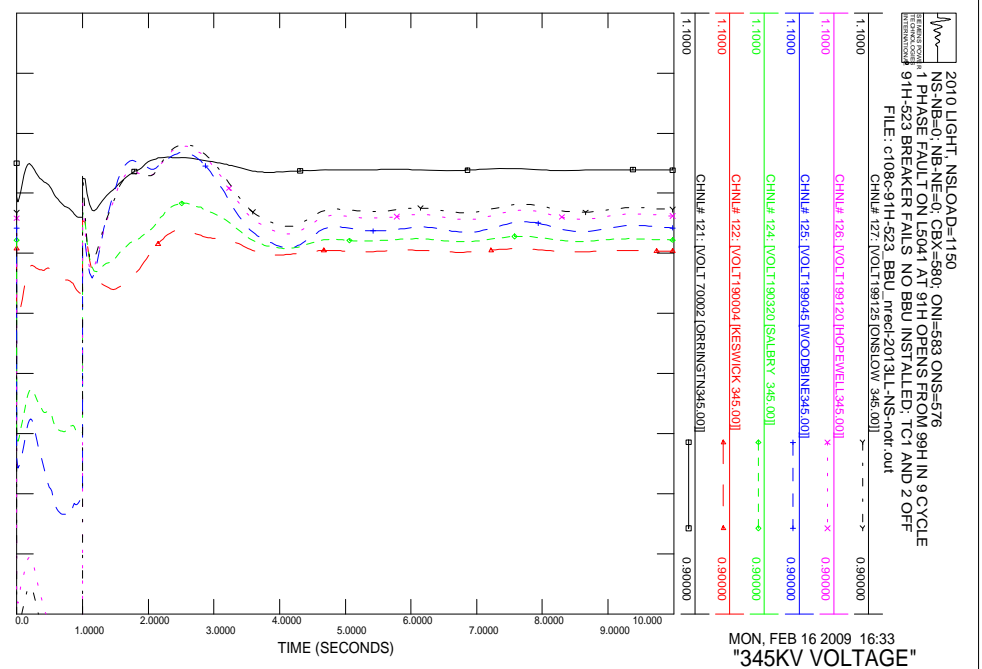
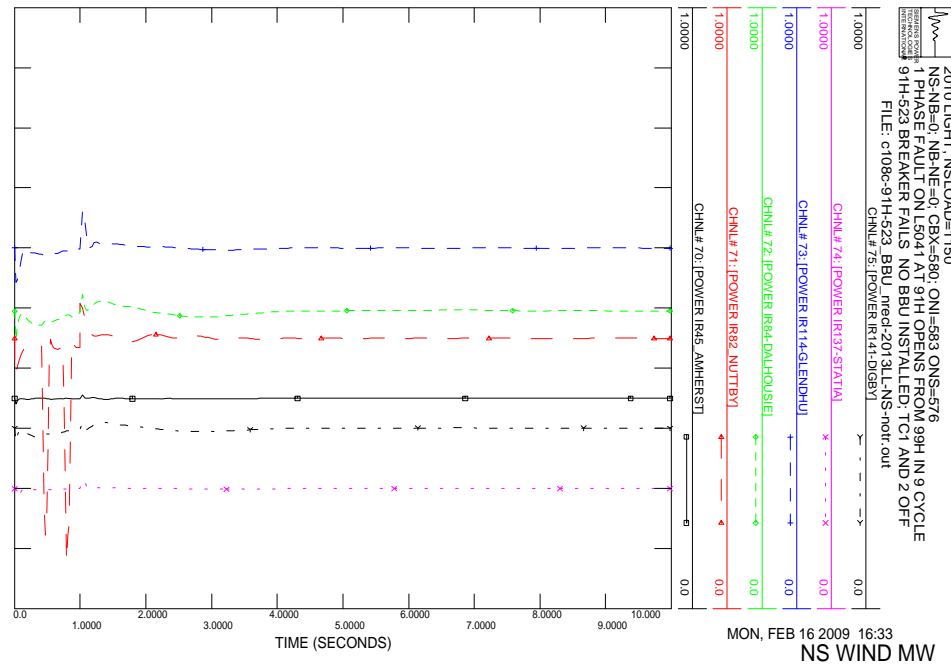
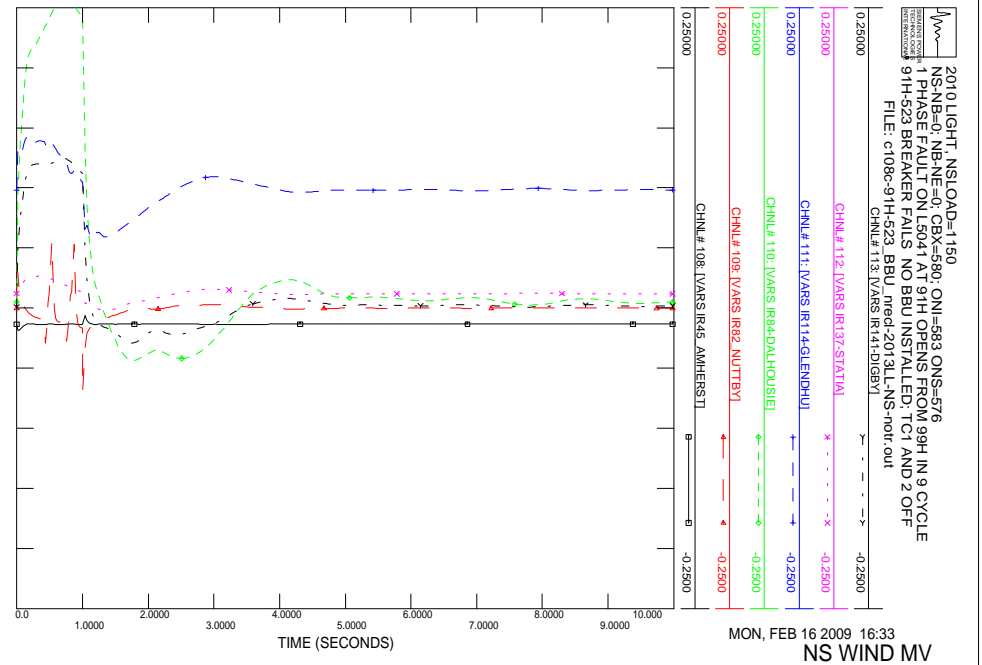

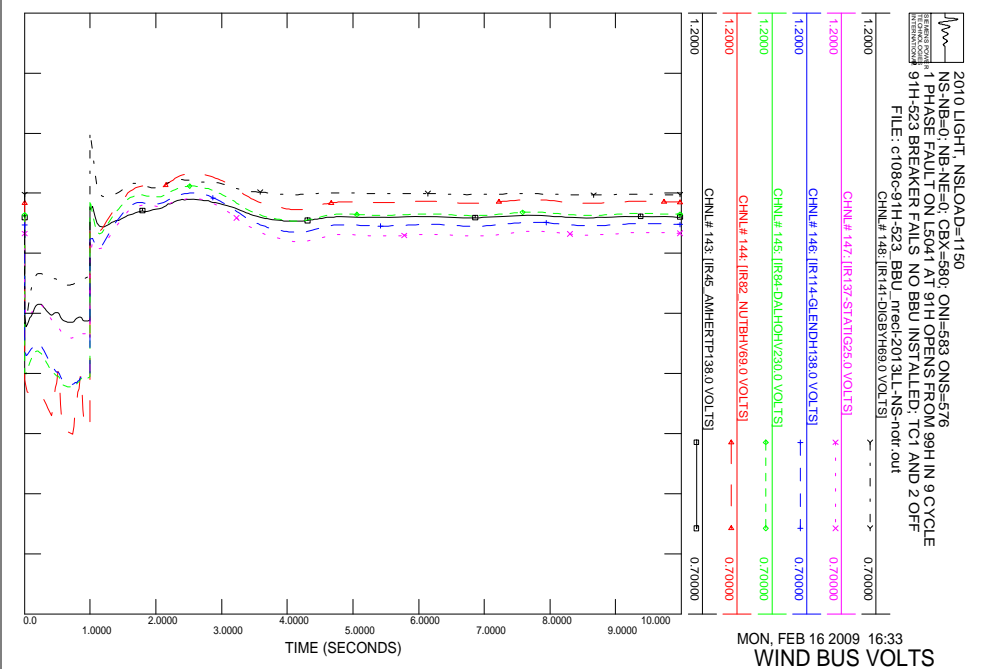
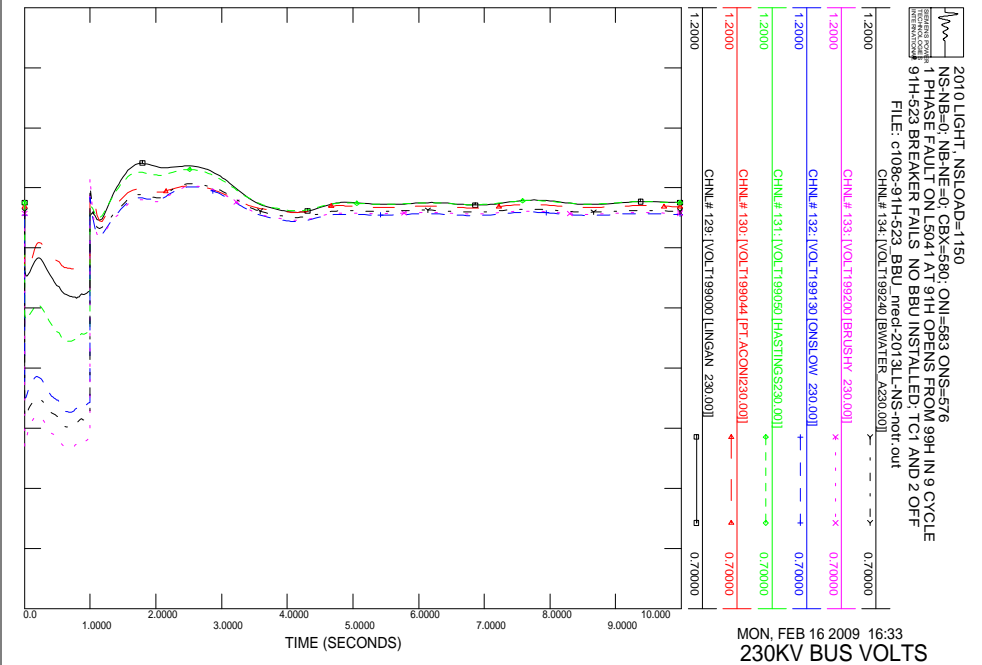
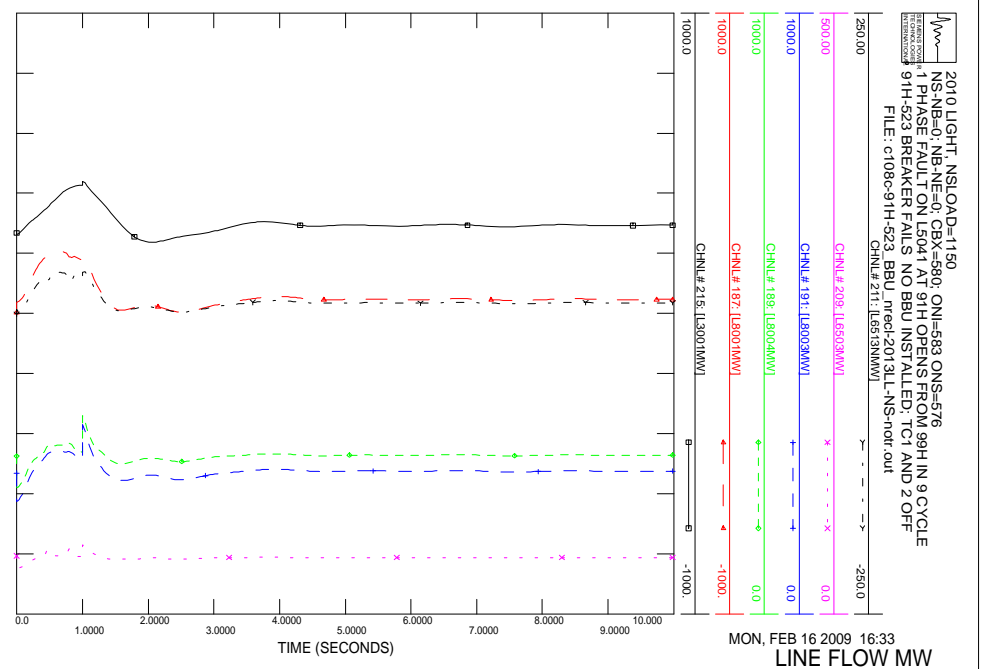
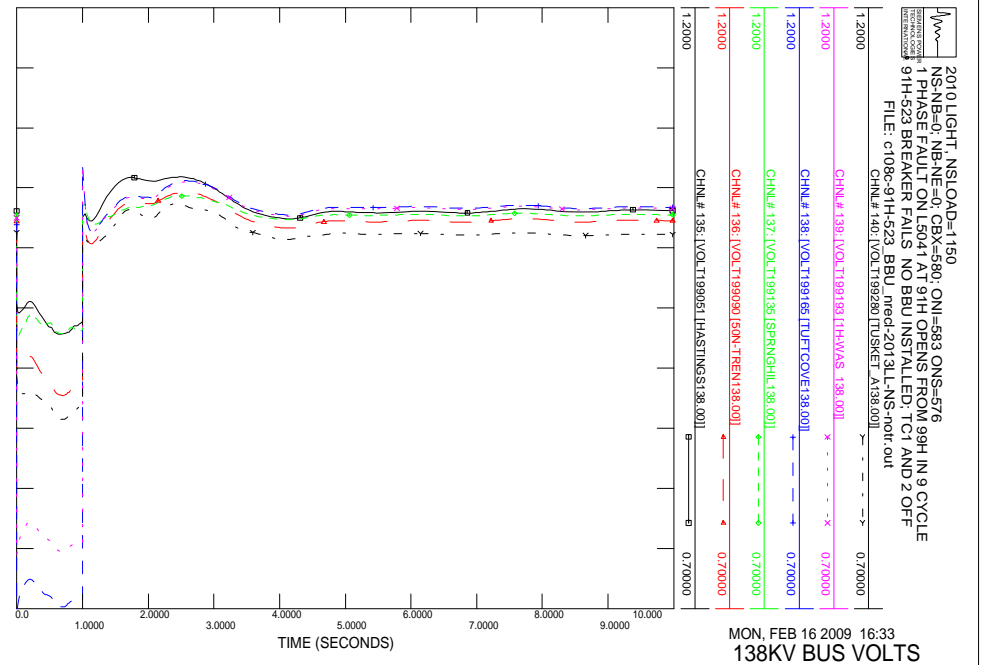

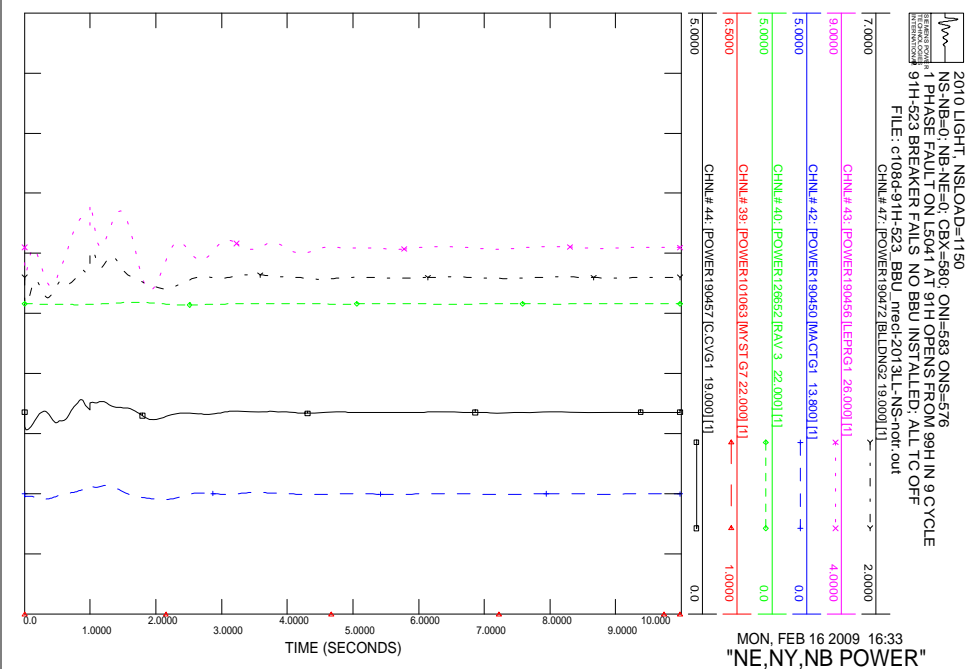
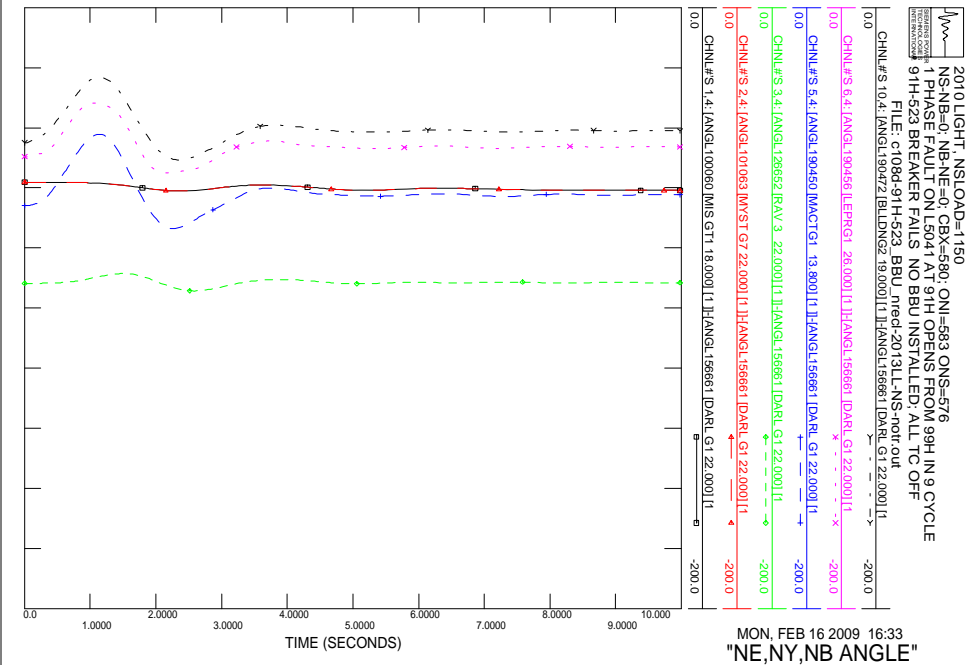
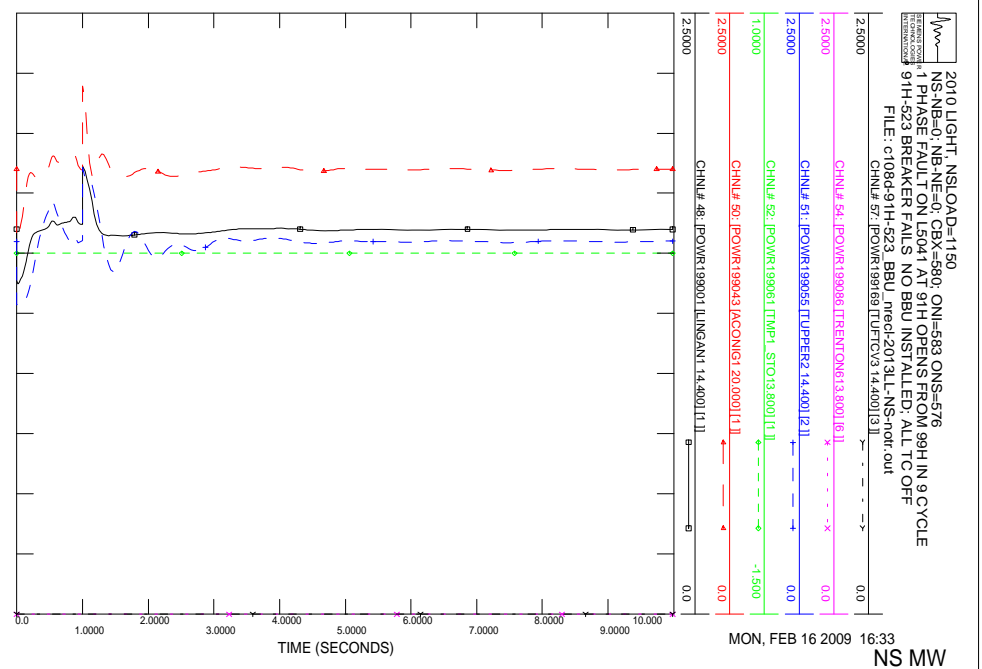
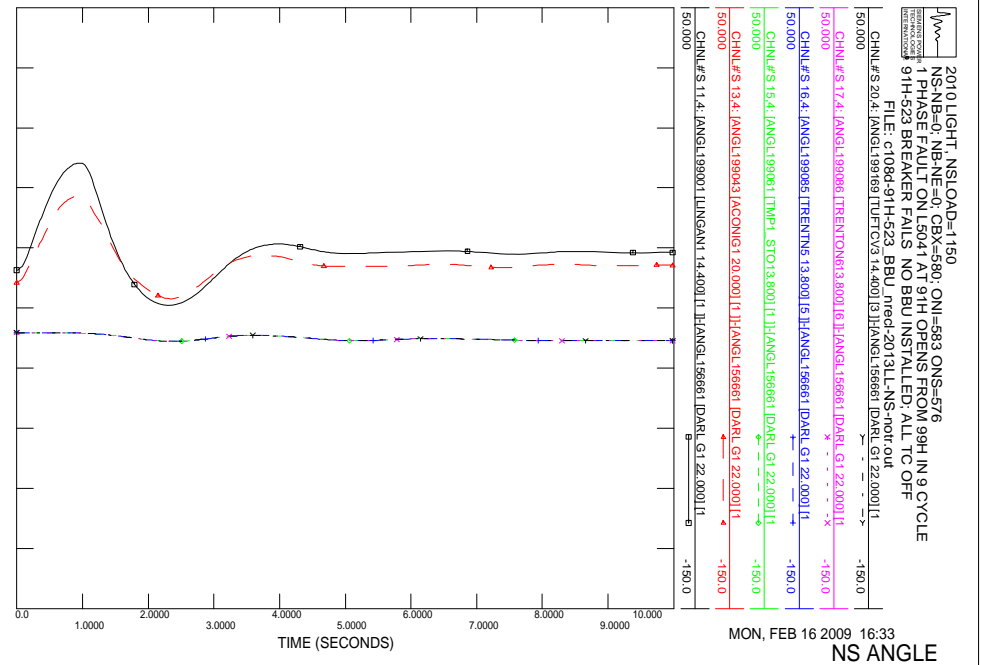

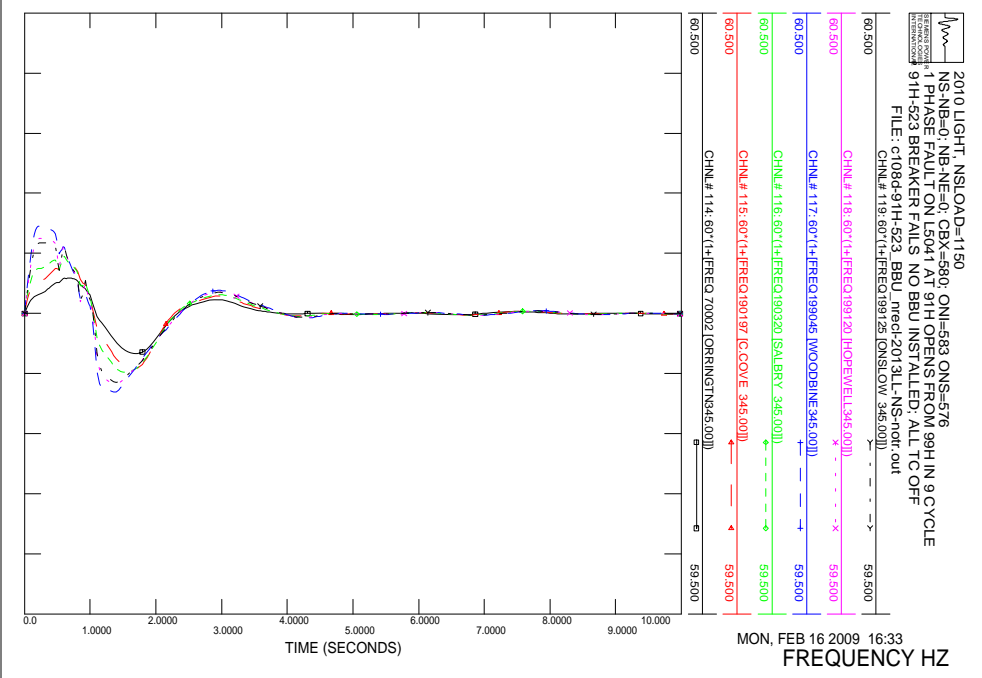
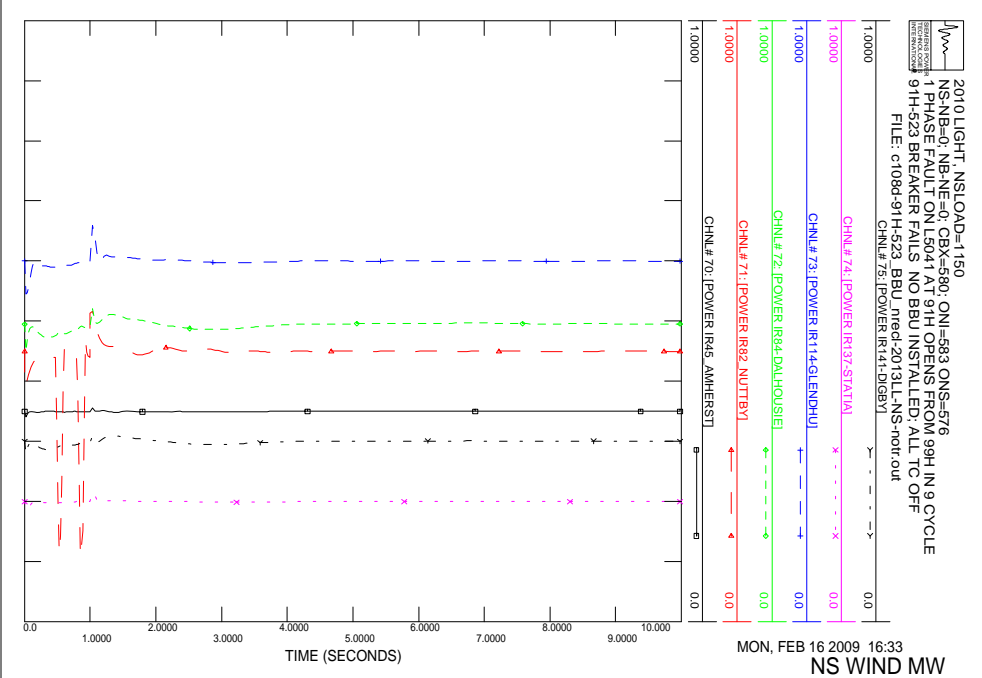
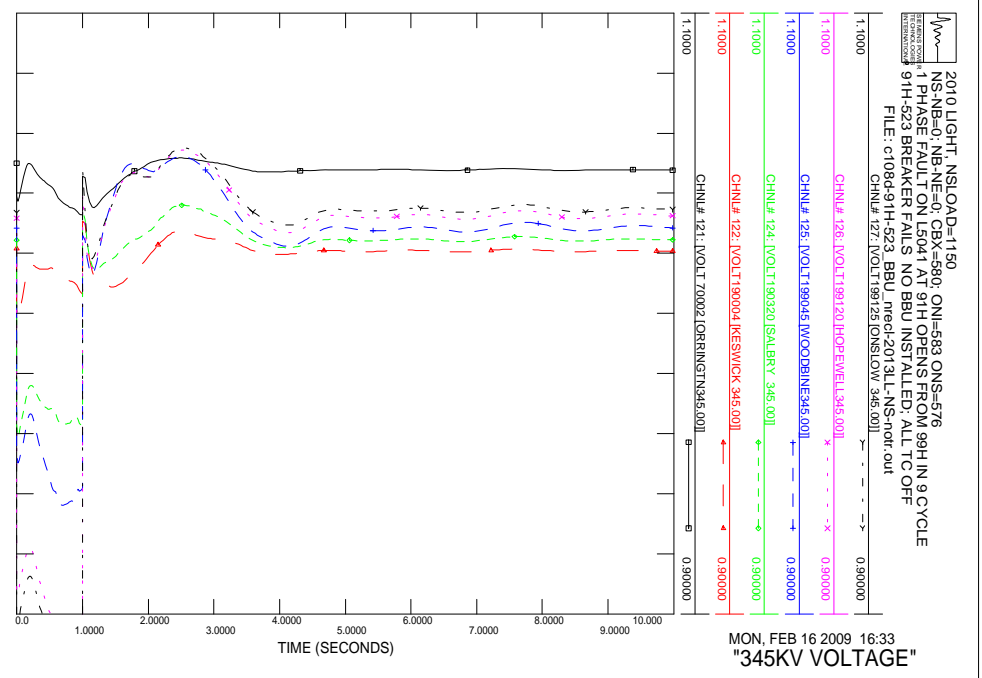
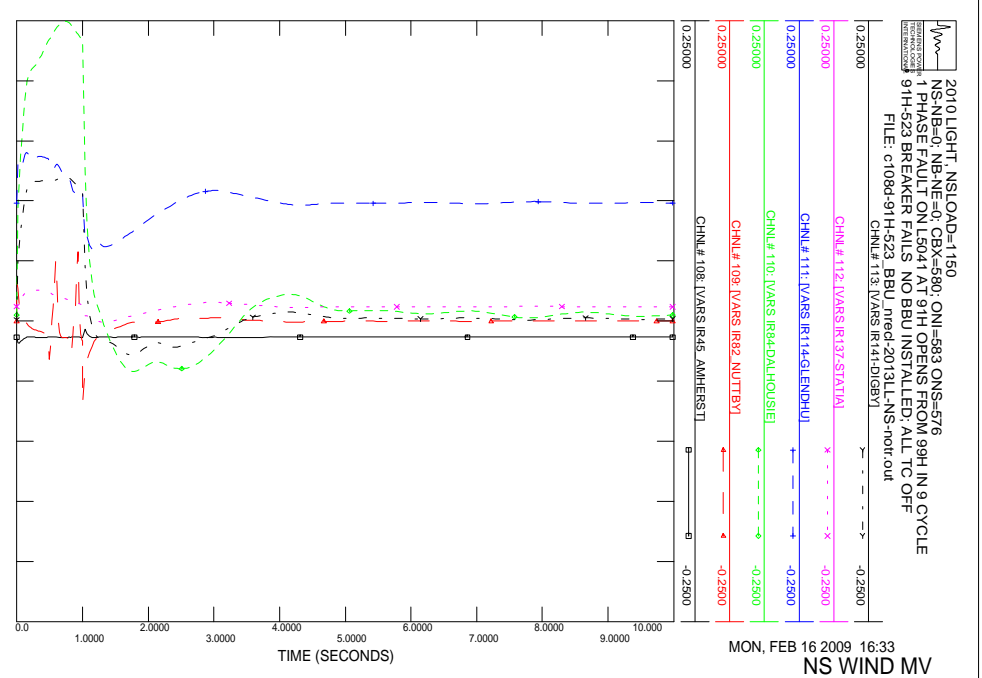

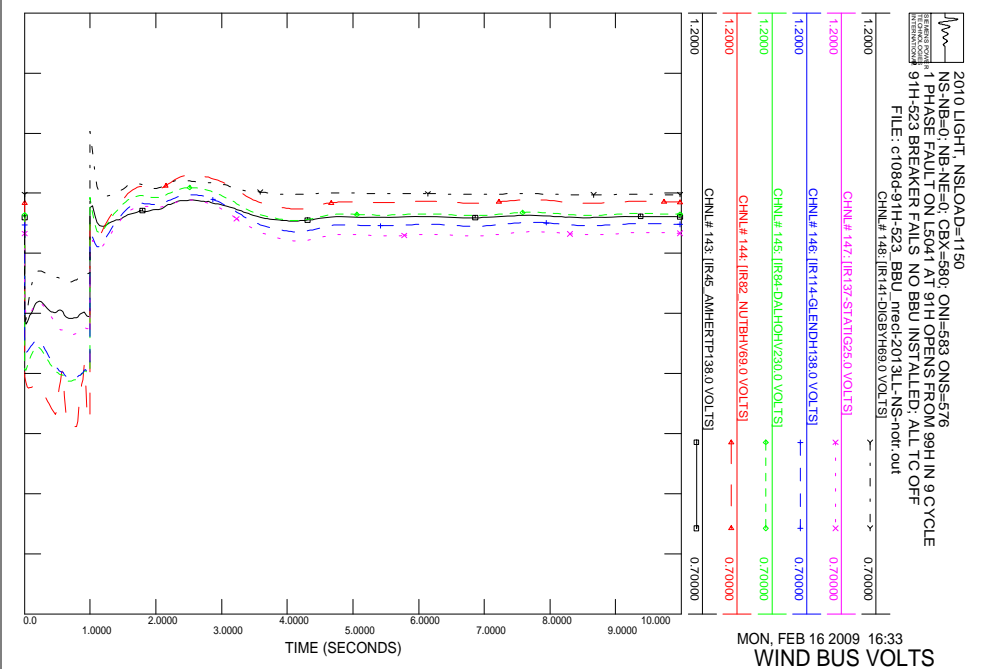
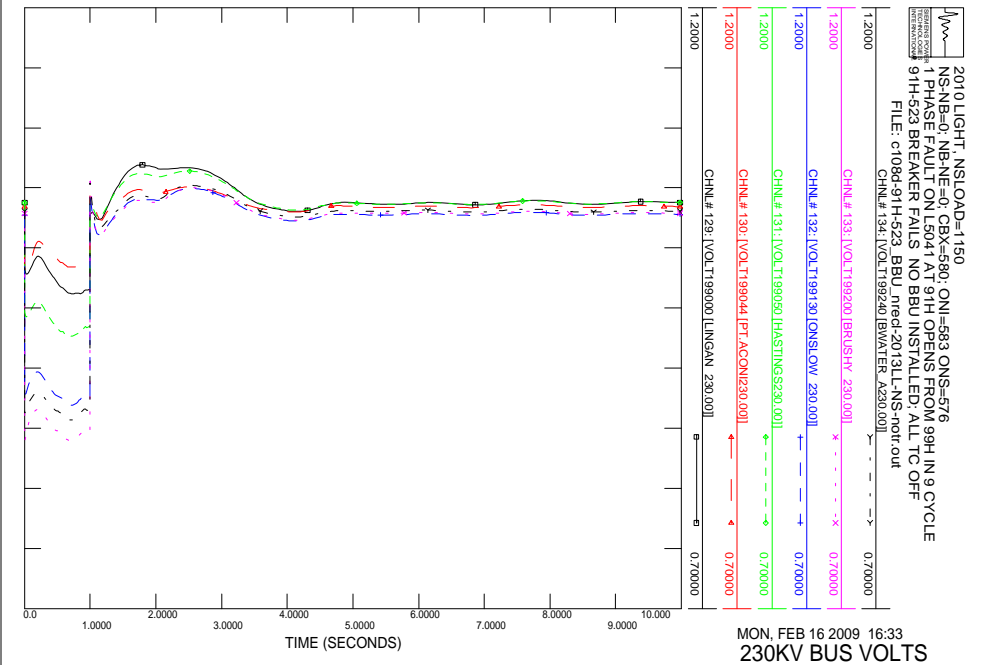
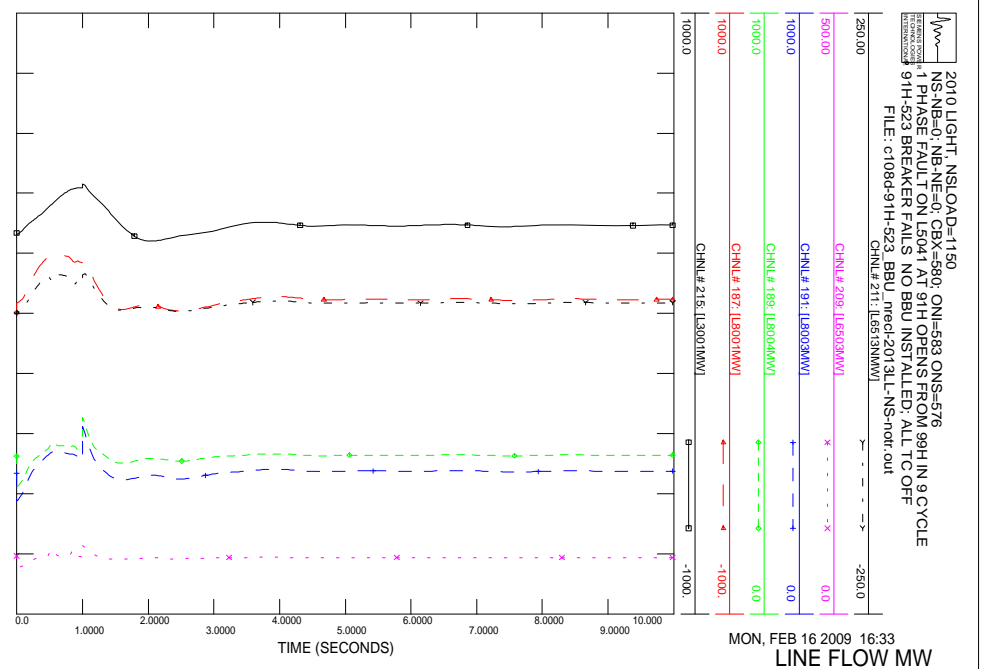
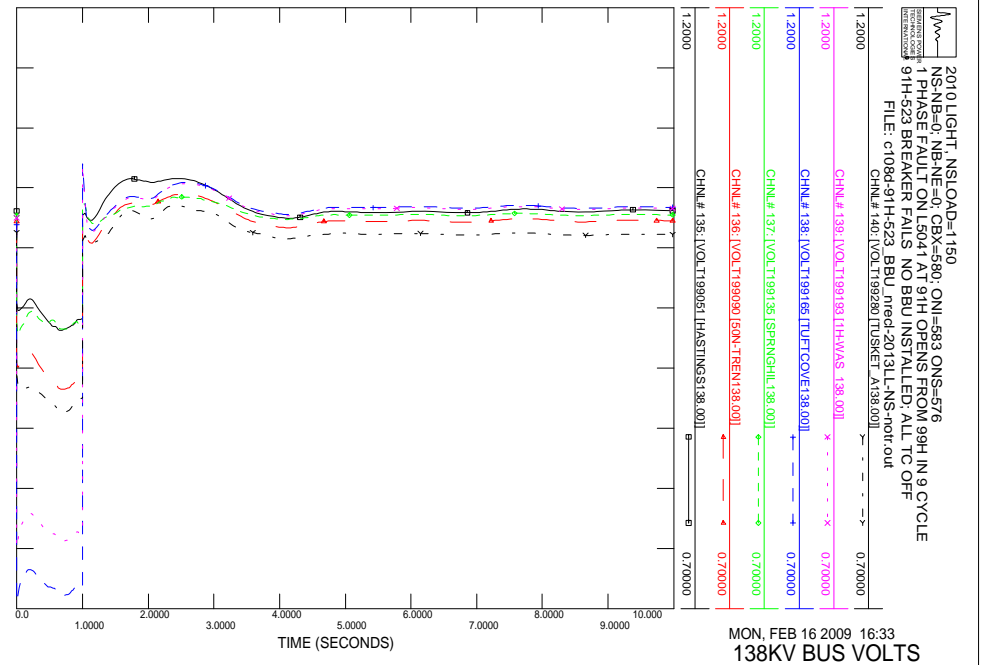

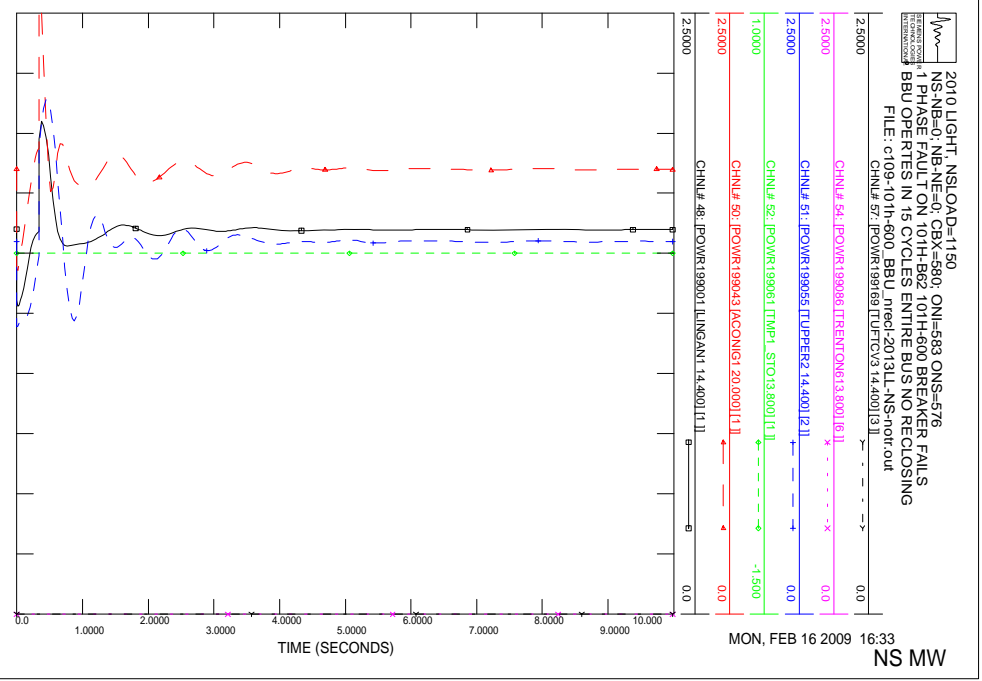
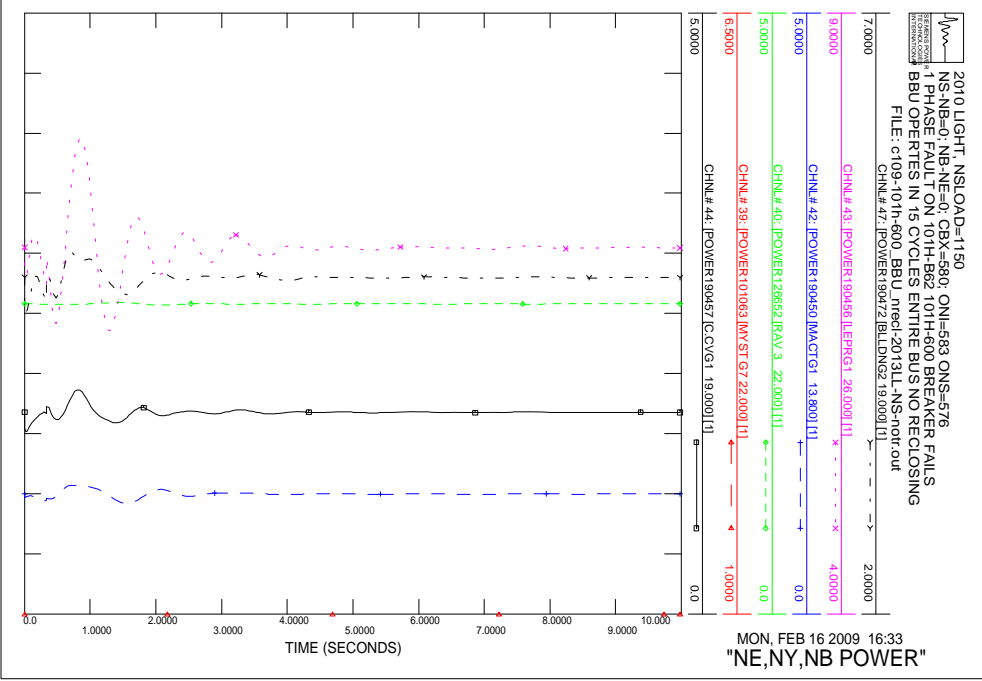
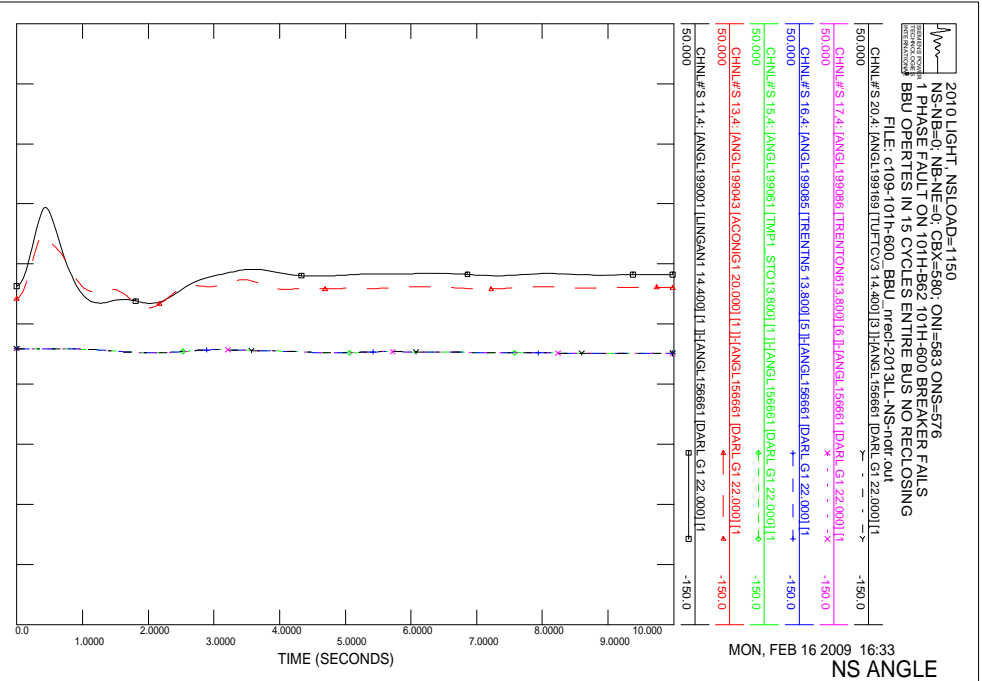
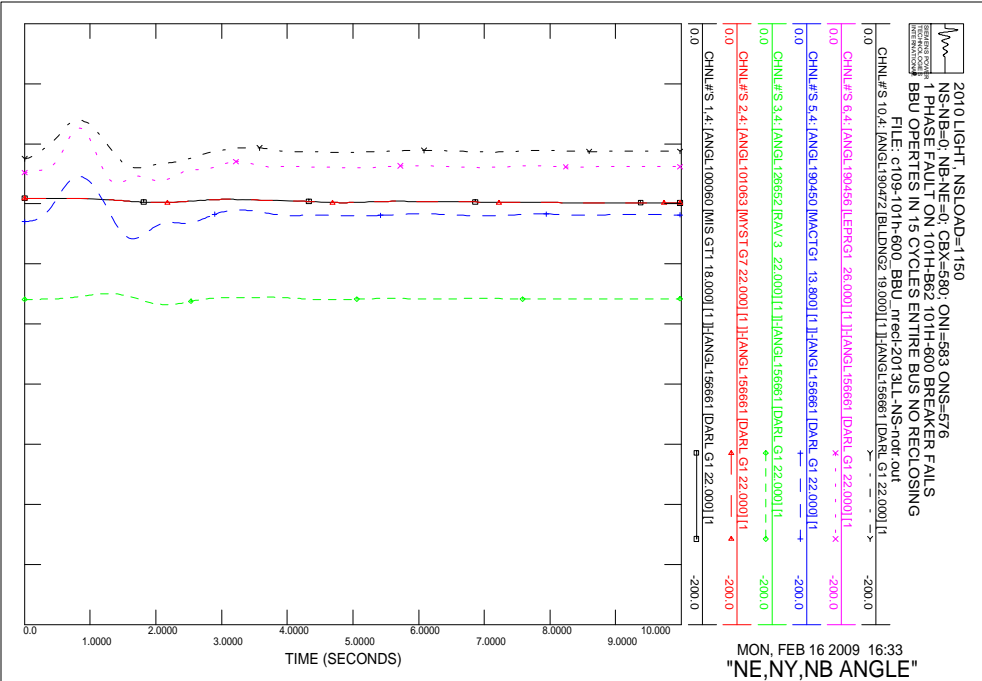

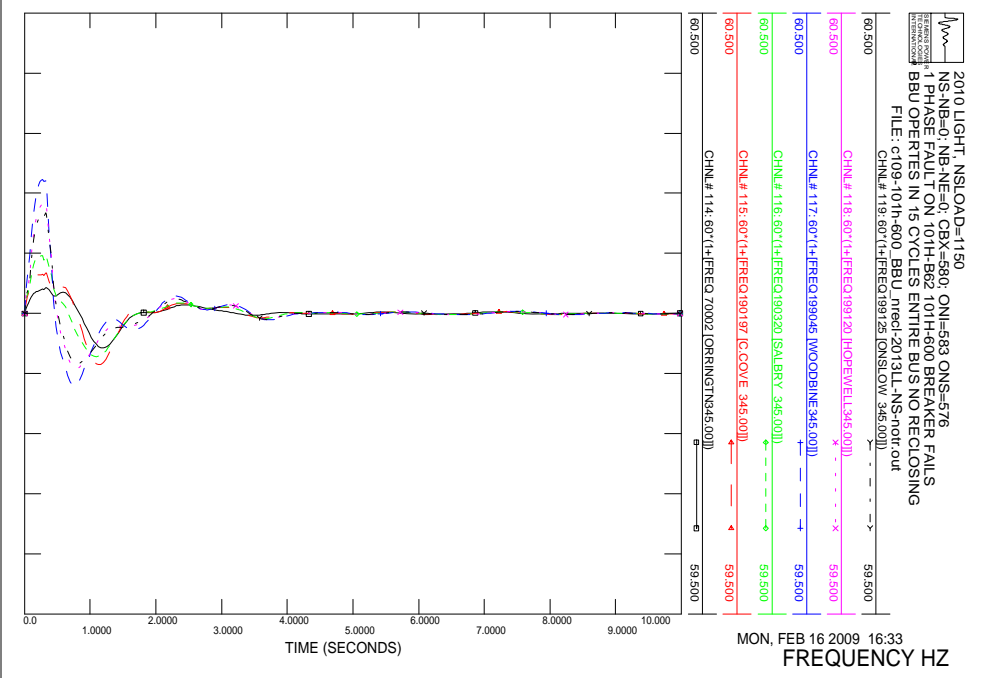
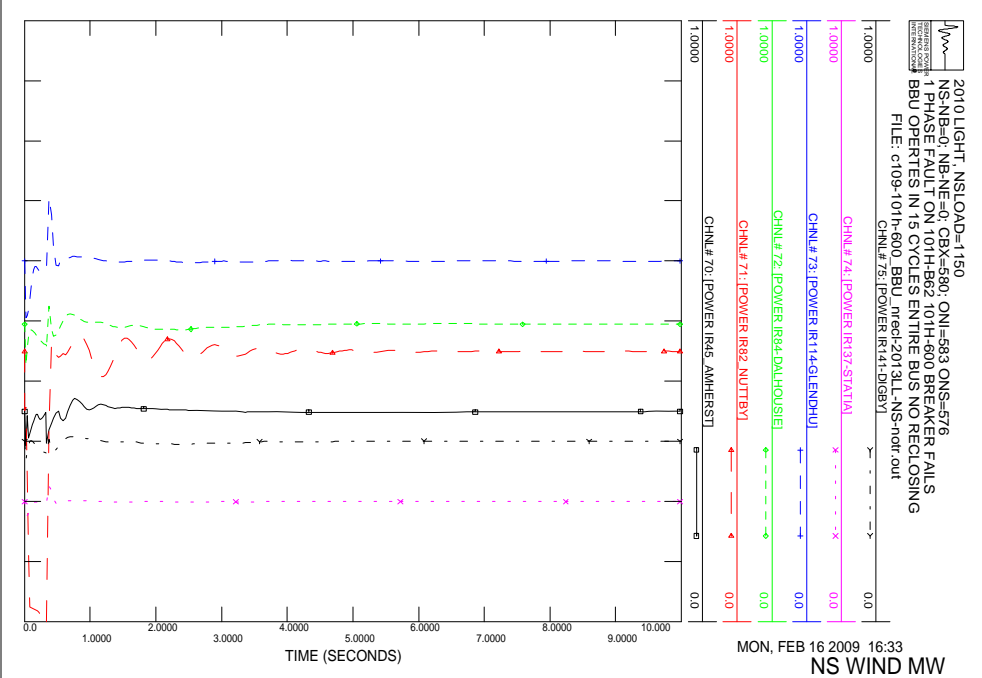
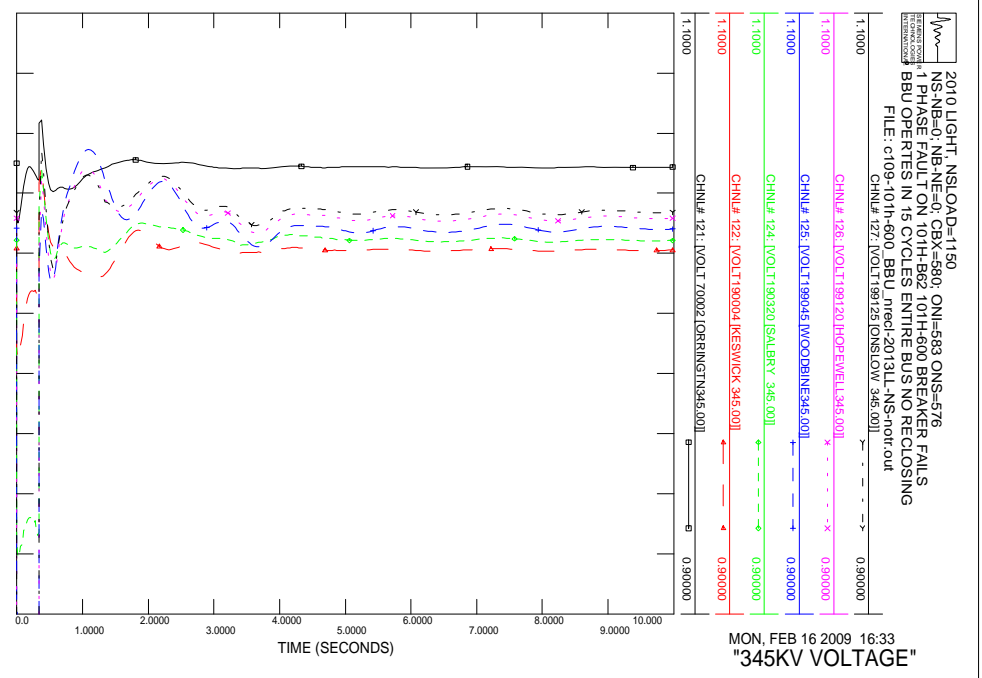
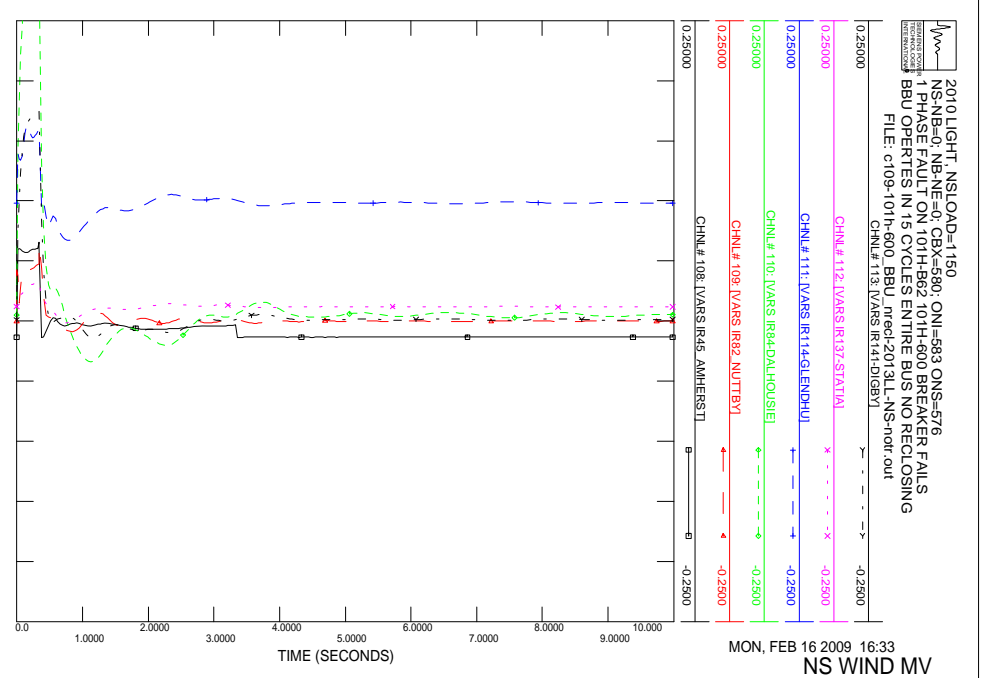

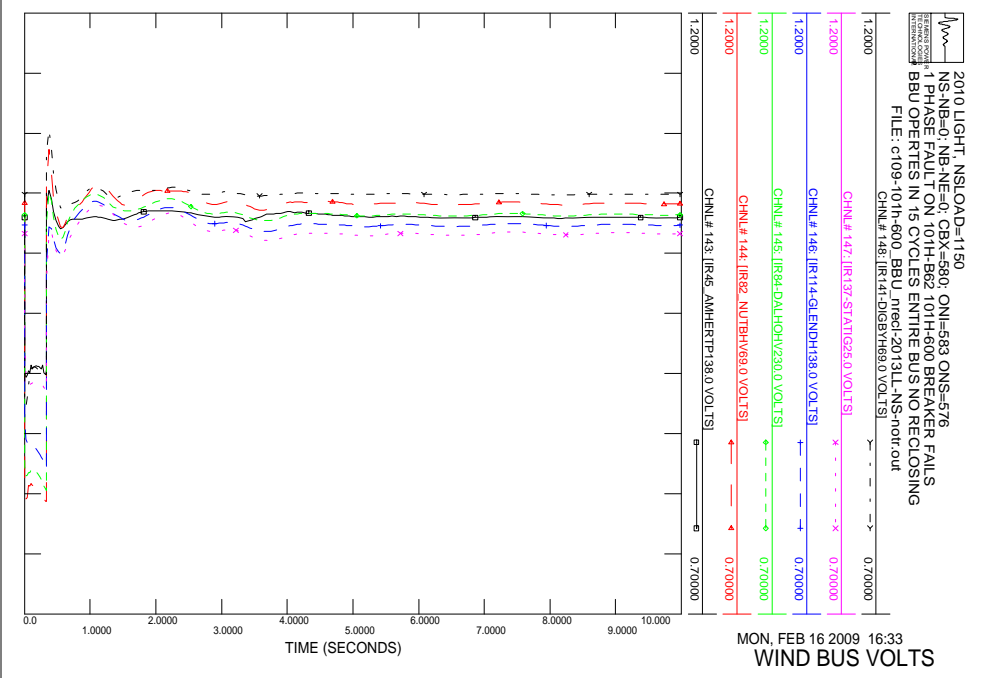
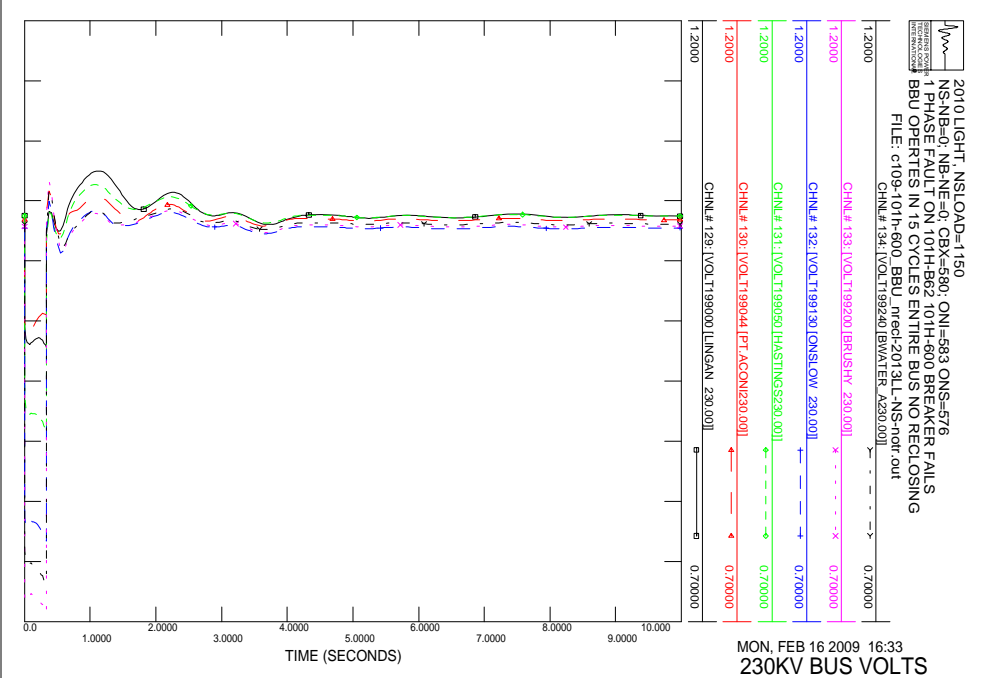
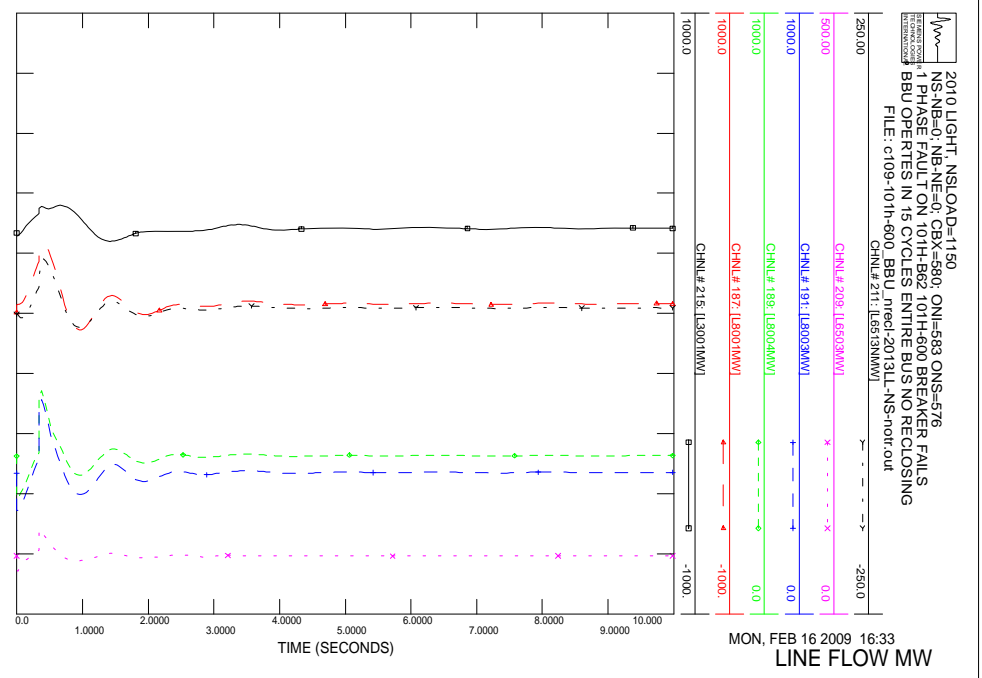
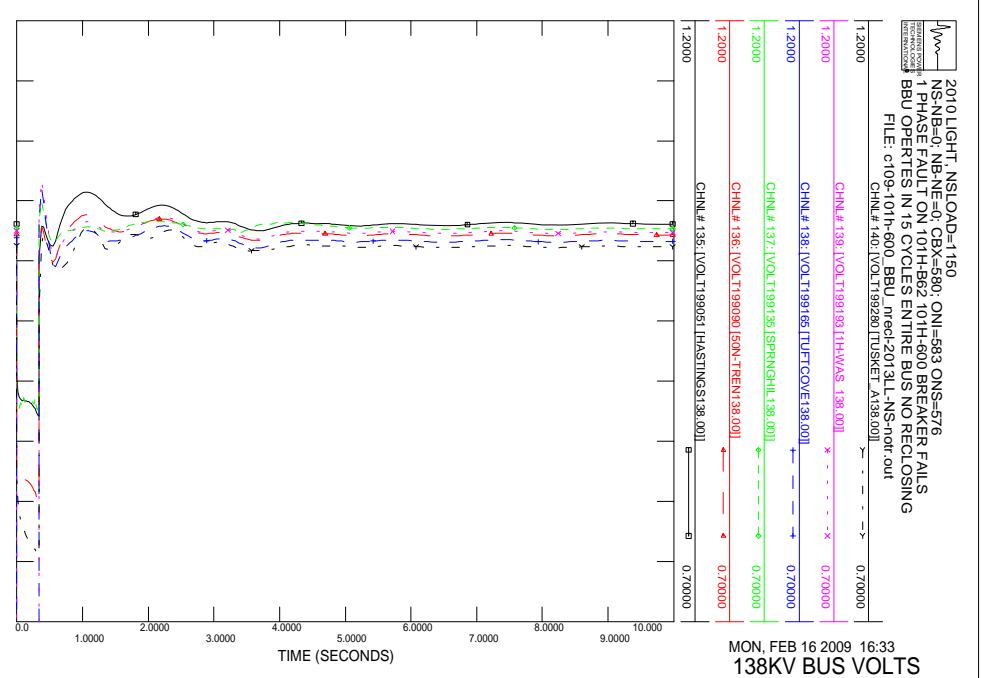

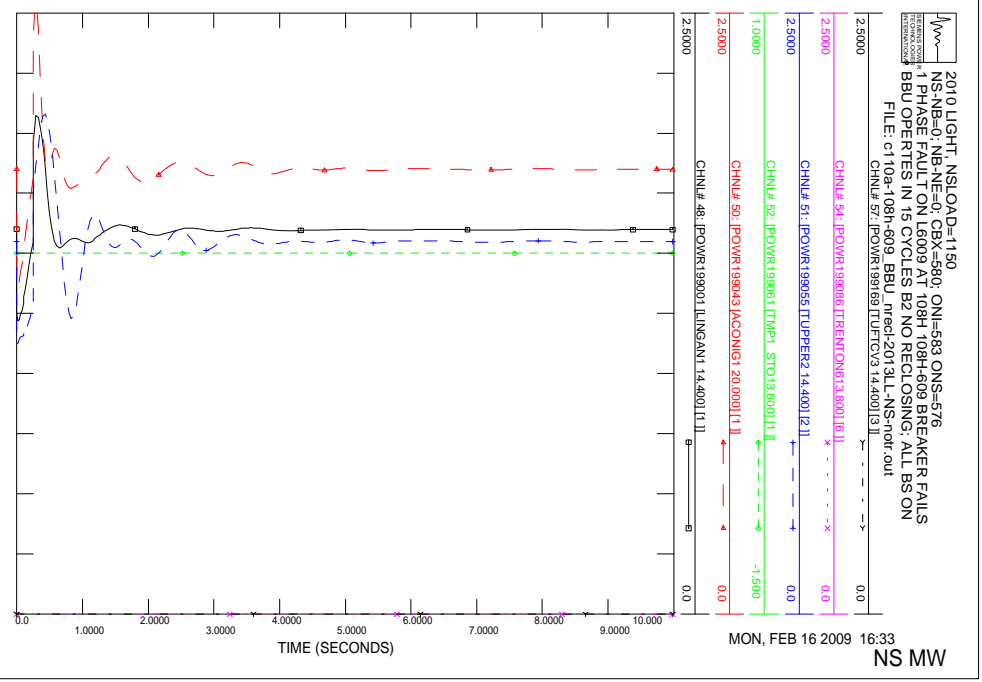
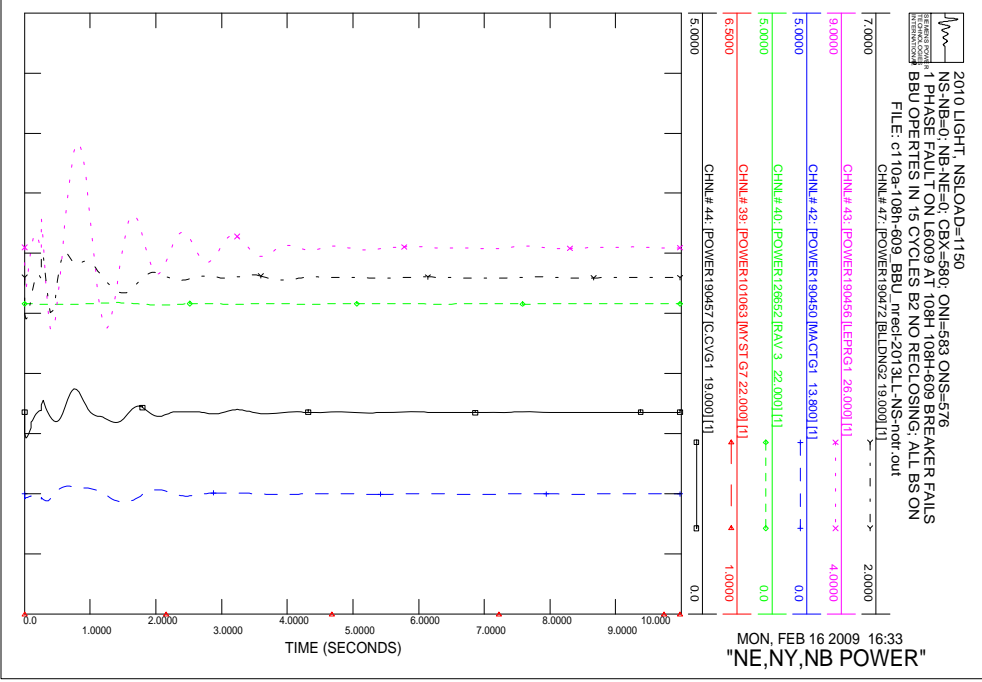
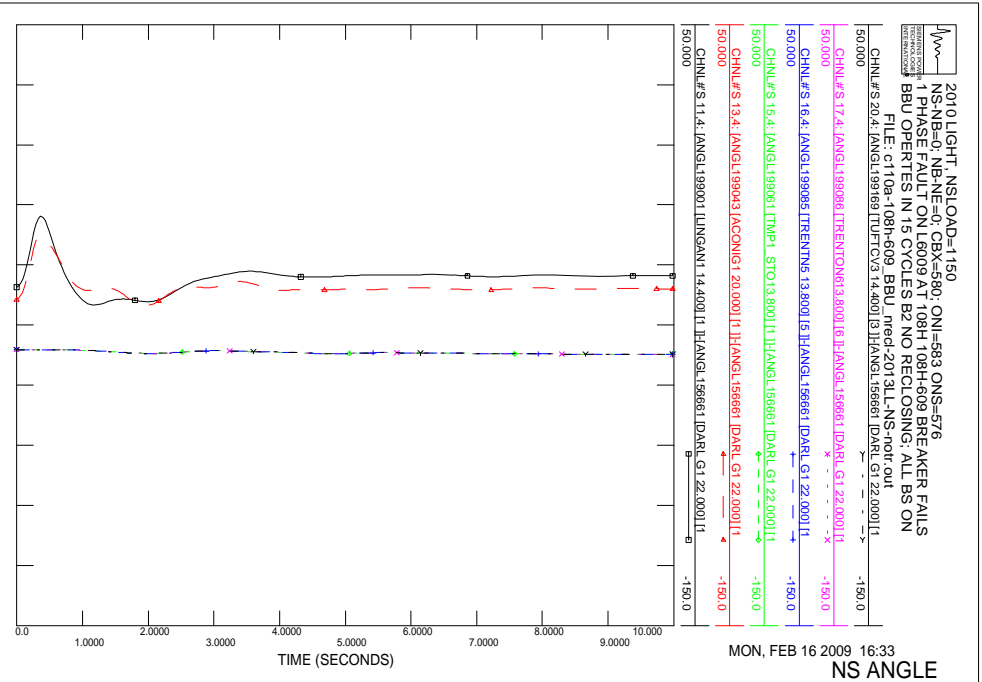
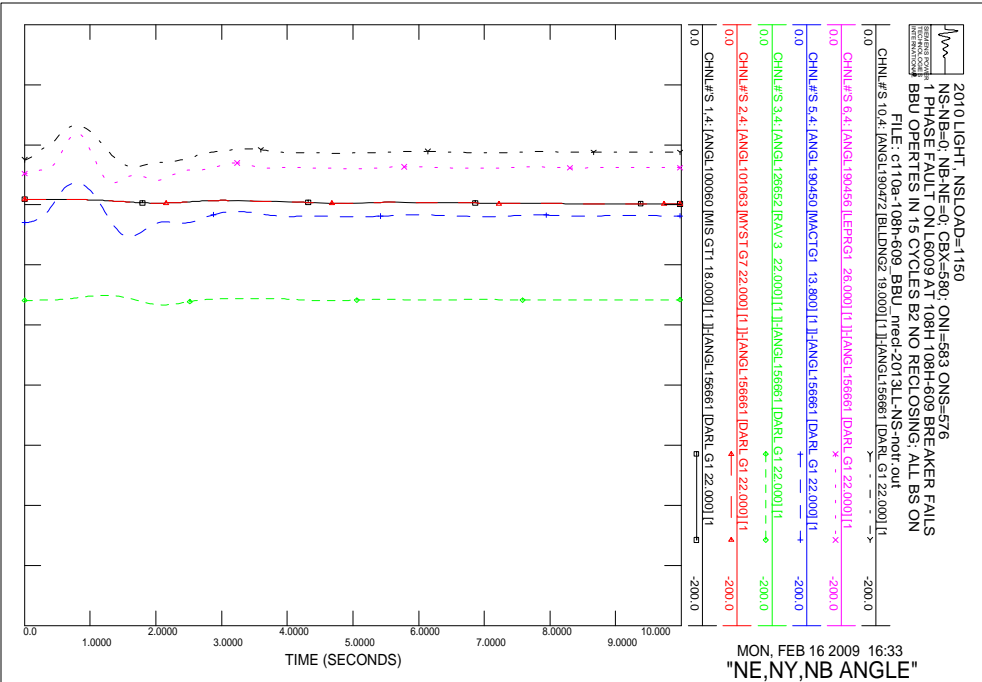

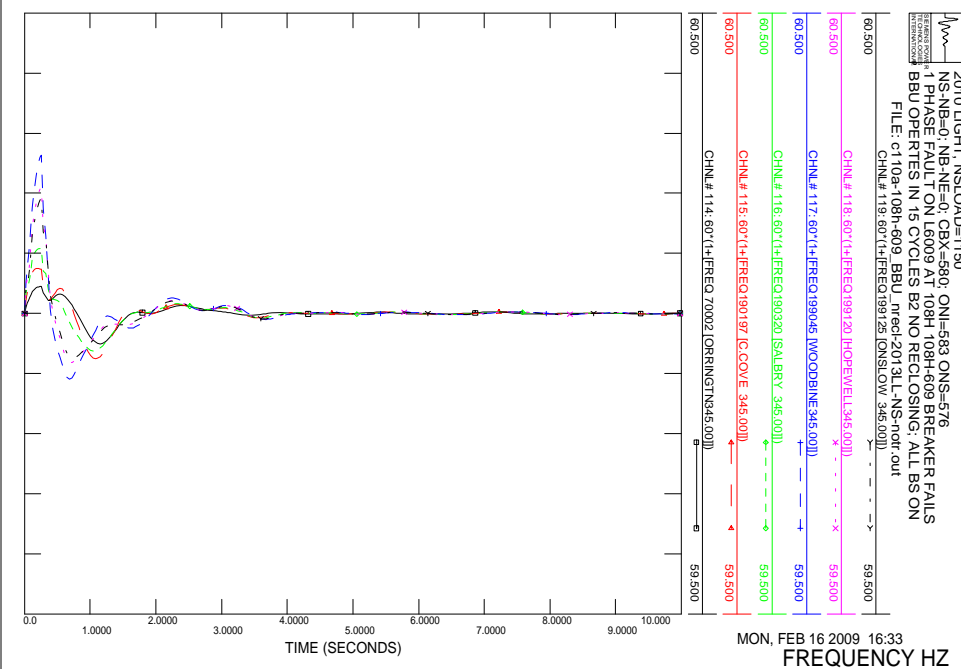
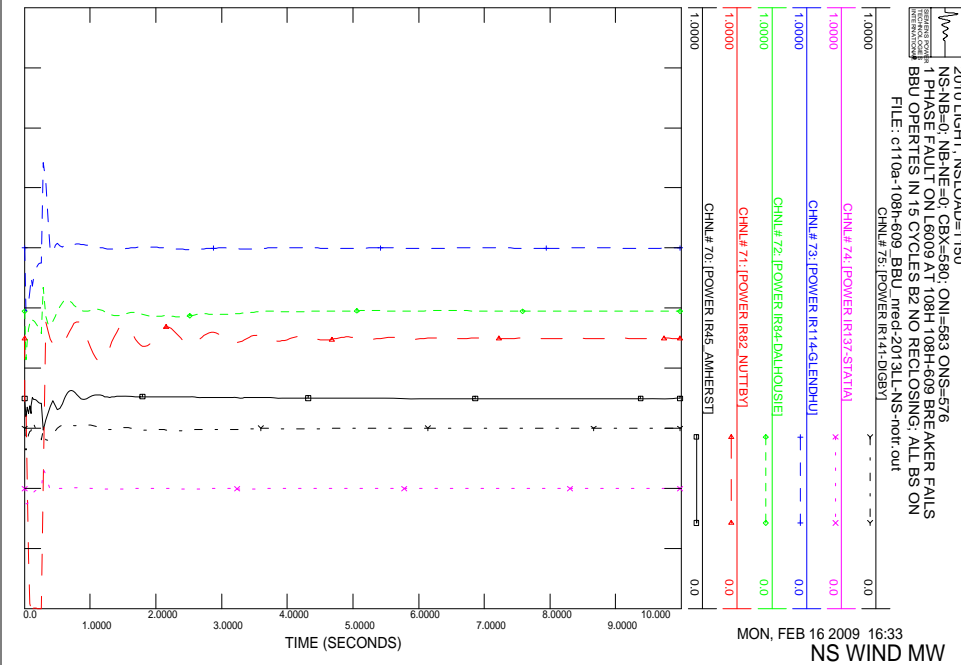
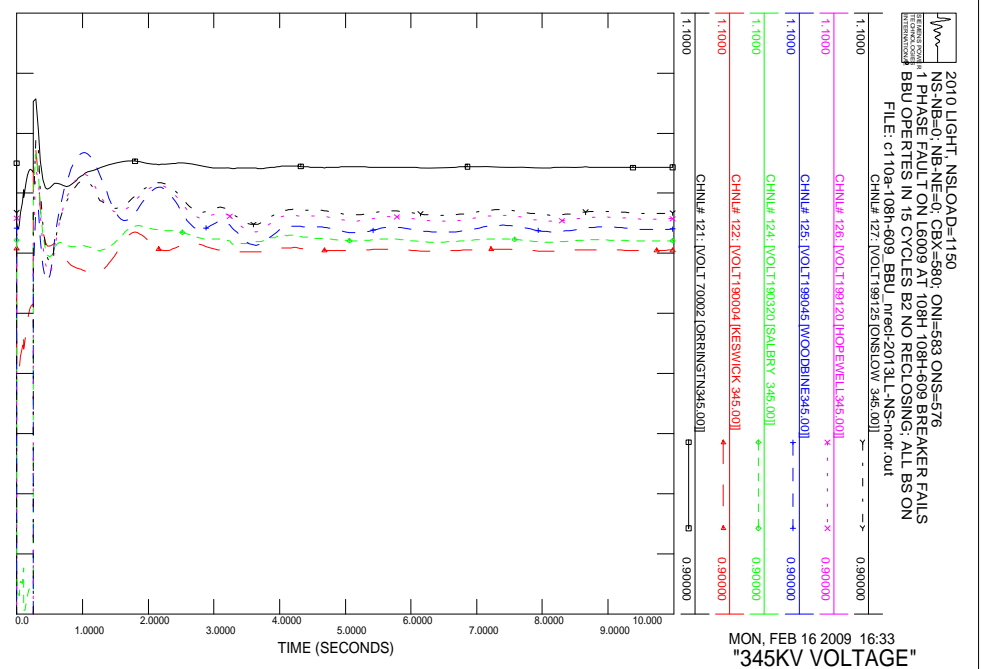
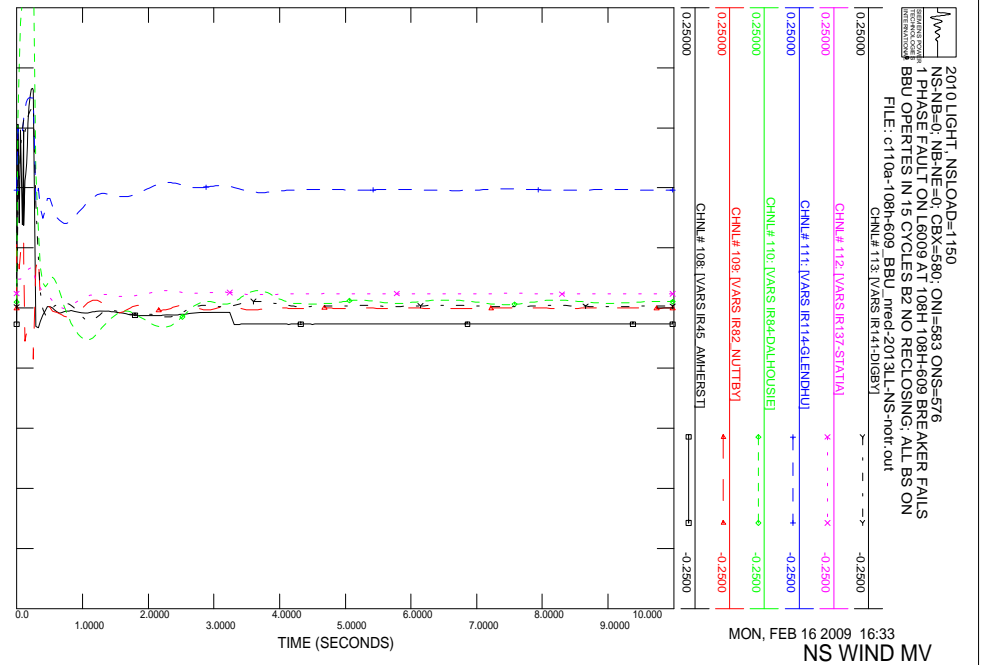

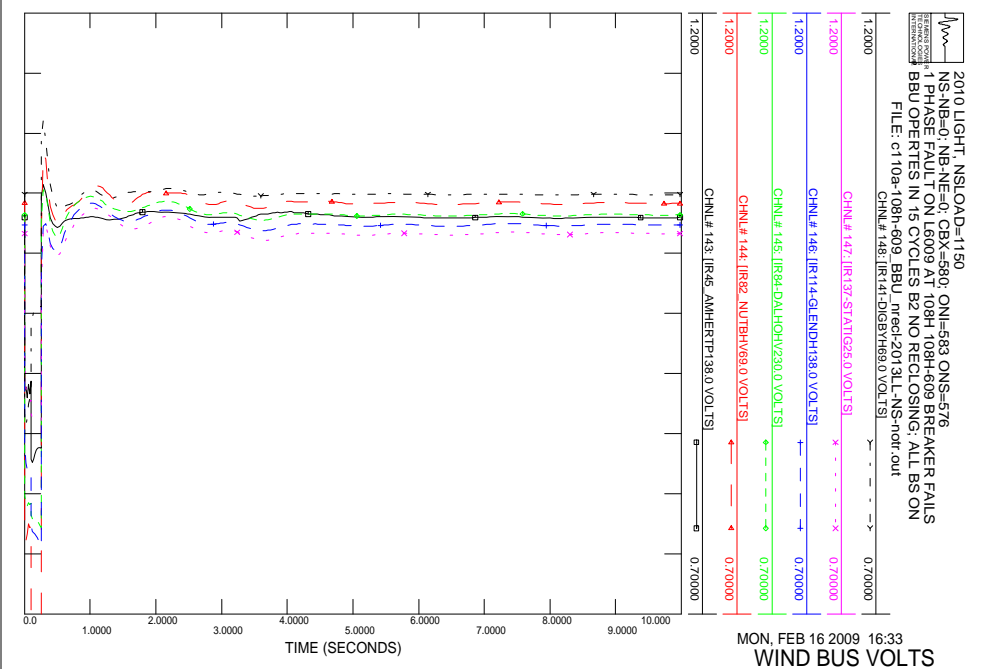
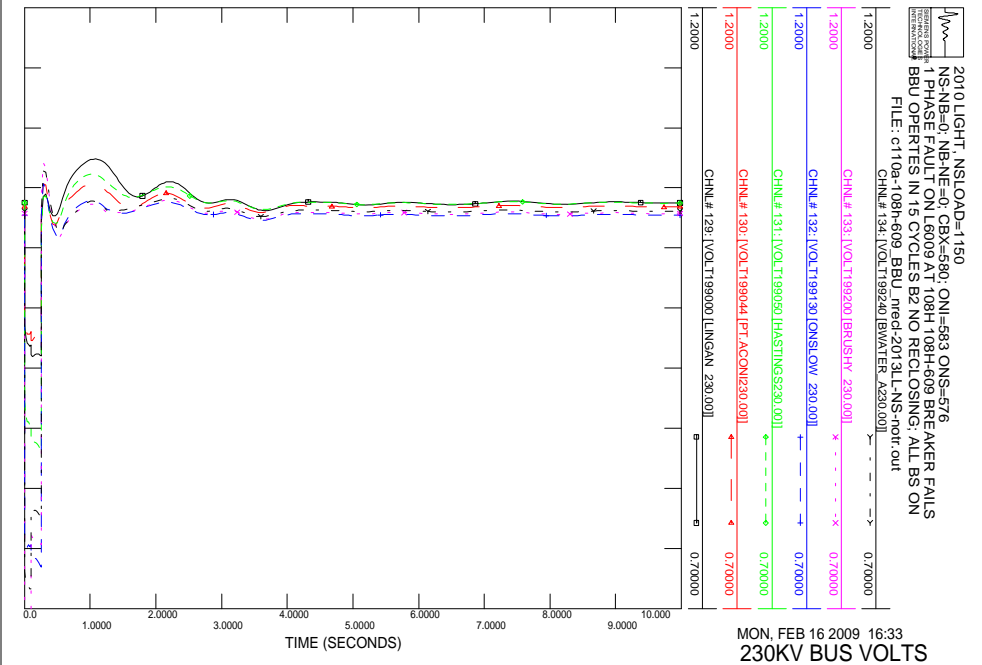
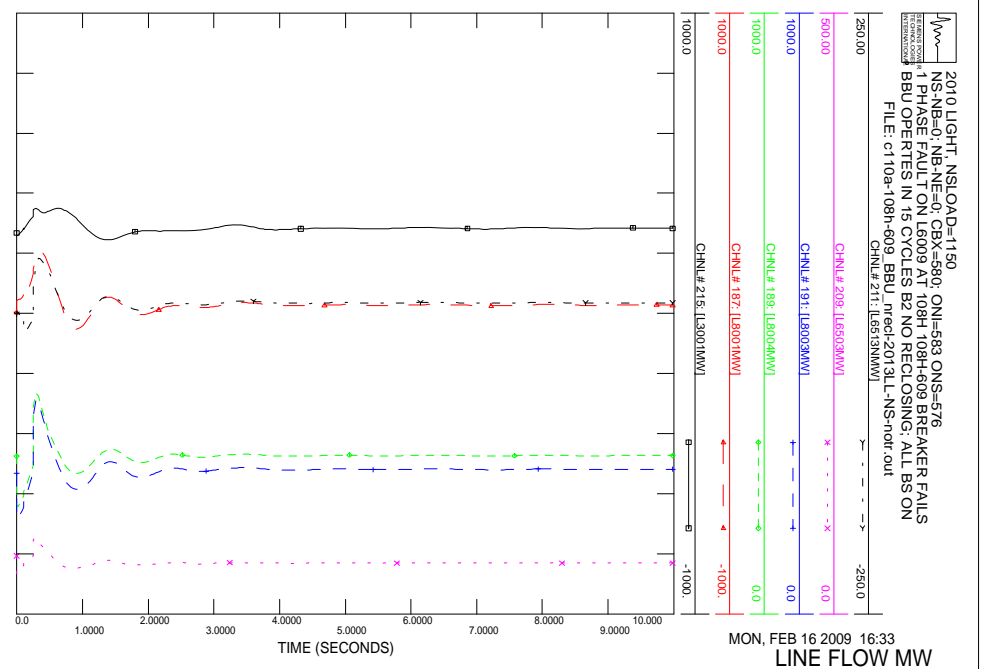
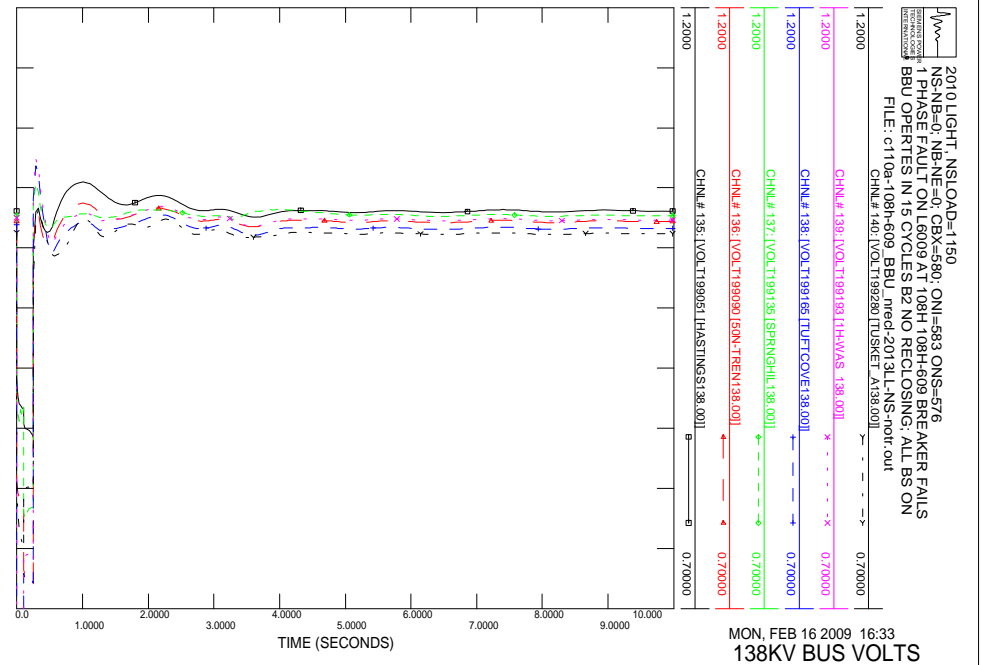

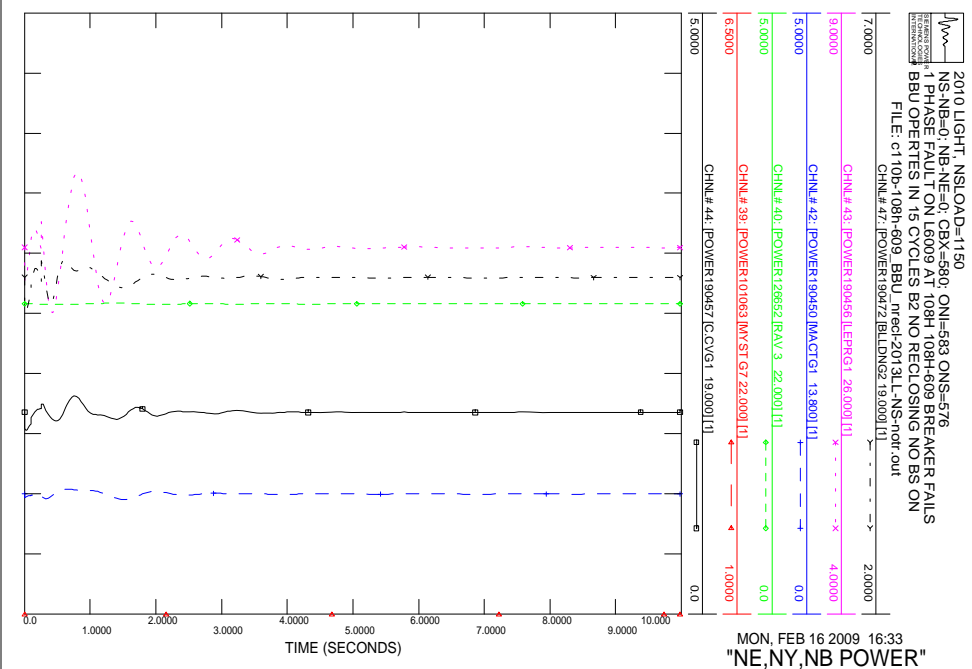
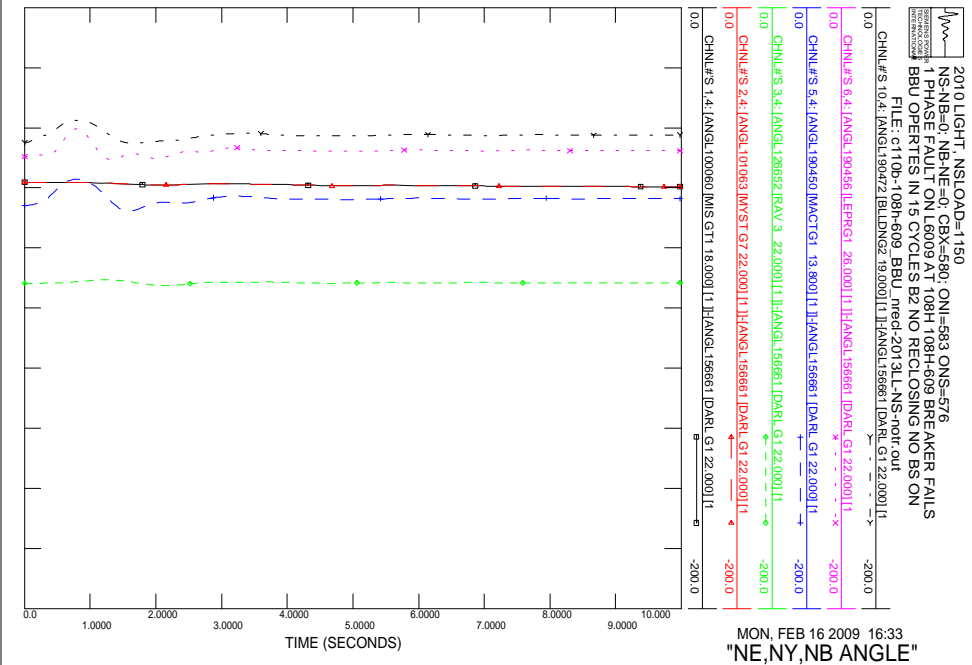
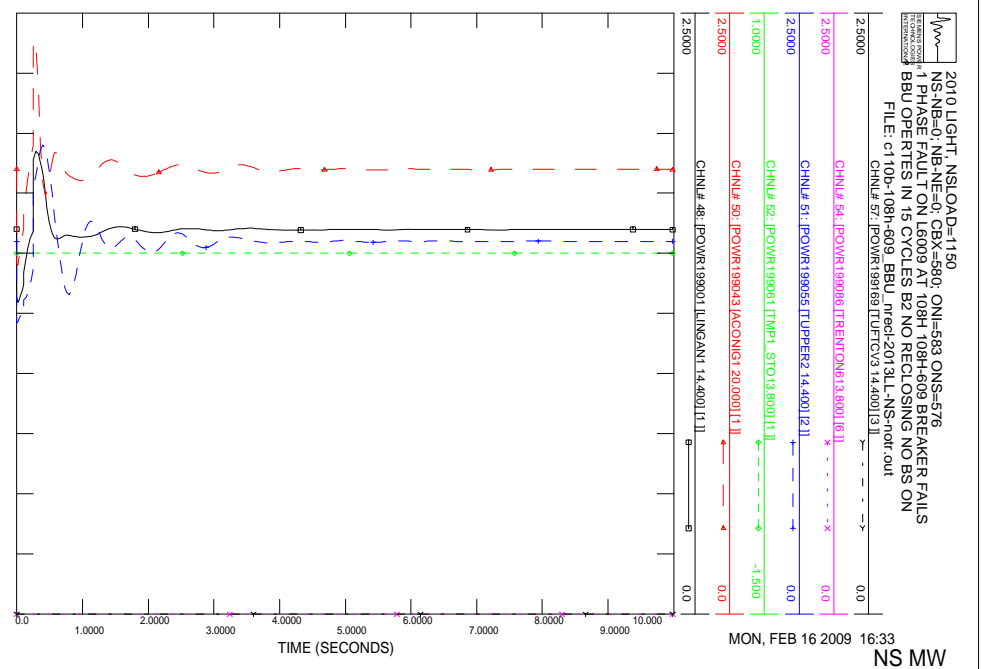
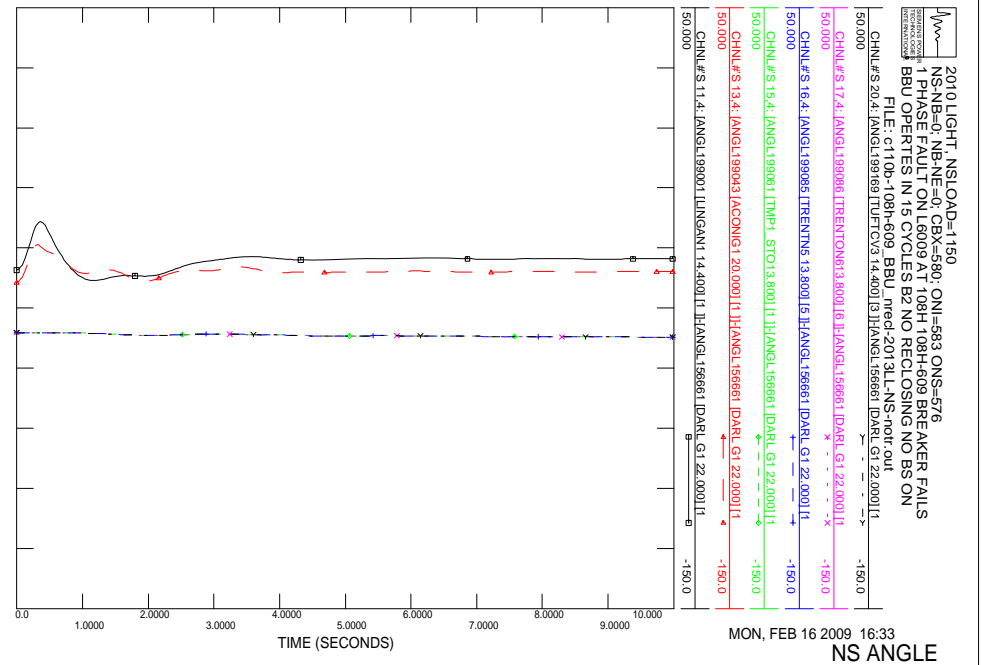

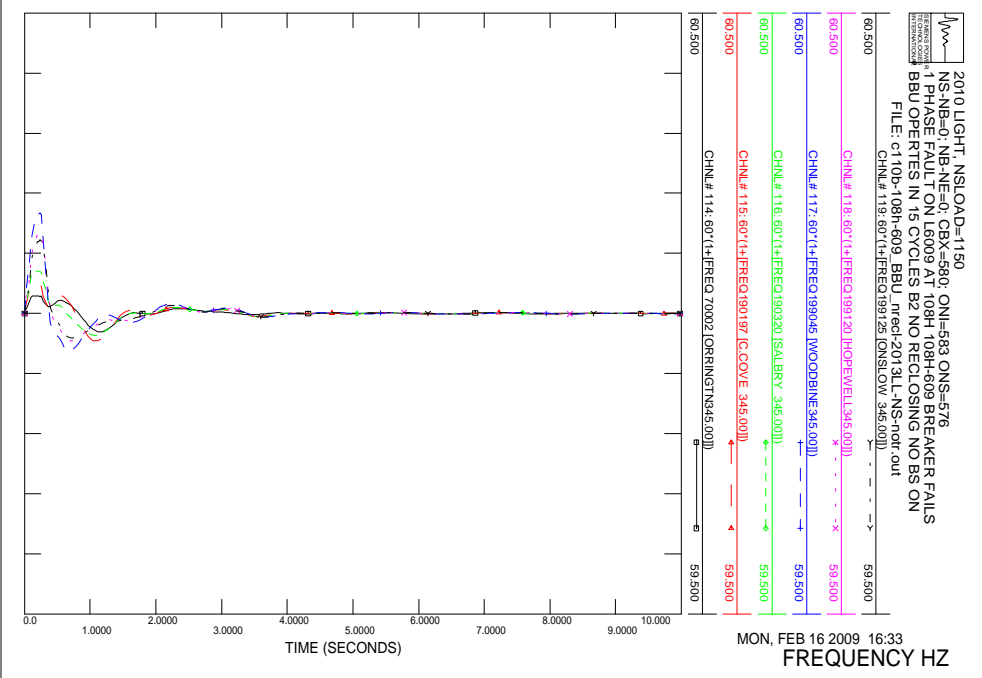
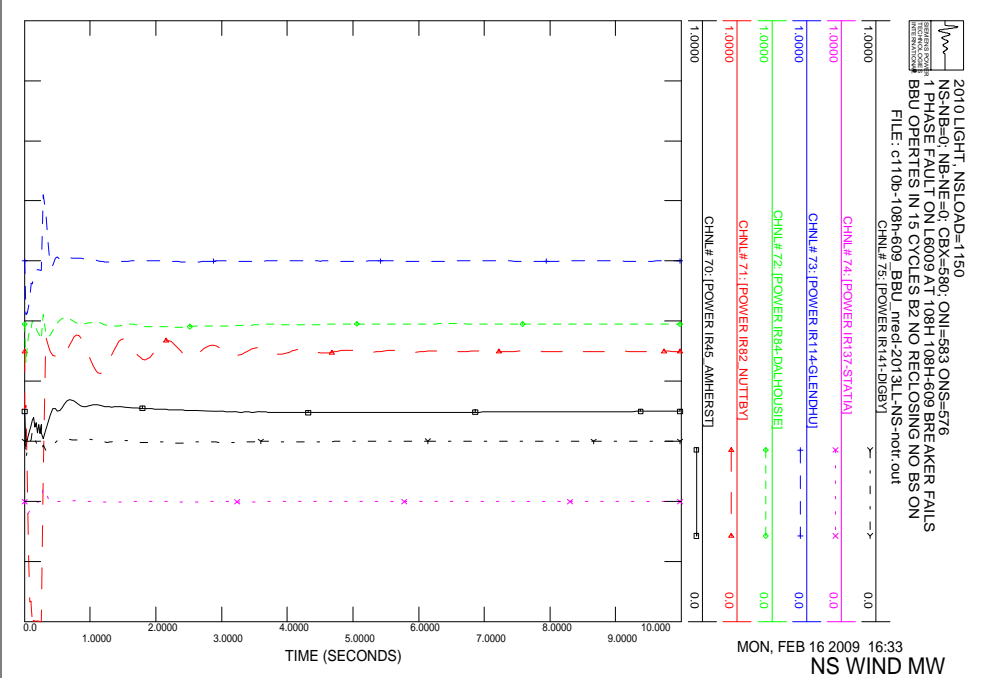
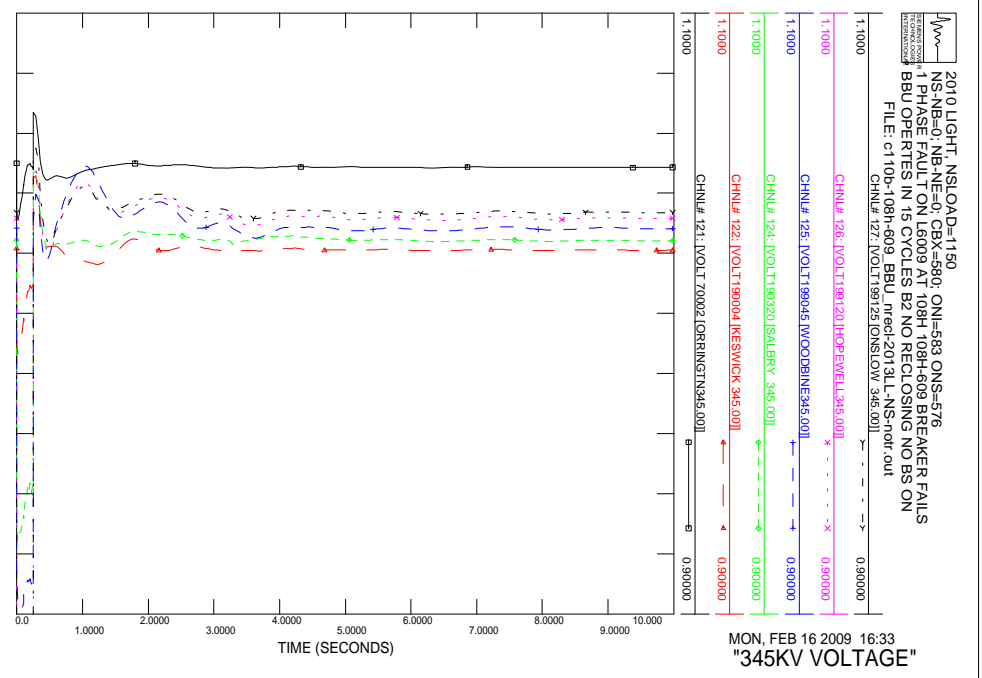
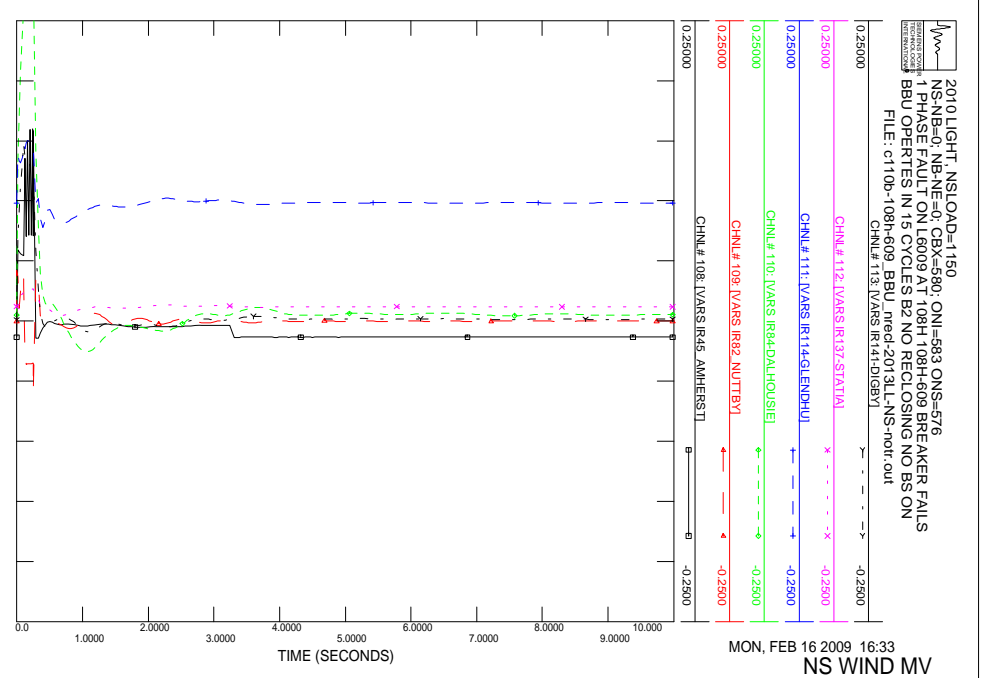

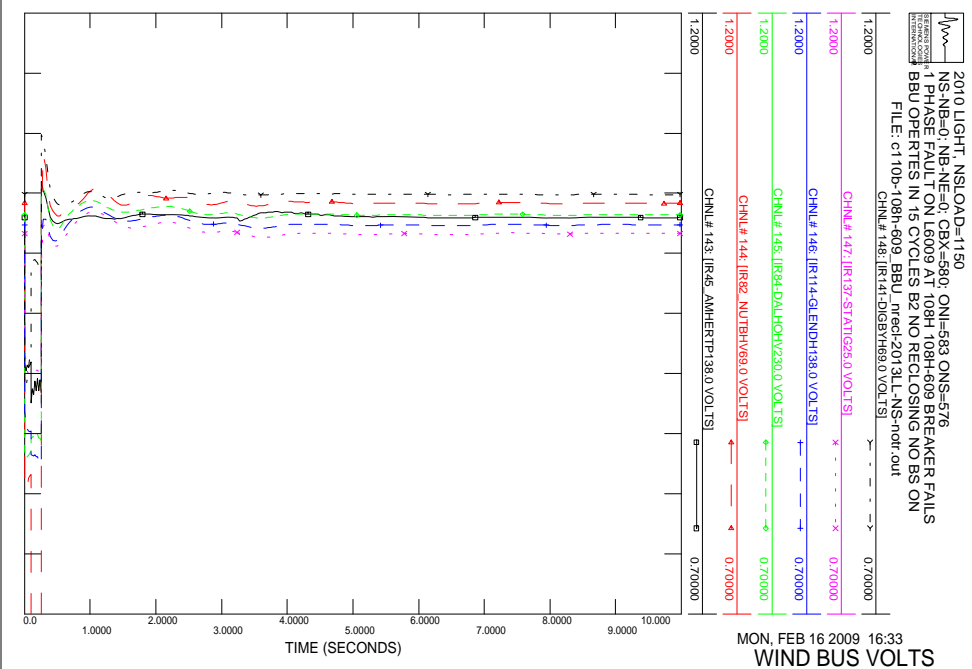
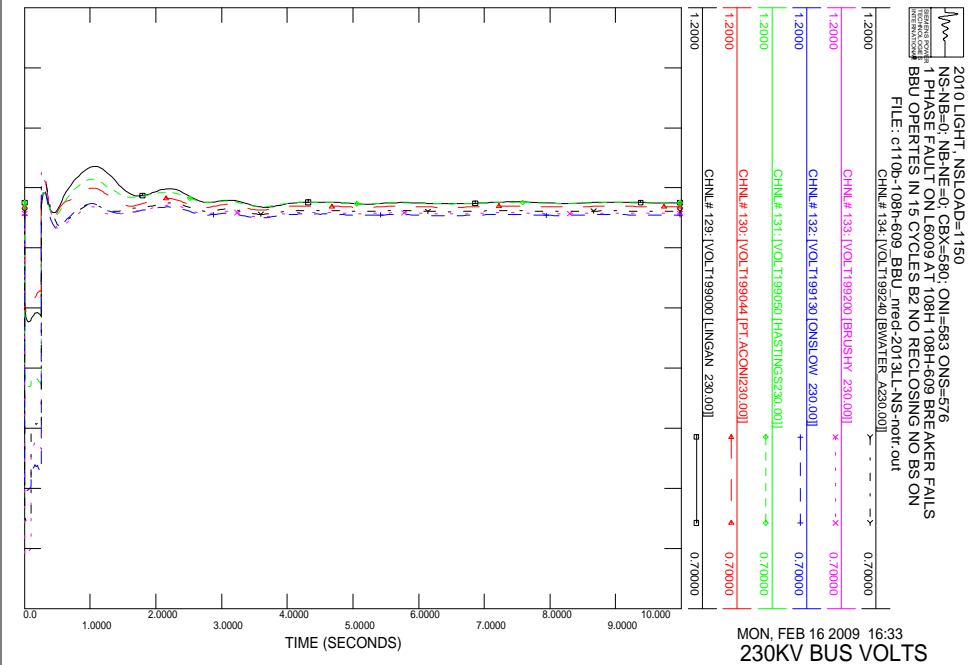
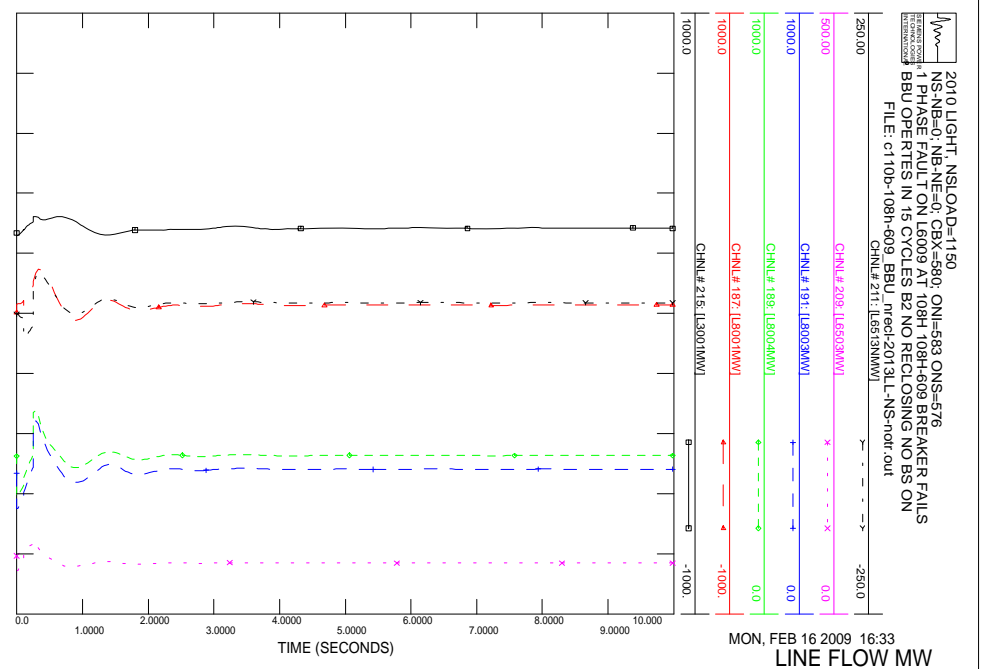
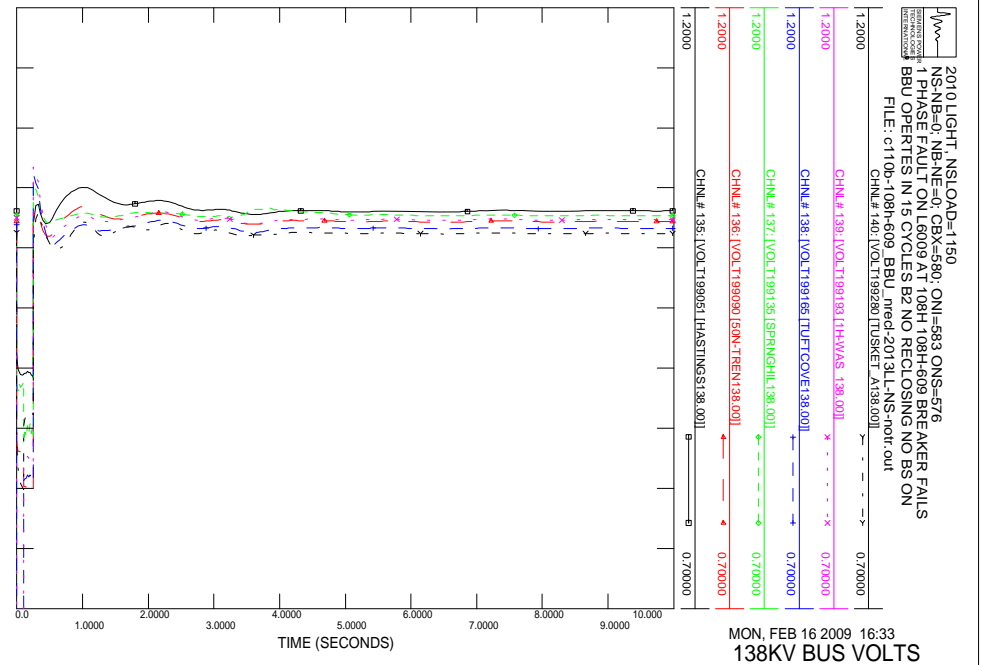

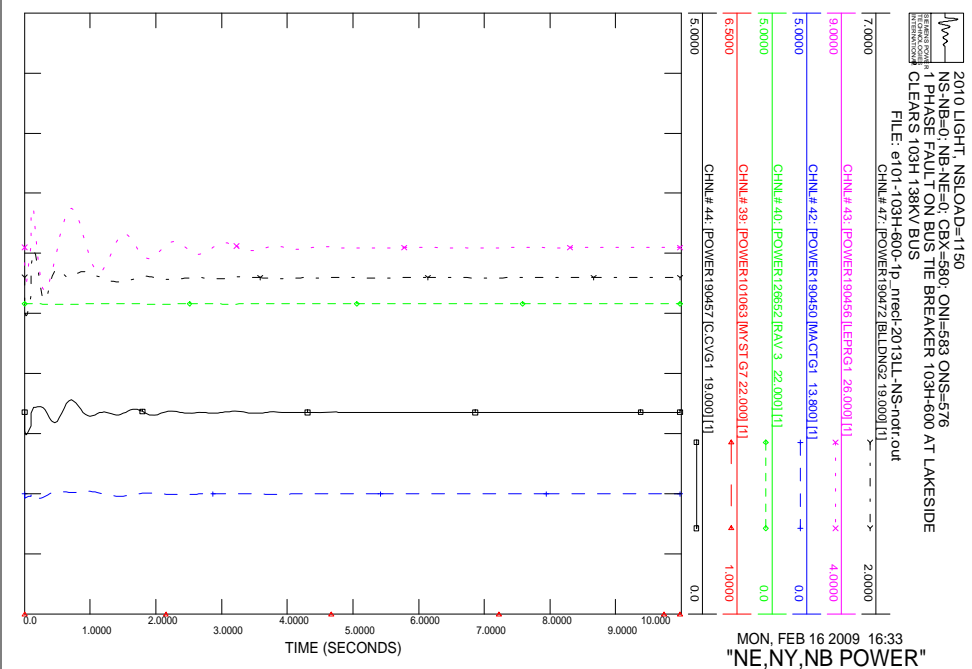
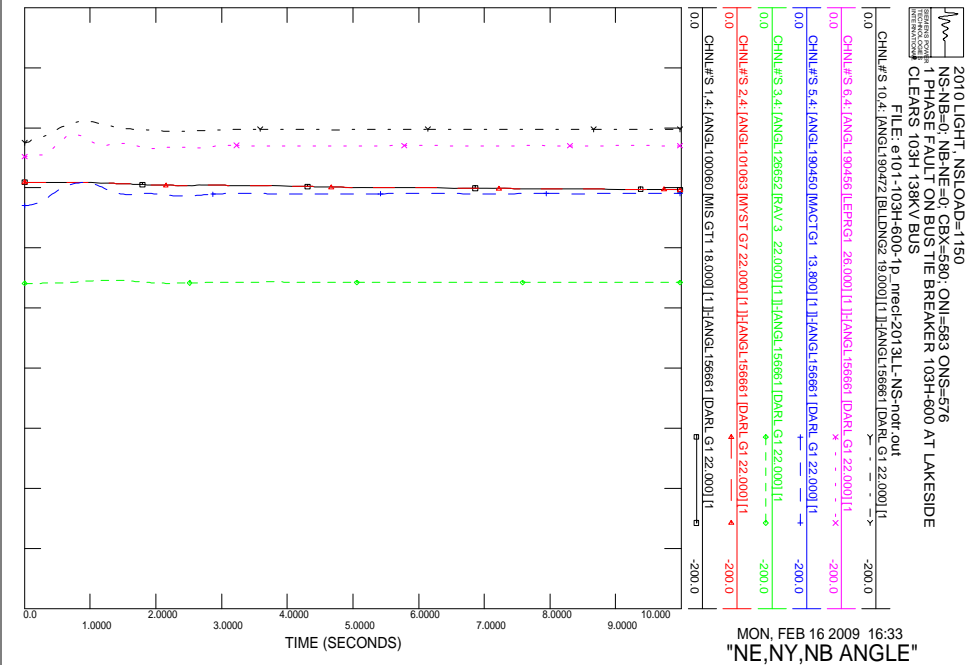
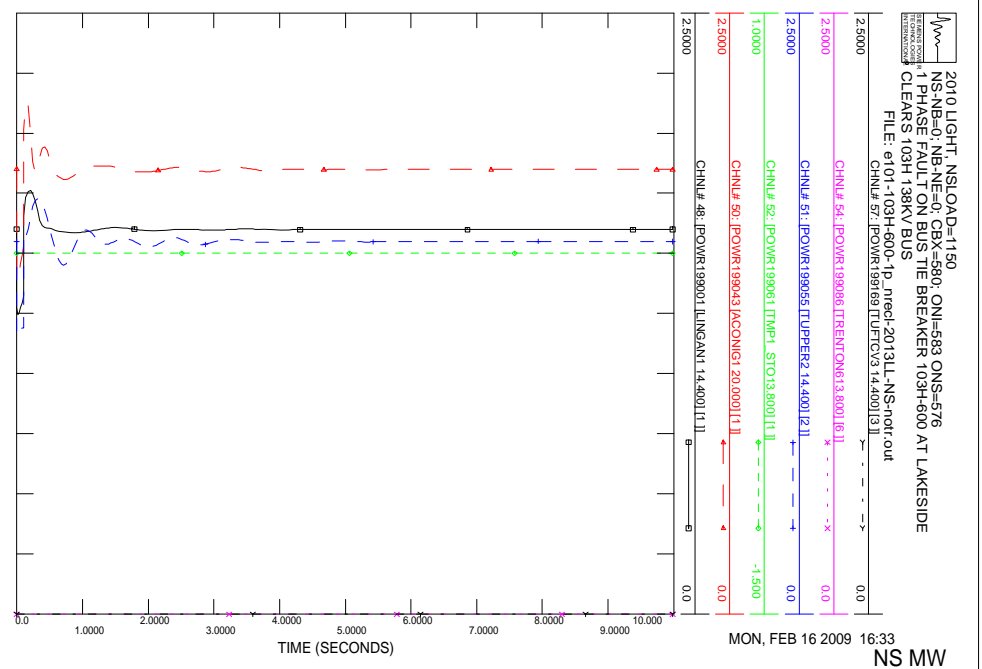
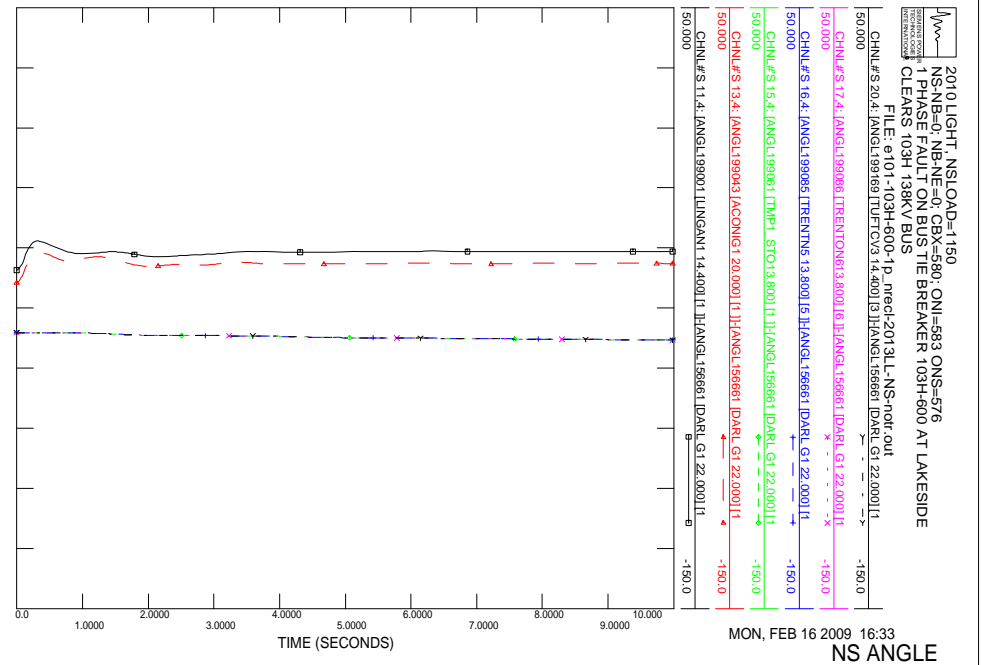

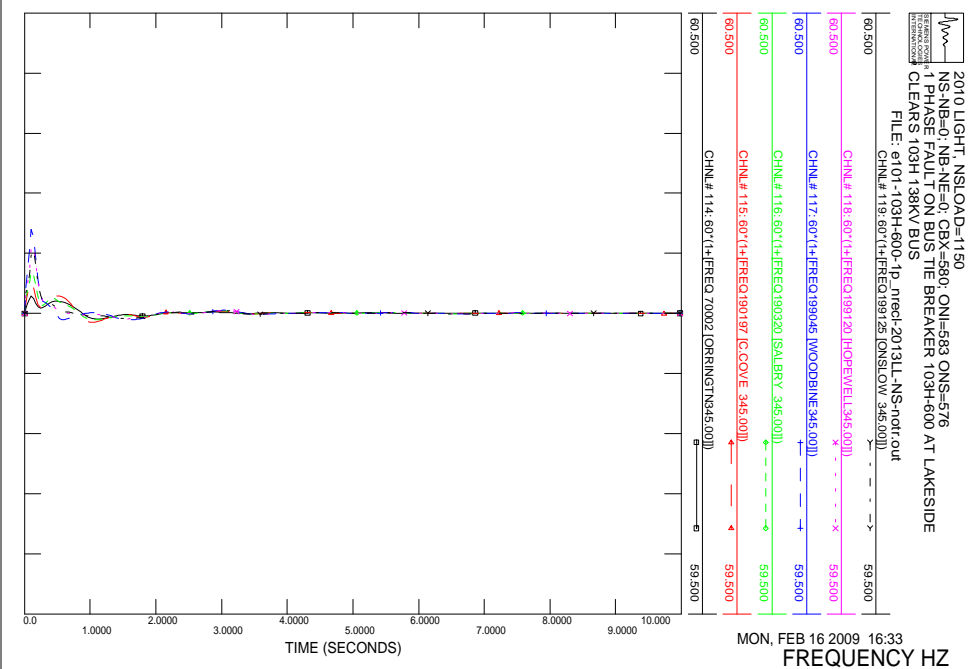
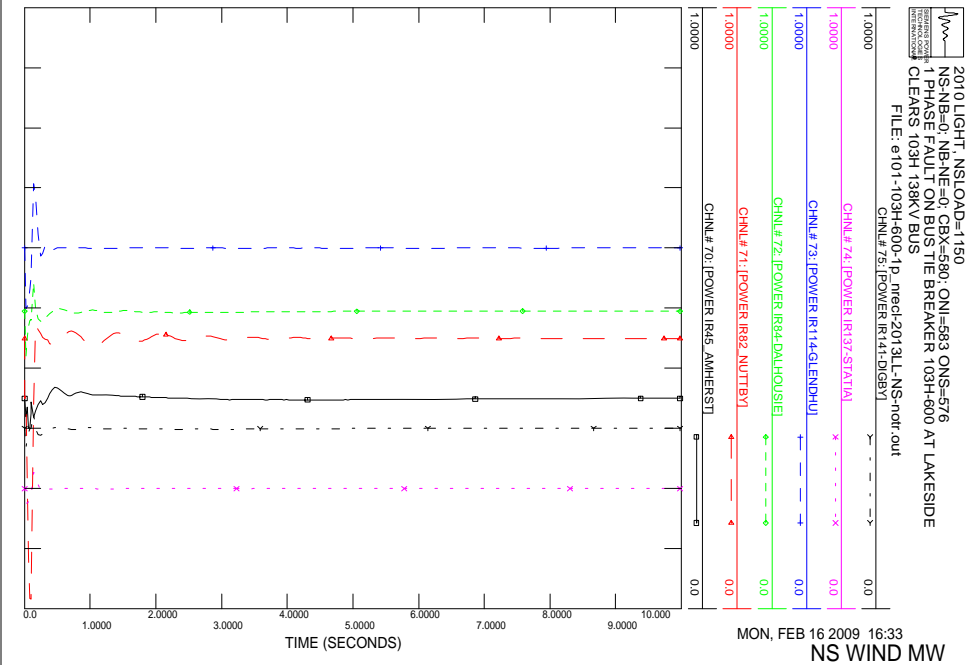
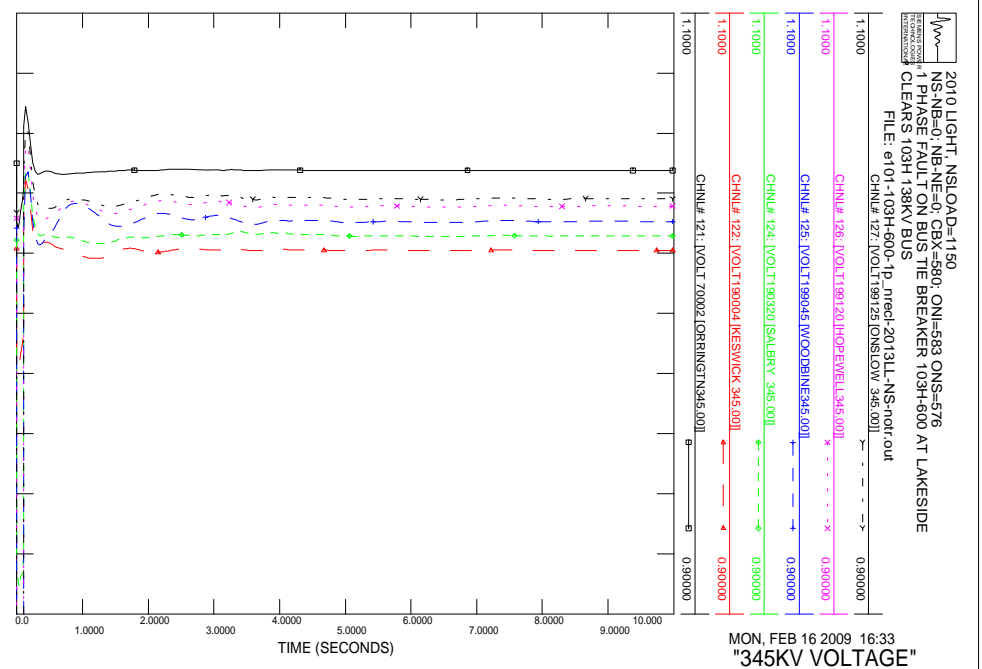
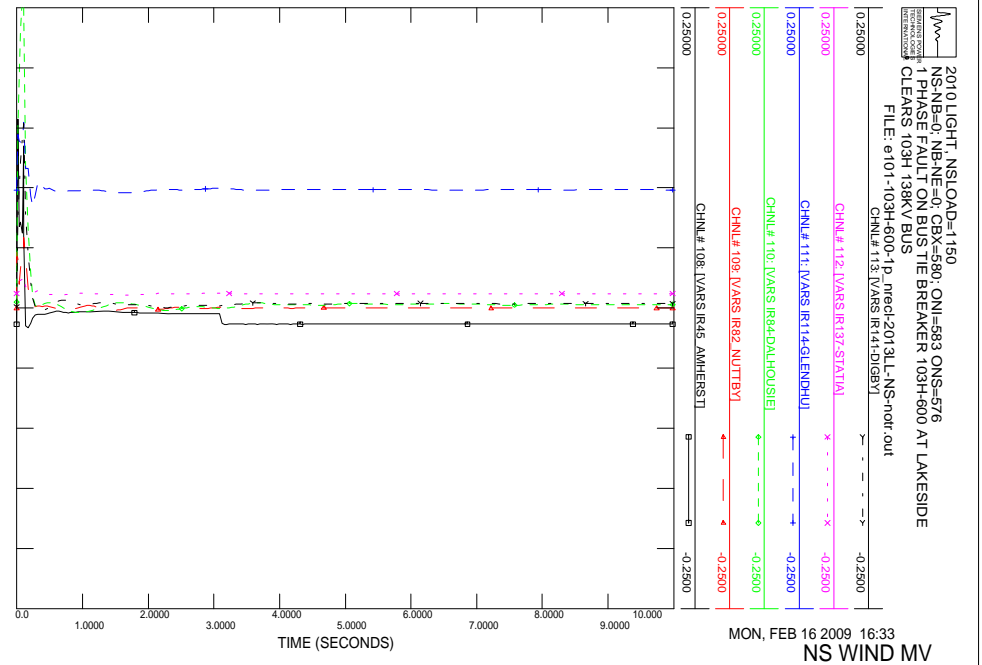

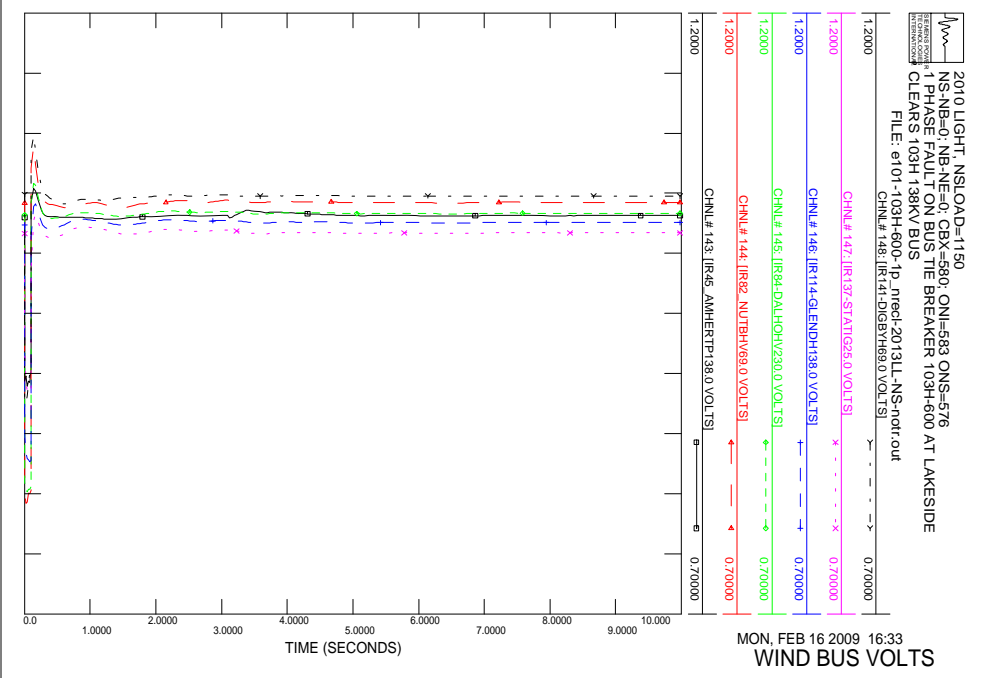
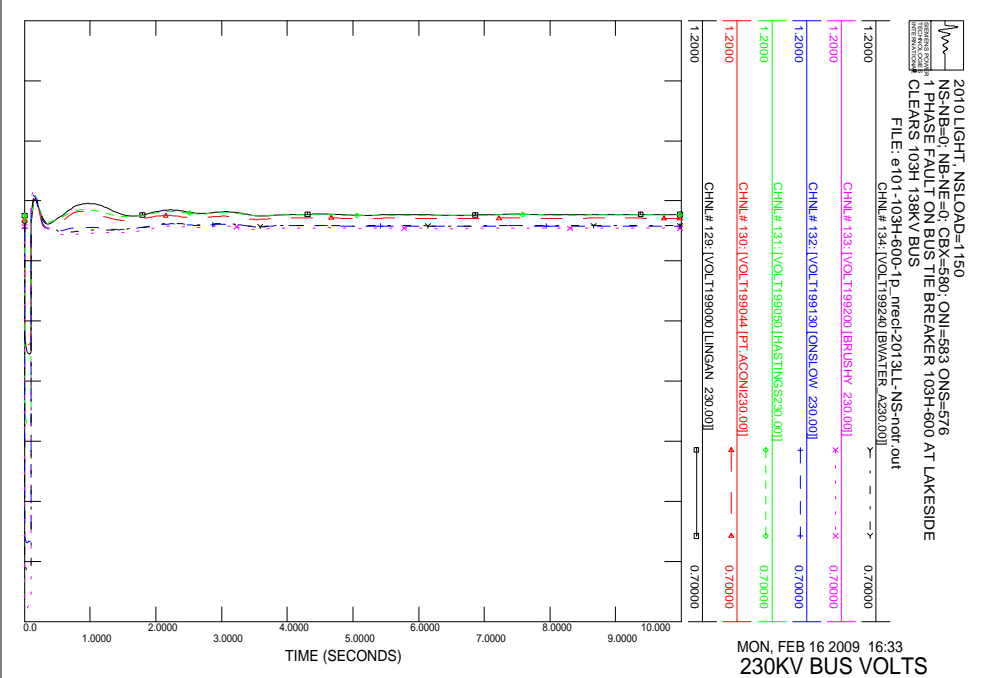
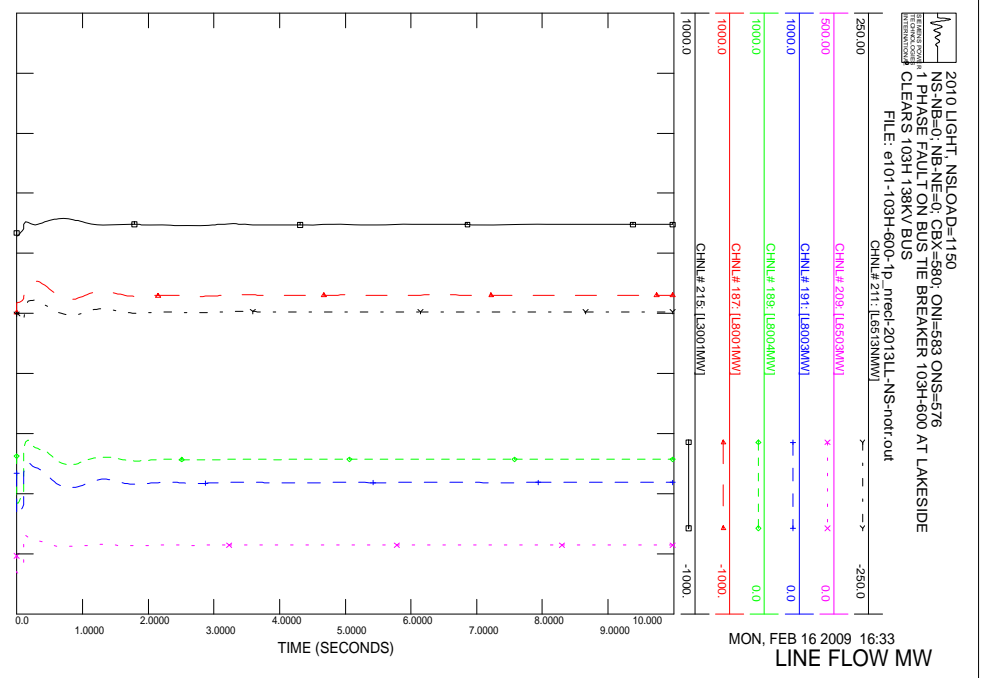
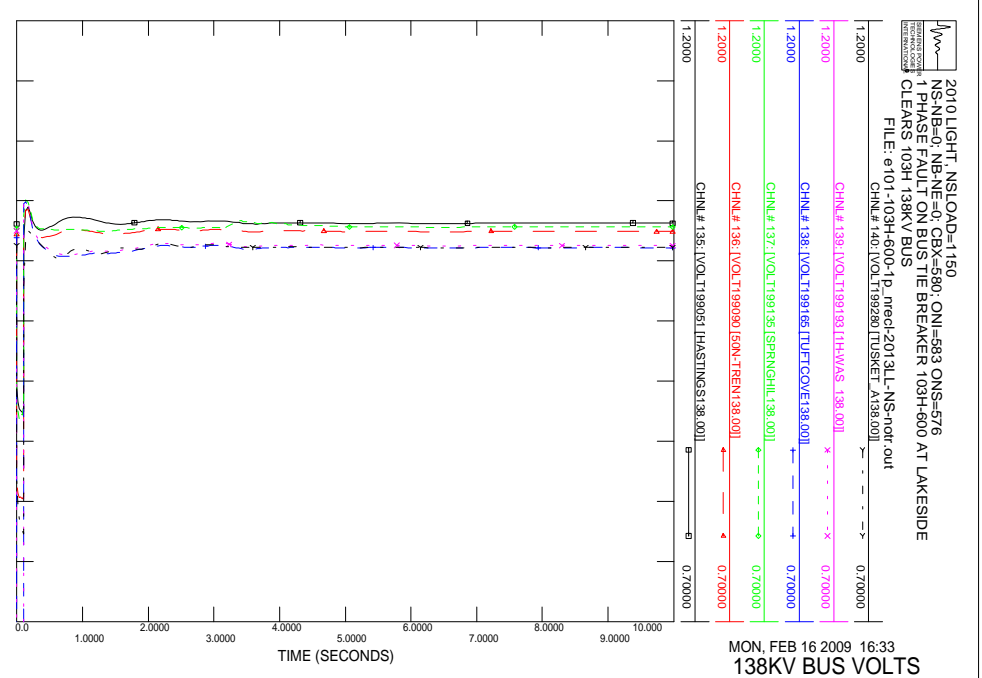

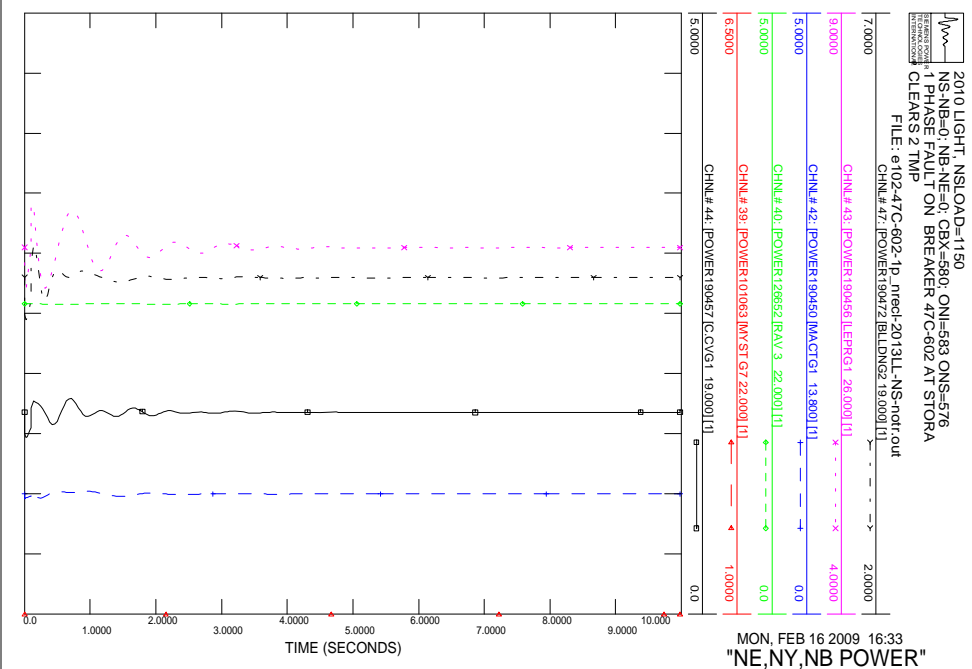
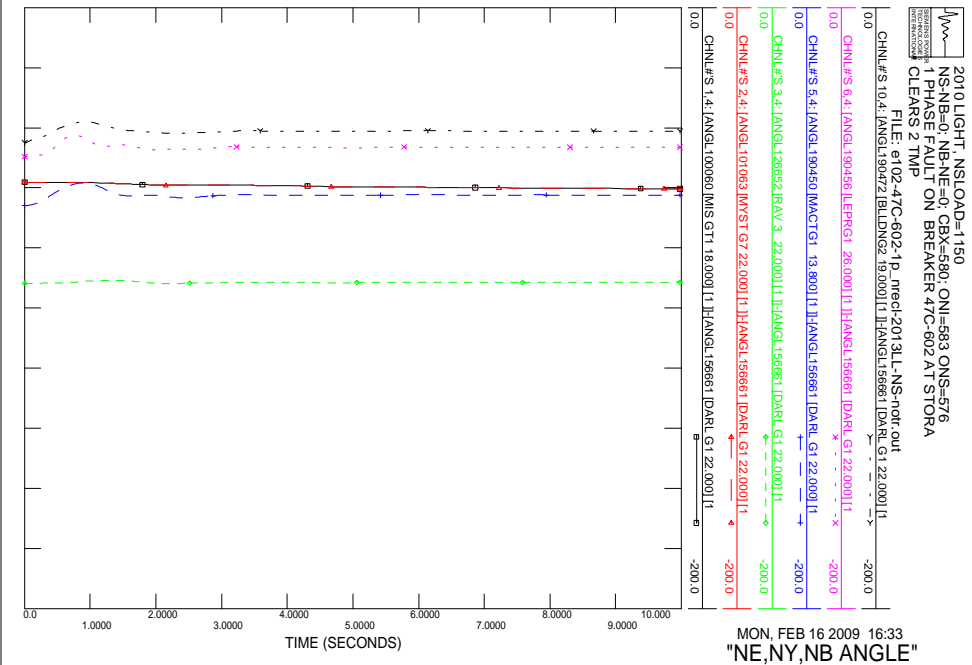
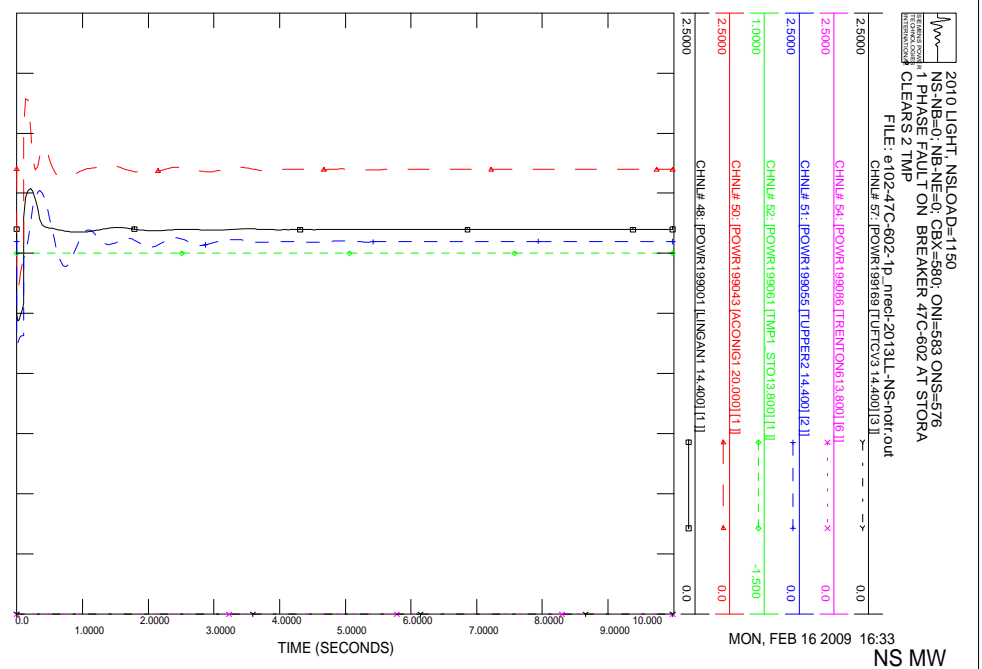
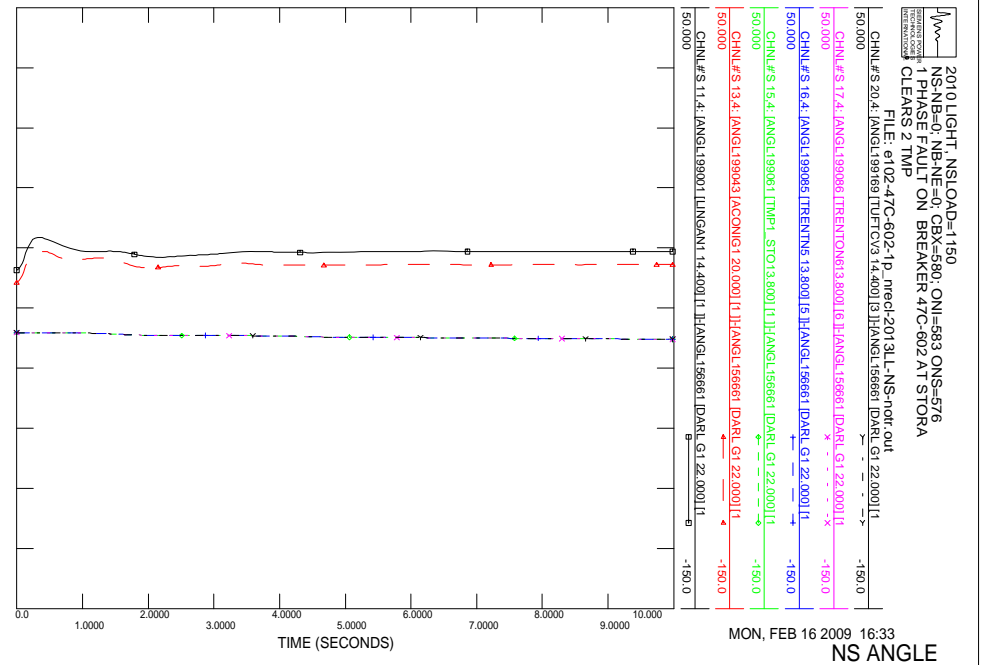

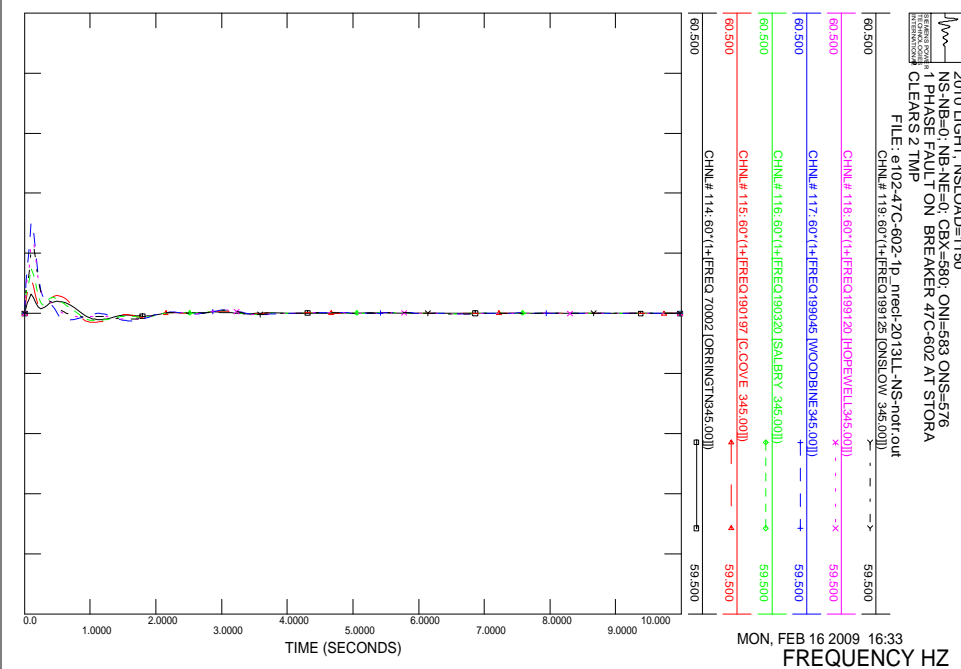
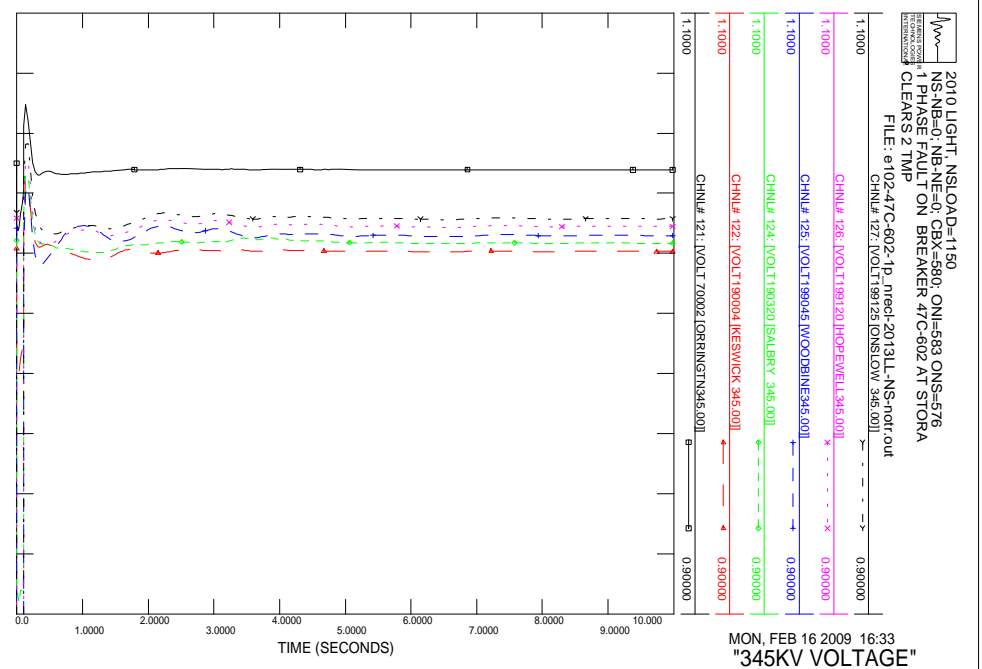
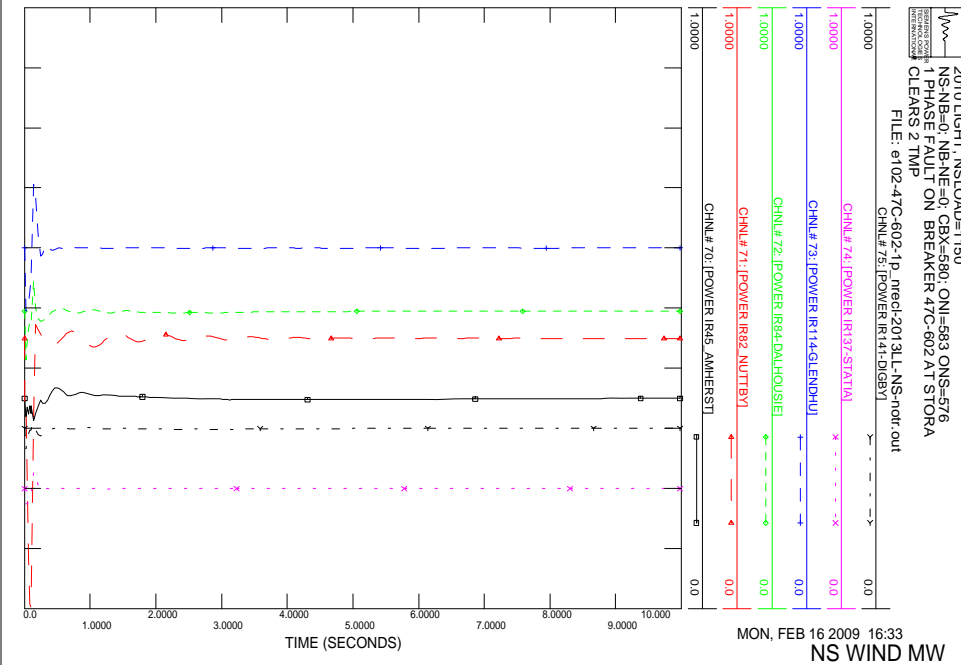
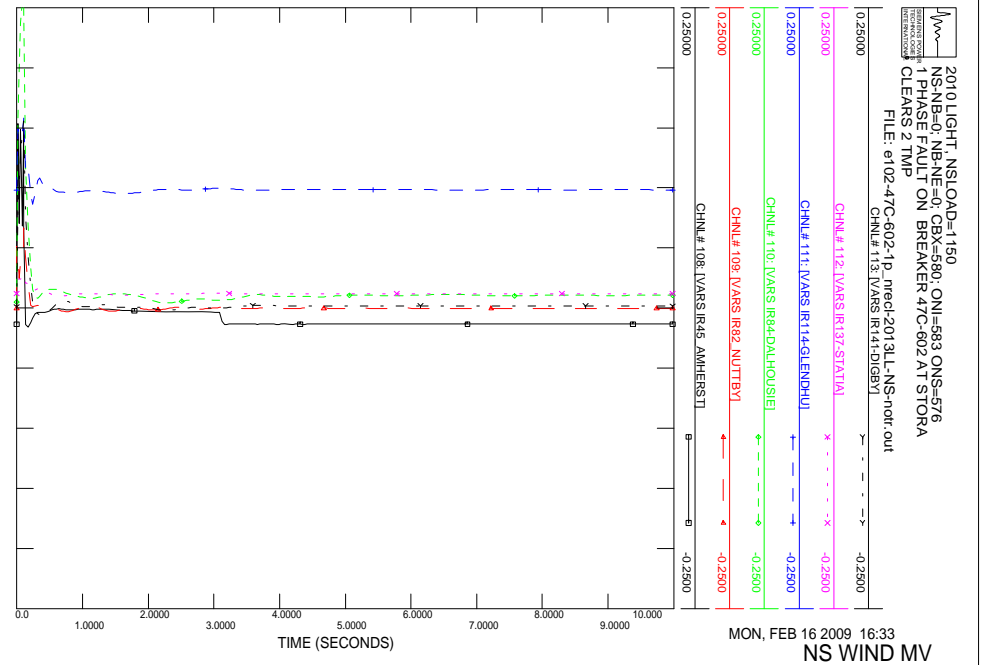

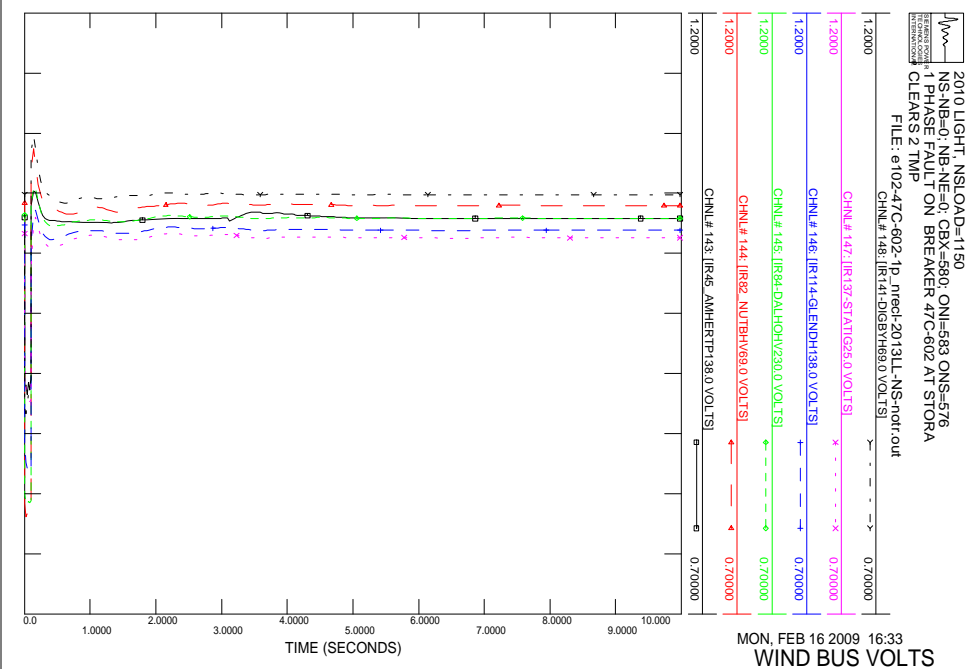
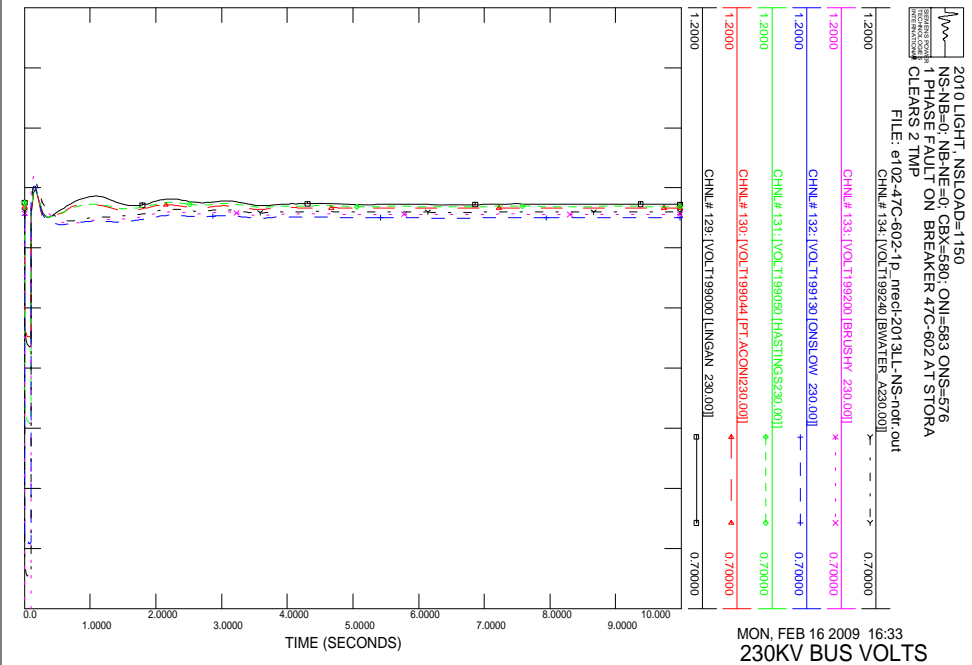
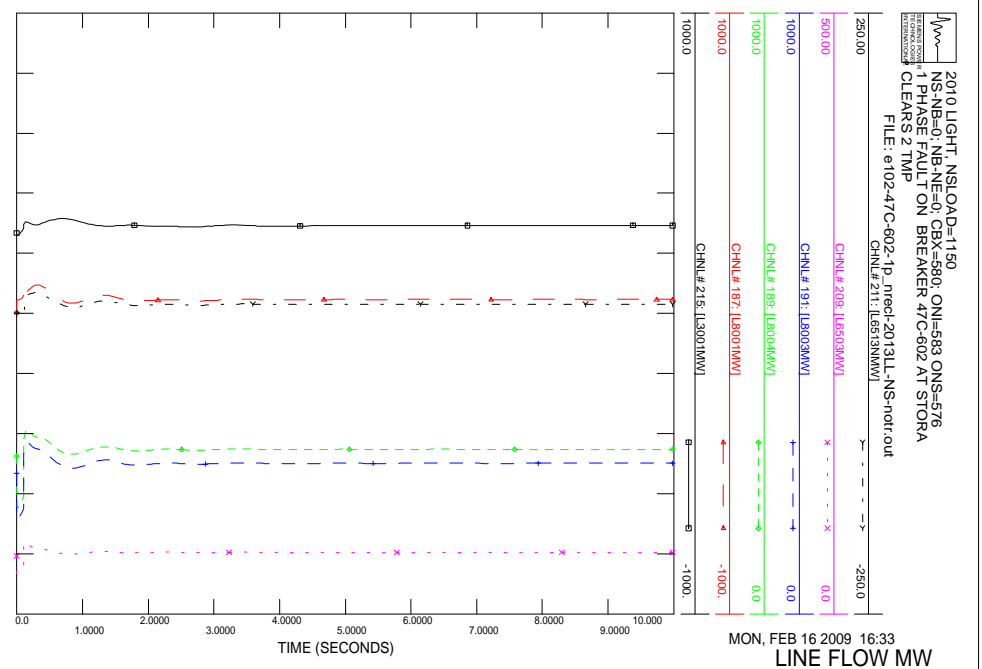
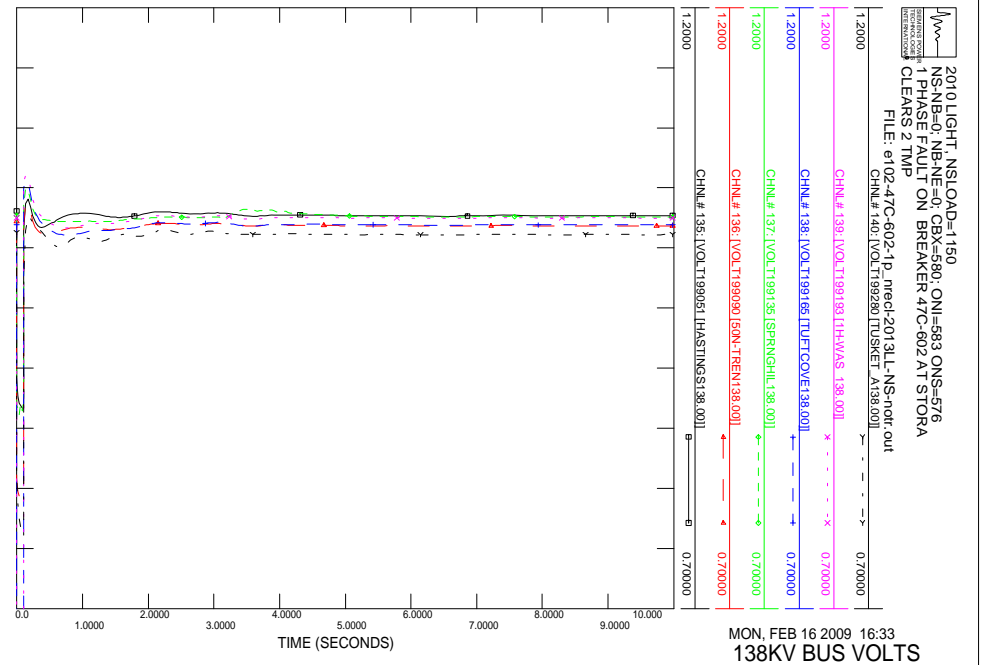

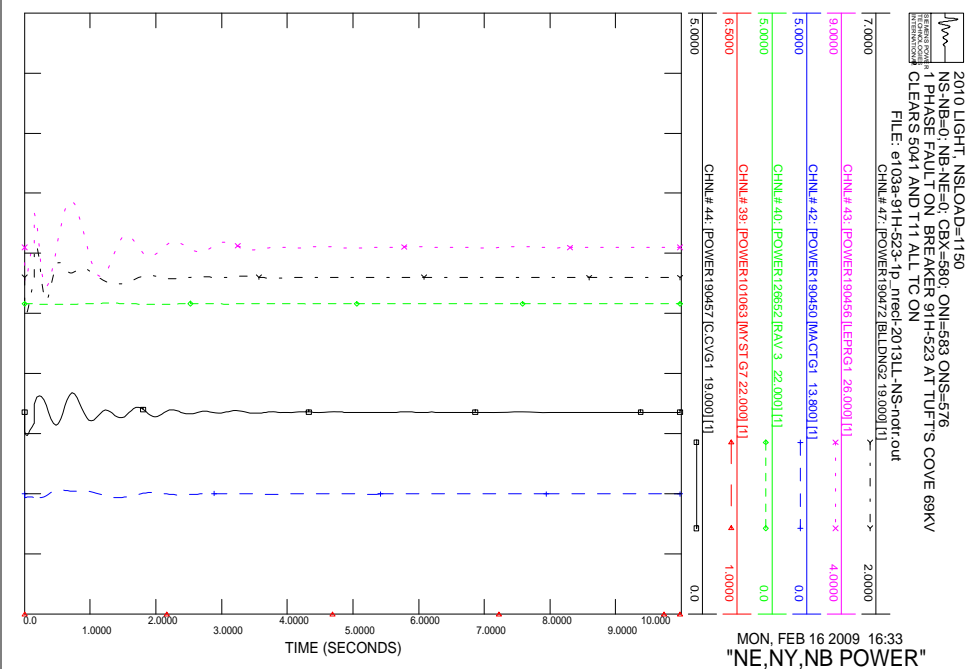
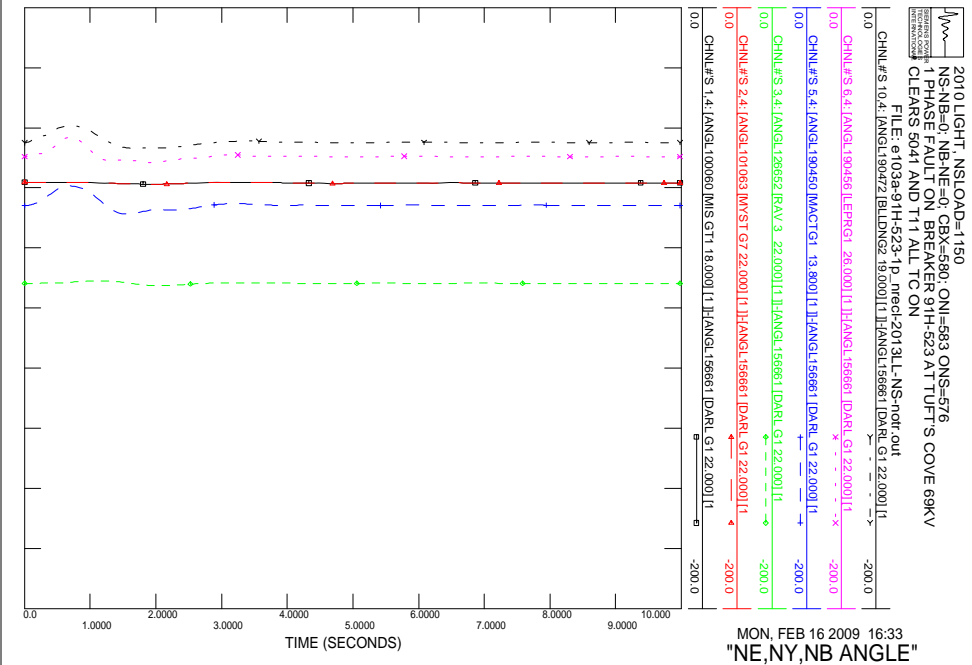
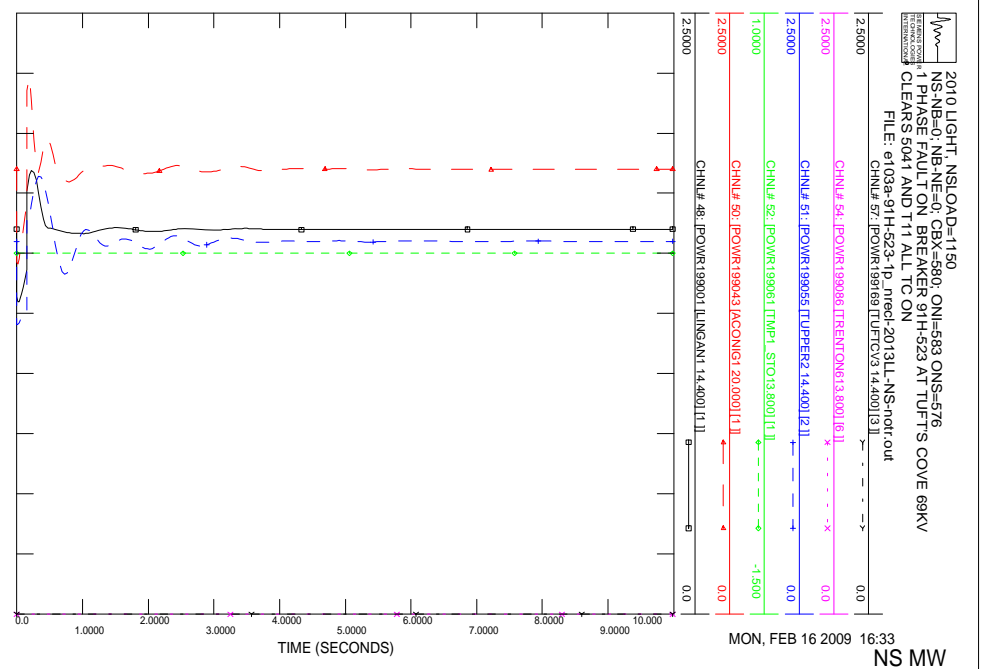
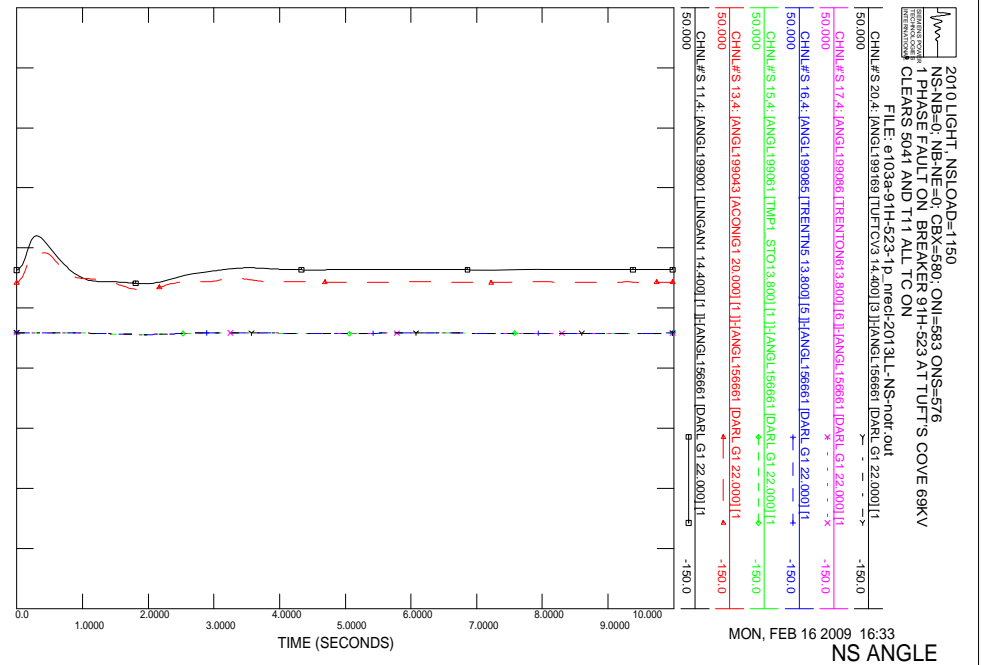

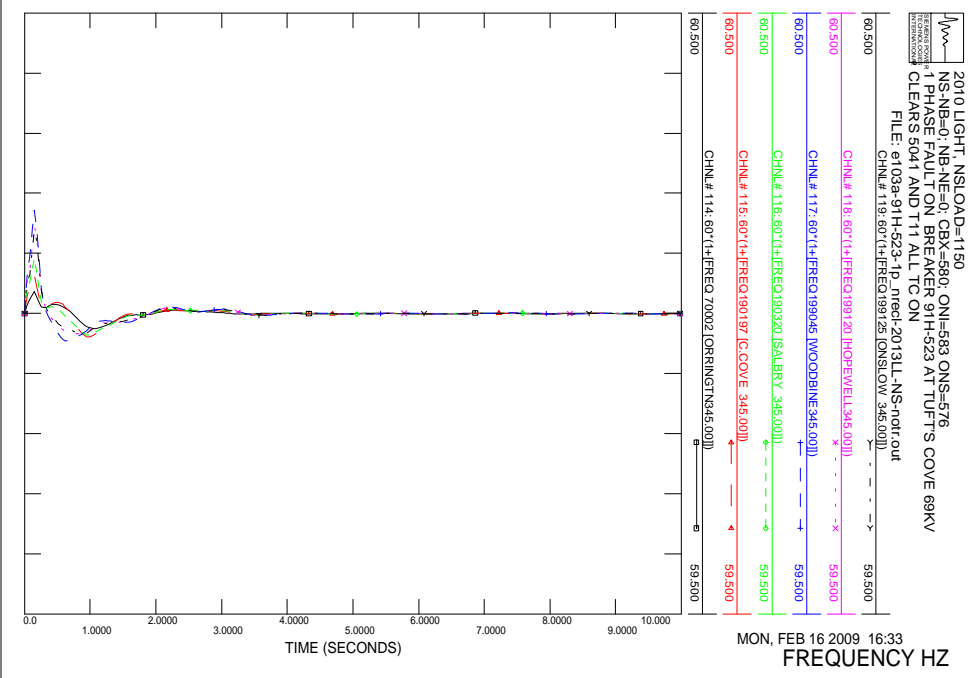
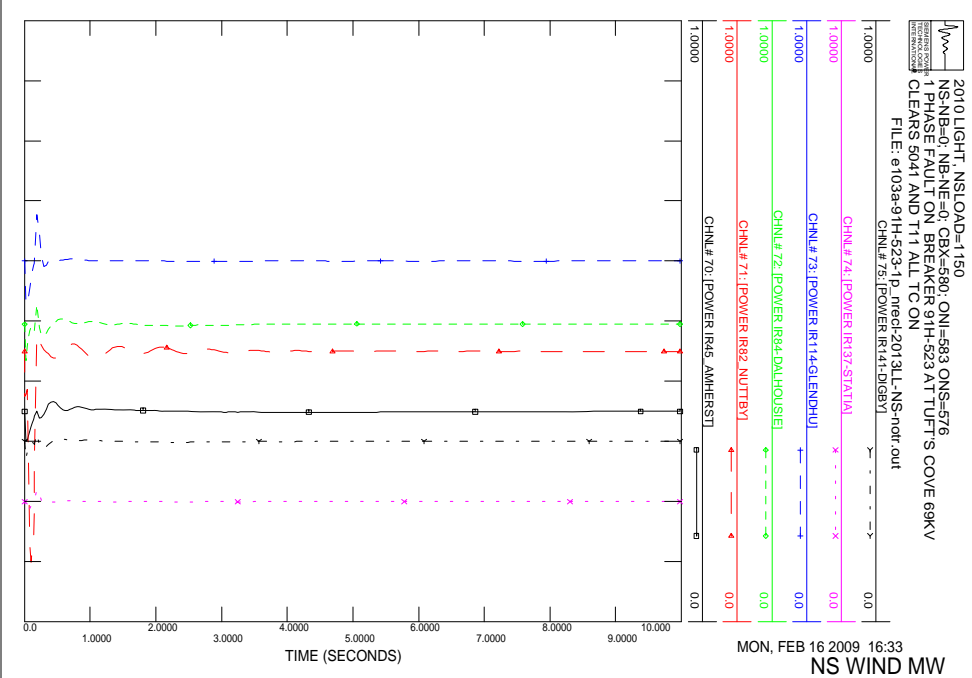
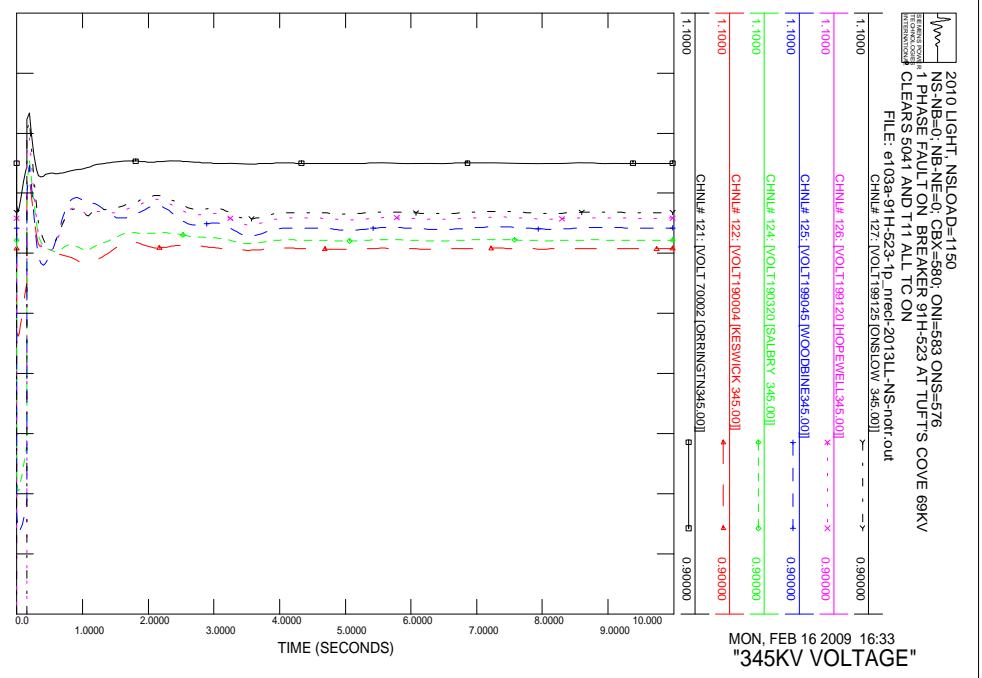
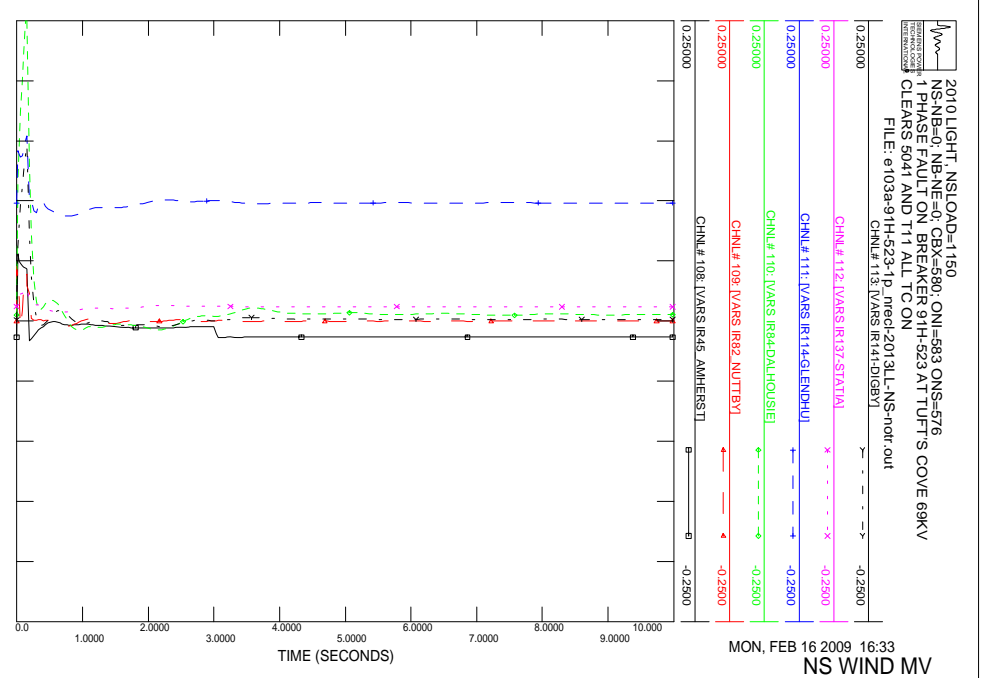

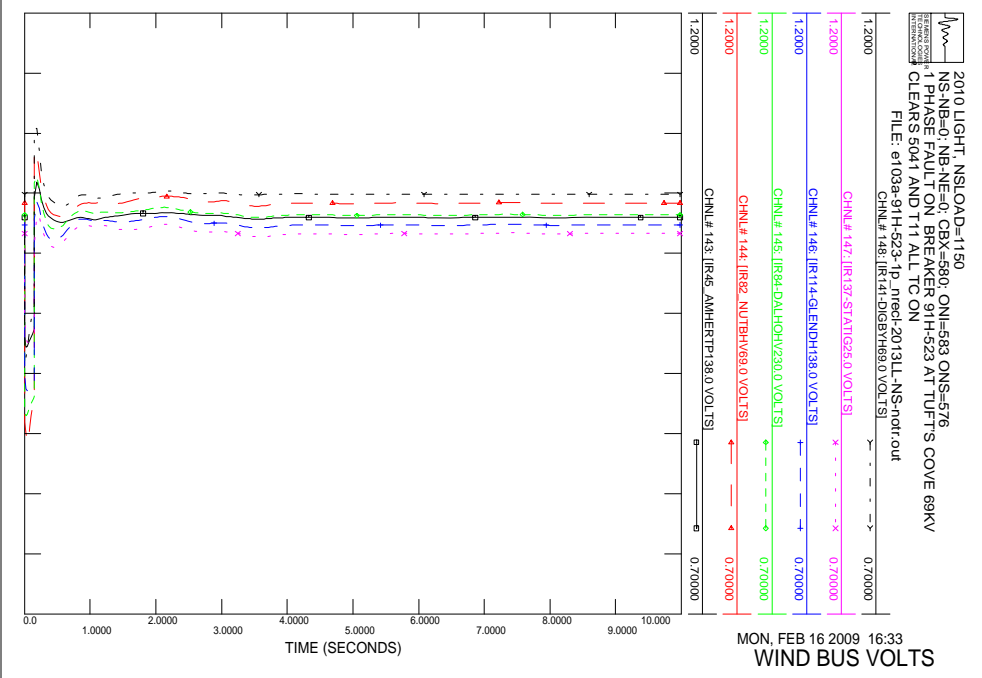
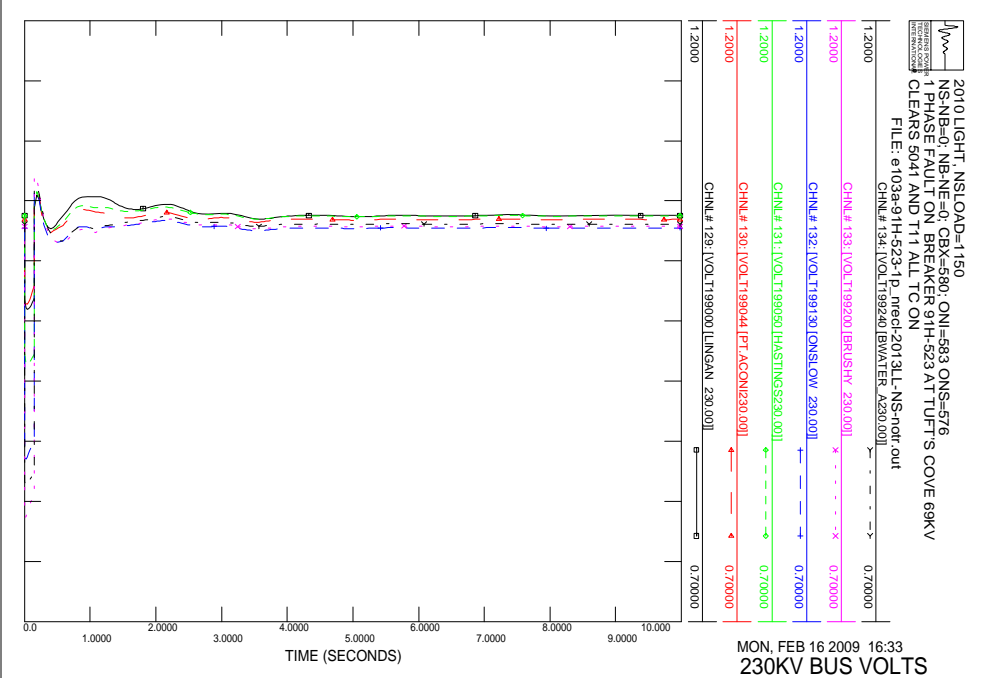
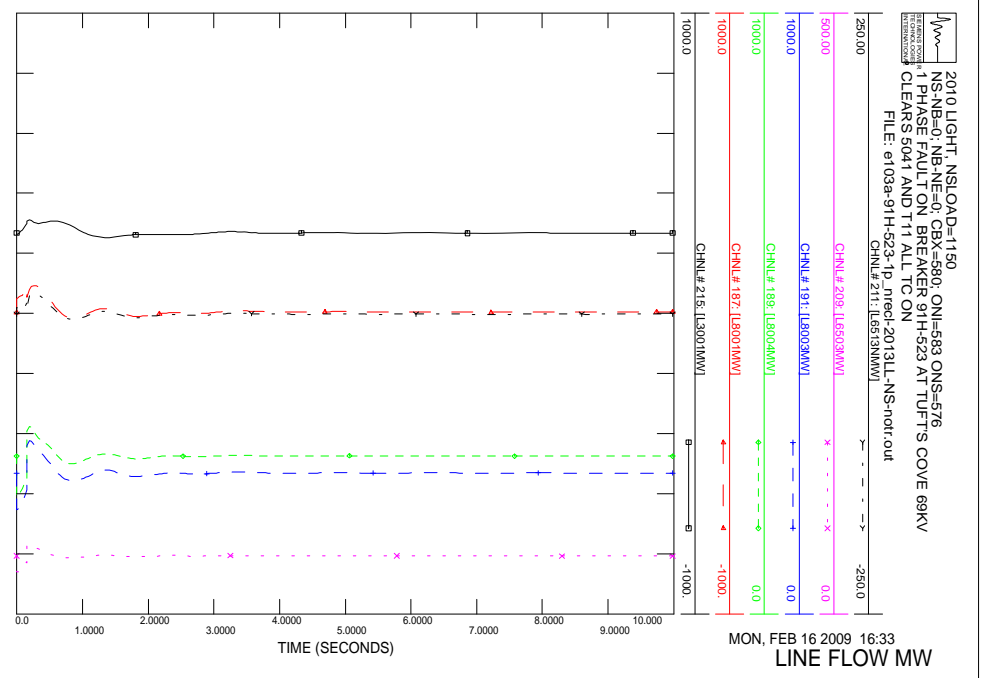
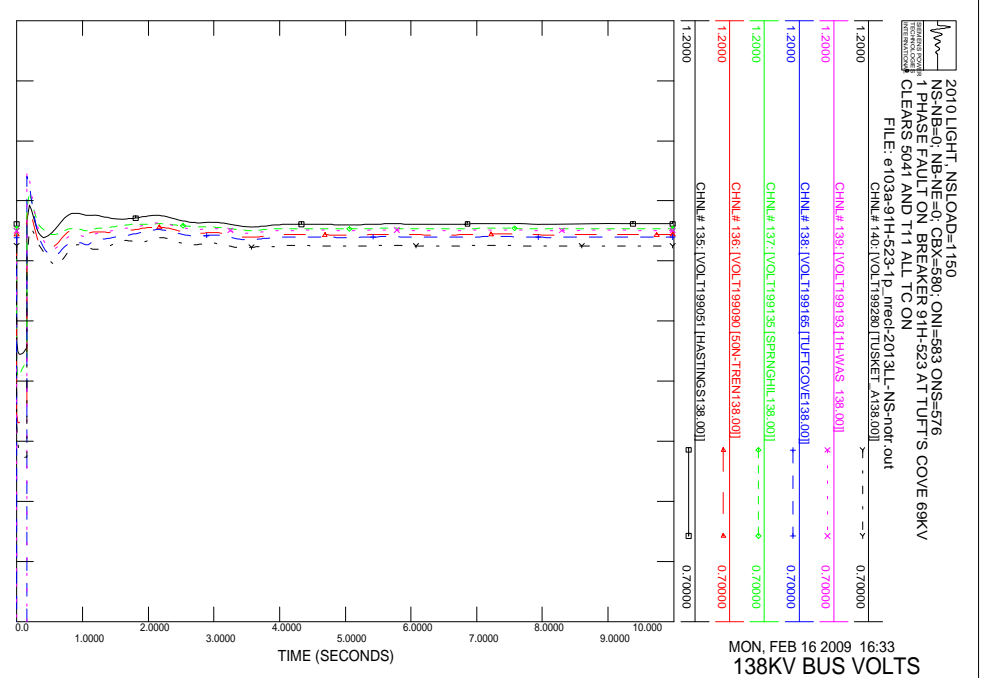

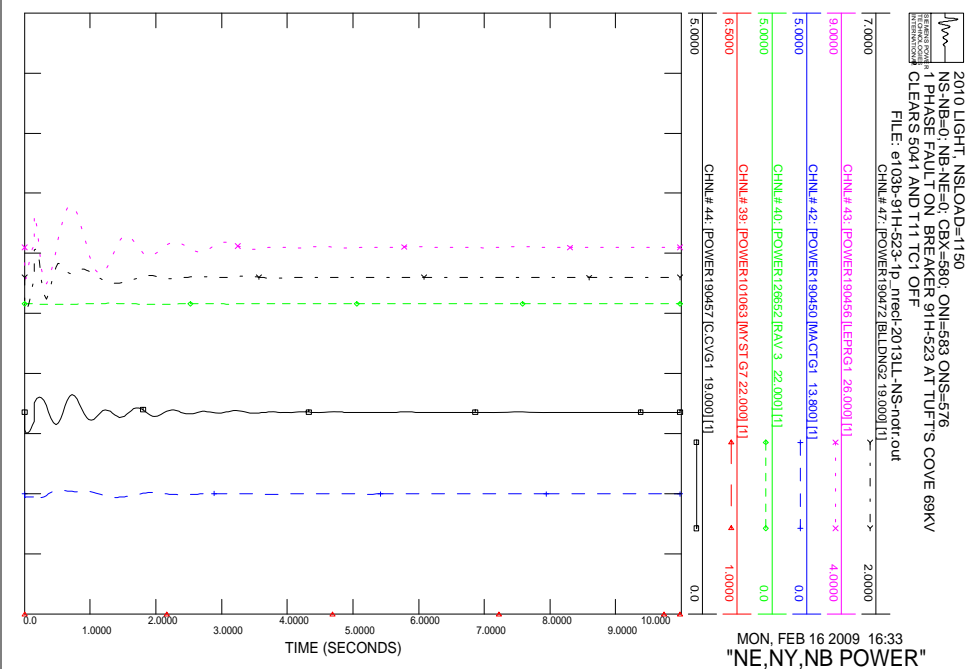
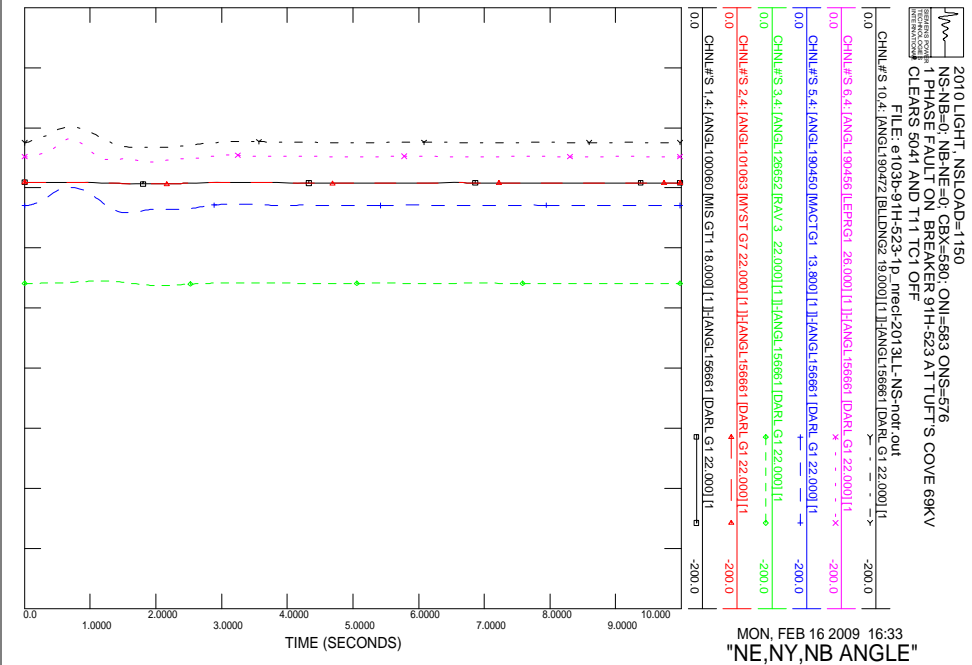
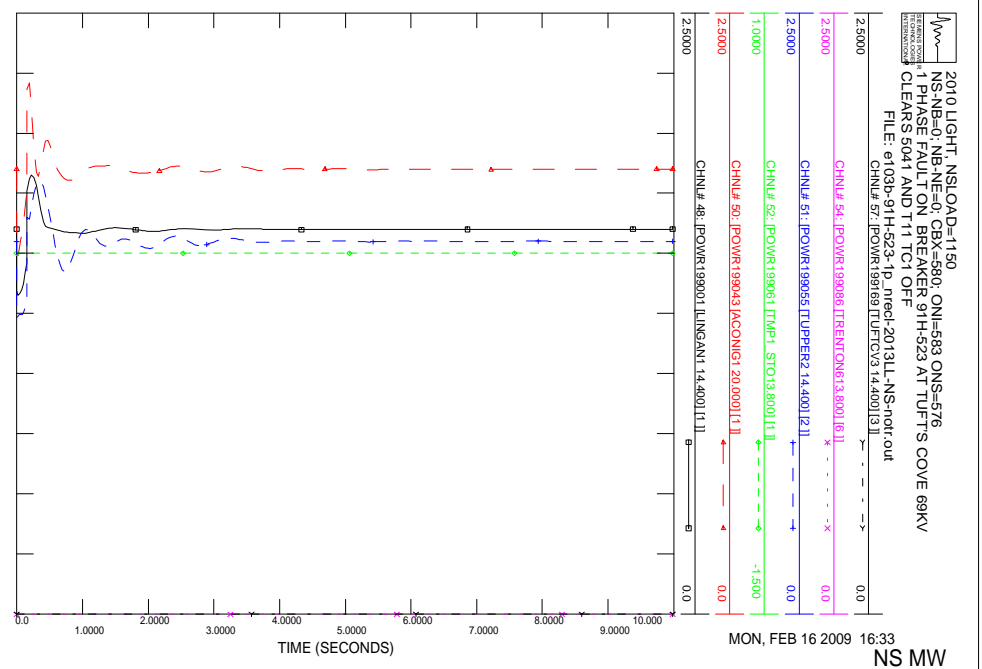
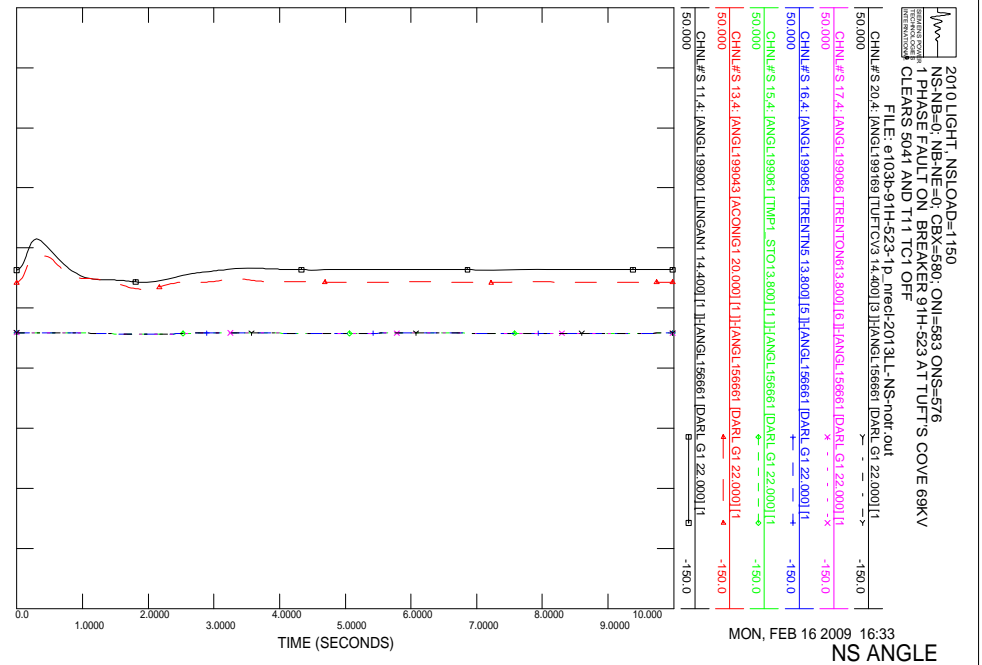

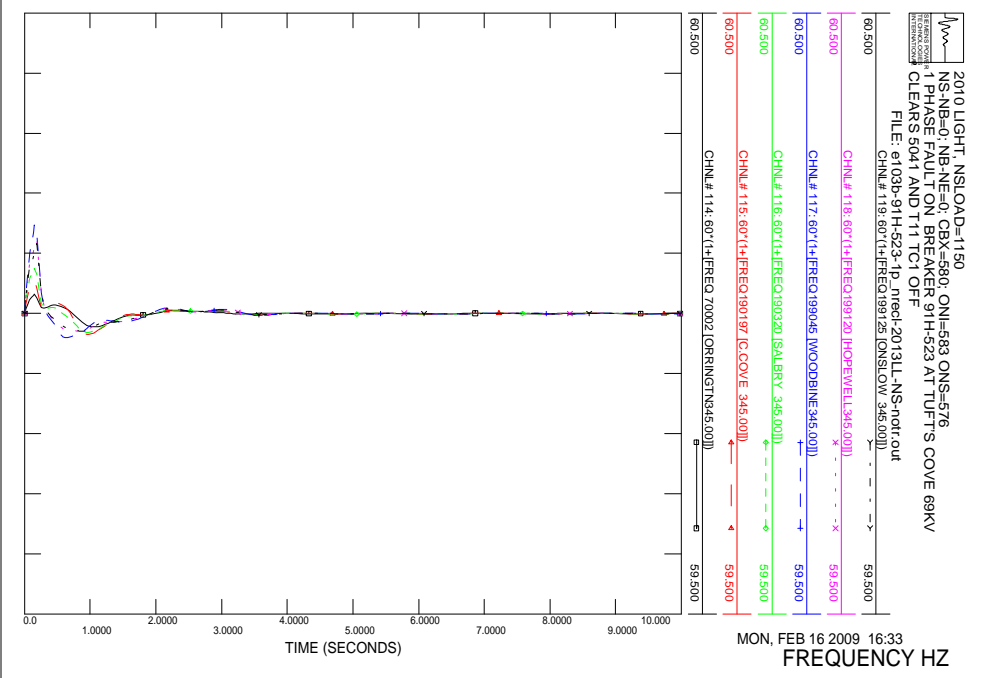
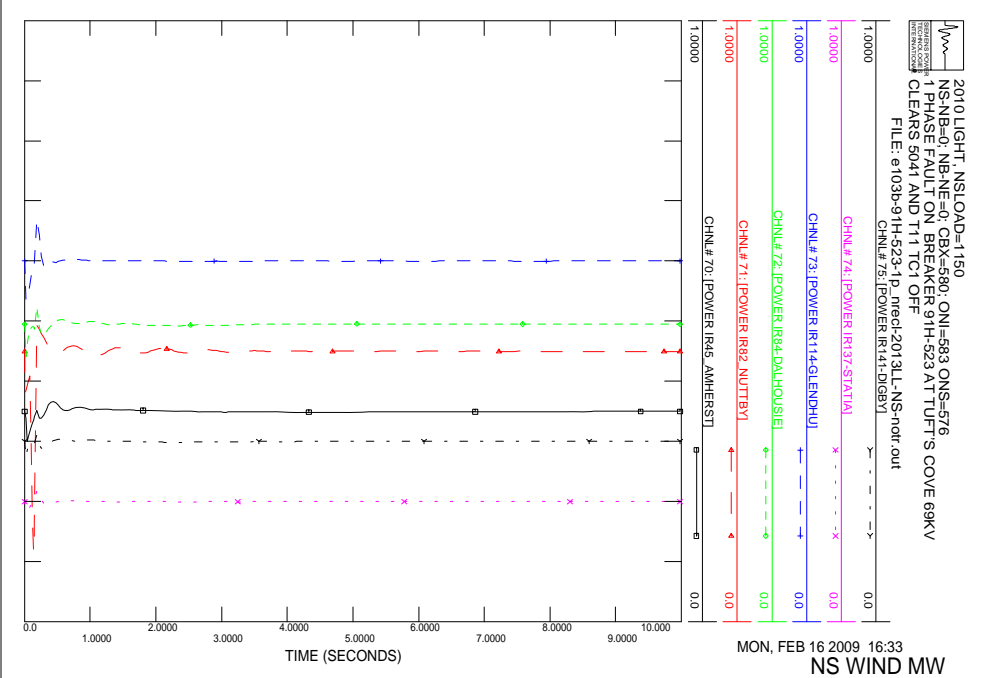
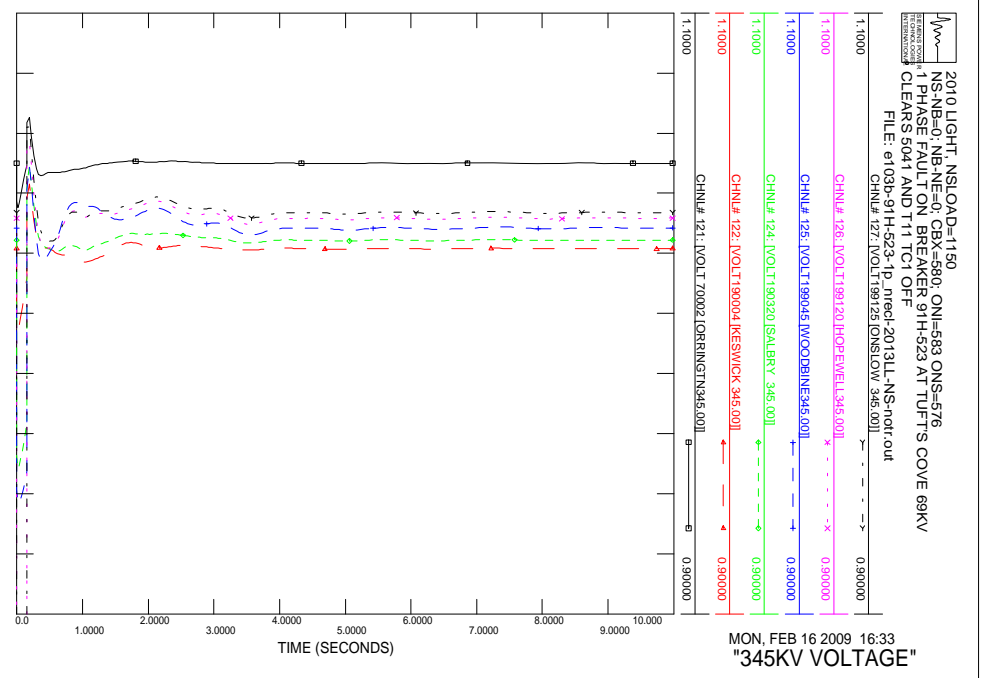
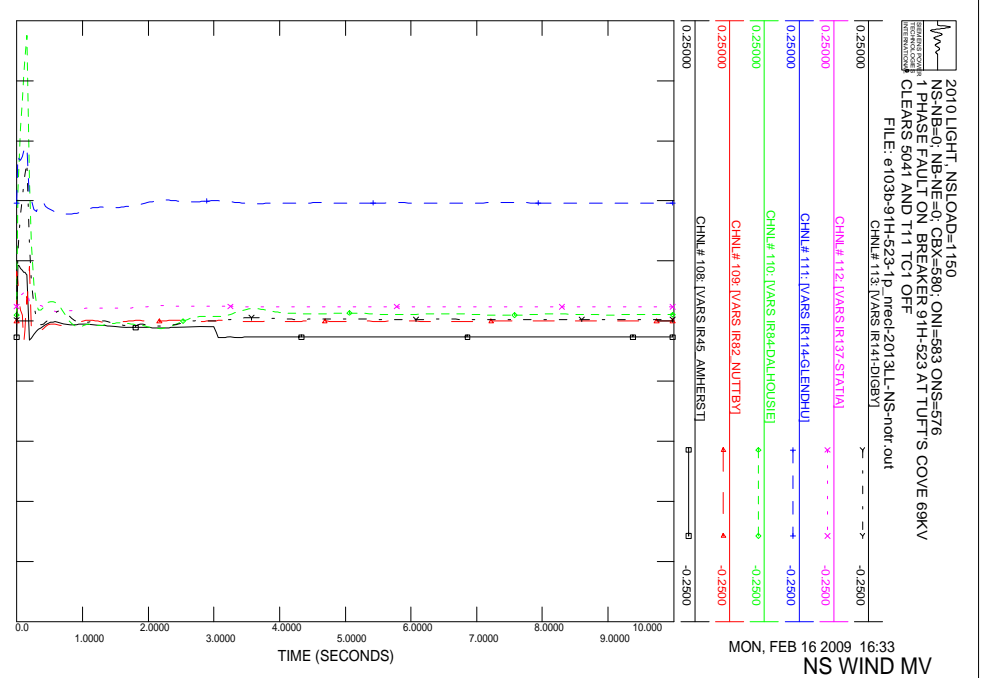

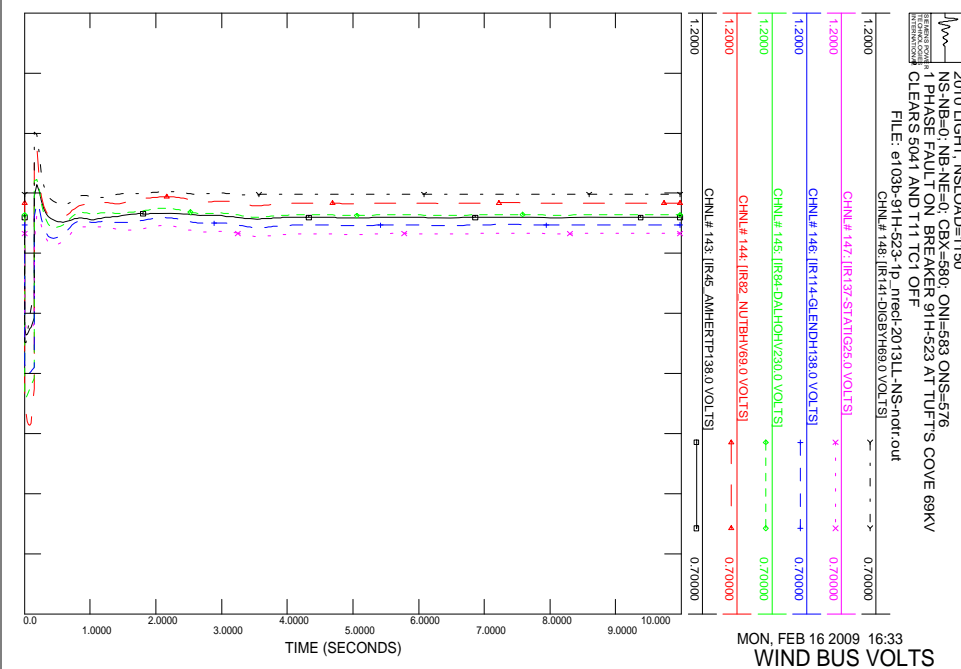
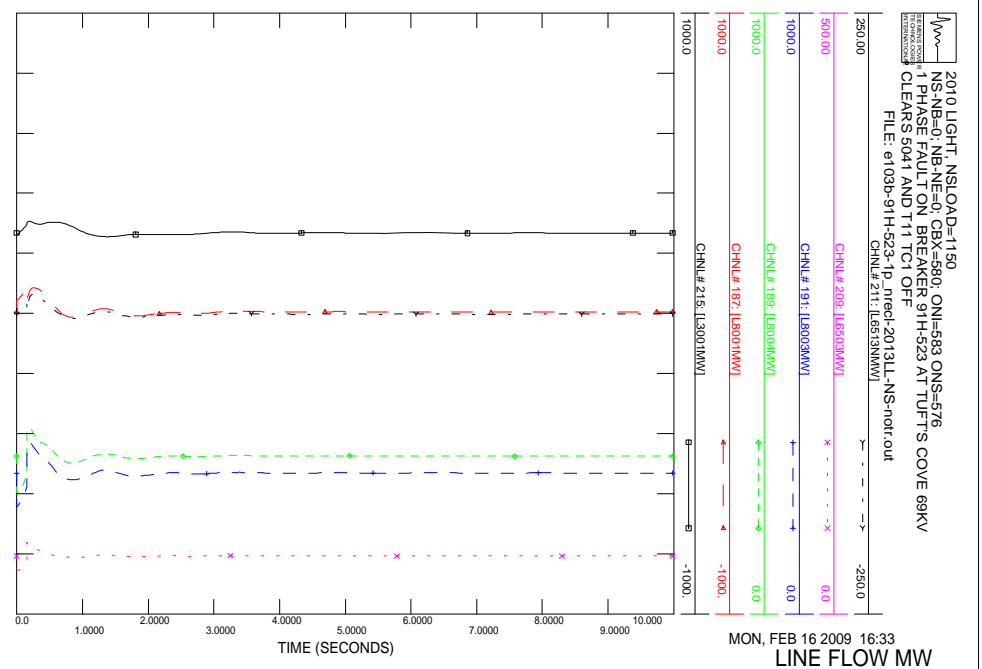
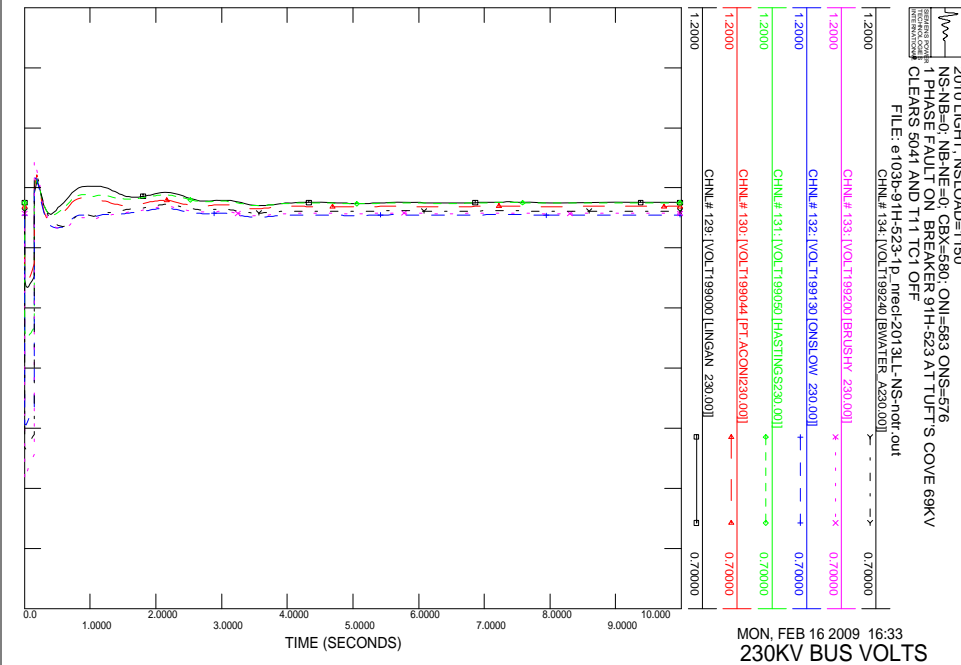
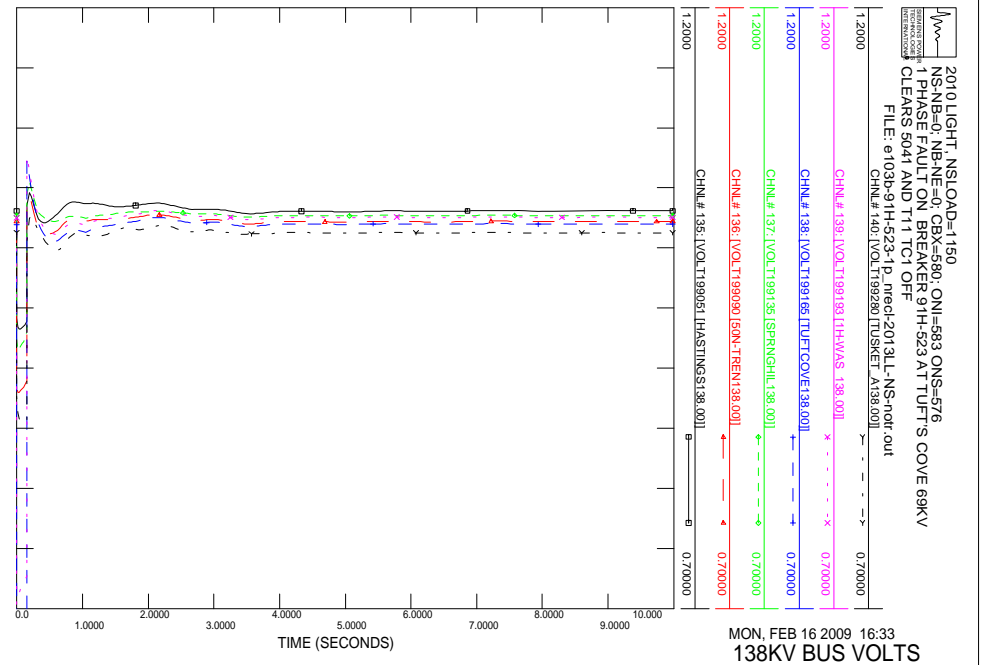

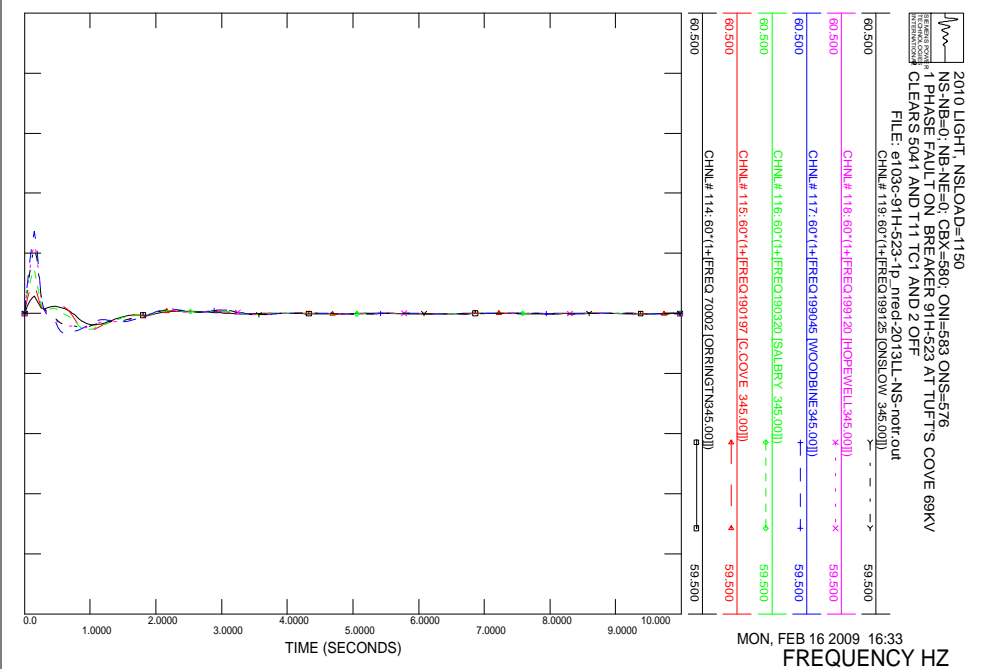
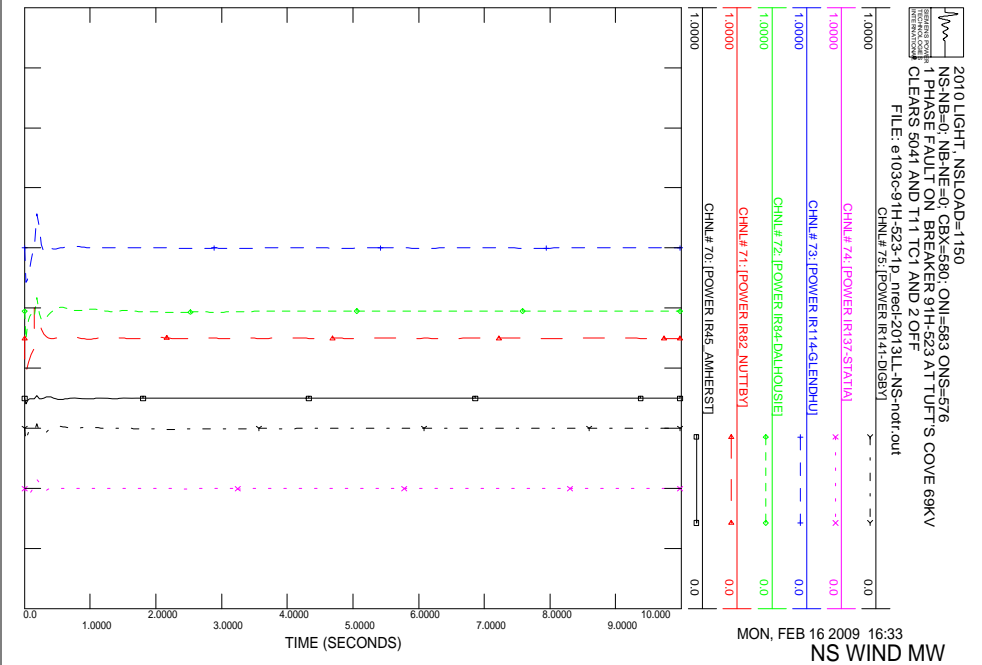
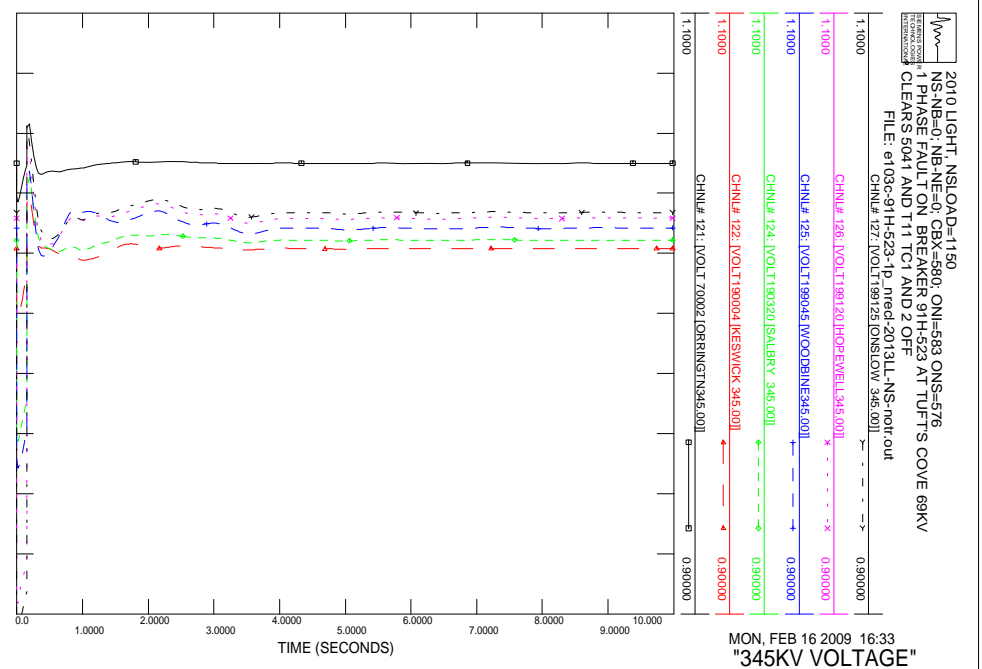
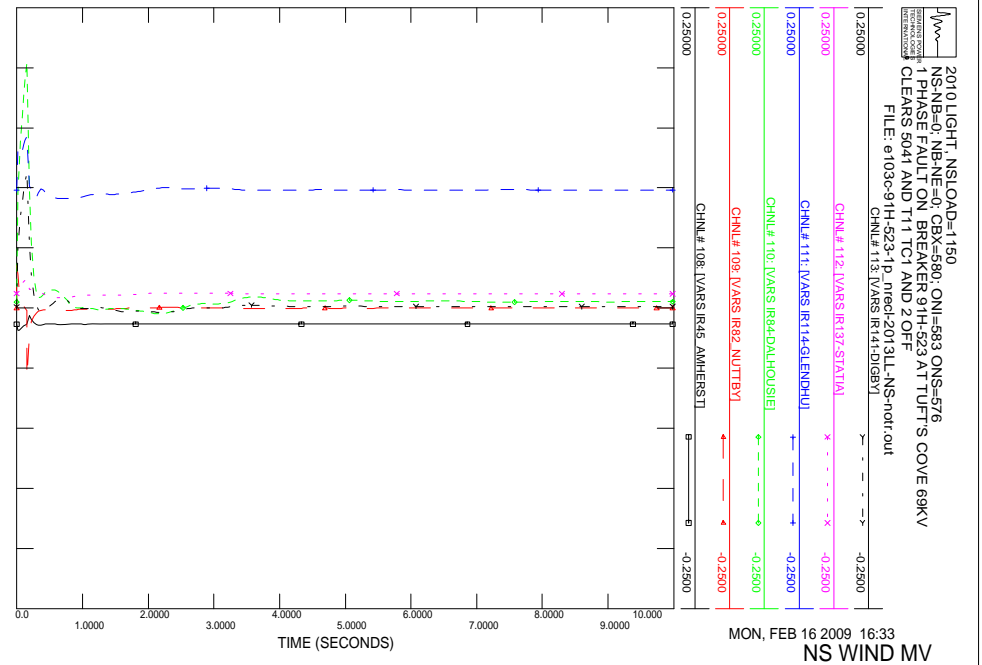

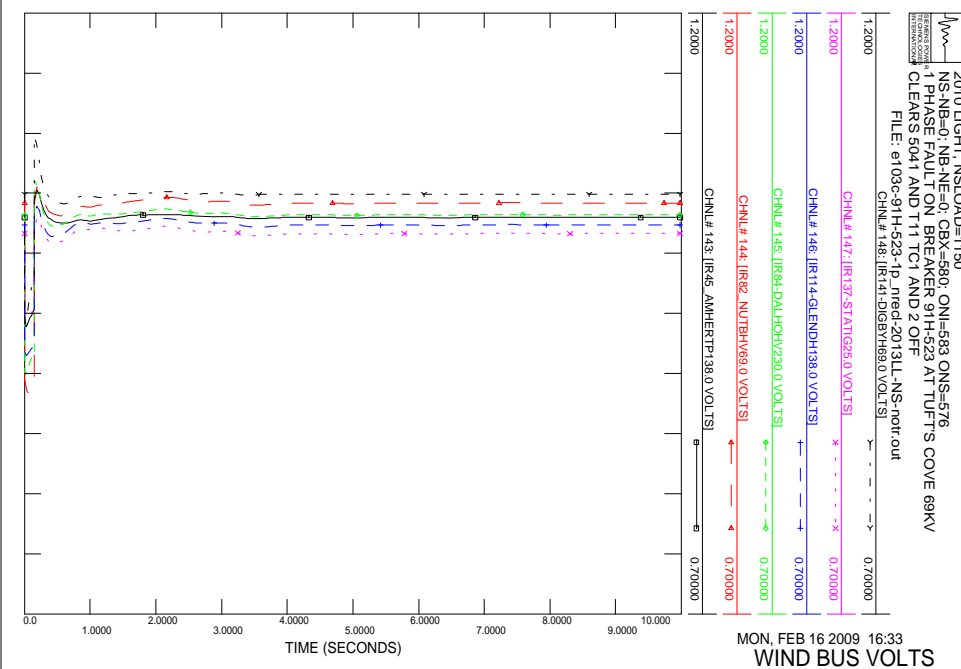
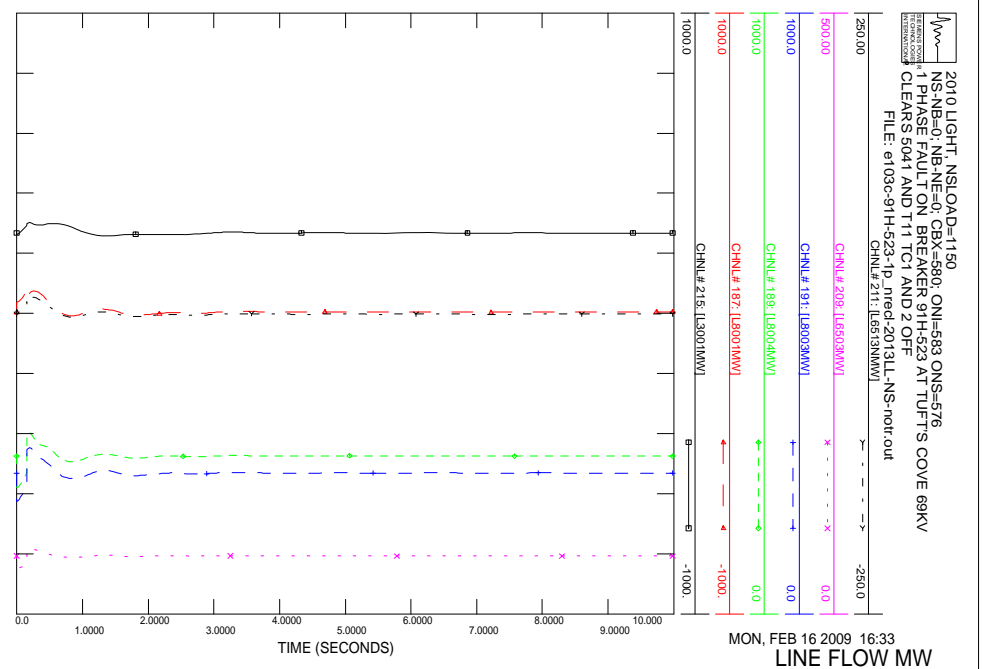
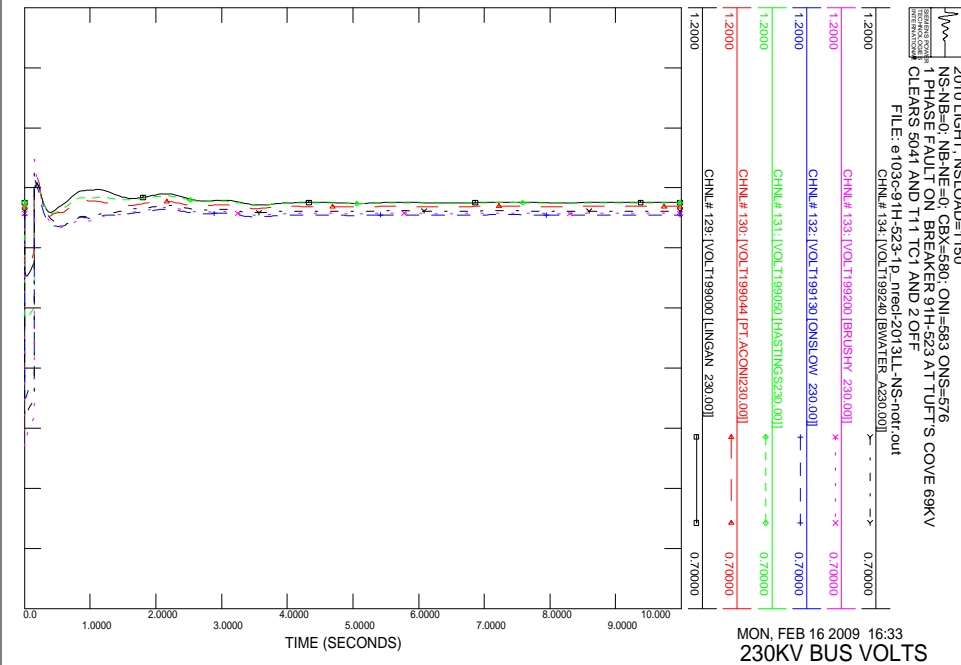
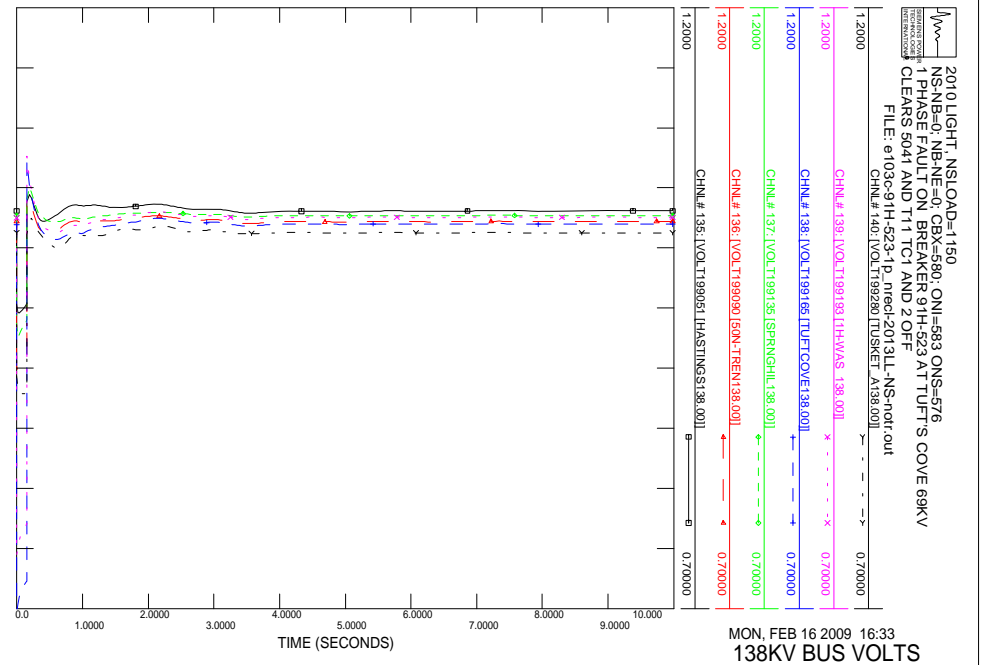

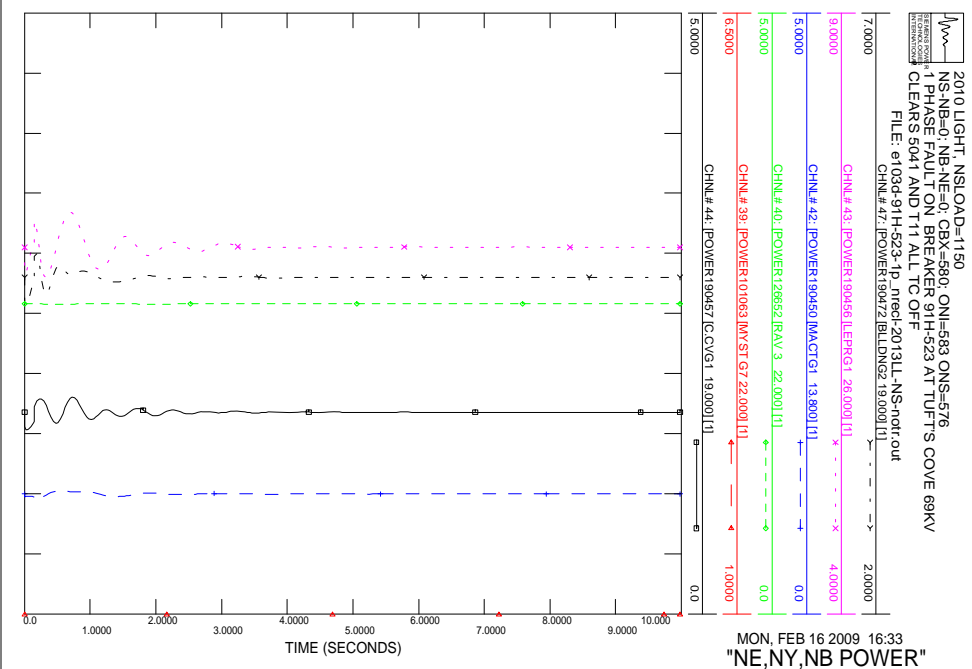
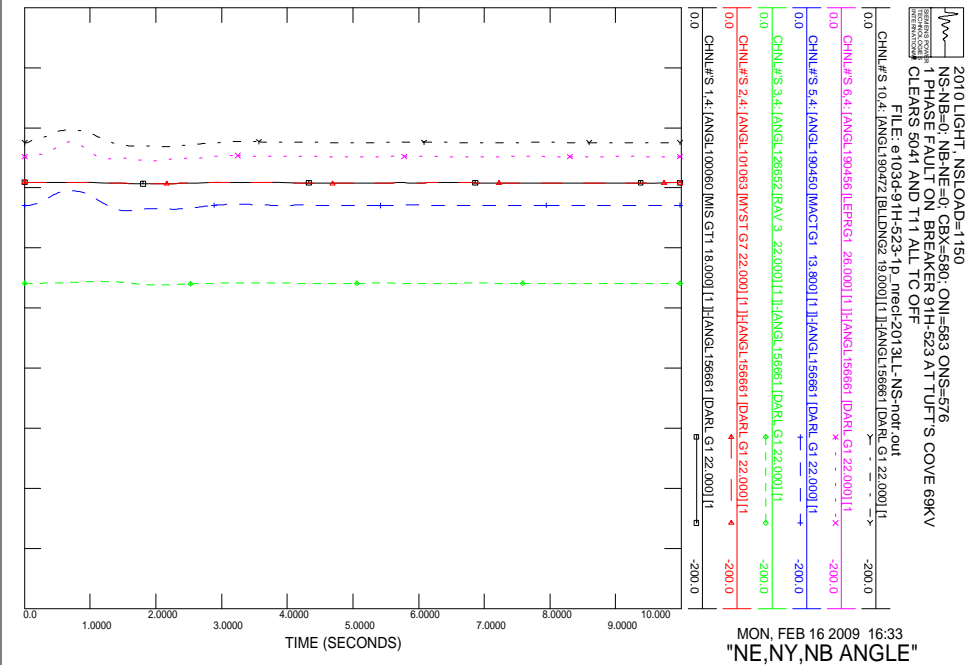
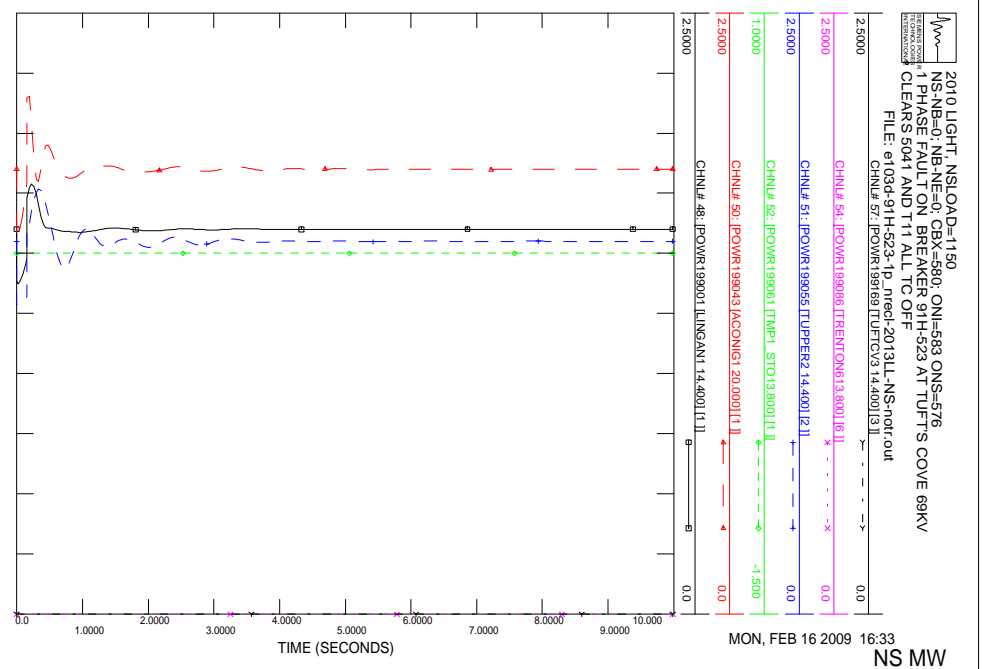
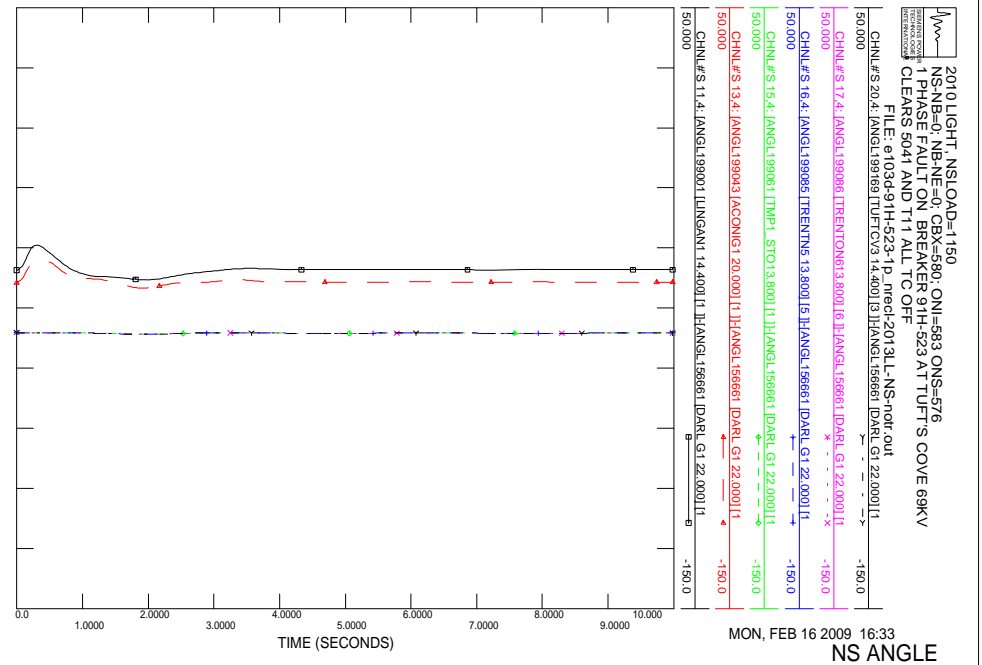

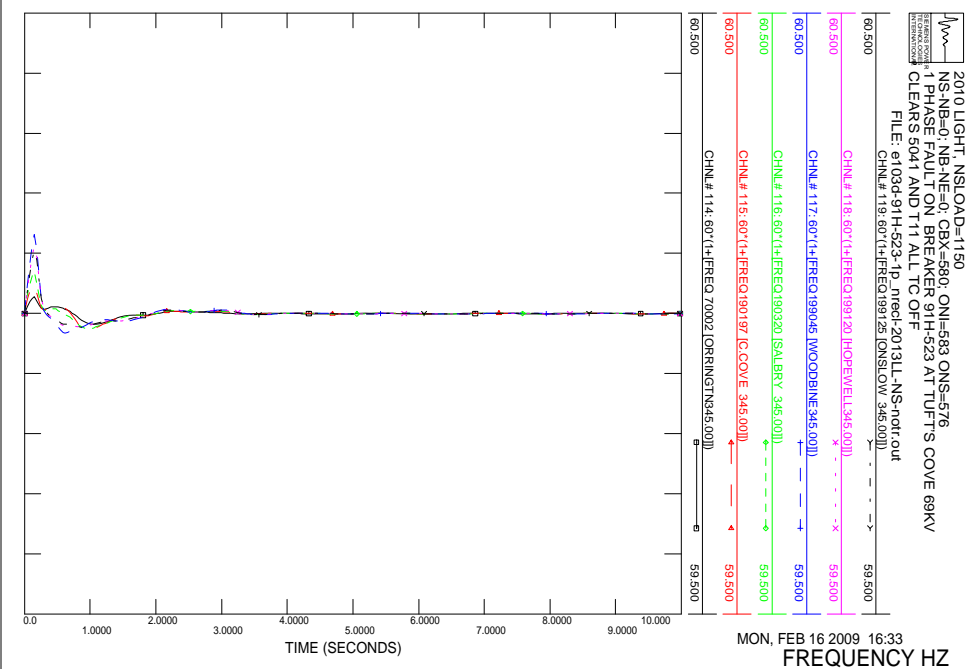
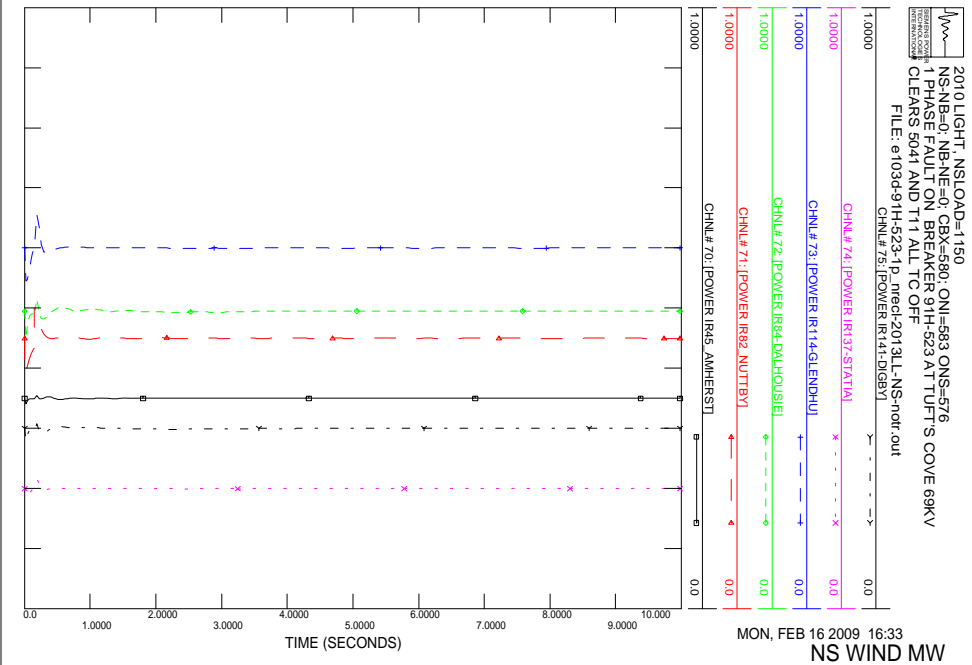
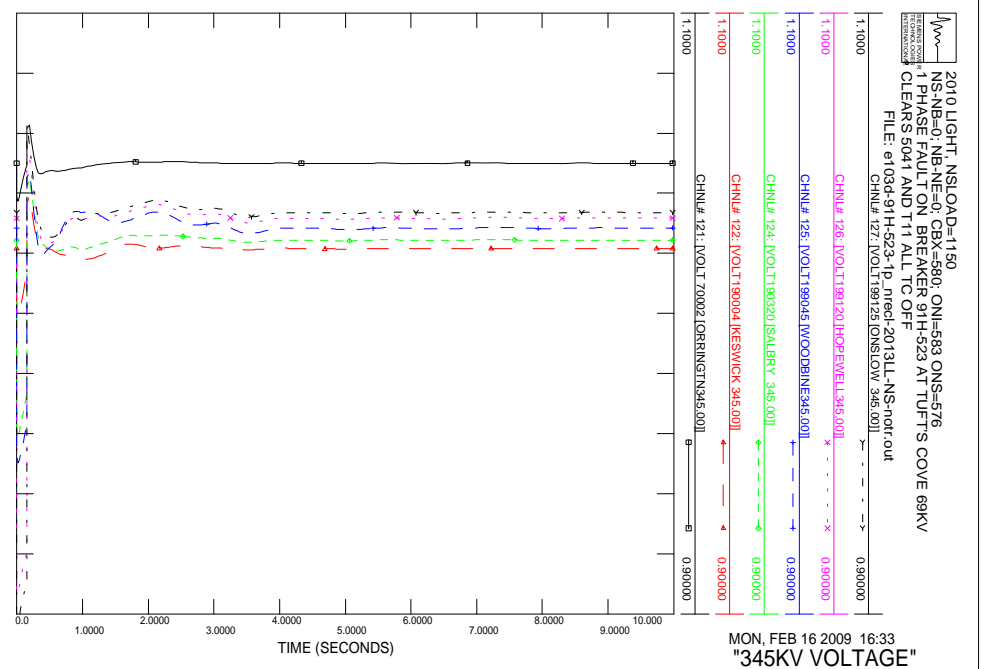
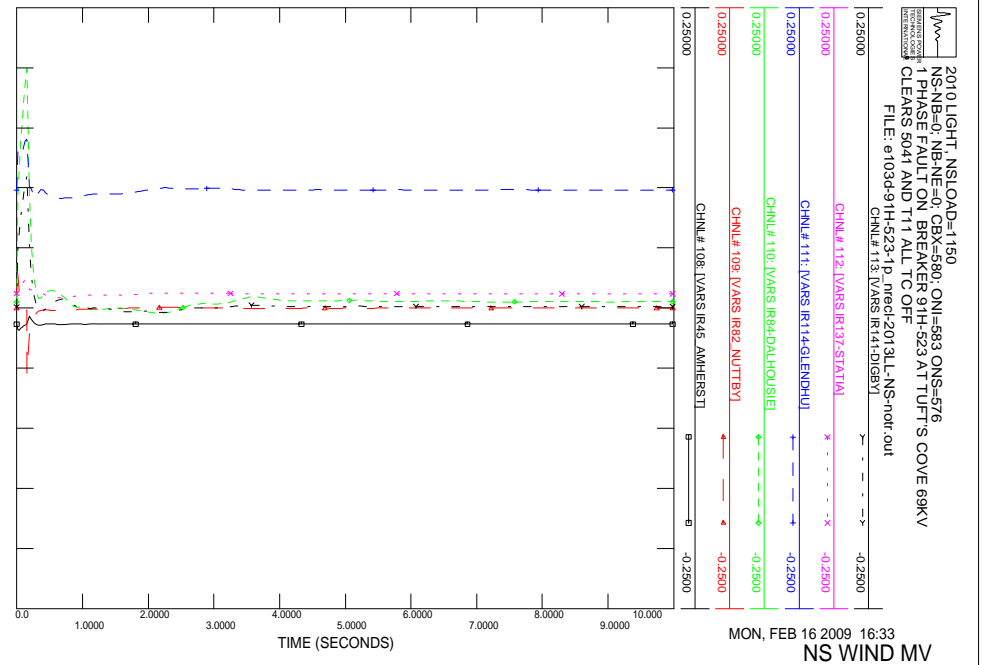

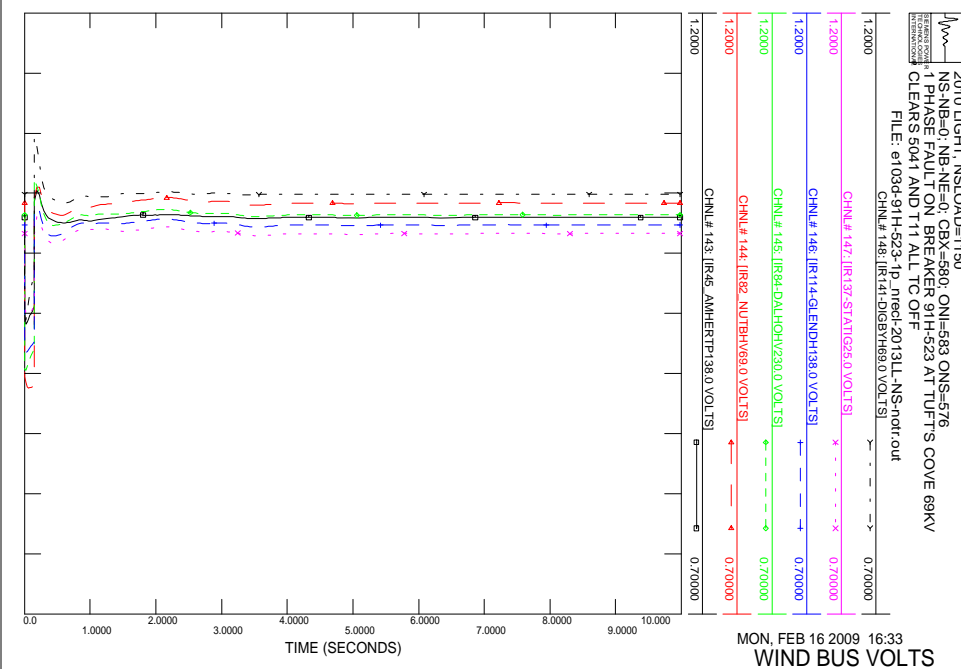
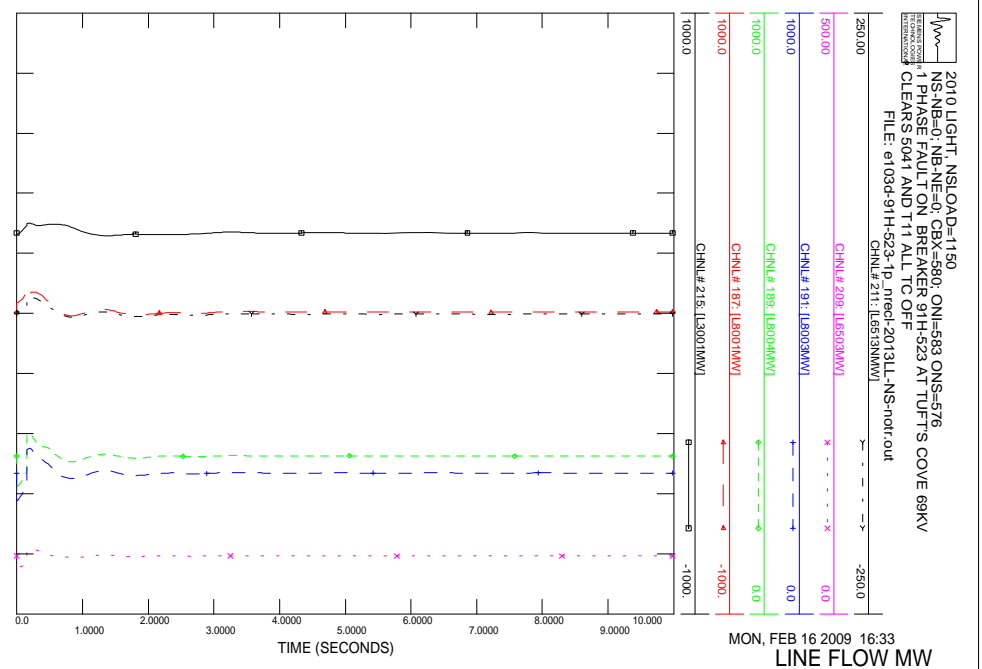
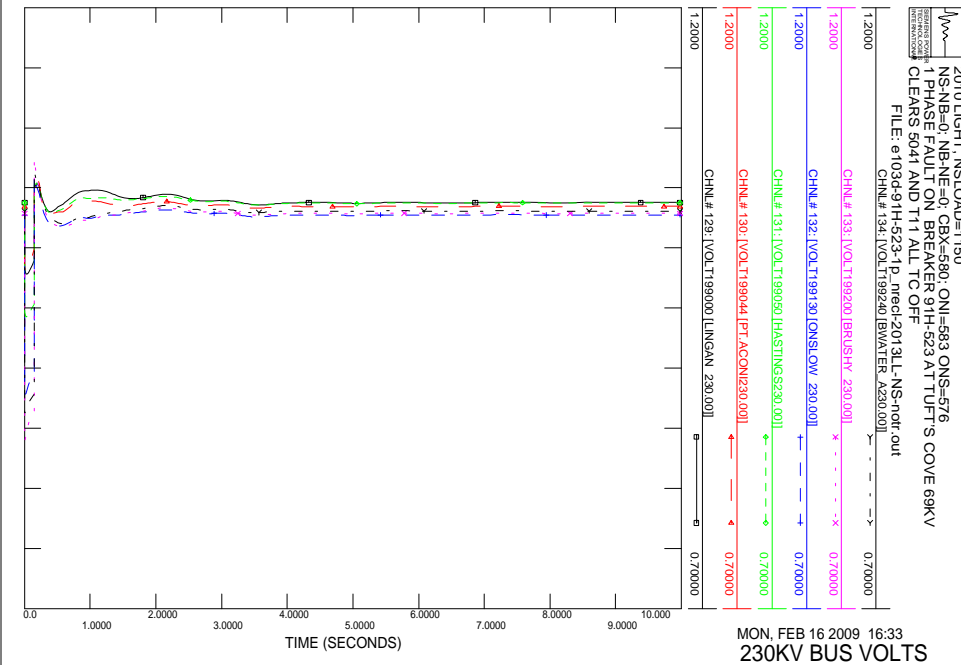
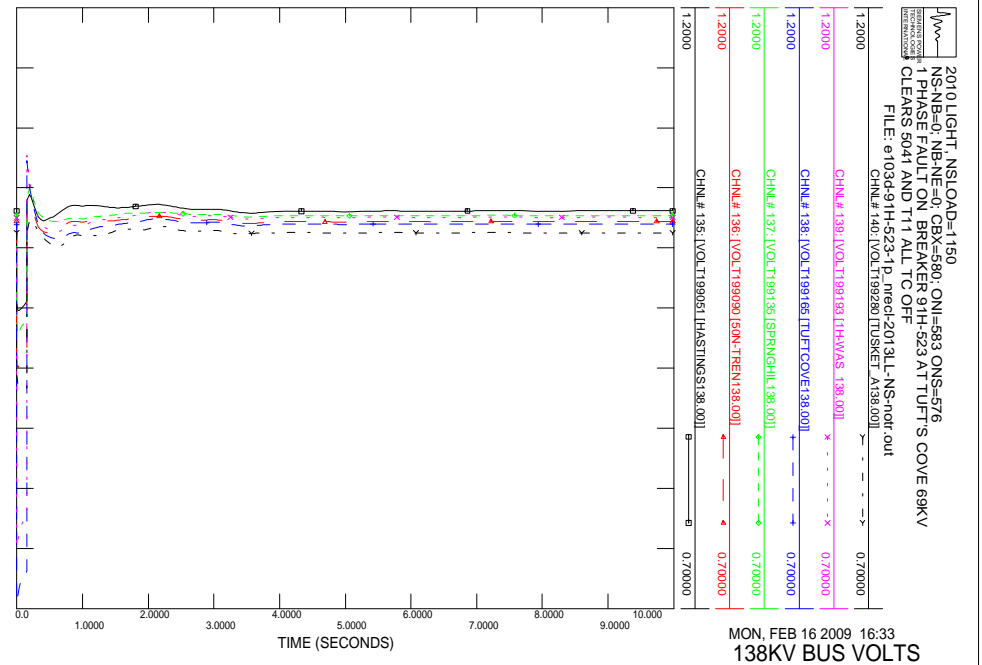

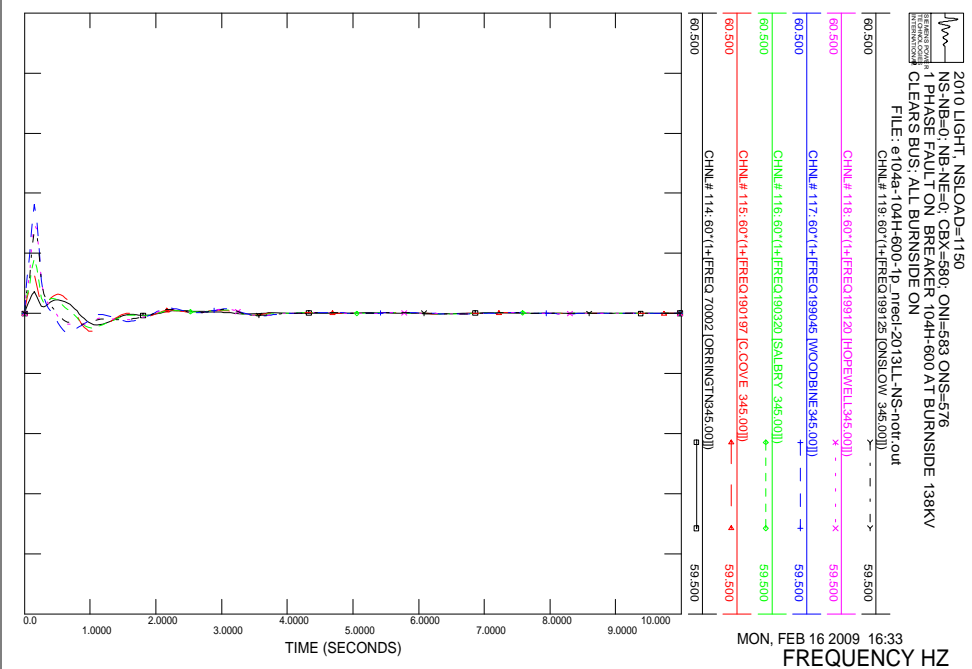
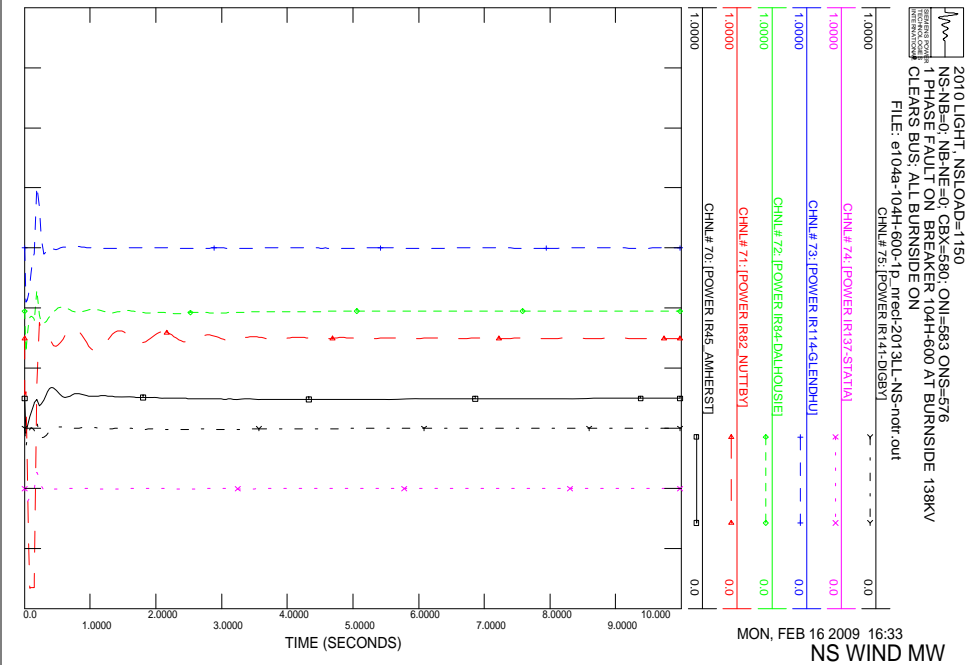
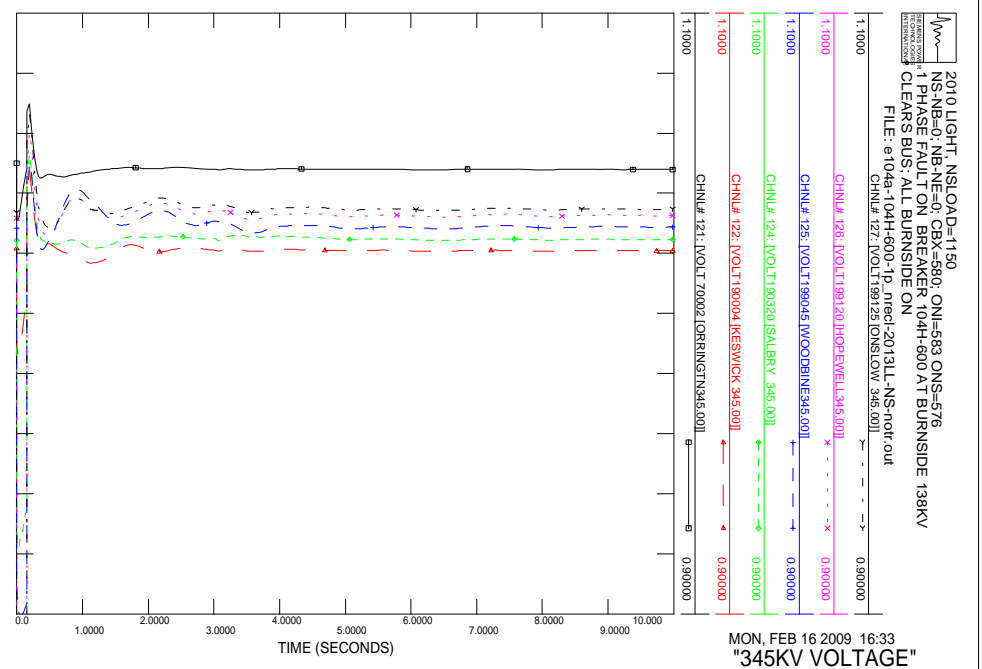
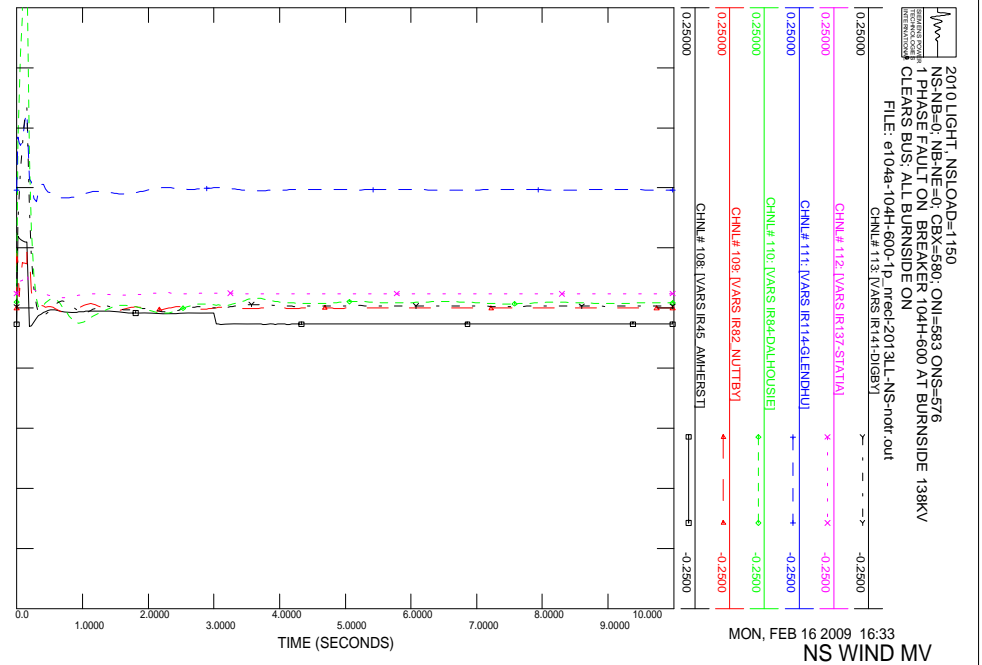

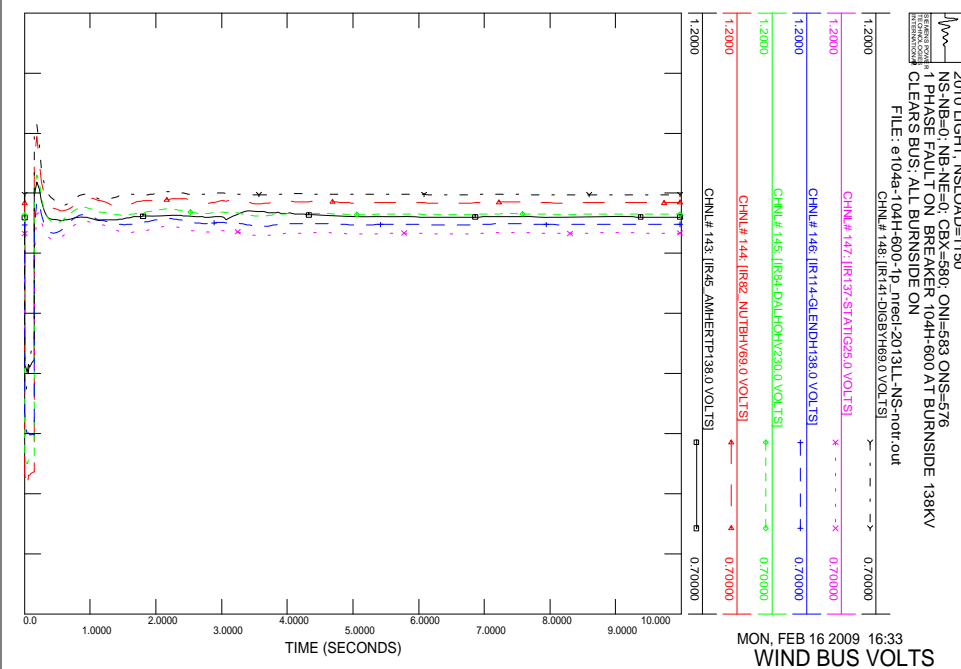
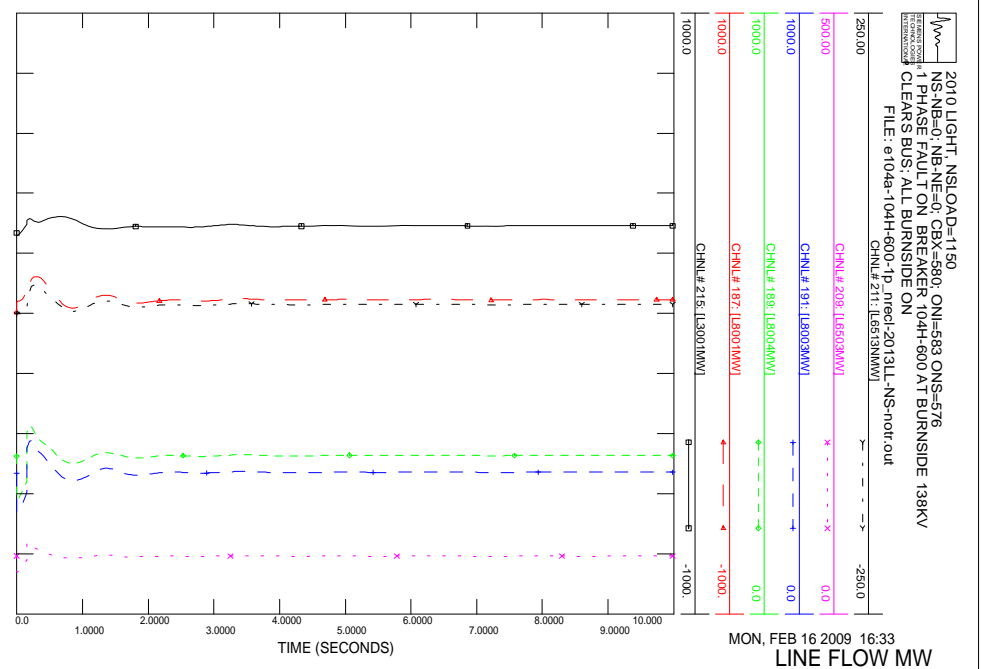
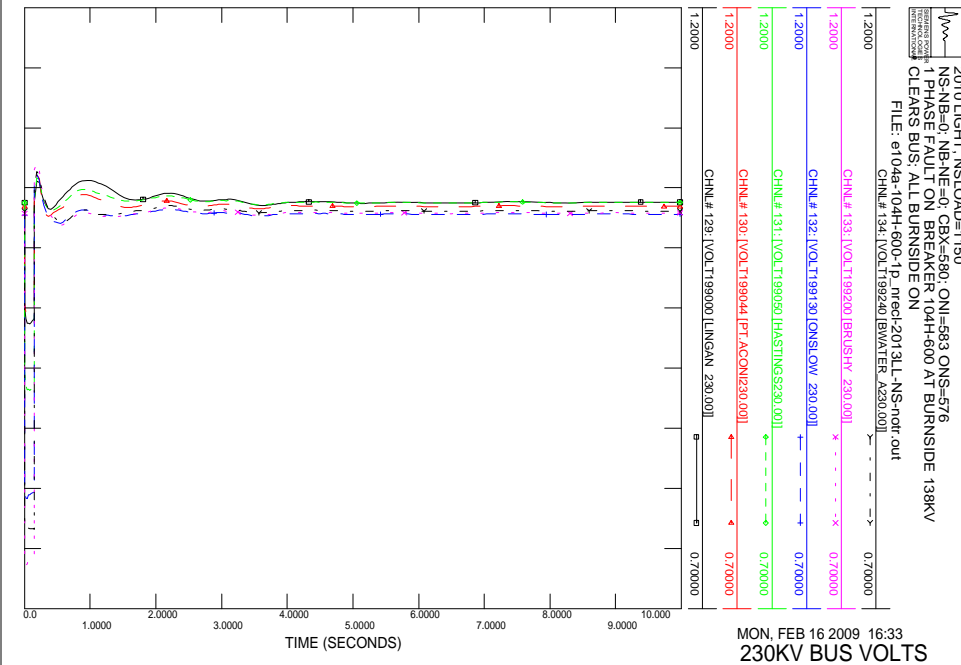
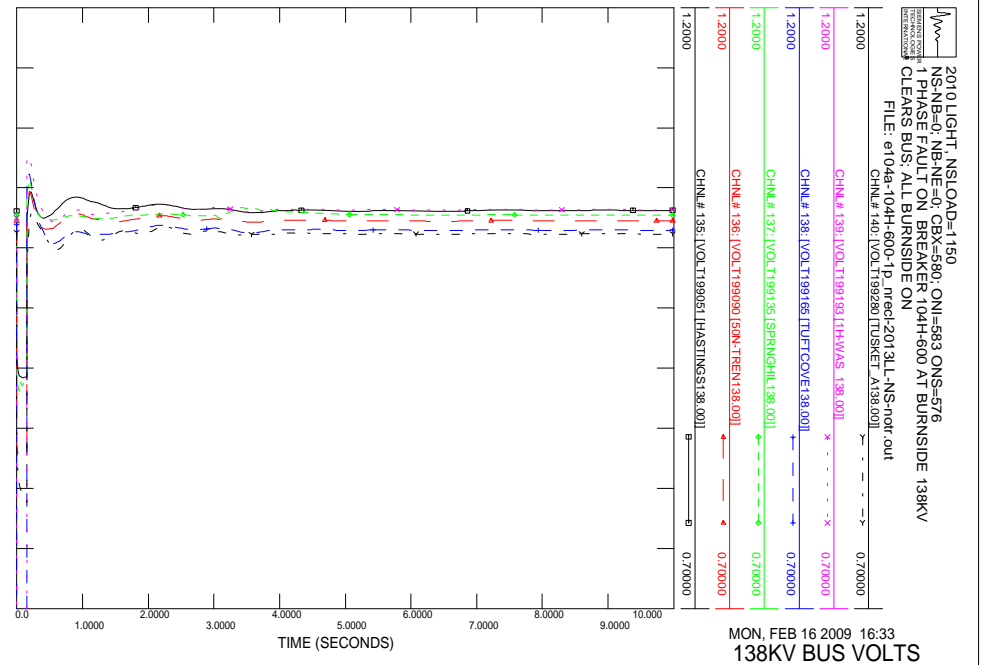

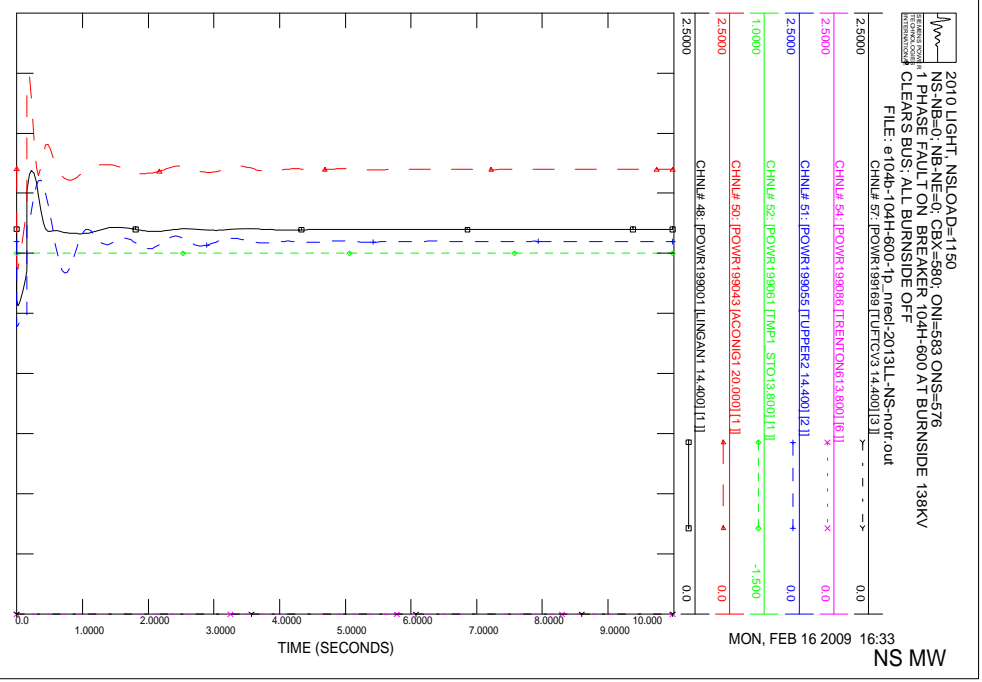
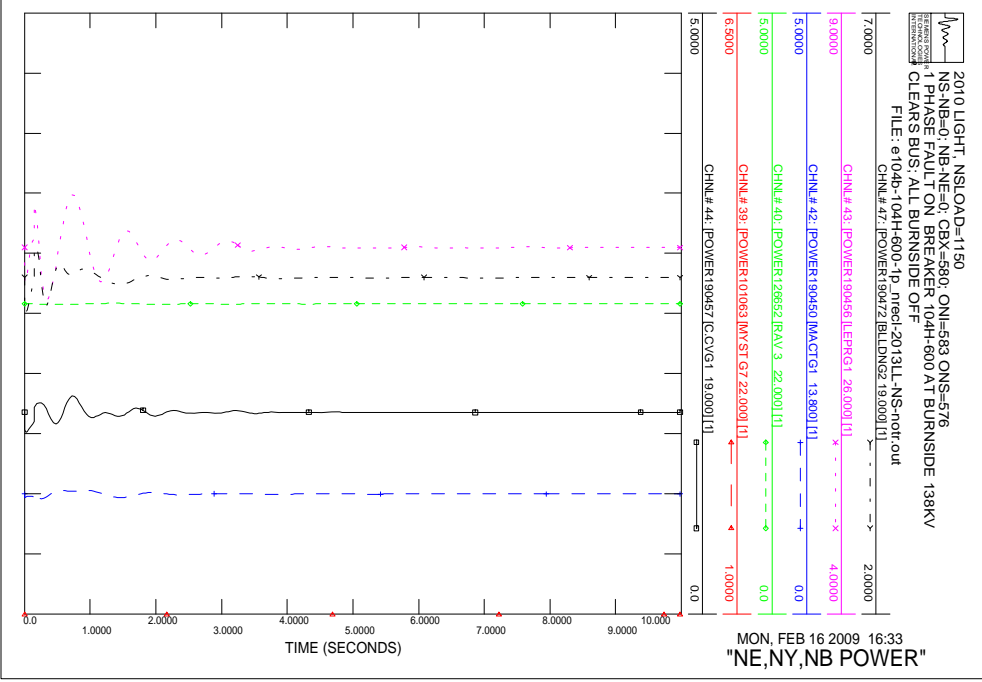
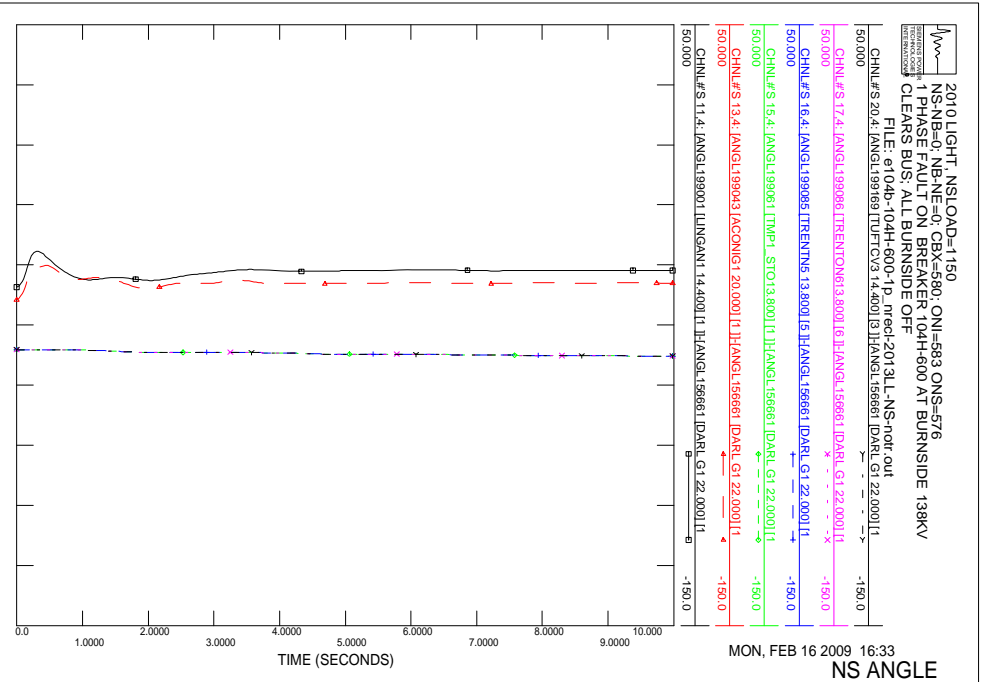
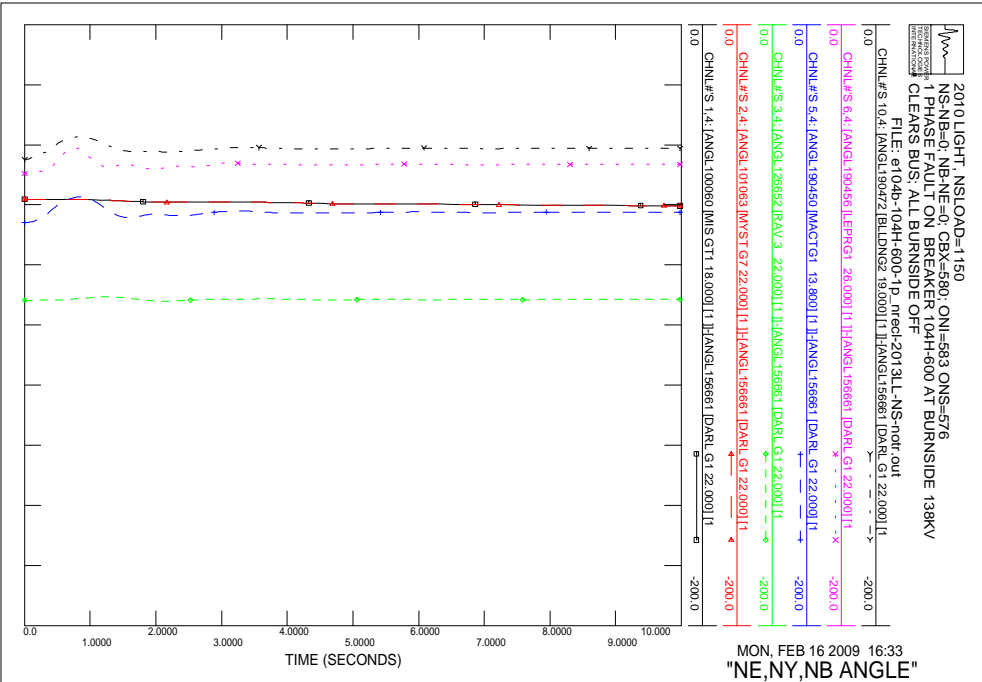

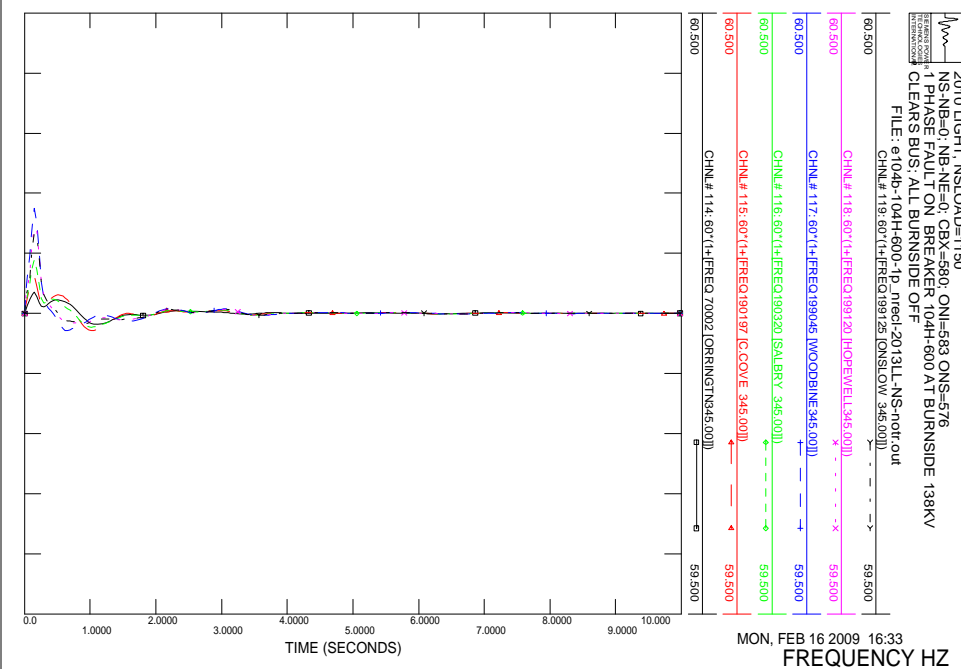
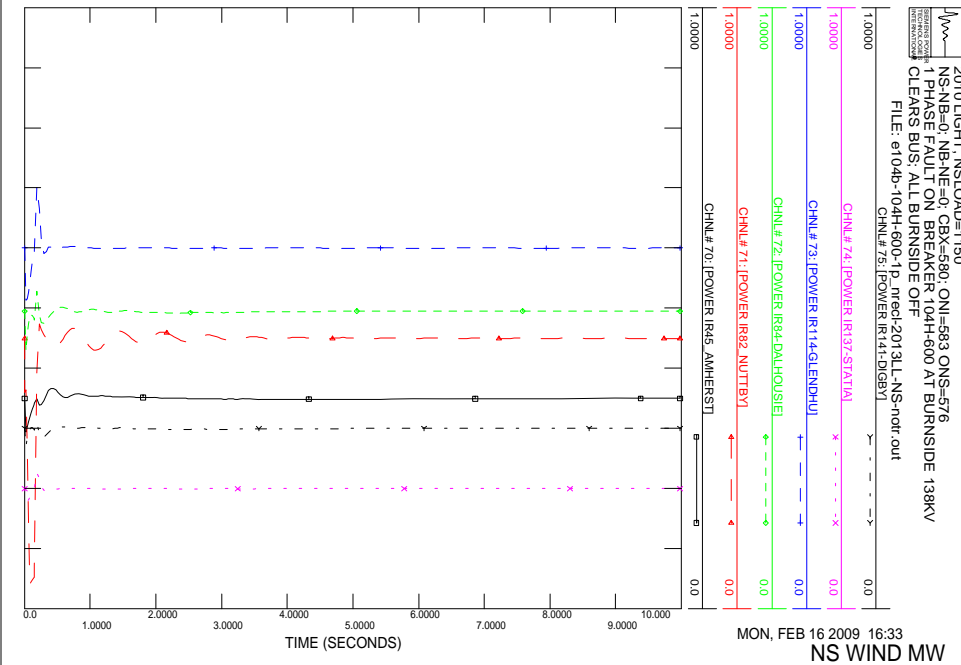
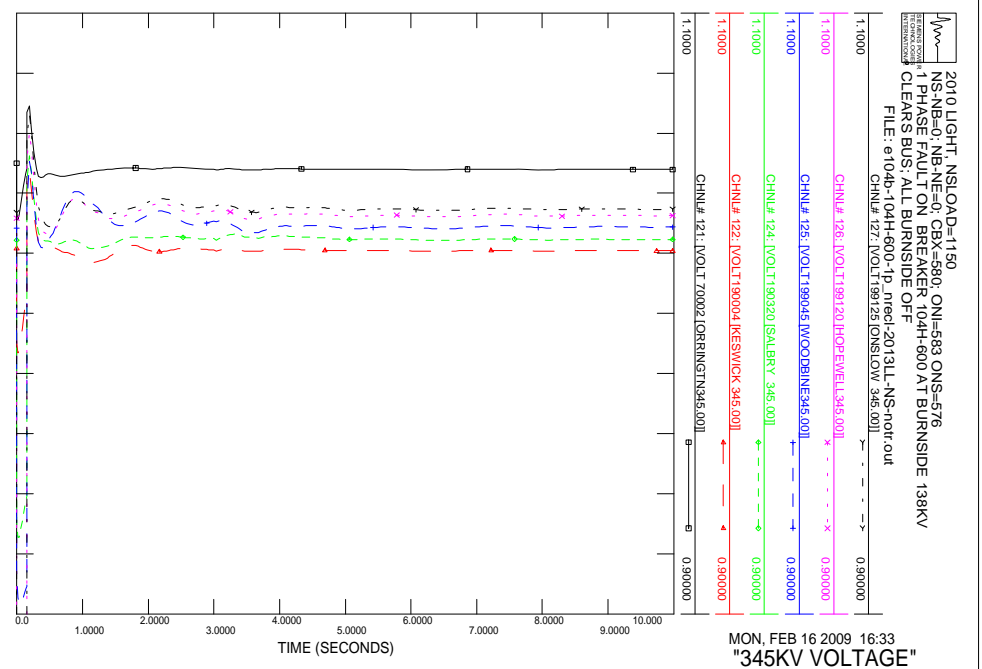
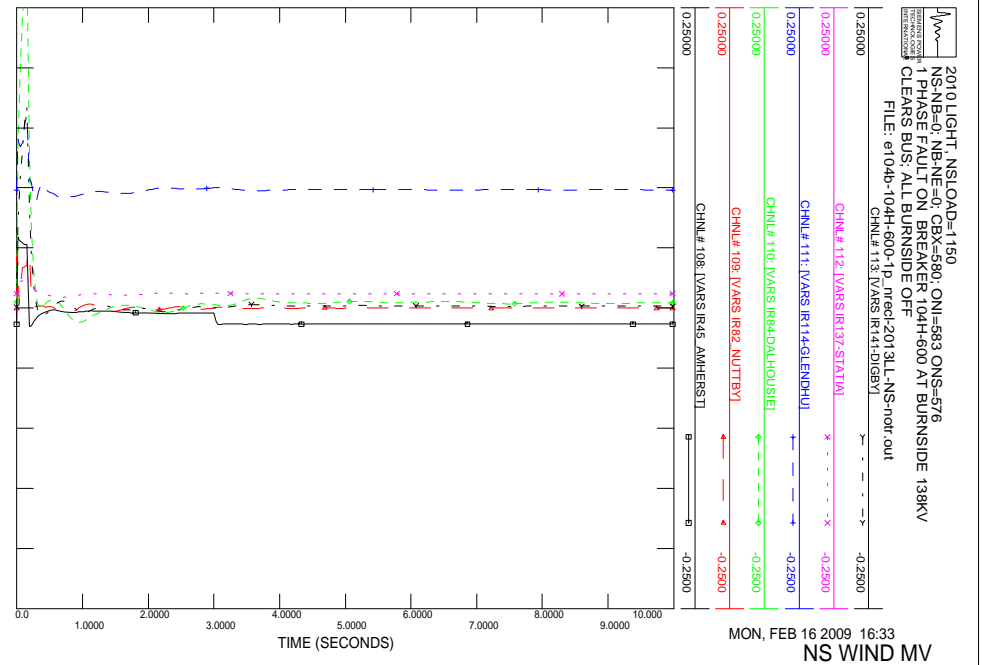

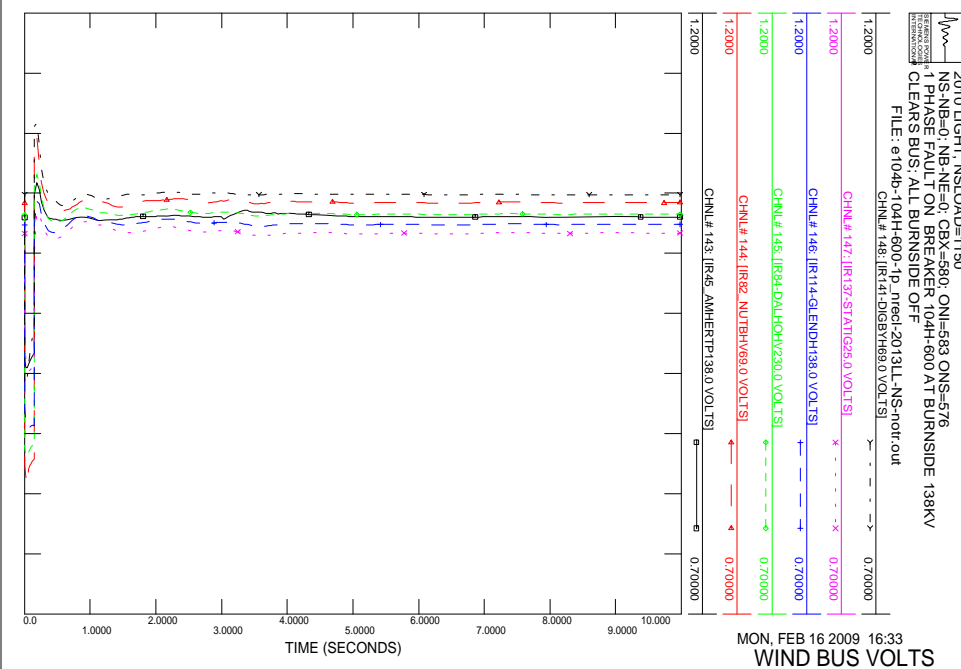
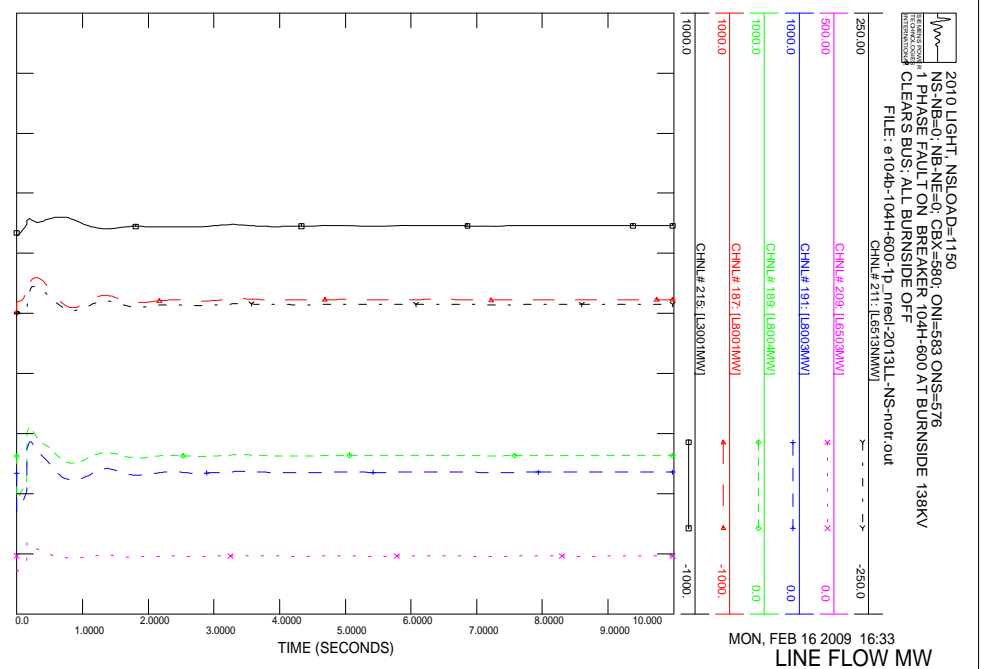
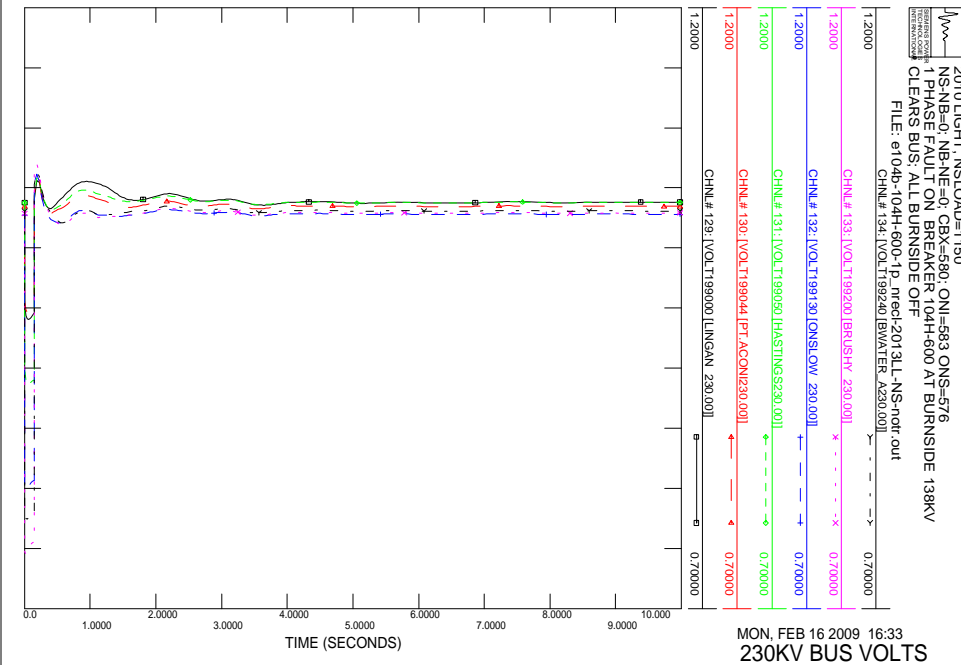
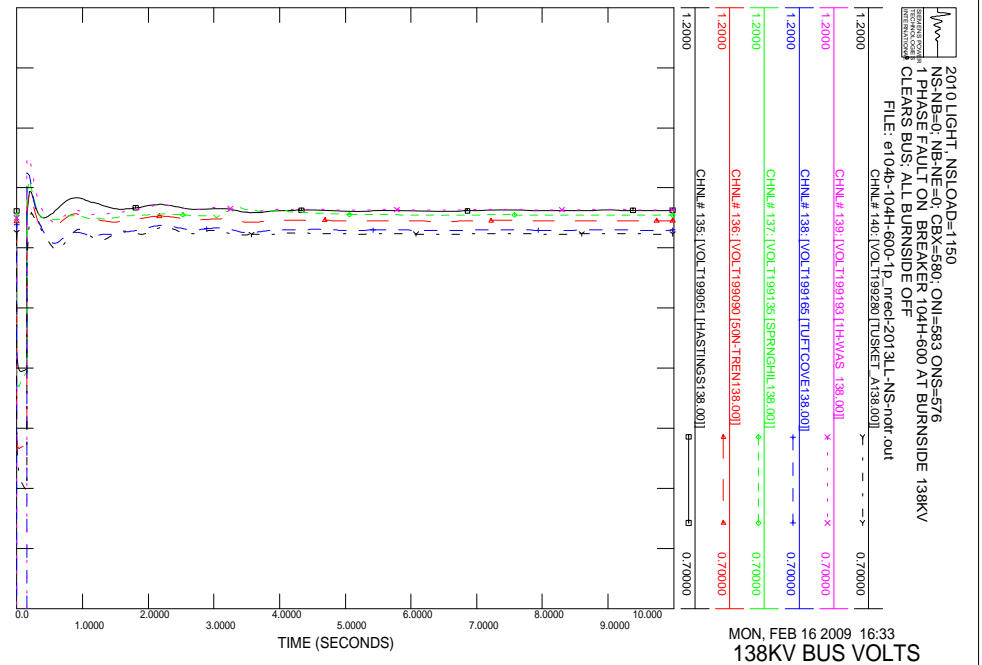

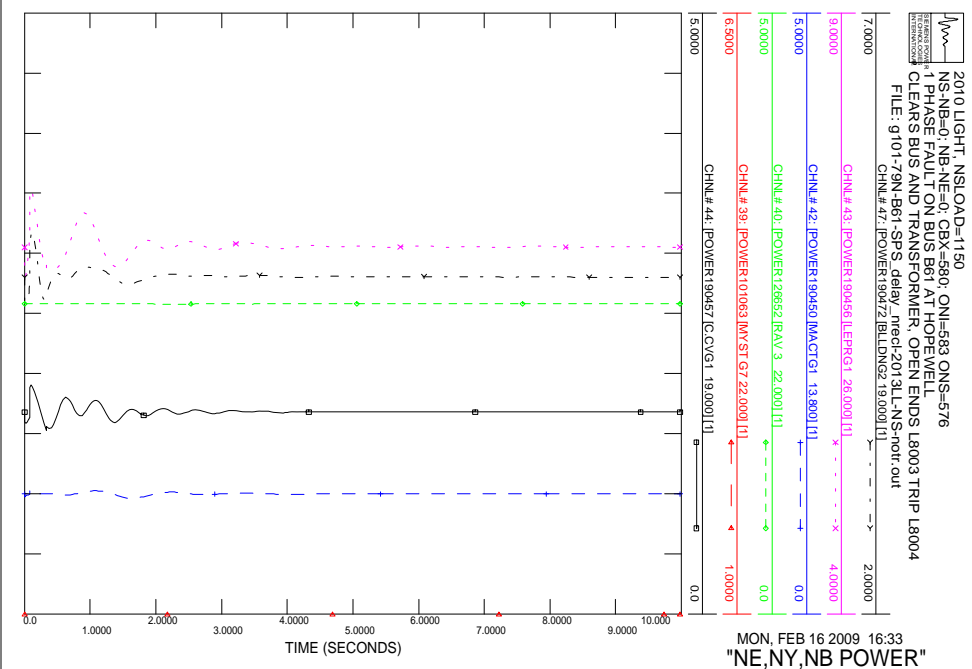
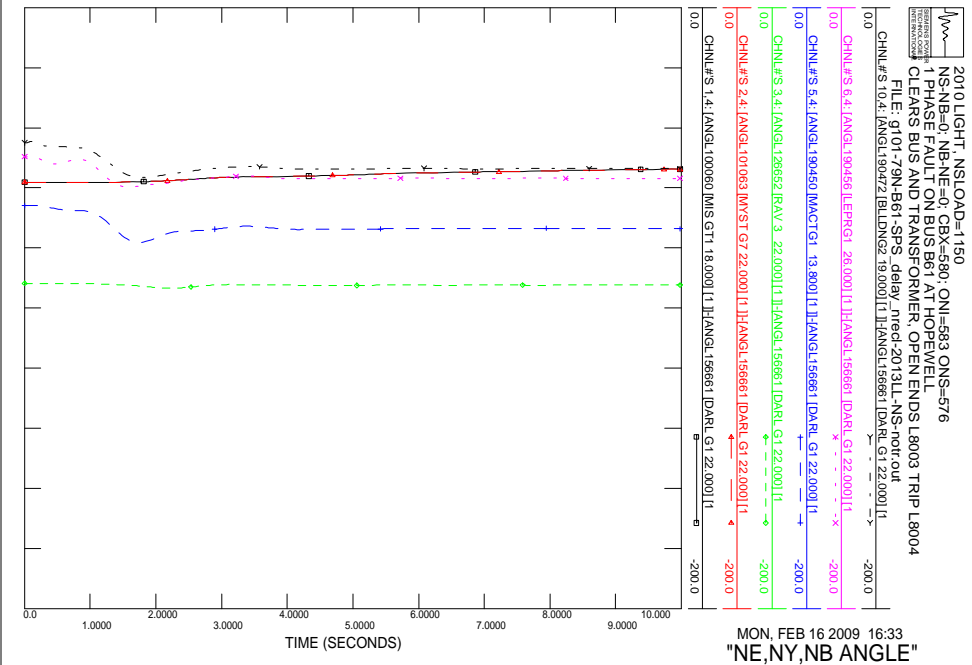
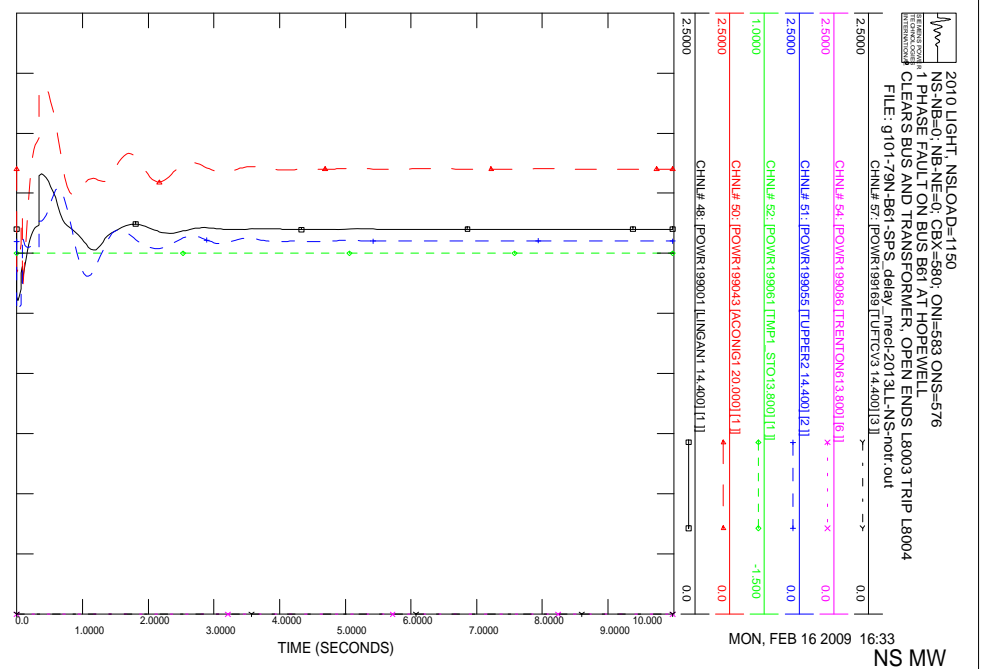
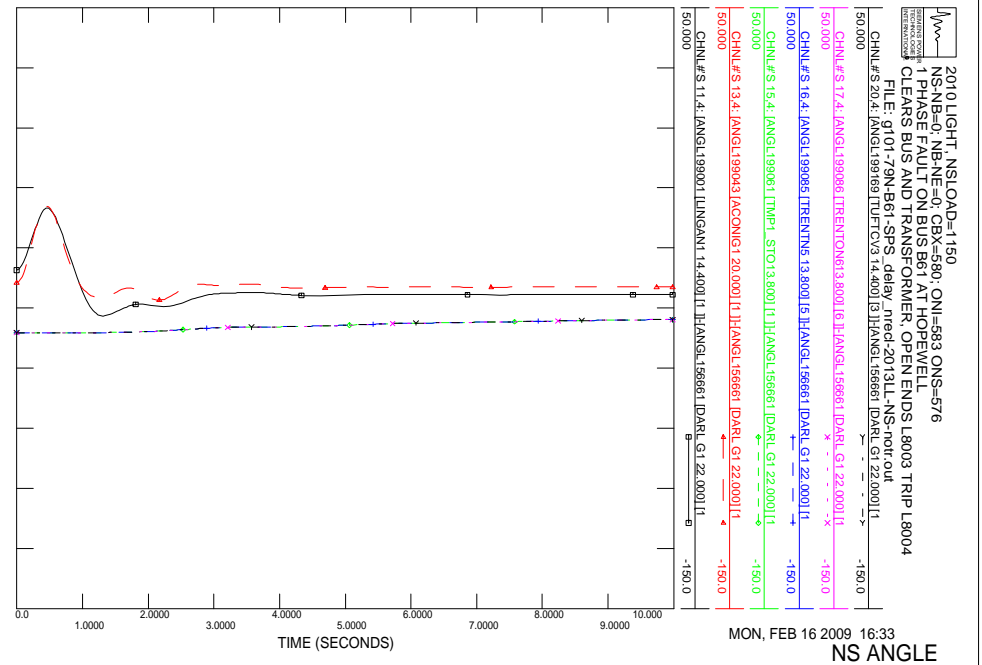

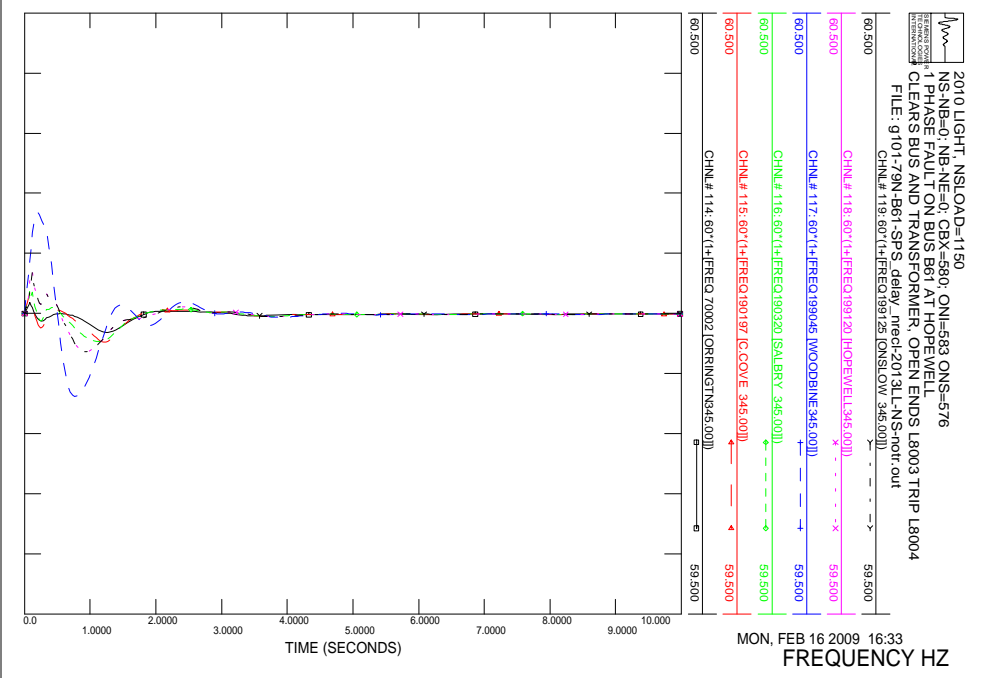
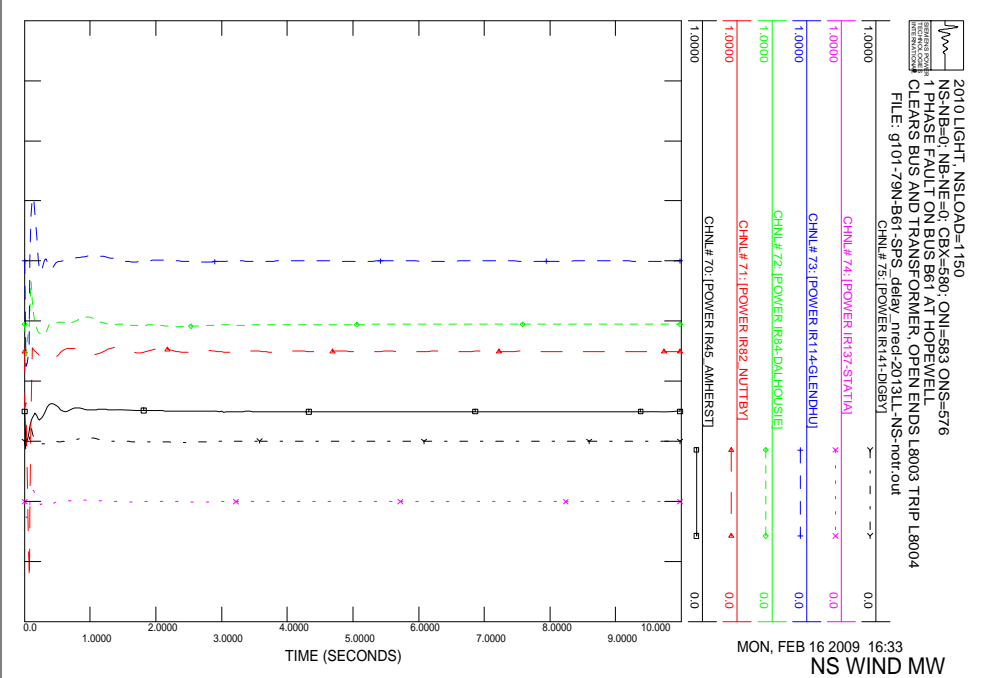
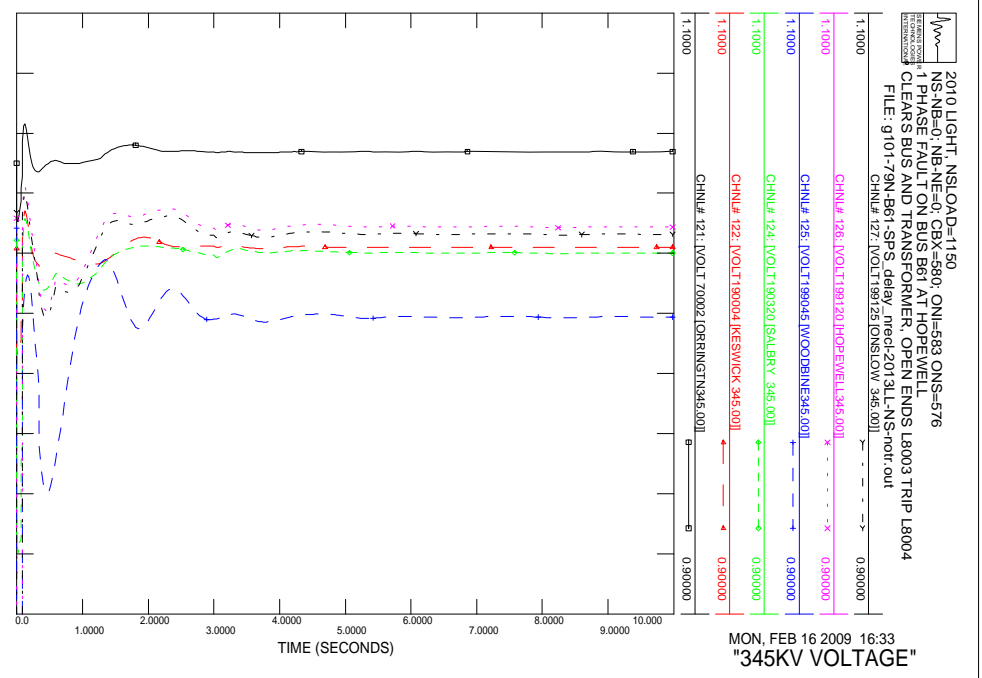
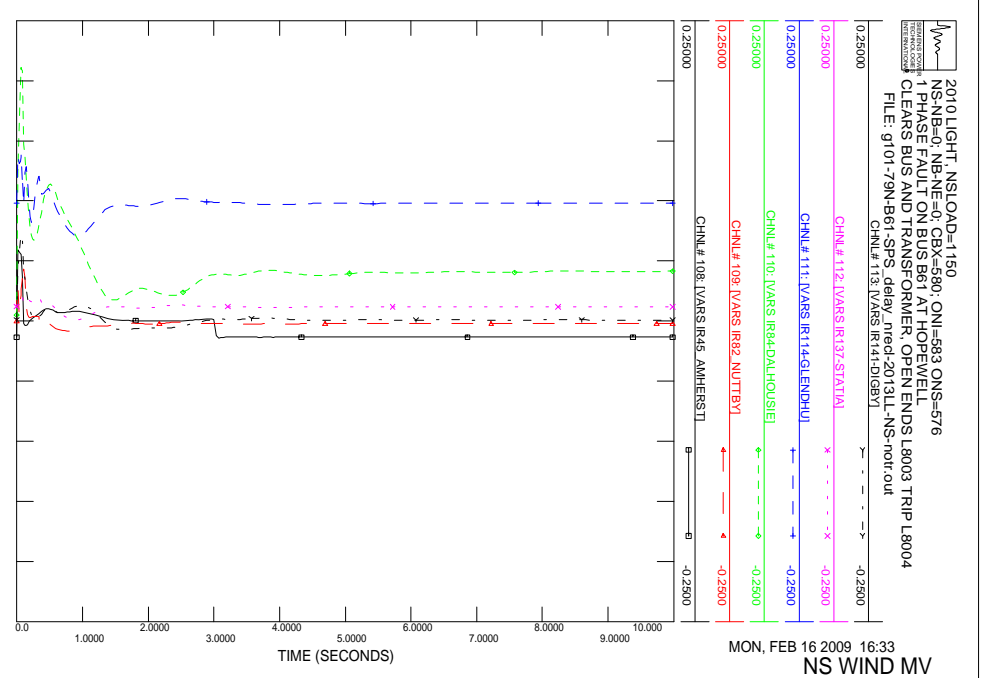

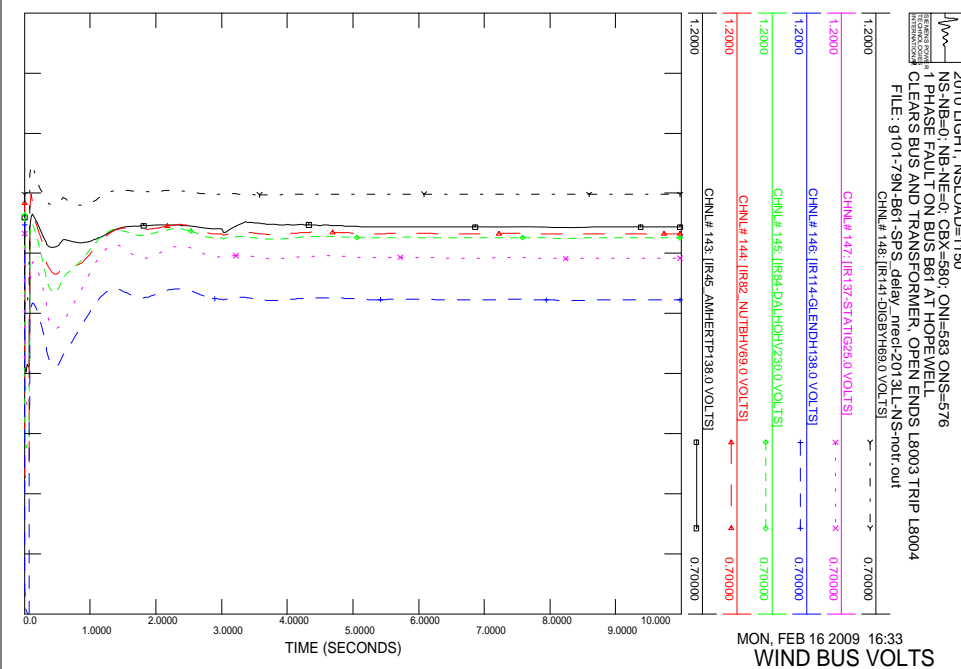
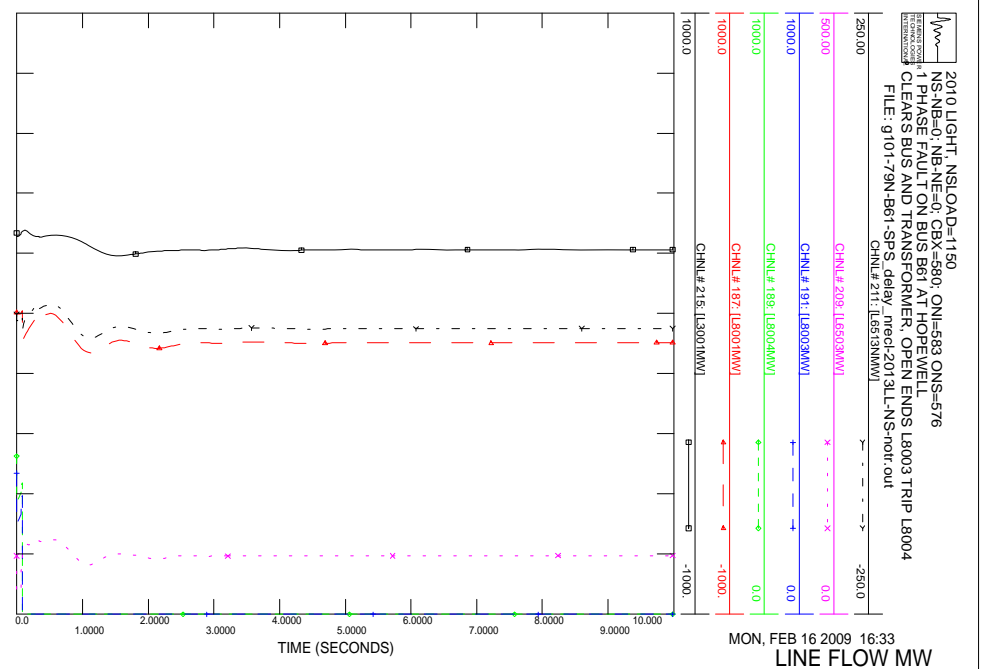
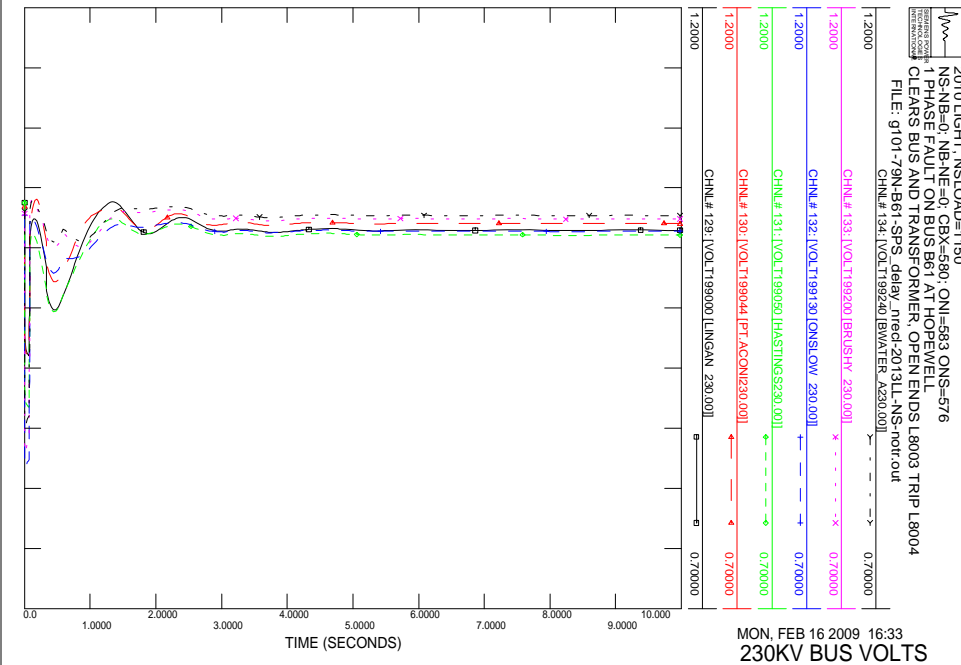
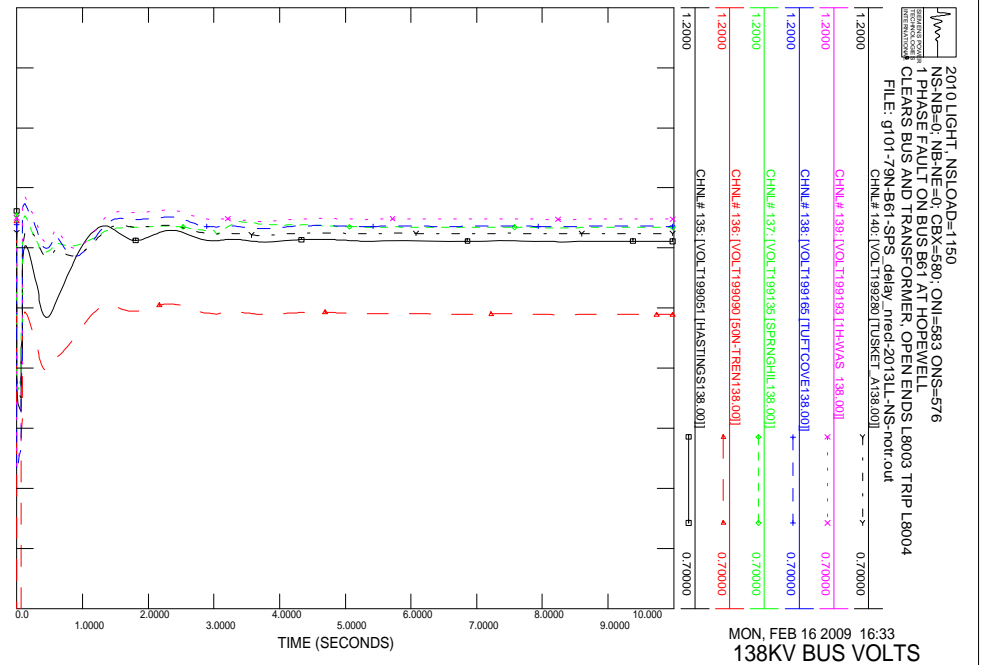

NSX 302.8 MW

CBX 511.4 MW

ONI 701.3 MW

ONS 856.1 MW

Nova Scotia New Brunswick

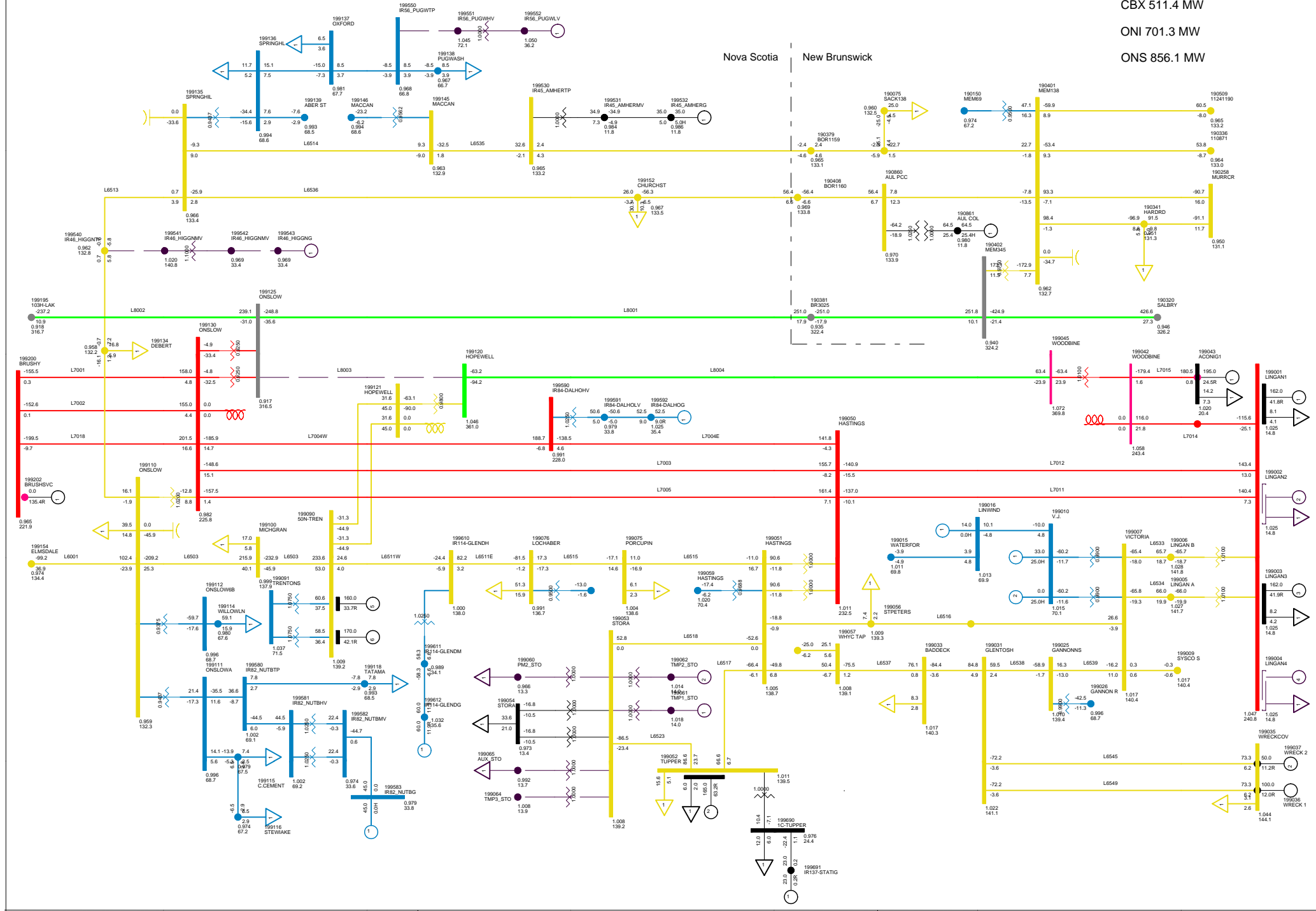

NSX 2.0 MW
 CBX 809.5 MW
 ONI 999.6 MW
 ONS 853.8 MW

Nova Scotia New Brunswick

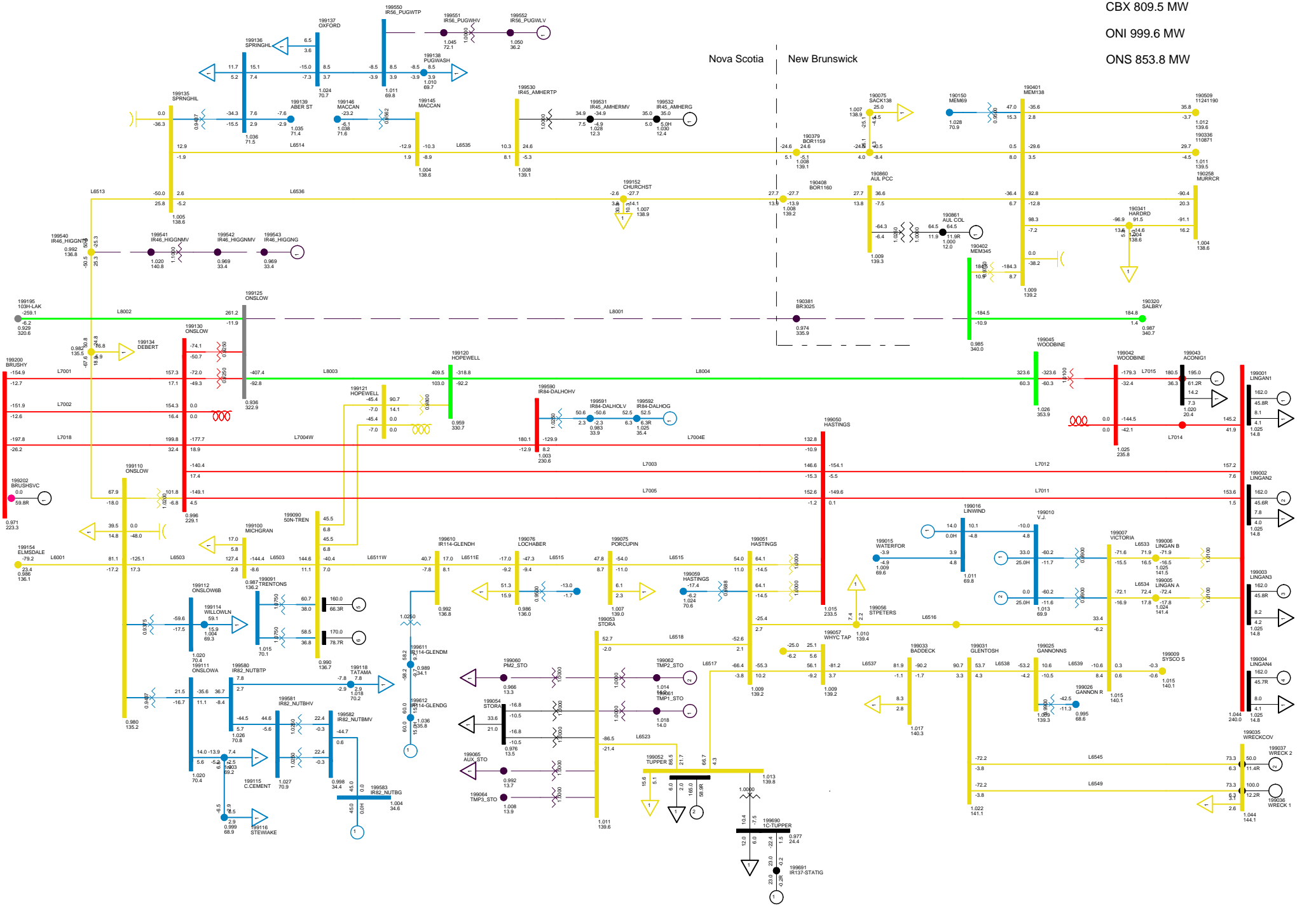

2013 EXTREME LOAD CONDITION
 C04 LOSE L8001 NO SPS
 NORTHEASTERN NS MON, JAN 05 2009 17:32

NSX 5.0 MW
 CBX 805.0 MW
 ONI 996.6 MW
 ONS 853.4 MW

Nova Scotia New Brunswick

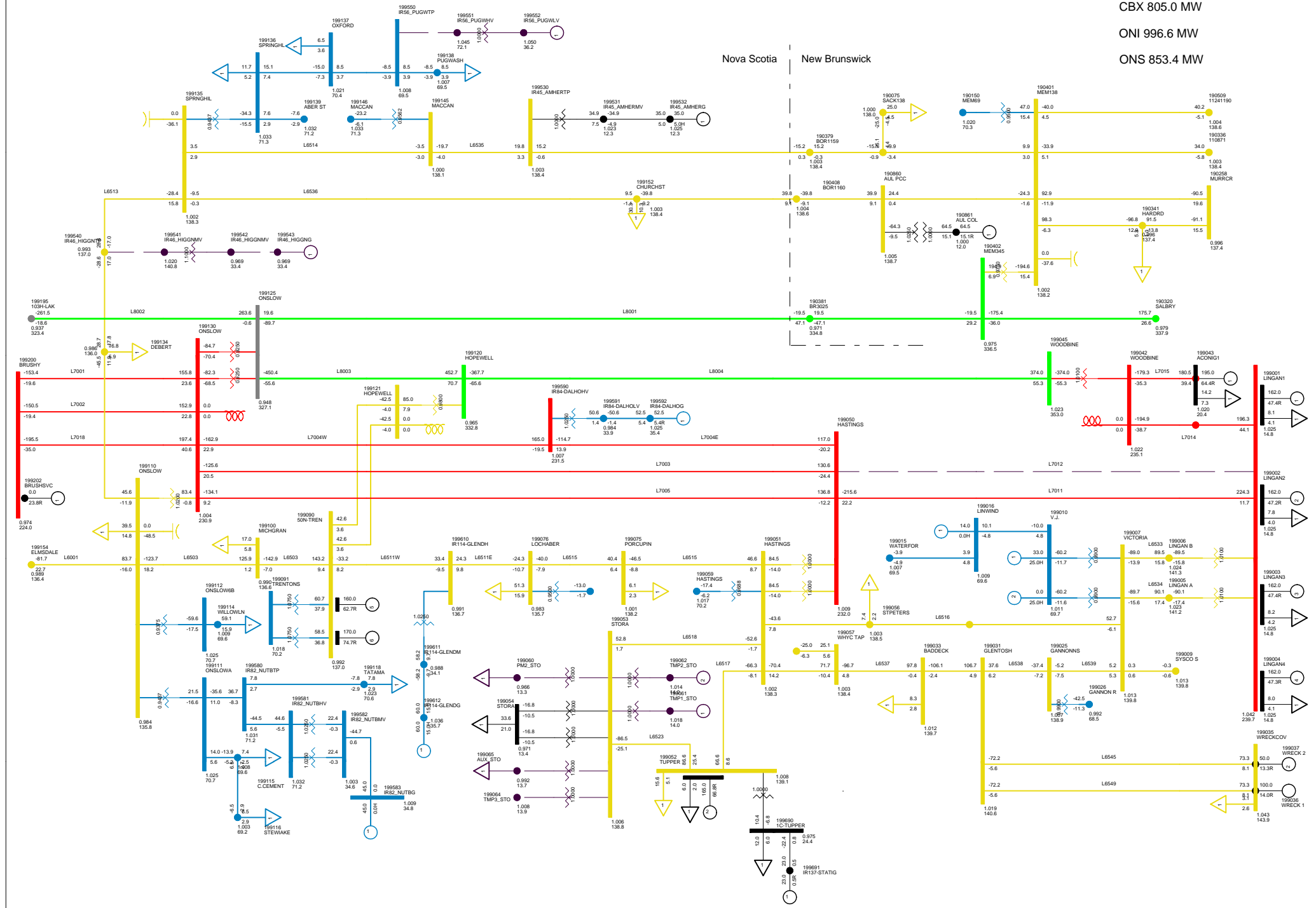

2013 EXTREME LOAD CONDITION
 C05 LOSE L7012 NO SPS
 NORTHEASTERN NS MON, JAN 05 2009 17:33

Total Wind Gen: 290.1 MW
 Gross Lingan 648.0 MW
 Gross Trenton 330.0 MW
 Gross Tuft's Cove 485.7 MW
 Gross Tupper 165.0 MW
 Gross Wreck Cove 150.0 MW
 Gross Gas Turbine 183.0 MW
 Gross Small Hydro 182.4 MW
 Net Stora Load 33.7 MW
 Total BMPC Load 9.5 MW

Bus - VOLTAGE (KV/PV)
 Branch - MW/MVAR
 Equipment - MW/MVAR
 110.0/24.0/1.0
 KV - <<25.000 <<49.000 <<138.000 <<230.000 <<345.000 >>345.000

Figure

ONI 859.8 MW
 ONS 853.3 MW

Nova Scotia New Brunswick

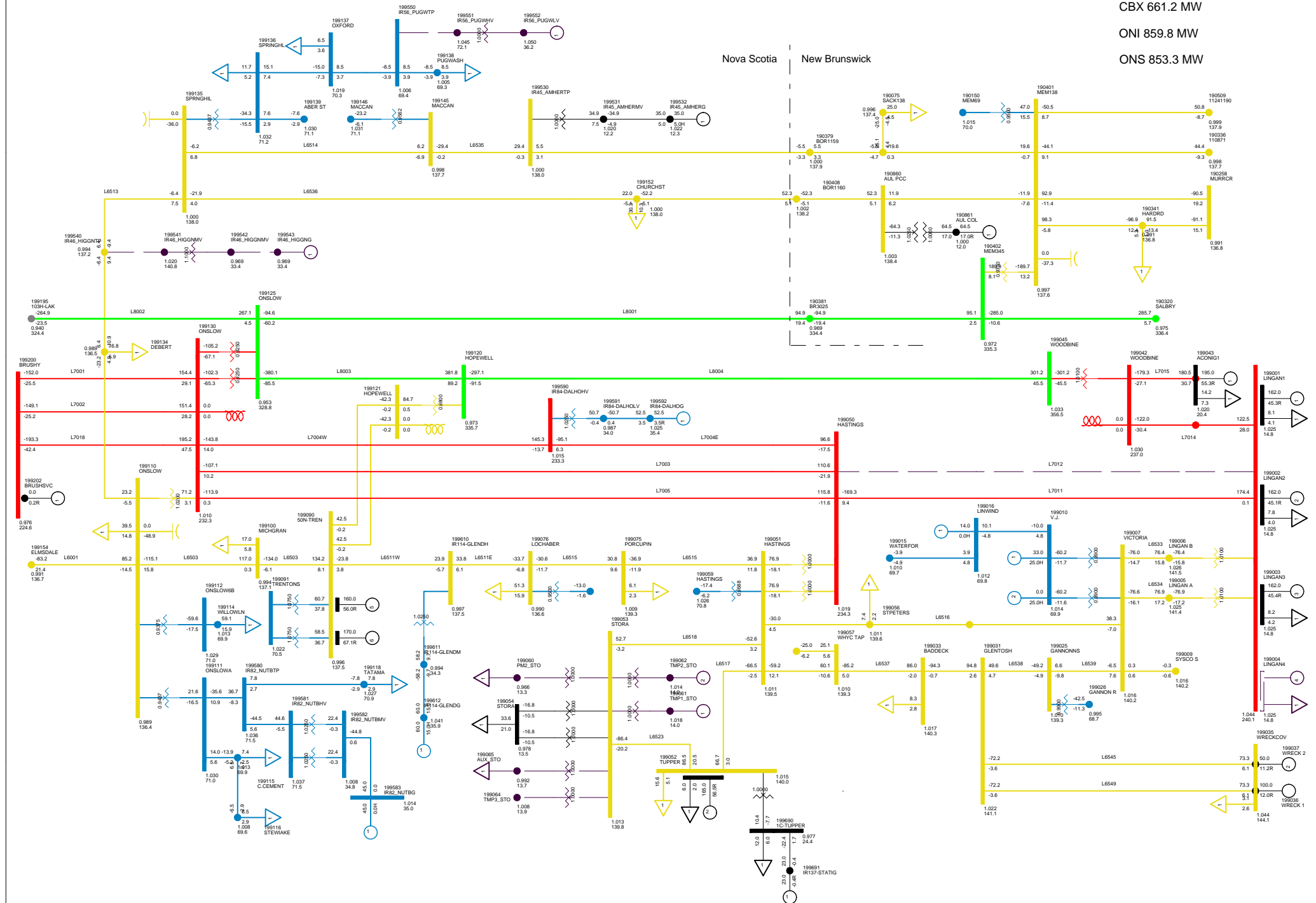

2013 EXTREME LOAD CONDITION
 C05S LOSE L7012 WITH SPS
 NORTHEASTERN NS MON, JAN 05 2009 17:33

Total Wind Gen: 290.1 MW
 Gross Lingan 486.0 MW
 Gross Trenton 330.0 MW
 Gross Tuft's Cove 485.7 MW
 Gross Tupper 165.0 MW
 Gross Wreck Cove 150.0 MW
 Gross Gas Turbine 183.0 MW
 Gross Small Hydro 182.4 MW
 Net Stora Load 33.7 MW
 Total BMPC Load 9.5 MW

Bus - VOLTAGE (KV/PU)
 Branch - MW/MVAR
 Equipment - MW/MVAR
 110.0PARATEB
 1.0000V 0.8500V
 KV <-<0.00 <-<69.00V <-<138.00V <-<230.00V <-<345.00V >345.00V

Figure

Nova Scotia New Brunswick

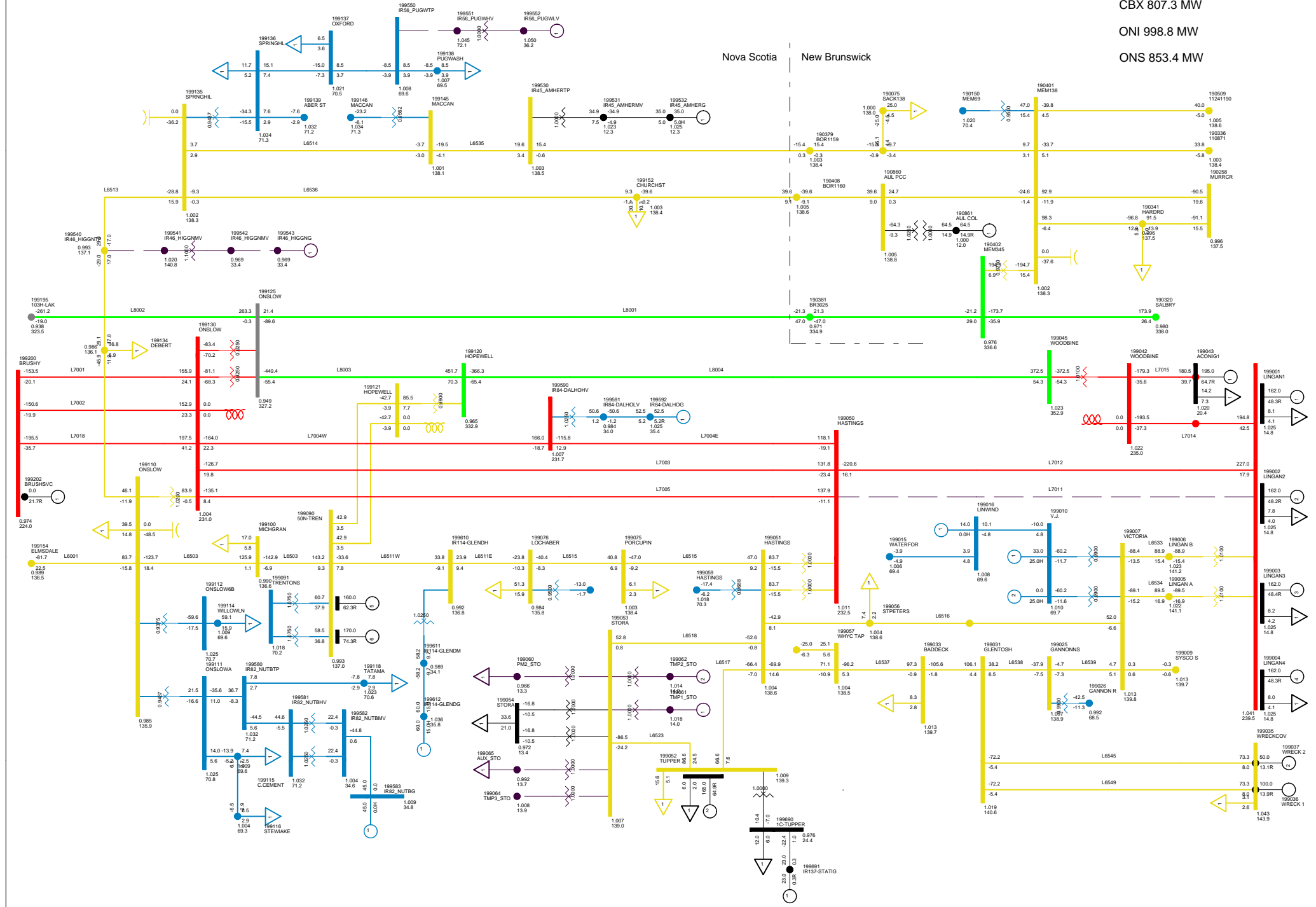

2013 EXTREME LOAD CONDITION
C06 LOSE L7011
NORTHEASTERN NS MON, JAN 05 2009 17:33

Total Wind Gen: 290.1 MW
Gross Ligan 648.0 MW
Gross Trenton 330.0 MW
Gross Tuft's Cove 485.7 MW
Gross Wreck Cove 150.0 MW
Gross Gas Turbine 183.0 MW
Gross Small Hydro 182.4 MW
Net Stora Load 33.7 MW
Total BMPC Load 9.5 MW

Bus - VOLTAGE (KV/PV)
Branch - MW/MVAR
Equipment - MW/MVAR
110.000kV
1.0000V 0.8500V
KV <-<0.00 <-<69.00V <-<138.000 <-<230.000 <-<345.000 >345.000

Figure

Nova Scotia New Brunswick

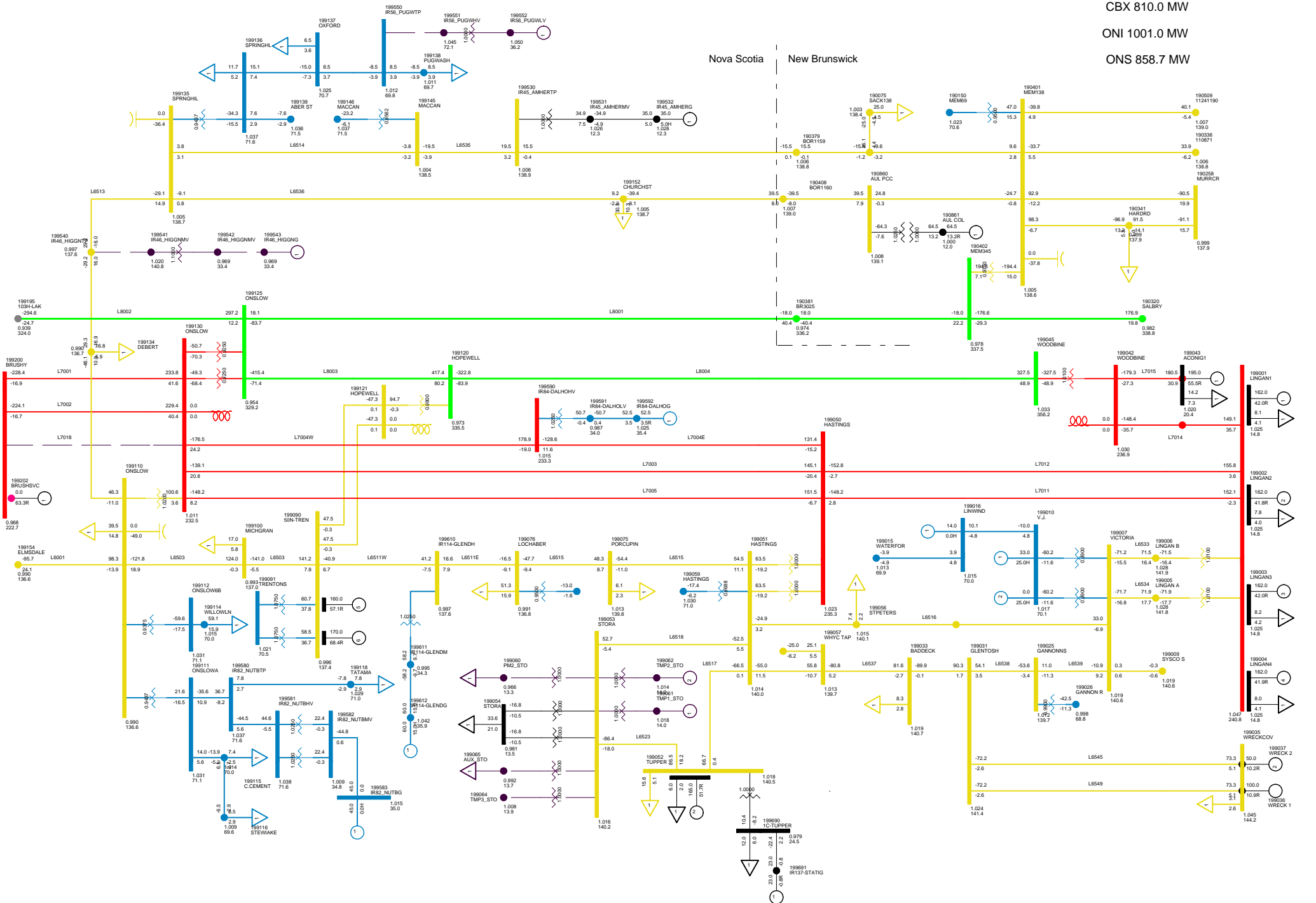

2013 EXTREME LOAD CONDITION
C08 LOSE L7018
NORTHEASTERN NS MON, JAN 05 2009 17:33

Total Wind Gen: 290.1 MW
Gross Ligan 648.0 MW
Gross Trenton 330.0 MW
Gross Tuft's Cove 485.7 MW
Gross Wreck Cove 150.0 MW
Gross Gas Turbine 183.0 MW
Gross Small Hydro 182.4 MW
Net Stora Load 33.7 MW
Total BMPC Load 9.5 MW

Bus - VOLTAGE (KV/PV)
Branch - MW/MVAR
Equipment - MW/MVAR
110.0/34.5/110.0
1.000/0.0 0.800/0.0
KV <-<0.000 <-<69.000 <-<138.000 <-<230.000 <-<345.000 >>345.000

Figure

Total Wind Gen: 290.1 MW
 Gross Tupper 165.0 MW
 Gross Wreck Cove 150.0 MW
 Gross Lingan 648.0 MW
 Gross Trenton 330.0 MW
 Gross Gas Turbine 183.0 MW
 Gross Pt Aconi 195.0 MW
 Gross Tuft's Cove 485.7 MW
 Gross Small Hydro 182.4 MW
 Net Stora Load 33.7 MW
 Total BMPC Load 9.5 MW

NSX -2.0 MW
 CBX 809.9 MW
 ONI 1000.7 MW
 ONS 854.5 MW

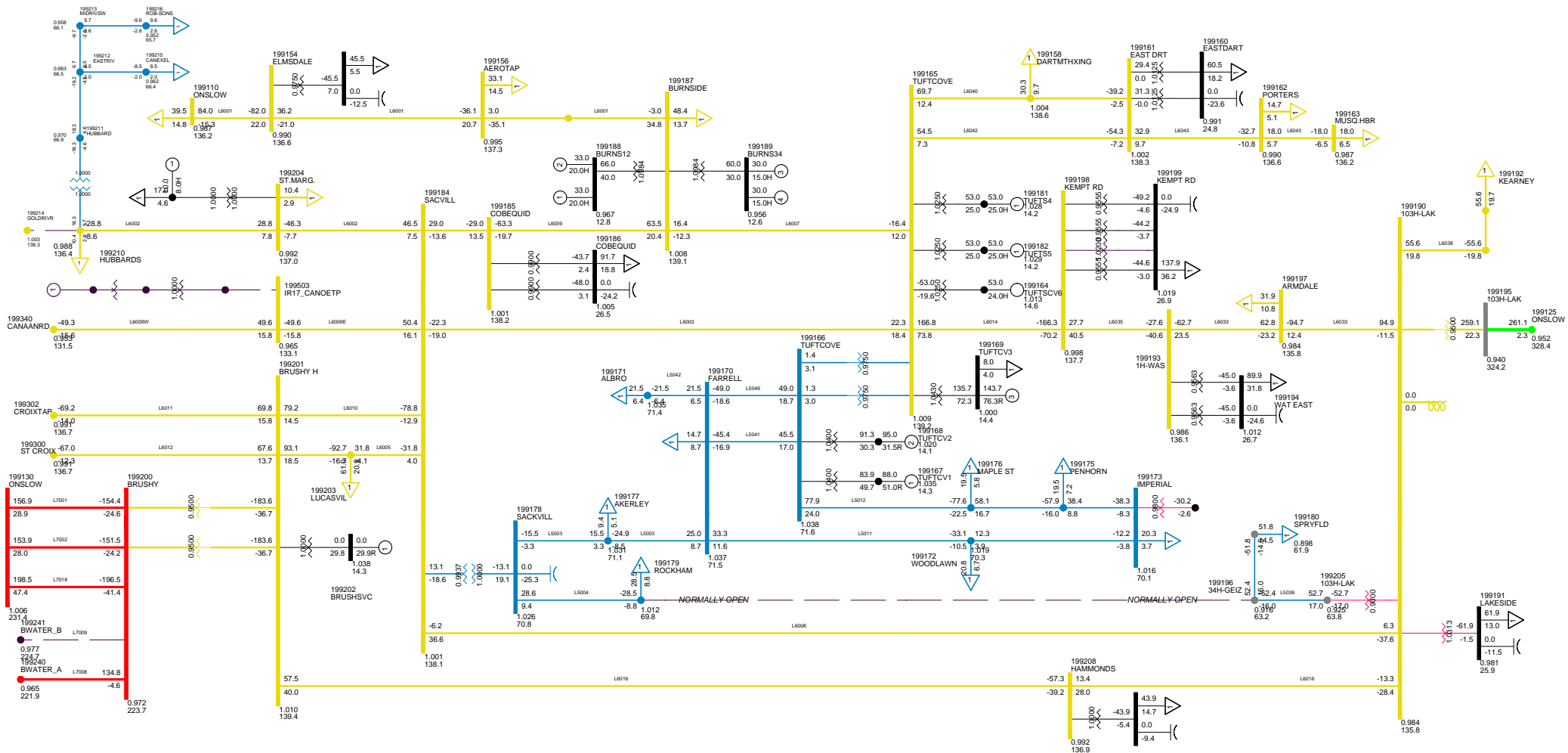

2013 EXTREME LOAD CONDITION
 C09 LOSE L7009
 METRO ZONE MON, JAN 05 2009 17:33

Bus - VOLTAGE (KV/PU)
 Break - MIN/MAX
 Equipment - MIN/MAX
 HV/RATE
 1.050KV 0.950V
 KV: <=30.000 >=60.000 <=138.000 <=230.000 <=345.000 >=345.000

Figure __

Nova Scotia New Brunswick

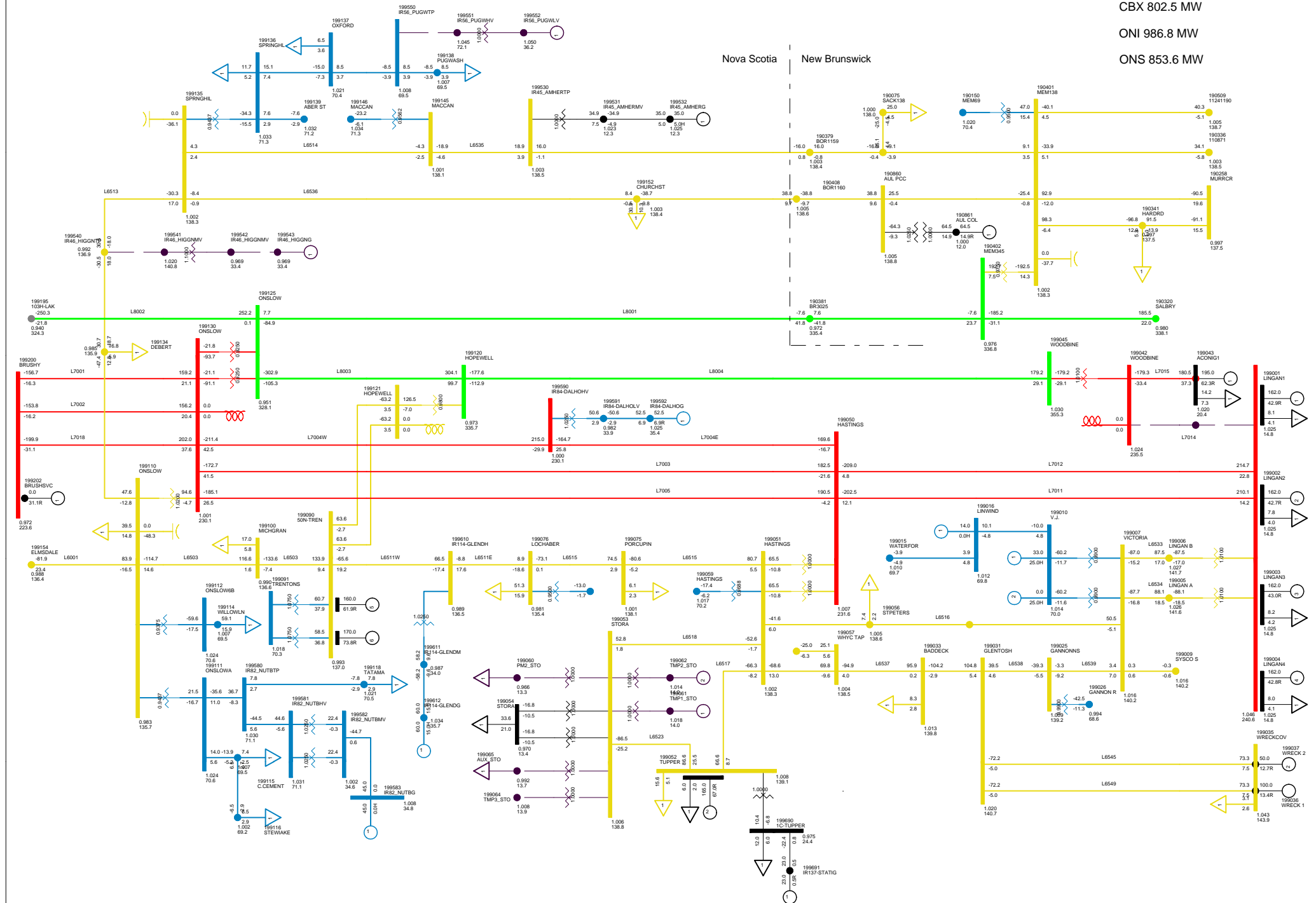

2013 EXTREME LOAD CONDITION
C11 LOSE L7014
NORTHEASTERN NS MON, JAN 05 2009 17:34

Total Wind Gen: 290.1 MW
Gross Ligan 648.0 MW
Gross Trenton 330.0 MW
Gross Pt Aconi 195.0 MW
Gross Tupper 165.0 MW
Gross Gas Turbine 183.0 MW
Gross Small Hydro 182.4 MW
Gross Wreck Cove 150.0 MW
Net Stora Load 33.7 MW
Total BMPC Load 9.5 MW

Bus - VOLTAGE (KV/PV)
Branch - MW/MVAR
Equipment - MW/MVAR
110.0/24.0/1.0
KV: <-25.0 <-69.0 <-138.0 <-230.0 <-345.0 >345.000

Figure

ONI 1015.1 MW
 ONS 853.1 MW

Nova Scotia New Brunswick

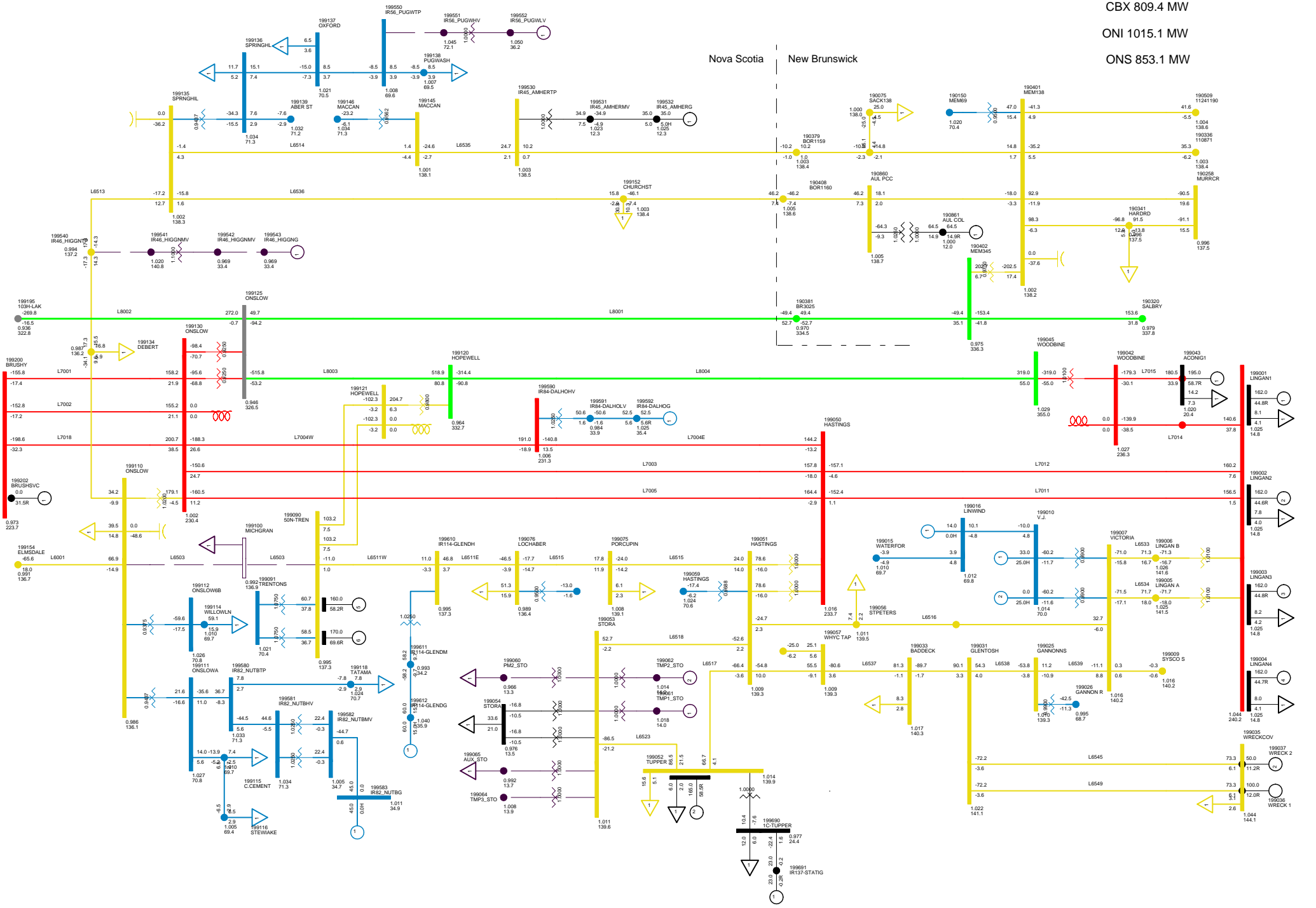

2013 EXTREME LOAD CONDITION
 C12 LOSE 6503
 NORTHEASTERN NS MON, JAN 05 2009 17:34

Total Wind Gen: 290.1 MW
 Gross Lingan 648.0 MW
 Gross Trenton 330.0 MW
 Gross Tuft's Cove 485.7 MW
 Gross Tupper 165.0 MW
 Gross Wreck Cove 150.0 MW
 Gross Gas Turbine 183.0 MW
 Gross Small Hydro 182.4 MW
 Net Stora Load 33.7 MW
 Total BMPC Load 9.5 MW

Bus - VOLTAGE (KV/PV)
 Branch - MW/MVAR
 Equipment - MW/MVAR
 110.0/34.5
 1.000/0.0
 KV <-< 200 <-< 230.0 <-< 138.0 <-< 230.0 <-< 345.0 >345.0

Figure

ONI 1005.3 MW
 ONS 853.3 MW

Nova Scotia New Brunswick

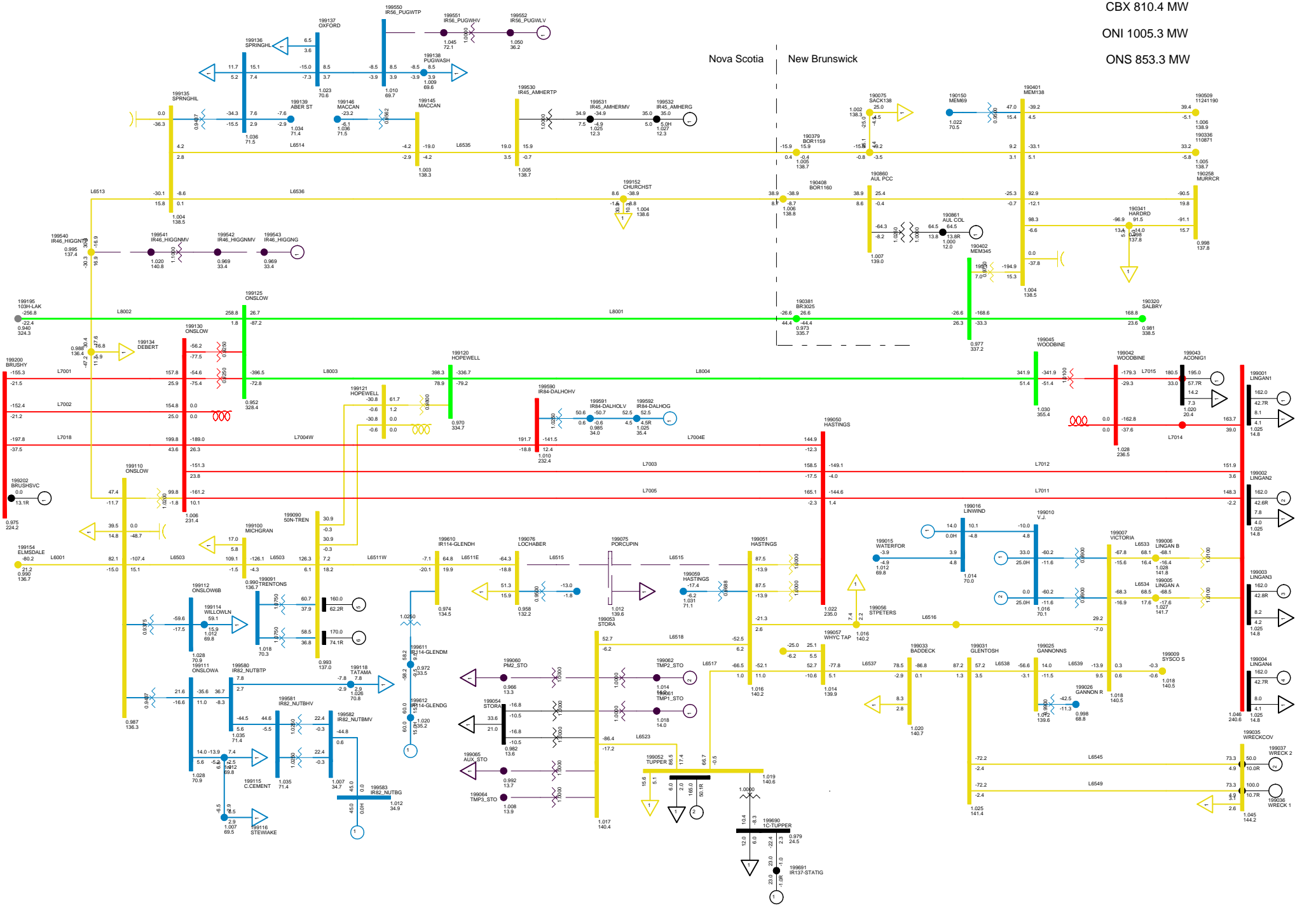

2013 EXTREME LOAD CONDITION
 C13 LOSE L6511
 NORTHEASTERN NS MON, JAN 05 2009 17:34

Total Wind Gen: 290.1 MW
 Gross Lingan 648.0 MW
 Gross Trenton 330.0 MW
 Gross Tuft's Cove 485.7 MW
 Gross Tupper 165.0 MW
 Gross Wreck Cove 150.0 MW
 Gross Gas Turbine 183.0 MW
 Gross Small Hydro 182.4 MW
 Net Stora Load 33.7 MW
 Total BMPC Load 9.5 MW

Bus - VOLTAGE (KV/PU)
 Branch - MW/MVAR
 Equipment - MW/MVAR
 110.0/1.0/1.0
 1.0/0.0/0.0
 KV <-20.0 <-69.0 <-138.0 <-230.0 <-345.0 >345.000

Figure

Nova Scotia New Brunswick

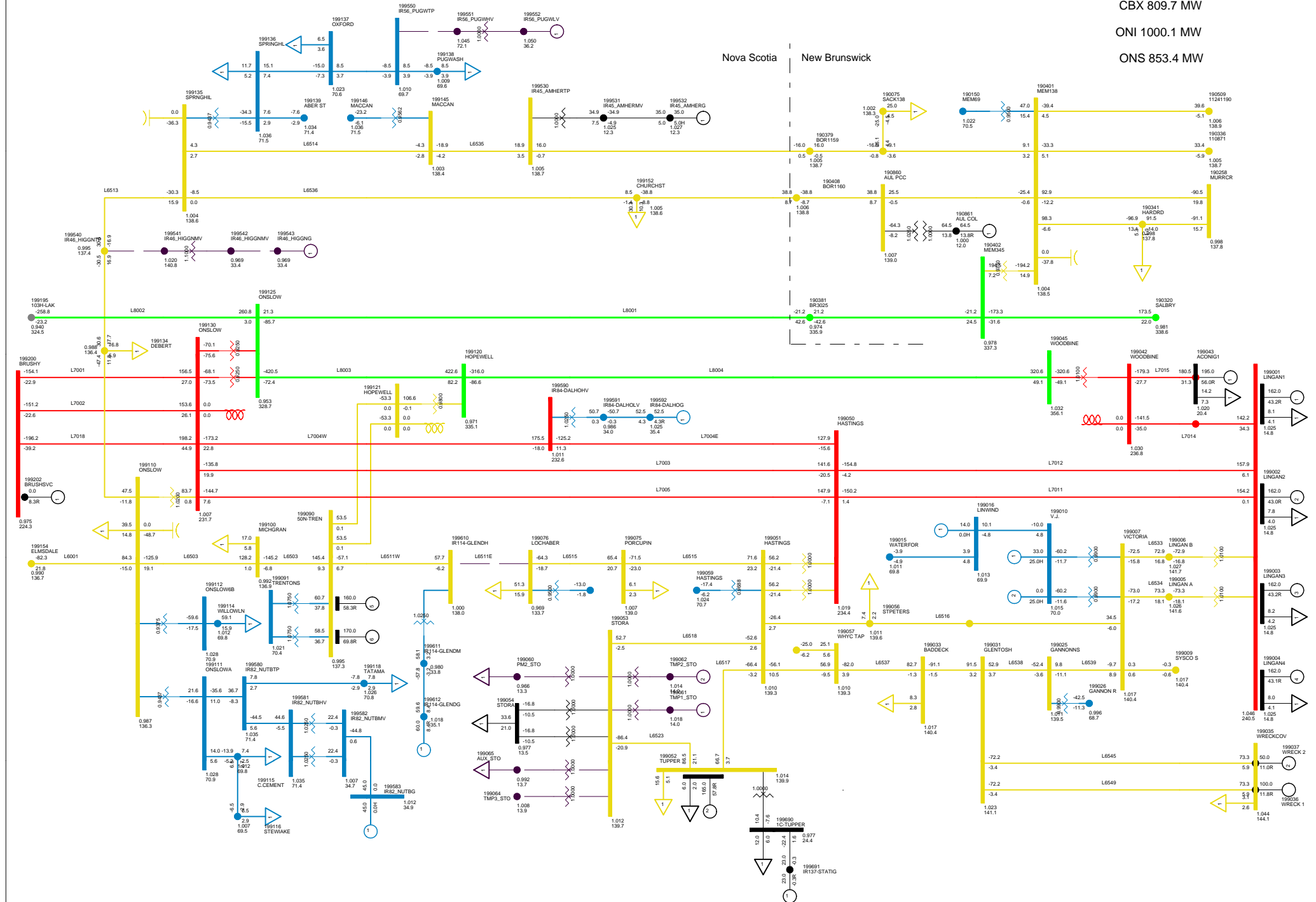

2013 EXTREME LOAD CONDITION
 C14 LOSE L6511E
 NORTHEASTERN NS MON, JAN 05 2009 17:34

Total Wind Gen: 290.1 MW
 Gross Lingan 648.0 MW
 Gross Trenton 330.0 MW
 Gross Tuft's Cove 485.7 MW
 Gross Tupper 165.0 MW
 Gross Wreck Cove 150.0 MW
 Gross Gas Turbine 183.0 MW
 Gross Small Hydro 182.4 MW
 Net Stora Load 33.7 MW
 Total BMPC Load 9.5 MW

Bus - VOLTAGE (KV/PV)
 Branch - MW/MVAR
 Equipment - MW/MVAR
 110.0/24.0
 1.000/0.050/0.050
 KV <-25.000 <-69.000 <-138.000 <-230.000 <-345.000 >345.000

Figure

NSX 1.5 MW
 CBX 810.2 MW
 ONI 1000.0 MW
 ONS 853.3 MW

Nova Scotia New Brunswick

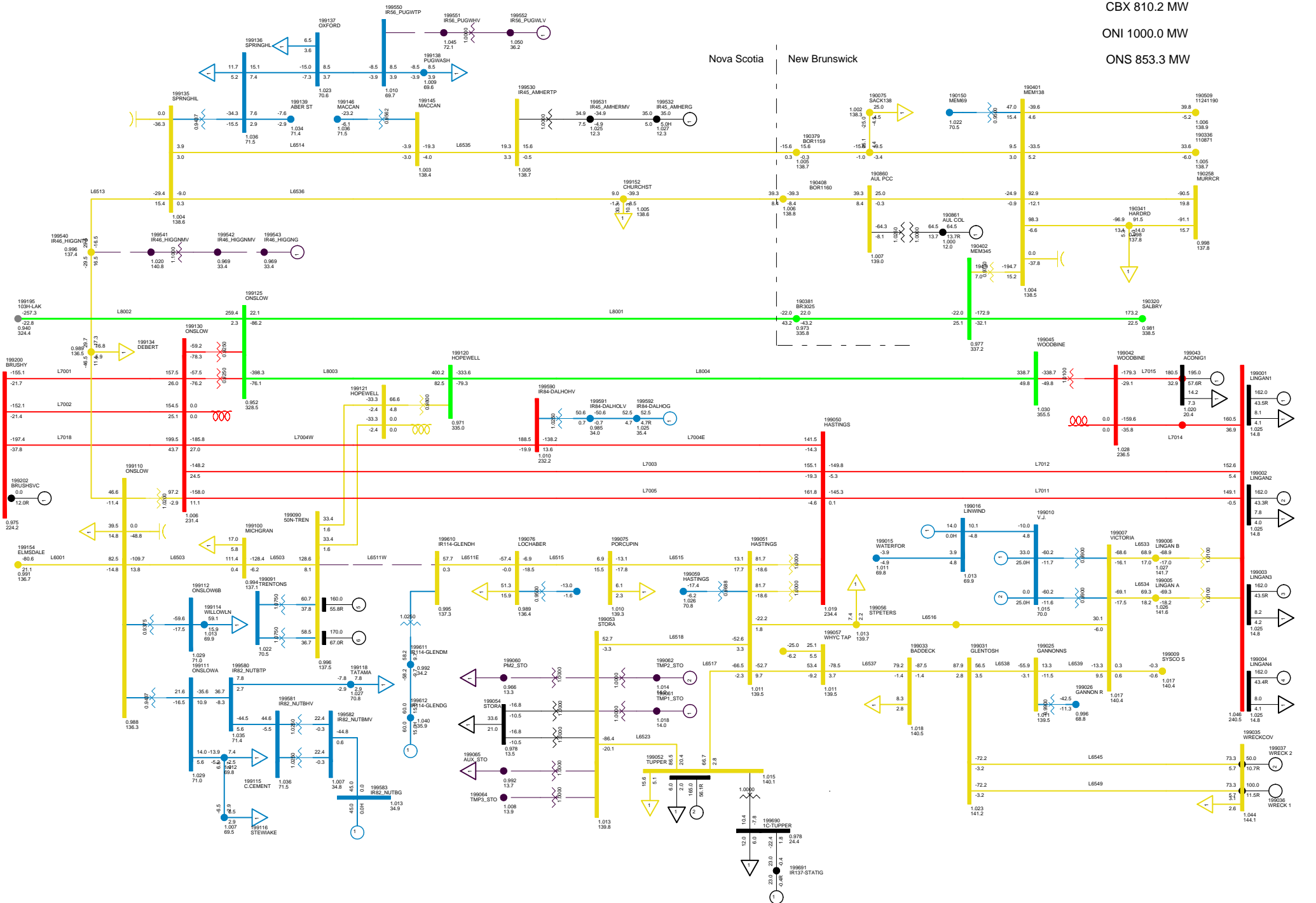

2013 EXTREME LOAD CONDITION
 C15 LOSE L6511W
 NORTHEASTERN NS MON, JAN 05 2009 17:34

Total Wind Gen: 290.1 MW
 Gross Ligan 648.0 MW
 Gross Trenton 330.0 MW
 Gross Tuft's Cove 485.7 MW
 Gross Tupper 165.0 MW
 Gross Wreck Cove 150.0 MW
 Gross Gas Turbine 183.0 MW
 Gross Small Hydro 182.4 MW
 Net Stora Load 33.7 MW
 Total BMPC Load 9.5 MW

Bus - VOLTAGE (KV/PU)
 Branch - MW/MVAR
 Equipment - MW/MVAR
 110.0/1.0/1.0
 1.0/0.0/0.0
 KV - <<20.000 <<69.000 <<138.000 <<230.000 <<345.000 >>345.000

Figure

ONI 1001.0 MW
 ONS 853.6 MW

Nova Scotia New Brunswick

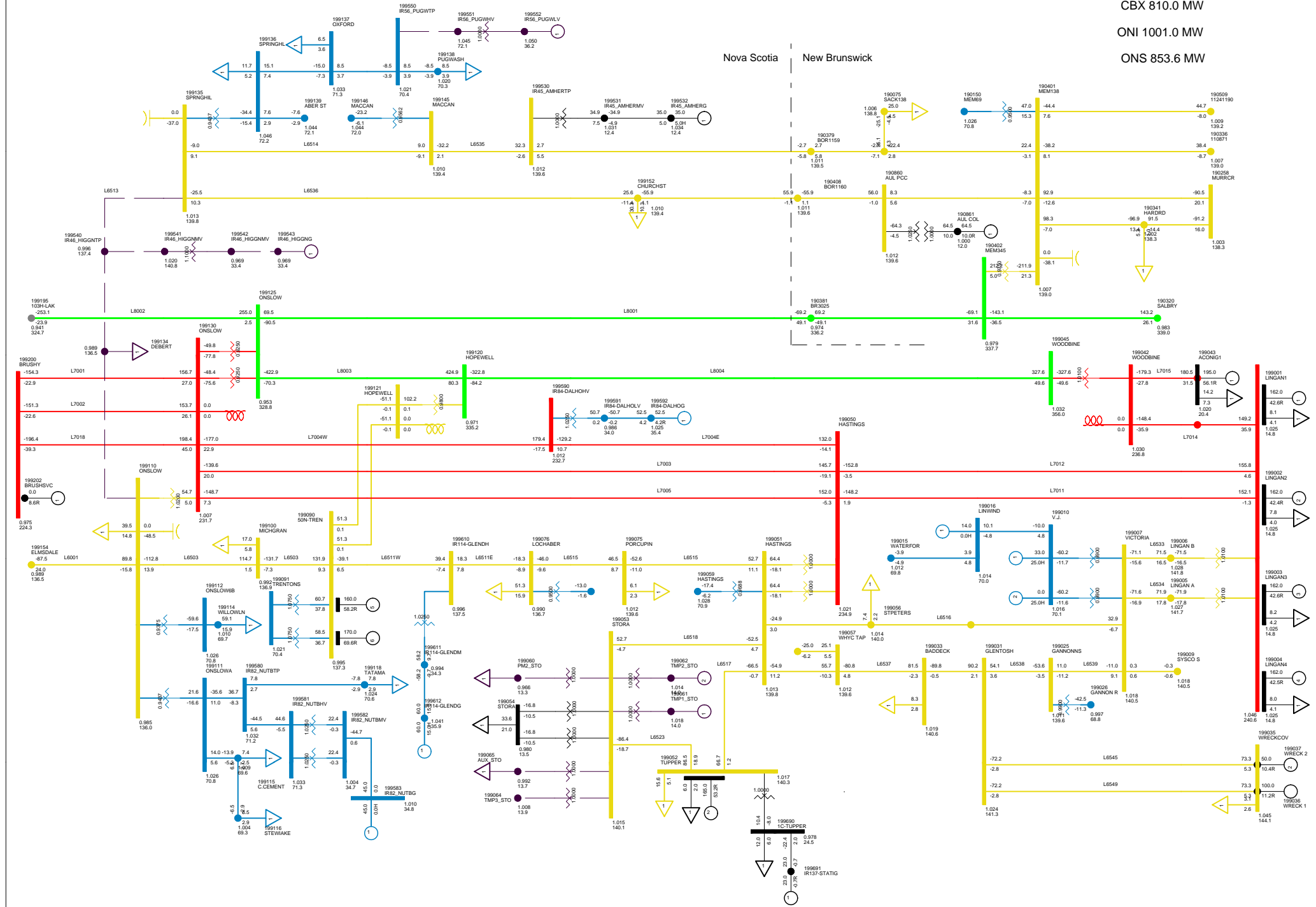

2013 EXTREME LOAD CONDITION
 C16 LOSE L6513
 NORTHEASTERN NS MON, JAN 05 2009 17:34

Total Wind Gen: 290.1 MW
 Gross Lingan 648.0 MW
 Gross Trenton 330.0 MW
 Gross Pt Aconi 195.0 MW
 Gross Tupper 165.0 MW
 Gross Wreck Cove 150.0 MW
 Gross Gas Turbine 183.0 MW
 Gross Small Hydro 182.4 MW
 Net Stora Load 33.7 MW
 Total BMPC Load 9.5 MW

Bus - VOLTAGE (KV/PU)
 Branch - MW/MVAR
 Equipment - MW/MVAR
 110.0KV/1.000V 0.850UV
 KV <-25.000 <-69.000 <-138.000 <-230.000 <-345.000 >345.000

Figure

ONI 1000.8 MW
 ONS 853.3 MW

Nova Scotia New Brunswick

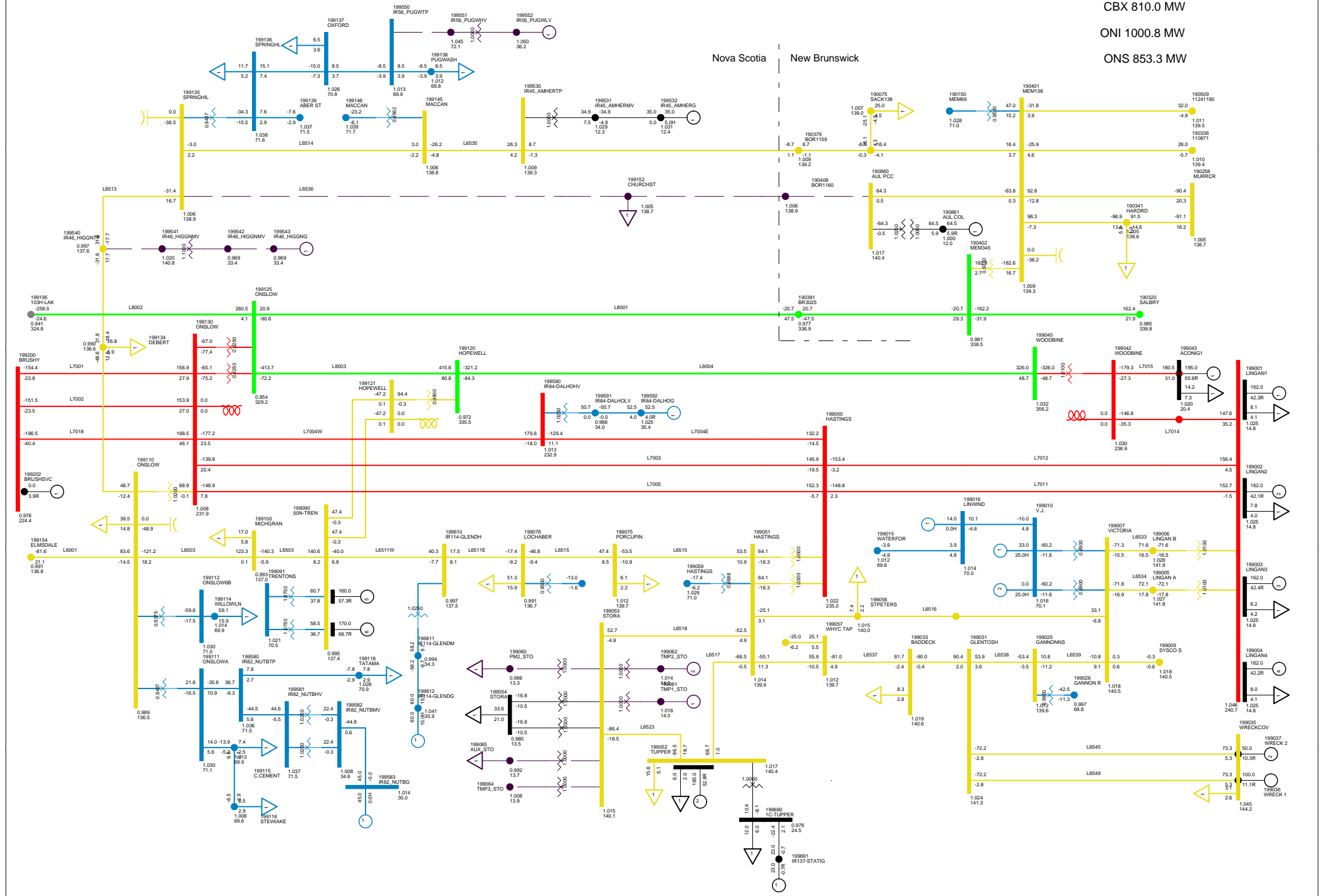

2013 EXTREME LOAD CONDITION
 C17 LOSE L6536
 NORTHEASTERN NS MON, JAN 05 2009 17:34

Total Wind Gen: 290.1 MW
 Gross Lingan 648.0 MW
 Gross Trenton 330.0 MW
 Gross Tuft's Cove 485.7 MW
 Gross Tupper 165.0 MW
 Gross Wreck Cove 150.0 MW
 Gross Gas Turbine 183.0 MW
 Gross Small Hydro 182.4 MW
 Net Stora Load 33.7 MW
 Total BMPC Load 9.5 MW

Bus - VOLTAGE (KV/PU)
 Branch - MW/MVAR
 Equipment - MW/MVAR
 110.0/0.875
 1.000/0.850/0.9
 KV - <<<0.00 <<<69.00V <<<138.000 <<<345.000 >>>345.000

Figure

NSX 11.0 MW
 CBX 809.9 MW
 ONI 1000.7 MW
 ONS 853.3 MW

Nova Scotia New Brunswick

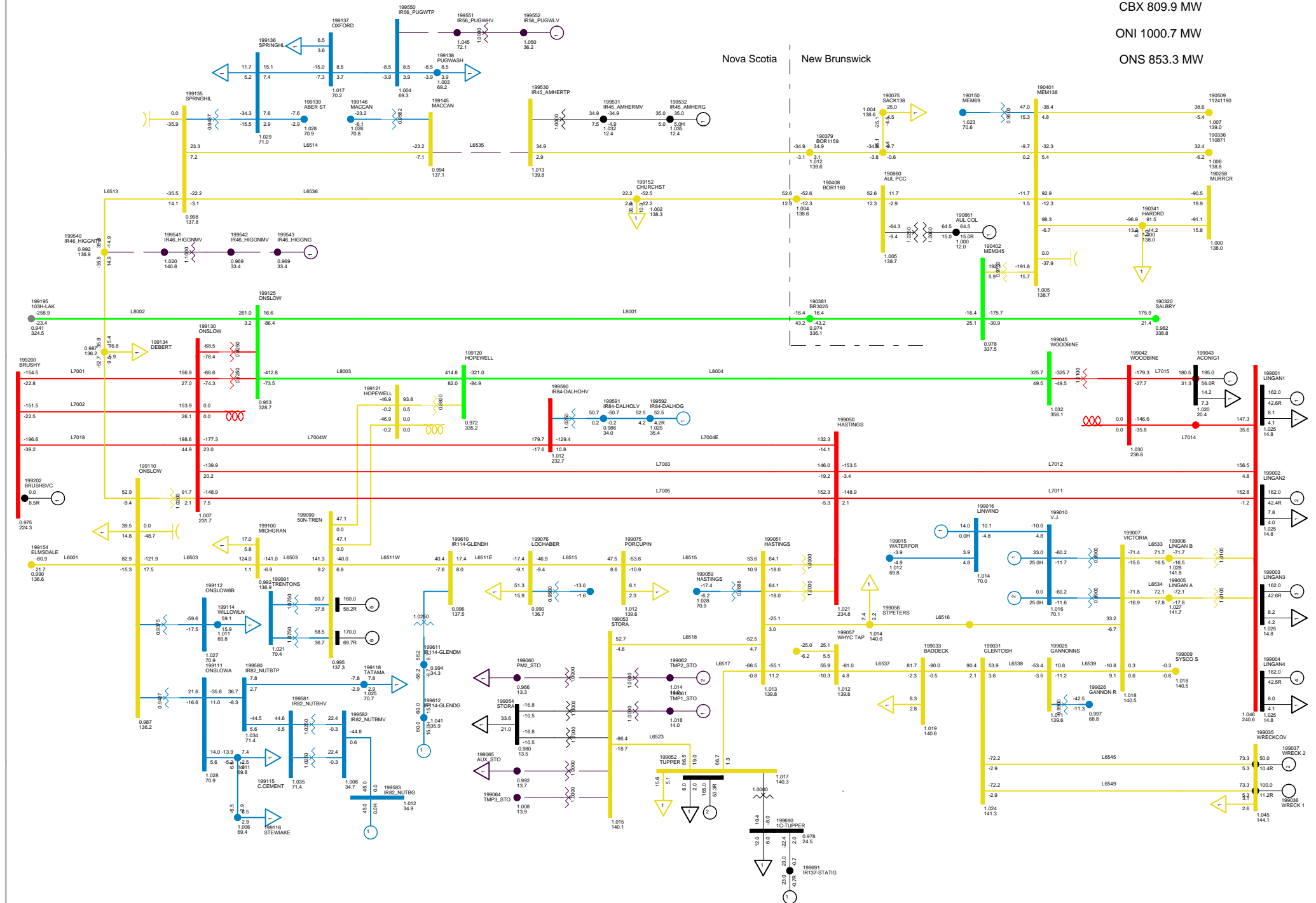

2013 EXTREME LOAD CONDITION
 C18 LOSE L6535S
 NORTHEASTERN NS MON, JAN 05 2009 17:34

Total Wind Gen: 290.1 MW
 Gross Ligan 648.0 MW
 Gross Trenton 330.0 MW
 Gross Tuft's Cove 485.7 MW
 Gross Tupper 165.0 MW
 Gross Wreck Cove 150.0 MW
 Gross Gas Turbine 183.0 MW
 Gross Small Hydro 182.4 MW
 Net Stora Load 33.7 MW
 Total BMPC Load 9.5 MW

Bus - VOLTAGE (KV/PU)
 Branch - MW/MVAR
 Equipment - MW/MVAR
 110.0/0.475
 1.000/0.050/0.050
 KV <-< 0.000 <-< 69.000 <-< 138.000 <-< 230.000 <-< 345.000 >> 345.000

Figure

Nova Scotia New Brunswick

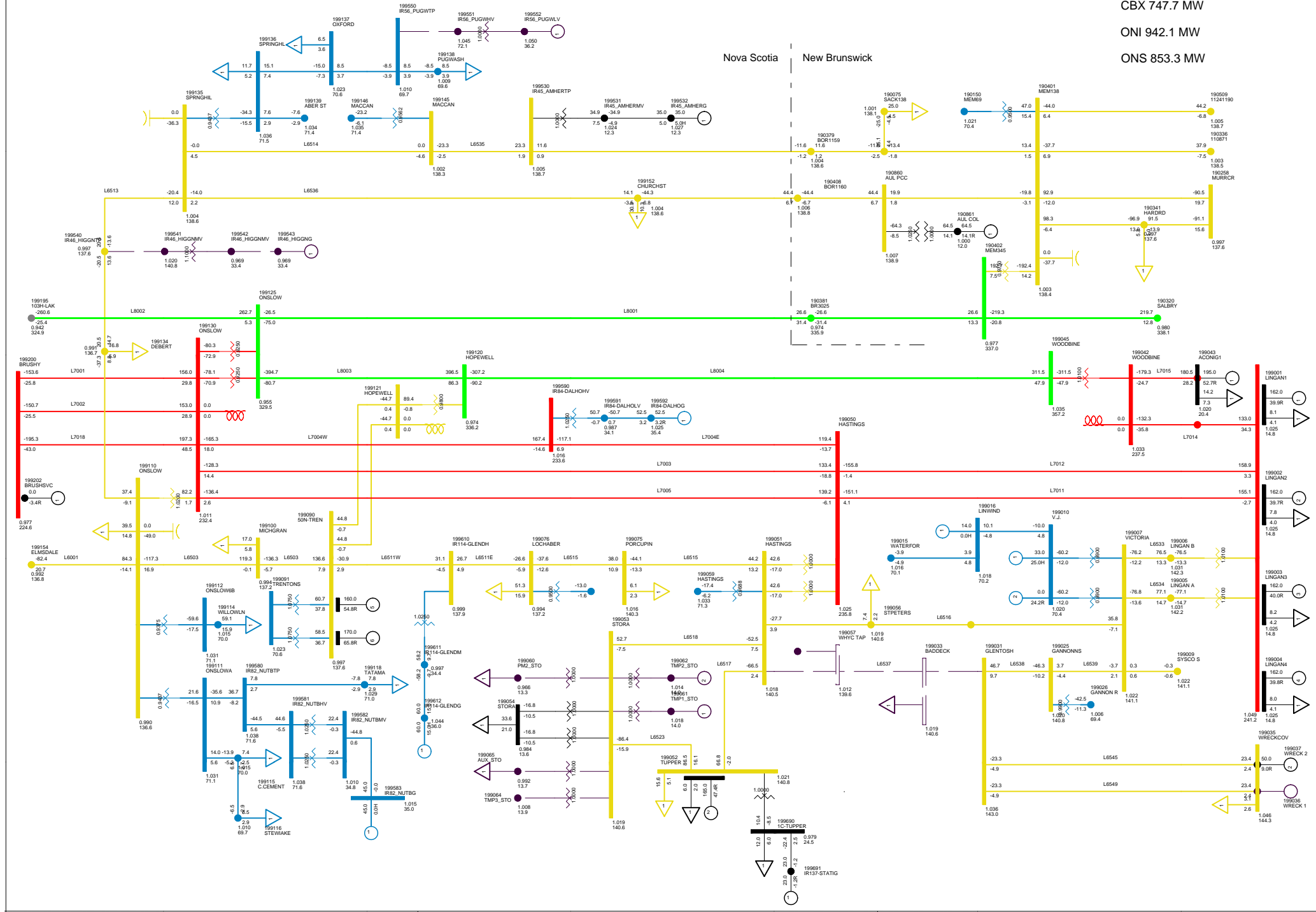

2013 EXTREME LOAD CONDITION
C20 LOSE L6537
NORTHEASTERN NS MON, JAN 05 2009 17:35

Total Wind Gen: 290.1 MW
Gross Ligan 648.0 MW
Gross Trenton 330.0 MW
Gross Tuft's Cove 485.7 MW
Gross Tupper 165.0 MW
Gross Wreck Cove 50.0 MW
Gross Gas Turbine 183.0 MW
Gross Small Hydro 182.4 MW
Net Stora Load 33.7 MW
Total BMPC Load 9.5 MW

Bus - VOLTAGE (KV/PV)
Branch - MW/MVAR
Equipment - MW/MVAR
110.0kV-138.0kV
1.0000V 0.8500V
KV- <<20.000 <<49.000 <<138.000 <<230.000 <<345.000 >>345.000

Figure

ONI 1007.4 MW
 ONS 853.4 MW

Nova Scotia New Brunswick

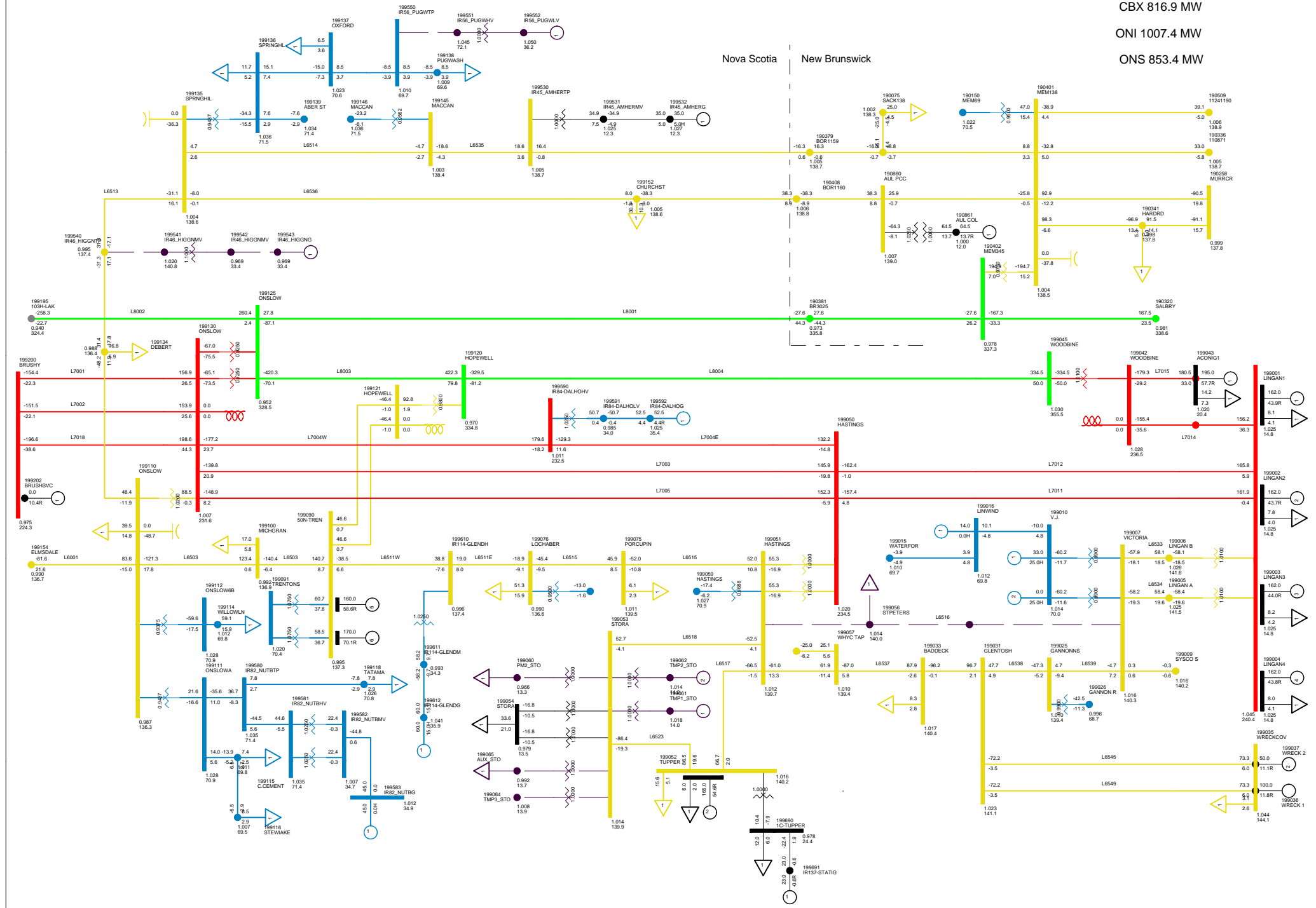

2013 EXTREME LOAD CONDITION
 C21 LOSE L6516
 NORTHEASTERN NS MON, JAN 05 2009 17:35

Total Wind Gen: 290.1 MW
 Gross Lingan 648.0 MW
 Gross Trenton 330.0 MW
 Gross Tuft's Cove 485.7 MW
 Gross Tupper 165.0 MW
 Gross Wreck Cove 150.0 MW
 Gross Gas Turbine 183.0 MW
 Gross Small Hydro 182.4 MW
 Net Stora Load 33.7 MW
 Total BMPC Load 9.5 MW

Bus - VOLTAGE (KV/PV)
 Branch - MW/MVAR
 Equipment - MW/MVAR
 110.0/24.0/1.0
 KV - <<<20.0 <<<69.0KV <<<138.0KV <<<230.0KV <<<345.0KV >>>345.0KV

Figure

Total Wind Gen: 290.1 MW Gross Tupper 165.0 MW Gross Wreck Cove 150.0 MW
 Gross Lingan 648.0 MW Gross Trenton 330.0 MW Gross Gas Turbine 183.0 MW
 Gross Pt Aconi 195.0 MW Gross Tuft's Cove 485.7 MW Gross Small Hydro 182.4 MW

Net Stora Load 33.7 MW Total BMPC Load 9.5 MW

NSX -0.8 MW
 CBX 809.9 MW
 ONI 1000.8 MW
 ONS 853.4 MW

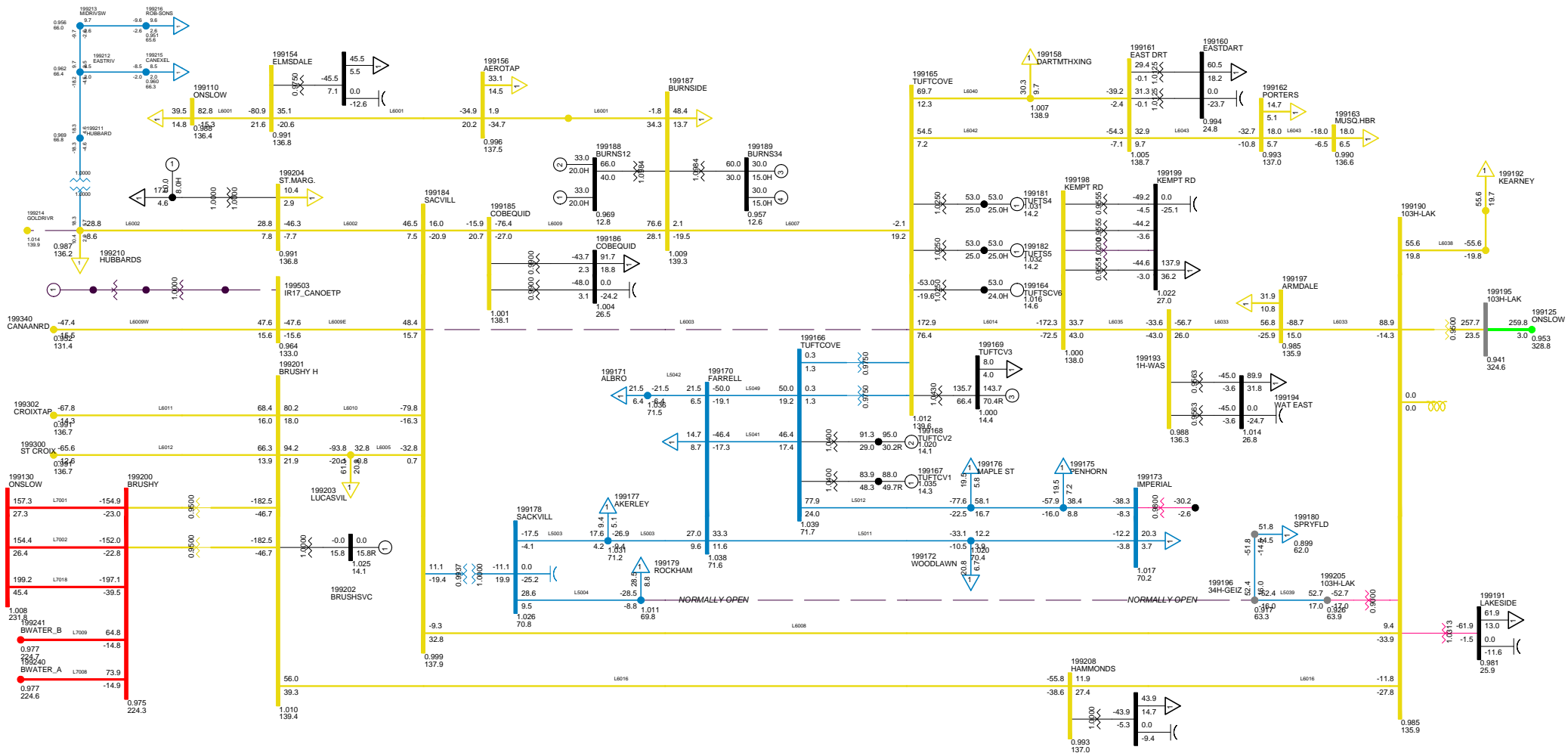

2013 EXTREME LOAD CONDITION
 C23 LOSE L6003
 METRO ZONE MON, JAN 05 2009 17:35

Bus - VOLTAGE (KV)PU
 Break - MIN/MAX
 Equipment - MIN/MAX
 HV/RATE
 1.050KV 0.950V
 KV: <=30.000 >=60.000 <=138.000 <=230.000 <=345.000 >=345.000

Figure __

Total Wind Gen: 290.1 MW
 Gross Tupper 165.0 MW
 Gross Wreck Cove 150.0 MW
 Gross Lingan 648.0 MW
 Gross Trenton 330.0 MW
 Gross Gas Turbine 183.0 MW
 Gross Pt Aconi 195.0 MW
 Gross Tuft's Cove 485.7 MW
 Gross Small Hydro 182.4 MW
 Net Stora Load 33.7 MW
 Total BMPC Load 9.5 MW

NSX 62.0 MW
 CBX 810.1 MW
 ONI 1001.1 MW
 ONS 790.6 MW

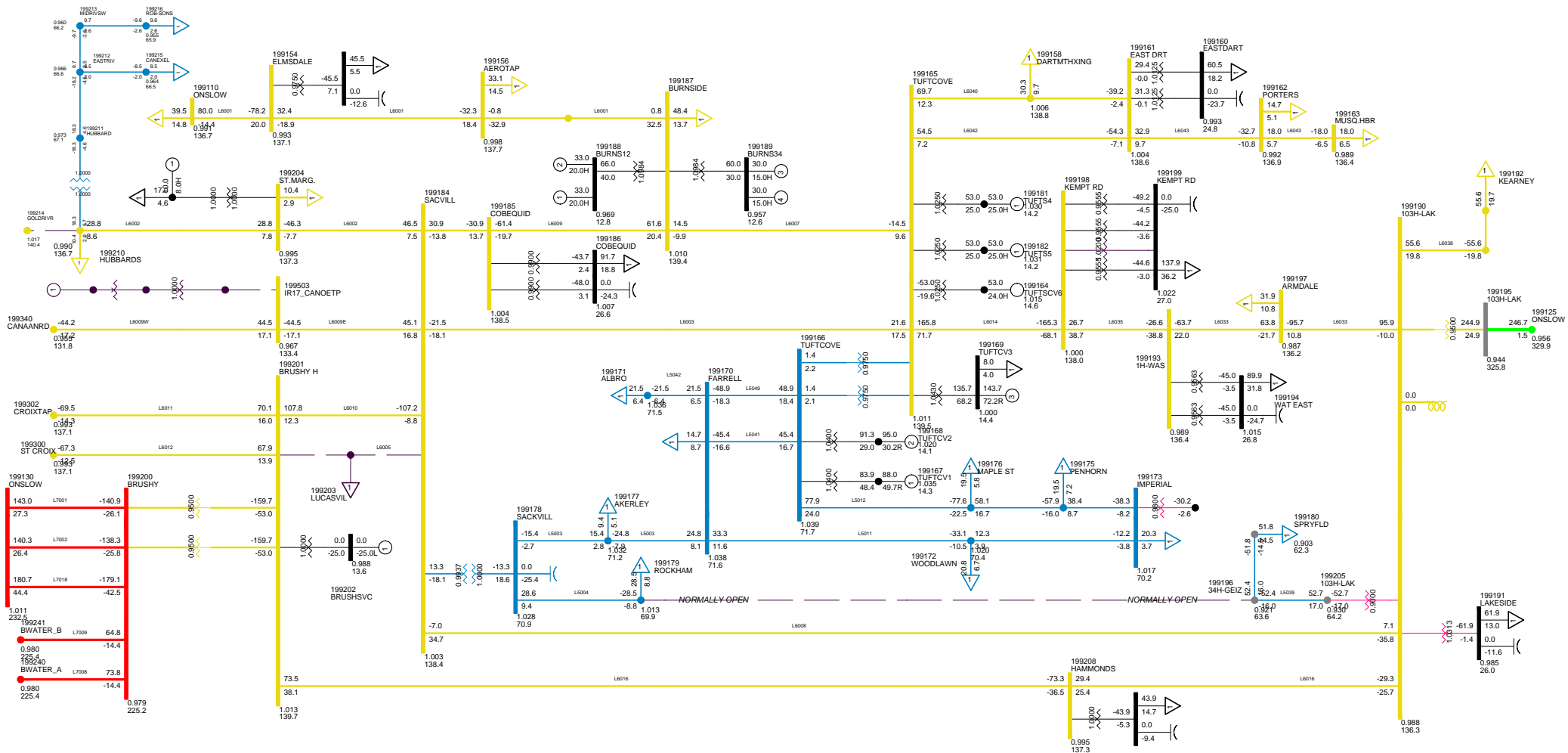

2013 EXTREME LOAD CONDITION
 C24 LOSE L6005
 METRO ZONE MON, JAN 05 2009 17:35

Bus - VOLTAGE (KV)PU
 Break - MIN/MAX
 Equipment - MIN/MAX
 HV/DIS/RATE
 1.050KV 0.950V
 KV <=30.000 >=48.000 <=138.000 <=230.000 <=345.000 >=345.000

Figure __

Total Wind Gen: 290.1 MW Gross Tupper 165.0 MW Gross Wreck Cove 150.0 MW
 Gross Lingan 648.0 MW Gross Trenton 330.0 MW Gross Gas Turbine 183.0 MW
 Gross Pt Aconi 195.0 MW Gross Tuft's Cove 485.7 MW Gross Small Hydro 182.4 MW

Net Stora Load 33.7 MW Total BMPC Load 9.5 MW

NSX -1.2 MW
 CBX 809.9 MW
 ONI 1000.6 MW
 ONS 853.6 MW

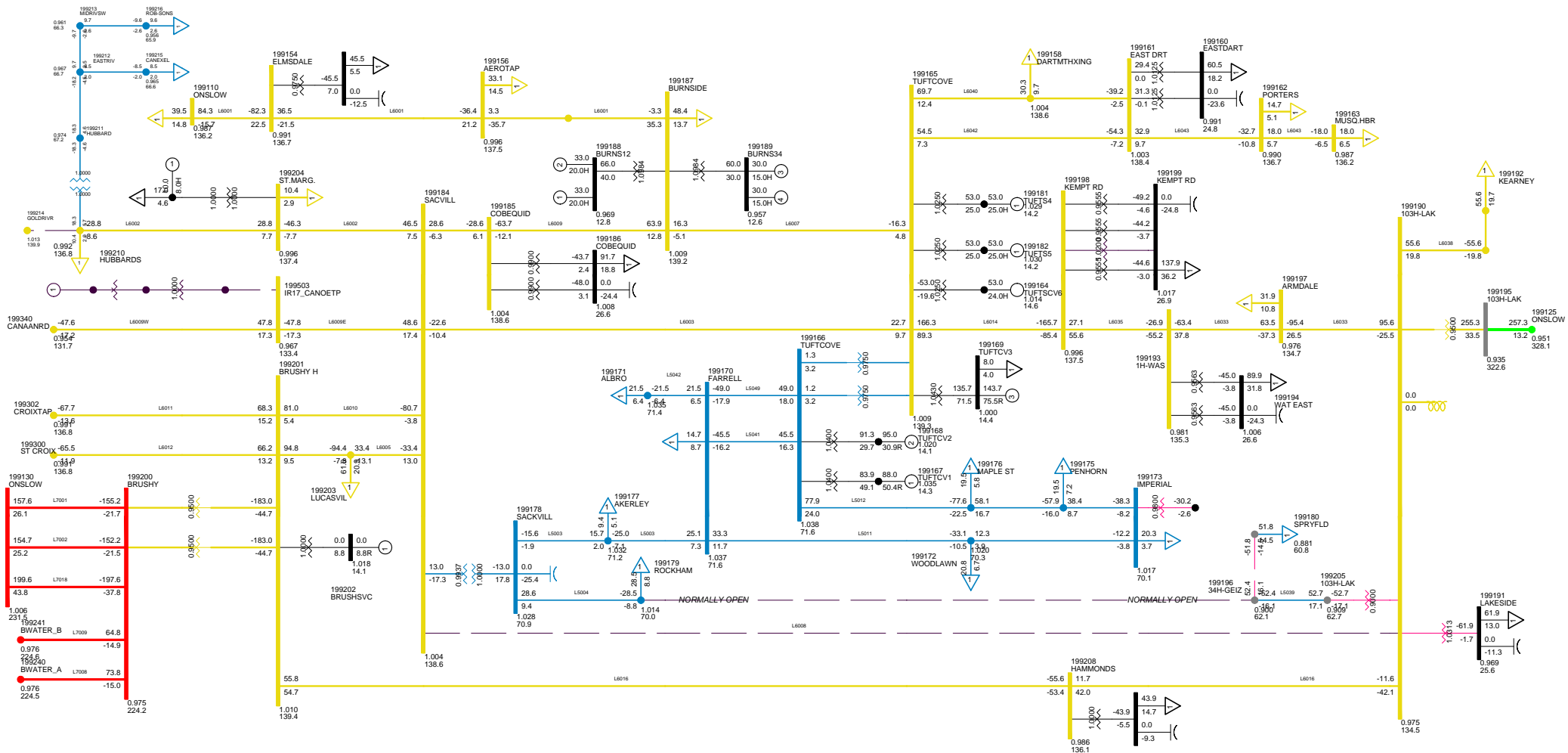

2013 EXTREME LOAD CONDITION
 C26 LOSE L6008
 METRO ZONE MON, JAN 05 2009 17:35

Bs - VOLTAGE (KV/PU)
 Break - MIN/MAX
 Equipment - MIN/MAX
 HV/DIS/RATE
 1.050KV 0.950KV
 KV: <=30.000 >=60.000 <=138.000 <=230.000 <=345.000 >=345.000

Figure __

Total Wind Gen: 290.1 MW
 Gross Tupper 165.0 MW
 Gross Wreck Cove 150.0 MW
 Gross Lingan 648.0 MW
 Gross Trenton 330.0 MW
 Gross Gas Turbine 183.0 MW
 Gross Pt Aconi 195.0 MW
 Gross Tuft's Cove 485.7 MW
 Gross Small Hydro 182.4 MW
 Net Stora Load 33.7 MW
 Total BMPC Load 9.5 MW

NSX 44.1 MW
 CBX 810.0 MW
 ONI 1000.9 MW
 ONS 808.4 MW

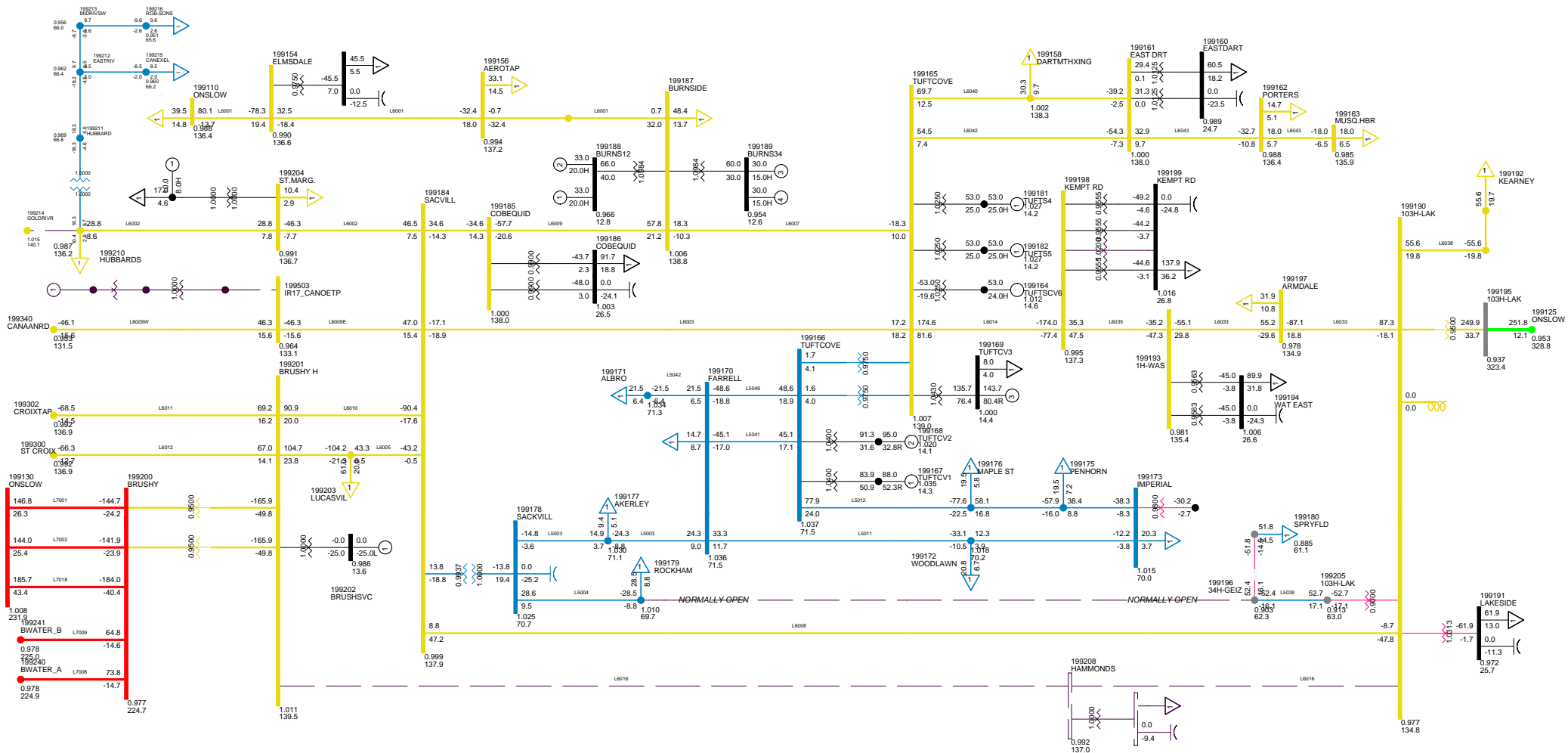

2013 EXTREME LOAD CONDITION
 C27 LOSE L6009
 METRO ZONE MON, JAN 05 2009 17:35

Bus - VOLTAGE (PO/PU)
 Branch - MIN/MAX
 Equipment - MIN/MAX VAR
 MW/MVAR
 1.0500V 0.9500V
 MW: <=30.000 >=48.000 <=138.000 <=230.000 <=345.000 >=345.000

Figure __

Total Wind Gen: 290.1 MW Gross Tupper 165.0 MW Gross Wreck Cove 150.0 MW
 Gross Lingan 648.0 MW Gross Trenton 330.0 MW Gross Gas Turbine 183.0 MW
 Gross Pt Aconi 195.0 MW Gross Tuft's Cove 485.7 MW Gross Small Hydro 182.4 MW

Net Stora Load 33.7 MW Total BMPC Load 9.5 MW

NSX -1.5 MW
 CBX 809.9 MW
 ONI 1000.7 MW
 ONS 854.0 MW

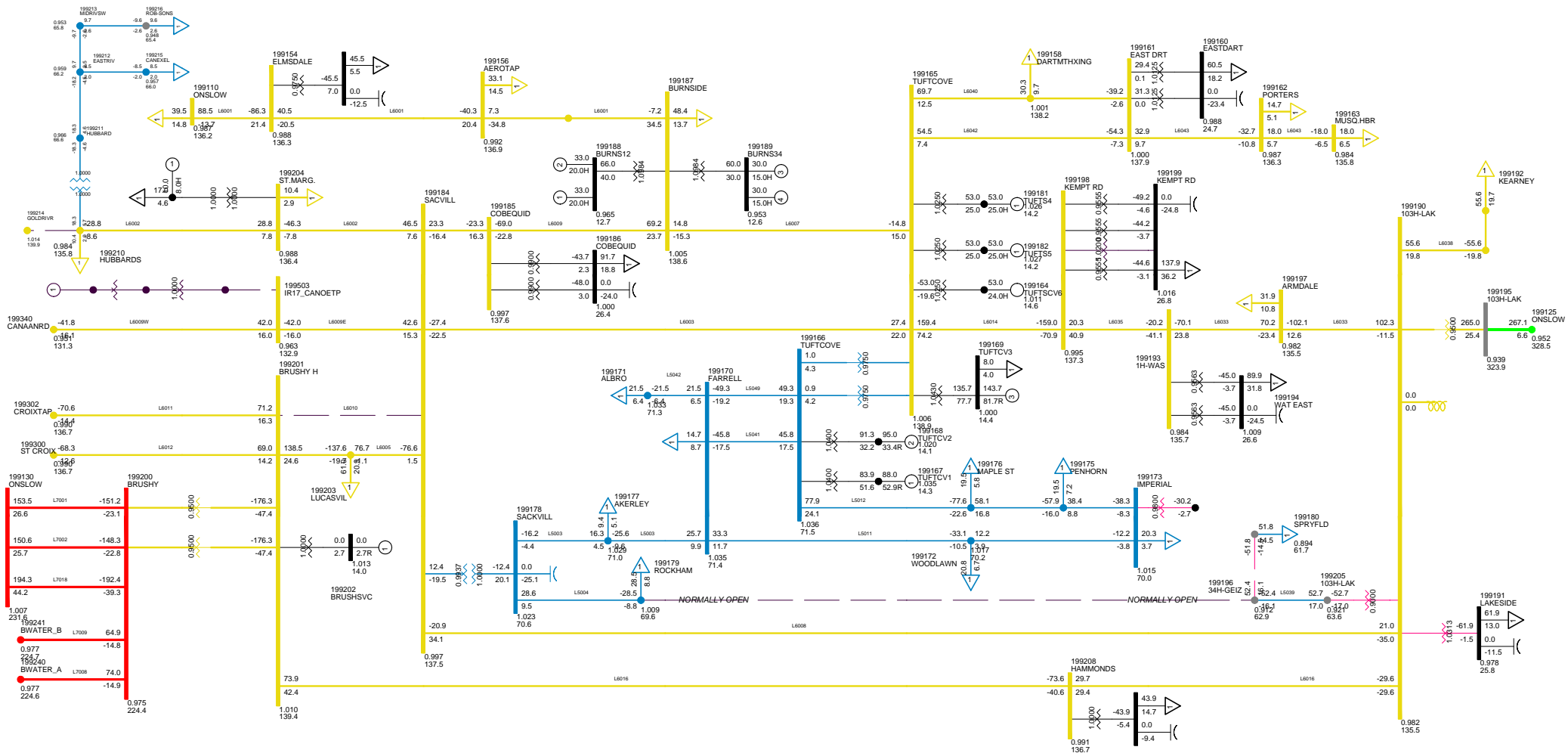

2013 EXTREME LOAD CONDITION
 C28 LOSE L6010
 METRO ZONE MON, JAN 05 2009 17:35

Bs - VOLTAGE (KV/PU)
 Bsch - MINIMUM
 Equipmt - MINIMUM
 HV - RATES
 1.050KV 0.950V
 KV: <30.000 >=48.000 <138.000 >=230.000 <345.000 >=345.000

Figure __

Total Wind Gen: 290.1 MW Gross Tupper 165.0 MW Gross Wreck Cove 150.0 MW
 Gross Lingan 648.0 MW Gross Trenton 330.0 MW Gross Gas Turbine 183.0 MW
 Gross Pt Aconi 195.0 MW Gross Tuft's Cove 485.7 MW Gross Small Hydro 182.4 MW

Net Stora Load 33.7 MW Total BMPC Load 9.5 MW

NSX -8.7 MW
 CBX 809.8 MW
 ONI 1000.4 MW
 ONS 860.9 MW

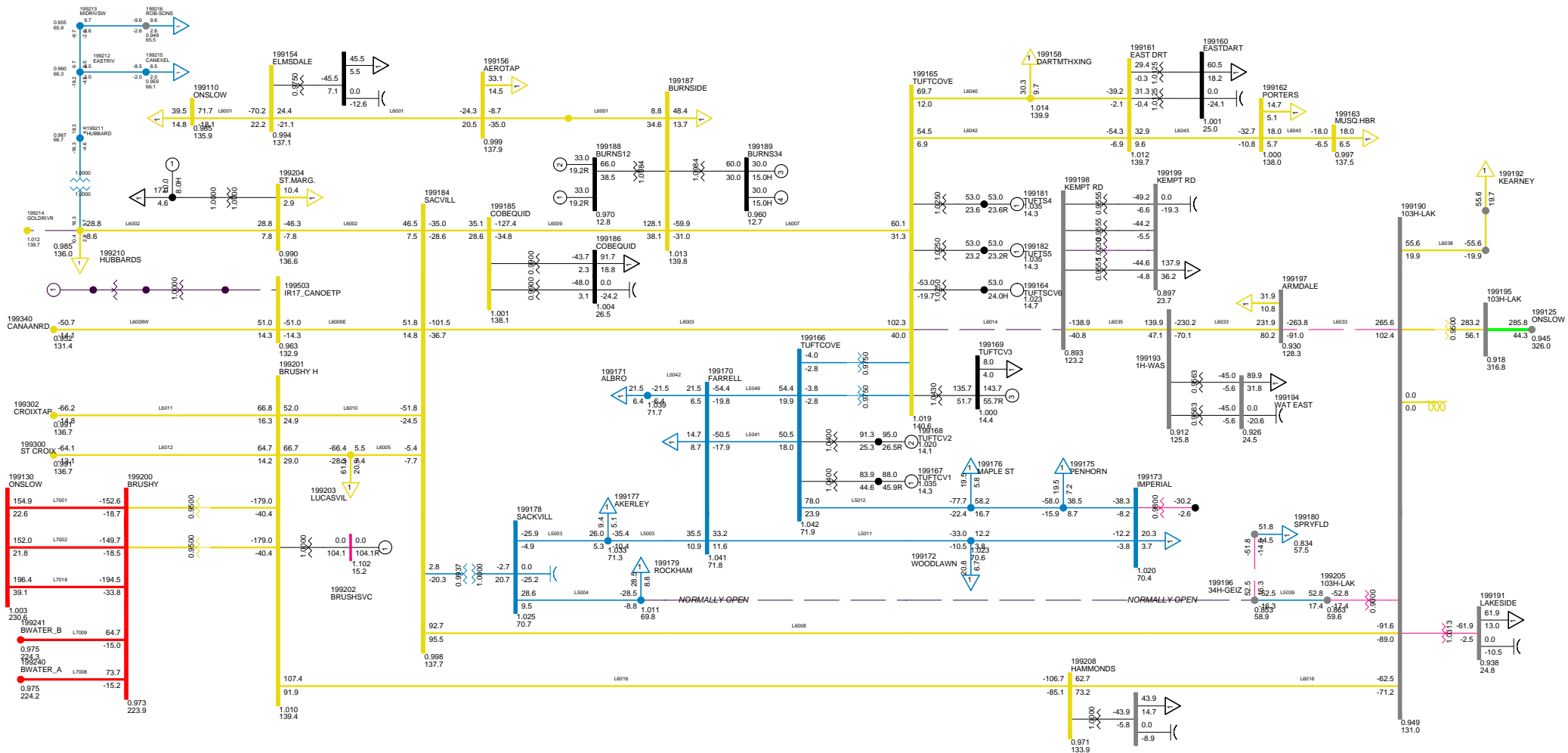

2013 EXTREME LOAD CONDITION
 C29 LOSE L6014
 METRO ZONE MON, JAN 05 2009 17:36

Bus - VOLTAGE (KV/PU)
 Branch - MVA/MVAR
 Equipment - MVA/MVAR
 HV/DISPATCH
 1.050KV 0.950PU
 KV: <=30.000 >=60.000 >=138.000 >=230.000 >=345.000 >=500.000

Figure __

Total Wind Gen: 290.1 MW
 Gross Tupper 165.0 MW
 Gross Wreck Cove 150.0 MW
 Gross Lingan 648.0 MW
 Gross Trenton 330.0 MW
 Gross Gas Turbine 183.0 MW
 Gross Pt Aconi 195.0 MW
 Gross Tuft's Cove 485.7 MW
 Gross Small Hydro 182.4 MW
 Net Stora Load 33.7 MW
 Total BMPC Load 9.5 MW

NSX 44.1 MW
 CBX 810.0 MW
 ONI 1000.9 MW
 ONS 808.4 MW

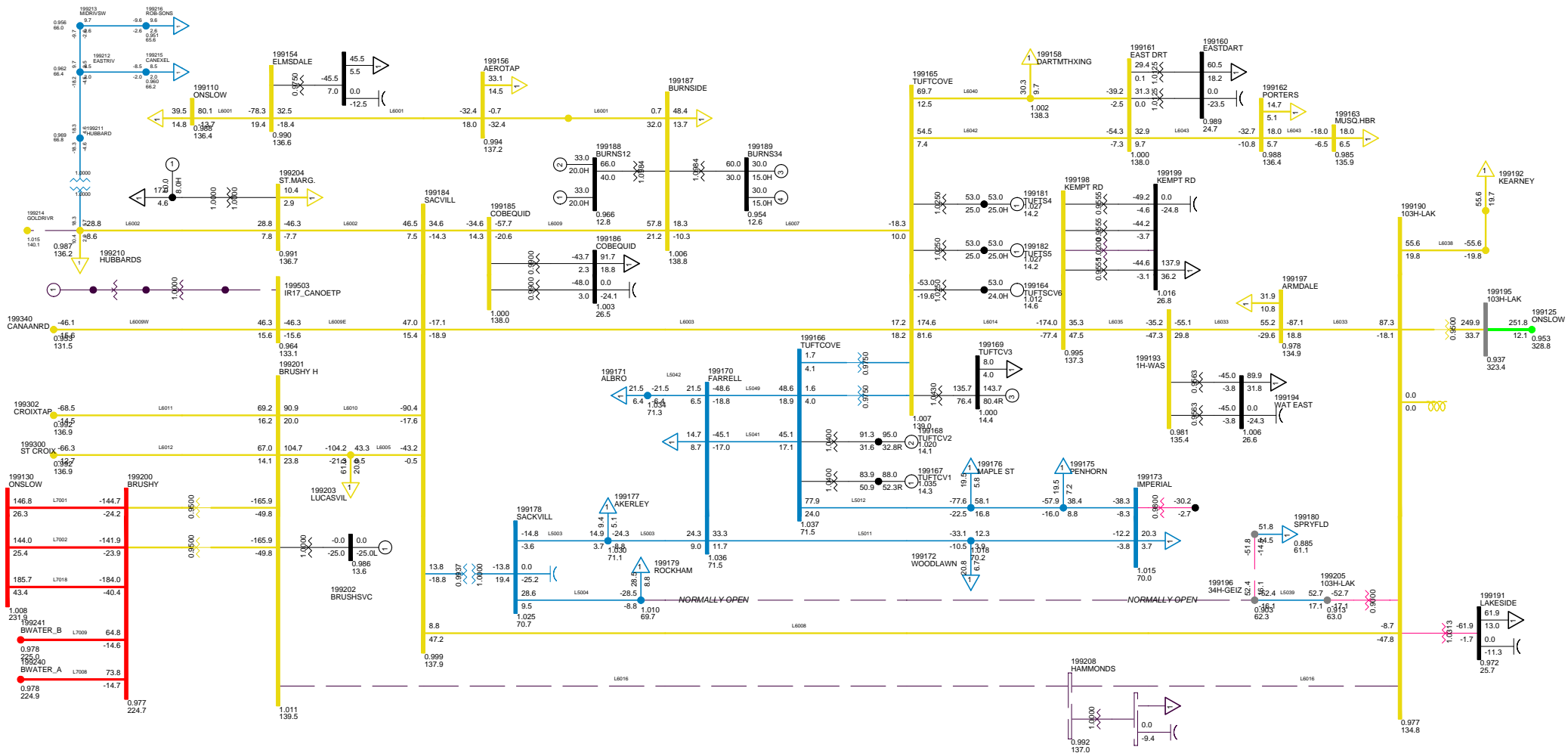

2013 EXTREME LOAD CONDITION
 C30 LOSE L6016
 METRO ZONE MON, JAN 05 2009 17:36

Bus - VOLTAGE (KV)PU
 Branch - MIN/MAX
 Equipment - MIN/MAX VAR
 HV/DIS/RATE
 1.050KV 0.950V
 KV: <30.000 >=48.000 <138.000 >=230.000 <=345.000 >=345.000

Figure __

Total Wind Gen: 290.1 MW Gross Tupper 165.0 MW Gross Wreck Cove 150.0 MW
 Gross Lingan 648.0 MW Gross Trenton 330.0 MW Gross Gas Turbine 183.0 MW
 Gross Pt Aconi 195.0 MW Gross Tuft's Cove 485.7 MW Gross Small Hydro 182.4 MW

Net Stora Load 33.7 MW Total BMPC Load 9.5 MW

NSX 76.3 MW
 CBX 810.0 MW
 ONI 1001.0 MW
 ONS 776.3 MW

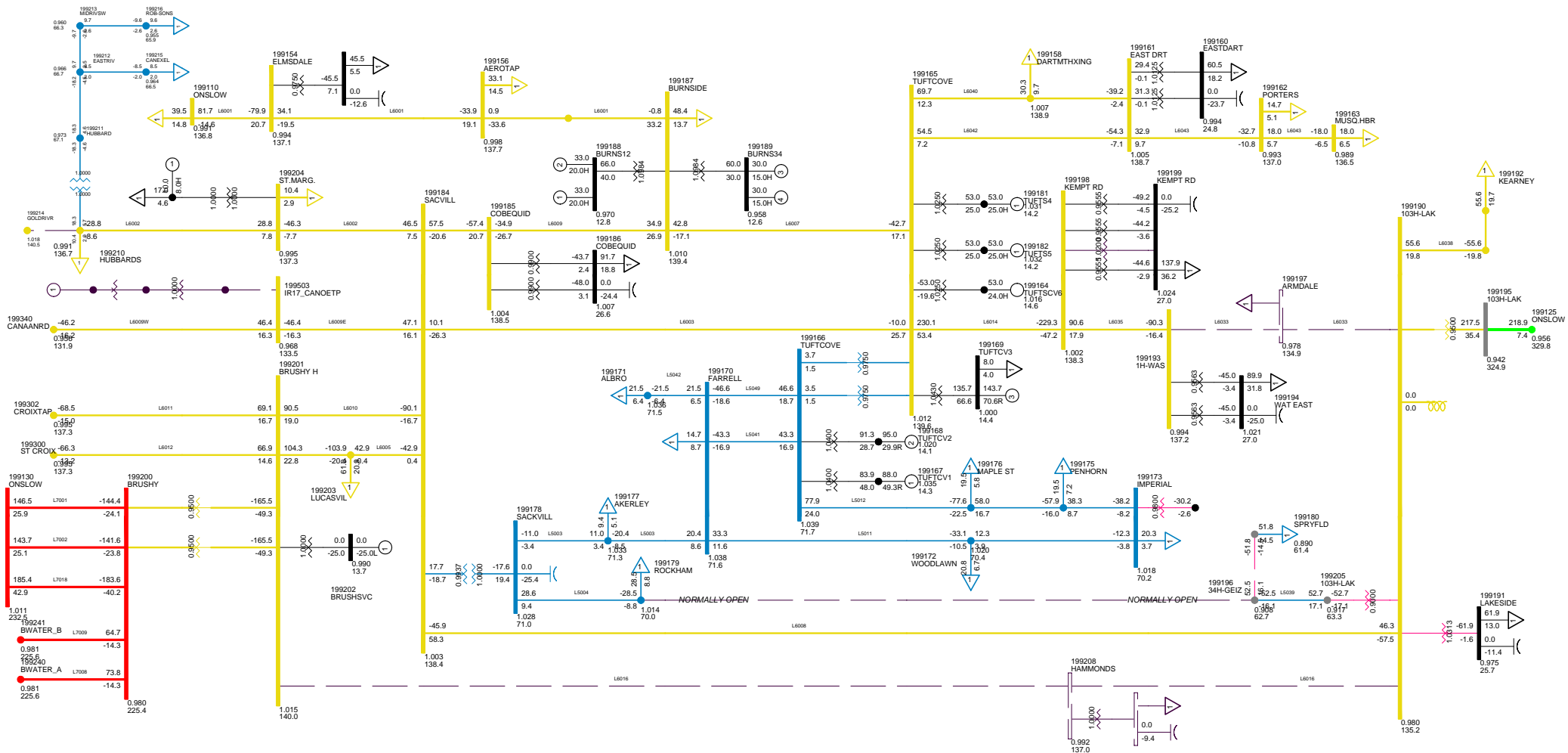

2013 EXTREME LOAD CONDITION
 C31 LOSE L6033
 METRO ZONE MON, JAN 05 2009 17:36

Bus - VOLTAGE (KV)PU
 Branch - MW/MVAR
 Equipment - MW/MVAR
 HV DISRATER
 1.0500V 0.9500V
 KV: v=30.000 v=40.000 v=50.000 v=60.000 v=70.000 v=80.000 v=90.000 v=100.000

Figure __

Total Wind Gen: 290.1 MW Gross Tupper 165.0 MW Gross Wreck Cove 150.0 MW
 Gross Lingan 648.0 MW Gross Trenton 330.0 MW Gross Gas Turbine 183.0 MW
 Gross Pt Aconi 195.0 MW Gross Tuft's Cove 485.7 MW Gross Small Hydro 182.4 MW

Net Stora Load 33.7 MW Total BMPC Load 9.5 MW

NSX -1.3 MW
 CBX 809.9 MW
 ONI 1000.6 MW
 ONS 853.8 MW

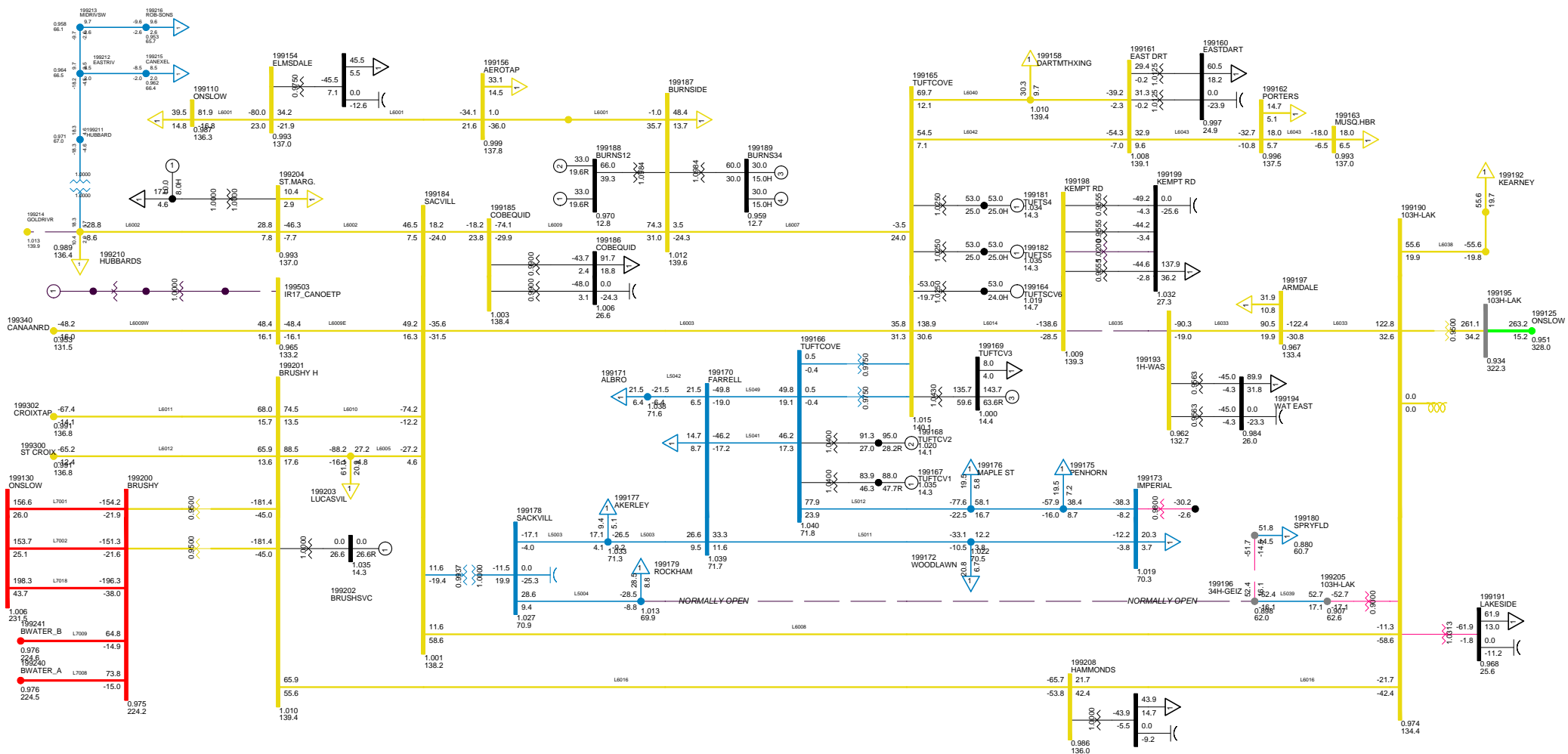

2013 EXTREME LOAD CONDITION
 C32 LOSE L6035
 METRO ZONE MON, JAN 05 2009 17:36

Bus - VOLTAGE (KV)PU
 Break - MIN/MAX
 Equipment - MIN/MAX
 HV/DIS/RATE
 1.050KV 0.950V
 KV <=30.000 >=68.000 <=138.000 <=230.000 <=345.000 >=345.000

Figure __

Total Wind Gen: 290.1 MW Gross Tupper 165.0 MW Gross Wreck Cove 150.0 MW
 Gross Lingan 648.0 MW Gross Trenton 330.0 MW Gross Gas Turbine 183.0 MW
 Gross Pt Aconi 195.0 MW Gross Tuft's Cove 432.7 MW Gross Small Hydro 182.4 MW

Net Stora Load 33.7 MW Total BMPC Load 9.5 MW

NSX -6.0 MW
 CBX 809.5 MW
 ONI 999.5 MW
 ONS 857.3 MW

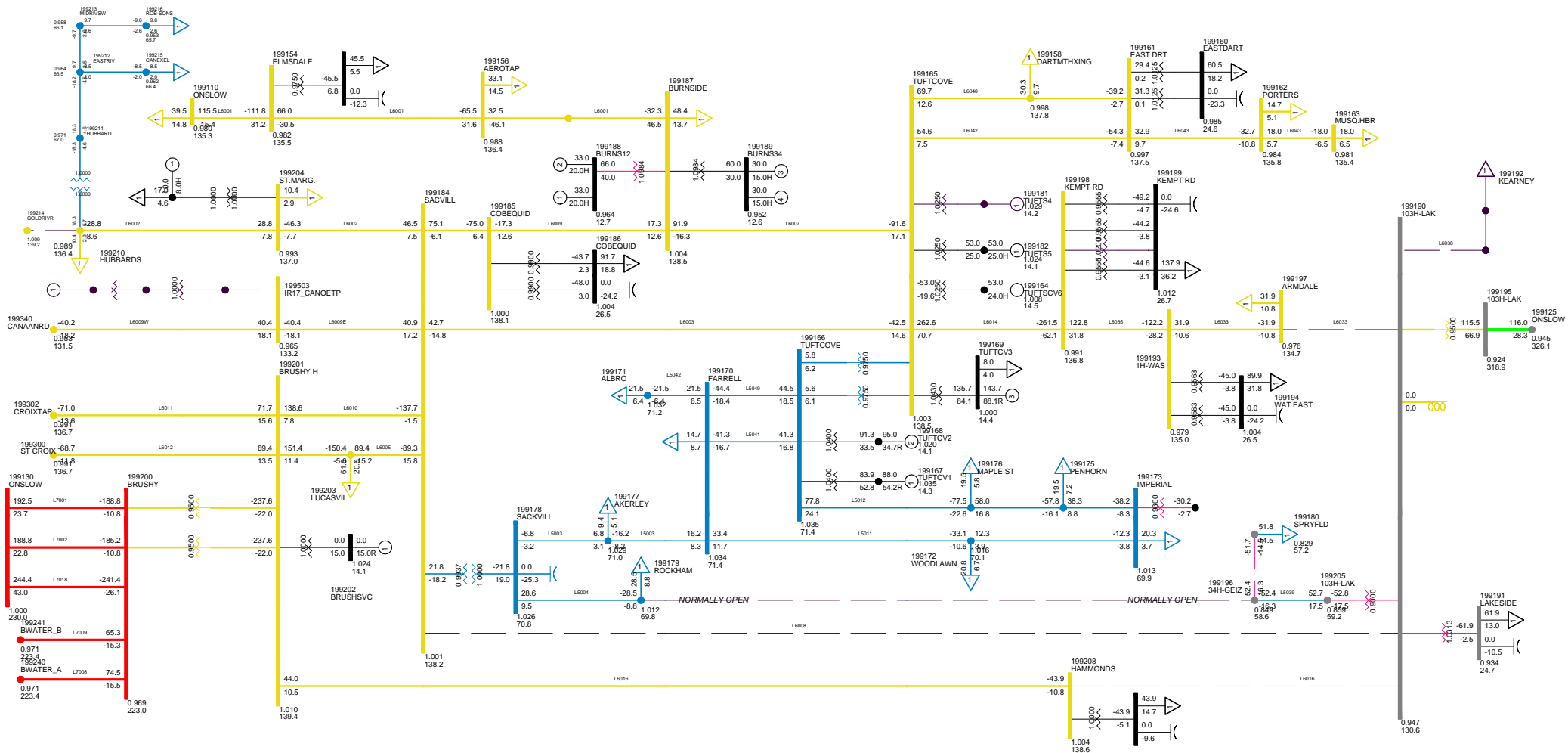

2013 EXTREME LOAD CONDITION
 C34 LOSE 103H-B62
 METRO ZONE MON, JAN 05 2009 17:36

Bs - VOLTAGE (KV/PU)
 Break - MVA/VA
 Equipment - MVA/VA
 HV - VOLTAGE
 1.0500V 0.9500V
 KV -<38.000 >=48.000 <=138.000 <=230.000 <=345.000 >=345.000

Figure __

Total Wind Gen: 290.1 MW Gross Tupper 165.0 MW Gross Wreck Cove 150.0 MW
 Gross Lingan 648.0 MW Gross Trenton 330.0 MW Gross Gas Turbine 183.0 MW
 Gross Pt Aconi 195.0 MW Gross Tuft's Cove 485.7 MW Gross Small Hydro 182.4 MW

Net Stora Load 33.7 MW Total BMPC Load 9.5 MW

NSX 60.8 MW
 CBX 810.1 MW
 ONI 1001.1 MW
 ONS 791.9 MW

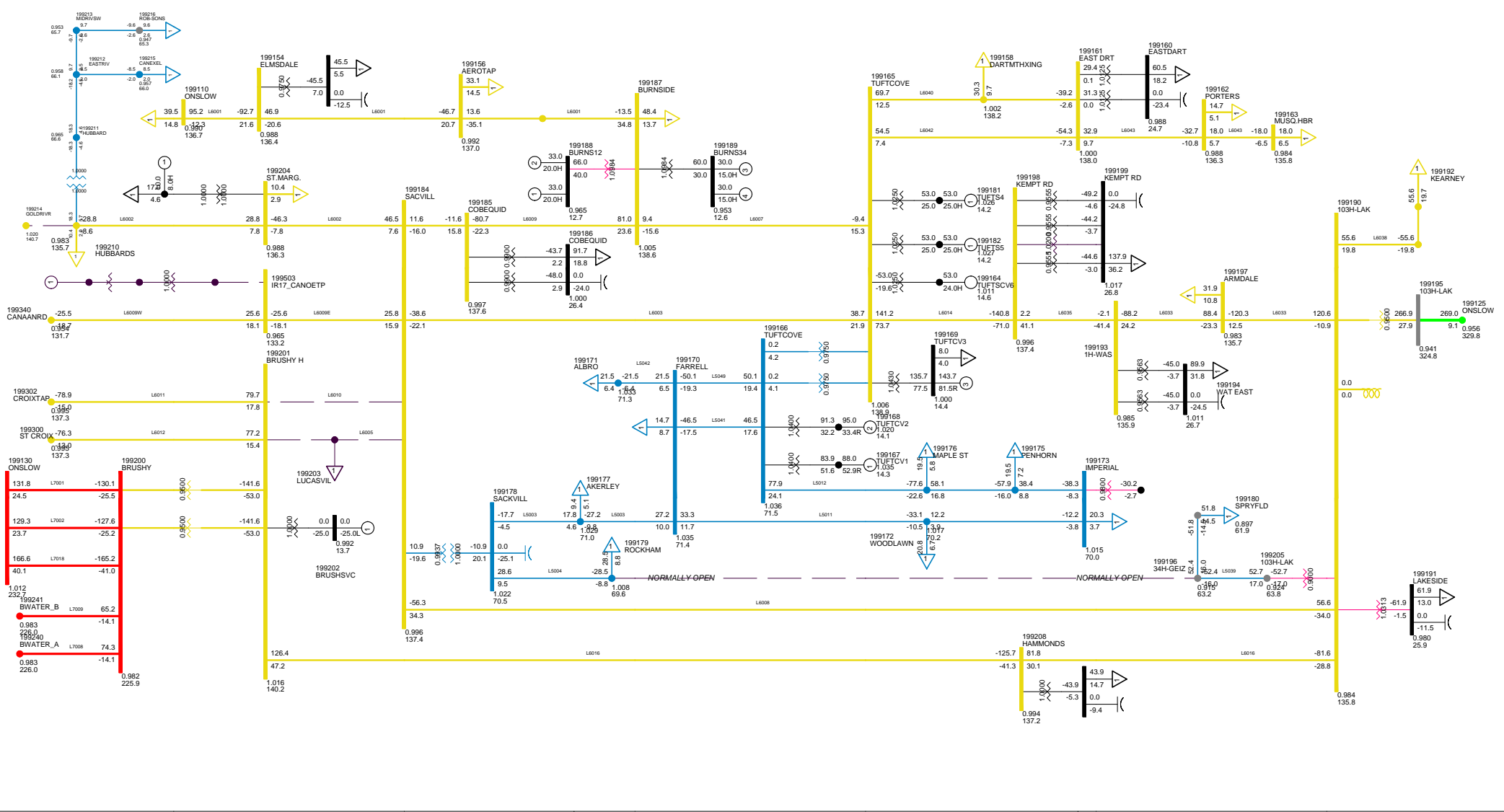

2013 EXTREME LOAD CONDITION
 C35 DCT L6005+L6010
 METRO ZONE MON, JAN 05 2009 17:36

Bus - VOLTAGE (P/UPU)
 Branch - MIN/MAX
 Equipment - MIN/MAX
 HV/DIS/RATE
 1.050KV 0.850KV
 KV =>0.000V =>0.000V =>138.000V =>230.000V =>345.000V =>345.000V

Figure __

Total Wind Gen: 290.1 MW
 Gross Tupper 165.0 MW
 Gross Wreck Cove 150.0 MW
 Gross Lingan 648.0 MW
 Gross Trenton 330.0 MW
 Gross Gas Turbine 183.0 MW
 Gross Pt Aconi 195.0 MW
 Gross Tuft's Cove 485.7 MW
 Gross Small Hydro 182.4 MW
 Net Stora Load 33.7 MW
 Total BMPC Load 9.5 MW

NSX 62.0 MW
 CBX 810.1 MW
 ONI 1001.1 MW
 ONS 790.6 MW

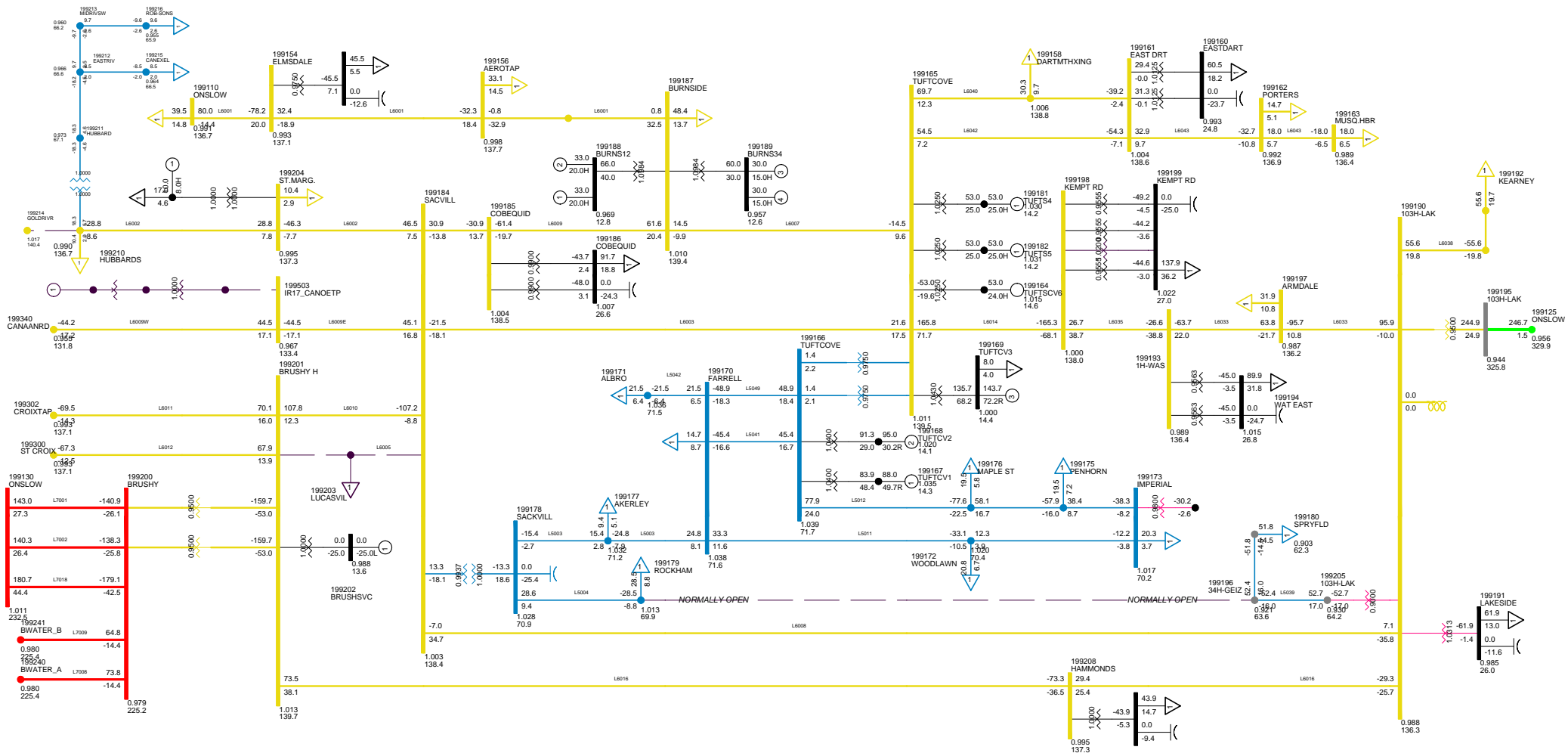

2013 EXTREME PEAK NS=2560; INDUSTRIAL MINIMUM
 NS-NB=0; NB-NE=500; CBX=732; ONI=926 ONS=778
 METRO ZONE MON, JAN 05 2009 17:37

Bus - VOLTAGE (KV/PU)
 Break - MIN/MAX
 Equipment - MIN/MAX
 HV - 0.950V
 1.050V 0.950V
 0.950V >=0.950V <=1.050V <=1.050V >=1.050V

Figure __

Total Wind Gen: 290.1 MW
 Gross Tupper 165.0 MW
 Gross Wreck Cove 150.0 MW
 Gross Lingan 648.0 MW
 Gross Trenton 330.0 MW
 Gross Gas Turbine 183.0 MW
 Gross Pt Aconi 195.0 MW
 Gross Tuft's Cove 485.7 MW
 Gross Small Hydro 182.4 MW
 Net Stora Load 33.7 MW
 Total BMPC Load 9.5 MW

NSX 107.3 MW
 CBX 810.2 MW
 ONI 1001.5 MW
 ONS 745.5 MW

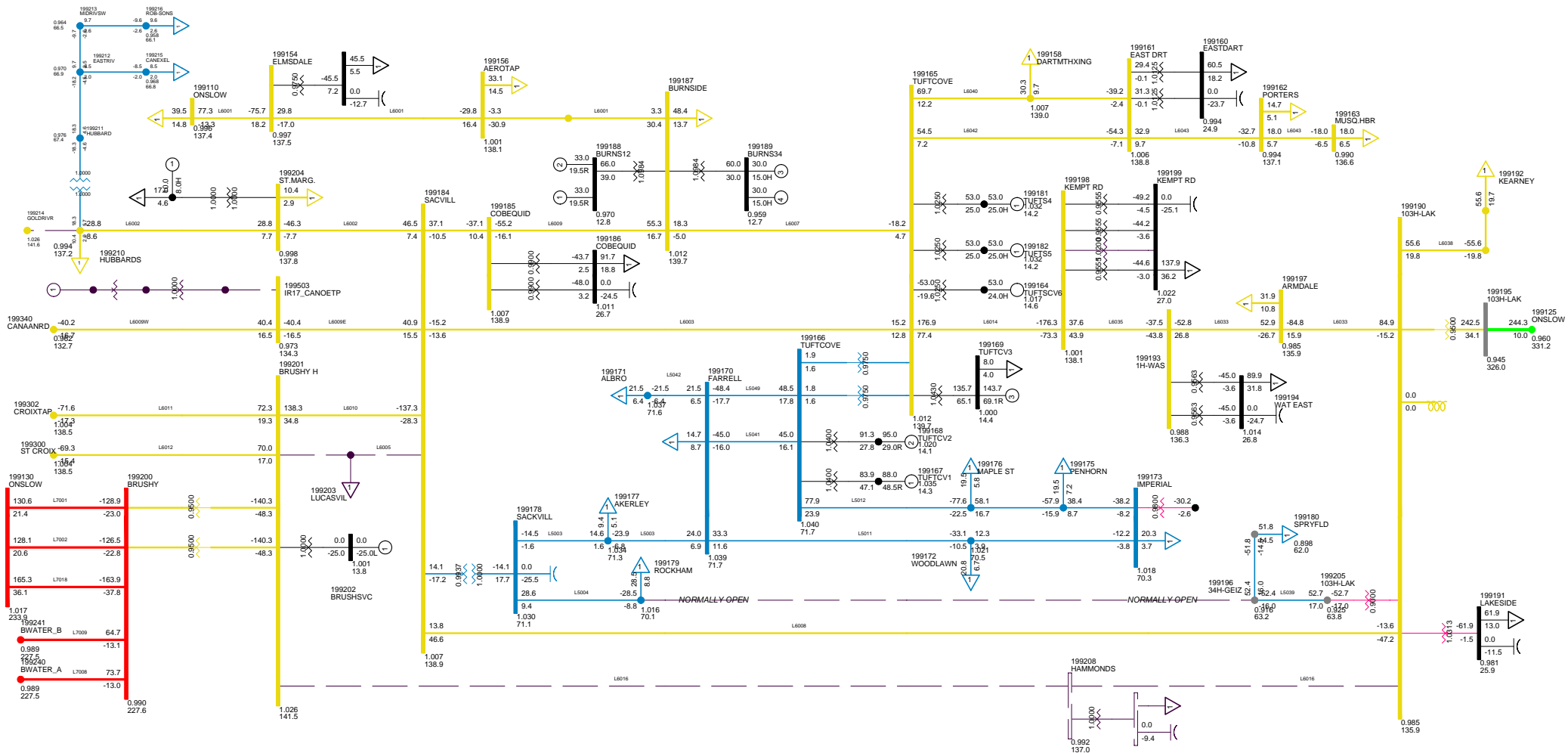

2013 EXTREME LOAD CONDITION
 C37 DCT L6005 L6016
 METRO ZONE MON, JAN 05 2009 17:37

Bus - VOLTAGE (KV/PU)
 Break - MIN/MAX
 Equipment - MIN/MAX
 DISCONNECT
 1.05KV 0.95KV
 KV: <30.000 >48.000 <138.000 <230.000 <345.000 >345.000

Figure __

Total Wind Gen: 290.1 MW
 Gross Tupper 165.0 MW
 Gross Wreck Cove 150.0 MW
 Gross Lingan 648.0 MW
 Gross Trenton 330.0 MW
 Gross Gas Turbine 183.0 MW
 Gross Pt Aconi 195.0 MW
 Gross Tuft's Cove 485.7 MW
 Gross Small Hydro 182.4 MW
 Net Stora Load 33.7 MW
 Total BMPC Load 9.5 MW

NSX 94.2 MW
 CBX 810.1 MW
 ONI 1001.2 MW
 ONS 758.3 MW

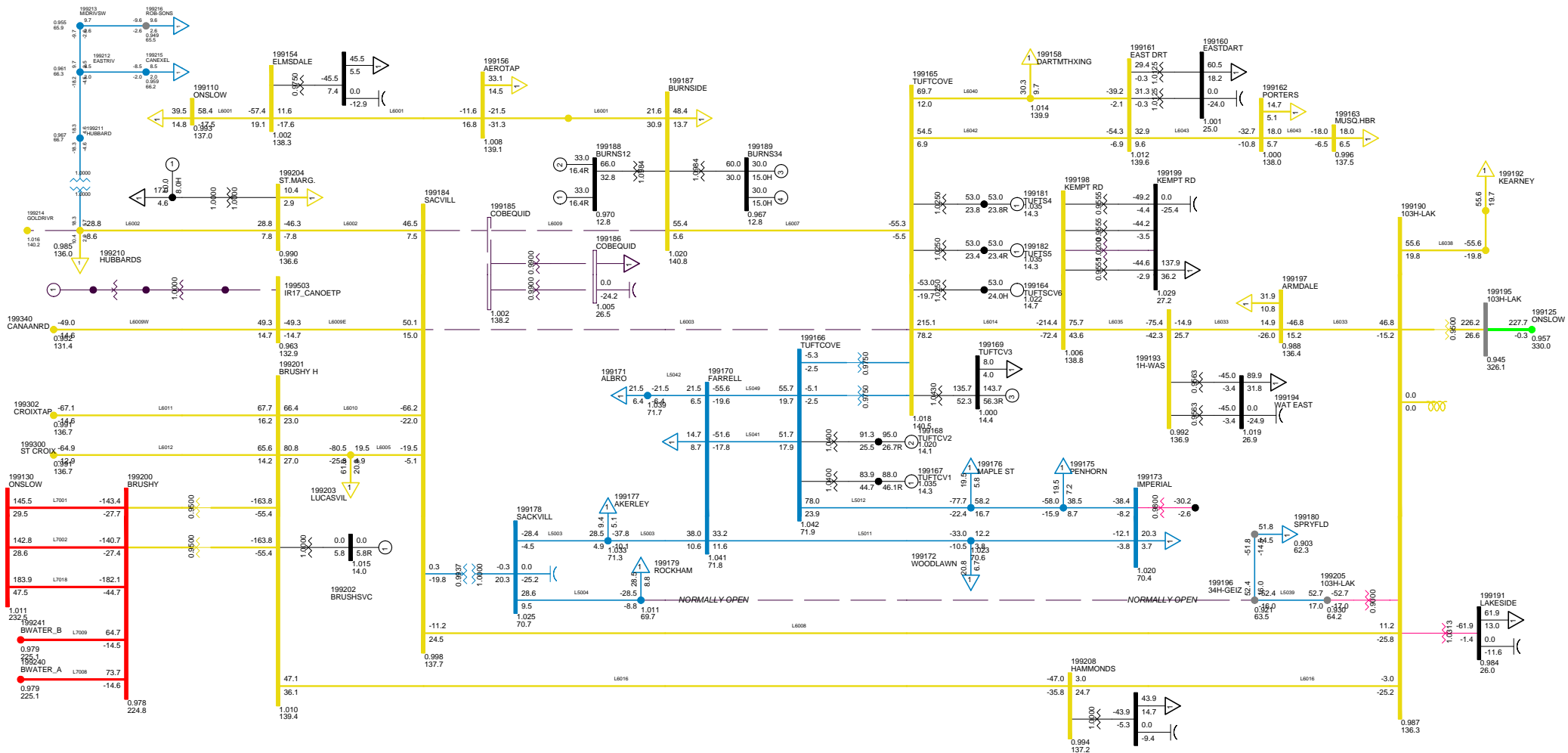

2013 EXTREME LOAD CONDITION
 C38 DCT L6003 L6009
 METRO ZONE MON, JAN 05 2009 17:37

Bus - VOLTAGE (PO/PU)
 Break - MIN/MAX
 Equipment - MIN/MAX
 HV/RATE
 1.0500V 0.9500V
 MV: <=30.000 >=48.000 <=138.000 <=230.000 <=345.000 >=345.000

Figure __

Total Wind Gen: 290.1 MW Gross Tupper 165.0 MW Gross Wreck Cove 150.0 MW
 Gross Lingan 648.0 MW Gross Trenton 330.0 MW Gross Gas Turbine 183.0 MW
 Gross Pt Aconi 195.0 MW Gross Tuft's Cove 485.7 MW Gross Small Hydro 182.4 MW

Net Stora Load 33.7 MW Total BMPC Load 9.5 MW

NSX -0.8 MW
 CBX 809.9 MW
 ONI 1000.8 MW
 ONS 853.4 MW

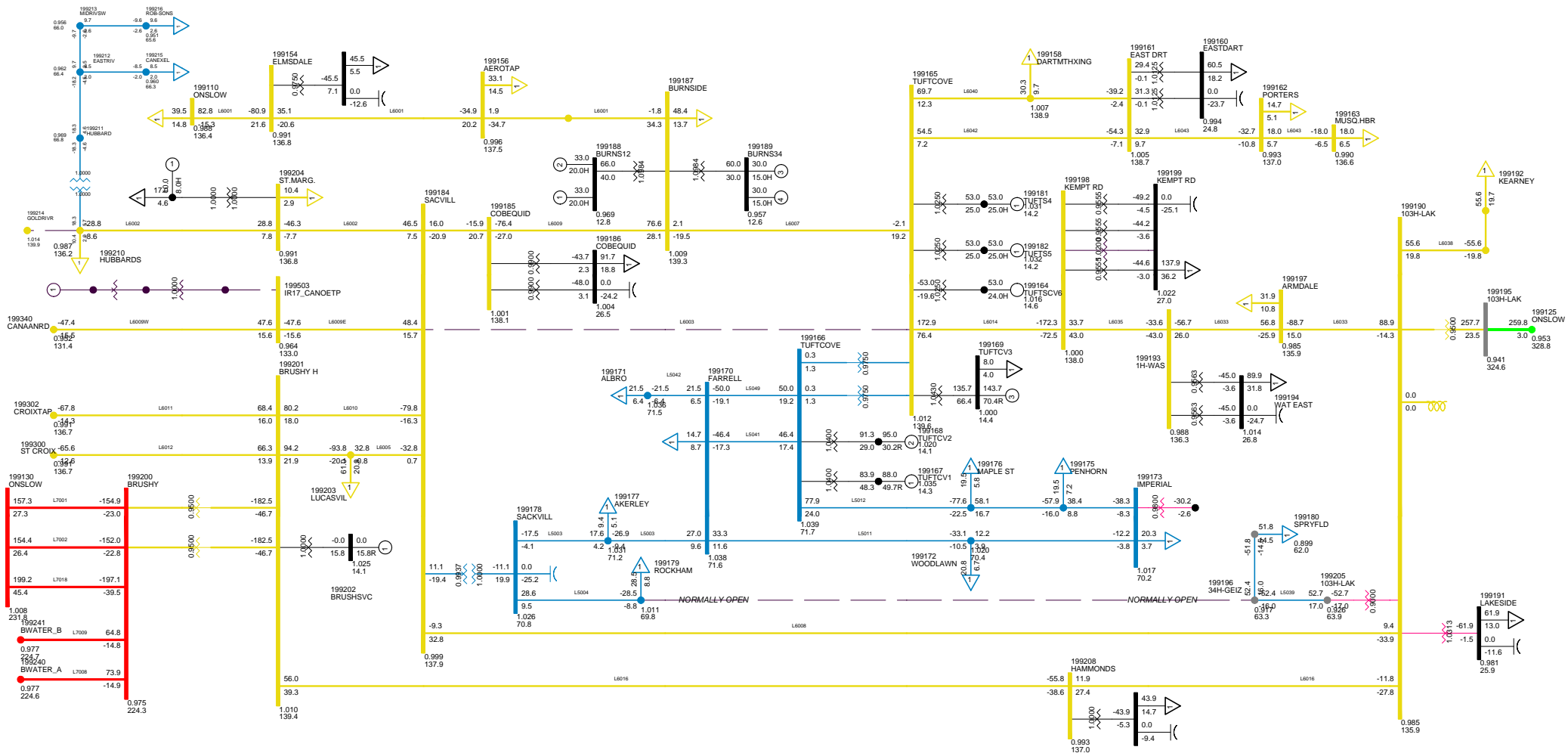

2013 EXTREME LOAD CONDITION
 C39 DCT L6003 L6007
 METRO ZONE MON, JAN 05 2009 17:37

Bus - VOLTAGE (KV/PU)
 Break - MIN/MAX
 Equipment - MIN/MAX
 HV/RATINGS
 1.050KV 0.950V
 KV: $=30.000$ $=48.000$ $=73.800$ $=138.000$ $=230.000$ $=345.000$ $=345.000$

Figure __

Total Wind Gen: 259.5 MW
 Gross Tupper 165.0 MW
 Gross Wreck Cove 150.0 MW
 Gross Lingan 648.0 MW
 Gross Trenton 330.0 MW
 Gross Gas Turbine 159.0 MW
 Gross Pt Aconi 195.0 MW
 Gross Tuft's Cove 485.7 MW
 Gross Small Hydro 130.4 MW
 Net Stora Load 33.7 MW
 Total BMPC Load 0.0 MW

NSX 144.7 MW
 CBX 810.1 MW
 ONI 1001.2 MW
 ONS 707.6 MW

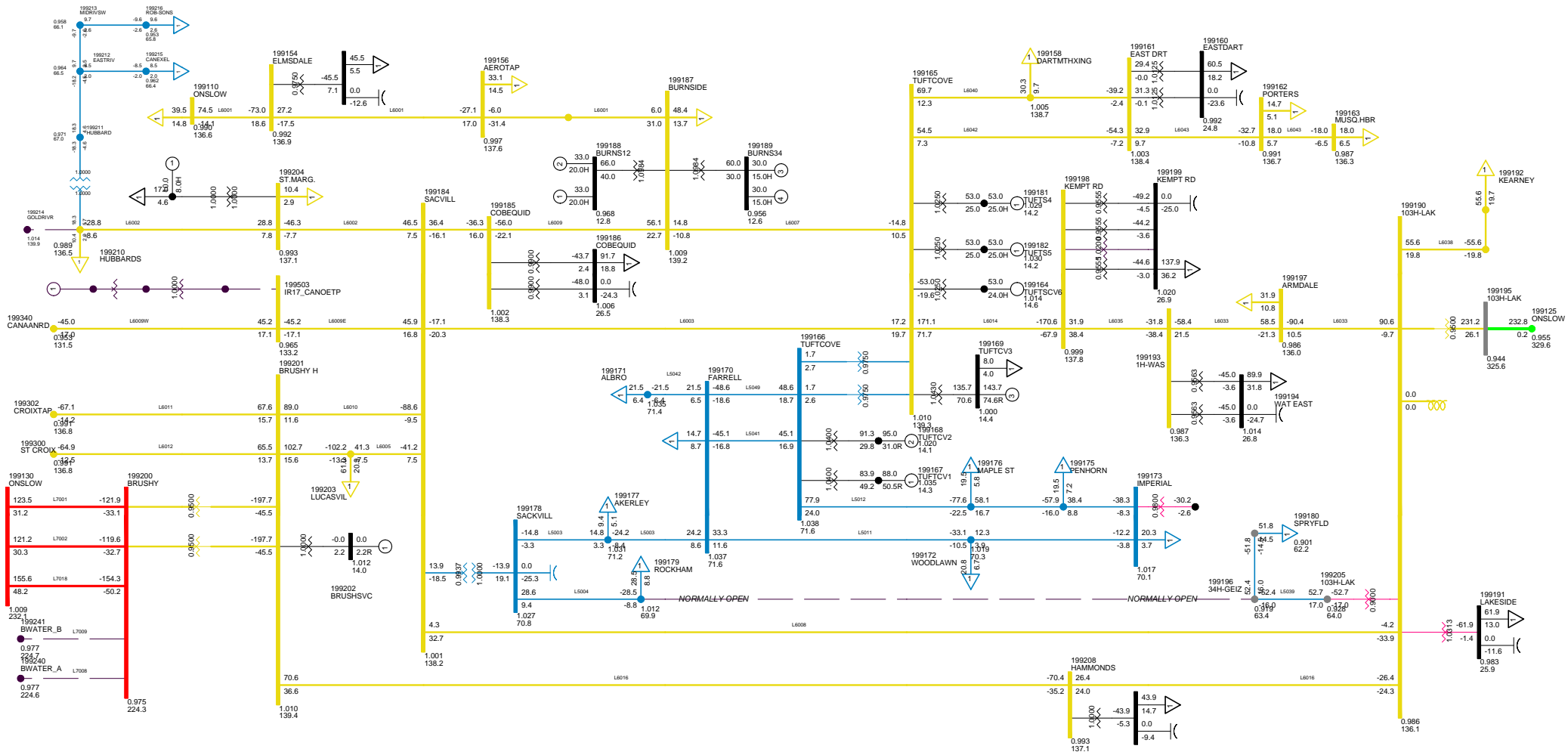

2013 EXTREME LOAD CONDITION
 C40 DCT L7008 L7009 ISOLATES WEST
 METRO ZONE MON, JAN 05 2009 17:37

Bus - VOLTAGE (KV/PU)
 Branch - MVA/MVAR
 Equipment - MVA/MVAR
 HV/DIS/RATE
 1.050KV 0.550UV
 KV: <=30.000 >=60.000 <=138.000 <=230.000 <=345.000 >=345.000

Figure __

Total Wind Gen: 290.1 MW
 Gross Tupper 165.0 MW
 Gross Wreck Cove 150.0 MW
 Gross Lingan 648.0 MW
 Gross Trenton 330.0 MW
 Gross Gas Turbine 183.0 MW
 Gross Pt Aconi 195.0 MW
 Gross Tuft's Cove 485.7 MW
 Gross Small Hydro 182.4 MW
 Net Stora Load 33.7 MW
 Total BMPC Load 9.5 MW

NSX 107.3 MW
 CBX 810.2 MW
 ONI 1001.5 MW
 ONS 745.5 MW

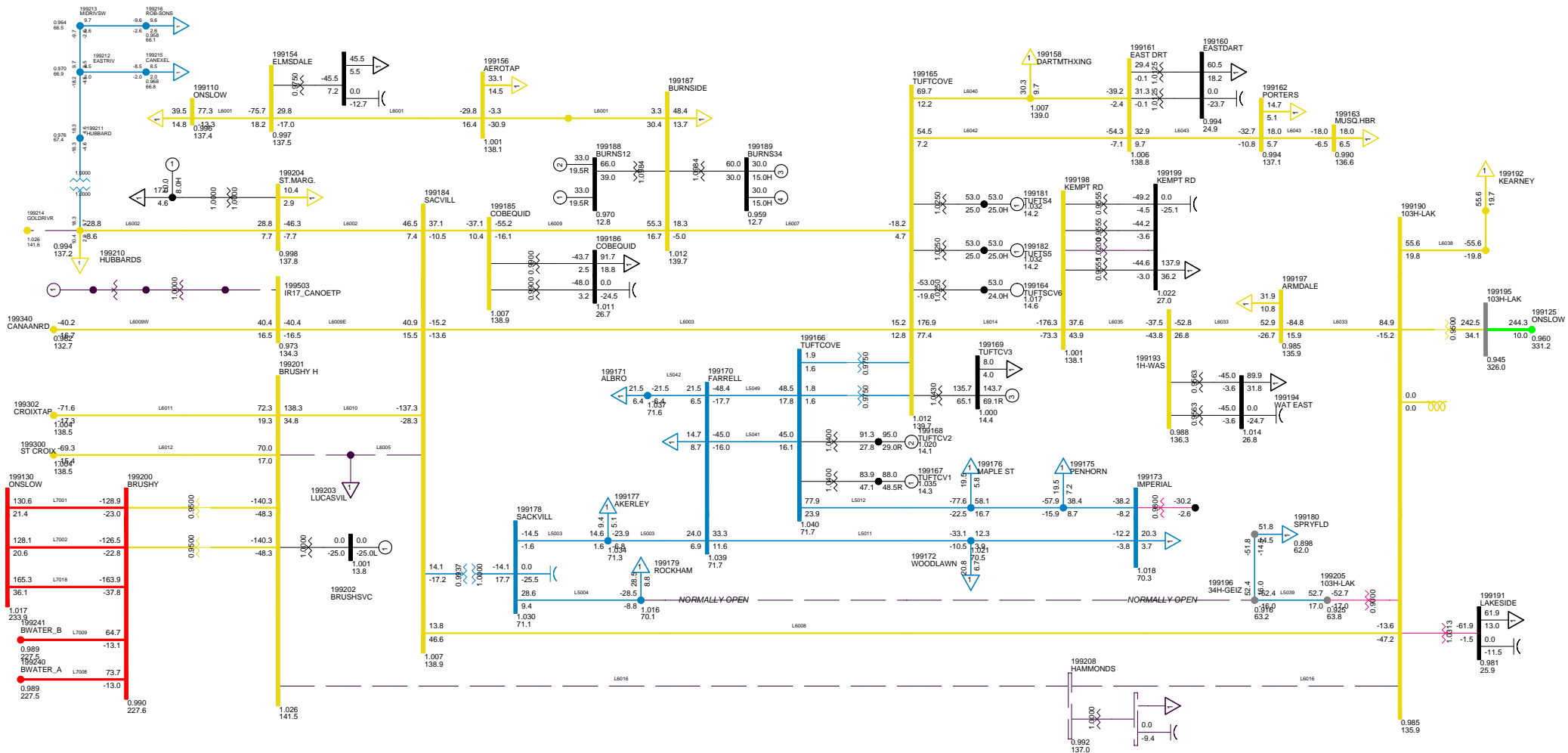

2013 EXTREME LOAD CONDITION
 C41 IP FAULT ON L6016, BBU 622
 METRO ZONE MON, JAN 05 2009 17:37

Bs - VOLTAGE (PO/PU)
 Bsch - MIN/MAX
 Equipmt - MIN/MAX
 HV/DIS/RATE
 1.050KV 0.950KV
 KV =>0.000 =>0.000 =>130.000 =>230.000 =>345.000 >345.000

Figure __

Total Wind Gen: 290.1 MW
 Gross Tupper 165.0 MW
 Gross Wreck Cove 150.0 MW
 Gross Lingan 648.0 MW
 Gross Trenton 330.0 MW
 Gross Gas Turbine 183.0 MW
 Gross Pt Aconi 195.0 MW
 Gross Tuft's Cove 485.7 MW
 Gross Small Hydro 182.4 MW
 Net Stora Load 33.7 MW
 Total BMPC Load 9.5 MW

NSX 94.1 MW
 CBX 810.0 MW
 ONI 1001.1 MW
 ONS 758.3 MW

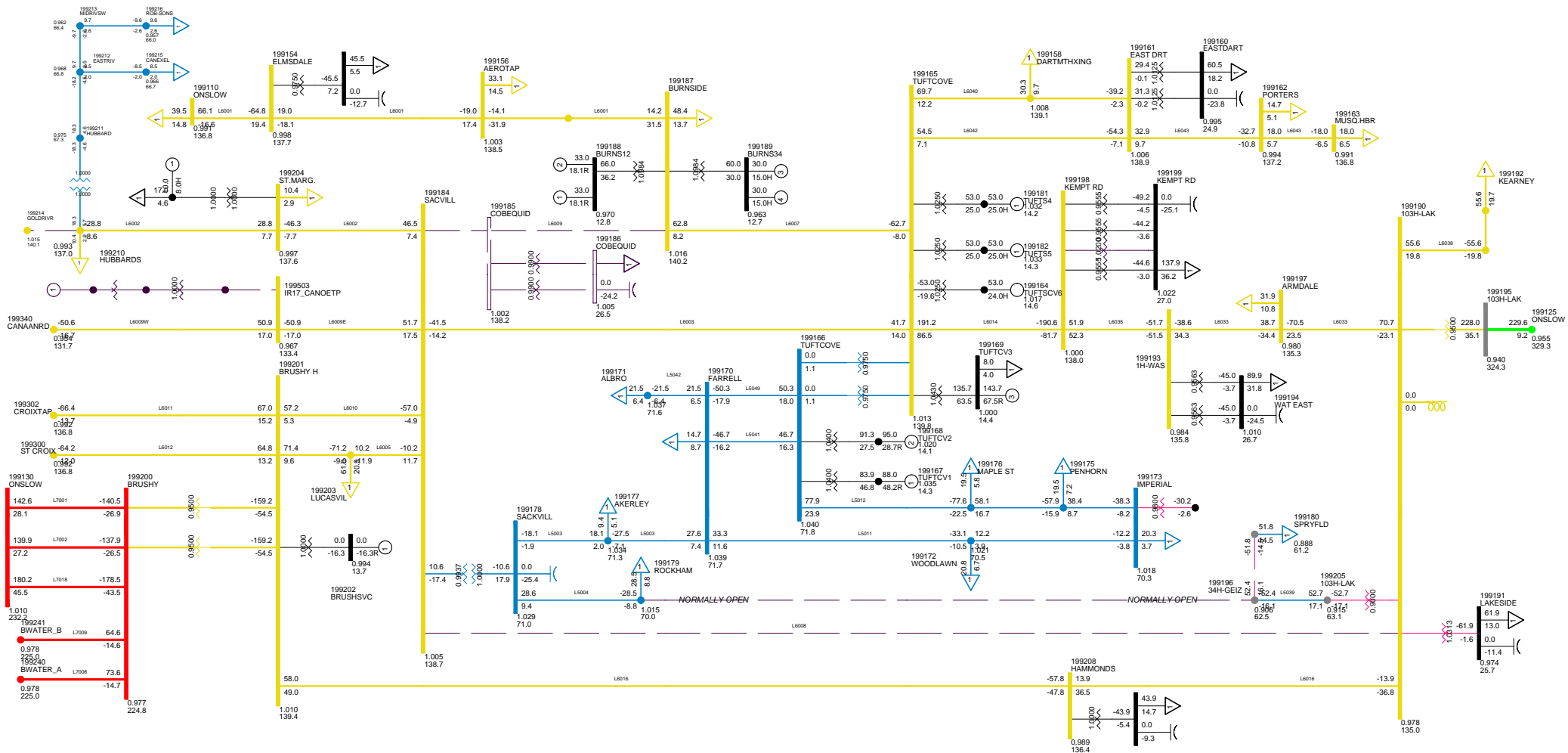

2013 EXTREME LOAD CONDITION
 C44 BBU L6008 L6009 90H-611
 METRO ZONE MON, JAN 05 2009 17:38

Figure __

Total Wind Gen: 290.1 MW	Gross Tupper 165.0 MW	Gross Wreck Cove 150.0 MW
Gross Lingan 648.0 MW	Gross Trenton 330.0 MW	Gross Gas Turbine 183.0 MW
Gross Pt Aconi 195.0 MW	Gross Tuft's Cove 143.7 MW	Gross Small Hydro 182.4 MW
Net Stora Load 33.5 MW	Total BMPC Load 9.3 MW	

NSX -277.6 MW
CBX 789.8 MW
ONI 960.7 MW
ONS 1074.1 MW

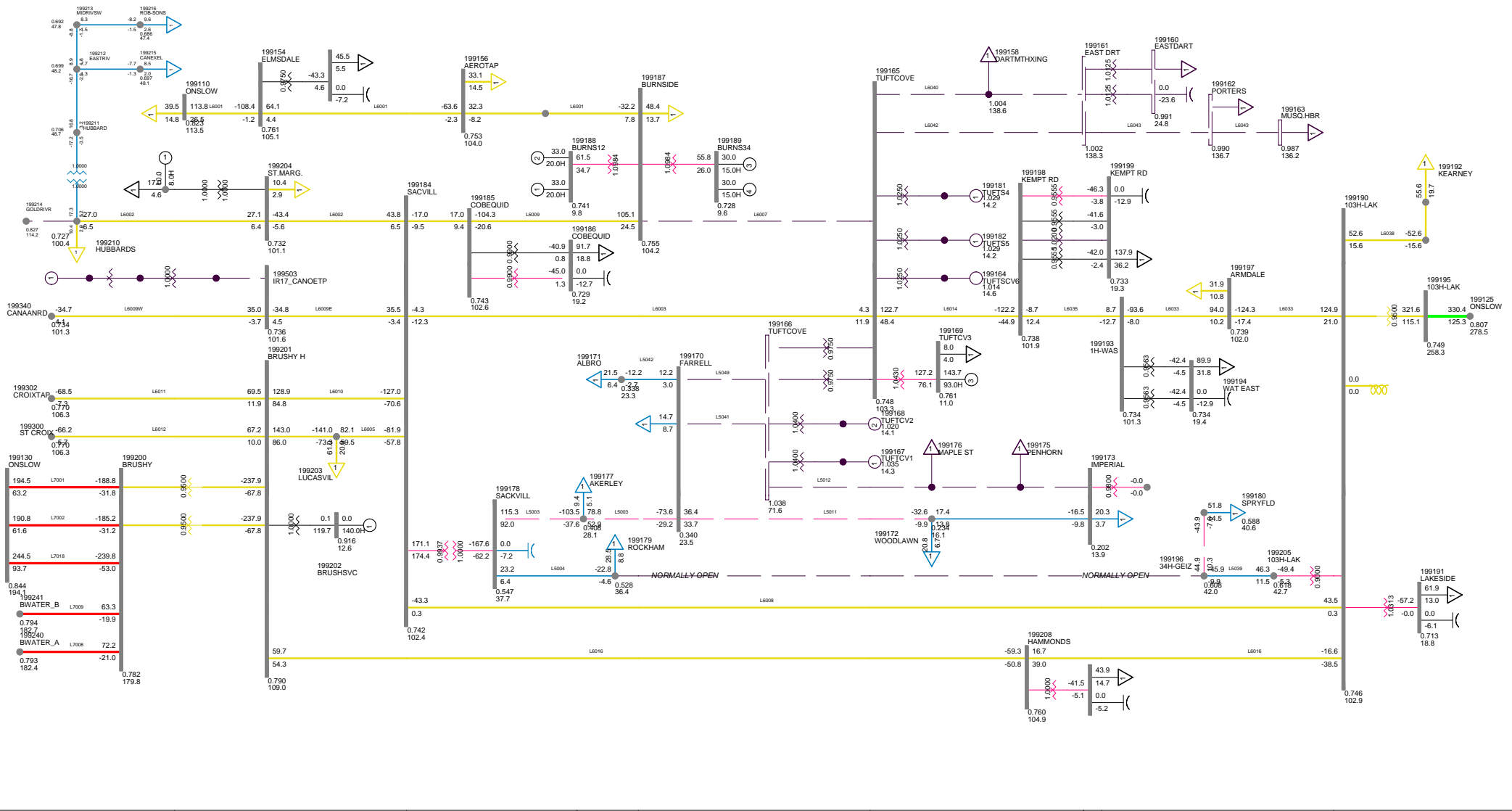

2013 EXTREME LOAD CONDITION
 C45 BBU ON 91H-523
 METRO ZONE MON, JAN 05 2009 17:38

Bus - VOLTAGE (KV/PU)
 Branch - MVA/MVAR
 Equipment - MVA/MVAR
 HV-RATE
 1.050KV 0.950V
 KV: <30.000 <=68.000 <=138.000 <=230.000 <=345.000 >345.000

Figure __

Total Wind Gen: 290.1 MW
 Gross Tupper 165.0 MW
 Gross Wreck Cove 150.0 MW
 Gross Lingan 648.0 MW
 Gross Trenton 330.0 MW
 Gross Gas Turbine 57.0 MW
 Gross Pt Aconi 195.0 MW
 Gross Tuft's Cove 485.7 MW
 Gross Small Hydro 182.4 MW
 Net Stora Load 33.7 MW
 Total BMPC Load 9.5 MW

NSX 14.7 MW
 CBX 809.8 MW
 ONI 1000.5 MW
 ONS 837.4 MW

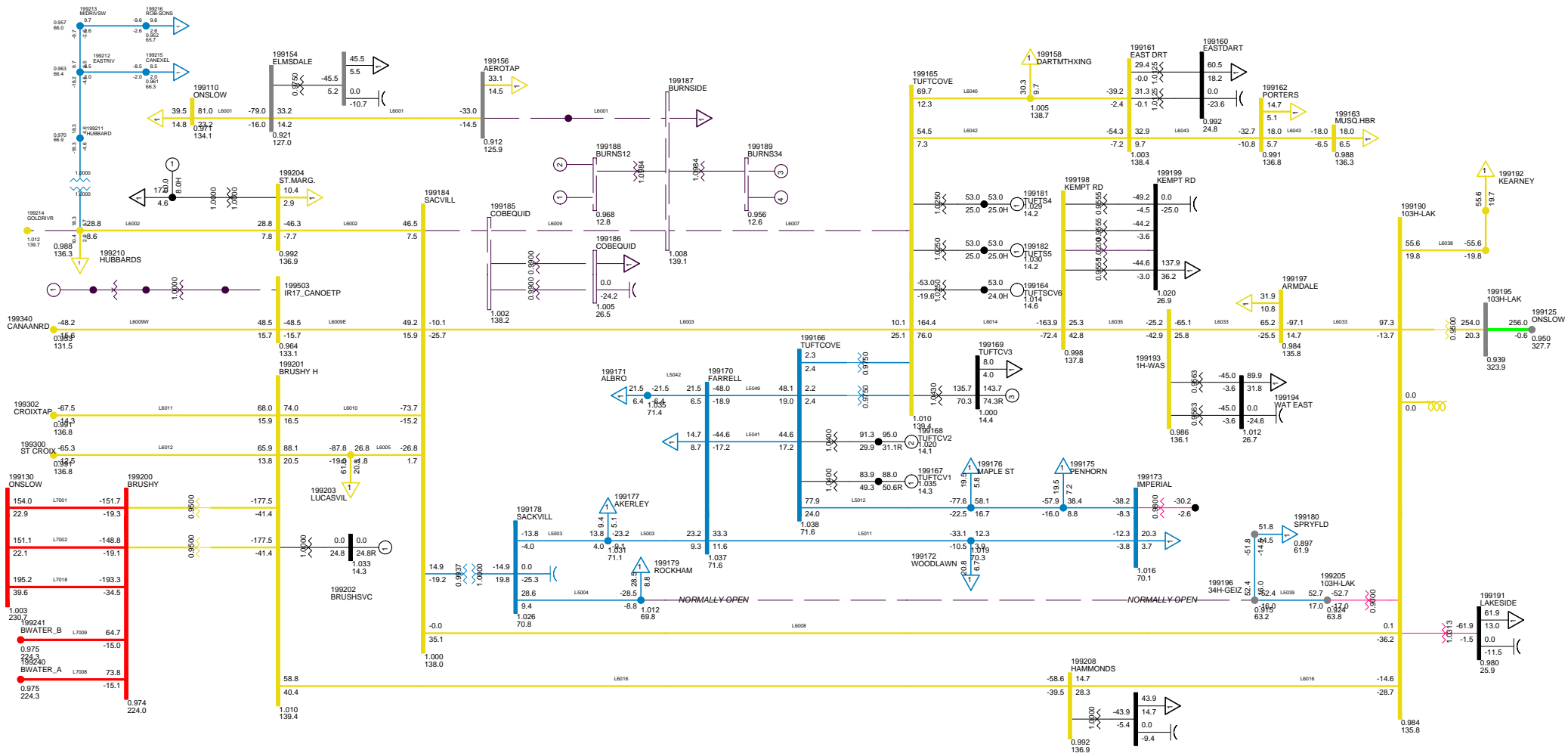

2013 EXTREME LOAD CONDITION
 C46 1P L6009 BBU ON 108H 607
 METRO ZONE MON, JAN 05 2009 17:38

Bus - VOLTAGE (KV/PU)
 Break - MIN/MAX
 Equipment - MIN/MAX
 HV/RATE
 1.050KV 0.950V
 KV <=30.000 >=48.000 >=138.000 <=230.000 <=345.000 >=345.000

Figure __

Total Wind Gen: 290.1 MW
 Gross Tupper 165.0 MW
 Gross Wreck Cove 150.0 MW
 Gross Lingan 648.0 MW
 Gross Trenton 330.0 MW
 Gross Gas Turbine 183.0 MW
 Gross Pt Aconi 195.0 MW
 Gross Tuft's Cove 485.7 MW
 Gross Small Hydro 182.4 MW
 Net Stora Load 33.7 MW
 Total BMPC Load 9.5 MW

NSX 167.6 MW
 CBX 810.0 MW
 ONI 1000.9 MW
 ONS 684.4 MW

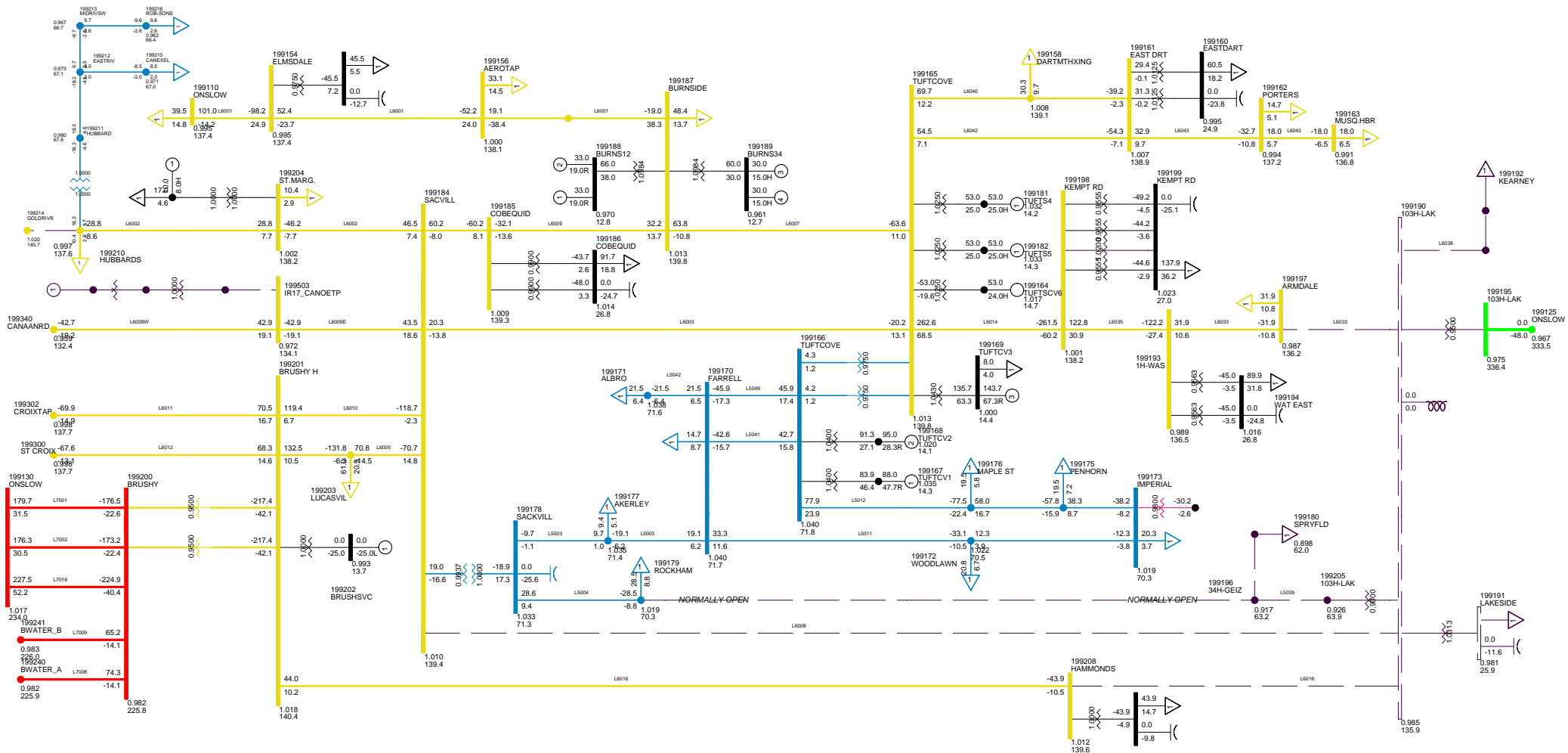

2013 EXTREME LOAD CONDITION
 C47 IP 103H-600
 METRO ZONE MON, JAN 05 2009 17:38

Bus - VOLTAGE (kV/PU)
 Branch - MIN/MAX
 Equipment - MIN/MAX
 MW/MVAR
 1.050kV 0.950kV
 MW: $=30.000$ $=48.000$ $=138.000$ $=230.000$ $=345.000$ $=345.000$

Figure __

Total Wind Gen: 290.1 MW Gross Tupper 165.0 MW Gross Wreck Cove 150.0 MW
 Gross Lingan 648.0 MW Gross Trenton 330.0 MW Gross Gas Turbine 183.0 MW
 Gross Pt Aconi 195.0 MW Gross Tuft's Cove 485.7 MW Gross Small Hydro 182.4 MW

Net Stora Load 33.7 MW Total BMPC Load 9.5 MW

NSX -0.8 MW
 CBX 809.9 MW
 ONI 1000.7 MW
 ONS 853.4 MW

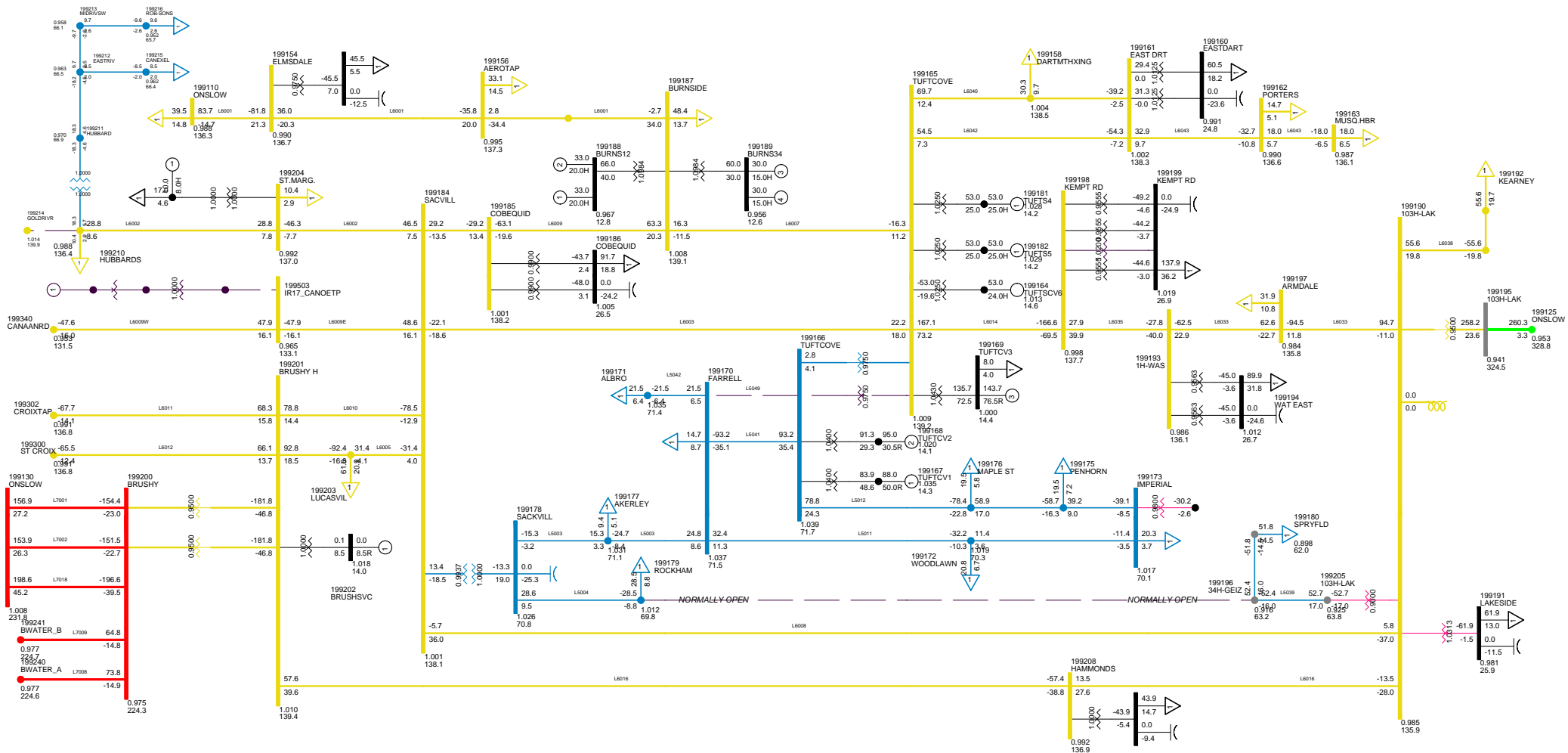

2013 EXTREME LOAD CONDITION
 C48 1P ON BREAKER 91H-523
 METRO ZONE MON, JAN 05 2009 17:38

Bus - VOLTAGE (KV)PU
 Branch - MIN/MAX
 Equipment - MIN/MAX
 HV/RATE
 1.050KV 0.950VU
 KV: $=30.000$ $=48.000$ $=73.800$ $=138.000$ $=230.000$ $=345.000$ $=345.000$

Figure __

NSX 306.0 MW

CBX 507.5 MW

ONI 698.0 MW

ONS 855.9 MW

Nova Scotia New Brunswick

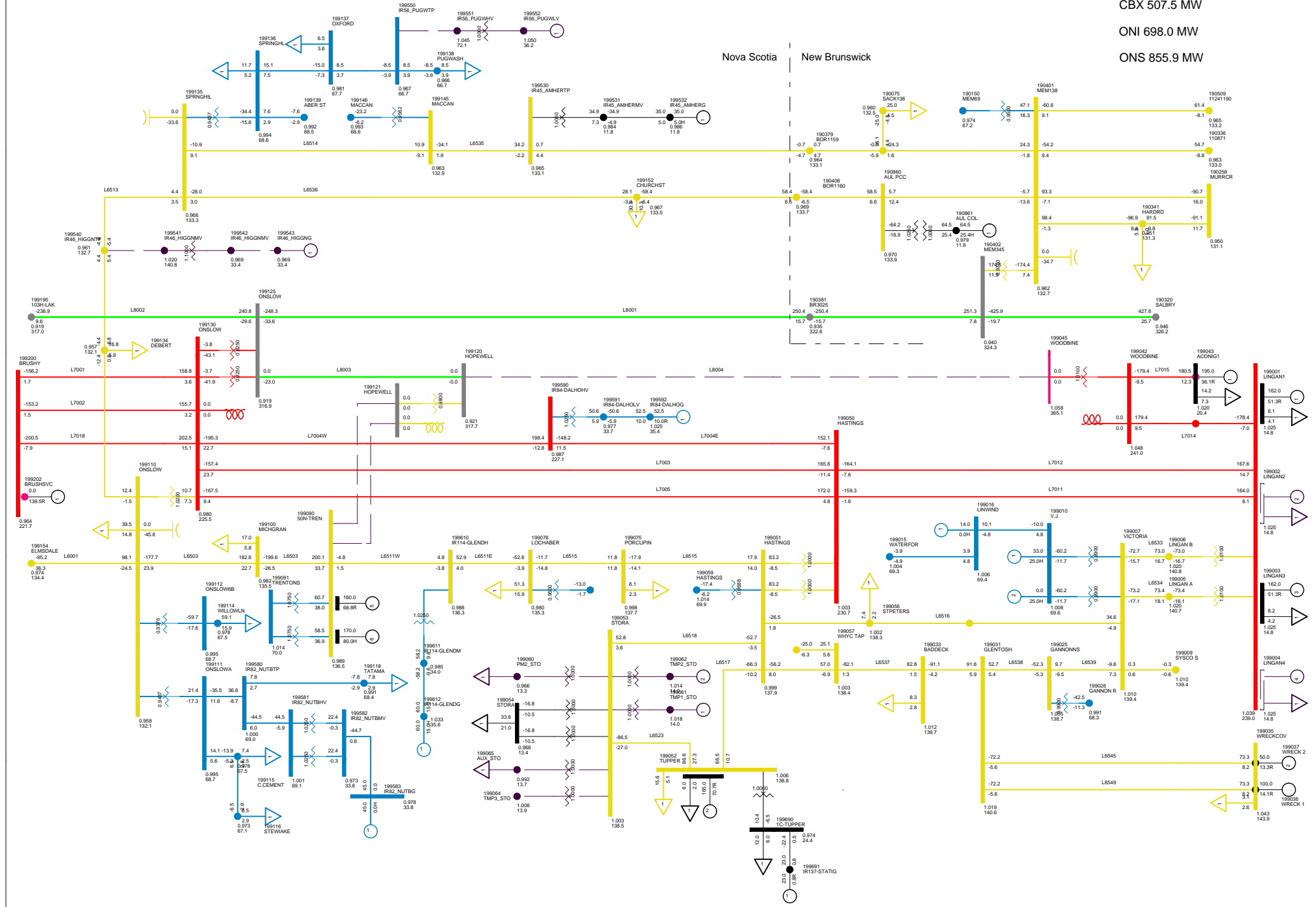

2013 EXTREME LOAD CONDITION
 C50SS 1P FAULT ON L6507, BBU 79N-606
 NORTHEASTERN NS MON, JAN 05 2009 17:39

Total Wind Gen: 290.1 MW
 Gross Lingan 324.0 MW
 Gross Trenton 330.0 MW
 Gross Tuft's Cove 485.7 MW
 Gross Tupper 165.0 MW
 Gross Wreck Cove 150.0 MW
 Gross Gas Turbine 183.0 MW
 Gross Small Hydro 182.4 MW
 Net Stora Load 33.7 MW
 Total BMPC Load 9.5 MW

Bus - VOLTAGE (KV/PU)
 Branch - MW/MVAR
 Equipment - MW/MVAR
 110.0/0.4745
 1.0000V 0.8500V
 KV: <-25.000 <-69.000 <-138.000 <-230.000 <-345.000 >345.000

Figure

Nova Scotia New Brunswick

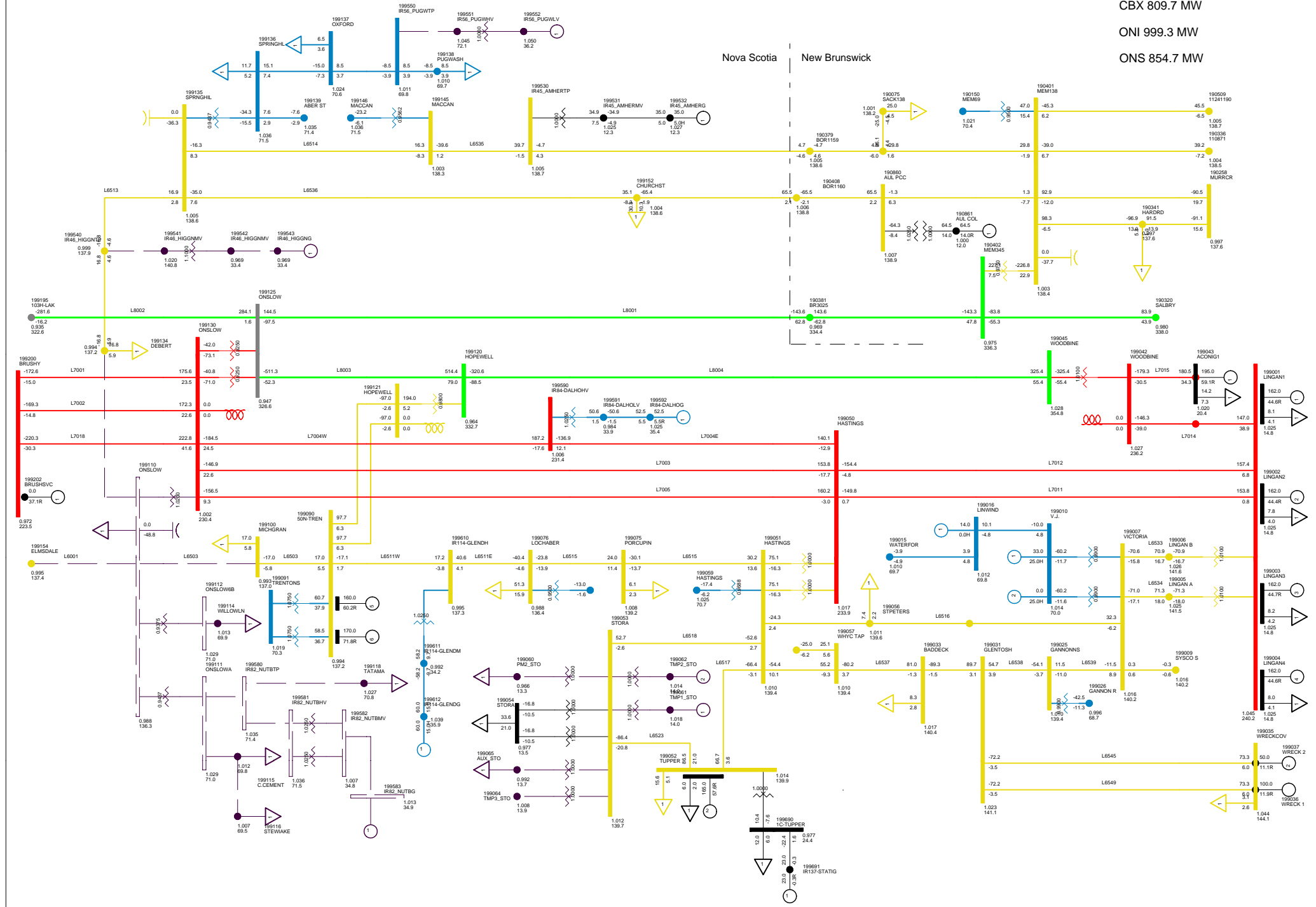

2013 EXTREME LOAD CONDITION
 C51 1P FAULT ON 1N BUS 61
 NORTHEASTERN NS MON, JAN 05 2009 17:39

Total Wind Gen: 245.1 MW
 Gross Lingan 648.0 MW
 Gross Trenton 330.0 MW
 Gross Tuft's Cove 485.7 MW
 Gross Tupper 165.0 MW
 Gross Wreck Cove 150.0 MW
 Gross Gas Turbine 183.0 MW
 Gross Small Hydro 182.4 MW
 Net Stora Load 33.7 MW
 Total BMPC Load 9.5 MW

Bus - VOLTAGE (KV/PU)
 Branch - MW/MVAR
 Equipment - MW/MVAR
 110.0KV/1.0
 1.000KV 0.850KV
 KV <-< 25.000 <-< 69.000 <-< 138.000 <-< 230.000 <-< 345.000 >> 345.000

Figure

NSX 0.8 MW
 CBX 809.9 MW
 ONI 1000.7 MW
 ONS 853.4 MW

Nova Scotia New Brunswick

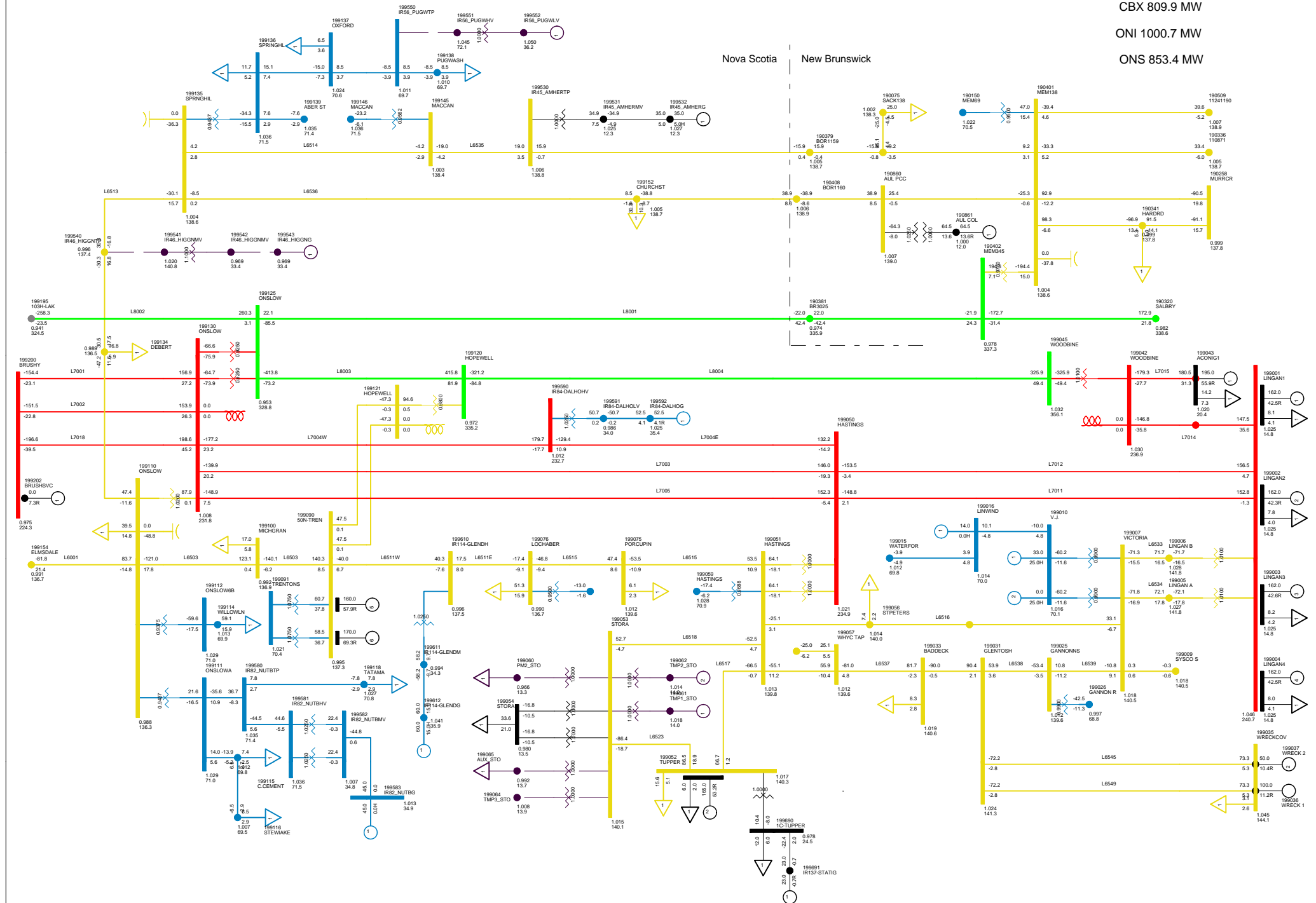

2013 EXTREME LOAD CONDITION
 C53 BREAKR 47C-602 FAULT
 NORTHEASTERN NS MON, JAN 05 2009 17:40

Total Wind Gen: 290.1 MW
 Gross Lingan 648.0 MW
 Gross Trenton 330.0 MW
 Gross Tuft's Cove 485.7 MW
 Gross Tupper 165.0 MW
 Gross Wreck Cove 150.0 MW
 Gross Gas Turbine 183.0 MW
 Gross Small Hydro 182.4 MW
 Net Stora Load 33.7 MW
 Total BMPC Load 9.5 MW

Bus - VOLTAGE (KV/PV)
 Branch - MW/MVAR
 Equipment - MW/MVAR
 HV PARALLEL
 1.0000V 0.8500V
 KV <-<0.00 <-<69.00 <-<138.00 <-<230.00 <-<345.00 >345.00

Figure

NSX 33.6 MW

CBX 785.1 MW

ONI 968.6 MW

ONS 854.0 MW

Nova Scotia New Brunswick

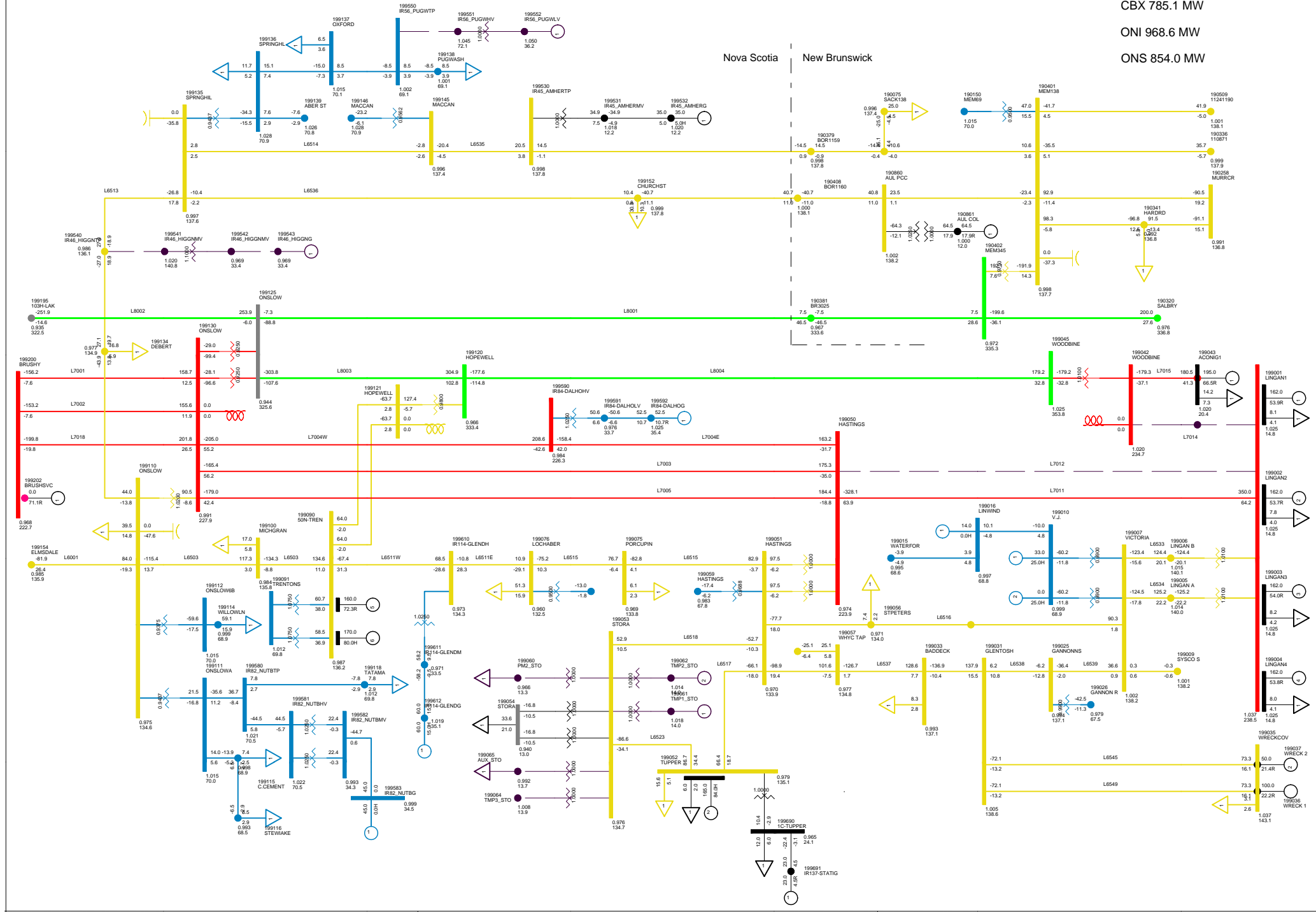

2013 EXTREME LOAD CONDITION
 C54 BBU 88S-723 NO SPS
 NORTHEASTERN NS MON, JAN 05 2009 17:40

Total Wind Gen: 290.1 MW
 Gross Lingan 648.0 MW
 Gross Trenton 330.0 MW
 Gross Tuft's Cove 485.7 MW
 Gross Tupper 165.0 MW
 Gross Wreck Cove 150.0 MW
 Gross Gas Turbine 183.0 MW
 Gross Small Hydro 182.4 MW
 Net Stora Load 33.7 MW
 Total BMPC Load 9.5 MW

Bus - VOLTAGE (KV/PV)
 Branch - MW/MVAR
 Equipment - MW/MVAR
 110.0/13.8/15.5
 1.000/0.0 0.80/0.7
 KV: <-20.0 <-69.0 <-138.0 <-230.0 <-345.0 >345.0

Figure

Nova Scotia New Brunswick

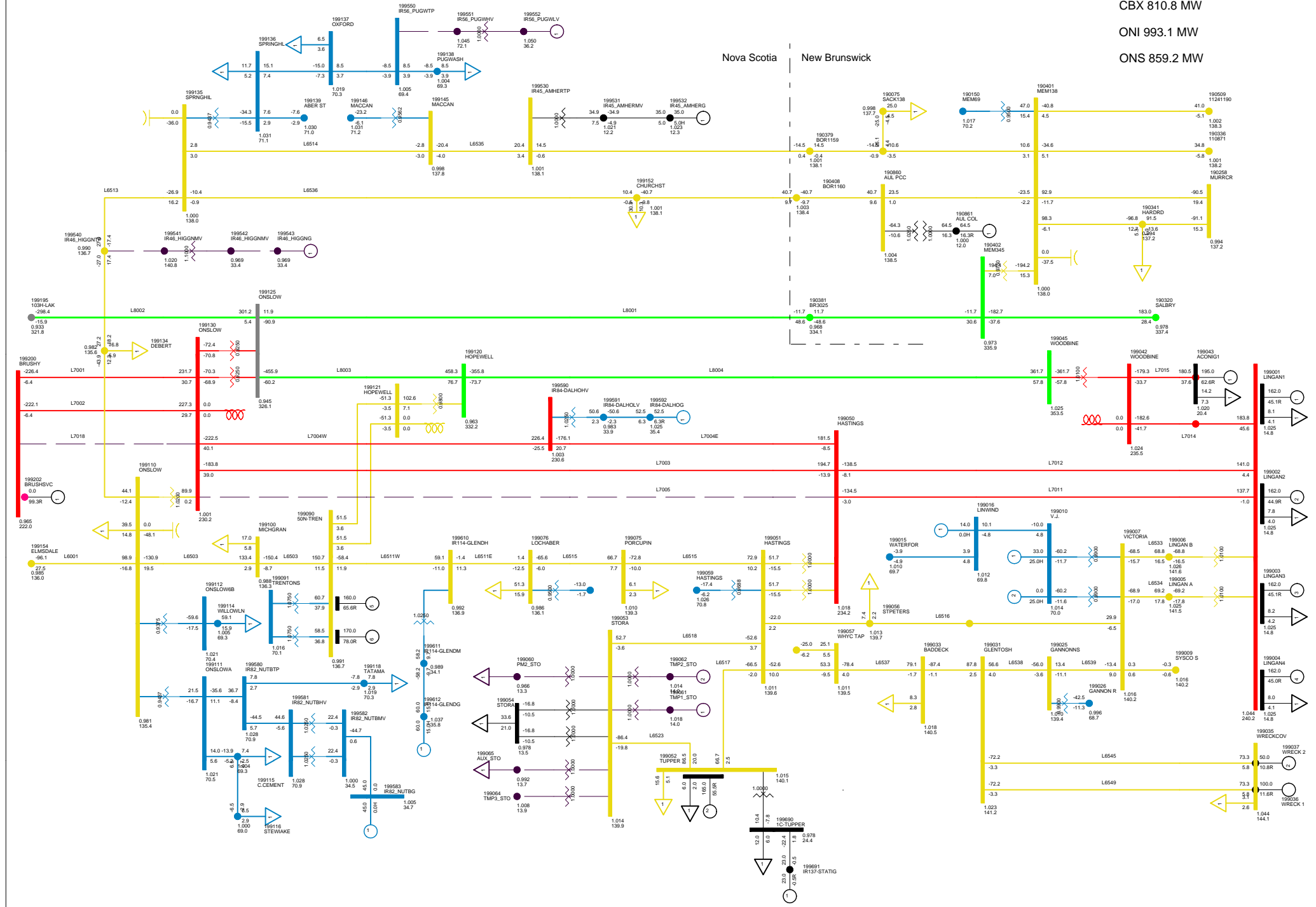

2013 EXTREME LOAD CONDITION
C55 BBU 67N-712
NORTHEASTERN NS MON, JAN 05 2009 17:40

Total Wind Gen: 290.1 MW
Gross Lingan 648.0 MW
Gross Trenton 330.0 MW
Gross Tuft's Cove 485.7 MW
Gross Tupper 165.0 MW
Gross Wreck Cove 150.0 MW
Gross Gas Turbine 183.0 MW
Gross Small Hydro 182.4 MW
Net Stora Load 33.7 MW
Total BMPC Load 9.5 MW

Bus - VOLTAGE (KV/PU)
Branch - MW/MVAR
Equipment - MW/MVAR
110.0/0.8747
1.0000V 0.8500V
KV <-<0.00 <-<69.00V <-<138.00V <-<230.00V <-<345.00V >345.000

Figure

Nova Scotia New Brunswick

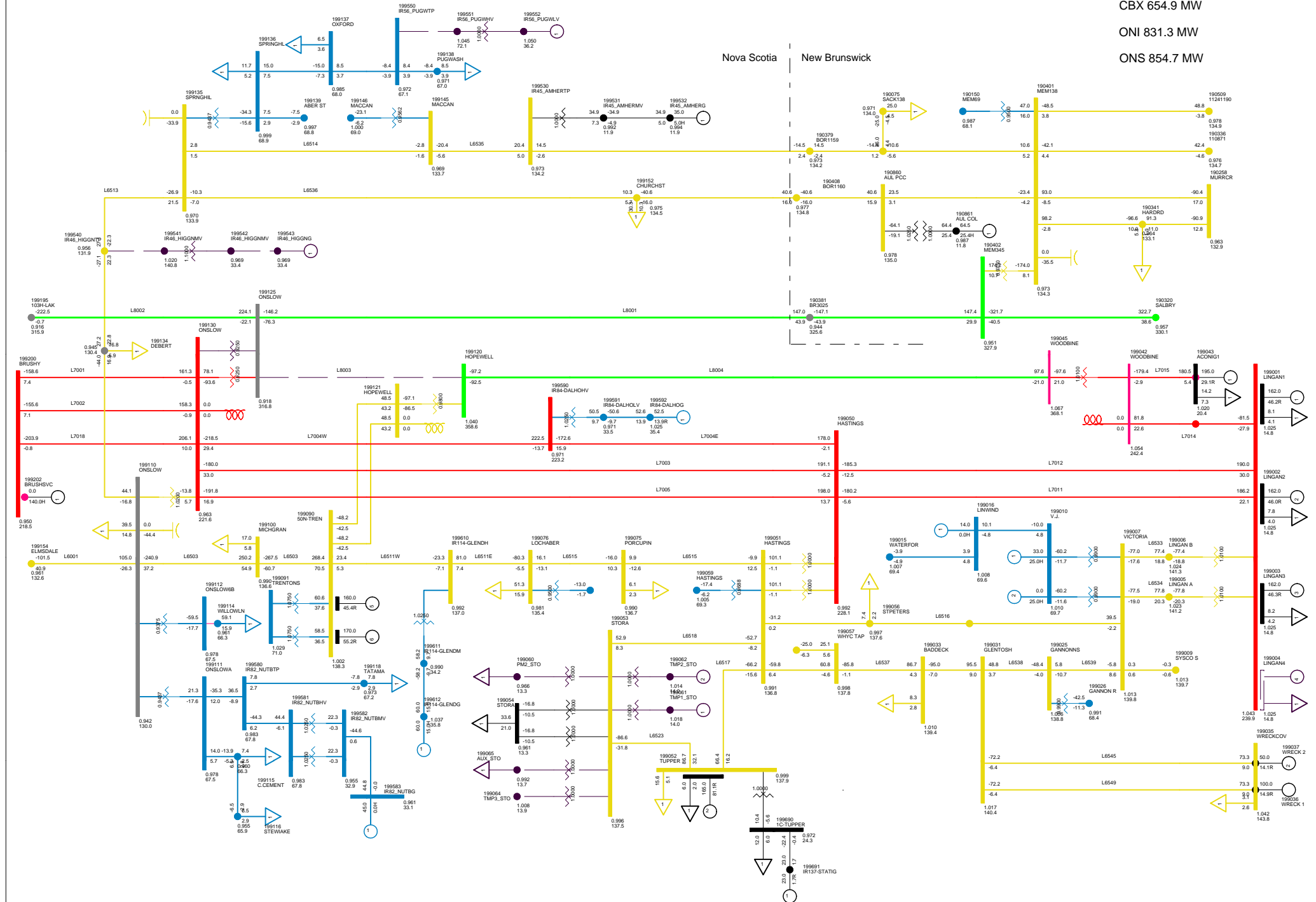

2013 EXTREME LOAD CONDITION
 C56S BBU 67N-811 L8003 + T82 1 UNIT SPS
 NORTHEASTERN NS MON, JAN 05 2009 17:40

Total Wind Gen: 290.1 MW
 Gross Lingan 486.0 MW
 Gross Trenton 330.0 MW
 Gross Tuft's Cove 485.7 MW
 Gross Tupper 165.0 MW
 Gross Wreck Cove 150.0 MW
 Gross Gas Turbine 183.0 MW
 Gross Small Hydro 182.4 MW
 Net Stora Load 33.7 MW
 Total BMPC Load 9.5 MW

Bus - VOLTAGE (KV/PU)
 Branch - MW/MVAR
 Equipment - MW/MVAR
 110.0KV/1.000V 0.850UV
 KV: <-25.000 <-69.00V <-138.000 <-230.000 <-345.000 >345.000

Figure

NSX 302.8 MW

CBX 511.3 MW

ONI 701.2 MW

ONS 856.0 MW

Nova Scotia New Brunswick

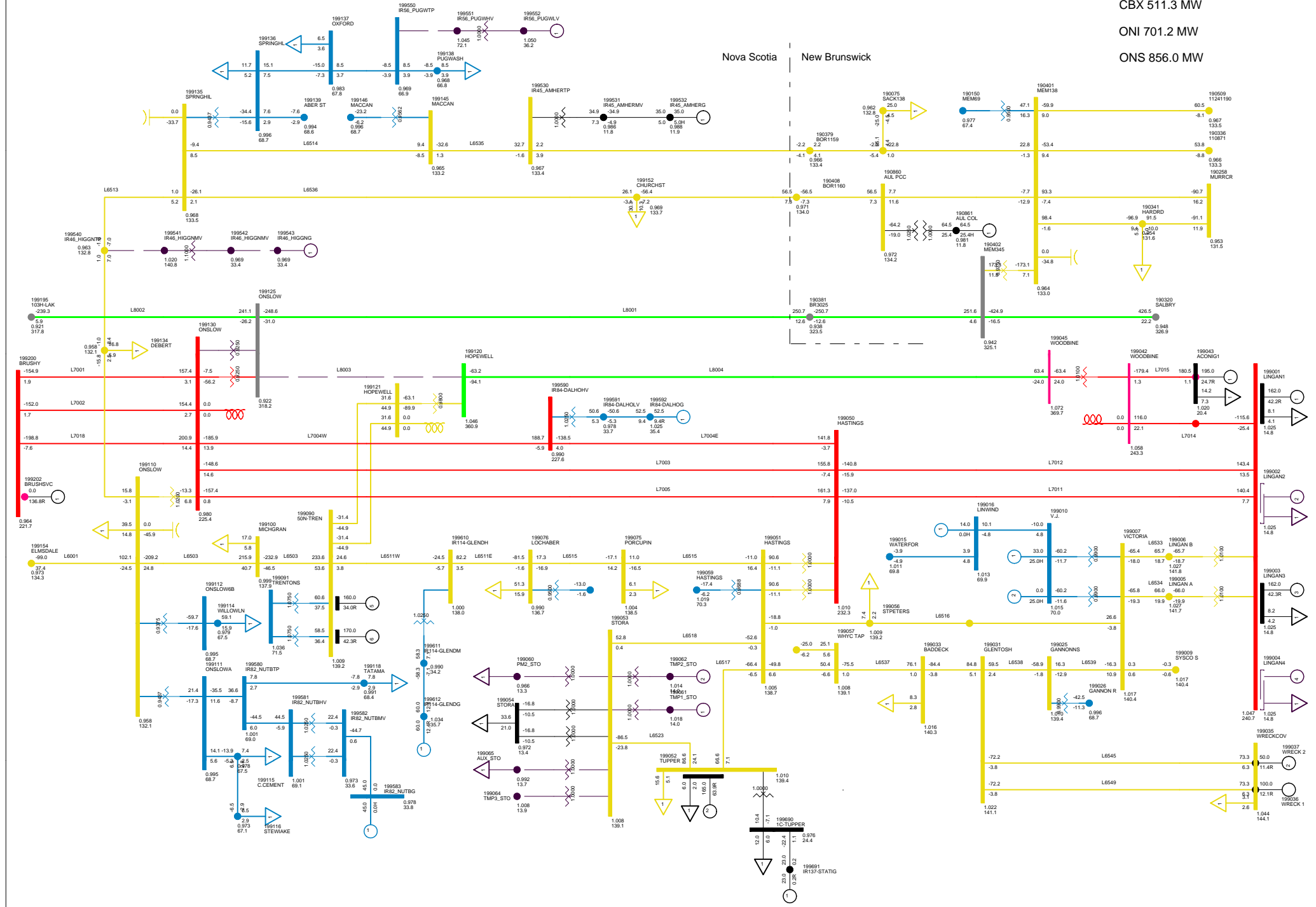

NSX 631.2 MW

CBX 396.3 MW

ONI 495.6 MW

ONS 717.4 MW

Nova Scotia New Brunswick

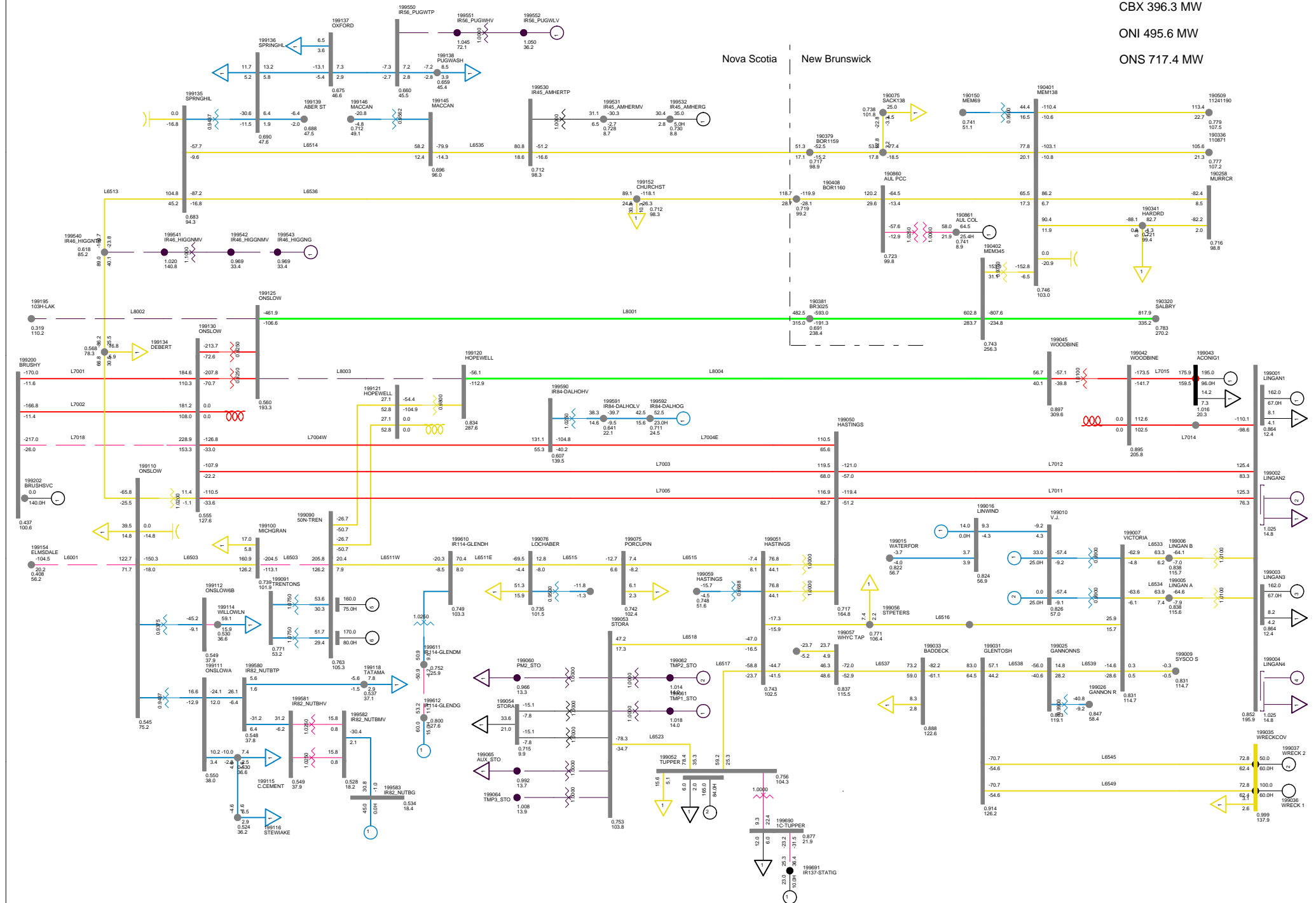

2013 EXTREME LOAD CONDITION
C57SS BBU 67N-812 2-UNIT SPS
NORTHEASTERN NS MON, JAN 05 2009 17:41

Total Wind Gen: 290.1 MW
Gross Lingan 324.0 MW
Gross Trenton 330.0 MW
Gross Tuft's Cove 485.7 MW
Gross Tupper 165.0 MW
Gross Wreck Cove 150.0 MW
Gross Gas Turbine 183.0 MW
Gross Small Hydro 182.4 MW
Net Stora Load 31.0 MW
Total BMPC Load 5.3 MW

Bus - VOLTAGE (KV/PV)
Branch - MW/MVAR
Equipment - MW/MVAR
110.0/34.5/11.0
1.000/0.0 0.80/0.0
KV: <-25.000 <-69.000 <-138.000 <-230.000 <-345.000 >345.000

Figure

NSX 306.2 MW

CBX 507.0 MW

ONI 697.0 MW

ONS 855.0 MW

Nova Scotia New Brunswick

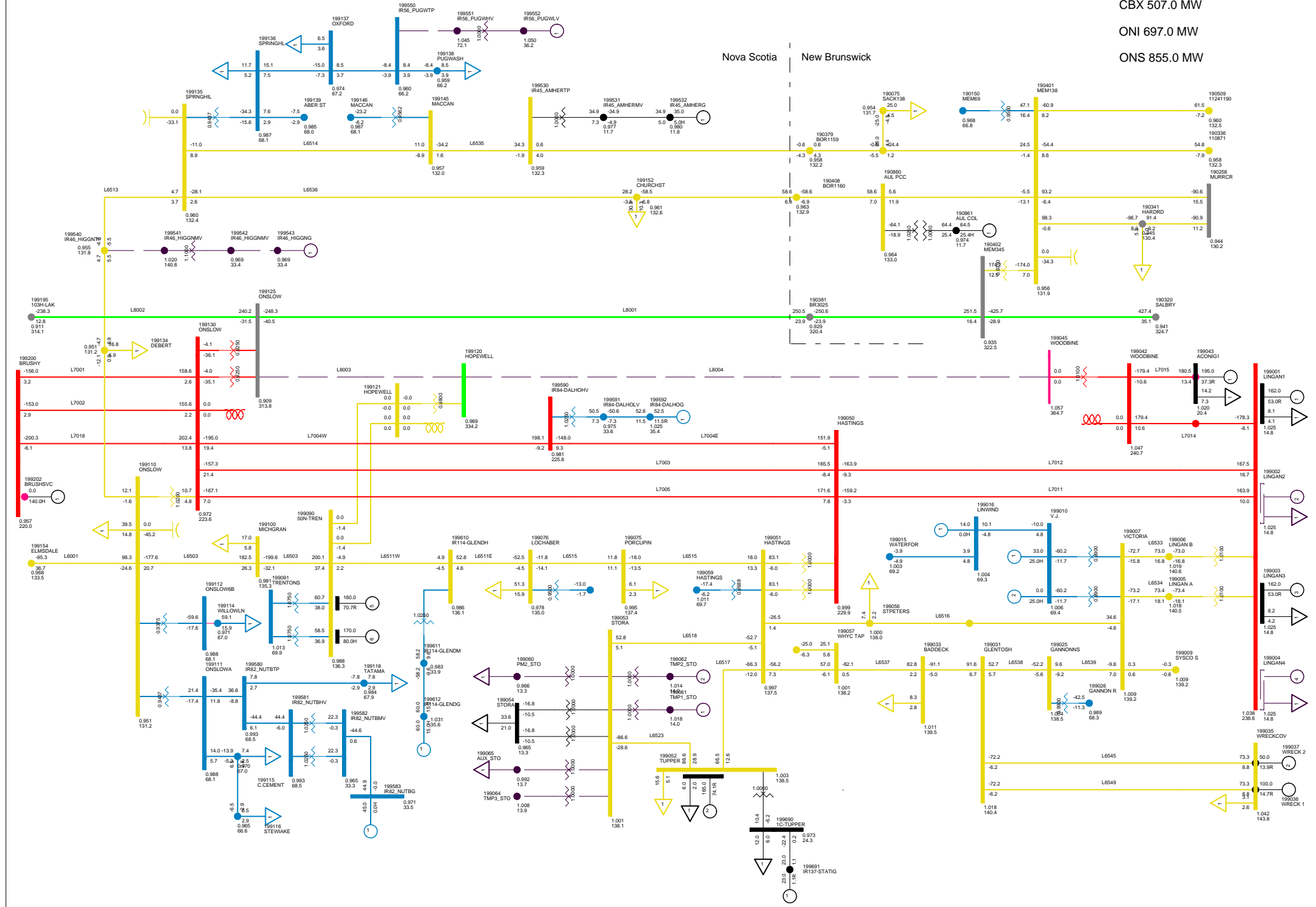

2013 EXTREME LOAD CONDITION
 C58SS BBU 79N-810 2-UNIT SPS
 NORTHEASTERN NS MON, JAN 05 2009 17:41

Total Wind Gen: 290.1 MW
 Gross Lingan 324.0 MW
 Gross Trenton 330.0 MW
 Gross Tuft's Cove 485.7 MW
 Gross Tupper 165.0 MW
 Gross Wreck Cove 150.0 MW
 Gross Gas Turbine 183.0 MW
 Gross Small Hydro 182.4 MW
 Net Stora Load 33.7 MW
 Total BMPC Load 9.5 MW

Bus - VOLTAGE (KV/PU)
 Branch - MW/MVAR
 Equipment - MW/MVAR
 110.0/0.4747
 1.000/0.0 0.800/0.0
 KV: <<25.000 <<69.000 <<138.000 <<230.000 <<345.000 >>345.000

Figure

NSX 280.9 MW

CBX 516.6 MW

ONI 720.4 MW

ONS 853.3 MW

Nova Scotia New Brunswick

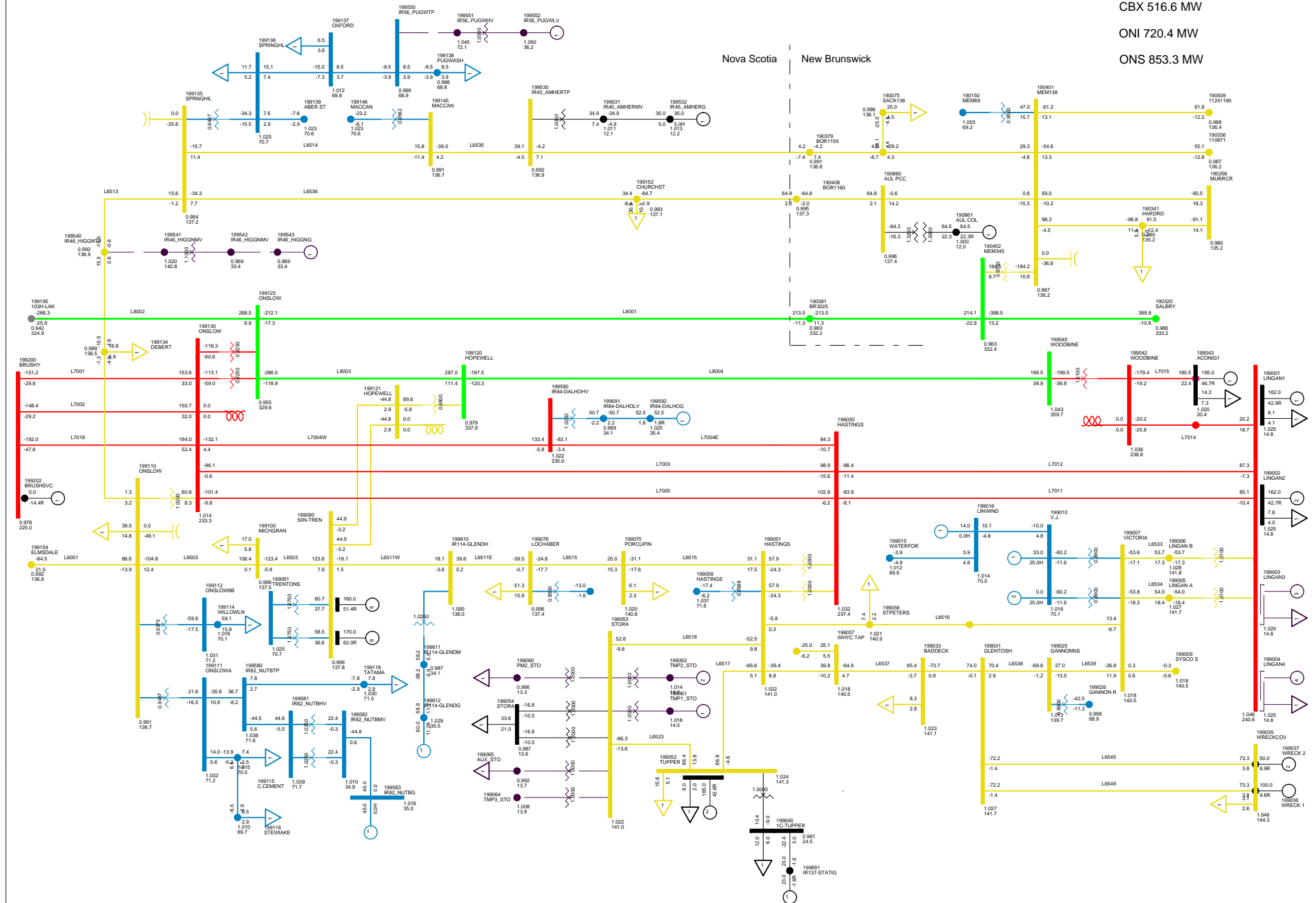

2013 EXTREME LOAD CONDITION
C59 BBU 88S-721 TRIP LINGAN 3 AND 4
NORTHEASTERN NS MON, JAN 05 2009 17:41

Total Wind Gen: 290.1 MW
Gross Lingan 324.0 MW
Gross Trenton 330.0 MW
Gross Tuft's Cove 485.7 MW
Gross Tupper 165.0 MW
Gross Wreck Cove 150.0 MW
Gross Gas Turbine 183.0 MW
Gross Small Hydro 182.4 MW
Net Stora Load 33.7 MW
Total BMPC Load 9.5 MW

Bus - VOLTAGE (KV/PV)
Branch - MW/MVAR
Equipment - MW/MVAR
110.0PARATEB
1.0000V 0.8500V
KV: <-<25.000 <-<69.00V <-<138.000 <-<230.000 <-<345.000 >>345.000

Figure

Nova Scotia New Brunswick

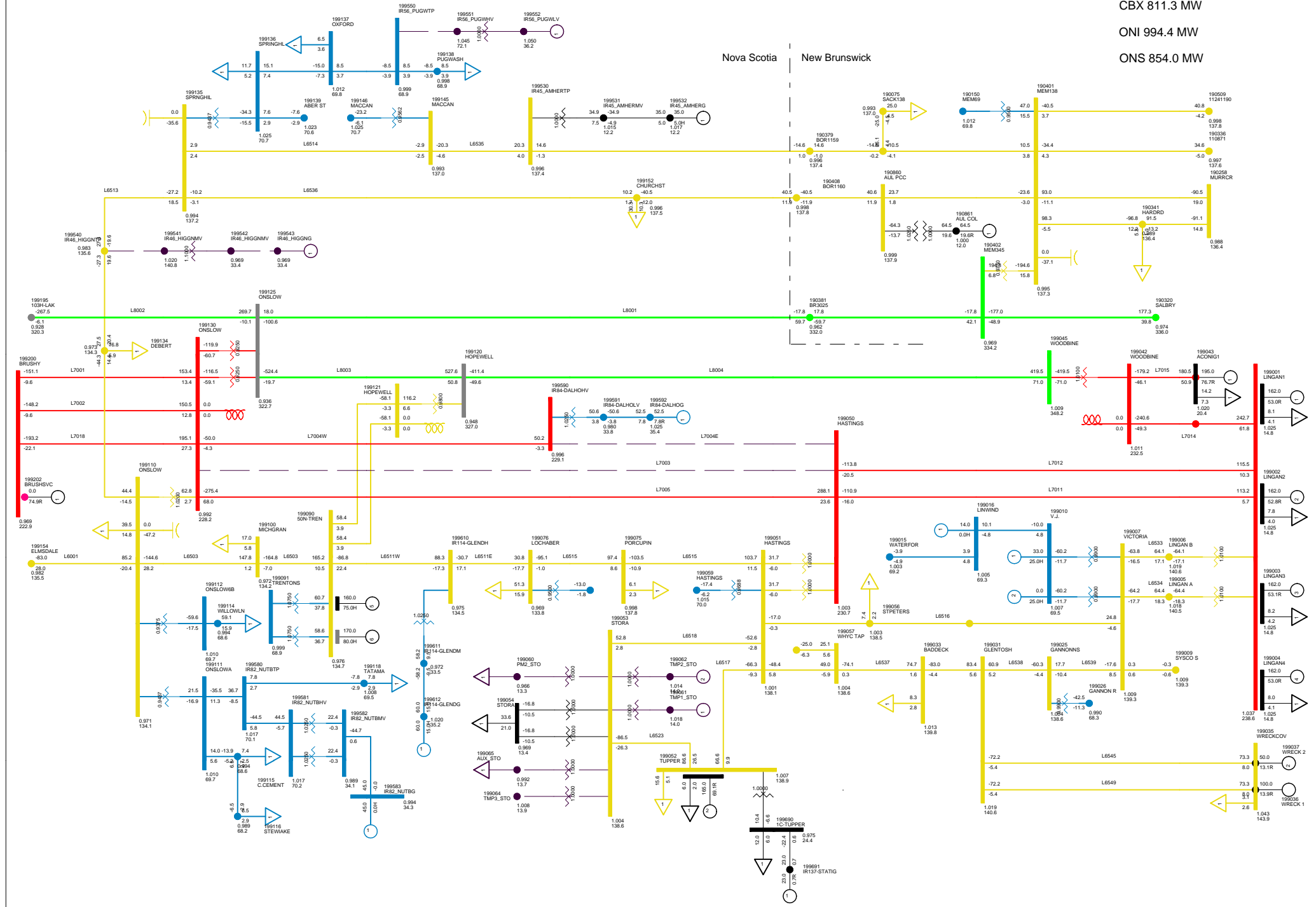

2013 EXTREME LOAD CONDITION
 C60 DCT ON L7003+L7004
 NORTHEASTERN NS MON, JAN 05 0099 17:41

Total Wind Gen: 290.1 MW
 Gross Lingan 648.0 MW
 Gross Trenton 330.0 MW
 Gross Pt Aconi 195.0 MW
 Gross Tupper 165.0 MW
 Gross Gas Turbine 183.0 MW
 Gross Small Hydro 182.4 MW
 Gross Wreck Cove 150.0 MW
 Net Stora Load 33.7 MW
 Total BMPC Load 9.5 MW

Bus - VOLTAGE (KV/PU)
 Branch - MW/MVAR
 Equipment - MW/MVAR
 110.0/1.0/1.0
 1.0/0.0/0.0/0.0
 KV: <-25.000 <-69.00V <-138.000 <-230.000 <-345.000 >345.000

Figure

CBX 506.4 MW
 ONI 688.4 MW
 ONS 852.8 MW

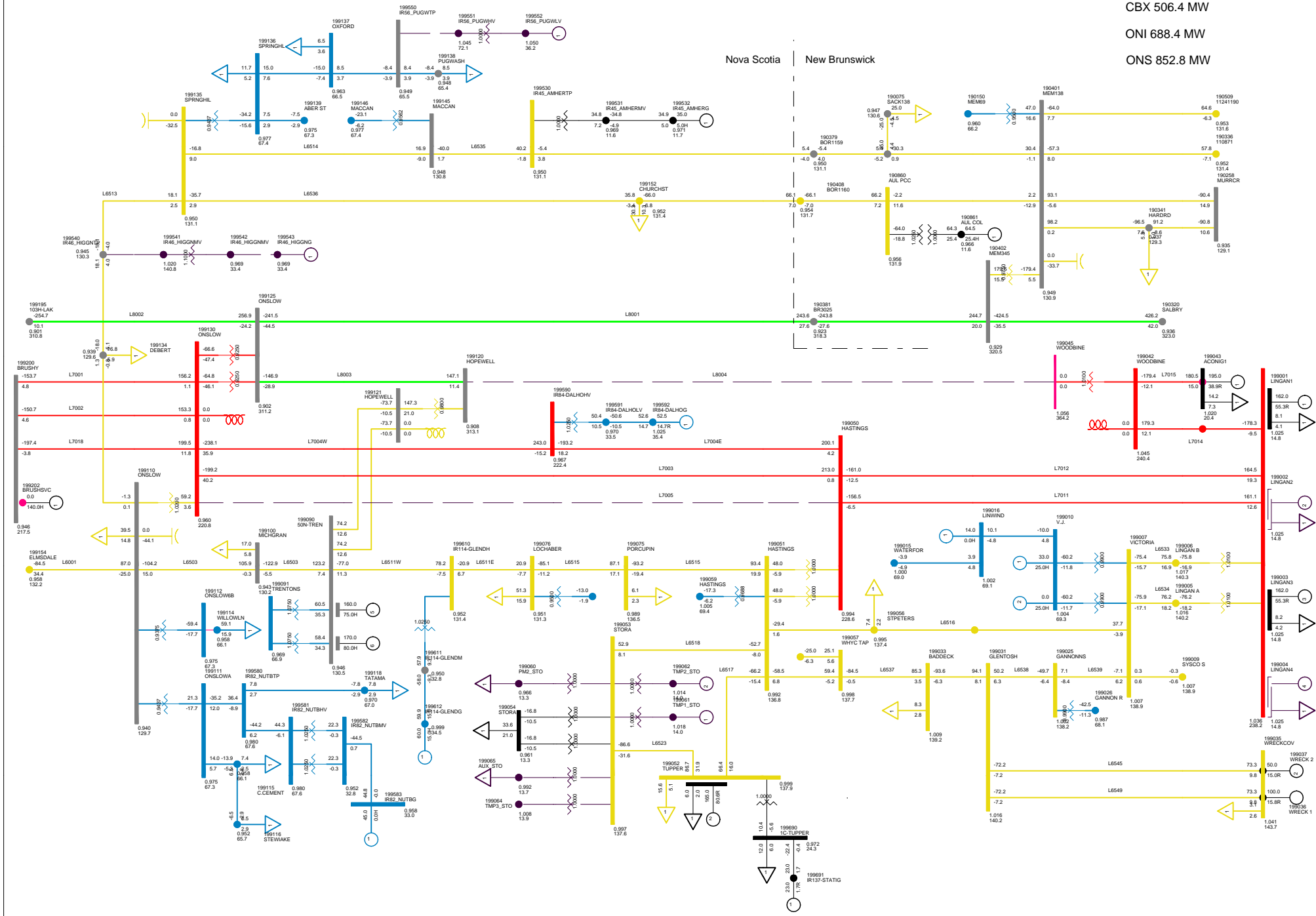

2013 EXTREME LOAD CONDITION
 C61SS DCT ON STRAIT CROSSING L8004-L7005 WITH 2-UNIT SPS
 NORTHEASTERN NS MON, JAN 05 2009 17:42

Total Wind Gen: 290.1 MW	Gross Tupper 165.0 MW	Gross Wreck Cove 150.0 MW	Net Stor Load 33.7 MW
Gross Lingan 324.0 MW	Gross Trenton 330.0 MW	Gross Gas Turbine 183.0 MW	Total BMPC Load 9.5 MW
Gross Pt Aconi 195.0 MW	Gross Tufts Cove 485.7 MW	Gross Small Hydro 182.4 MW	

Bus - VOLTAGE (KV/PU)
 Branch - MW/MVAR
 Equipment - MW/MVAR
 110 kV GATES
 KV: <-25.000V <-69.000V <-138.000V <-230.000V <-345.000V >345.000V

Figure

Nova Scotia New Brunswick

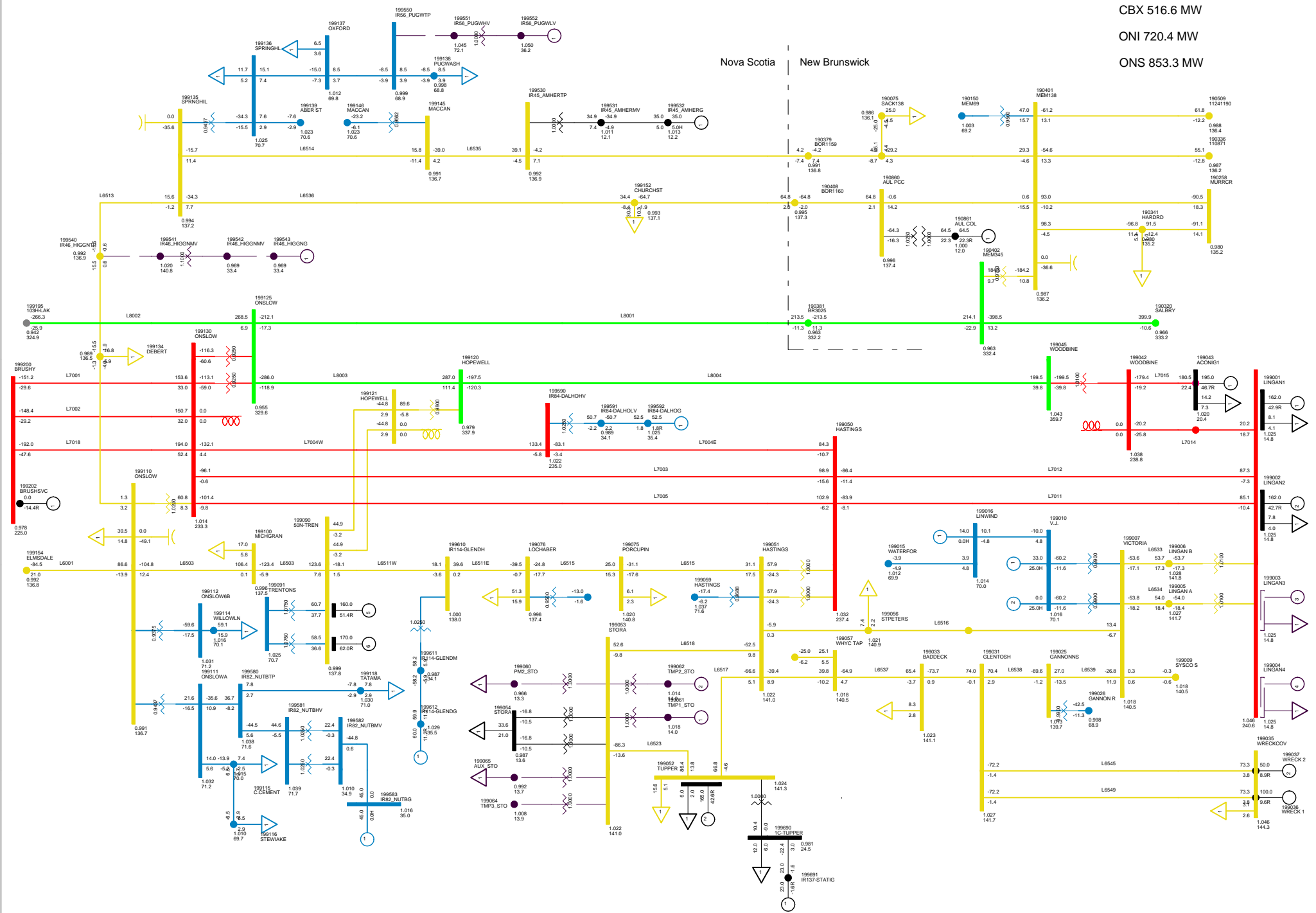

201

NS 2.2 MW

CBX 809.6 MW

ONI 999.9 MW

ONS 854.0 MW

Nova Scotia New Brunswick

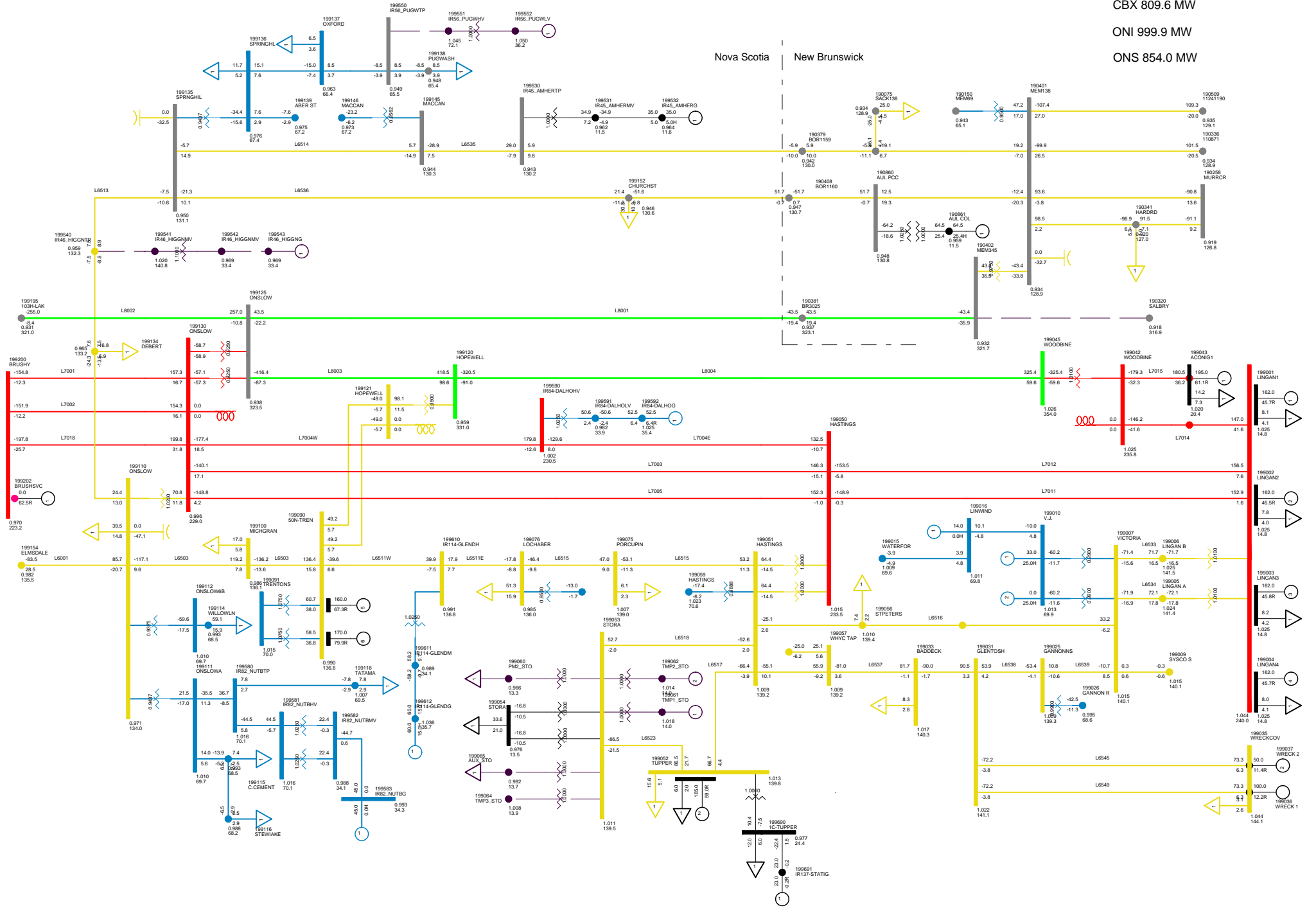

2013 EXTREME LOAD CONDITION
 C63 FAULT ON SALISBURY SA3-2 TRIPS L3006 AND L3017
 NORTHEASTERN NS MON, JAN 05 2009 17:42

Total Wind Gen: 290.1 MW	Gross Tupper 165.0 MW	Gross Wreck Cove 150.0 MW	Net Stora Load 33.7 MW
Gross Lingan 648.0 MW	Gross Trenton 330.0 MW	Gross Gas Turbine 183.0 MW	Total BMPC Load 9.5 MW
Gross Pt Aconi 195.0 MW	Gross Tuft's Cove 485.7 MW	Gross Small Hydro 182.4 MW	

Bus - VOLTAGE (KV/PU)
 Branch - MW/MVAR
 Equipment - MW/MVAR
 110.0kV/230kV
 1.0500V 0.9500V
 KV: <-25.000 <-138.000 <-230.000 <-345.000 >345.000

Figure ____

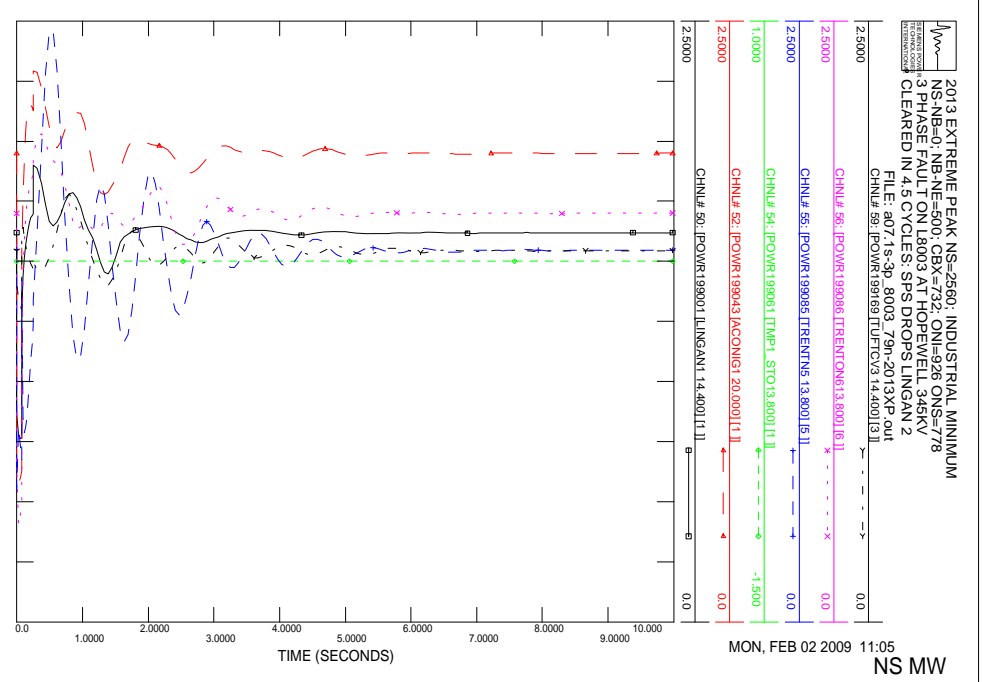
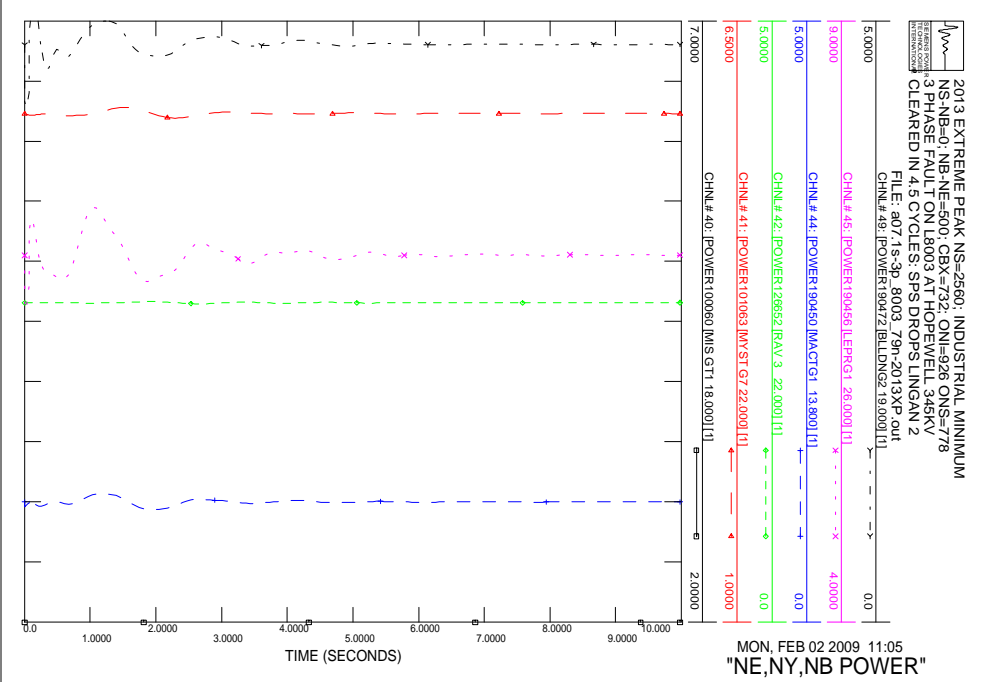
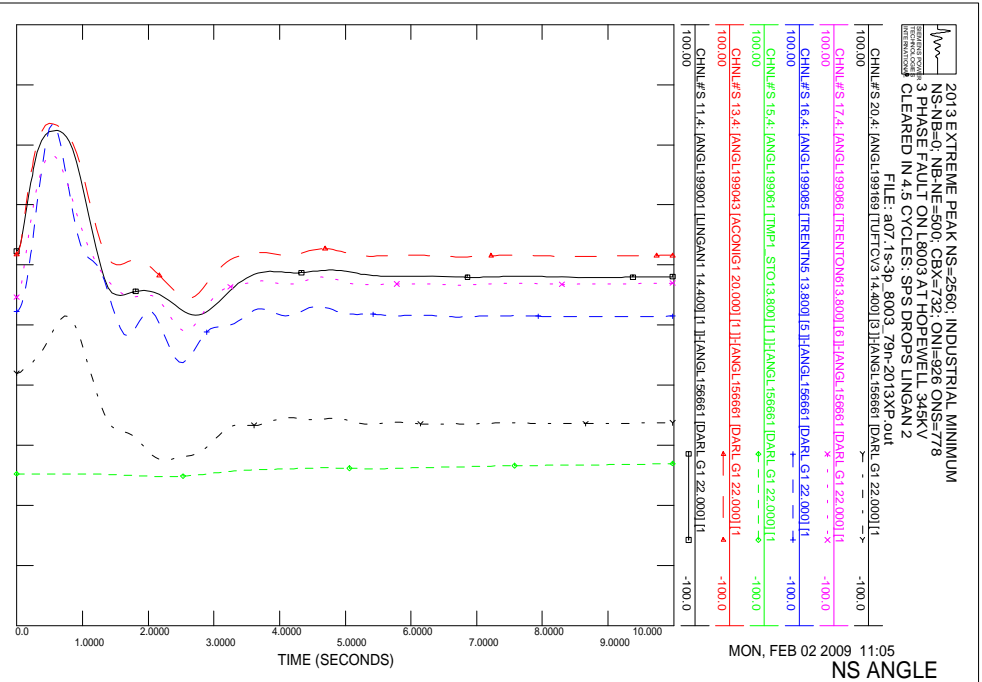
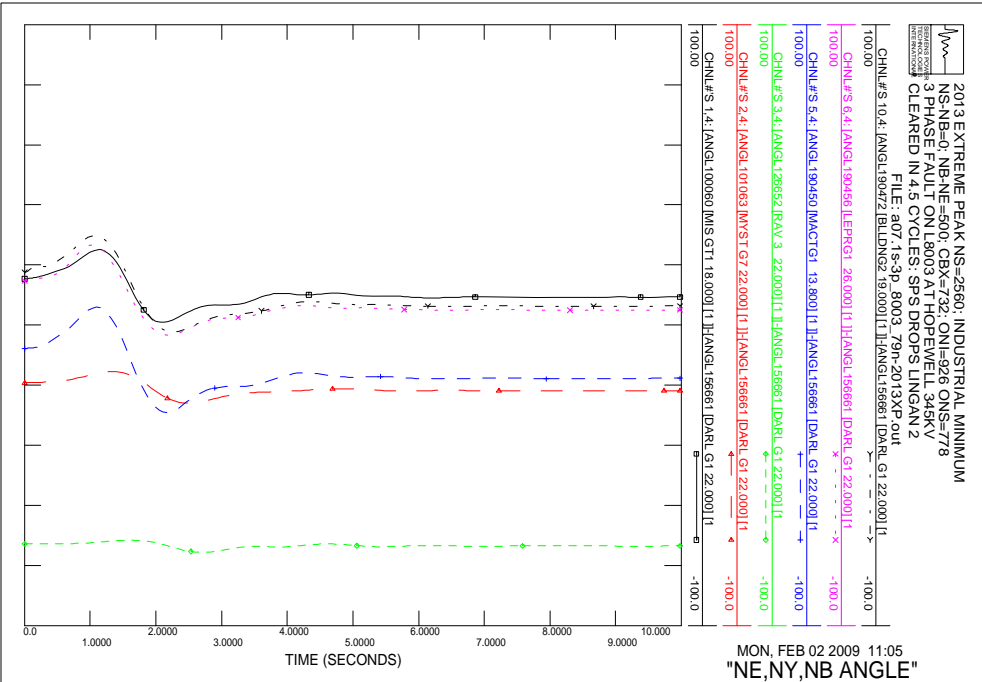

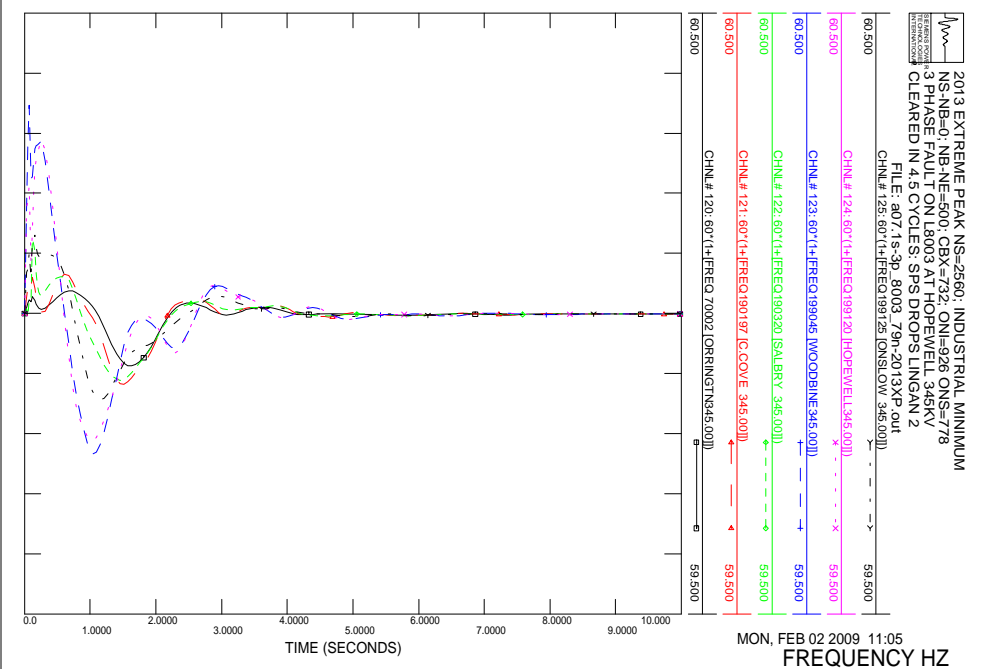
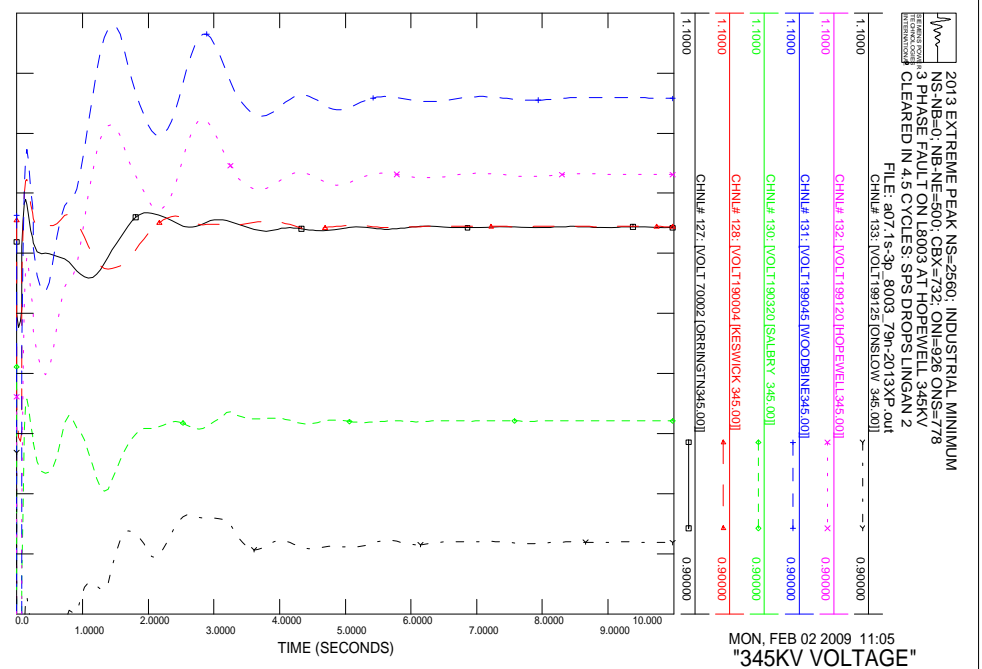
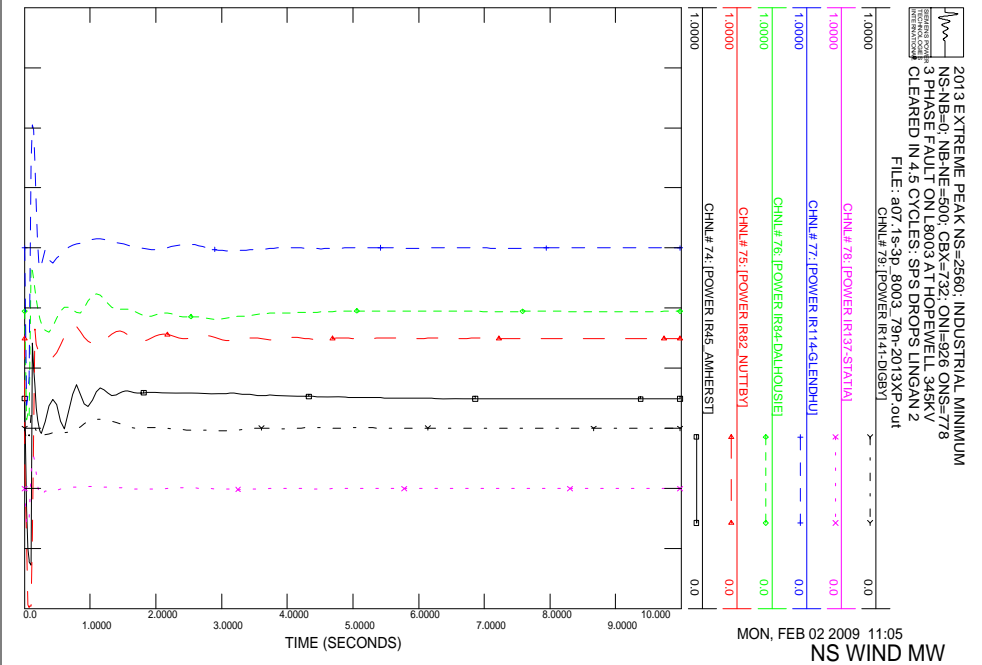
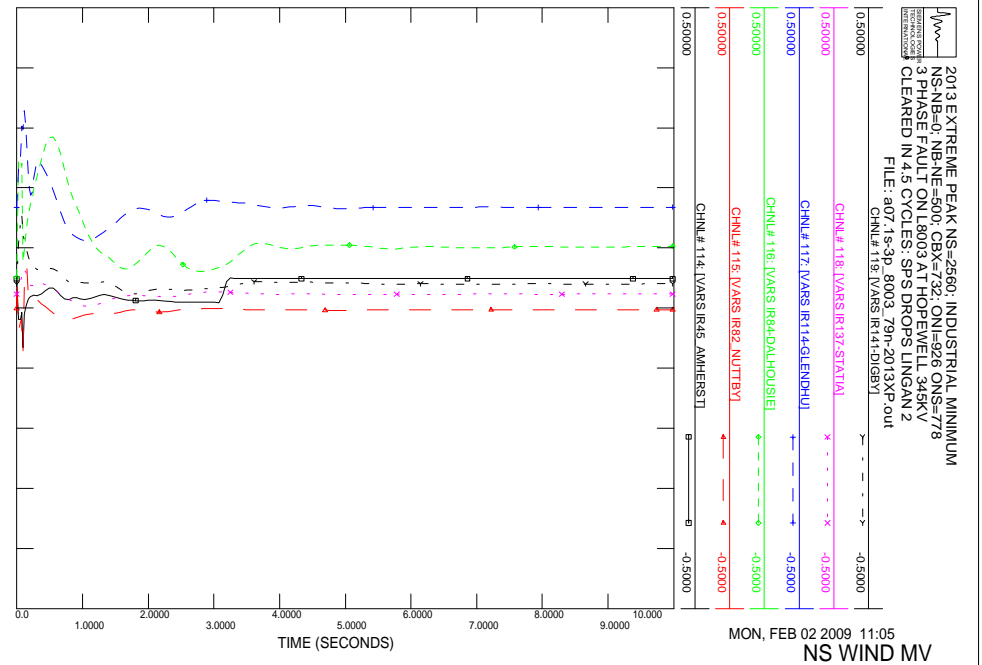

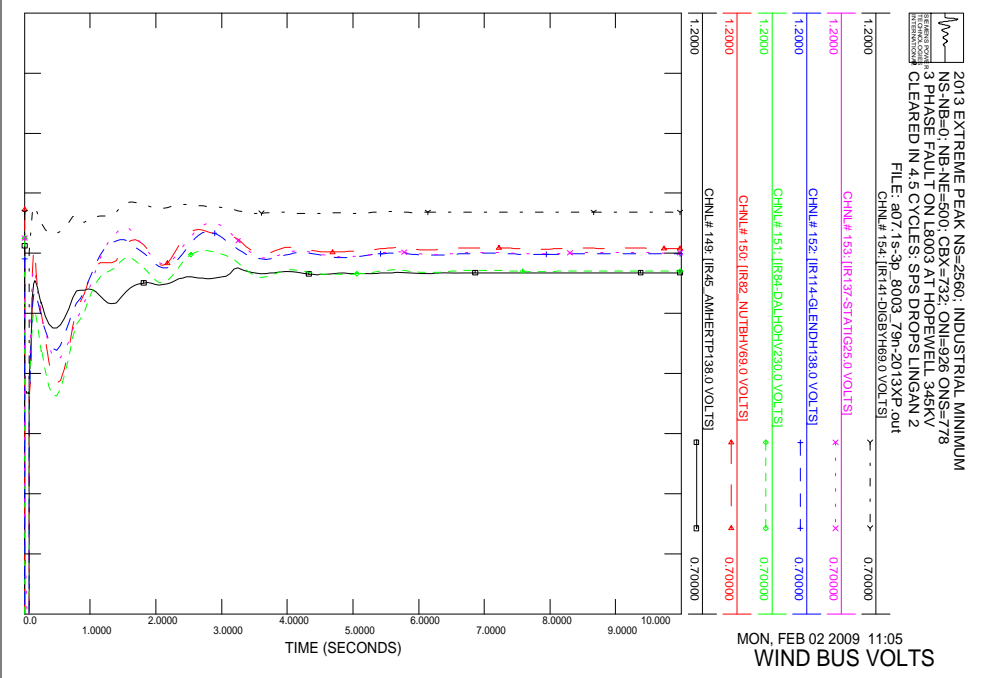
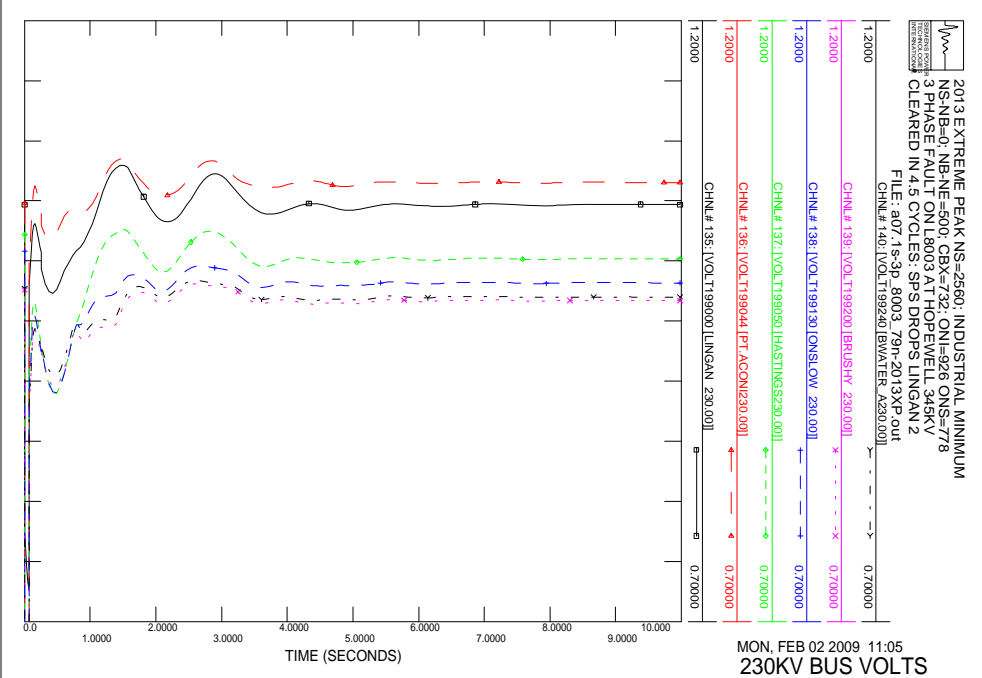
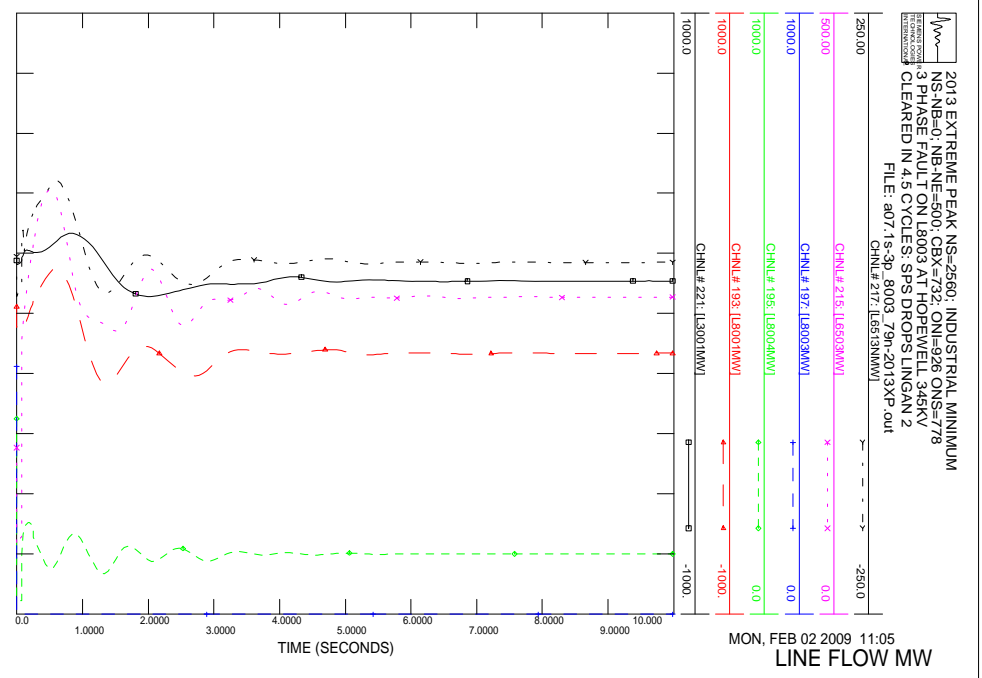
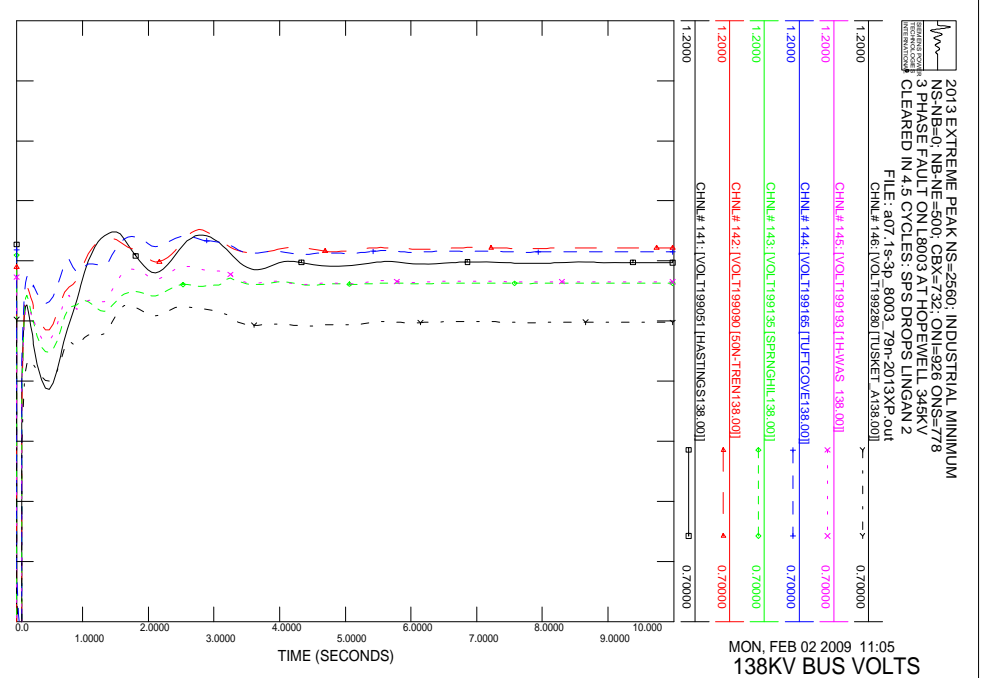

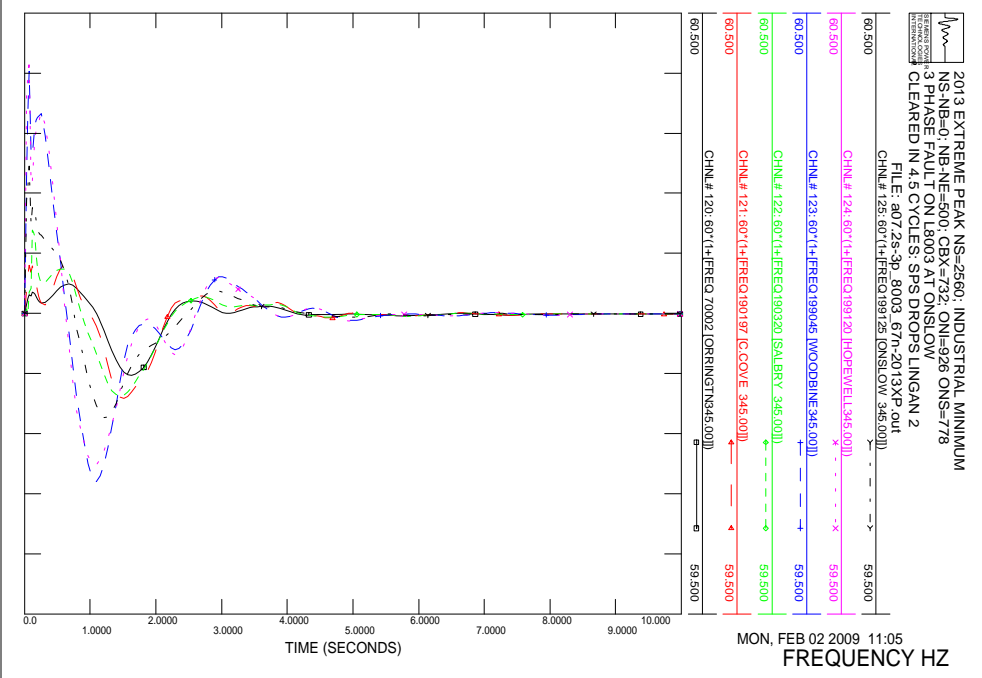
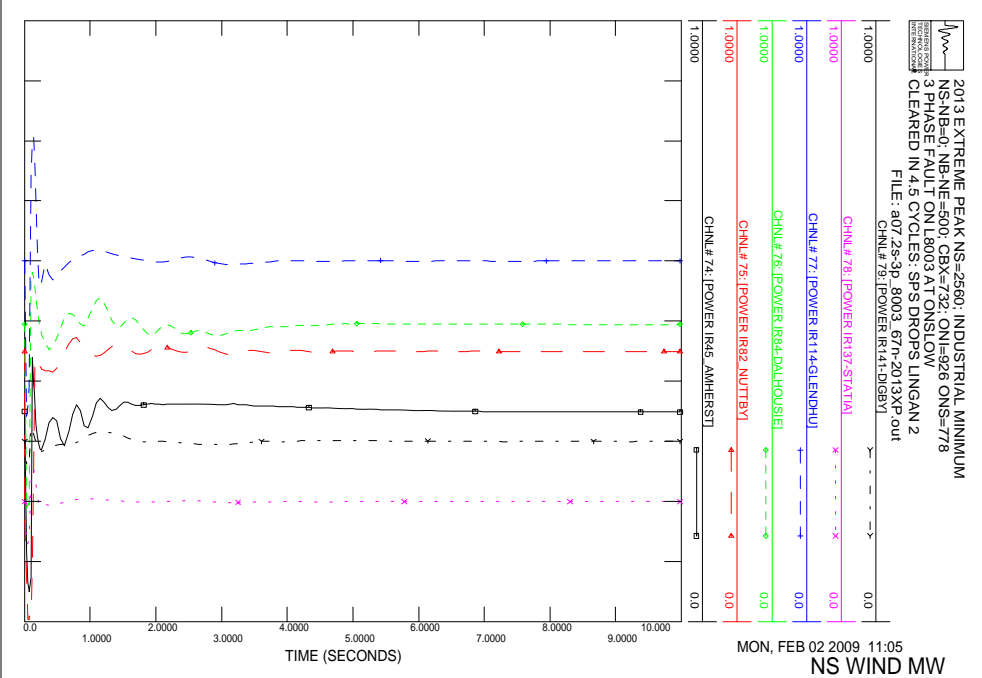
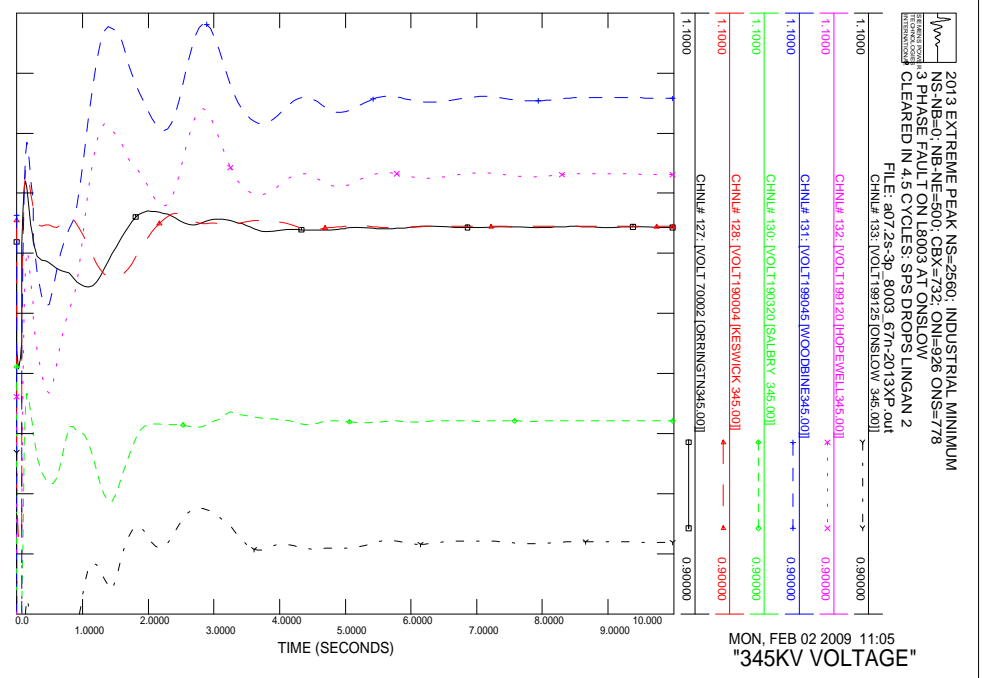
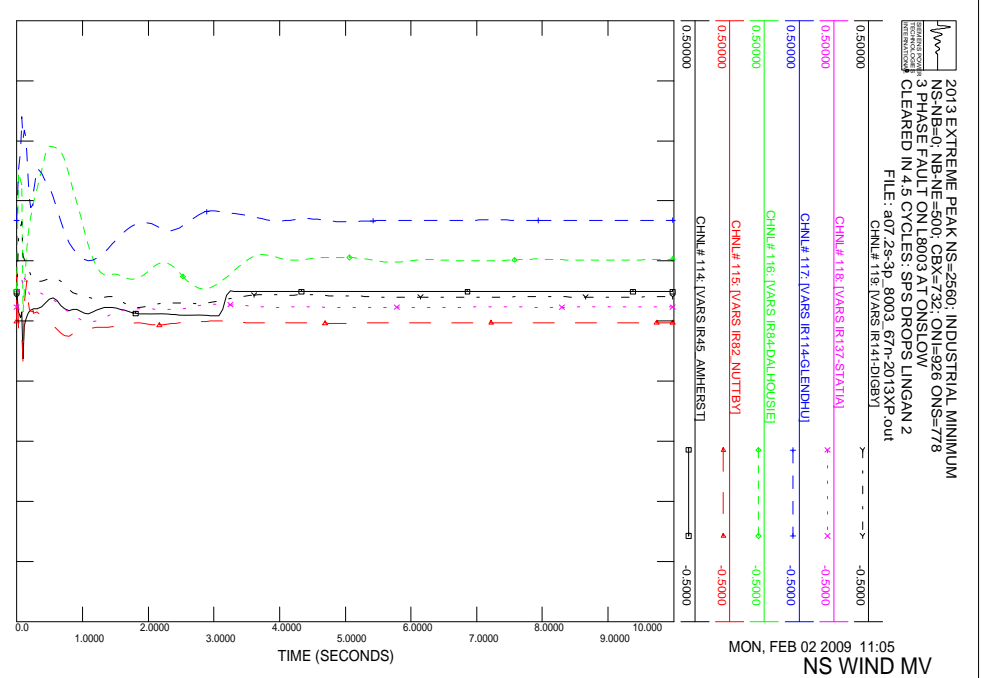

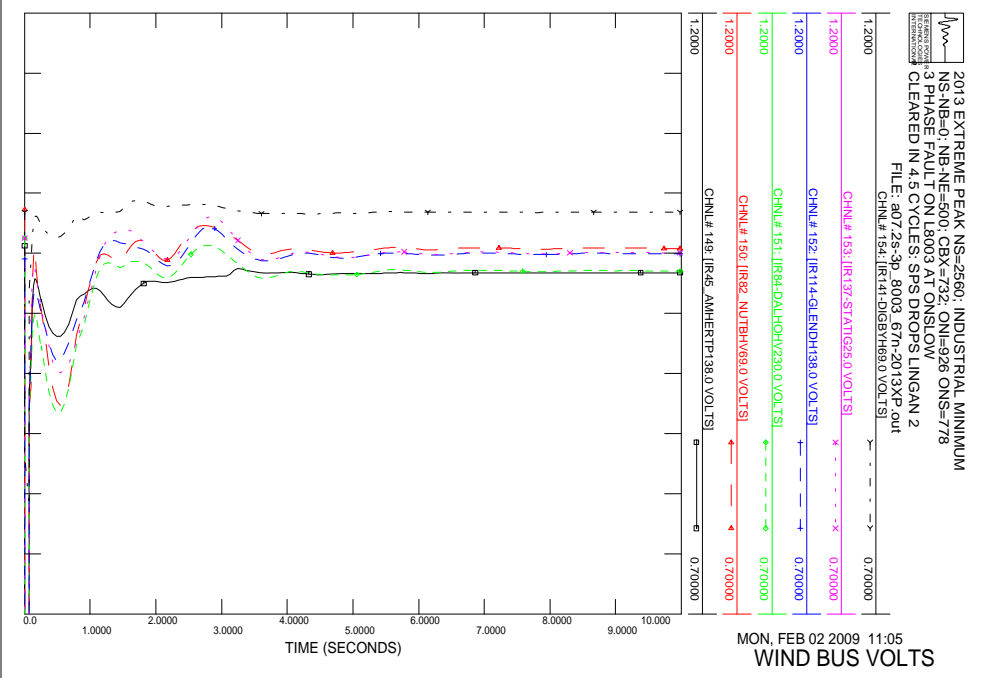
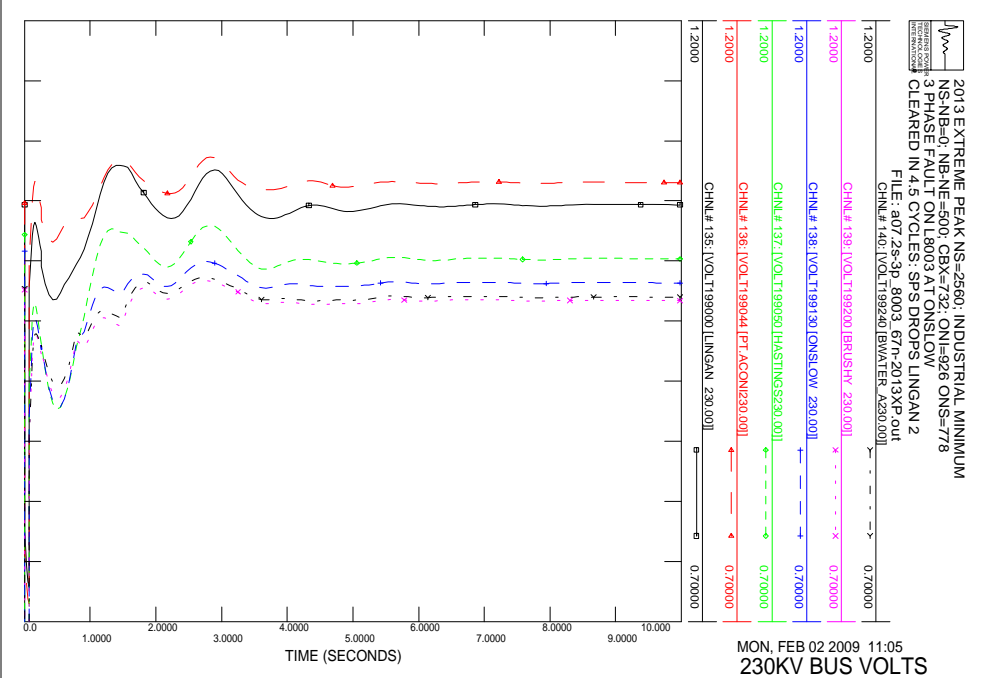
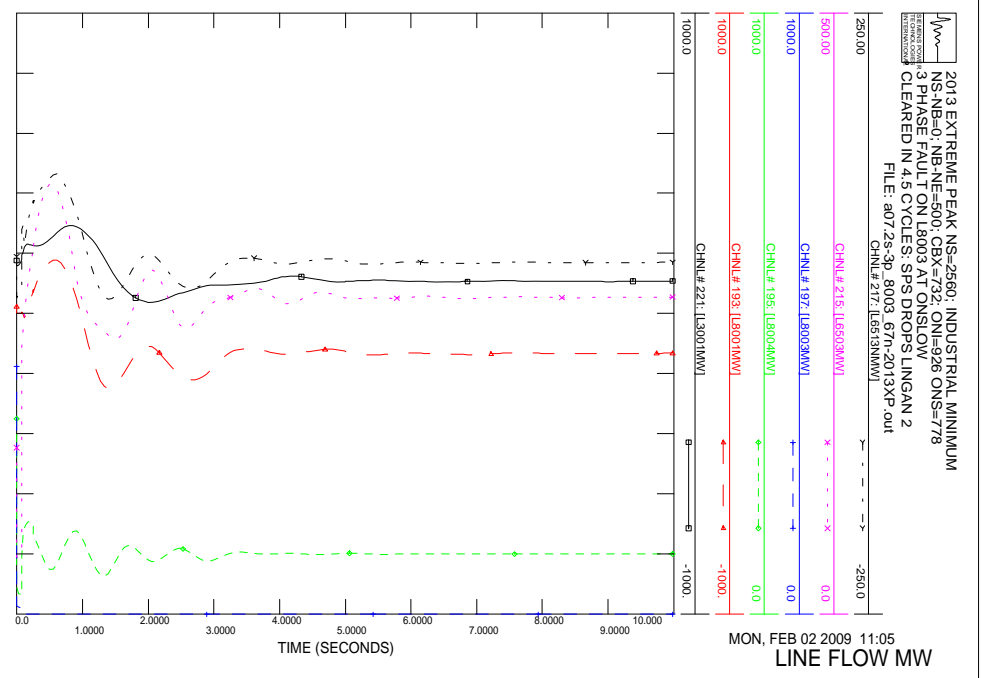
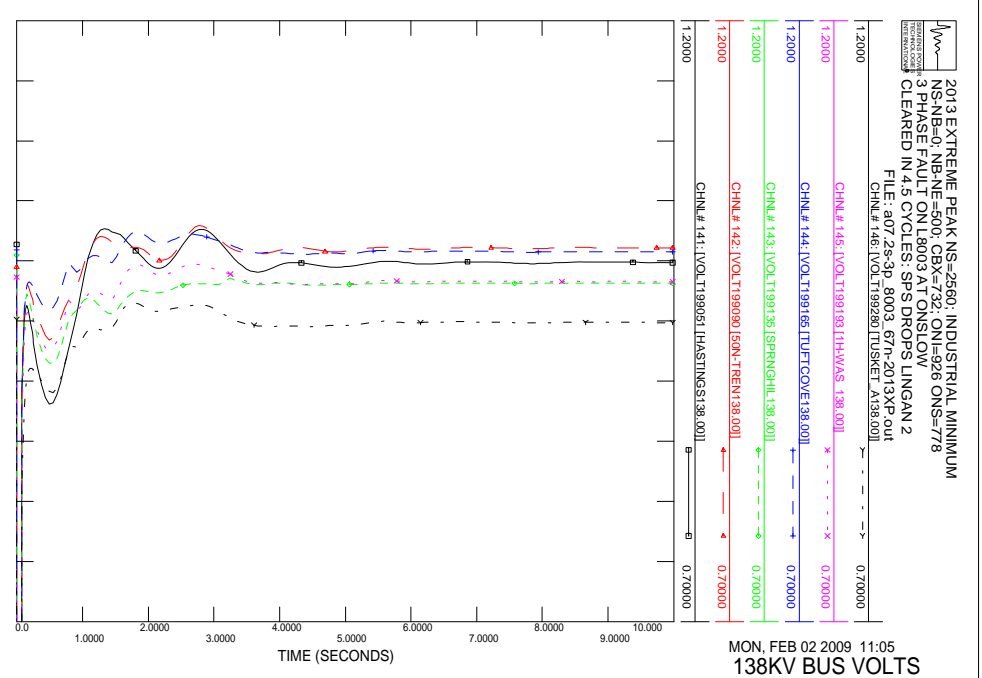

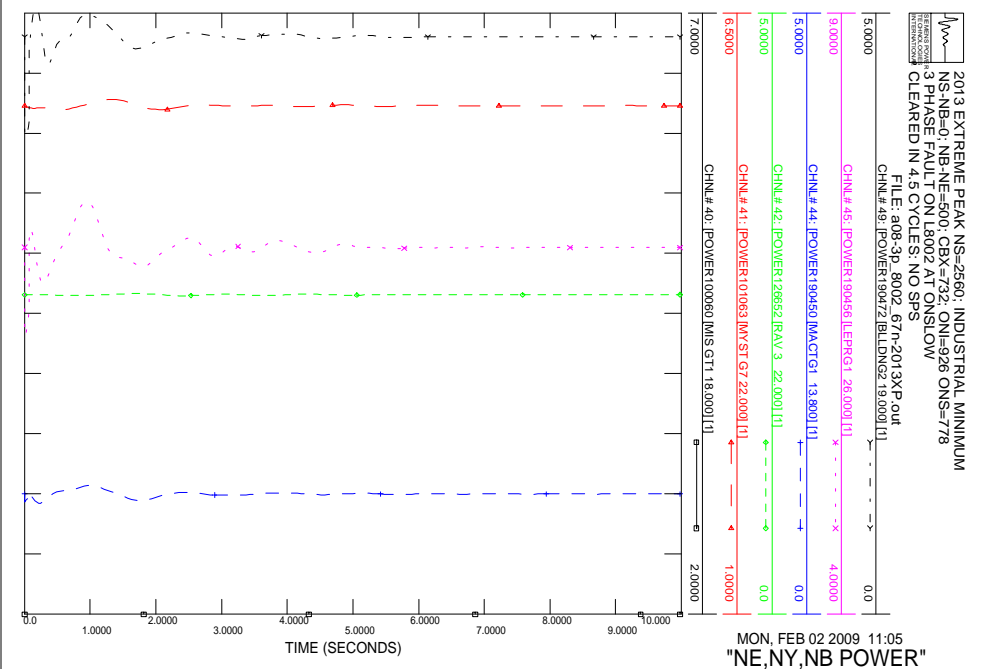
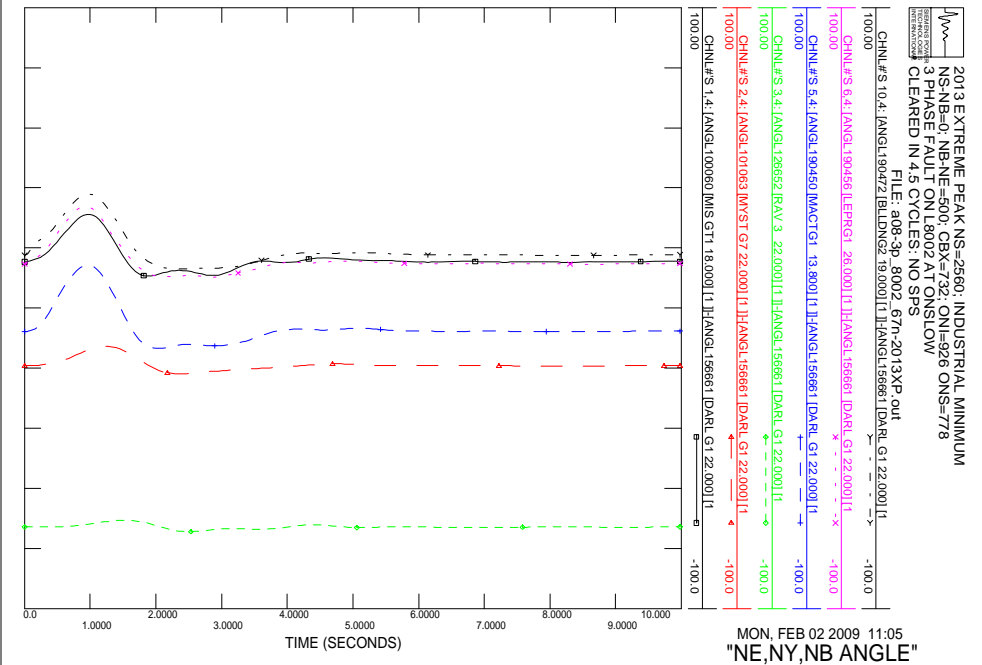
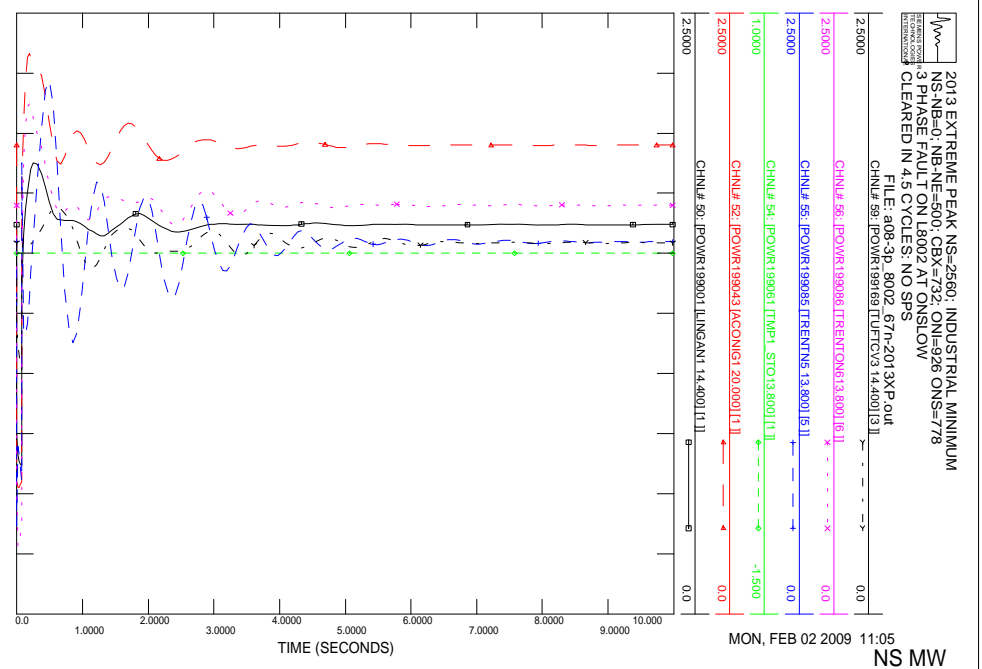
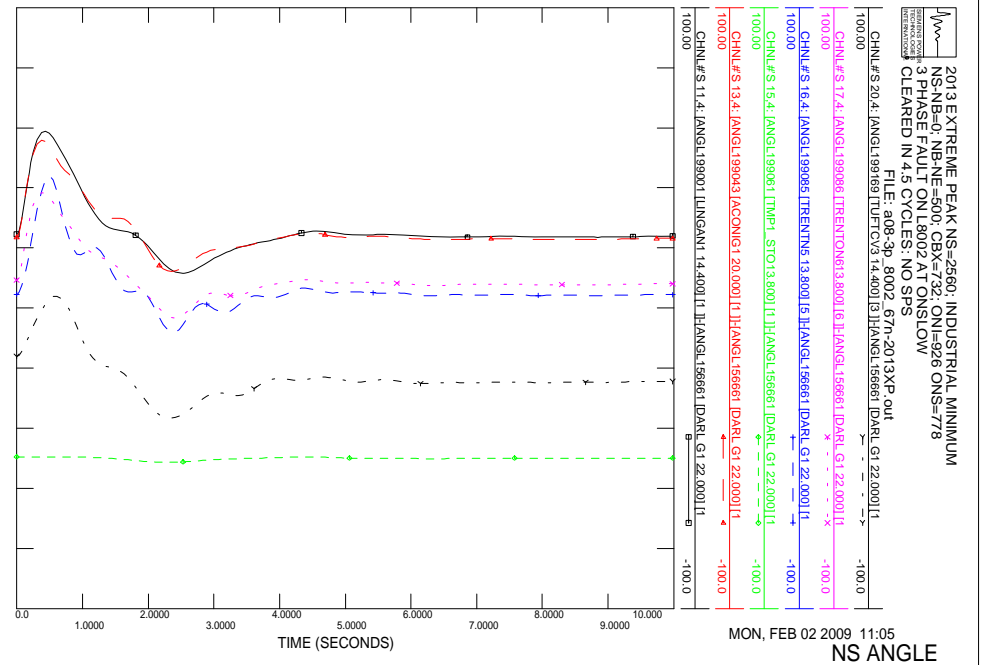

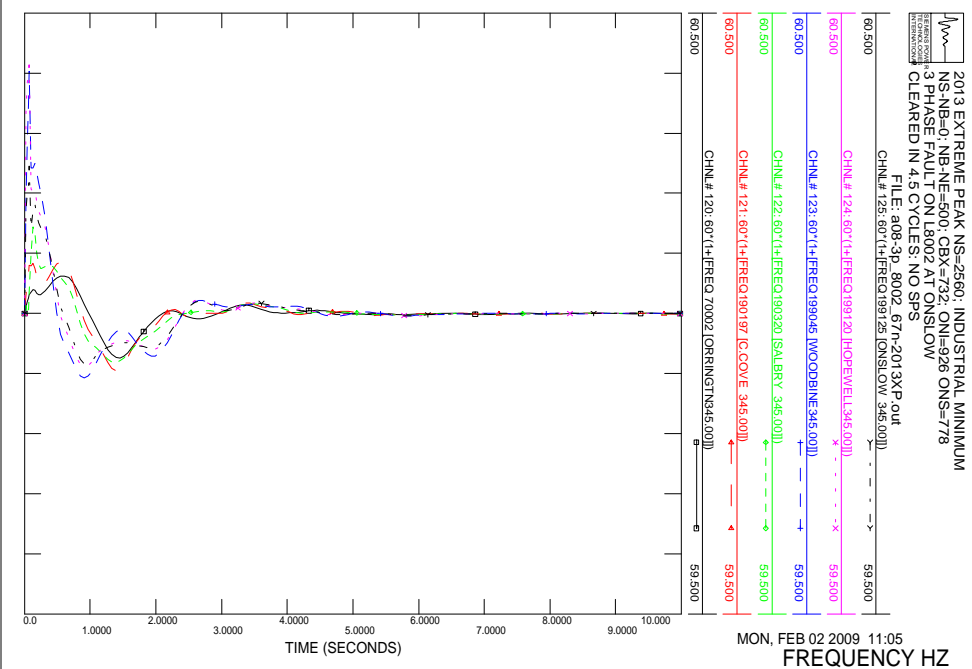
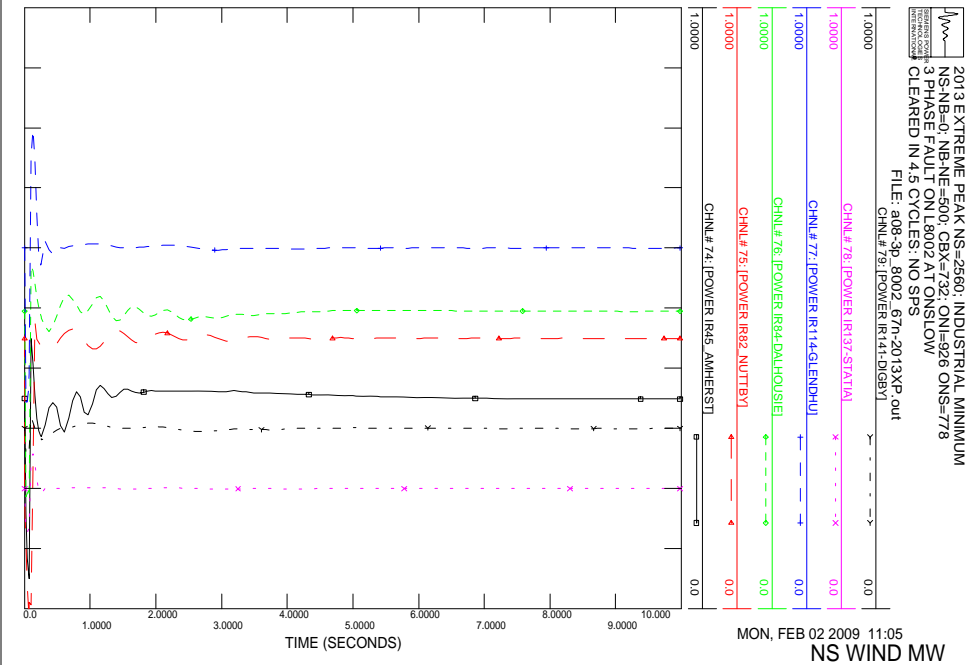
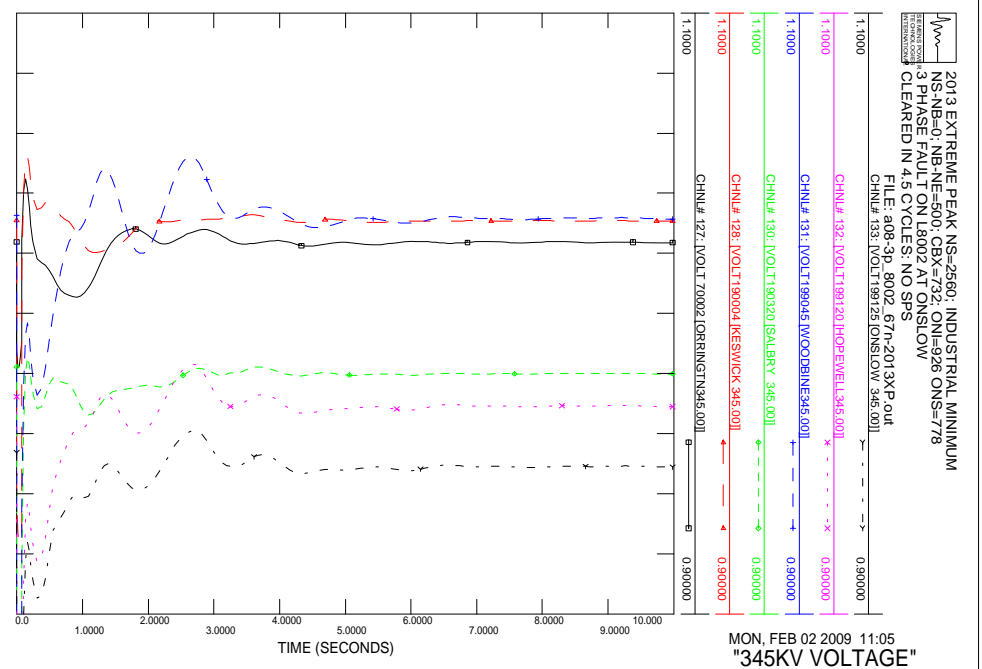
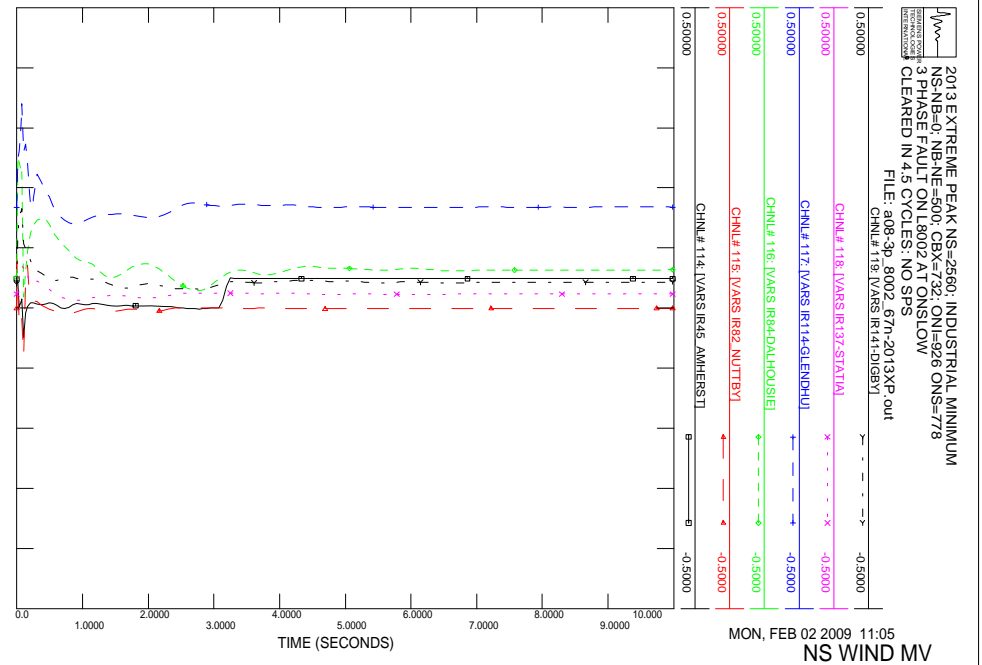

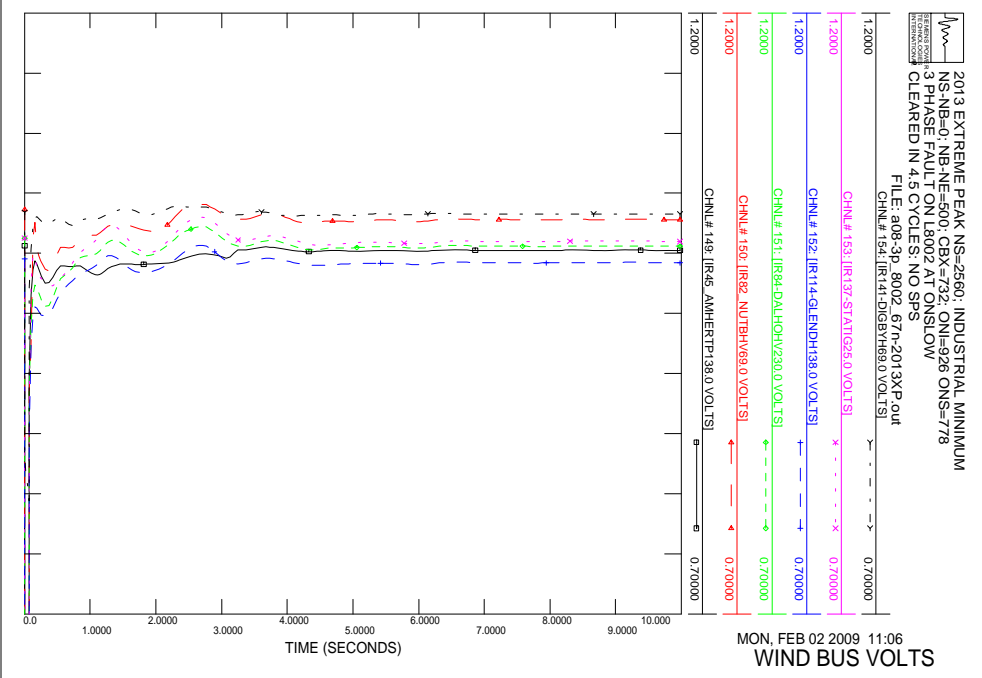
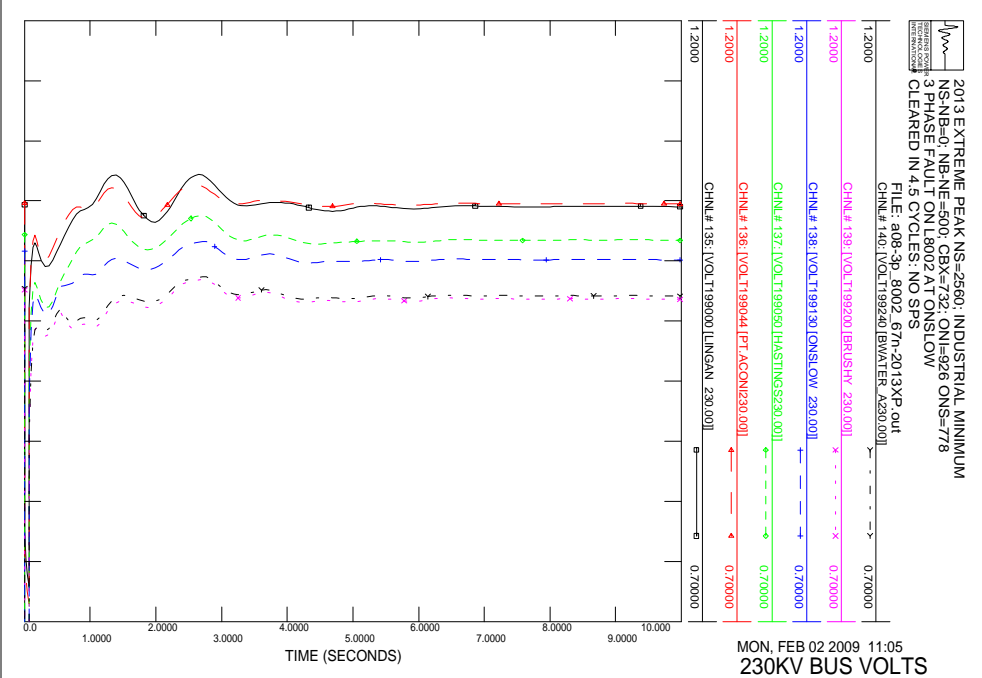
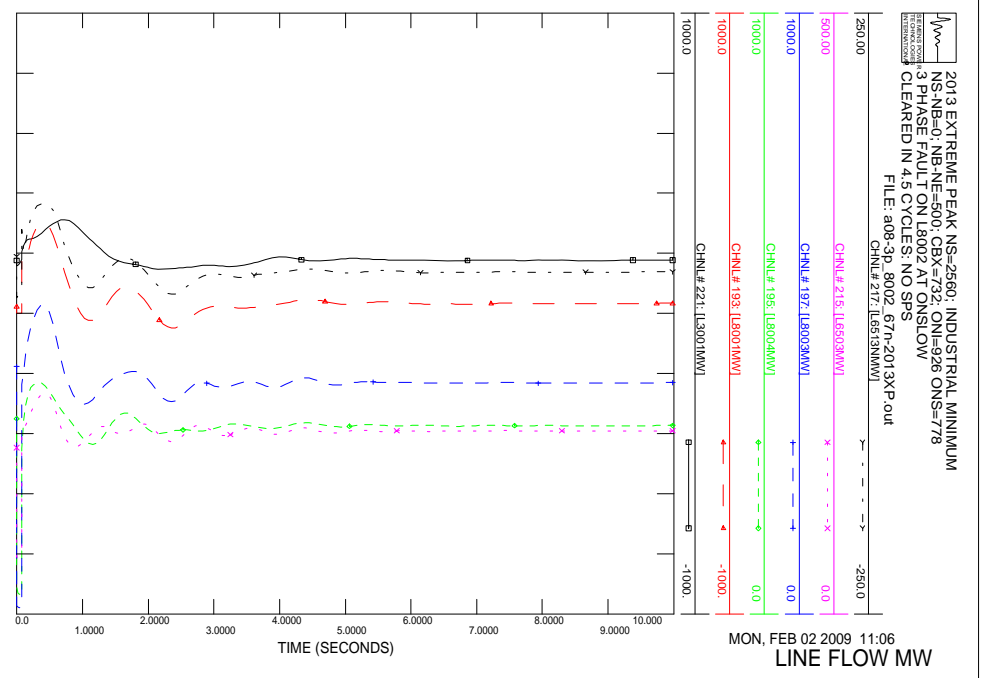
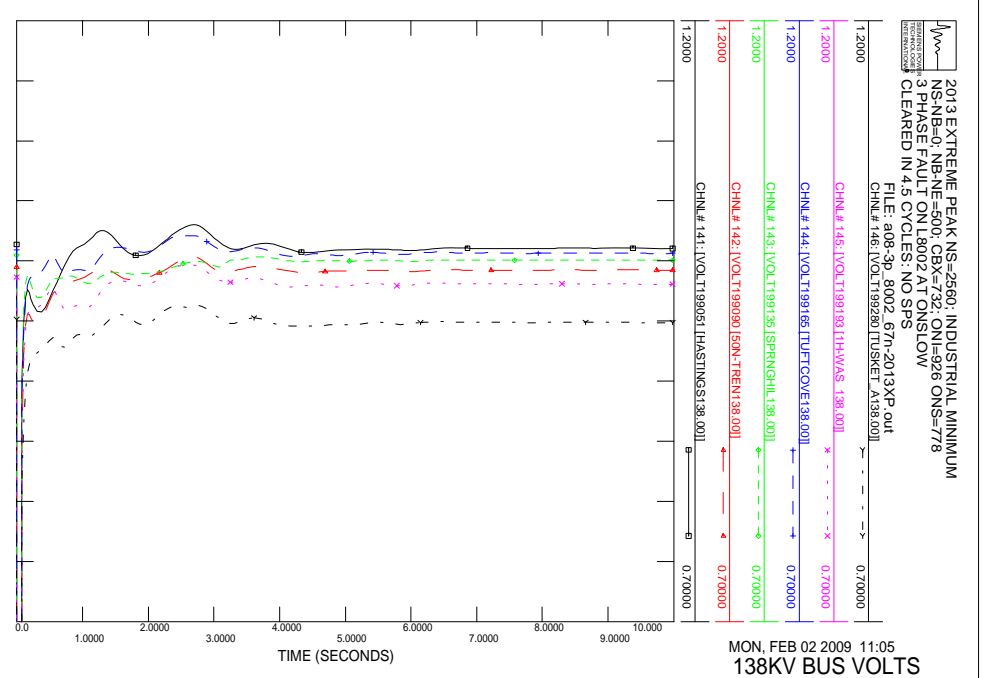

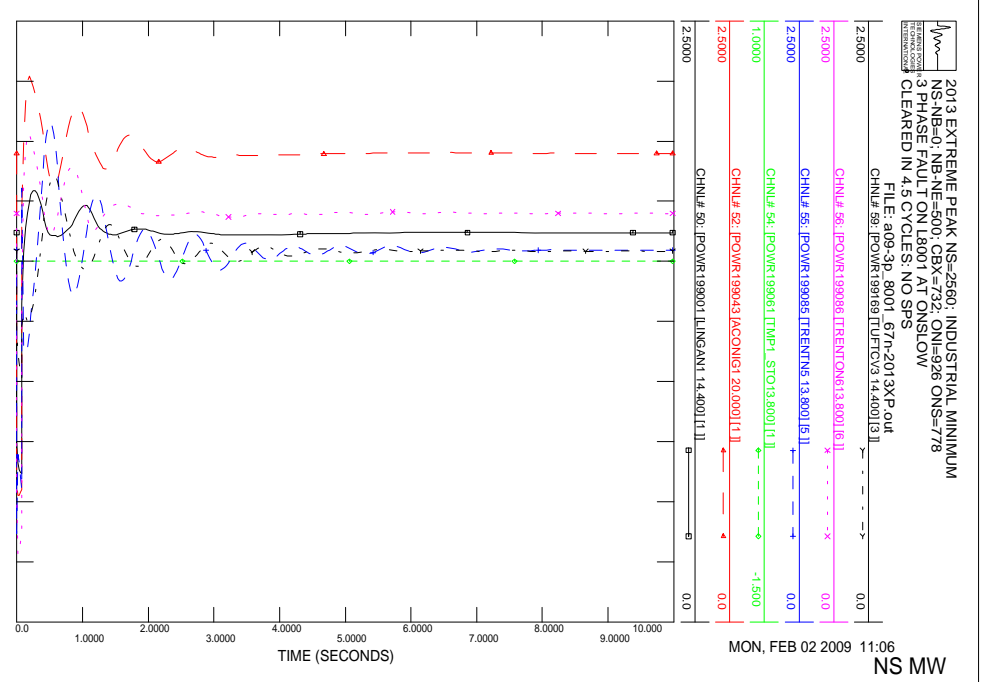
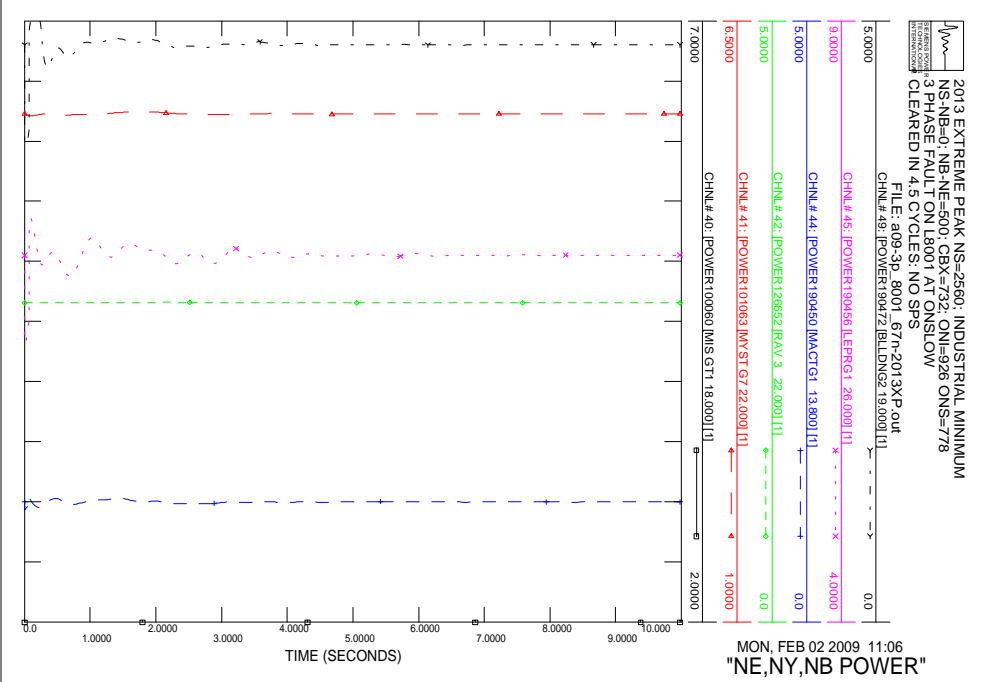
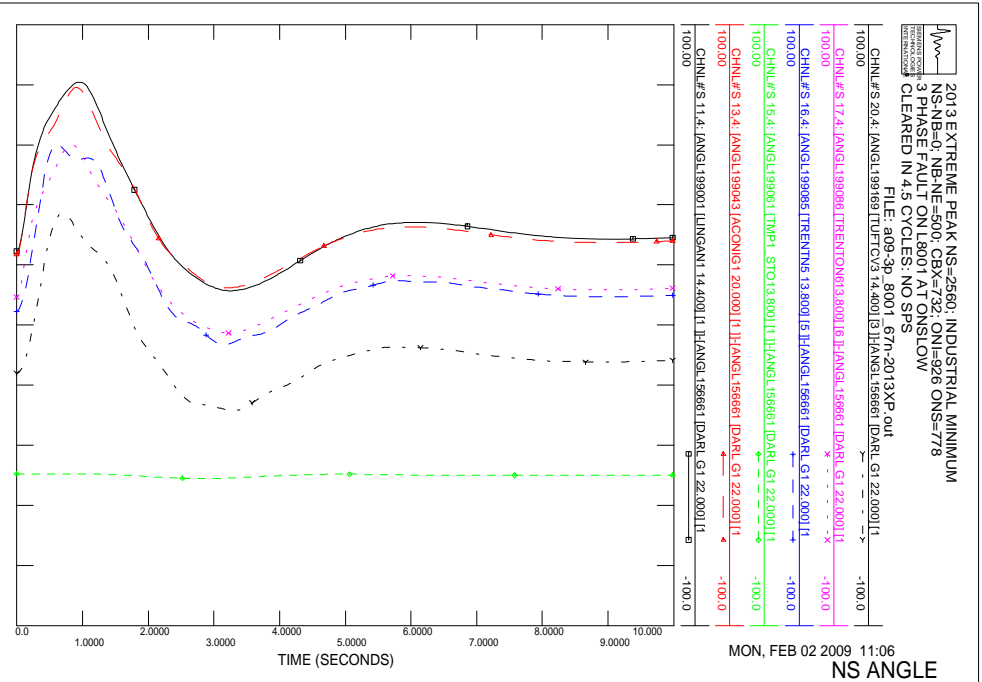
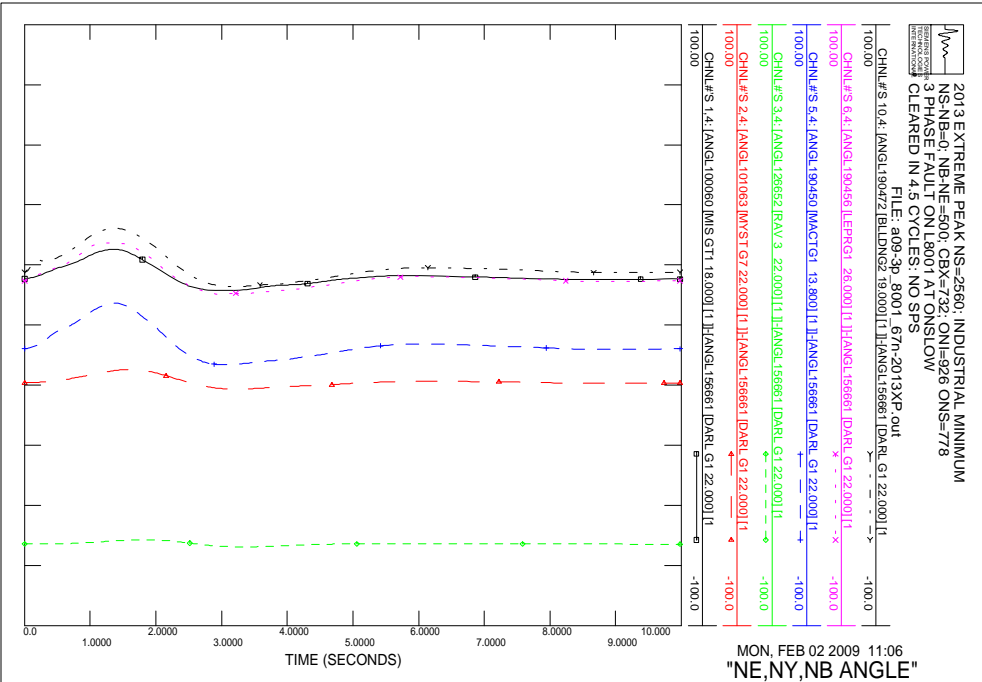

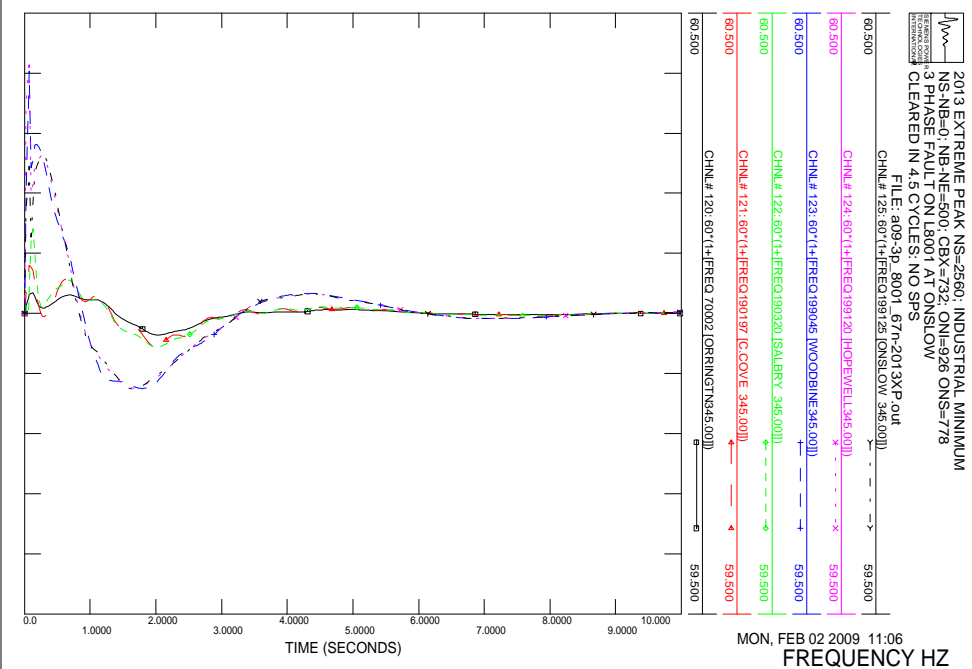
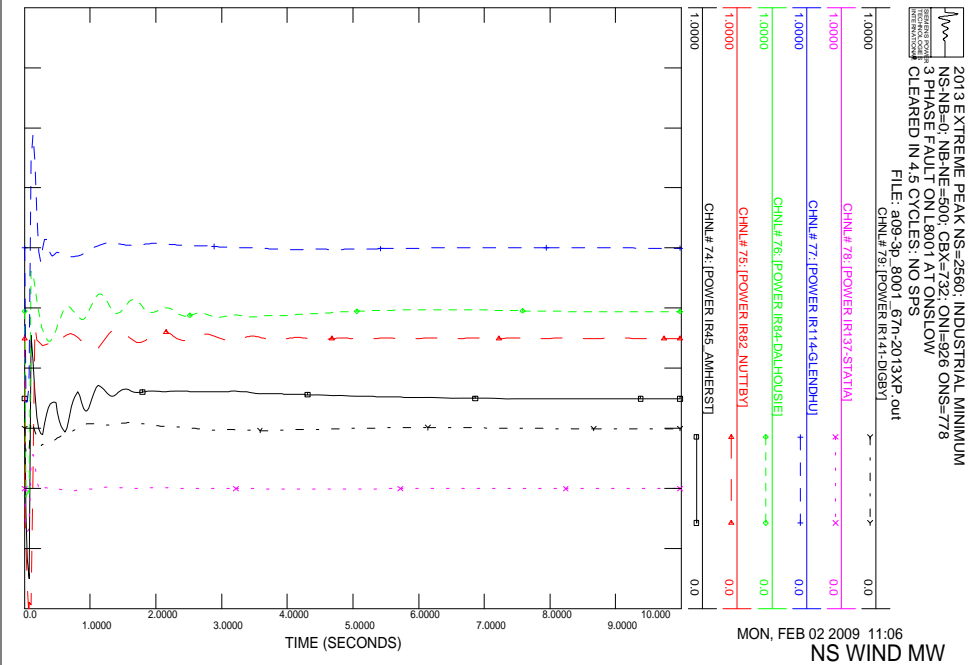
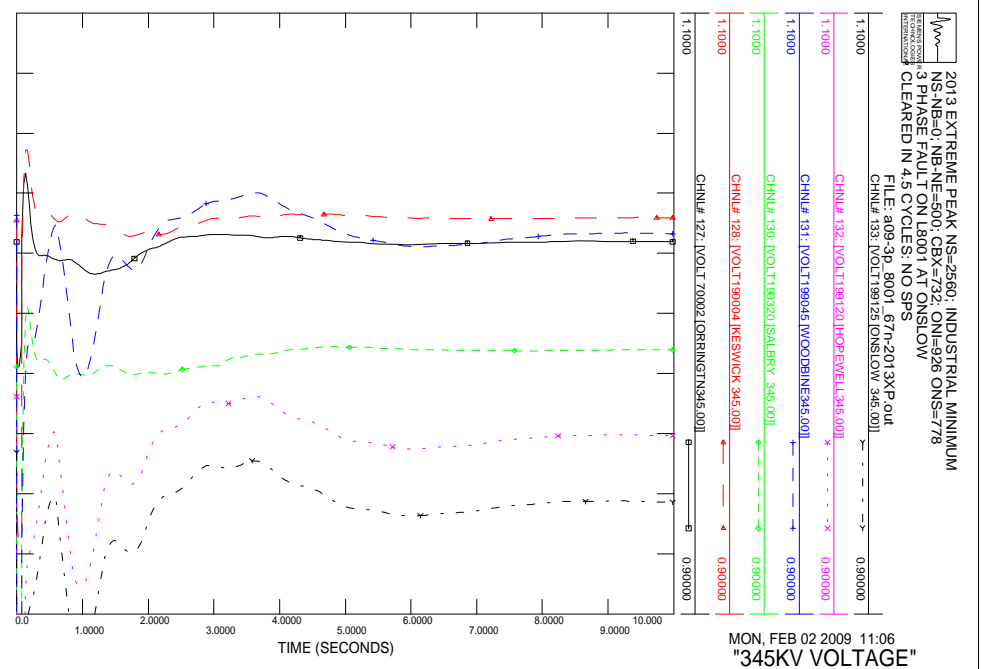
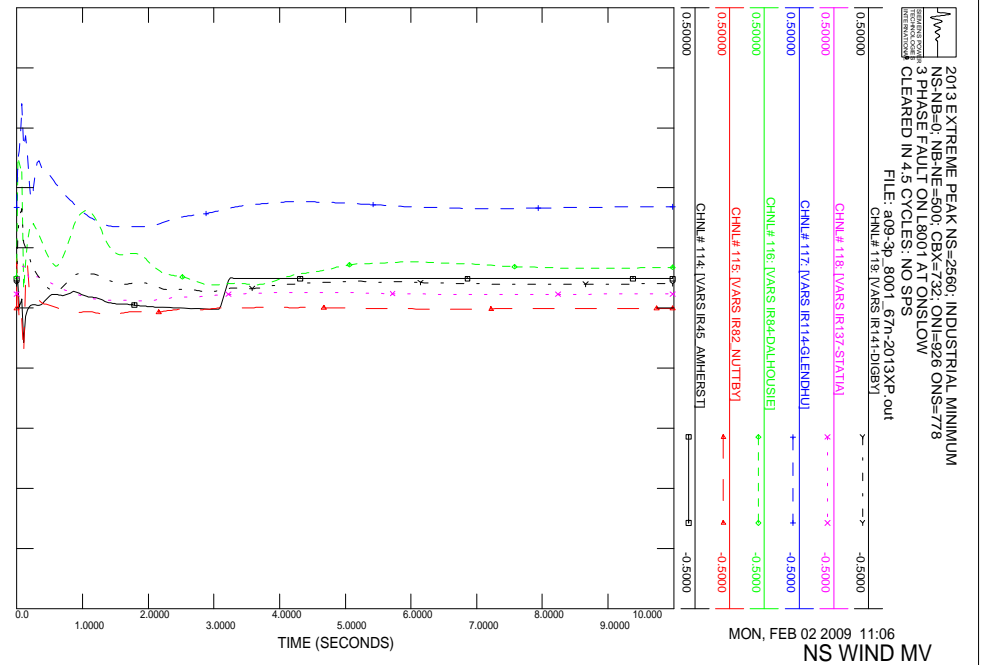

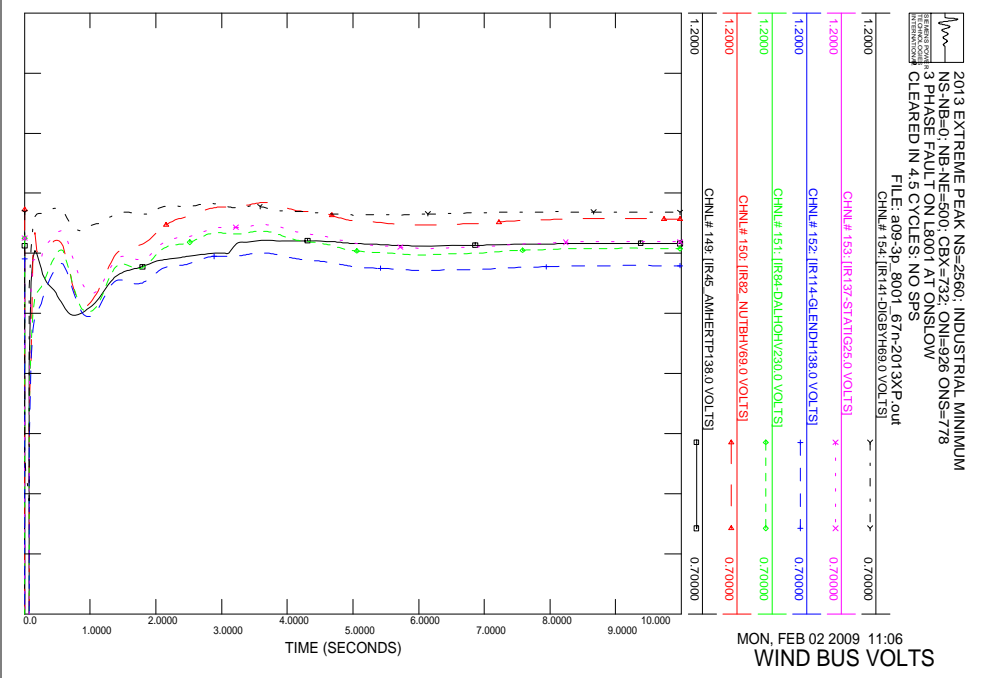
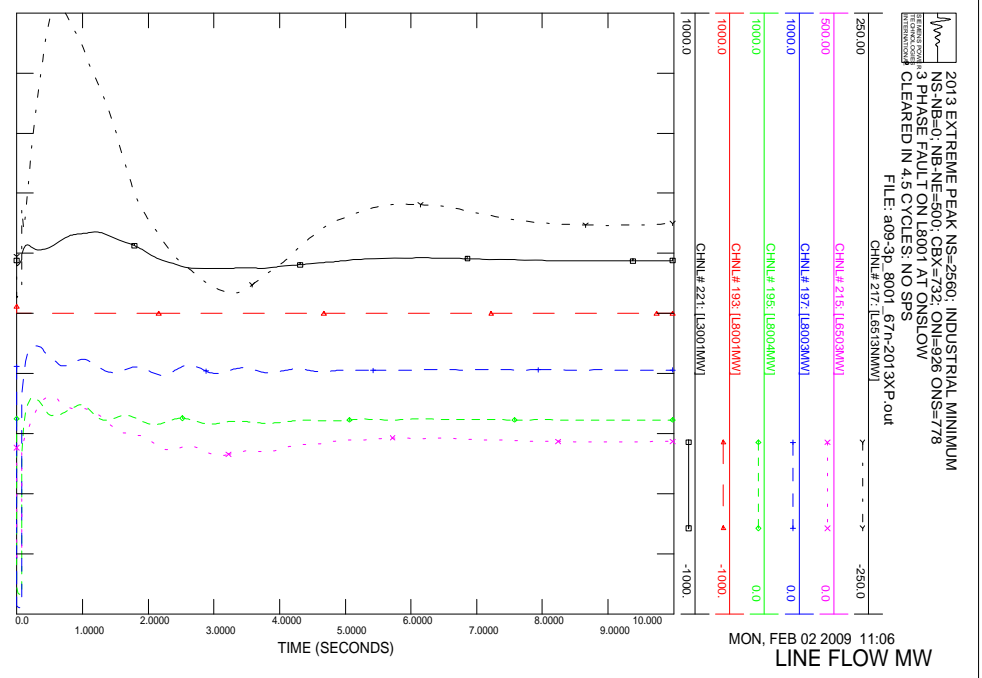
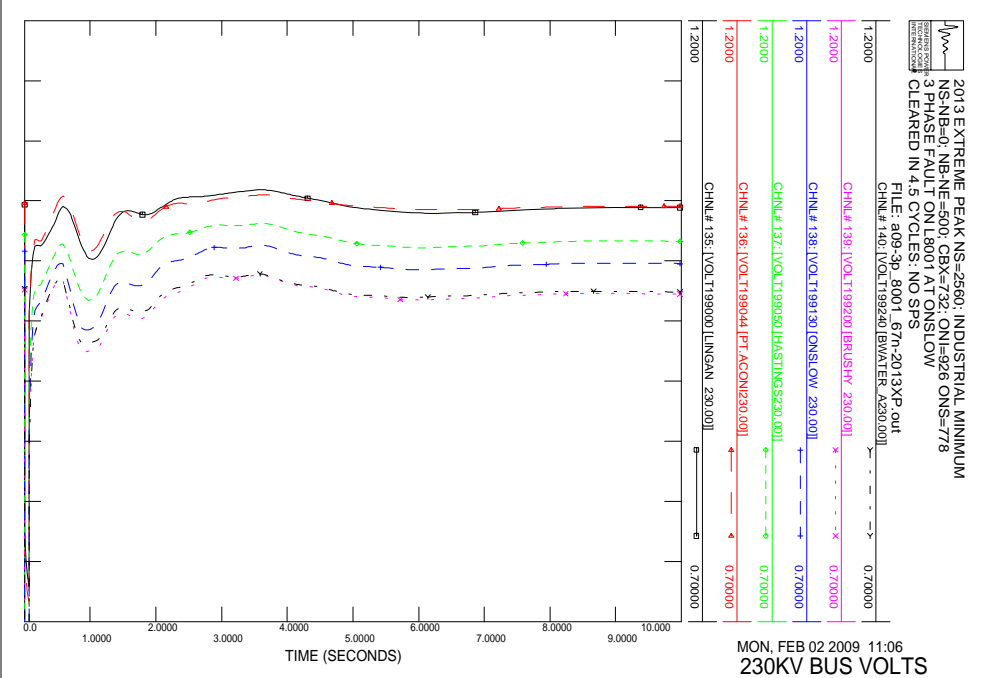
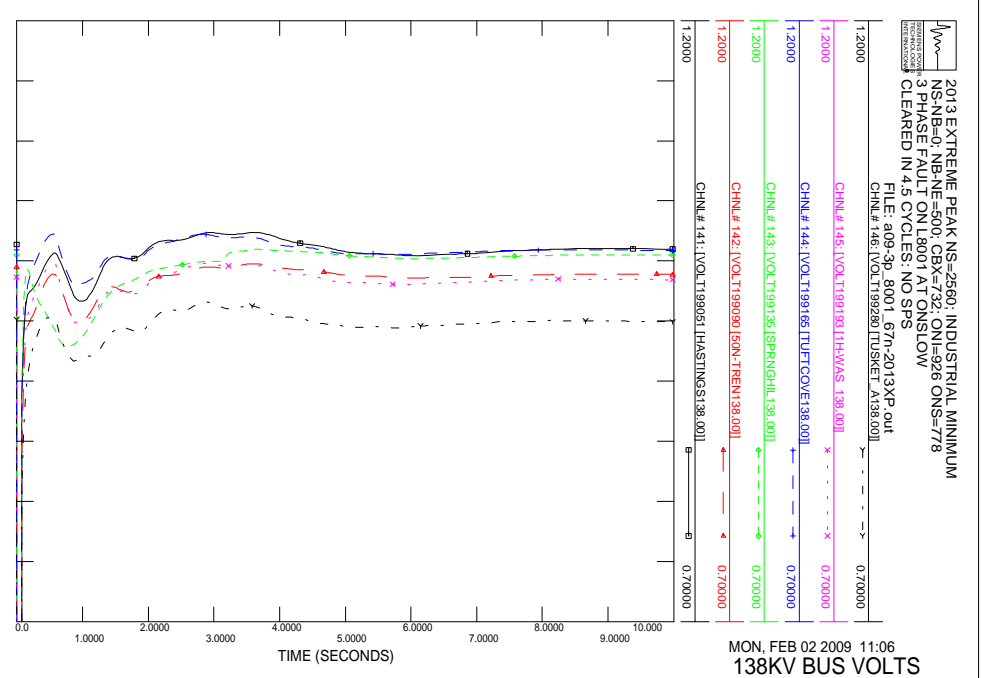

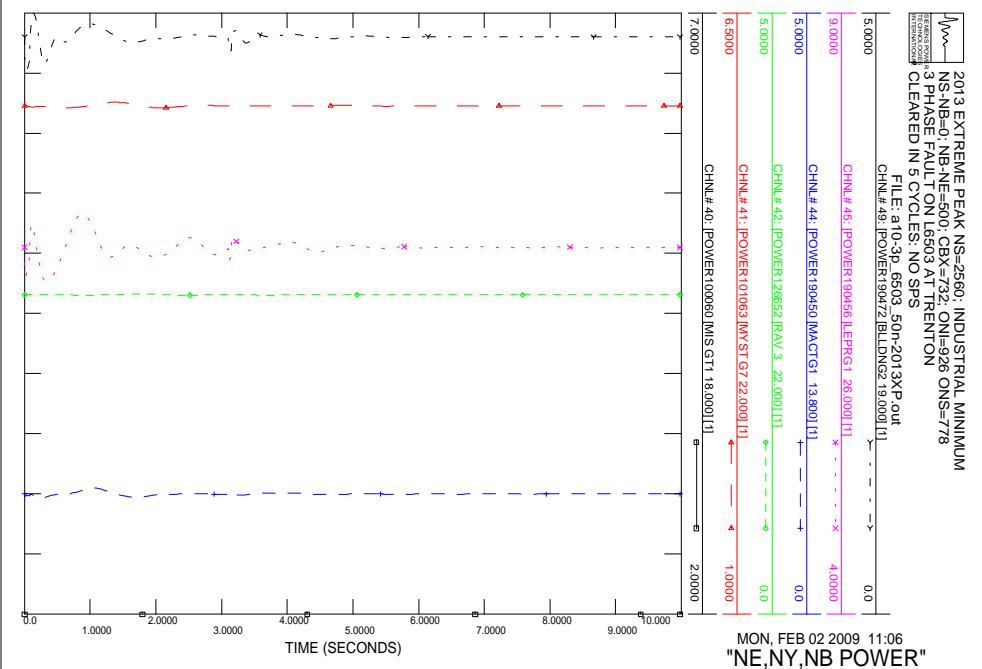
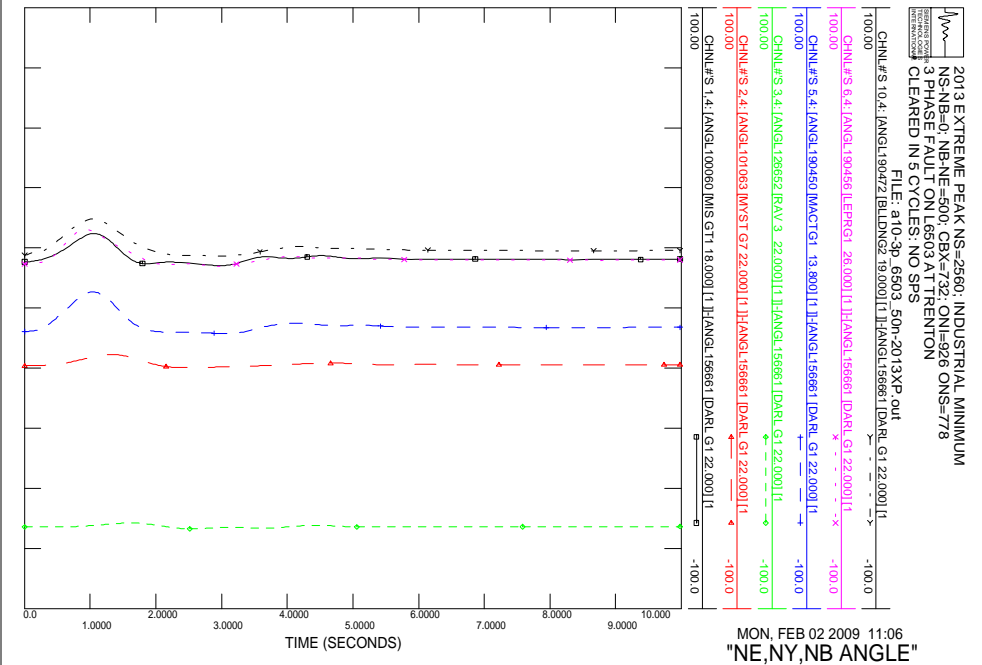
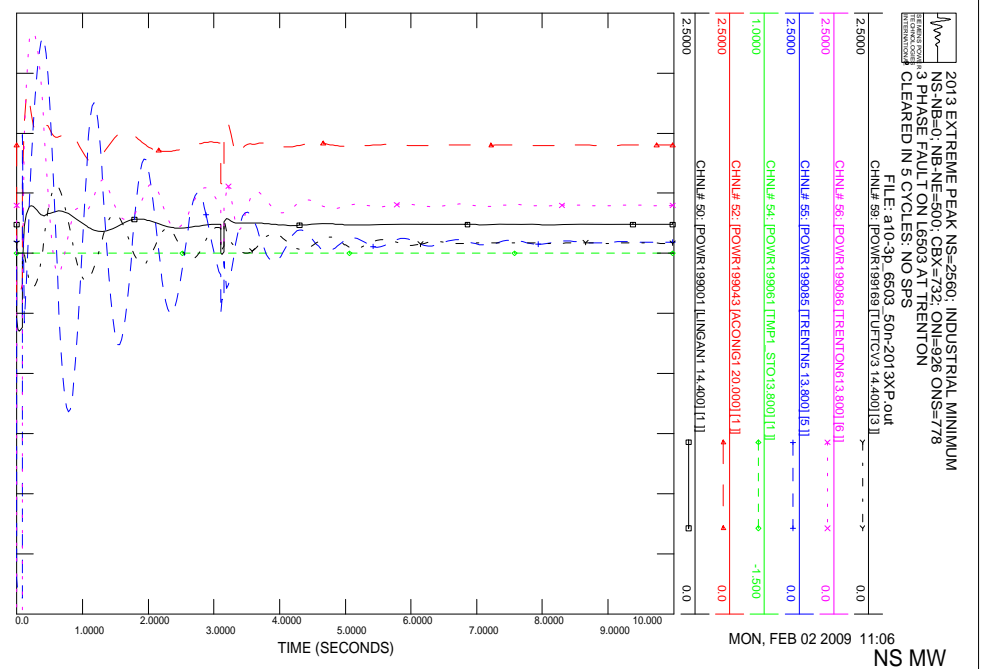
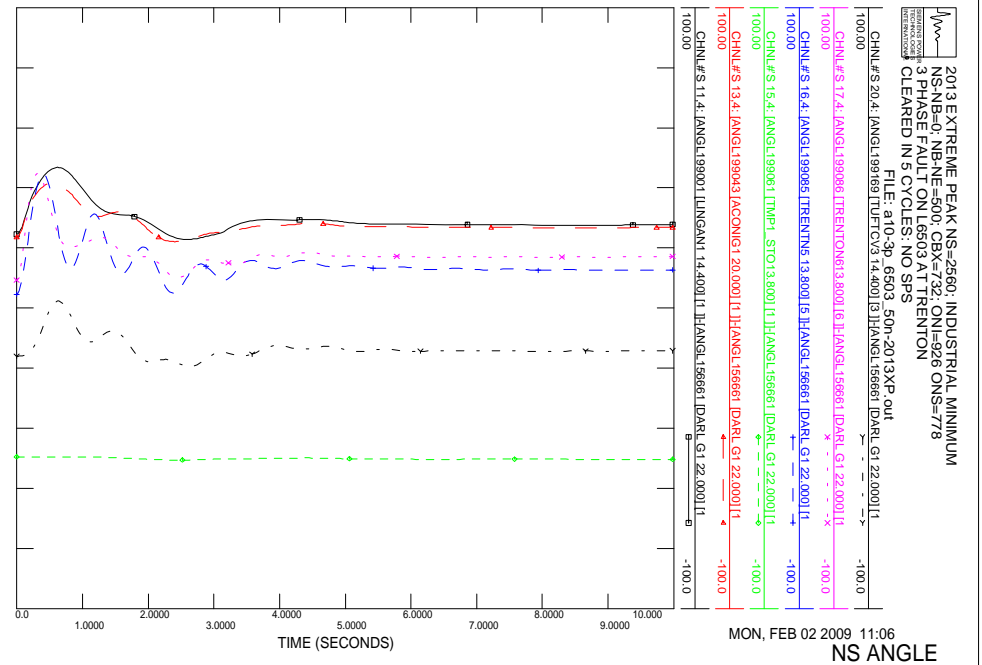

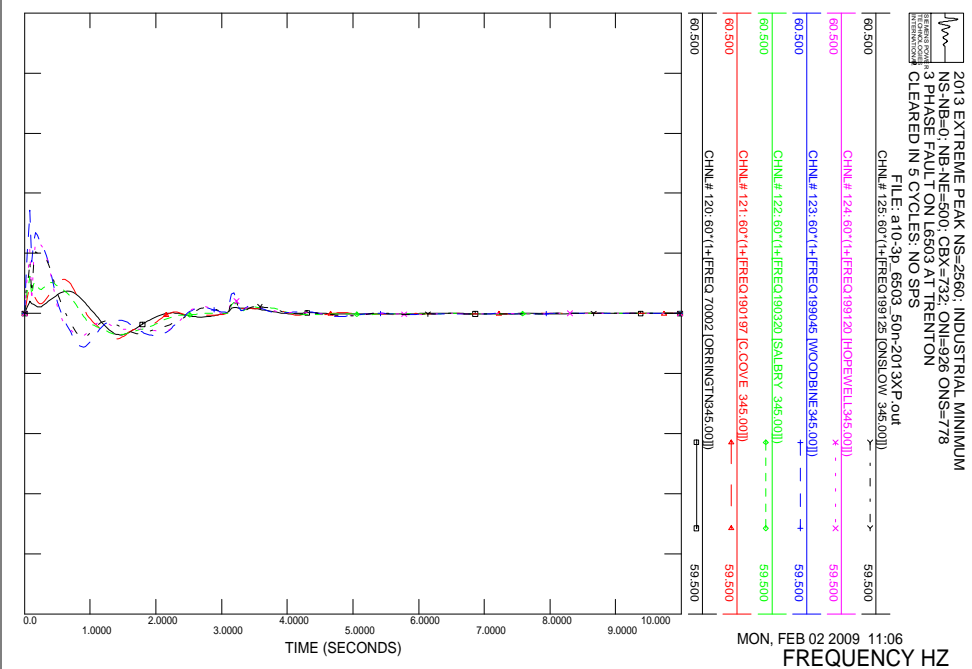
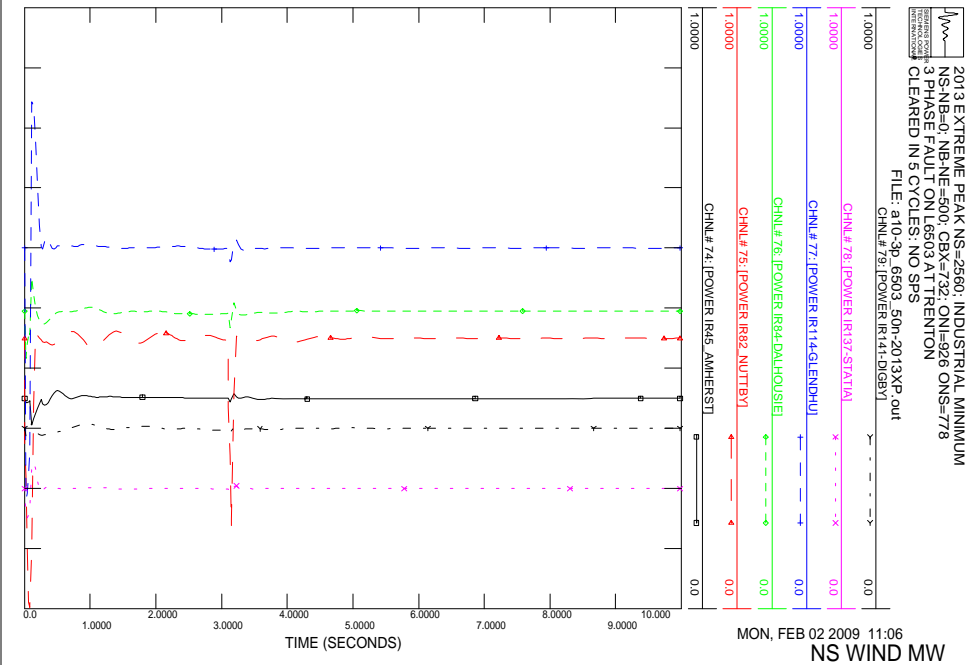
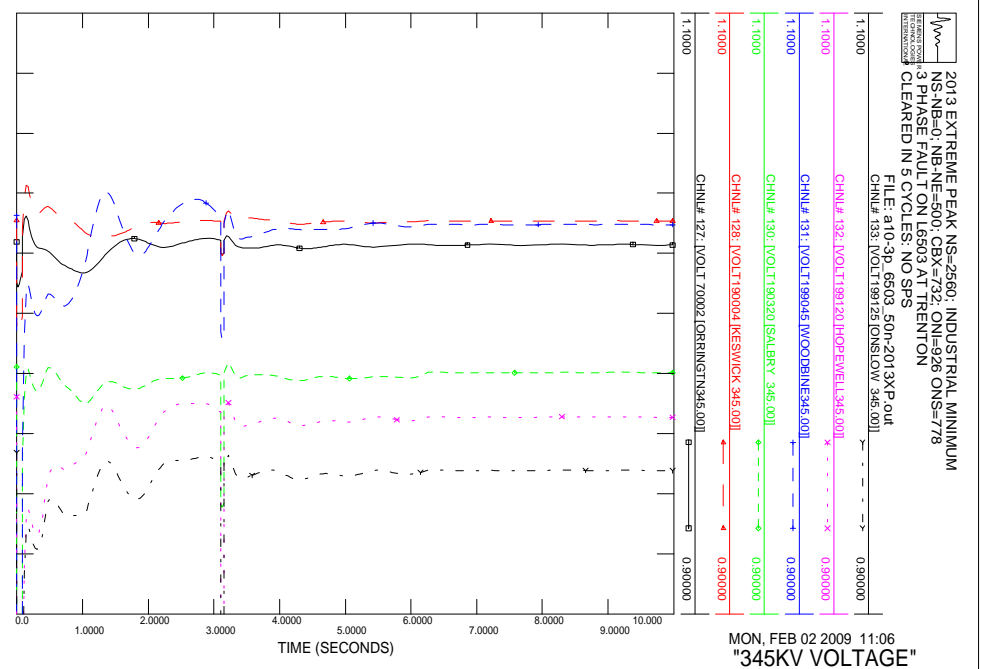
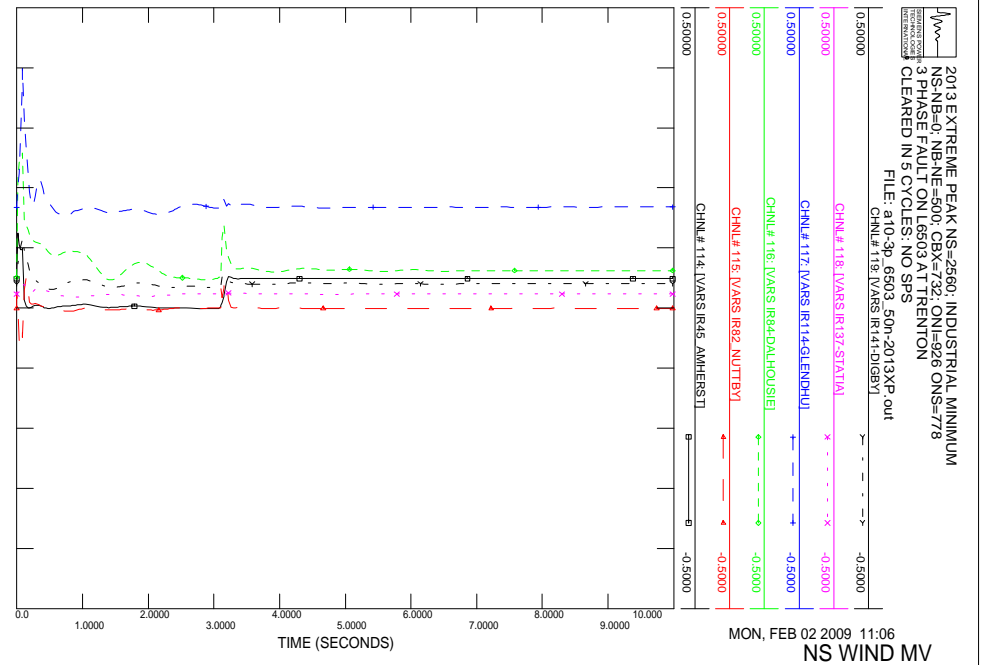

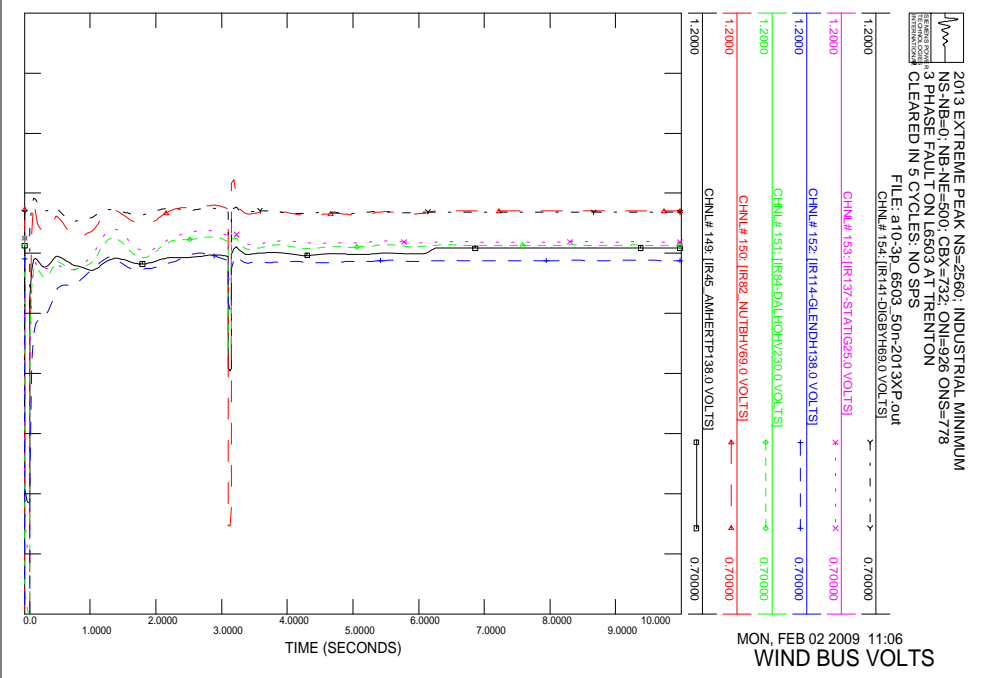
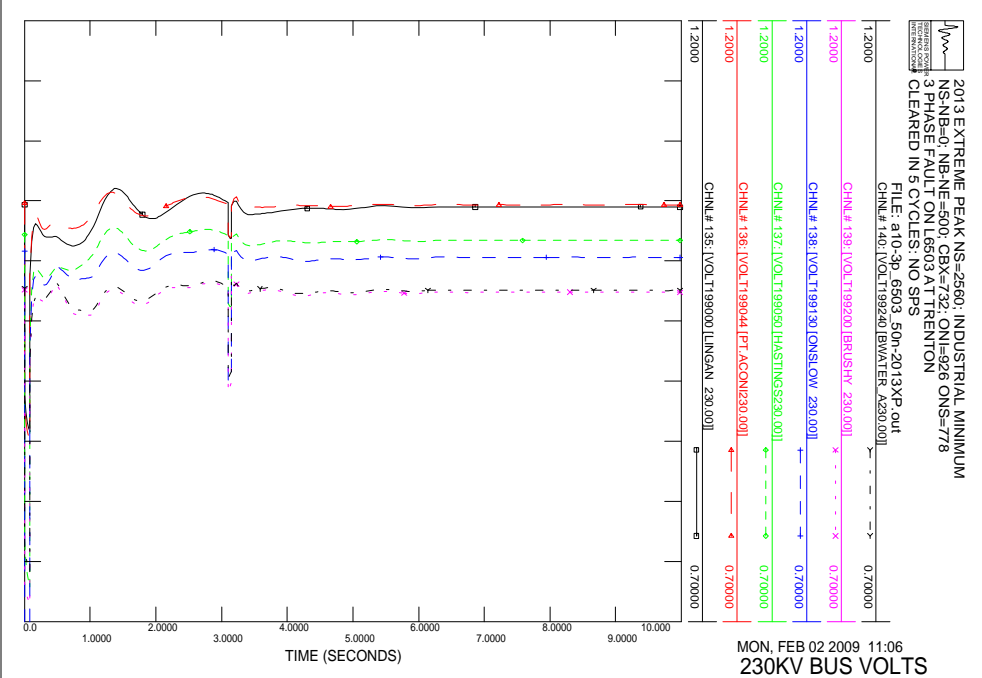
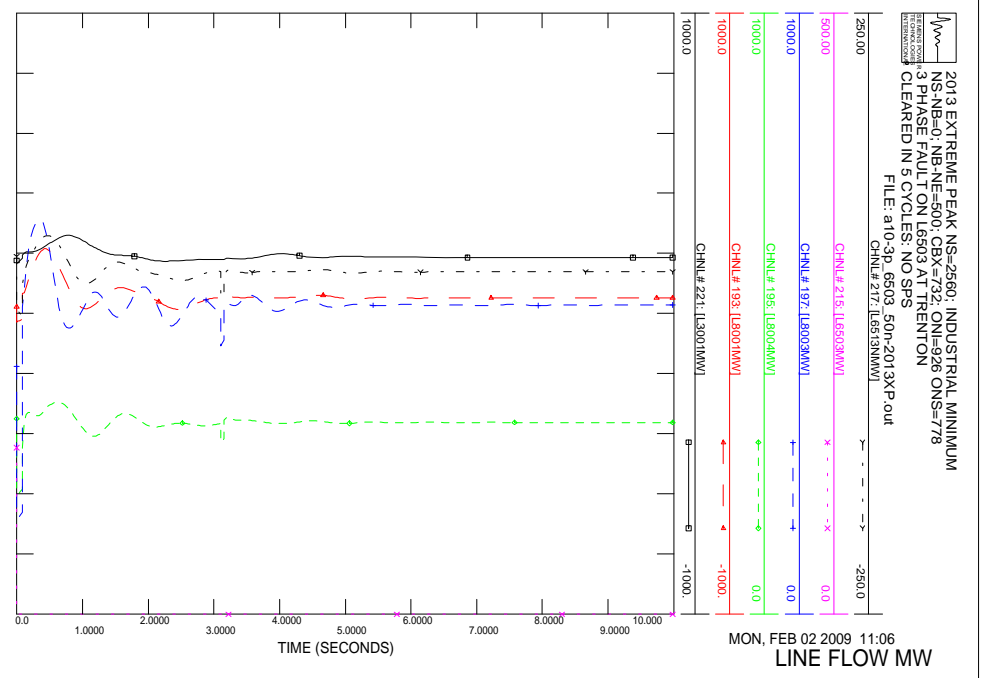
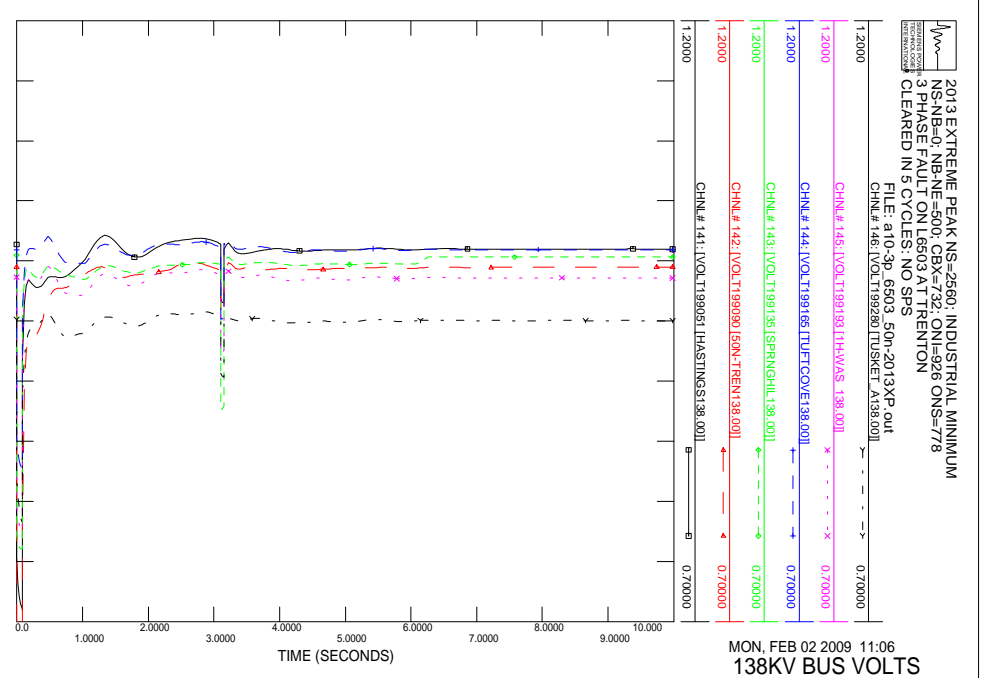

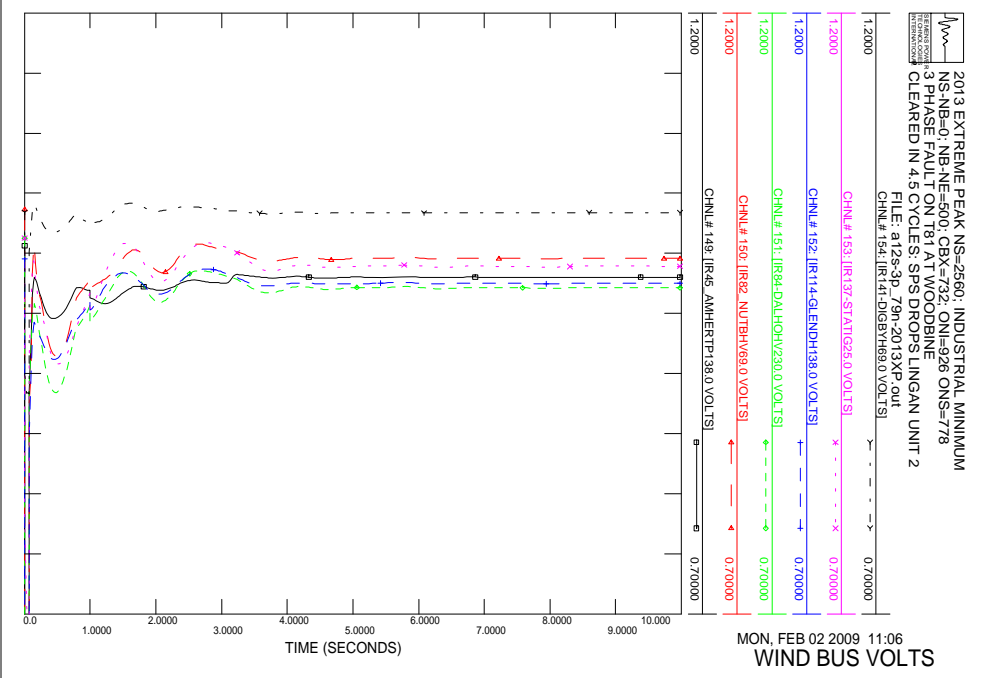
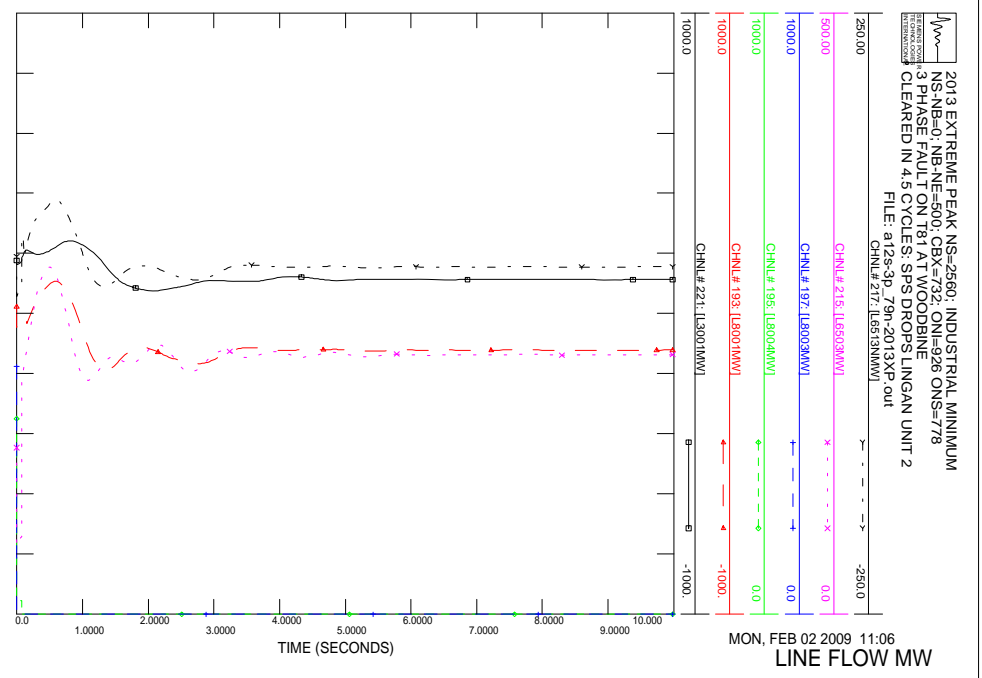
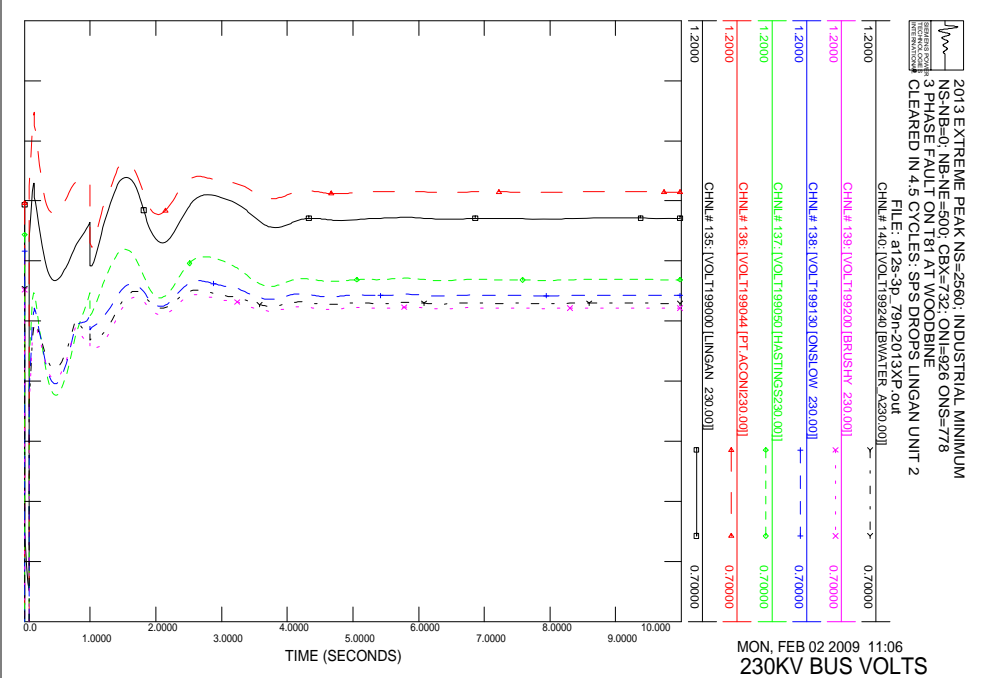
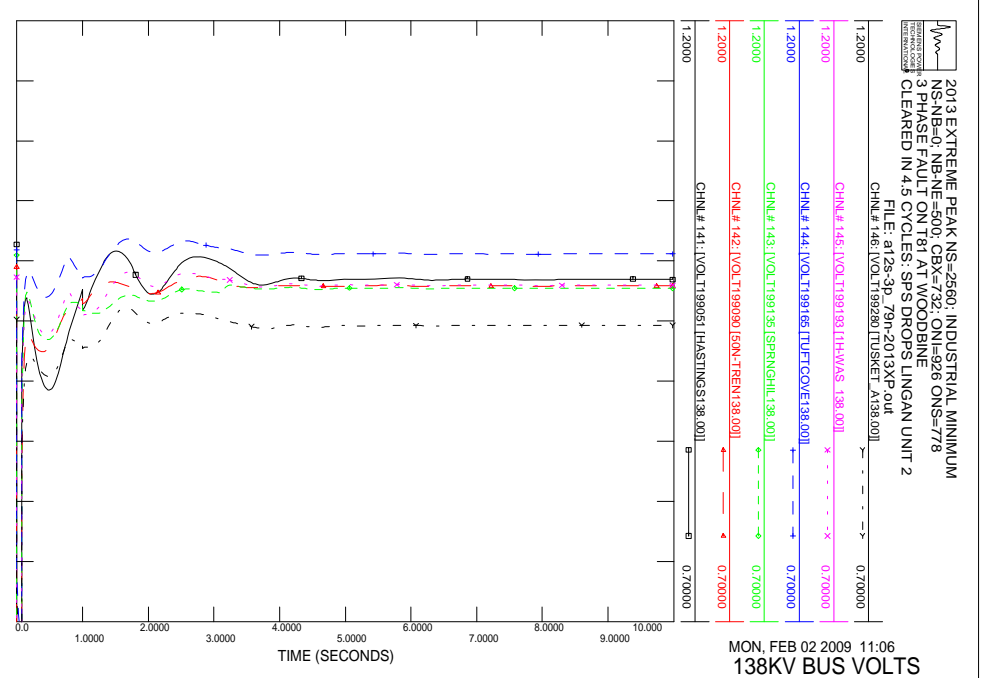

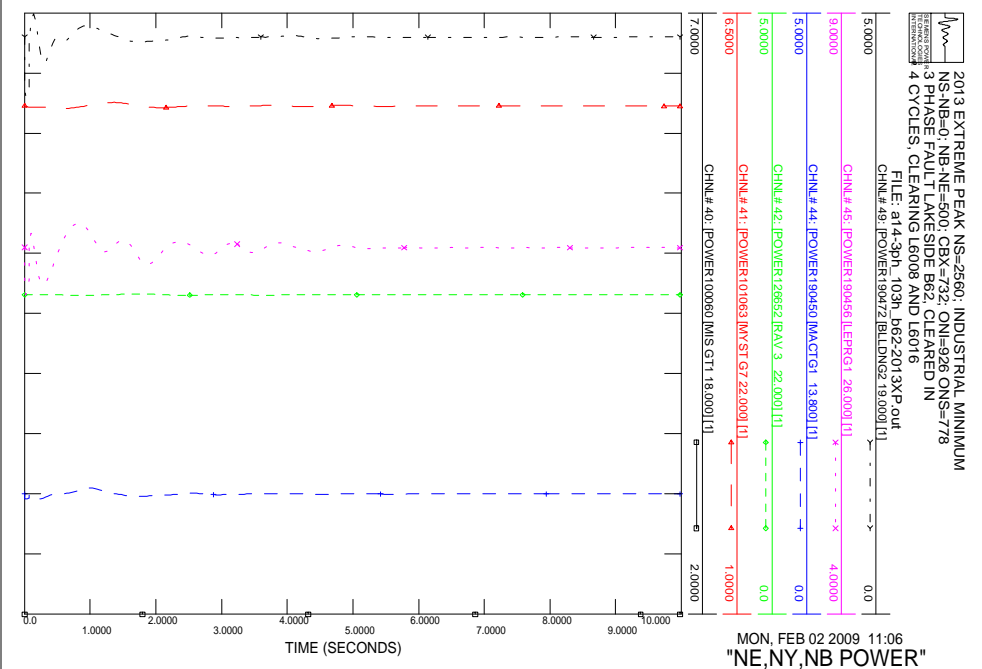
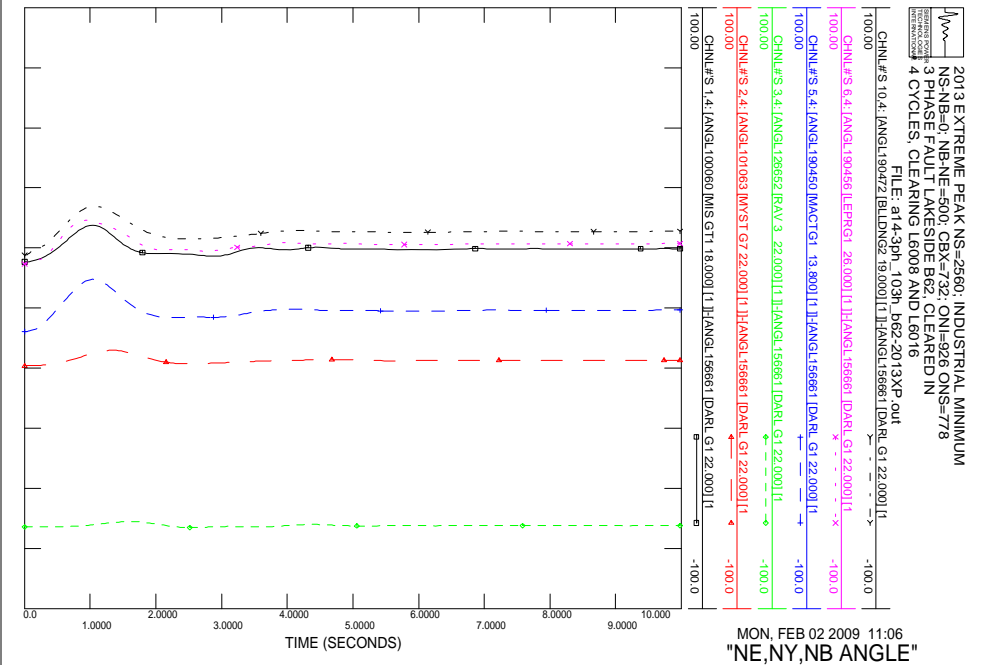
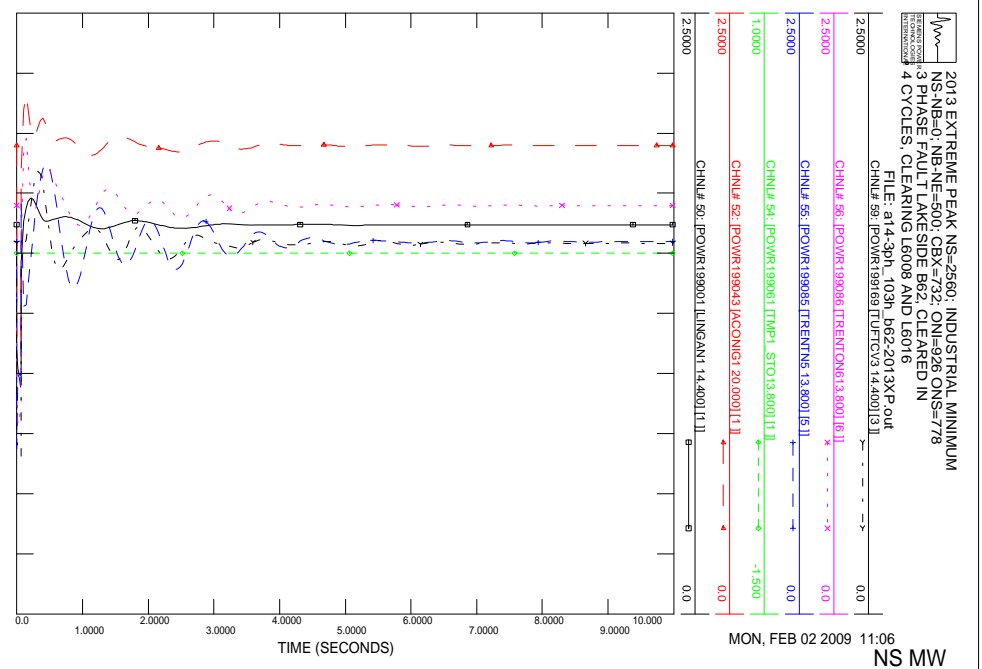
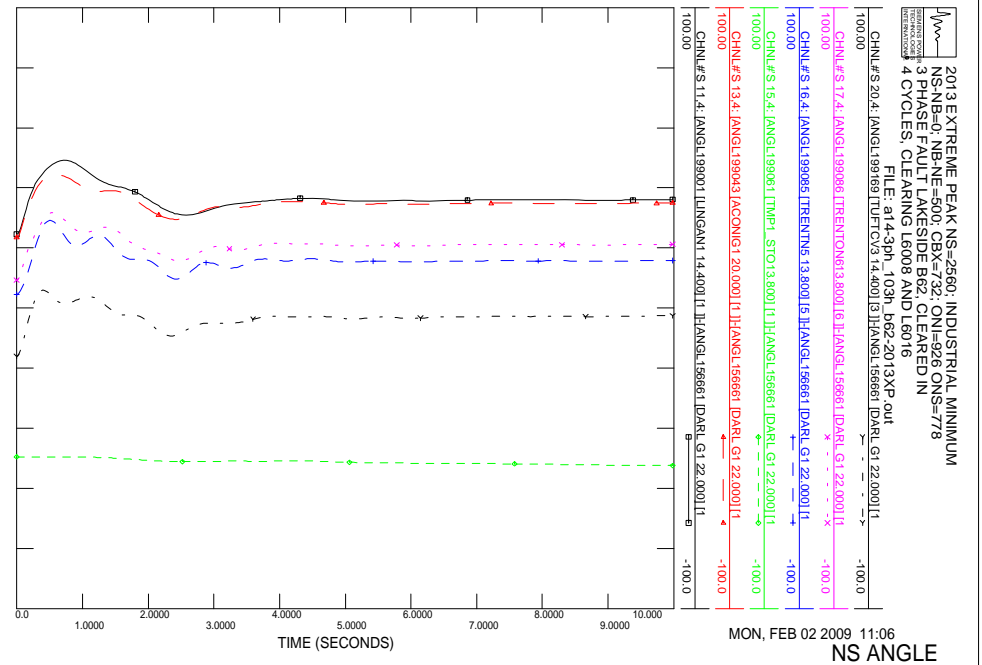

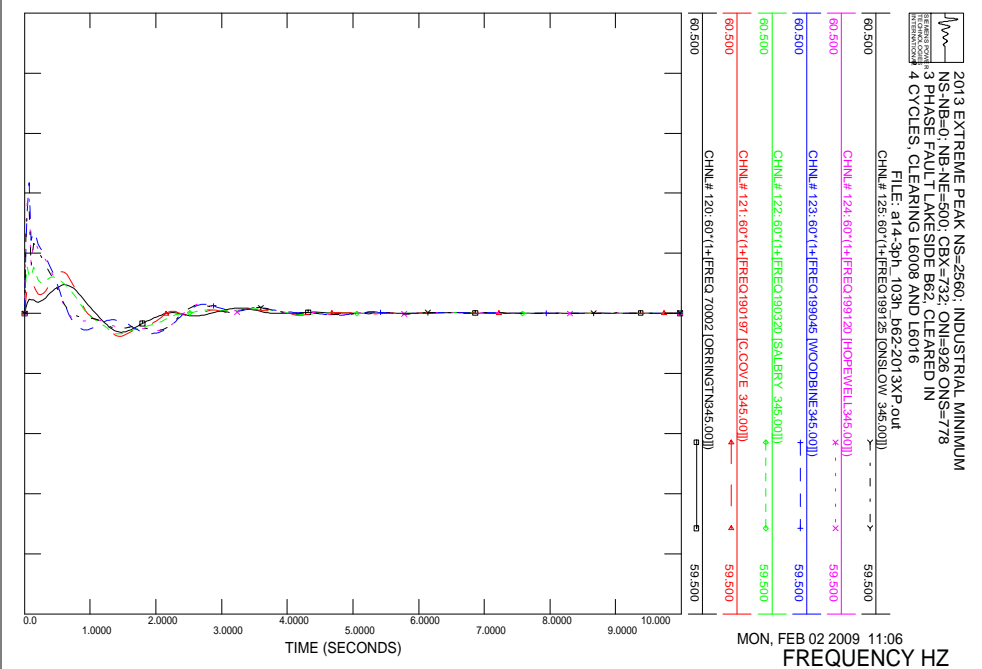
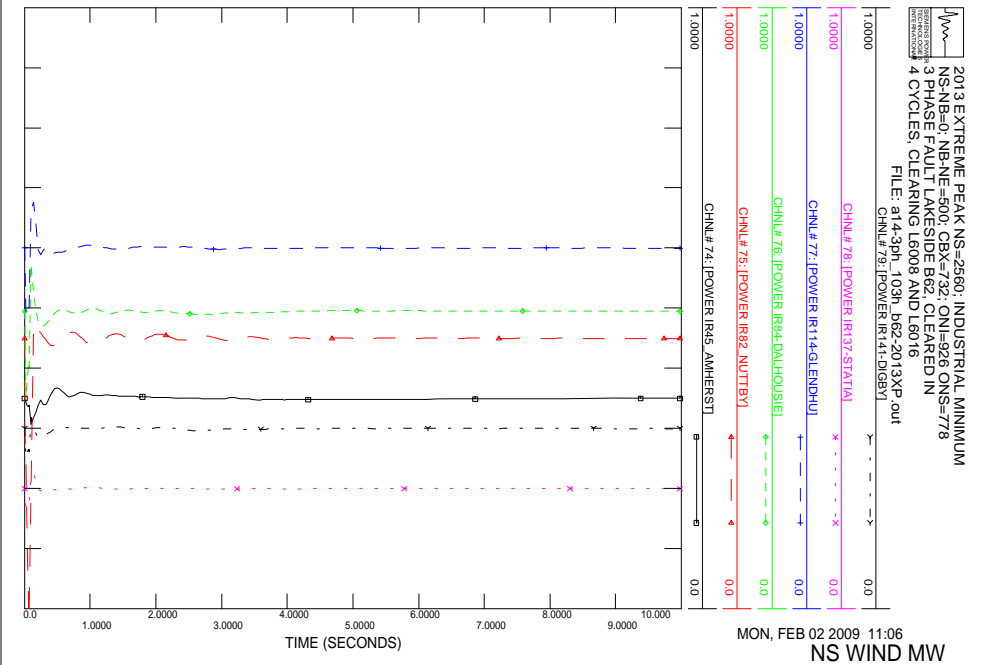
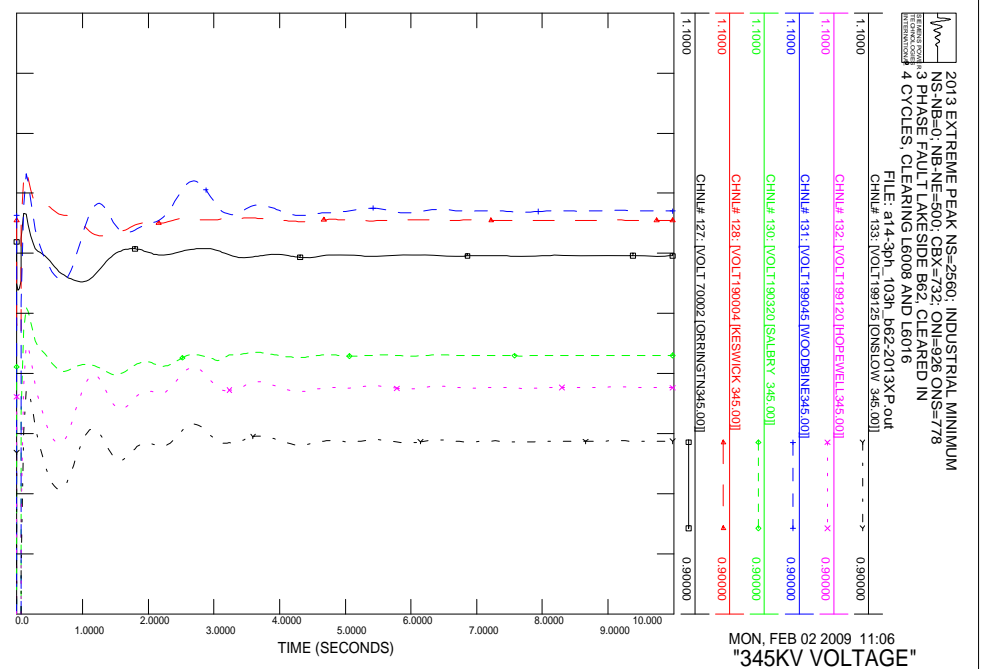
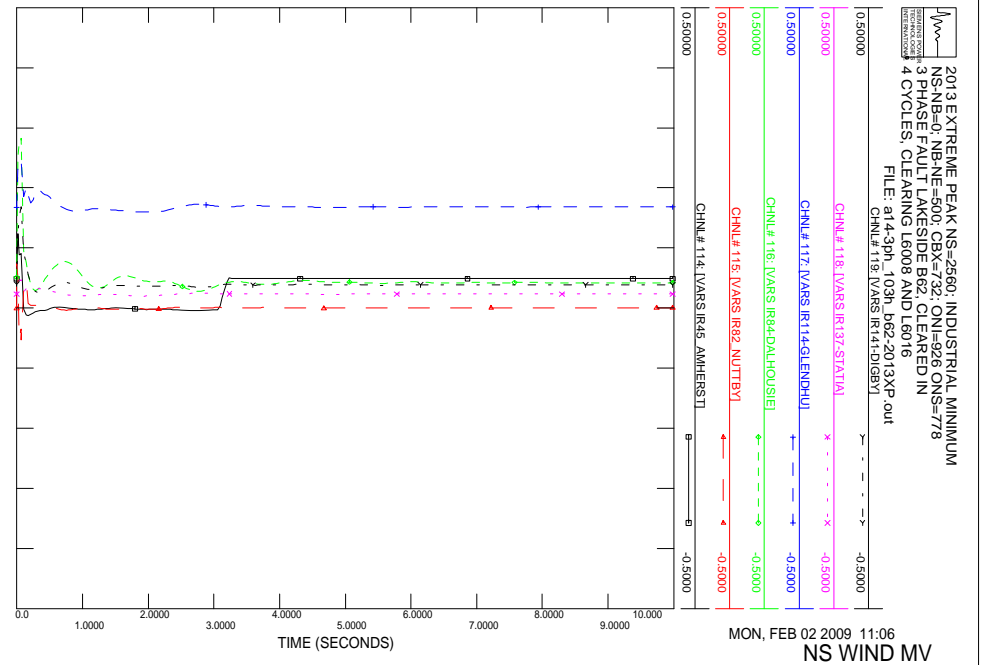

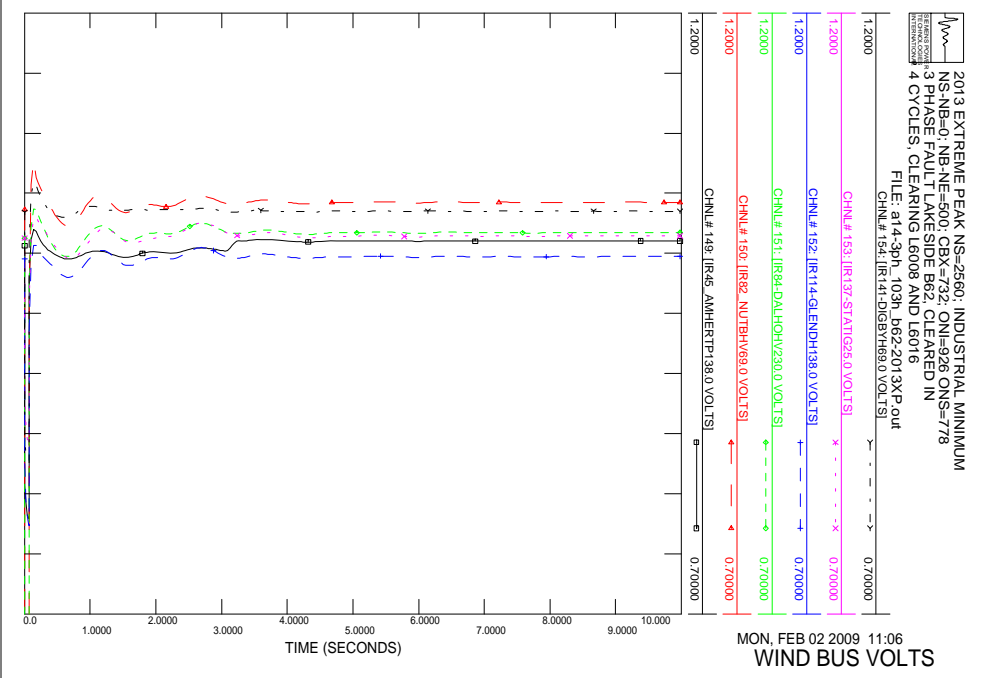
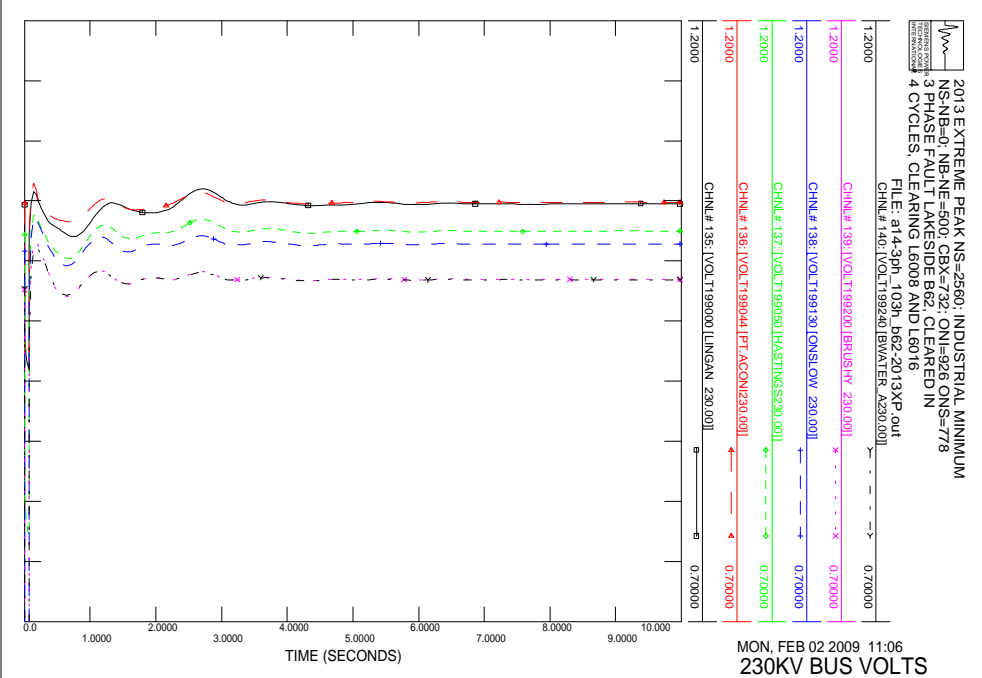
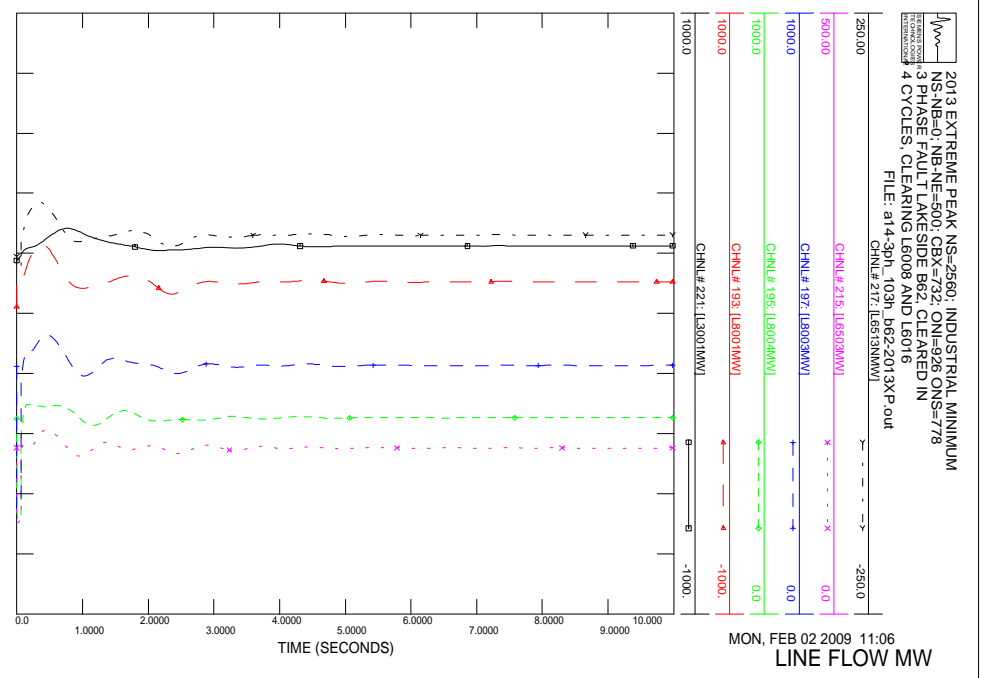
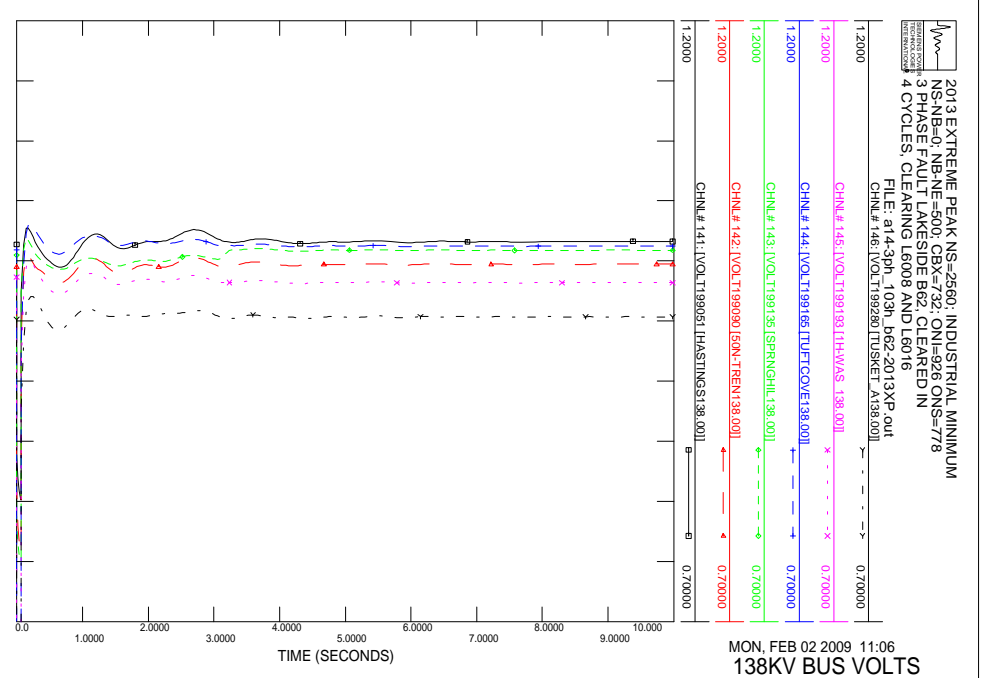

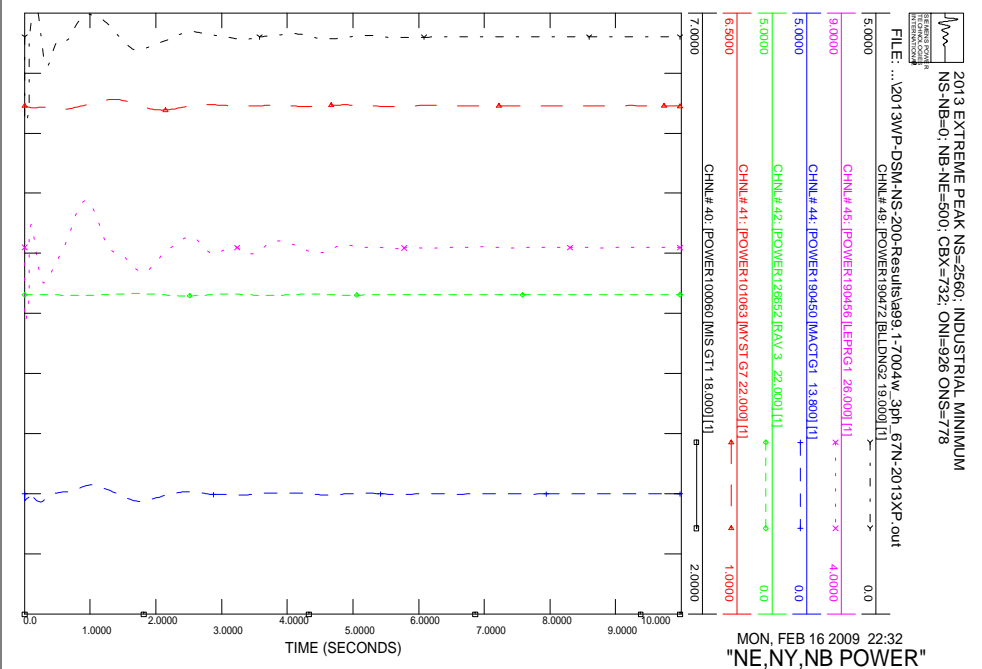
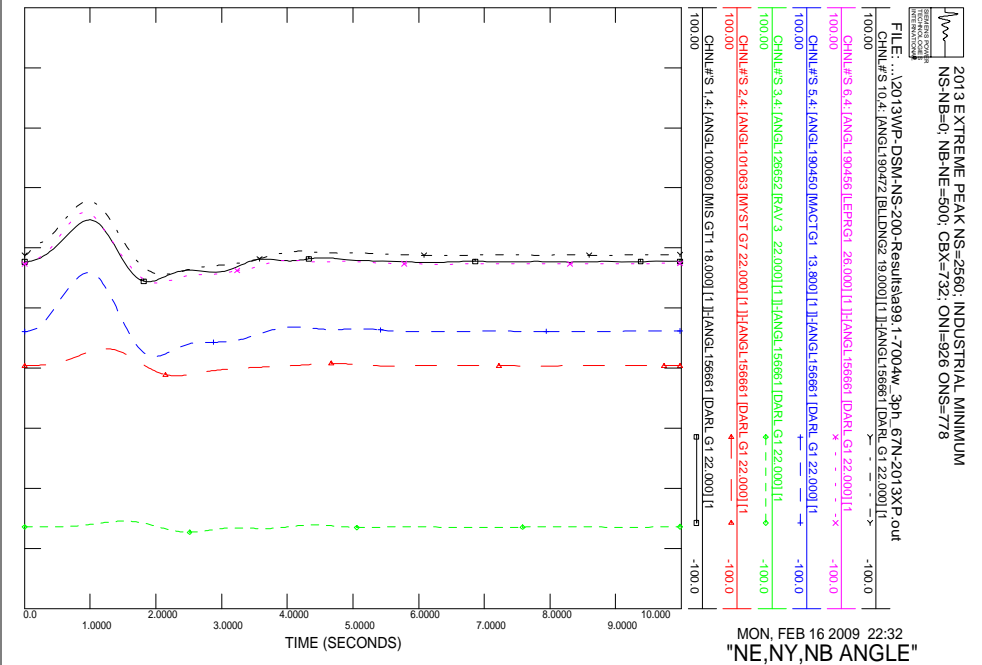
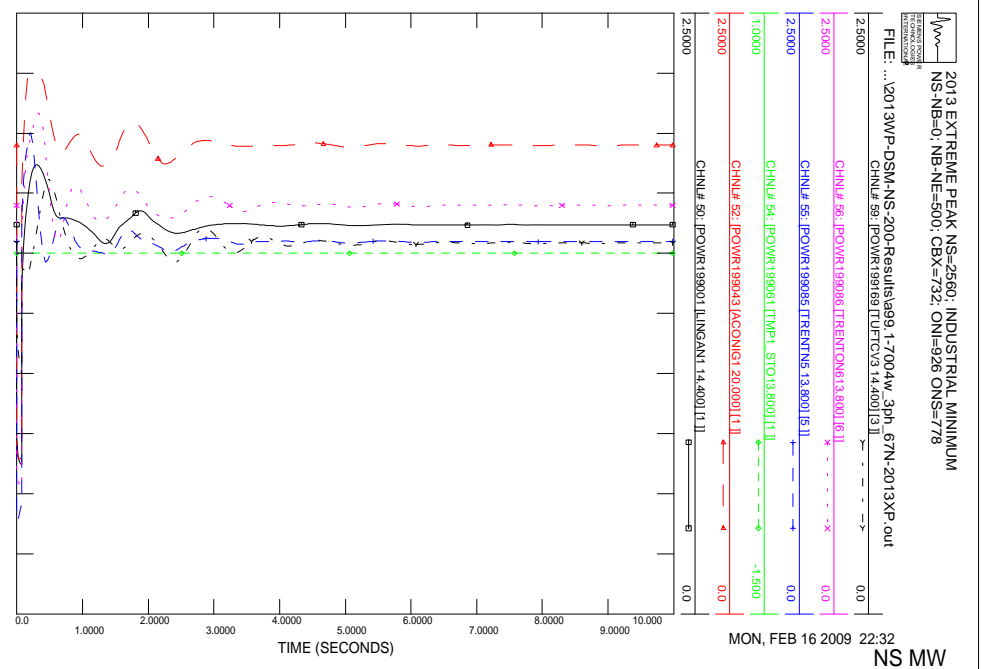
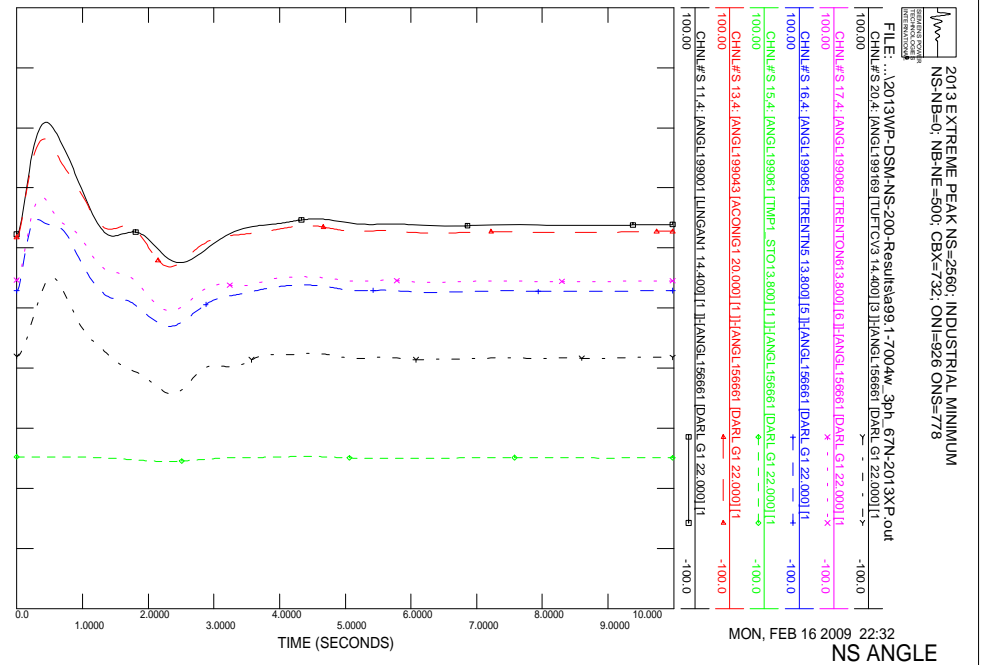

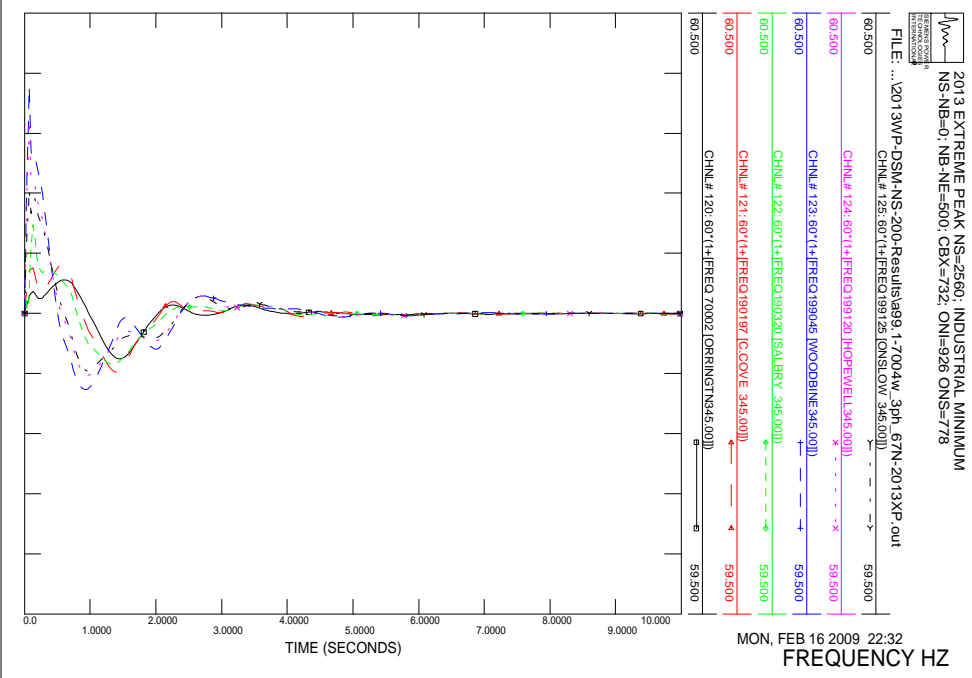
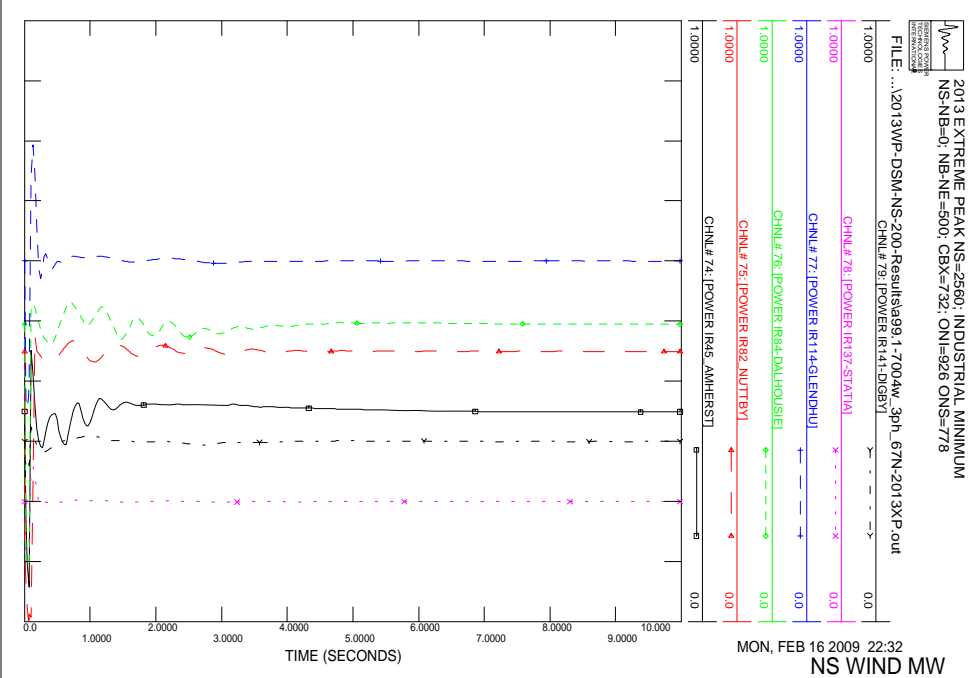
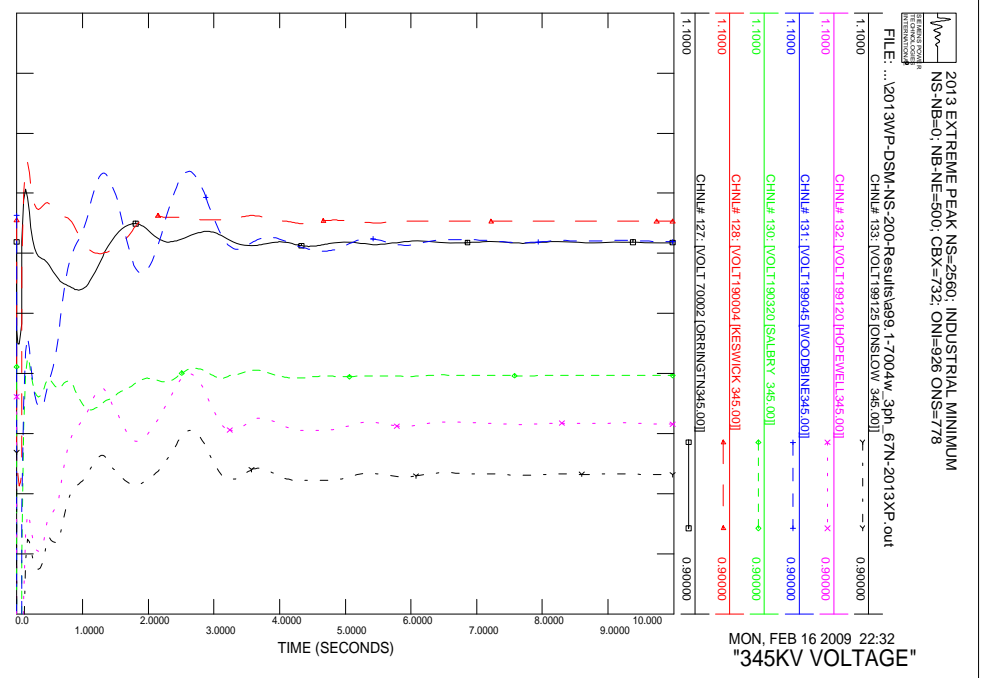
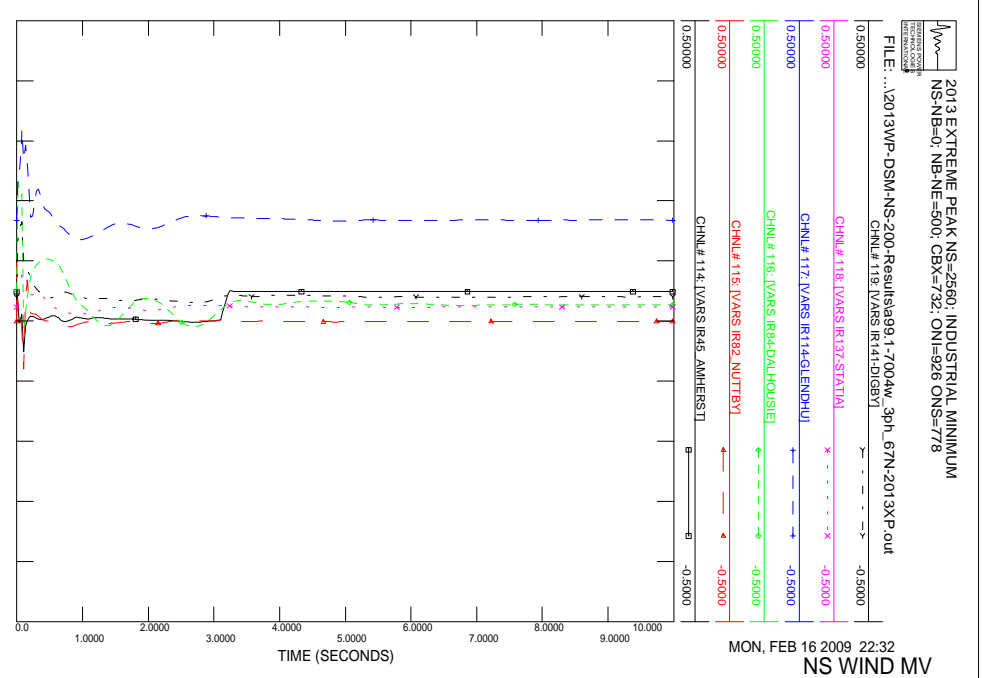

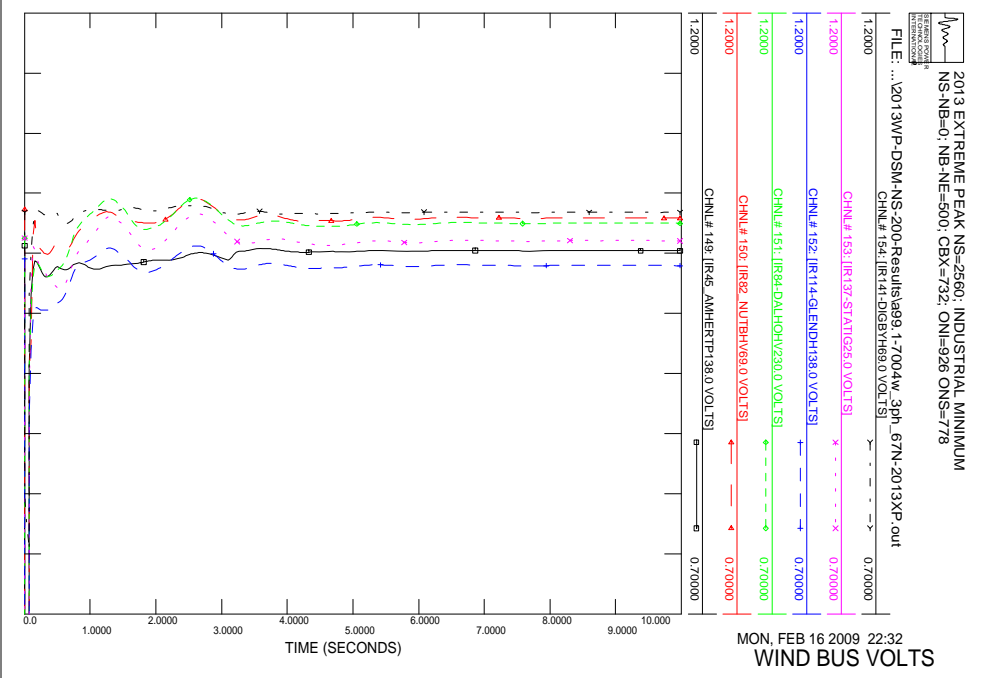
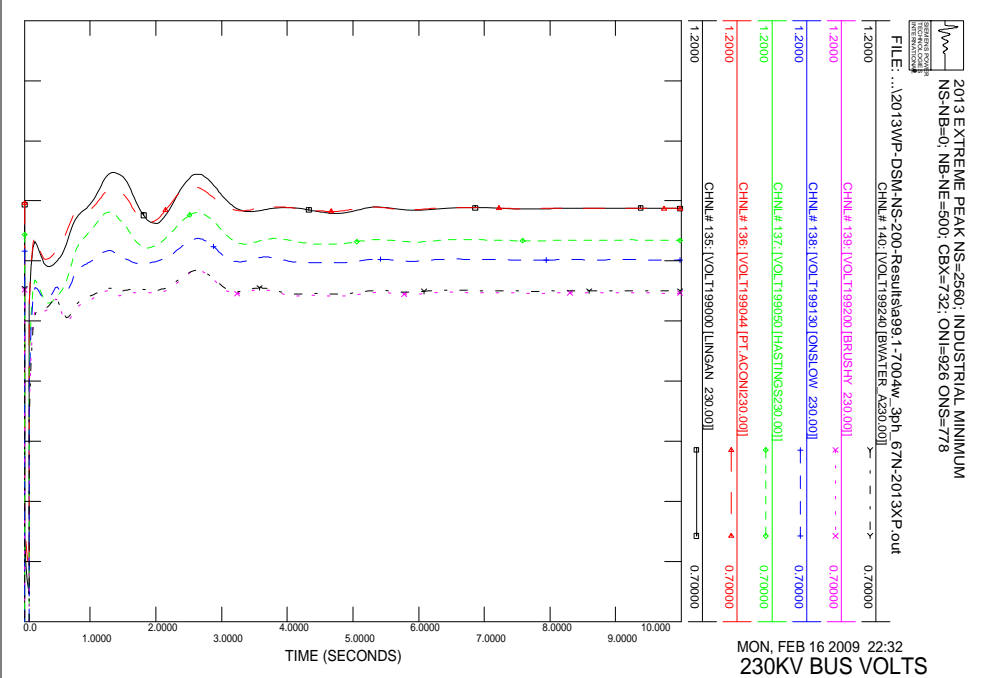
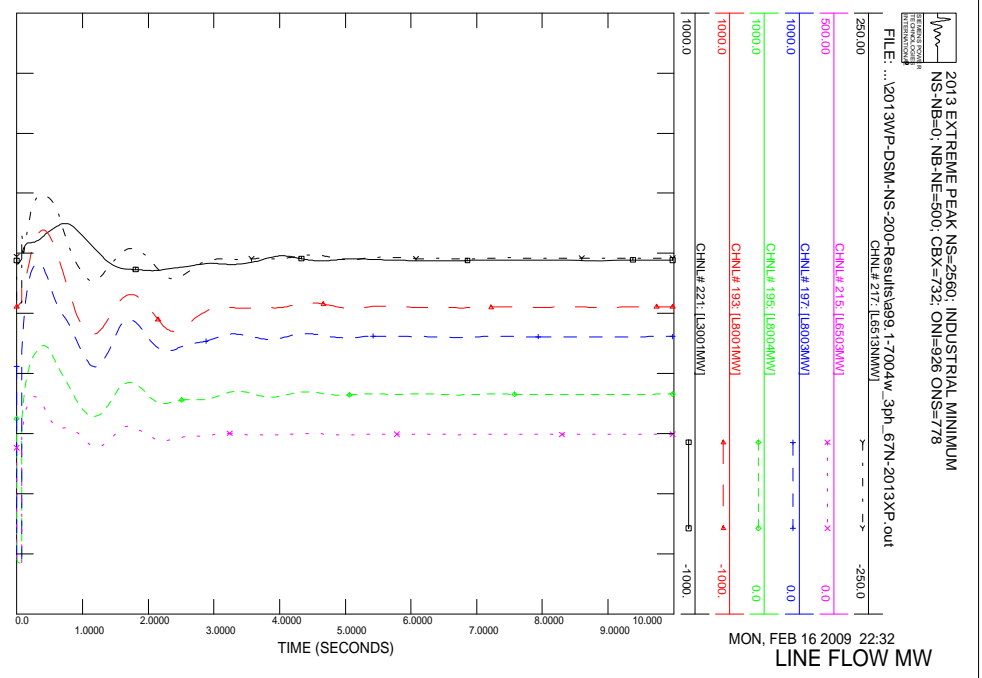
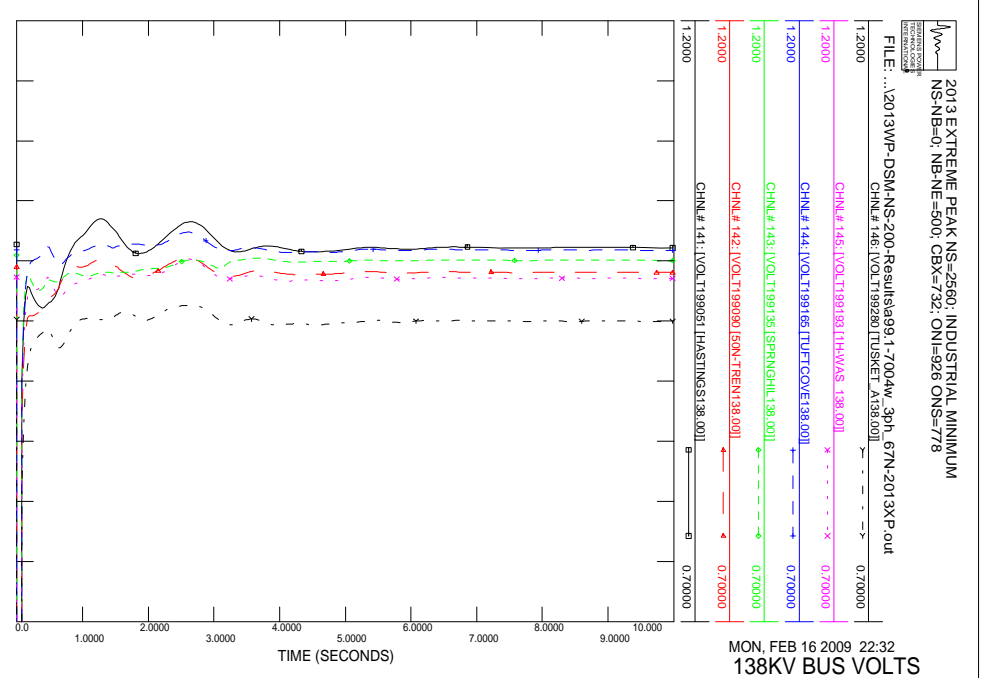

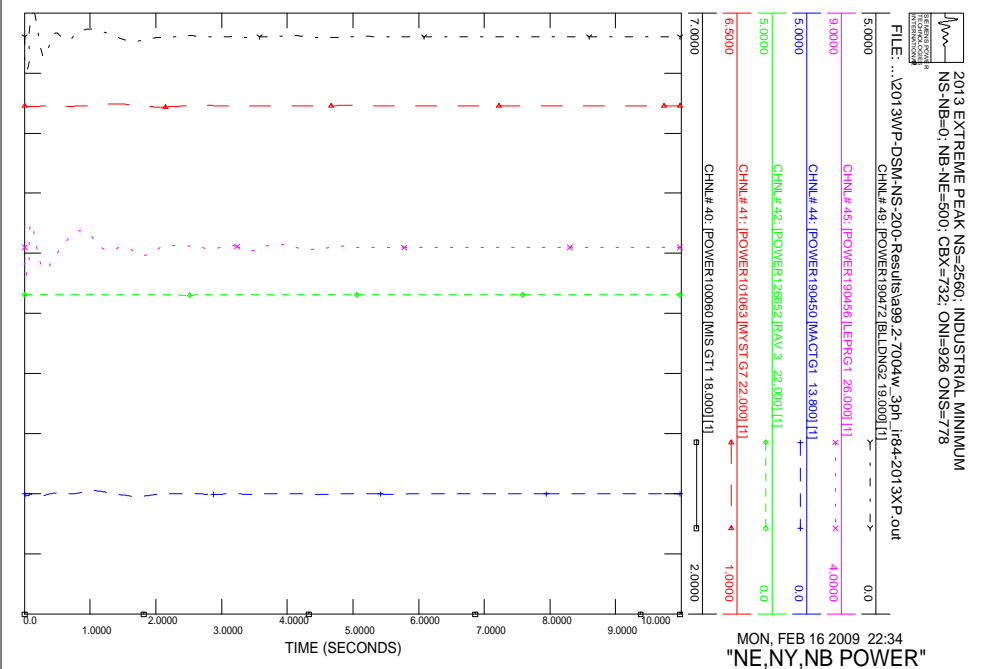
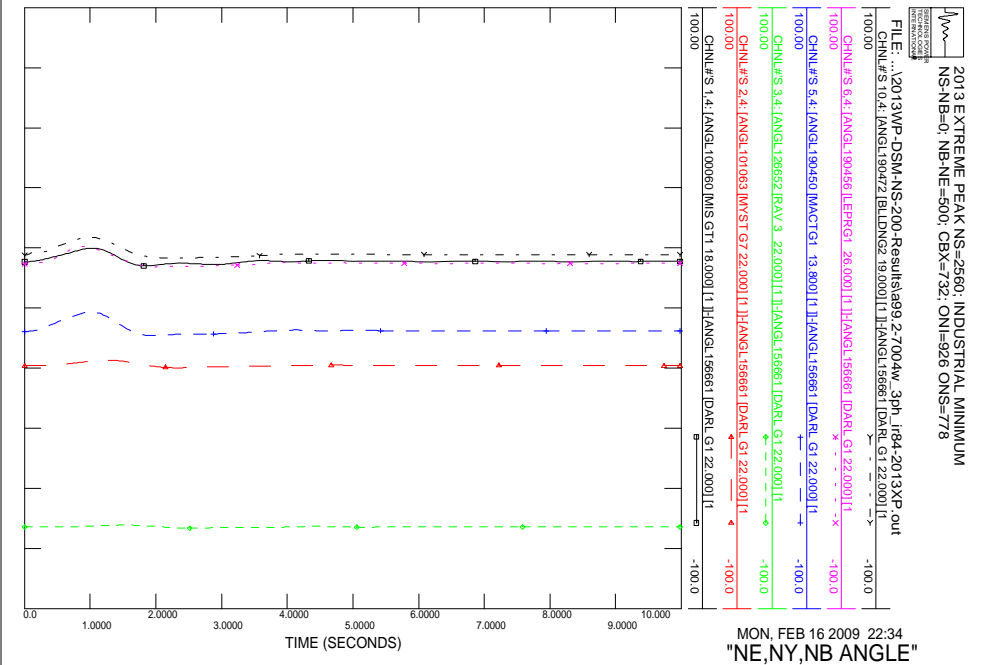
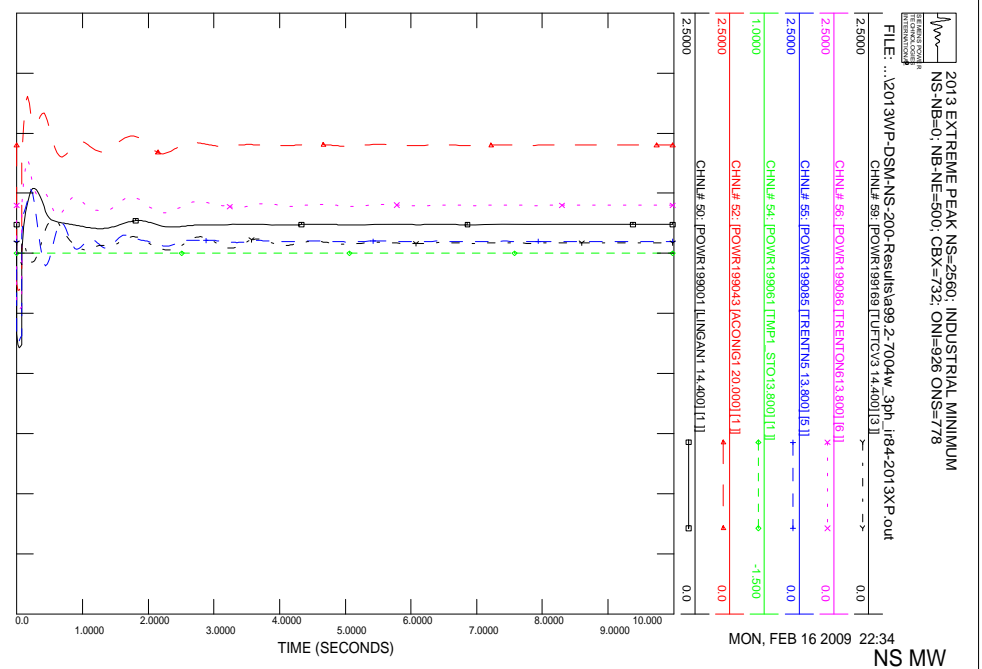
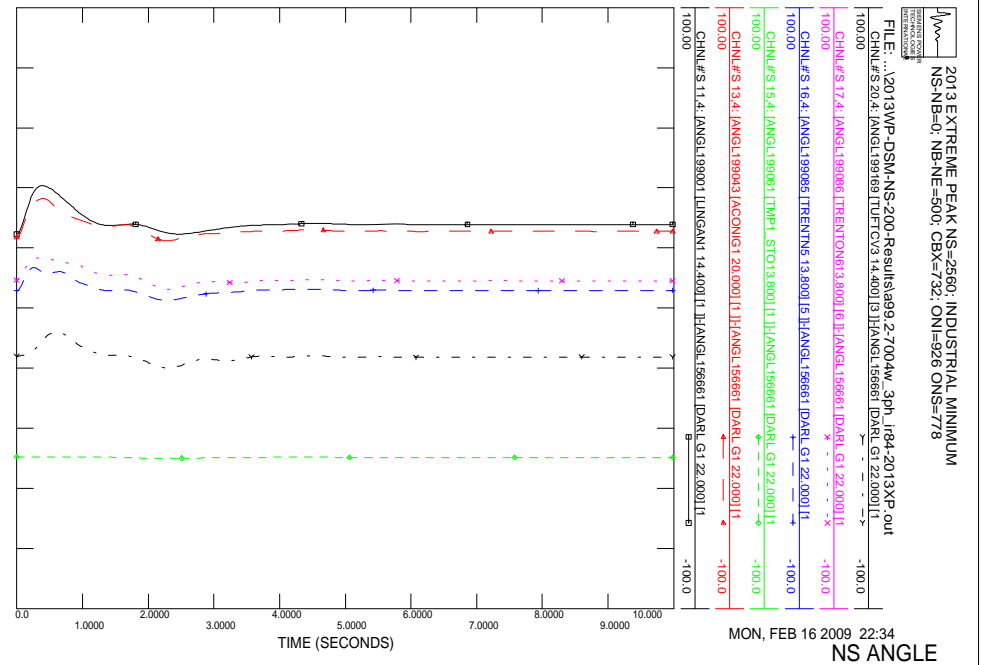

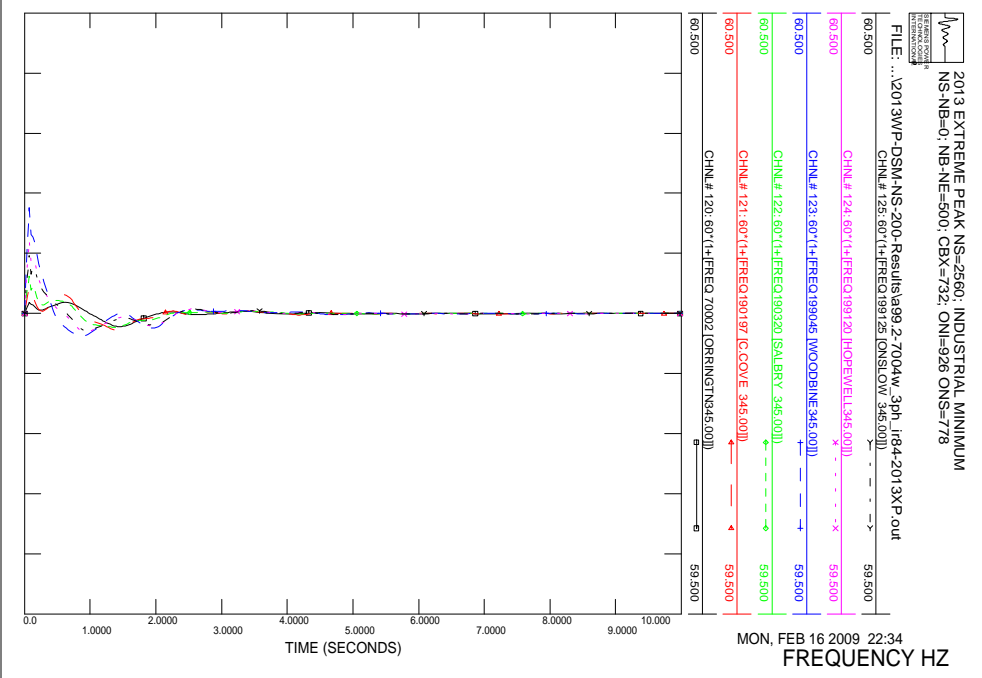
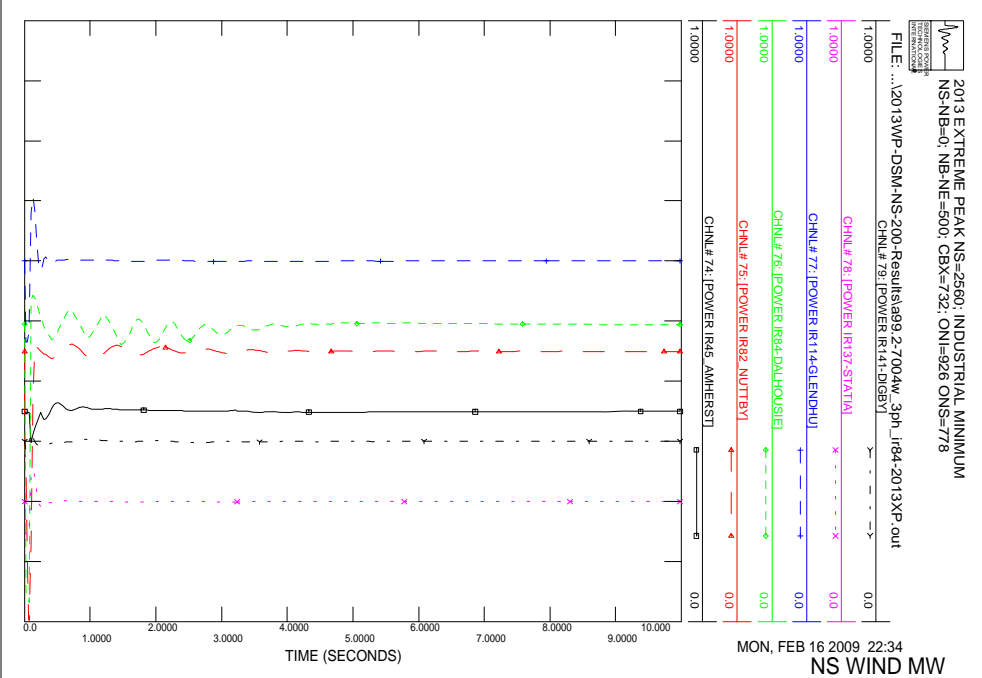
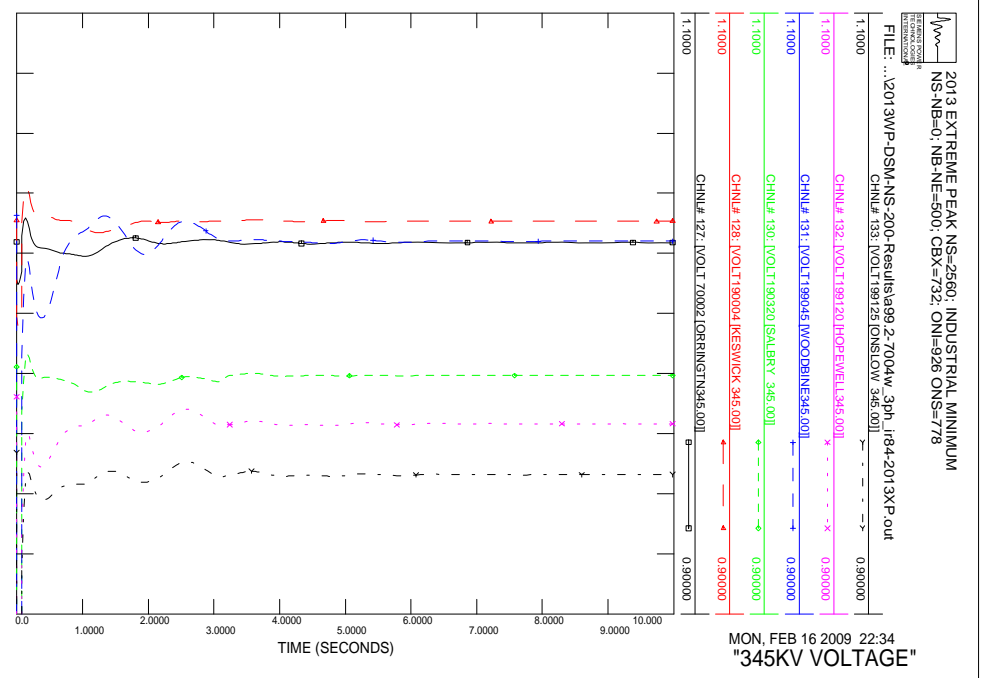
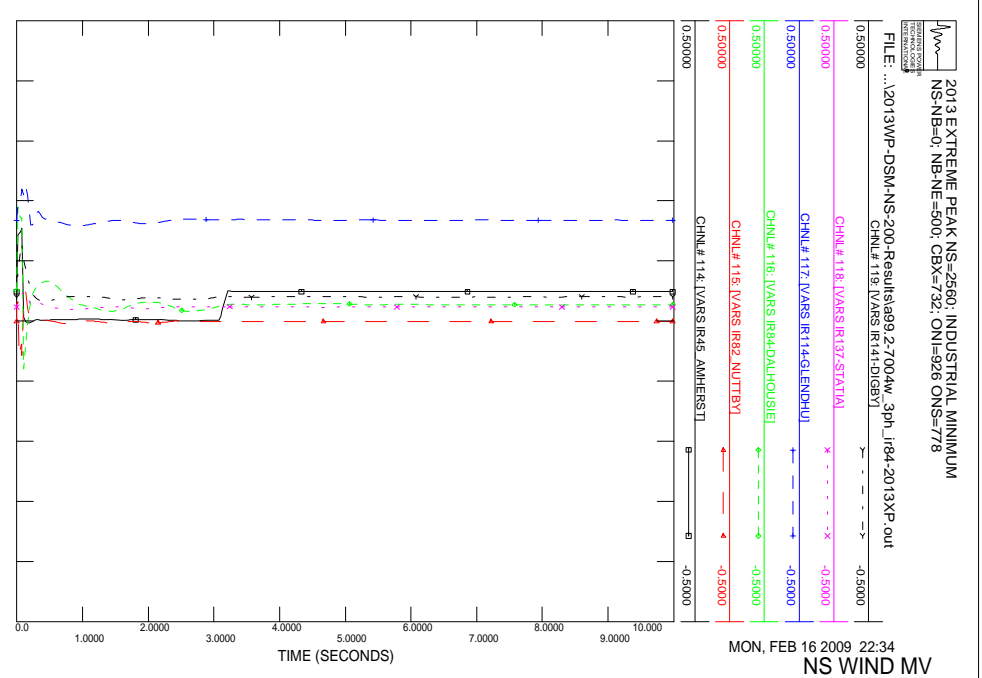

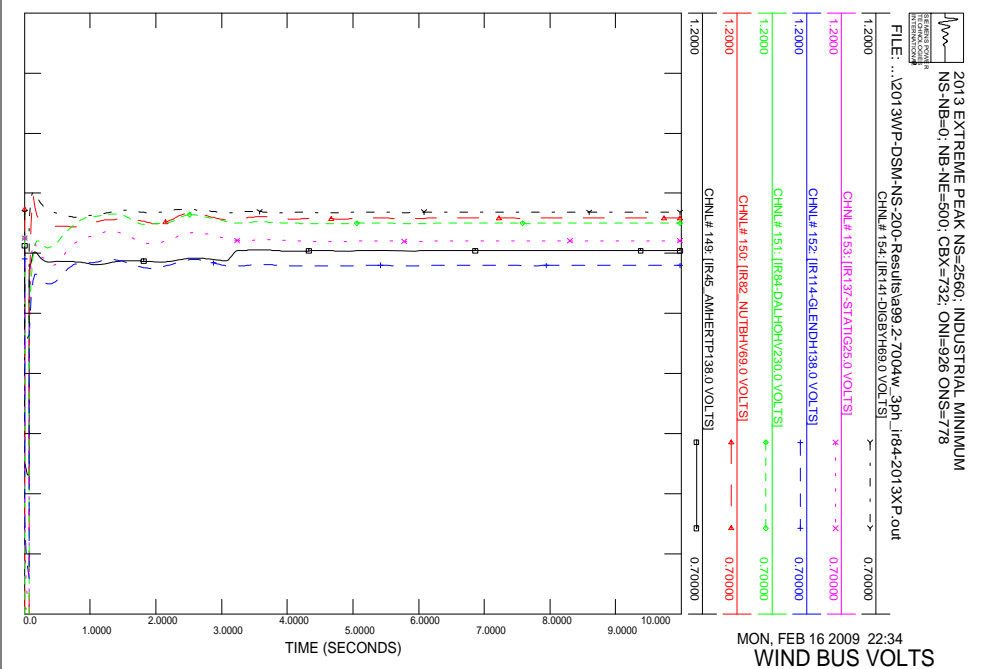
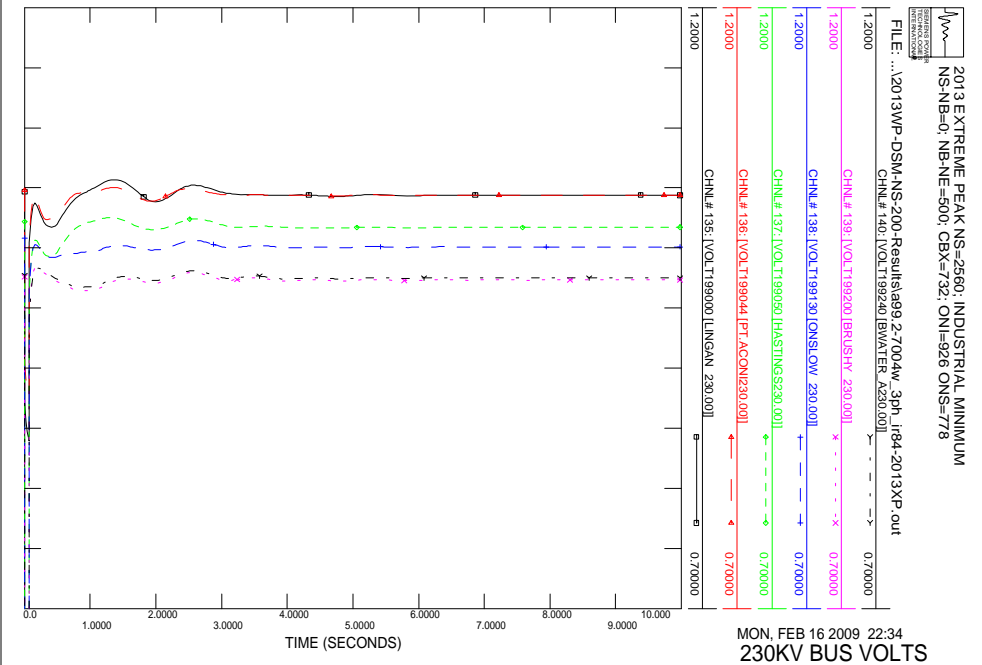
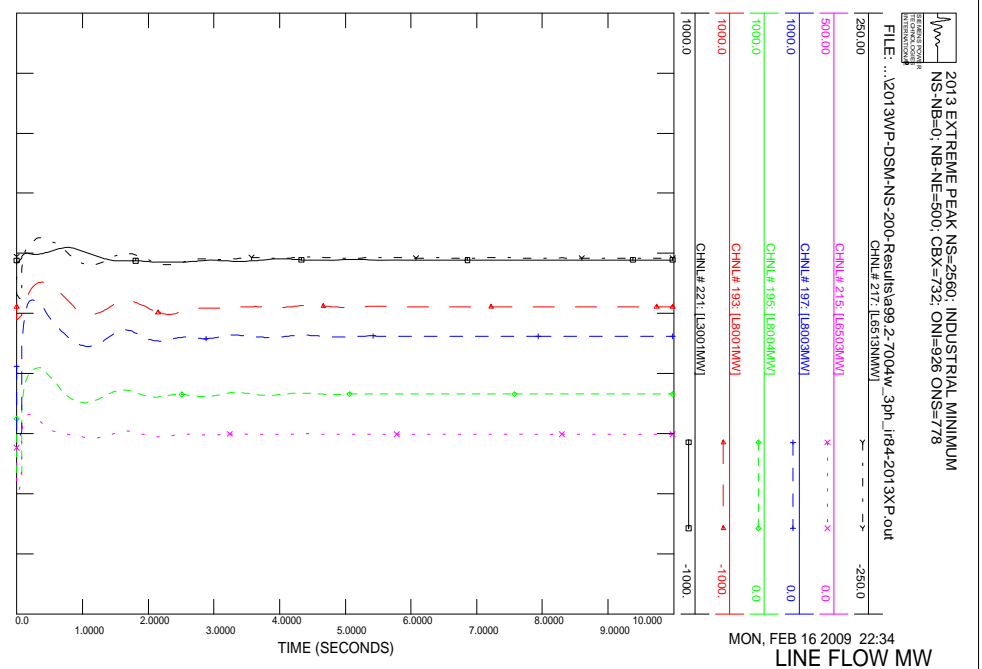
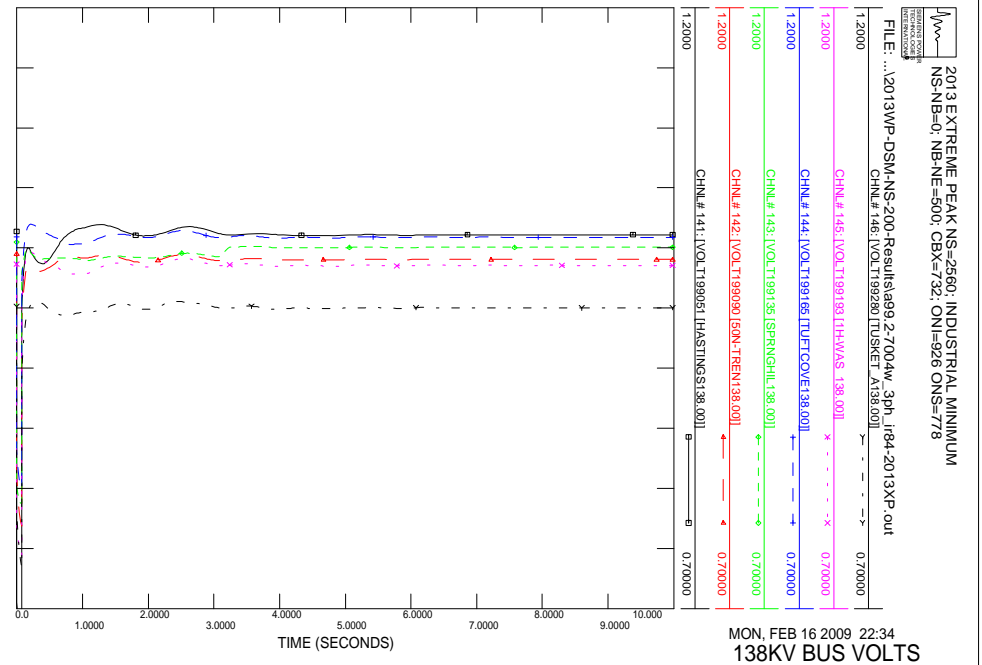

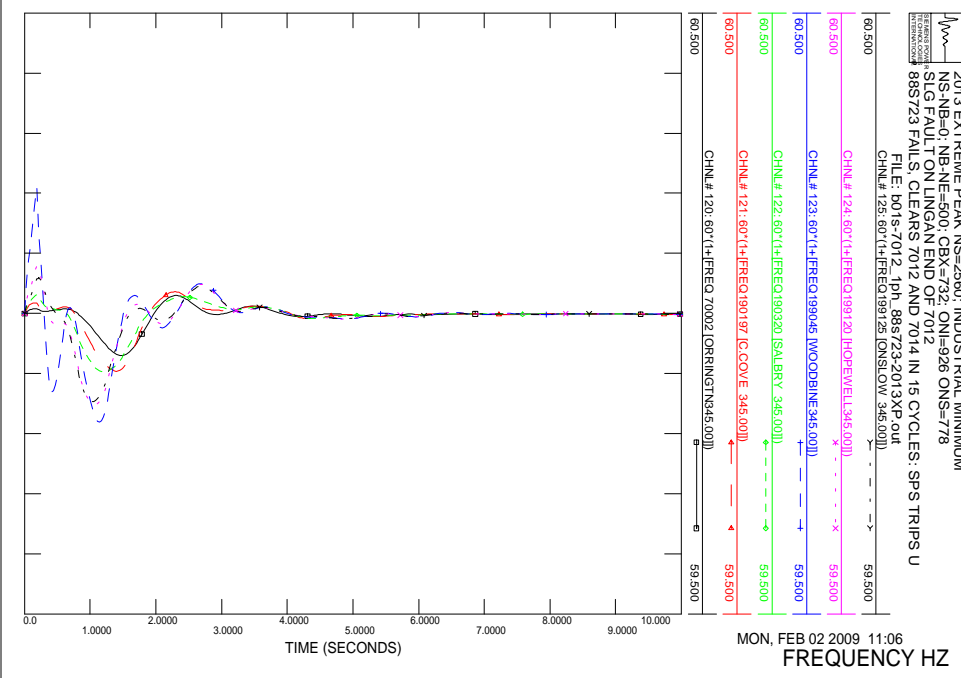
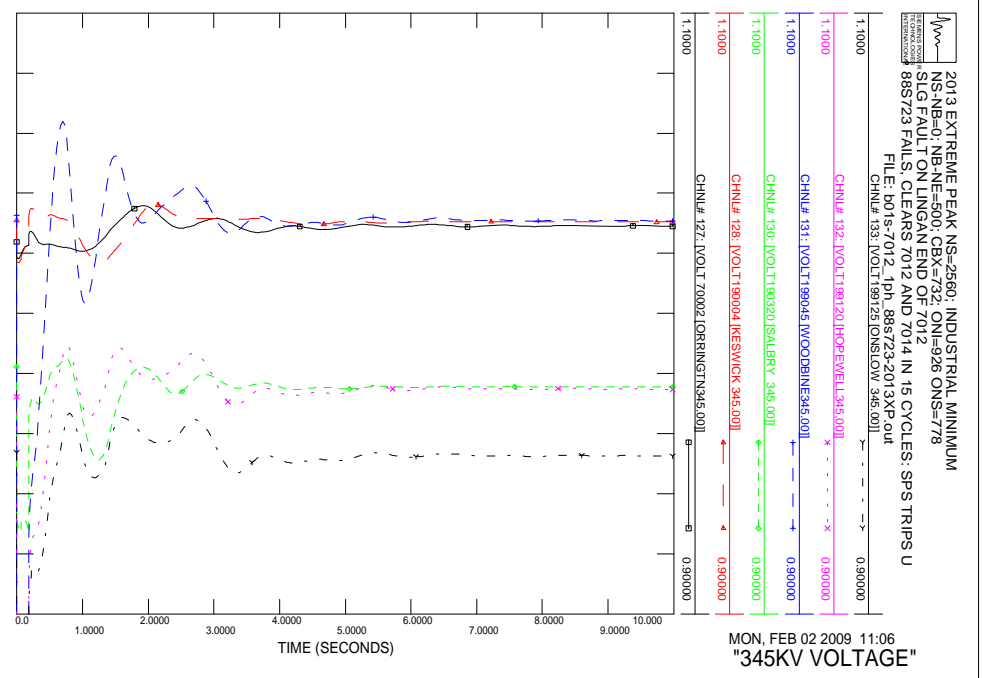
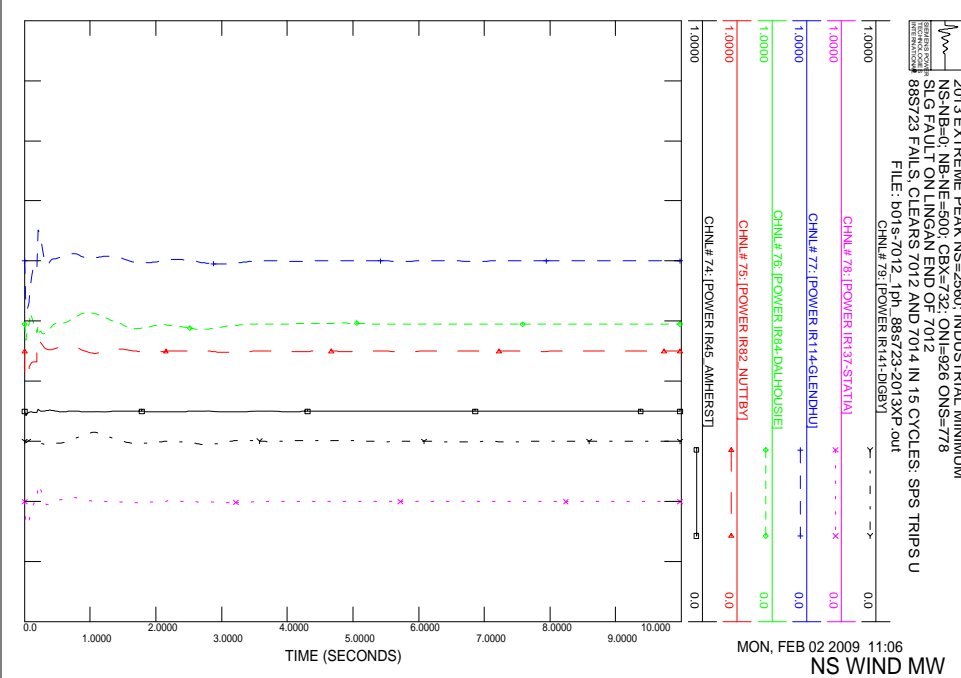
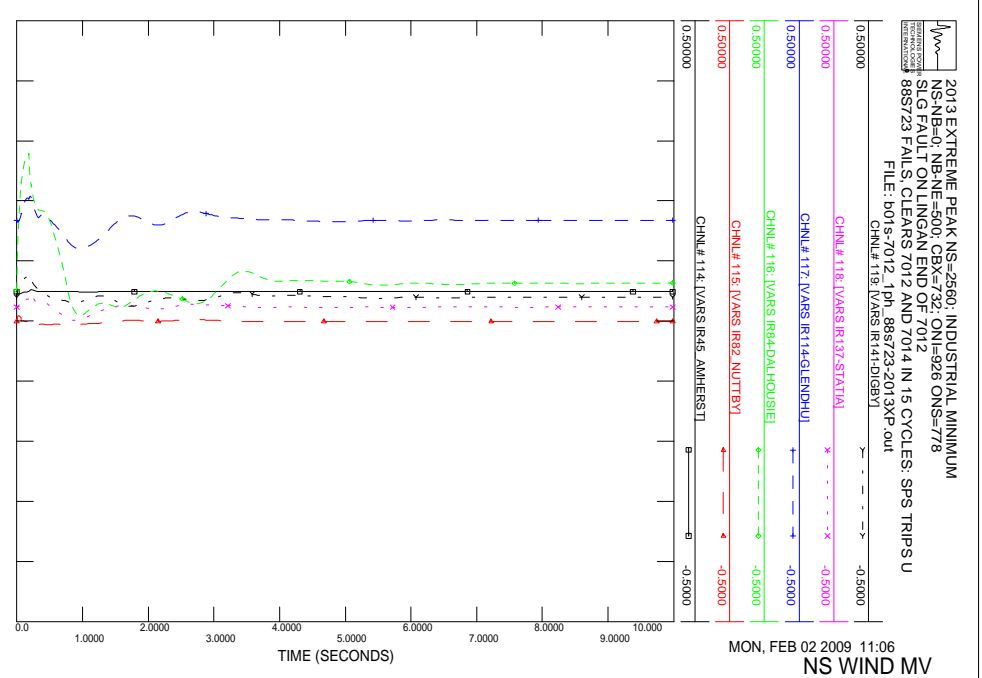

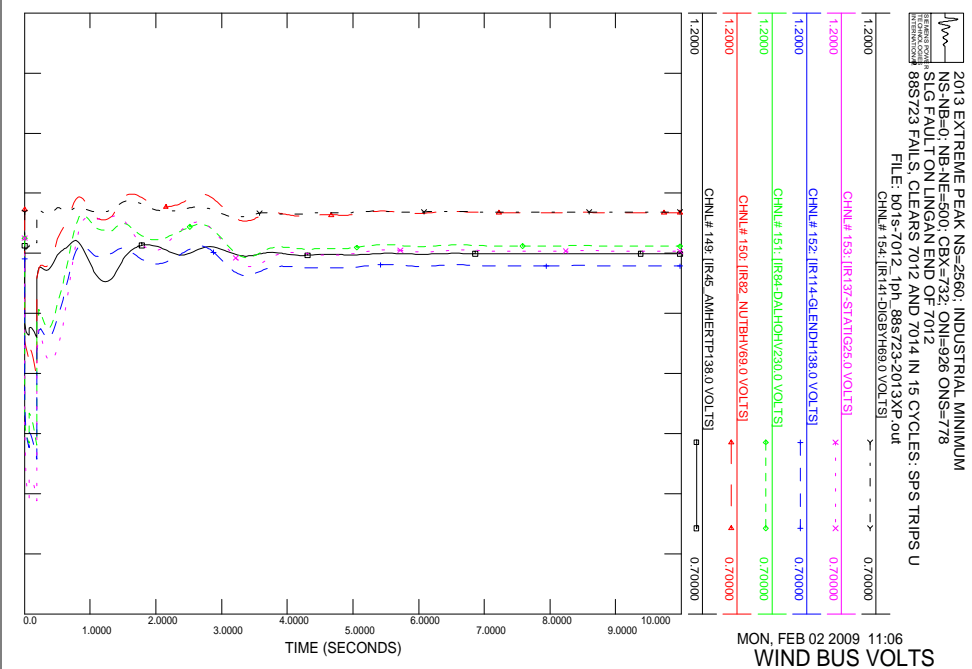
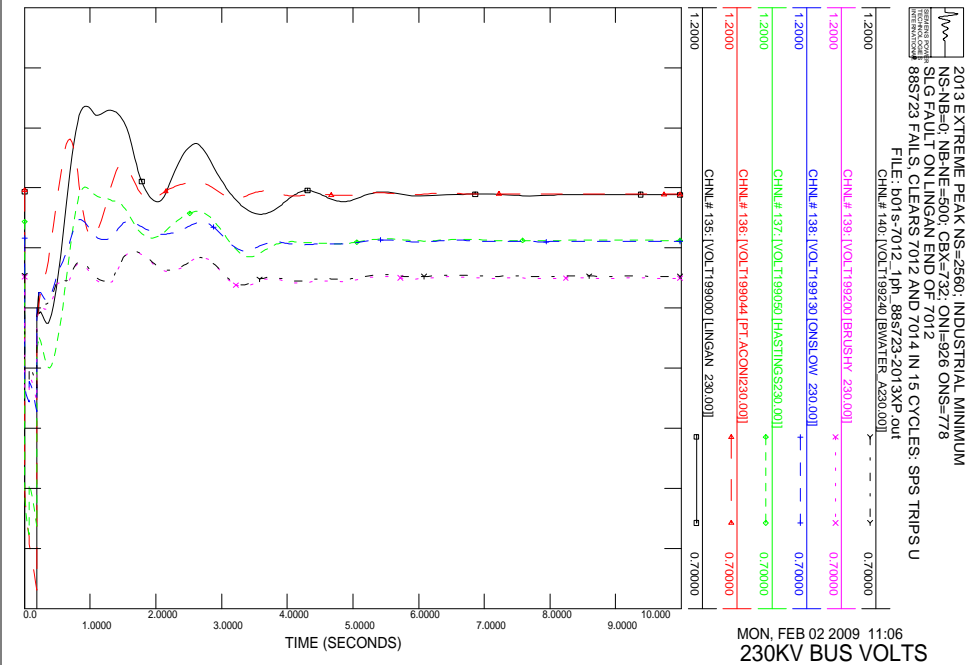
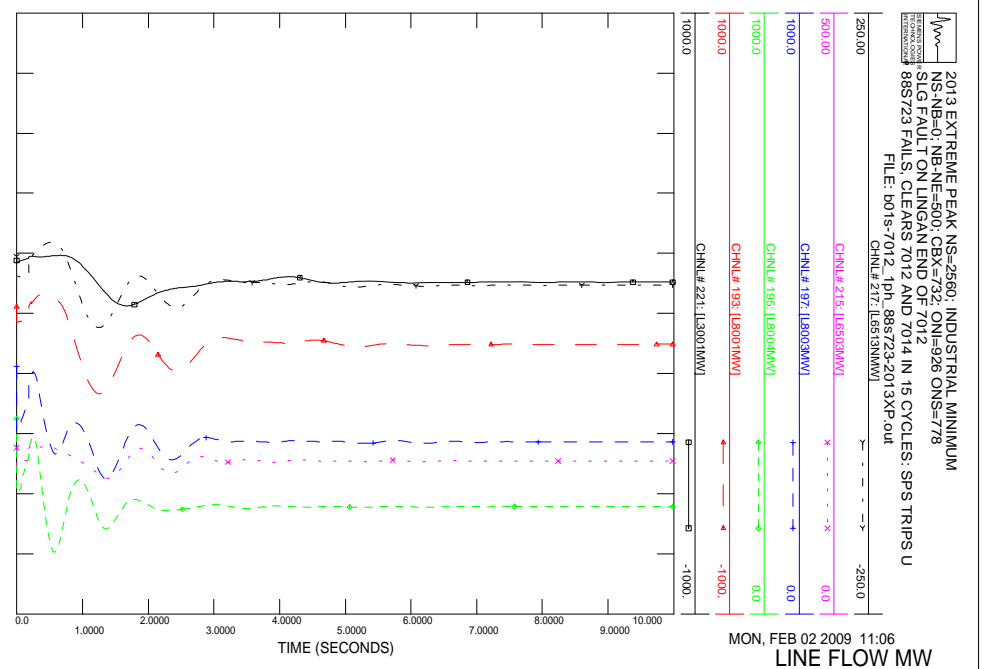
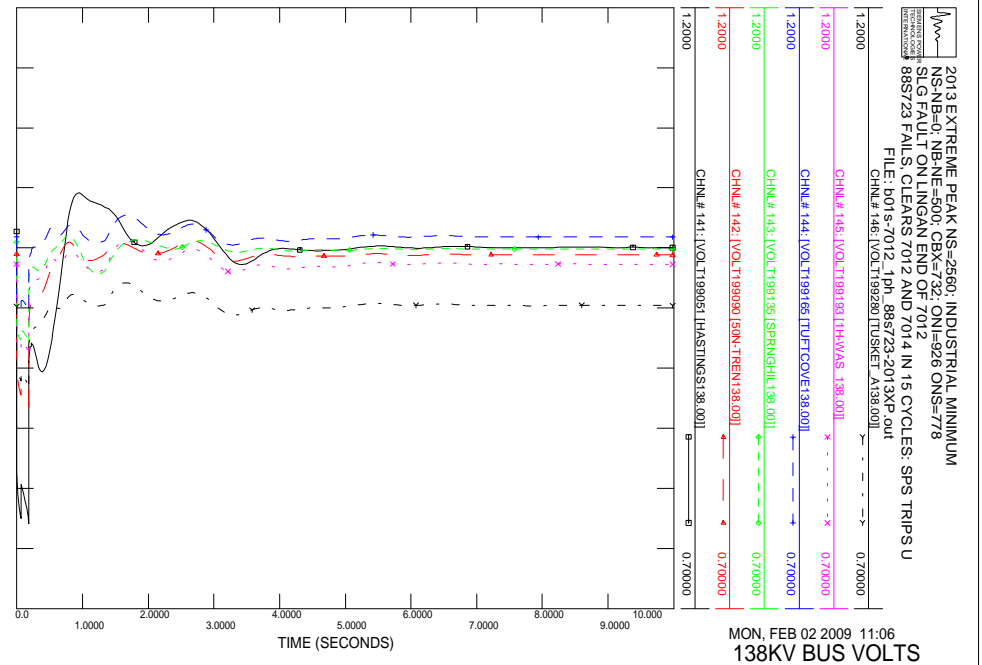

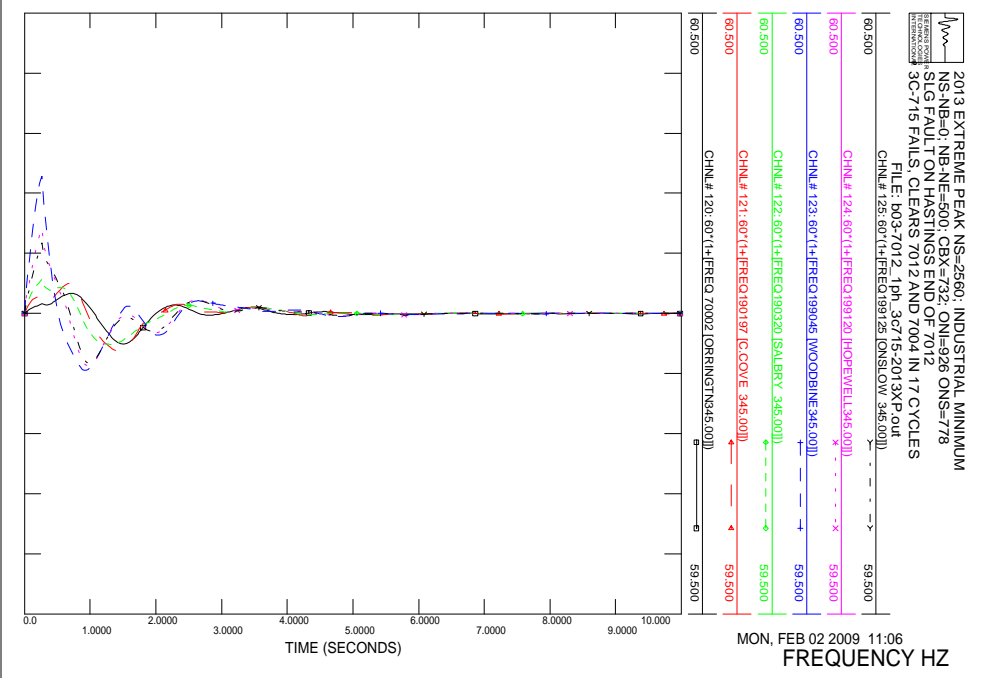
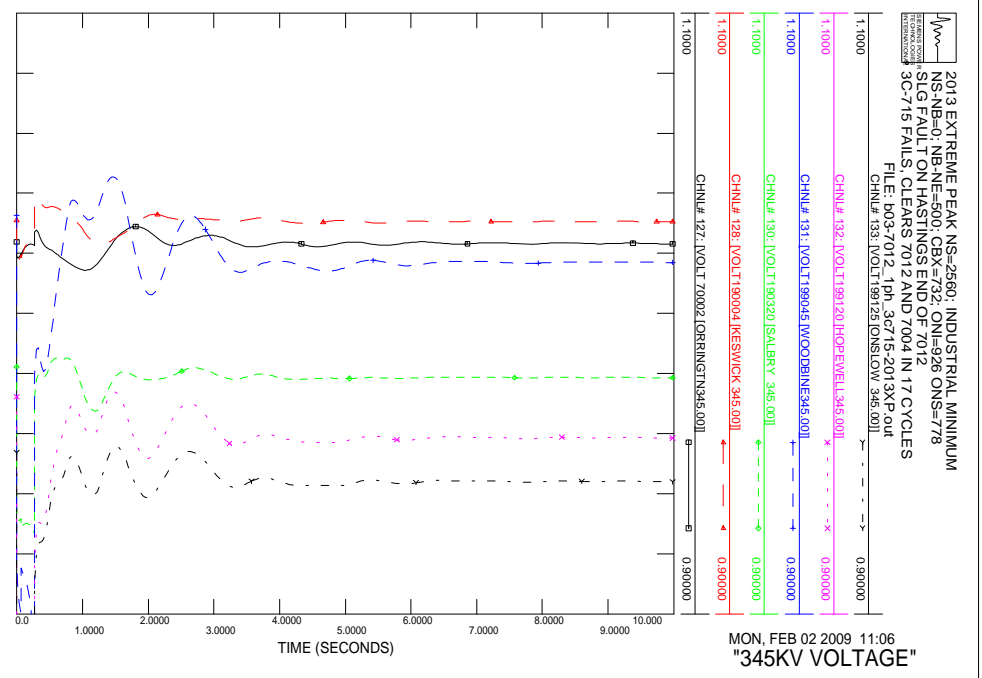
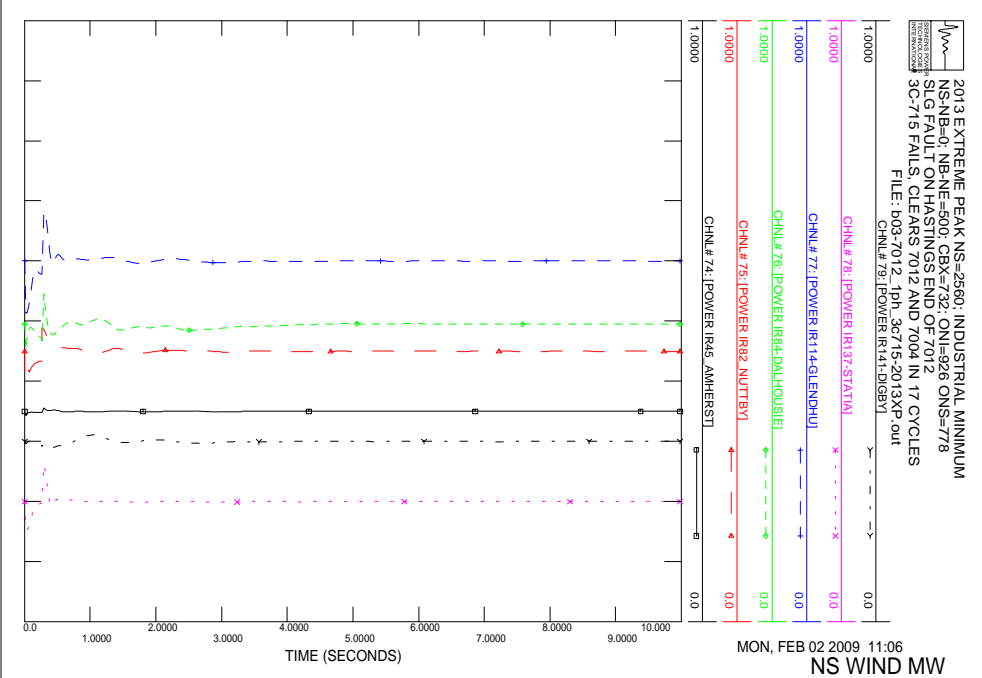
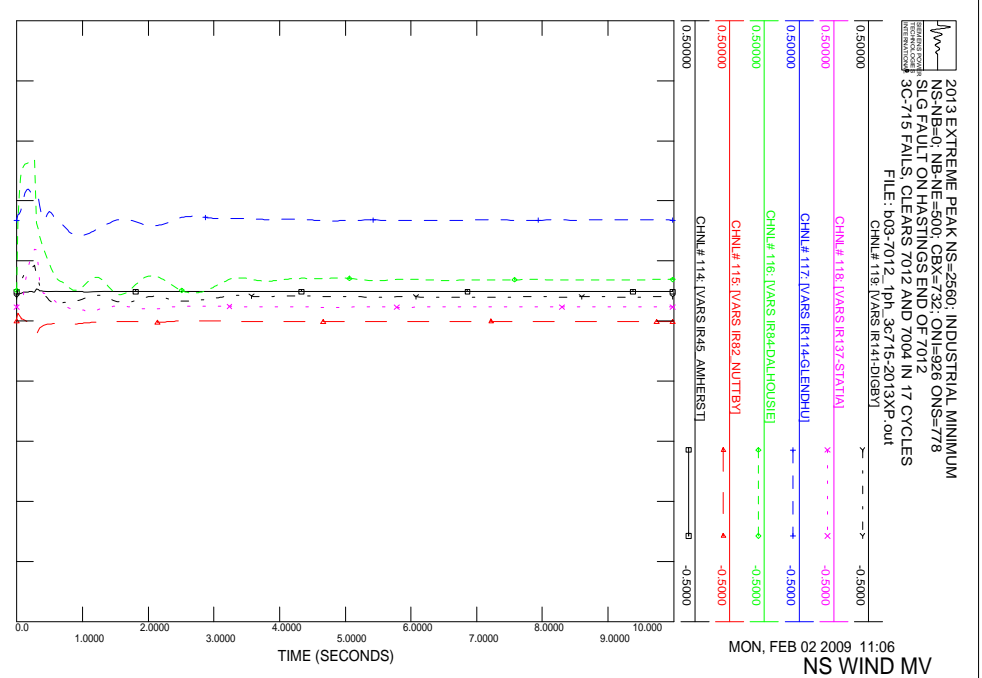

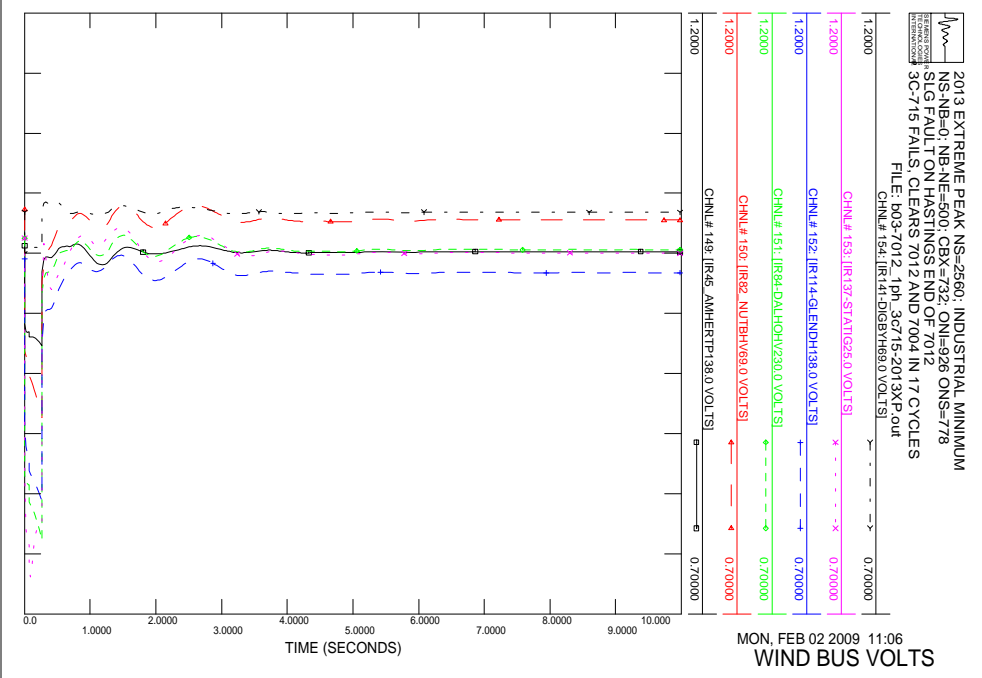
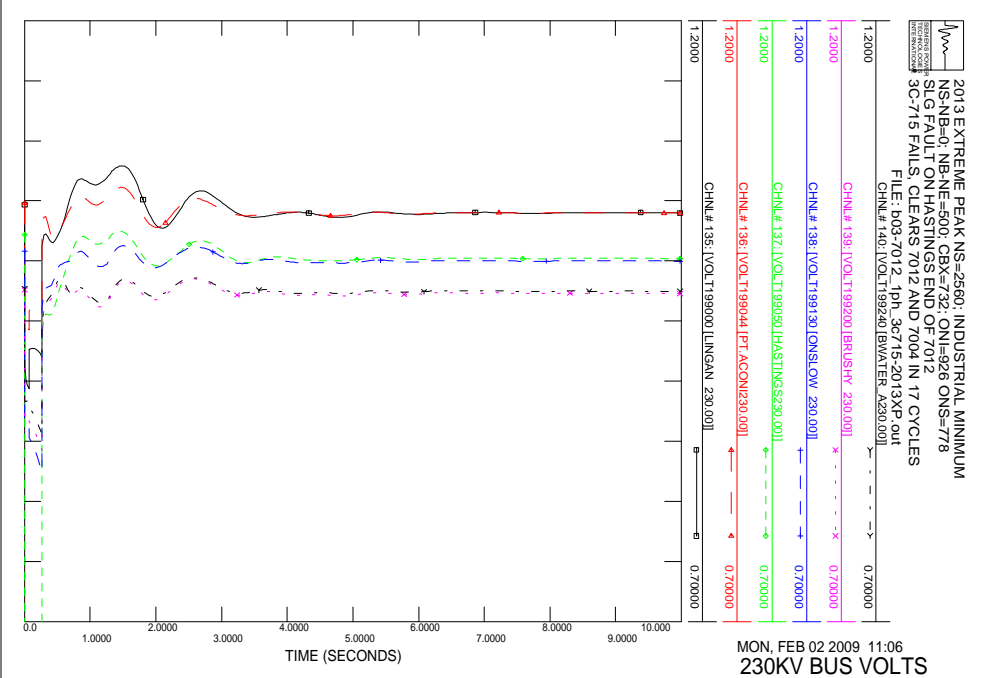
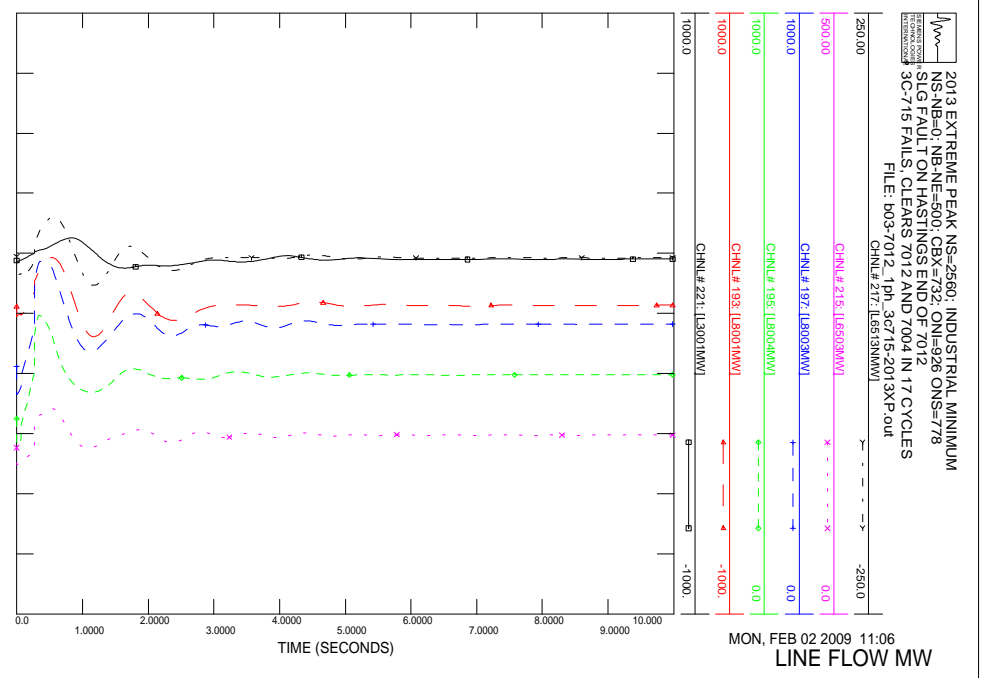
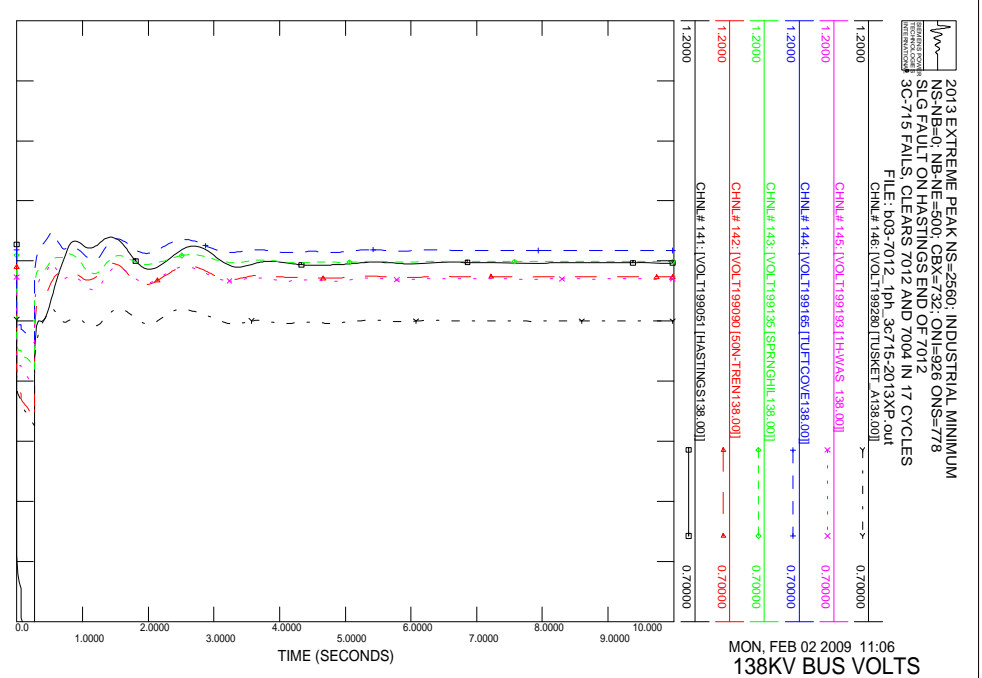

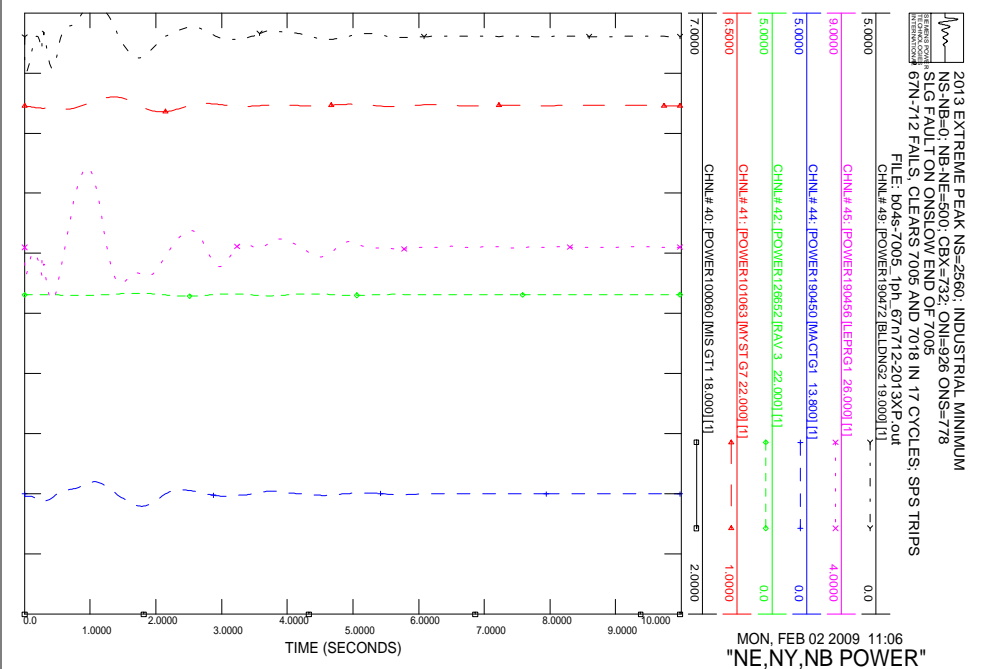
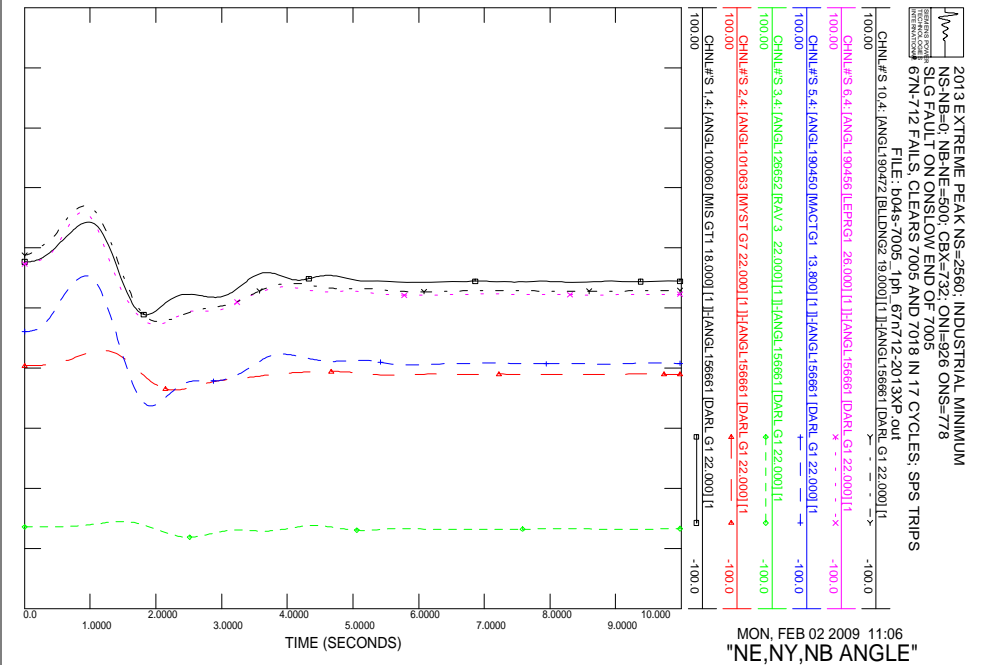
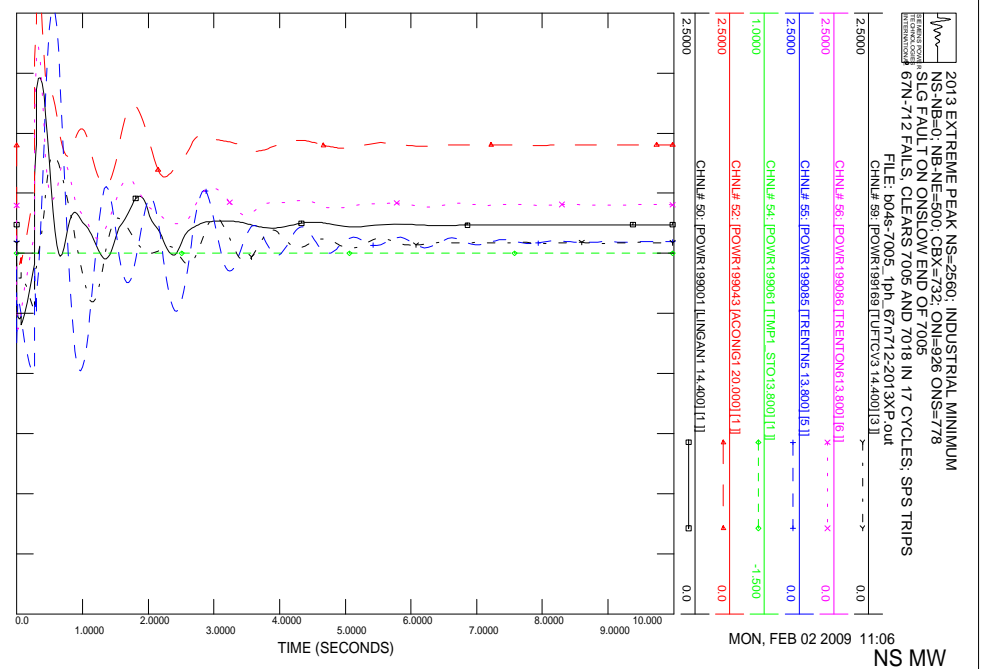
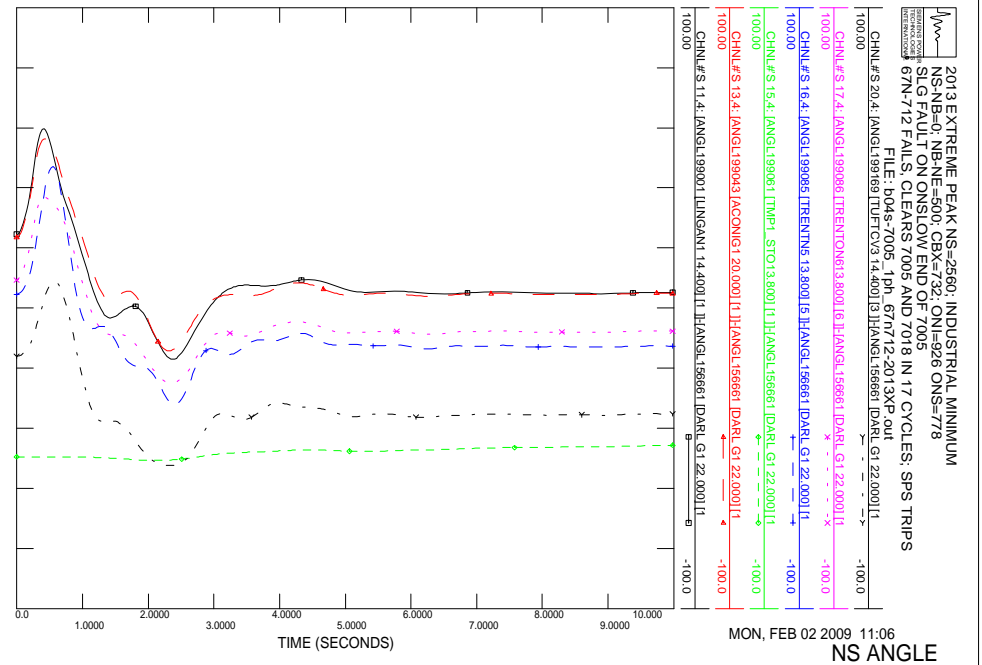

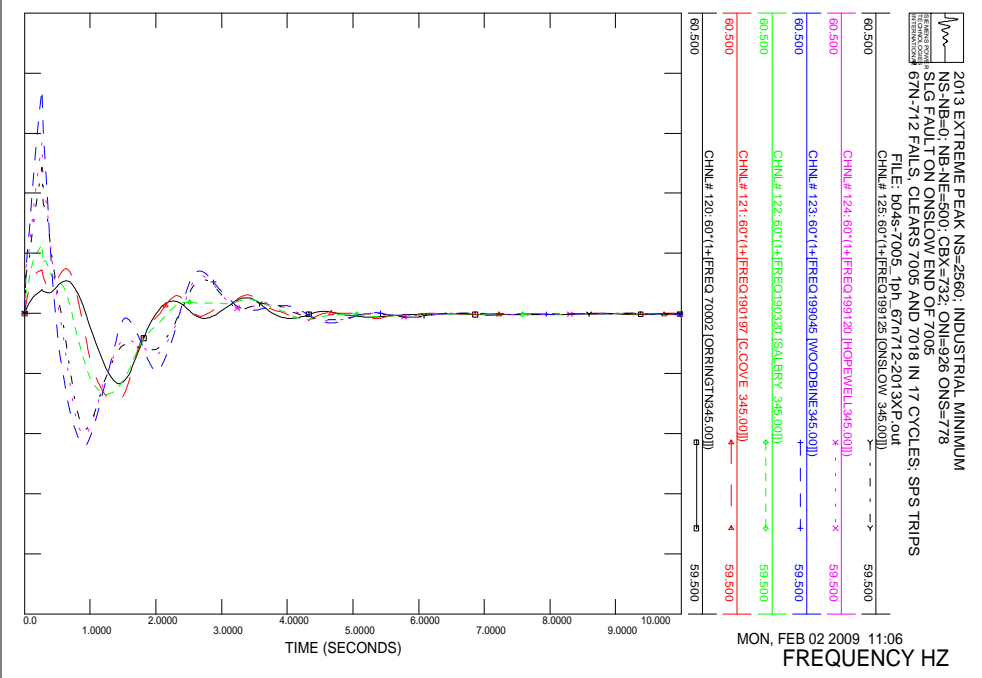
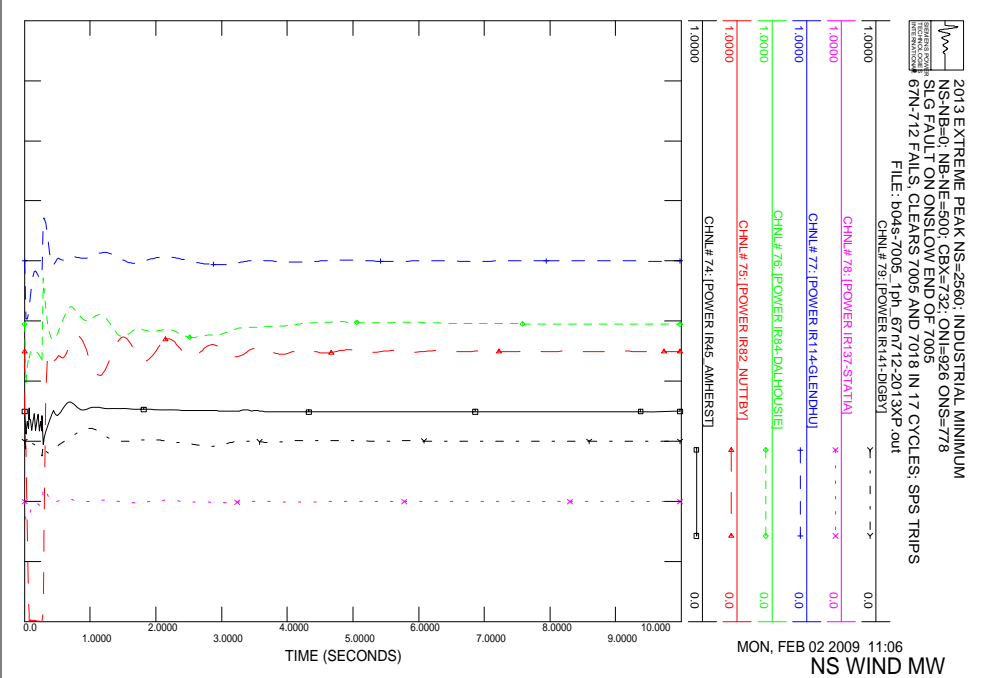
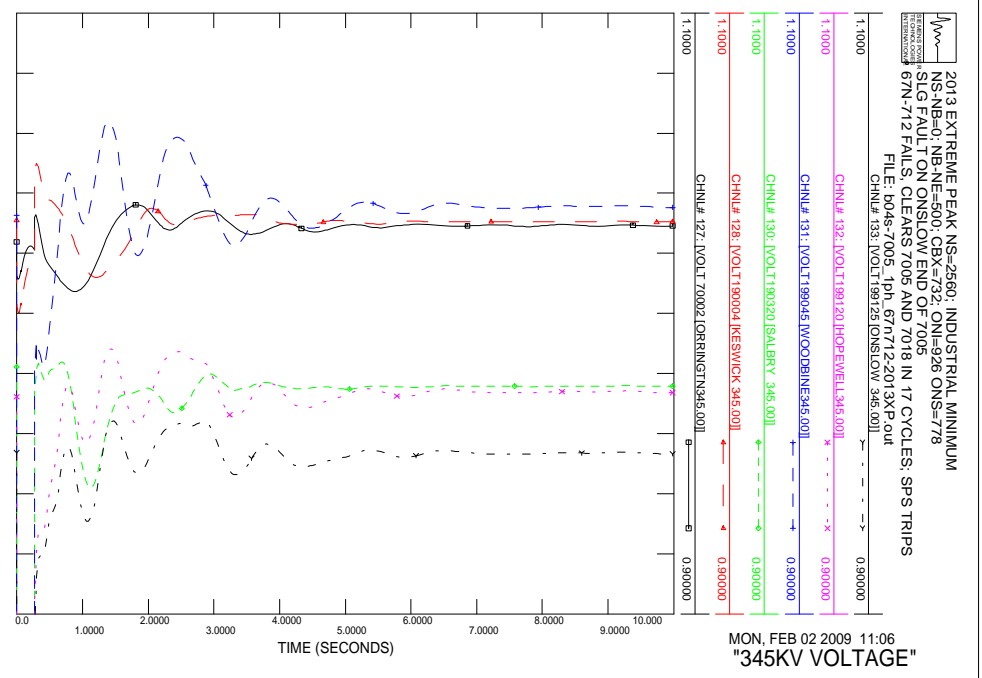
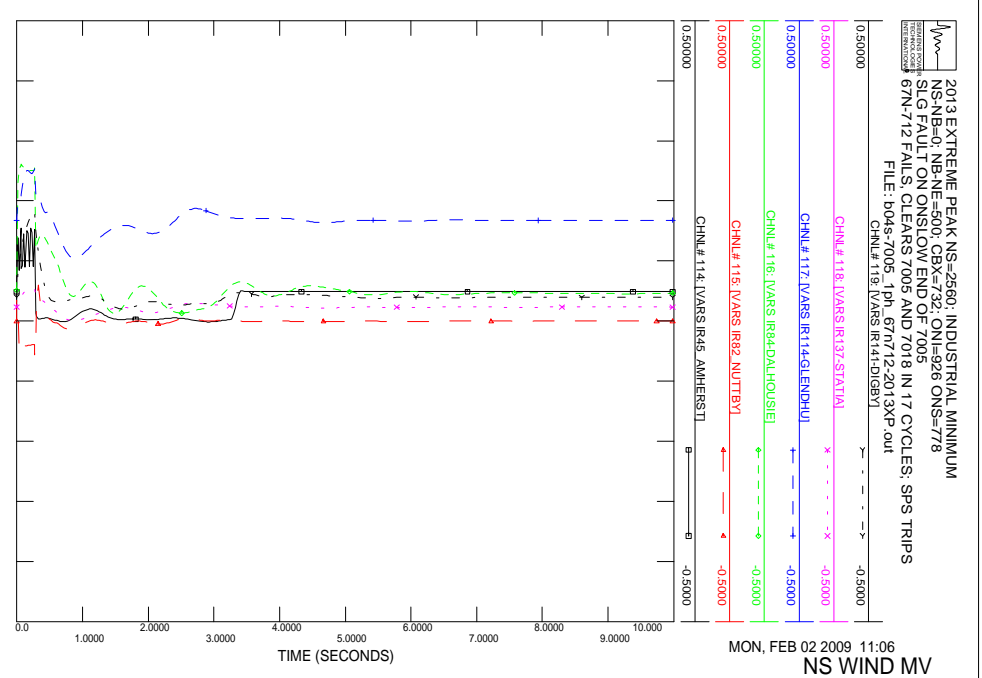

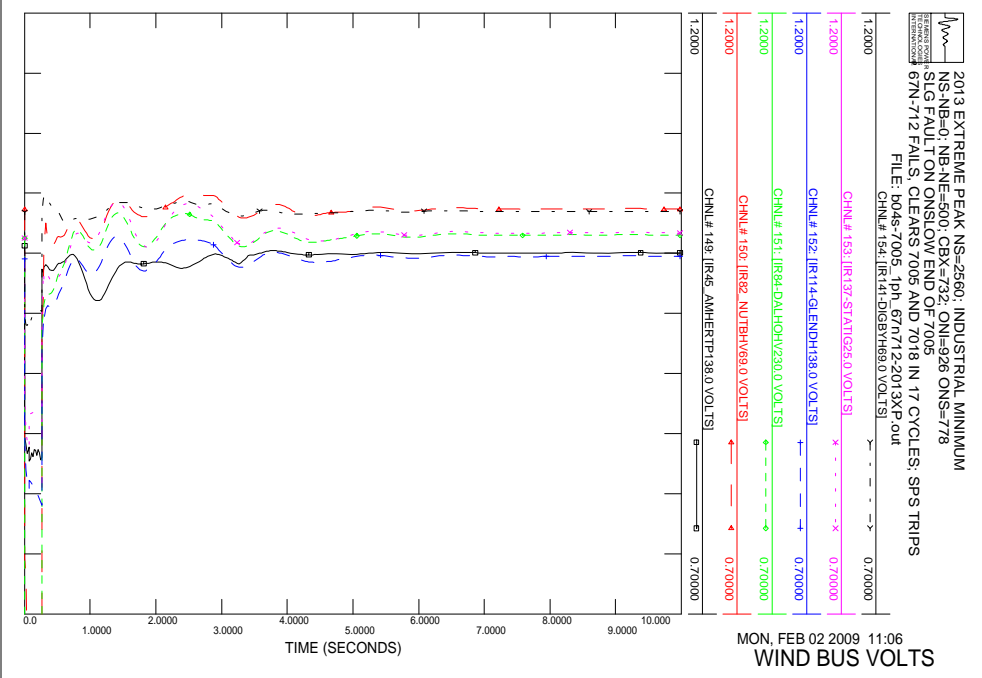
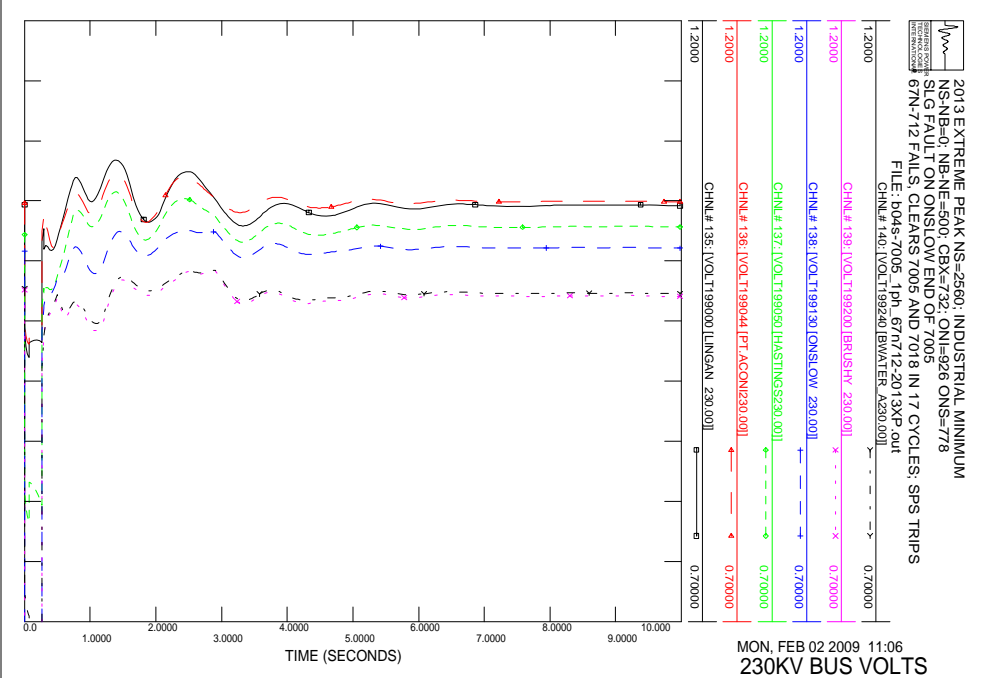
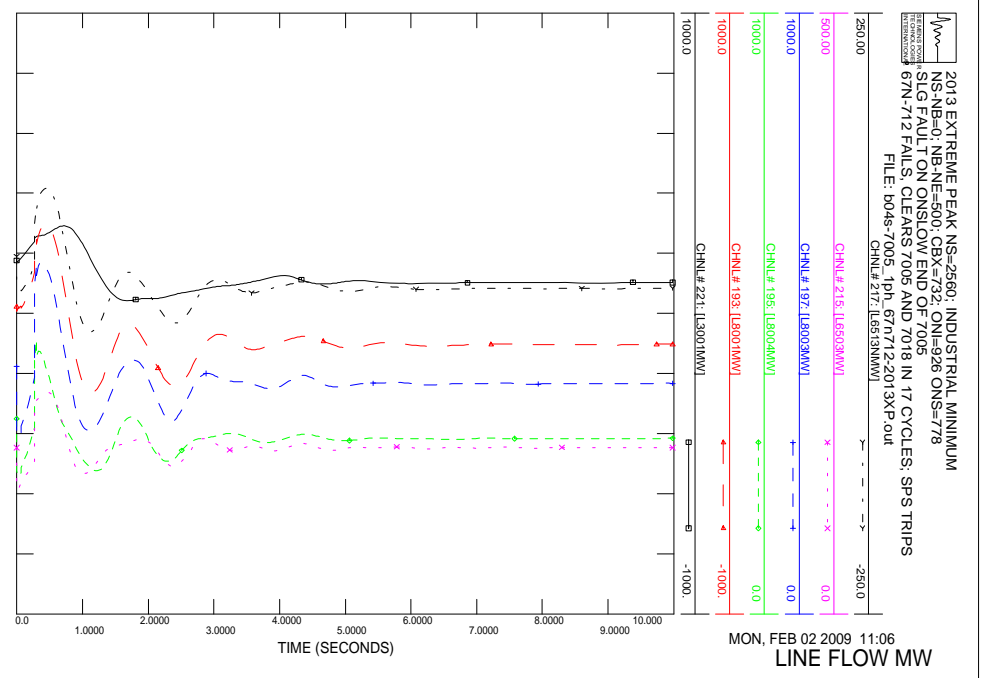
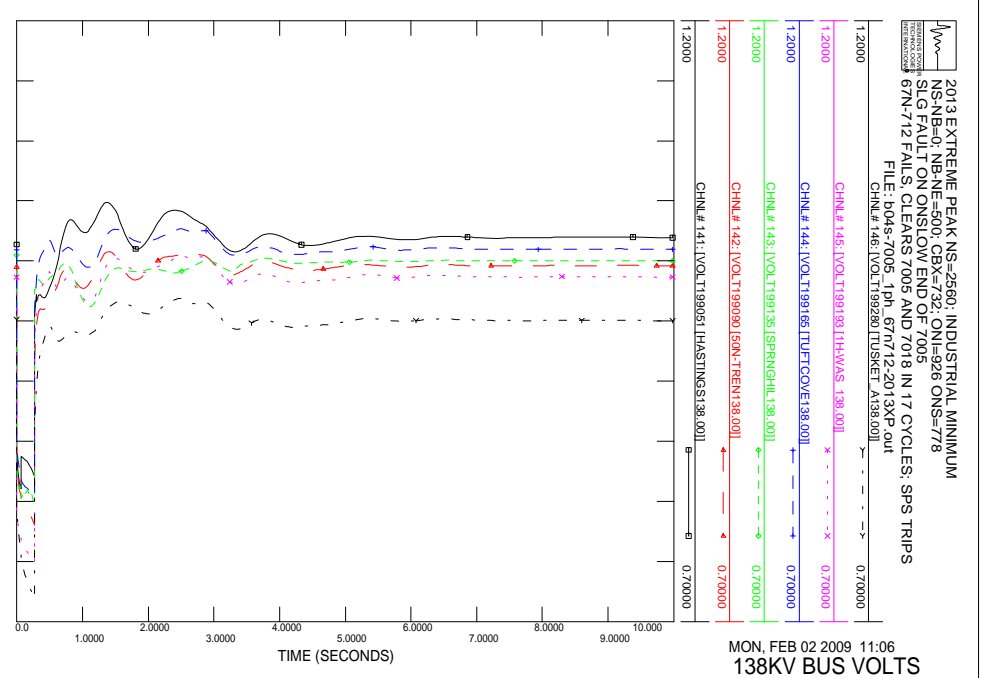

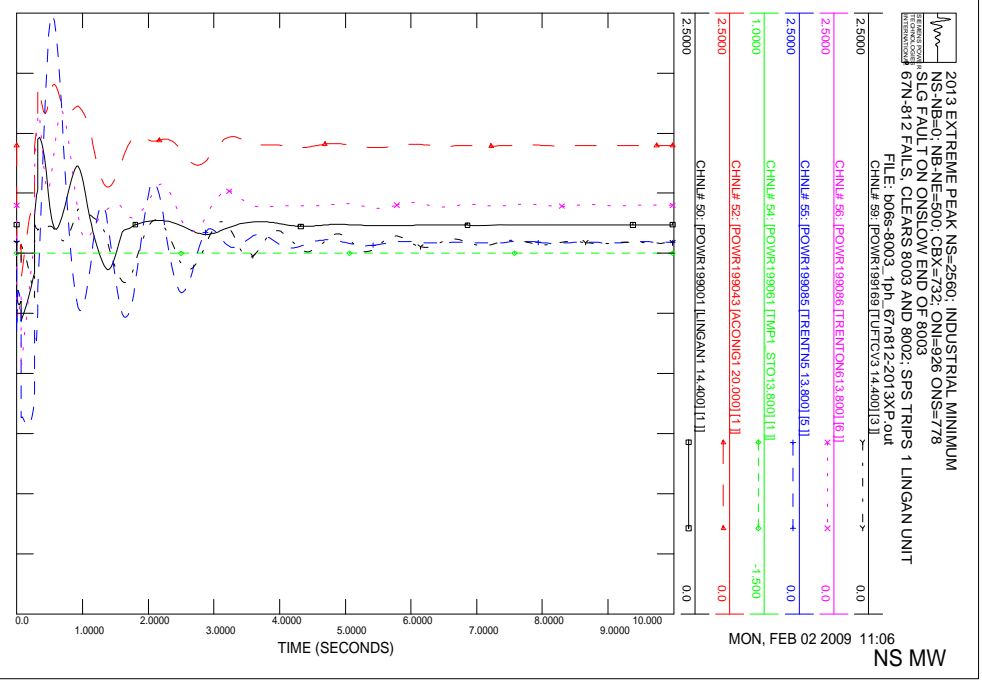
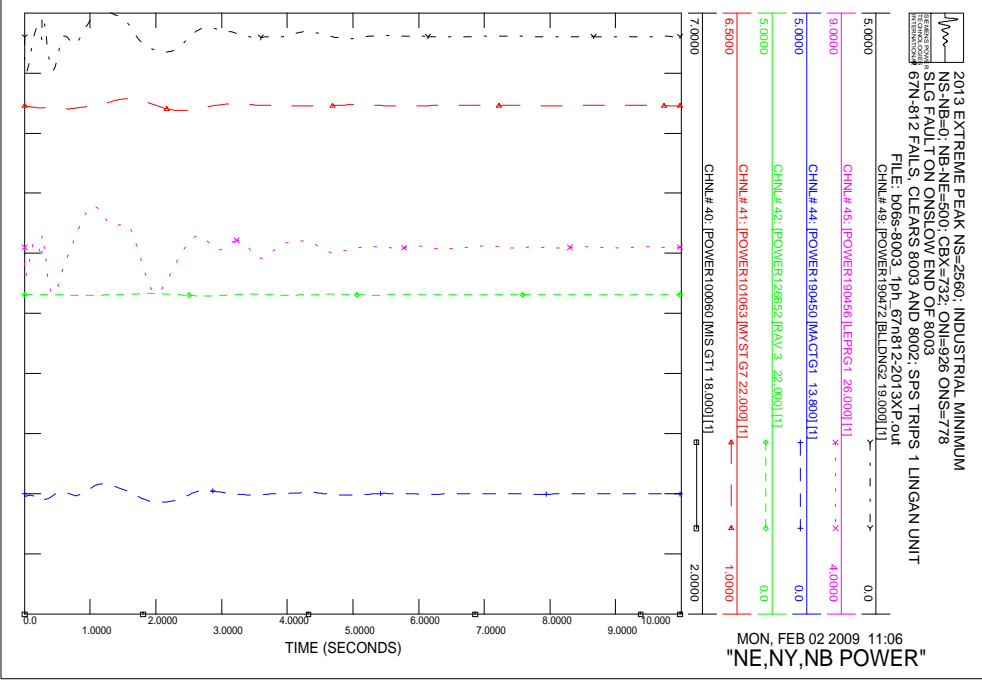
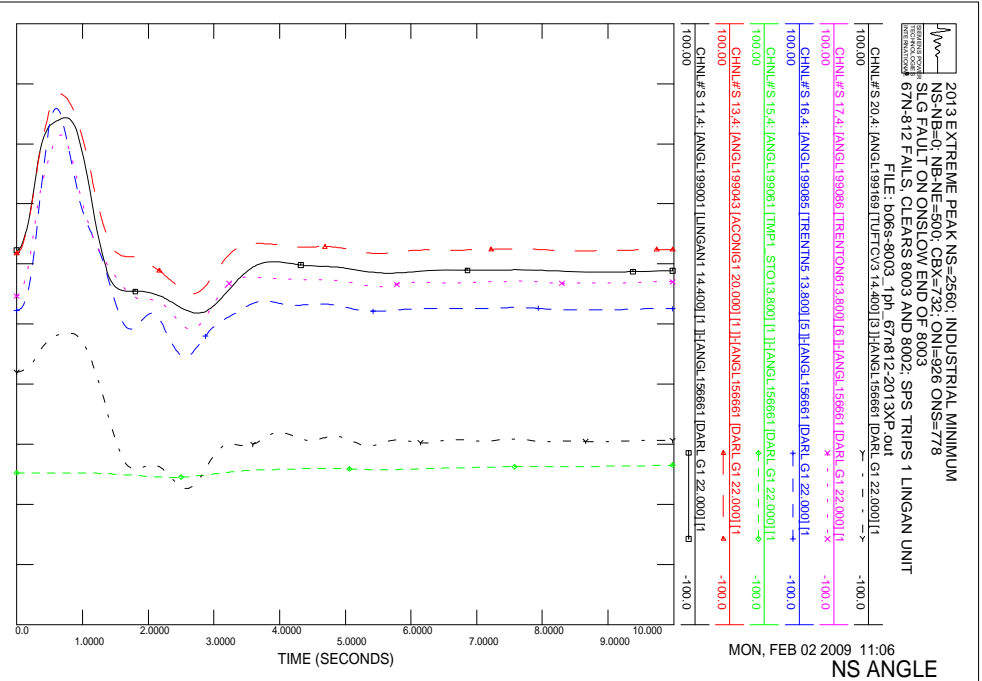
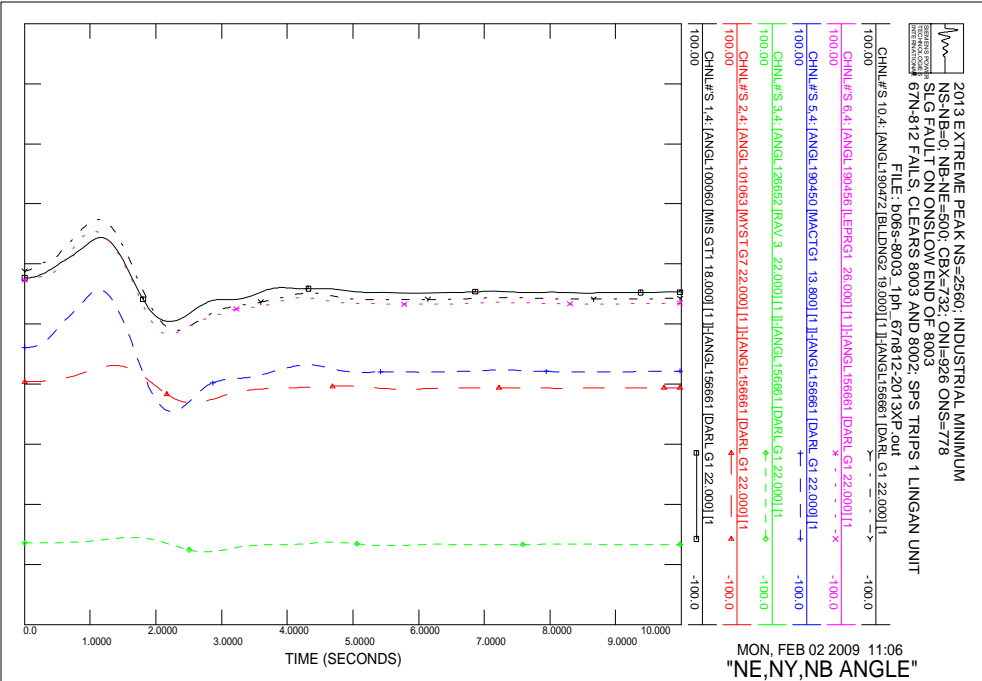

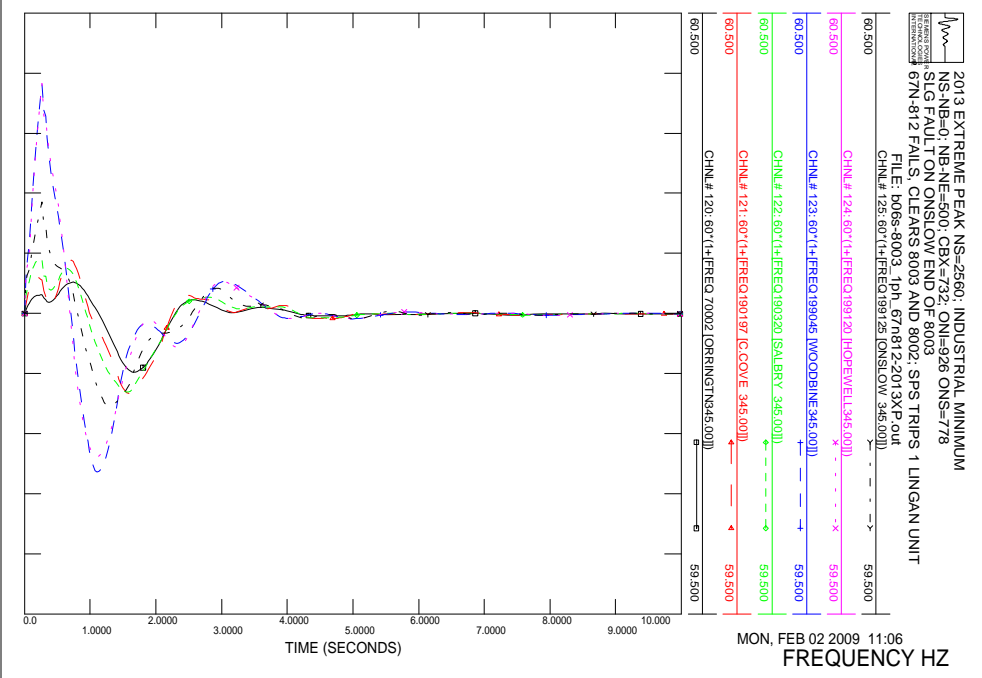
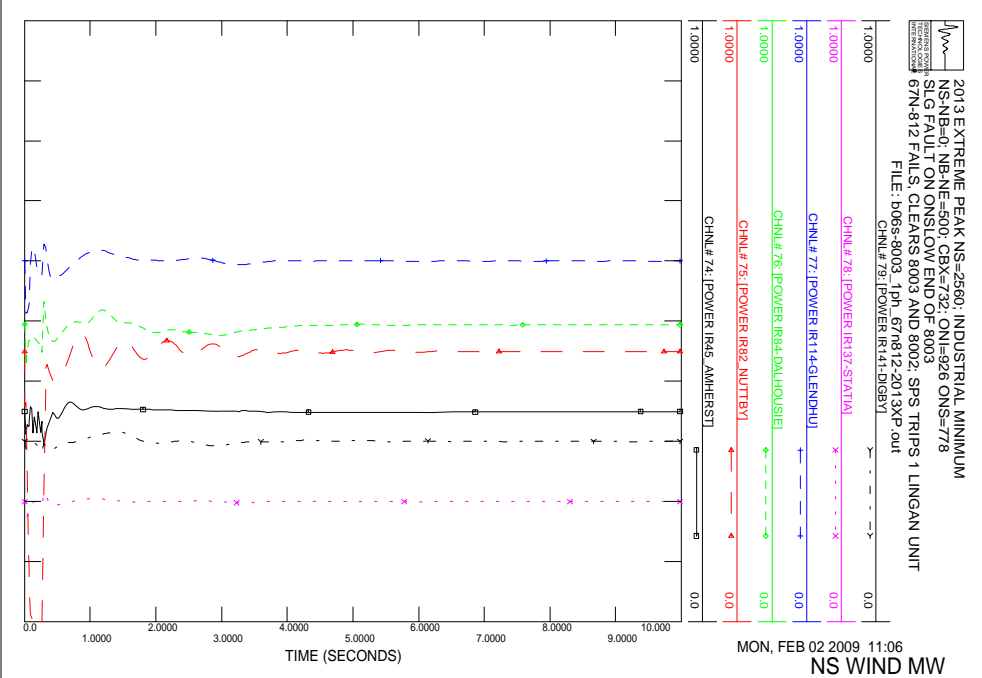
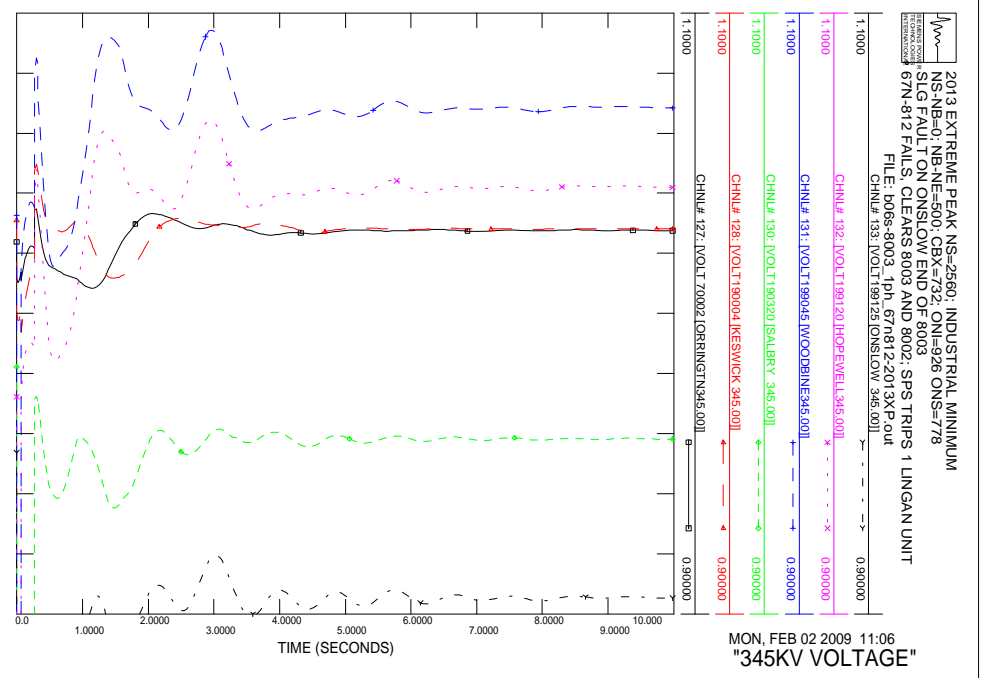
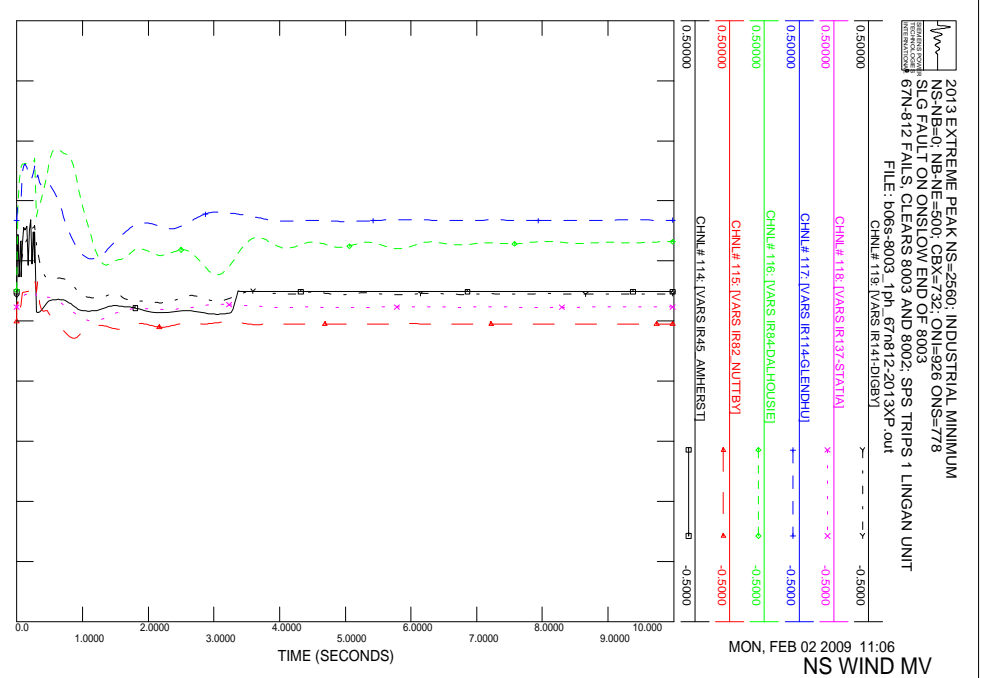

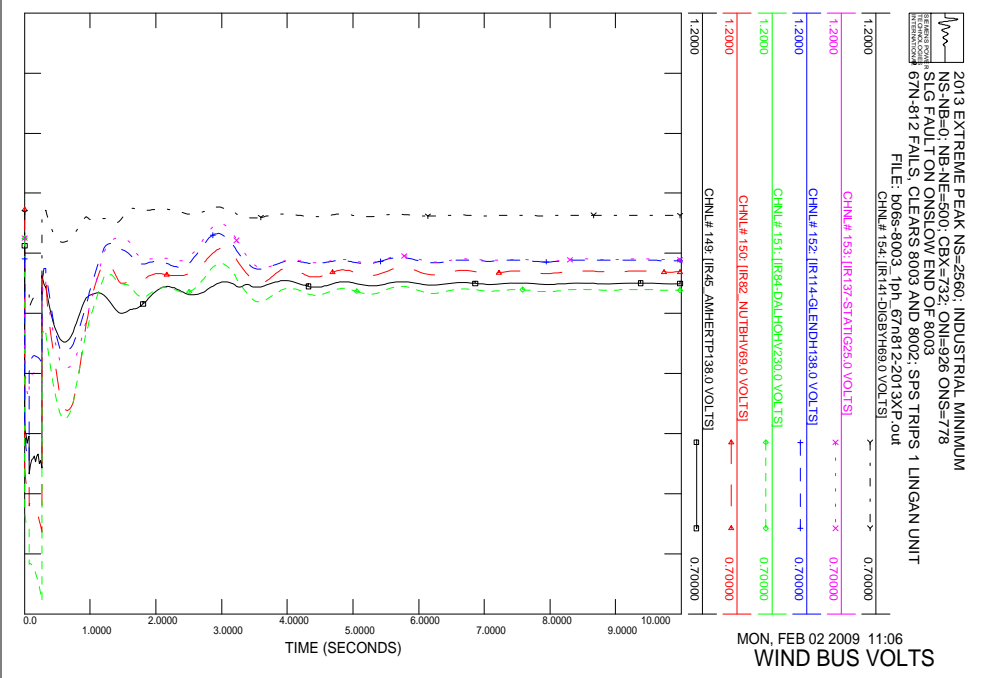
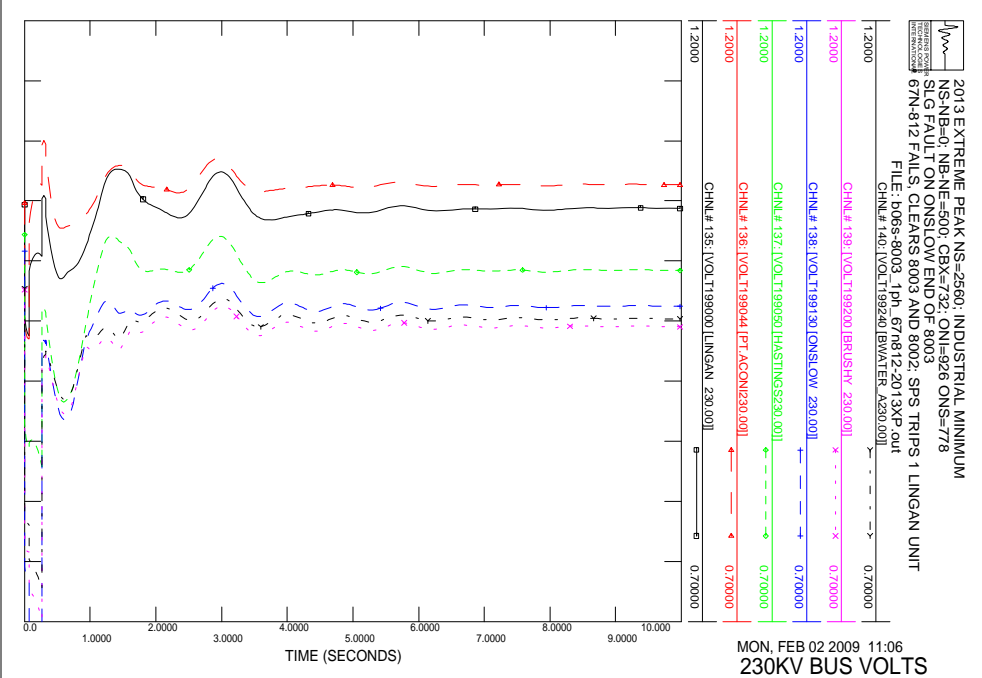
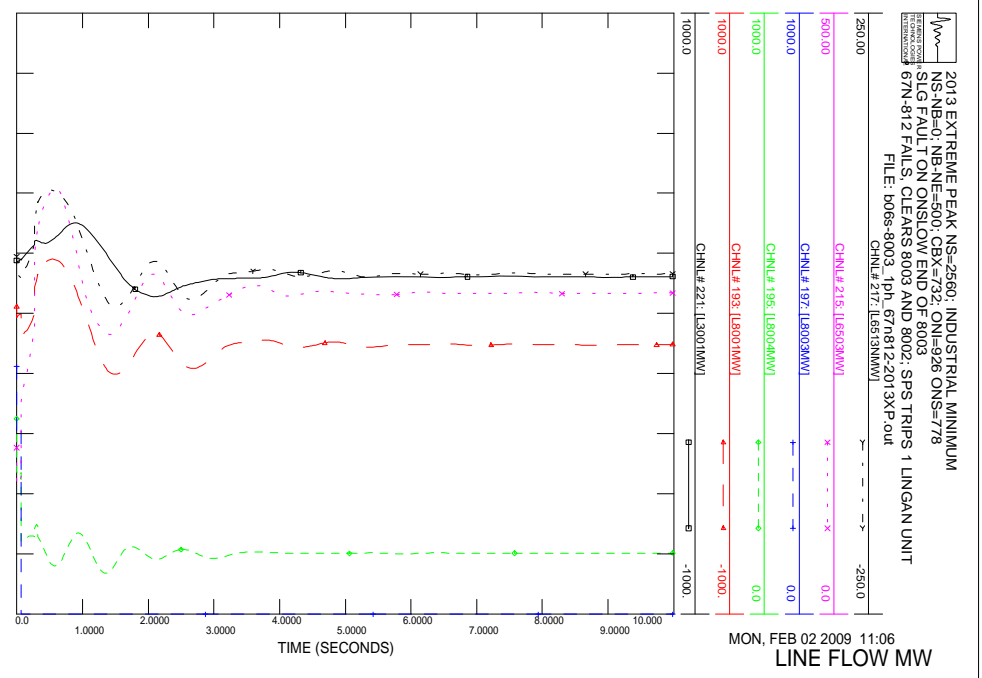
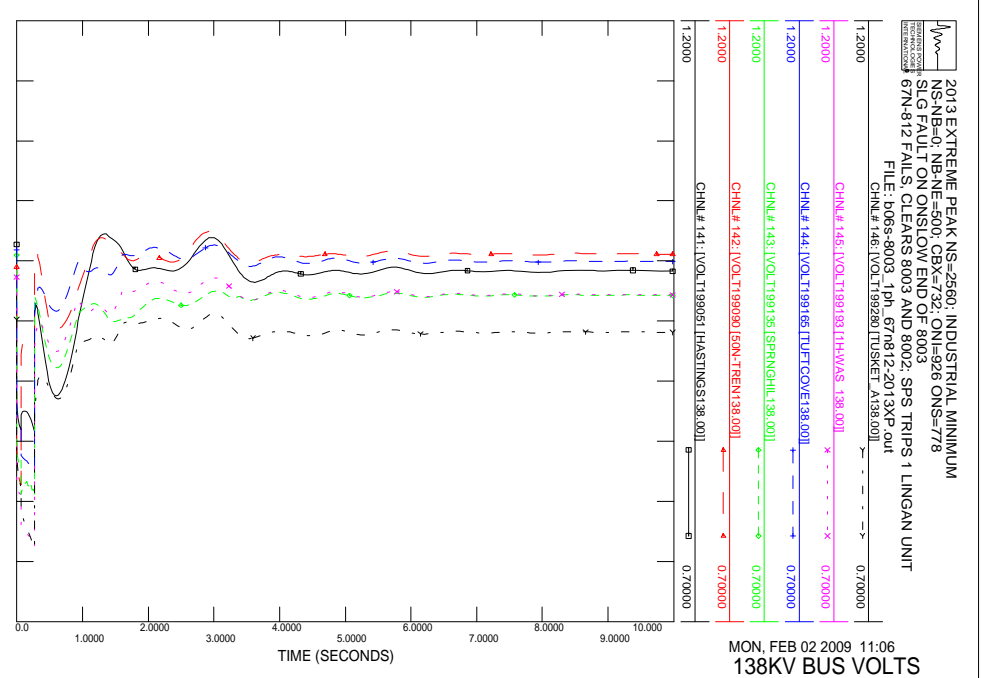

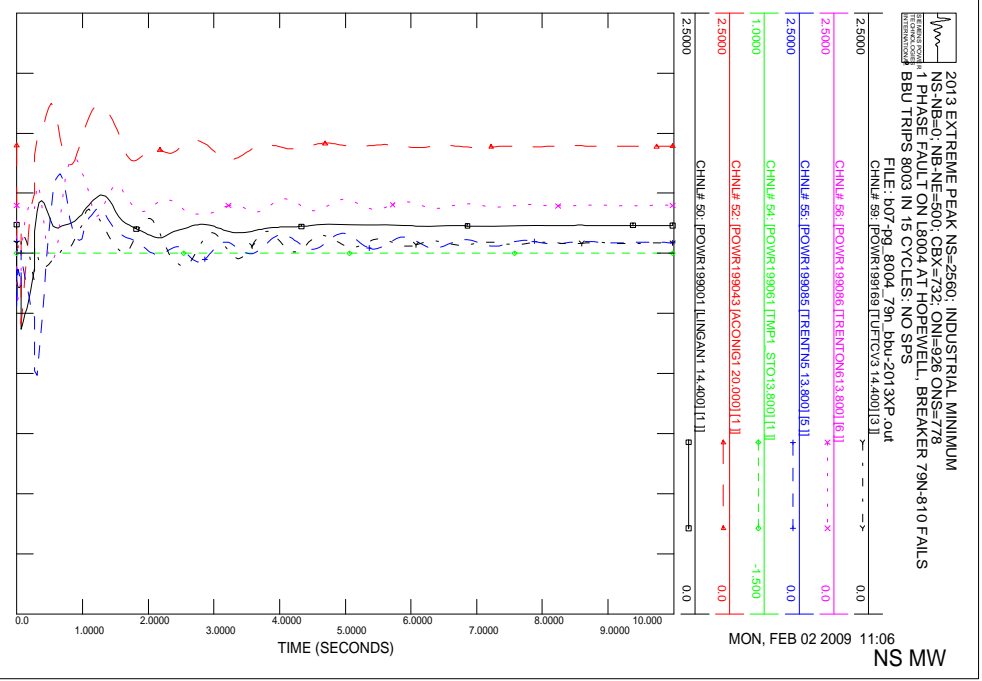
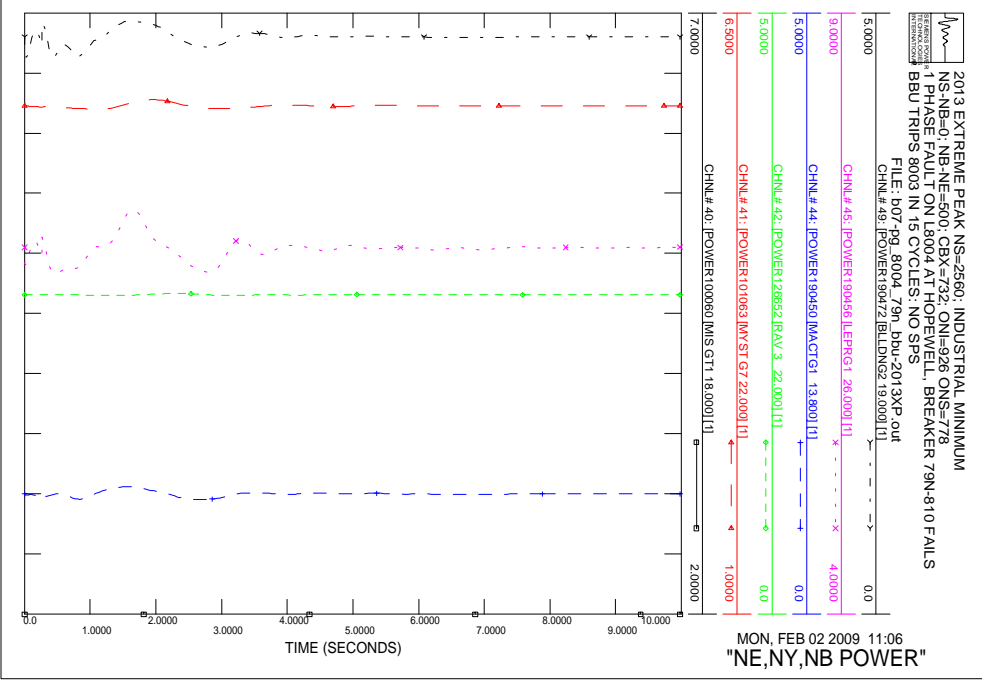
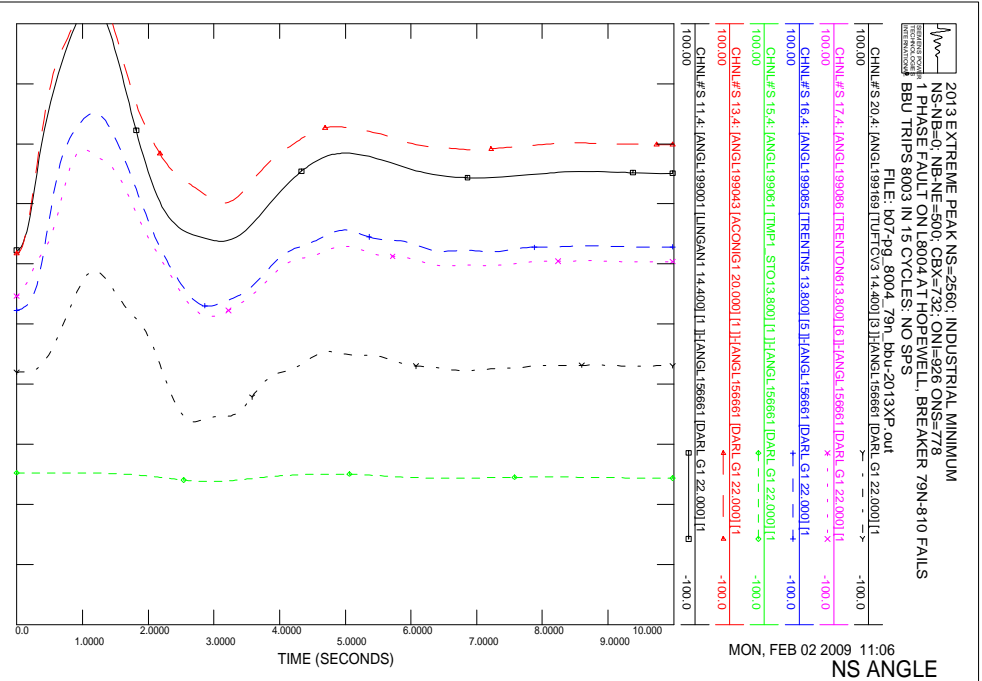
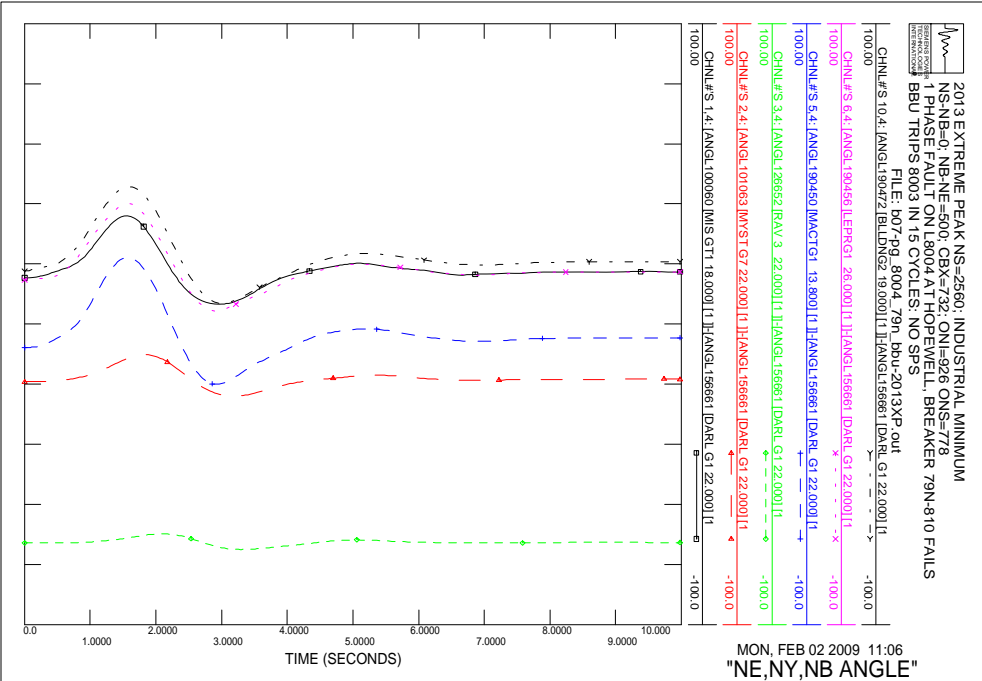

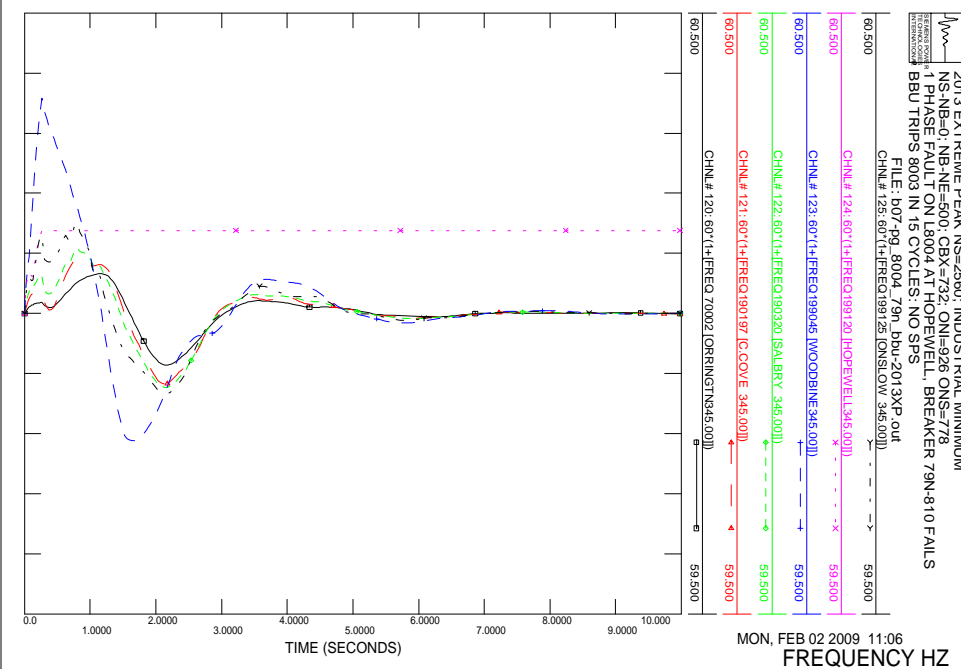
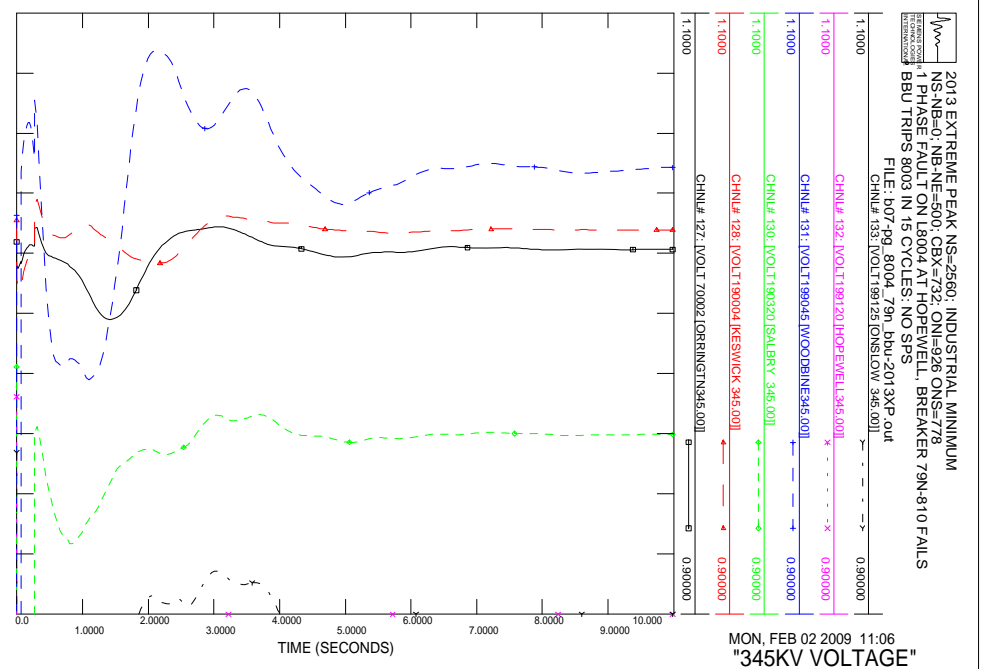
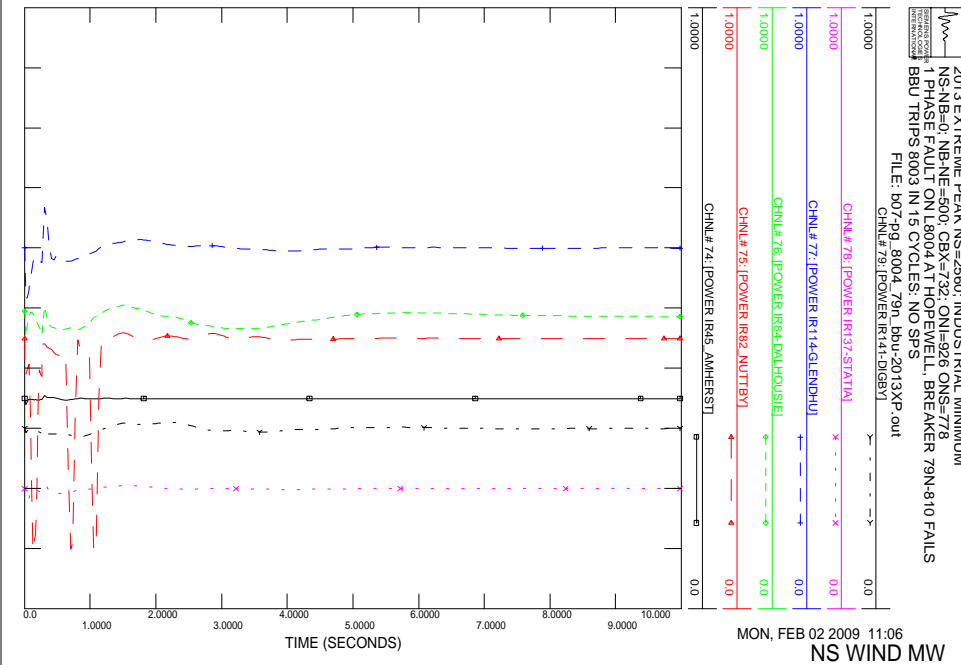
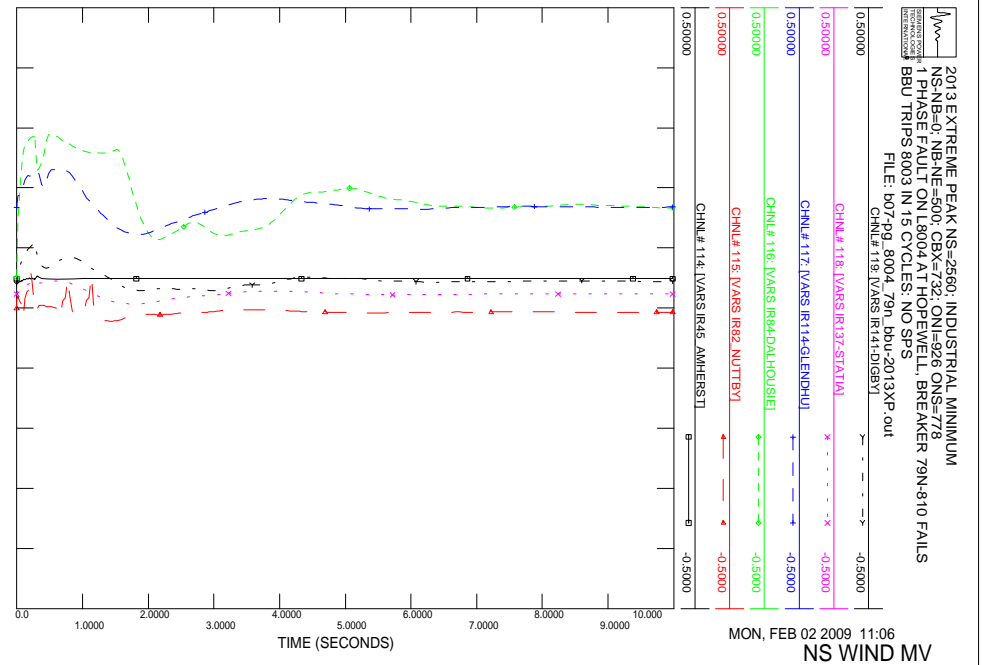

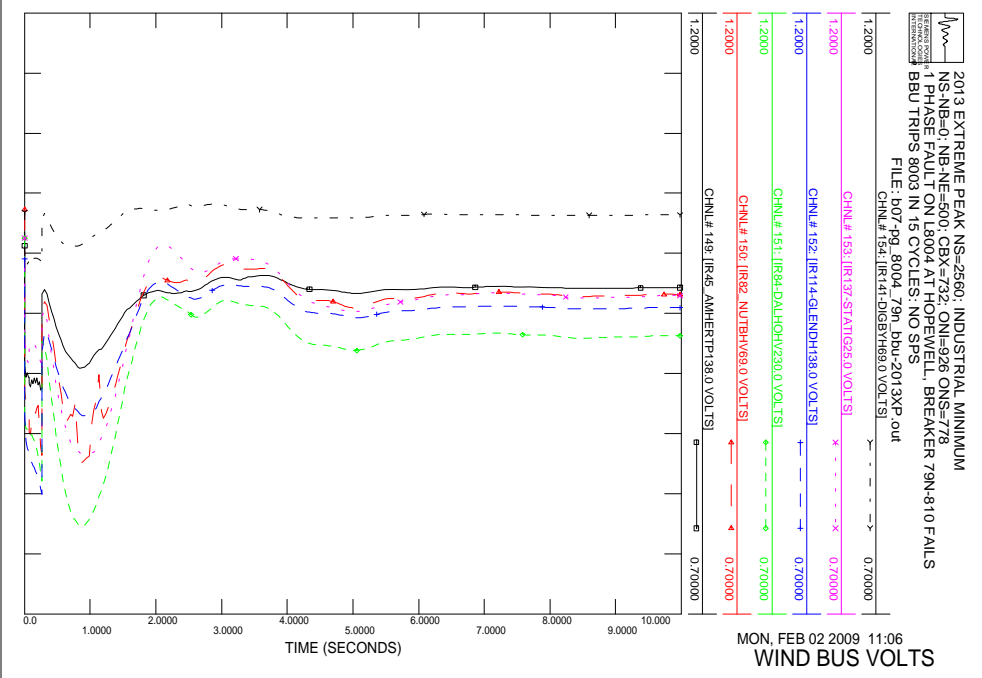
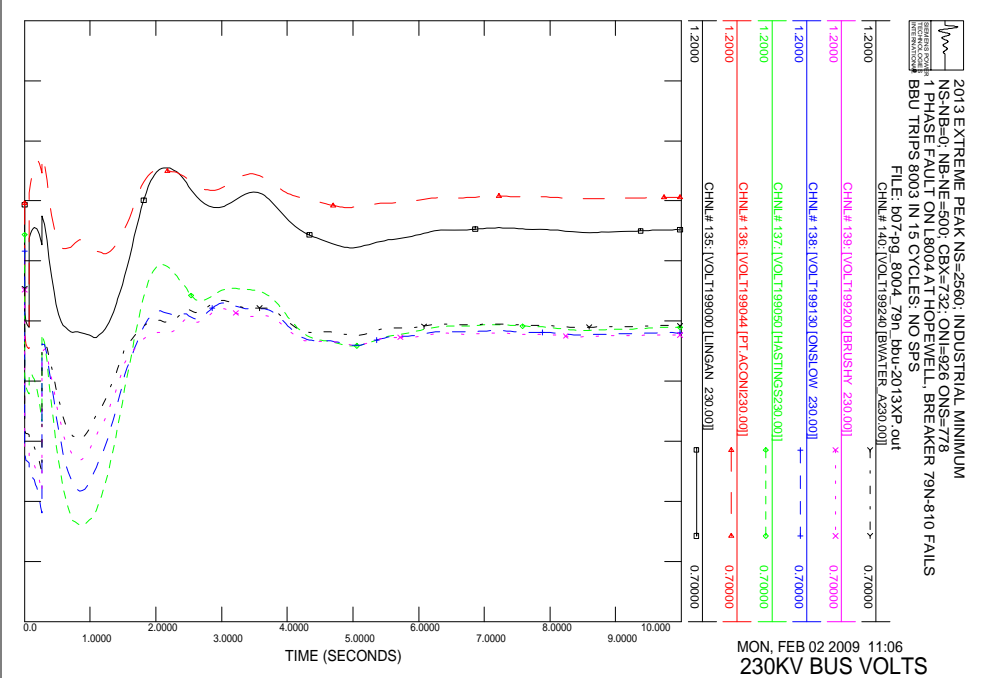
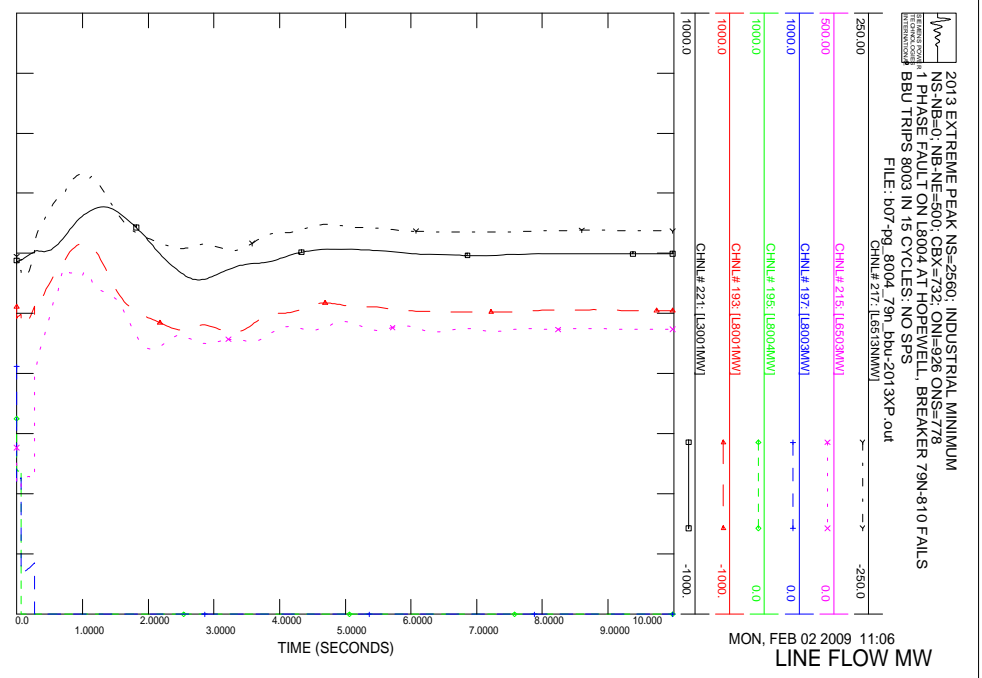
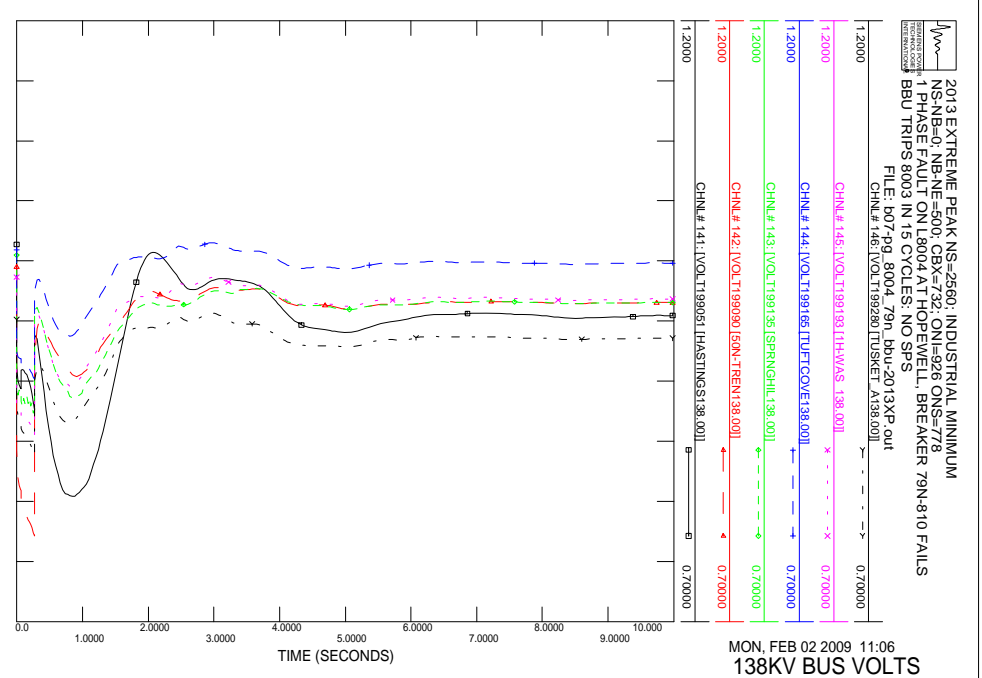

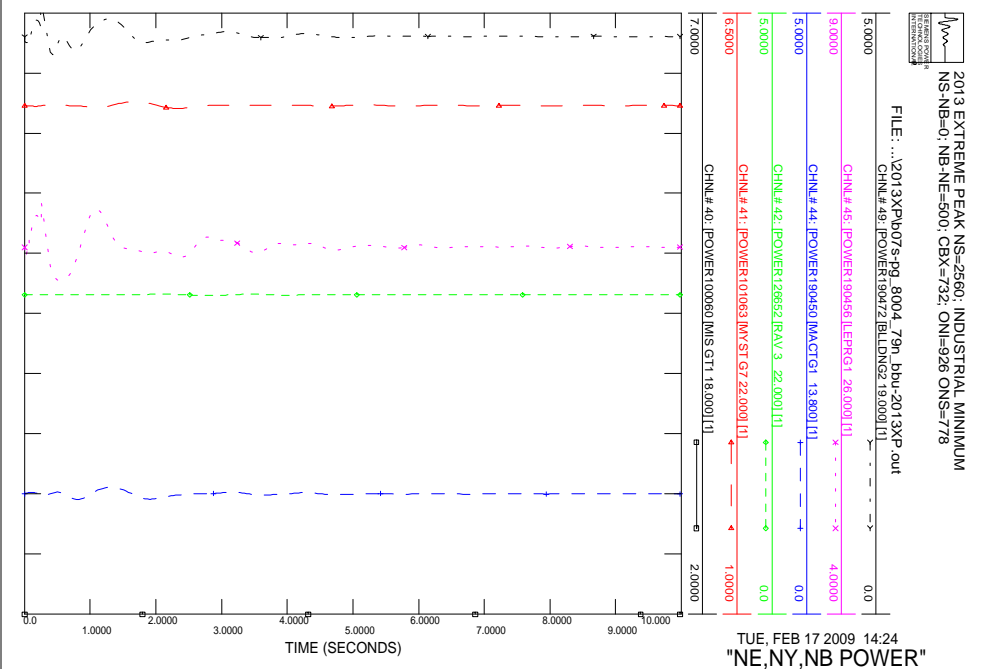
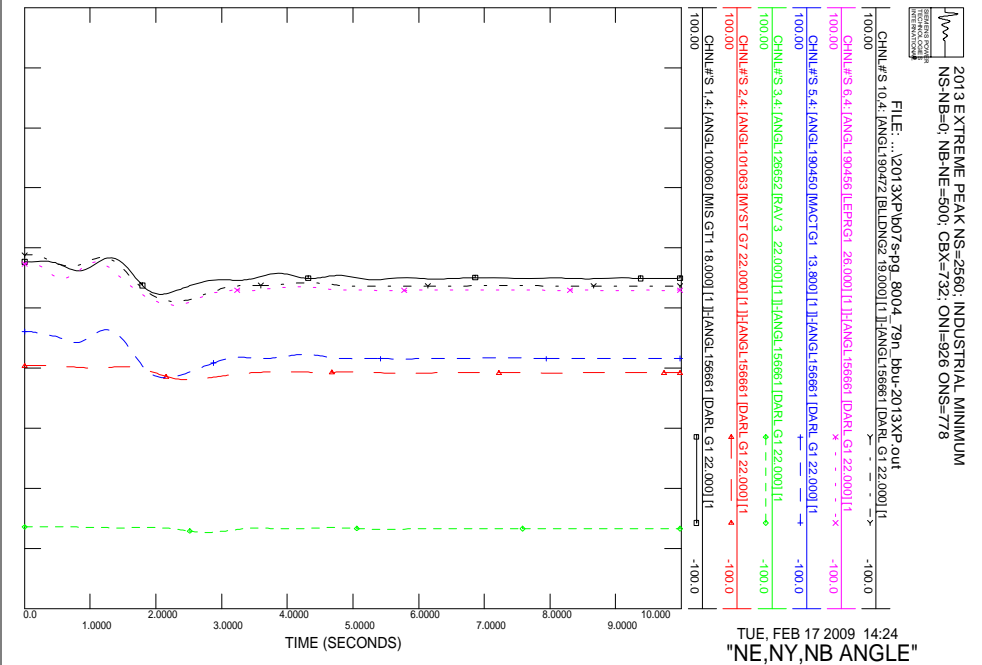
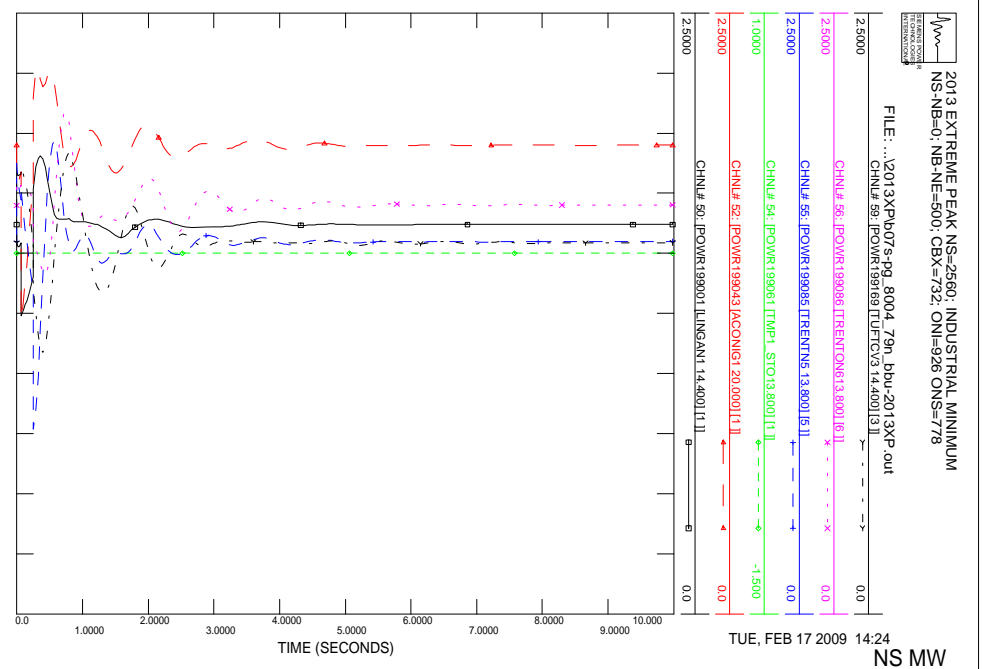
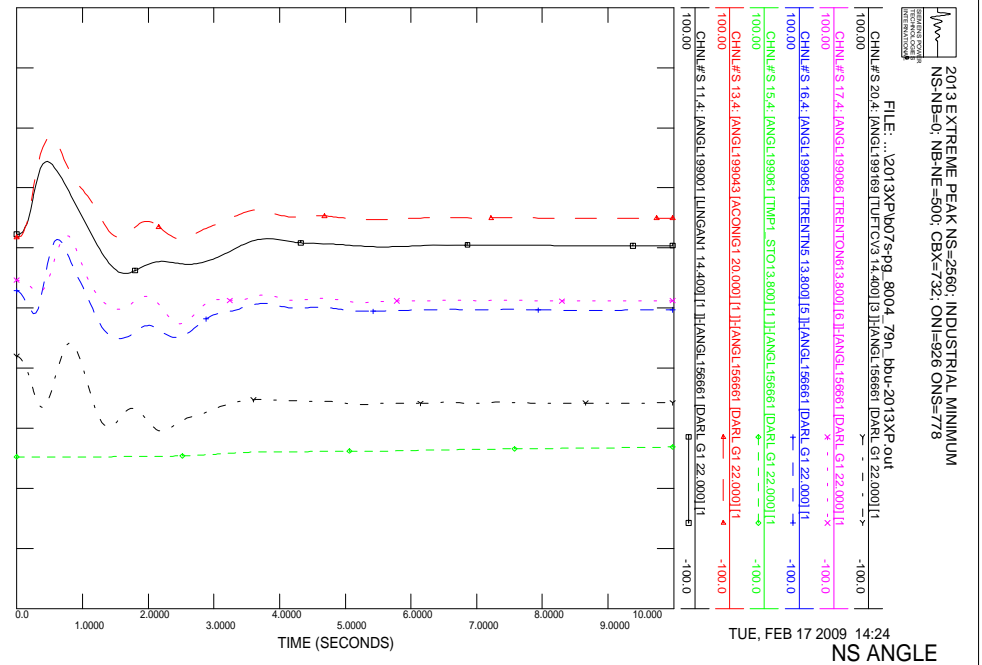

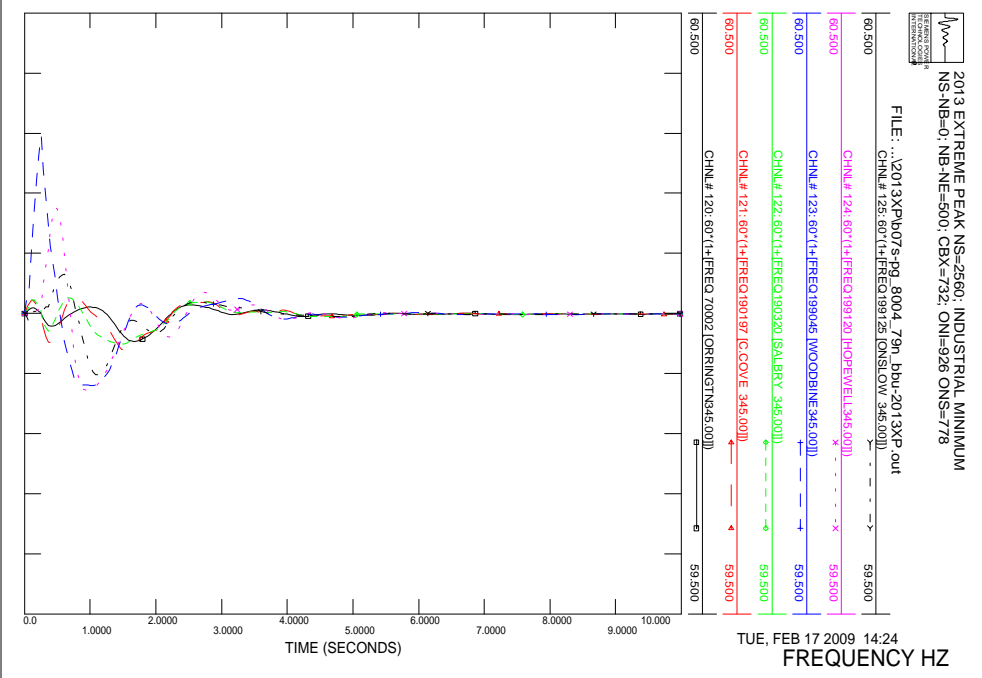
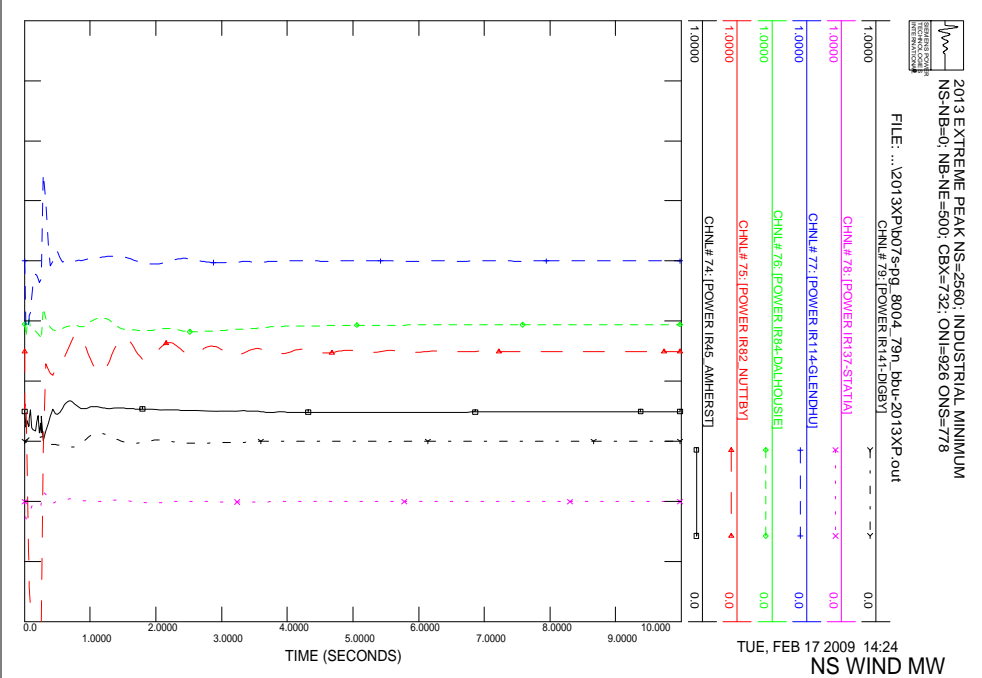
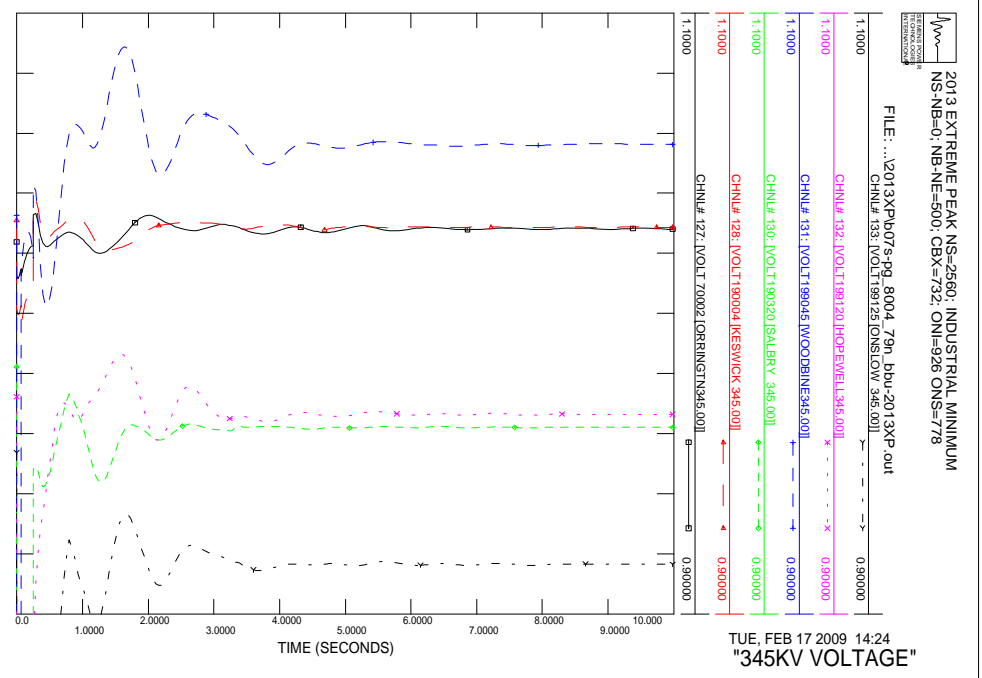
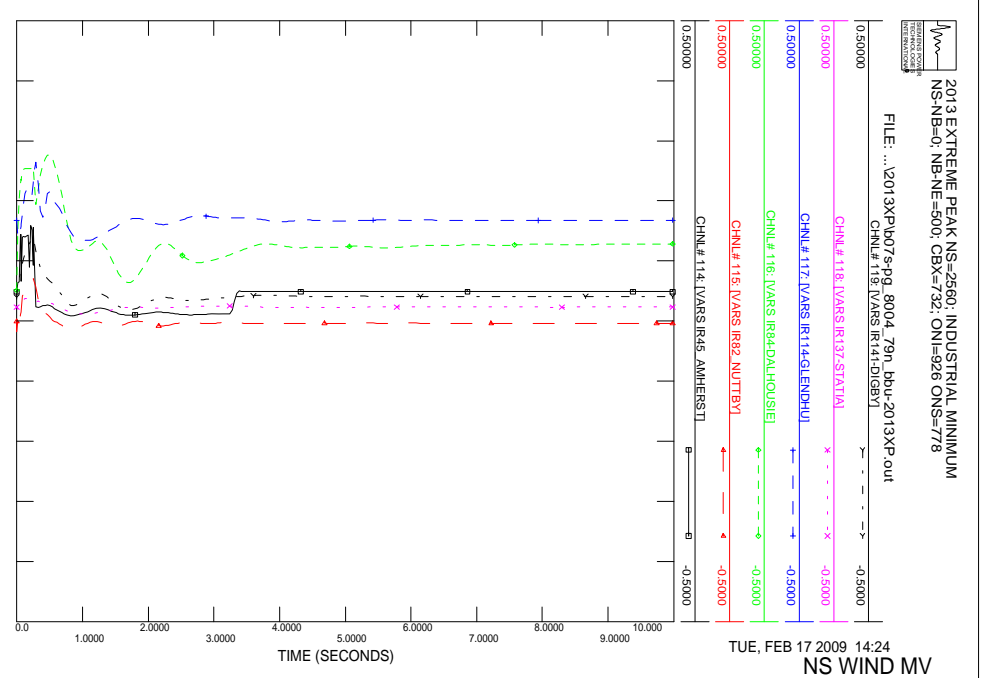

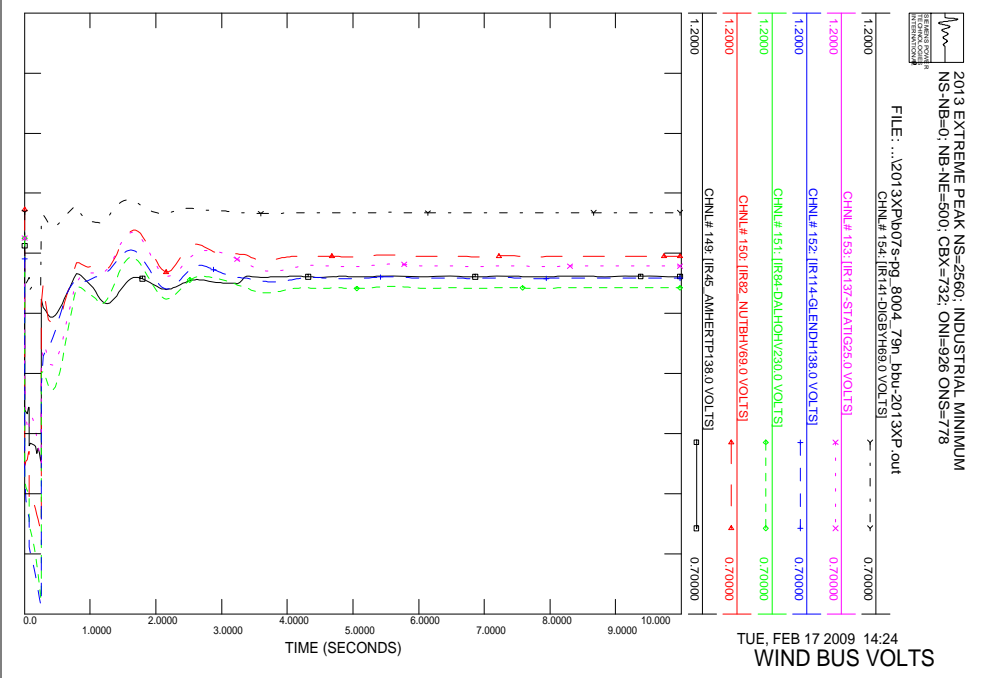
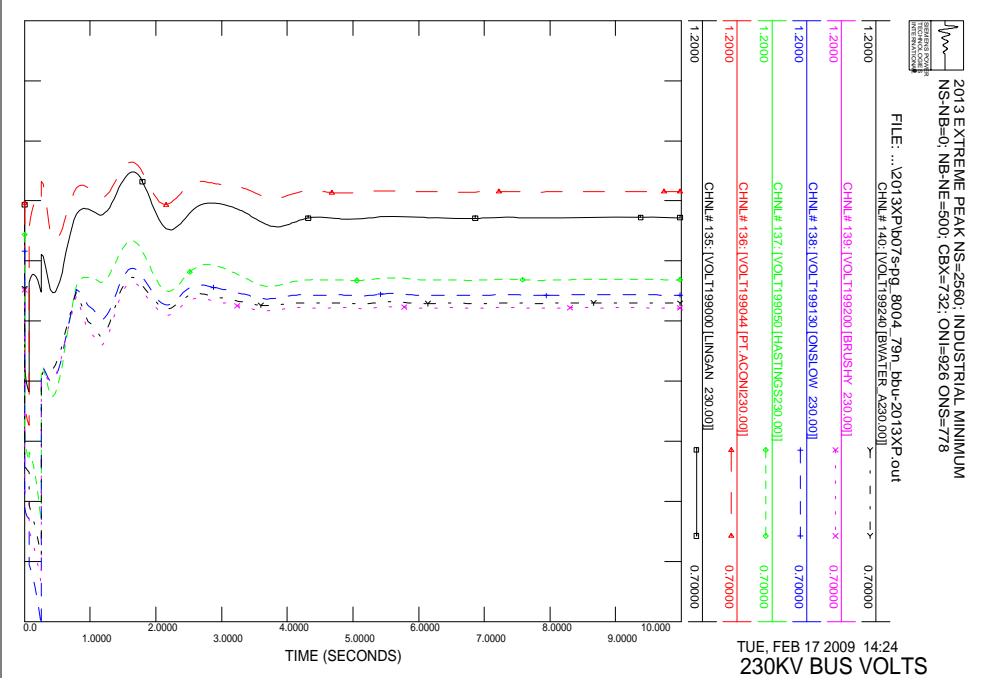
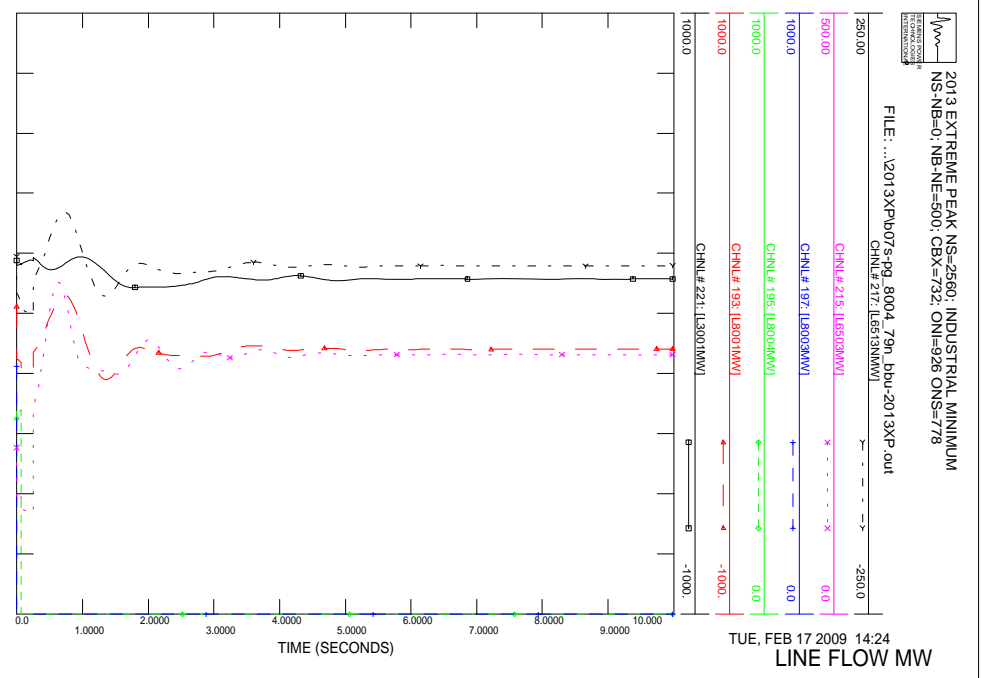
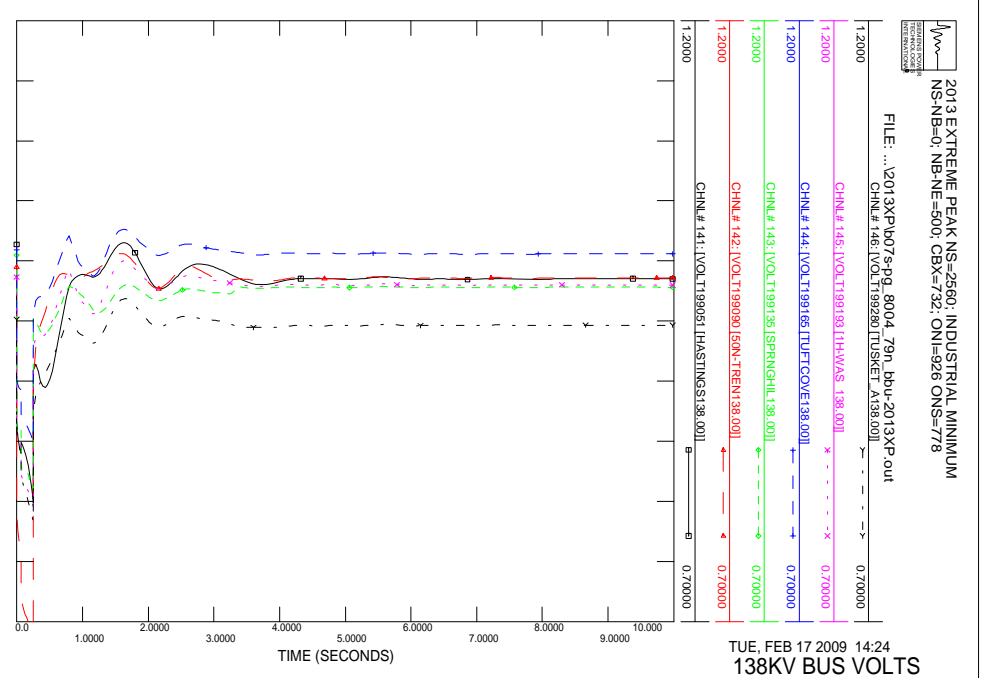

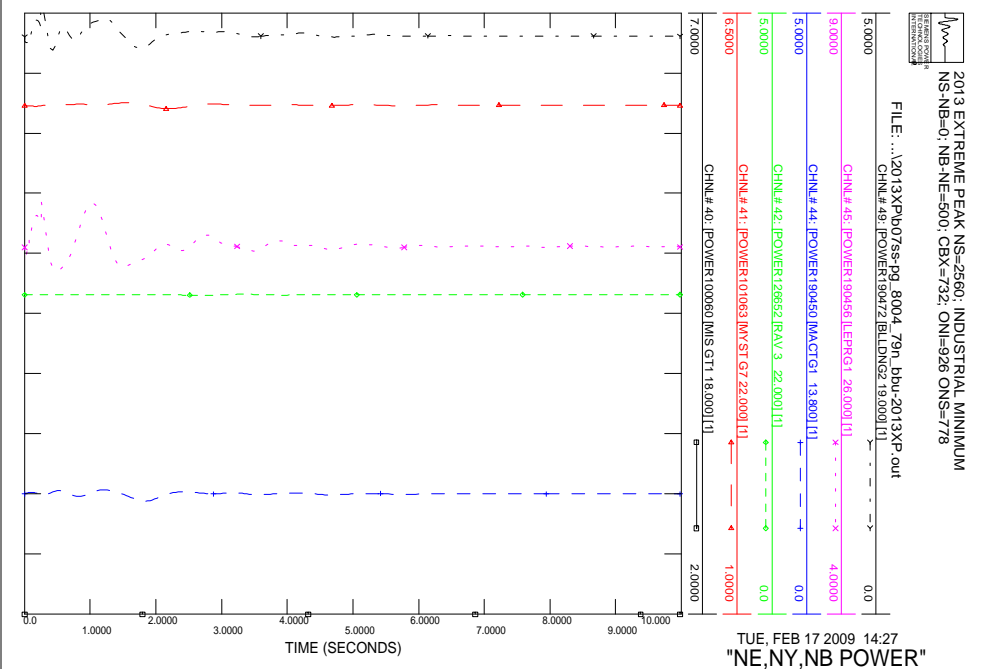
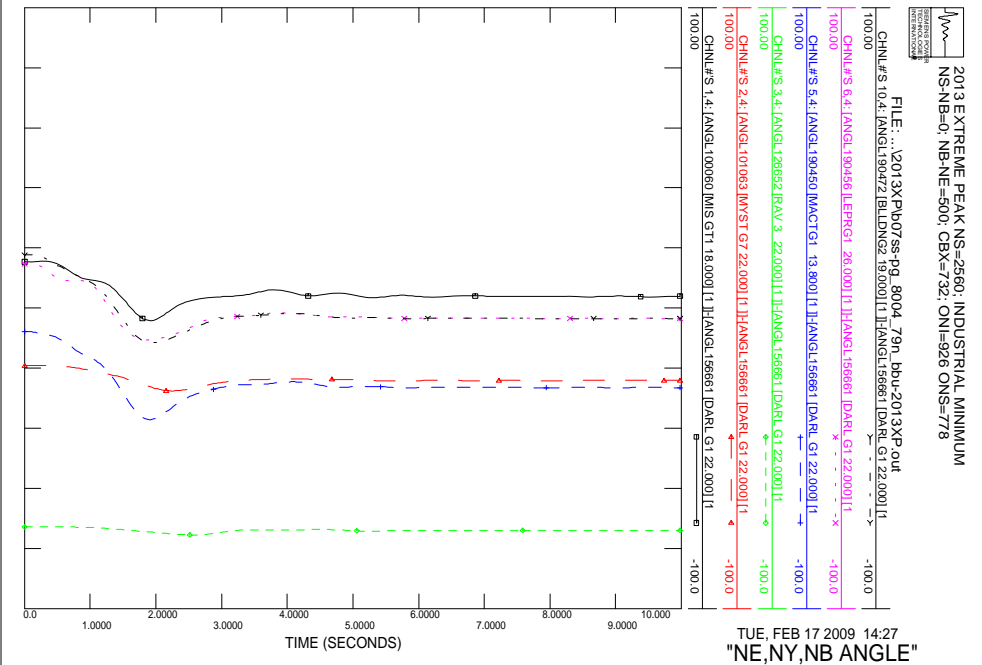
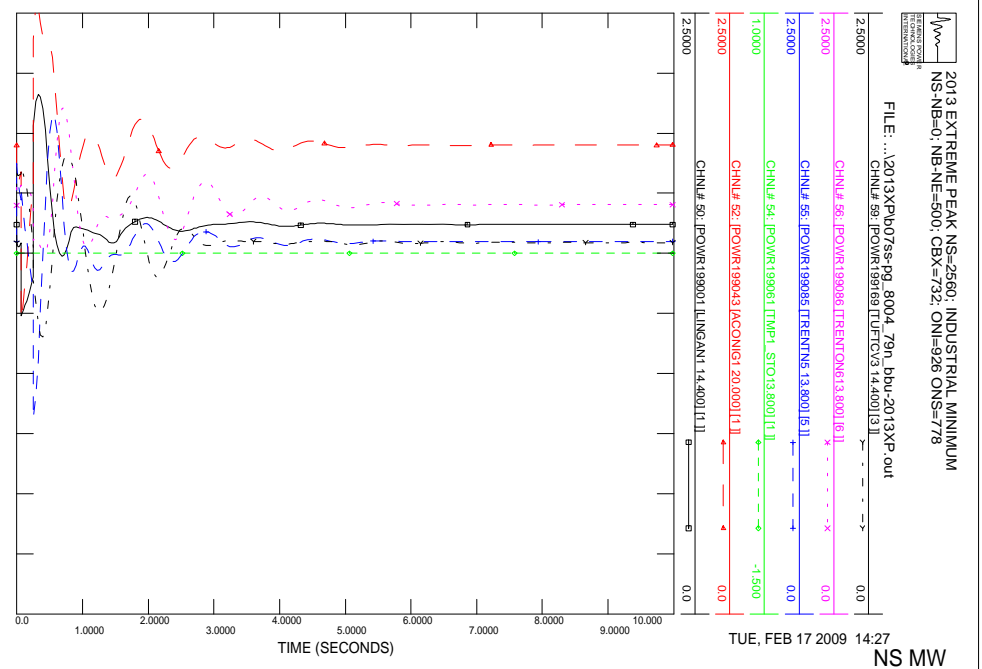
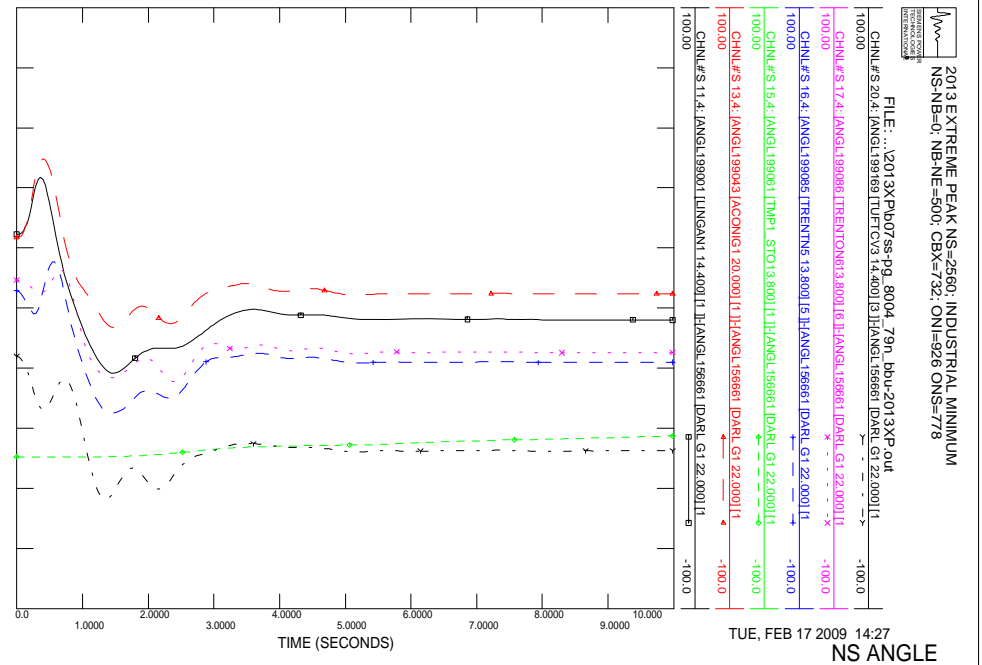

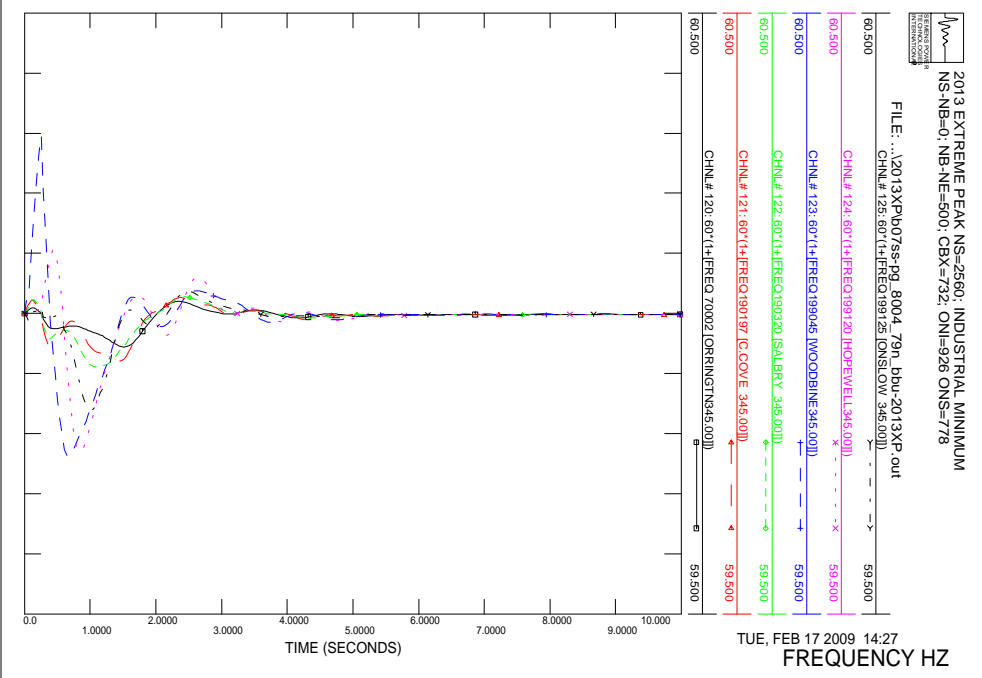
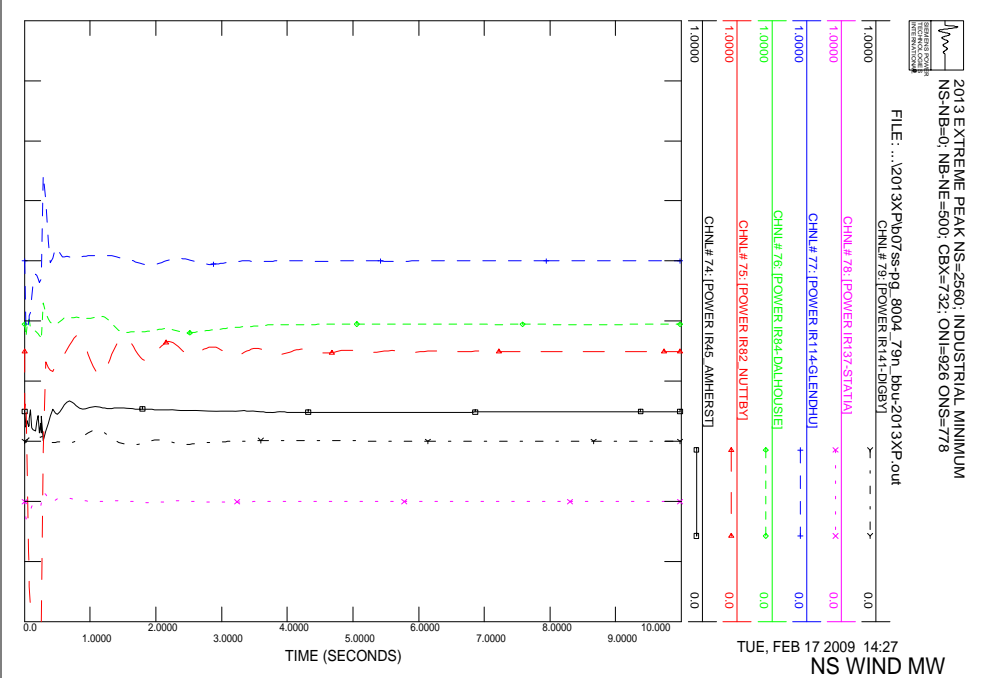
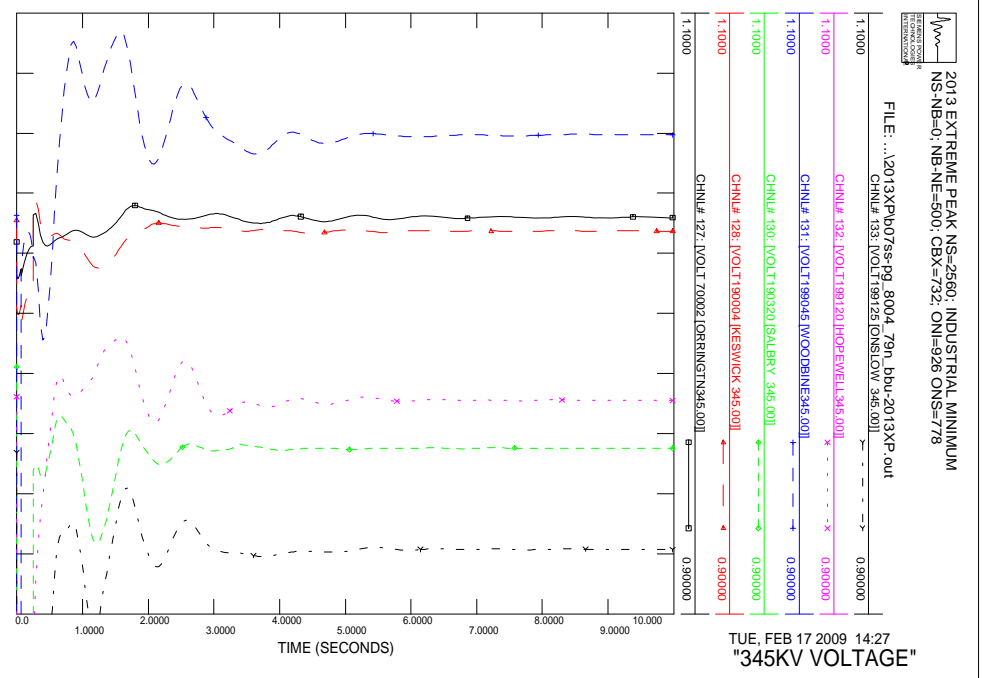
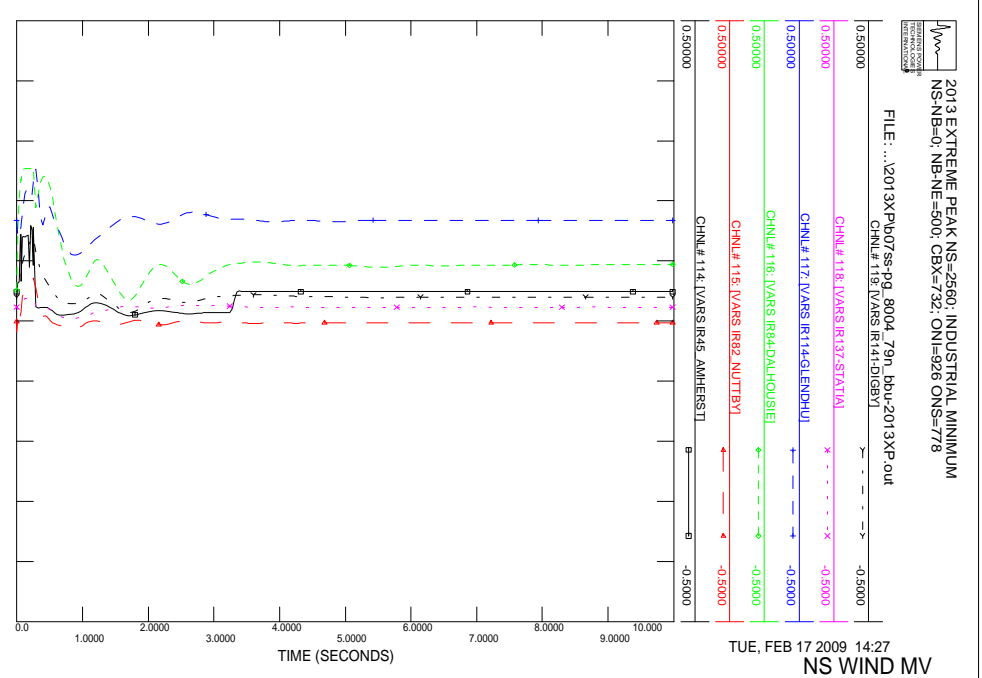

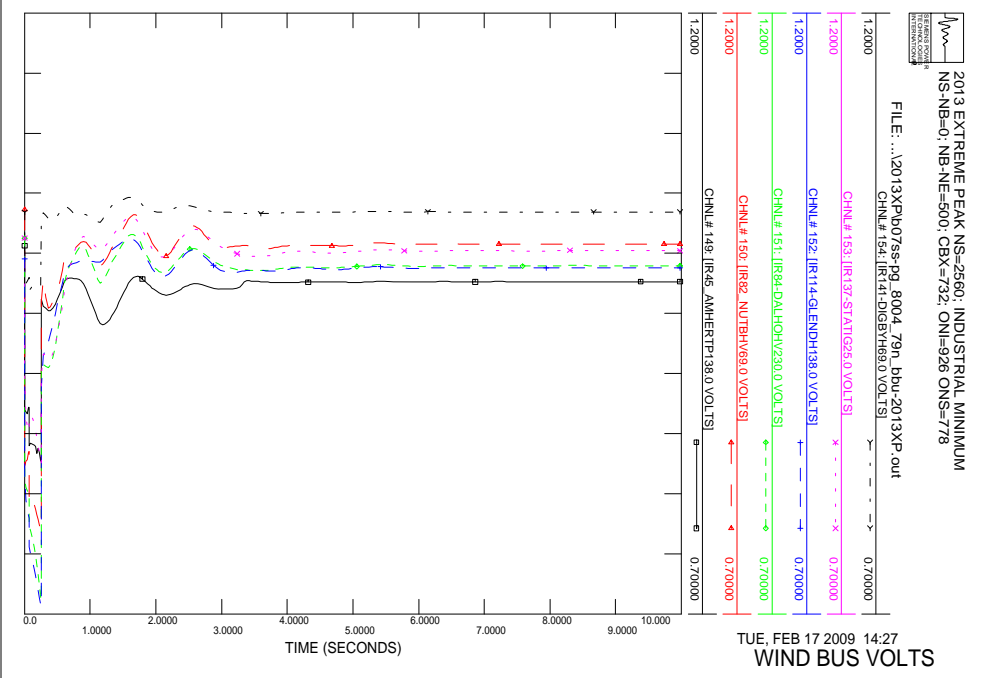
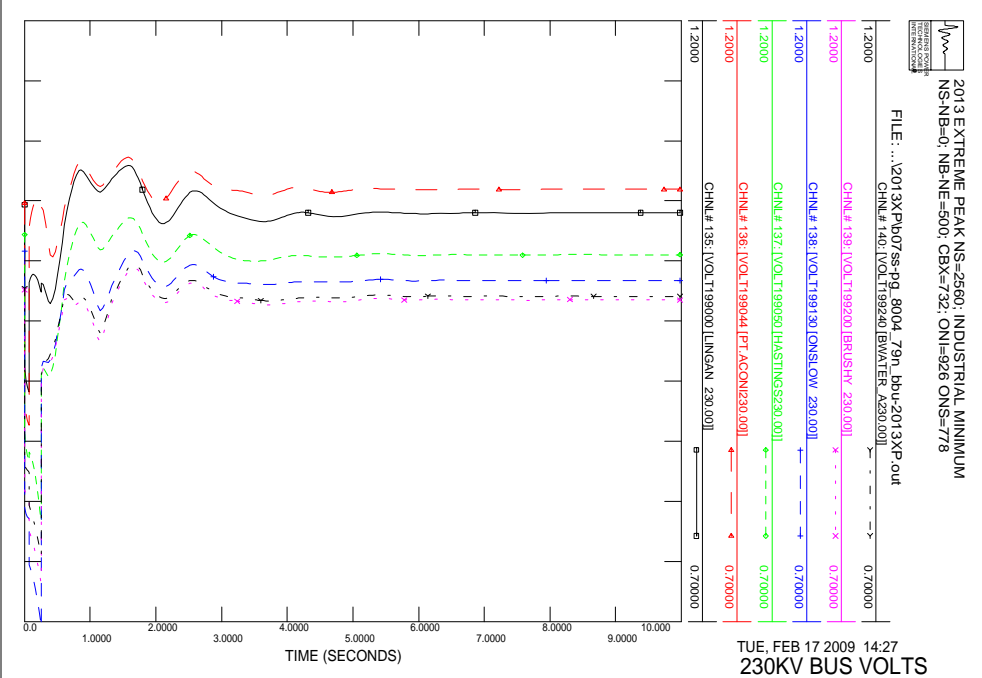
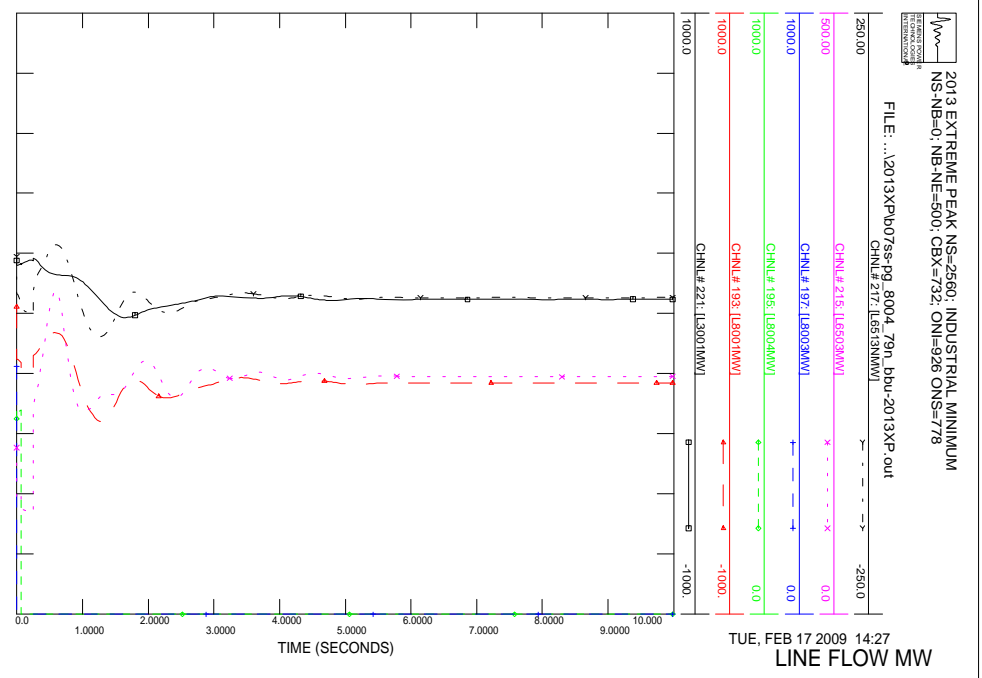
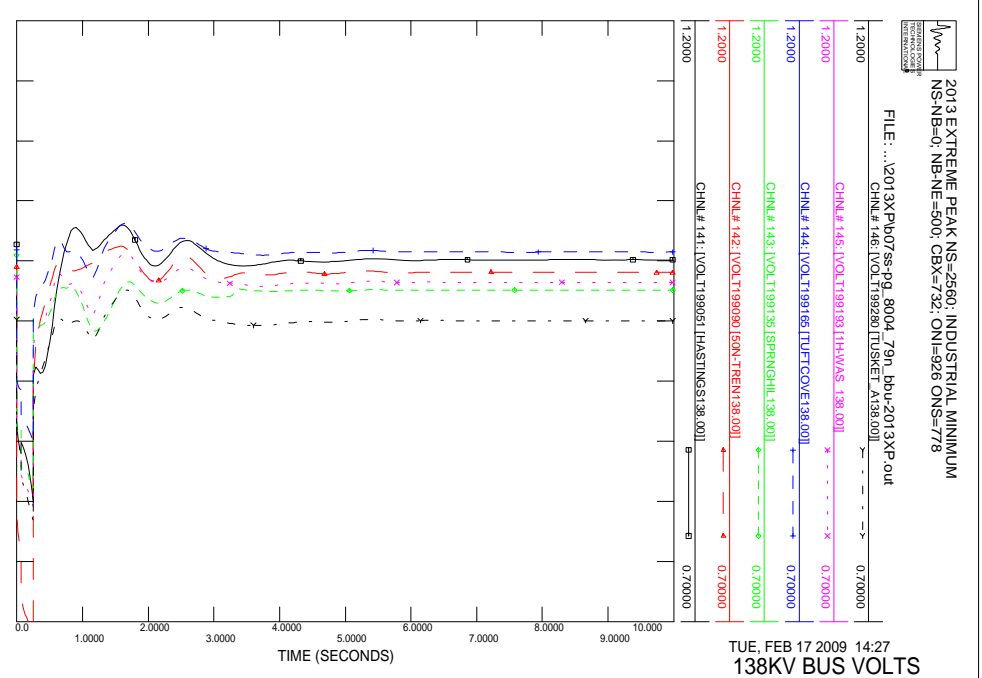

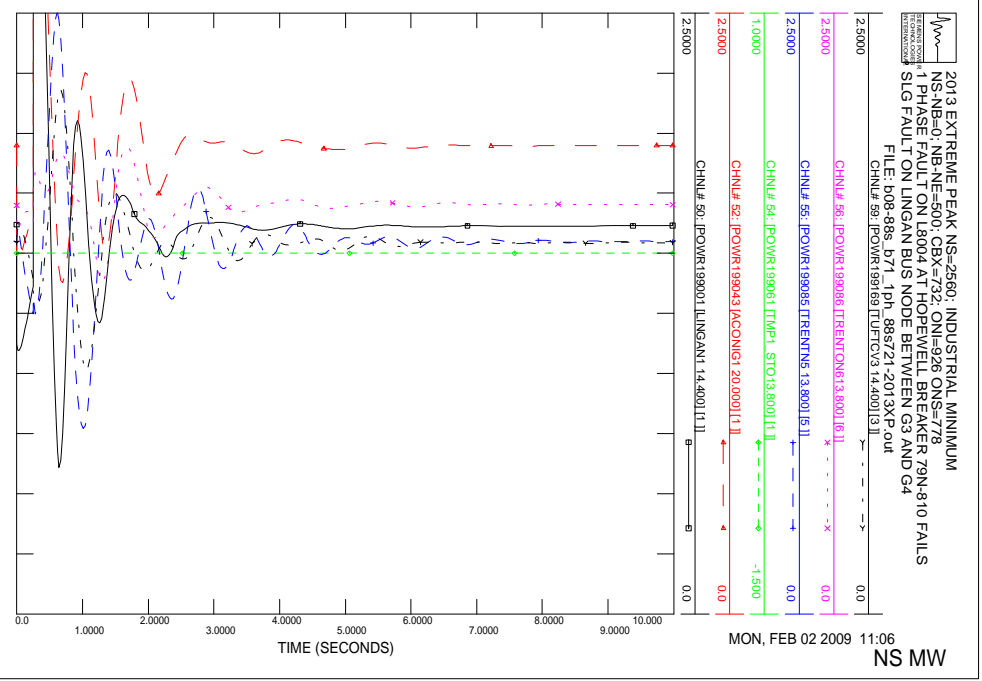
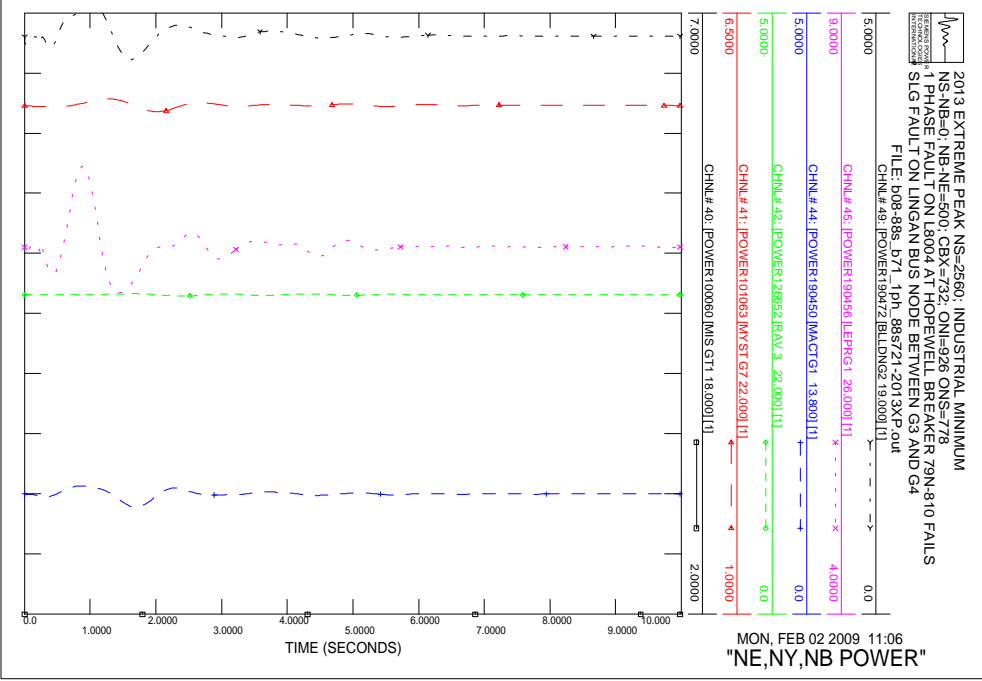
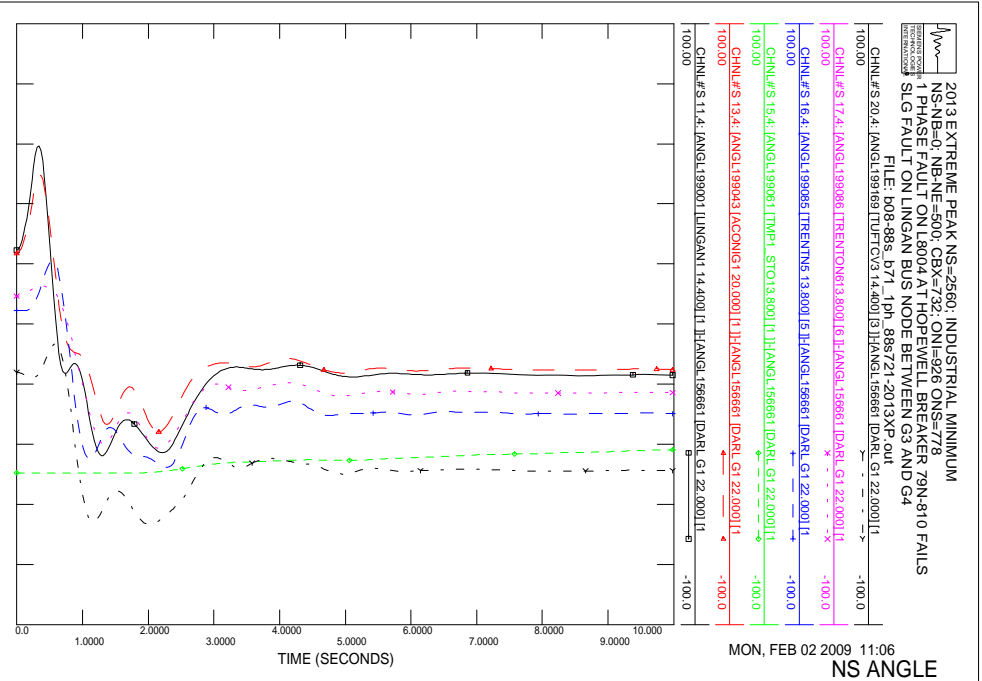
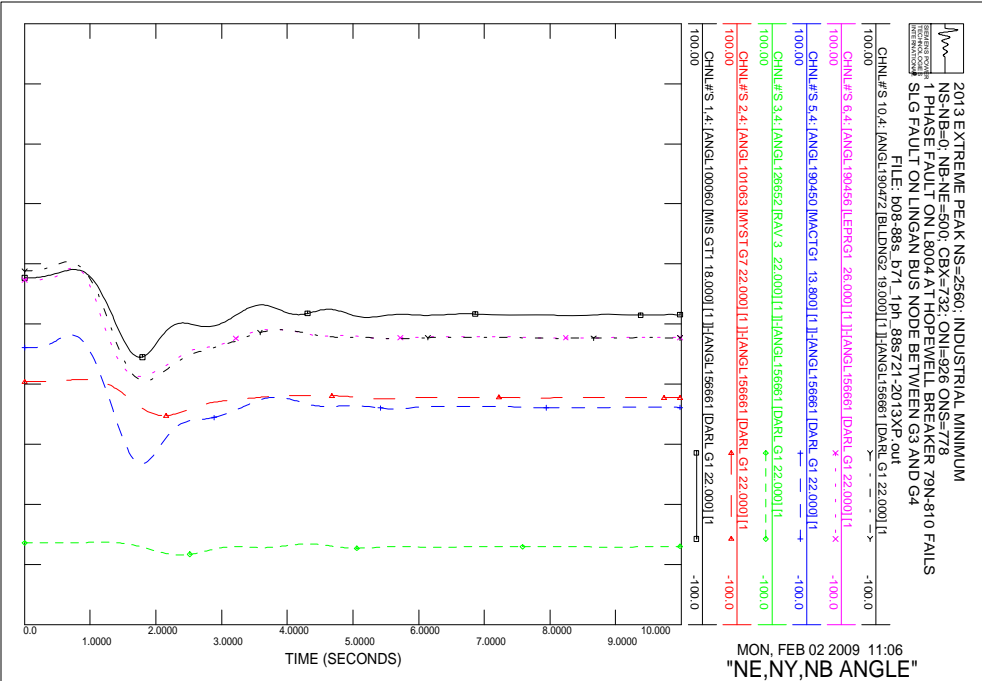

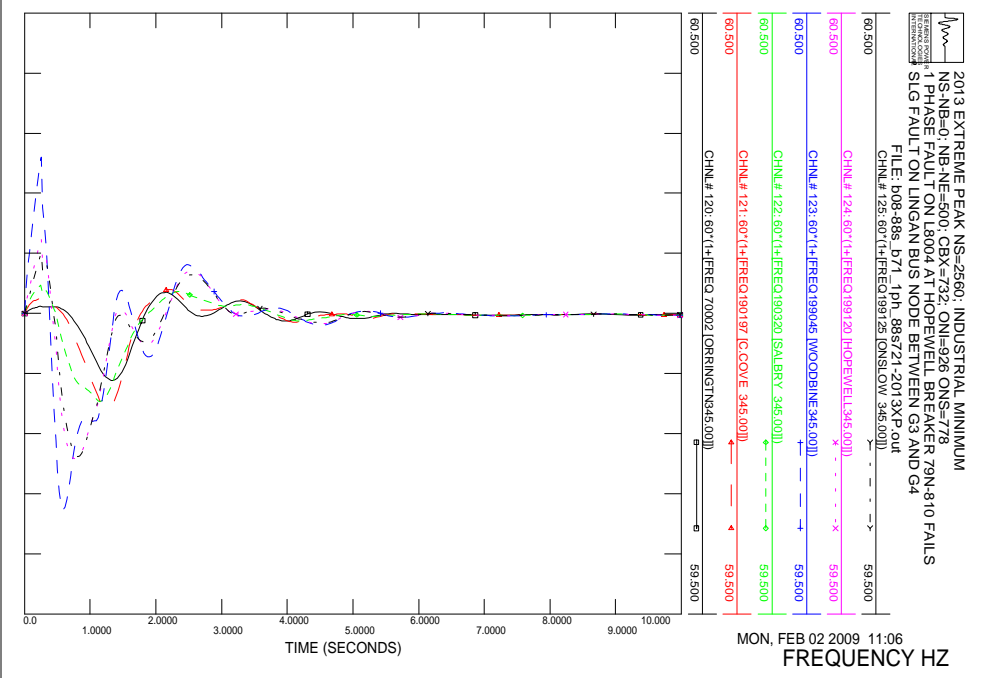
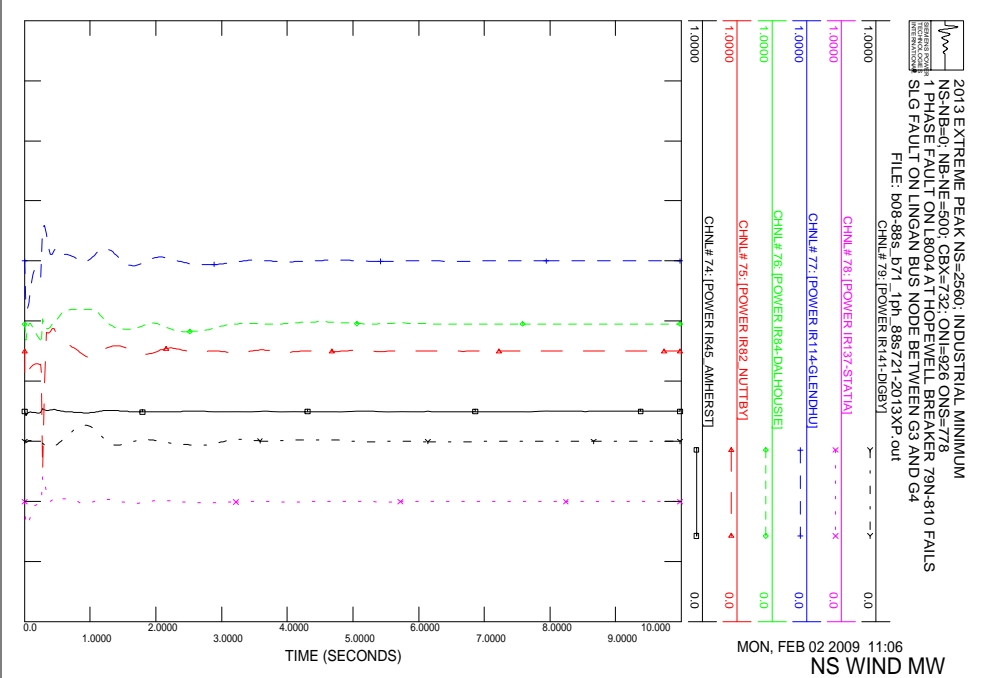
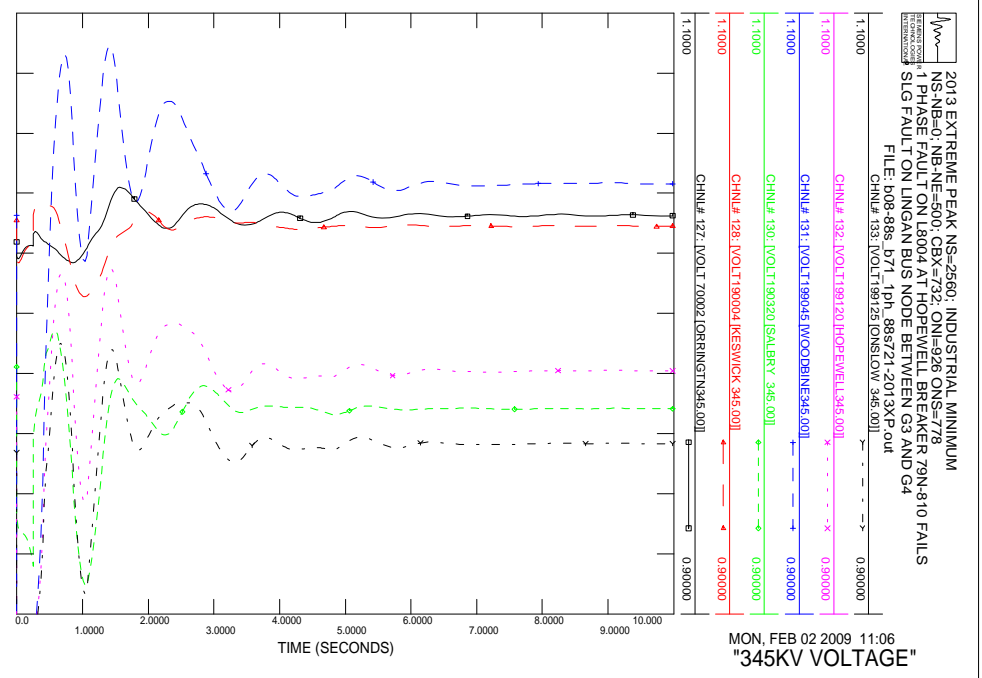
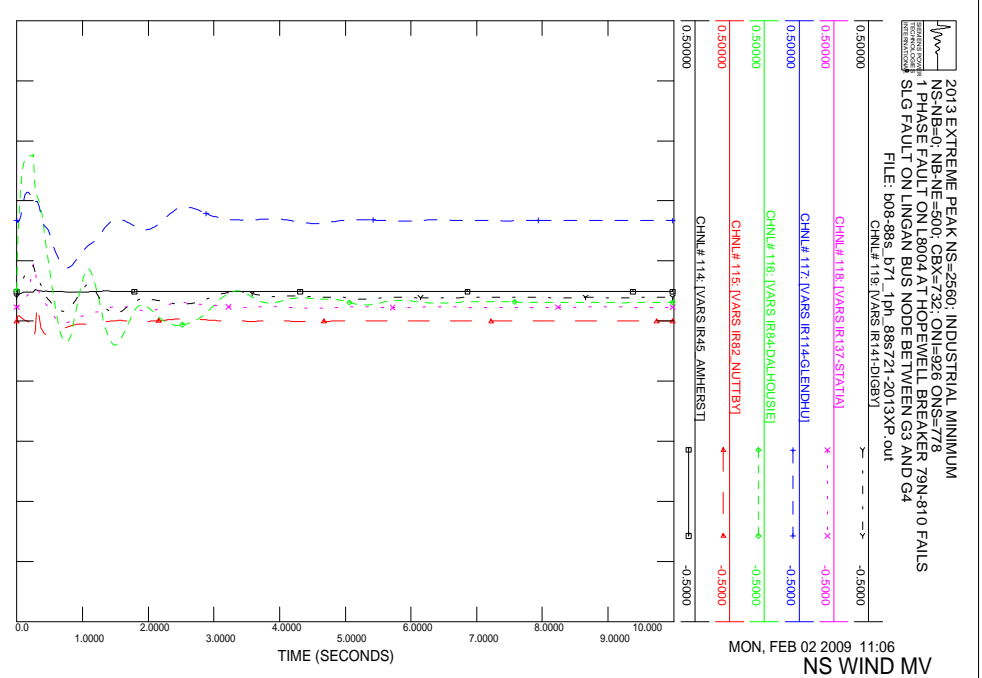

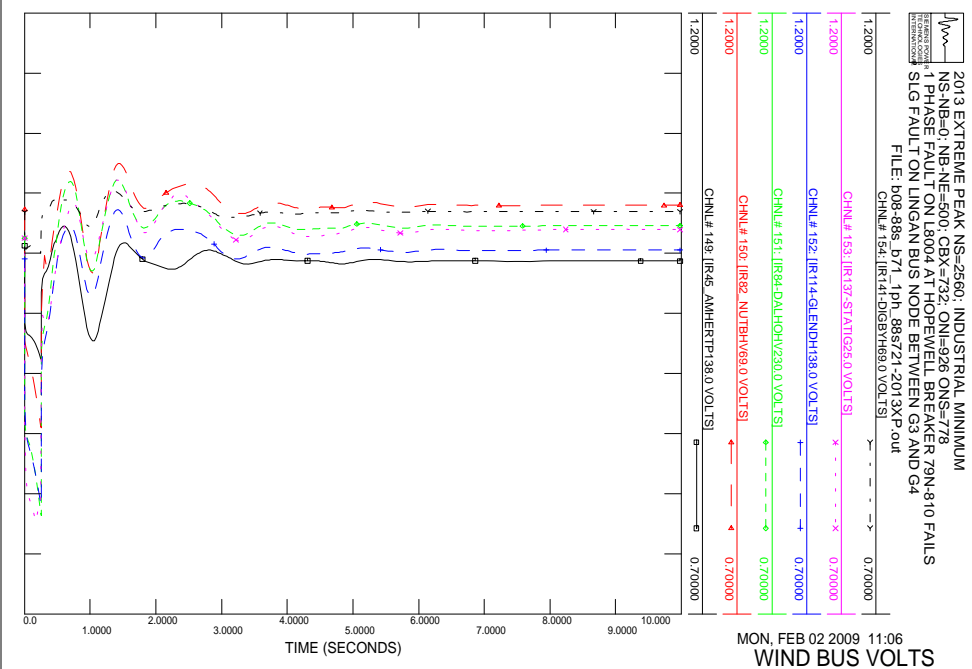
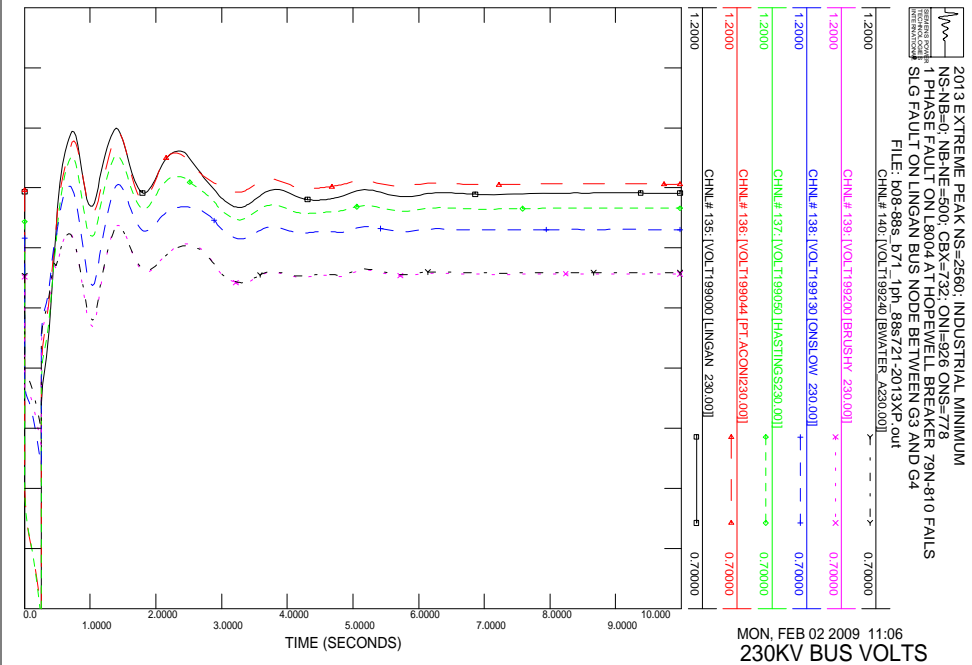
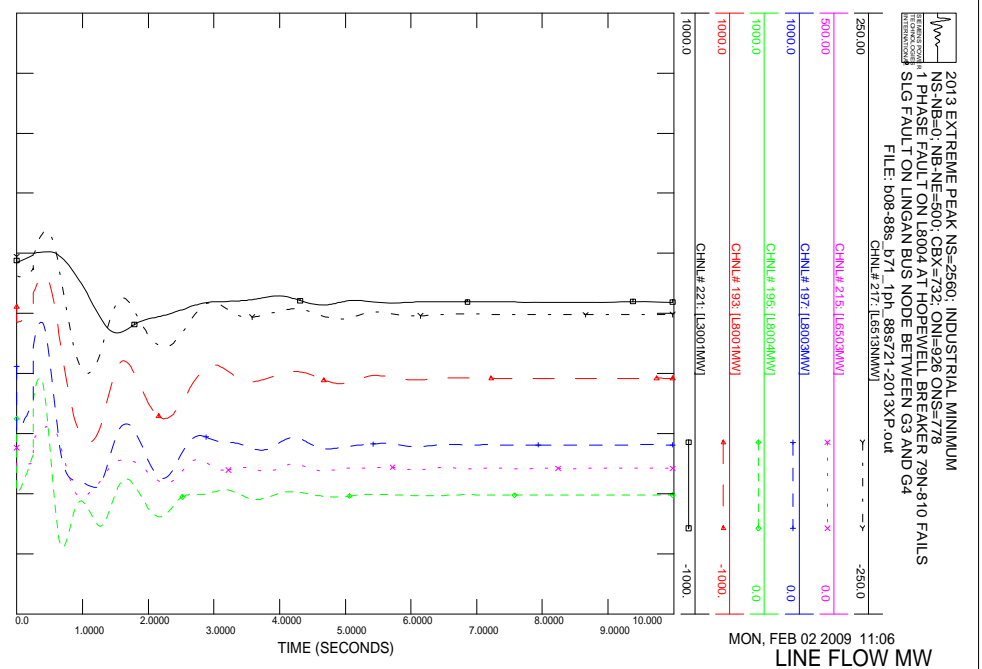
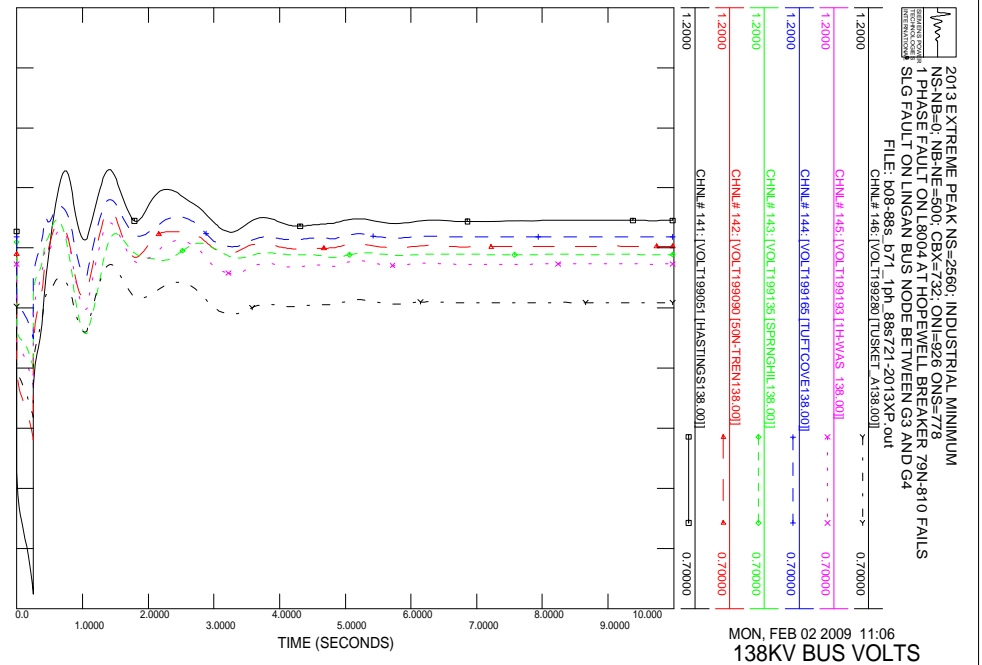

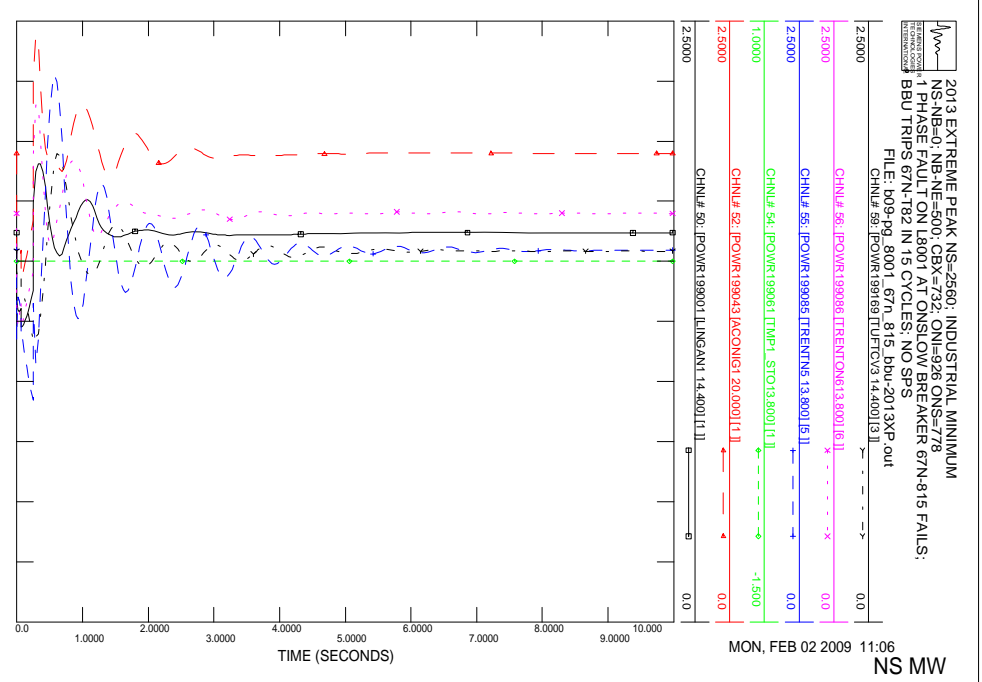
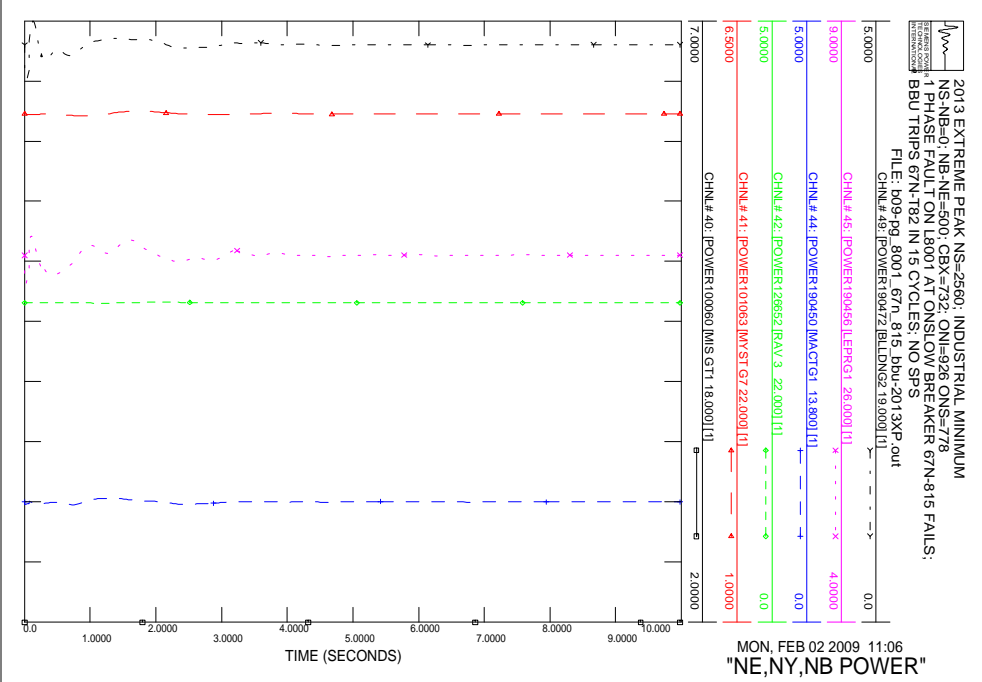
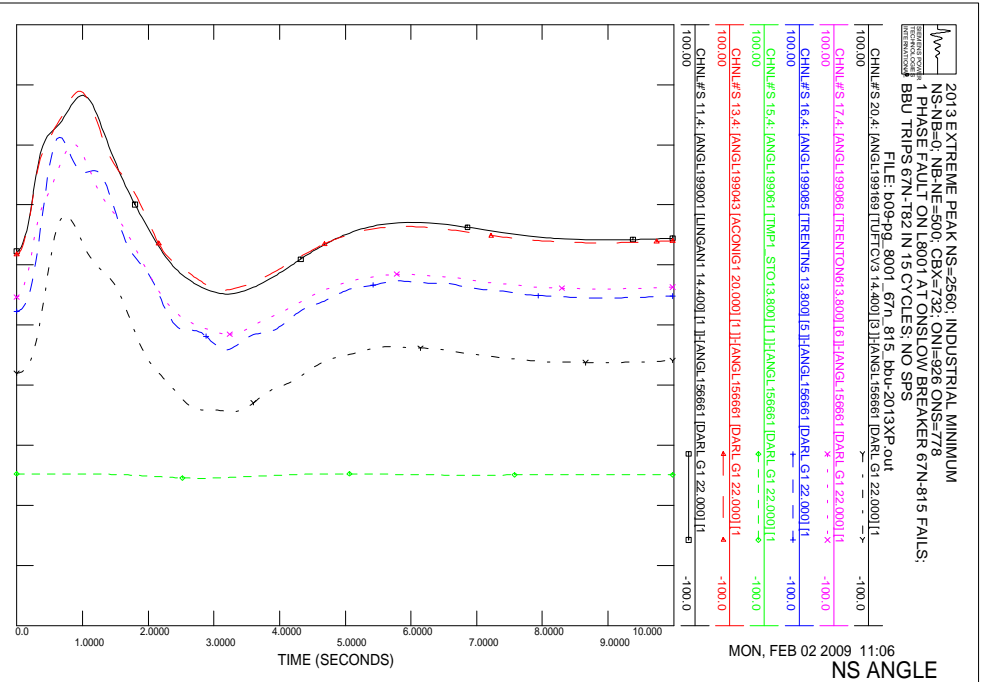
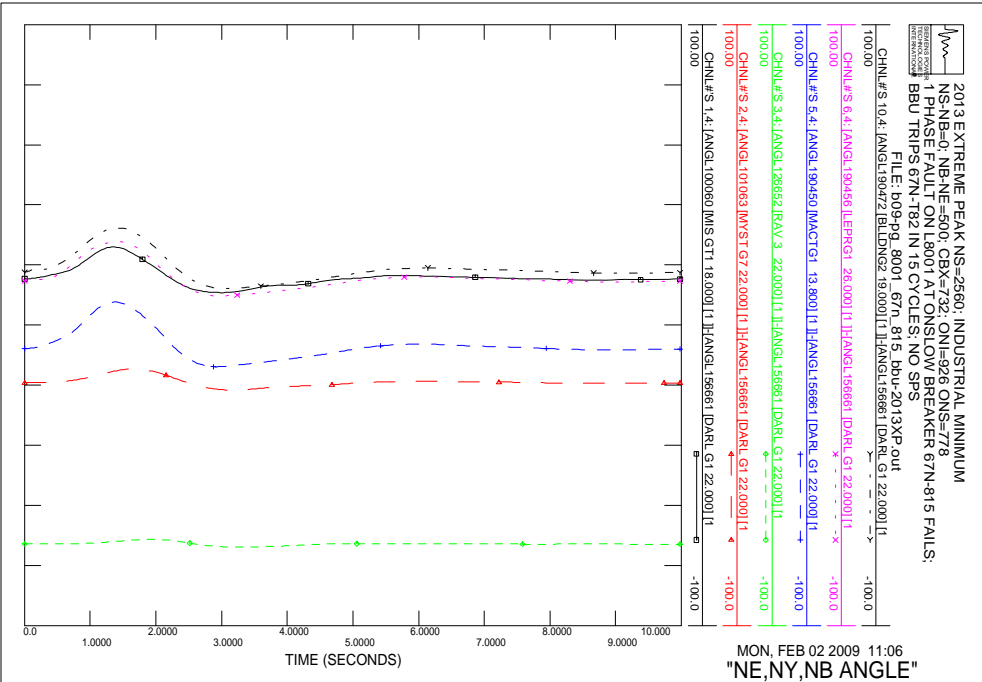

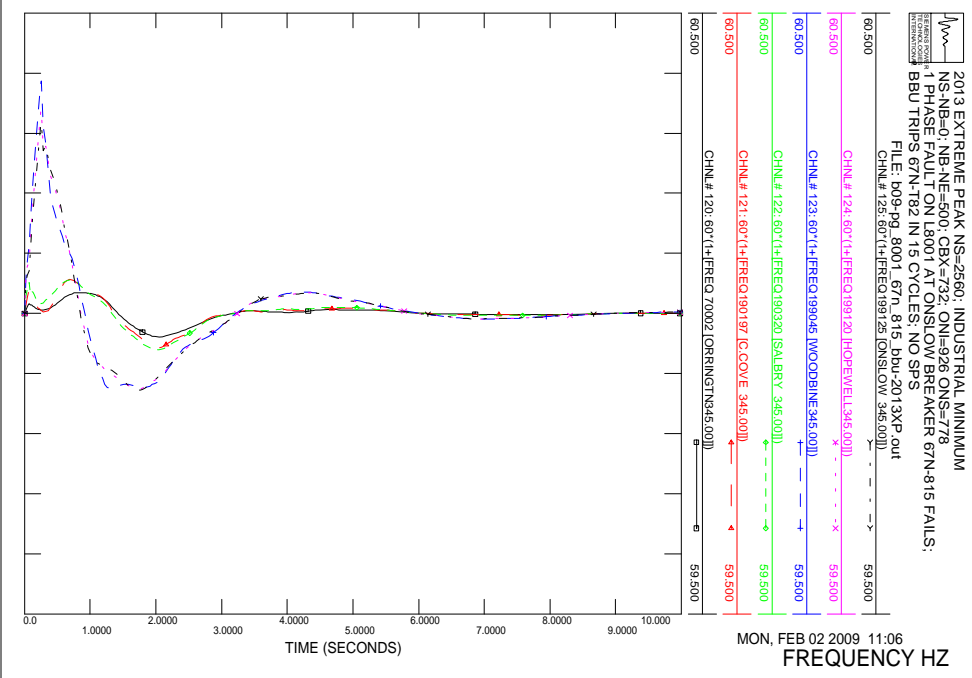
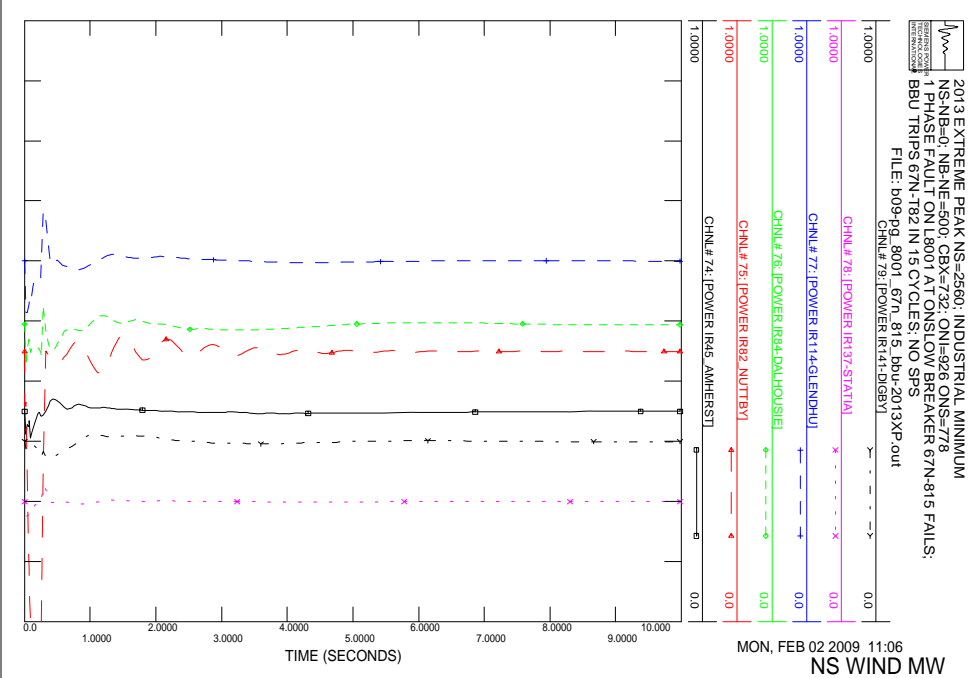
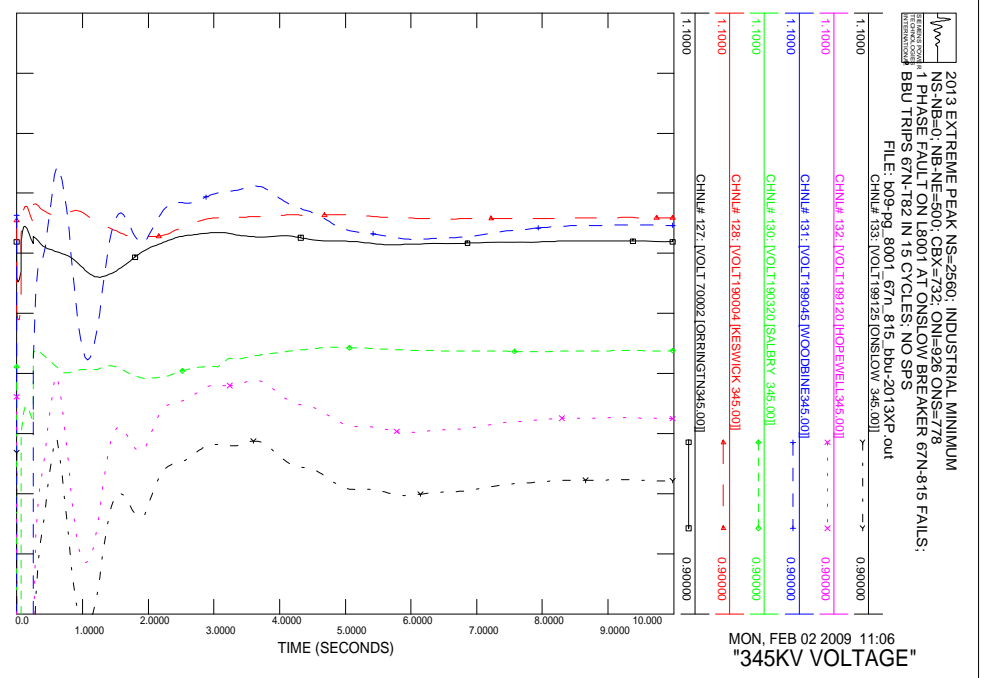
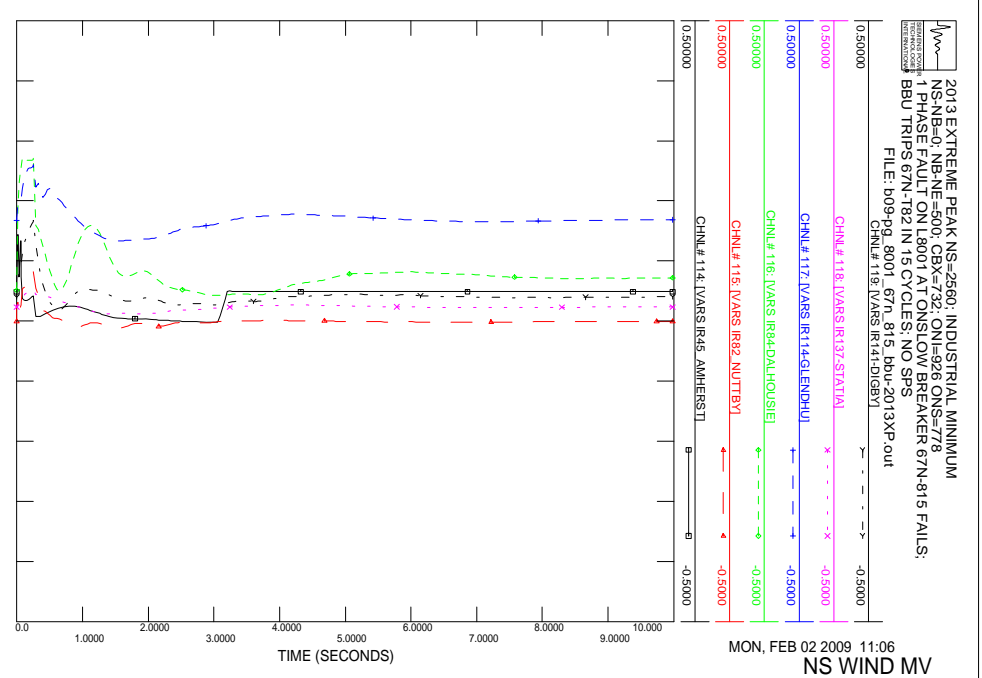

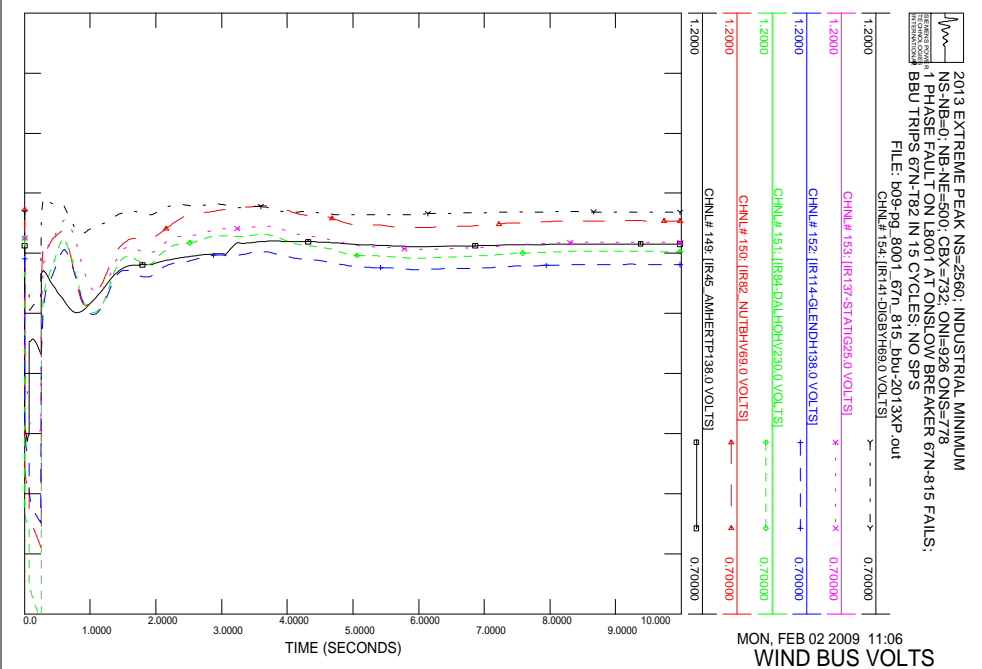
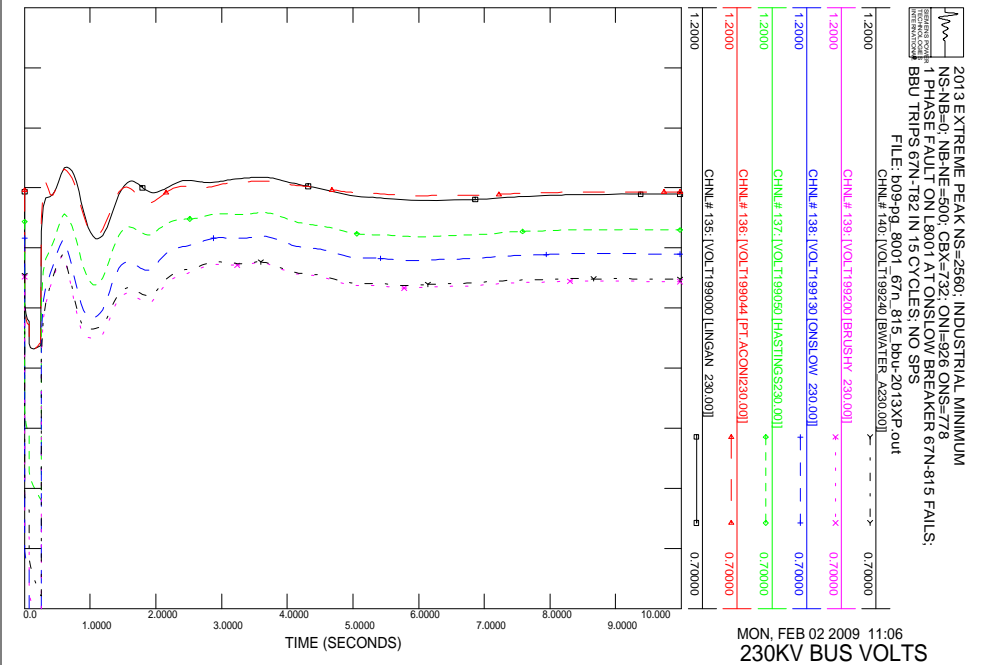
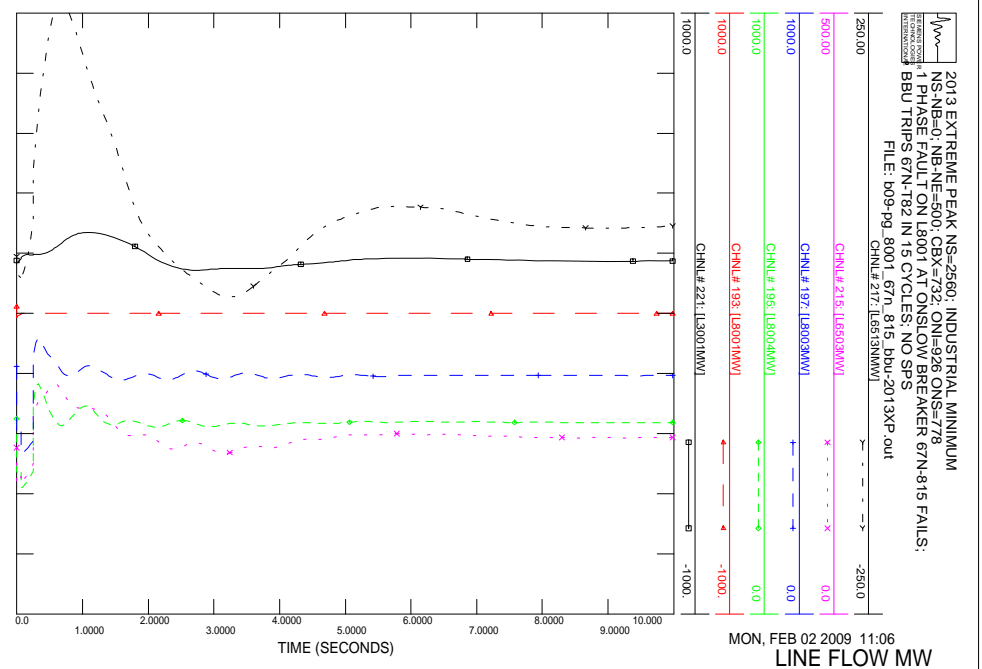
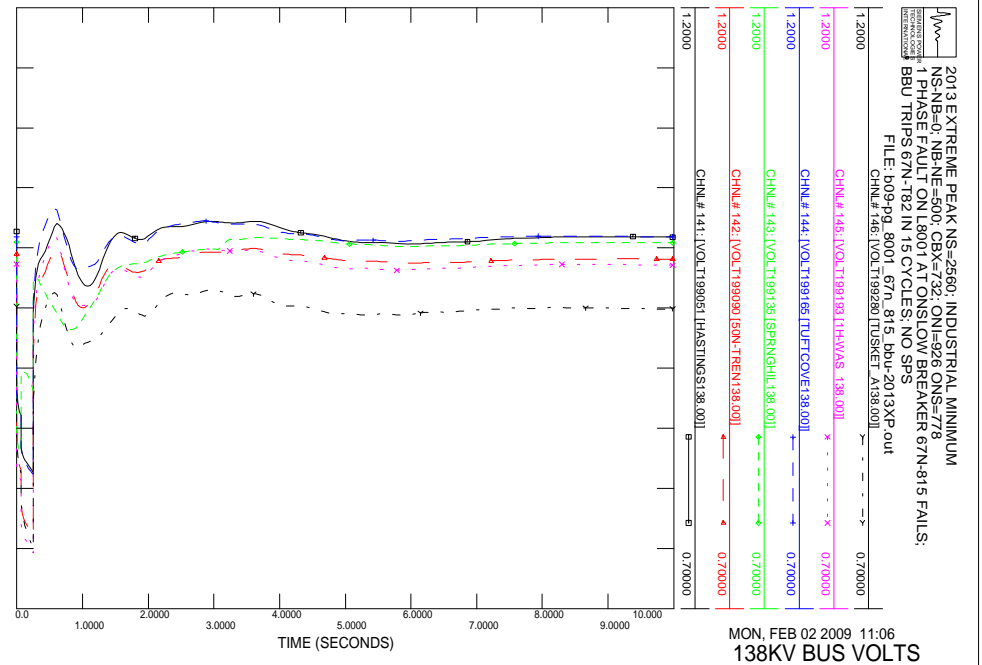

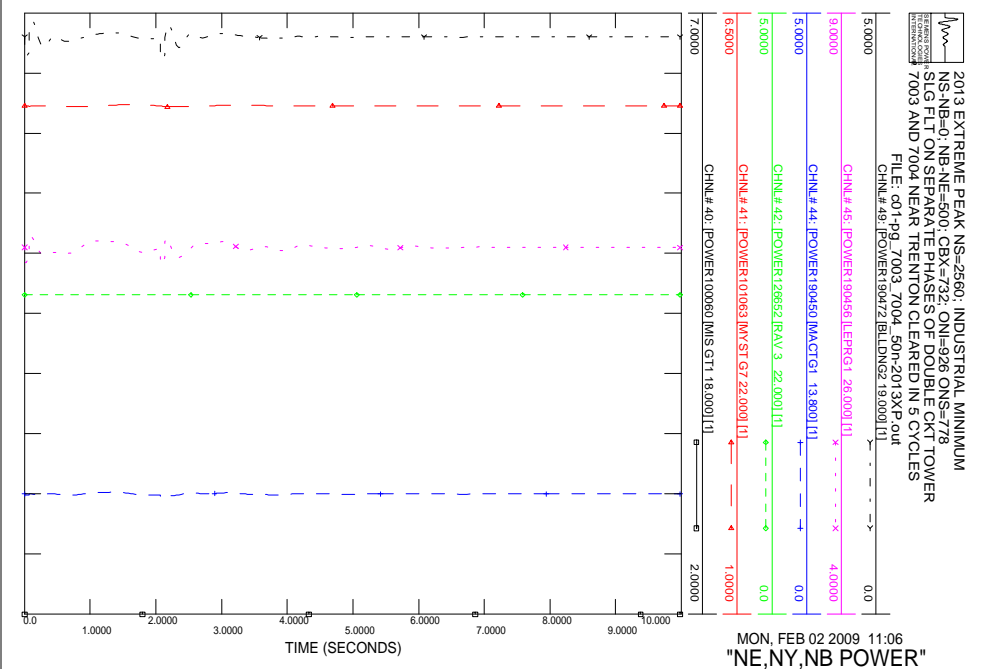
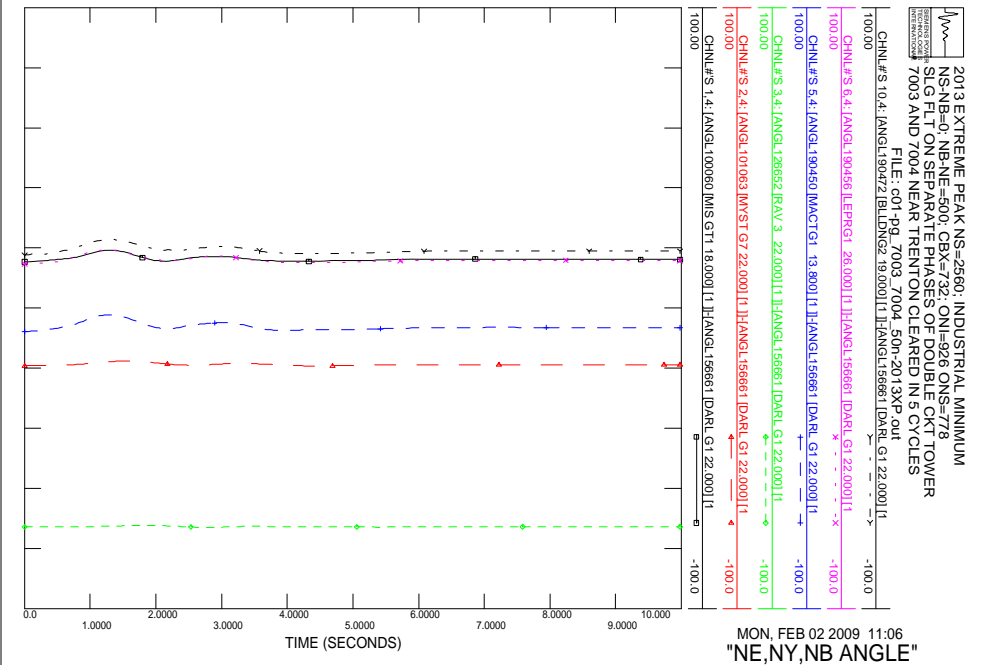
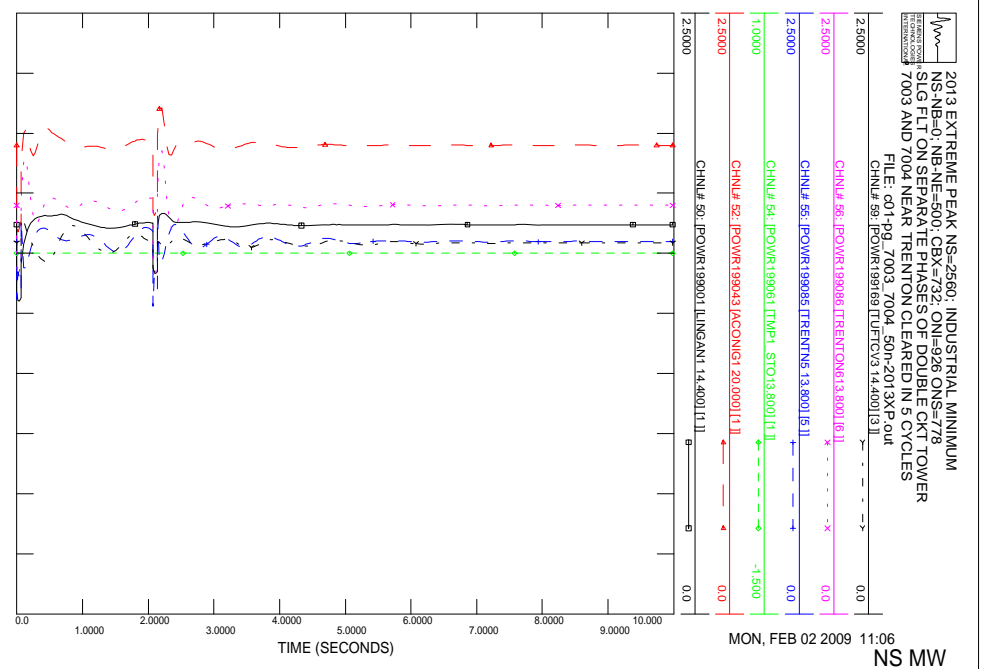
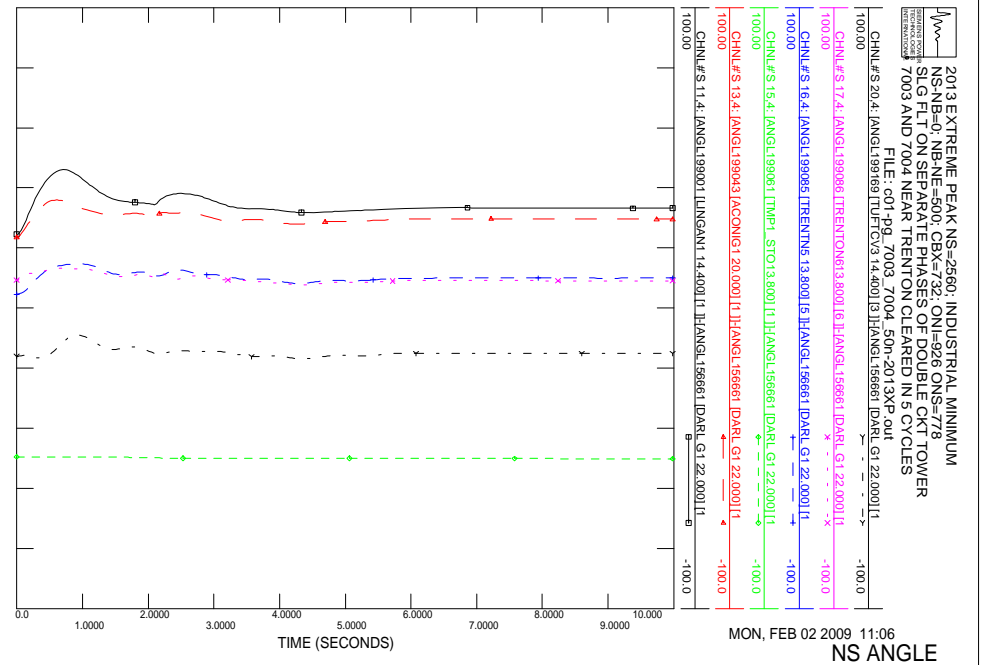

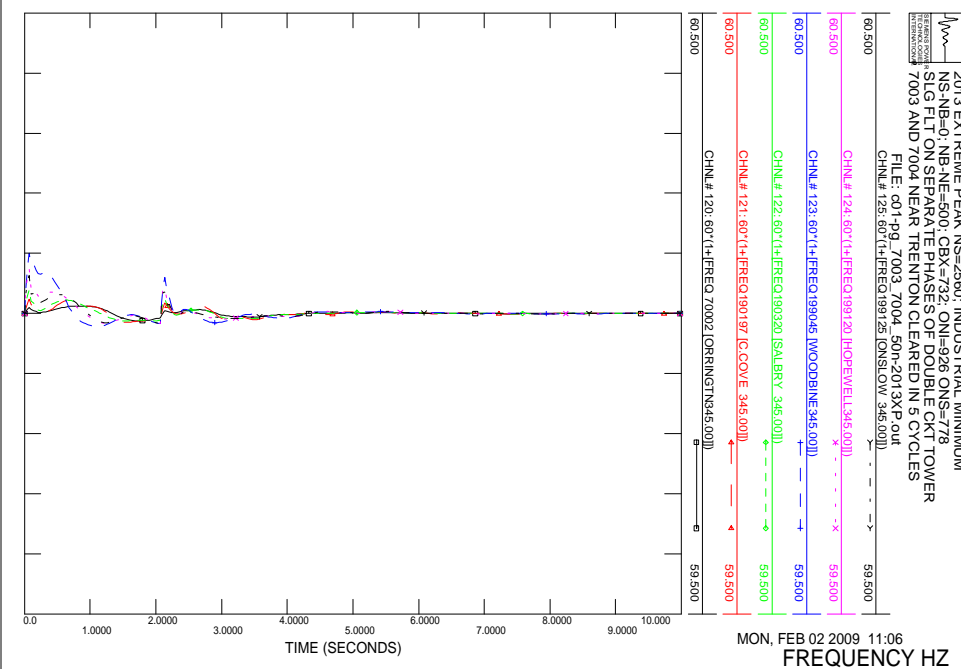
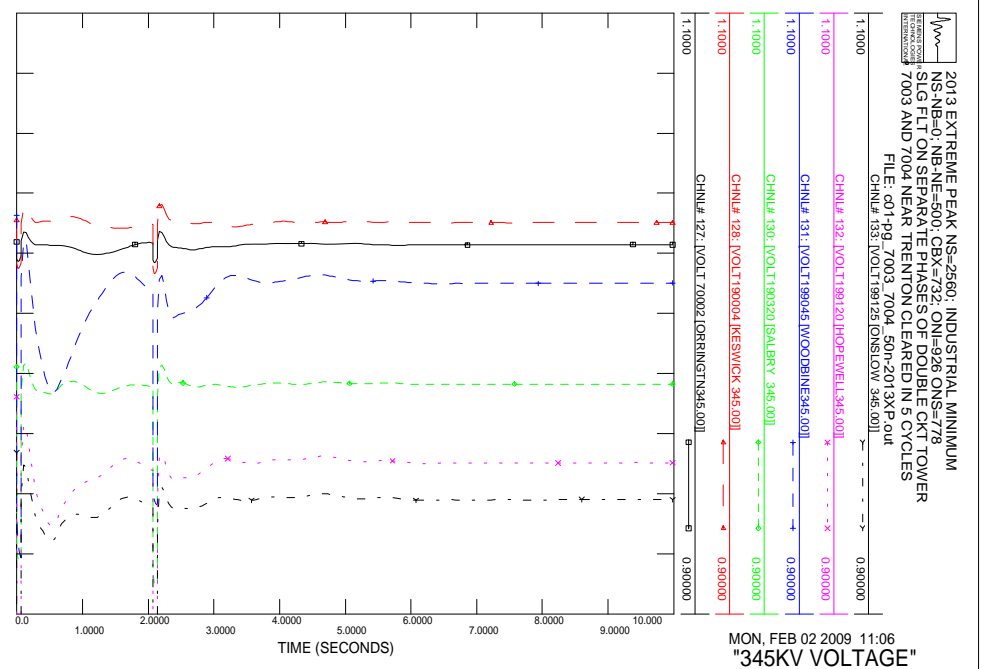
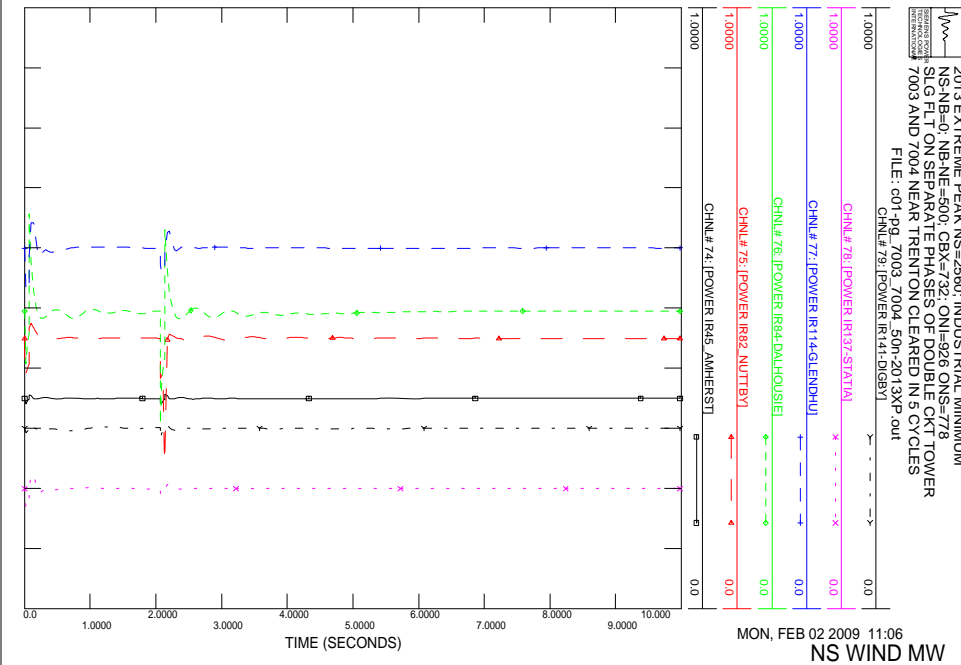
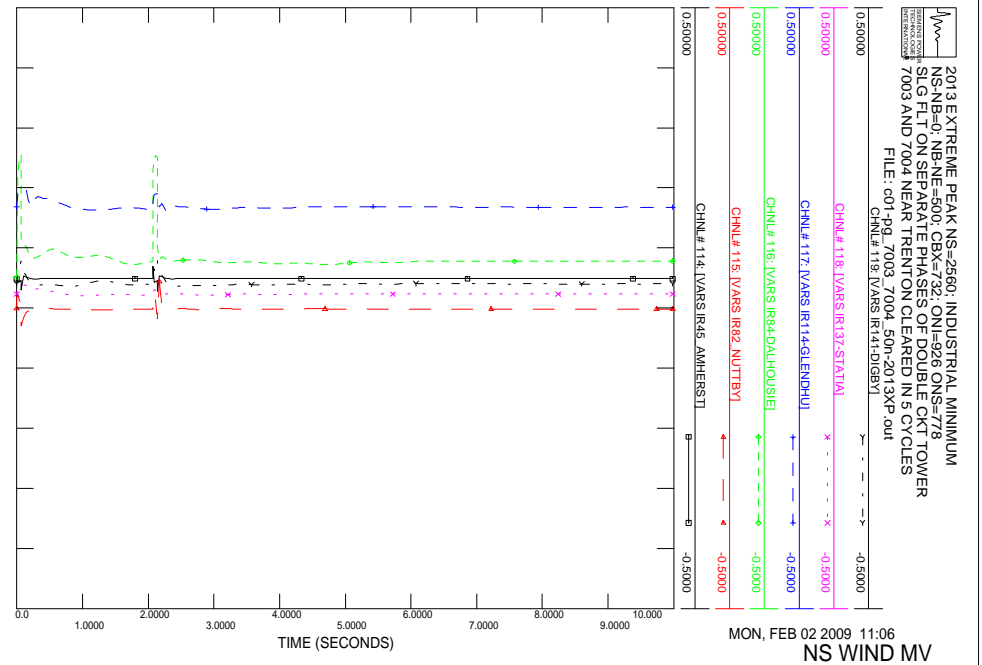

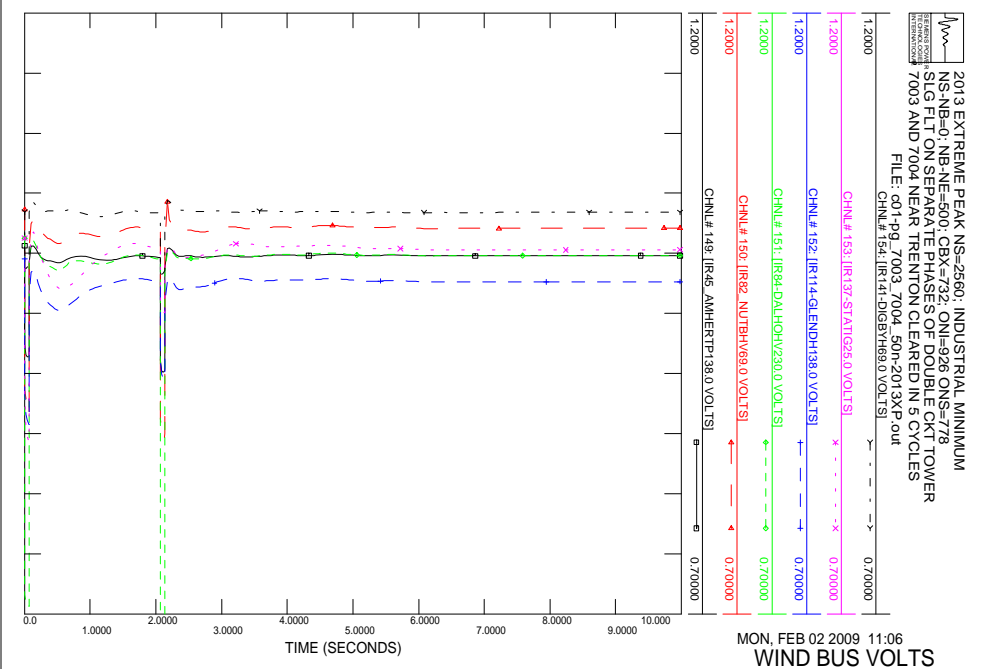
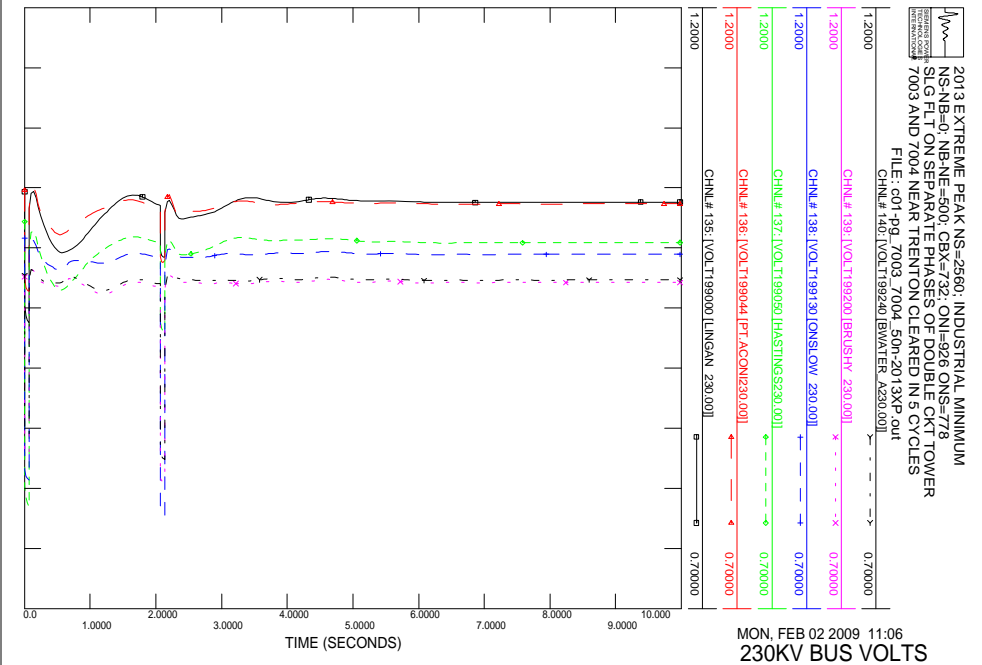
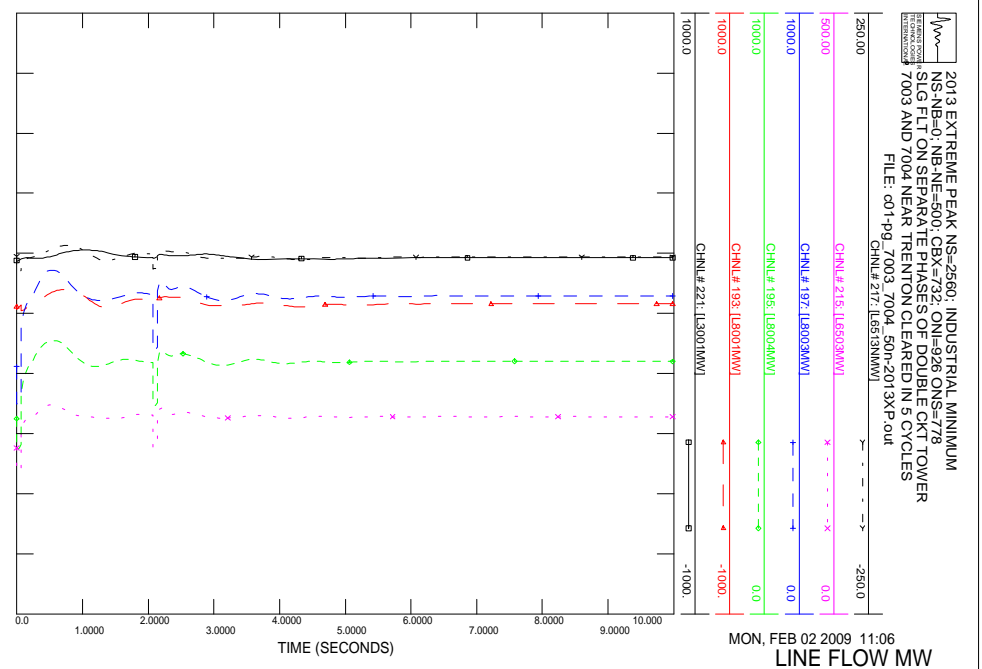
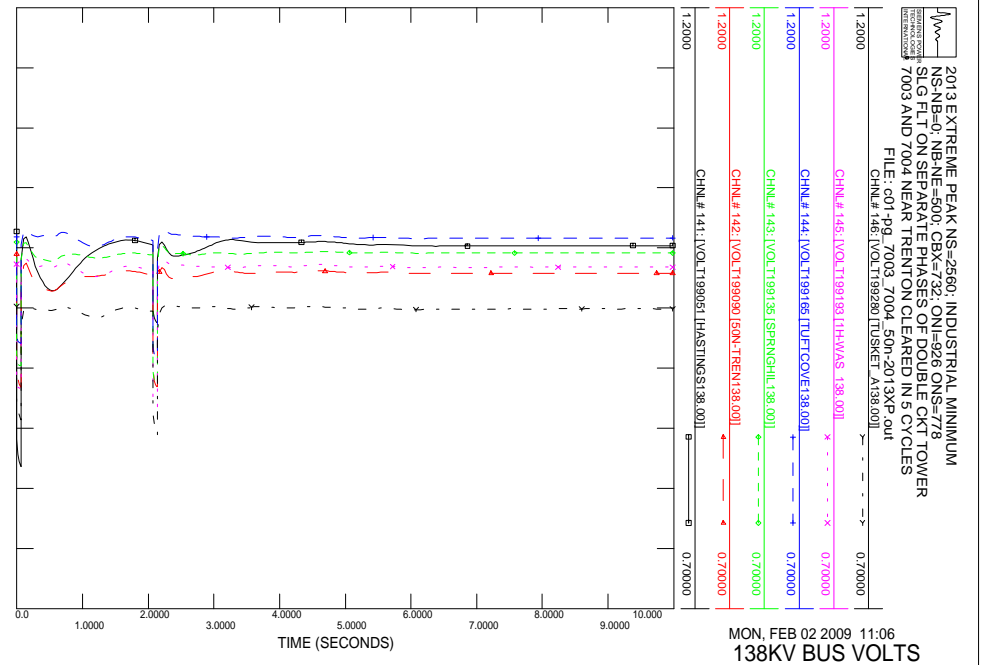

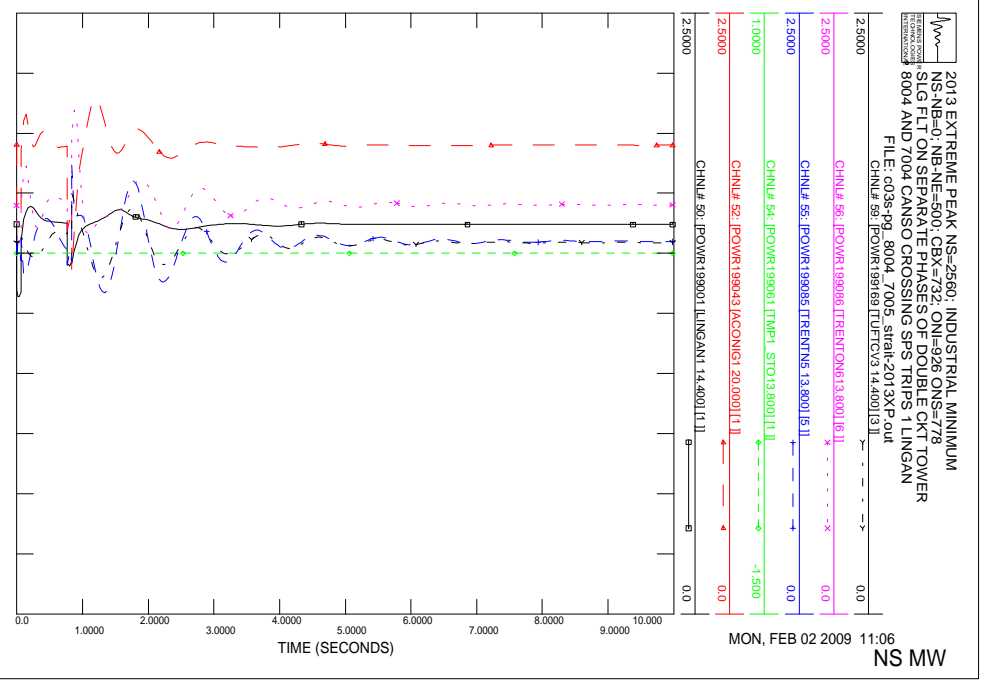
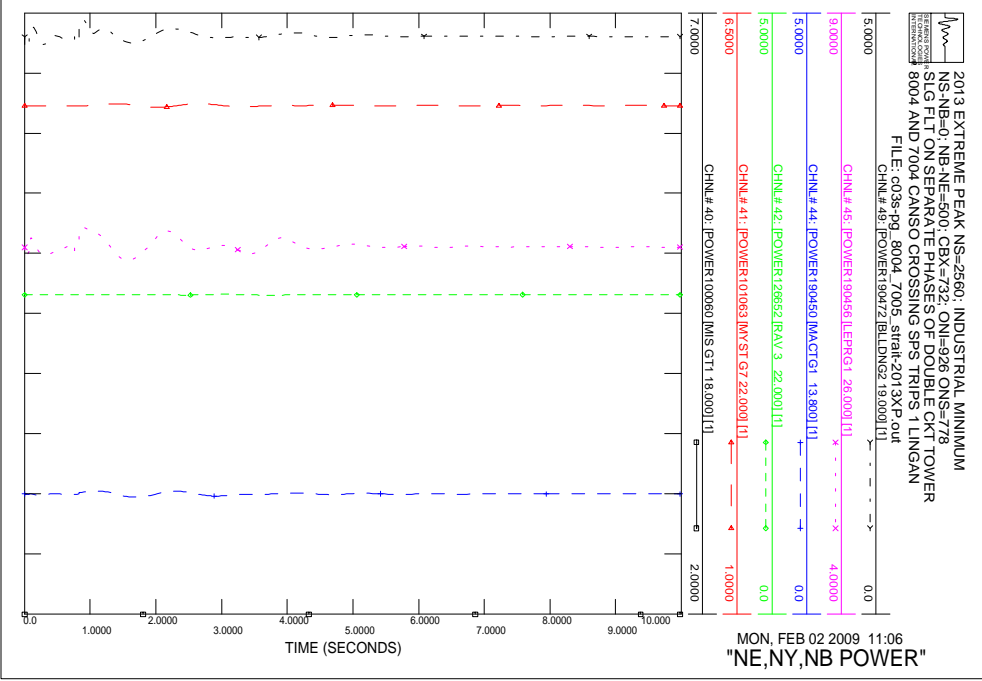
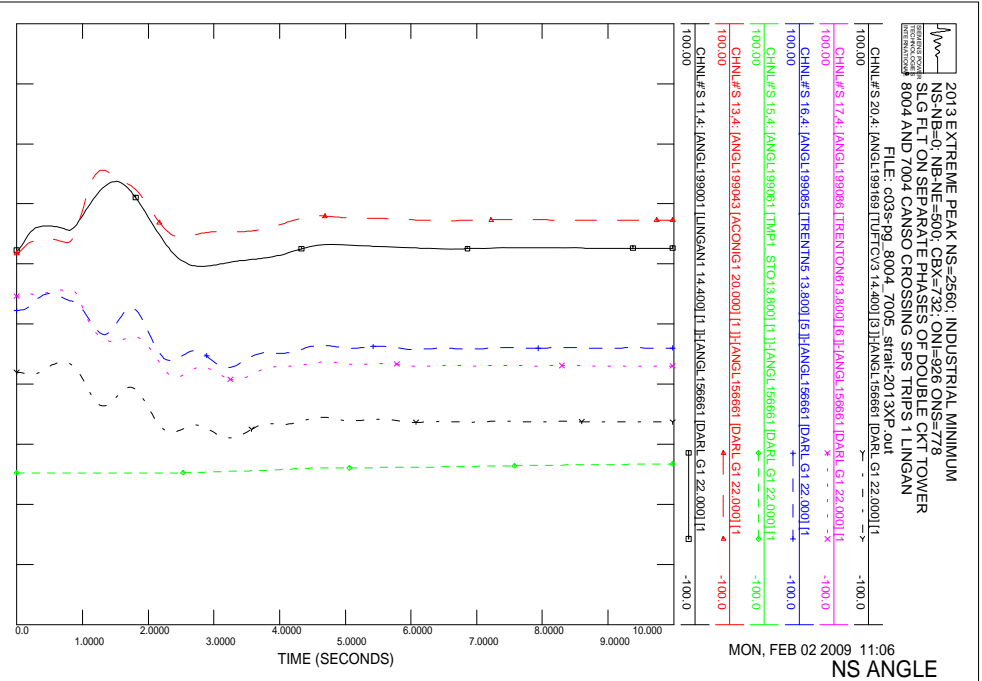
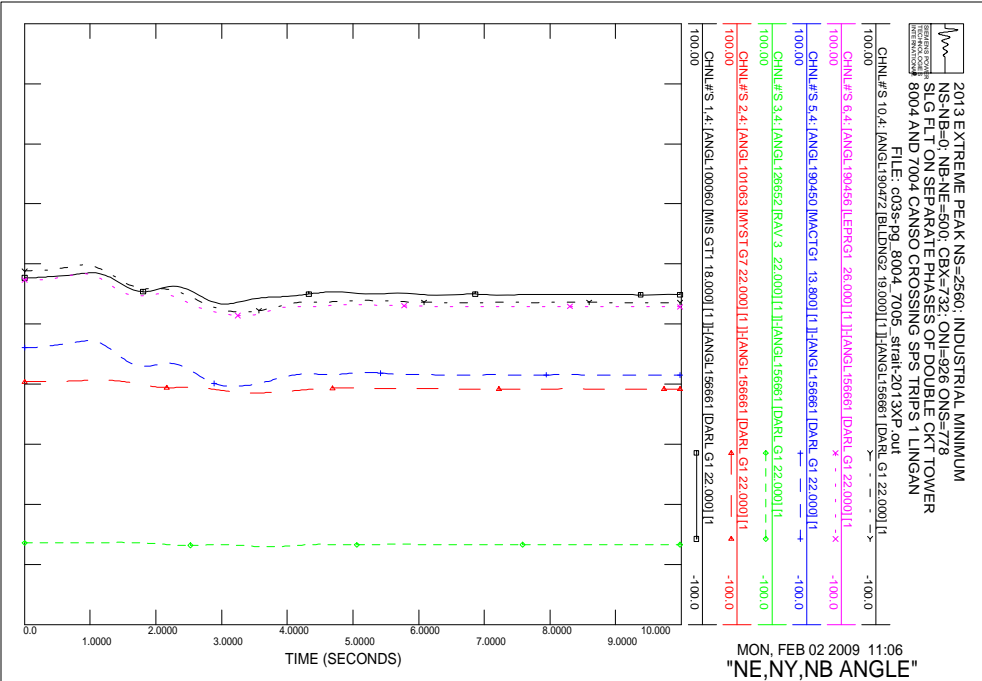

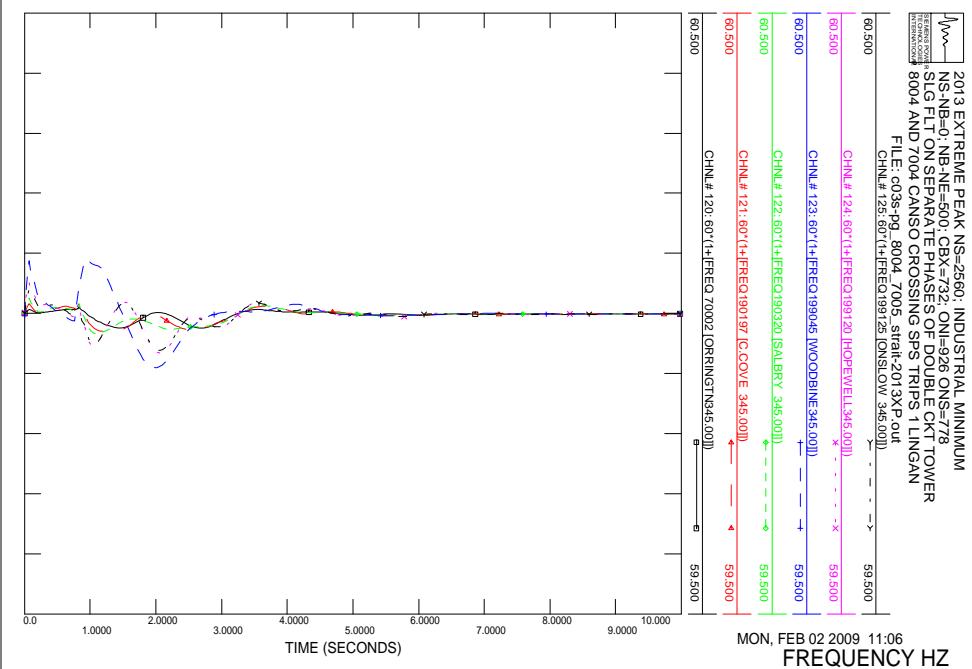
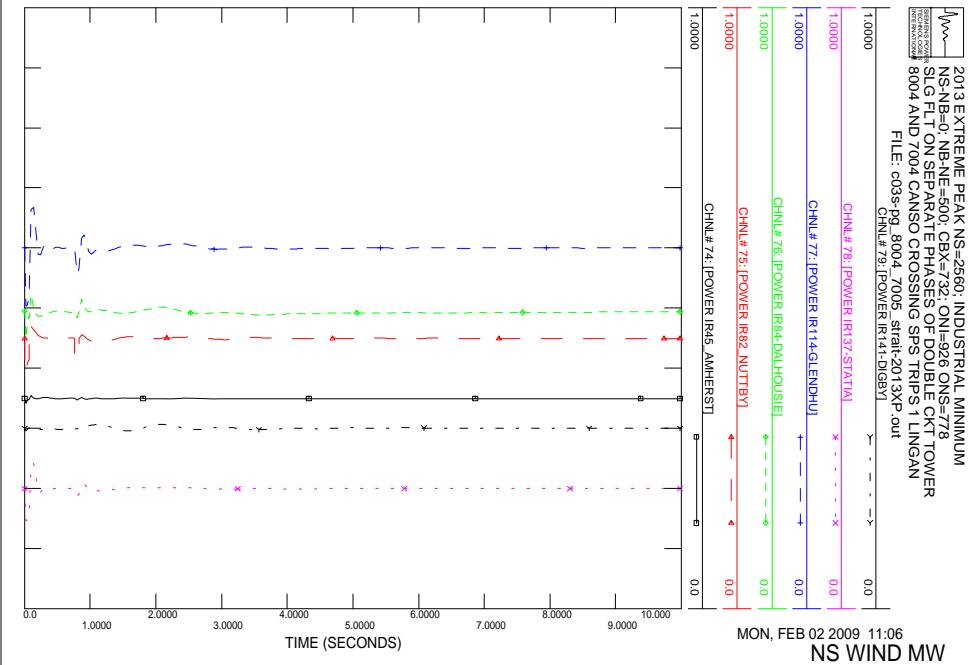
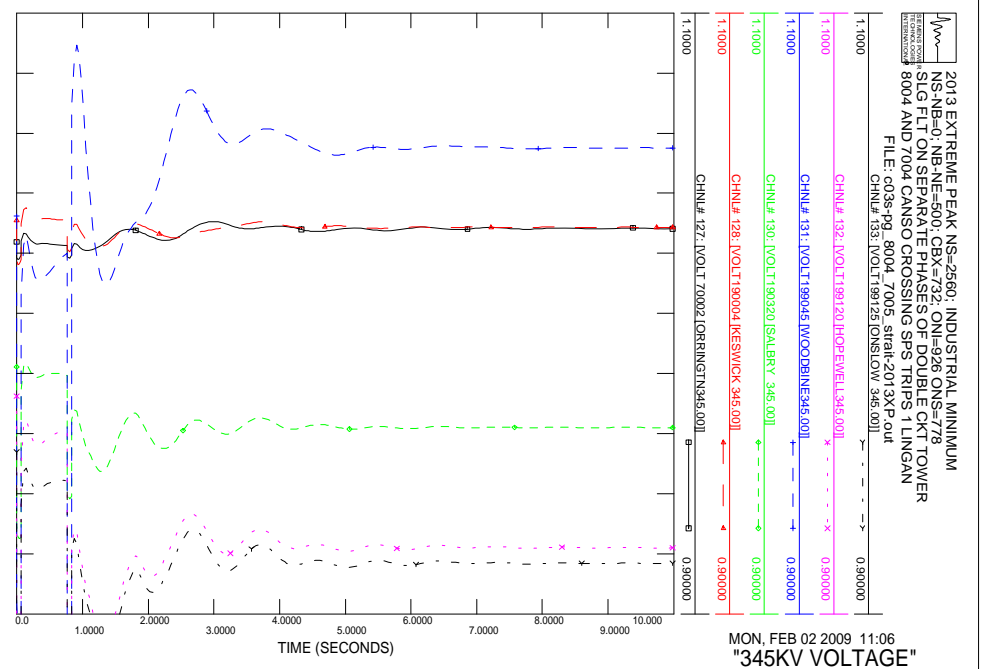
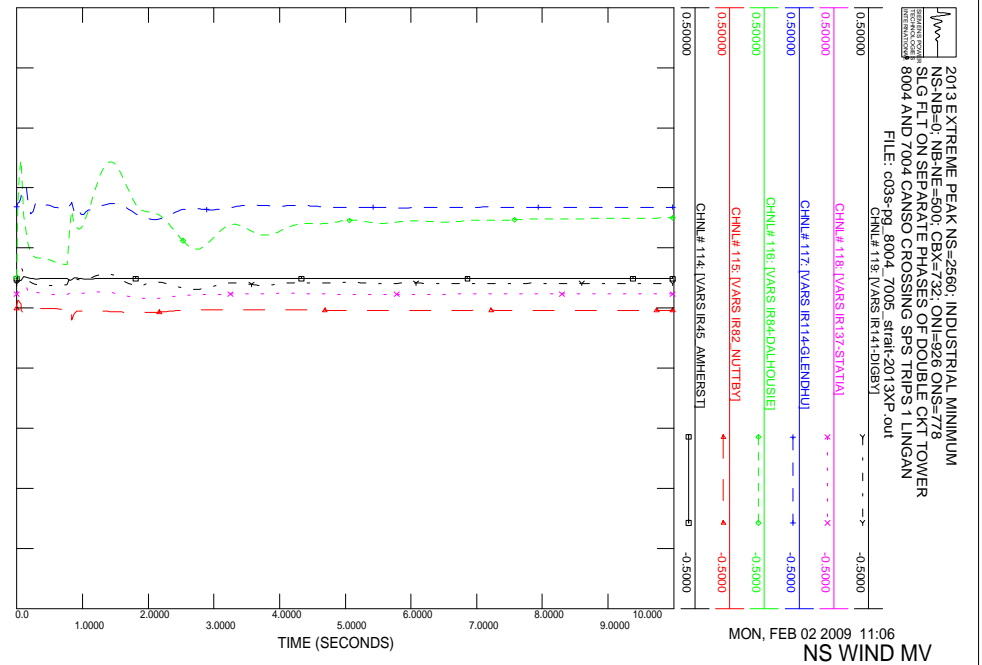

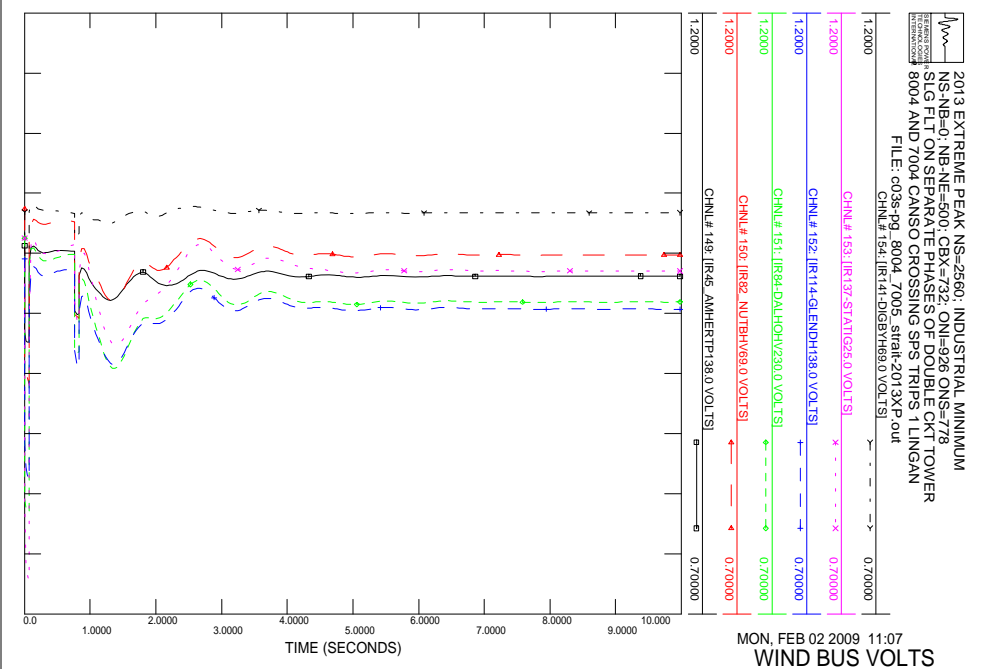
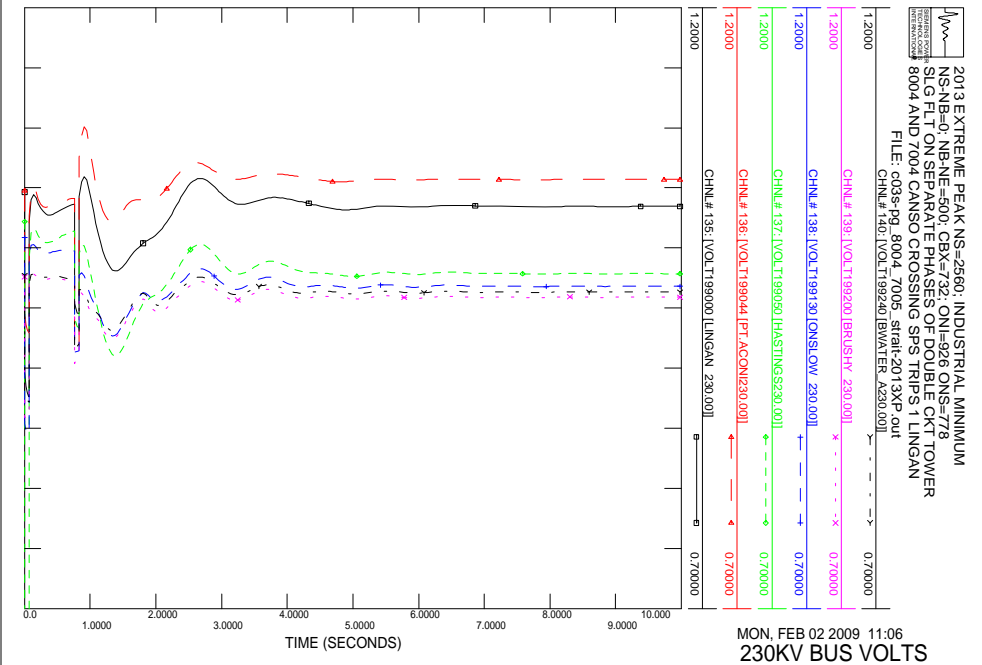
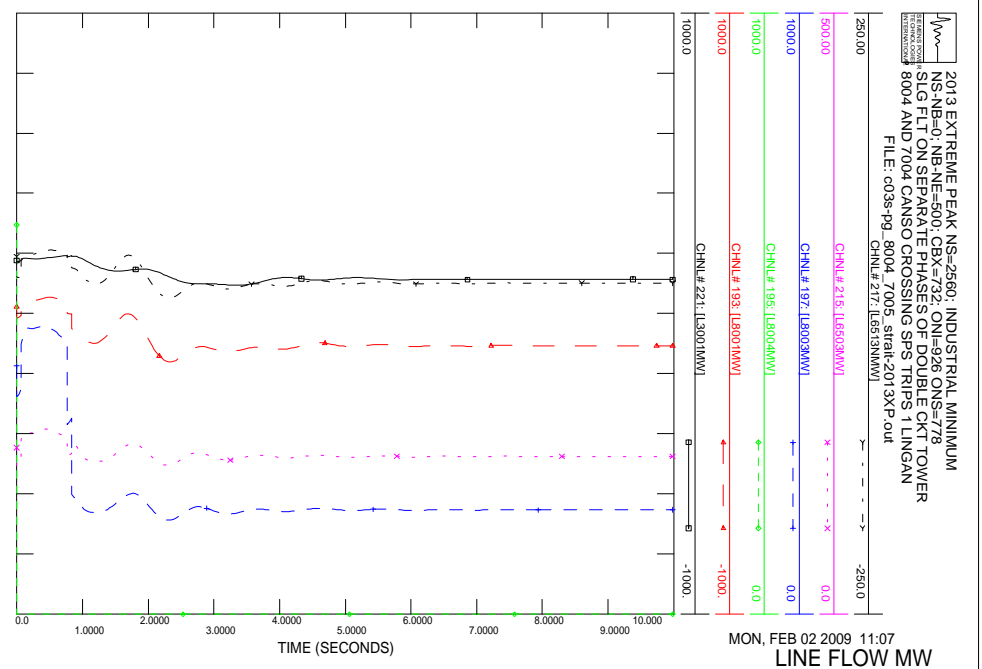
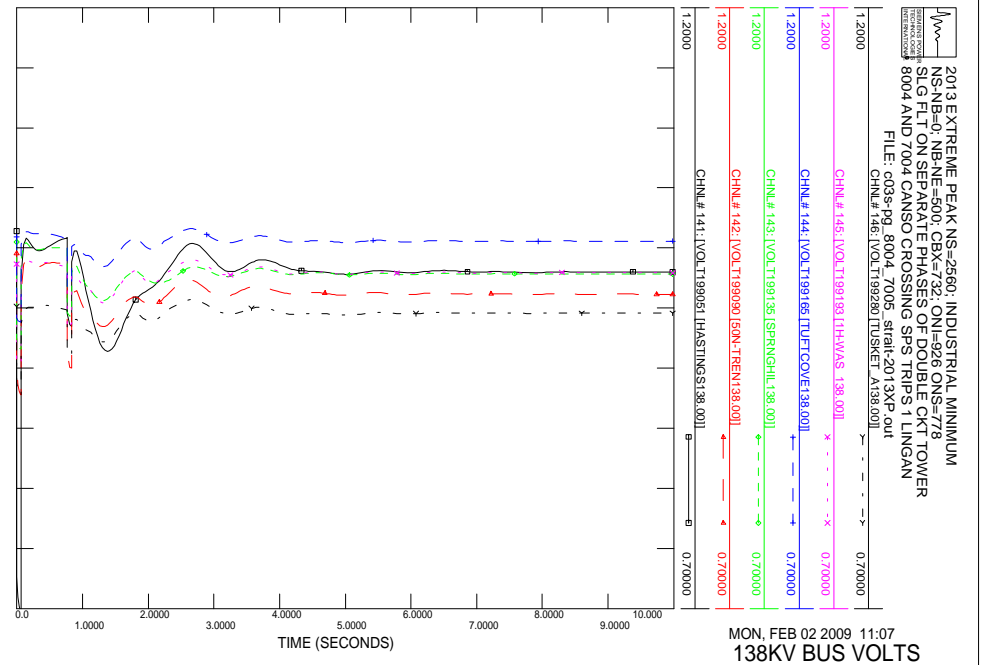

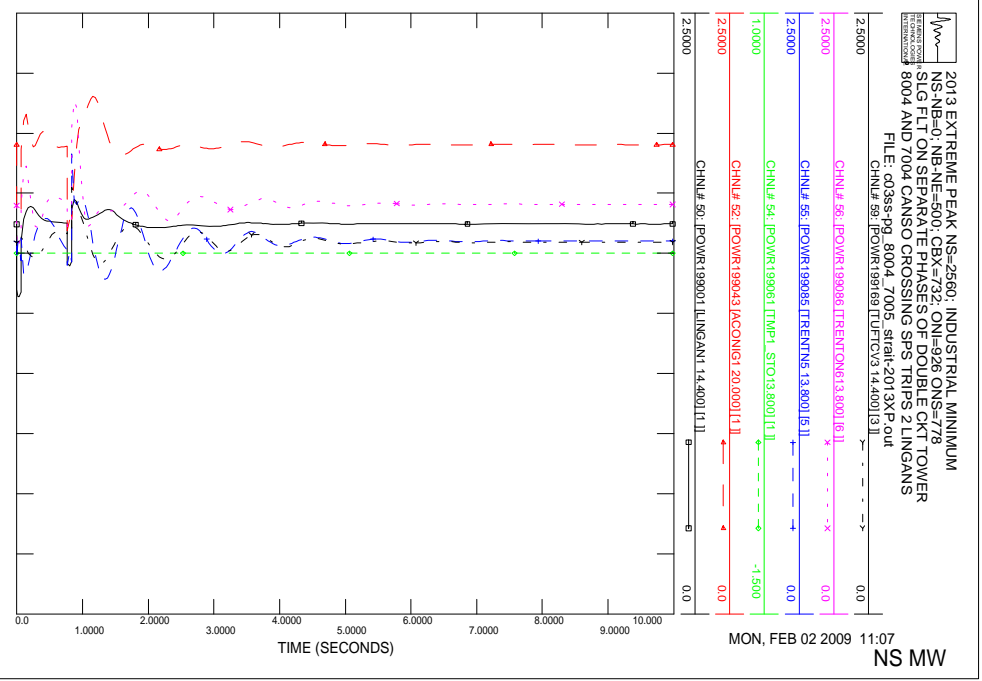
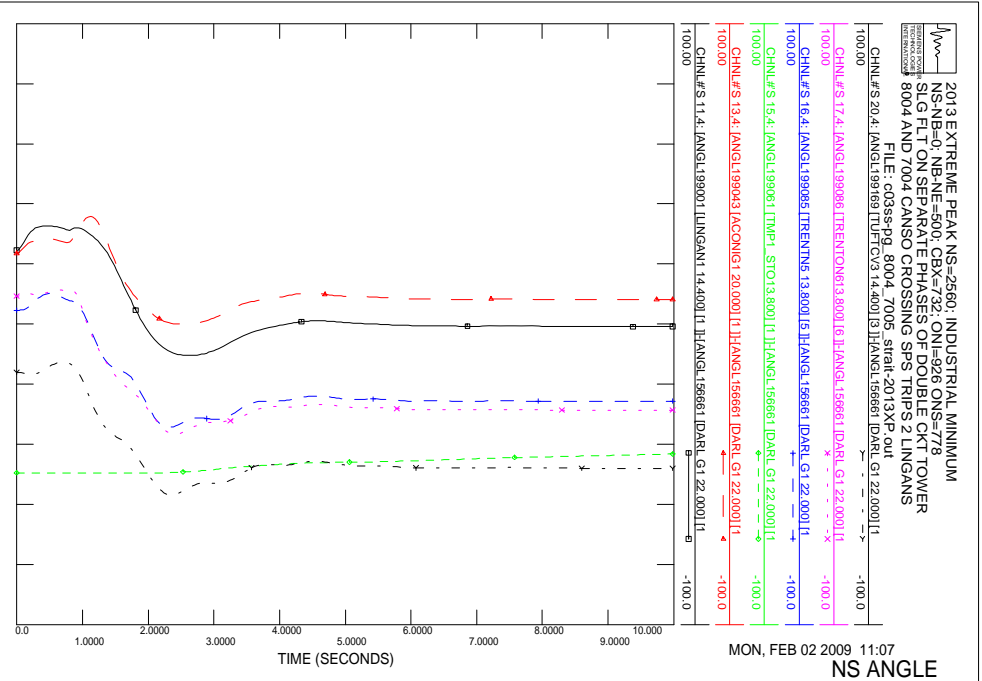
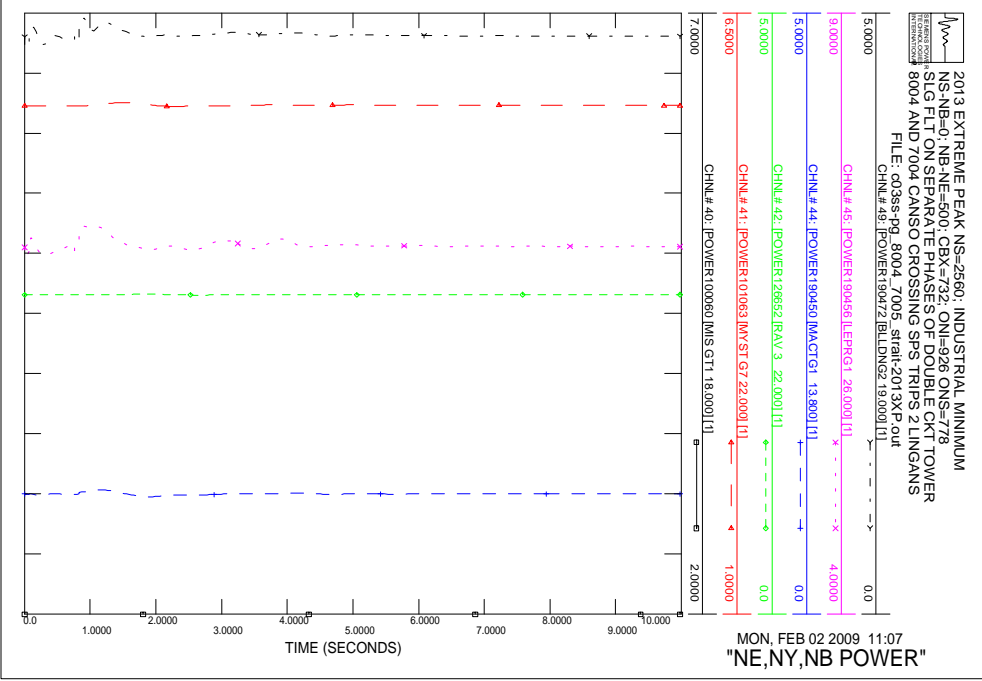
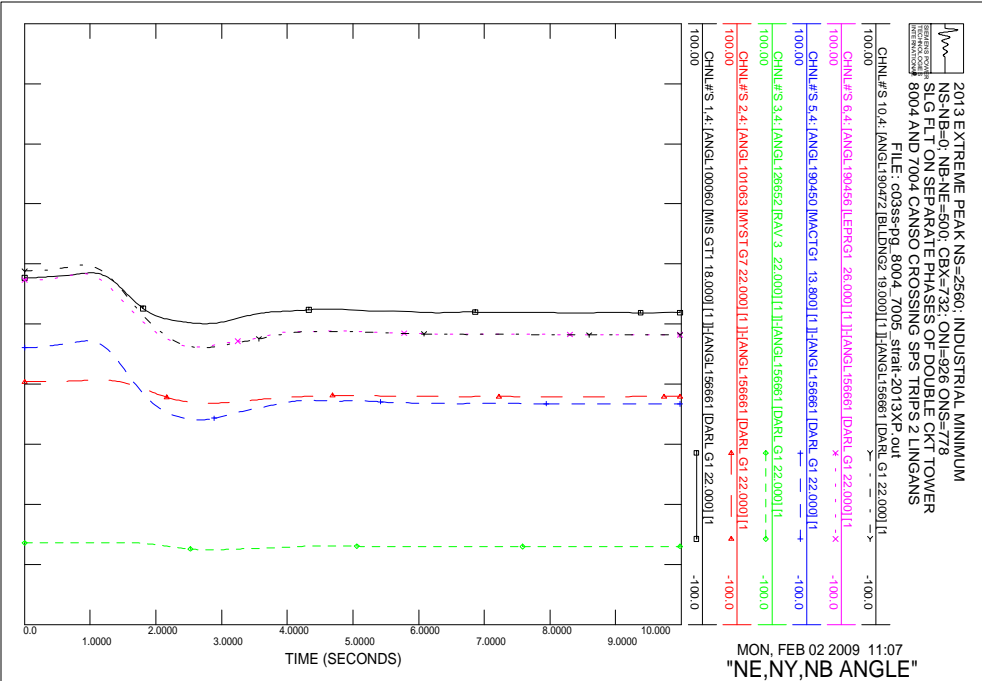

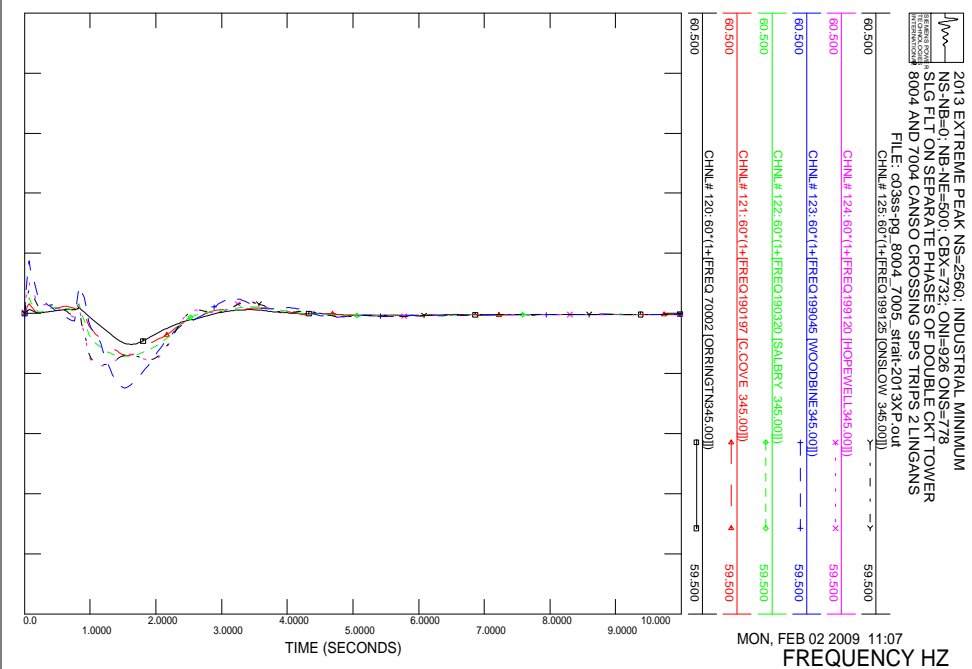
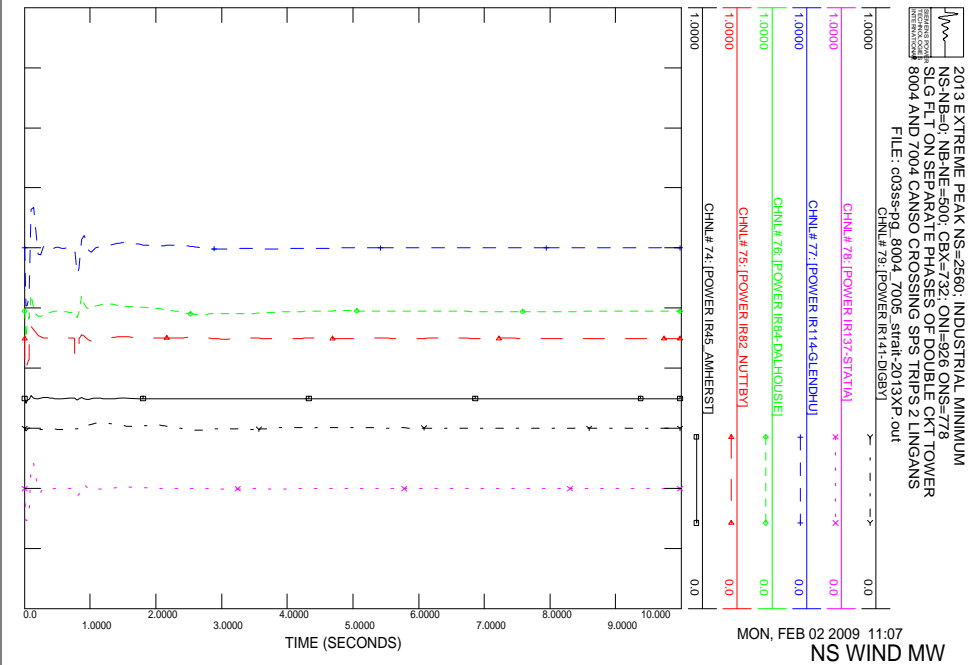
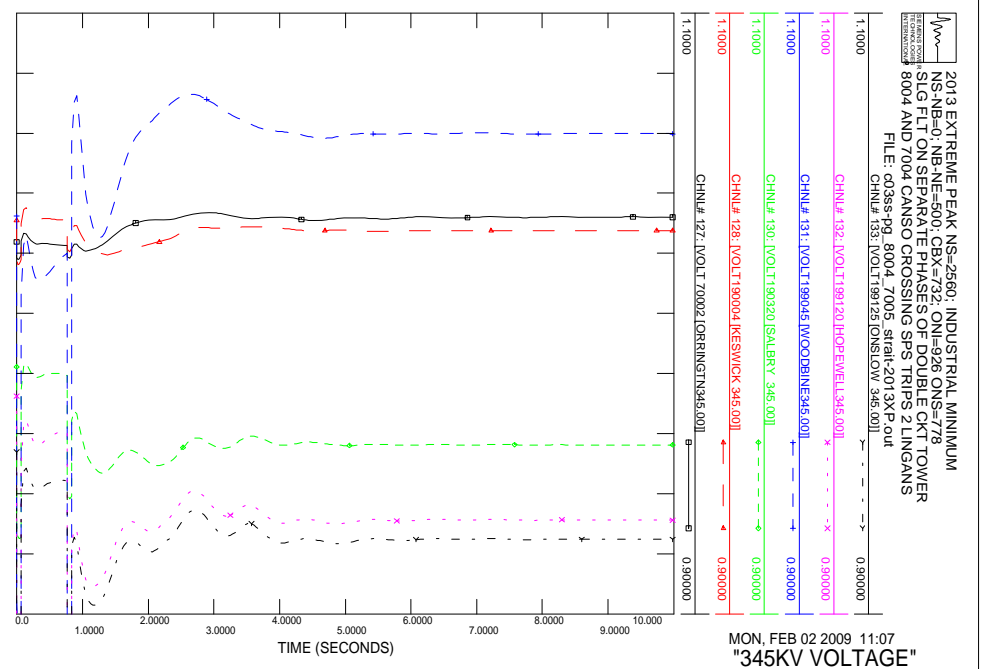
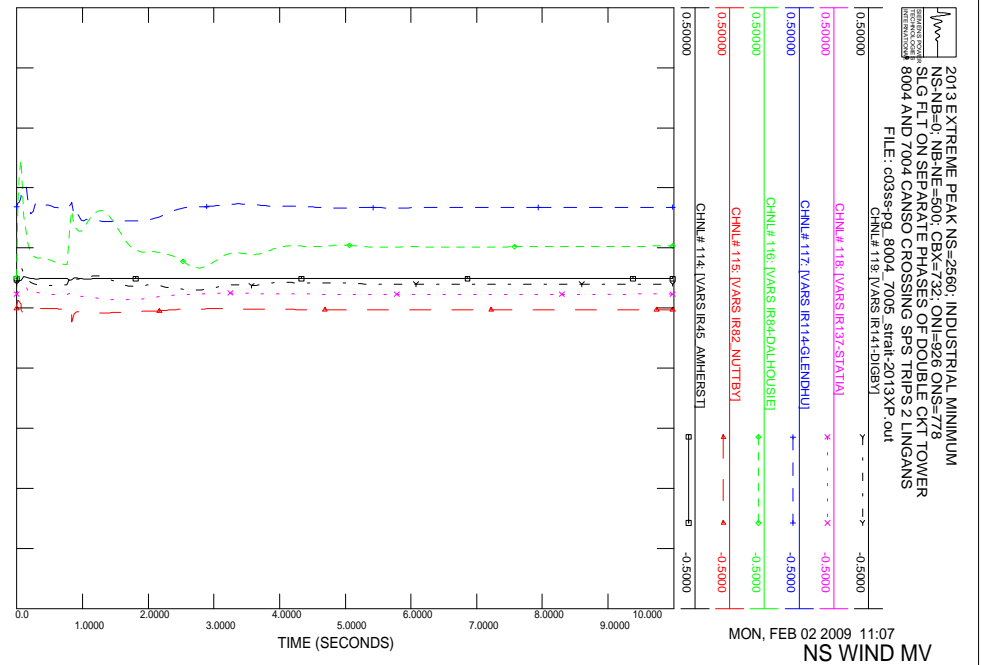

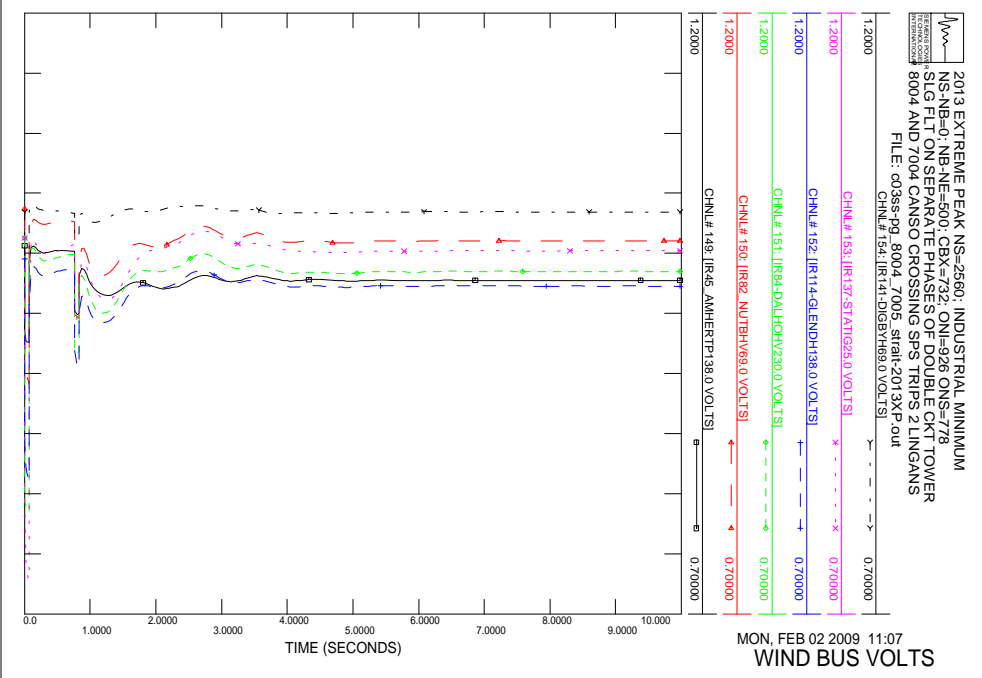
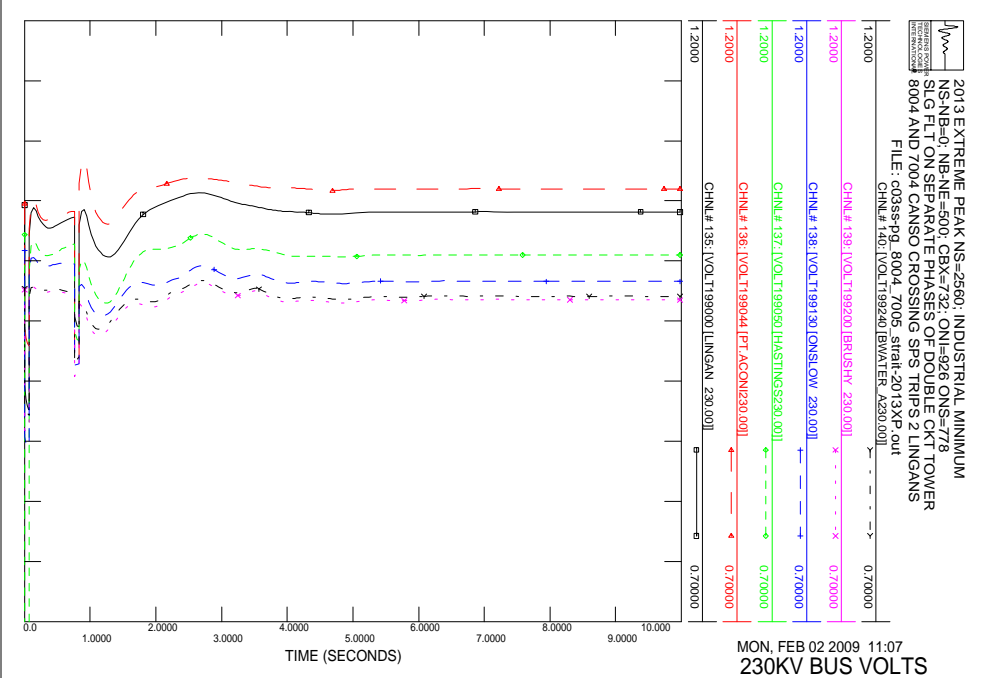
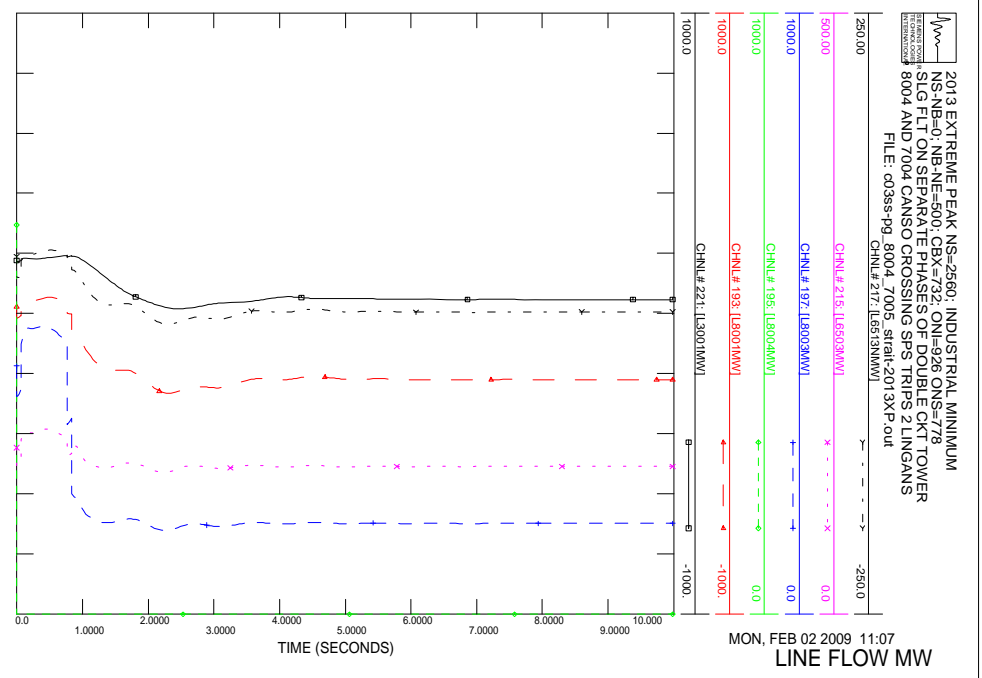
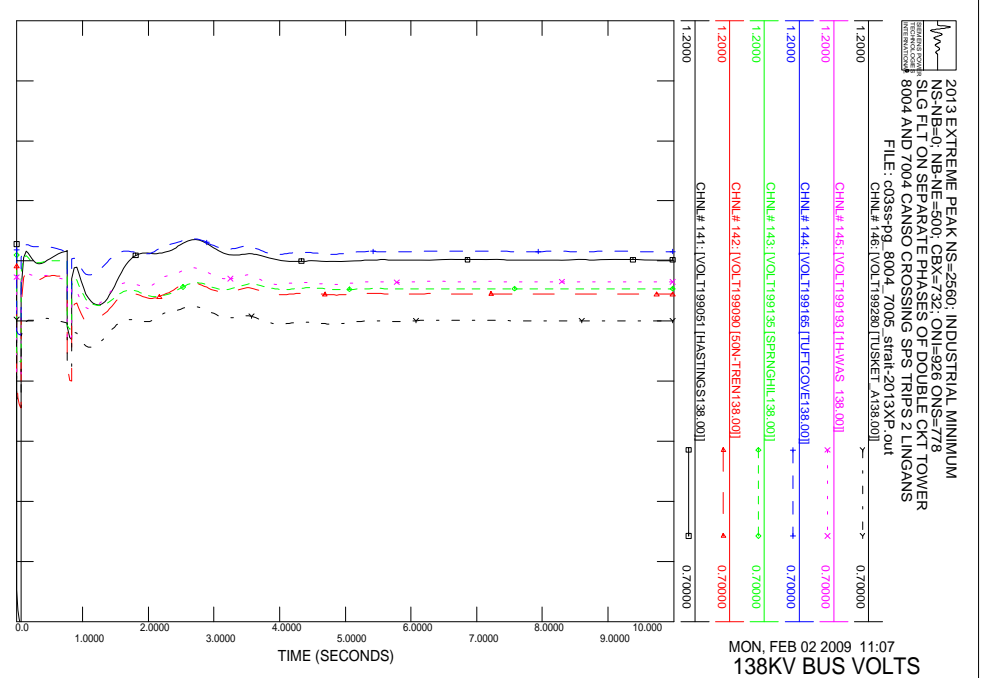

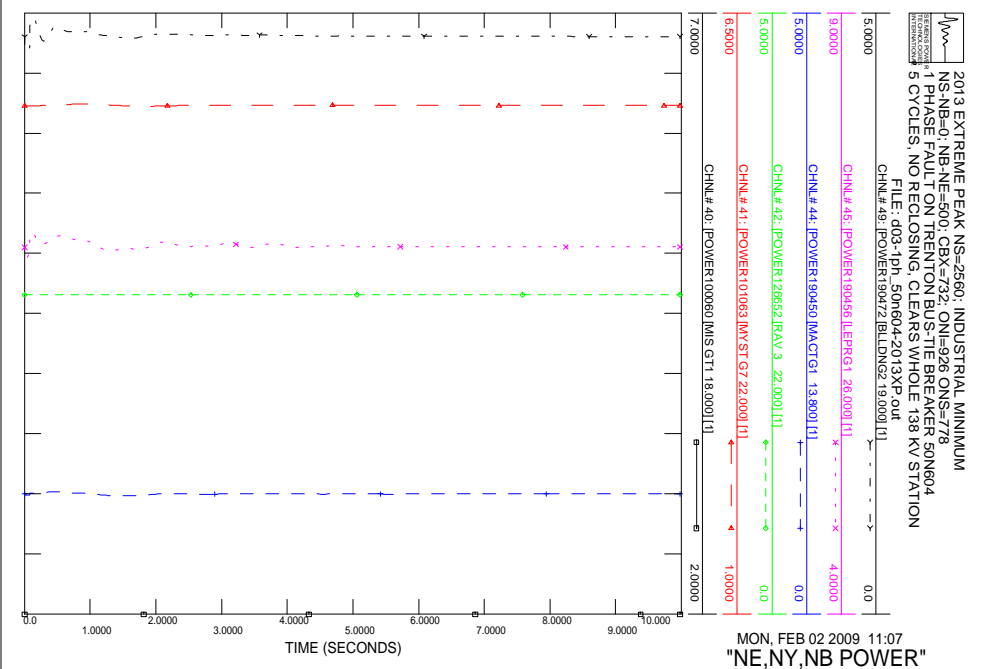
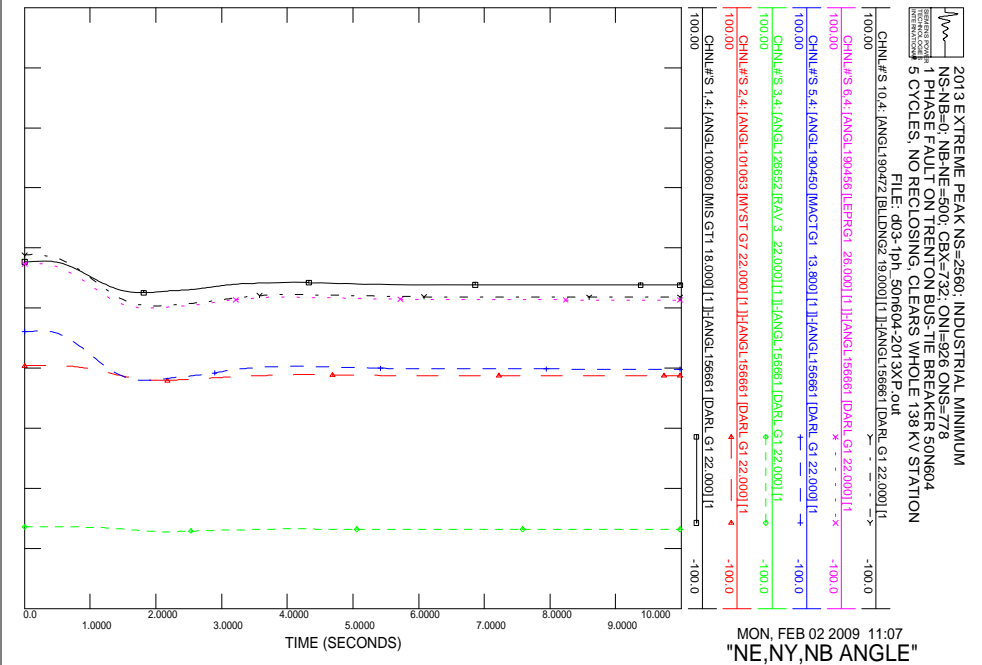
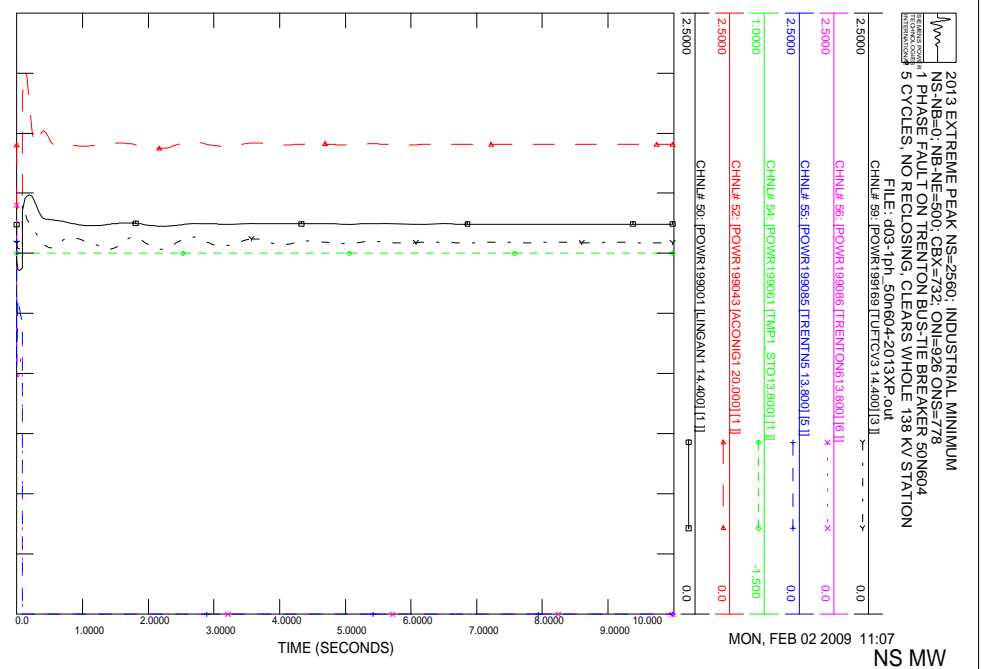
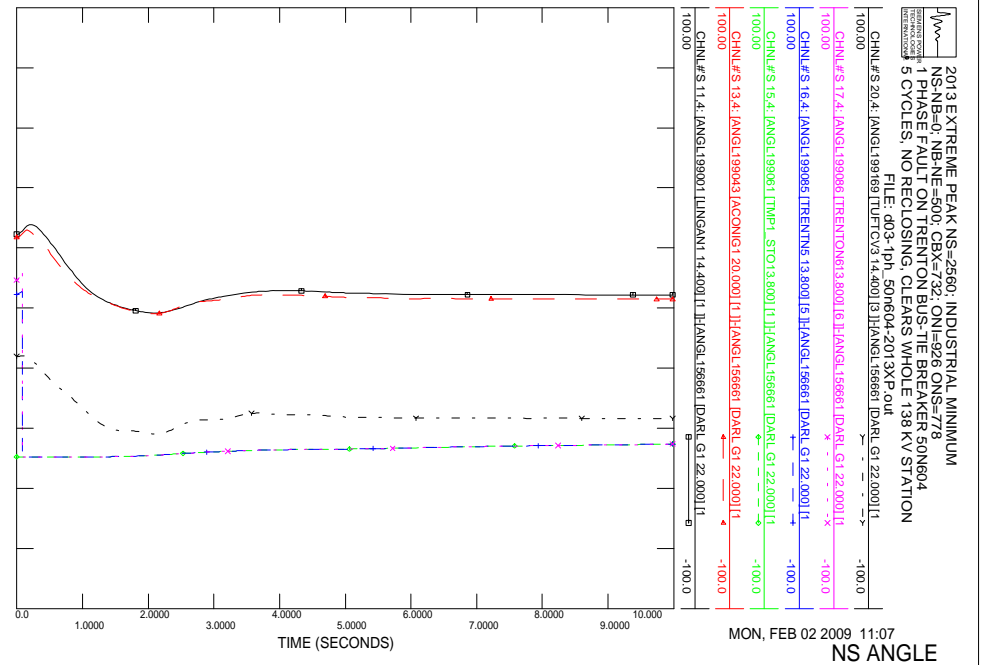

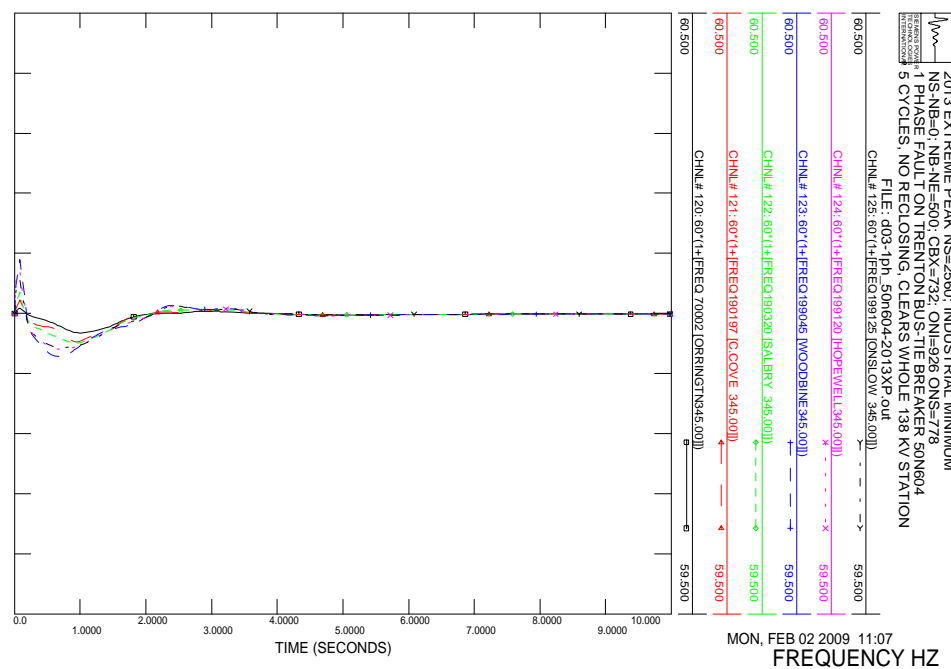
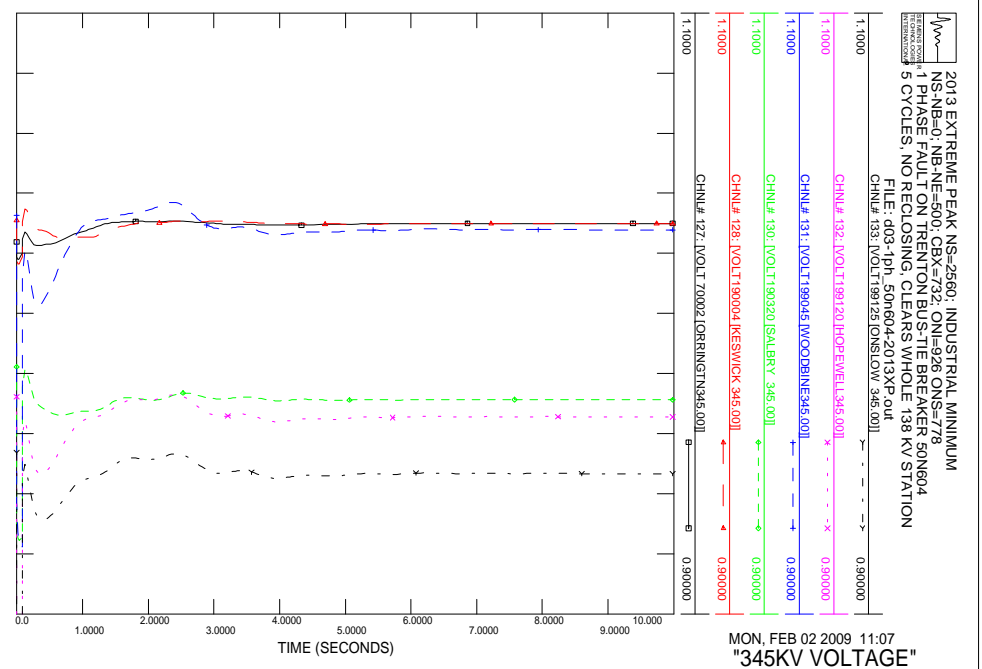
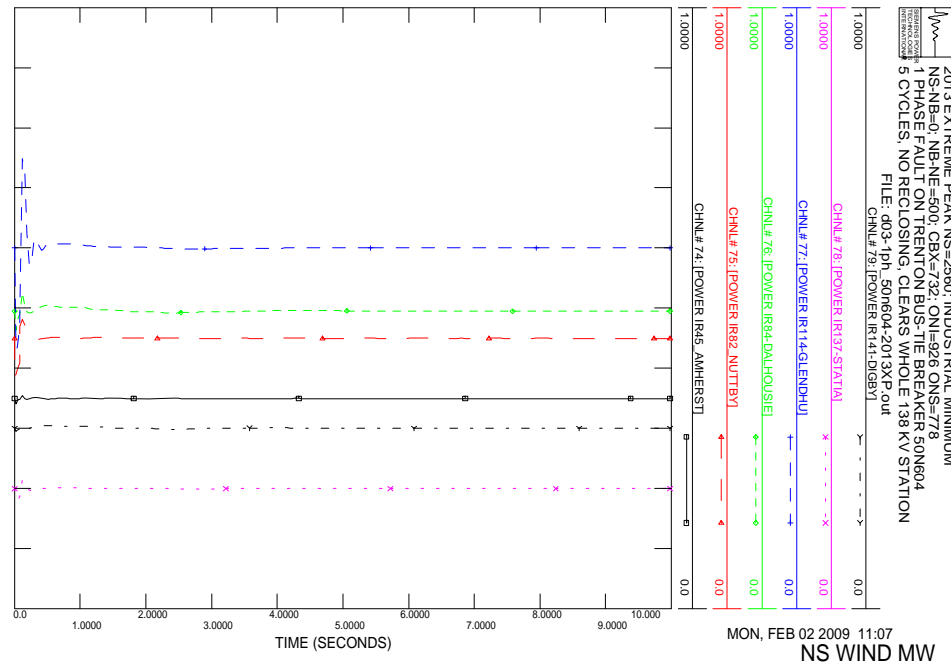
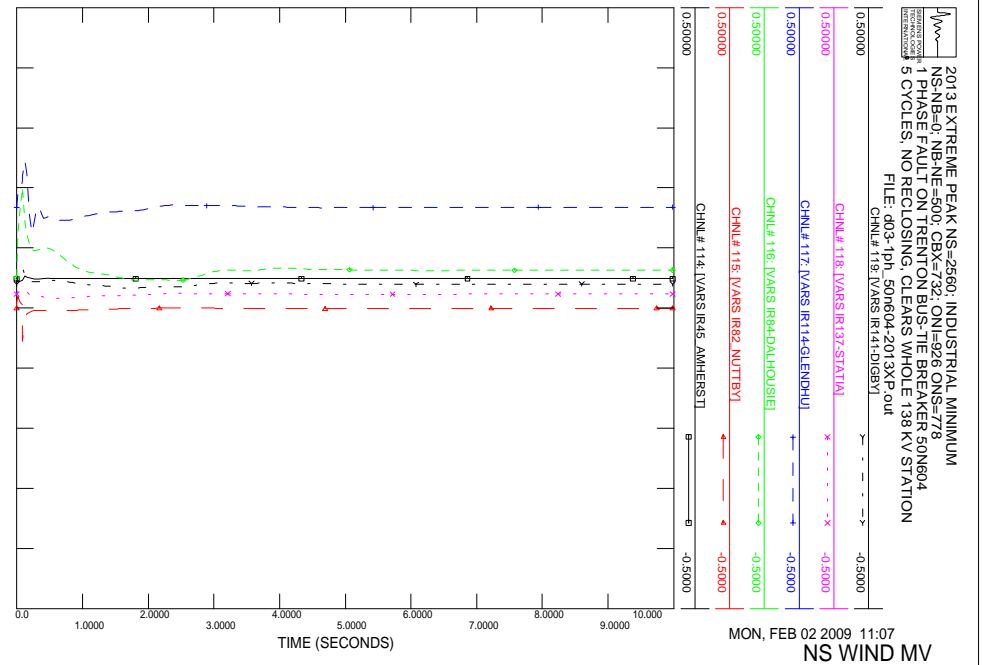

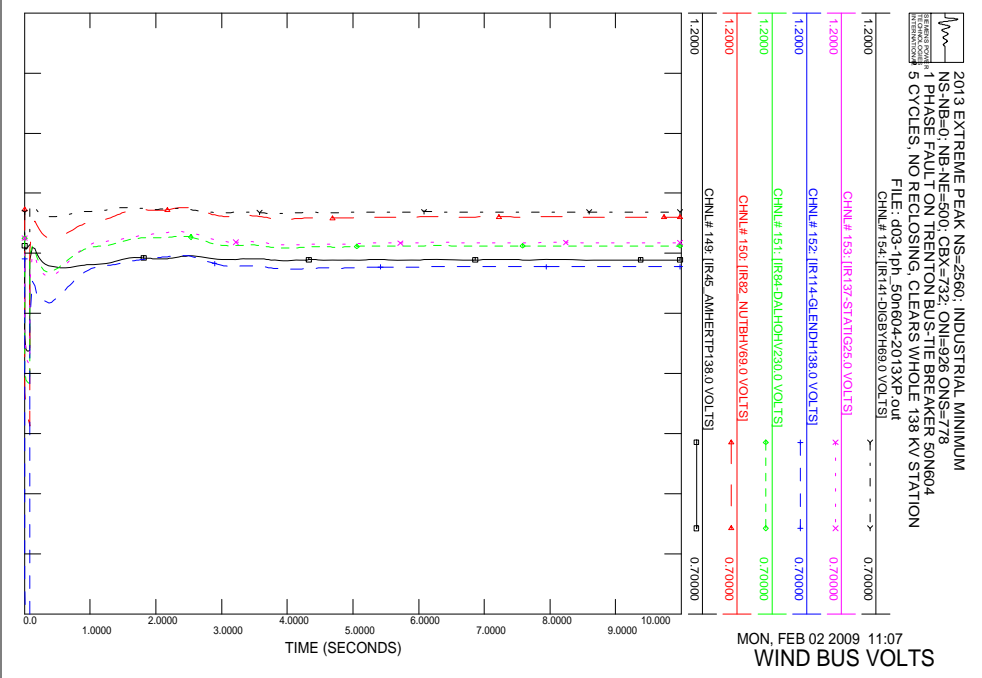
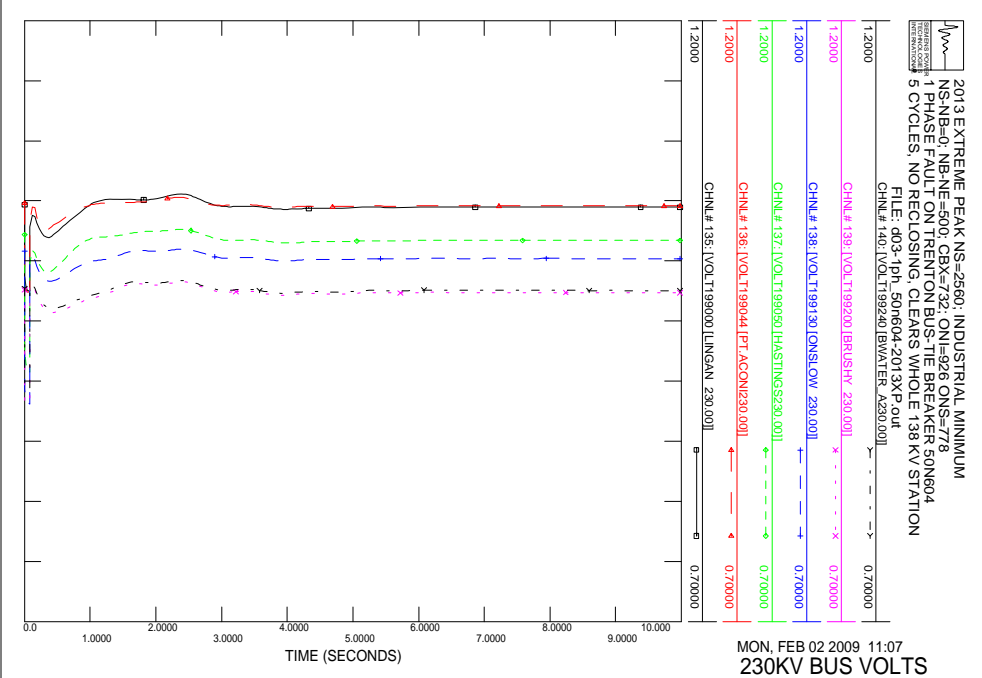
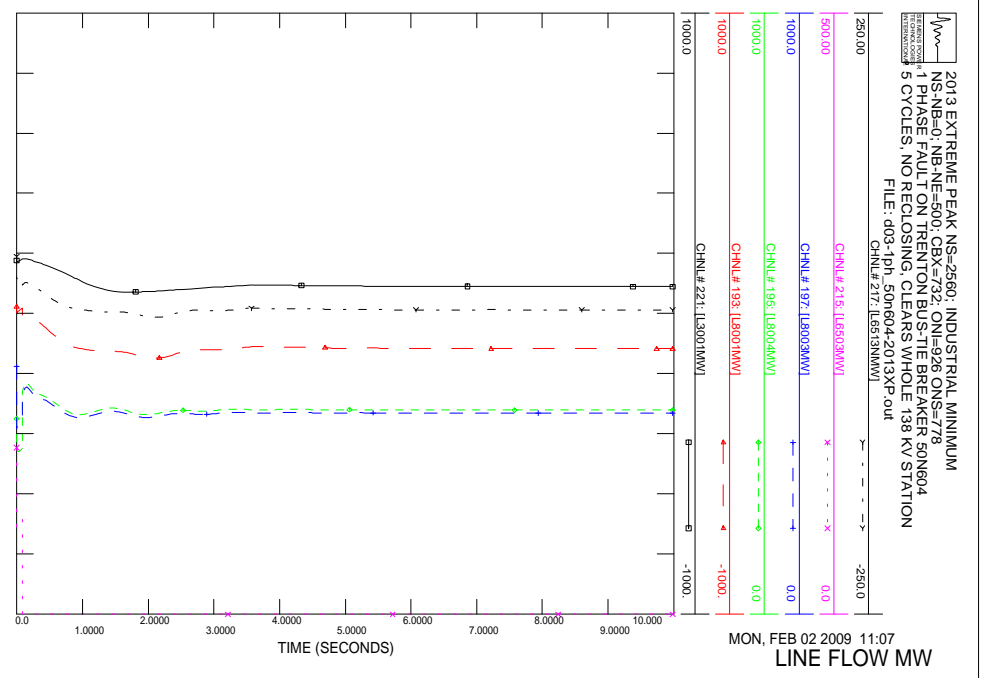
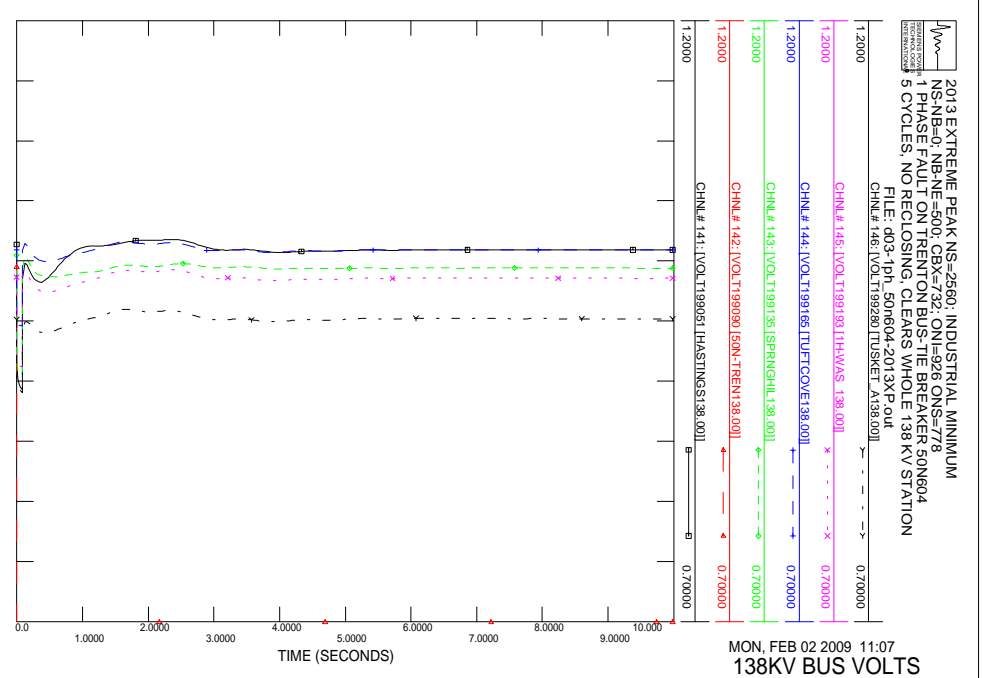

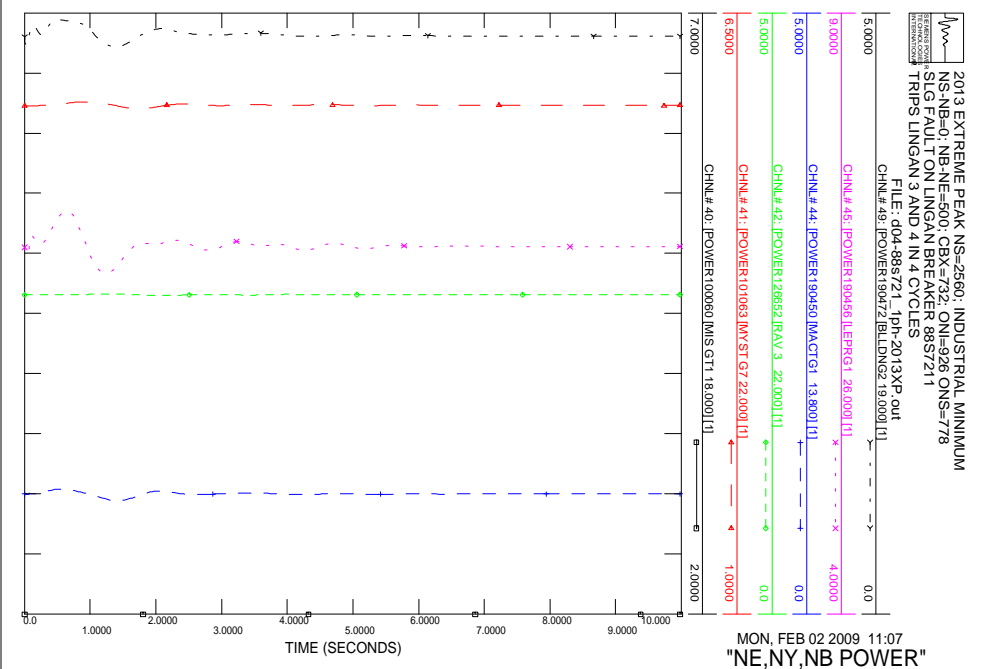
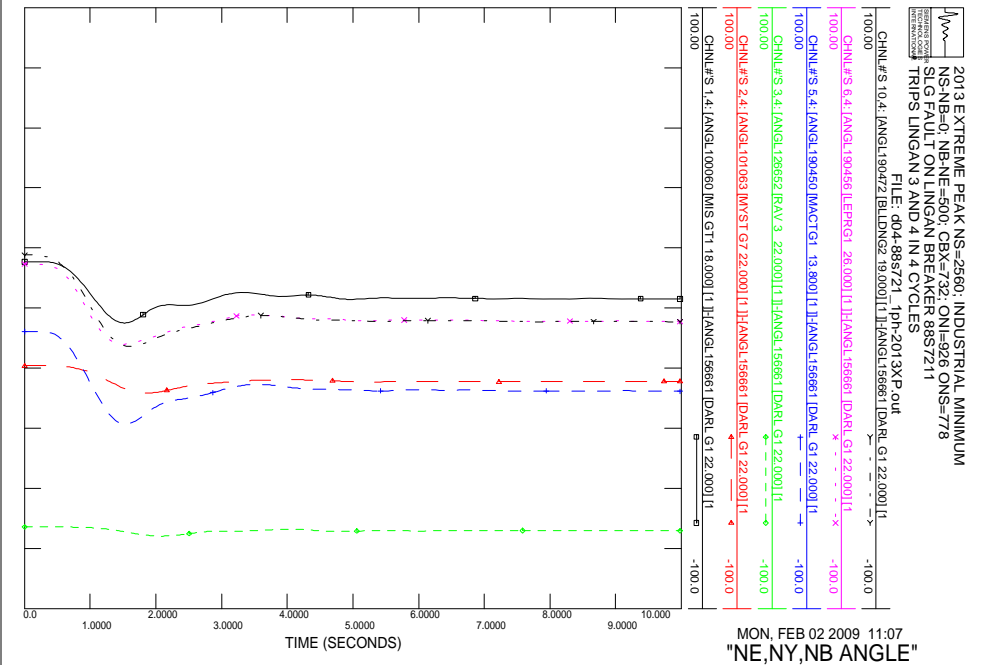
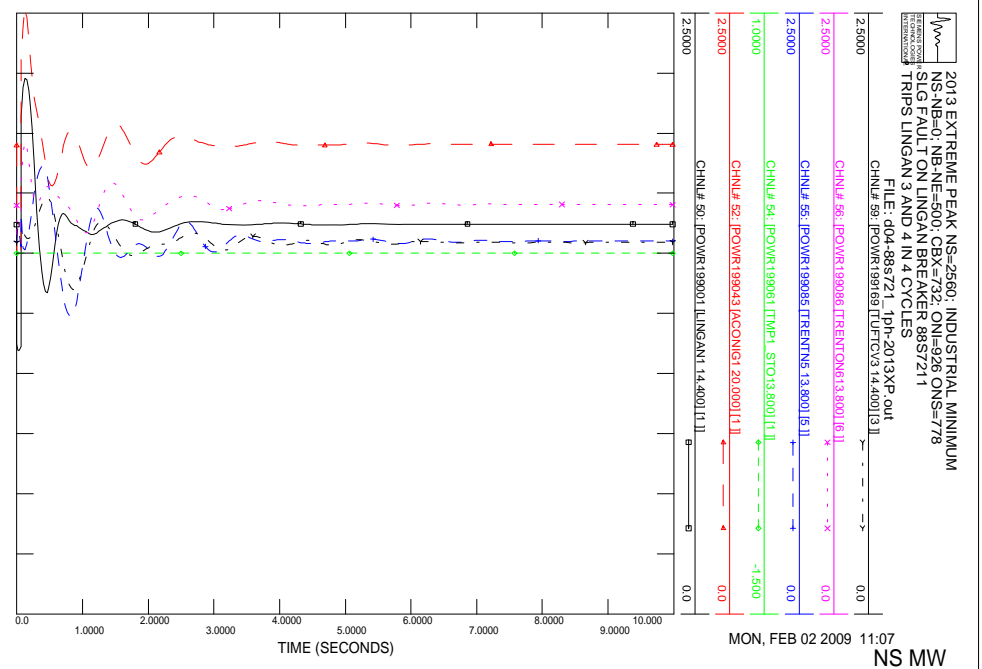
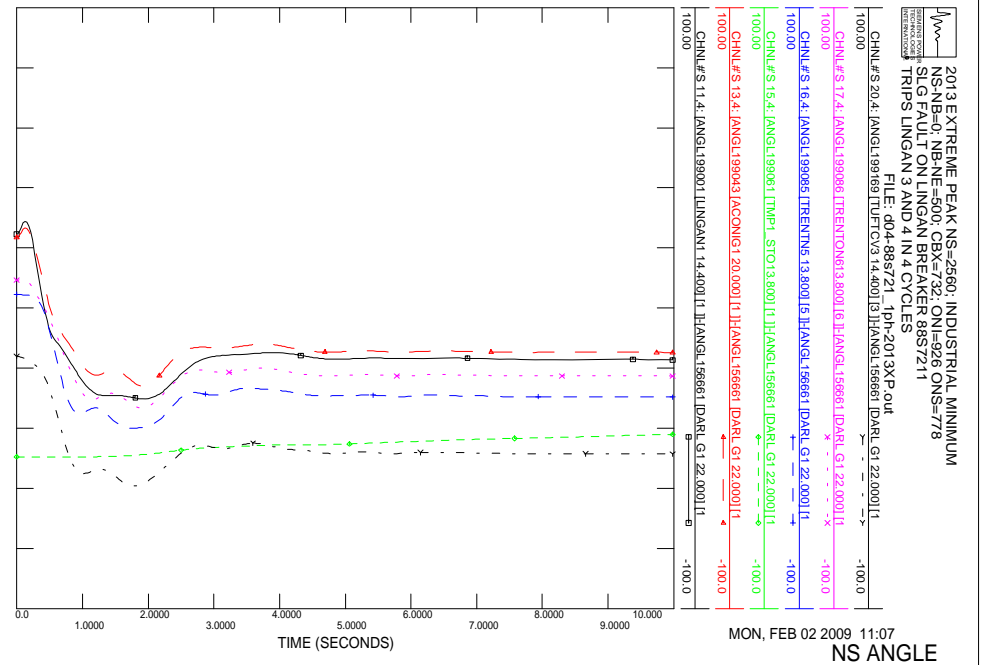

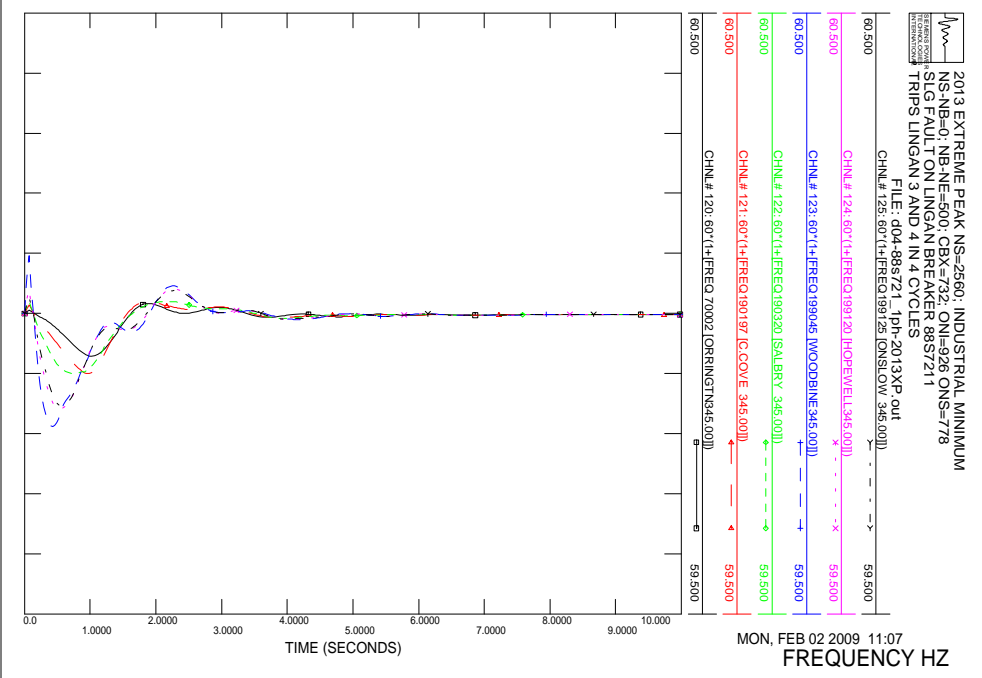
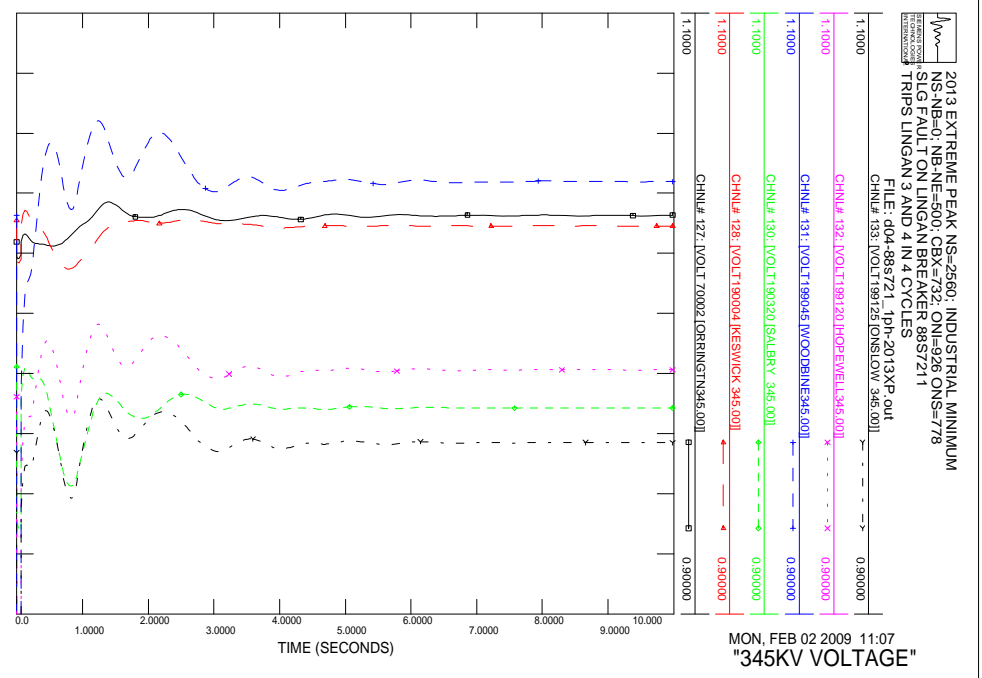
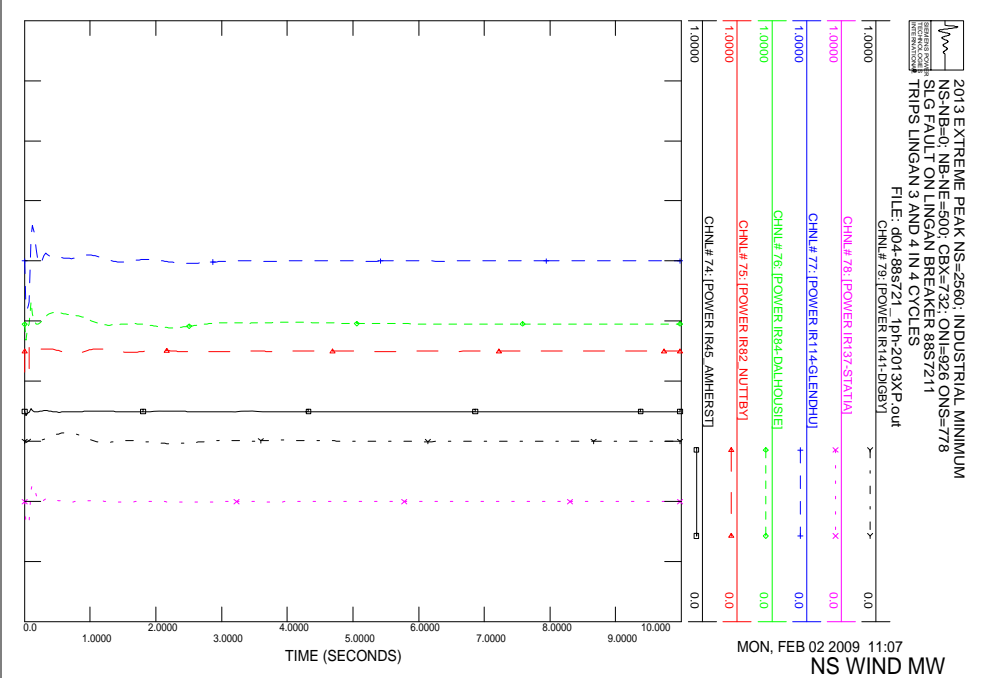
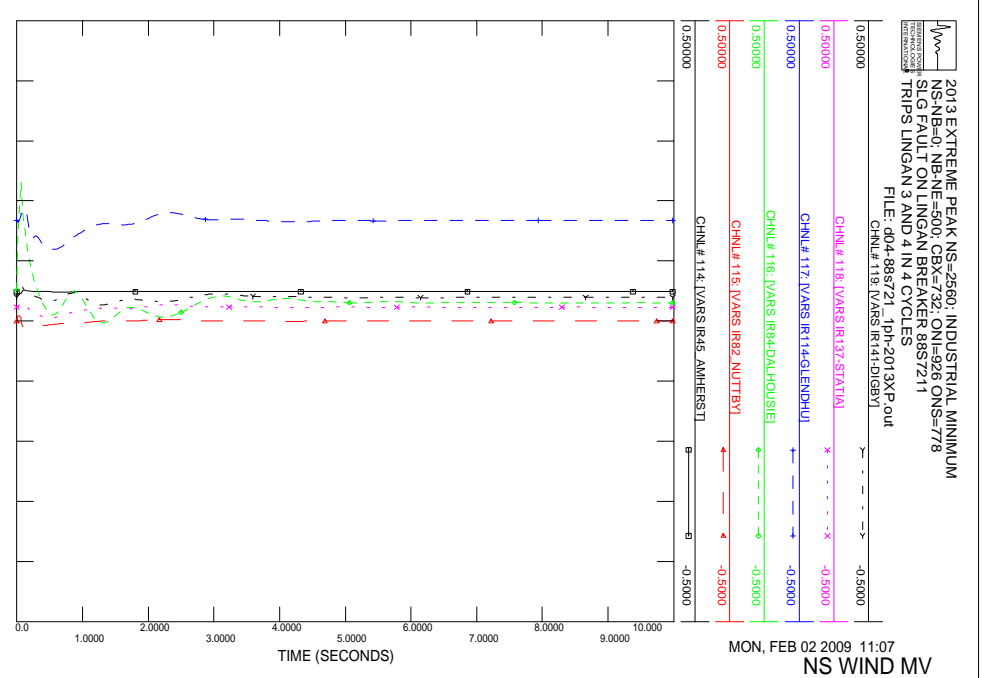

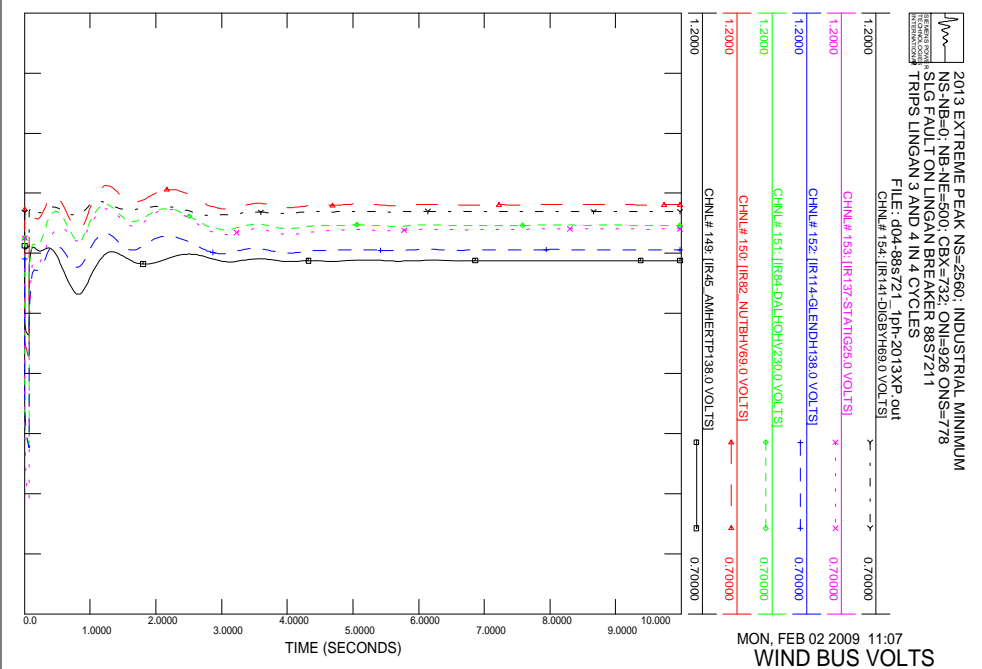
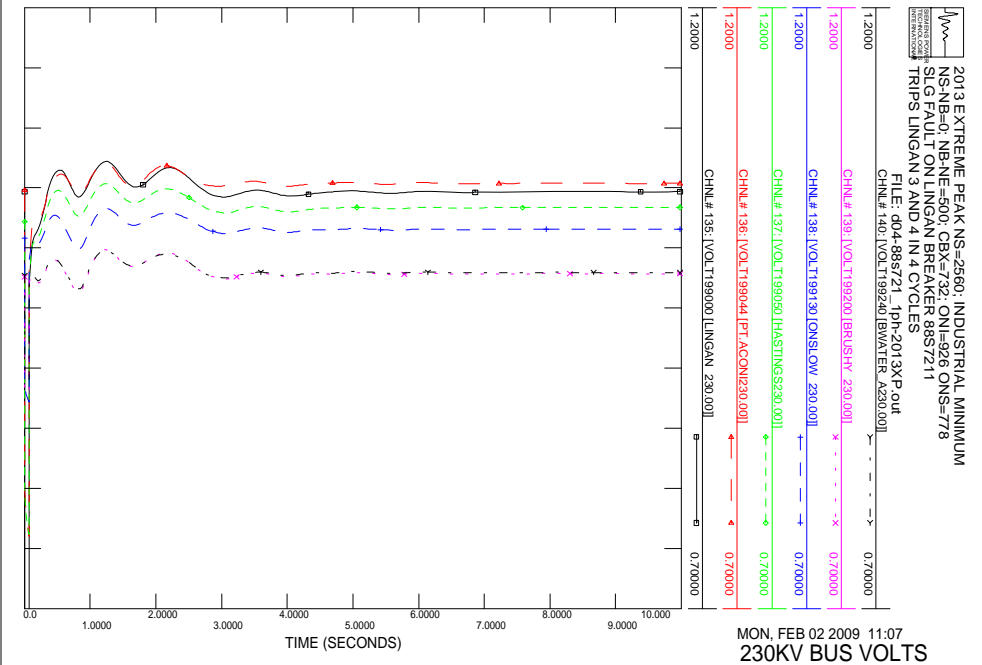
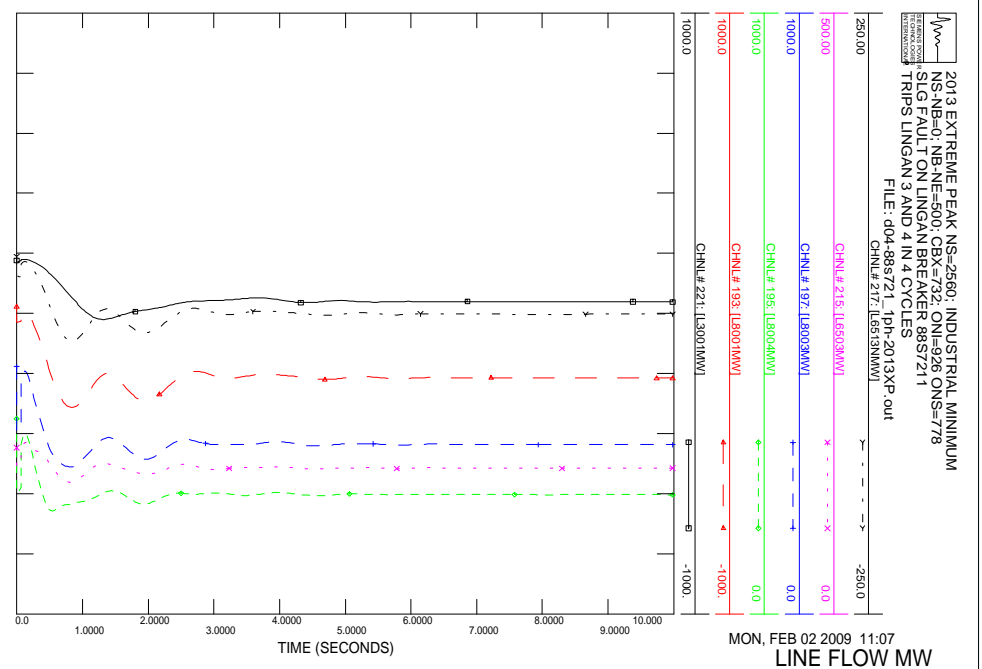
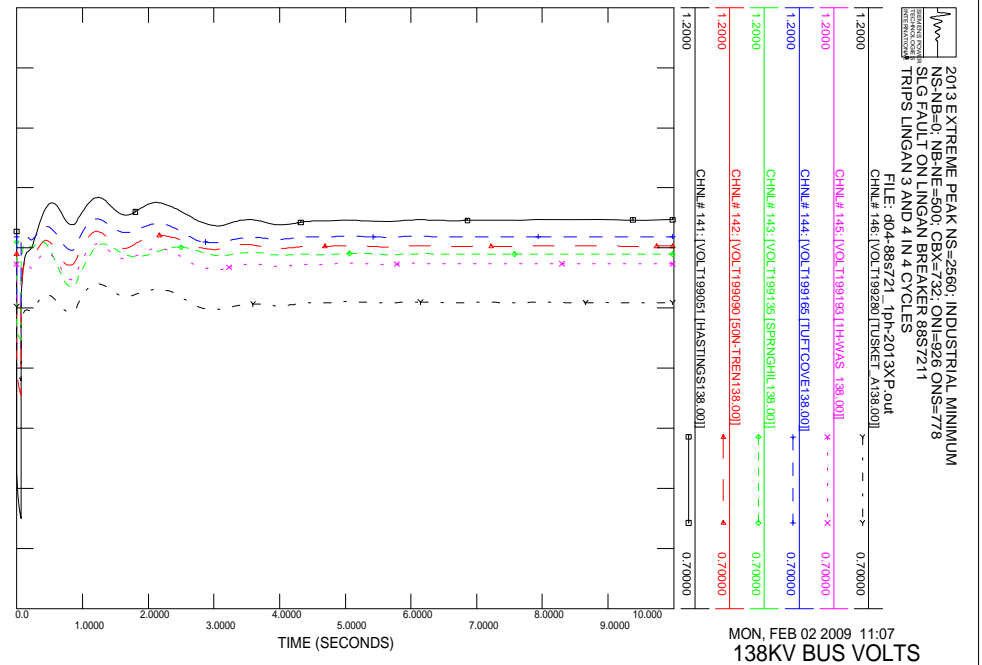

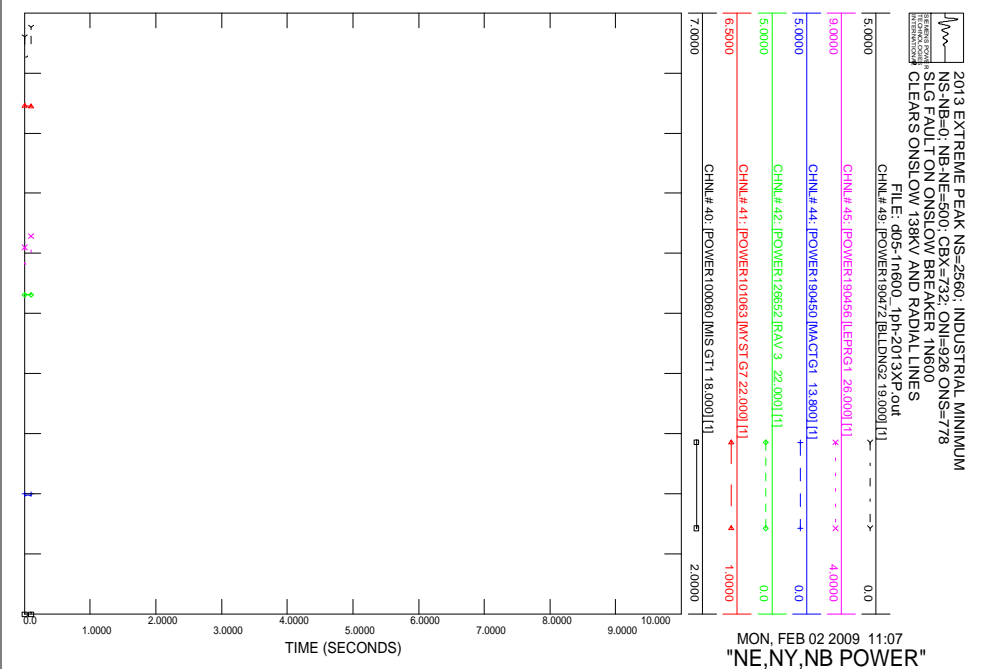
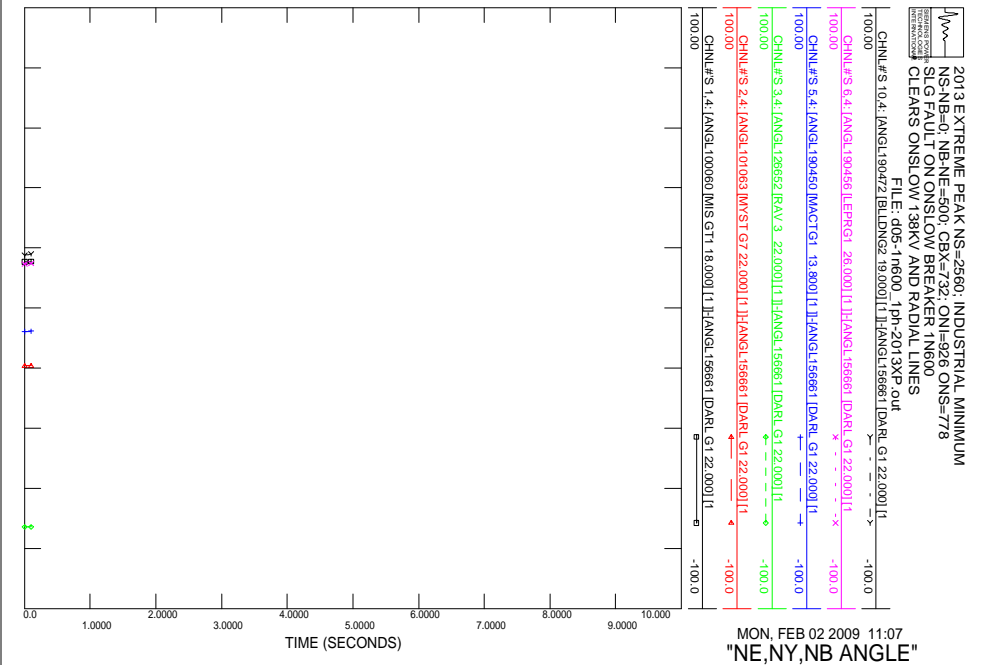
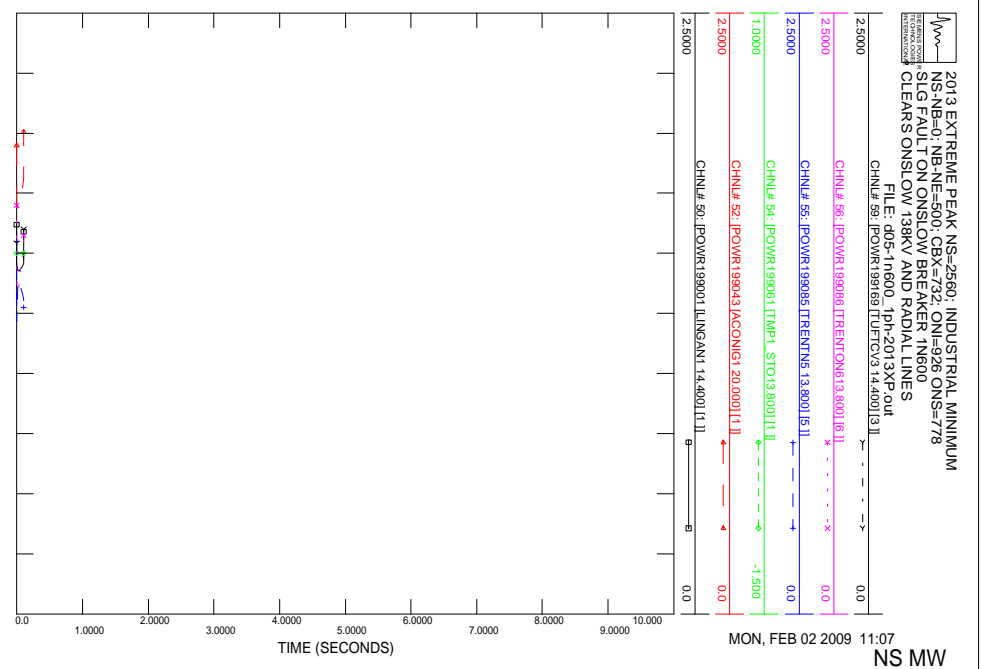
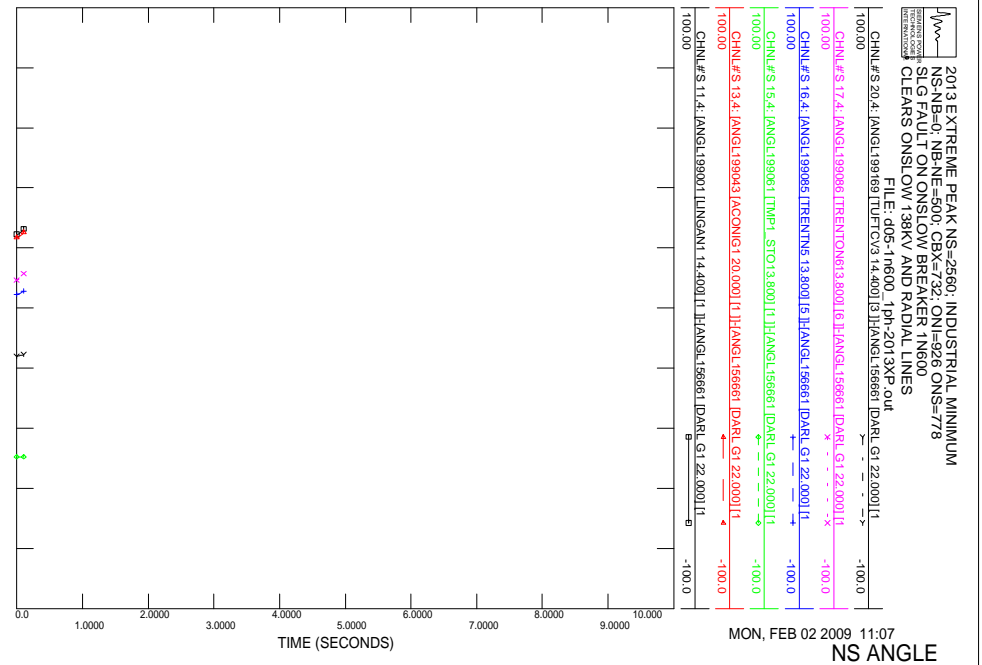

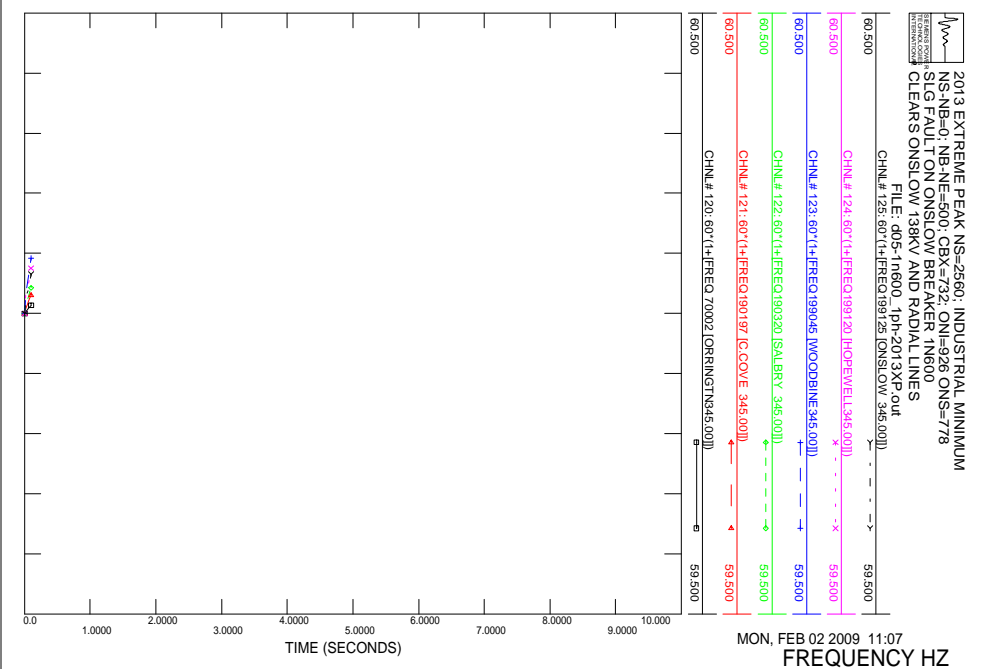
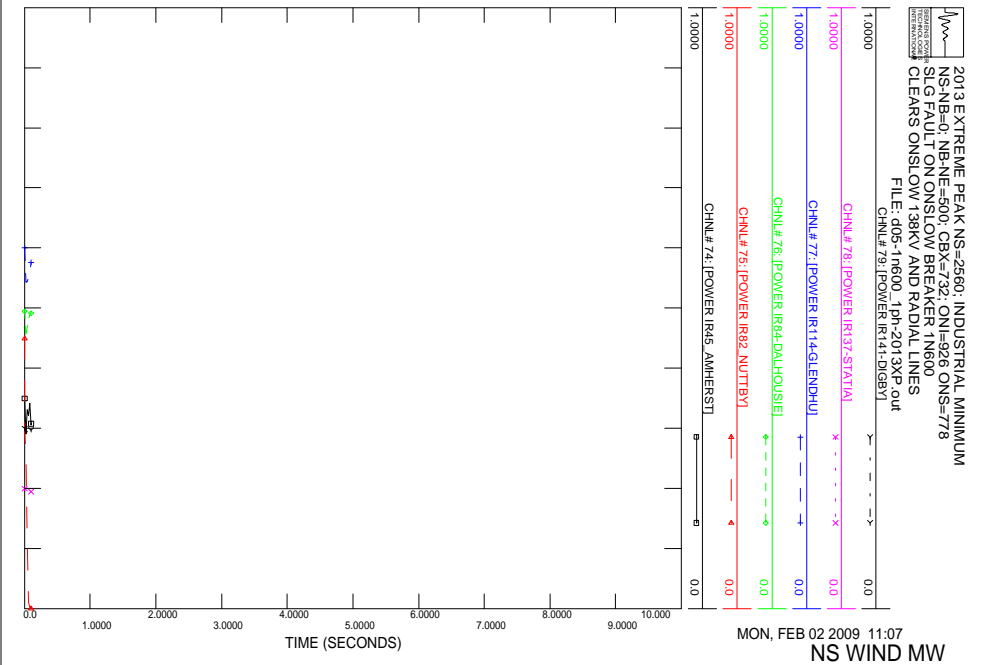
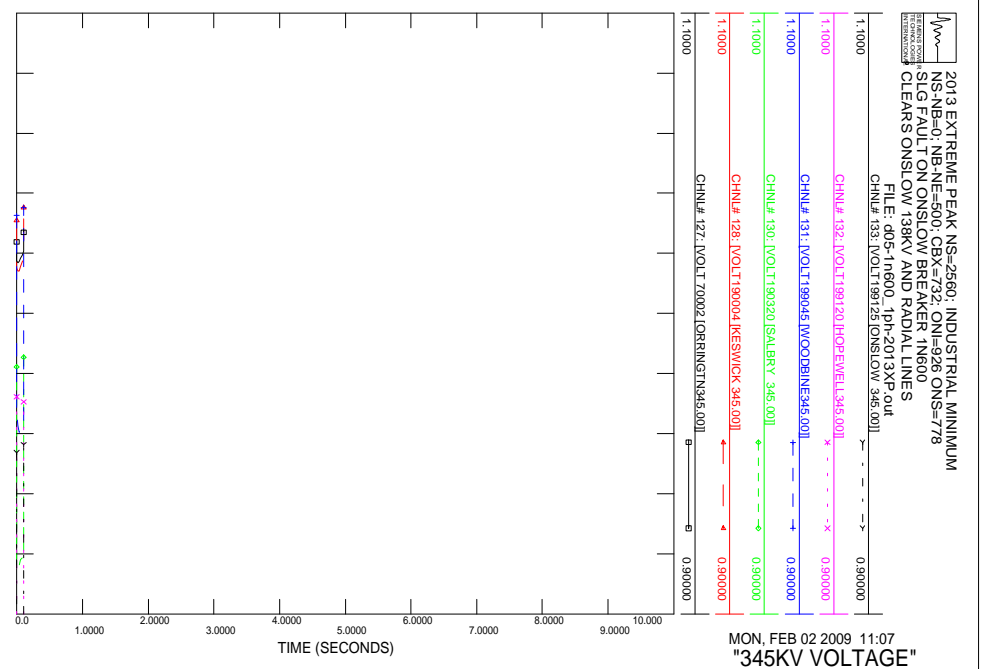
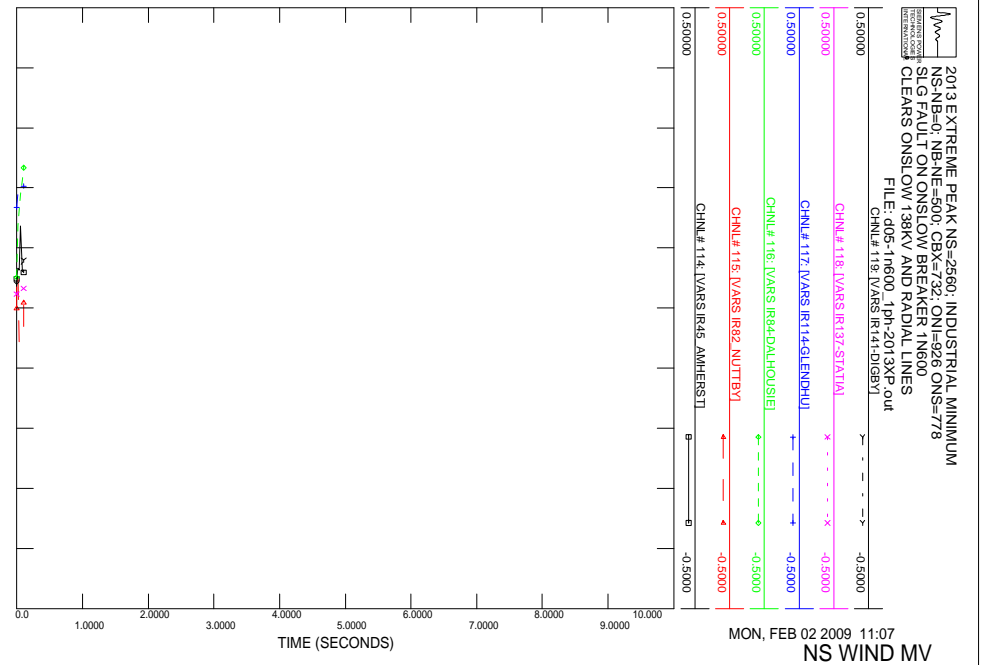

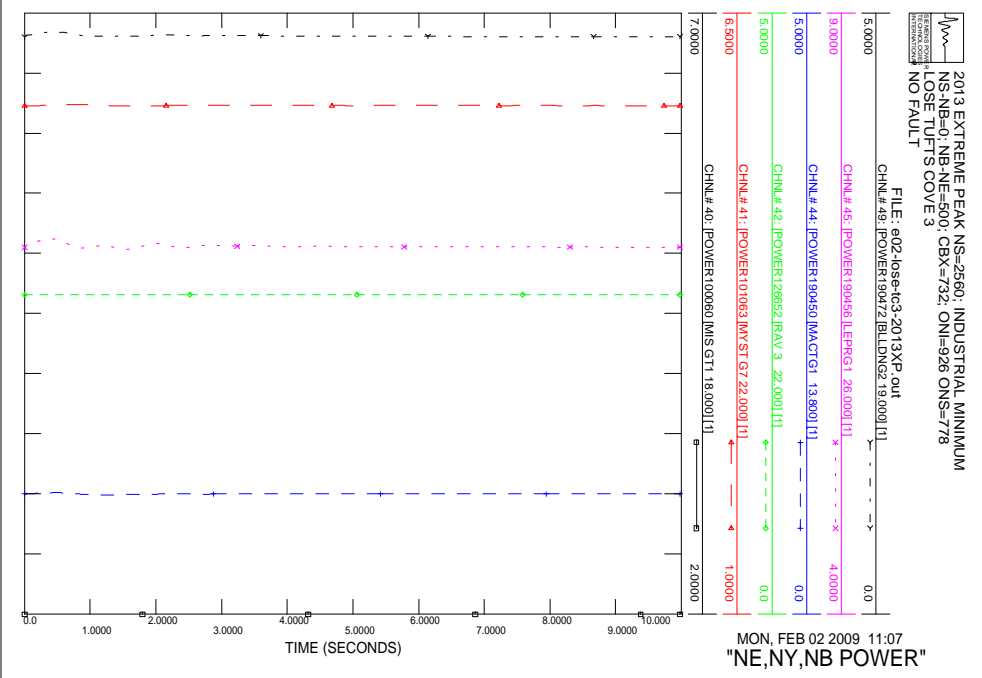
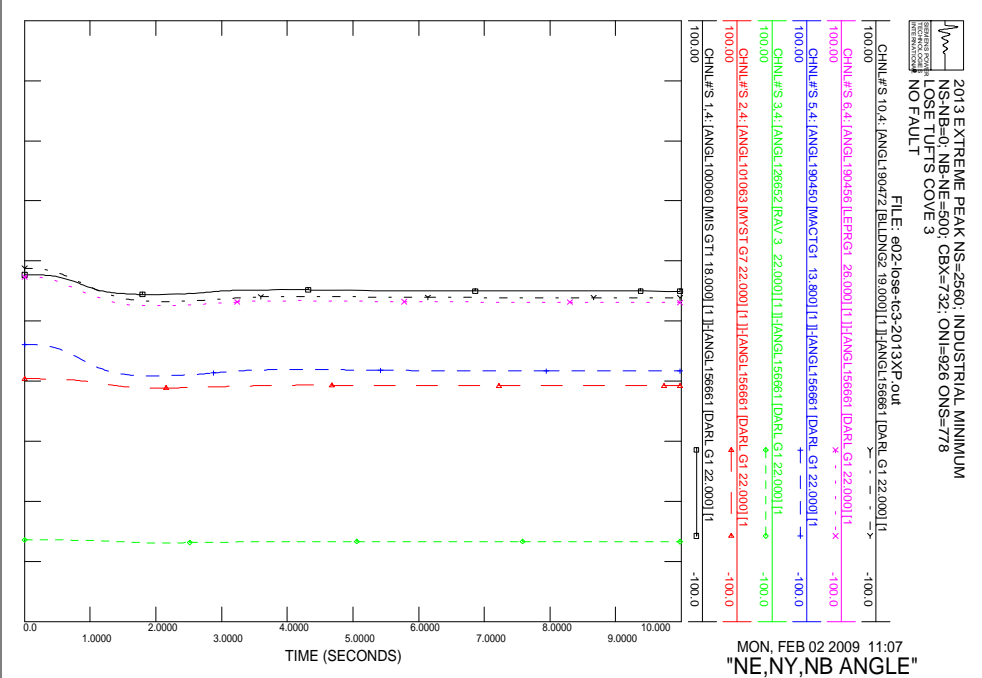
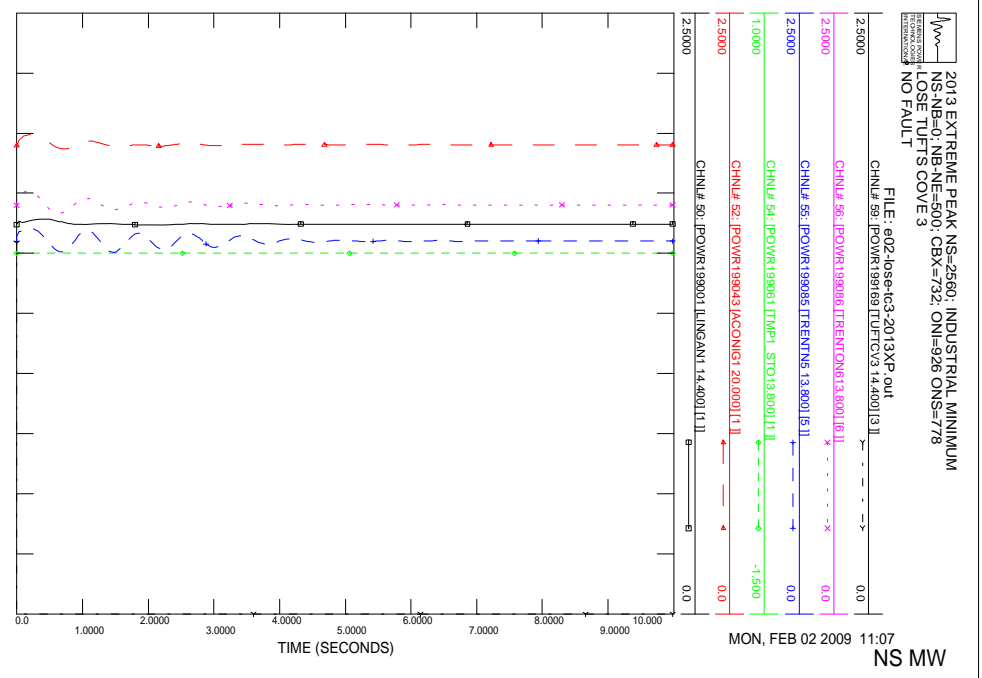
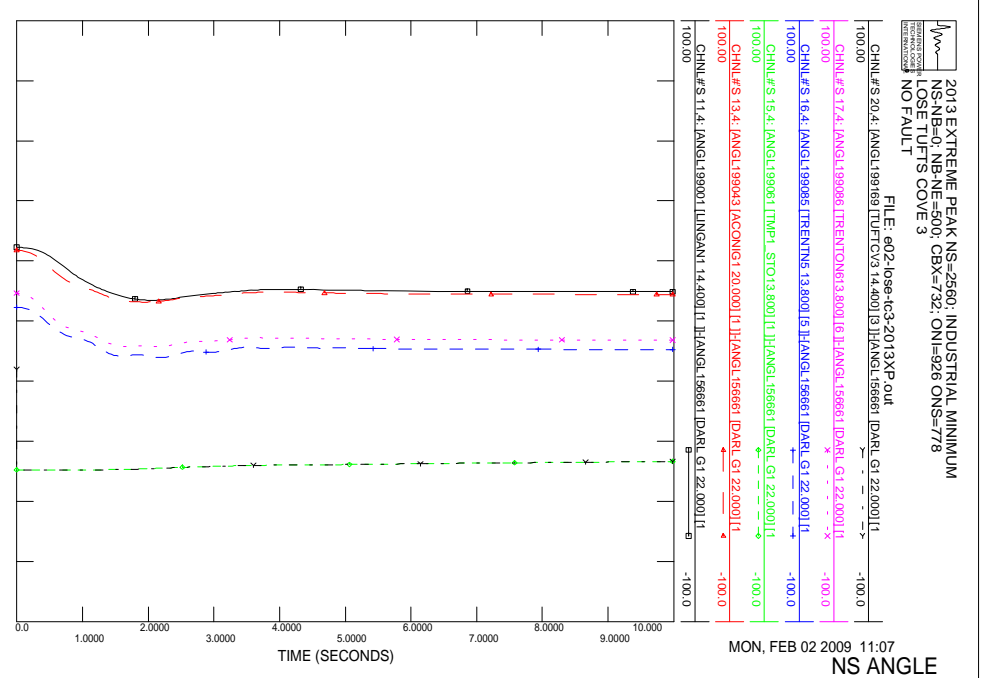

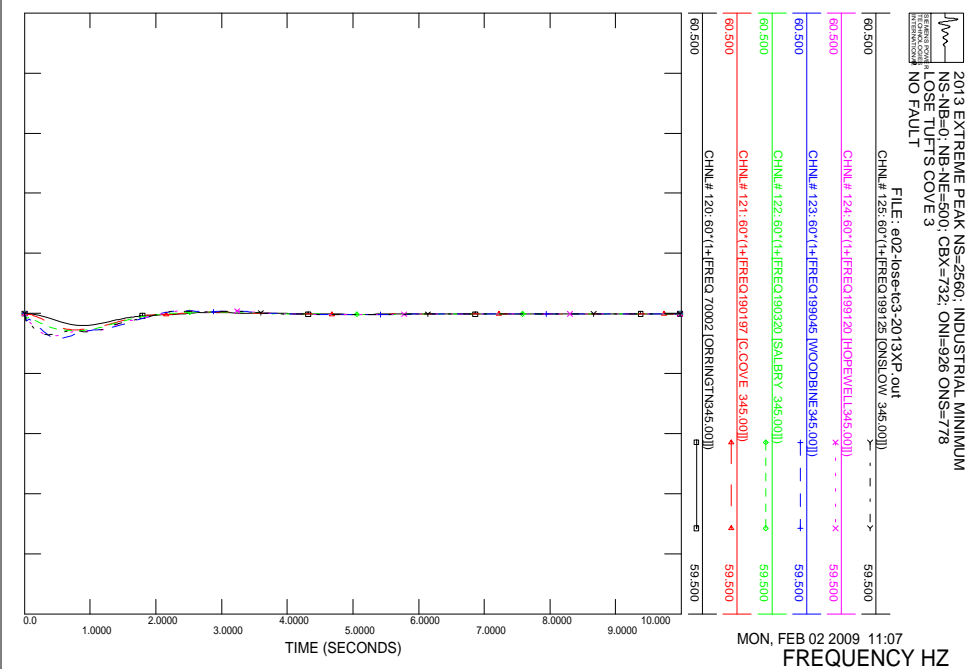
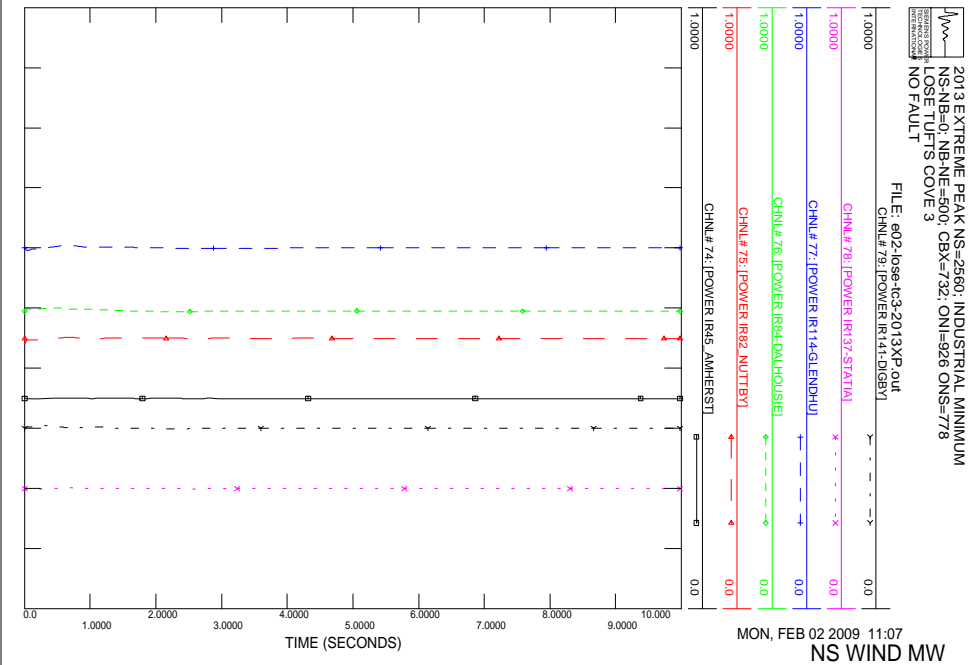
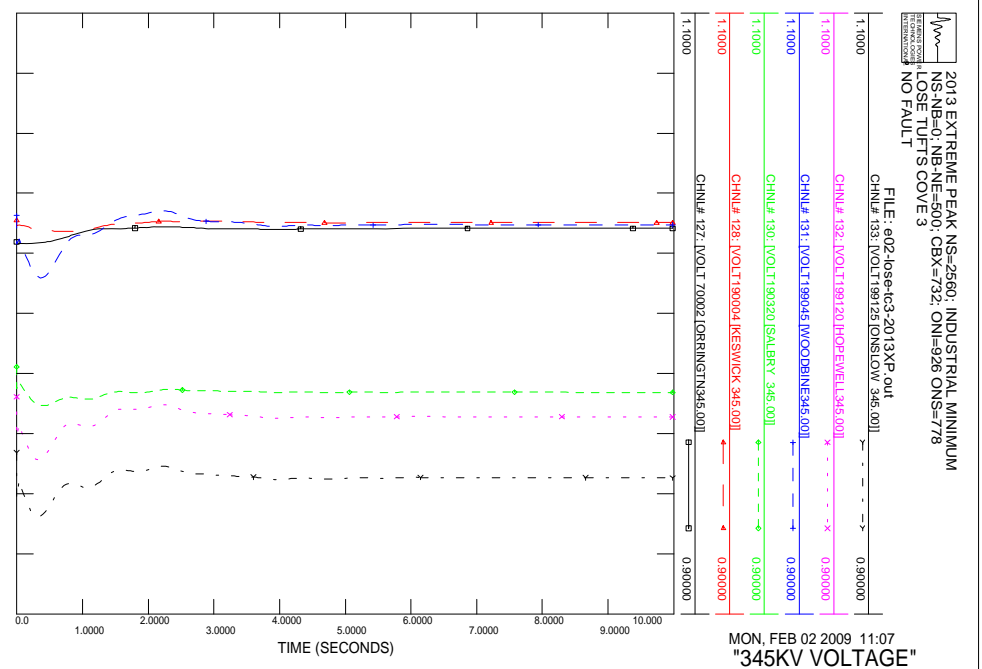
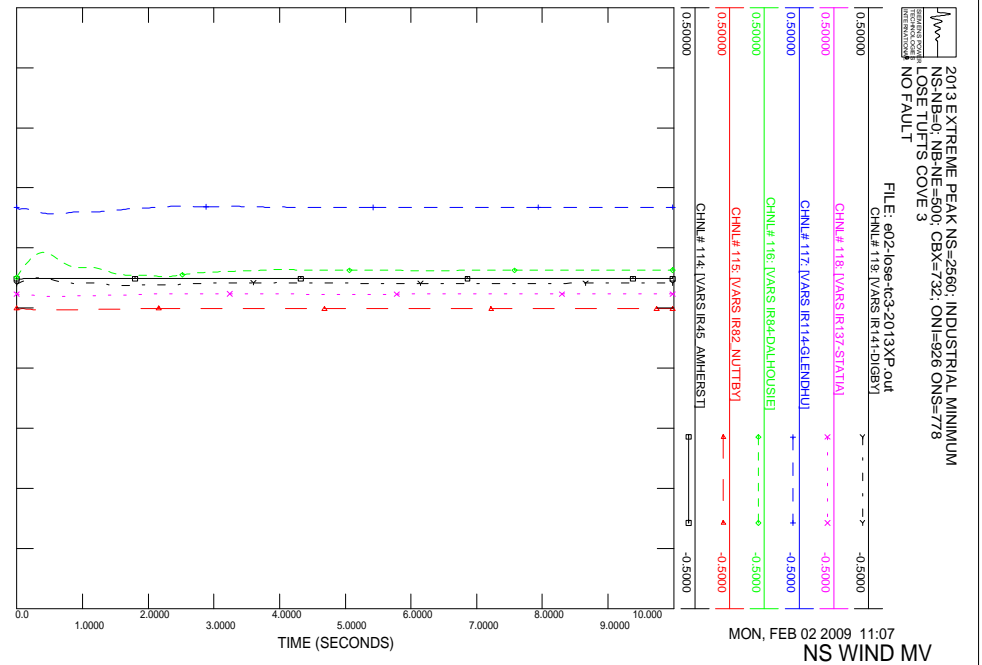

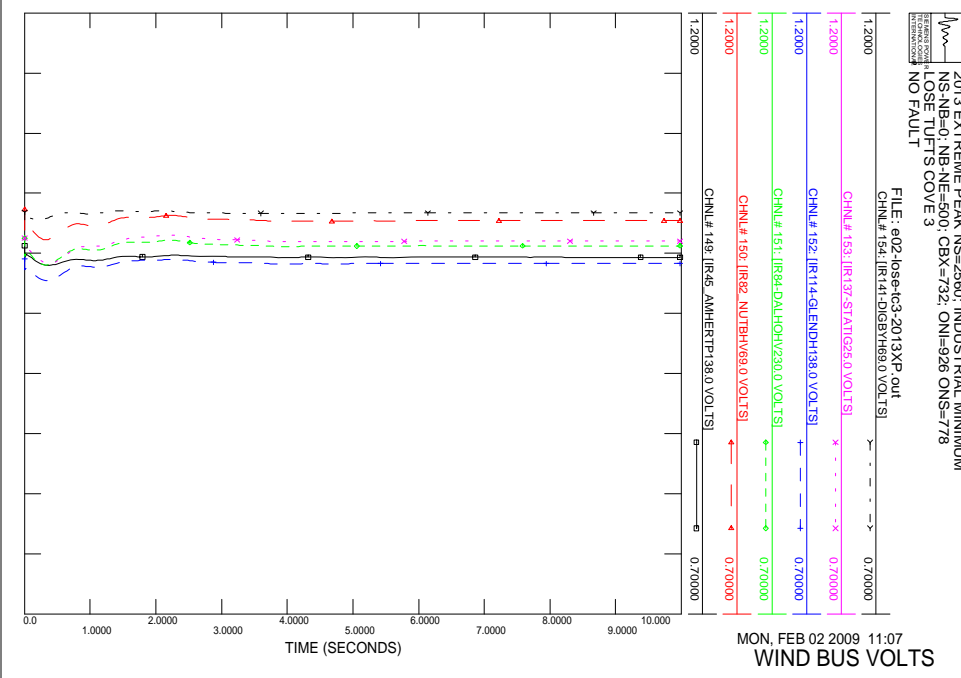
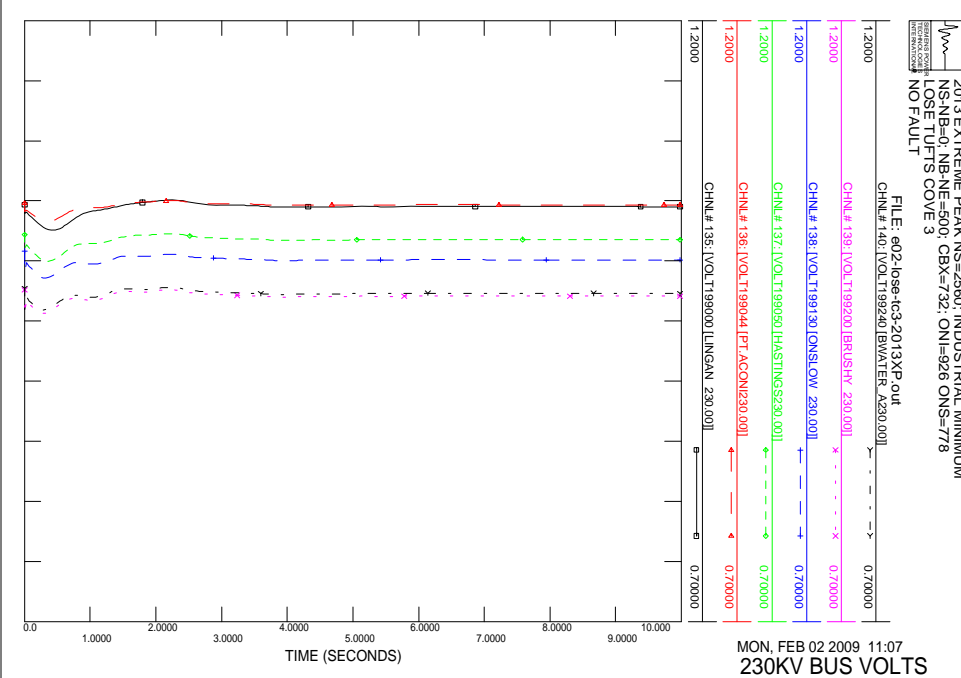
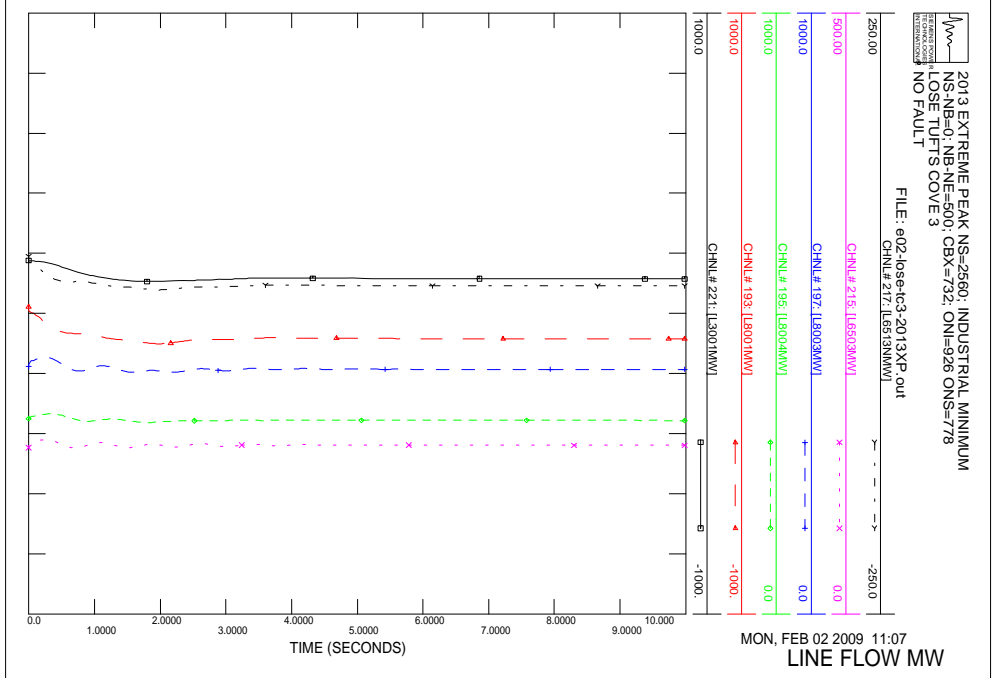
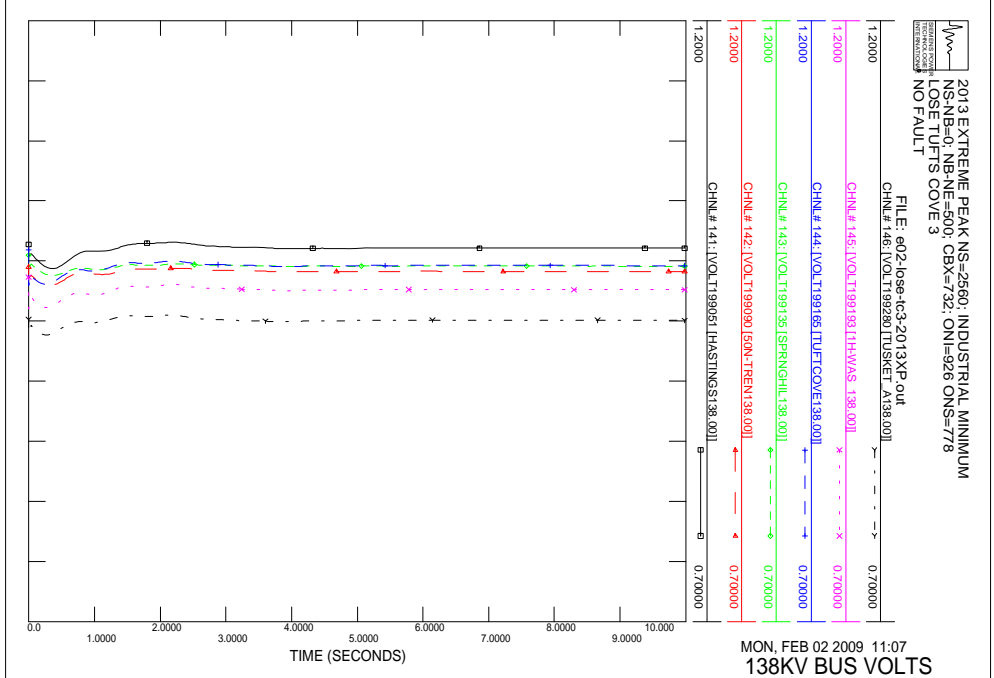

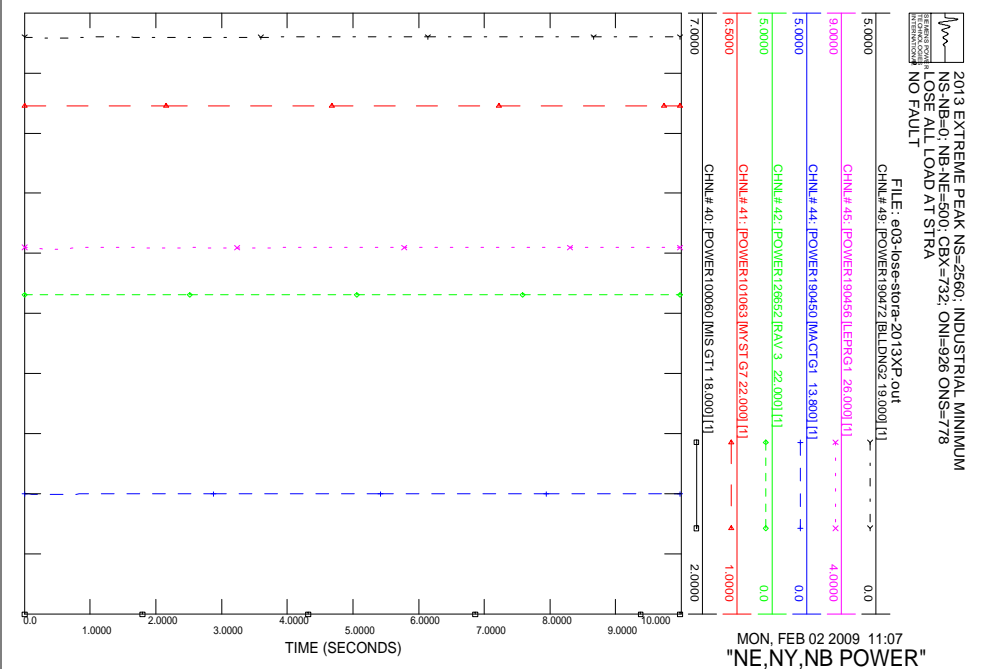
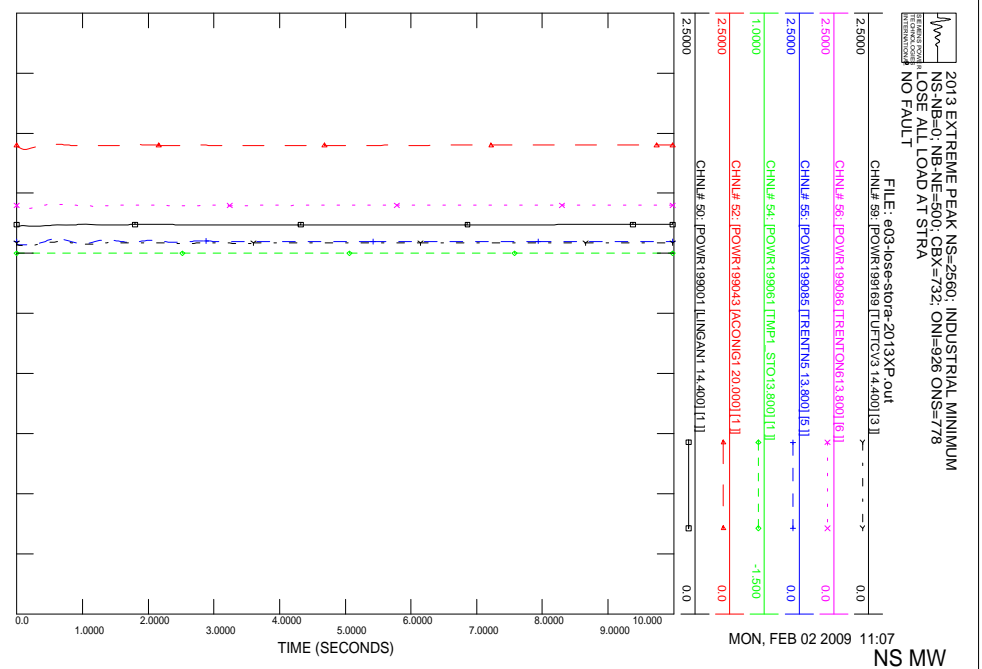
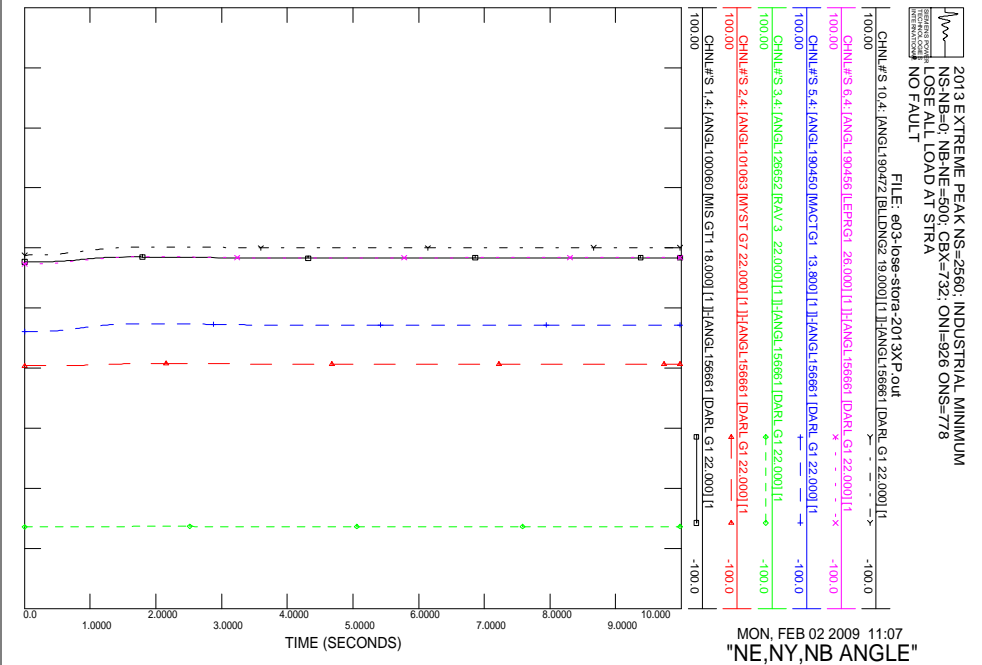
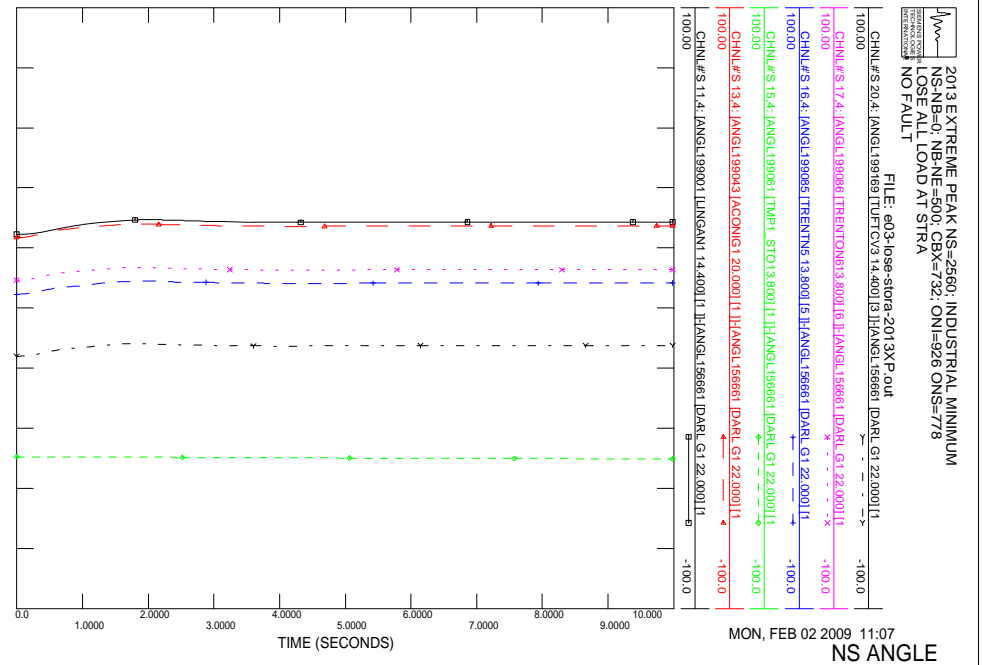

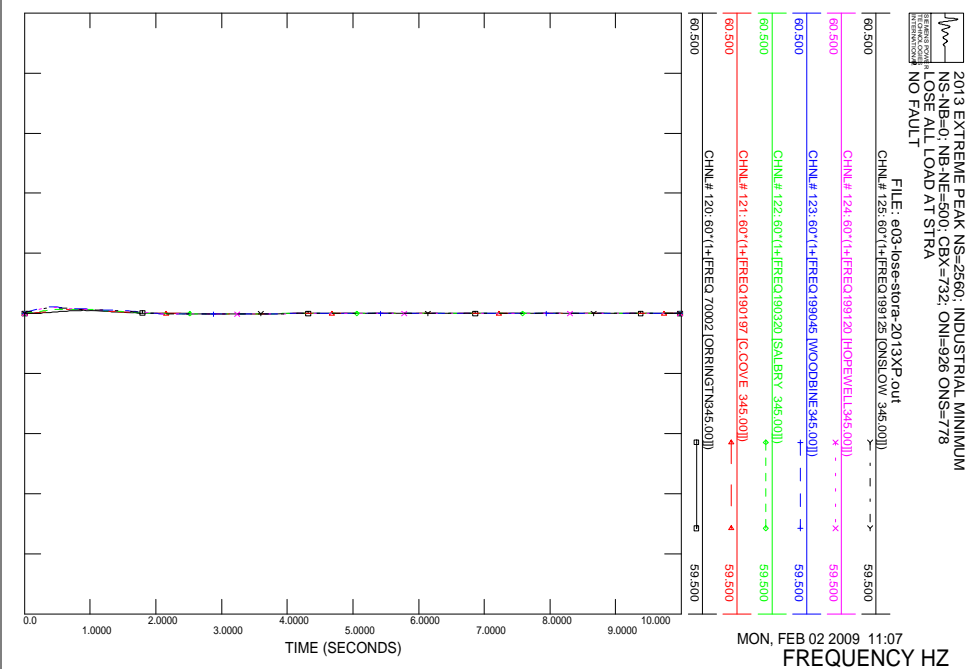
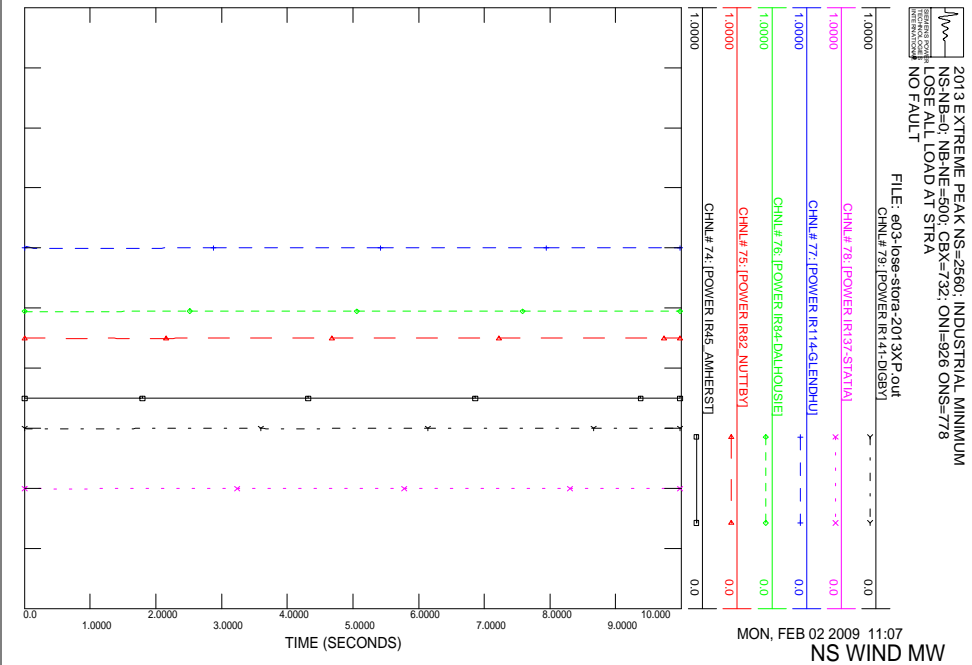
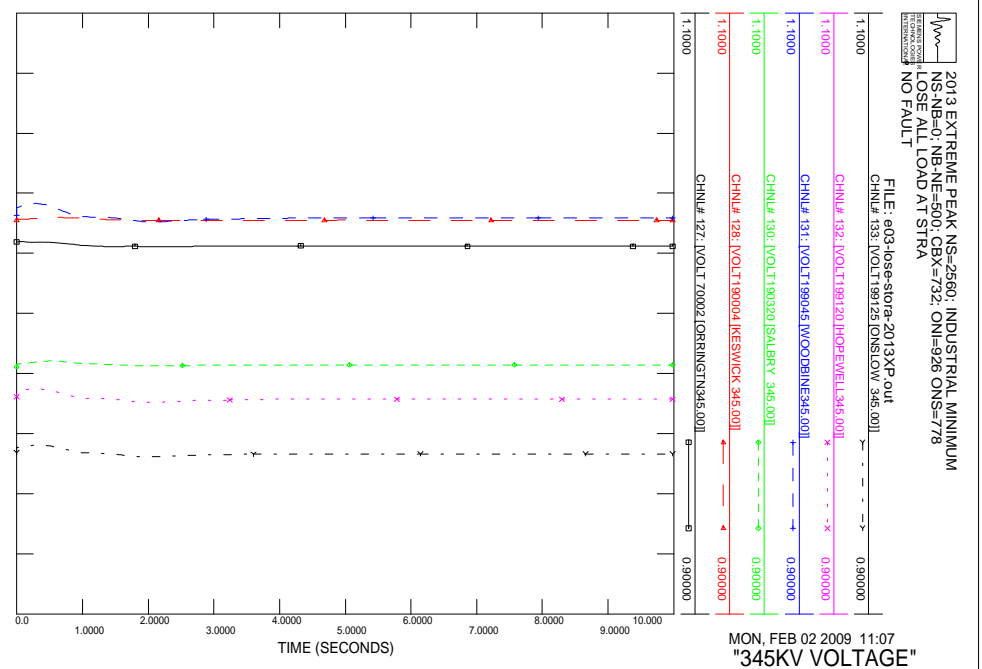
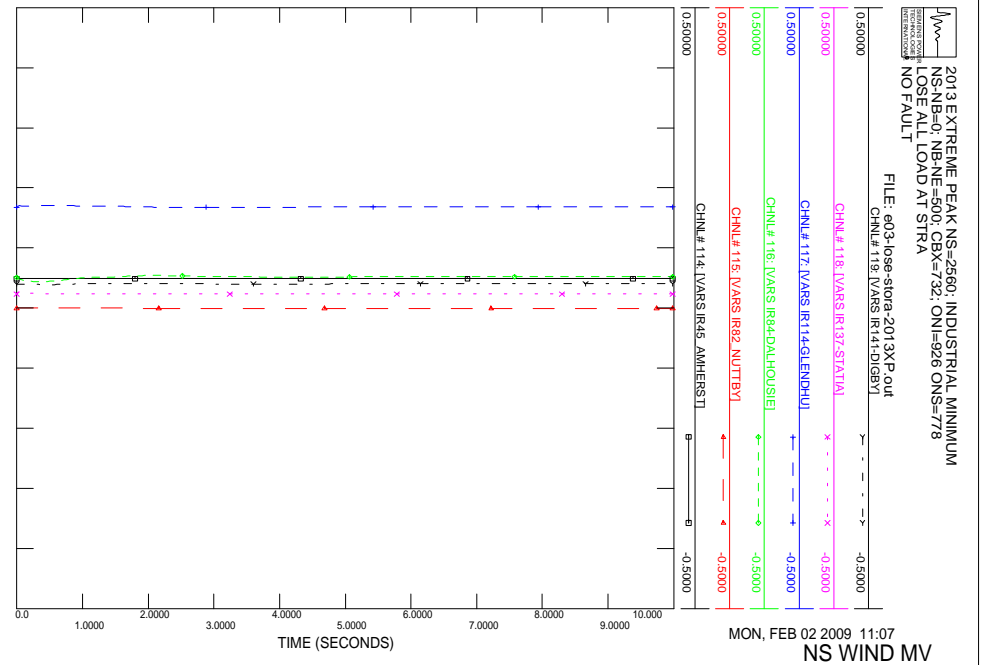

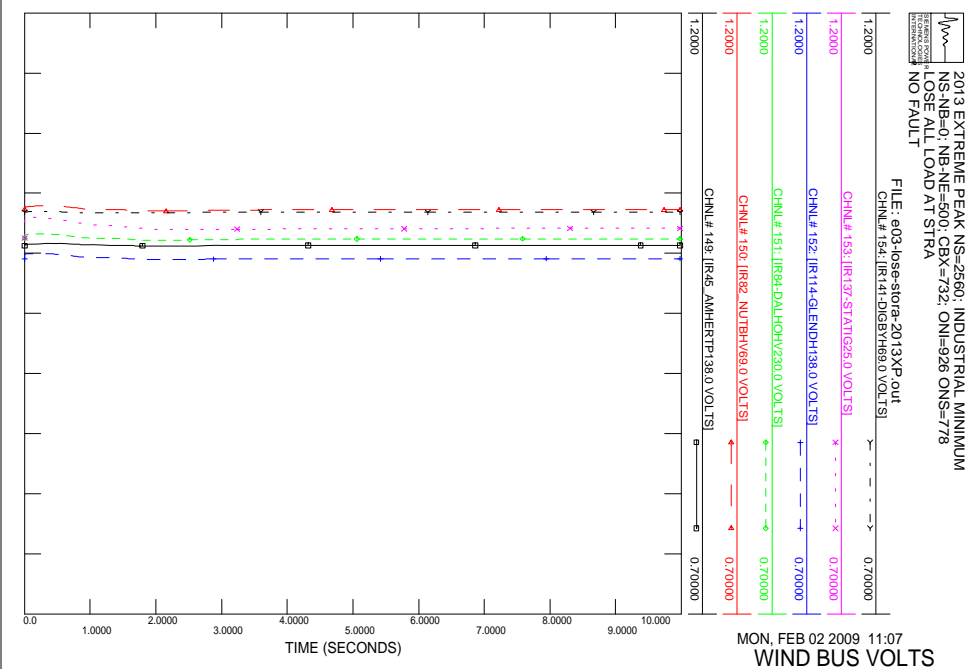
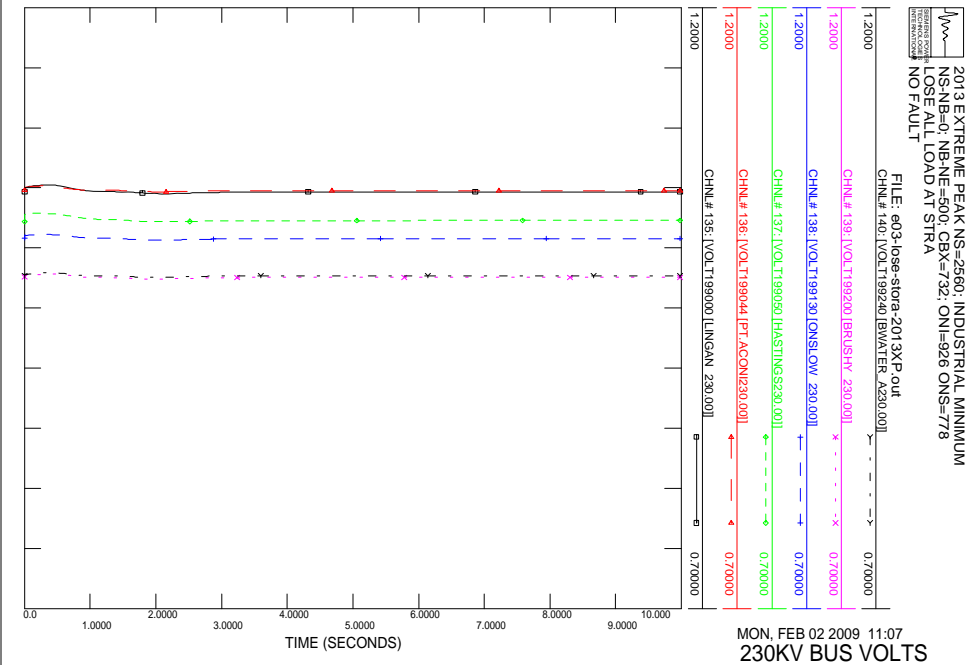
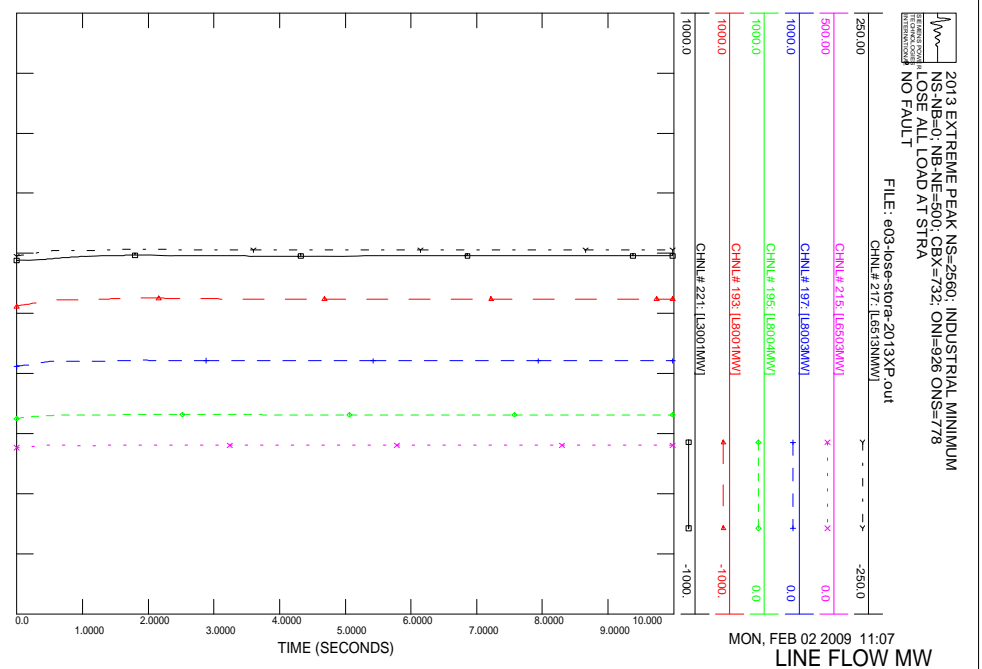
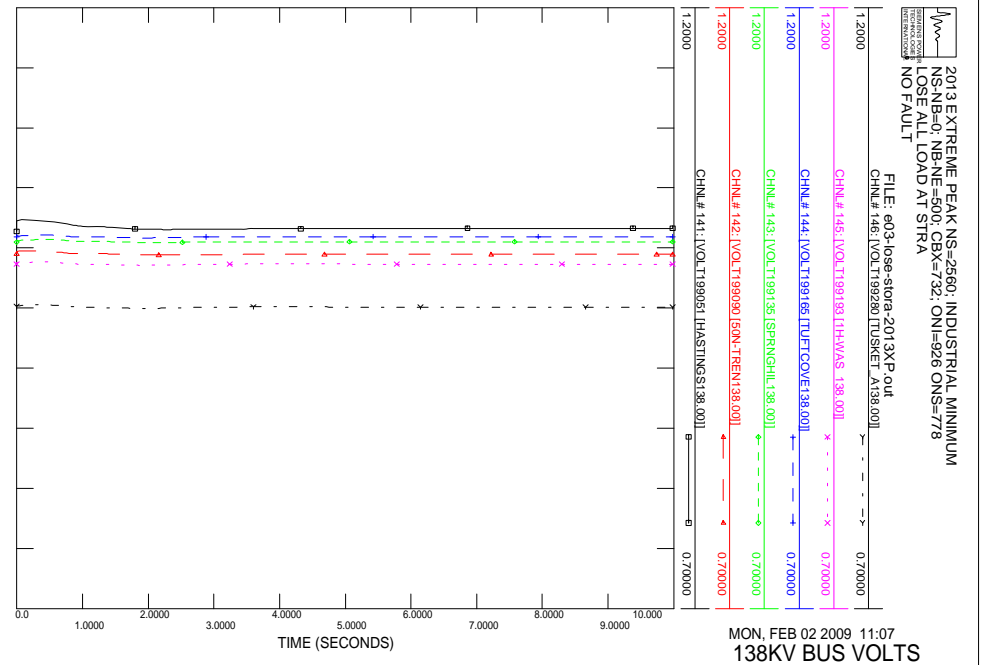

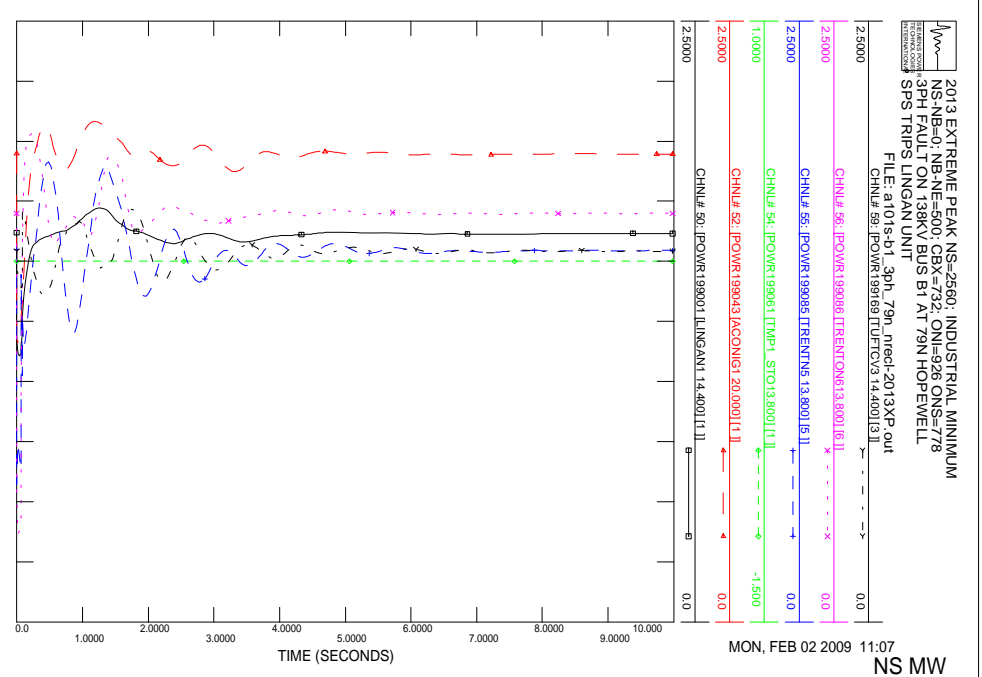
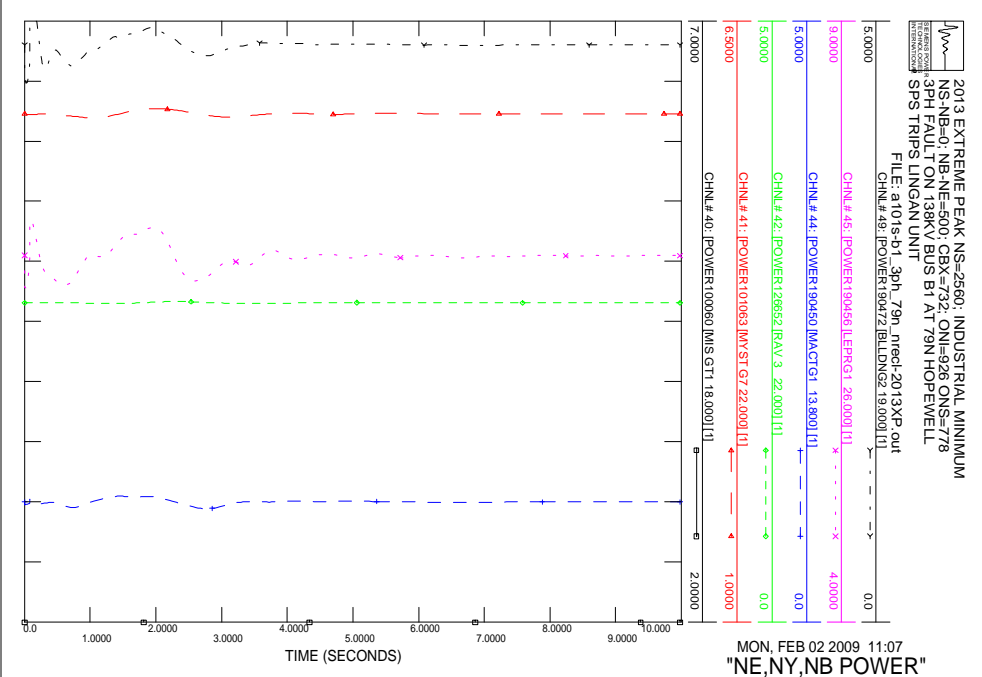
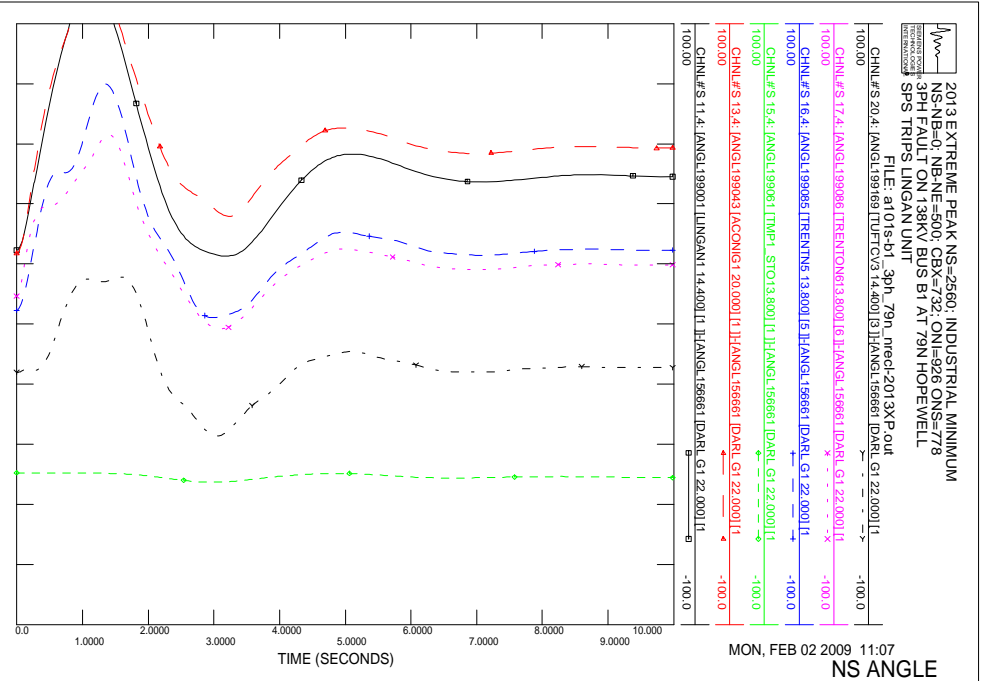
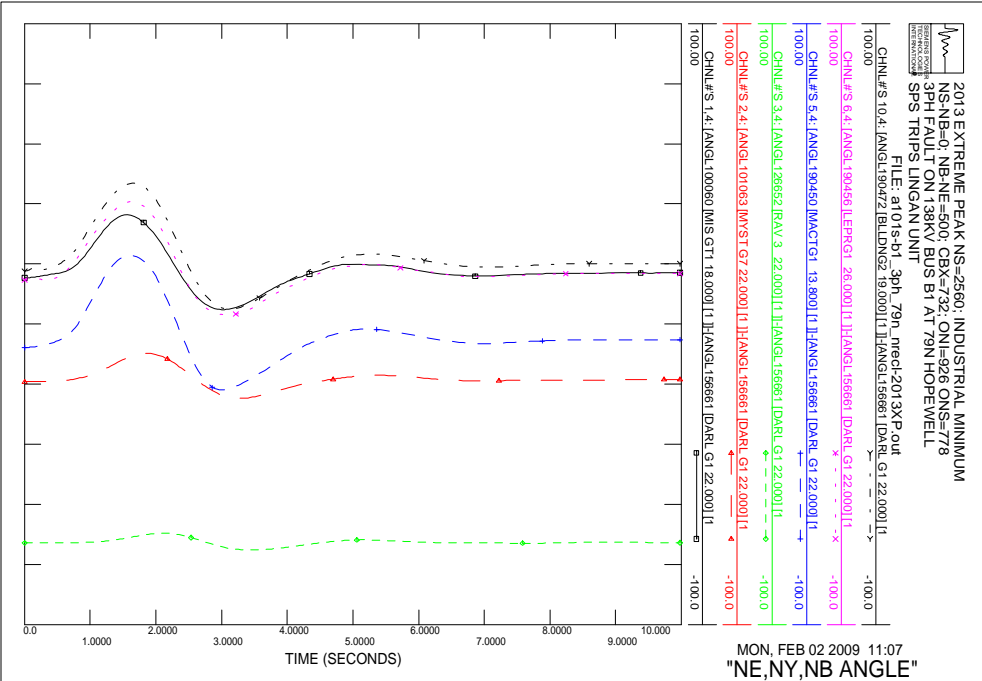

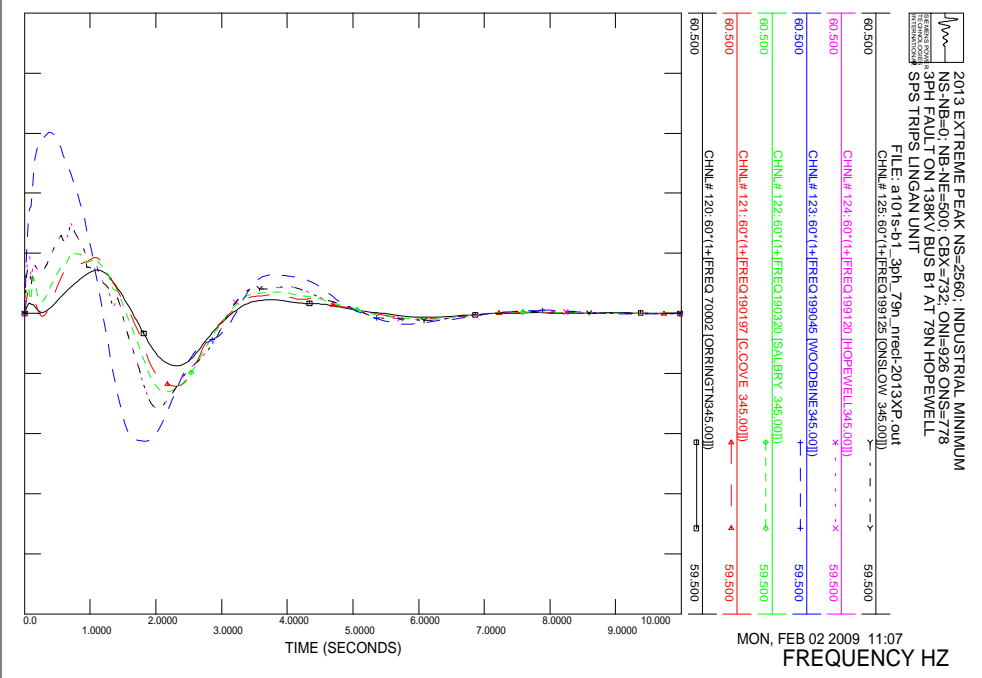
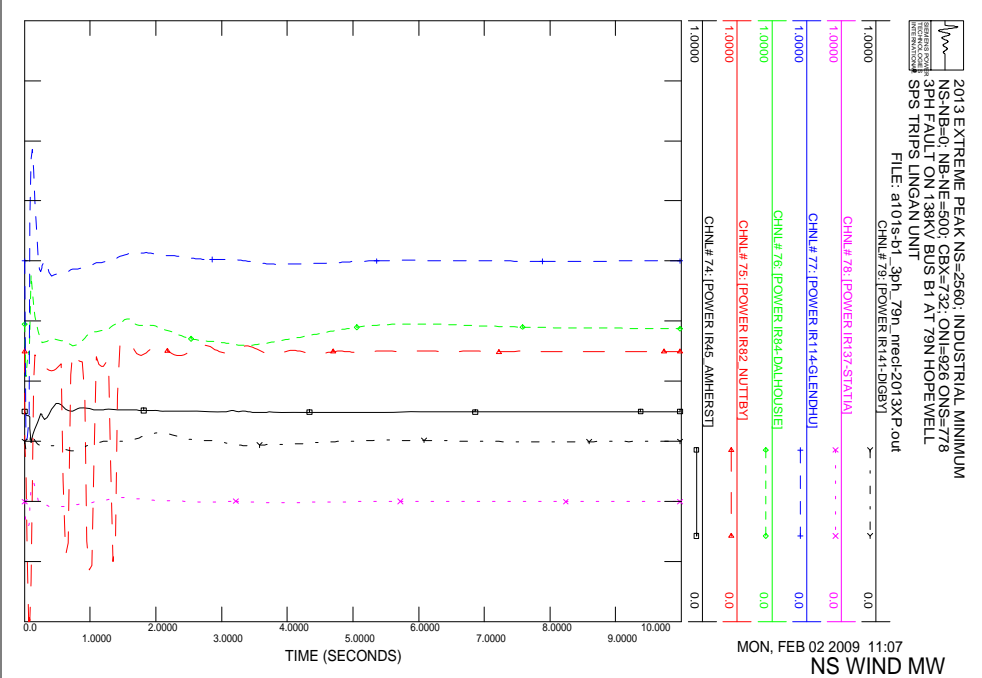
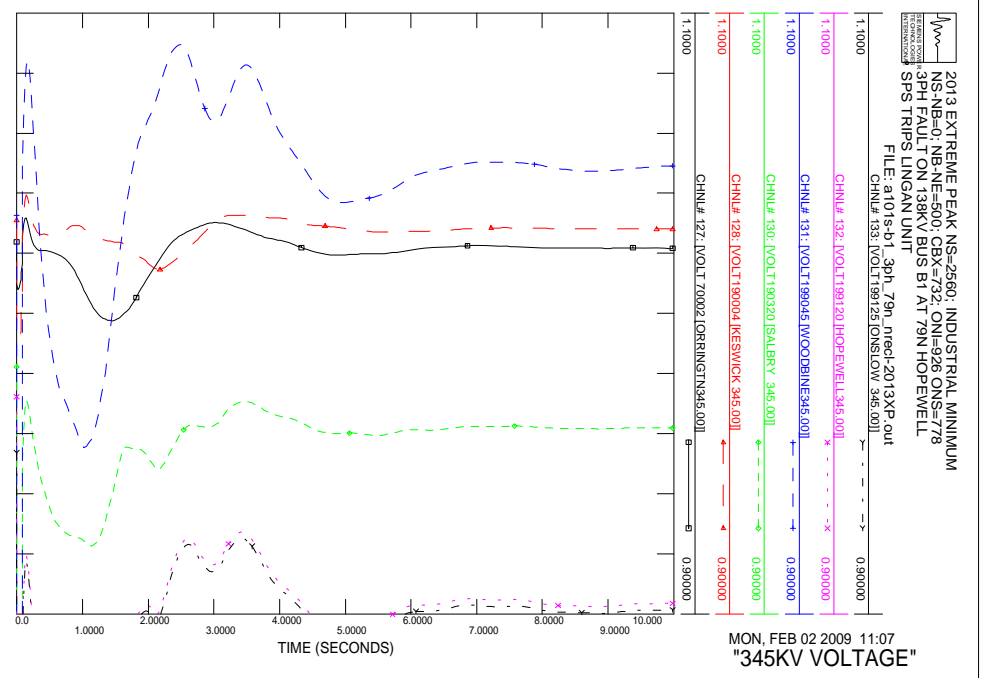
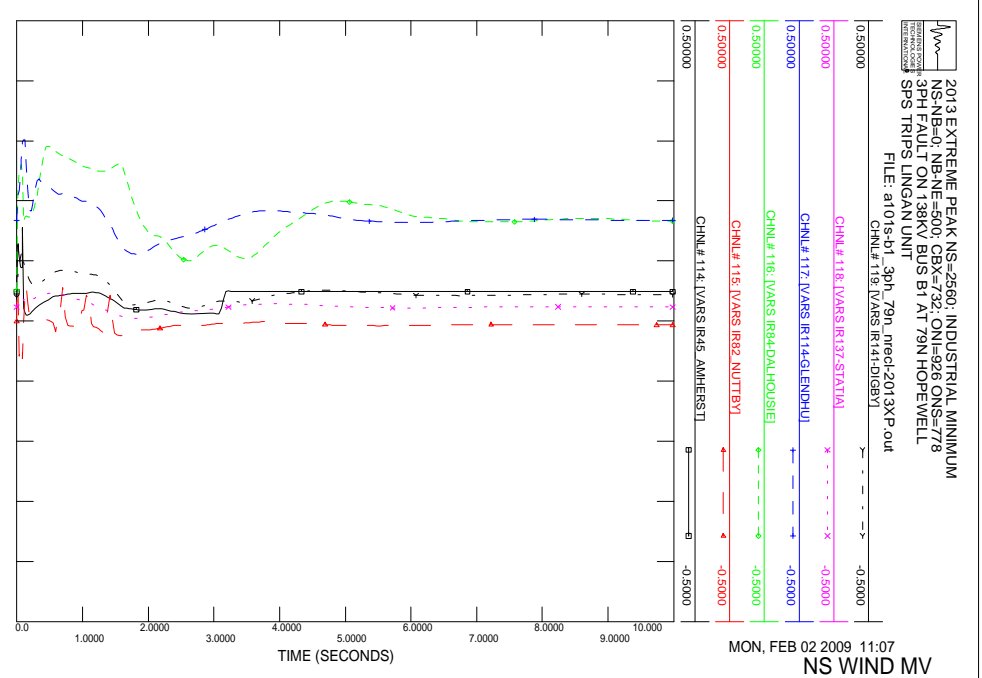

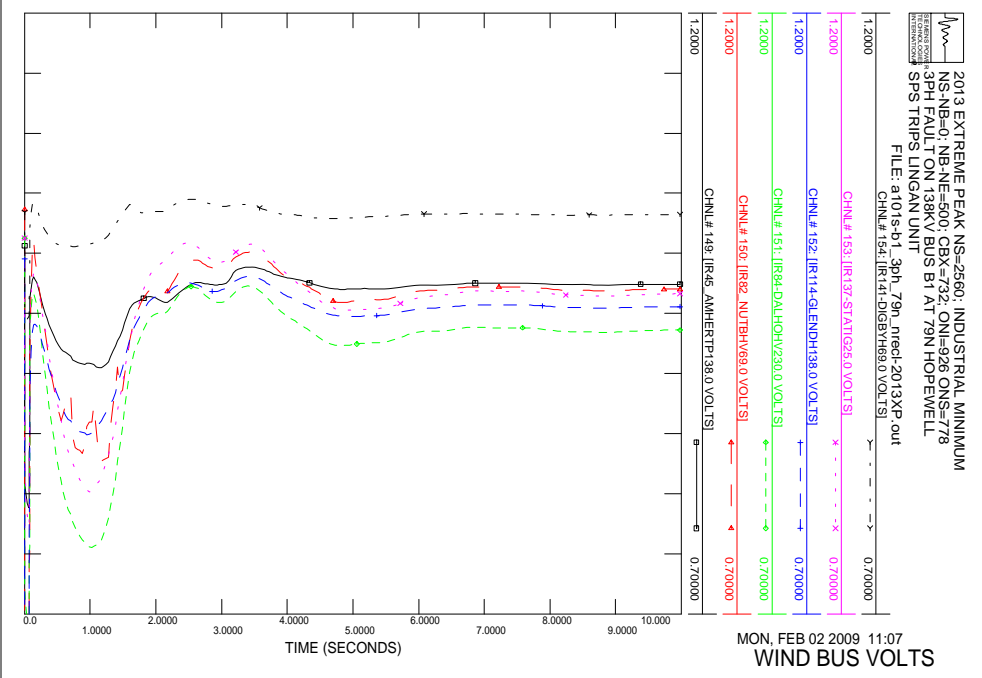
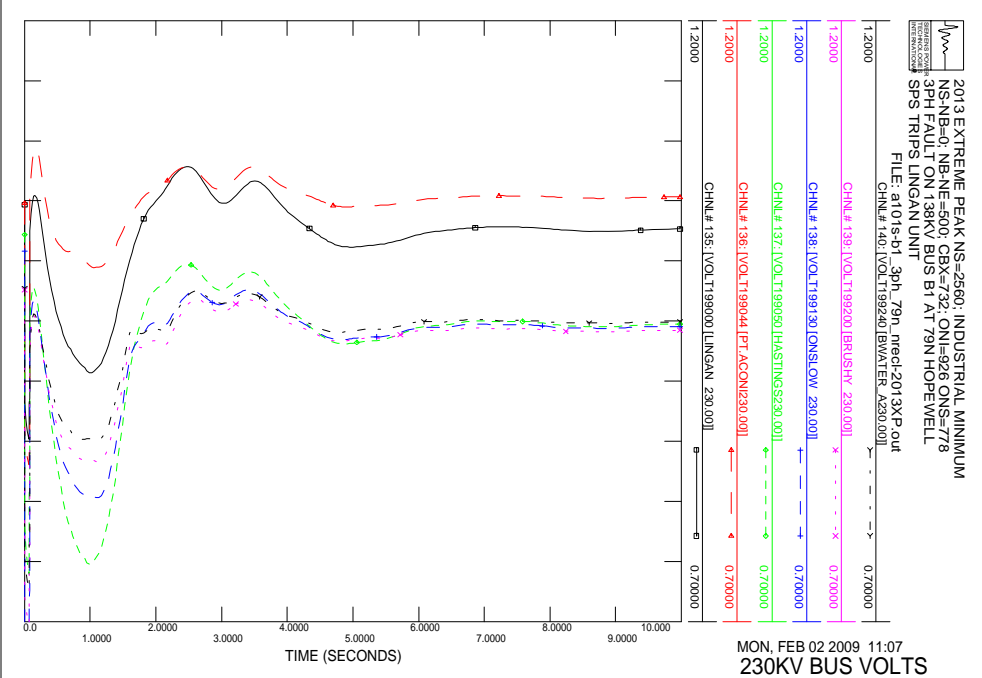
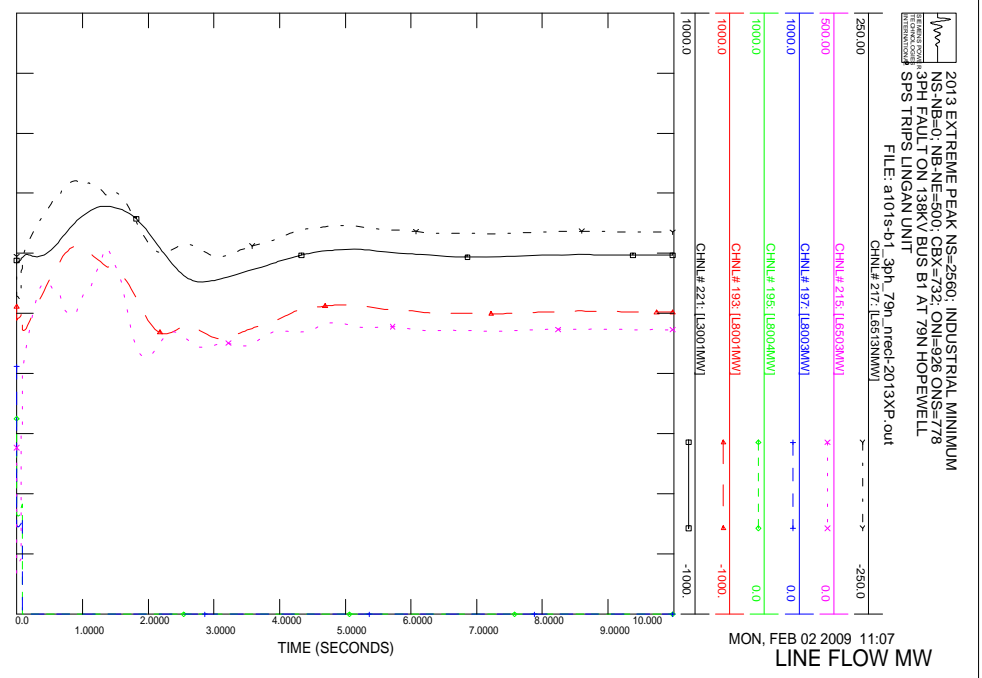
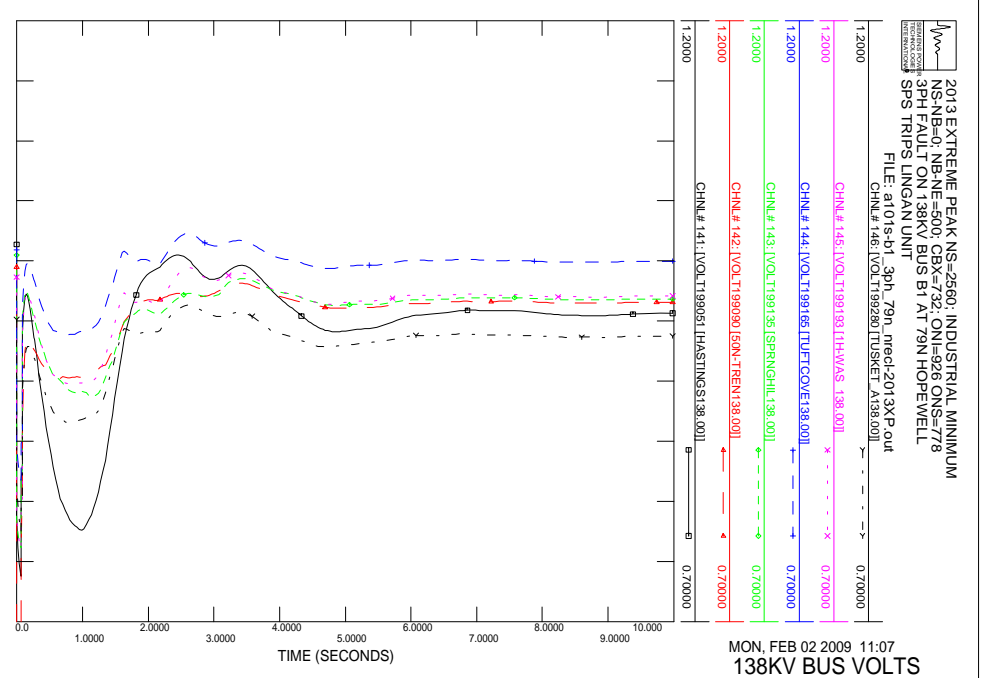

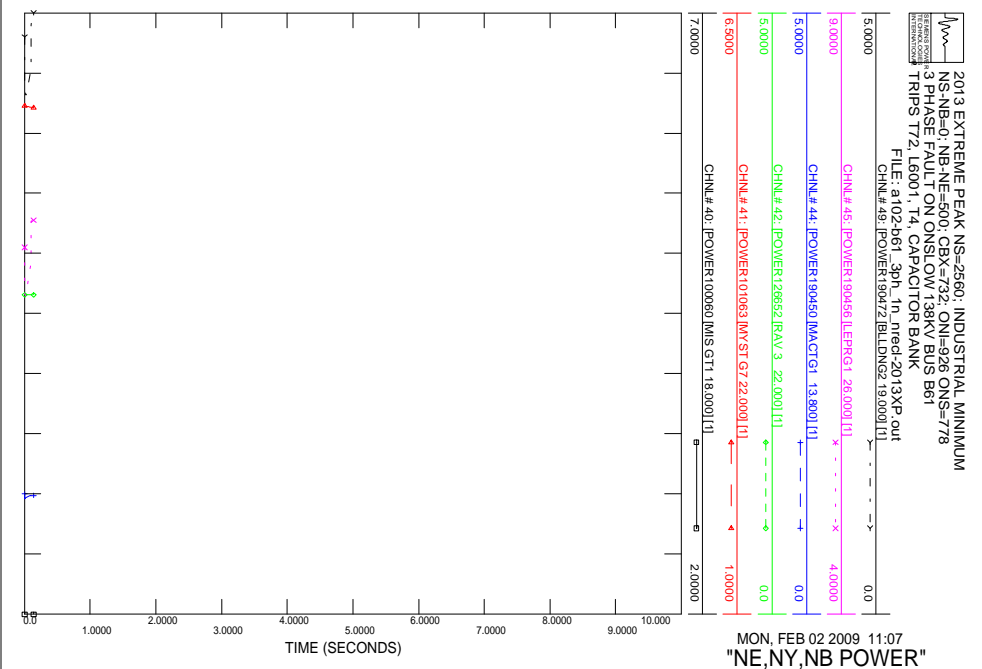
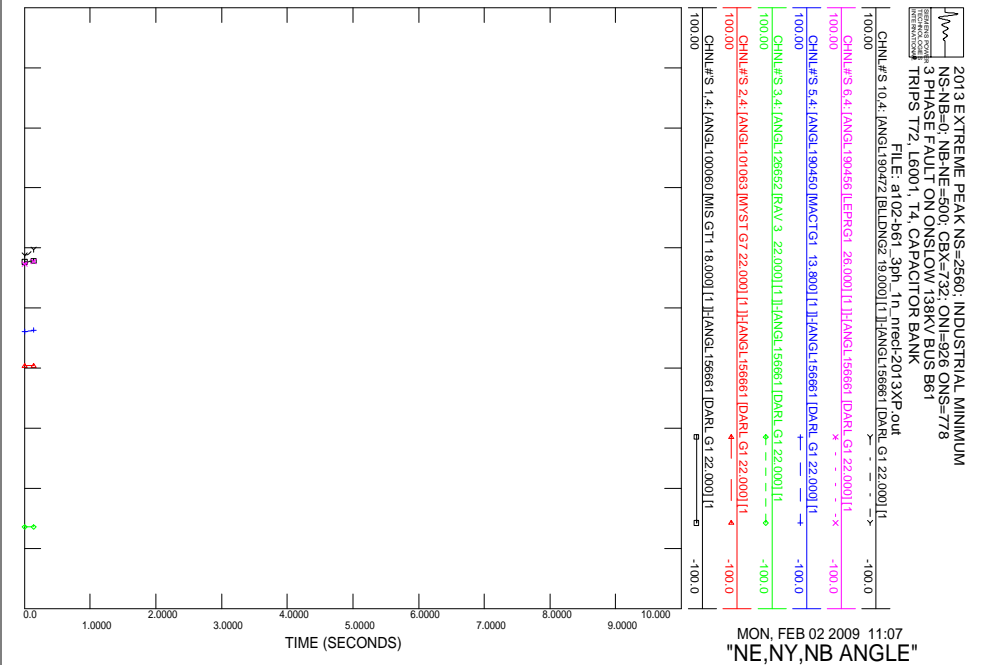
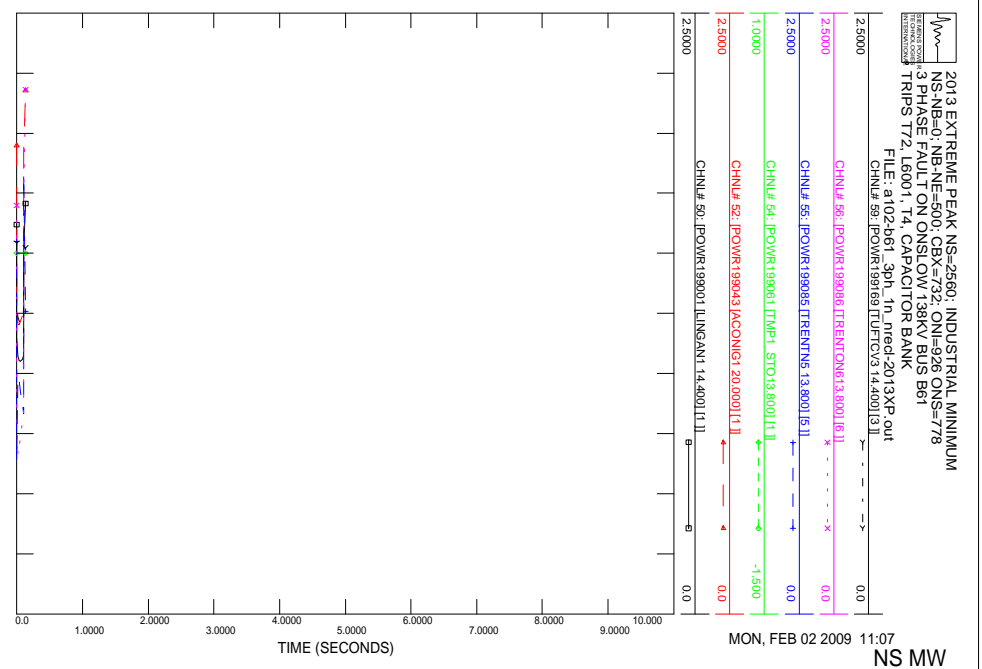
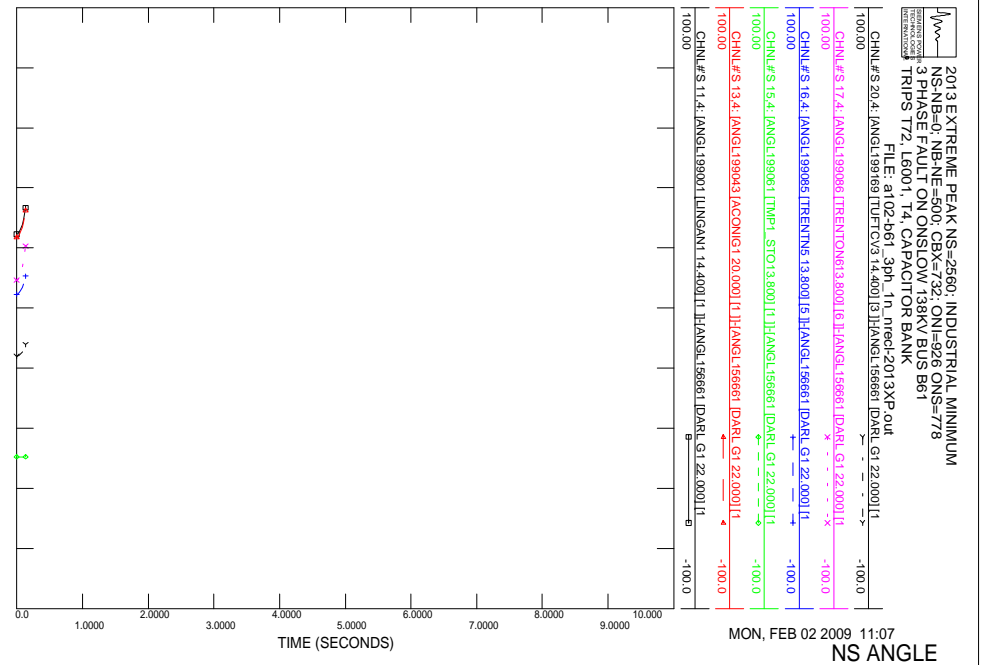

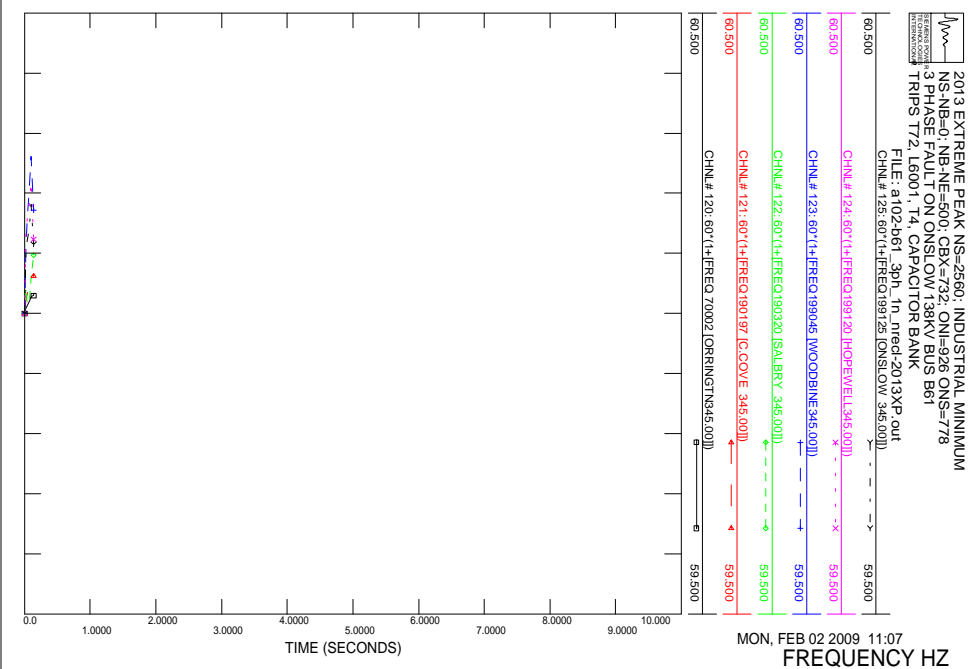
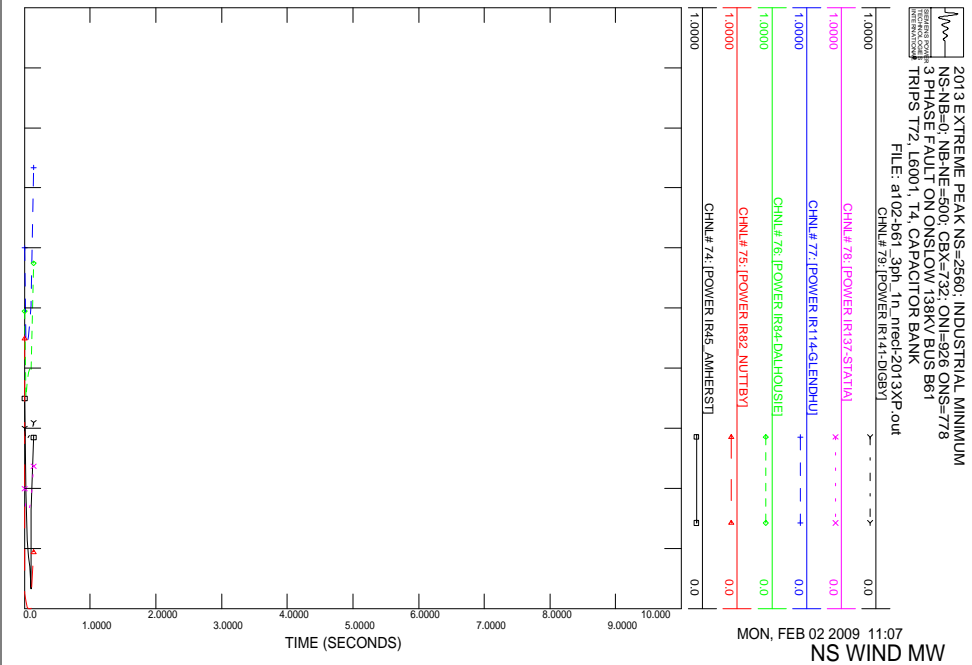
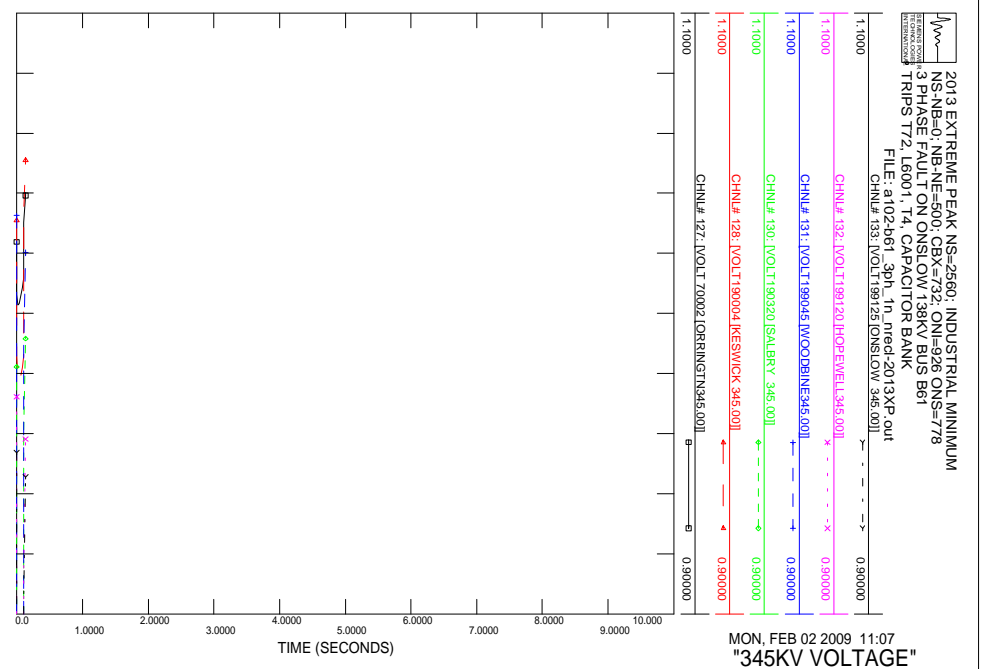
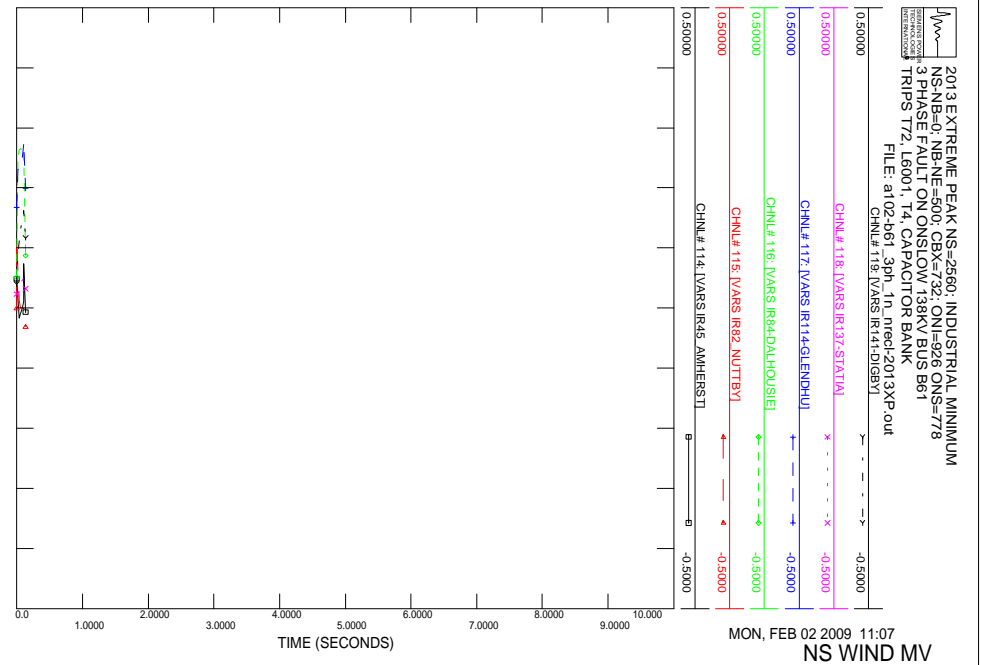

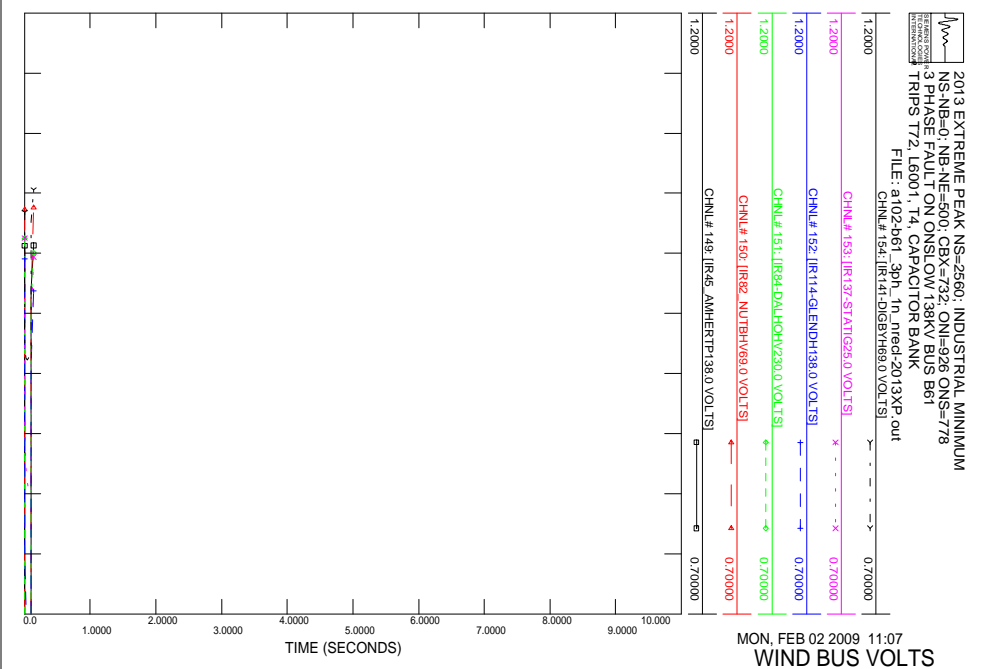
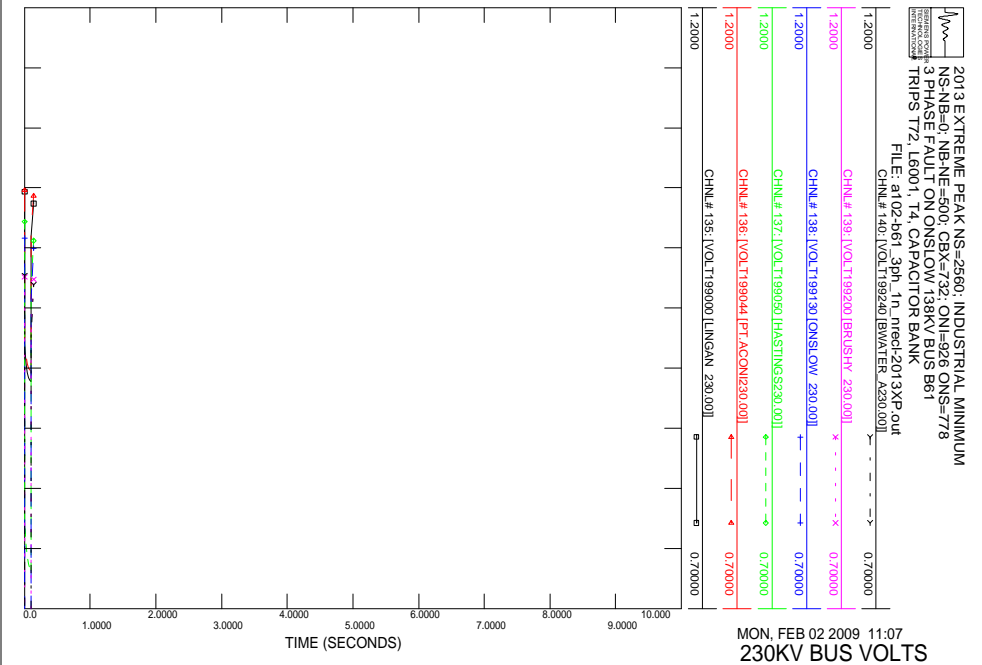
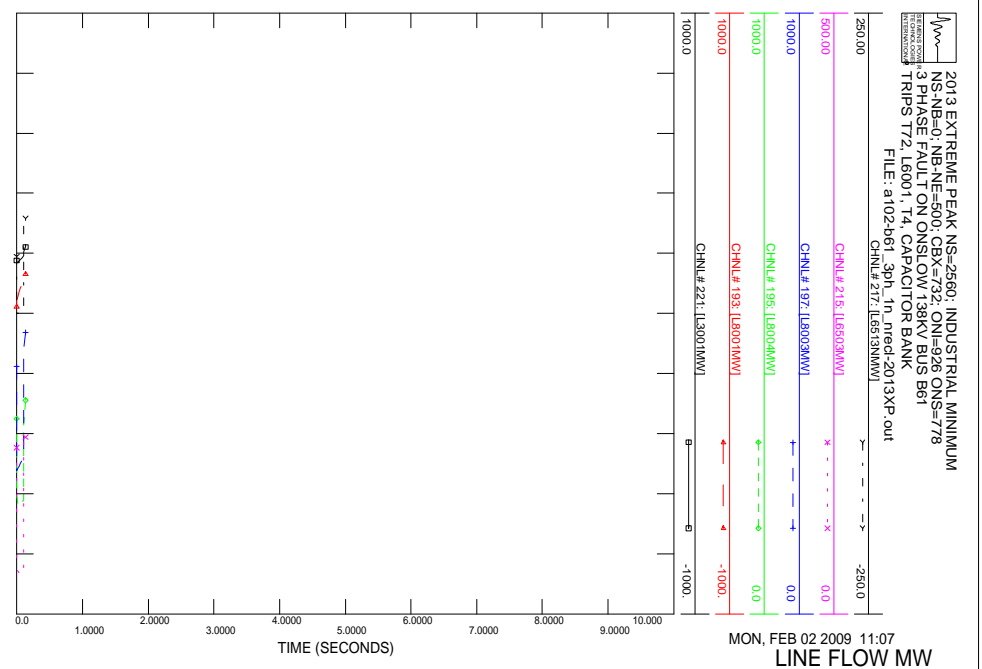
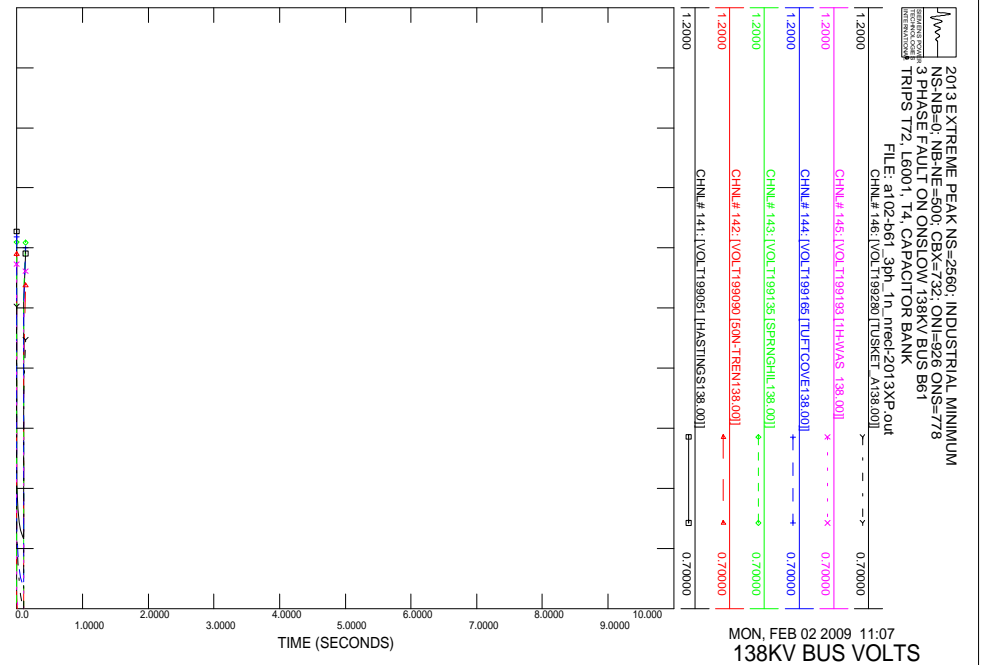

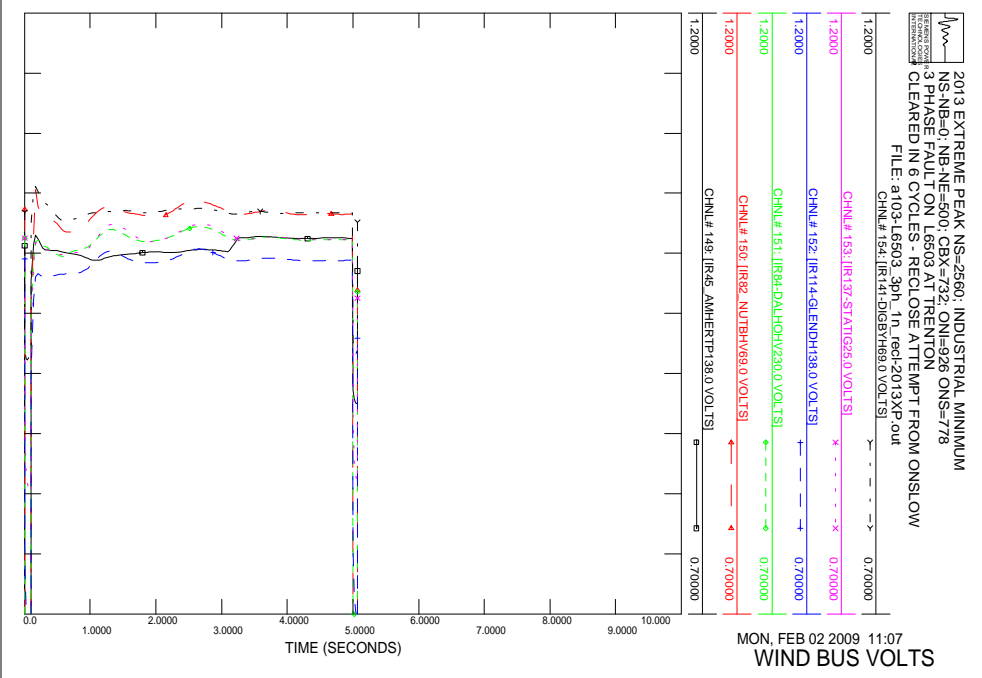
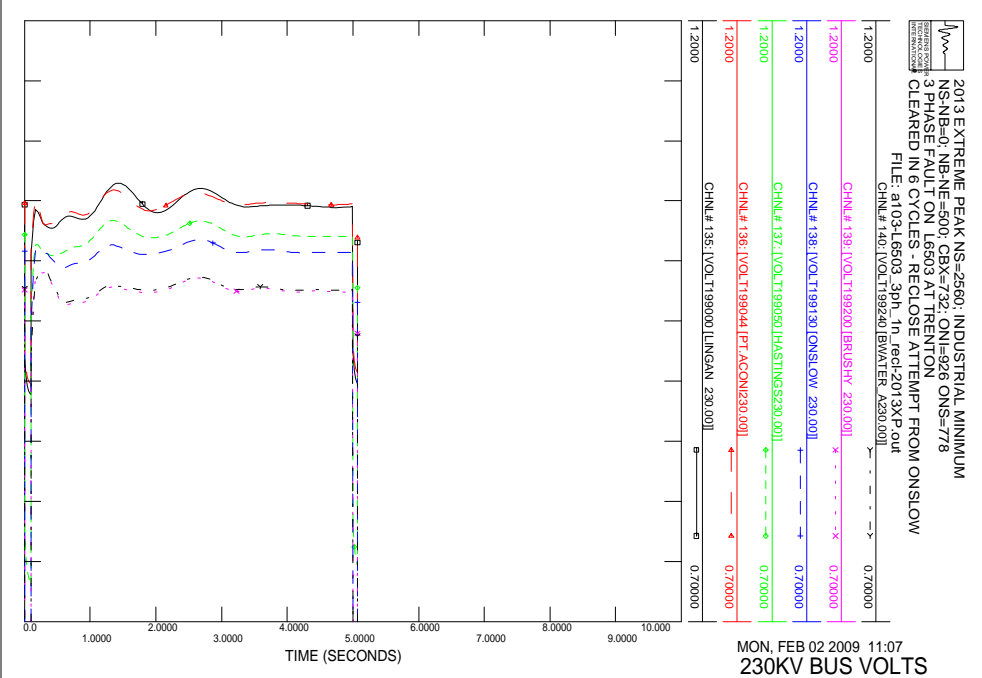
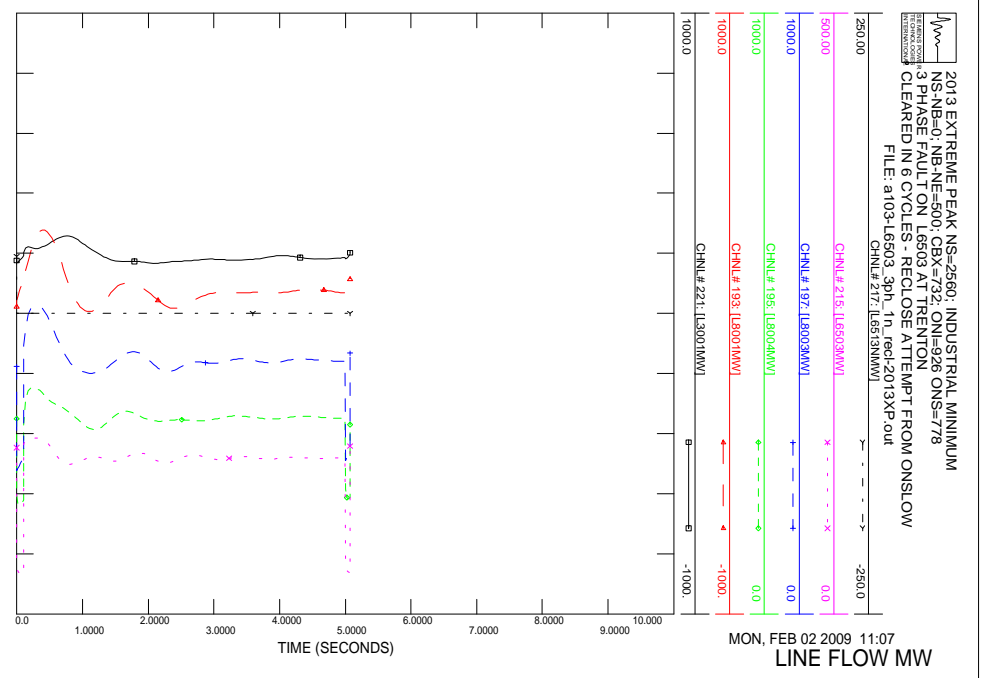
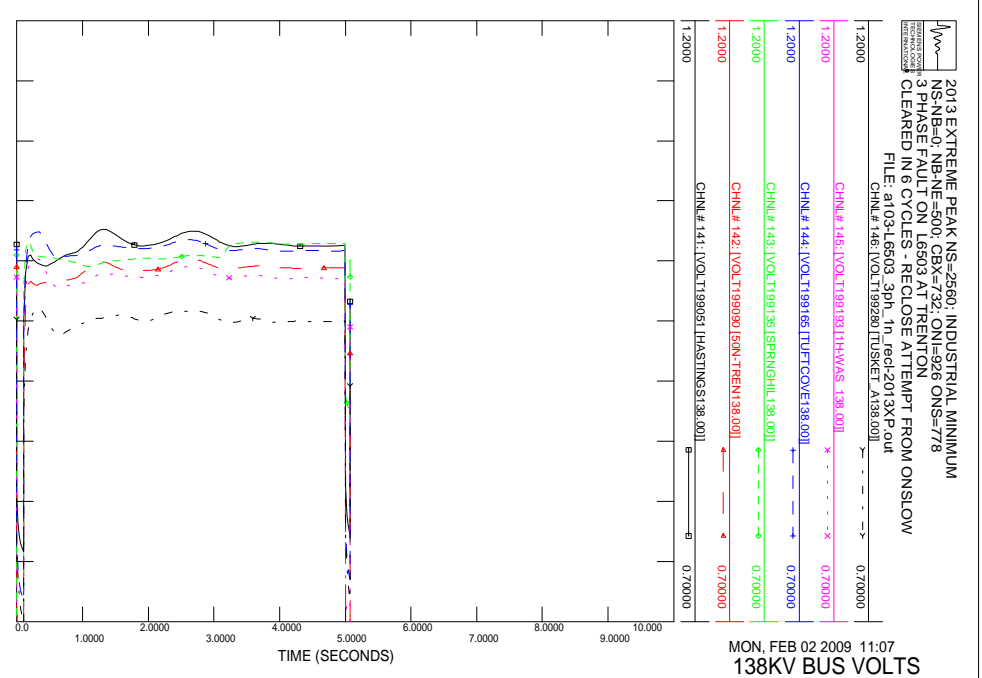

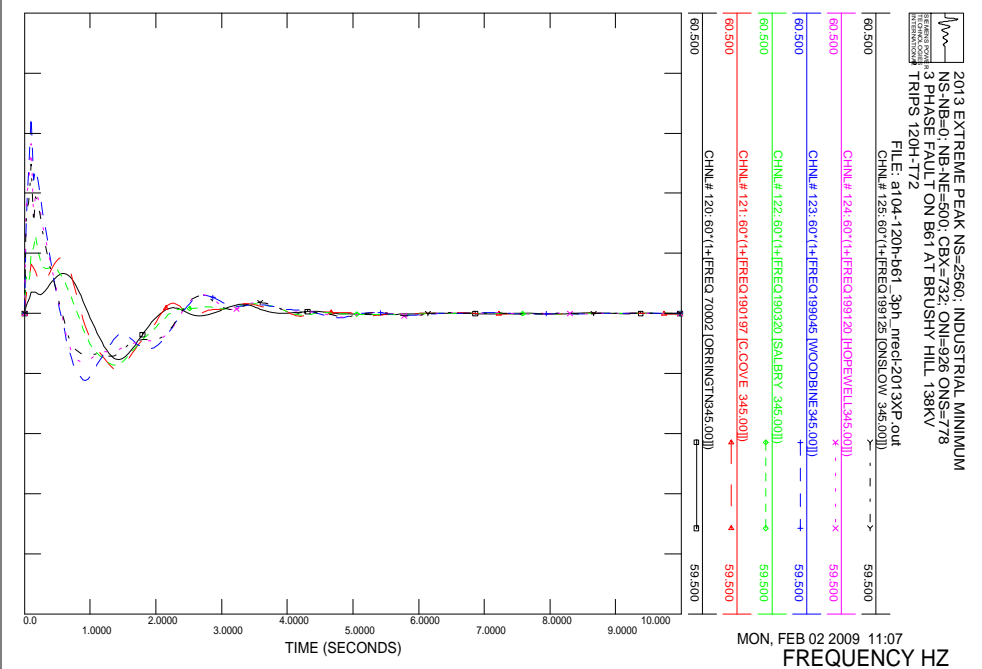
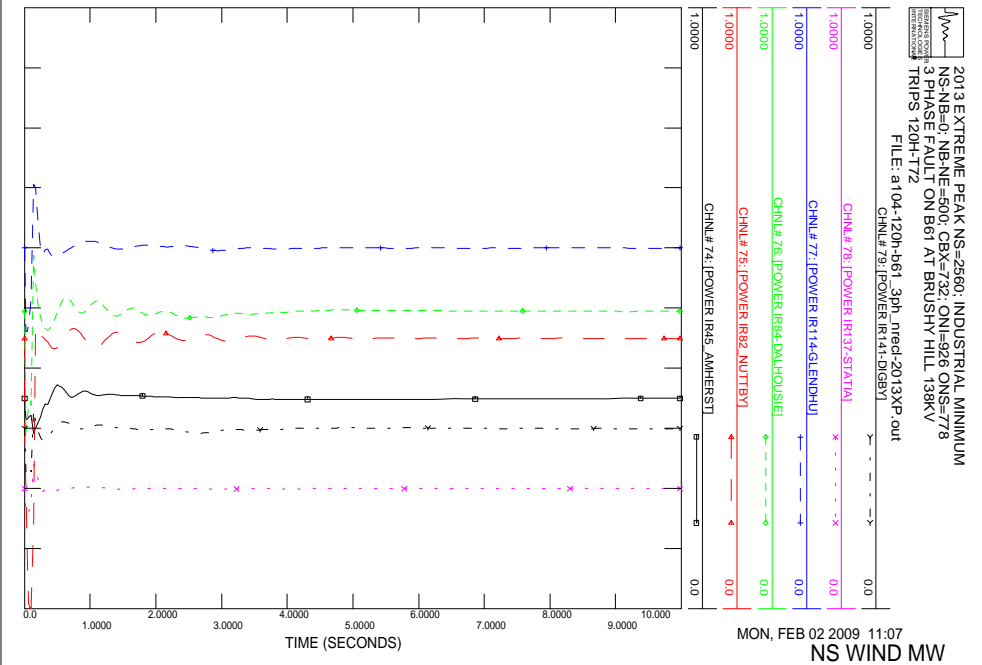
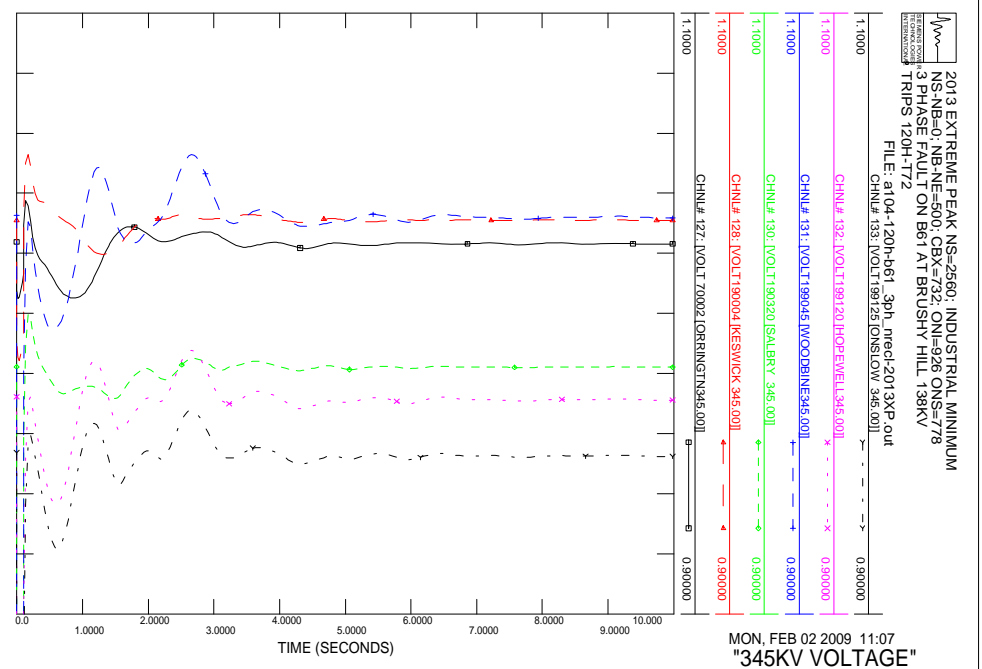
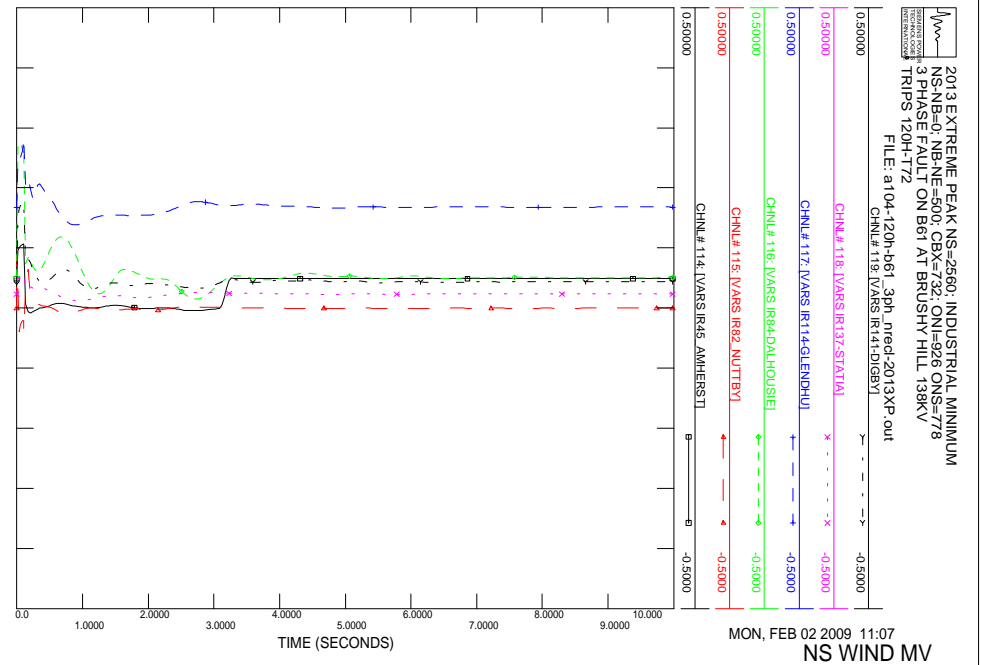

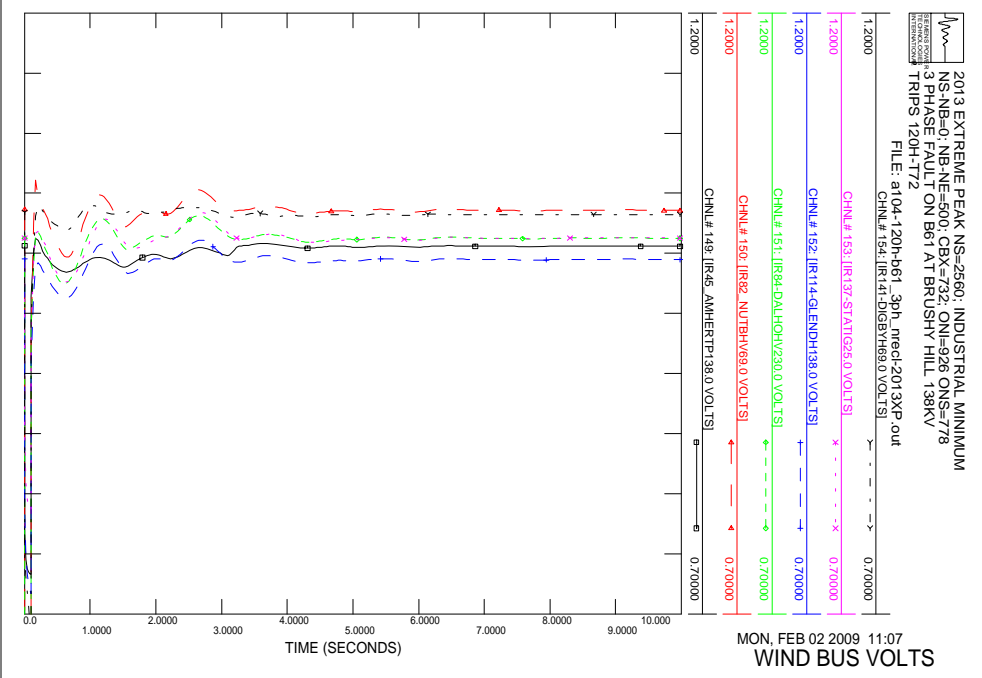
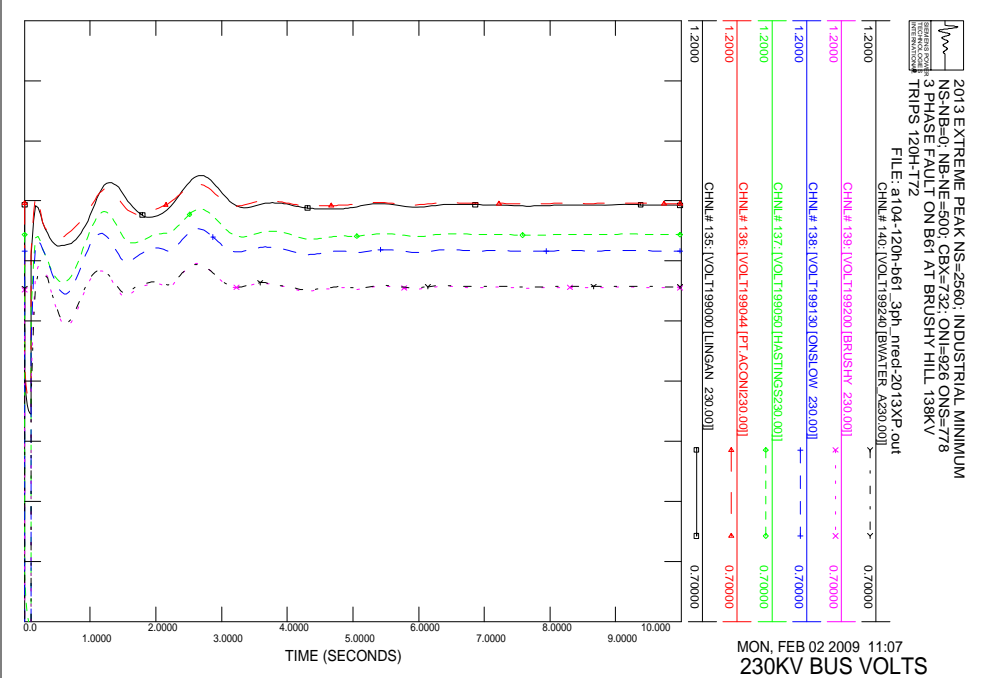
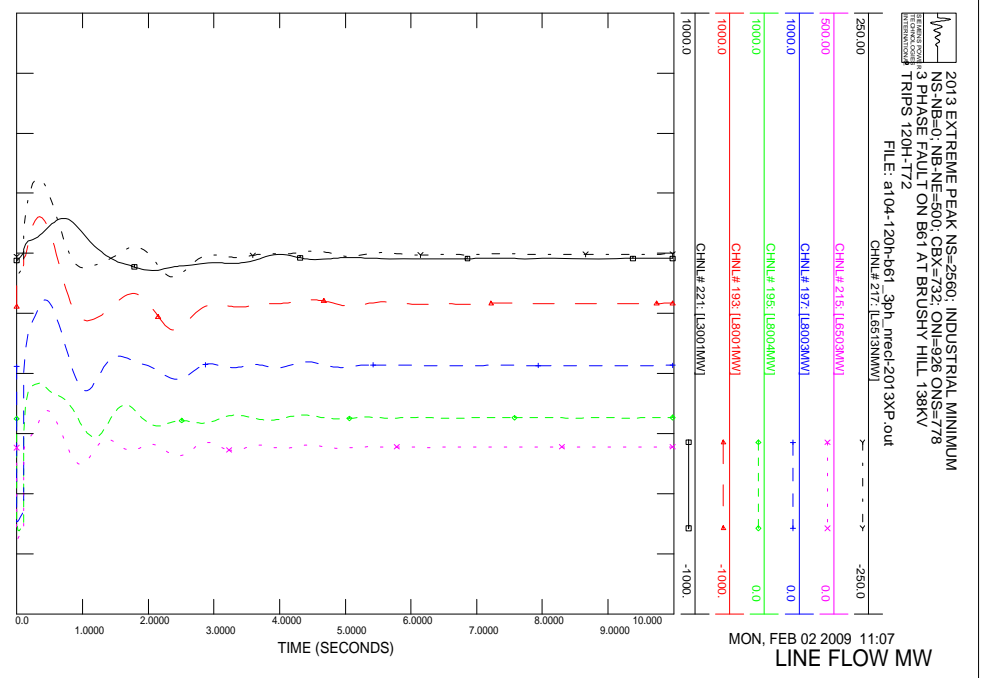
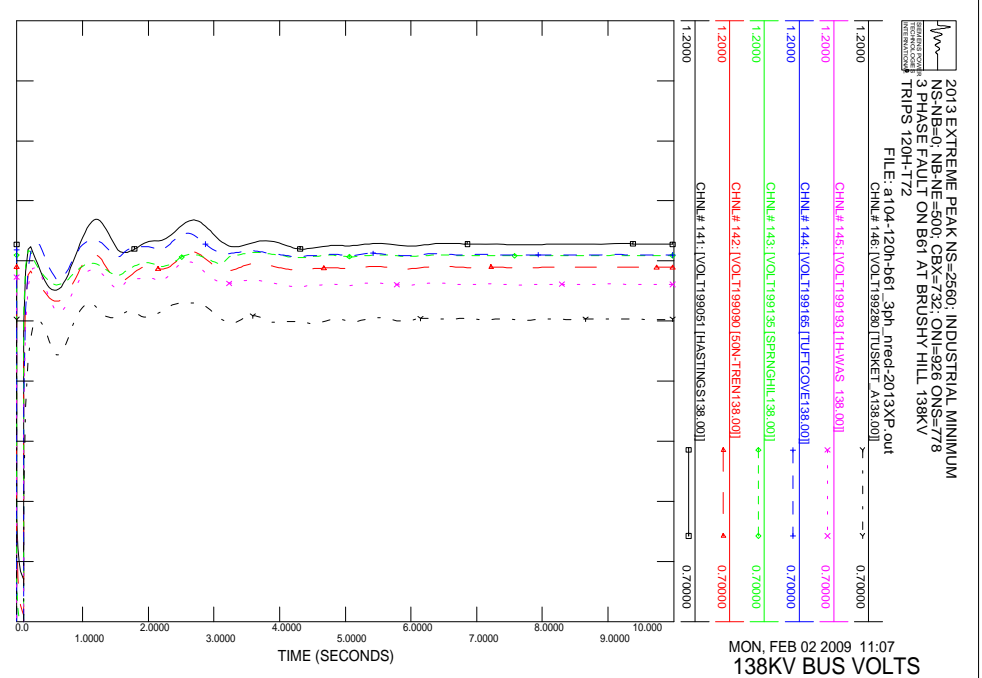

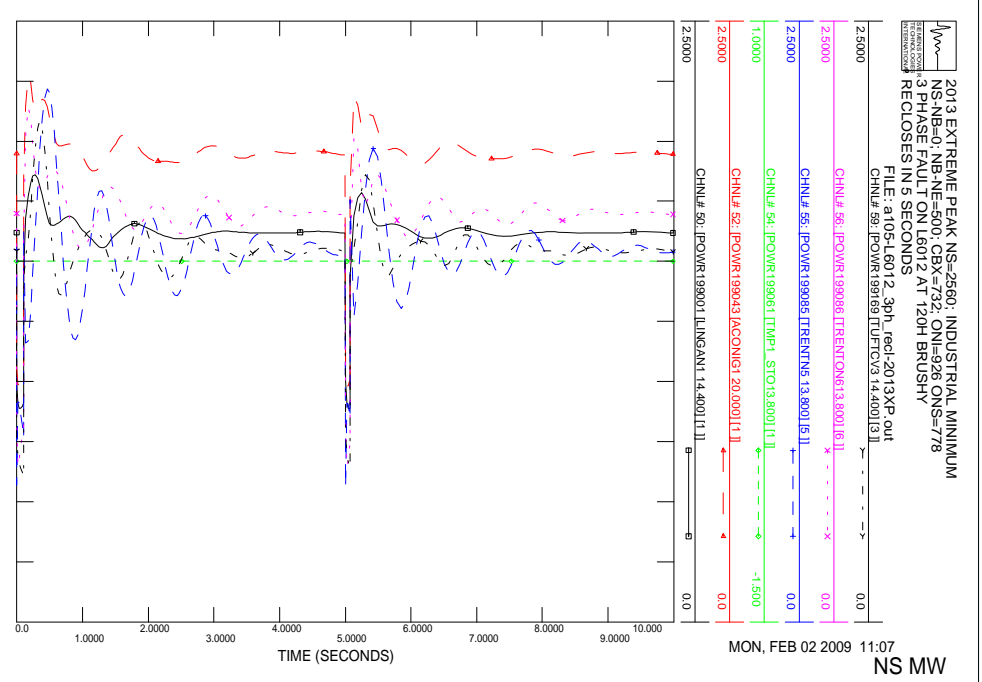
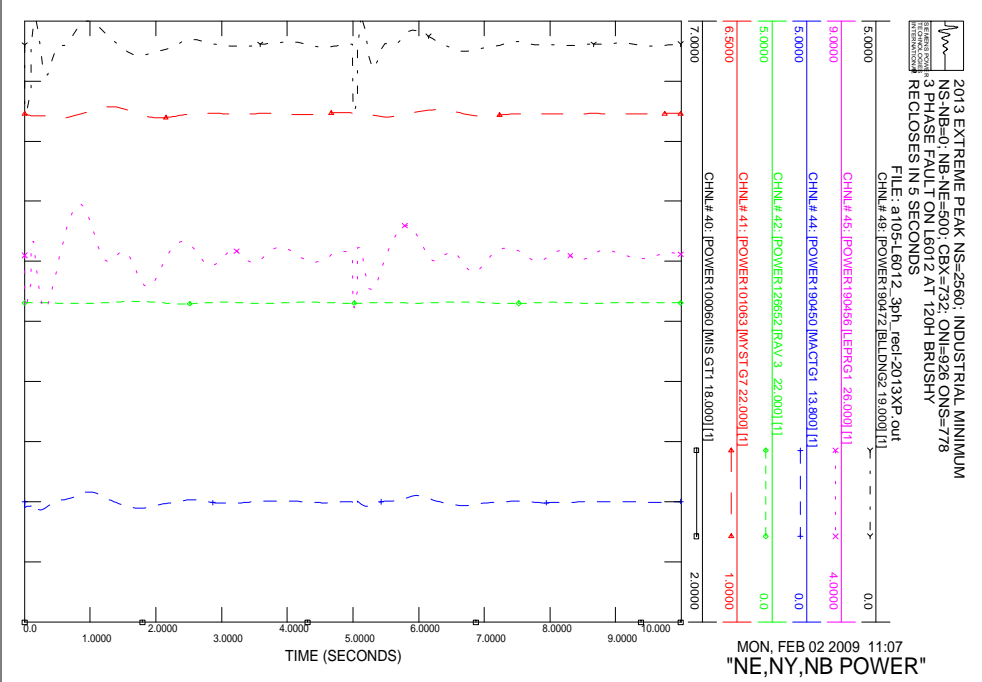
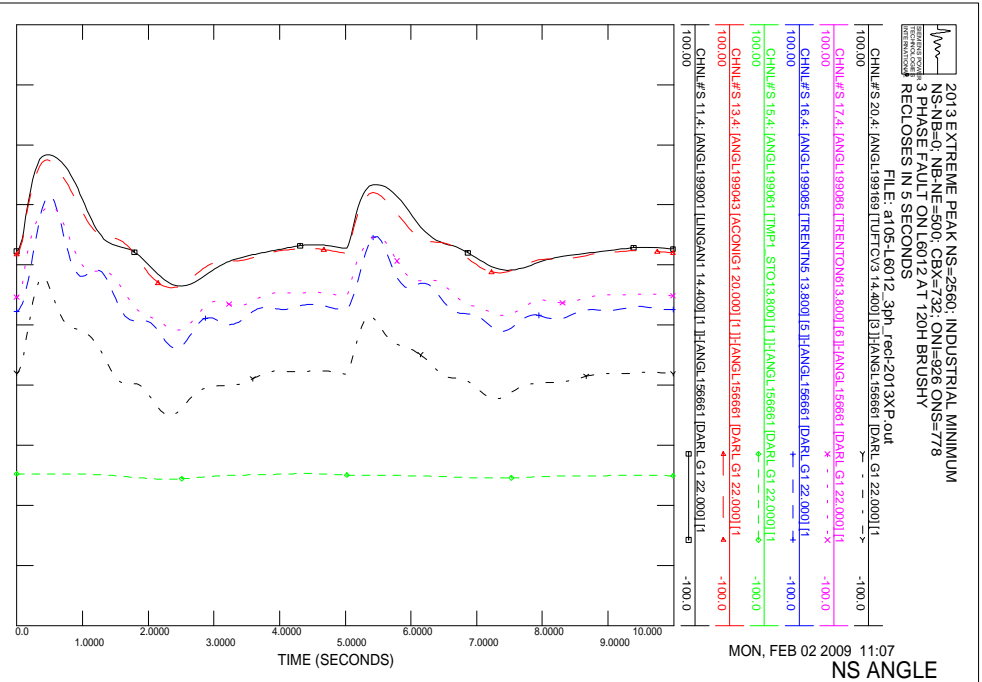
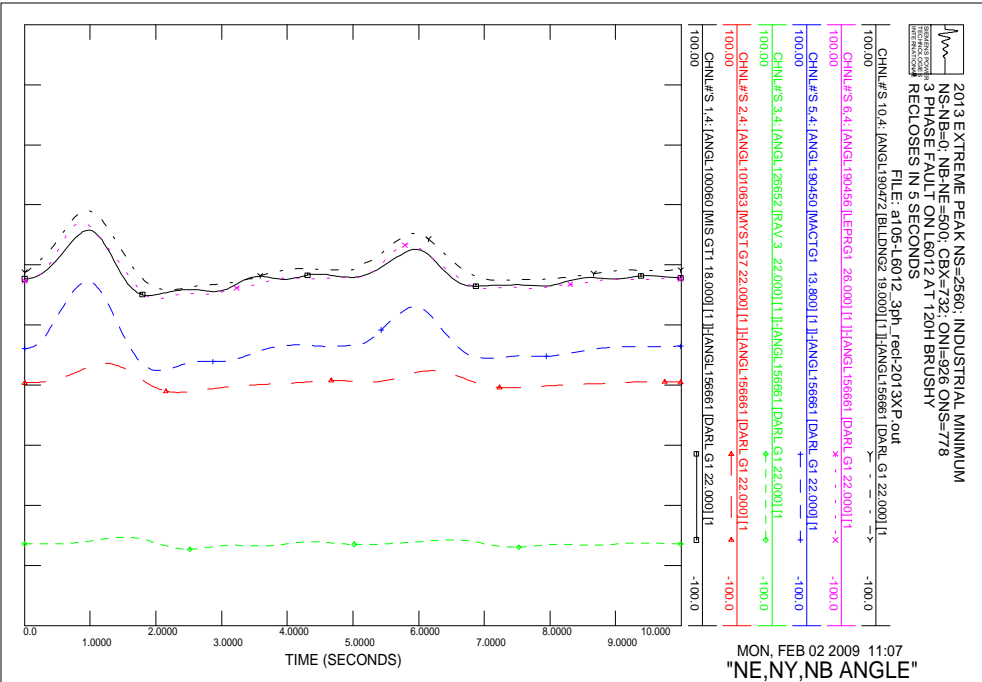

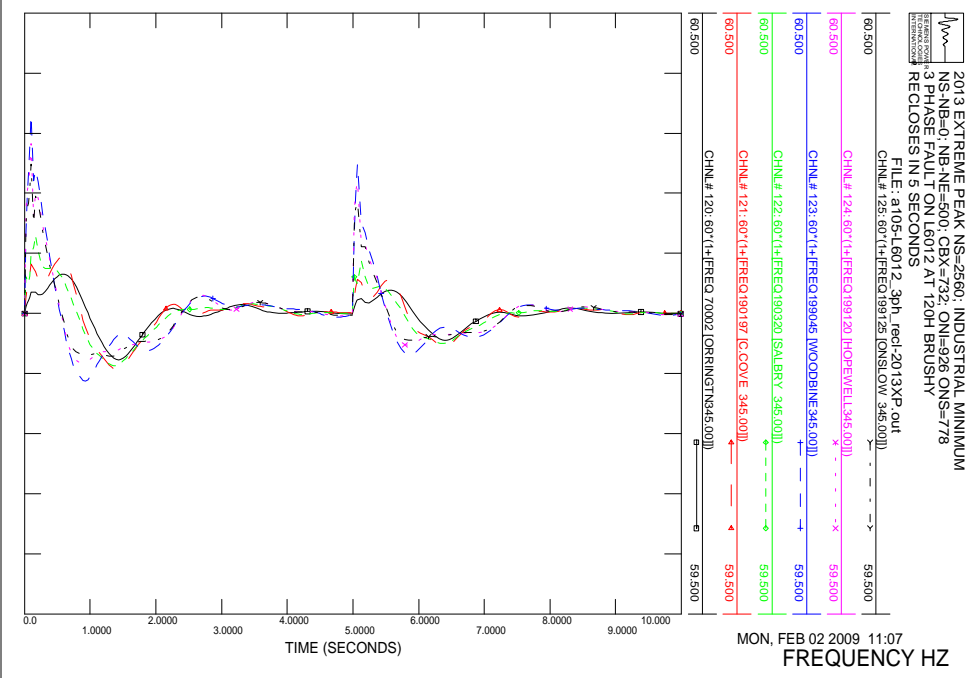
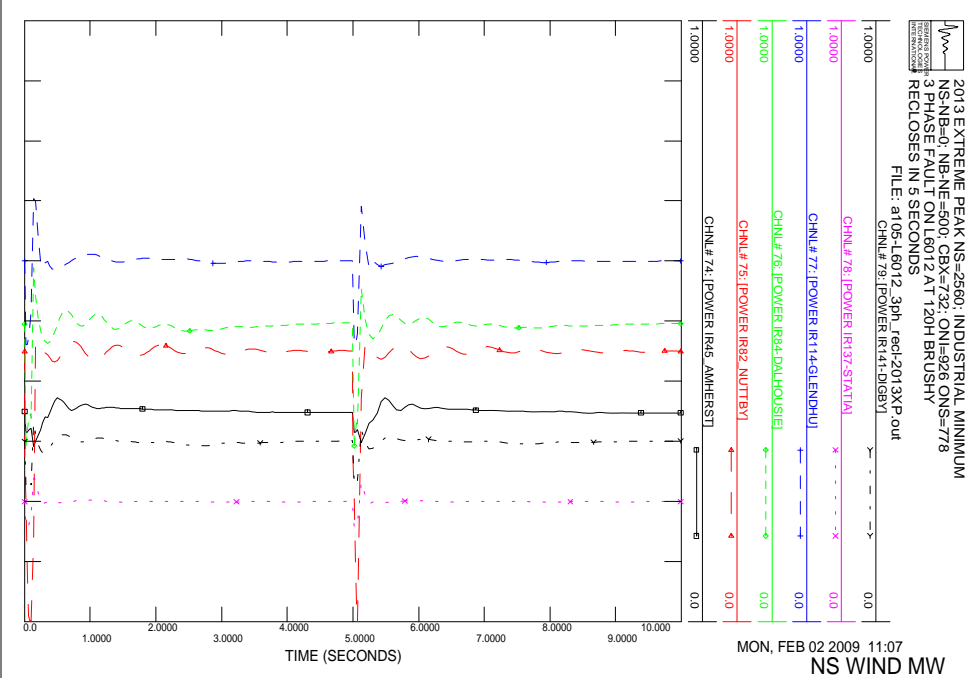
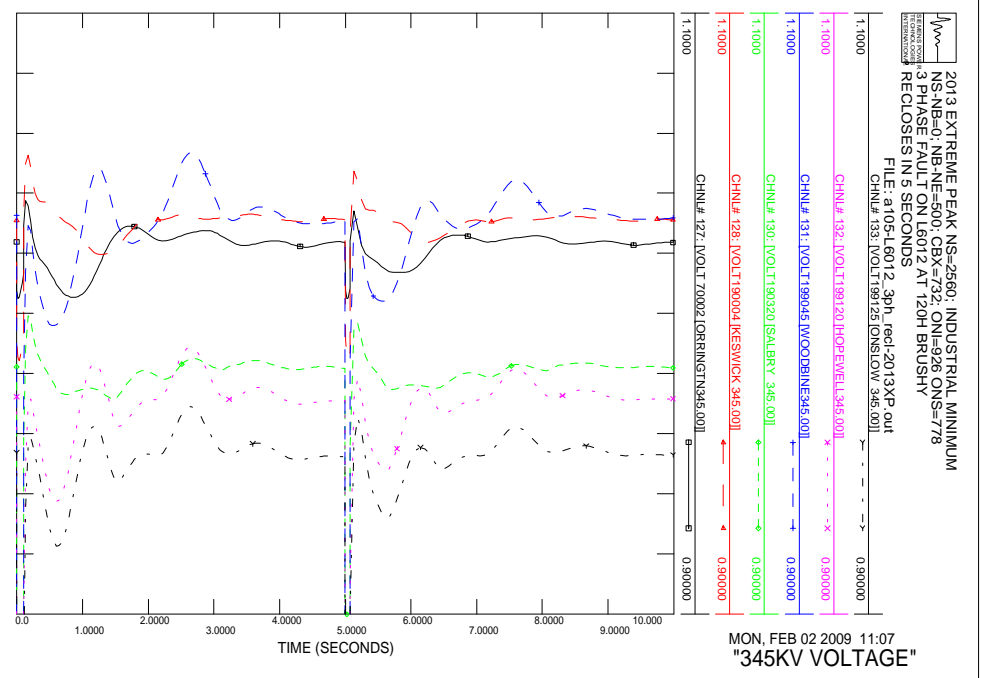
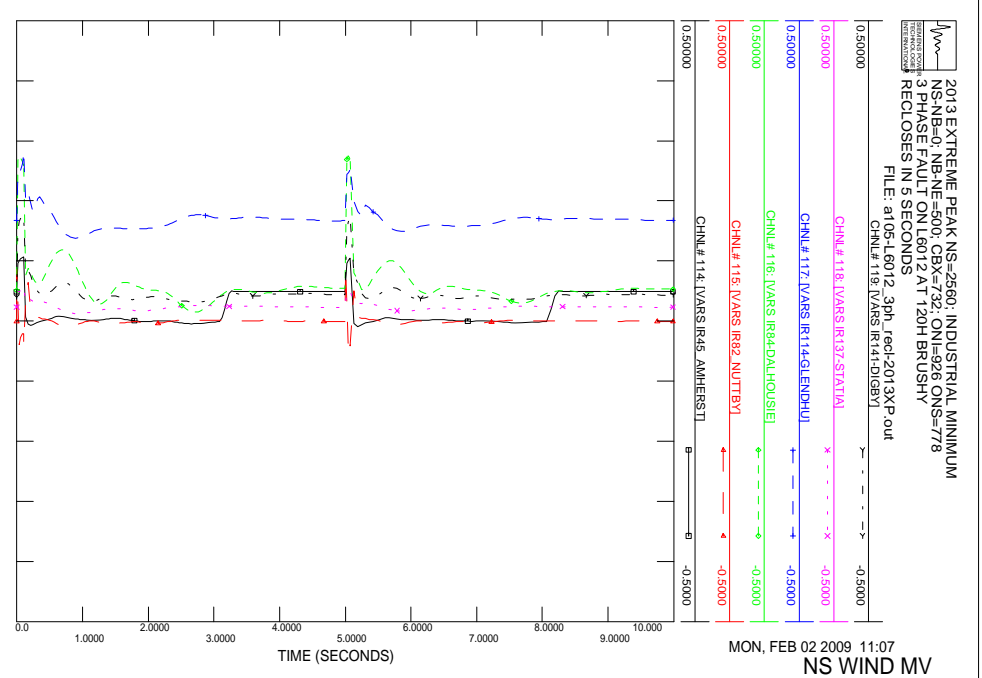

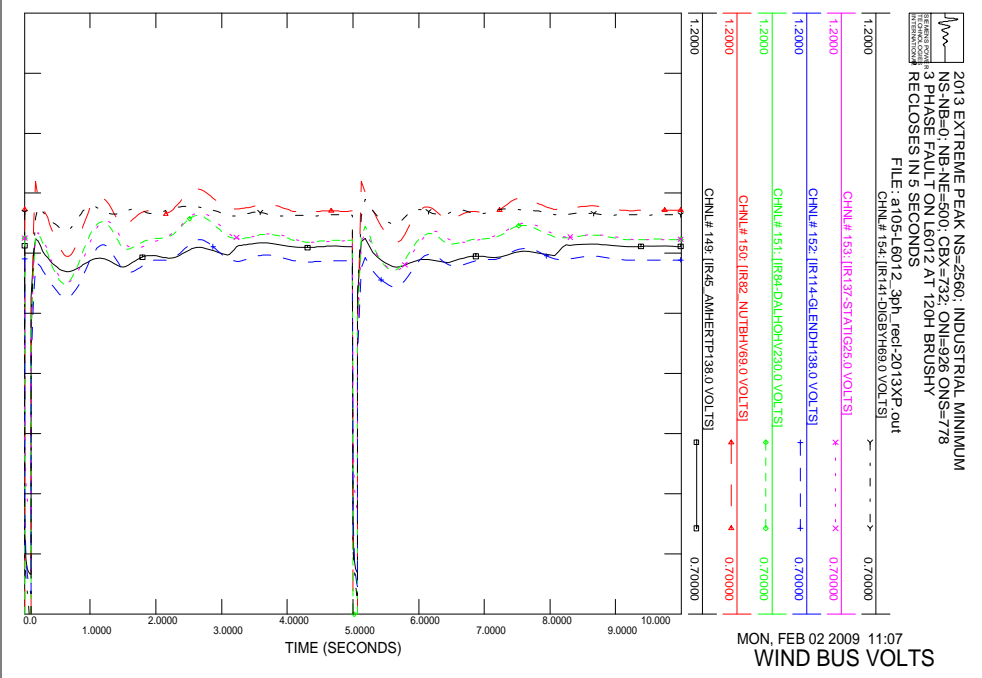
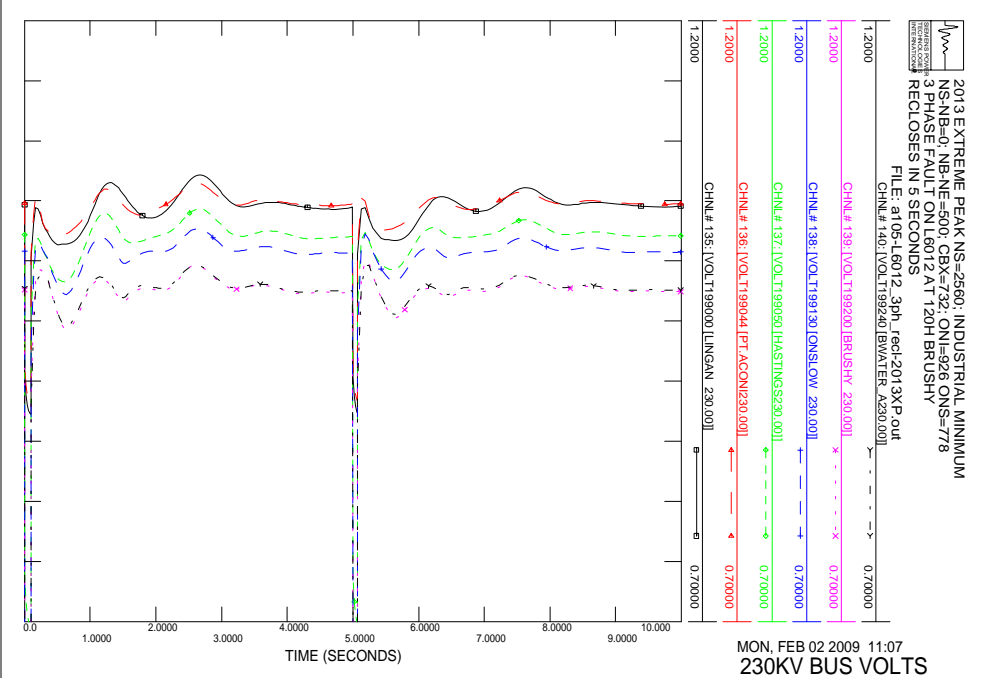
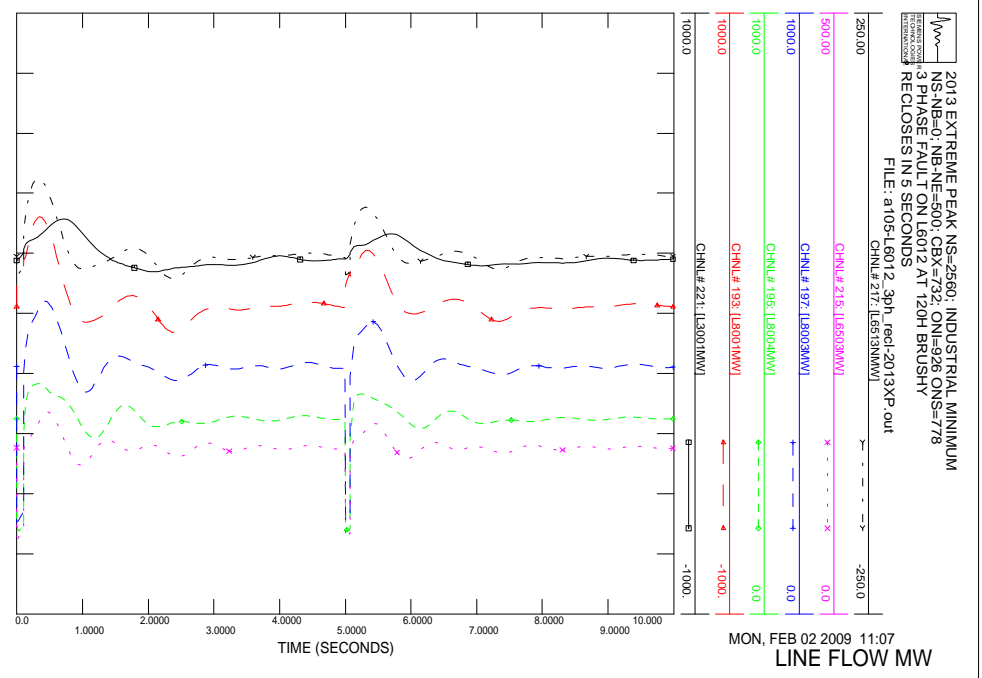
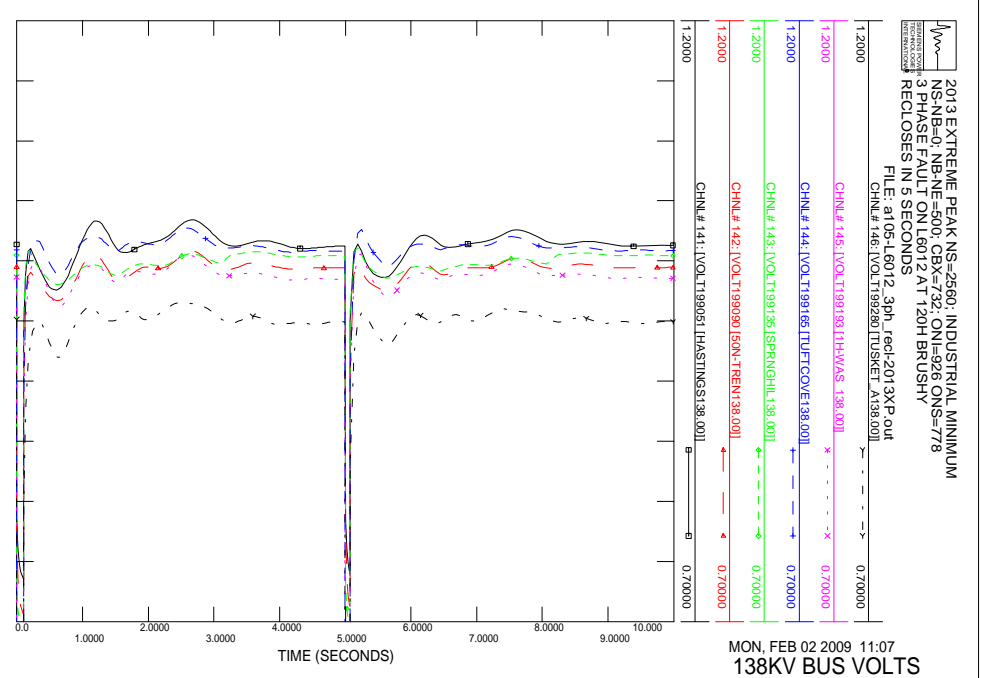

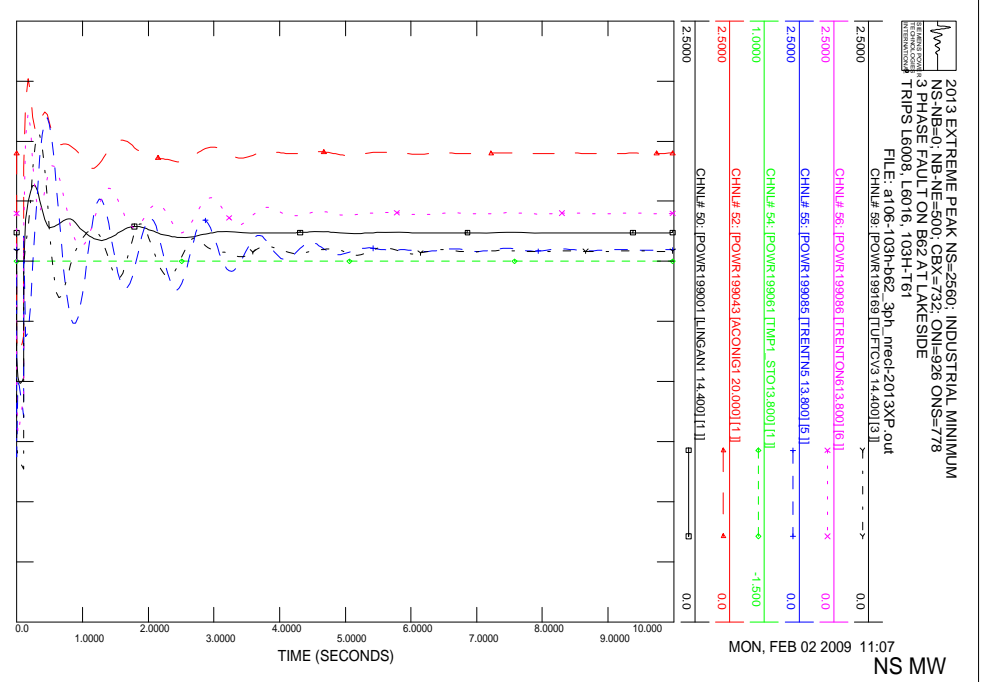
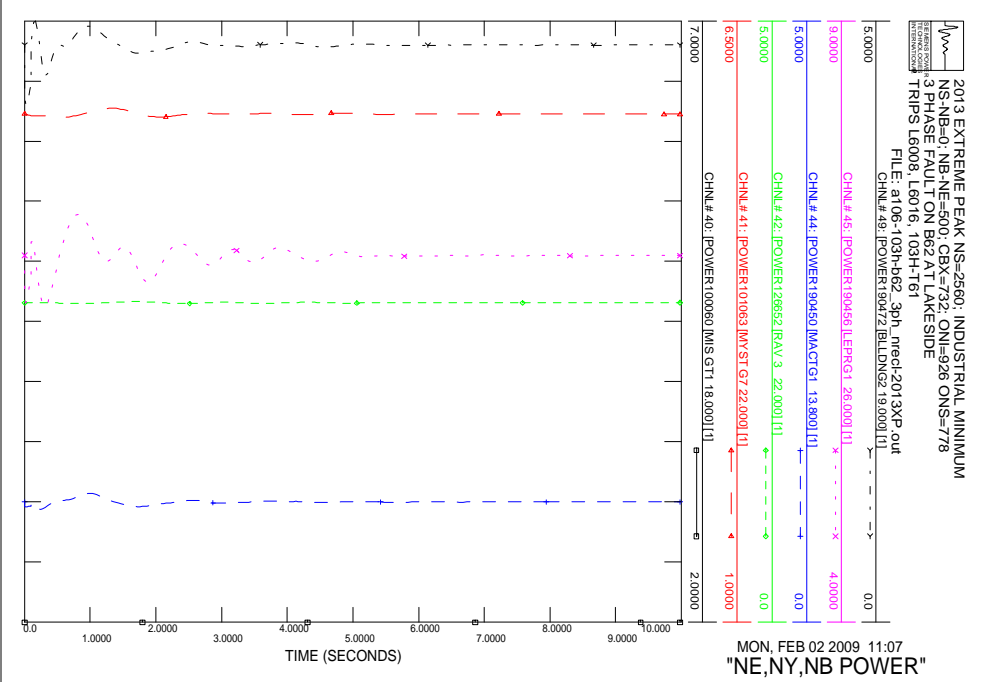
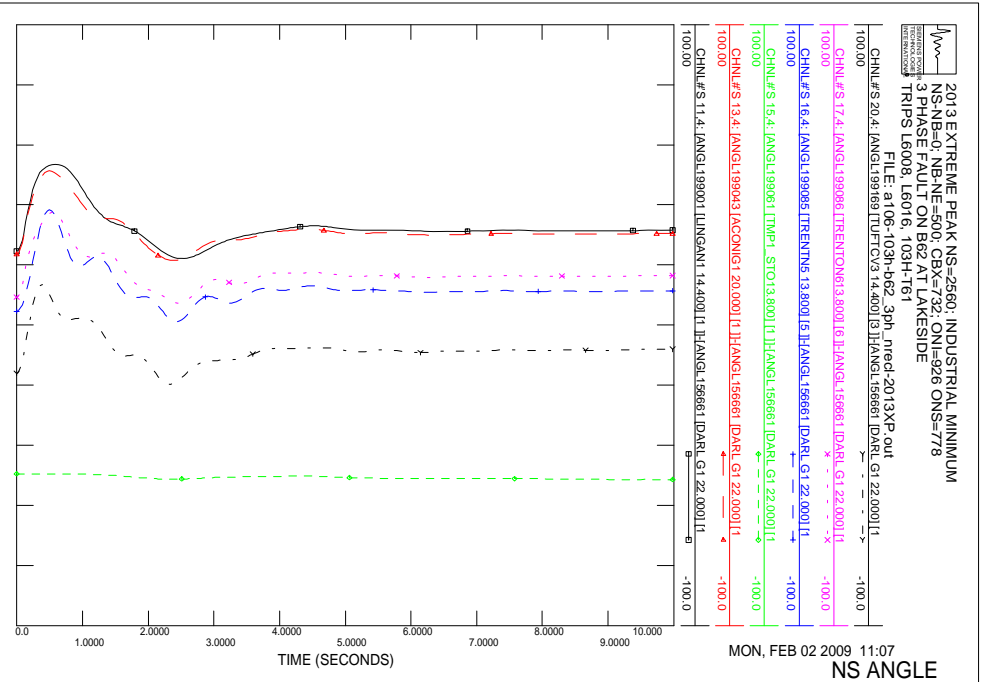
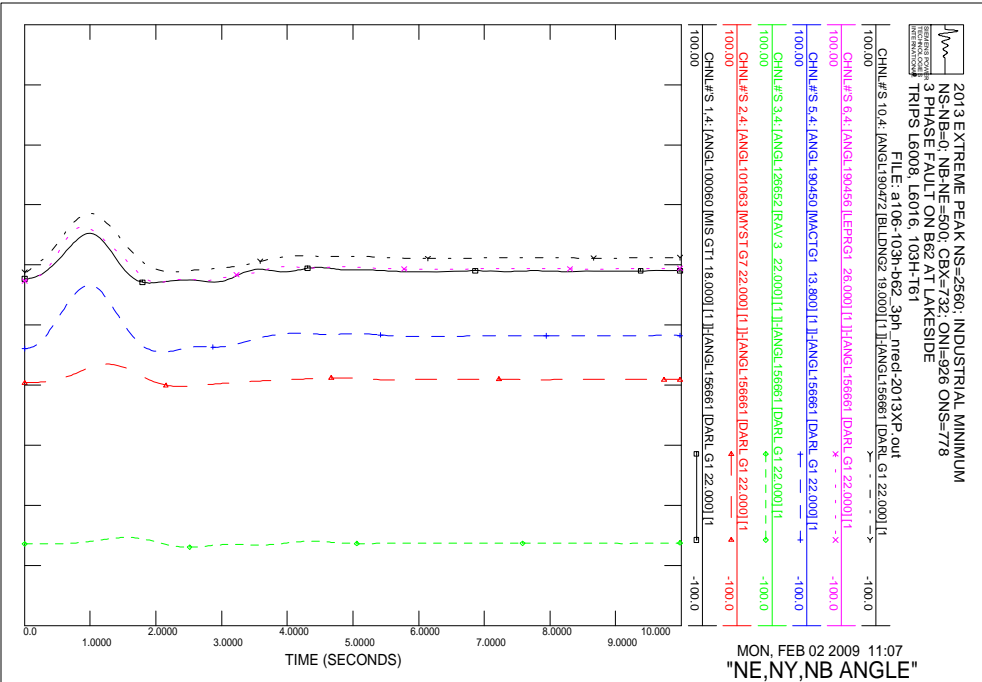

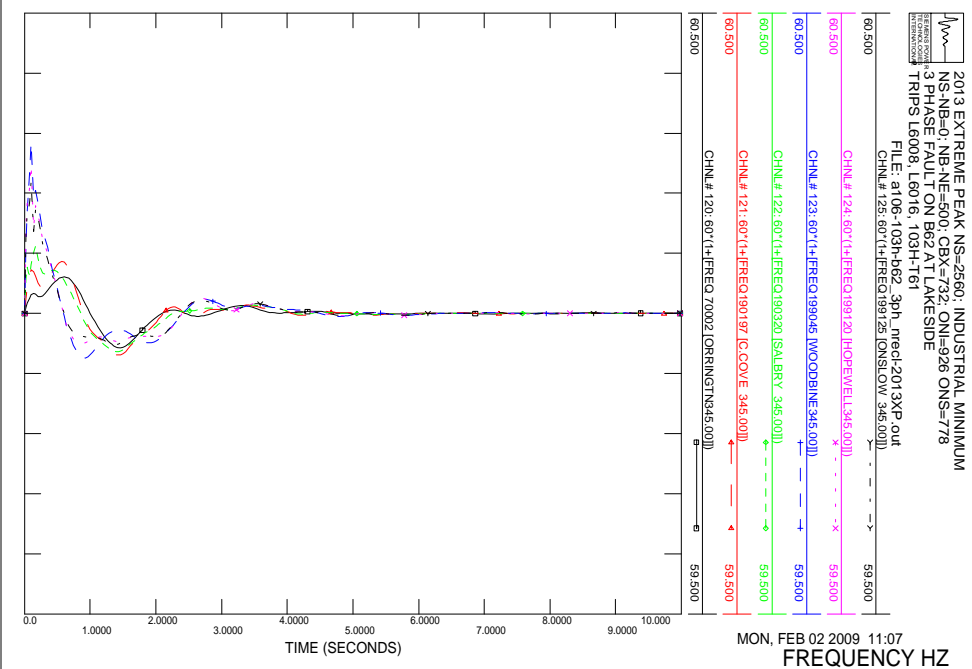
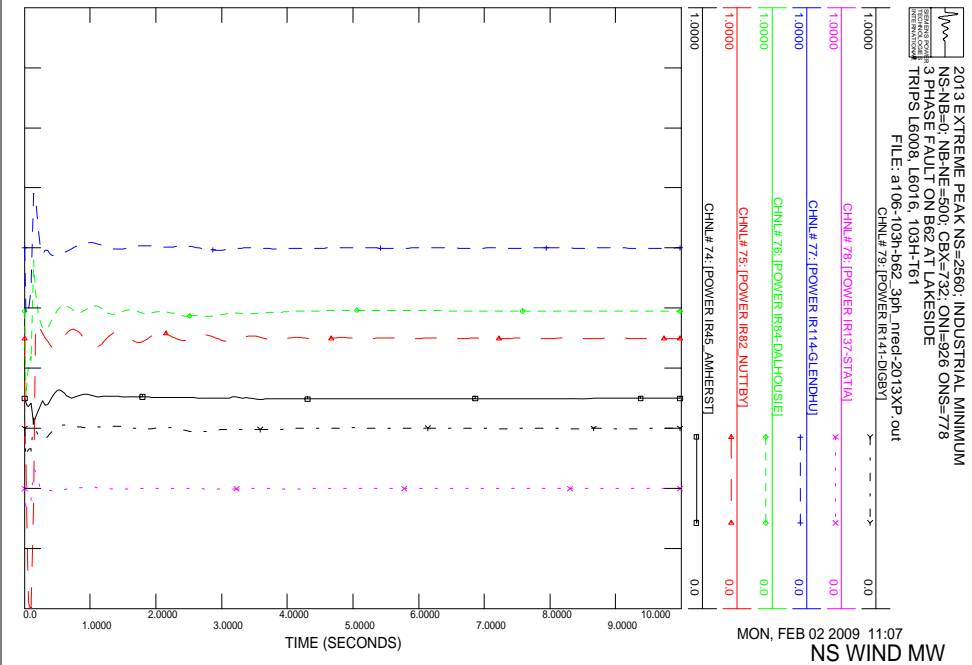
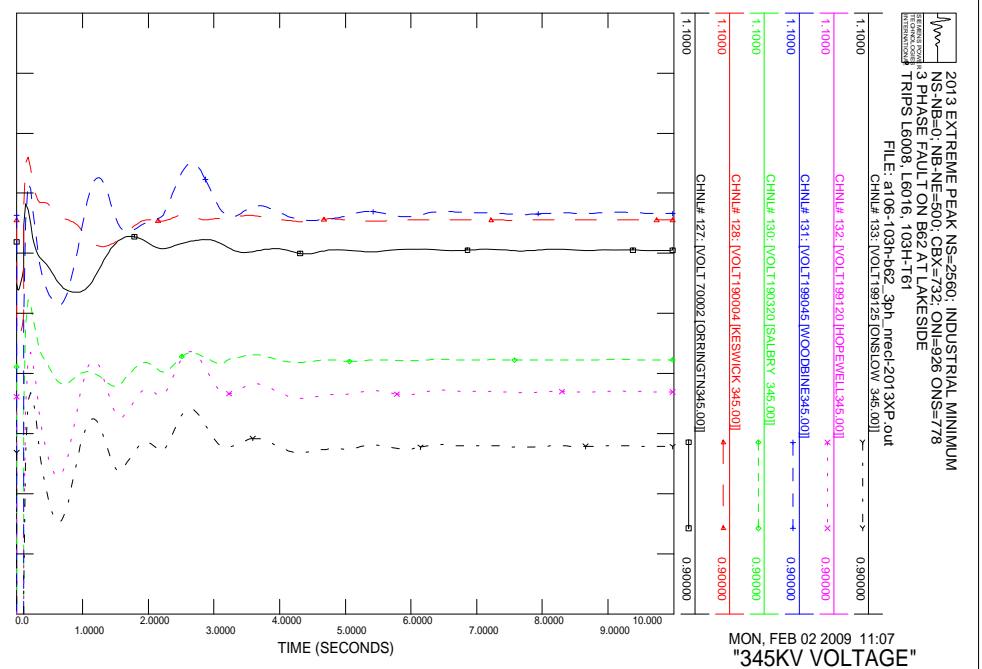
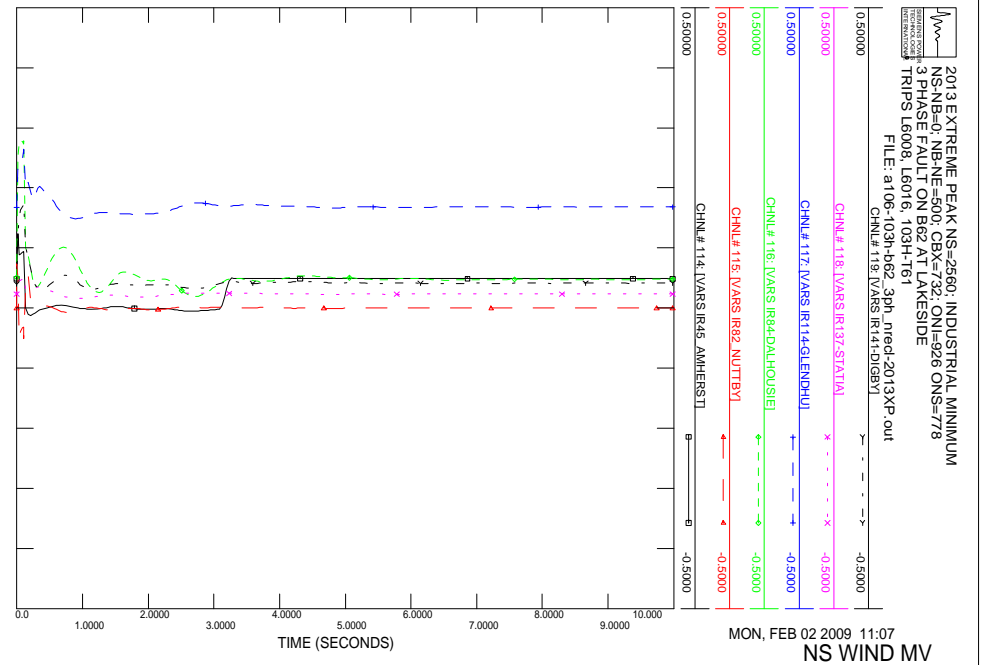

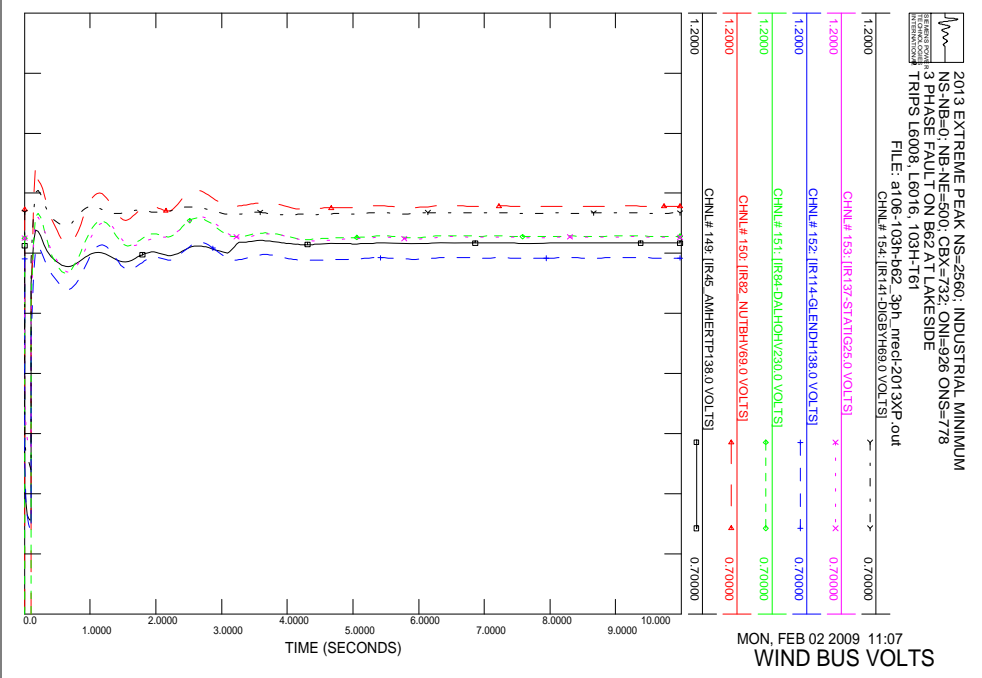
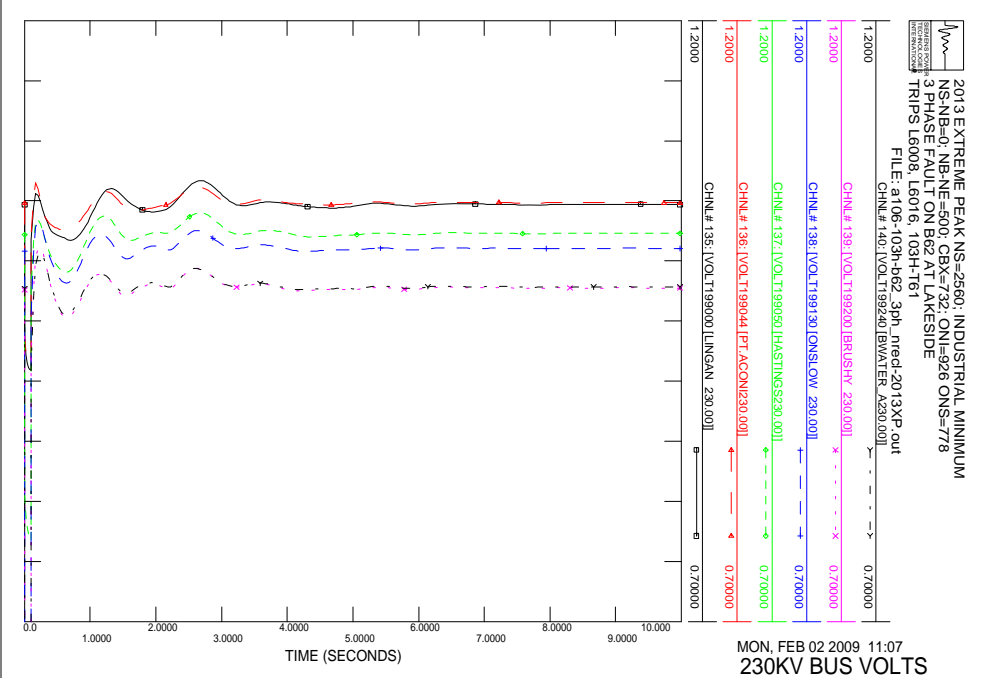
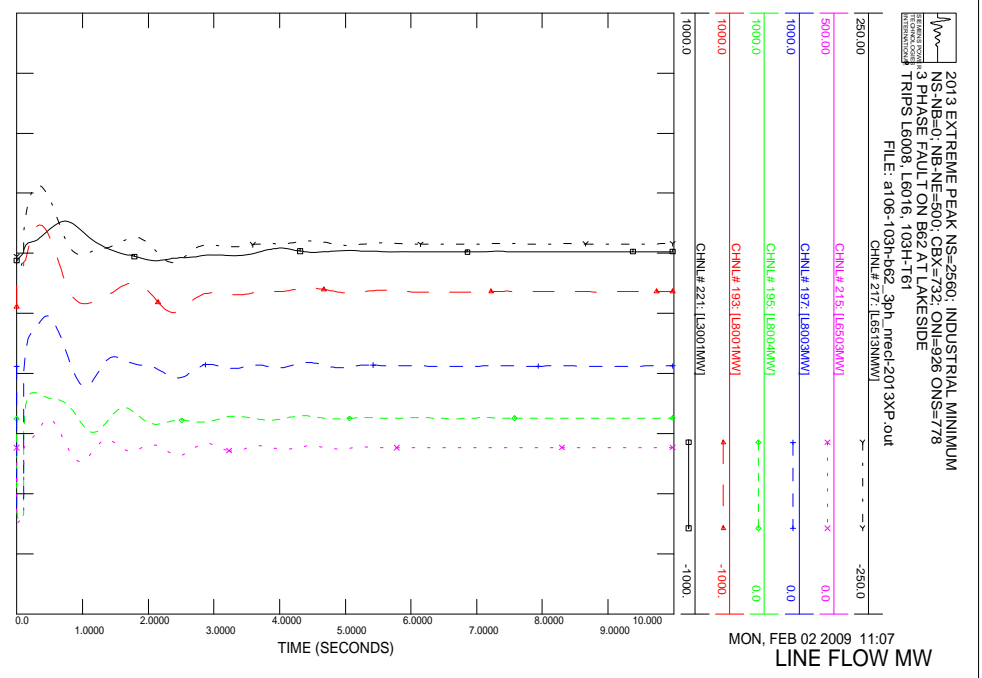
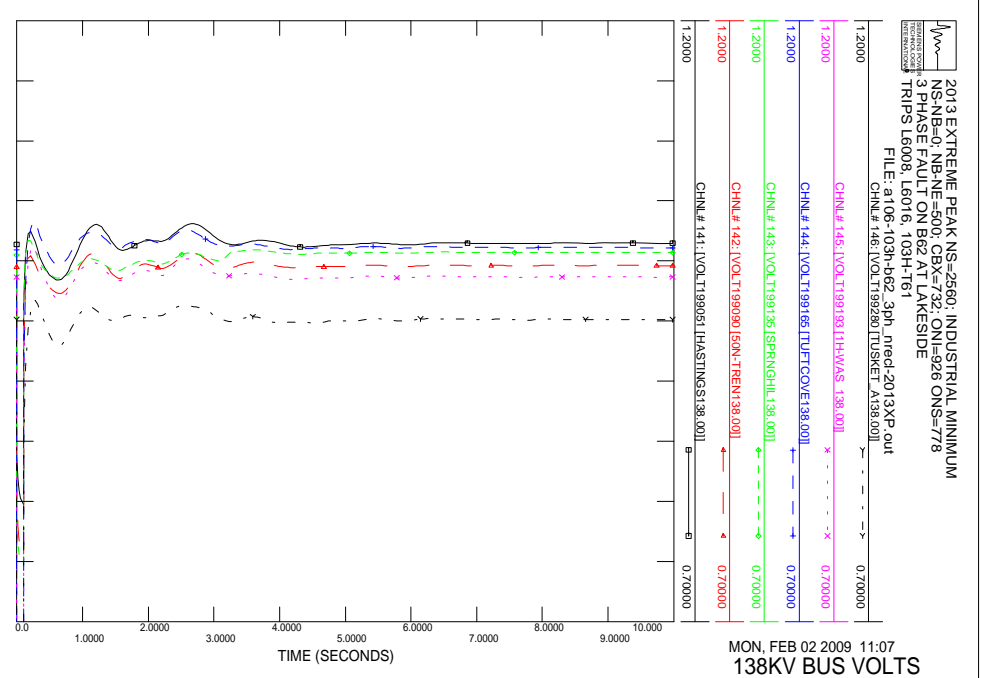

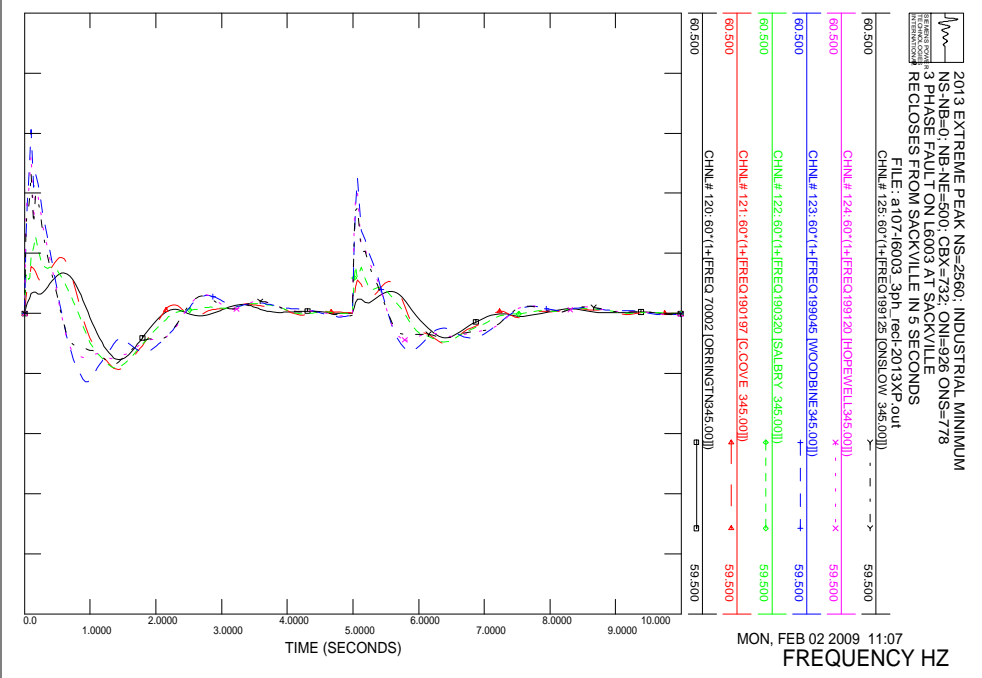
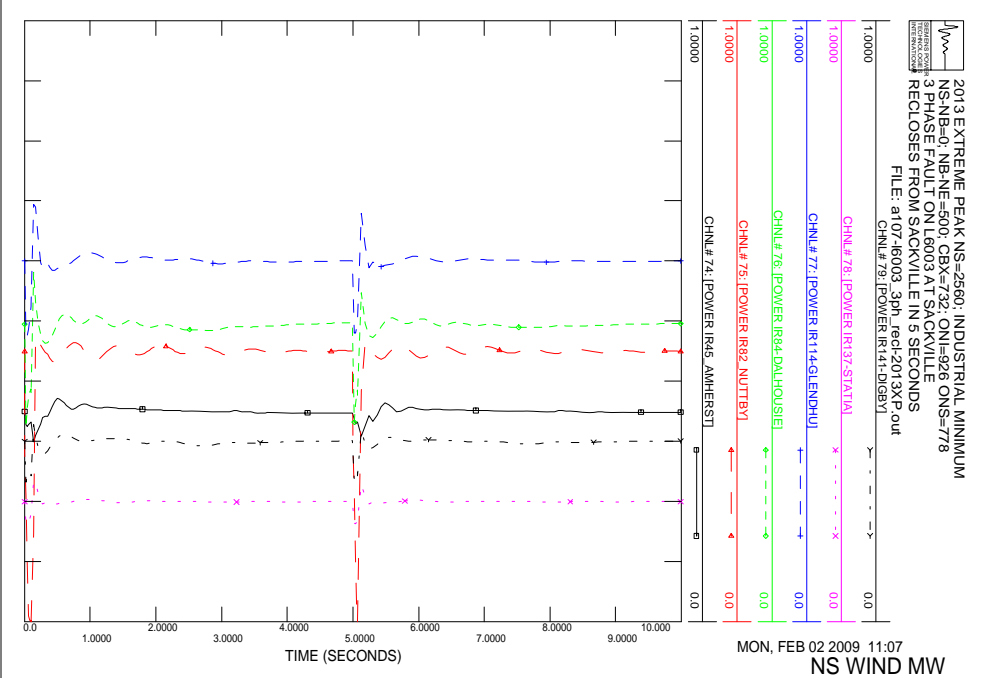
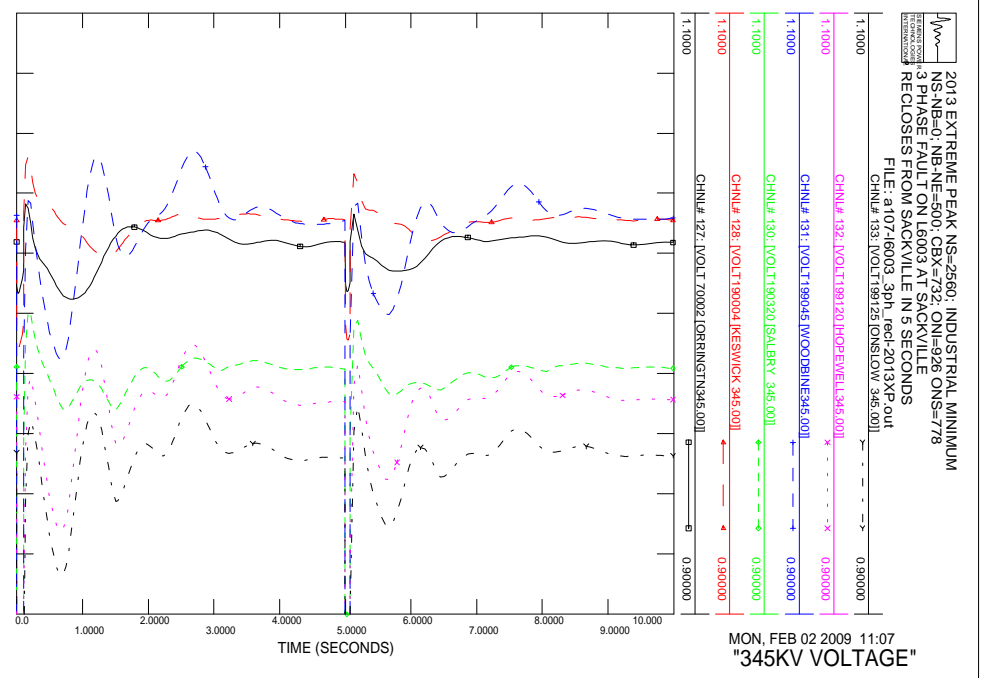
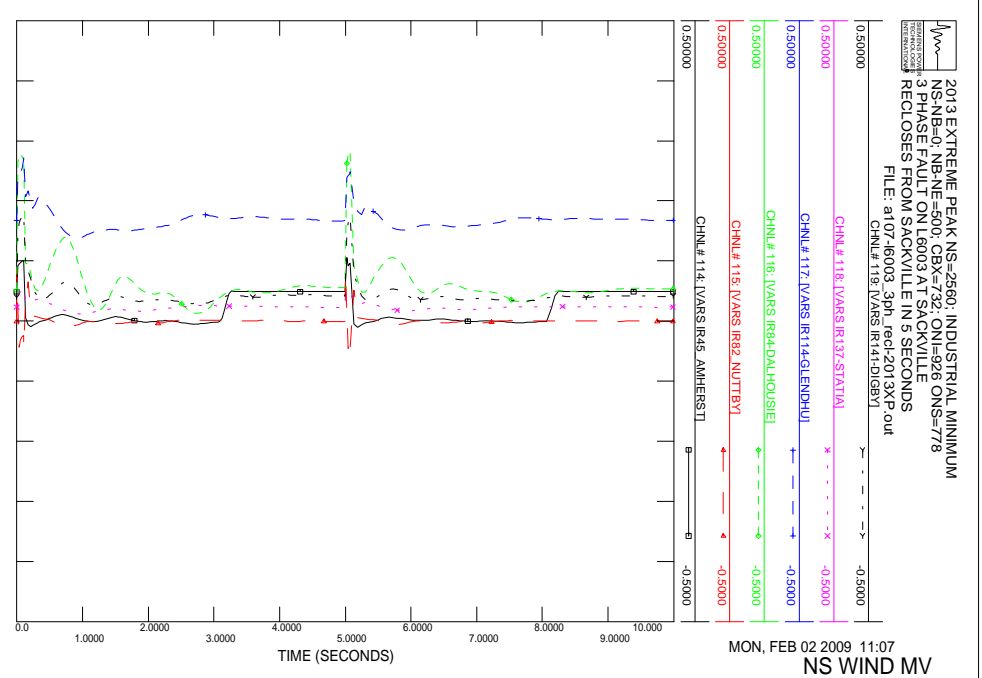

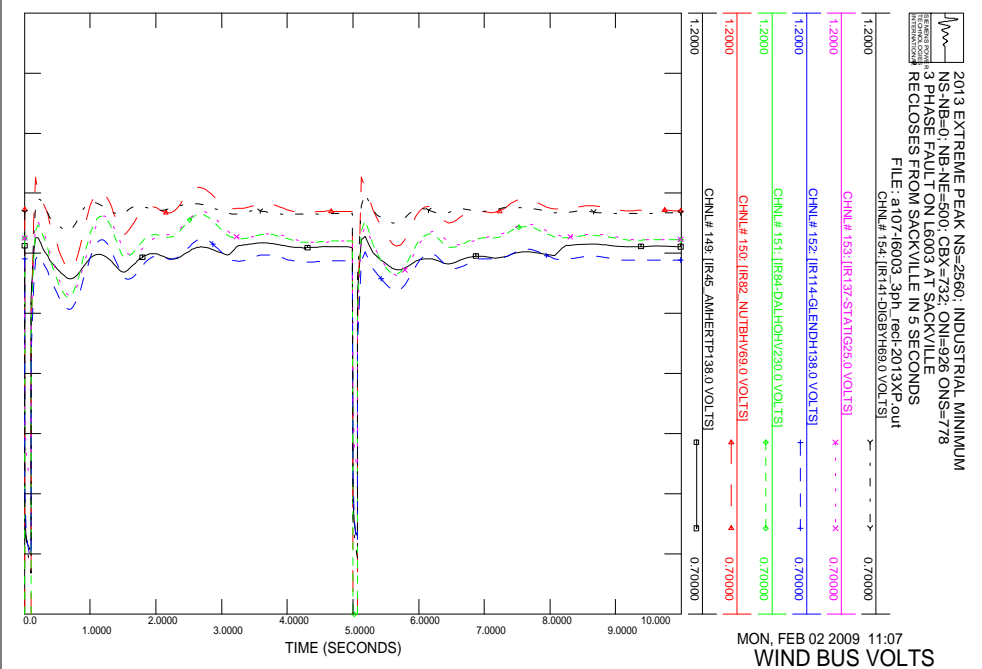
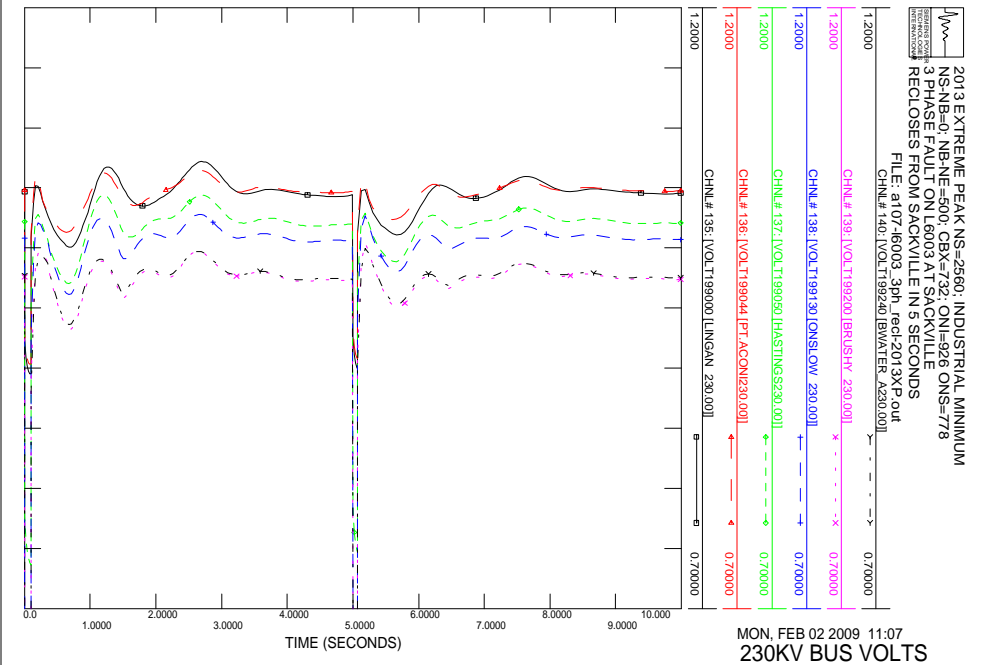
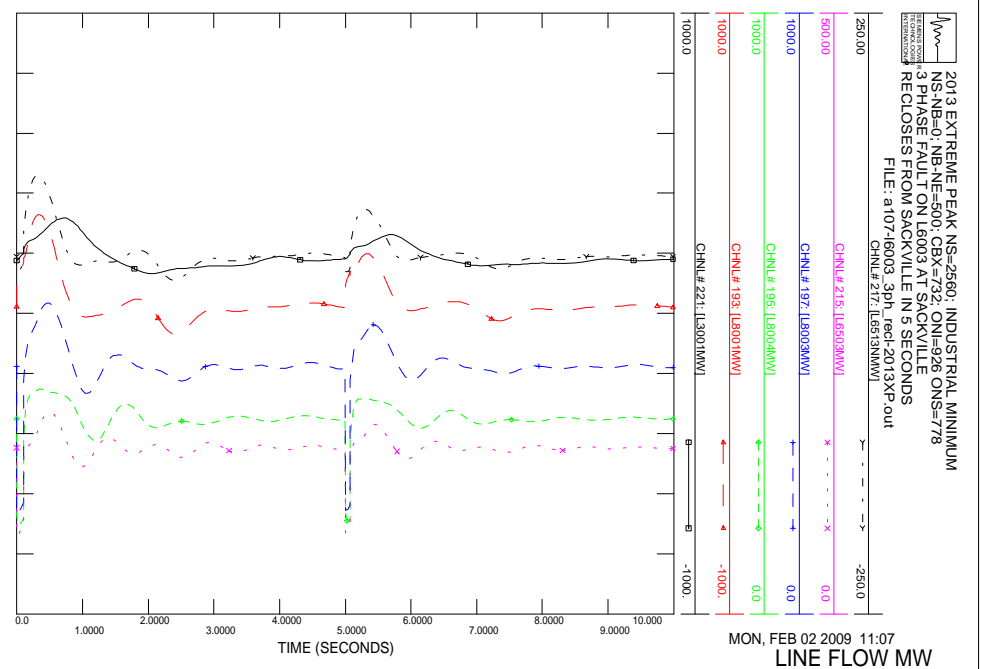
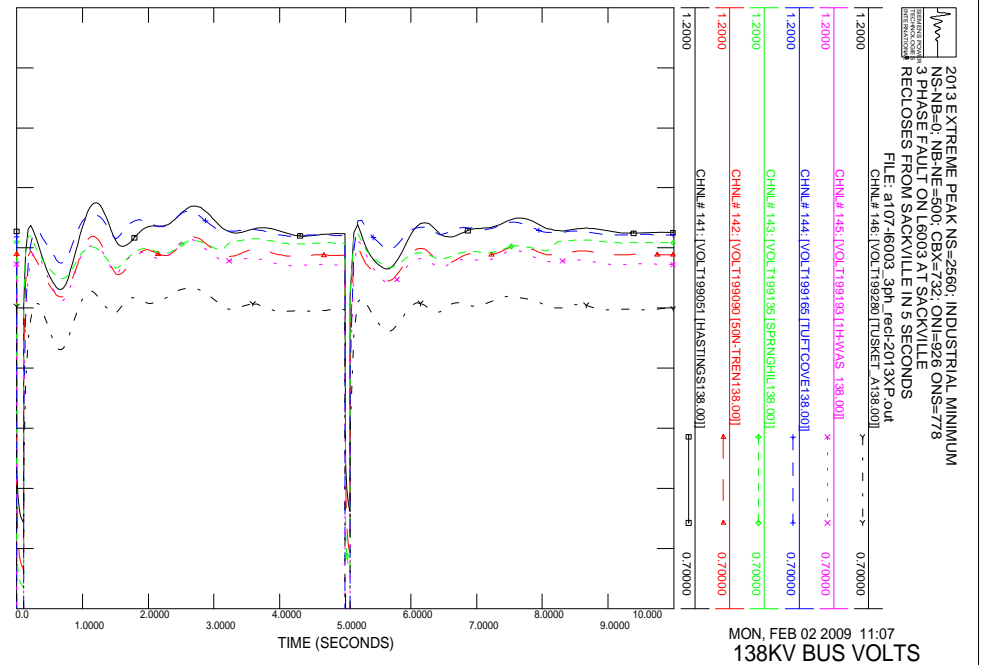

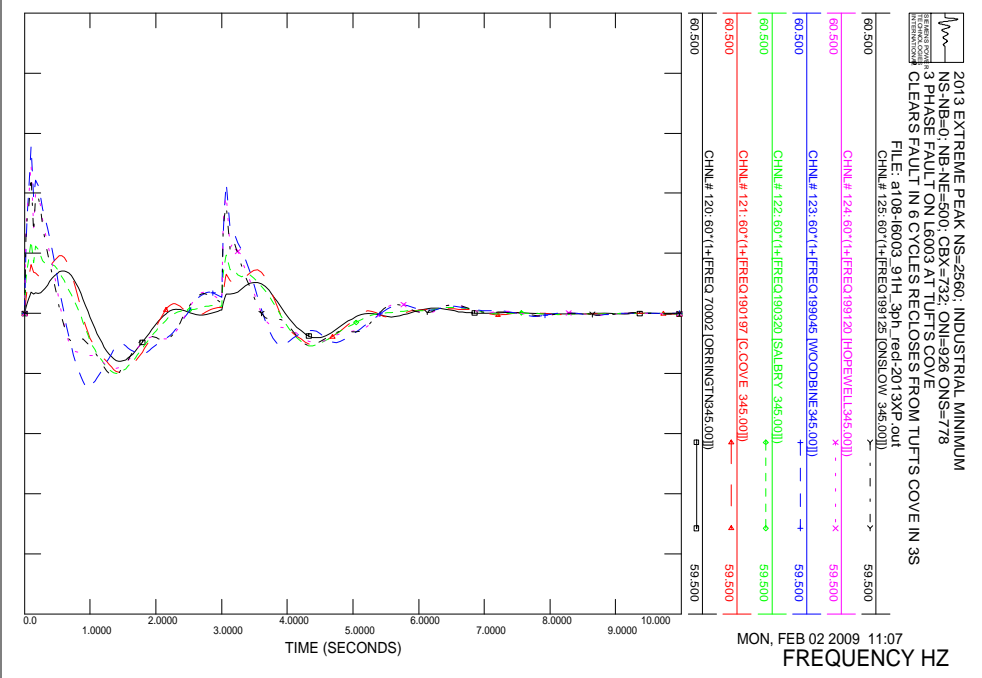
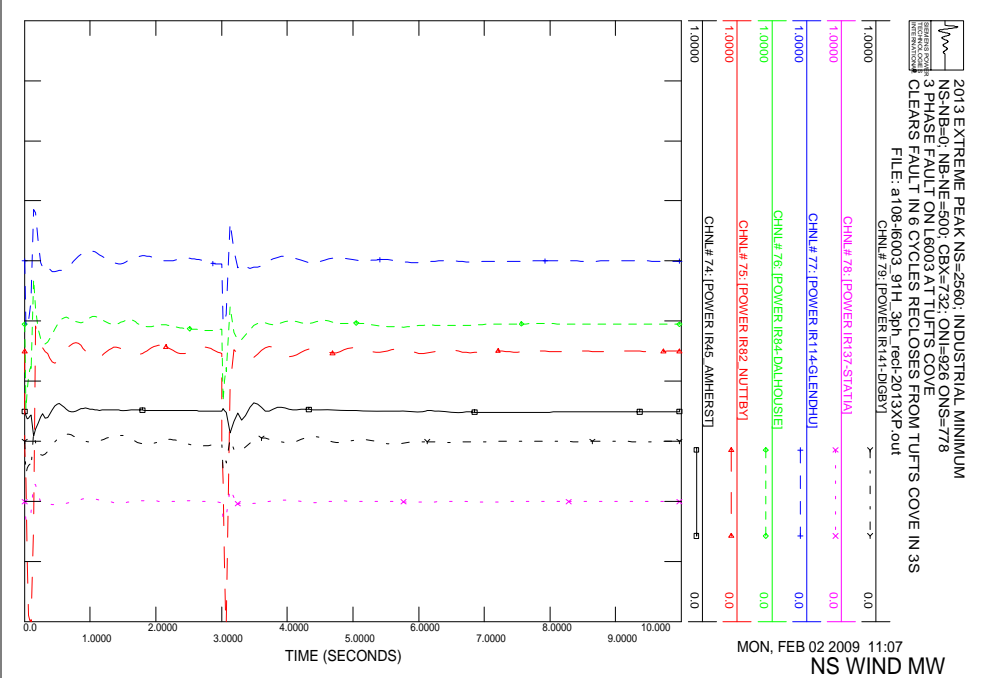
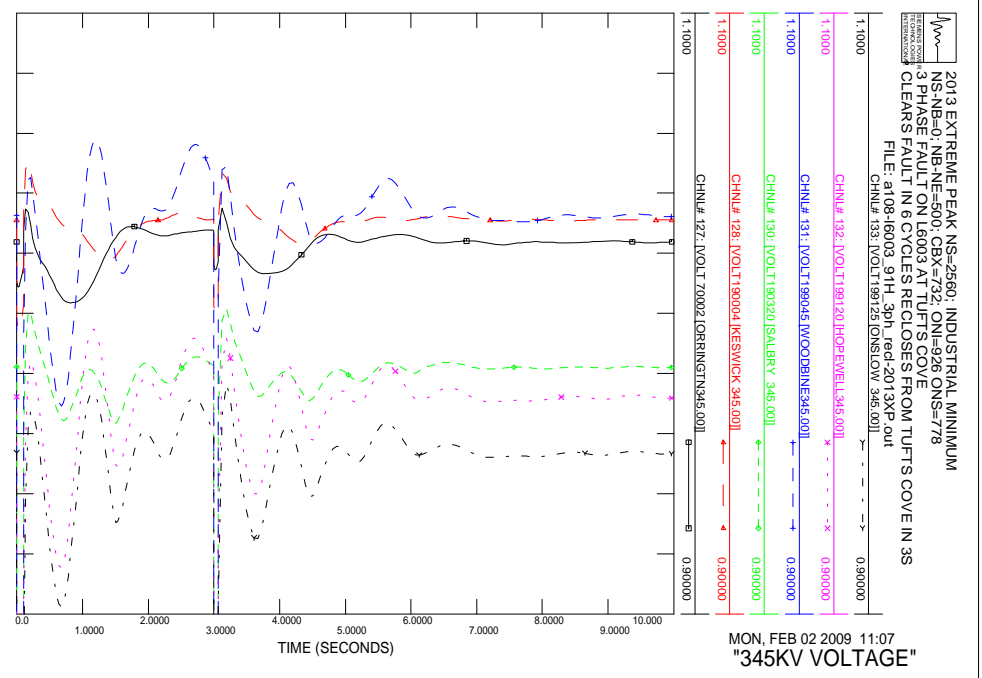
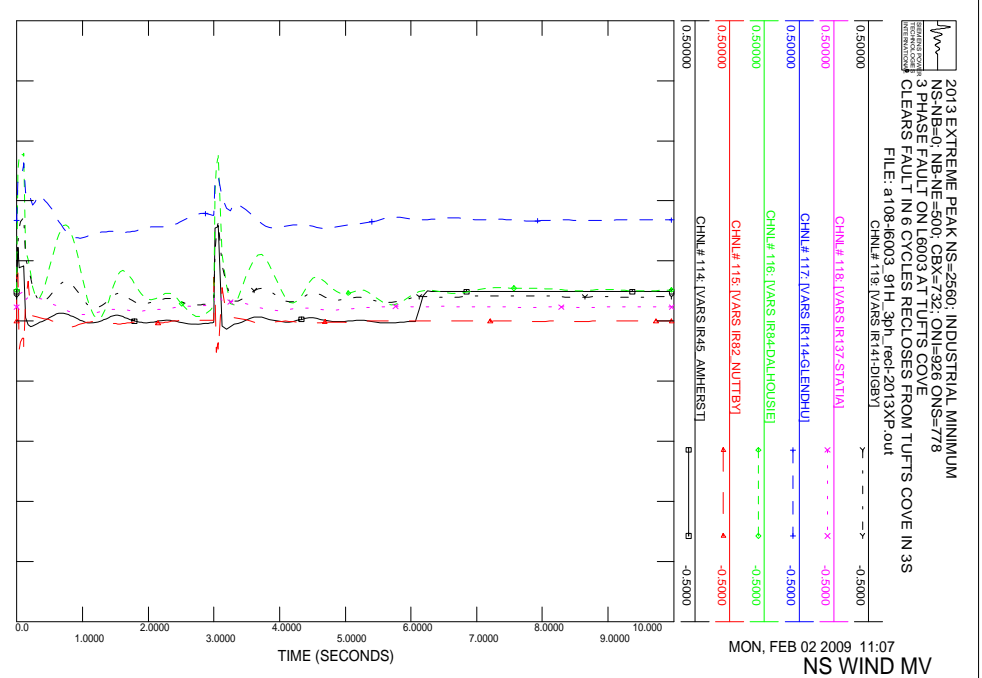

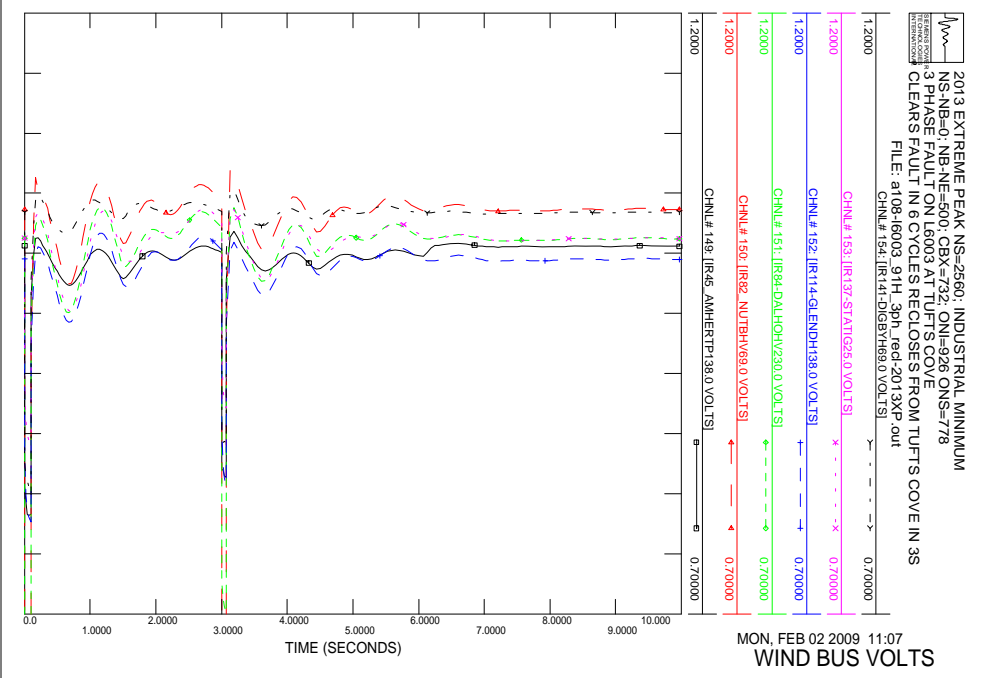
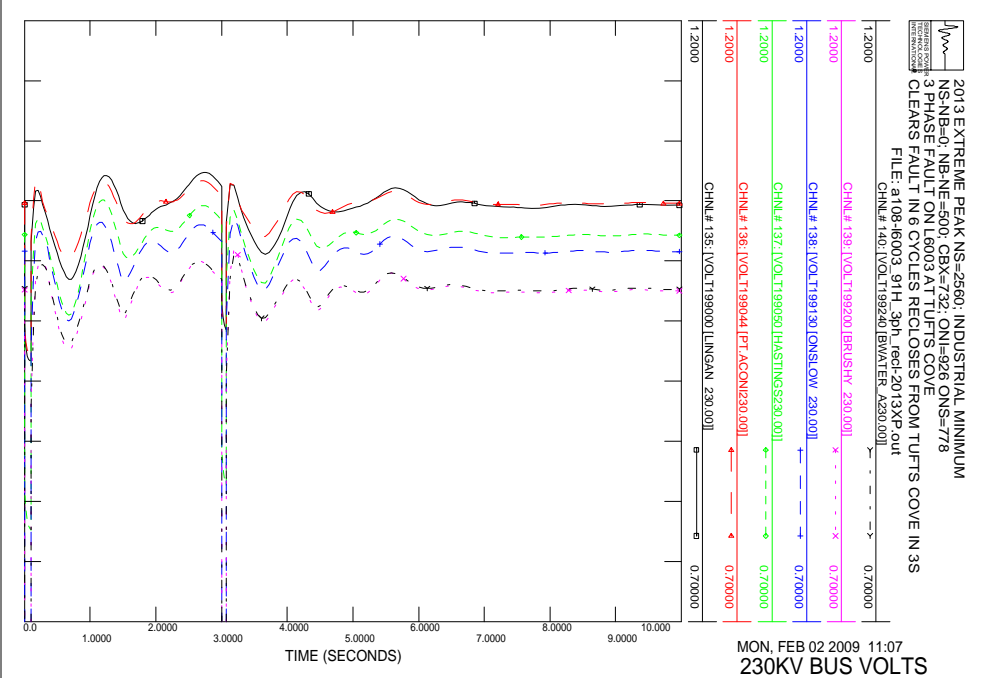
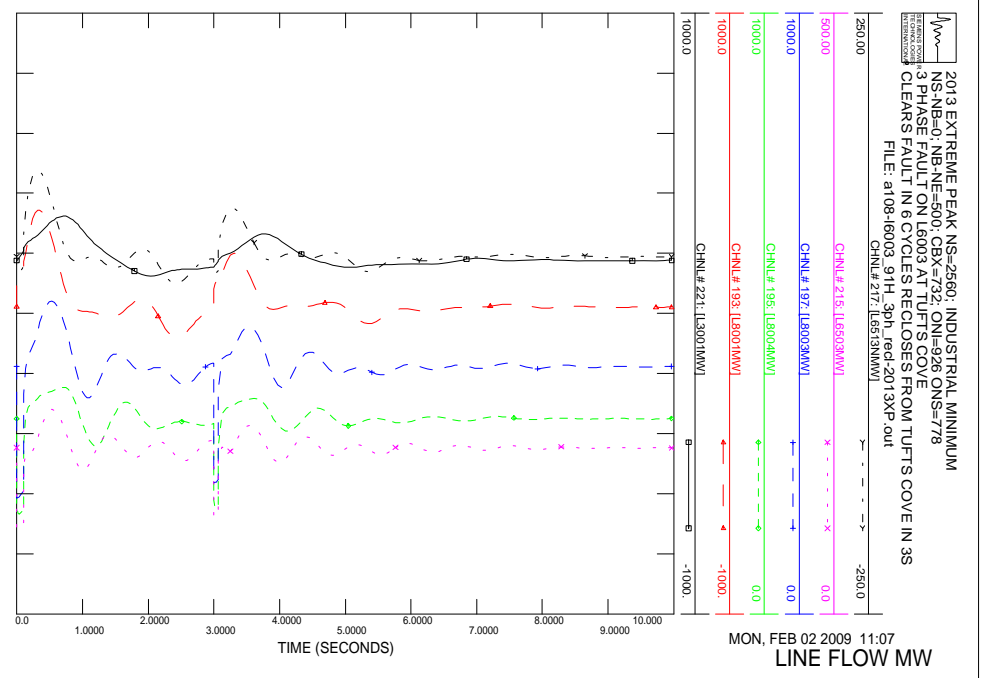
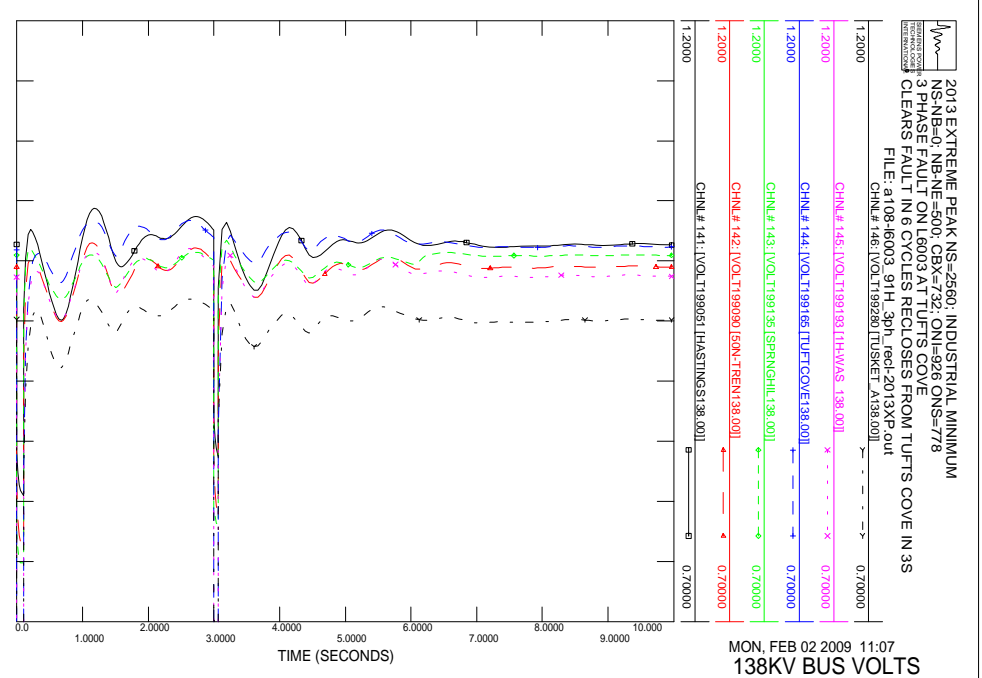

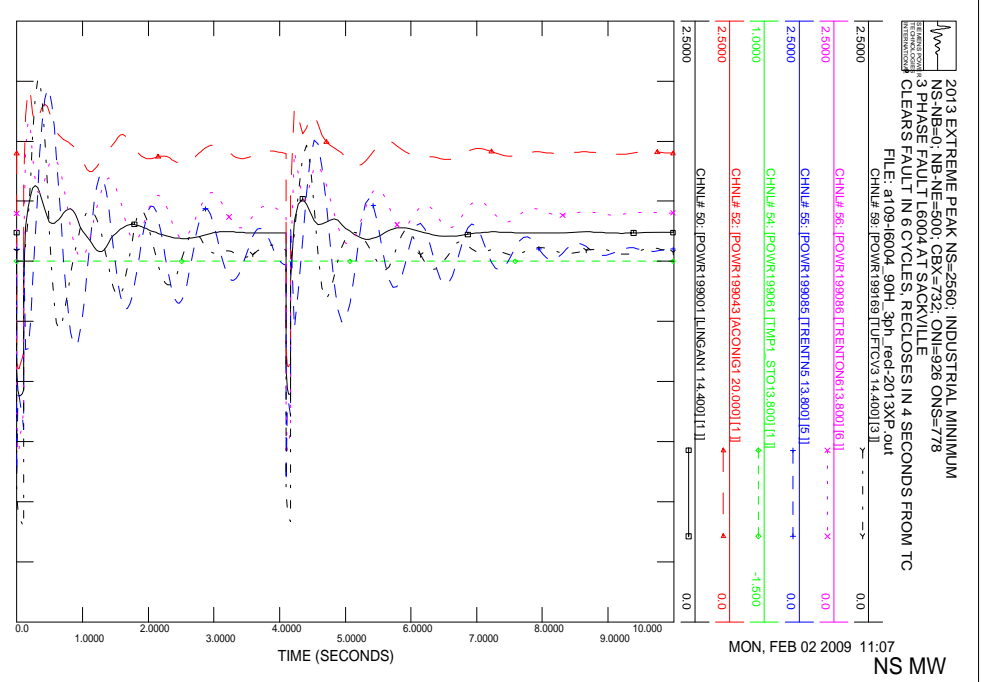
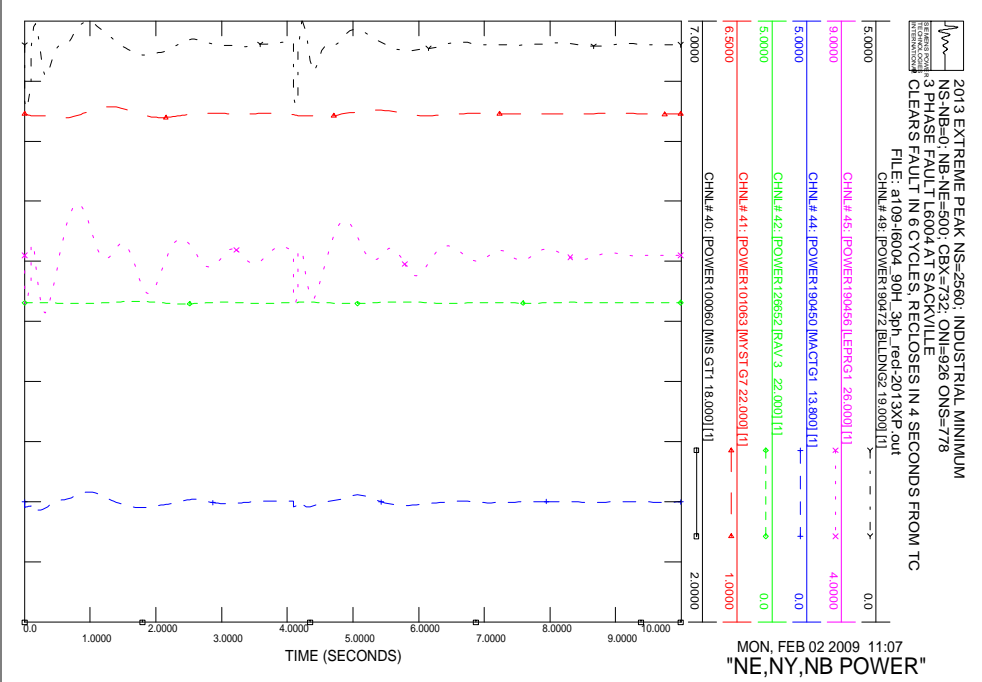
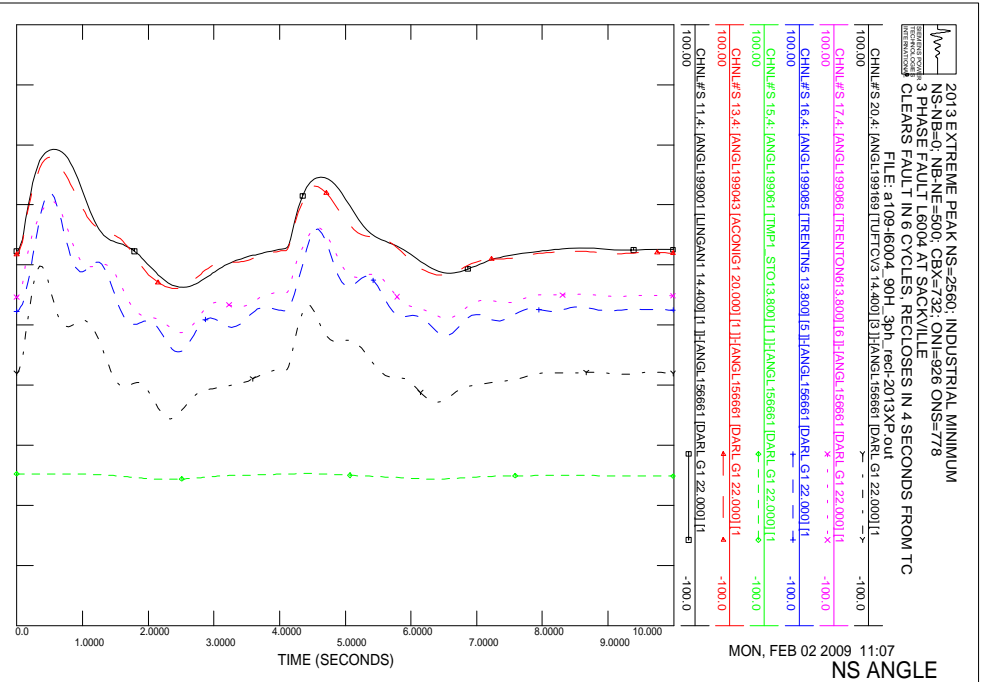
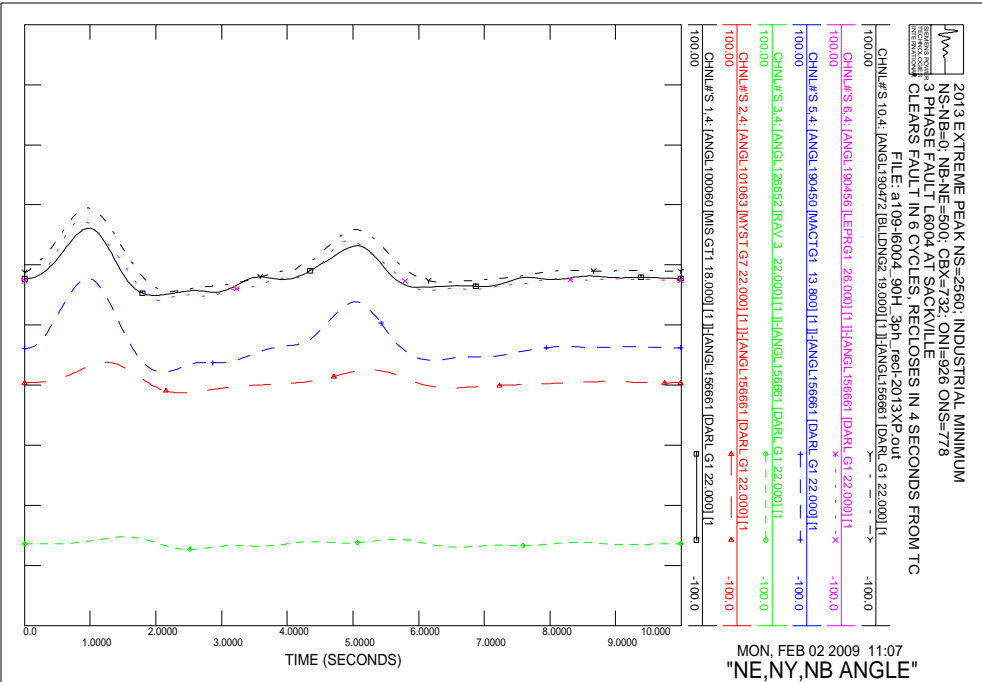

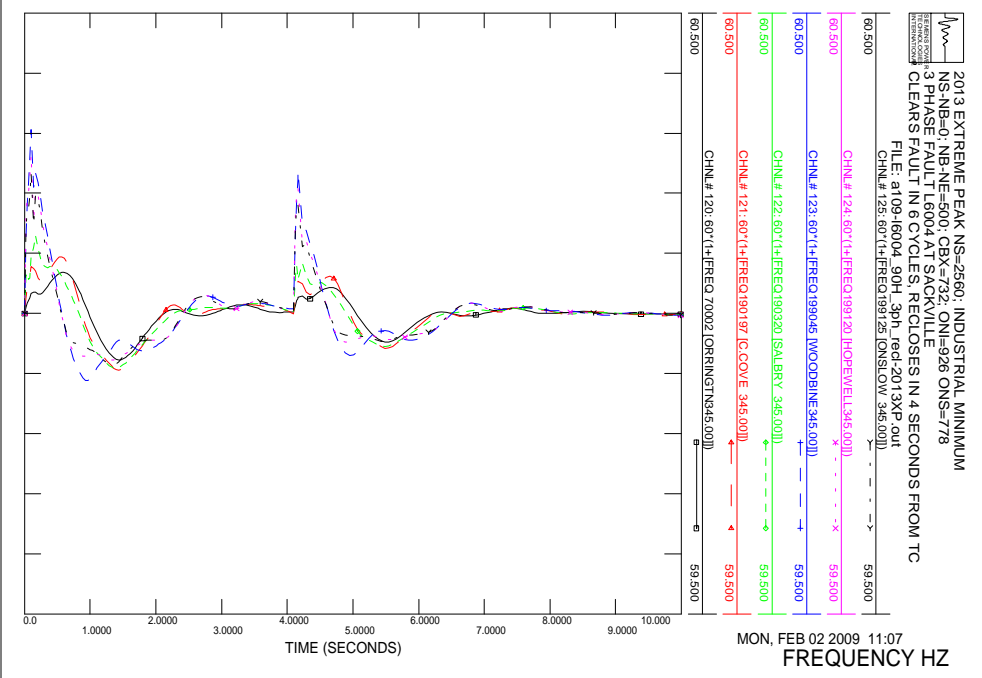
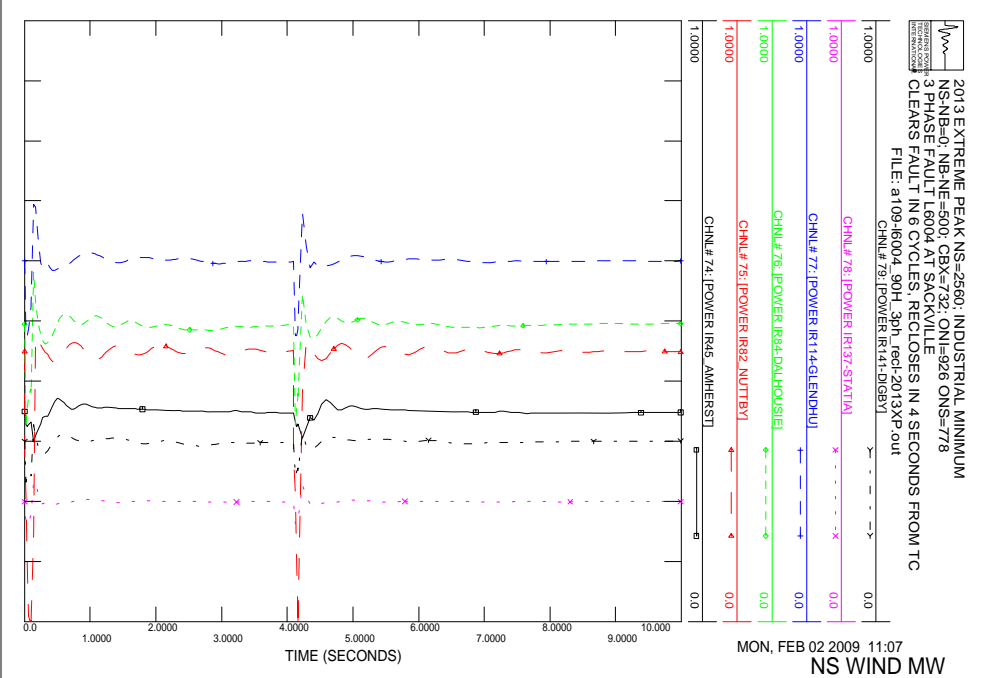
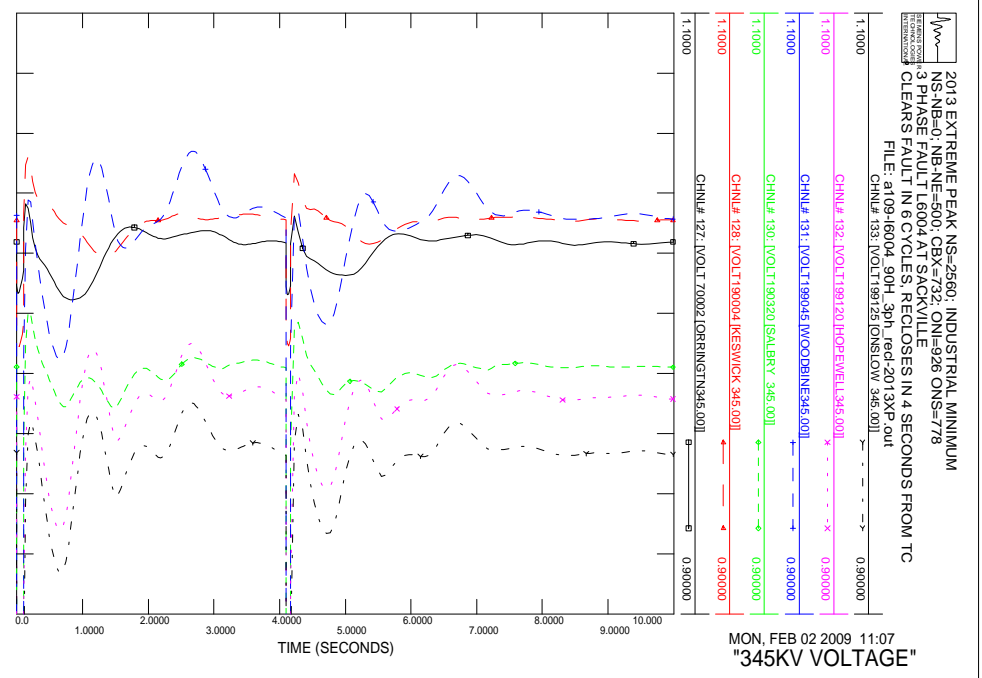
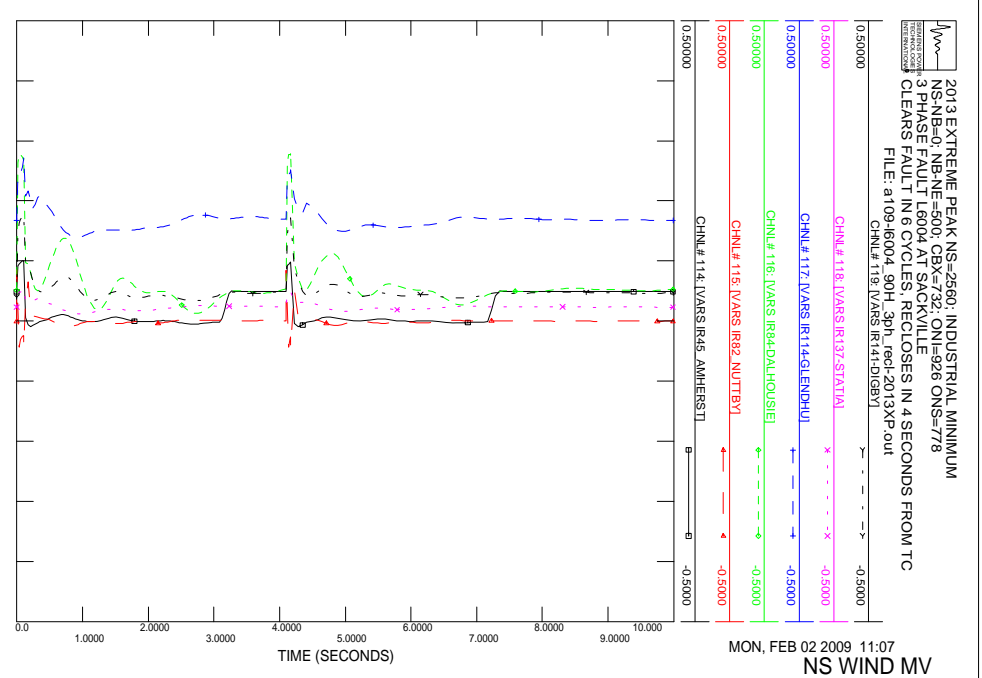

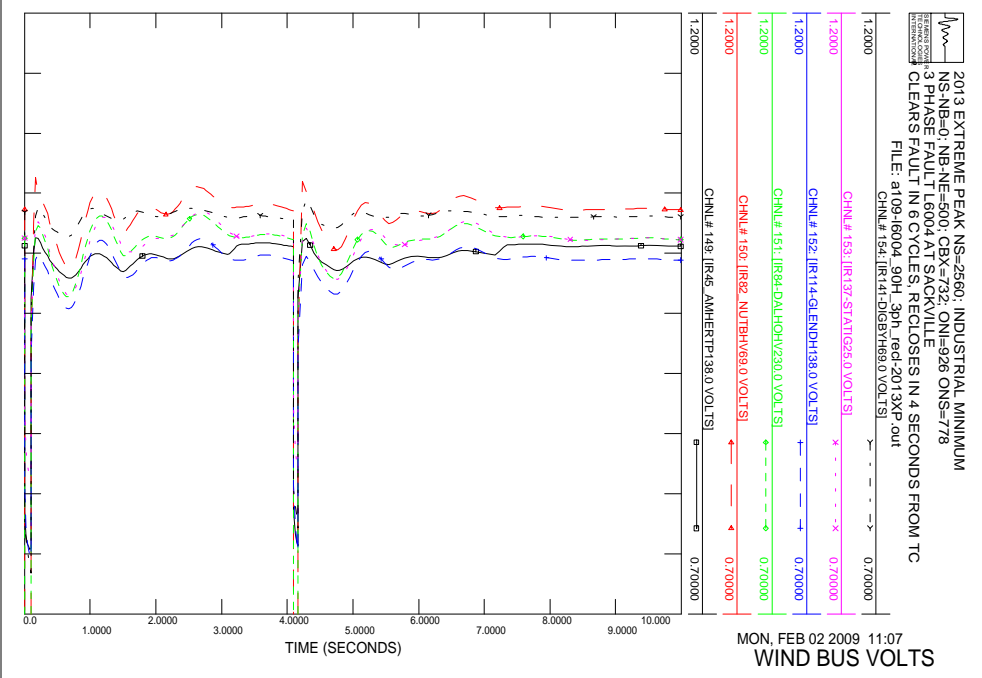
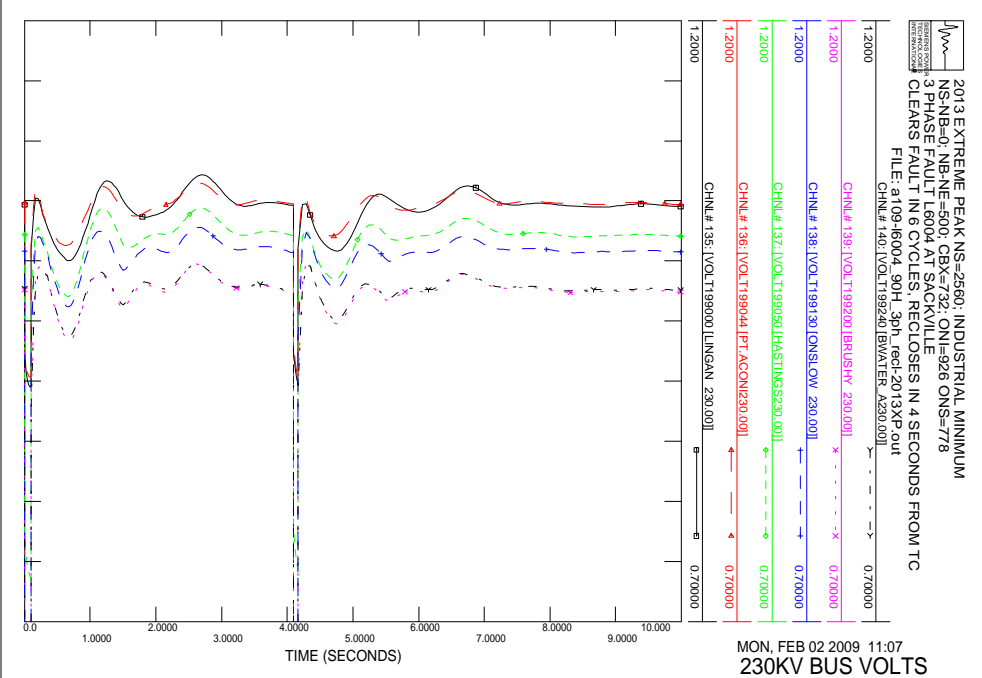
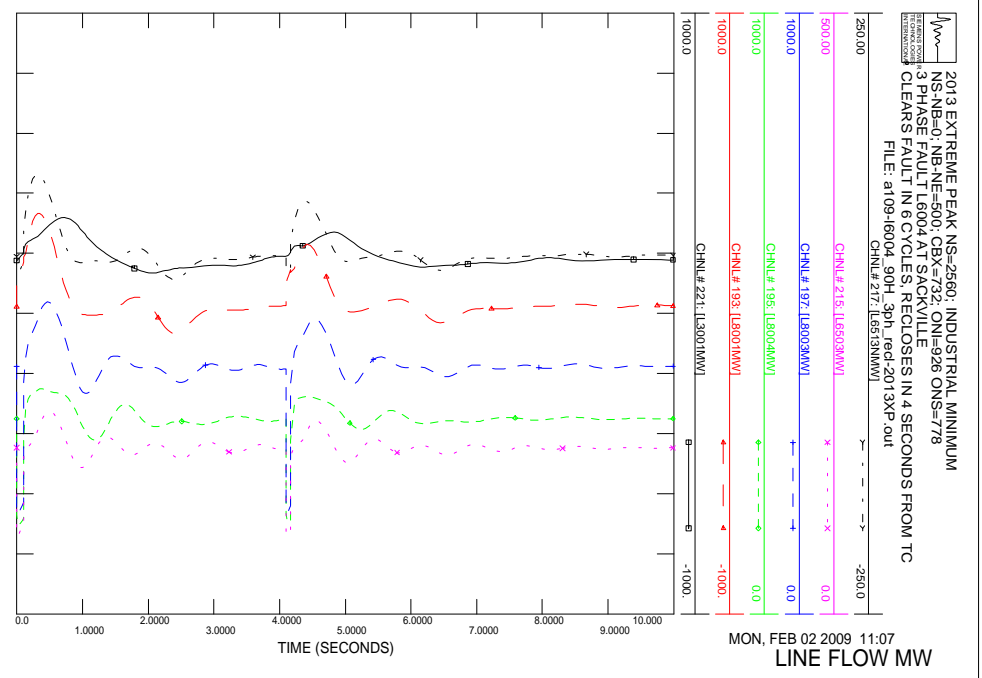
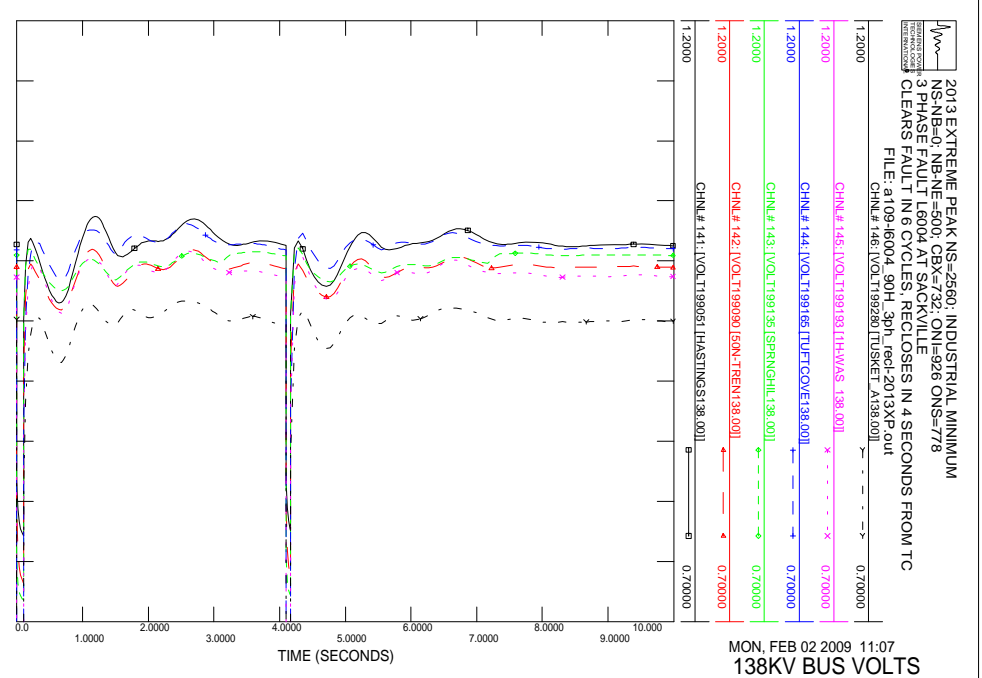

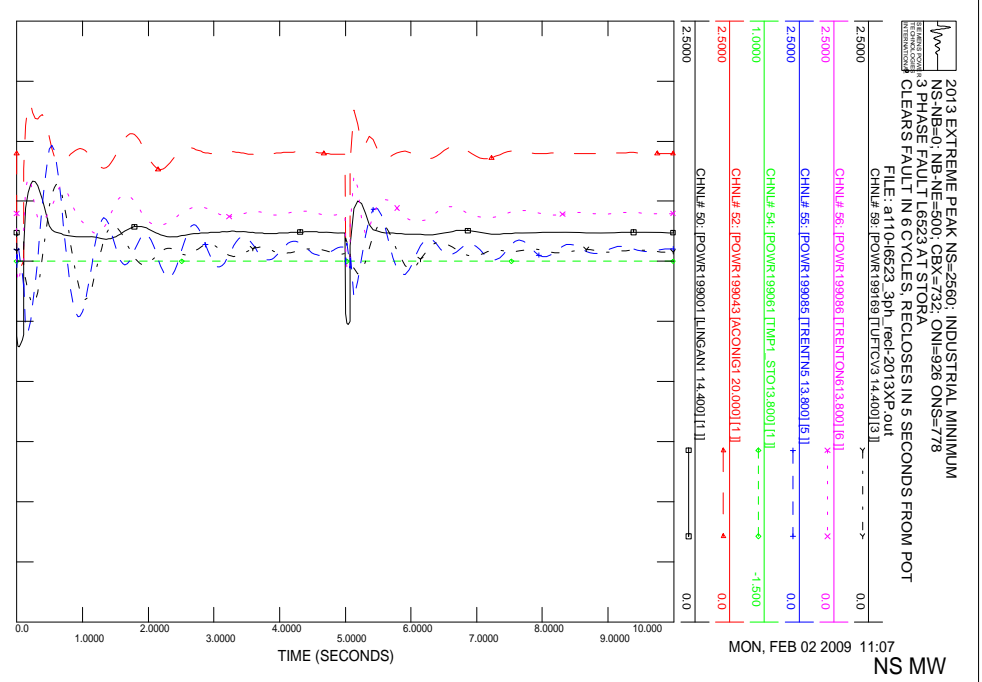
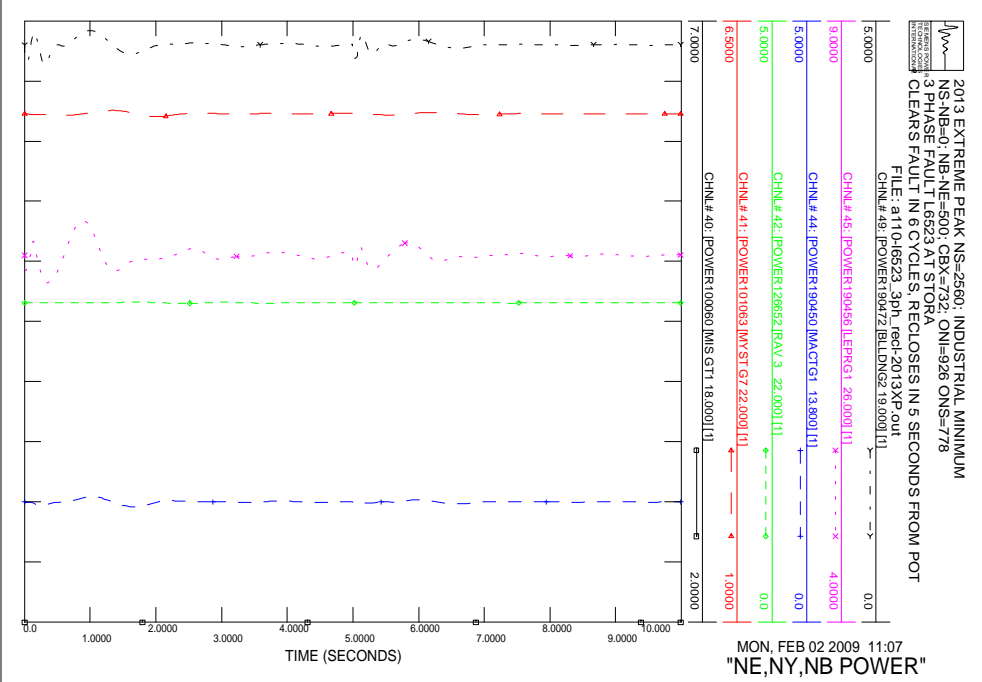
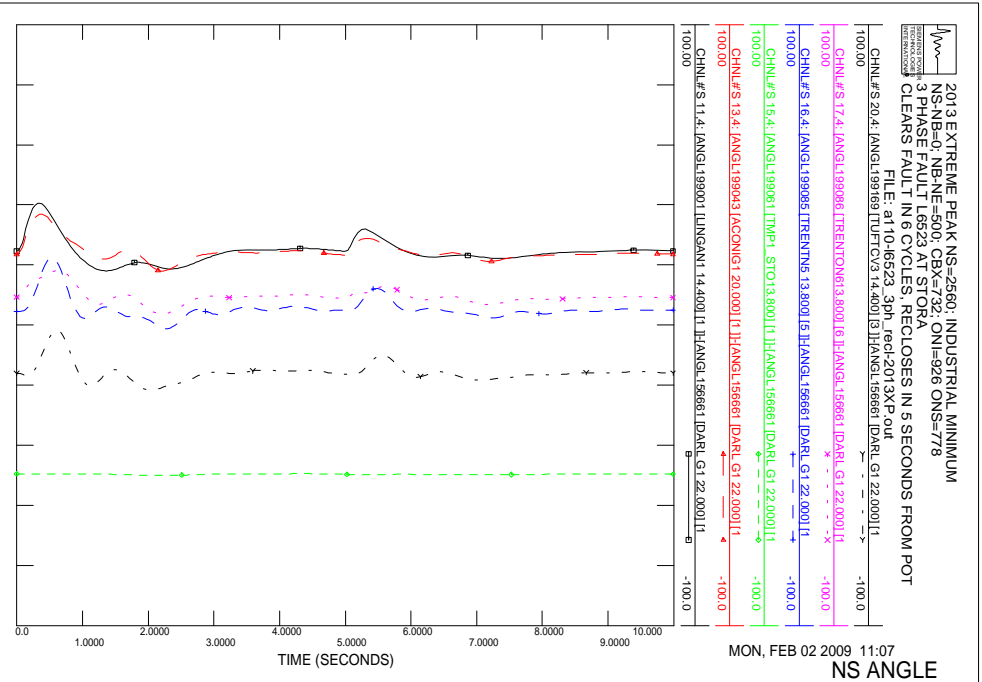
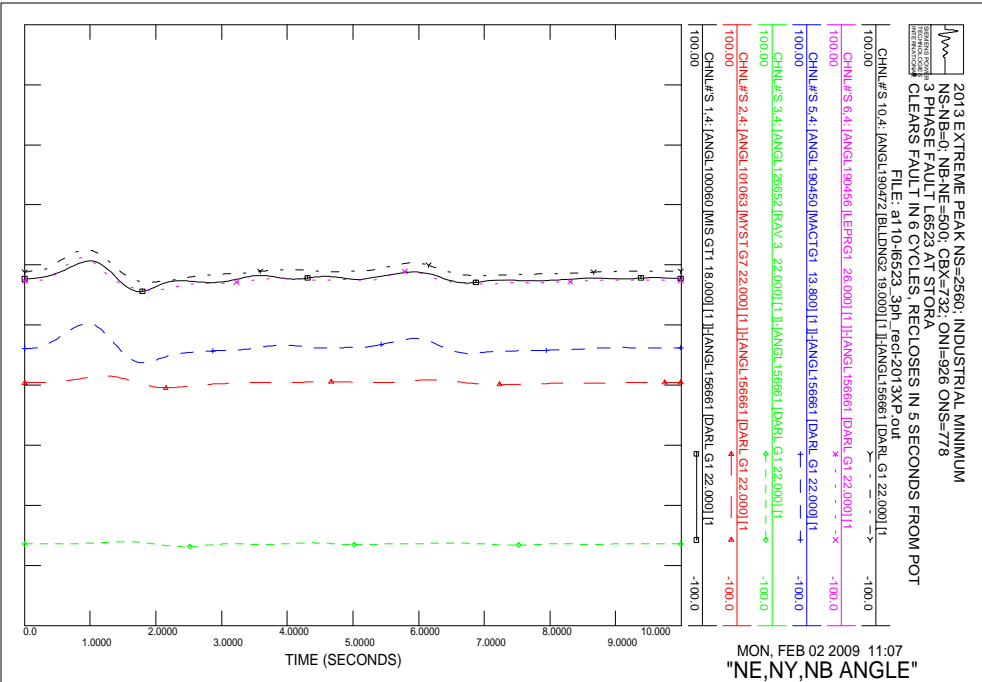

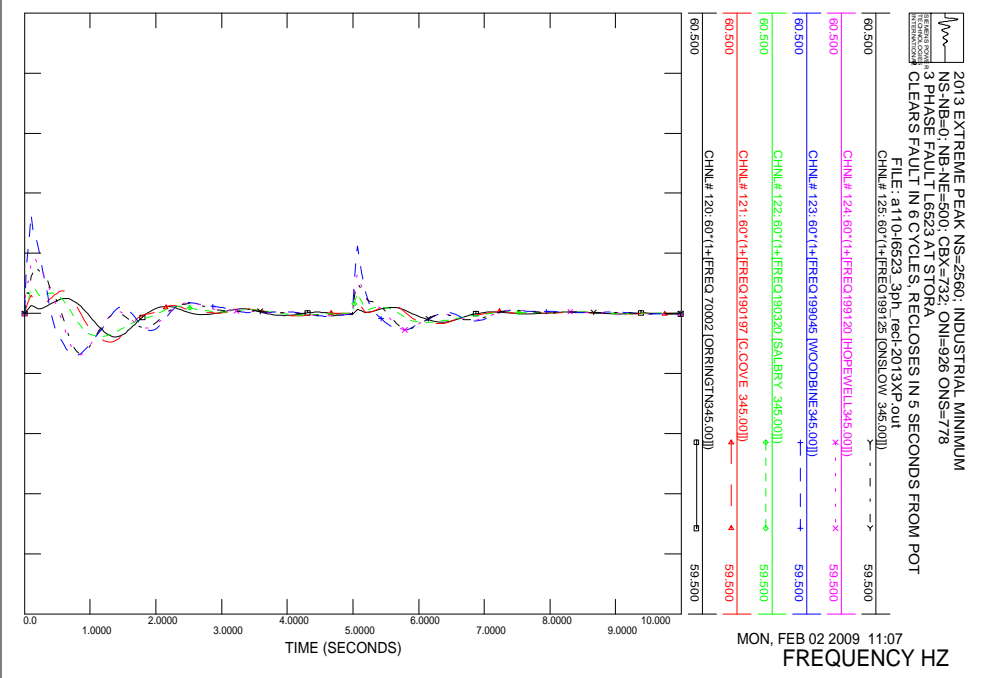
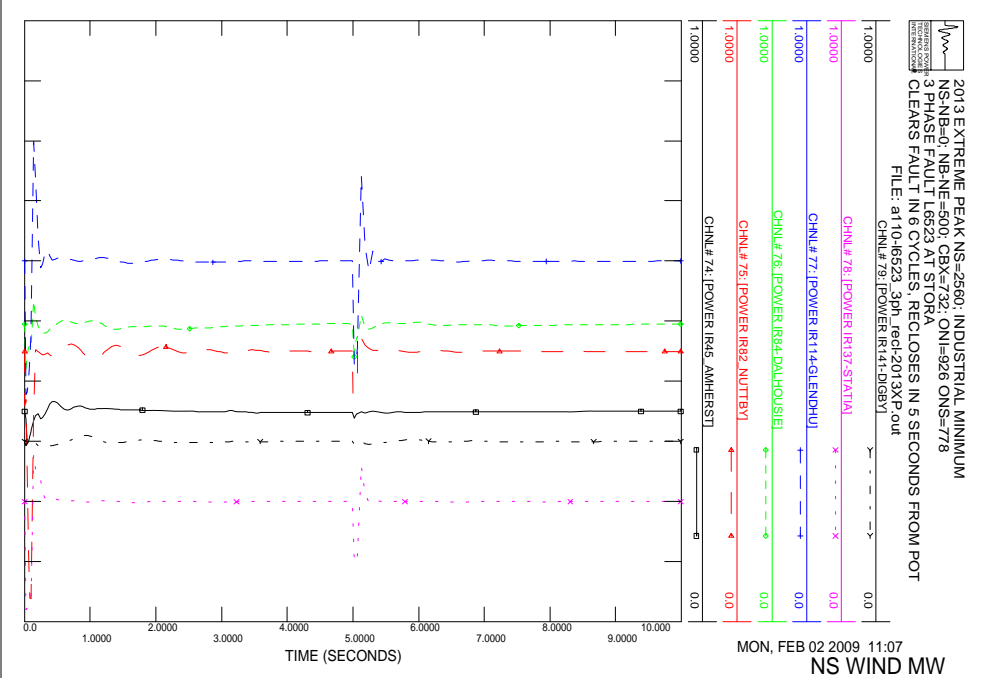
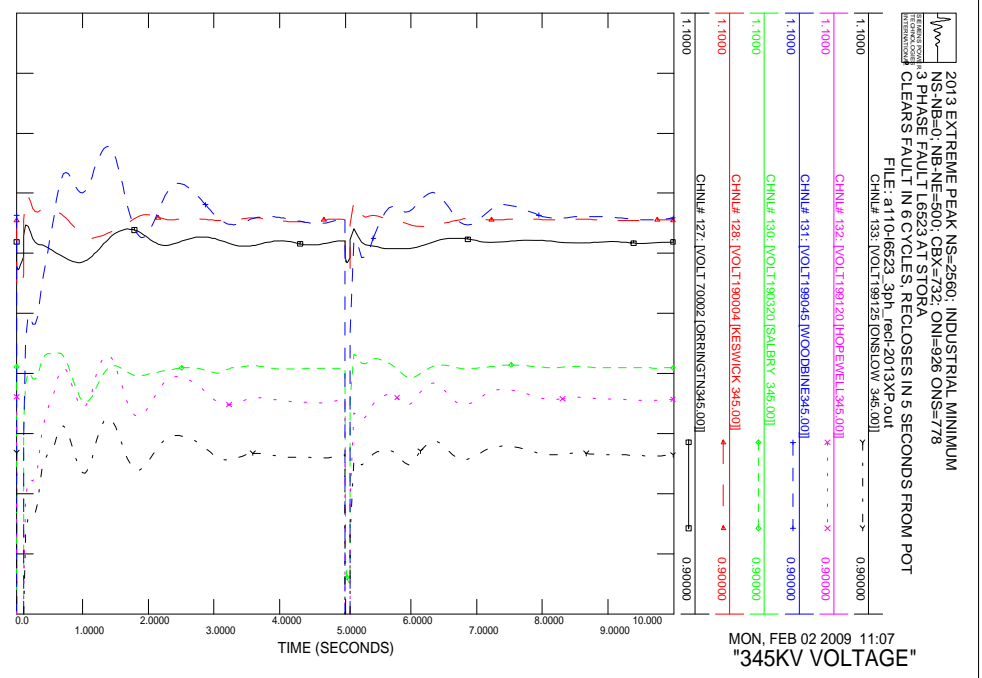
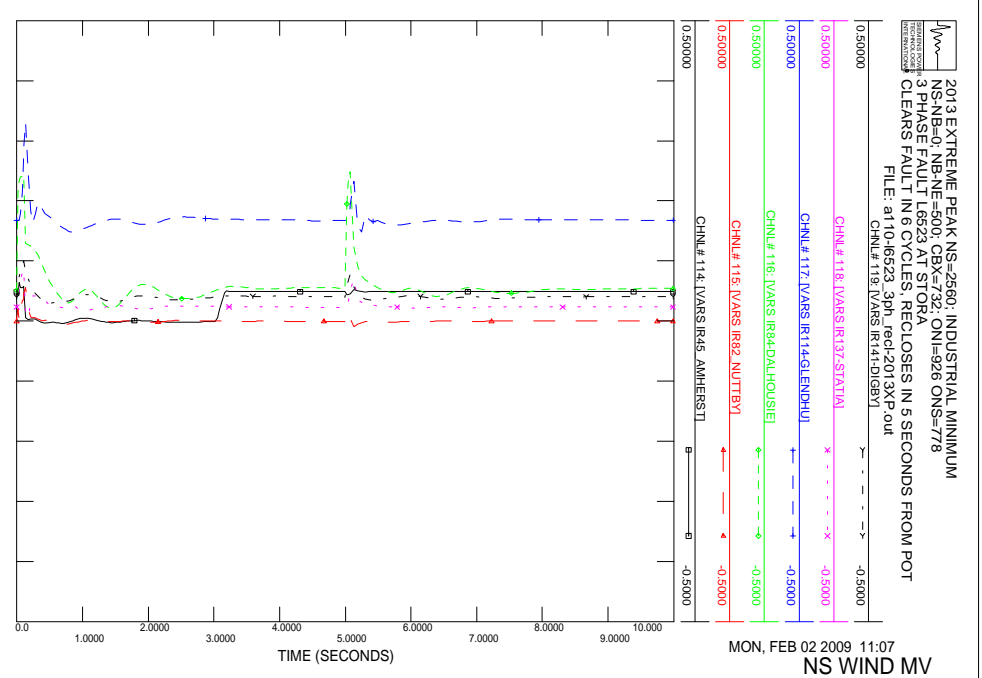

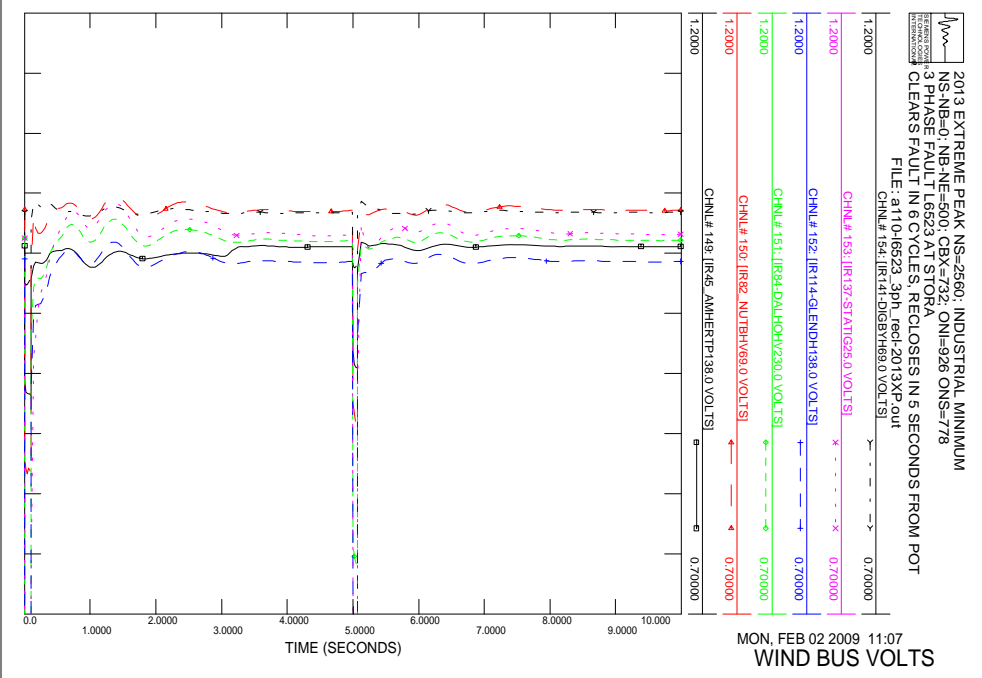
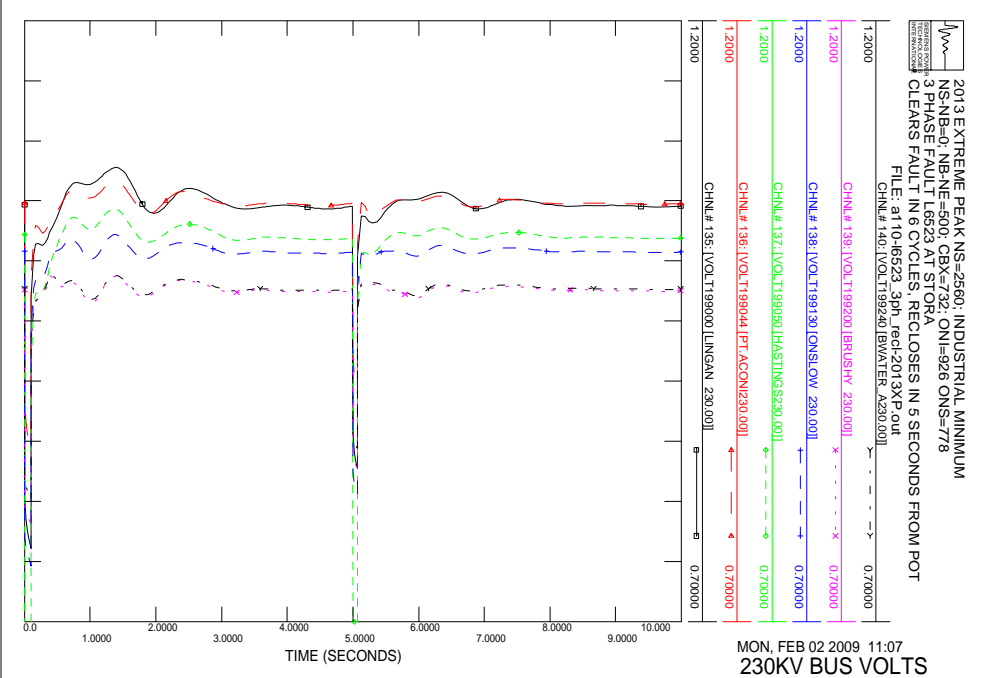
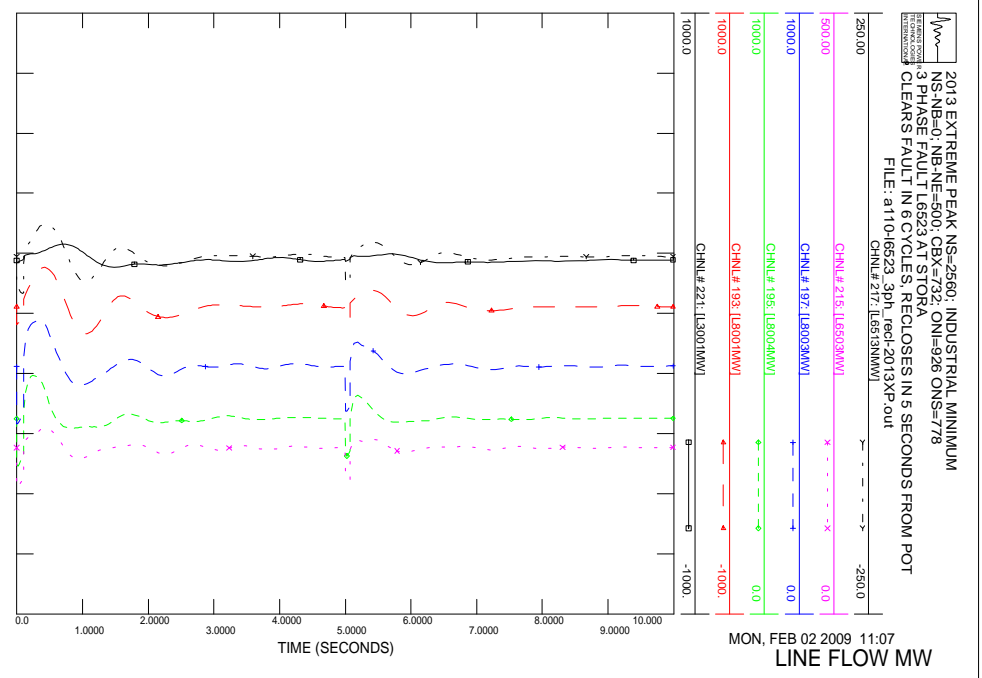
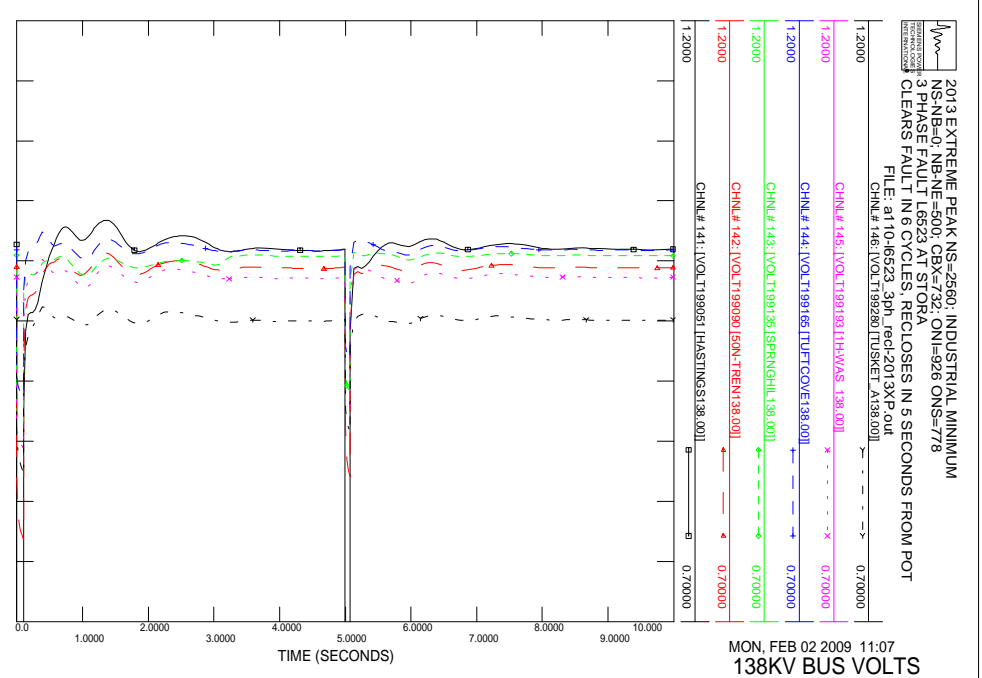

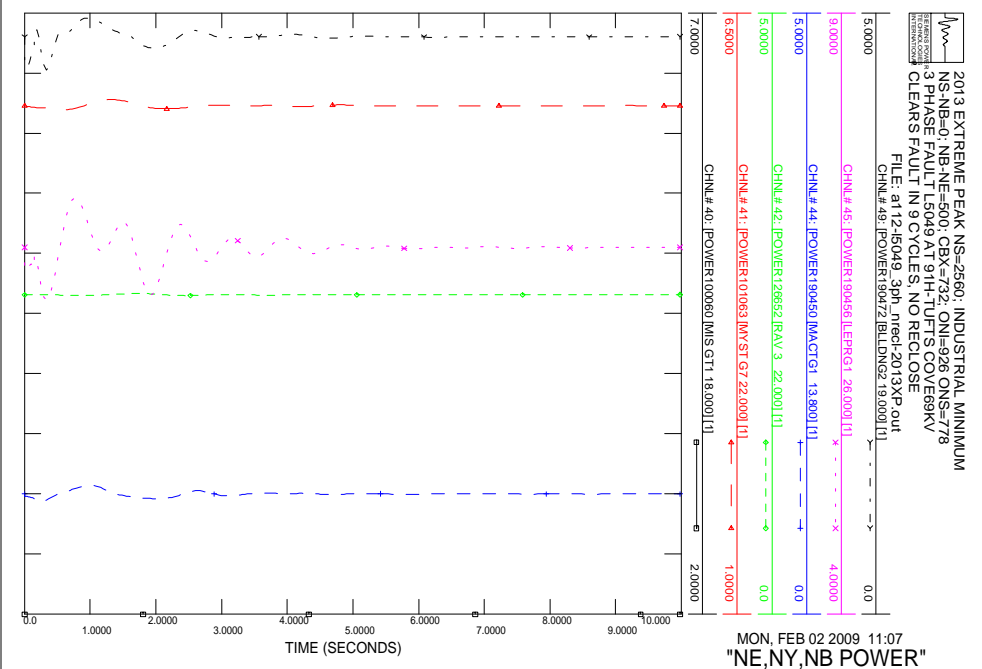
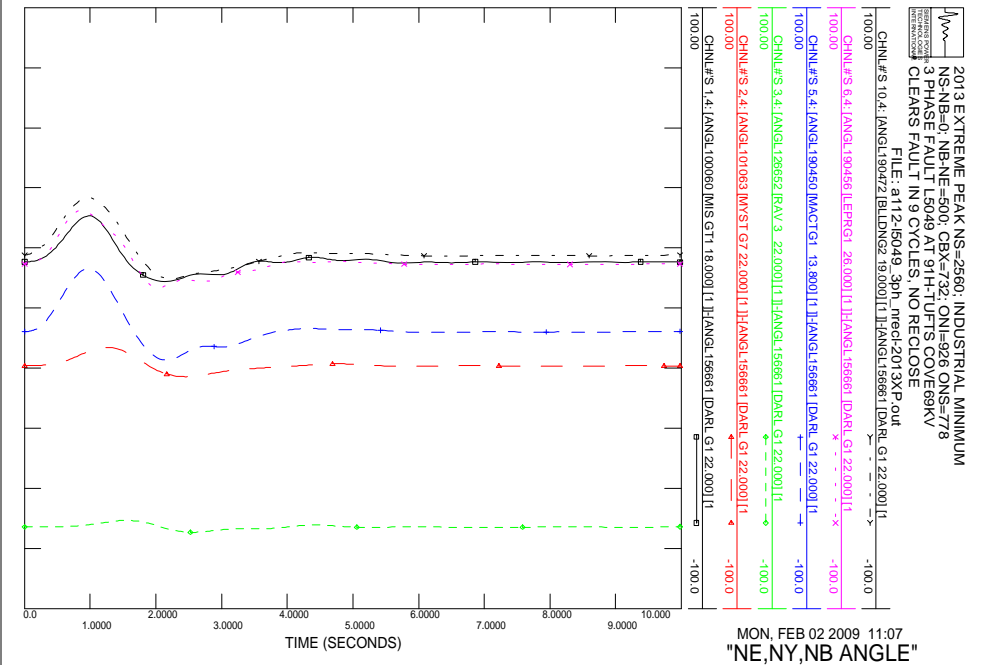
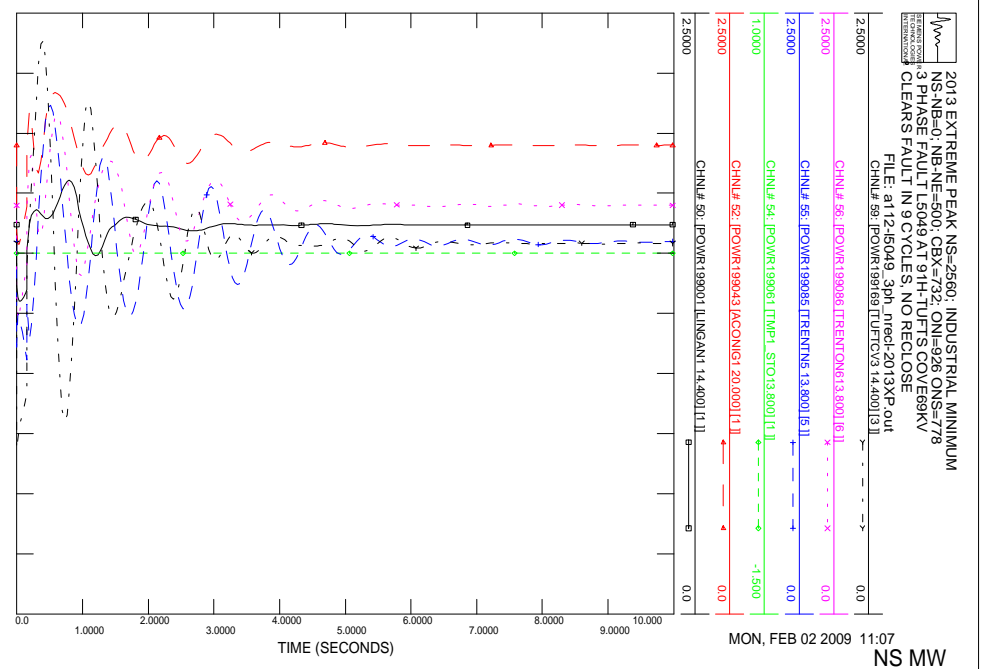
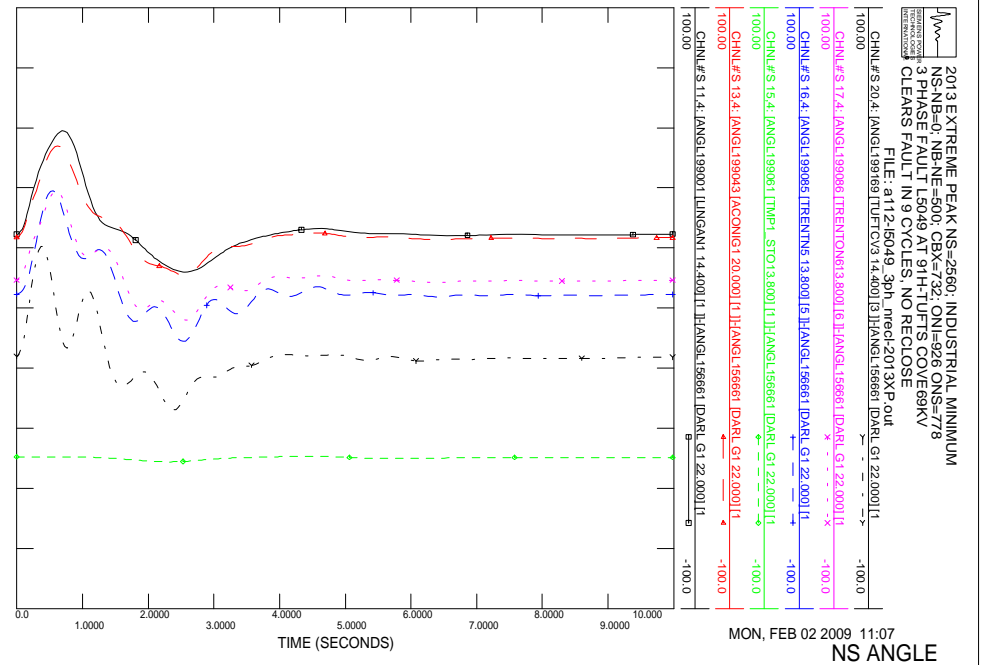

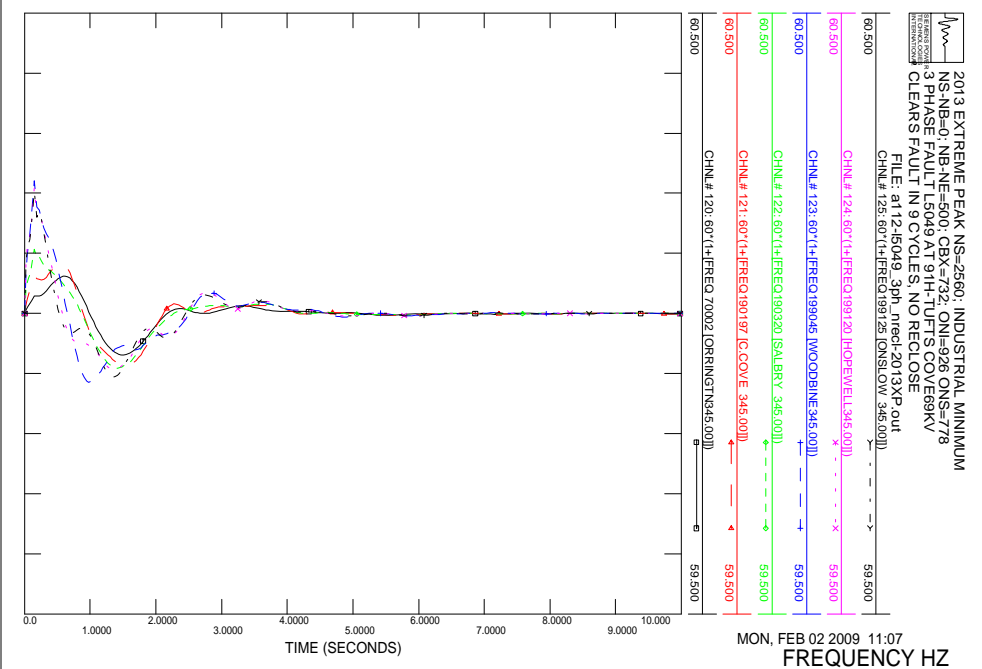
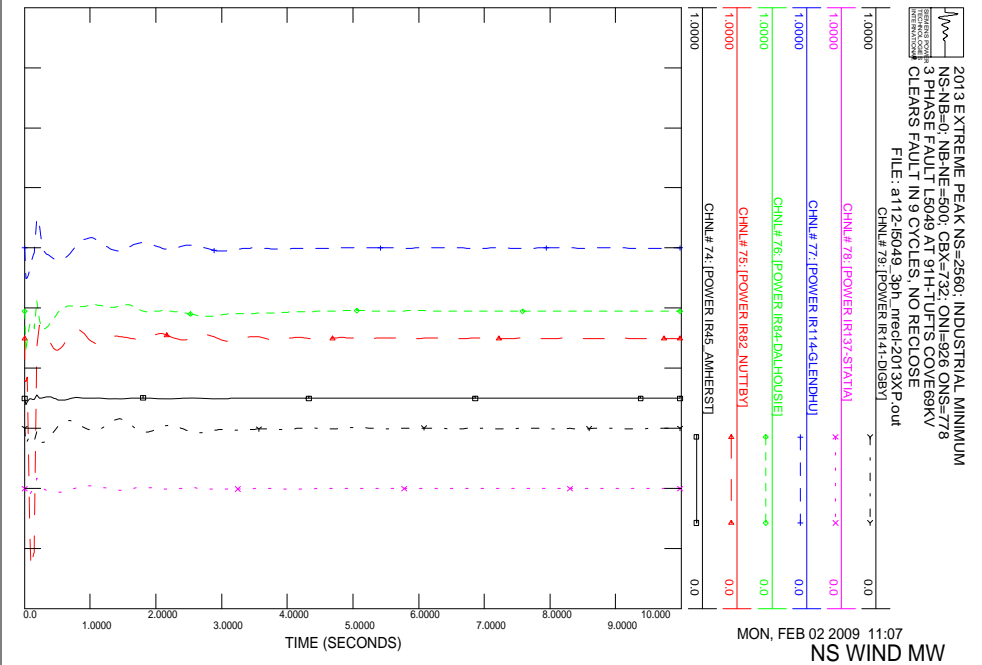
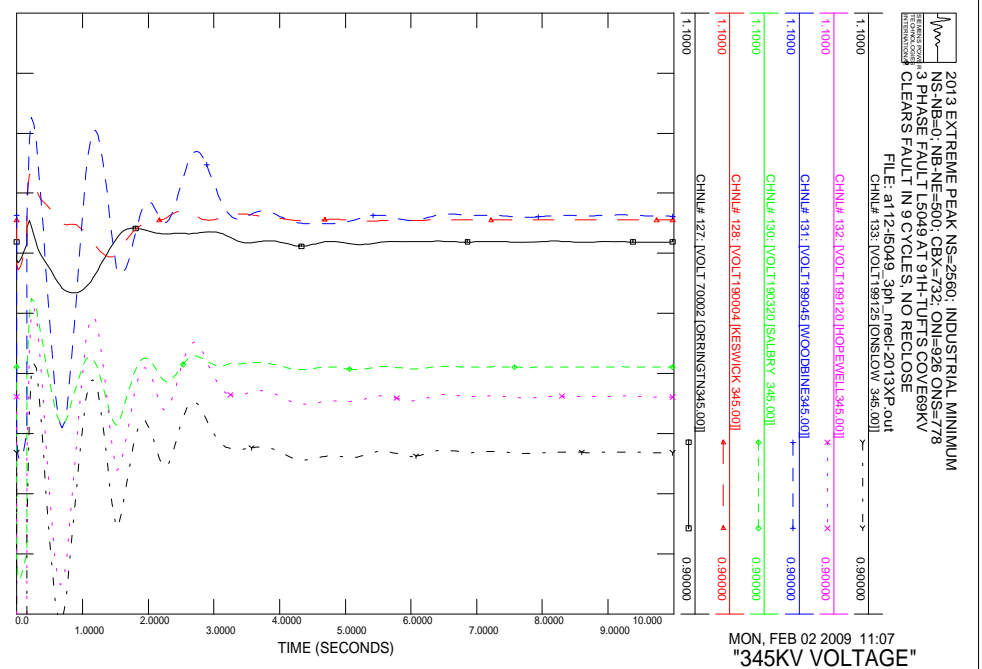
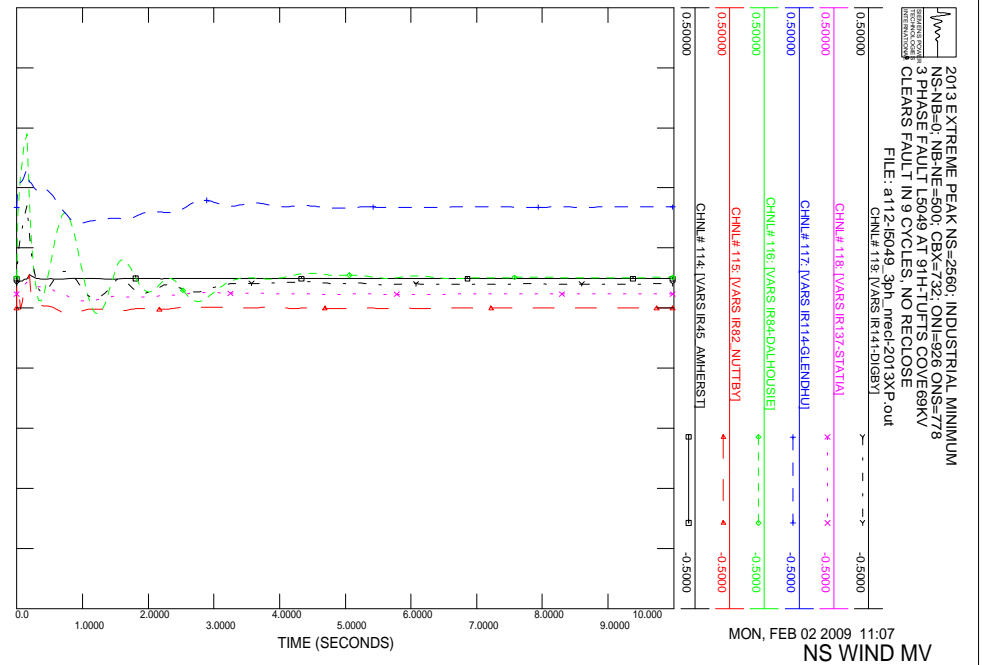

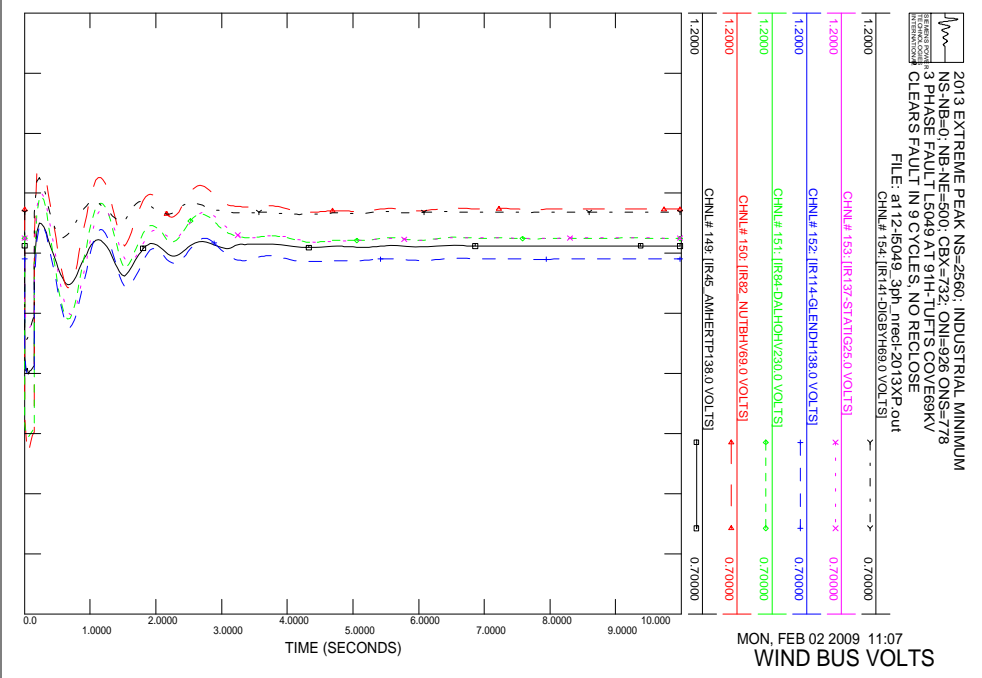
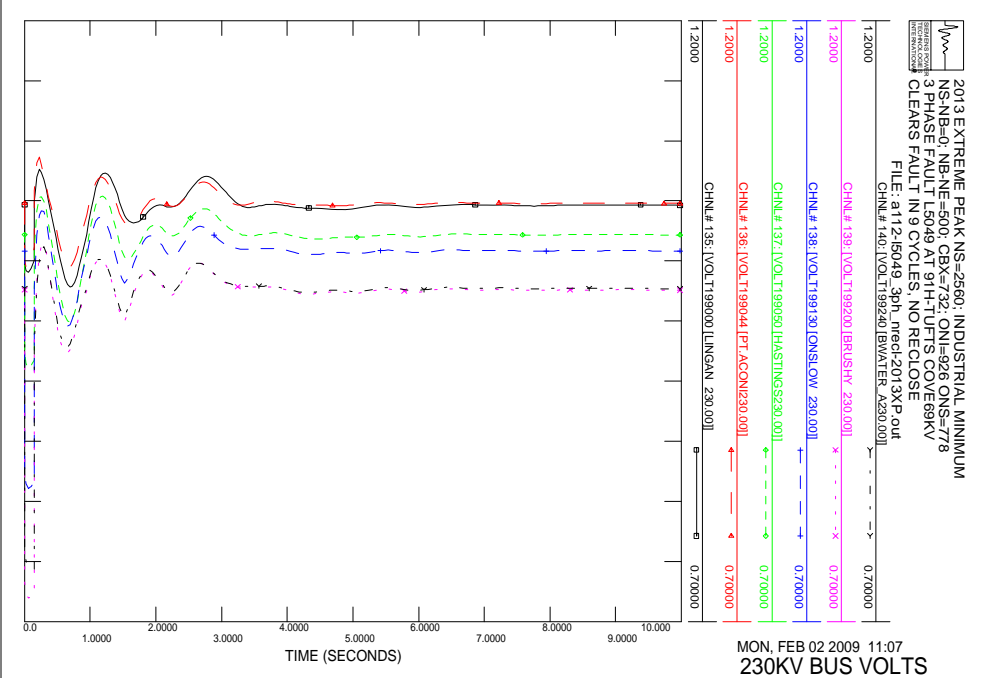
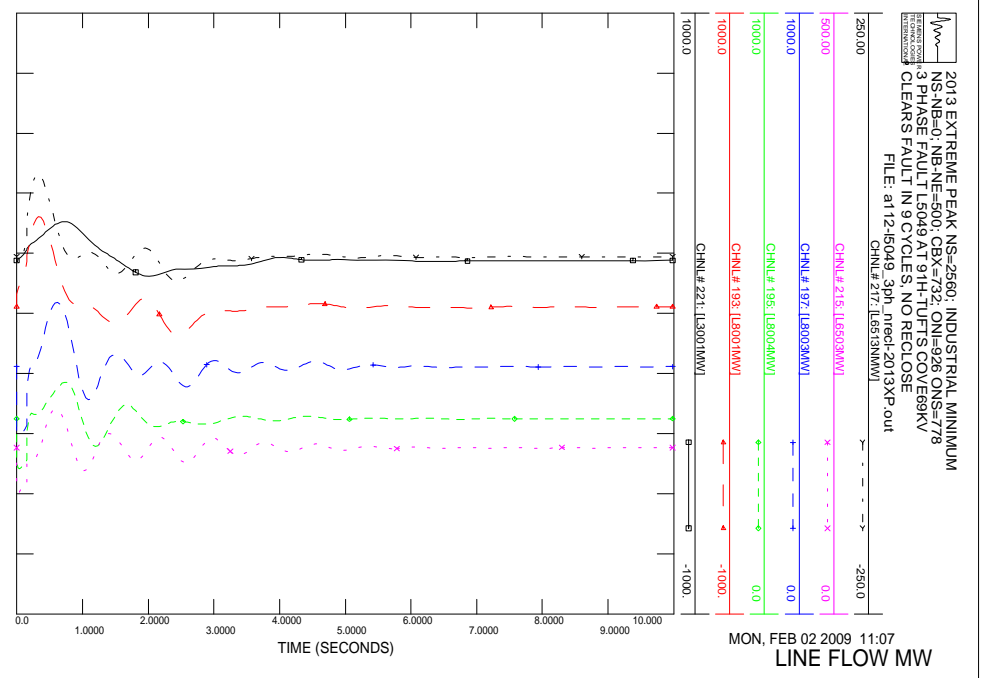
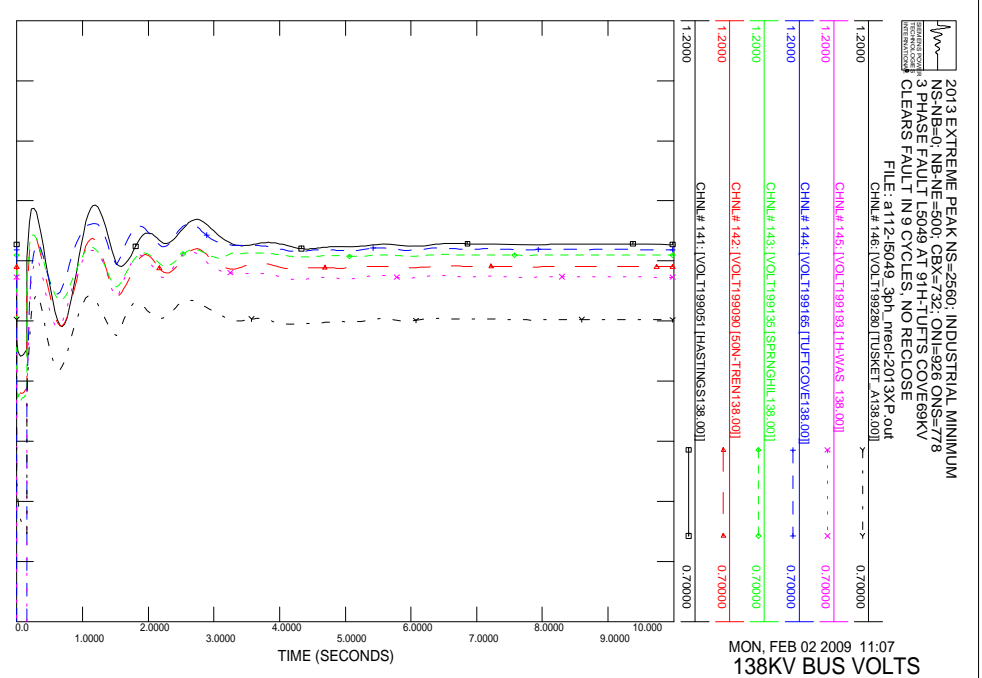

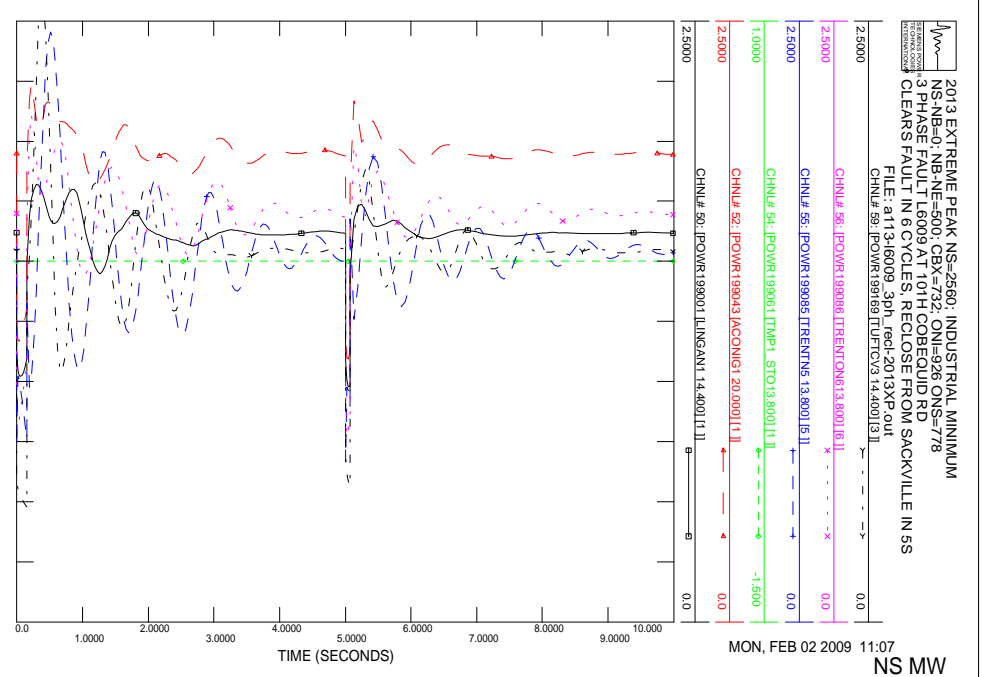
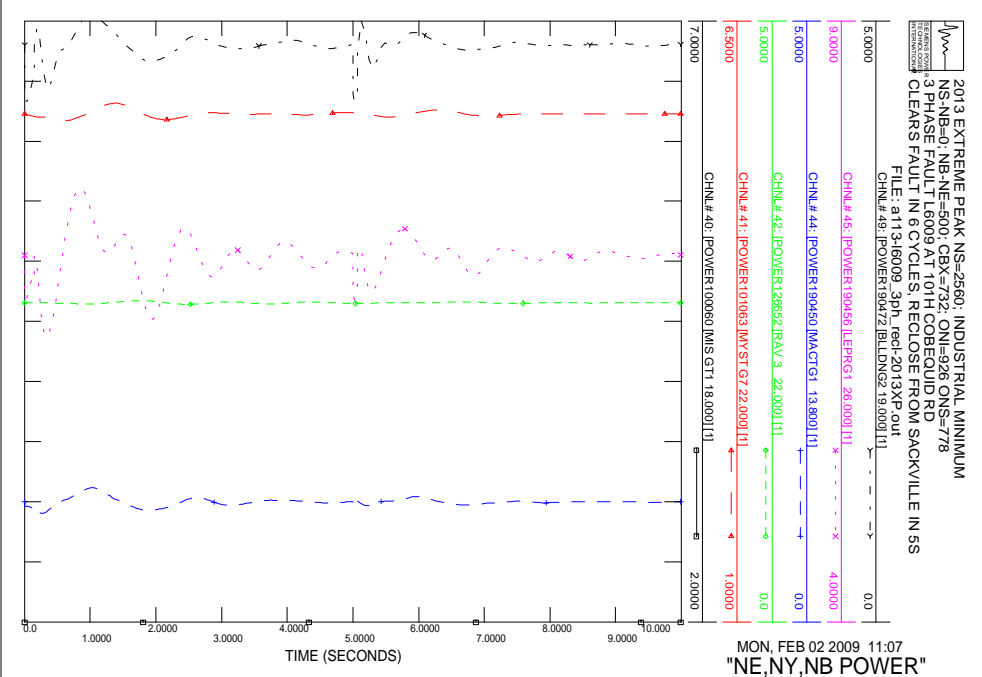
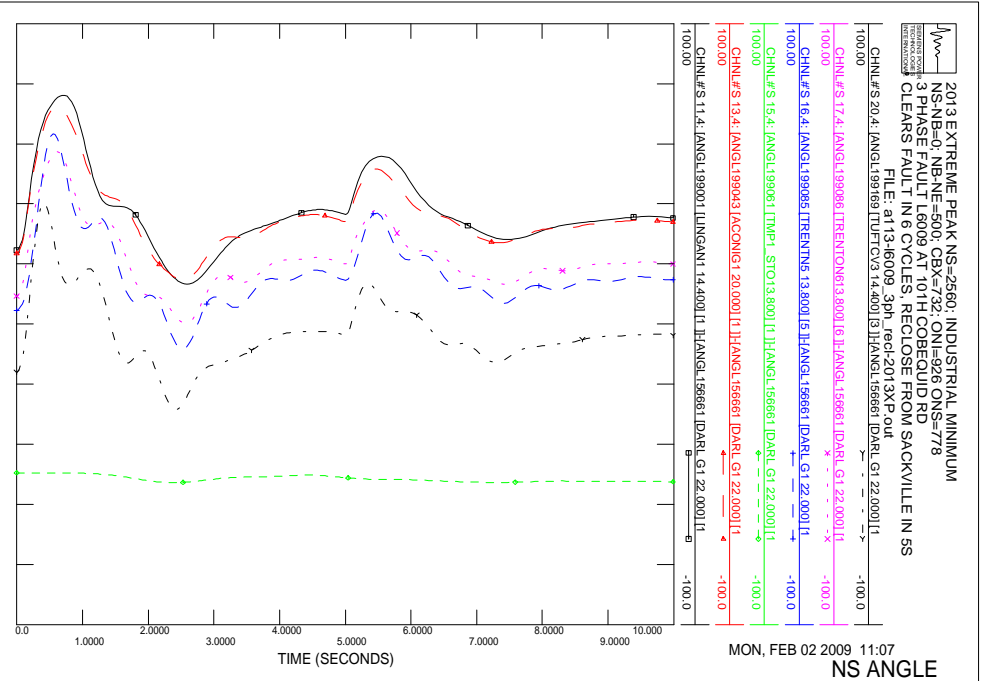
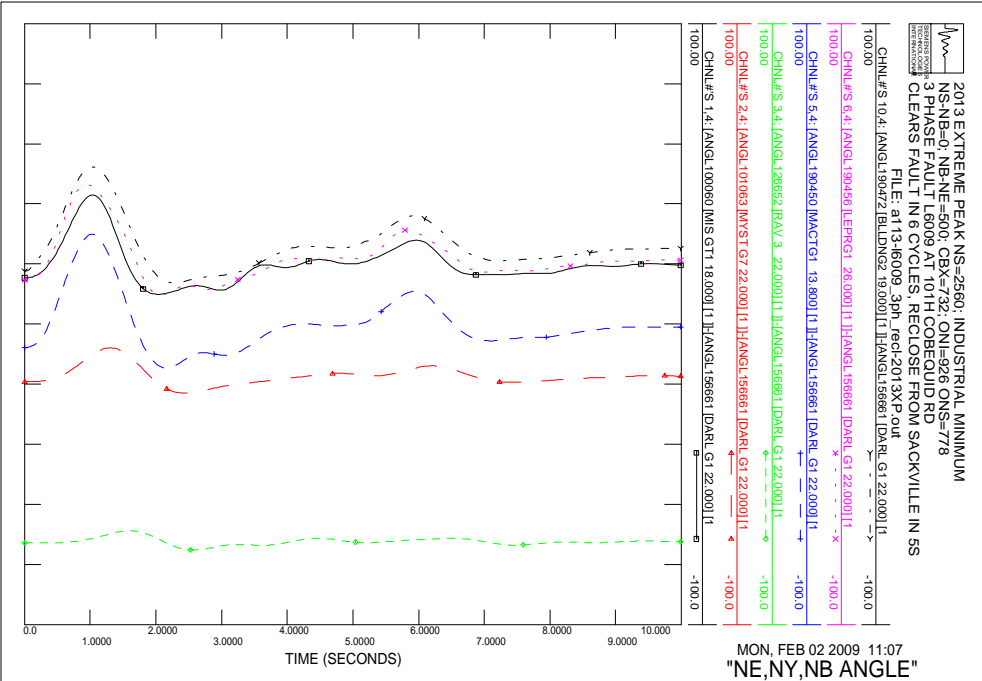

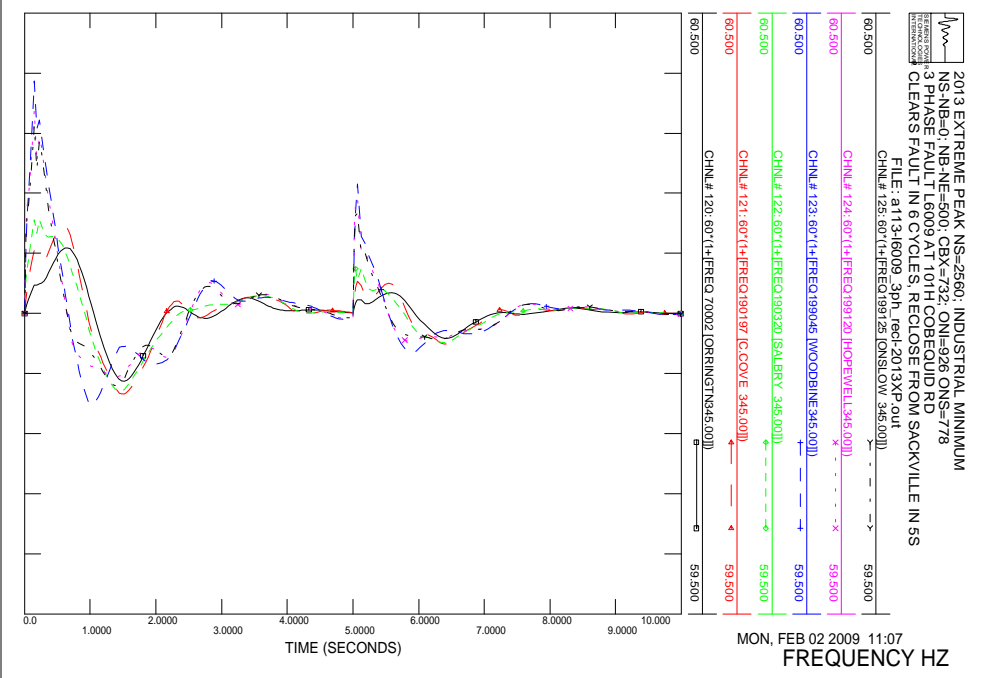
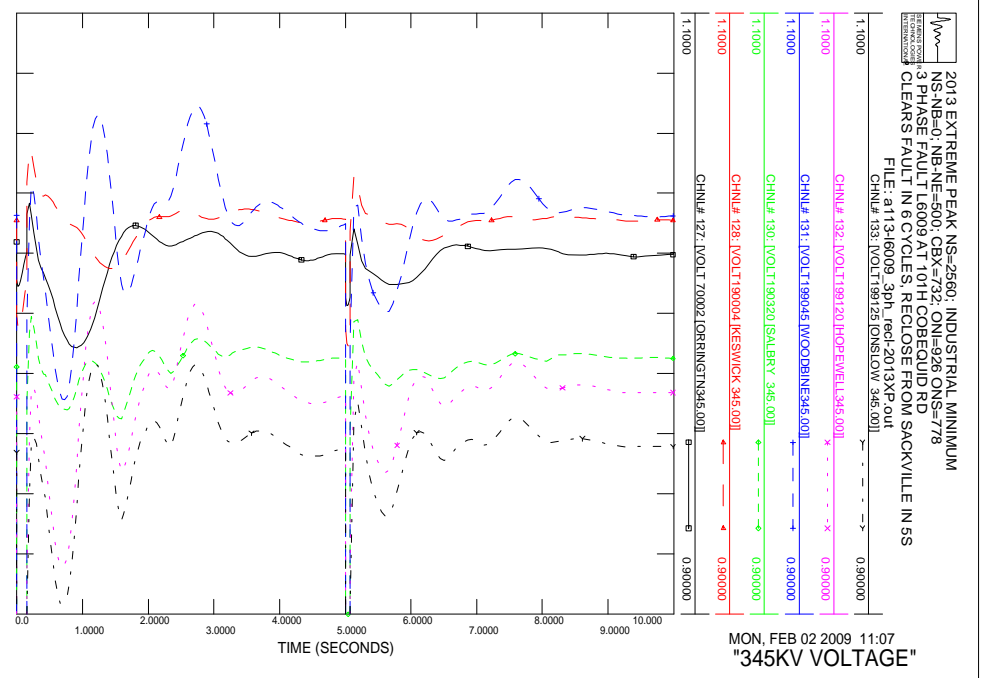
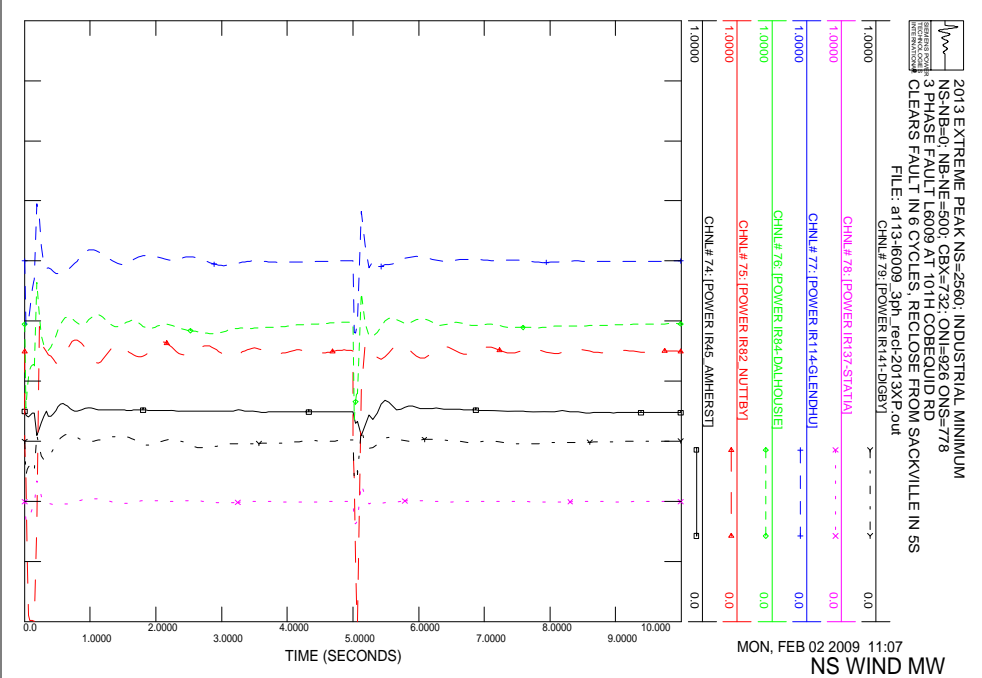
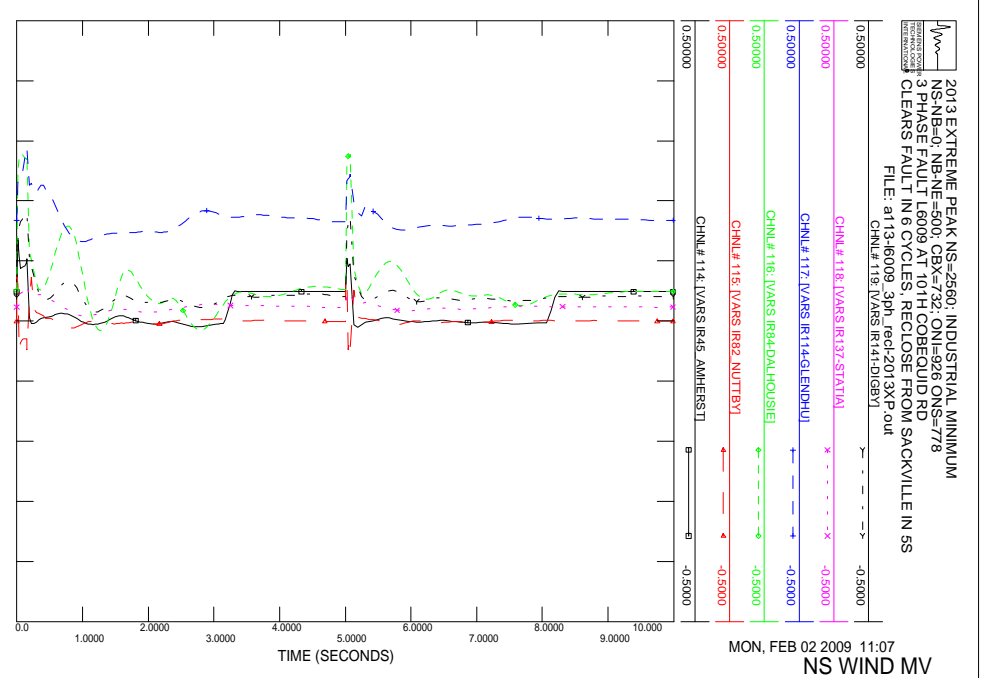

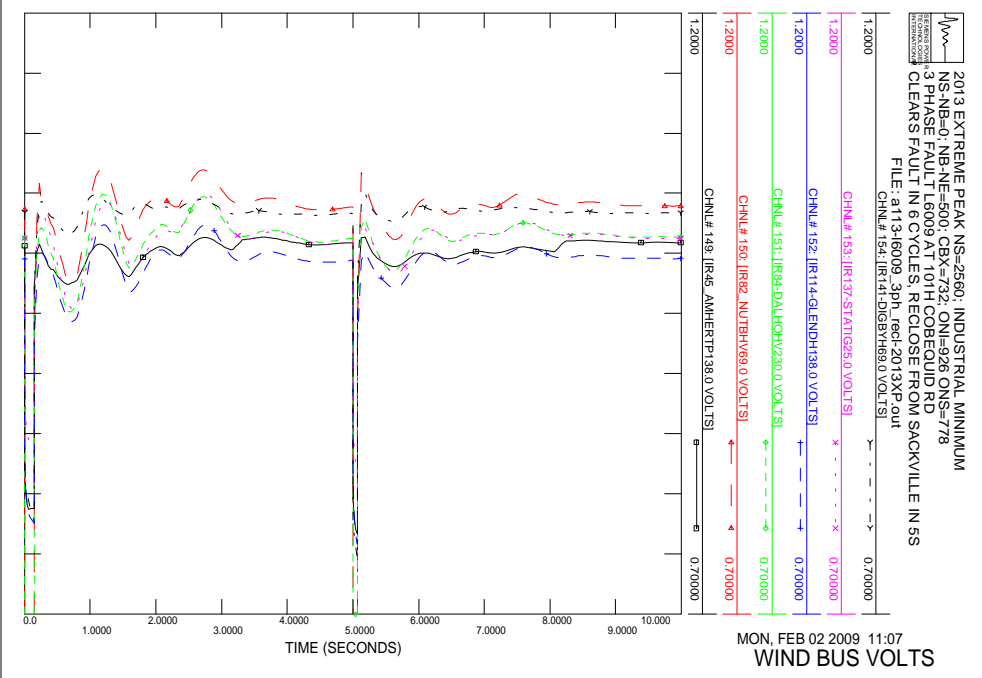
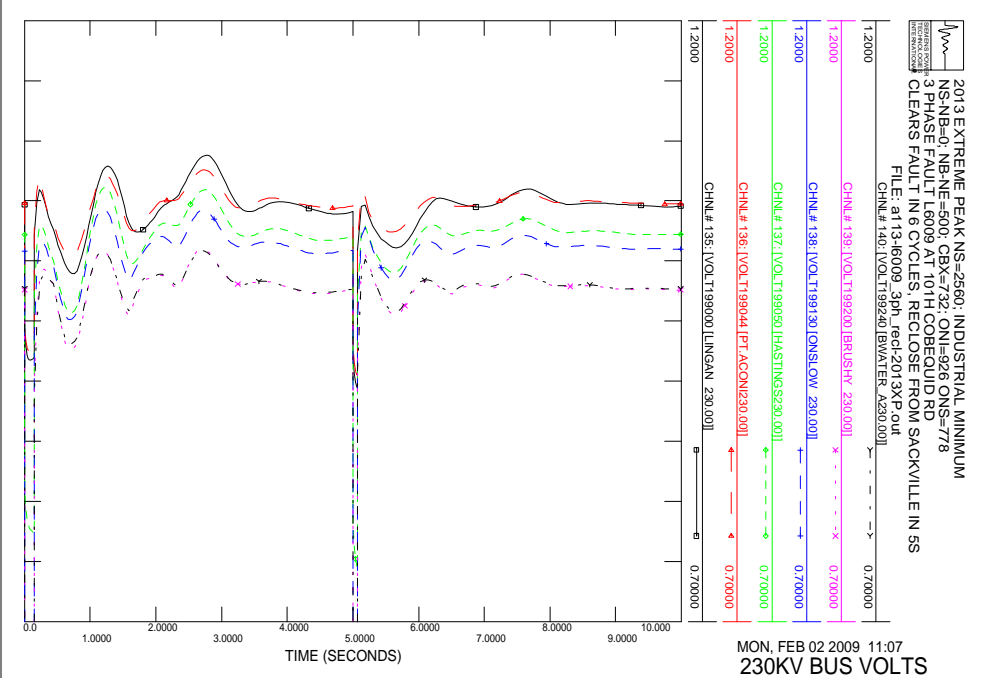
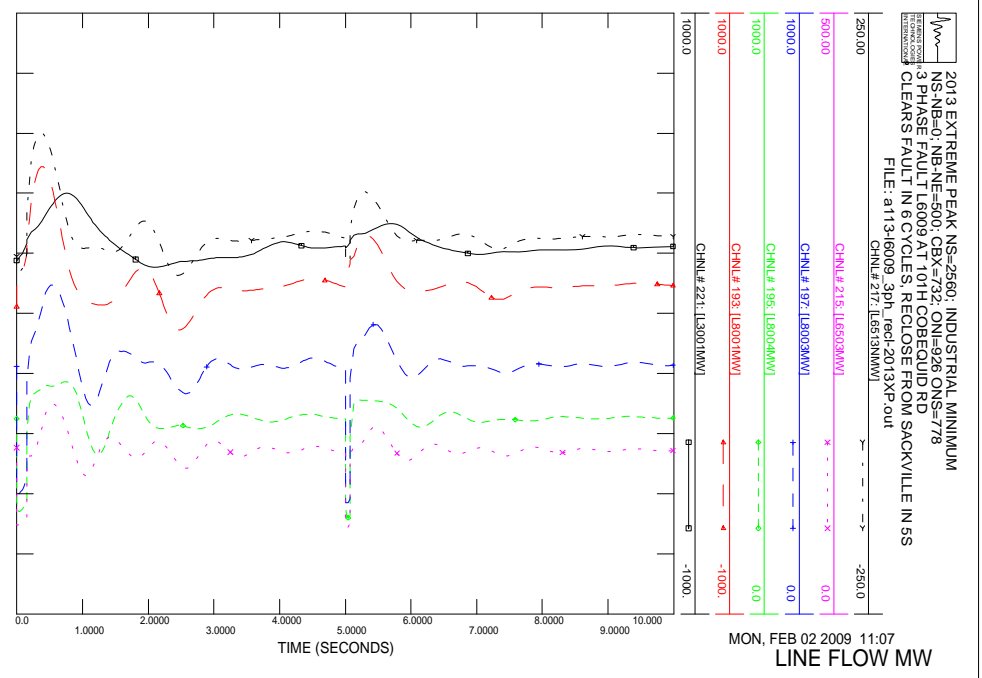
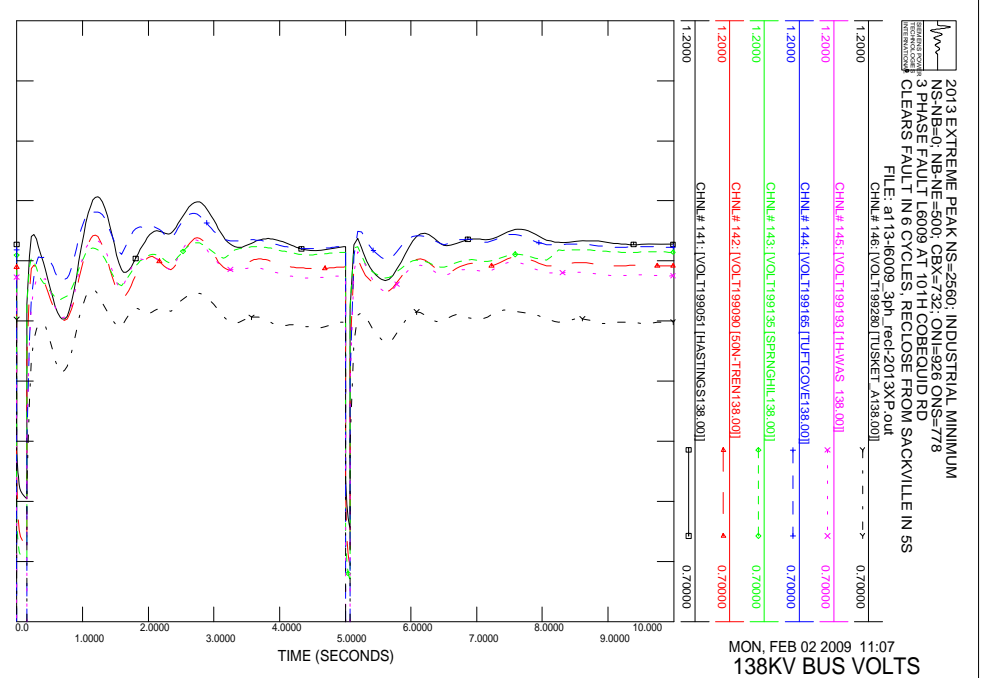

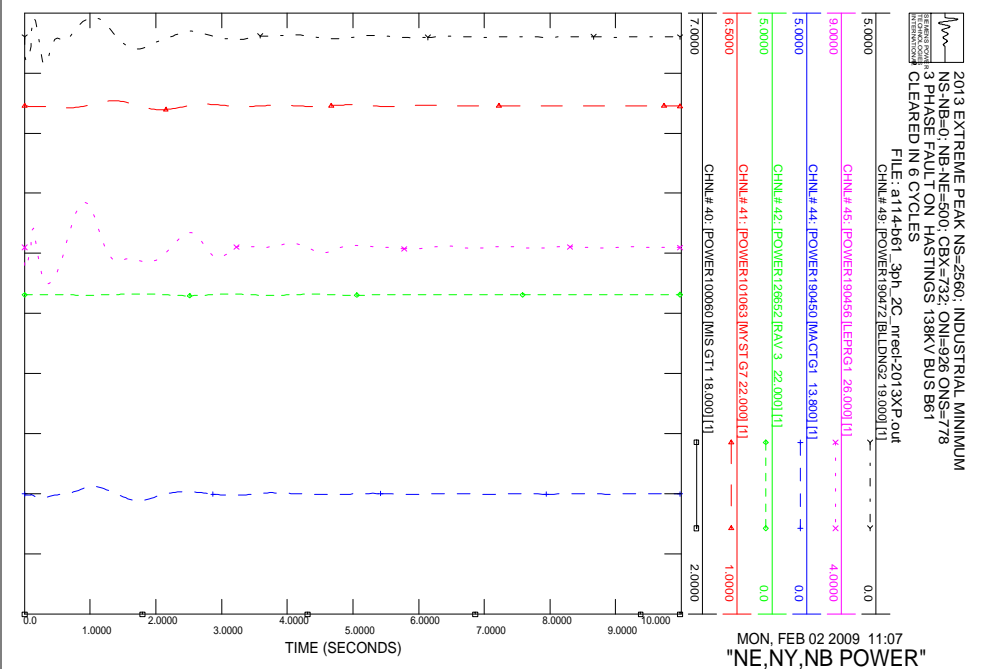
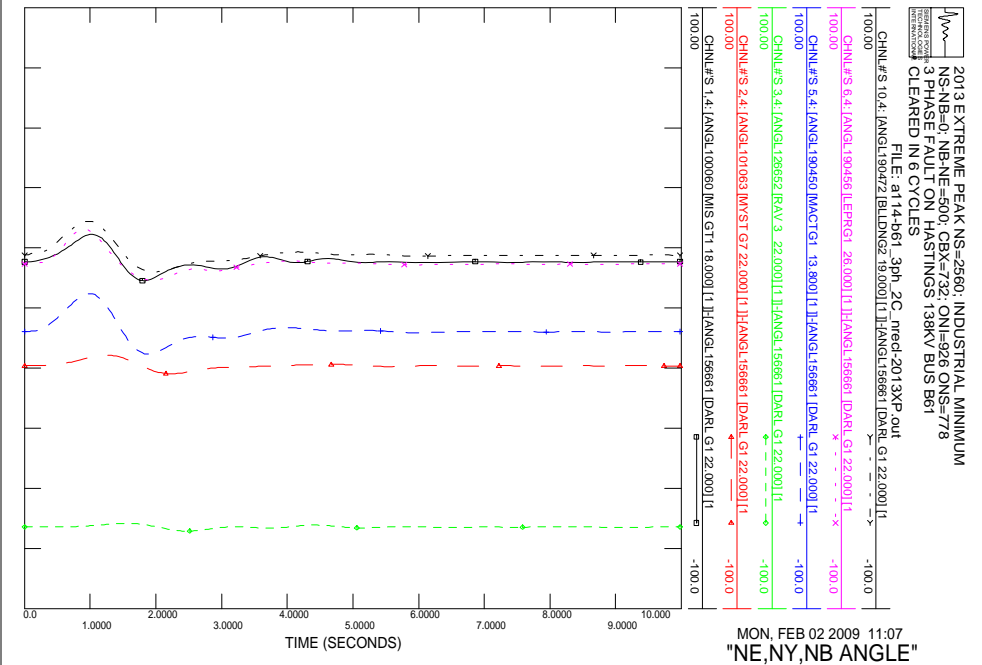
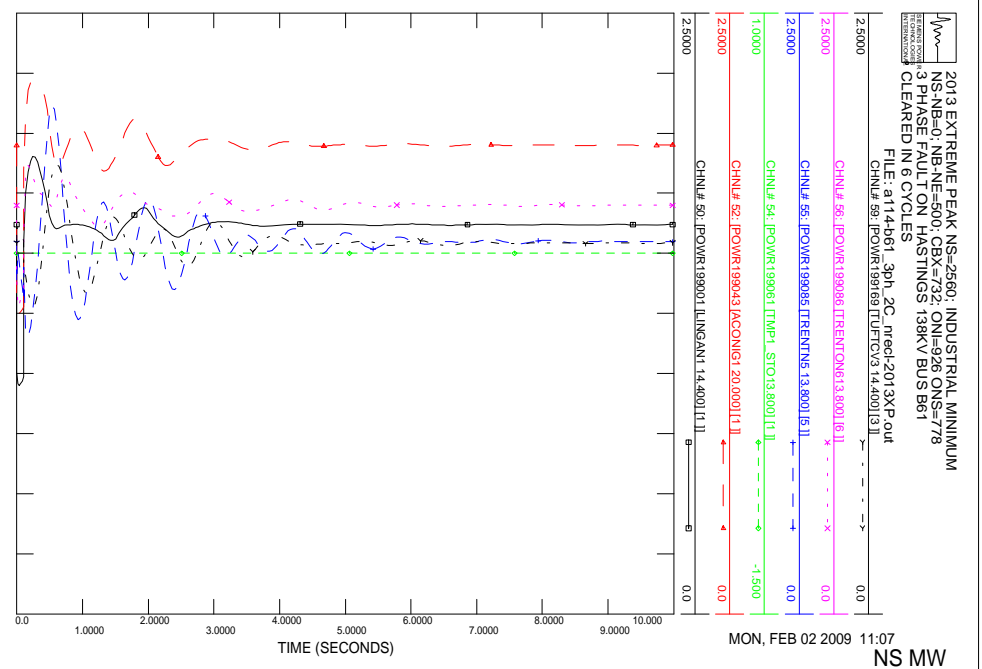
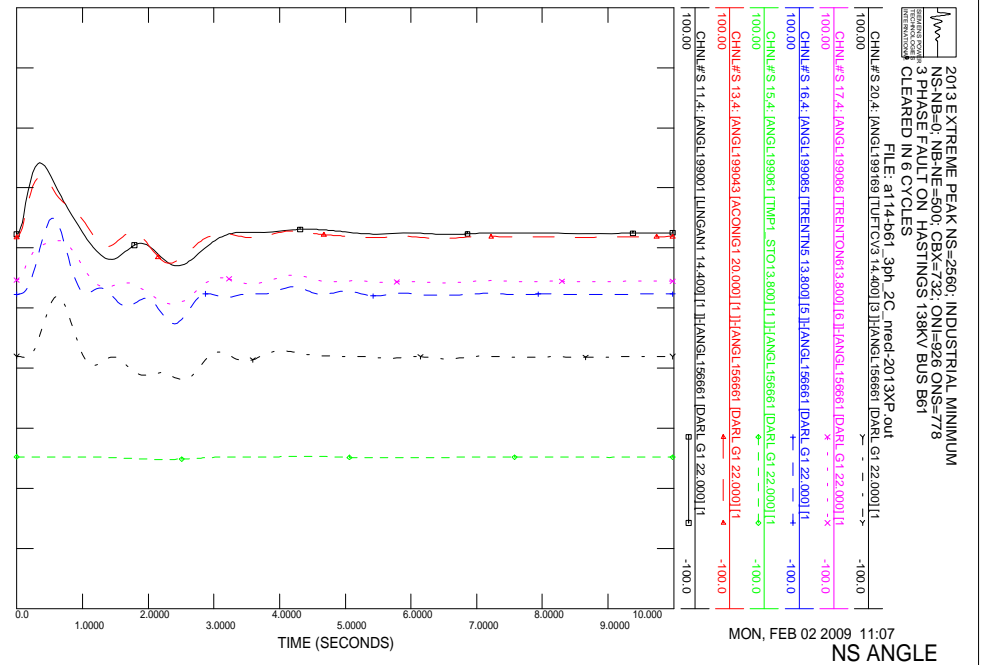

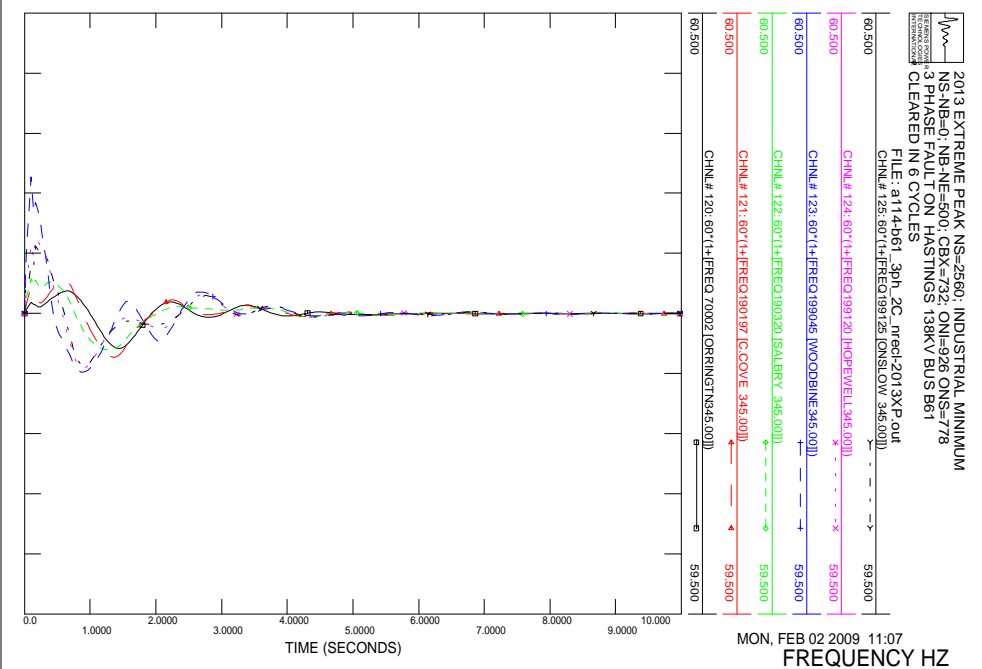
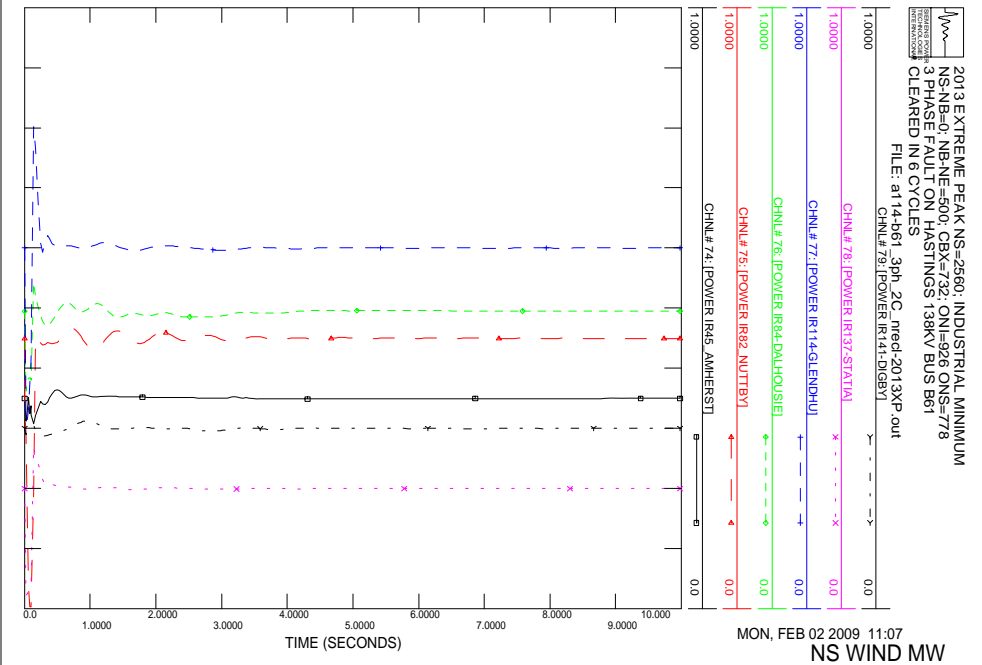
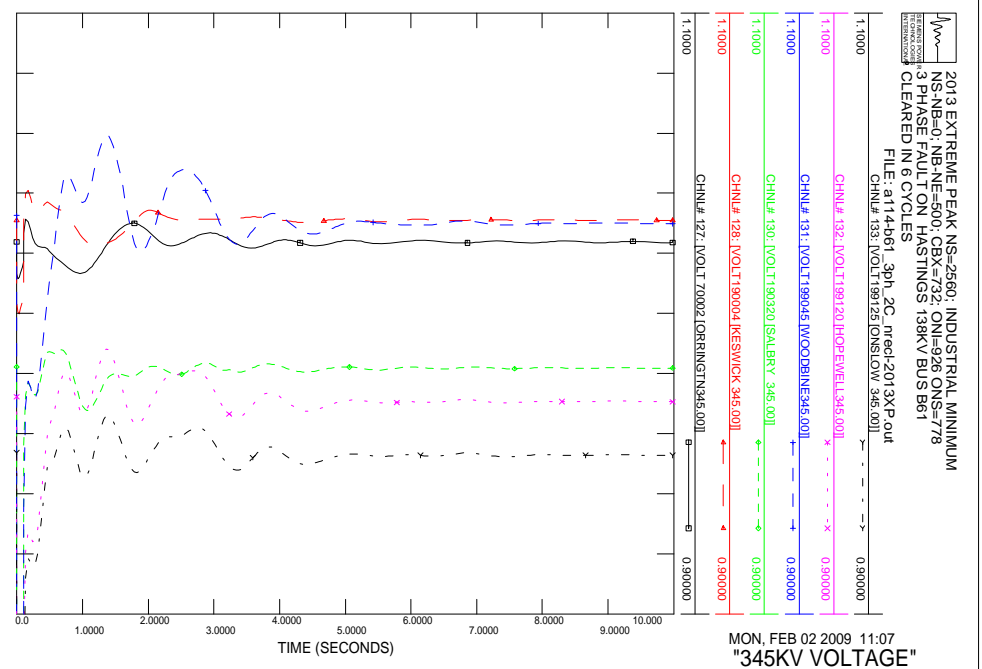
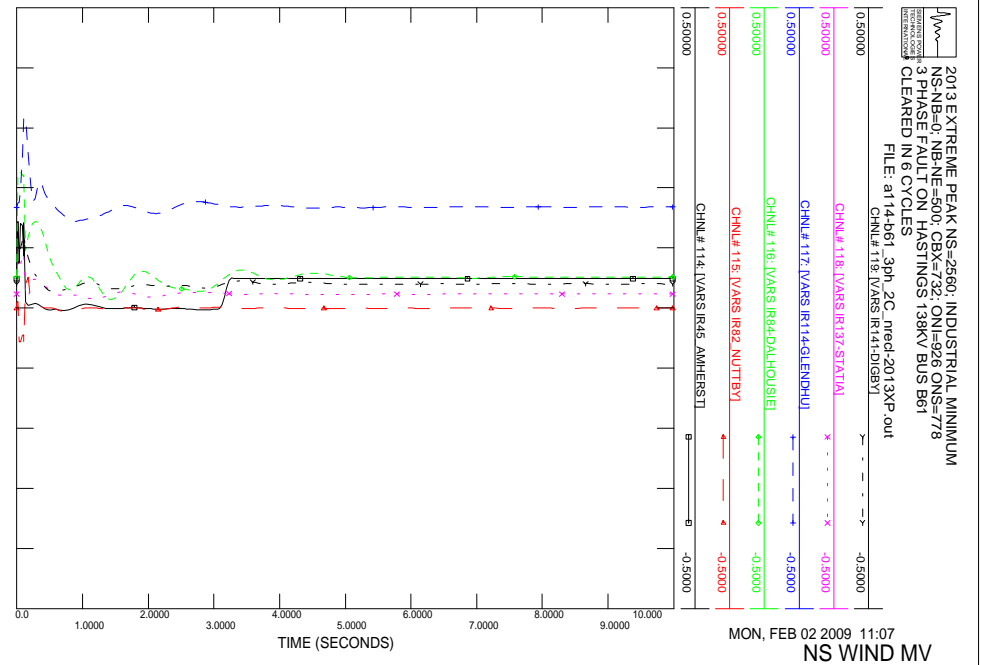

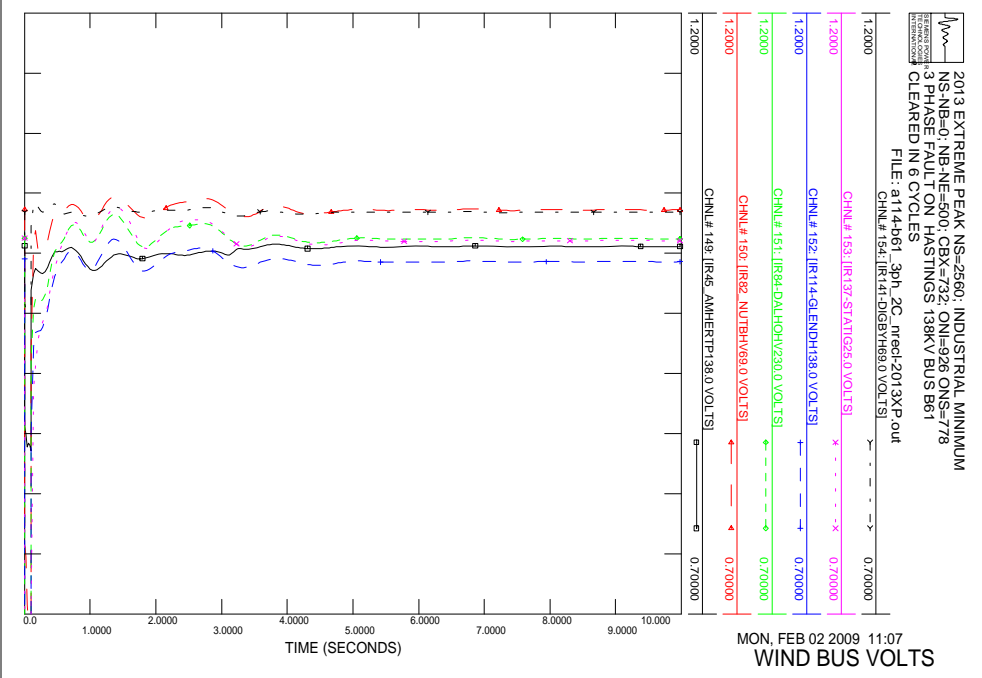
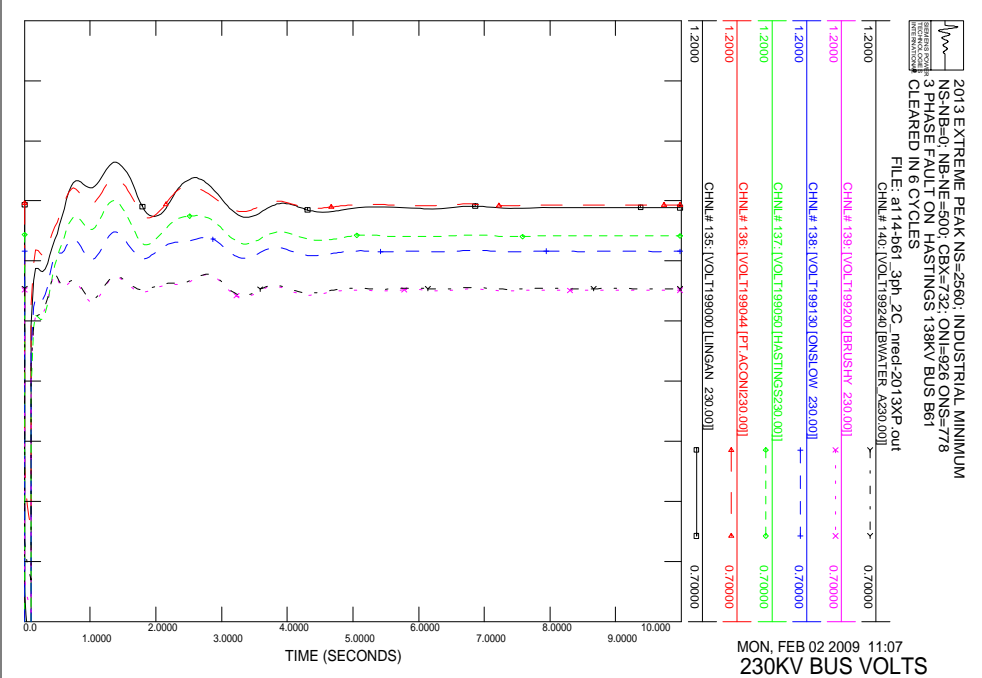
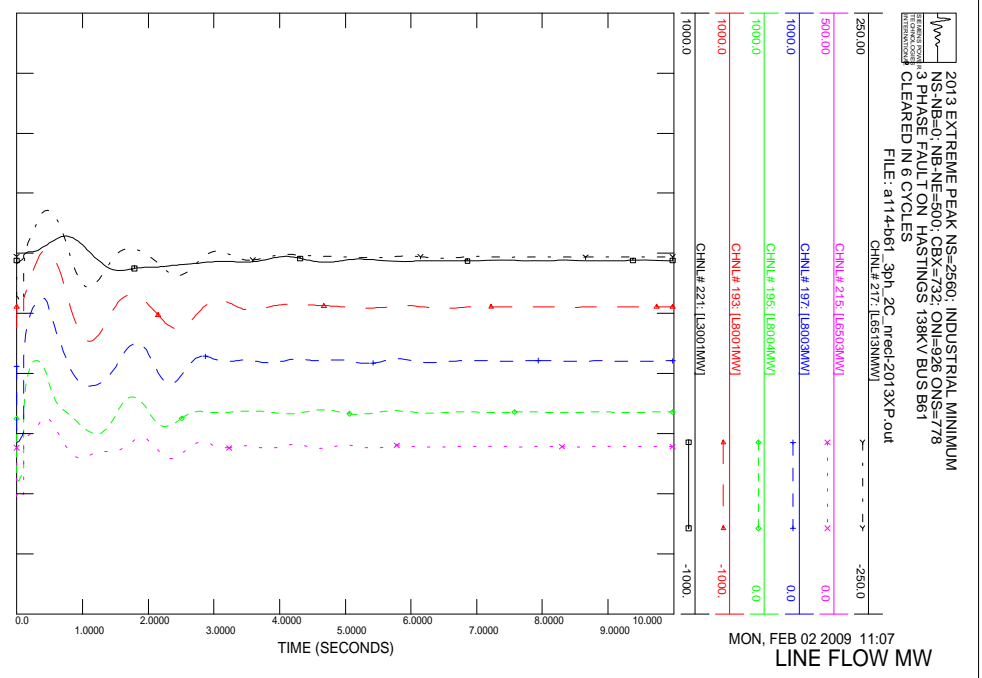
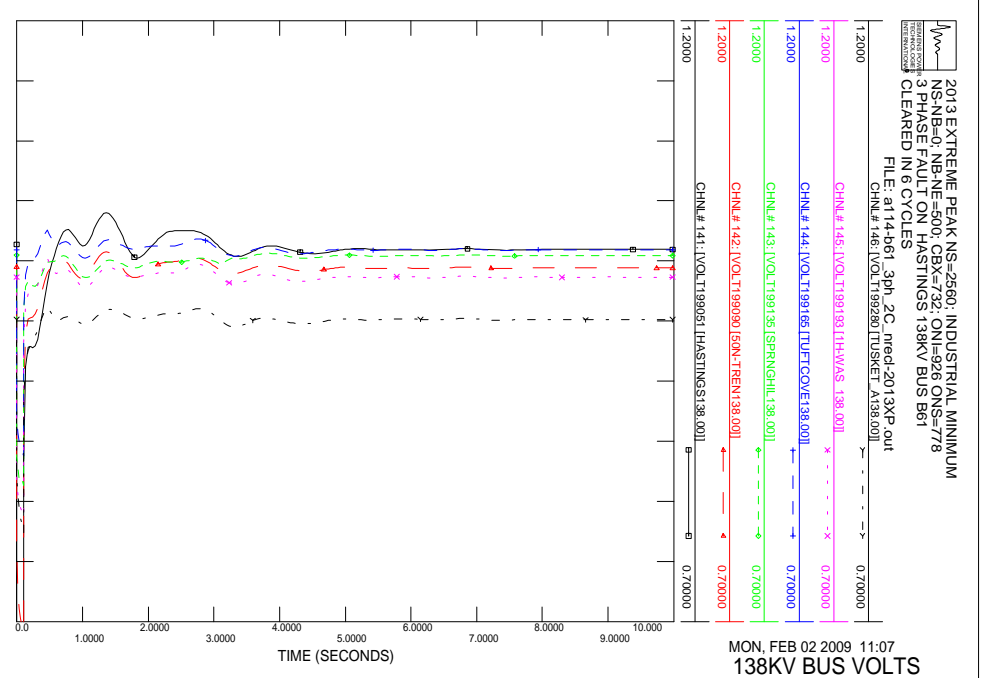

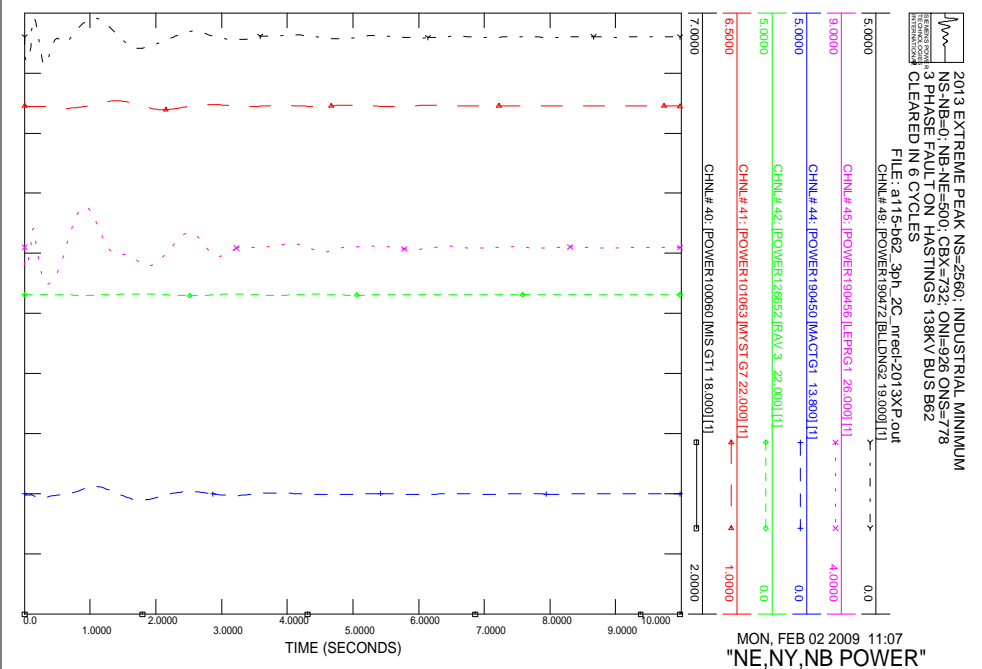
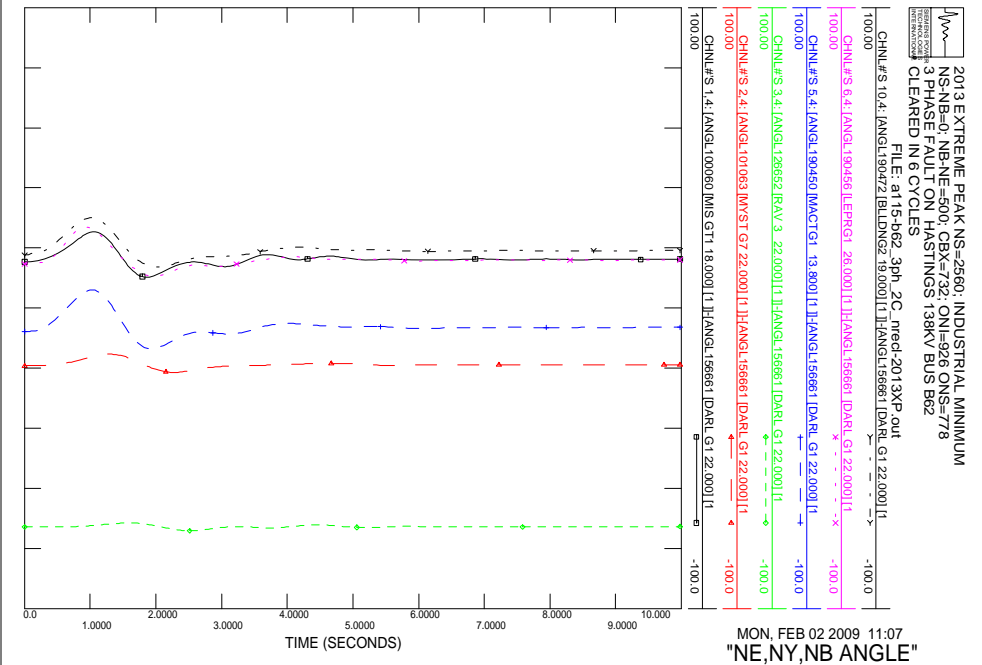
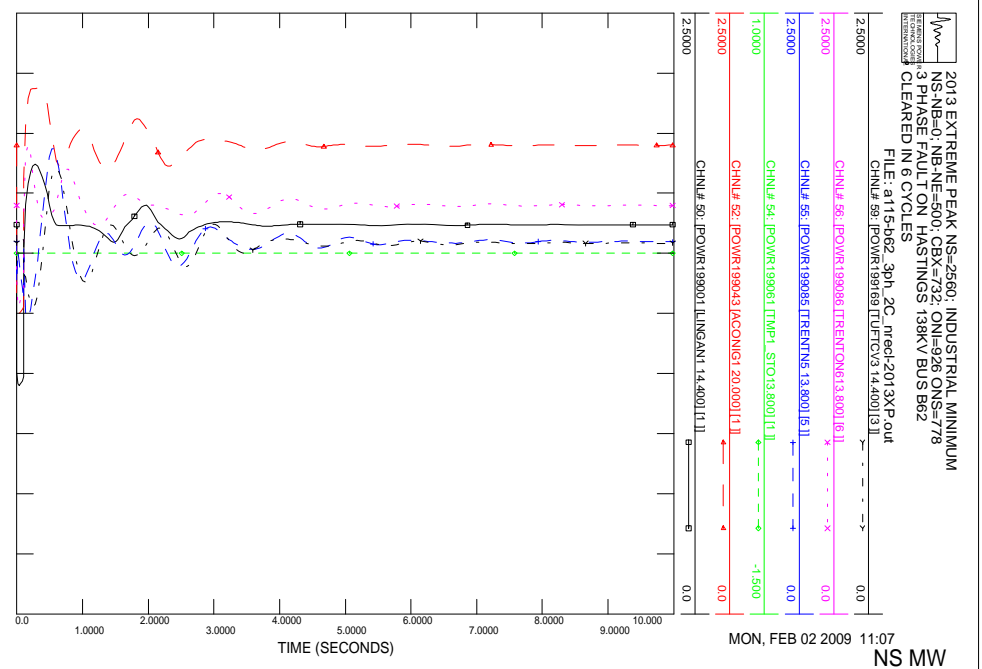
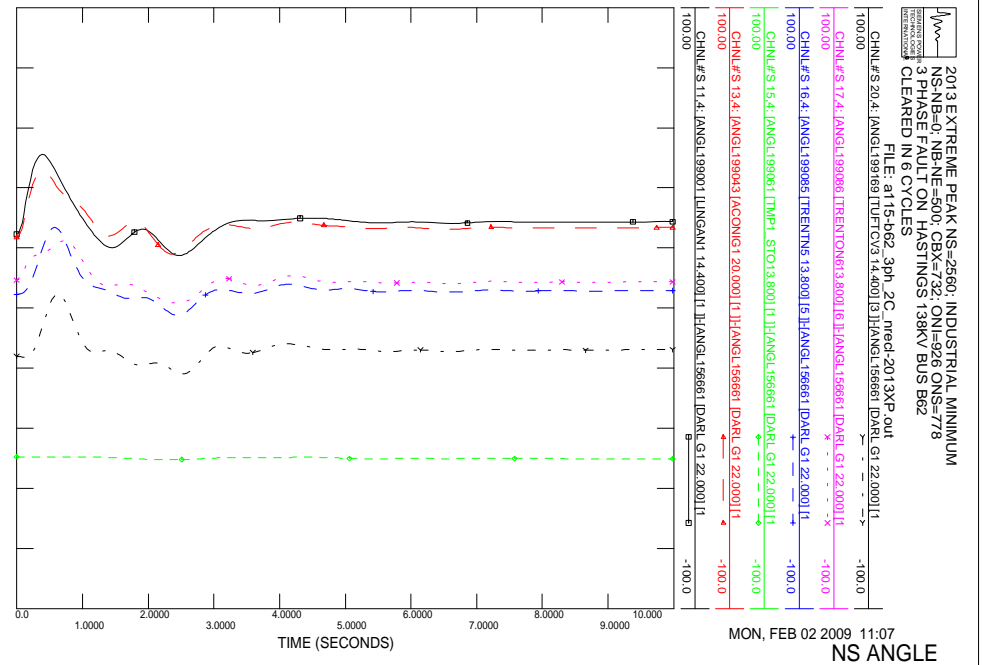

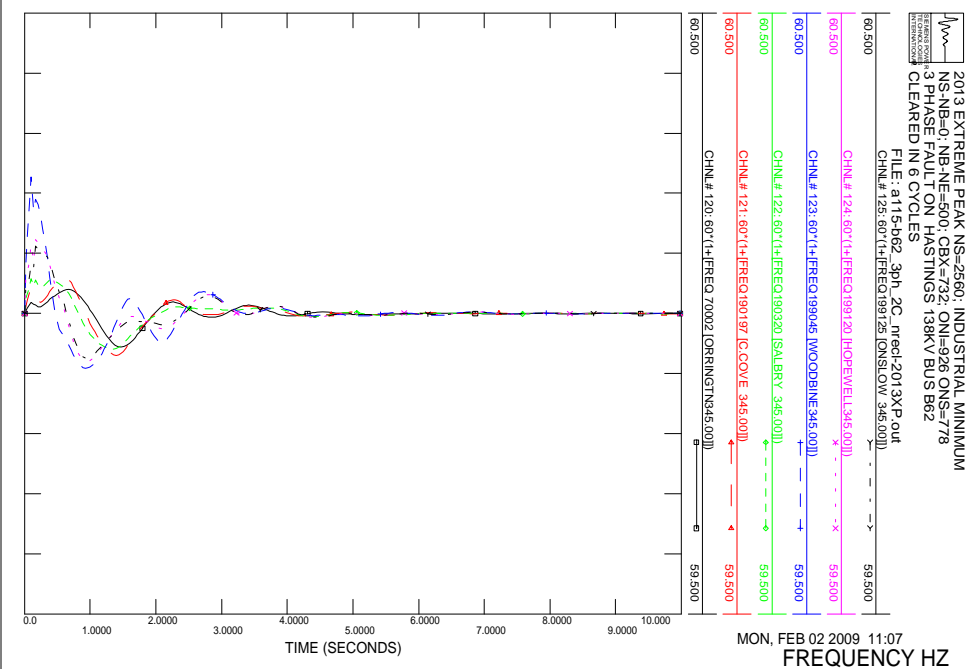
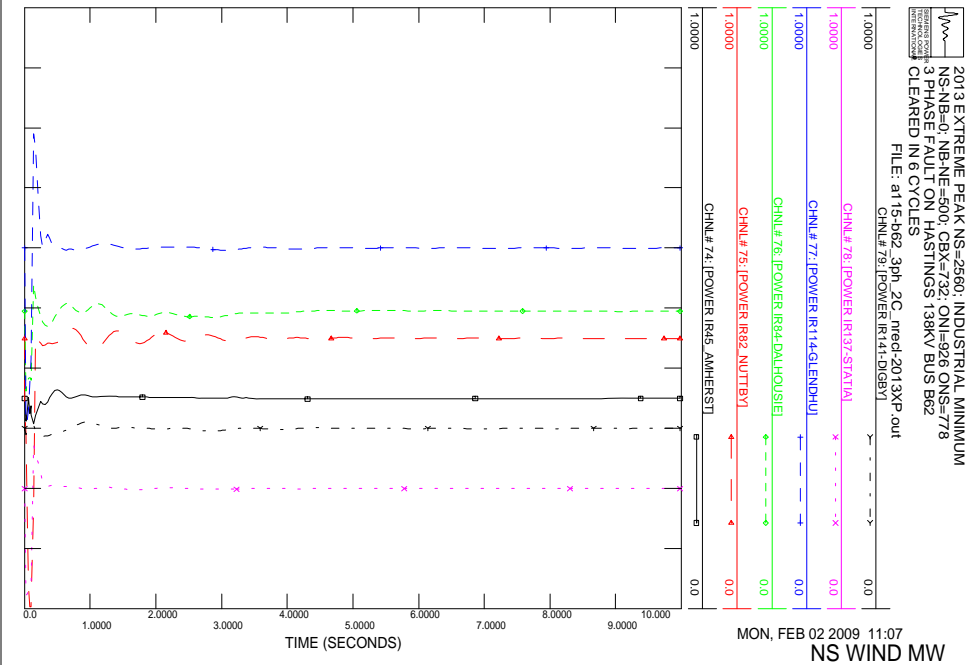
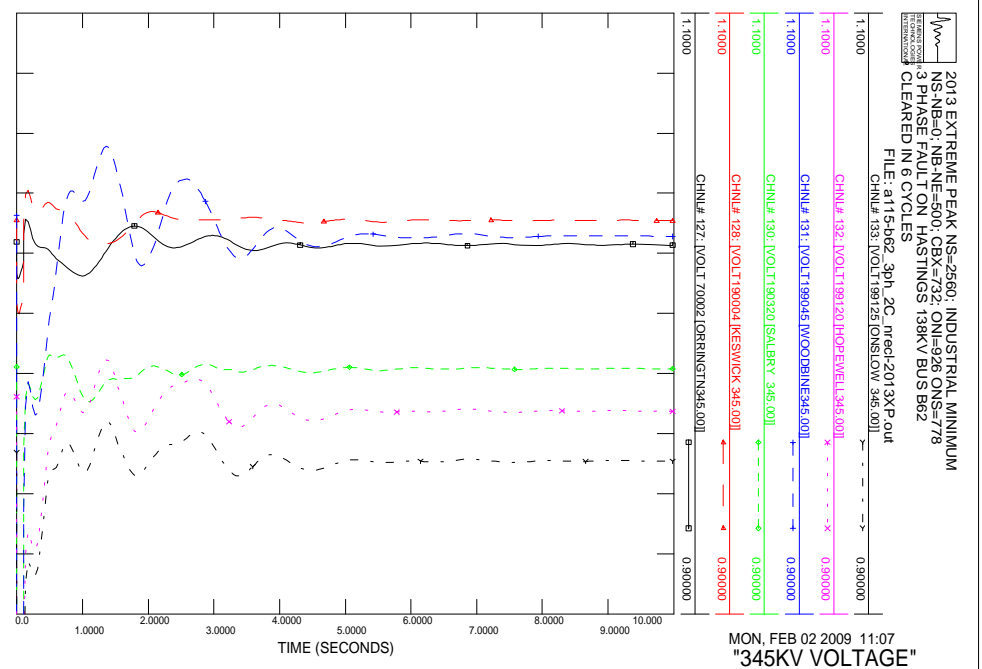
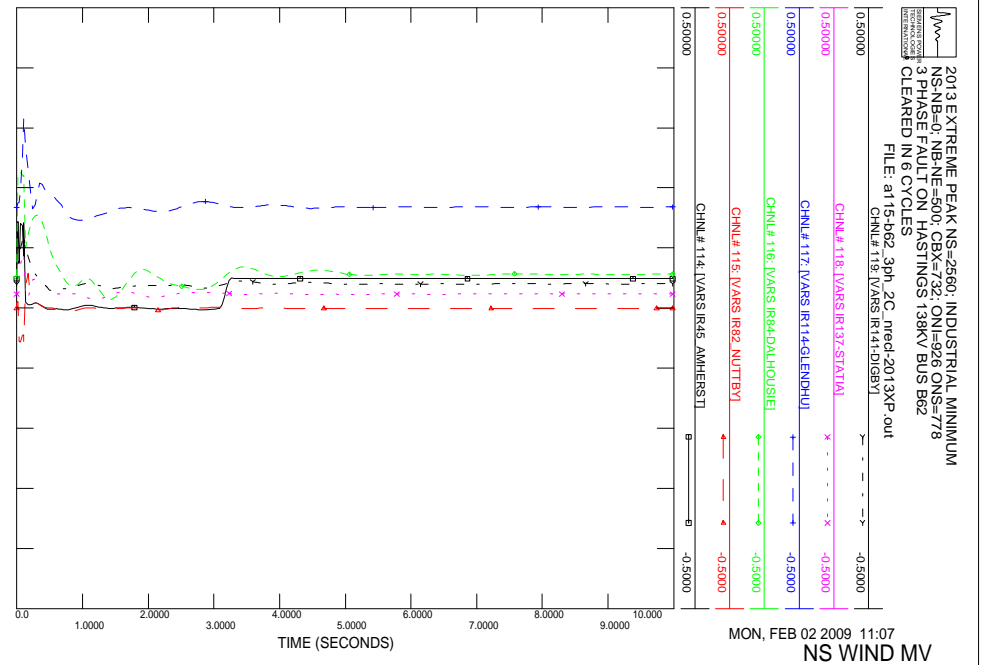

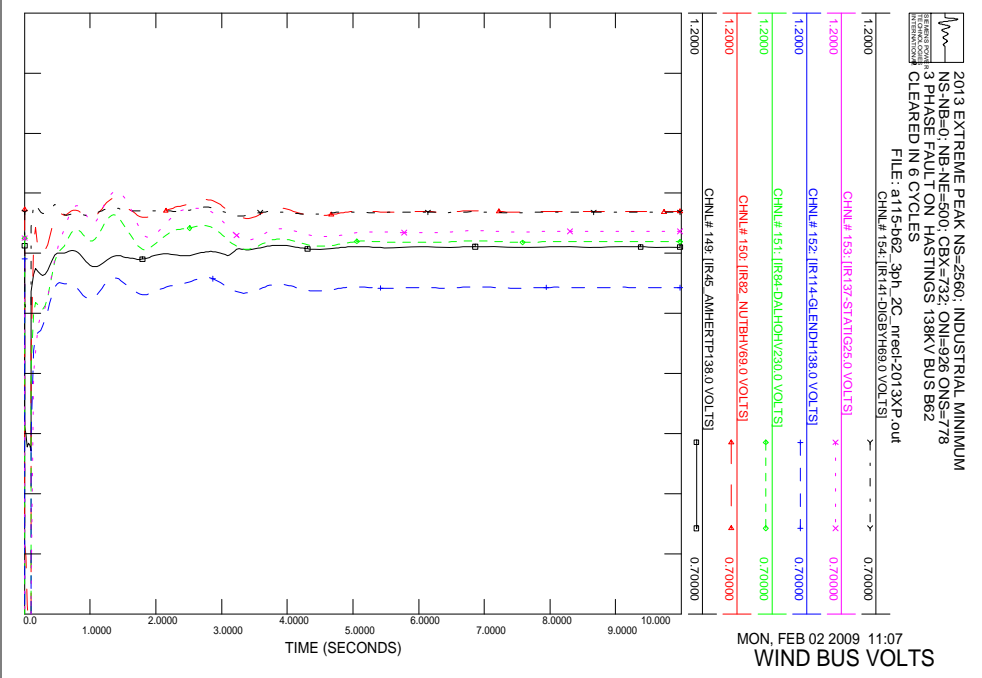
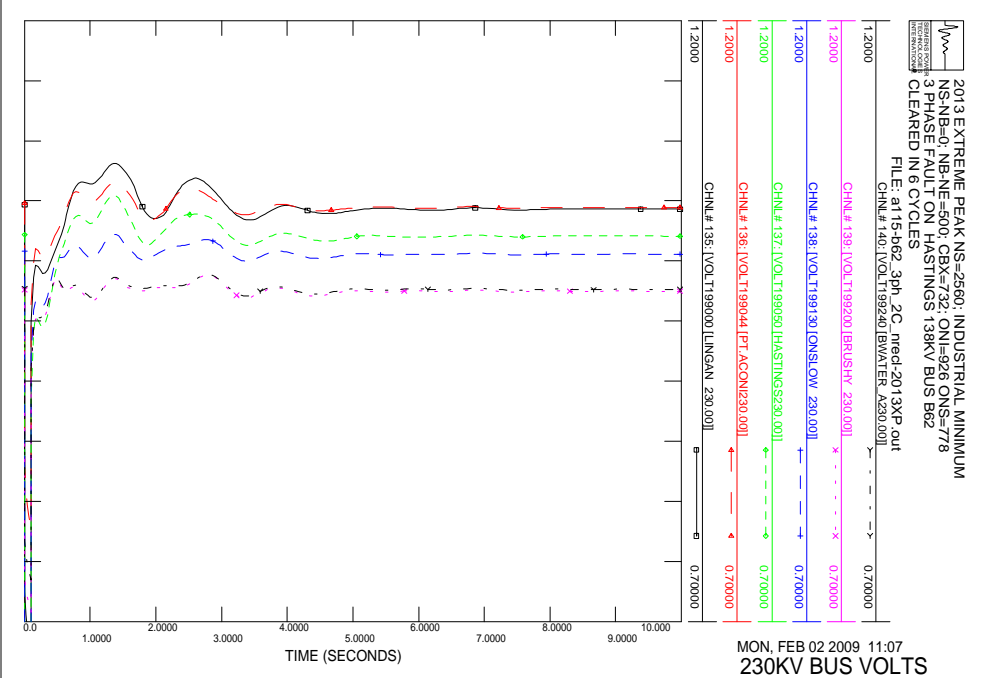
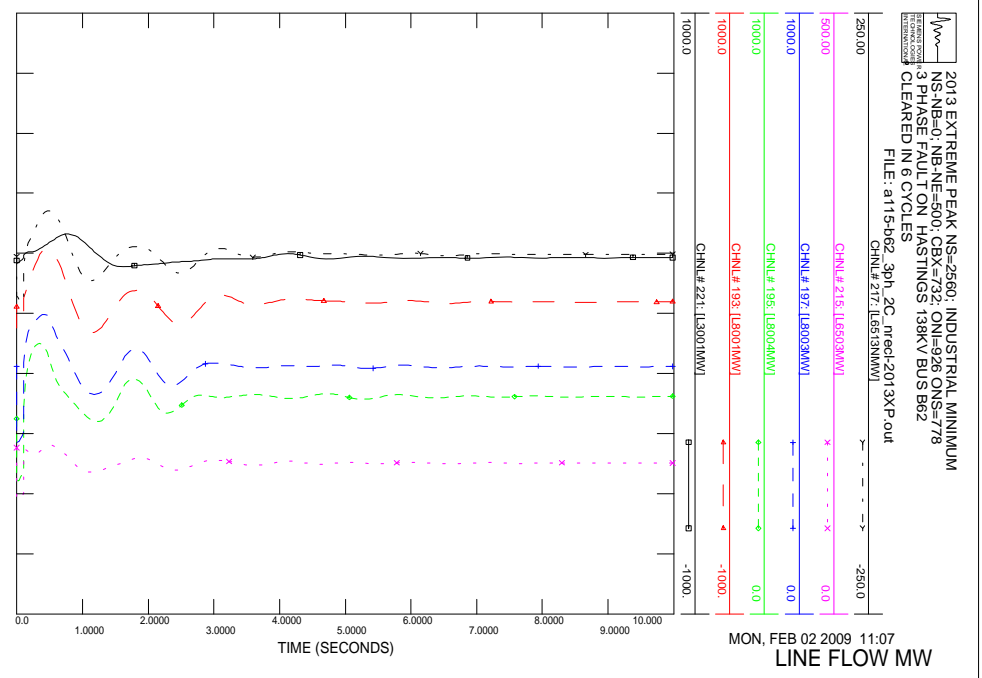
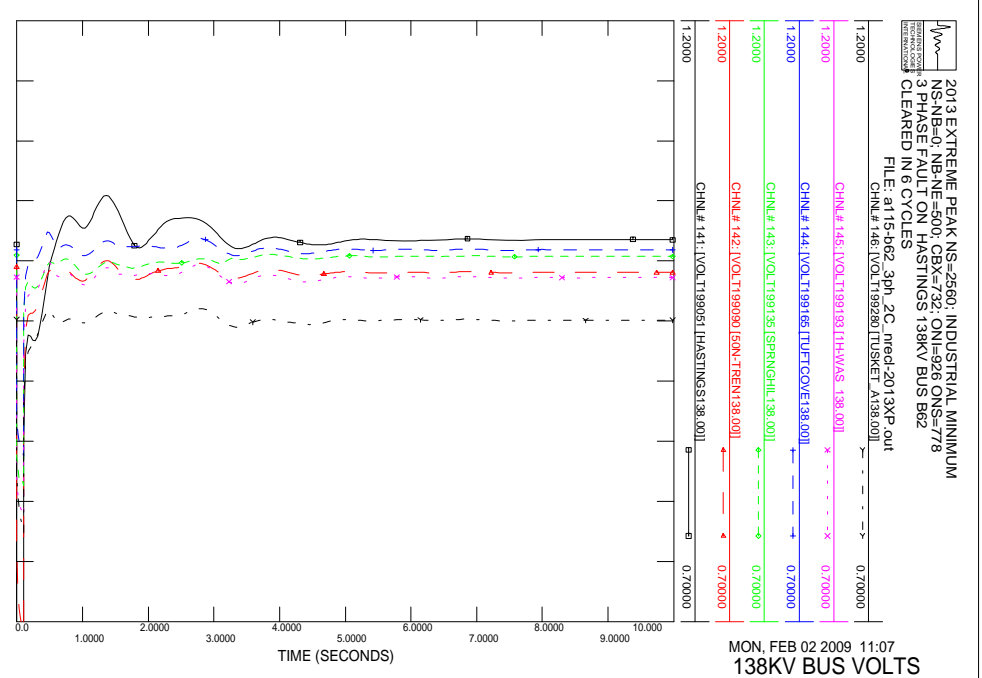

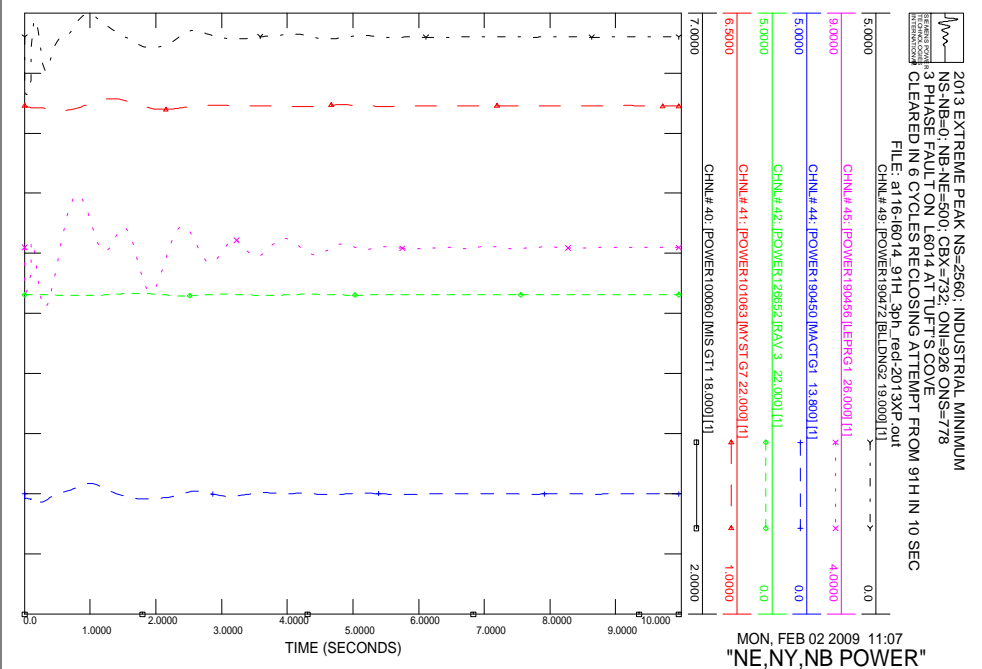
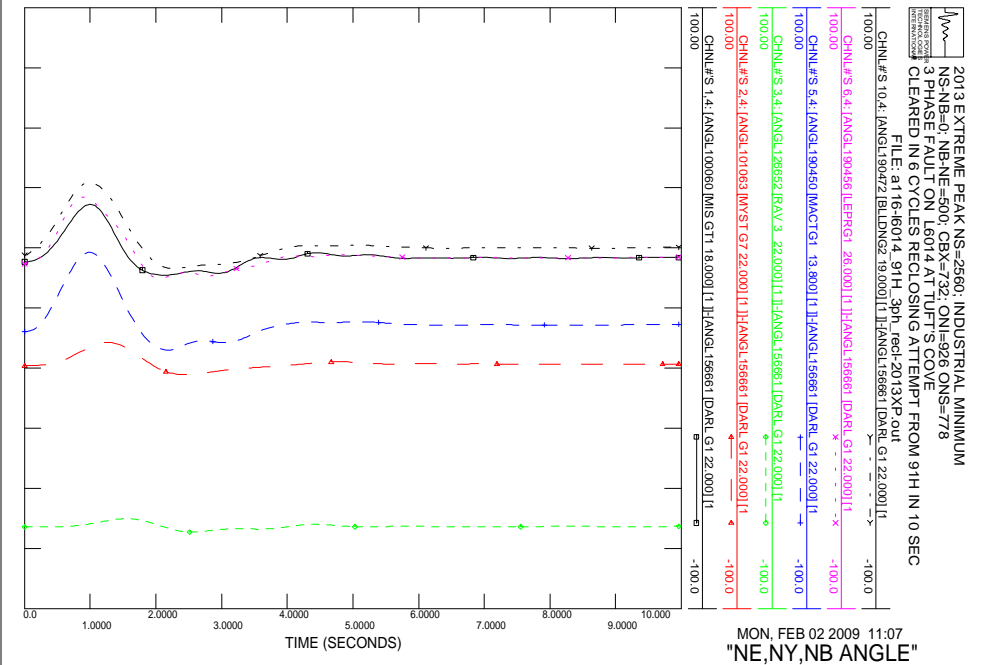
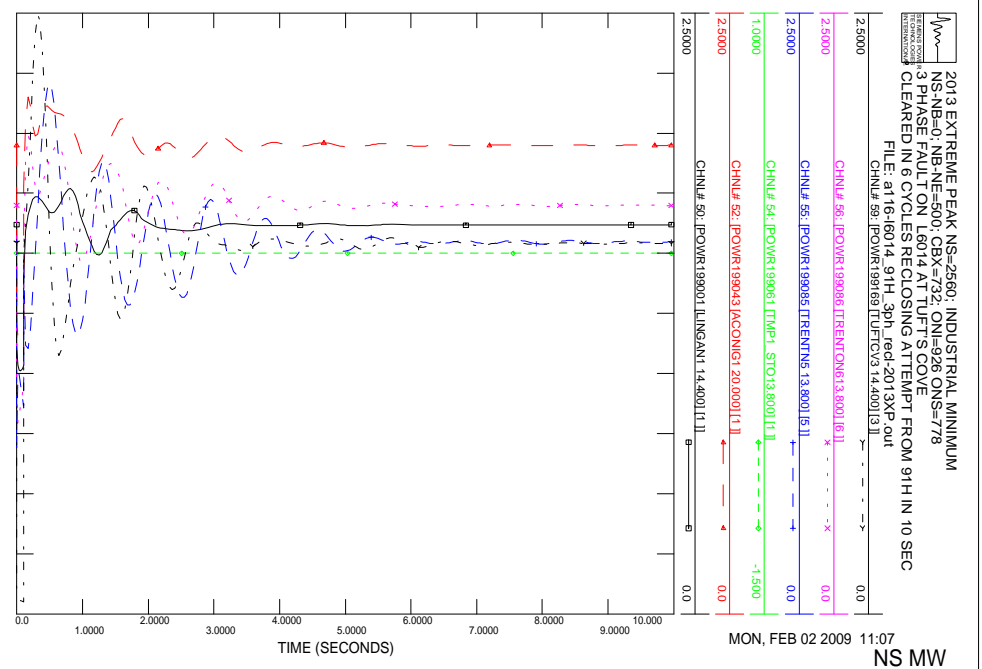
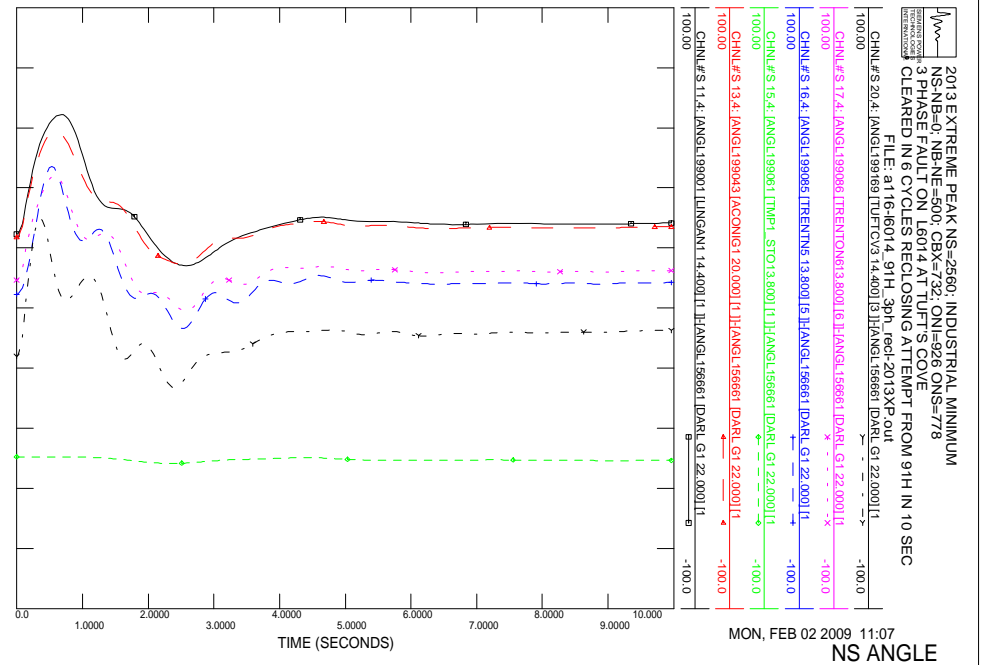

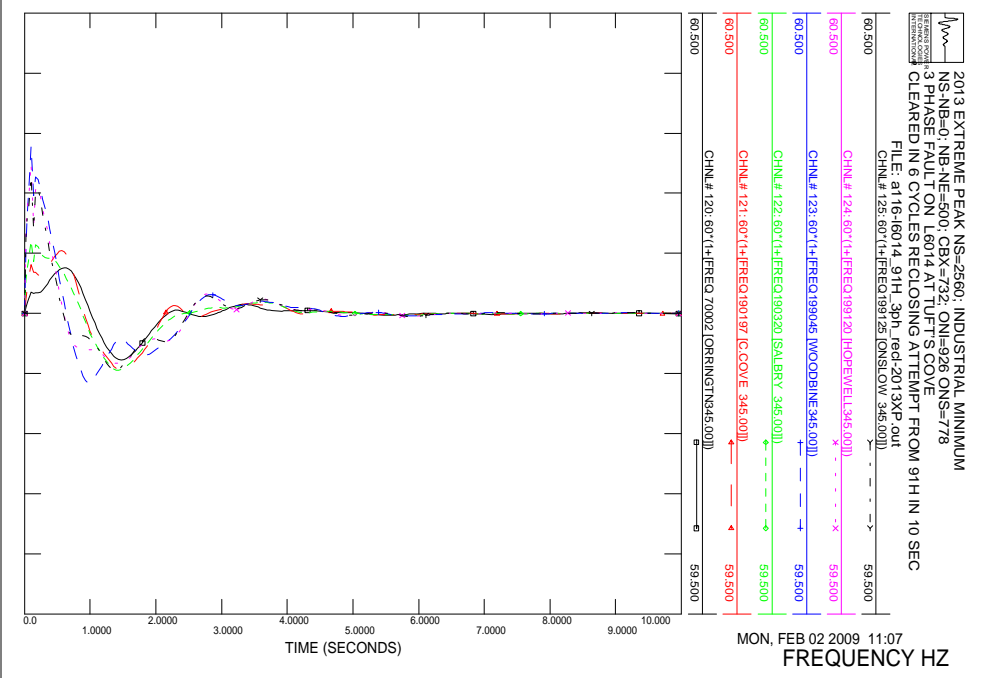
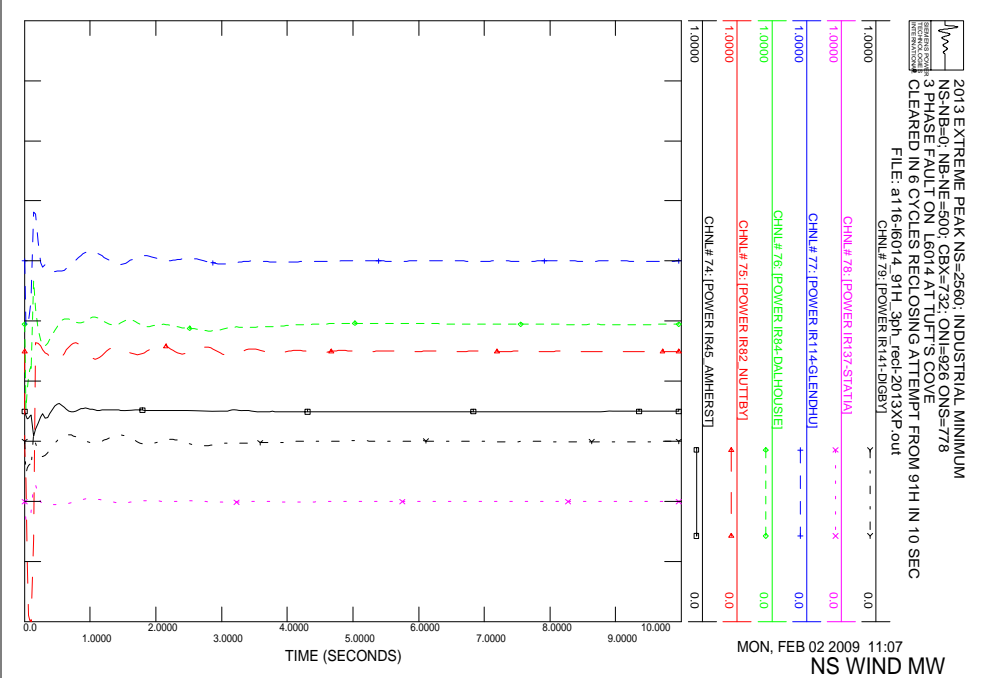
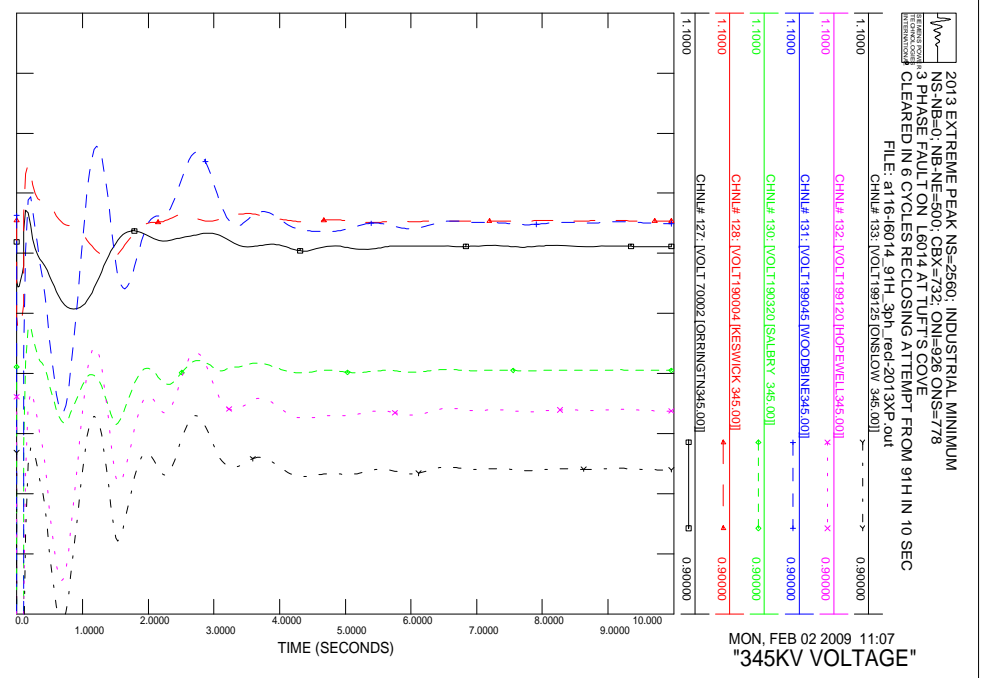
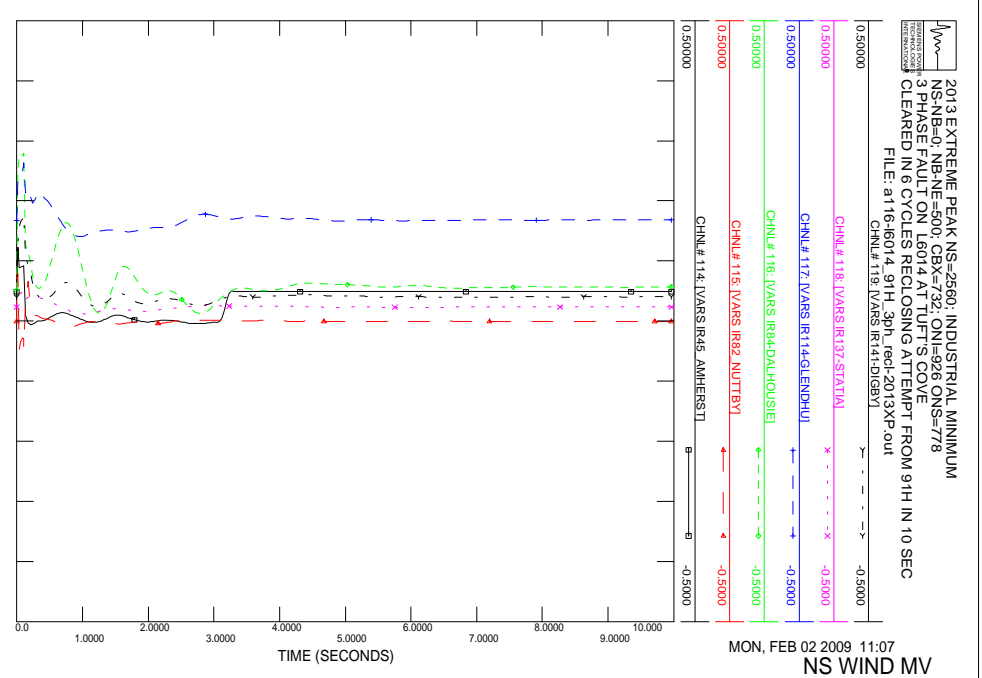

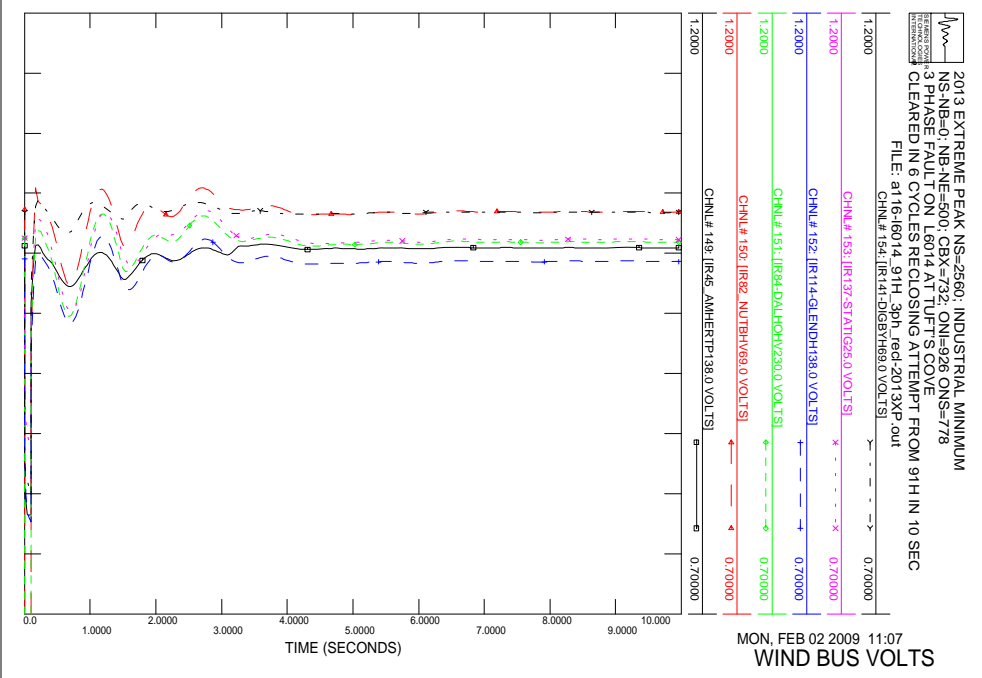
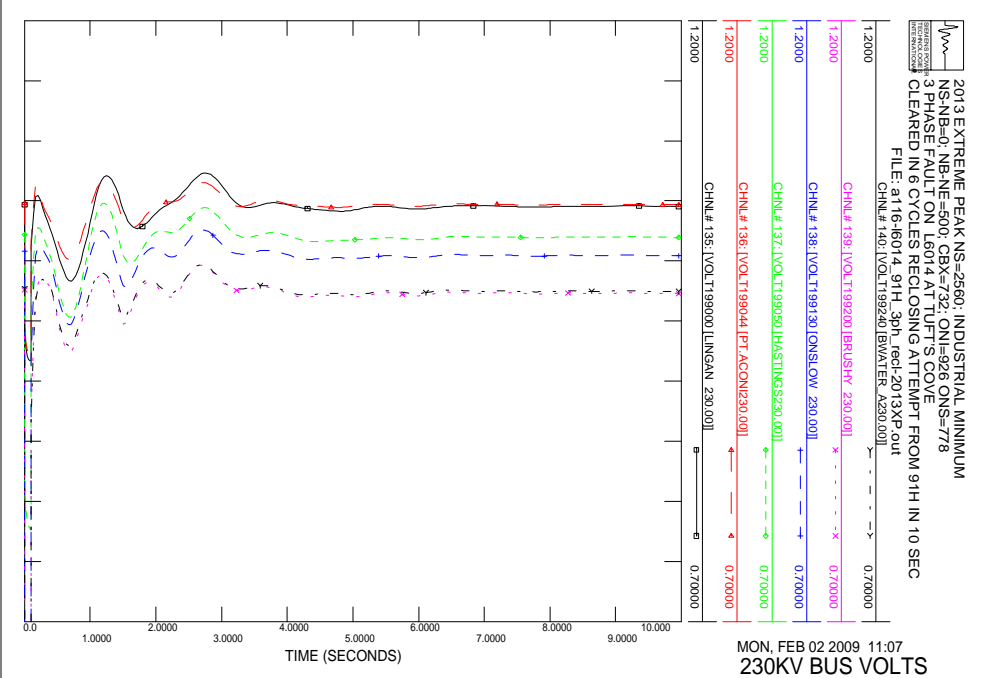
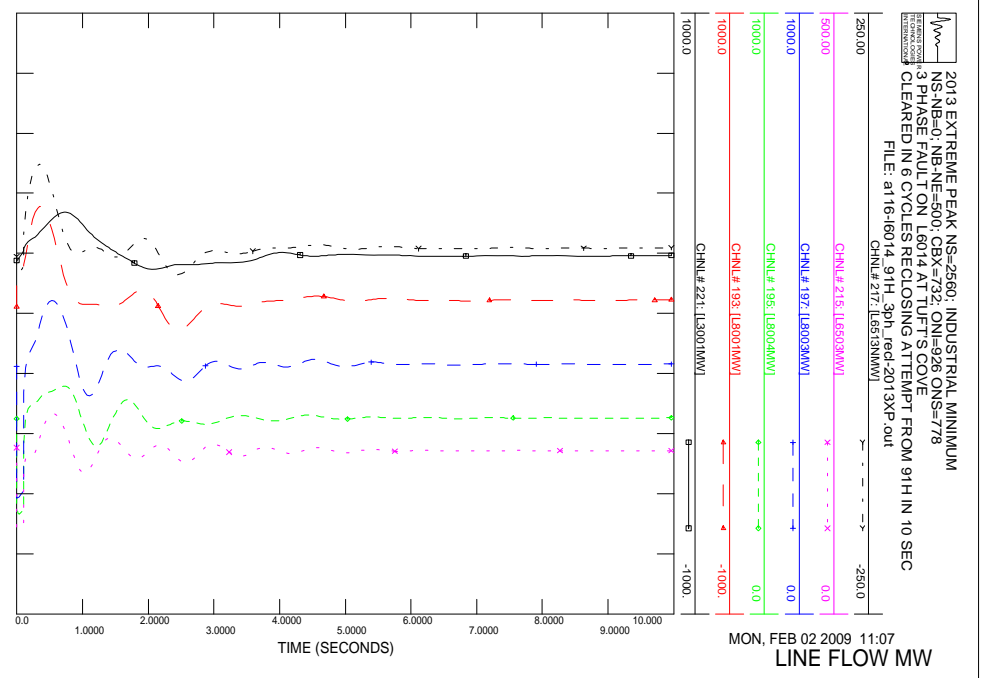
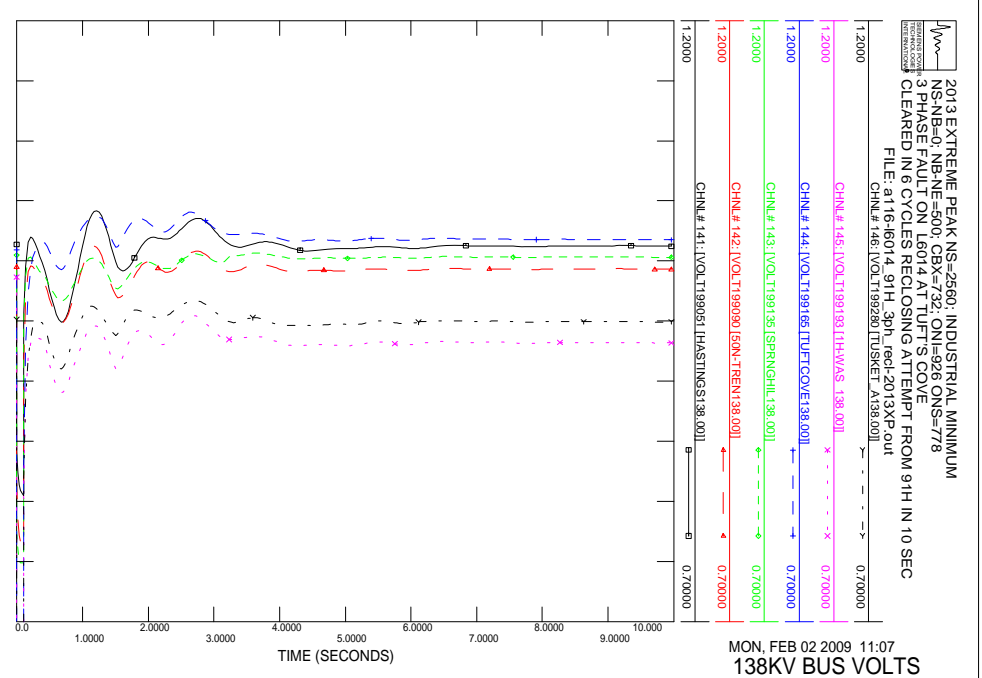

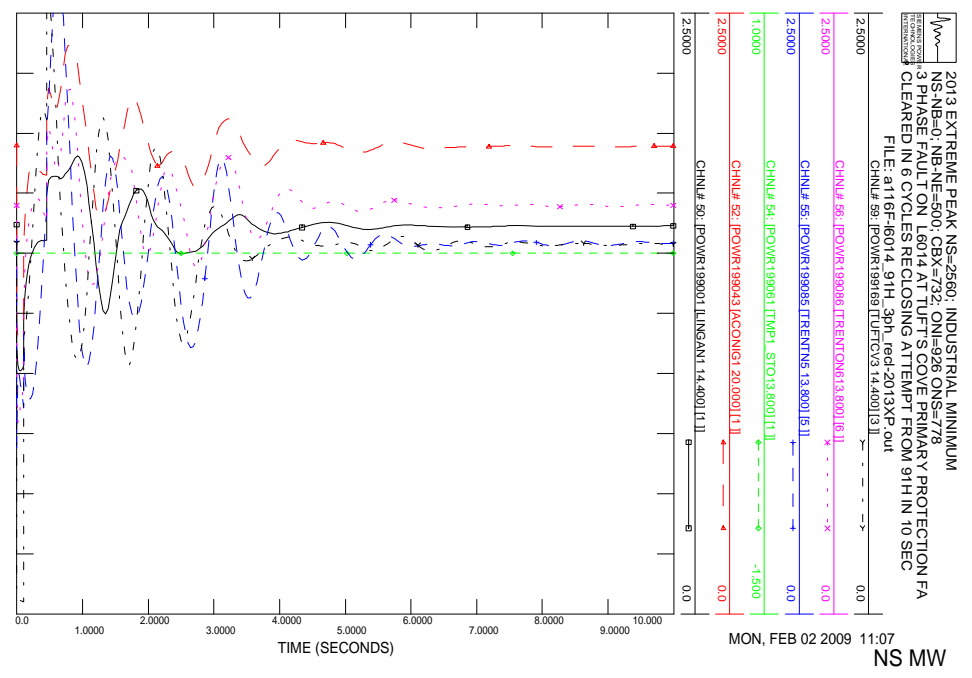
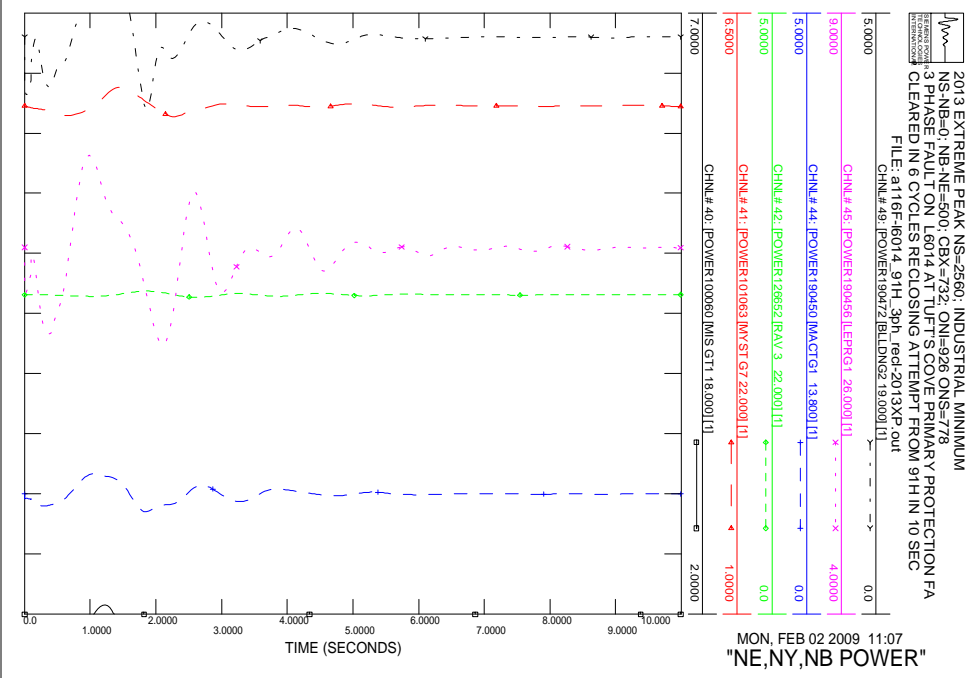
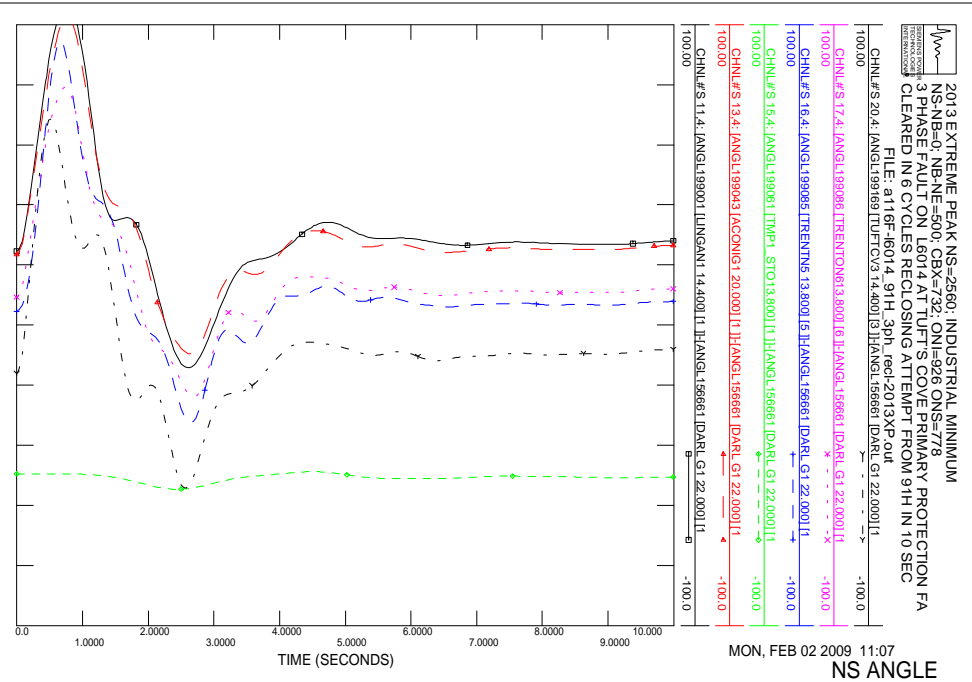
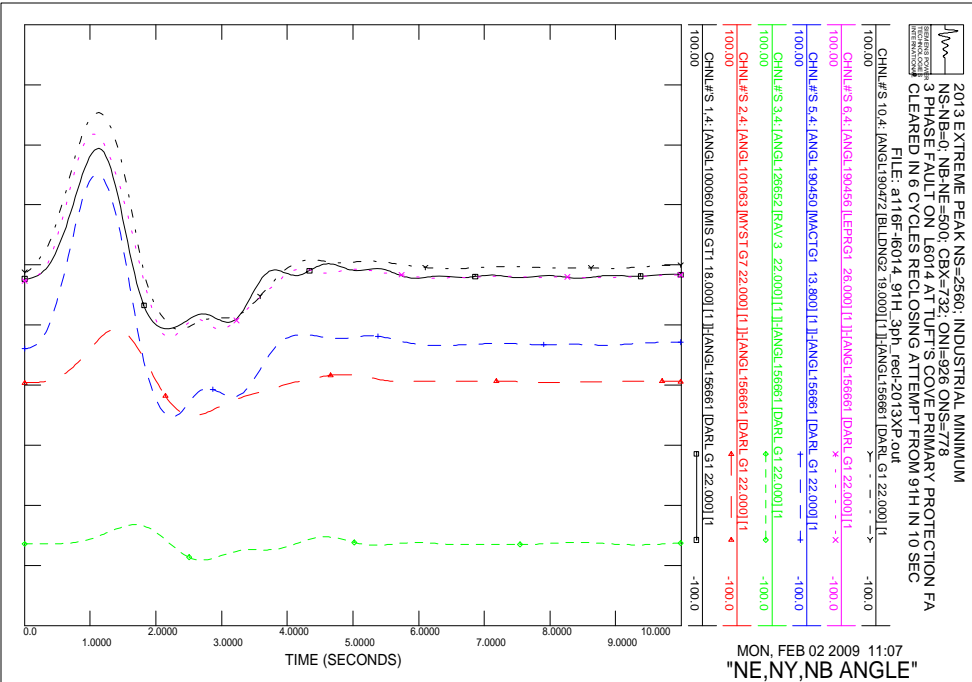

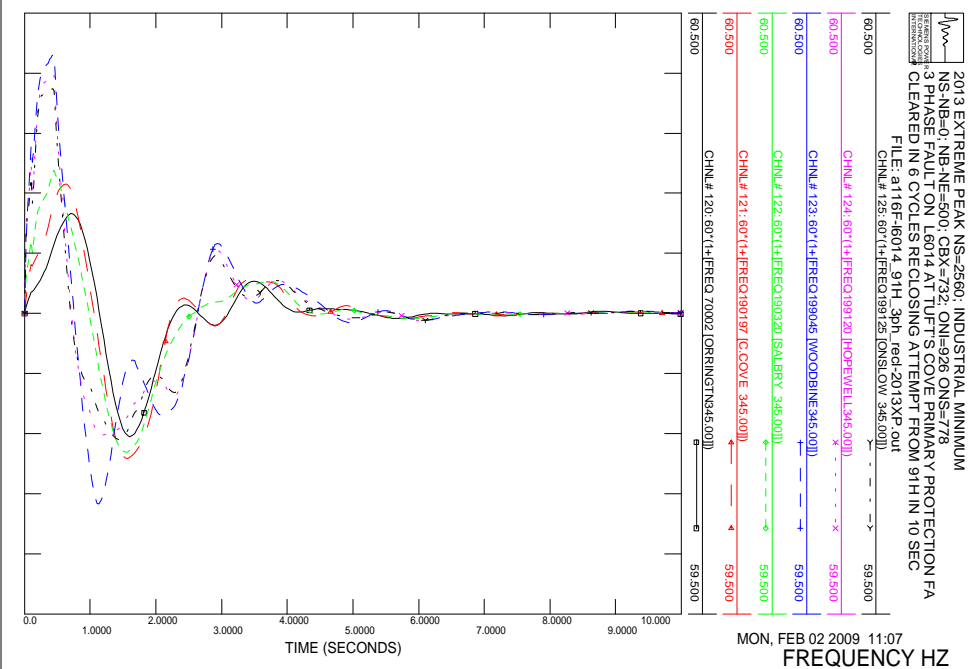
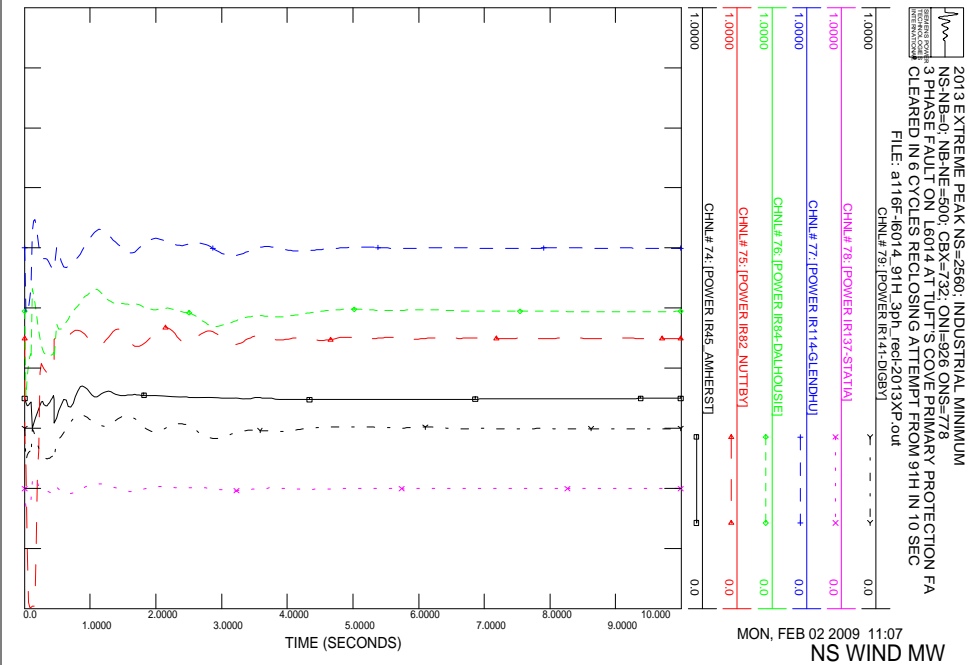
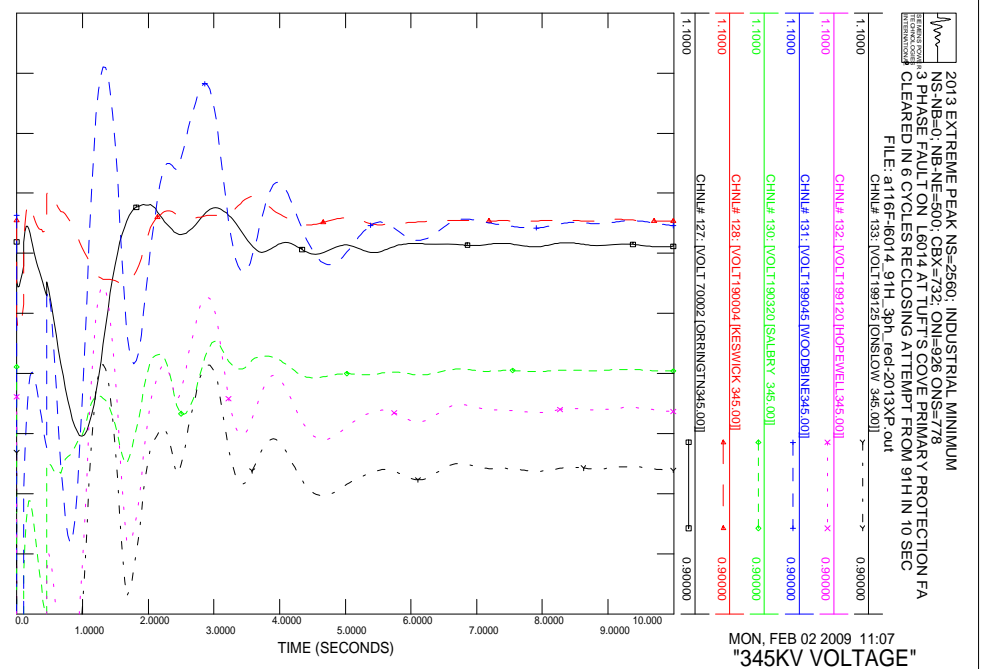
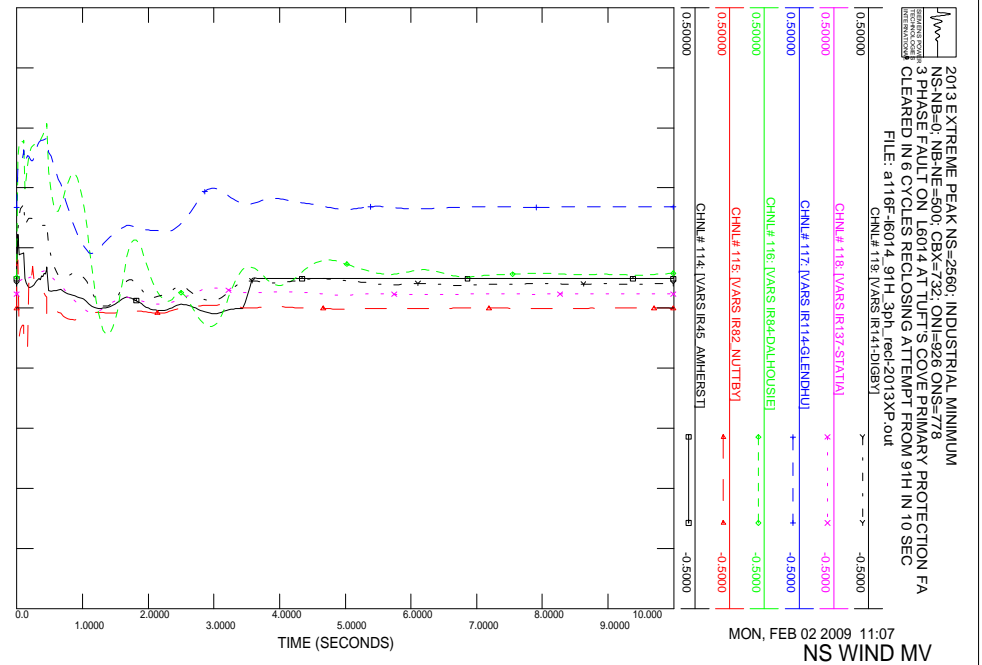

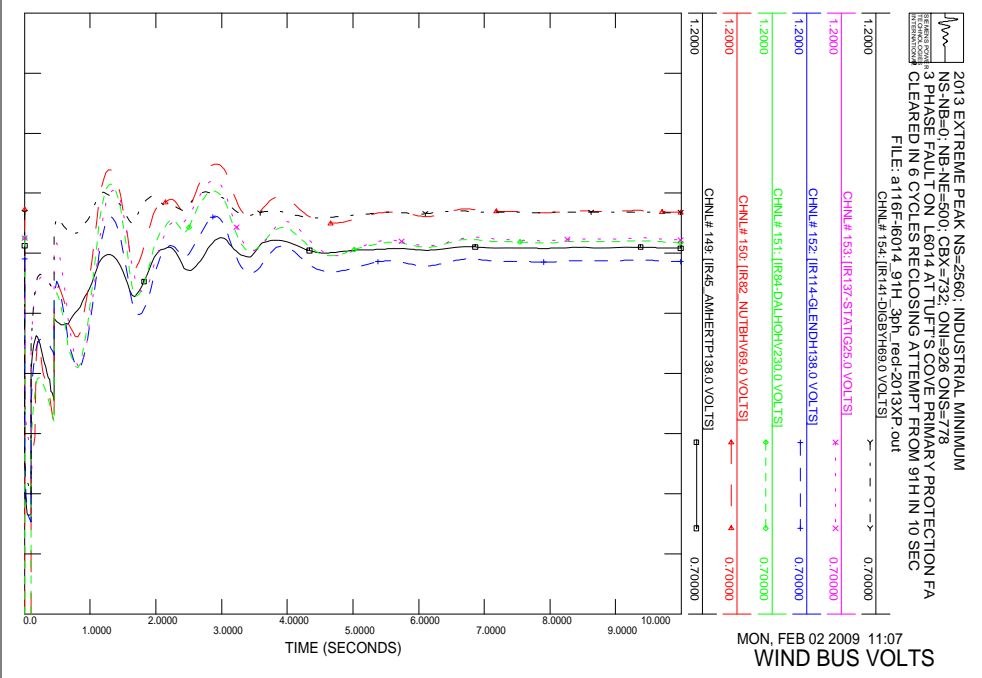
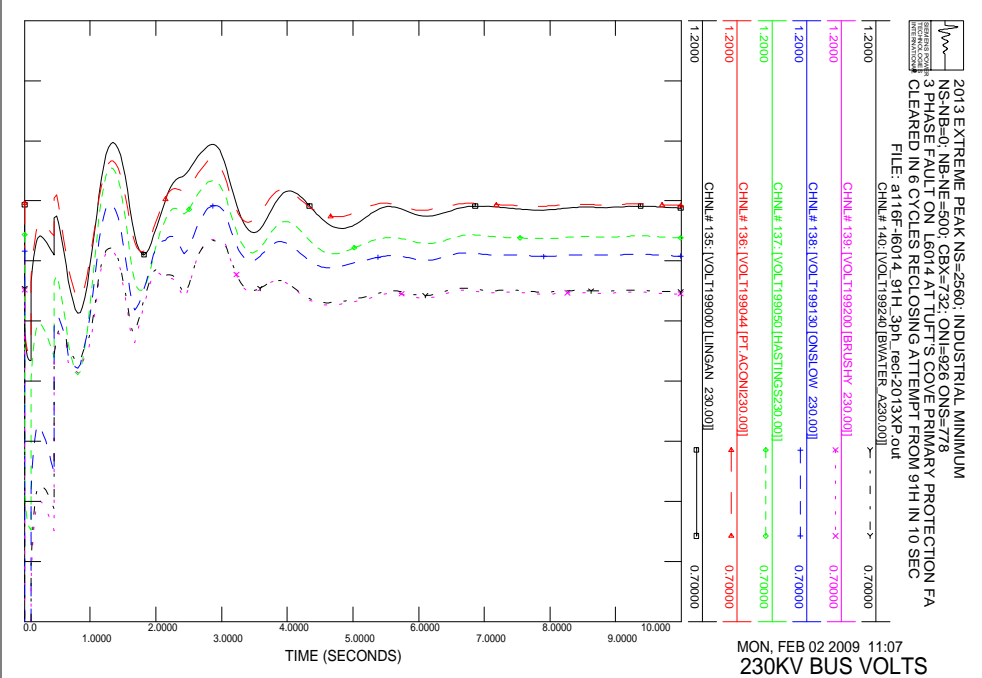
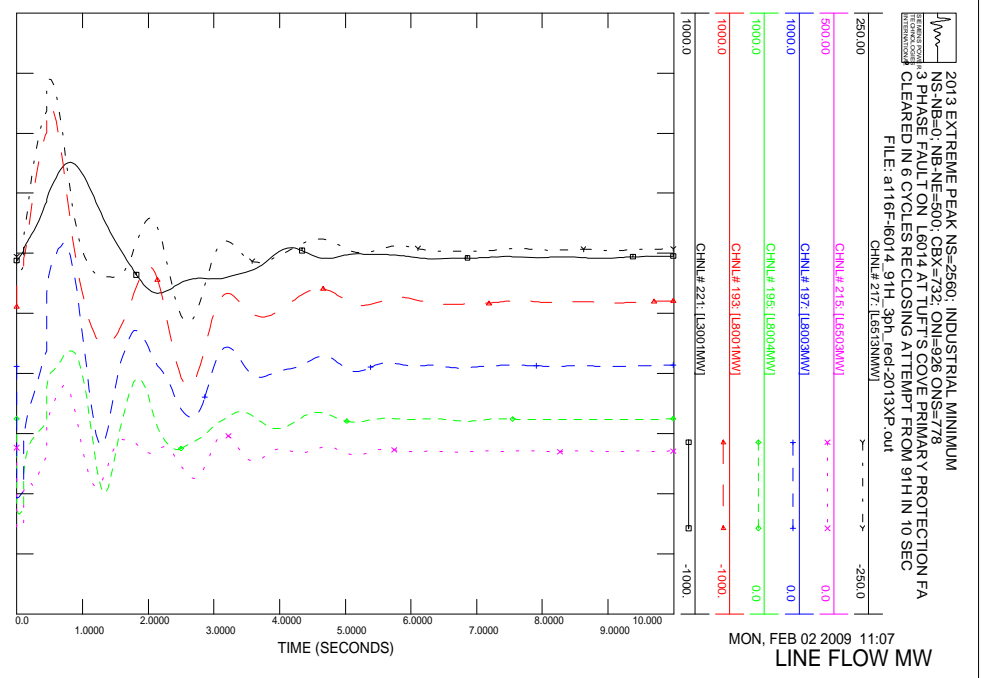
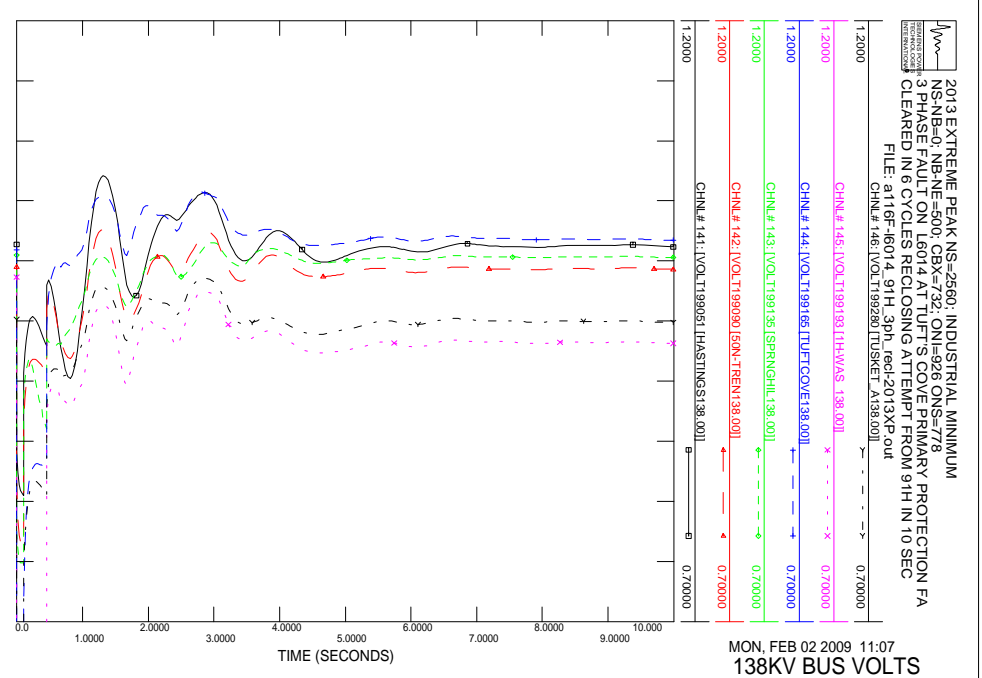

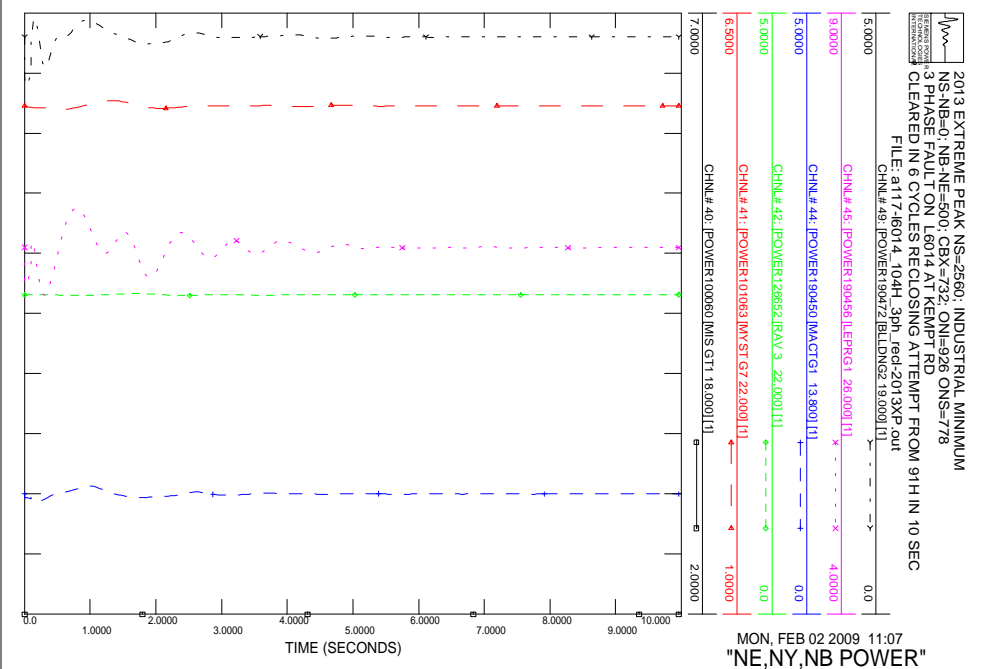
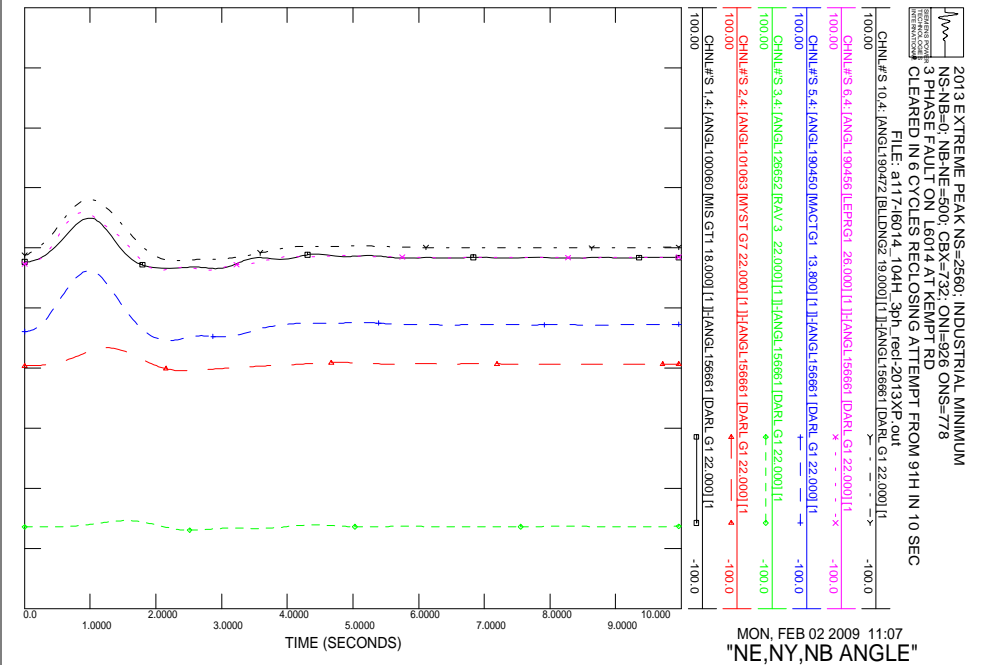
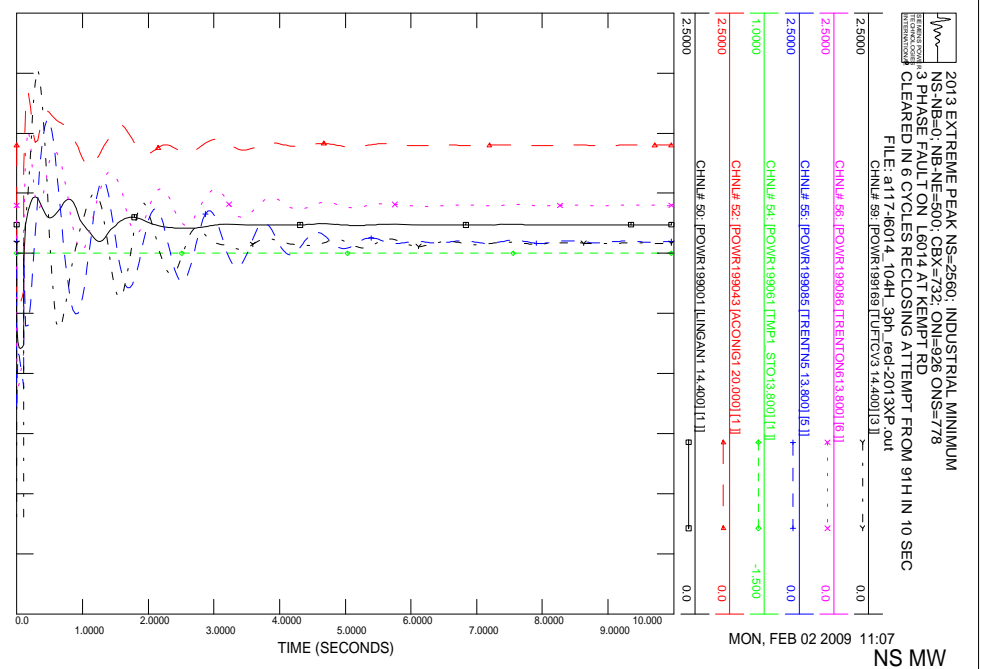
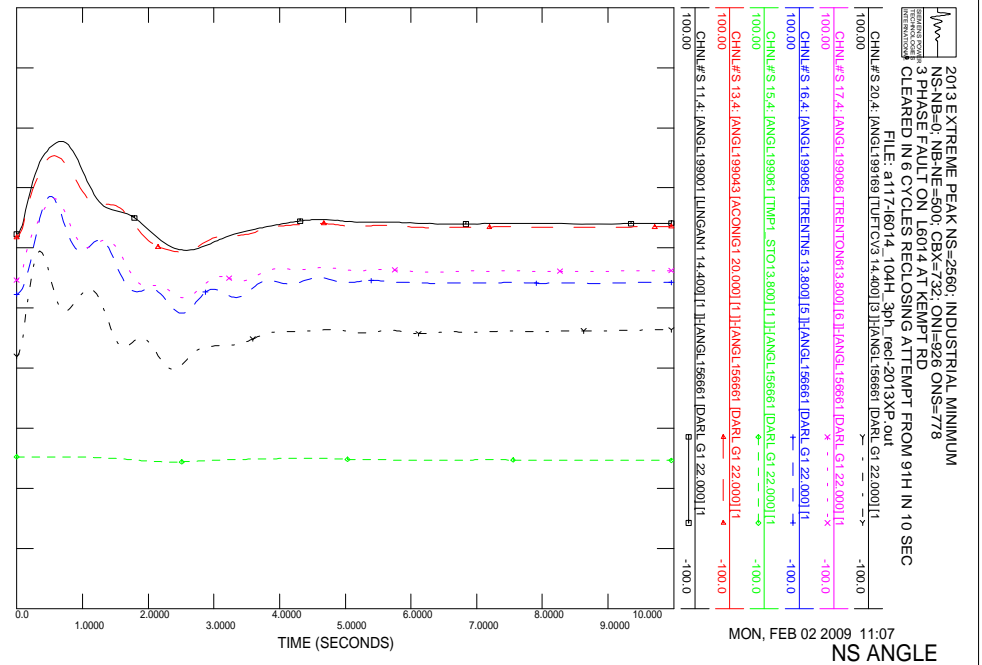

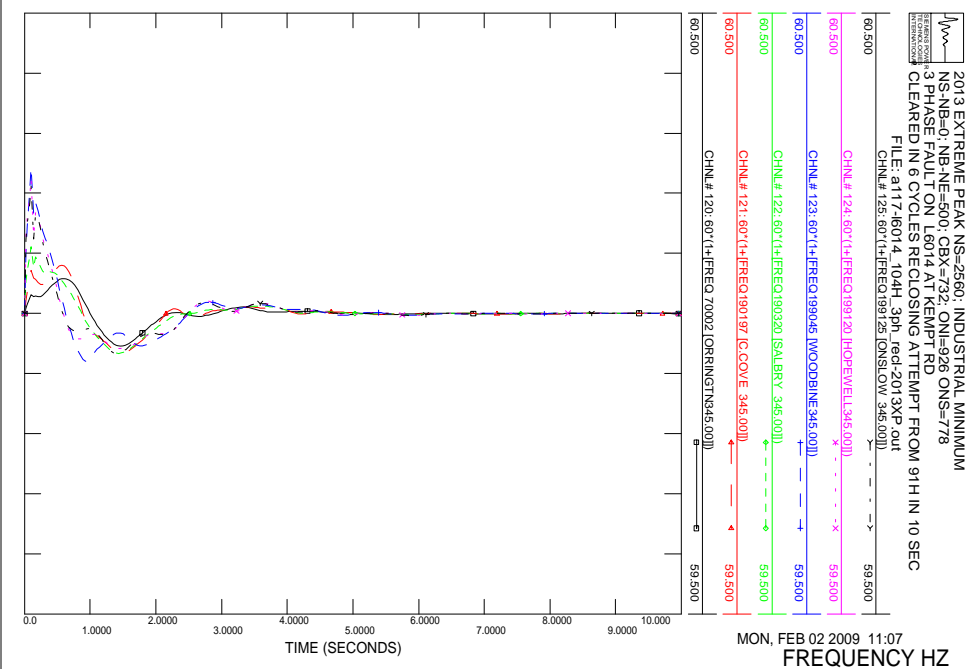
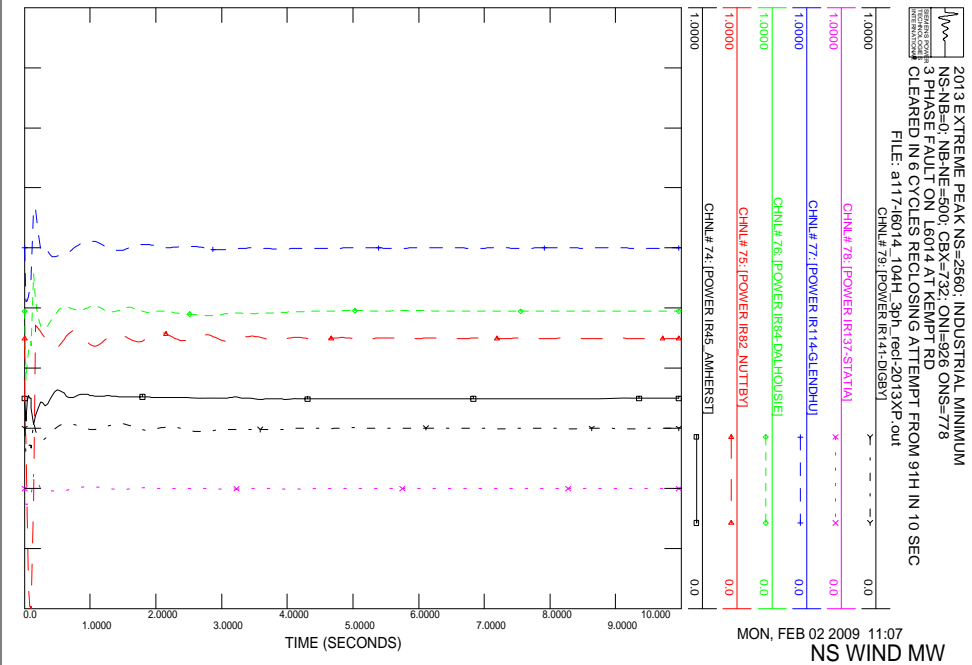
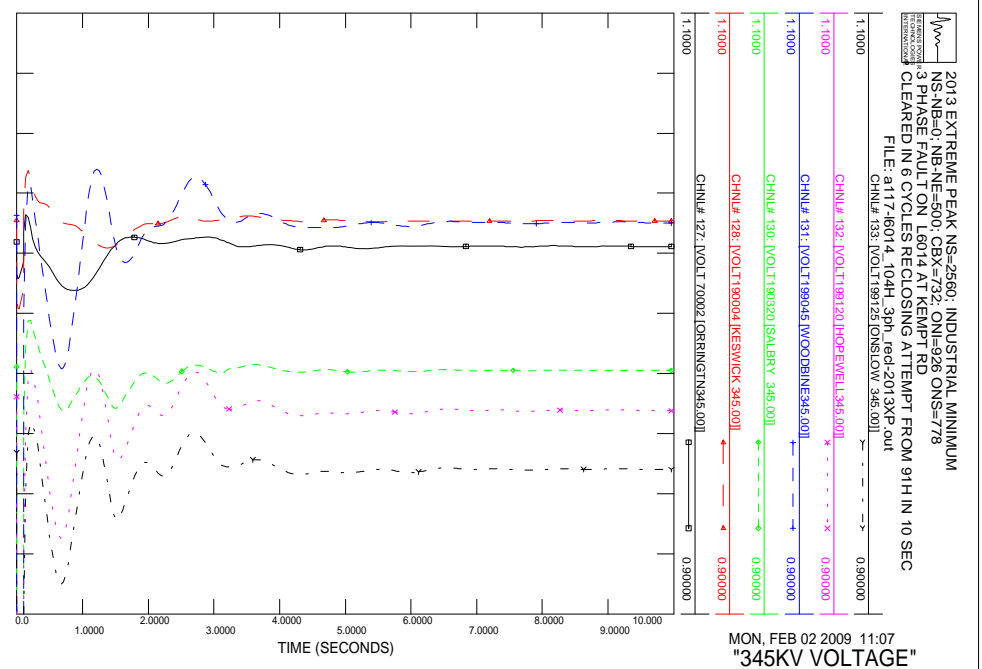
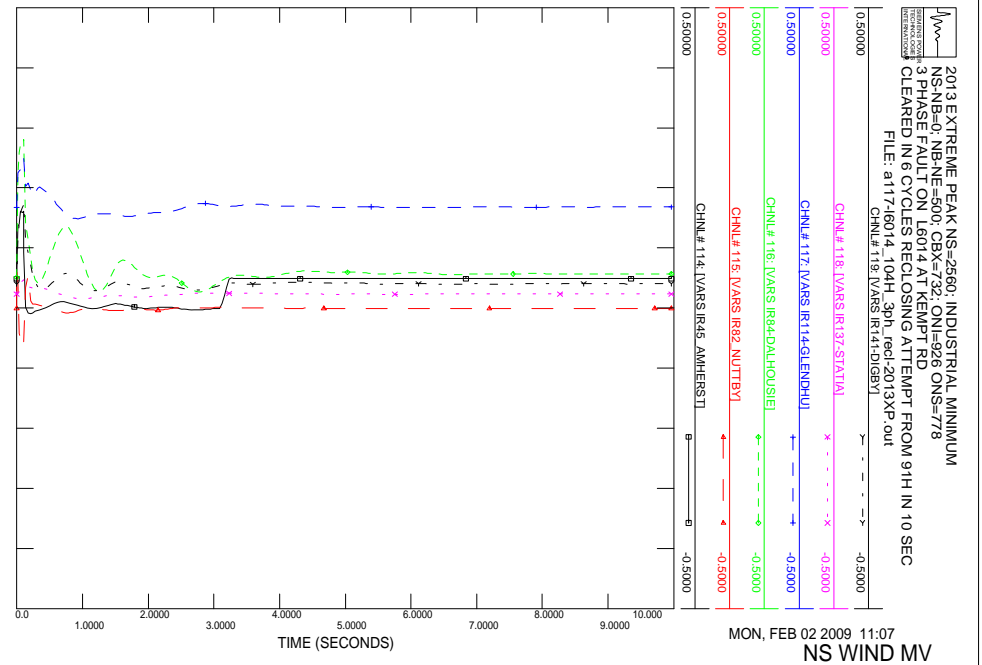

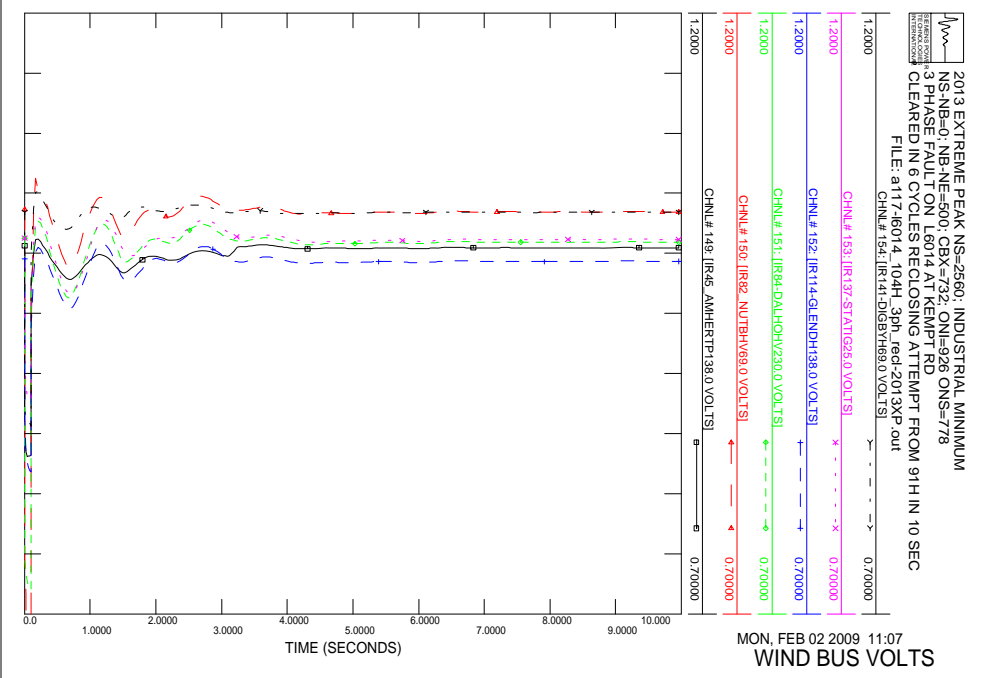
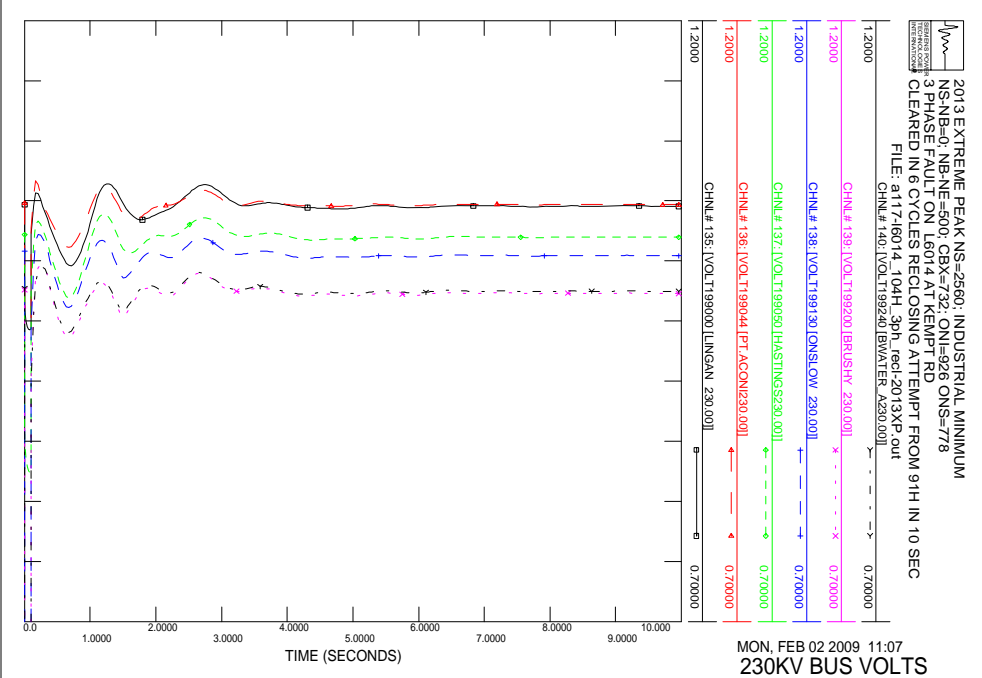
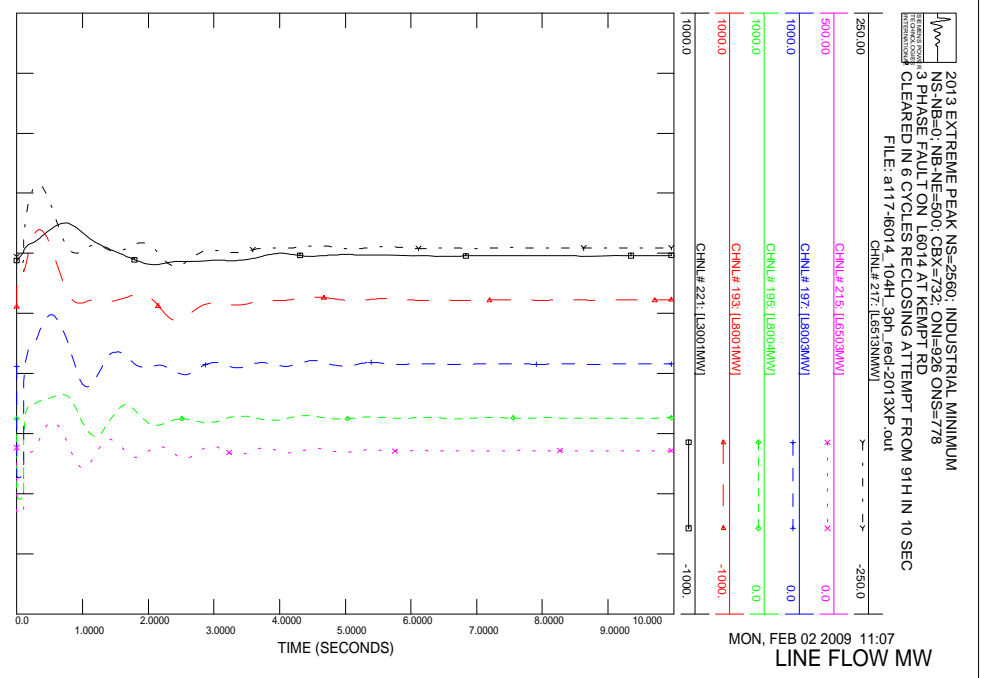
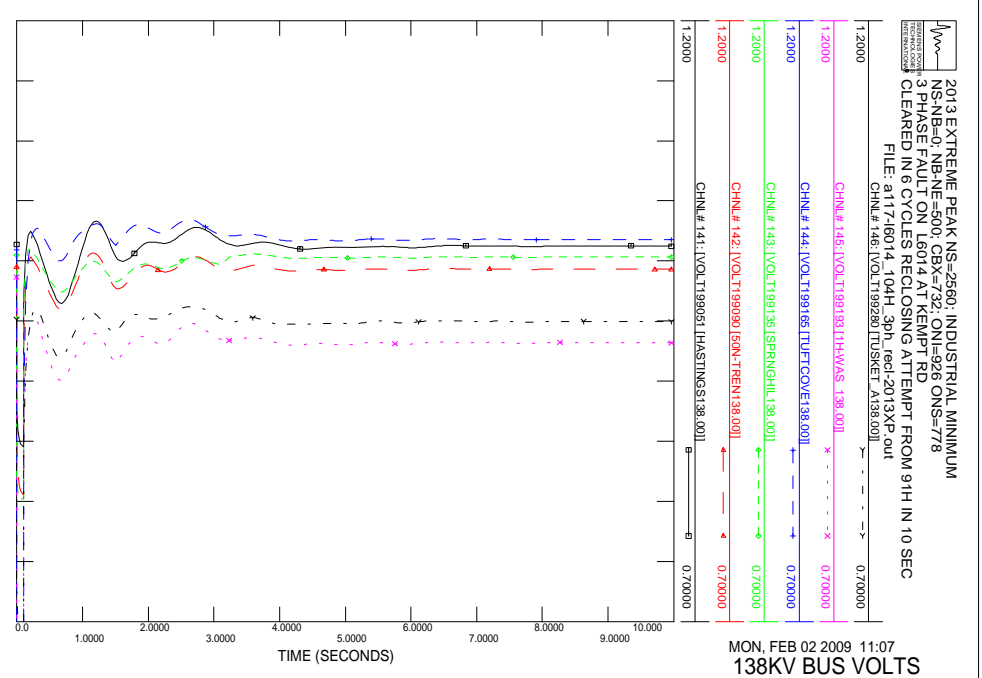

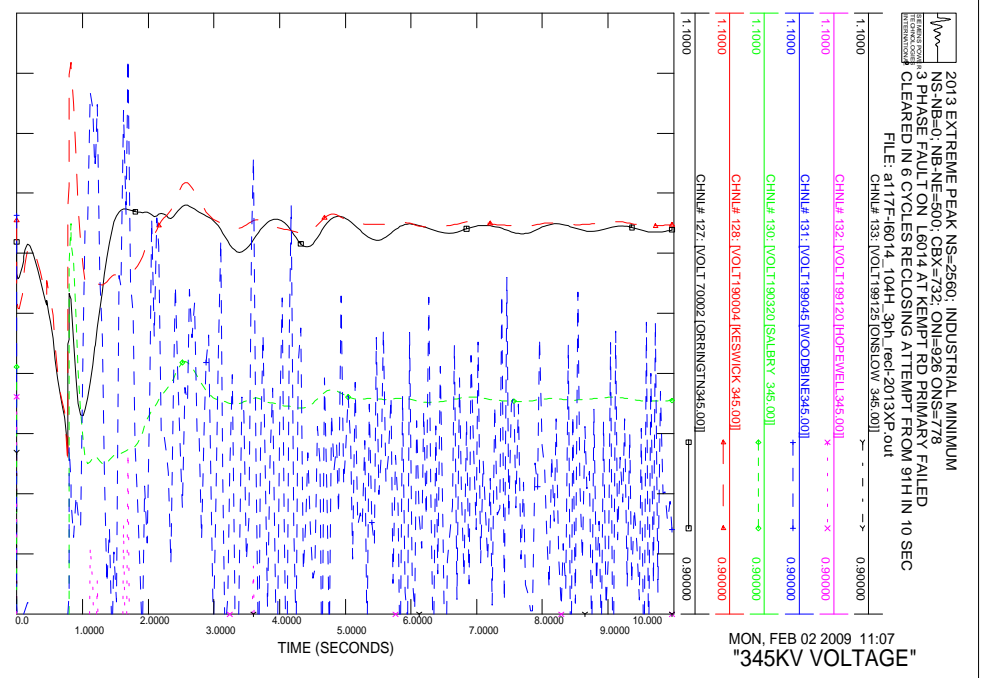
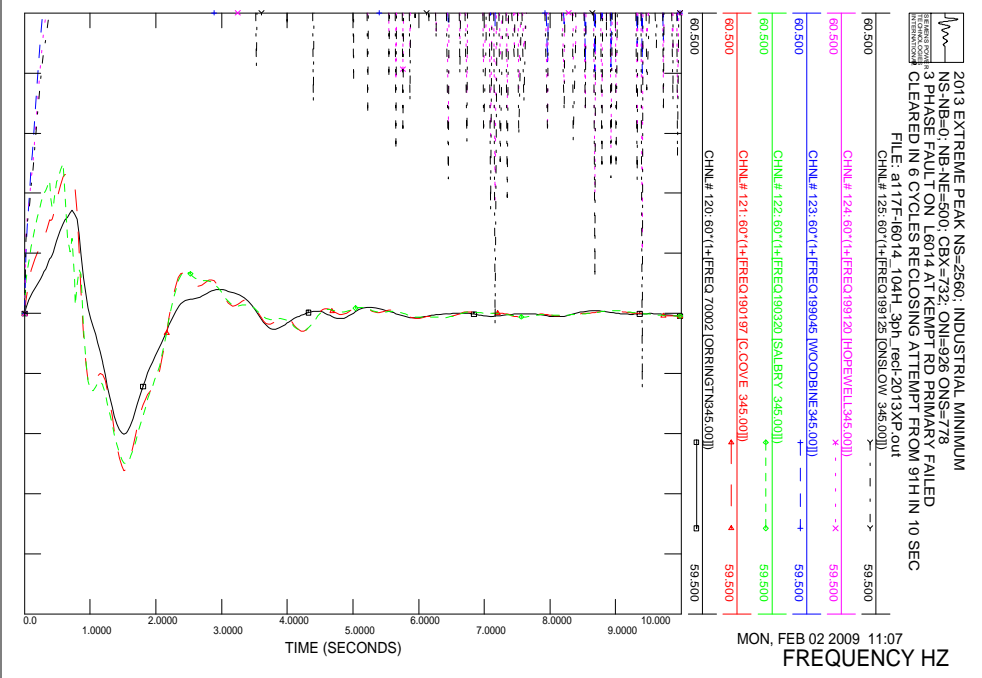
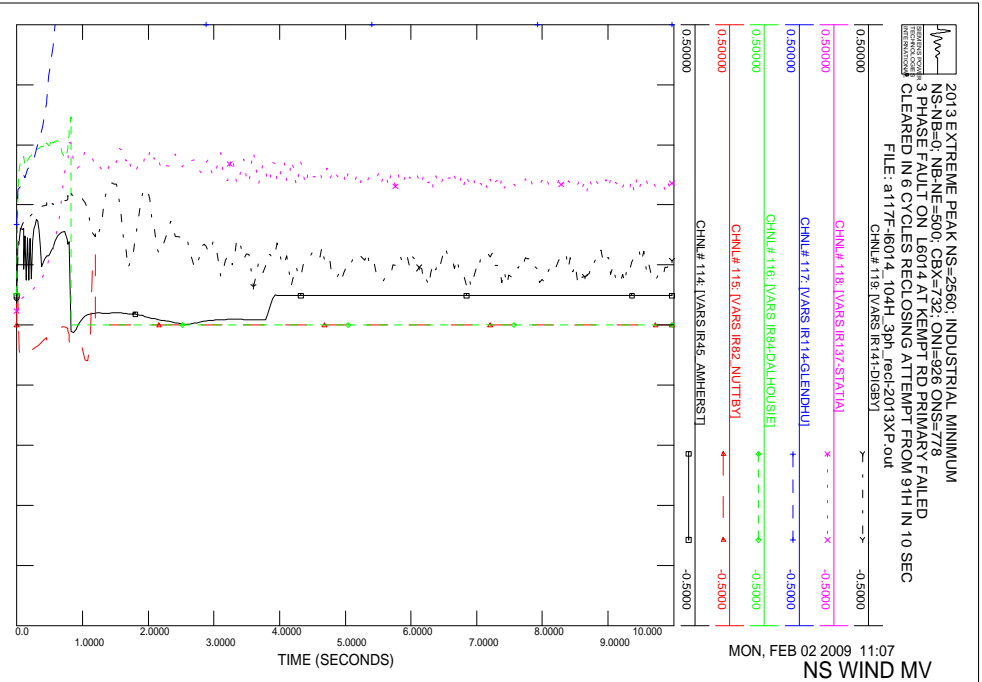
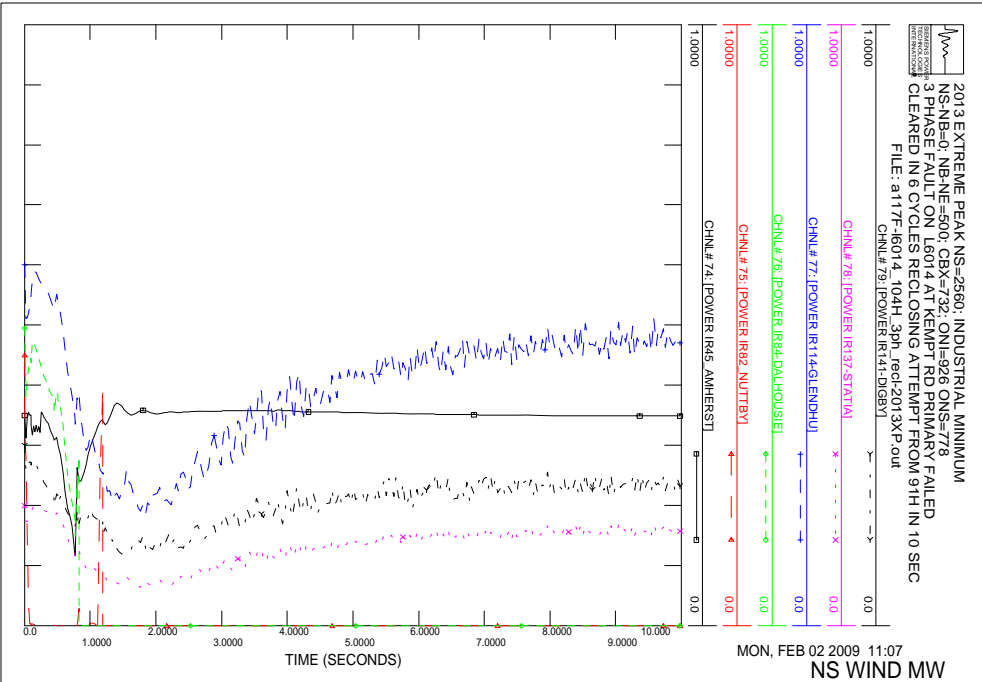

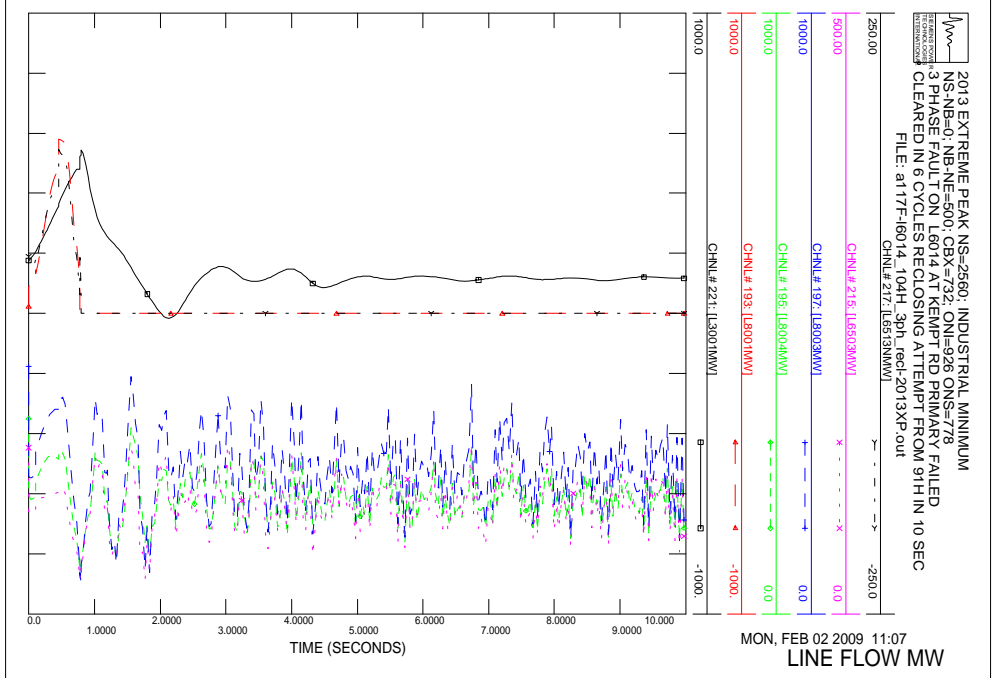
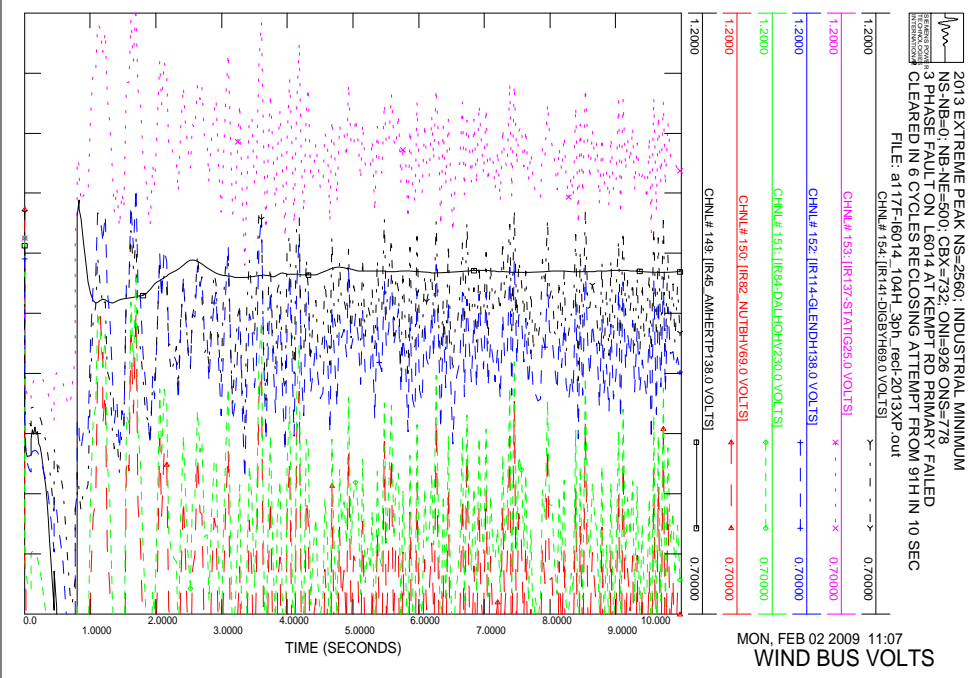
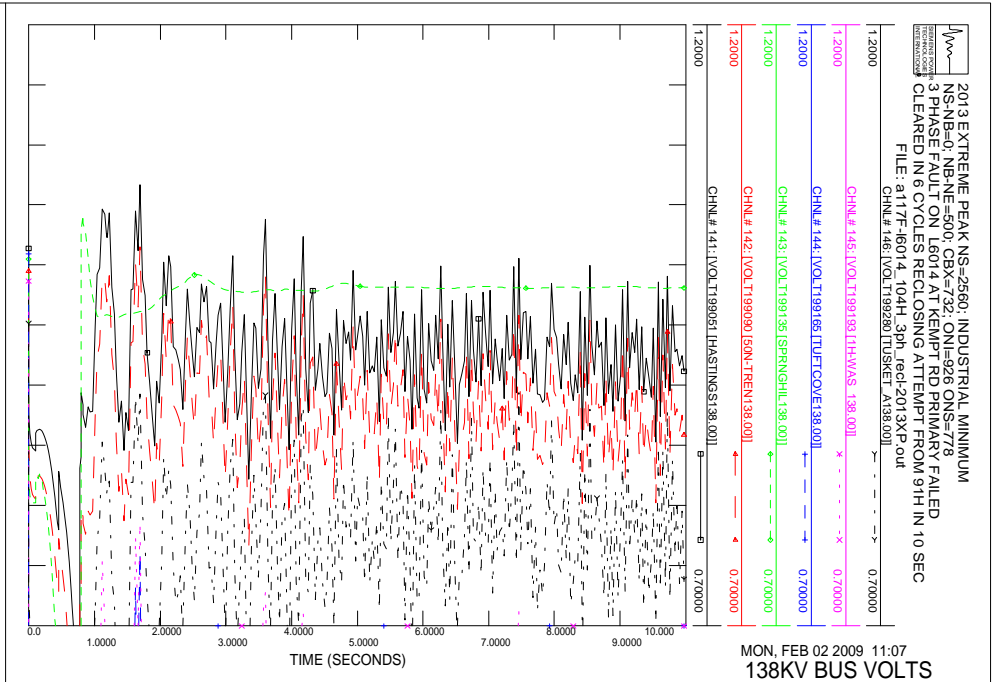
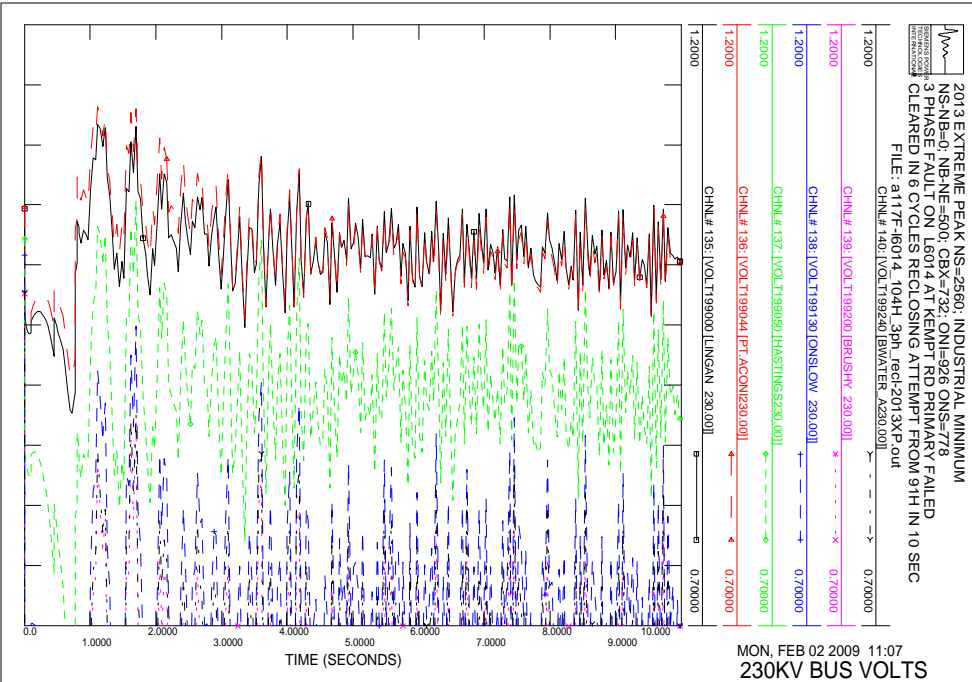

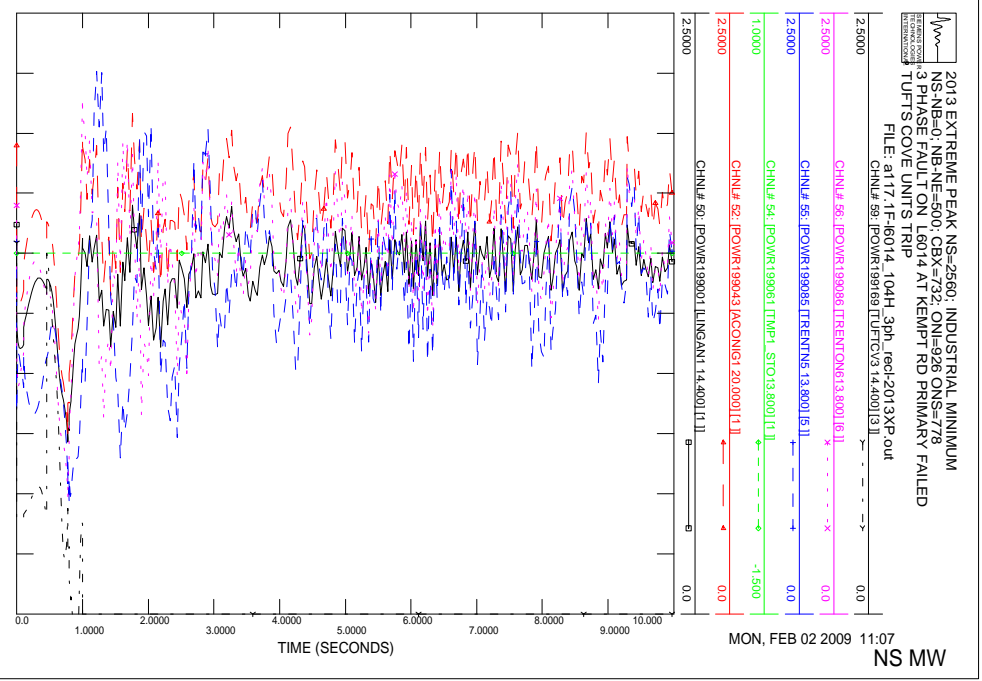
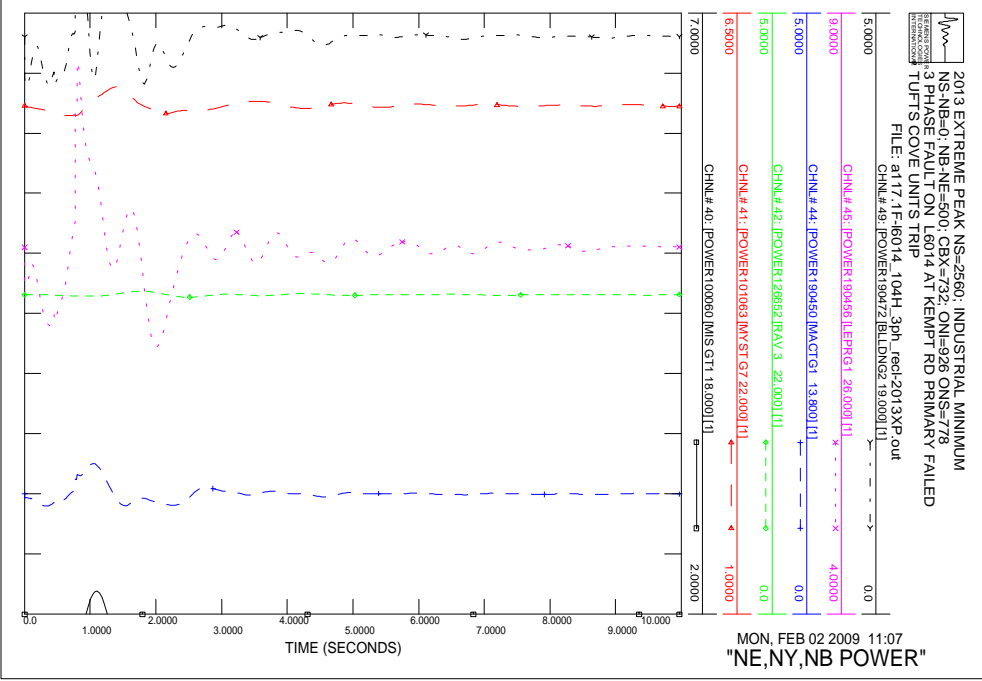
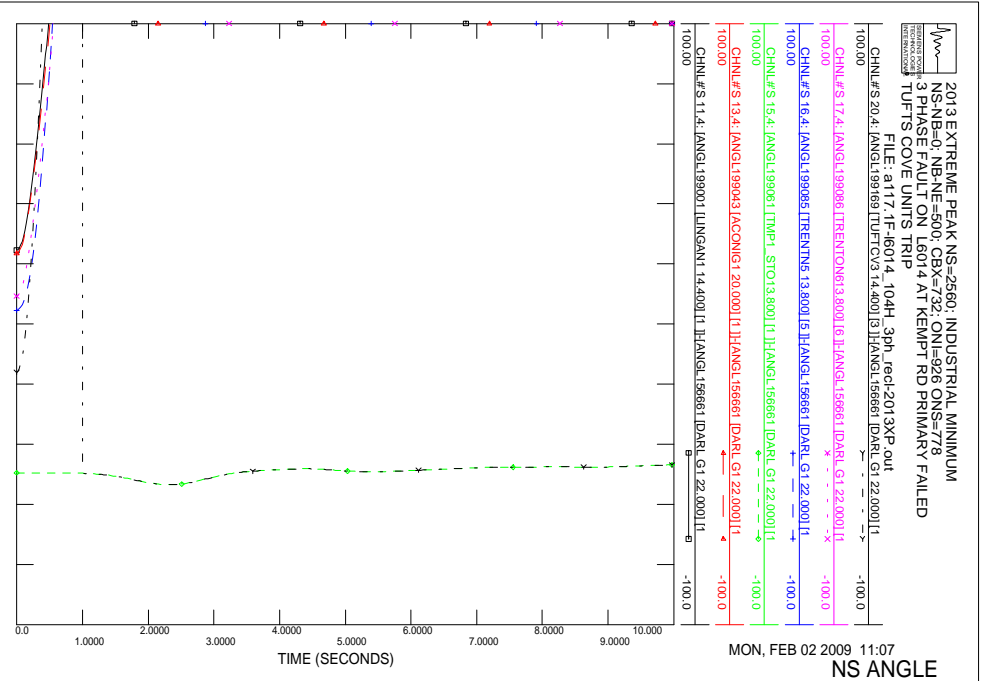
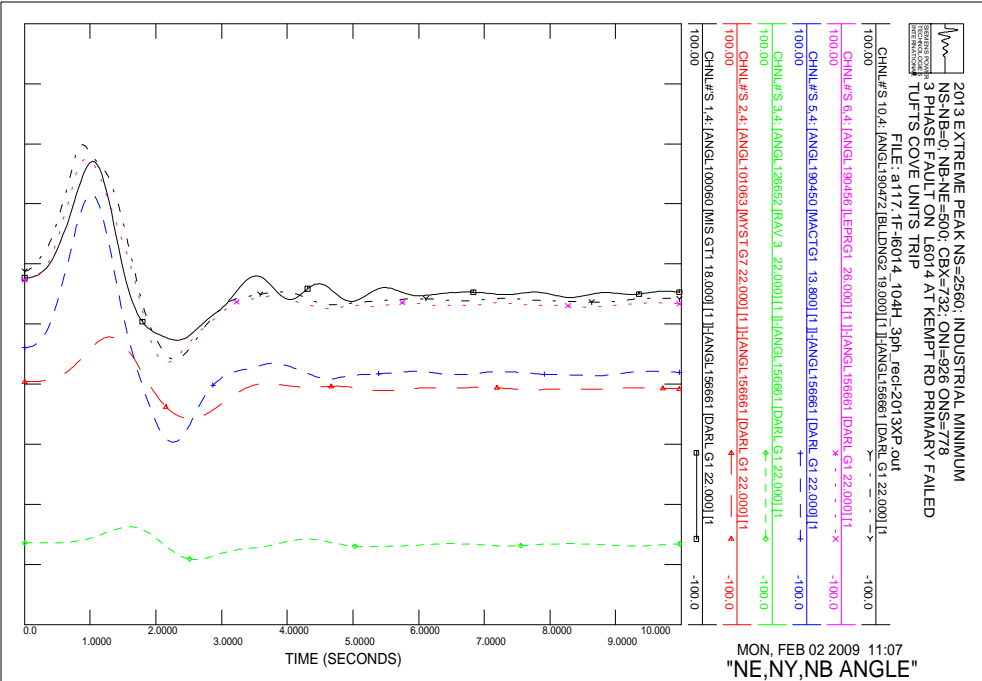

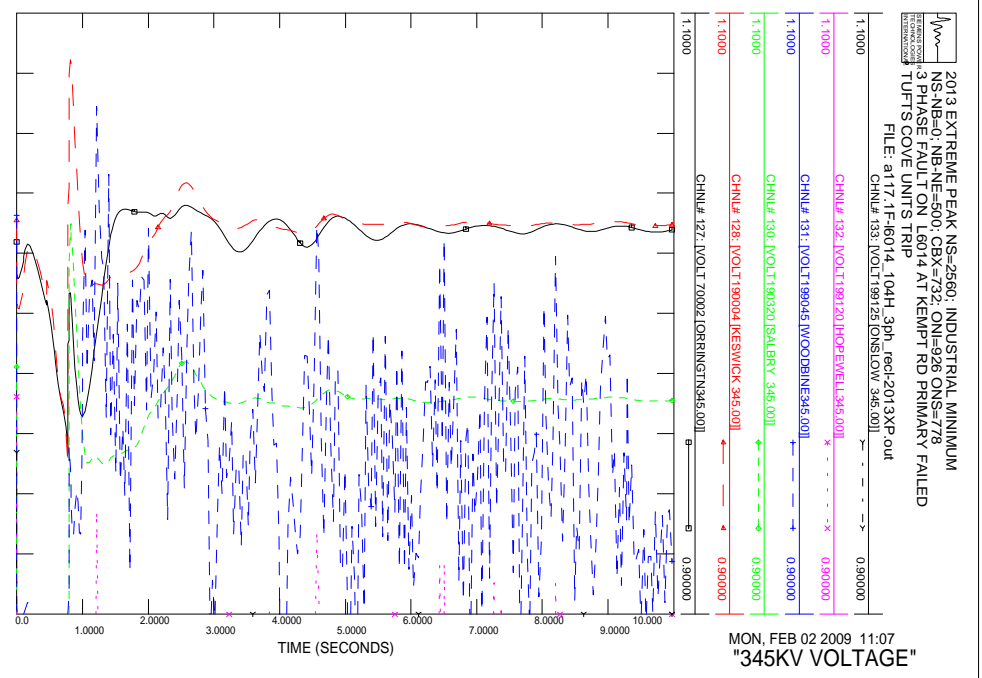
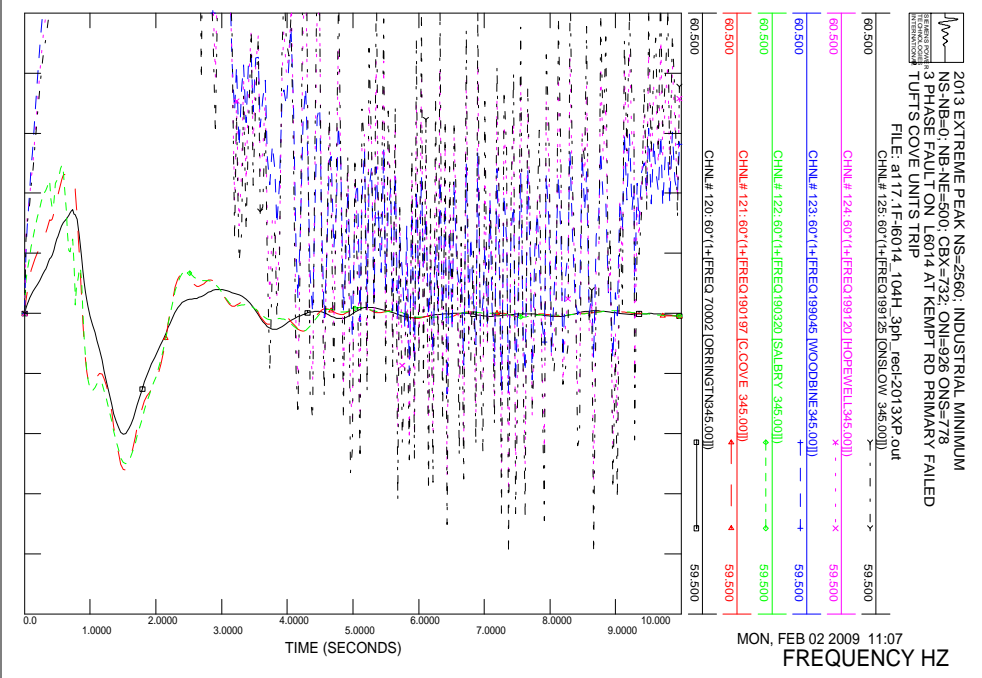
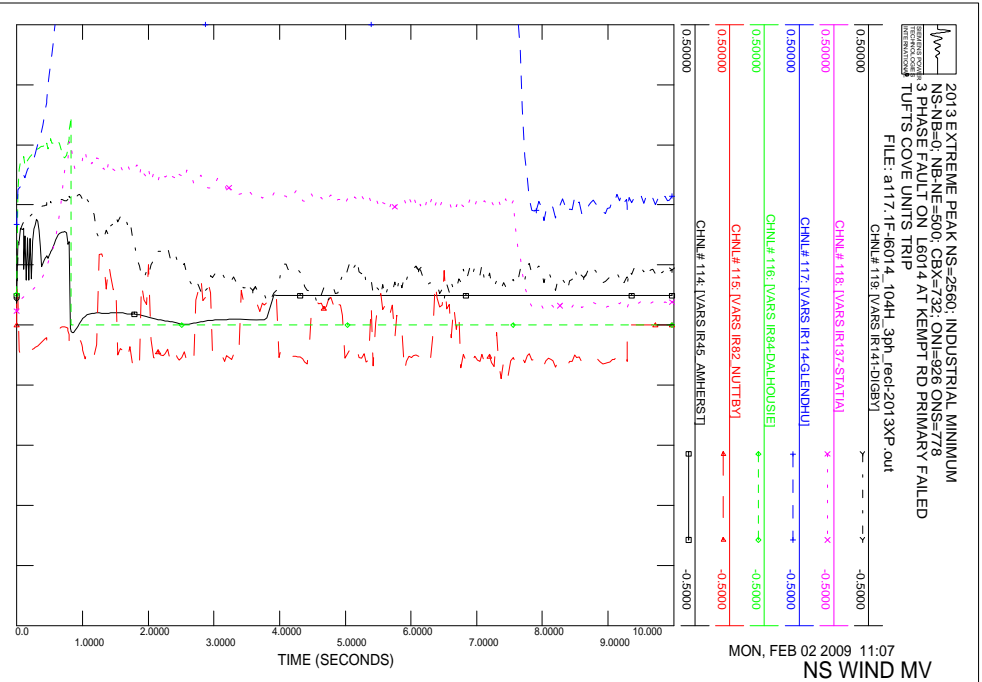
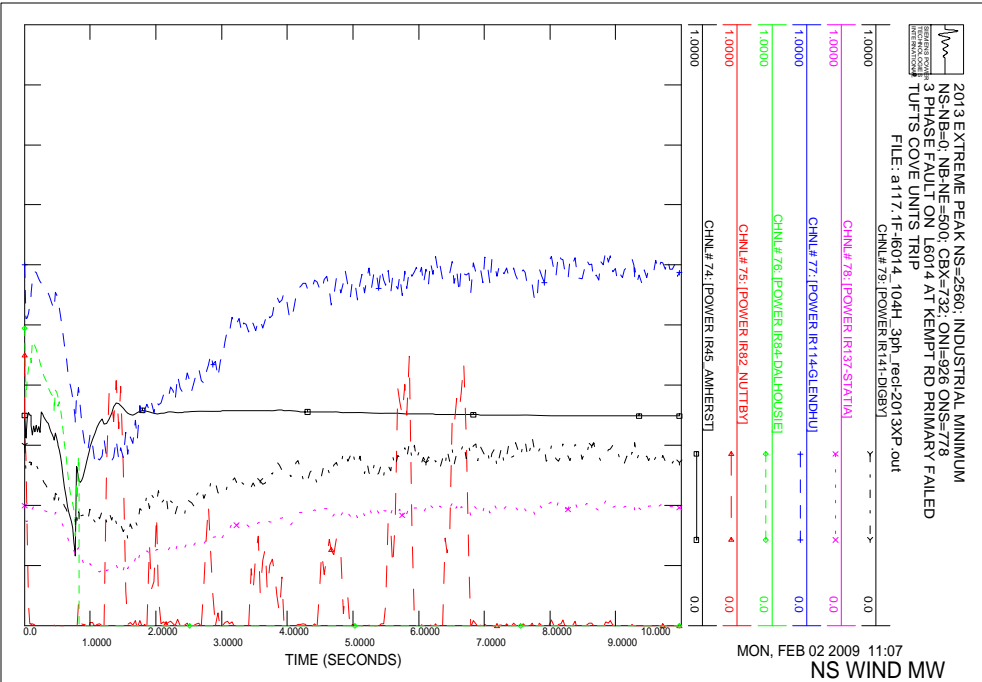

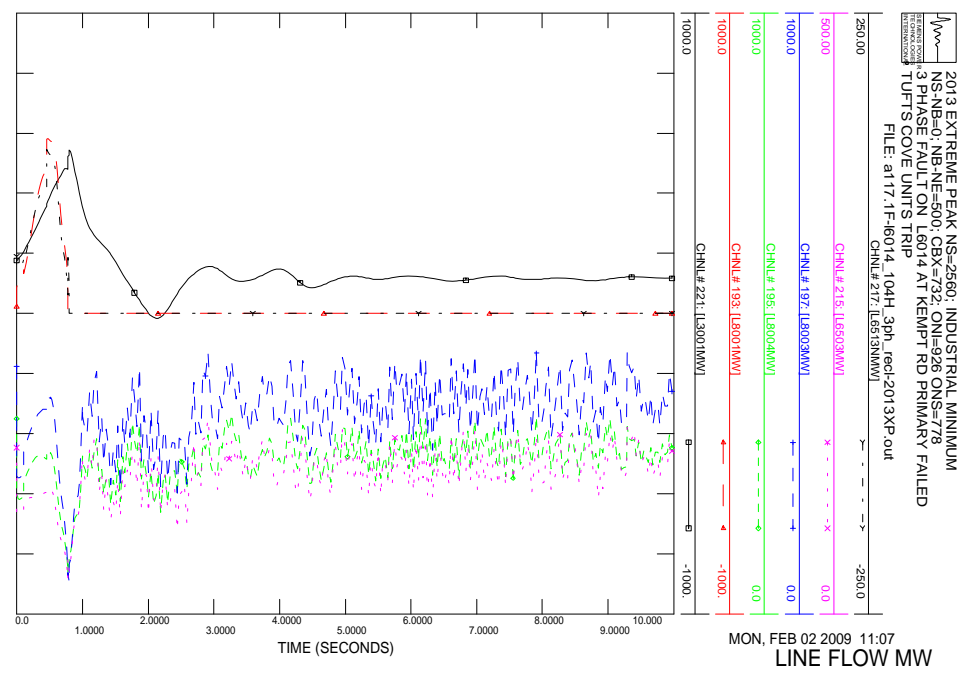
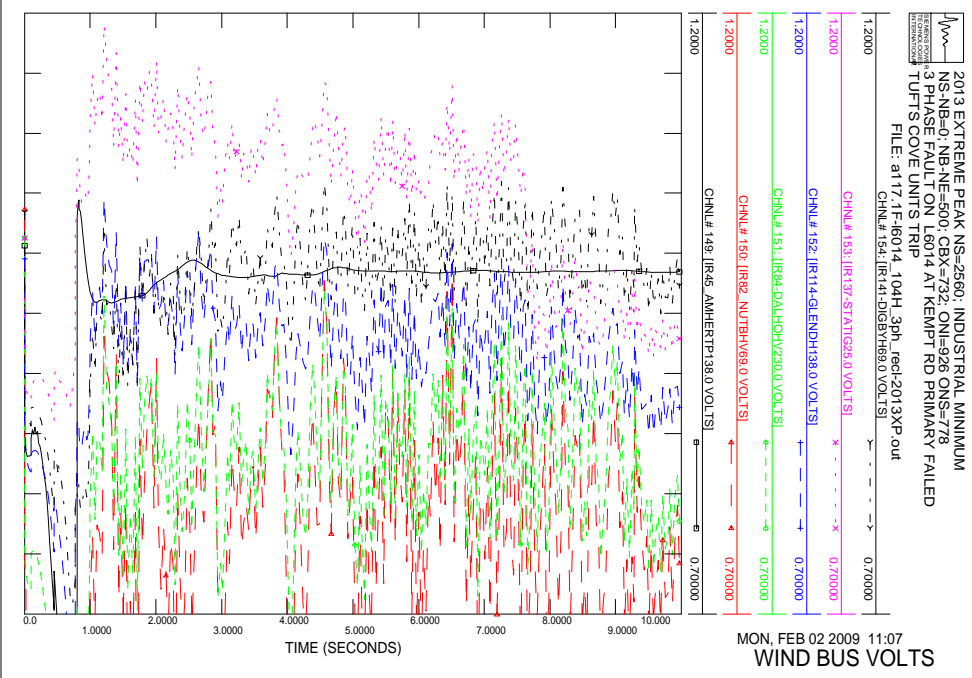
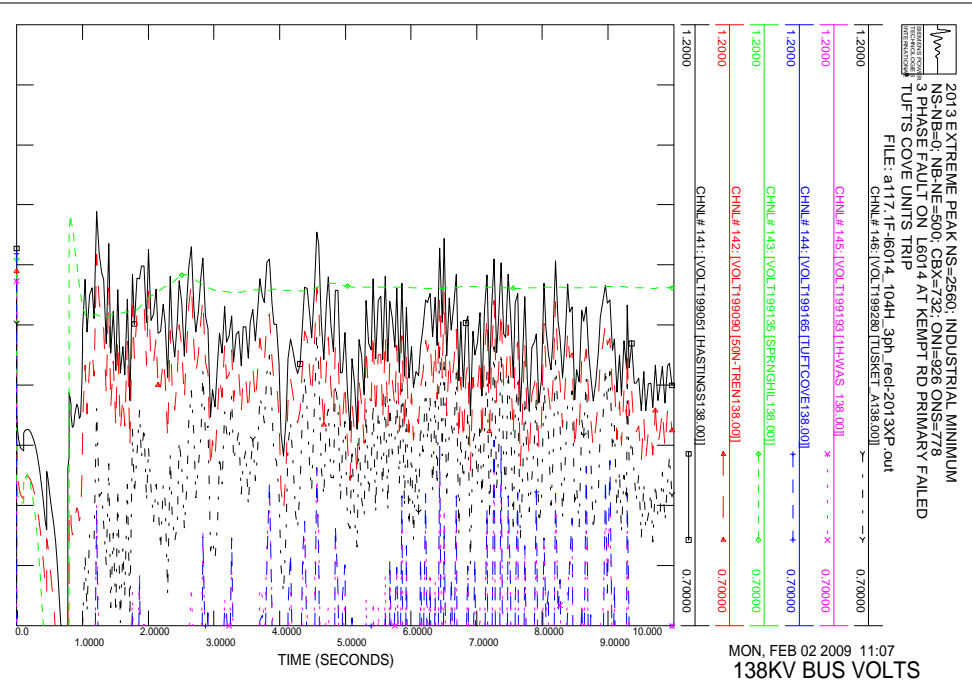
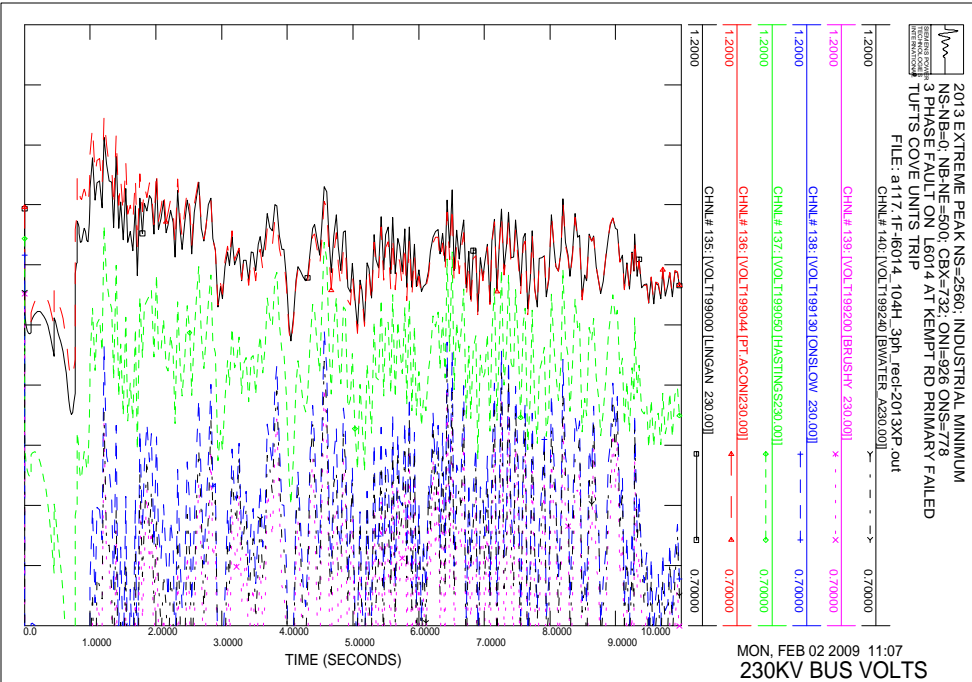

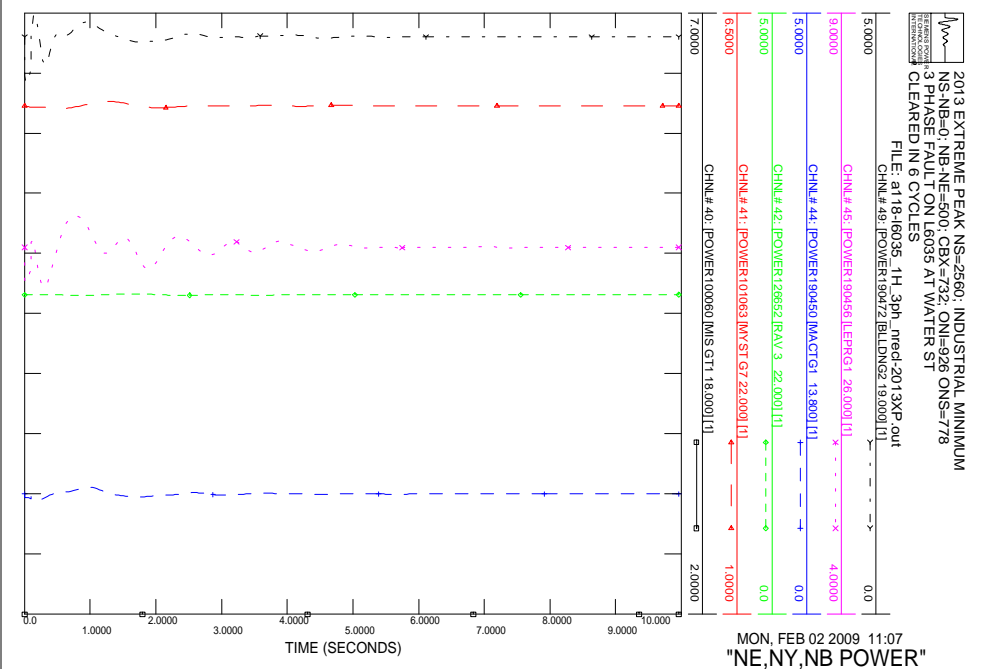
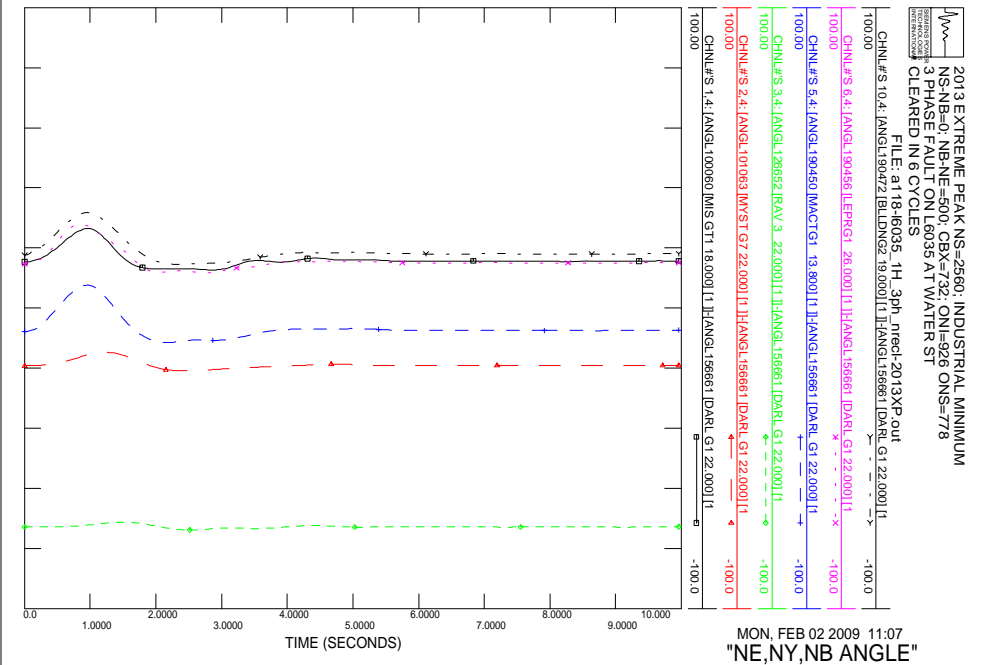
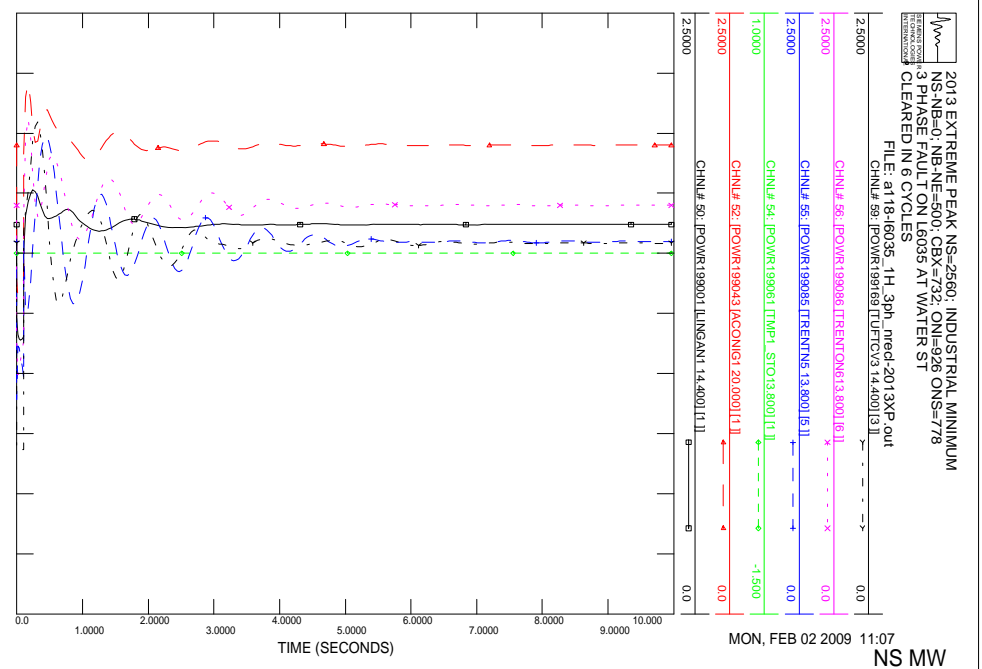
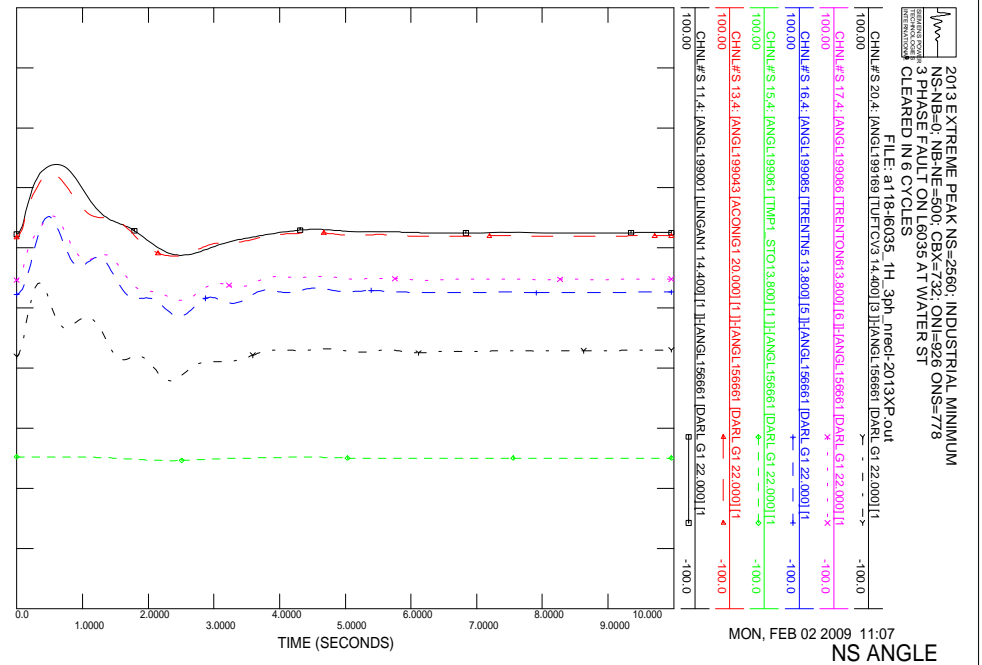

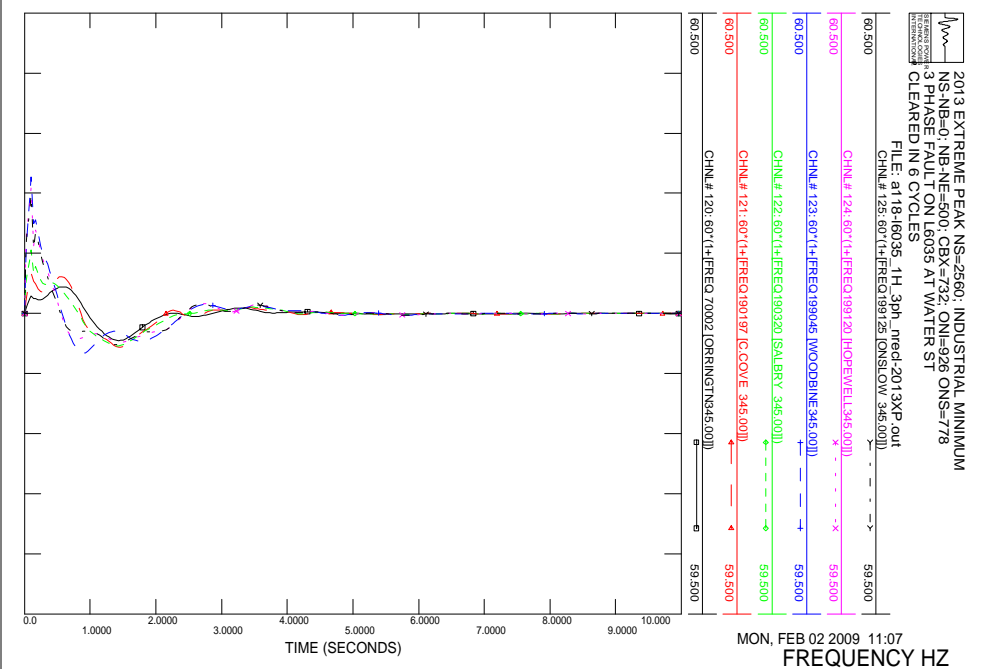
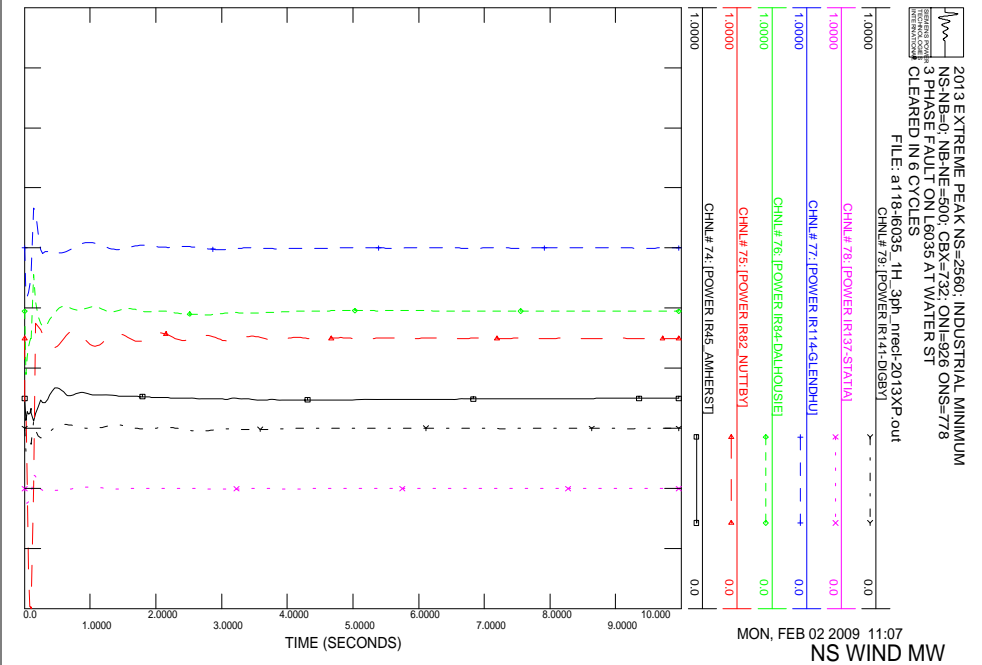
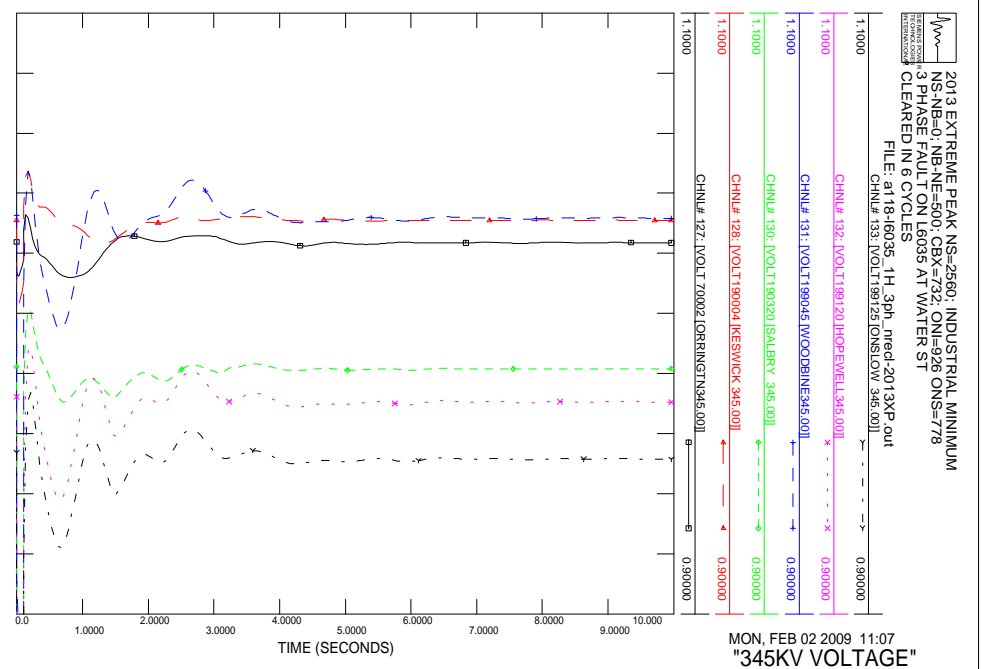
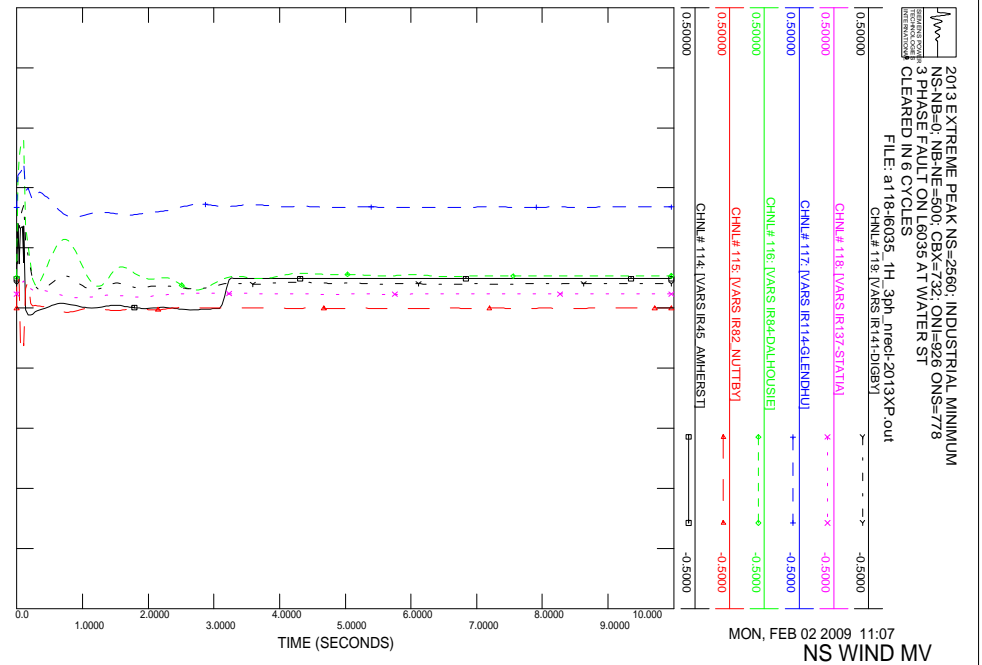

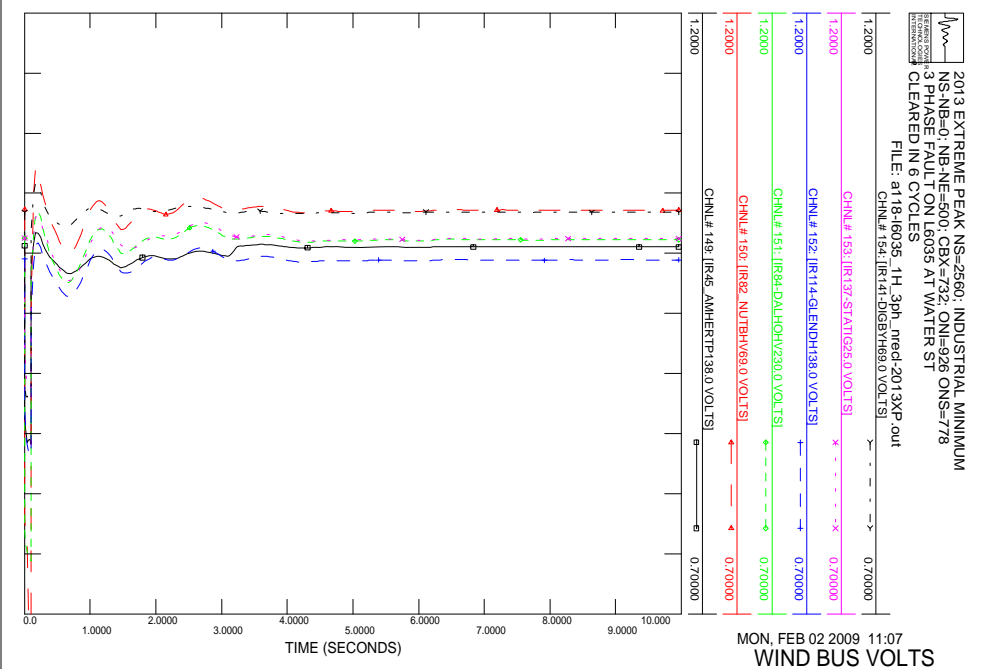
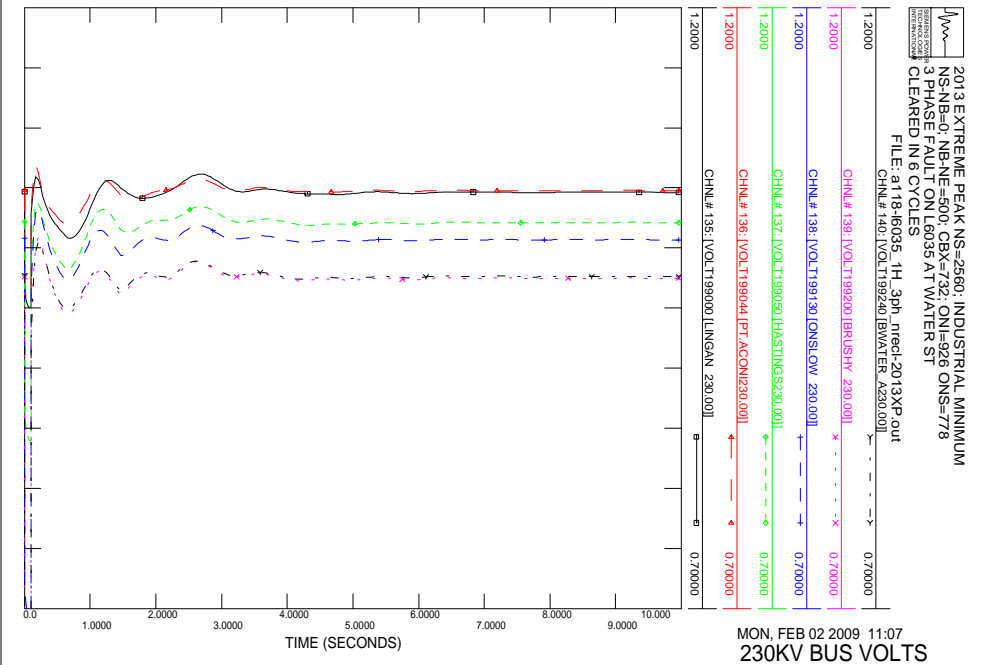
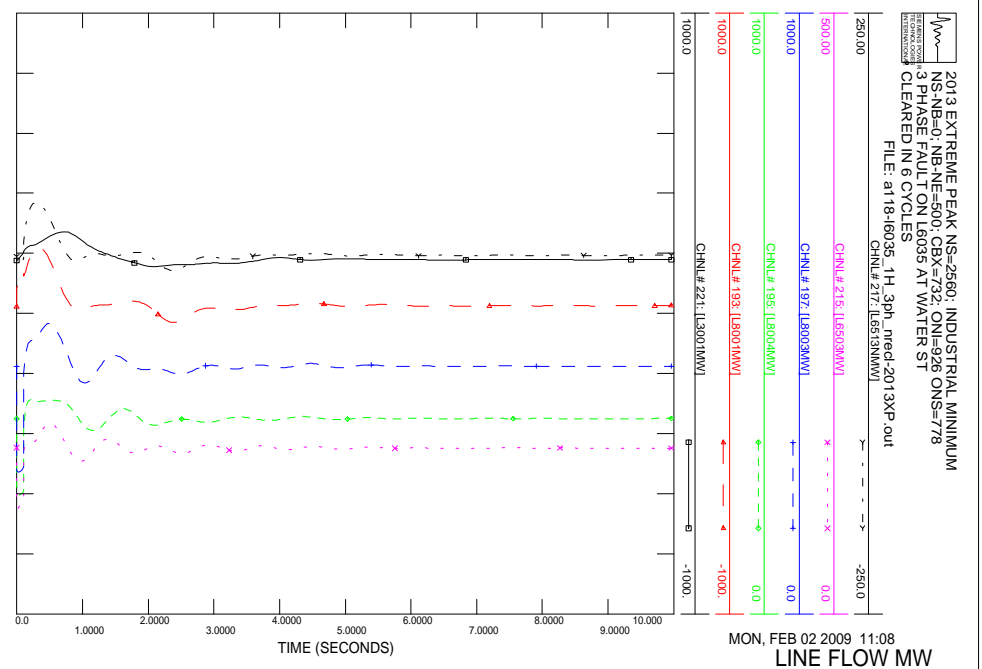
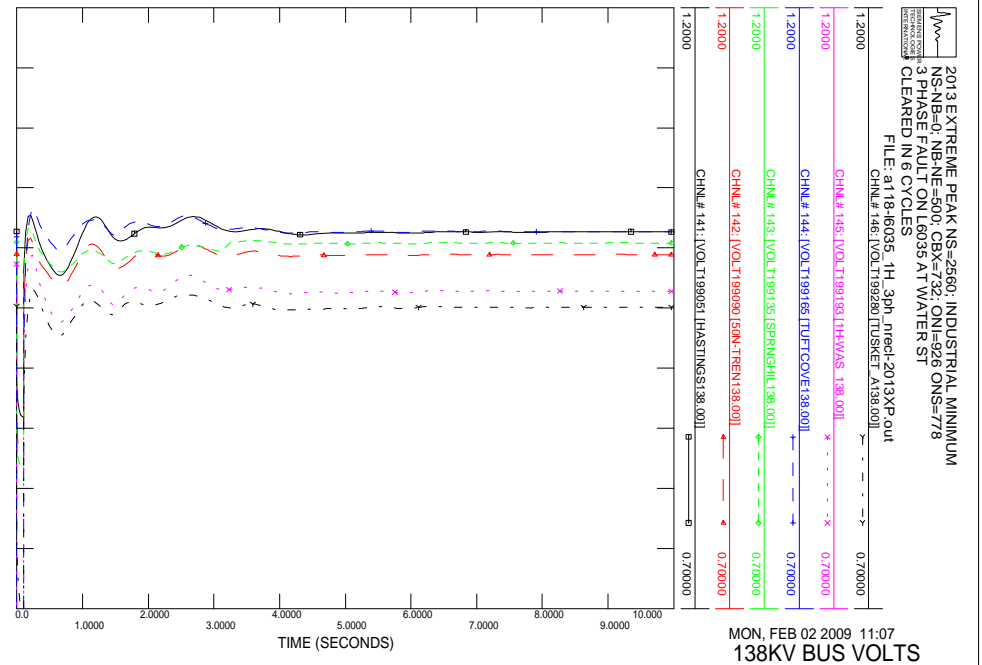

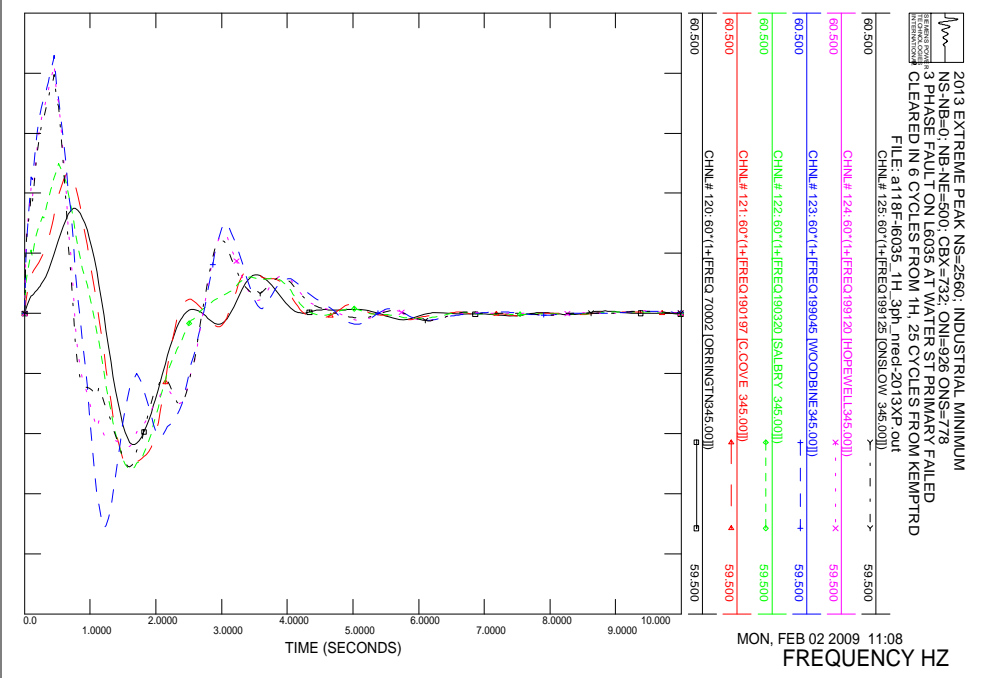
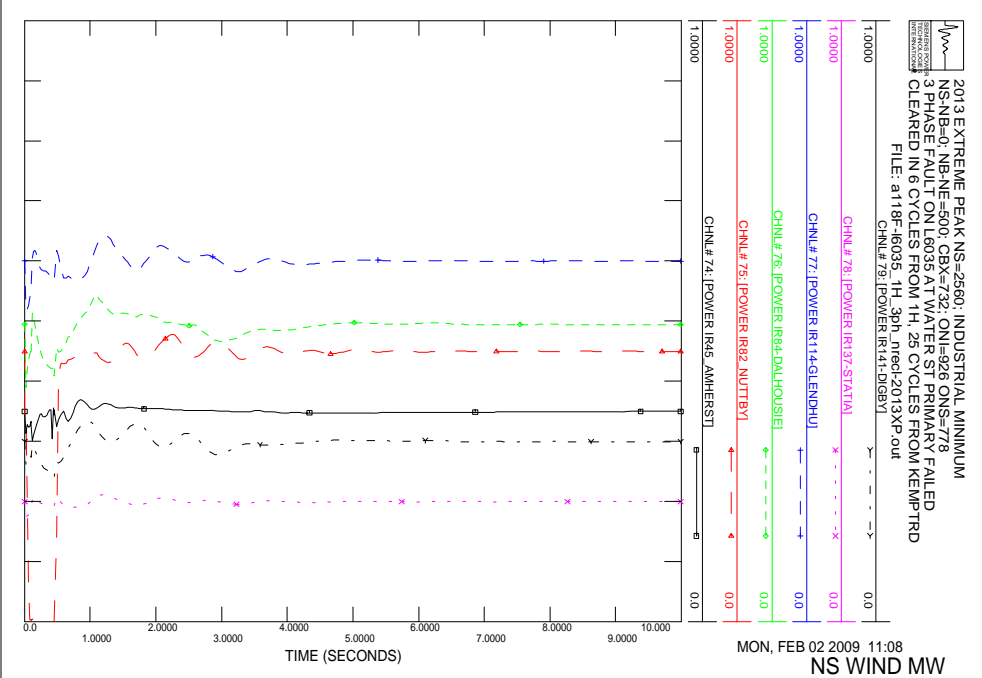
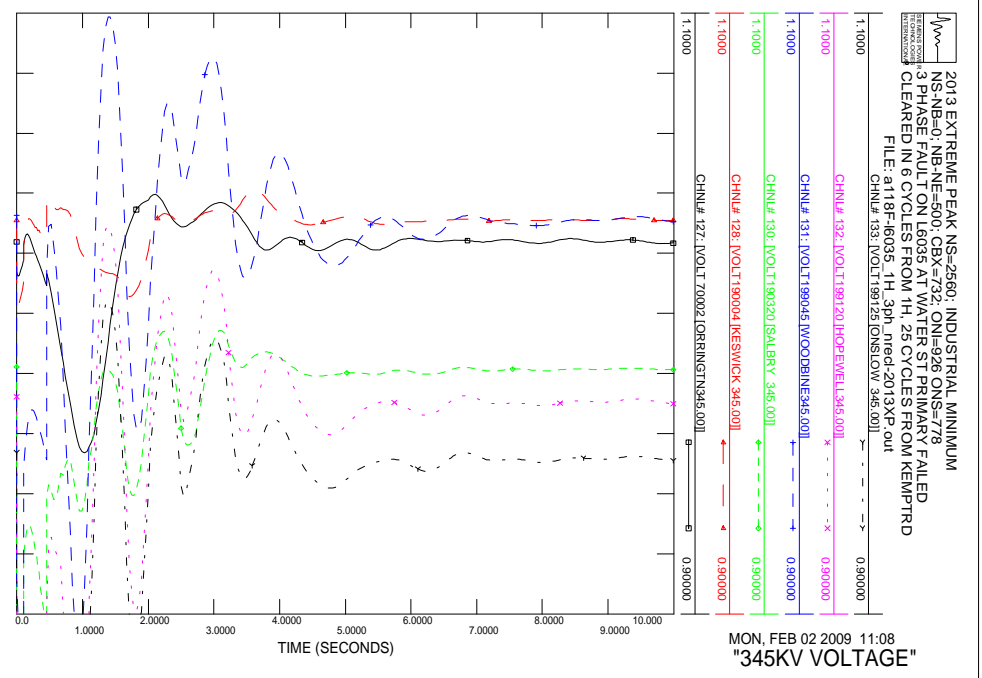
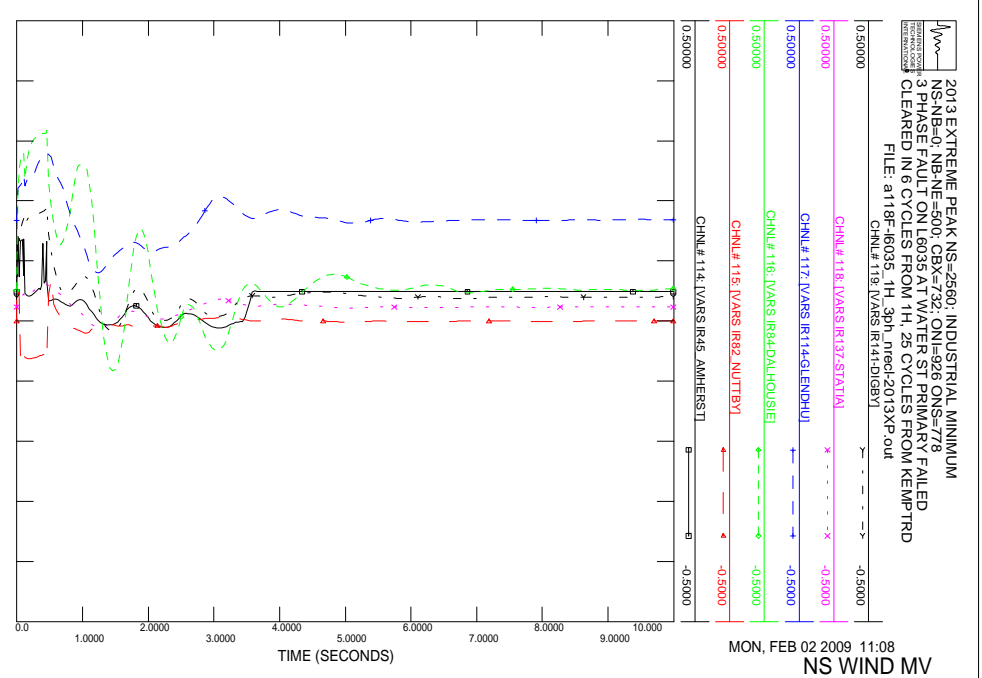

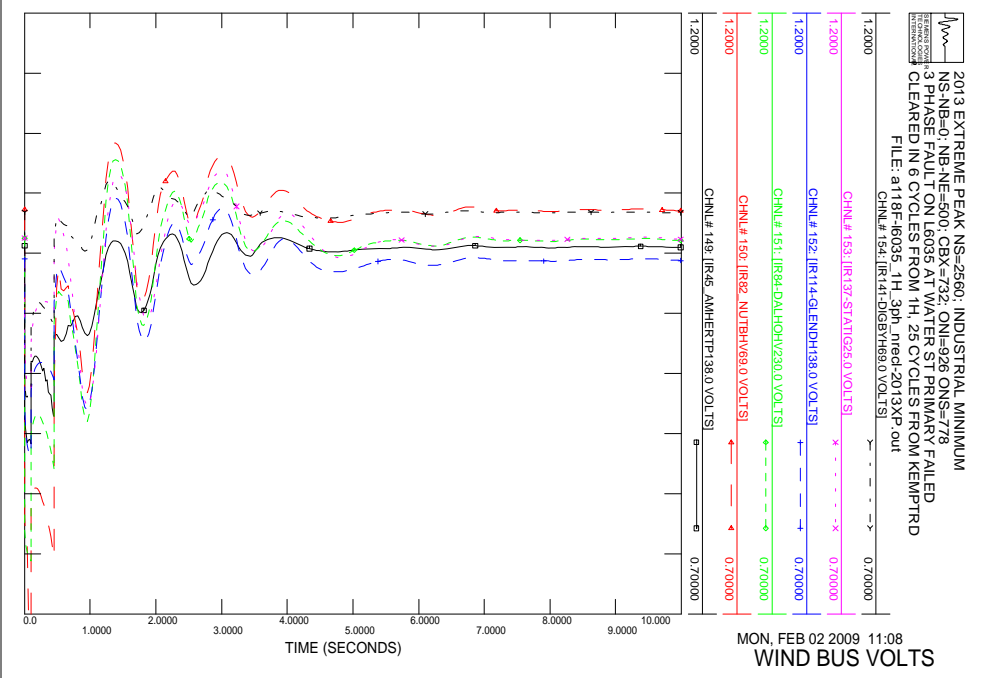
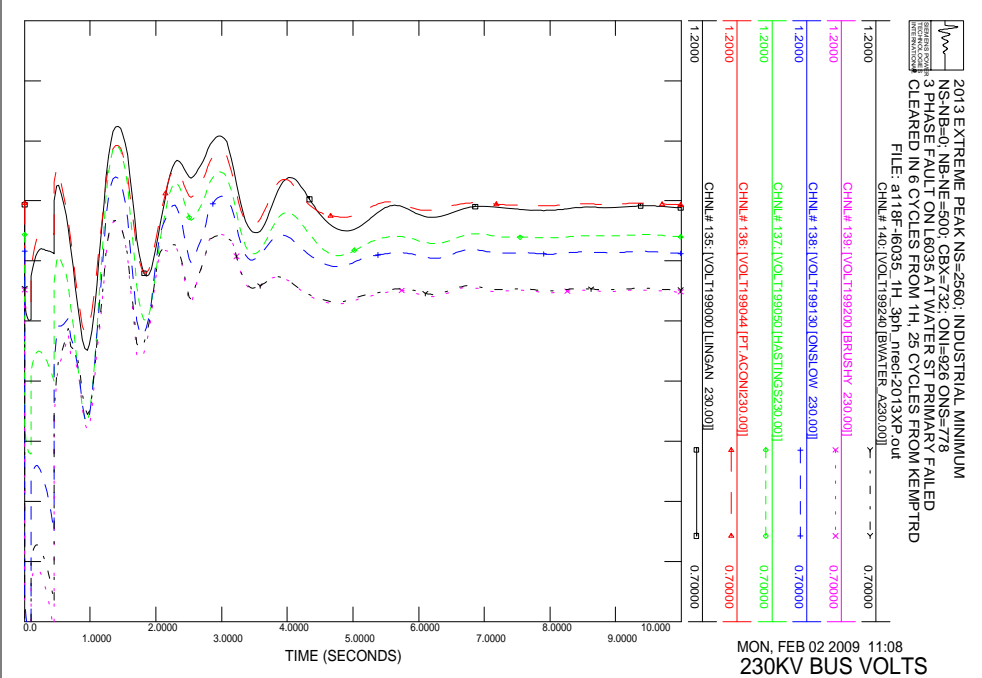
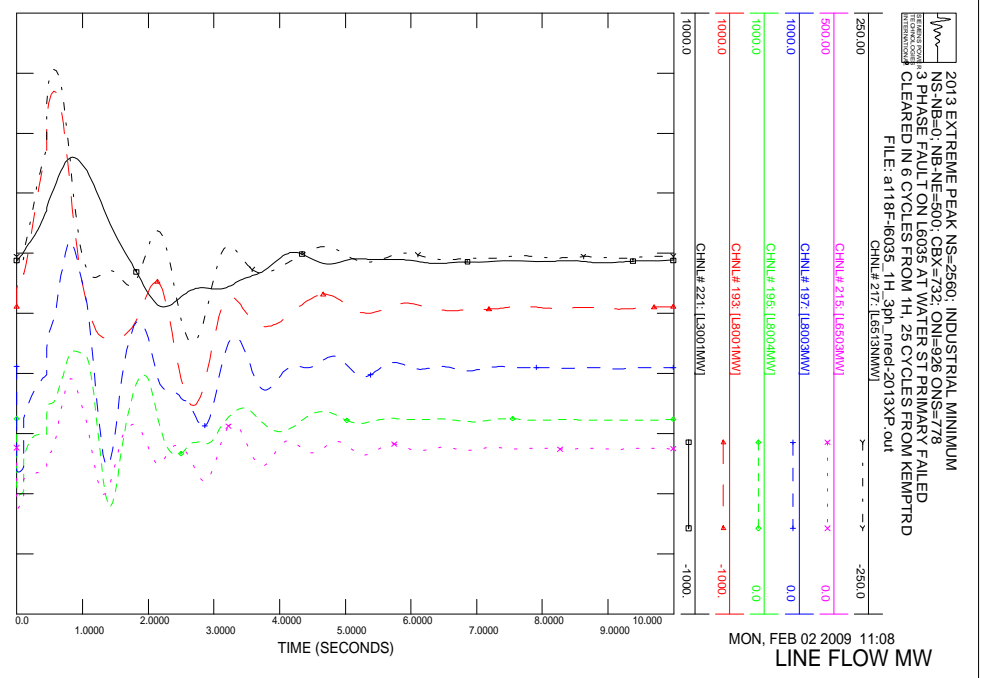
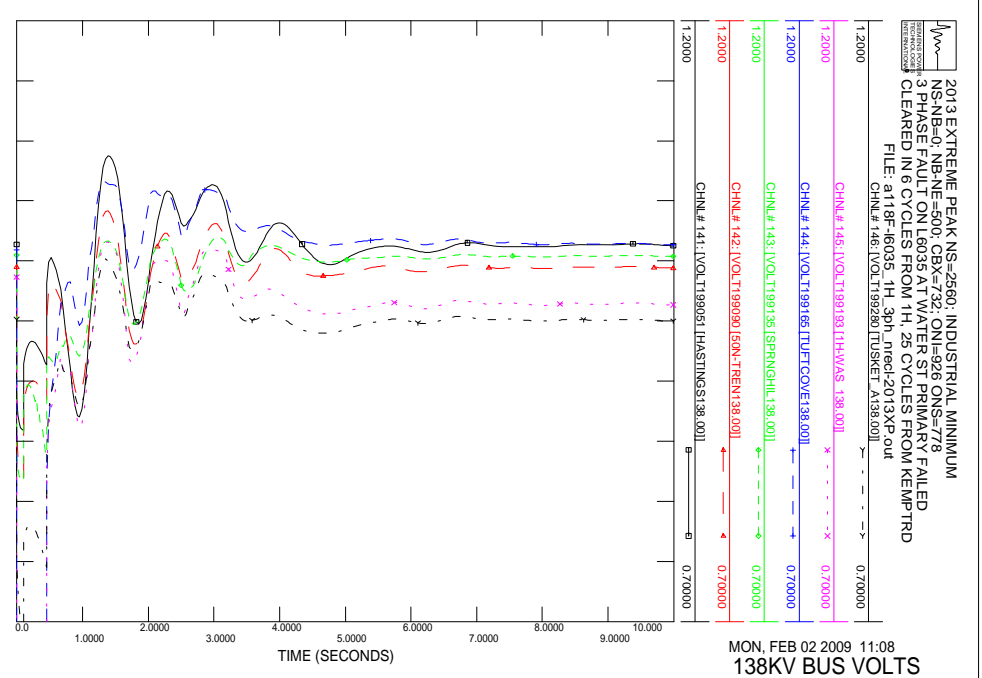

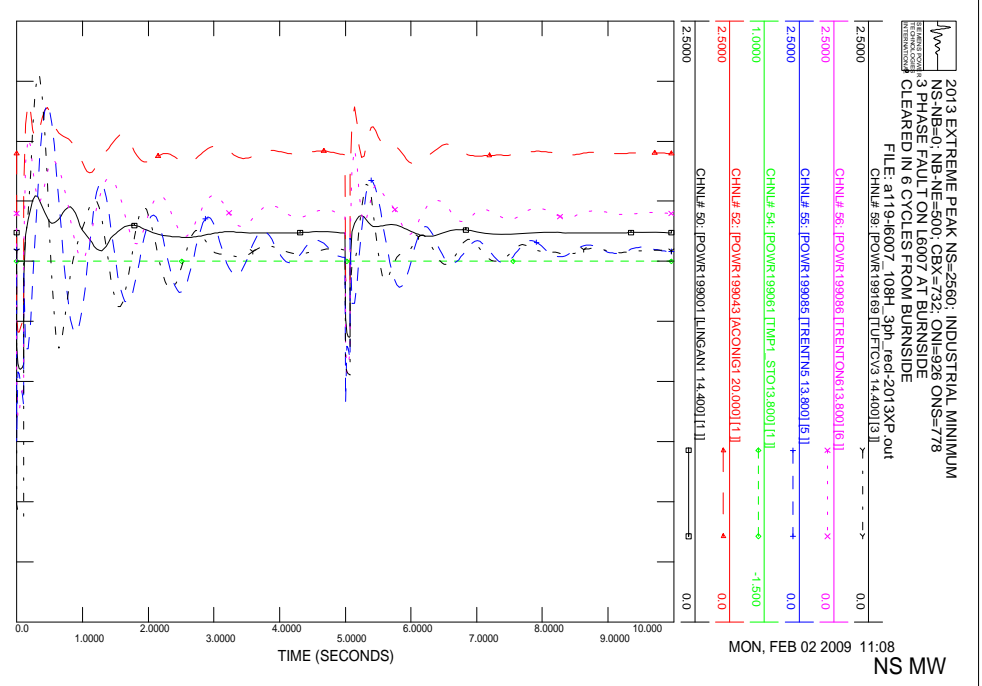
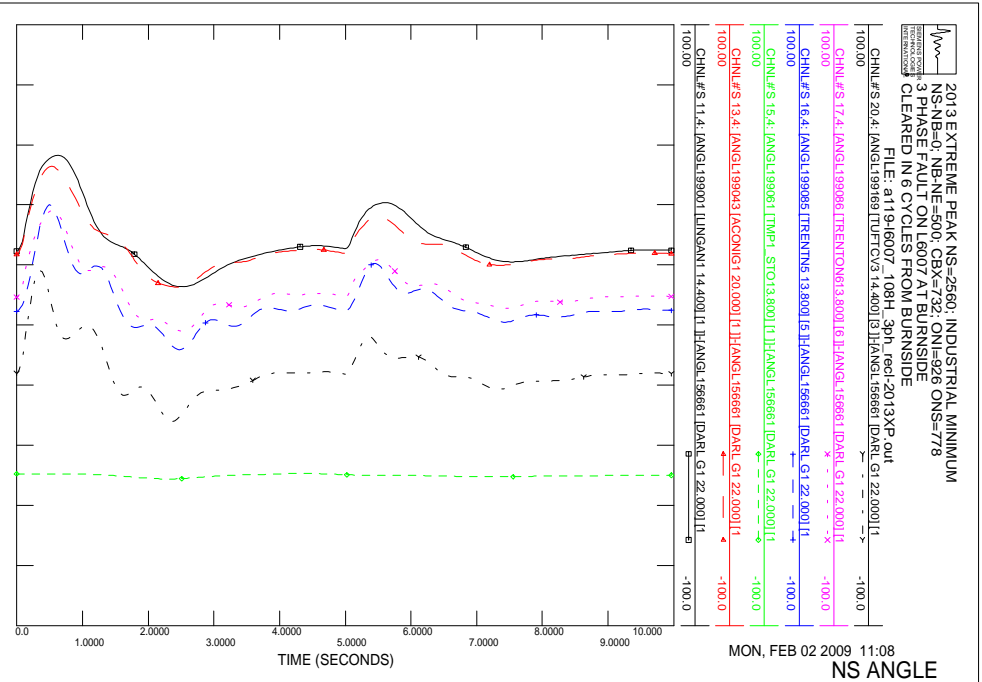
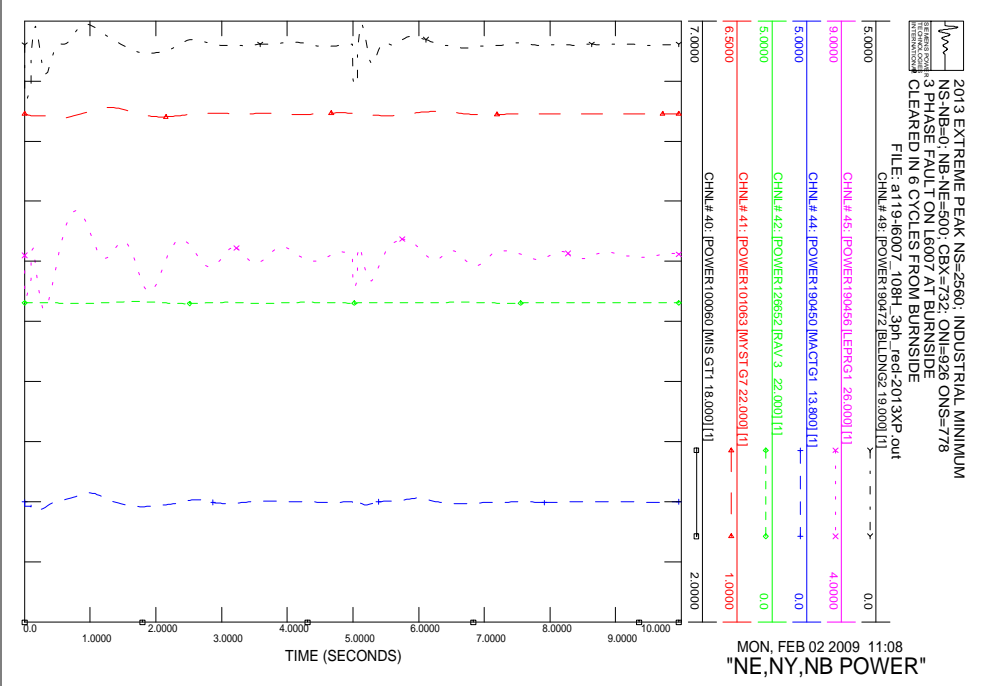
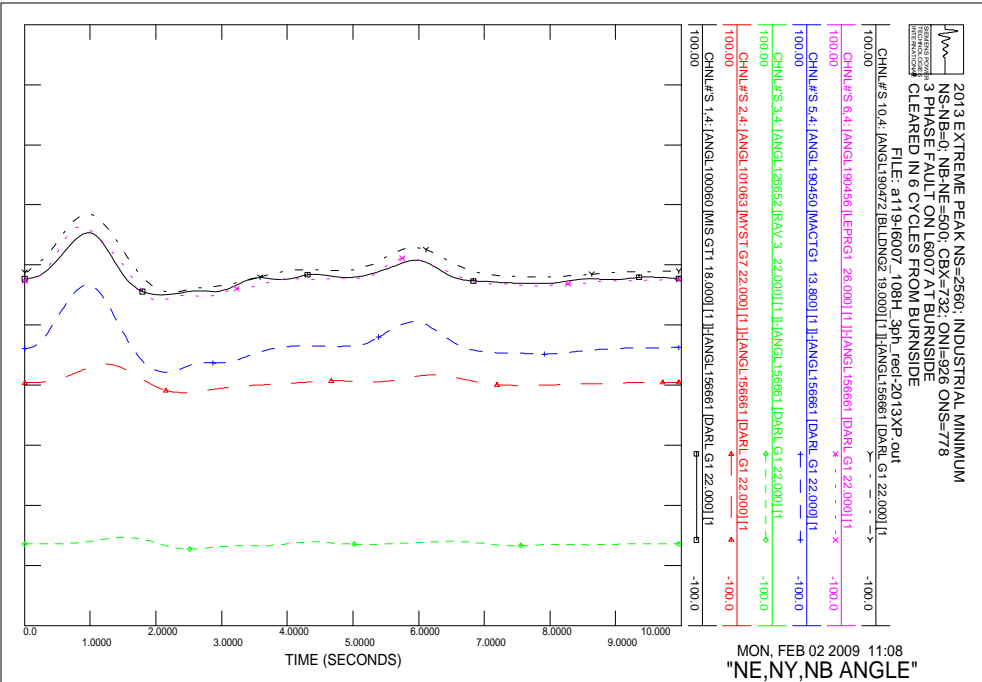

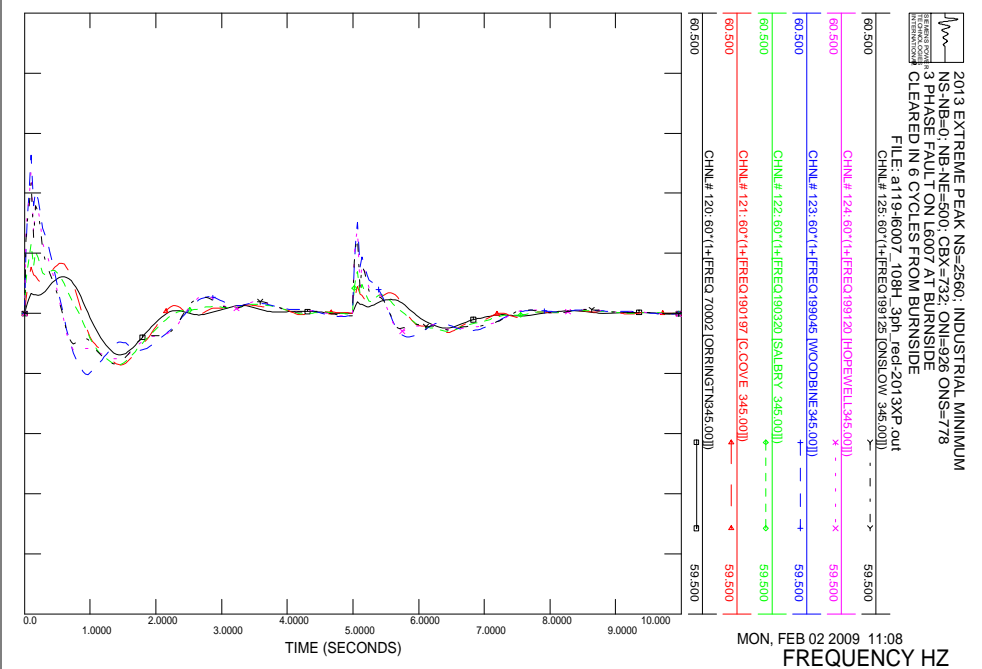
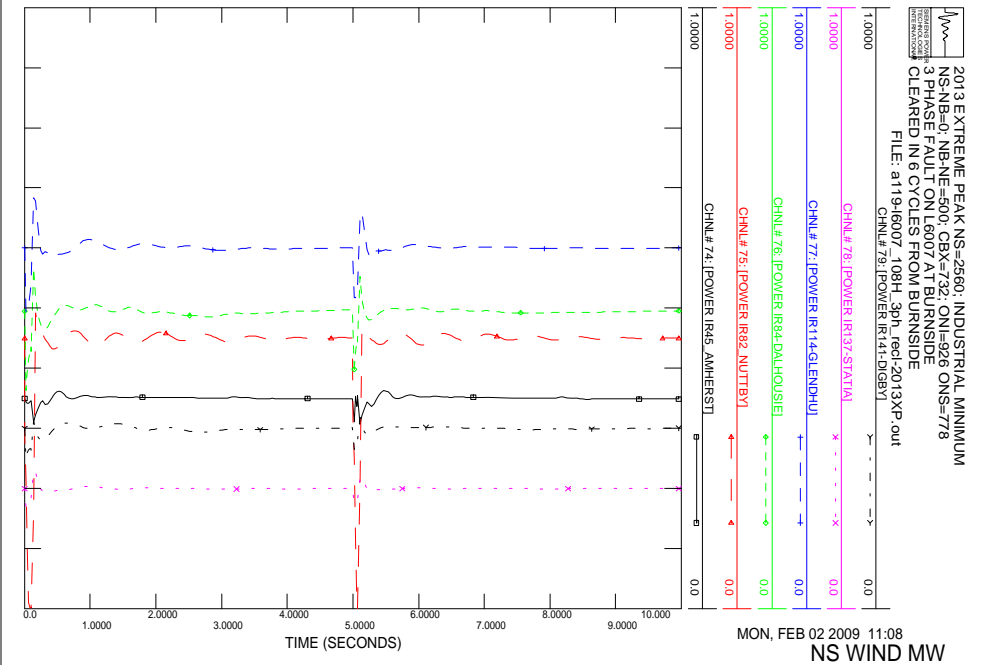
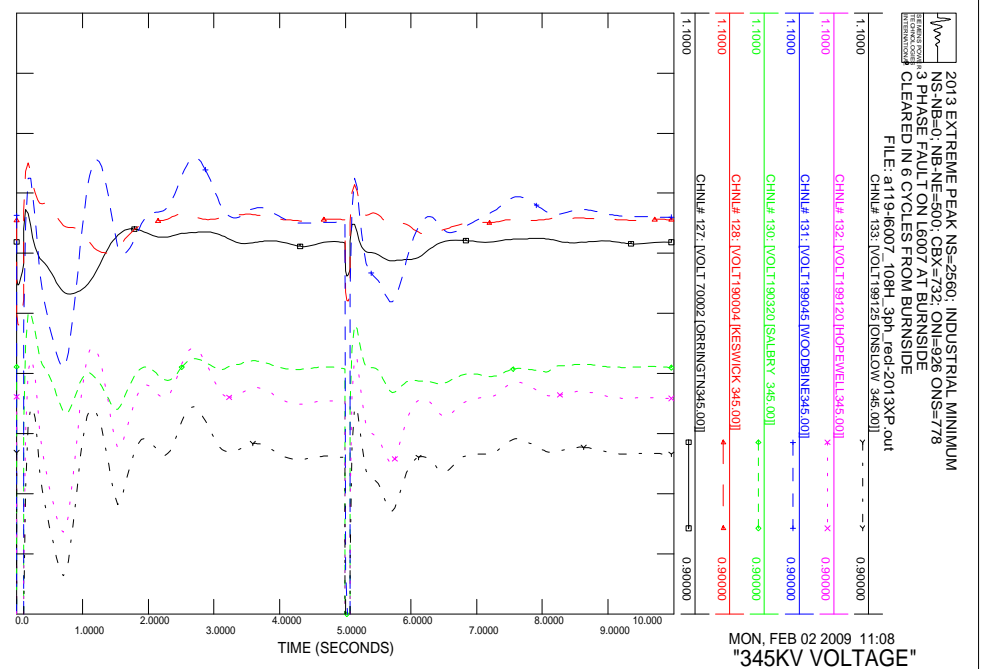
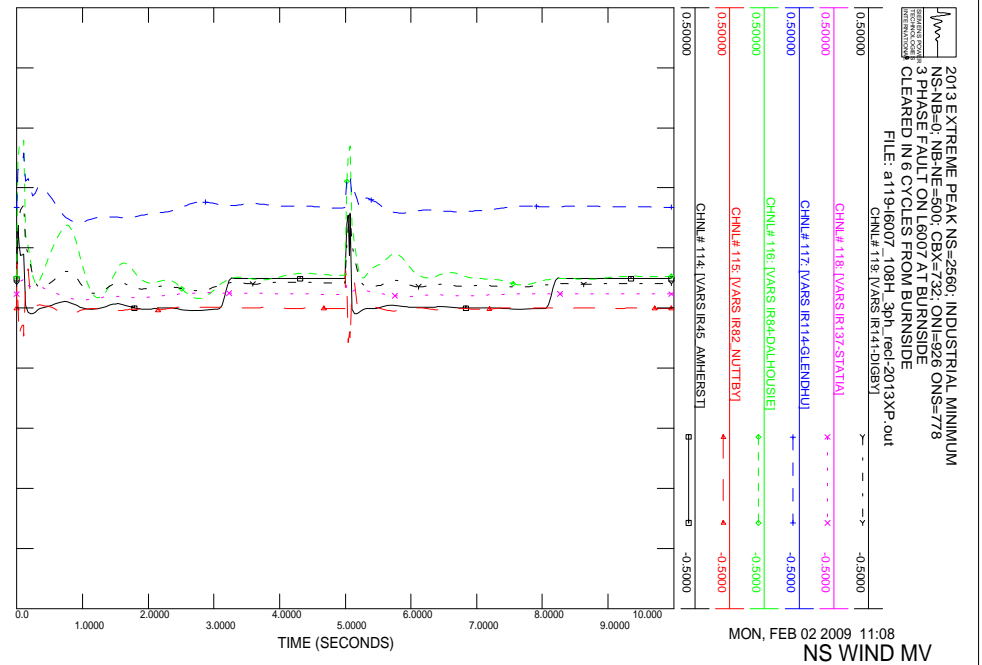

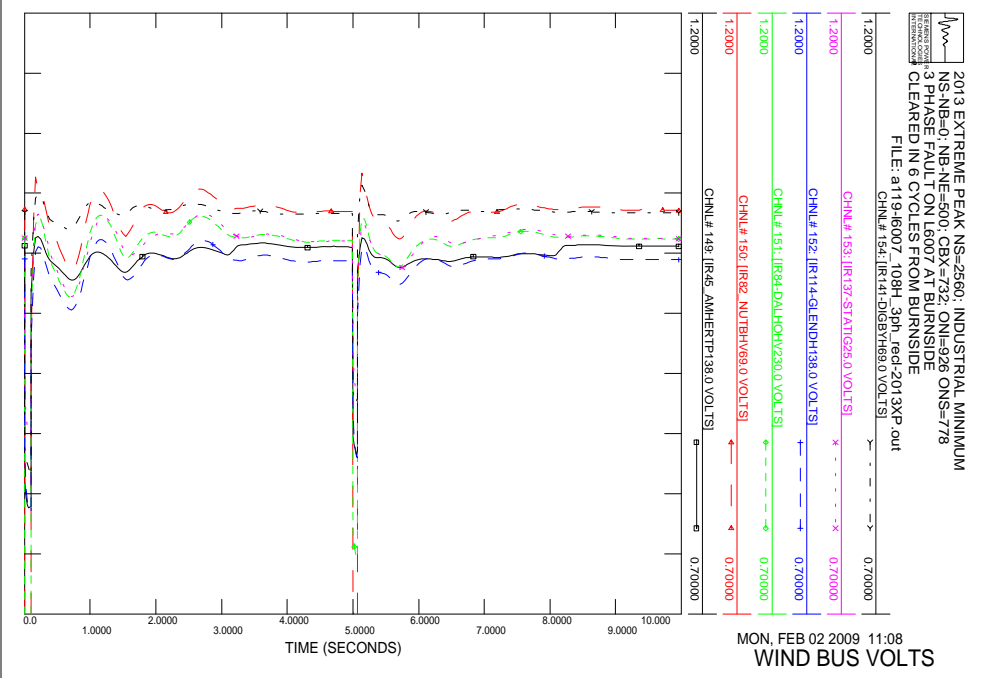
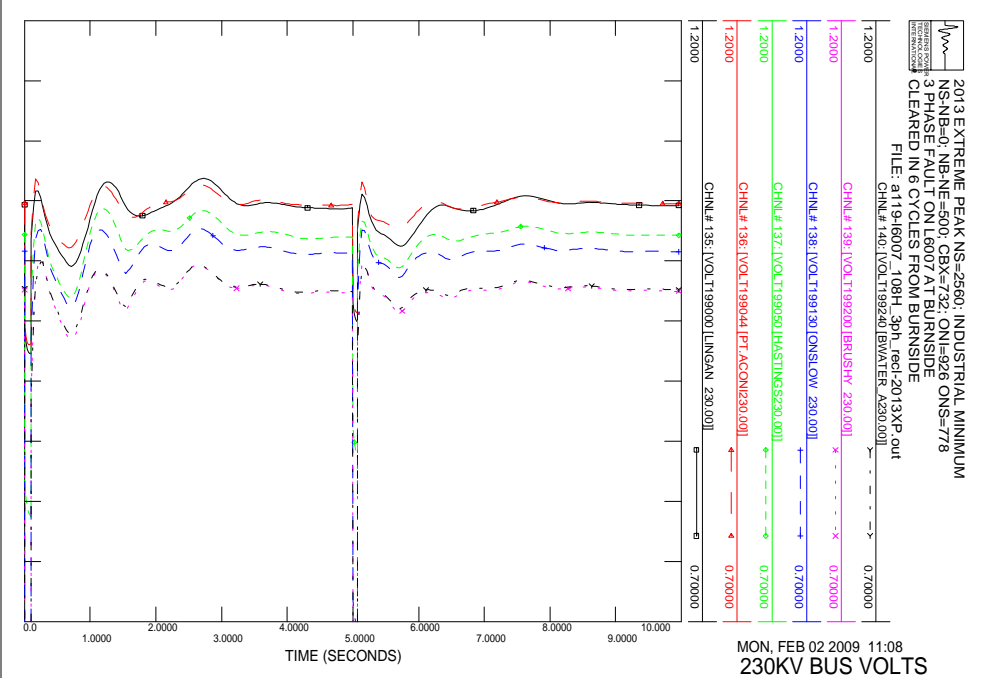
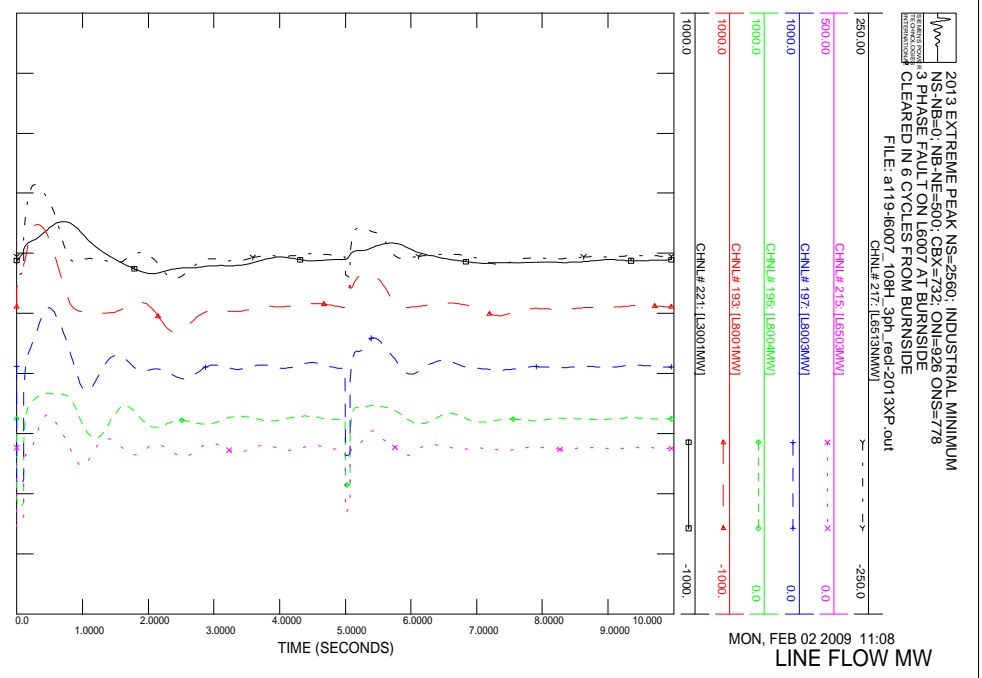
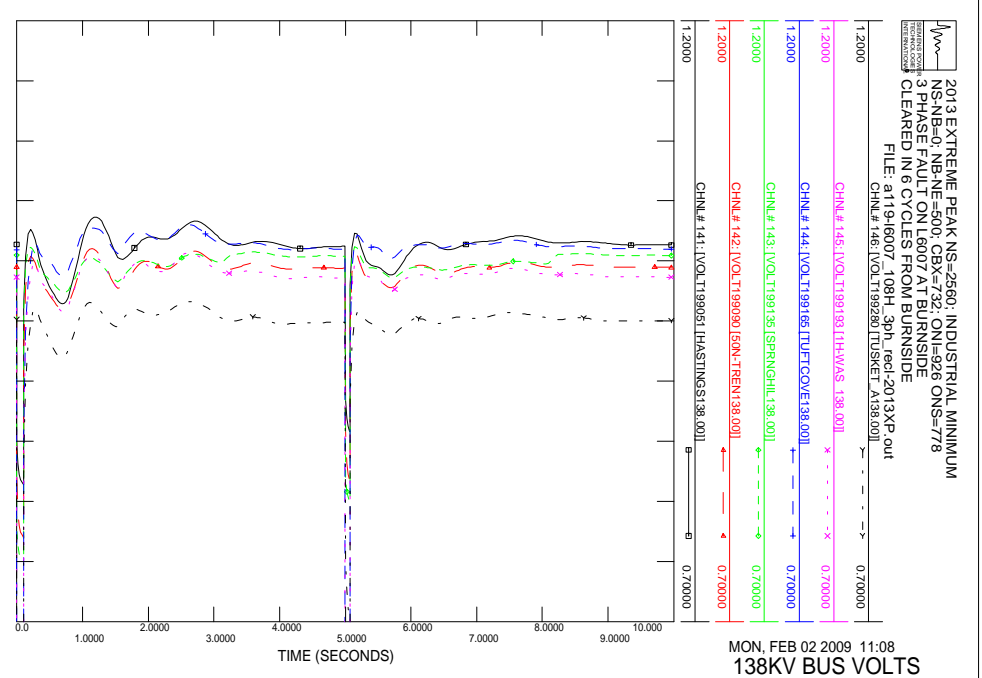

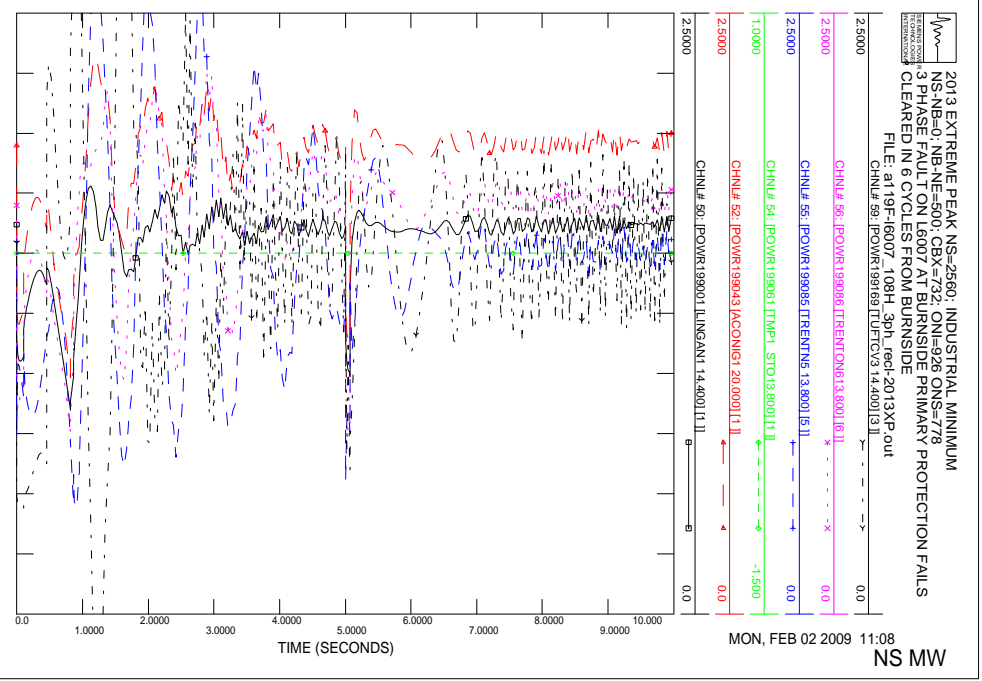
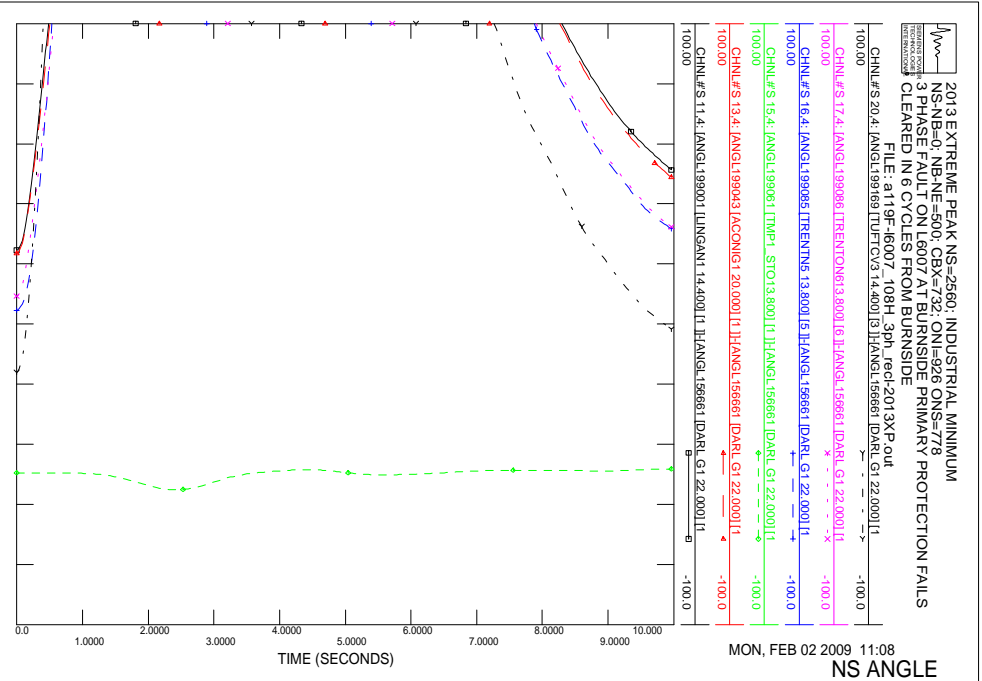
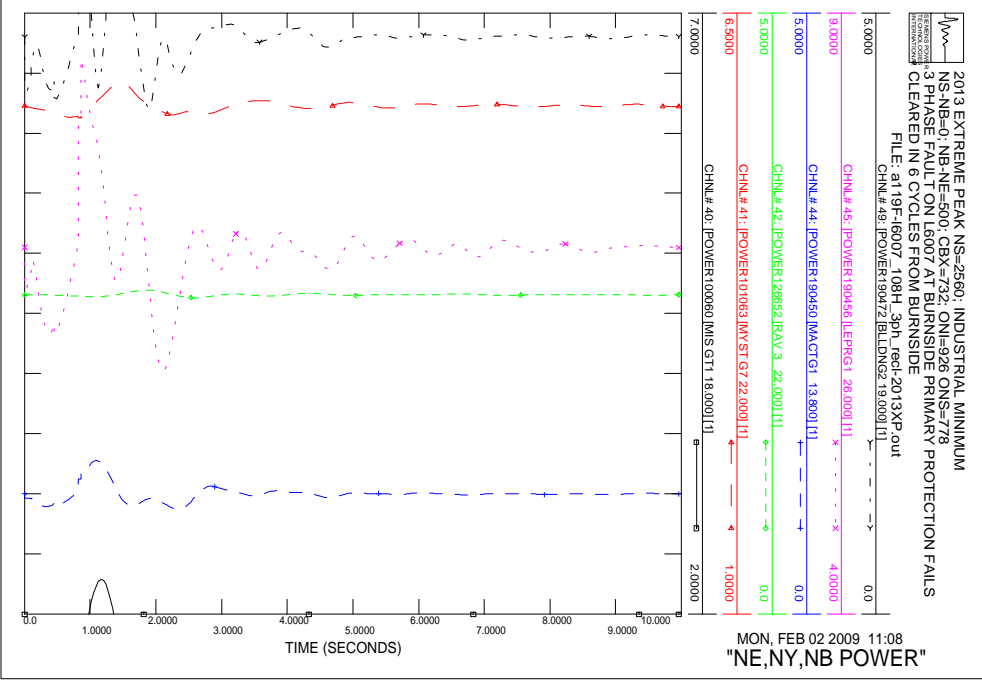
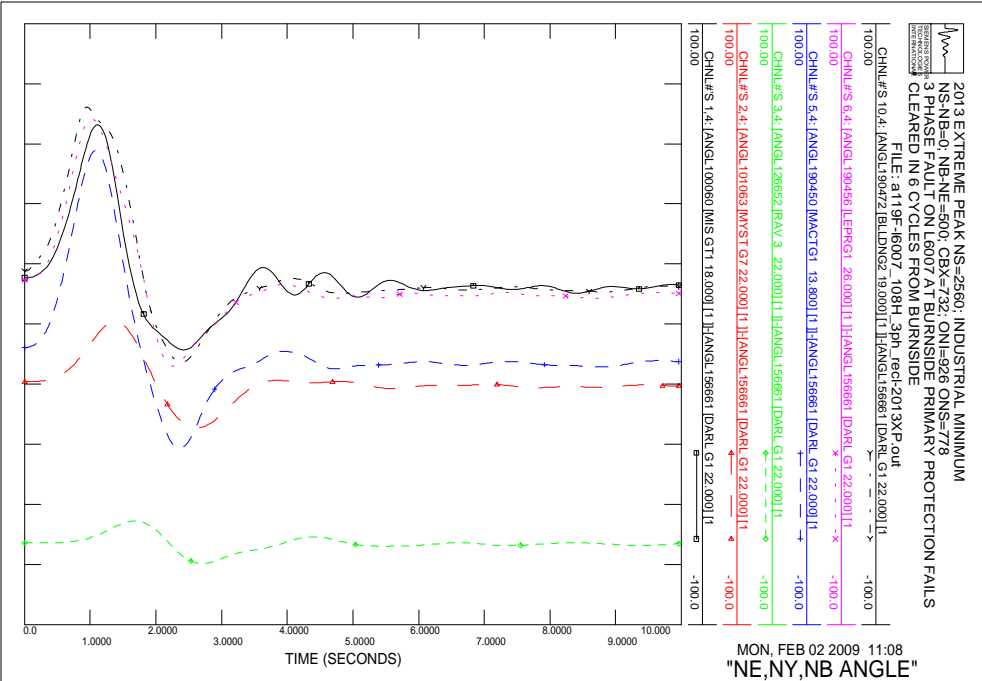

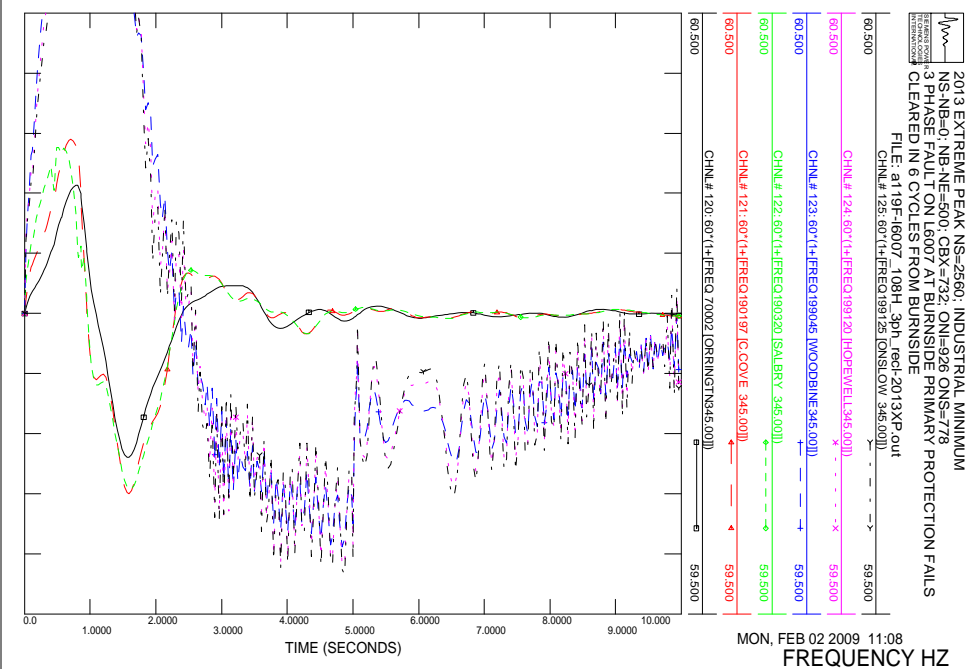
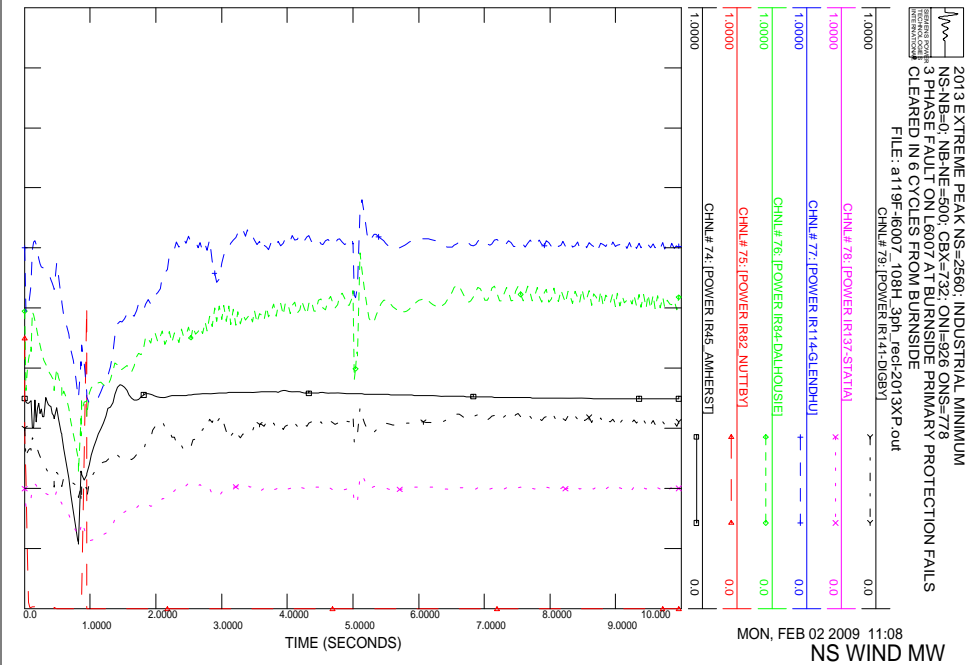
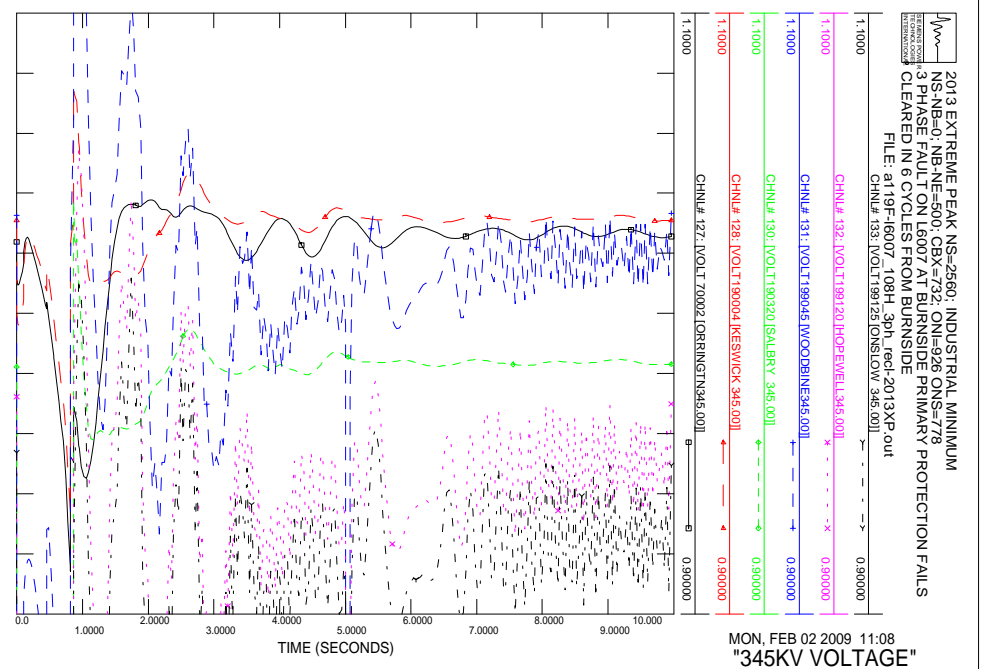
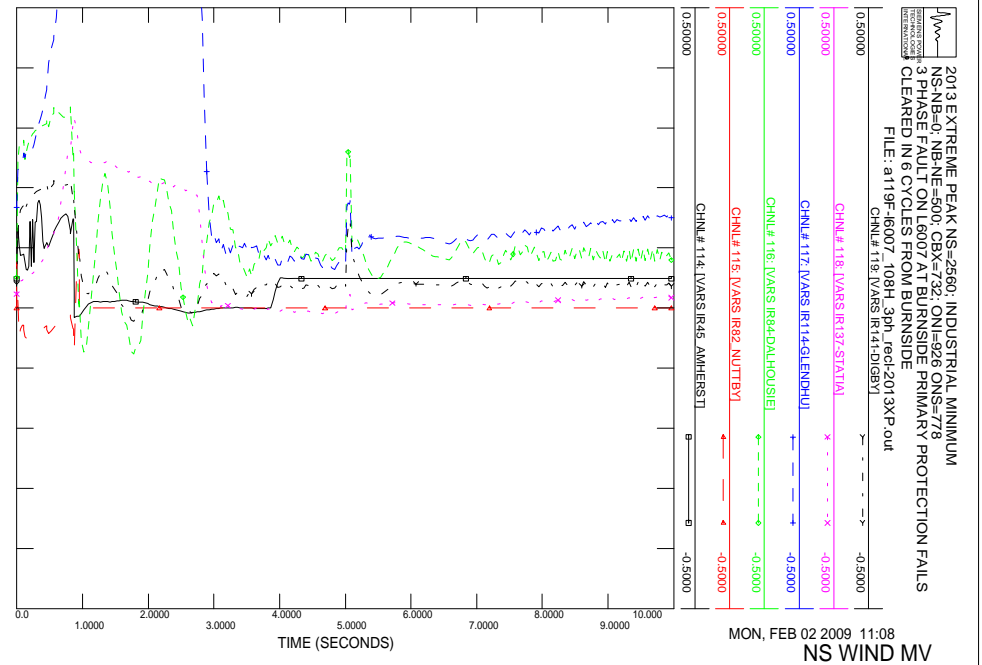

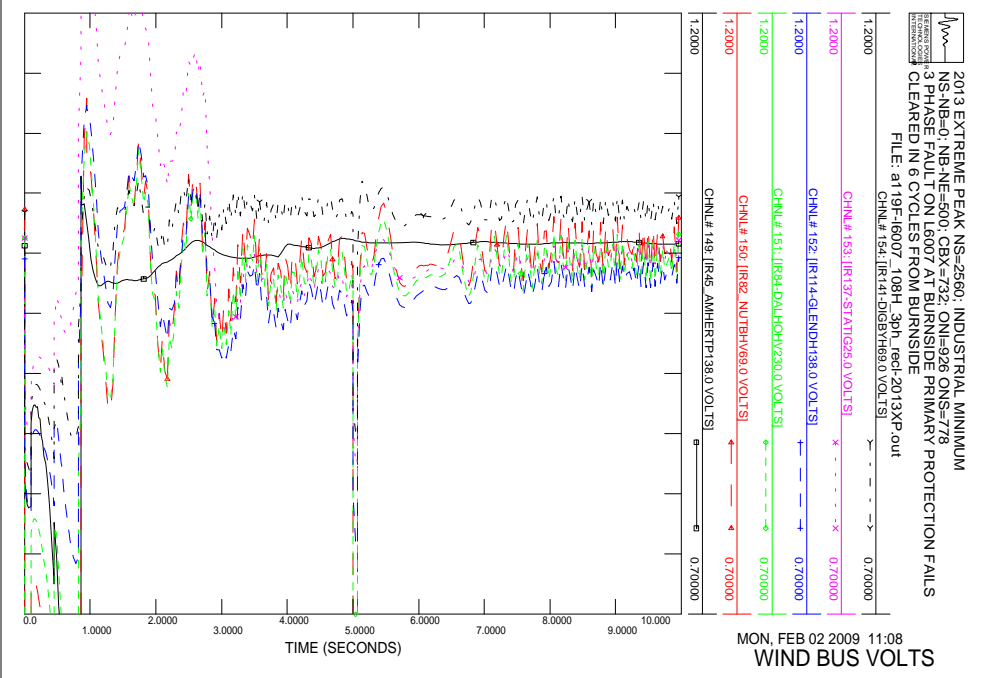
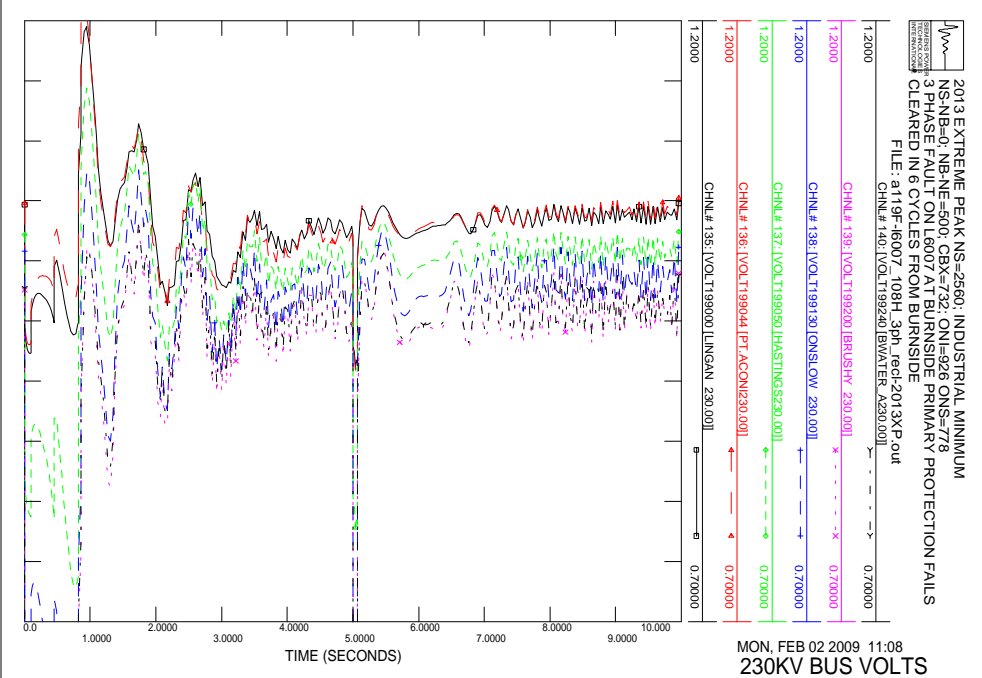
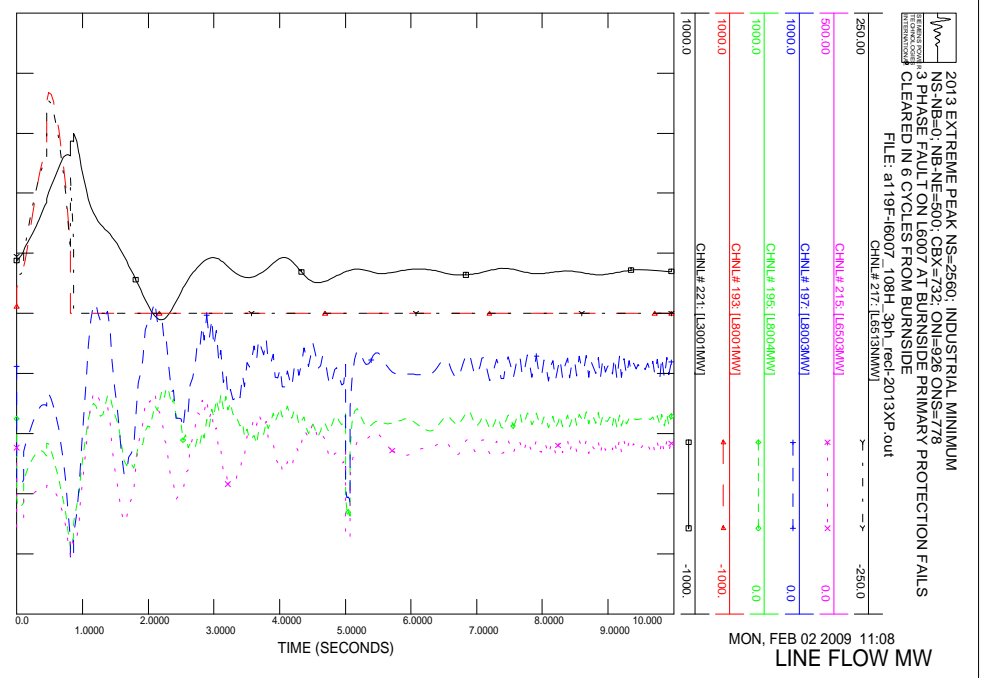
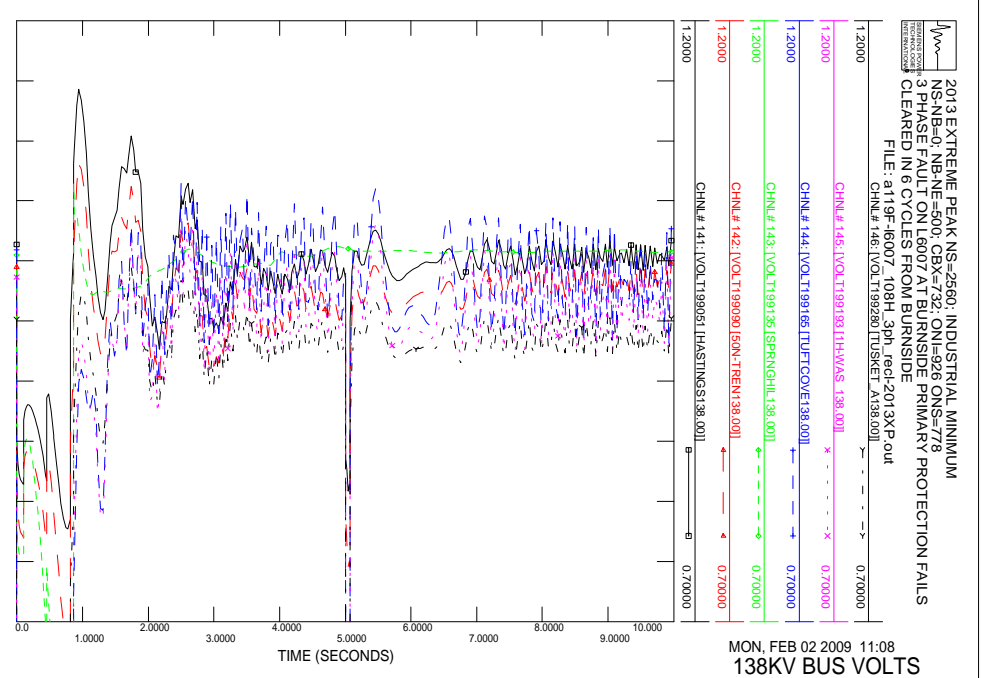

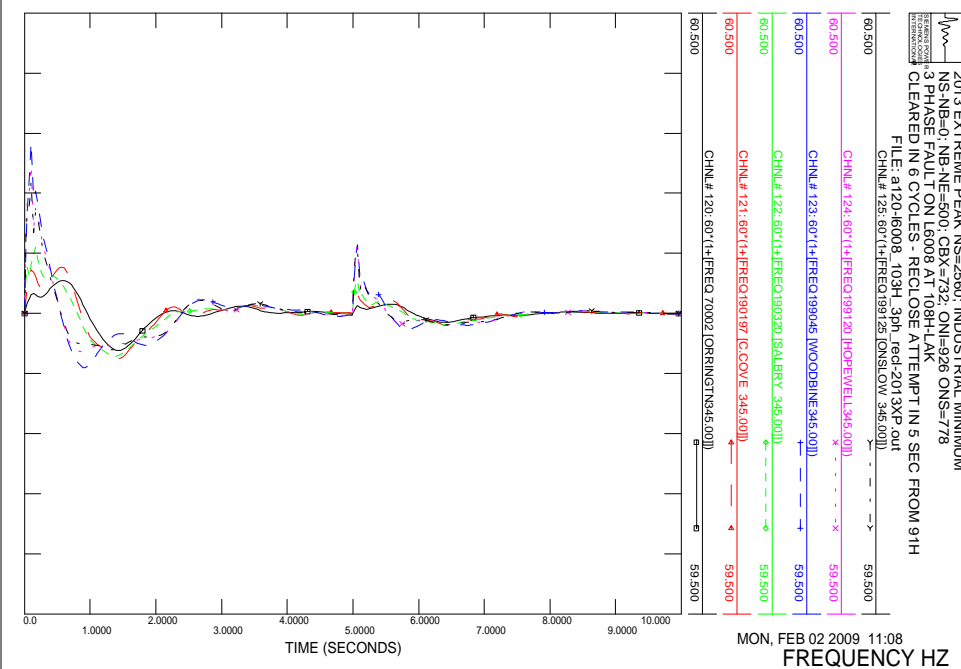
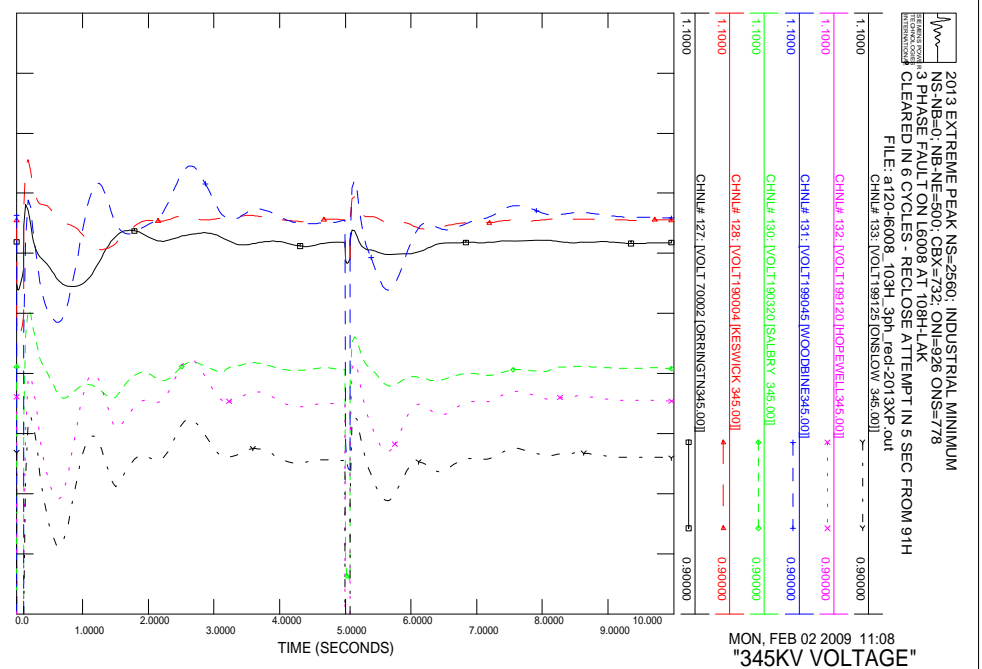
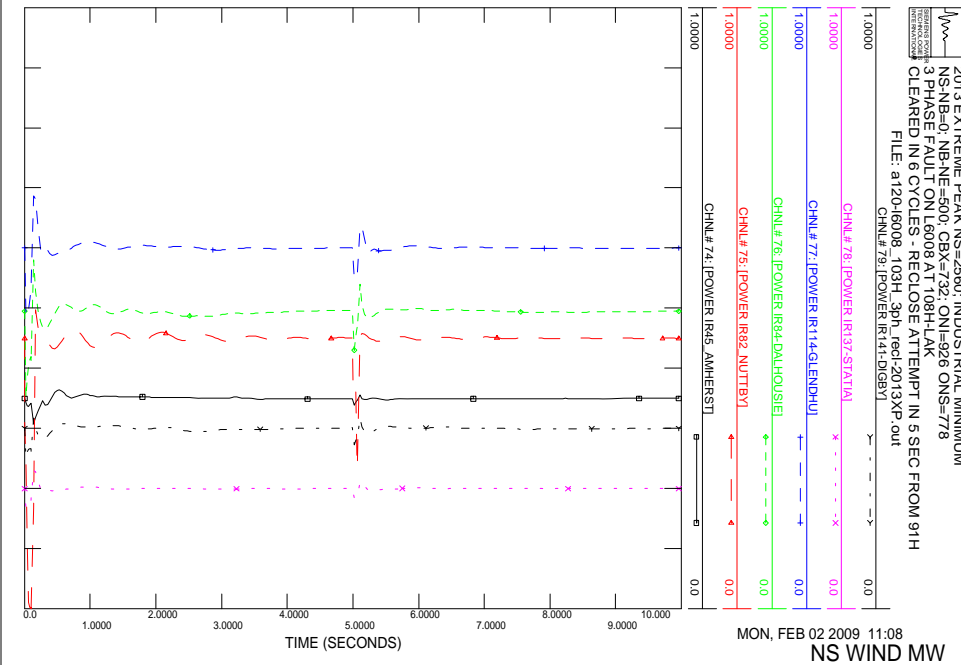
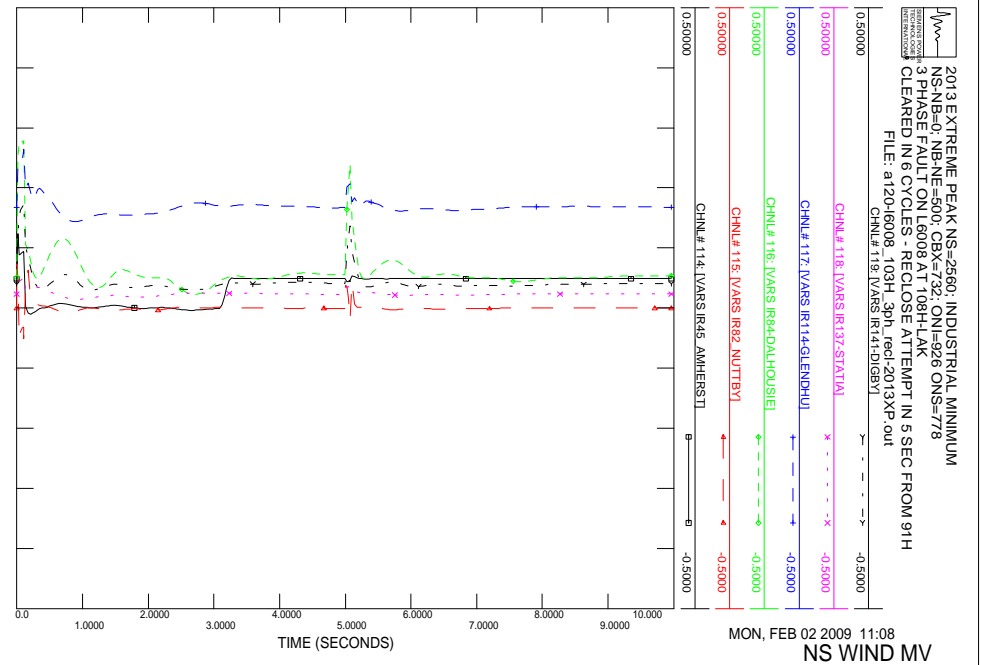

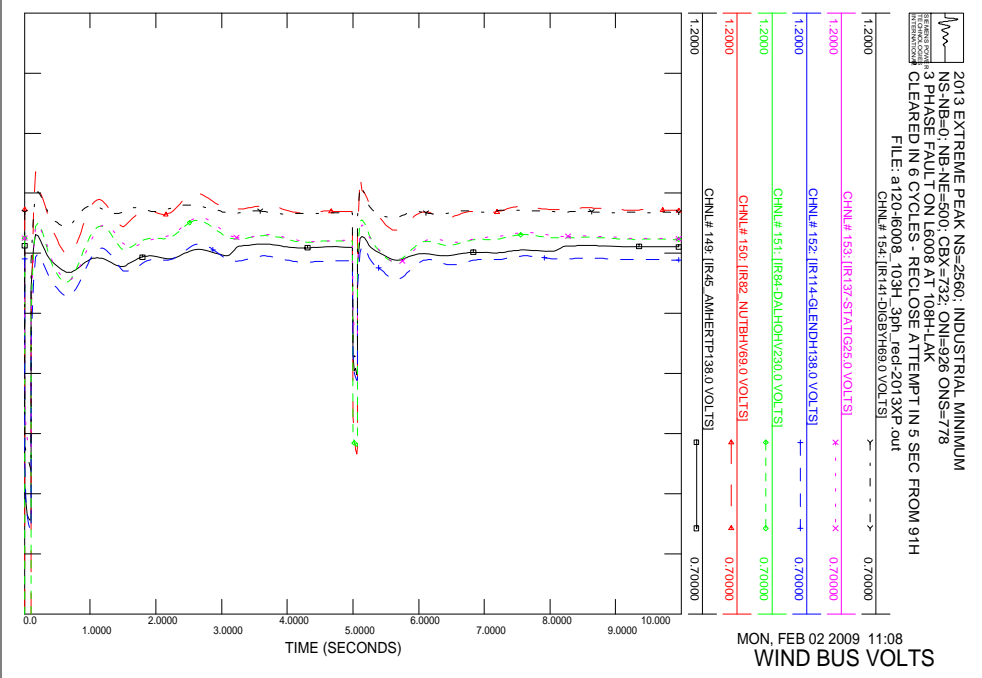
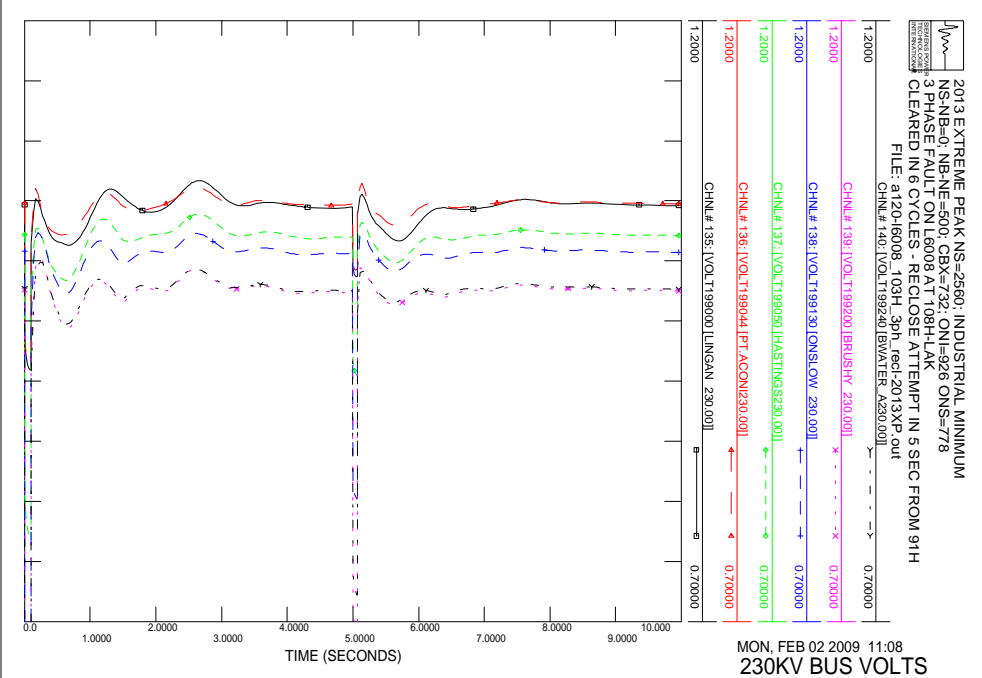
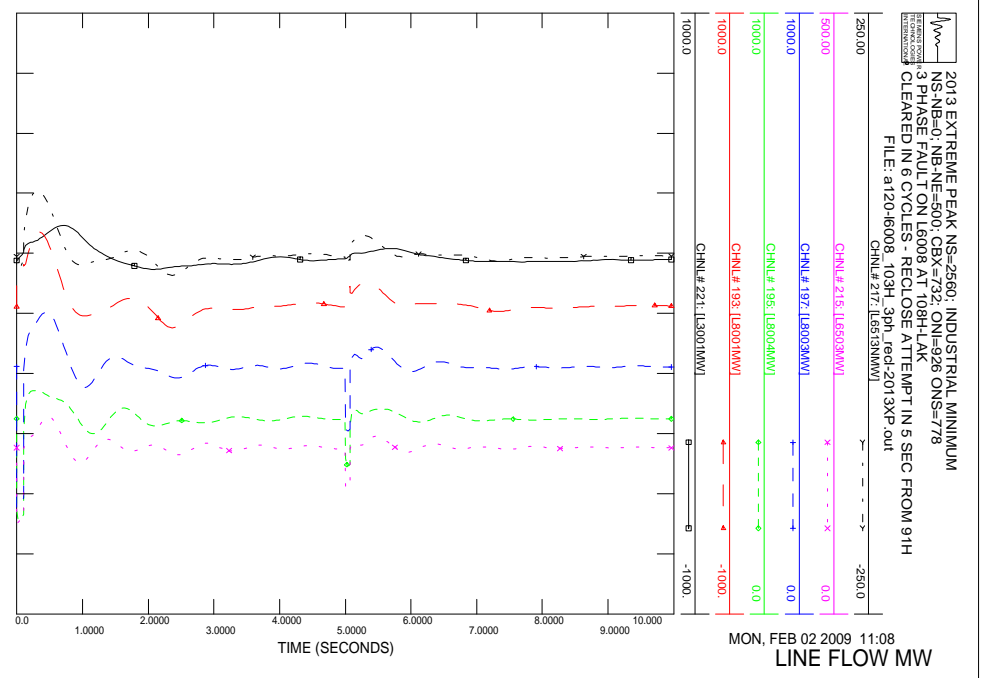
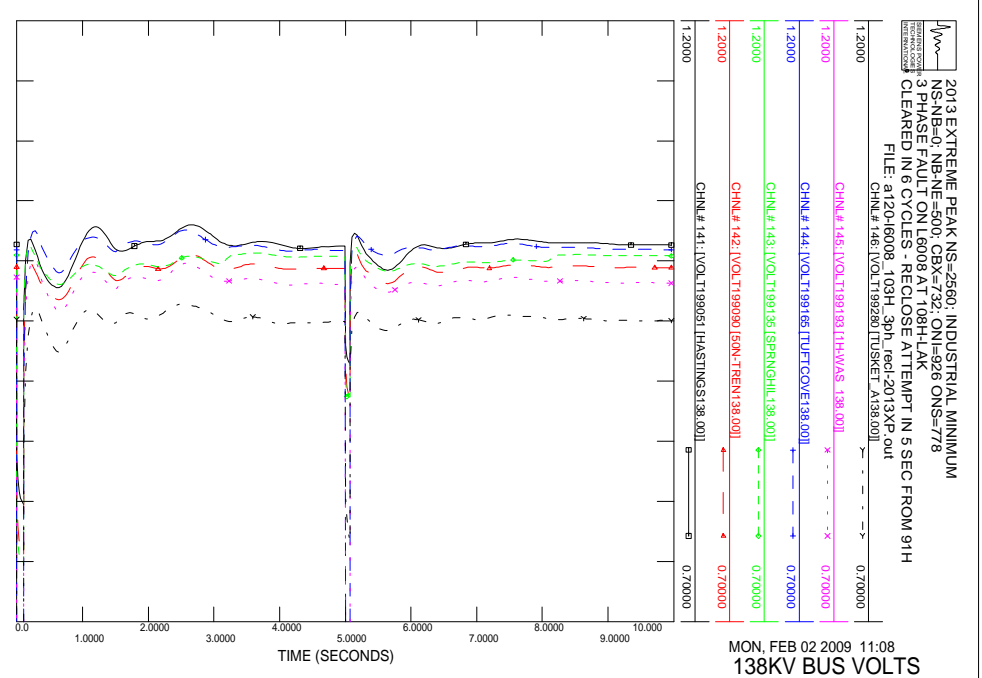

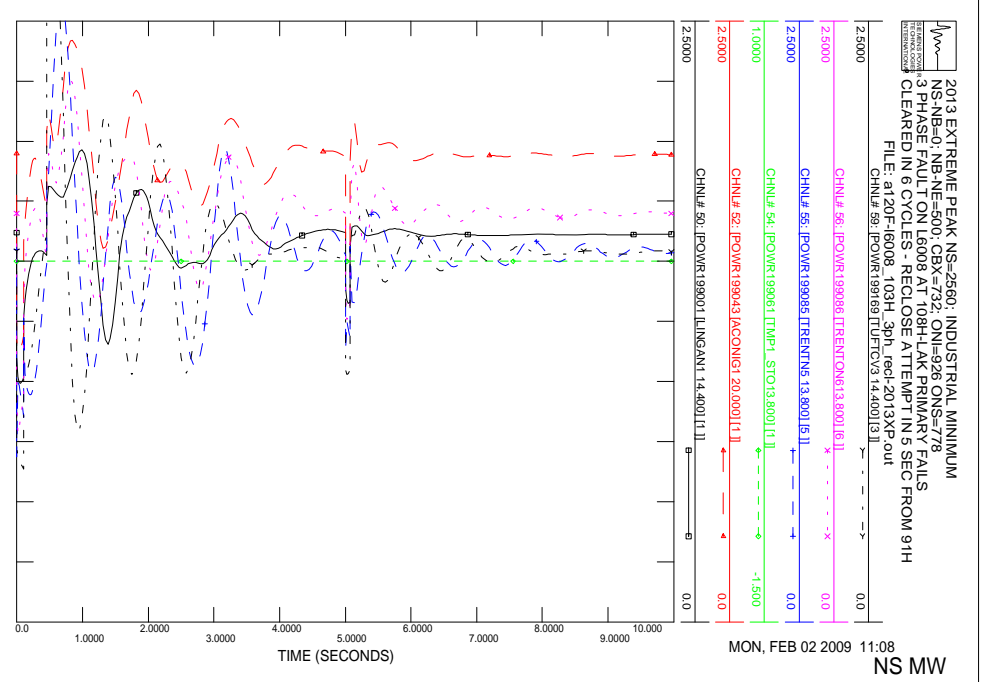
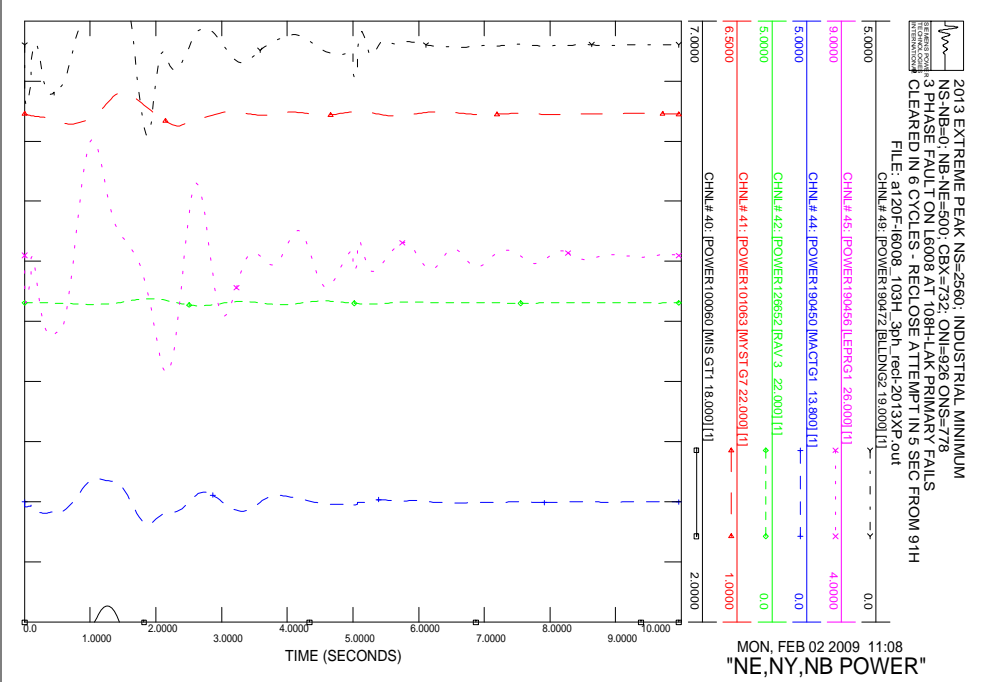
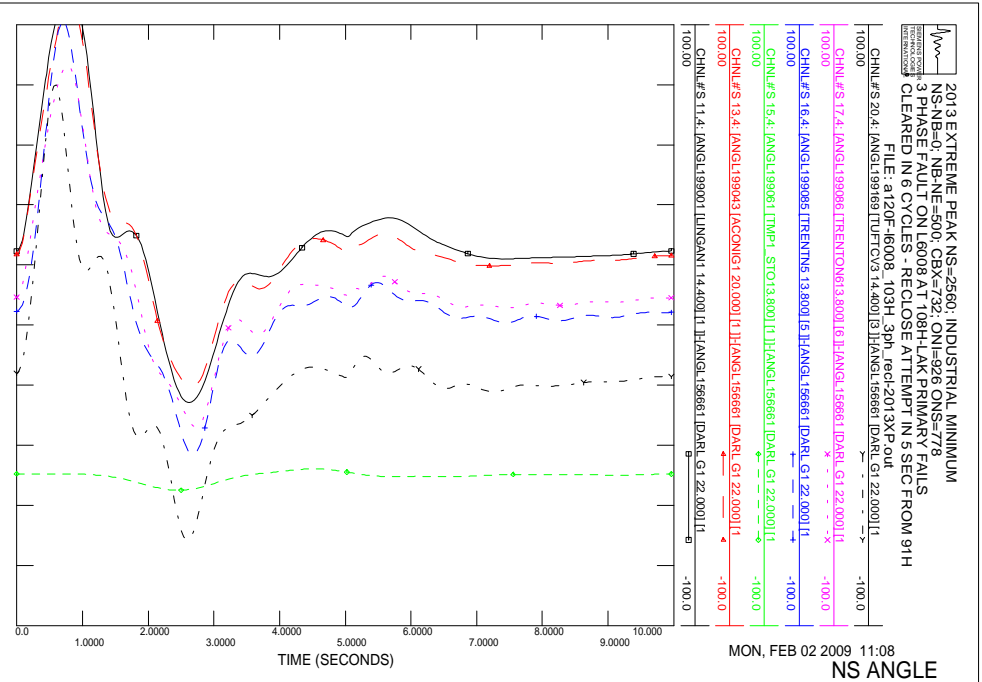
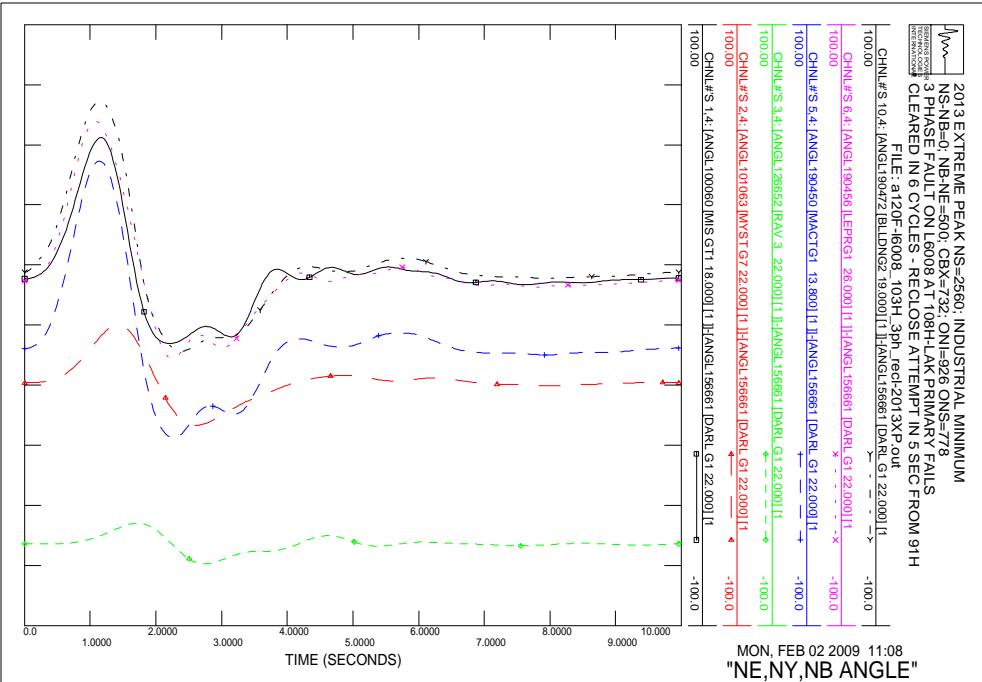

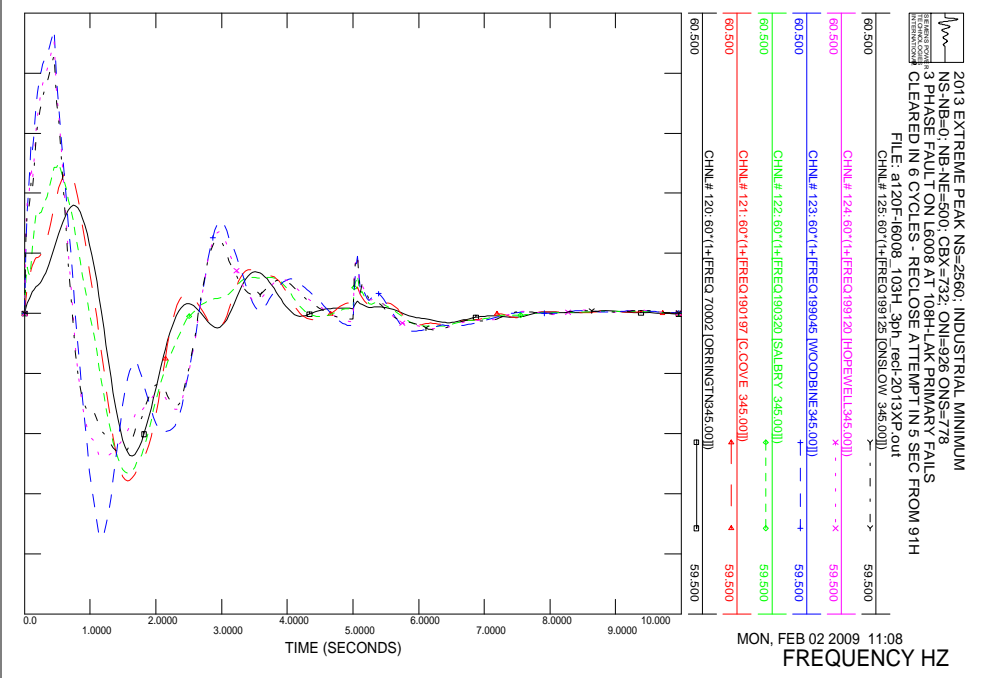
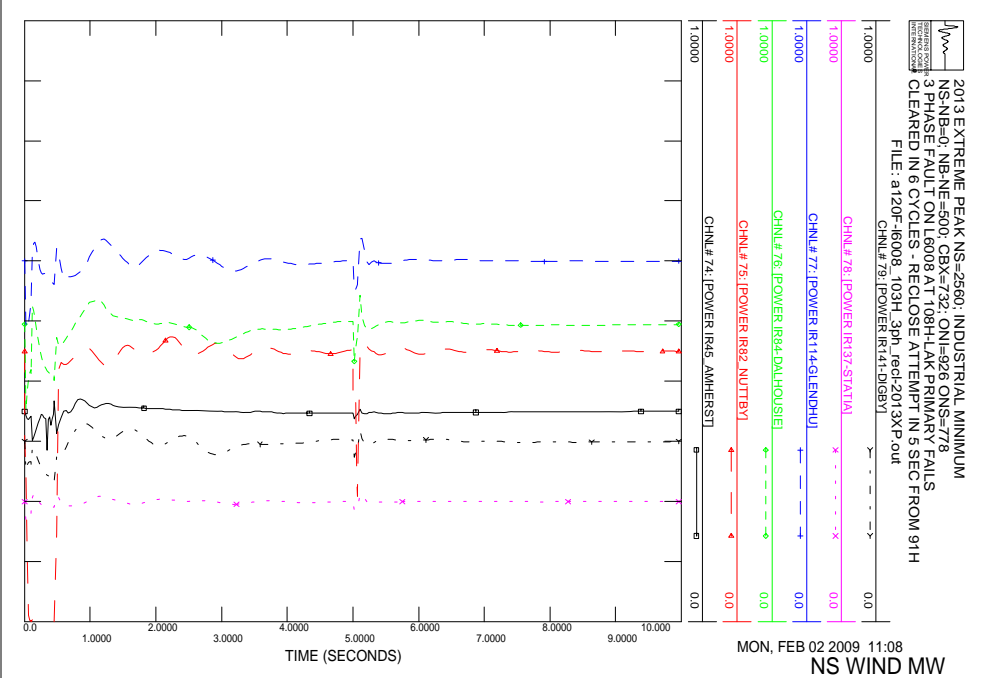
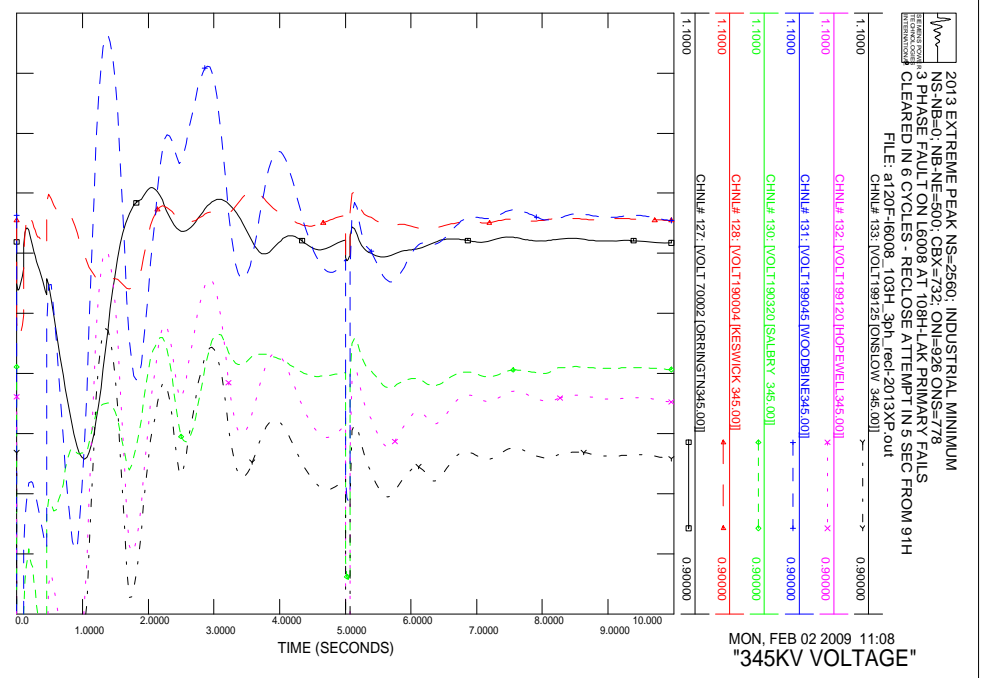
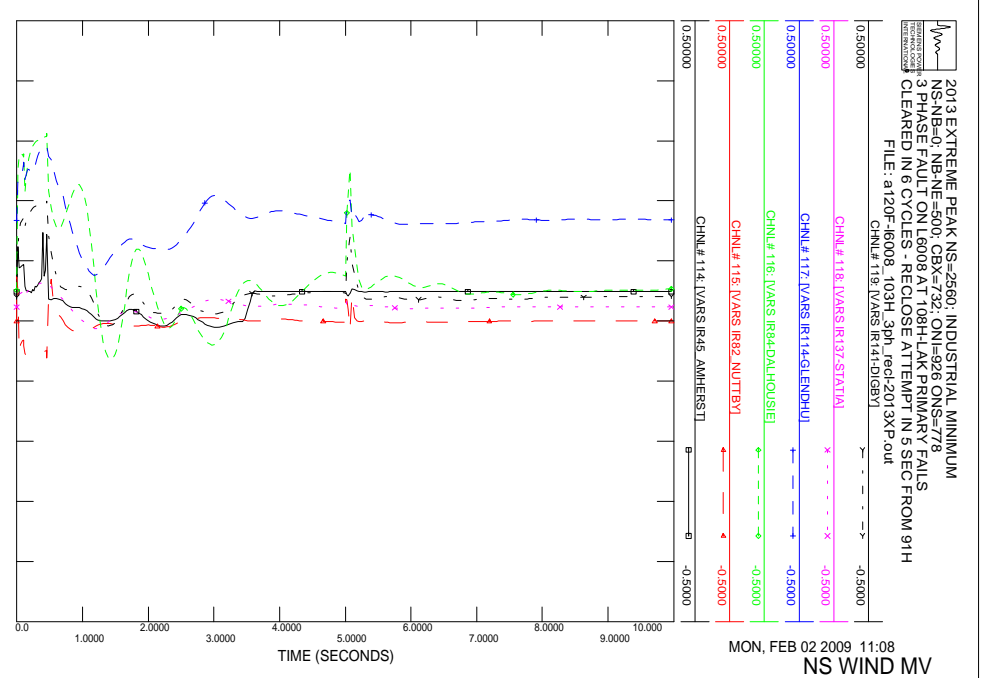

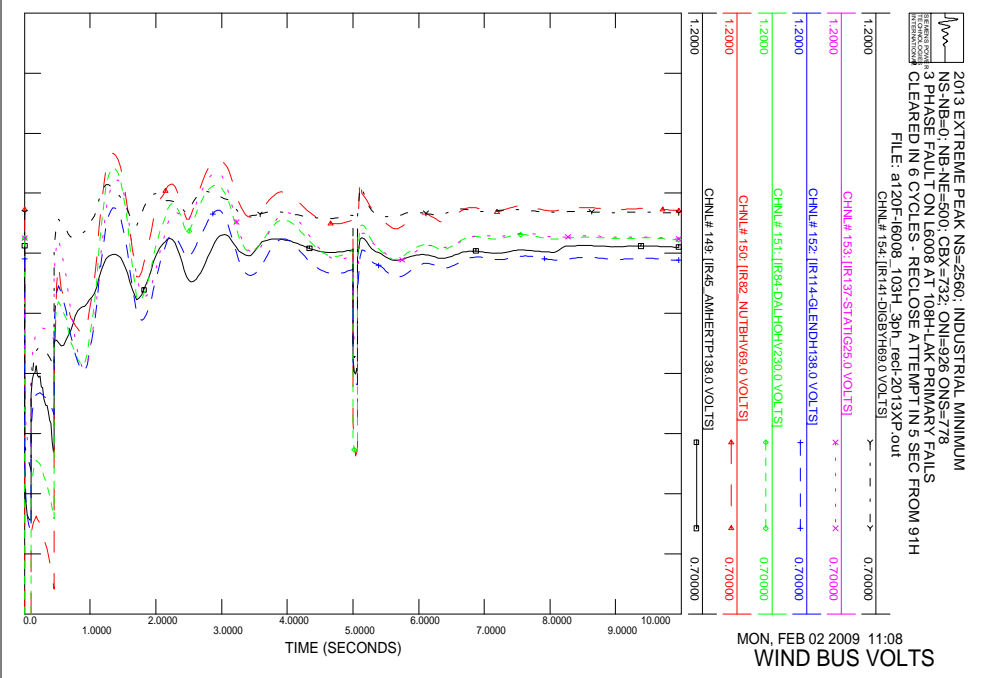
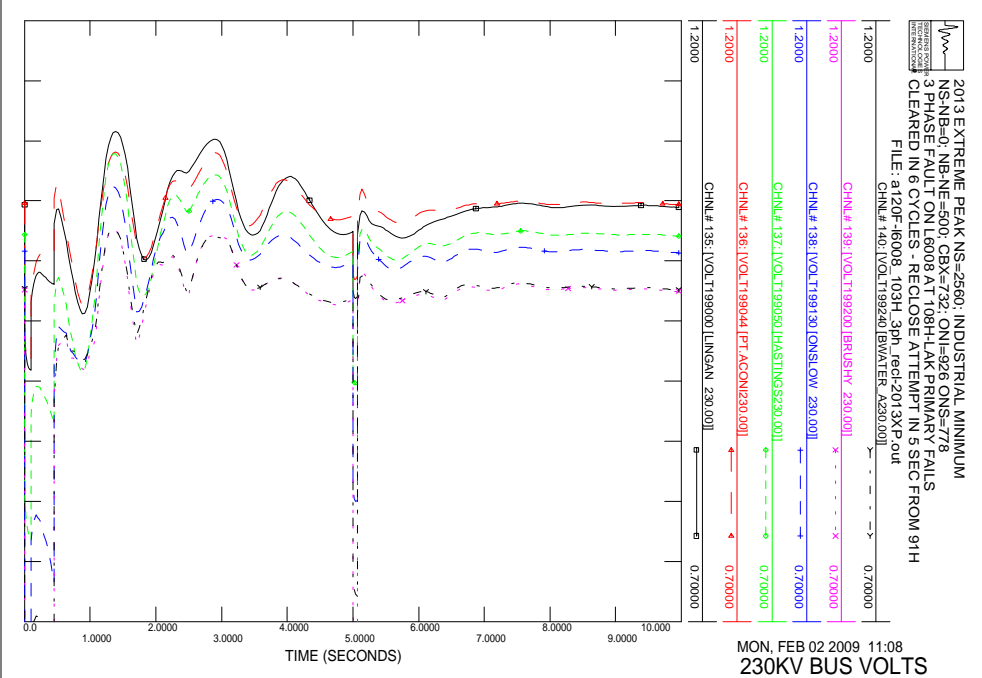
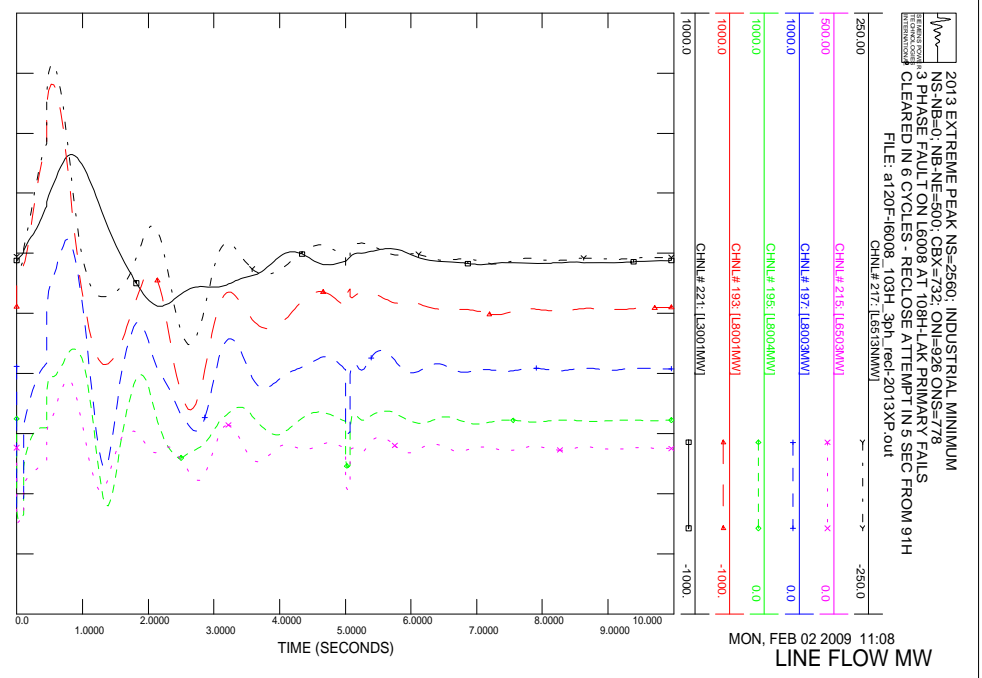
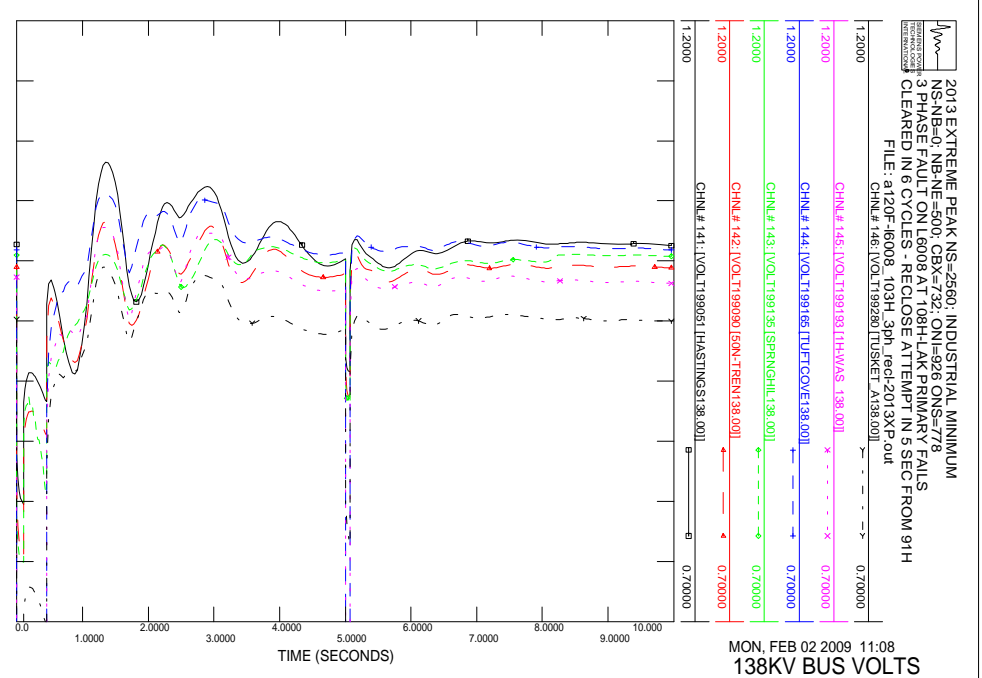

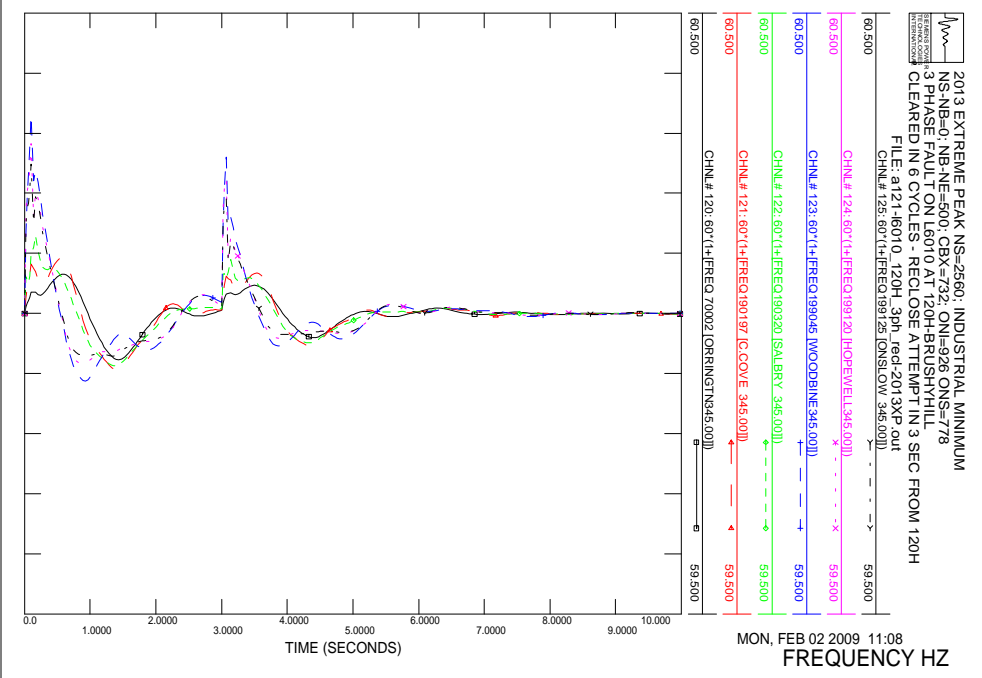
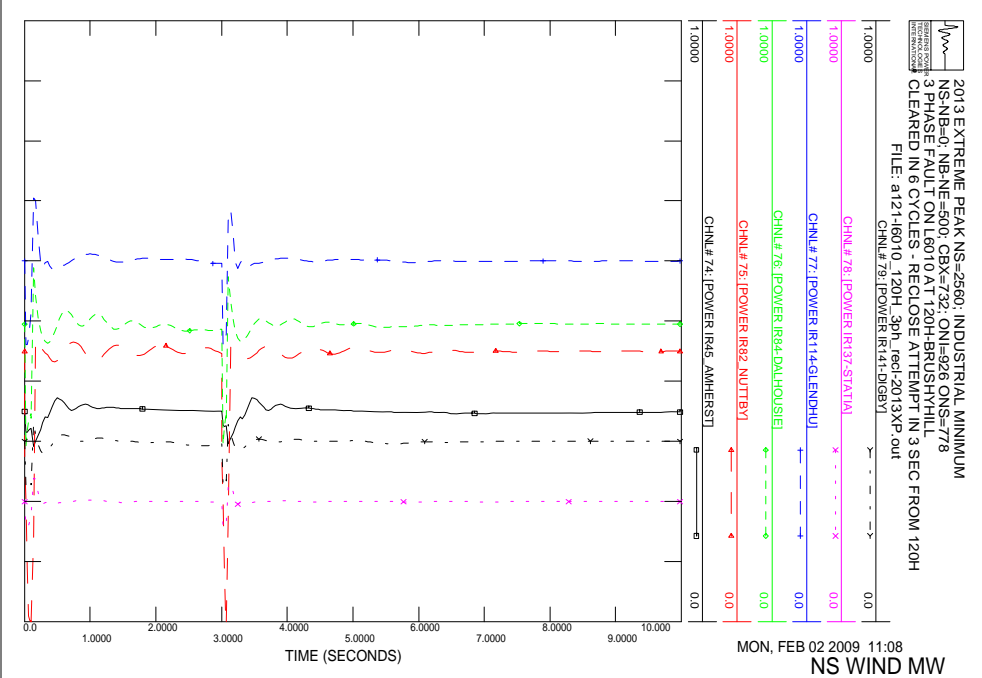
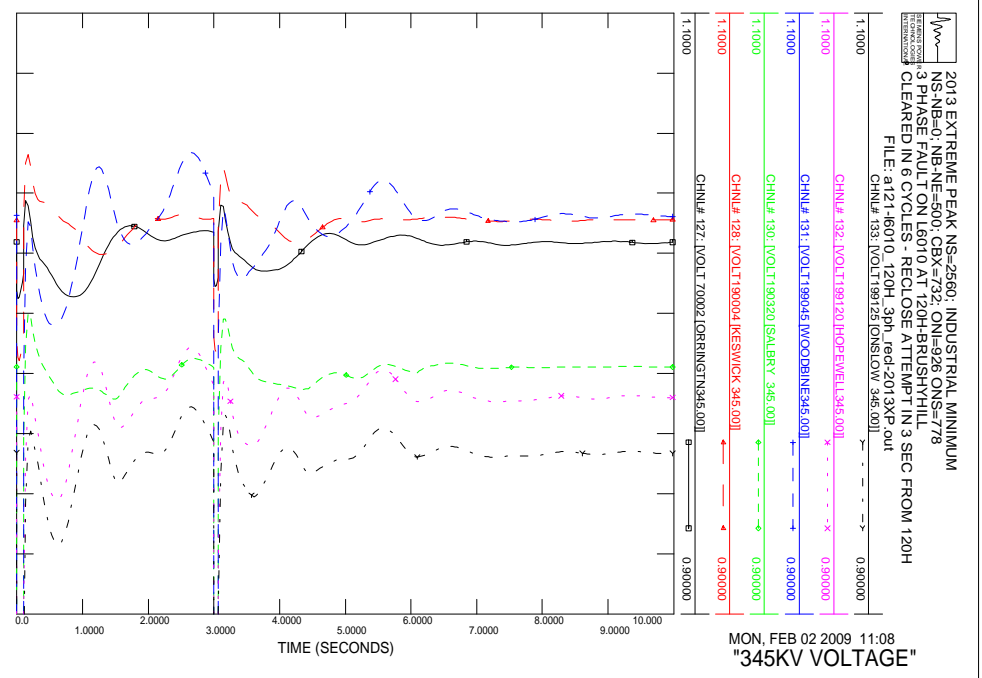
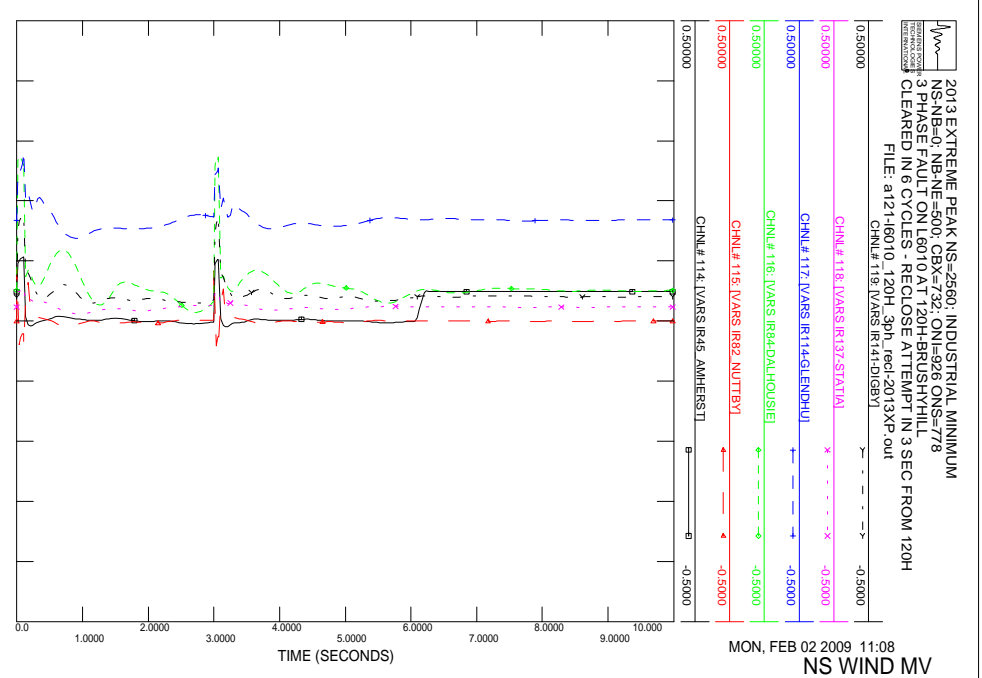

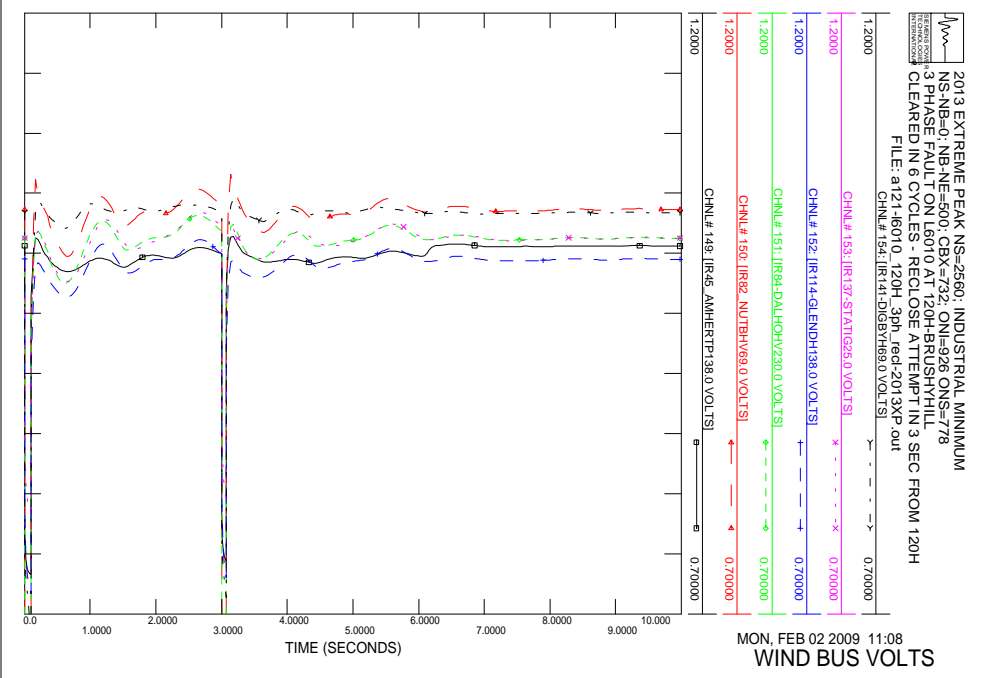
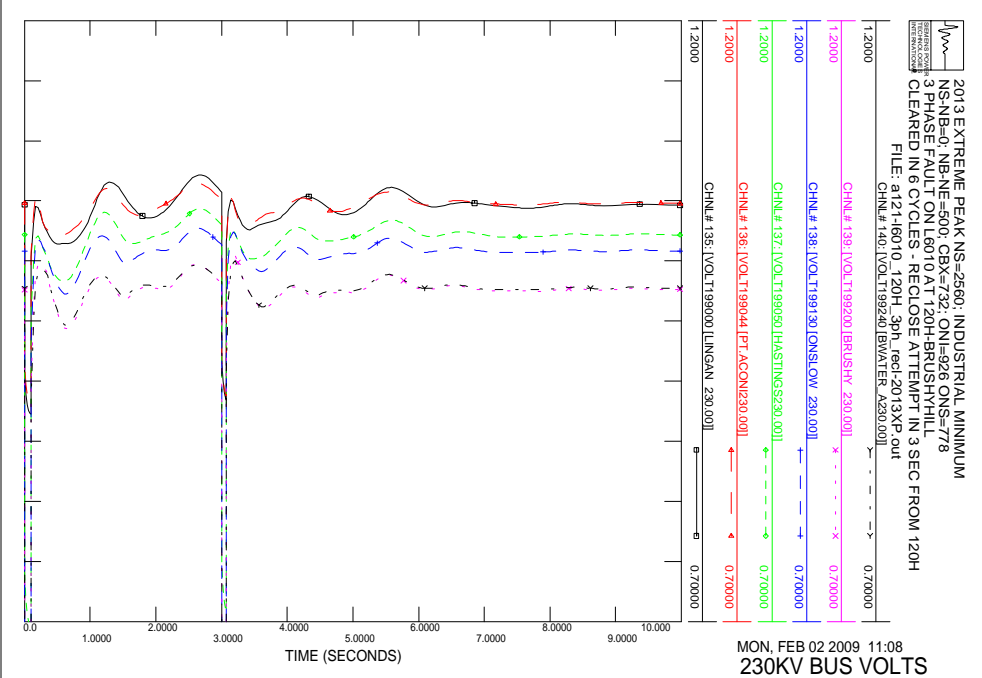
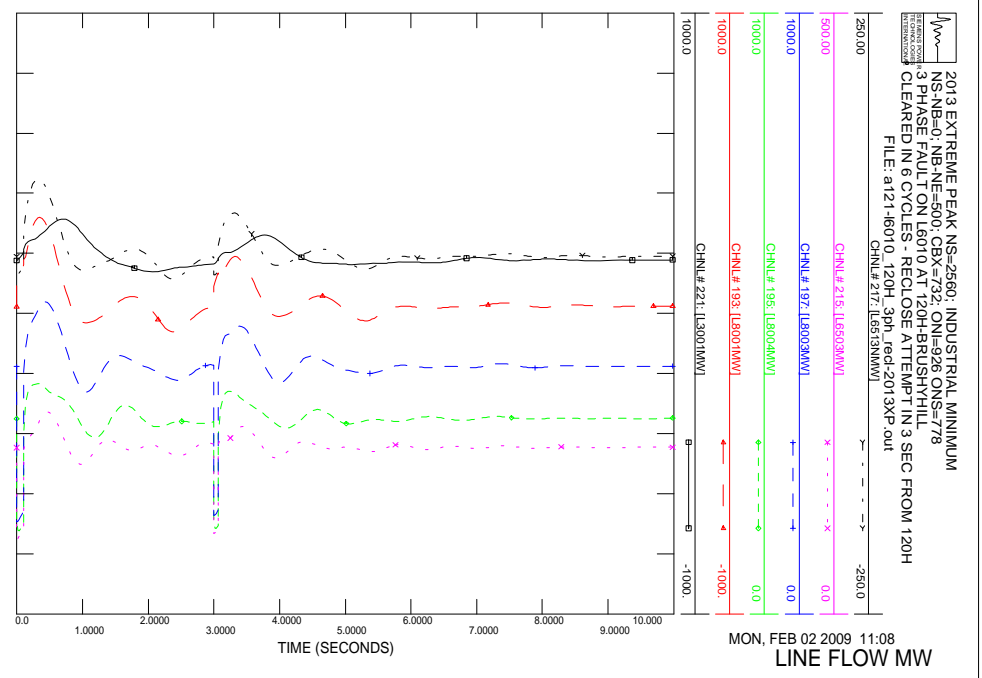
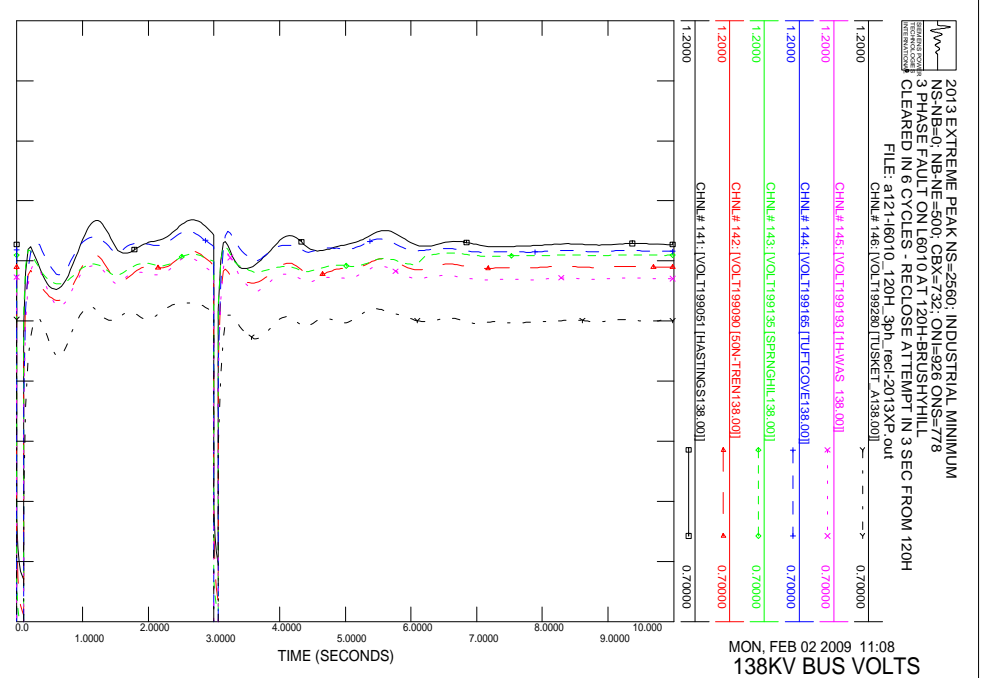

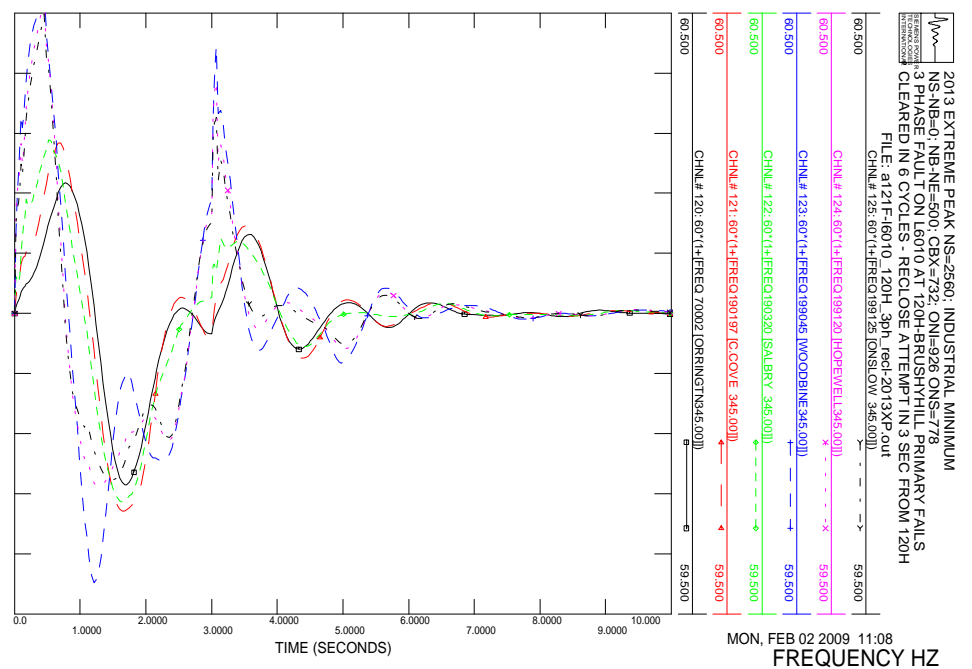
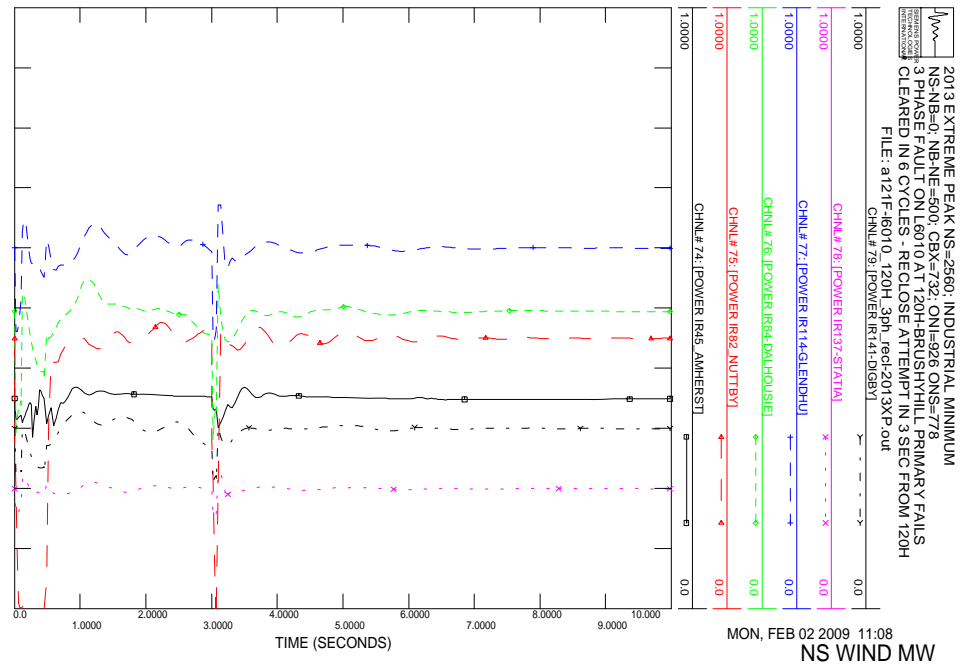
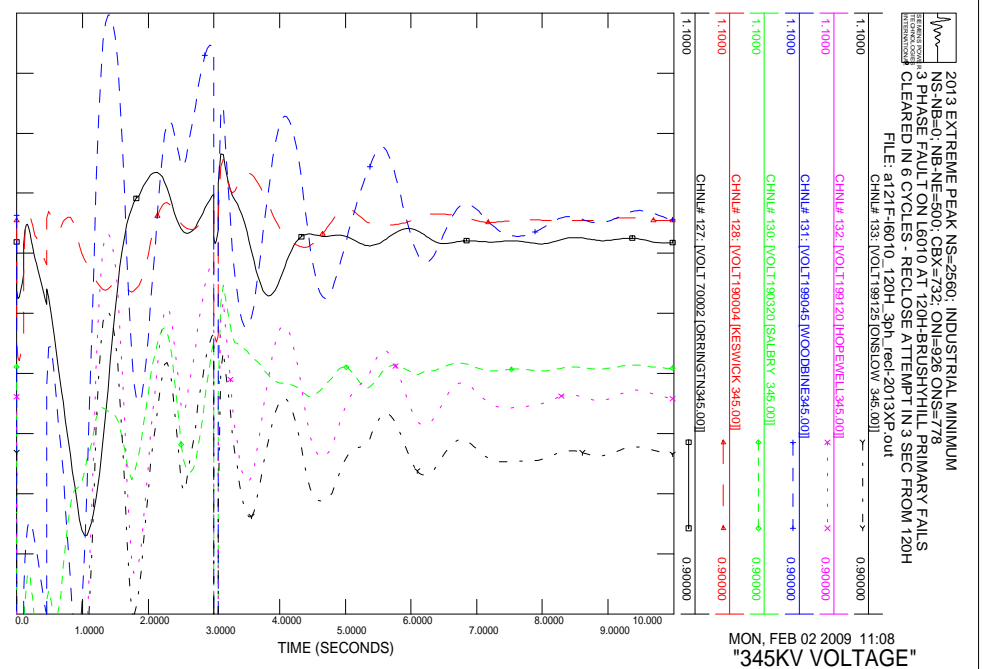
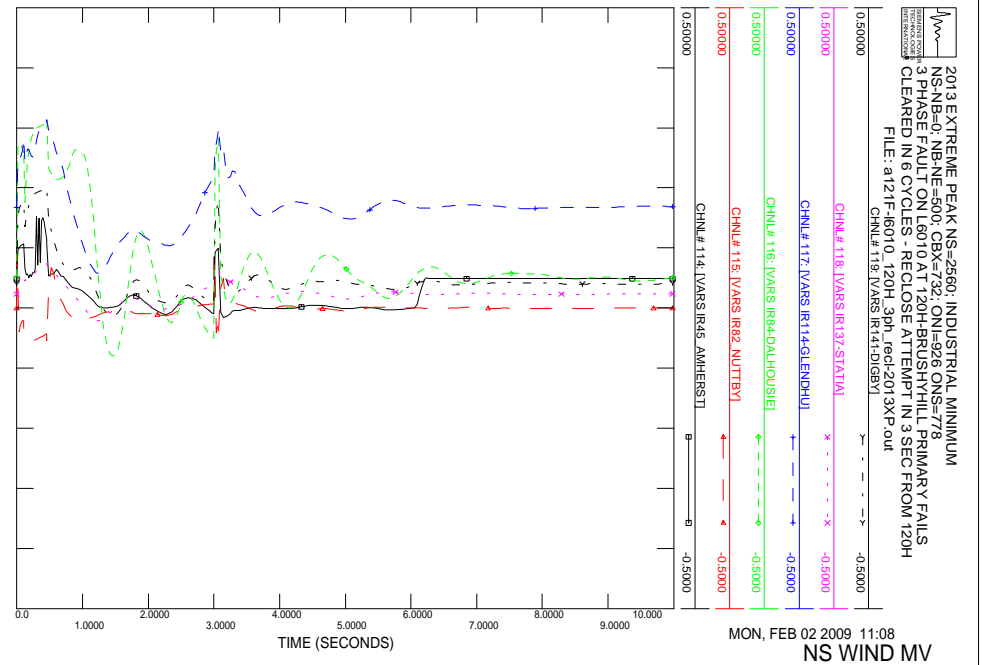

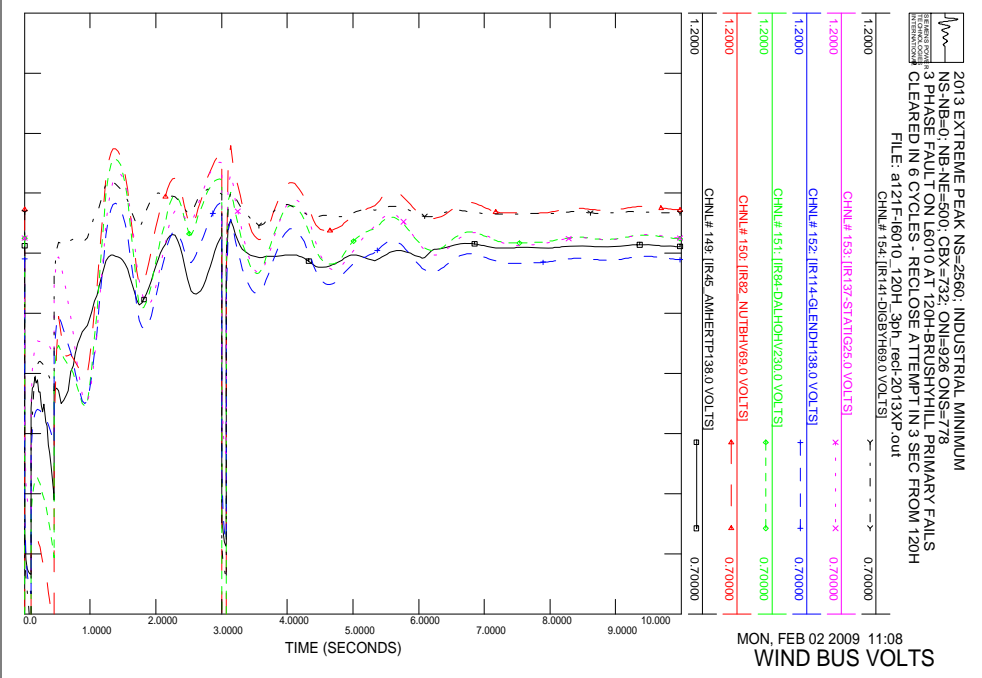
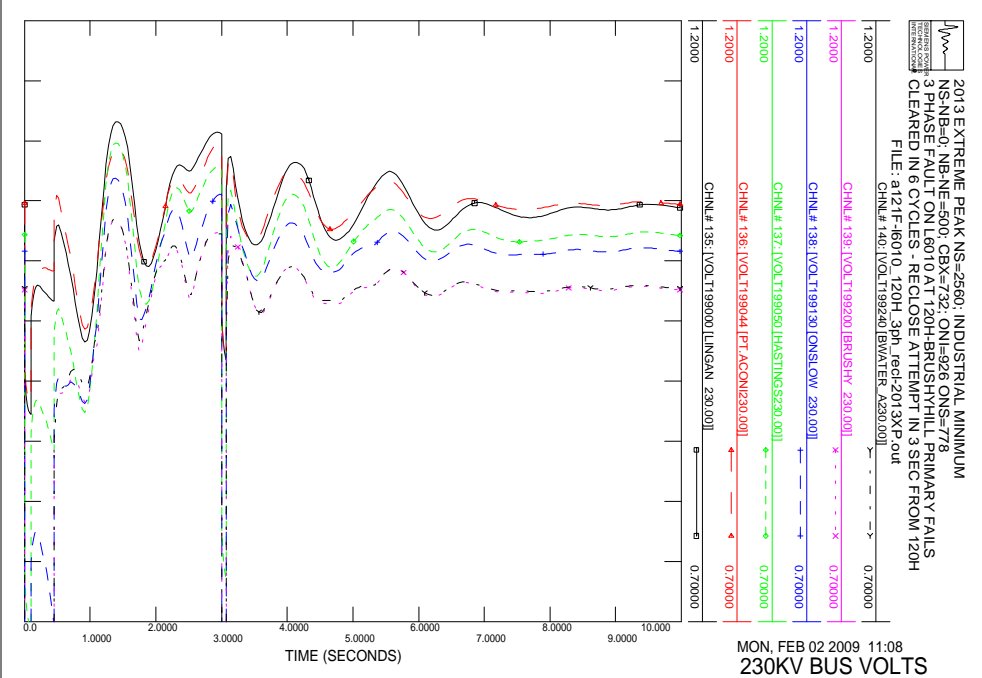
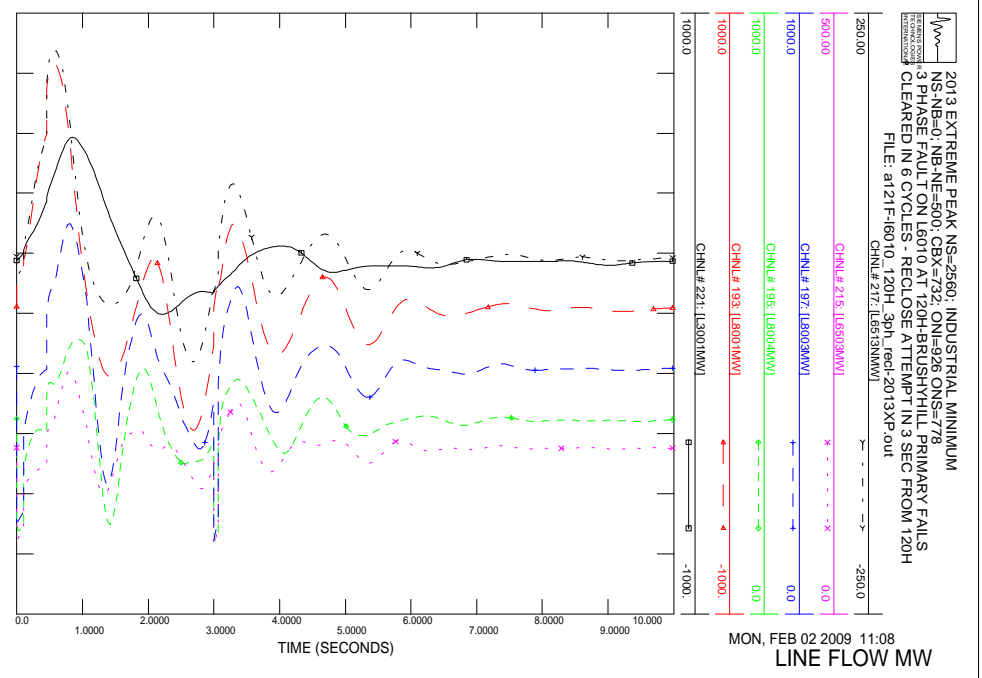
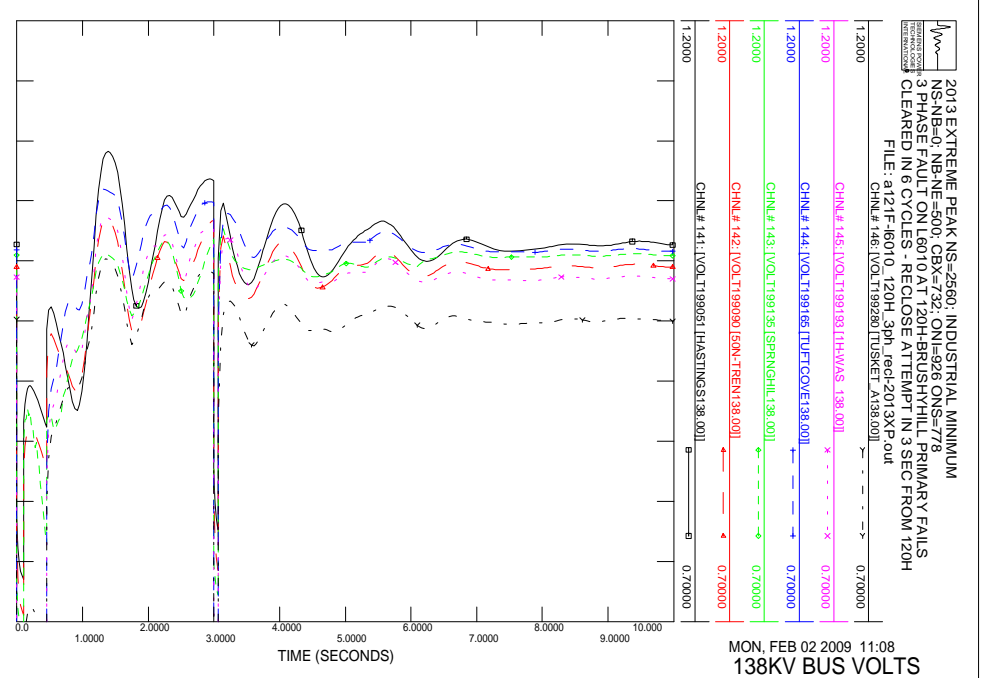

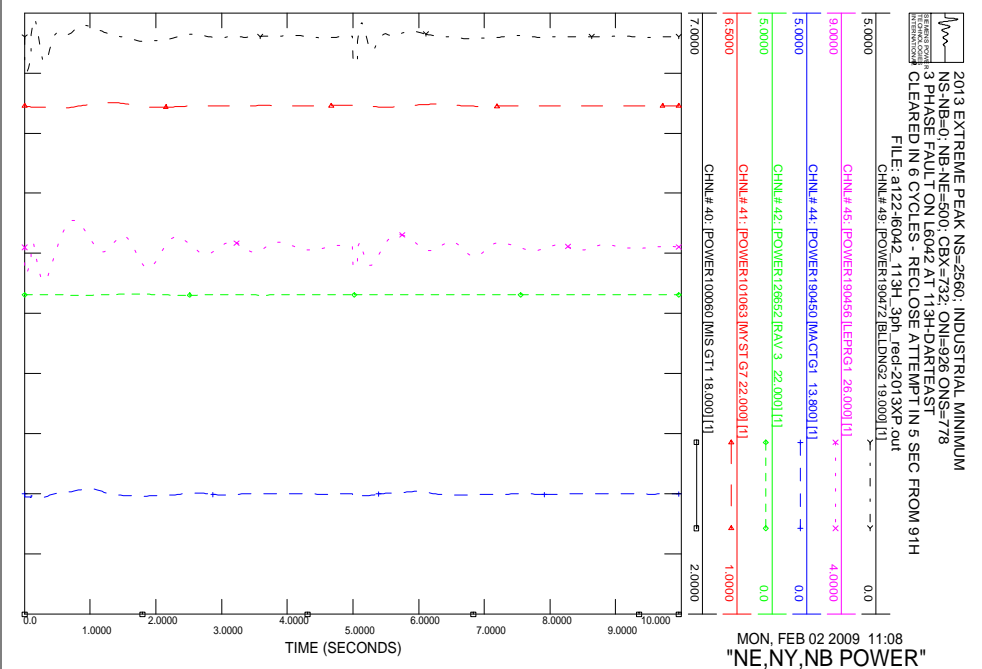
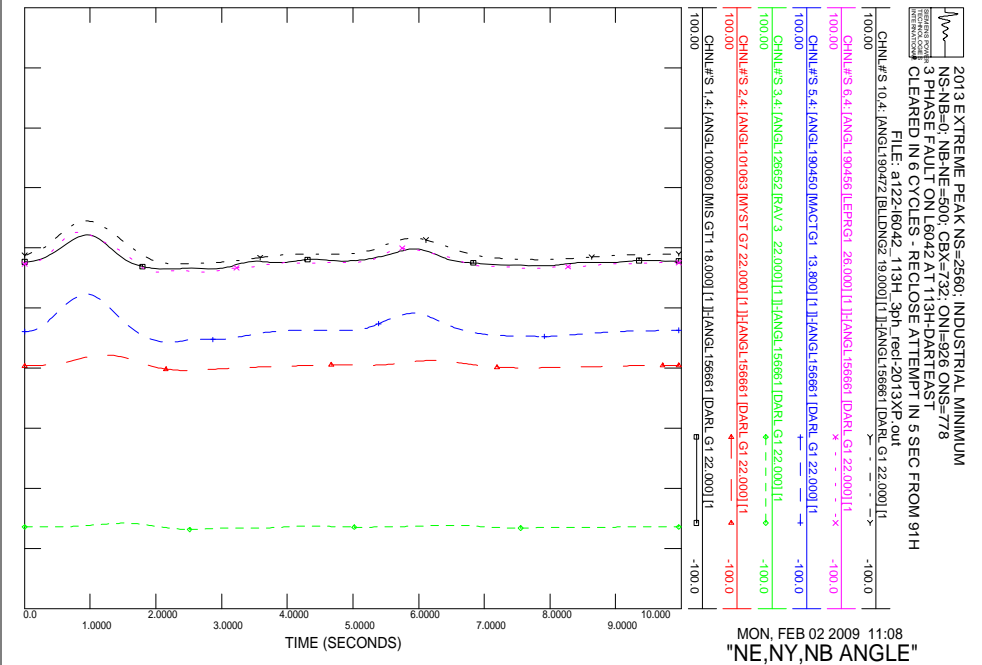
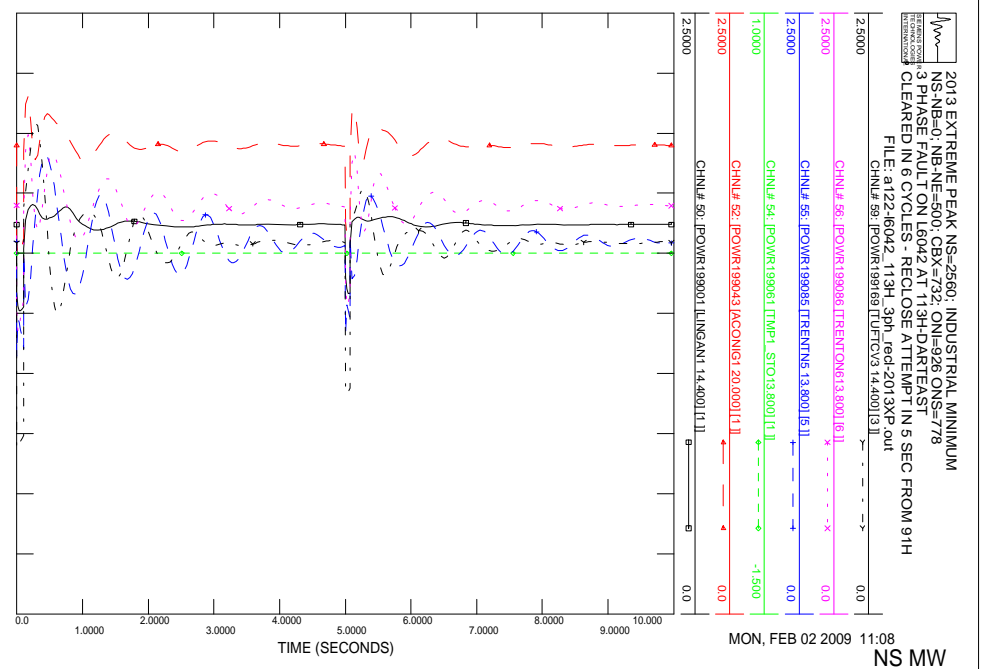
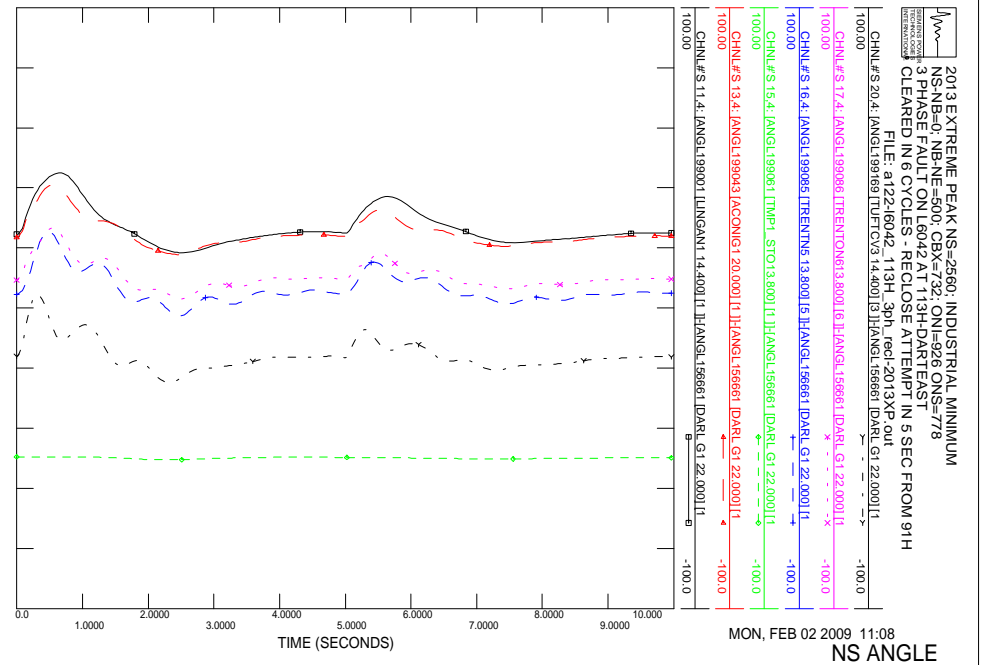

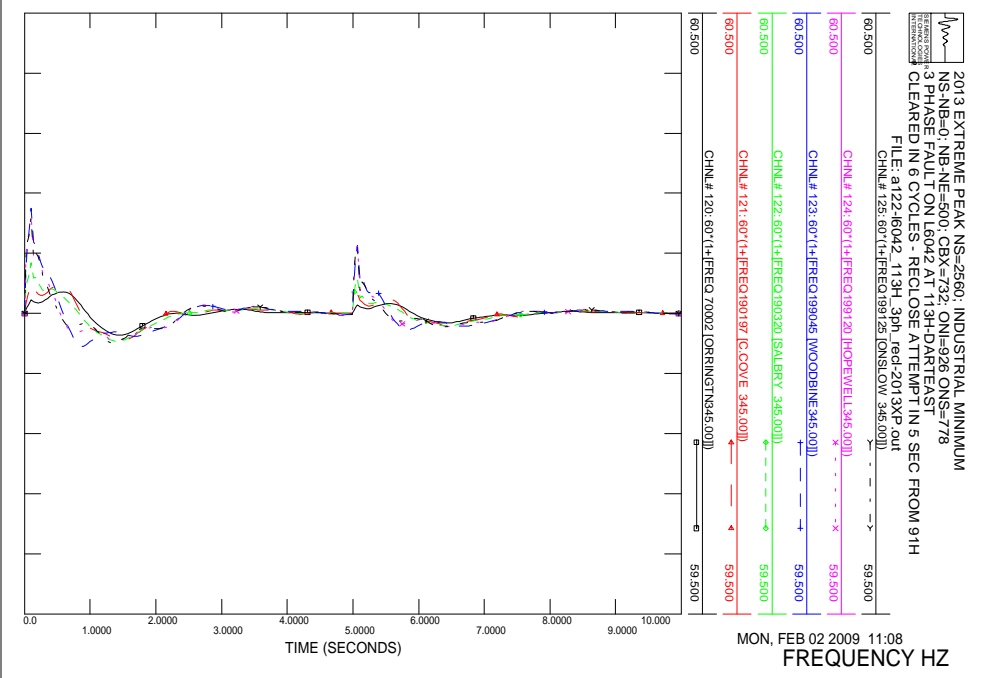
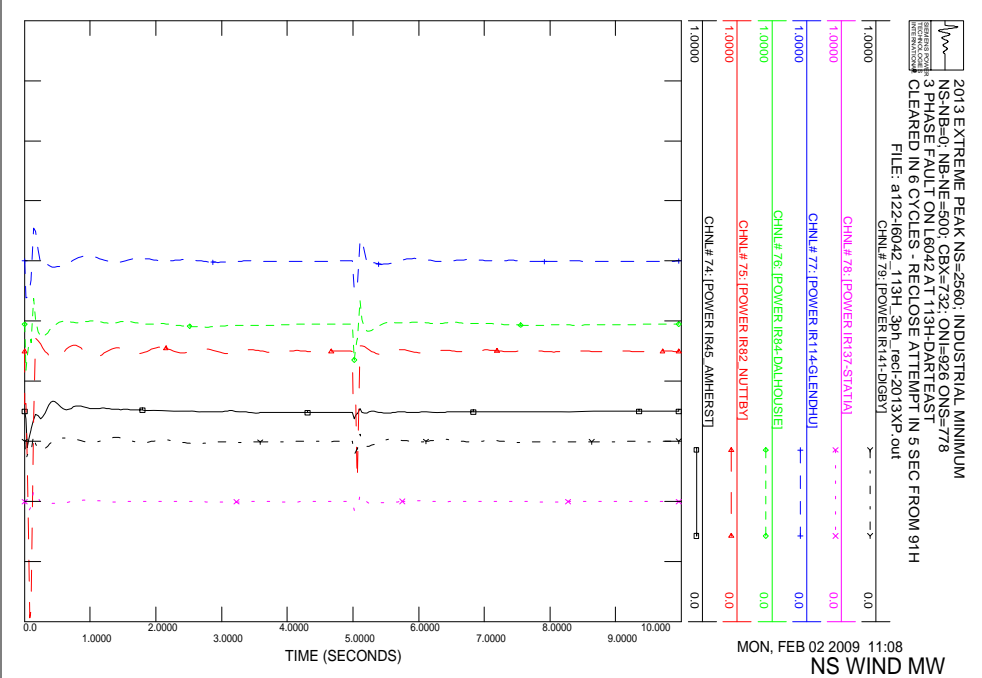
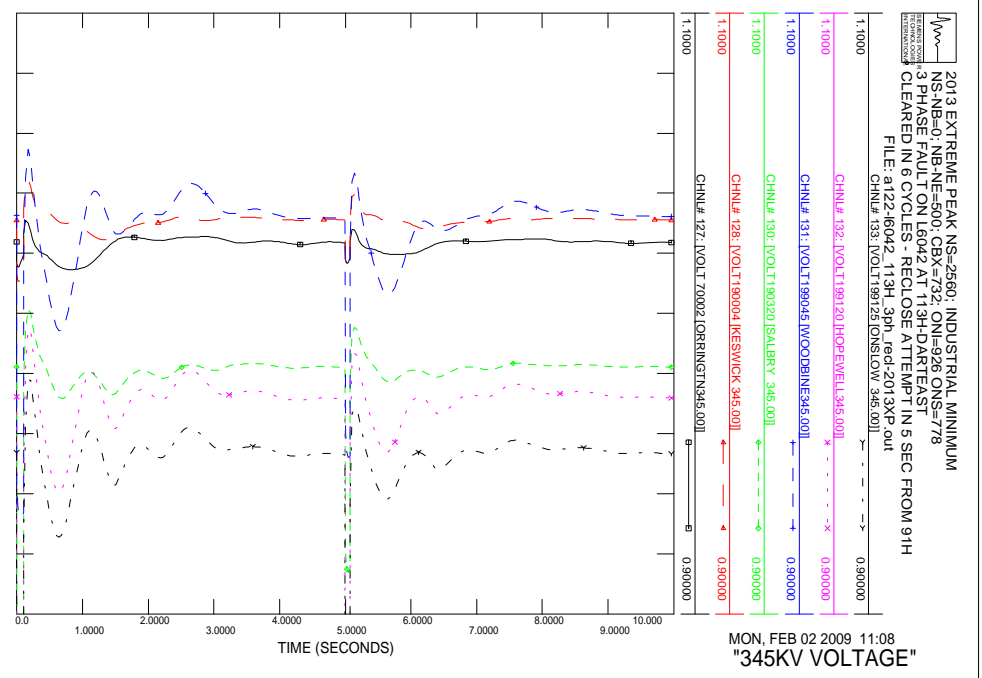
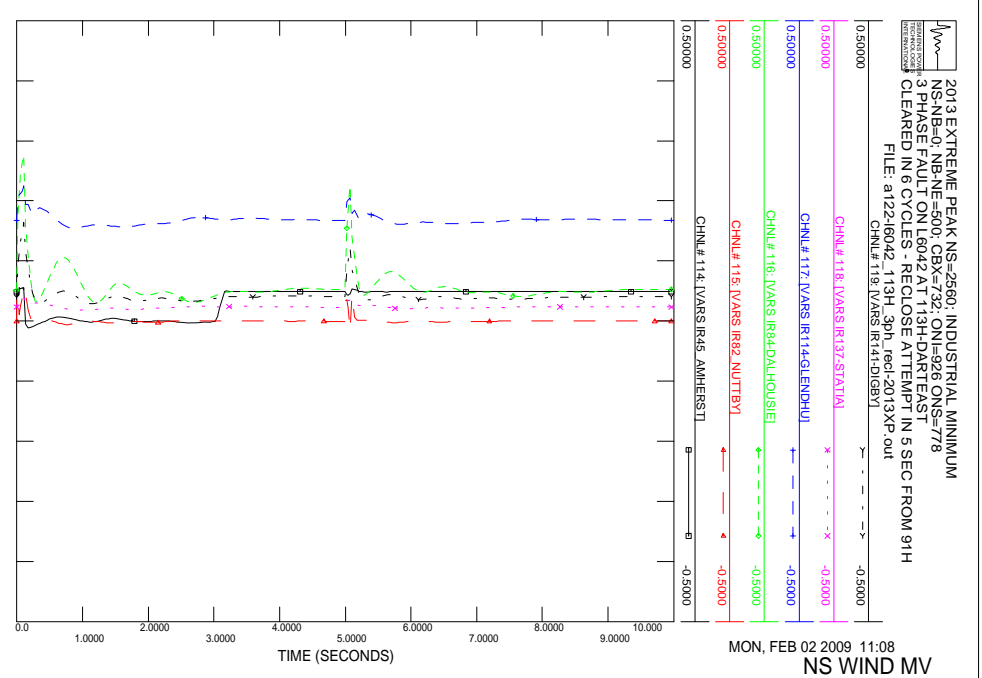

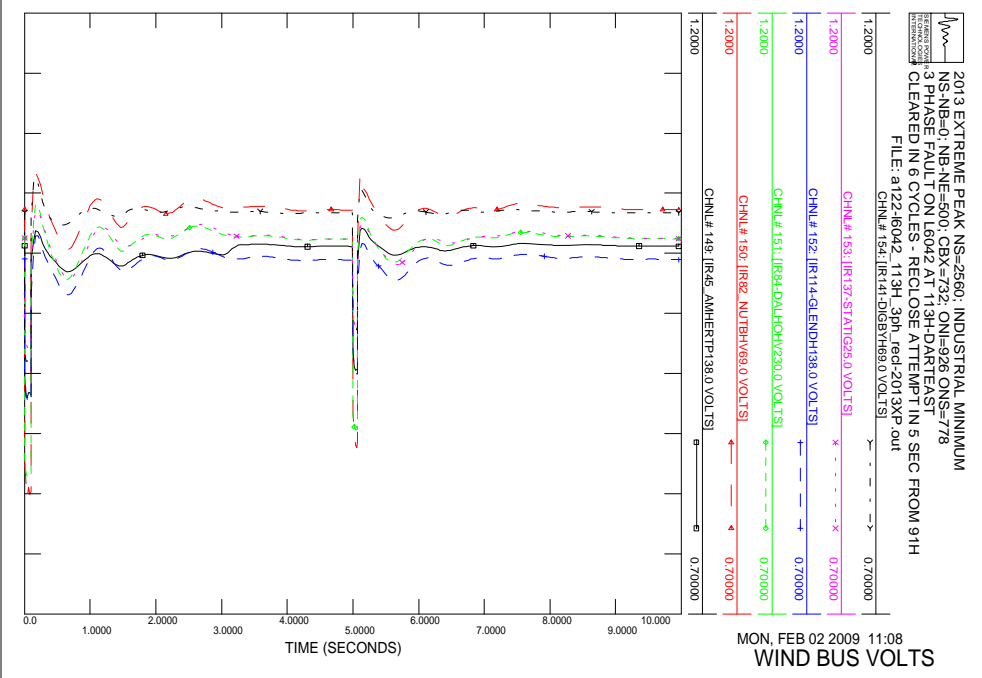
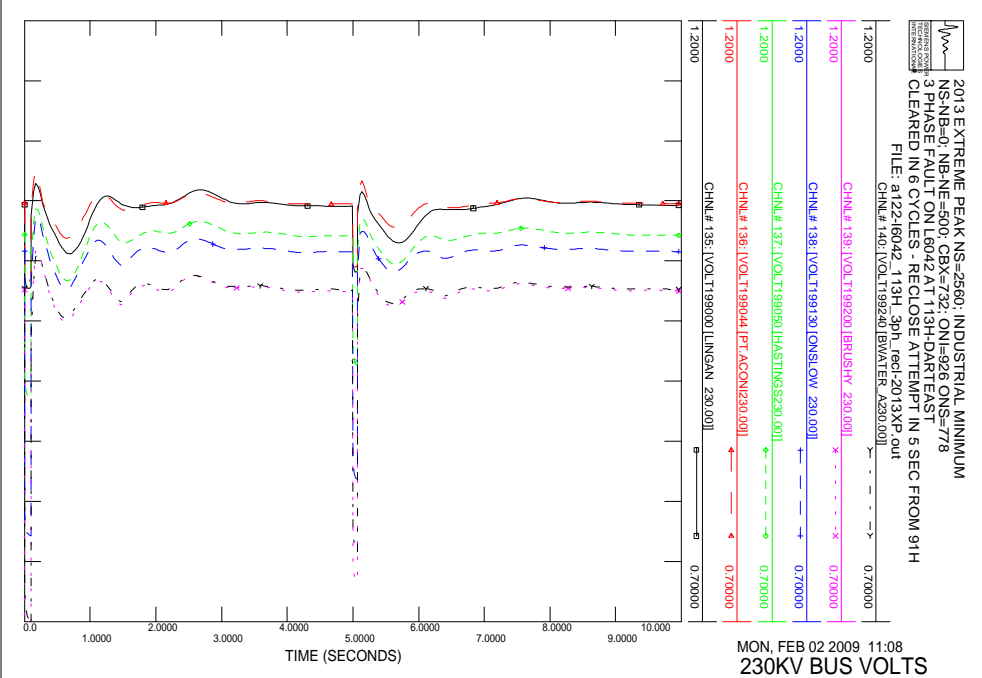
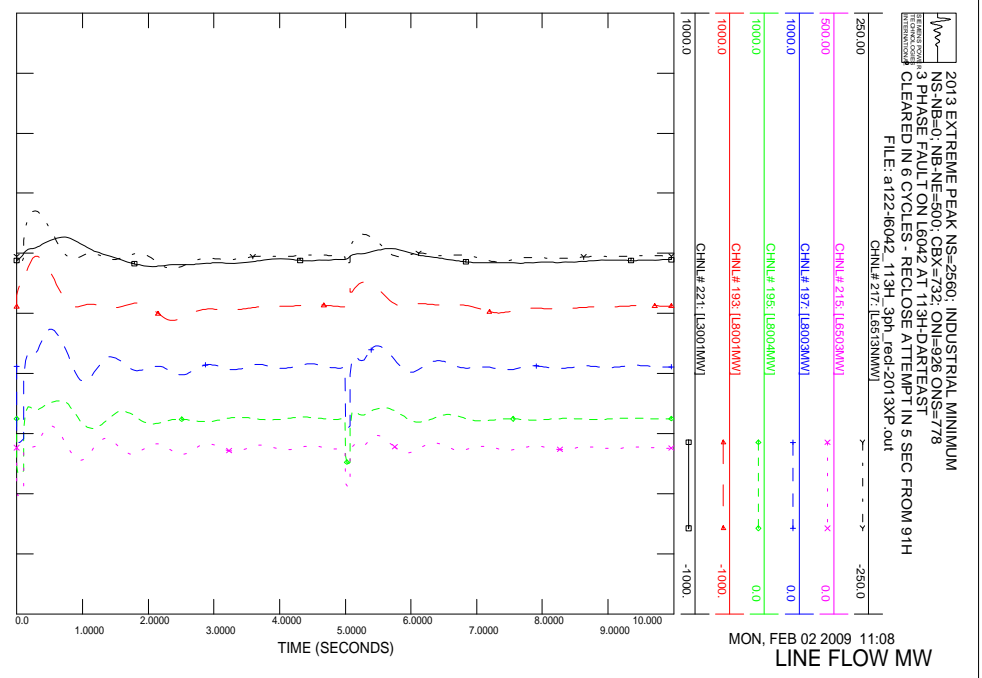
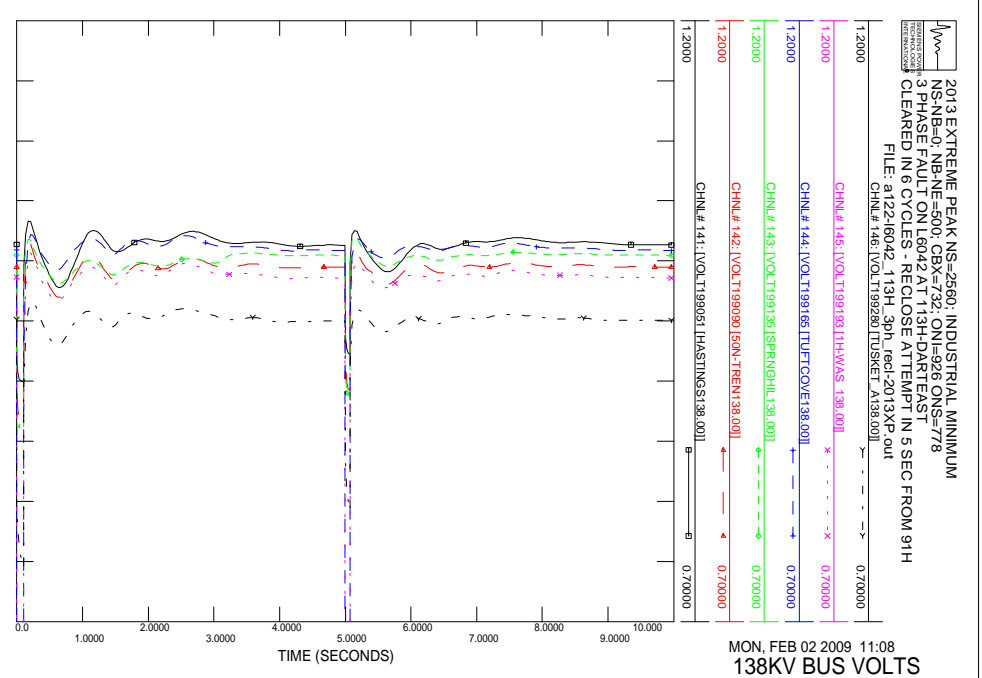

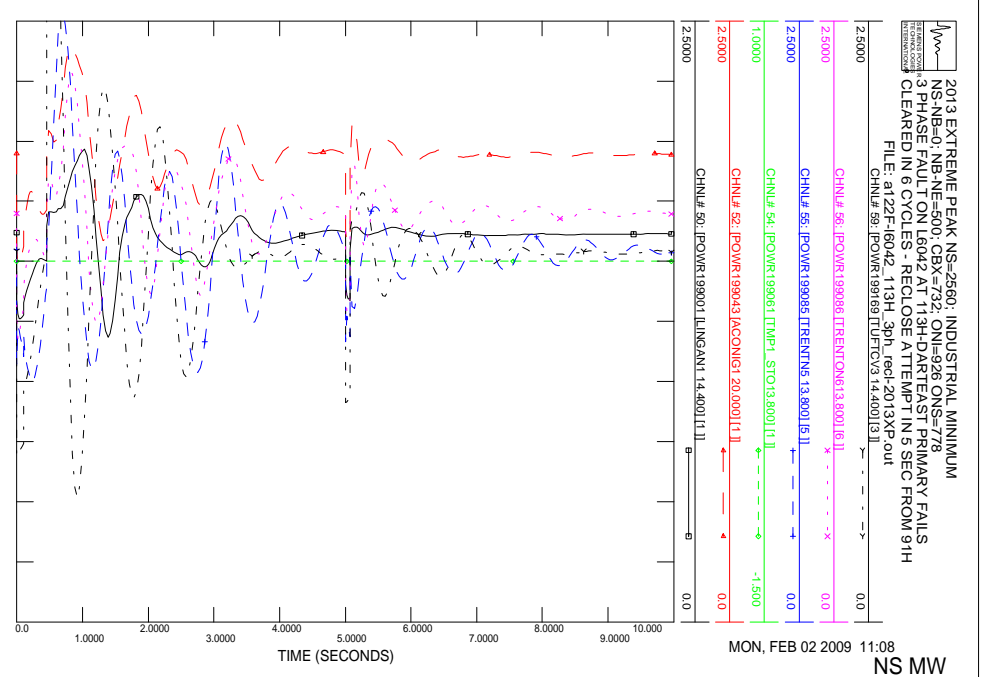
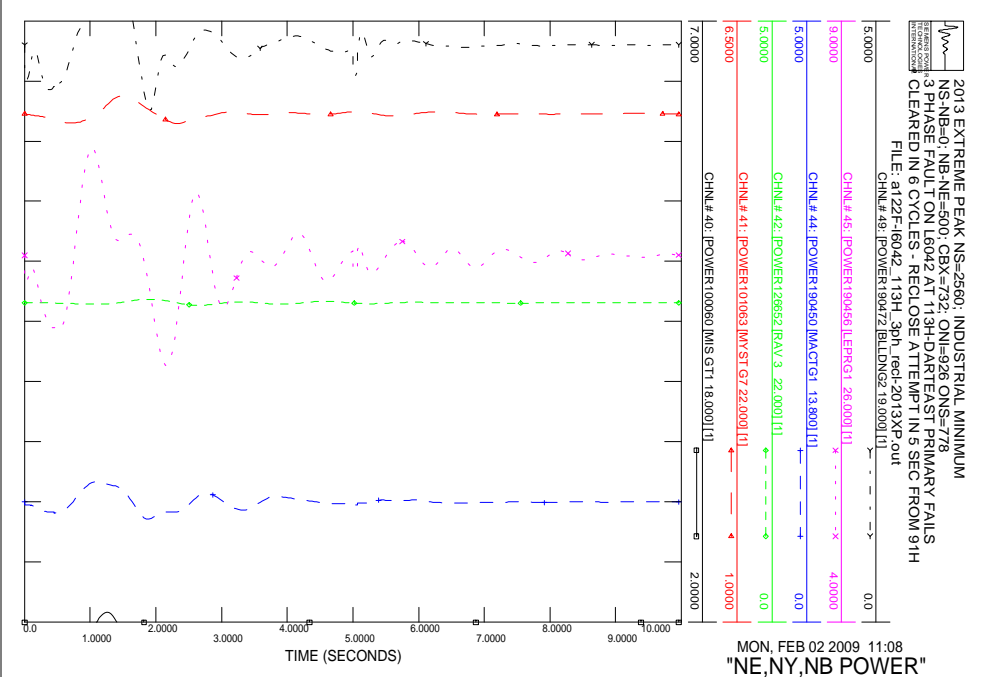
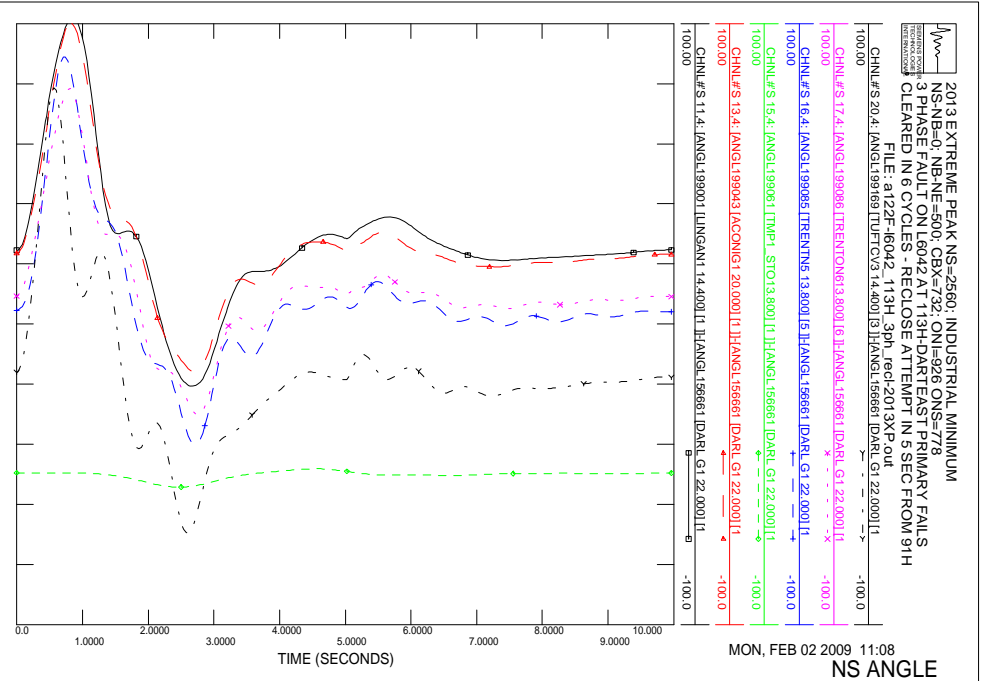
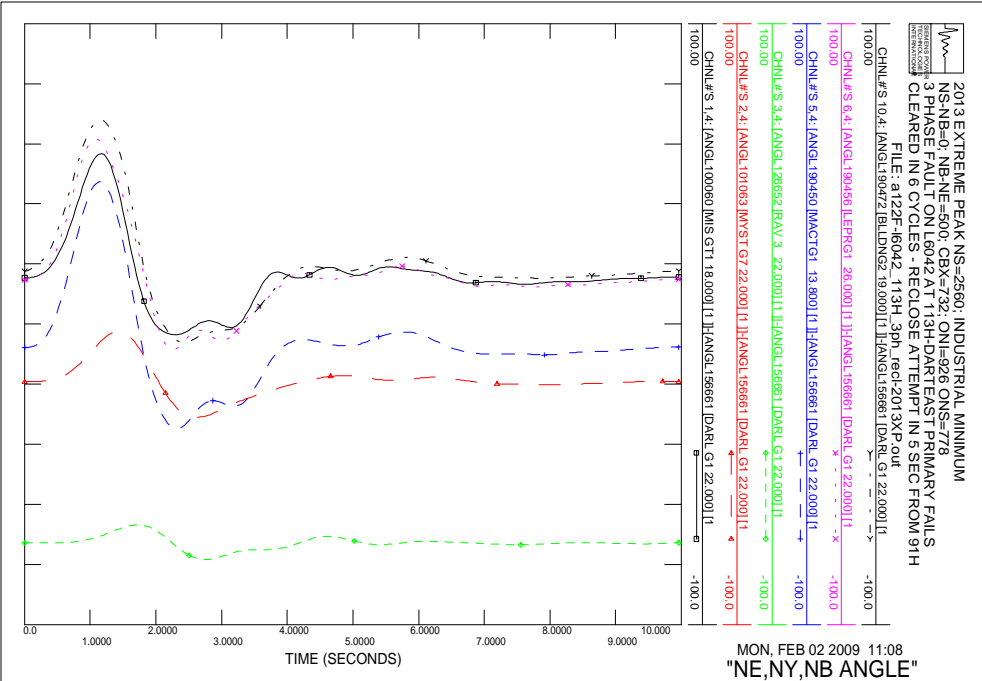

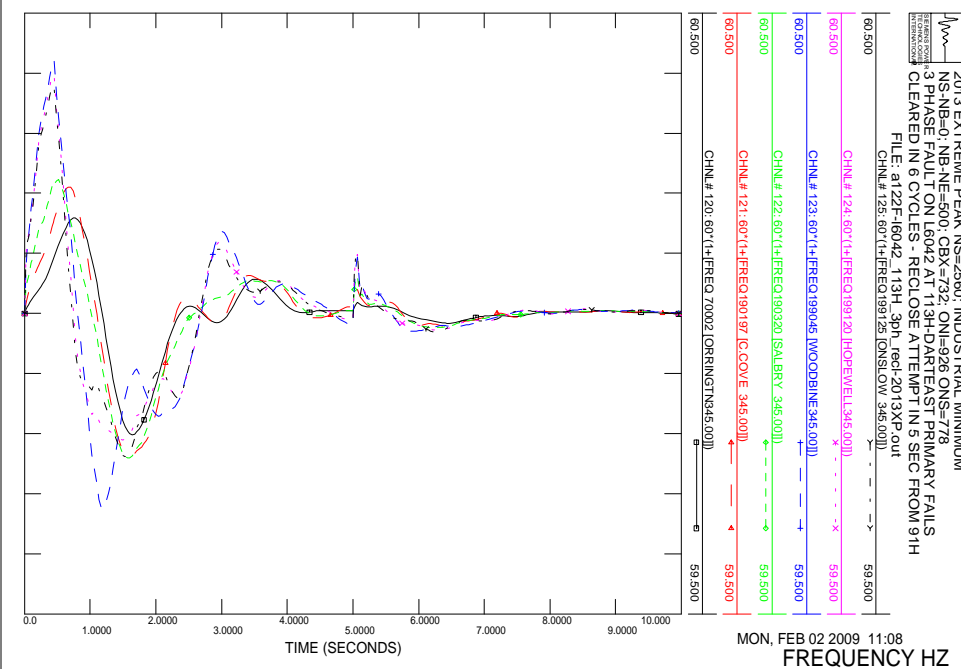
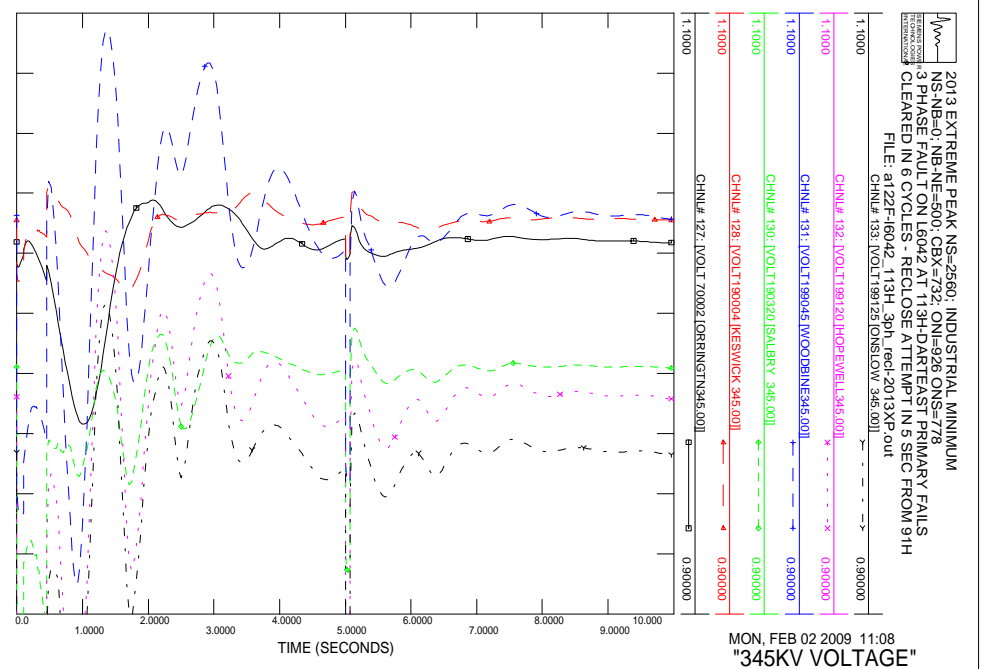
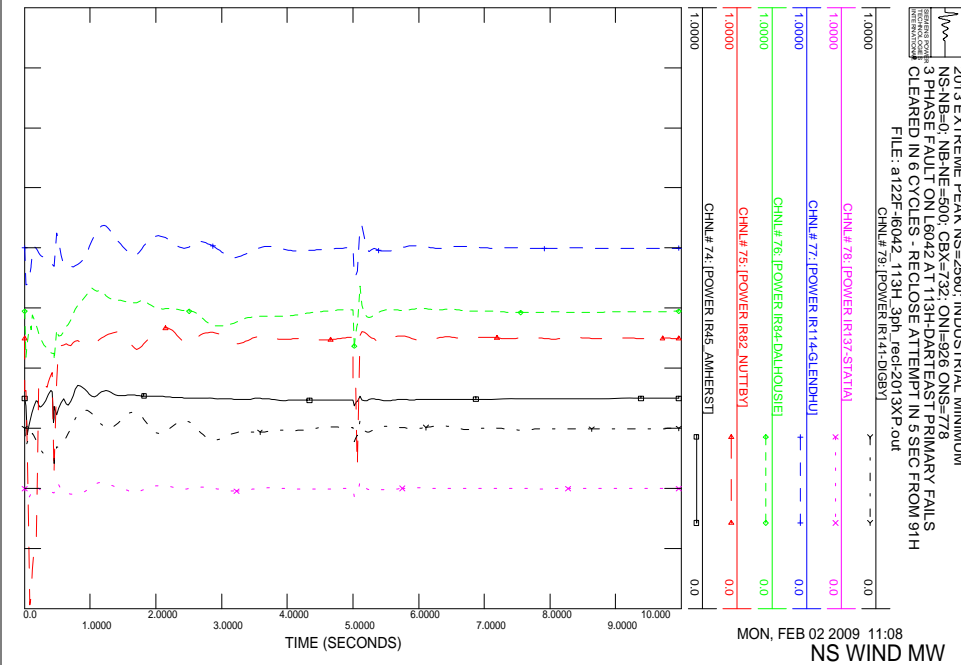
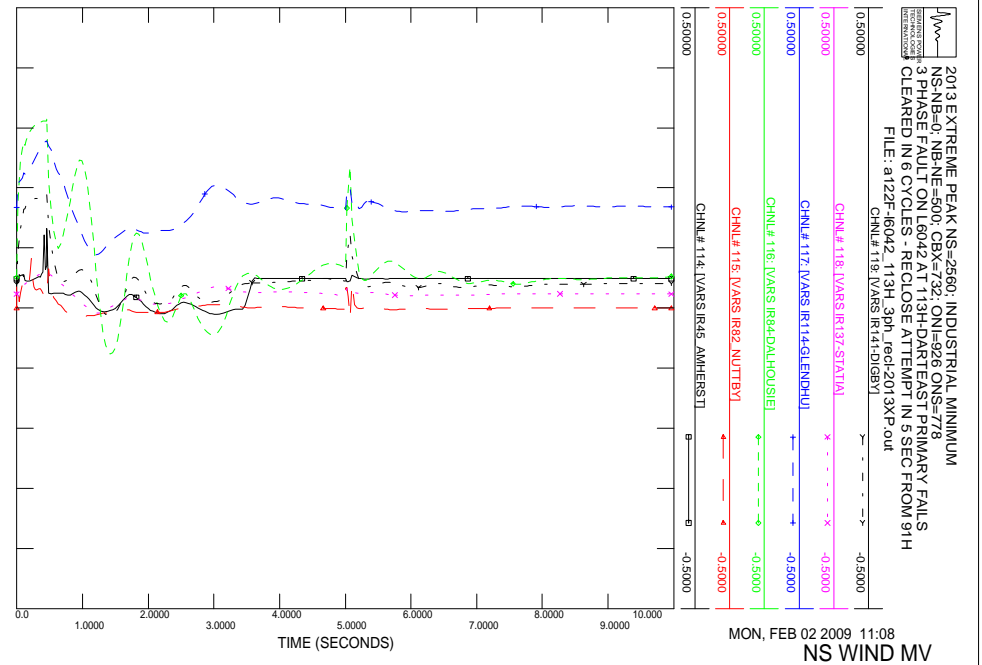

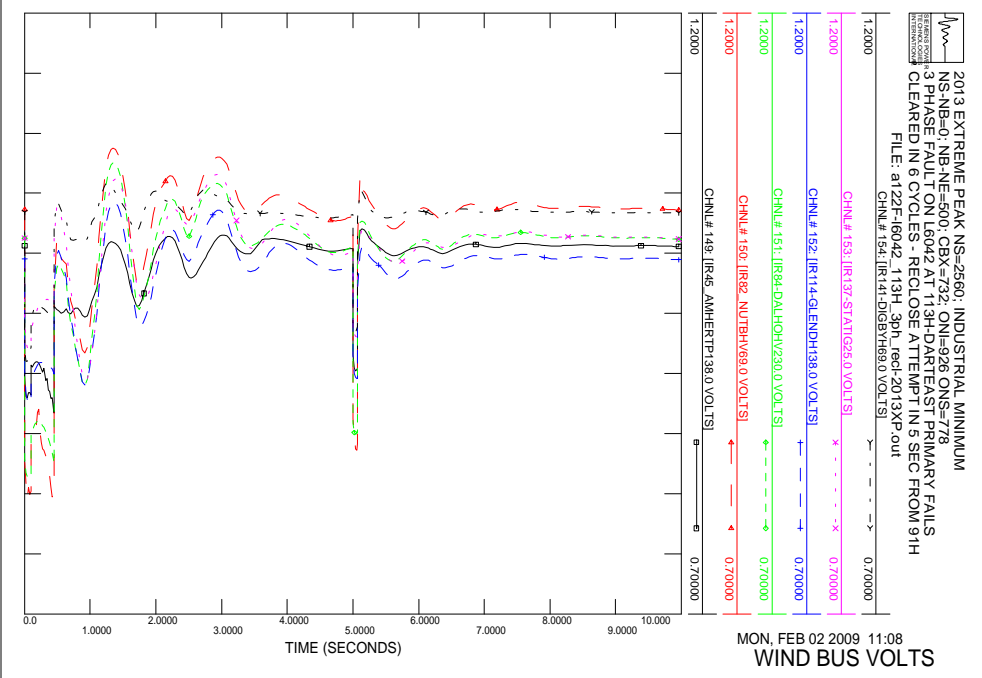
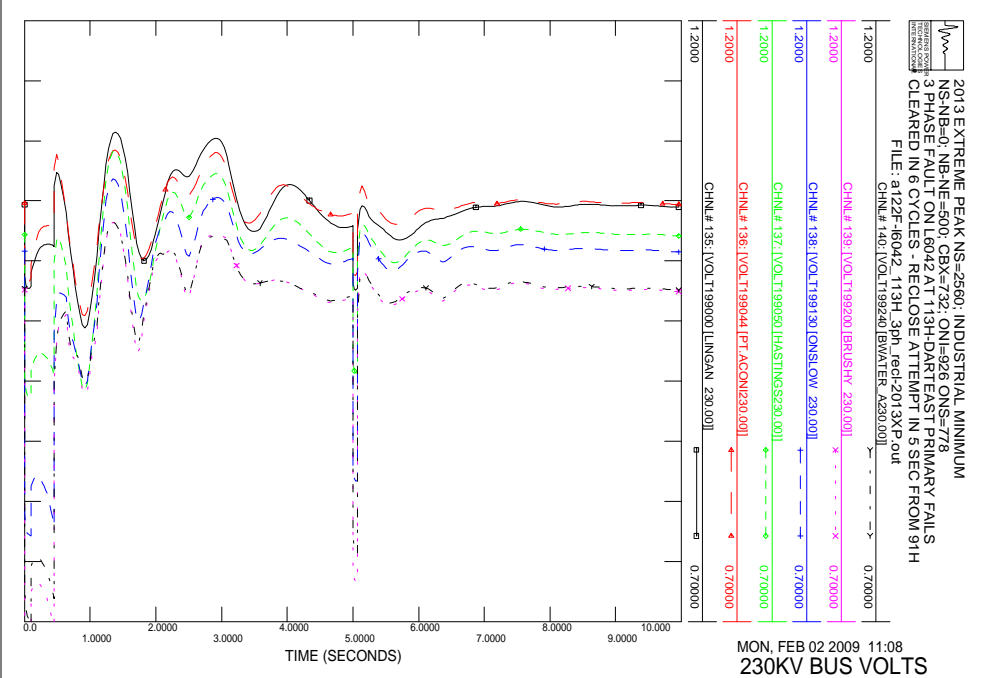
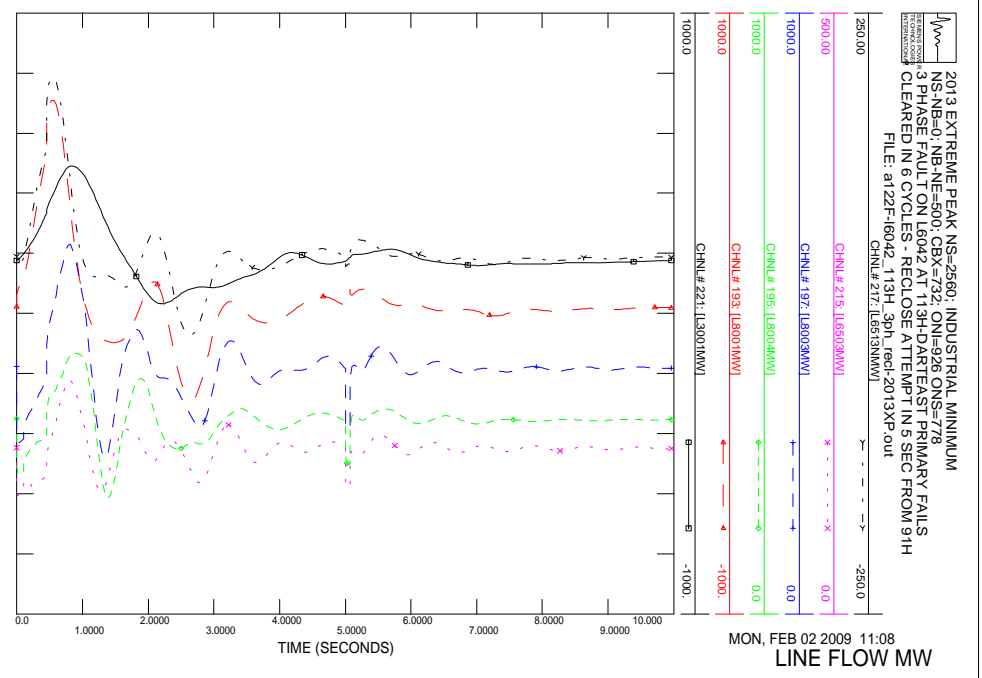
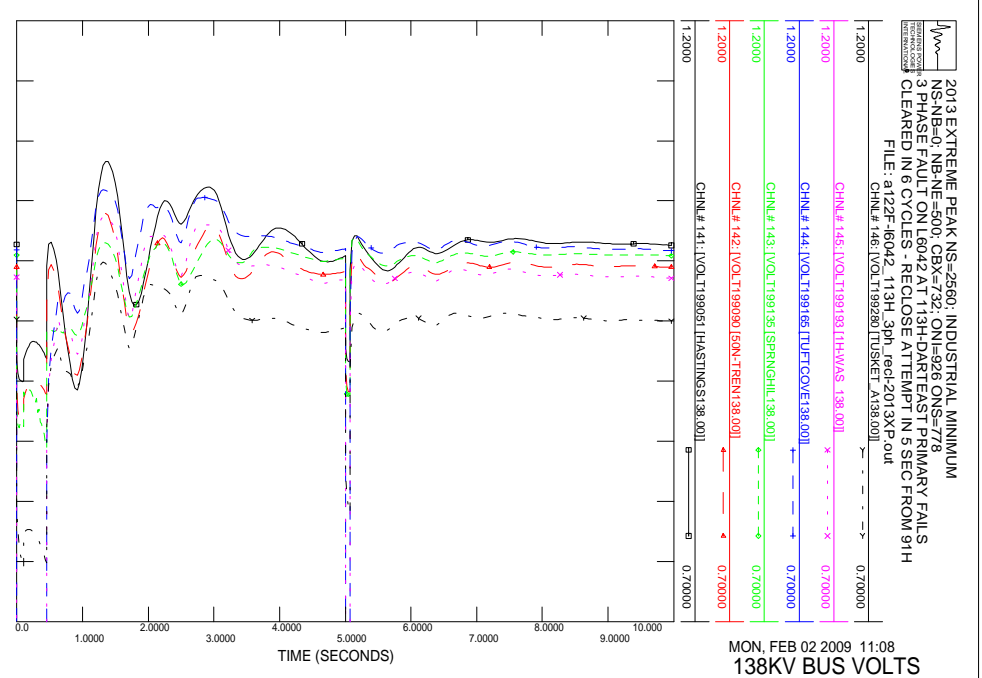

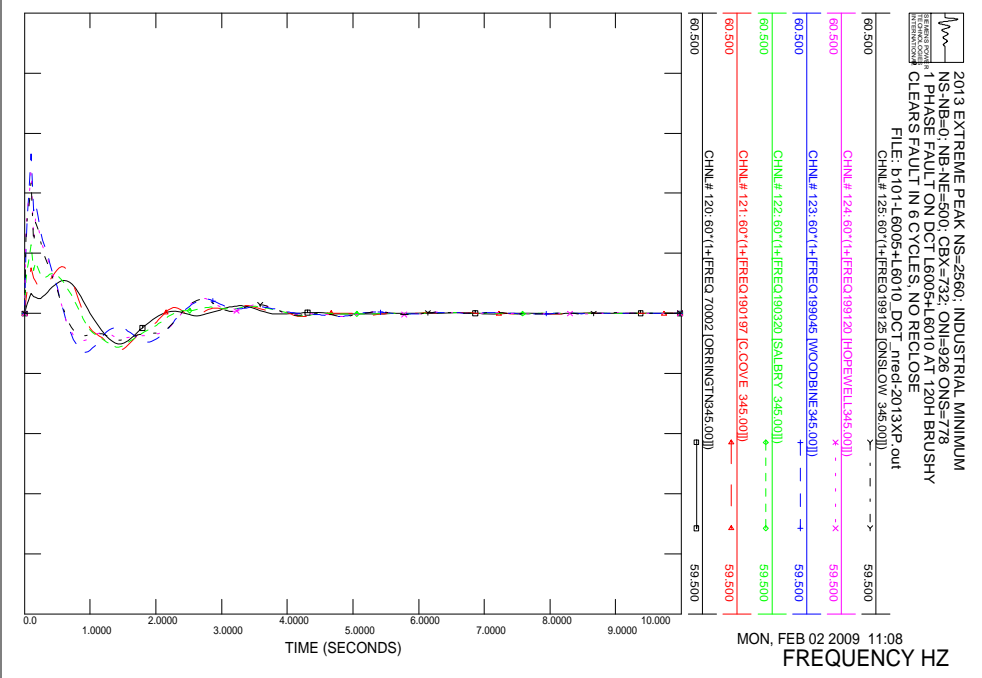
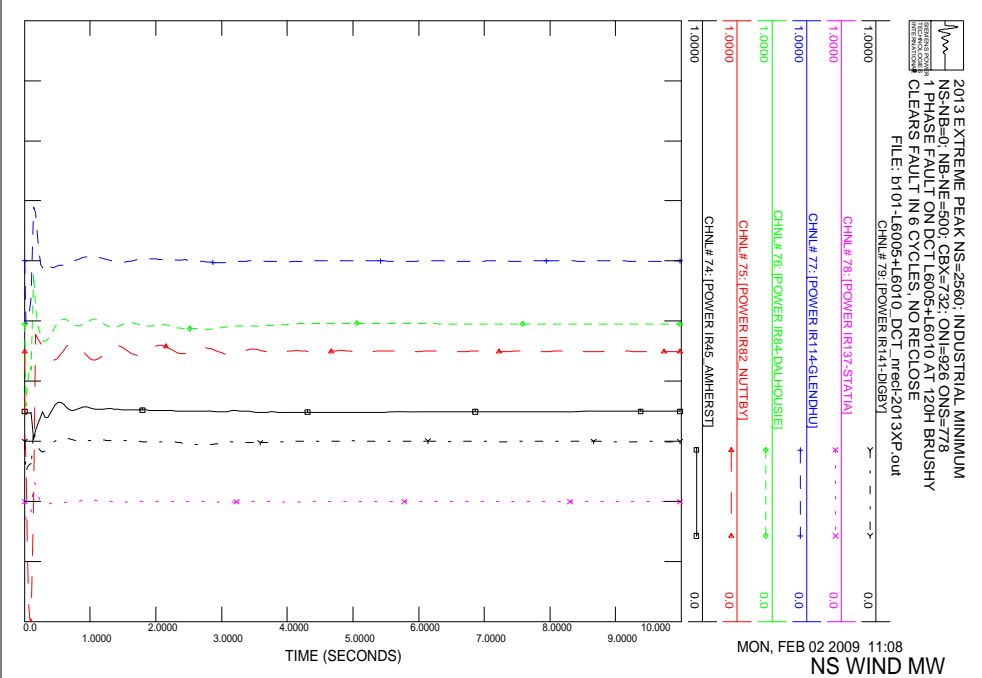
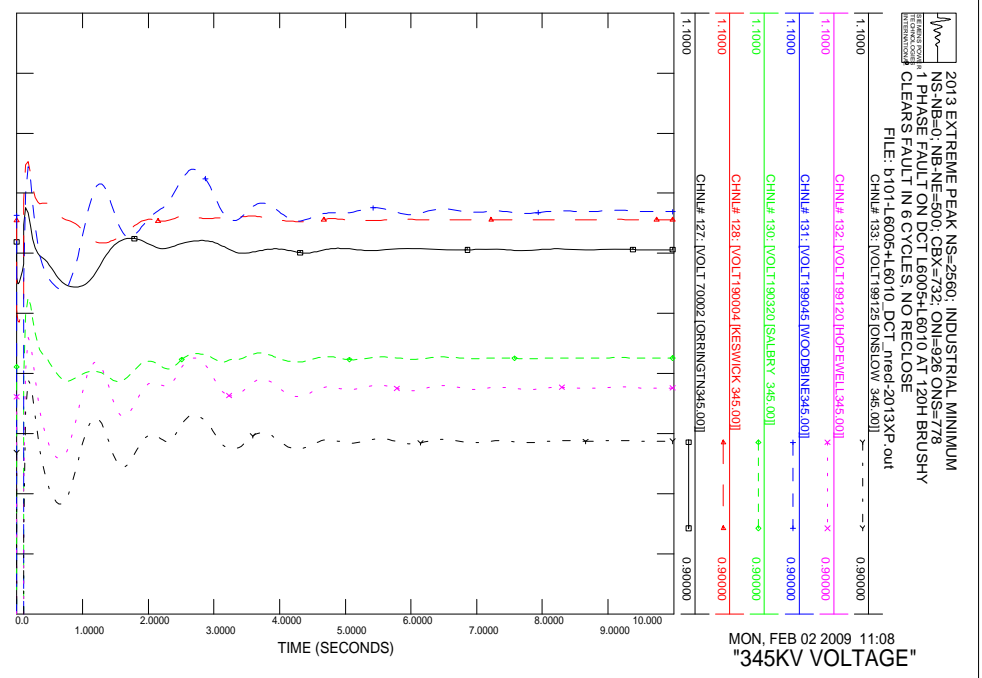
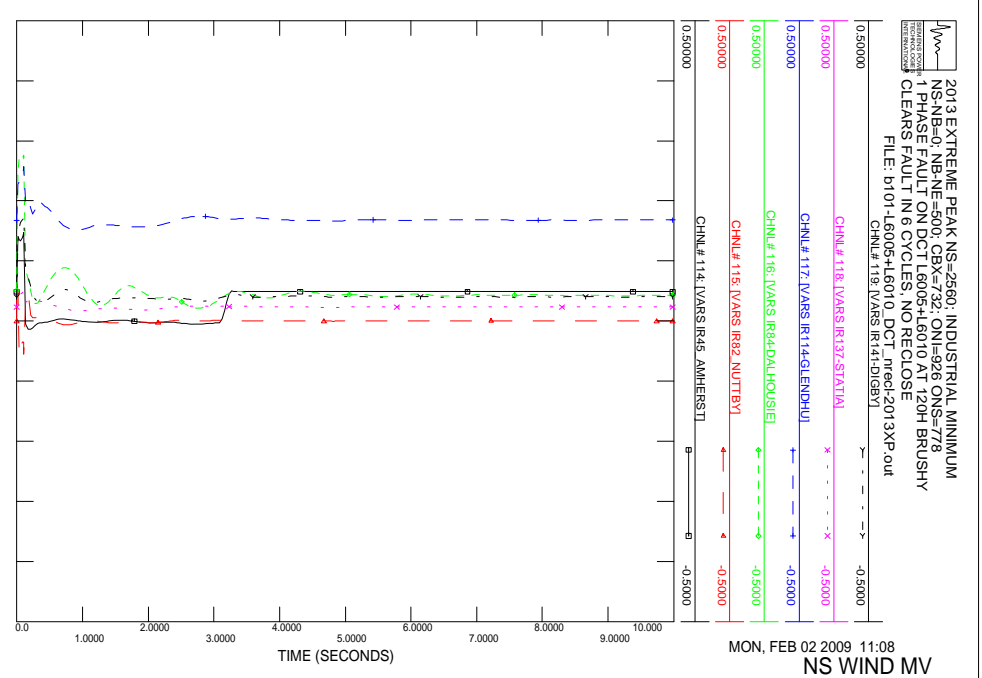

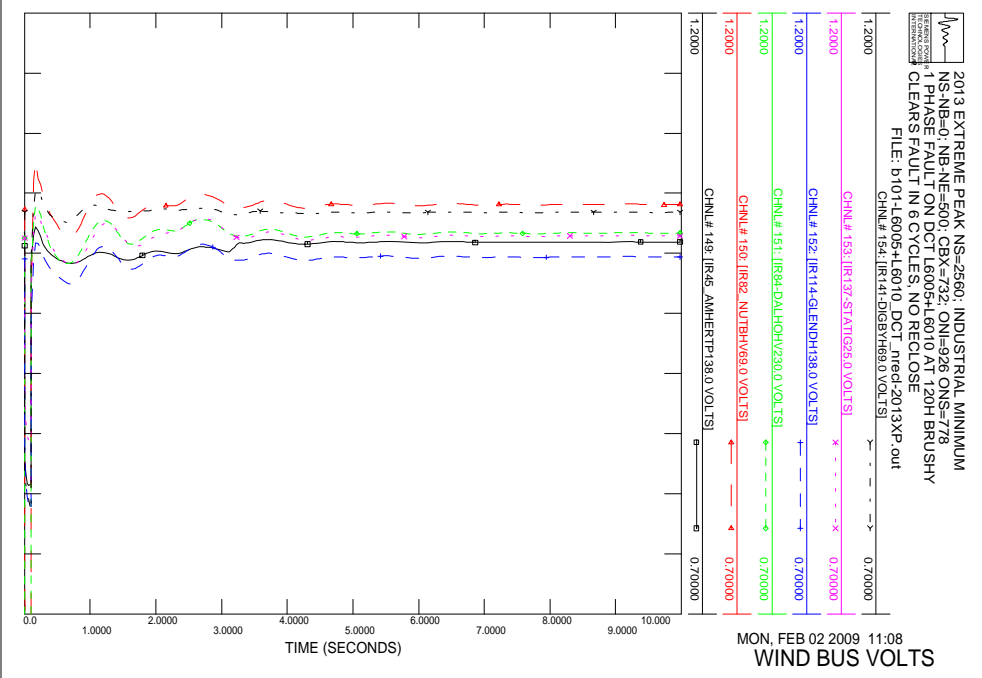
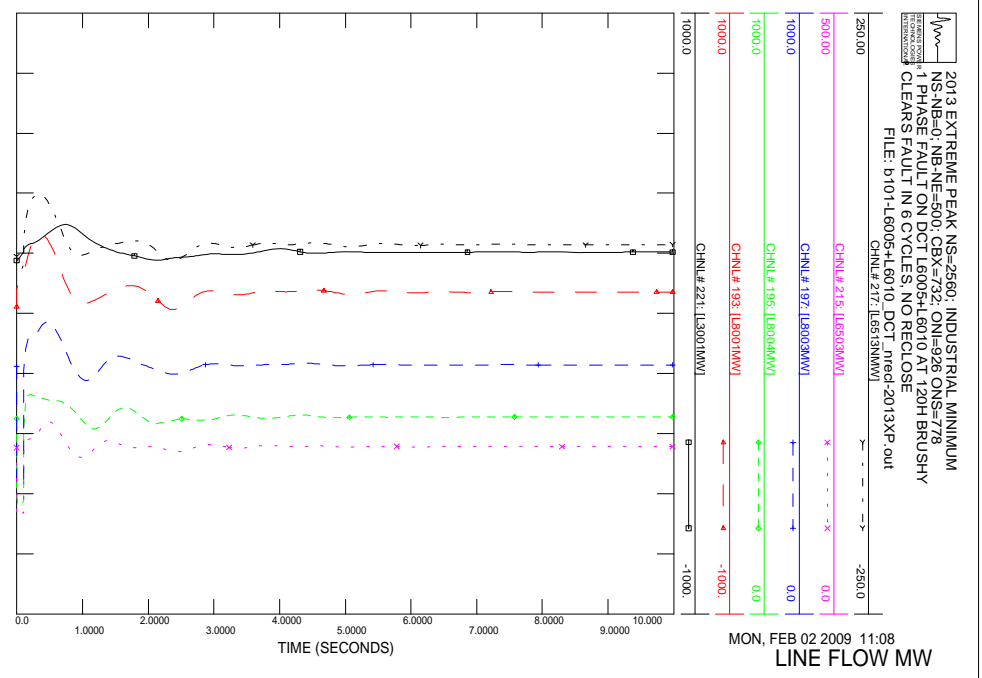
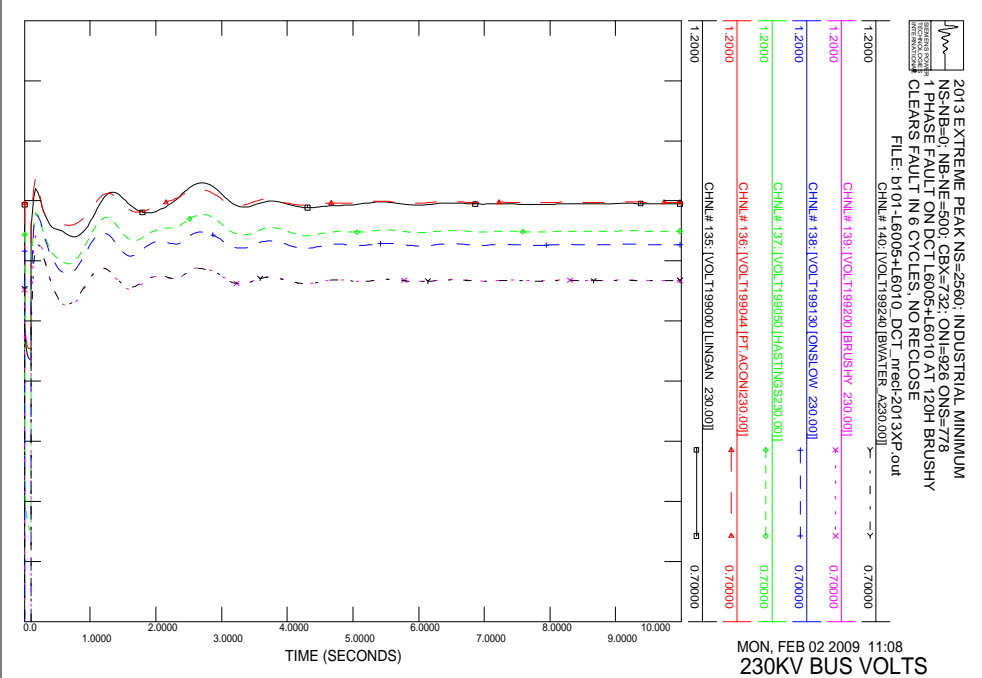
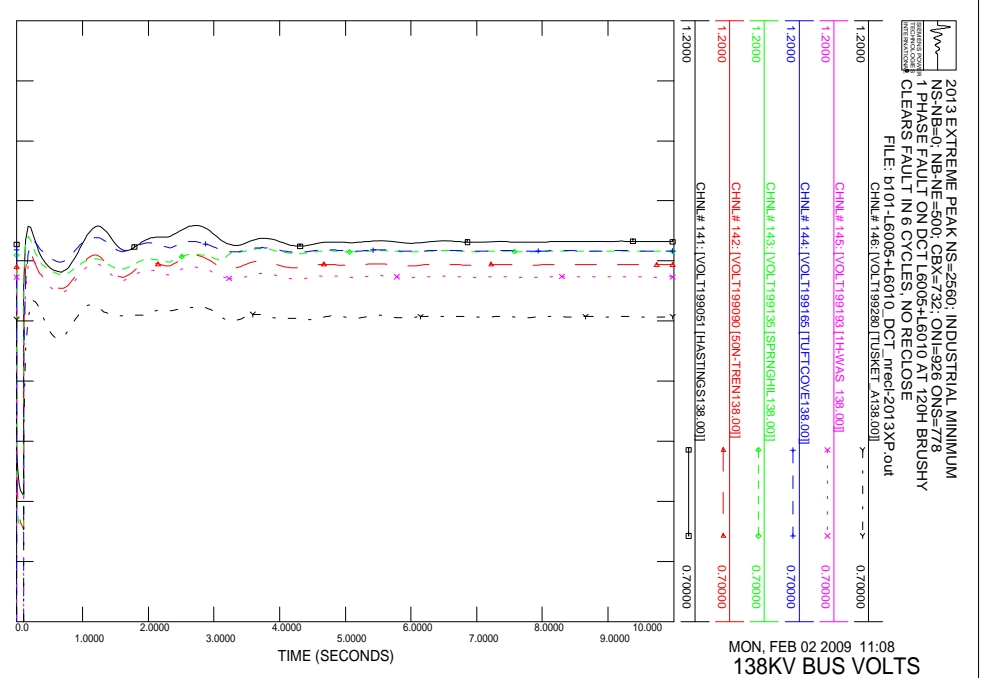

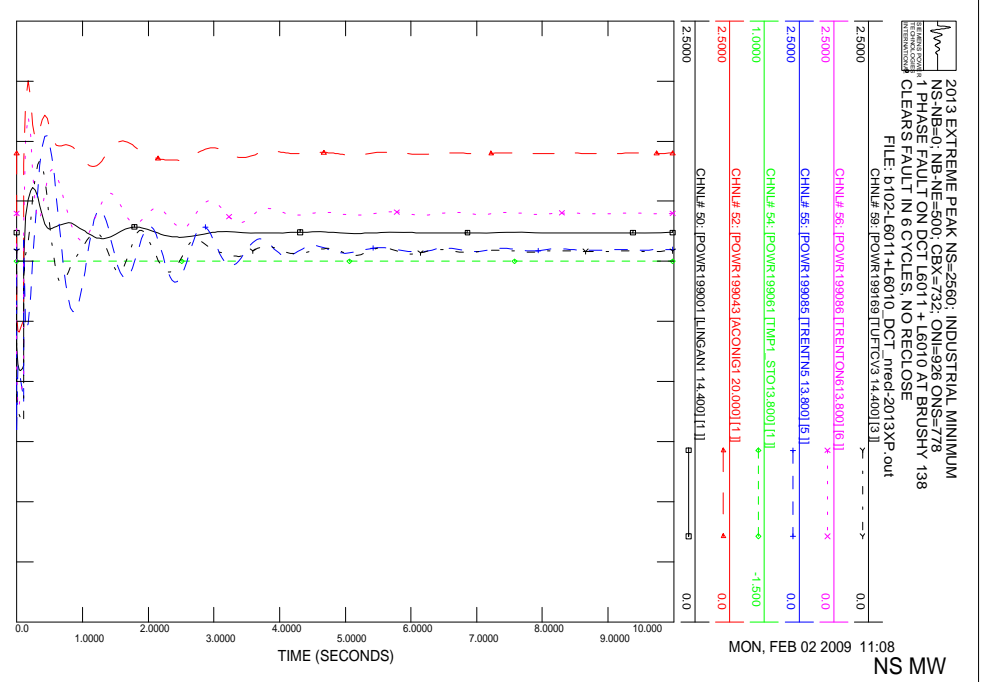
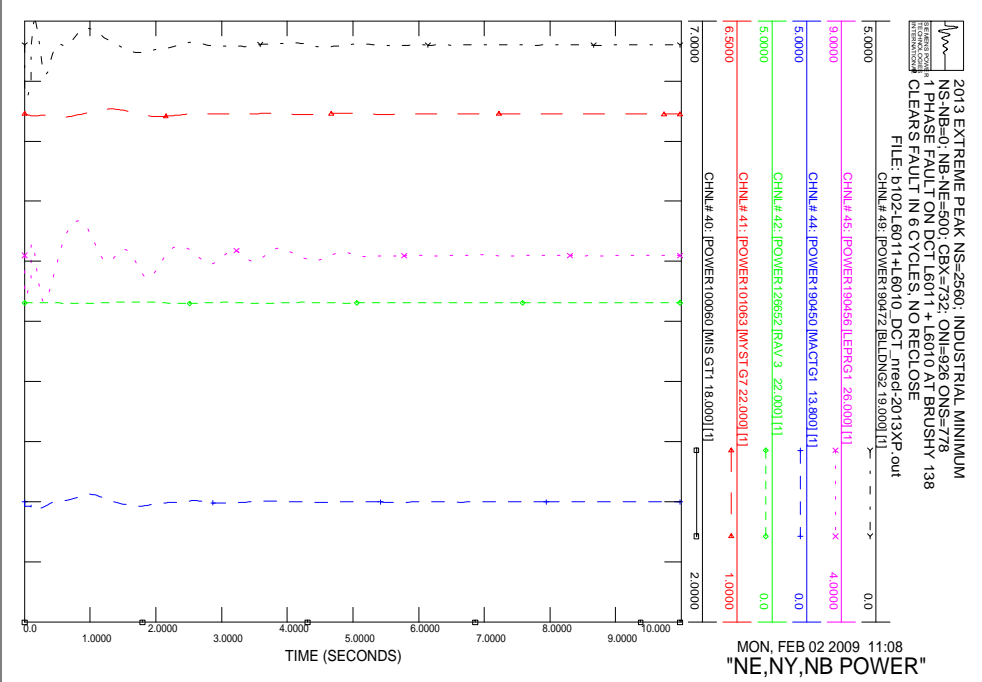
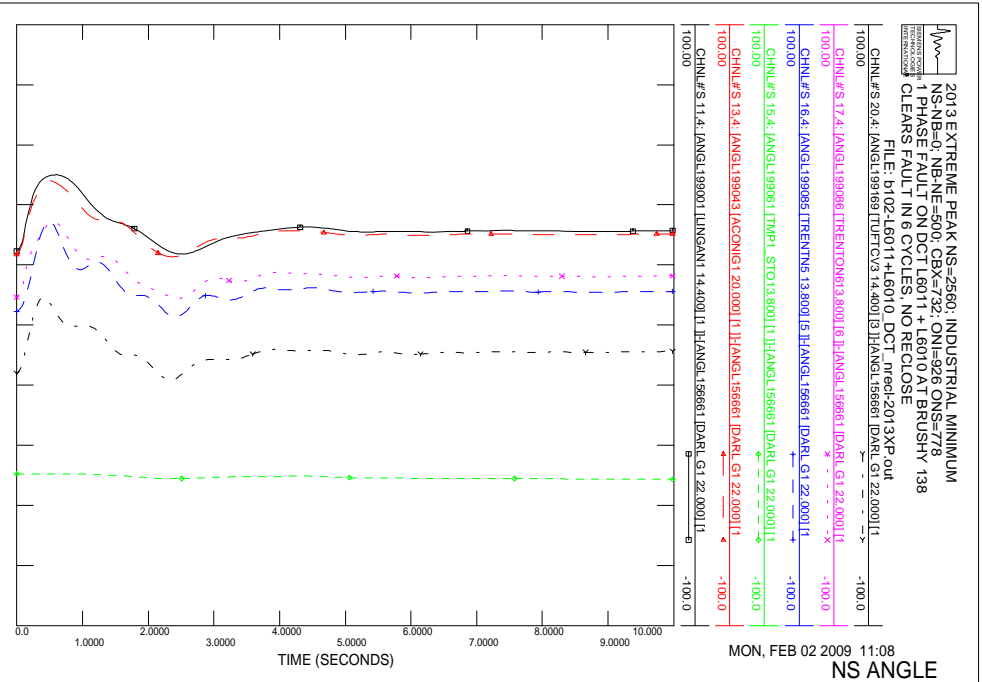
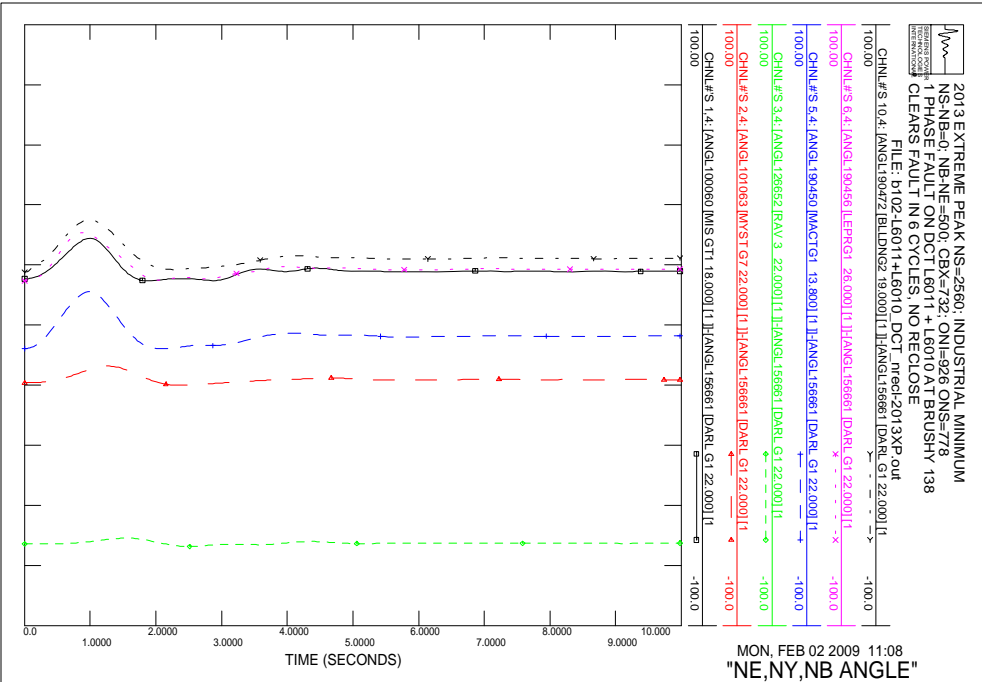

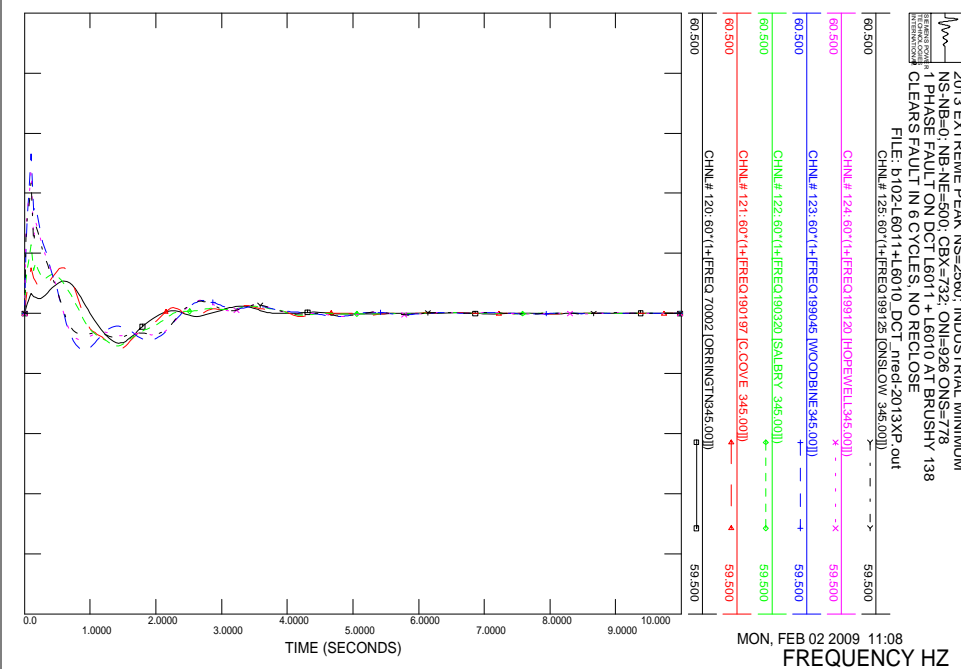
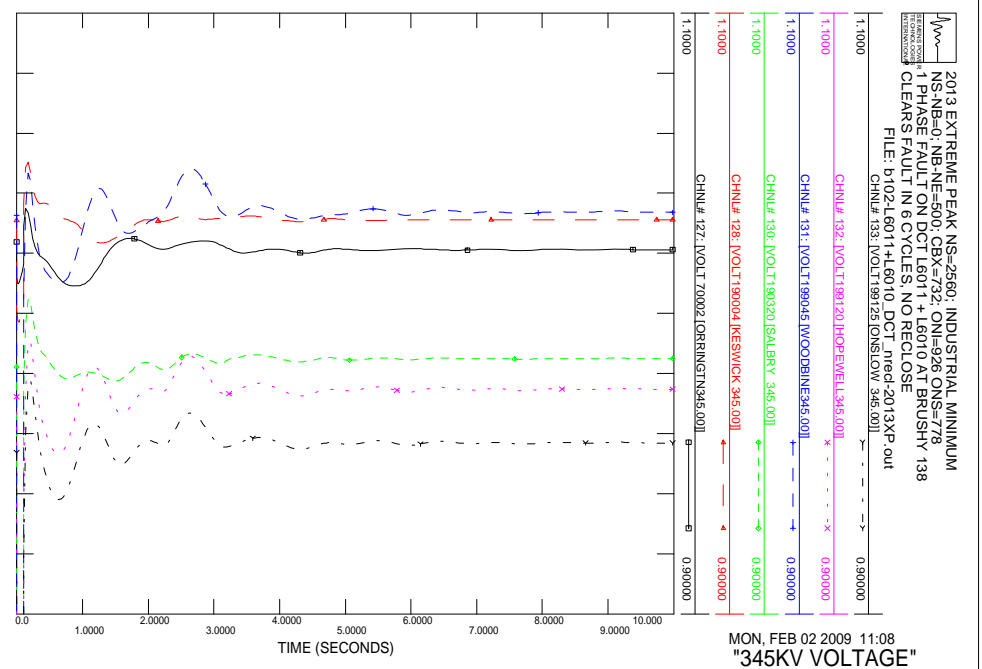
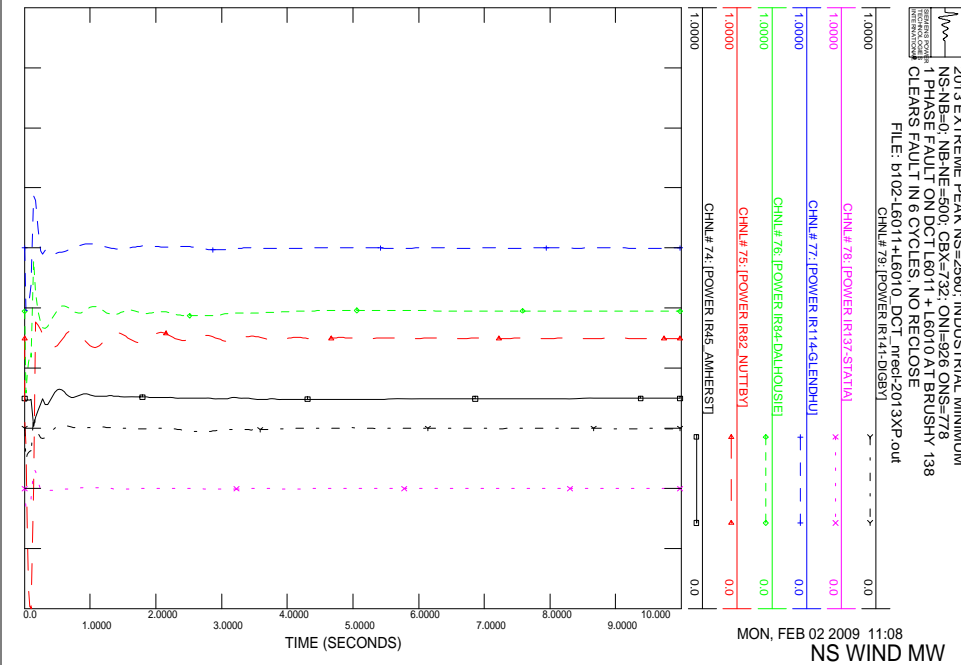
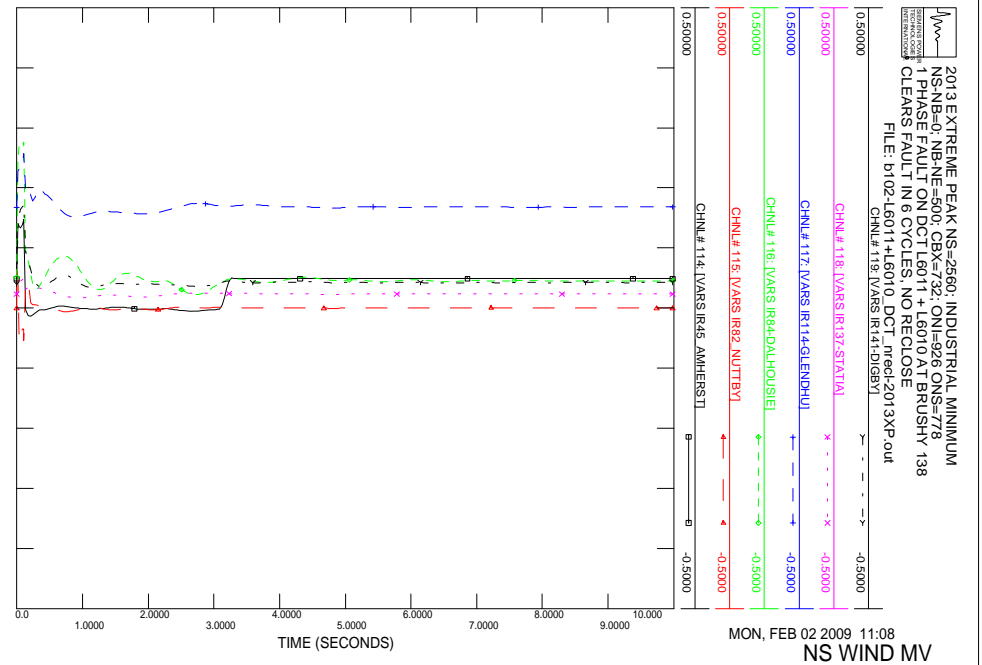

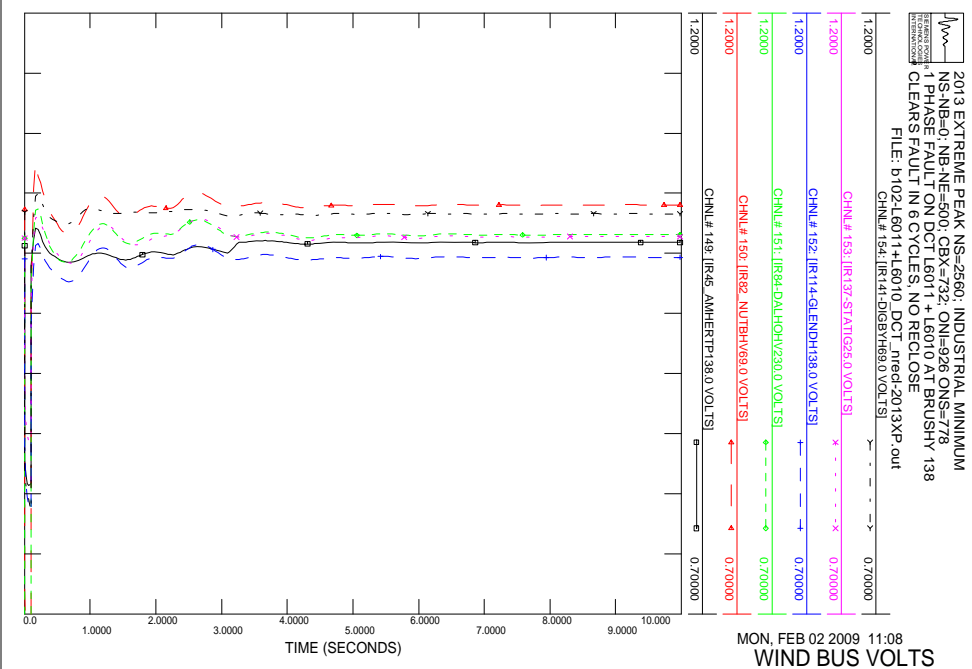
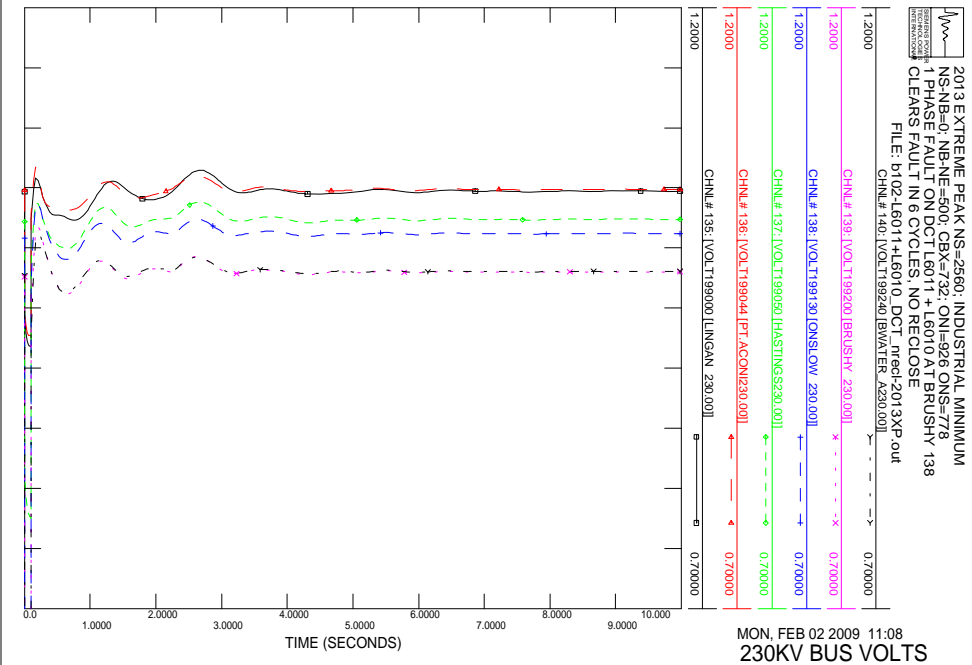
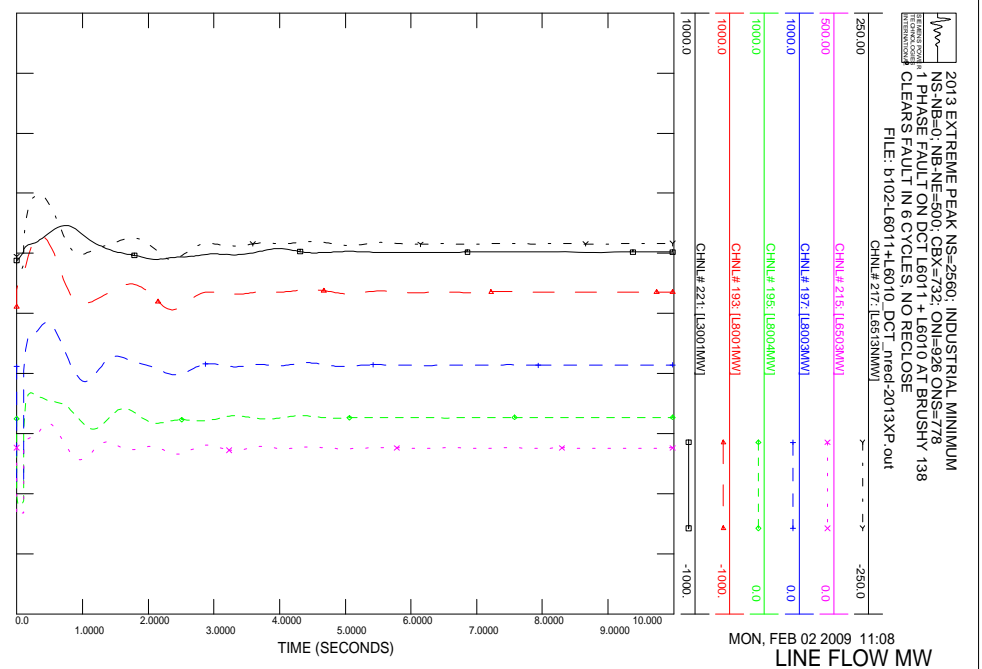
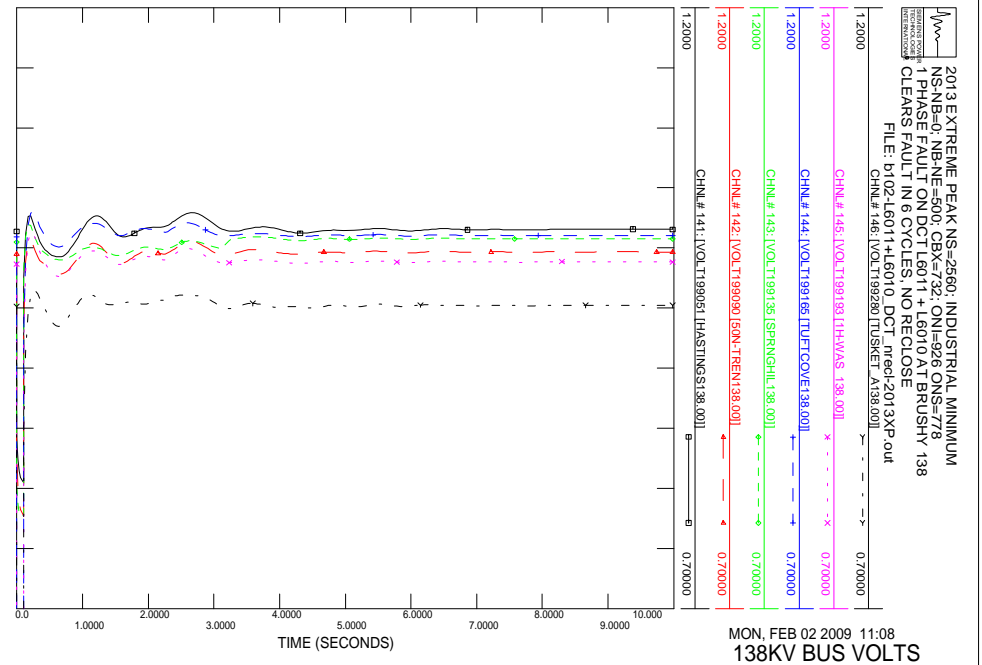

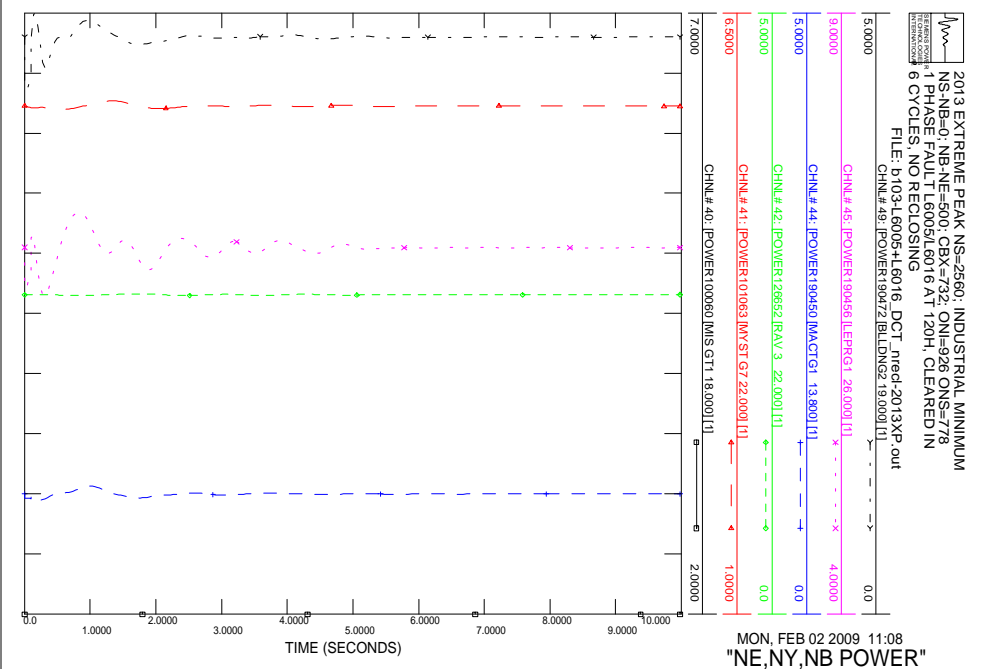
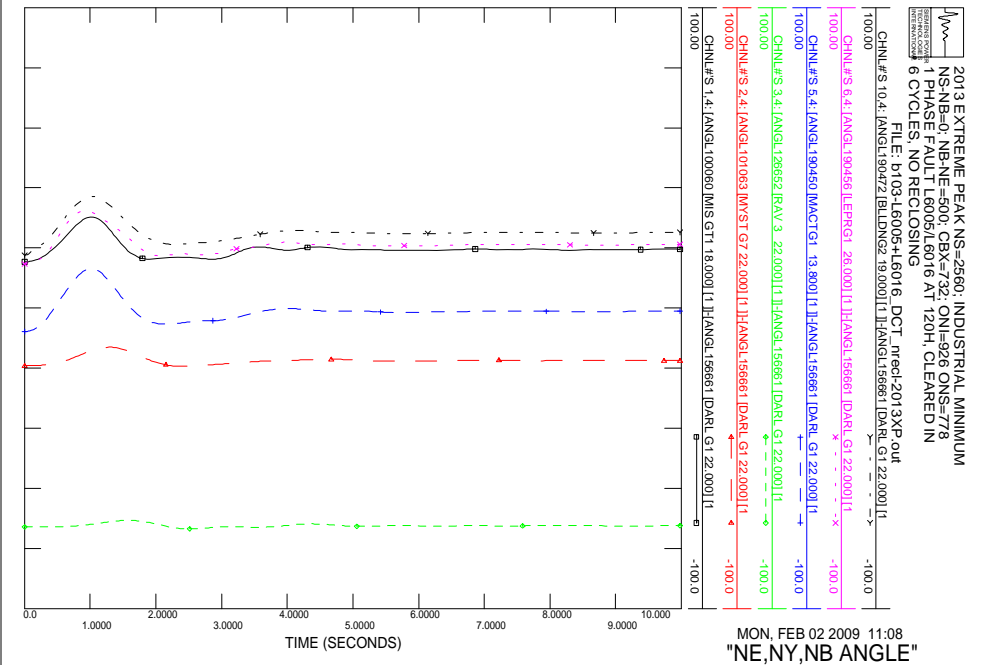
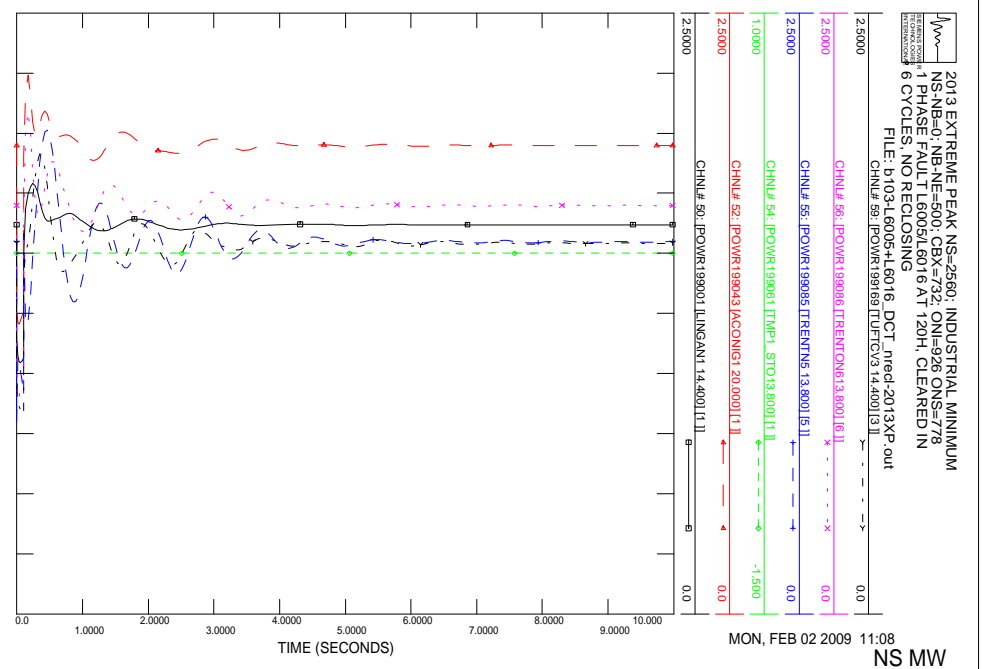
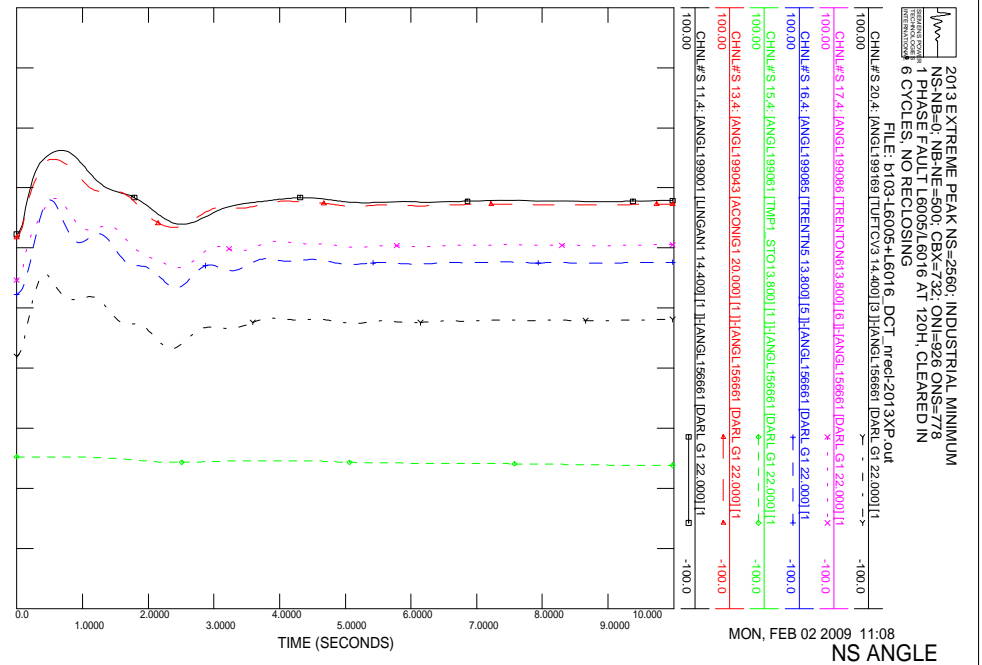

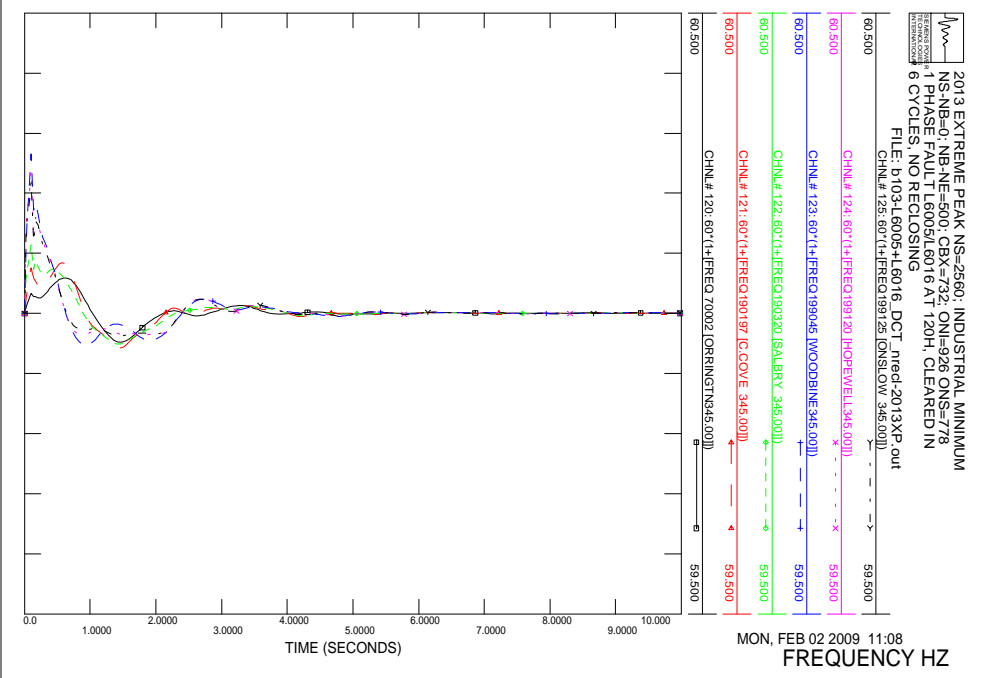
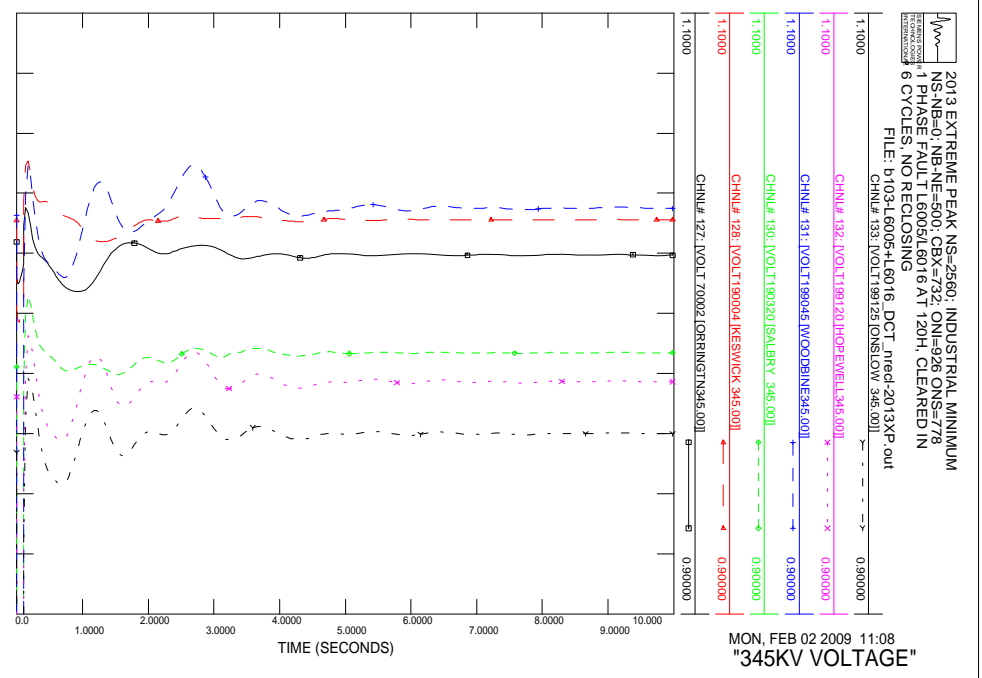
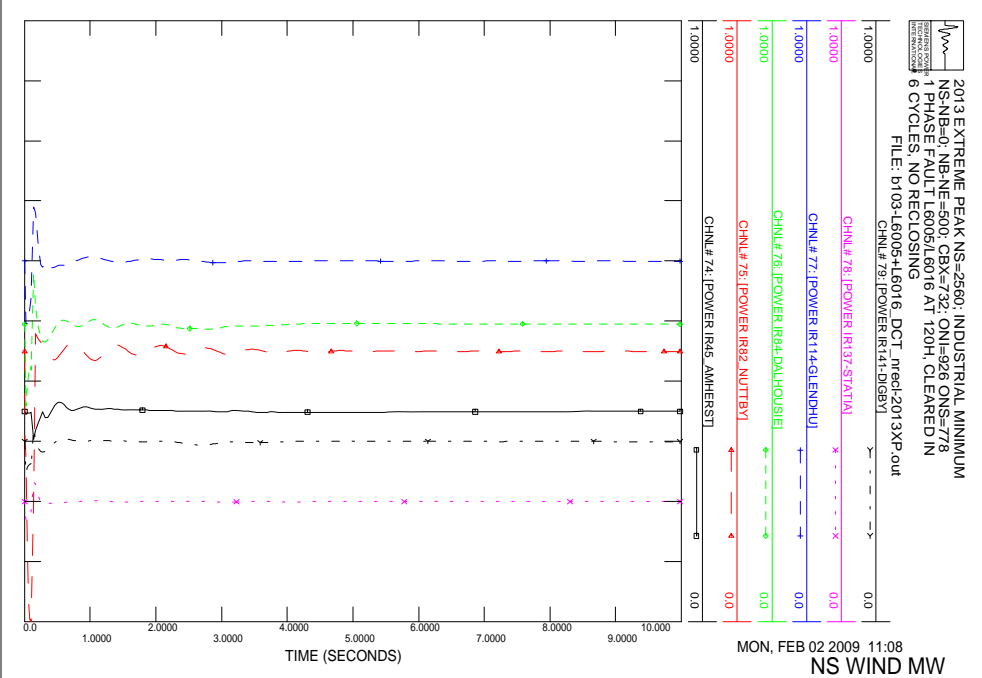
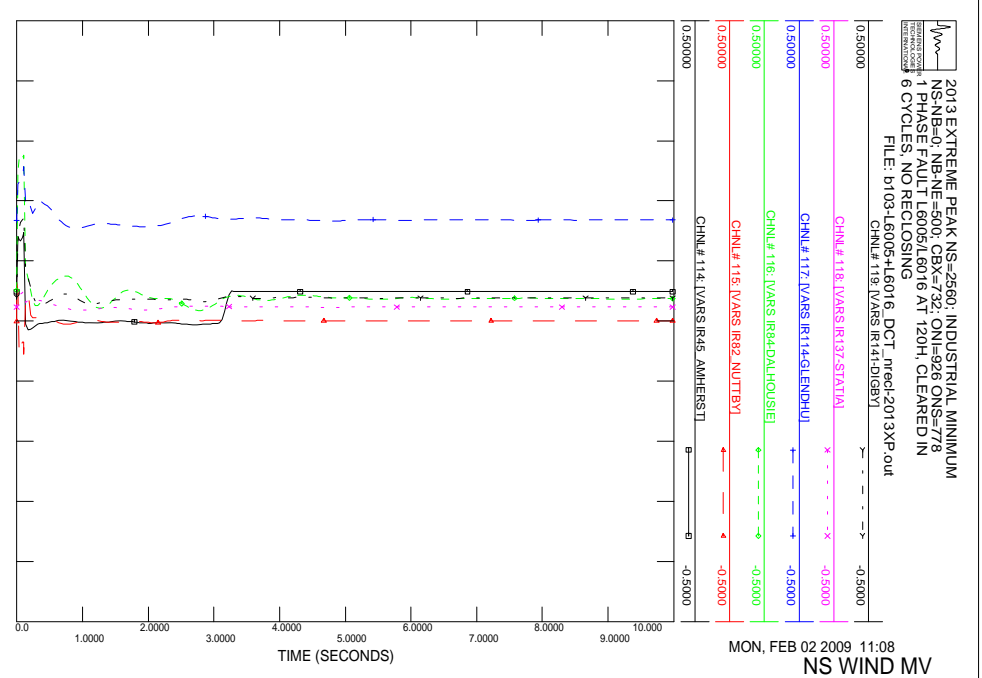

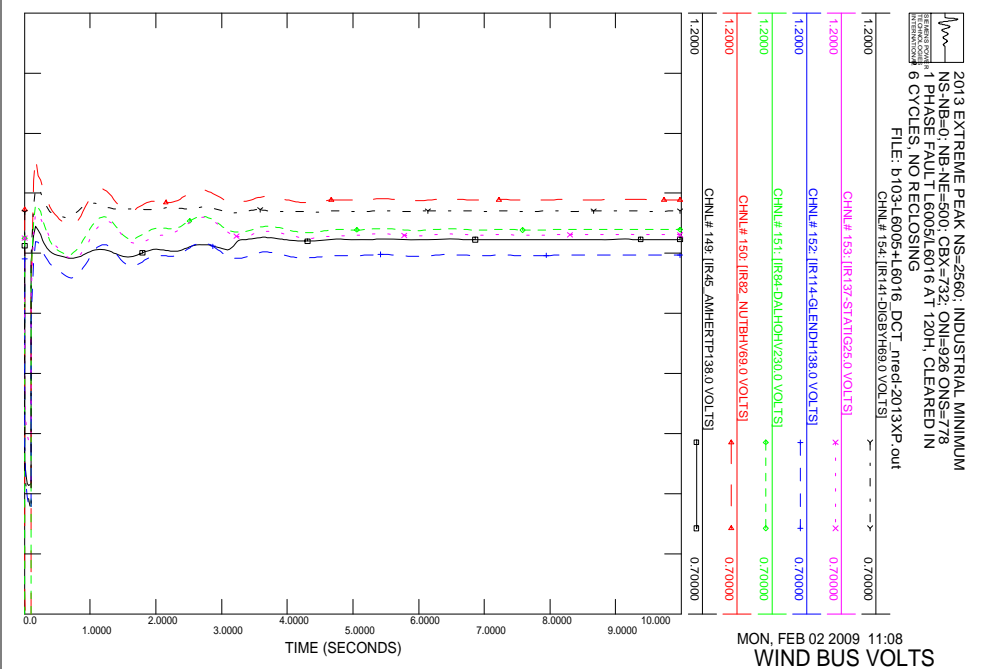
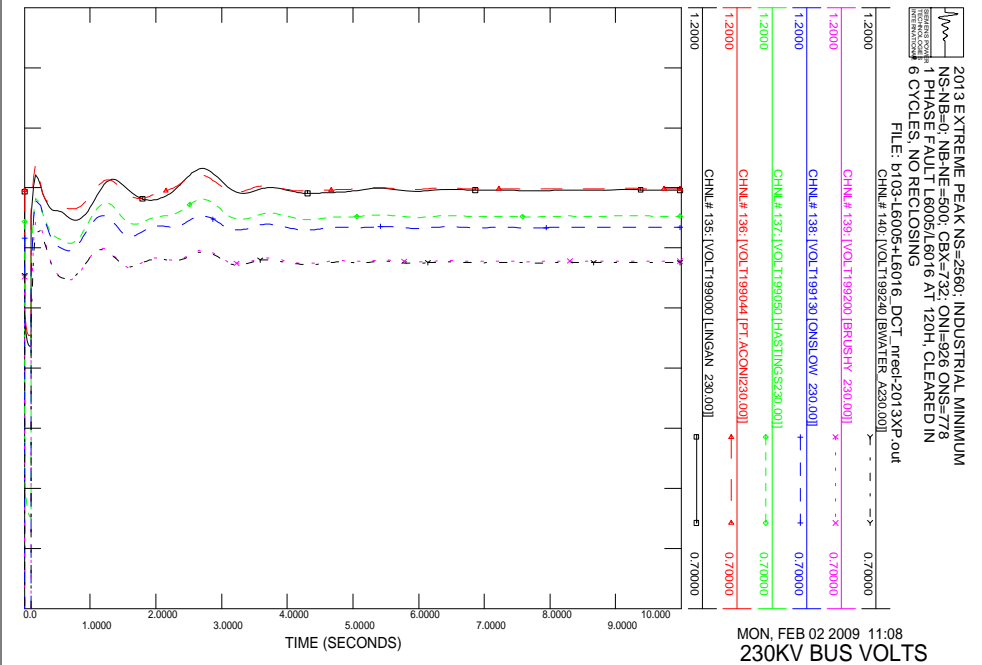
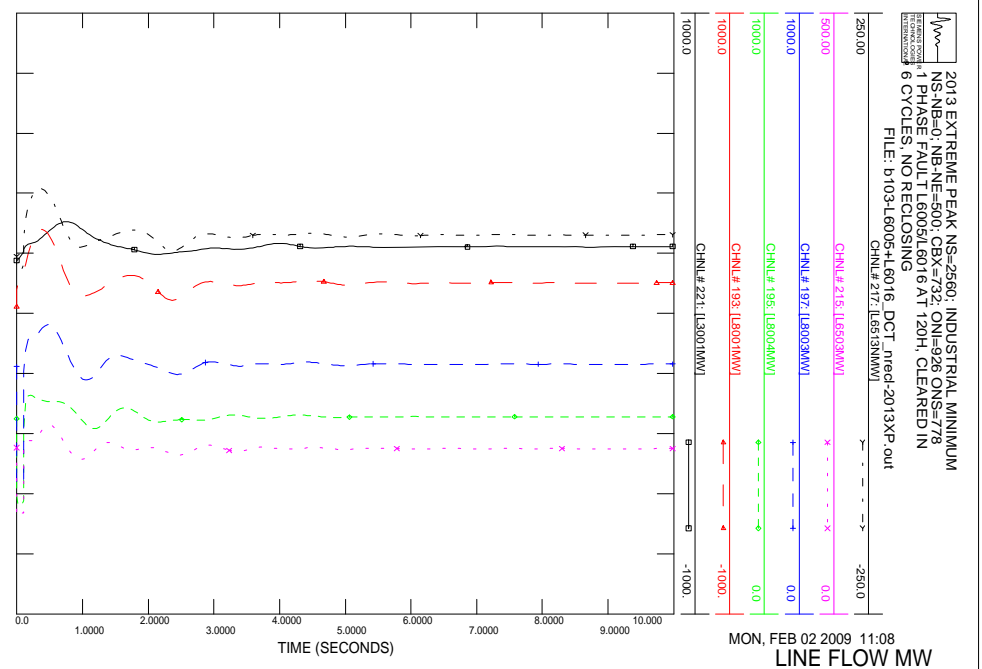
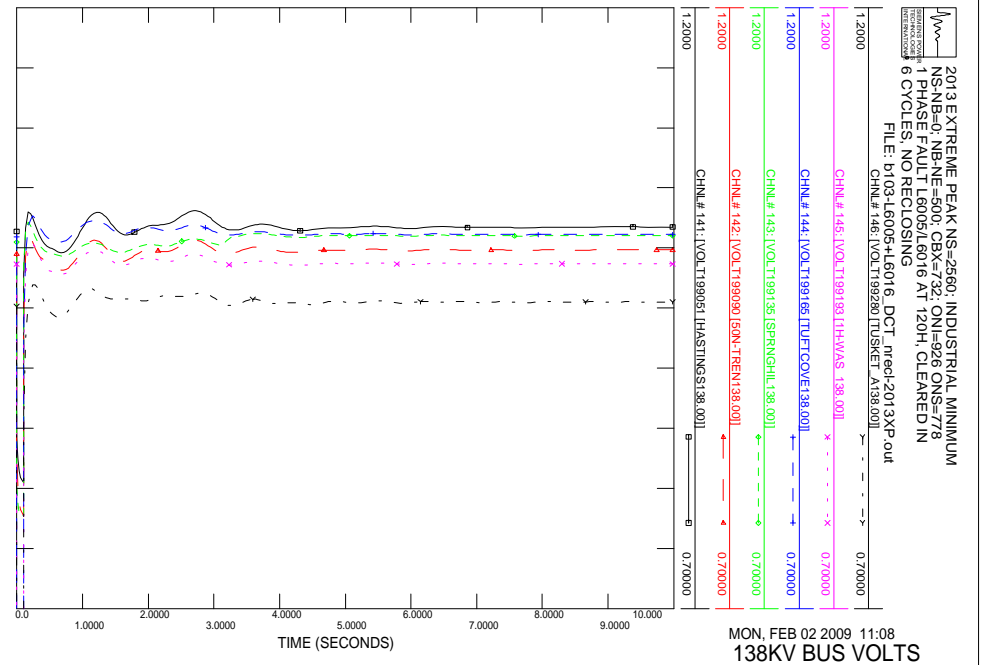

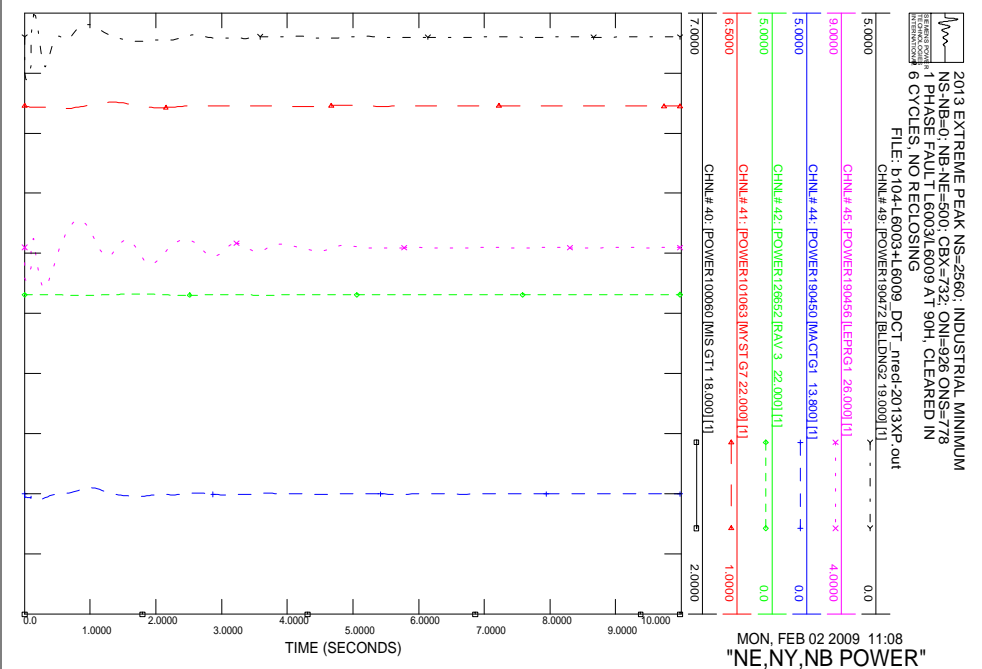
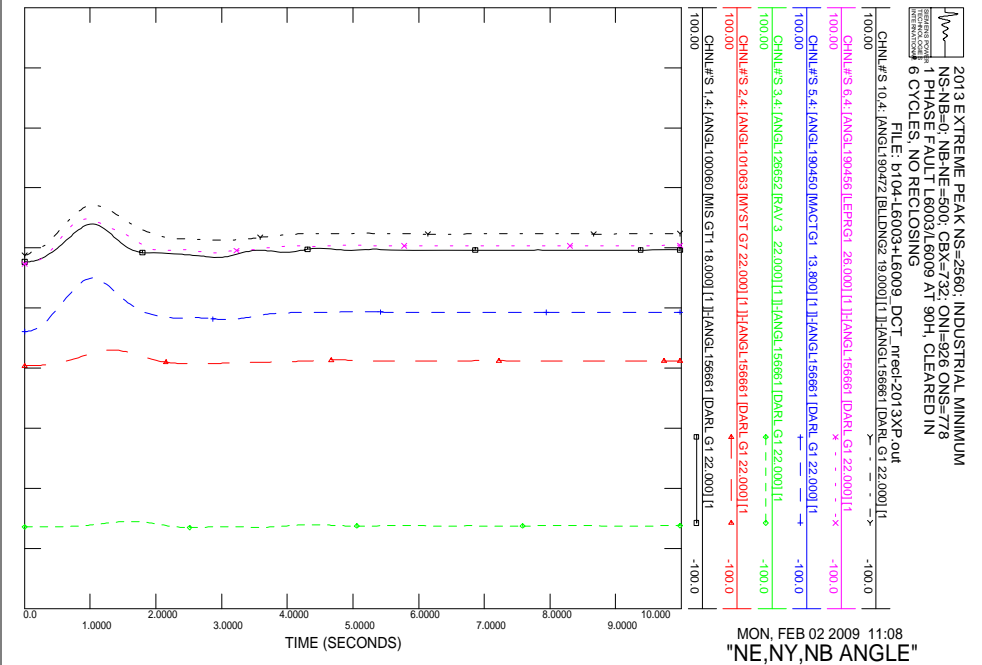
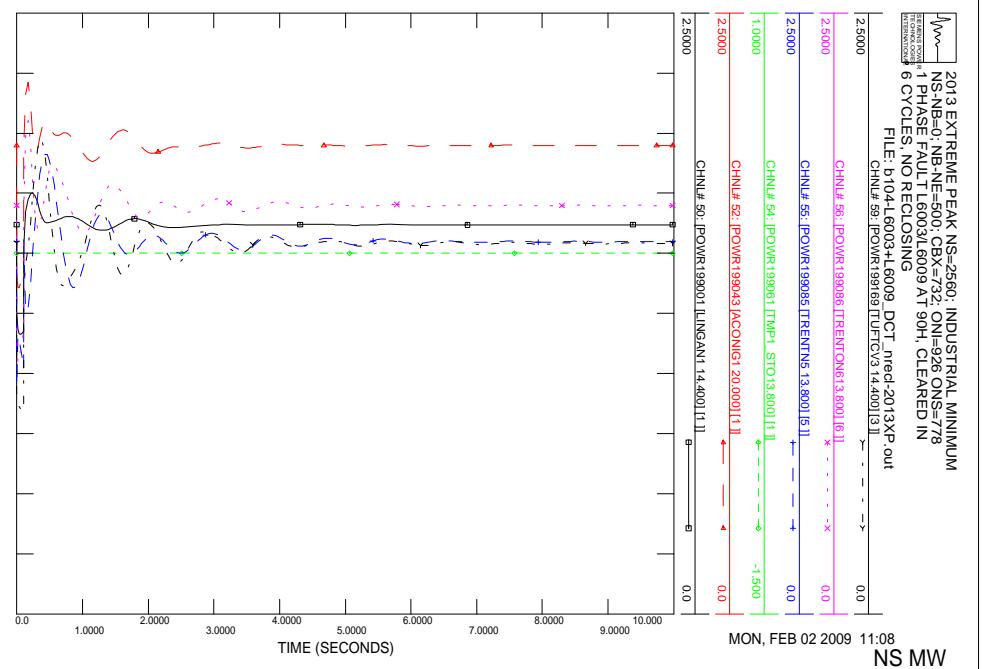
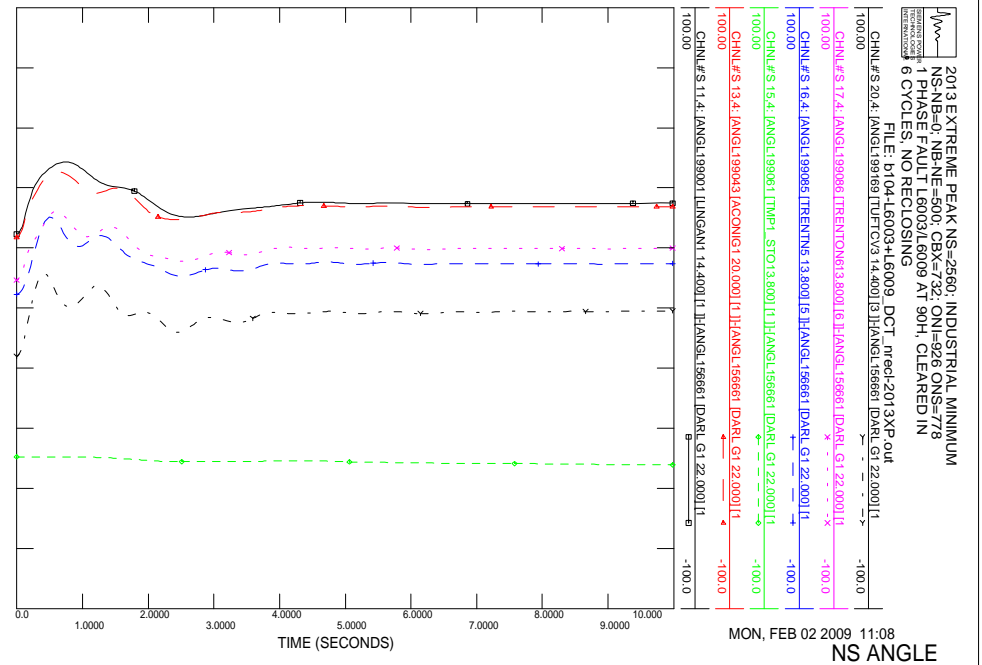

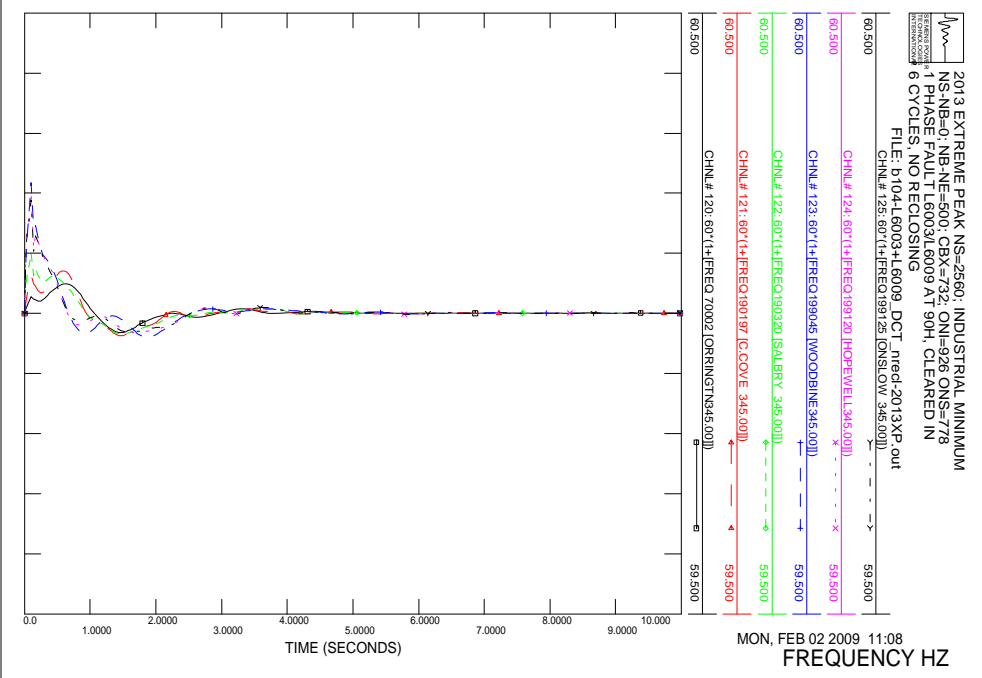
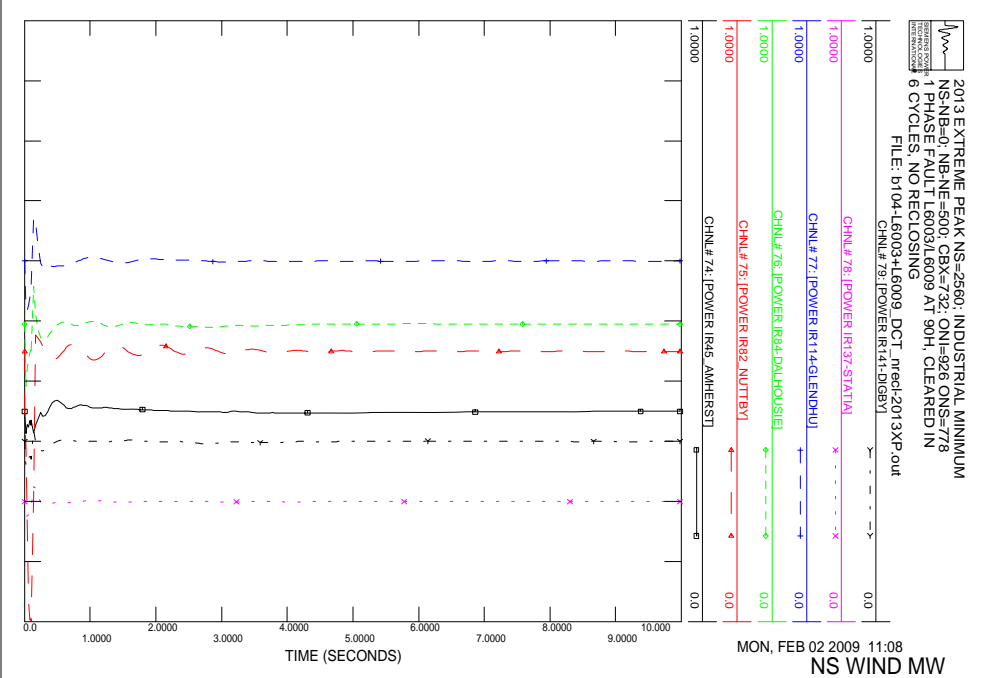
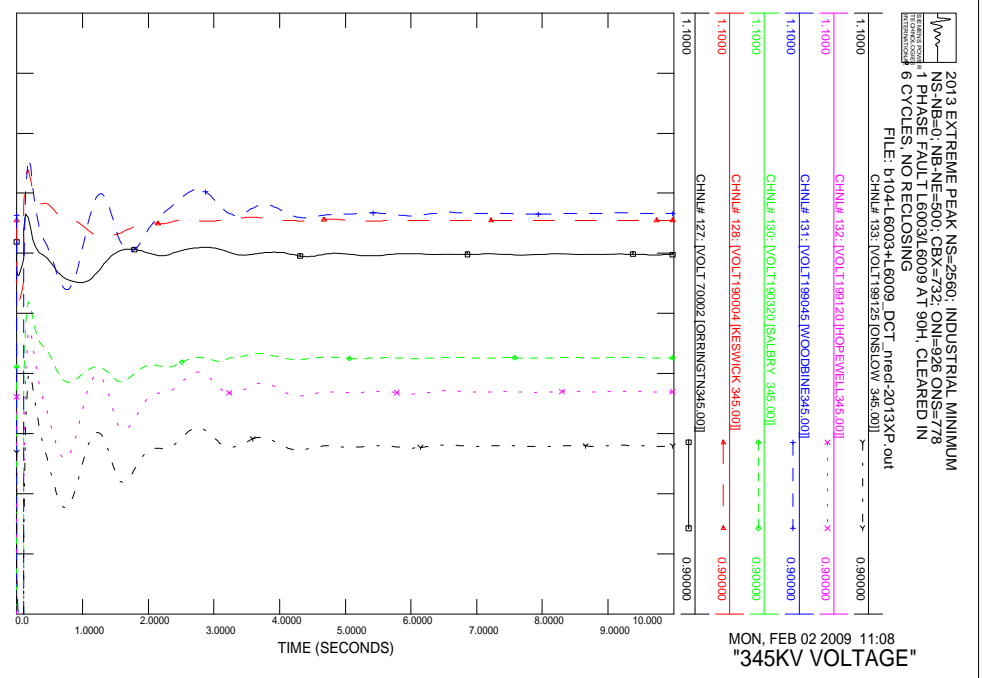
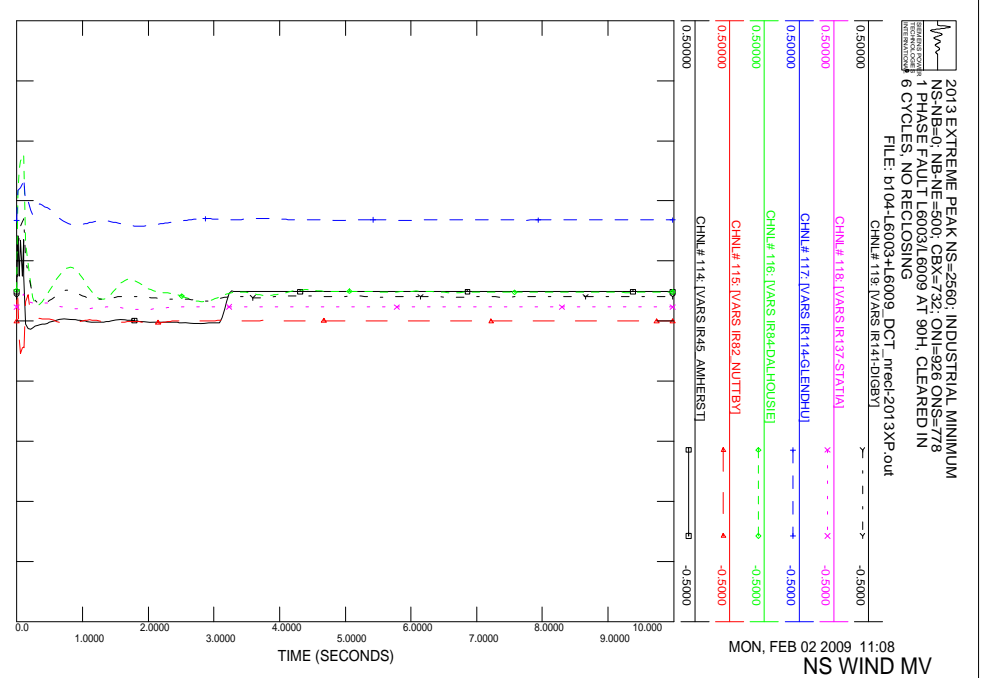

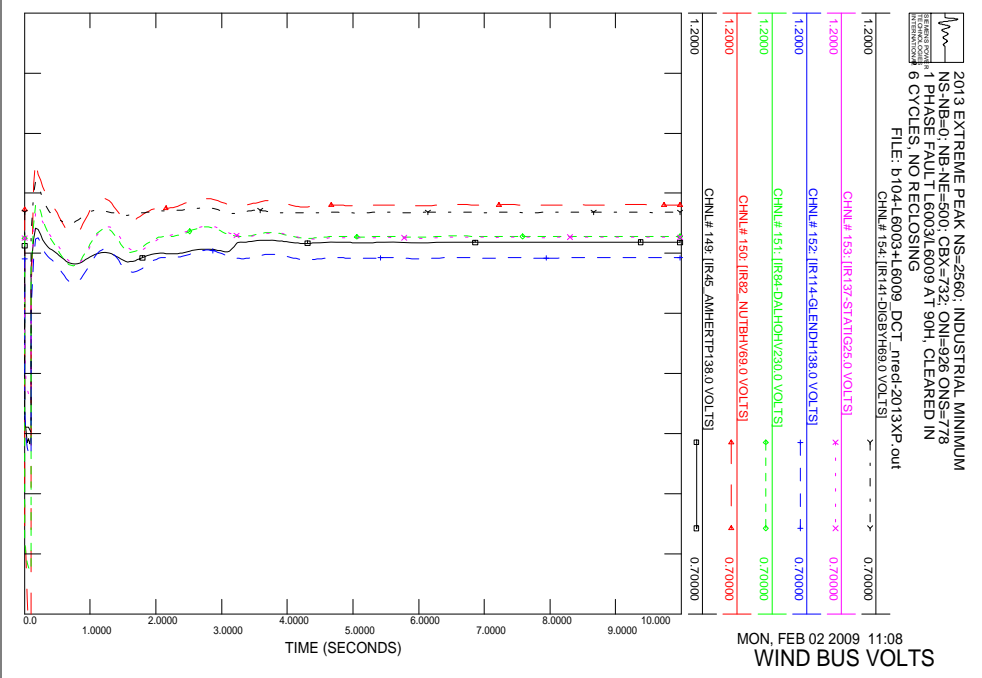
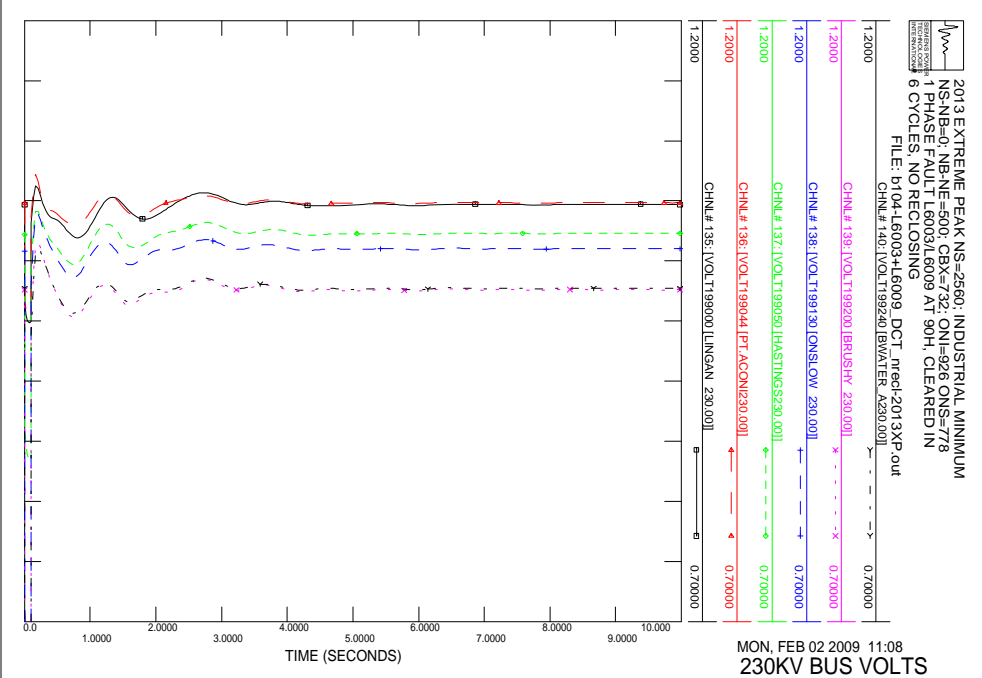
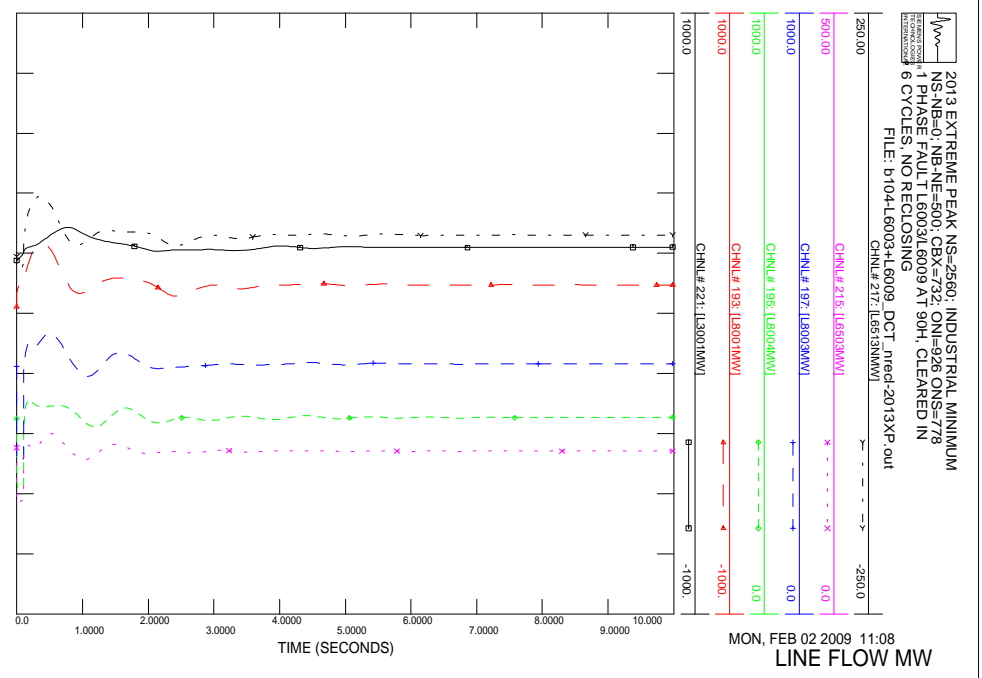
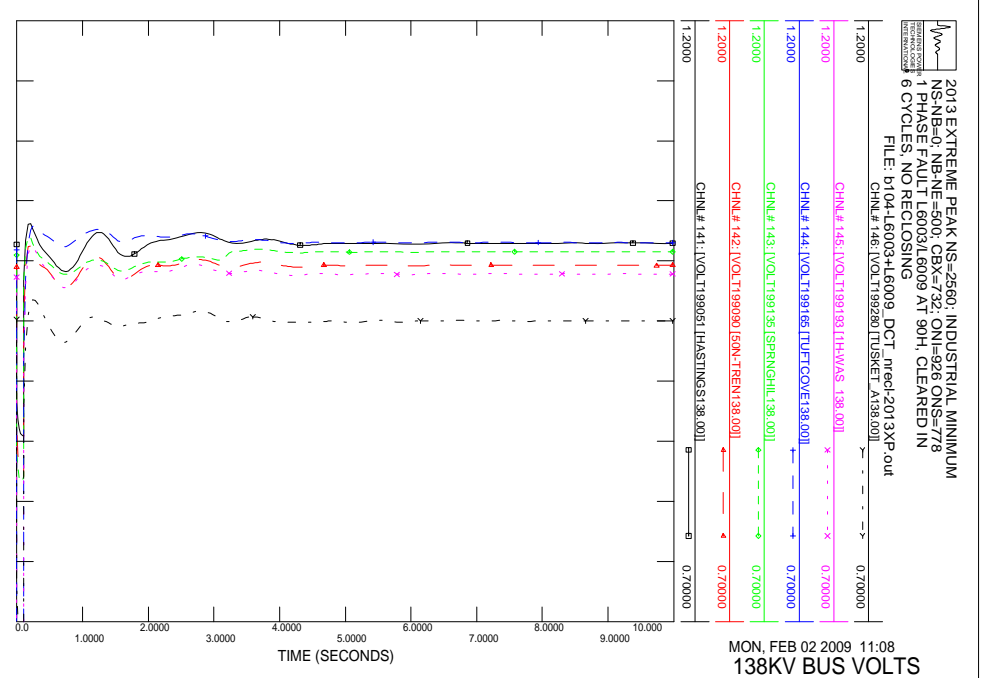

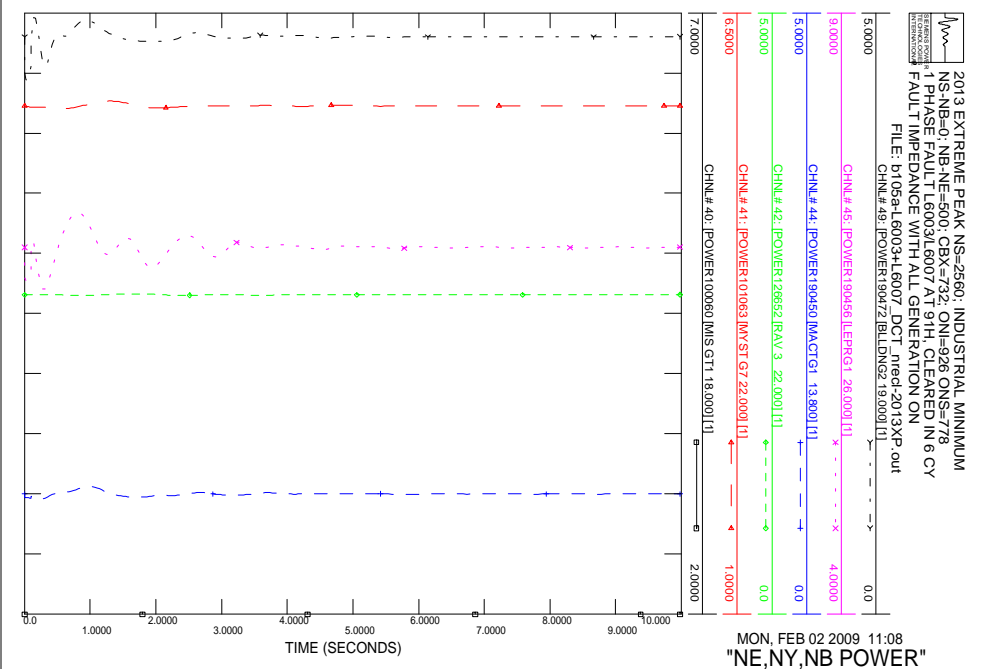
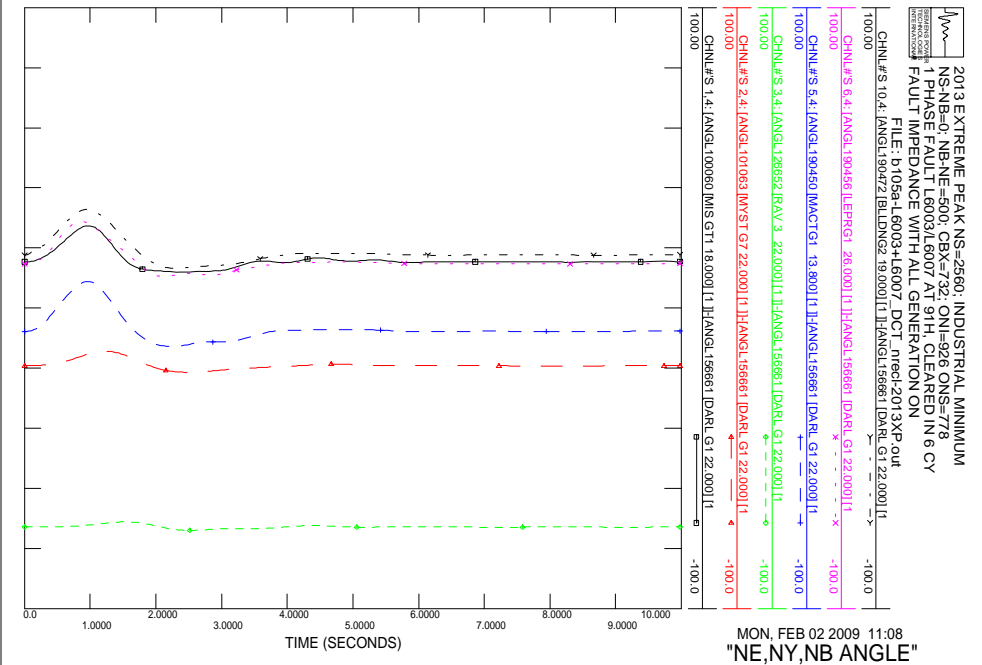
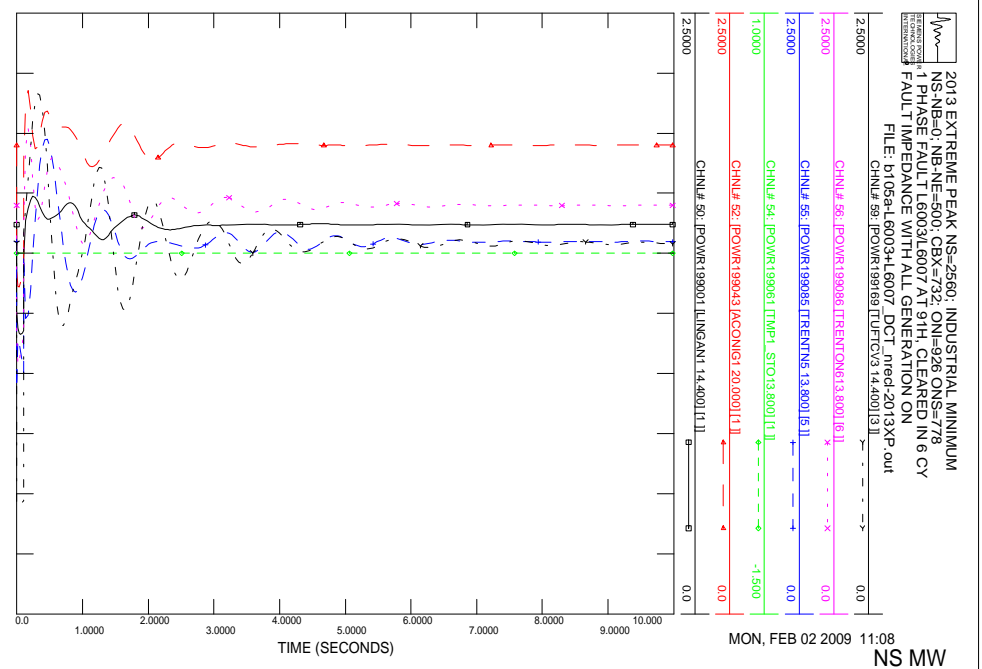
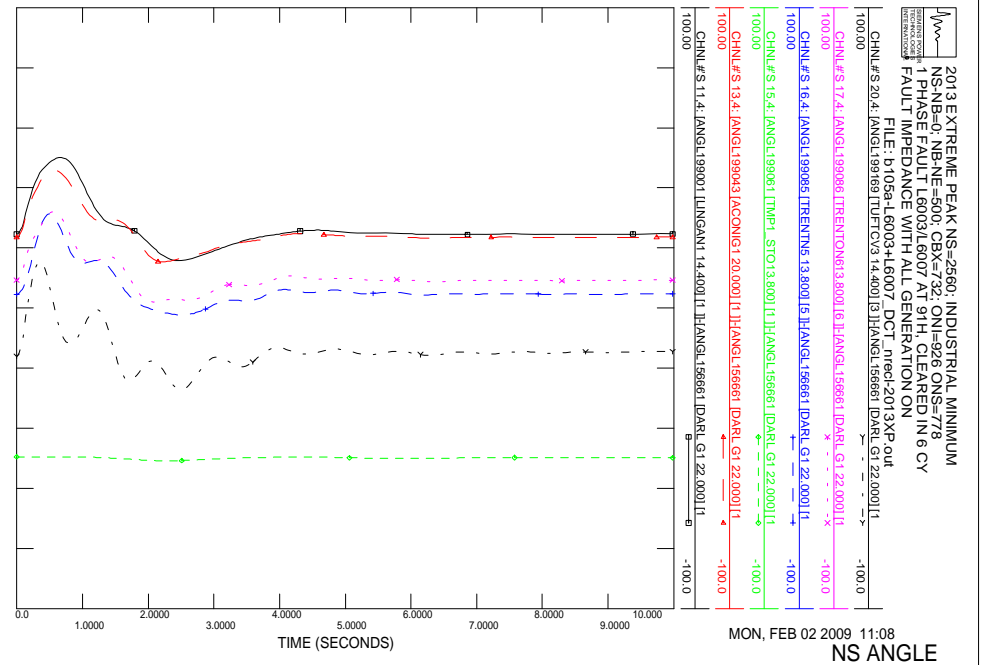

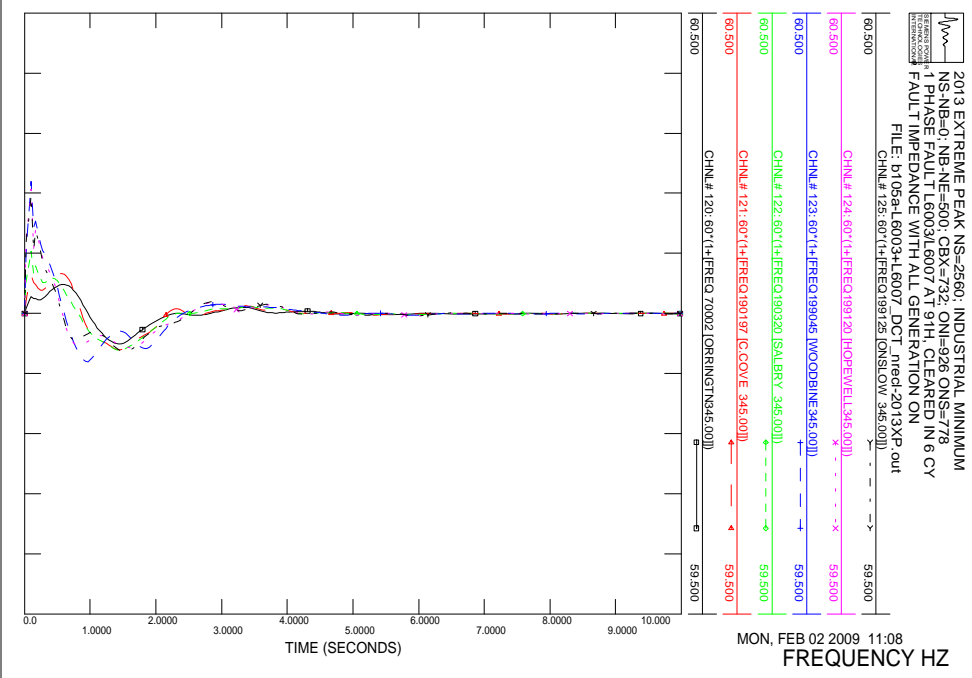
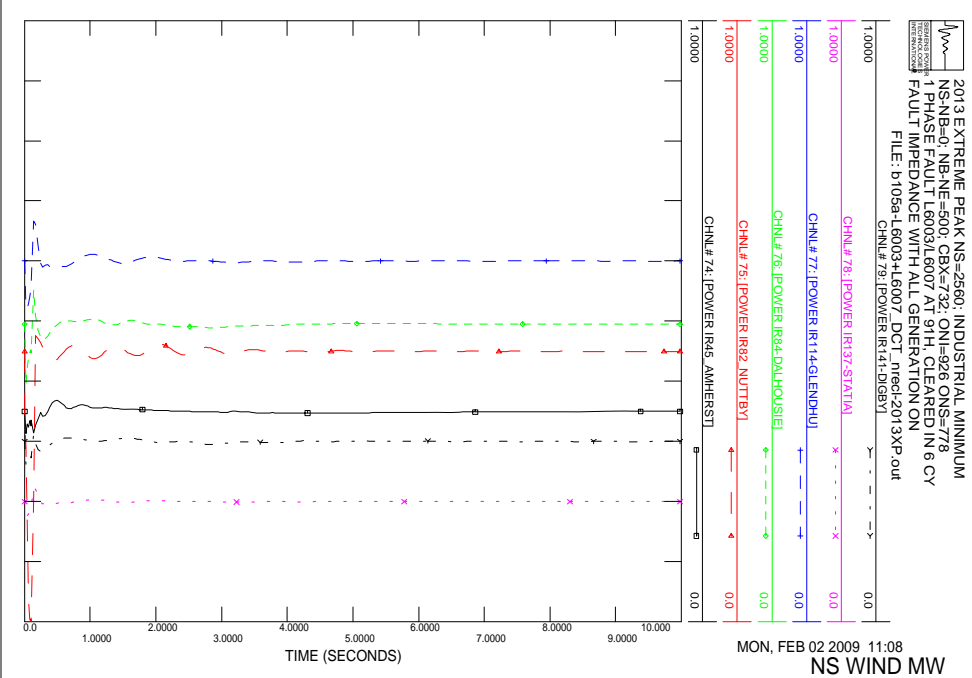
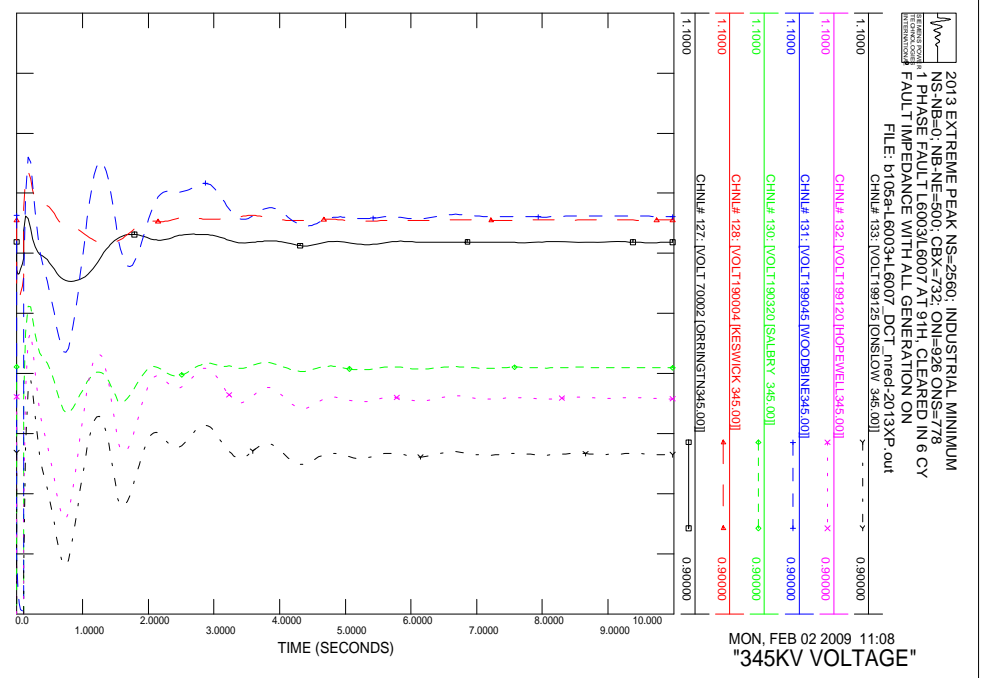
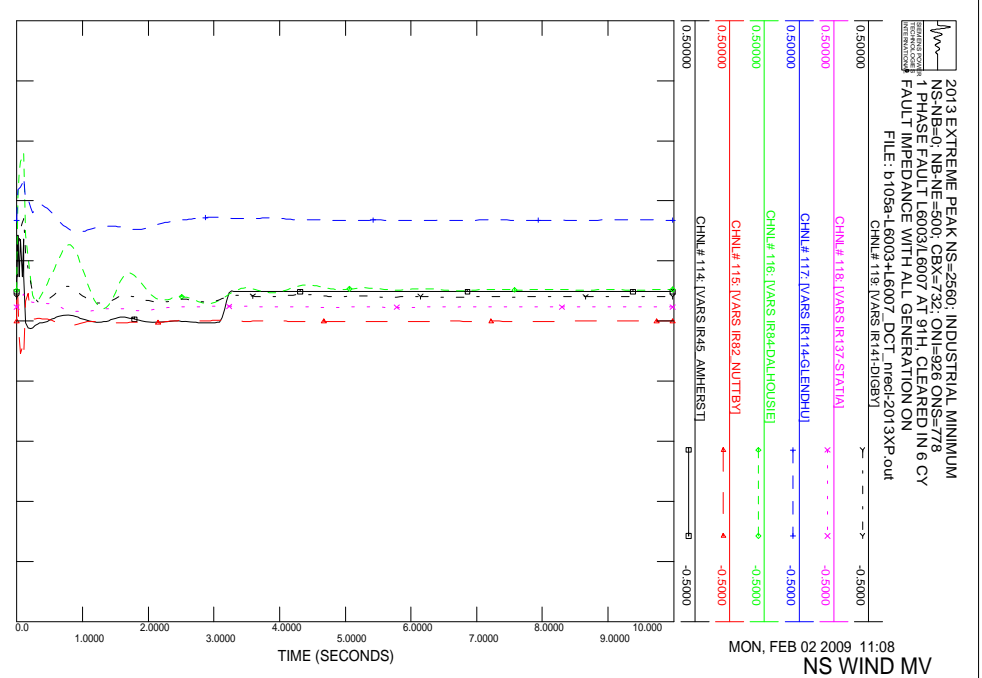

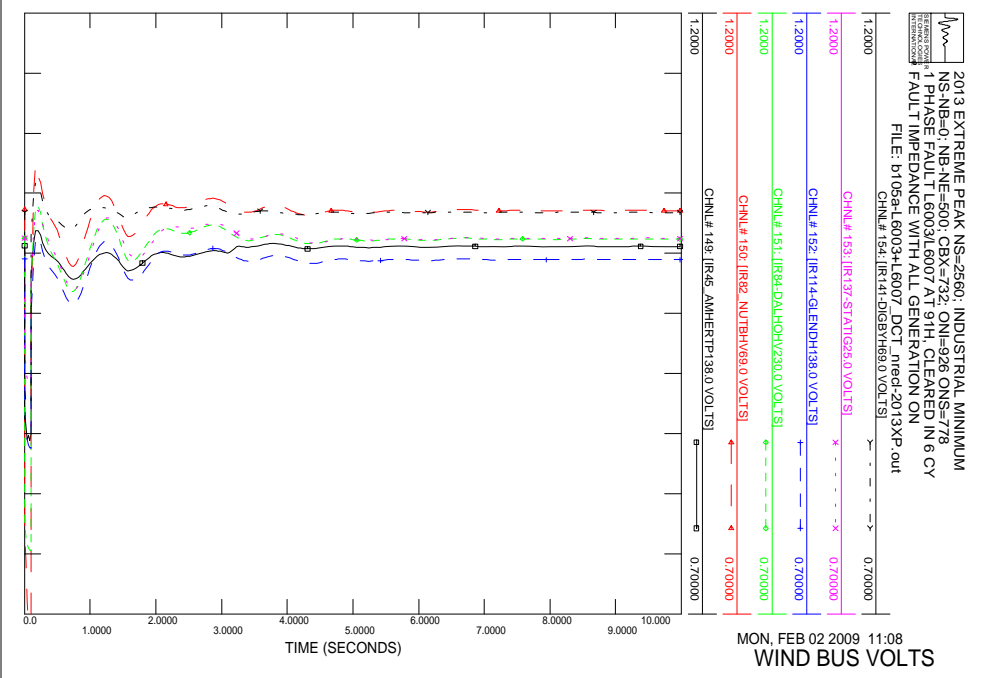
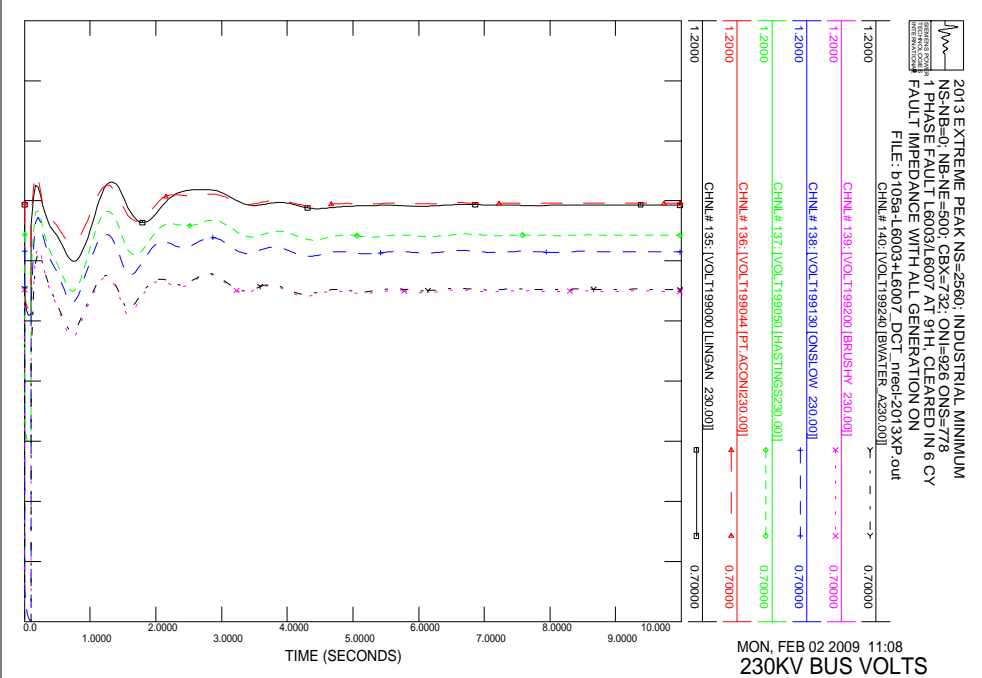
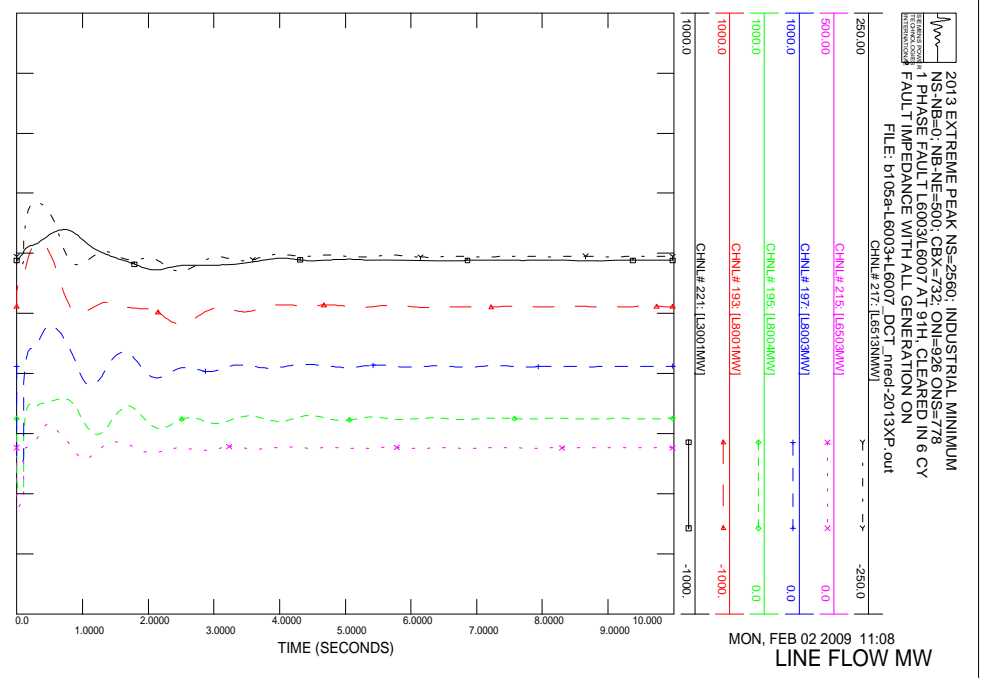
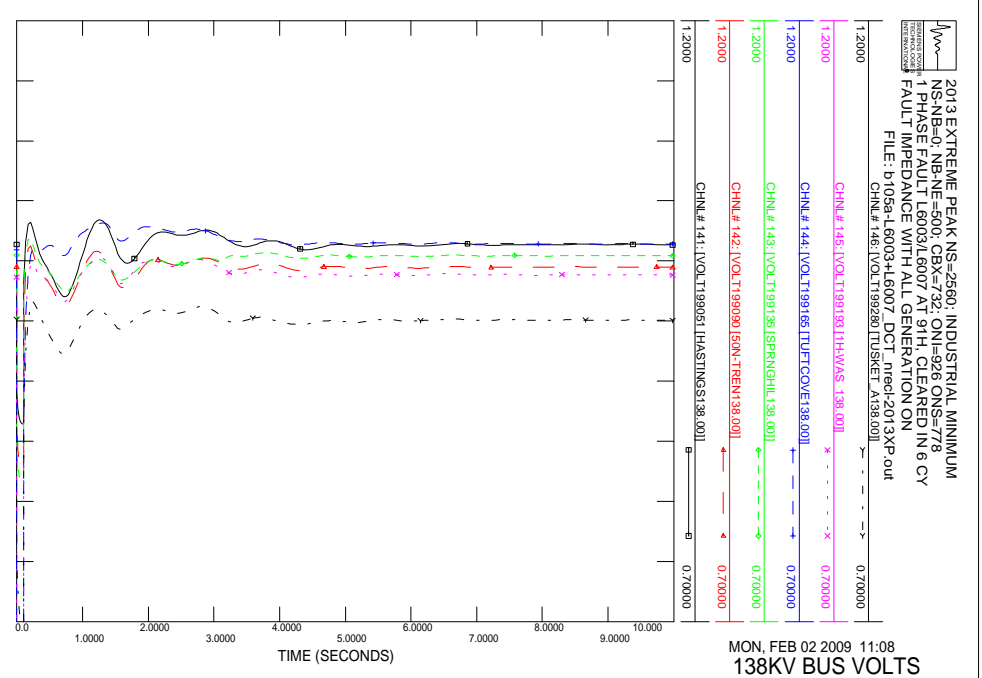

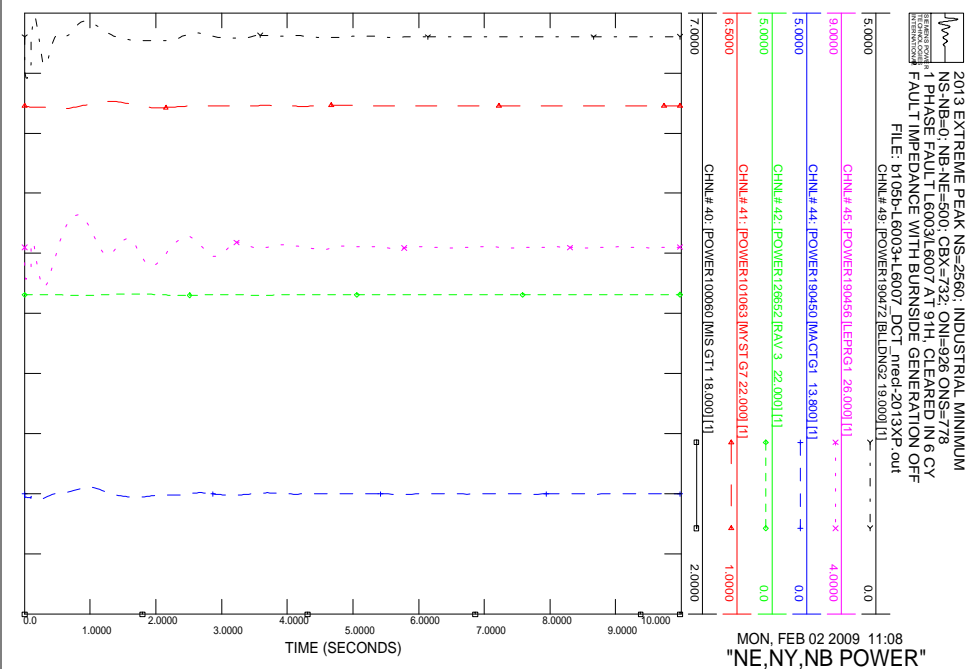
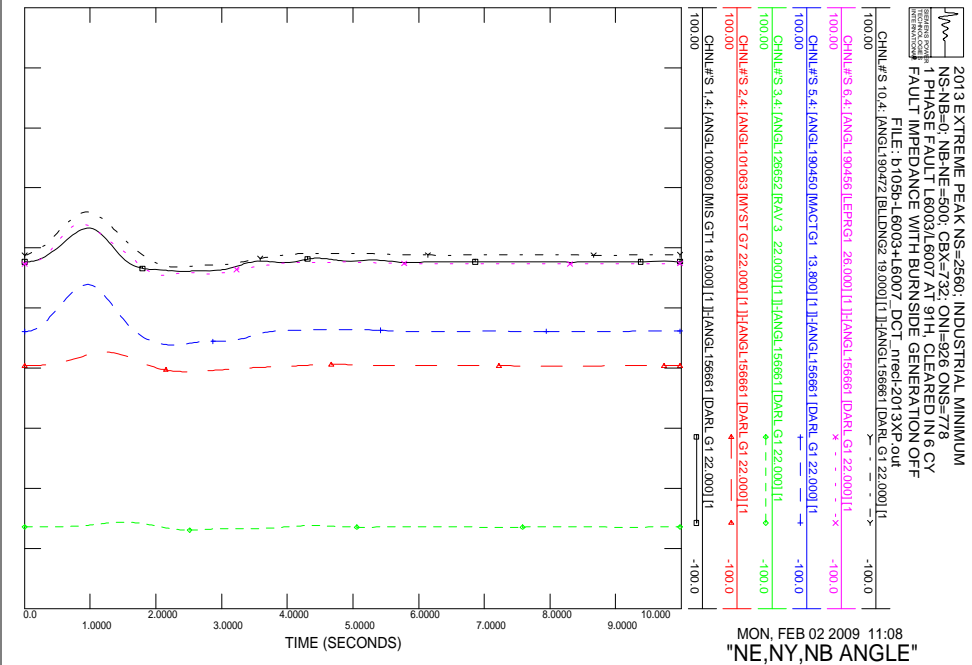
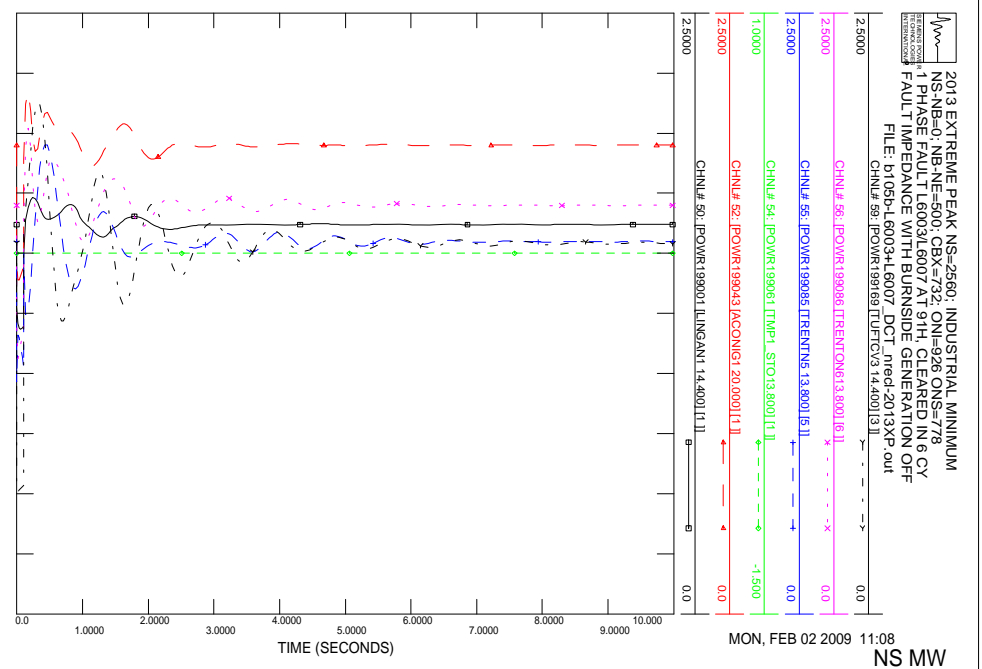
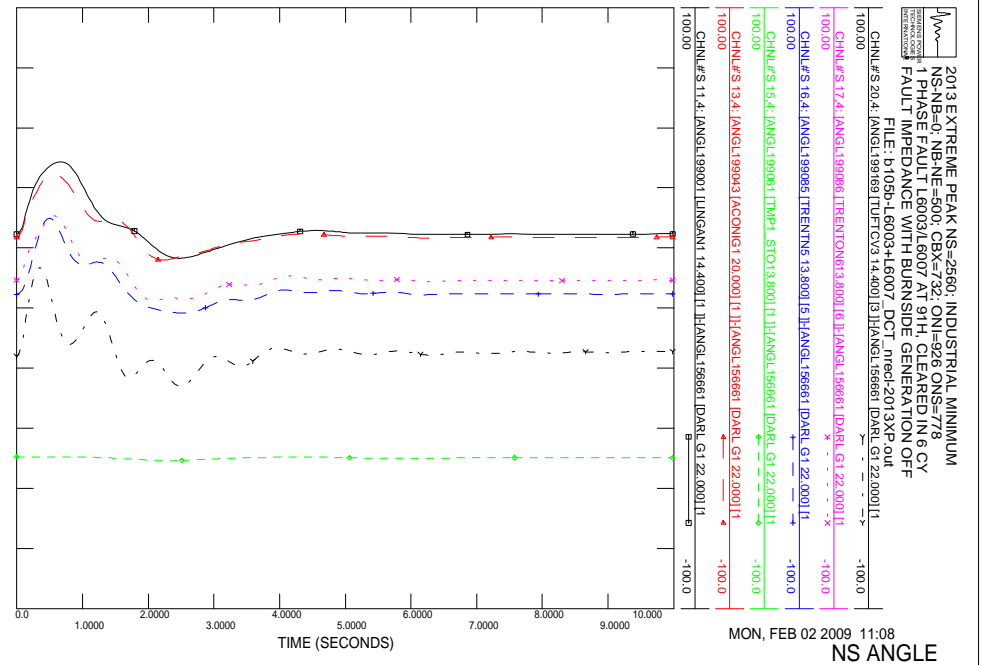

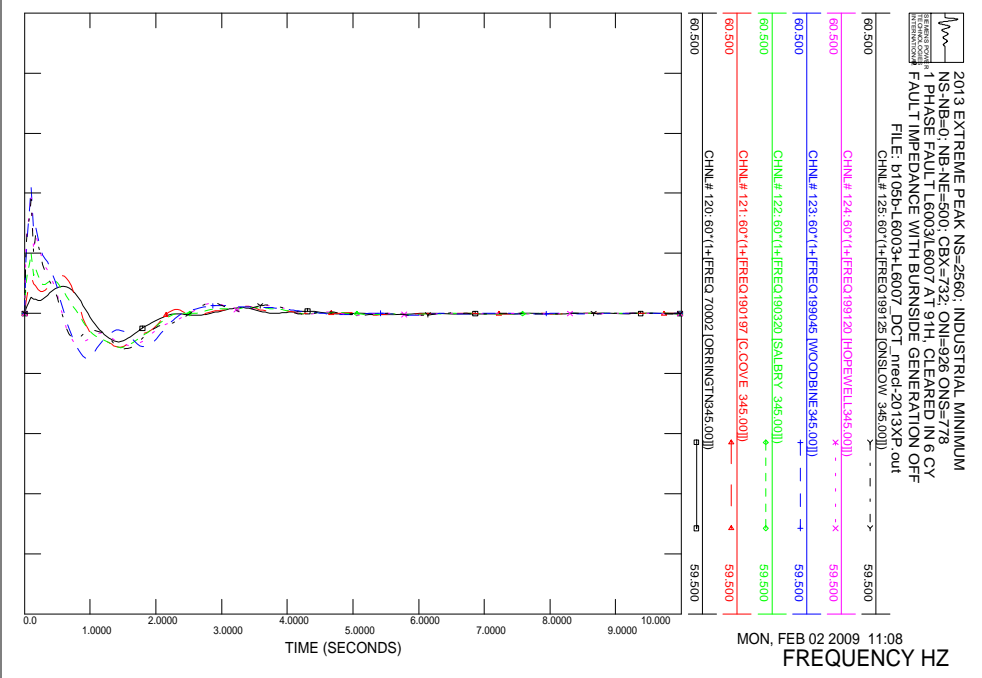
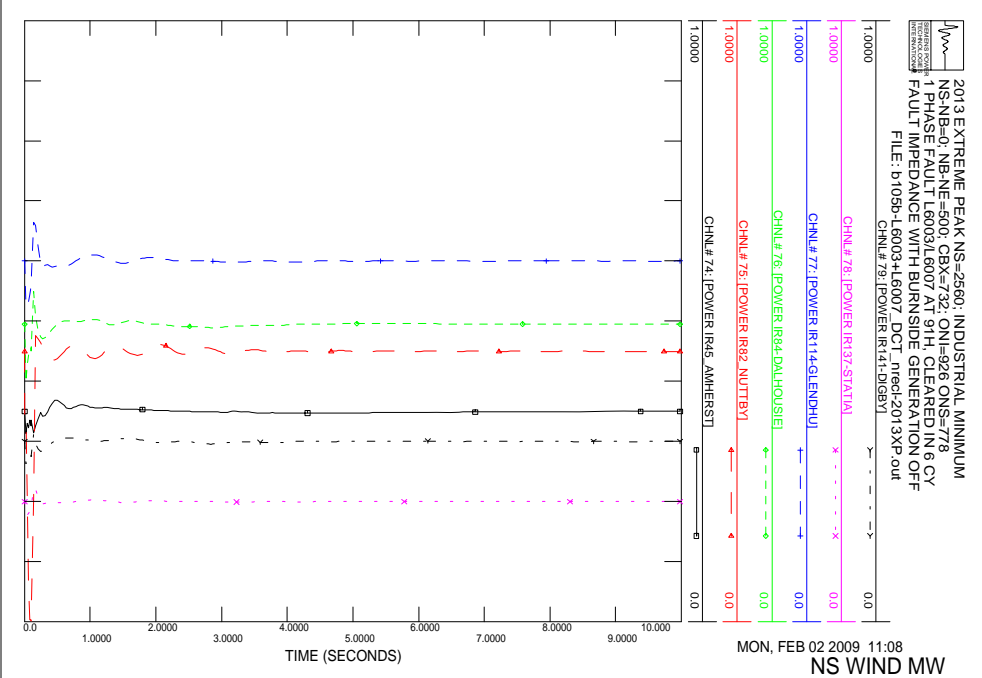
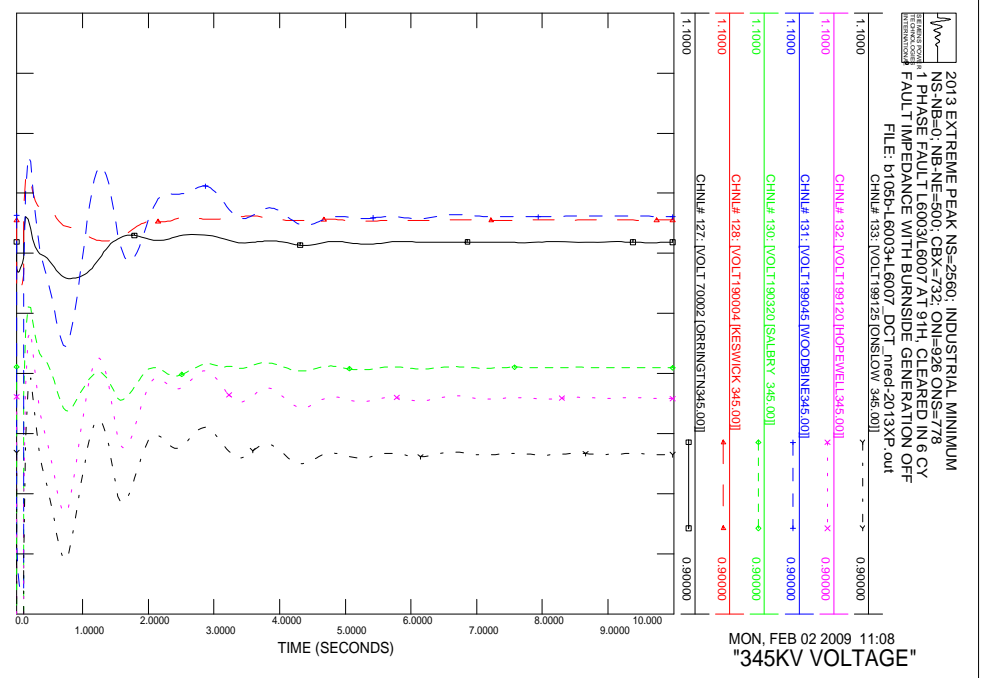
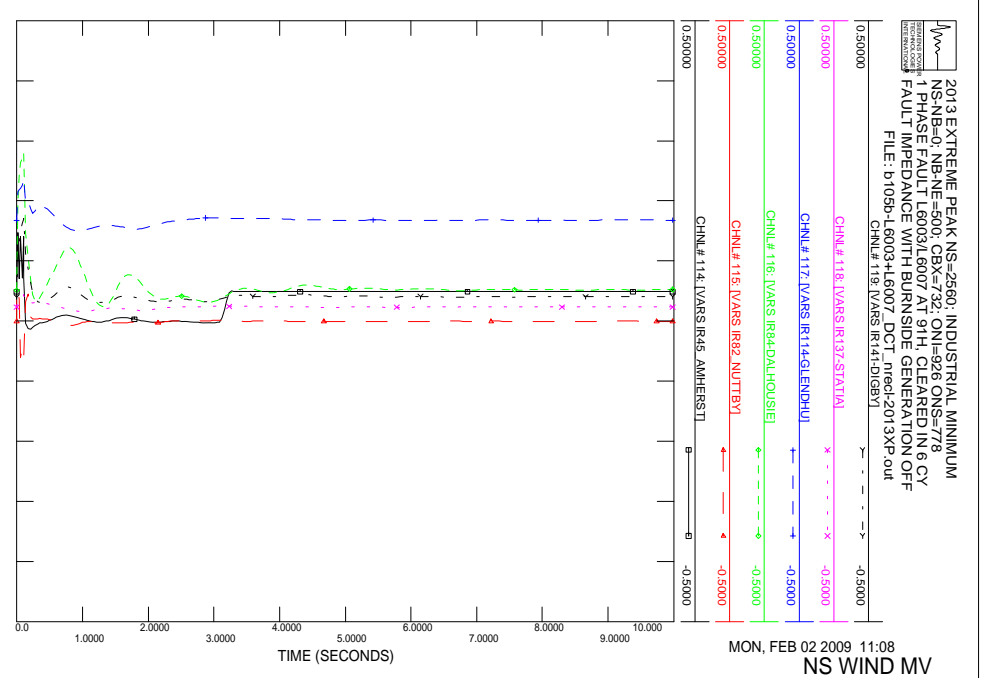

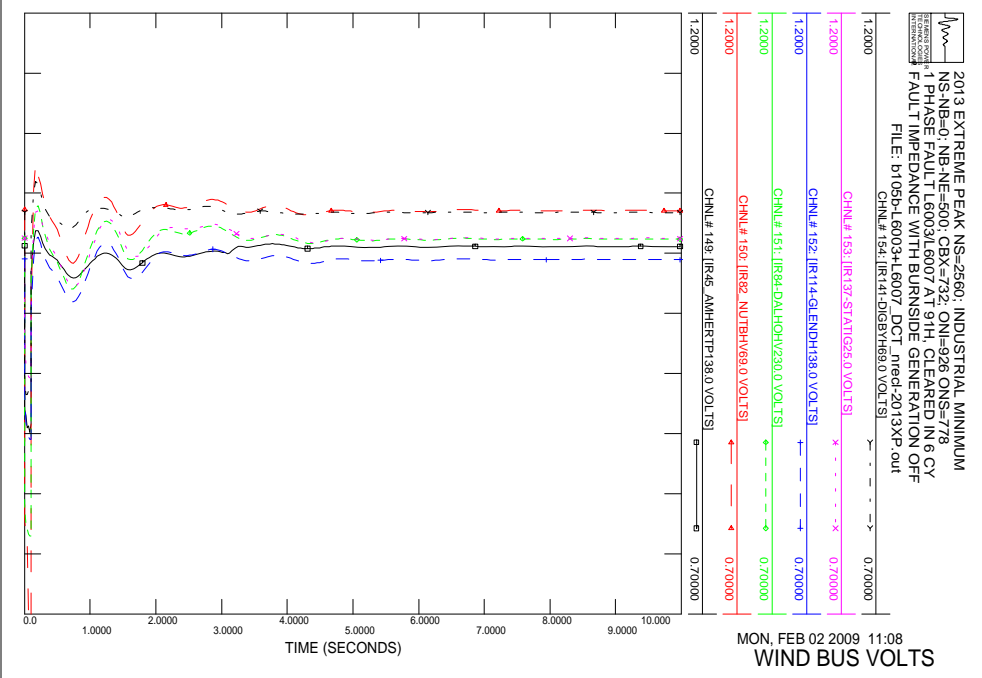
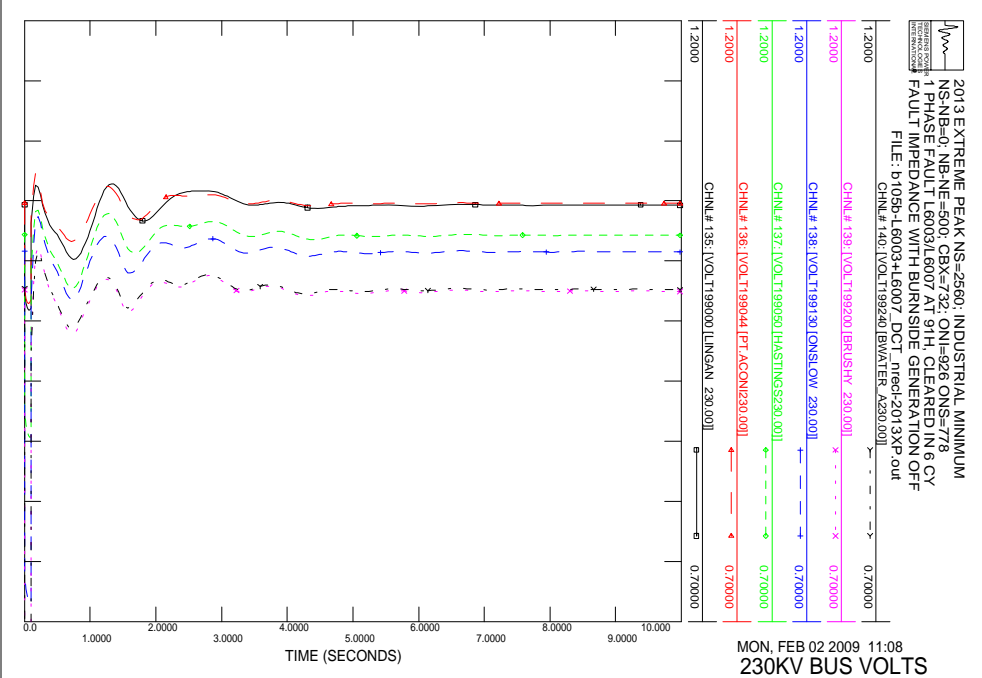
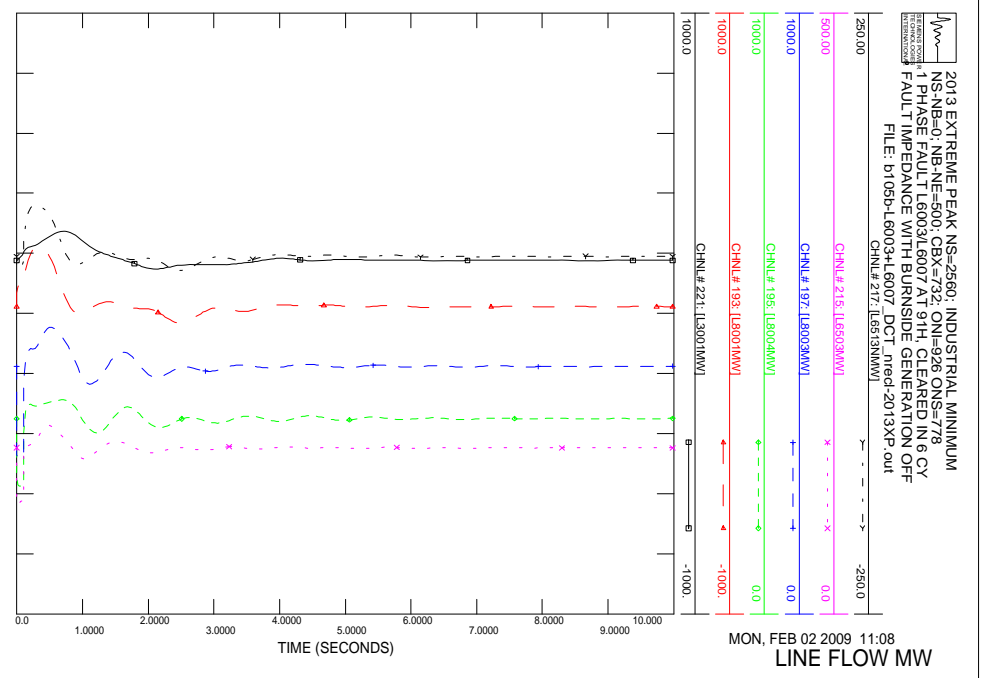
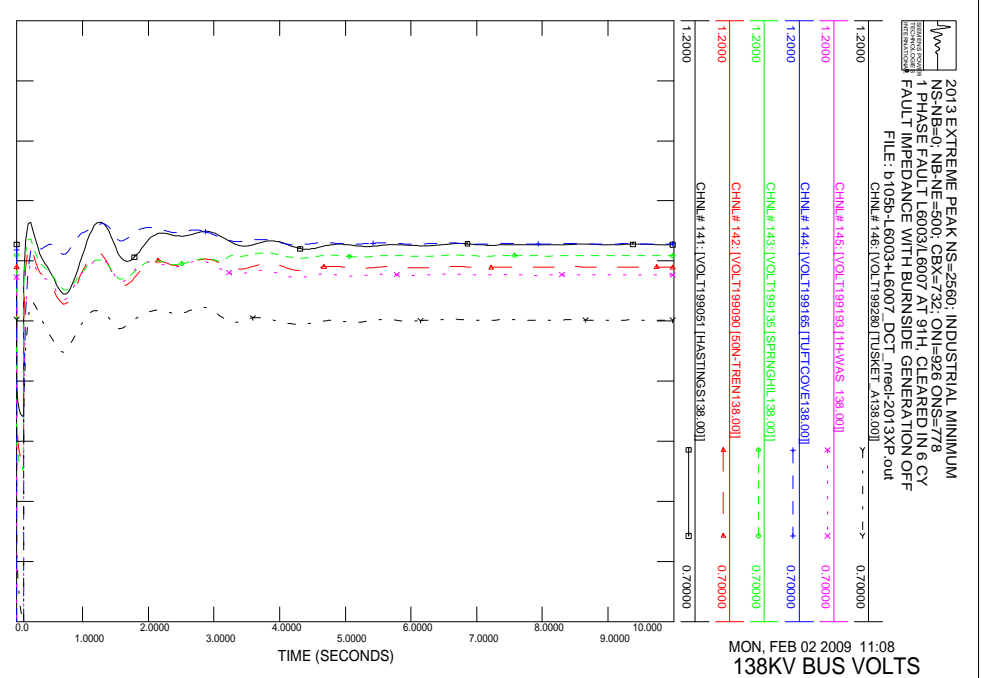

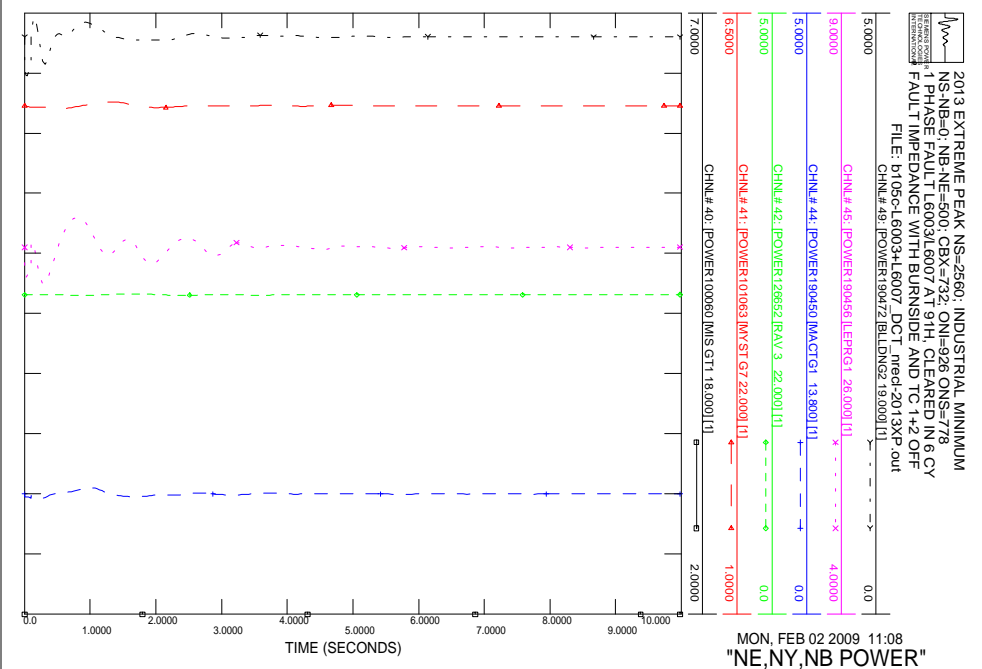
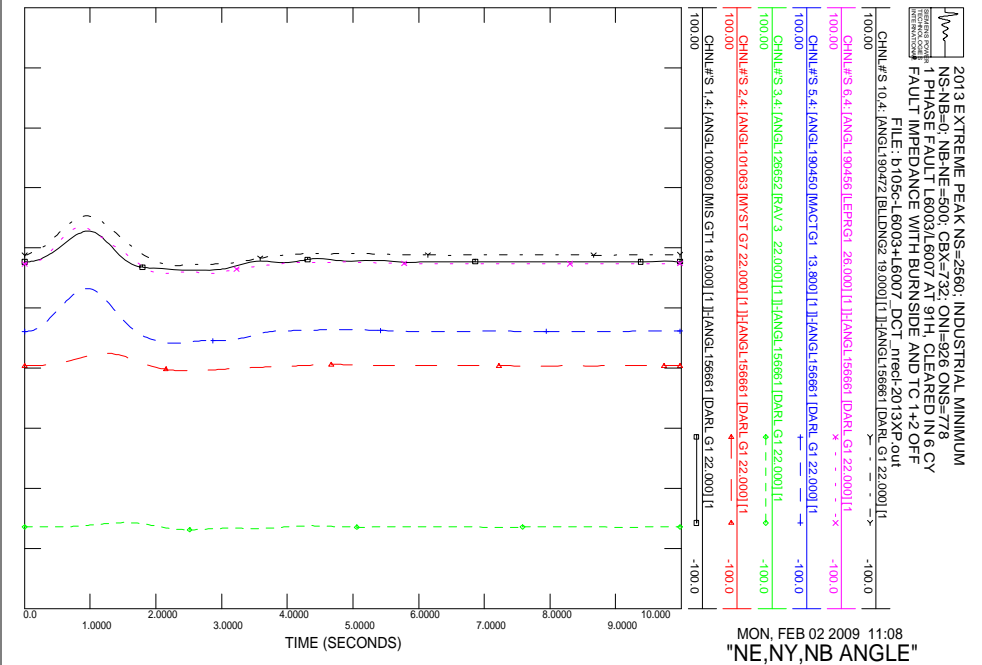
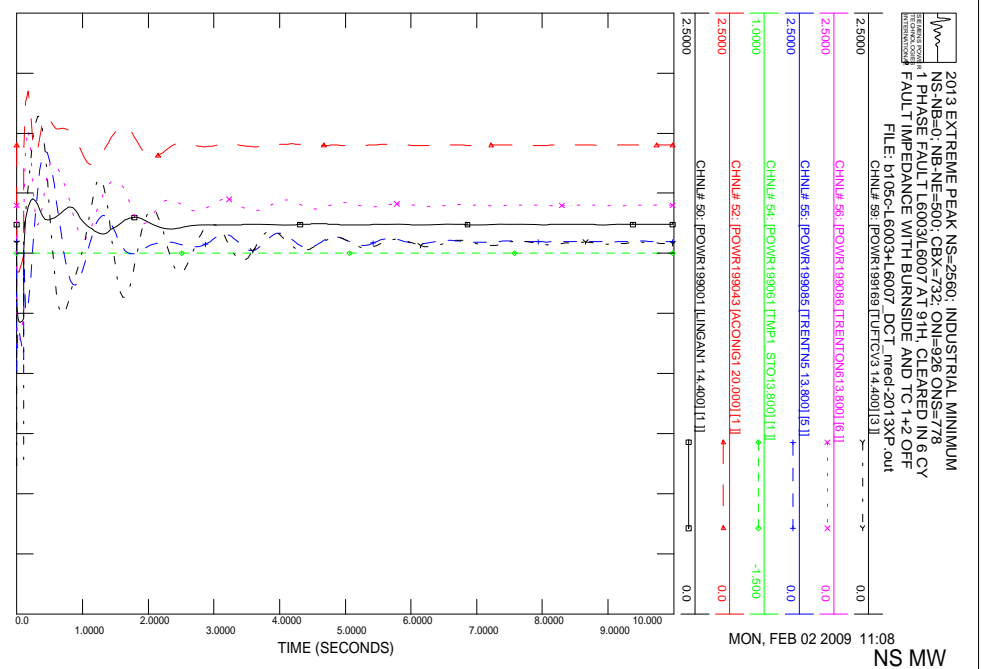
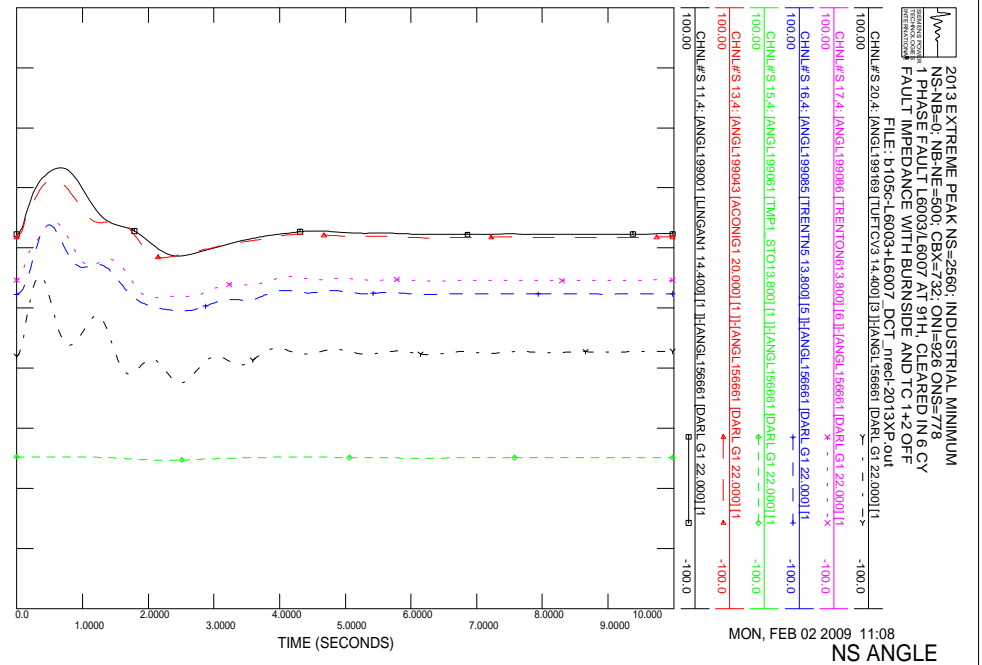

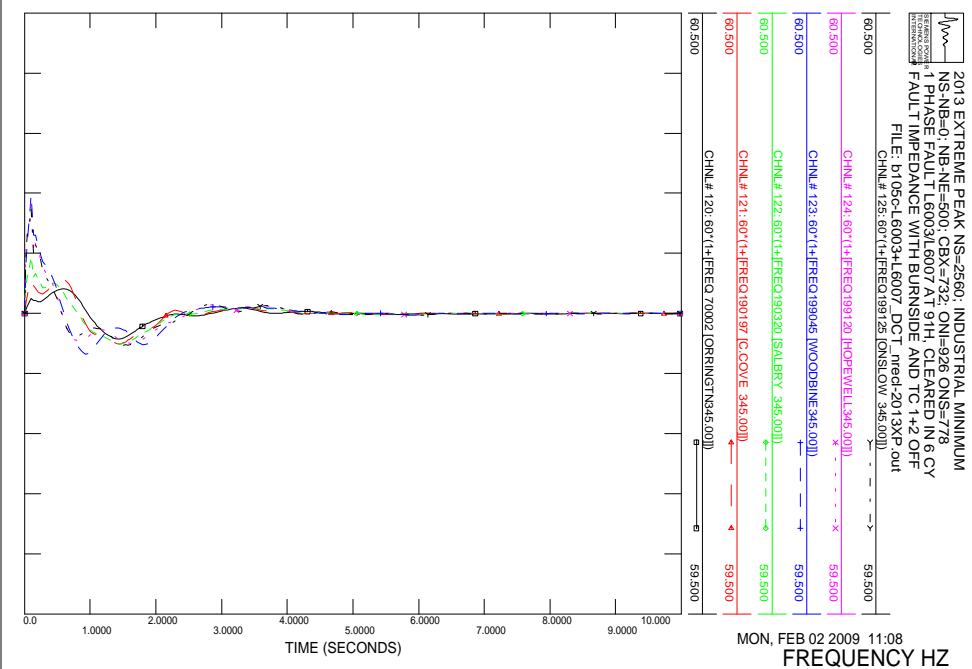
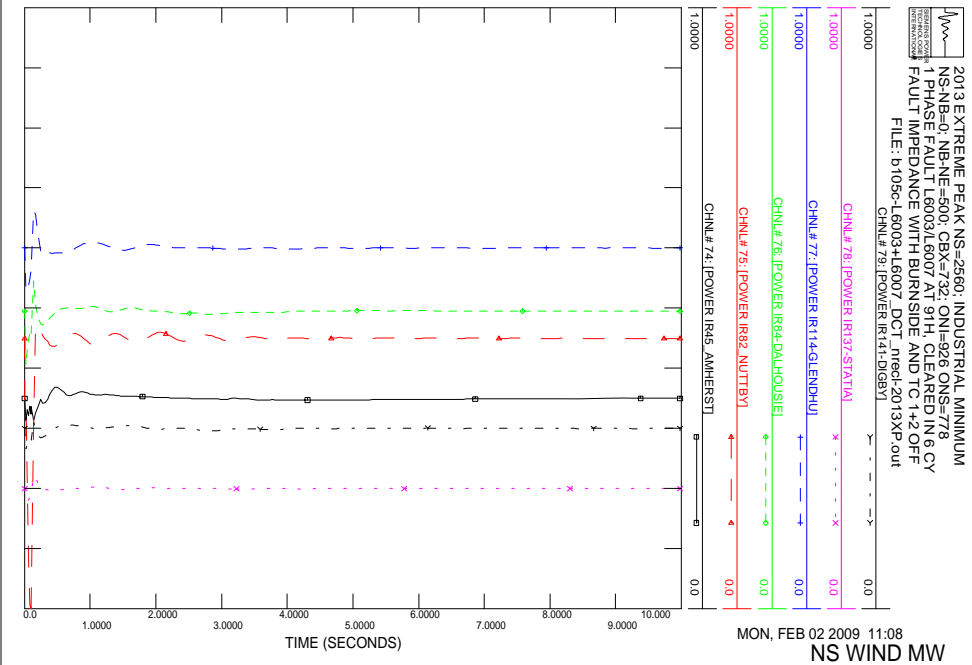
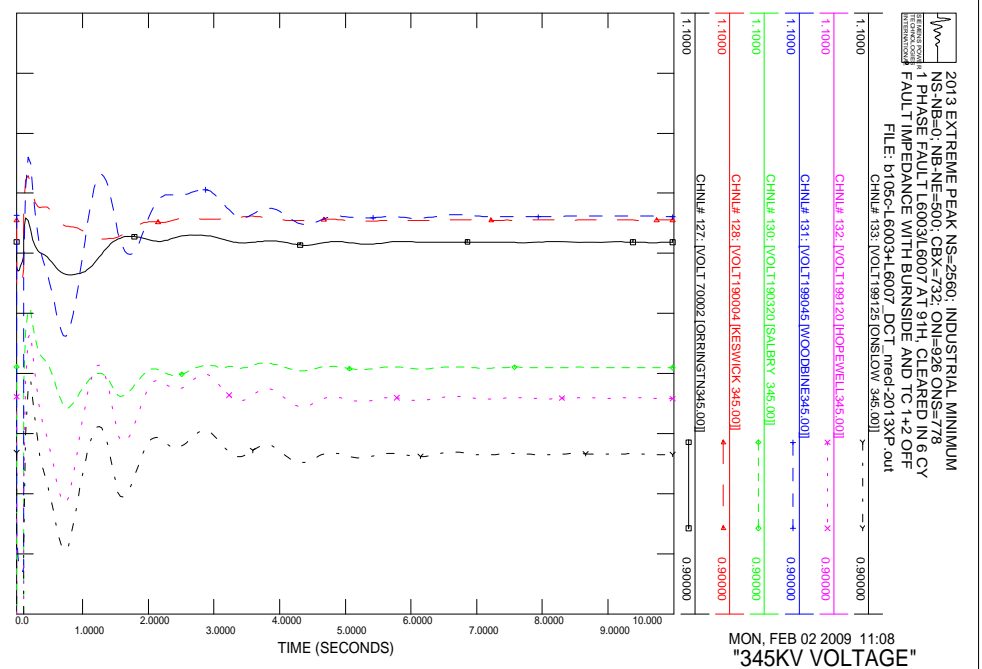
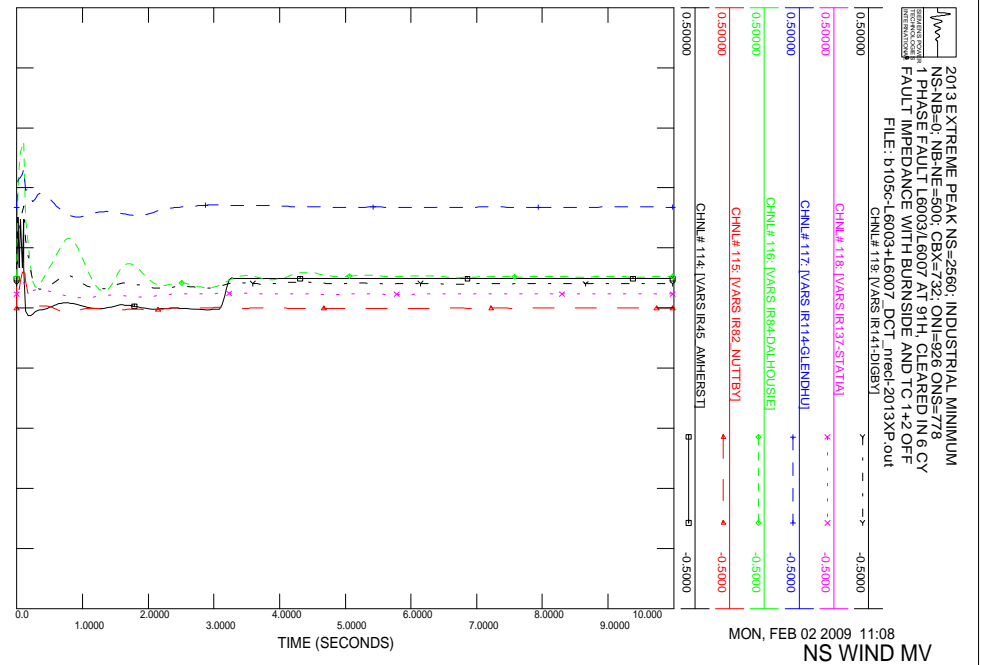

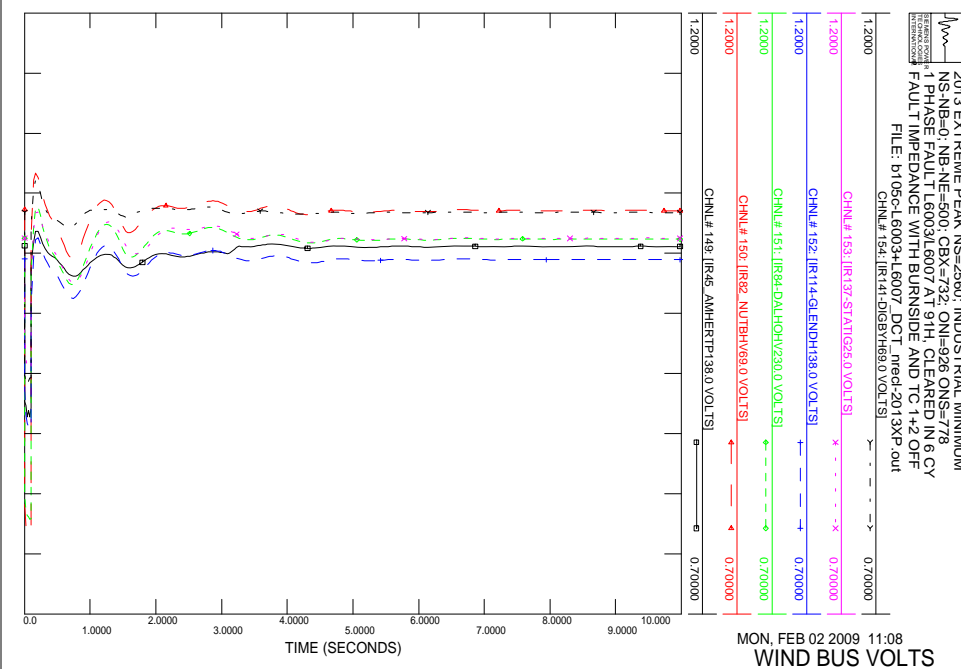
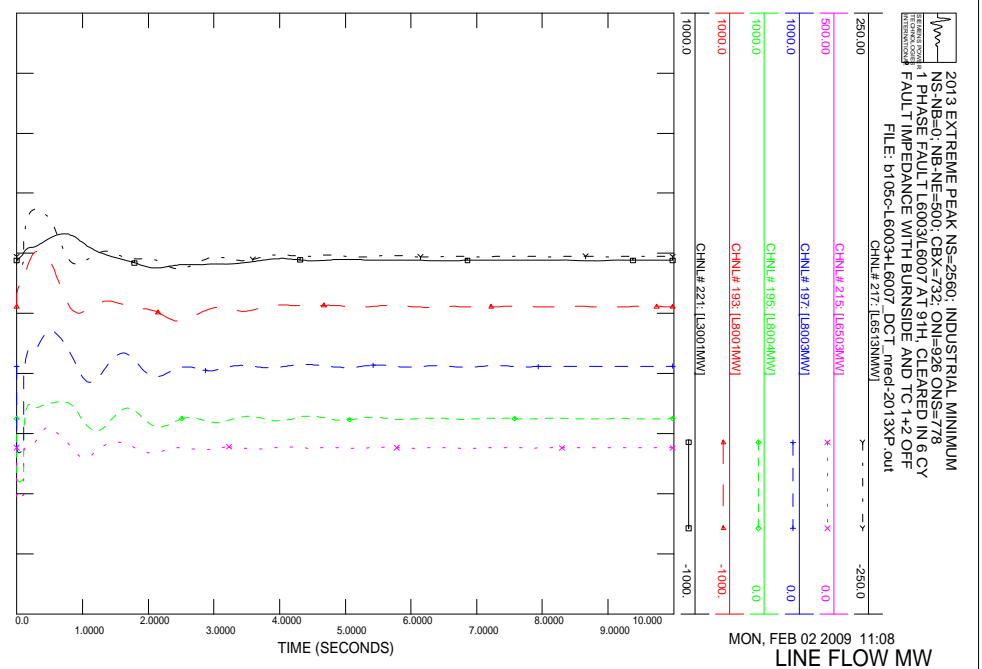
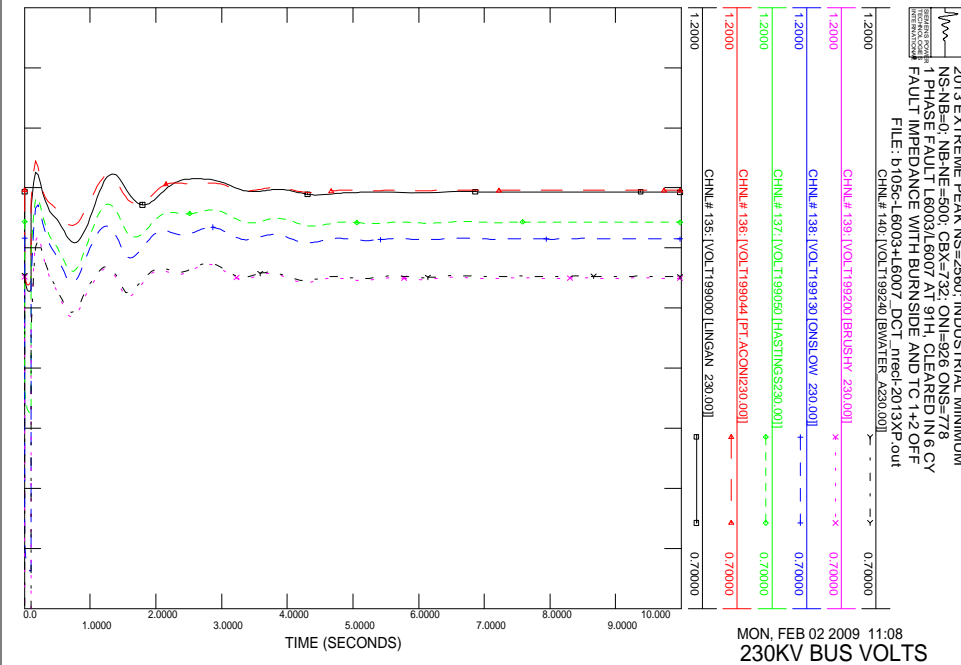
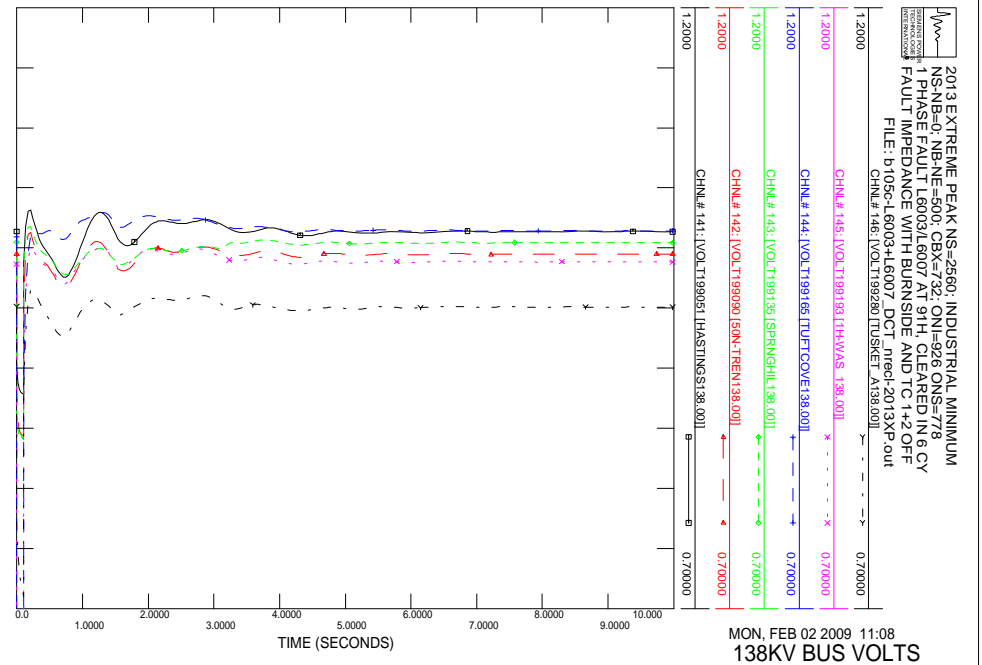

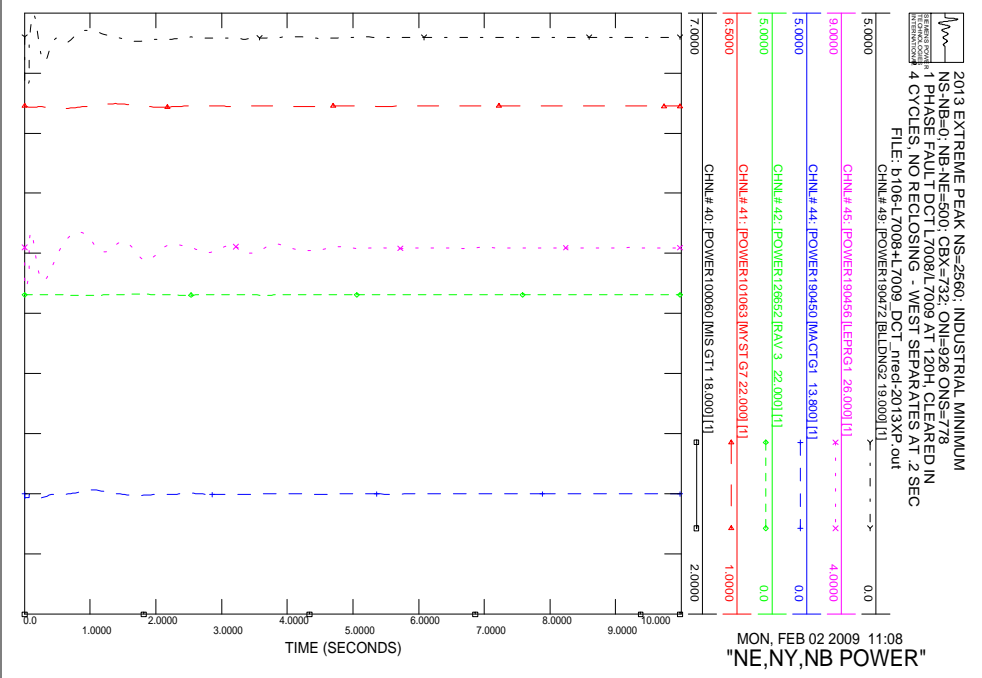
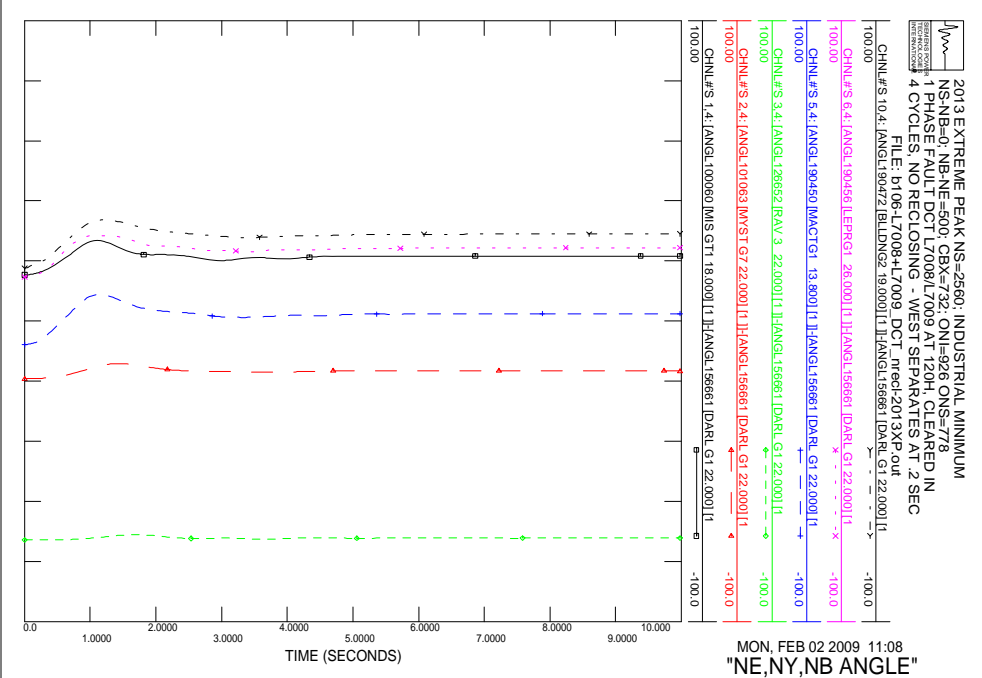
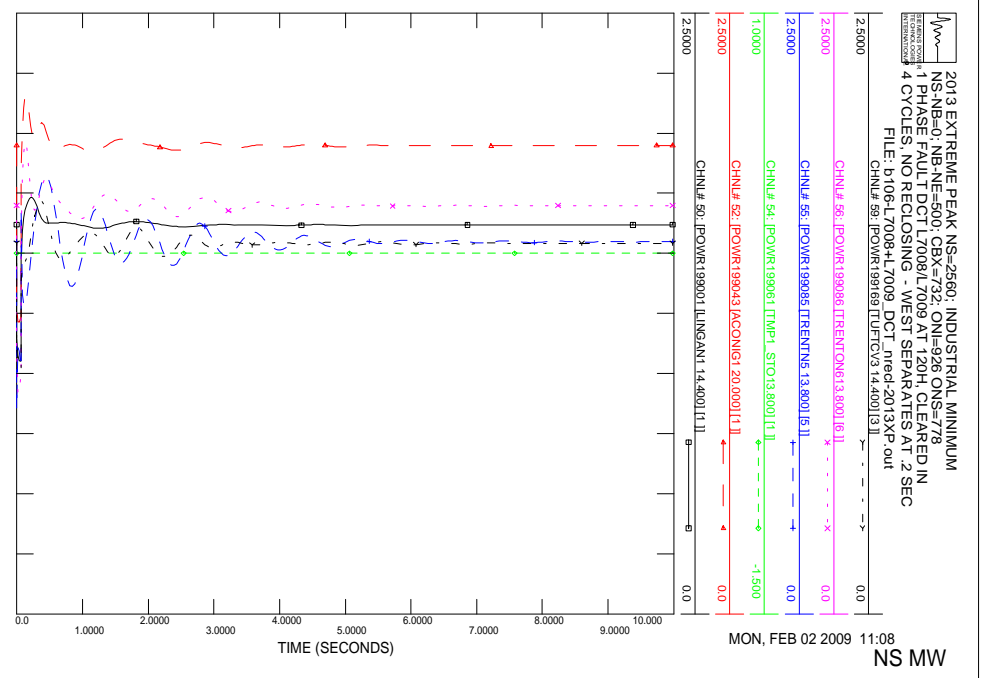
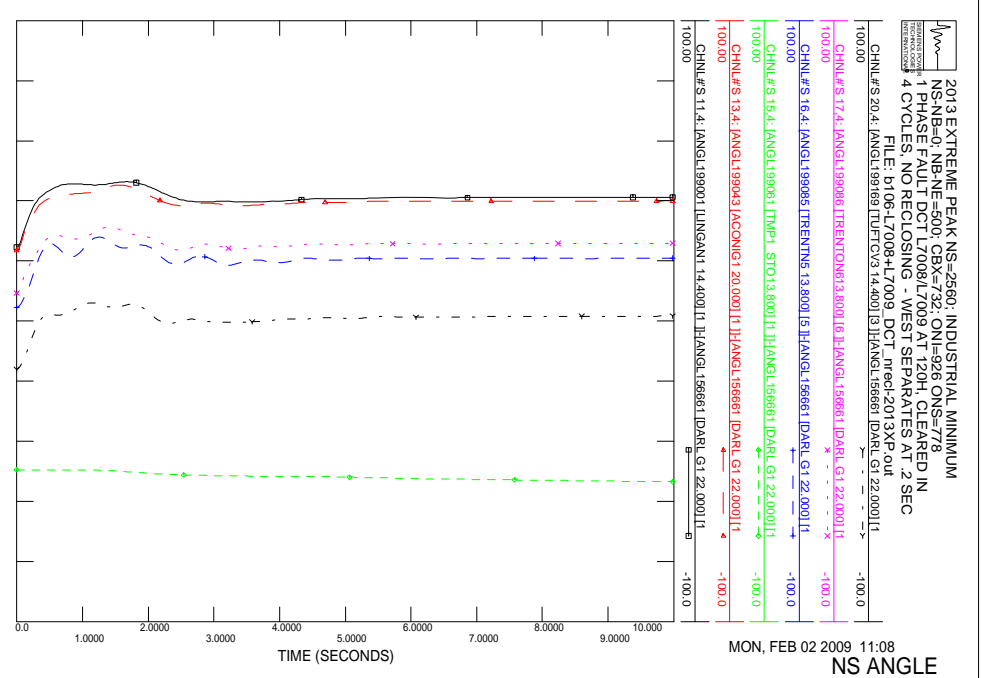

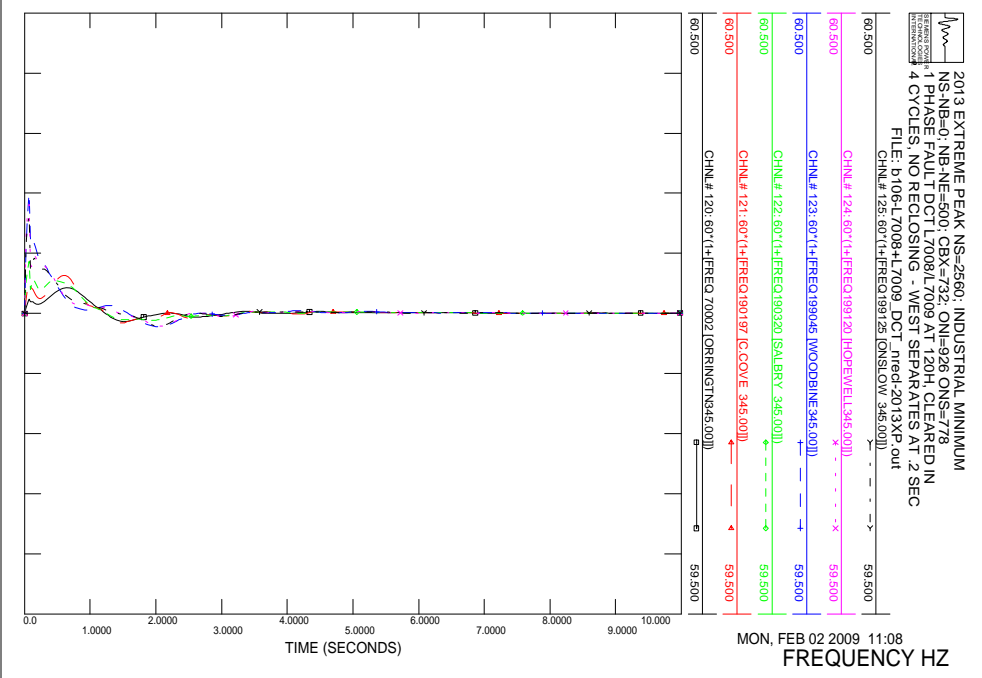
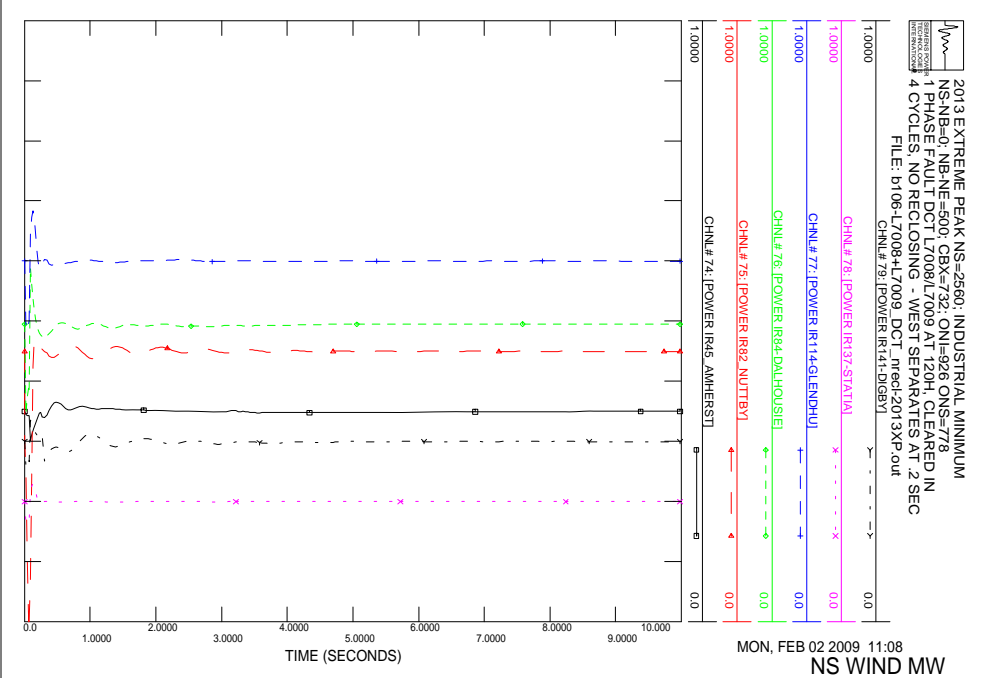
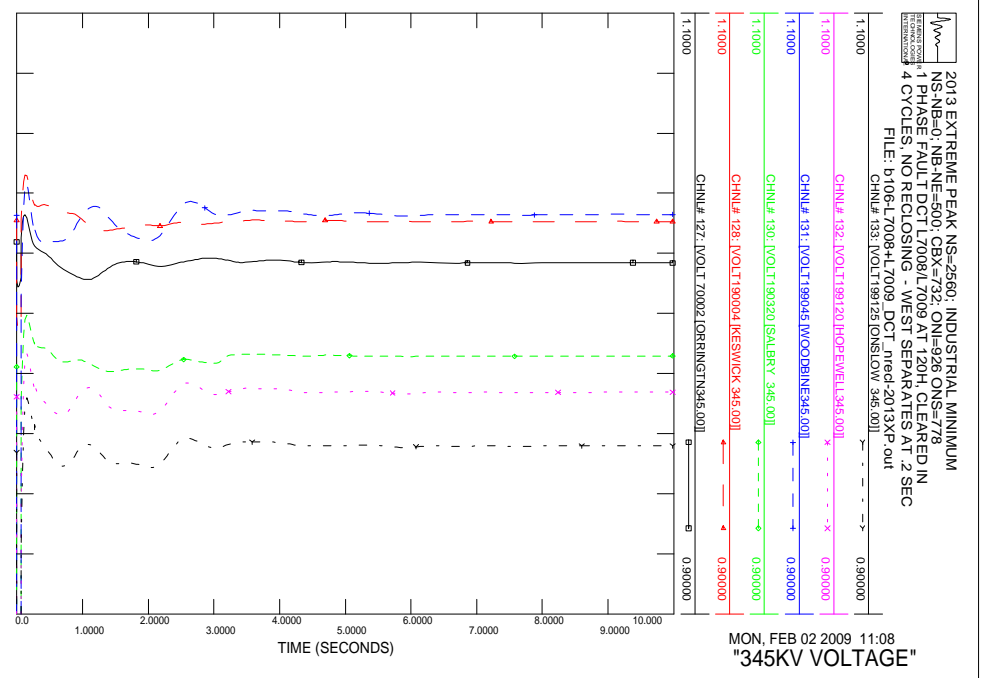
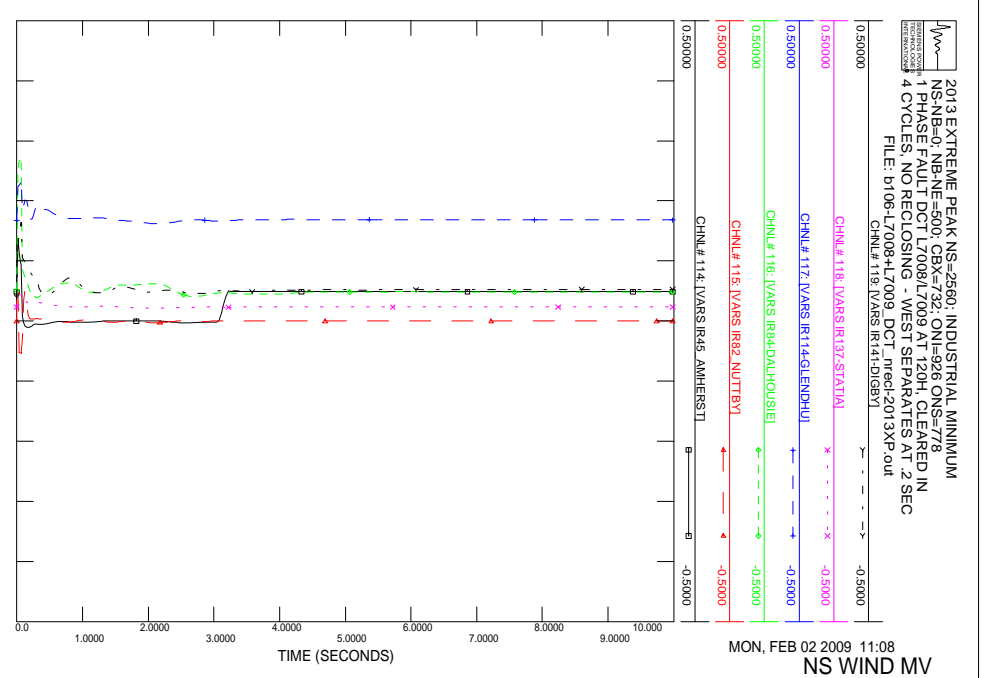

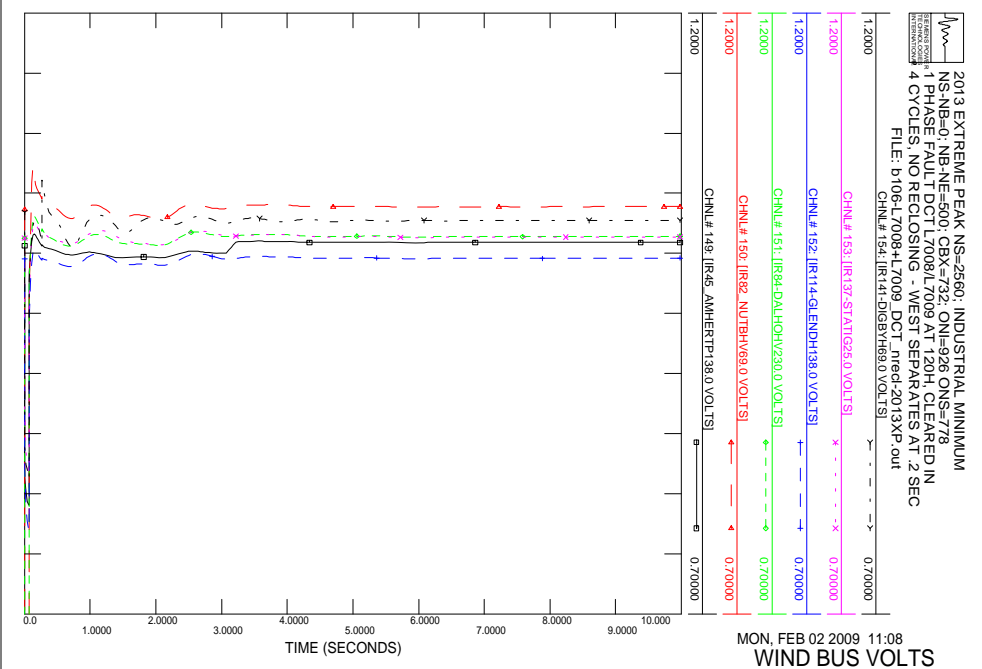
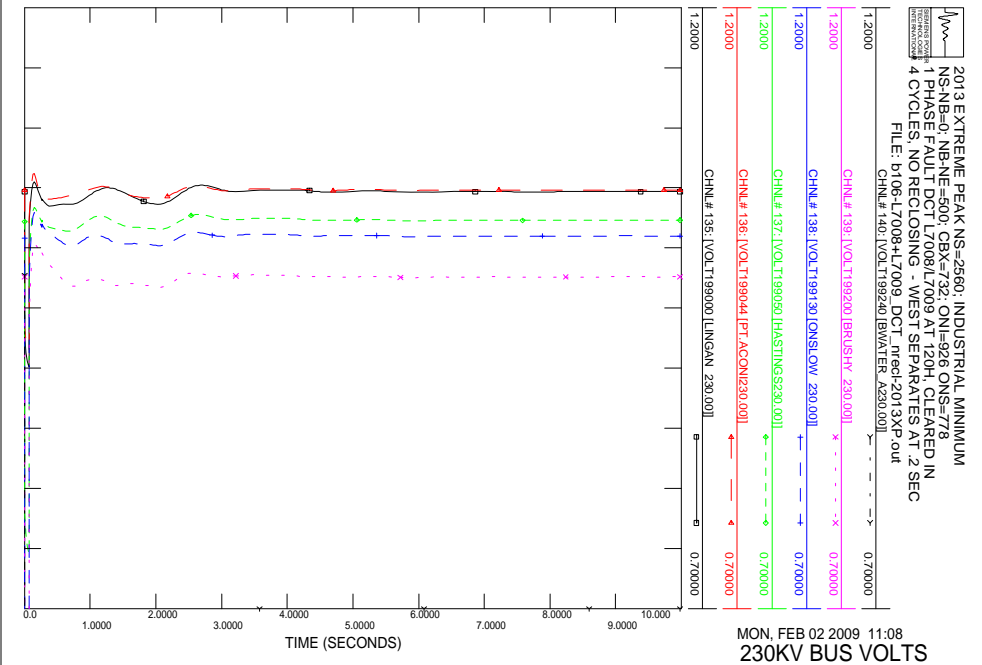
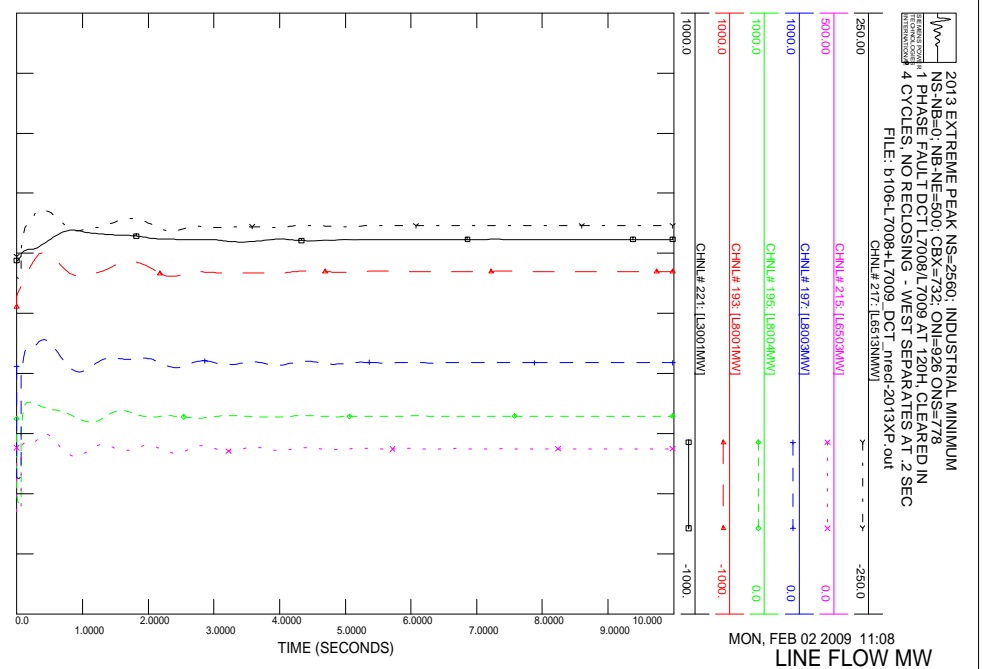
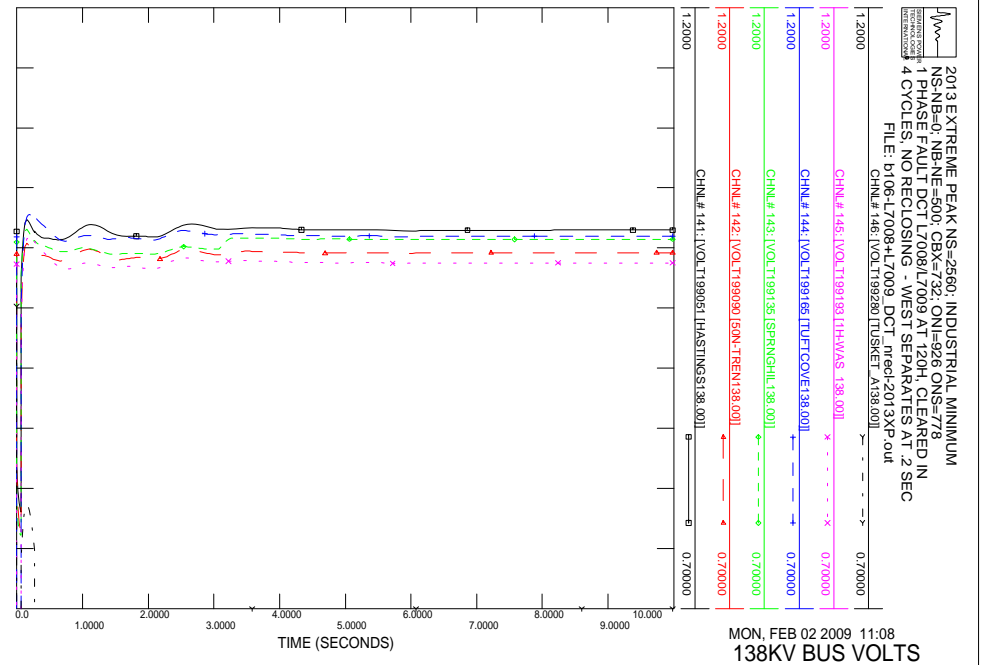

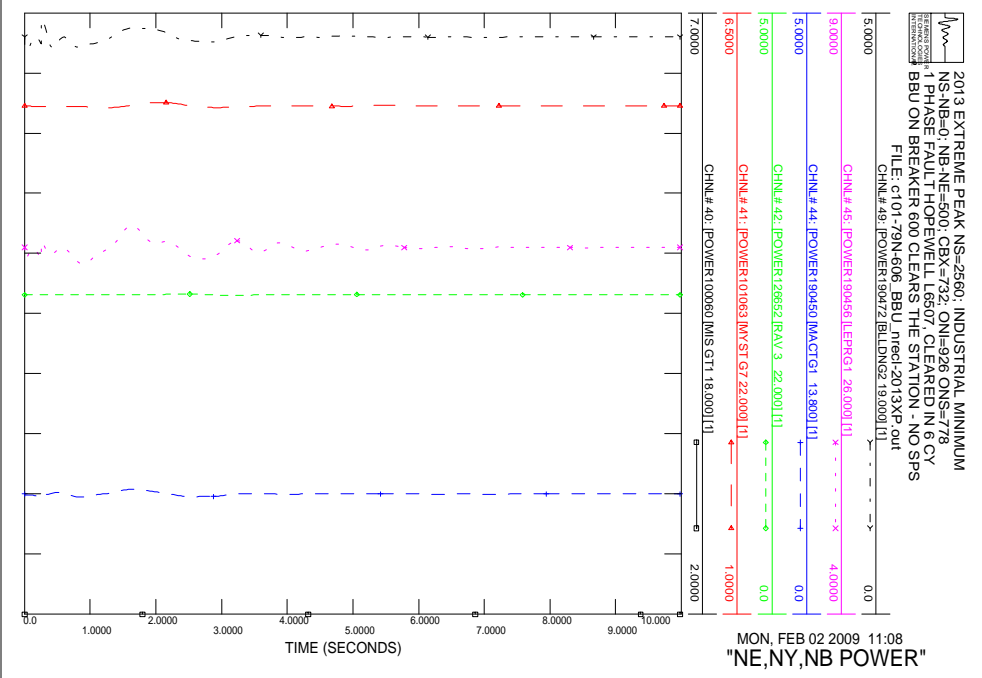
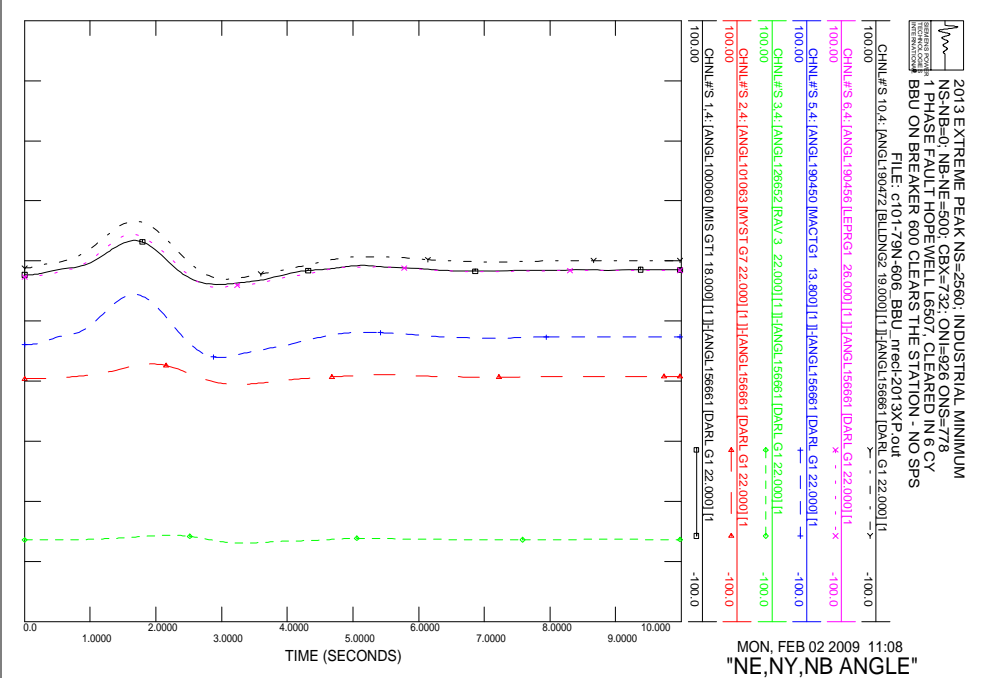
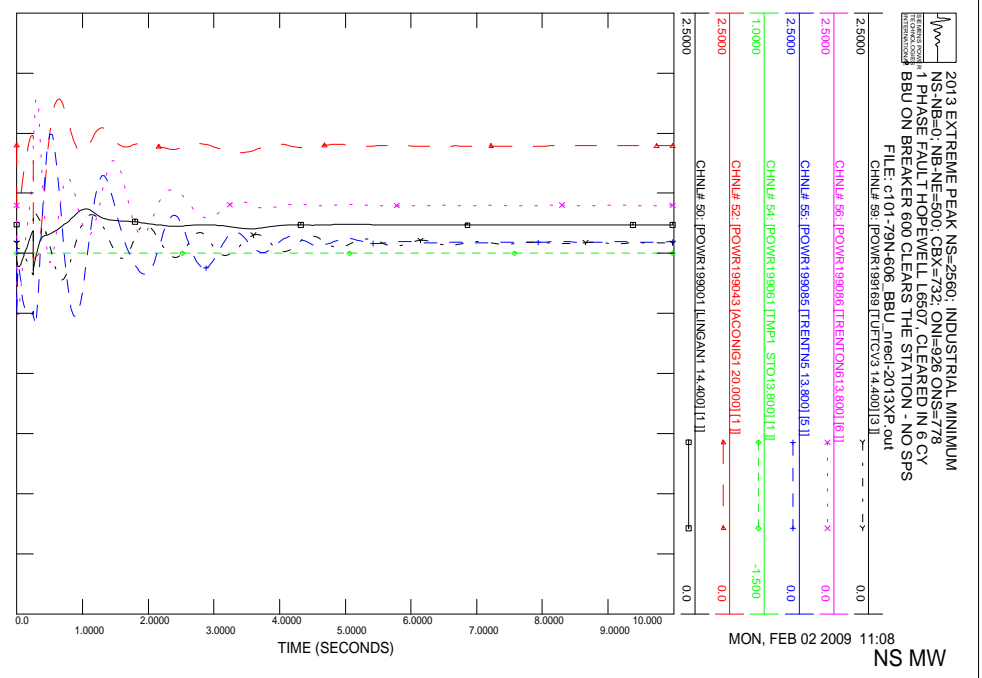
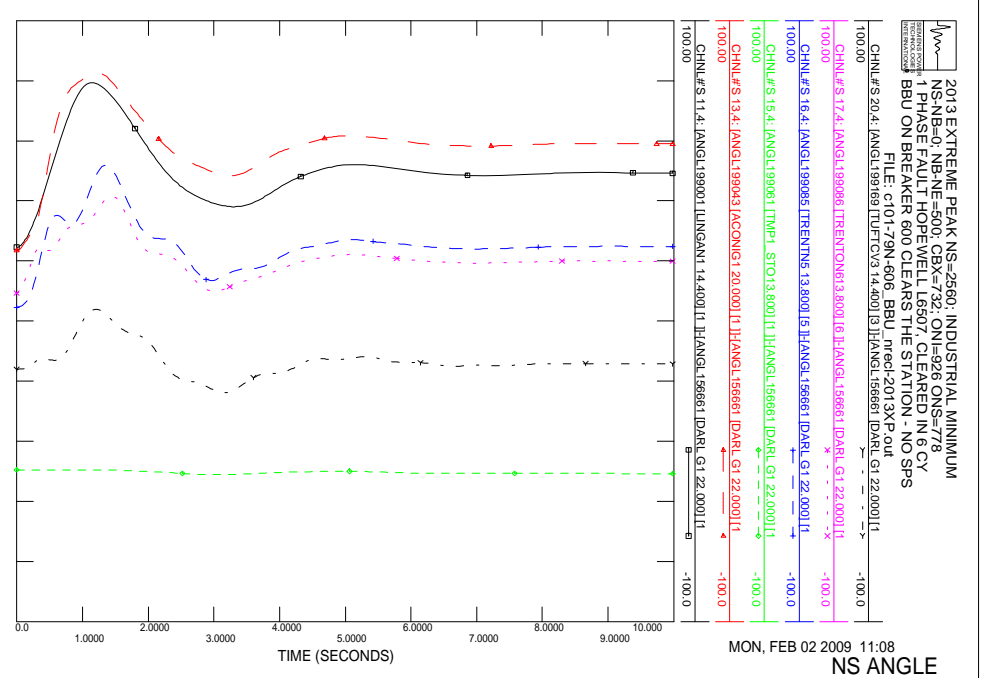

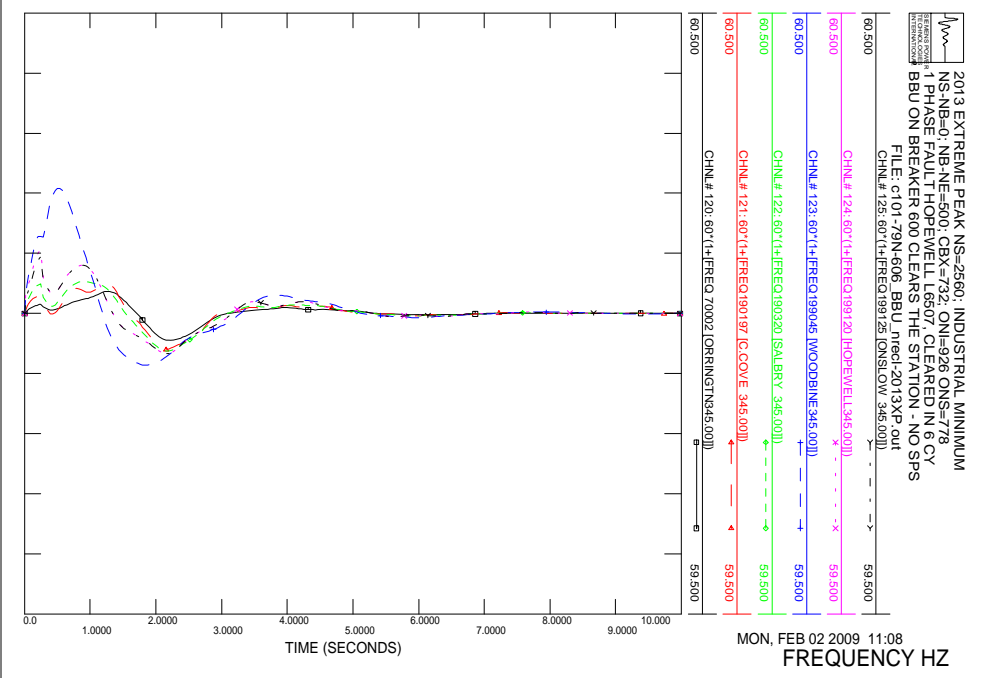
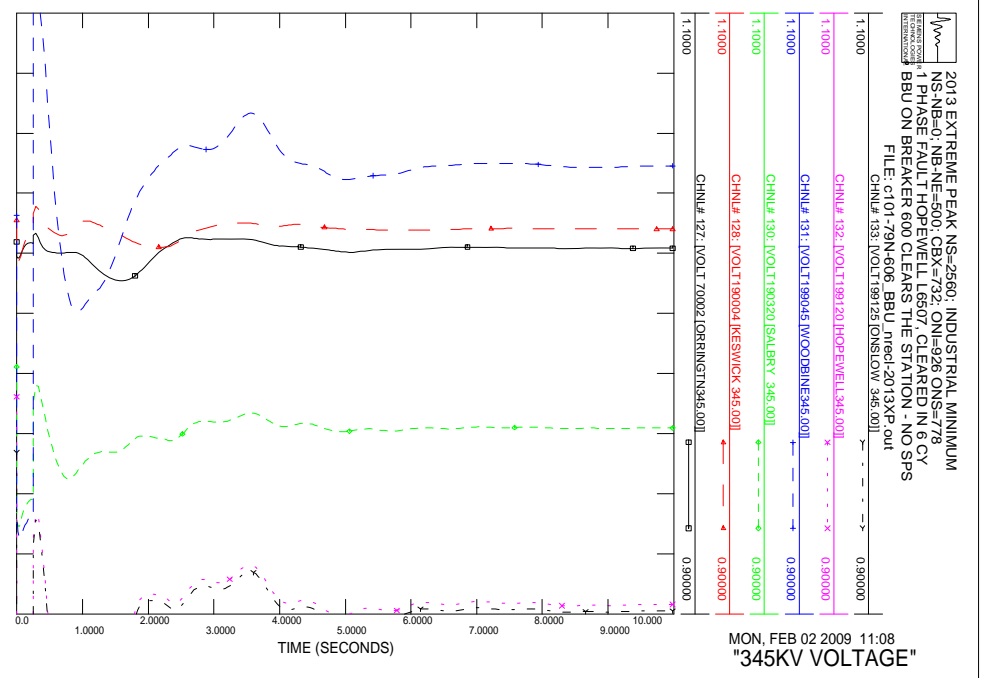
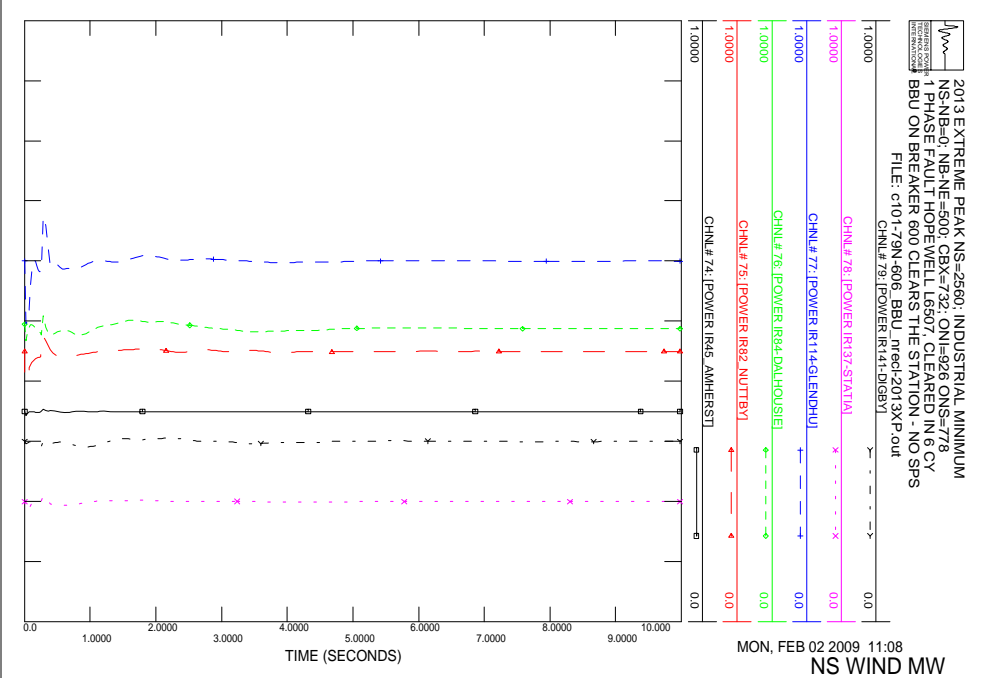
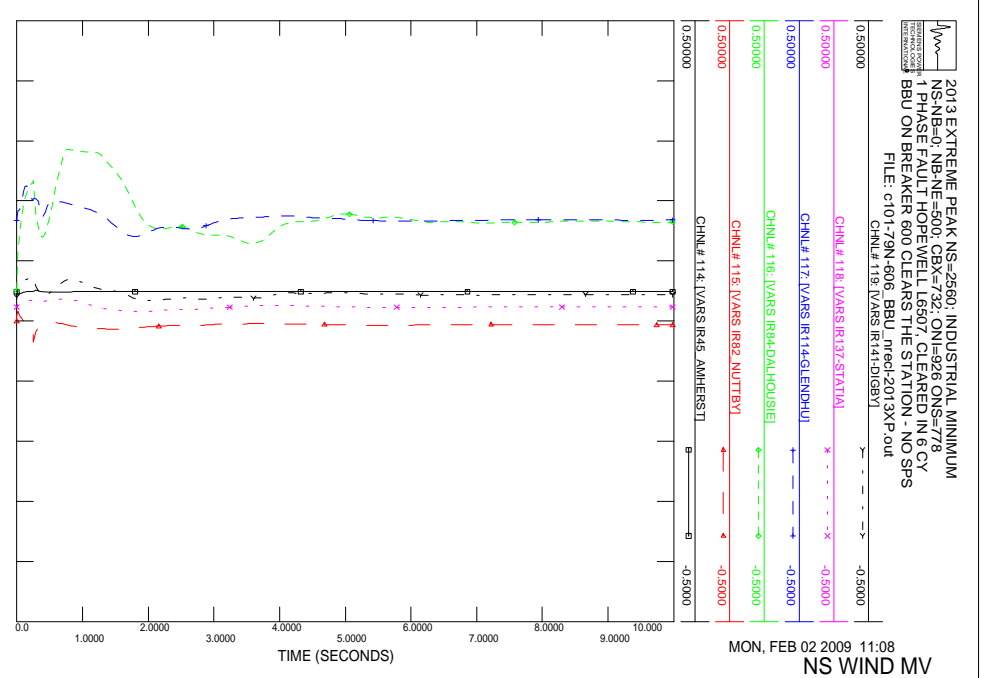

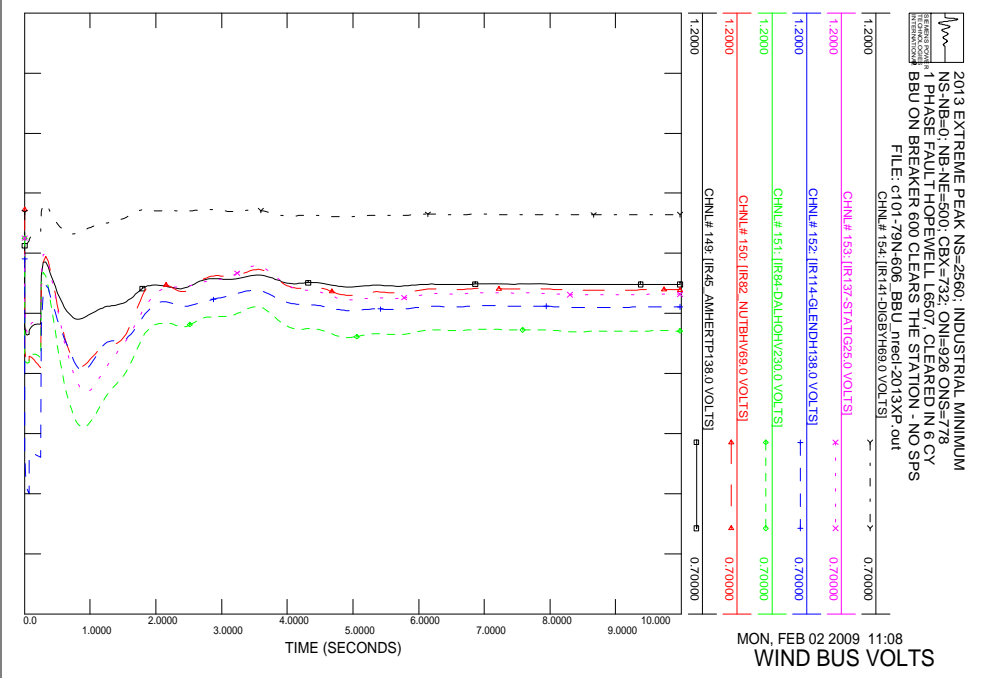
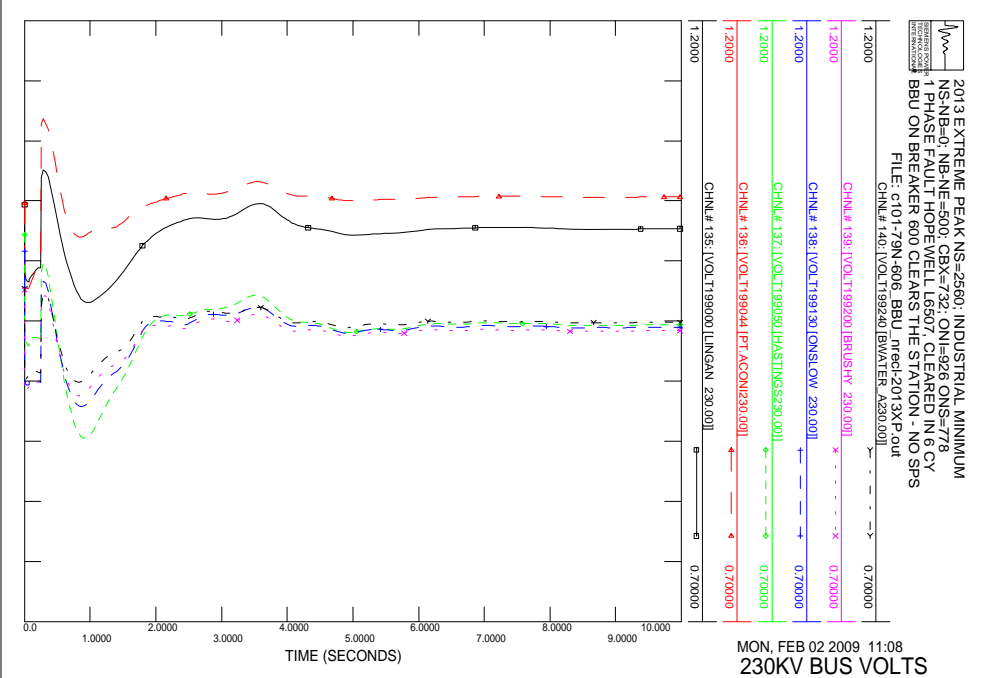
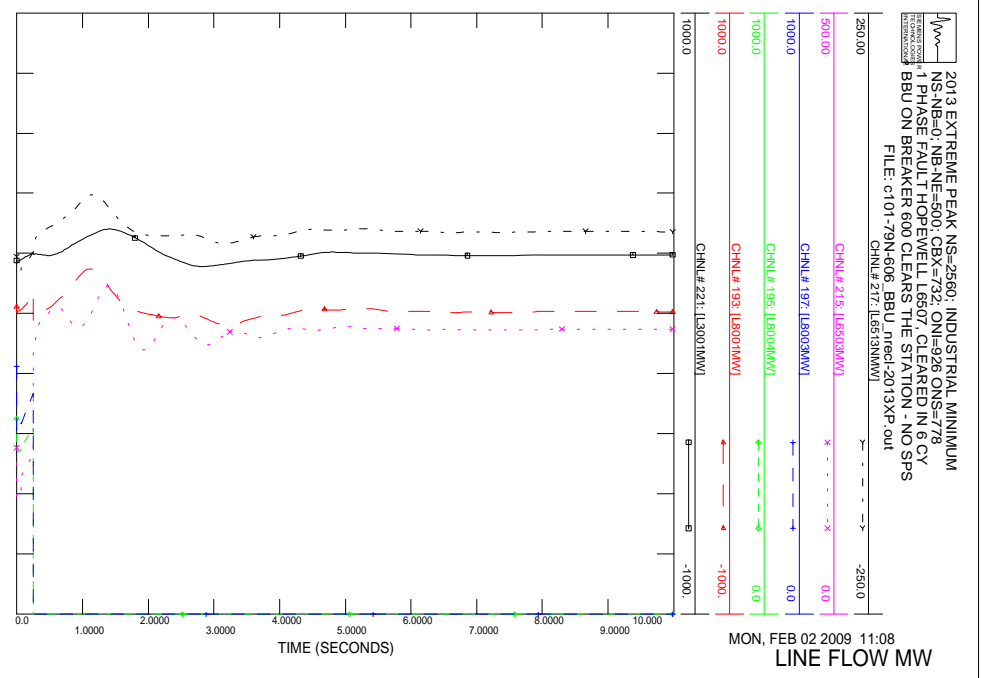
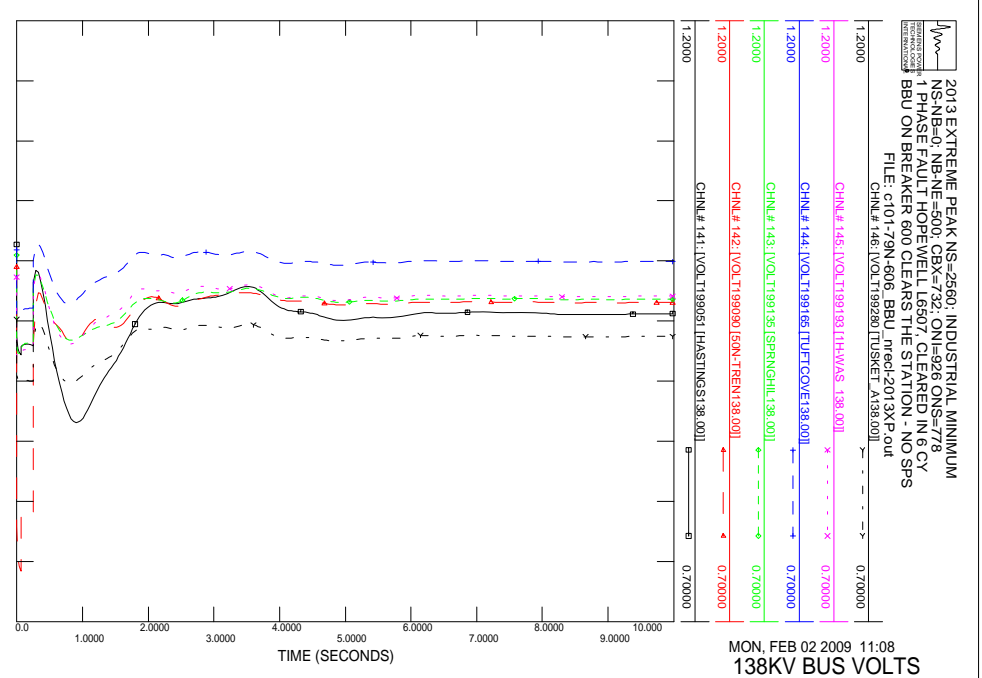

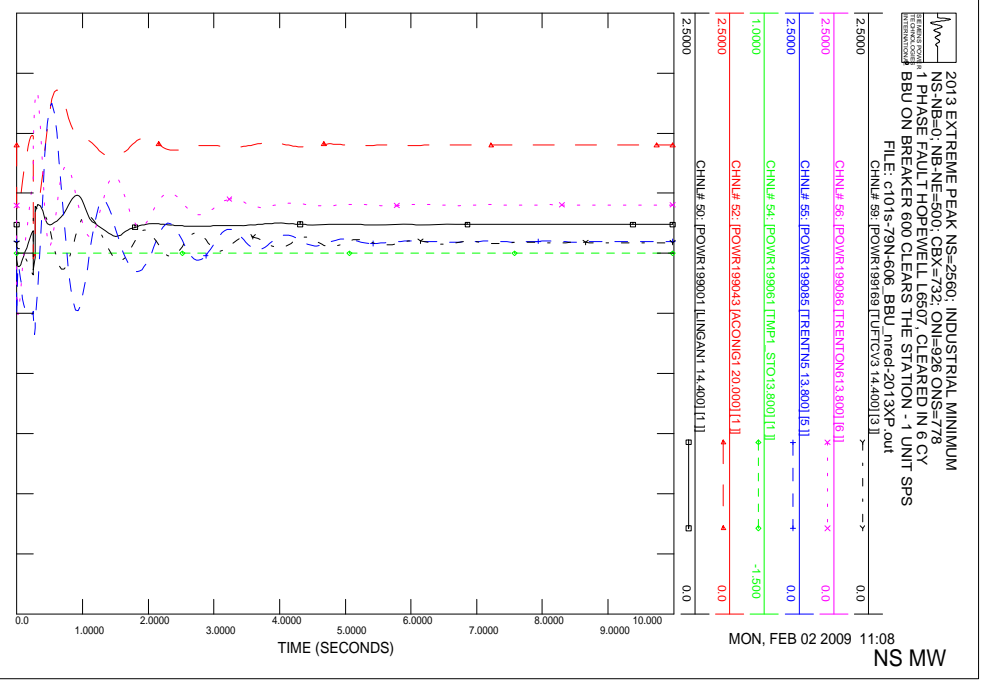
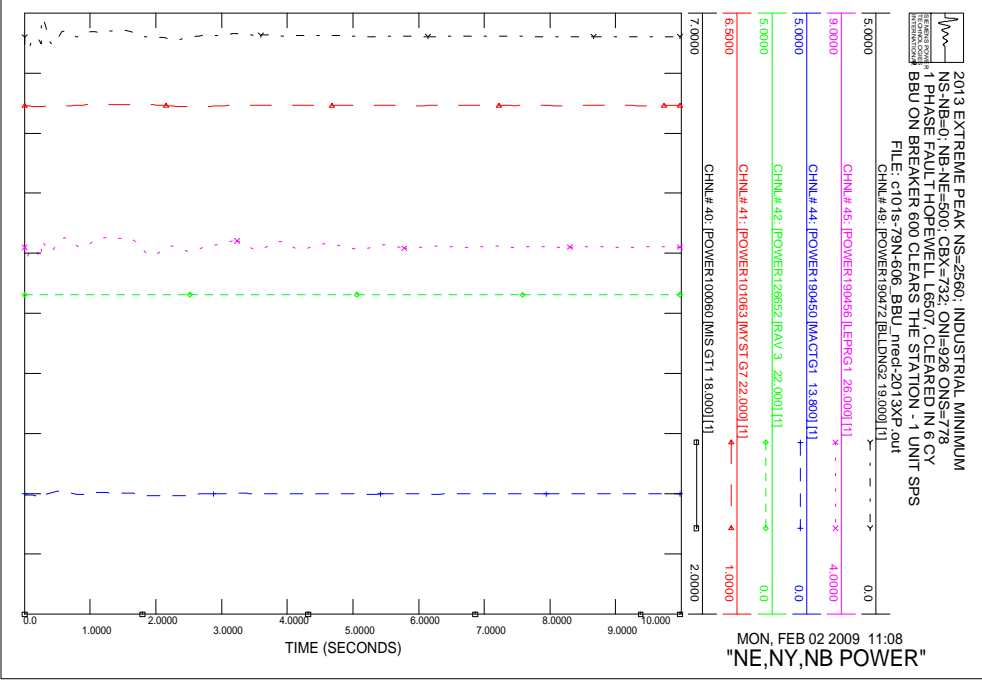
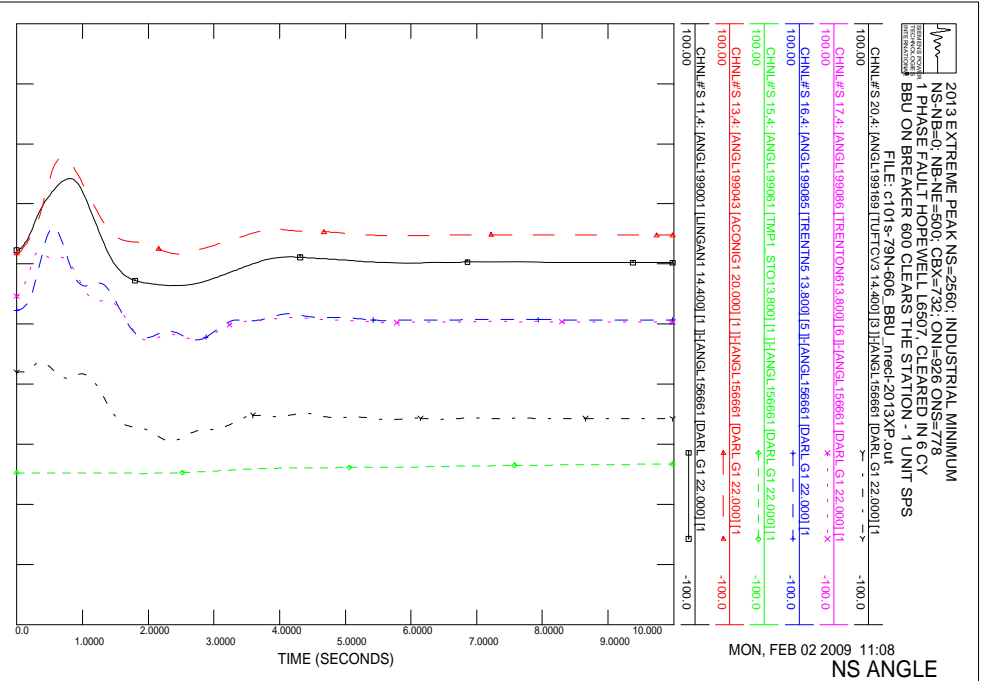
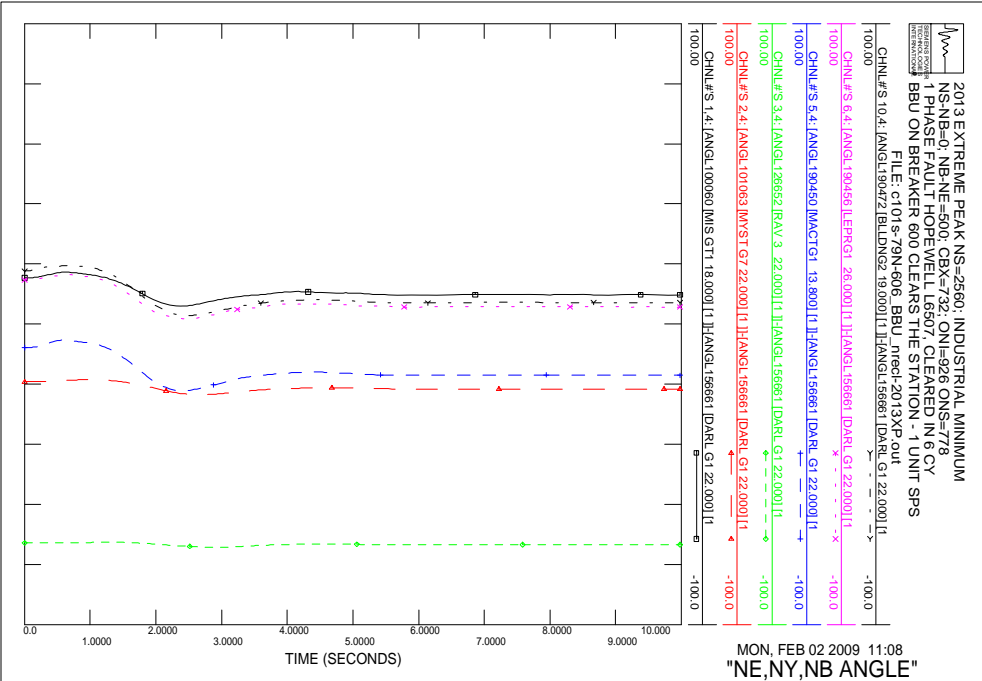

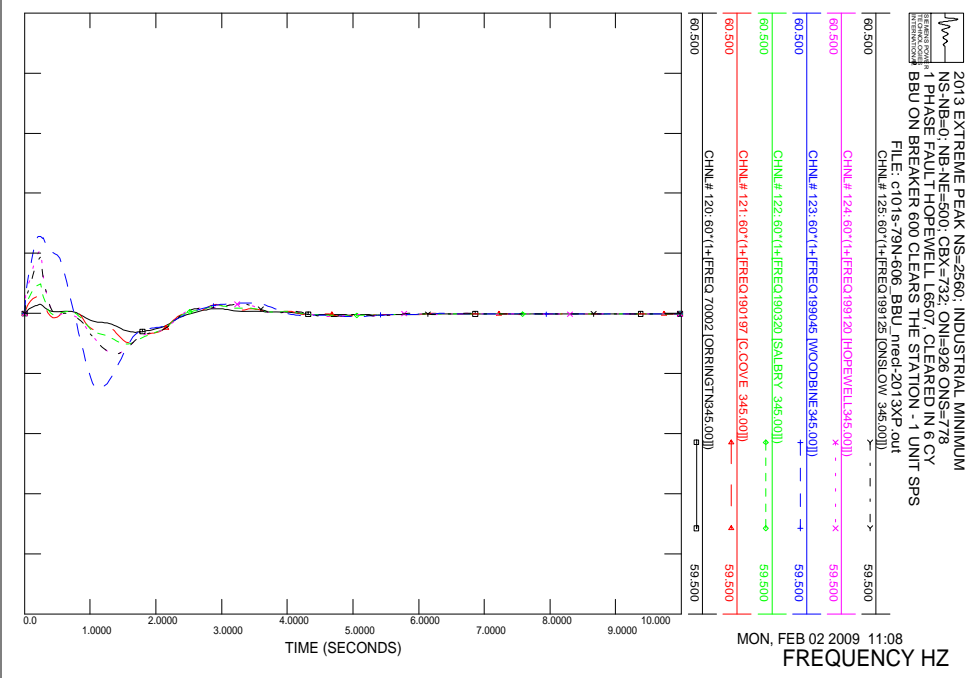
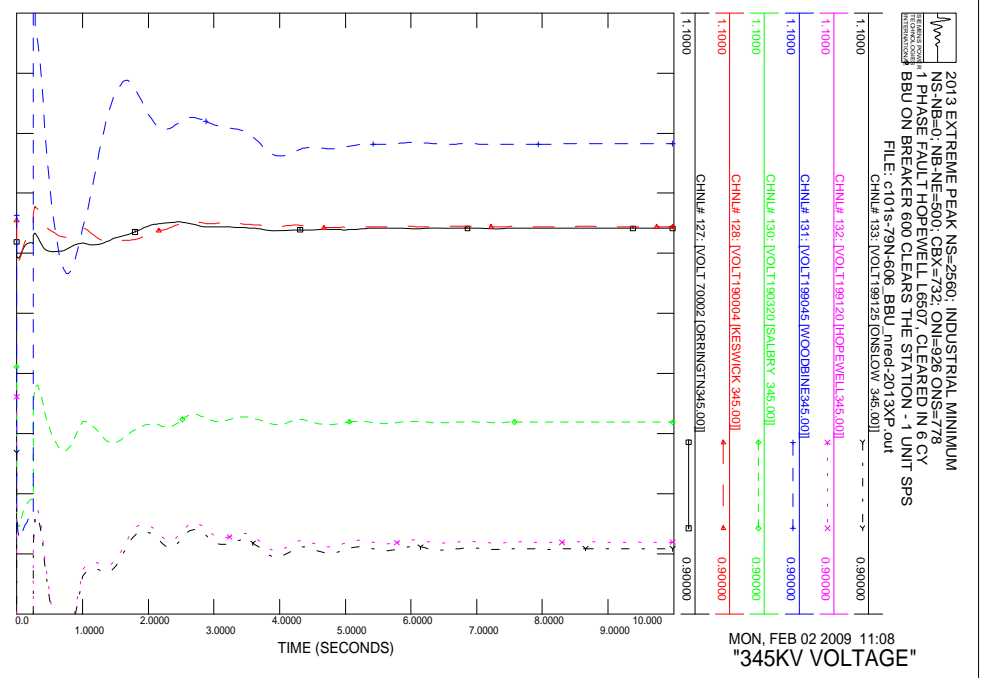
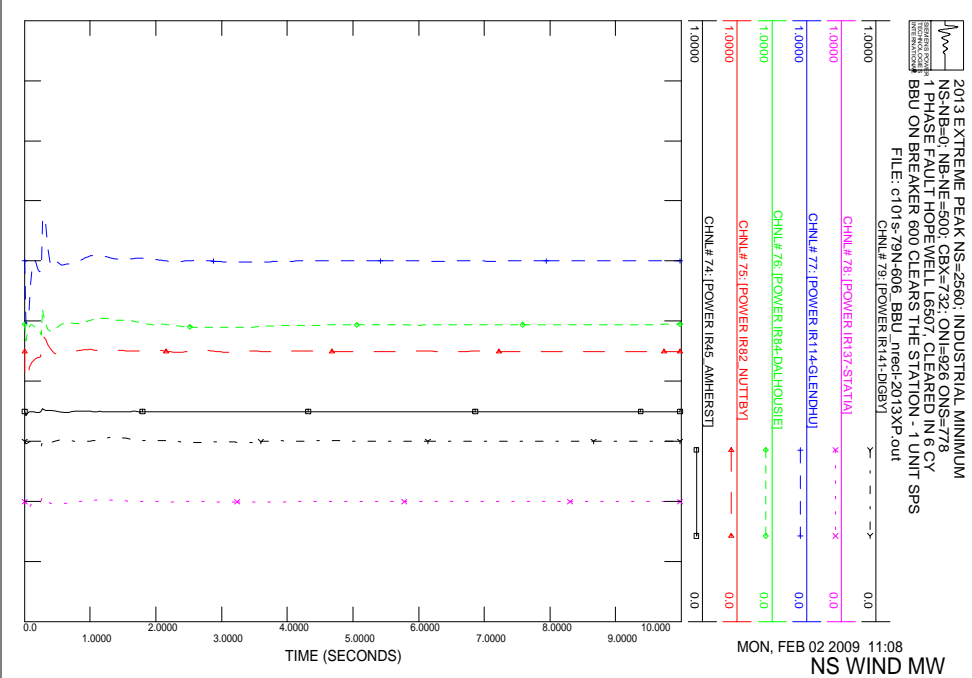
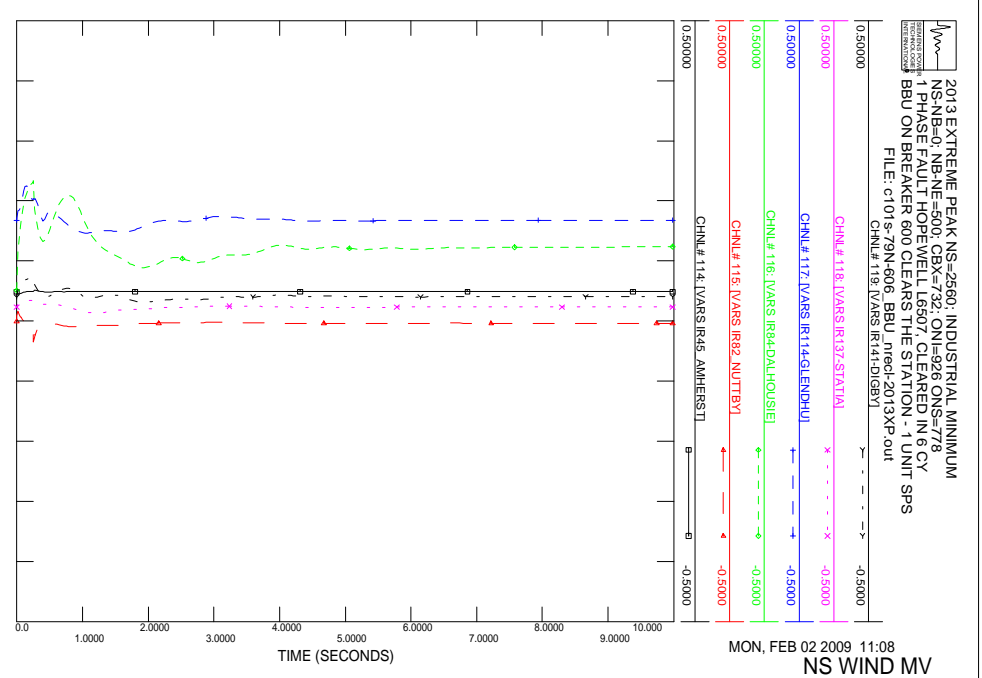

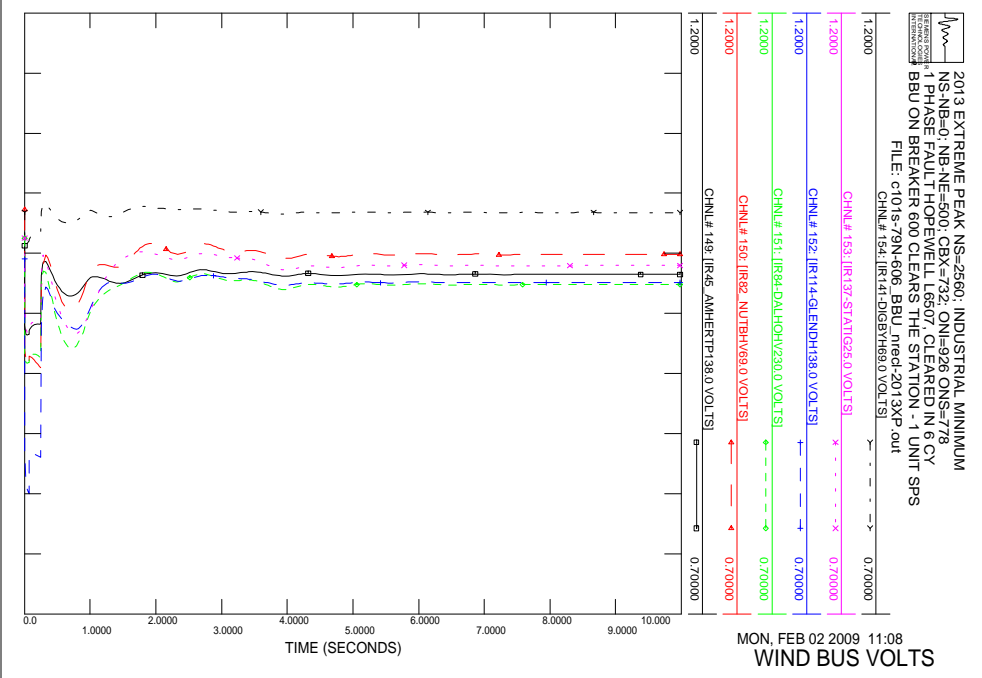
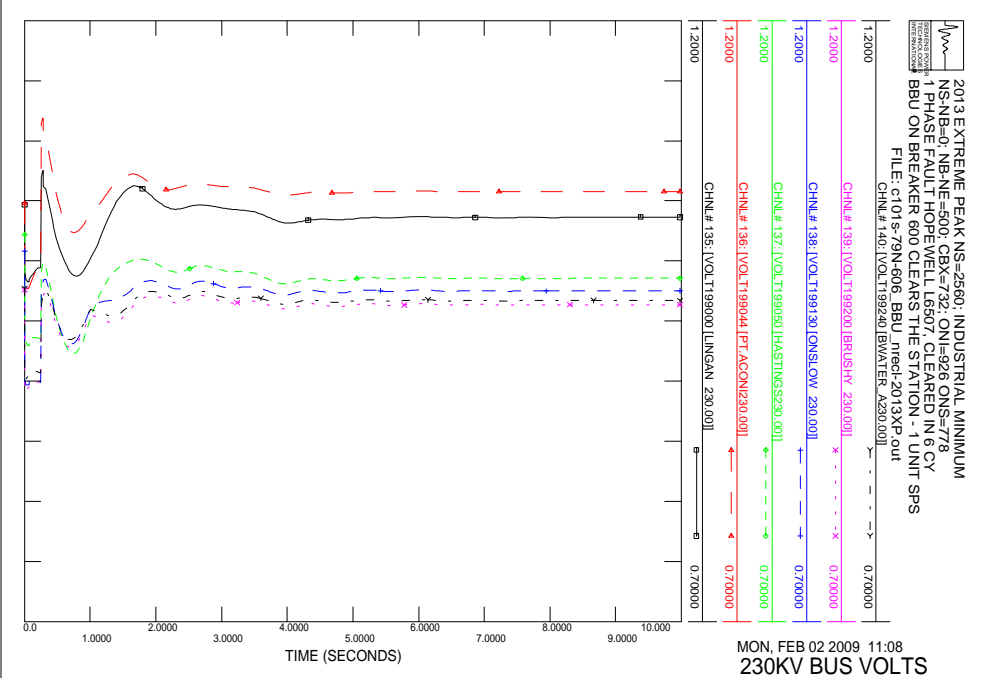
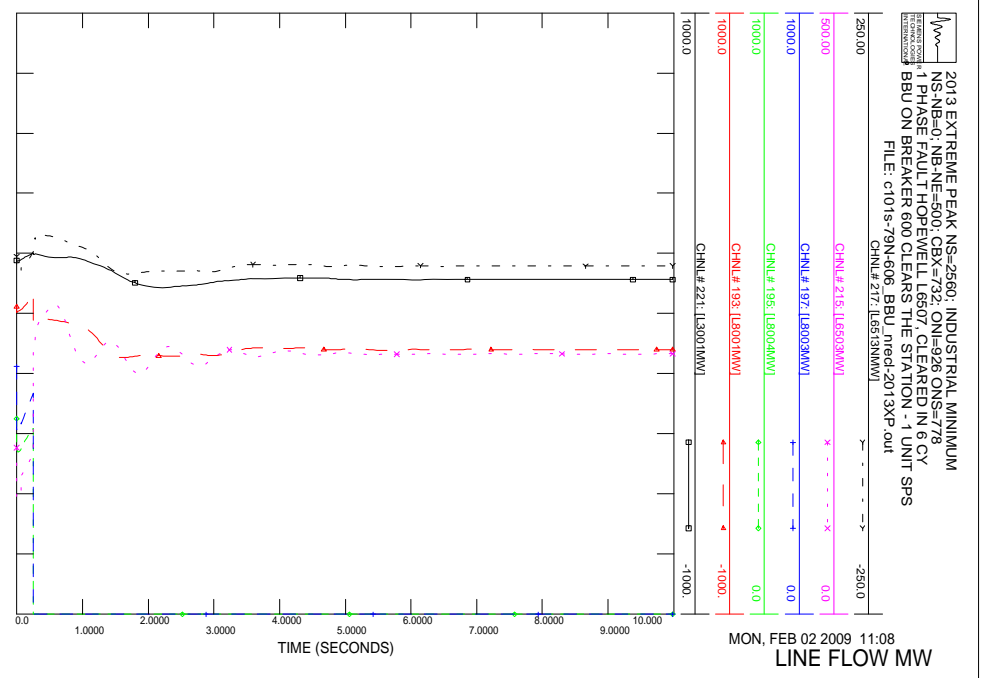
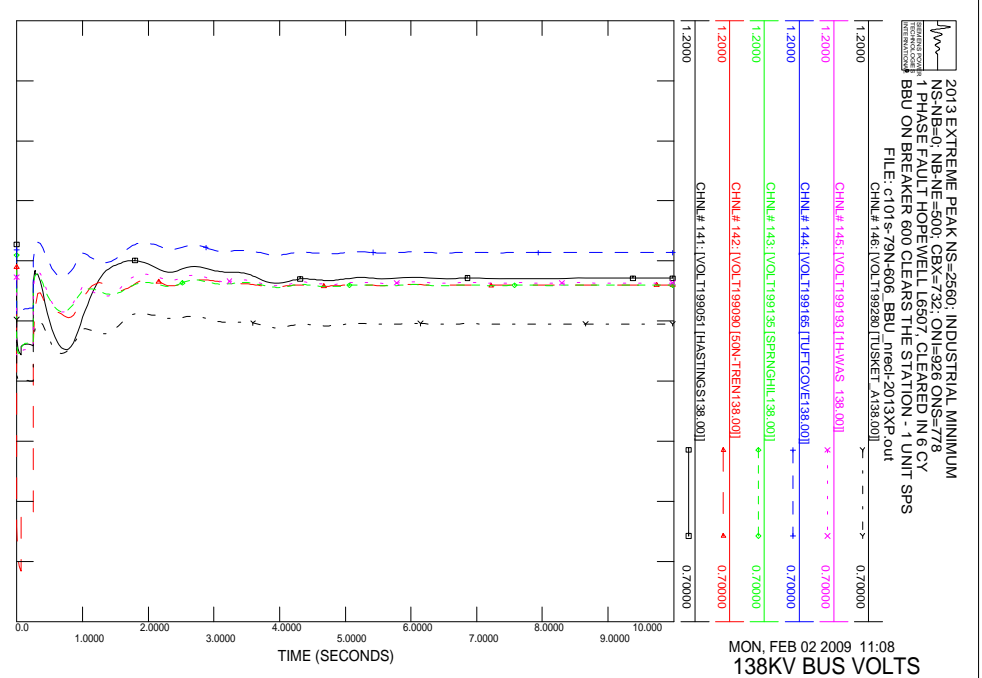

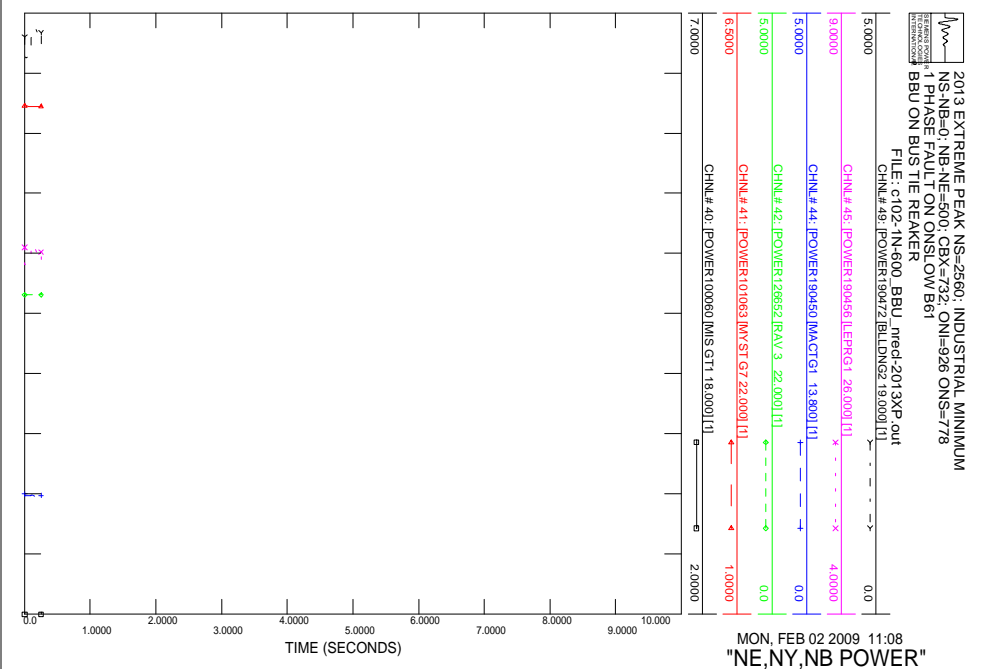
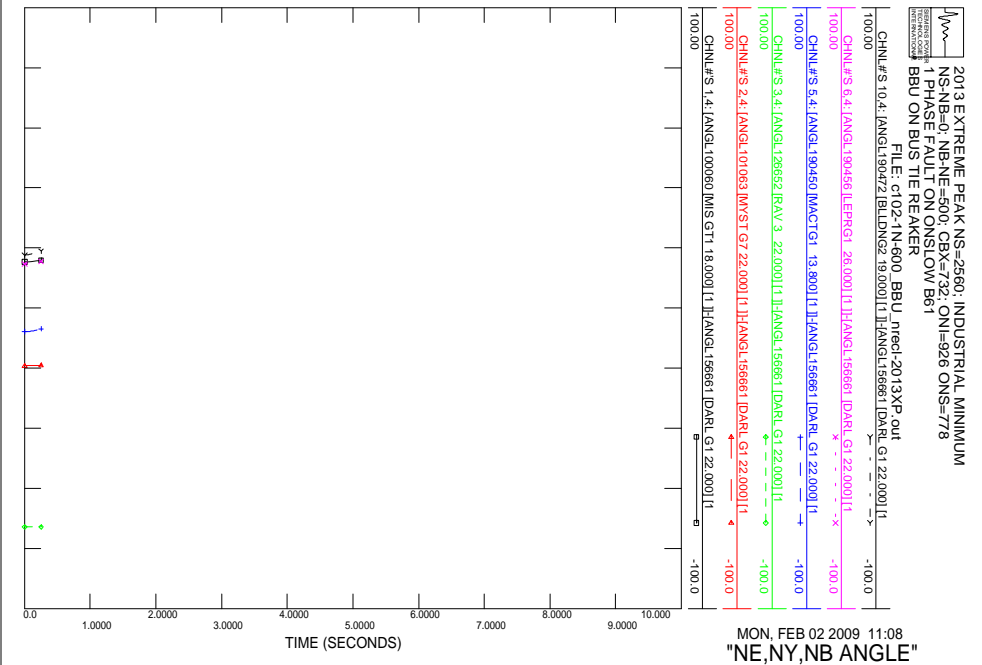
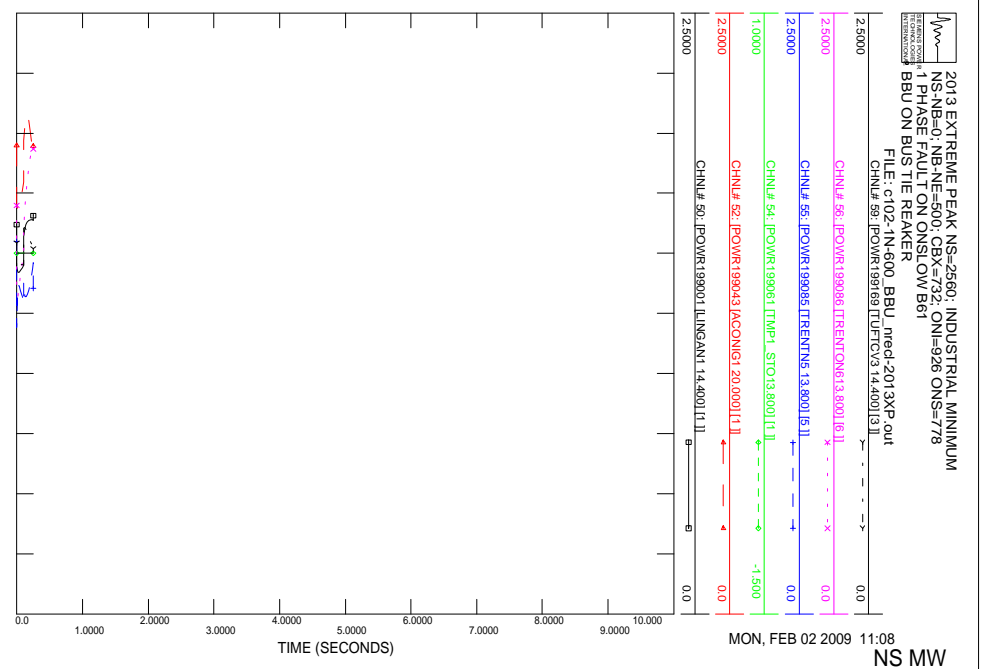
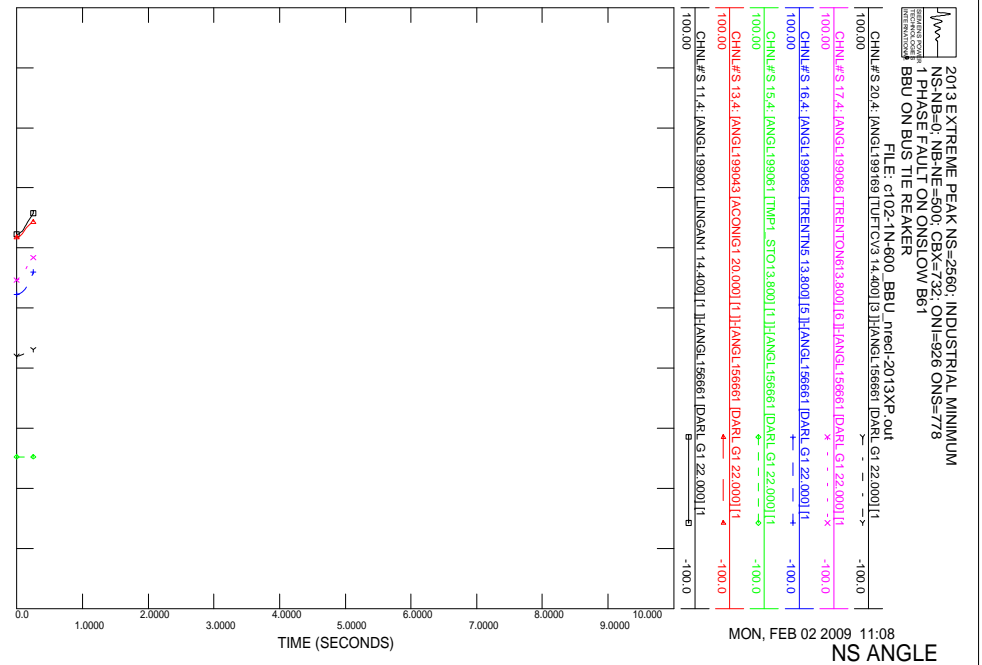

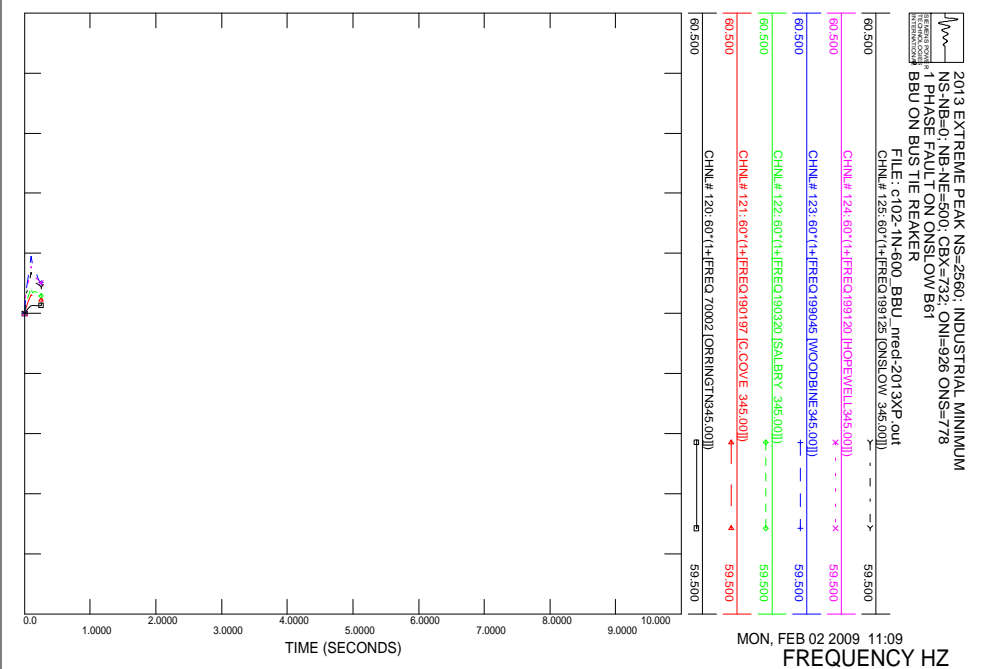
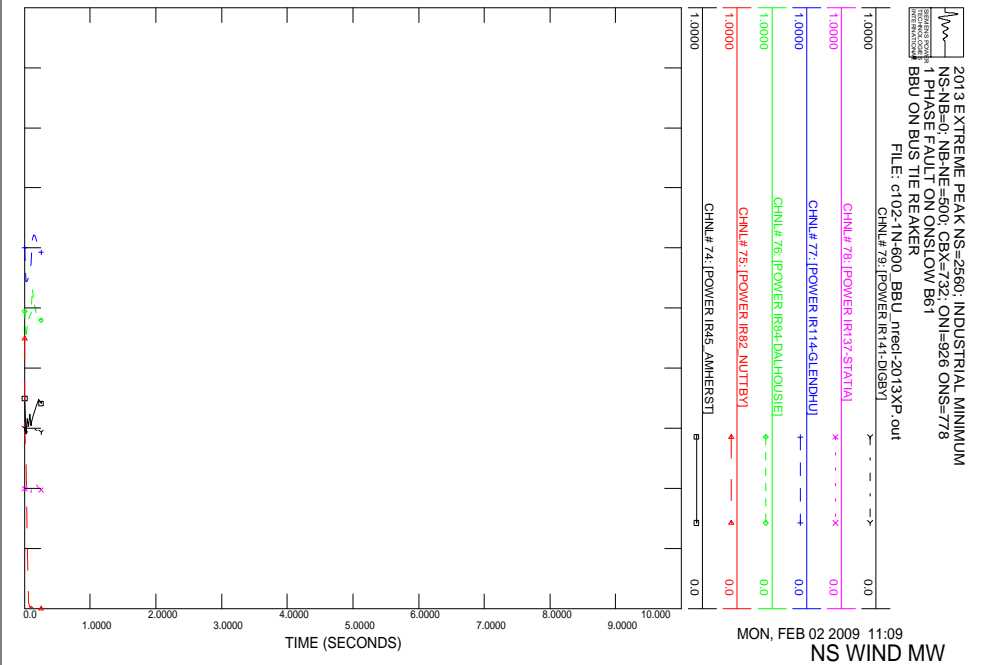
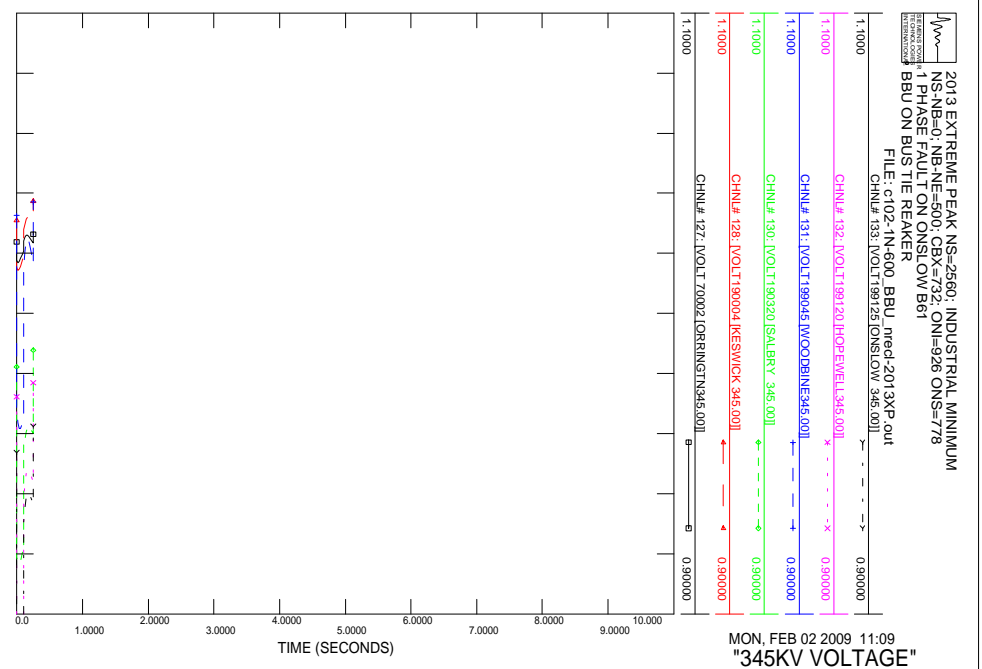
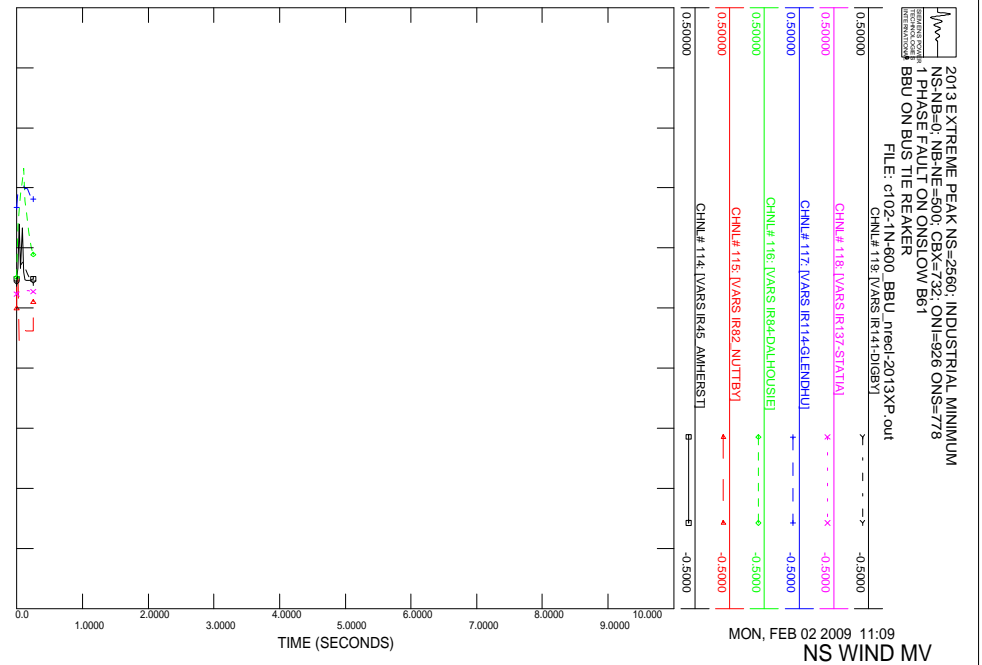

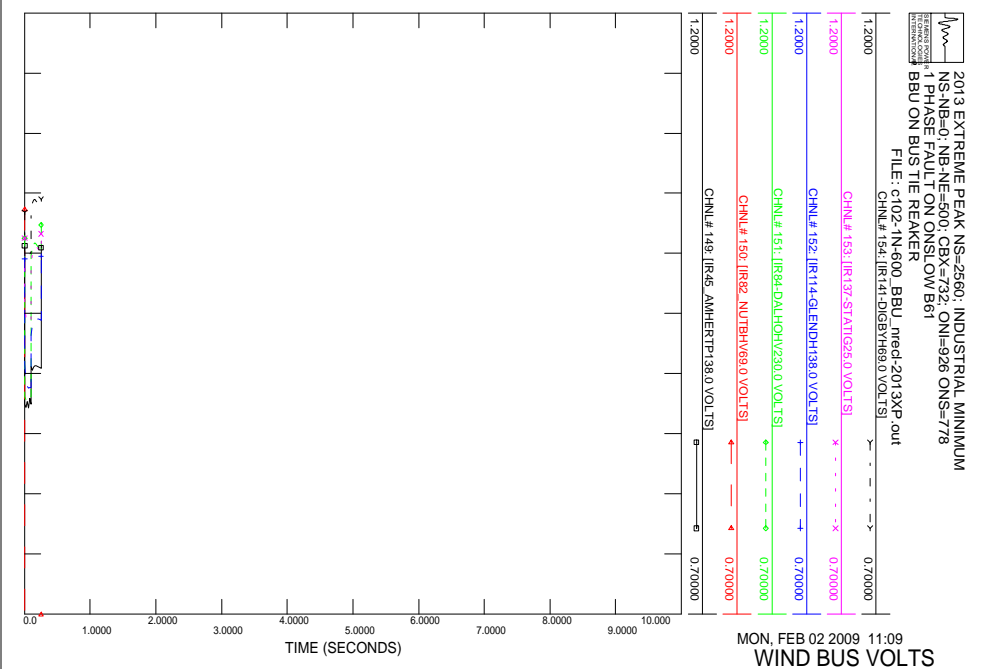
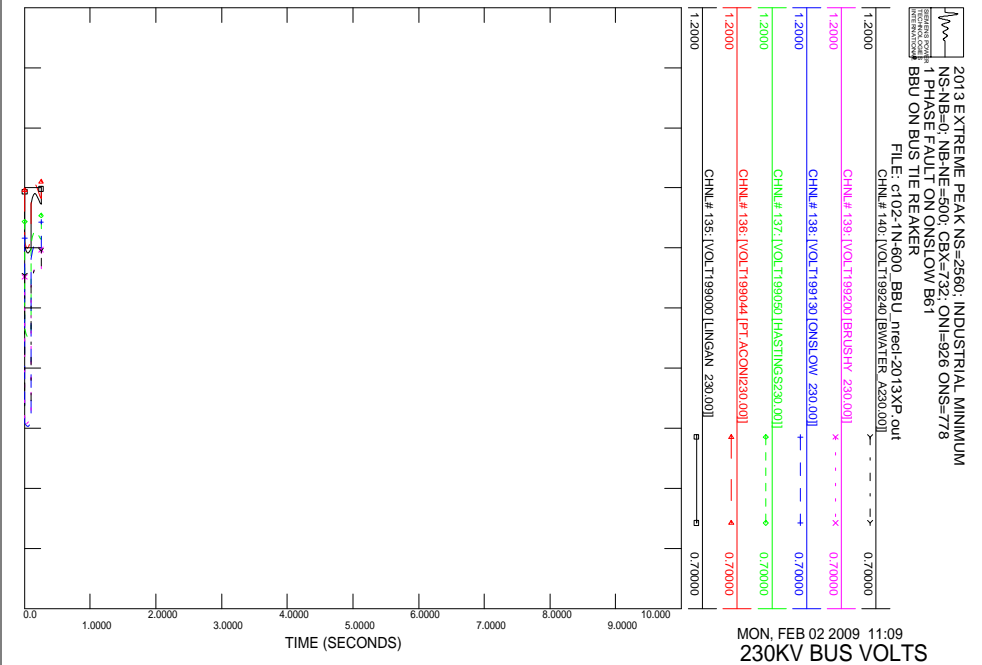
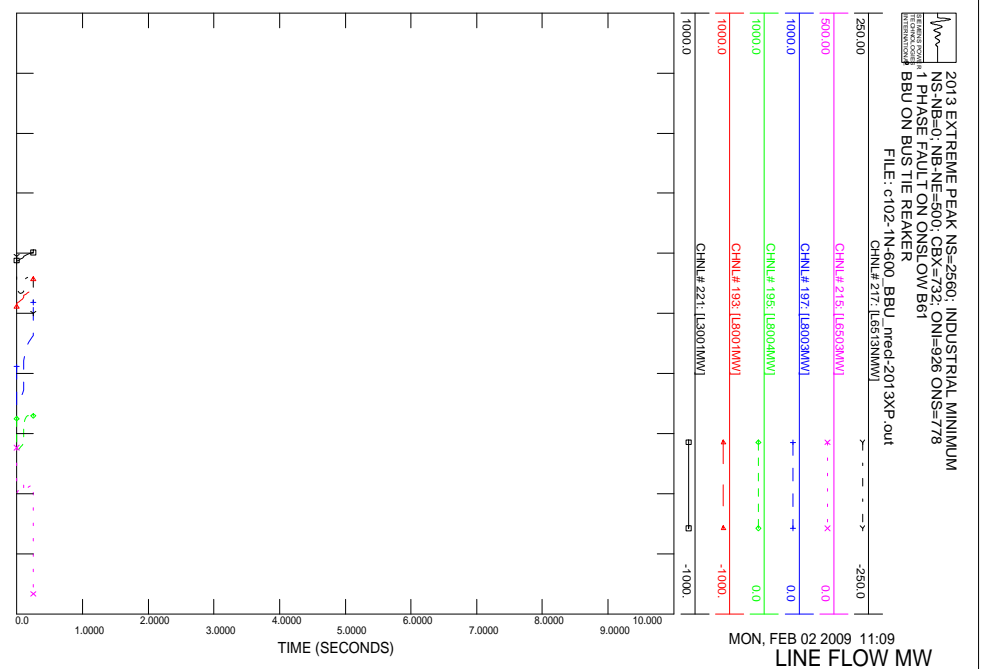
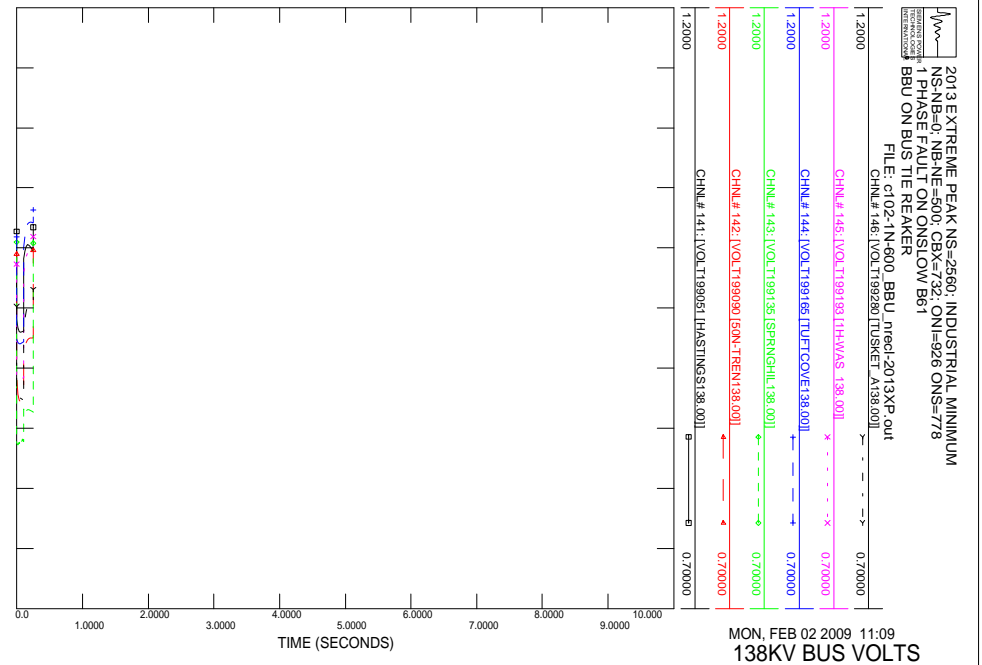

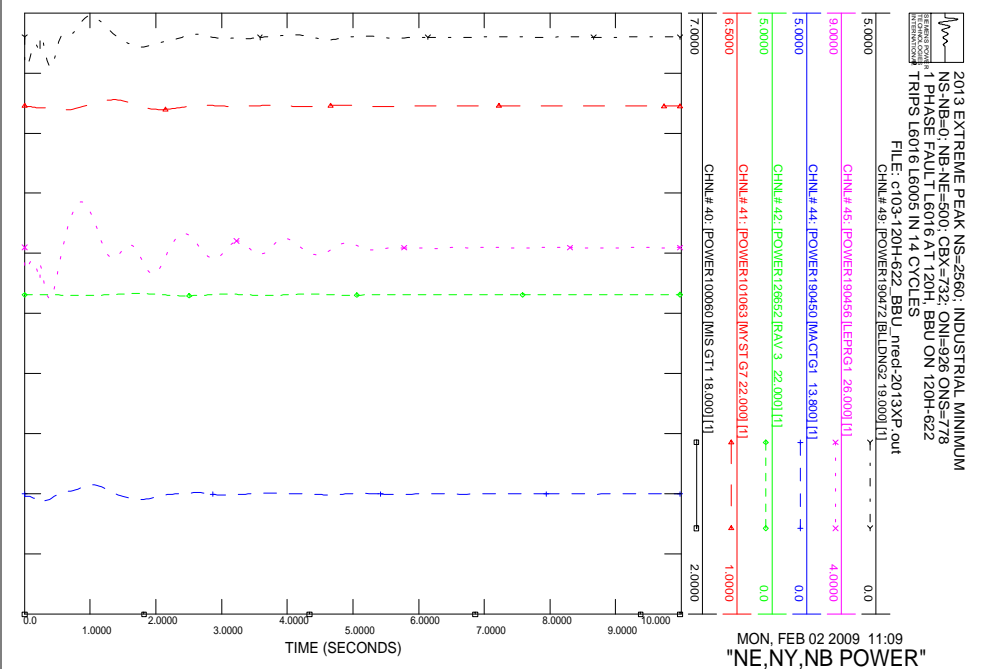
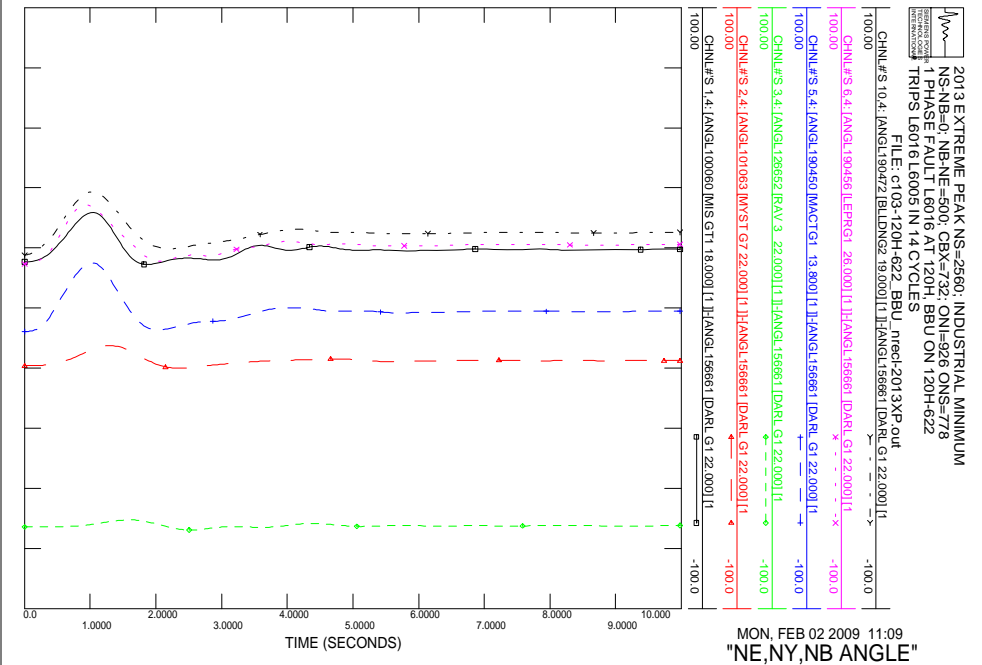
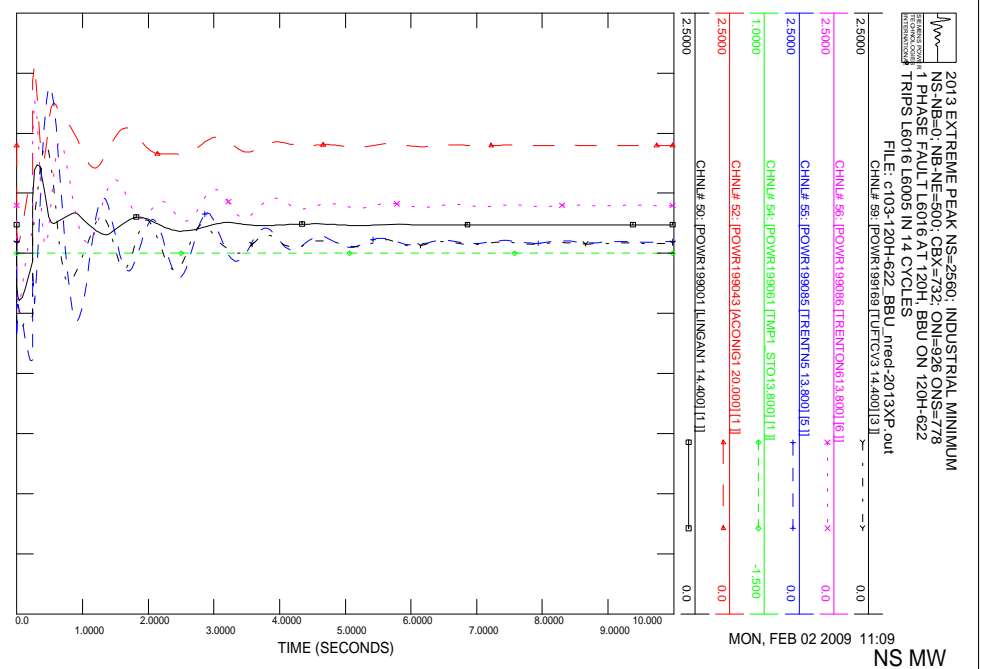
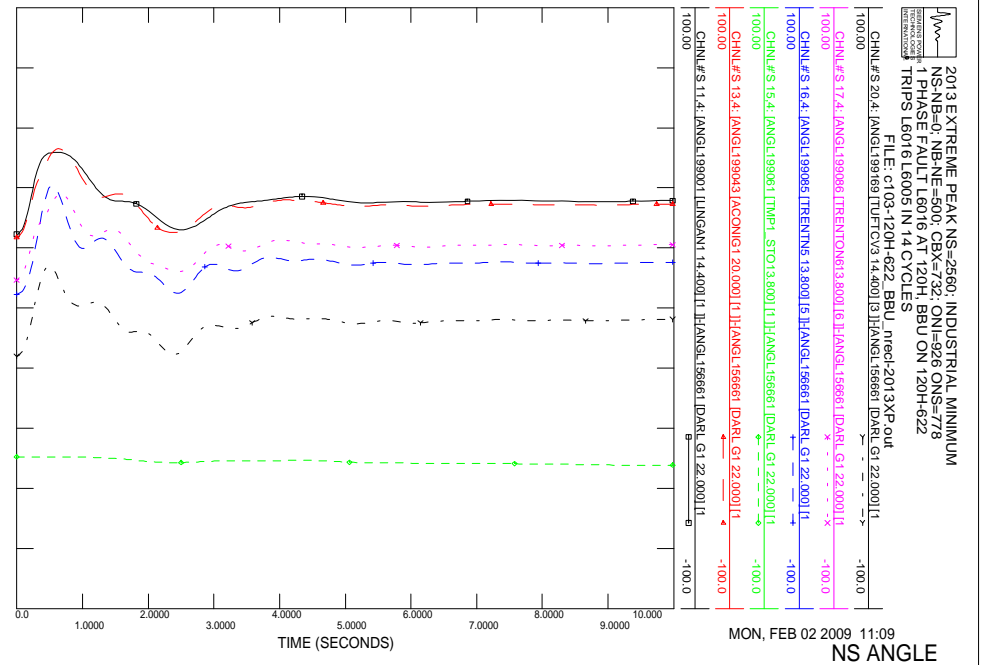

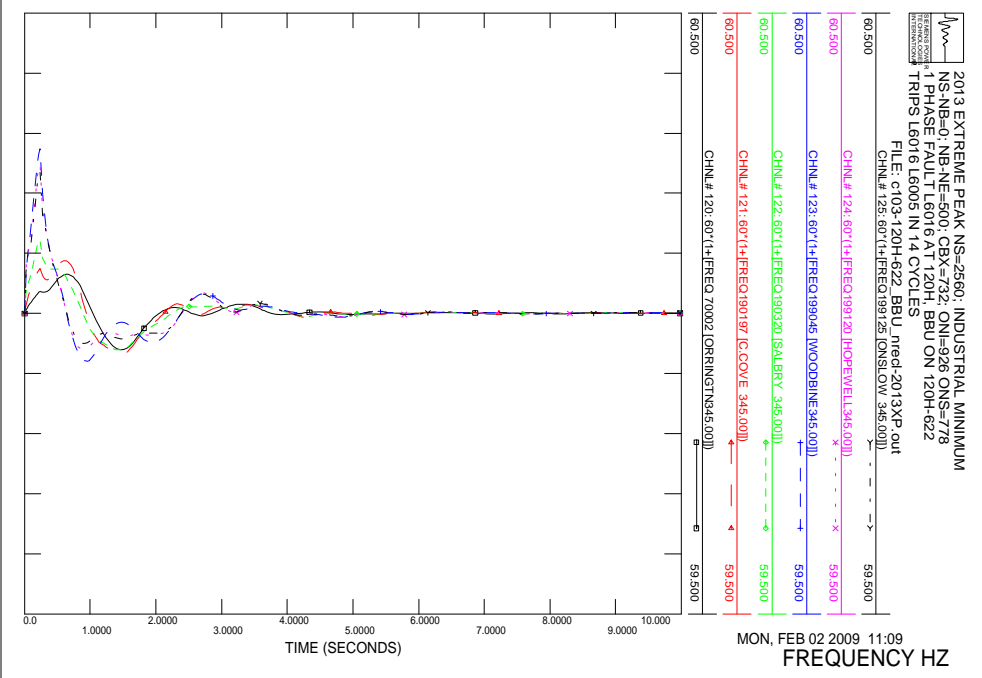
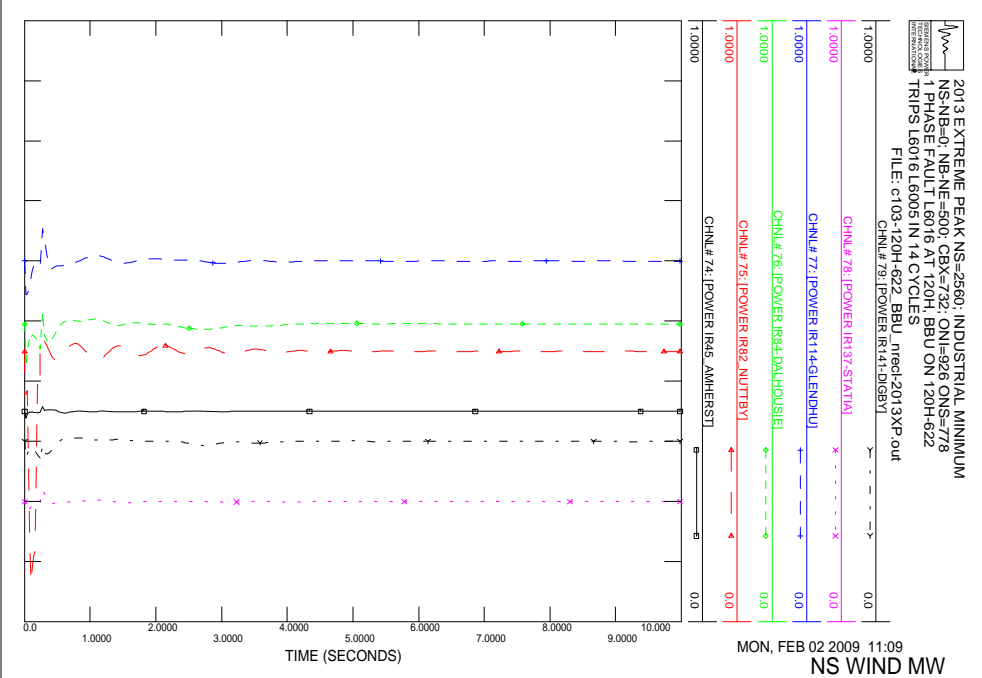
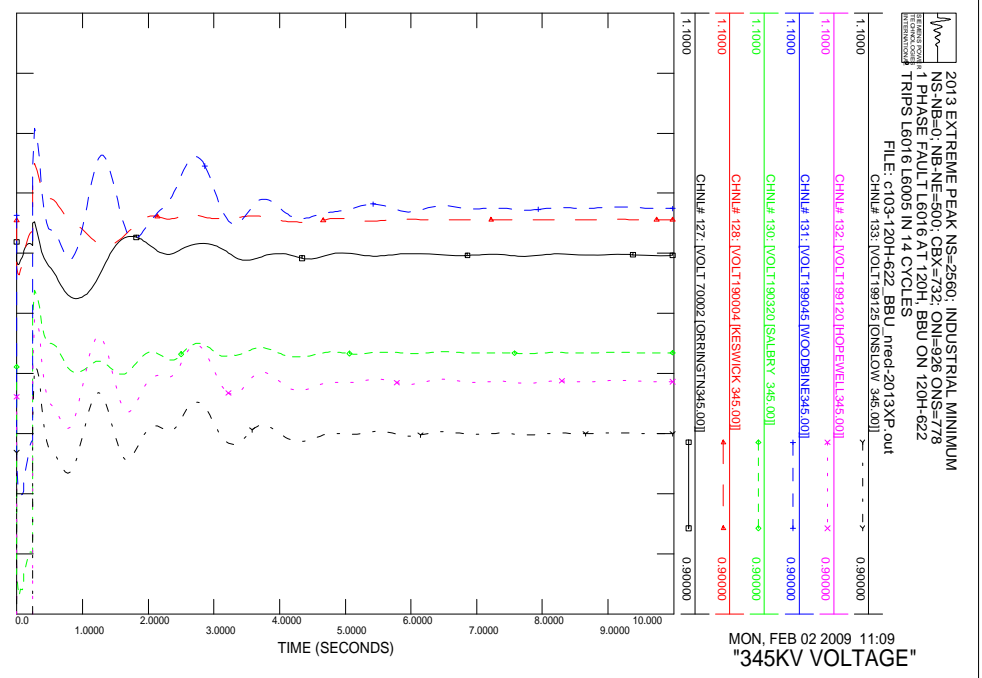
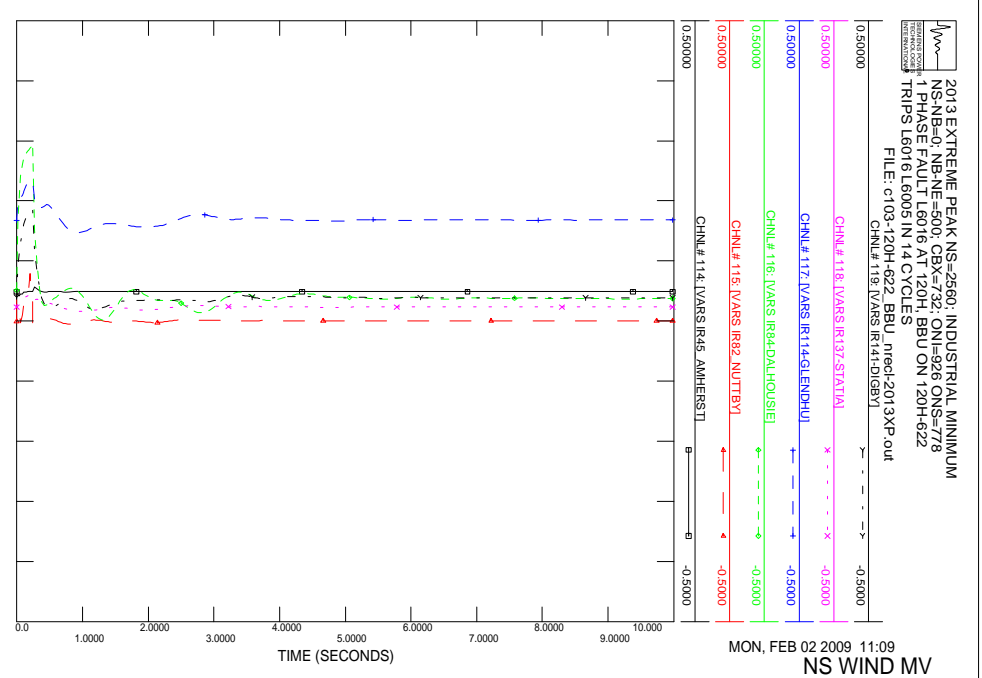

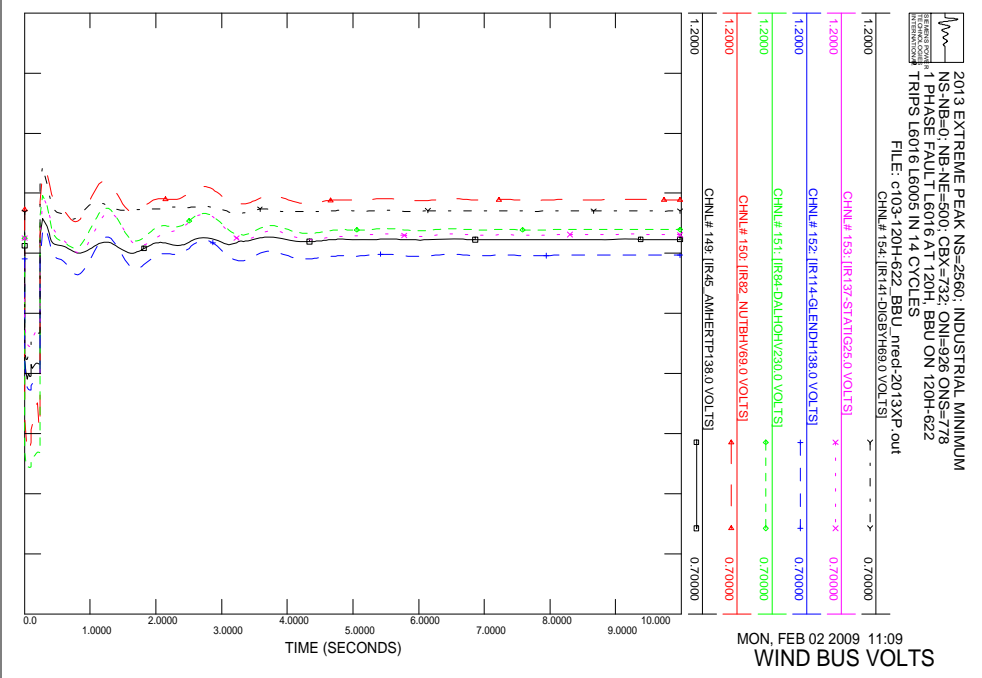
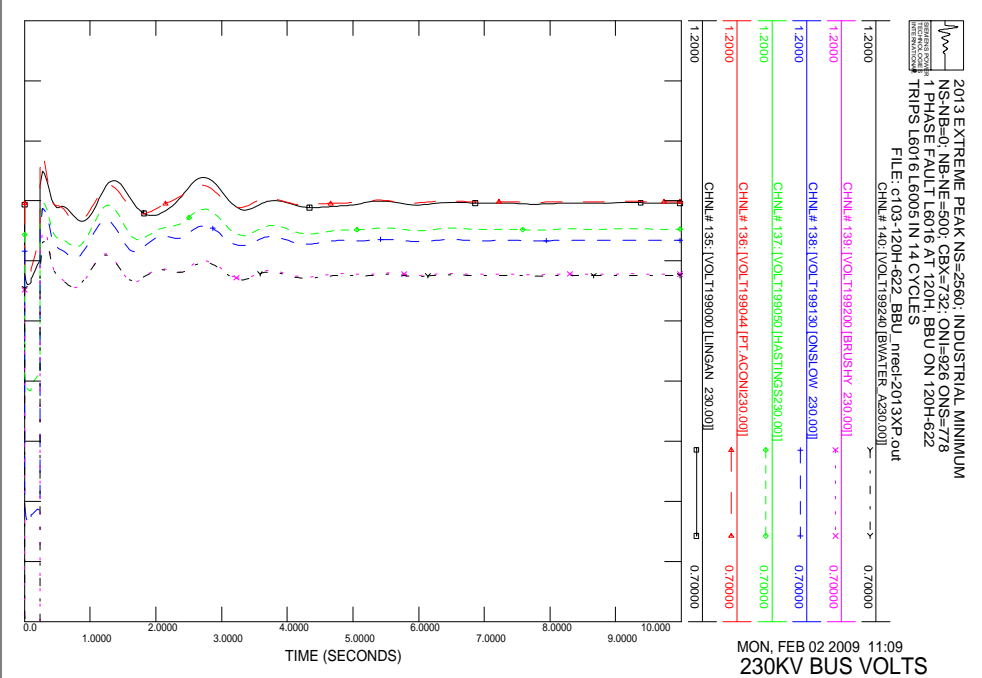
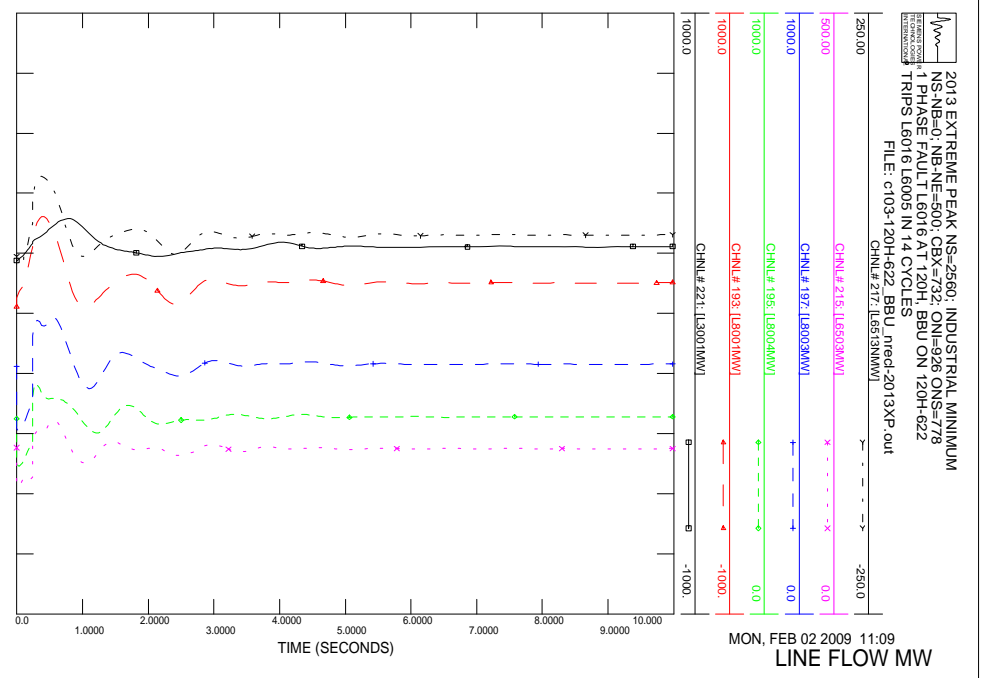
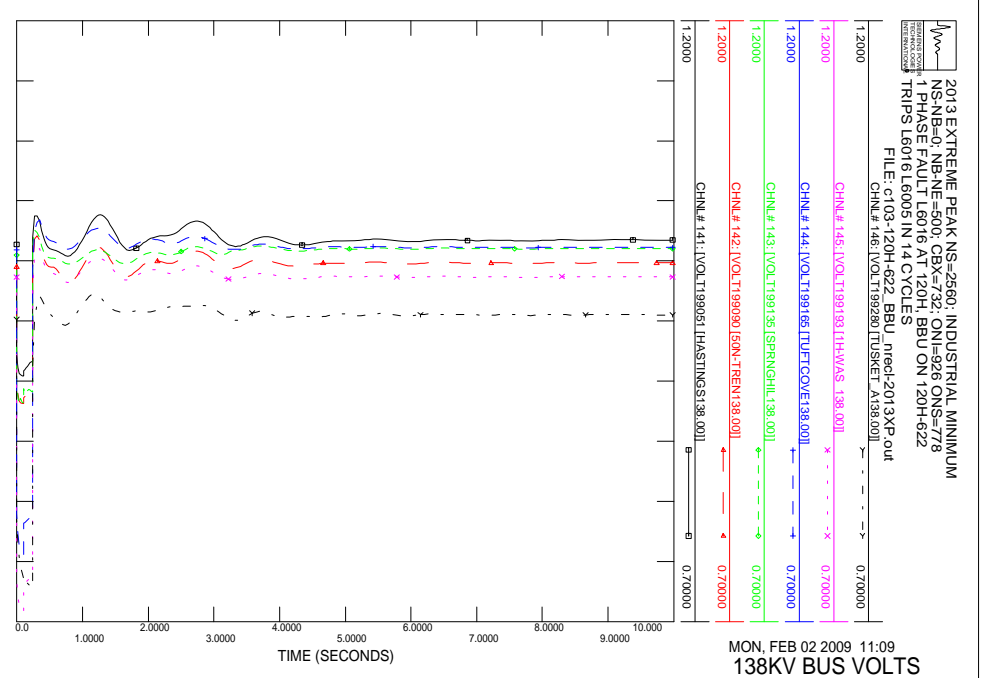

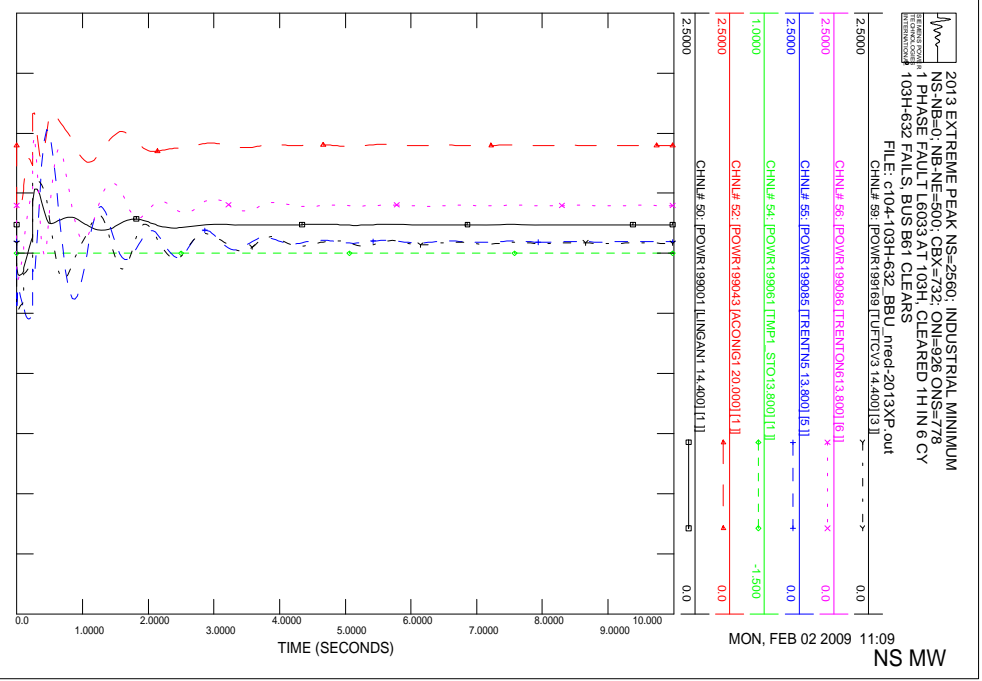
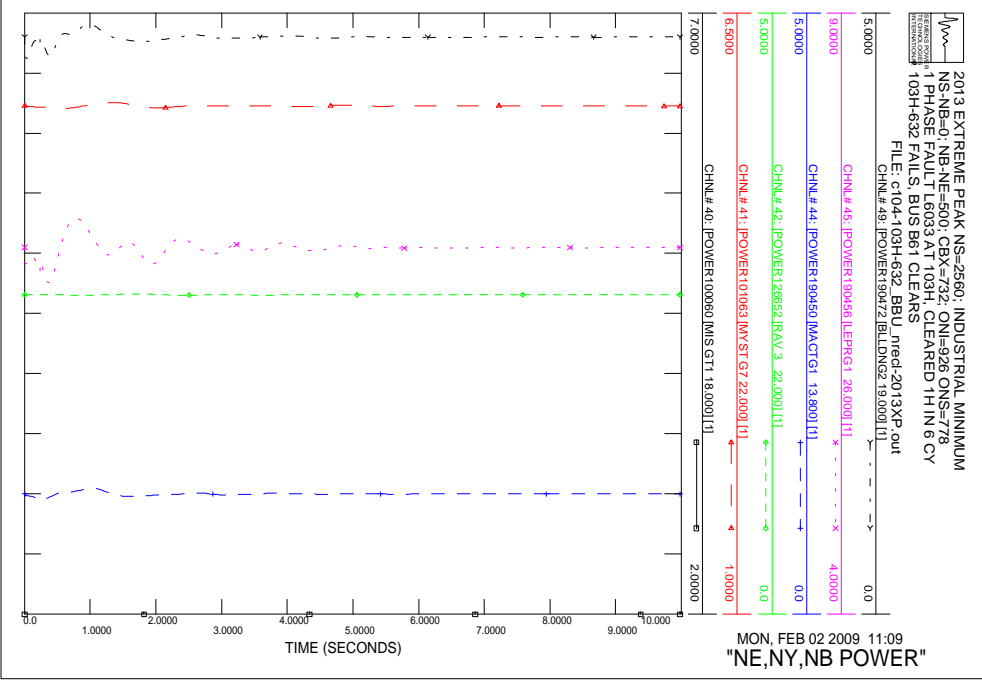
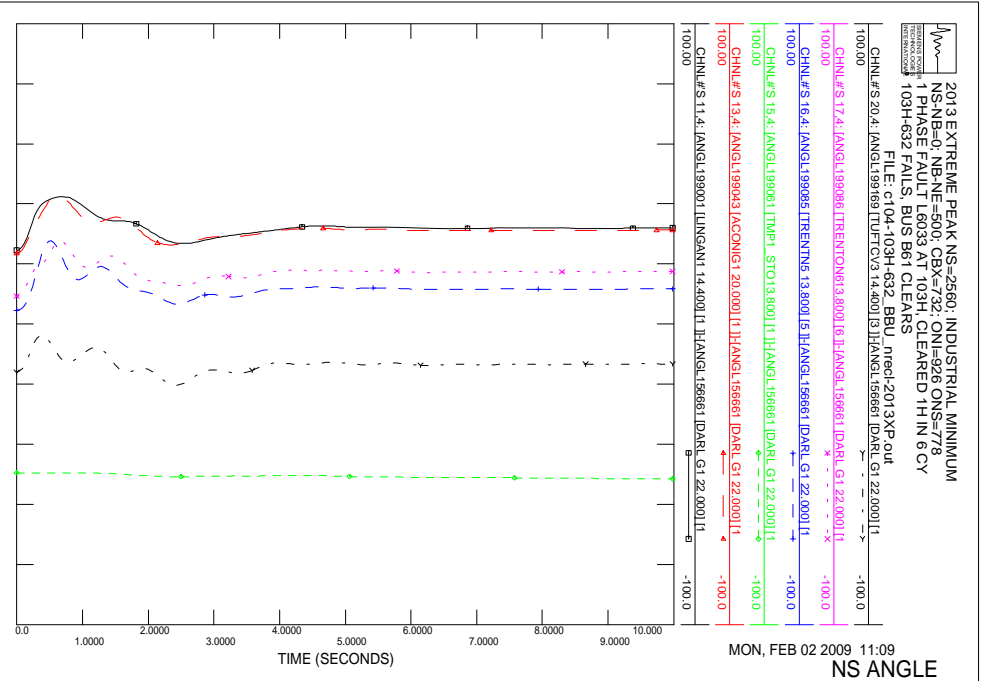
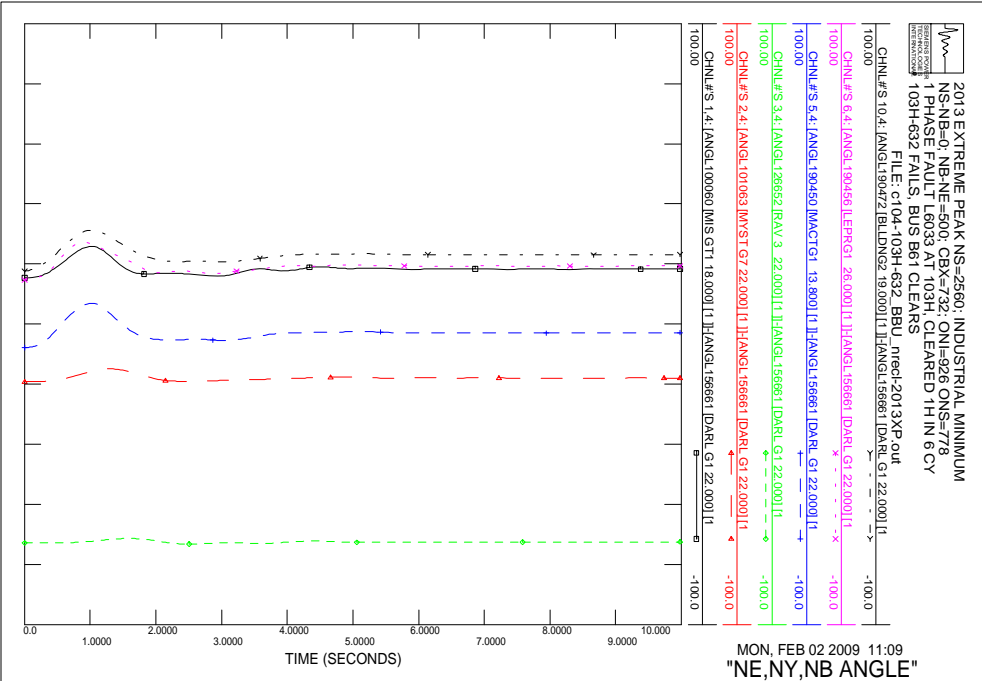

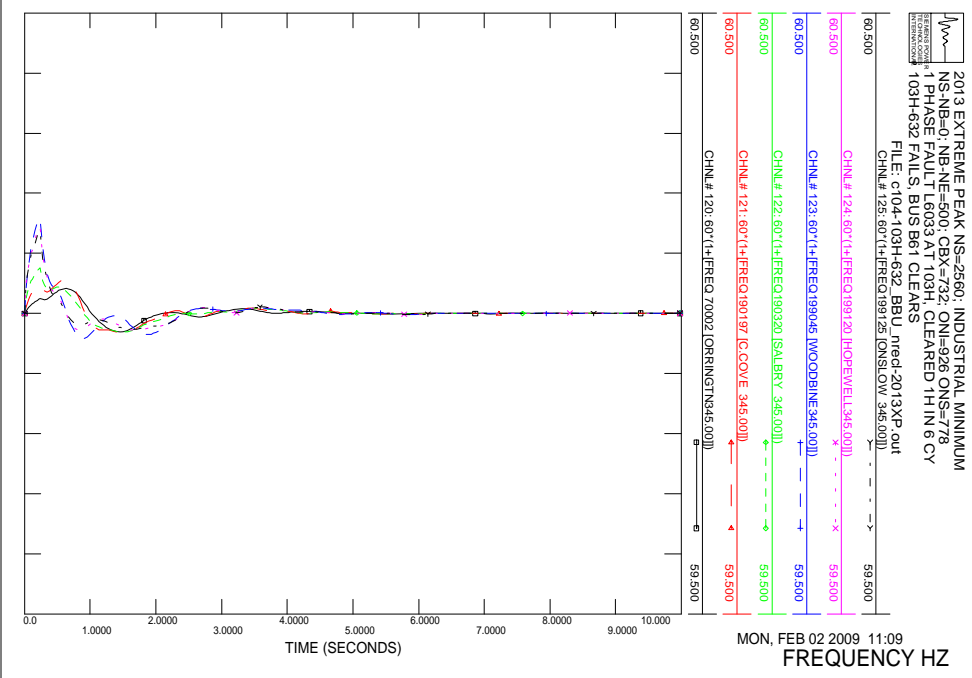
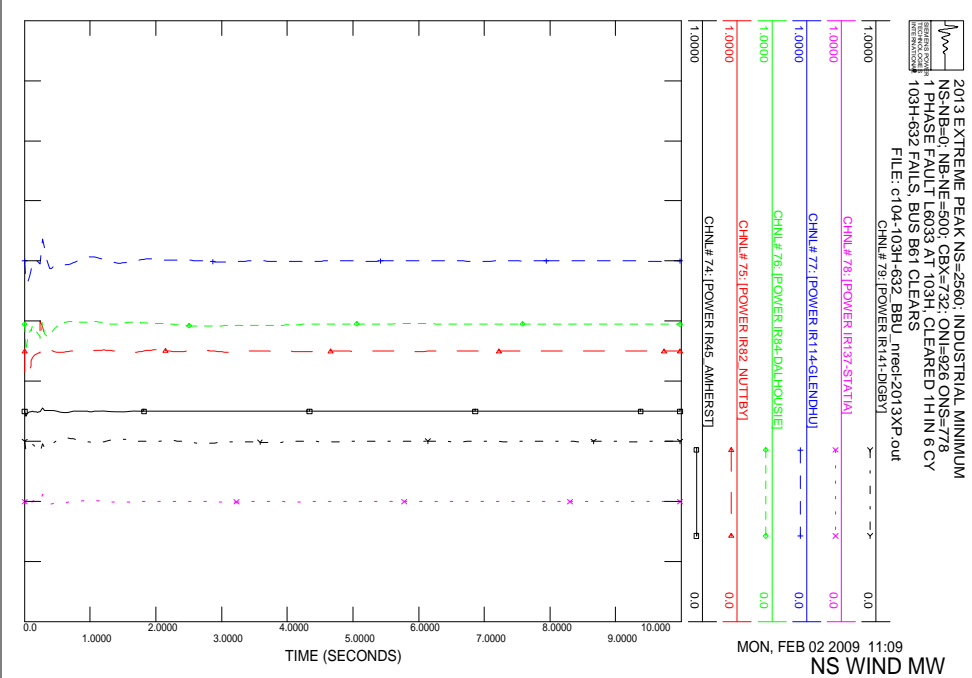
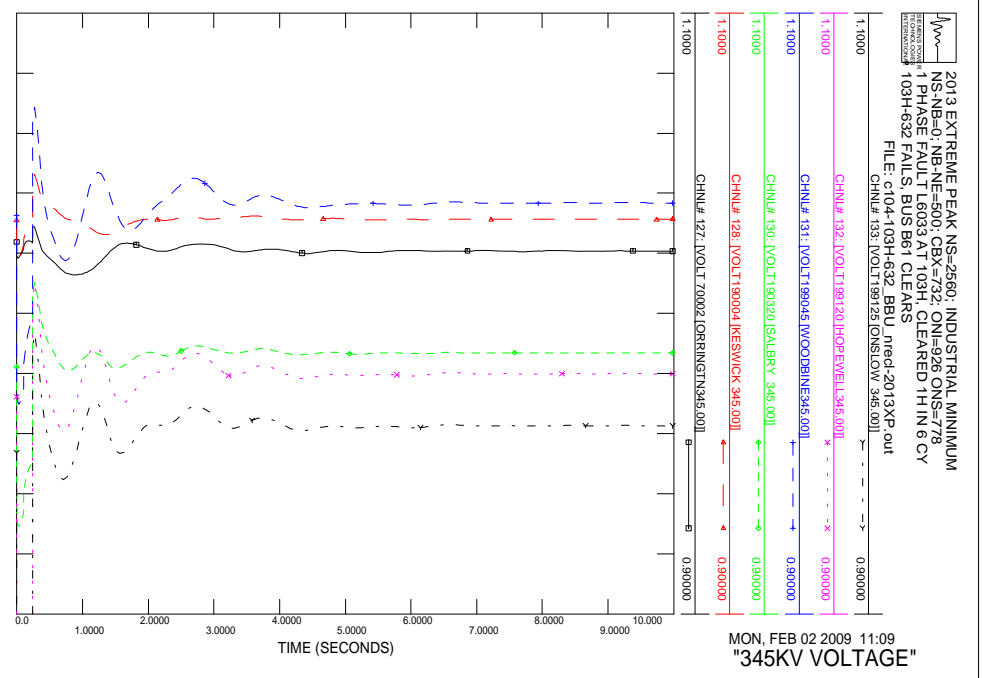
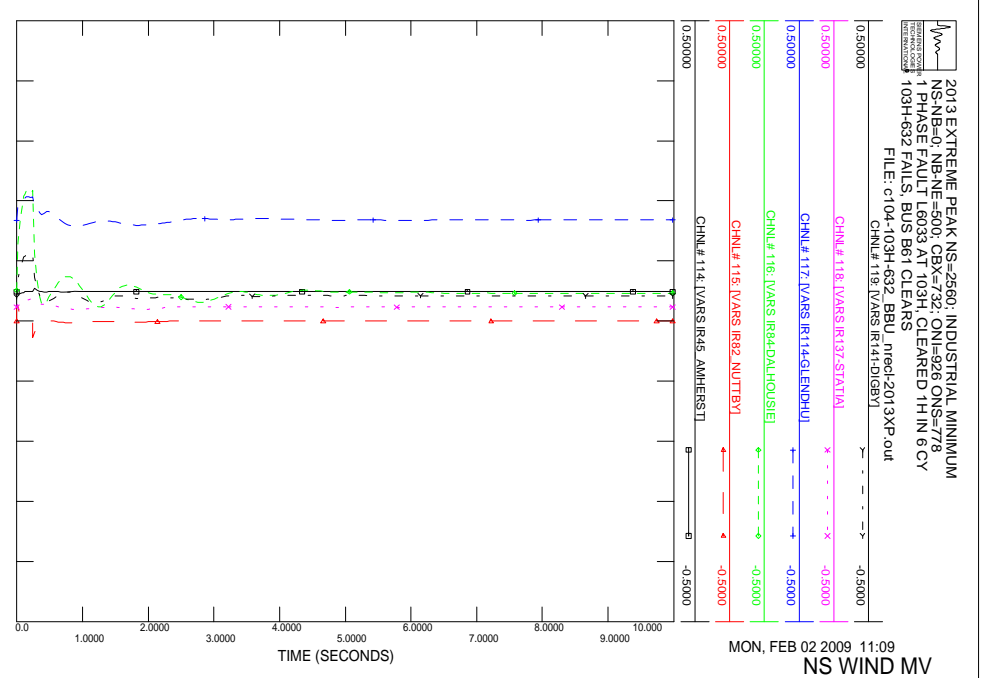

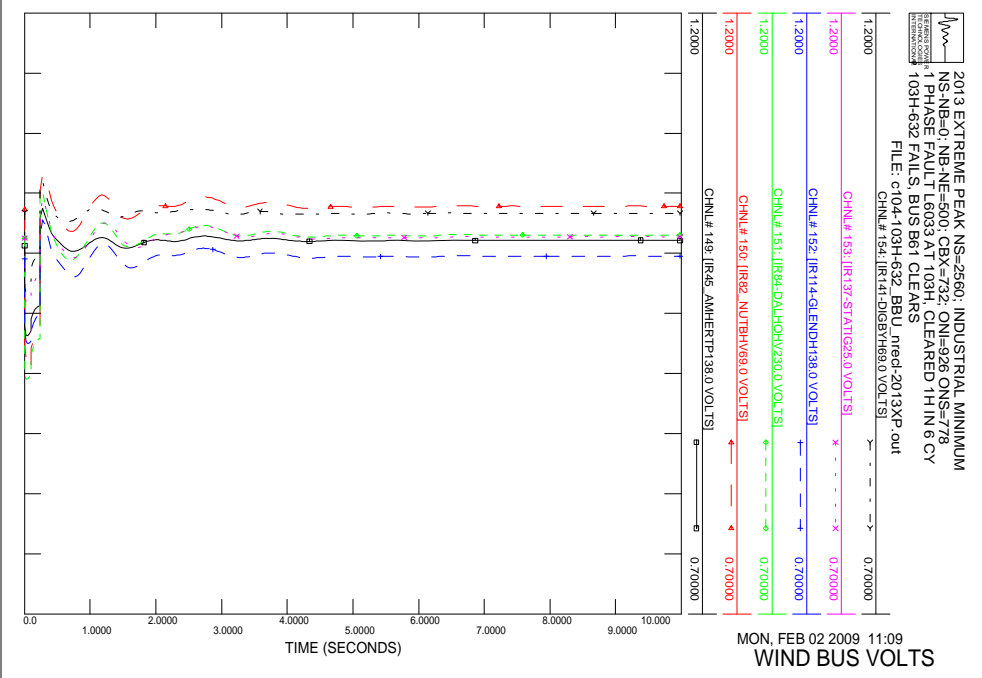
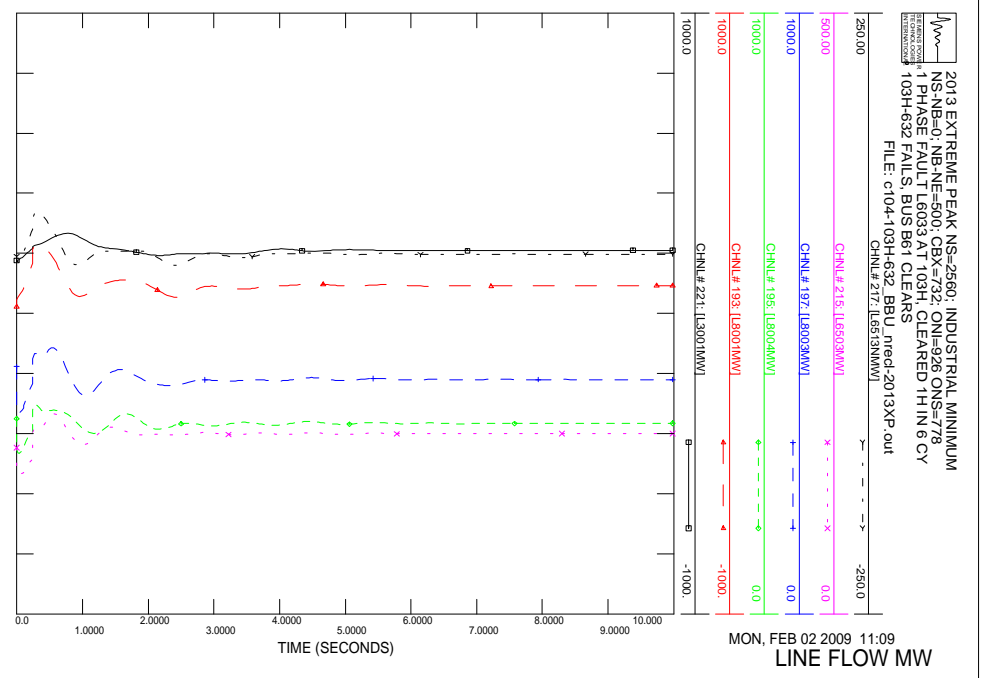
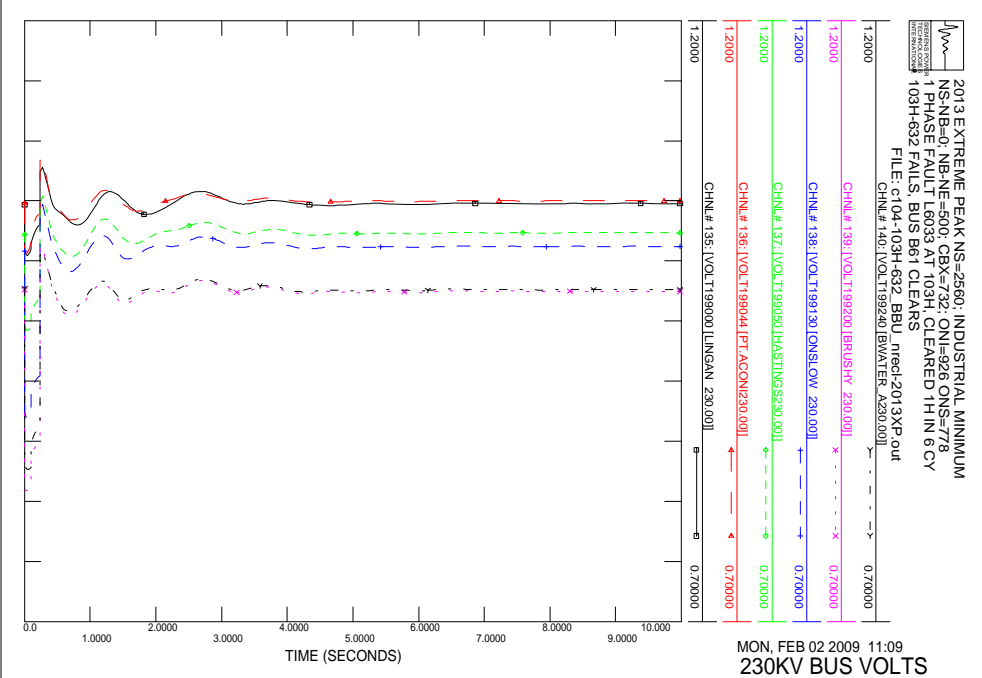
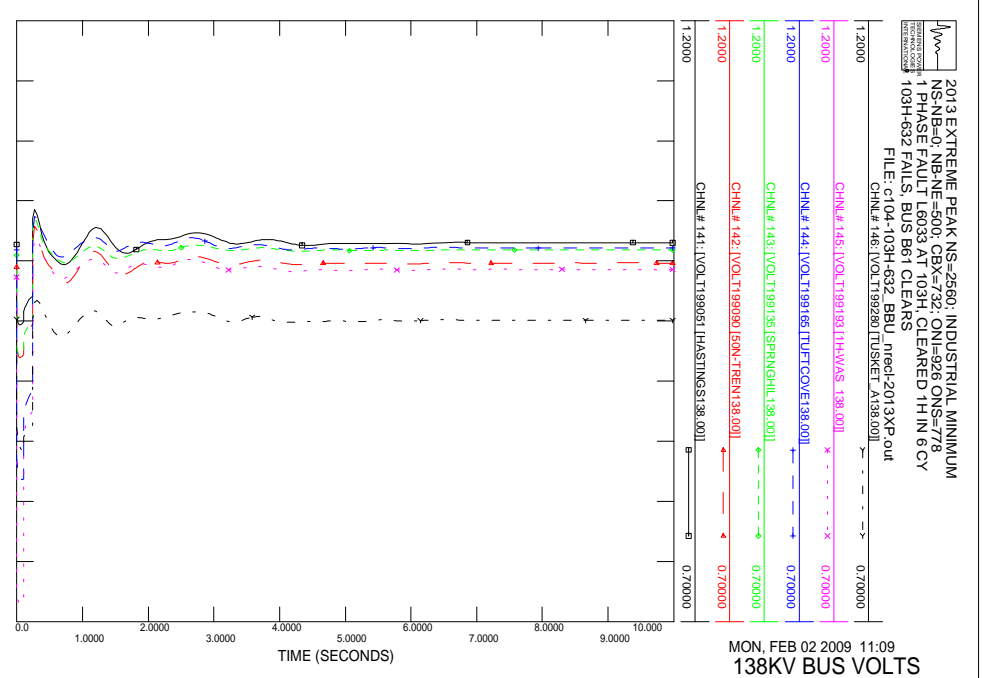

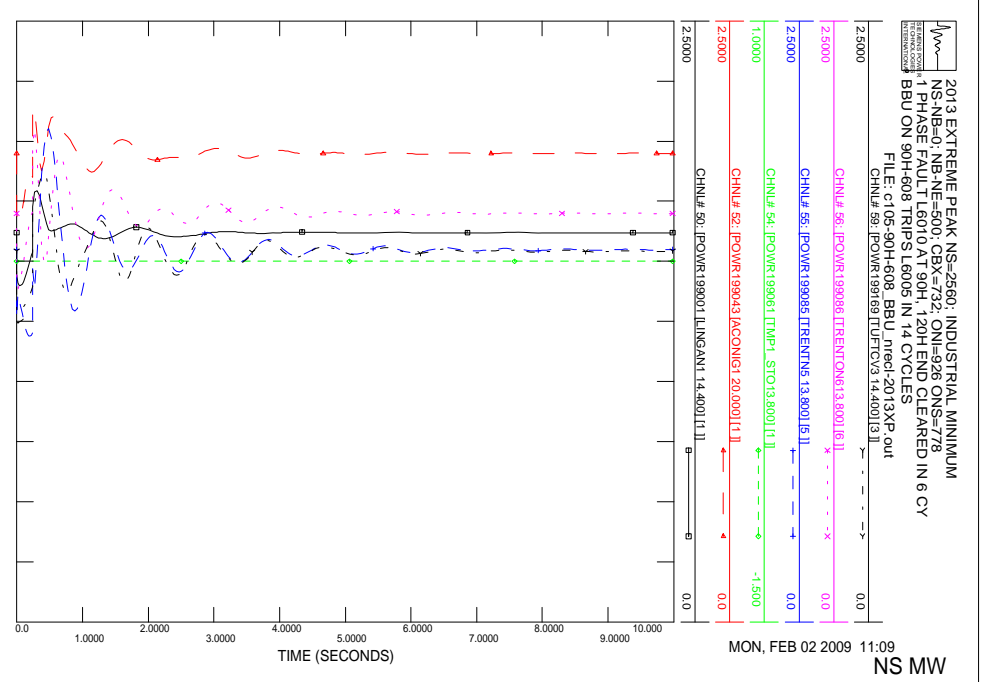
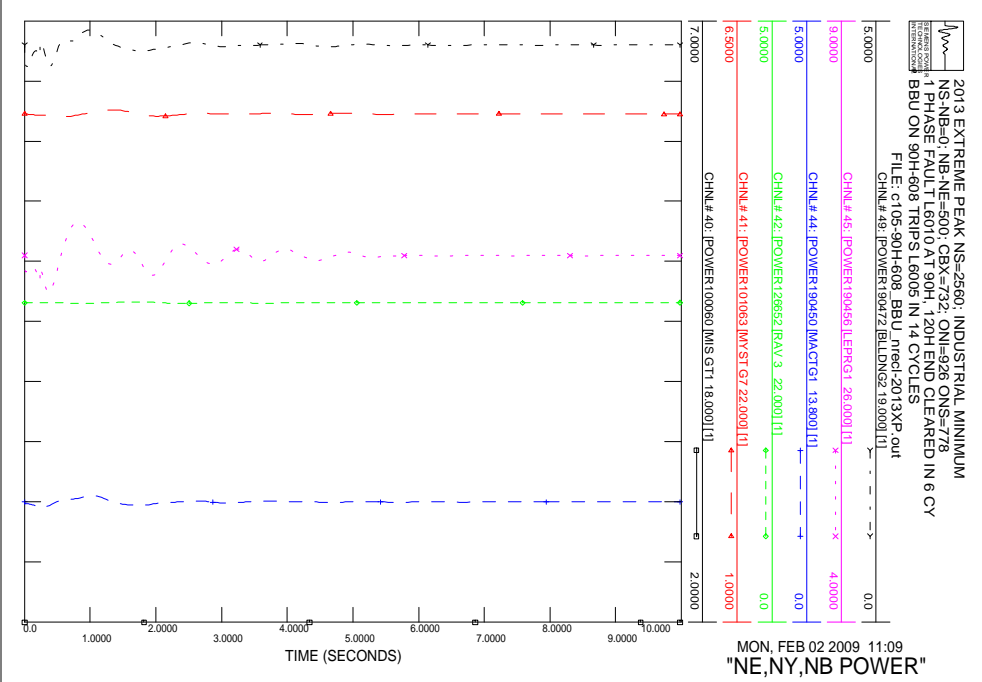
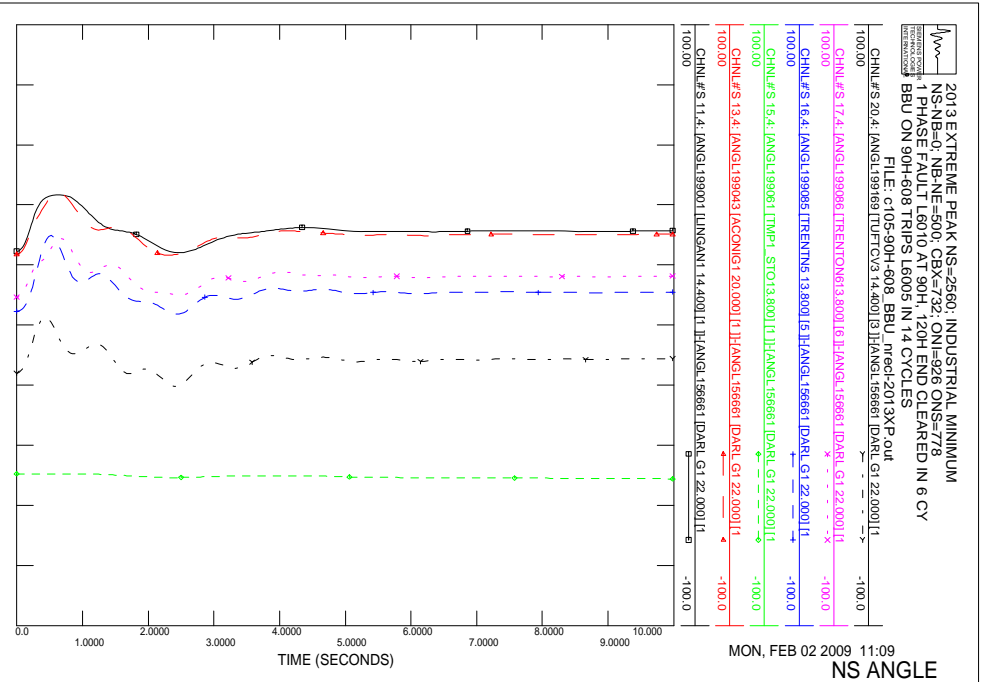
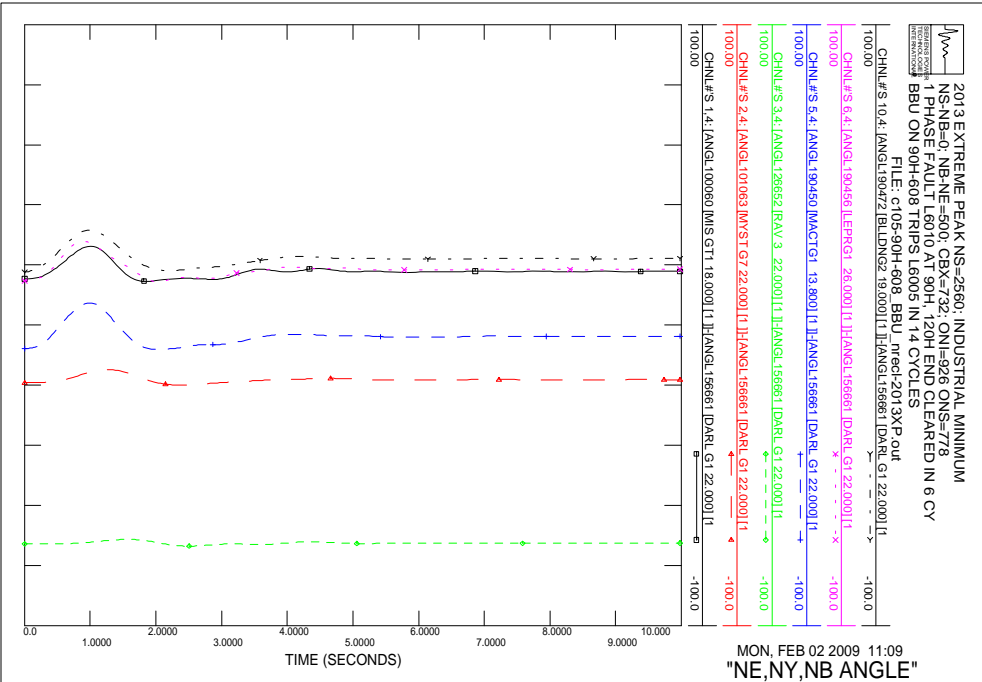

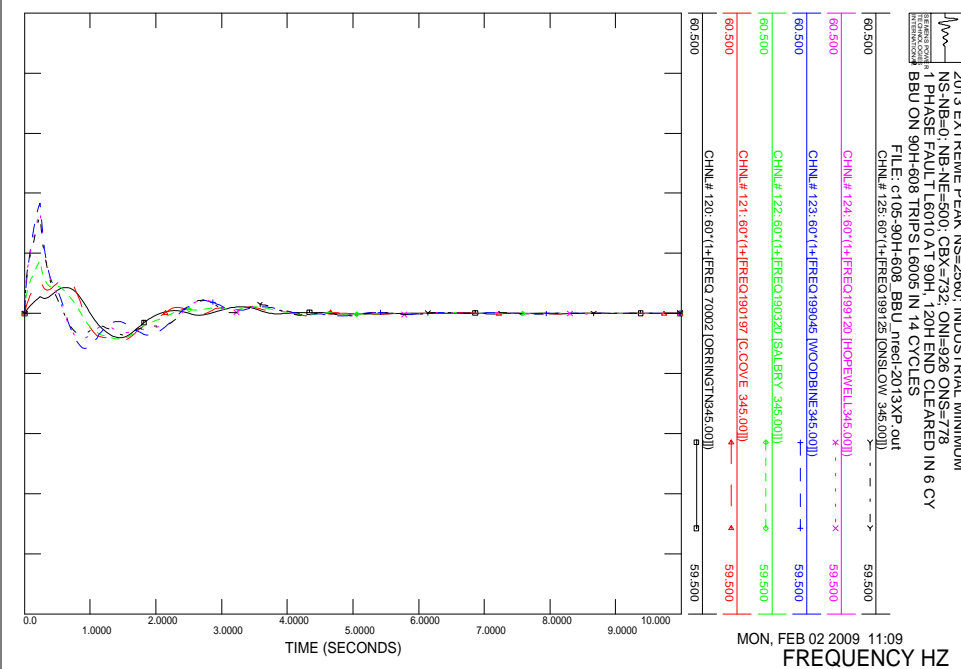
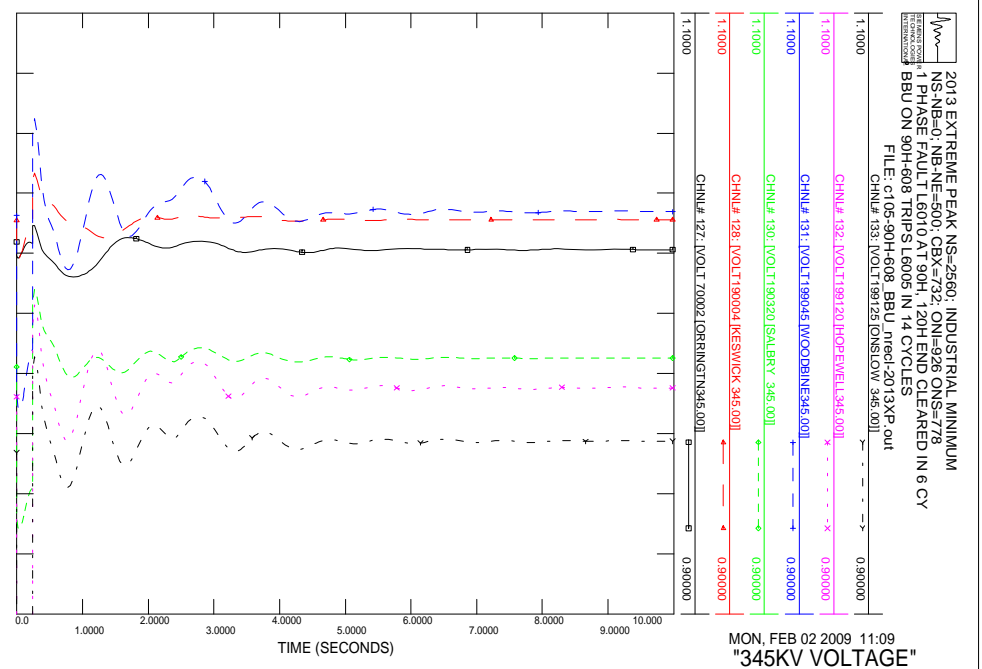
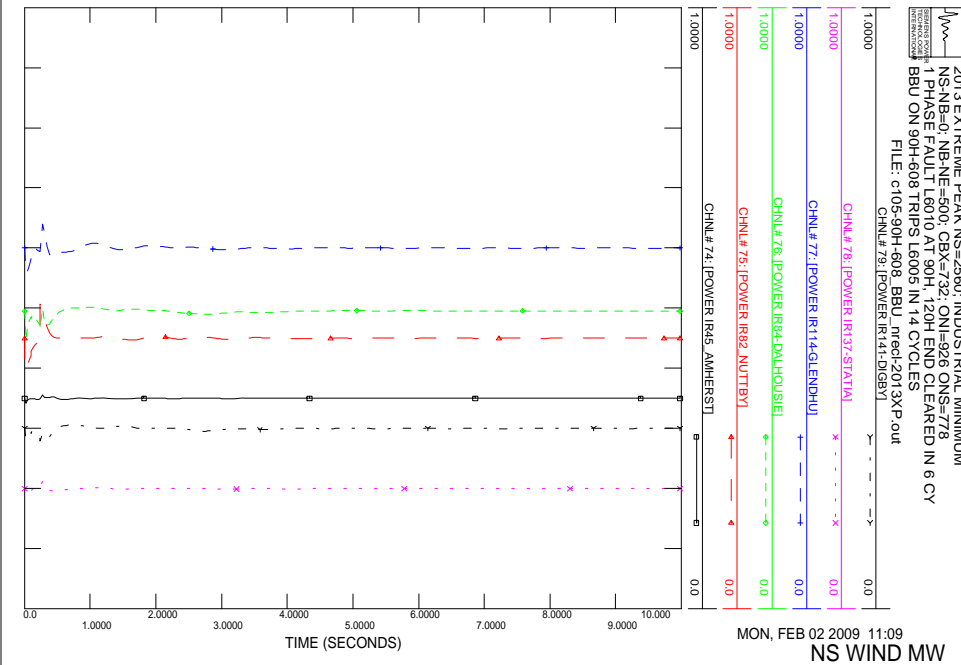
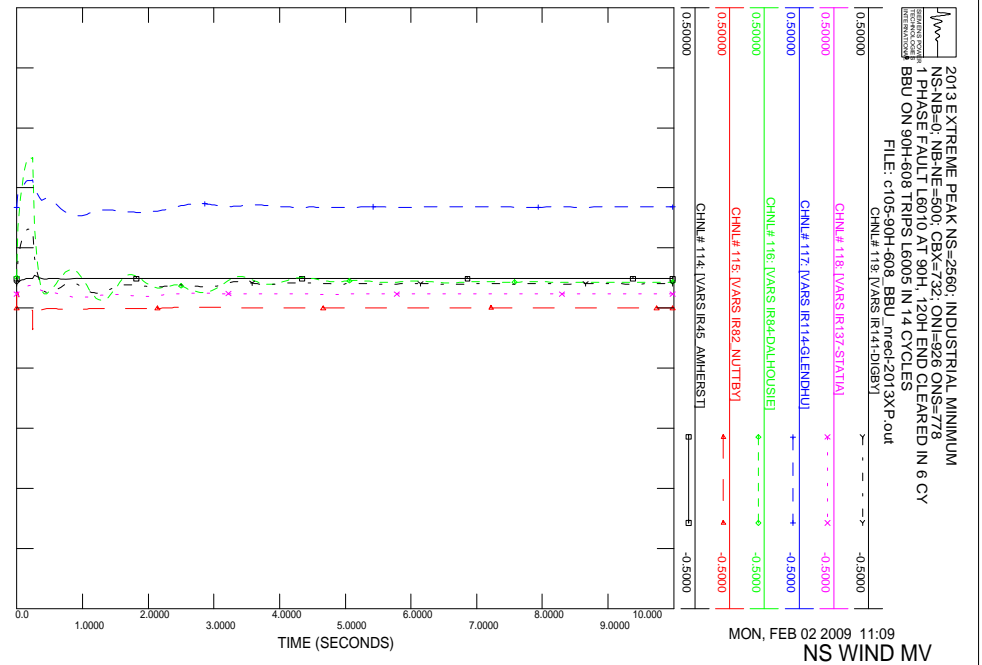

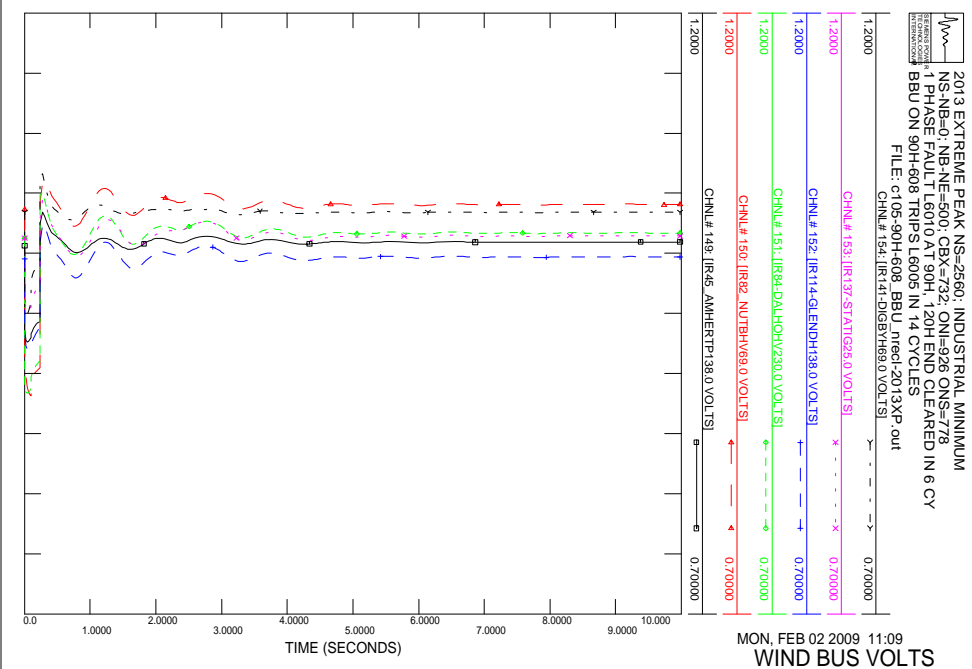
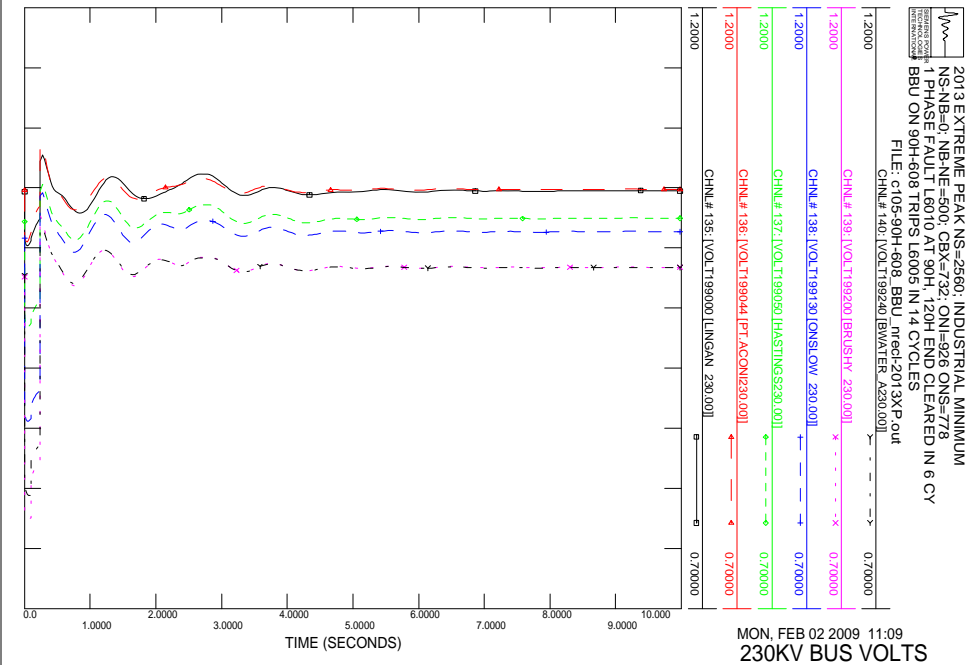
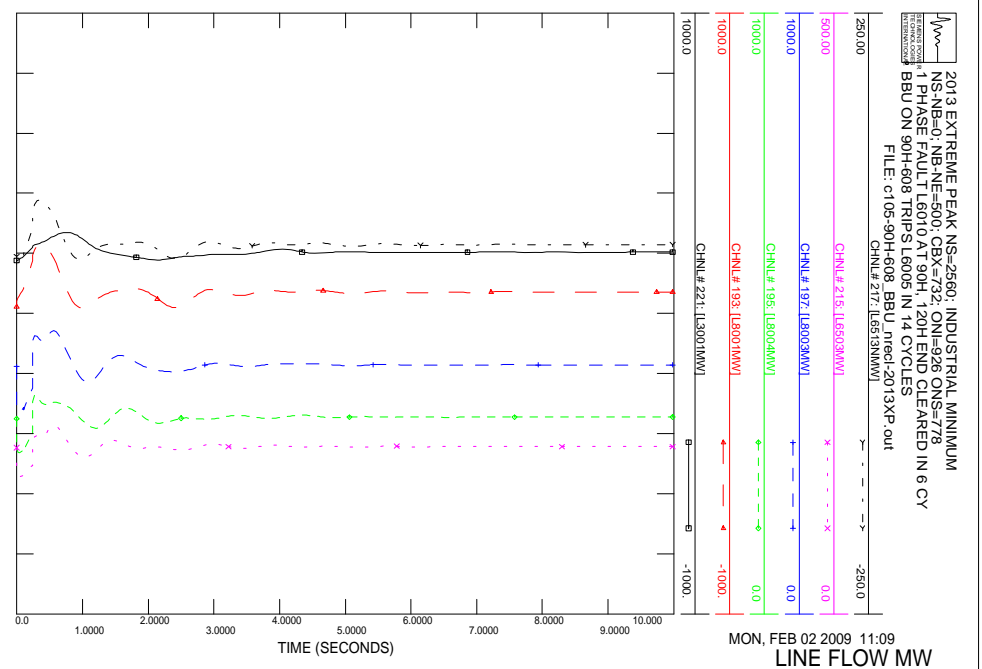
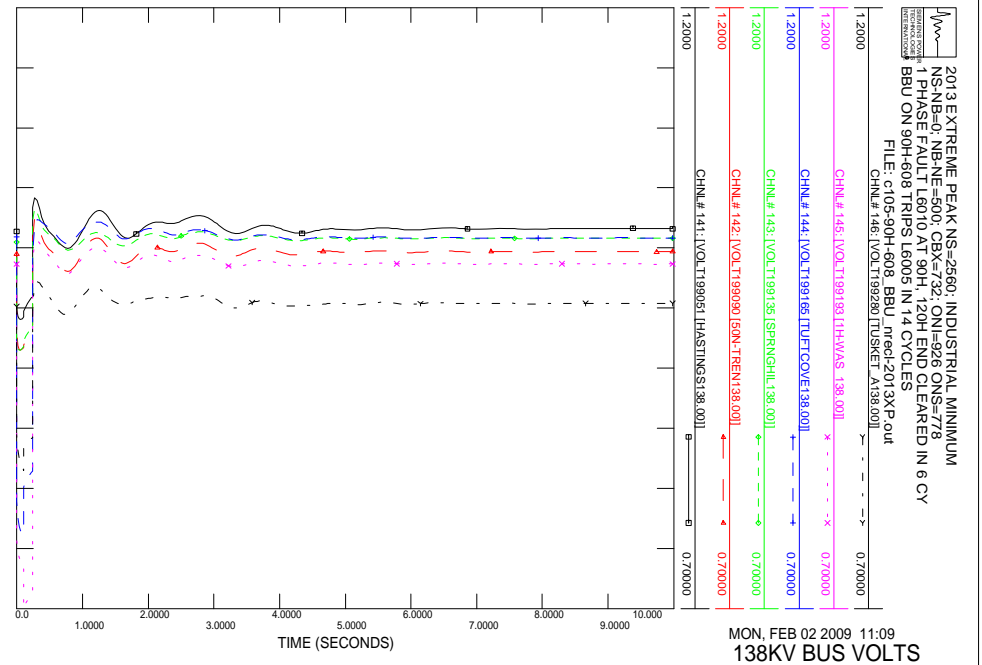

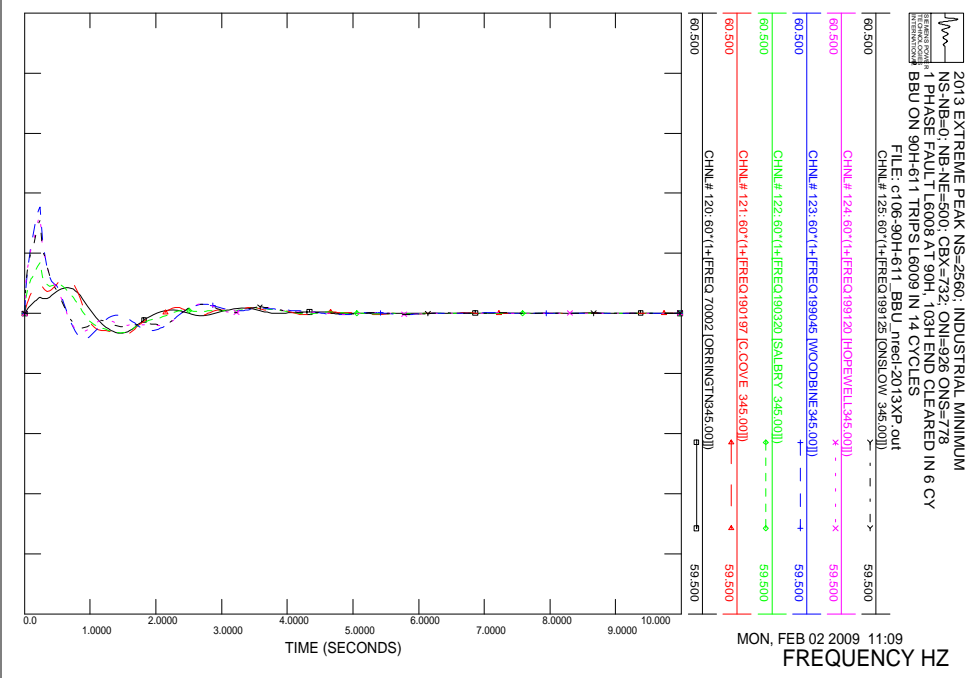
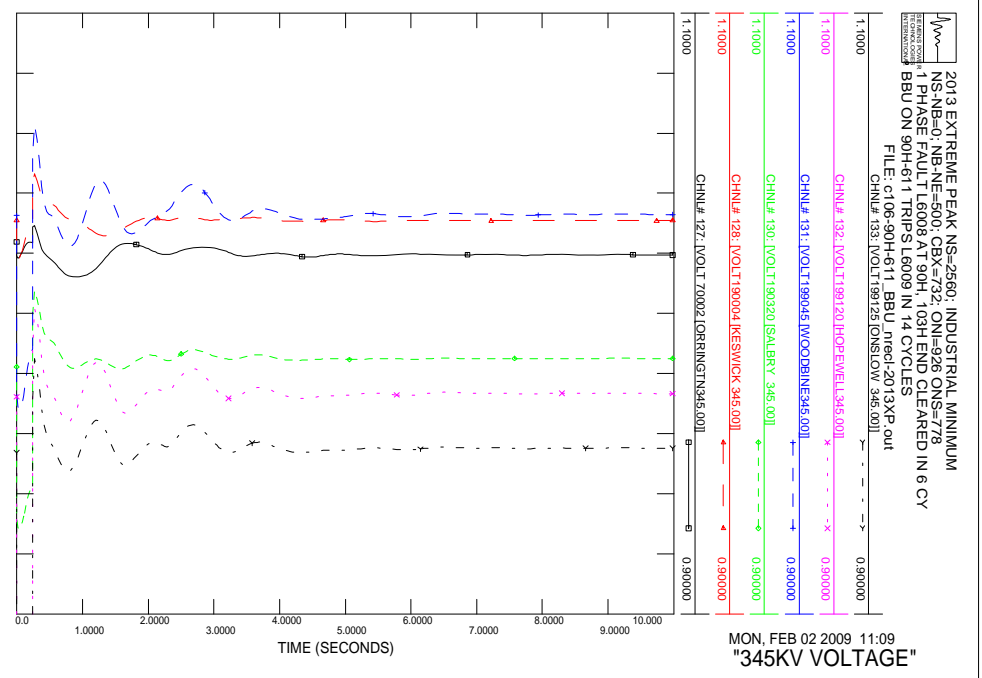
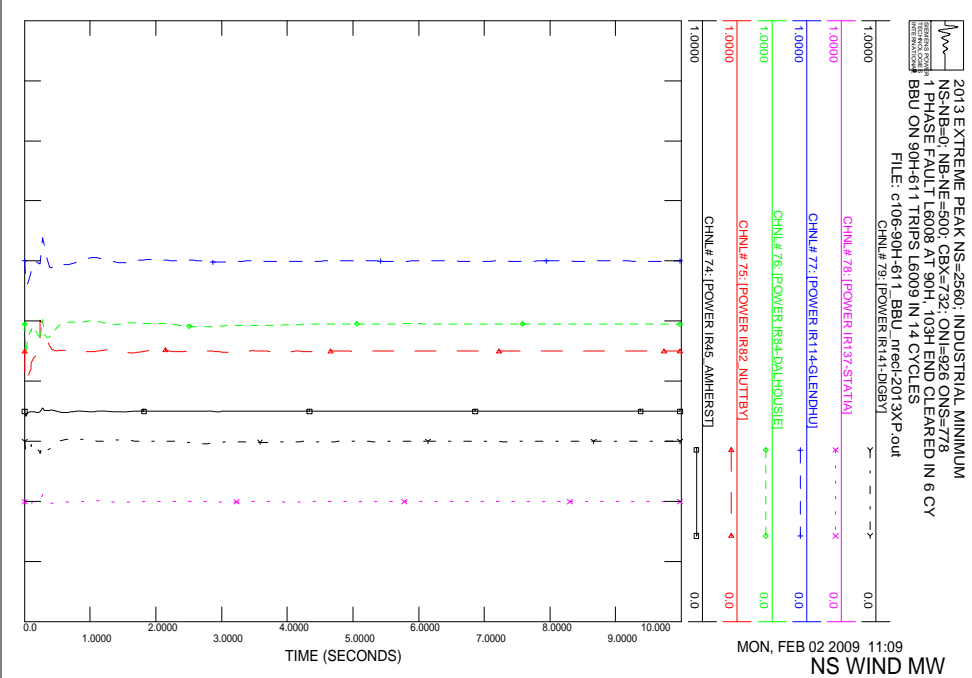
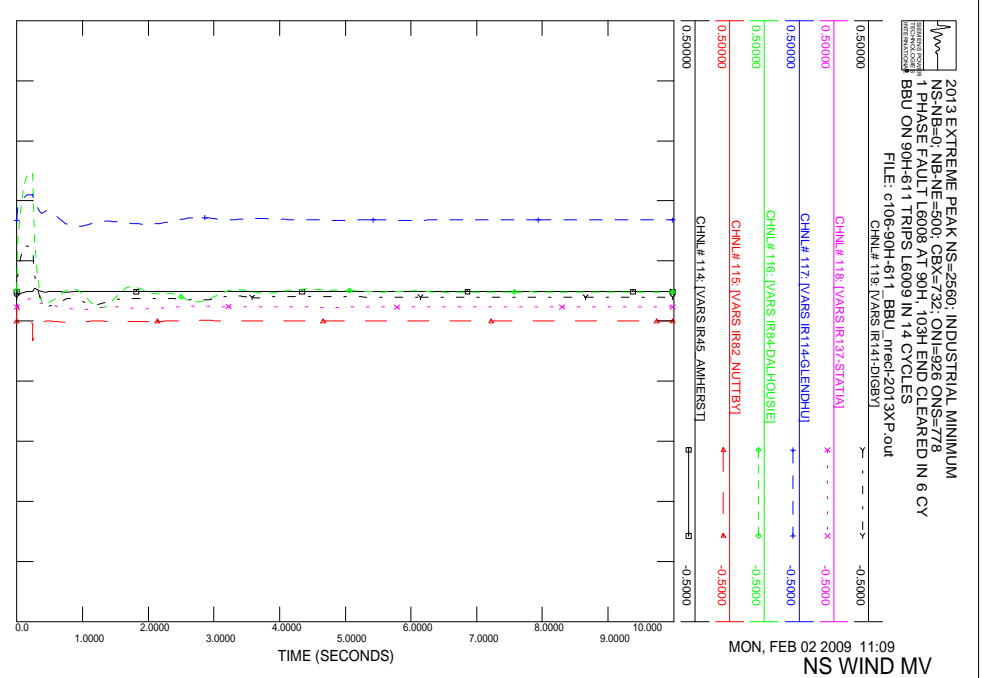

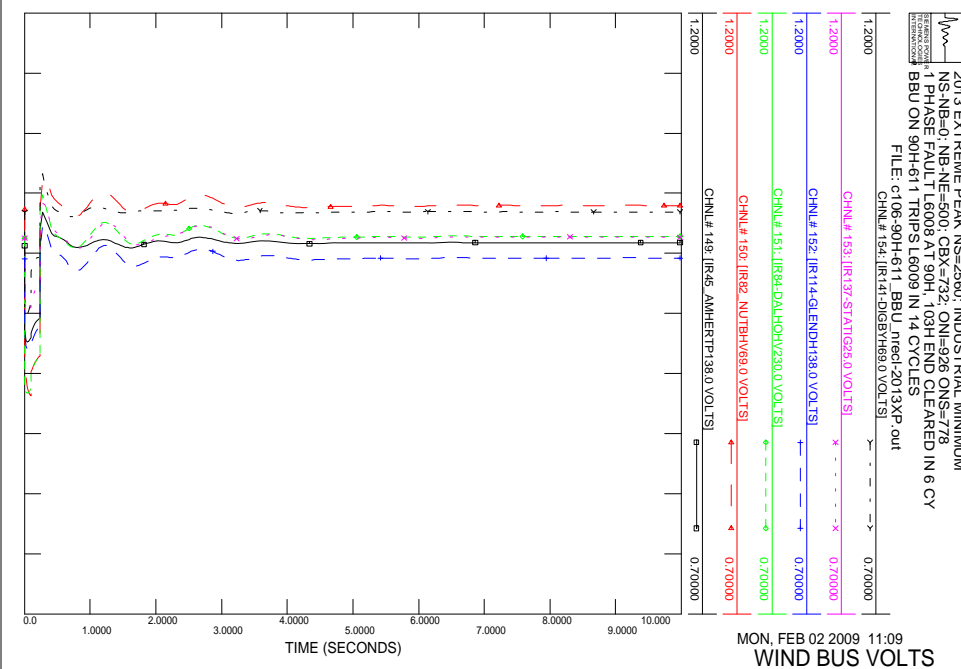
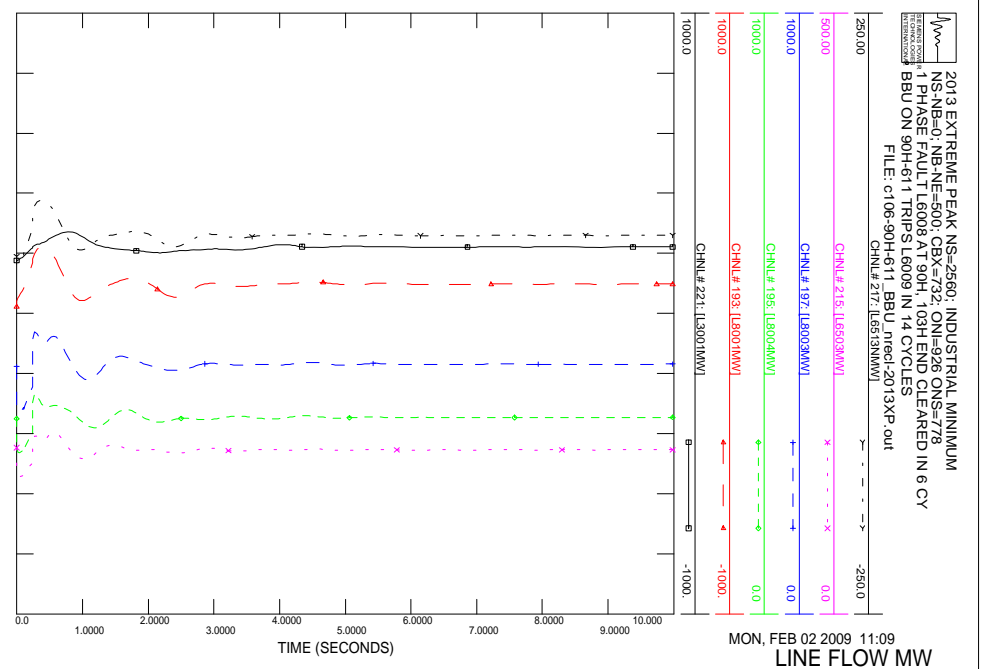
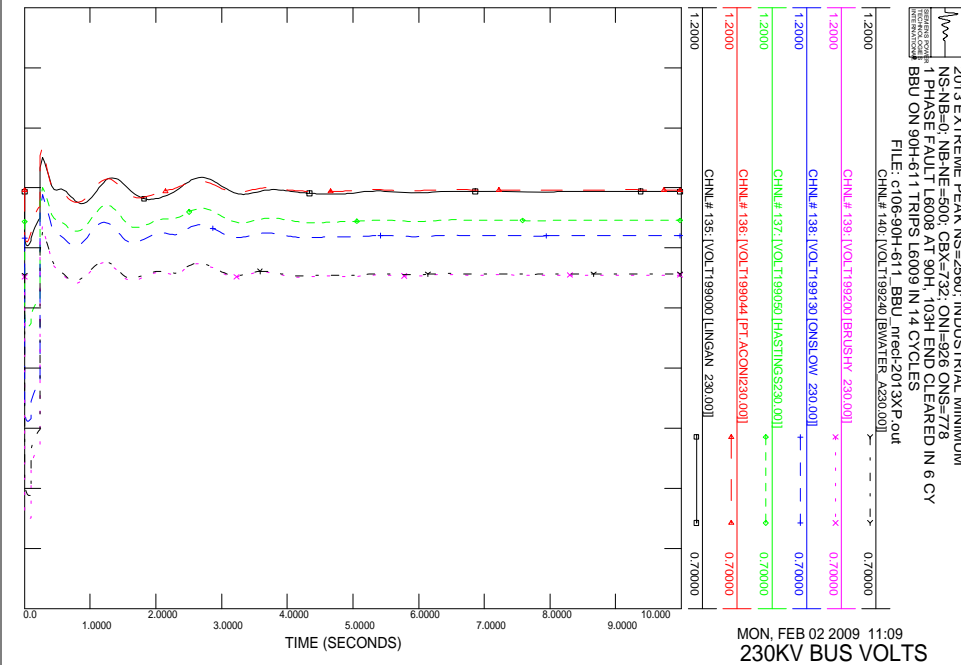
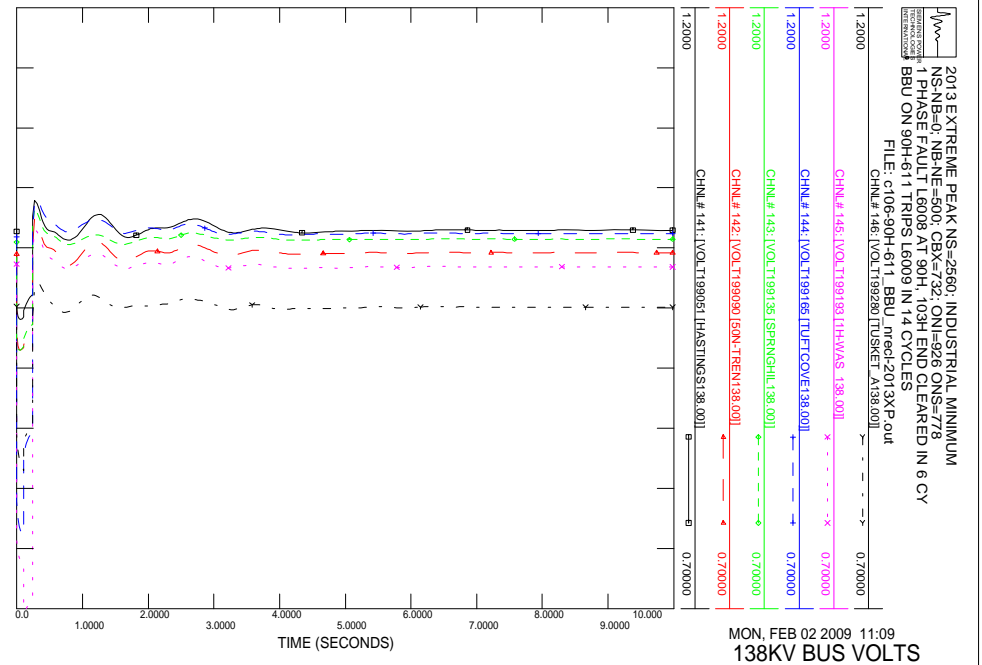

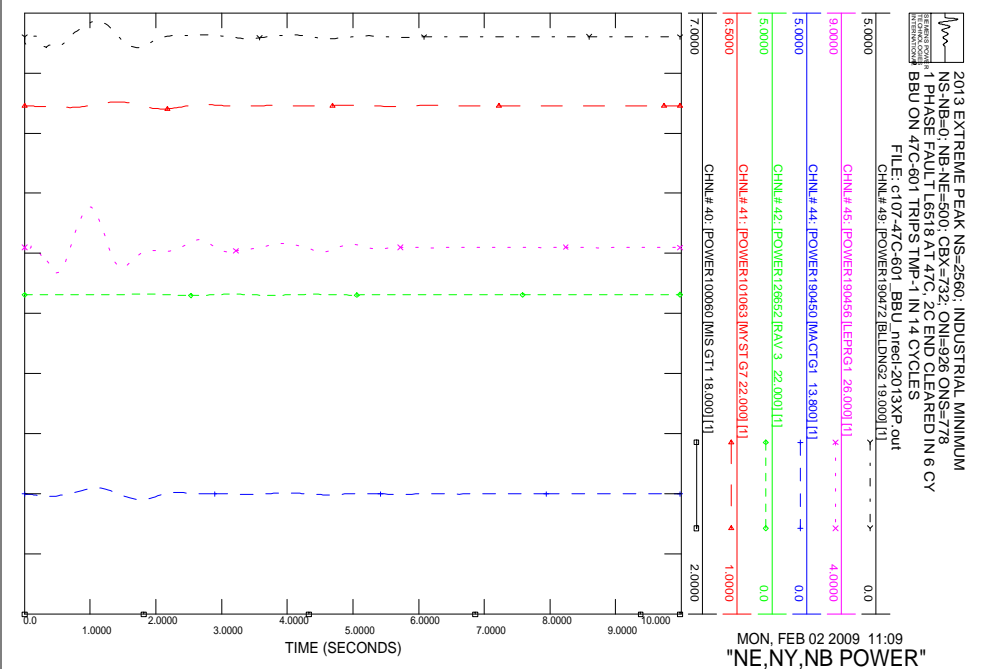
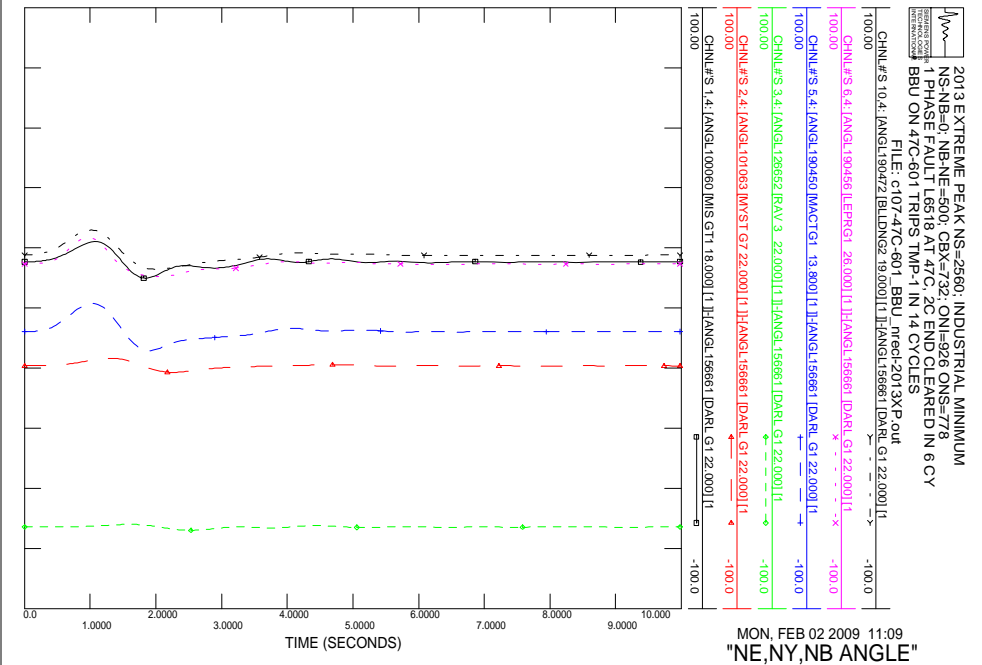
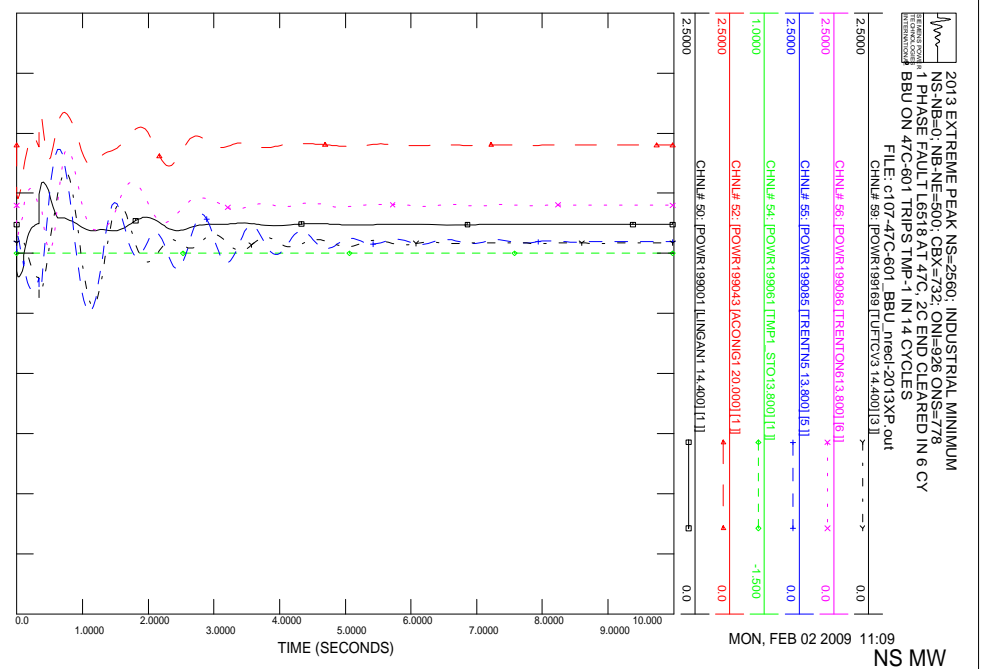
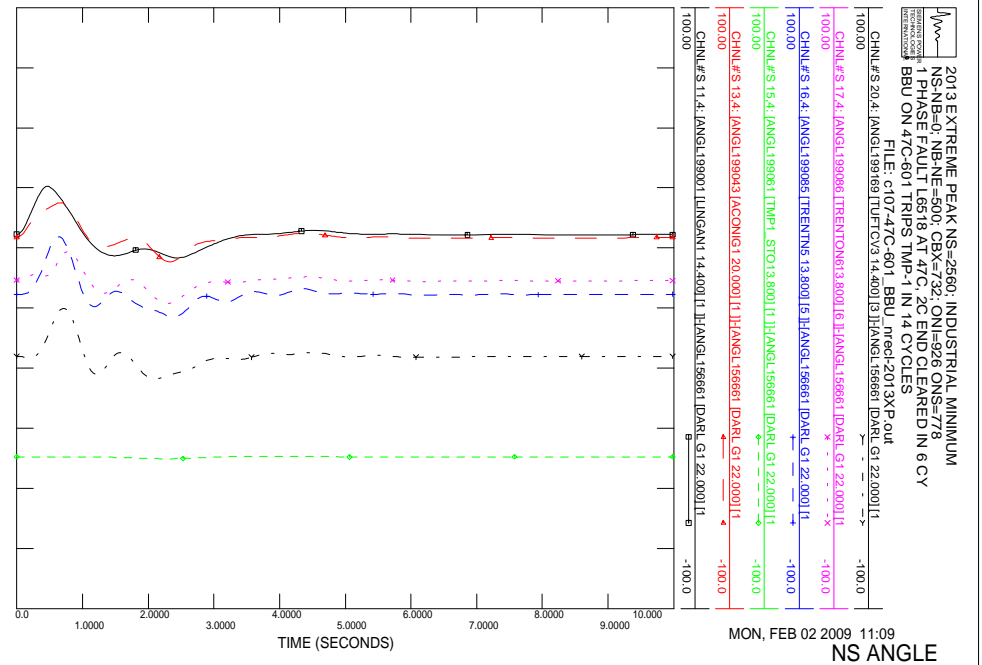

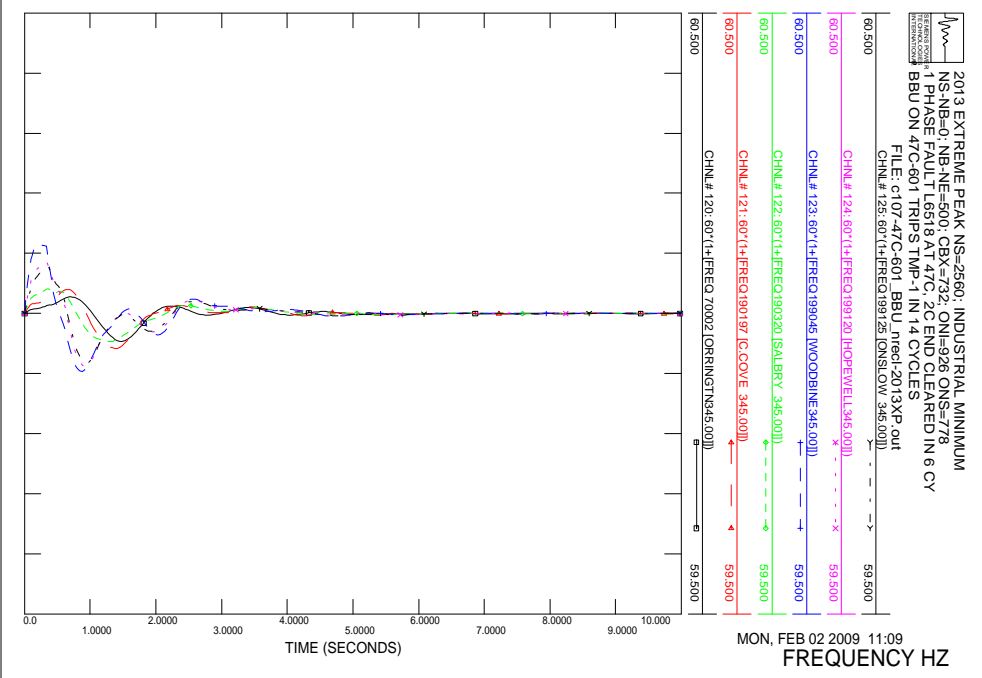
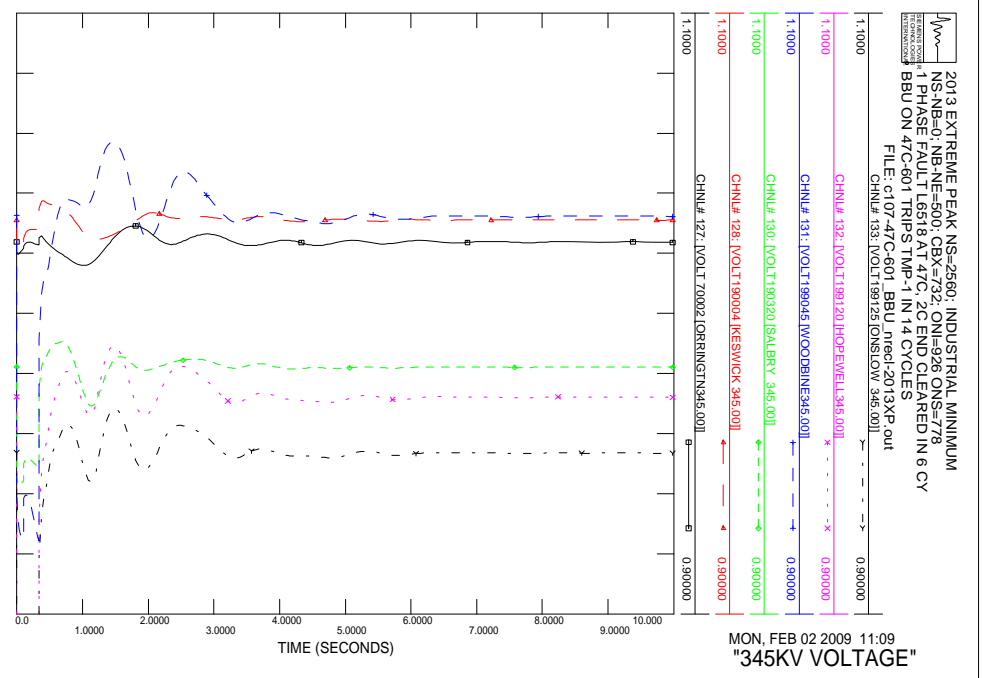
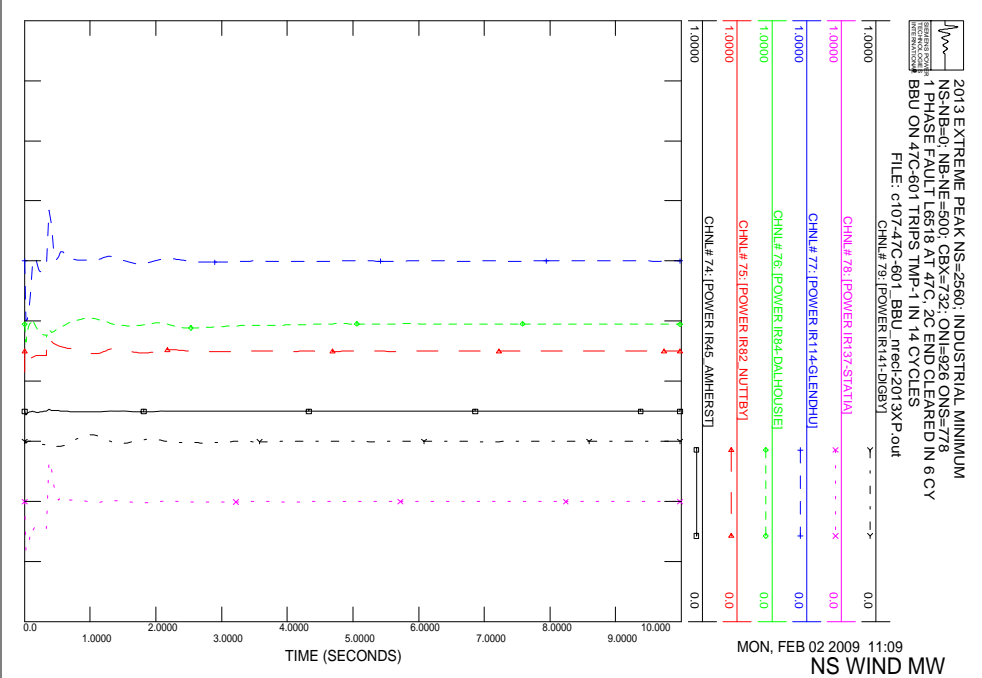
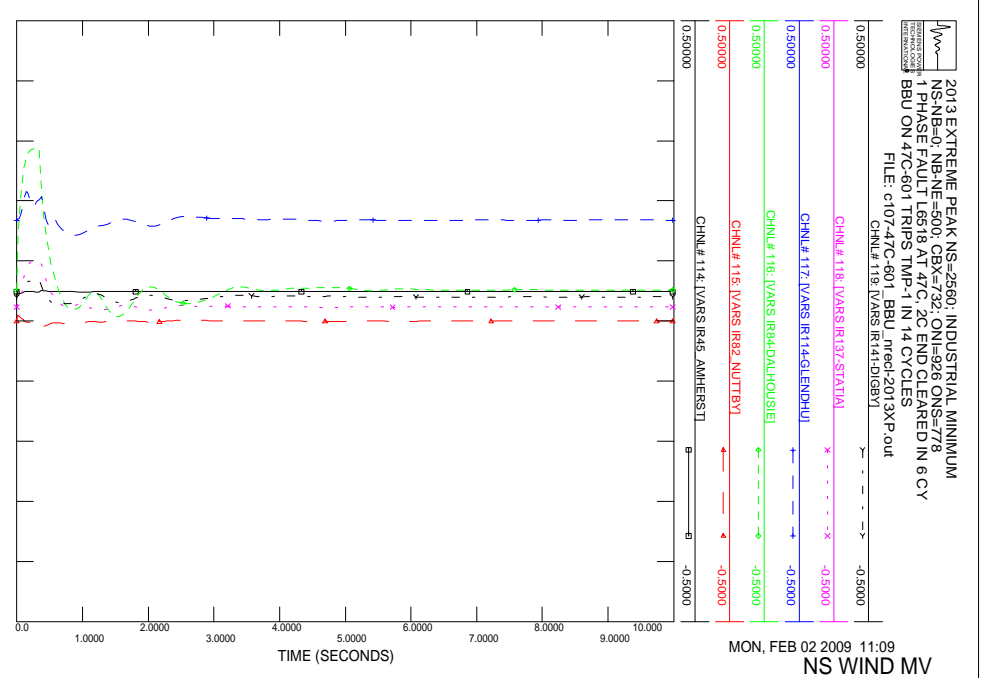

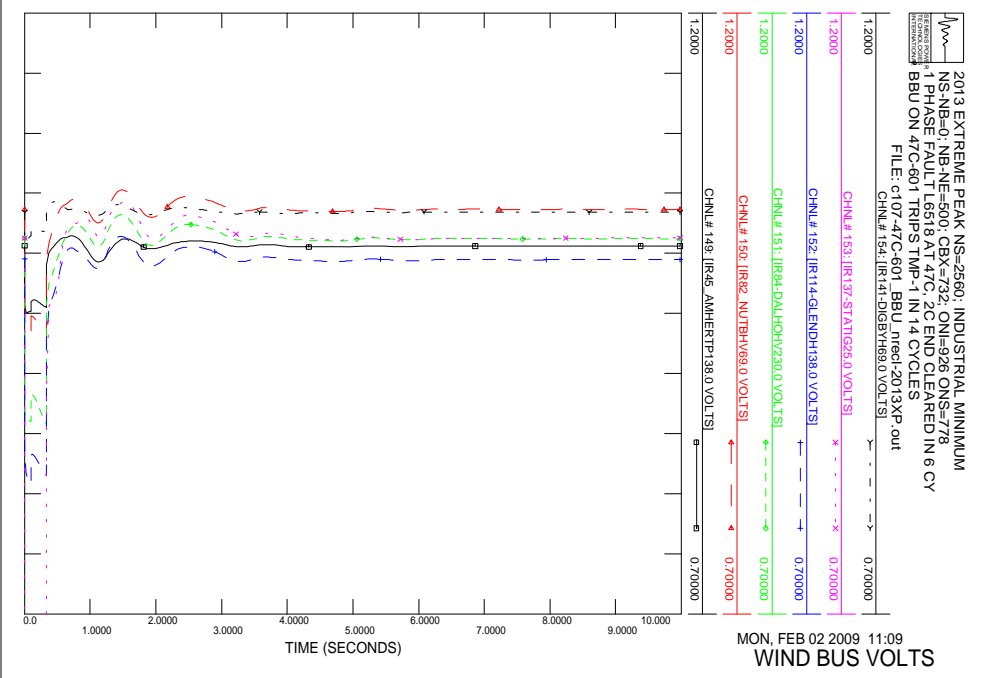
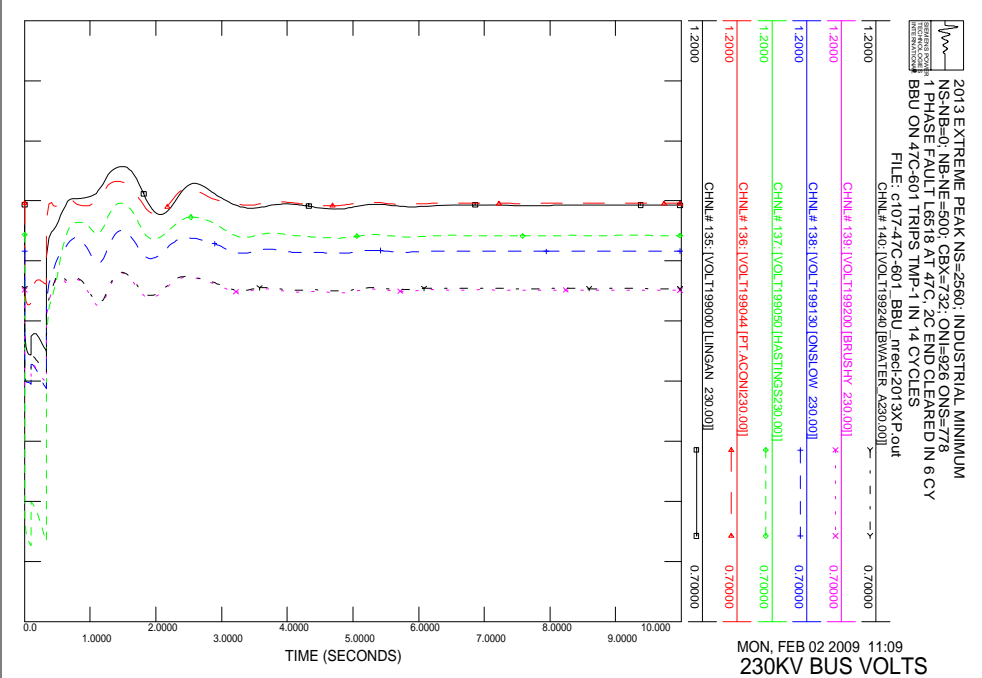
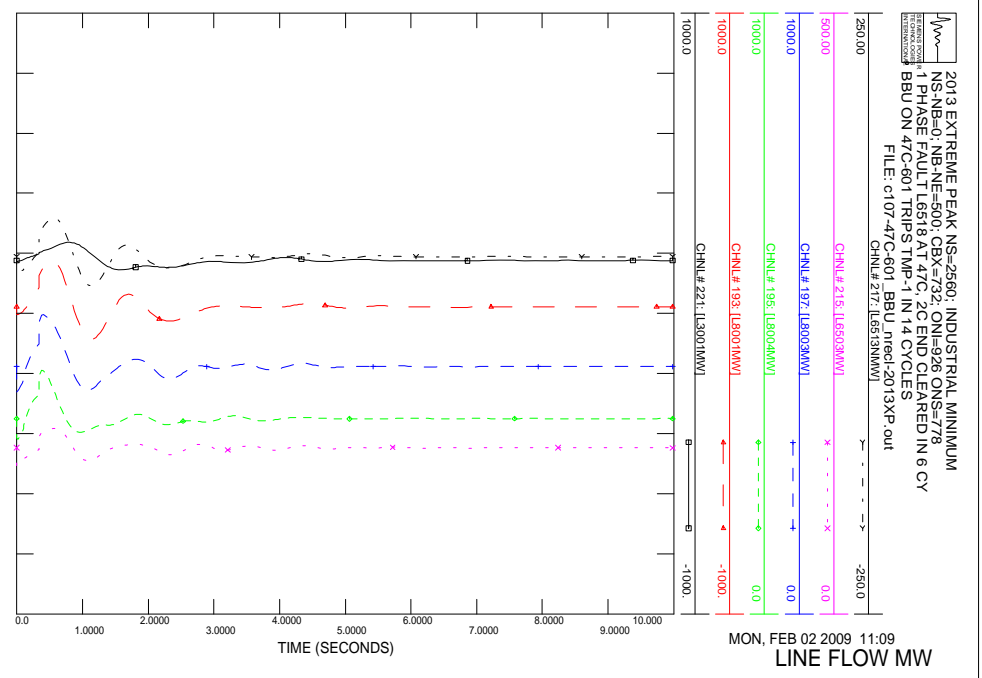
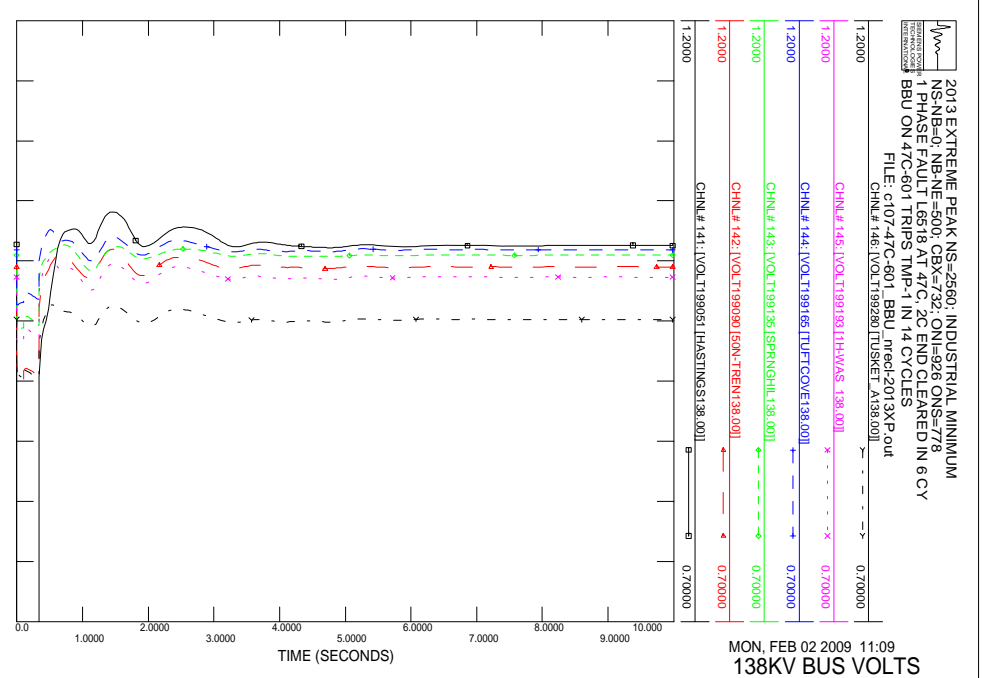

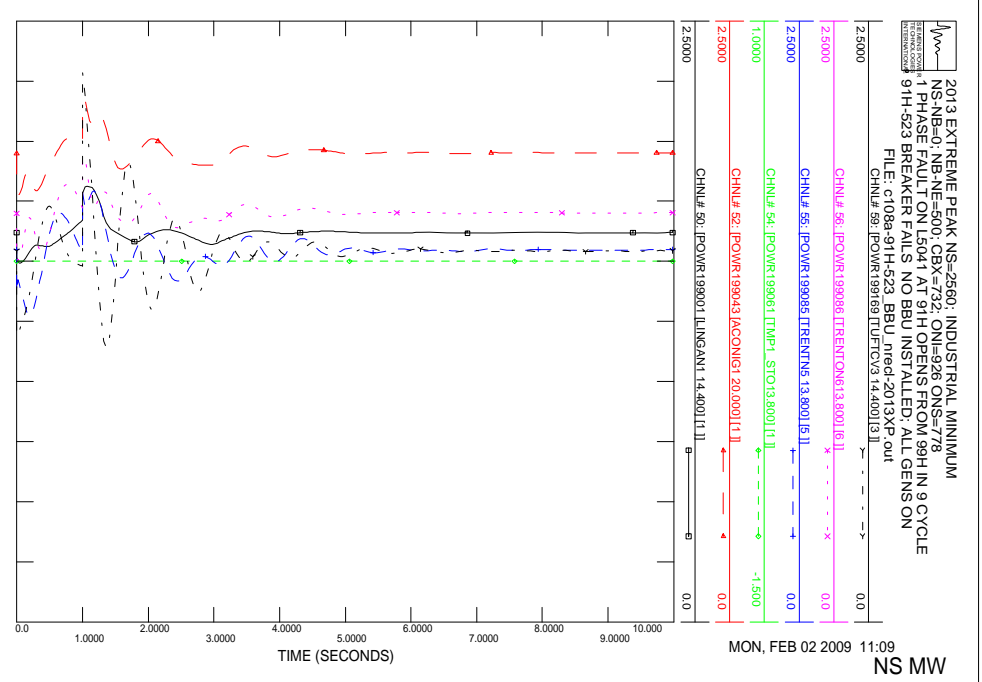
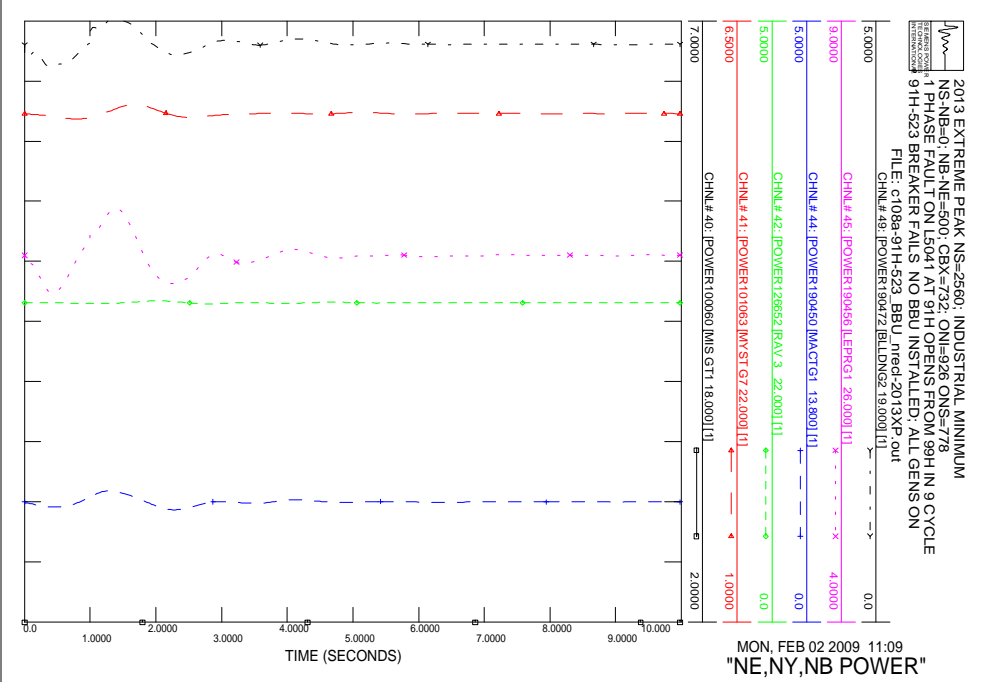
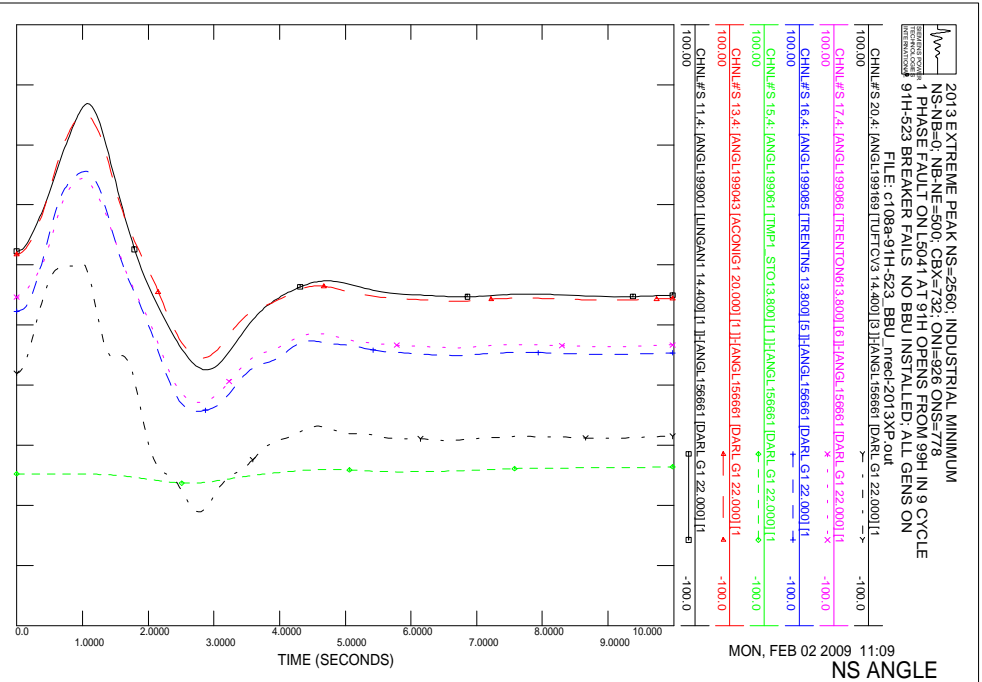
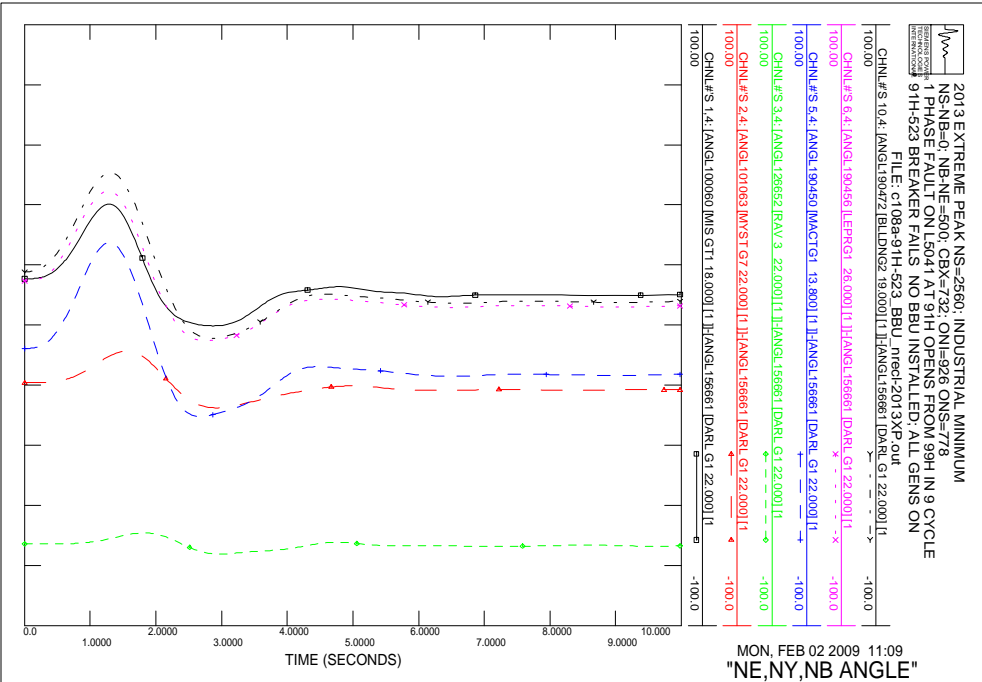

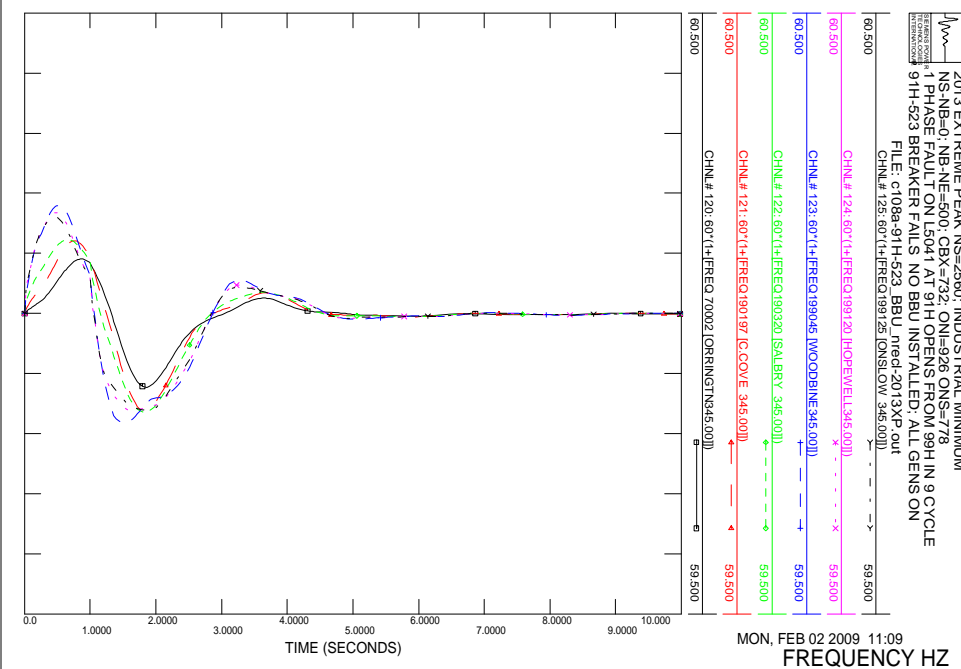
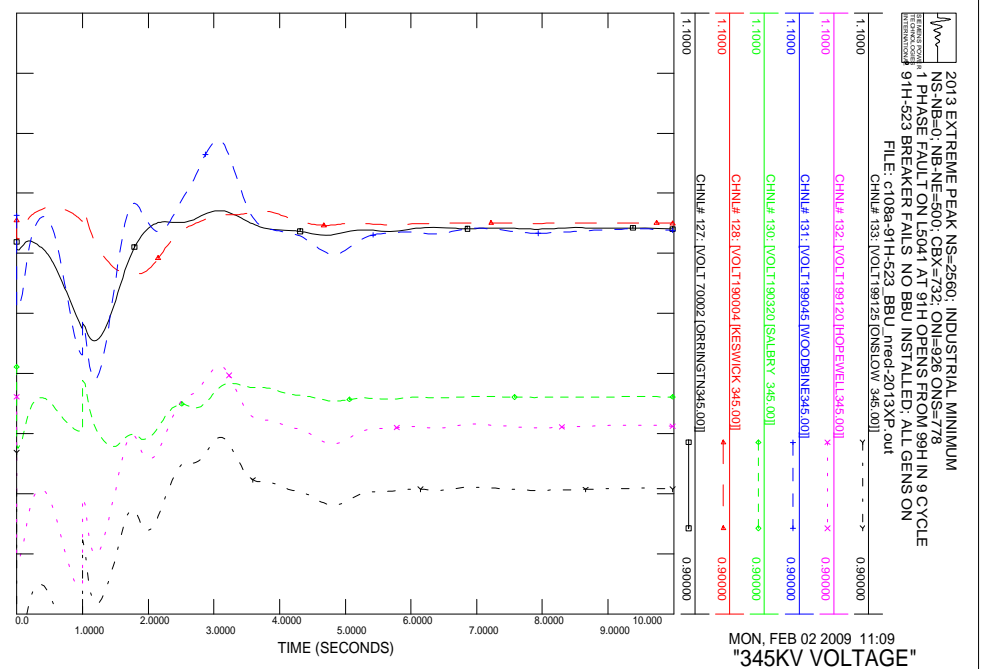
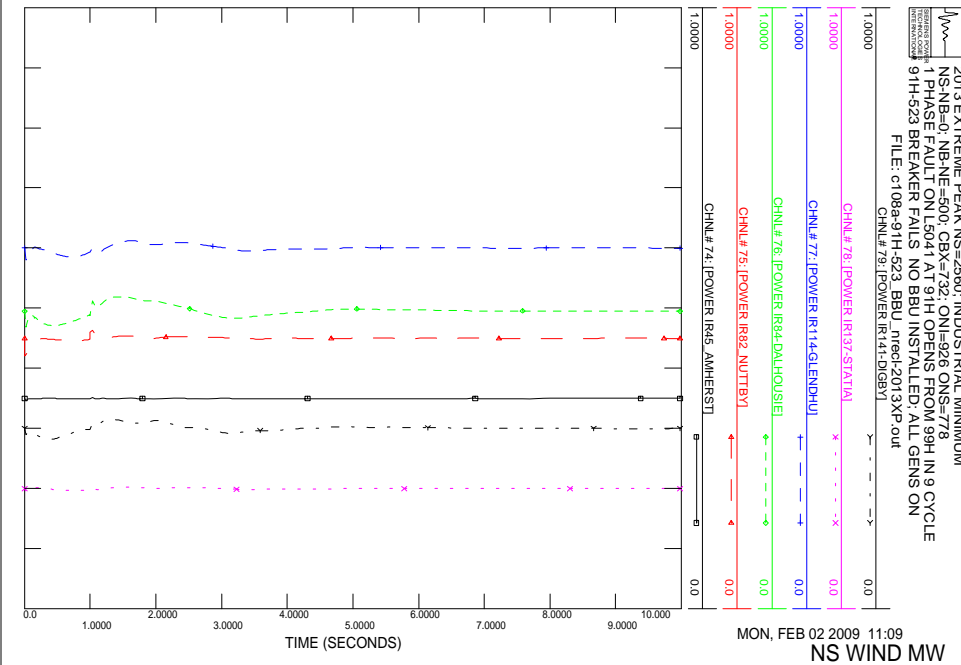
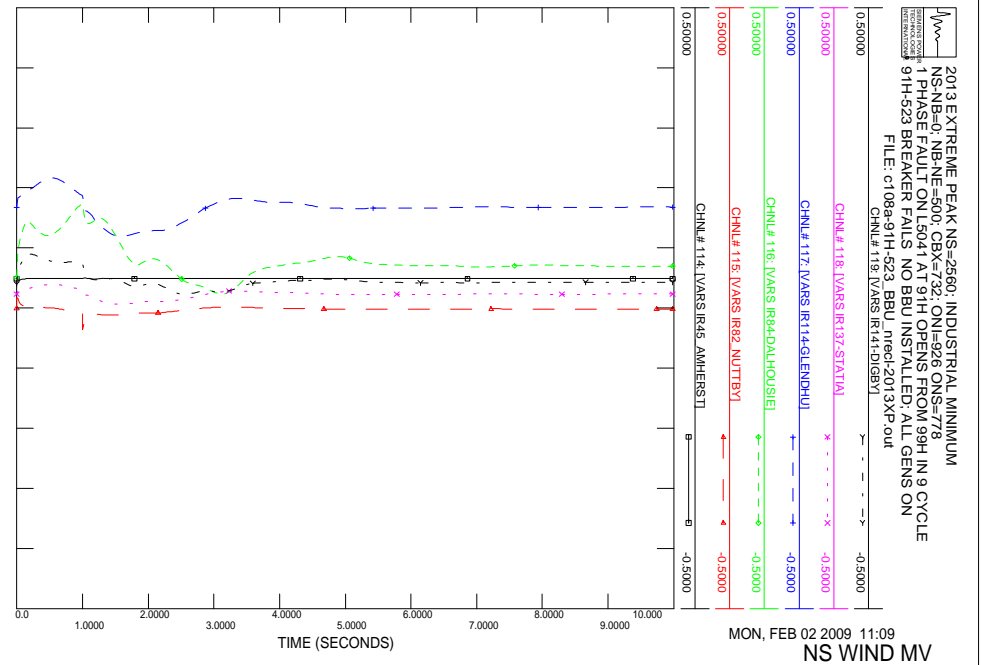

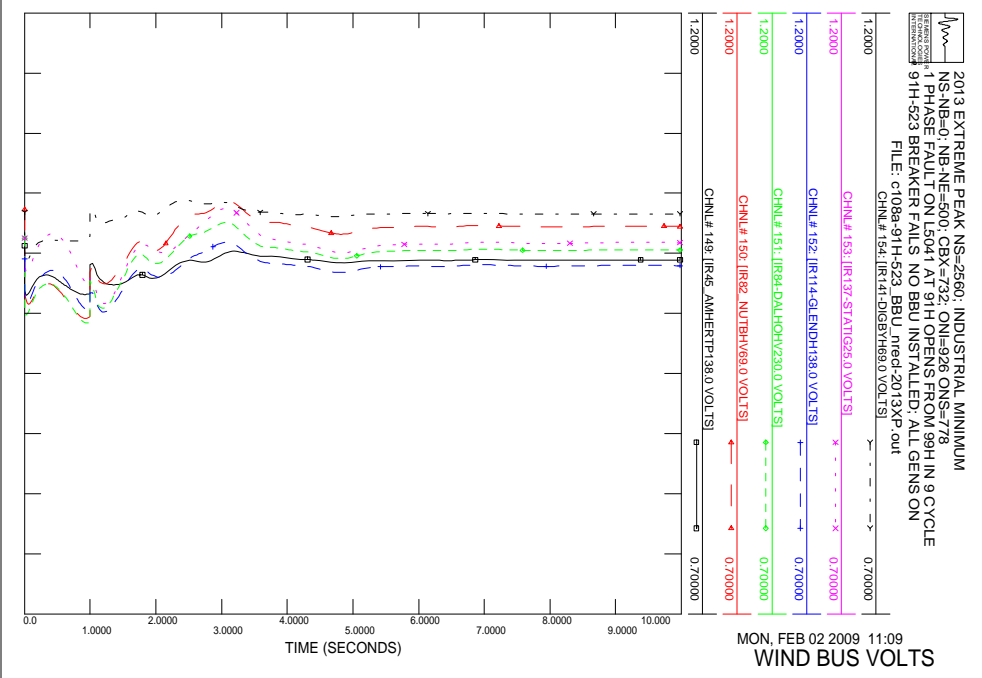
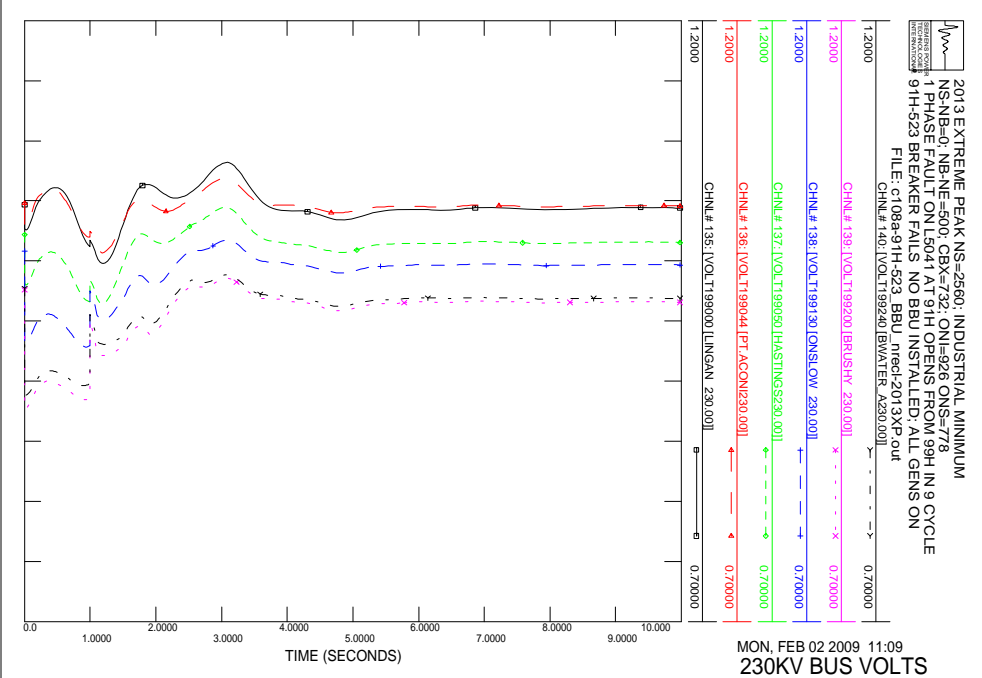
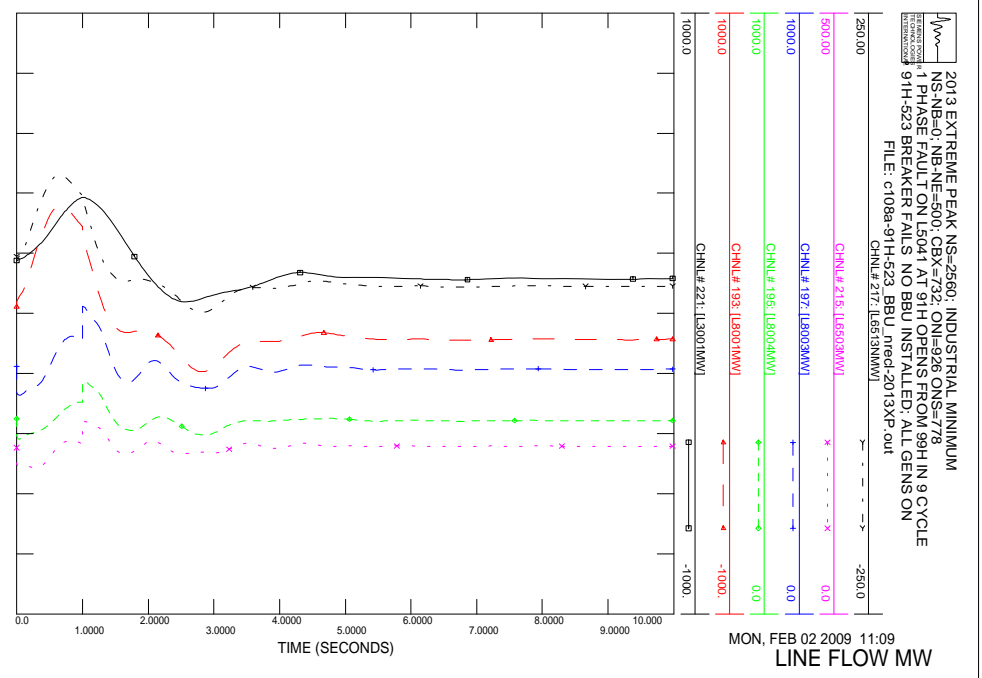
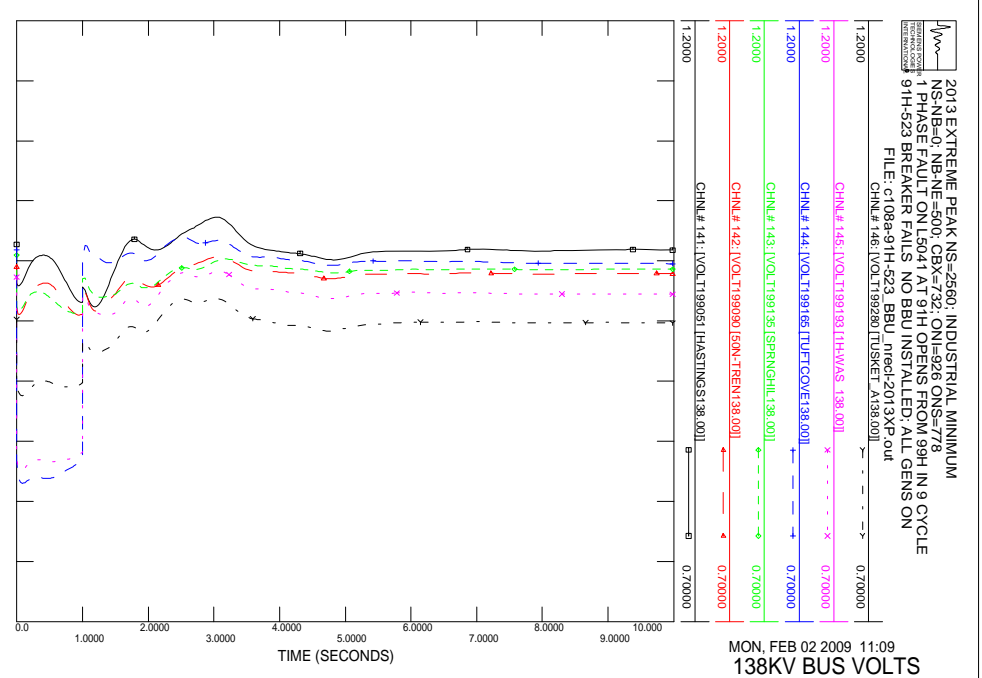

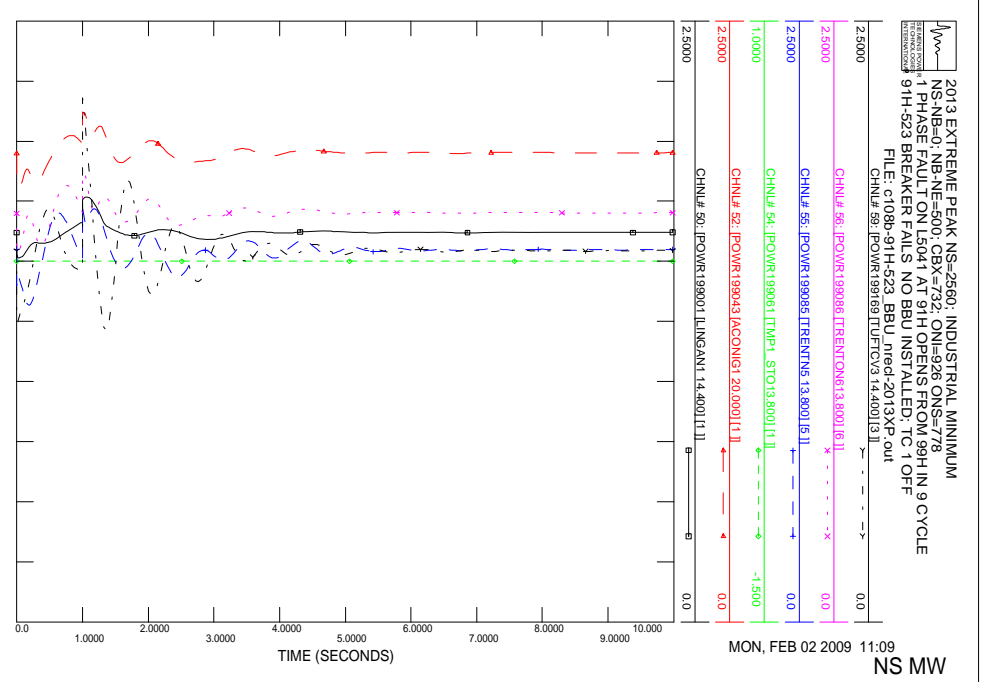
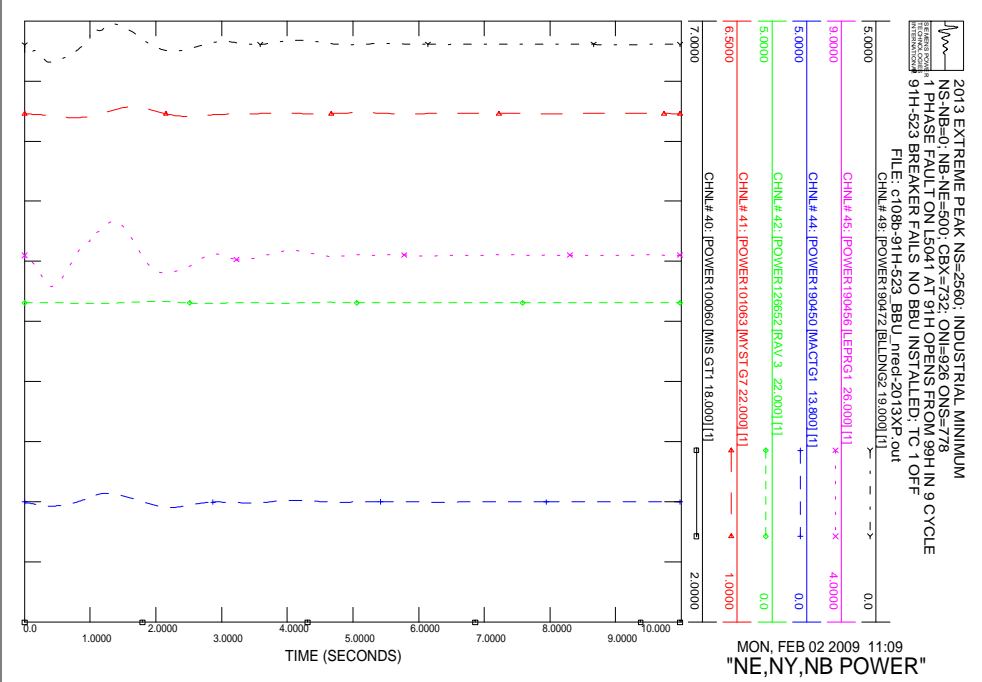
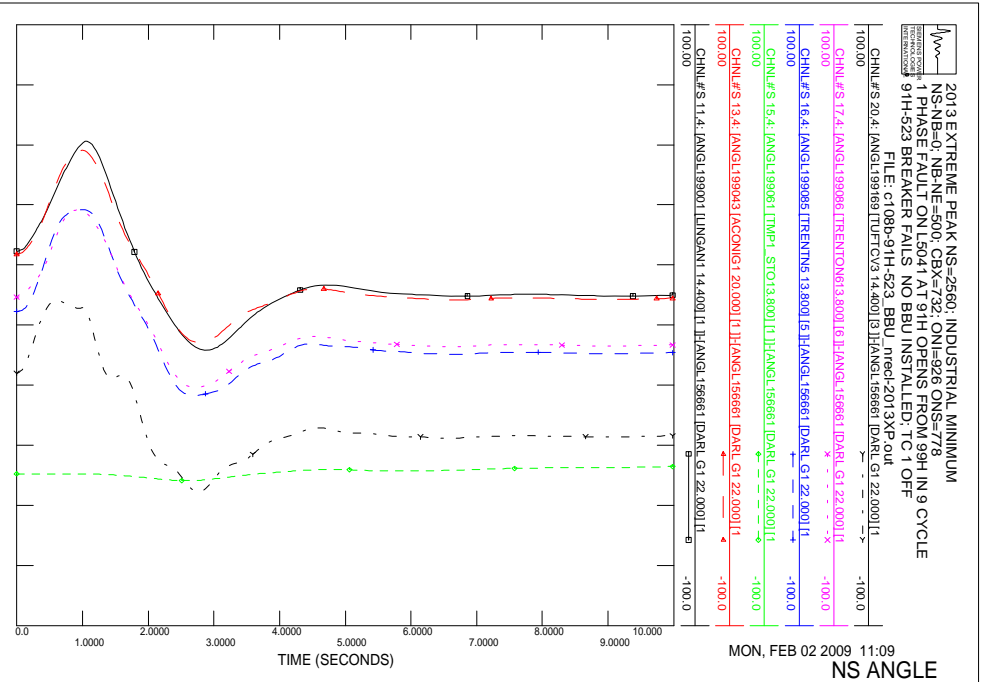
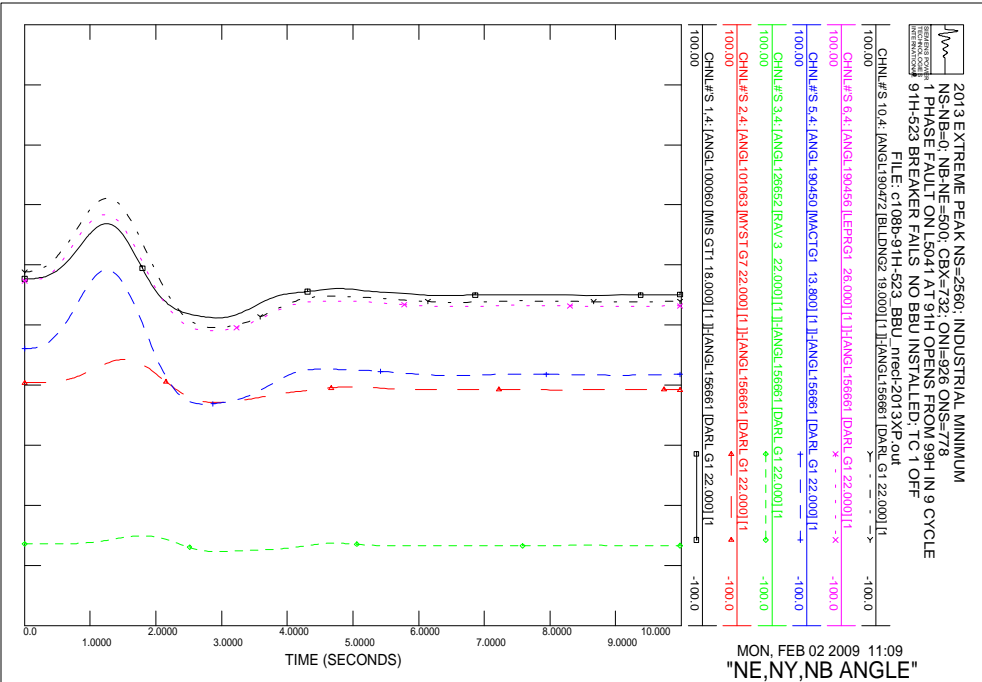

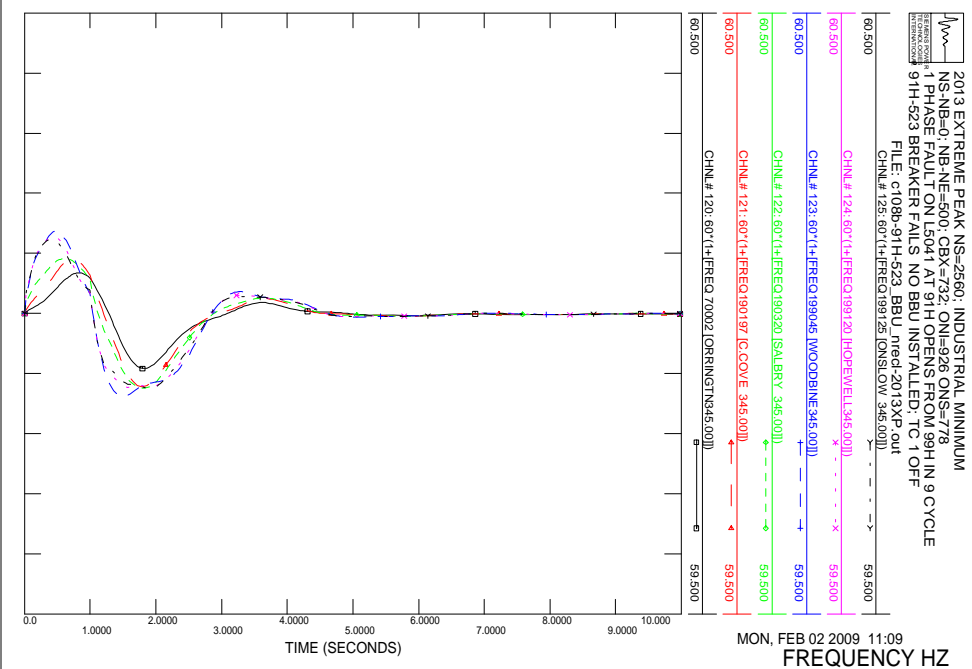
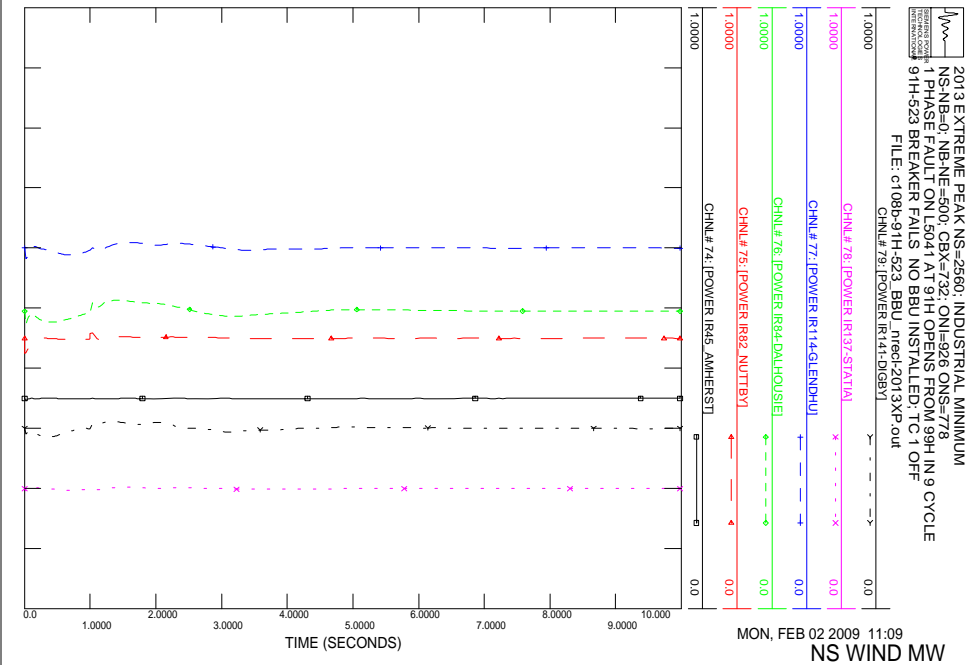
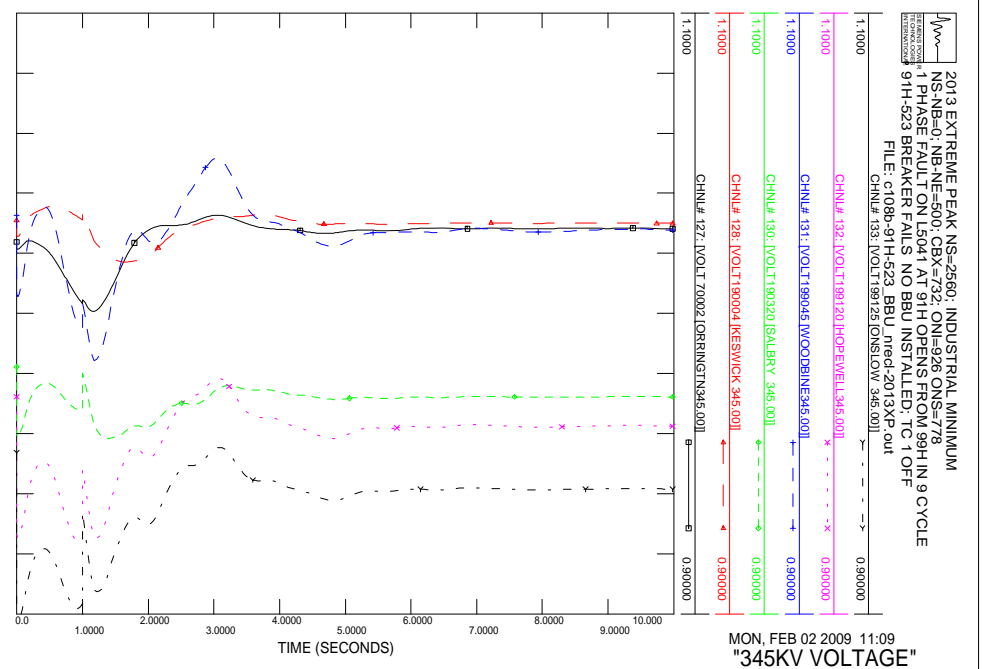
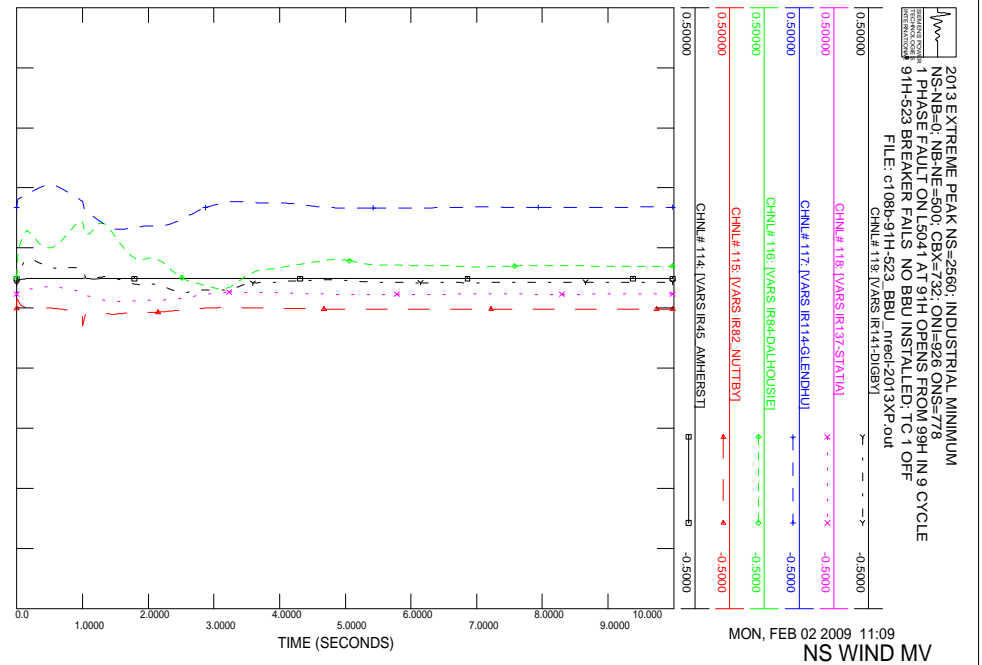

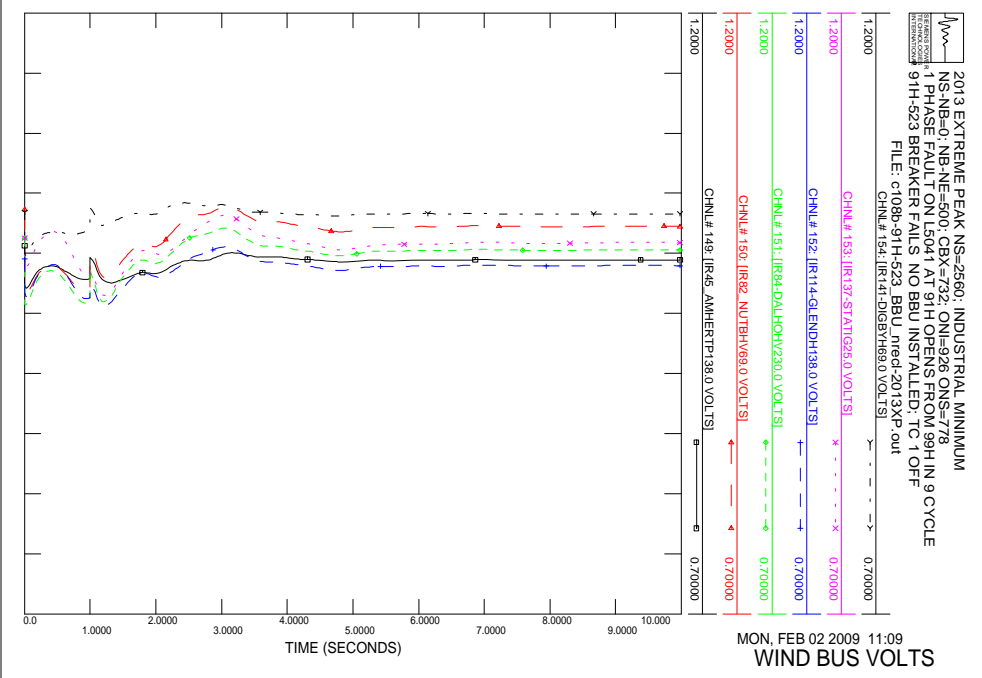
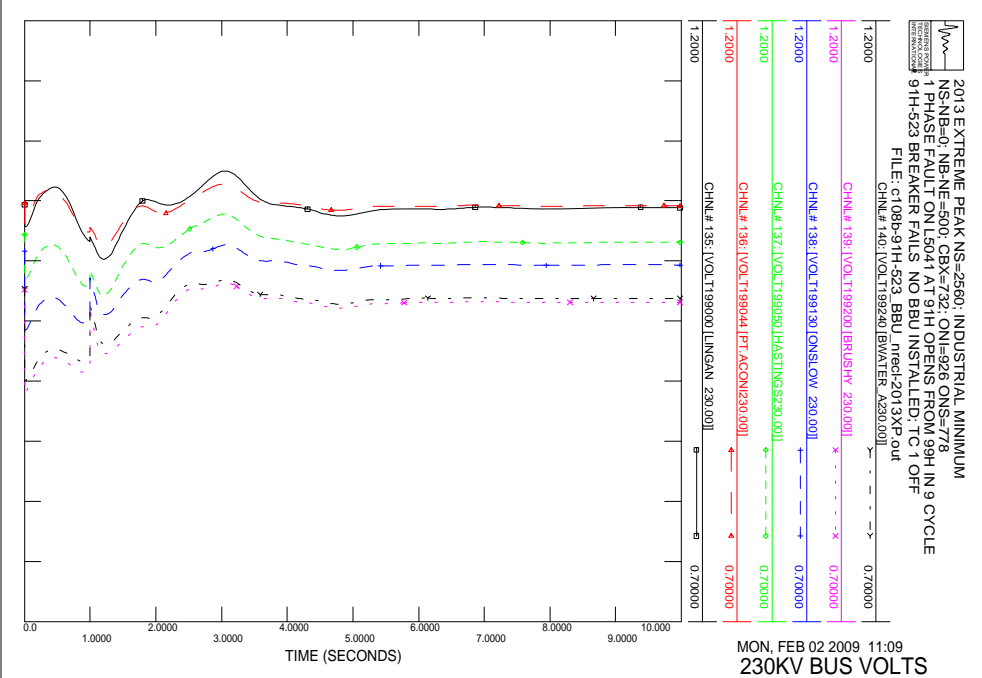
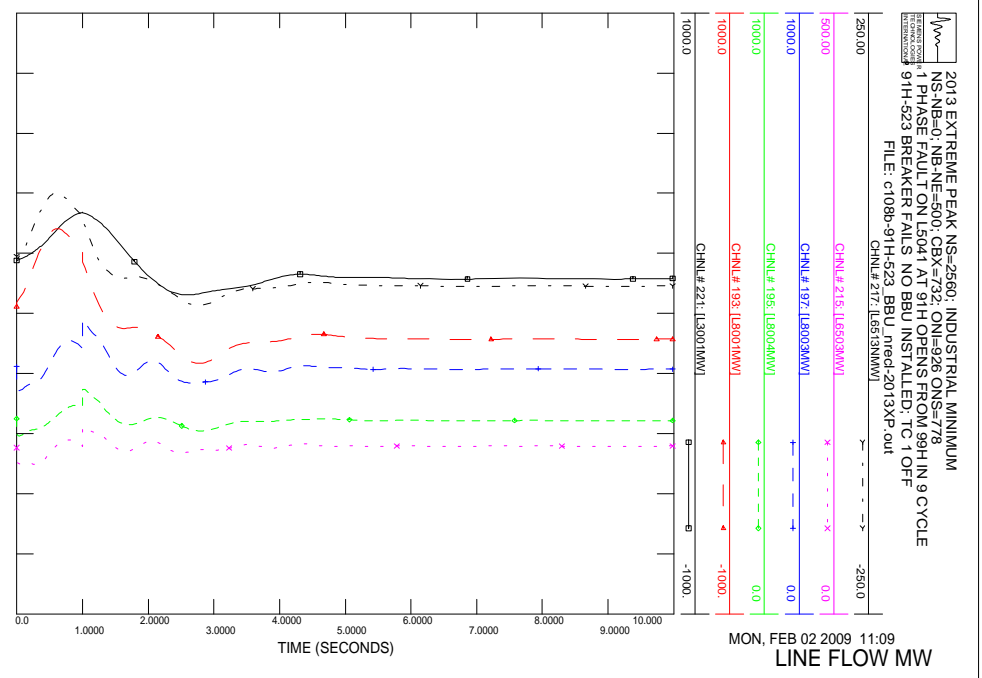
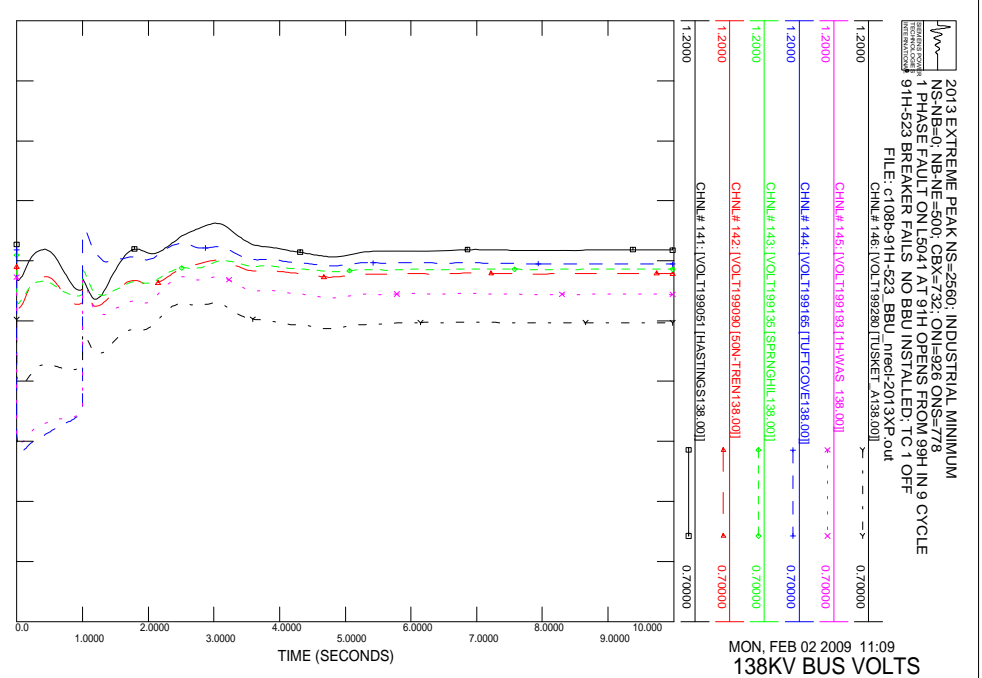

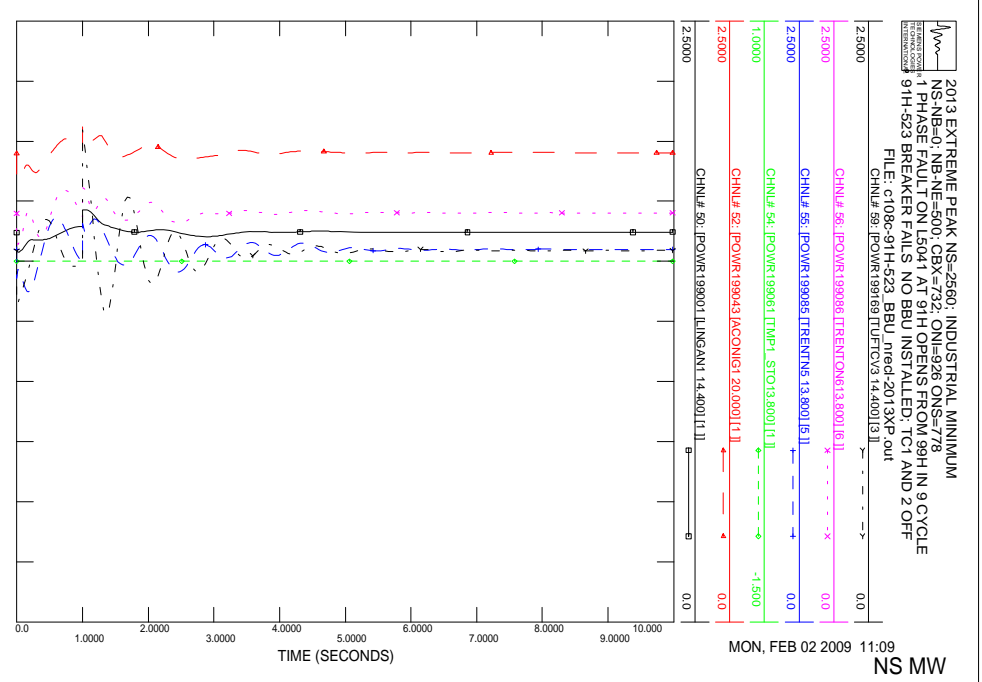
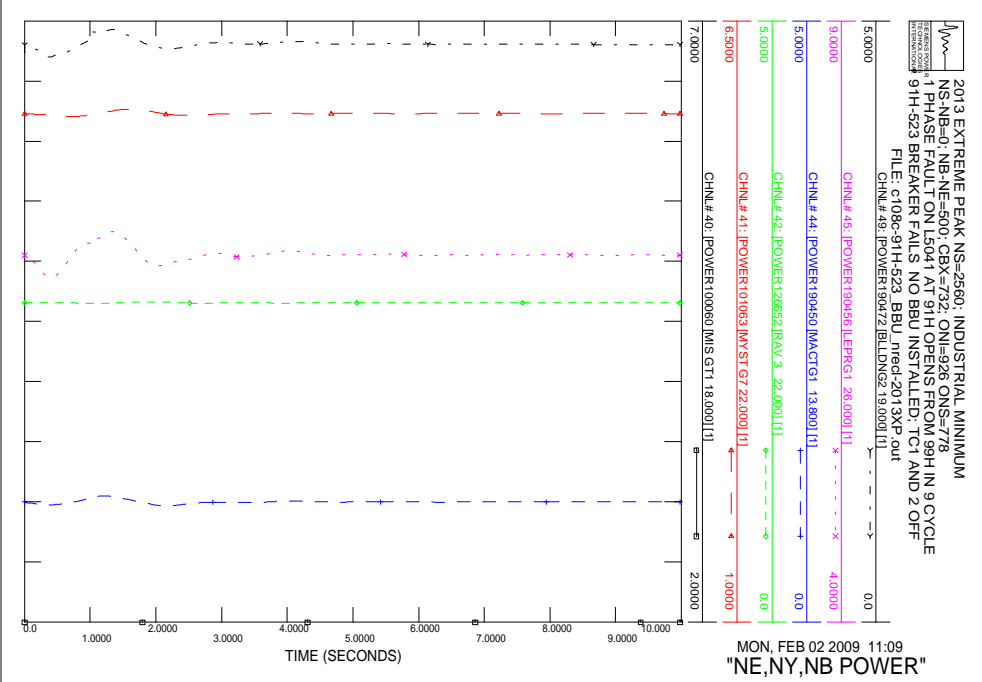
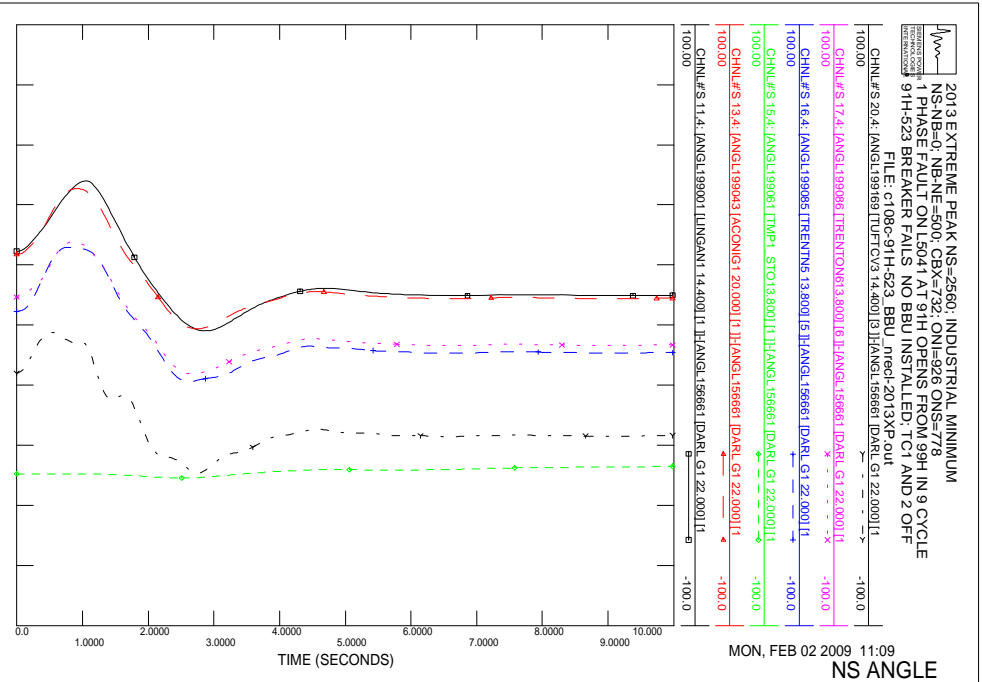
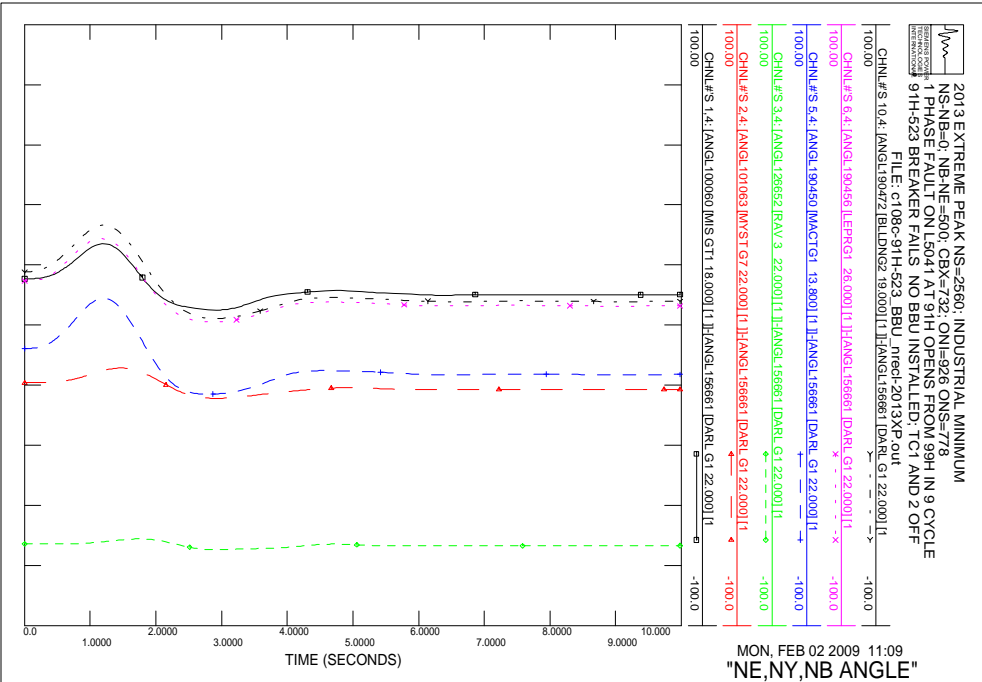

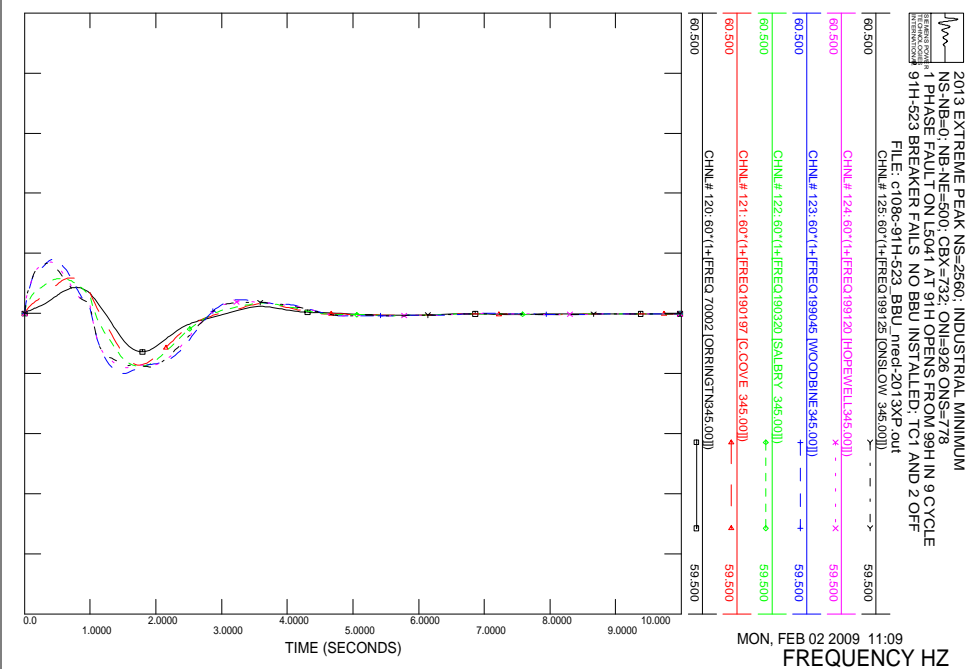
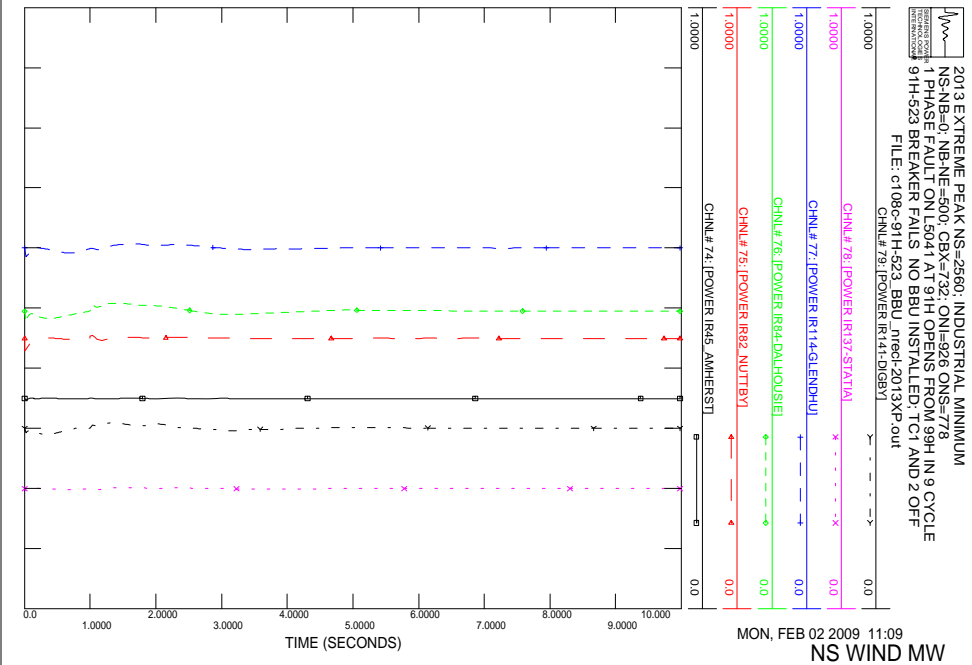
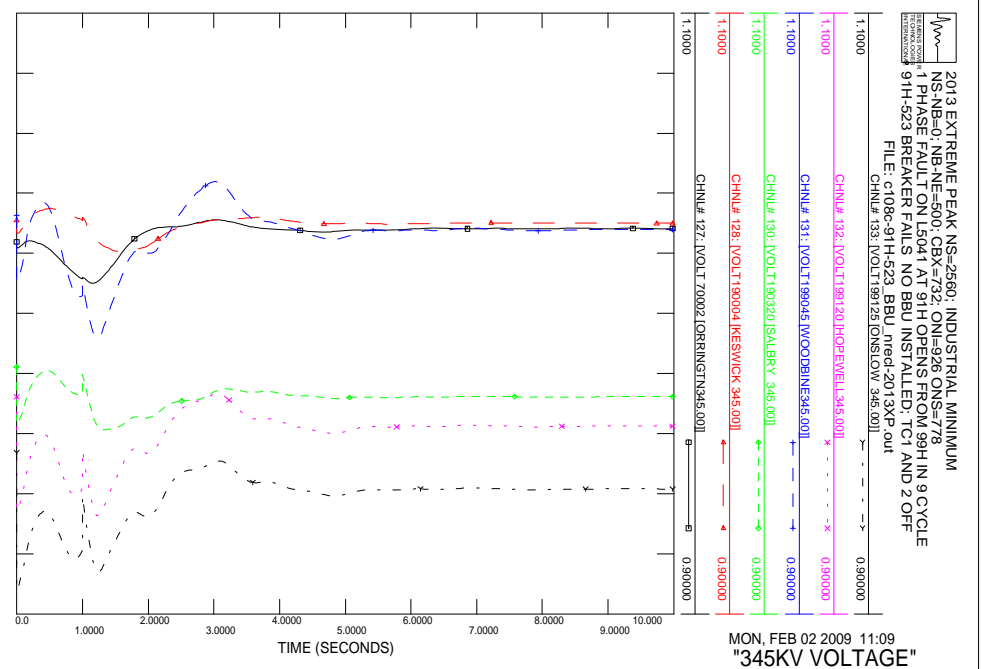
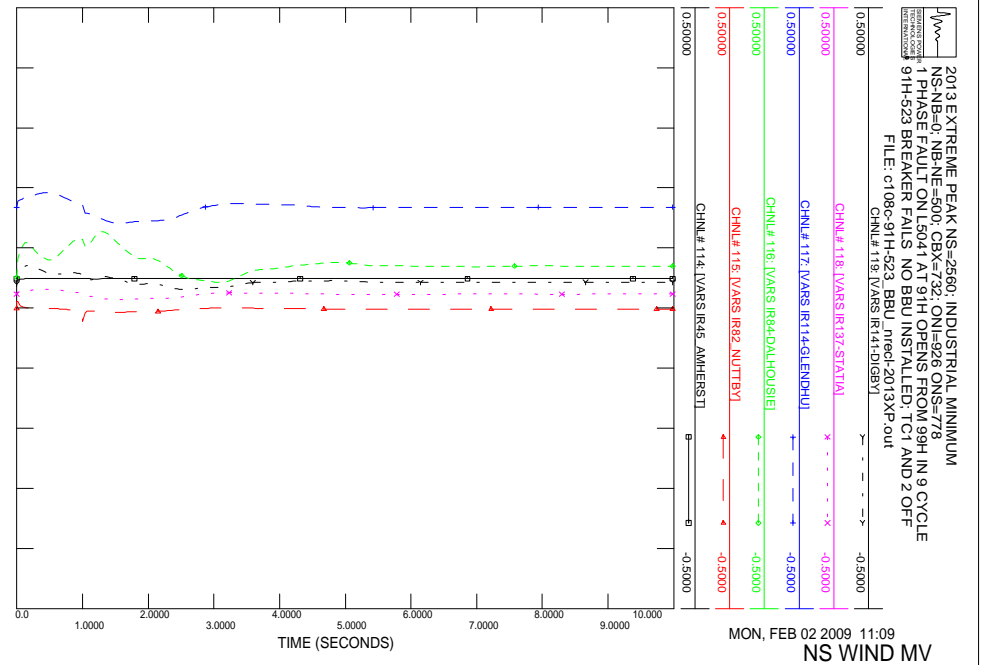

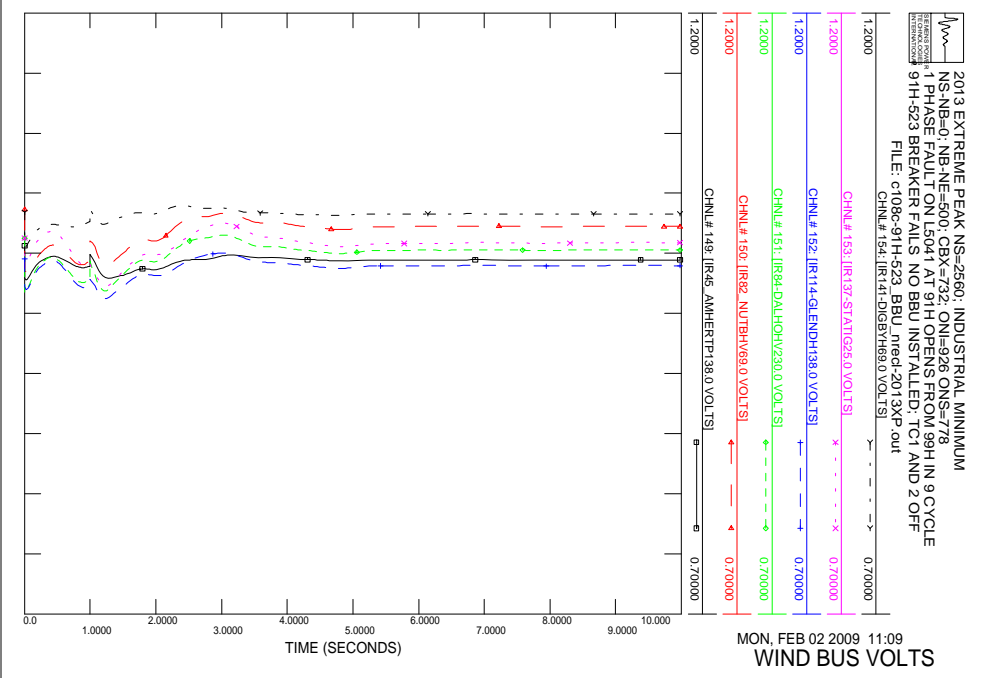
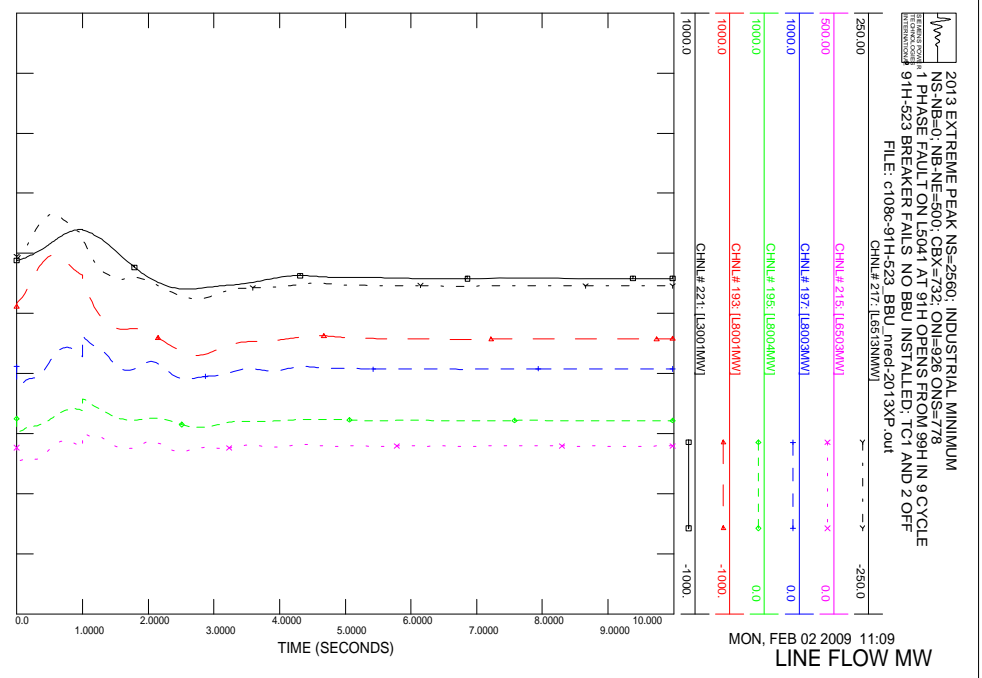
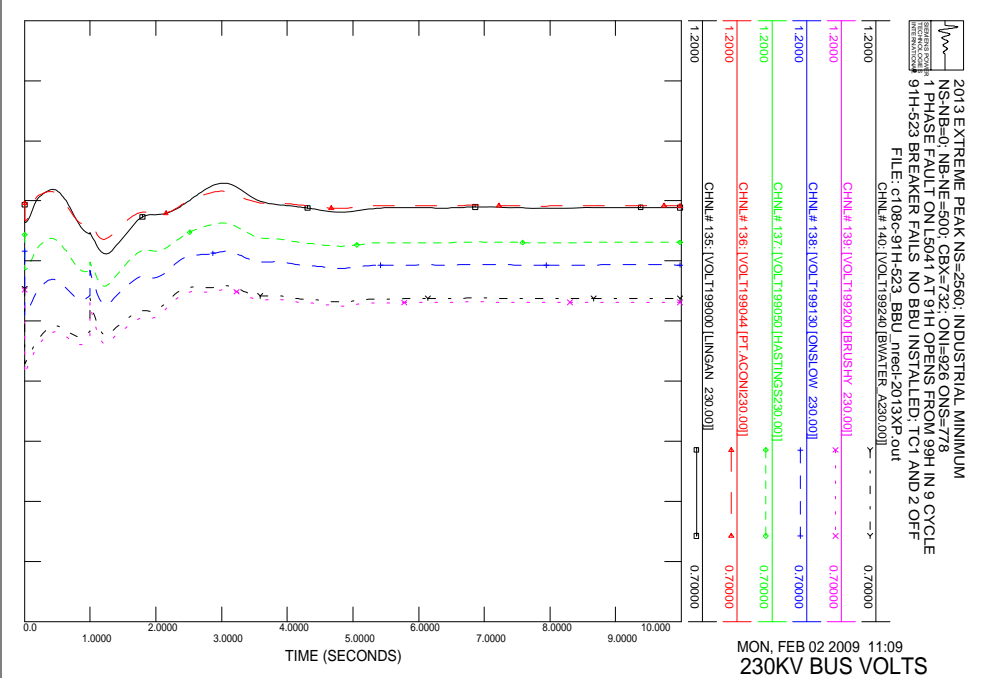
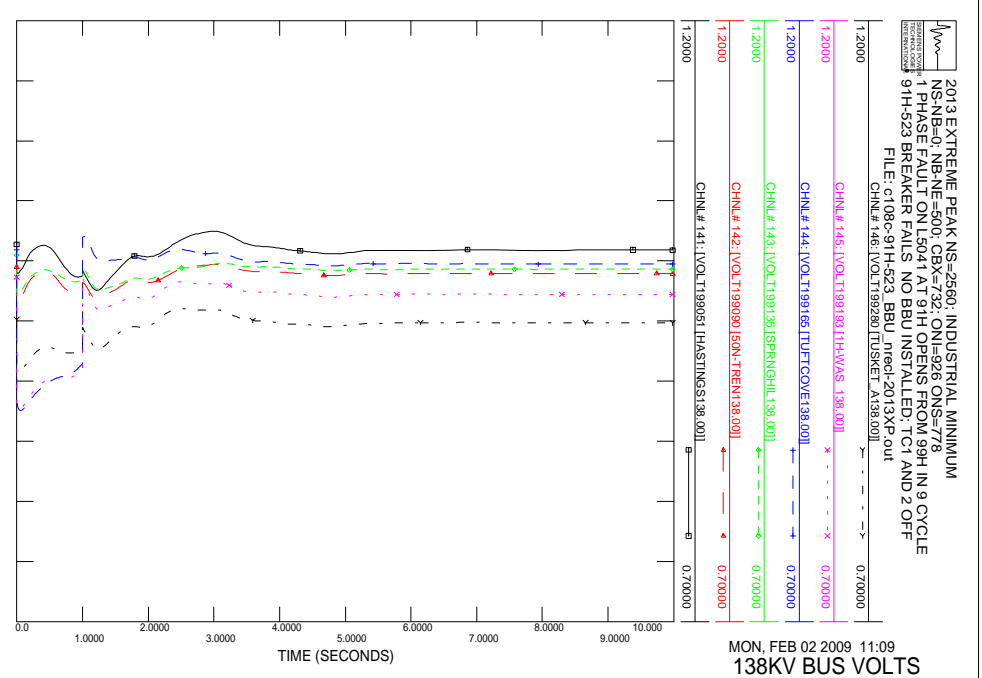

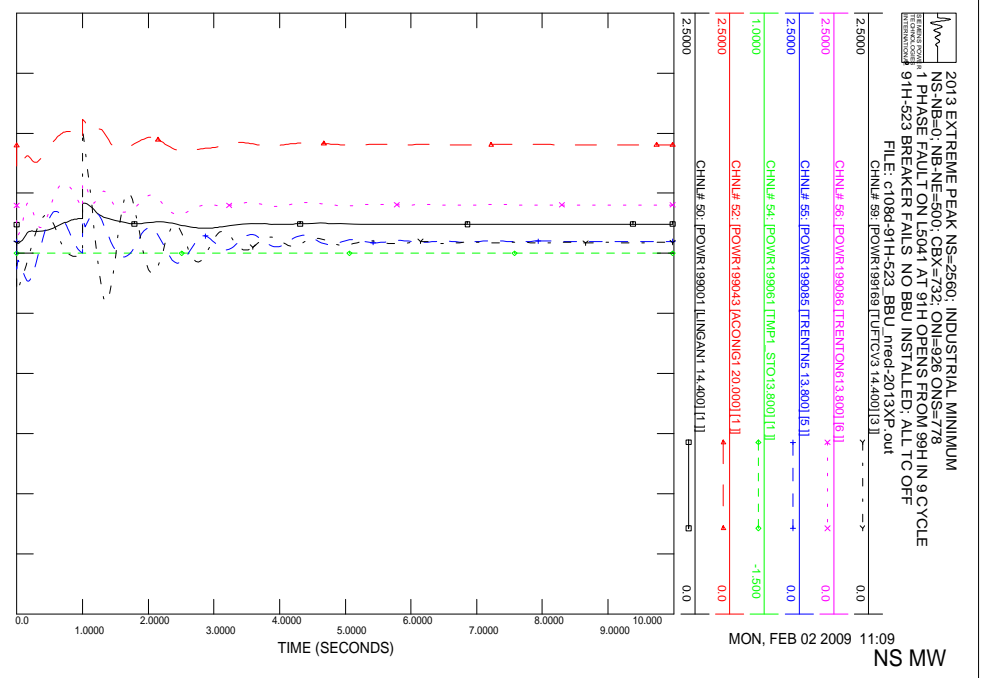
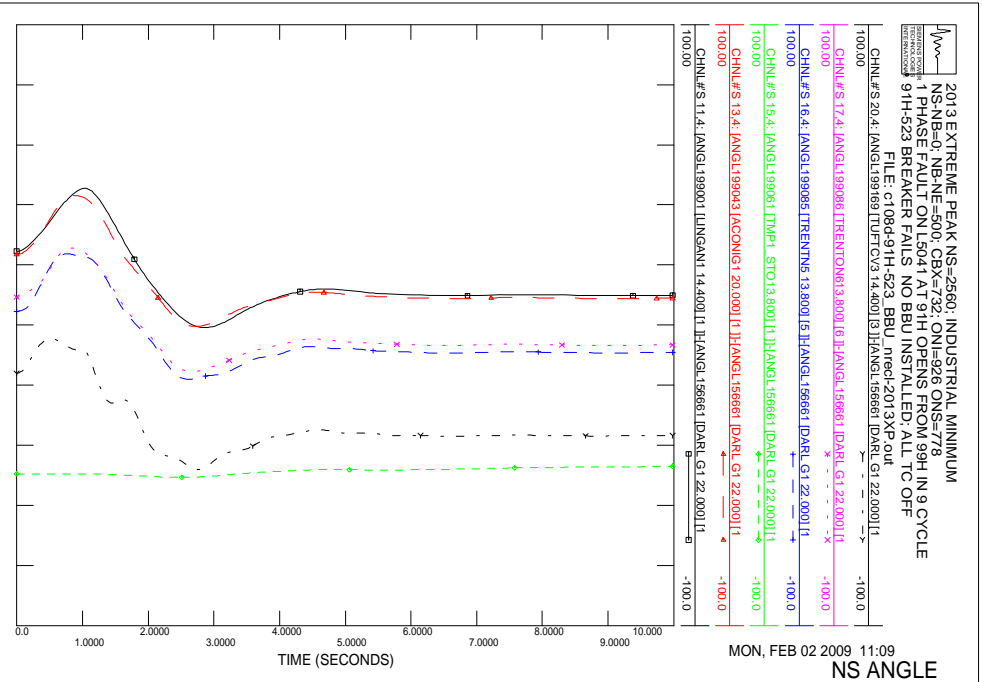
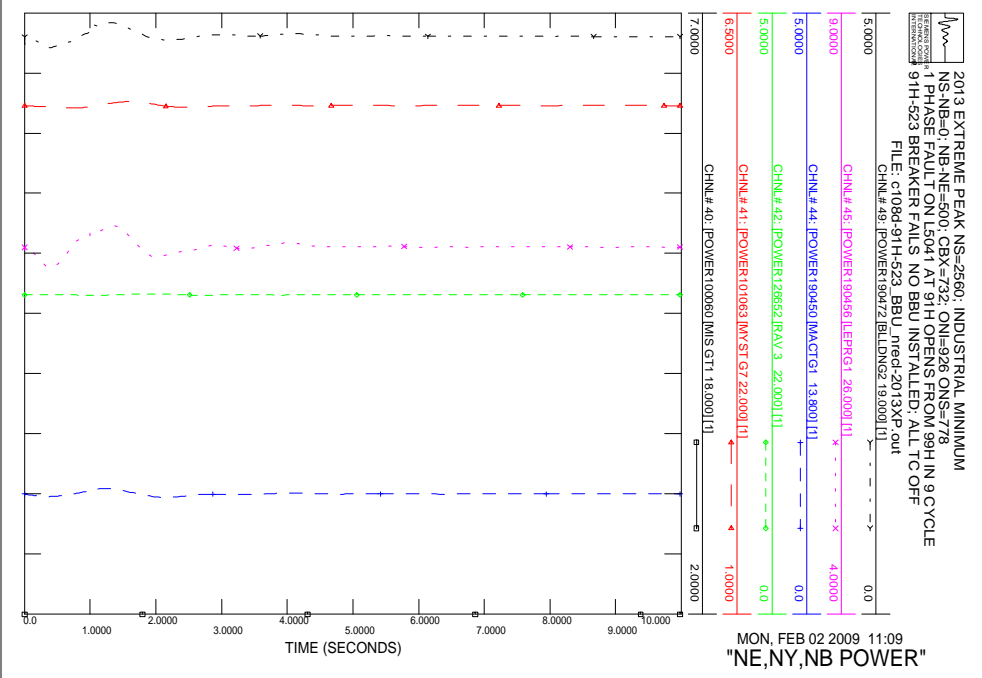
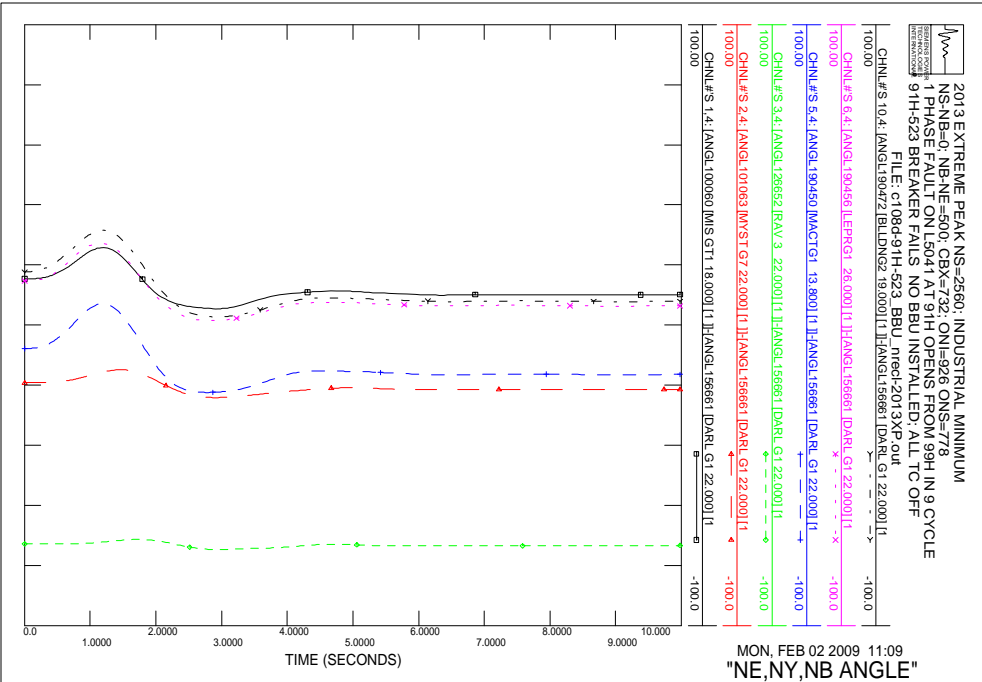

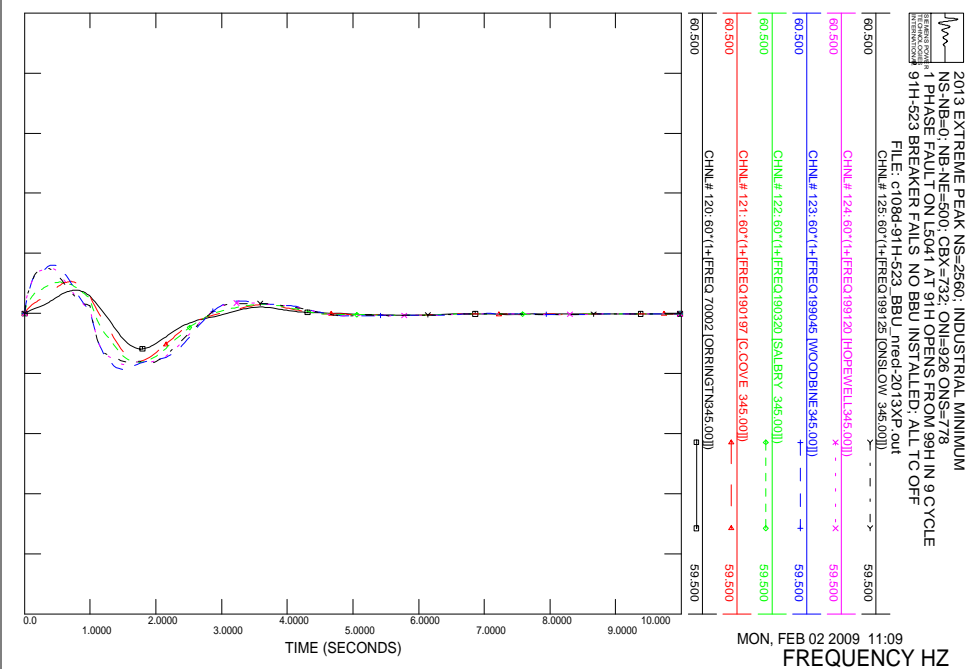
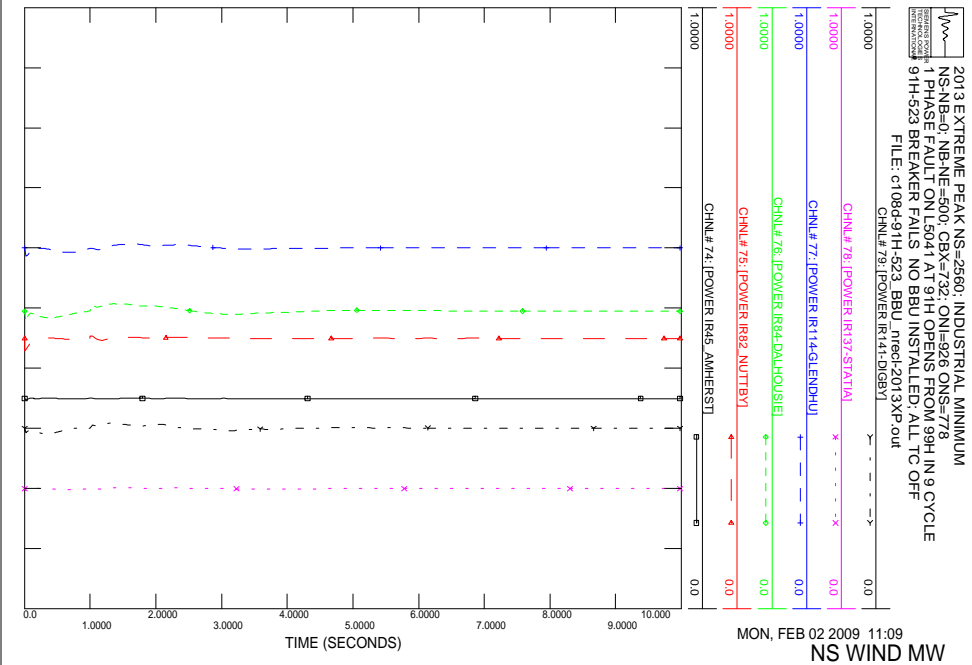
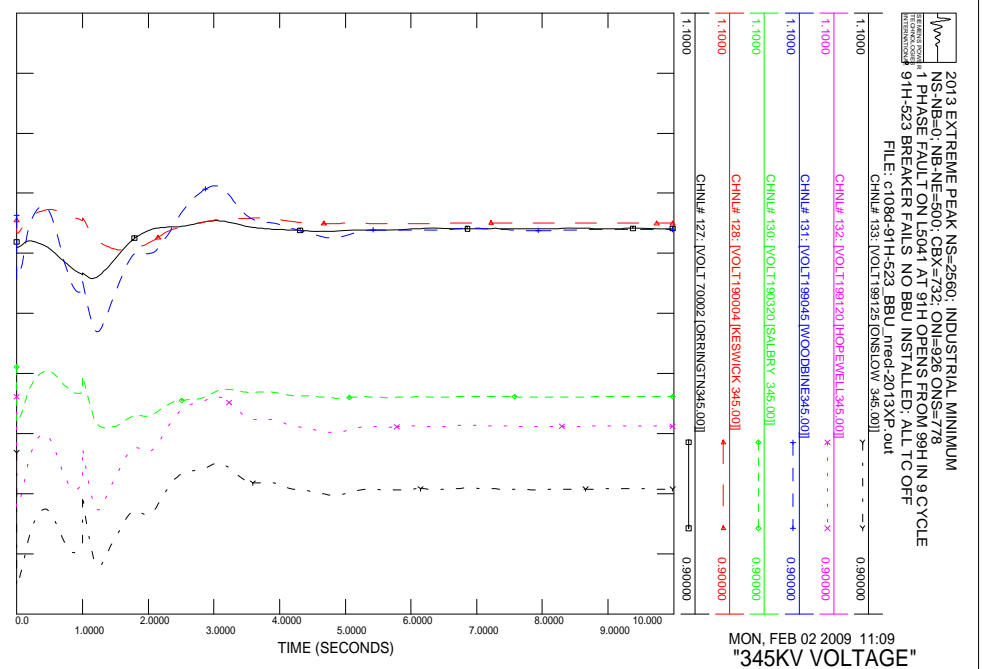
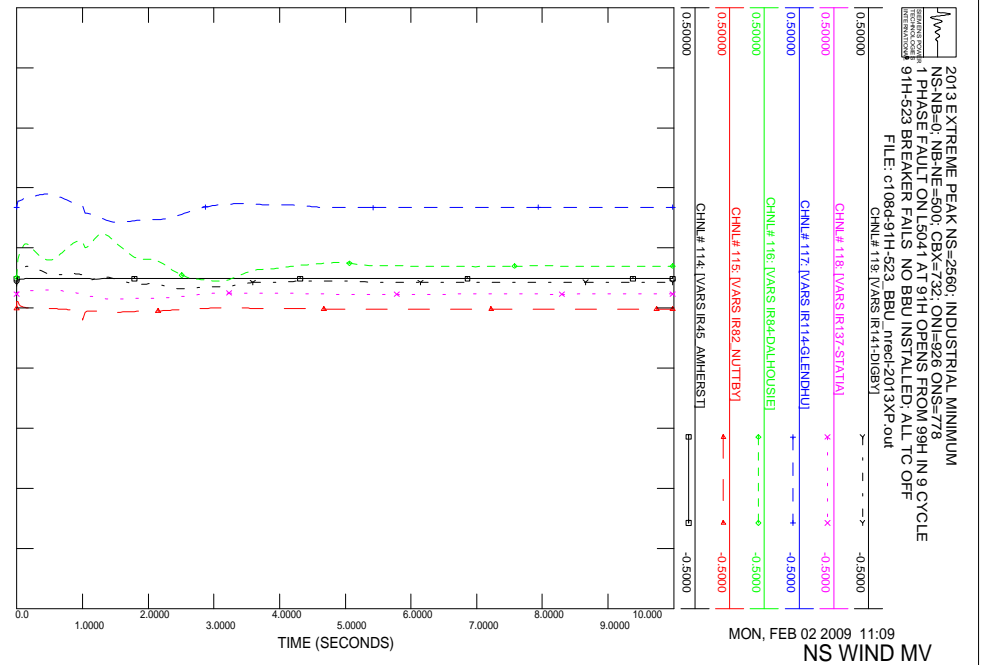

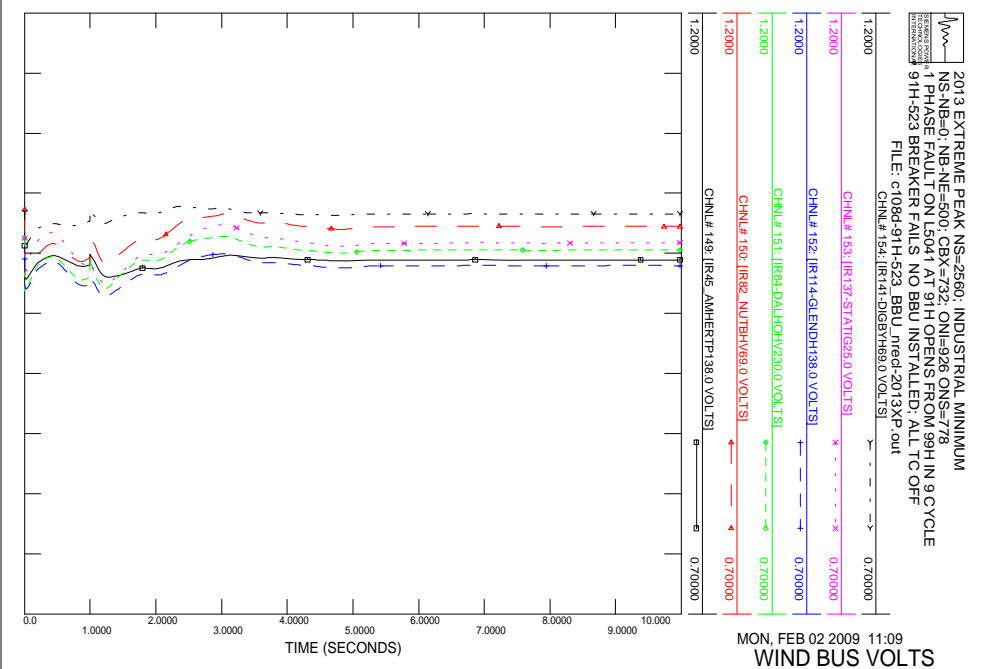
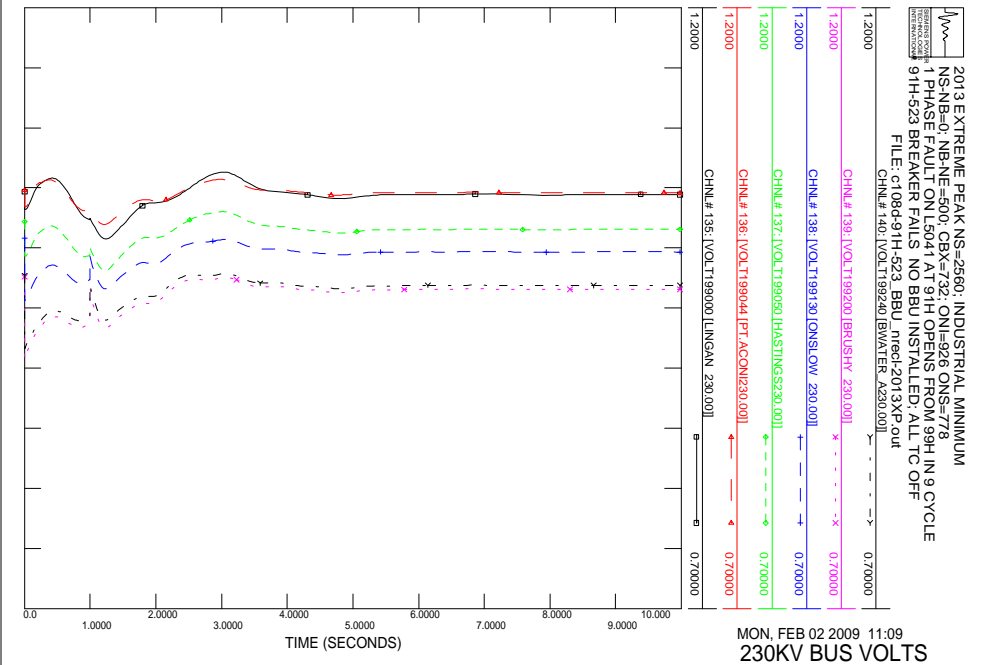
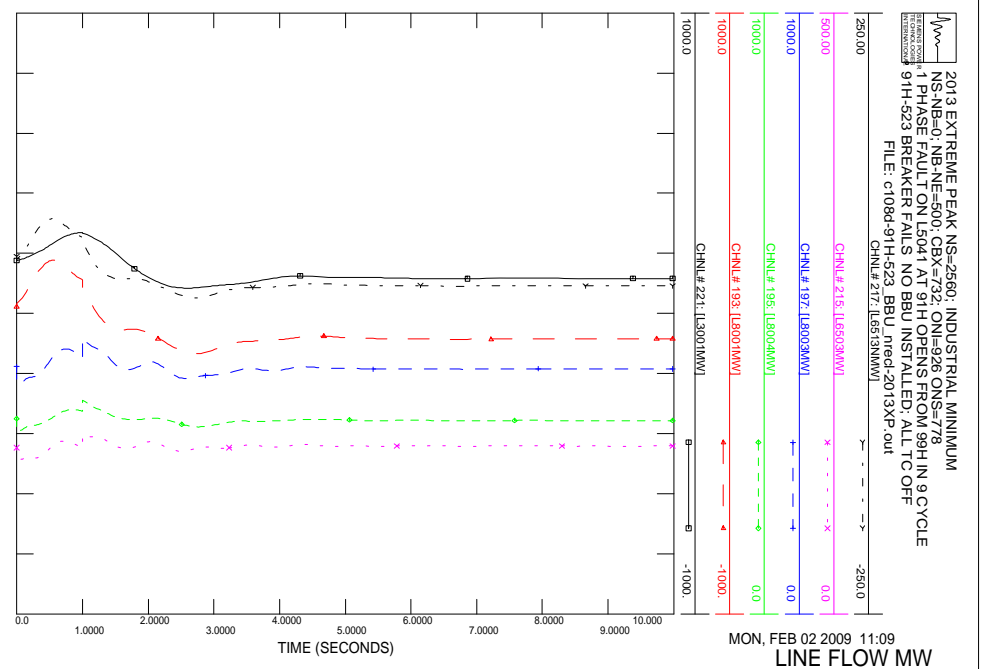
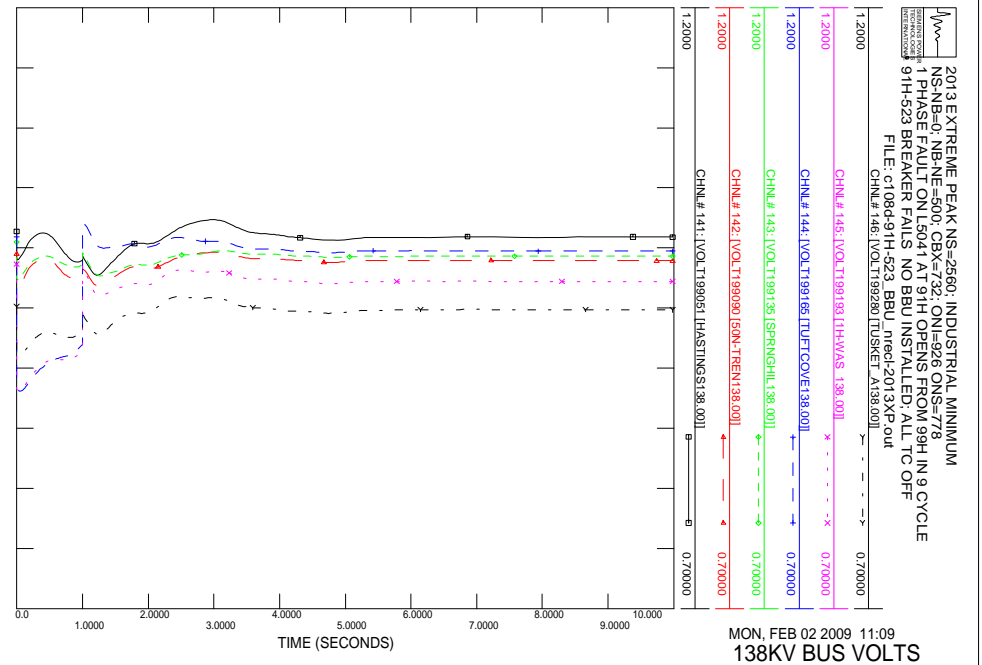

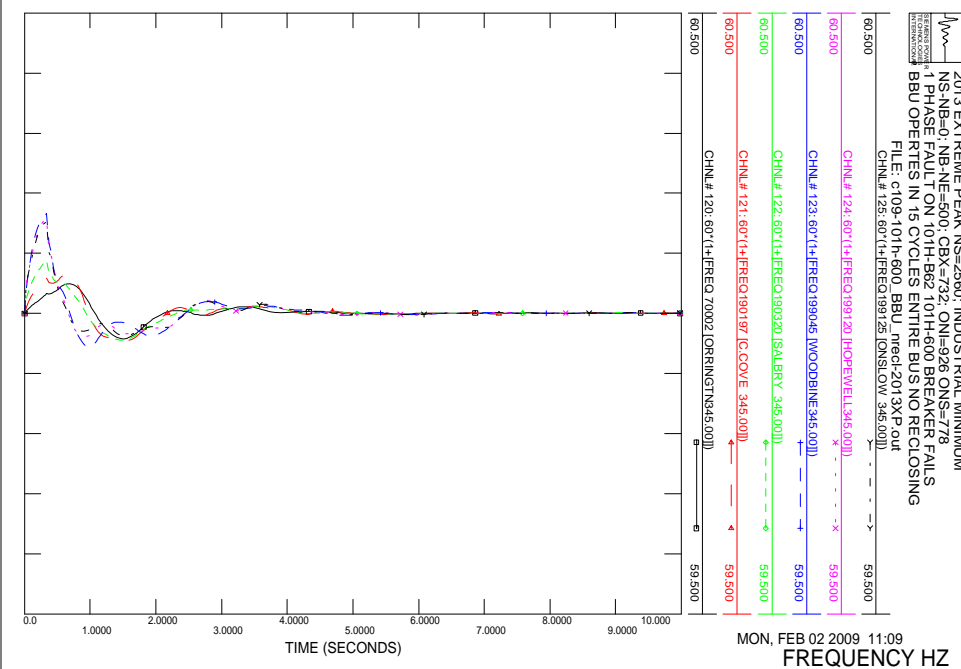
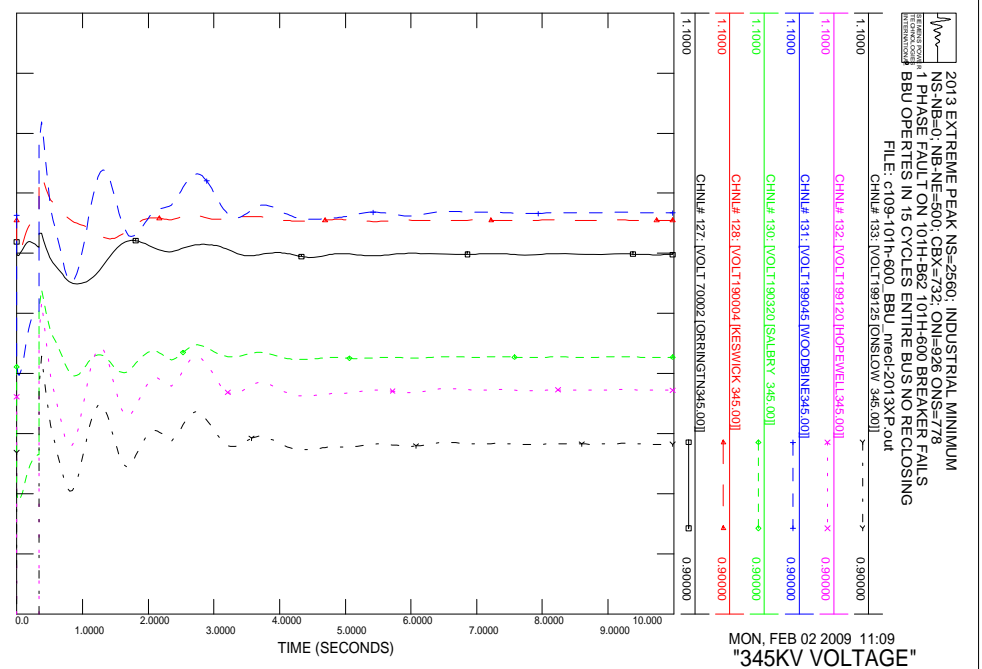
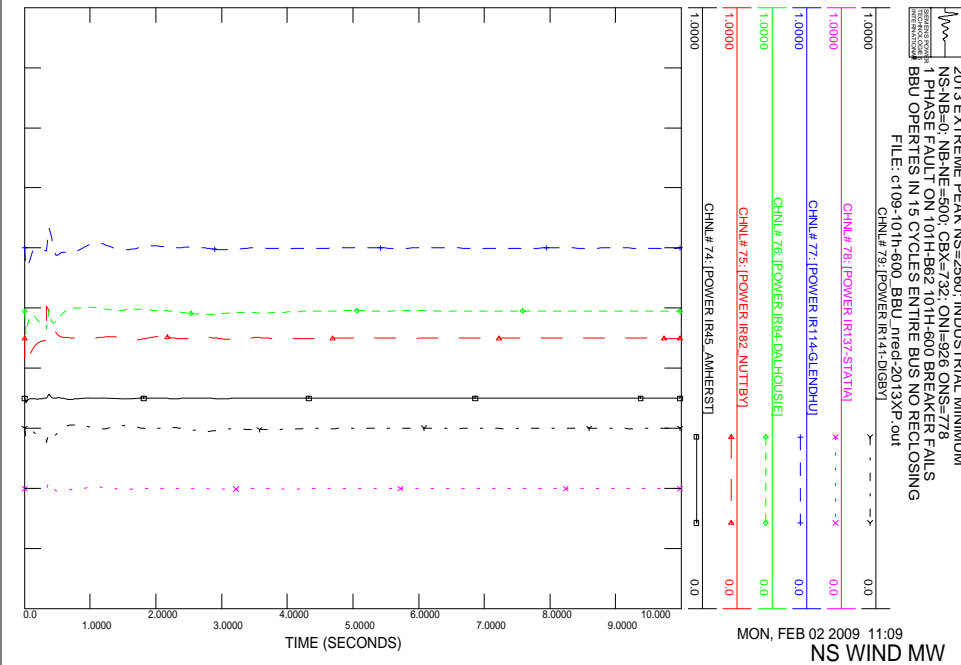
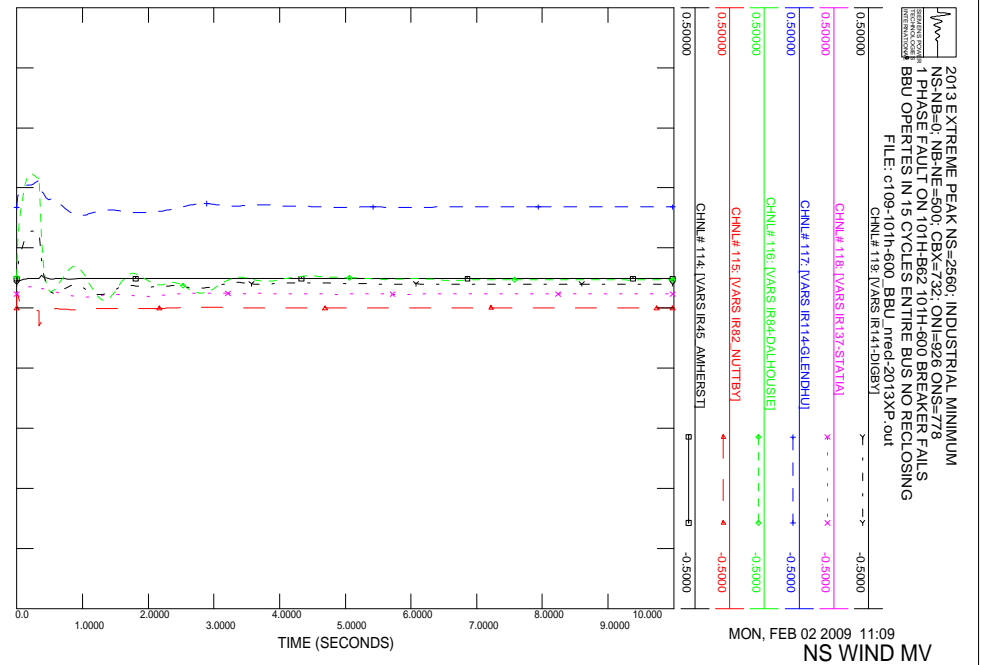

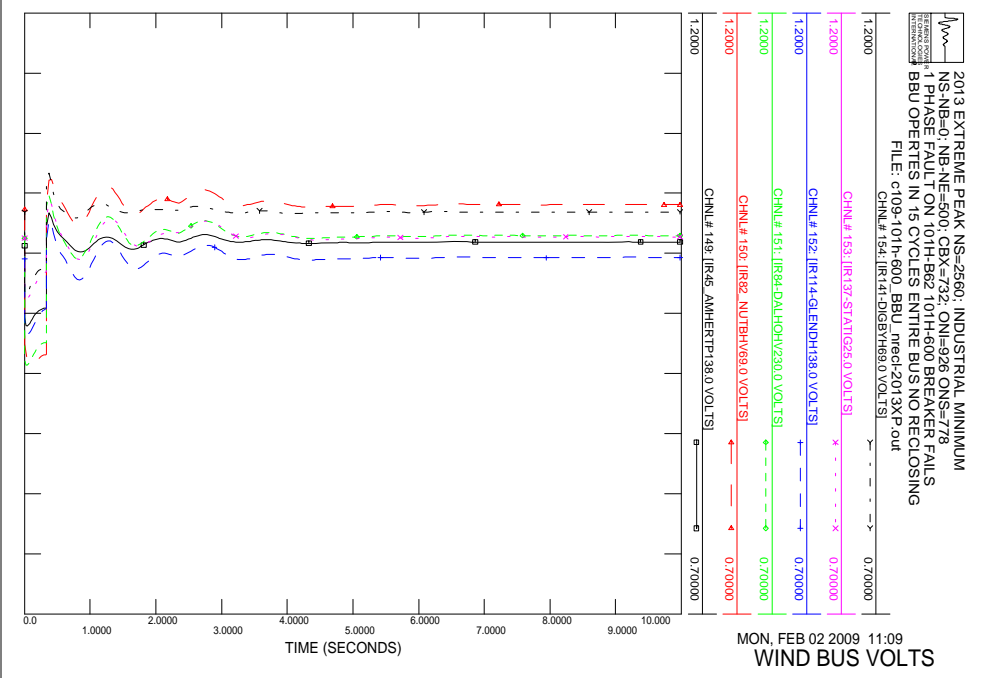
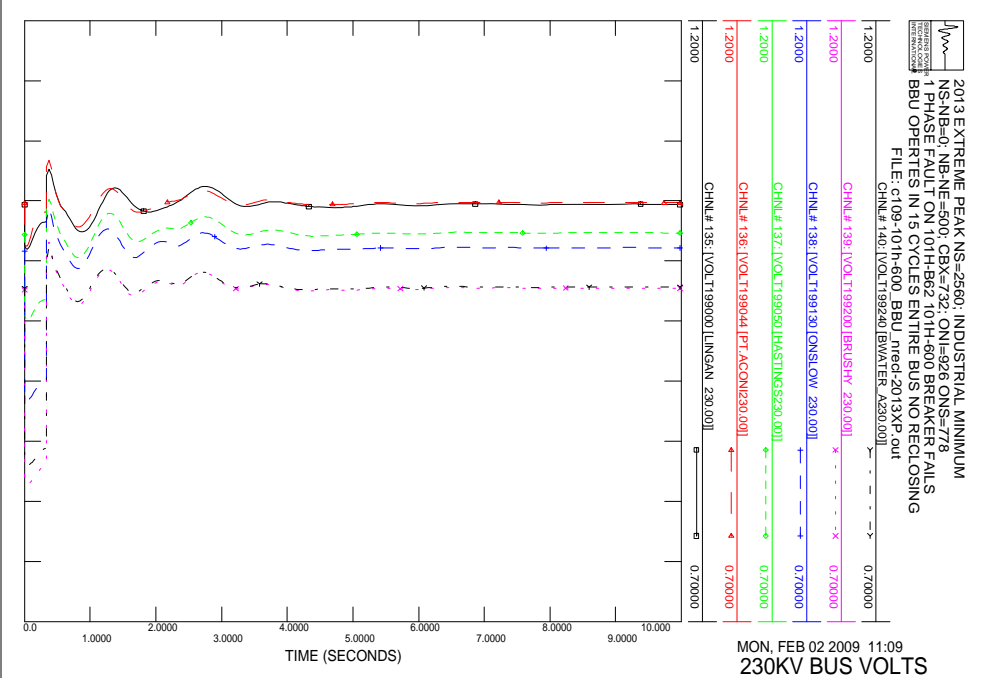
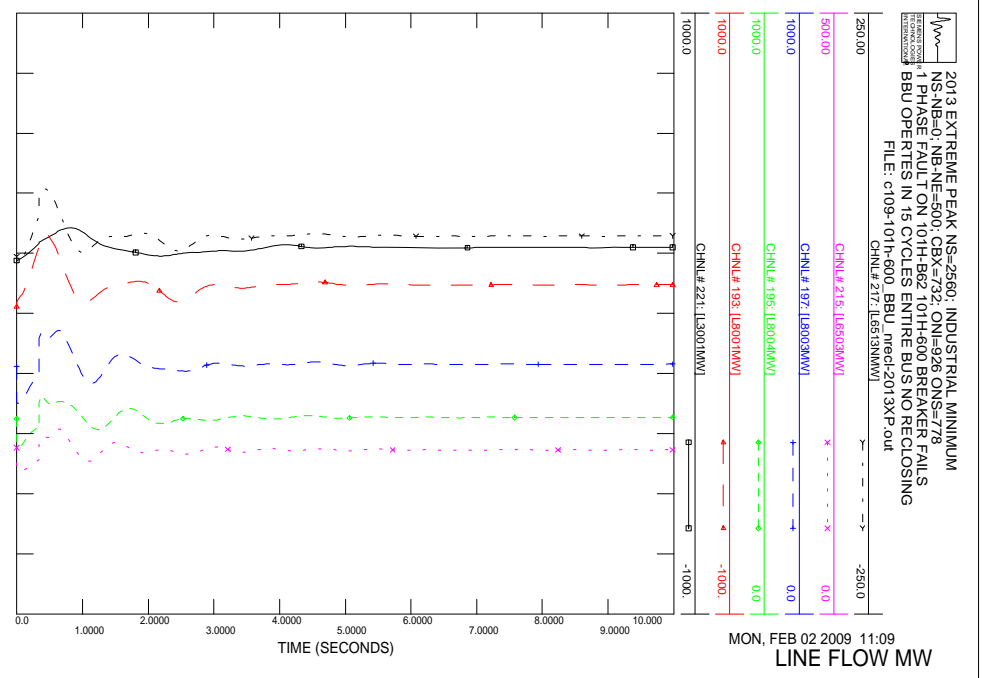
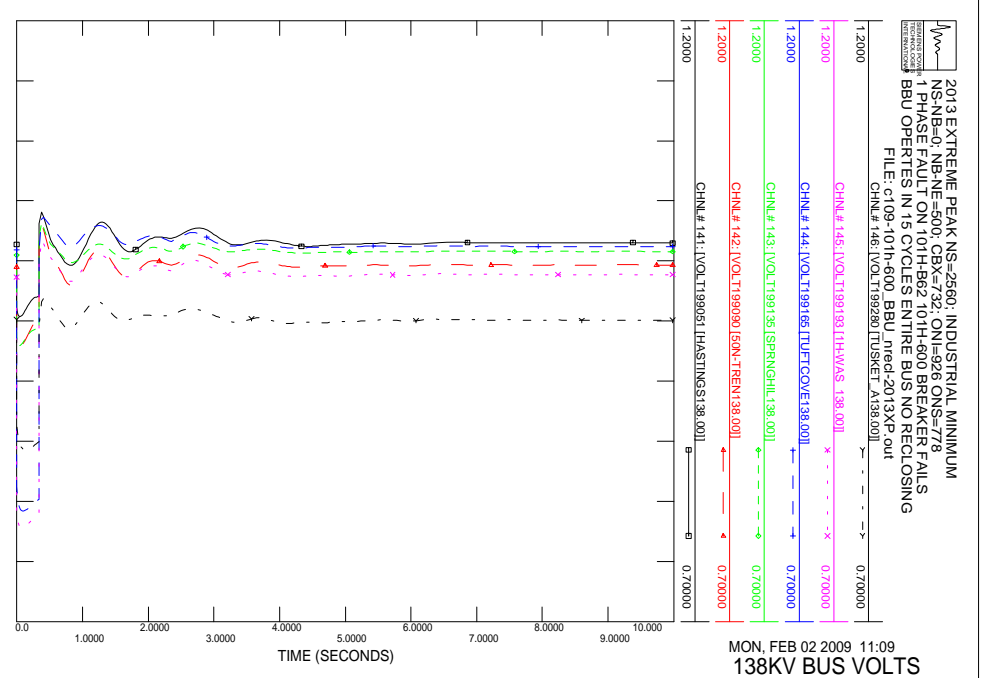

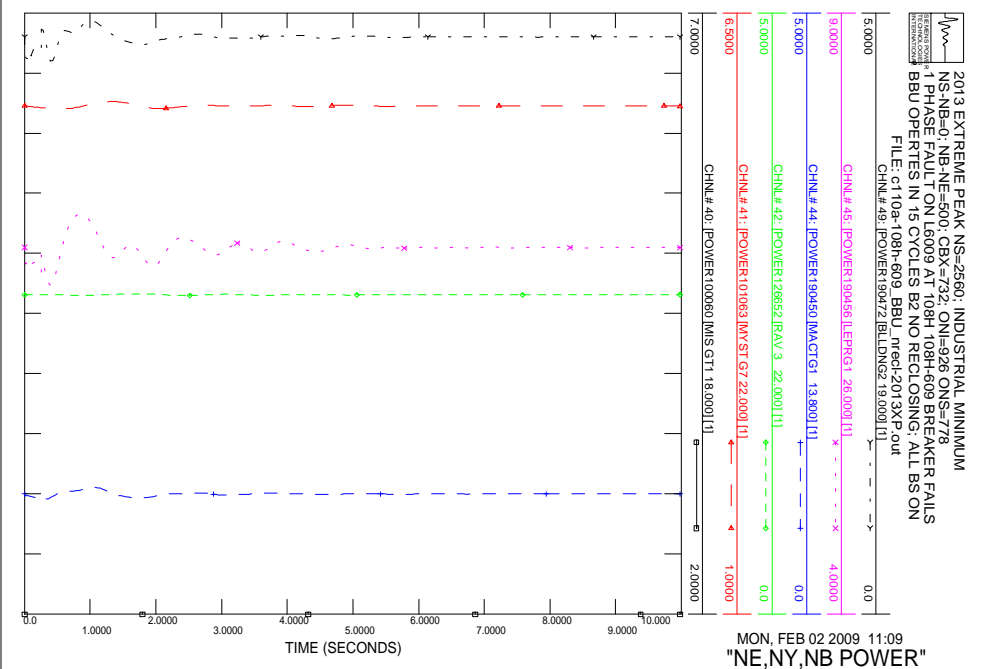
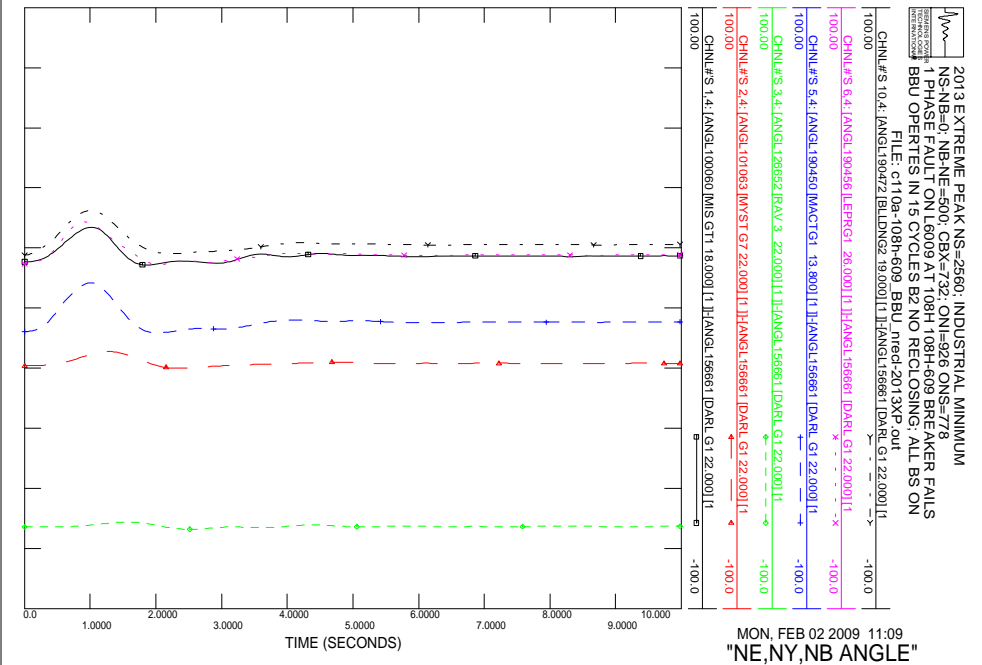
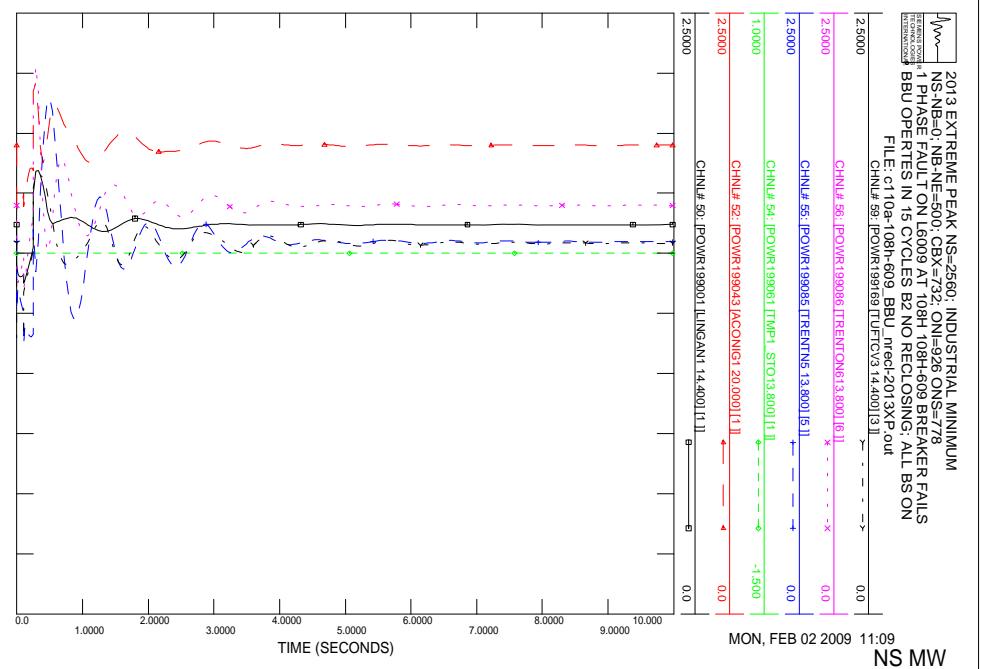
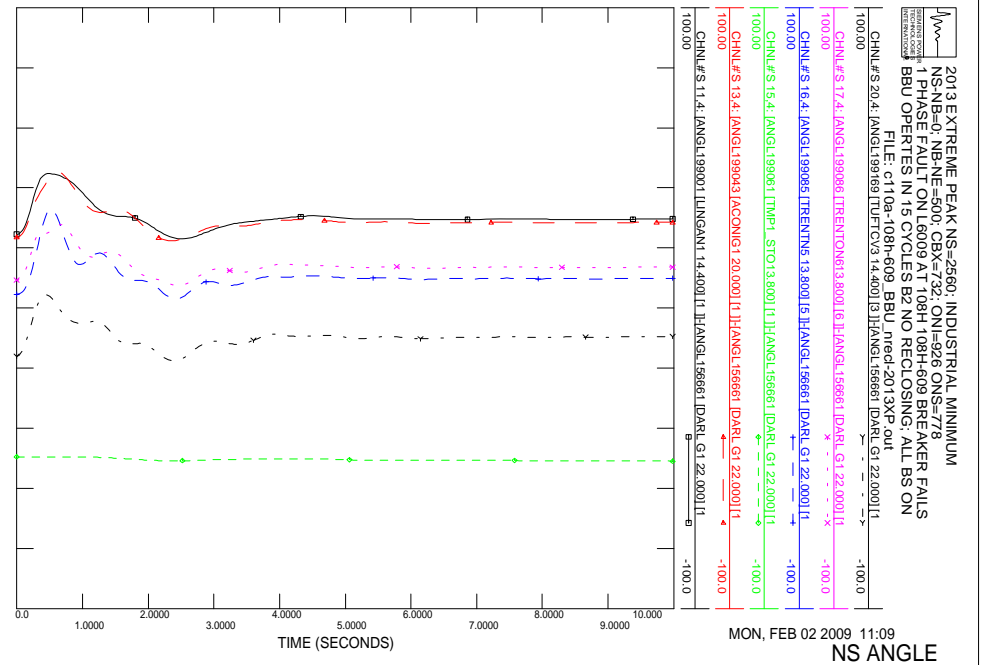

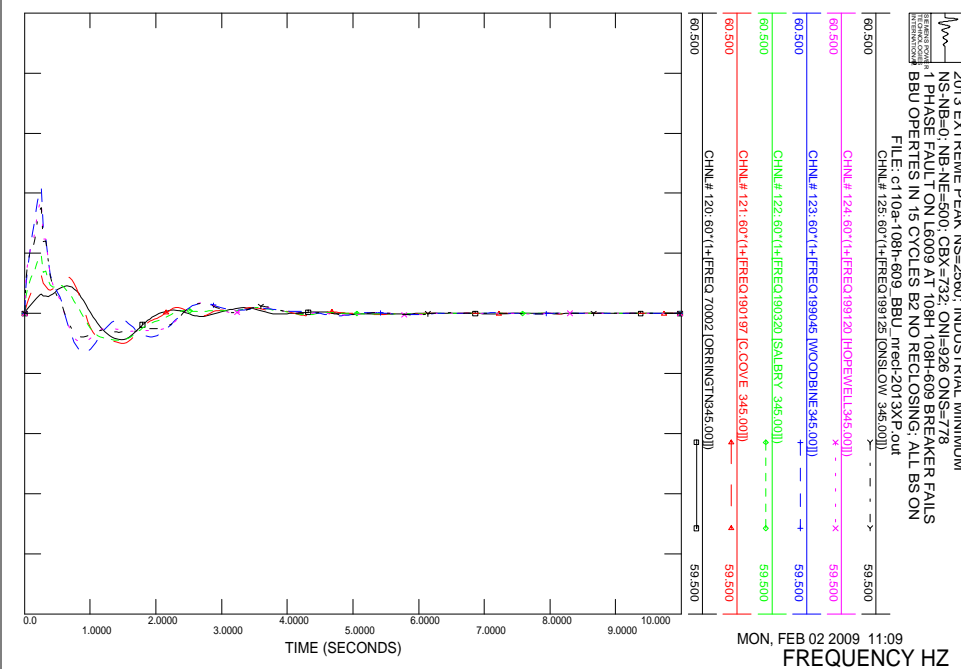
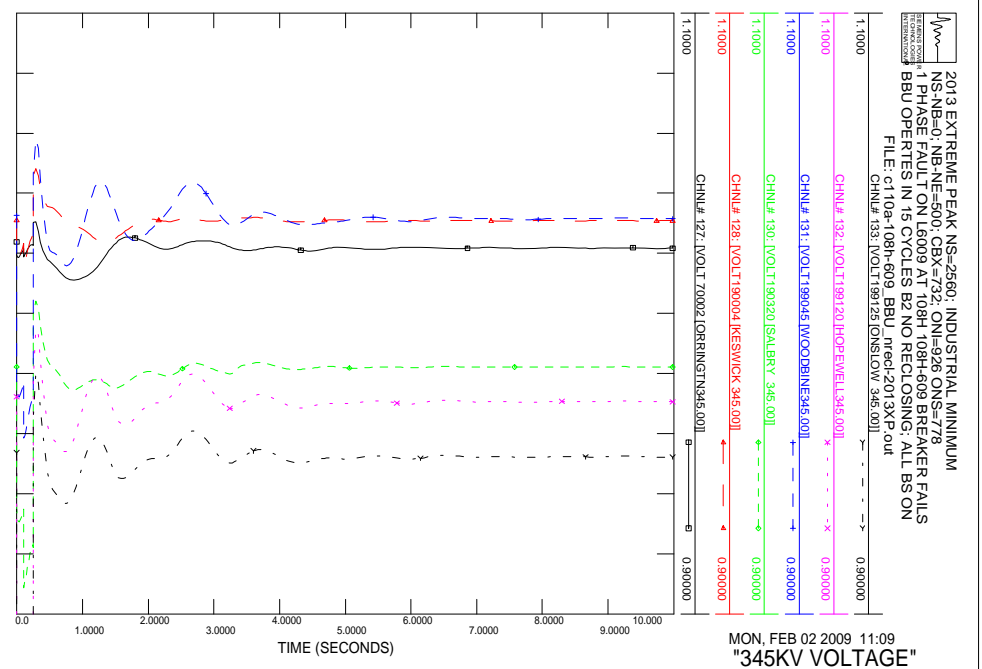
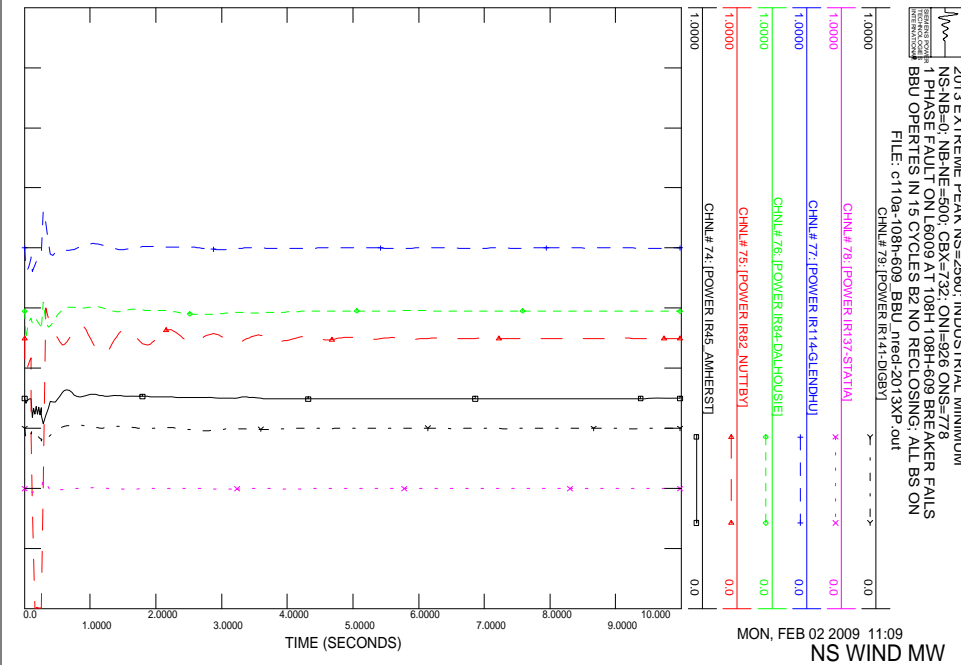
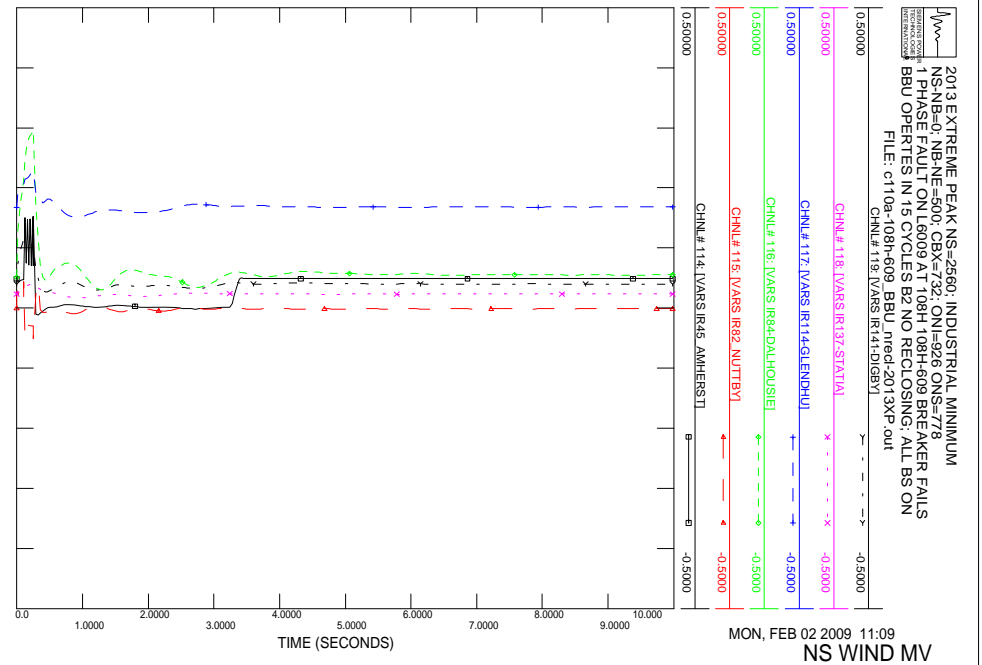

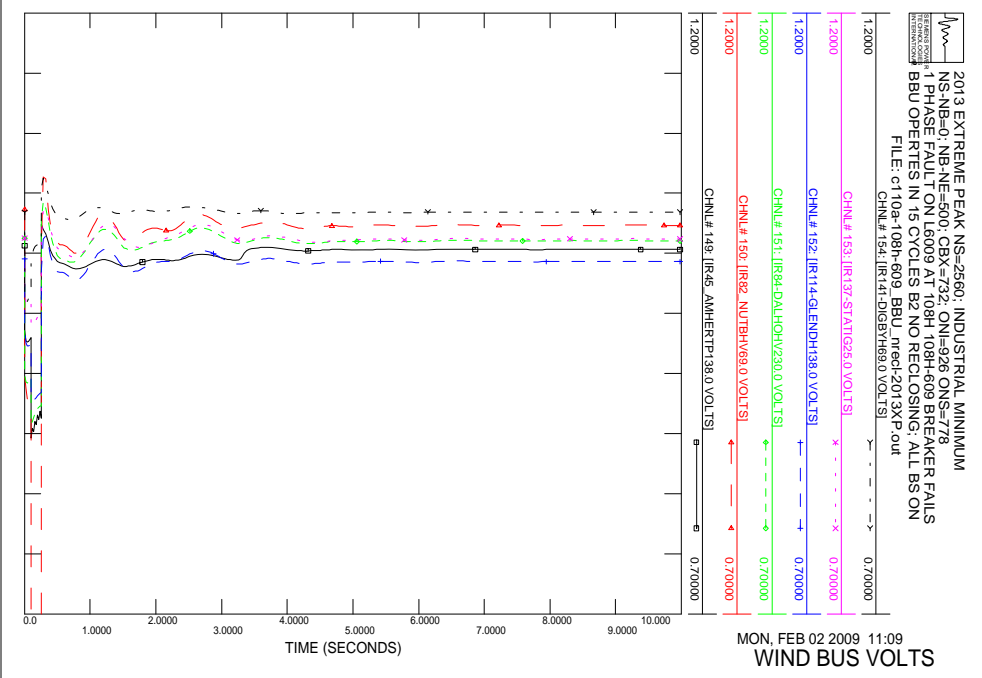
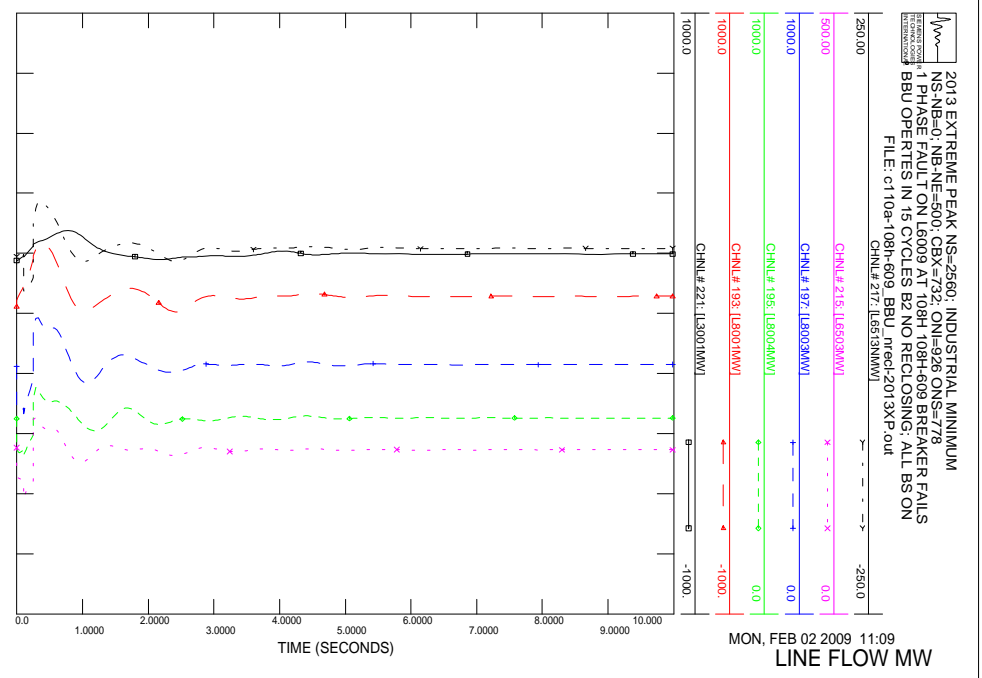
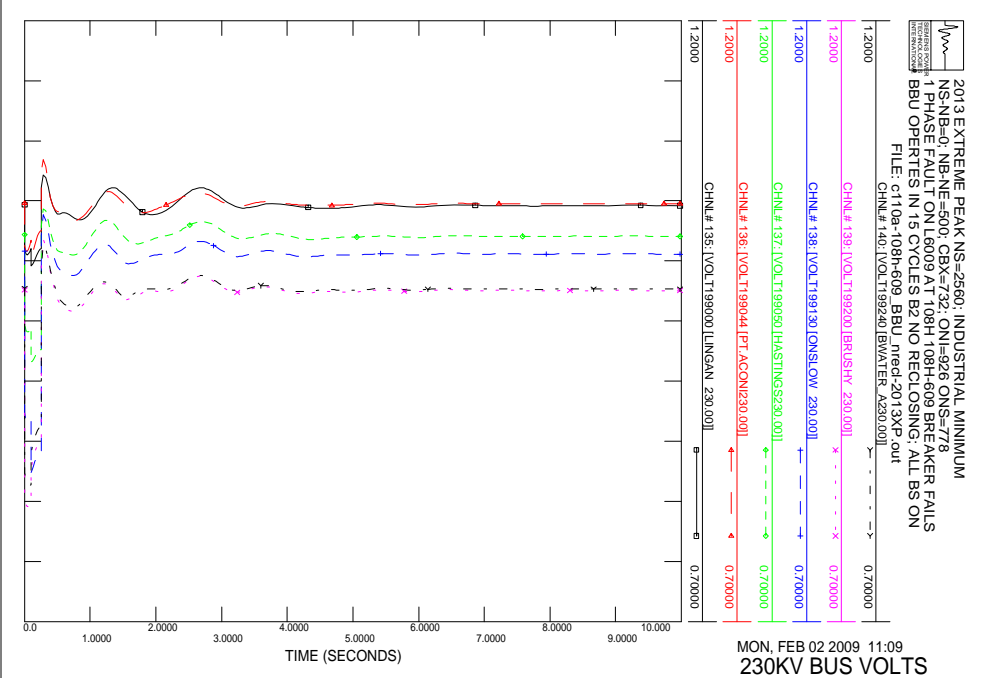
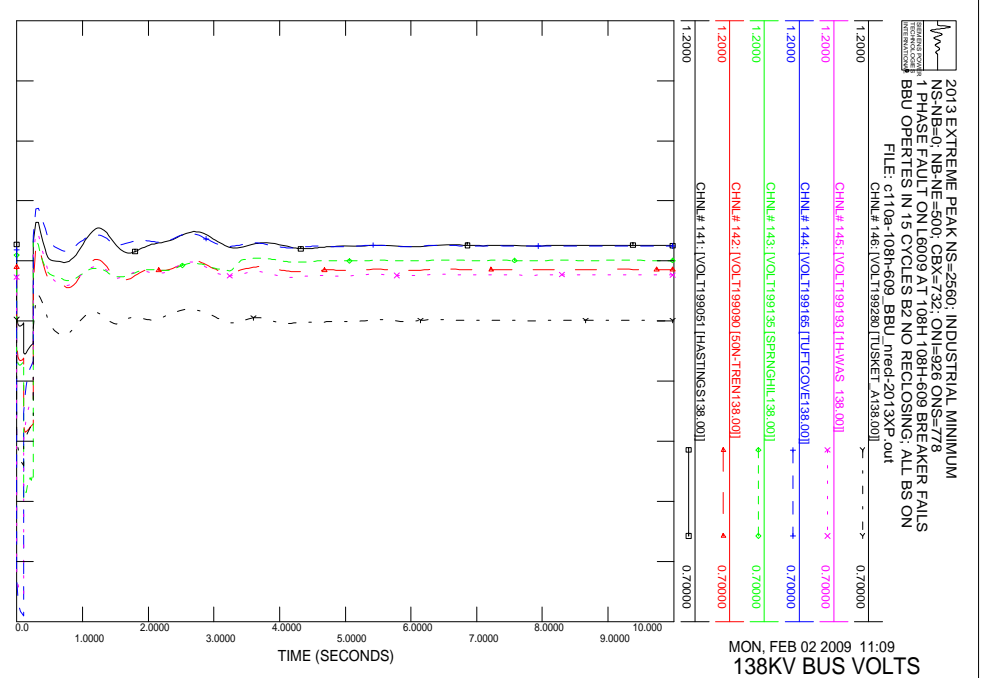

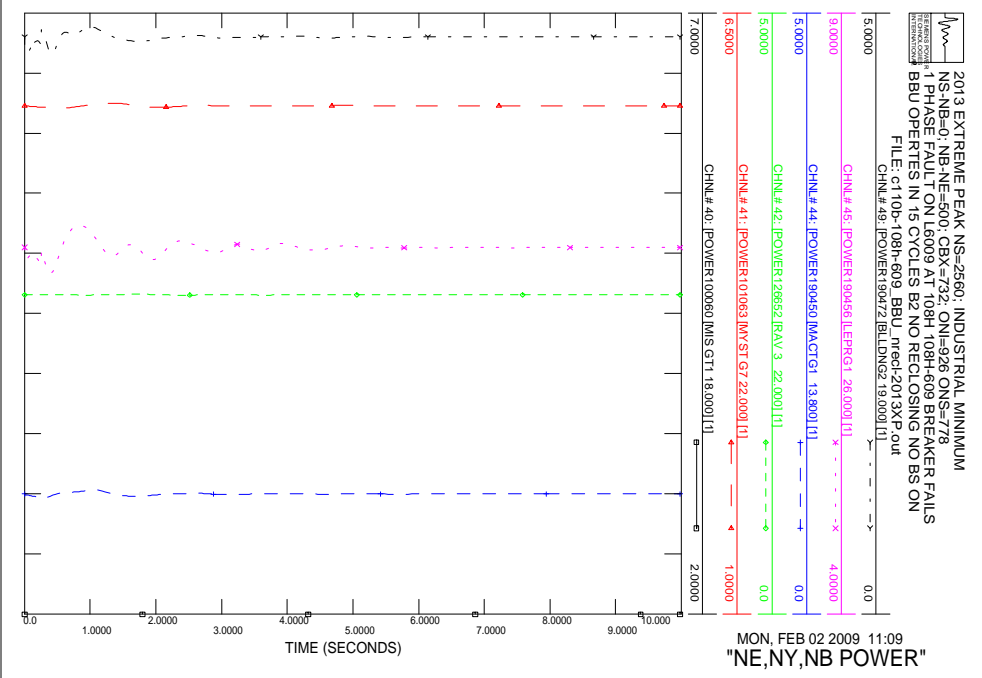
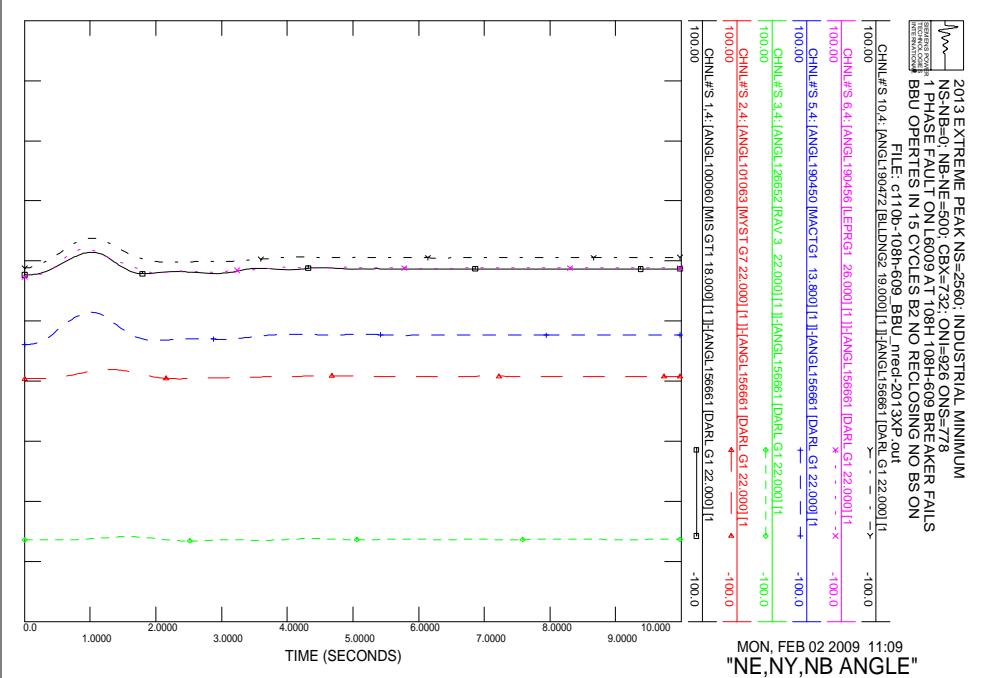
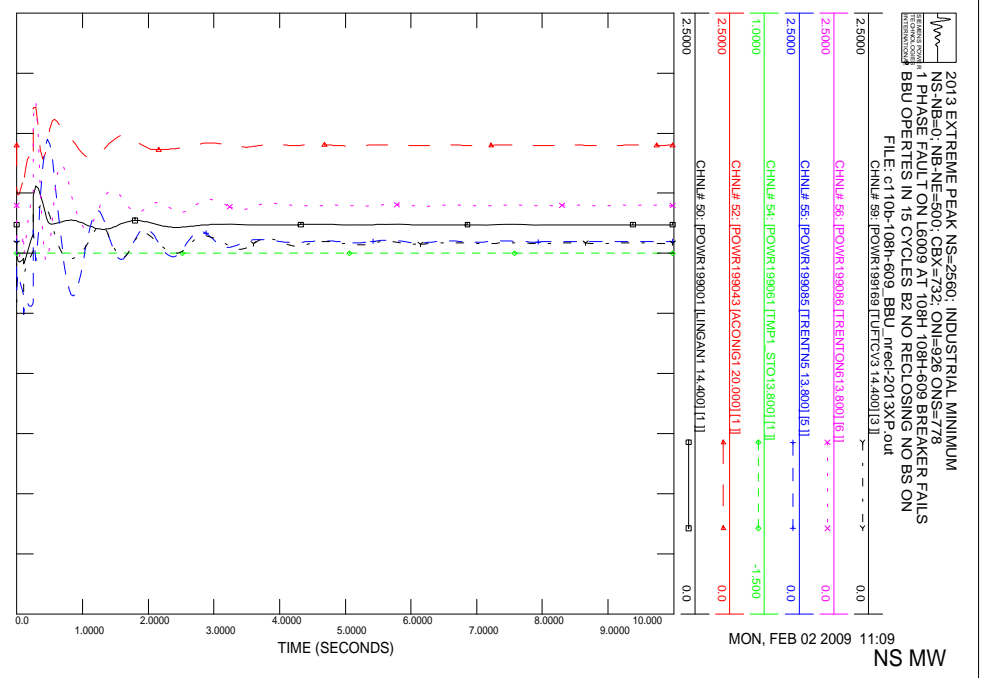
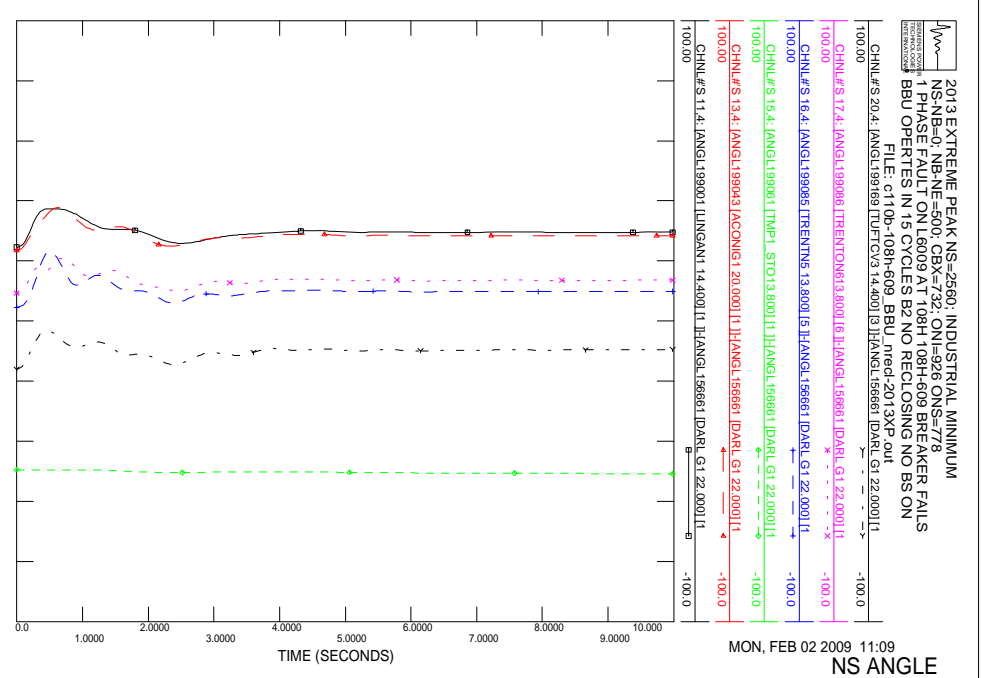

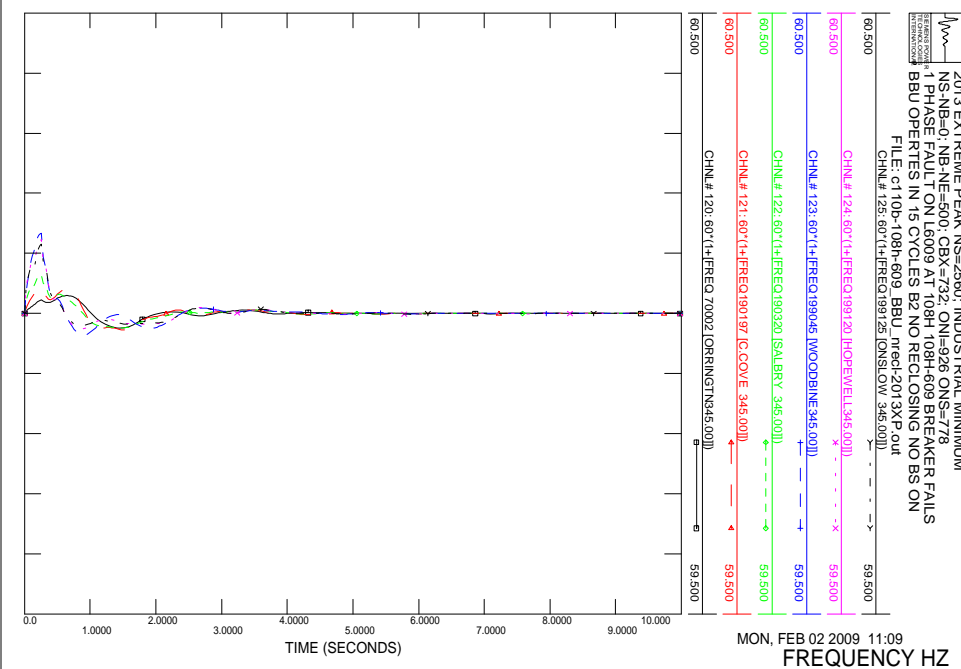
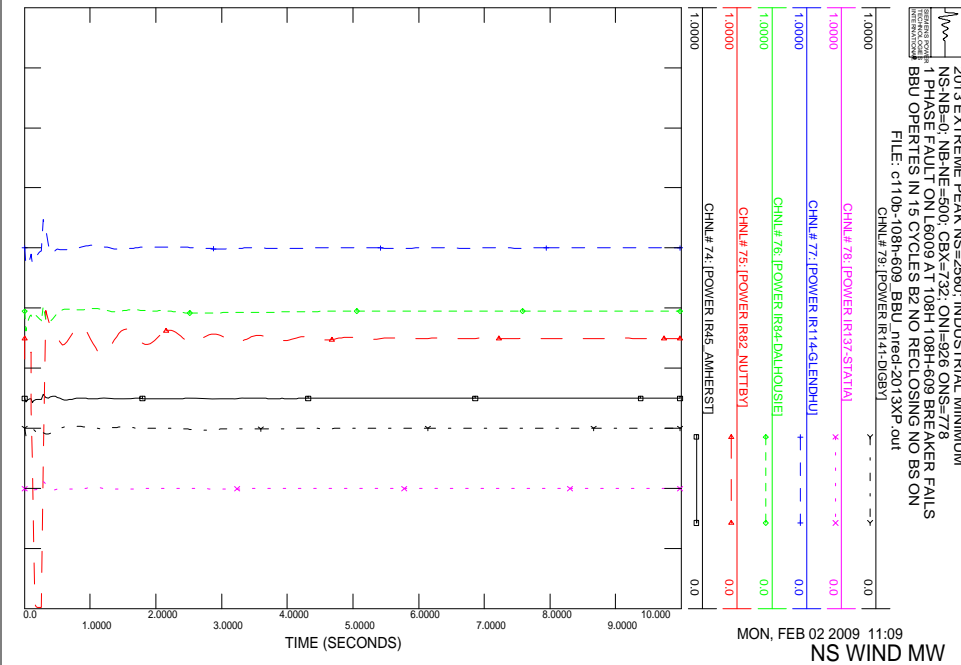
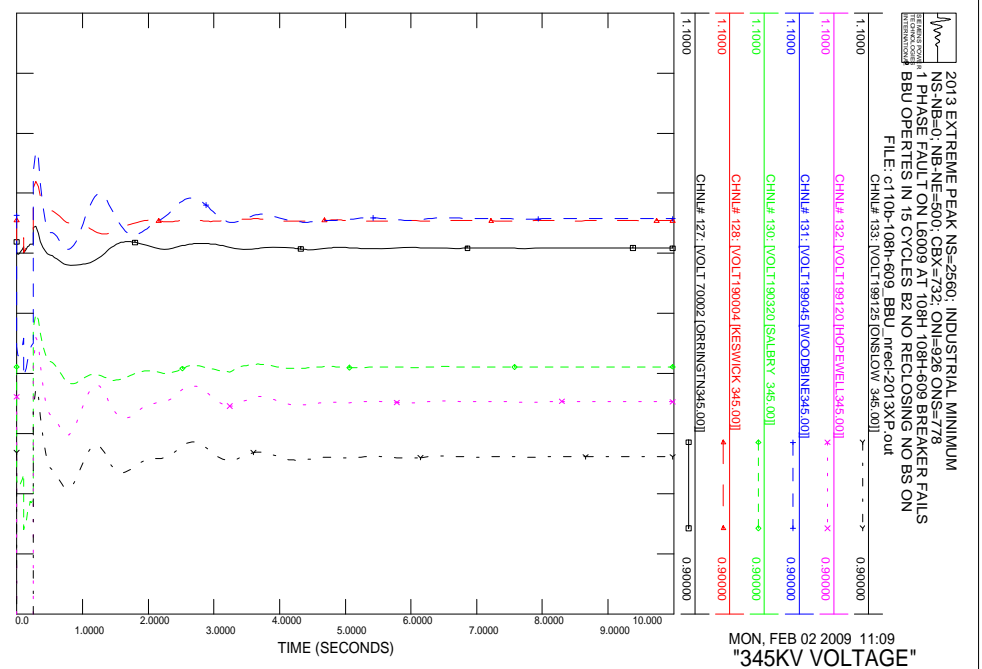
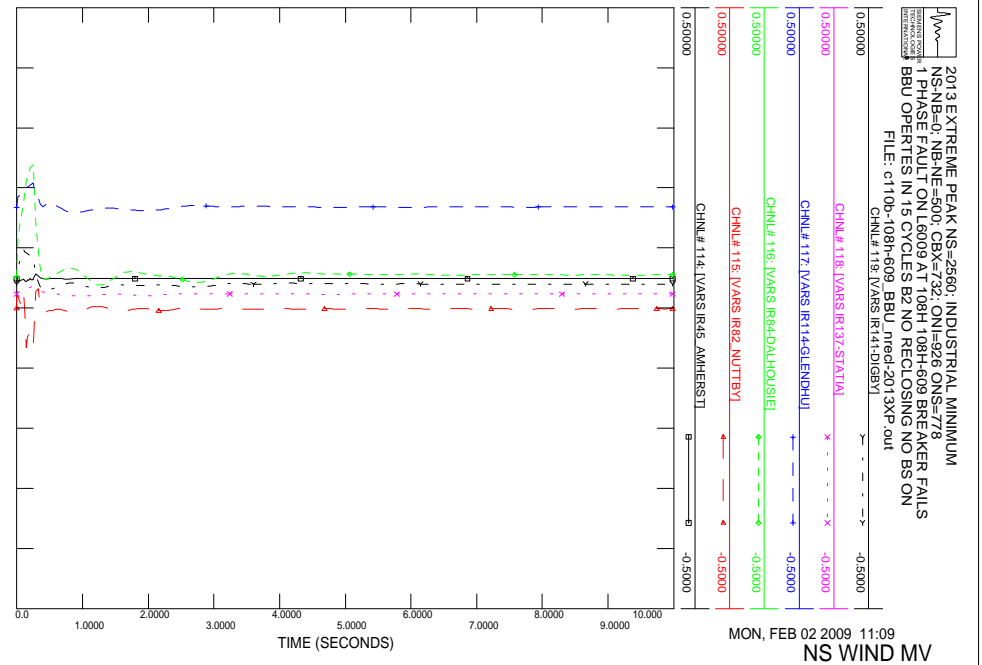

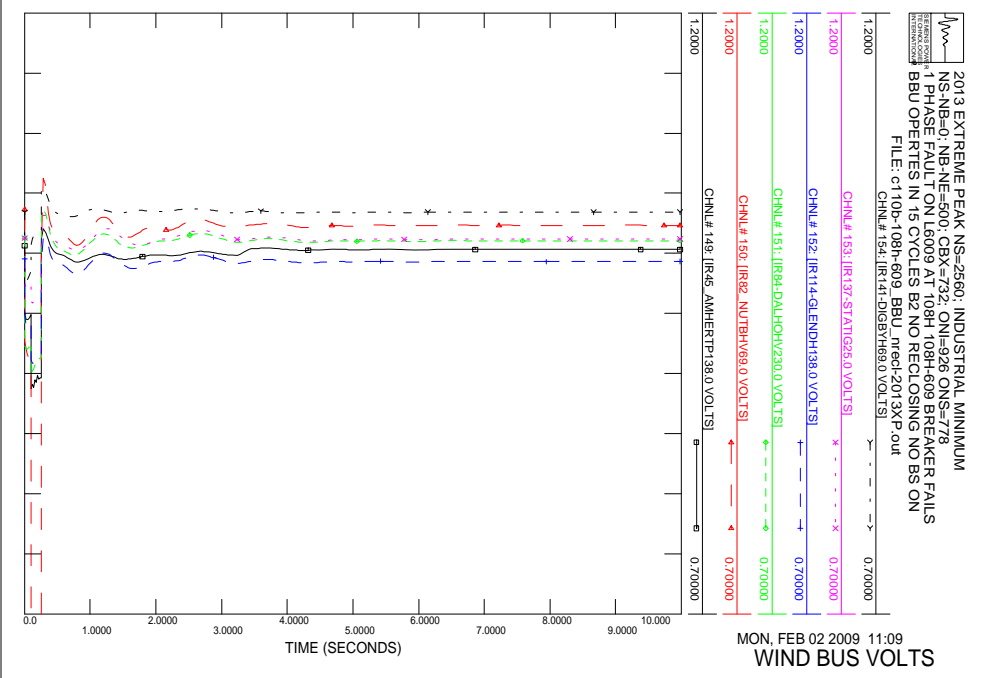
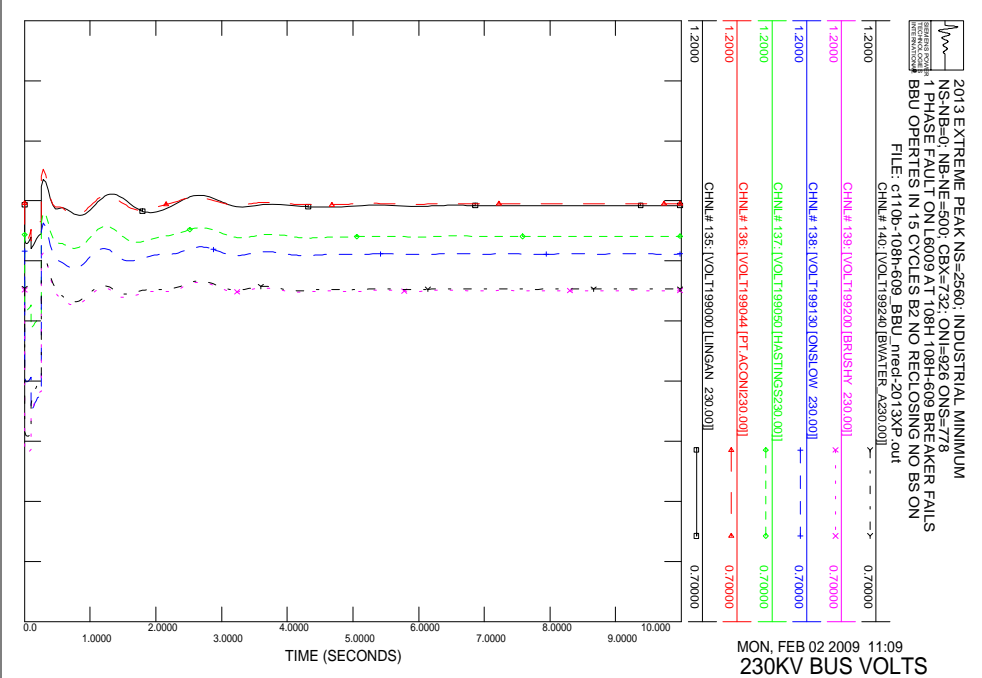
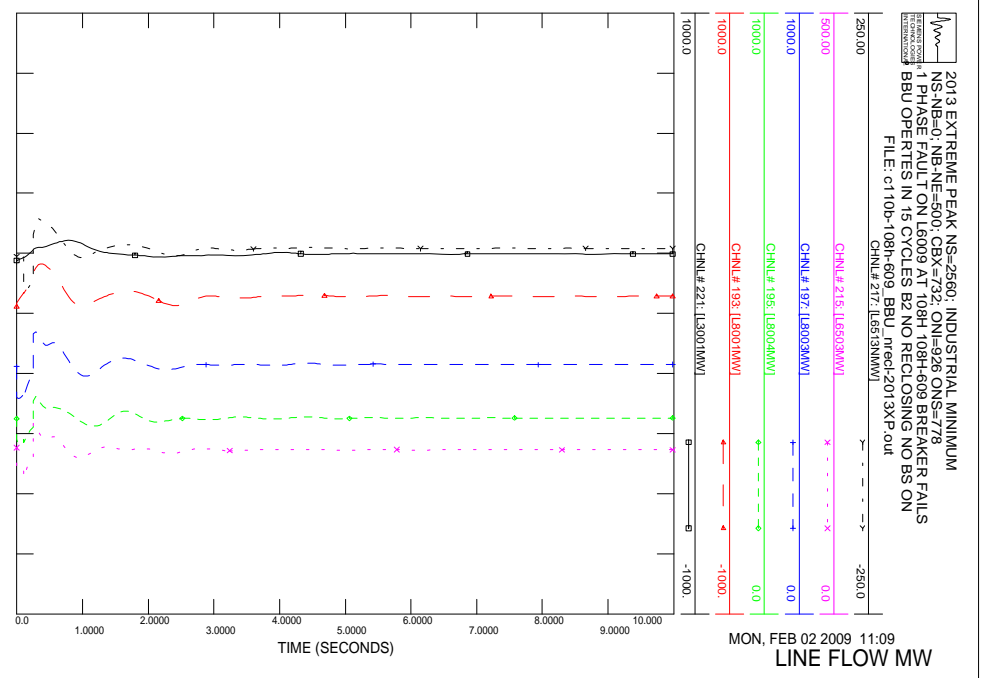
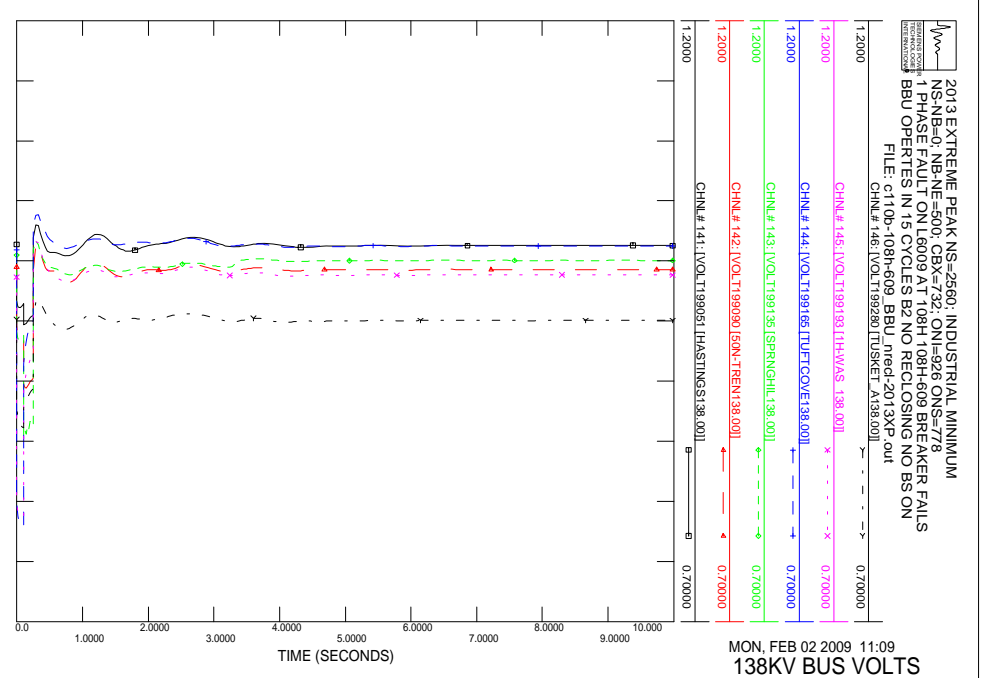

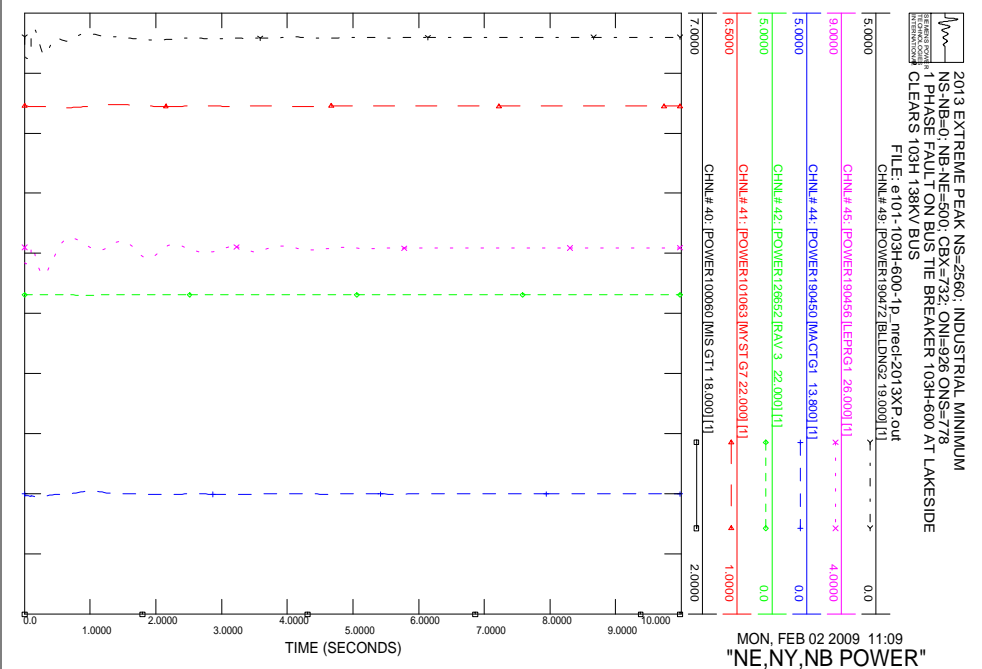
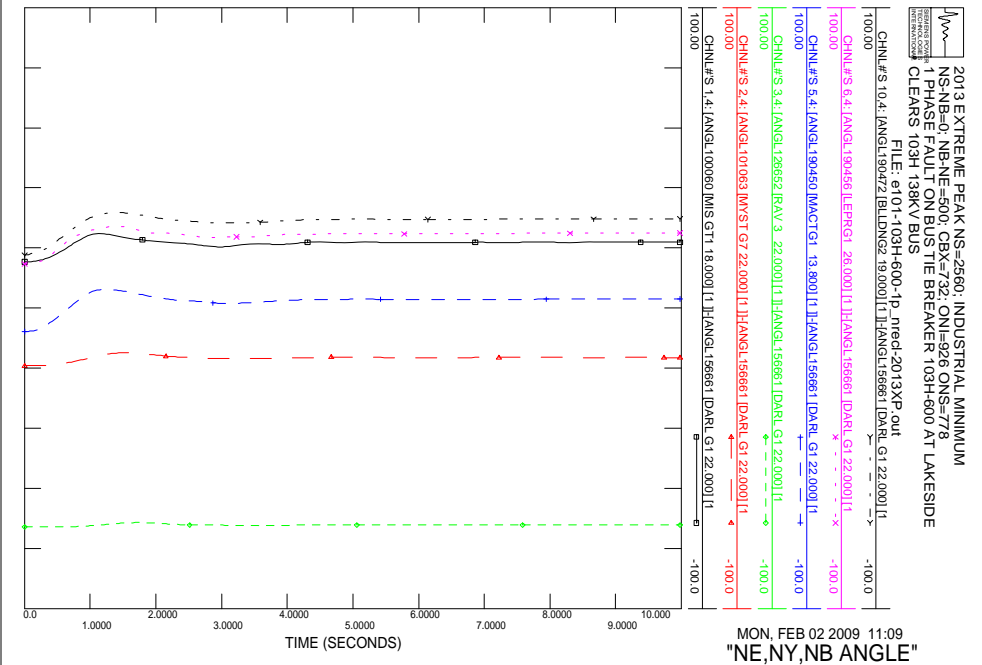
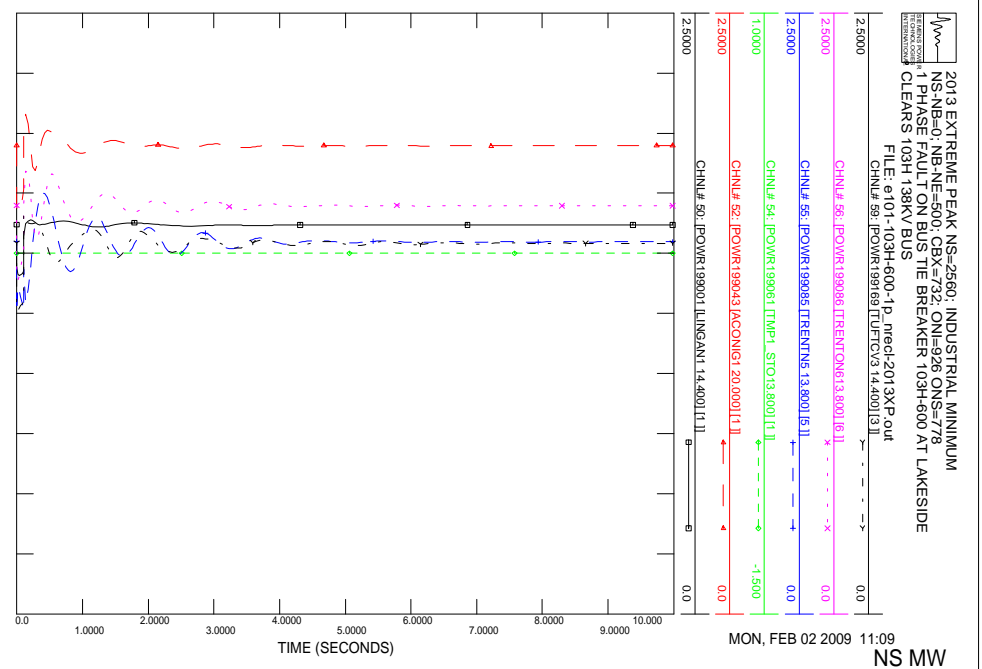
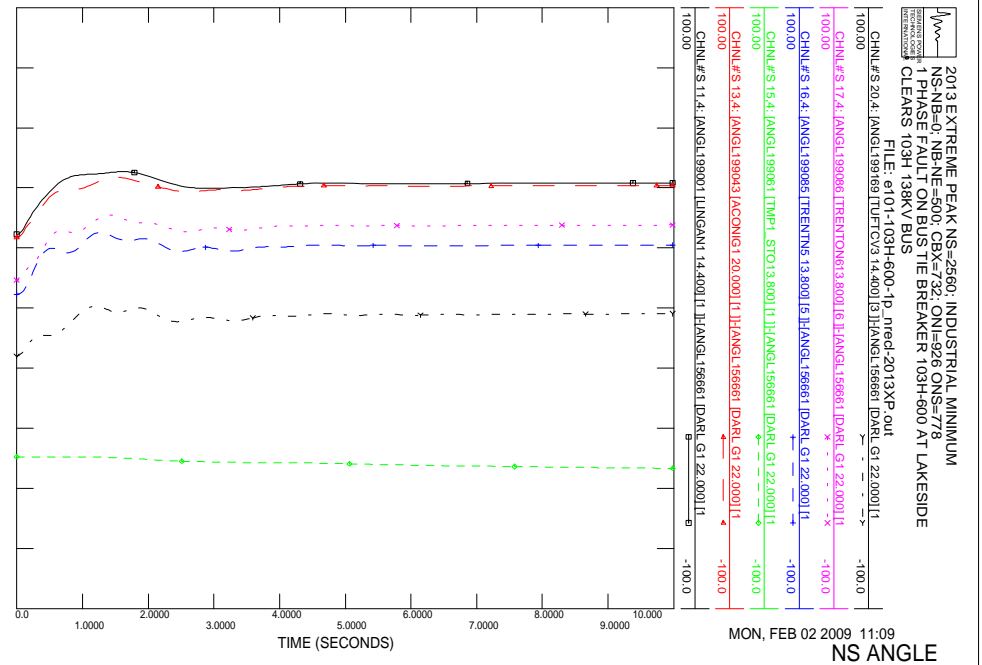

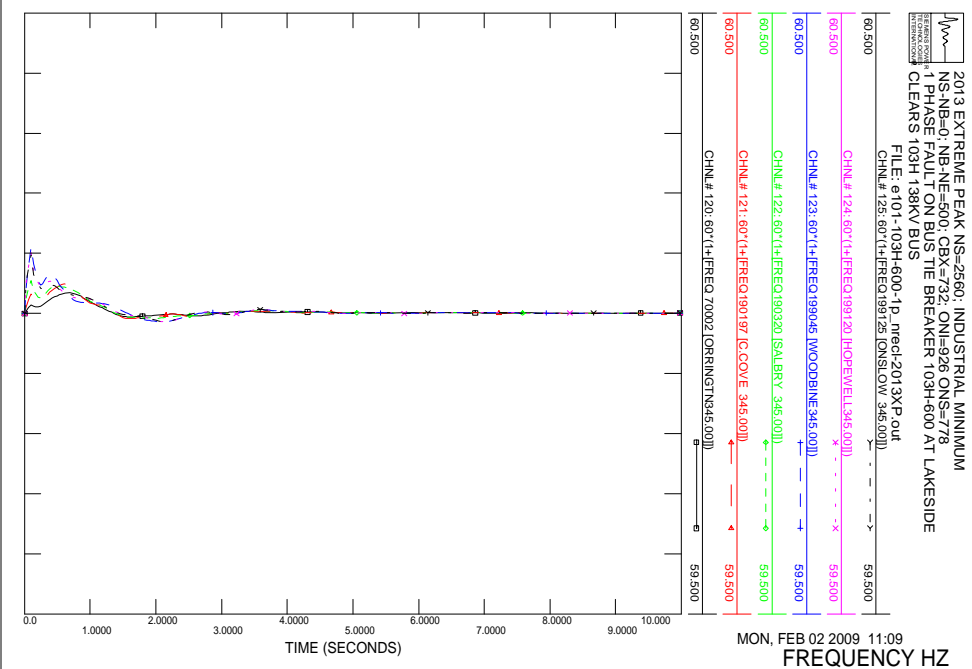
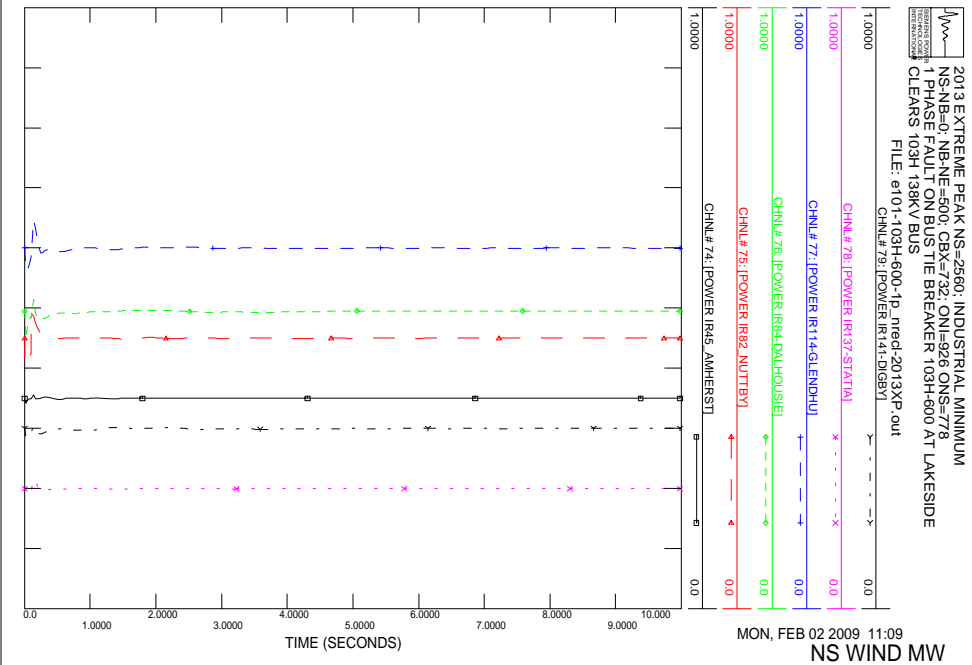
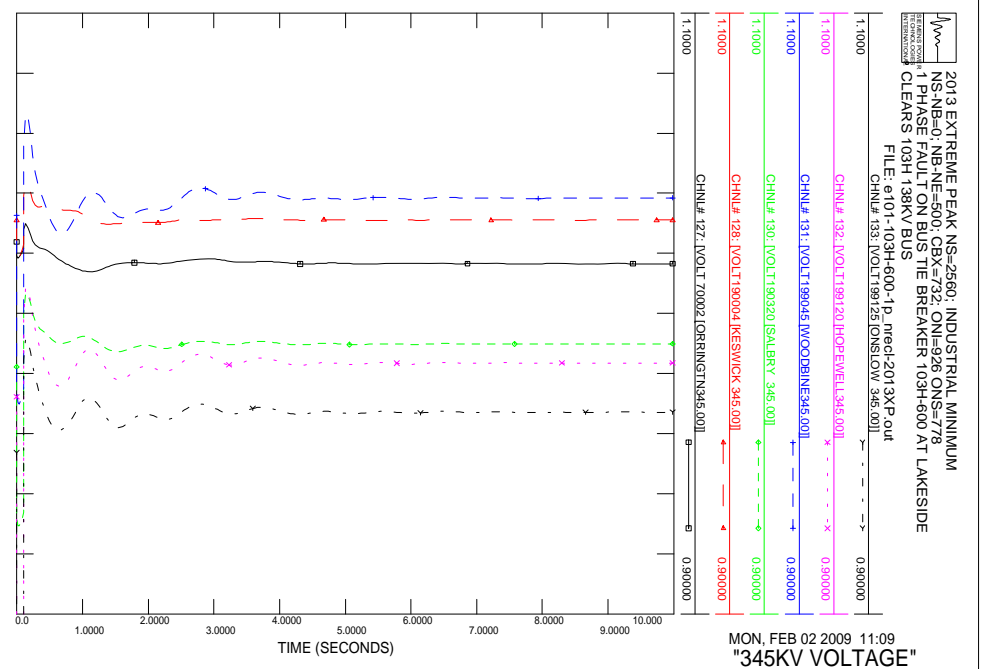
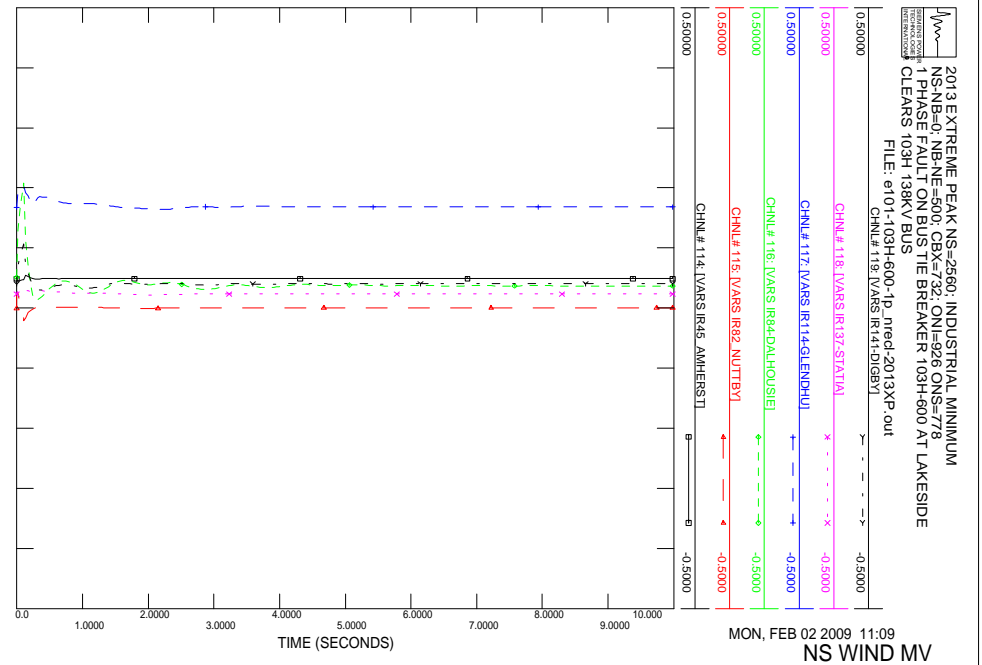

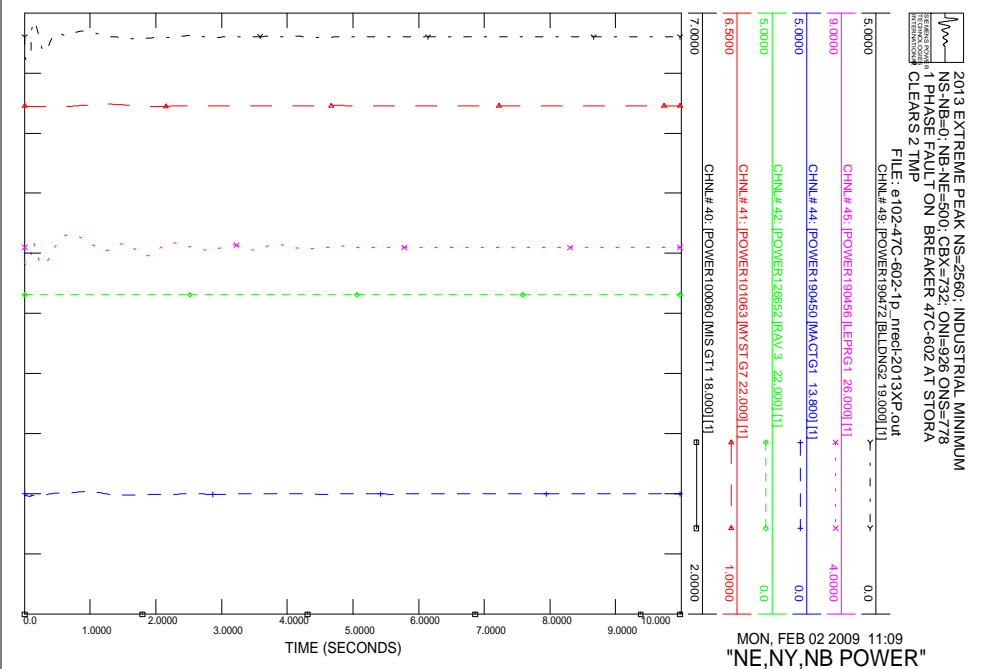
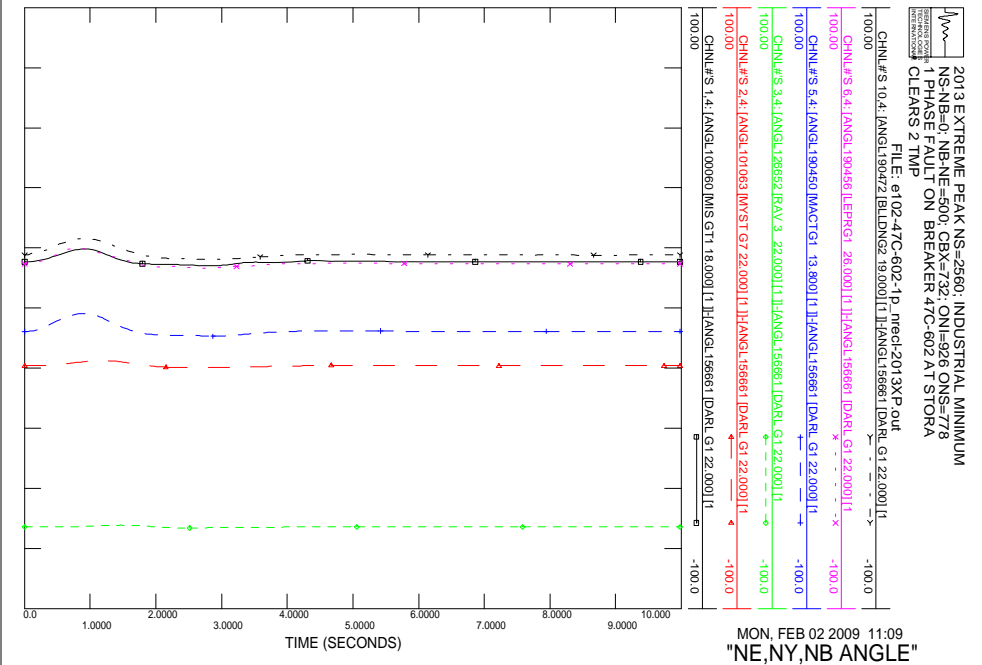
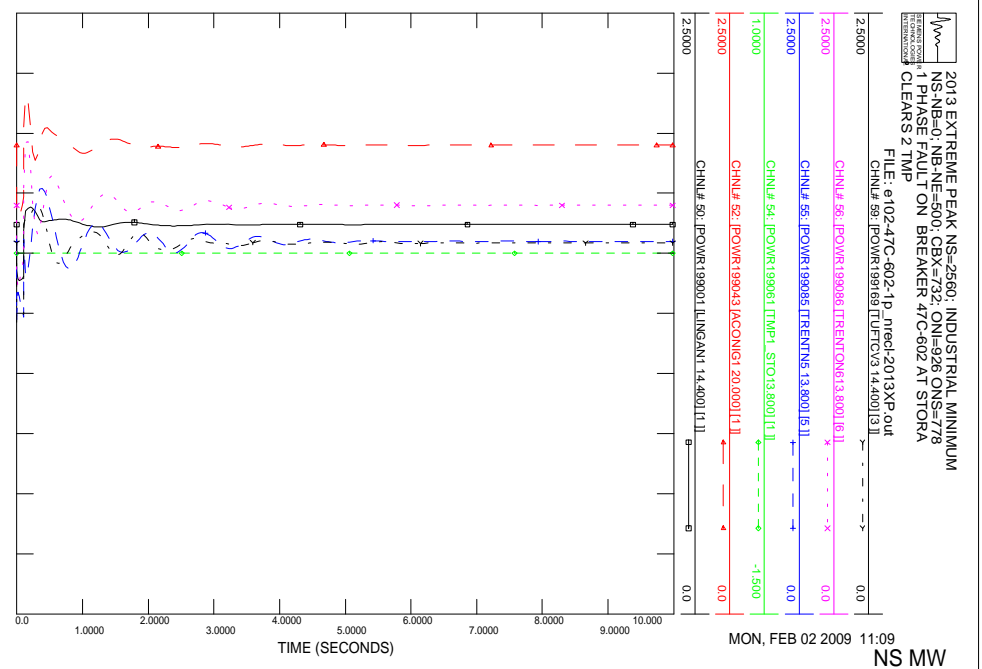
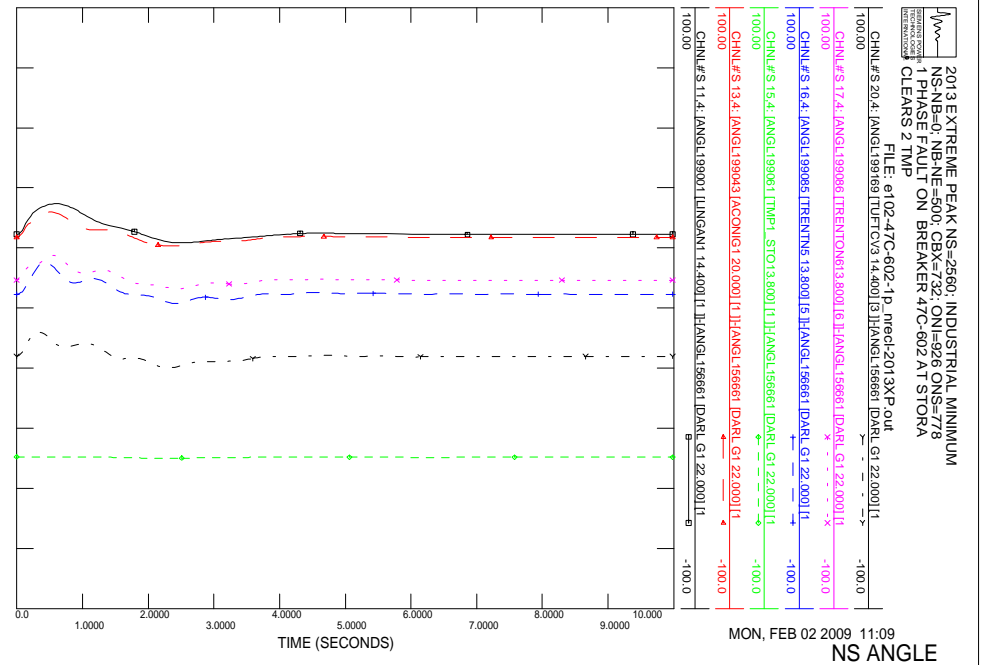

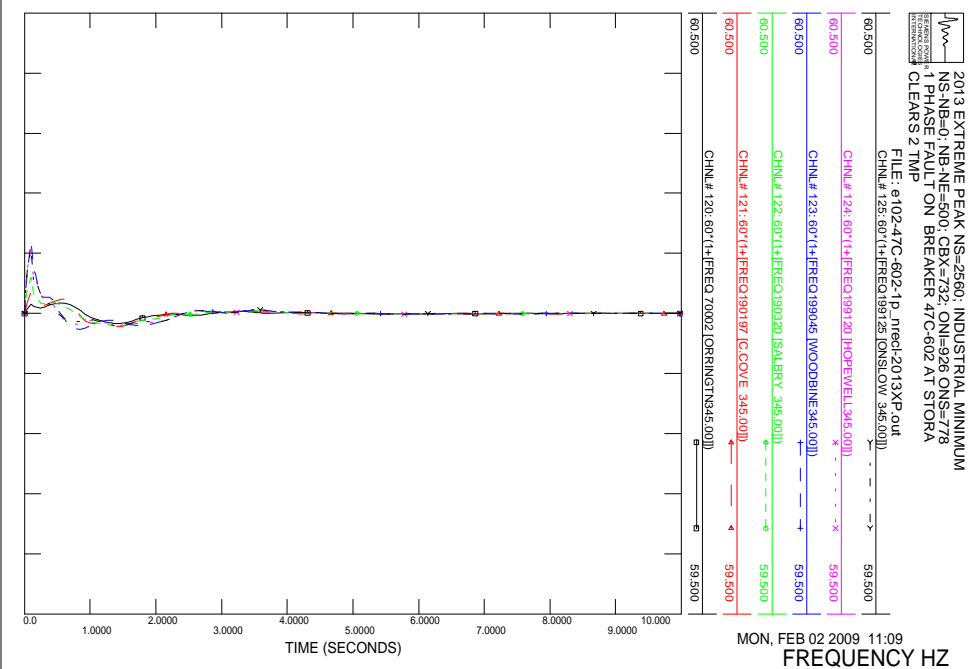
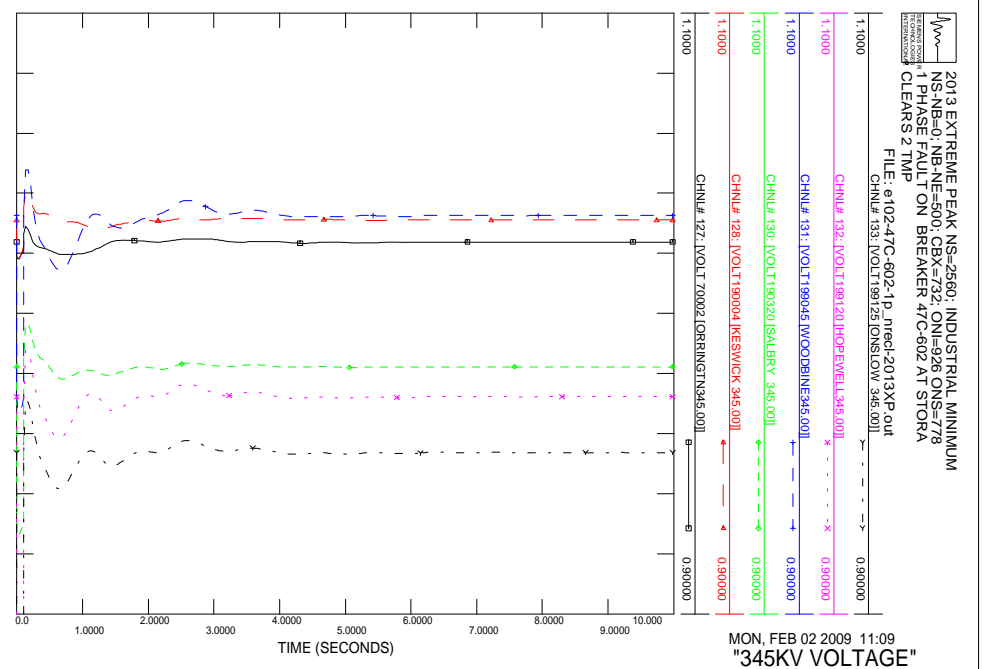
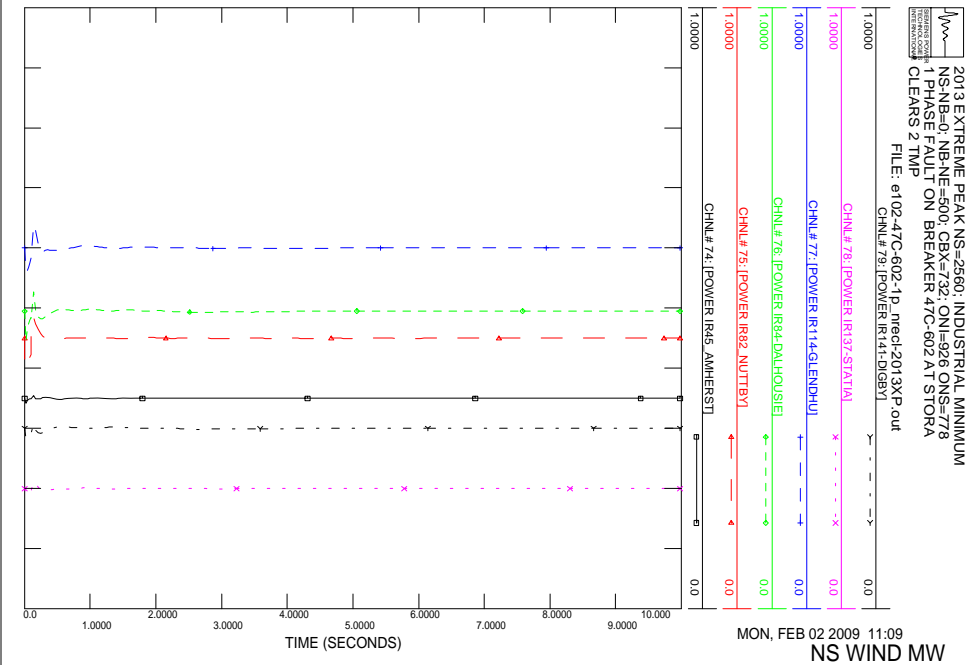
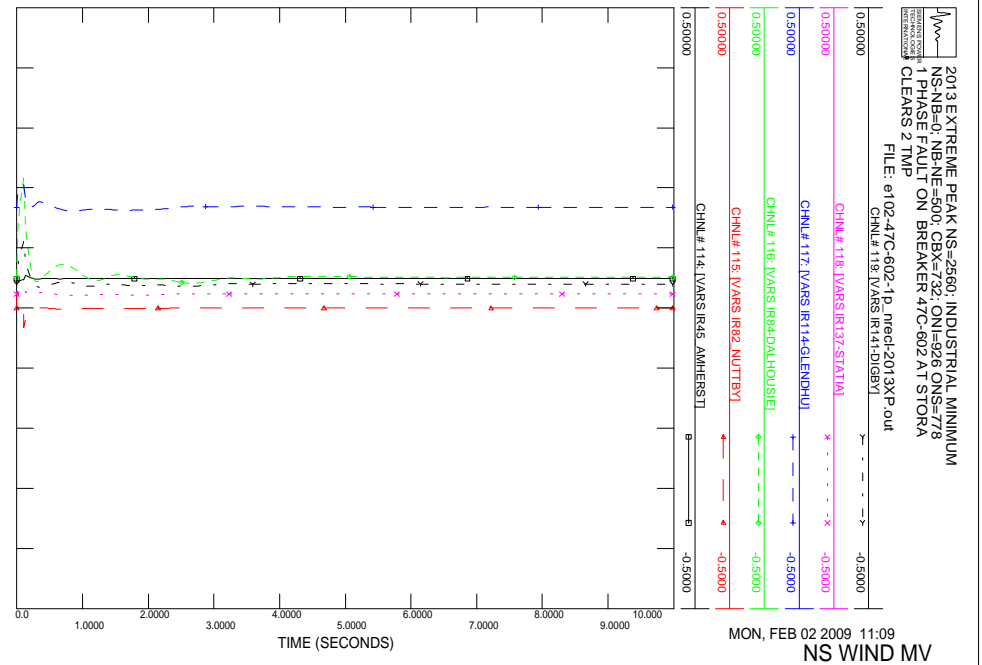

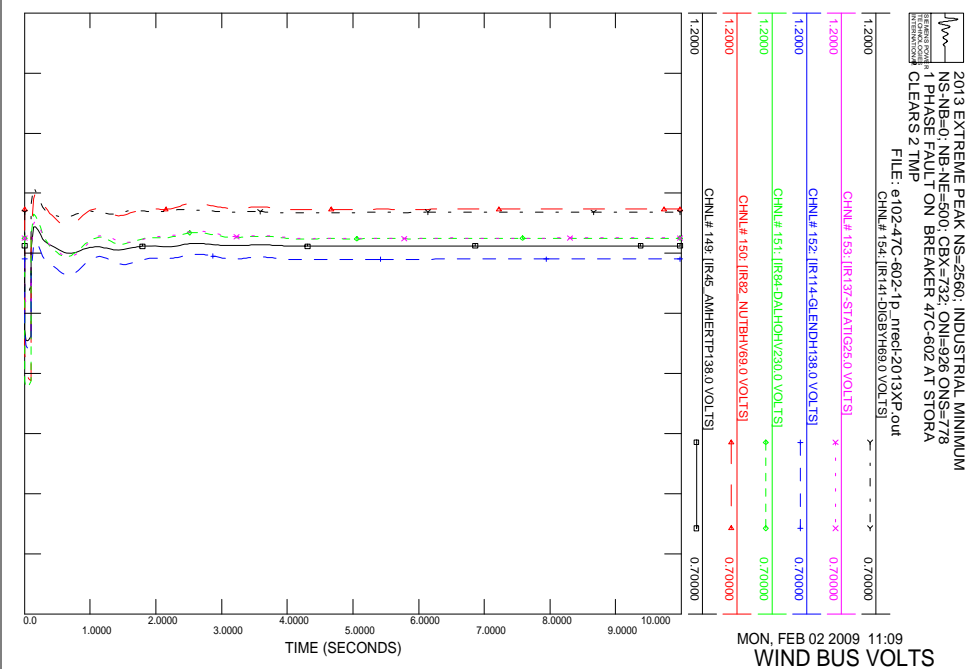
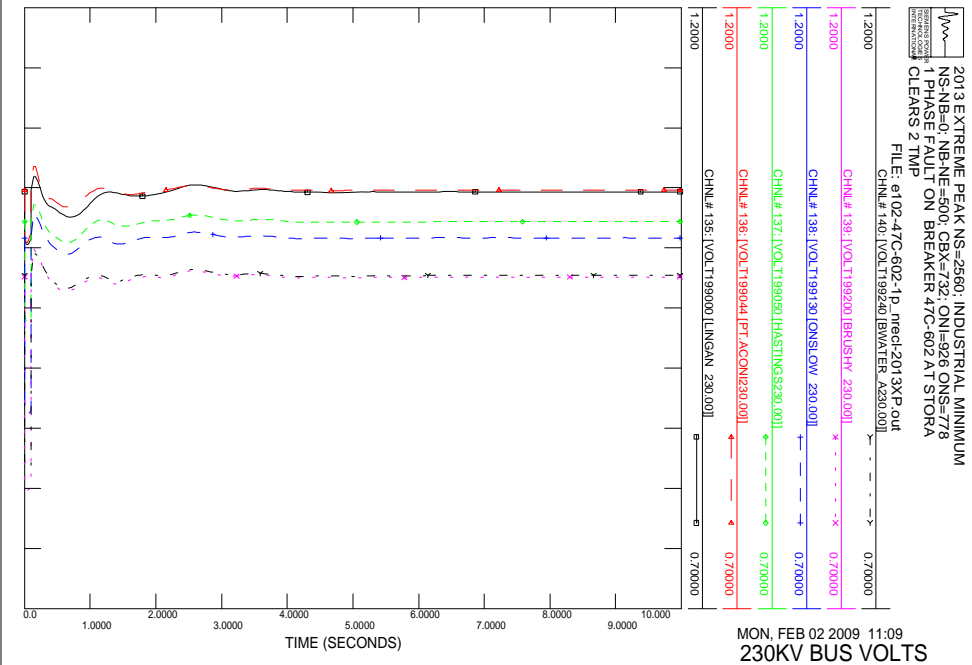
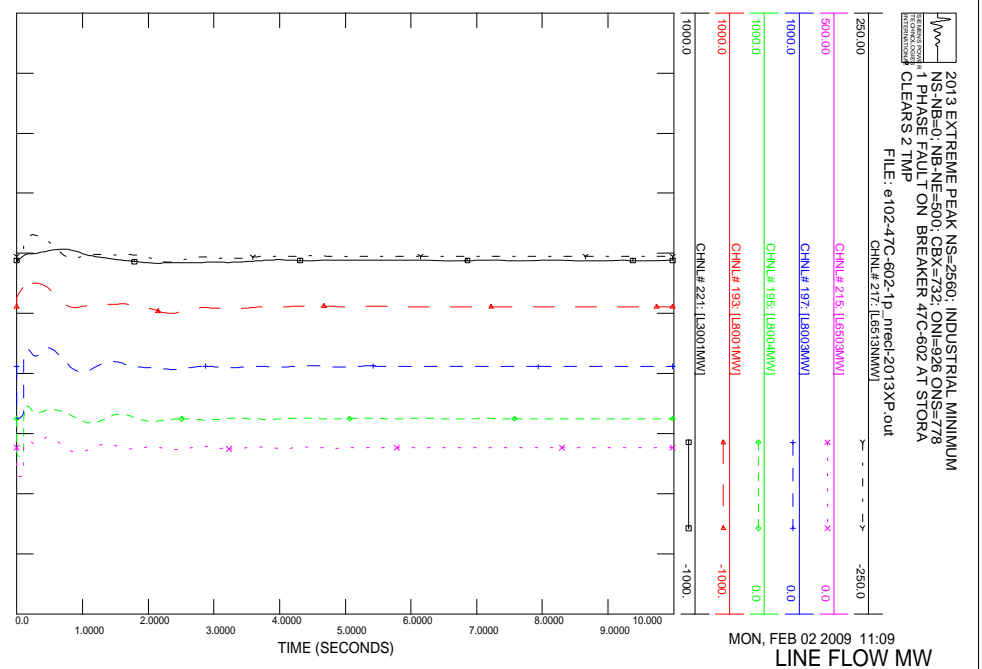
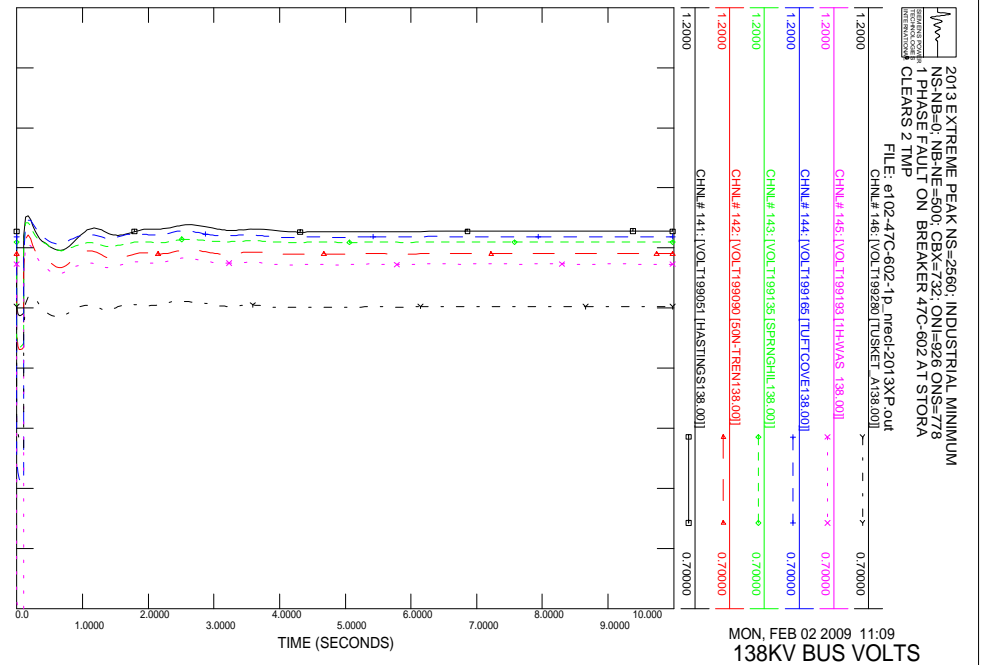

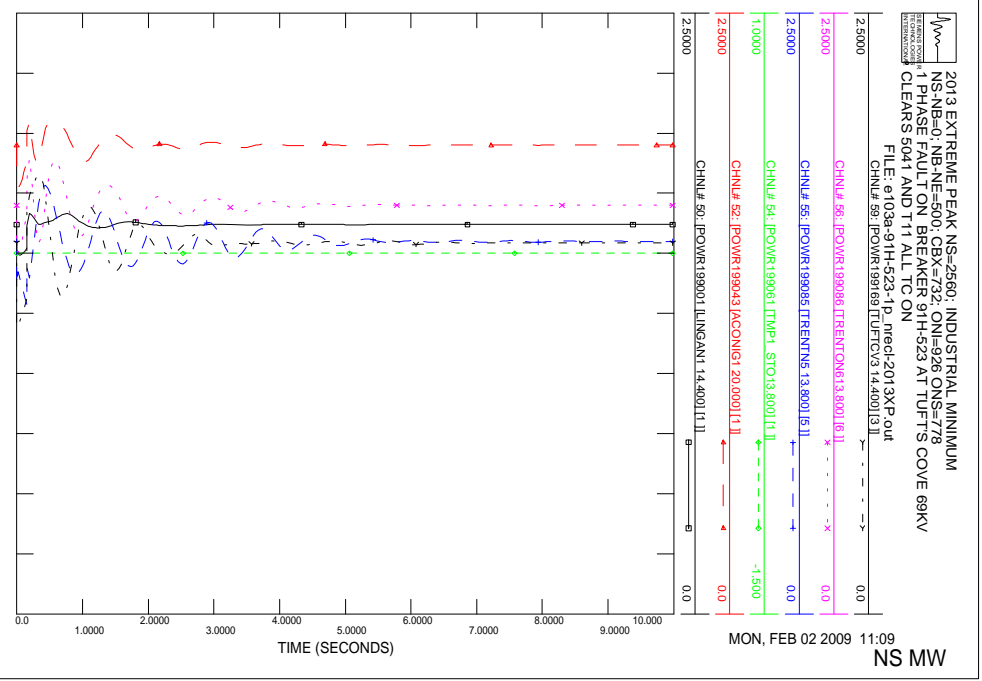
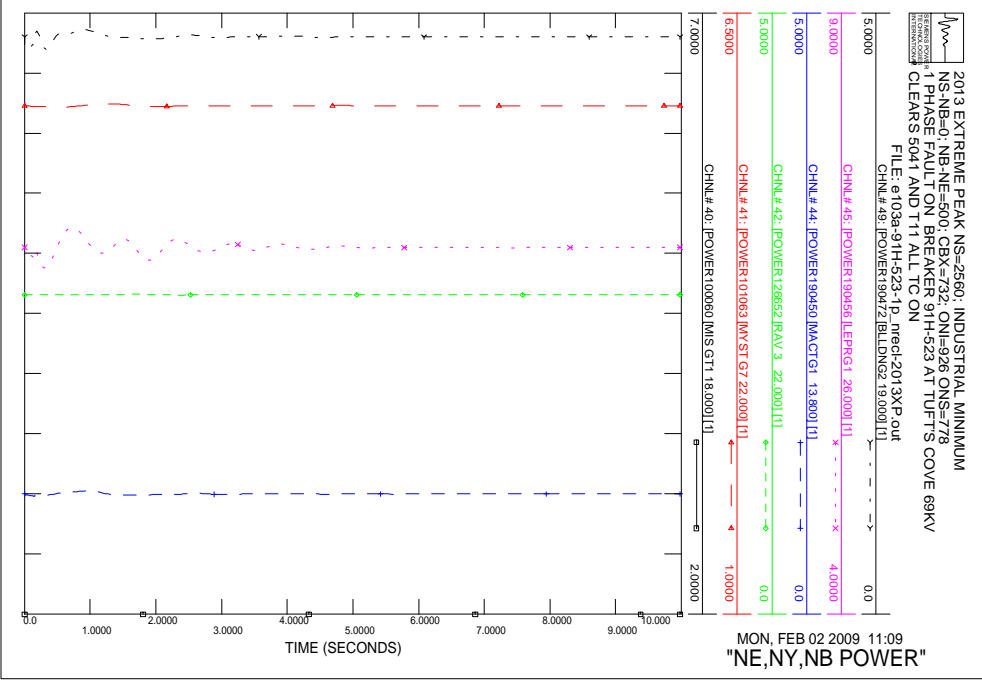
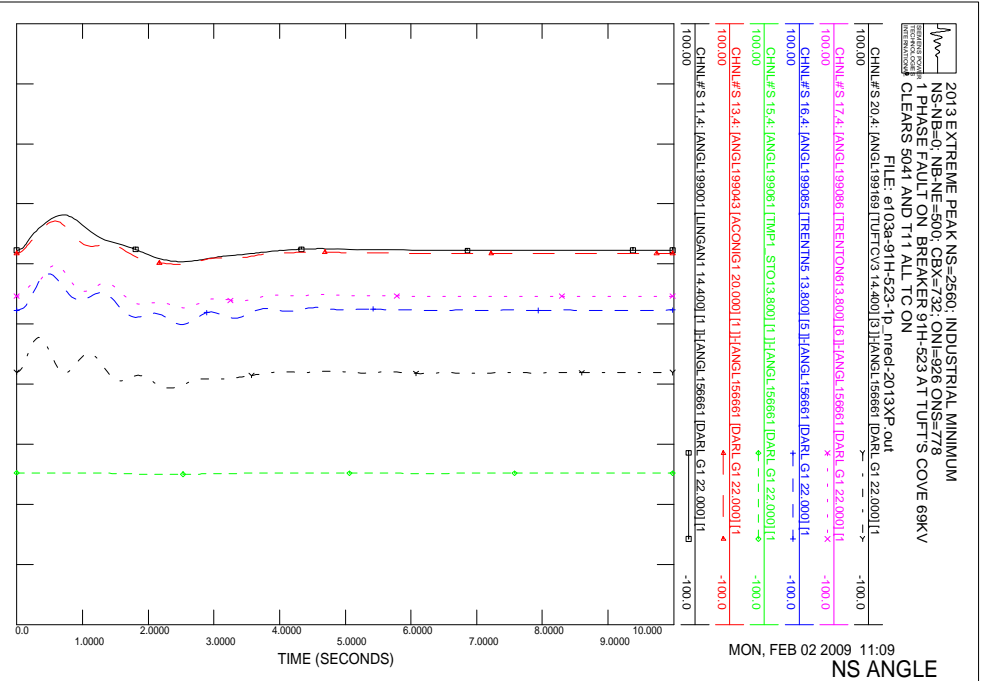
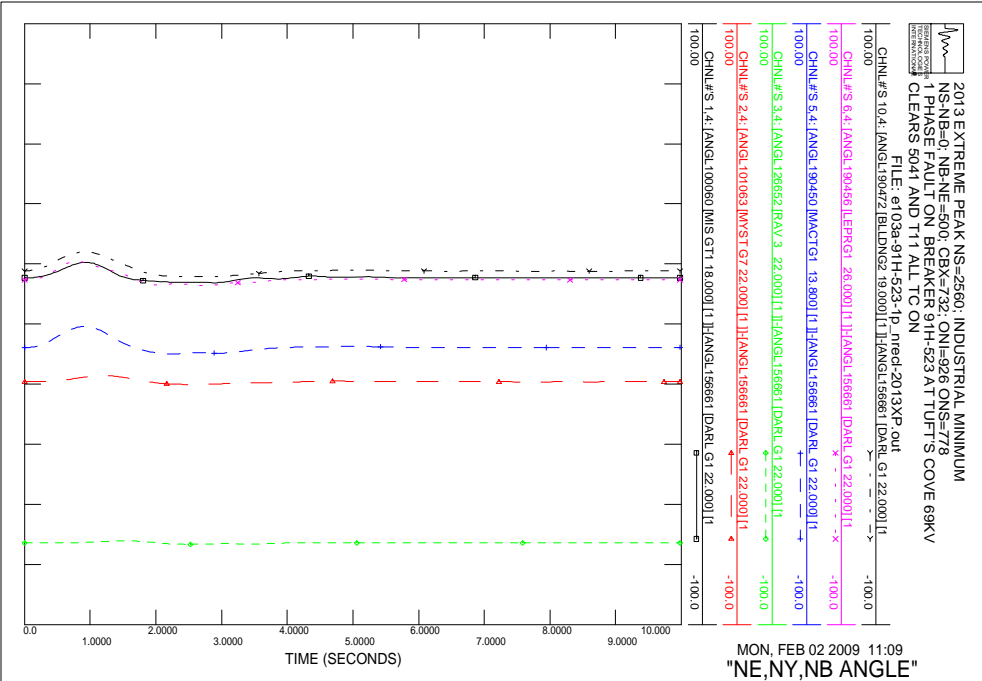

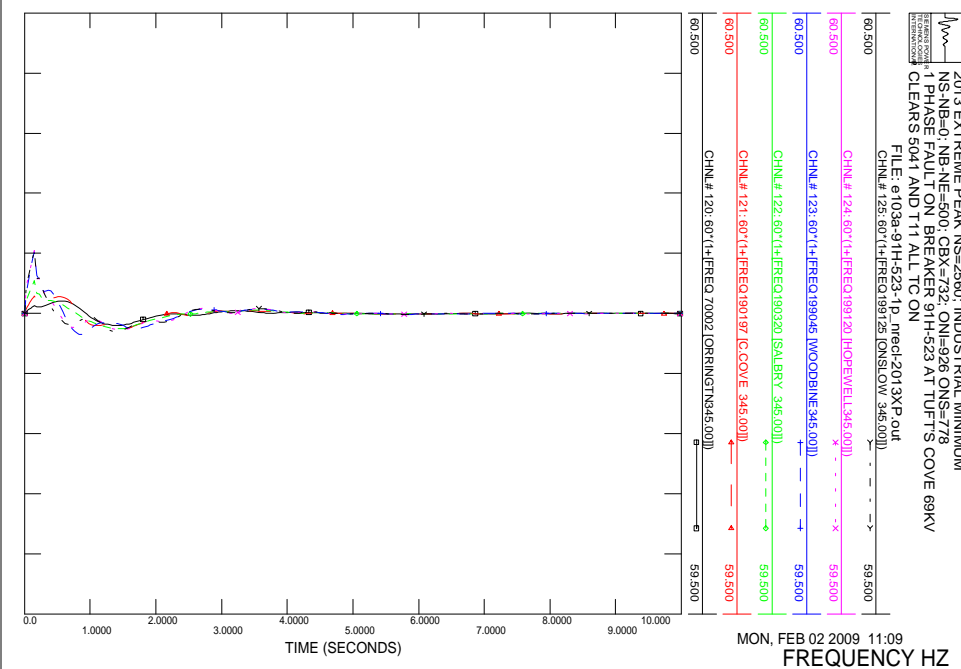
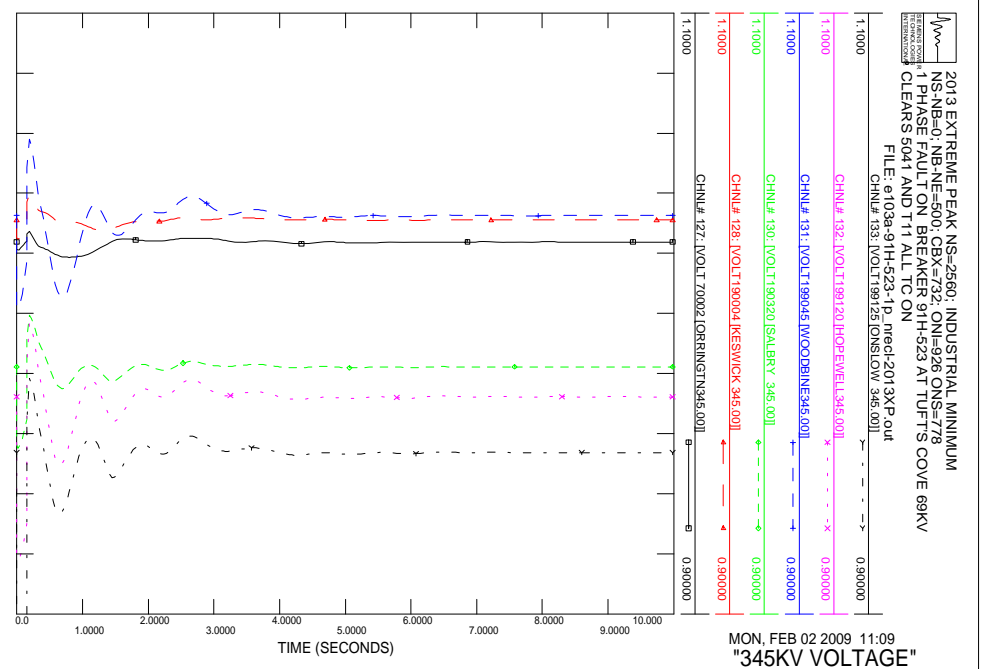
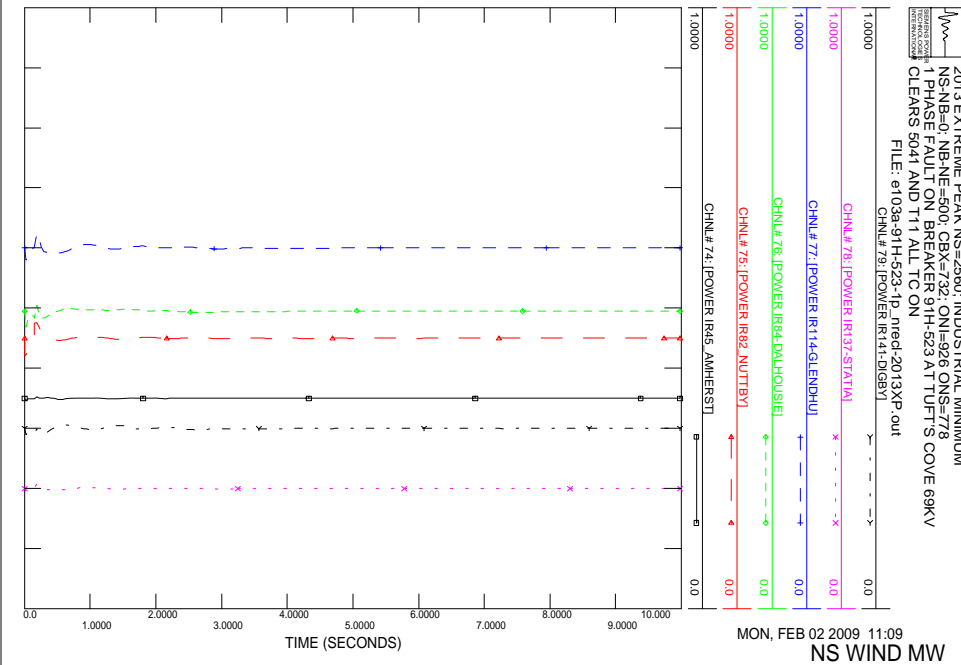
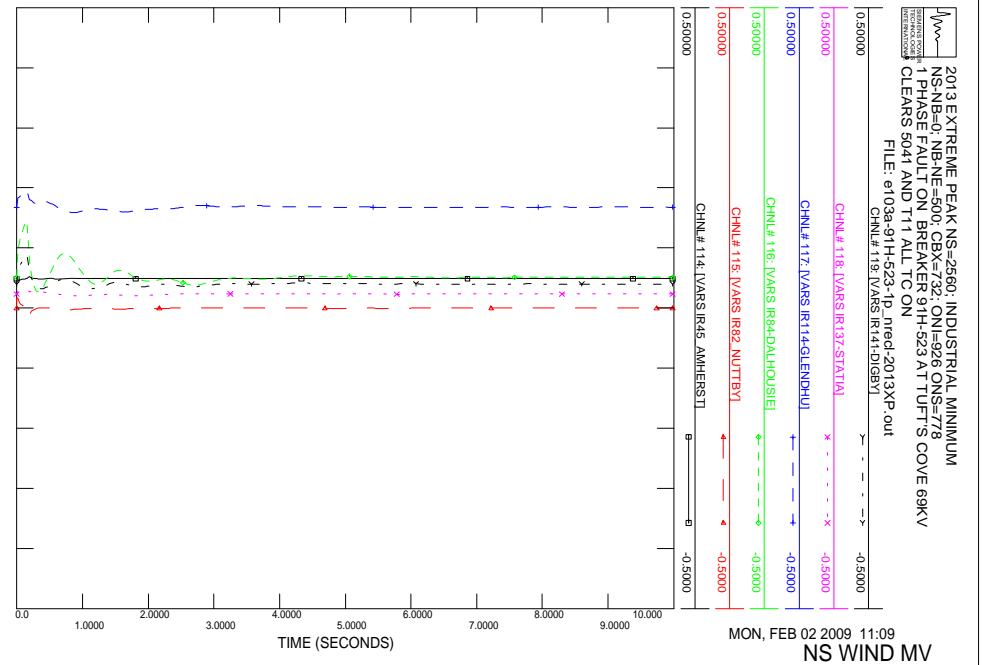

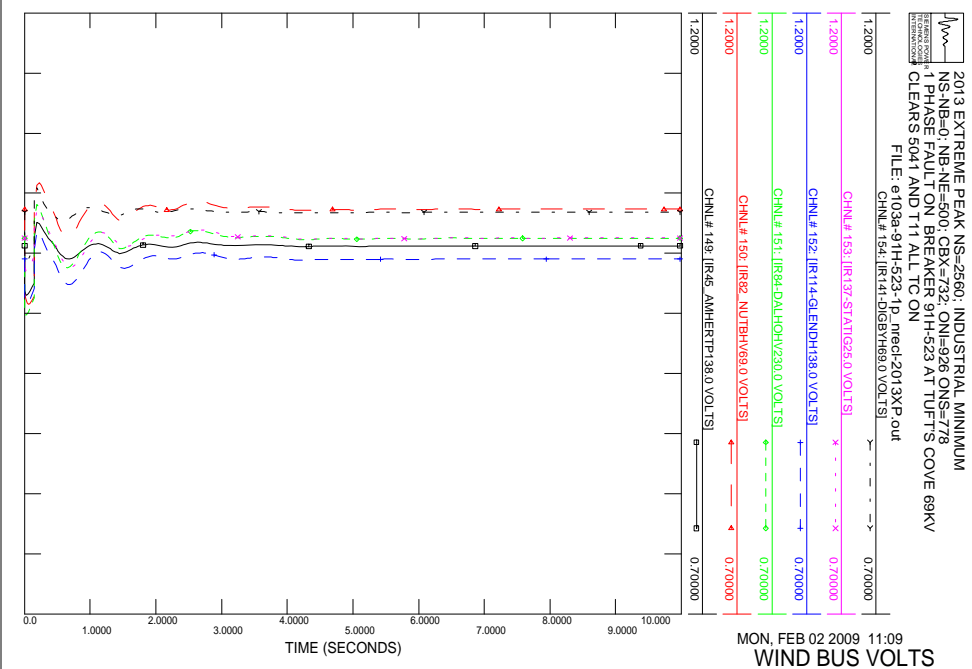
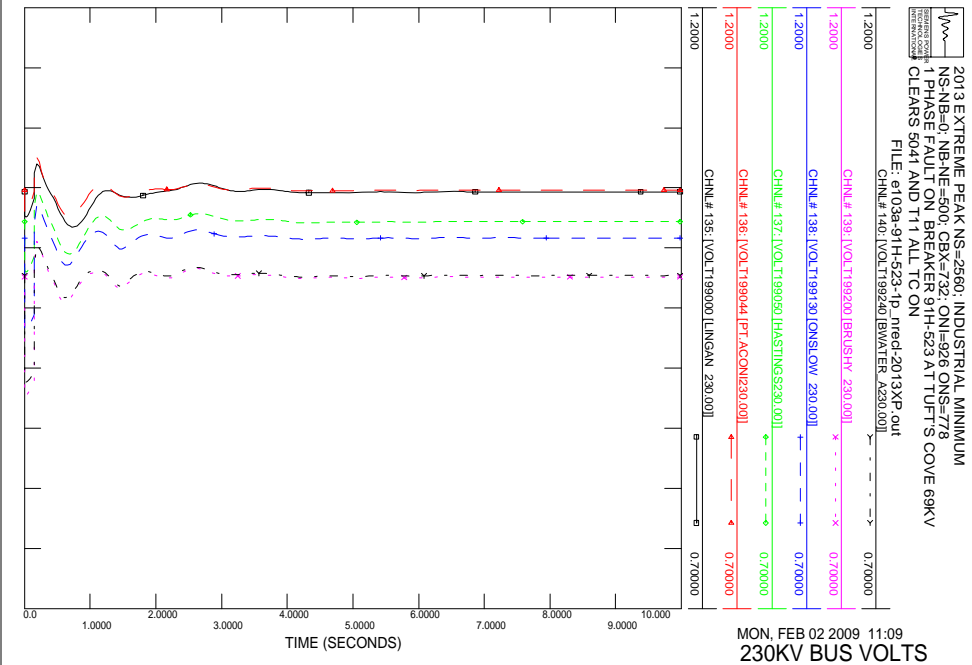
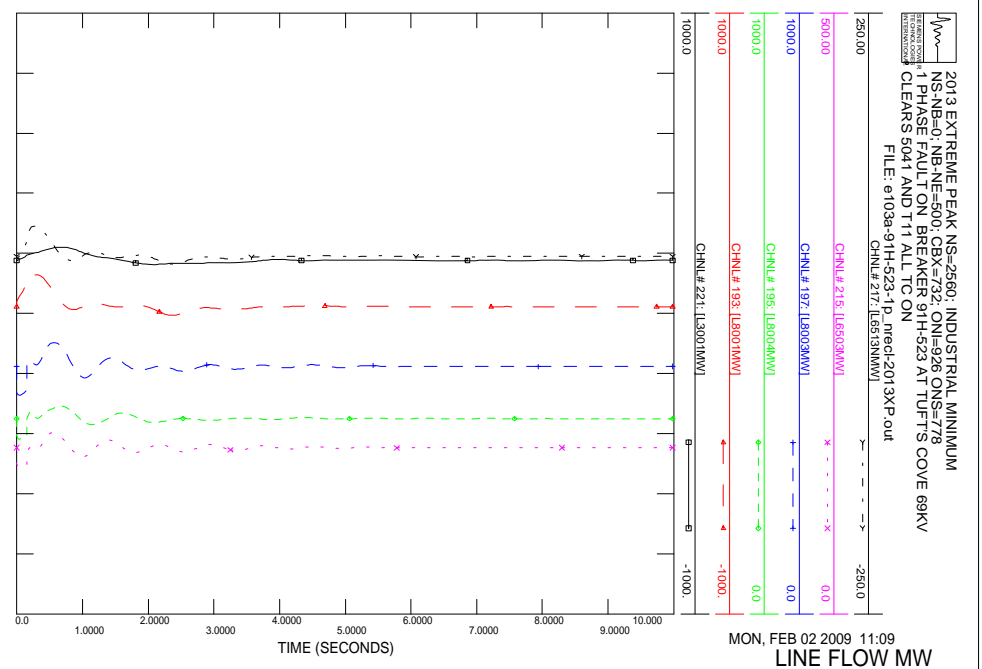
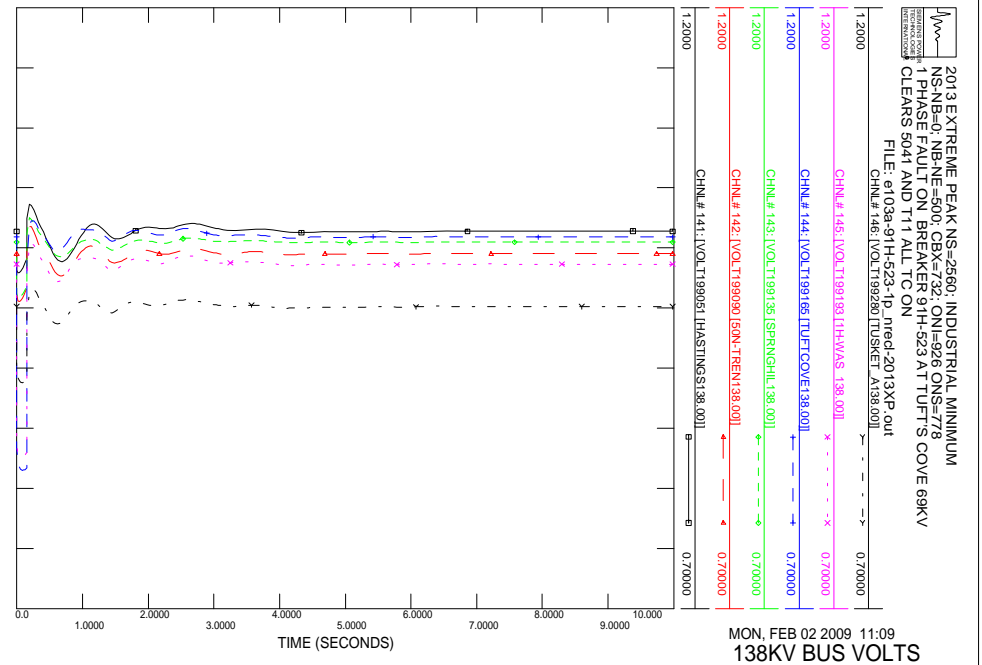

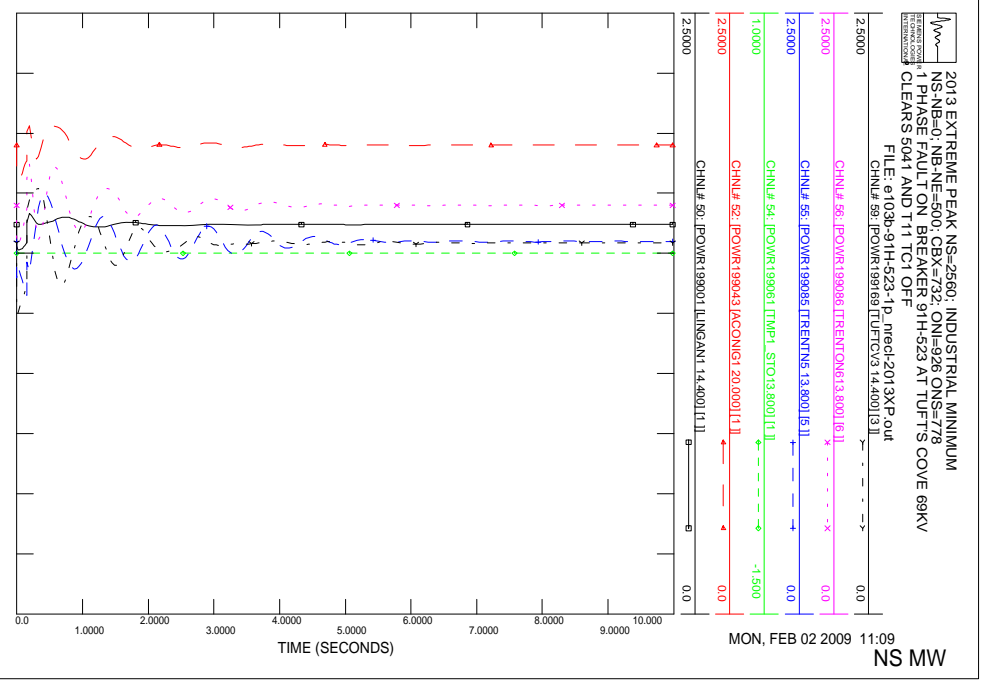
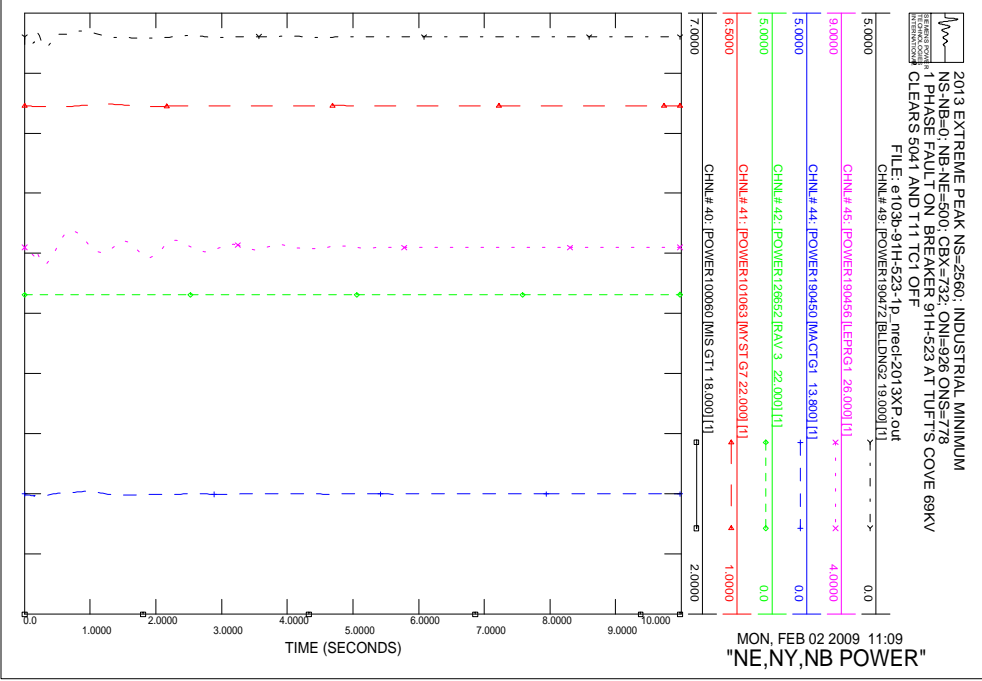
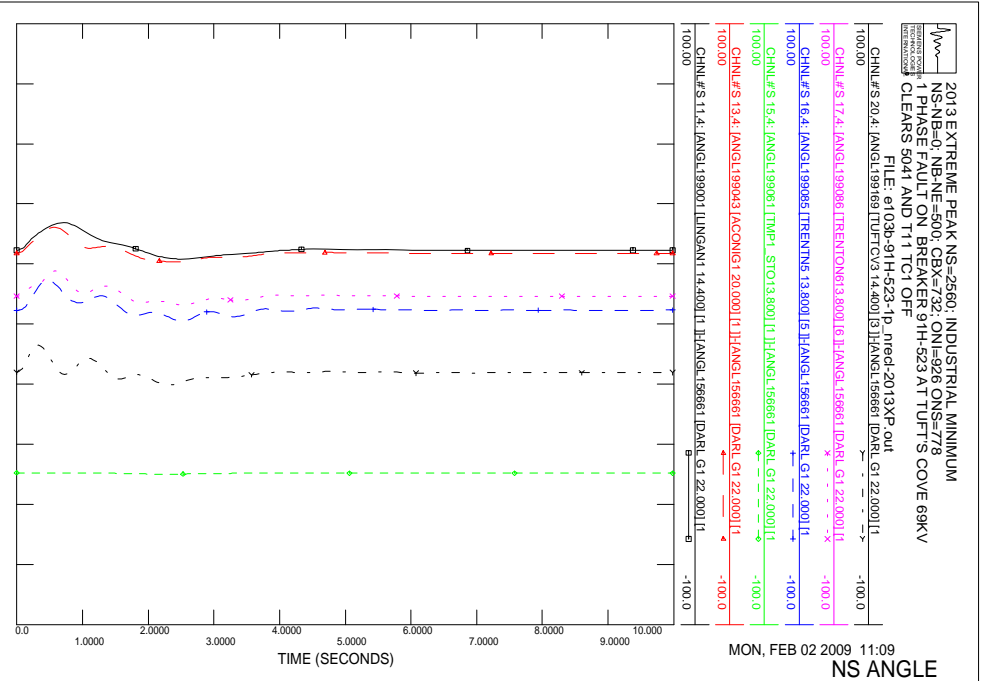
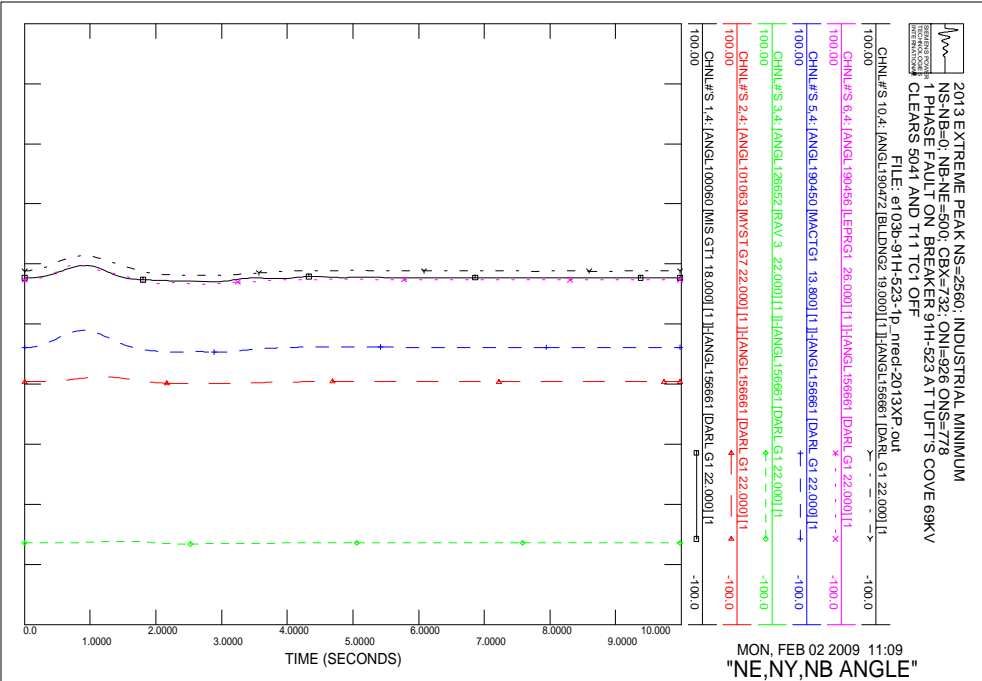

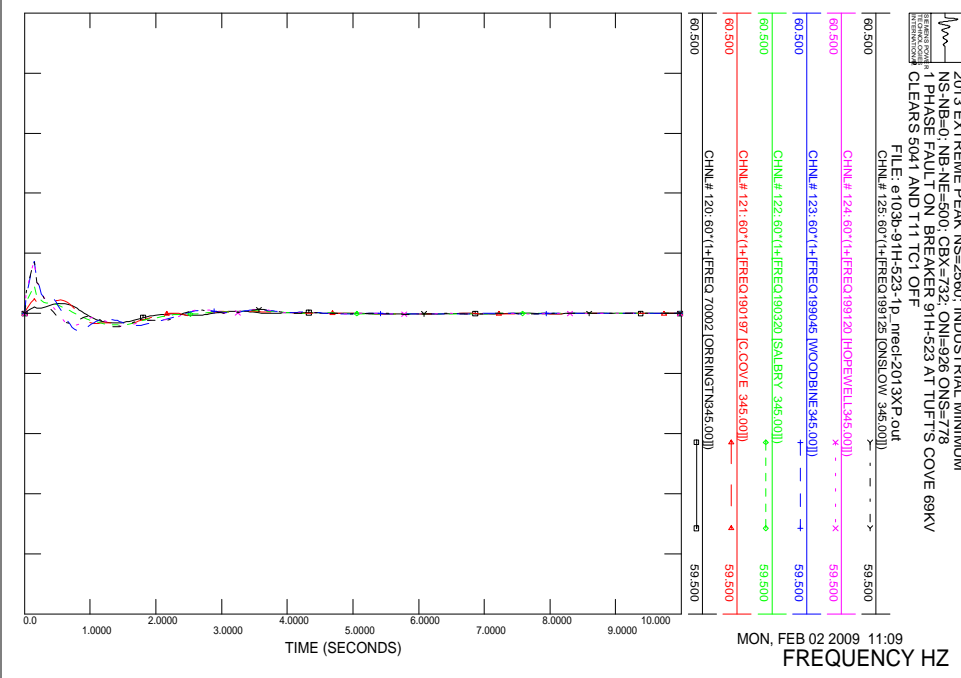
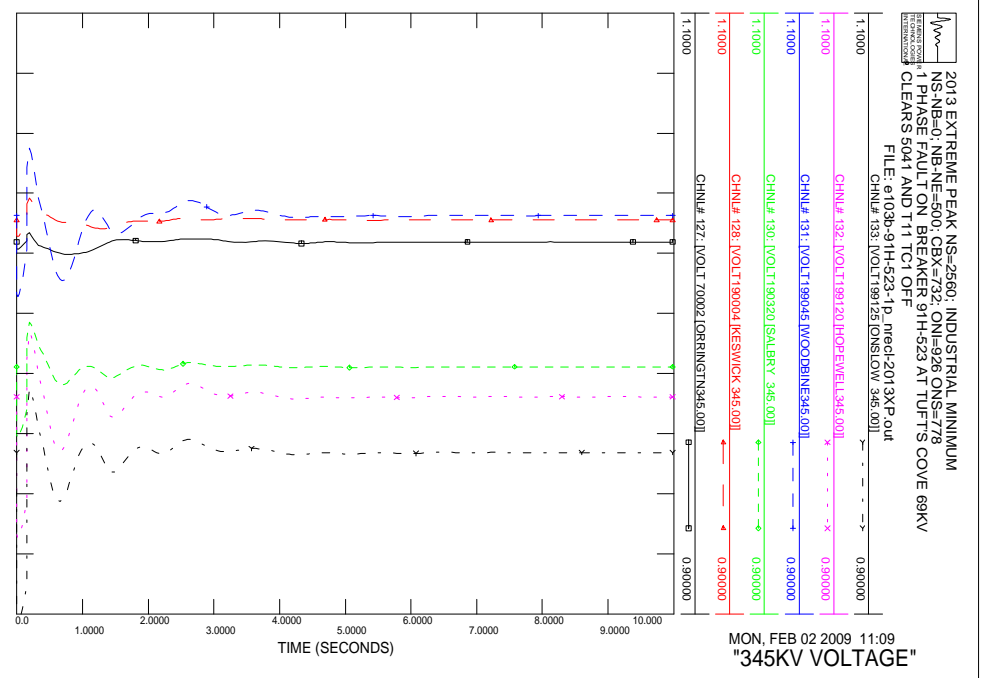
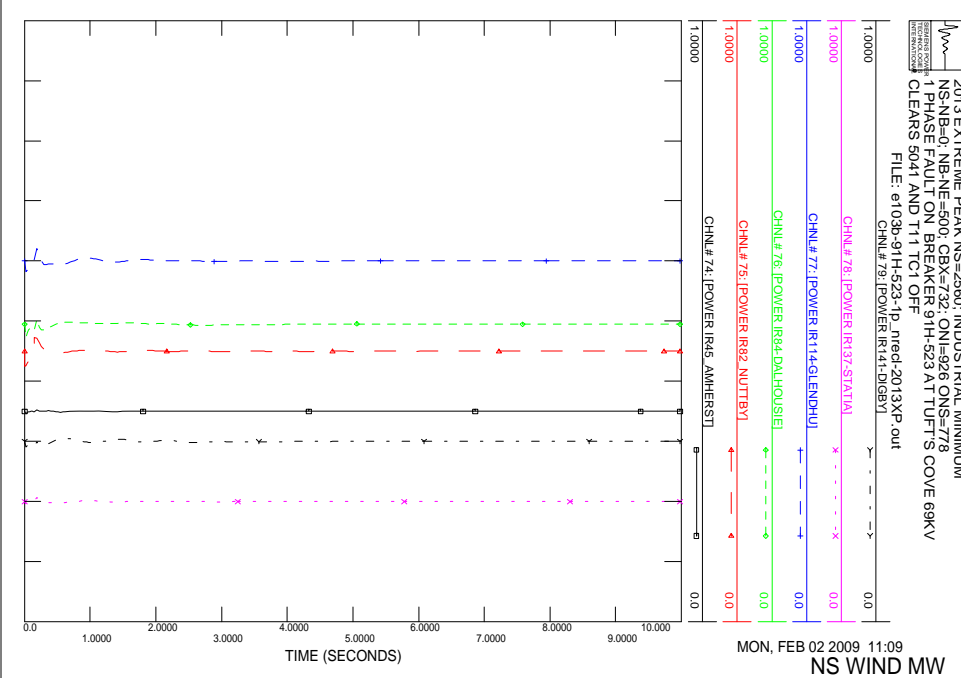
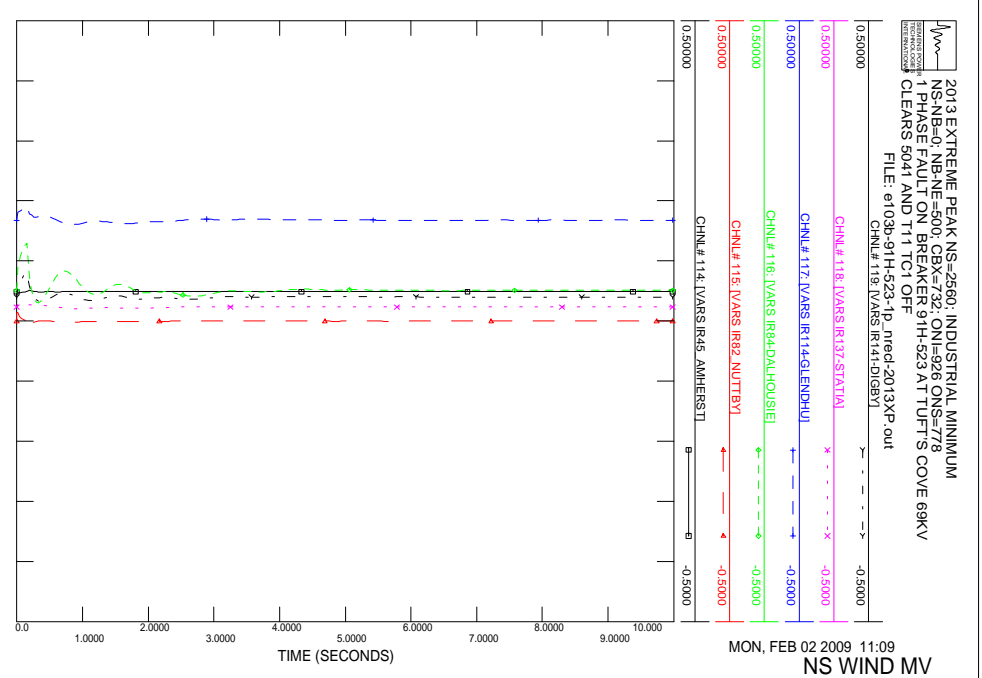

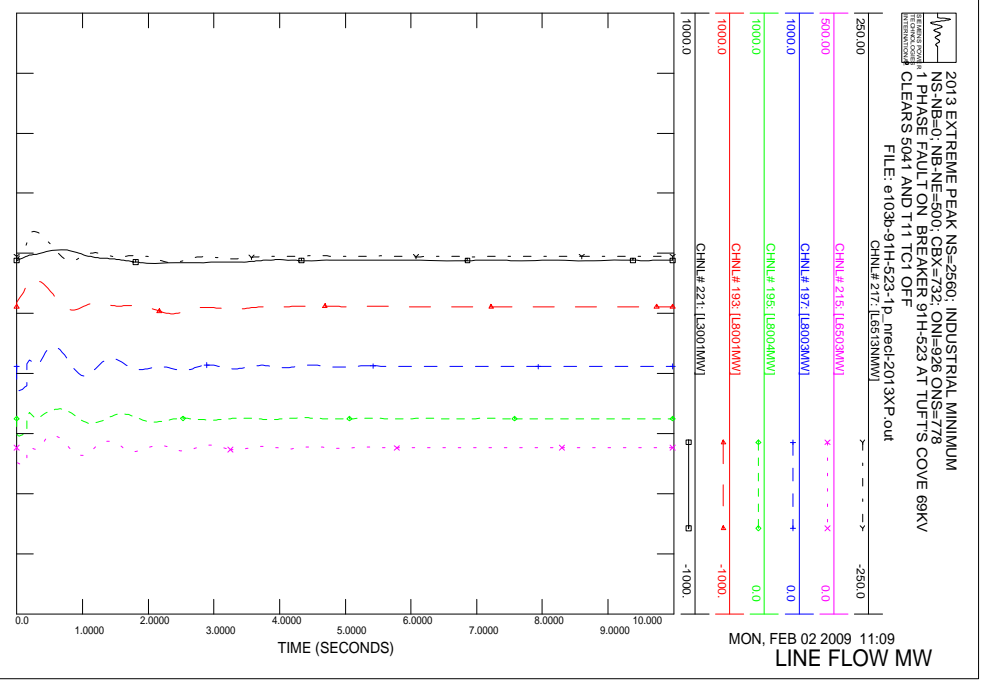
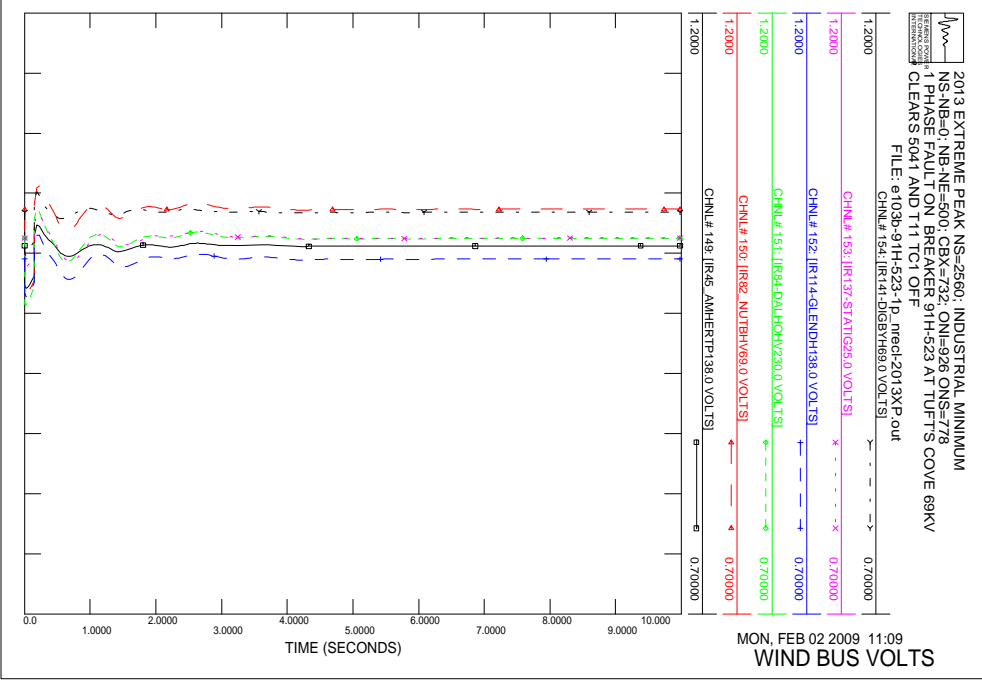
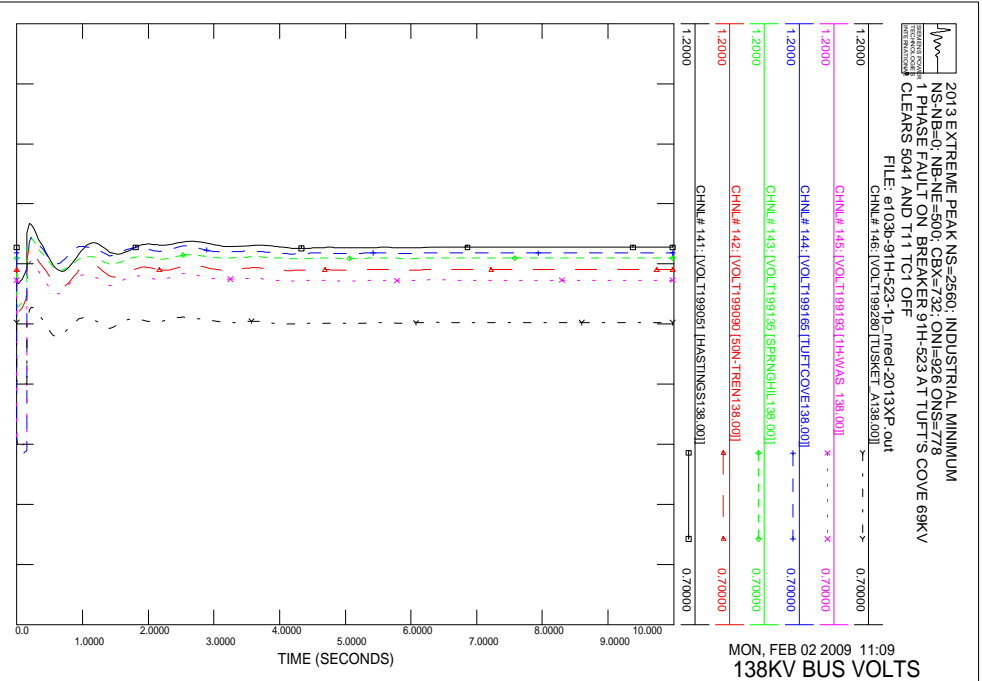
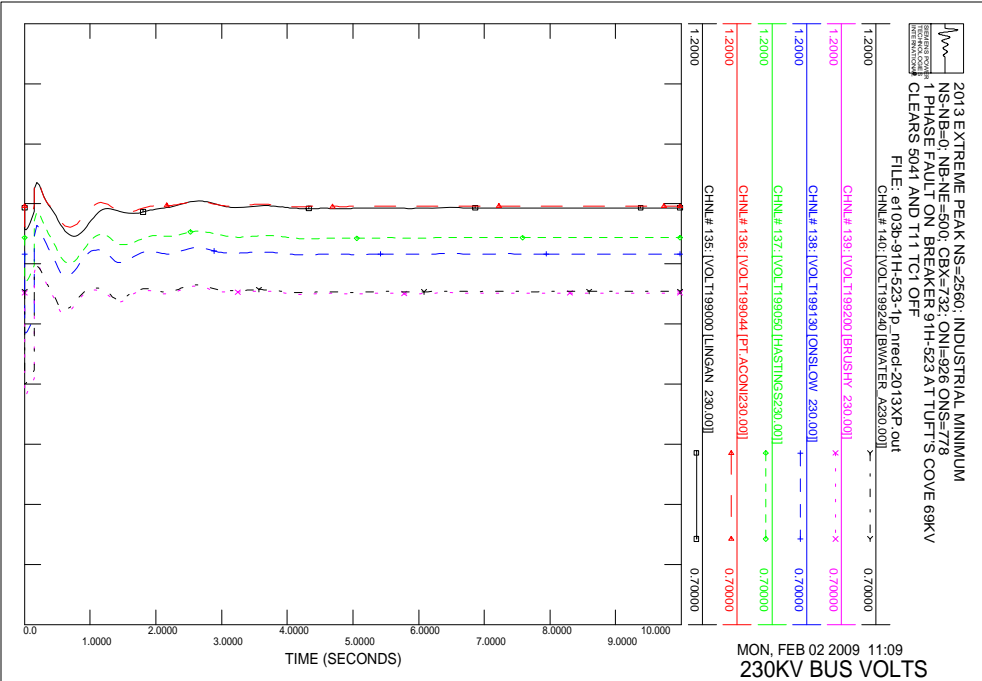

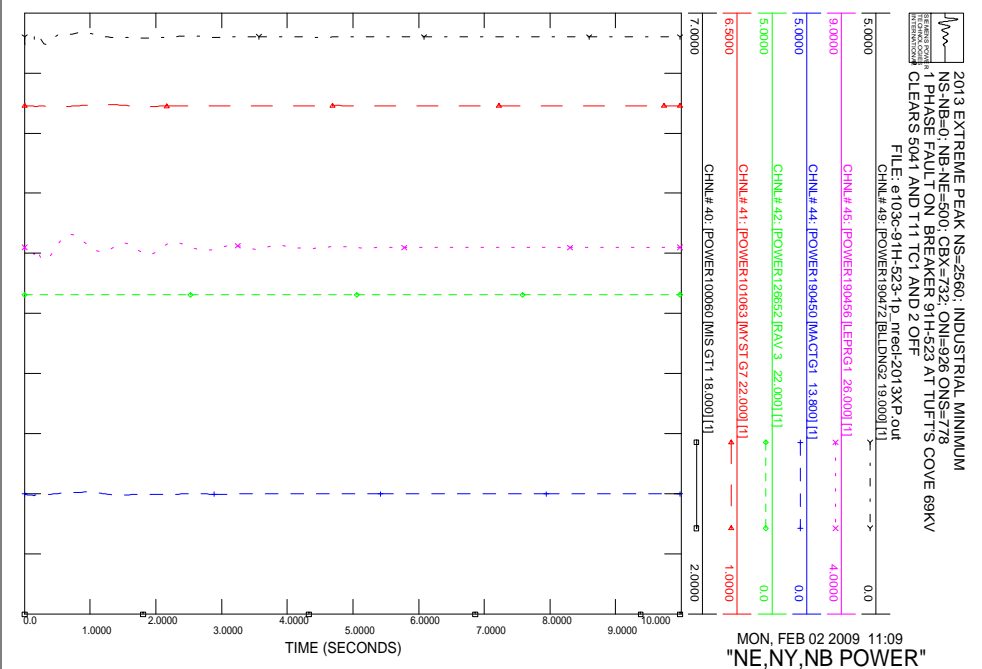
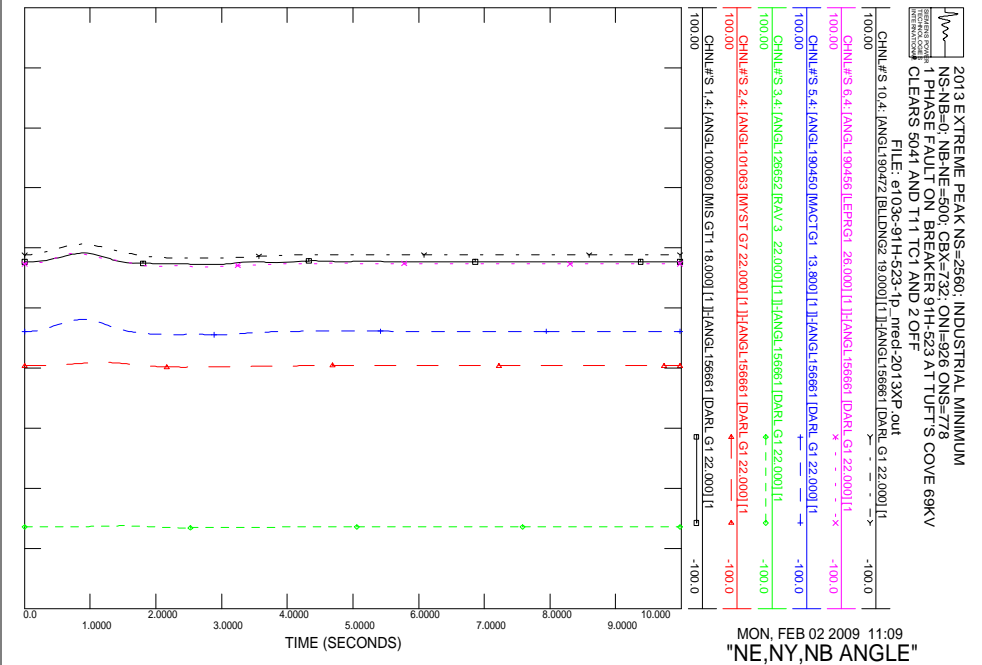
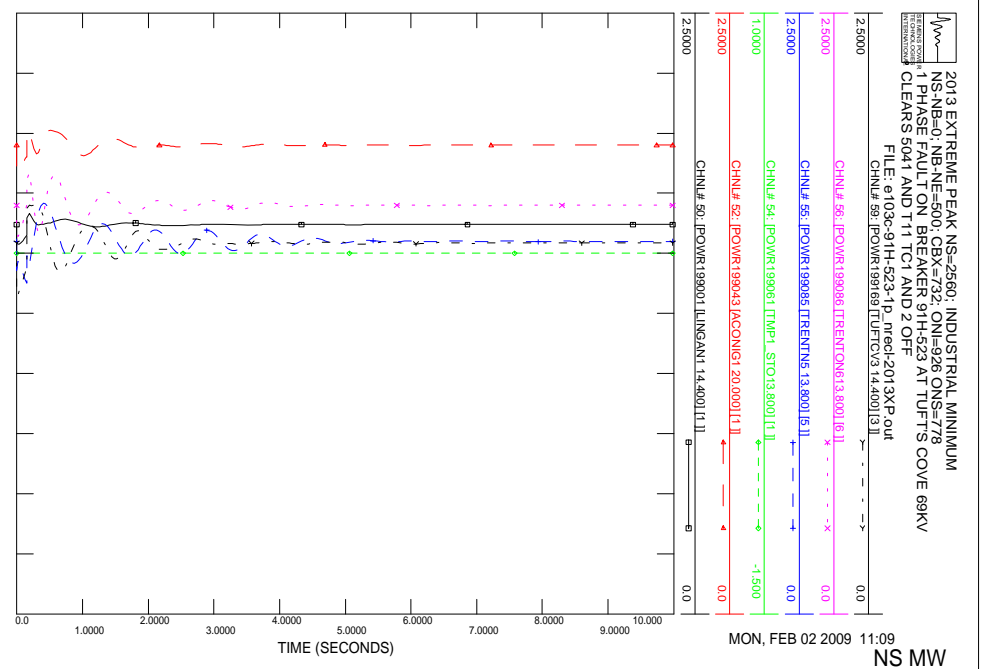
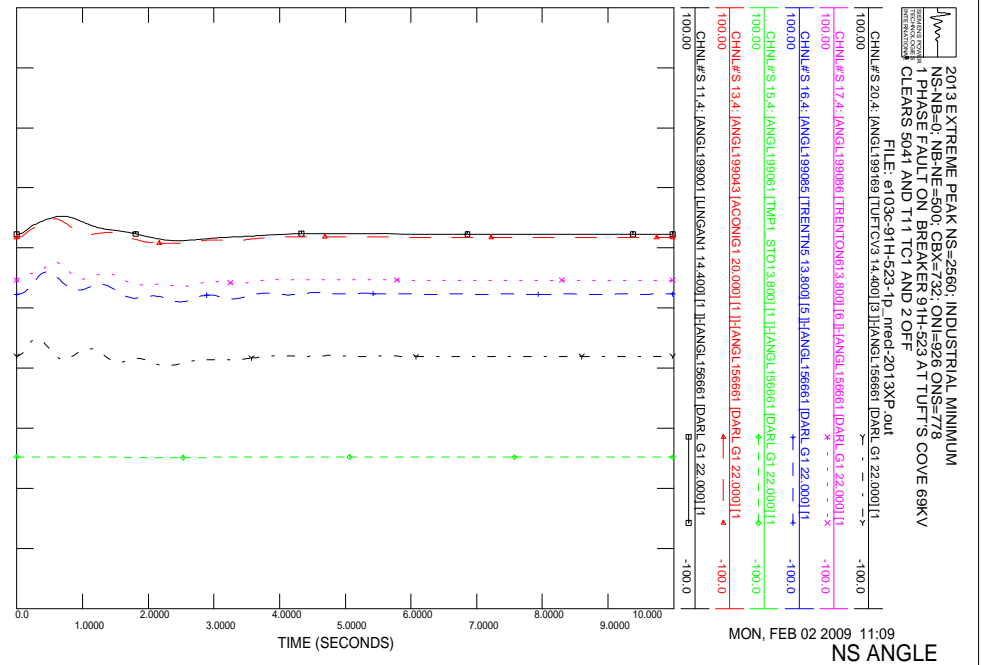

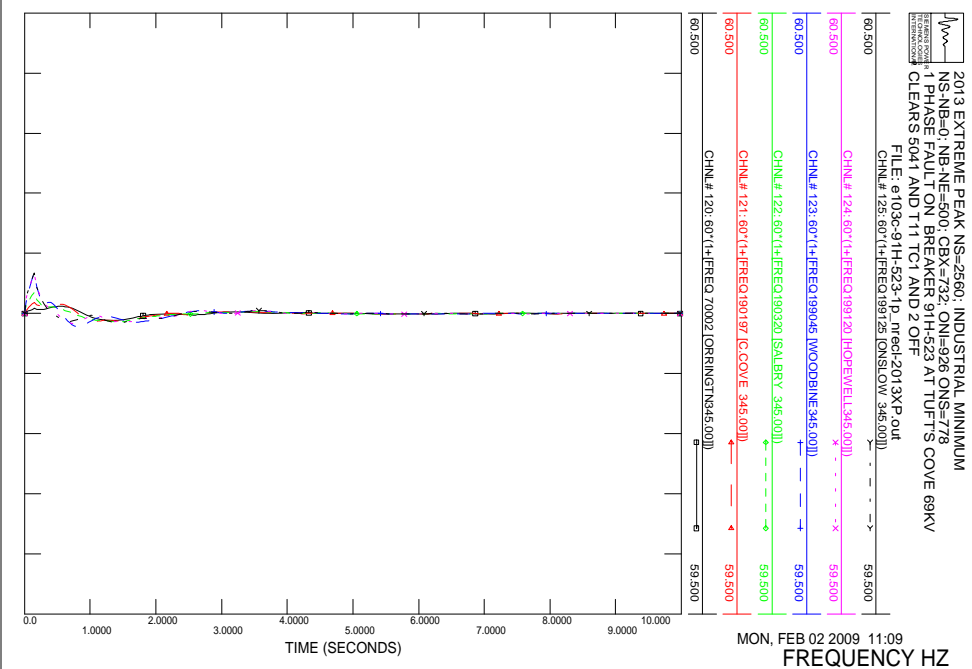
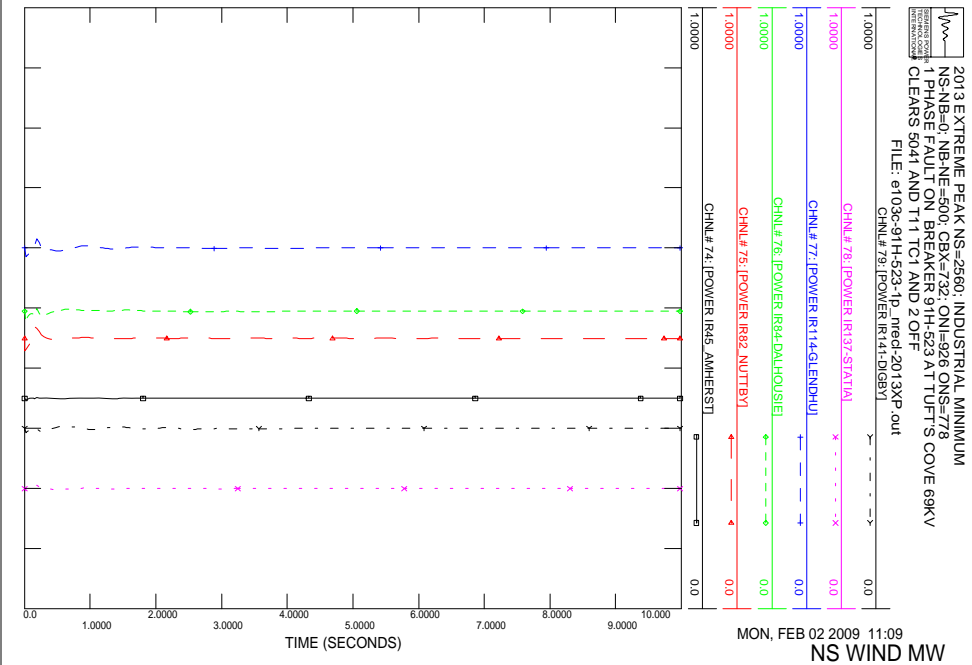
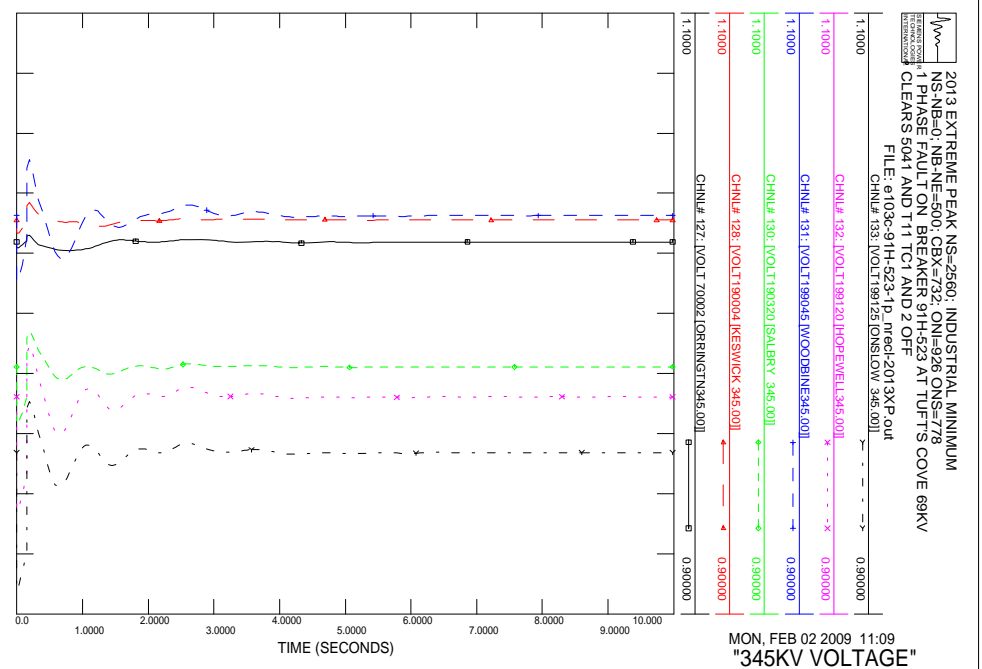
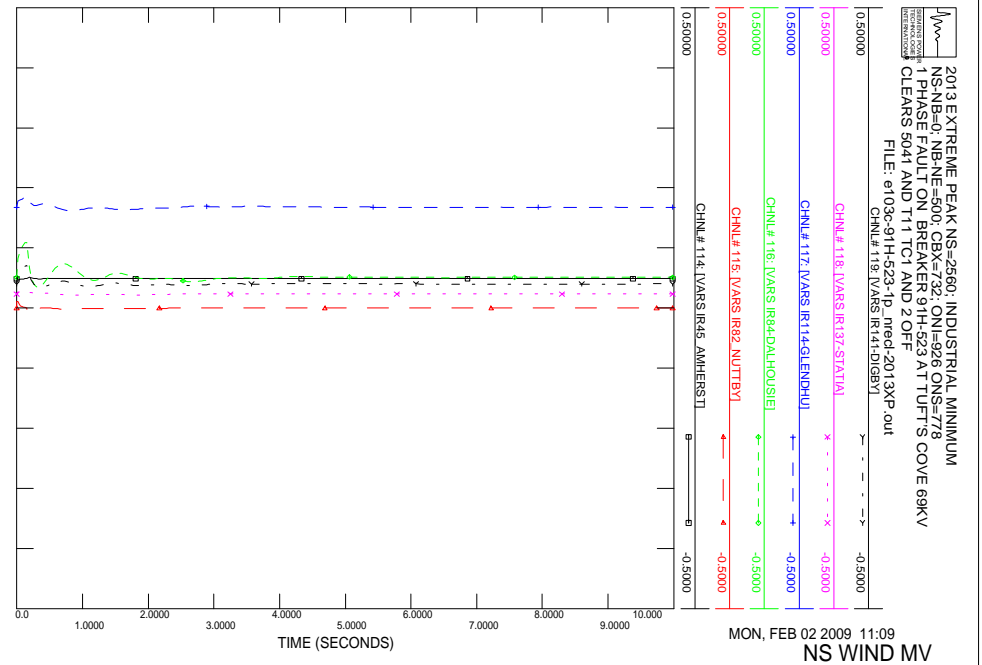

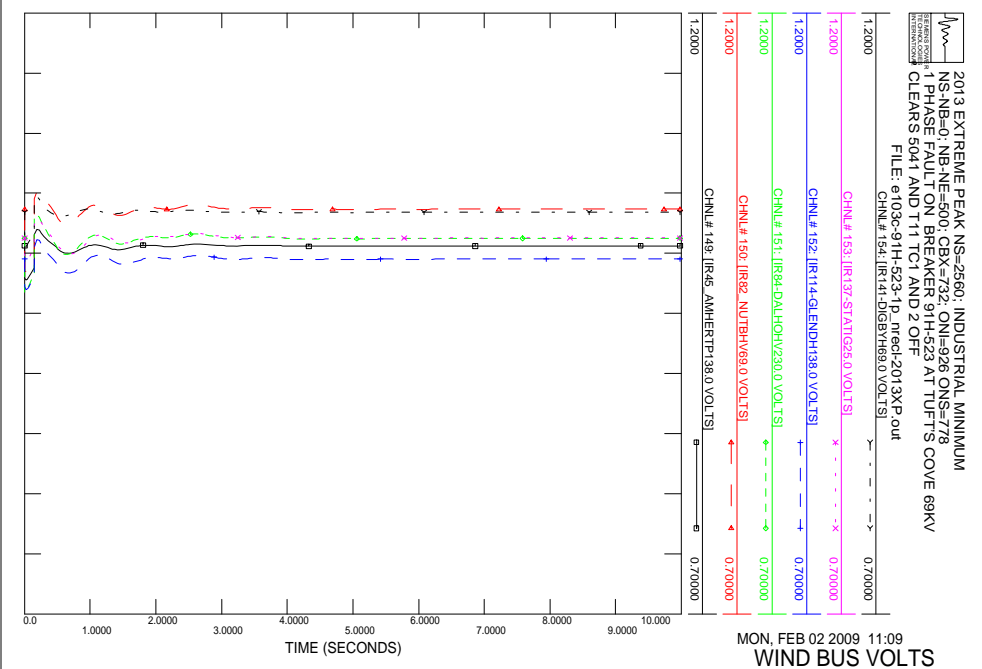
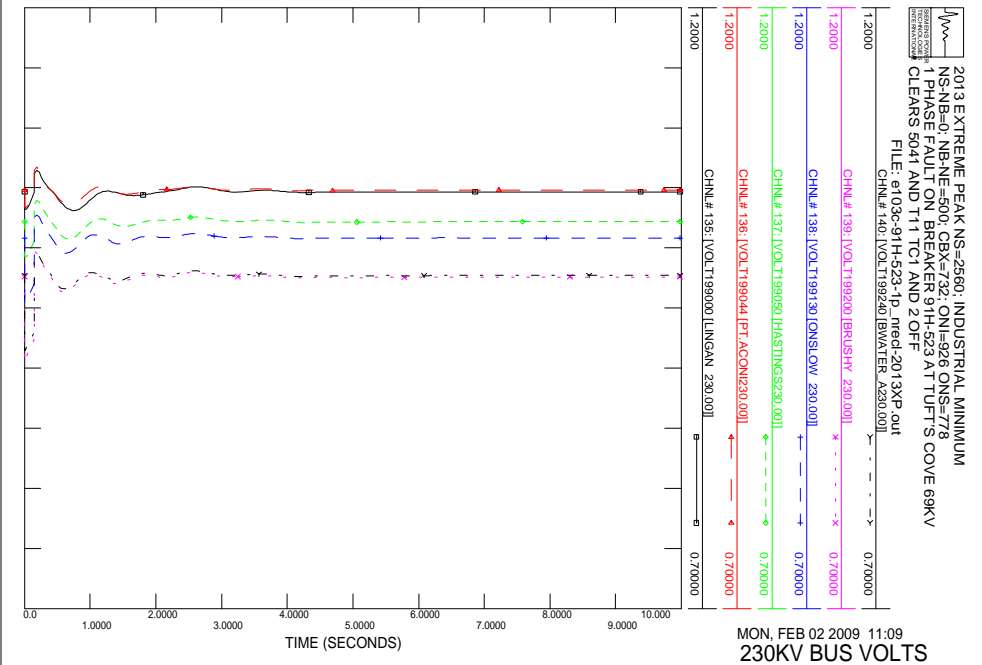
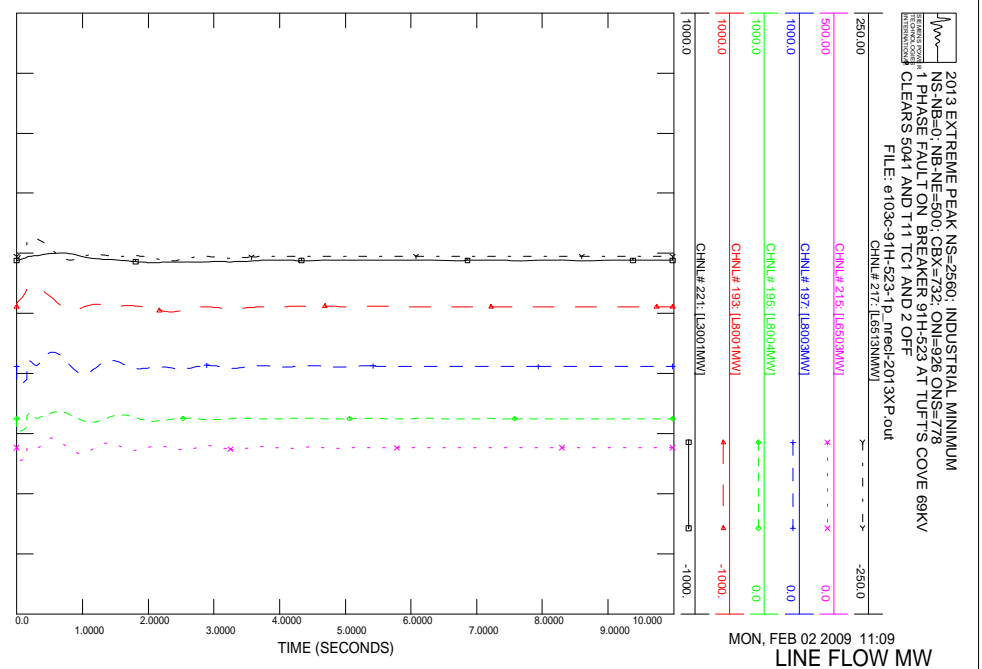
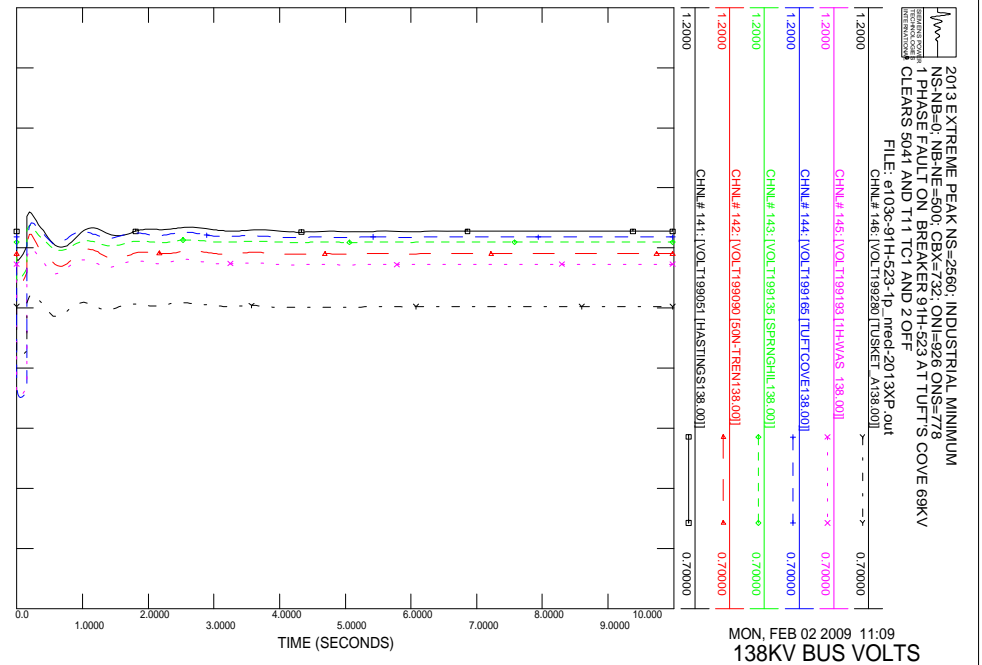

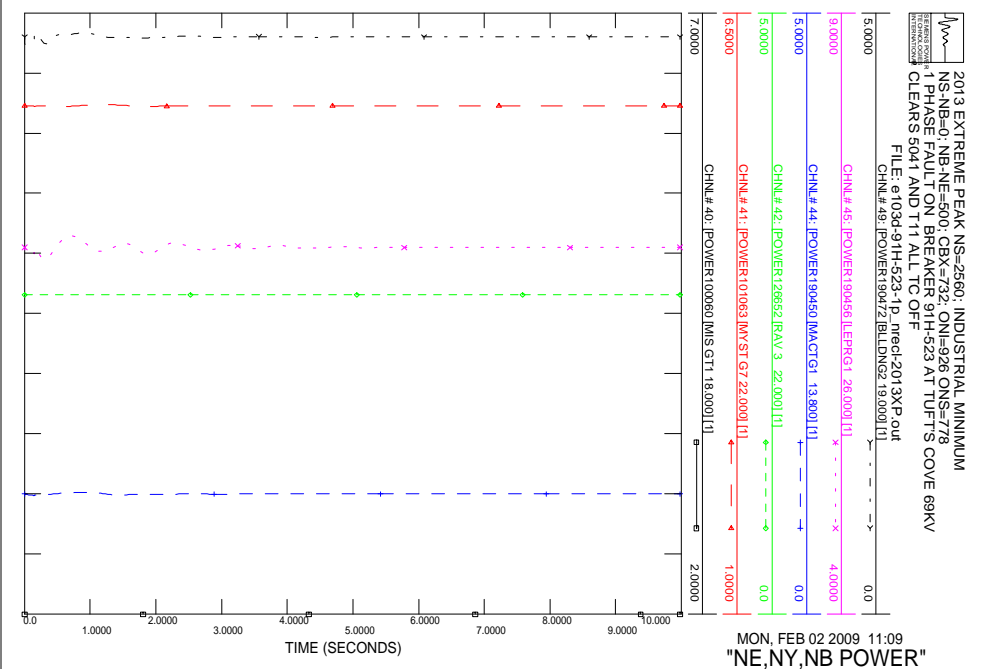
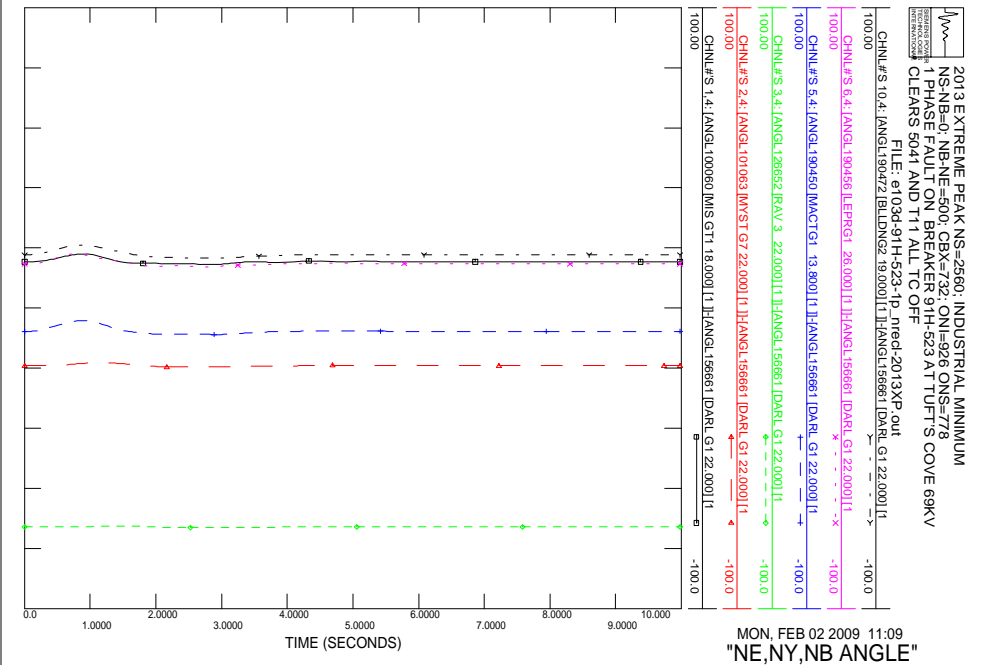
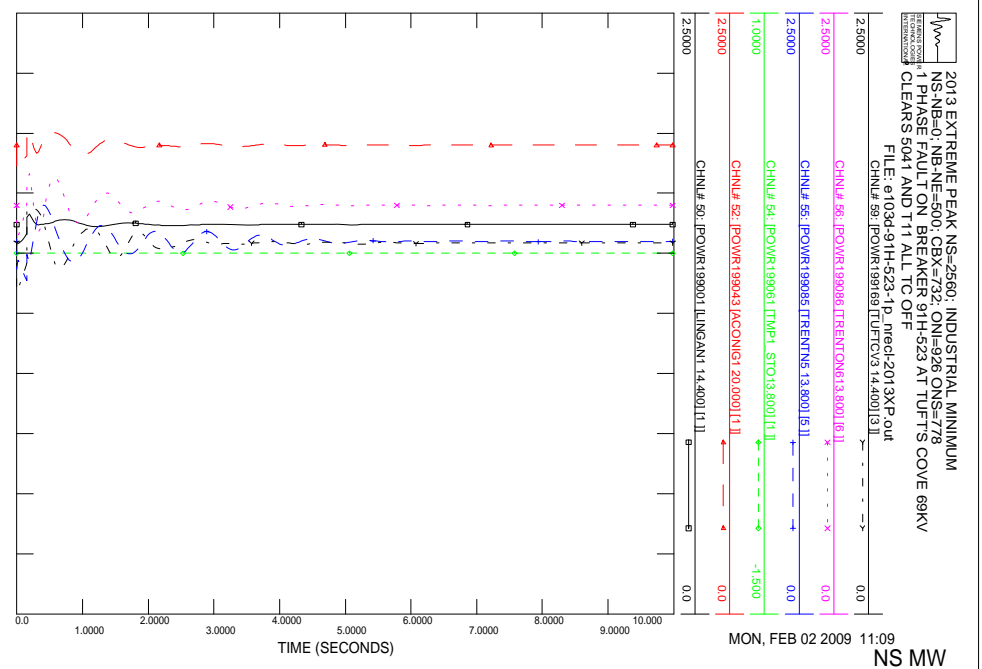
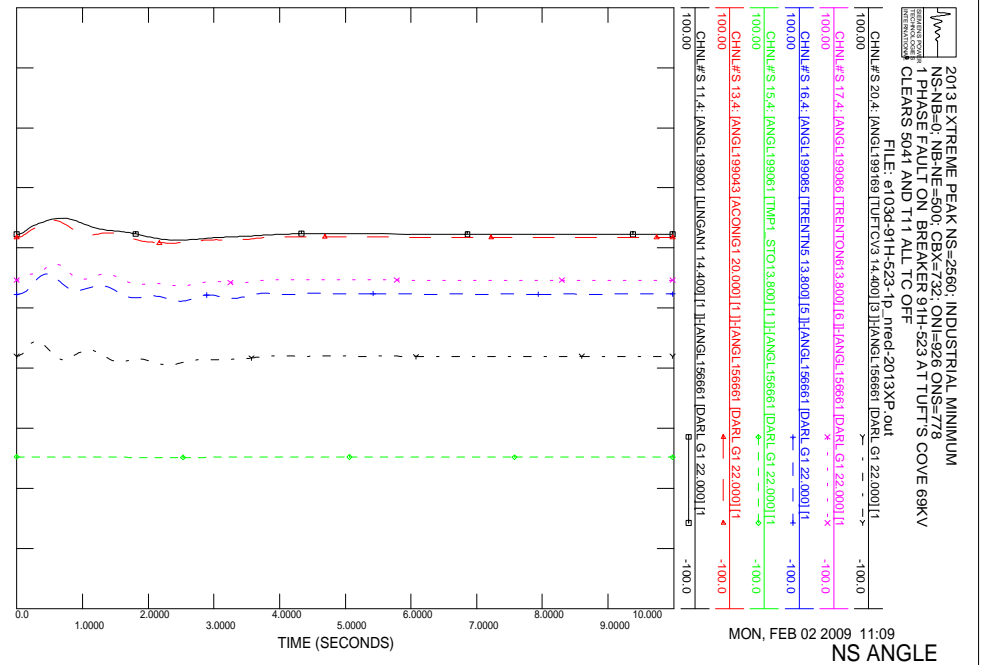

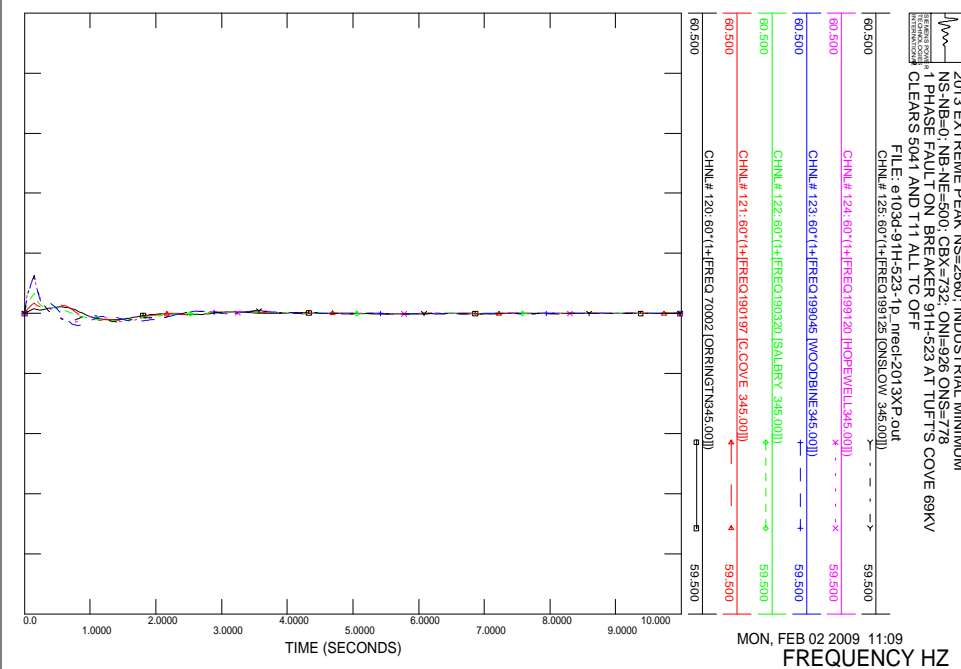
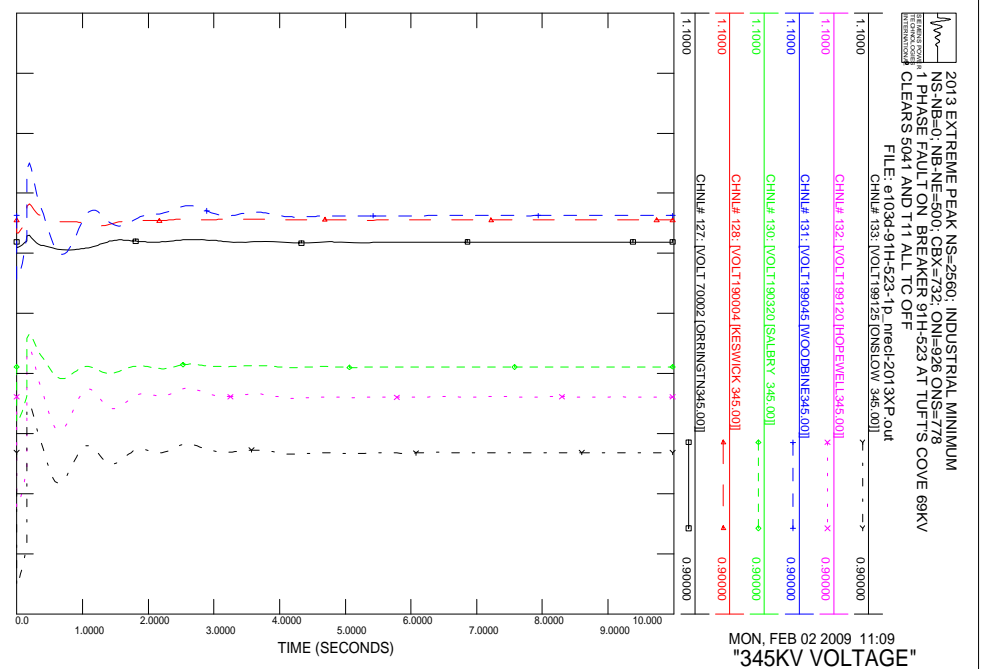
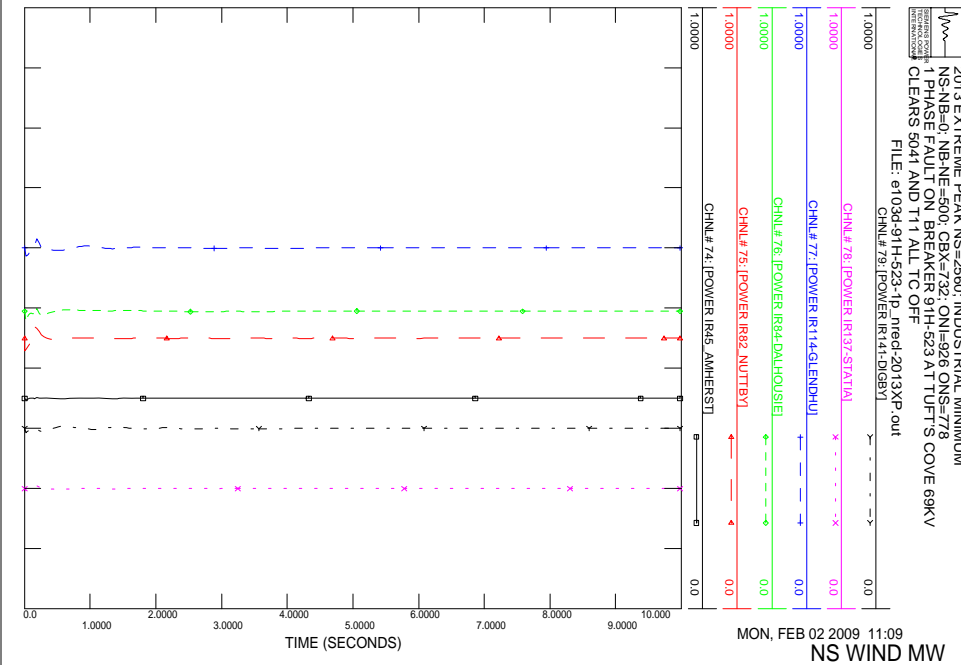
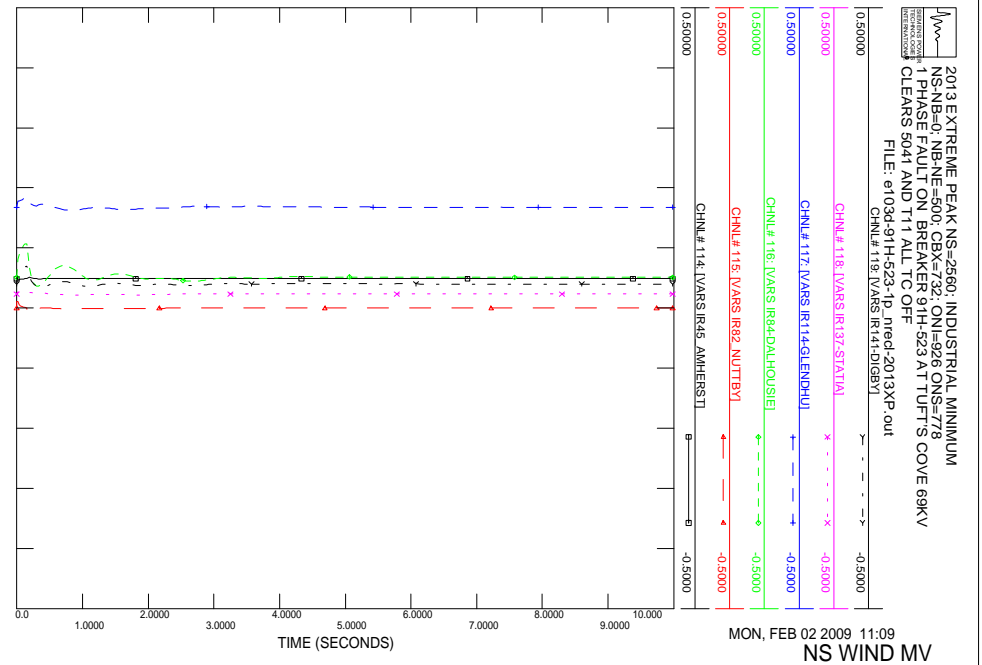

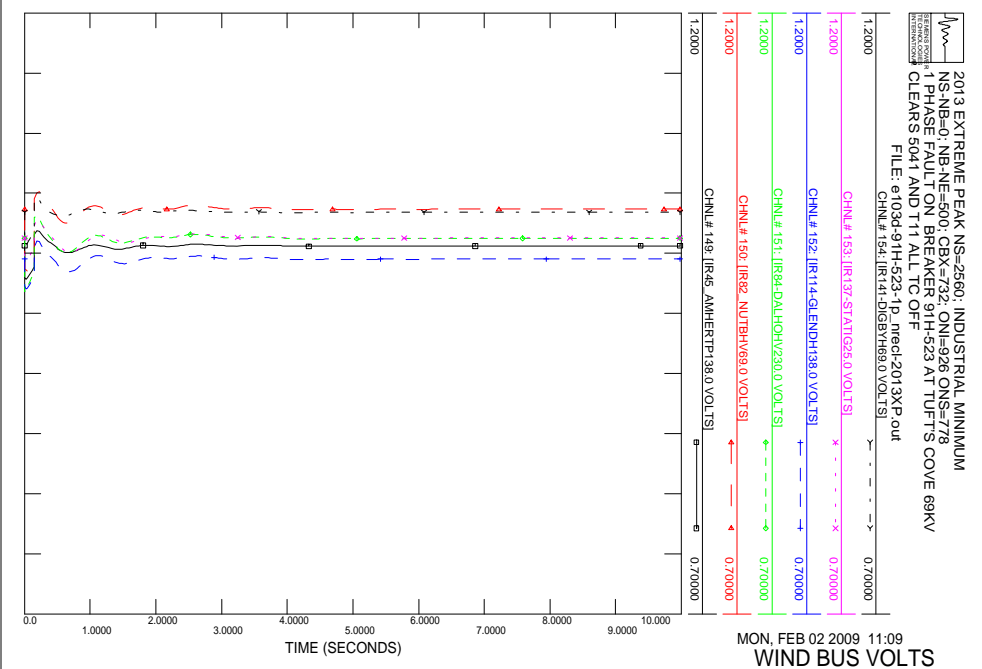
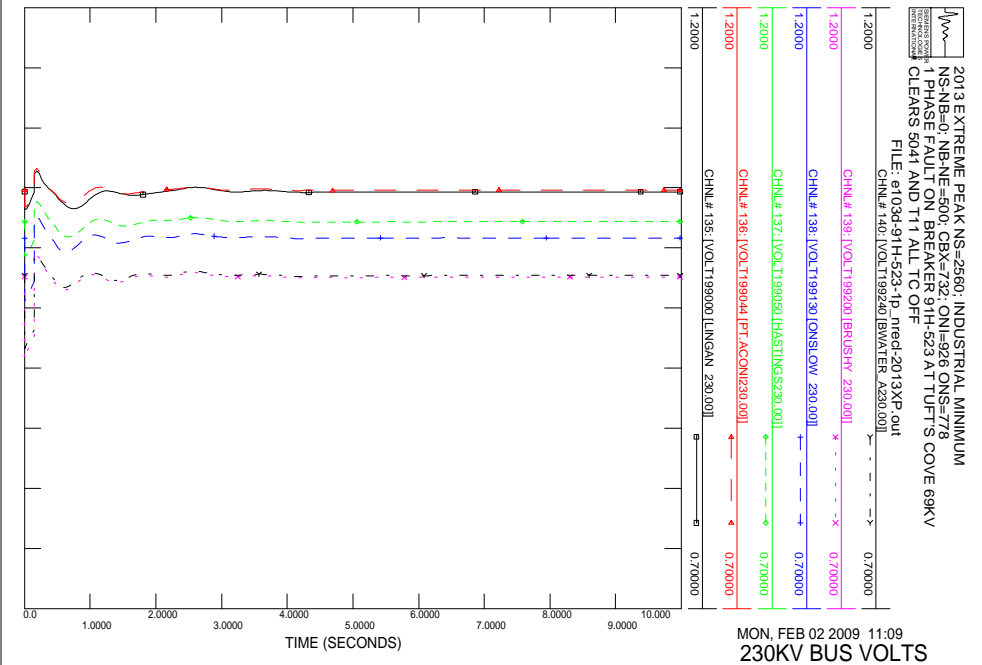
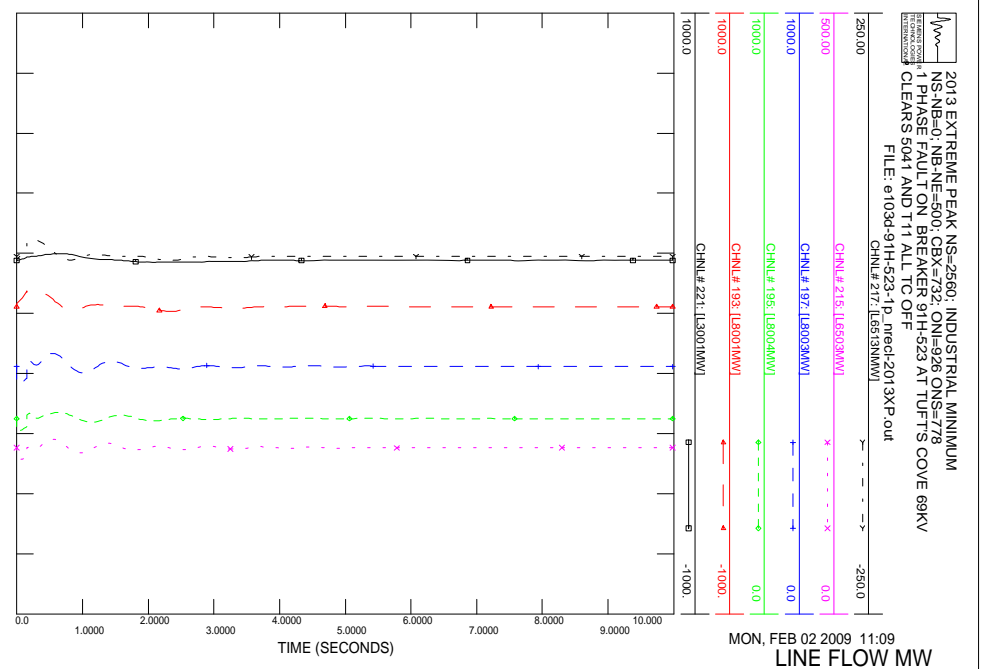
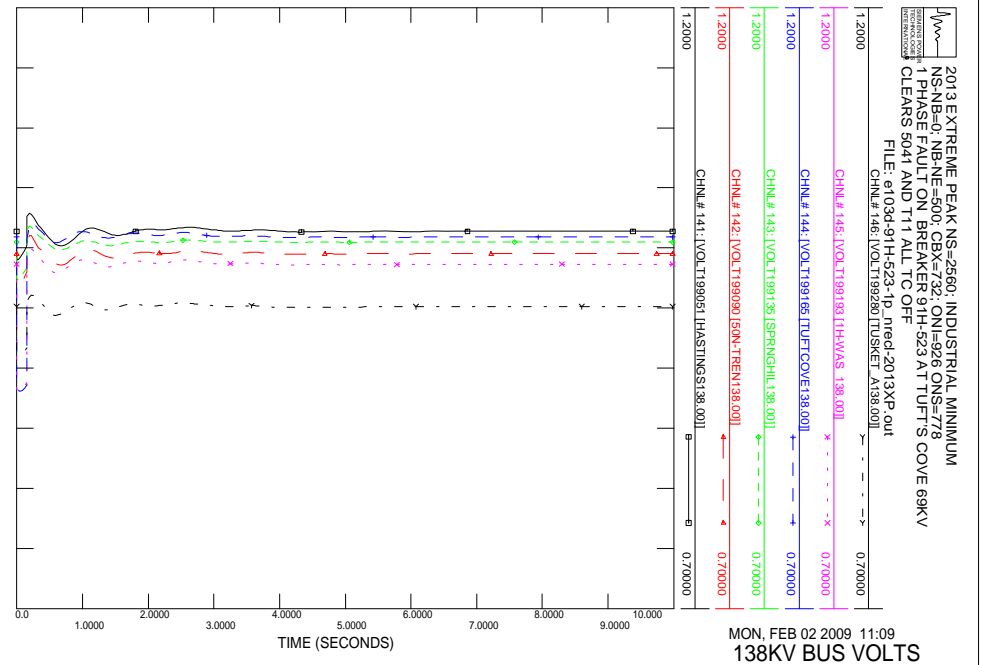

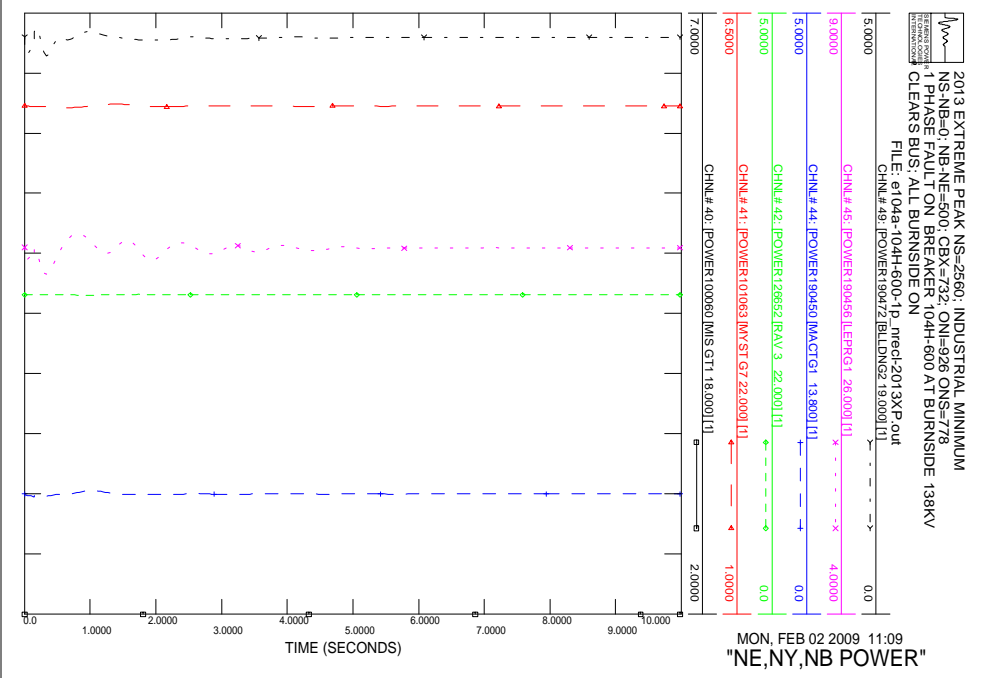
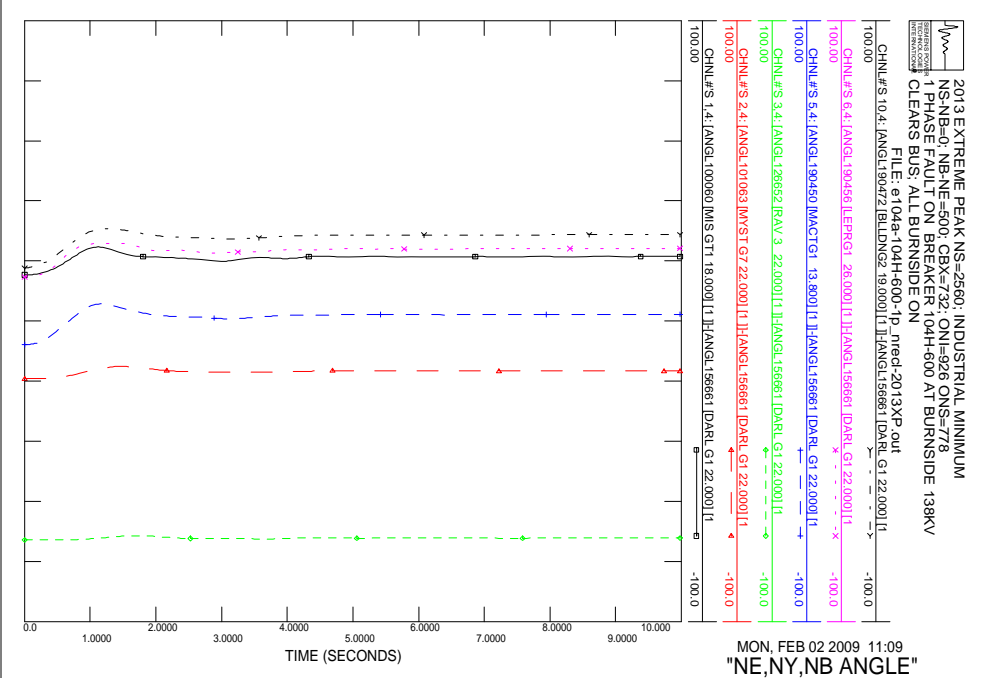
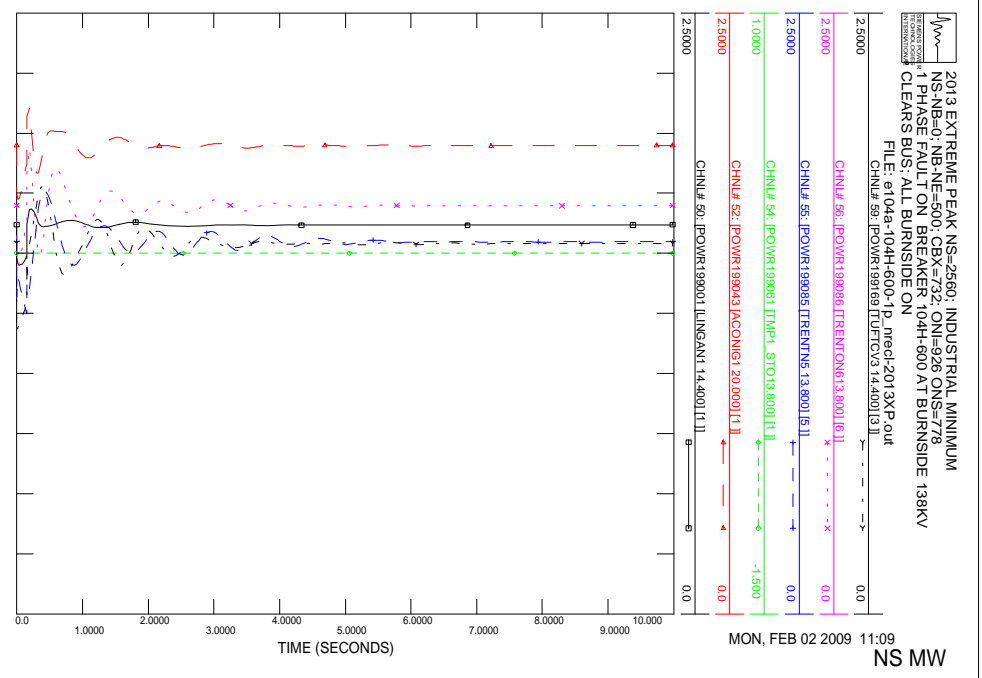
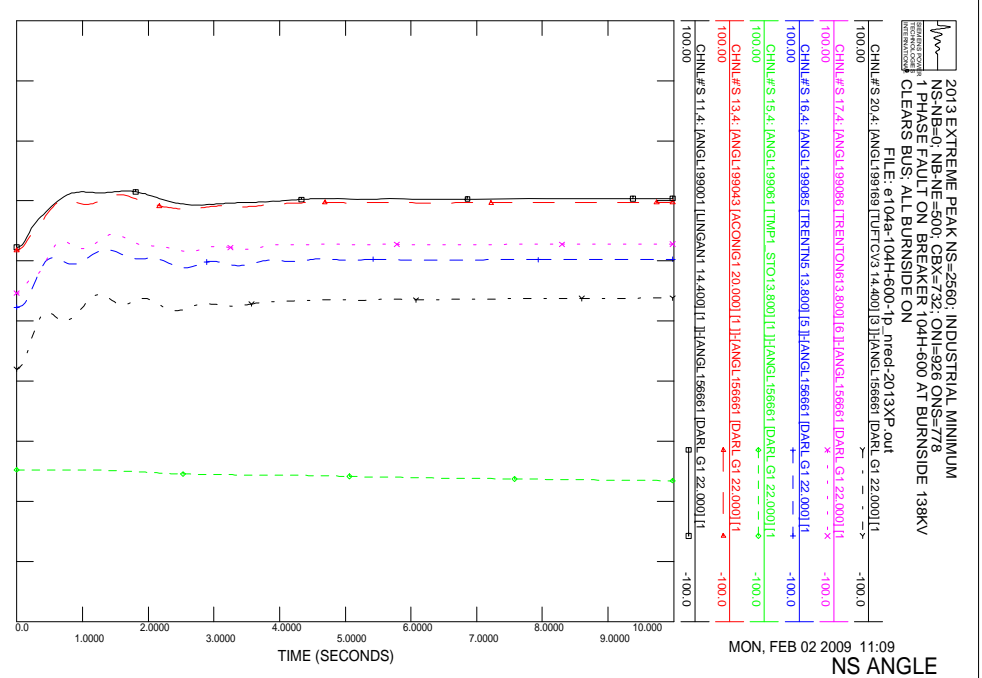

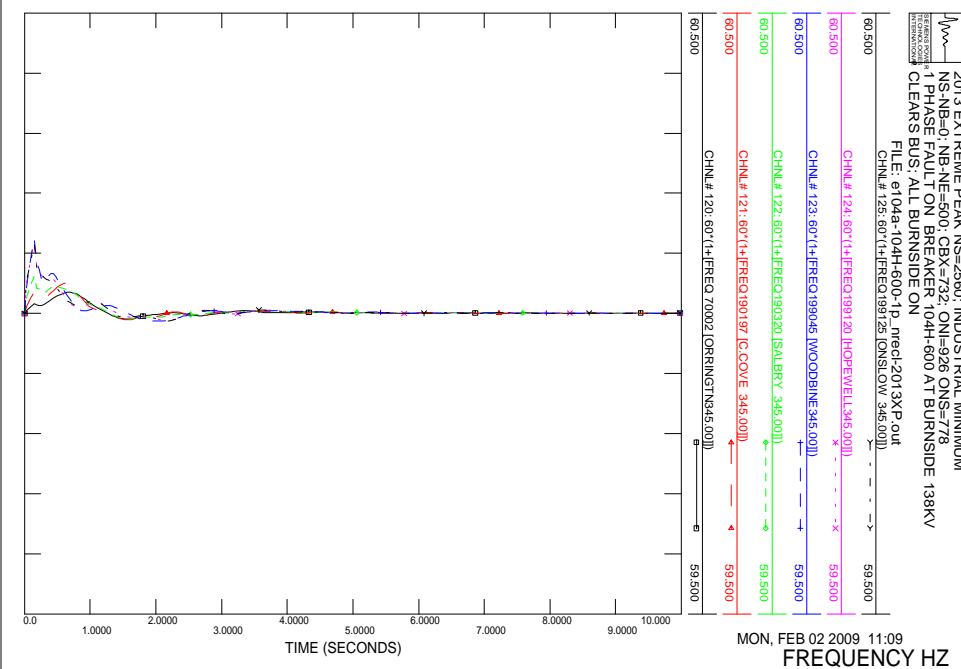
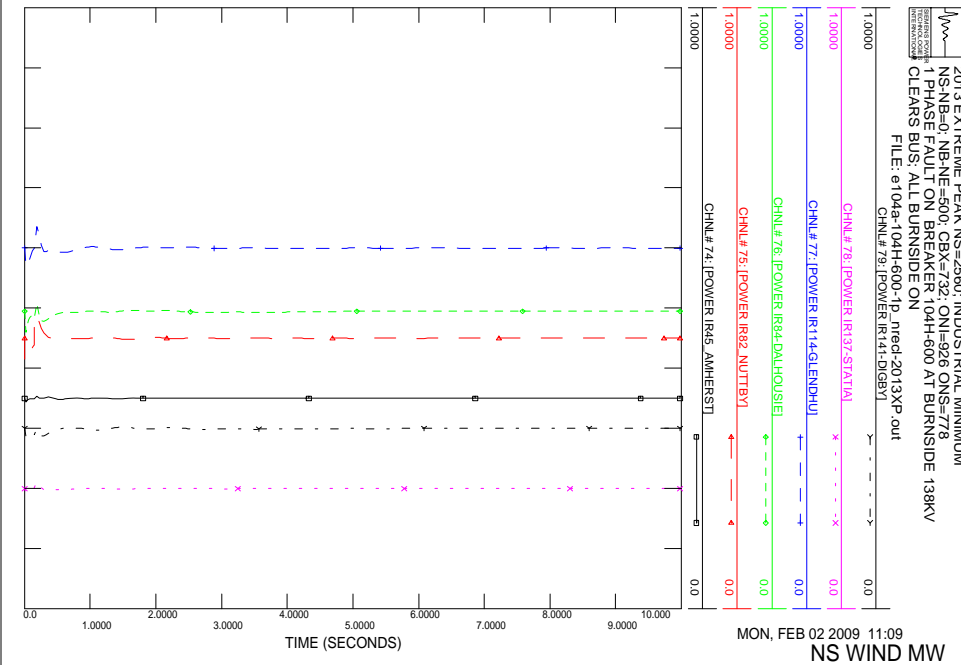
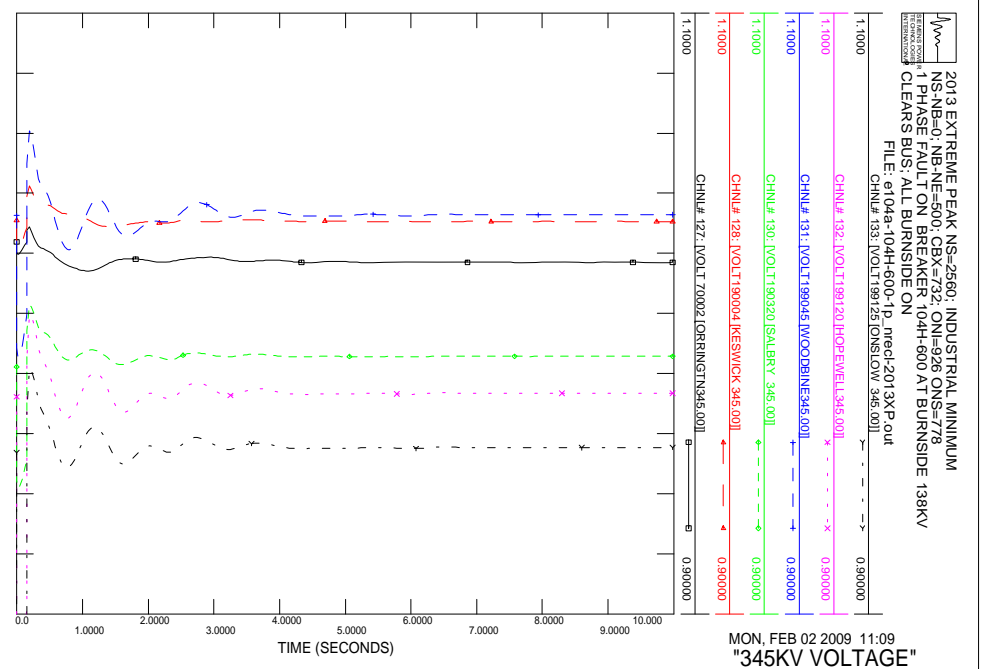
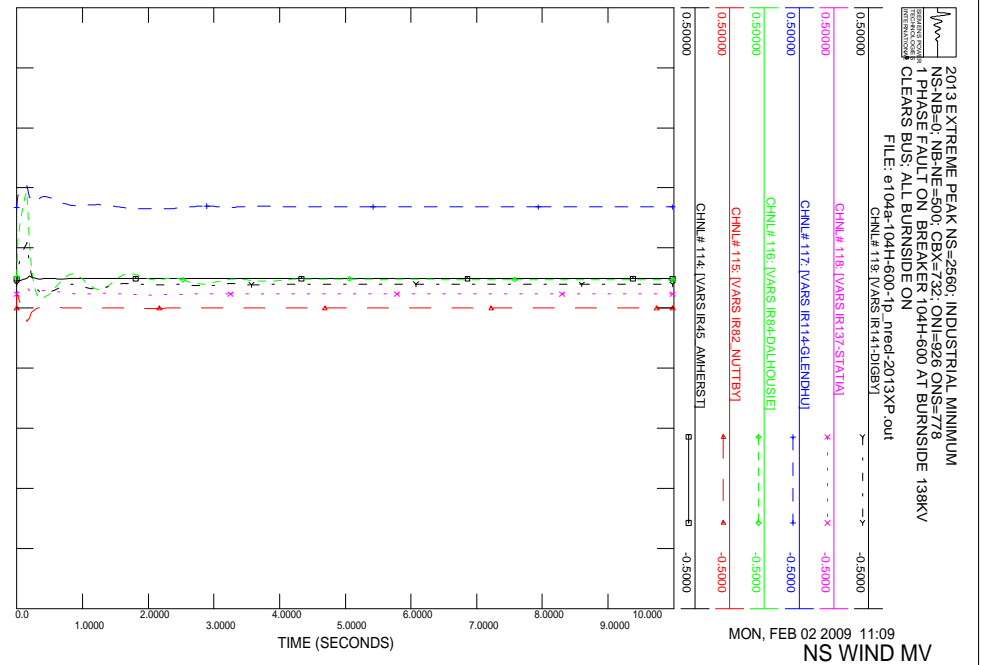

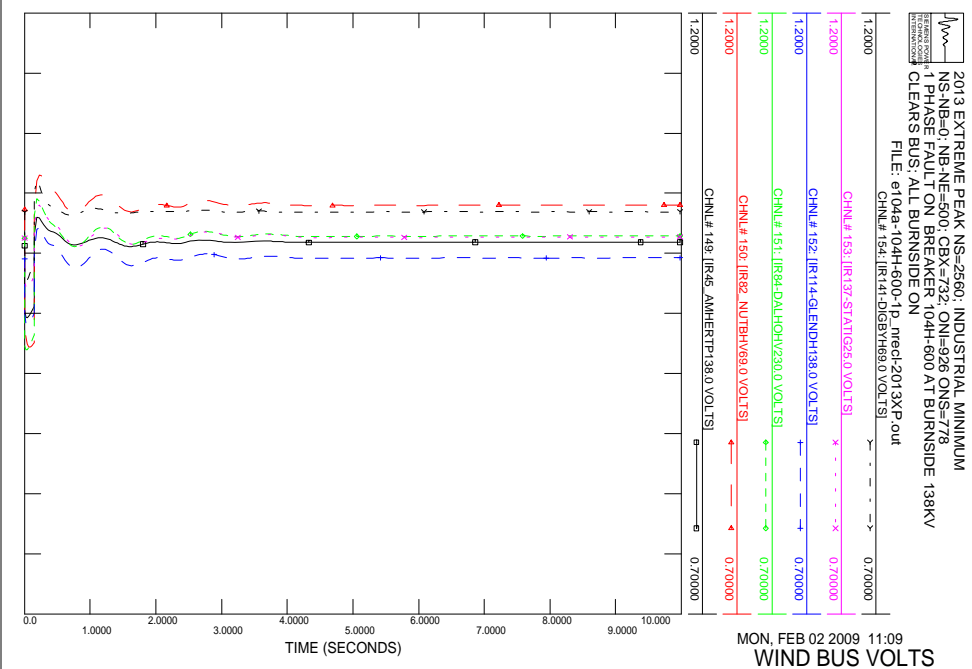
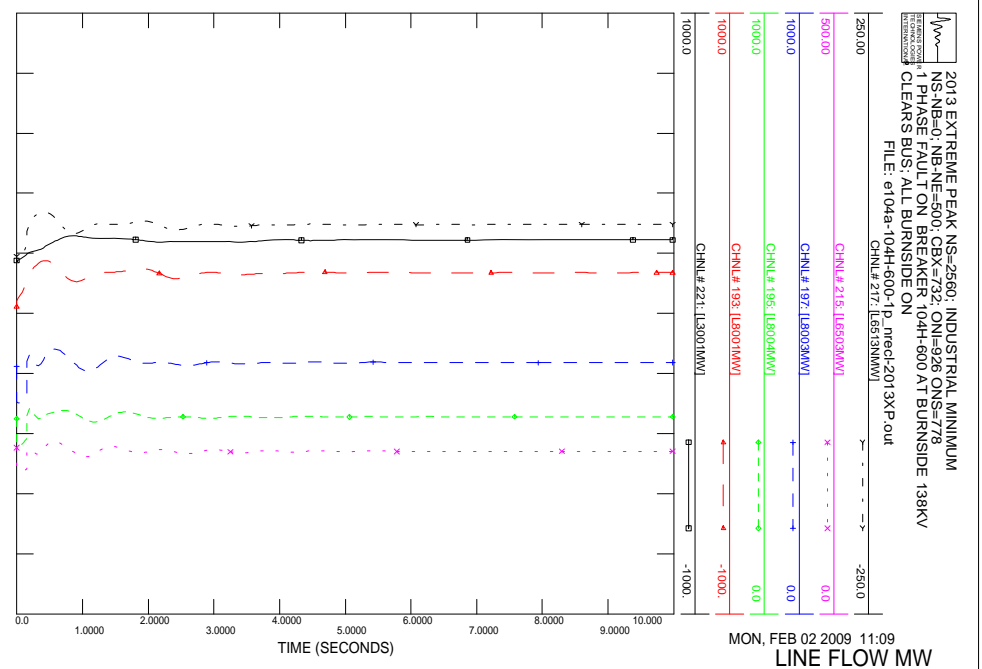
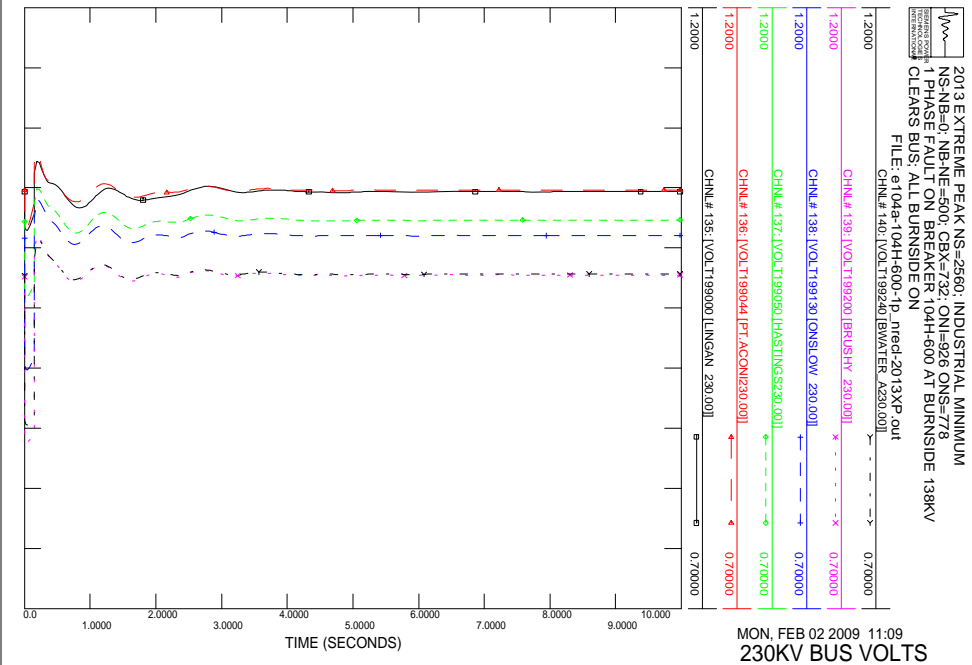
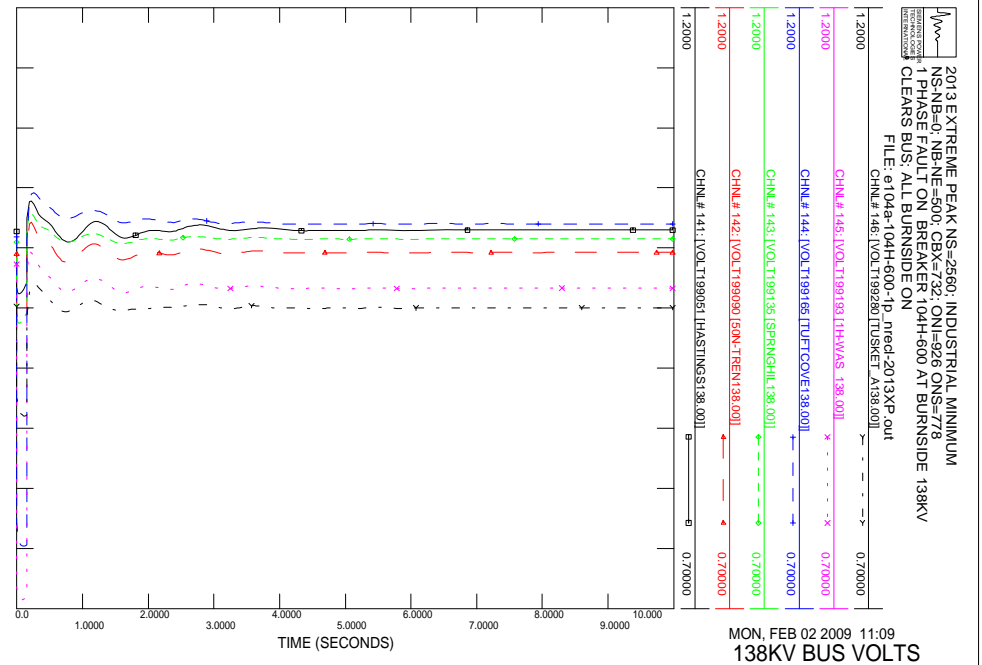

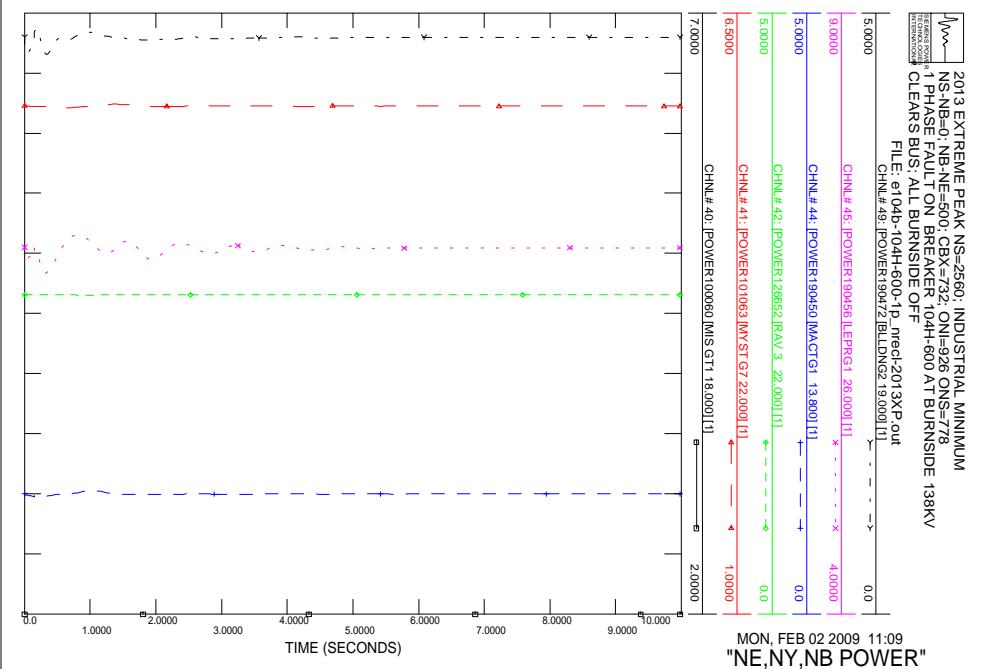
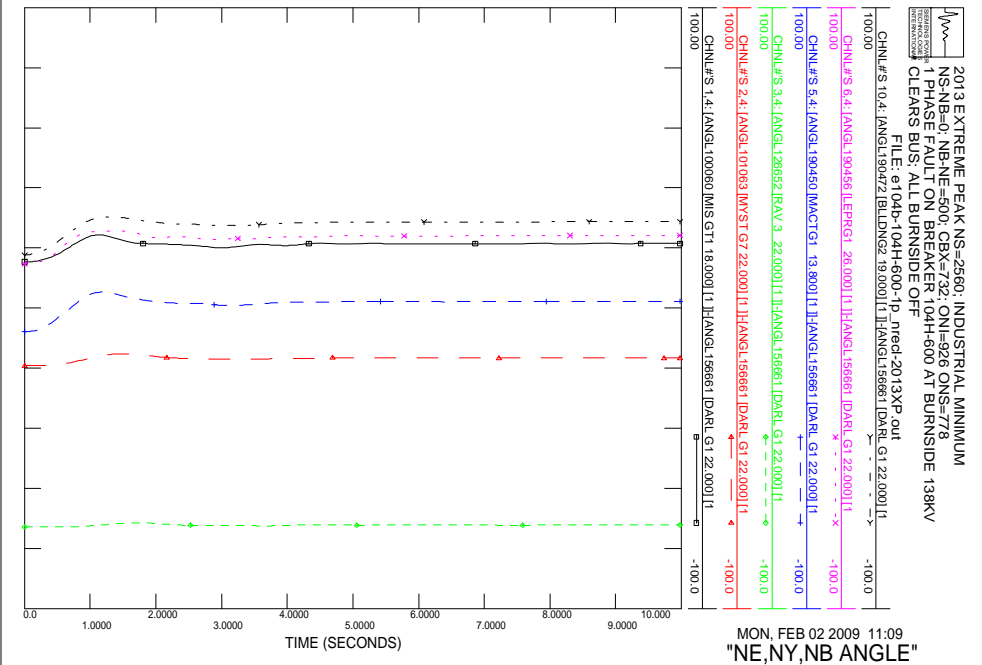
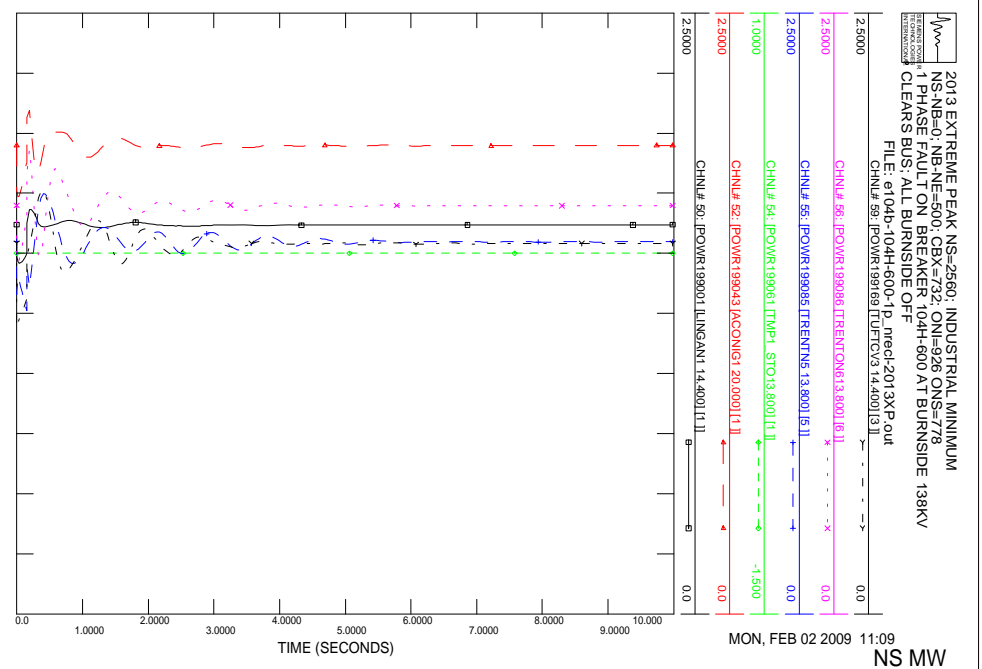
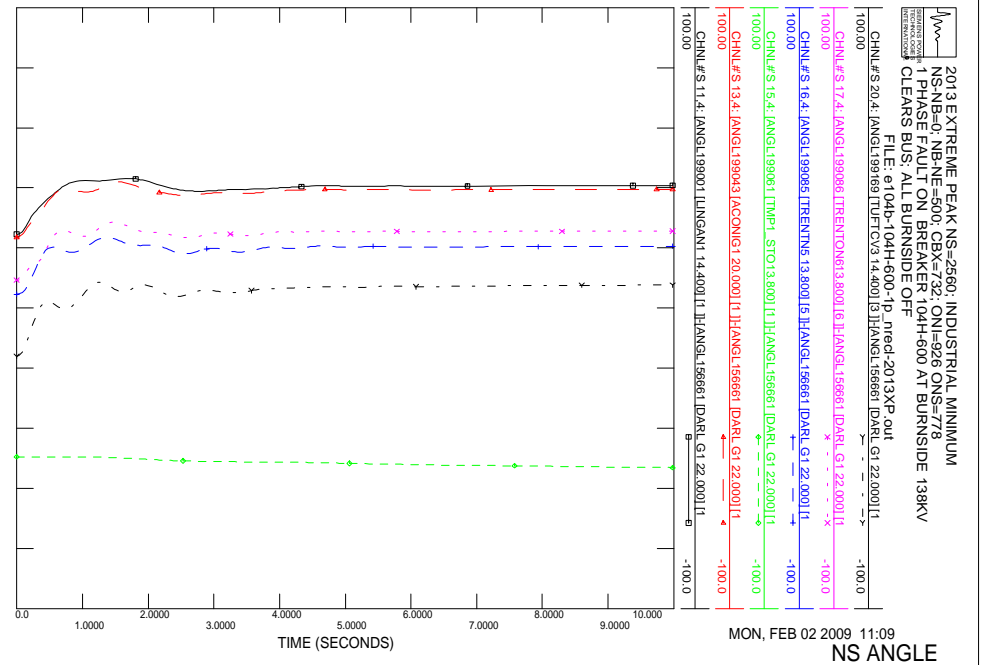

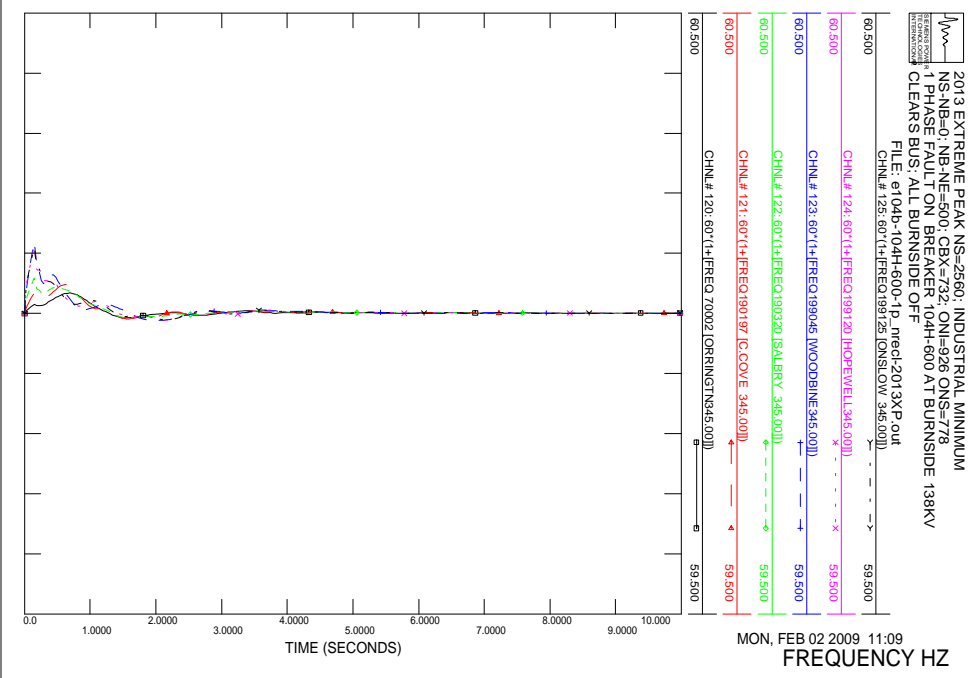
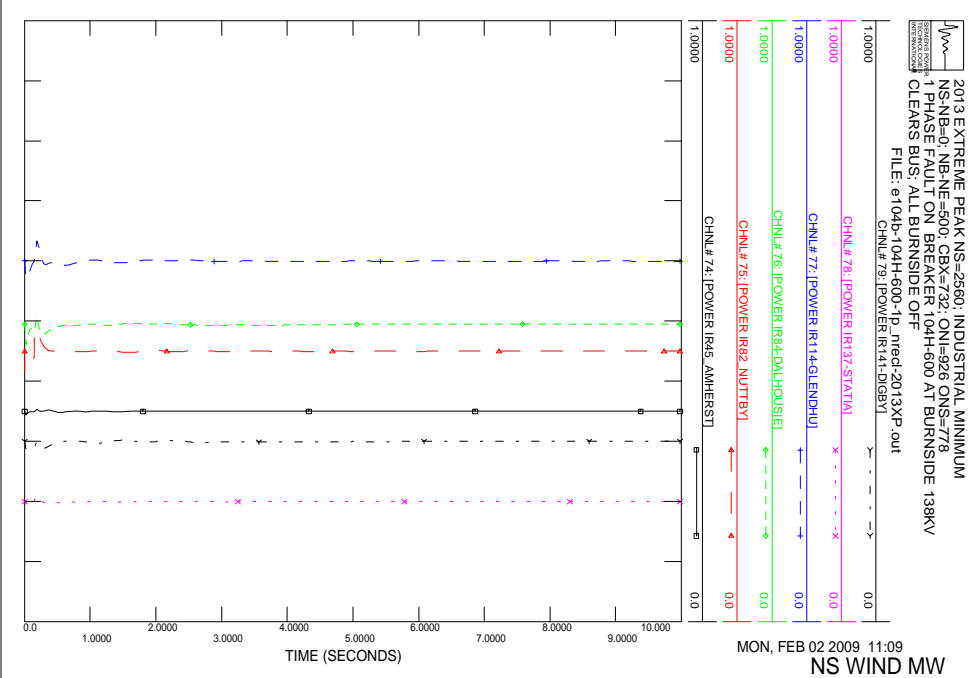
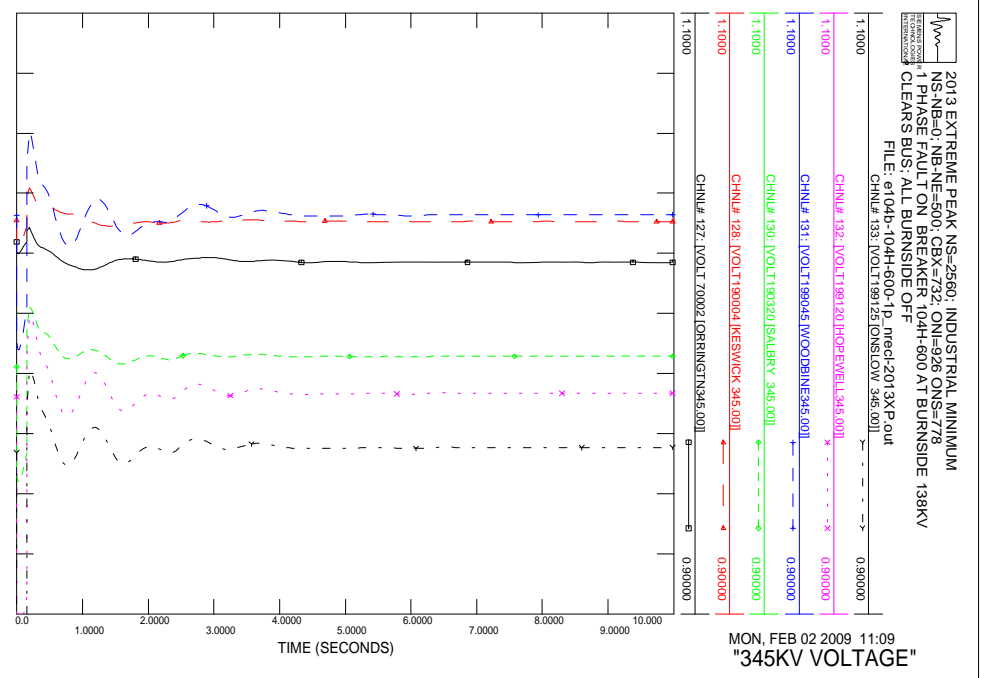
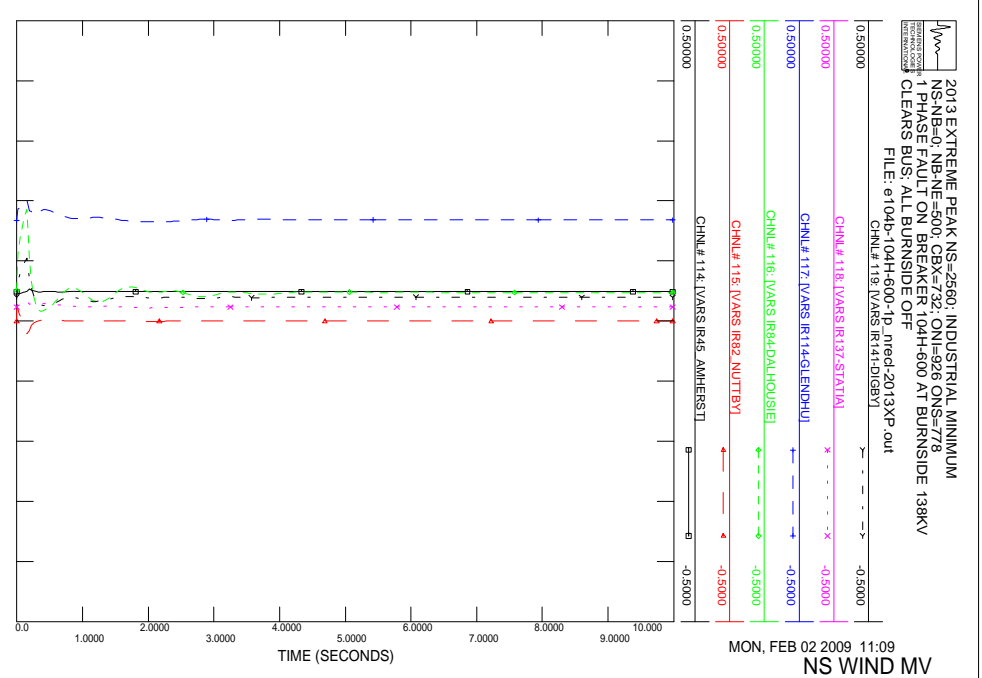

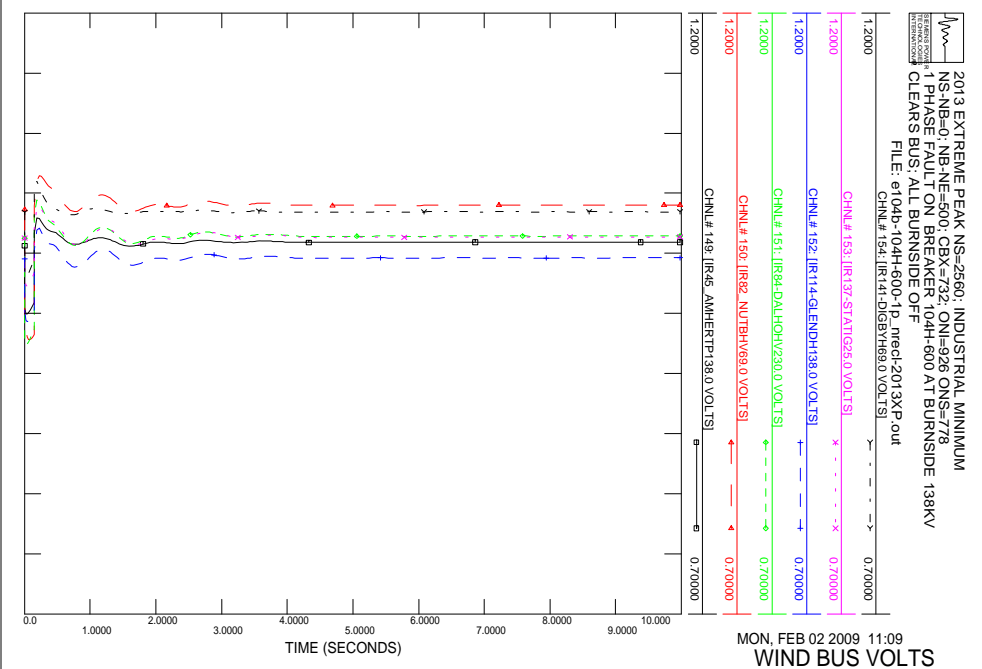
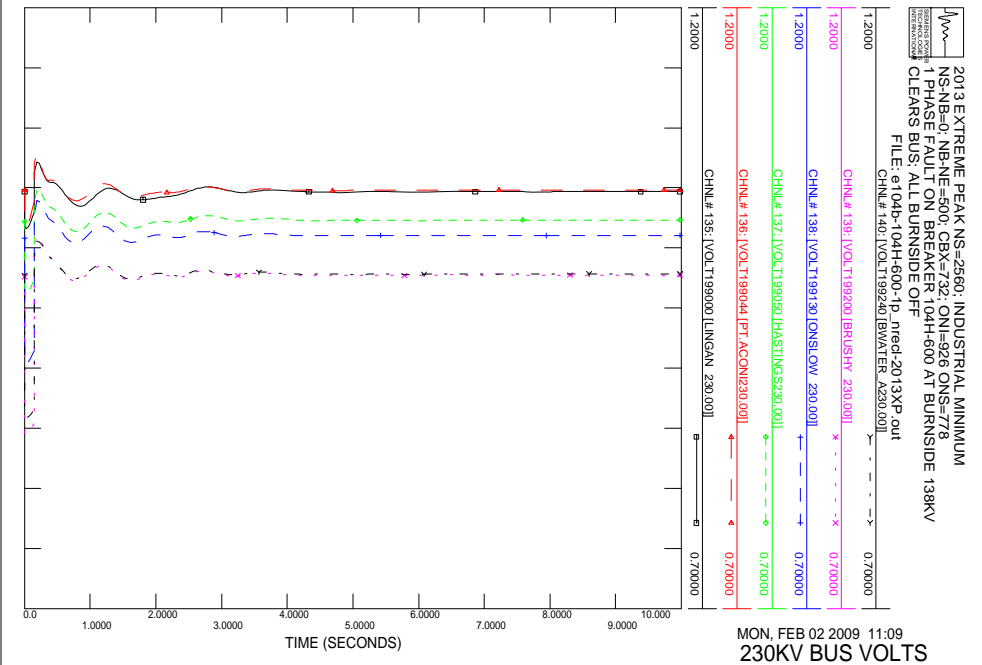
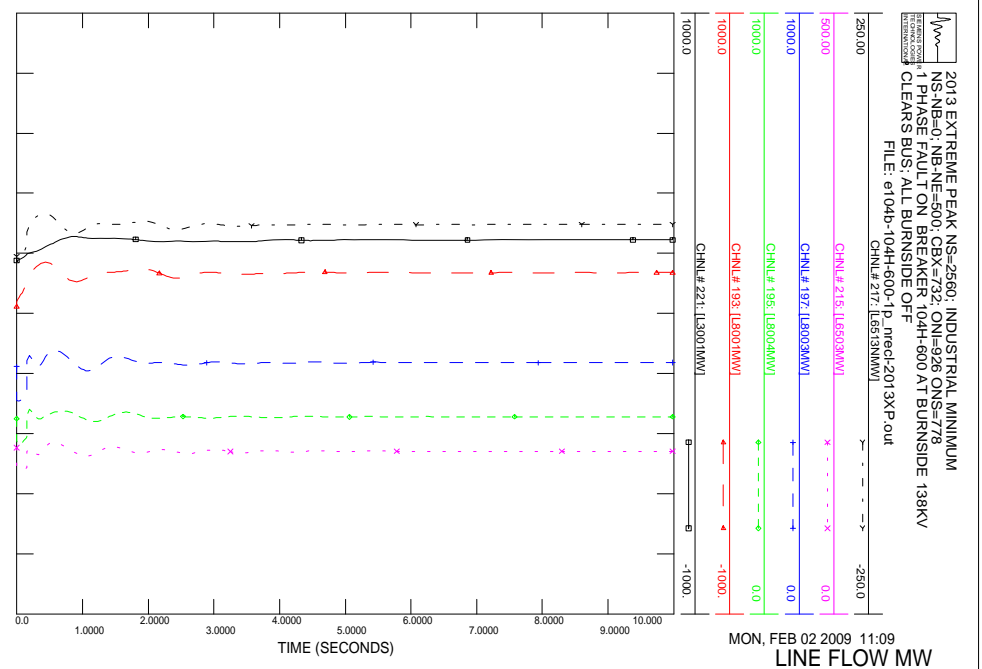
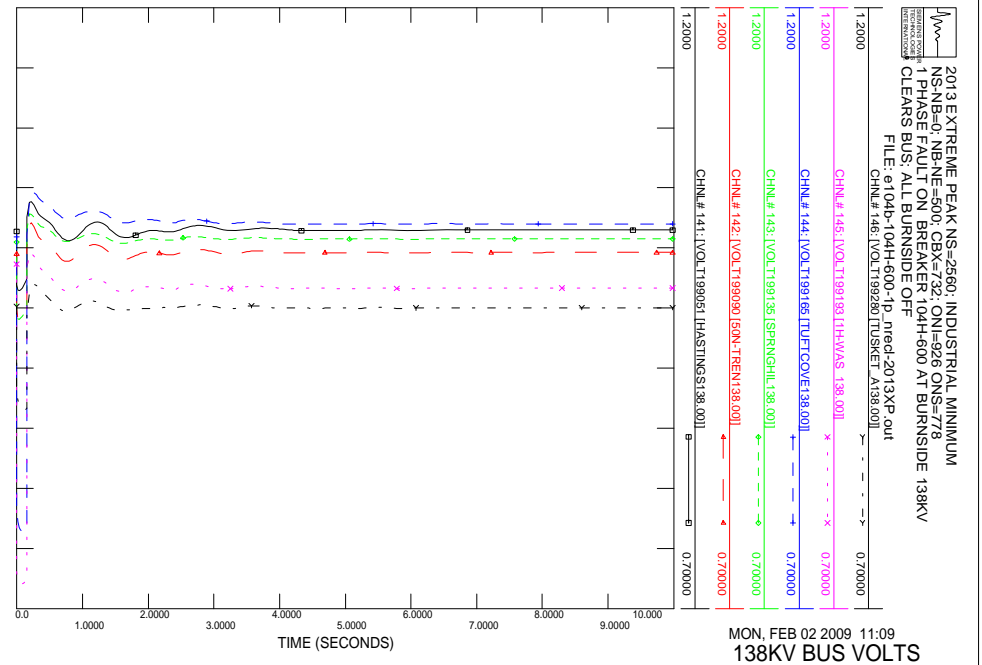

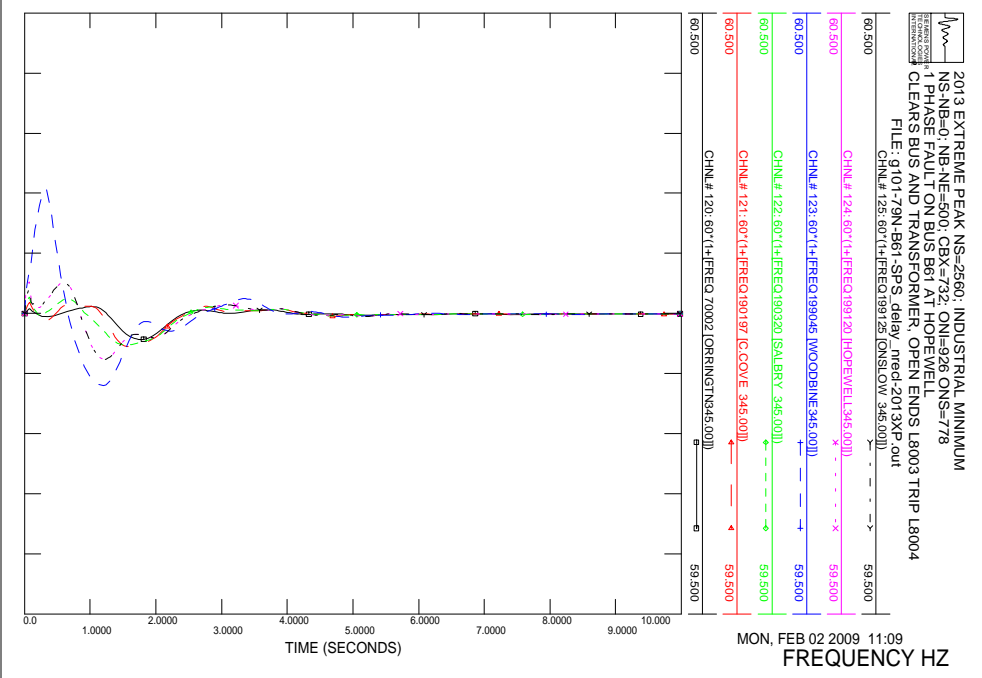
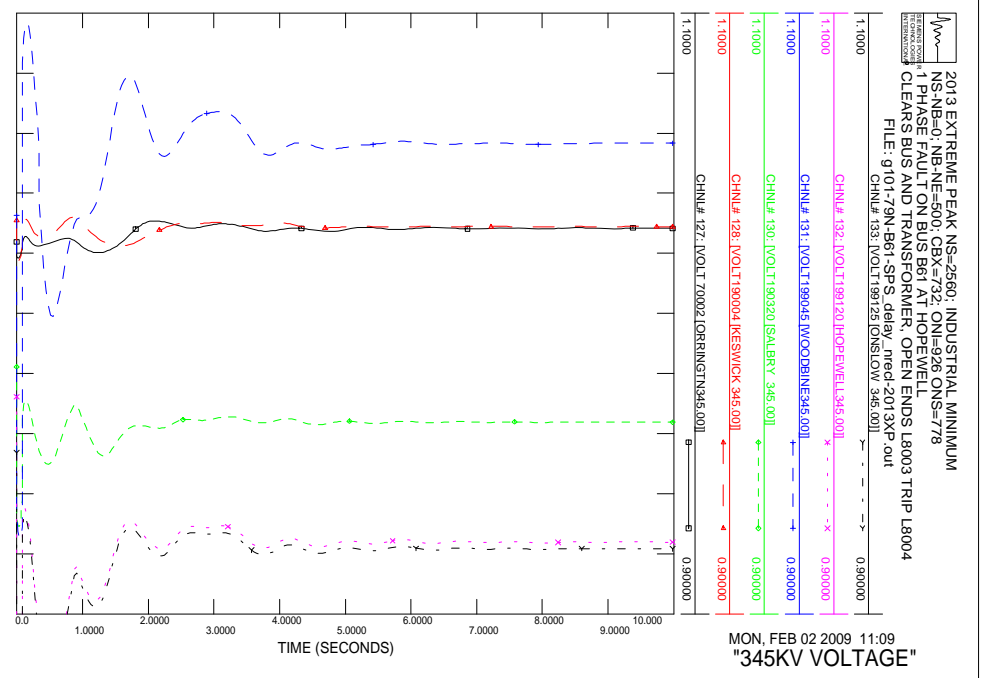
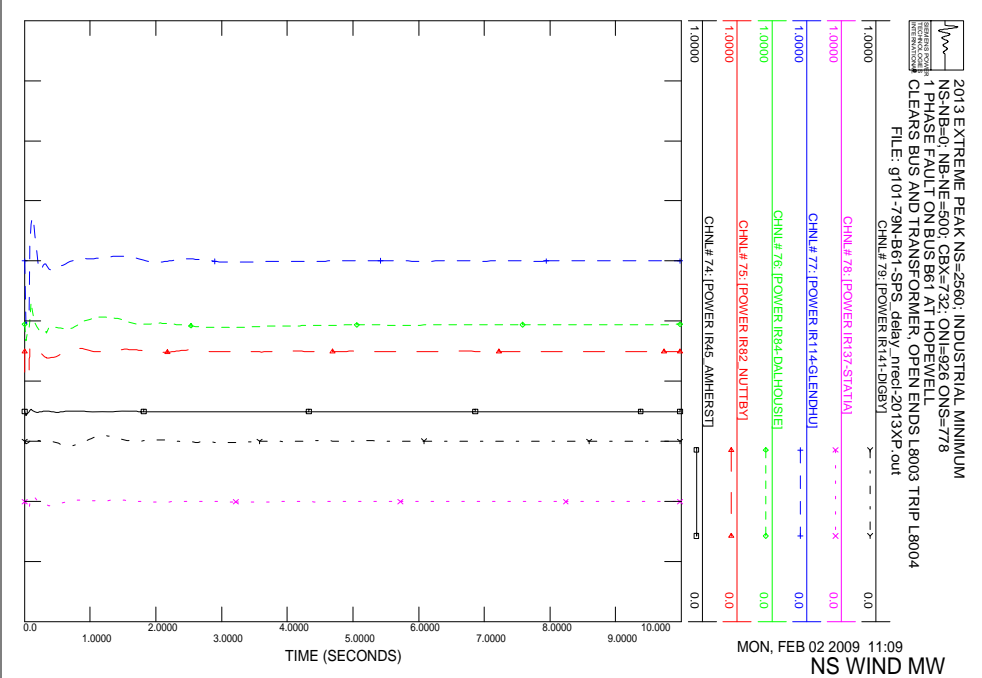
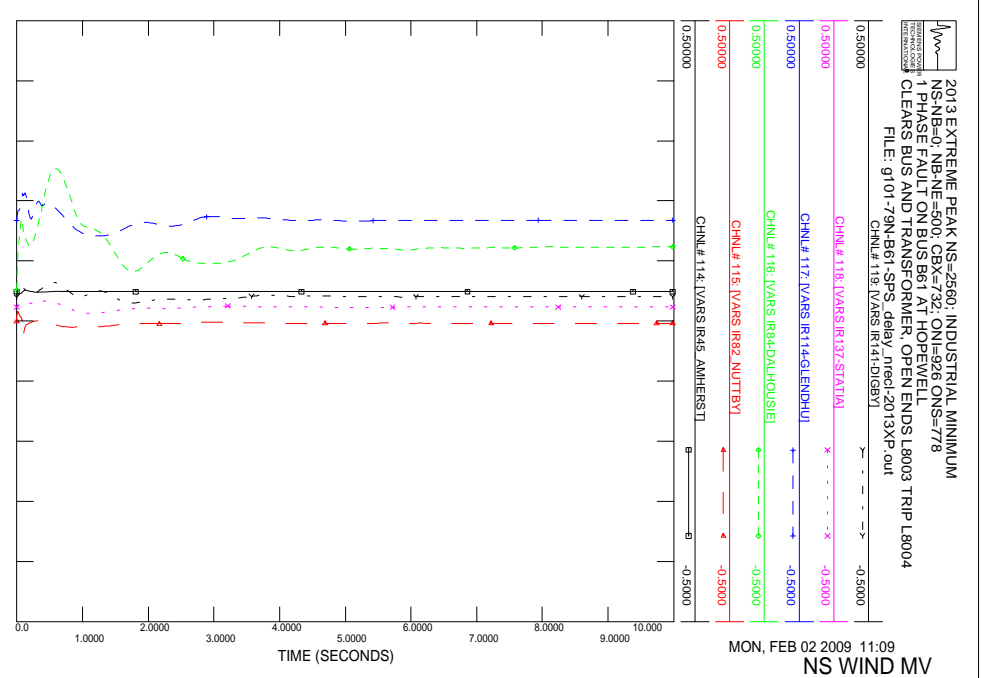

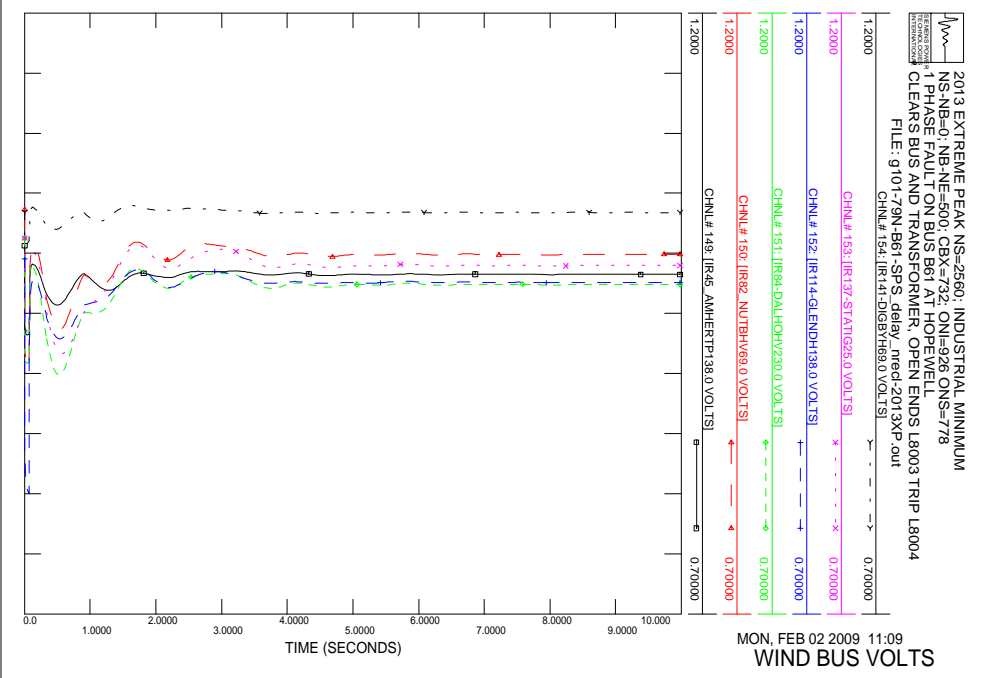
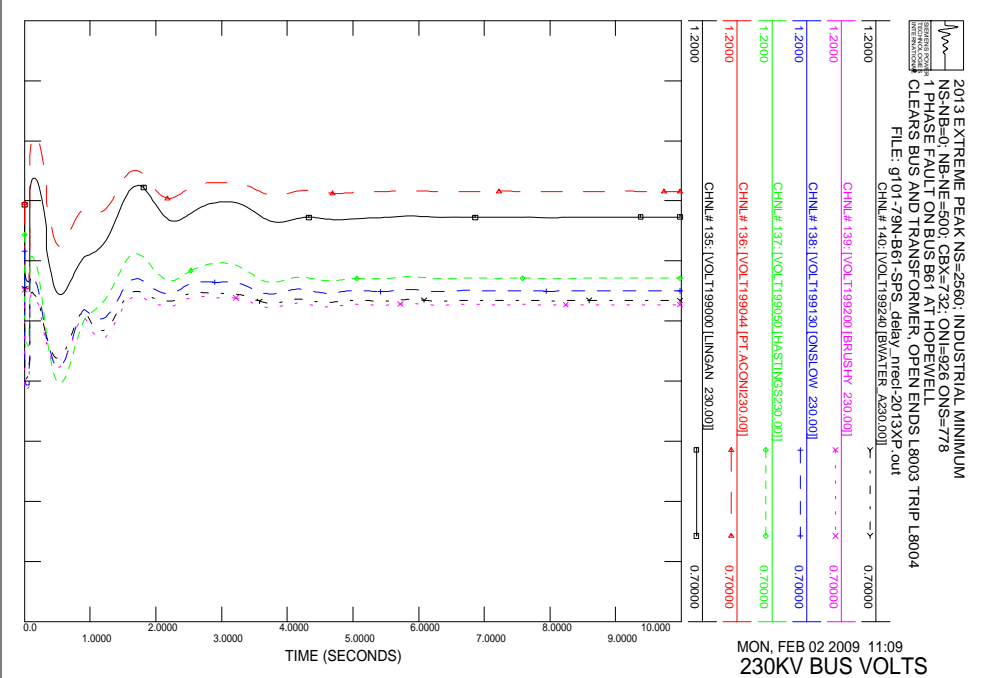
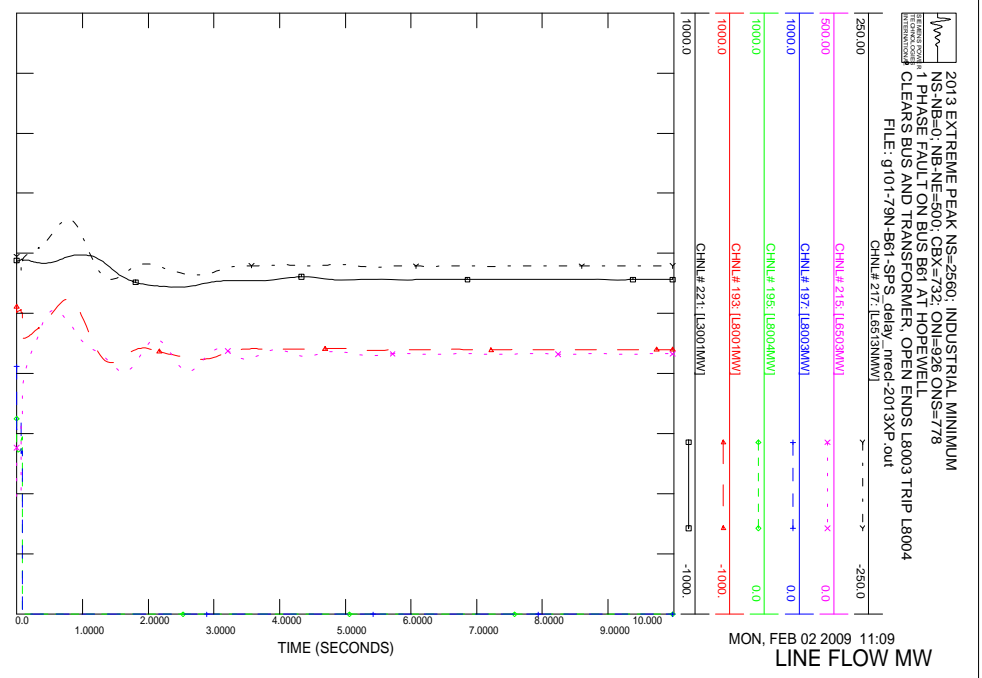
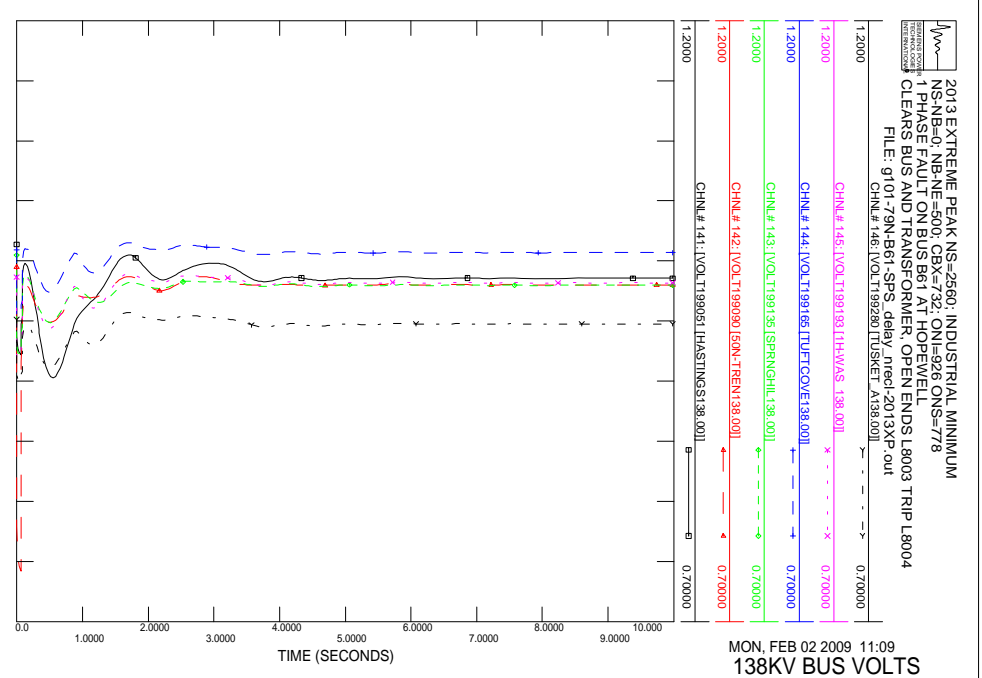

Nova Scotia New Brunswick

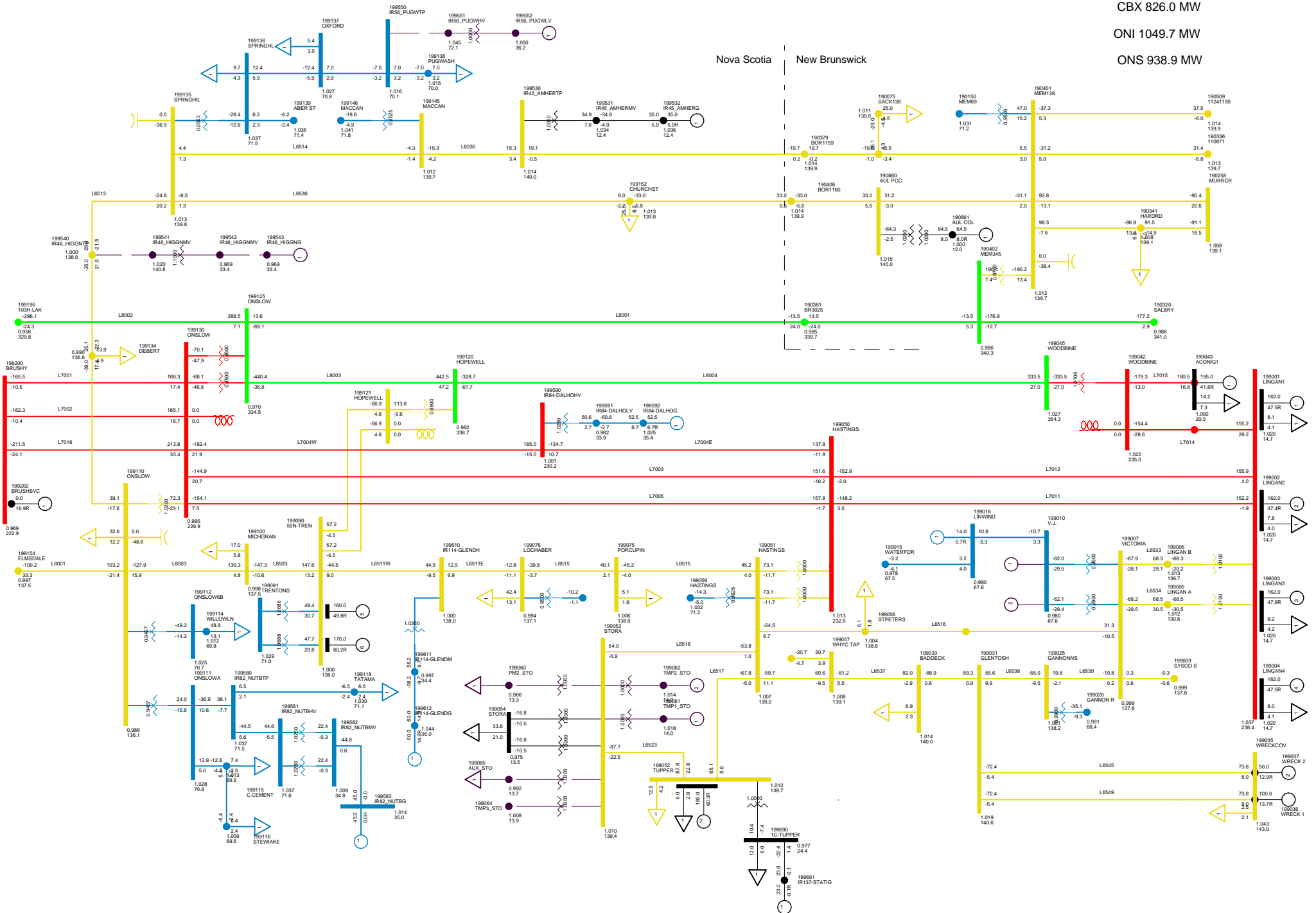

2013 WINTER PEAK MAXIMUM FLOW
 NS-NB=0; NB-NE=500; CBX=826; ONI=1050 ONS=939
 NORTHEASTERN NS SUN, FEB 15 2009 14:05

Total Wind Gen: 290.1 MW
 Gross Lingan 648.0 MW
 Gross Trenton 330.0 MW
 Gross Pt Aconi 195.0 MW
 Gross Tupper 165.0 MW
 Gross Trenton 330.0 MW
 Gross Tuft's Cove 310.4 MW
 Gross Wreck Cove 150.0 MW
 Gross Gas Turbine 24.0 MW
 Gross Small Hydro 182.4 MW
 Net Stora Load 33.7 MW
 Total BMPC Load 75.5 MW

Bus - VOLTAGE (KV/PU)
 Branch - MW/MVAR
 Equipment - MW/MVAR
 110.0/0.875
 1.000/0.850/UV
 KV - <25.000 <<69.000 <<138.000 <<230.000 <<345.000 >345.000

Figure

Nova Scotia New Brunswick

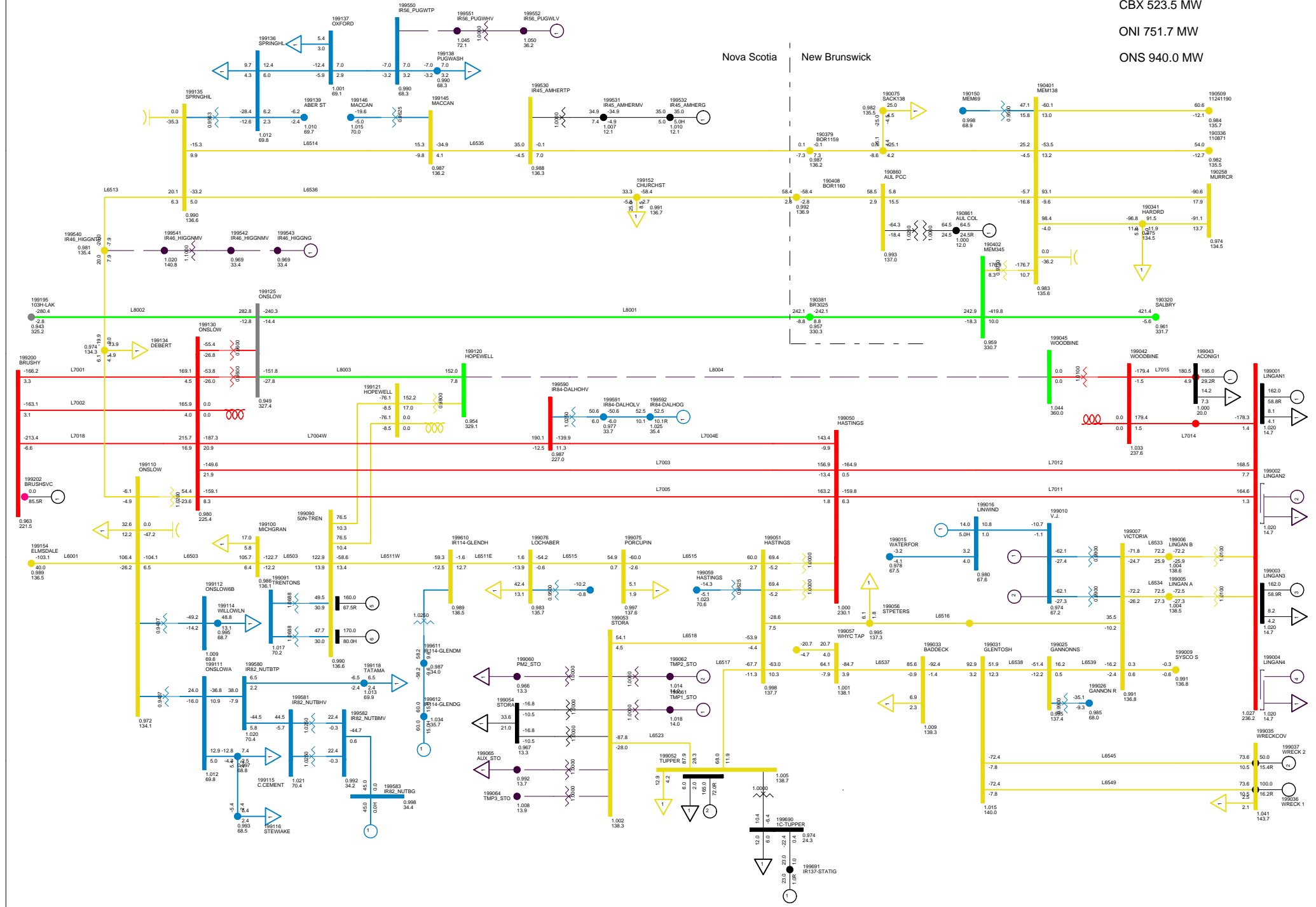

NSX 305.0 MW

CBX 526.9 MW

ONI 747.3 MW

ONS 941.9 MW

Nova Scotia New Brunswick

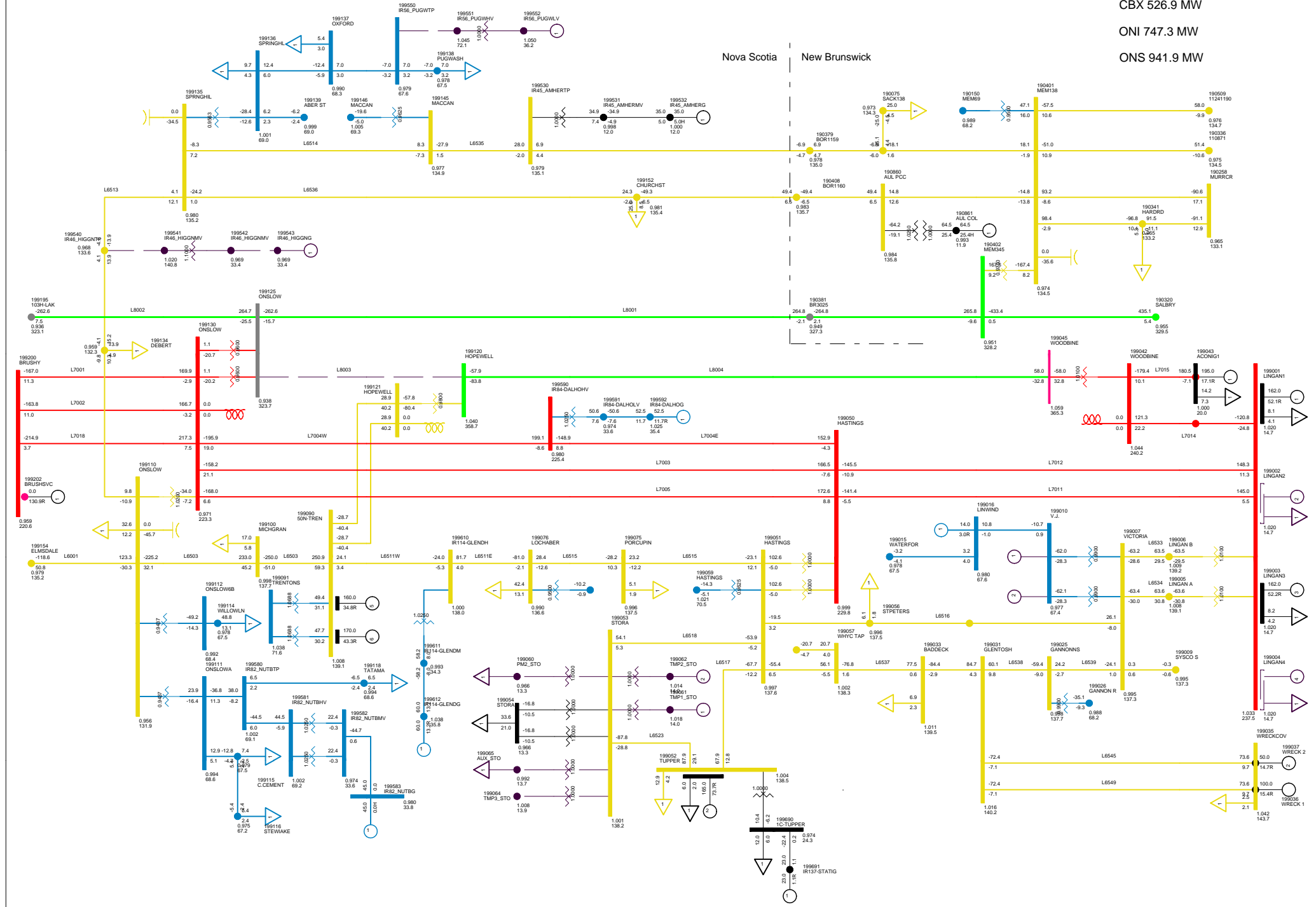

ONI 1047.2 MW
 ONS 954.9 MW

Nova Scotia New Brunswick

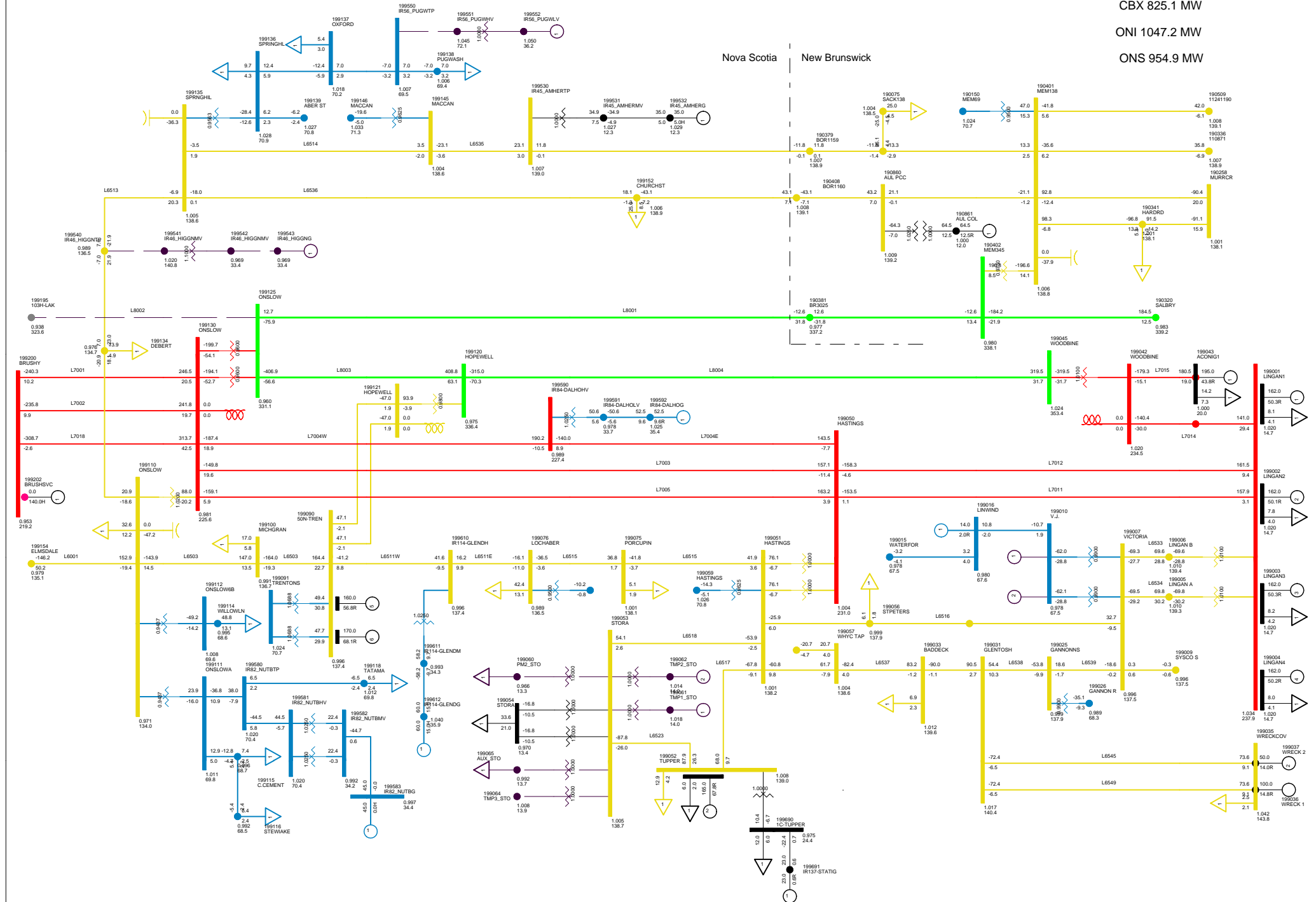

LABEL
 C03 LOSE L8002
 NORTHEASTERN NS SUN, FEB 15 2009 14:07

||
||
||

NSX 1.4 MW
 CBX 825.7 MW
 ONI 1048.8 MW
 ONS 939.3 MW

Nova Scotia New Brunswick

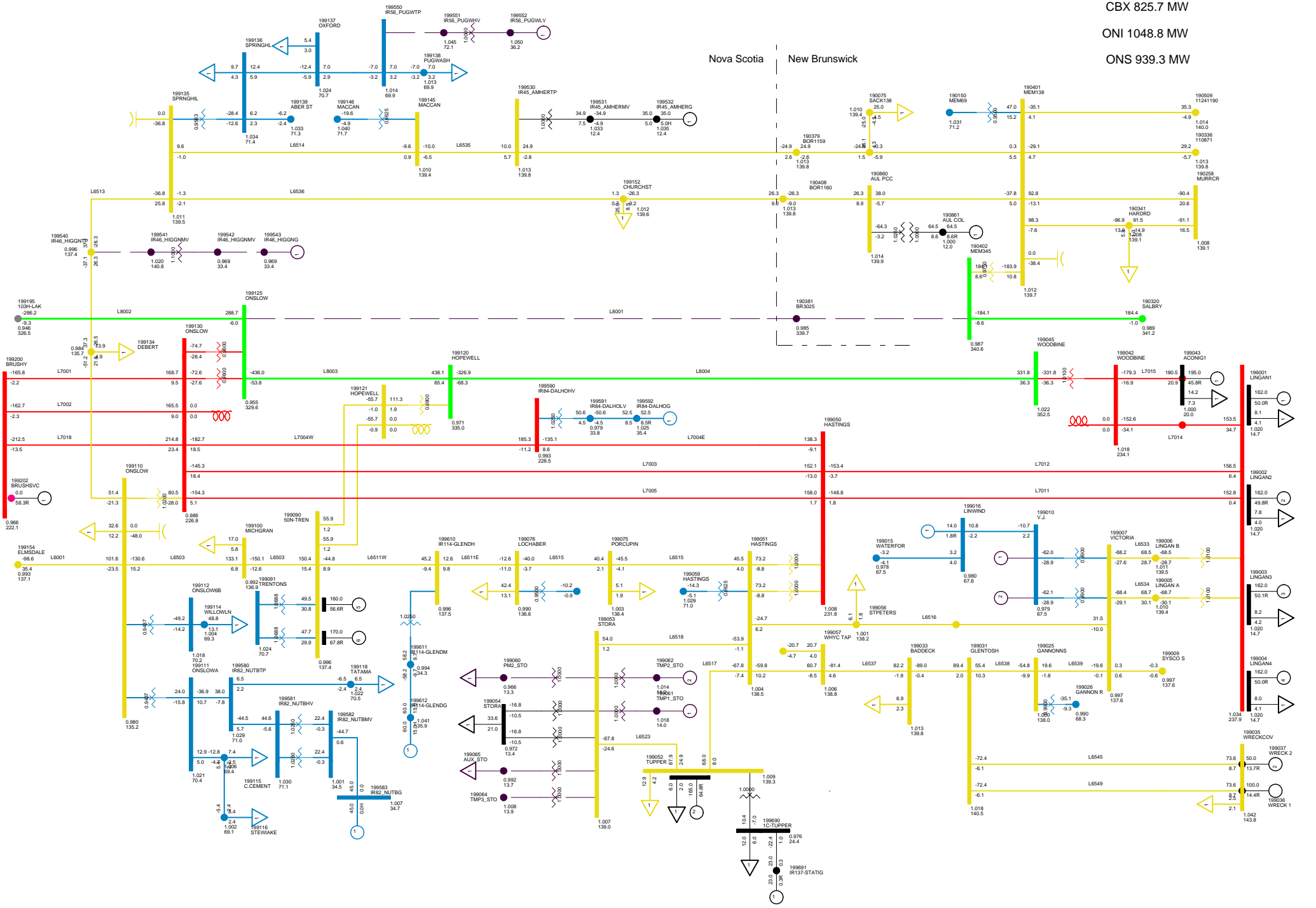

LABEL
 C04 LOSE L8001 NO SPS
 NORTHEASTERN NS SUN, FEB 15 2009 14:07

Total Wind Gen: 290.1 MW	Gross Tupper 165.0 MW	Gross Wreck Cove 150.0 MW	Net Stora Load 33.7 MW
Gross Lingan 648.0 MW	Gross Trenton 330.0 MW	Gross Gas Turbine 24.0 MW	Total BMPC Load 75.5 MW
Gross Pt Aconi 195.0 MW	Gross Tuft's Cove 310.4 MW	Gross Small Hydro 182.4 MW	

Bus - VOLTAGE (KV/PU)
 Branch - MW/MVAR
 Equipment - MW/MVAR
 110.0/1.0/1.0
 1.0/0.0/0.0
 KV <=25.0 <<=69.0 <<=138.0 <<=230.0 <<=345.0 >=450.0

Figure

Nova Scotia New Brunswick

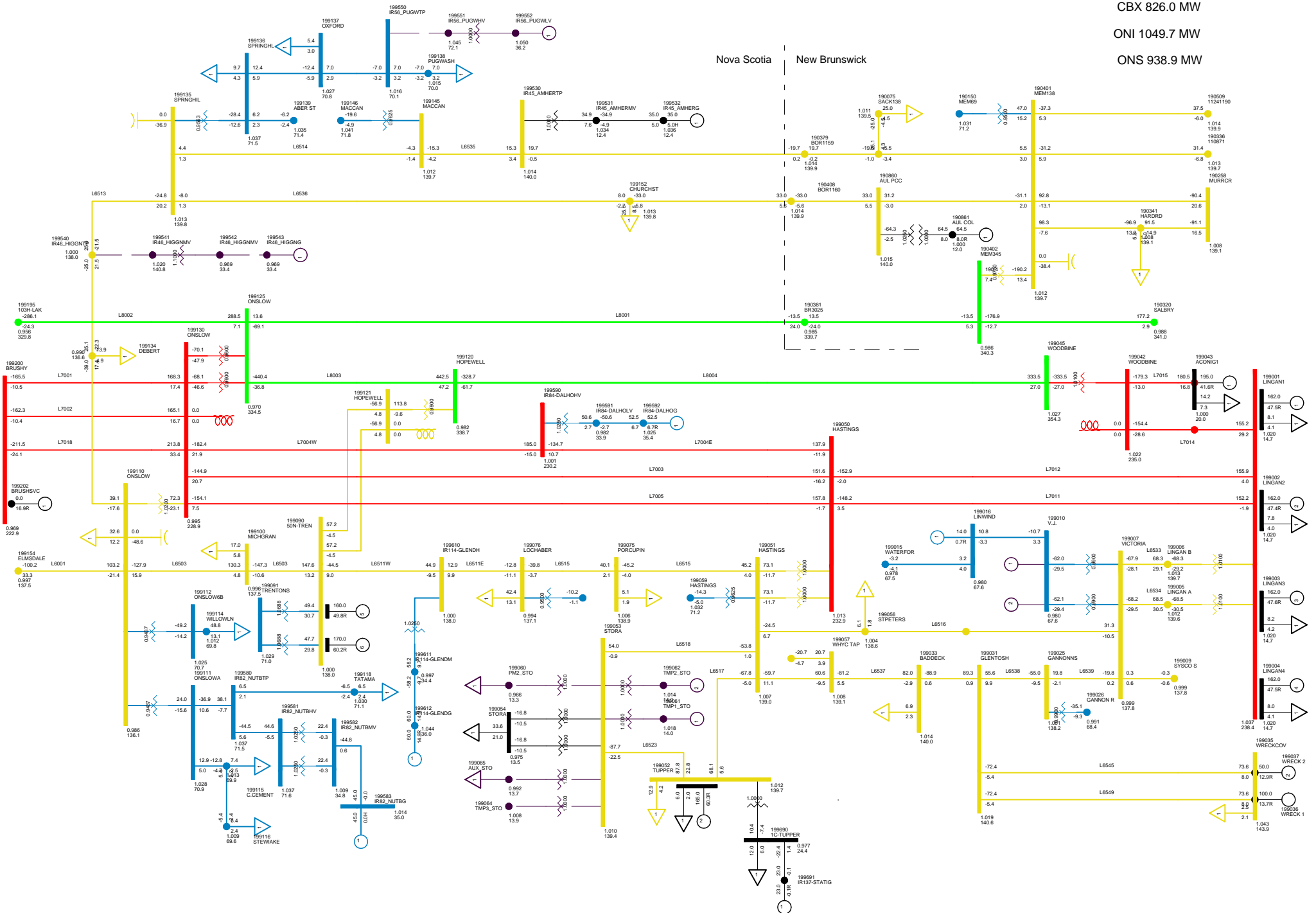

2013 WINTER PEAK MAXIMUM FLOW
 NS-NB=0; NB-NE=500; CBX=826; ONI=1050 ONS=939
 NORTHEASTERN NS SUN, FEB 15 2009 14:07

Total Wind Gen: 290.1 MW
 Gross Lingan 648.0 MW
 Gross Trenton 330.0 MW
 Gross Tuft's Cove 310.4 MW
 Gross Tupper 165.0 MW
 Gross Wreck Cove 150.0 MW
 Gross Gas Turbine 24.0 MW
 Gross Small Hydro 182.4 MW
 Net Stora Load 33.7 MW
 Total BMPC Load 75.5 MW

Bus - VOLTAGE (KV/PU)
 Branch - MW/MVAR
 Equipment - MW/MVAR
 110.0KV/1.000V 0.650V
 KV <25.000 <<69.000 <<138.000 <<230.000 <<345.000 >345.000

Figure

ONI 1045.6 MW
 ONS 939.0 MW

Nova Scotia New Brunswick

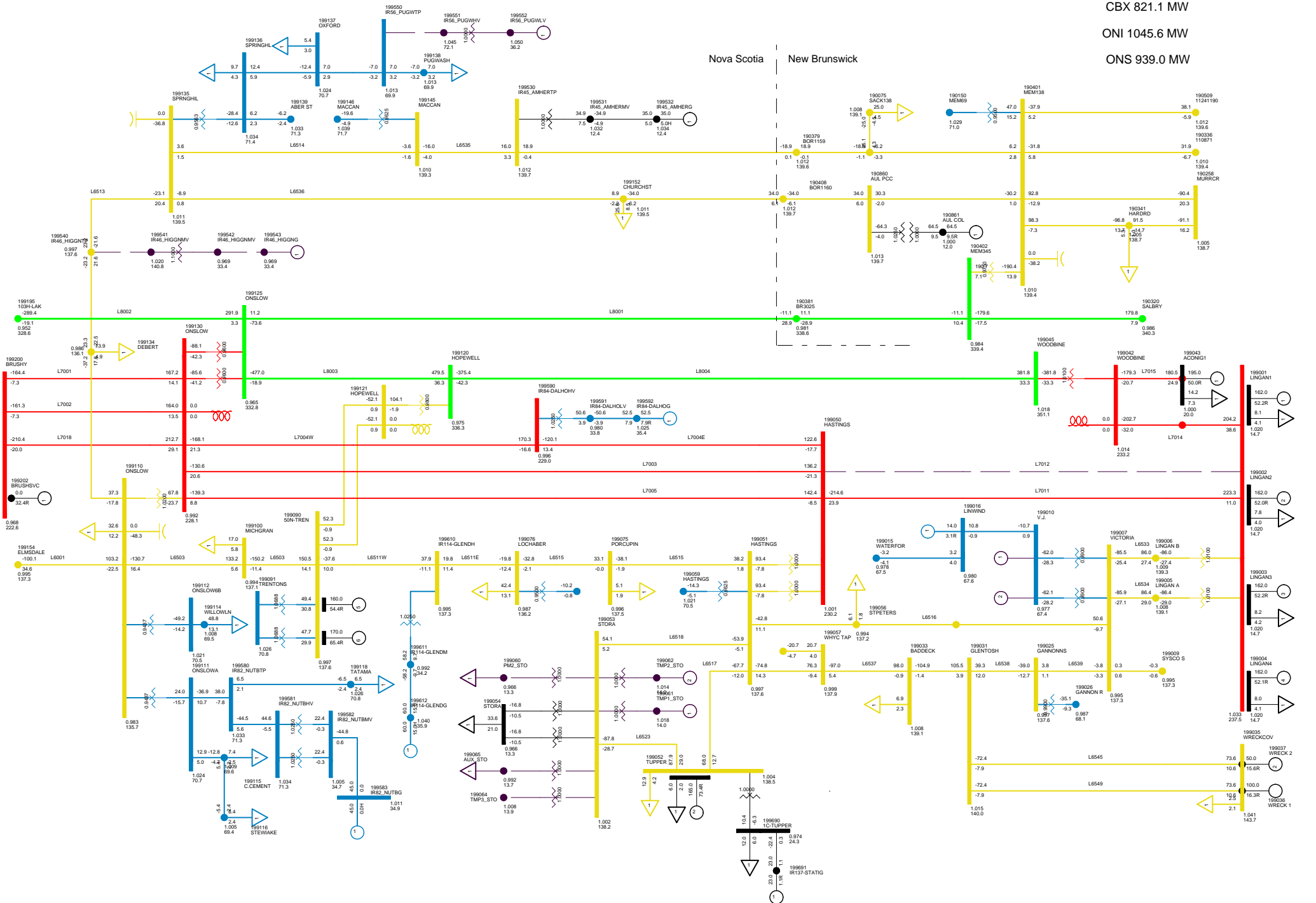

LABEL
 C05 LOSE L7012 NO SPS
 NORTHEASTERN NS SUN, FEB 15 2009 14:07

Total Wind Gen: 290.1 MW
 Gross Lingan 648.0 MW
 Gross Trenton 330.0 MW
 Gross Pt Aconi 195.0 MW
 Gross Tupper 165.0 MW
 Gross Gas Turbine 24.0 MW
 Gross Small Hydro 182.4 MW
 Gross Wreck Cove 150.0 MW
 Net Stora Load 33.7 MW
 Total BMPC Load 75.5 MW

Bus - VOLTAGE (KV/PU)
 Branch - MW/MVAR
 Equipment - MW/MVAR
 110.0/0.0
 1.000/0.0
 KV: <25.000 <<69.000 <<138.000 <<230.000 <<345.000 >>450.000

Figure

NSX 139.9 MW

CBX 677.4 MW

ONI 909.3 MW

ONS 938.9 MW

Nova Scotia New Brunswick

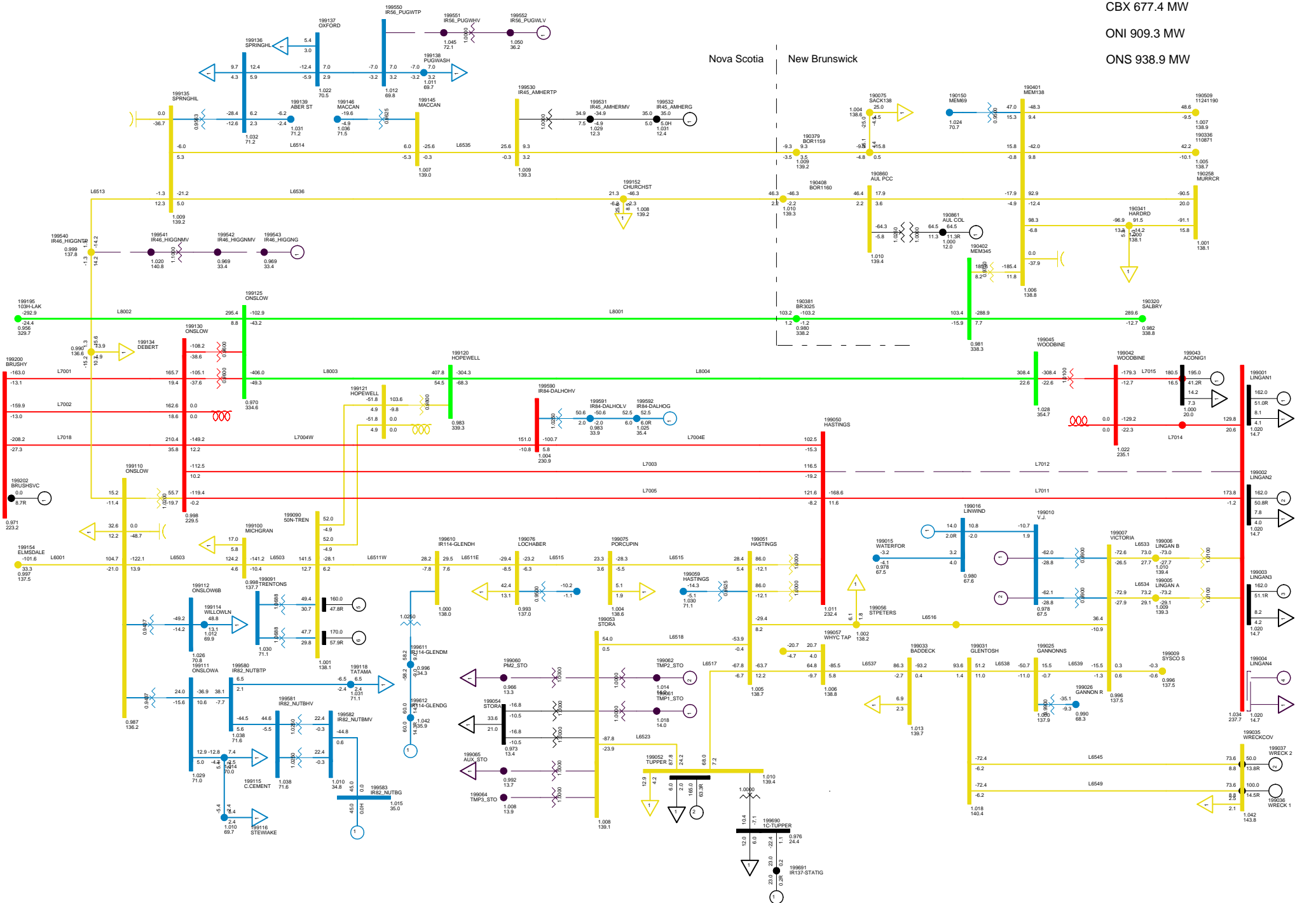

LABEL
C05S LOSE L7012 WITH SPS
NORTHEASTERN NS SUN, FEB 15 2009 14:07

Total Wind Gen: 290.1 MW
 Gross Tupper 165.0 MW
 Gross Wreck Cove 150.0 MW
 Net Stora Load 33.7 MW
 Gross Lingan 486.0 MW
 Gross Trenton 330.0 MW
 Gross Gas Turbine 24.0 MW
 Total BMPC Load 75.5 MW
 Gross Tuft's Cove 310.4 MW
 Gross Small Hydro 182.4 MW

Bus - VOLTAGE (KV/PU)
 Branch - MW/MVAR
 Equipment - MW/MVAR
 110.0/0.97478
 1.0000V 0.8500V
 KV <-25.000 <<-69.000 <<-138.000 <<-230.000 <<-345.000 >>345.000

Figure

Nova Scotia New Brunswick

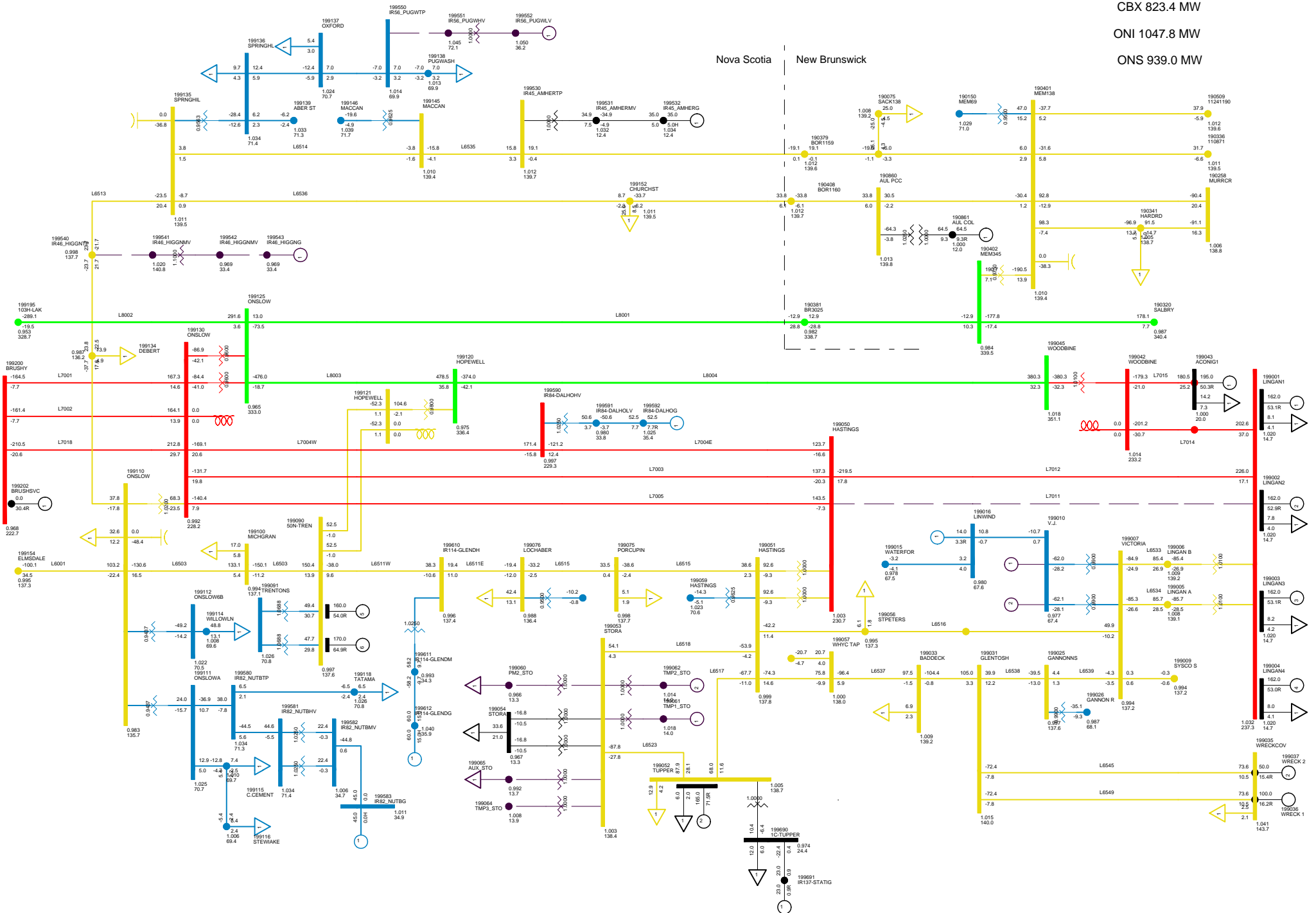

LABEL
C06 LOSE L7011
NORTHEASTERN NS SUN, FEB 15 2009 14:07

Total Wind Gen: 290.1 MW
Gross Ligan 648.0 MW
Gross Trenton 330.0 MW
Gross Pt Aconi 195.0 MW
Gross Tupper 165.0 MW
Gross Stora 33.7 MW
Gross Wreck Cove 150.0 MW
Gross Gas Turbine 24.0 MW
Gross Small Hydro 182.4 MW
Net Stora Load 33.7 MW
Total BMPC Load 75.5 MW

Bus - VOLTAGE (KV/PU)
Branch - MW/MVAR
Equipment - MW/MVAR
110.0/1.0/1.0
KV: <25.000 <<69.000 <<138.000 <<230.000 <<345.000 >345.000

Figure

ONI 1049.8 MW
 ONS 945.3 MW

Nova Scotia New Brunswick

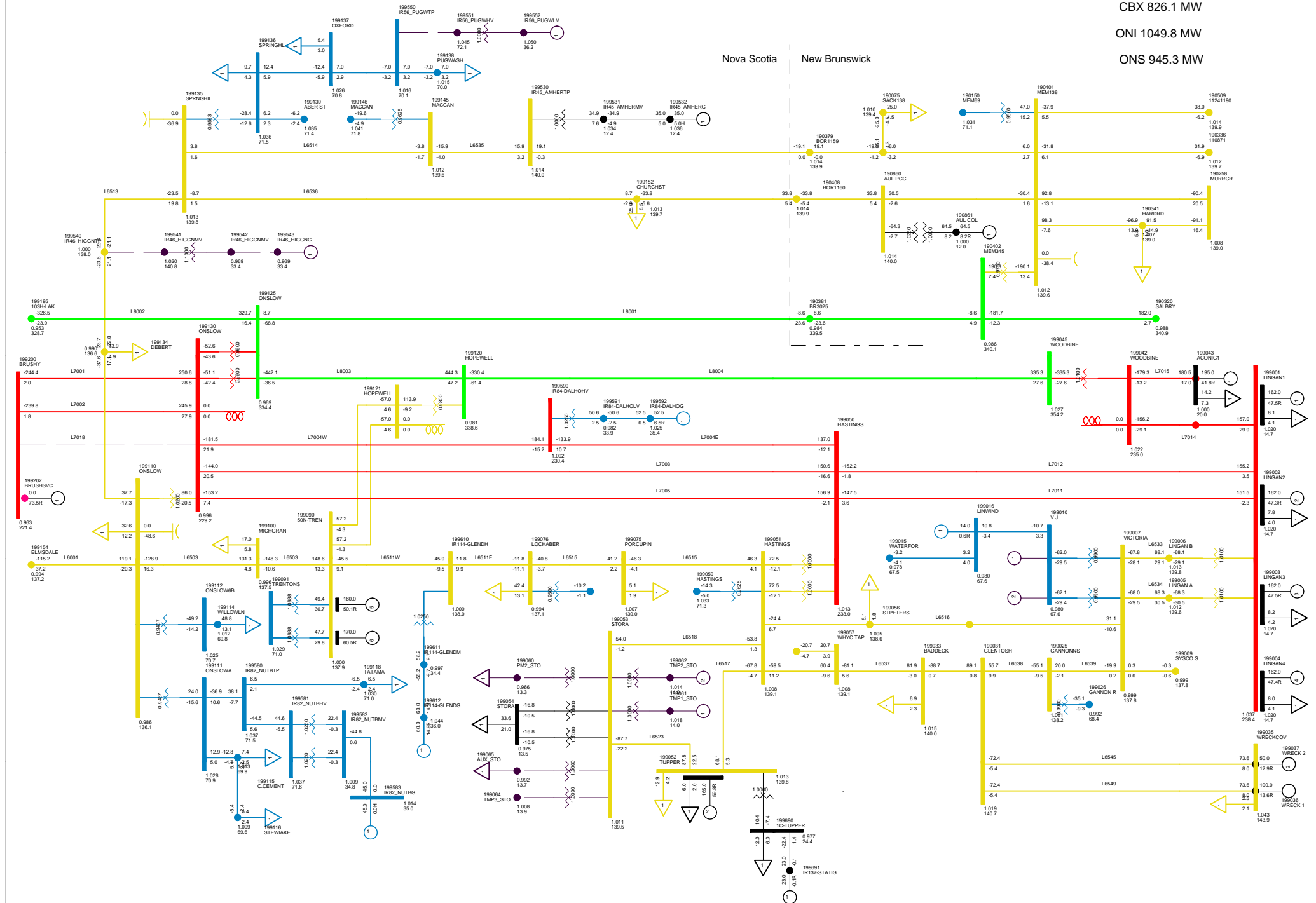

LABEL
 C08 LOSE L7018
 NORTHEASTERN NS SUN, FEB 15 2009 14:07

Total Wind Gen: 290.1 MW	Gross Tupper 165.0 MW	Gross Wreck Cove 150.0 MW	Net Stora Load 33.7 MW
Gross Lingan 648.0 MW	Gross Trenton 330.0 MW	Gross Gas Turbine 24.0 MW	Total BMPC Load 75.5 MW
Gross Pt Aconi 195.0 MW	Gross Tuft's Cove 310.4 MW	Gross Small Hydro 182.4 MW	

Bus - VOLTAGE (KV/PU)	Branch - MW/MVAR
Equipment - MW/MVAR	
110.0/0.7475	1.000/0.050/0.050
KV <25.000	<<138.000 <<230.000 <<345.000 >345.000

Figure

Total Wind Gen: 290.1 MW Gross Tupper 165.0 MW Gross Wreck Cove 150.0 MW
 Gross Lingan 648.0 MW Gross Trenton 330.0 MW Gross Gas Turbine 24.0 MW
 Gross Pt Aconi 195.0 MW Gross Tuft's Cove 310.4 MW Gross Small Hydro 182.4 MW

Net Stora Load 33.7 MW Total BMPC Load 75.5 MW

NSX -1.6 MW
 CBX 826.0 MW
 ONI 1049.5 MW
 ONS 940.7 MW

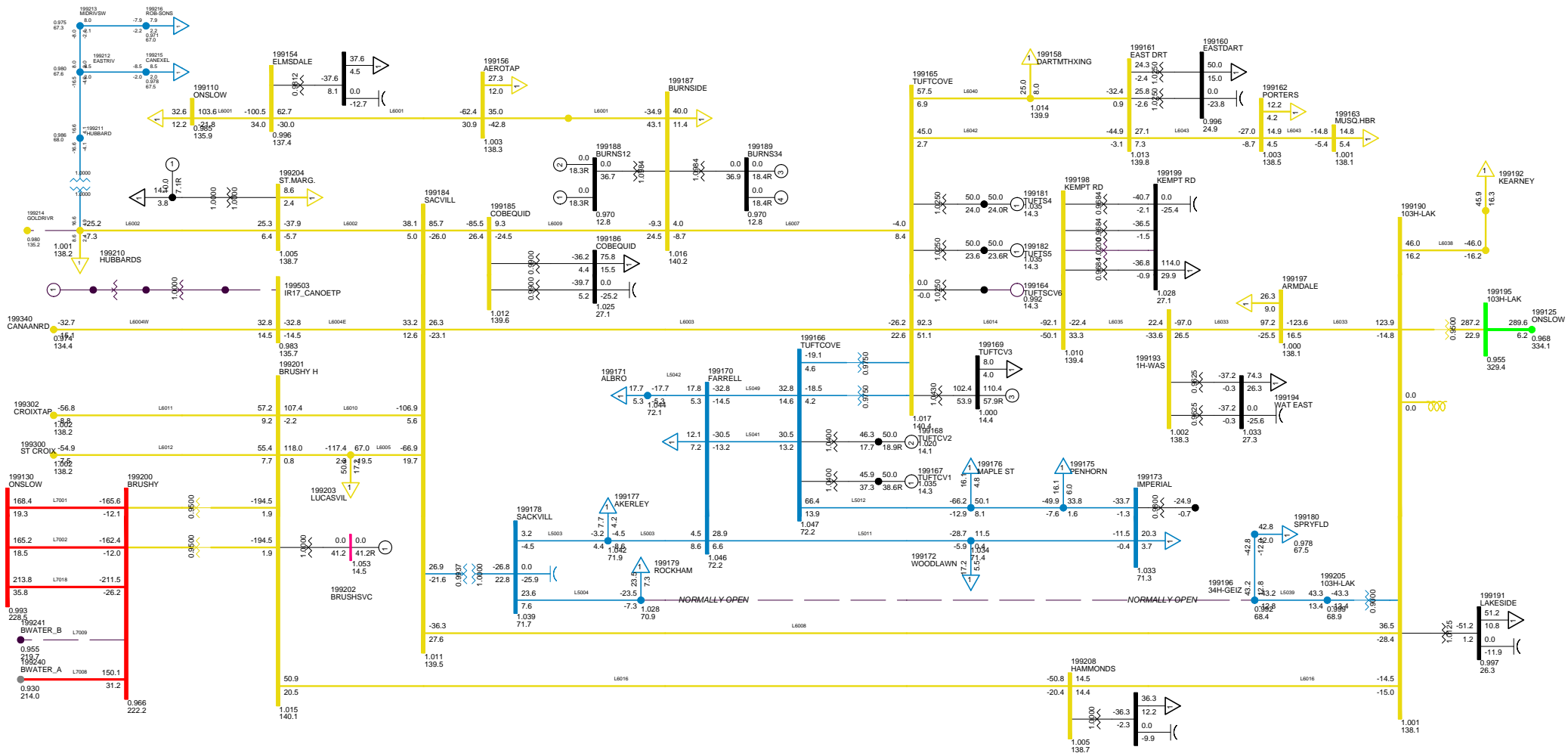

LABEL
 C09 LOSE L7009
 METRO ZONE SUN, FEB 15 2009 14:08

Bus - VOLTAGE (KV/PU)
 Branch - MVA/MVAR
 Equipment - MVA/MVAR
 HV RATES
 1.050KV 0.950VU
 KV: <30.000 <=69.000 <=138.000 <=230.000 <=345.000 >=345.000

Figure __

ONI 1063.5 MW
 ONS 938.6 MW

Nova Scotia New Brunswick

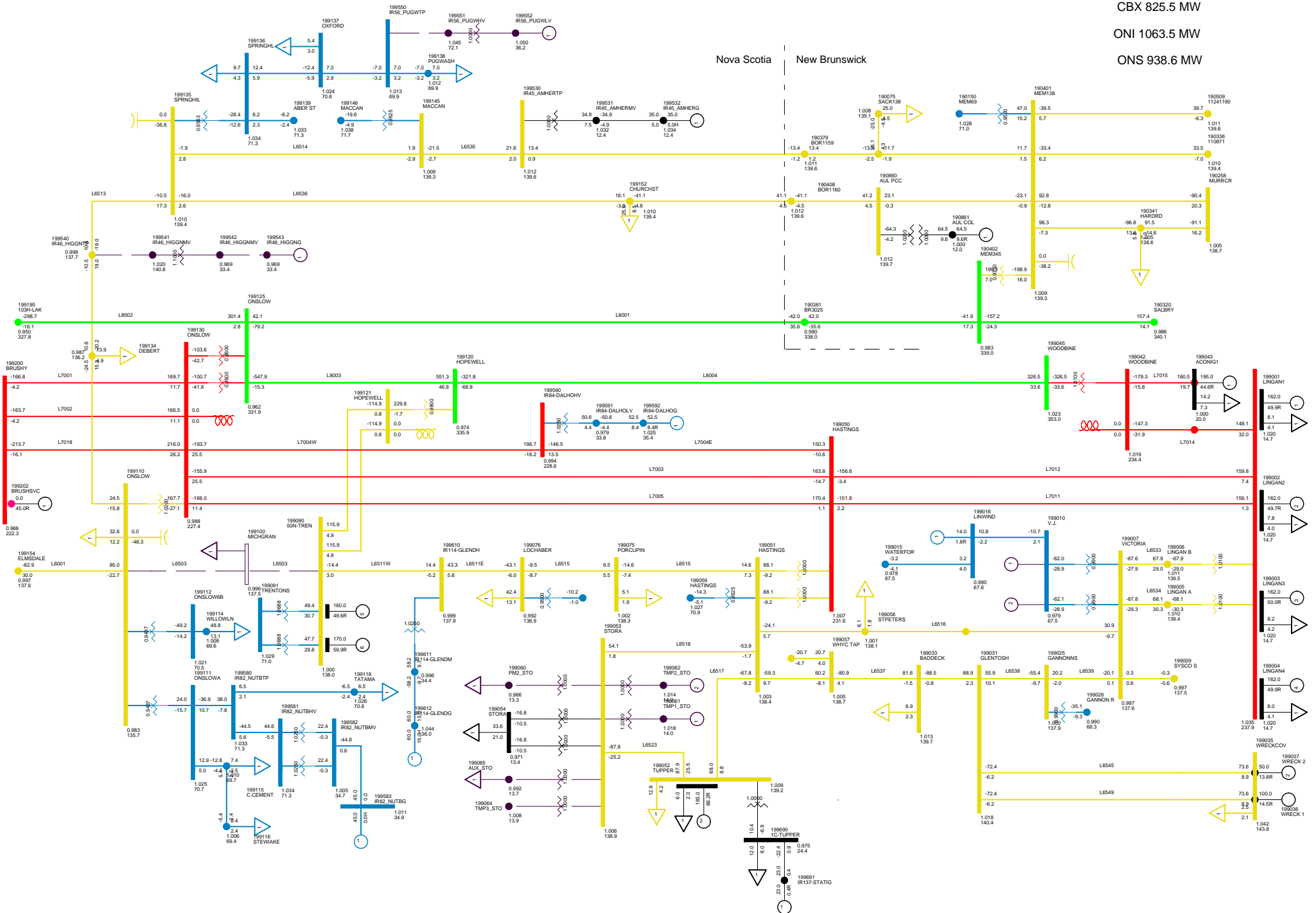

LABEL
 C12 LOSE 6503
 NORTHEASTERN NS SUN, FEB 15 2009 14:08

Total Wind Gen: 290.1 MW
 Gross Lingan 648.0 MW
 Gross Trenton 330.0 MW
 Gross Pt Aconi 195.0 MW
 Gross Tupper 165.0 MW
 Gross Gas Turbine 24.0 MW
 Gross Small Hydro 182.4 MW
 Gross Wreck Cove 150.0 MW
 Net Stora Load 33.7 MW
 Total BMPC Load 75.5 MW

Bus - VOLTAGE (KV/PU)
 Branch - MW/MVAR
 Equipment - MW/MVAR
 110/138/155
 KV: <25.000 <<69.000 <<138.000 <<230.000 <<345.000 >345.000

Figure

ONI 1049.2 MW
 ONS 939.0 MW

Nova Scotia New Brunswick

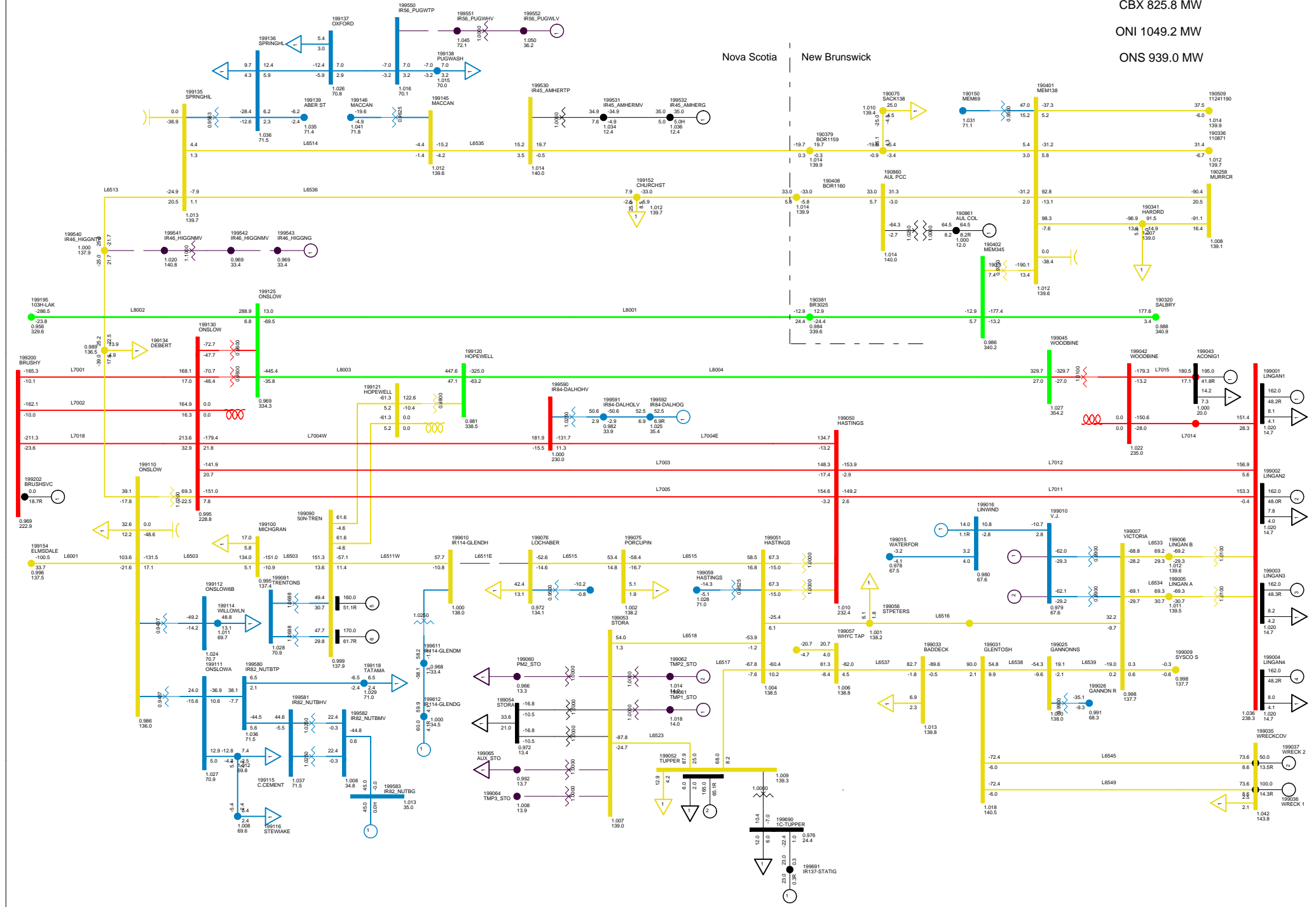

LABEL
 C14 LOSE L6511E
 NORTHEASTERN NS SUN, FEB 15 2009 14:08

Total Wind Gen: 290.1 MW
 Gross Lingan 648.0 MW
 Gross Trenton 330.0 MW
 Gross Tuft's Cove 310.4 MW
 Gross Tupper 165.0 MW
 Gross Wreck Cove 150.0 MW
 Gross Gas Turbine 24.0 MW
 Gross Small Hydro 182.4 MW
 Net Stora Load 33.7 MW
 Total BMPC Load 75.5 MW

Bus - VOLTAGE (KV/PU)
 Branch - MW/MVAR
 Equipment - MW/MVAR
 110.0/0.475
 1.000/0.0
 KV: <25.000 <<69.000 <<138.000 <<230.000 <<345.000 >345.000

Figure

NSX 9.8 MW
 CBX 826.3 MW
 ONI 1048.6 MW
 ONS 938.9 MW

Nova Scotia New Brunswick

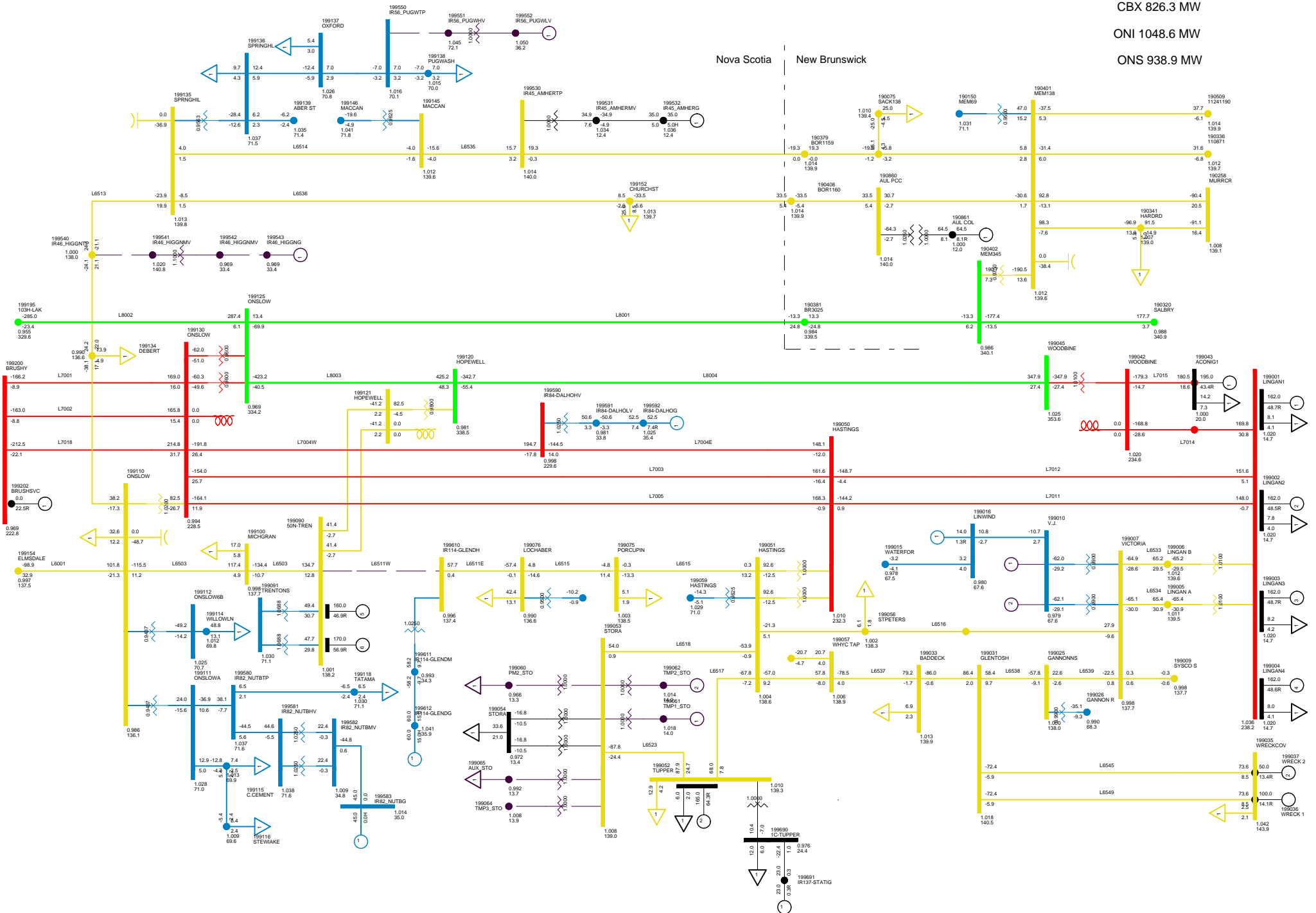

LABEL
 C15 LOSE L6511W
 NORTHEASTERN NS SUN, FEB 15 2009 14:08

Total Wind Gen: 290.1 MW
 Gross Lingan 648.0 MW
 Gross Trenton 330.0 MW
 Gross Pt Aconi 195.0 MW
 Gross Tupper 165.0 MW
 Gross Gas Turbine 24.0 MW
 Gross Small Hydro 182.4 MW
 Gross Wreck Cove 150.0 MW
 Net Stora Load 33.7 MW
 Total BMPC Load 75.5 MW

Bus - VOLTAGE (KV/PU)
 Branch - MW/MVAR
 Equipment - MW/MVAR
 HIGHLIGHTS
 1.0000V 0.8500V
 KV: <25.000 <<69.000 <<138.000 <<230.000 <<345.000 >345.000

Figure

ONI 1049.6 MW
 ONS 938.9 MW

Nova Scotia New Brunswick

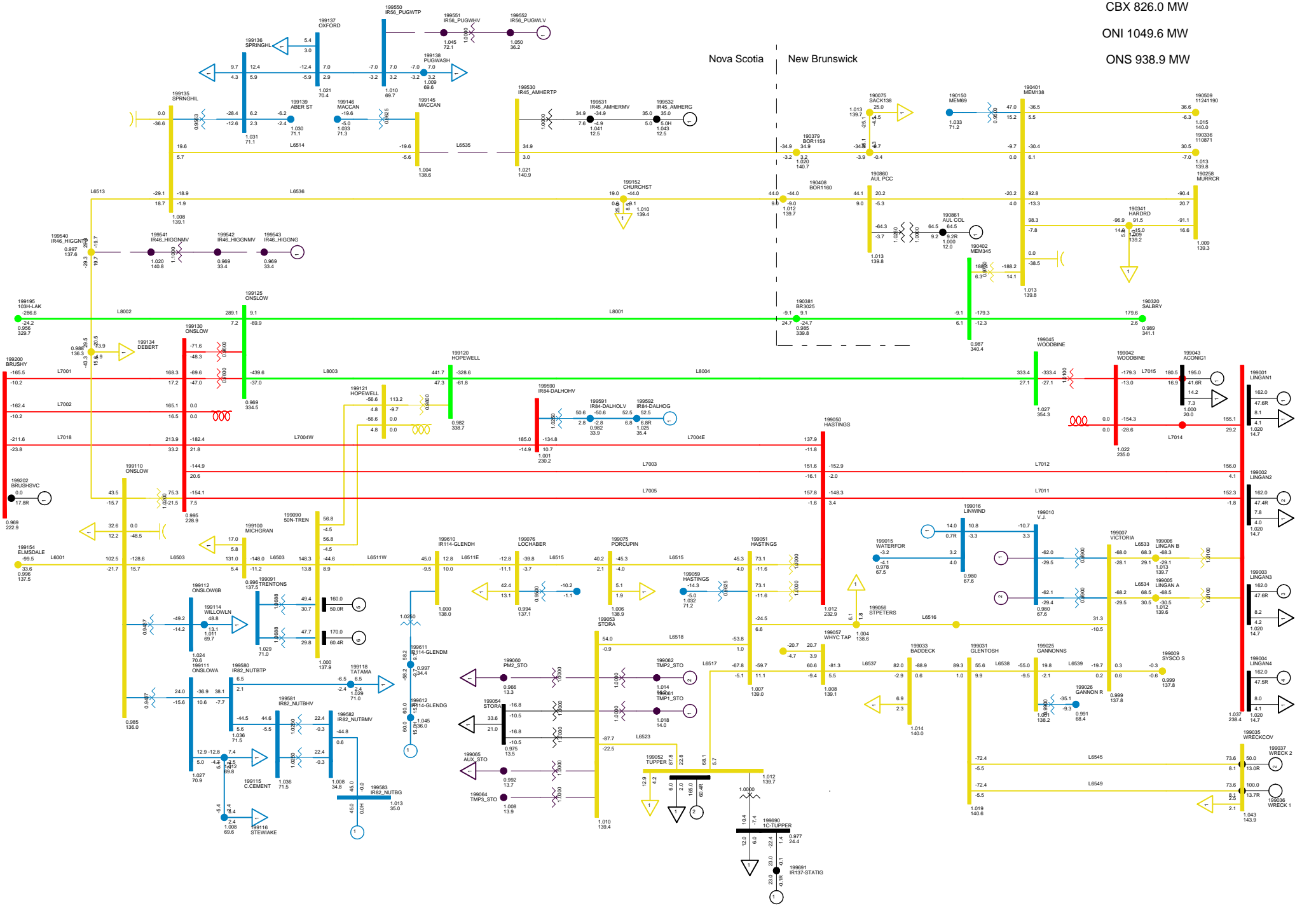

LABEL
C18 LOSE L6535S
NORTHEASTERN NS **SUN, FEB 15 2009 14:09**

Total Wind Gen: 290.1 MW	Gross Tupper 165.0 MW	Gross Wreck Cove 150.0 MW	Net Stora Load 33.7 MW
Gross Lingan 648.0 MW	Gross Trenton 330.0 MW	Gross Gas Turbine 24.0 MW	Total BMPC Load 75.5 MW
Gross Pt Aconi 195.0 MW	Gross Tuft's Cove 310.4 MW	Gross Small Hydro 182.4 MW	

Bus - VOLTAGE (KV/PU)
 Branch - MW/MVAR
 Equipment - MW/MVAR
 HIGHLIGHTS
 1.0000V 0.8500V
 KV <=25.000 <<=69.000 <<=138.000 <<=230.000 <<=345.000 >=345.000

Figure

ONI 1049.6 MW
 ONS 938.9 MW

Nova Scotia New Brunswick

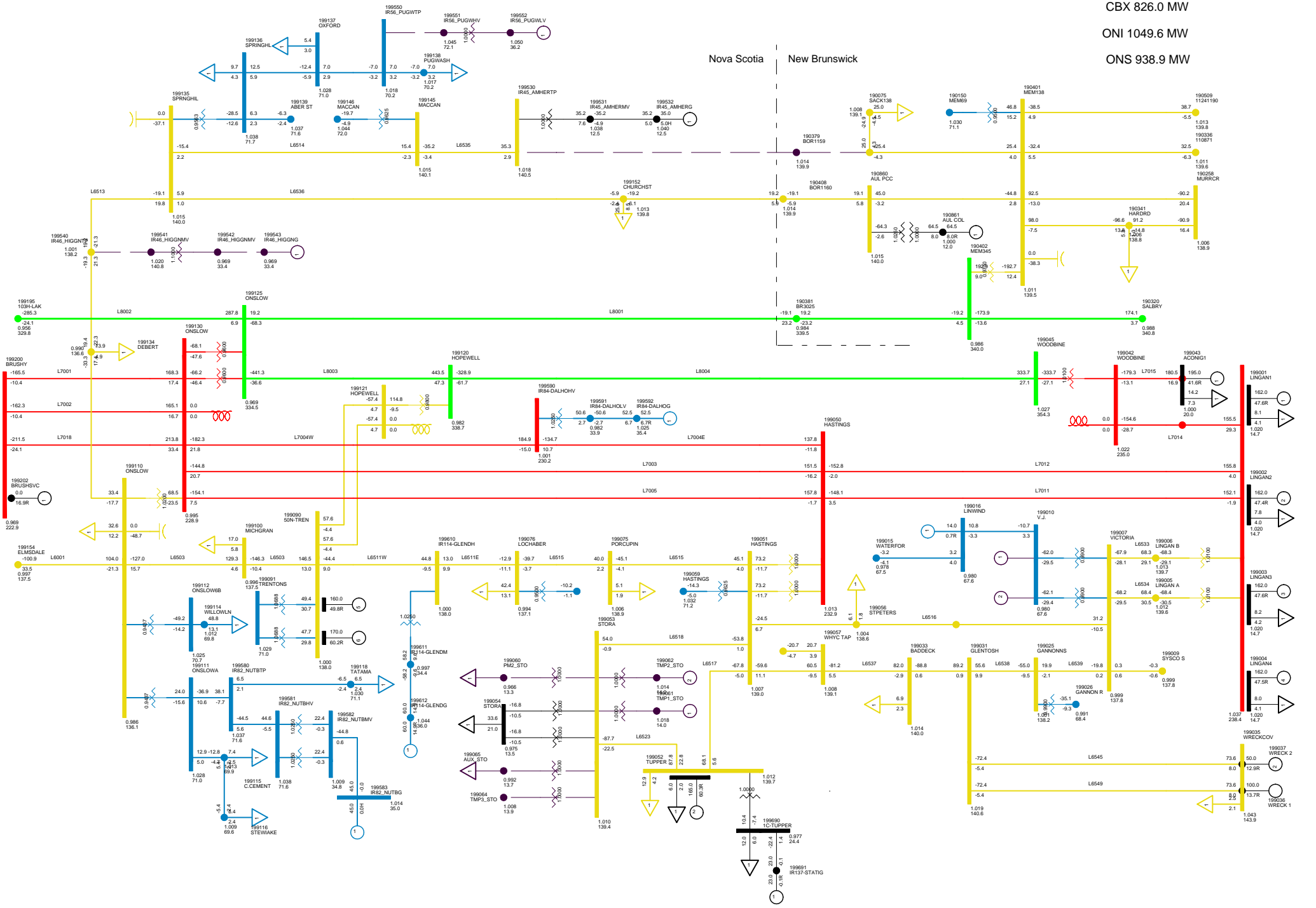

LABEL
 C19 LOSE L6535N
 NORTHEASTERN NS SUN, FEB 15 2009 14:09

Total Wind Gen: 290.1 MW	Gross Tupper 165.0 MW	Gross Wreck Cove 150.0 MW	Net Stora Load 33.7 MW
Gross Lingan 648.0 MW	Gross Trenton 330.0 MW	Gross Gas Turbine 24.0 MW	Total BMPC Load 75.5 MW
Gross Pt Aconi 195.0 MW	Gross Tuft's Cove 310.4 MW	Gross Small Hydro 182.4 MW	

Bus - VOLTAGE (KV/PU)	Branch - MW/MVAR
Equipment - MW/MVAR	
110.0 KV/PU	1.0000V 0.8500V
KV <=25.000	<=69.000 <=138.000 <=230.000 <=345.000 >=345.000

Figure

ONI 985.8 MW
 ONS 938.9 MW

Nova Scotia New Brunswick

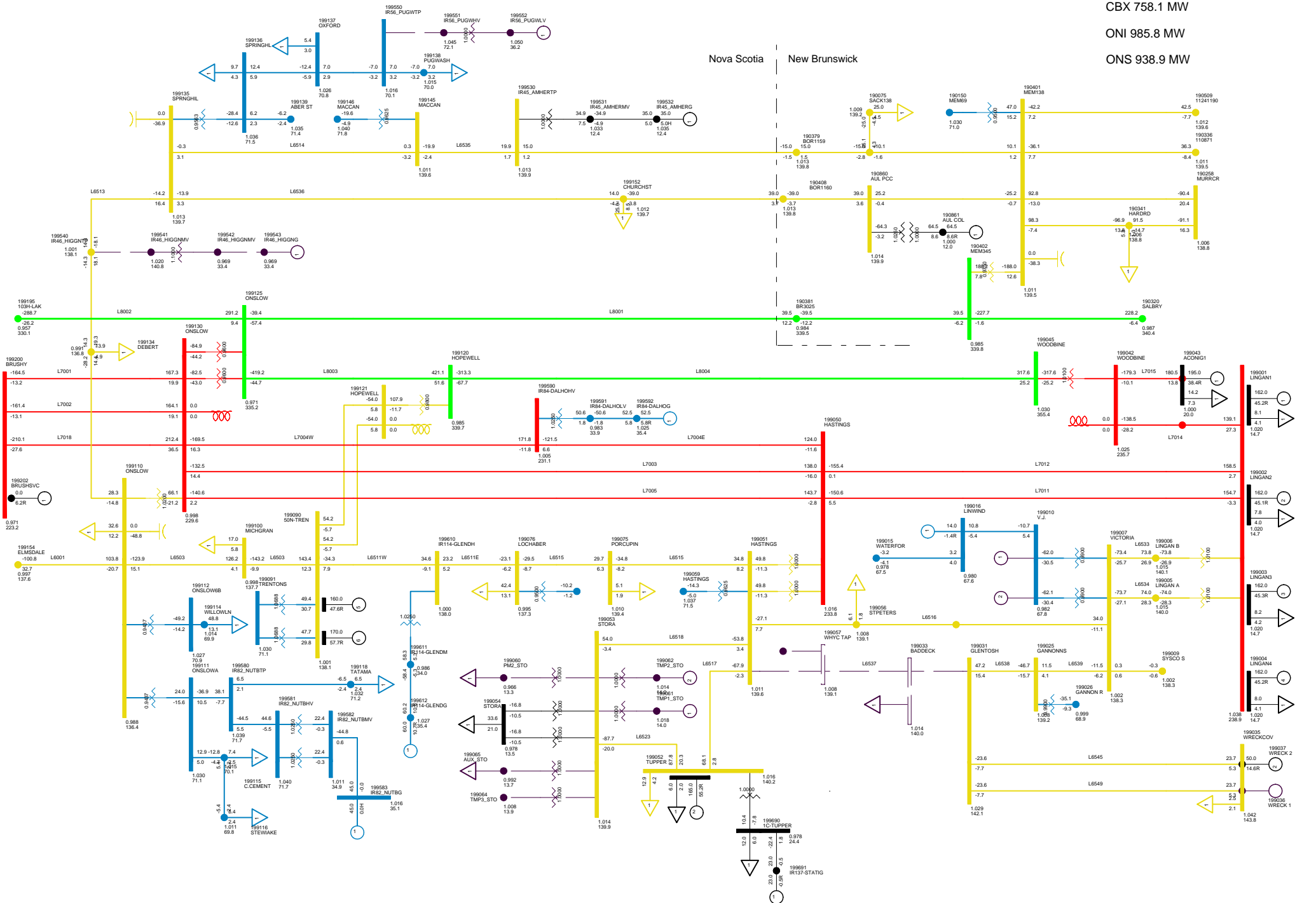

LABEL
 C20 LOSE L6537
 NORTHEASTERN NS SUN, FEB 15 2009 14:09

Total Wind Gen: 290.1 MW
 Gross Lingan 648.0 MW
 Gross Trenton 330.0 MW
 Gross Pt Aconi 195.0 MW
 Gross Tupper 165.0 MW
 Gross Trent 330.0 MW
 Gross Gas Turbine 24.0 MW
 Gross Small Hydro 182.4 MW
 Gross Wreck Cove 50.0 MW
 Gross Stora Load 33.7 MW
 Net Stora Load 33.7 MW
 Total BMPC Load 75.5 MW

Bus - VOLTAGE (KV/PU)
 Branch - MW/MVAR
 Equipment - MW/MVAR
 HIGHLIGHTS
 1.0000V 0.8000V
 KV <25.000 <<69.000 <<138.000 <<230.000 <<345.000 >345.000

Figure

Nova Scotia New Brunswick

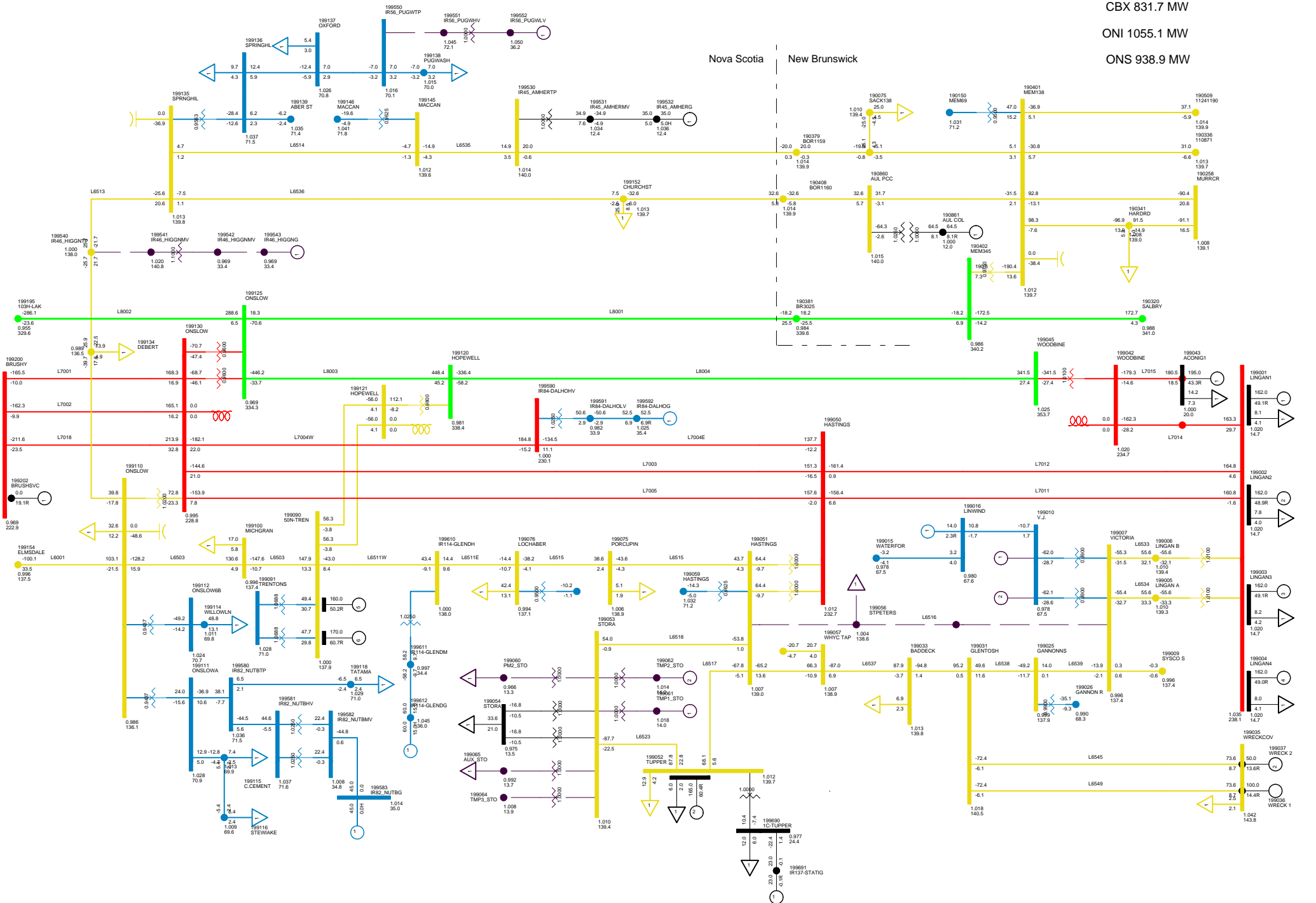

LABEL
C21 LOSE L6516
NORTHEASTERN NS SUN, FEB 15 2009 14:09

Total Wind Gen: 290.1 MW
Gross Ligan 648.0 MW
Gross Trenton 330.0 MW
Gross Tuft's Cove 310.4 MW
Gross Tupper 165.0 MW
Gross Wreck Cove 150.0 MW
Gross Gas Turbine 24.0 MW
Gross Small Hydro 182.4 MW
Net Stora Load 33.7 MW
Total BMPC Load 75.5 MW

Bus - VOLTAGE (KV/PU)
Branch - MW/MVAR
Equipment - MW/MVAR
HIGHLIGHTS
KV: <25.000 <<69.000 <<138.000 <<230.000 <<345.000 >345.000

Figure

Nova Scotia New Brunswick

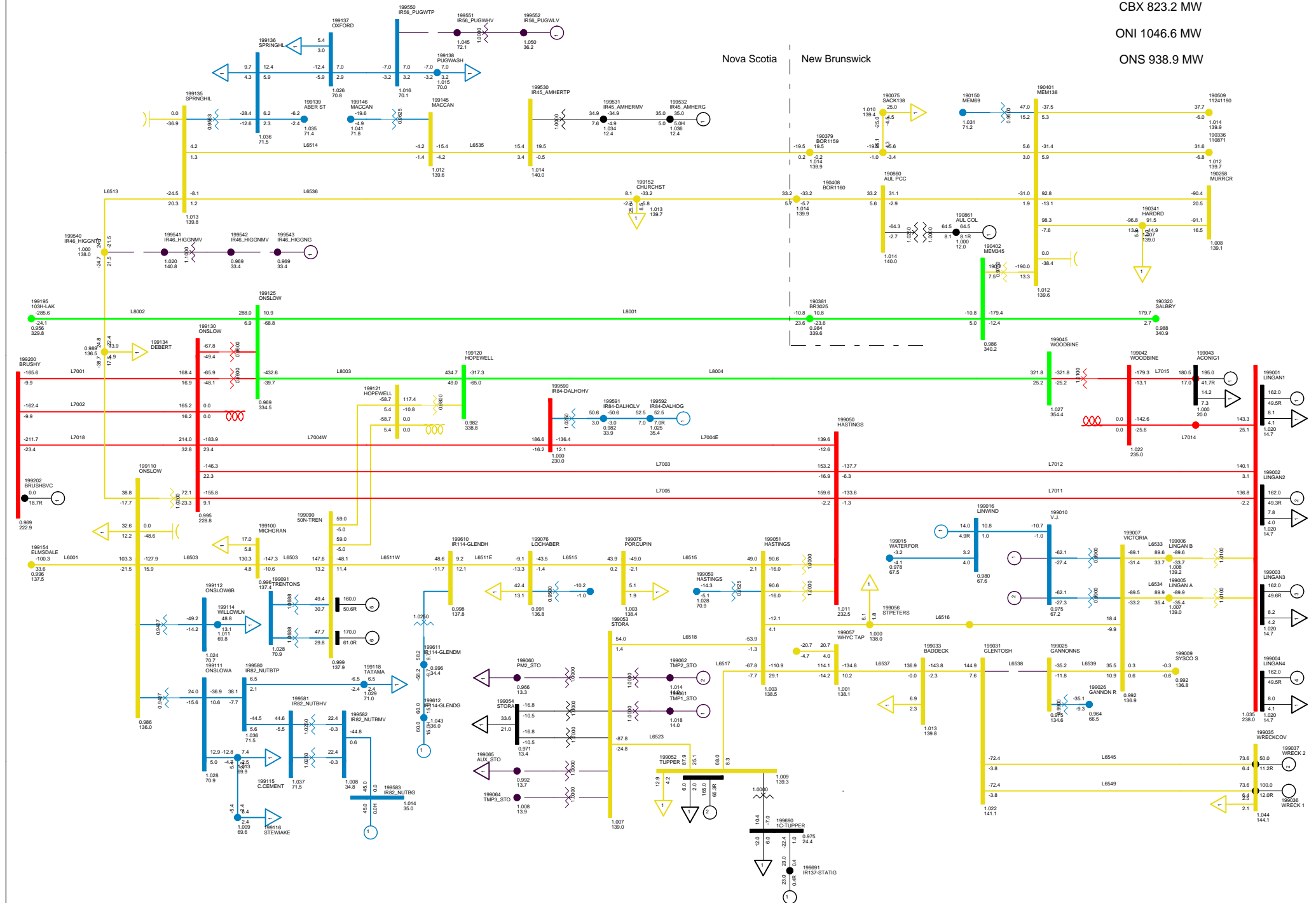

LABEL
C22 LOSE L6538
NORTHEASTERN NS SUN, FEB 15 2009 14:09

Total Wind Gen: 290.1 MW	Gross Tupper 165.0 MW	Gross Wreck Cove 150.0 MW	Net Stora Load 33.7 MW
Gross Lingan 648.0 MW	Gross Trenton 330.0 MW	Gross Gas Turbine 24.0 MW	Total BMPC Load 75.5 MW
Gross Pt Aconi 195.0 MW	Gross Tuft's Cove 310.4 MW	Gross Small Hydro 182.4 MW	

Bus - VOLTAGE (KV/PU)
Branch - MW/MVAR
Equipment - MW/MVAR
110.0/1.0/1.0
1.000/0.0/0.0
KV <25.000 <<69.000 <<138.000 <<230.000 <<345.000 >>345.000

Figure

Total Wind Gen: 290.1 MW Gross Tupper 165.0 MW Gross Wreck Cove 150.0 MW
 Gross Lingan 648.0 MW Gross Trenton 330.0 MW Gross Gas Turbine 24.0 MW
 Gross Pt Aconi 195.0 MW Gross Tuft's Cove 310.4 MW Gross Small Hydro 182.4 MW

Net Stora Load 33.7 MW Total BMPC Load 75.5 MW

NSX 0.2 MW
 CBX 826.0 MW
 ONI 1049.7 MW
 ONS 938.9 MW

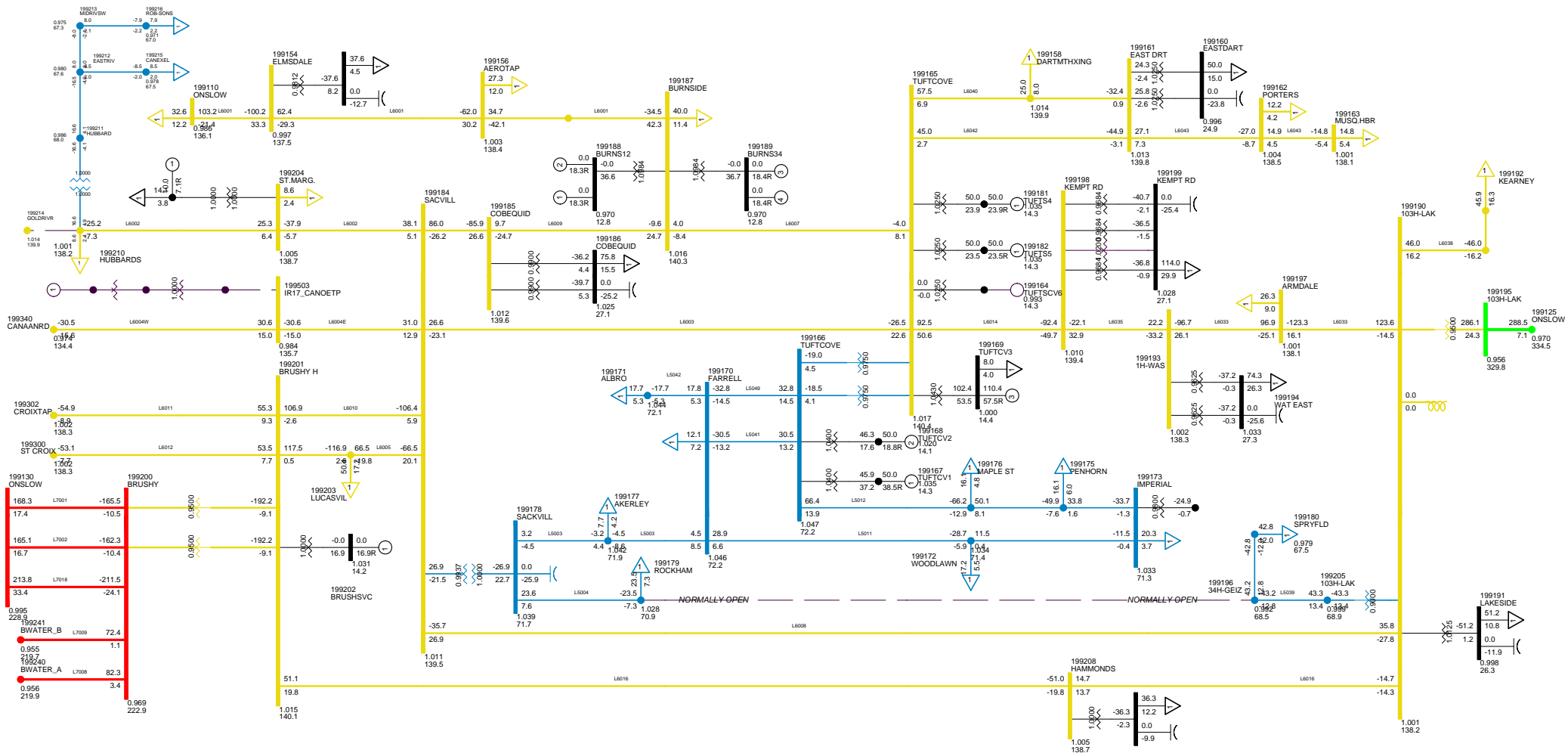

2013 WINTER PEAK MAXIMUM FLOW
 NS-NB=0; NB-NE=500; CBX=826; ONI=1050 ONS=939
 METRO ZONE SUN, FEB 15 2009 14:09

Figure __

Total Wind Gen: 290.1 MW Gross Tupper 165.0 MW Gross Wreck Cove 150.0 MW
 Gross Lingan 648.0 MW Gross Trenton 330.0 MW Gross Gas Turbine 24.0 MW
 Gross Pt Aconi 195.0 MW Gross Tuft's Cove 310.4 MW Gross Small Hydro 182.4 MW

Net Stora Load 33.7 MW Total BMPC Load 75.5 MW

NSX 0.2 MW
 CBX 826.0 MW
 ONI 1049.6 MW
 ONS 939.0 MW

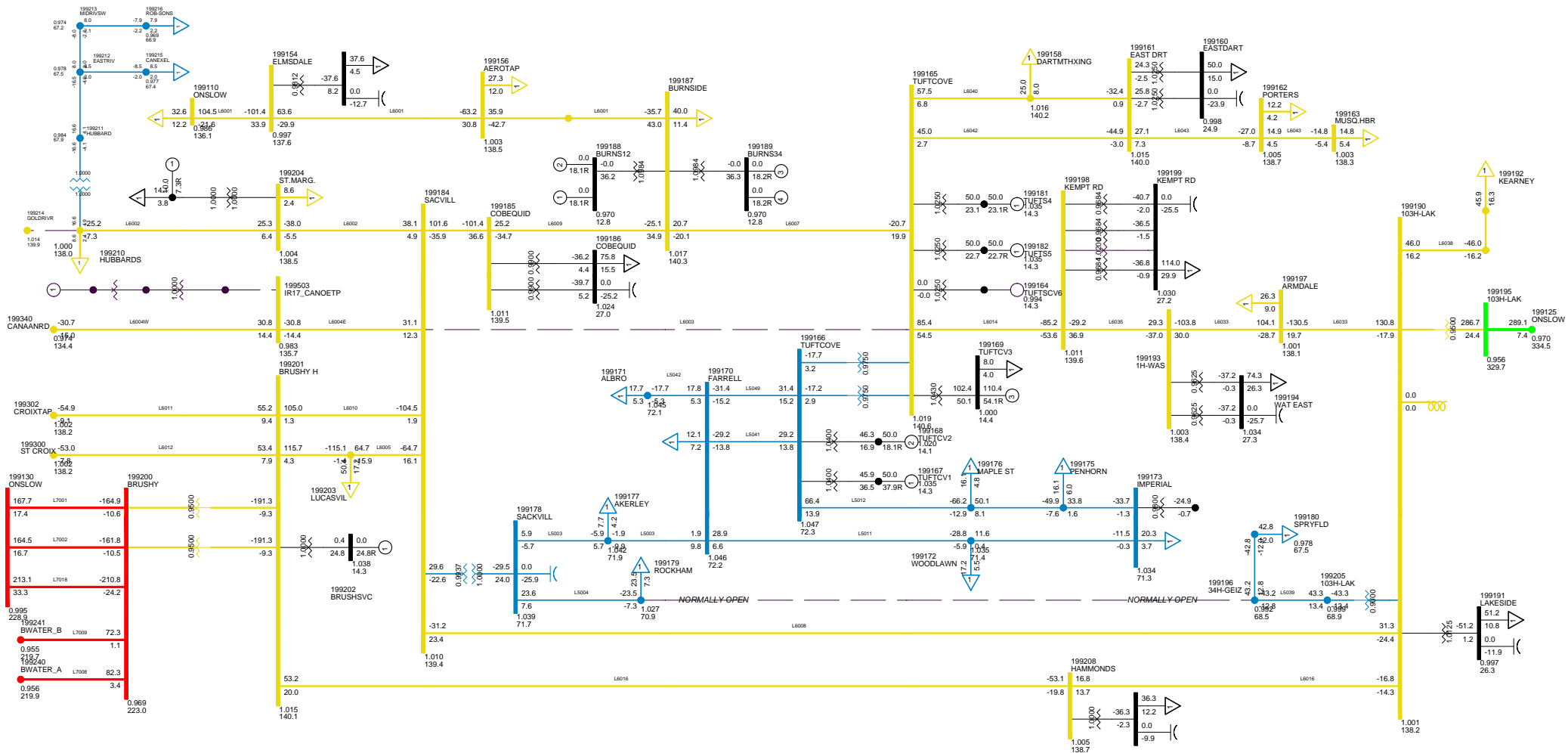

LABEL
 C23 LOSE L6003
 METRO ZONE SUN, FEB 15 2009 14:09

Bus - VOLTAGE (KV/PU)
 Branch - MVA/MVAR
 Equipment - MVA/MVAR
 LOSS/RATE
 1.050KV 0.550LV
 KV: <30.000 <=69.000 <=138.000 <=230.000 <=345.000 >=345.000

Figure __

Total Wind Gen: 290.1 MW
 Gross Tupper 165.0 MW
 Gross Wreck Cove 150.0 MW
 Gross Lingan 648.0 MW
 Gross Trenton 330.0 MW
 Gross Gas Turbine 24.0 MW
 Gross Pt Aconi 195.0 MW
 Gross Tuft's Cove 310.4 MW
 Gross Small Hydro 182.4 MW
 Net Stora Load 33.7 MW
 Total BMPC Load 75.5 MW

NSX 51.9 MW
 CBX 826.1 MW
 ONI 1049.9 MW
 ONS 887.3 MW

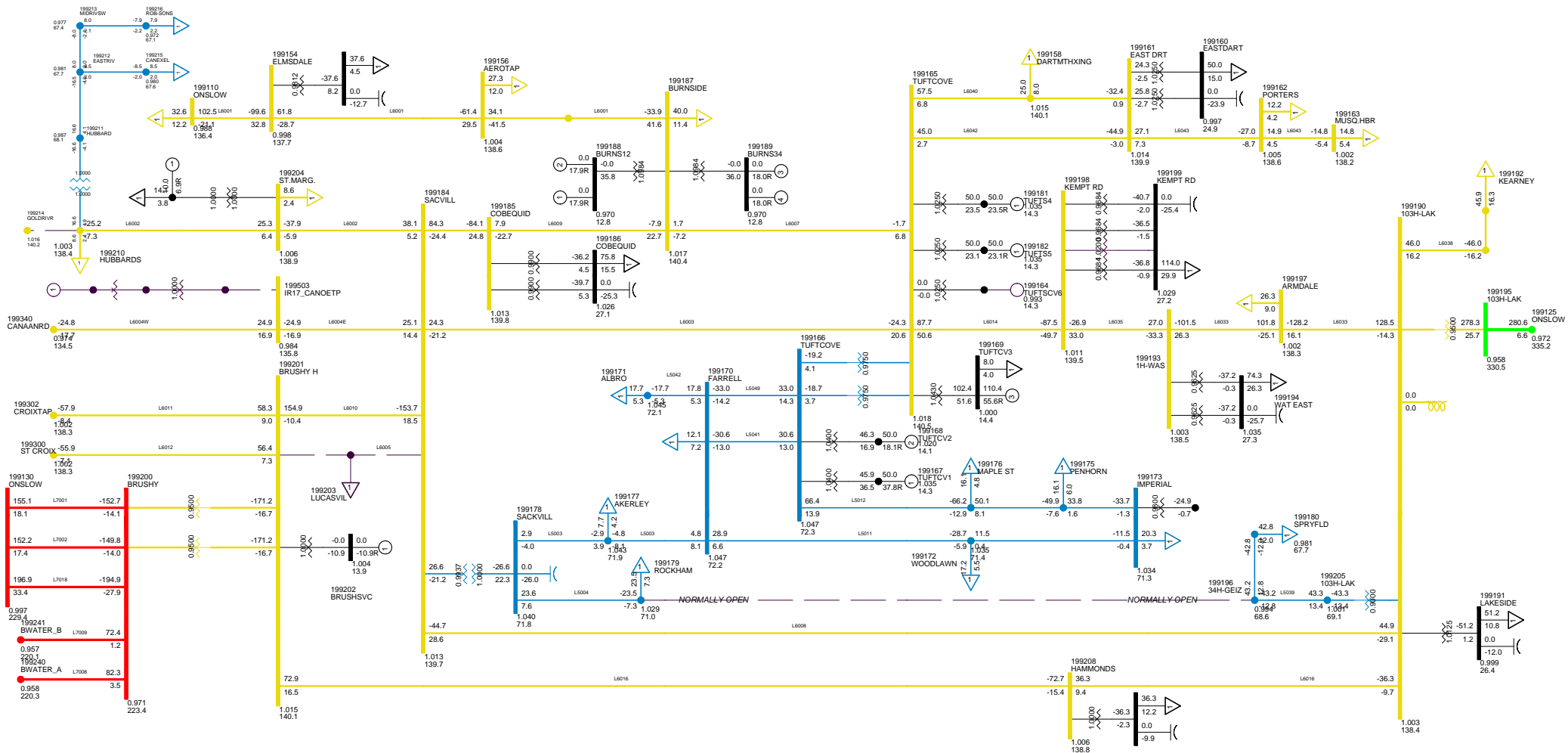

LABEL
 C24 LOSE L6005
 METRO ZONE SUN, FEB 15 2009 14:09

Bus - VOLTAGE (KV/PU)
 Branch - MVA/MVAR
 Equipment - MVA/MVAR
 HV-RATE:
 1.050KV 0.950VU
 KV: <30.000 <=69.000 <=138.000 <=230.000 <=345.000 >=345.000

Figure __

Total Wind Gen: 290.1 MW Gross Tupper 165.0 MW Gross Wreck Cove 150.0 MW
 Gross Lingan 648.0 MW Gross Trenton 330.0 MW Gross Gas Turbine 24.0 MW
 Gross Pt Aconi 195.0 MW Gross Tuft's Cove 310.4 MW Gross Small Hydro 182.4 MW

Net Stora Load 33.7 MW Total BMPC Load 75.5 MW

NSX 0.2 MW
 CBX 826.0 MW
 ONI 1049.6 MW
 ONS 938.9 MW

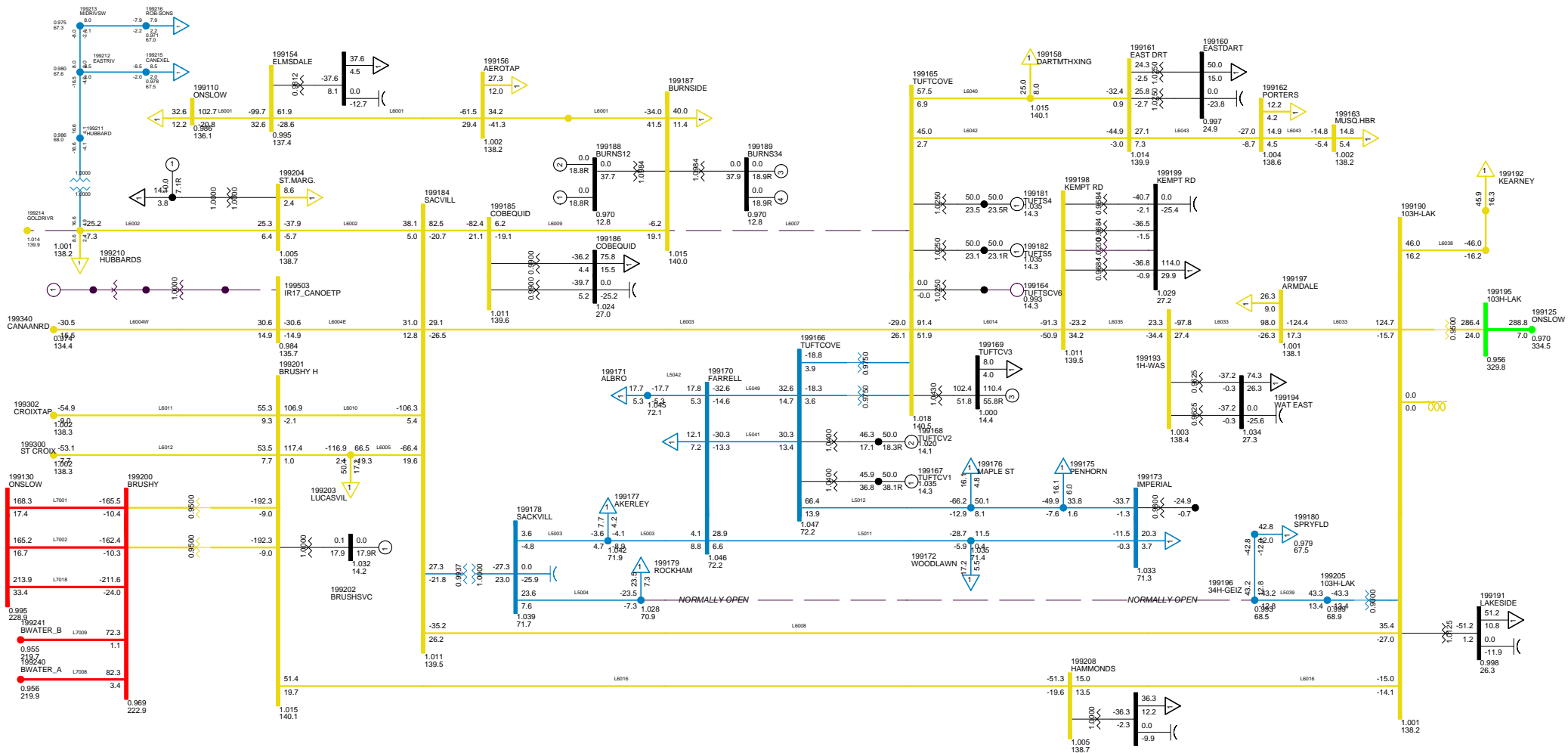

LABEL
 C25 LOSE L6007
 METRO ZONE SUN, FEB 15 2009 14:10

Bus - VOLTAGE (KV/PU)
 Branch - MVA/MVAR
 Equipment - MVA/MVAR
 LOSS/RATE:
 1.050KV 0.950LV
 KV <-30.000 <-60.000 <-130.000 <-230.000 <-345.000 >345.000

Figure __

Total Wind Gen: 290.1 MW Gross Tupper 165.0 MW Gross Wreck Cove 150.0 MW
 Gross Lingan 648.0 MW Gross Trenton 330.0 MW Gross Gas Turbine 24.0 MW
 Gross Pt Aconi 195.0 MW Gross Tuft's Cove 310.4 MW Gross Small Hydro 182.4 MW

Net Stora Load 33.7 MW Total BMPC Load 75.5 MW

NSX -0.3 MW
 CBX 826.0 MW
 ONI 1049.5 MW
 ONS 939.4 MW

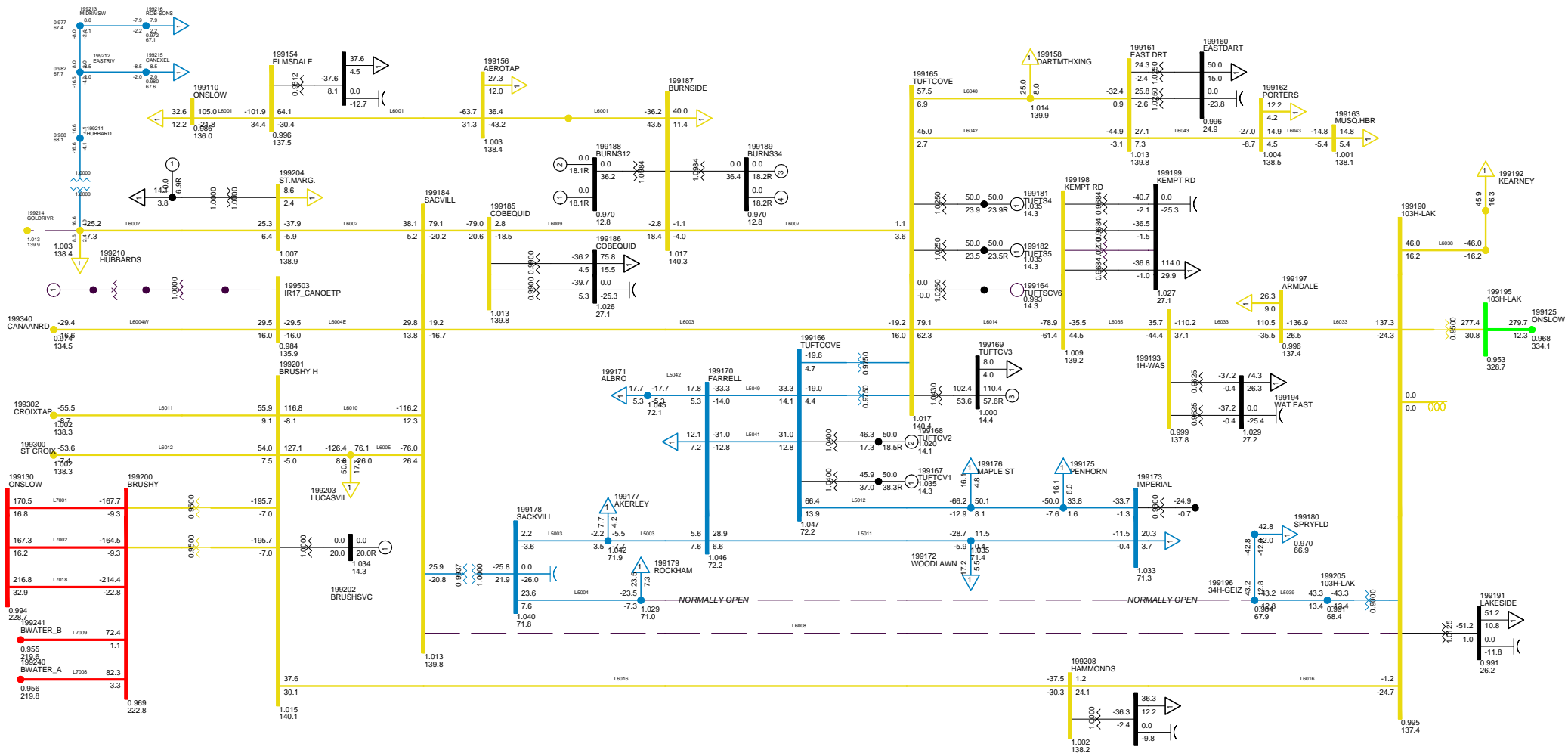

LABEL
 C26 LOSE L6008
 METRO ZONE SUN, FEB 15 2009 14:10

Bus - VOLTAGE (KV)PU
 Branch - MVA/MVAR
 Equipment - MVA/MVAR
 HV RATES
 1.050KV 0.950V <138.000 <230.000 <345.000 >345.000
 KV <138.000 <230.000 <345.000 >345.000

Figure __

Total Wind Gen: 290.1 MW Gross Tupper 165.0 MW Gross Wreck Cove 150.0 MW
 Gross Lingan 648.0 MW Gross Trenton 330.0 MW Gross Gas Turbine 24.0 MW
 Gross Pt Aconi 195.0 MW Gross Tuft's Cove 310.4 MW Gross Small Hydro 182.4 MW

Net Stora Load 33.7 MW Total BMPC Load 75.5 MW

NSX 37.5 MW
 CBX 826.1 MW
 ONI 1049.8 MW
 ONS 901.6 MW

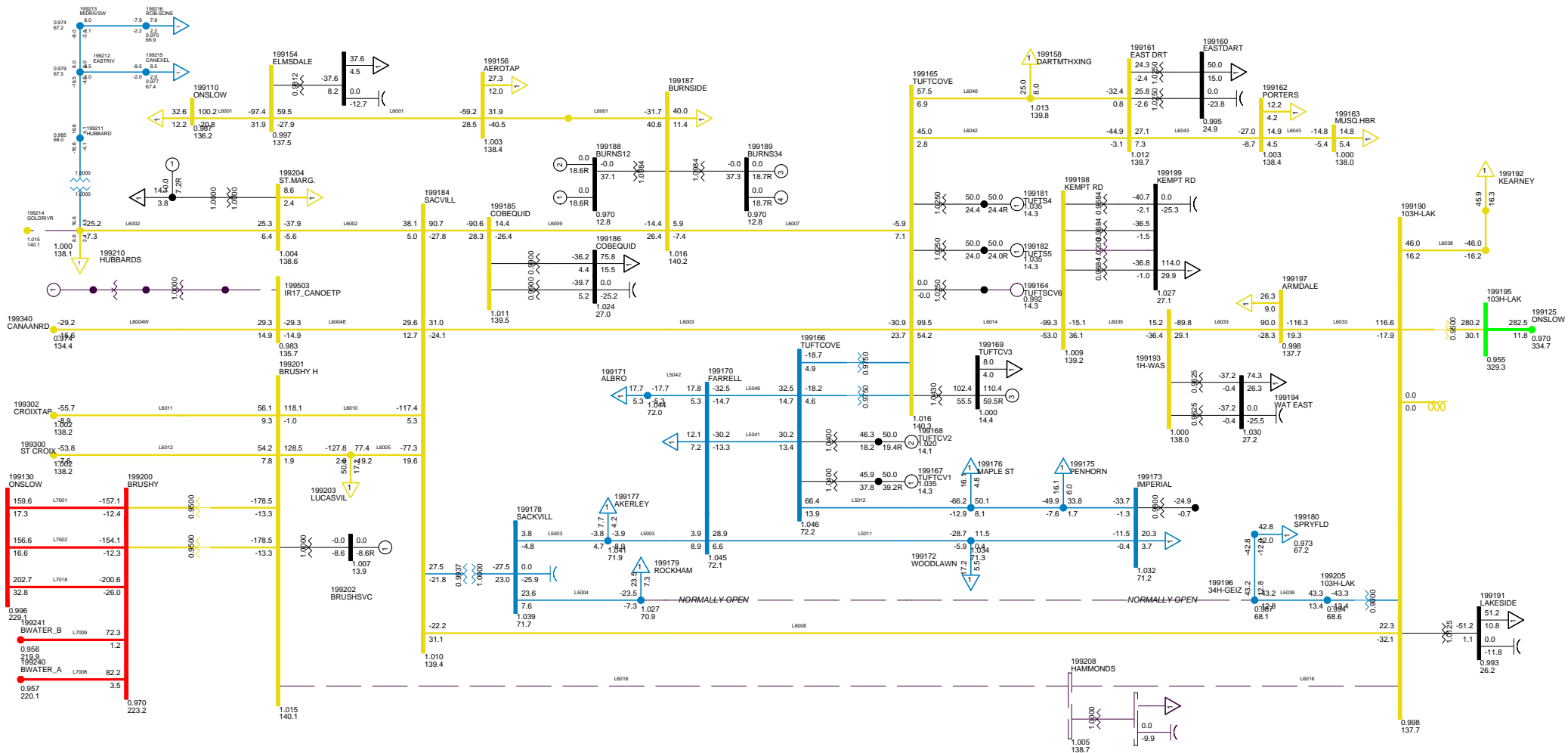

LABEL
 C27 LOSE L6009
 METRO ZONE SUN, FEB 15 2009 14:10

Bus - VOLTAGE (KV/PU)
 Branch - MVA/MVAR
 Equipment - MVA/MVAR
 HV-RATE
 1.050KV 0.950KV
 KV <=30.000 <=65.000 <=138.000 <=230.000 <=345.000 >=345.000

Figure __

Total Wind Gen: 290.1 MW Gross Tupper 165.0 MW Gross Wreck Cove 150.0 MW
 Gross Lingan 648.0 MW Gross Trenton 330.0 MW Gross Gas Turbine 24.0 MW
 Gross Pt Aconi 195.0 MW Gross Tuft's Cove 310.4 MW Gross Small Hydro 182.4 MW

Net Stora Load 33.7 MW Total BMPC Load 75.5 MW

NSX -0.8 MW
 CBX 826.0 MW
 ONI 1049.6 MW
 ONS 940.0 MW

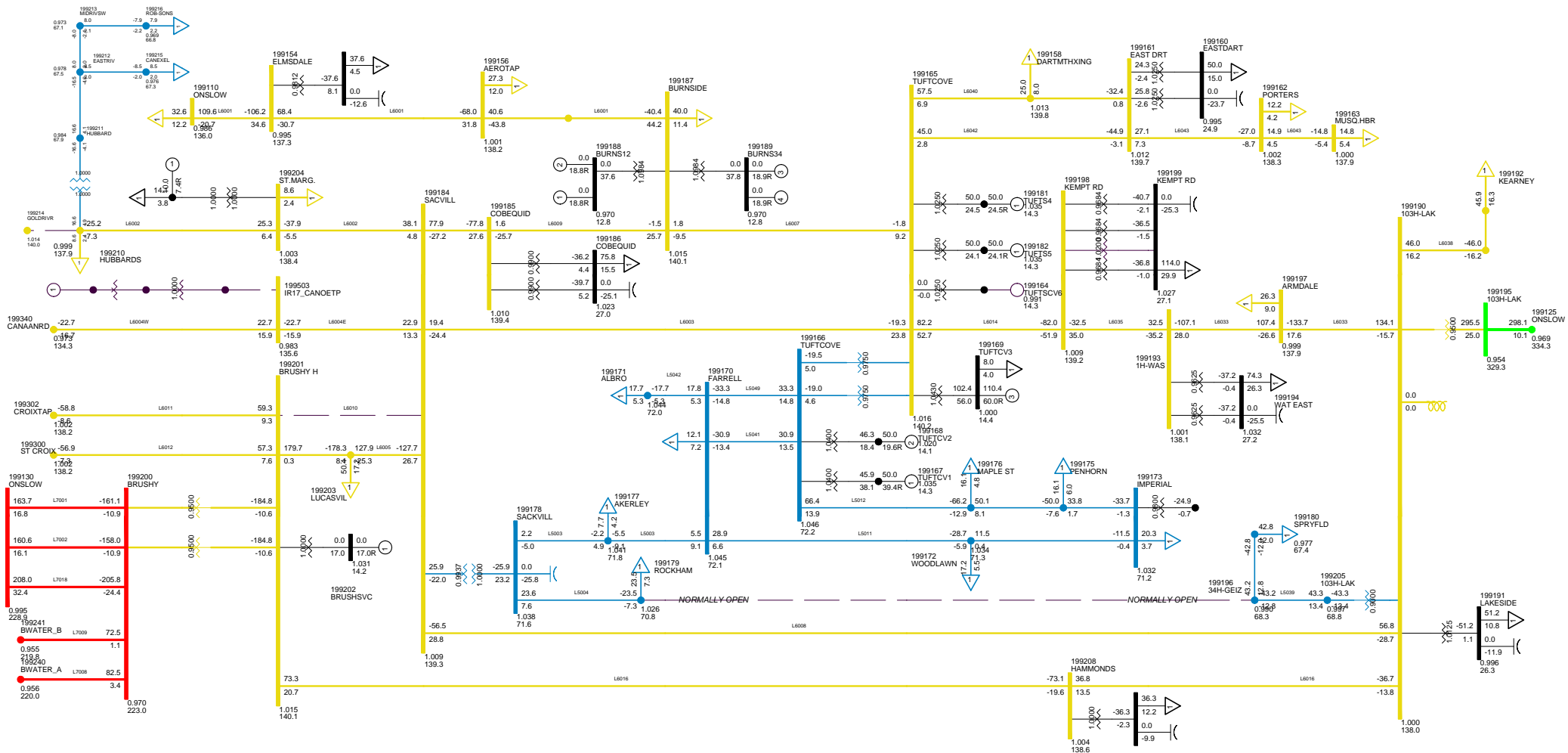

LABEL
 C28 LOSE L6010
 METRO ZONE SUN, FEB 15 2009 14:10

Bus - VOLTAGE (KV/PU)
 Break - MIN/MAX
 Equipment - MIN/MAX
 MIN/RATE
 1.050KV 0.950V
 KV: <30.000 <=60.000 <=138.000 <=230.000 <=345.000 >345.000

Figure __

Total Wind Gen: 290.1 MW Gross Tupper 165.0 MW Gross Wreck Cove 150.0 MW
 Gross Lingan 648.0 MW Gross Trenton 330.0 MW Gross Gas Turbine 24.0 MW
 Gross Pt Aconi 195.0 MW Gross Tuft's Cove 310.4 MW Gross Small Hydro 182.4 MW

Net Stora Load 33.7 MW Total BMPC Load 75.5 MW

NSX 37.5 MW
 CBX 826.1 MW
 ONI 1049.8 MW
 ONS 901.6 MW

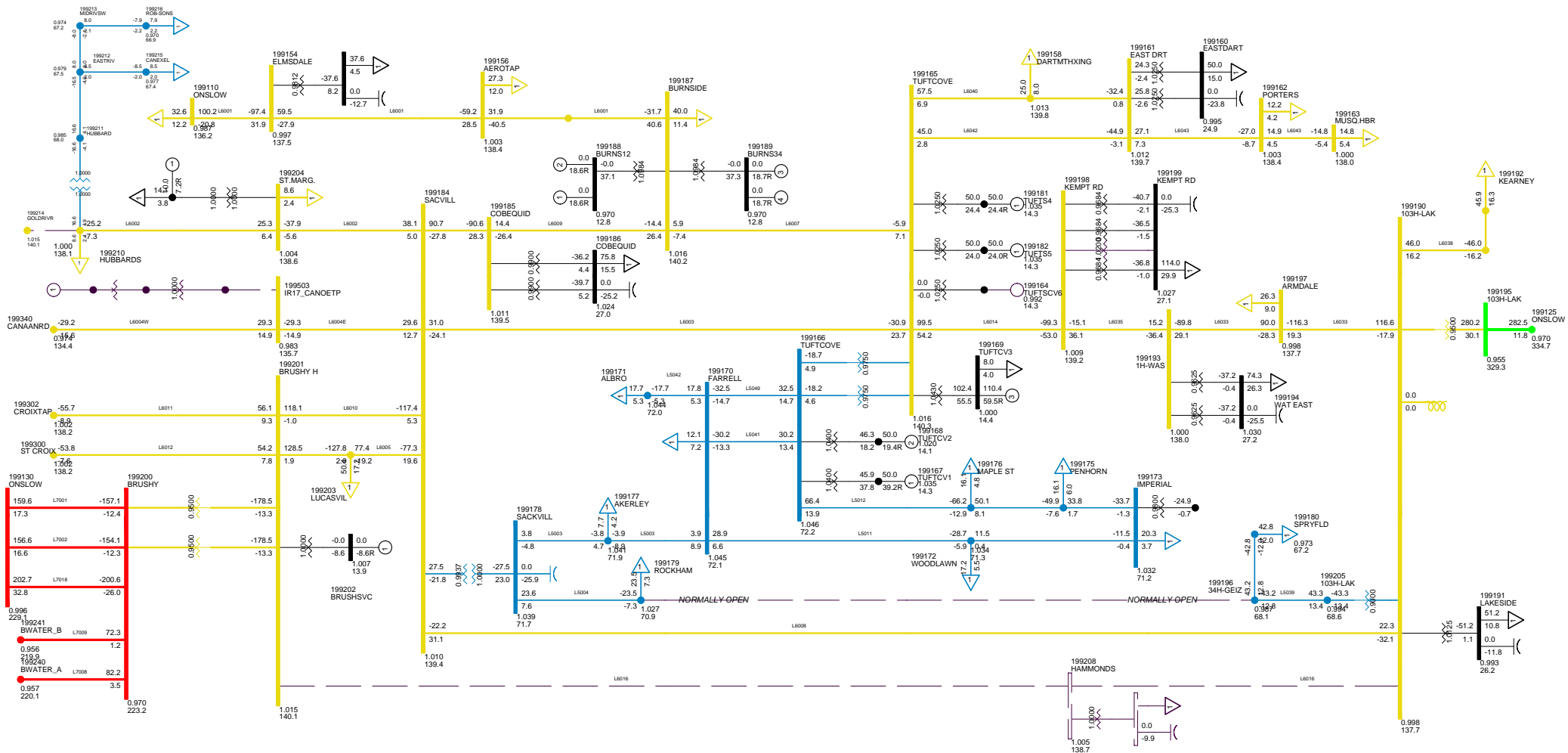

LABEL
 C30 LOSE L6016
 METRO ZONE SUN, FEB 15 2009 14:10

Bus - VOLTAGE (KV/PU)
 Branch - MVA/MVAR
 Equipment - MVA/MVAR
 HV-RATE
 1.050KV 0.950KV
 KV <-0.000 <-0.000 <+0.000 <+0.000 <+0.000 <+0.000

Figure __

Total Wind Gen: 290.1 MW
 Gross Tupper 165.0 MW
 Gross Wreck Cove 150.0 MW
 Gross Lingan 648.0 MW
 Gross Trenton 330.0 MW
 Gross Gas Turbine 24.0 MW
 Gross Pt Aconi 195.0 MW
 Gross Tuft's Cove 310.4 MW
 Gross Small Hydro 182.4 MW
 Net Stora Load 33.7 MW
 Total BMPC Load 75.5 MW

NSX 62.4 MW
 CBX 826.1 MW
 ONI 1049.8 MW
 ONS 876.6 MW

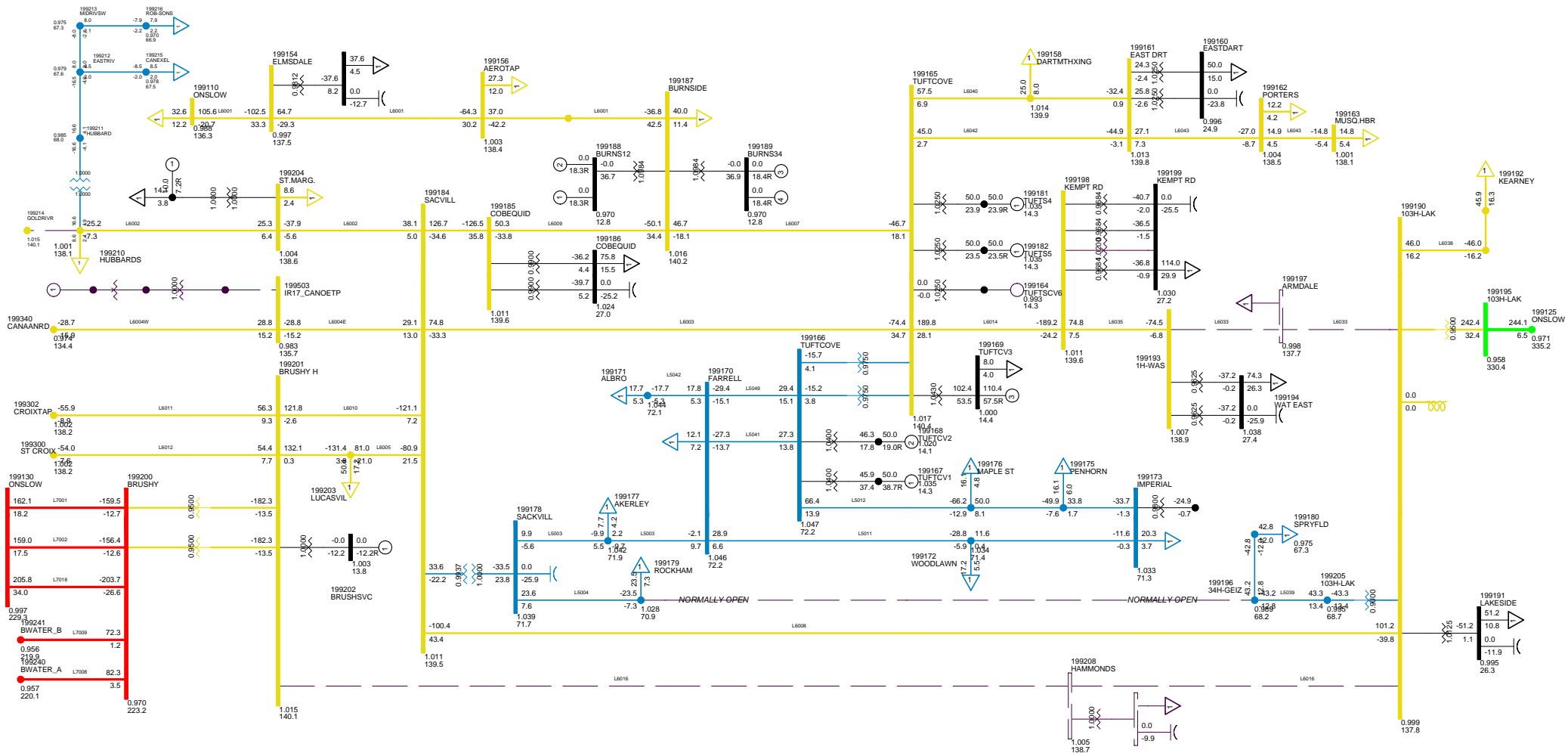

Bus - VOLTAGE (KV/PU)
 Break - MIN/MAX
 Equipment - MIN/MAX
 HV/RATE
 1.050KV 0.950V
 KV: <30.000 <=65.000 <=138.000 <=230.000 <=345.000 >=345.000

Figure __

Total Wind Gen: 290.1 MW Gross Tupper 165.0 MW Gross Wreck Cove 150.0 MW
 Gross Lingan 648.0 MW Gross Trenton 330.0 MW Gross Gas Turbine 24.0 MW
 Gross Pt Aconi 195.0 MW Gross Tuft's Cove 310.4 MW Gross Small Hydro 182.4 MW

Net Stora Load 33.7 MW Total BMPC Load 75.5 MW

NSX -0.3 MW
 CBX 826.0 MW
 ONI 1049.5 MW
 ONS 939.3 MW

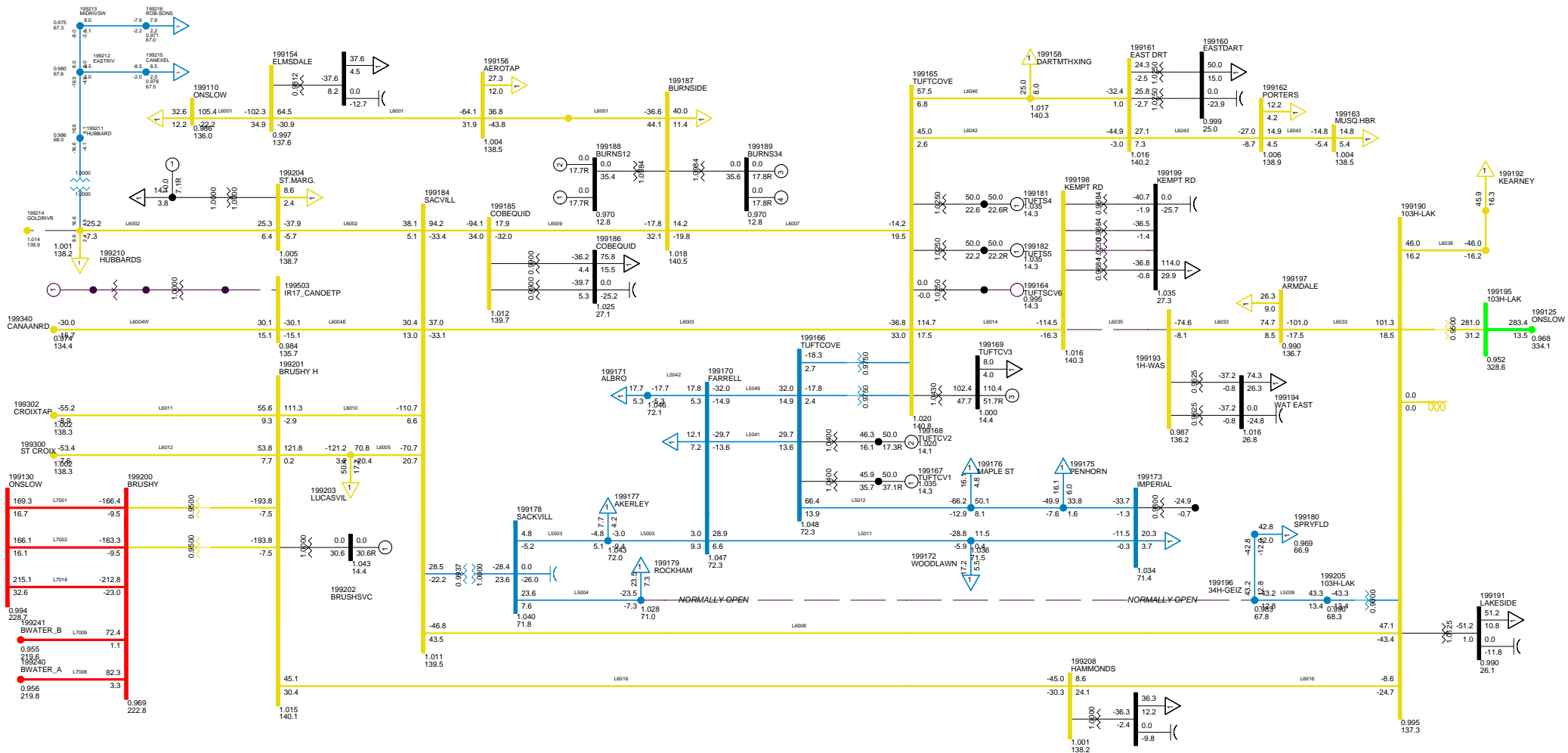

LABEL
 C32 LOSE L6035
 METRO ZONE SUN, FEB 15 2009 14:11

Bus - VOLTAGE (KV/PU)
 Branch - MVA/MVAR
 Equipment - MVA/MVAR
 HV/RATE
 1.050KV 0.550V
 KV: <30.000 <=69.000 <=138.000 <=230.000 <=345.000 >=345.000

Figure __

Total Wind Gen: 290.1 MW Gross Tupper 165.0 MW Gross Wreck Cove 150.0 MW
 Gross Lingan 648.0 MW Gross Trenton 330.0 MW Gross Gas Turbine 24.0 MW
 Gross Pt Aconi 195.0 MW Gross Tuft's Cove 310.4 MW Gross Small Hydro 182.4 MW

Net Stora Load 33.7 MW Total BMPC Load 75.5 MW

NSX 29.5 MW
 CBX 825.6 MW
 ONI 1048.5 MW
 ONS 908.3 MW

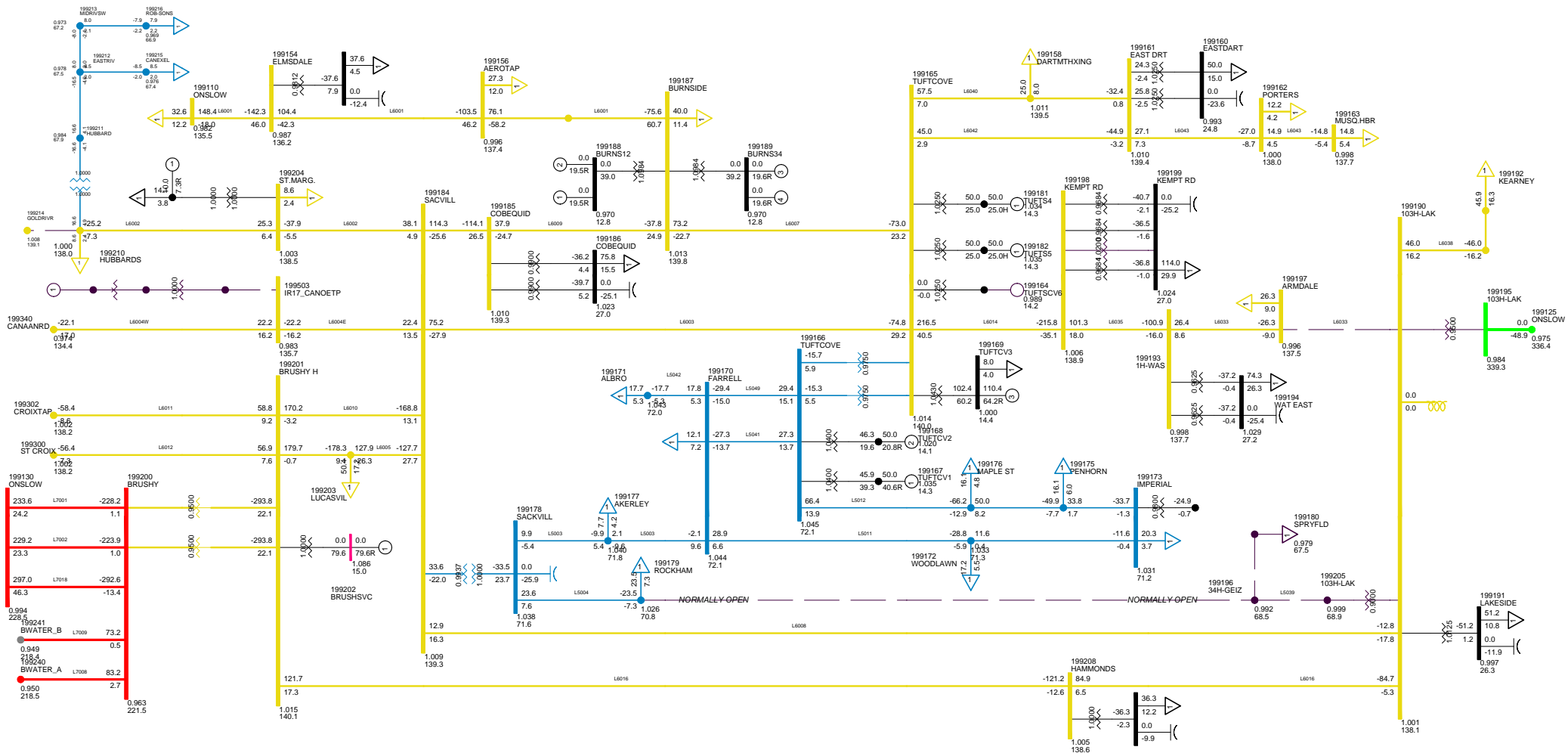

LABEL
 C33 LOSE 103H-B61
 METRO ZONE SUN, FEB 15 2009 14:11

Bus - VOLTAGE (KV/PU)
 Branch - MVA/MVAR
 Equipment - MVA/MVAR
 HV/RATINGS
 1.050KV 0.550LV
 KV: <138.000 <=138.000 <=230.000 <=345.000 >345.000

Figure __

Total Wind Gen: 290.1 MW Gross Tupper 165.0 MW Gross Wreck Cove 150.0 MW
 Gross Lingan 648.0 MW Gross Trenton 330.0 MW Gross Gas Turbine 24.0 MW
 Gross Pt Aconi 195.0 MW Gross Tuft's Cove 260.4 MW Gross Small Hydro 182.4 MW

Net Stora Load 33.7 MW Total BMPC Load 75.5 MW

NSX -16.8 MW
 CBX 825.6 MW
 ONI 1048.4 MW
 ONS 954.6 MW

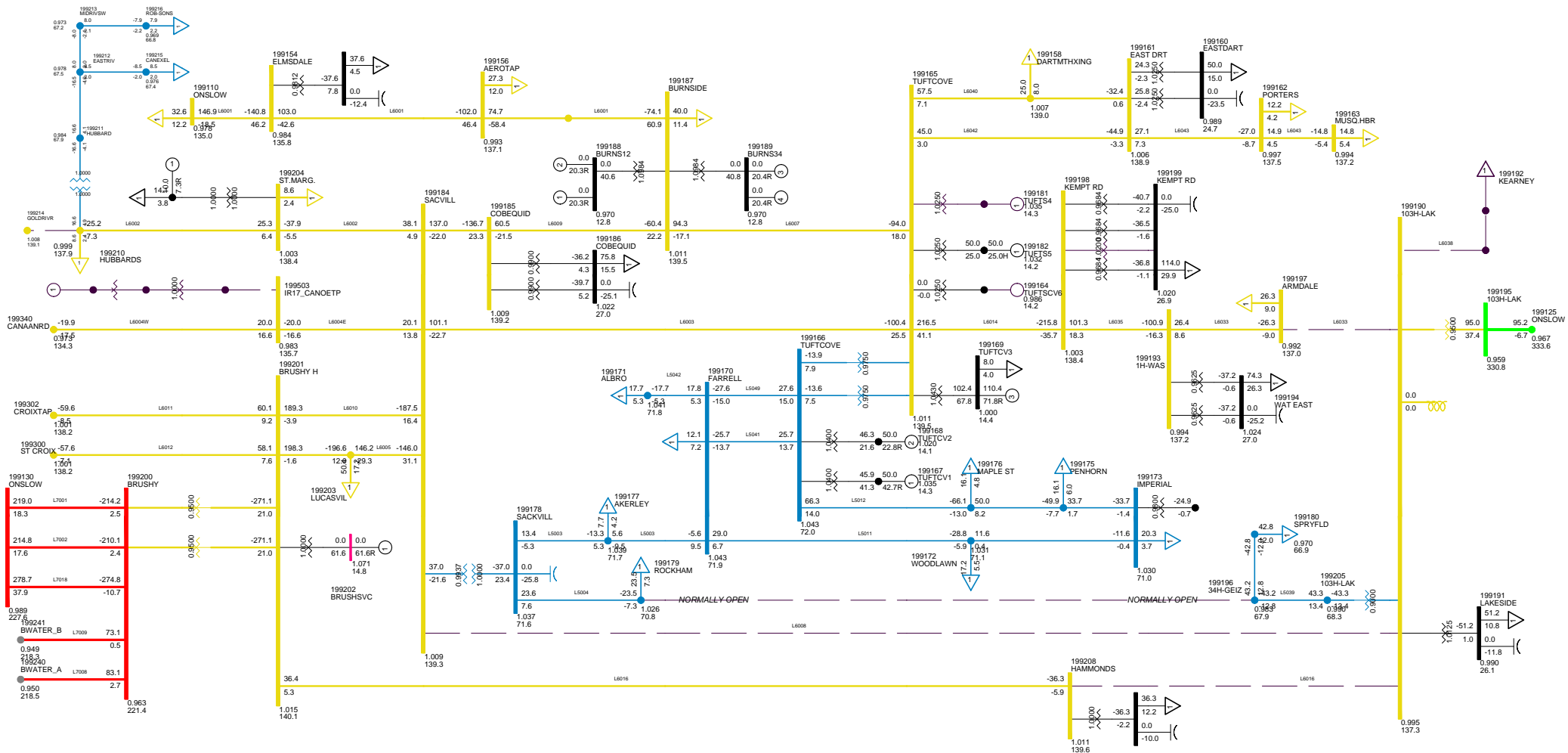

LABEL
 C34 LOSE 103H-B62
 METRO ZONE SUN, FEB 15 2009 14:11

Bus - VOLTAGE (KV/PU)
 Branch - MVA/MVAR
 Equipment - MVA/MVAR
 LOSS/RATE:
 1.050KV 0.550LV
 KV <-30.000 <-60.000 <-130.000 <-230.000 <-345.000 >345.000

Figure __

Total Wind Gen: 290.1 MW Gross Tupper 165.0 MW Gross Wreck Cove 150.0 MW
 Gross Lingan 648.0 MW Gross Trenton 330.0 MW Gross Gas Turbine 24.0 MW
 Gross Pt Aconi 195.0 MW Gross Tuft's Cove 310.4 MW Gross Small Hydro 182.4 MW

Net Stora Load 33.7 MW Total BMPC Load 75.5 MW

NSX 0.2 MW
 CBX 826.0 MW
 ONI 1049.7 MW
 ONS 938.9 MW

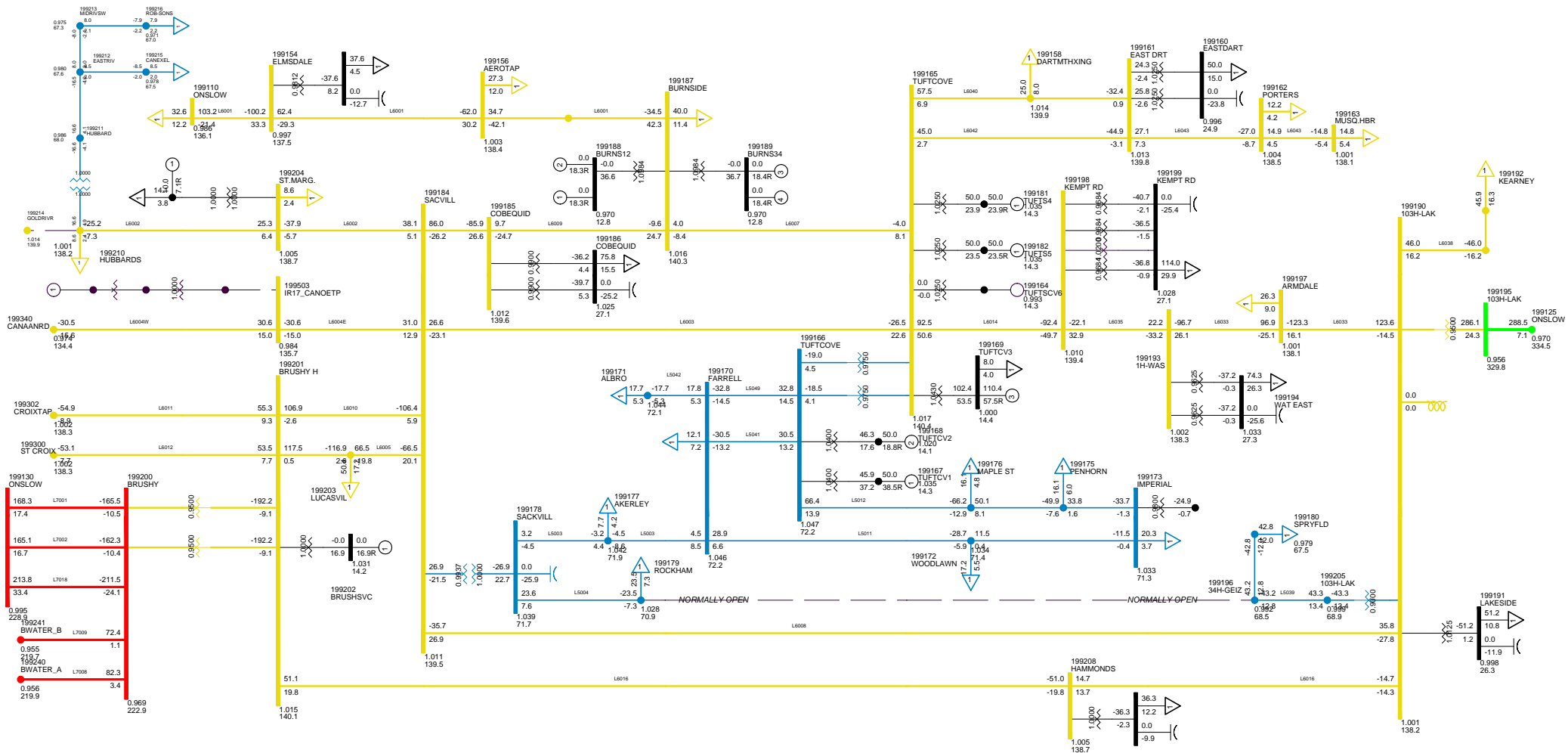

2013 WINTER PEAK MAXIMUM FLOW
 NS-NB=0; NB-NE=500; CBX=826; ONI=1050 ONS=939
 METRO ZONE SUN, FEB 15 2009 14:11

Bus - VOLTAGE (KV/PU)
 Branch - MVA/MVAR
 Equipment - MVA/MVAR
 Flow Rates
 1.050KV 0.550PU
 KV: <30.000 <=65.000 <=130.000 <=230.000 <=345.000 >=345.000

Figure __

Total Wind Gen: 290.1 MW
 Gross Tupper 165.0 MW
 Gross Wreck Cove 150.0 MW
 Gross Lingan 648.0 MW
 Gross Trenton 330.0 MW
 Gross Gas Turbine 24.0 MW
 Gross Pt Aconi 195.0 MW
 Gross Tuft's Cove 310.4 MW
 Gross Small Hydro 182.4 MW
 Net Stora Load 33.7 MW
 Total BMPC Load 75.5 MW

NSX 49.0 MW
 CBX 826.2 MW
 ONI 1049.9 MW
 ONS 890.3 MW

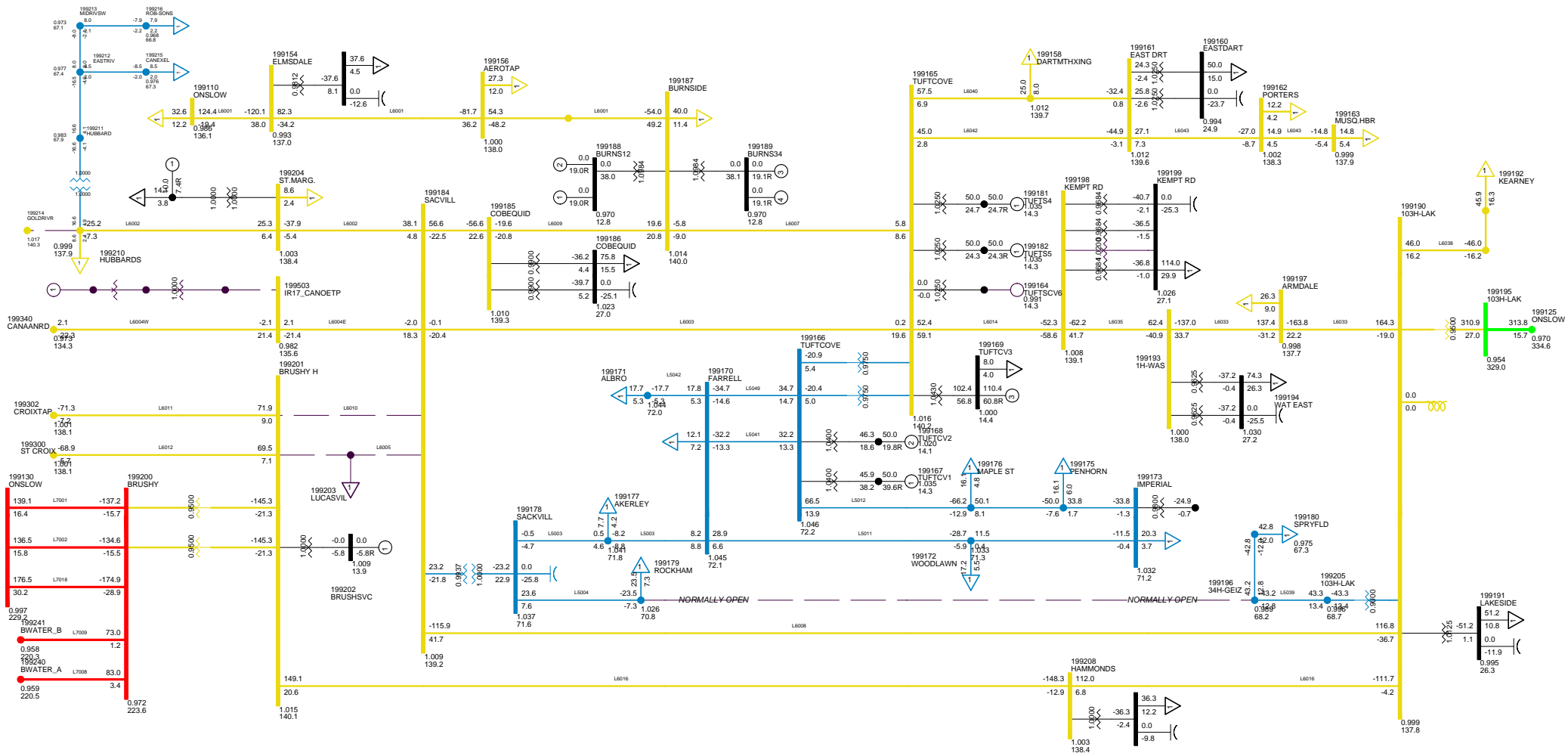

LABEL
 C35 DCT L6005+L6010
 METRO ZONE SUN, FEB 15 2009 14:11

Bus - VOLTAGE (KV/PU)
 Branch - MIN/MAX
 Equipment - MIN/MAX
 MIN/RATE
 1.050KV 0.850KV
 KV: <0.800 <0.600 <0.400 <0.200 <0.000 <0.450 >0.450 >0.600 >0.800

Figure __

Total Wind Gen: 290.1 MW
 Gross Tupper 165.0 MW
 Gross Wreck Cove 150.0 MW
 Gross Lingan 648.0 MW
 Gross Trenton 330.0 MW
 Gross Gas Turbine 24.0 MW
 Gross Pt Aconi 195.0 MW
 Gross Tuft's Cove 310.4 MW
 Gross Small Hydro 182.4 MW
 Net Stora Load 33.7 MW
 Total BMPC Load 75.5 MW

NSX 51.9 MW
 CBX 826.1 MW
 ONI 1049.9 MW
 ONS 887.3 MW

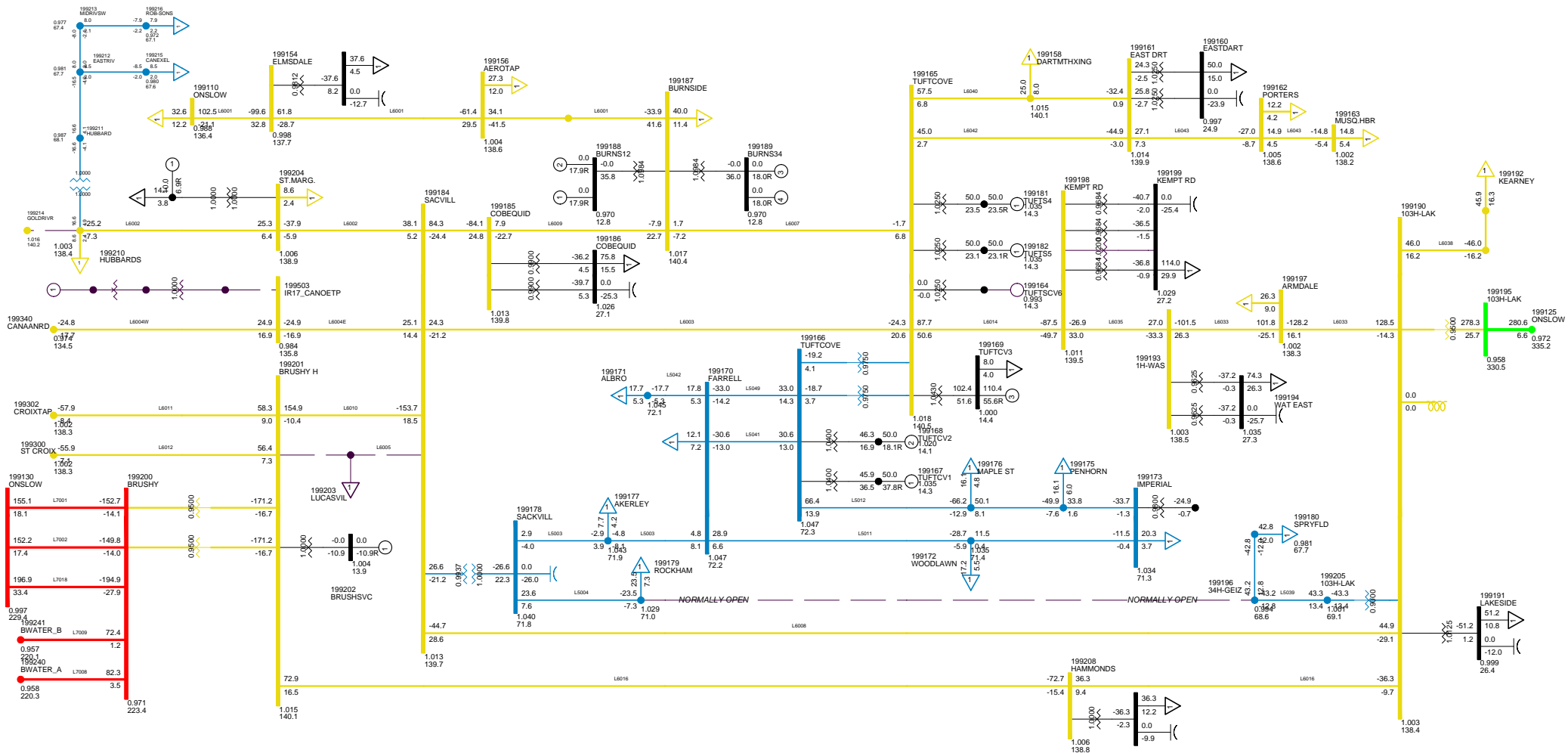
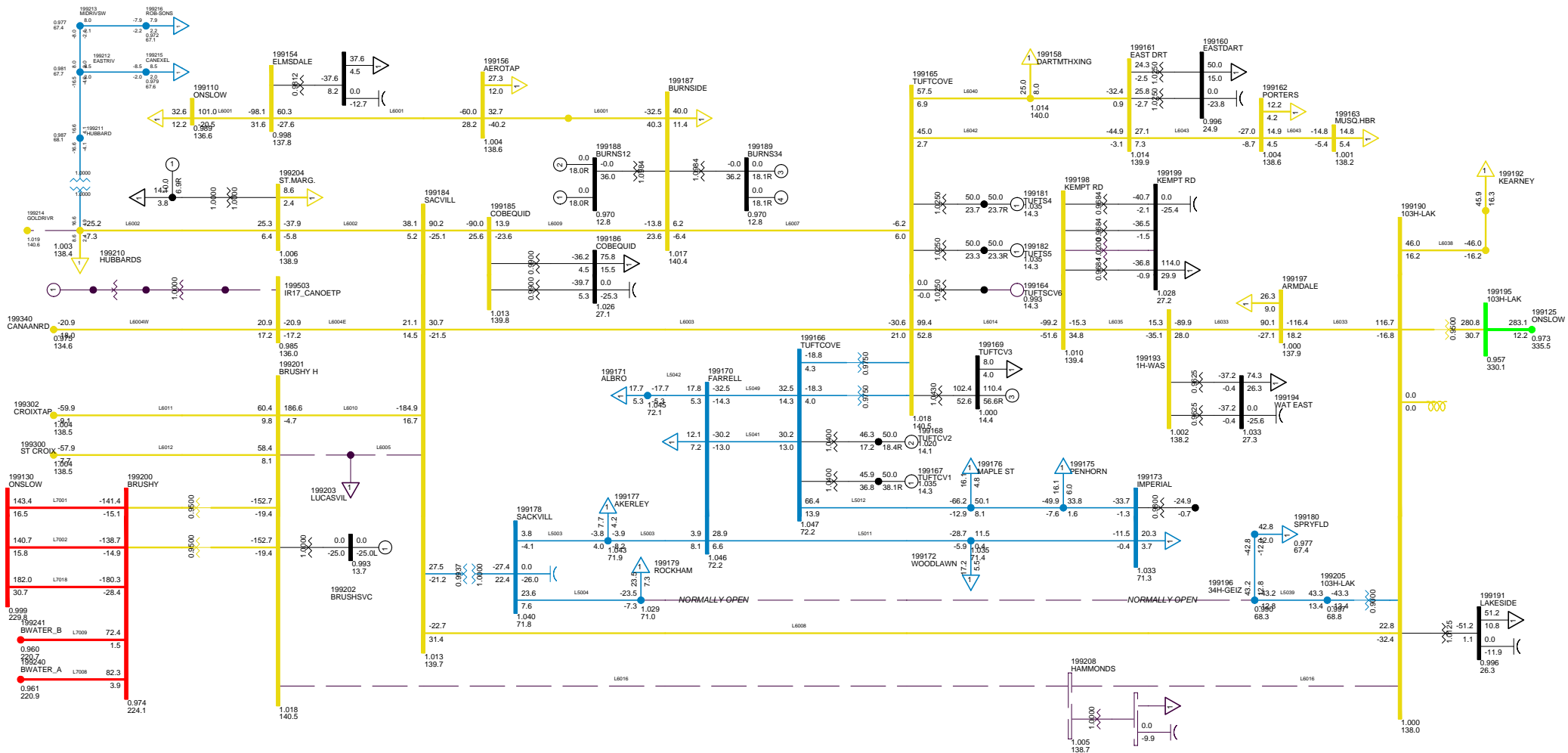

Figure __

Total Wind Gen: 290.1 MW
 Gross Tupper 165.0 MW
 Gross Wreck Cove 150.0 MW
 Gross Lingan 648.0 MW
 Gross Trenton 330.0 MW
 Gross Gas Turbine 24.0 MW
 Gross Pt Aconi 195.0 MW
 Gross Tuft's Cove 310.4 MW
 Gross Small Hydro 182.4 MW
 Net Stora Load 33.7 MW
 Total BMPC Load 75.5 MW

NSX 89.1 MW
 CBX 826.2 MW
 ONI 1050.1 MW
 ONS 850.2 MW



LABEL
 C37 DCT L6005 L6016
 METRO ZONE SUN, FEB 15 2009 14:11

Bus - VOLTAGE (KV)PU
 Branch - MIN/MAX
 Equipment - MIN/MAX
 MW/RATE
 1.050KV 0.950V
 KV: <30.000 <=60.000 <=138.000 <=230.000 <=345.000 >=345.000

Figure __

Total Wind Gen: 290.1 MW Gross Tupper 165.0 MW Gross Wreck Cove 150.0 MW
 Gross Lingan 648.0 MW Gross Trenton 330.0 MW Gross Gas Turbine 24.0 MW
 Gross Pt Aconi 195.0 MW Gross Tuft's Cove 310.4 MW Gross Small Hydro 182.4 MW

Net Stora Load 33.7 MW Total BMPC Load 75.5 MW

NSX 79.1 MW
 CBX 826.2 MW
 ONI 1050.0 MW
 ONS 860.2 MW

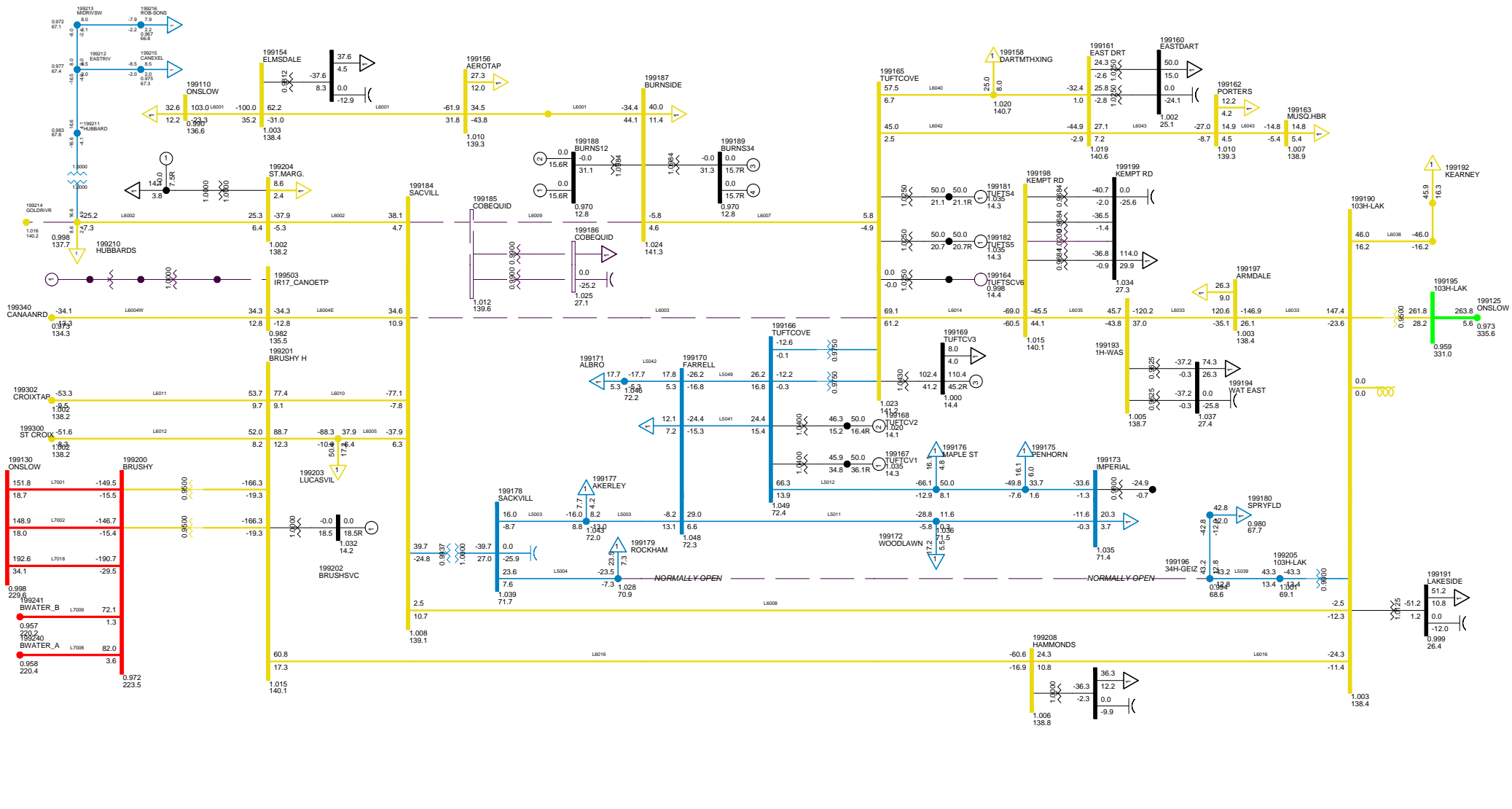

LABEL
 C38 DCT L6003 L6009
 METRO ZONE SUN, FEB 15 2009 14:12

Bus - VOLTAGE (KV)UP
 Branch - MINIMUM
 Equipment - MINIMUM
 MINUS RATES
 1.050KV 0.850KV
 KV <-30.000 <-60.000 <-138.000 <-230.000 <-345.000 >345.000

Figure __

Total Wind Gen: 290.1 MW Gross Tupper 165.0 MW Gross Wreck Cove 150.0 MW
 Gross Lingan 648.0 MW Gross Trenton 330.0 MW Gross Gas Turbine 24.0 MW
 Gross Pt Aconi 195.0 MW Gross Tuft's Cove 310.4 MW Gross Small Hydro 182.4 MW

Net Stora Load 33.7 MW Total BMPC Load 75.5 MW

NSX 0.2 MW
 CBX 826.0 MW
 ONI 1049.6 MW
 ONS 939.0 MW

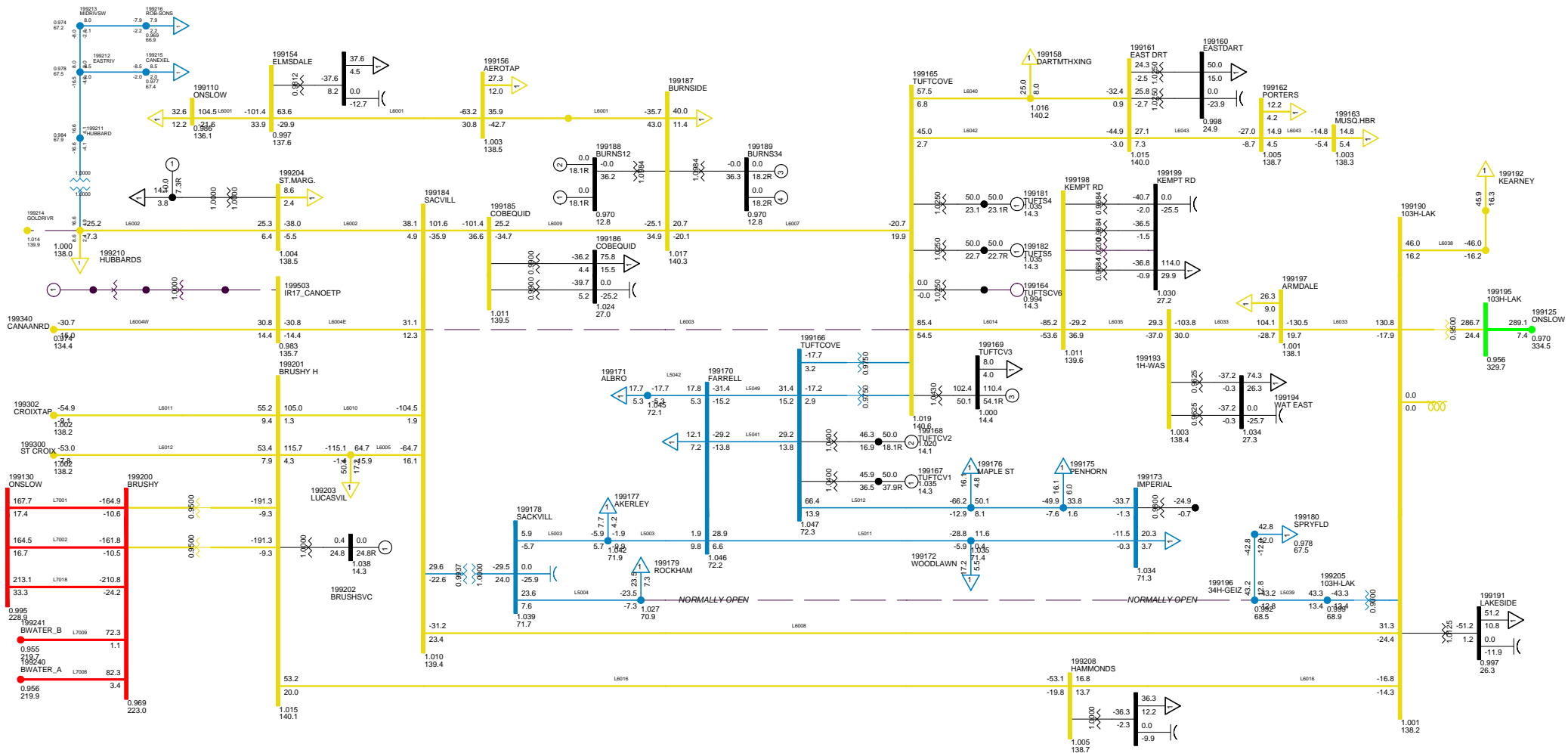

Bus - VOLTAGE (KV/PU)
 Branch - MW/MVAR
 Equipment - MW/MVAR
 HV/RATE
 1.050KV 0.950PU
 KV: <30.000 <=69.000 <=138.000 <=230.000 <=345.000 >=345.000

LABEL
 C39 DCT L6003 L6007
 METRO ZONE SUN, FEB 15 2009 14:12

Figure __

Total Wind Gen: 259.5 MW
 Gross Tupper 165.0 MW
 Gross Wreck Cove 150.0 MW
 Gross Lingan 648.0 MW
 Gross Trenton 330.0 MW
 Gross Gas Turbine 0.0 MW
 Gross Pt Aconi 195.0 MW
 Gross Tuft's Cove 310.4 MW
 Gross Small Hydro 130.4 MW
 Net Stora Load 33.7 MW
 Total BMPC Load 0.0 MW

NSX 169.8 MW
 CBX 826.3 MW
 ONI 1050.3 MW
 ONS 769.1 MW

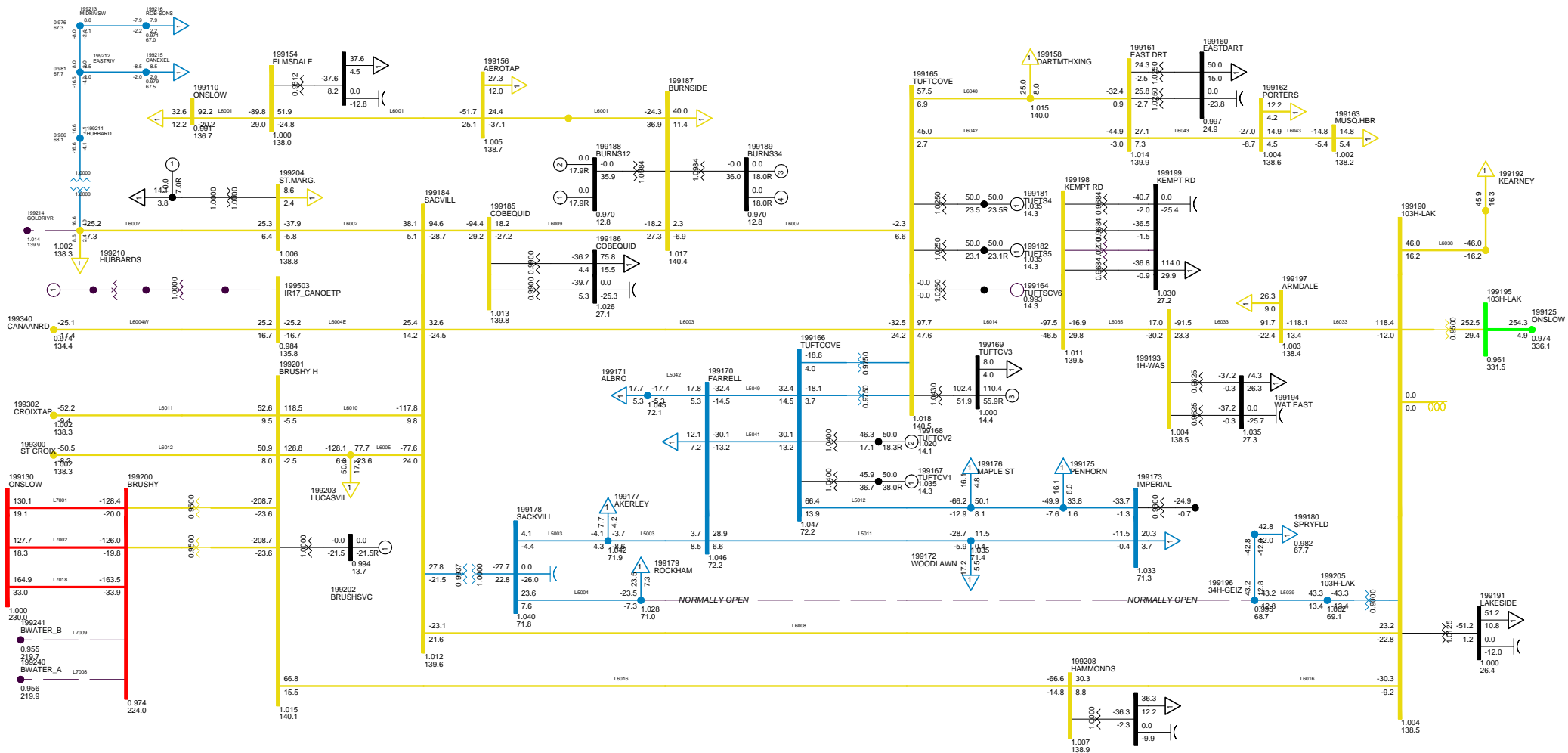

LABEL
 C40 DCT L7008 L7009 ISOLATES WEST
 METRO ZONE SUN, FEB 15 2009 14:12

Bus - VOLTAGE (KV/PU)
 Break - MIN/MAX
 Equipment - MIN/MAX
 DISCR/RATE
 1.050KV 0.950V
 KV: <30.000 <=69.000 <=138.000 <=230.000 <=345.000 >=345.000

Figure __

Total Wind Gen: 290.1 MW Gross Tupper 165.0 MW Gross Wreck Cove 150.0 MW
 Gross Lingan 648.0 MW Gross Trenton 330.0 MW Gross Gas Turbine 24.0 MW
 Gross Pt Aconi 195.0 MW Gross Tuft's Cove 310.4 MW Gross Small Hydro 182.4 MW

Net Stora Load 33.7 MW Total BMPC Load 75.5 MW

NSX 89.1 MW
 CBX 826.2 MW
 ONI 1050.1 MW
 ONS 850.2 MW

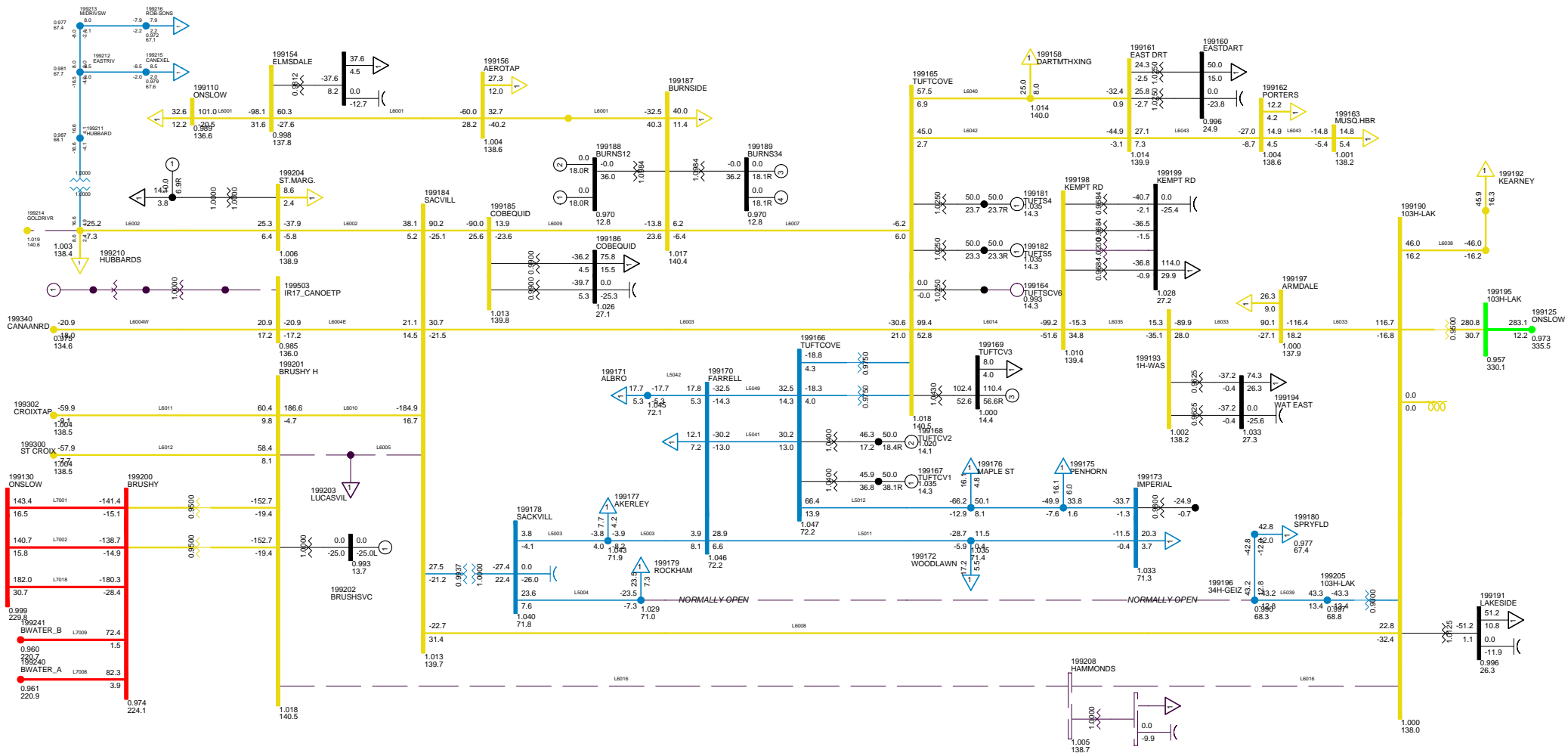

LABEL
 C41 IP FAULT ON L6016, BBU 622
 METRO ZONE SUN, FEB 15 2009 14:12

Bus - VOLTAGE (kV/PU)
 Break - MIN/MAX
 Equipment - MIN/MAX
 MIN/RATE
 1.050kV 0.950kV
 0.950kV 0.850kV
 0.850kV 0.750kV
 0.750kV 0.650kV
 0.650kV 0.550kV

Figure __

Total Wind Gen: 290.1 MW
 Gross Tupper 165.0 MW
 Gross Wreck Cove 150.0 MW
 Gross Lingan 648.0 MW
 Gross Trenton 330.0 MW
 Gross Gas Turbine 24.0 MW
 Gross Pt Aconi 195.0 MW
 Gross Tuft's Cove 310.4 MW
 Gross Small Hydro 182.4 MW
 Net Stora Load 33.7 MW
 Total BMPC Load 75.5 MW

NSX 49.0 MW
 CBX 826.2 MW
 ONI 1049.9 MW
 ONS 890.3 MW

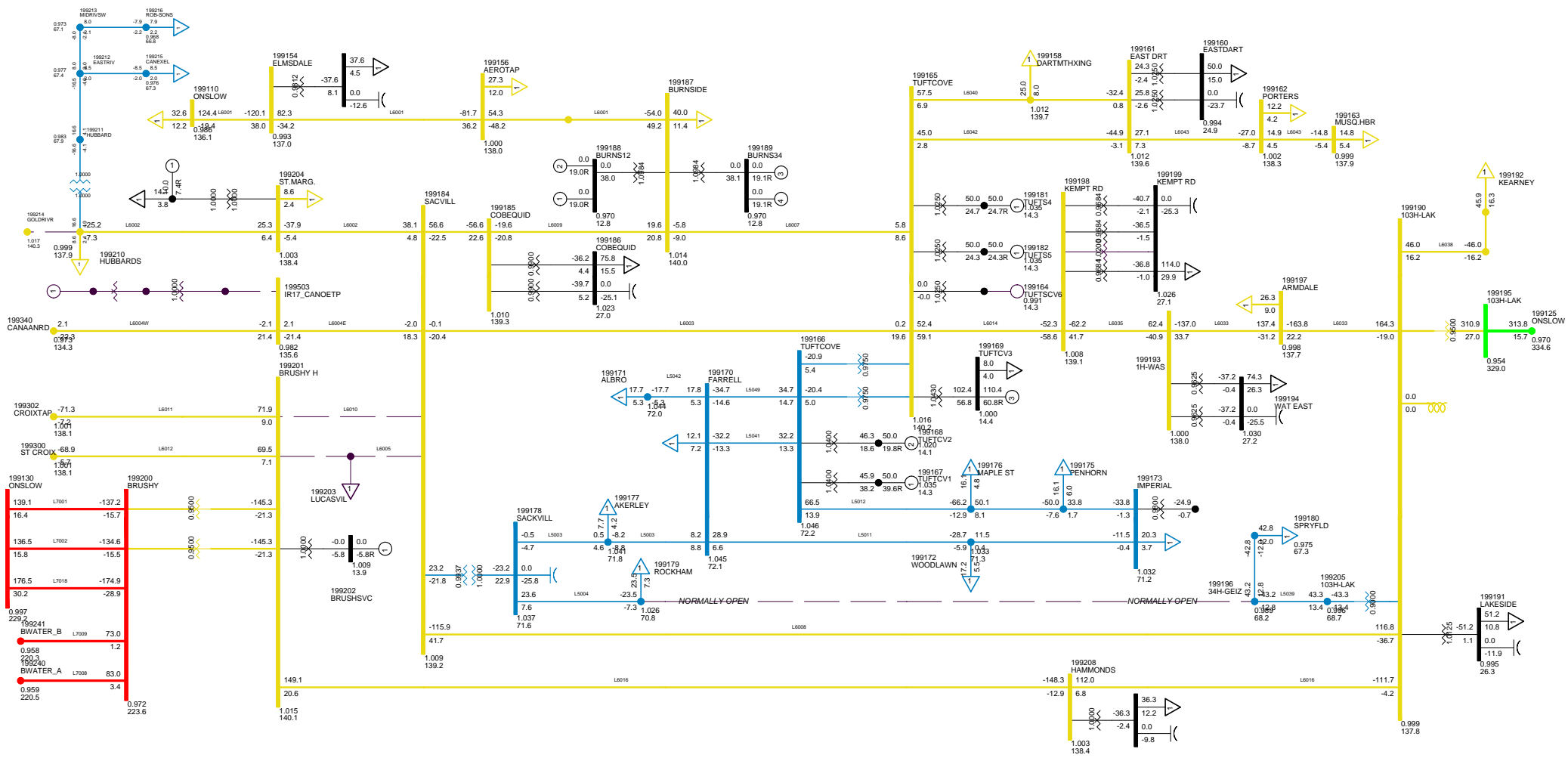

LABEL
 C43 BBU L6005 L6010 90H-608
 METRO ZONE SUN, FEB 15 2009 14:12

Bus - VOLTAGE (KV/PU)
 Branch - MIN/MAX
 Equipment - MIN/MAX
 MW/RATE
 1.050KV 0.950PU
 KV: <30.000 <=69.000 <=138.000 <=230.000 <=345.000 >=345.000

Figure __

Total Wind Gen: 290.1 MW
 Gross Tupper 165.0 MW
 Gross Wreck Cove 150.0 MW
 Gross Lingan 648.0 MW
 Gross Trenton 330.0 MW
 Gross Gas Turbine 24.0 MW
 Gross Pt Aconi 195.0 MW
 Gross Tuft's Cove 310.4 MW
 Gross Small Hydro 182.4 MW
 Net Stora Load 33.7 MW
 Total BMPC Load 75.5 MW

NSX 79.2 MW
 CBX 826.1 MW
 ONI 1049.9 MW
 ONS 860.0 MW

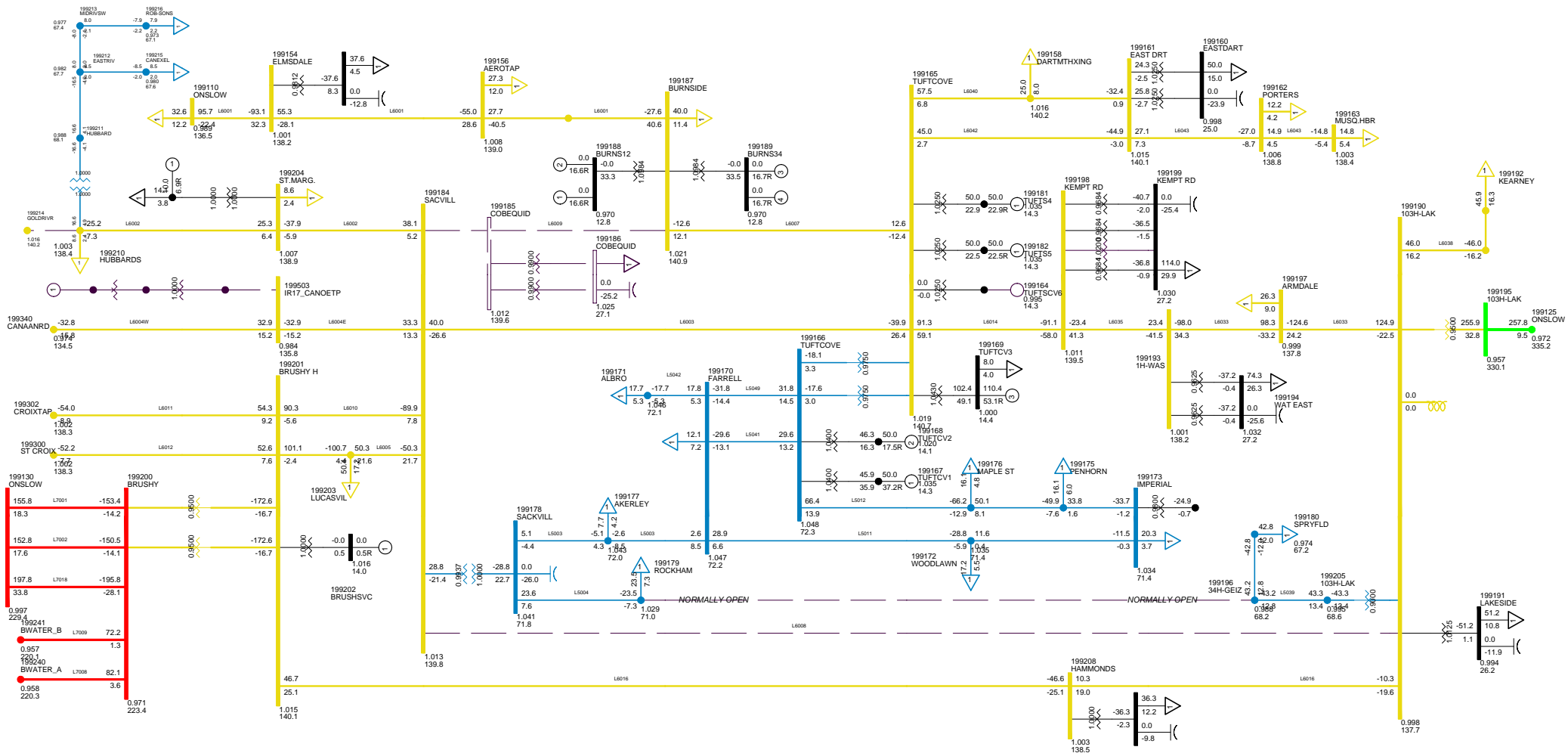

LABEL
 C44 BBU L6008 L6009 90H-611
 METRO ZONE SUN, FEB 15 2009 14:12

Bus - VOLTAGE (KV/PU)
 Break - MM/MVAR
 Equipment - MM/MVAR
 DISCONNECT
 1.050KV 0.550V
 KV: <30.000 <69.000 <138.000 <230.000 <345.000 >345.000

Figure __

Total Wind Gen: 290.1 MW
 Gross Tupper 165.0 MW
 Gross Wreck Cove 150.0 MW
 Gross Lingan 648.0 MW
 Gross Trenton 330.0 MW
 Gross Gas Turbine 24.0 MW
 Gross Pt Aconi 195.0 MW
 Gross Tuft's Cove 310.4 MW
 Gross Small Hydro 182.4 MW
 Net Stora Load 33.7 MW
 Total BMPC Load 75.5 MW

NSX 121.1 MW
 CBX 826.1 MW
 ONI 1049.9 MW
 ONS 817.6 MW

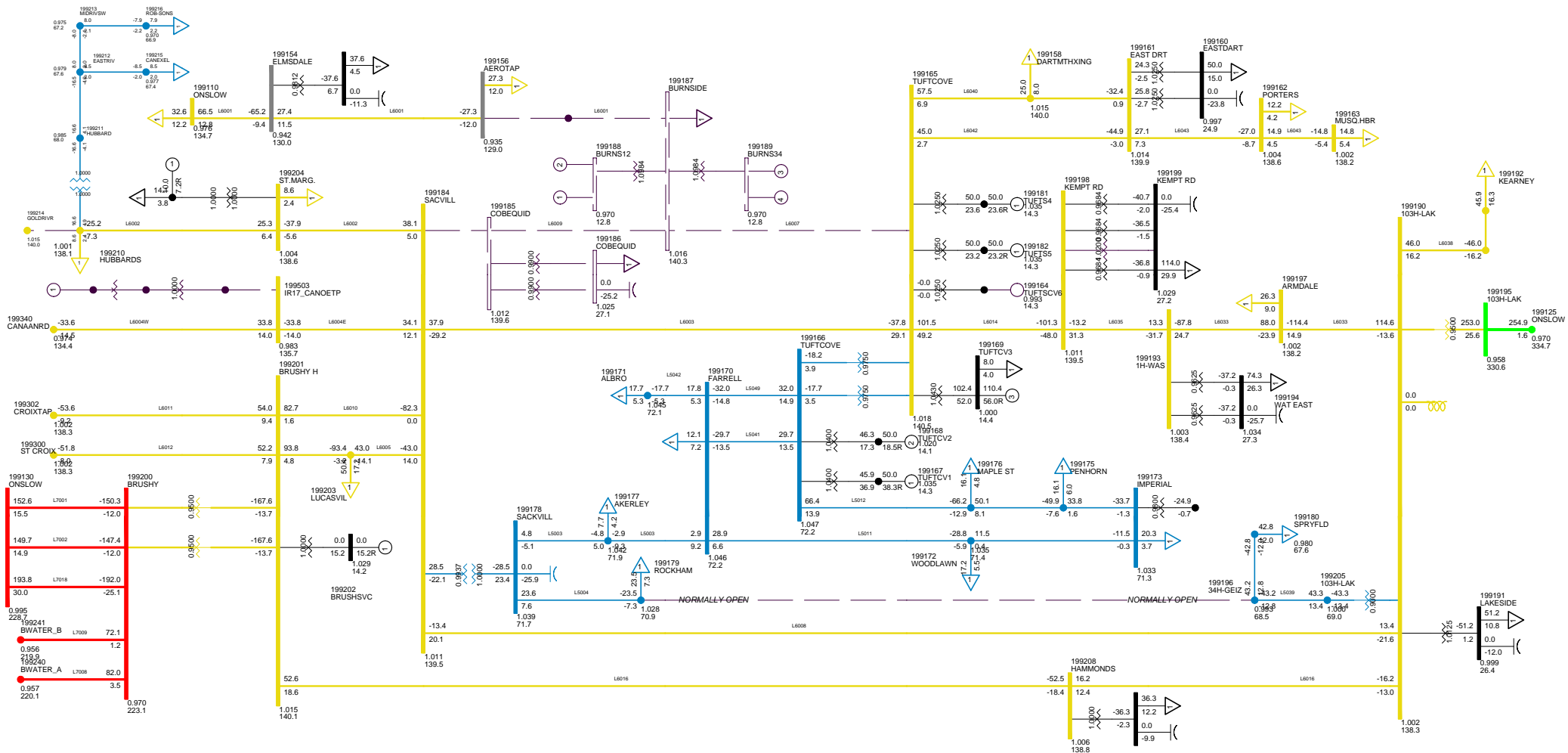

LABEL
 C46 1P L6009 BBU ON 108H 607
 METRO ZONE SUN, FEB 15 2009 14:13

Bus - VOLTAGE (KV/PU)
 Branch - MVA/MVA
 Equipment - MVA/MVA
 HV - 1.050KV 0.950KV
 MV - 0.950KV 0.850KV
 LV - 0.850KV 0.750KV
 1.050KV 0.950KV 0.850KV 0.750KV

Figure __

Total Wind Gen: 290.1 MW Gross Tupper 165.0 MW Gross Wreck Cove 150.0 MW
 Gross Lingan 648.0 MW Gross Trenton 330.0 MW Gross Gas Turbine 24.0 MW
 Gross Pt Aconi 195.0 MW Gross Tuft's Cove 310.4 MW Gross Small Hydro 182.4 MW

Net Stora Load 33.7 MW Total BMPC Load 75.5 MW

NSX 0.2 MW
 CBX 826.0 MW
 ONI 1049.6 MW
 ONS 939.0 MW

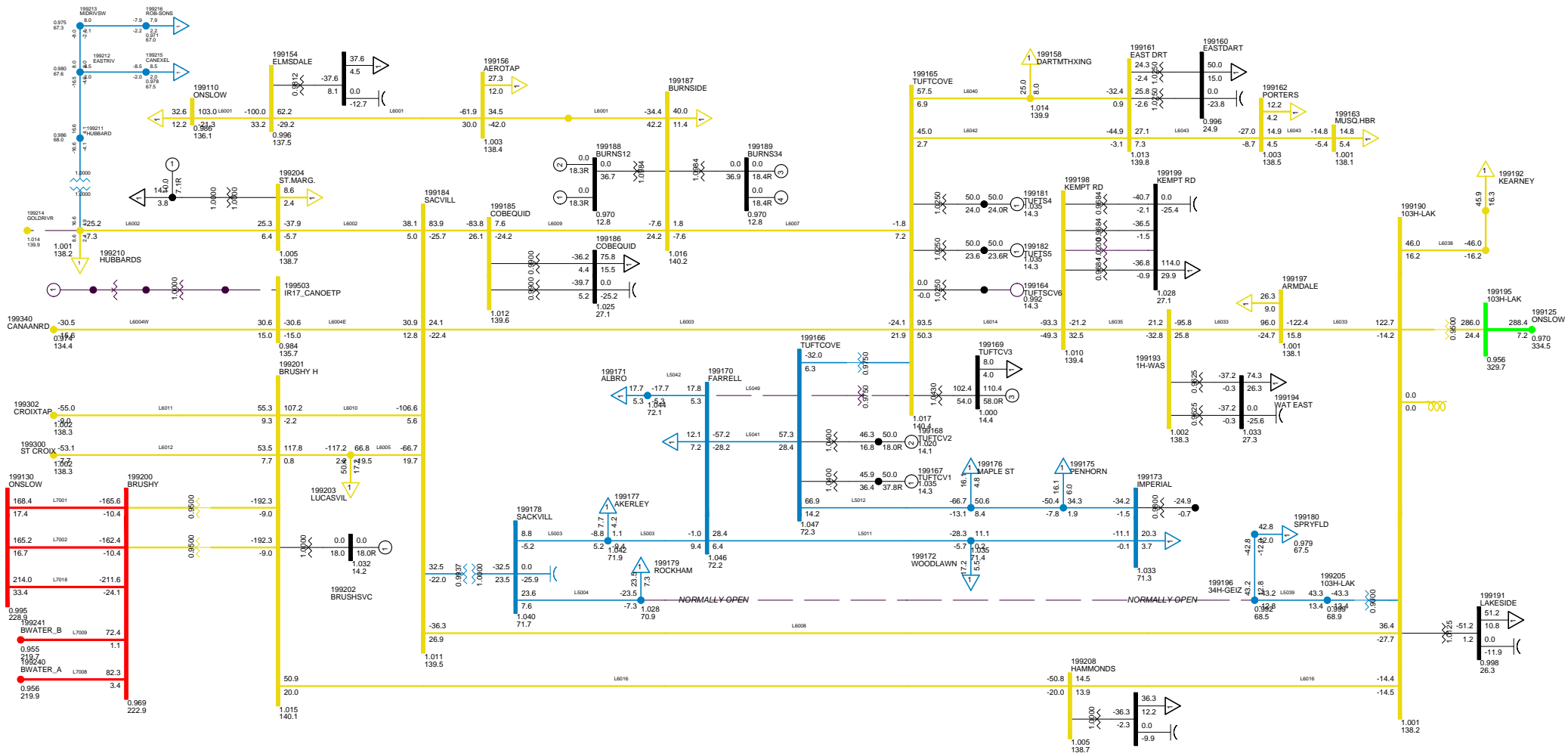

LABEL
 C48 1P ON BREAKER 91H-523
 METRO ZONE SUN, FEB 15 2009 14:13

Bus - VOLTAGE (KV/PU)
 Branch - MVA/MVA
 Equipment - MVA/MVA
 MIN/RATE
 1.050KV 0.950KV
 KV <-0.000 >=0.000 <+0.000 <+0.000 <+0.000 >+0.000

Figure __

Total Wind Gen: 290.1 MW
 Gross Tupper 165.0 MW
 Gross Wreck Cove 150.0 MW
 Gross Lingan 648.0 MW
 Gross Trenton 330.0 MW
 Gross Gas Turbine 24.0 MW
 Gross Pt Aconi 195.0 MW
 Gross Tuft's Cove 310.4 MW
 Gross Small Hydro 182.4 MW
 Net Stora Load 33.7 MW
 Total BMPC Load 75.5 MW

NSX 119.3 MW
 CBX 826.2 MW
 ONI 1050.1 MW
 ONS 819.8 MW

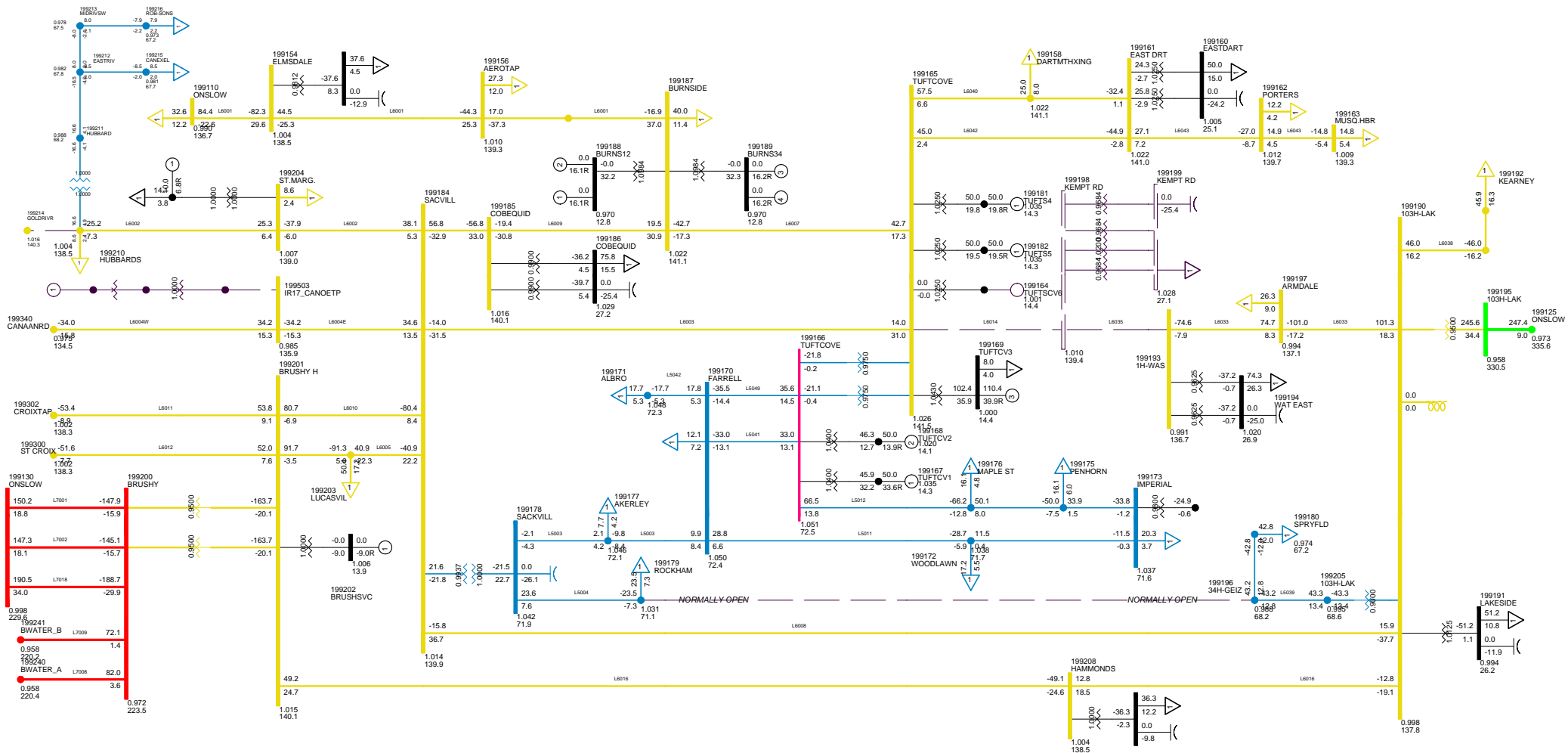

LABEL
 C49 1-PH ON 104H-600
 METRO ZONE SUN, FEB 15 2009 14:13

Bus - VOLTAGE (KV/PU)
 Break - MIN/MAX
 Equipment - MIN/MAX
 MIN/RATE
 1.050KV 0.950V
 KV: <30.000 <=60.000 <=138.000 <=230.000 <=345.000 >345.000

Figure __

ONI 1049.7 MW
 ONS 938.9 MW

Nova Scotia New Brunswick

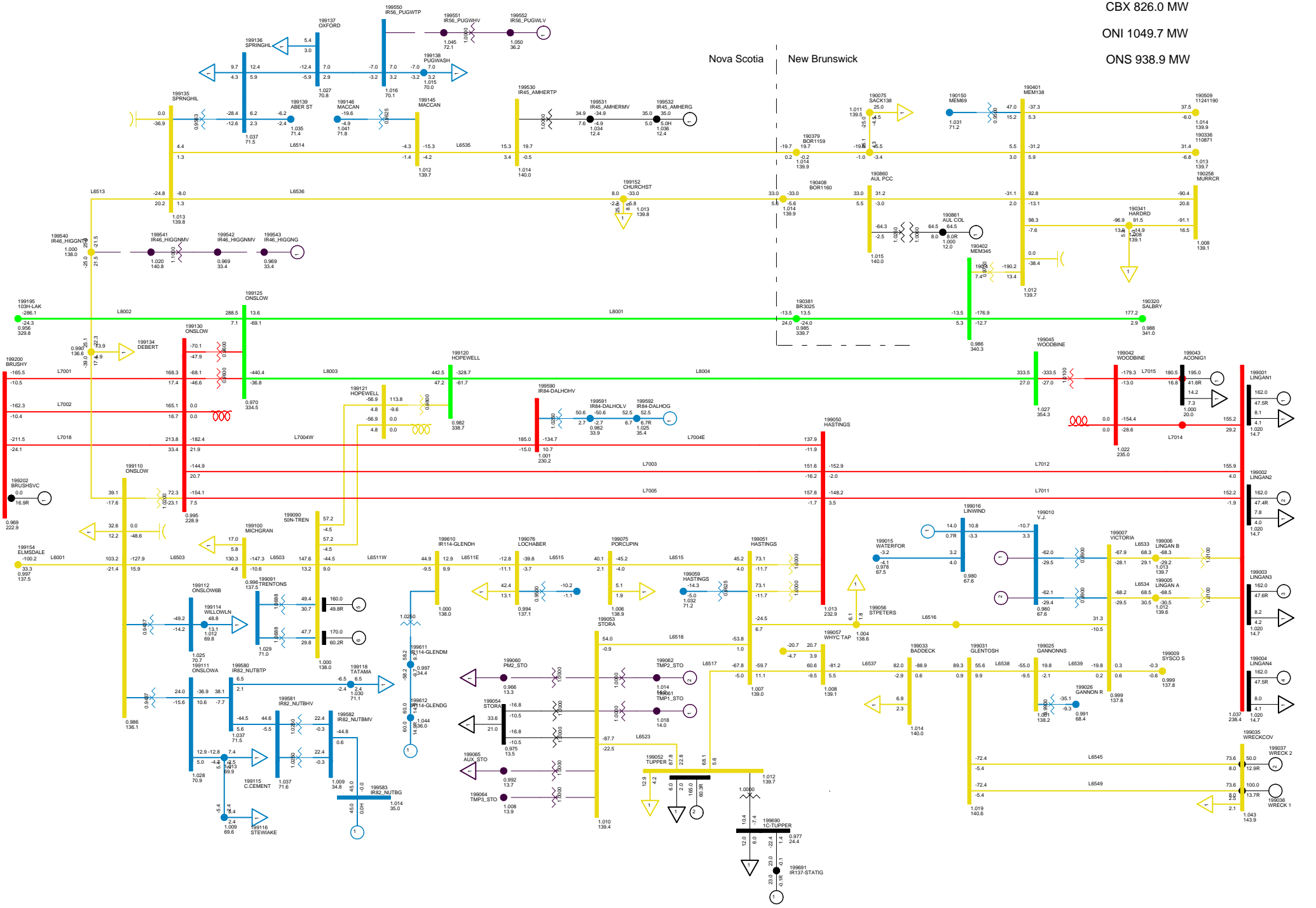

2013 WINTER PEAK MAXIMUM FLOW
 NS-NB=0; NB-NE=500; CBX=826; ONI=1050 ONS=939
 NORTHEASTERN NS SUN, FEB 15 2009 14:13

Total Wind Gen: 290.1 MW
 Gross Lingan 648.0 MW
 Gross Trenton 330.0 MW
 Gross Pt Aconi 195.0 MW
 Gross Tupper 165.0 MW
 Gross Wreck Cove 150.0 MW
 Gross Gas Turbine 24.0 MW
 Gross Small Hydro 182.4 MW
 Net Stora Load 33.7 MW
 Total BMPC Load 75.5 MW

Bus - VOLTAGE (KV/PU)
 Branch - MW/MVAR
 Equipment - MW/MVAR
 110.0/0.8478
 1.000/0.800/0.9
 KV - <25.000 <<-69.000 <<-138.000 <<-230.000 <<-345.000 >>345.000

Figure

ONI 1049.3 MW
 ONS 938.9 MW

Nova Scotia New Brunswick

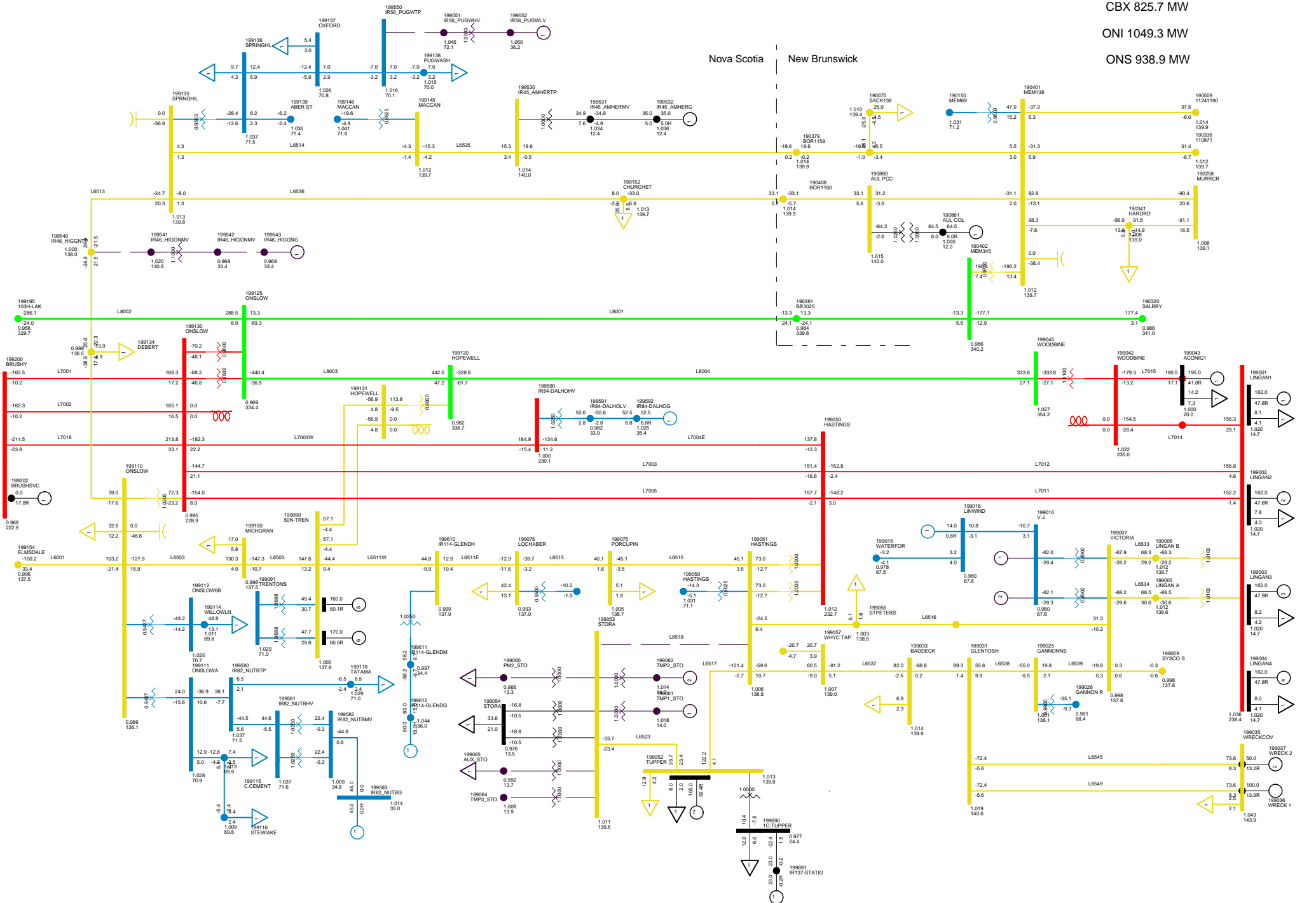

LABEL
 C52 BBU 47C-601
 NORTHEASTERN NS SUN, FEB 15 2009 14:14

Total Wind Gen: 290.1 MW
 Gross Lingan 648.0 MW
 Gross Trenton 330.0 MW
 Gross Tuft's Cove 310.4 MW
 Gross Tupper 165.0 MW
 Gross Wreck Cove 150.0 MW
 Gross Gas Turbine 24.0 MW
 Gross Small Hydro 182.4 MW
 Net Stora Load 33.7 MW
 Total BMPC Load 75.5 MW

Bus - VOLTAGE (KV/PU)
 Branch - MW/MVAR
 Equipment - MW/MVAR
 HIGHLIGHTS
 1.0000V 0.8500V
 KV <=25.000 <<=138.000 <<=230.000 <<=345.000 >=345.000

Figure

ONI 1049.7 MW
 ONS 938.9 MW

Nova Scotia New Brunswick

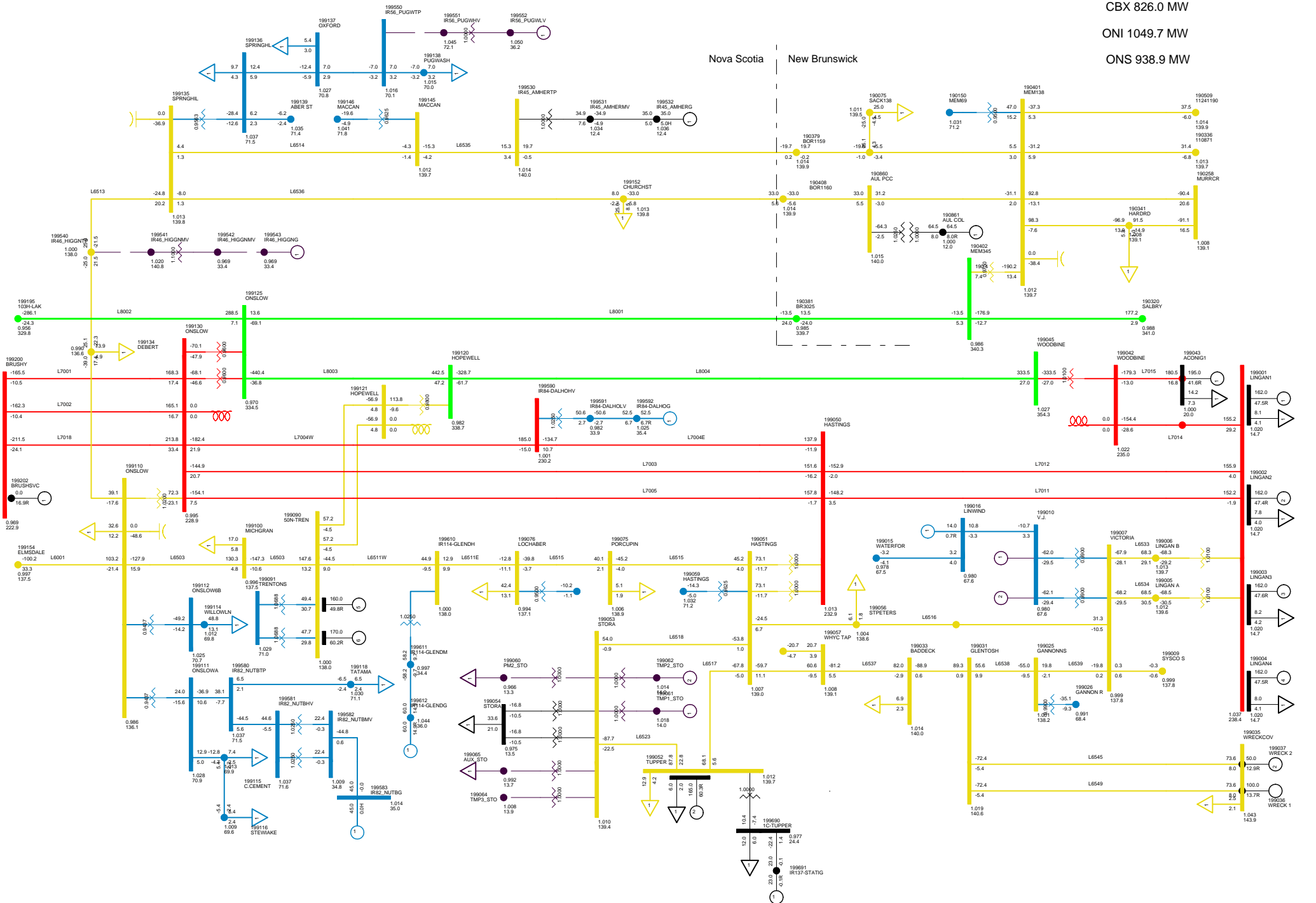

LABEL
C53 BREAKR 47C-602 FAULT
NORTHEASTERN NS SUN, FEB 15 2009 14:14

Total Wind Gen: 290.1 MW
 Gross Tupper 165.0 MW
 Gross Wreck Cove 150.0 MW
 Net Stora Load 33.7 MW
 Gross Lingan 648.0 MW
 Gross Trenton 330.0 MW
 Gross Gas Turbine 24.0 MW
 Total BMPC Load 75.5 MW
 Gross Tuft's Cove 310.4 MW
 Gross Small Hydro 182.4 MW

Bus - VOLTAGE (KV/PU)
 Branch - MW/MVAR
 Equipment - MW/MVAR
 110.0KV/47.5
 1.000KV 0.800V
 KV <-25.000 <<-69.000 <<-138.000 <<-230.000 <<-345.000 >>345.000

Figure

NSX 15.3 MW

CBX 826.9 MW

ONI 1041.2 MW

ONS 946.0 MW

Nova Scotia New Brunswick

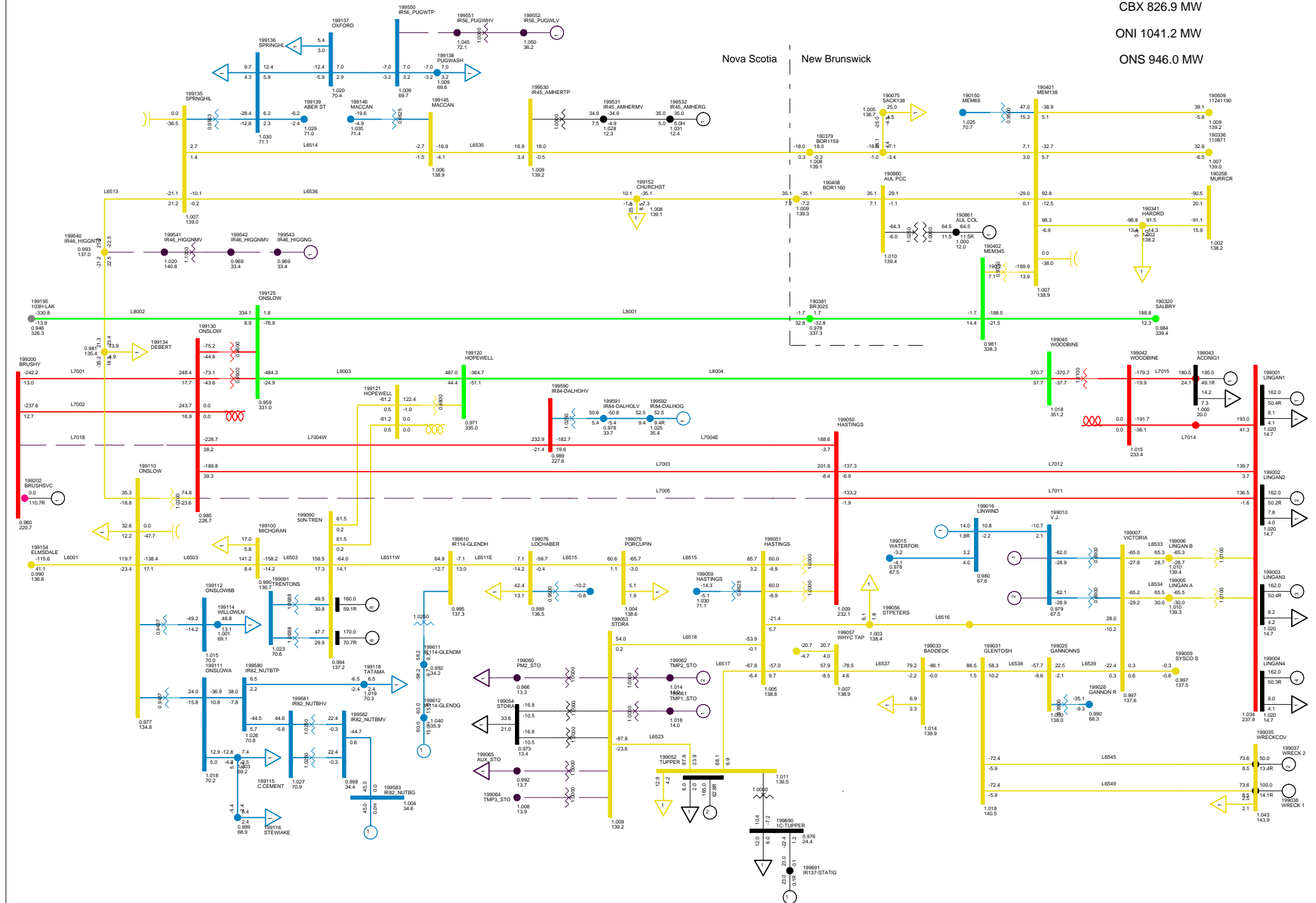

LABEL
C55 BBU 67N-712
NORTHEASTERN NS SUN, FEB 15 2009 14:15

Total Wind Gen: 290.1 MW
Gross Lingan 648.0 MW
Gross Trenton 330.0 MW
Gross Tuft's Cove 310.4 MW
Gross Tupper 165.0 MW
Gross Wreck Cove 150.0 MW
Gross Gas Turbine 24.0 MW
Gross Small Hydro 182.4 MW
Net Stora Load 33.7 MW
Total BMPC Load 75.5 MW

Bus - VOLTAGE (KV/PU)
Branch - MW/MVAR
Equipment - MW/MVAR
HIGHLIGHTS
1.0000V 0.8500V
KV <=25.000 <<=69.000 <<=138.000 <<=230.000 <<=345.000 >=450.000

Figure

ONI 510.9 MW
 ONS 590.9 MW

Nova Scotia New Brunswick

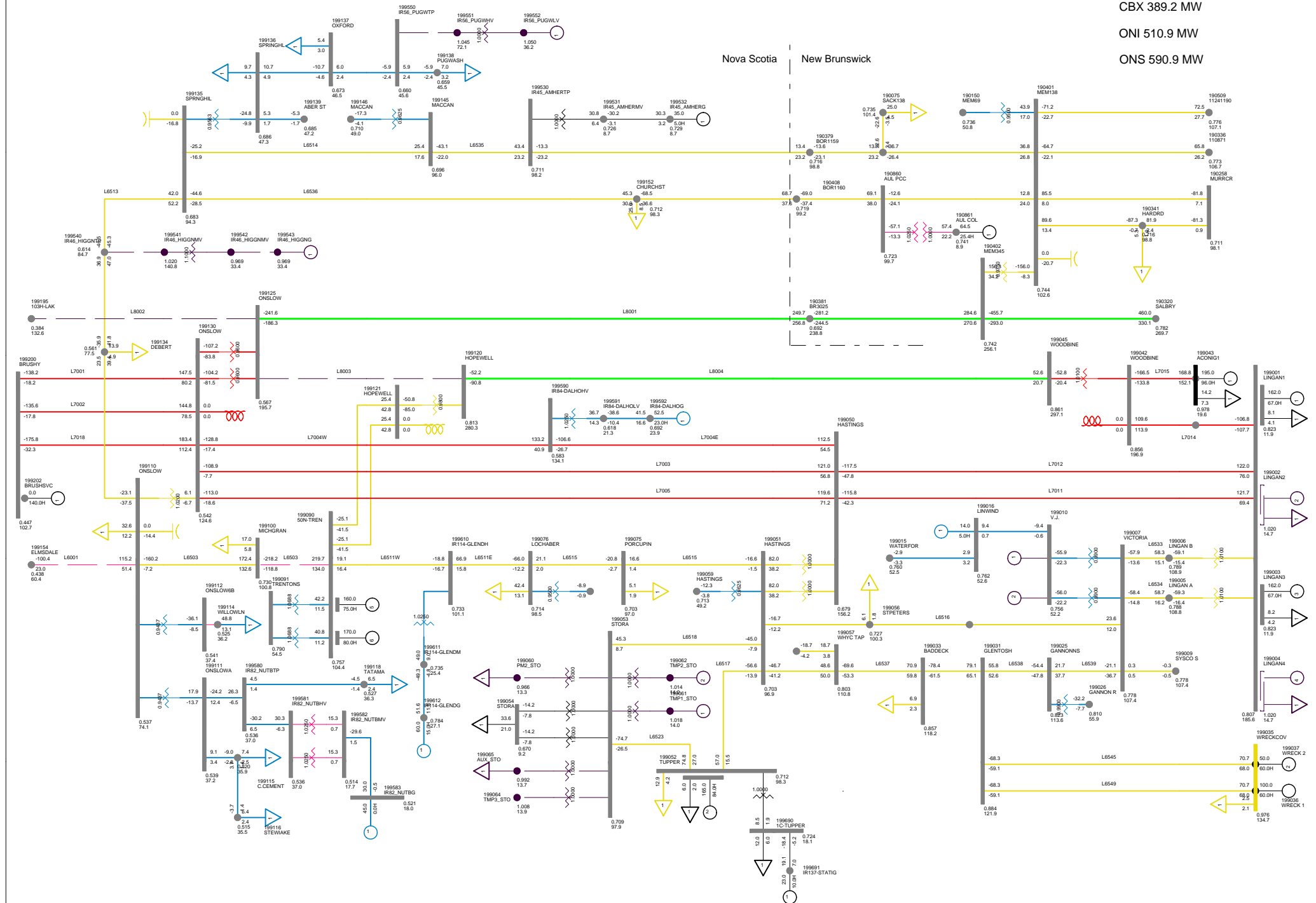

LABEL
 C57SS BBU 67N-812 2-UNIT SPS
 NORTHEASTERN NS SUN, FEB 15 2009 14:16

Total Wind Gen: 290.1 MW
 Gross Lingan 324.0 MW
 Gross Trenton 330.0 MW
 Gross Tuft's Cove 310.4 MW
 Gross Tupper 165.0 MW
 Gross Wreck Cove 150.0 MW
 Gross Gas Turbine 24.0 MW
 Gross Small Hydro 182.4 MW
 Net Stora Load 29.4 MW
 Total BMPC Load 40.9 MW

Bus - VOLTAGE (KV/PU)
 Branch - MW/MVAR
 Equipment - MW/MVAR
 HV - VOLTAGE (KV)
 HV - CURRENT (KA)
 HV - CAPACITANCE (PF)
 HV - INDUCTIVE REACTANCE (OHM)
 HV - RESISTANCE (OHM)
 HV - CAPACITANCE (PF)
 HV - INDUCTIVE REACTANCE (OHM)
 HV - RESISTANCE (OHM)

Figure

CBX 522.9 MW
 ONI 737.5 MW
 ONS 940.5 MW

Nova Scotia | New Brunswick

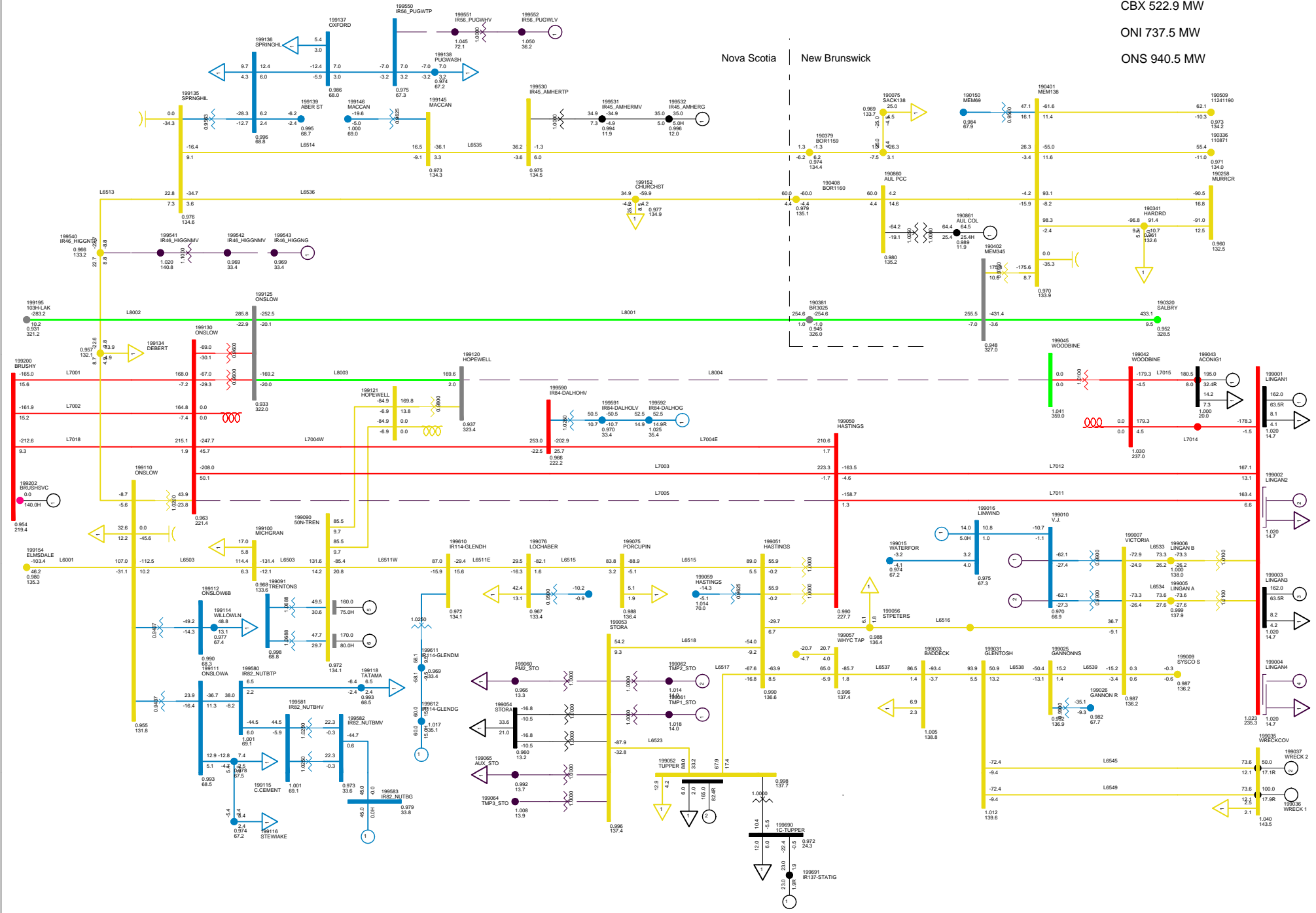

LABEL

C61SS DCT ON STRAIT CROSSING L8004-L7005 WITH 2-UNIT SPS
 NORTHEASTERN NS SUN, FEB 15 2009 14:17

Total Wind Gen: 290.1 MW	Gross Tupper 165.0 MW	Gross Wreck Cove 150.0 MW	Net Stor Load 33.7 MW
Gross Lingan 324.0 MW	Gross Trenton 330.0 MW	Gross Gas Turbine 24.0 MW	Total BMPC Load 75.5 MW
Gross Pt Aconi 195.0 MW	Gross Tufts Cove 310.4 MW	Gross Small Hydro 182.4 MW	

Bus - VOLTAGE (KV/PV)
 Branch - MW/MVAR
 Equipment - MW/MVAR
 110 kV GATES
 1.0500V 0.9500V
 KV: <-25.000 <-69.000 <-138.000 <-230.000 <-345.000 >345.000

Figure _____

Nova Scotia New Brunswick

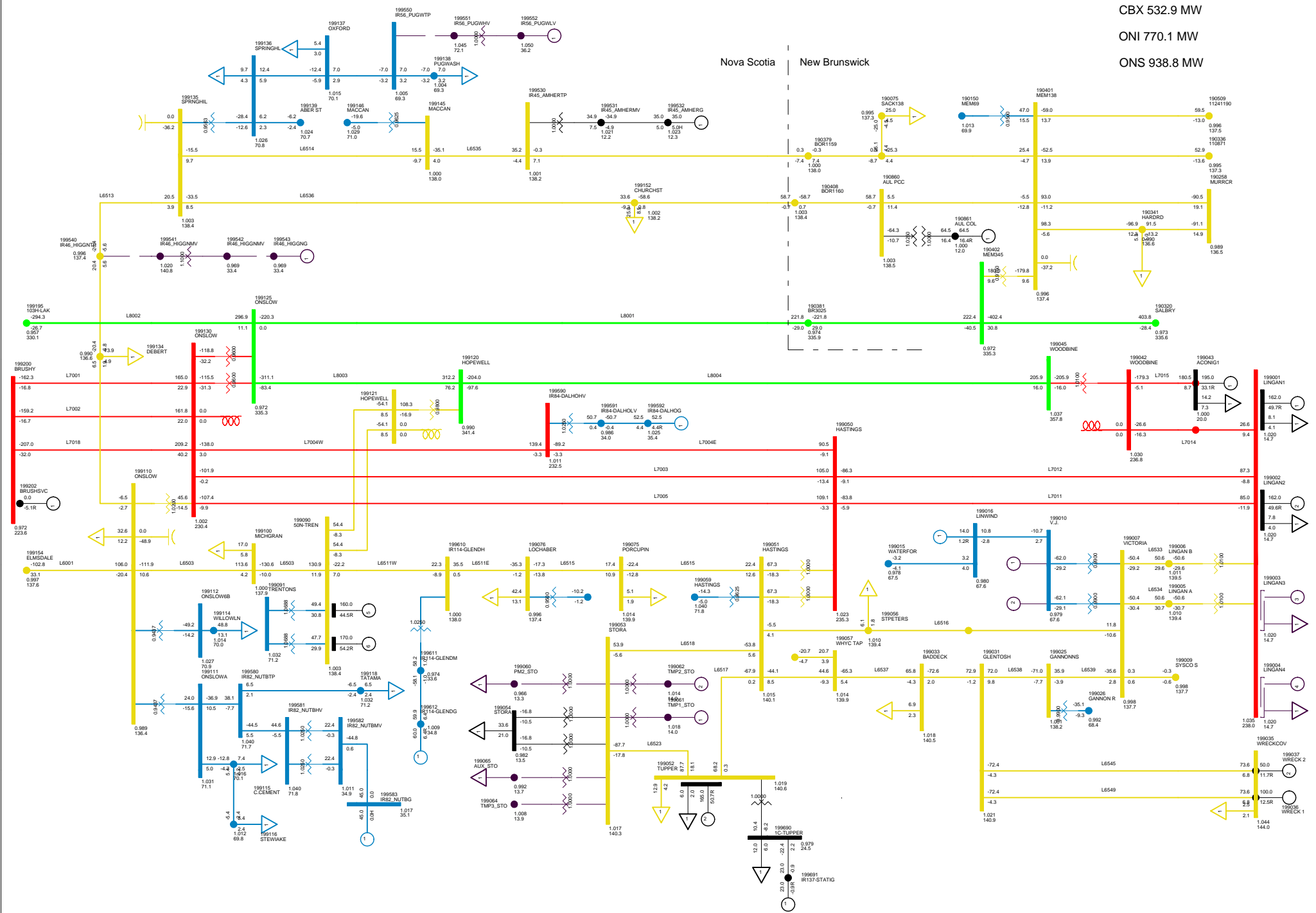

LABEL

C62 FAULT ON BREAKER 88S-721 TRIPS LINGAN 3 AND 4 NORTHEASTERN NS SUN, FEB 15 2009 14:17

Total Wind Gen: 290.1 MW	Gross Tupper 165.0 MW	Gross Wreck Cove 150.0 MW	Net Stora Load 33.7 MW
Gross Lingan 324.0 MW	Gross Trenton 330.0 MW	Gross Gas Turbine 24.0 MW	Total BMPC Load 75.5 MW
Gross Pt Aconi 195.0 MW	Gross Tuft's Cove 310.4 MW	Gross Small Hydro 182.4 MW	

Bus - VOLTAGE (KV/PV)
Branch - MW/MVAR
Equipment - MW/MVAR
110:66:34.75
1:0500V 0.9500V
KV: <-25.000 <-69.000 <-138.000 <-230.000 <-345.000 >345.000

Figure ____

NS 60.8 MW

CBX 825.7 MW

ONI 1049.0 MW

ONS 939.6 MW

Nova Scotia New Brunswick

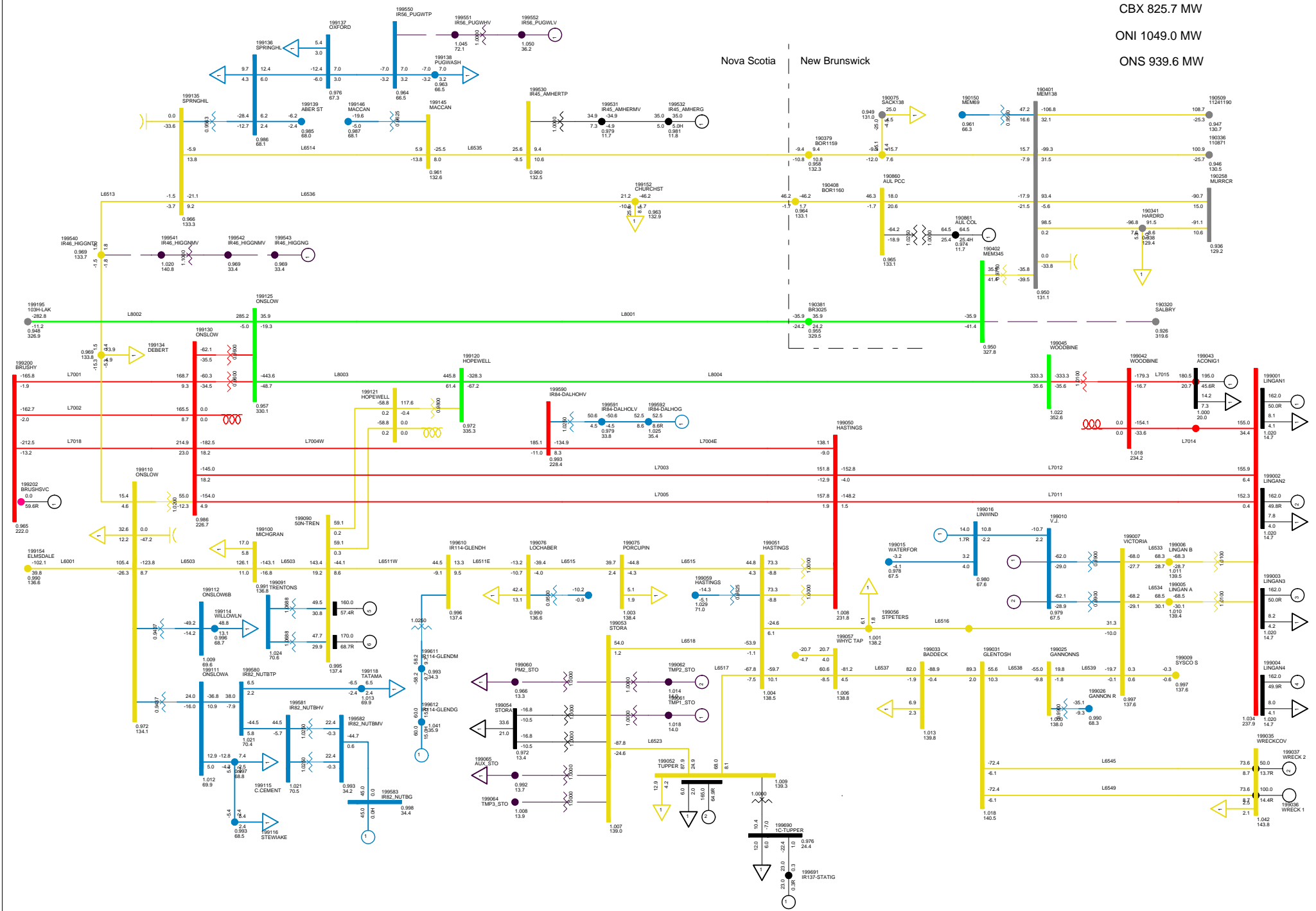

LABEL
C63 FAULT ON SALISBURY SA3-2 TRIPS L3006 AND L3017
NORTHEASTERN NS SUN, FEB 15 2009 14:17

Total Wind Gen: 290.1 MW	Gross Tupper 165.0 MW	Gross Wreck Cove 150.0 MW	Net Stora Load 33.7 MW
Gross Lingan 648.0 MW	Gross Trenton 330.0 MW	Gross Gas Turbine 24.0 MW	Total BMPC Load 75.5 MW
Gross Pt Aconi 195.0 MW	Gross Tuft's Cove 310.4 MW	Gross Small Hydro 182.4 MW	

Bus - VOLTAGE (KV/PU)
 Branch - MW/MVAR
 Equipment - MW/MVAR
 110.0kV/1.000V
 138.0kV/0.950V
 230.0kV/0.900V
 500.0kV/0.800V

Figure ____

CBX 825.8 MW

ONI 1049.0 MW

ONS 939.3 MW

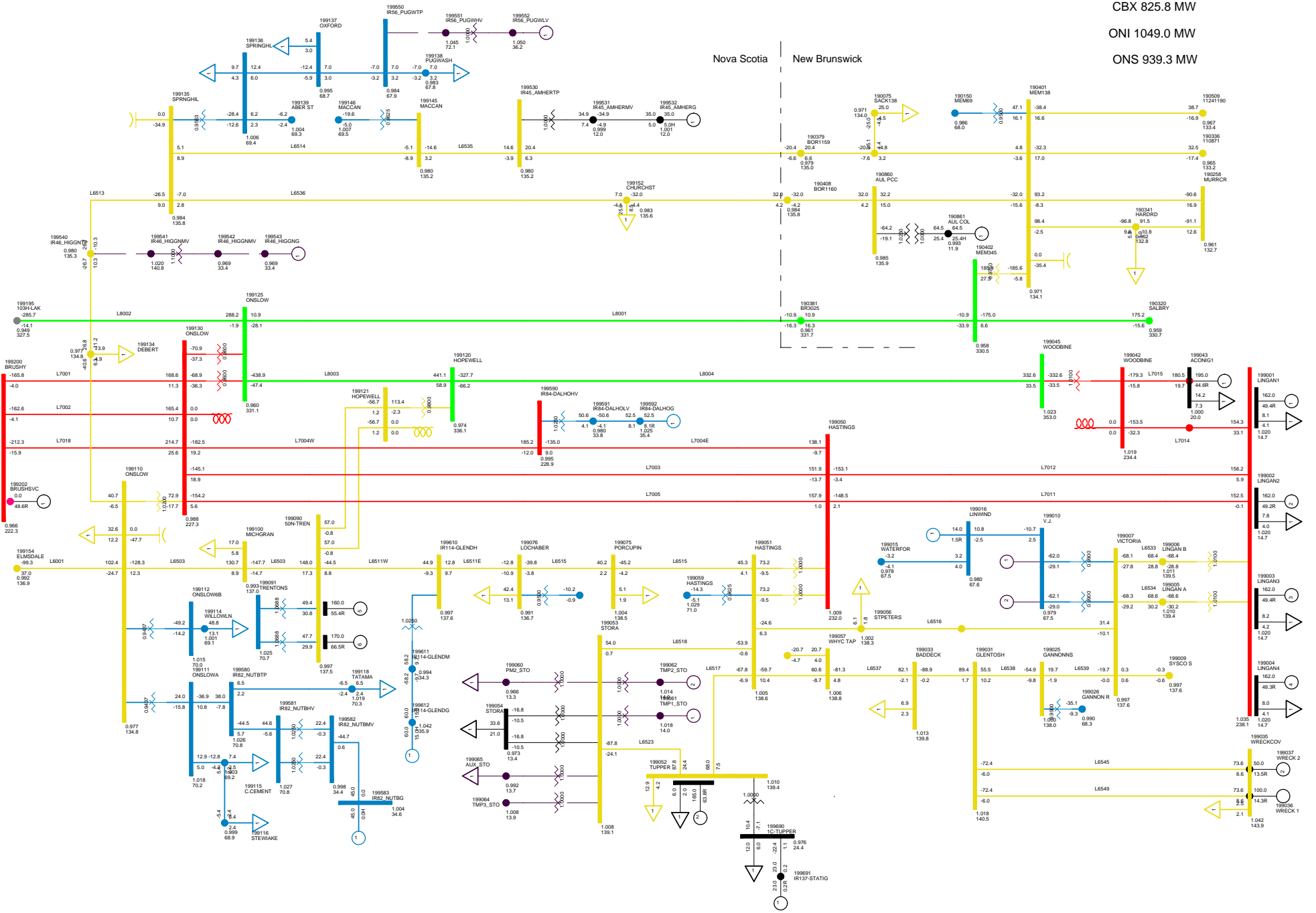

LABEL
C64 FAULT ON BREAKER SALISBURY BREAKER SA3-4 TRIPS L3013 AND
NORTHEASTERN NS SUN, FEB 15 2009 14:17

Total Wind Gen: 290.1 MW
Gross Ligan 648.0 MW
Gross Pt Aconi 195.0 MW
Gross Tupper 165.0 MW
Gross Trenton 330.0 MW
Gross Tuff's Cove 310.4 MW
Gross Wreck Cove 150.0 MW
Gross Gas Turbine 24.0 MW
Gross Small Hydro 182.4 MW
Net Stora Load 33.7 MW
Total BMPC Load 75.5 MW

Bus - VOLTAGE (KV/PU)
Branch - M/M/M/V
Equipment - M/M/M/V
110.0KV/1.0000
KV <-25.000 <-69.000 <-138.000 <-230.000 <-345.000 <345.000

Figure ___

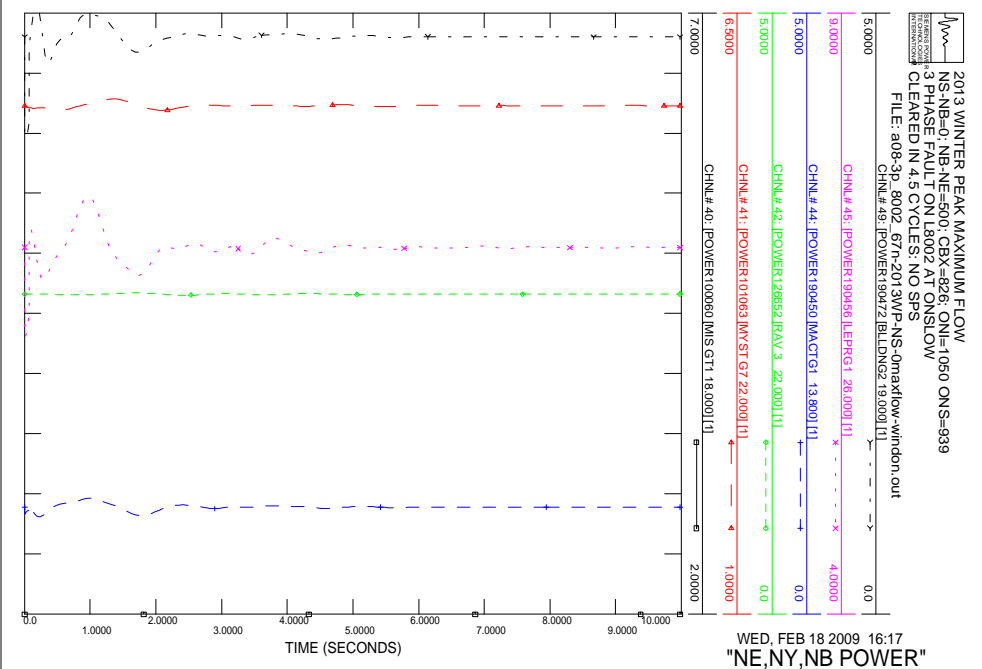
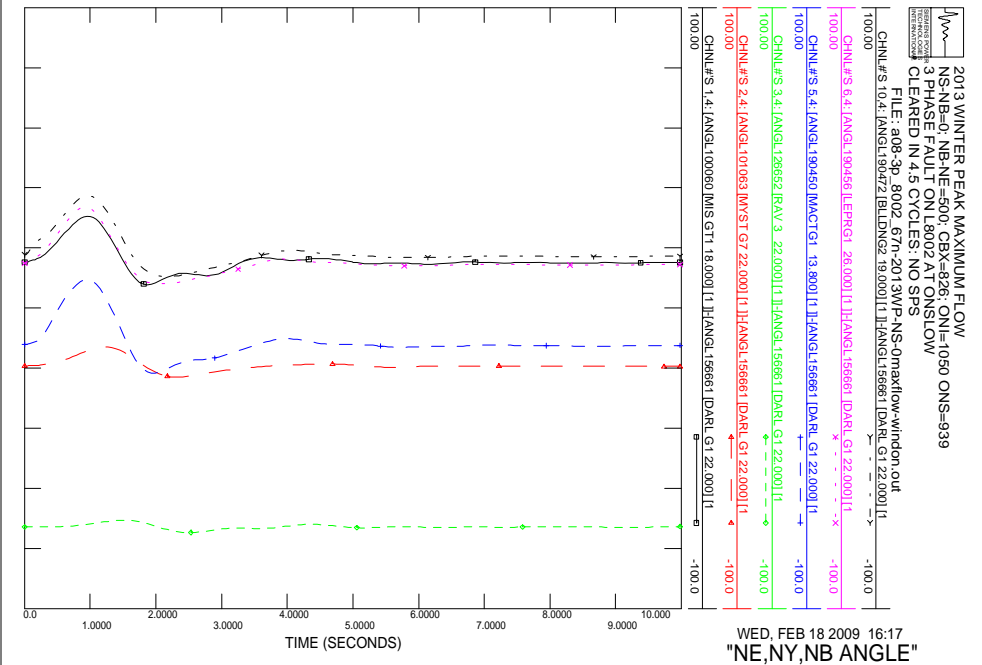
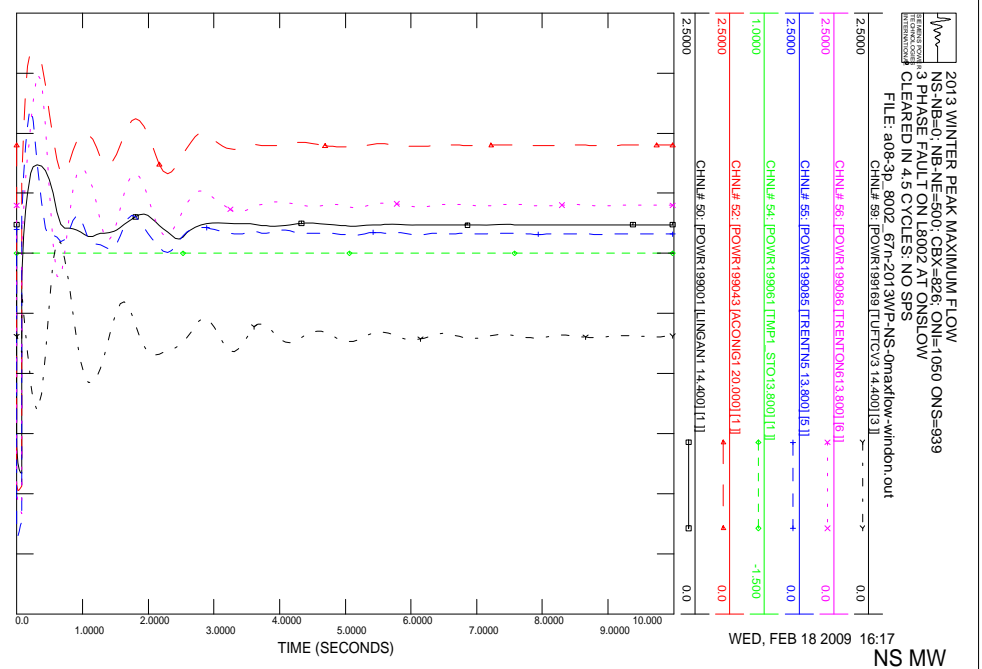
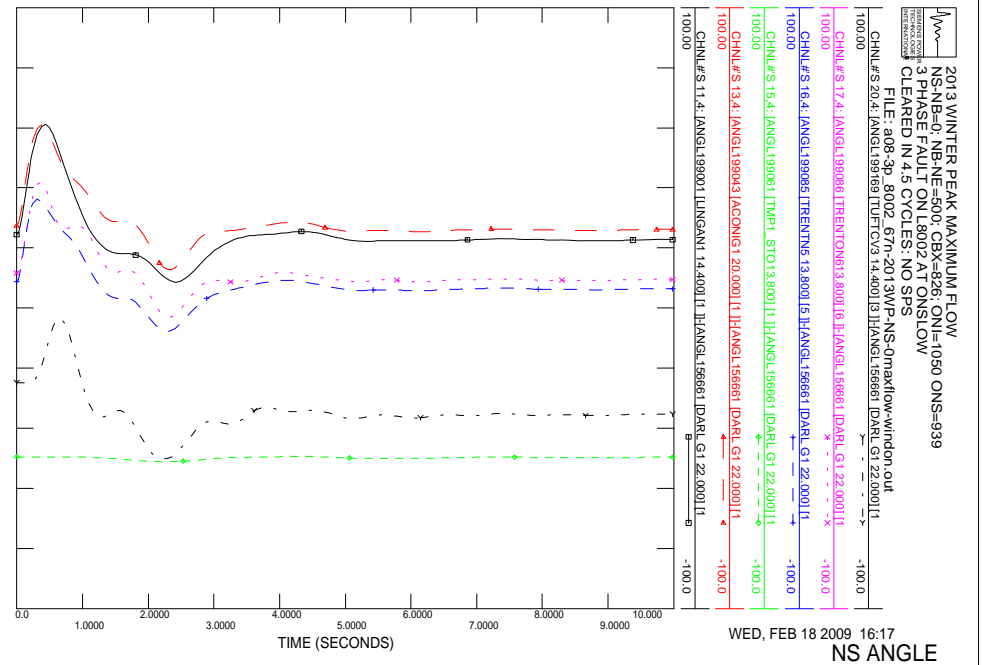

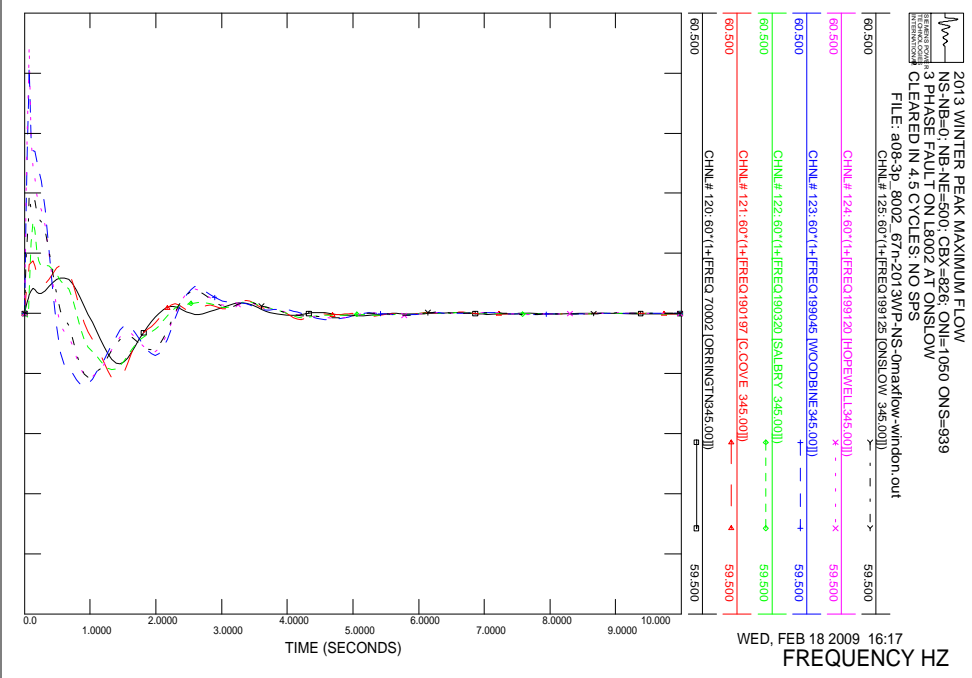
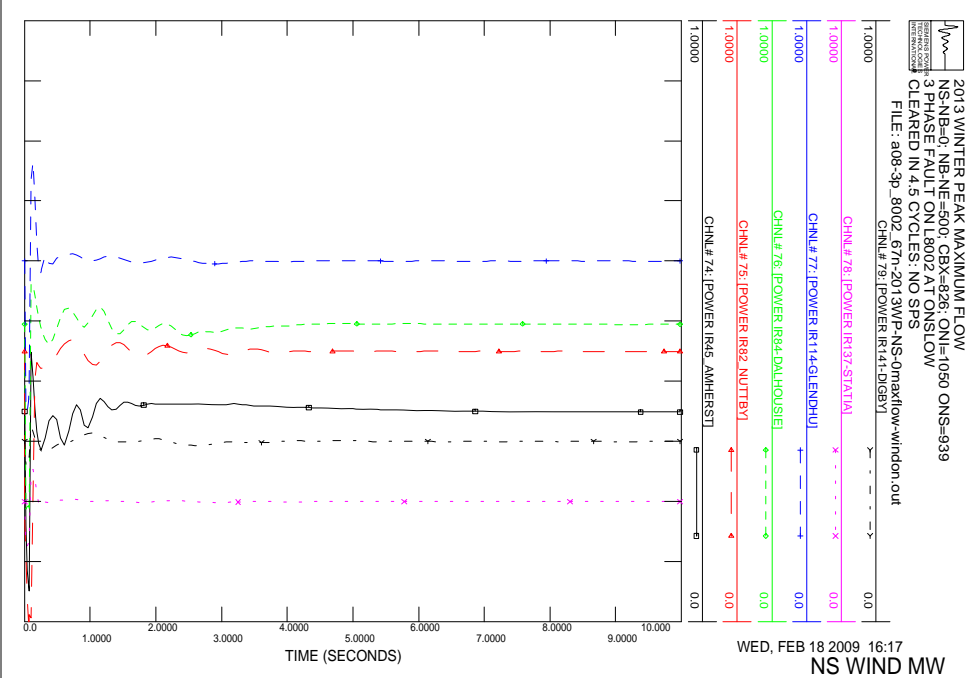
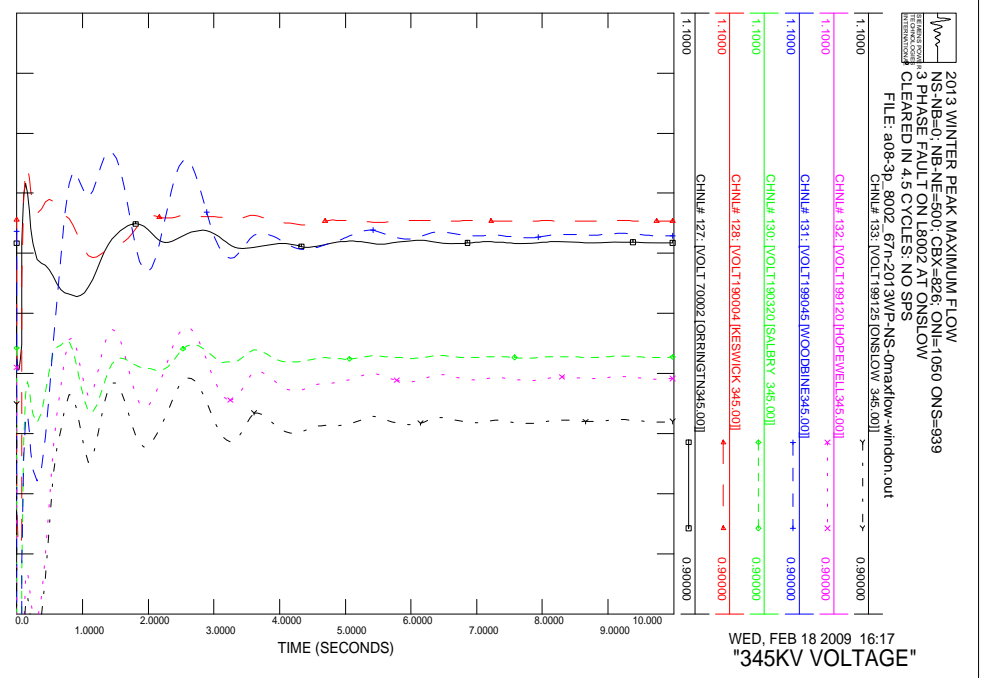
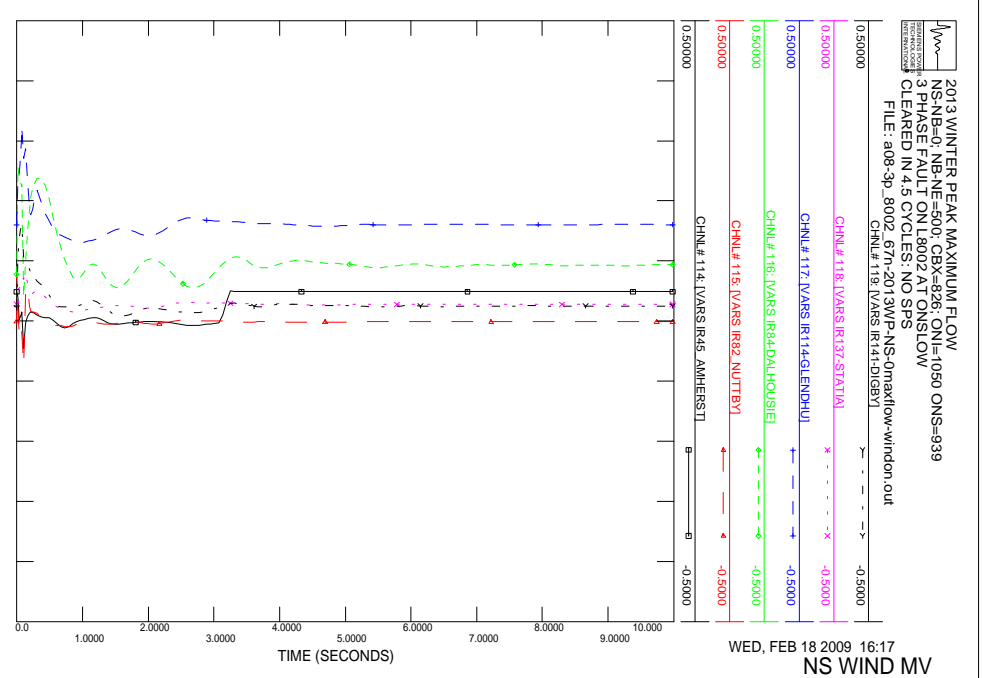

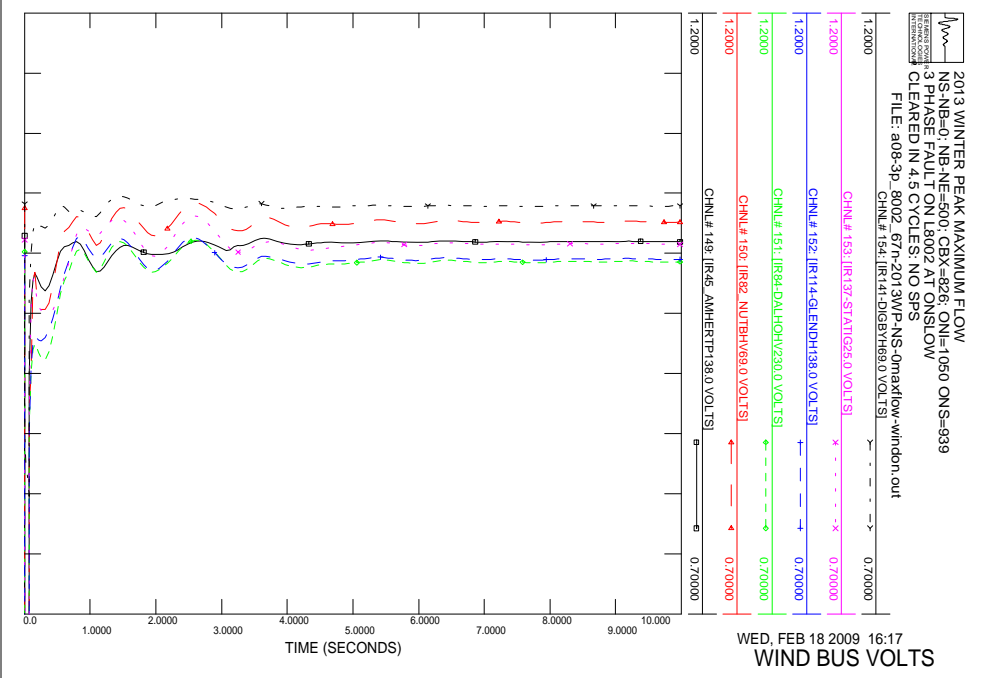
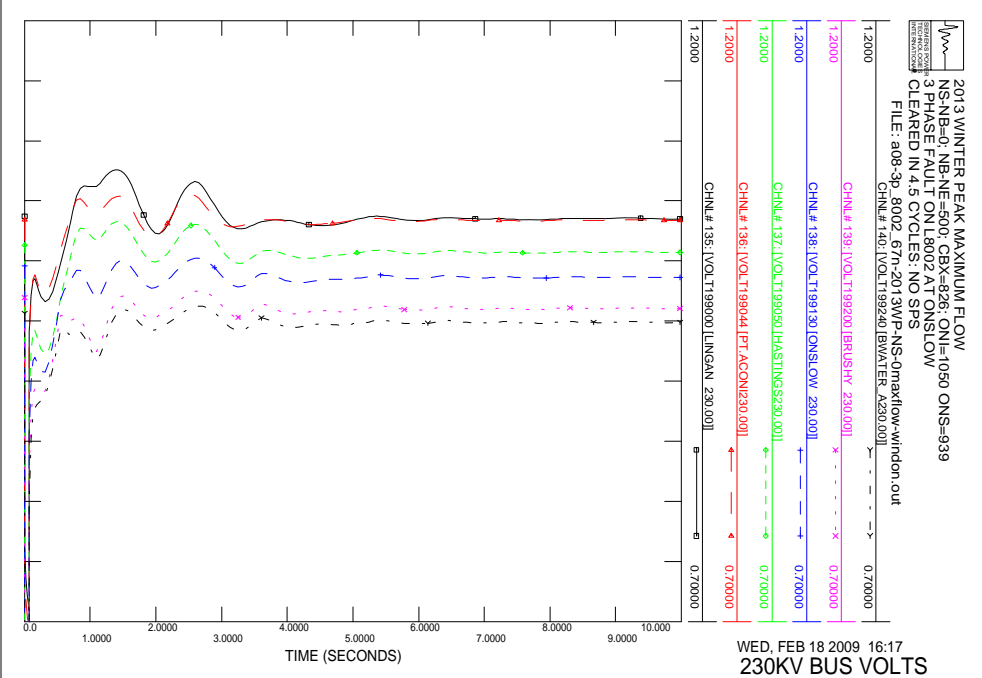
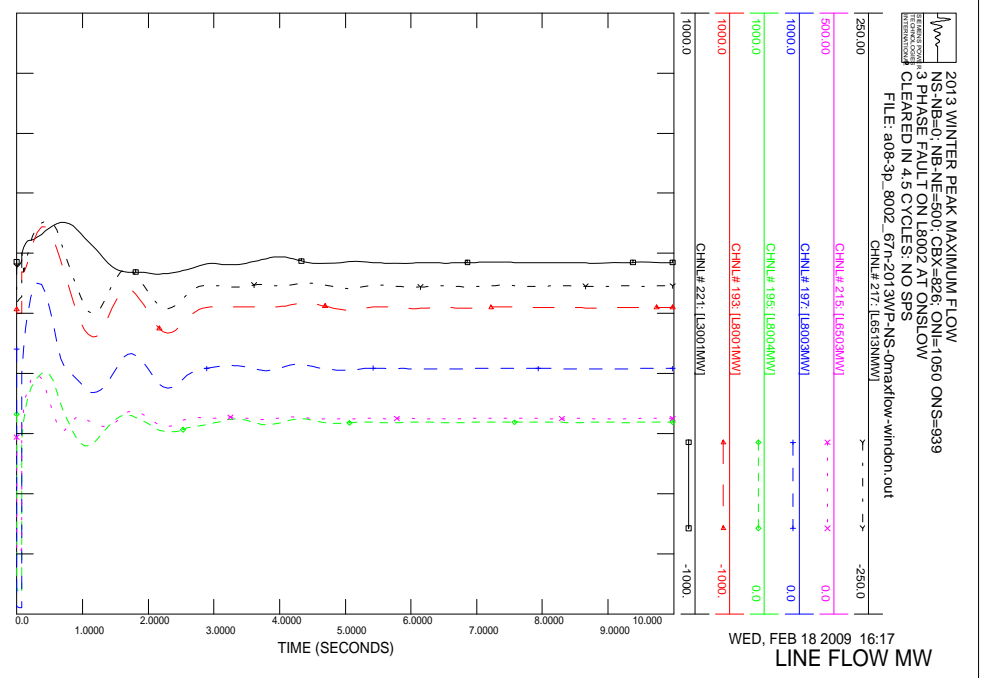
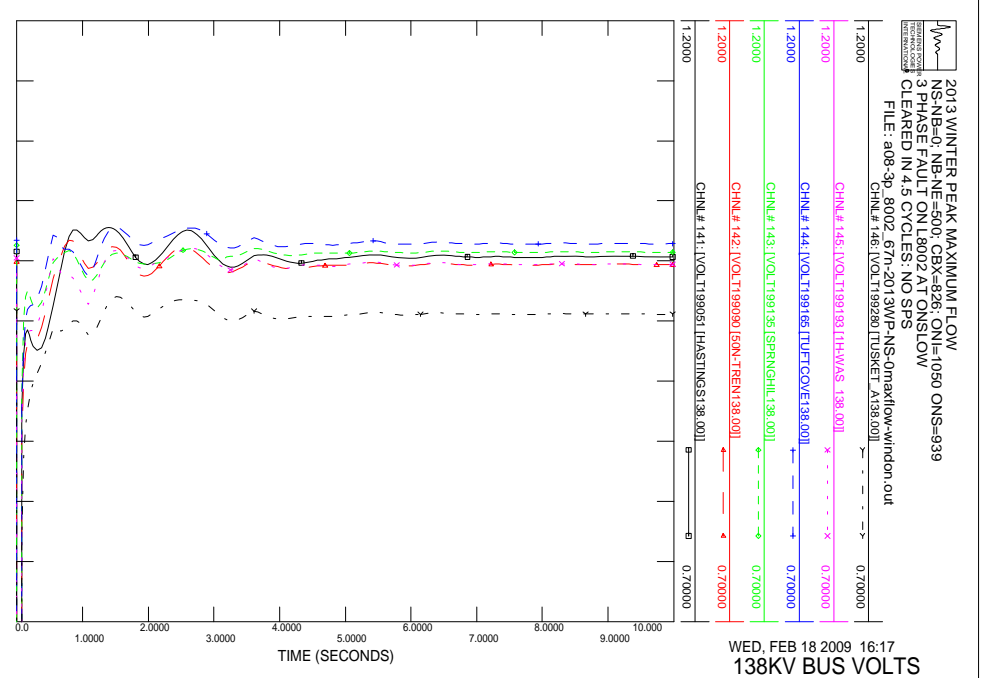

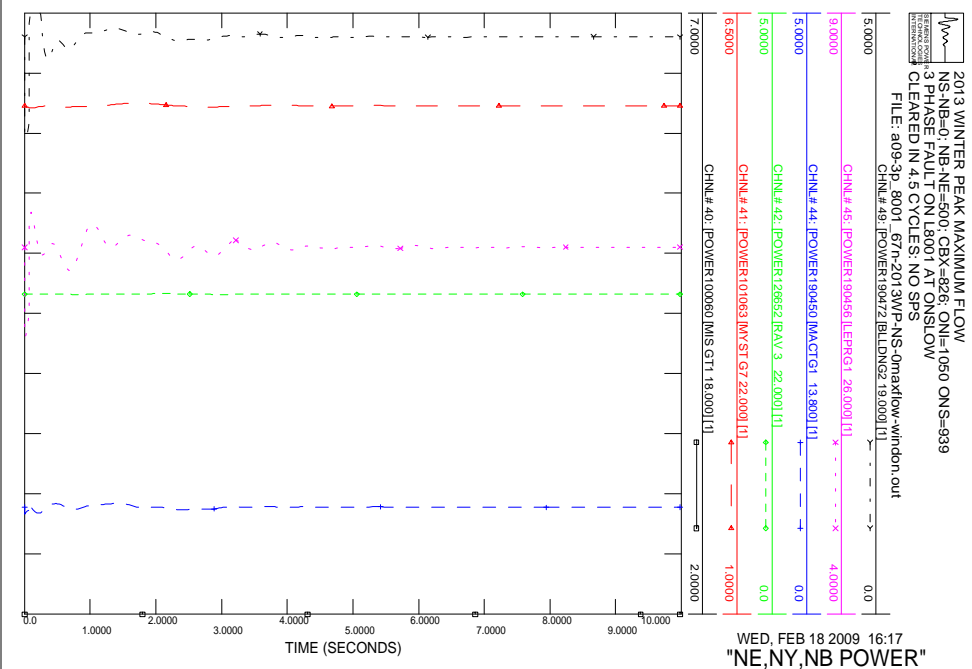
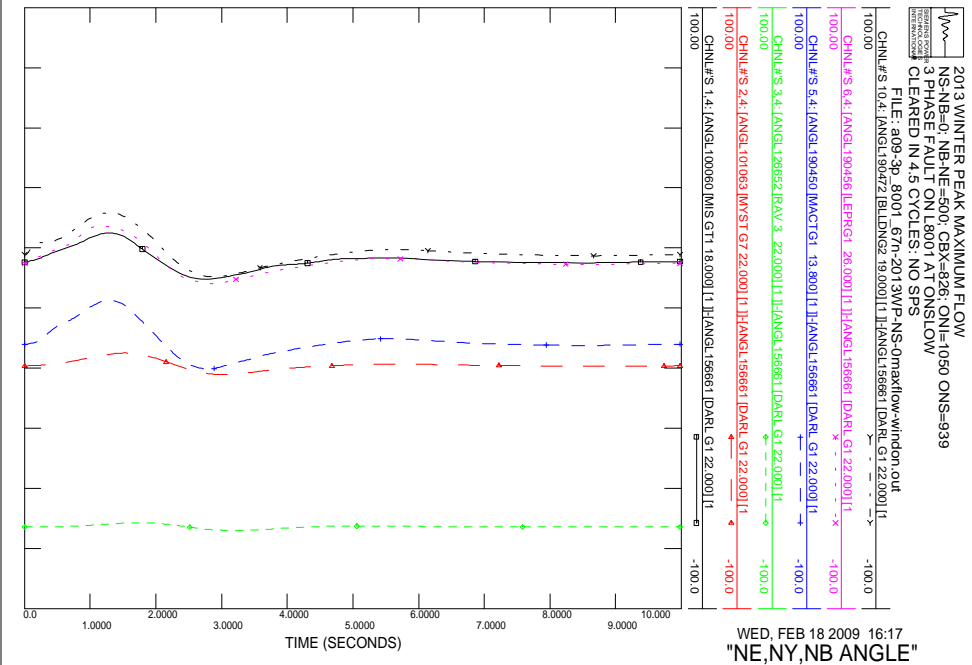
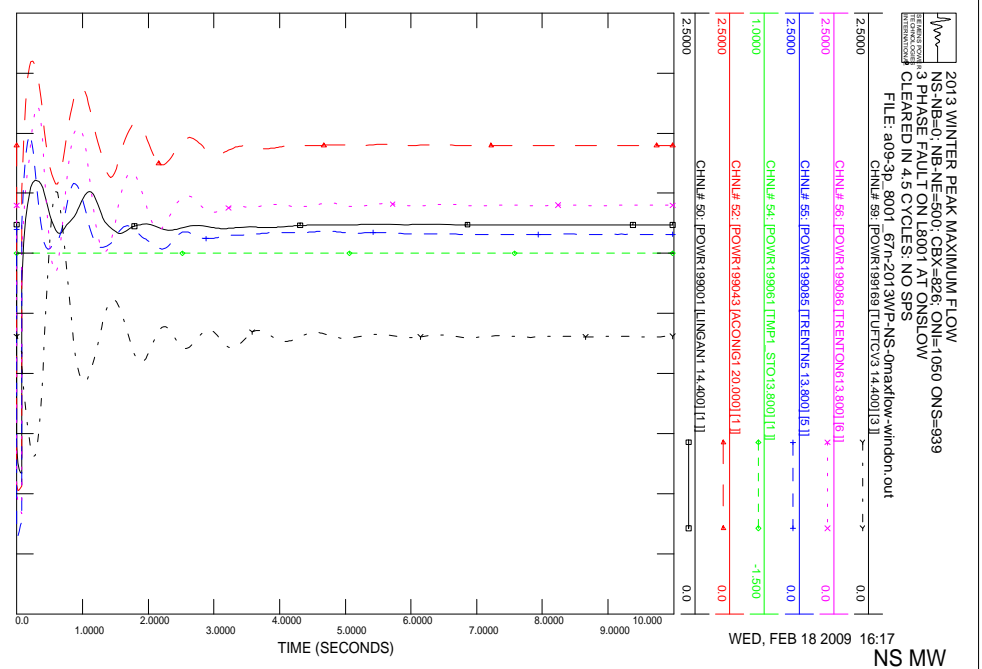
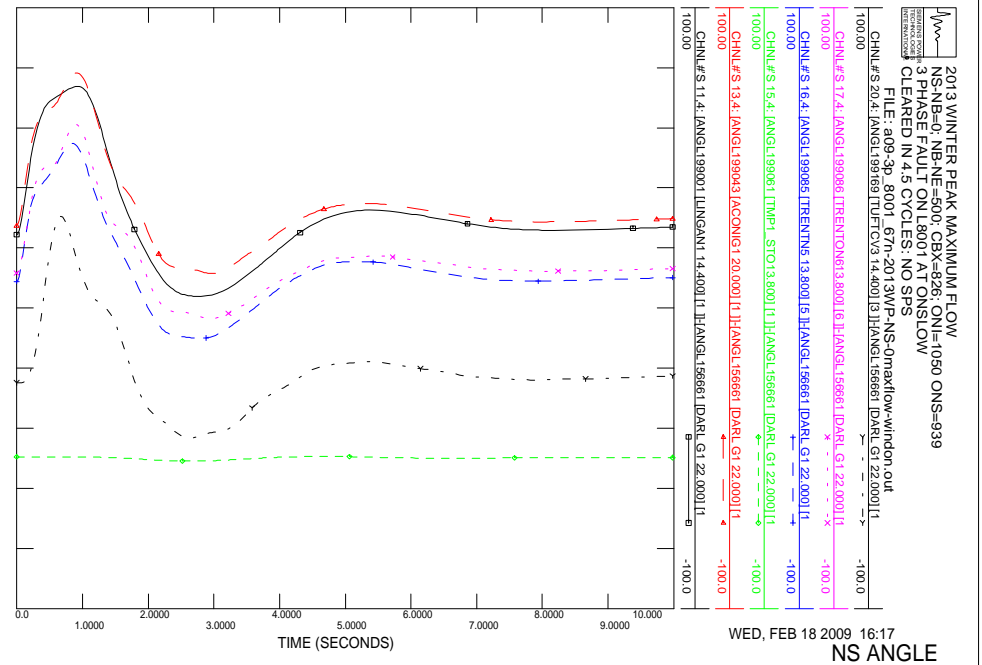

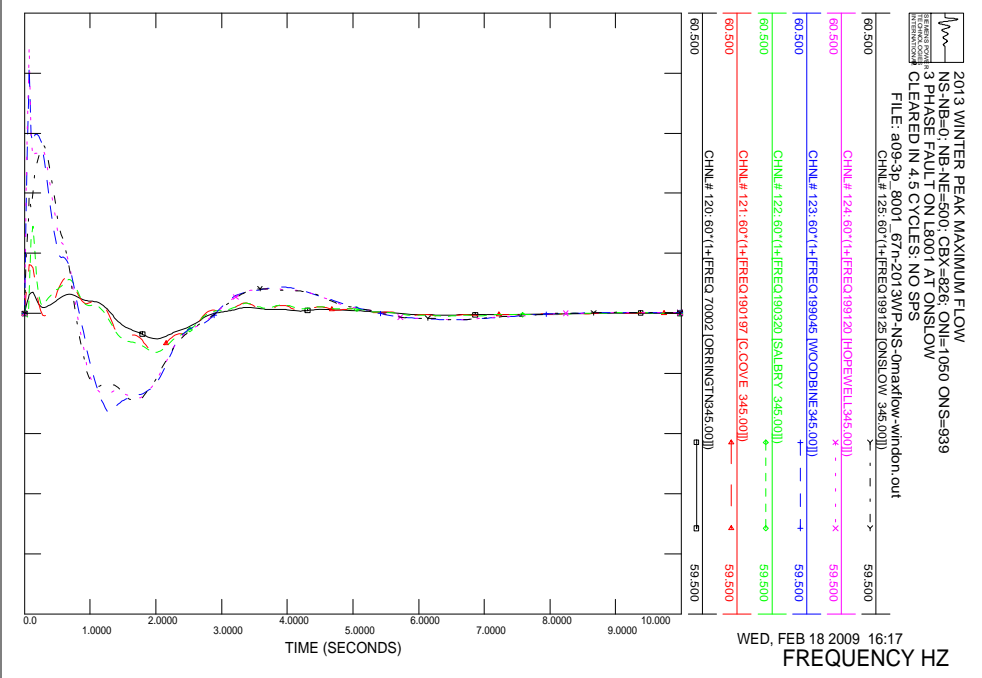
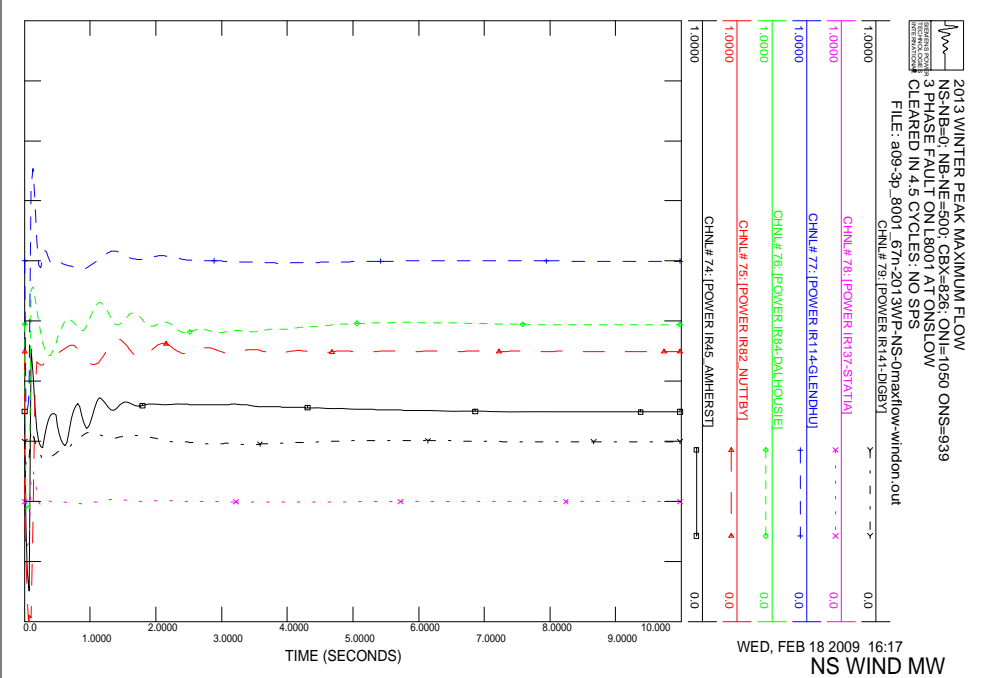
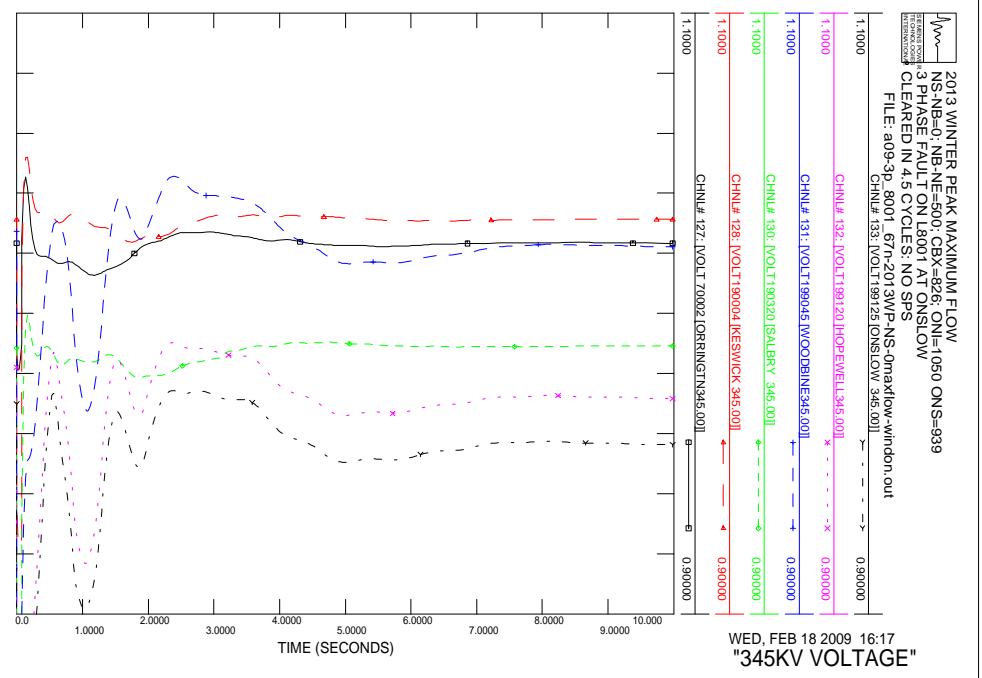
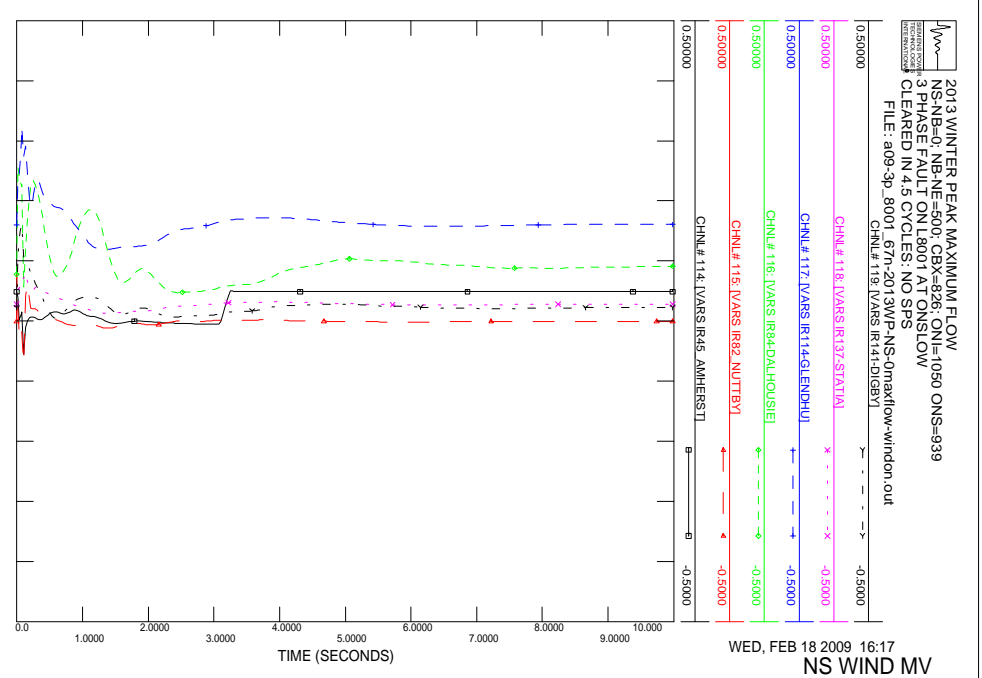

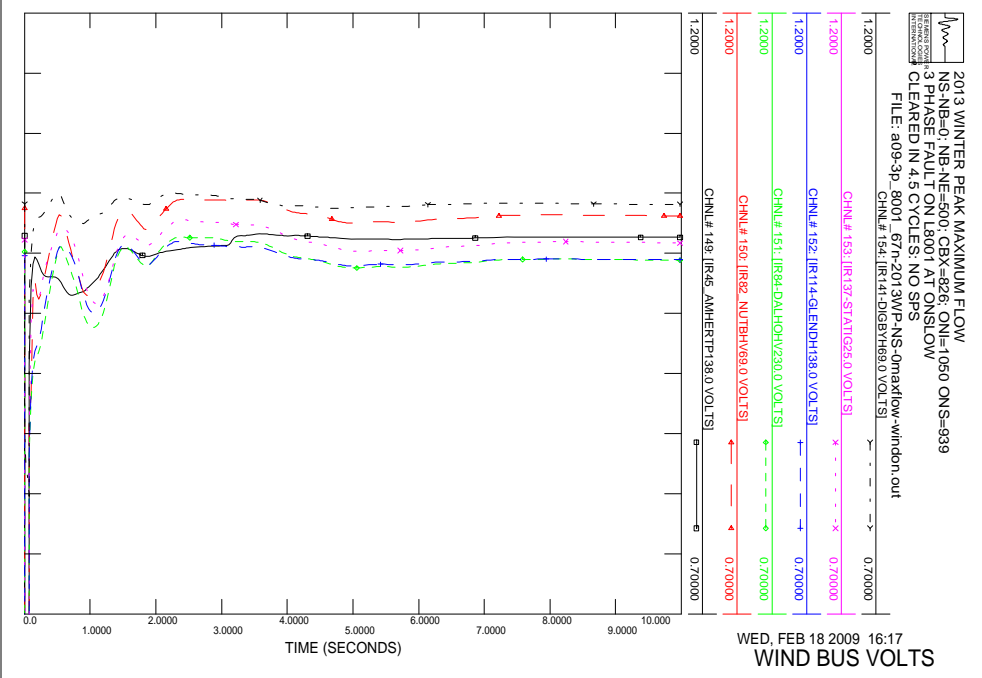
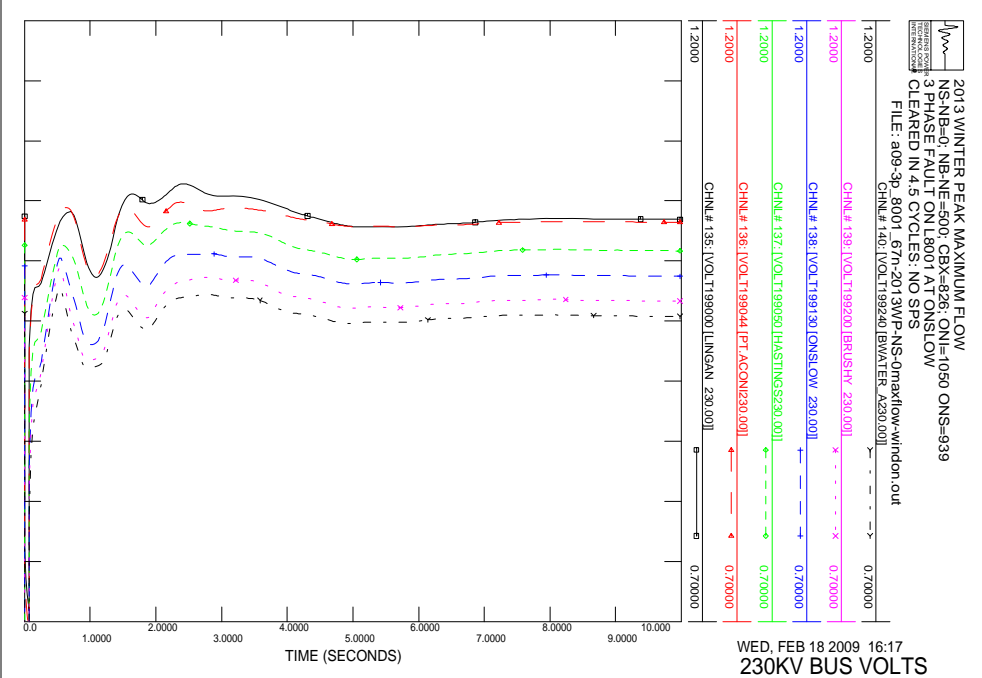
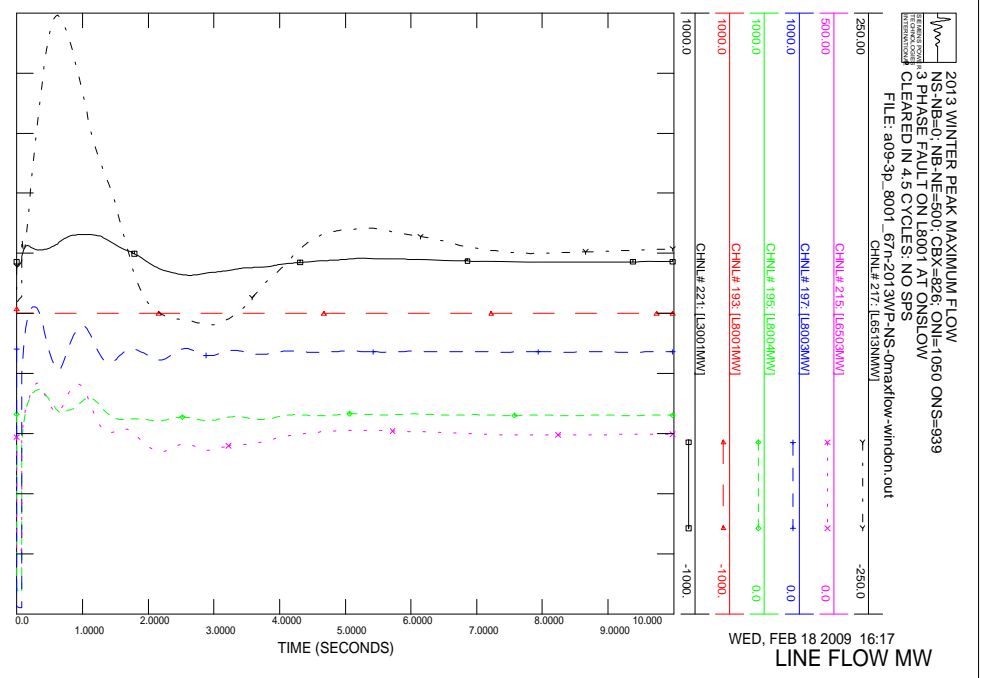
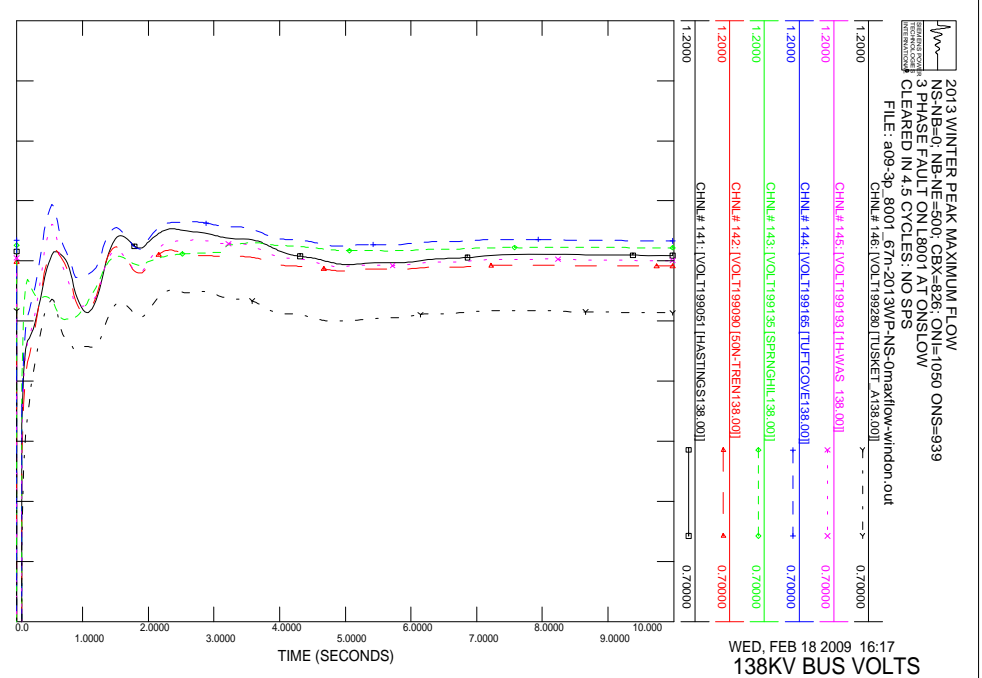

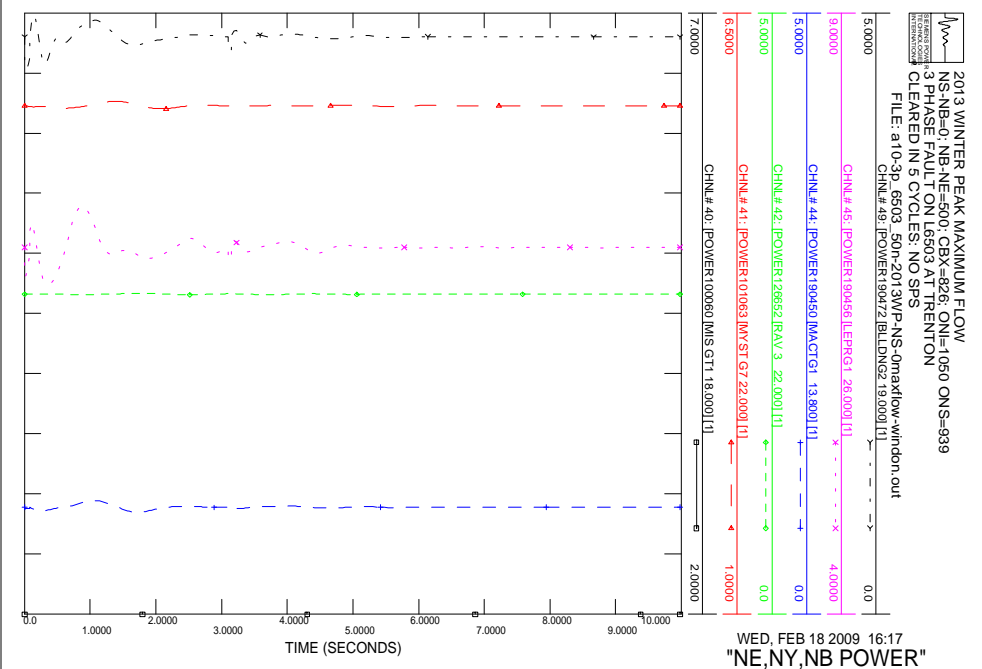
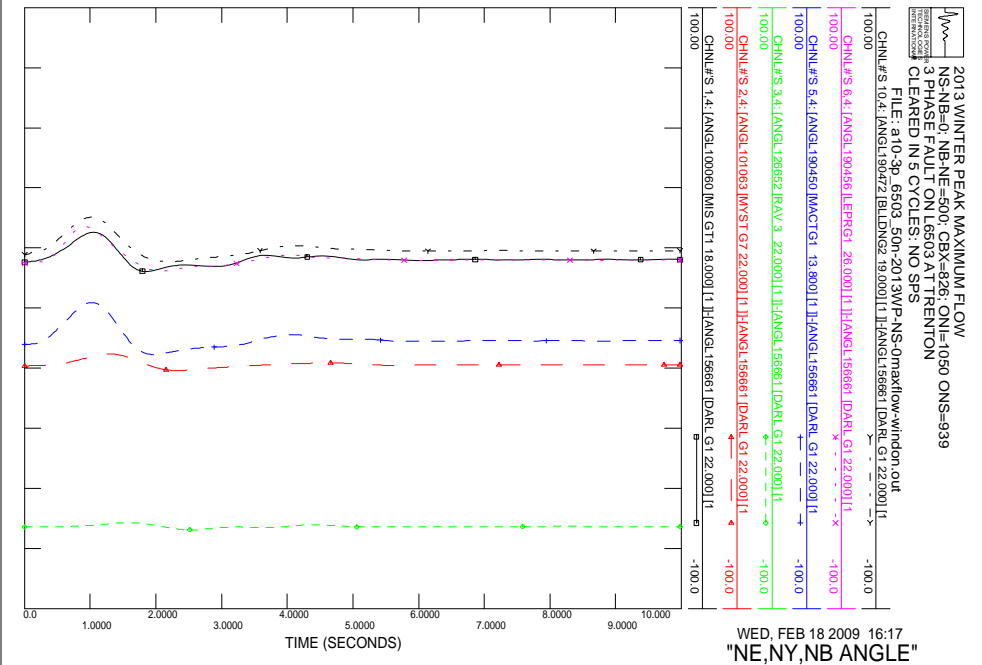
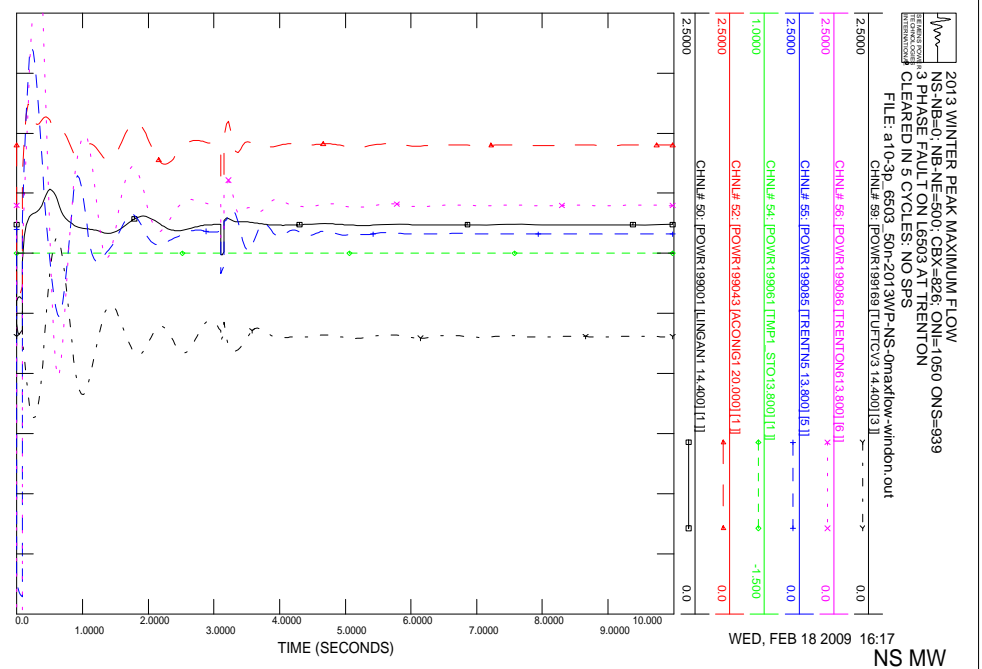
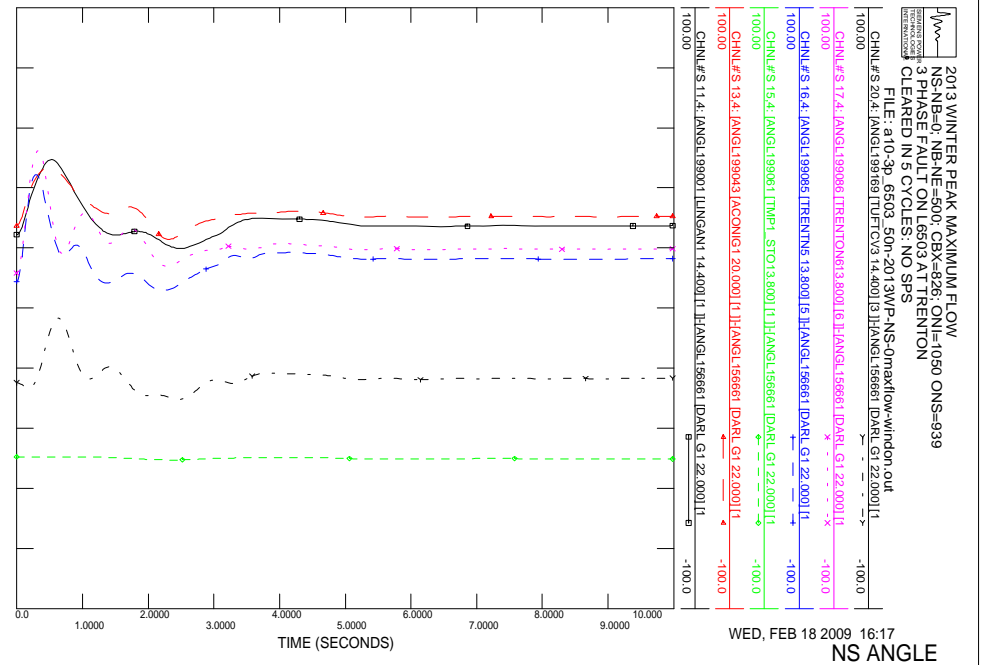

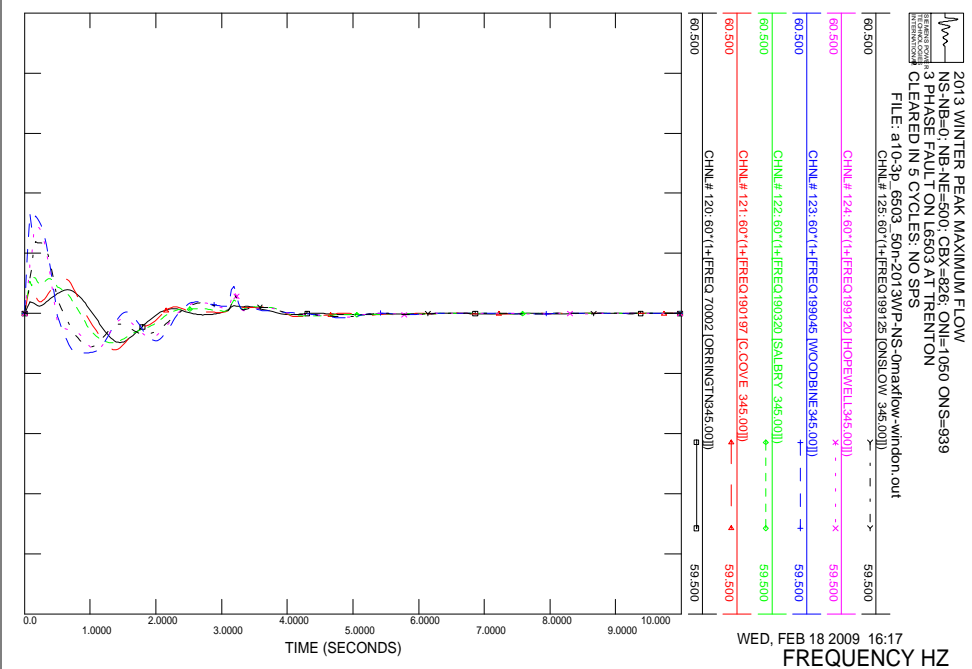
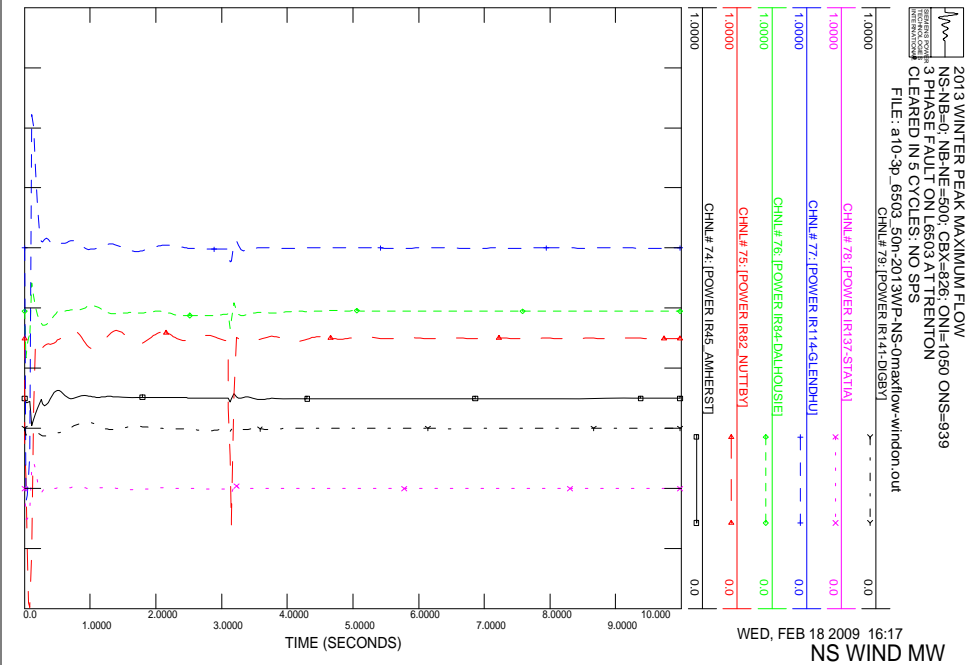
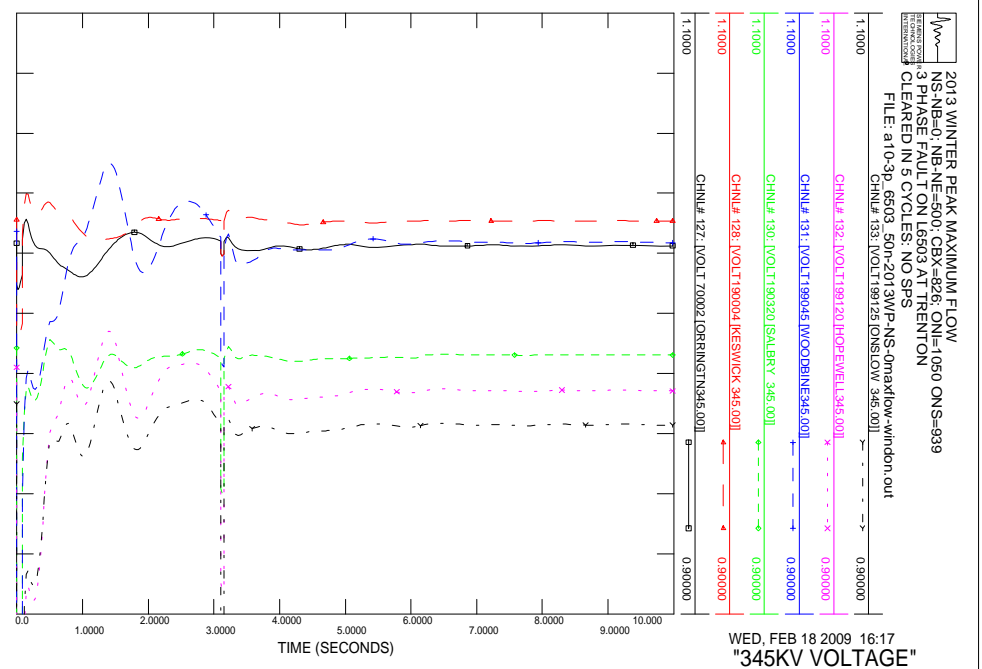
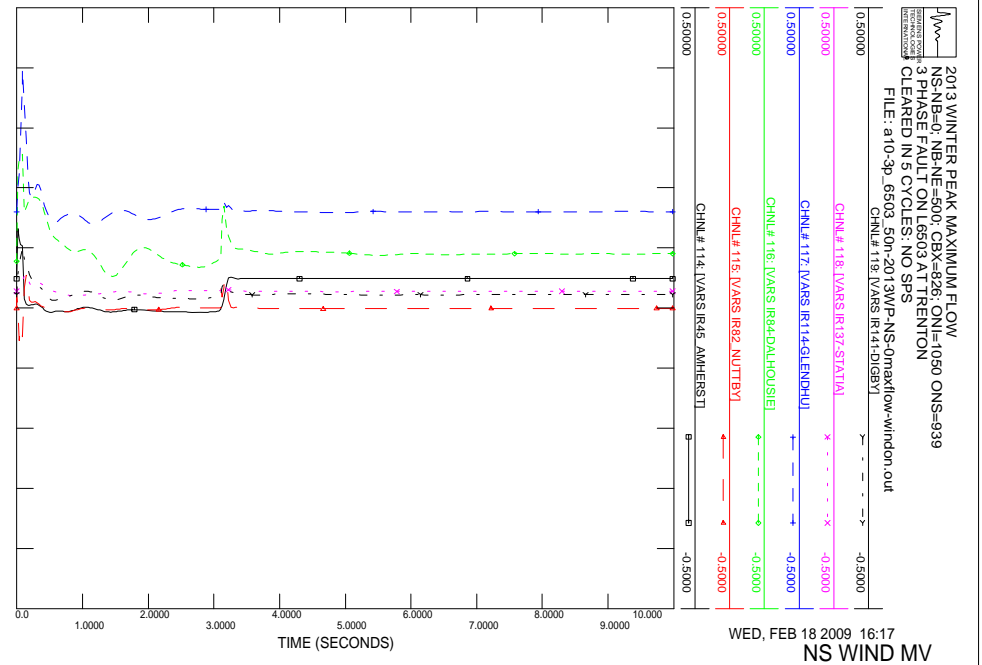

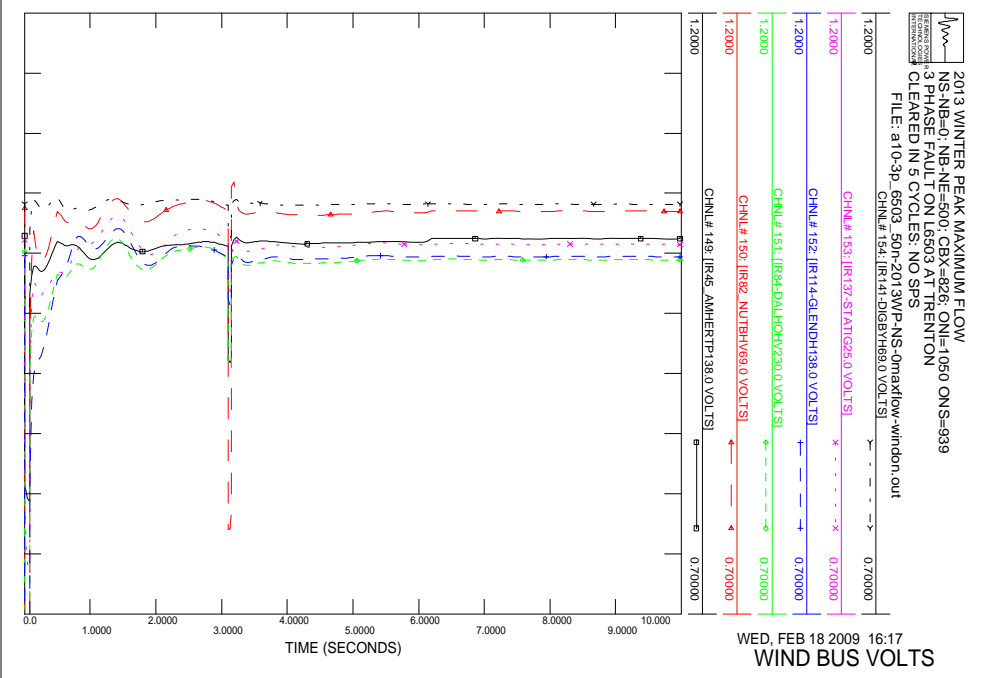
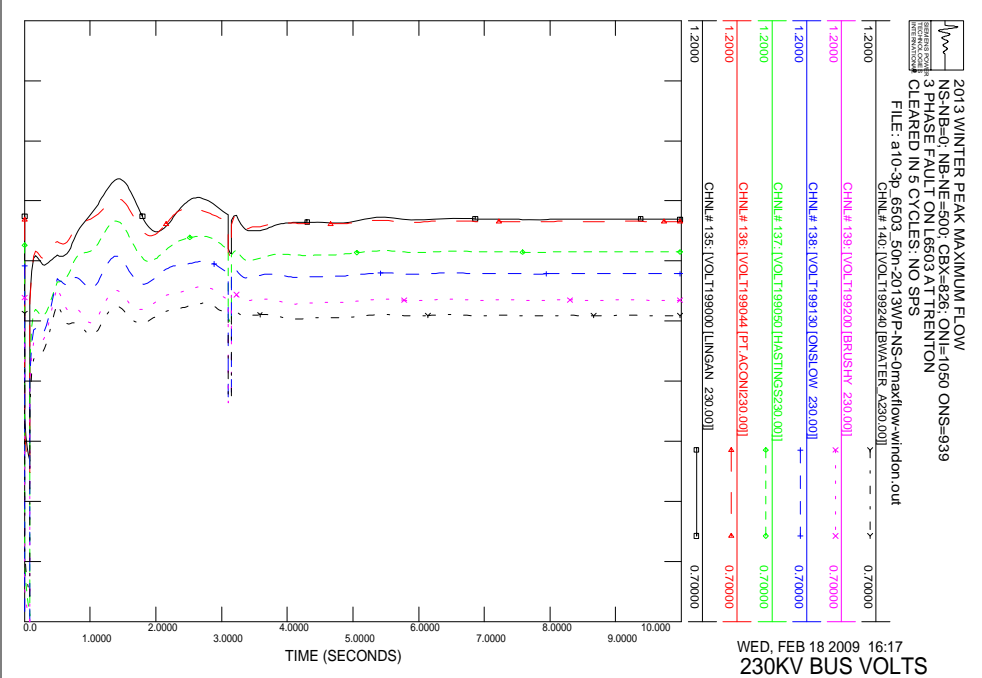
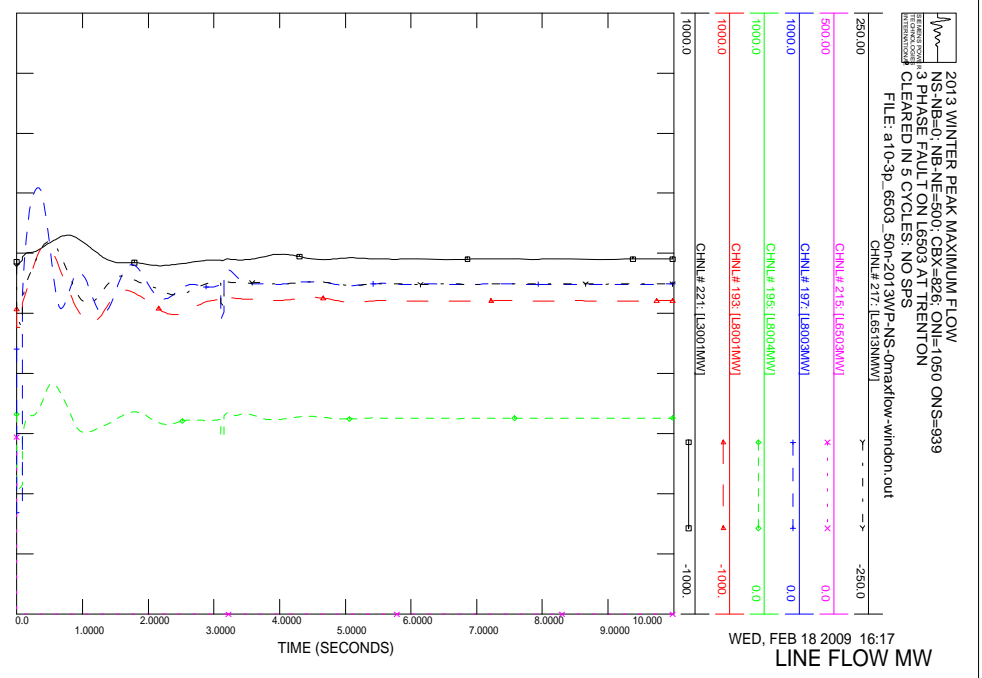
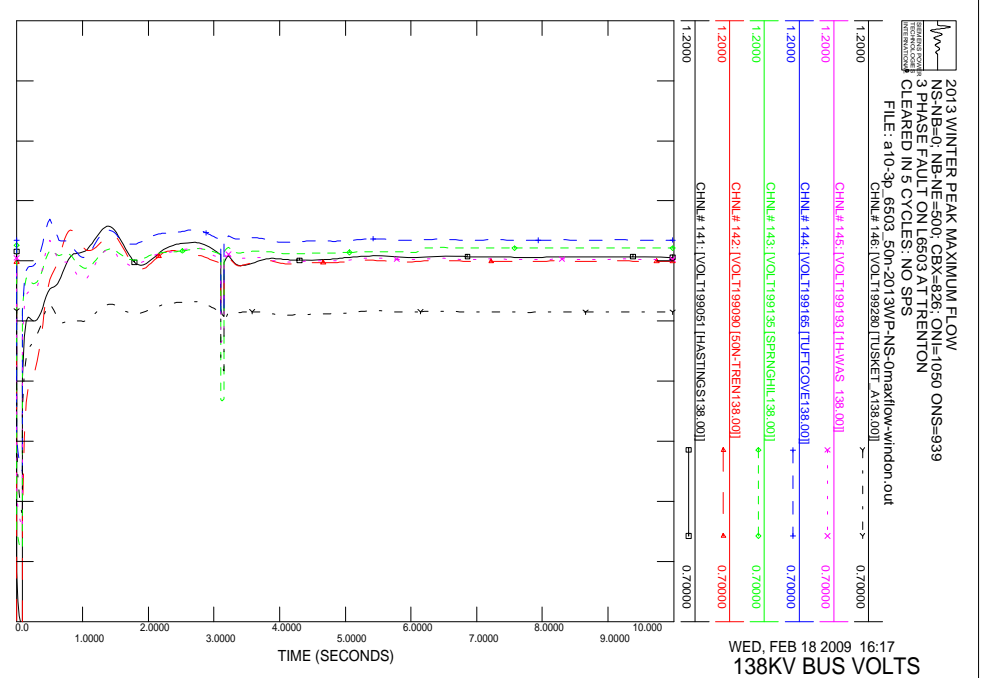

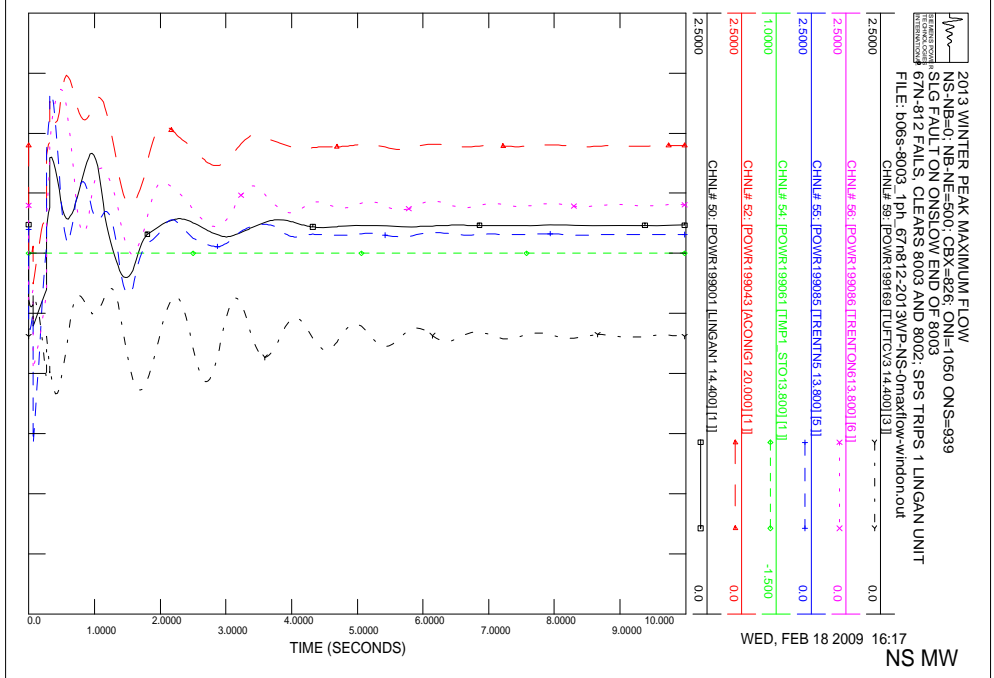
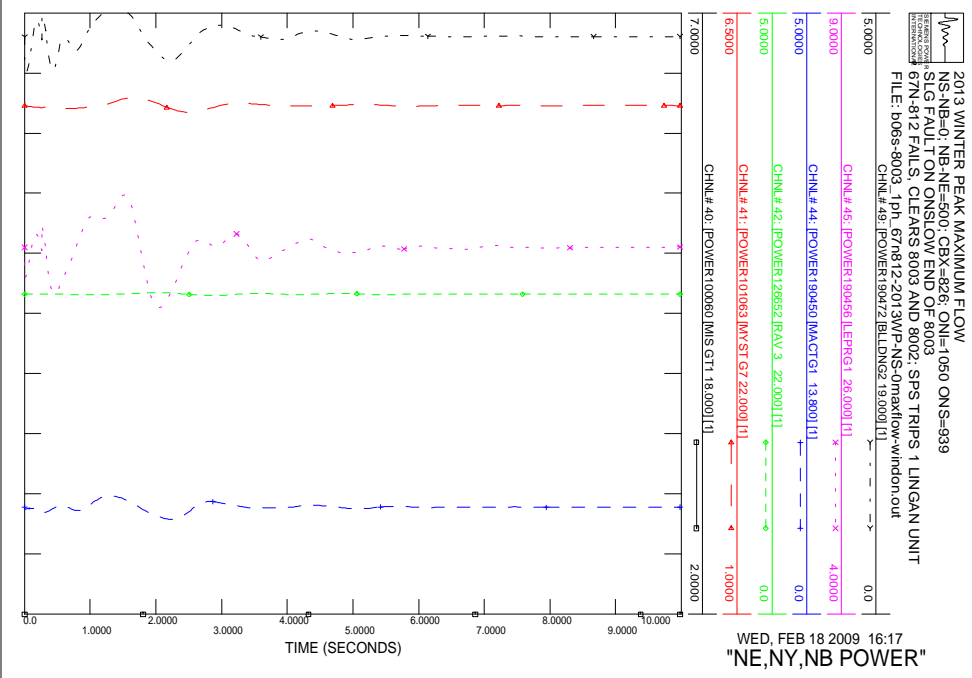
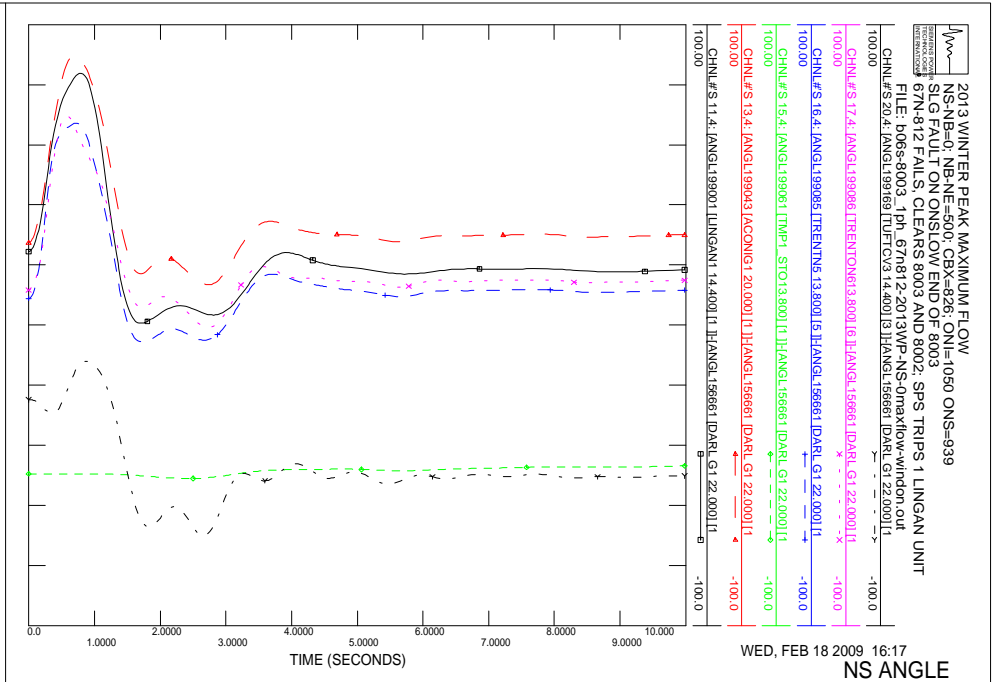
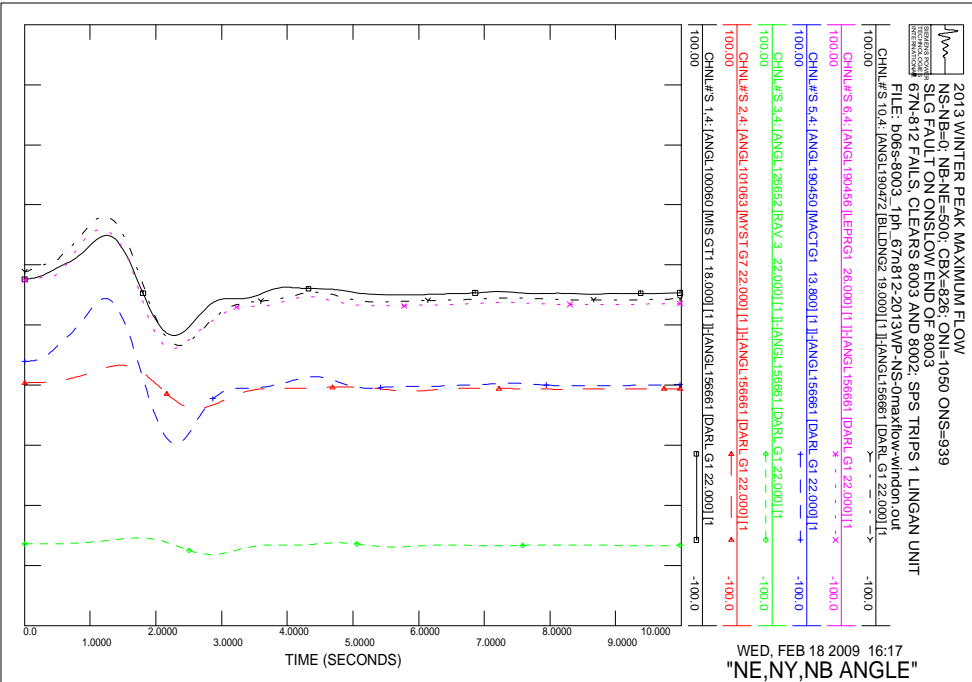

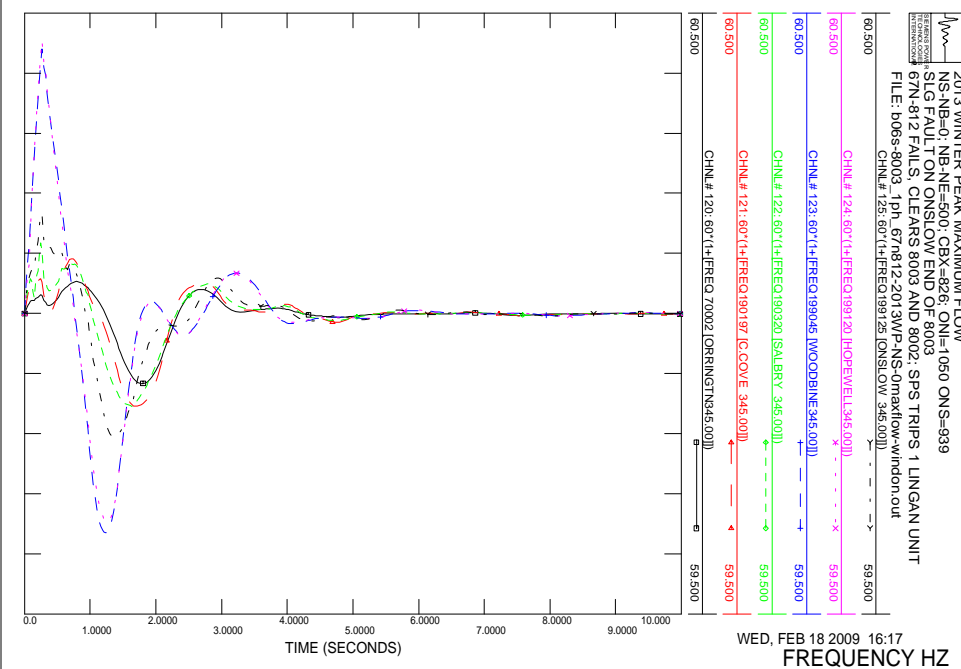
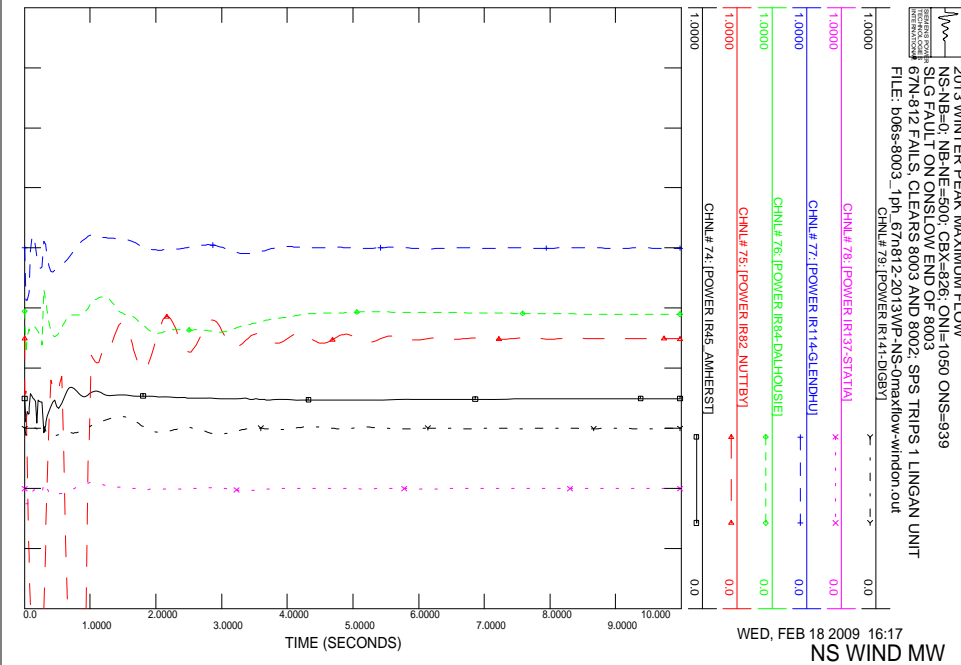
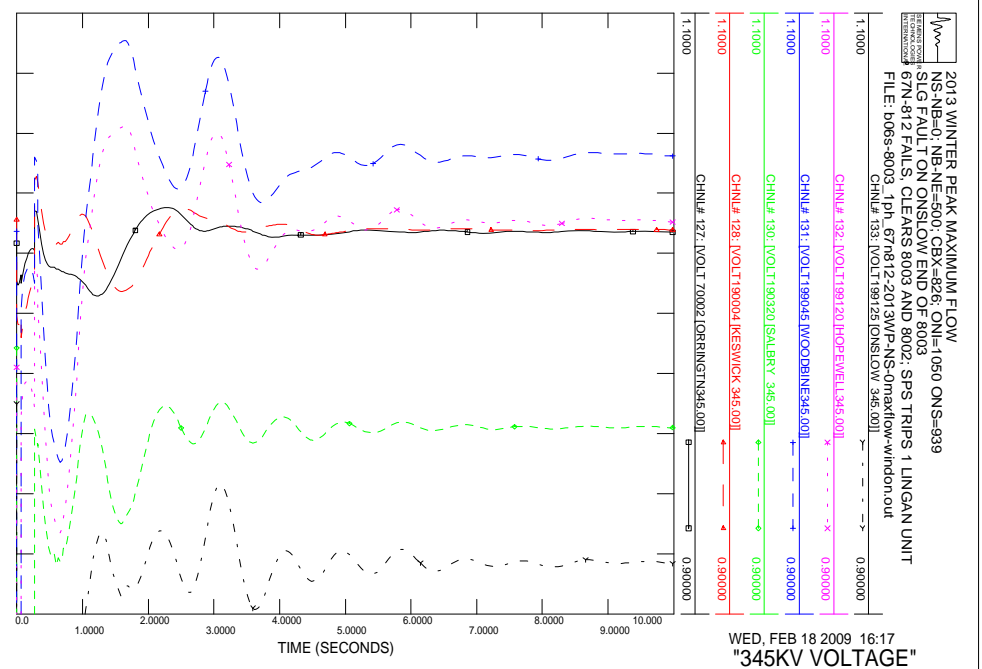
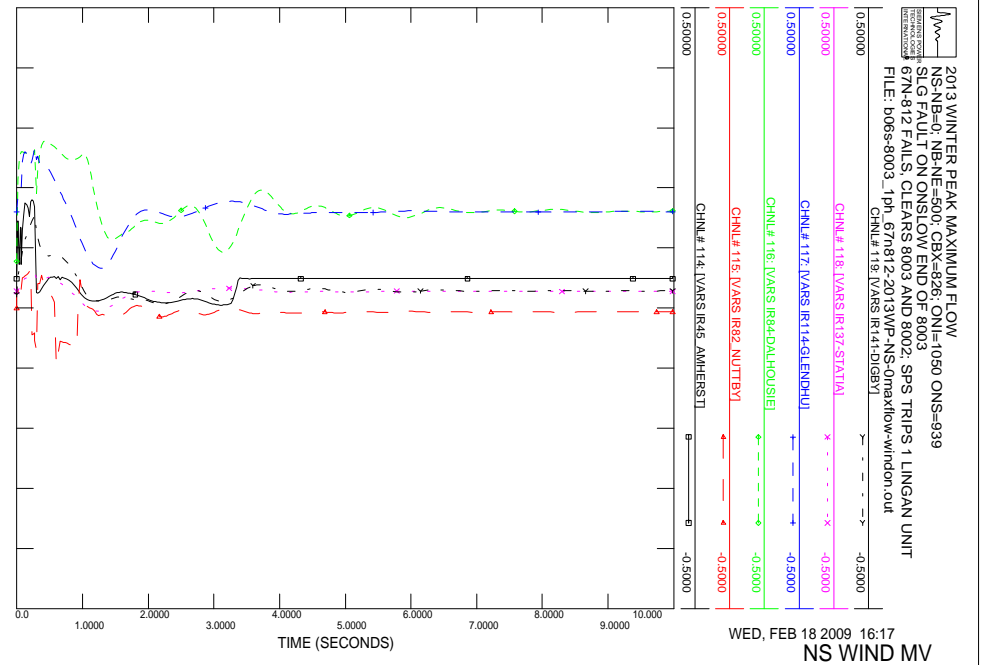

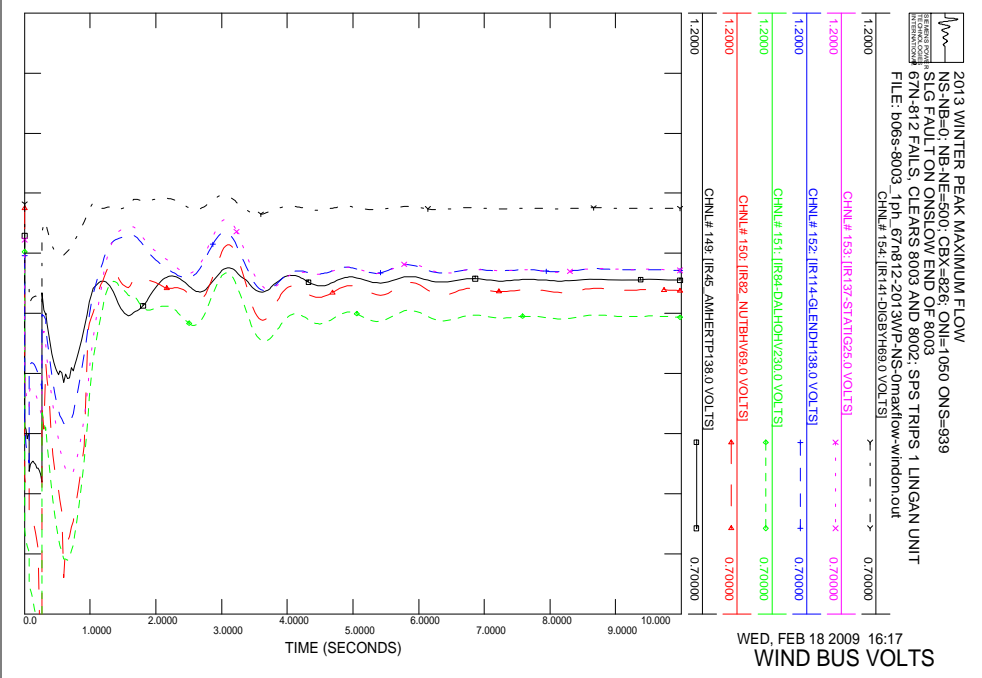
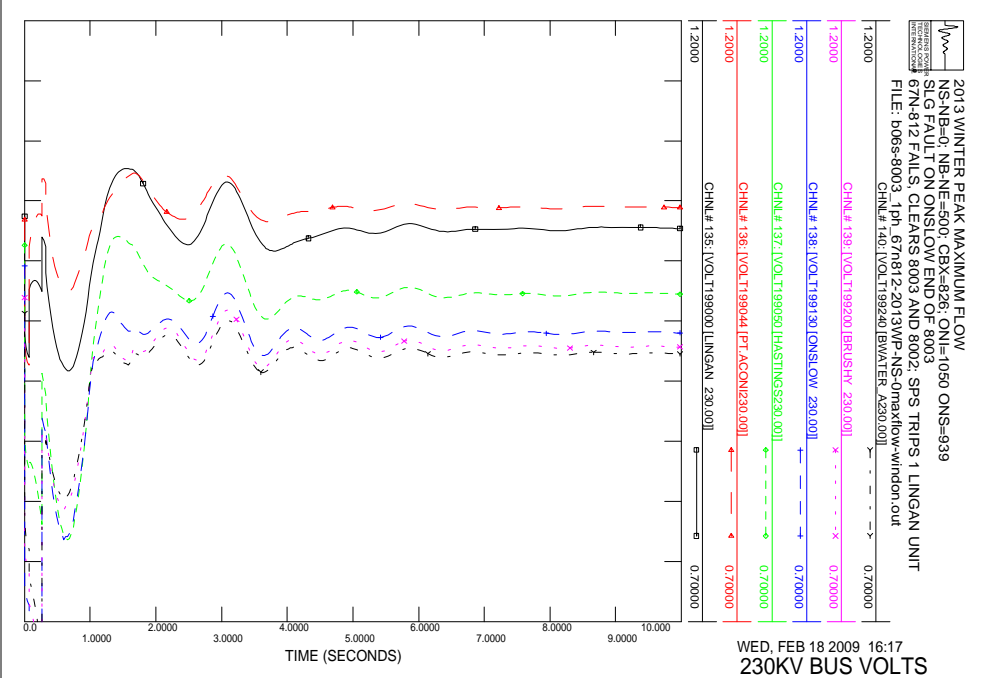
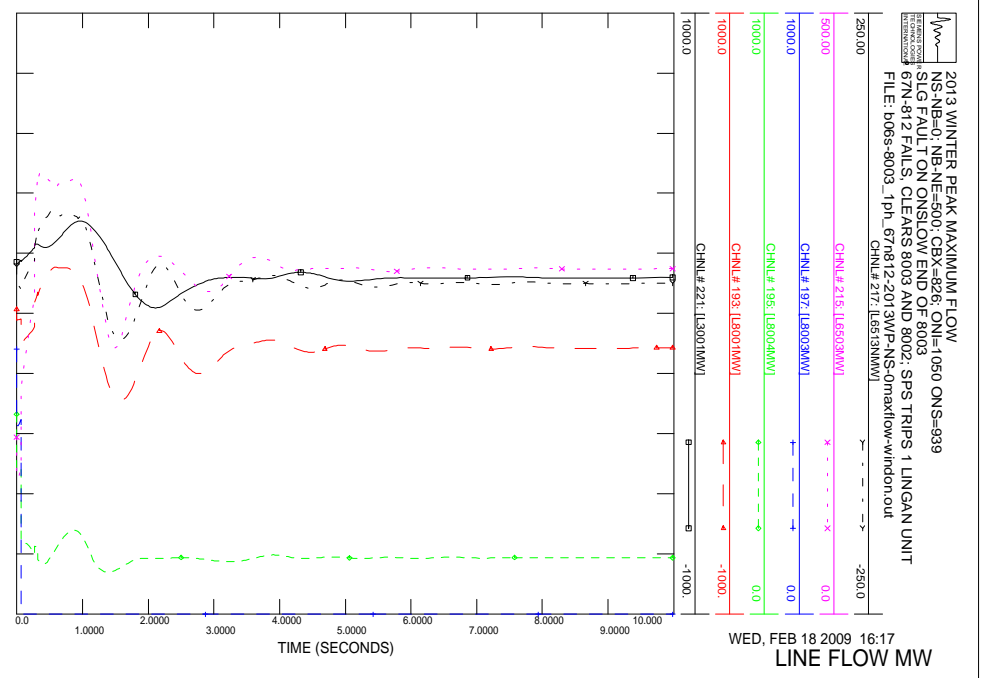
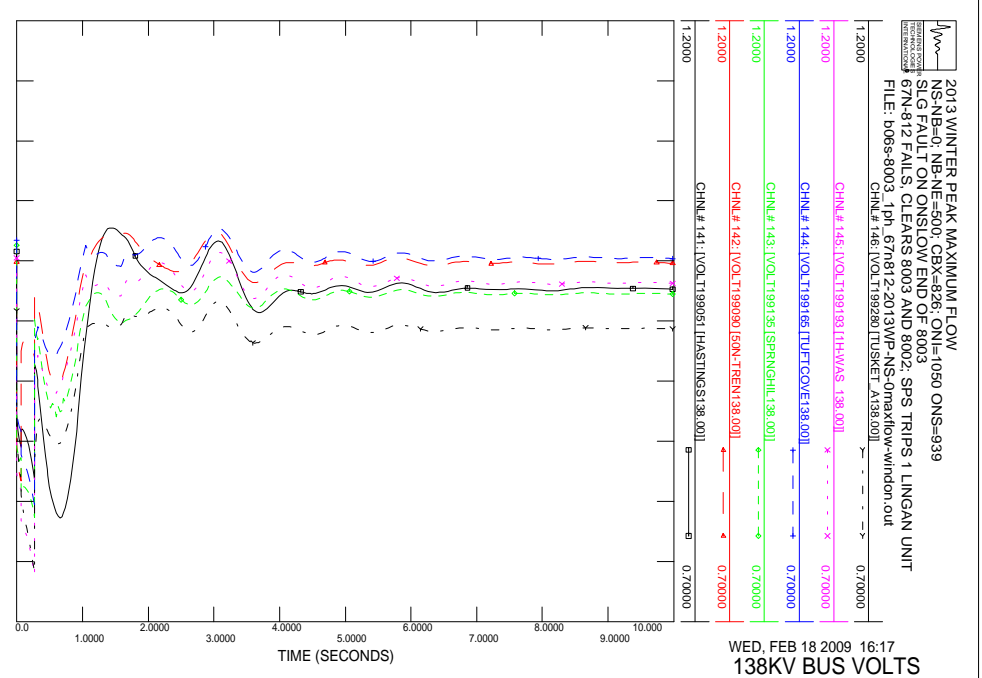

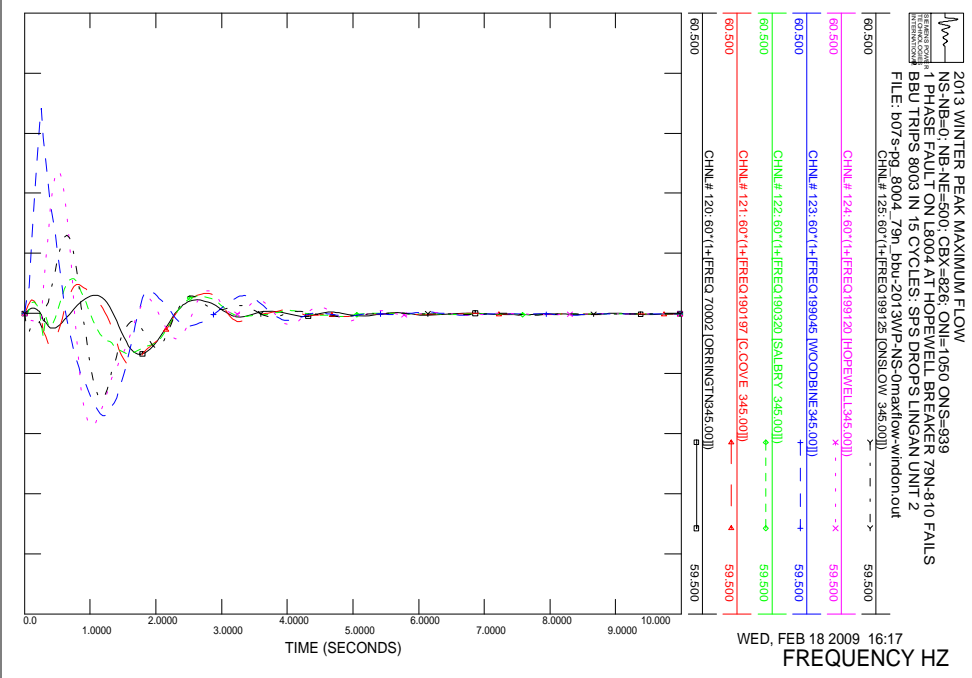
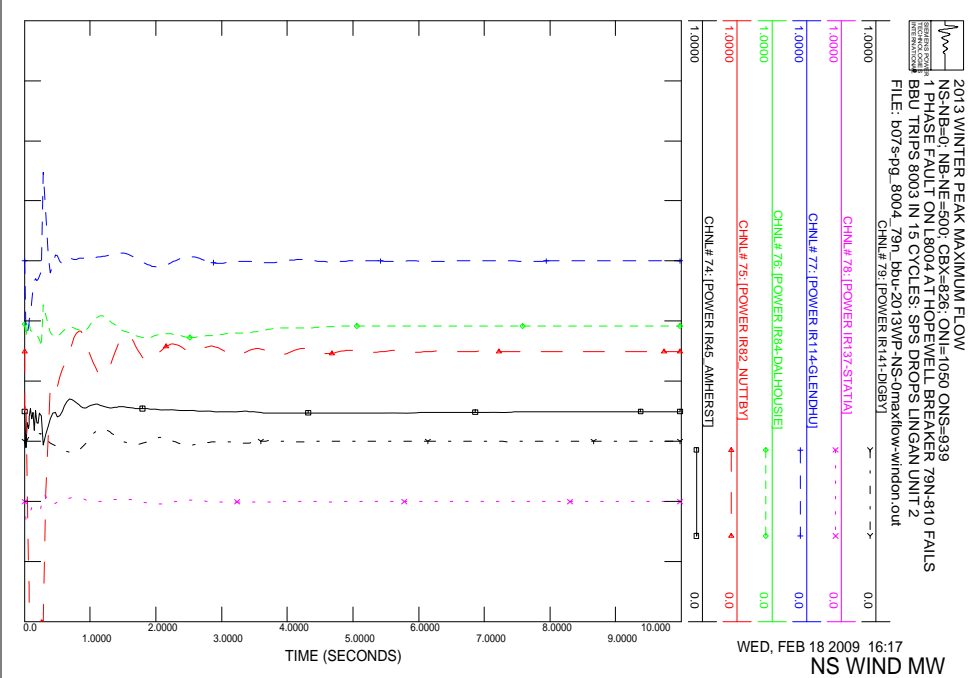
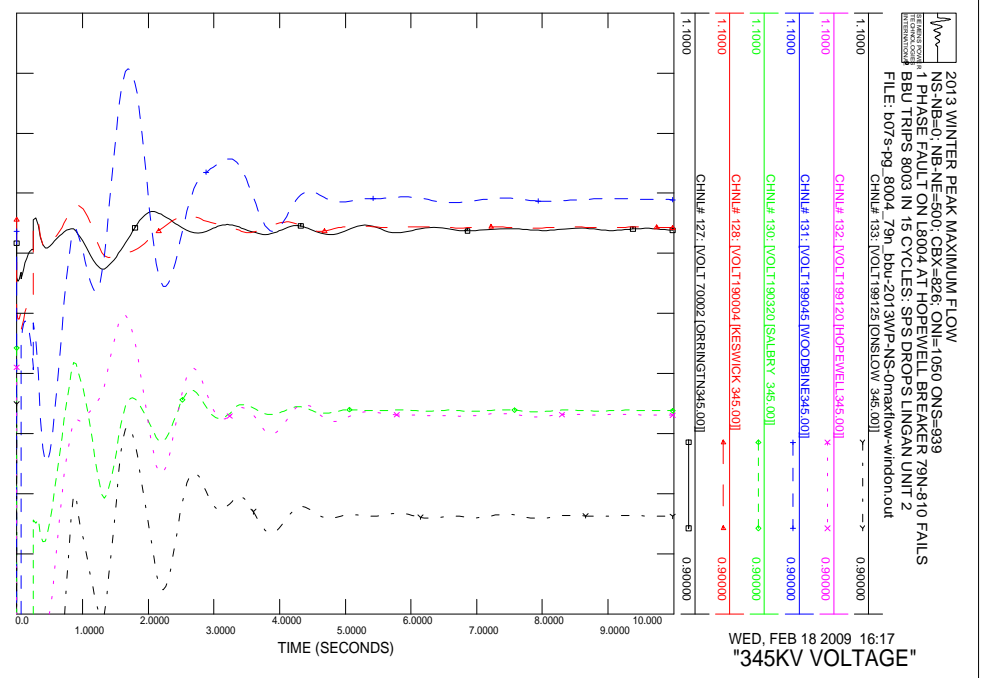
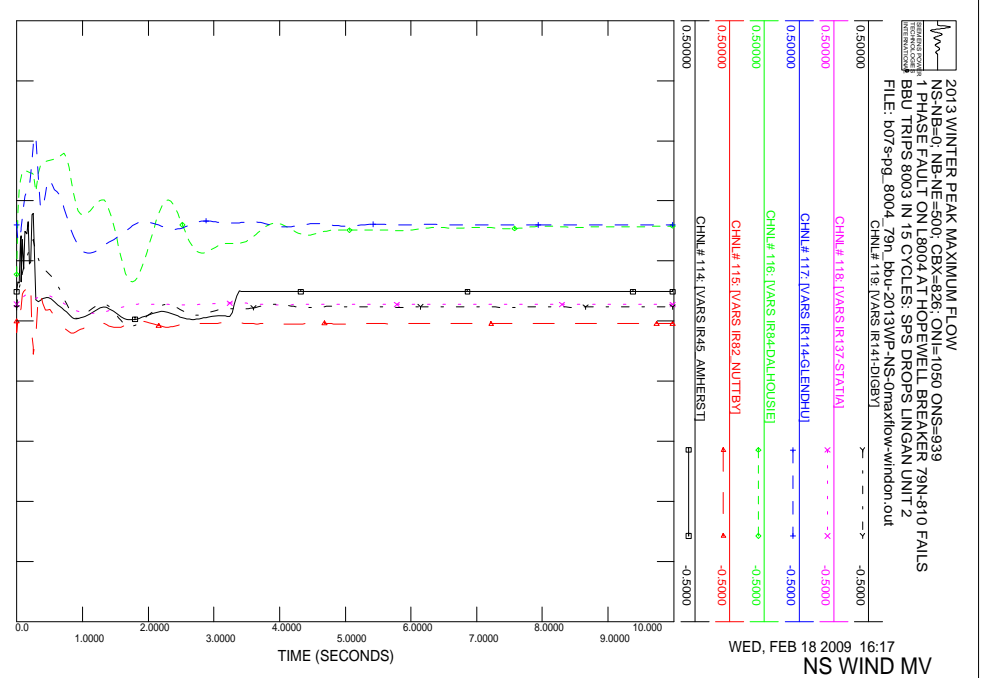

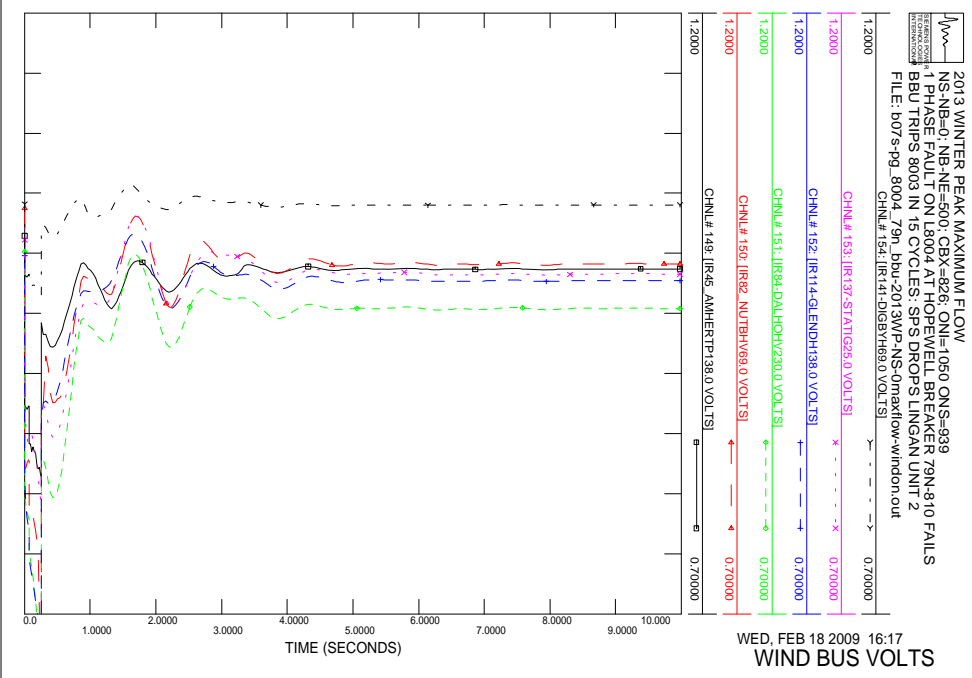
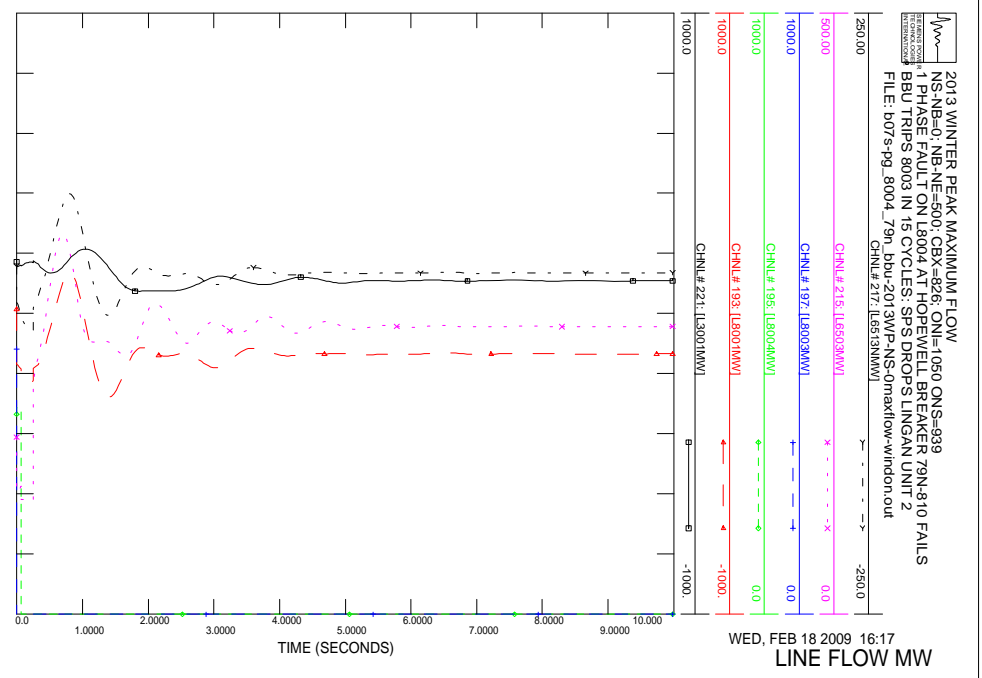
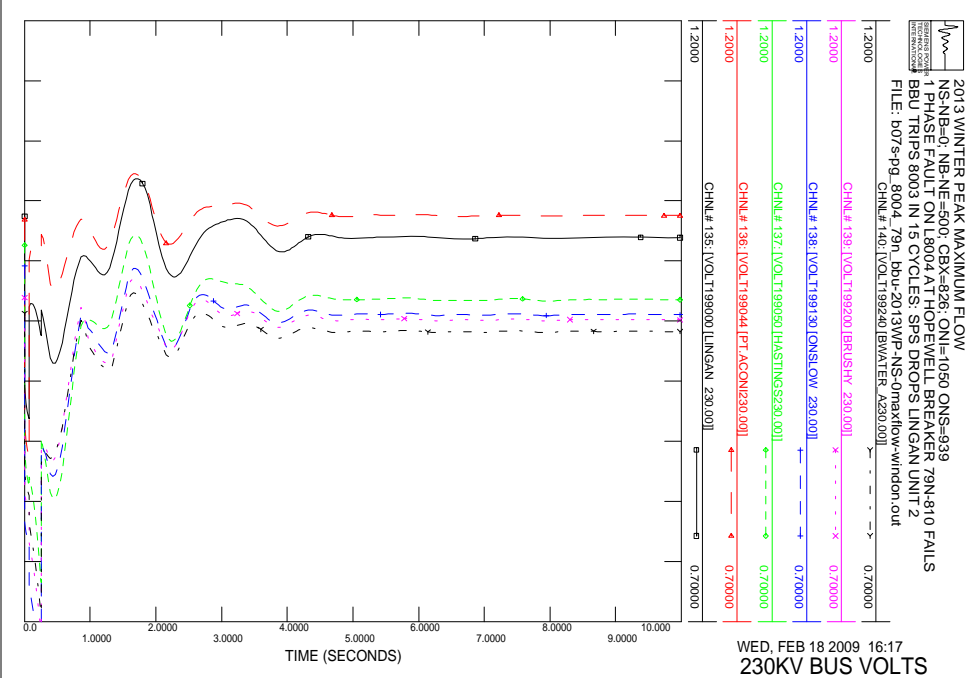
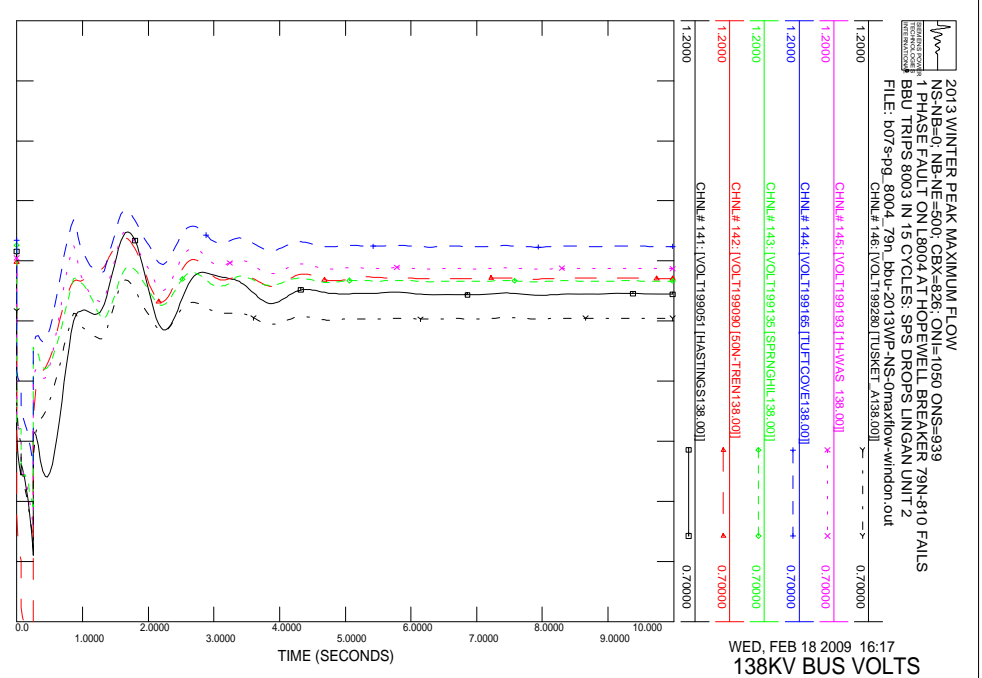

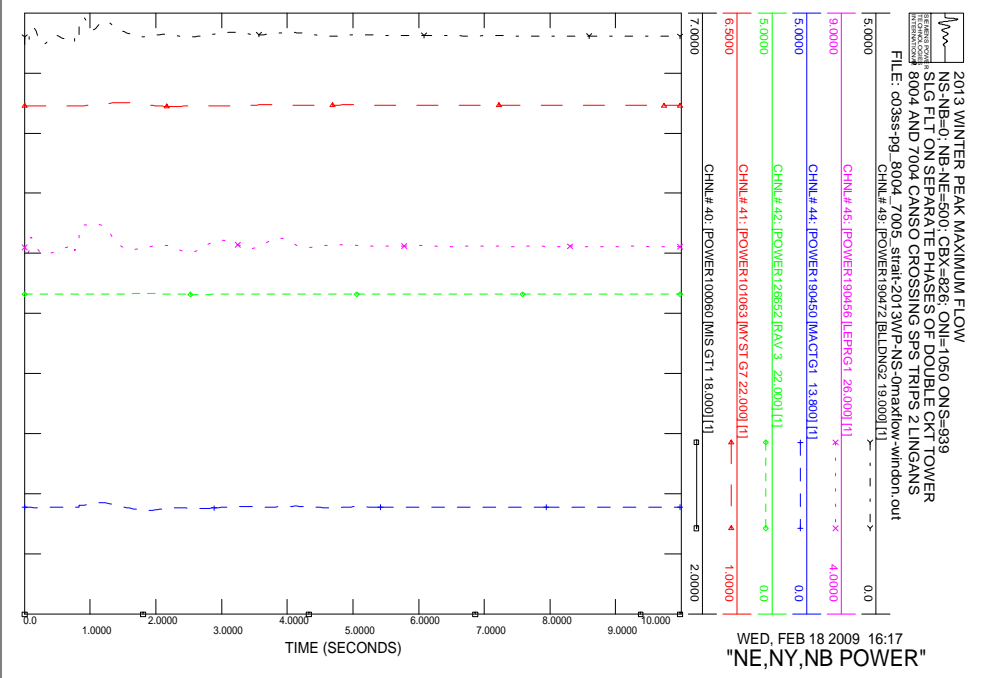
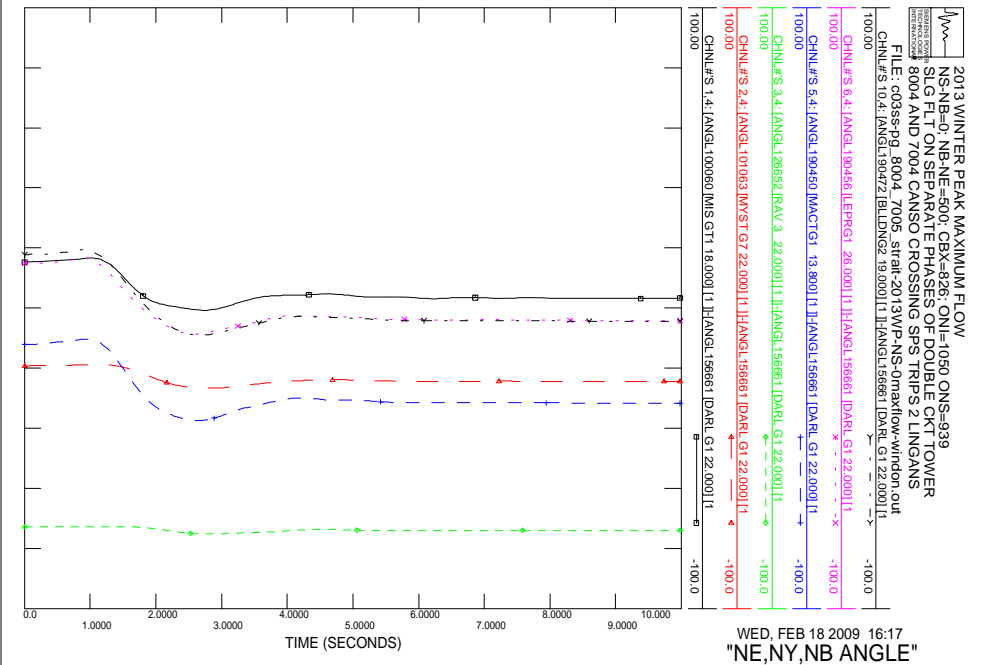
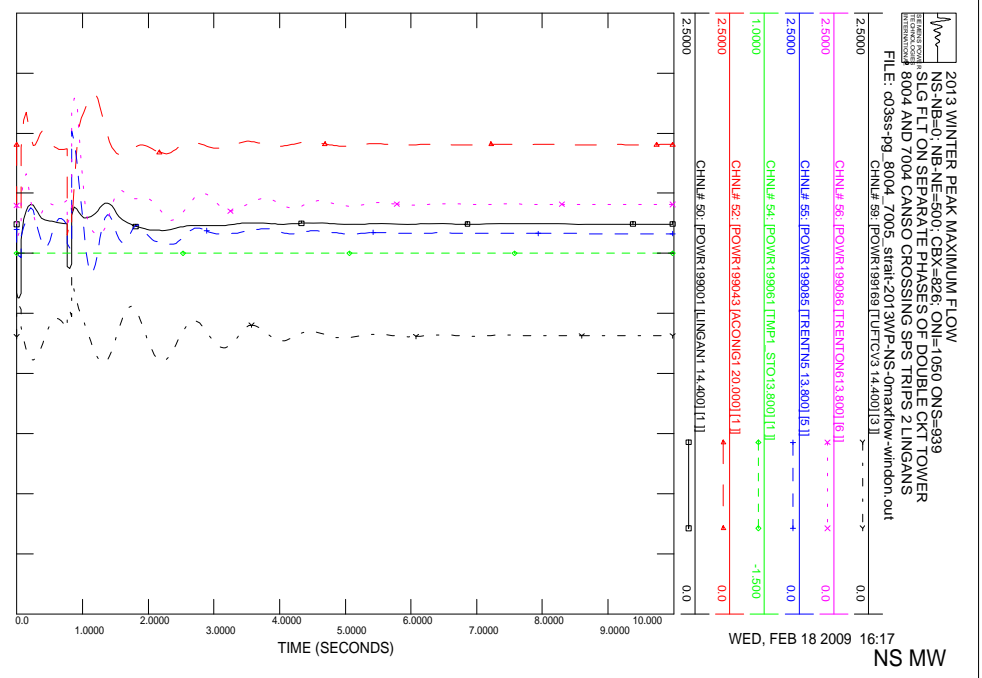
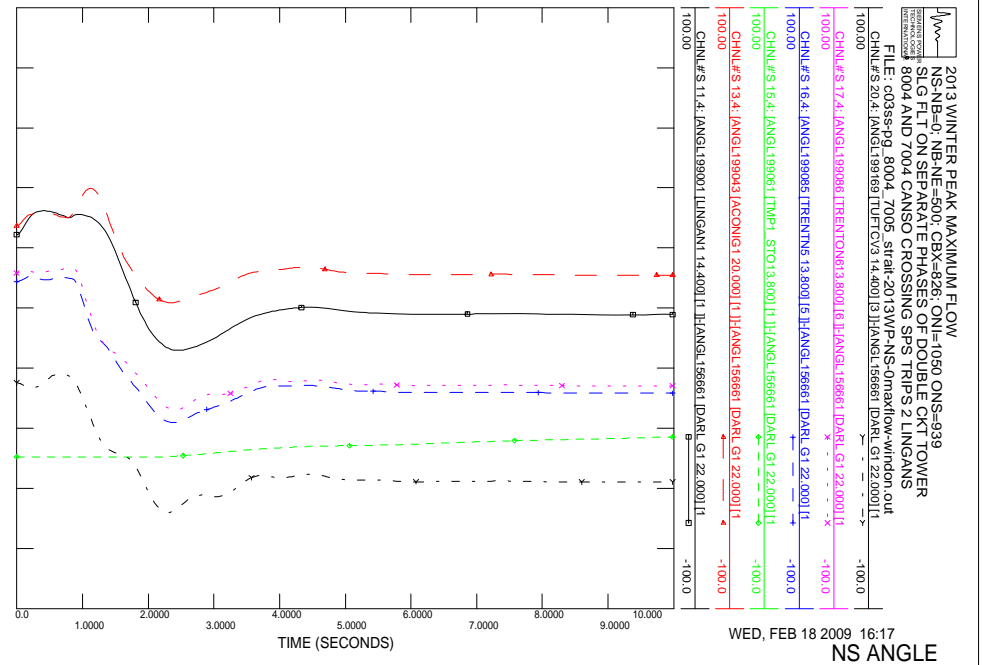

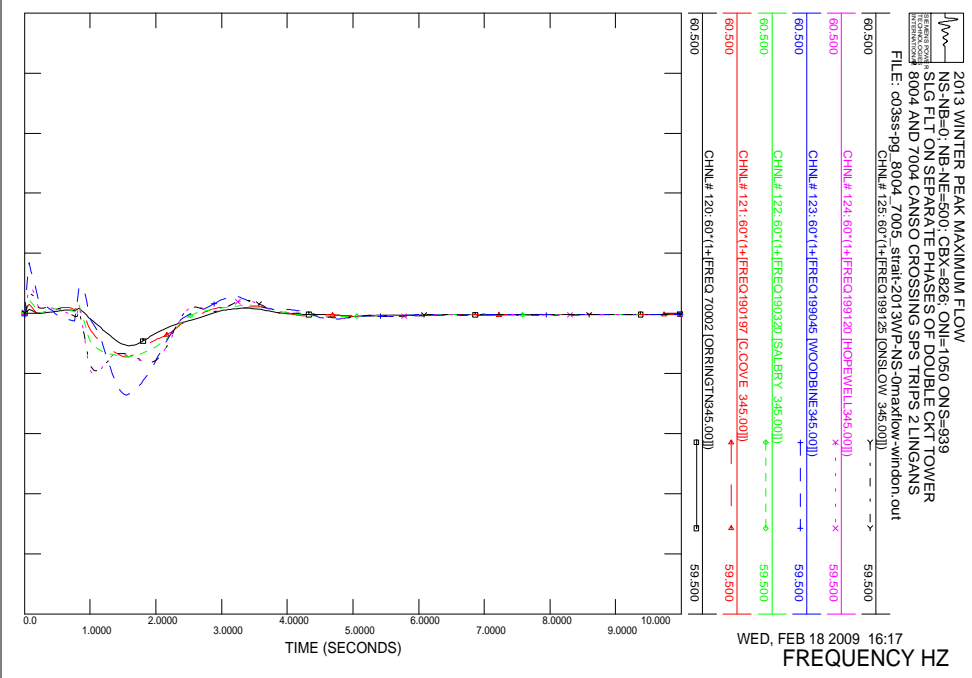
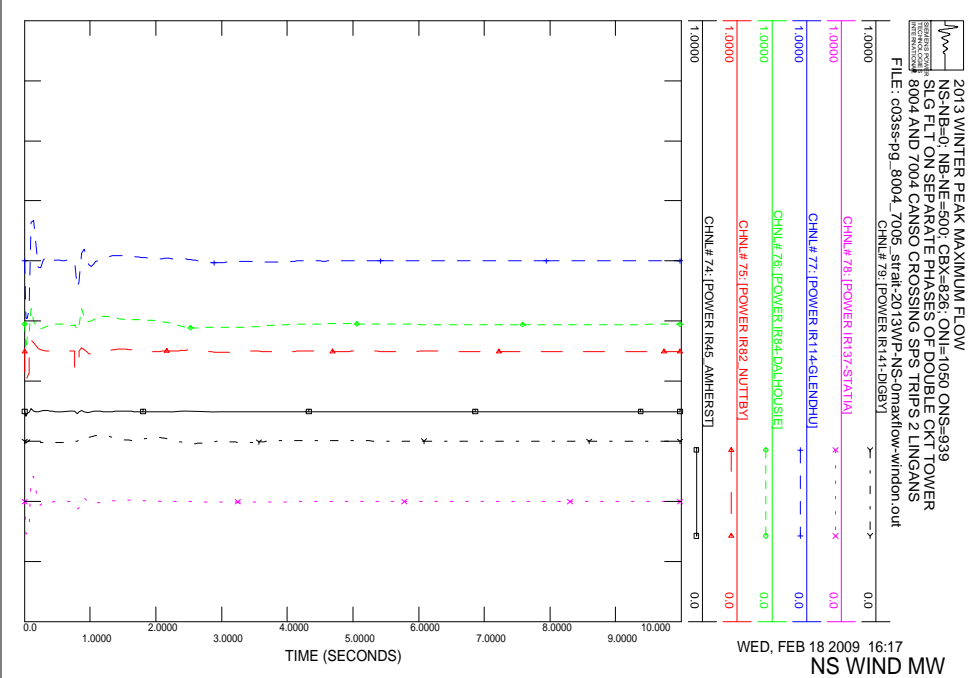
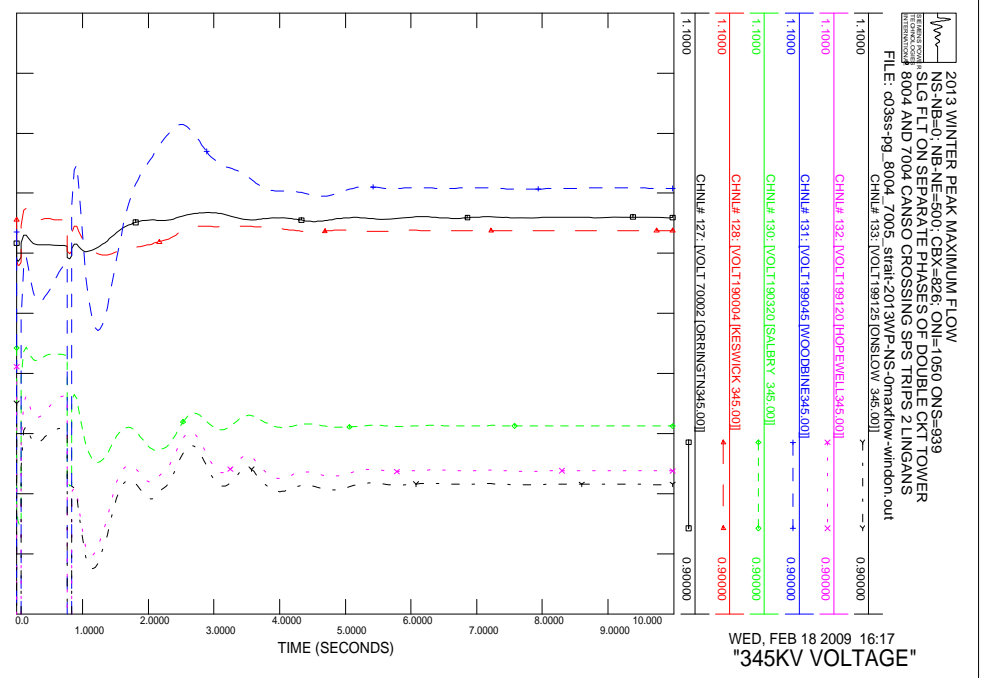
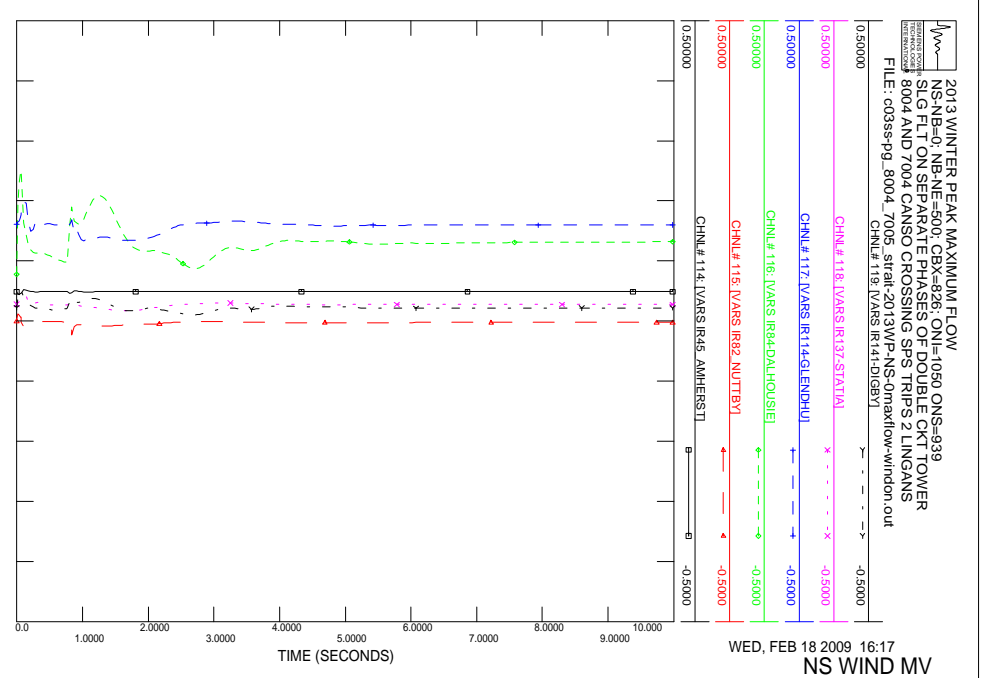

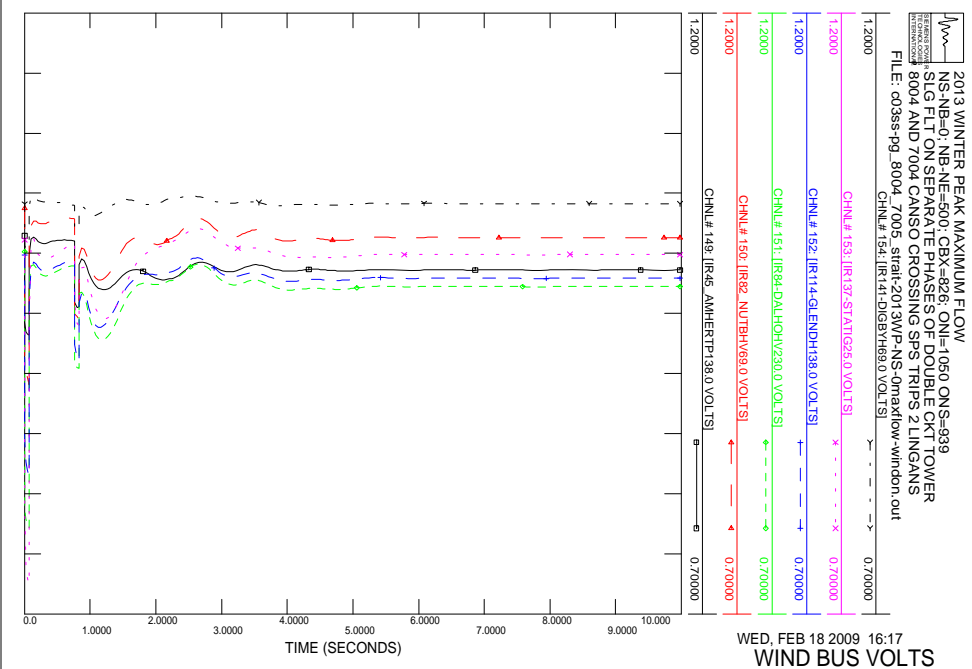
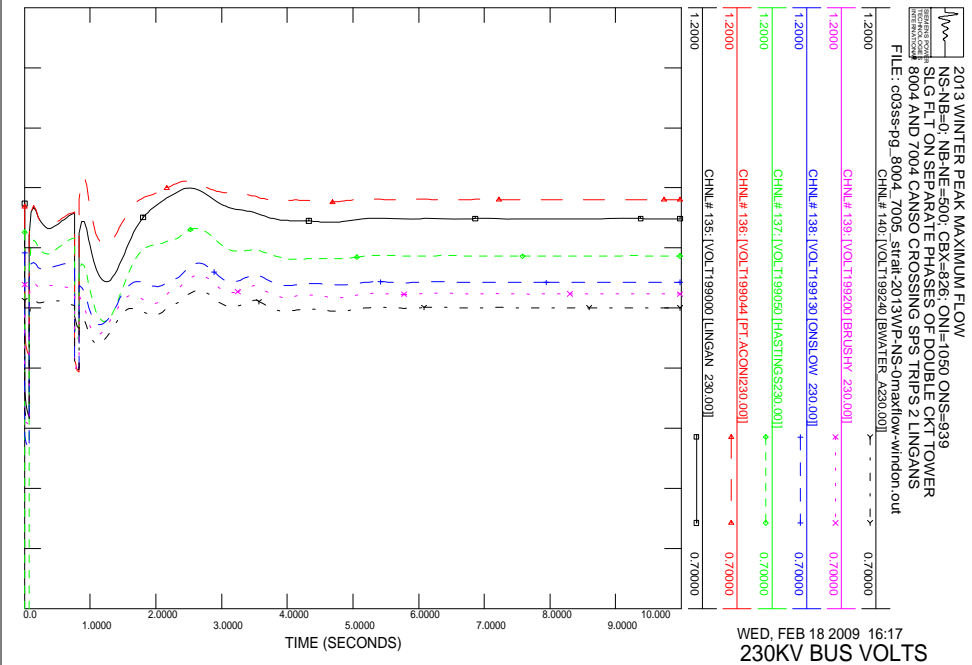
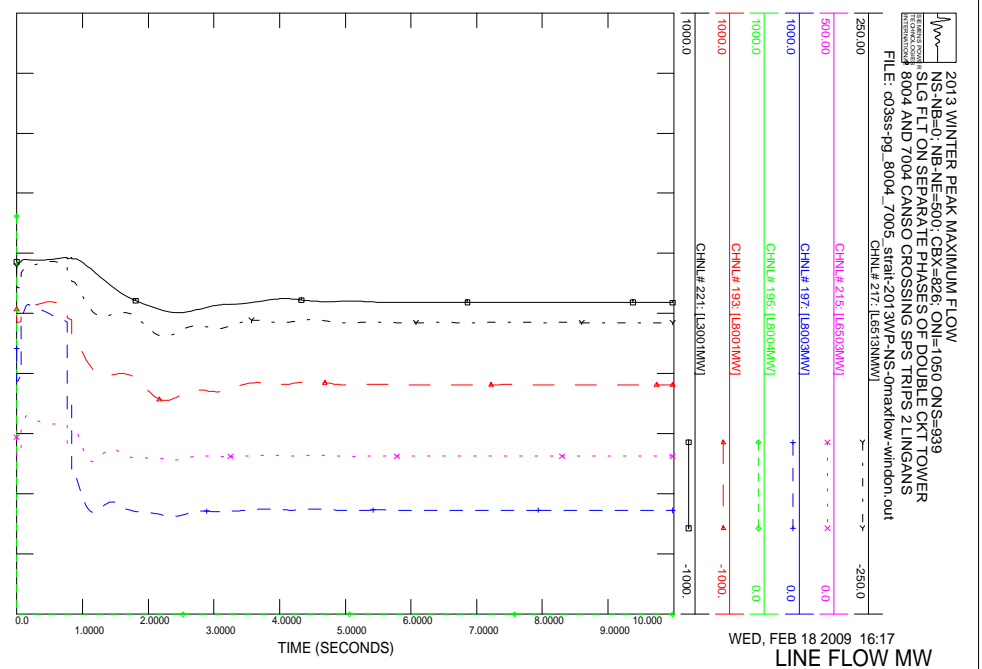
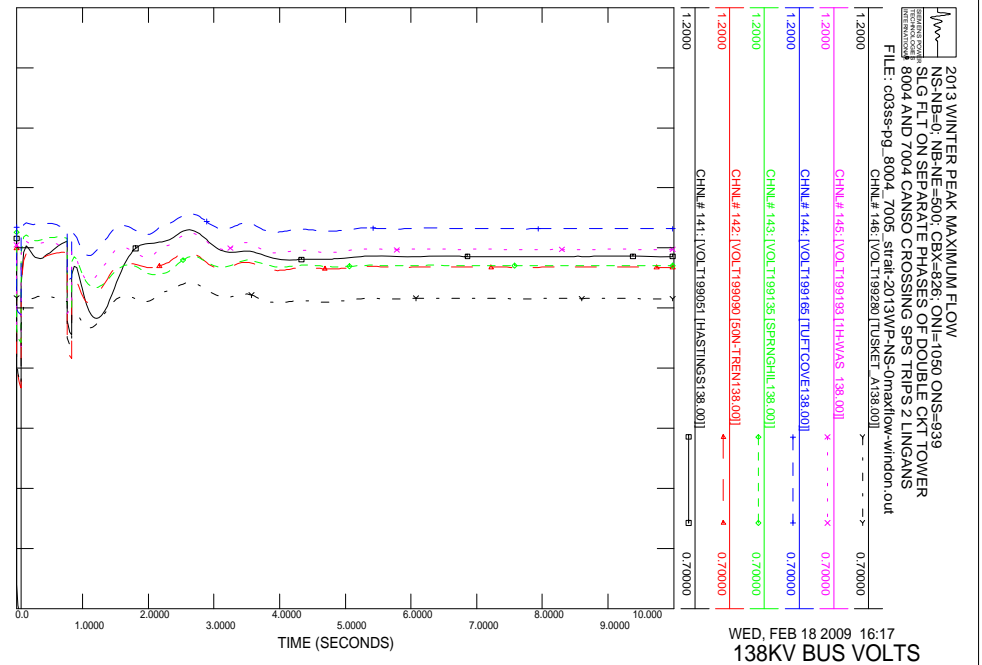

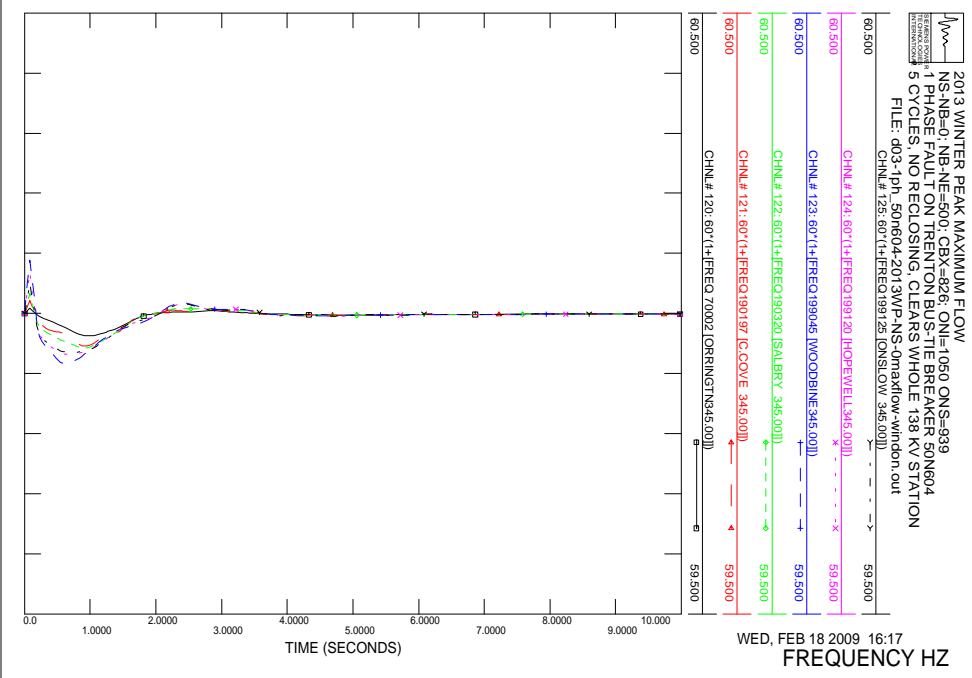
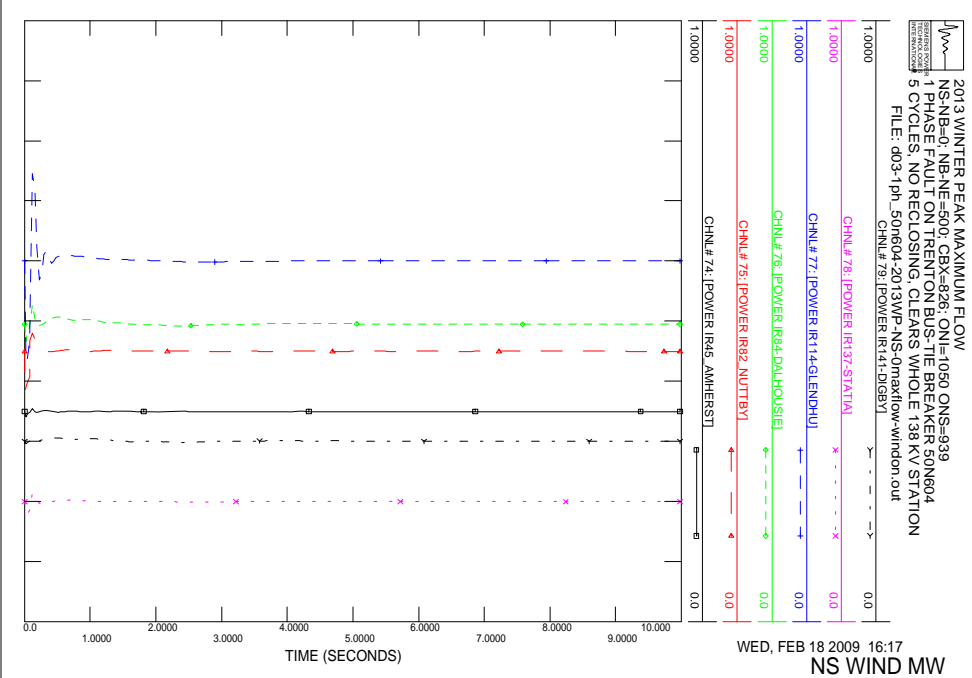
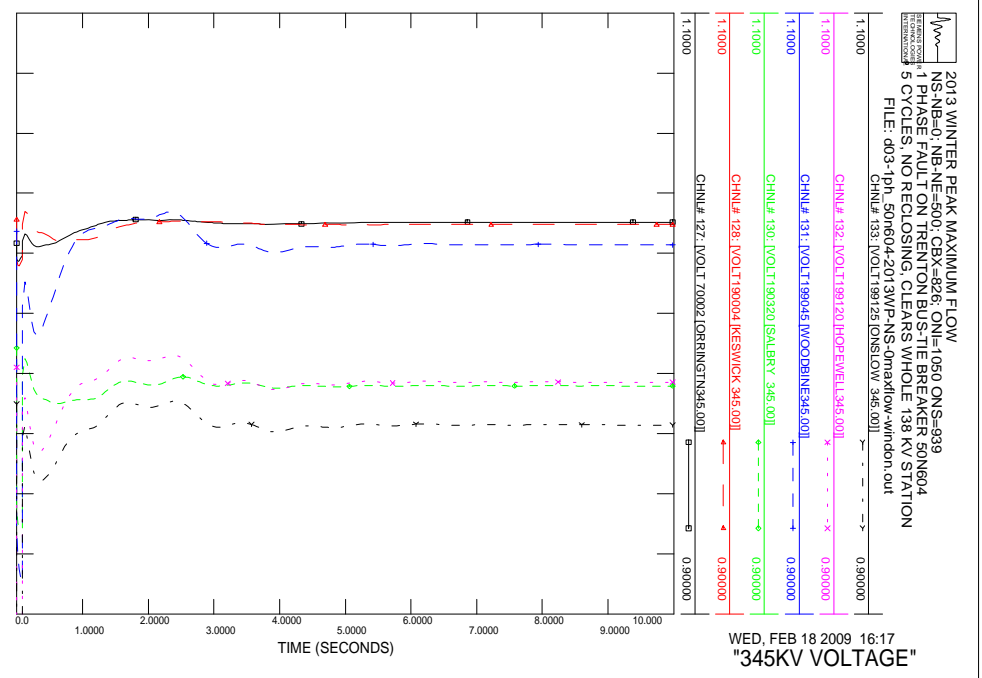
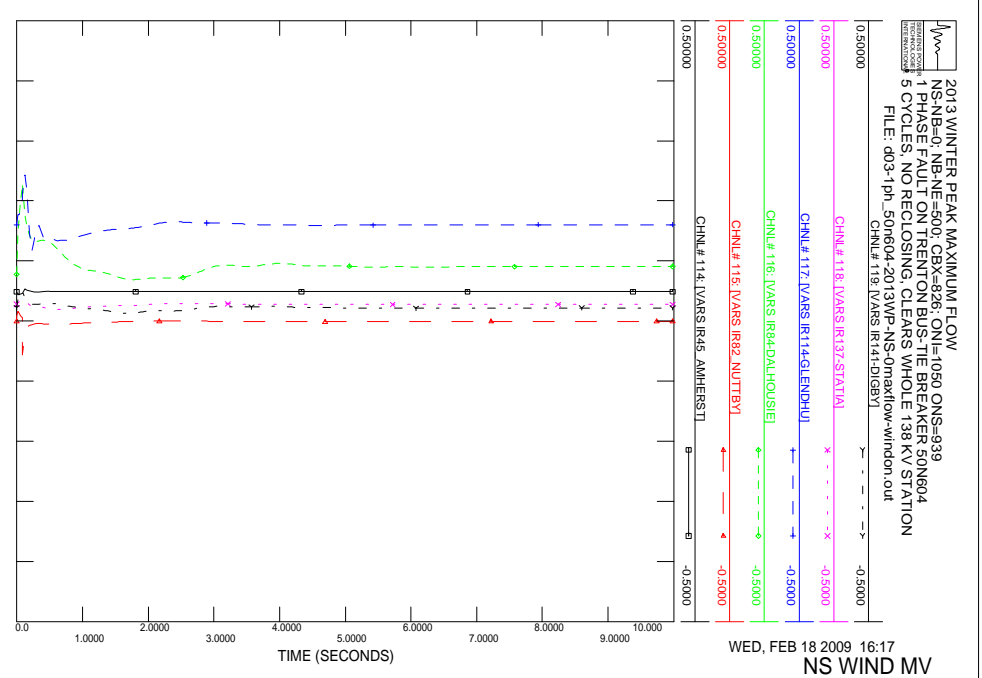

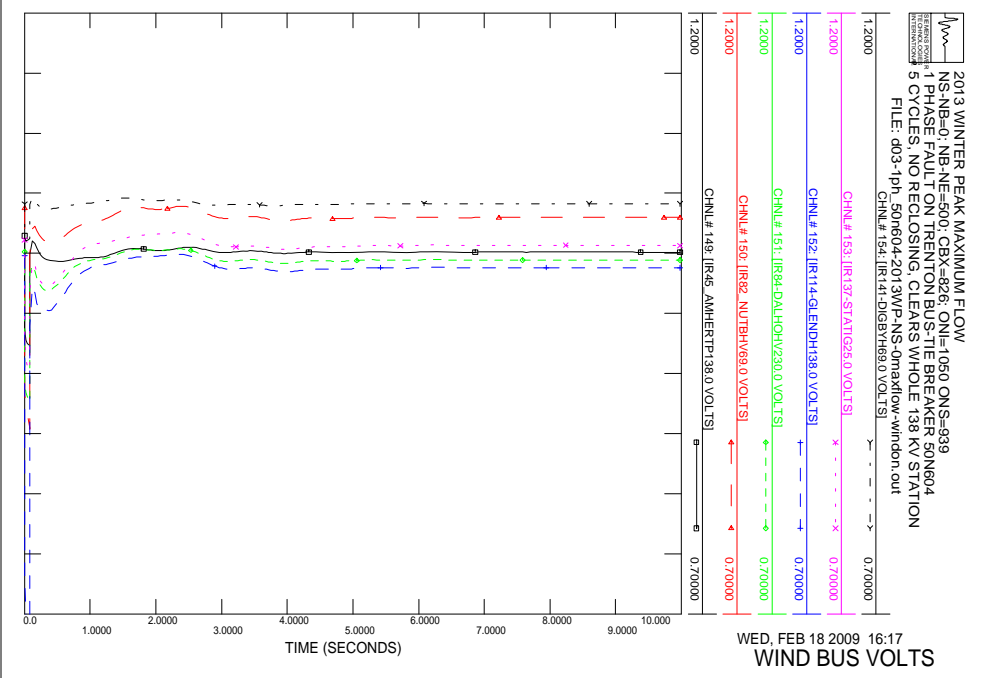
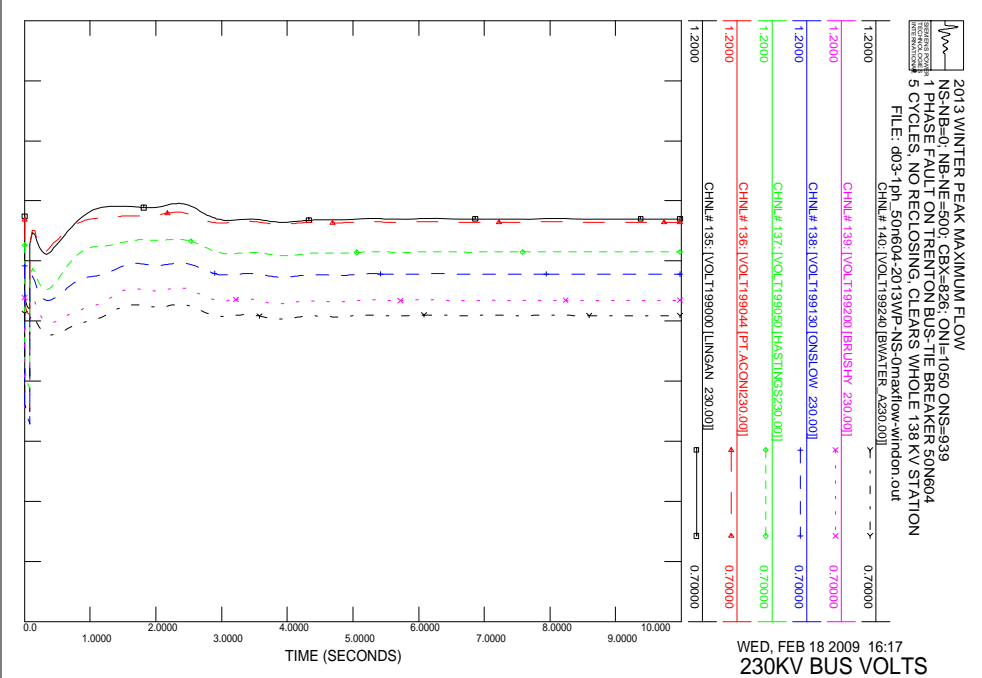
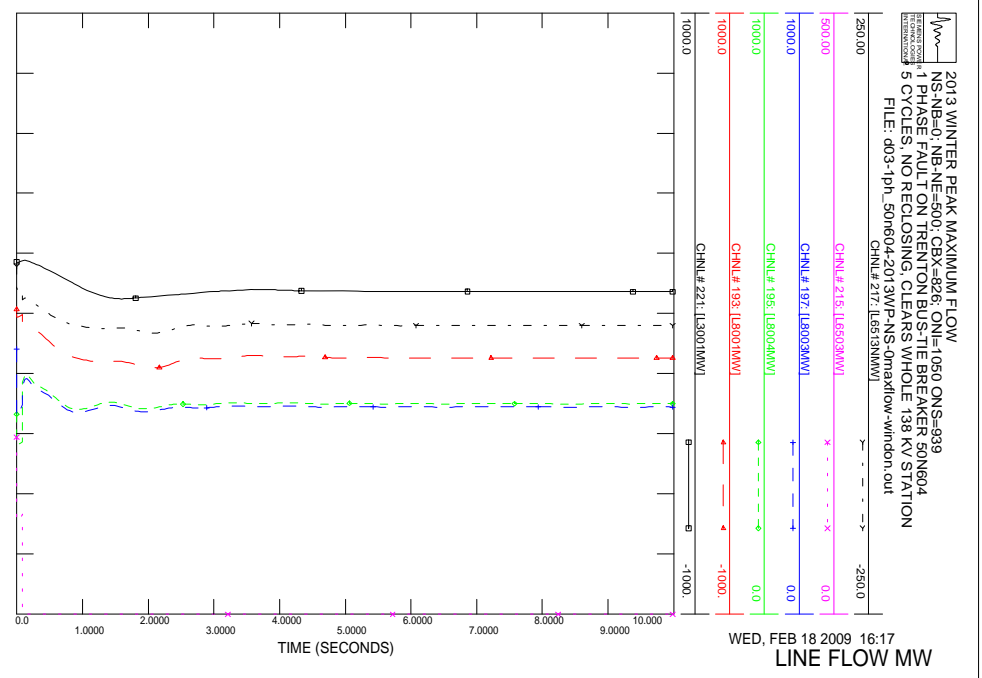
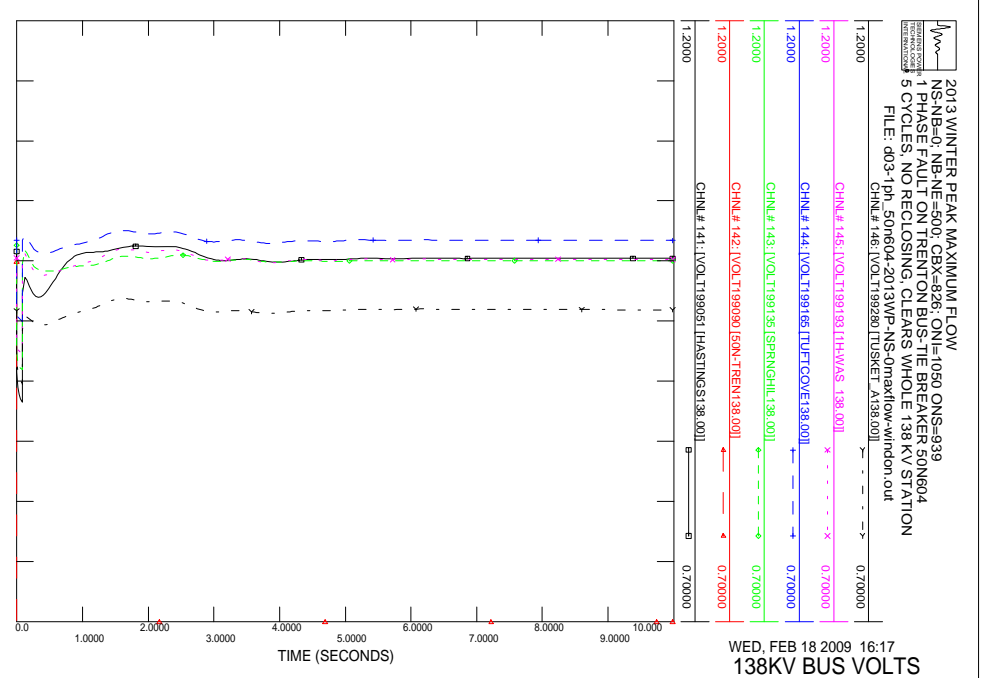

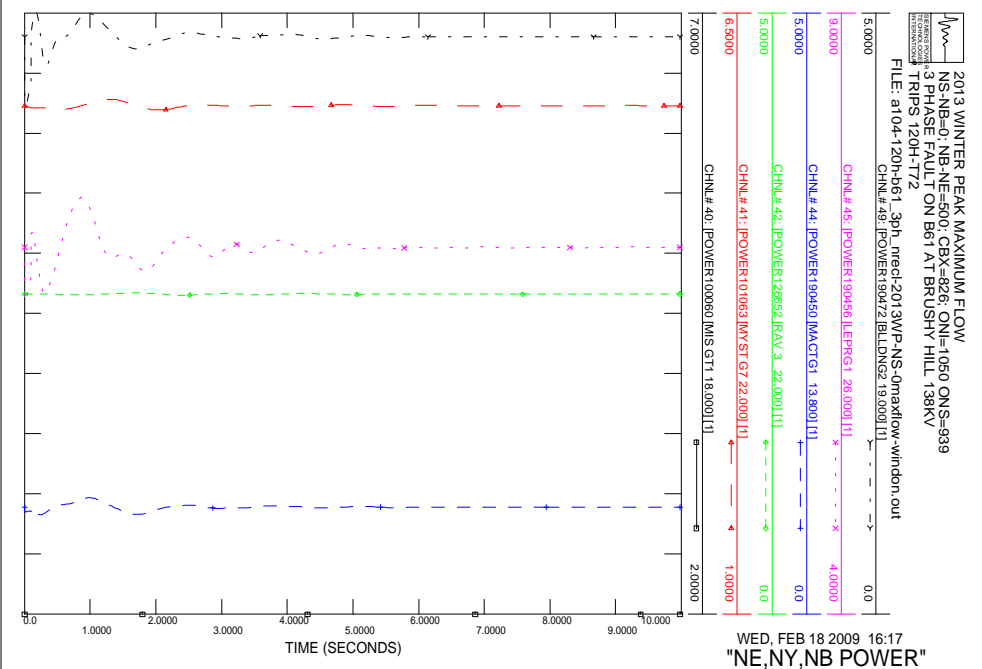
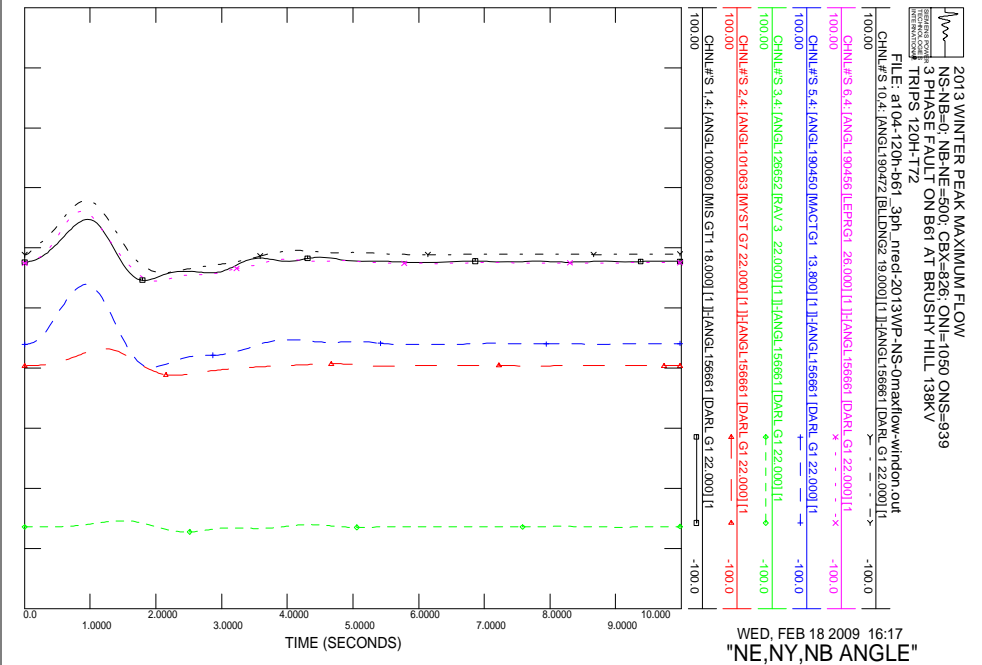
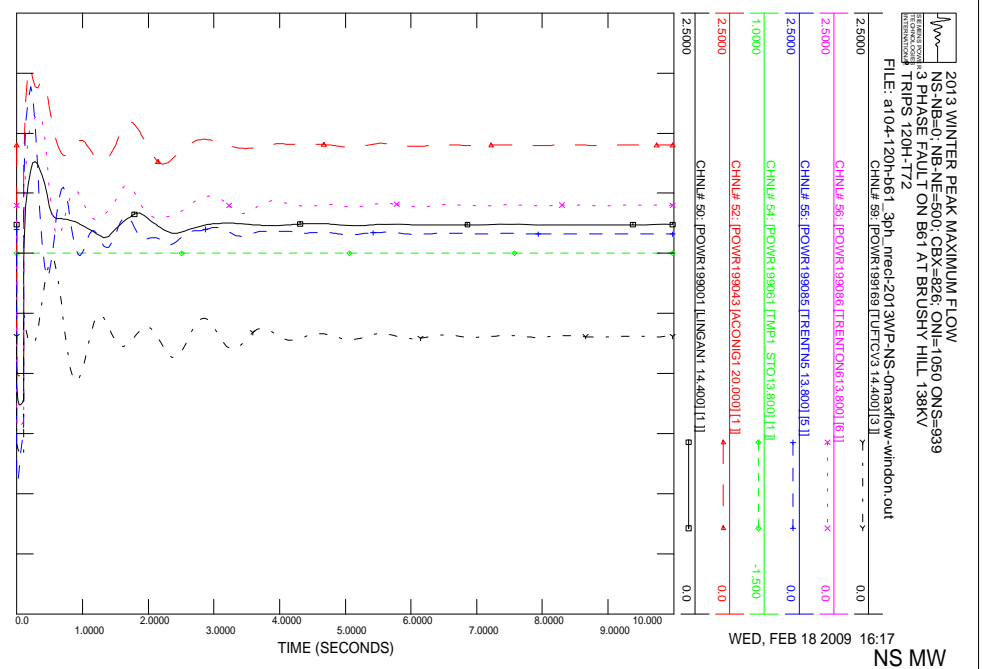
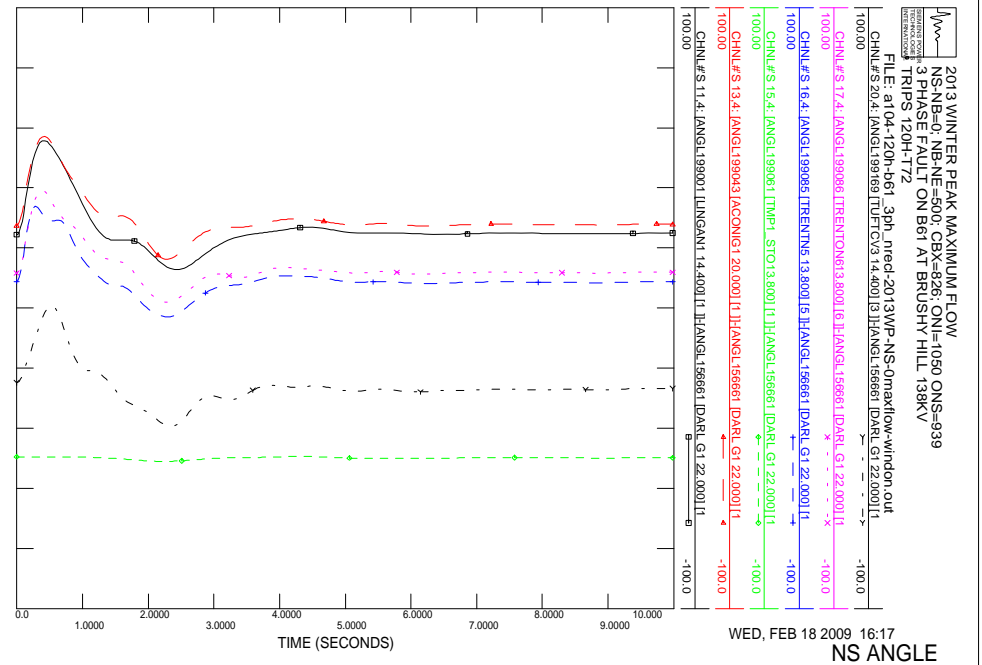

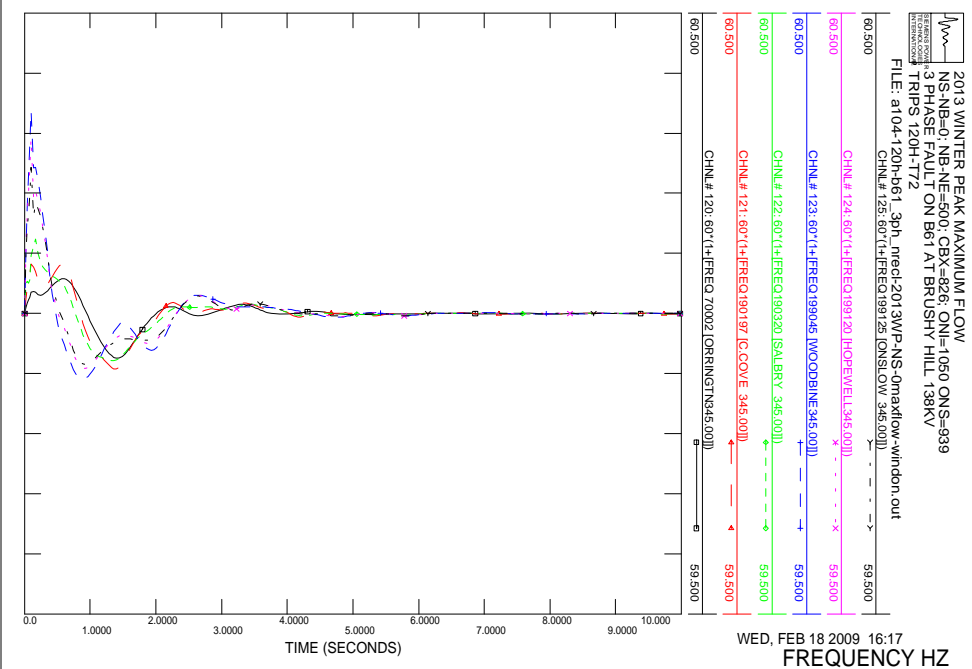
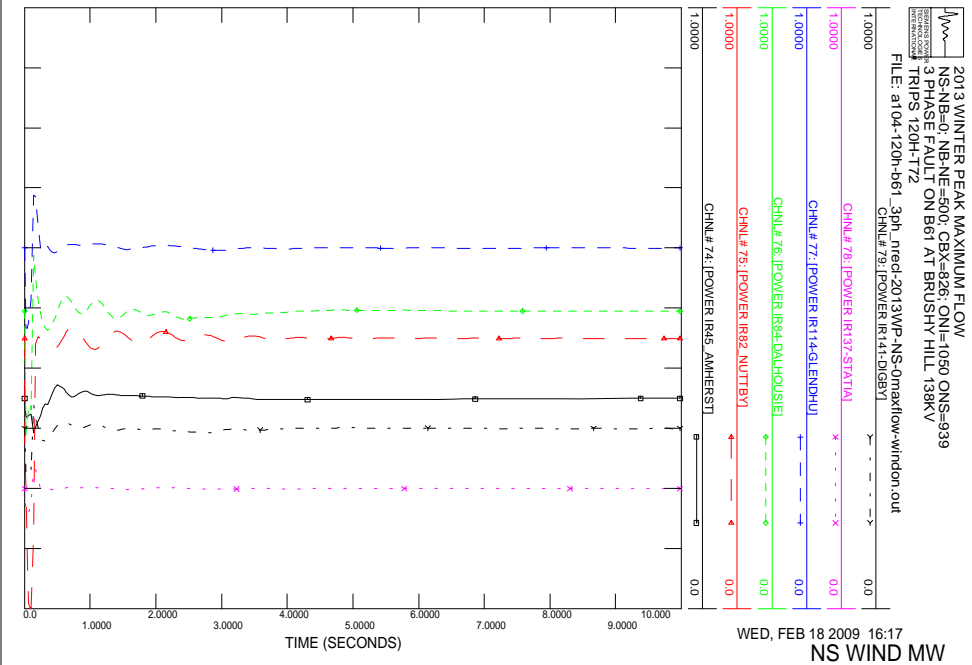
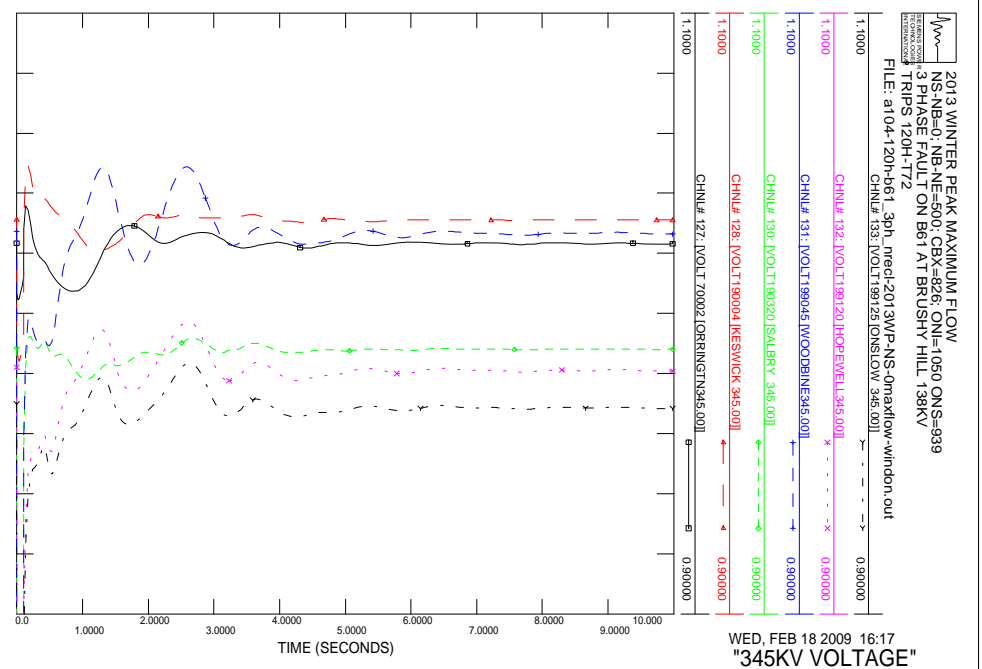
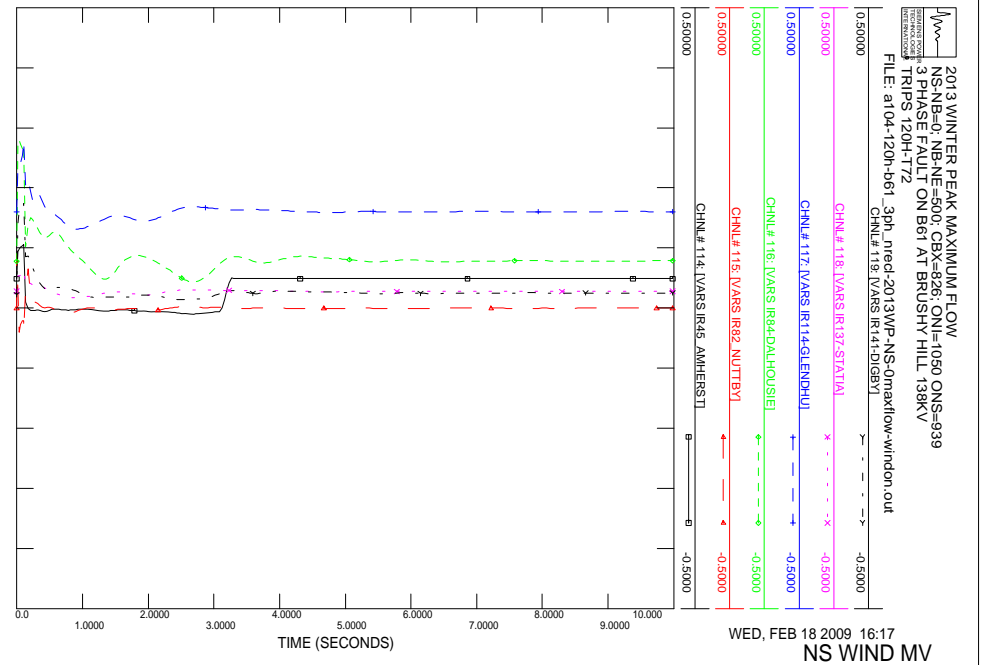

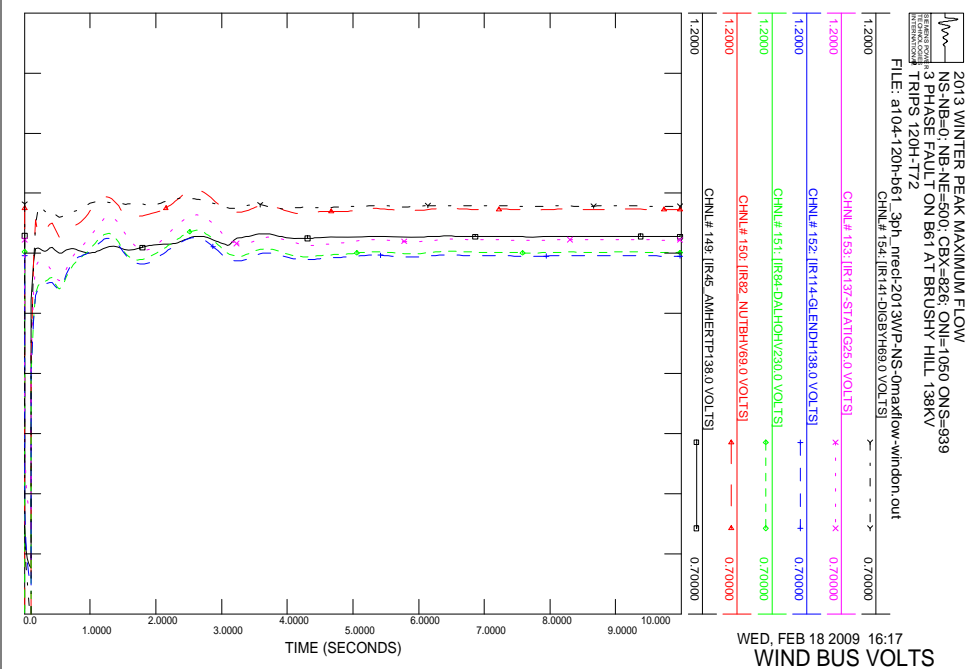
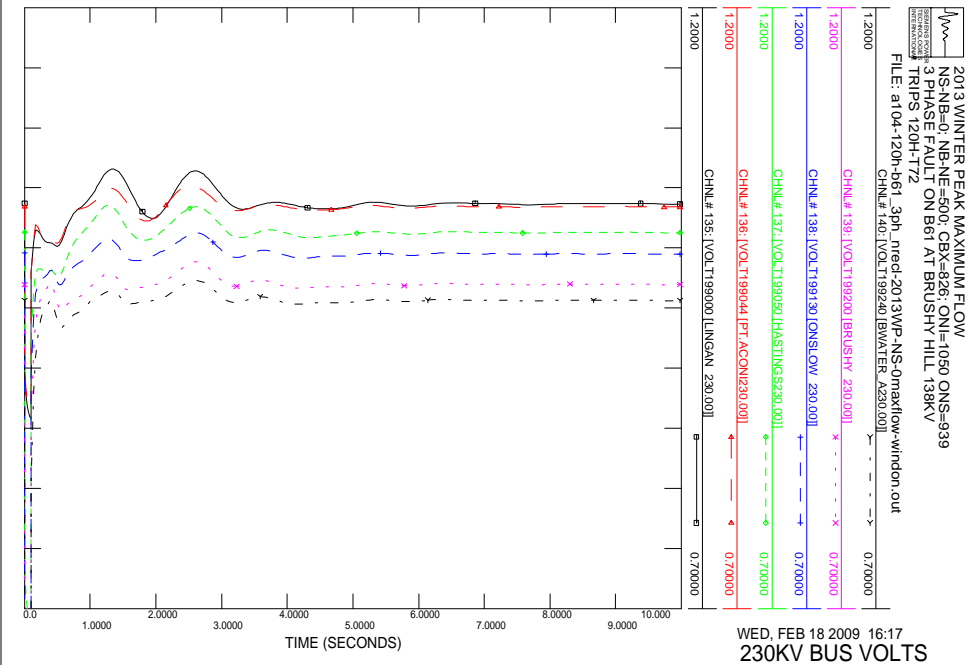
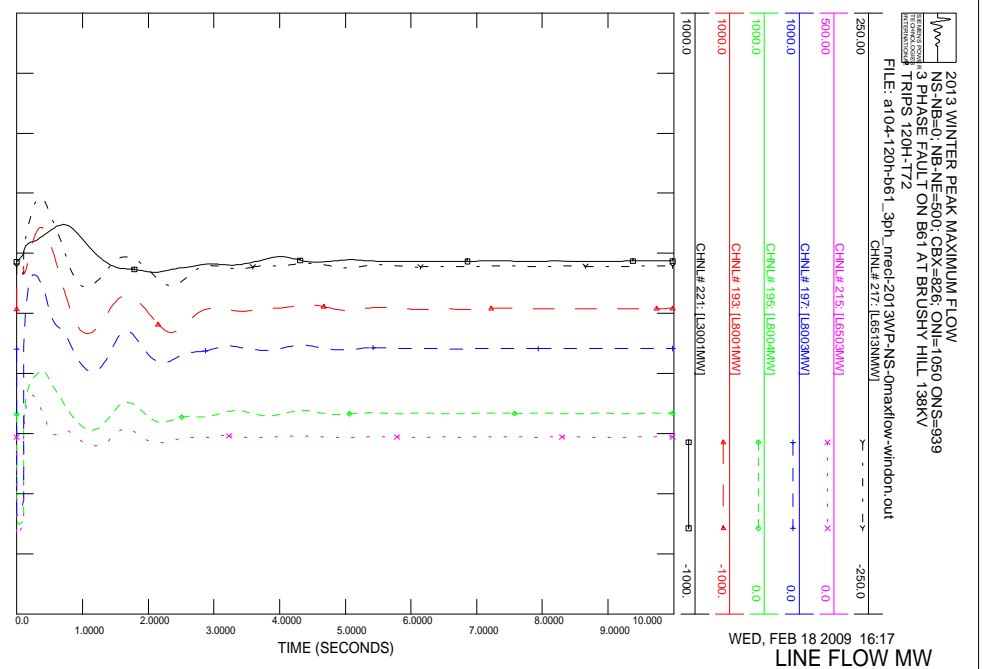
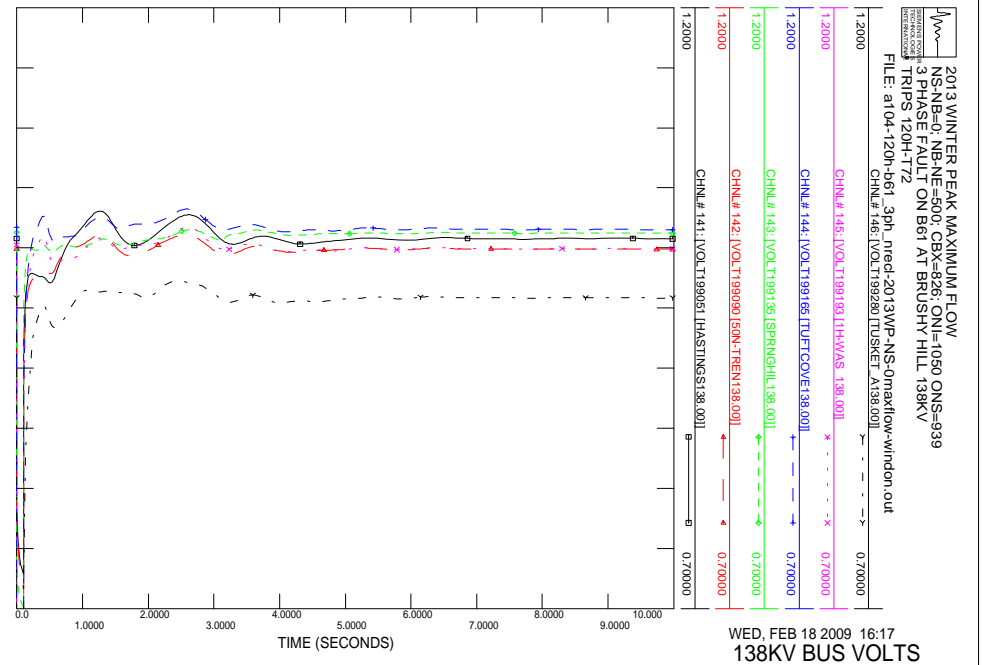

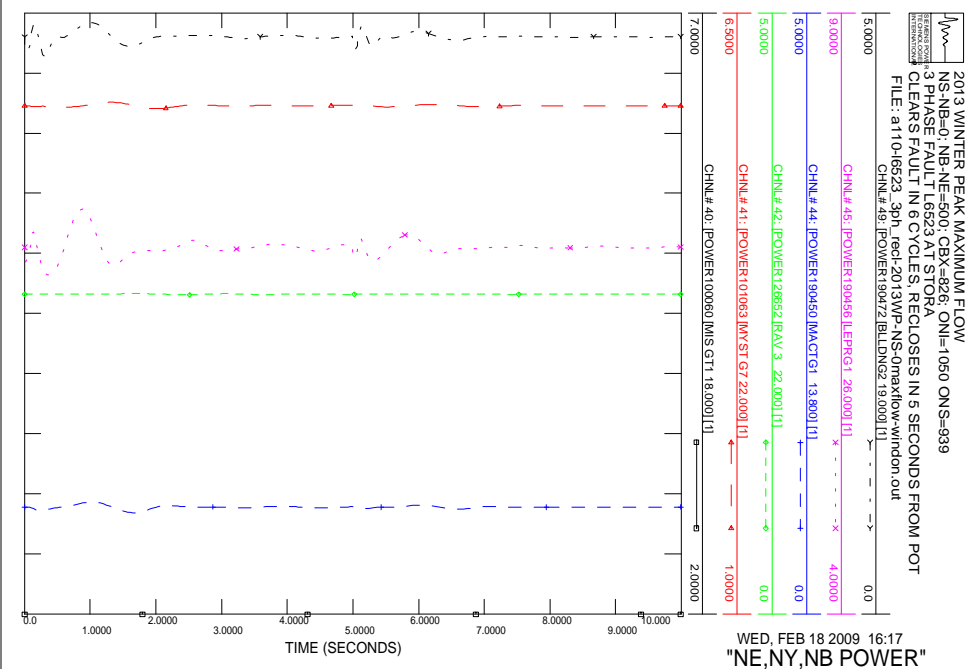
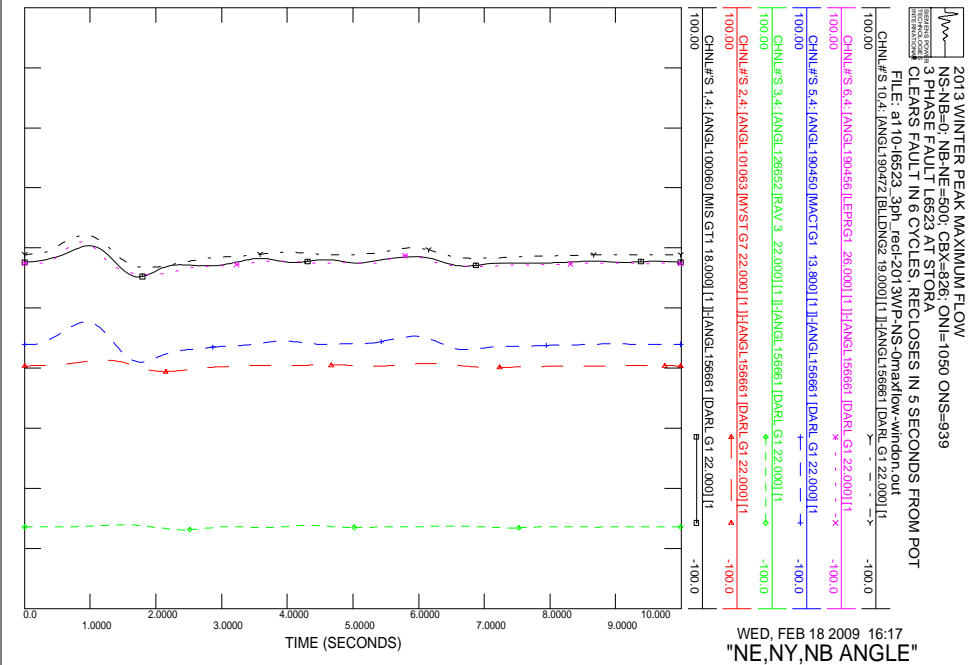
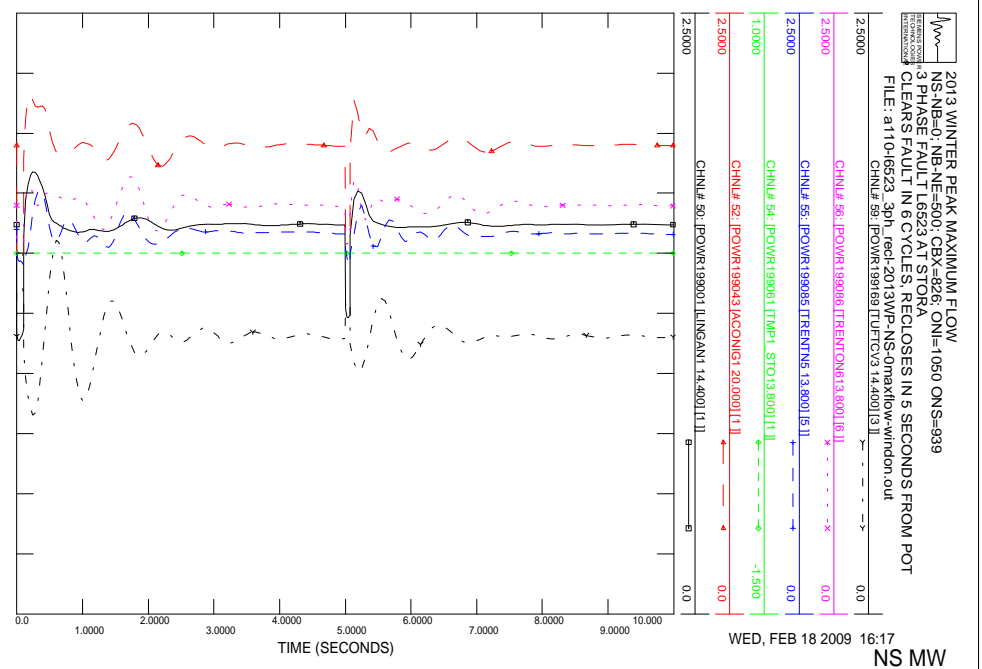
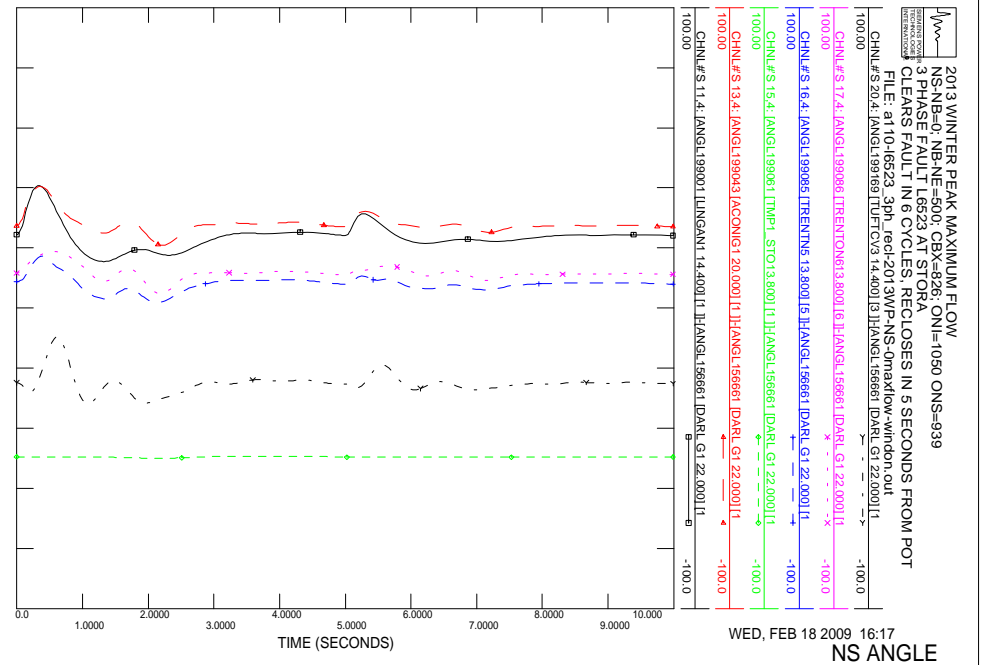

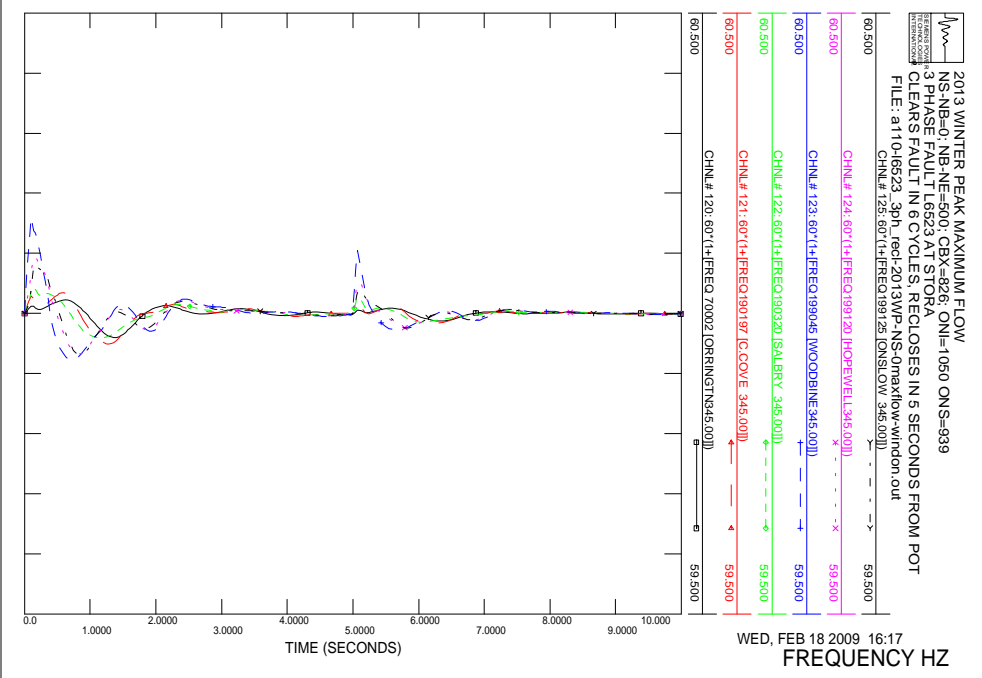
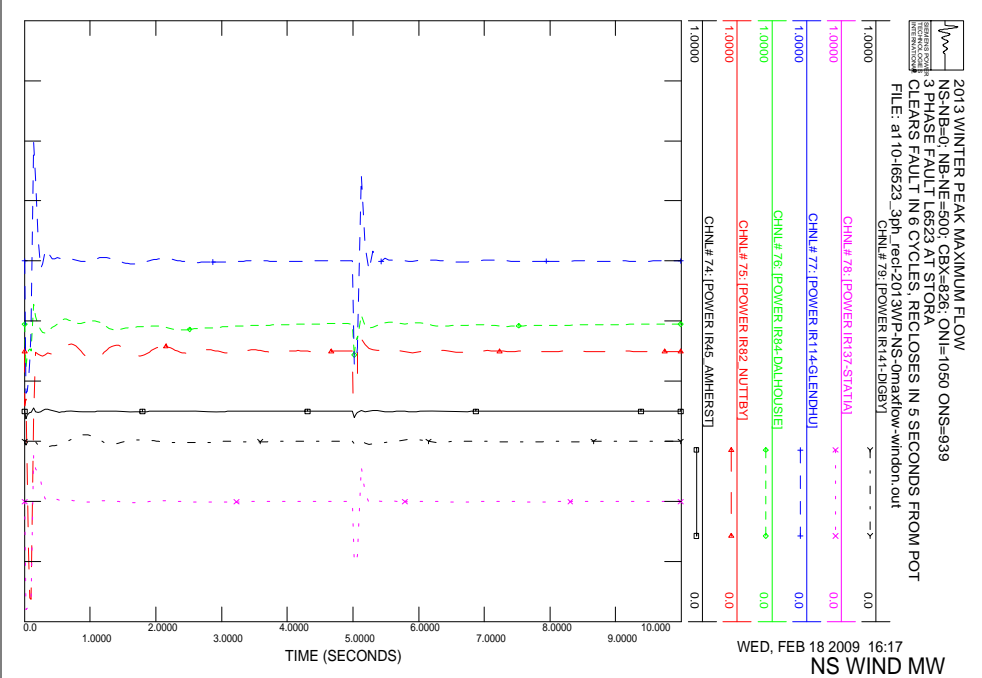
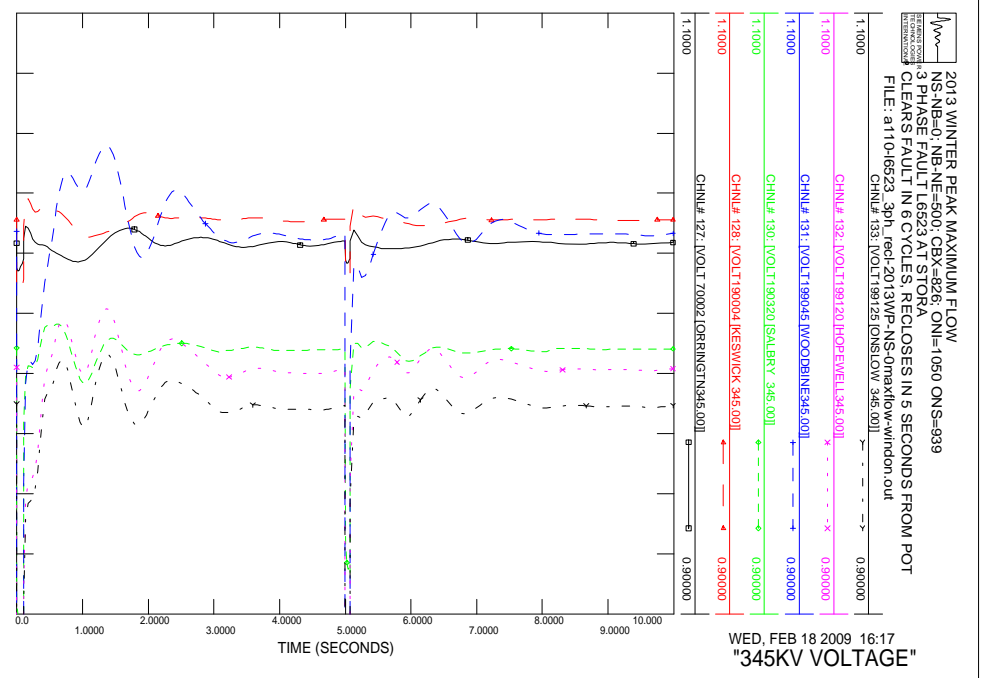
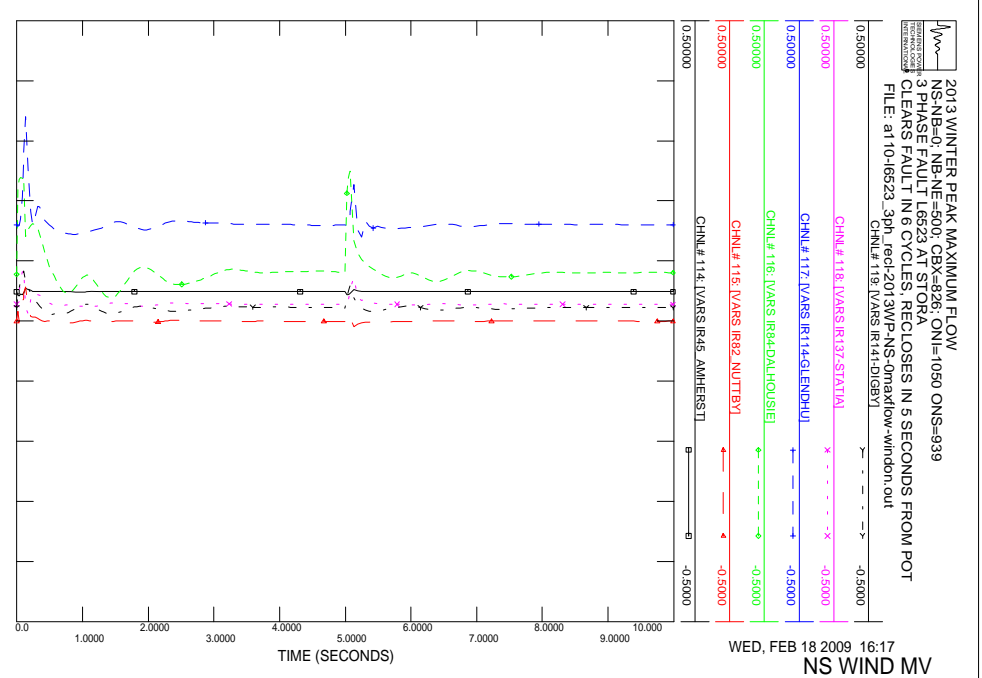

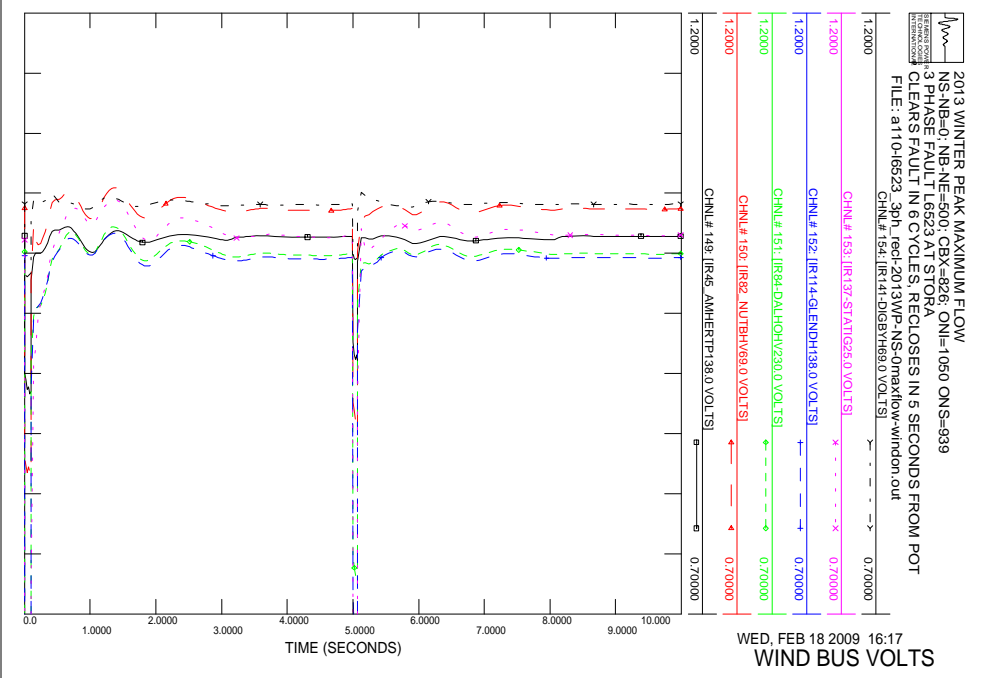
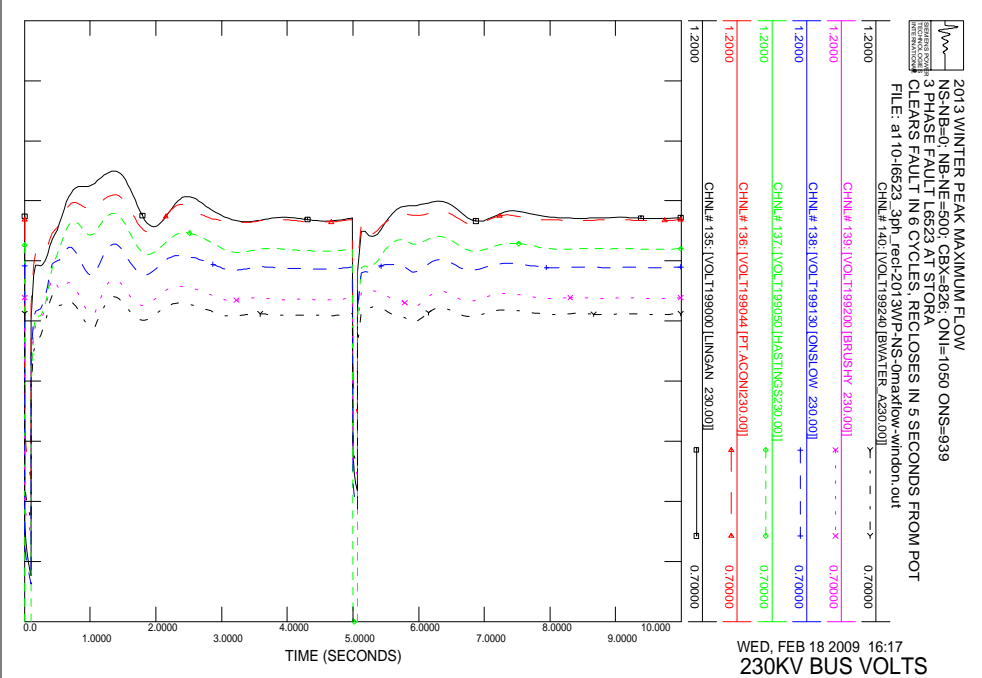
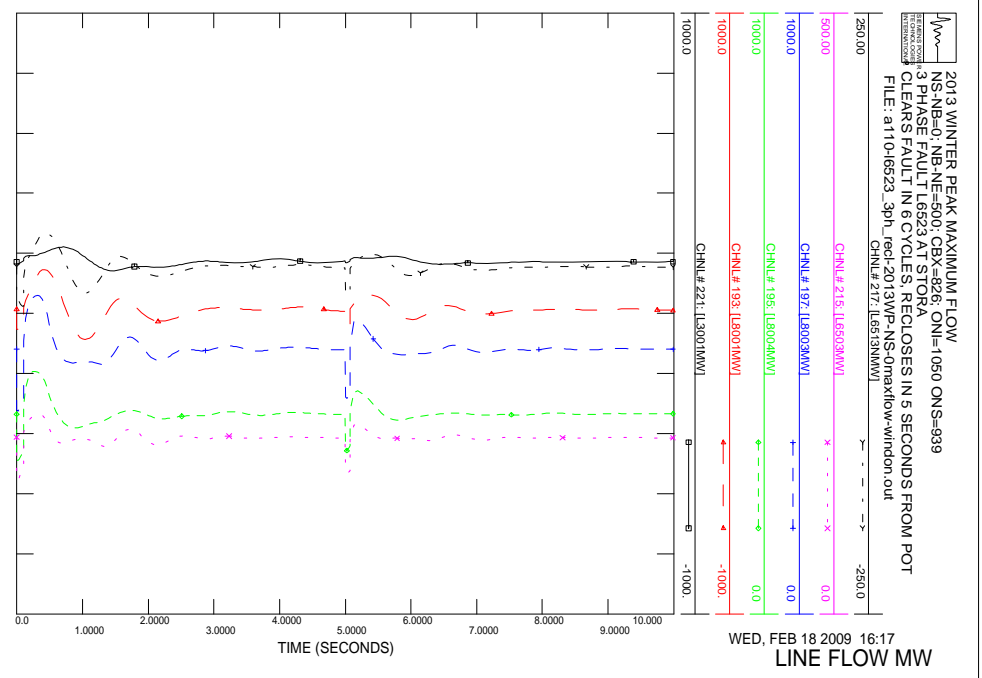
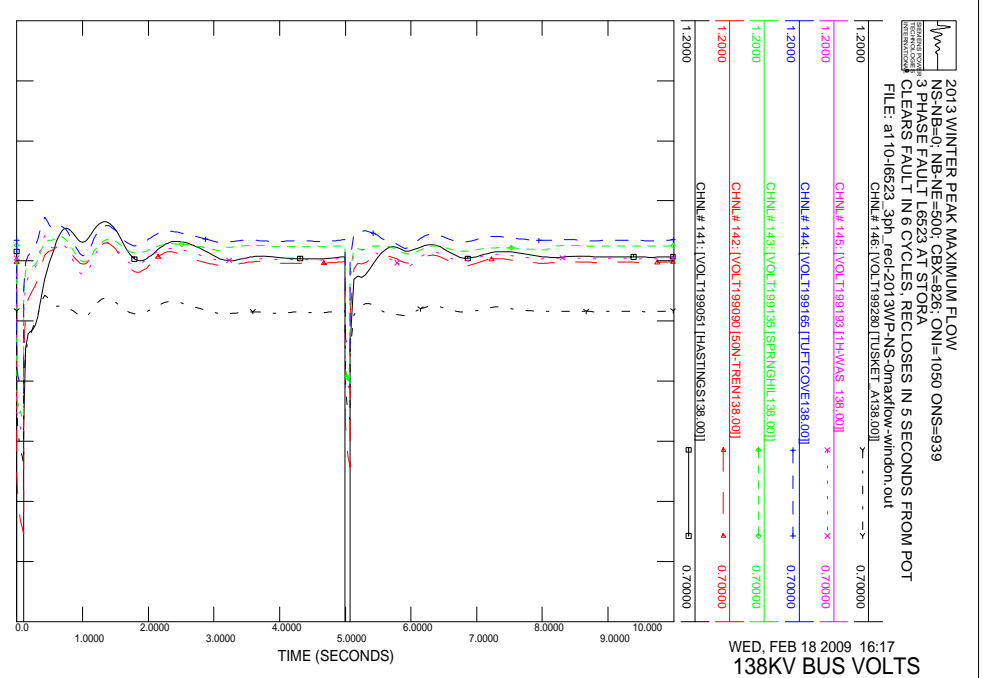

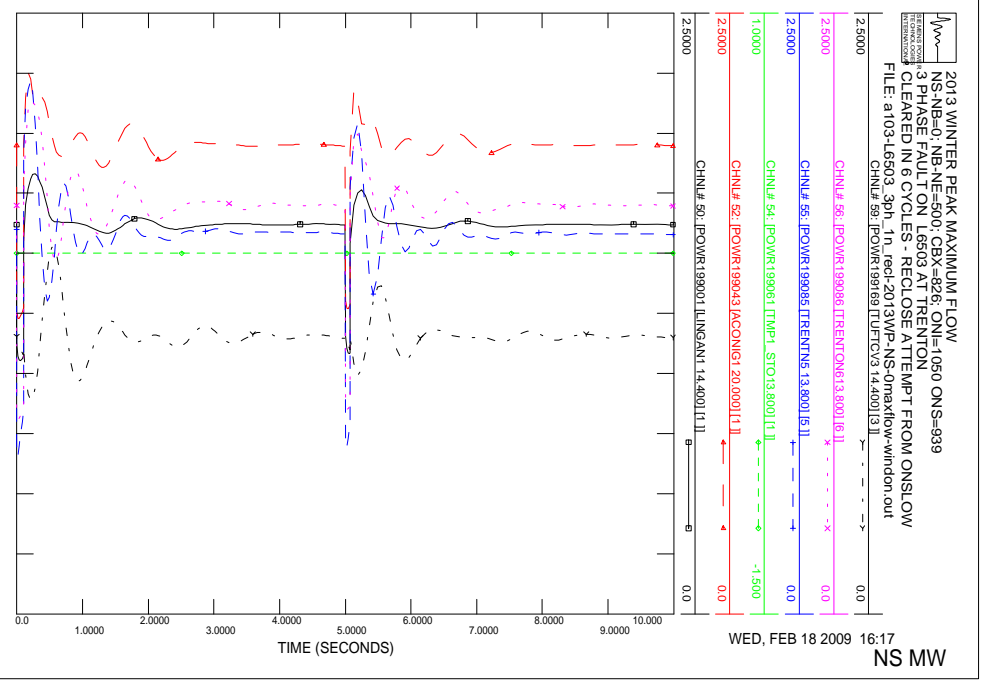
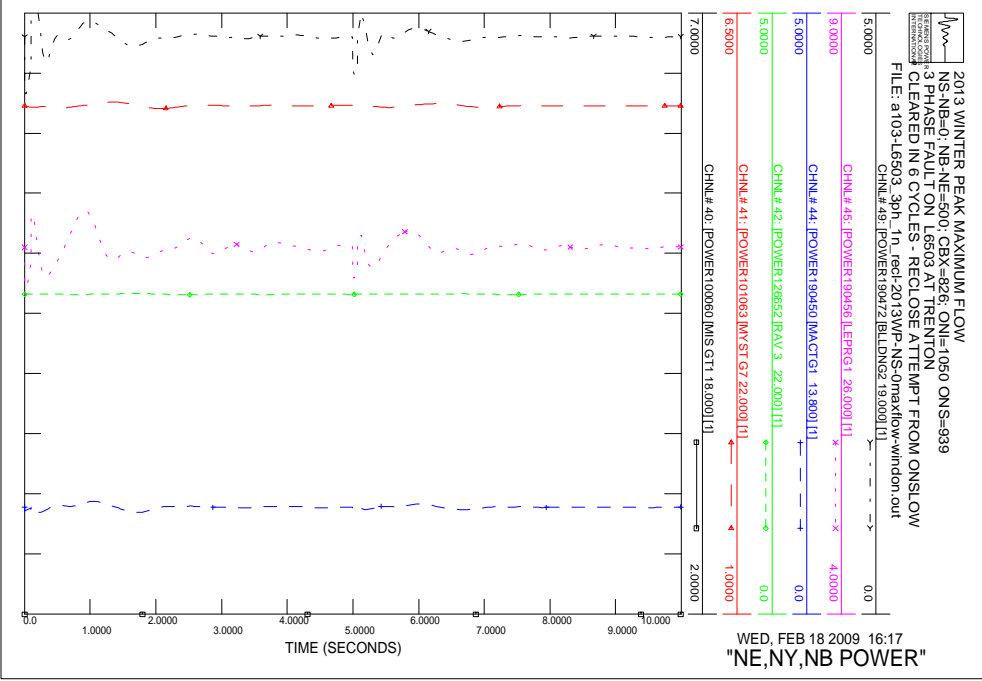
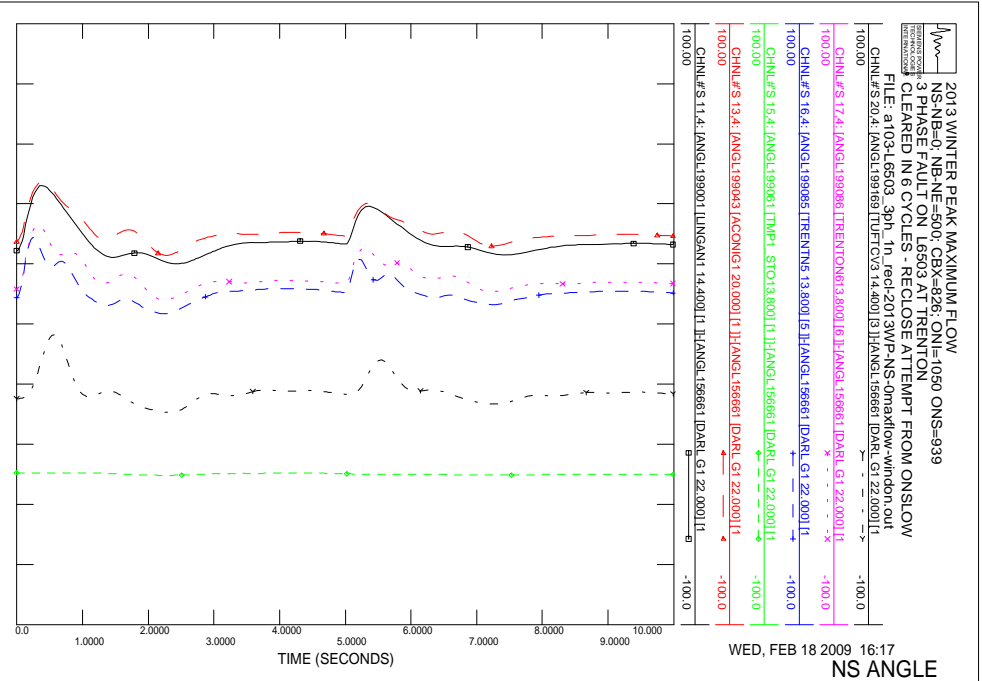
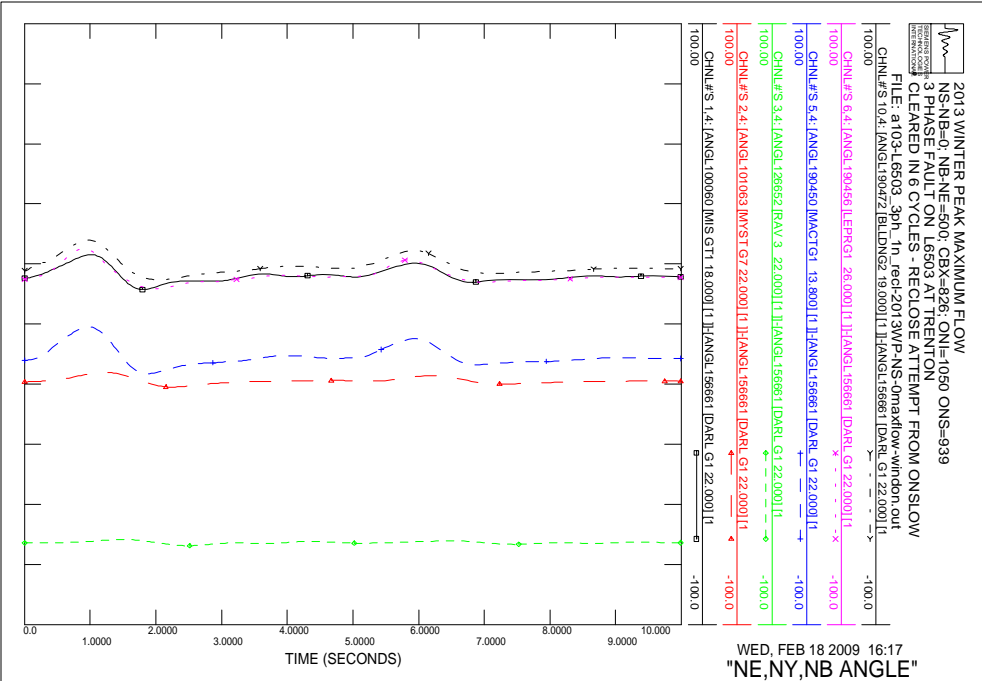

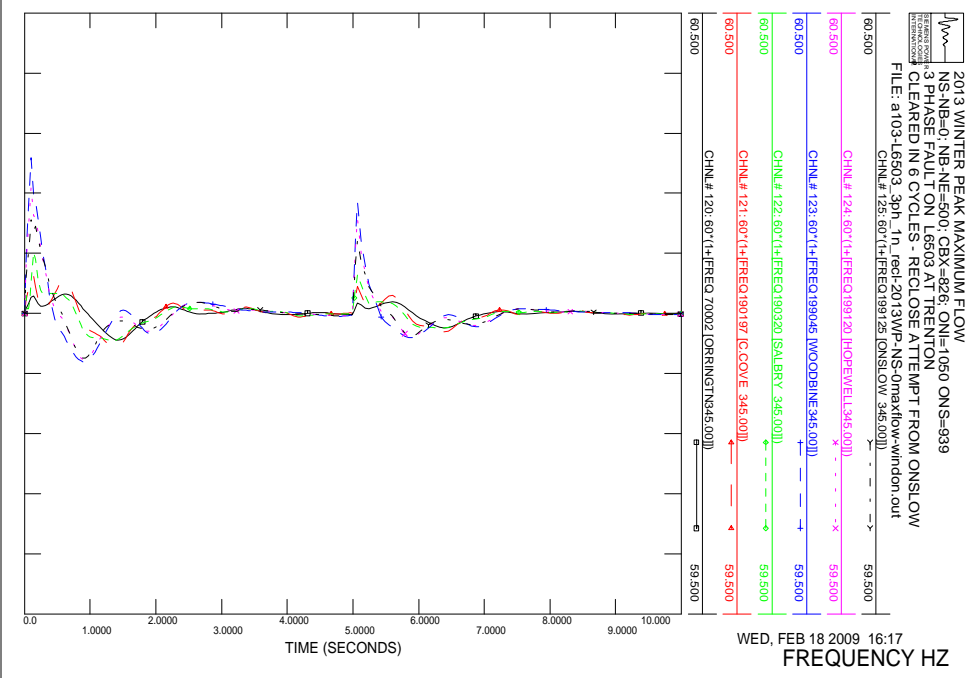
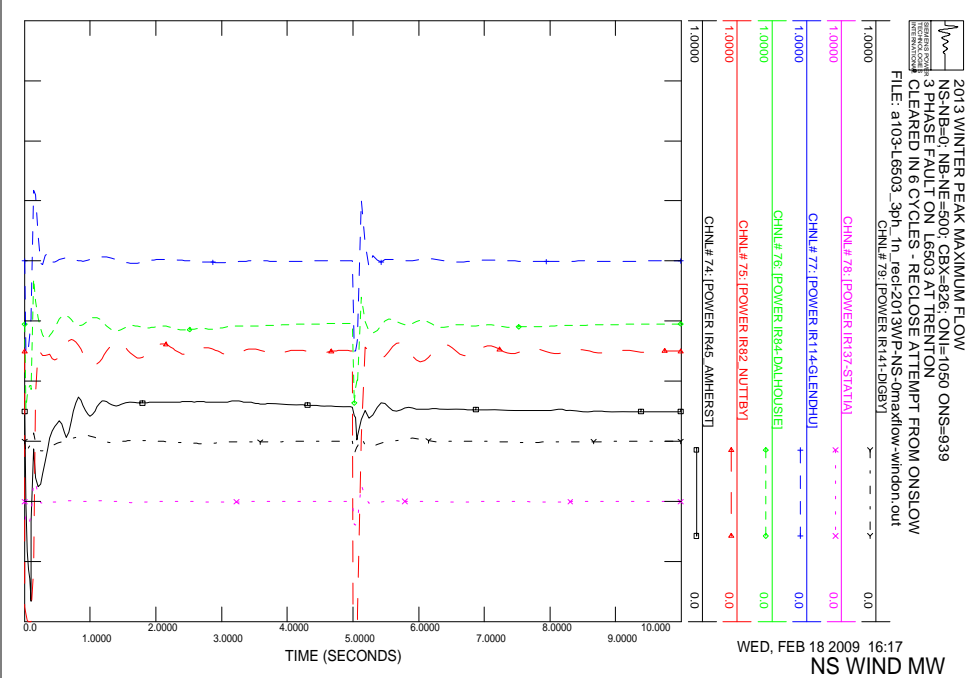
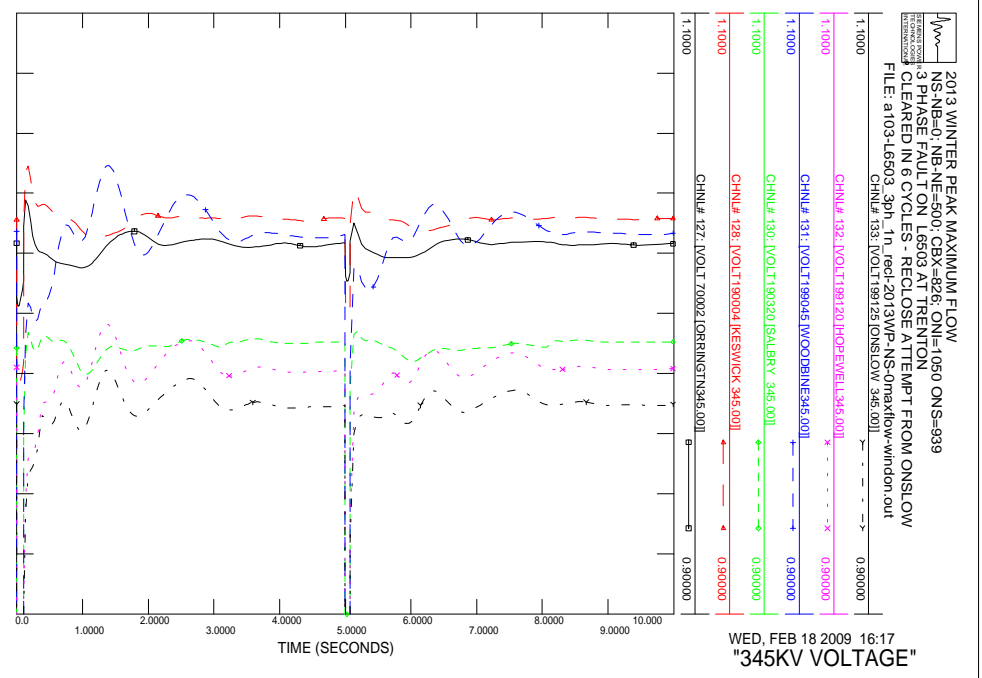
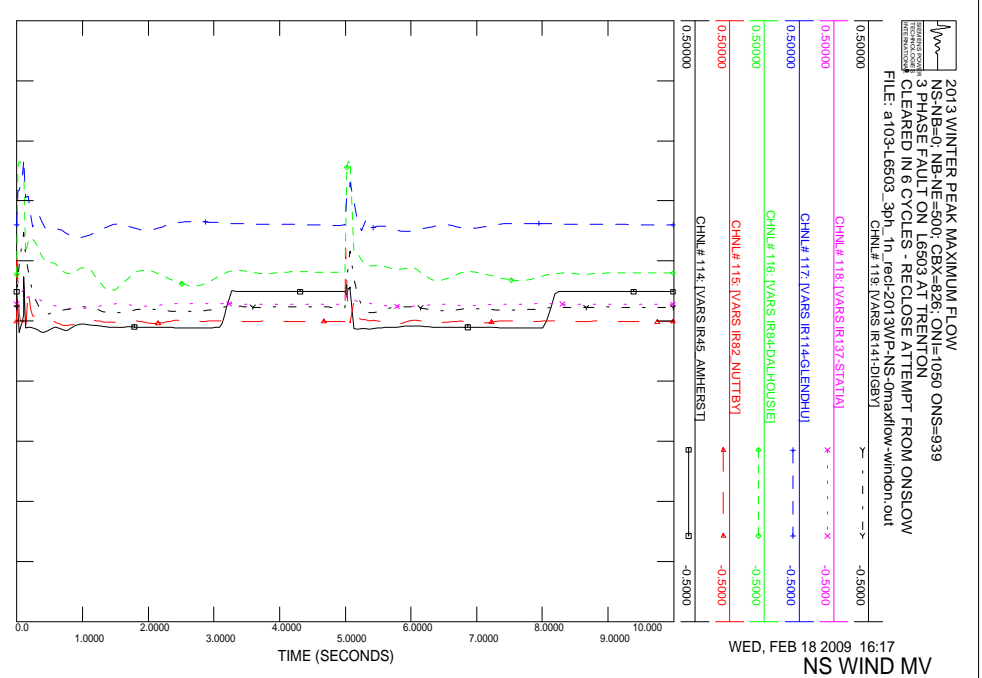

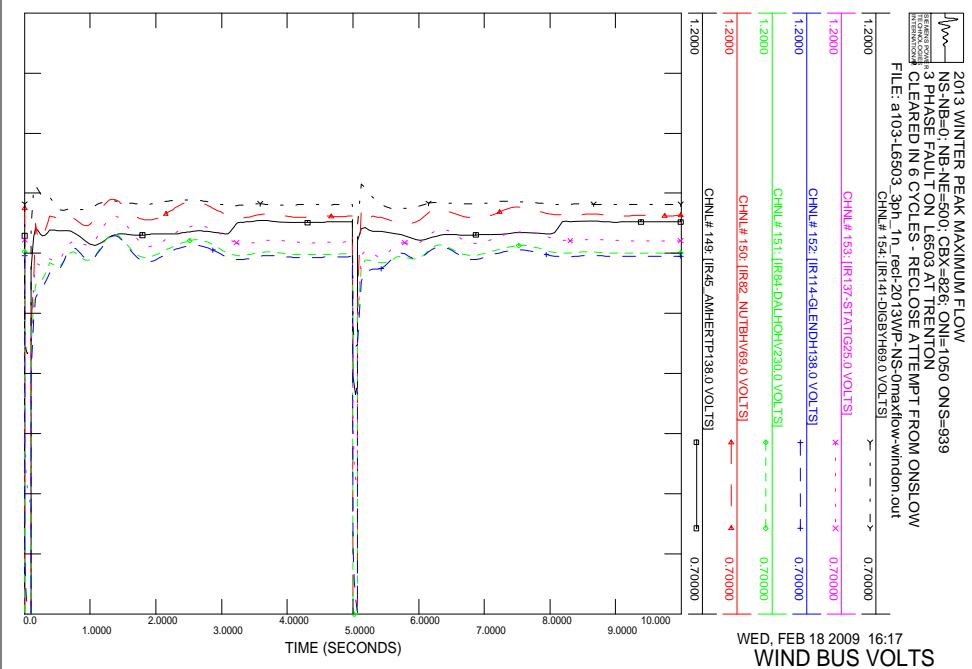
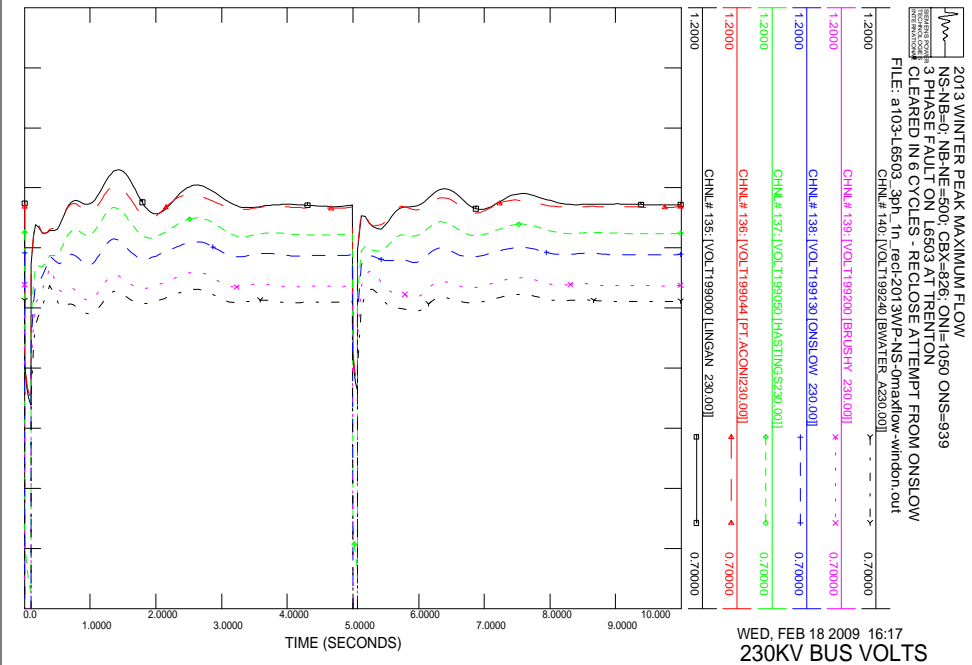
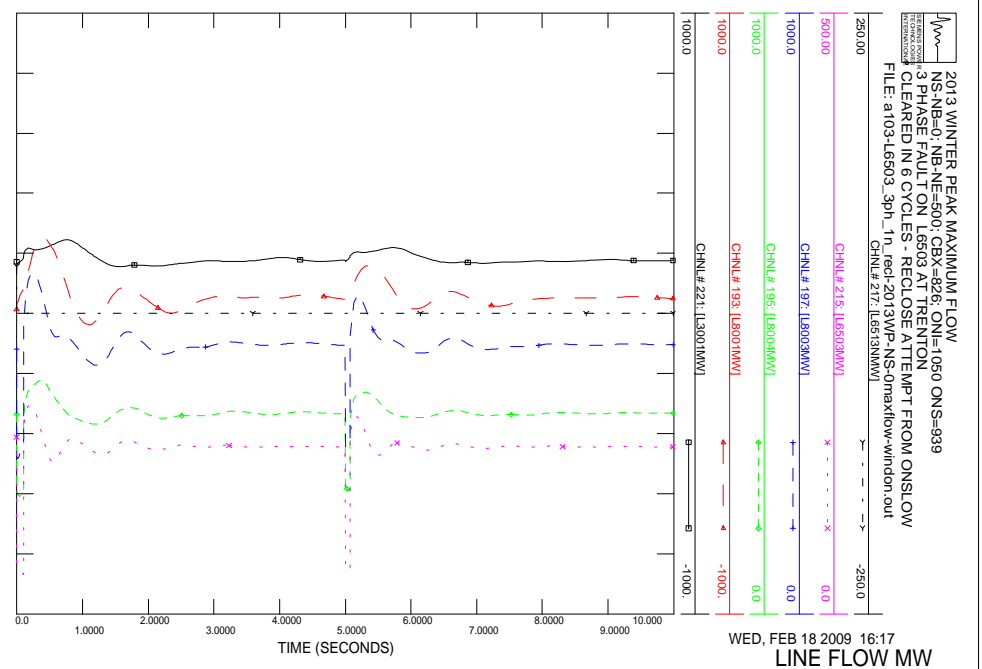
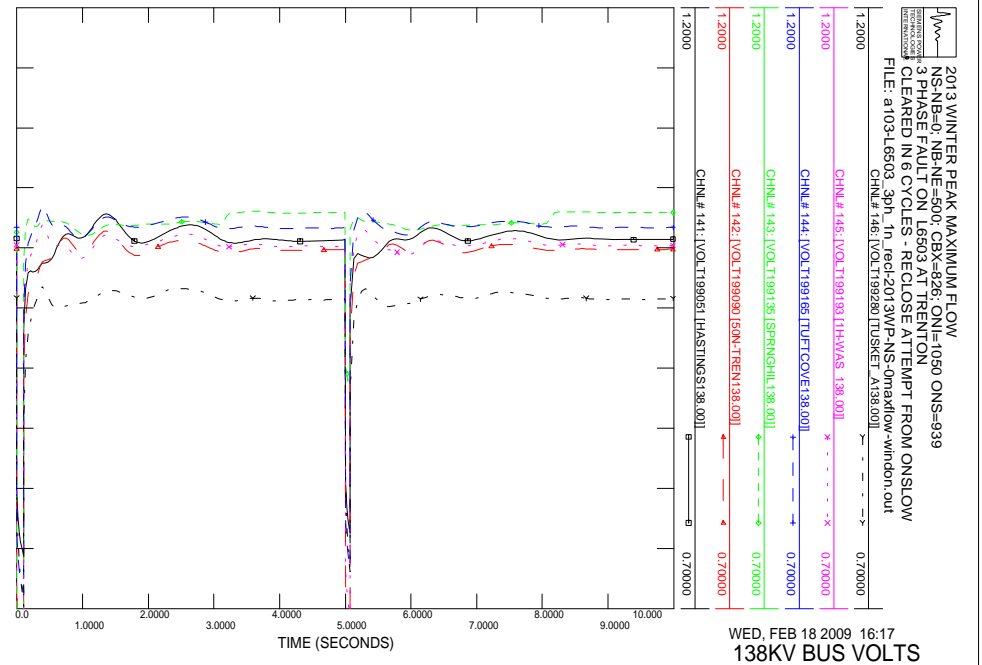

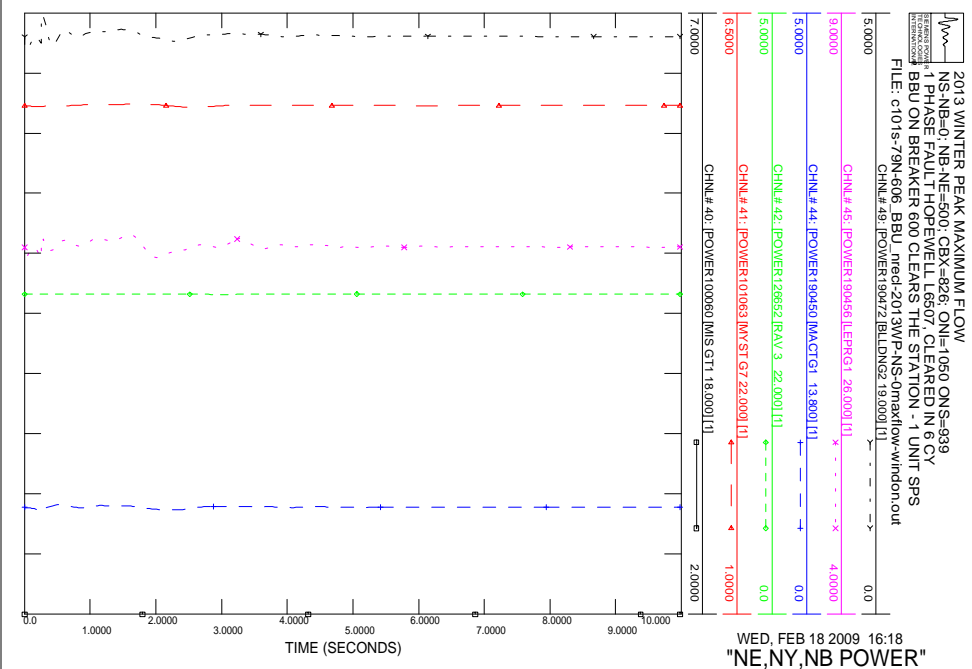
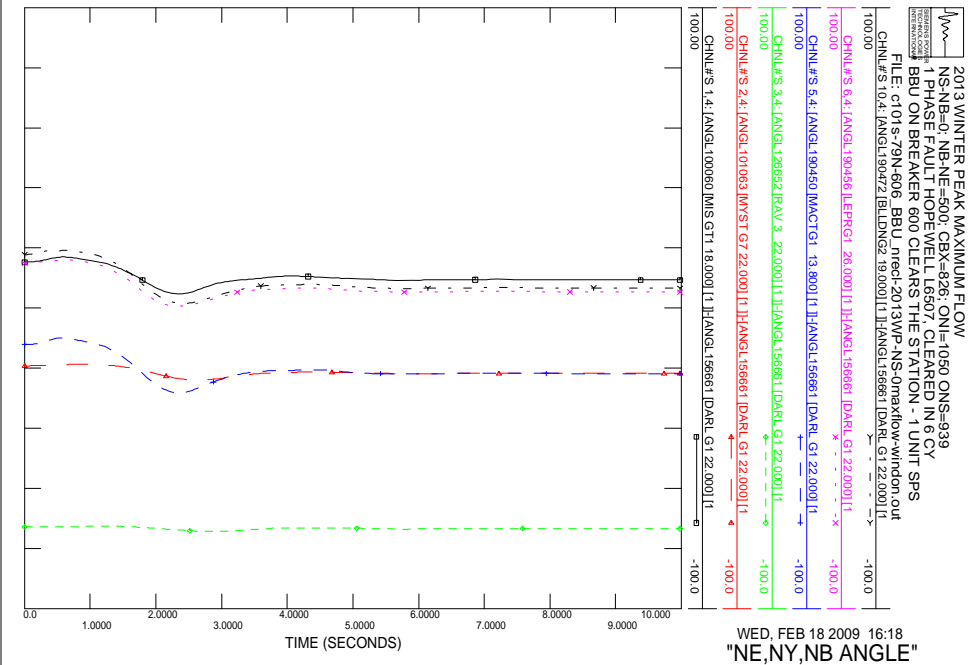
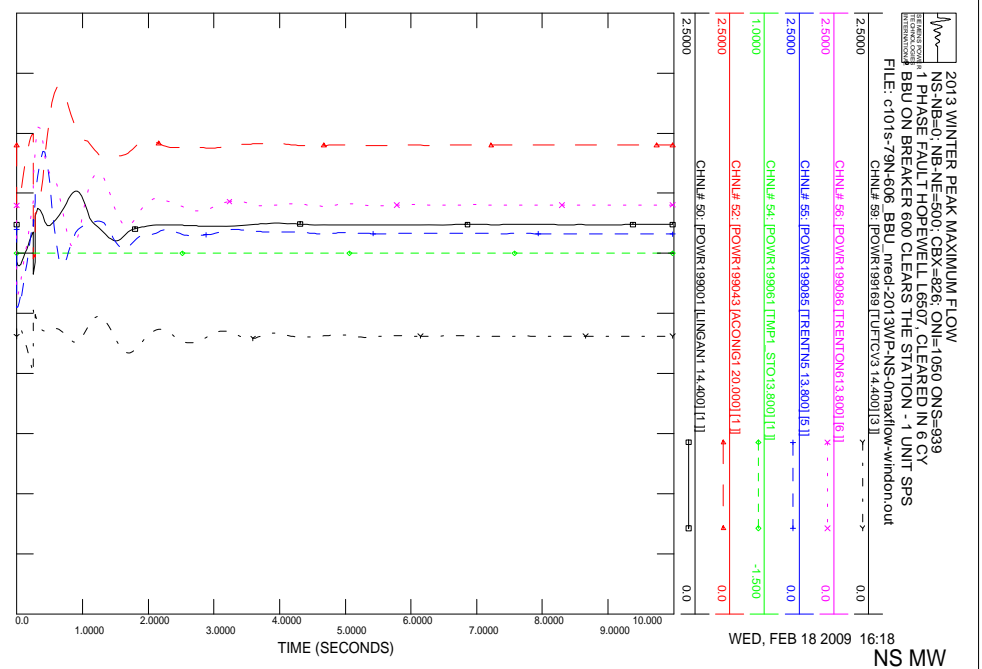
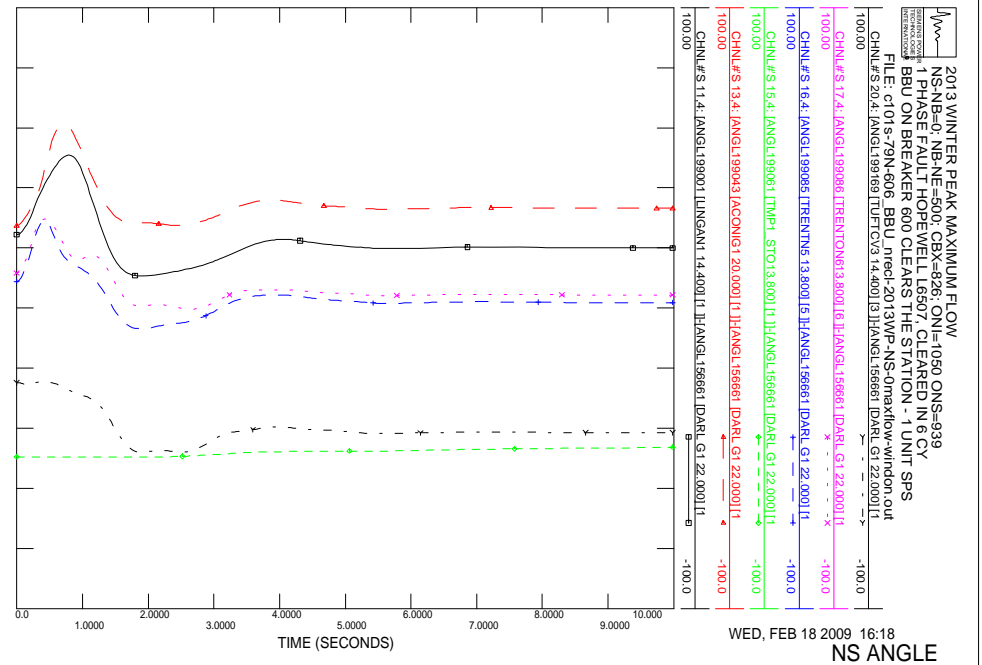

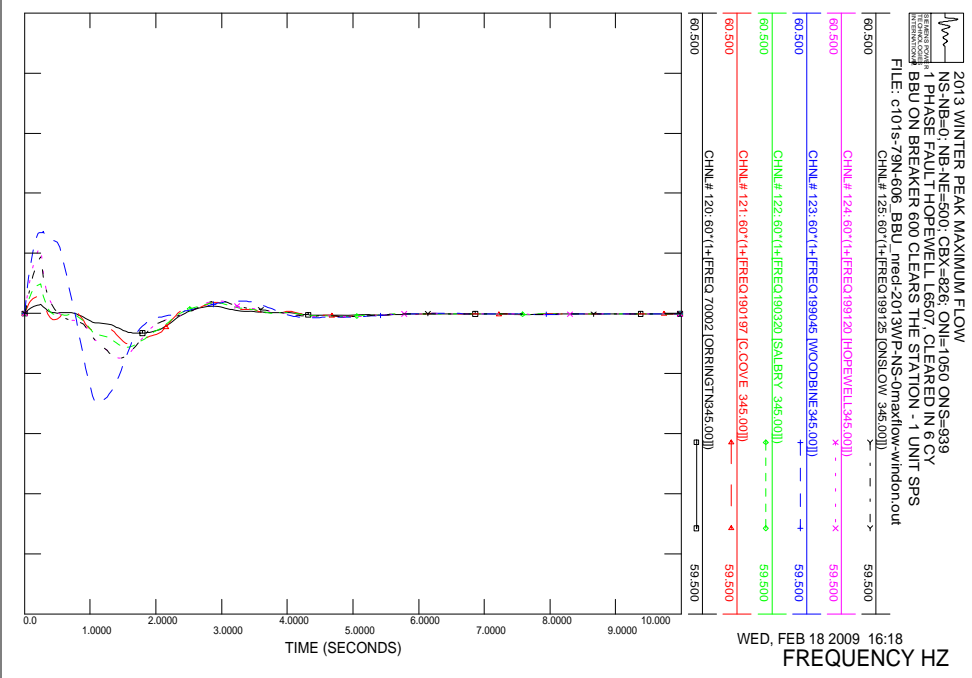
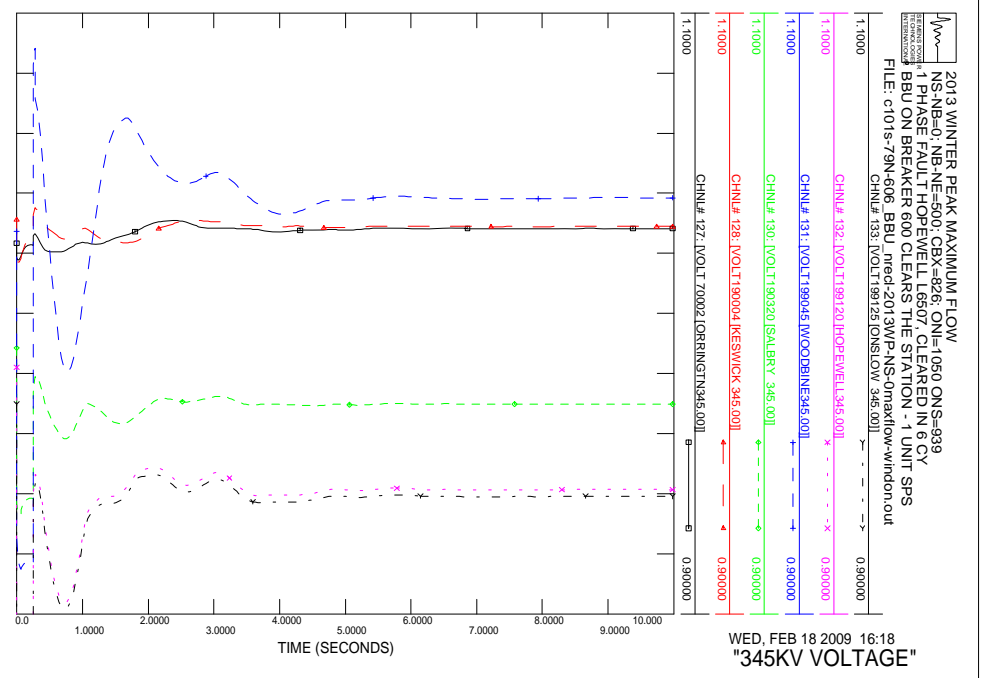
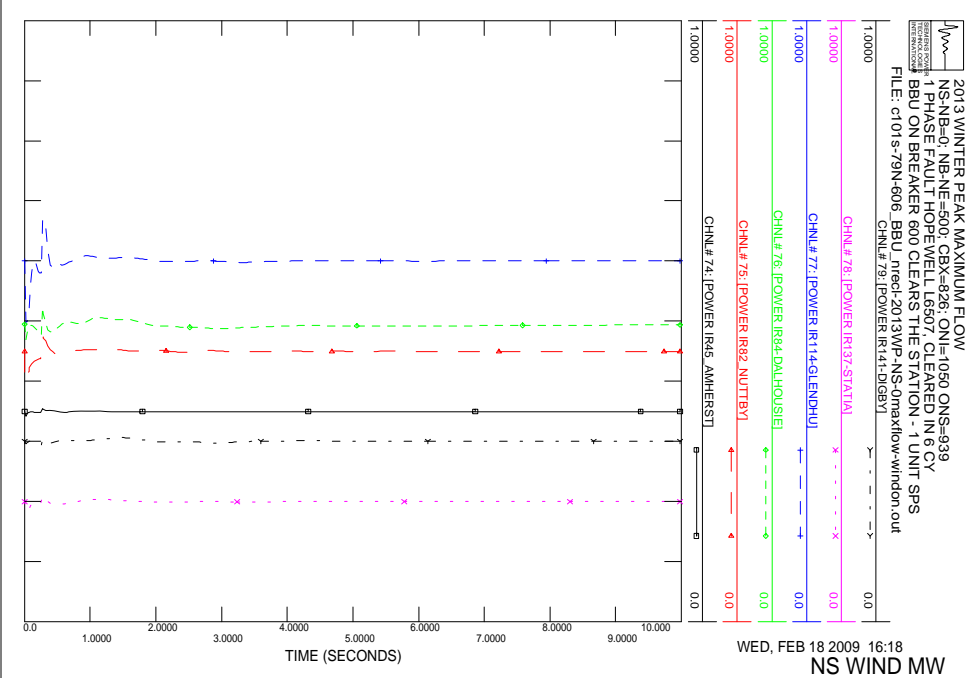
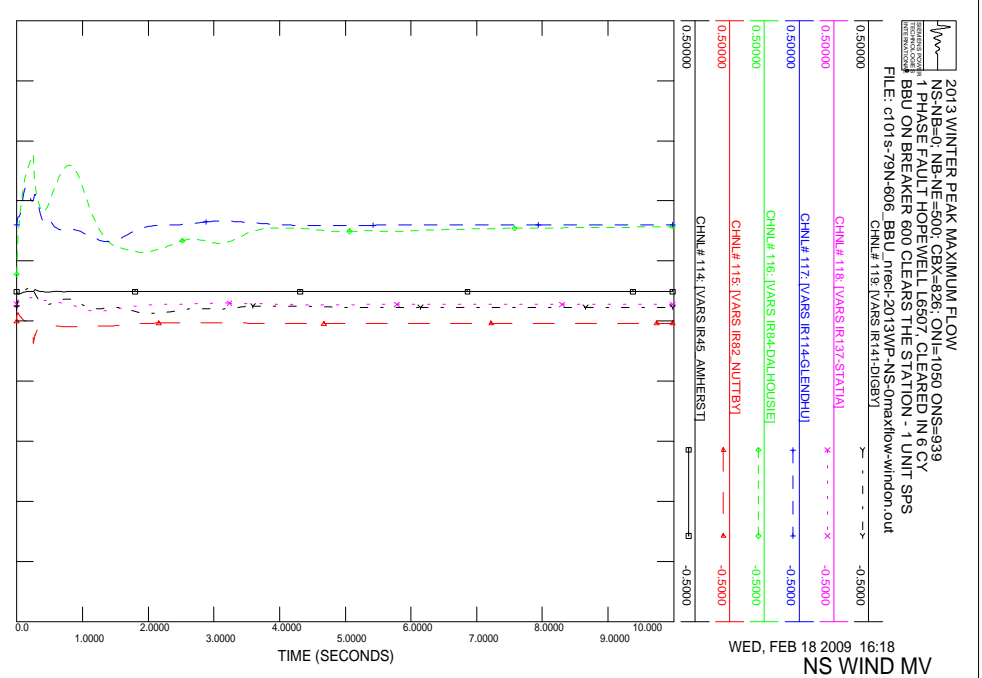

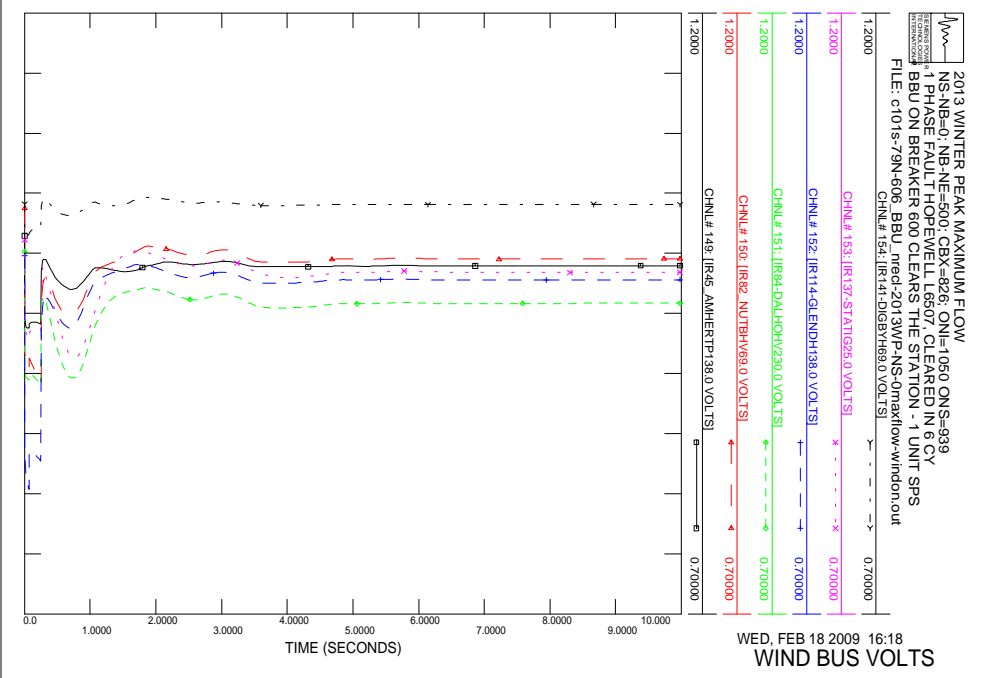
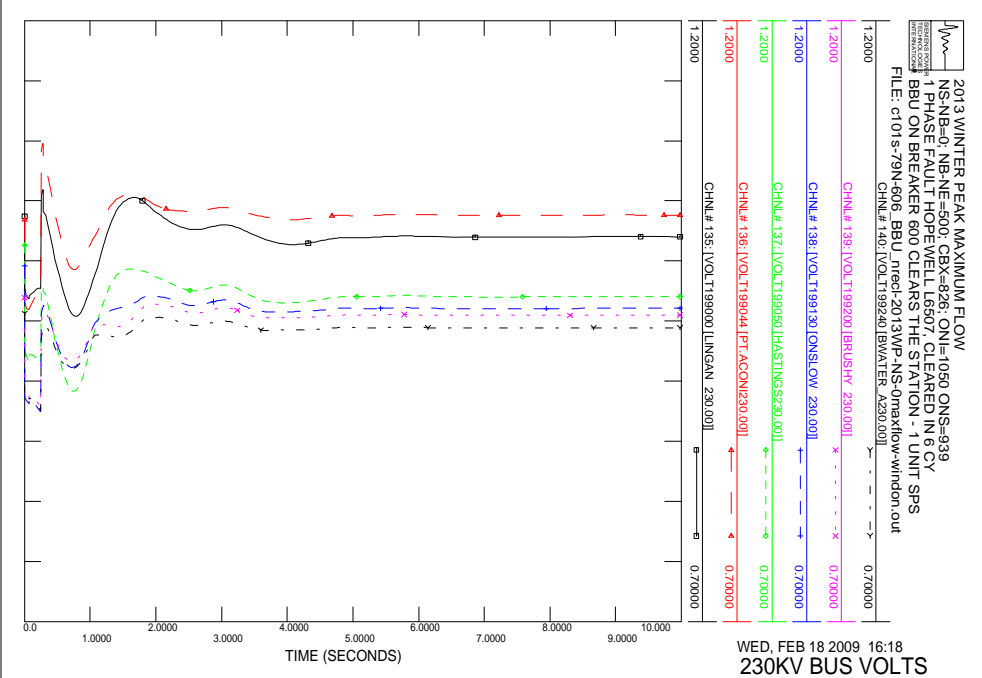
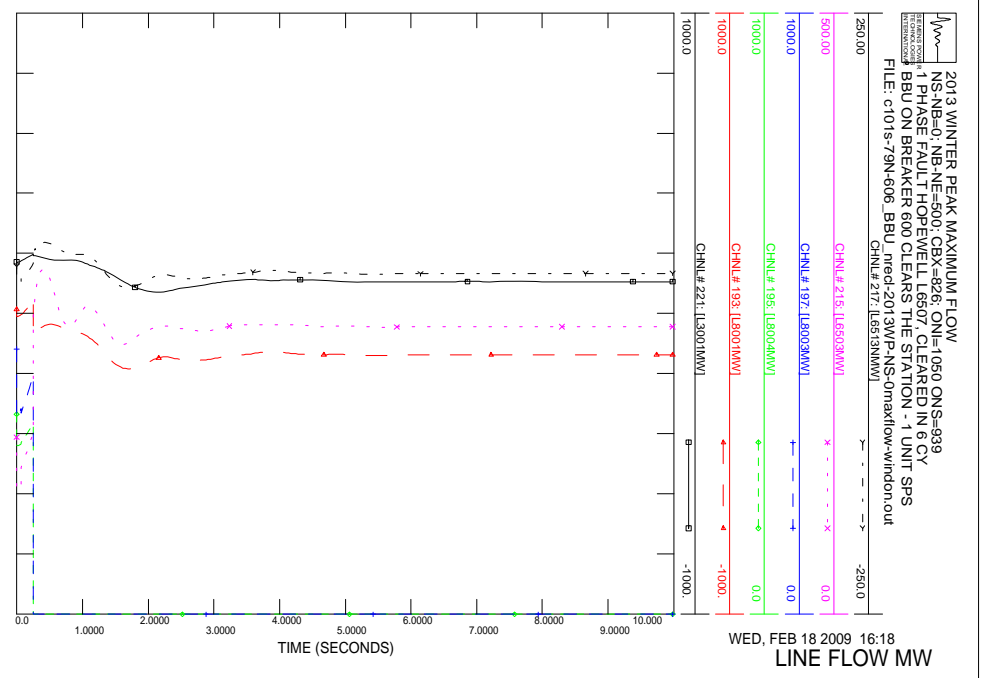
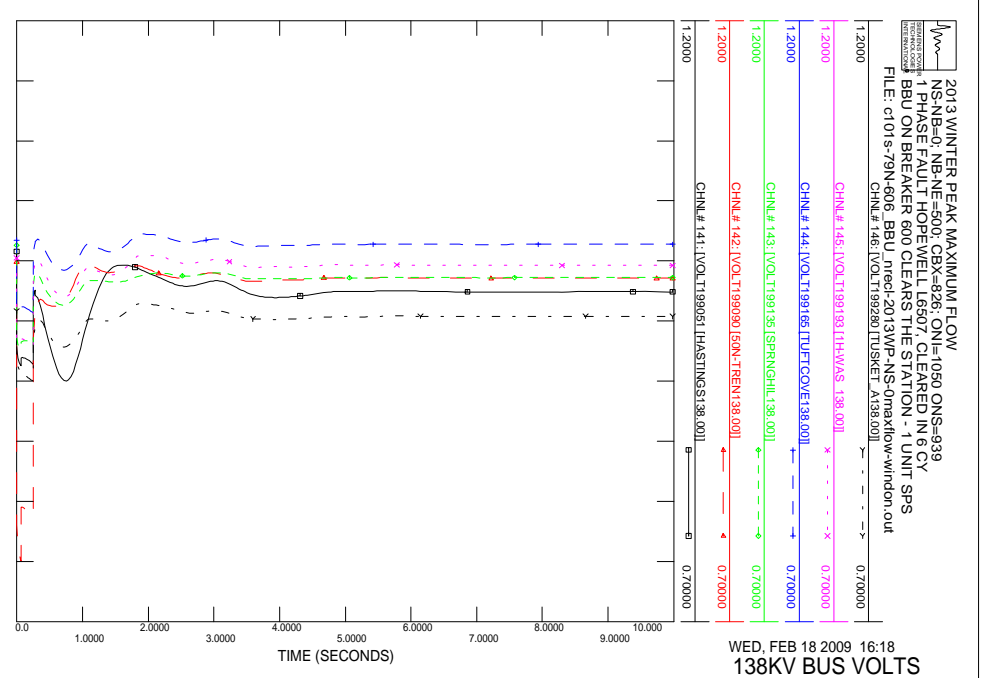

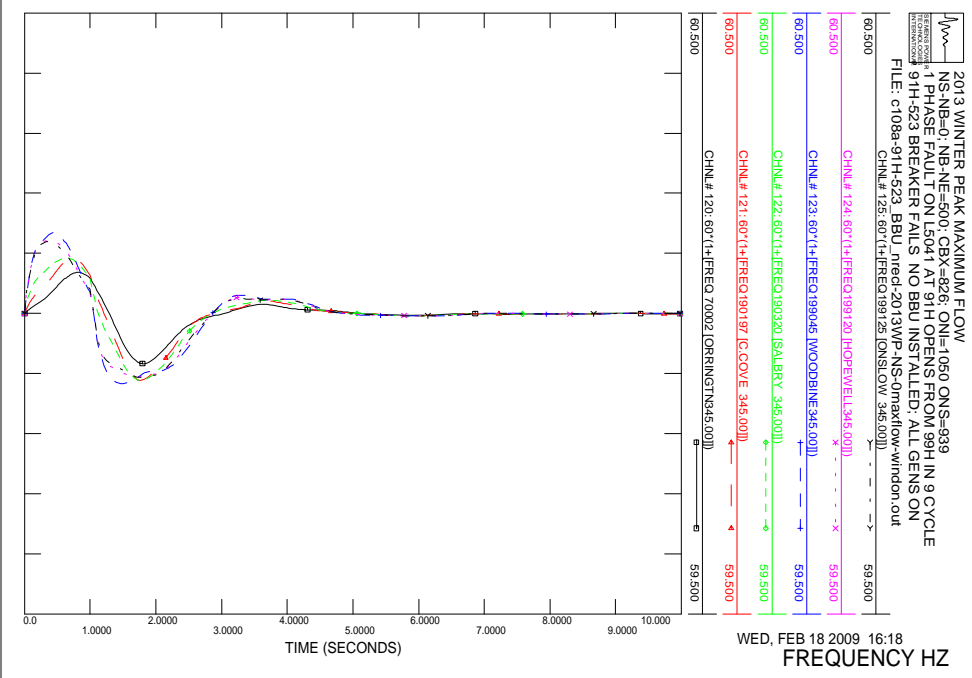
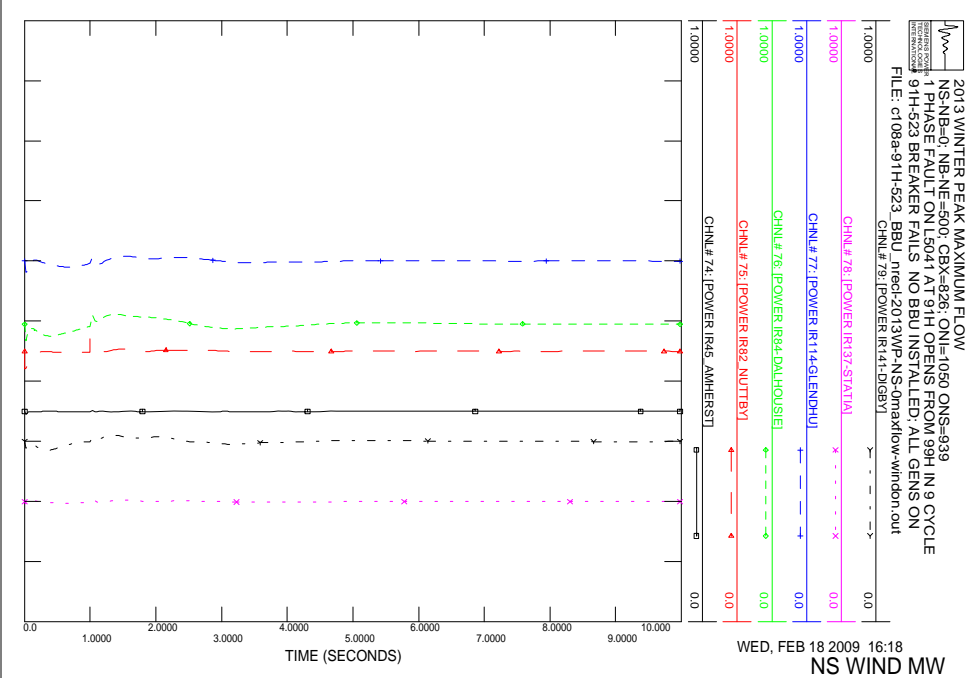
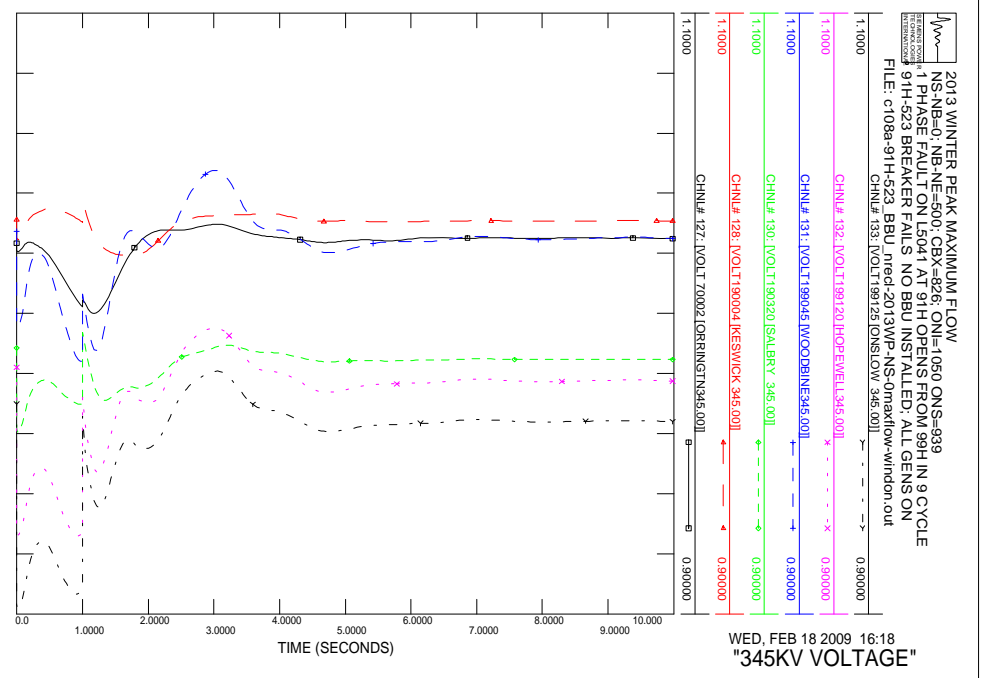
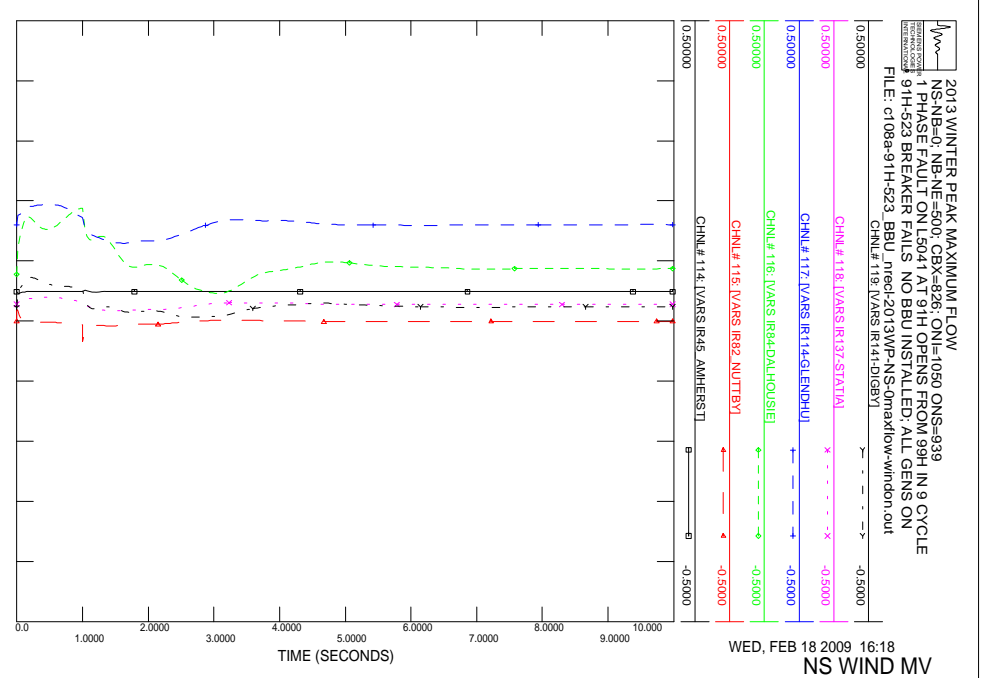

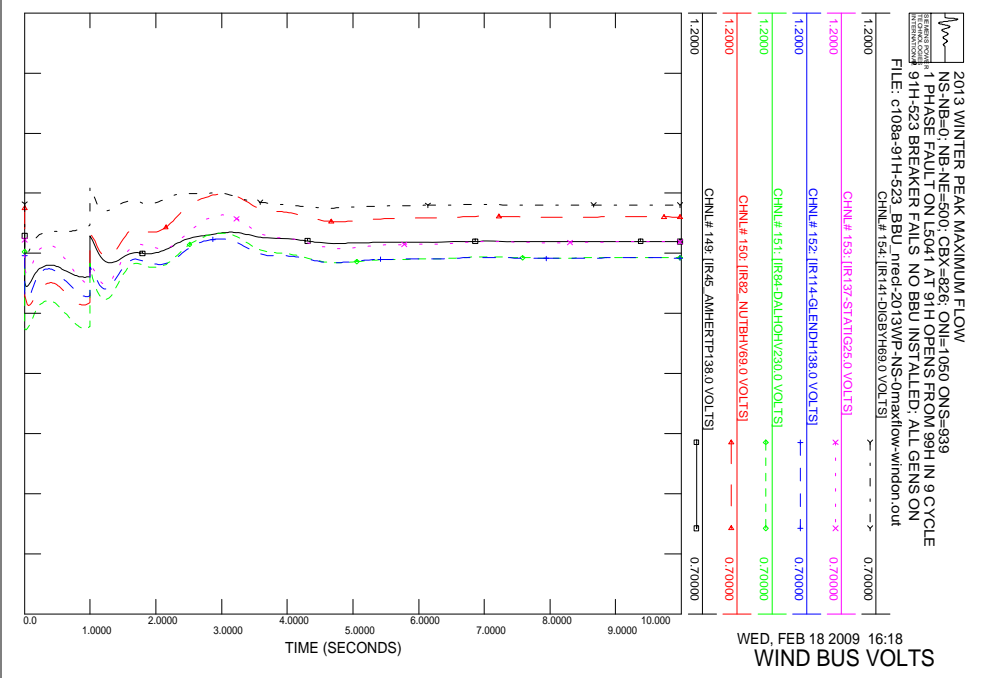
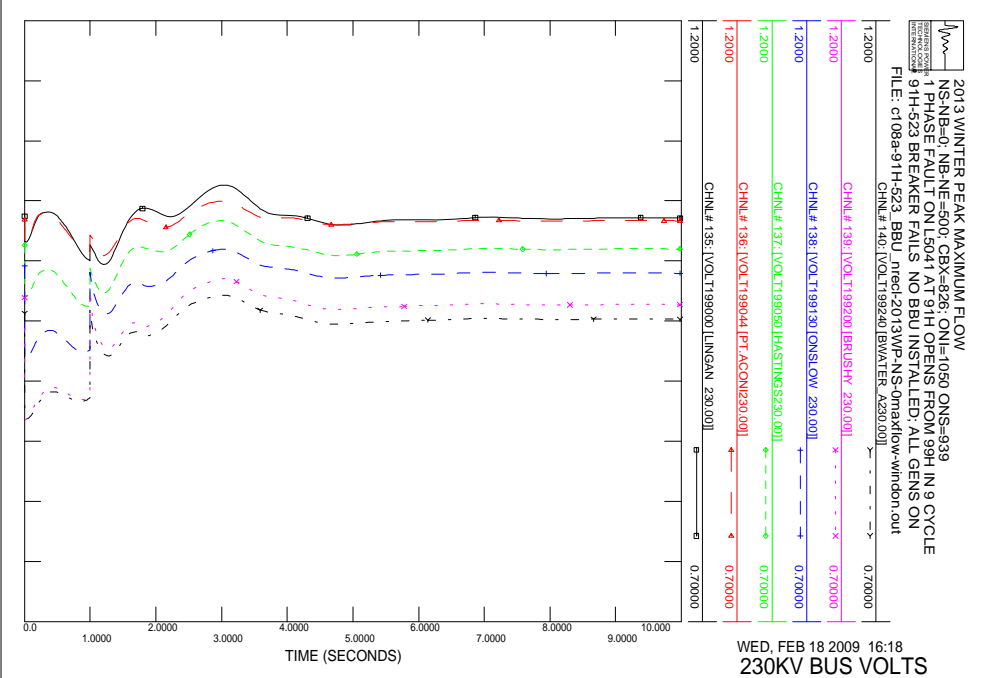
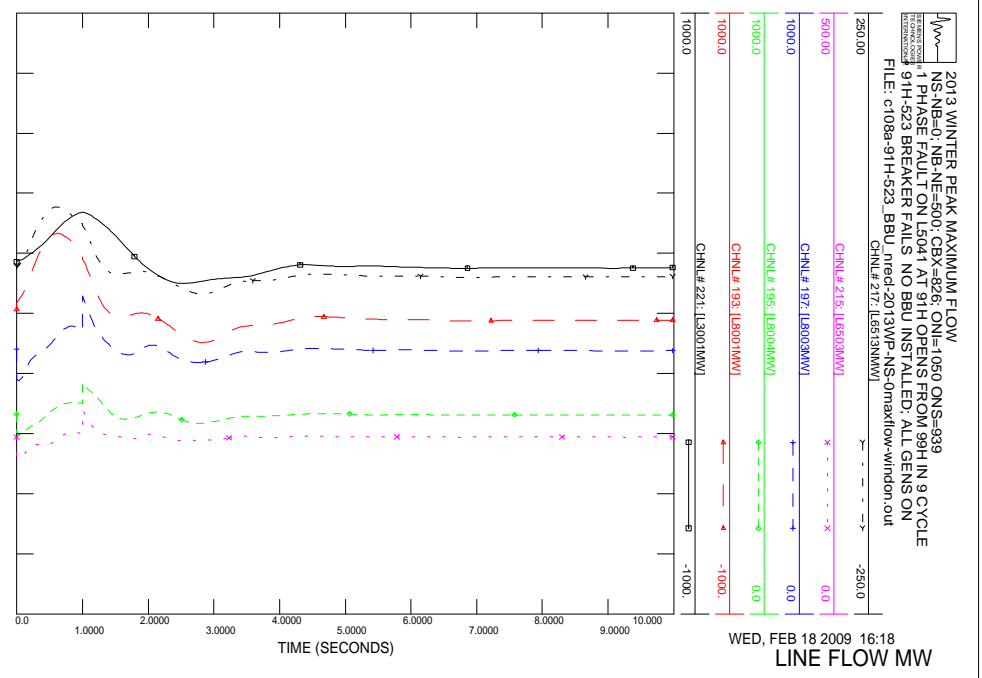
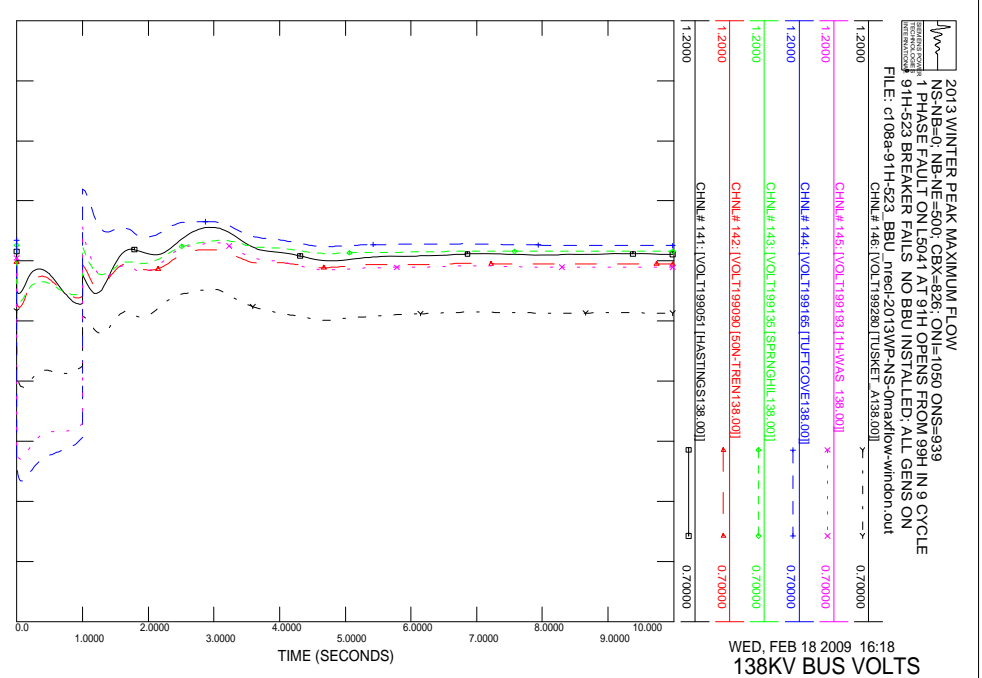

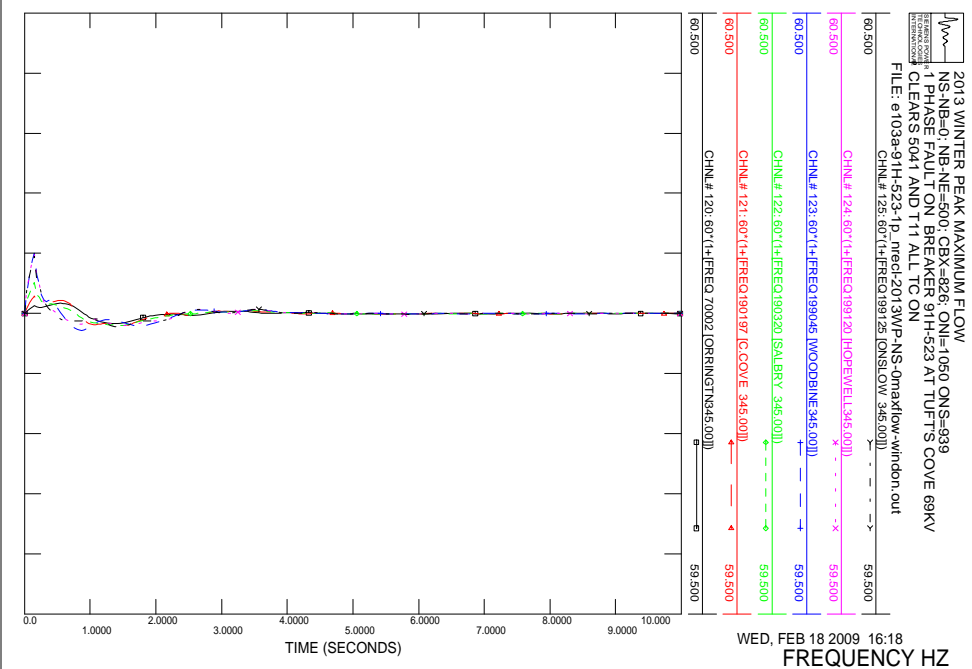
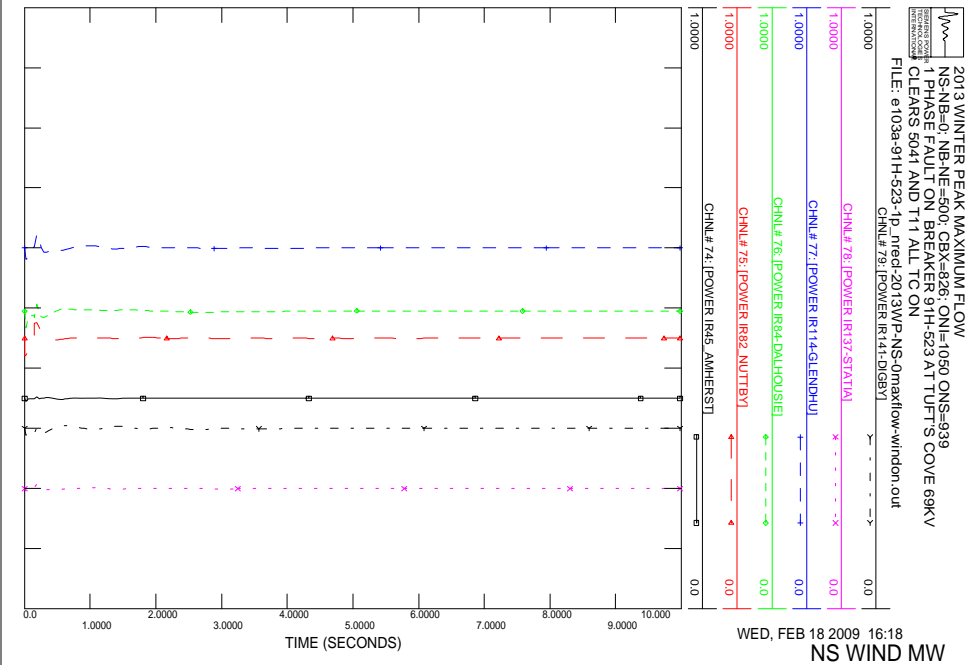
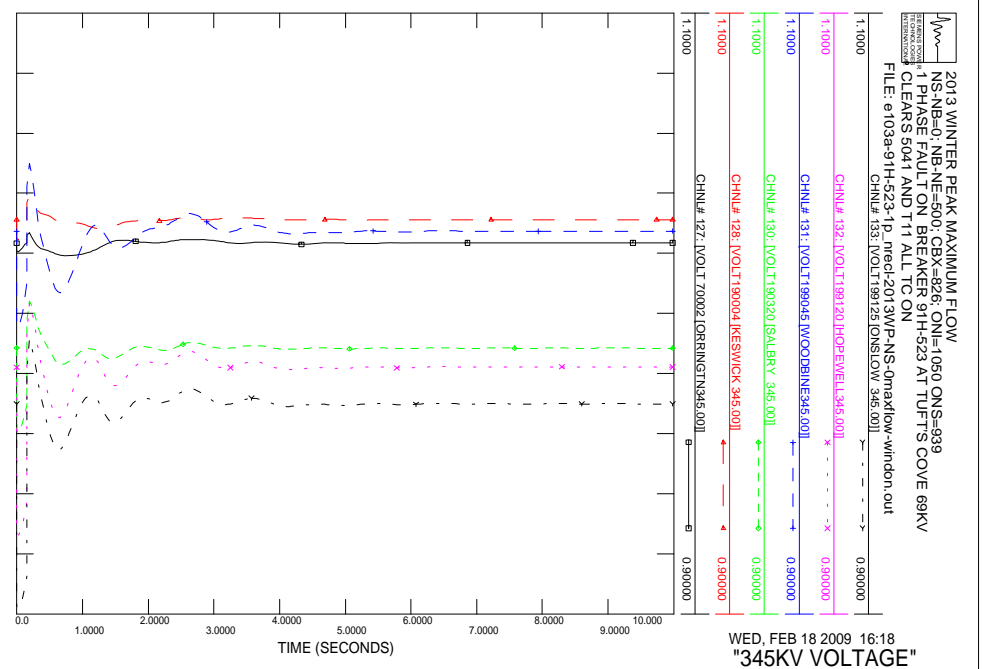
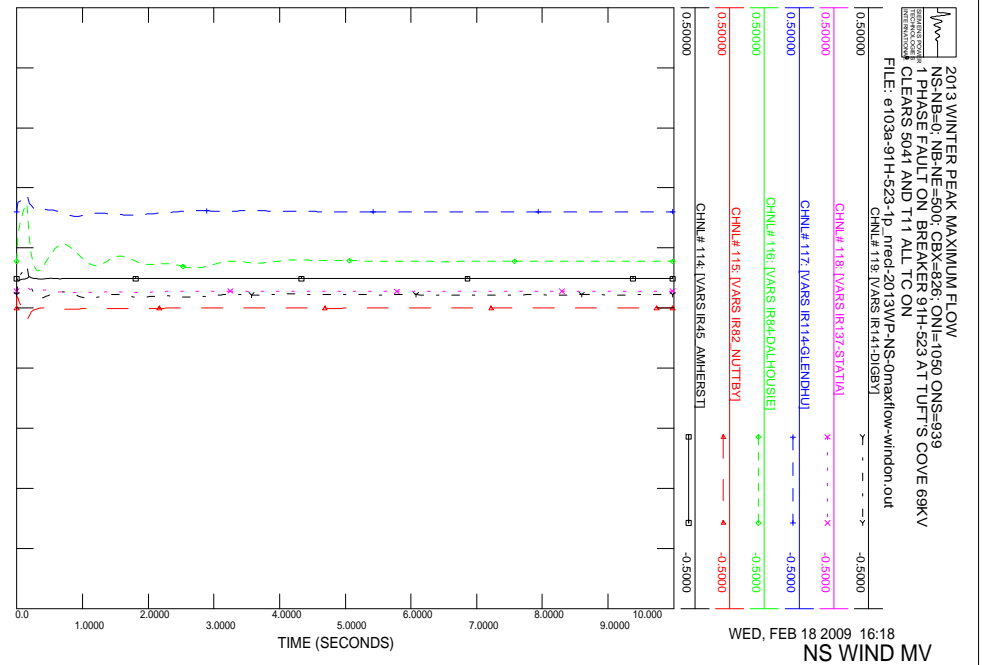

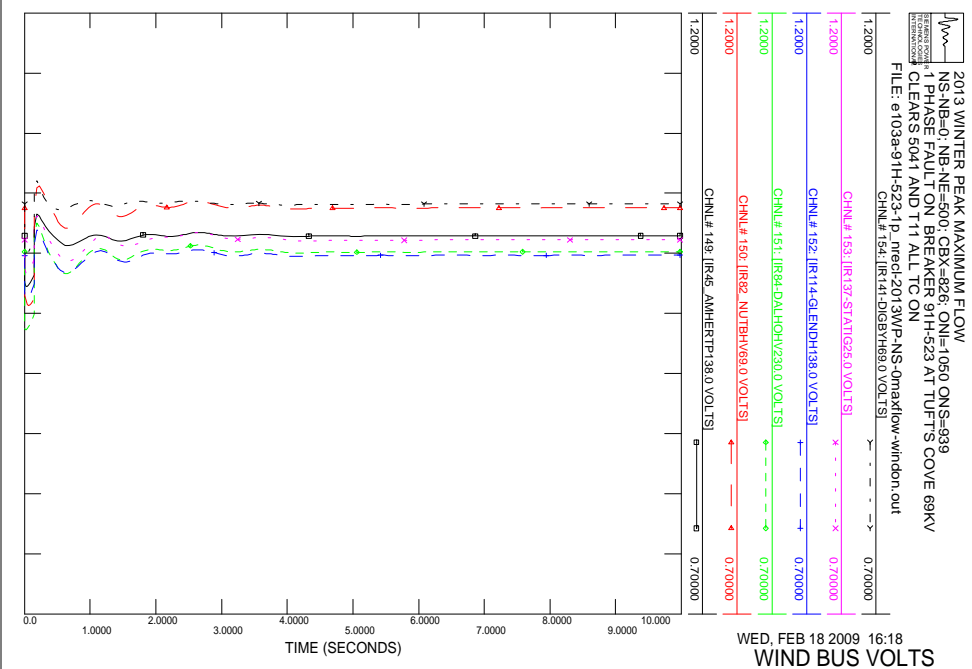
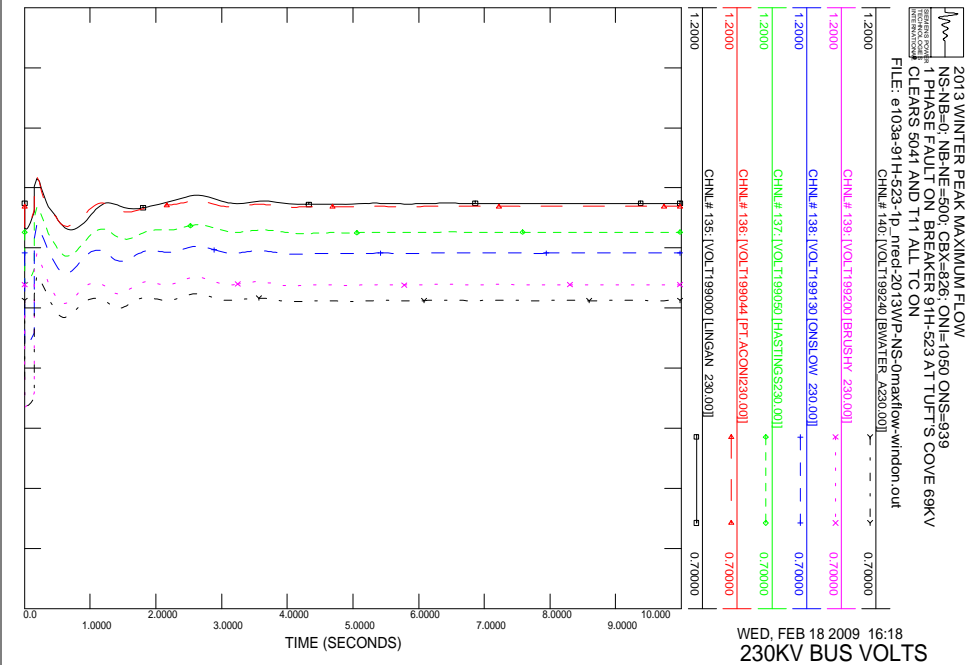
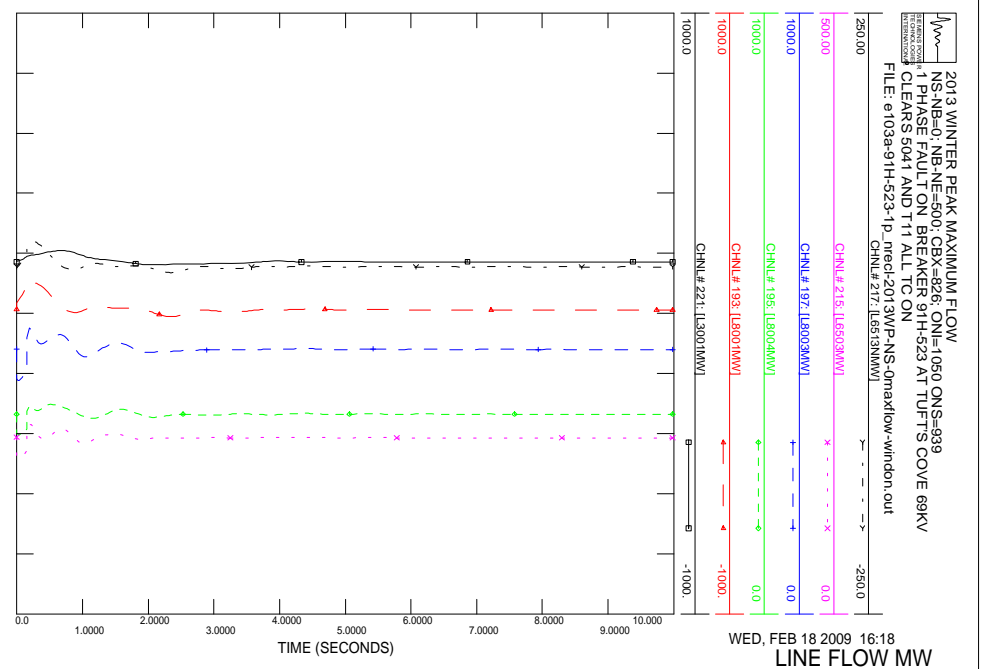
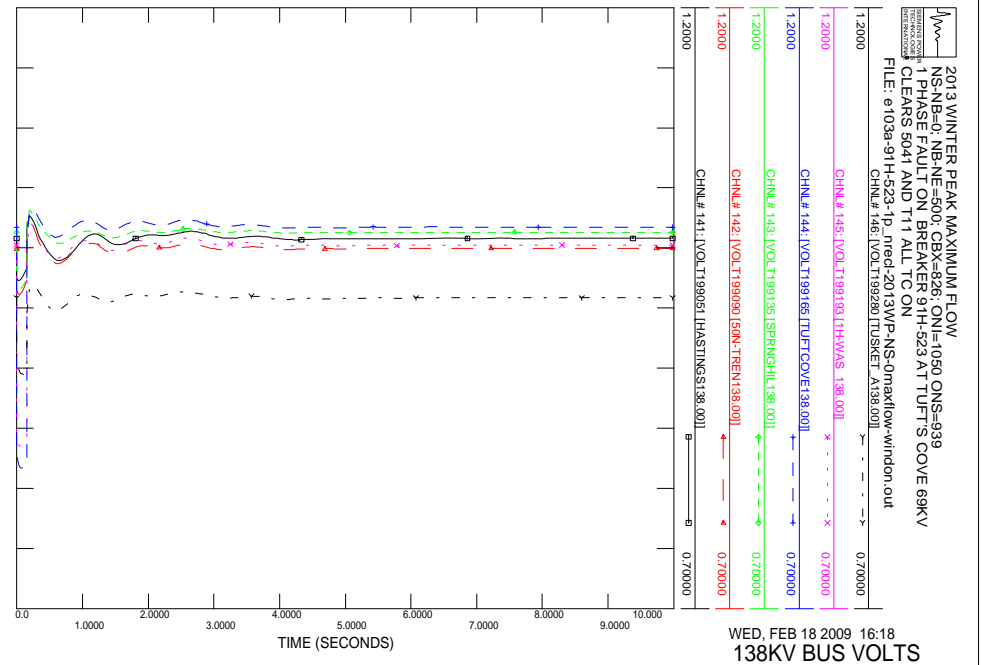

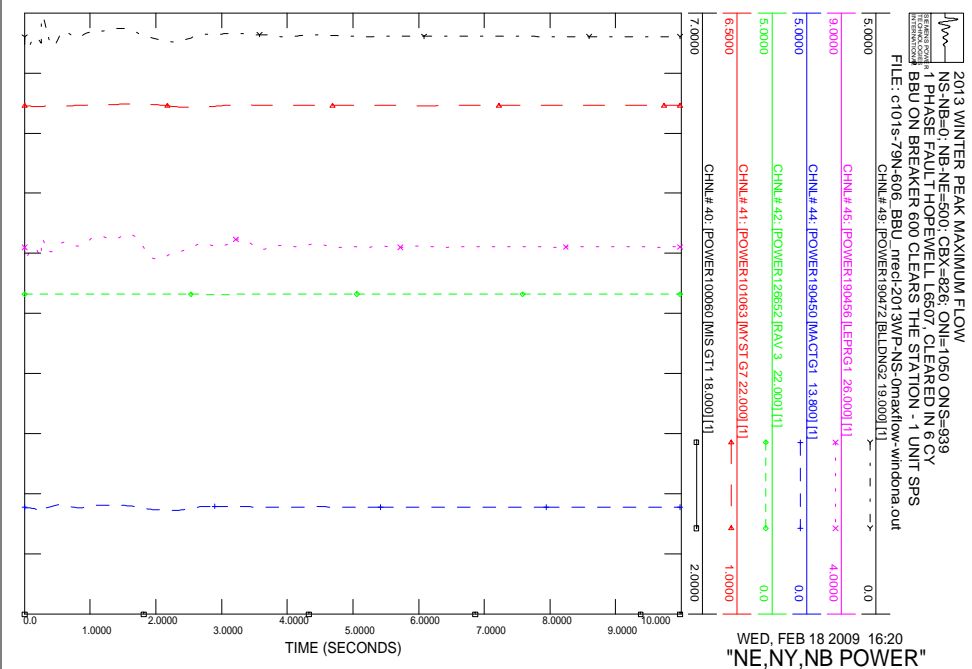
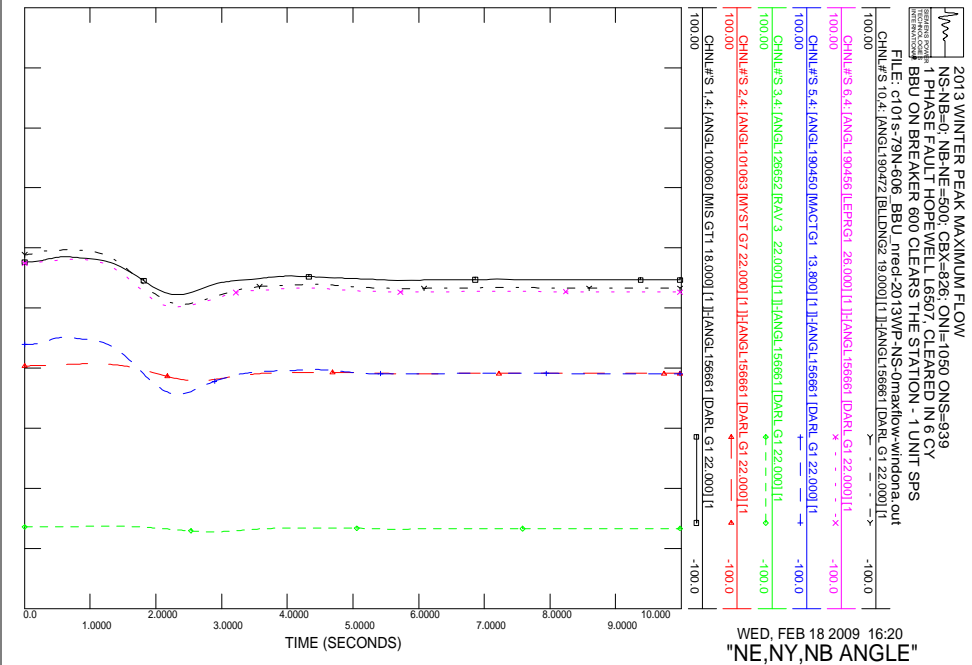
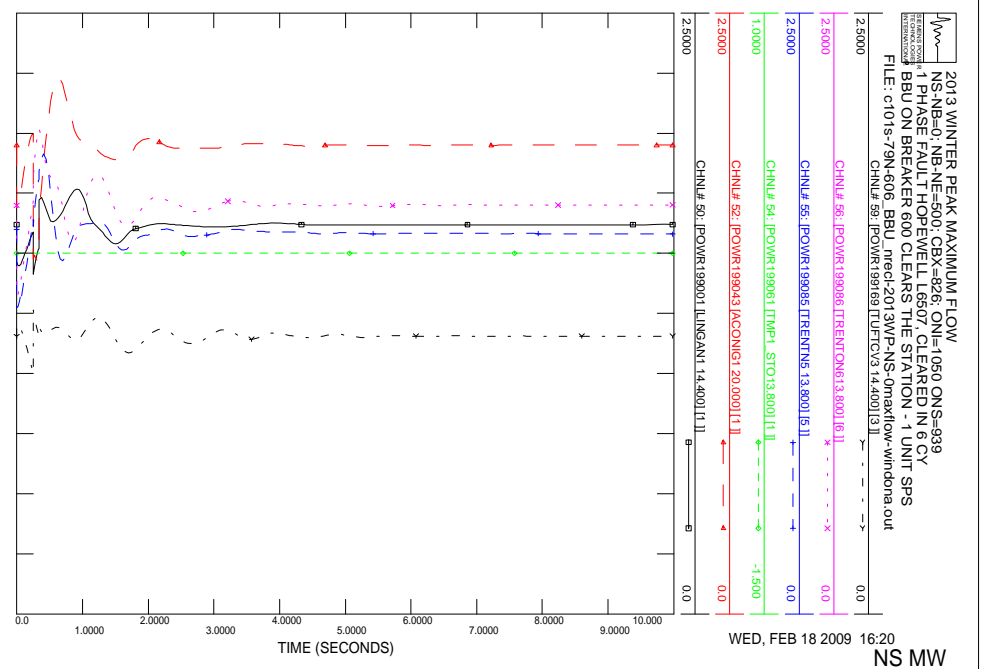
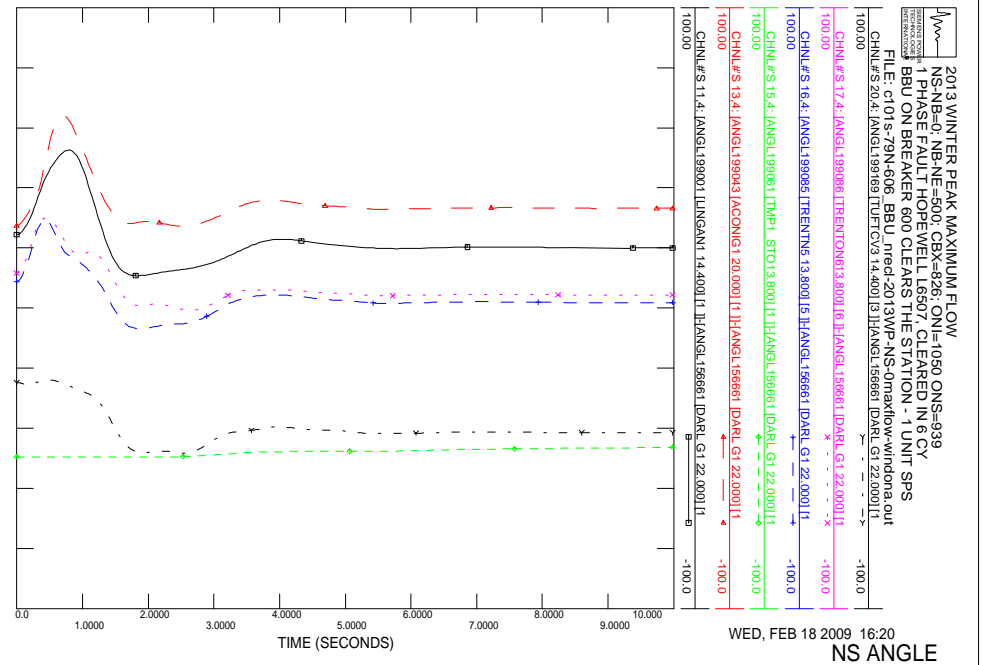

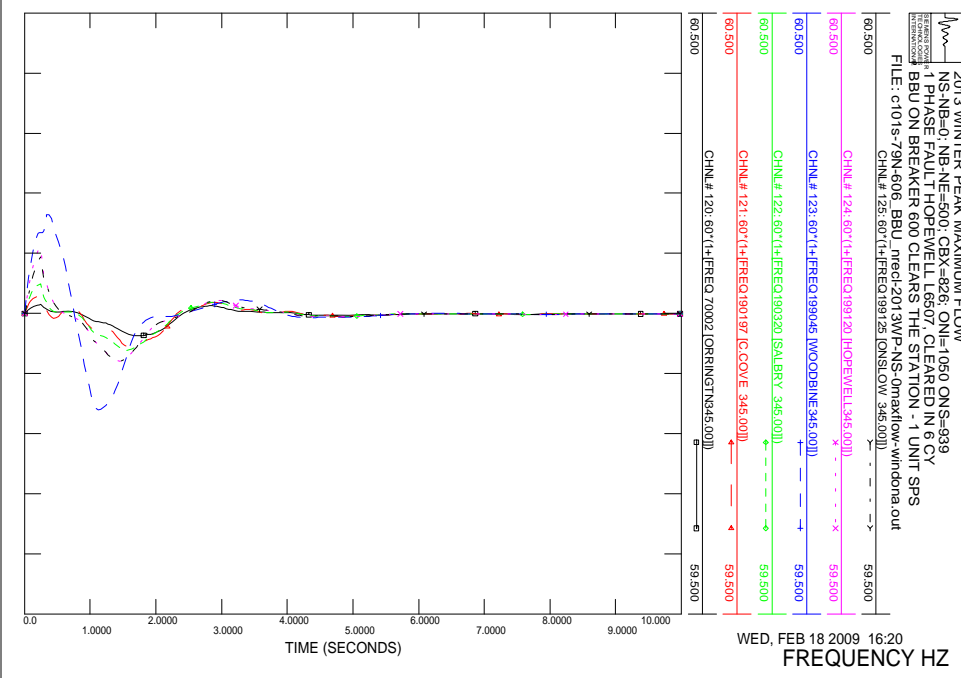
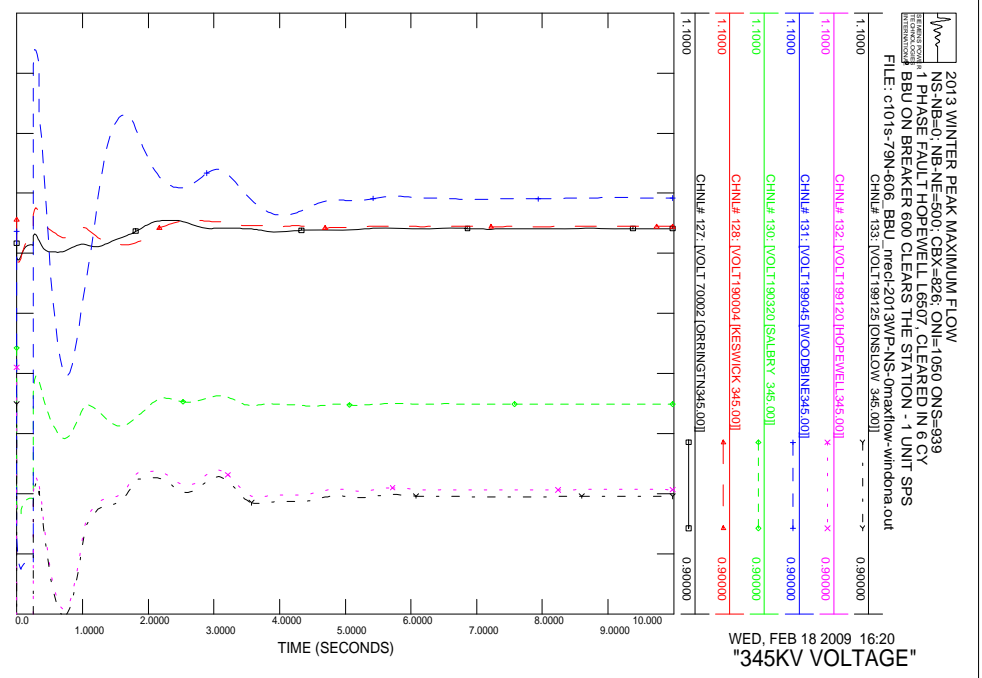
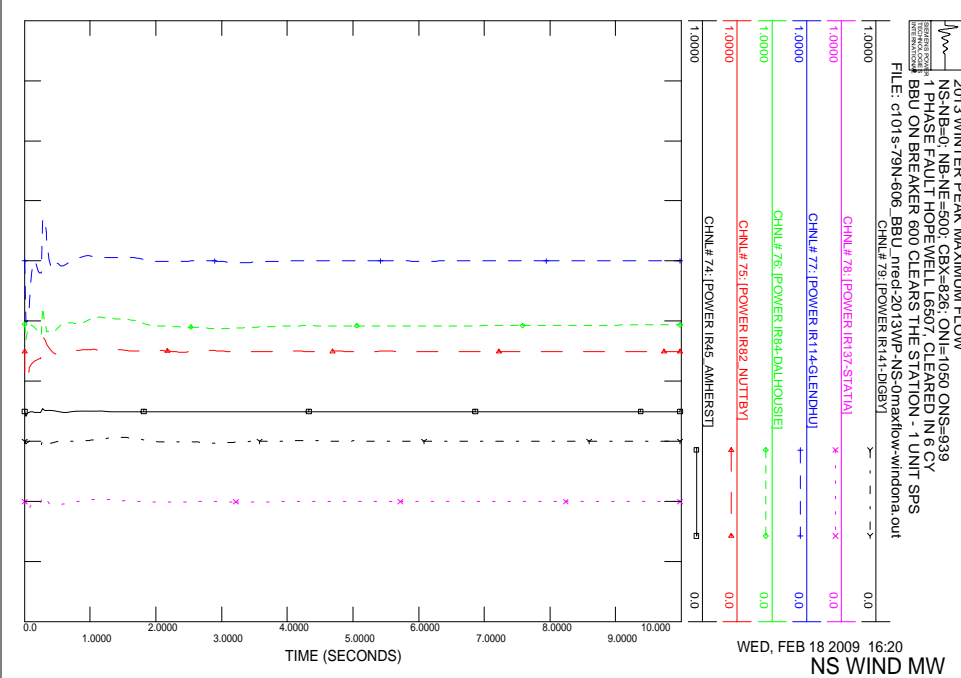
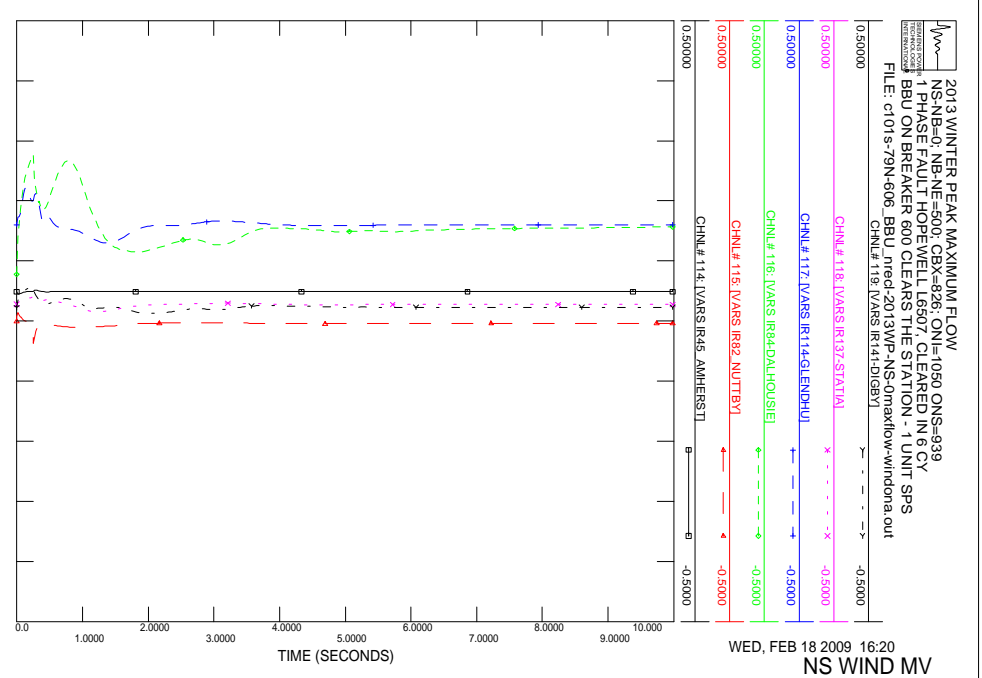

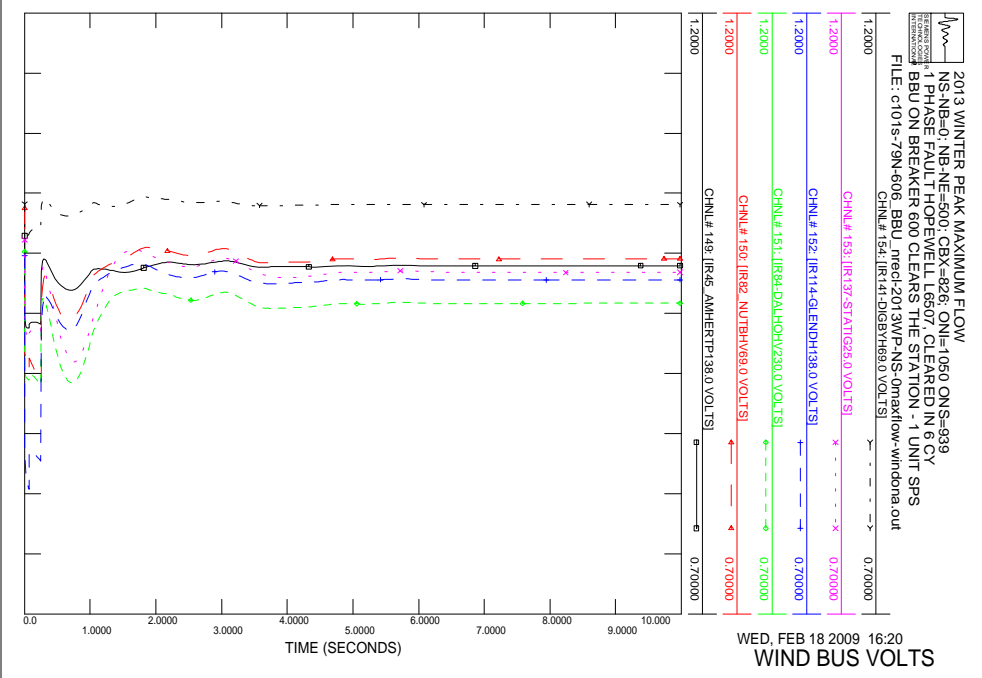
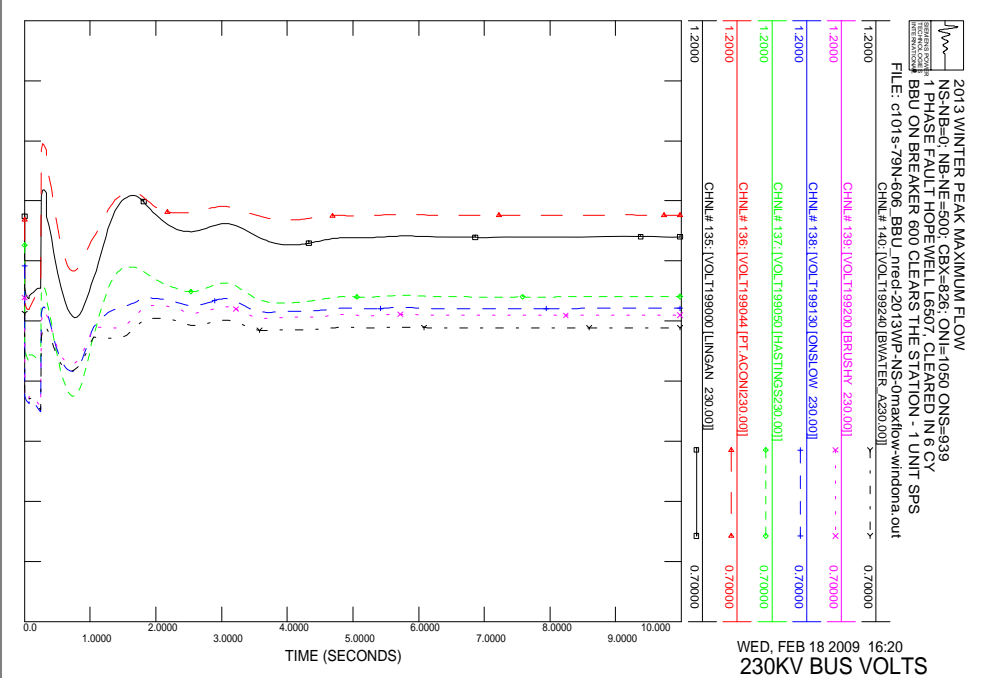
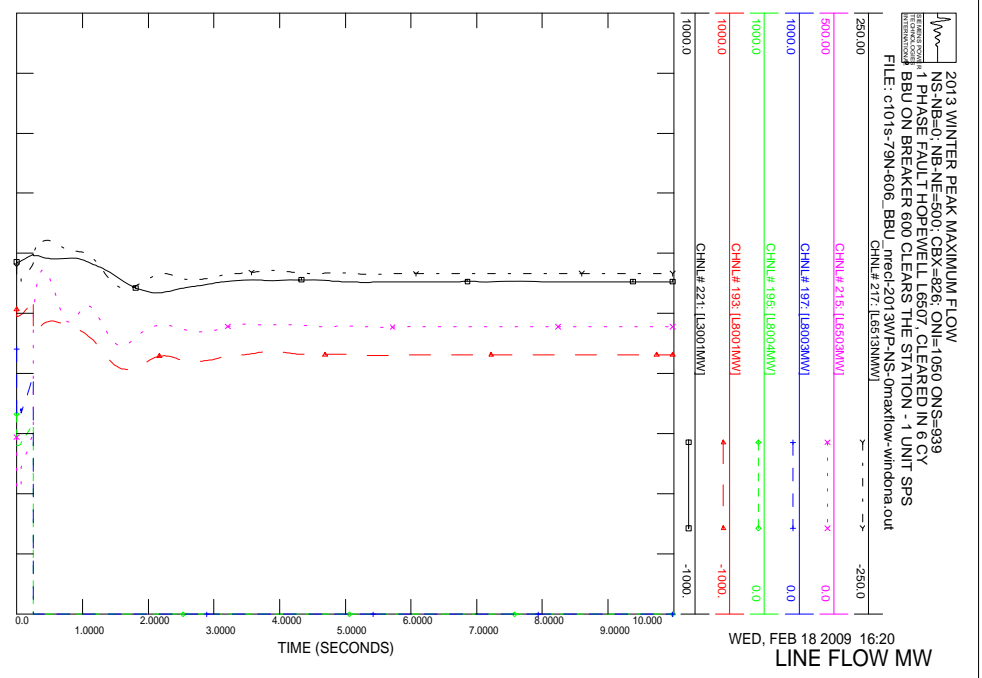
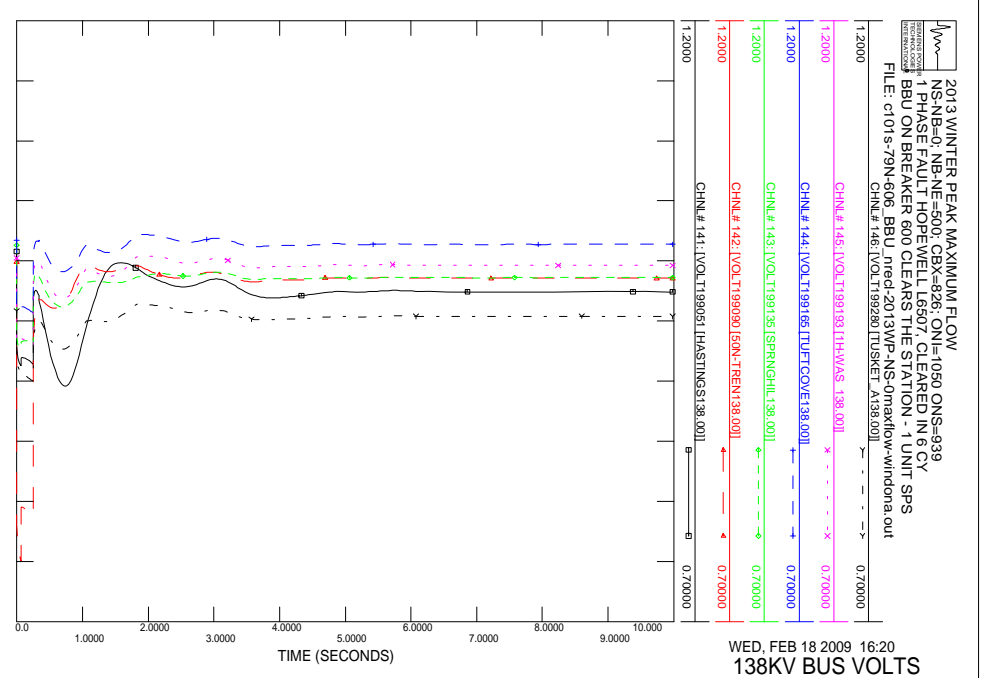

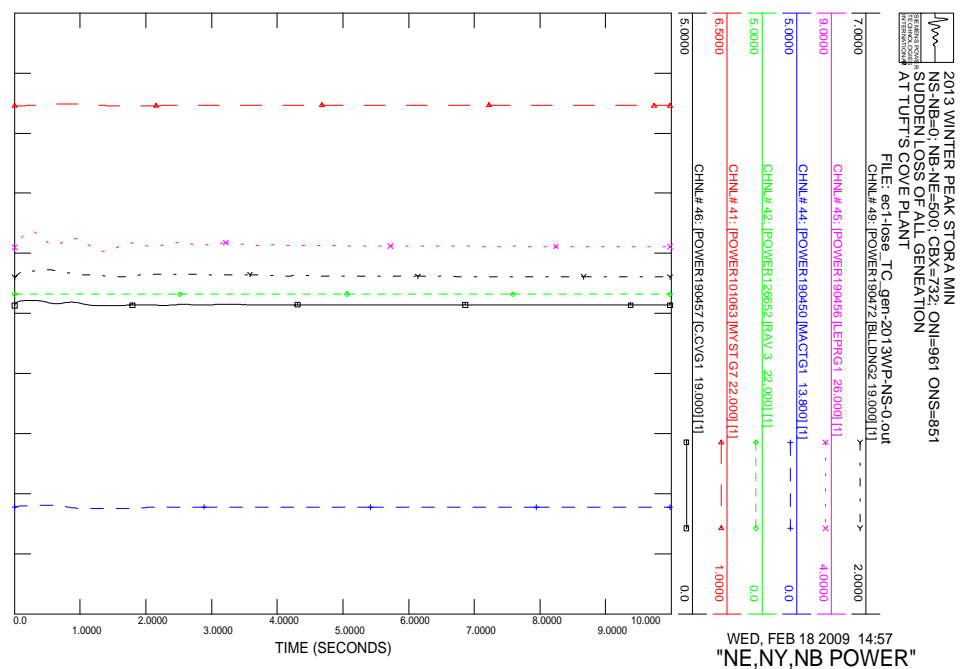
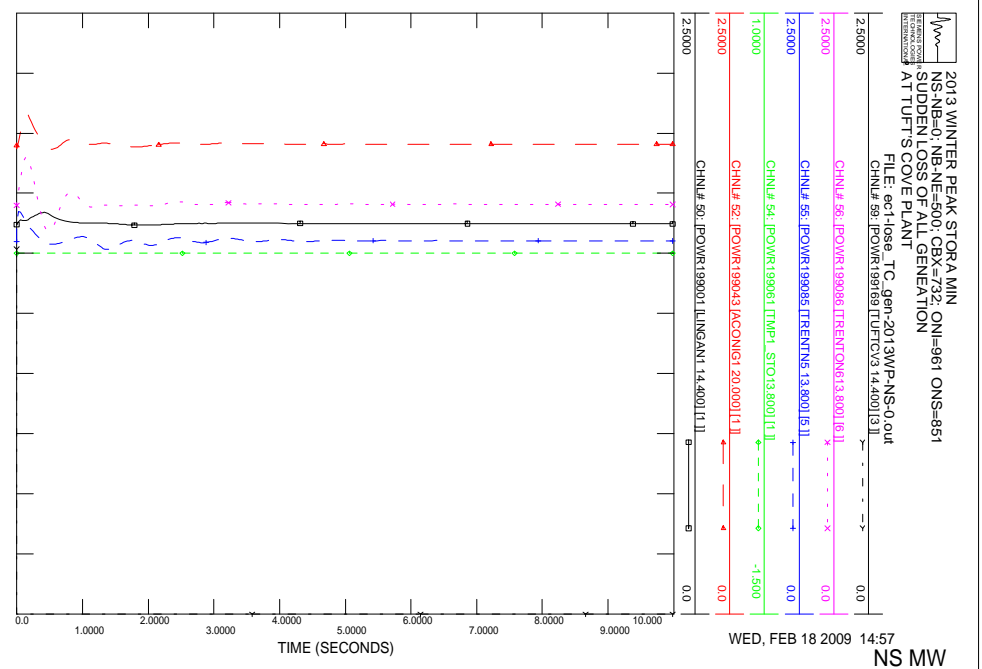
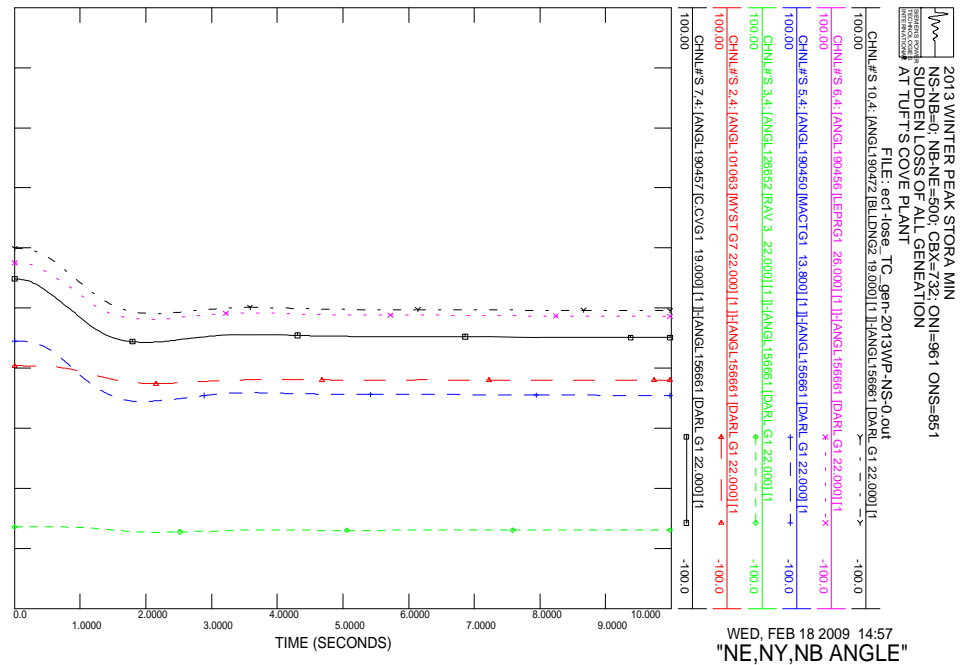
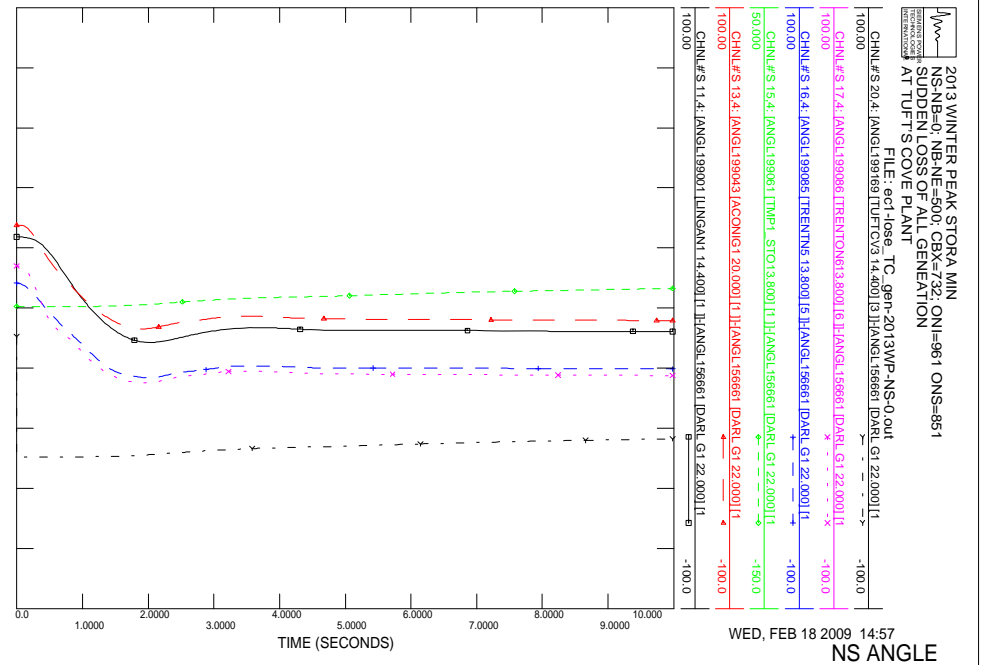

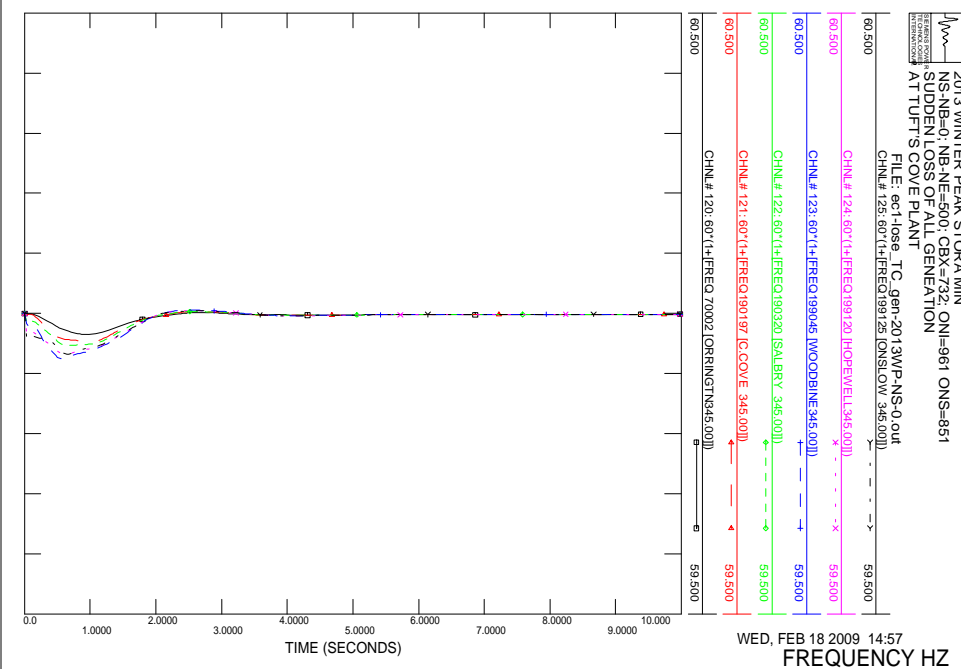
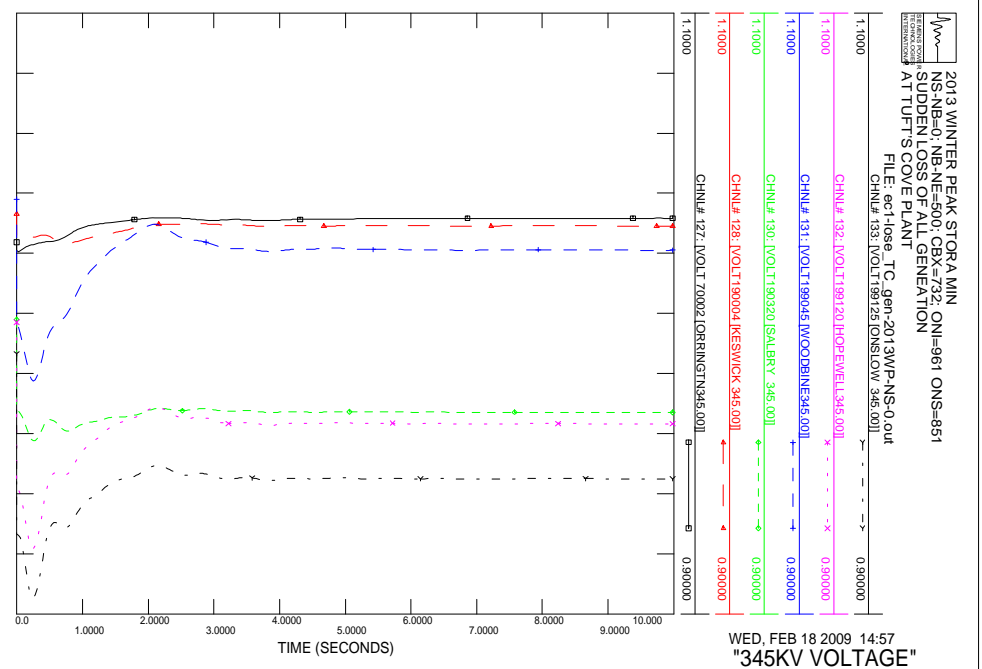
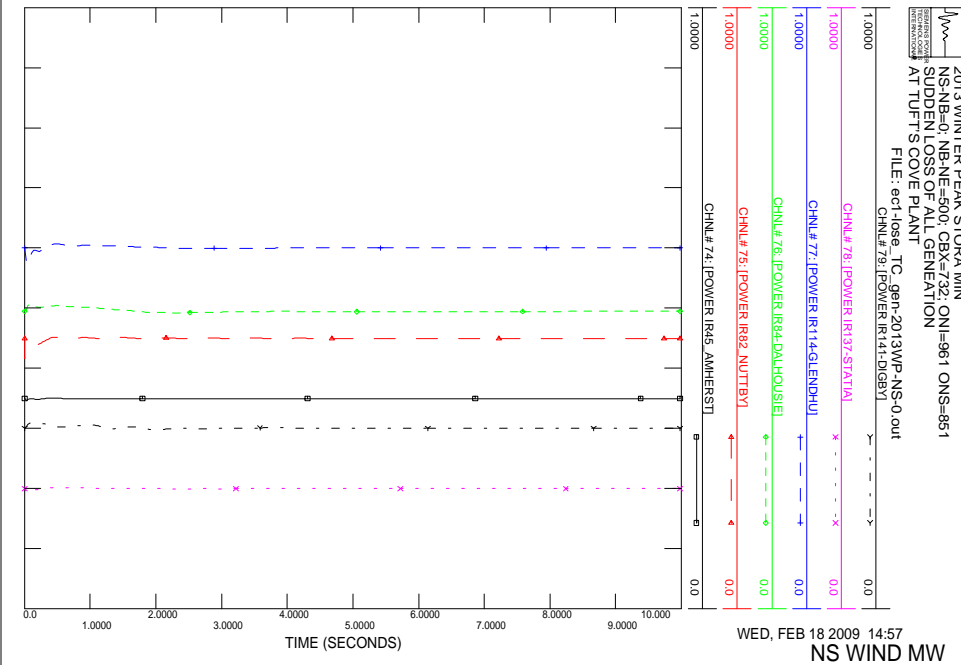
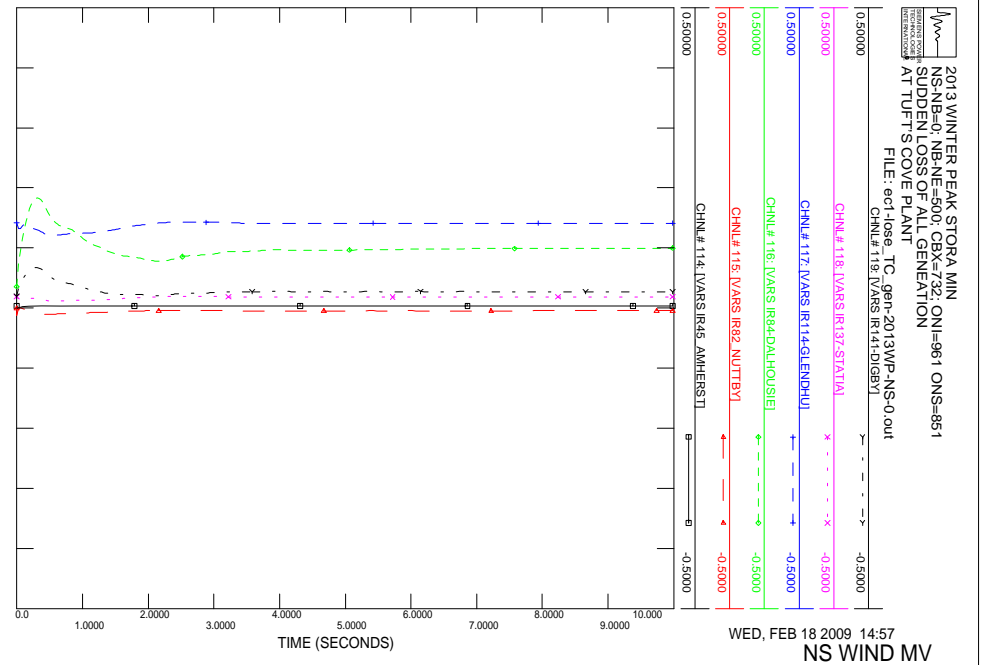

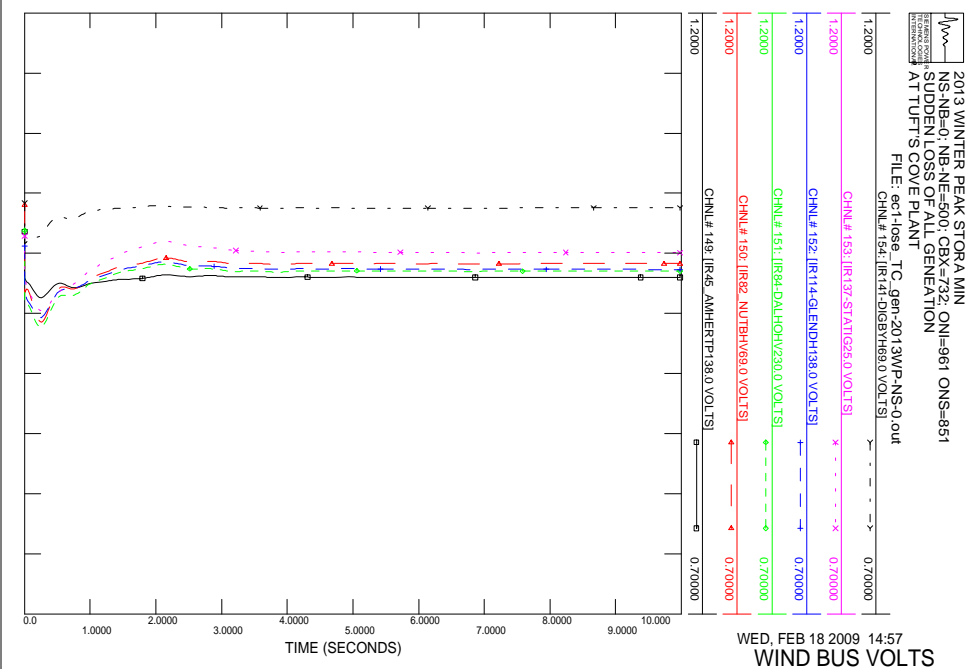
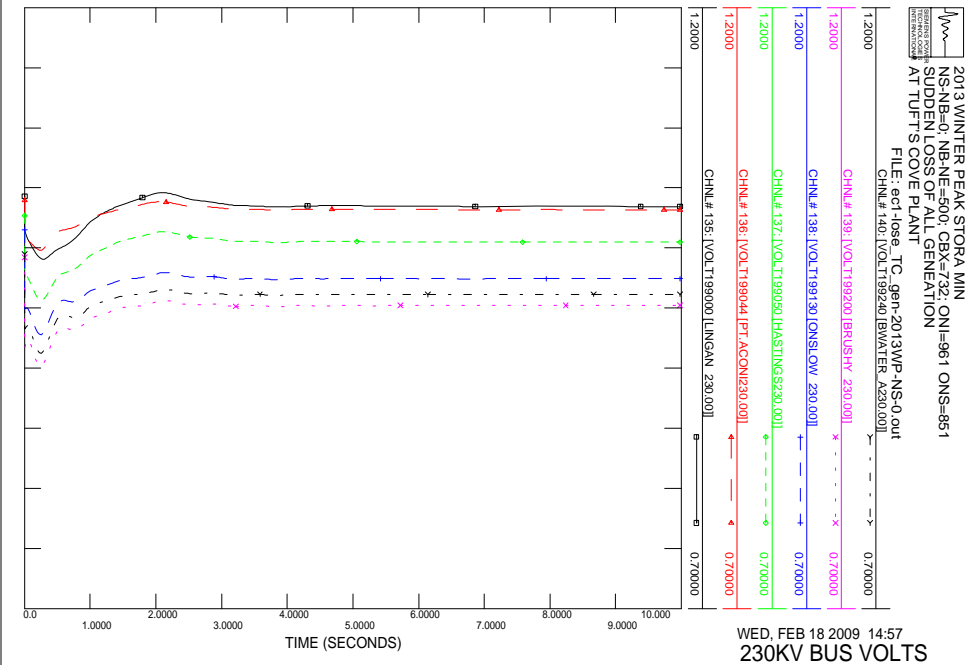
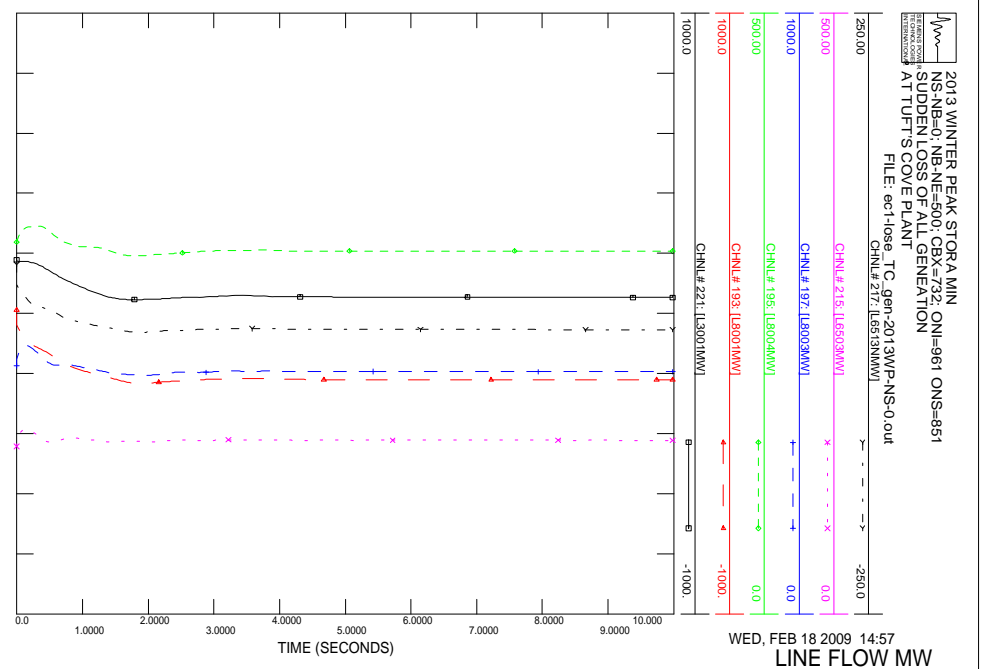
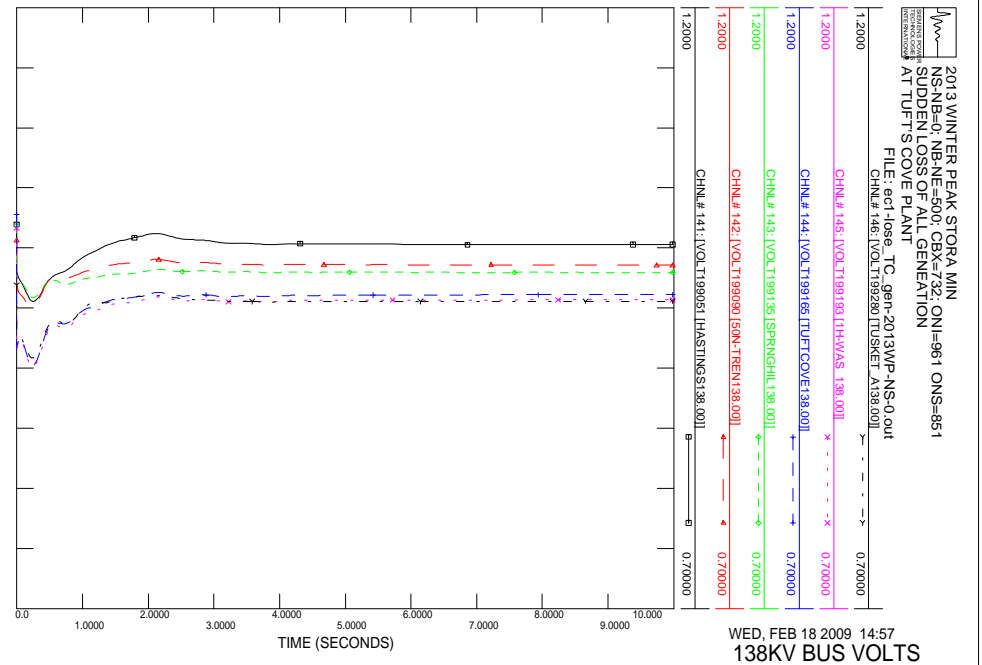

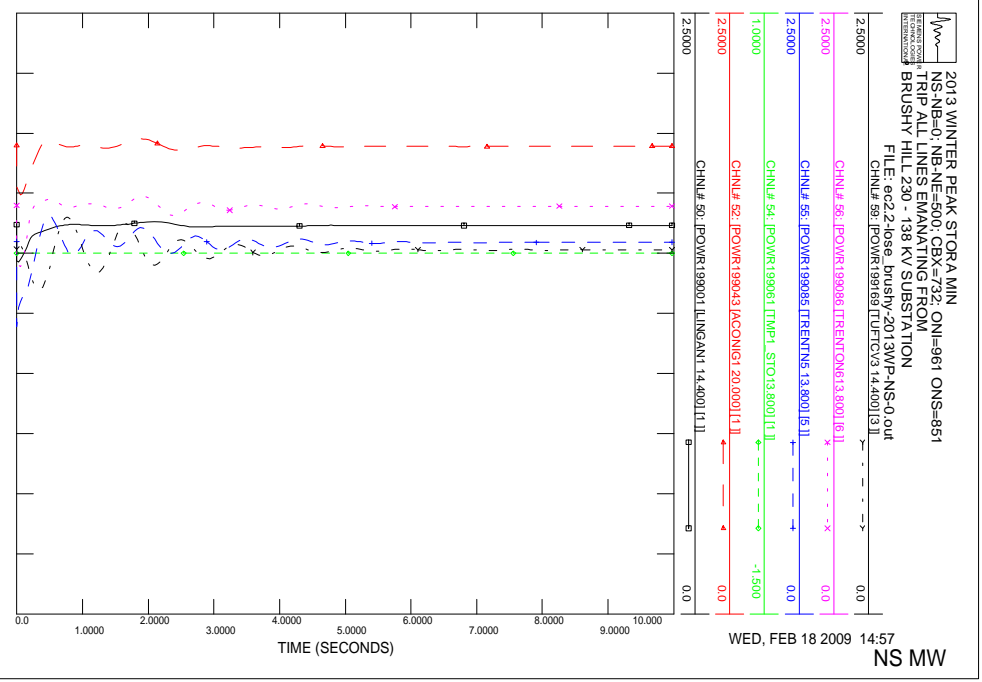
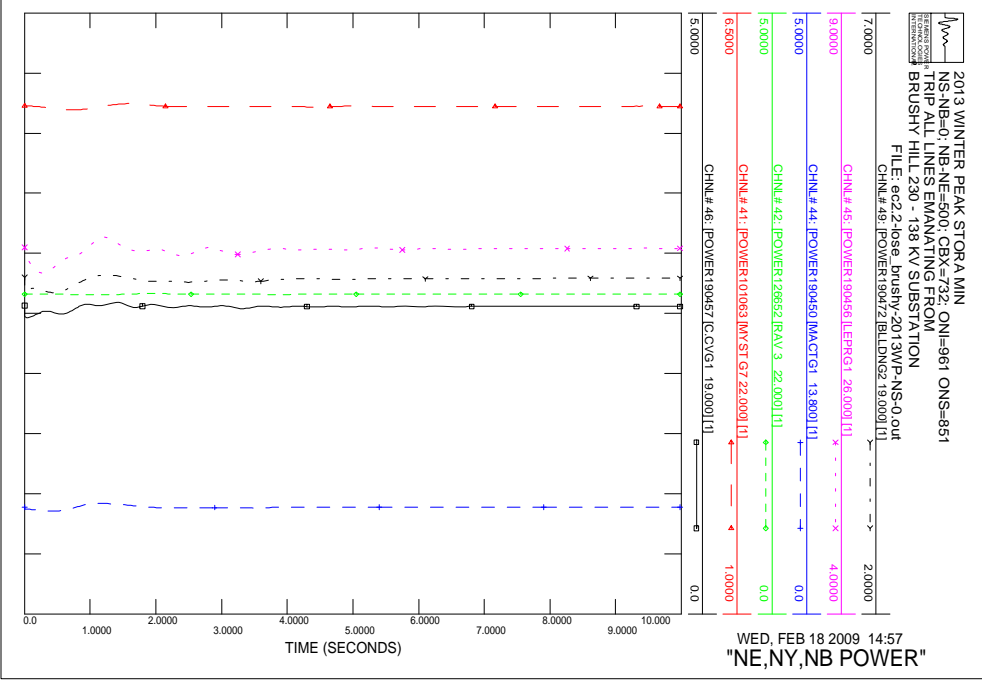
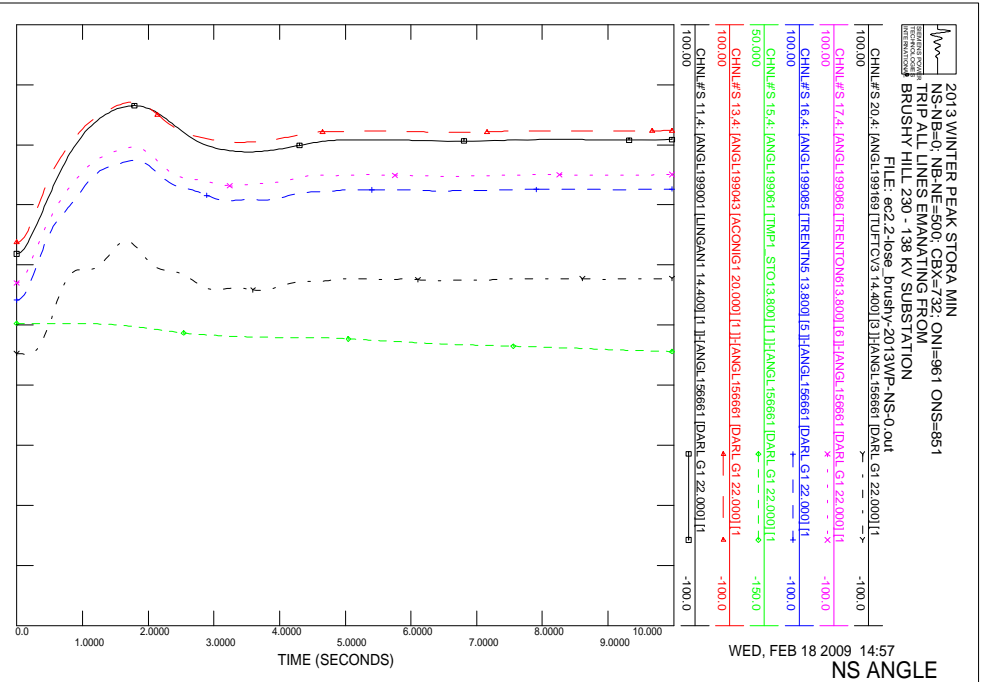
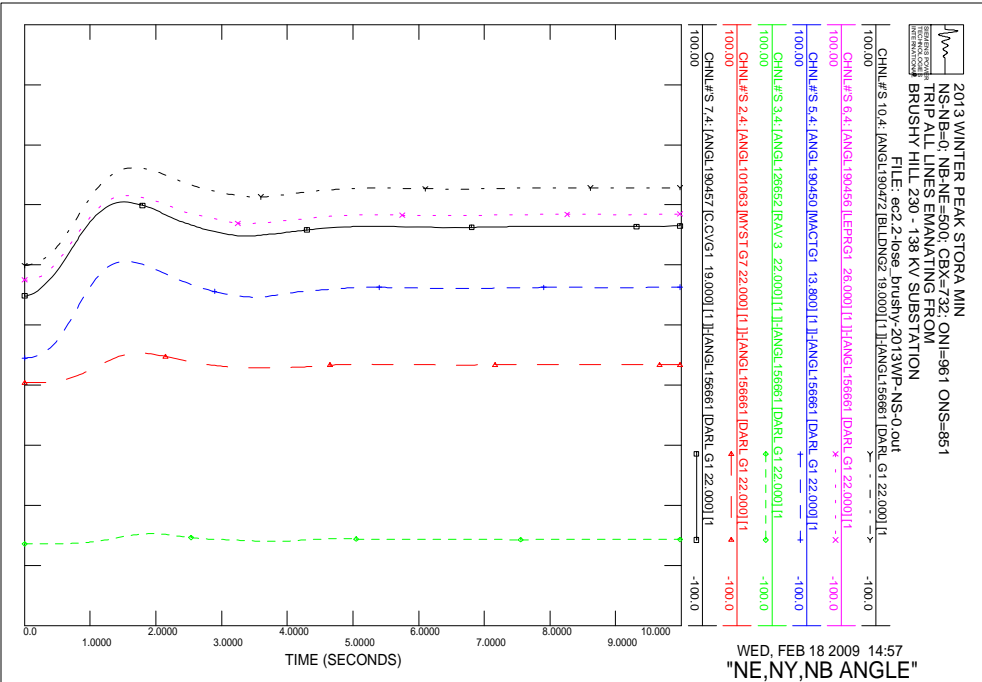

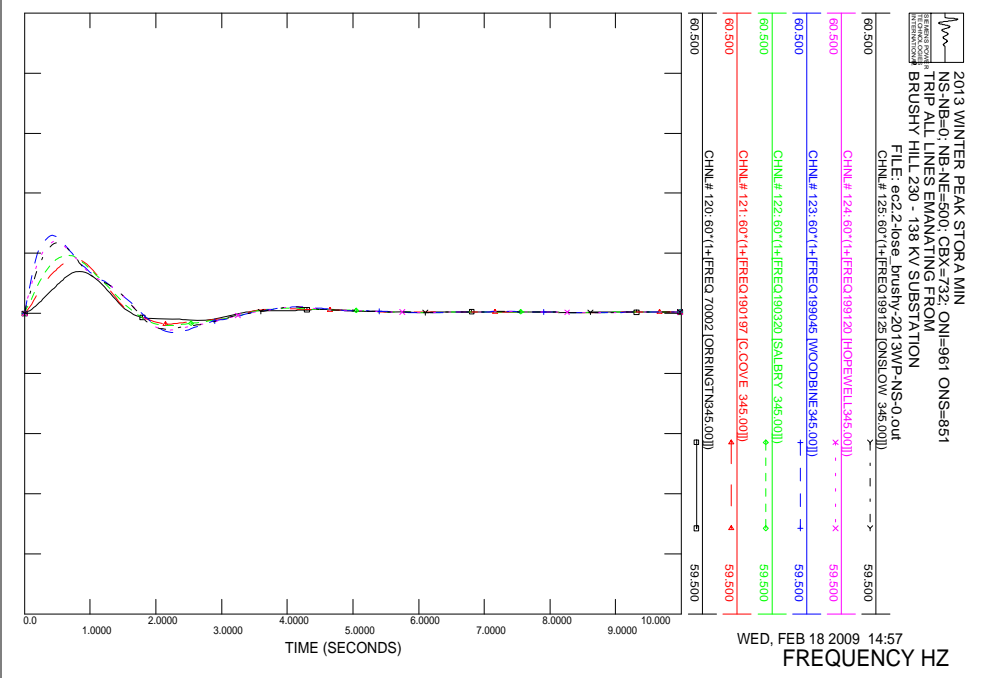
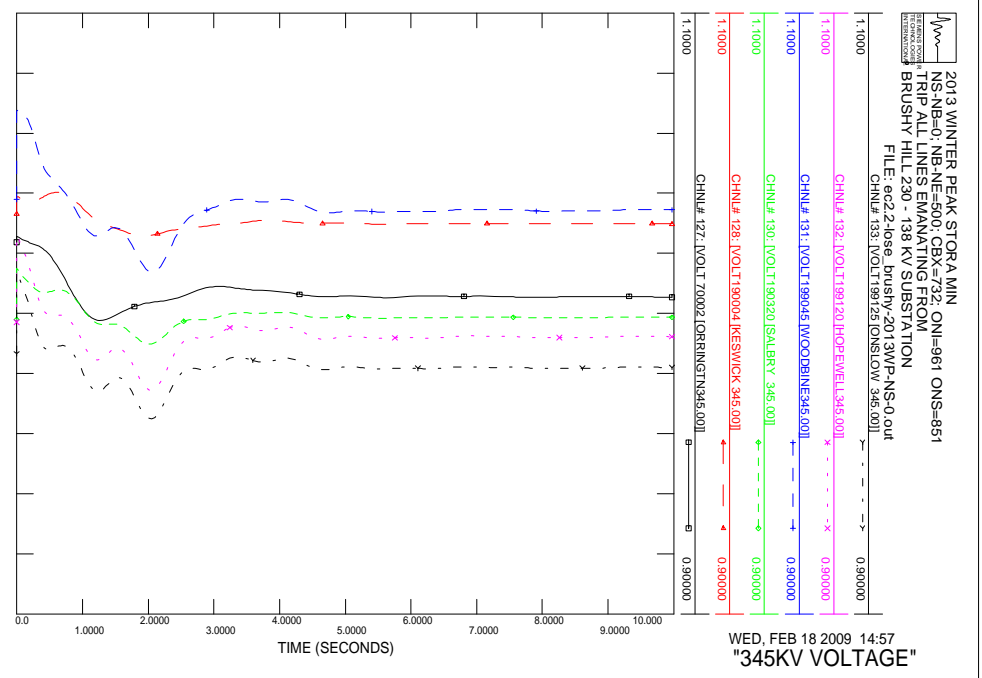
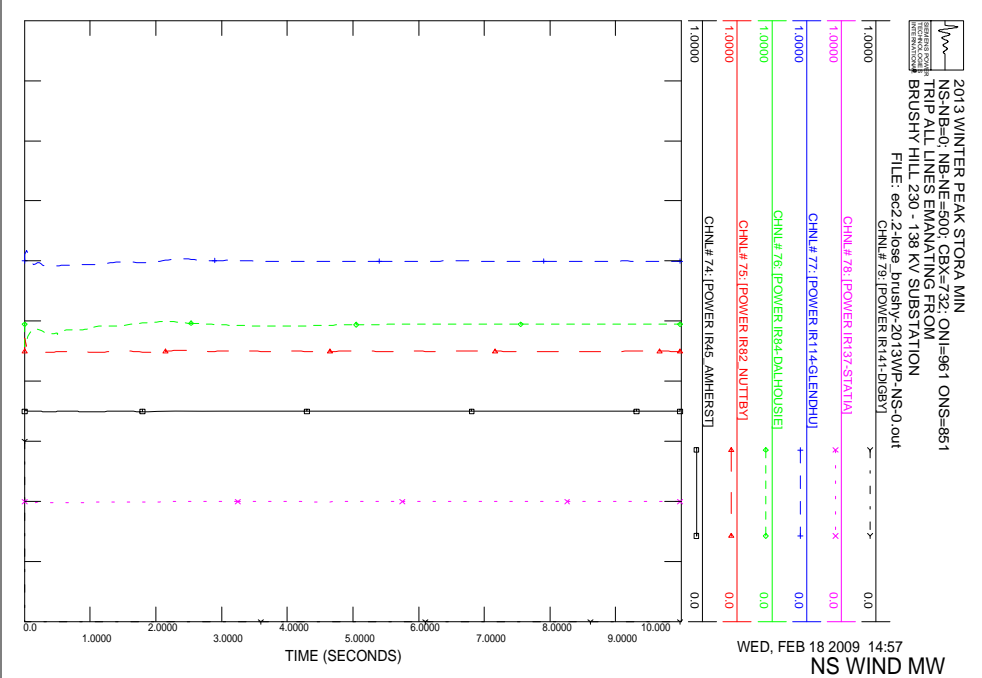
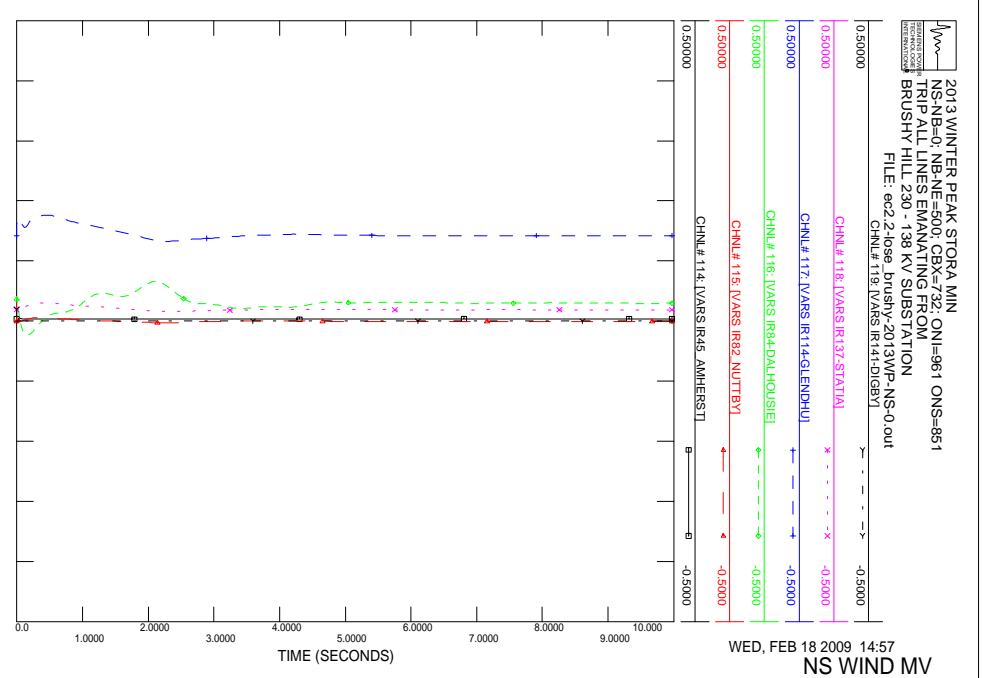

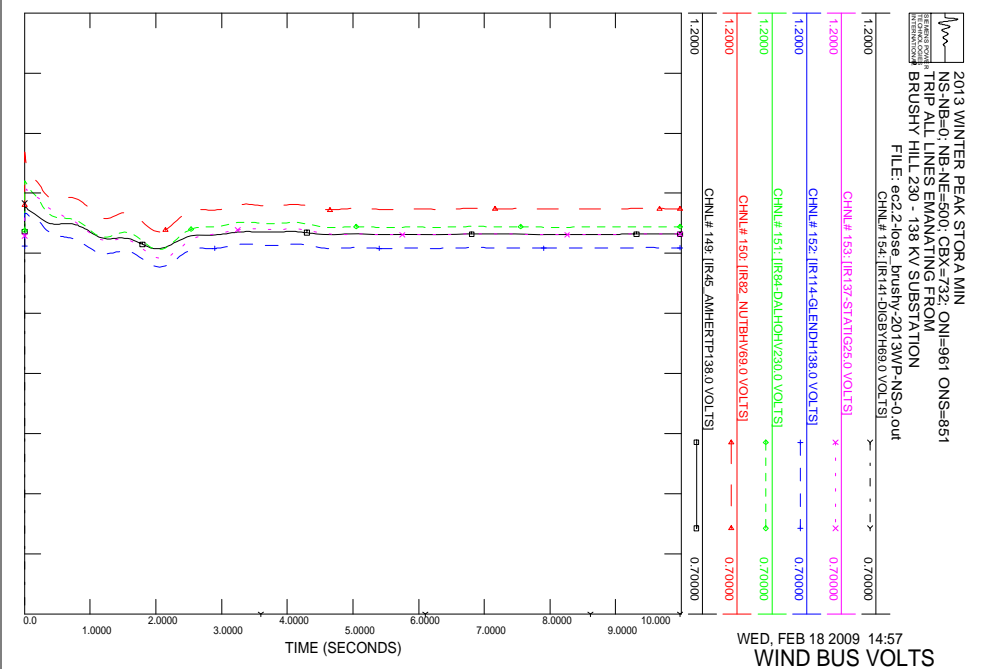
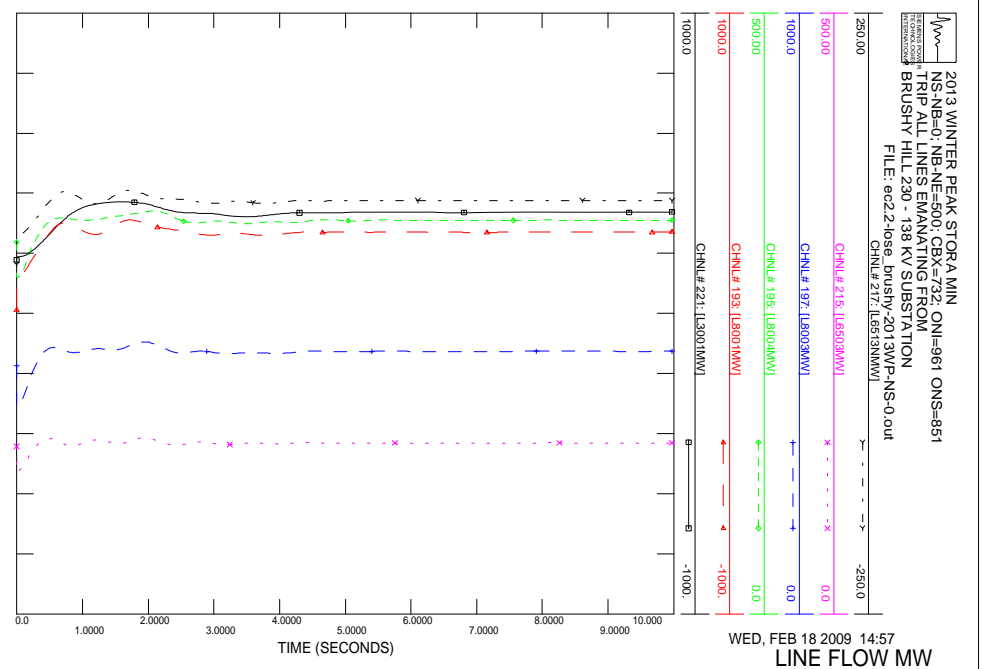
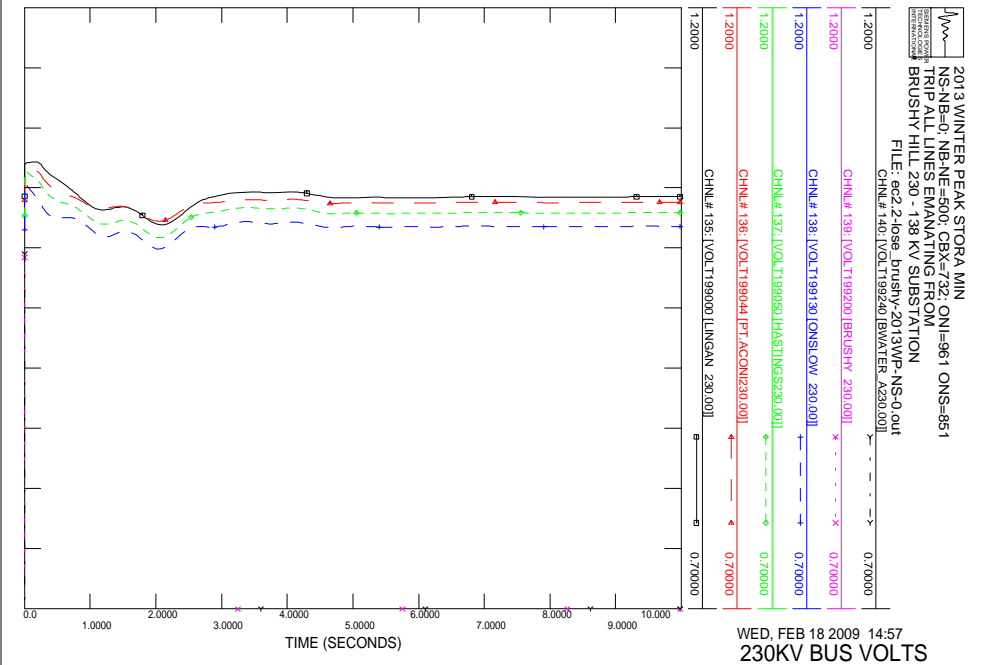
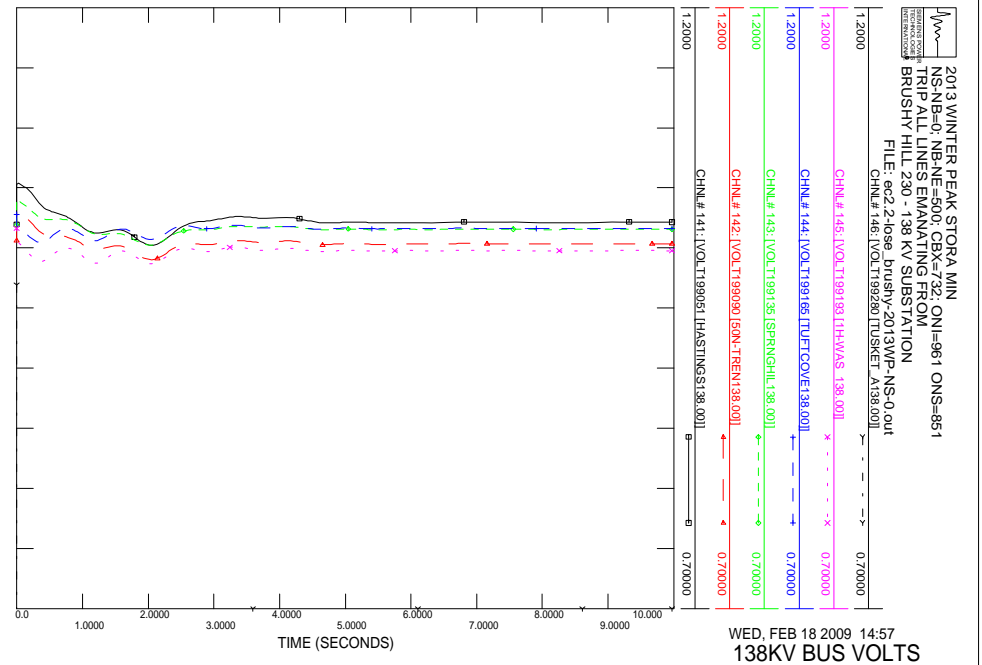

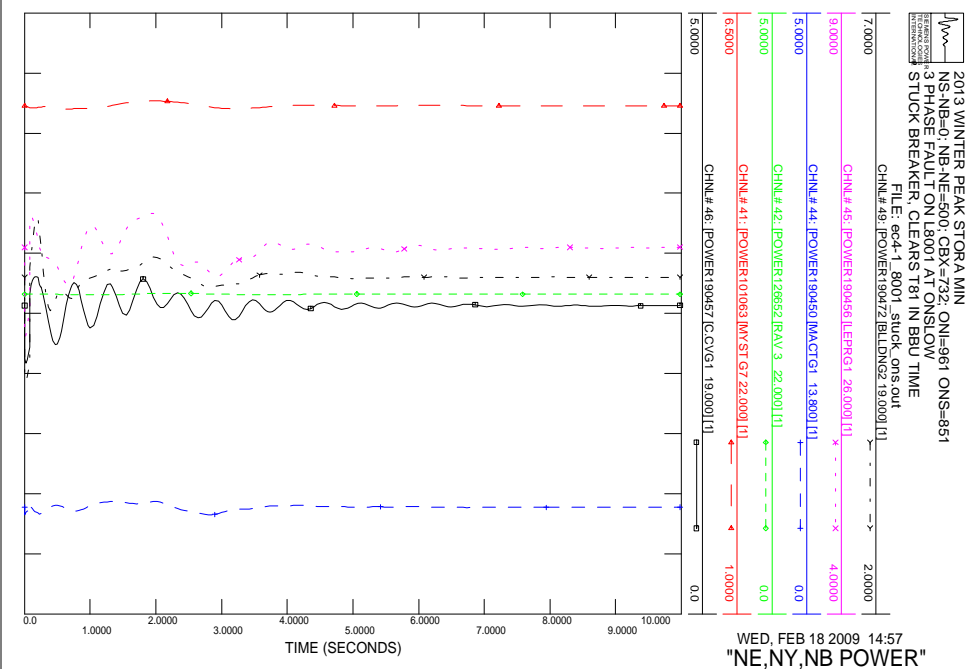
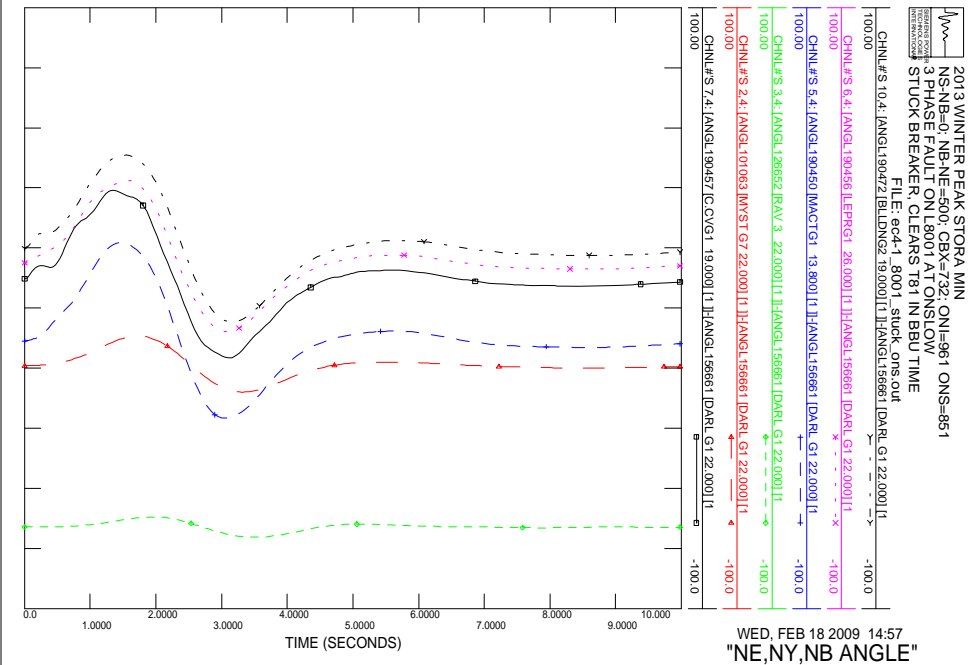
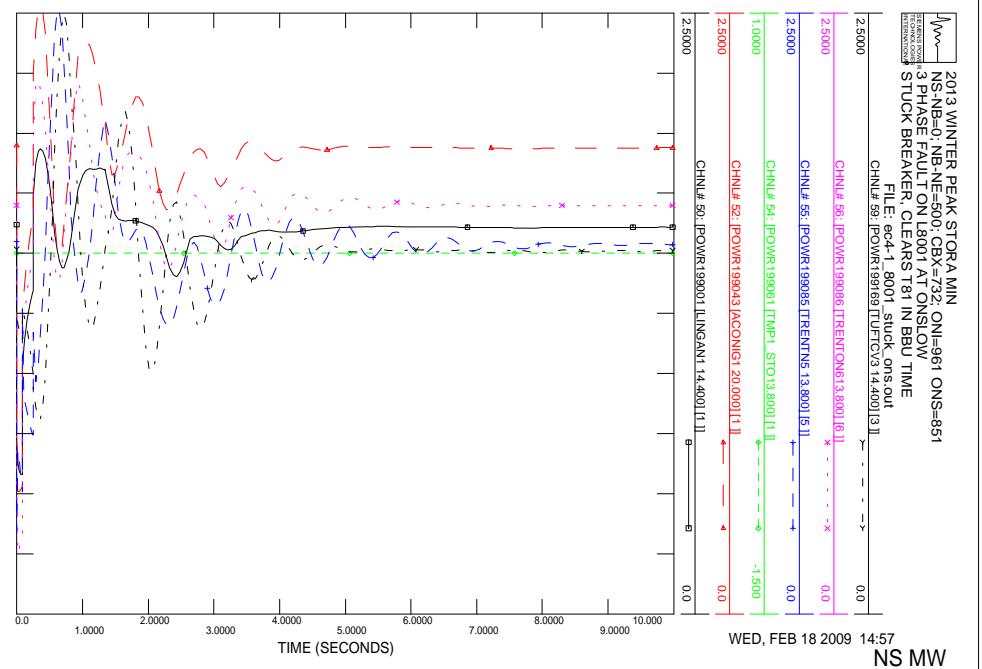
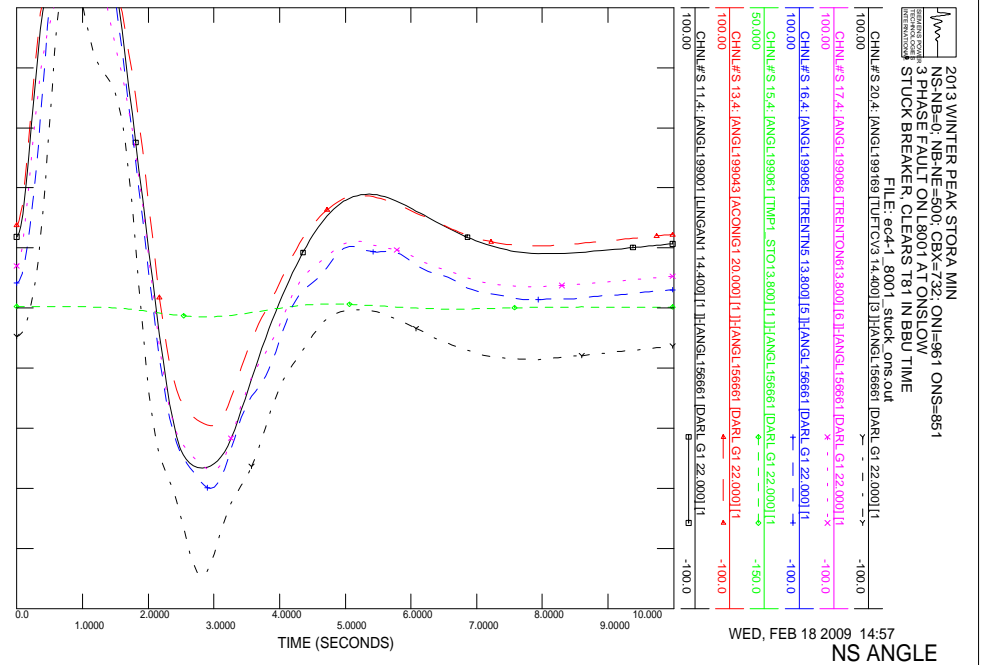

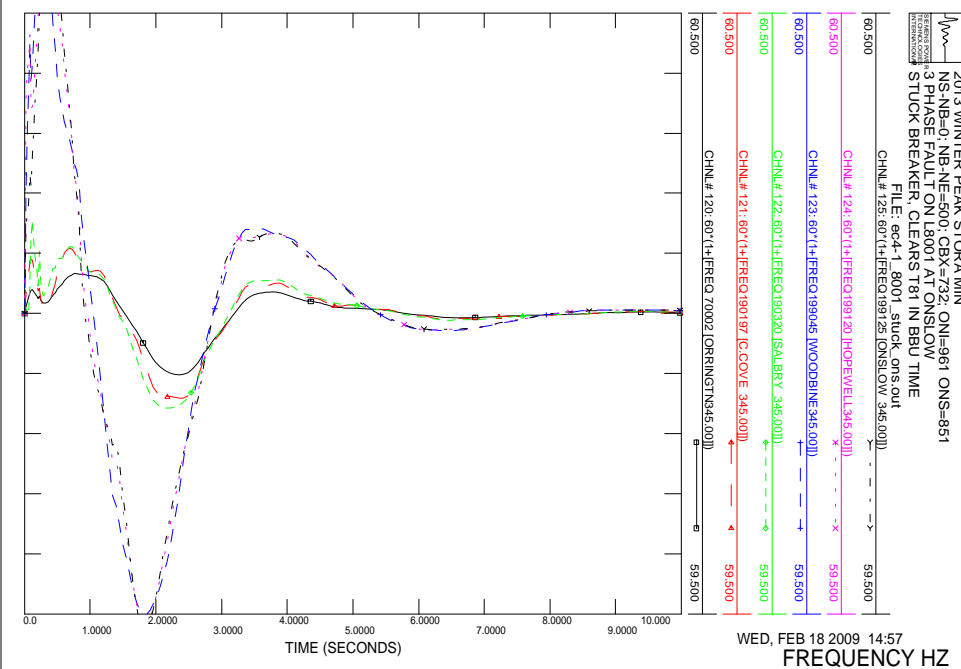
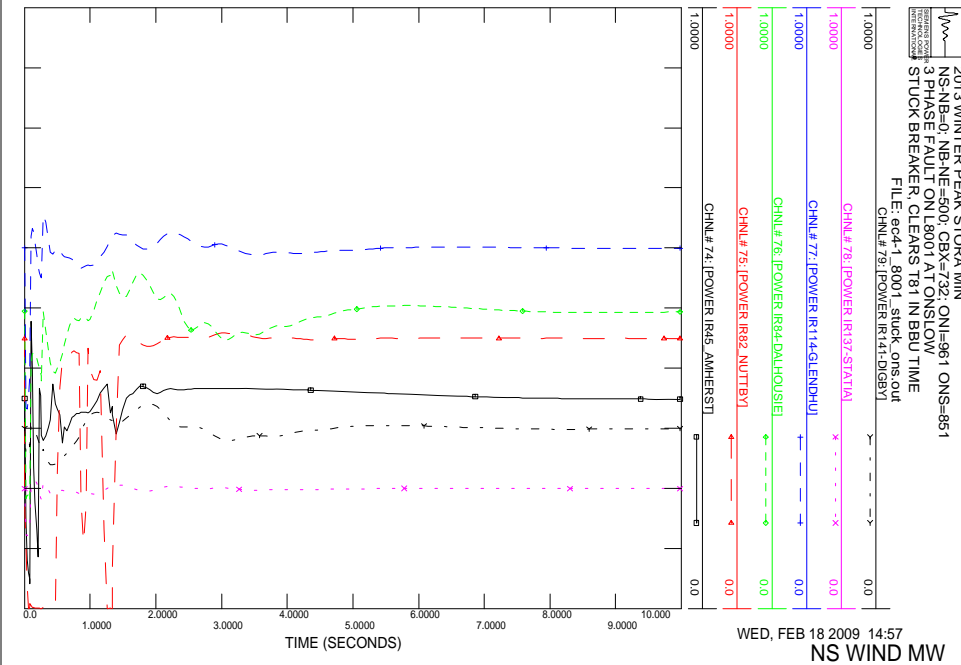
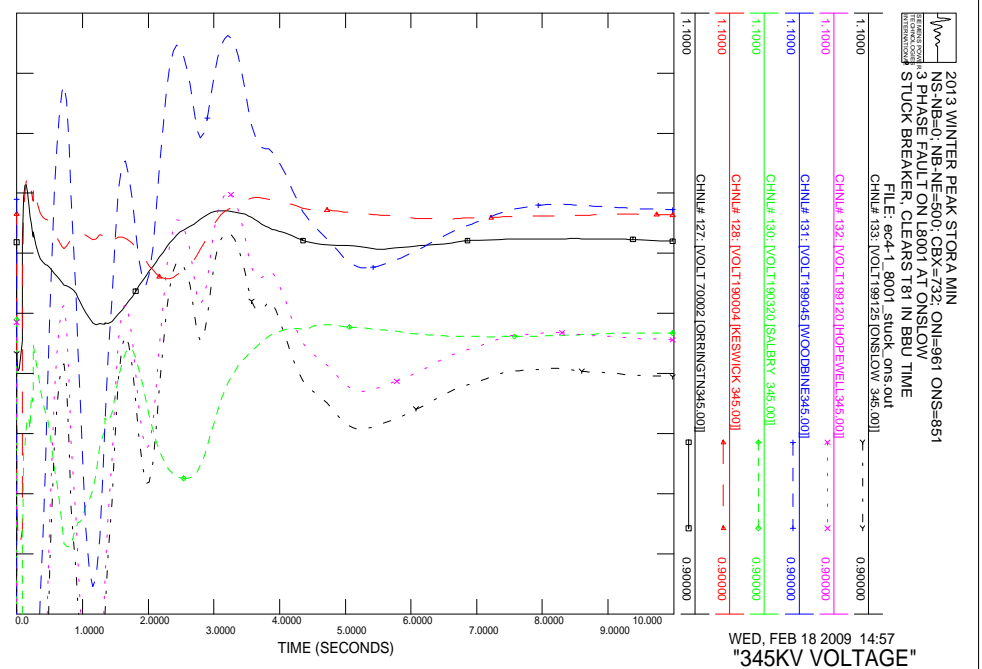
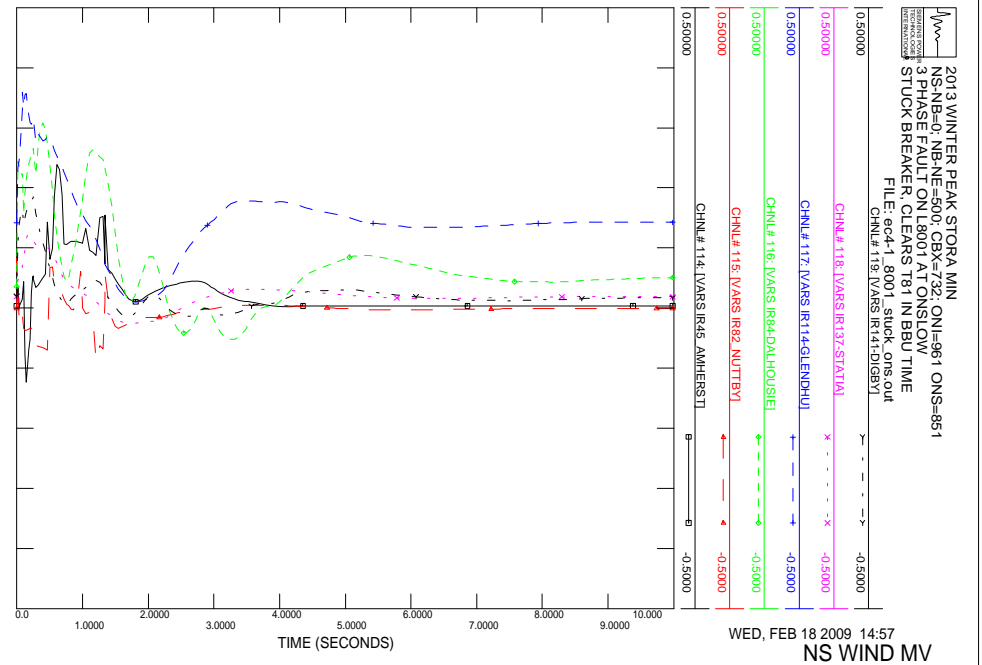

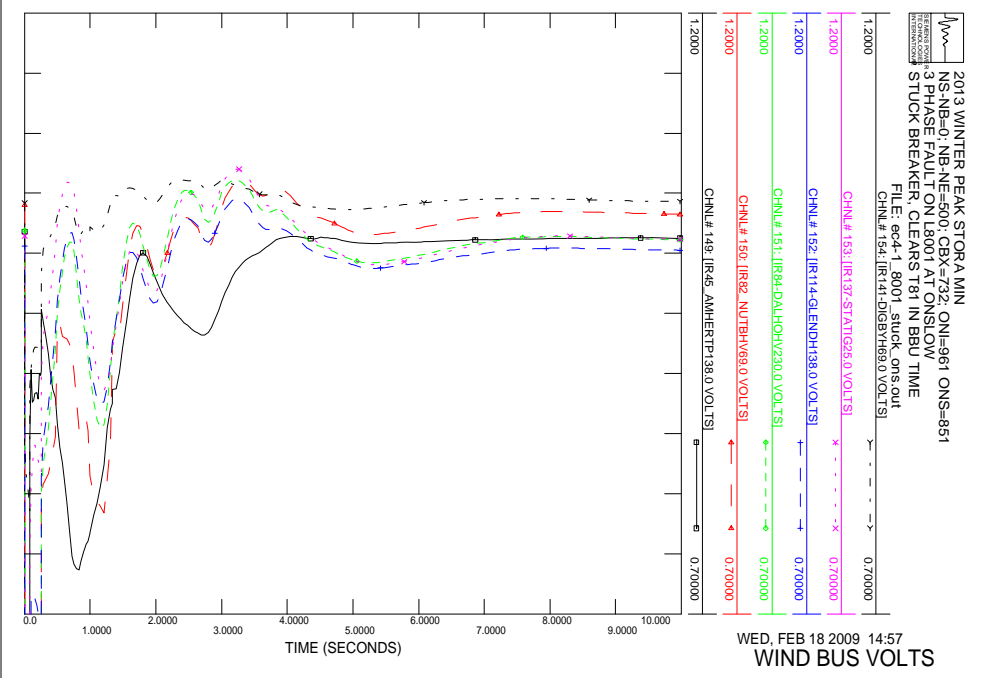
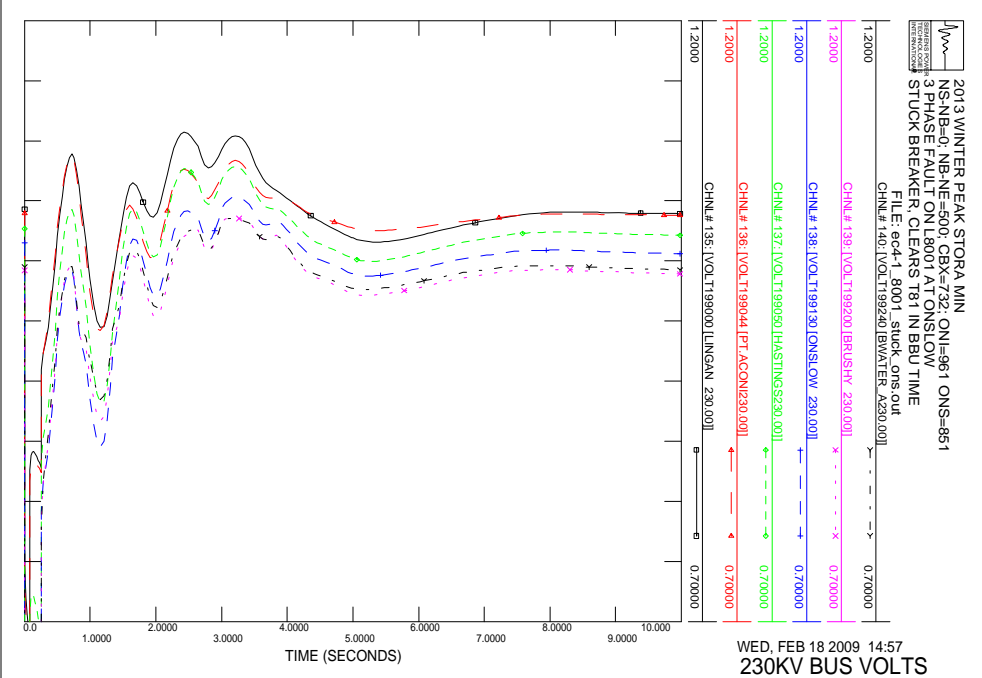
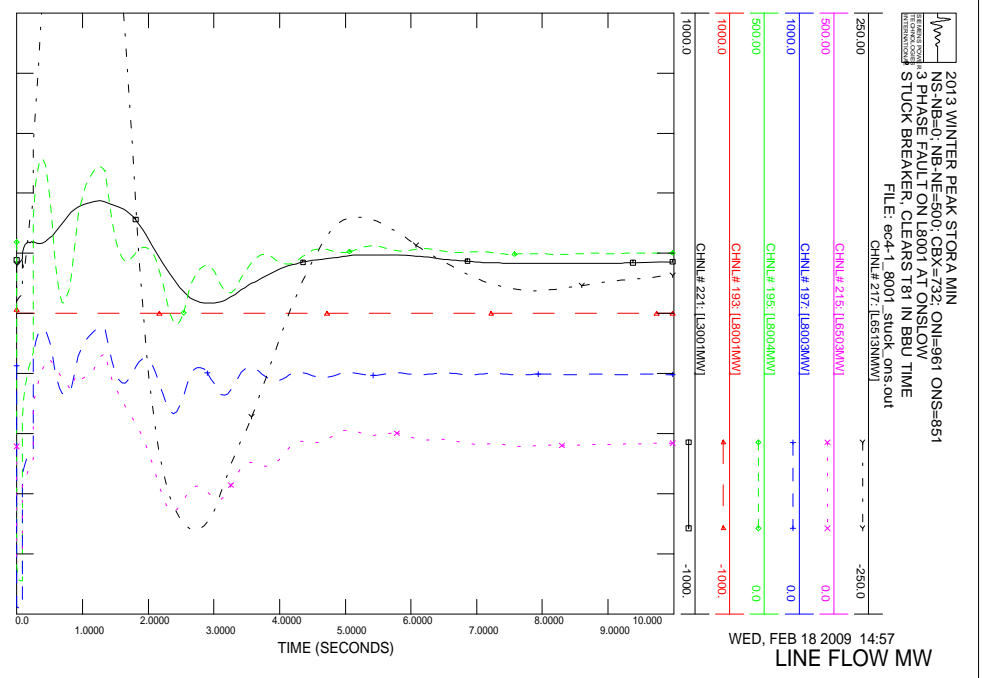
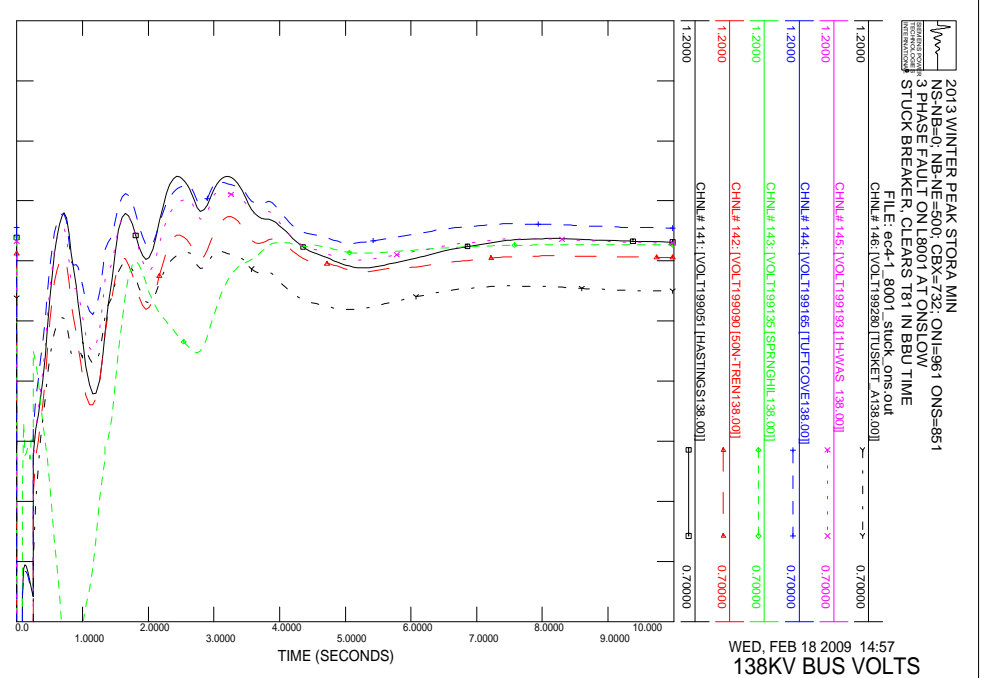

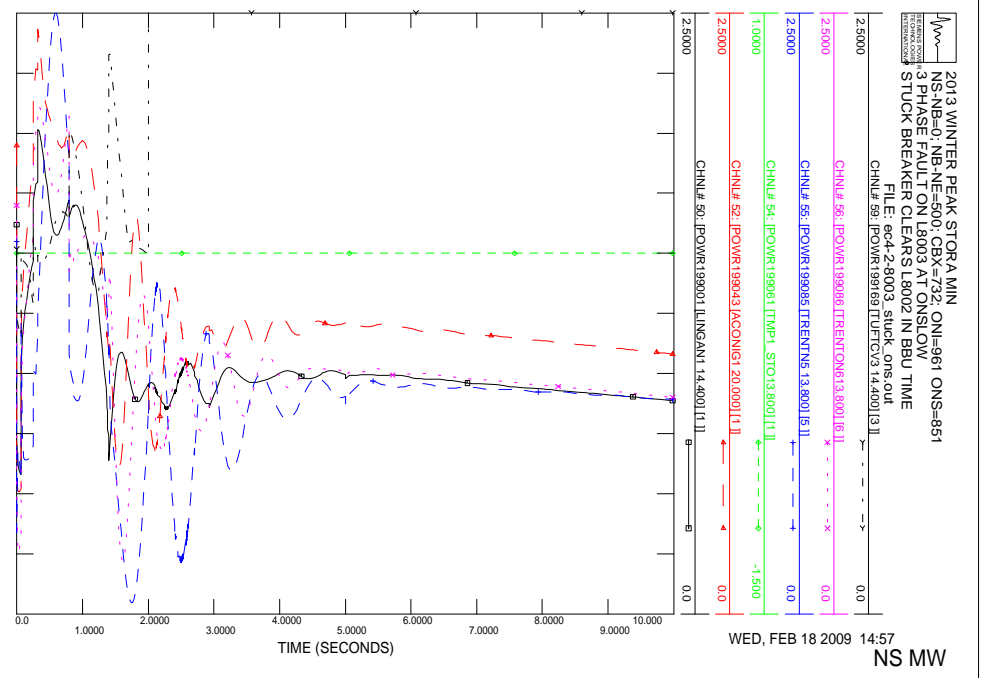
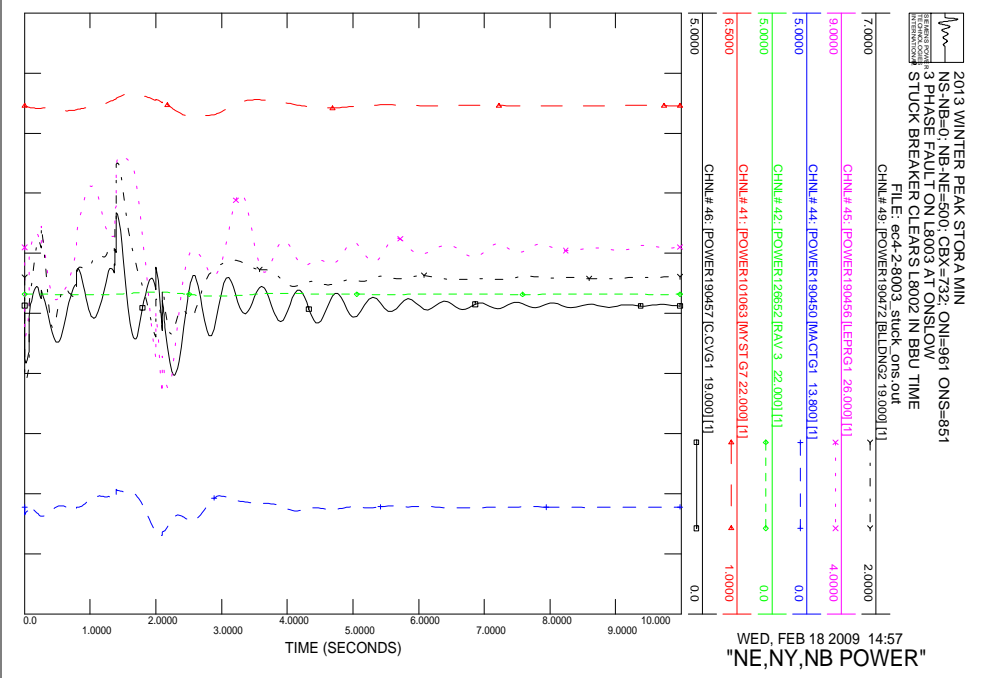
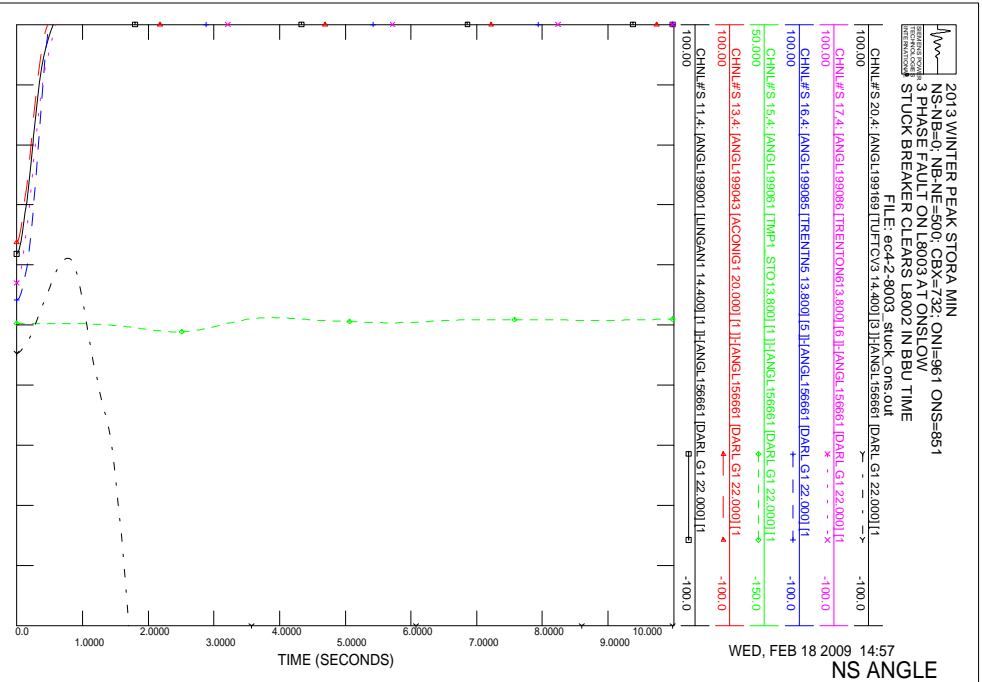
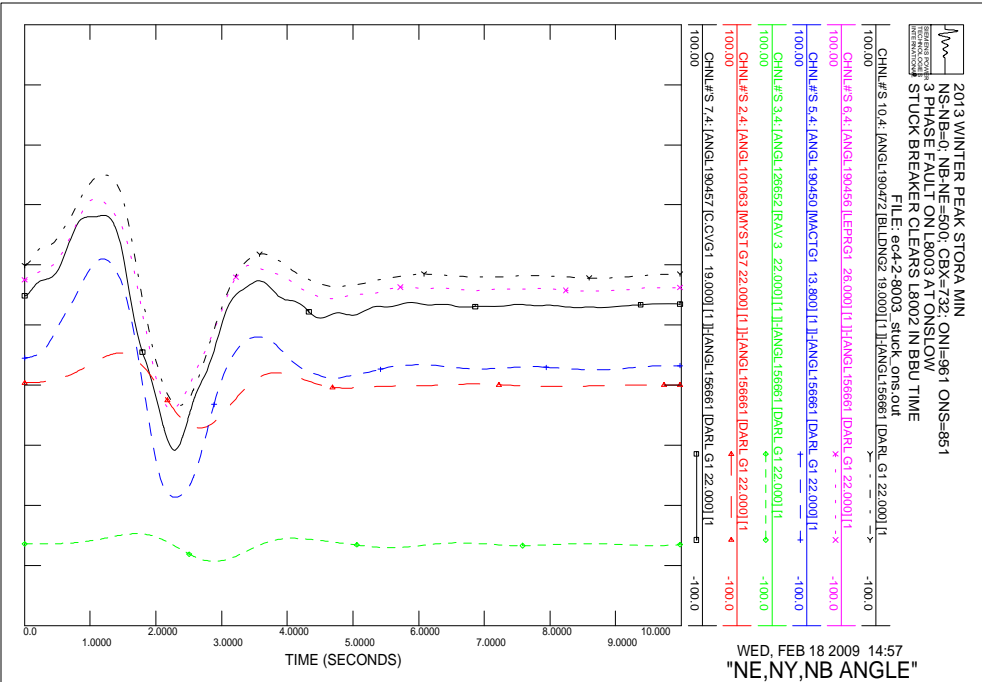

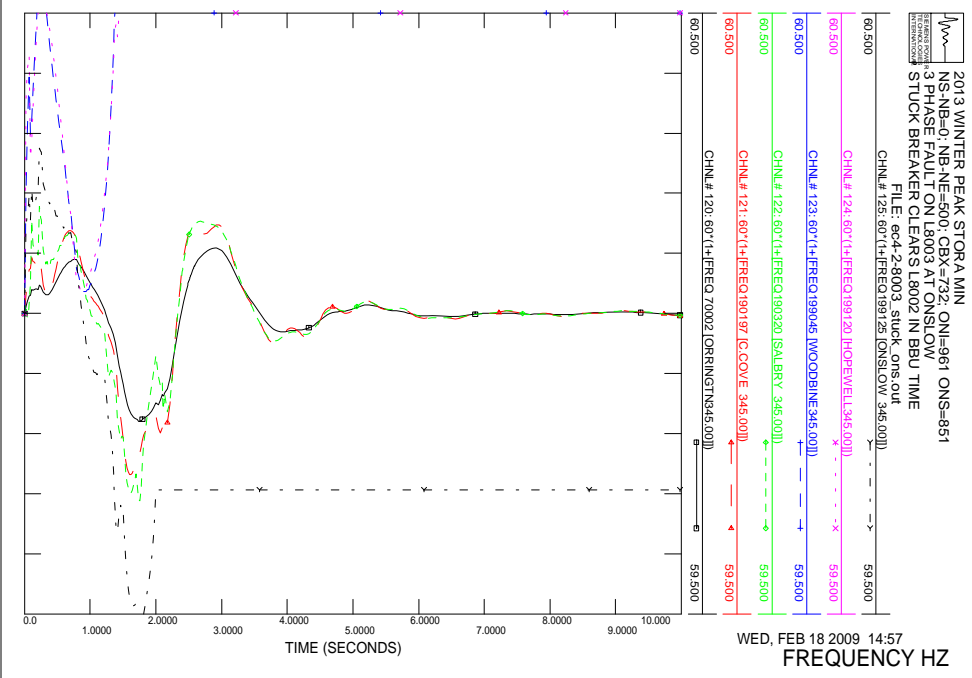
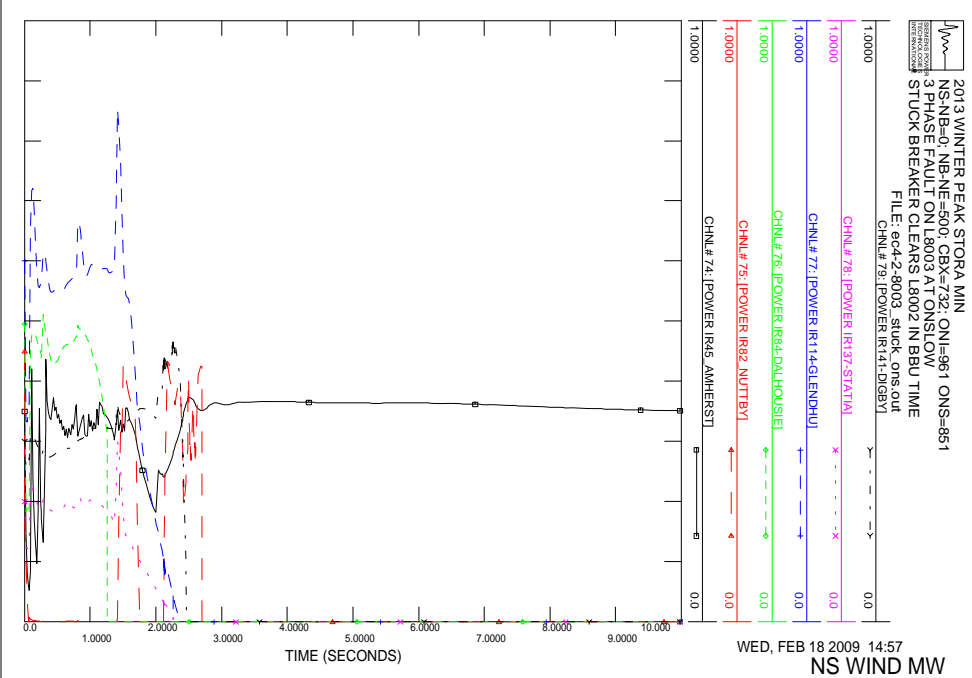
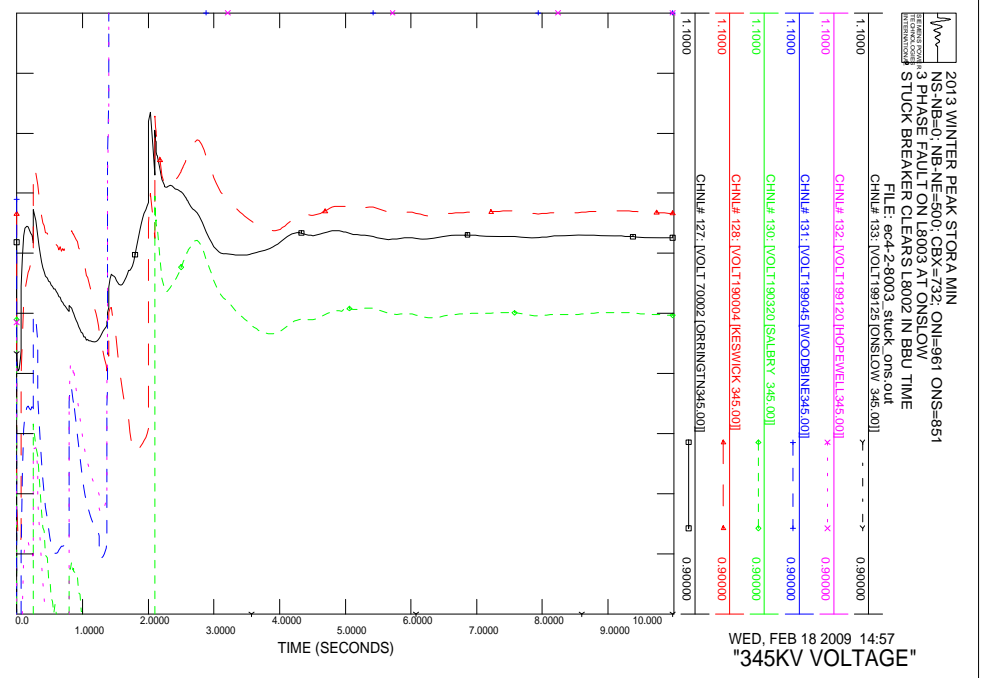
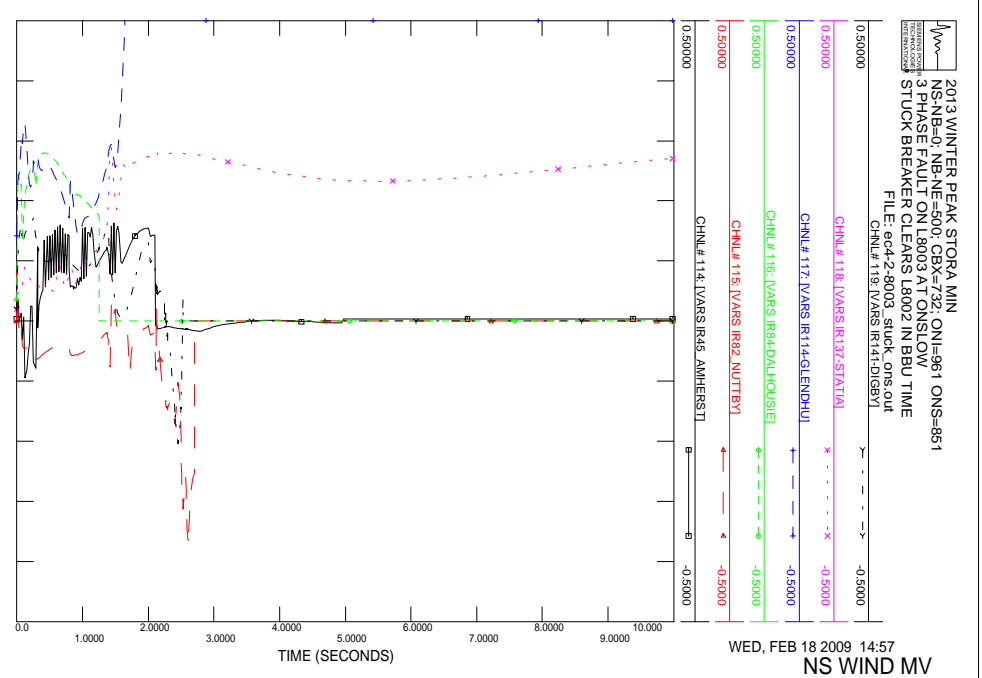

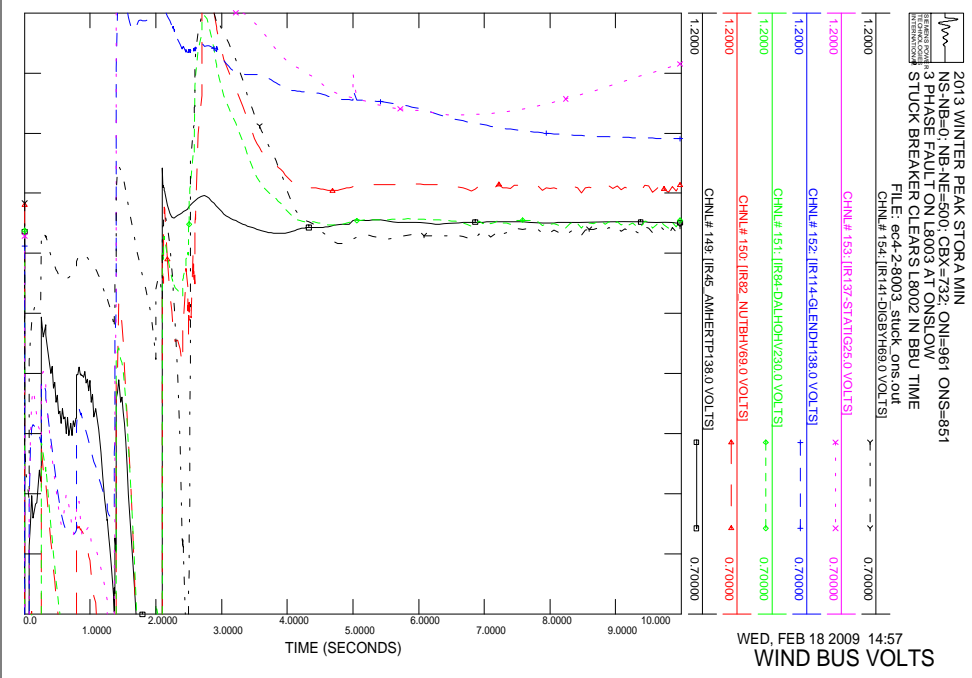
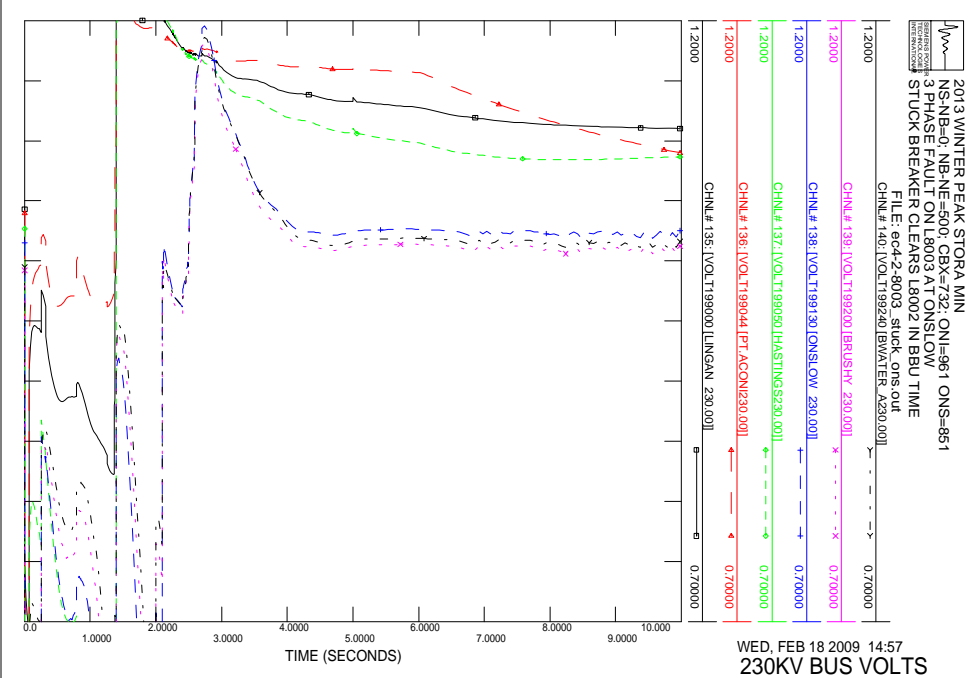
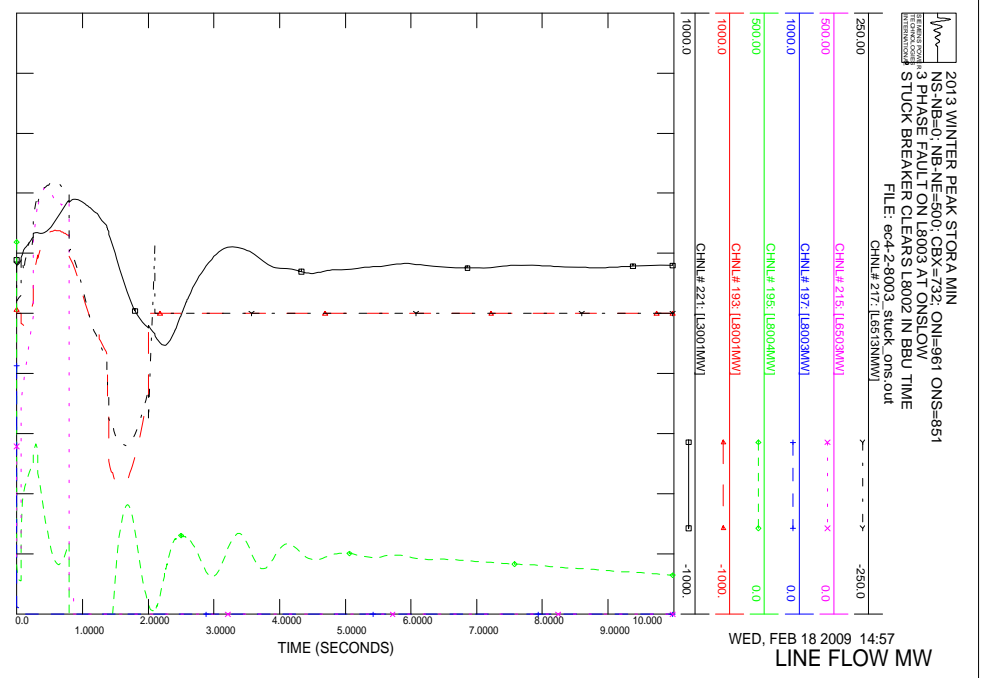
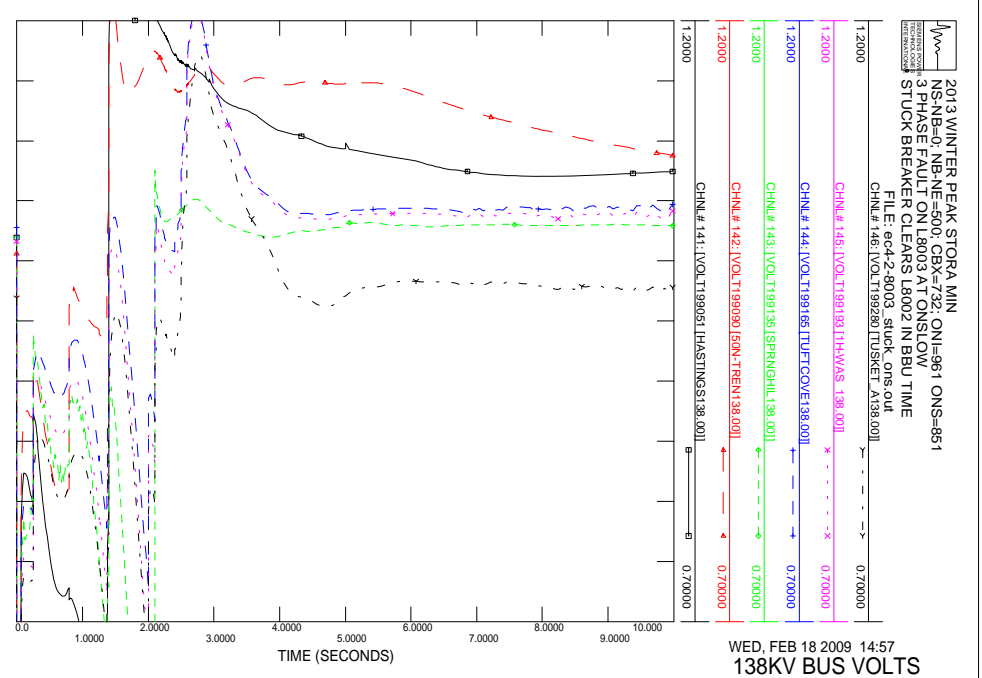

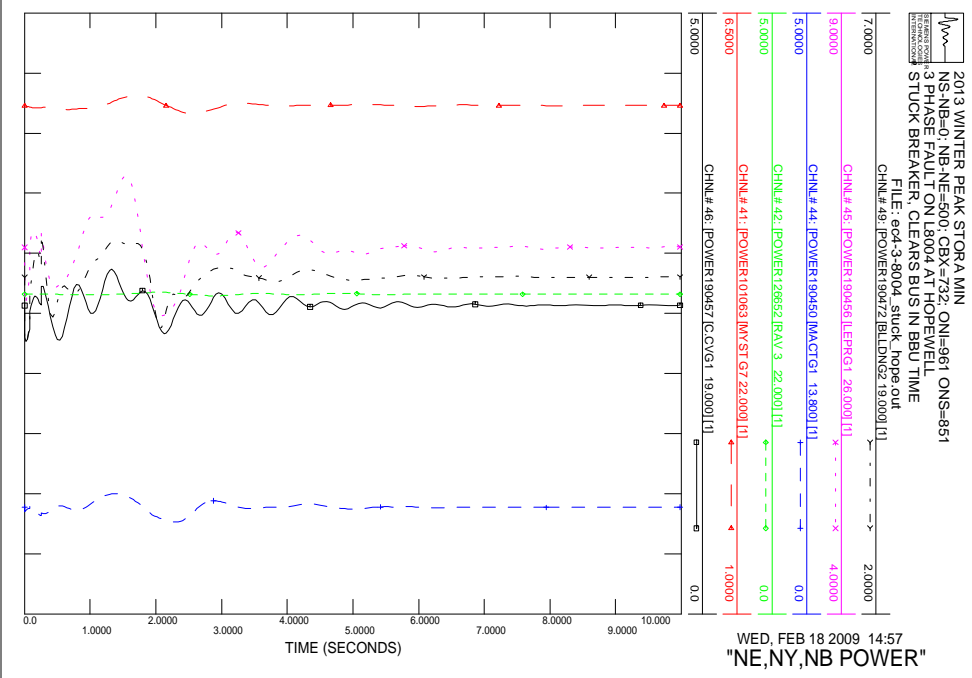
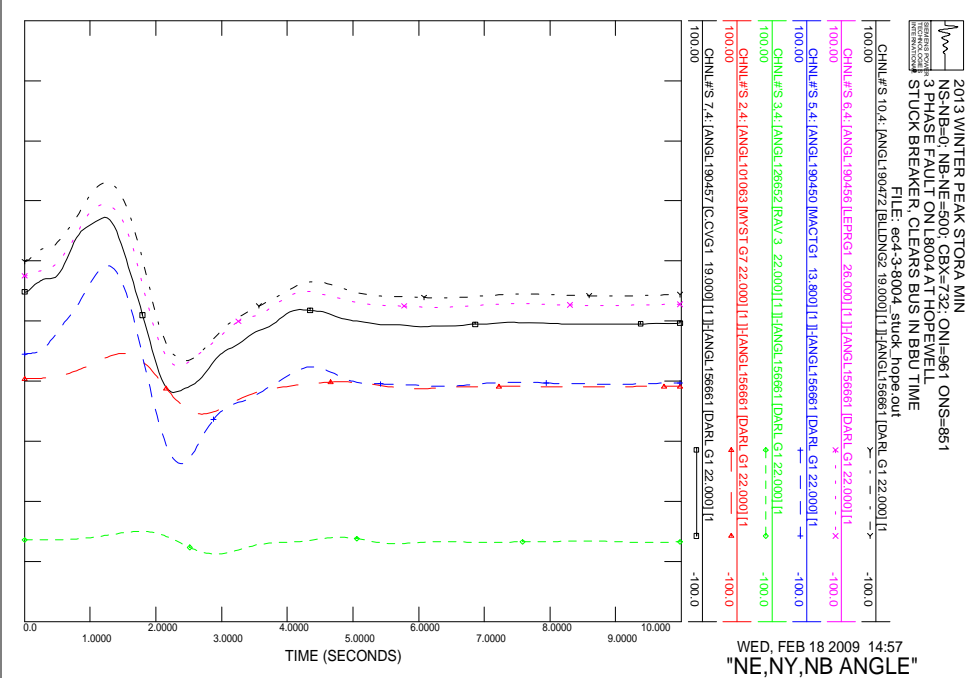
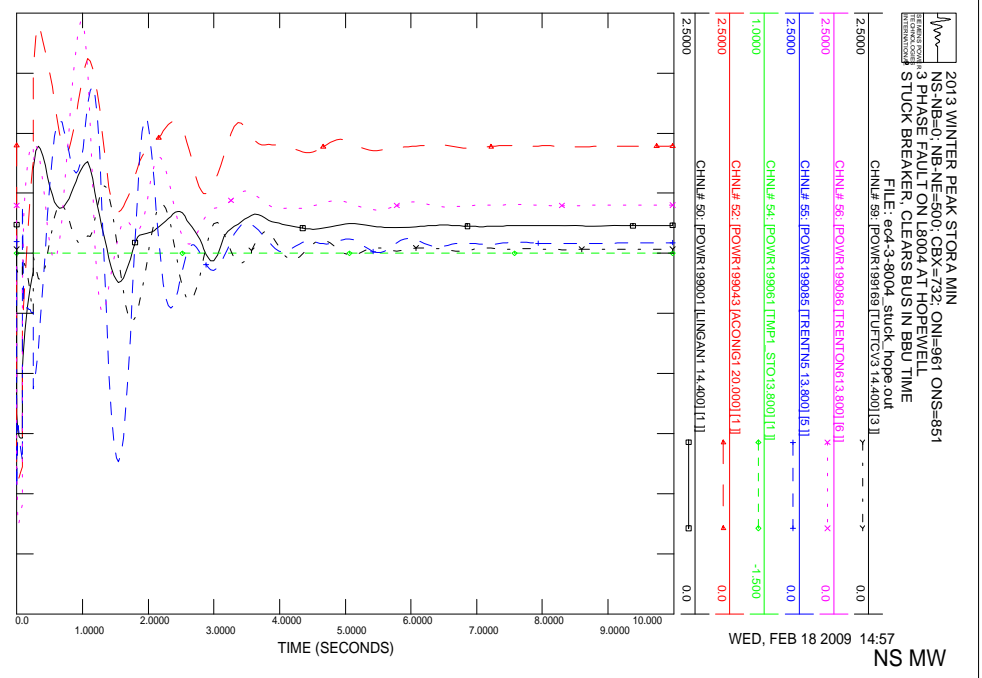
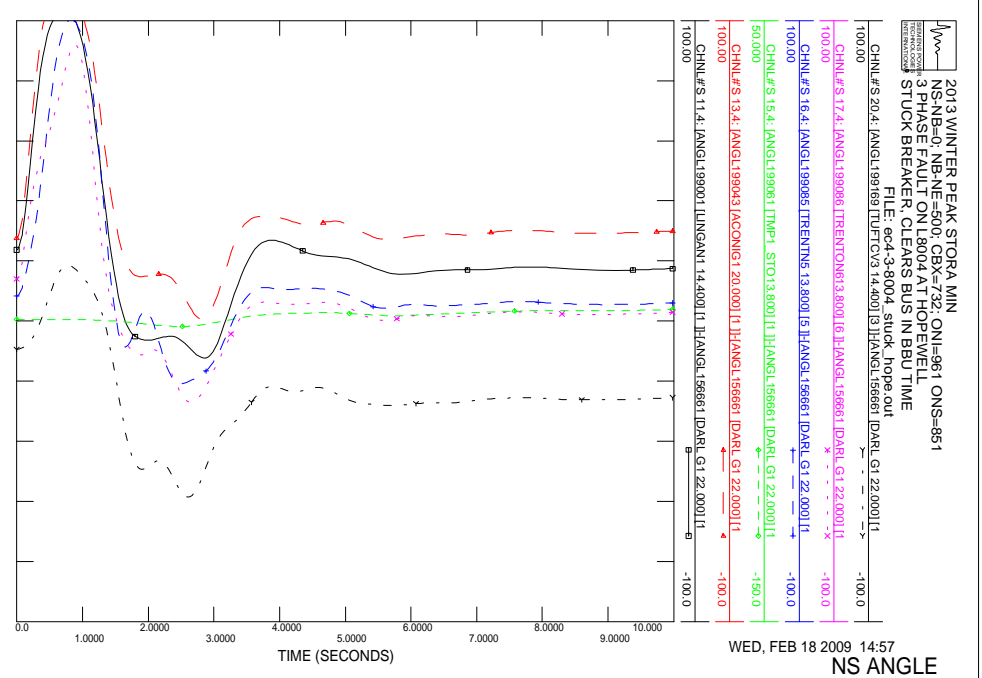

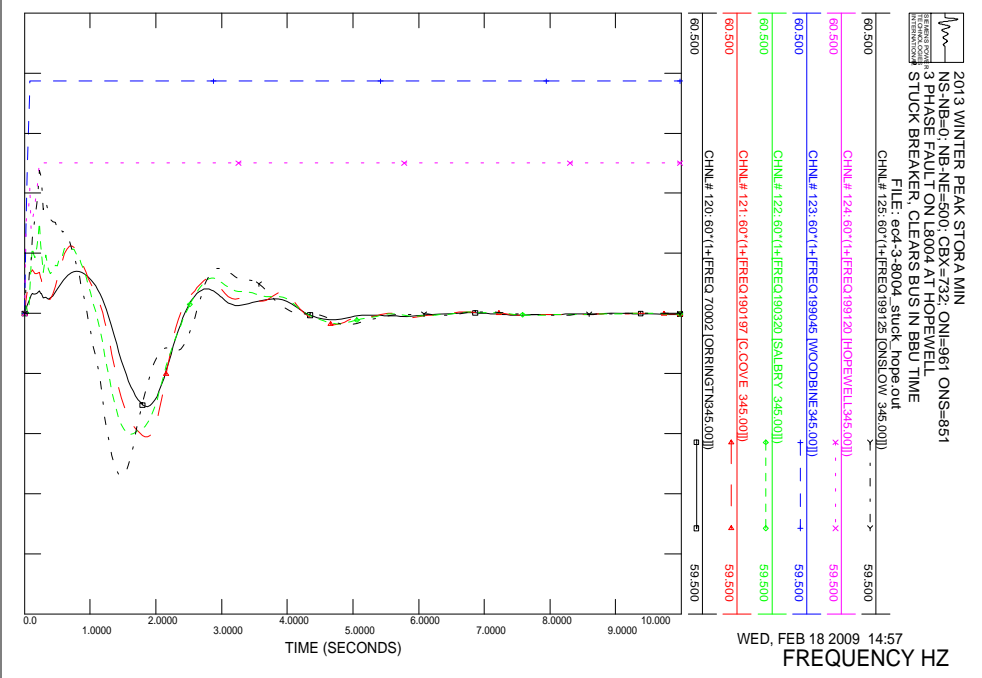
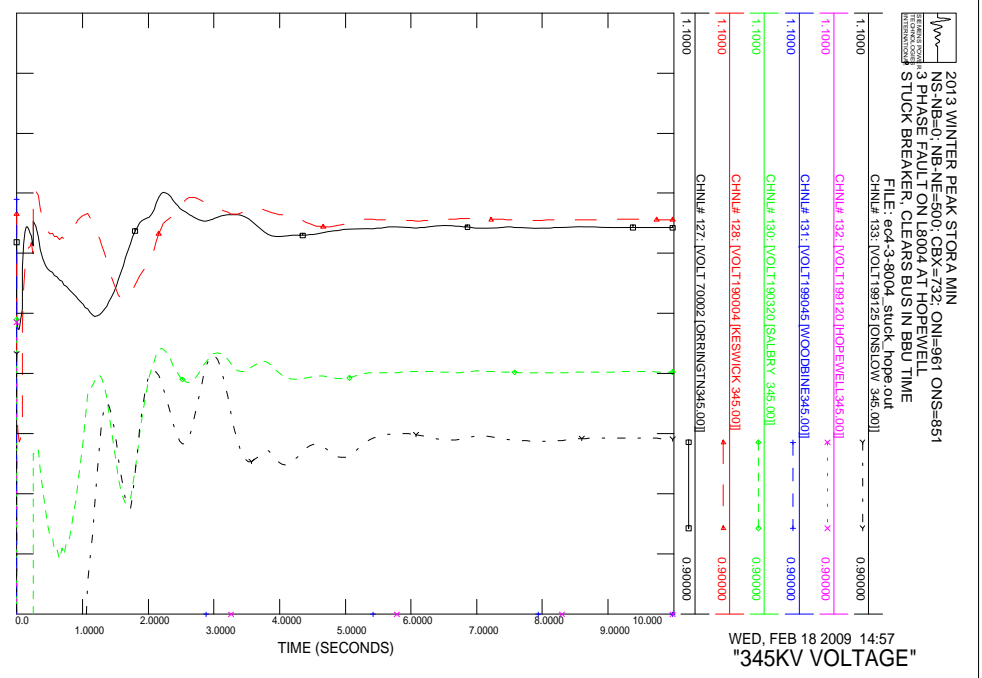
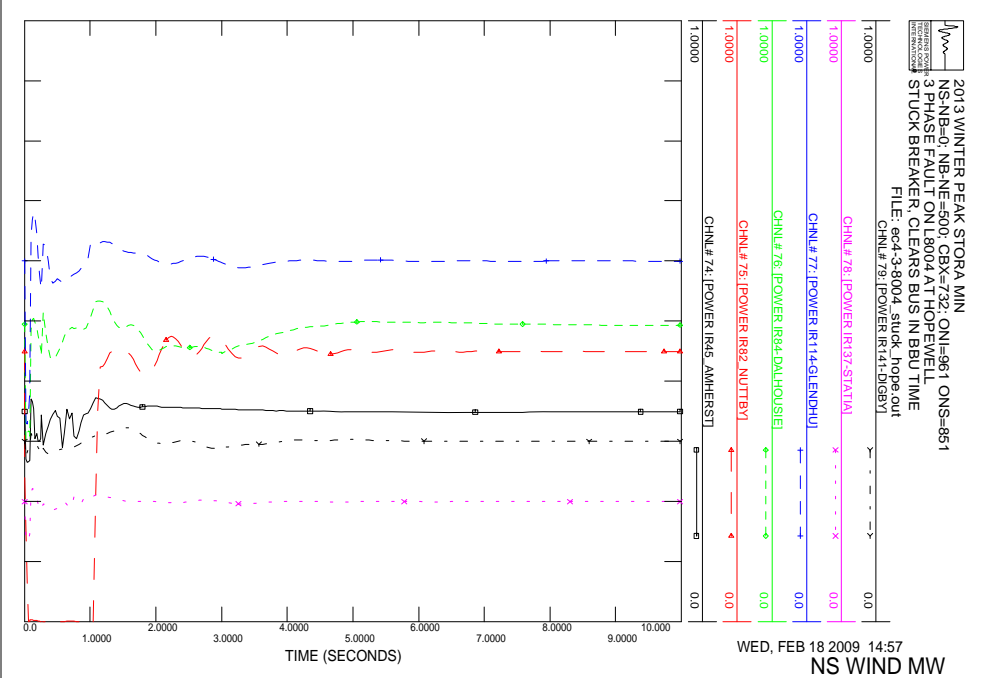
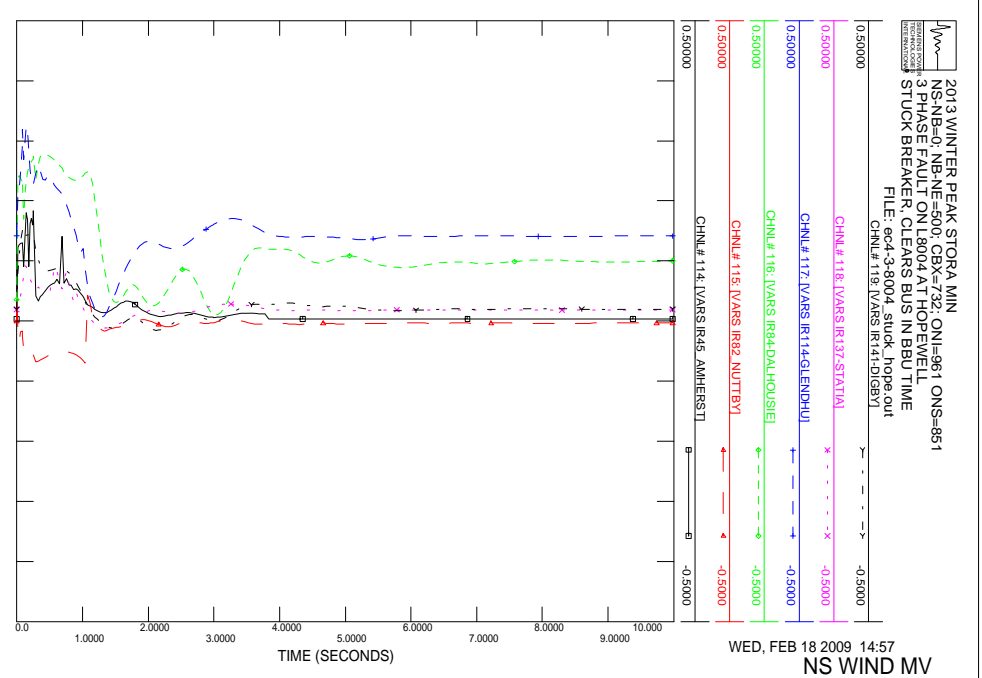

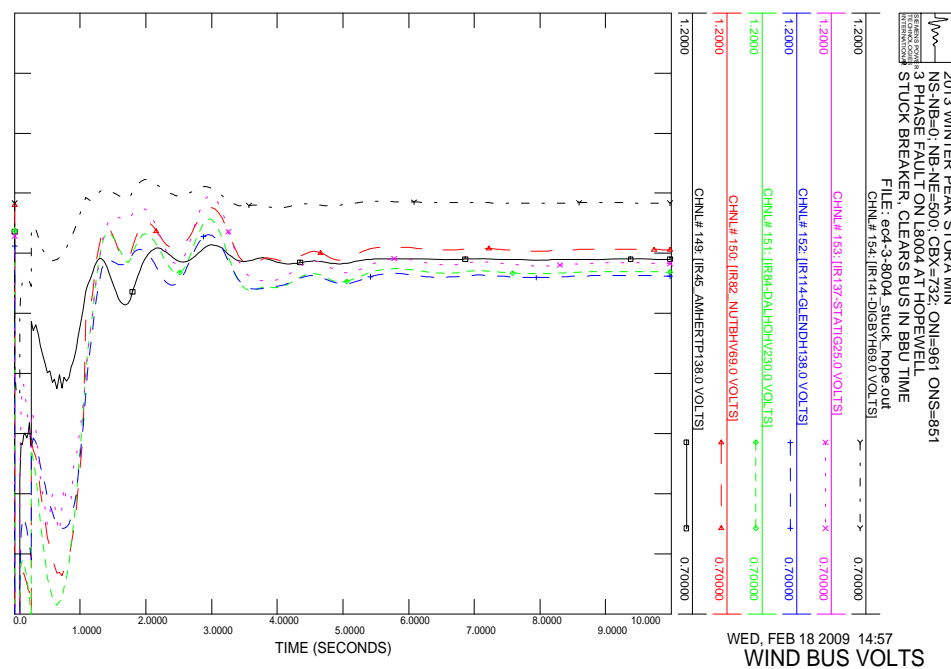
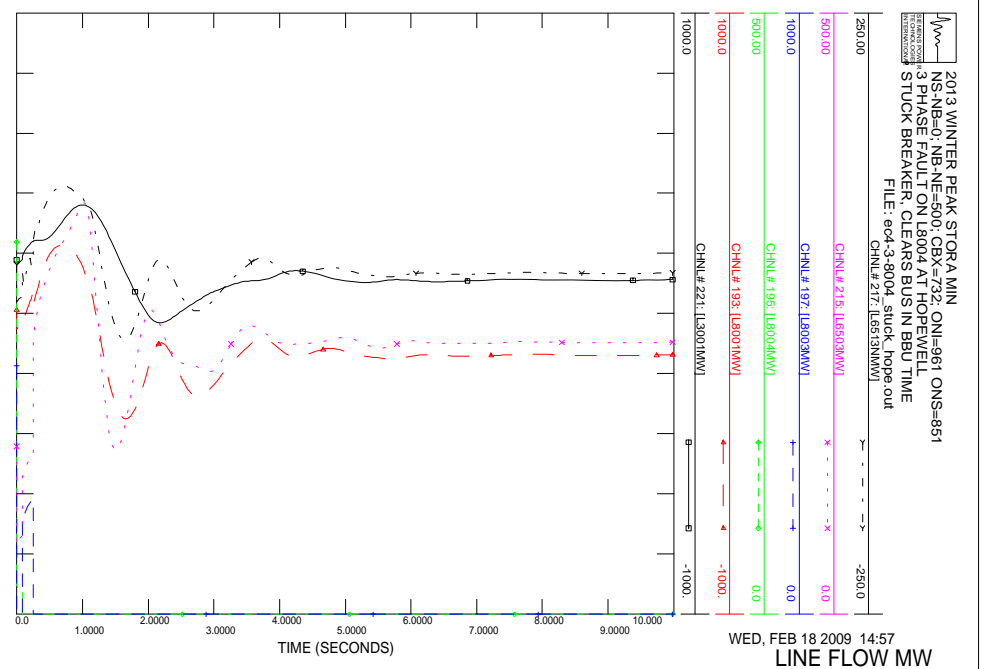
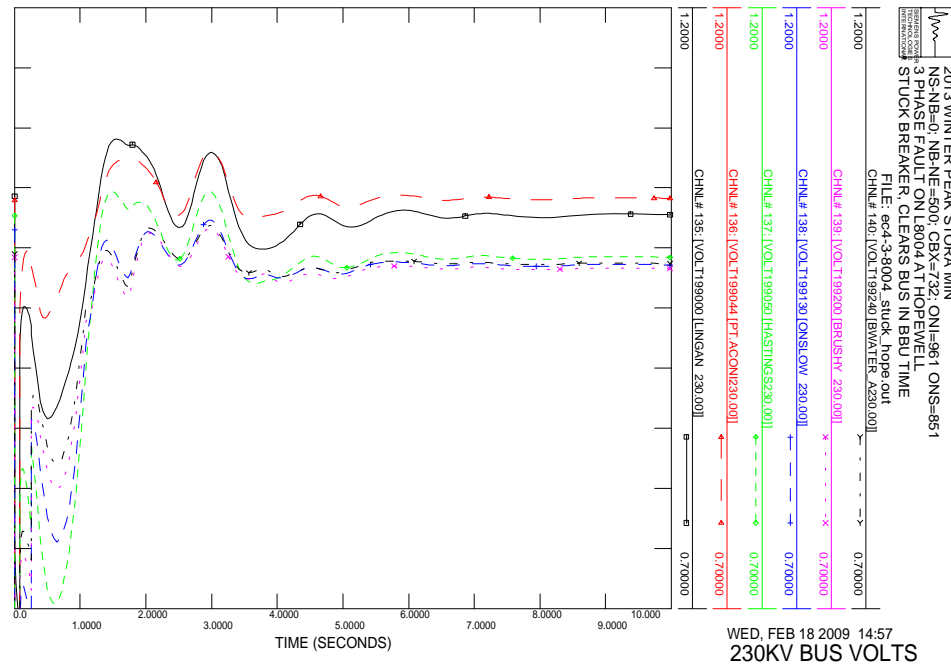
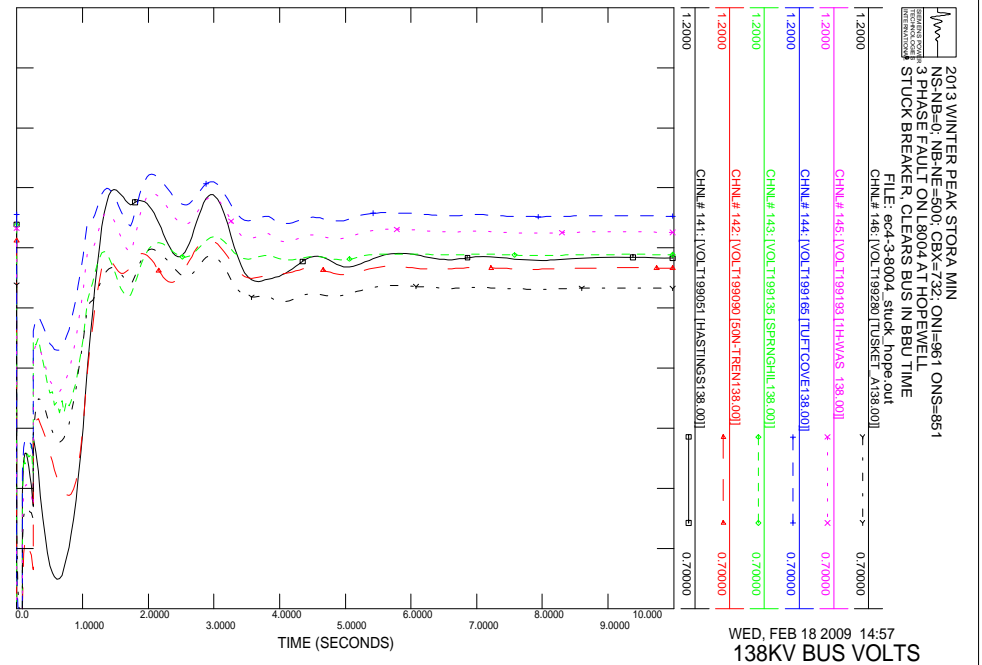

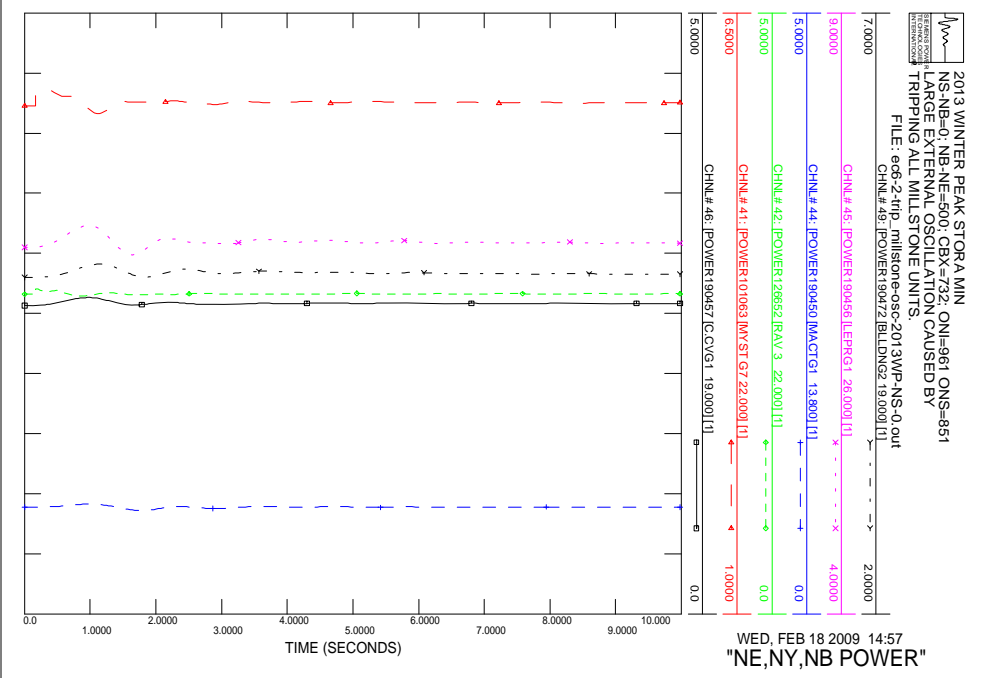
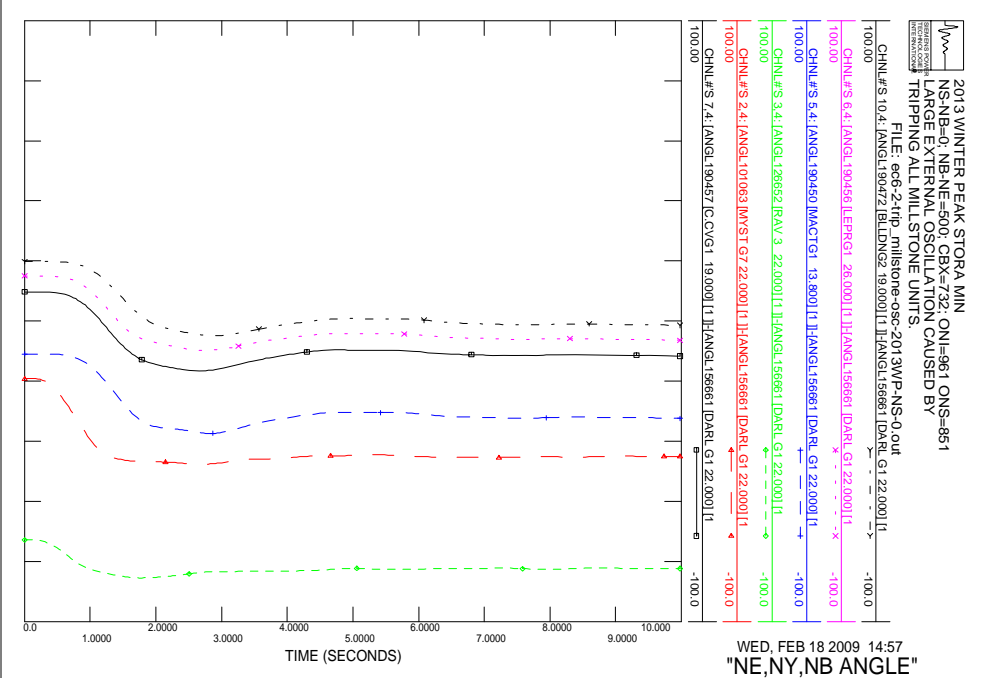
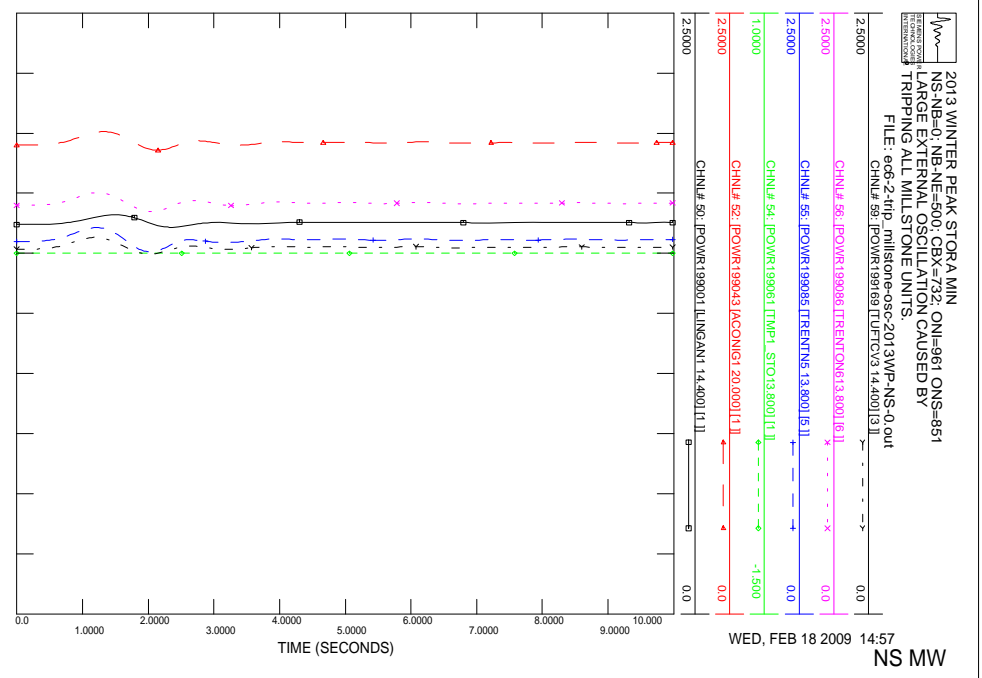
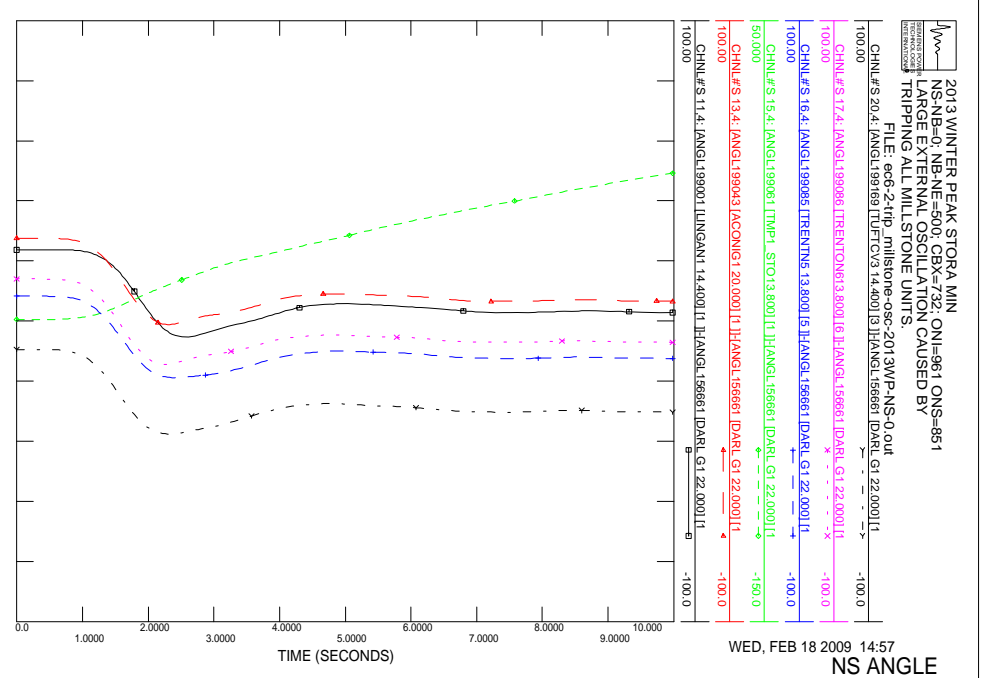

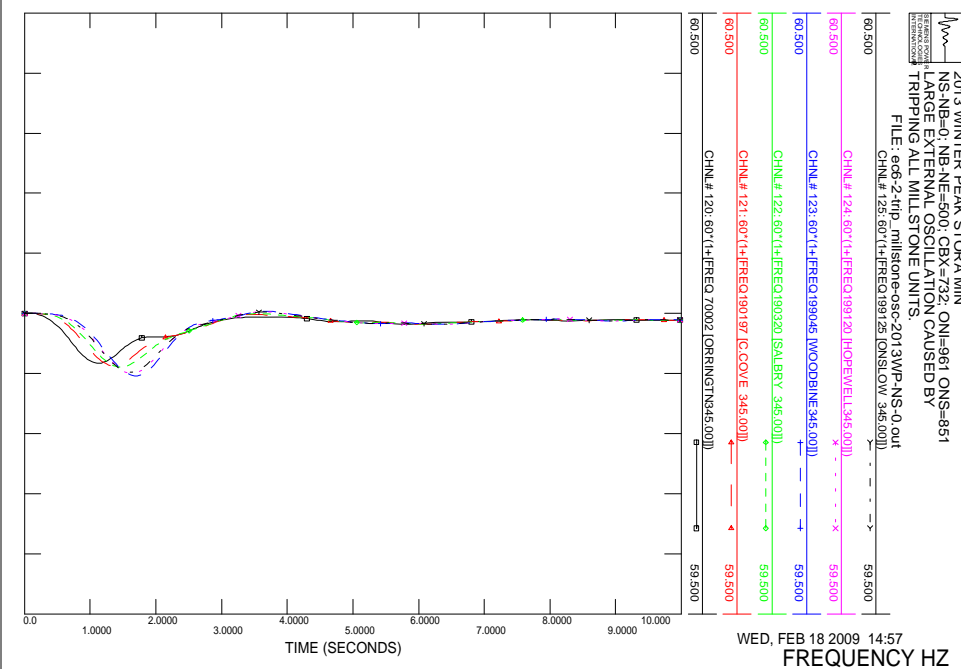
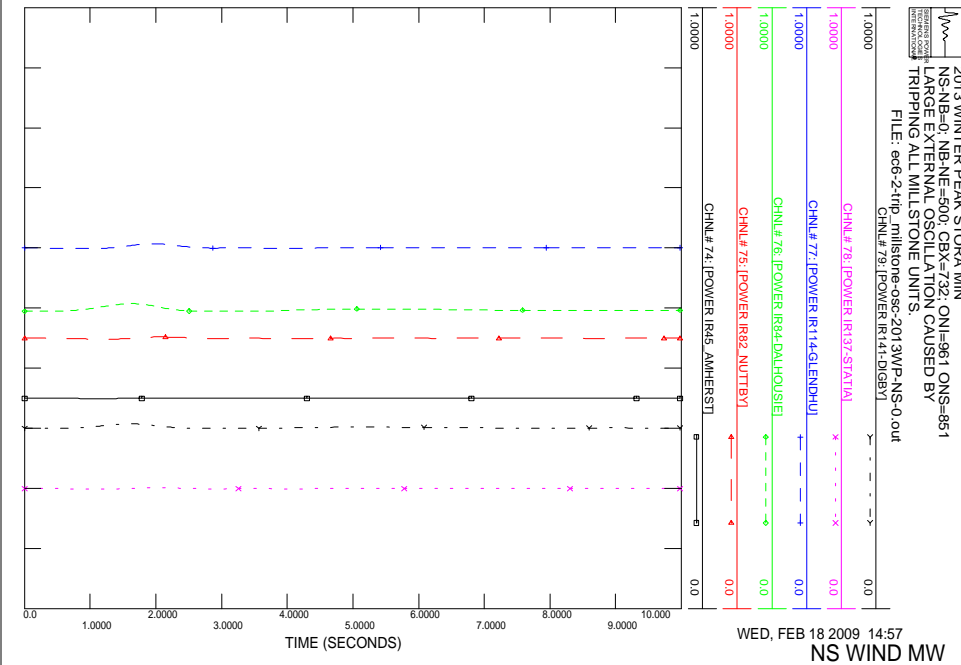
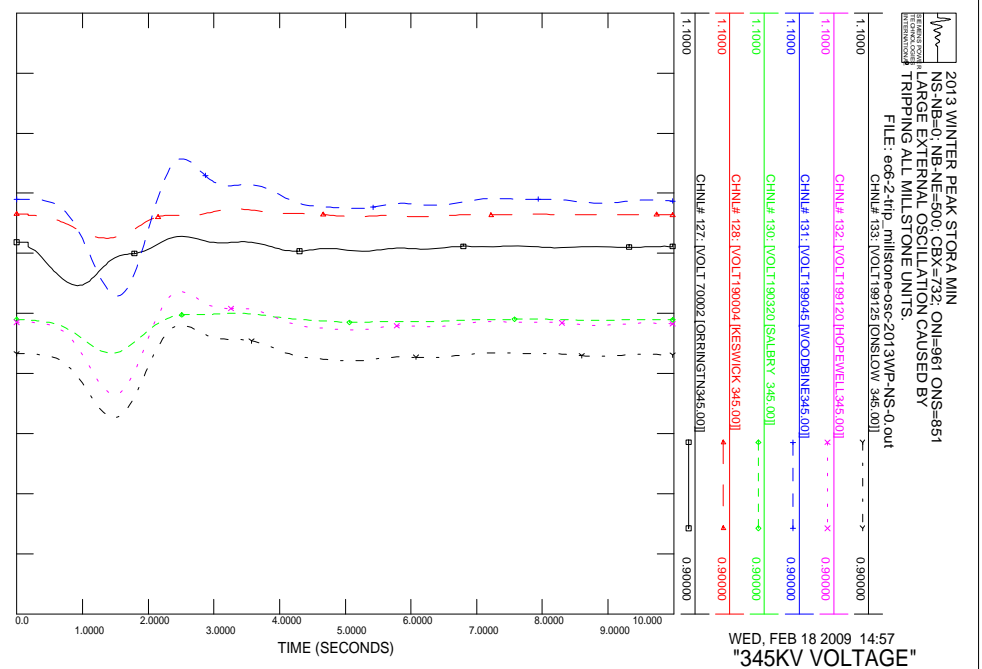
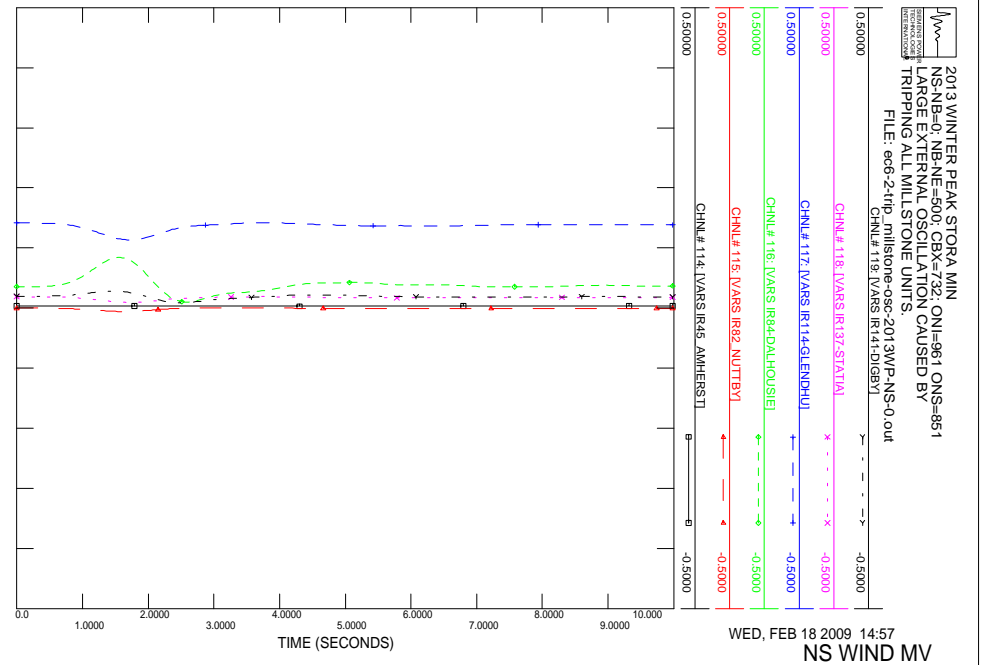

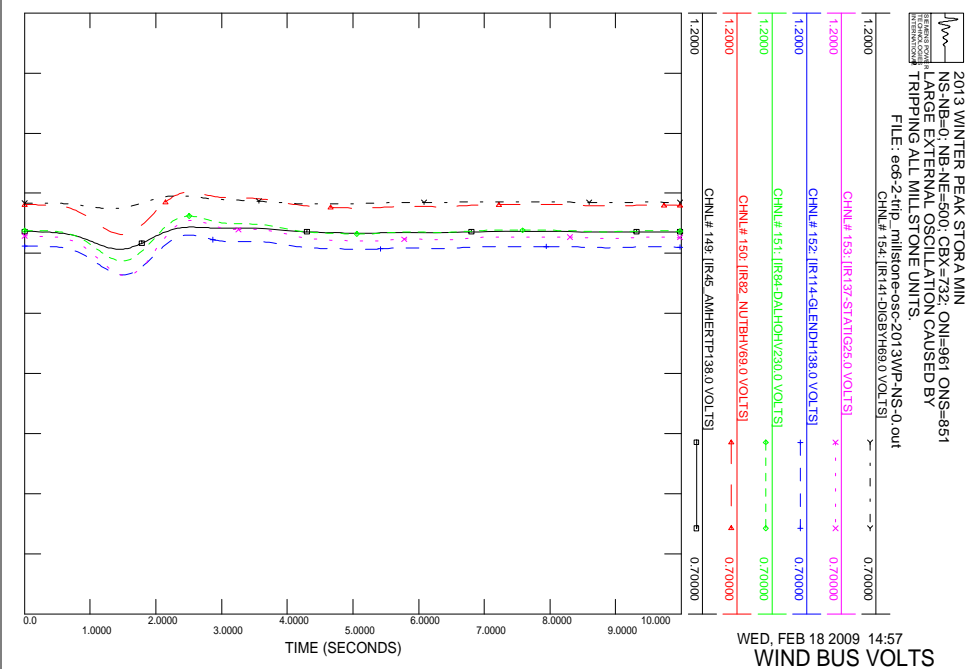
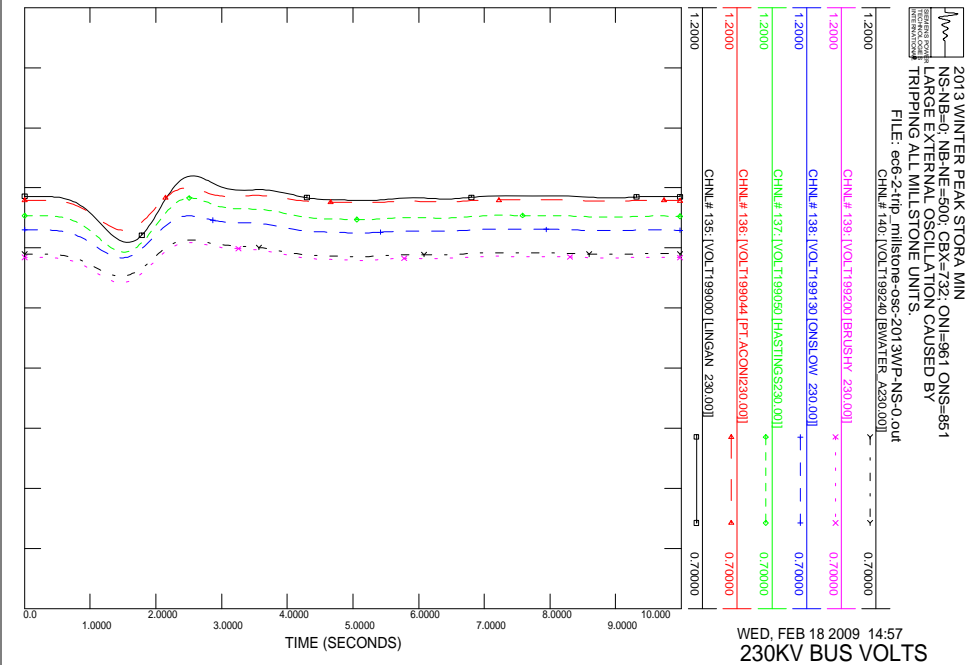
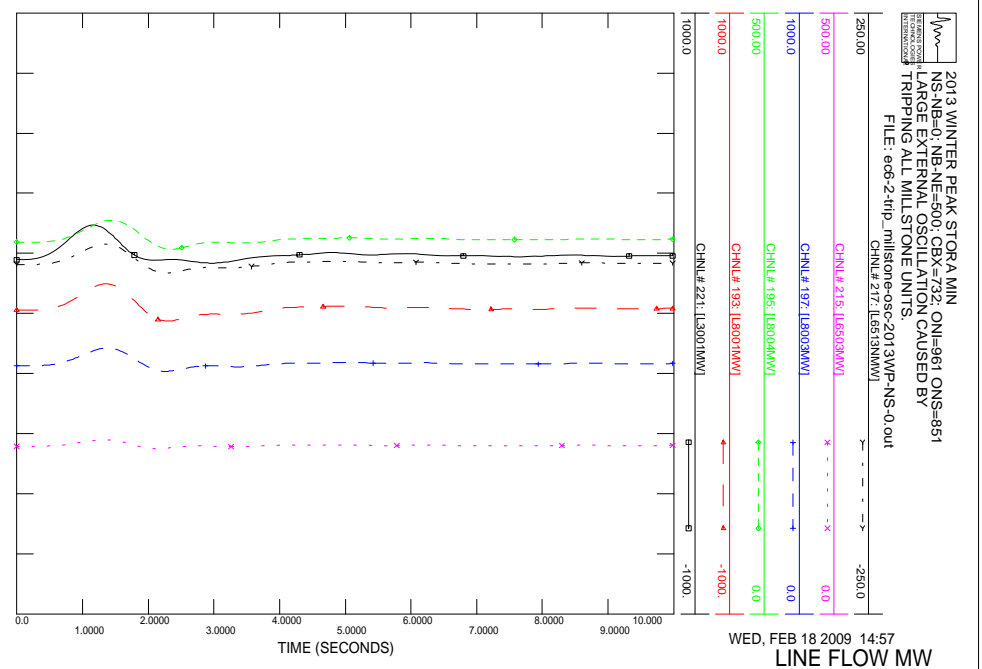
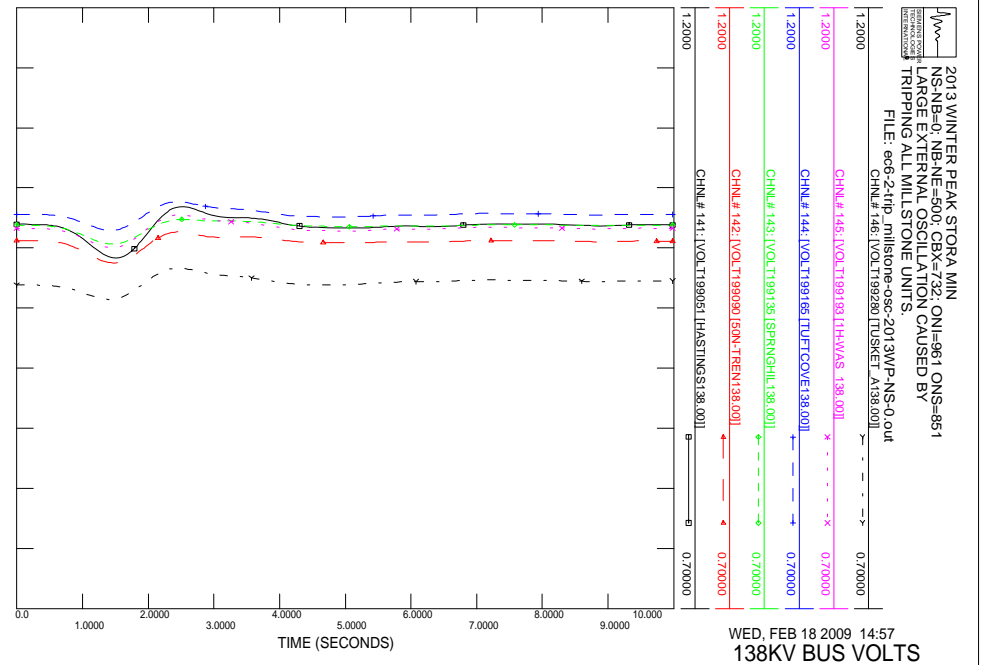



2013 WINTER PEAKL8004 OUT N-1
NS-NB=0; NB-NE=500; CBX=660 ONI=819 ONS=709
3 PHASE FAULT ON L8003 AT HOPEWELL 345KV
CLEARED IN 4.5 CYCLES: SPS DROPS LINGAN 2

FILE: a07.1s-3p_8003_79n-2013WP-N-1-8004.out

CHNL#*S 20,4:	[ANGL199169 [TUFTCV3 14.400] [3]]-[ANGL156661 [DARL G1 22.000] [1]]	-100.0
100.00		
CHNL#*S 17,4:	[ANGL199086 [TRENTON613.800] [6]]-[ANGL156661 [DARL G1 22.000] [1]]	-100.0
100.00		
CHNL#*S 16,4:	[ANGL199085 [TRENTN5 13.800] [5]]-[ANGL156661 [DARL G1 22.000] [1]]	-100.0
100.00		
CHNL#*S 15,4:	[ANGL199061 [TMP1_STO13.800] [1]]-[ANGL156661 [DARL G1 22.000] [1]]	-150.0
50.0000		
CHNL#*S 13,4:	[ANGL199043 [ACONIG1 20.000] [1]]-[ANGL156661 [DARL G1 22.000] [1]]	-100.0
100.00		
CHNL#*S 11,4:	[ANGL199001 [LINGANI 14.400] [1]]-[ANGL156661 [DARL G1 22.000] [1]]	-100.0
100.00		

FRI, FEB 13 2009 22:13
NS ANGLE

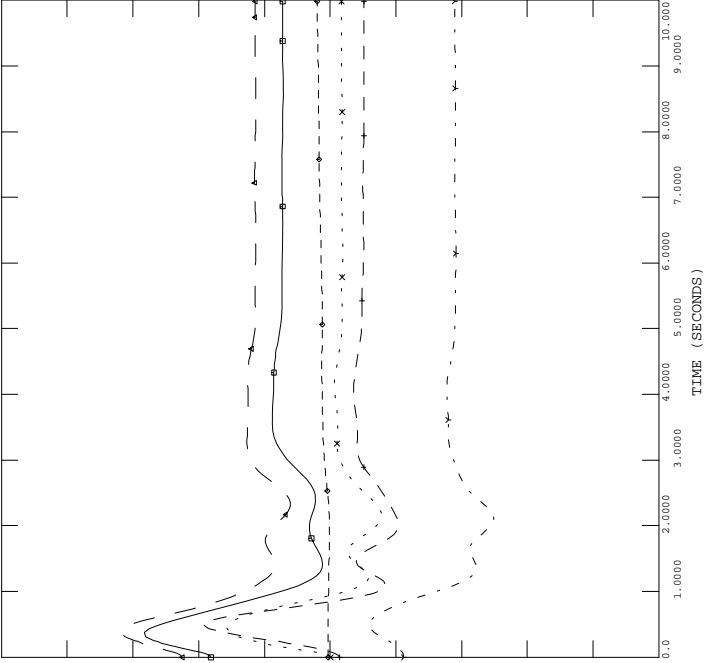

2013 WINTER PEAKL8004 OUT N-1
NS-NB=0; NB-NE=500; CBX=660 ONI=819 ONS=709
3 PHASE FAULT ON L8003 AT HOPEWELL 345KV
CLEARED IN 4.5 CYCLES: SPS DROPS LINGAN 2

FILE: a07.1s-3p_8003_79n-2013WP-N-1-8004.out

CHNL# 56:	[POWR199086 [TRENTON613.800] [6]]	0.0
2.5000		
CHNL# 55:	[POWR199085 [TRENTN5 13.800] [5]]	0.0
2.5000		
CHNL# 54:	[POWR199061 [TMP1_STO13.800] [1]]	0.0
1.0000		
CHNL# 52:	[POWR199043 [ACONIG1 20.000] [1]]	-1.500
2.5000		
CHNL# 50:	[POWR199001 [LINGANI 14.400] [1]]	0.0
2.5000		

FRI, FEB 13 2009 22:13
NS MW

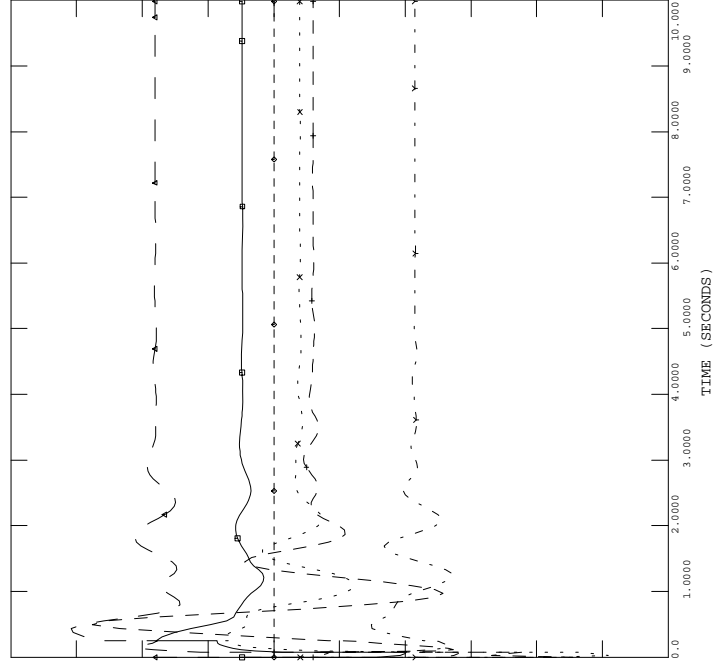

2013 WINTER PEAKL8004 OUT N-1
NS-NB=0; NB-NE=500; CBX=660 ONI=819 ONS=709
3 PHASE FAULT ON L8003 AT HOPEWELL 345KV
CLEARED IN 4.5 CYCLES: SPS DROPS LINGAN 2

FILE: a07.1s-3p_8003_79n-2013WP-N-1-8004.out

CHNL#*S 10,4:	[ANGL190472 [BLDNG2 19.000] [1]]-[ANGL156661 [DARL G1 22.000] [1]]	-100.0
100.00		
CHNL#*S 6,4:	[ANGL190456 [LEPRG1 26.000] [1]]-[ANGL156661 [DARL G1 22.000] [1]]	-100.0
100.00		
CHNL#*S 5,4:	[ANGL190450 [MACTG1 13.800] [1]]-[ANGL156661 [DARL G1 22.000] [1]]	-100.0
100.00		
CHNL#*S 3,4:	[ANGL126652 [RAV 3 22.000] [1]]-[ANGL156661 [DARL G1 22.000] [1]]	-100.0
100.00		
CHNL#*S 2,4:	[ANGL101063 [MYST G7 22.000] [1]]-[ANGL156661 [DARL G1 22.000] [1]]	-100.0
100.00		
CHNL#*S 7,4:	[ANGL190457 [C.CVGI 19.000] [1]]-[ANGL156661 [DARL G1 22.000] [1]]	-100.0
100.00		

FRI, FEB 13 2009 22:13
"NE, NY, NB ANGLE"

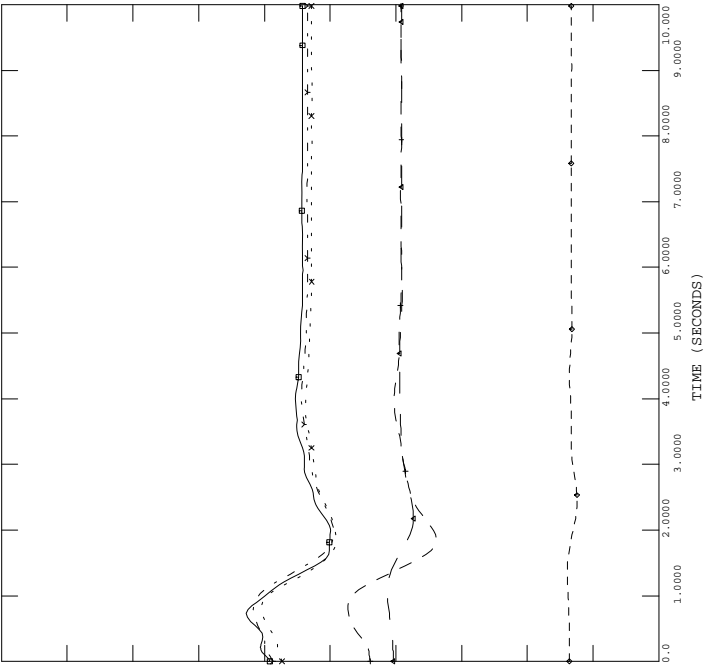

2013 WINTER PEAKL8004 OUT N-1
NS-NB=0; NB-NE=500; CBX=660 ONI=819 ONS=709
3 PHASE FAULT ON L8003 AT HOPEWELL 345KV
CLEARED IN 4.5 CYCLES: SPS DROPS LINGAN 2

FILE: a07.1s-3p_8003_79n-2013WP-N-1-8004.out

CHNL# 49:	[POWER190472 [BLDNG2 19.000] [1]]	2.0000
7.0000		
CHNL# 45:	[POWER190456 [LEPRG1 26.000] [1]]	4.0000
9.0000		
CHNL# 44:	[POWER190450 [MACTG1 13.800] [1]]	0.0
5.0000		
CHNL# 42:	[POWER126652 [RAV 3 22.000] [1]]	0.0
5.0000		
CHNL# 41:	[POWER101063 [MYST G7 22.000] [1]]	1.0000
6.5000		
CHNL# 46:	[POWER190457 [C.CVGI 19.000] [1]]	0.0
5.0000		

FRI, FEB 13 2009 22:13
"NE, NY, NB POWER"

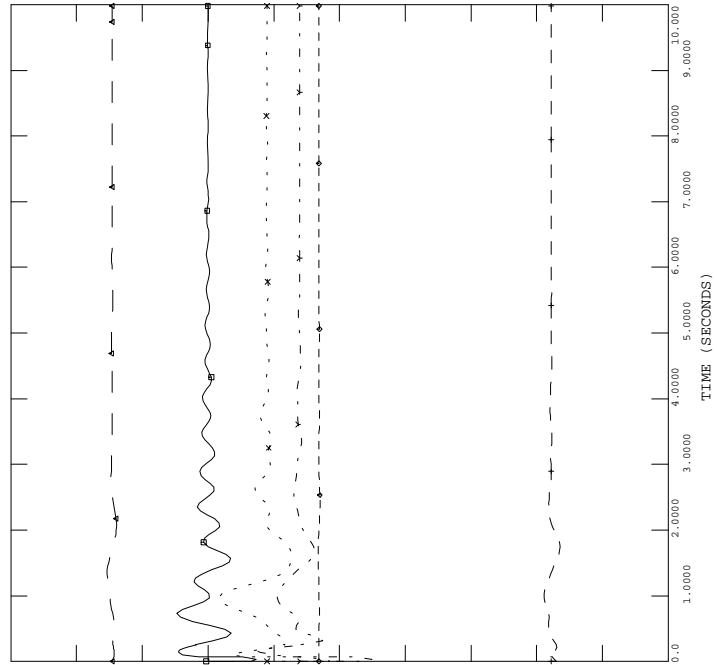



2013 WINTER PEAKL8004 OUT N-1
 NS-NB=0; NB-NE=500; CBX=660 ONI=819 ONS=709
 3 PHASE FAULT ON L8003 AT HOPEWELL 345KV
 CLEARED IN 4.5 CYCLES: SPS DROPS LINGAN 2
 FILE: a07.1s-3p_8003_79n-2013WP-N-1-8004.out
 CHNL# 119: [VARS IR141-DIGBY]

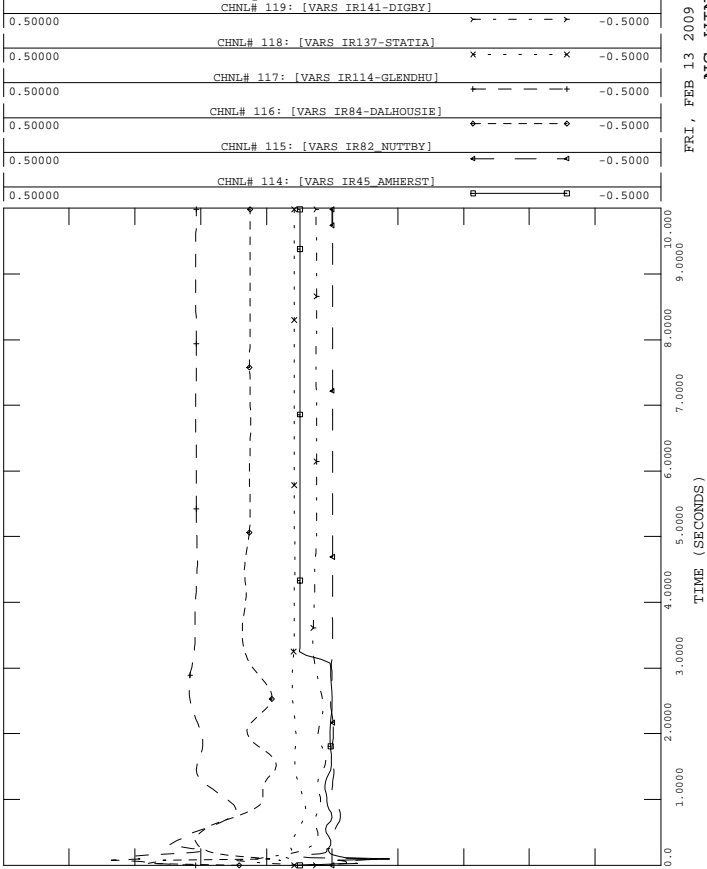

FRI, FEB 13 2009 22:13
 NS WIND MV



2013 WINTER PEAKL8004 OUT N-1
 NS-NB=0; NB-NE=500; CBX=660 ONI=819 ONS=709
 3 PHASE FAULT ON L8003 AT HOPEWELL 345KV
 CLEARED IN 4.5 CYCLES: SPS DROPS LINGAN 2
 FILE: a07.1s-3p_8003_79n-2013WP-N-1-8004.out
 CHNL# 133: [VOLT199125 [ONSLow 345.00]]

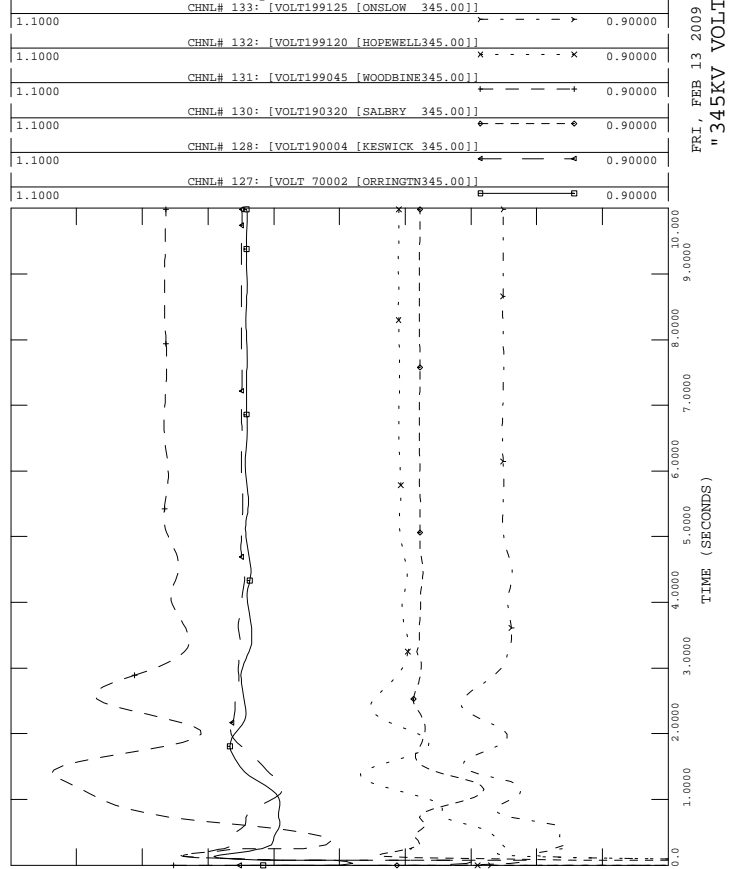

FRI, FEB 13 2009 22:13
 "# 345KV VOLTAGE"



2013 WINTER PEAKL8004 OUT N-1
 NS-NB=0; NB-NE=500; CBX=660 ONI=819 ONS=709
 3 PHASE FAULT ON L8003 AT HOPEWELL 345KV
 CLEARED IN 4.5 CYCLES: SPS DROPS LINGAN 2
 FILE: a07.1s-3p_8003_79n-2013WP-N-1-8004.out
 CHNL# 79: [POWER IR141-DIGBY]

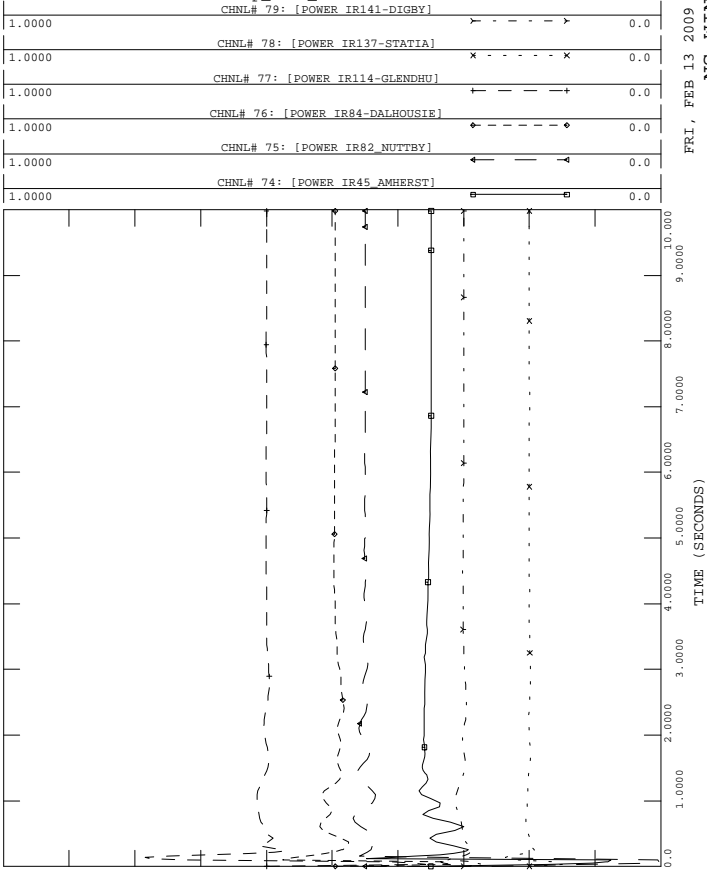

FRI, FEB 13 2009 22:13
 NS WIND MW



2013 WINTER PEAKL8004 OUT N-1
 NS-NB=0; NB-NE=500; CBX=660 ONI=819 ONS=709
 3 PHASE FAULT ON L8003 AT HOPEWELL 345KV
 CLEARED IN 4.5 CYCLES: SPS DROPS LINGAN 2
 FILE: a07.1s-3p_8003_79n-2013WP-N-1-8004.out
 CHNL# 125: 60*(1+[FREQ199125 [ONSLow 345.00]])

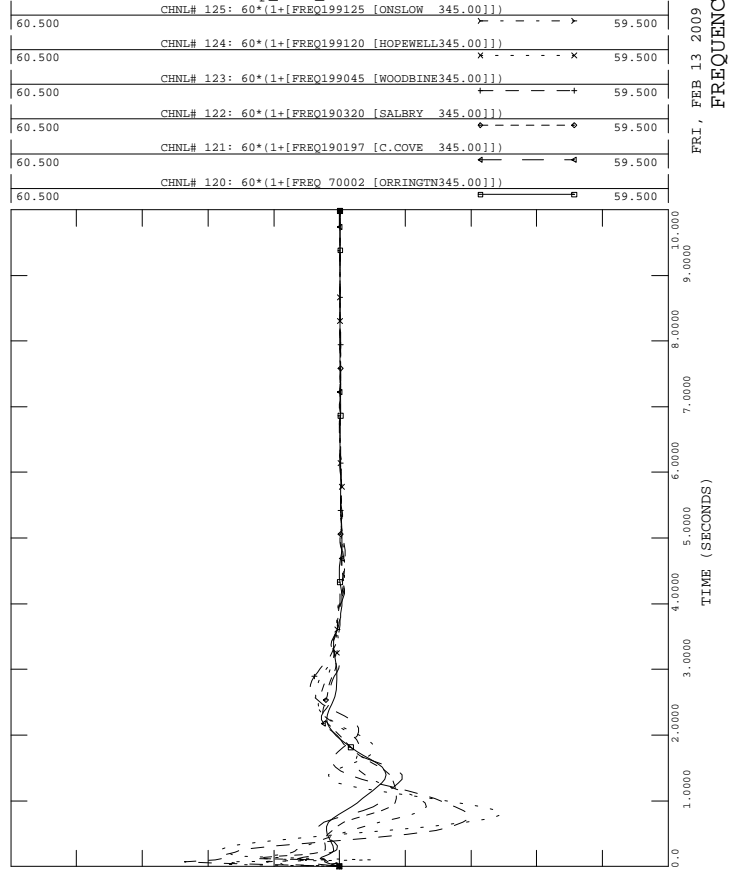

FRI, FEB 13 2009 22:13
 FREQUENCY HZ



2013 WINTER PEAKL8004 OUT N-1
 NS-NB=0; NB-NE=500; CBX=660 ONI=819 ONS=709
 3 PHASE FAULT ON L8003 AT HOPEWELL 345KV
 CLEARED IN 4.5 CYCLES: SPS DROPS LINGAN 2
 FILE: a07.1s-3p_8003_79n-2013WP-N-1-8004.out
 CHNL# 146: [VOLT199280 [TUSKET_A138.00]]

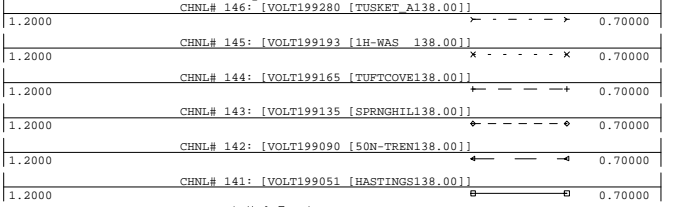

FRI, FEB 13 2009 22:13
 138KV BUS VOLTS



2013 WINTER PEAKL8004 OUT N-1
 NS-NB=0; NB-NE=500; CBX=660 ONI=819 ONS=709
 3 PHASE FAULT ON L8003 AT HOPEWELL 345KV
 CLEARED IN 4.5 CYCLES: SPS DROPS LINGAN 2
 FILE: a07.1s-3p_8003_79n-2013WP-N-1-8004.out
 CHNL# 217: [L6513MMW]

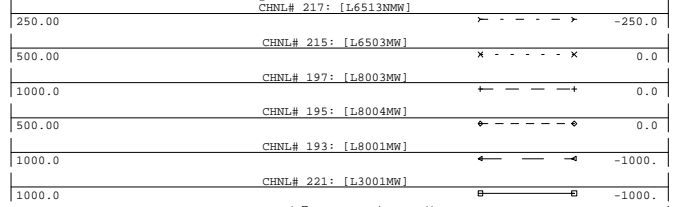

FRI, FEB 13 2009 22:13
 LINE FLOW MW



2013 WINTER PEAKL8004 OUT N-1
 NS-NB=0; NB-NE=500; CBX=660 ONI=819 ONS=709
 3 PHASE FAULT ON L8003 AT HOPEWELL 345KV
 CLEARED IN 4.5 CYCLES: SPS DROPS LINGAN 2
 FILE: a07.1s-3p_8003_79n-2013WP-N-1-8004.out
 CHNL# 140: [VOLT199240 [BRATER_A230.00]]

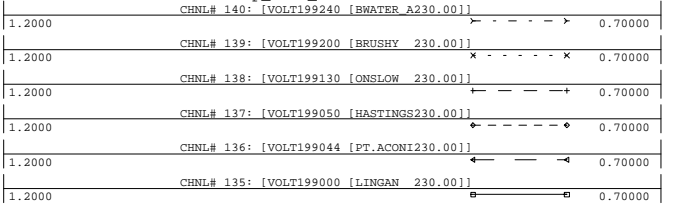

FRI, FEB 13 2009 22:13
 230KV BUS VOLTS



2013 WINTER PEAKL8004 OUT N-1
 NS-NB=0; NB-NE=500; CBX=660 ONI=819 ONS=709
 3 PHASE FAULT ON L8003 AT HOPEWELL 345KV
 CLEARED IN 4.5 CYCLES: SPS DROPS LINGAN 2
 FILE: a07.1s-3p_8003_79n-2013WP-N-1-8004.out
 CHNL# 154: [IR141-DIGBYH69.0 VOLTS]

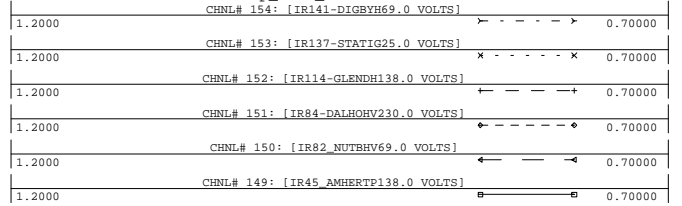

FRI, FEB 13 2009 22:13
 WIND BUS VOLTS

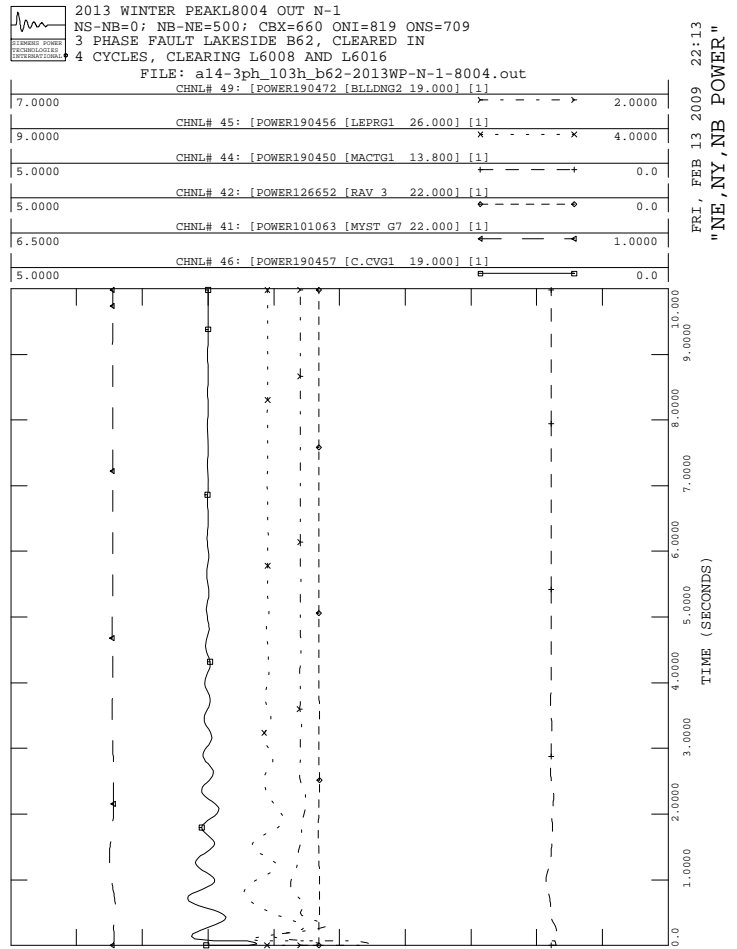
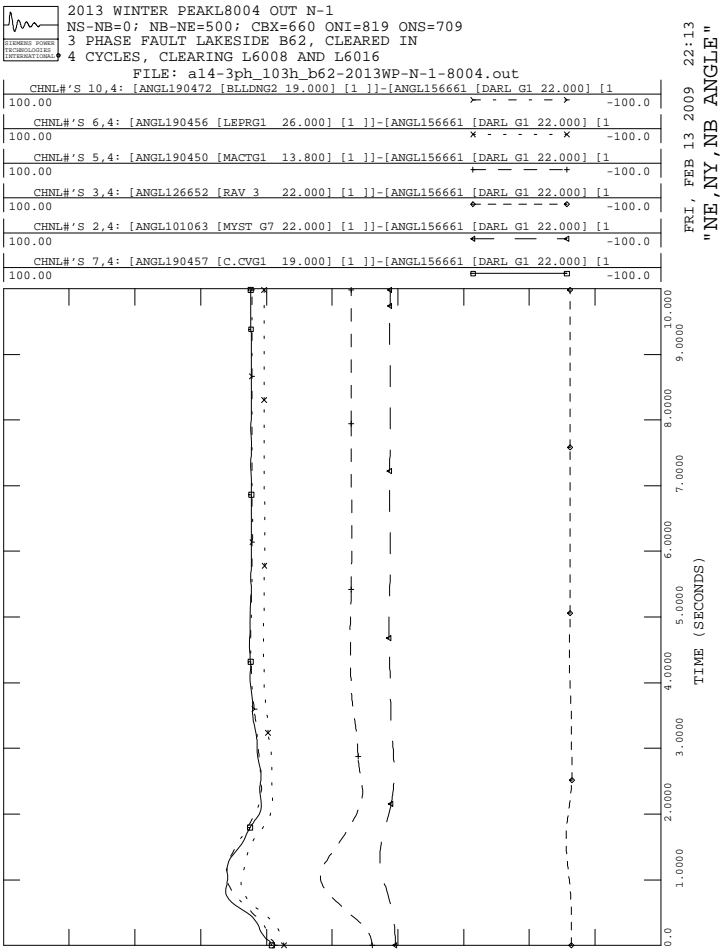
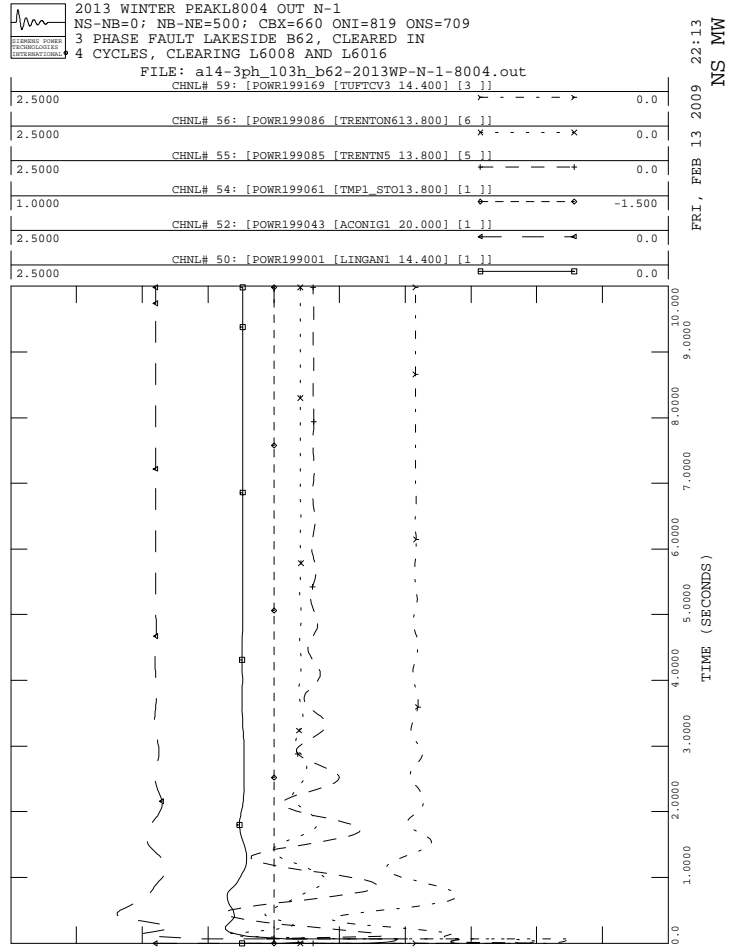
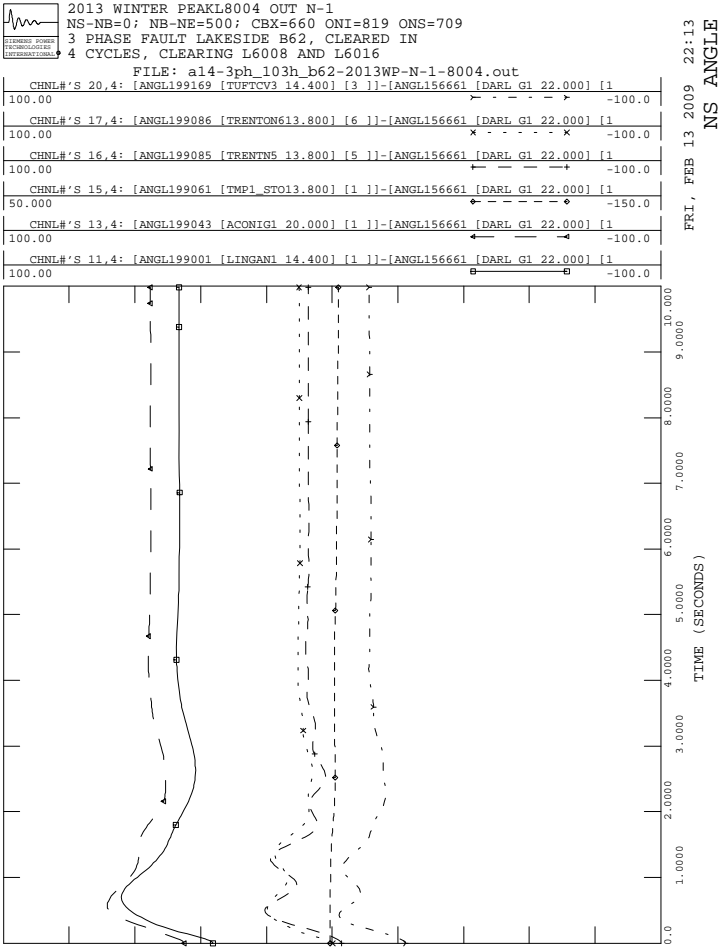



2013 WINTER PEAKL8004 OUT N-1
 NS-NB=0; NB-NE=500; CBX=660 ONI=819 ONS=709
 3 PHASE FAULT LAKESIDE B62, CLEARED IN
 4 CYCLES, CLEARING L6008 AND L6016
 FILE: a14-3ph_103h_b62-2013WP-N-1-8004.out
 CHNL# 119: [VARS IR141-DIGBY]

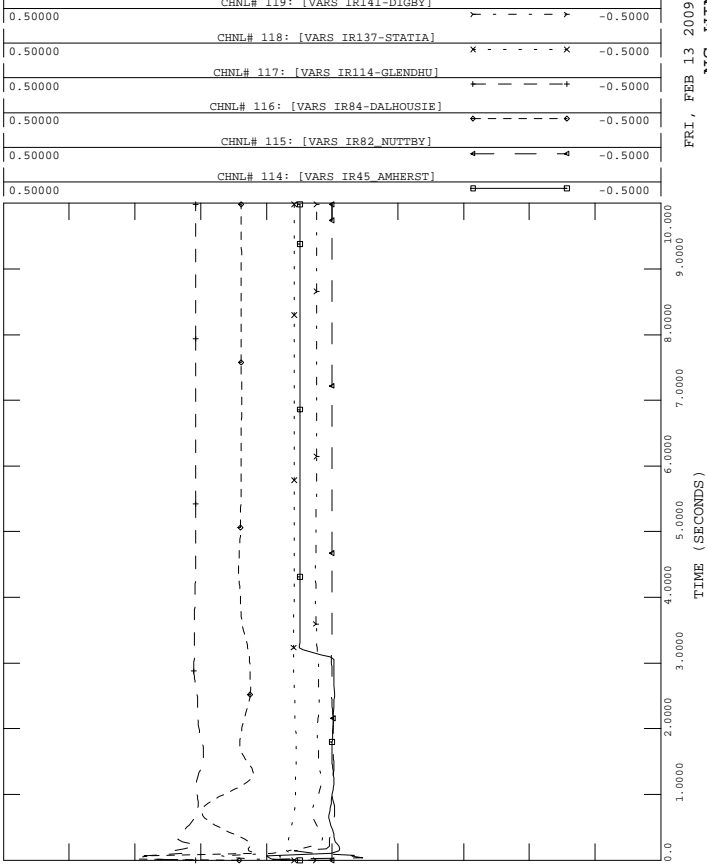

2013 WINTER PEAKL8004 OUT N-1
 NS-NB=0; NB-NE=500; CBX=660 ONI=819 ONS=709
 3 PHASE FAULT LAKESIDE B62, CLEARED IN
 4 CYCLES, CLEARING L6008 AND L6016
 FILE: a14-3ph_103h_b62-2013WP-N-1-8004.out
 CHNL# 133: [VOLT199125 [ONSLOW 345.00]]

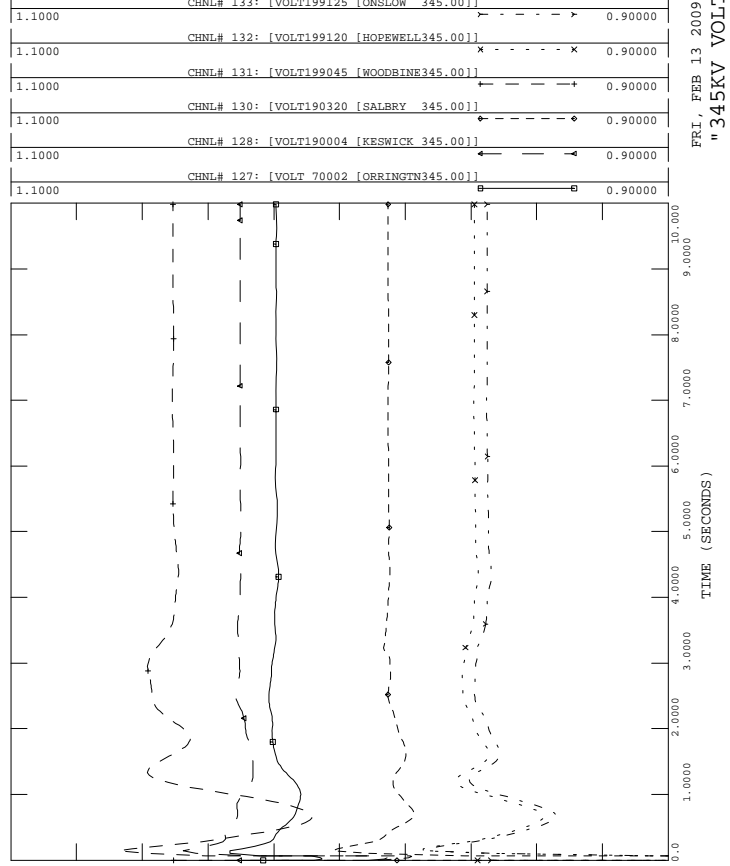

2013 WINTER PEAKL8004 OUT N-1
 NS-NB=0; NB-NE=500; CBX=660 ONI=819 ONS=709
 3 PHASE FAULT LAKESIDE B62, CLEARED IN
 4 CYCLES, CLEARING L6008 AND L6016
 FILE: a14-3ph_103h_b62-2013WP-N-1-8004.out
 CHNL# 79: [POWER IR141-DIGBY]

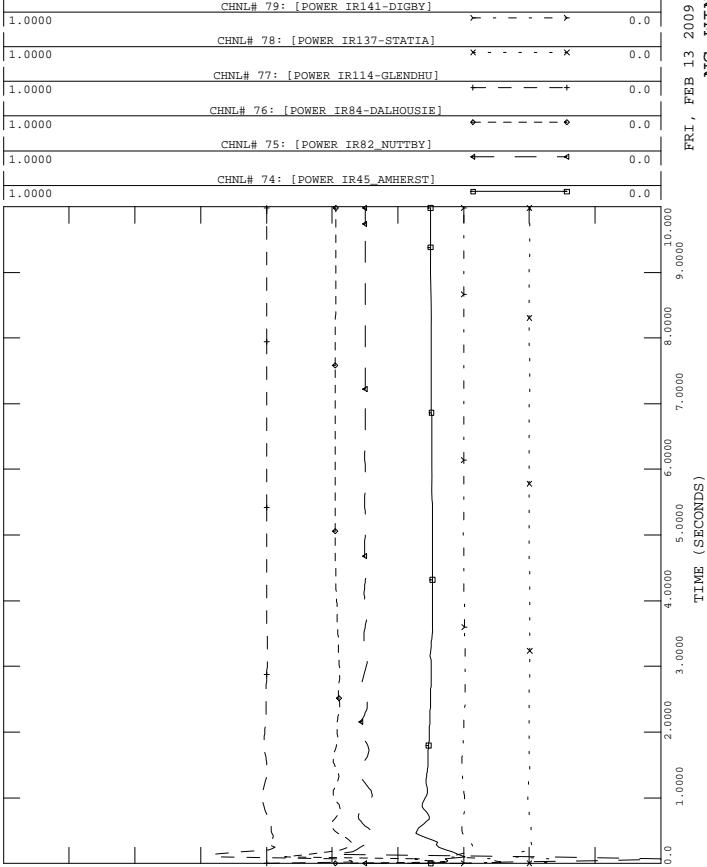

2013 WINTER PEAKL8004 OUT N-1
 NS-NB=0; NB-NE=500; CBX=660 ONI=819 ONS=709
 3 PHASE FAULT LAKESIDE B62, CLEARED IN
 4 CYCLES, CLEARING L6008 AND L6016
 FILE: a14-3ph_103h_b62-2013WP-N-1-8004.out
 CHNL# 125: 60*(1+[FREQ199125 [ONSLOW 345.00]])

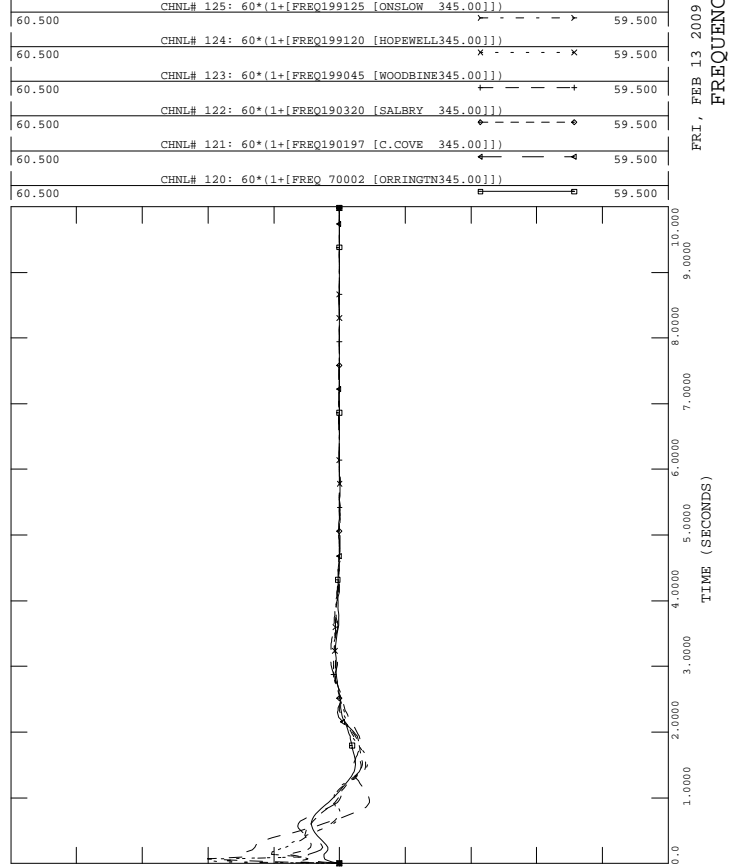



2013 WINTER PEAKL8004 OUT N-1
 NS-NB=0; NB-NE=500; CBX=660 ONI=819 ONS=709
 3 PHASE FAULT LAKESIDE B62, CLEARED IN
 4 CYCLES, CLEARING L6008 AND L6016

FILE: a14-3ph_103h_b62-2013WP-N-1-8004.out
 CHNL# 146: [VOLT199280 [TUSKET_A138.00]]

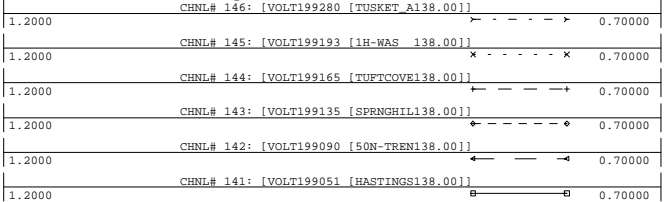

FRI, FEB 13 2009 22:13
 138KV BUS VOLTS



2013 WINTER PEAKL8004 OUT N-1
 NS-NB=0; NB-NE=500; CBX=660 ONI=819 ONS=709
 3 PHASE FAULT LAKESIDE B62, CLEARED IN
 4 CYCLES, CLEARING L6008 AND L6016

FILE: a14-3ph_103h_b62-2013WP-N-1-8004.out
 CHNL# 217: [L6513MMW]

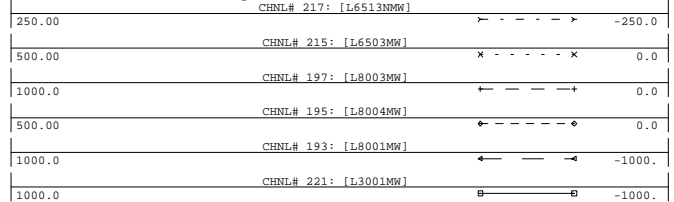

FRI, FEB 13 2009 22:13
 LINE FLOW MW



2013 WINTER PEAKL8004 OUT N-1
 NS-NB=0; NB-NE=500; CBX=660 ONI=819 ONS=709
 3 PHASE FAULT LAKESIDE B62, CLEARED IN
 4 CYCLES, CLEARING L6008 AND L6016

FILE: a14-3ph_103h_b62-2013WP-N-1-8004.out
 CHNL# 140: [VOLT199240 [BRATER_A230.00]]

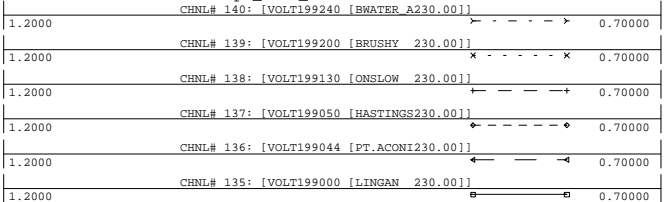

FRI, FEB 13 2009 22:13
 230KV BUS VOLTS



2013 WINTER PEAKL8004 OUT N-1
 NS-NB=0; NB-NE=500; CBX=660 ONI=819 ONS=709
 3 PHASE FAULT LAKESIDE B62, CLEARED IN
 4 CYCLES, CLEARING L6008 AND L6016

FILE: a14-3ph_103h_b62-2013WP-N-1-8004.out
 CHNL# 154: [IR141-DIGBYH69.0 VOLTS]

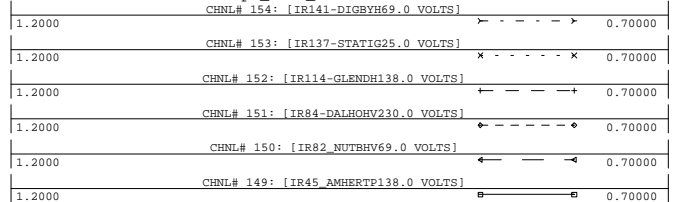

FRI, FEB 13 2009 22:13
 WIND BUS VOLTS



2013 WINTER PEAKL8004 OUT N-1
NS-NB=0; NB-NE=500; CBX=660 ONI=819 ONS=709
SLG FAULT ON HASTINGS END OF 7012 3C-715 FAILS,
CLEARS 7012 AND 7004 IN 17 CYCLES SPS TRIPS

FILE: b03s-7012_lph_3c715-2013WP-N-1-8004.out

CHNL#*S 20,4:	[ANGL199169 [TUFTCV3 14.400] [3]]	[ANGL156661 [DARL G1 22.000] [1]]	-100.0
100.00			
CHNL#*S 17,4:	[ANGL199086 [TRENTON613.800] [6]]	[ANGL156661 [DARL G1 22.000] [1]]	-100.0
100.00			
CHNL#*S 16,4:	[ANGL199085 [TRENTN5 13.800] [5]]	[ANGL156661 [DARL G1 22.000] [1]]	-100.0
100.00			
CHNL#*S 15,4:	[ANGL199061 [TMP1_STO13.800] [1]]	[ANGL156661 [DARL G1 22.000] [1]]	-150.0
50.0000			
CHNL#*S 13,4:	[ANGL199043 [ACONIG1 20.000] [1]]	[ANGL156661 [DARL G1 22.000] [1]]	-100.0
100.00			
CHNL#*S 11,4:	[ANGL199001 [LINGANI 14.400] [1]]	[ANGL156661 [DARL G1 22.000] [1]]	-100.0
100.00			

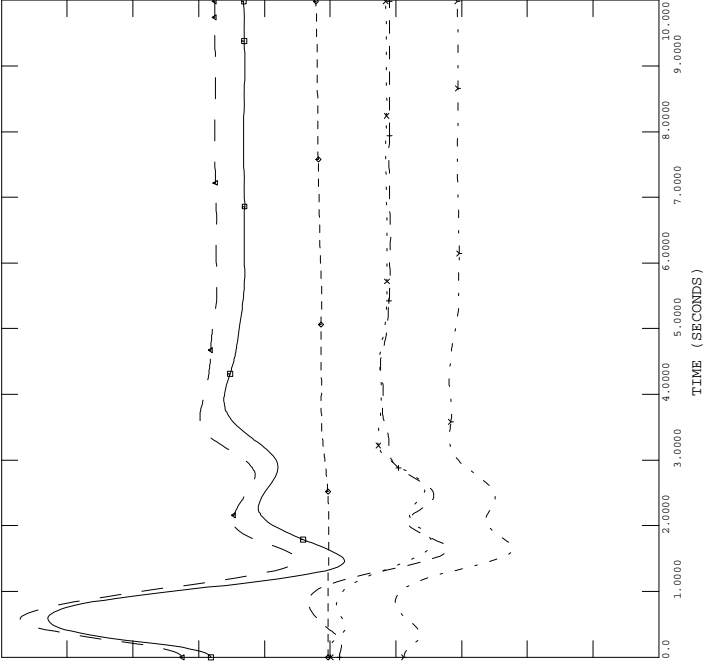

NS ANGLE
FRI, FEB 13 2009 22:13



2013 WINTER PEAKL8004 OUT N-1
NS-NB=0; NB-NE=500; CBX=660 ONI=819 ONS=709
SLG FAULT ON HASTINGS END OF 7012 3C-715 FAILS,
CLEARS 7012 AND 7004 IN 17 CYCLES SPS TRIPS

FILE: b03s-7012_lph_3c715-2013WP-N-1-8004.out

CHNL# 56:	[POWR199086 [TRENTON613.800] [6]]	0.0
2.5000		
CHNL# 55:	[POWR199085 [TRENTN5 13.800] [5]]	0.0
2.5000		
CHNL# 54:	[POWR199061 [TMP1_STO13.800] [1]]	0.0
1.0000		
CHNL# 52:	[POWR199043 [ACONIG1 20.000] [1]]	-1.500
2.5000		
CHNL# 50:	[POWR199001 [LINGANI 14.400] [1]]	0.0
2.5000		

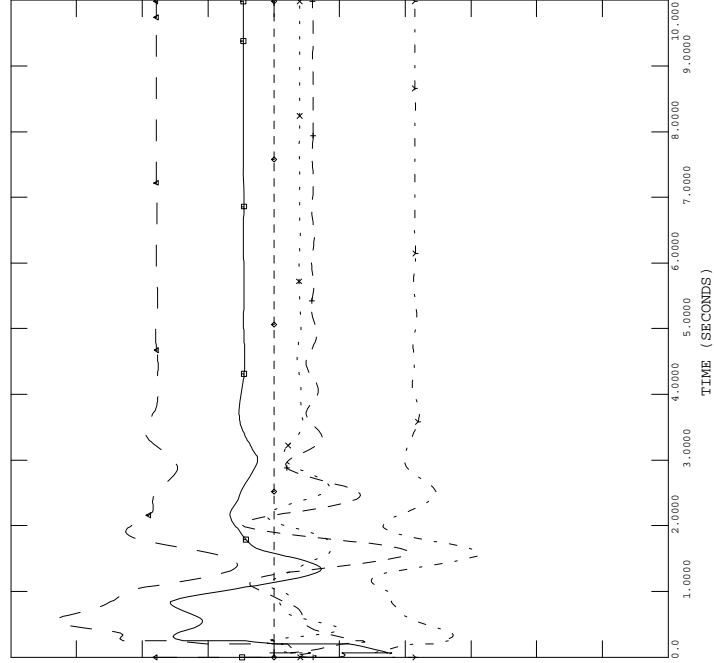

NS ANGLE
FRI, FEB 13 2009 22:13



2013 WINTER PEAKL8004 OUT N-1
NS-NB=0; NB-NE=500; CBX=660 ONI=819 ONS=709
SLG FAULT ON HASTINGS END OF 7012 3C-715 FAILS,
CLEARS 7012 AND 7004 IN 17 CYCLES SPS TRIPS

FILE: b03s-7012_lph_3c715-2013WP-N-1-8004.out

CHNL#*S 10,4:	[ANGL190472 [BLDNG2 19.000] [1]]	[ANGL156661 [DARL G1 22.000] [1]]	-100.0
100.00			
CHNL#*S 6,4:	[ANGL190456 [LEPRG1 26.000] [1]]	[ANGL156661 [DARL G1 22.000] [1]]	-100.0
100.00			
CHNL#*S 5,4:	[ANGL190450 [MACTG1 13.800] [1]]	[ANGL156661 [DARL G1 22.000] [1]]	-100.0
100.00			
CHNL#*S 3,4:	[ANGL126652 [RAV 3 22.000] [1]]	[ANGL156661 [DARL G1 22.000] [1]]	-100.0
100.00			
CHNL#*S 2,4:	[ANGL101063 [MYST G7 22.000] [1]]	[ANGL156661 [DARL G1 22.000] [1]]	-100.0
100.00			
CHNL#*S 7,4:	[ANGL190457 [C.CVG1 19.000] [1]]	[ANGL156661 [DARL G1 22.000] [1]]	-100.0
100.00			

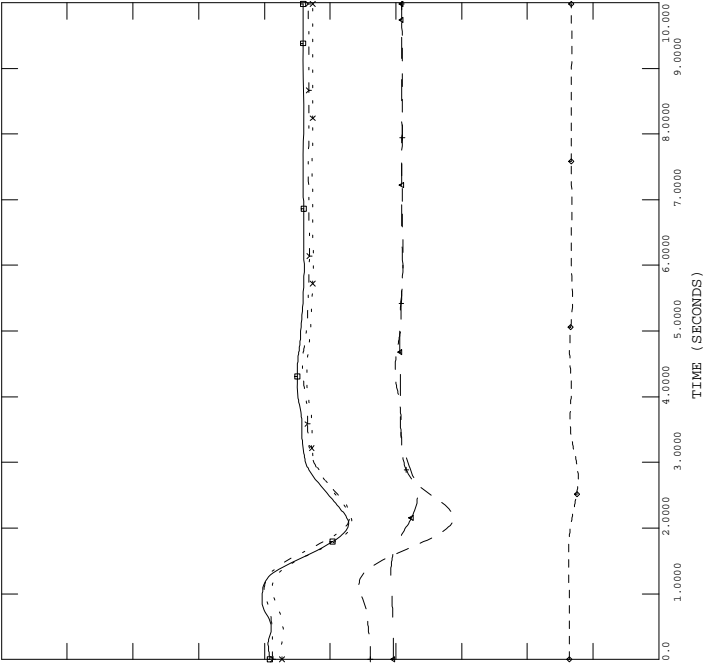

NE, NY, NB ANGLE
FRI, FEB 13 2009 22:13



2013 WINTER PEAKL8004 OUT N-1
NS-NB=0; NB-NE=500; CBX=660 ONI=819 ONS=709
SLG FAULT ON HASTINGS END OF 7012 3C-715 FAILS,
CLEARS 7012 AND 7004 IN 17 CYCLES SPS TRIPS

FILE: b03s-7012_lph_3c715-2013WP-N-1-8004.out

CHNL# 49:	[POWER190472 [BLDNG2 19.000] [1]]	2.0000
7.0000		
CHNL# 45:	[POWER190456 [LEPRG1 26.000] [1]]	4.0000
9.0000		
CHNL# 44:	[POWER190450 [MACTG1 13.800] [1]]	0.0
5.0000		
CHNL# 42:	[POWER126652 [RAV 3 22.000] [1]]	0.0
5.0000		
CHNL# 41:	[POWER101063 [MYST G7 22.000] [1]]	1.0000
6.5000		
CHNL# 46:	[POWER190457 [C.CVG1 19.000] [1]]	0.0
5.0000		

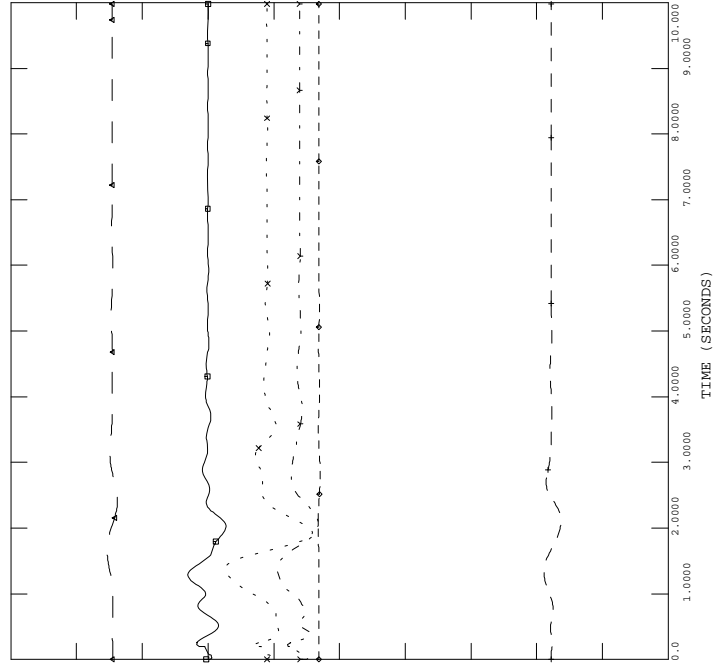

NE, NY, NB POWER
FRI, FEB 13 2009 22:13



2013 WINTER PEAKL8004 OUT N-1
 NS-NB=0; NB-NE=500; CBX=660 ONI=819 ONS=709
 SLG FAULT ON HASTINGS END OF 7012 3C-715 FAILS,
 CLEARS 7012 AND 7004 IN 17 CYCLES SPS TRIPS
 FILE: b03s-7012_lph_3c715-2013WP-N-1-8004.out
 CHNL# 119: [VARS IR141-DIGBY]

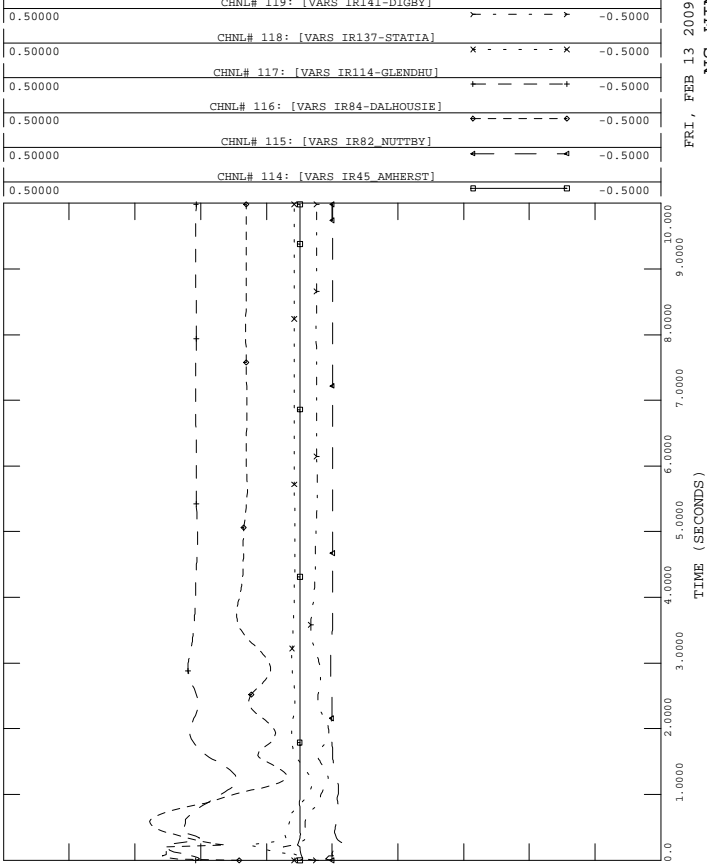

FRI, FEB 13 2009 22:13
 NS WIND MV



2013 WINTER PEAKL8004 OUT N-1
 NS-NB=0; NB-NE=500; CBX=660 ONI=819 ONS=709
 SLG FAULT ON HASTINGS END OF 7012 3C-715 FAILS,
 CLEARS 7012 AND 7004 IN 17 CYCLES SPS TRIPS
 FILE: b03s-7012_lph_3c715-2013WP-N-1-8004.out
 CHNL# 133: [VOLT199125 [ONSLW 345.00]]

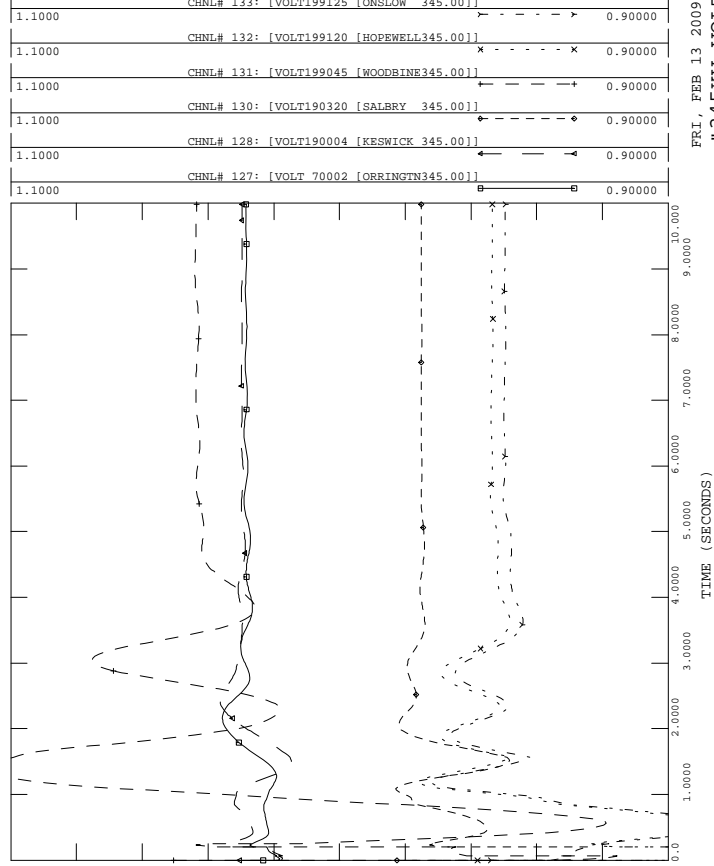

FRI, FEB 13 2009 22:13
 "# 345KV VOLTAGE"



2013 WINTER PEAKL8004 OUT N-1
 NS-NB=0; NB-NE=500; CBX=660 ONI=819 ONS=709
 SLG FAULT ON HASTINGS END OF 7012 3C-715 FAILS,
 CLEARS 7012 AND 7004 IN 17 CYCLES SPS TRIPS
 FILE: b03s-7012_lph_3c715-2013WP-N-1-8004.out
 CHNL# 79: [POWER IR141-DIGBY]

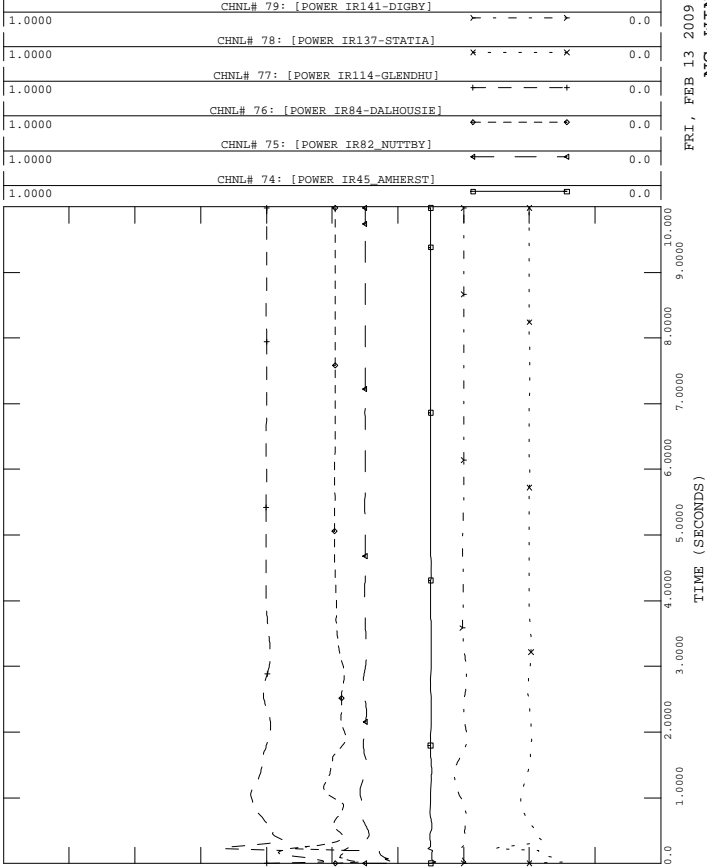

FRI, FEB 13 2009 22:13
 NS WIND MW



2013 WINTER PEAKL8004 OUT N-1
 NS-NB=0; NB-NE=500; CBX=660 ONI=819 ONS=709
 SLG FAULT ON HASTINGS END OF 7012 3C-715 FAILS,
 CLEARS 7012 AND 7004 IN 17 CYCLES SPS TRIPS
 FILE: b03s-7012_lph_3c715-2013WP-N-1-8004.out
 CHNL# 125: 60*(1+[FREQ199125 [ONSLW 345.00]])

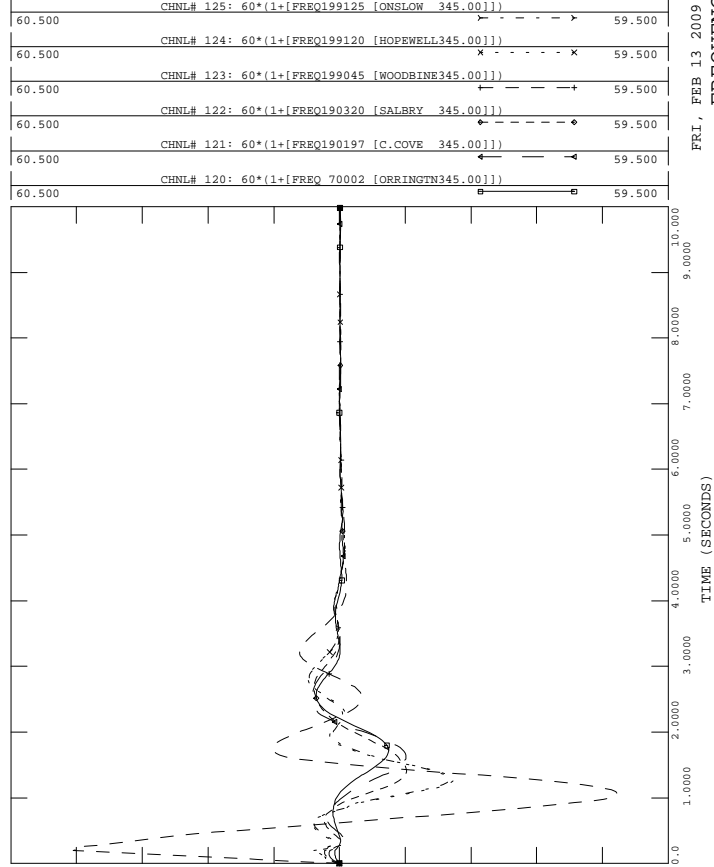

FRI, FEB 13 2009 22:13
 FREQUENCY HZ



2013 WINTER PEAKL8004 OUT N-1
NS-NB=0; NB-NE=500; CBX=660 ONI=819 ONS=709
SLG FAULT ON HASTINGS END OF 7012 3C-715 FAILS,
CLEARS 7012 AND 7004 IN 17 CYCLES SPS TRIPS
FILE: b03s-7012_lph_3c715-2013WP-N-1-8004.out
CHNL# 146: [VOLT199280 [TUSKET_A138.00]]

Table with 2 columns: Time (1.2000) and Voltage (0.70000). Rows list channel numbers and names: CHNL# 145: [VOLT199193 [1H-WAS 138.00]], CHNL# 144: [VOLT199165 [TUFTCOVER138.00]], CHNL# 143: [VOLT199135 [SPRNGHIL138.00]], CHNL# 142: [VOLT199090 [50N-TREN138.00]], CHNL# 141: [VOLT199051 [HASTINGS138.00]].

FRI, FEB 13 2009 22:13
138KV BUS VOLTS

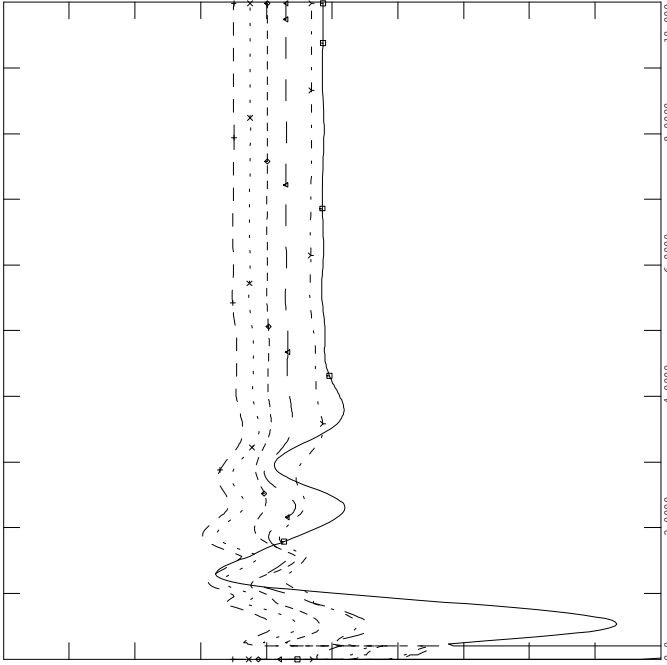

2013 WINTER PEAKL8004 OUT N-1
NS-NB=0; NB-NE=500; CBX=660 ONI=819 ONS=709
SLG FAULT ON HASTINGS END OF 7012 3C-715 FAILS,
CLEARS 7012 AND 7004 IN 17 CYCLES SPS TRIPS
FILE: b03s-7012_lph_3c715-2013WP-N-1-8004.out
CHNL# 217: [L6513NMW]

Table with 2 columns: Time (1.2000) and Voltage (-1000.0 to 250.00). Rows list channel numbers and names: CHNL# 215: [L6503MMW], CHNL# 197: [L8003MMW], CHNL# 195: [L8004MMW], CHNL# 193: [L8001MMW], CHNL# 221: [L3001MMW].

FRI, FEB 13 2009 22:13
LINE FLOW MW

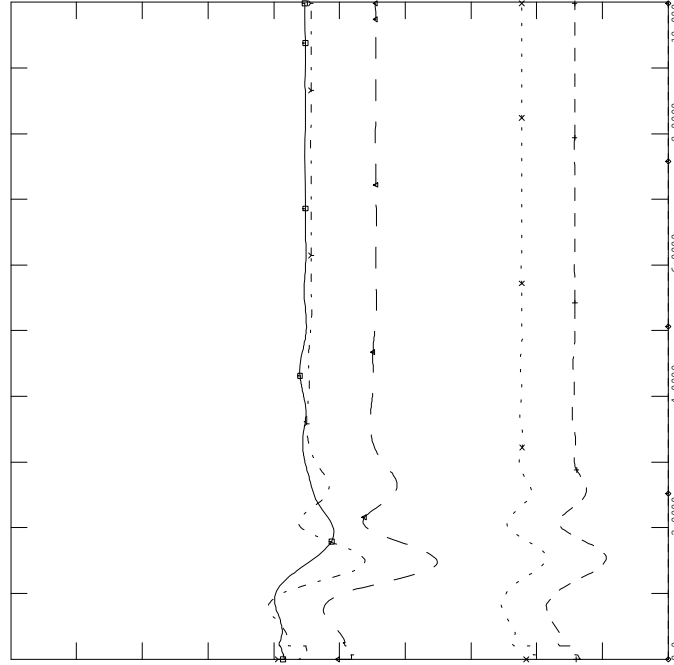

2013 WINTER PEAKL8004 OUT N-1
NS-NB=0; NB-NE=500; CBX=660 ONI=819 ONS=709
SLG FAULT ON HASTINGS END OF 7012 3C-715 FAILS,
CLEARS 7012 AND 7004 IN 17 CYCLES SPS TRIPS
FILE: b03s-7012_lph_3c715-2013WP-N-1-8004.out
CHNL# 140: [VOLT199240 [BRATER_A230.00]]

Table with 2 columns: Time (1.2000) and Voltage (0.70000). Rows list channel numbers and names: CHNL# 139: [VOLT199200 [BRUSHY 230.00]], CHNL# 138: [VOLT199130 [ONSLow 230.00]], CHNL# 137: [VOLT199050 [HASTINGS230.00]], CHNL# 136: [VOLT199044 [PT.ACON1230.00]], CHNL# 135: [VOLT199000 [LINGAN 230.00]].

FRI, FEB 13 2009 22:13
230KV BUS VOLTS

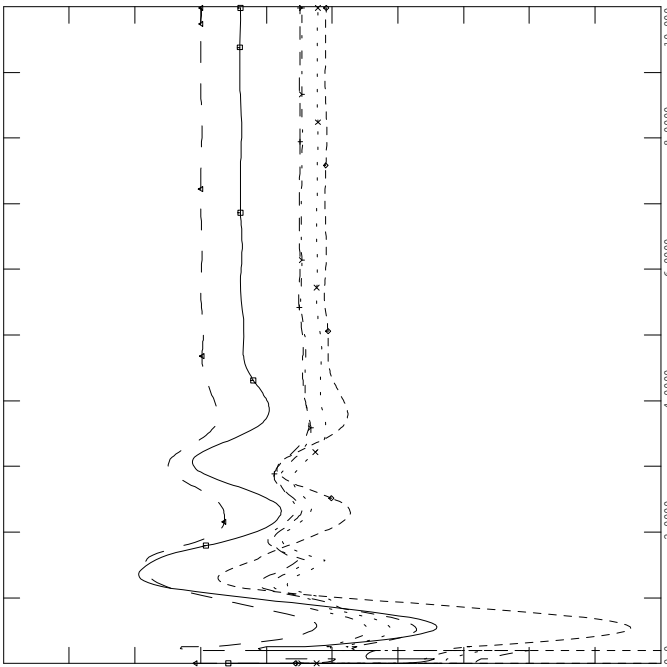

2013 WINTER PEAKL8004 OUT N-1
NS-NB=0; NB-NE=500; CBX=660 ONI=819 ONS=709
SLG FAULT ON HASTINGS END OF 7012 3C-715 FAILS,
CLEARS 7012 AND 7004 IN 17 CYCLES SPS TRIPS
FILE: b03s-7012_lph_3c715-2013WP-N-1-8004.out
CHNL# 154: [IR141-DIGBYH69.0 VOLTS]

Table with 2 columns: Time (1.2000) and Voltage (0.70000). Rows list channel numbers and names: CHNL# 153: [IR137-STATIG25.0 VOLTS], CHNL# 152: [IR114-GLENDH138.0 VOLTS], CHNL# 151: [IR84-DALHOHV230.0 VOLTS], CHNL# 150: [IR82-NUTBHV69.0 VOLTS], CHNL# 149: [IR45-AMHERTP138.0 VOLTS].

FRI, FEB 13 2009 22:13
WIND BUS VOLTS

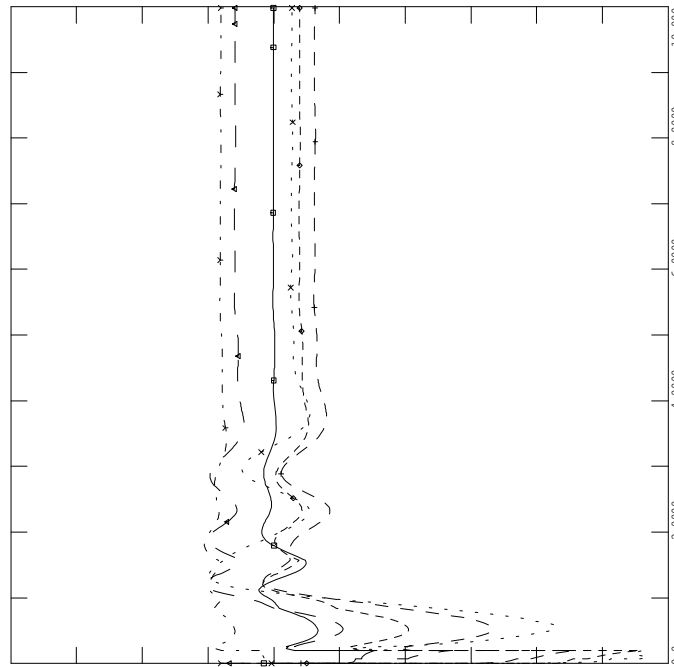

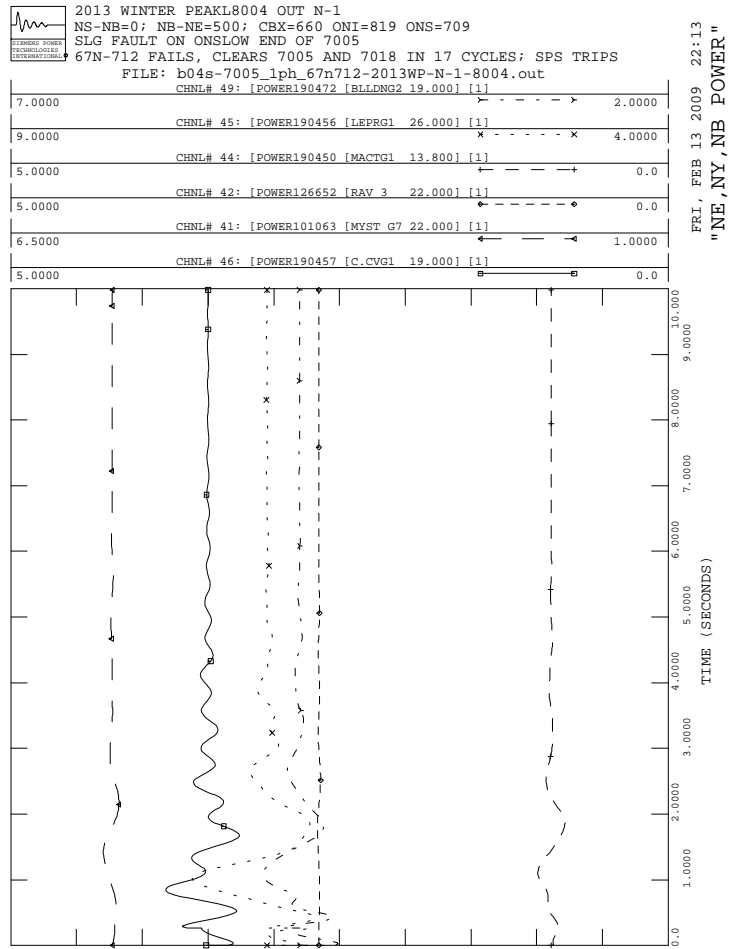
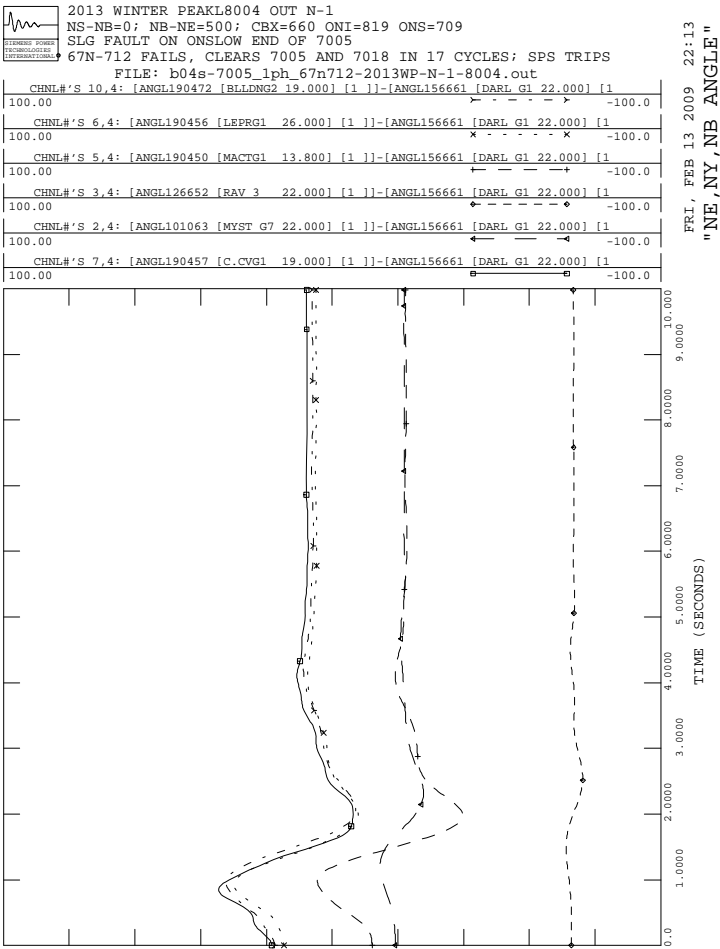
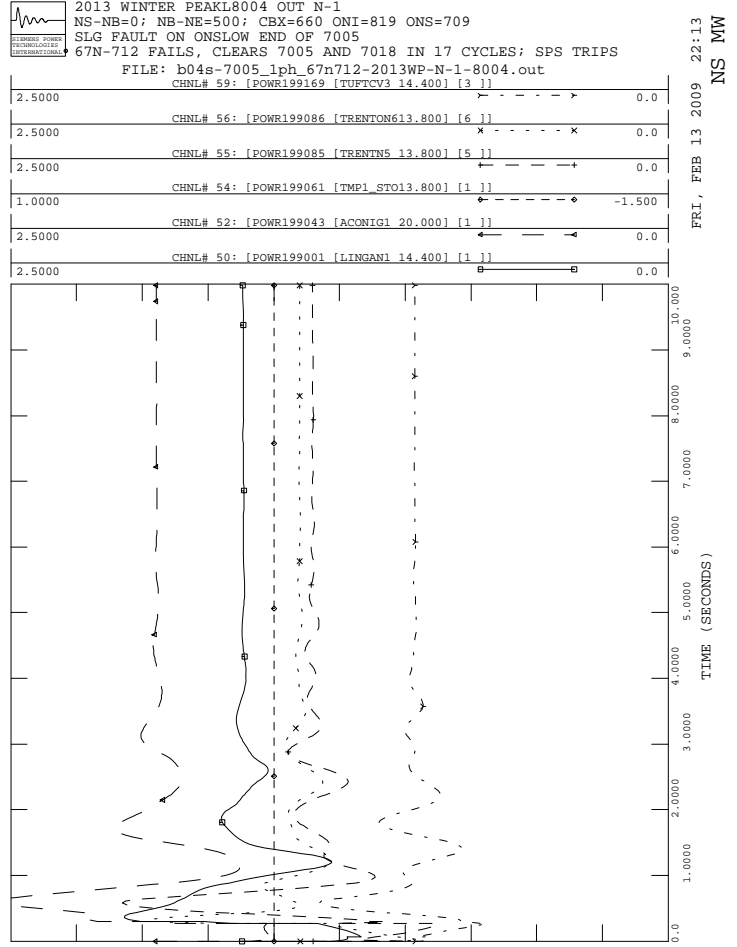
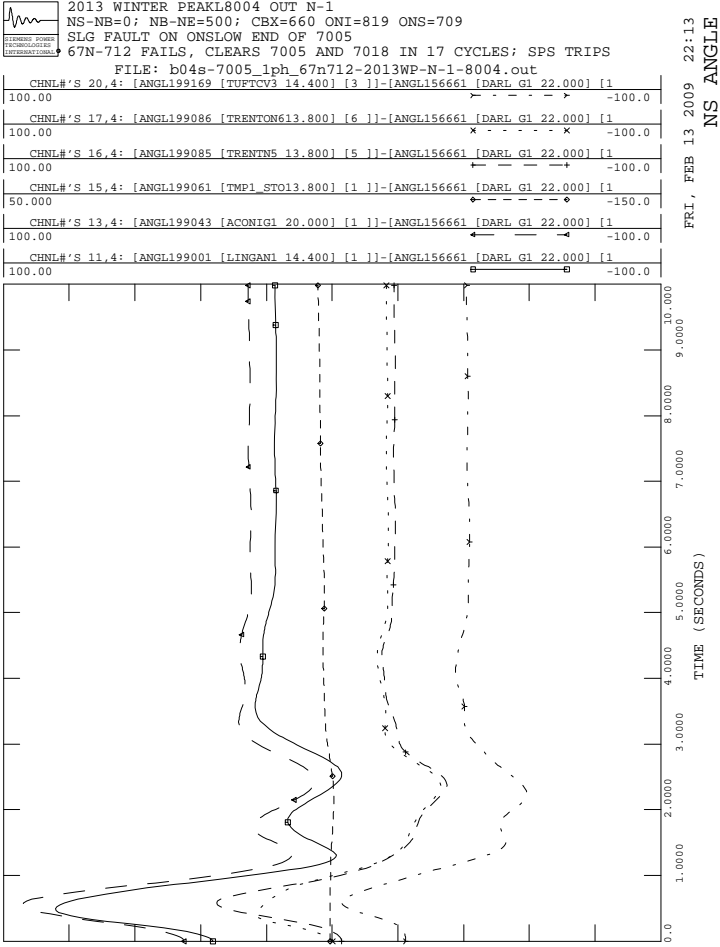



2013 WINTER PEAKL8004 OUT N-1
 NS-NB=0; NB-NE=500; CBX=660 ONI=819 ONS=709
 SLG FAULT ON ONSLOW END OF 7005
 67N-712 FAILS, CLEARS 7005 AND 7018 IN 17 CYCLES; SPS TRIPS
 FILE: b04s-7005_lph_67n712-2013WP-N-1-8004.out
 CHNL# 119: [VARS IR141-DIGBY]

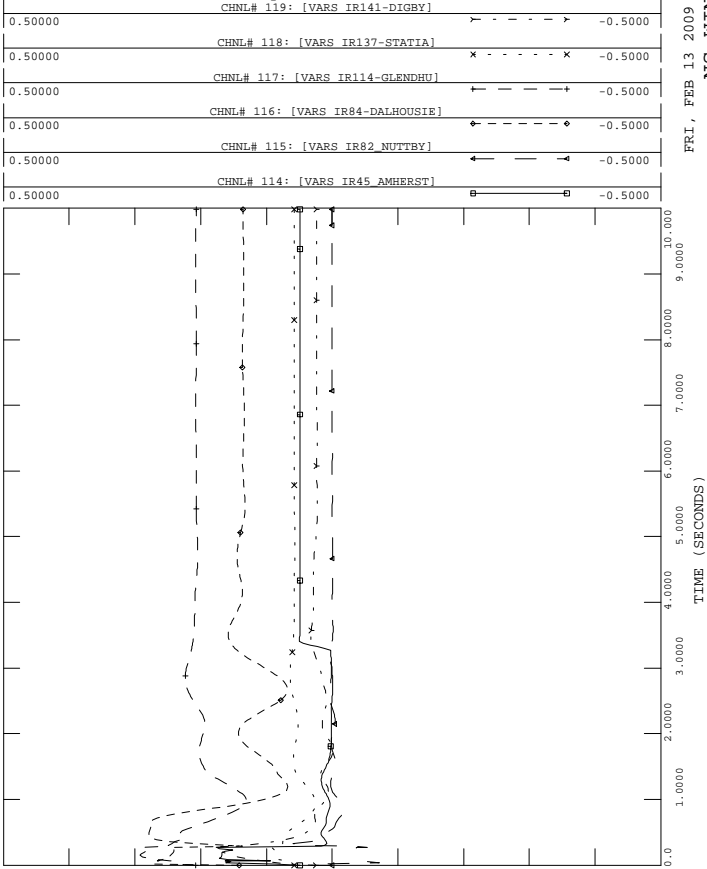

2013 WINTER PEAKL8004 OUT N-1
 NS-NB=0; NB-NE=500; CBX=660 ONI=819 ONS=709
 SLG FAULT ON ONSLOW END OF 7005
 67N-712 FAILS, CLEARS 7005 AND 7018 IN 17 CYCLES; SPS TRIPS
 FILE: b04s-7005_lph_67n712-2013WP-N-1-8004.out
 CHNL# 133: [VOLT199125 [ONSLow 345.00]]

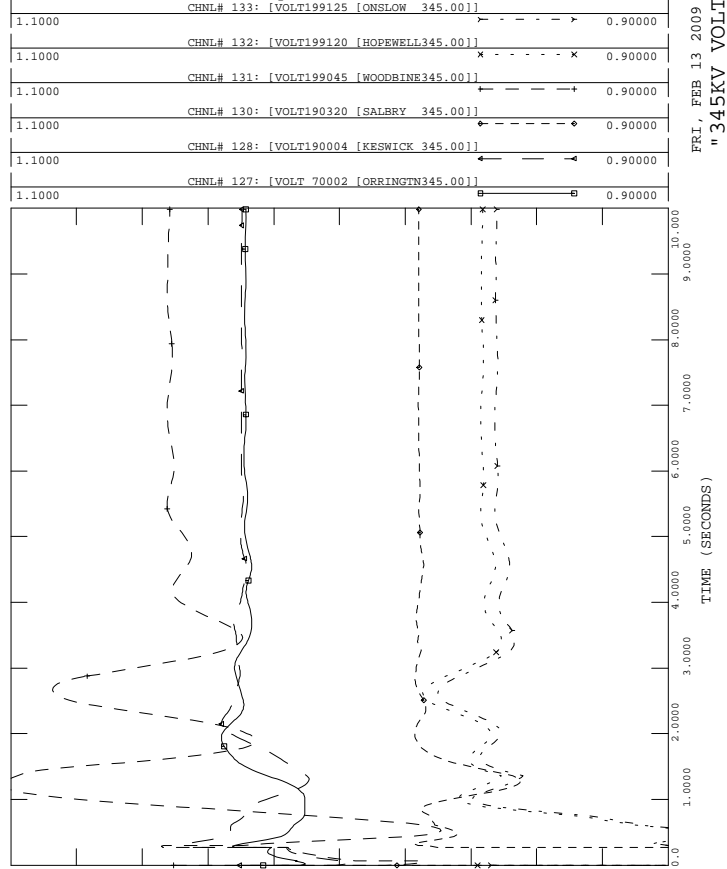

2013 WINTER PEAKL8004 OUT N-1
 NS-NB=0; NB-NE=500; CBX=660 ONI=819 ONS=709
 SLG FAULT ON ONSLOW END OF 7005
 67N-712 FAILS, CLEARS 7005 AND 7018 IN 17 CYCLES; SPS TRIPS
 FILE: b04s-7005_lph_67n712-2013WP-N-1-8004.out
 CHNL# 79: [POWER IR141-DIGBY]

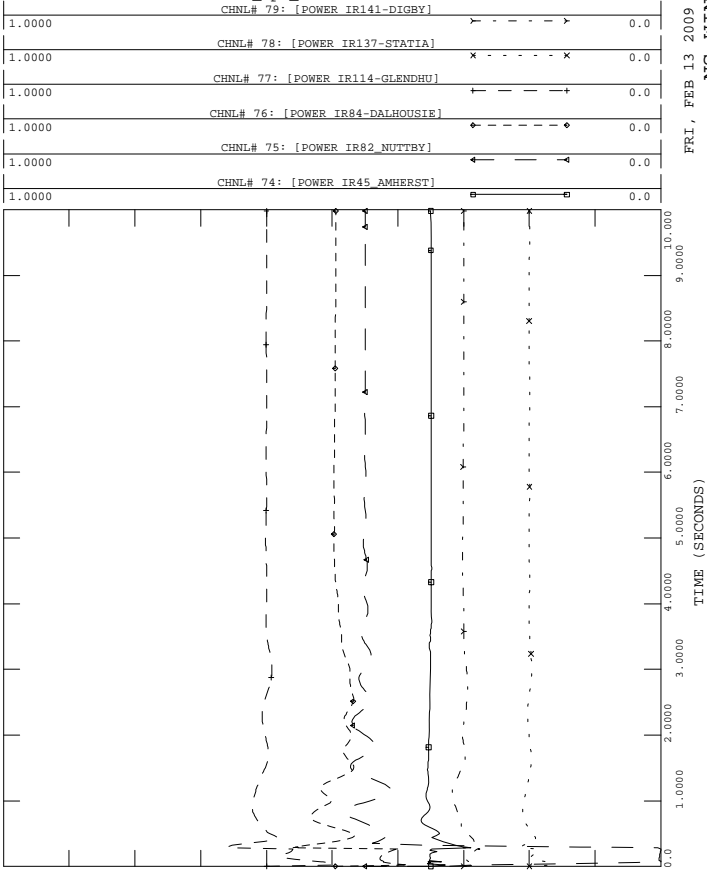

2013 WINTER PEAKL8004 OUT N-1
 NS-NB=0; NB-NE=500; CBX=660 ONI=819 ONS=709
 SLG FAULT ON ONSLOW END OF 7005
 67N-712 FAILS, CLEARS 7005 AND 7018 IN 17 CYCLES; SPS TRIPS
 FILE: b04s-7005_lph_67n712-2013WP-N-1-8004.out
 CHNL# 125: 60*(1+[FREQ199125 [ONSLow 345.00]])

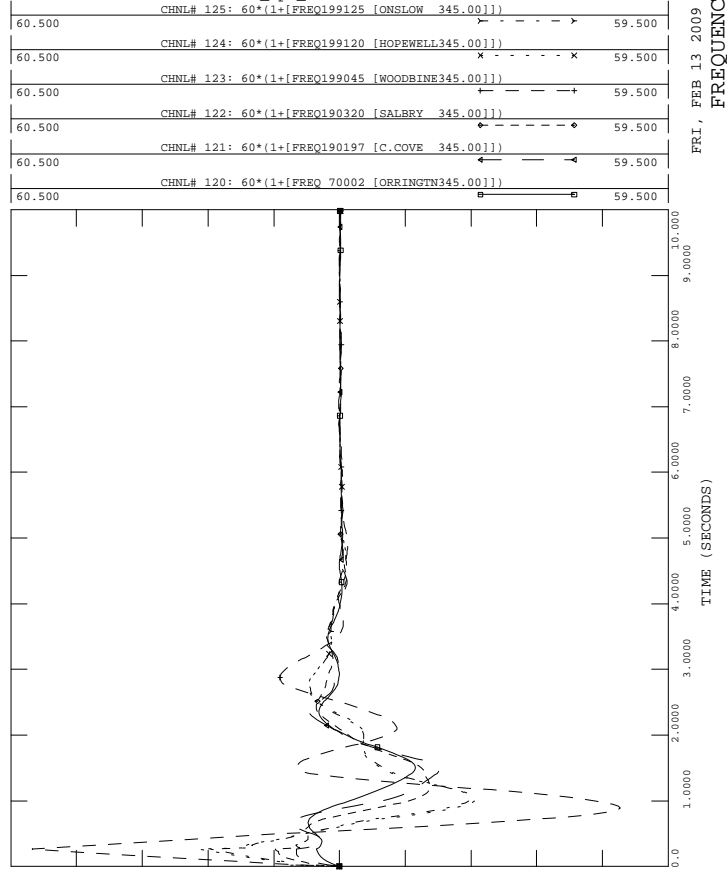

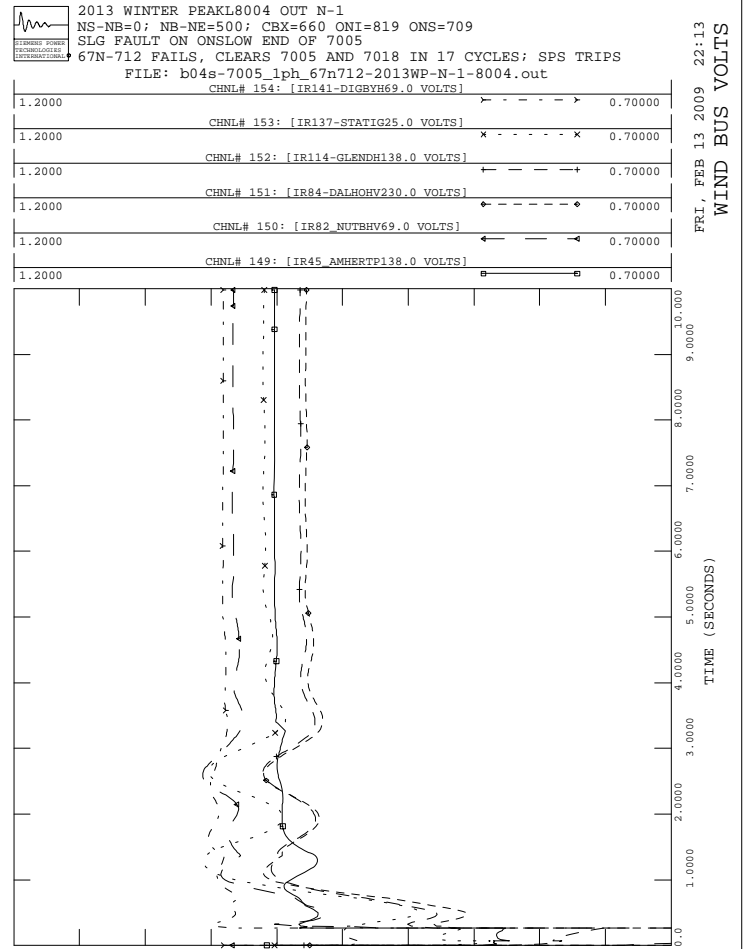
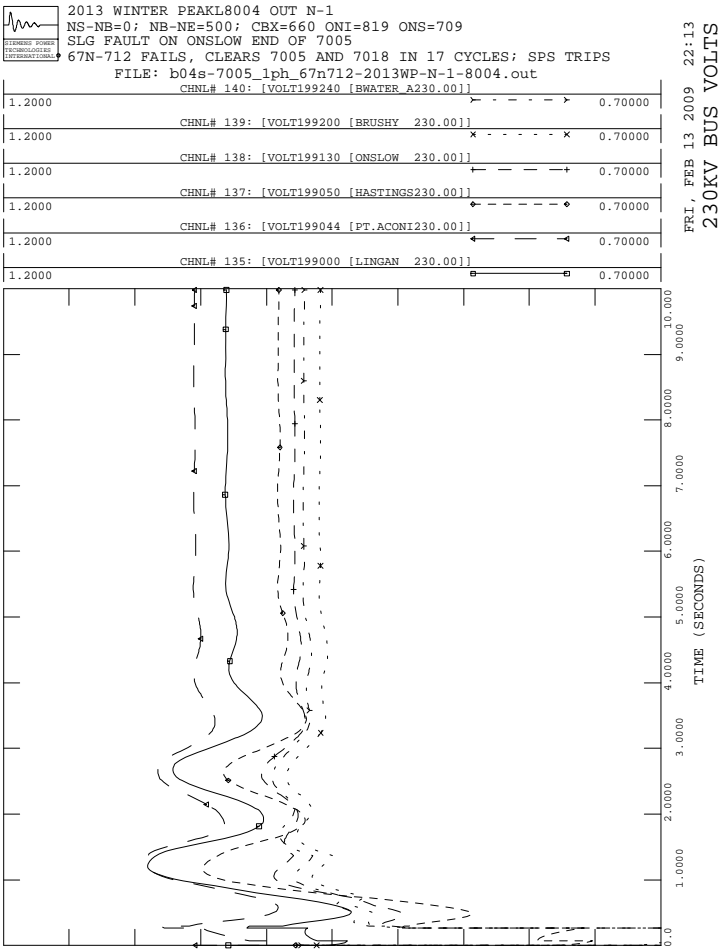
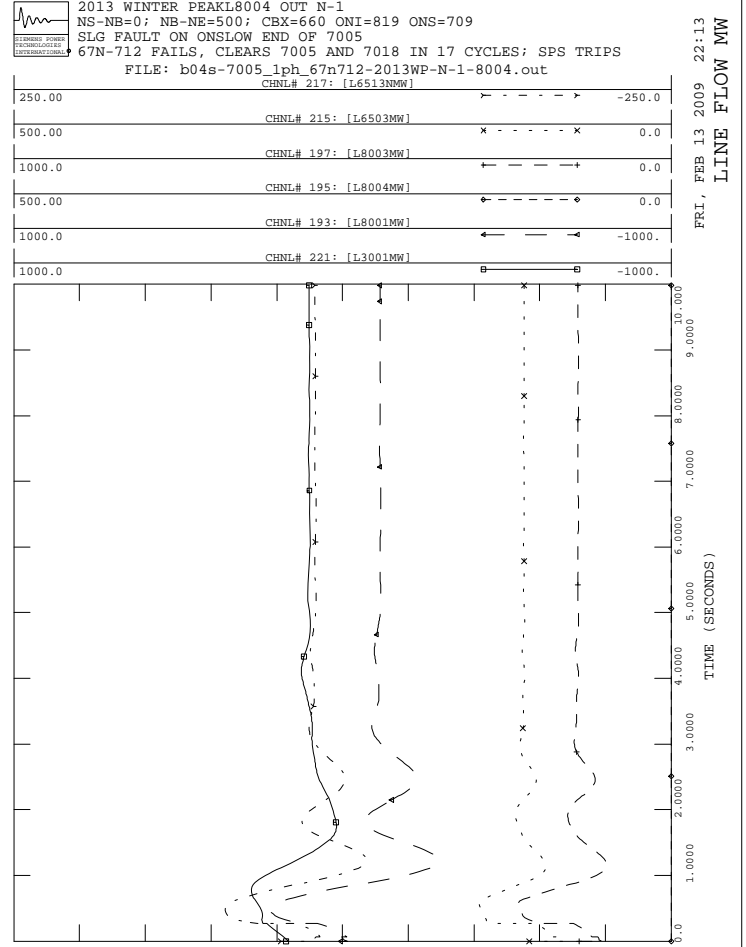
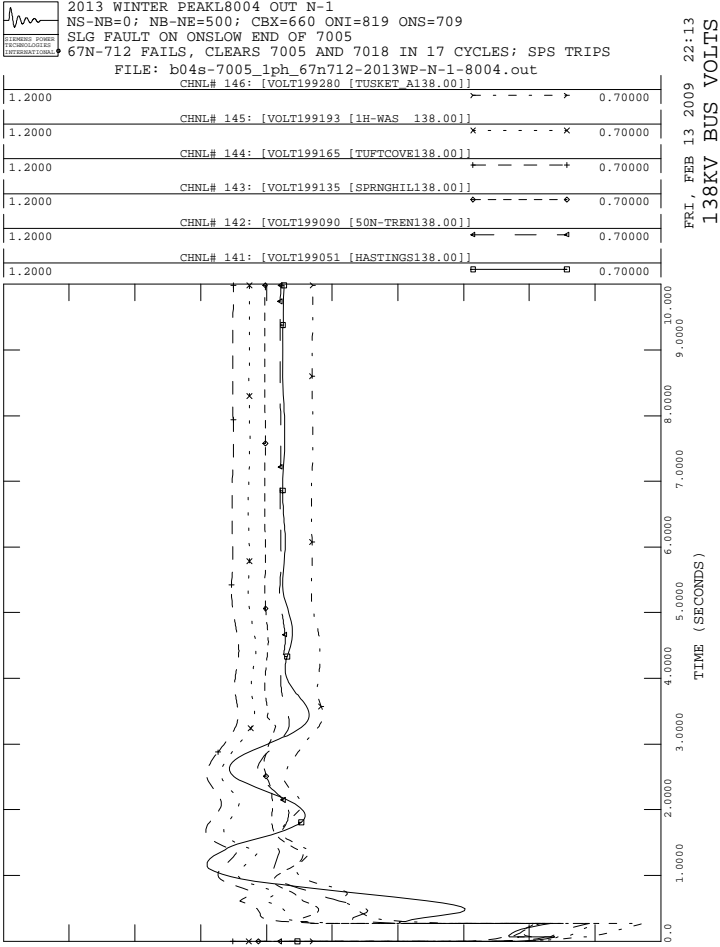

2013 WINTER PEAKL8004 OUT N-1
NS-NB=0; NB-NE=500; CBX=660 ONI=819 ONS=709
SLG FAULT ON ONSLOW END OF 8003
67N-812 FAILS, CLEARS 8003 AND 8002; SPS TRIPS 1 LINGAN UNIT
FILE: b06s-8003_lph_67n812-2013WP-N-1-8004.out

Table with 3 columns: CHNL#S, parameters, and values. Includes entries for CHNL#S 20, 4, 17, 4, 16, 4, 15, 4, 13, 4, and 11, 4.

NS ANGLE
FRI, FEB 13 2009 22:13

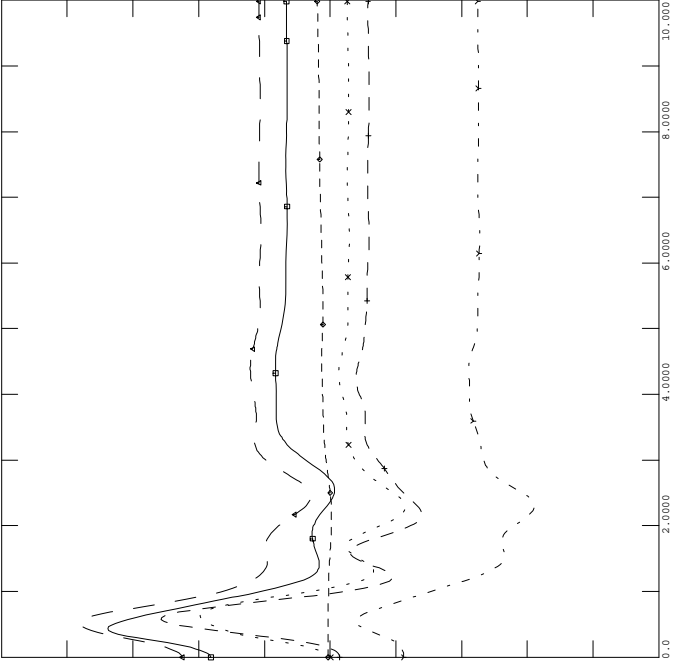

2013 WINTER PEAKL8004 OUT N-1
NS-NB=0; NB-NE=500; CBX=660 ONI=819 ONS=709
SLG FAULT ON ONSLOW END OF 8003
67N-812 FAILS, CLEARS 8003 AND 8002; SPS TRIPS 1 LINGAN UNIT
FILE: b06s-8003_lph_67n812-2013WP-N-1-8004.out

Table with 3 columns: CHNL#S, parameters, and values. Includes entries for CHNL# 56, 55, 54, 52, and 50.

NS MW
FRI, FEB 13 2009 22:13

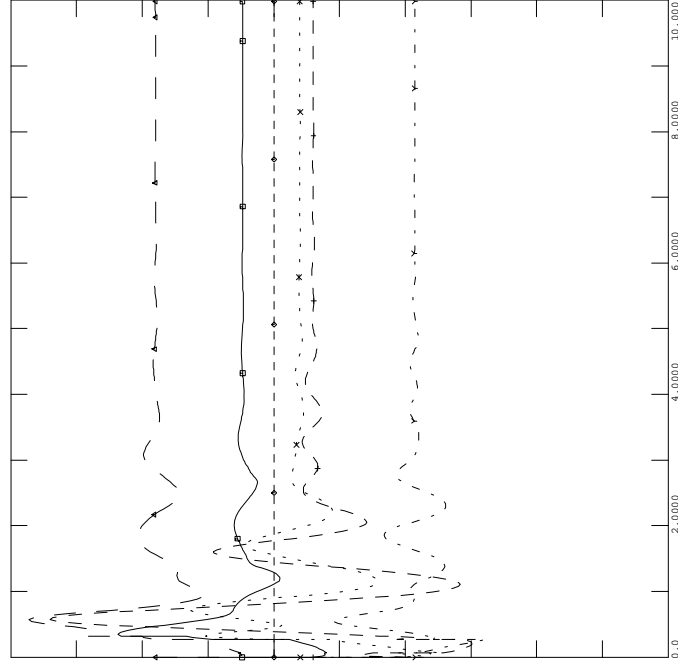

2013 WINTER PEAKL8004 OUT N-1
NS-NB=0; NB-NE=500; CBX=660 ONI=819 ONS=709
SLG FAULT ON ONSLOW END OF 8003
67N-812 FAILS, CLEARS 8003 AND 8002; SPS TRIPS 1 LINGAN UNIT
FILE: b06s-8003_lph_67n812-2013WP-N-1-8004.out

Table with 3 columns: CHNL#S, parameters, and values. Includes entries for CHNL#S 10, 4, 6, 4, 5, 4, 3, 4, 2, 4, and 7, 4.

"NE, NY, NB ANGLE"
FRI, FEB 13 2009 22:13

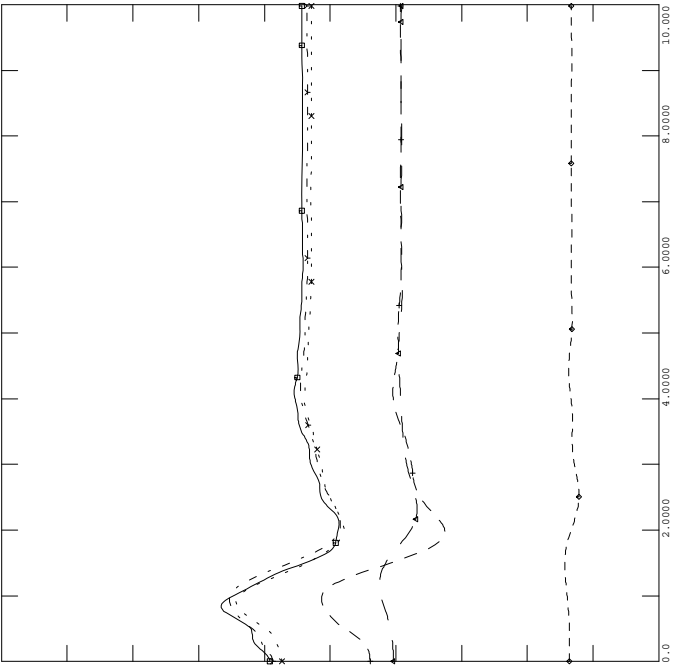

2013 WINTER PEAKL8004 OUT N-1
NS-NB=0; NB-NE=500; CBX=660 ONI=819 ONS=709
SLG FAULT ON ONSLOW END OF 8003
67N-812 FAILS, CLEARS 8003 AND 8002; SPS TRIPS 1 LINGAN UNIT
FILE: b06s-8003_lph_67n812-2013WP-N-1-8004.out

Table with 3 columns: CHNL#S, parameters, and values. Includes entries for CHNL# 49, 45, 44, 42, 41, and 46.

"NE, NY, NB POWER"
FRI, FEB 13 2009 22:13

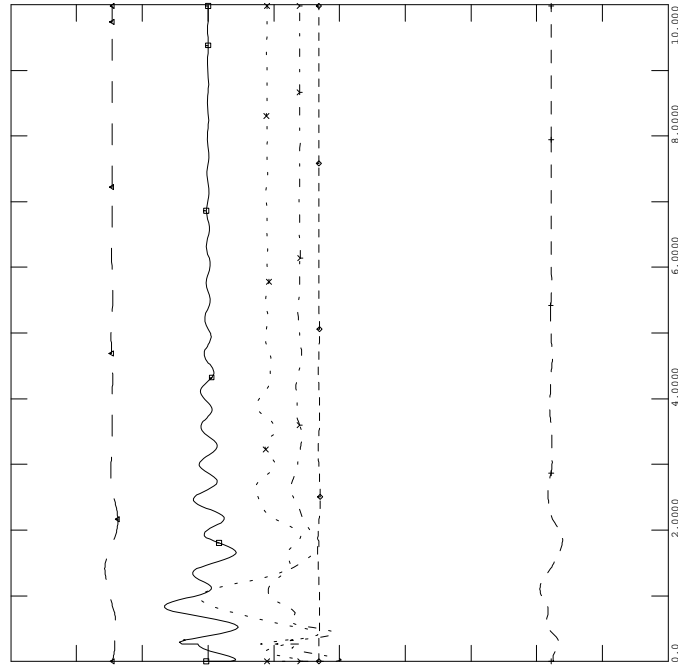



2013 WINTER PEAKL8004 OUT N-1
NS-NB=0; NB-NE=500; CBX=660 ONI=819 ONS=709
SLG FAULT ON ONSLOW END OF 8003
67N-812 FAILS, CLEARS 8003 AND 8002; SPS TRIPS 1 LINGAN UNIT
FILE: b06s-8003_lph_67n812-2013WP-N-1-8004.out
CHNL# 119: [VARS IR141-DIGBY]

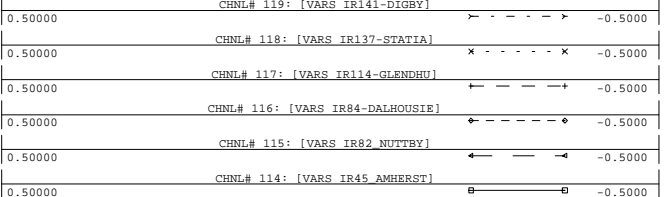

FRI, FEB 13 2009 22:13
NS WIND MV

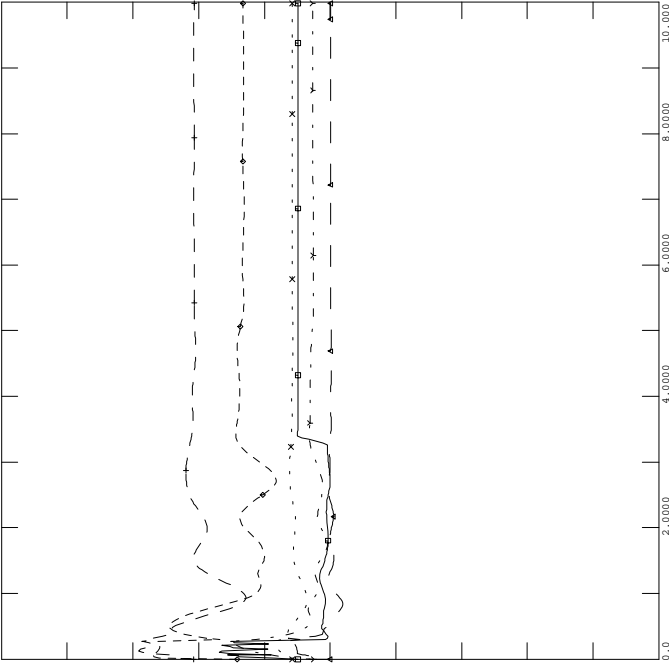

2013 WINTER PEAKL8004 OUT N-1
NS-NB=0; NB-NE=500; CBX=660 ONI=819 ONS=709
SLG FAULT ON ONSLOW END OF 8003
67N-812 FAILS, CLEARS 8003 AND 8002; SPS TRIPS 1 LINGAN UNIT
FILE: b06s-8003_lph_67n812-2013WP-N-1-8004.out
CHNL# 133: [VOLT199125 [ONSLW 345.00]]

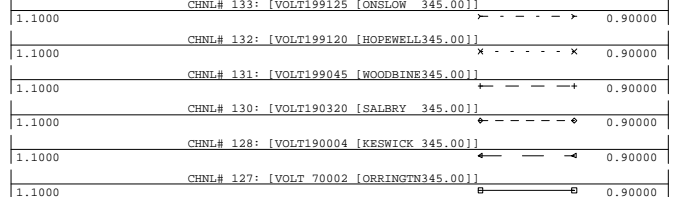

FRI, FEB 13 2009 22:13
"345KV VOLTAGE"

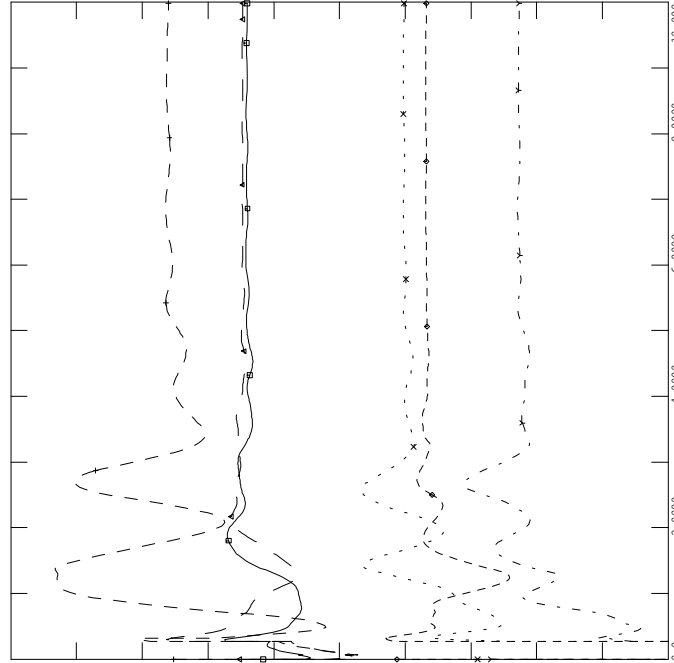

2013 WINTER PEAKL8004 OUT N-1
NS-NB=0; NB-NE=500; CBX=660 ONI=819 ONS=709
SLG FAULT ON ONSLOW END OF 8003
67N-812 FAILS, CLEARS 8003 AND 8002; SPS TRIPS 1 LINGAN UNIT
FILE: b06s-8003_lph_67n812-2013WP-N-1-8004.out
CHNL# 79: [POWER IR141-DIGBY]

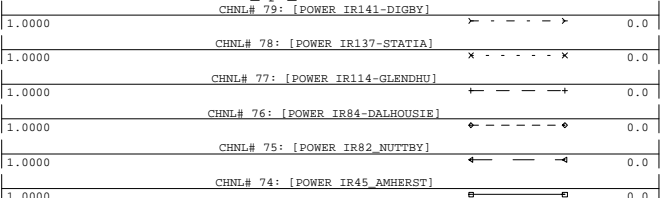

FRI, FEB 13 2009 22:13
NS WIND MW

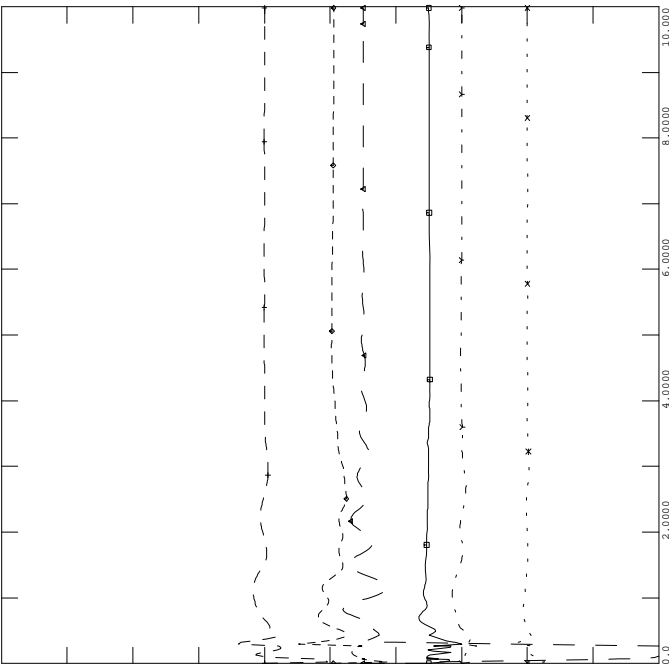

2013 WINTER PEAKL8004 OUT N-1
NS-NB=0; NB-NE=500; CBX=660 ONI=819 ONS=709
SLG FAULT ON ONSLOW END OF 8003
67N-812 FAILS, CLEARS 8003 AND 8002; SPS TRIPS 1 LINGAN UNIT
FILE: b06s-8003_lph_67n812-2013WP-N-1-8004.out
CHNL# 125: 60*(1+[FREQ199125 [ONSLW 345.00]])

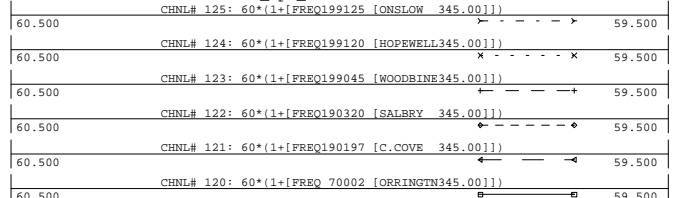

FRI, FEB 13 2009 22:13
FREQUENCY HZ

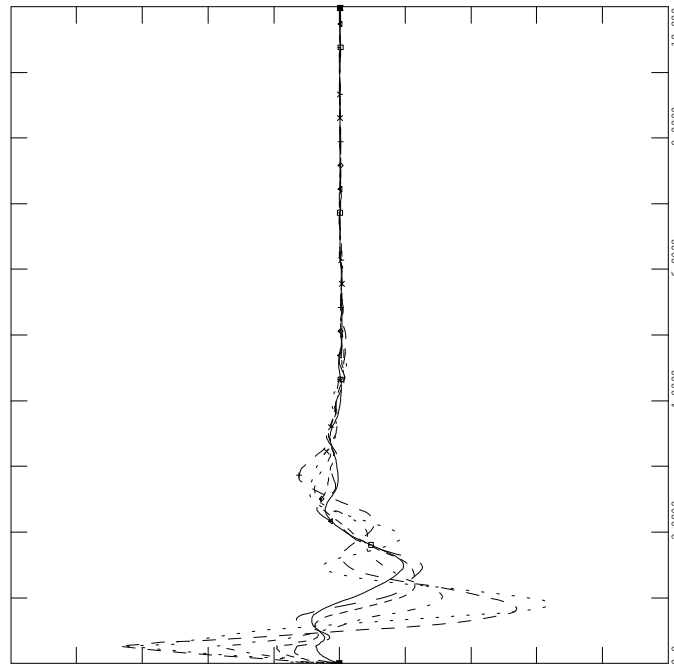

2013 WINTER PEAKL8004 OUT N-1
NS-NB=0; NB-NE=500; CBX=660 ONI=819 ONS=709
SLG FAULT ON ONSLOW END OF 8003
67N-812 FAILS, CLEARS 8003 AND 8002; SPS TRIPS 1 LINGAN UNIT
FILE: b06s-8003_lph_67n812-2013WP-N-1-8004.out
CHNL# 146: [VOLT199280 [TUSKET_A138.00]]

Table with 2 columns: Time (1.2000) and Voltage (0.70000). Rows list channels 145 to 146 with their respective voltage levels and channel identifiers.

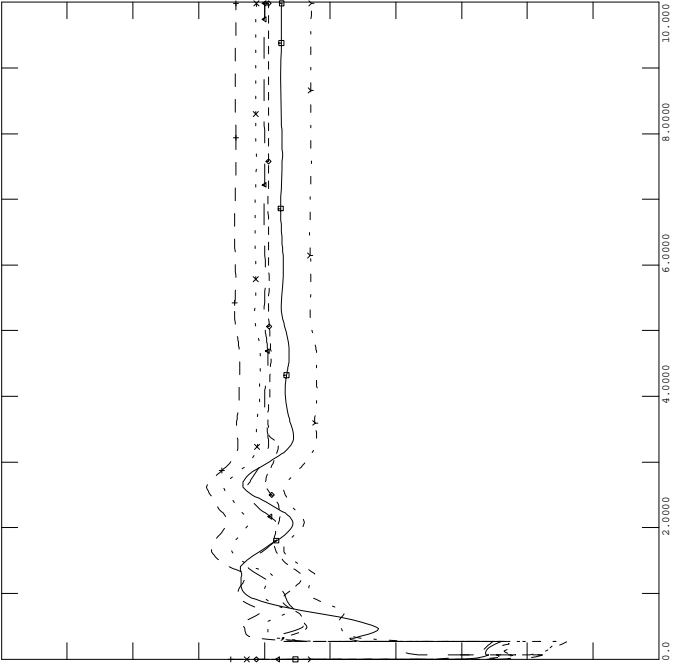

FRI, FEB 13 2009 22:13
138KV BUS VOLTS

2013 WINTER PEAKL8004 OUT N-1
NS-NB=0; NB-NE=500; CBX=660 ONI=819 ONS=709
SLG FAULT ON ONSLOW END OF 8003
67N-812 FAILS, CLEARS 8003 AND 8002; SPS TRIPS 1 LINGAN UNIT
FILE: b06s-8003_lph_67n812-2013WP-N-1-8004.out
CHNL# 217: [L6513MMW]

Table with 2 columns: Time (1.2000) and Voltage (-1000.0 to 250.0). Rows list channels 215 to 221 with their respective voltage levels and channel identifiers.

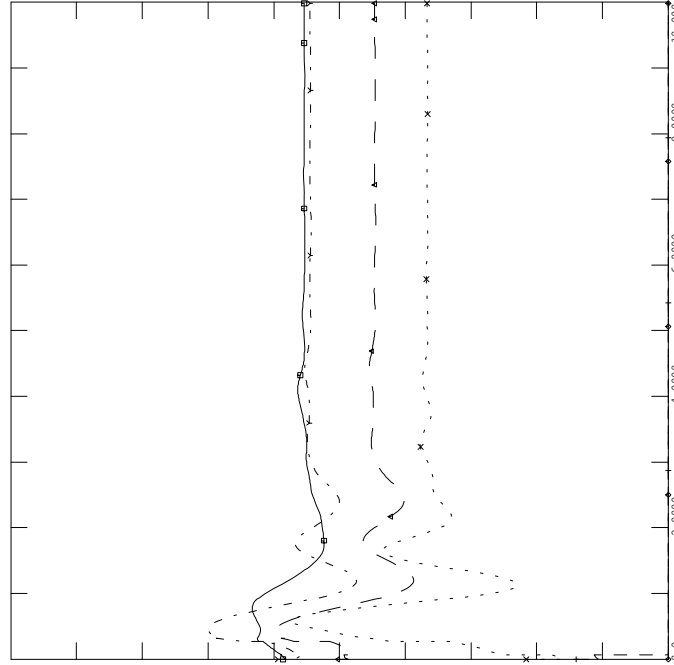

FRI, FEB 13 2009 22:13
LINE FLOW MW

2013 WINTER PEAKL8004 OUT N-1
NS-NB=0; NB-NE=500; CBX=660 ONI=819 ONS=709
SLG FAULT ON ONSLOW END OF 8003
67N-812 FAILS, CLEARS 8003 AND 8002; SPS TRIPS 1 LINGAN UNIT
FILE: b06s-8003_lph_67n812-2013WP-N-1-8004.out
CHNL# 140: [VOLT199240 [BRATER_A230.00]]

Table with 2 columns: Time (1.2000) and Voltage (0.70000). Rows list channels 139 to 140 with their respective voltage levels and channel identifiers.

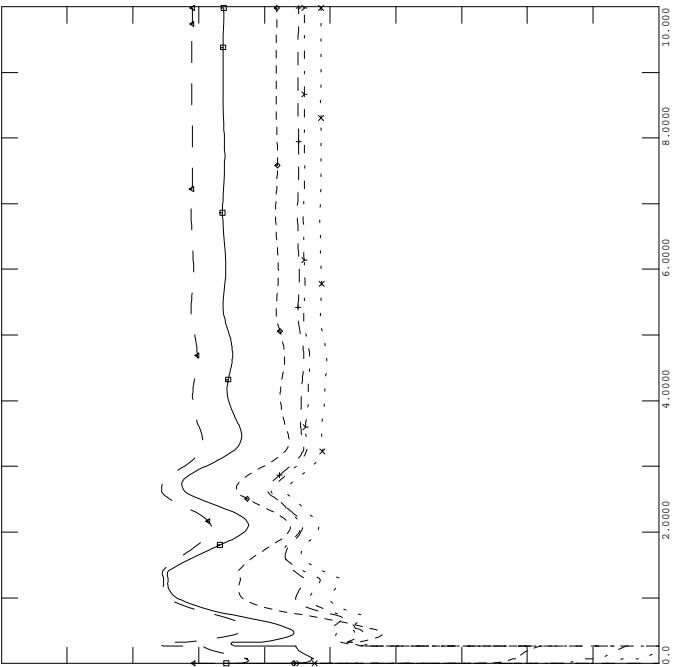

FRI, FEB 13 2009 22:13
230KV BUS VOLTS

2013 WINTER PEAKL8004 OUT N-1
NS-NB=0; NB-NE=500; CBX=660 ONI=819 ONS=709
SLG FAULT ON ONSLOW END OF 8003
67N-812 FAILS, CLEARS 8003 AND 8002; SPS TRIPS 1 LINGAN UNIT
FILE: b06s-8003_lph_67n812-2013WP-N-1-8004.out
CHNL# 154: [IR141-DIGBYH69.0 VOLTS]

Table with 2 columns: Time (1.2000) and Voltage (0.70000). Rows list channels 153 to 154 with their respective voltage levels and channel identifiers.

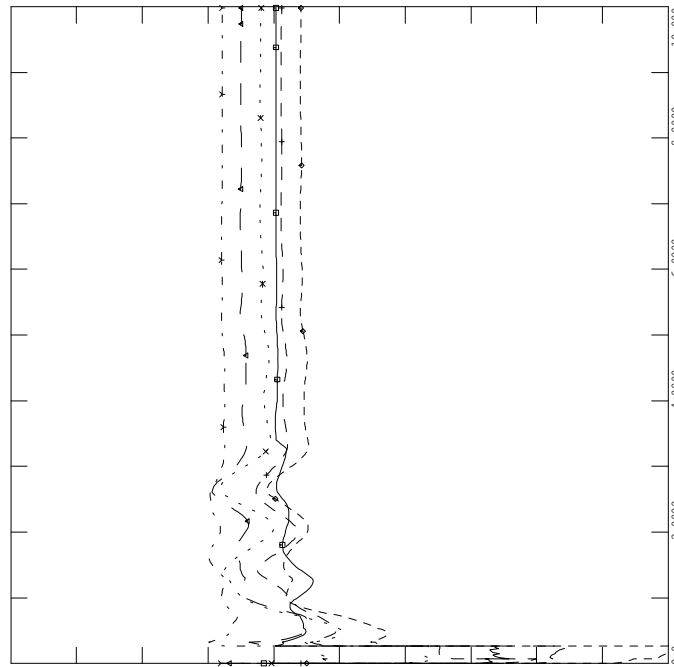

FRI, FEB 13 2009 22:13
WIND BUS VOLTS



2013 WINTER PEAKL8004 OUT N-1
NS-NB=0; NB-NE=500; CBX=660 ONI=819 ONS=709
SLG FLT ON SEPARATE PHASES OF DOUBLE CKT TOWER
7003 AND 7004 NEAR TRENTON CLEARED IN 5 CYCLES

FILE: c01s-pg_7003_7004_50n-2013WP-N-1-8004.out

CHNL#*S 20,4:	[ANGL199169 [TUFTCV3 14.400] [3]]-[ANGL156661 [DARL G1 22.000] [1]]	-100.0
100.00		
CHNL#*S 17,4:	[ANGL199086 [TRENTON613.800] [6]]-[ANGL156661 [DARL G1 22.000] [1]]	-100.0
100.00		
CHNL#*S 16,4:	[ANGL199085 [TRENTN5 13.800] [5]]-[ANGL156661 [DARL G1 22.000] [1]]	-100.0
100.00		
CHNL#*S 15,4:	[ANGL199061 [TMP1_STO13.800] [1]]-[ANGL156661 [DARL G1 22.000] [1]]	-150.0
50.0000		
CHNL#*S 13,4:	[ANGL199043 [ACONIG1 20.000] [1]]-[ANGL156661 [DARL G1 22.000] [1]]	-100.0
100.00		
CHNL#*S 11,4:	[ANGL199001 [LINGANI 14.400] [1]]-[ANGL156661 [DARL G1 22.000] [1]]	-100.0
100.00		

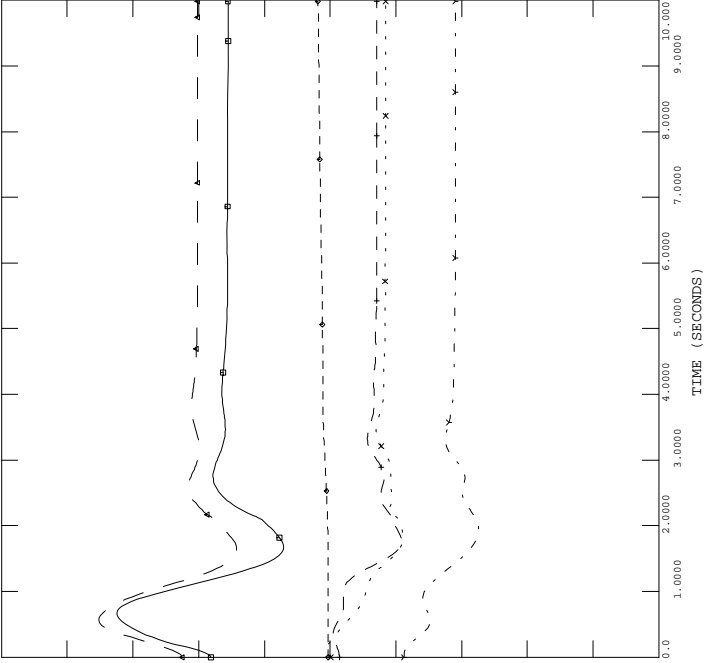

NS ANGLE
FRI, FEB 13 2009 22:13



2013 WINTER PEAKL8004 OUT N-1
NS-NB=0; NB-NE=500; CBX=660 ONI=819 ONS=709
SLG FLT ON SEPARATE PHASES OF DOUBLE CKT TOWER
7003 AND 7004 NEAR TRENTON CLEARED IN 5 CYCLES

FILE: c01s-pg_7003_7004_50n-2013WP-N-1-8004.out

CHNL# 56:	[POWR199086 [TRENTON613.800] [6]]	0.0
2.5000		
CHNL# 55:	[POWR199085 [TRENTN5 13.800] [5]]	0.0
2.5000		
CHNL# 54:	[POWR199061 [TMP1_STO13.800] [1]]	0.0
1.0000		
CHNL# 52:	[POWR199043 [ACONIG1 20.000] [1]]	-1.500
2.5000		
CHNL# 50:	[POWR199001 [LINGANI 14.400] [1]]	0.0
2.5000		

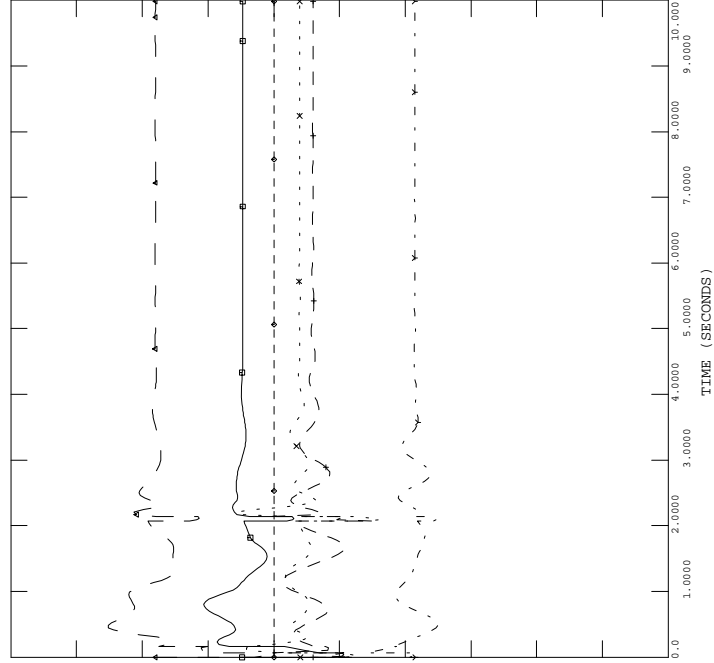

NS MW
FRI, FEB 13 2009 22:13



2013 WINTER PEAKL8004 OUT N-1
NS-NB=0; NB-NE=500; CBX=660 ONI=819 ONS=709
SLG FLT ON SEPARATE PHASES OF DOUBLE CKT TOWER
7003 AND 7004 NEAR TRENTON CLEARED IN 5 CYCLES

FILE: c01s-pg_7003_7004_50n-2013WP-N-1-8004.out

CHNL#*S 10,4:	[ANGL190472 [BLDNG2 19.000] [1]]-[ANGL156661 [DARL G1 22.000] [1]]	-100.0
100.00		
CHNL#*S 6,4:	[ANGL190456 [LEPRG1 26.000] [1]]-[ANGL156661 [DARL G1 22.000] [1]]	-100.0
100.00		
CHNL#*S 5,4:	[ANGL190450 [MACTG1 13.800] [1]]-[ANGL156661 [DARL G1 22.000] [1]]	-100.0
100.00		
CHNL#*S 3,4:	[ANGL126652 [RAV 3 22.000] [1]]-[ANGL156661 [DARL G1 22.000] [1]]	-100.0
100.00		
CHNL#*S 2,4:	[ANGL101063 [MYST G7 22.000] [1]]-[ANGL156661 [DARL G1 22.000] [1]]	-100.0
100.00		
CHNL#*S 7,4:	[ANGL190457 [C.CVGI 19.000] [1]]-[ANGL156661 [DARL G1 22.000] [1]]	-100.0
100.00		

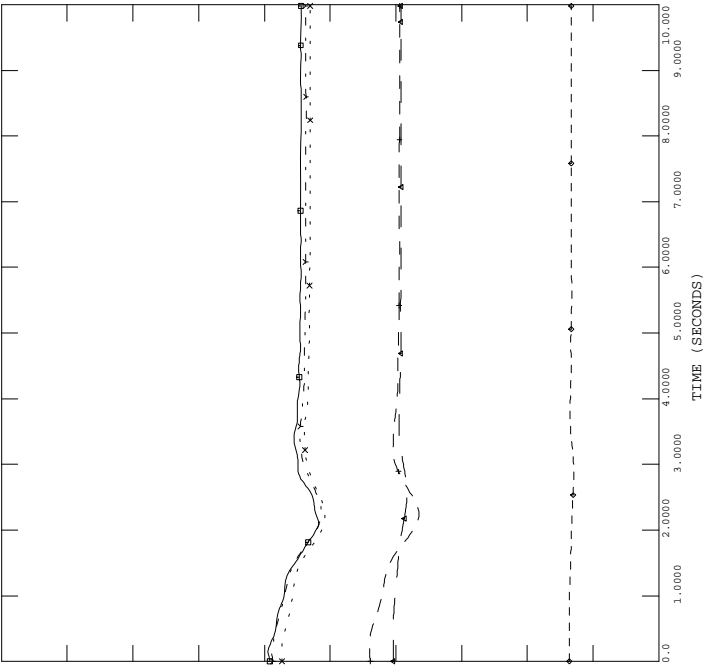

"NE, NY, NB ANGLE"
FRI, FEB 13 2009 22:13



2013 WINTER PEAKL8004 OUT N-1
NS-NB=0; NB-NE=500; CBX=660 ONI=819 ONS=709
SLG FLT ON SEPARATE PHASES OF DOUBLE CKT TOWER
7003 AND 7004 NEAR TRENTON CLEARED IN 5 CYCLES

FILE: c01s-pg_7003_7004_50n-2013WP-N-1-8004.out

CHNL# 49:	[POWER190472 [BLDNG2 19.000] [1]]	2.0000
7.0000		
CHNL# 45:	[POWER190456 [LEPRG1 26.000] [1]]	4.0000
9.0000		
CHNL# 44:	[POWER190450 [MACTG1 13.800] [1]]	0.0
5.0000		
CHNL# 42:	[POWER126652 [RAV 3 22.000] [1]]	0.0
5.0000		
CHNL# 41:	[POWER101063 [MYST G7 22.000] [1]]	1.0000
6.5000		
CHNL# 46:	[POWER190457 [C.CVGI 19.000] [1]]	0.0
5.0000		

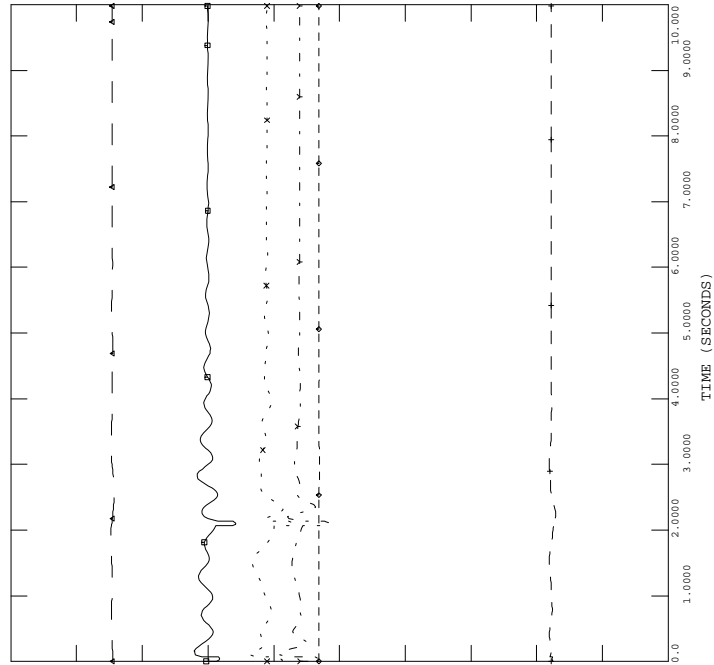

"NE, NY, NB POWER"
FRI, FEB 13 2009 22:13



2013 WINTER PEAKL8004 OUT N-1
NS-NB=0; NB-NE=500; CBX=660 ONI=819 ONS=709
SLG FLT ON SEPARATE PHASES OF DOUBLE CKT TOWER
7003 AND 7004 NEAR TRENTON CLEARED IN 5 CYCLES
FILE: c01s-pg_7003_7004_50n-2013WP-N-1-8004.out

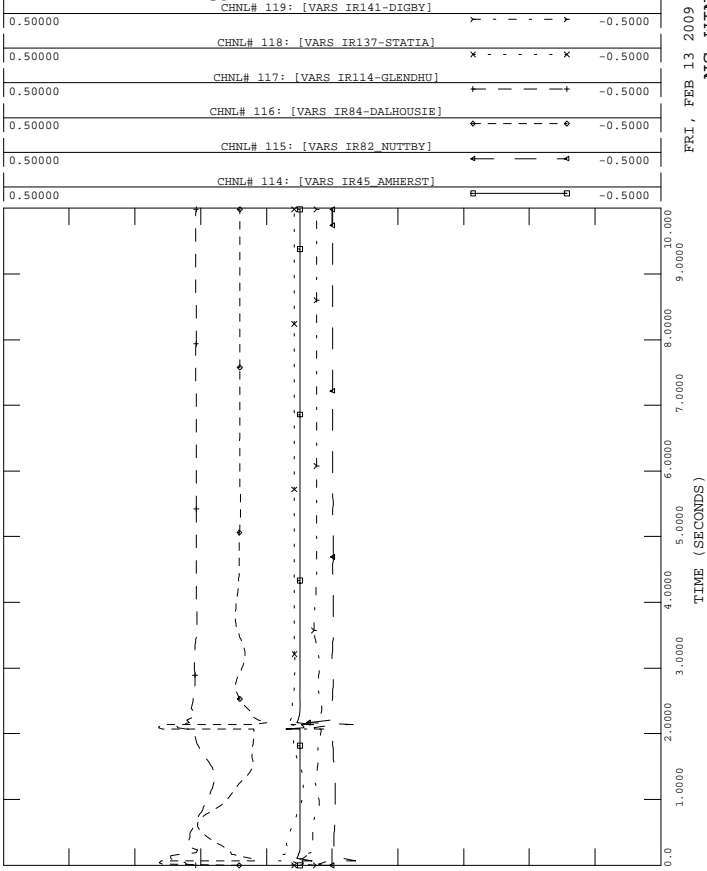

FRI, FEB 13 2009 22:13
NS WIND MV



2013 WINTER PEAKL8004 OUT N-1
NS-NB=0; NB-NE=500; CBX=660 ONI=819 ONS=709
SLG FLT ON SEPARATE PHASES OF DOUBLE CKT TOWER
7003 AND 7004 NEAR TRENTON CLEARED IN 5 CYCLES
FILE: c01s-pg_7003_7004_50n-2013WP-N-1-8004.out

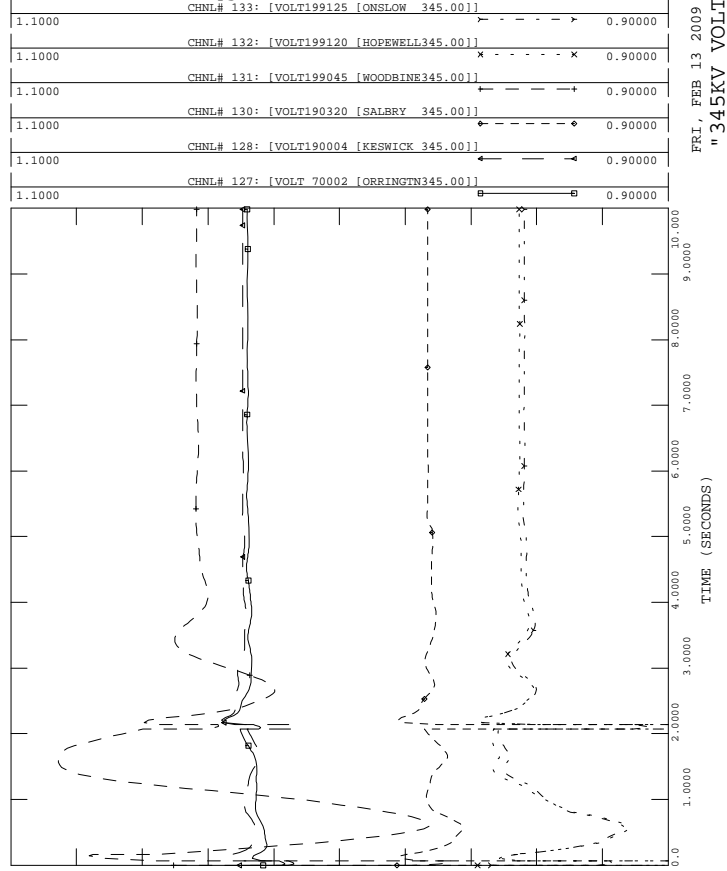

FRI, FEB 13 2009 22:13
" 345KV VOLTAGE "



2013 WINTER PEAKL8004 OUT N-1
NS-NB=0; NB-NE=500; CBX=660 ONI=819 ONS=709
SLG FLT ON SEPARATE PHASES OF DOUBLE CKT TOWER
7003 AND 7004 NEAR TRENTON CLEARED IN 5 CYCLES
FILE: c01s-pg_7003_7004_50n-2013WP-N-1-8004.out

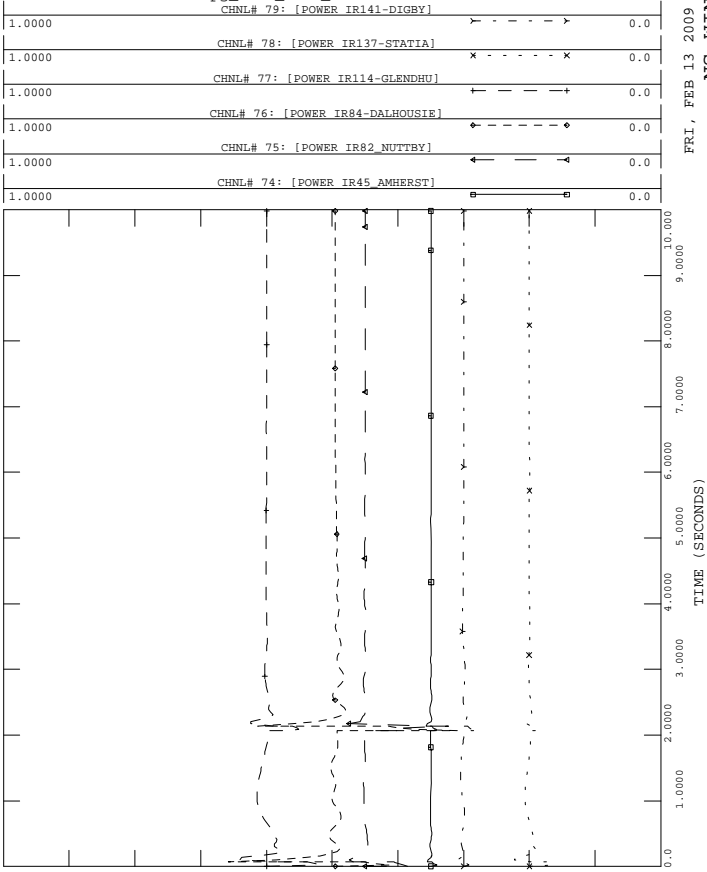

FRI, FEB 13 2009 22:13
NS WIND MW



2013 WINTER PEAKL8004 OUT N-1
NS-NB=0; NB-NE=500; CBX=660 ONI=819 ONS=709
SLG FLT ON SEPARATE PHASES OF DOUBLE CKT TOWER
7003 AND 7004 NEAR TRENTON CLEARED IN 5 CYCLES
FILE: c01s-pg_7003_7004_50n-2013WP-N-1-8004.out

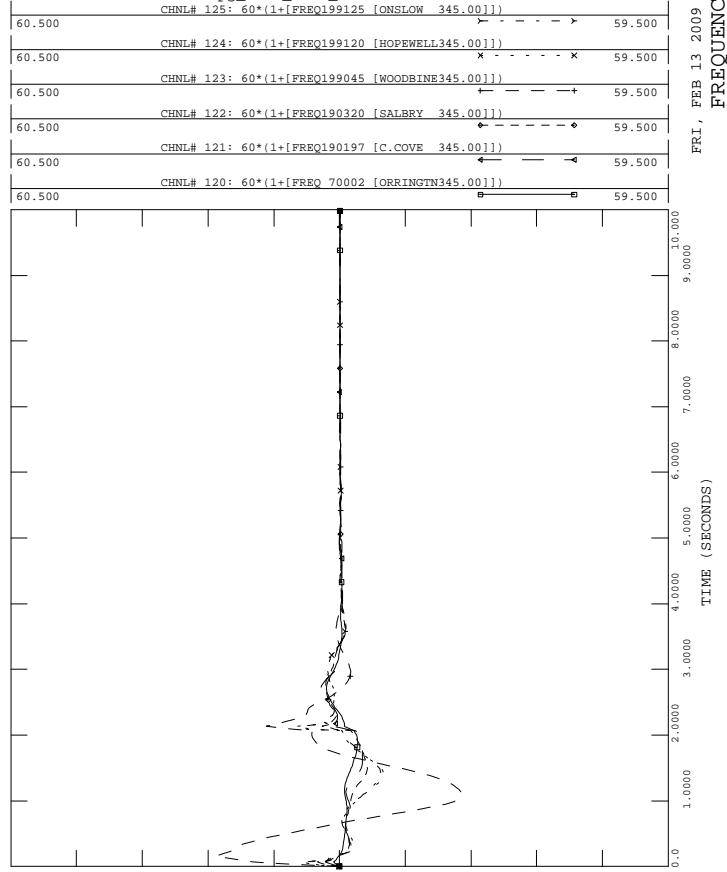

FRI, FEB 13 2009 22:13
FREQUENCY HZ



2013 WINTER PEAKL8004 OUT N-1
NS-NB=0; NB-NE=500; CBX=660 ONI=819 ONS=709
SLG FLT ON SEPARATE PHASES OF DOUBLE CKT TOWER
7003 AND 7004 NEAR TRENTON CLEARED IN 5 CYCLES
FILE: c01s-pg_7003_7004_50n-2013WP-N-1-8004.out
CHNL# 146: [VOLT199280 [TUSKET_A138.00]]

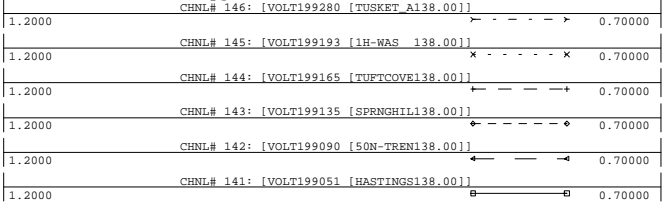

FRI, FEB 13 2009 22:13
138KV BUS VOLTS



2013 WINTER PEAKL8004 OUT N-1
NS-NB=0; NB-NE=500; CBX=660 ONI=819 ONS=709
SLG FLT ON SEPARATE PHASES OF DOUBLE CKT TOWER
7003 AND 7004 NEAR TRENTON CLEARED IN 5 CYCLES
FILE: c01s-pg_7003_7004_50n-2013WP-N-1-8004.out
CHNL# 217: [L6513NMW]

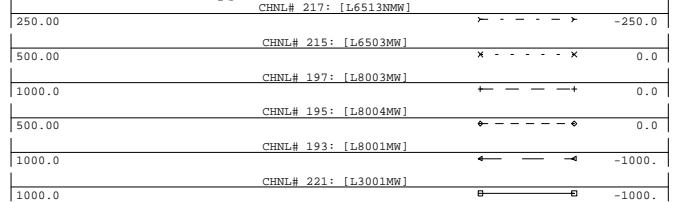

FRI, FEB 13 2009 22:13
LINE FLOW MW



2013 WINTER PEAKL8004 OUT N-1
NS-NB=0; NB-NE=500; CBX=660 ONI=819 ONS=709
SLG FLT ON SEPARATE PHASES OF DOUBLE CKT TOWER
7003 AND 7004 NEAR TRENTON CLEARED IN 5 CYCLES
FILE: c01s-pg_7003_7004_50n-2013WP-N-1-8004.out
CHNL# 140: [VOLT199240 [BRATER_A230.00]]

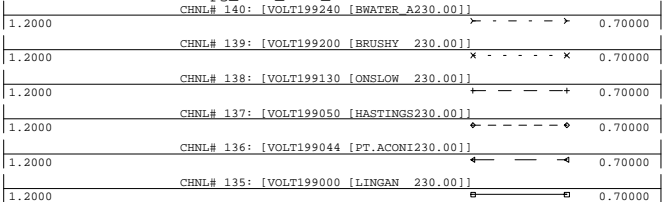

FRI, FEB 13 2009 22:13
230KV BUS VOLTS



2013 WINTER PEAKL8004 OUT N-1
NS-NB=0; NB-NE=500; CBX=660 ONI=819 ONS=709
SLG FLT ON SEPARATE PHASES OF DOUBLE CKT TOWER
7003 AND 7004 NEAR TRENTON CLEARED IN 5 CYCLES
FILE: c01s-pg_7003_7004_50n-2013WP-N-1-8004.out
CHNL# 154: [IR141-DIGBYH69.0 VOLTS]

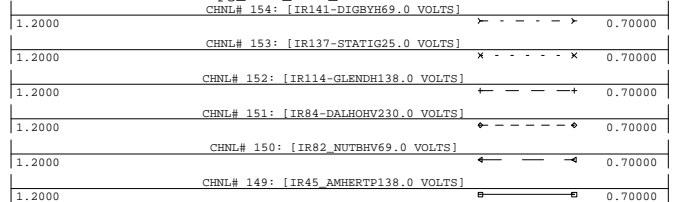

FRI, FEB 13 2009 22:13
WIND BUS VOLTS

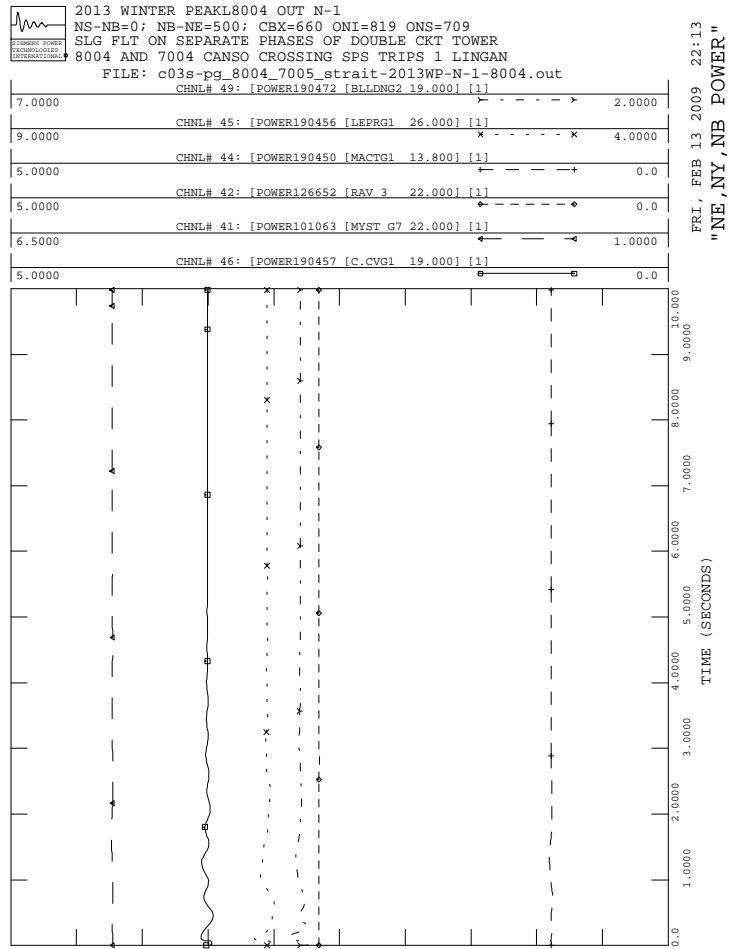
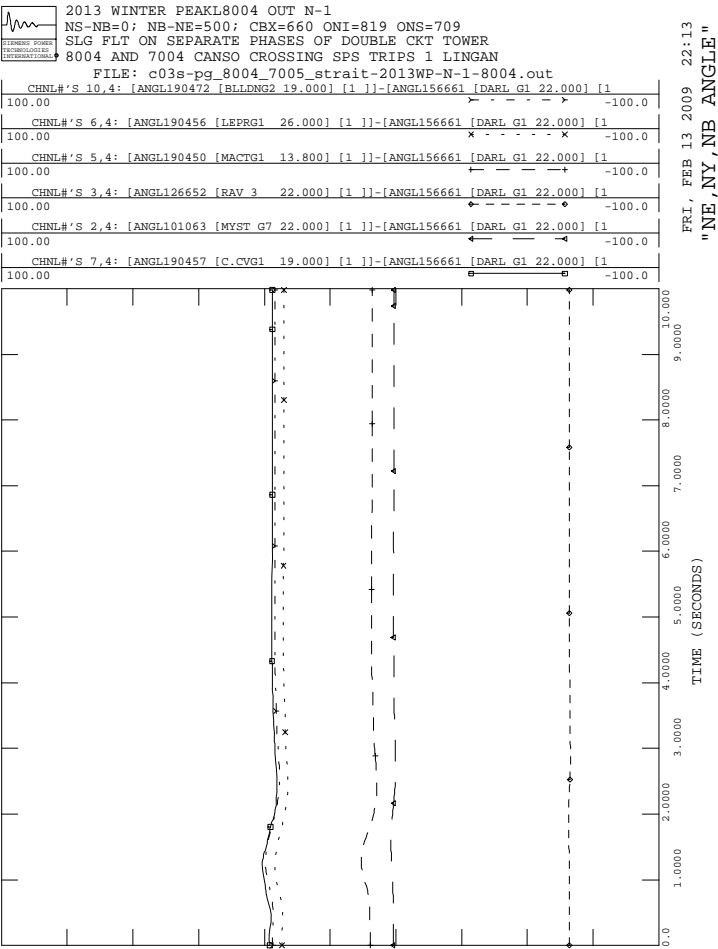
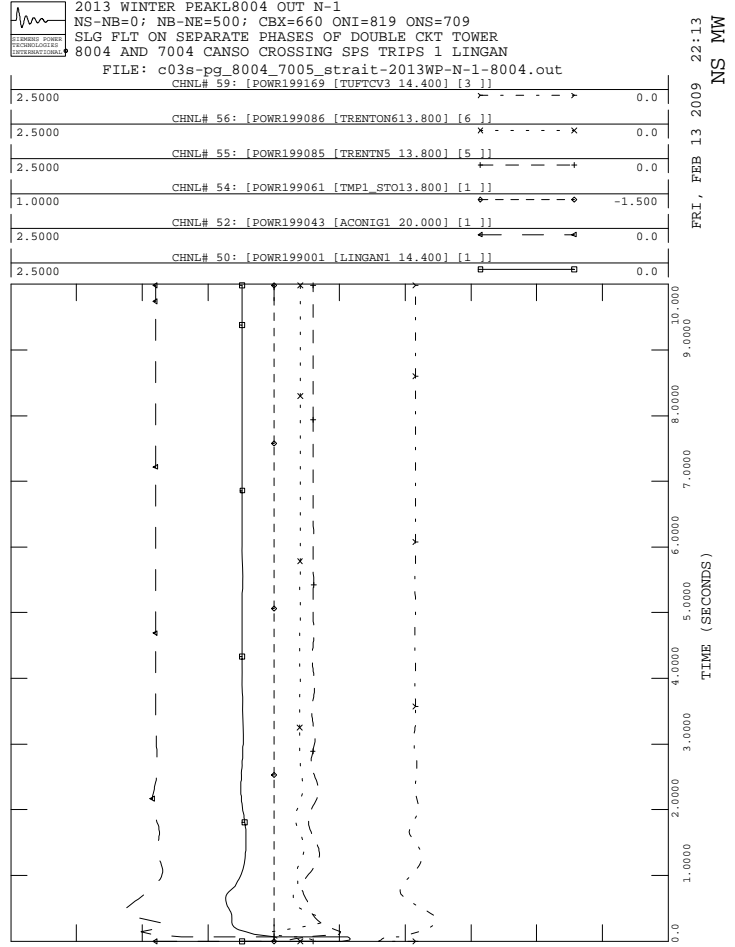
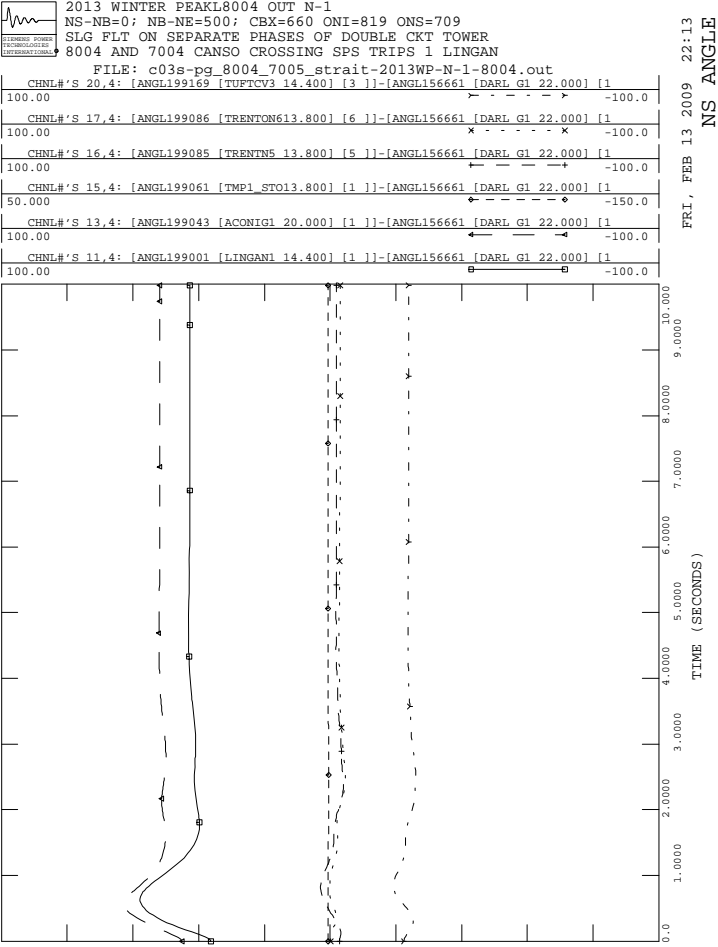



2013 WINTER PEAKL8004 OUT N-1
NS-NB=0; NB-NE=500; CBX=660 ONI=819 ONS=709
SLG FLT ON SEPARATE PHASES OF DOUBLE CKT TOWER
8004 AND 7004 CANSO CROSSING SPS TRIPS 1 LINGAN
FILE: c03s-pg_8004_7005_strait-2013WP-N-1-8004.out
CHNL# 119: [VARS IR141-DIGBY]

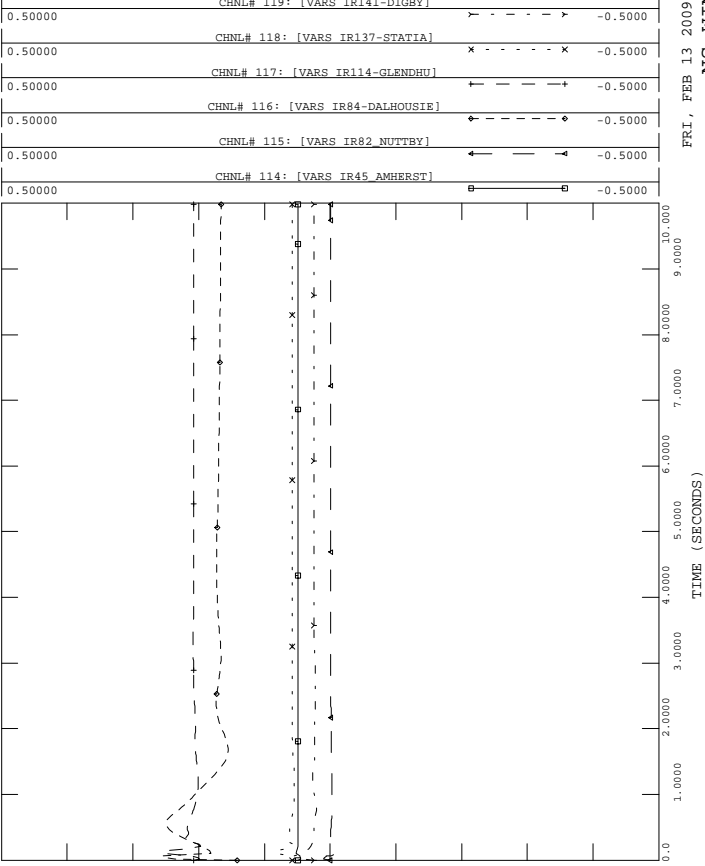

FRI, FEB 13 2009 22:13
NS WIND MV



2013 WINTER PEAKL8004 OUT N-1
NS-NB=0; NB-NE=500; CBX=660 ONI=819 ONS=709
SLG FLT ON SEPARATE PHASES OF DOUBLE CKT TOWER
8004 AND 7004 CANSO CROSSING SPS TRIPS 1 LINGAN
FILE: c03s-pg_8004_7005_strait-2013WP-N-1-8004.out
CHNL# 133: [VOLT199125 [ONSLW 345.00]]

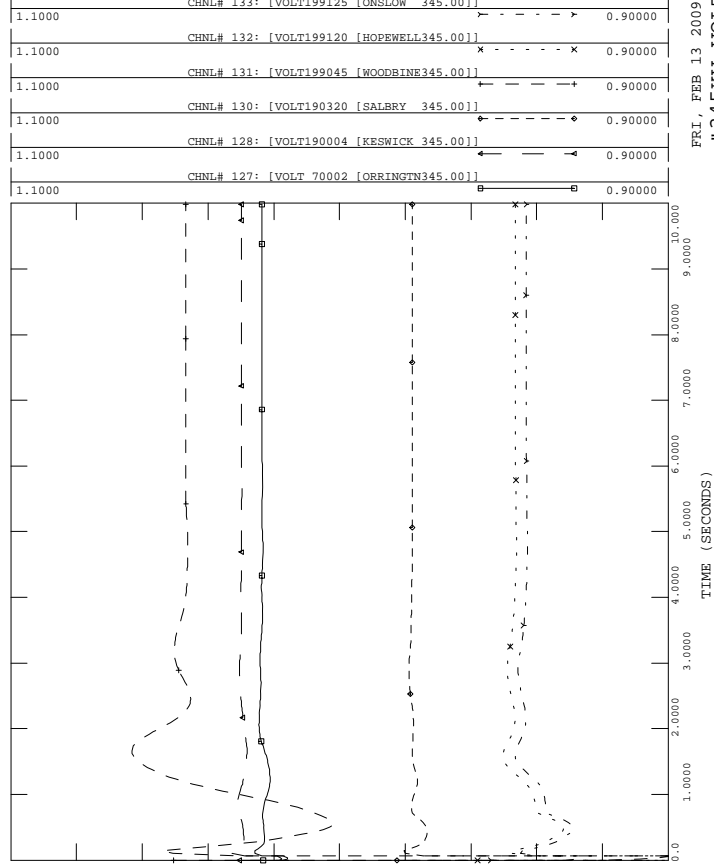

FRI, FEB 13 2009 22:13
" 345KV VOLTAGE "



2013 WINTER PEAKL8004 OUT N-1
NS-NB=0; NB-NE=500; CBX=660 ONI=819 ONS=709
SLG FLT ON SEPARATE PHASES OF DOUBLE CKT TOWER
8004 AND 7004 CANSO CROSSING SPS TRIPS 1 LINGAN
FILE: c03s-pg_8004_7005_strait-2013WP-N-1-8004.out
CHNL# 79: [POWER IR141-DIGBY]

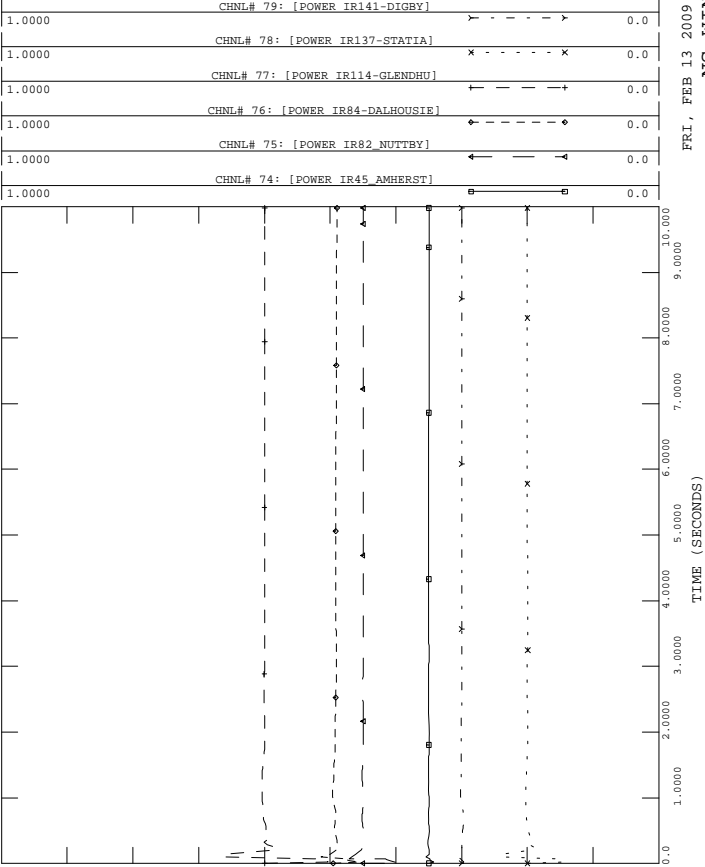

FRI, FEB 13 2009 22:13
NS WIND MW



2013 WINTER PEAKL8004 OUT N-1
NS-NB=0; NB-NE=500; CBX=660 ONI=819 ONS=709
SLG FLT ON SEPARATE PHASES OF DOUBLE CKT TOWER
8004 AND 7004 CANSO CROSSING SPS TRIPS 1 LINGAN
FILE: c03s-pg_8004_7005_strait-2013WP-N-1-8004.out
CHNL# 125: 60*(1+[FREQ199125 [ONSLW 345.00]])

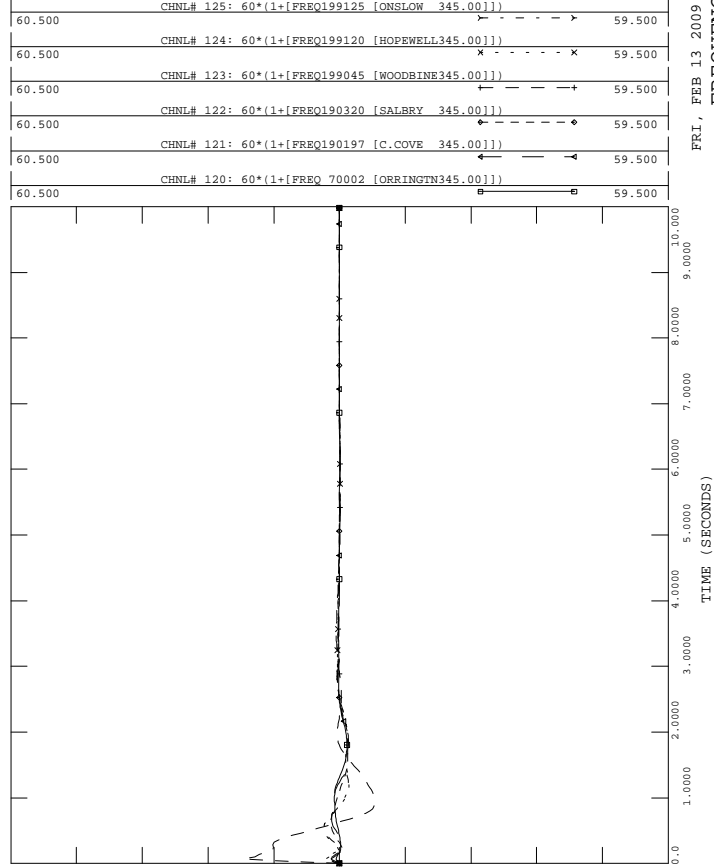

FRI, FEB 13 2009 22:13
FREQUENCY HZ

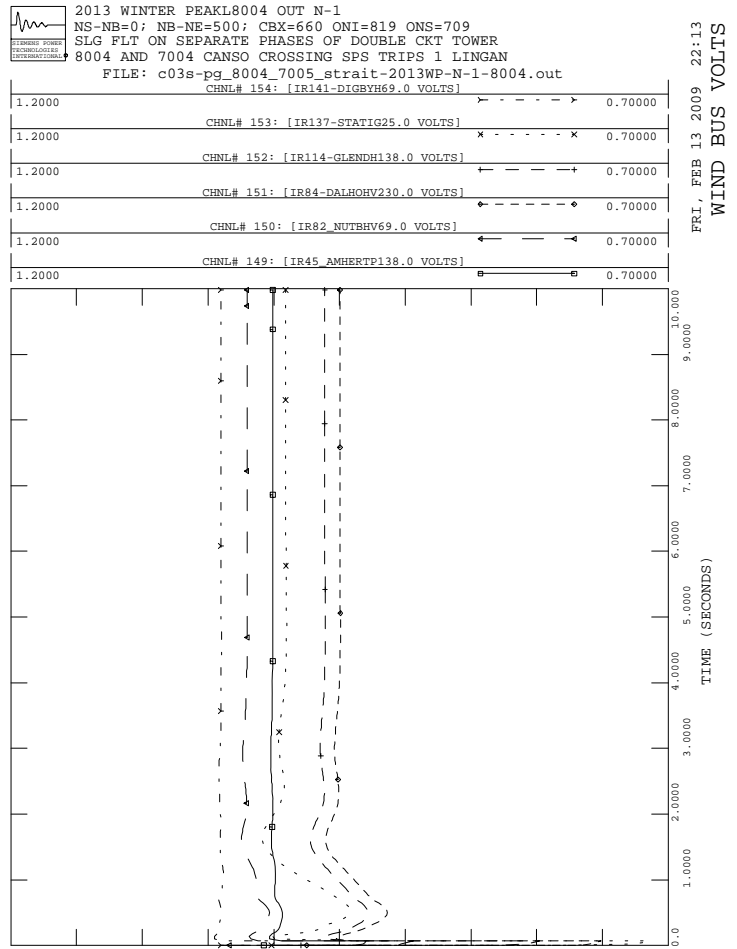
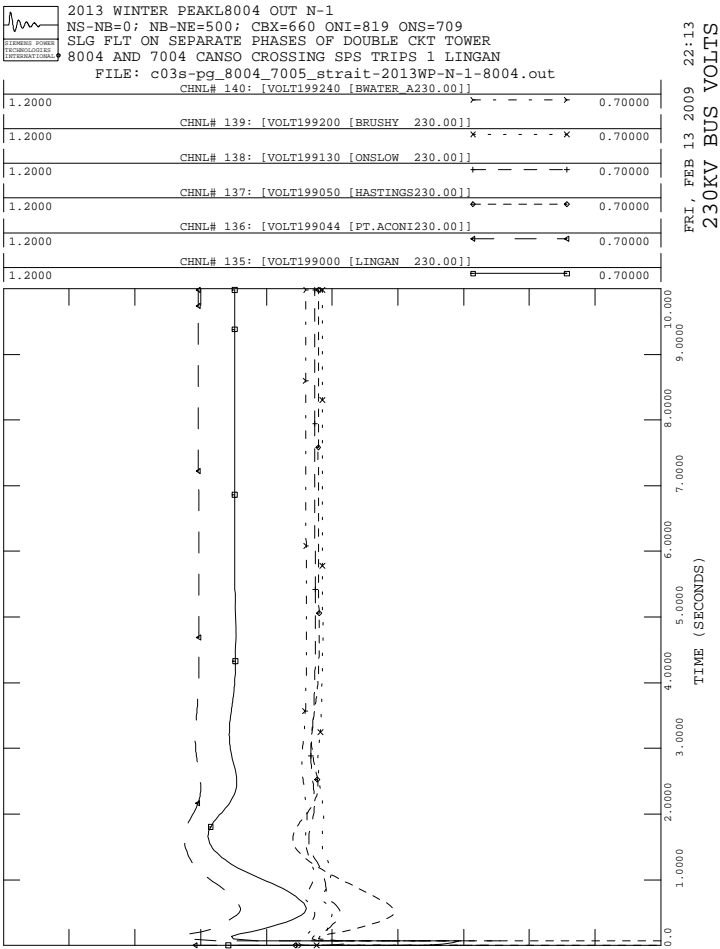
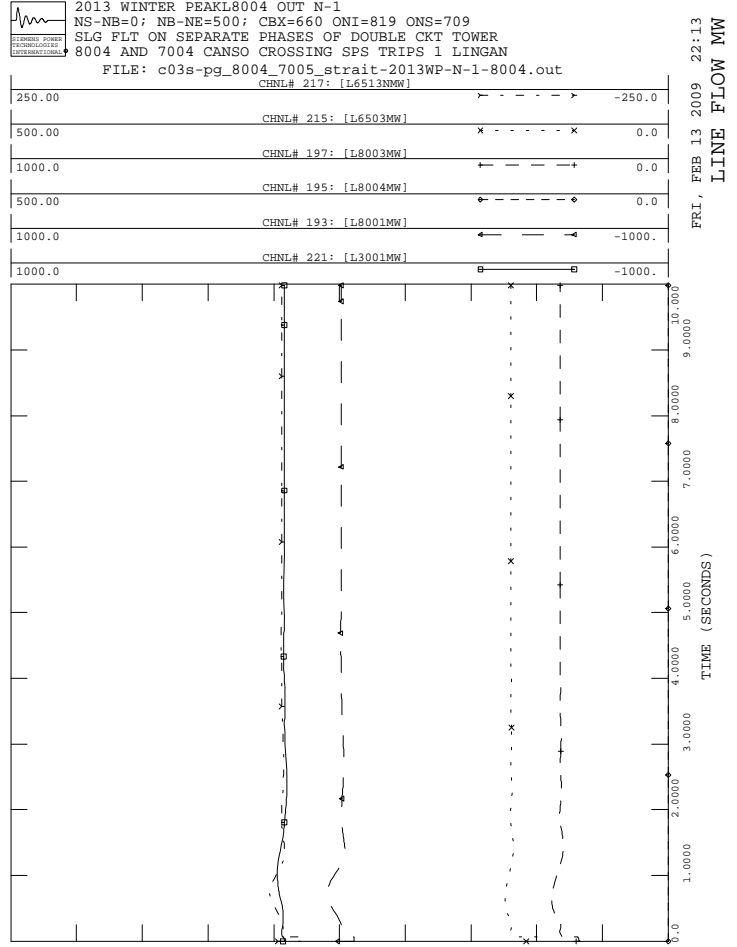
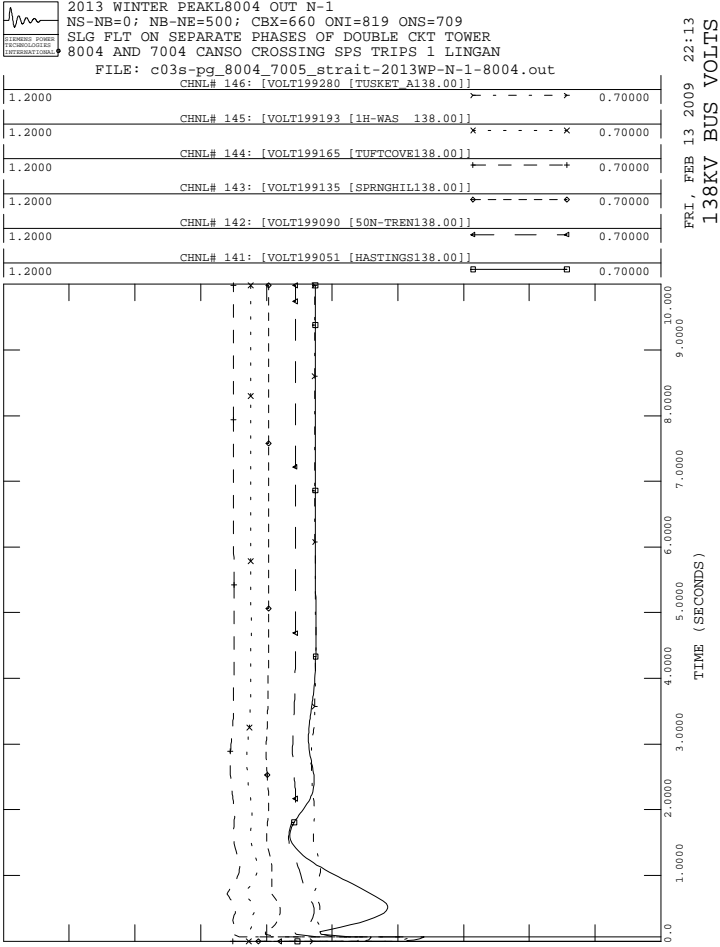



2013 WINTER PEAKL8004 OUT N-1
NS-NB=0; NB-NE=500; CBX=660 ONI=819 ONS=709
3 PHASE FAULT ON B62 AT LAKESIDE
TRIPS L6008, L6016, 103H-T61

FILE: a106-103h-b62_3ph_nrecl-2013WP-N-1-8004.out

CHNL# 'S 20,4:	[ANGL199169 [TUFTCV3 14.400] [3]]-[ANGL156661 [DARL G1 22.000] [1]]	-100.0
CHNL# 'S 17,4:	[ANGL199086 [TRENTON613.800] [6]]-[ANGL156661 [DARL G1 22.000] [1]]	-100.0
CHNL# 'S 16,4:	[ANGL199085 [TRENTN5 13.800] [5]]-[ANGL156661 [DARL G1 22.000] [1]]	-100.0
CHNL# 'S 15,4:	[ANGL199061 [TMP1_STO13.800] [1]]-[ANGL156661 [DARL G1 22.000] [1]]	-150.0
CHNL# 'S 13,4:	[ANGL199043 [ACONIG1 20.000] [1]]-[ANGL156661 [DARL G1 22.000] [1]]	-100.0
CHNL# 'S 11,4:	[ANGL199001 [LINGANI 14.400] [1]]-[ANGL156661 [DARL G1 22.000] [1]]	-100.0

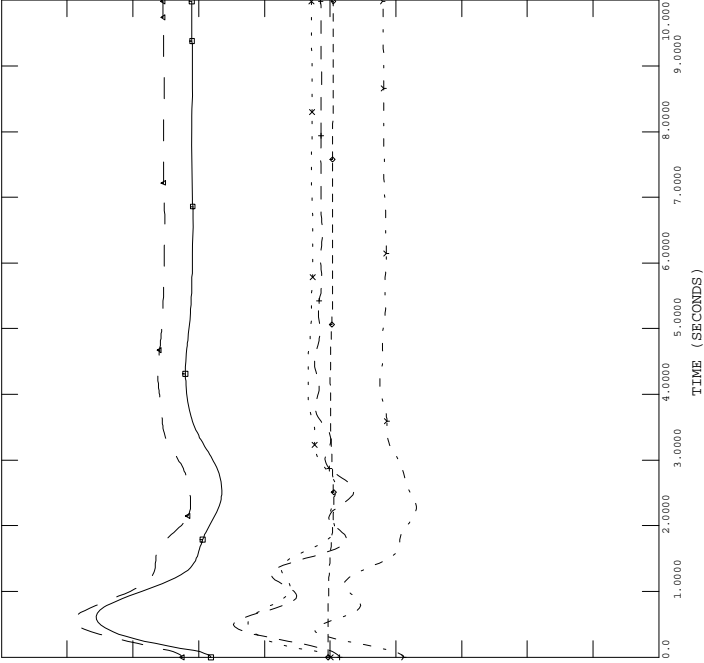

NS ANGLE
FRI, FEB 13 2009 22:13



2013 WINTER PEAKL8004 OUT N-1
NS-NB=0; NB-NE=500; CBX=660 ONI=819 ONS=709
3 PHASE FAULT ON B62 AT LAKESIDE
TRIPS L6008, L6016, 103H-T61

FILE: a106-103h-b62_3ph_nrecl-2013WP-N-1-8004.out

CHNL# 56:	[POWR199086 [TRENTON613.800] [6]]	0.0
CHNL# 55:	[POWR199085 [TRENTN5 13.800] [5]]	0.0
CHNL# 54:	[POWR199061 [TMP1_STO13.800] [1]]	0.0
CHNL# 52:	[POWR199043 [ACONIG1 20.000] [1]]	-1.500
CHNL# 59:	[POWR199169 [TUFTCV3 14.400] [3]]	0.0
CHNL# 50:	[POWR199001 [LINGANI 14.400] [1]]	0.0

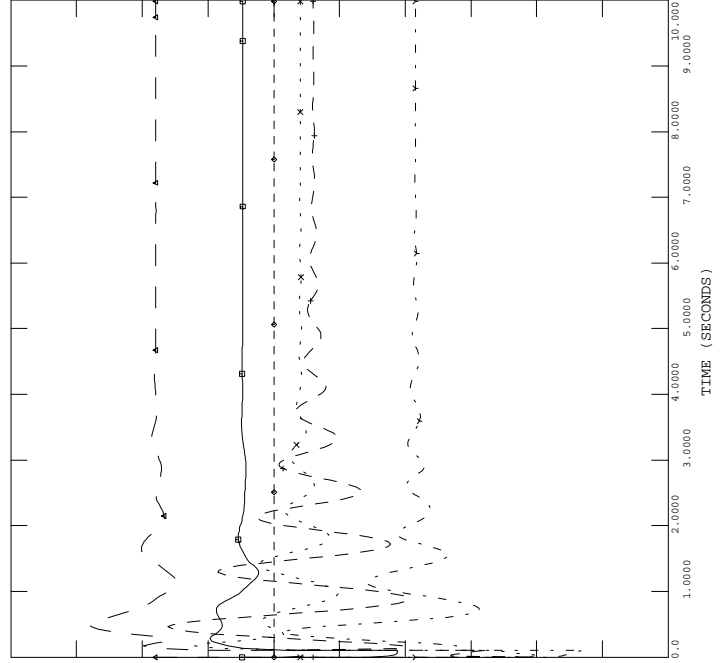

NS MW
FRI, FEB 13 2009 22:13



2013 WINTER PEAKL8004 OUT N-1
NS-NB=0; NB-NE=500; CBX=660 ONI=819 ONS=709
3 PHASE FAULT ON B62 AT LAKESIDE
TRIPS L6008, L6016, 103H-T61

FILE: a106-103h-b62_3ph_nrecl-2013WP-N-1-8004.out

CHNL# 'S 10,4:	[ANGL190472 [BLDNG2 19.000] [1]]-[ANGL156661 [DARL G1 22.000] [1]]	-100.0
CHNL# 'S 6,4:	[ANGL190456 [LEPRG1 26.000] [1]]-[ANGL156661 [DARL G1 22.000] [1]]	-100.0
CHNL# 'S 5,4:	[ANGL190450 [MACTG1 13.800] [1]]-[ANGL156661 [DARL G1 22.000] [1]]	-100.0
CHNL# 'S 3,4:	[ANGL126652 [RAV 3 22.000] [1]]-[ANGL156661 [DARL G1 22.000] [1]]	-100.0
CHNL# 'S 2,4:	[ANGL101063 [MYST G7 22.000] [1]]-[ANGL156661 [DARL G1 22.000] [1]]	-100.0
CHNL# 'S 7,4:	[ANGL190457 [C.CVG1 19.000] [1]]-[ANGL156661 [DARL G1 22.000] [1]]	-100.0

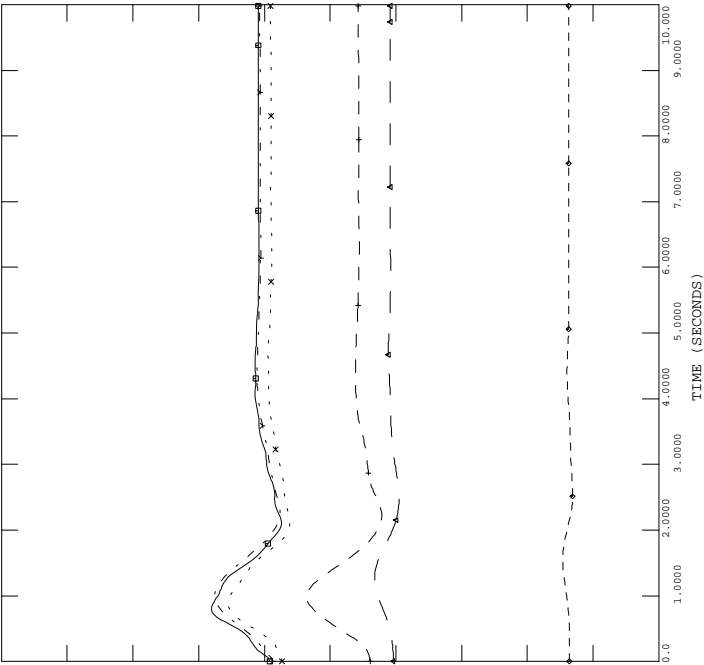

"NE, NY, NB ANGLE"
FRI, FEB 13 2009 22:13



2013 WINTER PEAKL8004 OUT N-1
NS-NB=0; NB-NE=500; CBX=660 ONI=819 ONS=709
3 PHASE FAULT ON B62 AT LAKESIDE
TRIPS L6008, L6016, 103H-T61

FILE: a106-103h-b62_3ph_nrecl-2013WP-N-1-8004.out

CHNL# 49:	[POWER190472 [BLDNG2 19.000] [1]]	2.0000
CHNL# 45:	[POWER190456 [LEPRG1 26.000] [1]]	4.0000
CHNL# 44:	[POWER190450 [MACTG1 13.800] [1]]	0.0
CHNL# 42:	[POWER126652 [RAV 3 22.000] [1]]	0.0
CHNL# 41:	[POWER101063 [MYST G7 22.000] [1]]	0.0
CHNL# 46:	[POWER190457 [C.CVG1 19.000] [1]]	1.0000

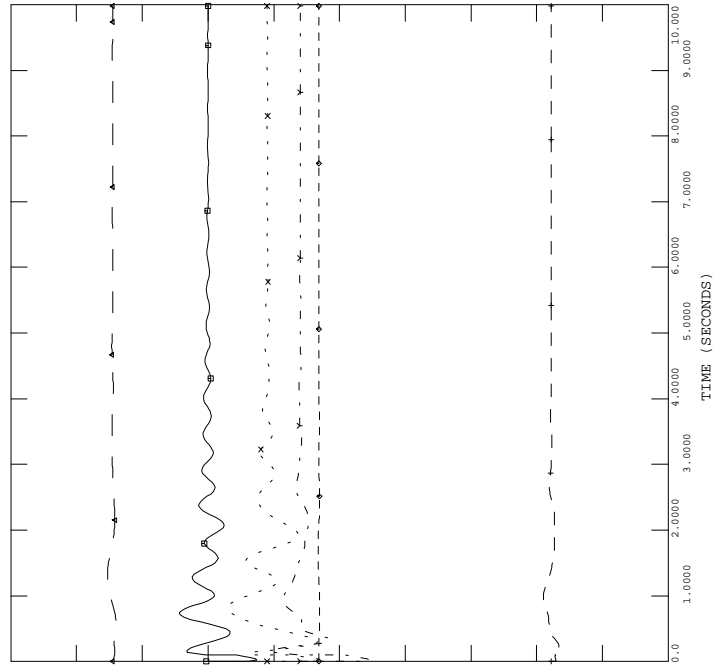

"NE, NY, NB POWER"
FRI, FEB 13 2009 22:13



2013 WINTER PEAKL8004 OUT N-1
 NS-NB=0; NB-NE=500; CBX=660 ONI=819 ONS=709
 3 PHASE FAULT ON B62 AT LAKESIDE
 TRIPS L6008, L6016, 103H-T61

FILE: a106-103h-b62_3ph_nrecl-2013WP-N-1-8004.out
 CHNL# 119: [VARS IR141-DIGBY]

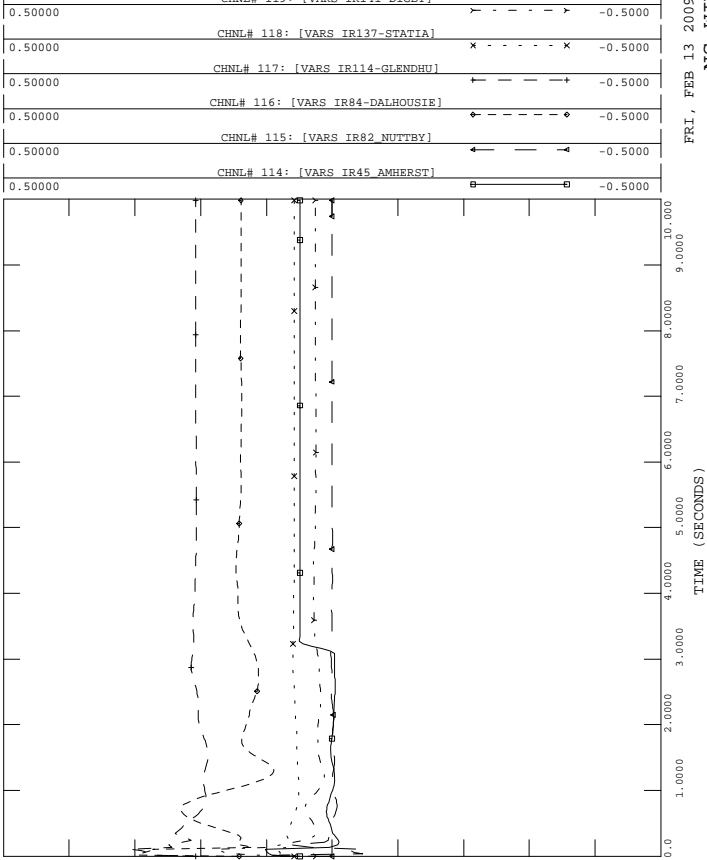

FRI, FEB 13 2009 22:13
NS WIND MV



2013 WINTER PEAKL8004 OUT N-1
 NS-NB=0; NB-NE=500; CBX=660 ONI=819 ONS=709
 3 PHASE FAULT ON B62 AT LAKESIDE
 TRIPS L6008, L6016, 103H-T61

FILE: a106-103h-b62_3ph_nrecl-2013WP-N-1-8004.out
 CHNL# 133: [VOLT199125 [ONSLow 345.00]]

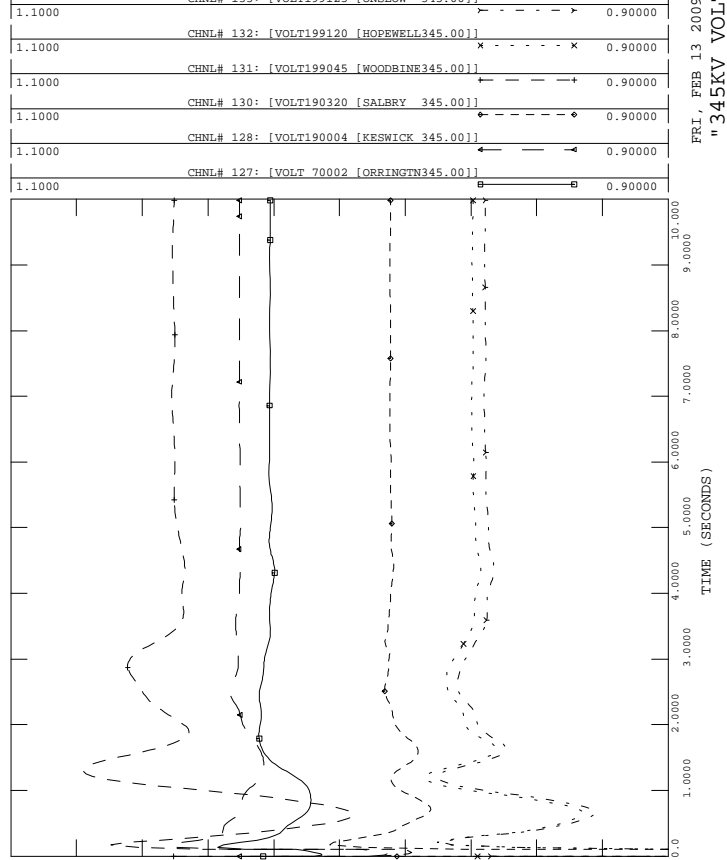

FRI, FEB 13 2009 22:13
"345KV VOLTAGE"



2013 WINTER PEAKL8004 OUT N-1
 NS-NB=0; NB-NE=500; CBX=660 ONI=819 ONS=709
 3 PHASE FAULT ON B62 AT LAKESIDE
 TRIPS L6008, L6016, 103H-T61

FILE: a106-103h-b62_3ph_nrecl-2013WP-N-1-8004.out
 CHNL# 79: [POWER IR141-DIGBY]

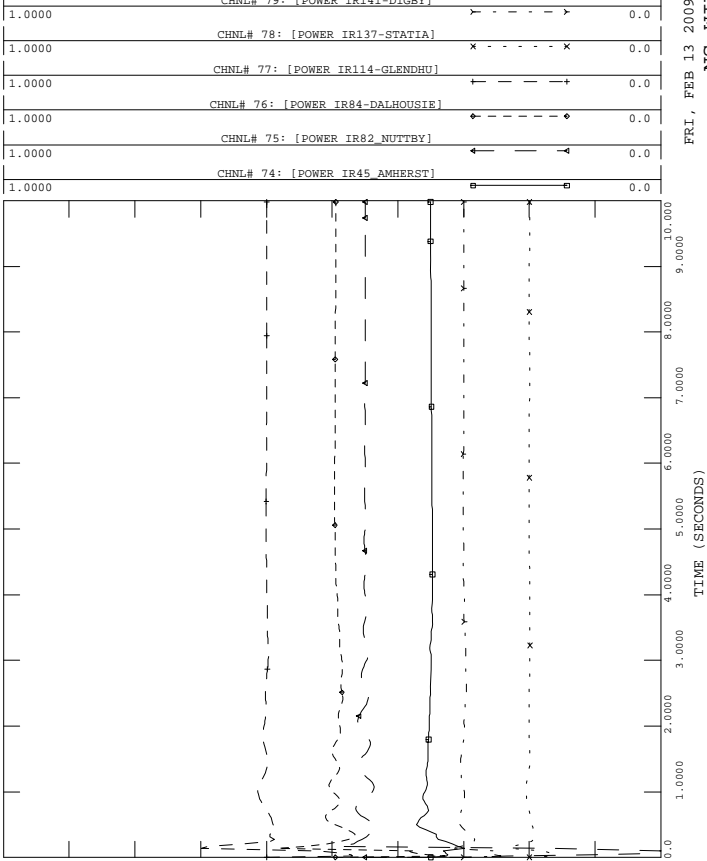

FRI, FEB 13 2009 22:13
NS WIND MW



2013 WINTER PEAKL8004 OUT N-1
 NS-NB=0; NB-NE=500; CBX=660 ONI=819 ONS=709
 3 PHASE FAULT ON B62 AT LAKESIDE
 TRIPS L6008, L6016, 103H-T61

FILE: a106-103h-b62_3ph_nrecl-2013WP-N-1-8004.out
 CHNL# 125: 60*(1+[FREQ199125 [ONSLow 345.00]])

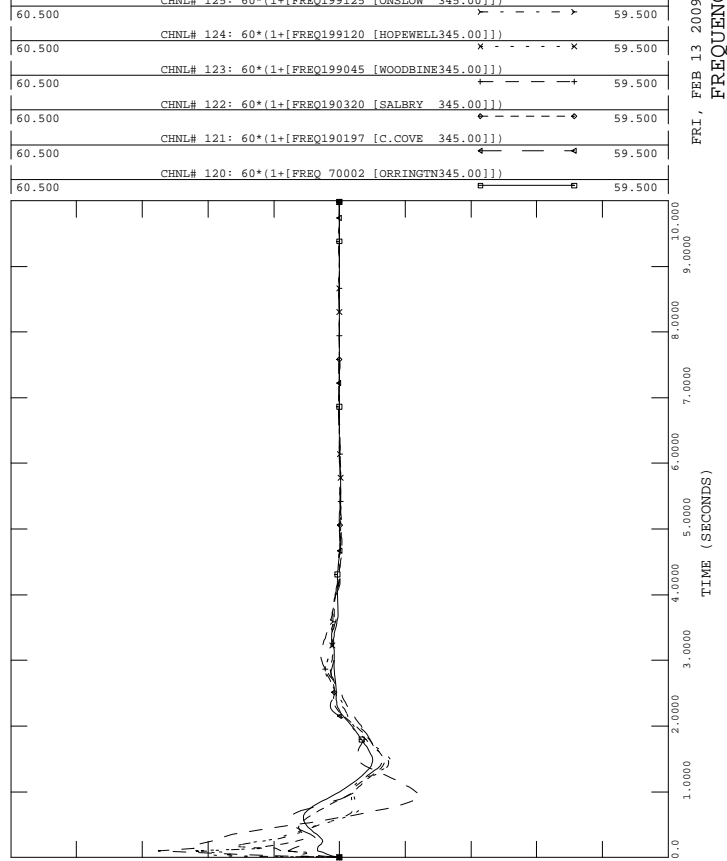

FRI, FEB 13 2009 22:13
FREQUENCY HZ



2013 WINTER PEAKL8004 OUT N-1
NS-NB=0; NB-NE=500; CBX=660 ONI=819 ONS=709
3 PHASE FAULT ON B62 AT LAKESIDE
TRIPS L6008, L6016, 103H-T61

FILE: a106-103h-b62_3ph_nrecl-2013WP-N-1-8004.out
CHNL# 146: [VOLT199280 [TUSKET_A138.00]]

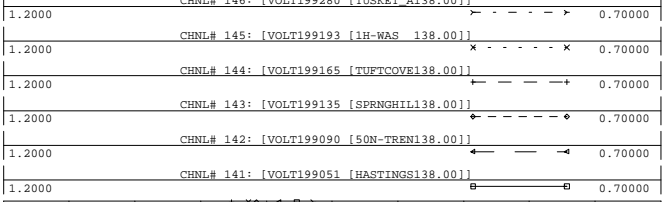

FRI, FEB 13 2009 22:13
138KV BUS VOLTS



2013 WINTER PEAKL8004 OUT N-1
NS-NB=0; NB-NE=500; CBX=660 ONI=819 ONS=709
3 PHASE FAULT ON B62 AT LAKESIDE
TRIPS L6008, L6016, 103H-T61

FILE: a106-103h-b62_3ph_nrecl-2013WP-N-1-8004.out
CHNL# 217: [L6513NMW]

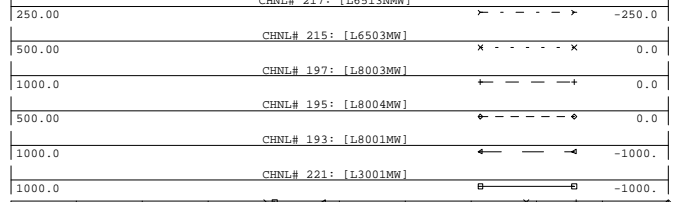

FRI, FEB 13 2009 22:13
LINE FLOW MW



2013 WINTER PEAKL8004 OUT N-1
NS-NB=0; NB-NE=500; CBX=660 ONI=819 ONS=709
3 PHASE FAULT ON B62 AT LAKESIDE
TRIPS L6008, L6016, 103H-T61

FILE: a106-103h-b62_3ph_nrecl-2013WP-N-1-8004.out
CHNL# 140: [VOLT199240 [BWATER_A230.00]]

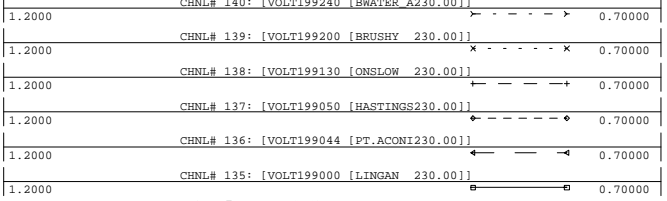

FRI, FEB 13 2009 22:13
230KV BUS VOLTS



2013 WINTER PEAKL8004 OUT N-1
NS-NB=0; NB-NE=500; CBX=660 ONI=819 ONS=709
3 PHASE FAULT ON B62 AT LAKESIDE
TRIPS L6008, L6016, 103H-T61

FILE: a106-103h-b62_3ph_nrecl-2013WP-N-1-8004.out
CHNL# 154: [IR141-DIGBYH69.0 VOLTS]

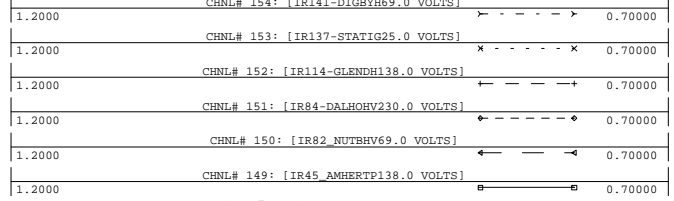

FRI, FEB 13 2009 22:13
WIND BUS VOLTS

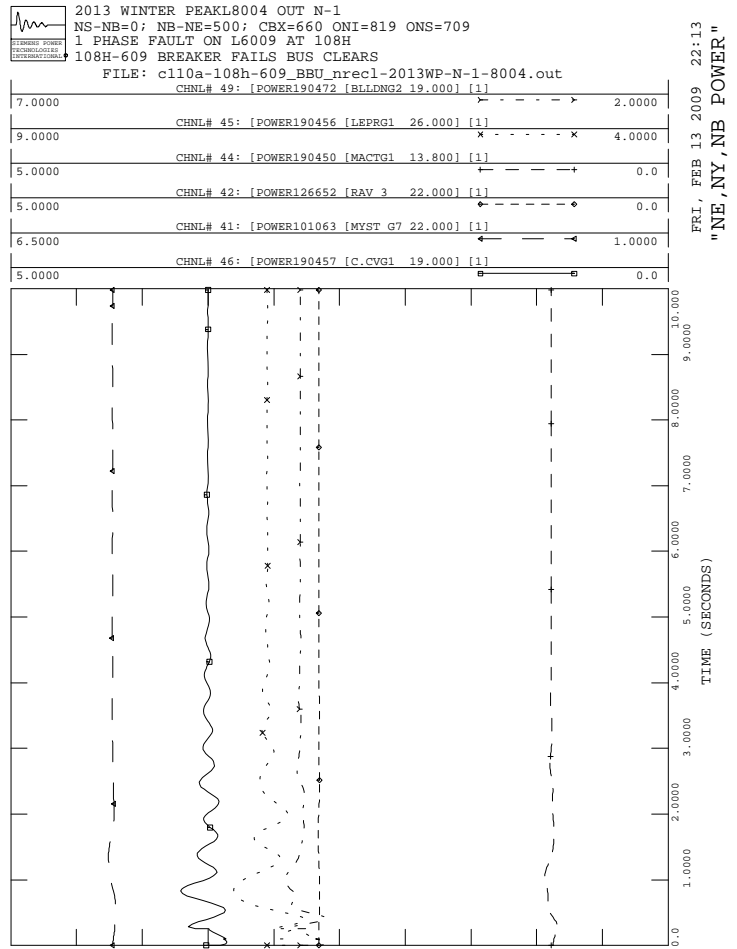
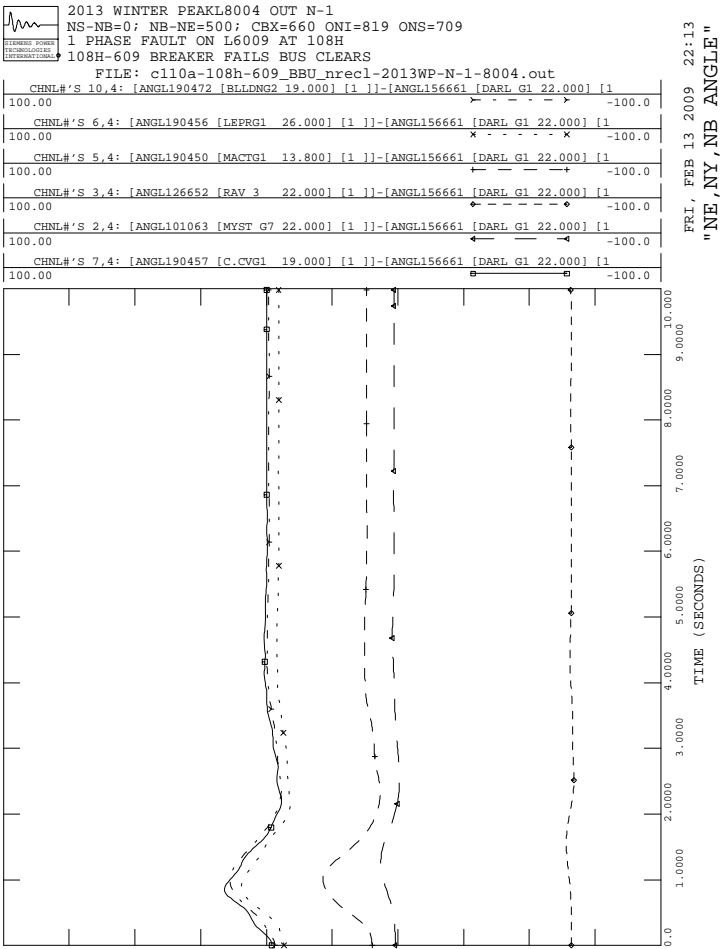
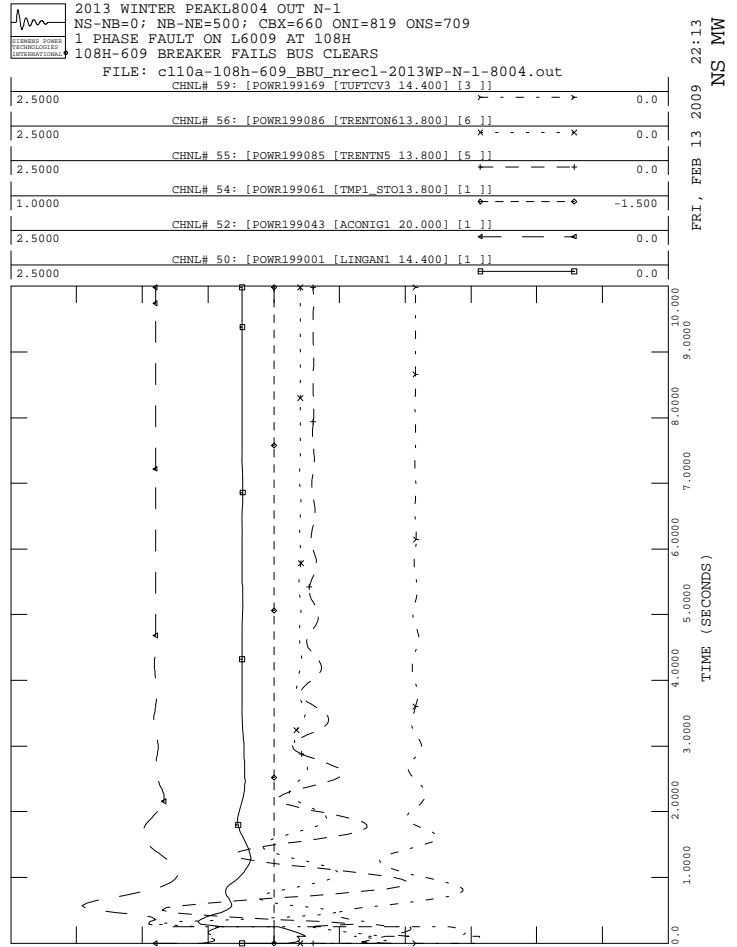
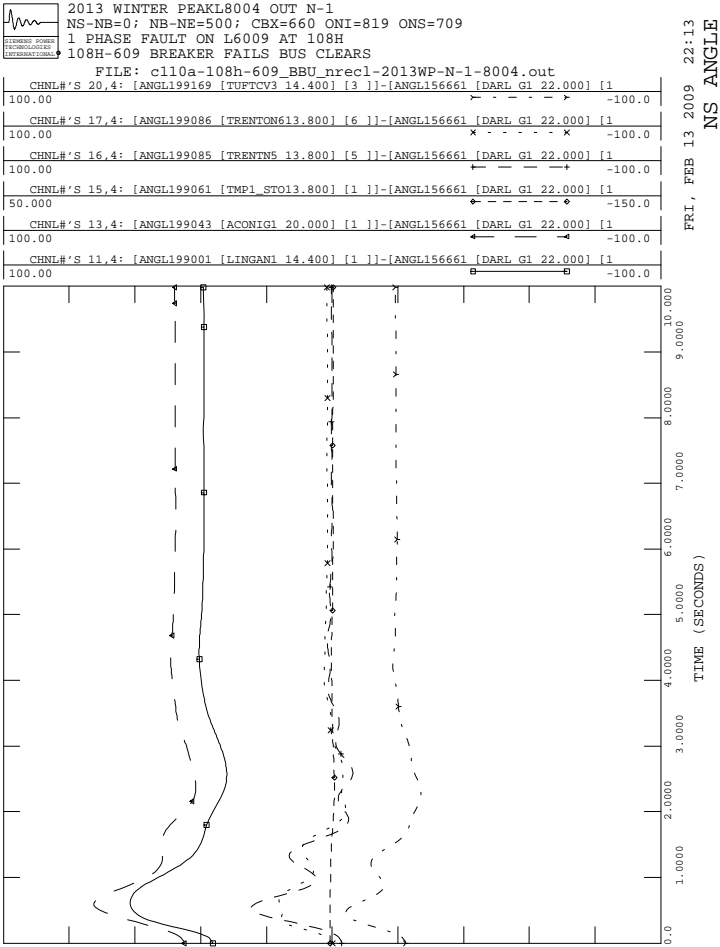



2013 WINTER PEAKL8004 OUT N-1
 NS-NB=0; NB-NE=500; CBX=660 ONI=819 ONS=709
 1 PHASE FAULT ON L6009 AT 108H
 108H-609 BREAKER FAILS BUS CLEARS

FILE: c110a-108h-609_BBU_nrecl-2013WP-N-1-8004.out
 CHNL# 119: [VARS IR141-DIGBY]

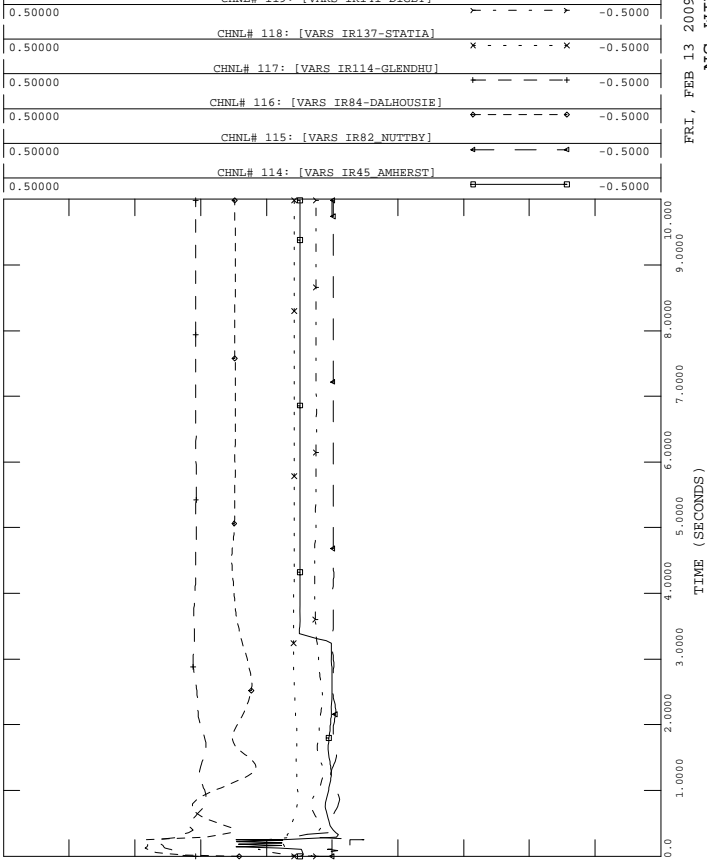

FRI, FEB 13 2009 22:13
 NS WIND MV



2013 WINTER PEAKL8004 OUT N-1
 NS-NB=0; NB-NE=500; CBX=660 ONI=819 ONS=709
 1 PHASE FAULT ON L6009 AT 108H
 108H-609 BREAKER FAILS BUS CLEARS

FILE: c110a-108h-609_BBU_nrecl-2013WP-N-1-8004.out
 CHNL# 133: [VOLT199125 [ONSLow 345.00]]

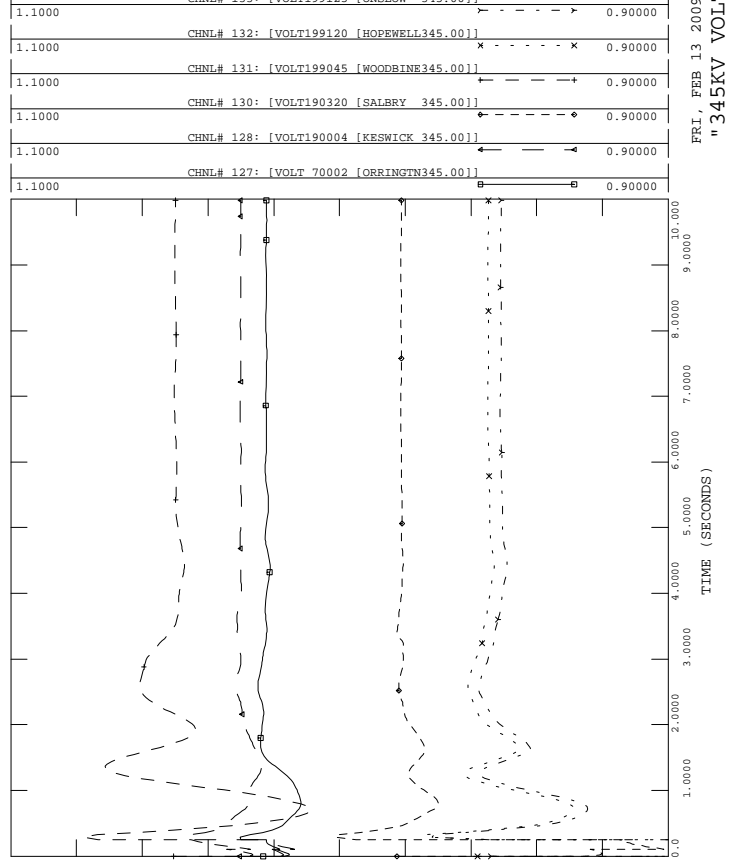

FRI, FEB 13 2009 22:13
 # 345KV VOLTAGE"



2013 WINTER PEAKL8004 OUT N-1
 NS-NB=0; NB-NE=500; CBX=660 ONI=819 ONS=709
 1 PHASE FAULT ON L6009 AT 108H
 108H-609 BREAKER FAILS BUS CLEARS

FILE: c110a-108h-609_BBU_nrecl-2013WP-N-1-8004.out
 CHNL# 79: [POWER IR141-DIGBY]

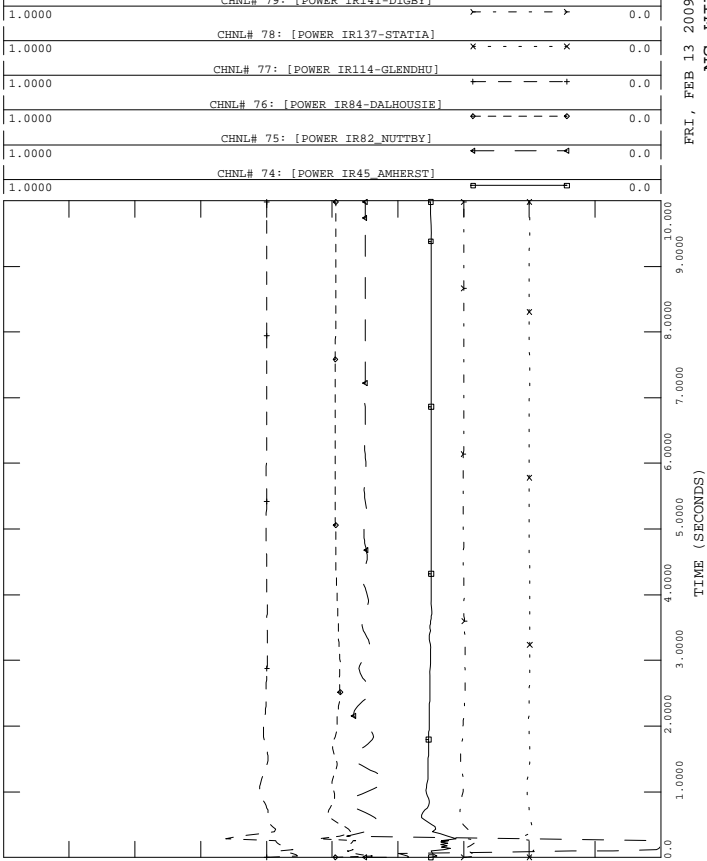

FRI, FEB 13 2009 22:13
 NS WIND MW



2013 WINTER PEAKL8004 OUT N-1
 NS-NB=0; NB-NE=500; CBX=660 ONI=819 ONS=709
 1 PHASE FAULT ON L6009 AT 108H
 108H-609 BREAKER FAILS BUS CLEARS

FILE: c110a-108h-609_BBU_nrecl-2013WP-N-1-8004.out
 CHNL# 125: 60*(1+[FREQ199125 [ONSLow 345.00]])

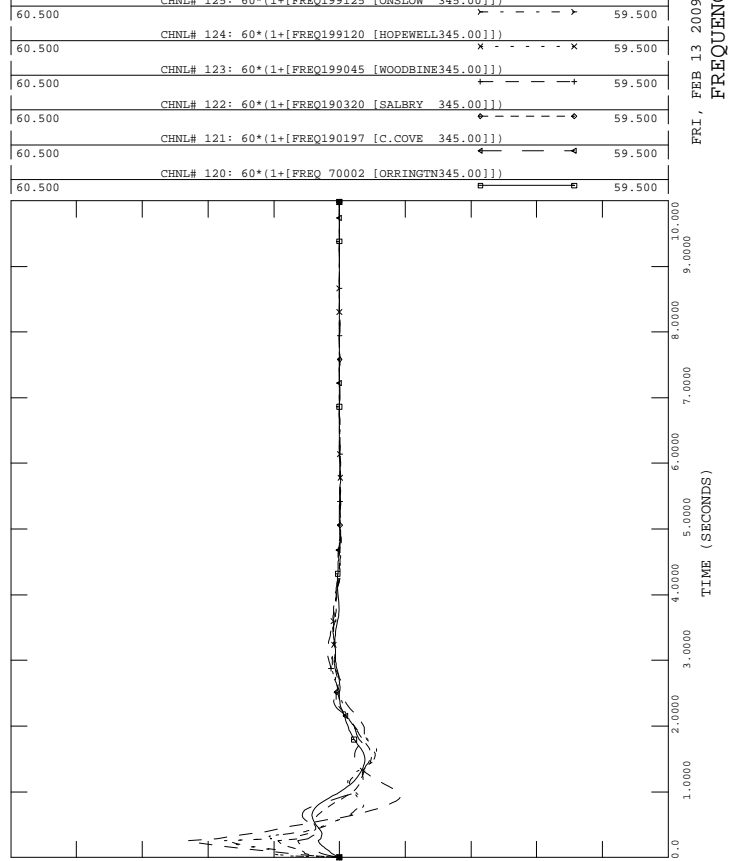

FRI, FEB 13 2009 22:13
 FREQUENCY HZ

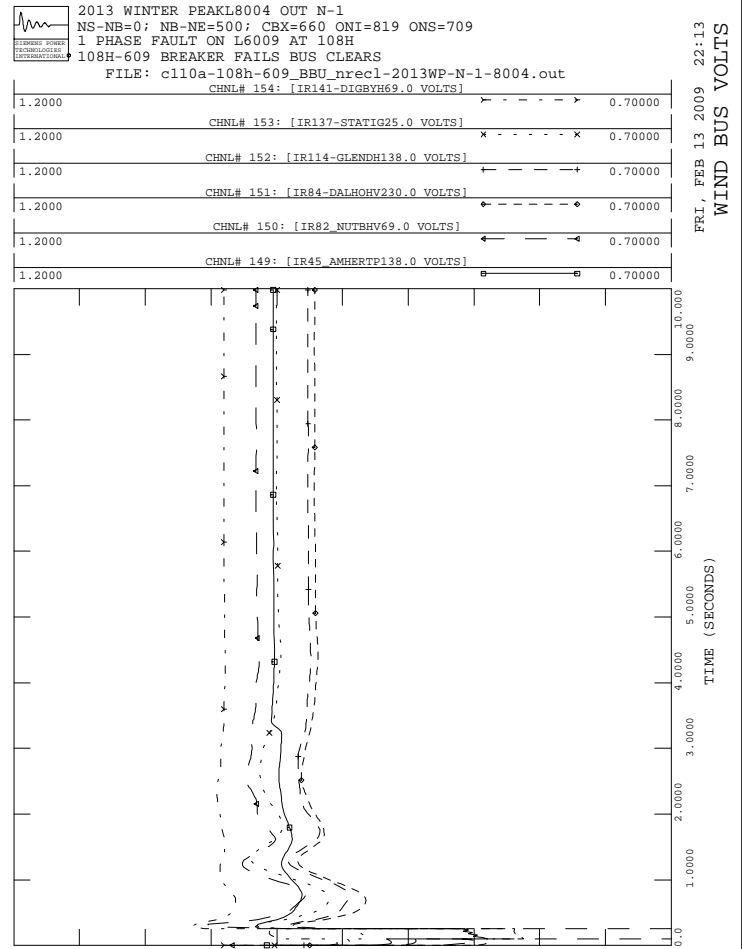
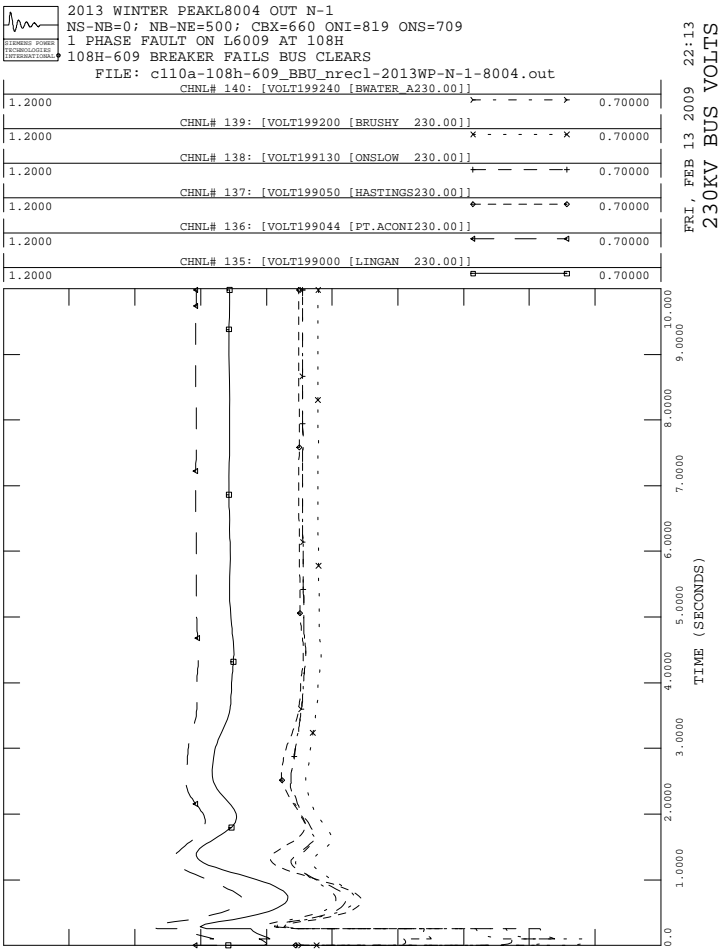
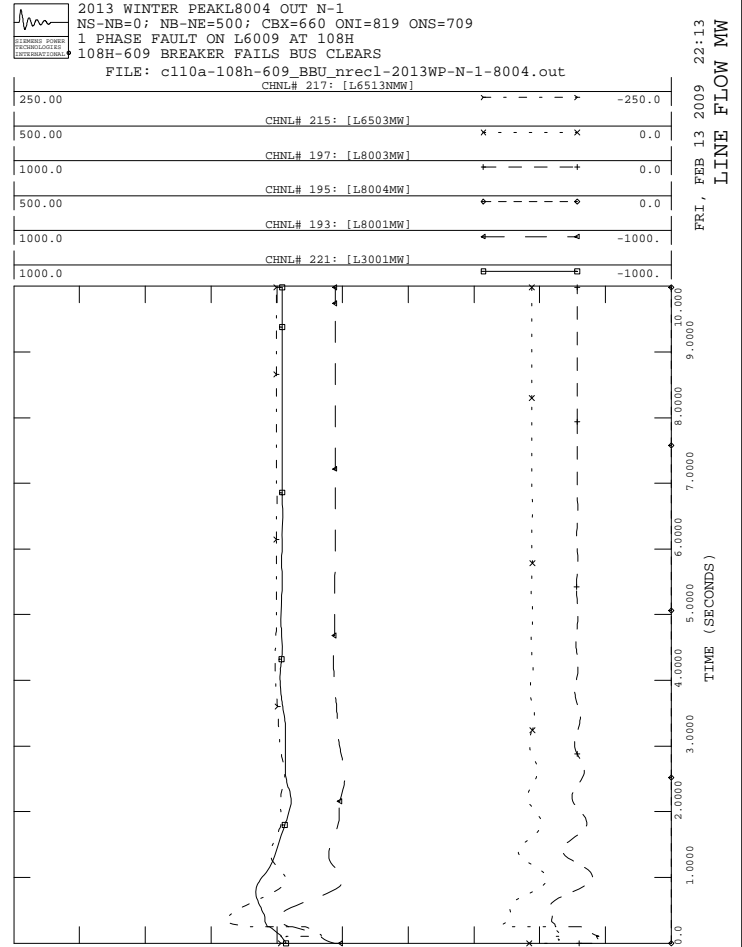
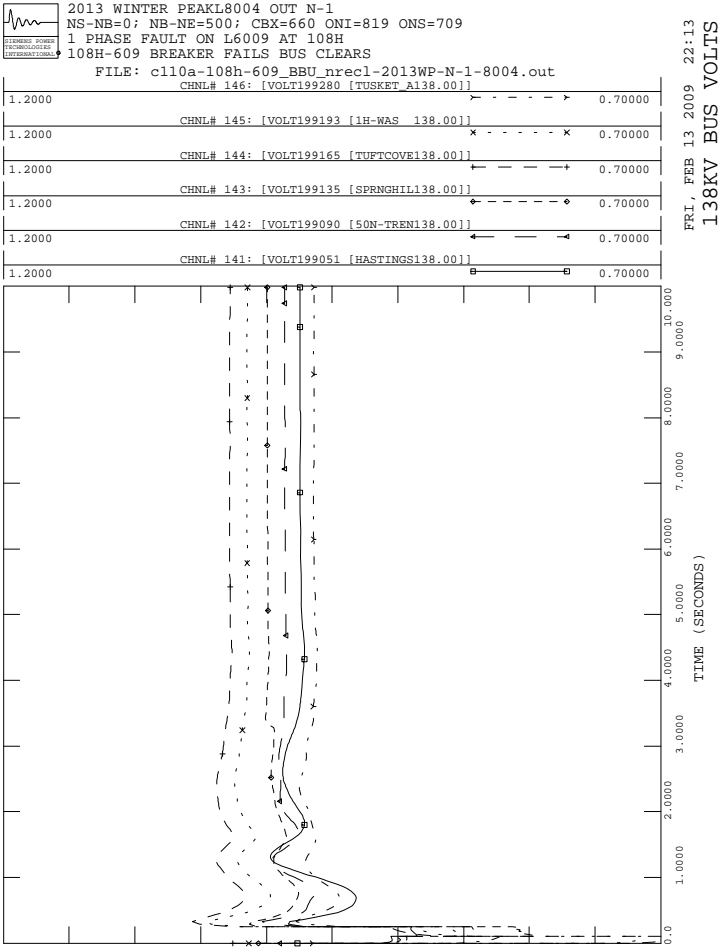

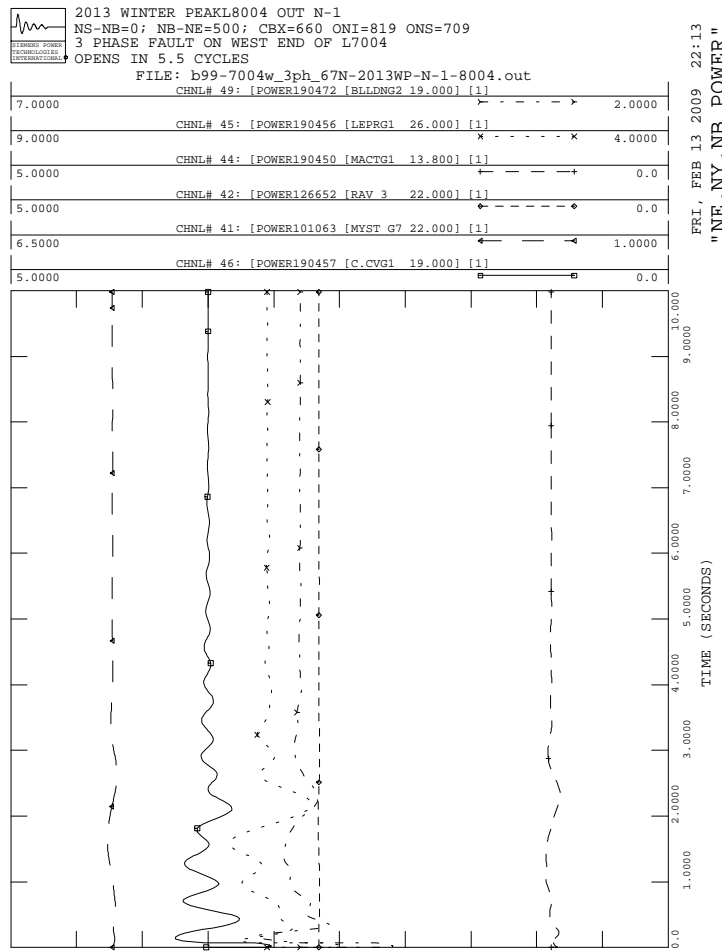
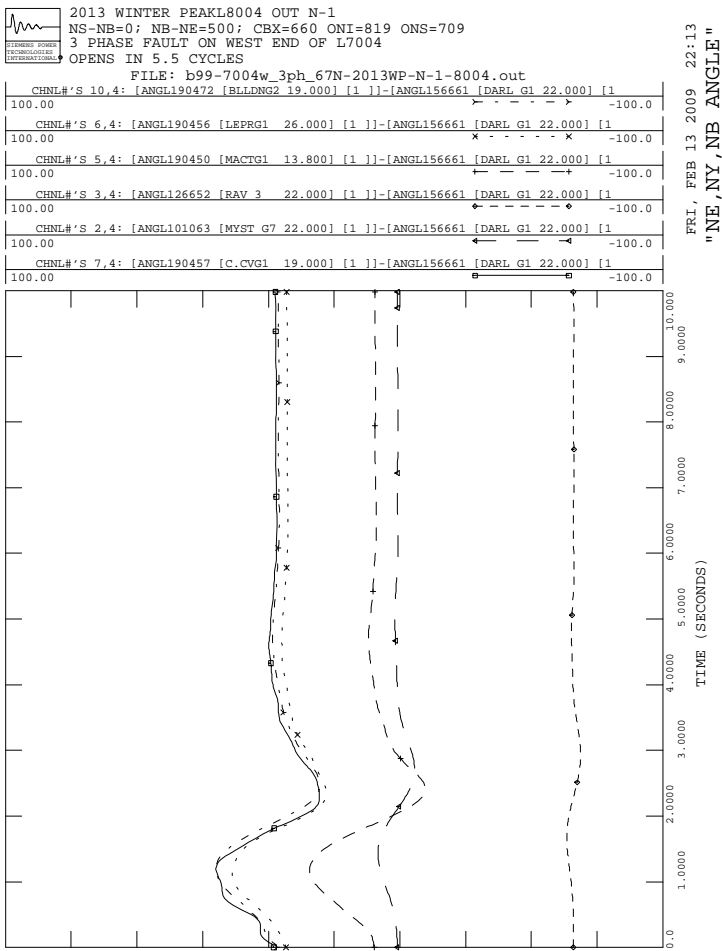
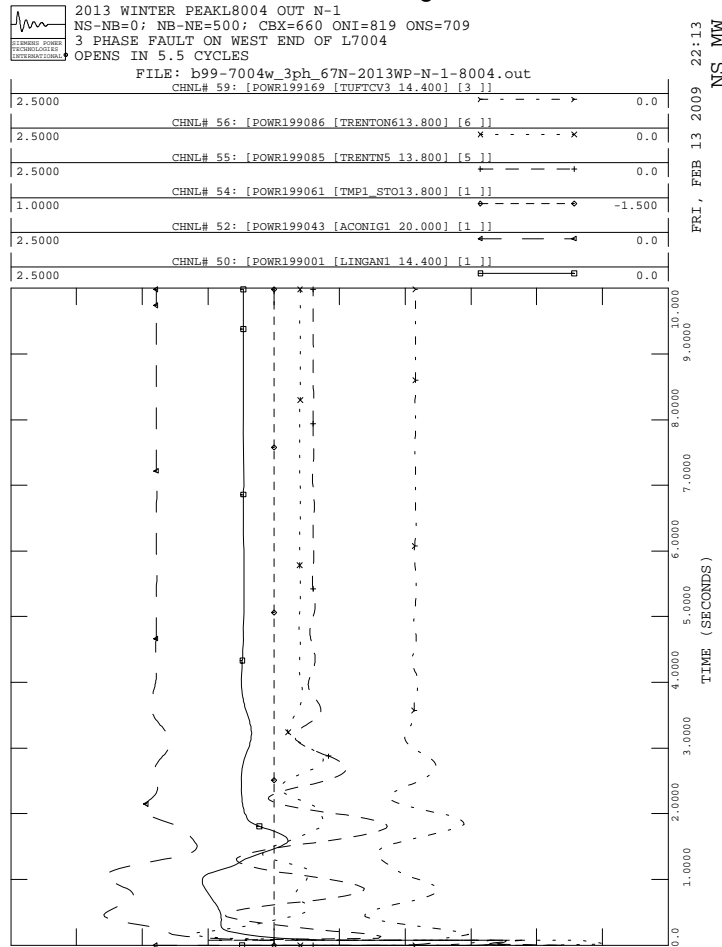
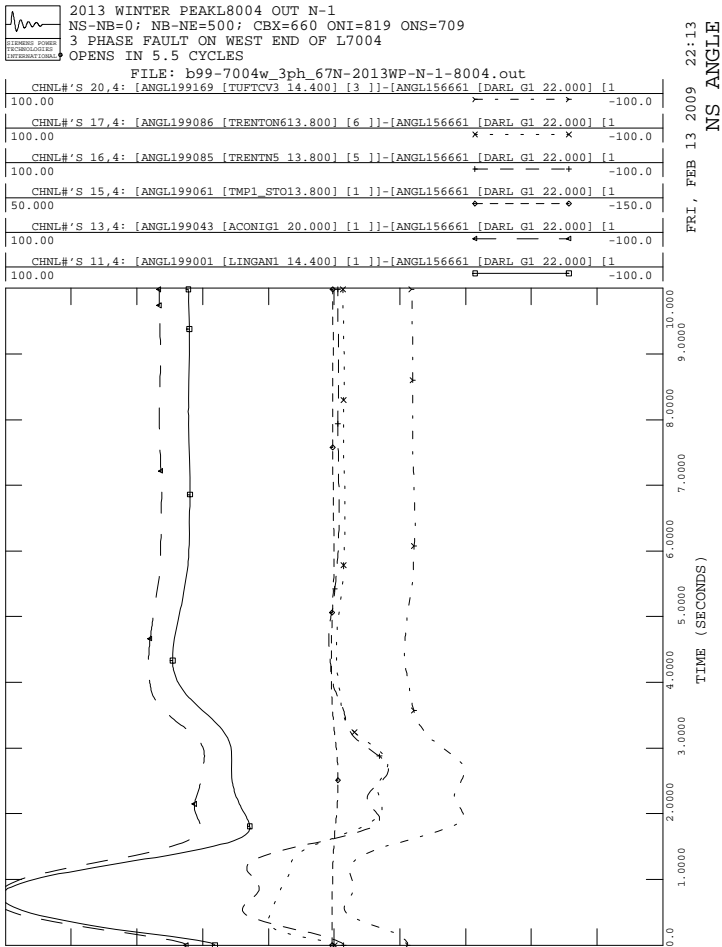



2013 WINTER PEAKL8004 OUT N-1
 NS-NB=0; NB-NE=500; CBX=660 ONI=819 ONS=709
 3 PHASE FAULT ON WEST END OF L7004
 OPENS IN 5.5 CYCLES

FILE: b99-7004w_3ph_67N-2013WP-N-1-8004.out
 CHNL# 119: [VARS IR141-DIGBY]

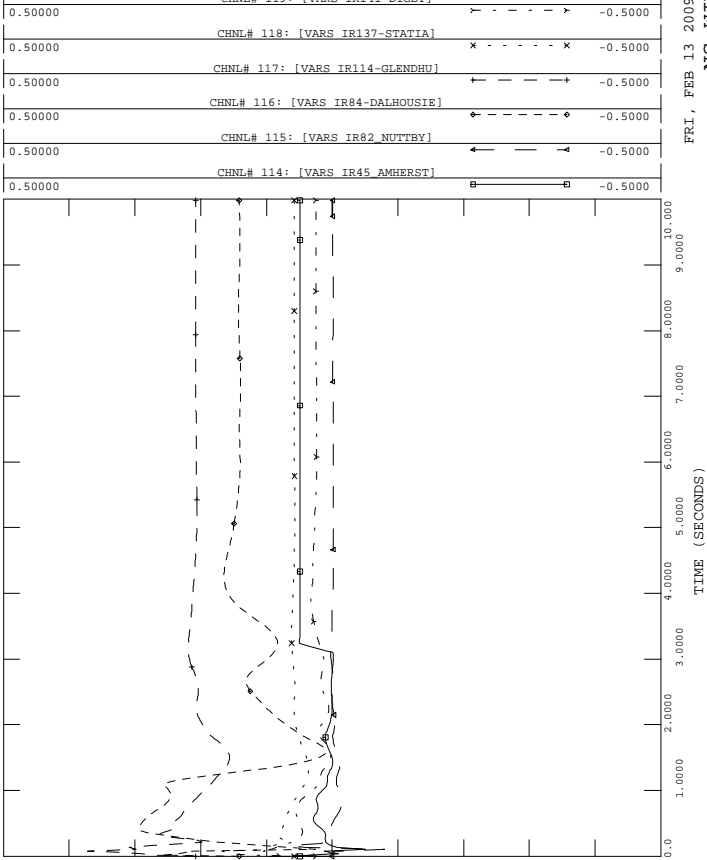

FRI, FEB 13 2009 22:13
NS WIND MV



2013 WINTER PEAKL8004 OUT N-1
 NS-NB=0; NB-NE=500; CBX=660 ONI=819 ONS=709
 3 PHASE FAULT ON WEST END OF L7004
 OPENS IN 5.5 CYCLES

FILE: b99-7004w_3ph_67N-2013WP-N-1-8004.out
 CHNL# 133: [VOLT199125 [ONSLow 345.00]]

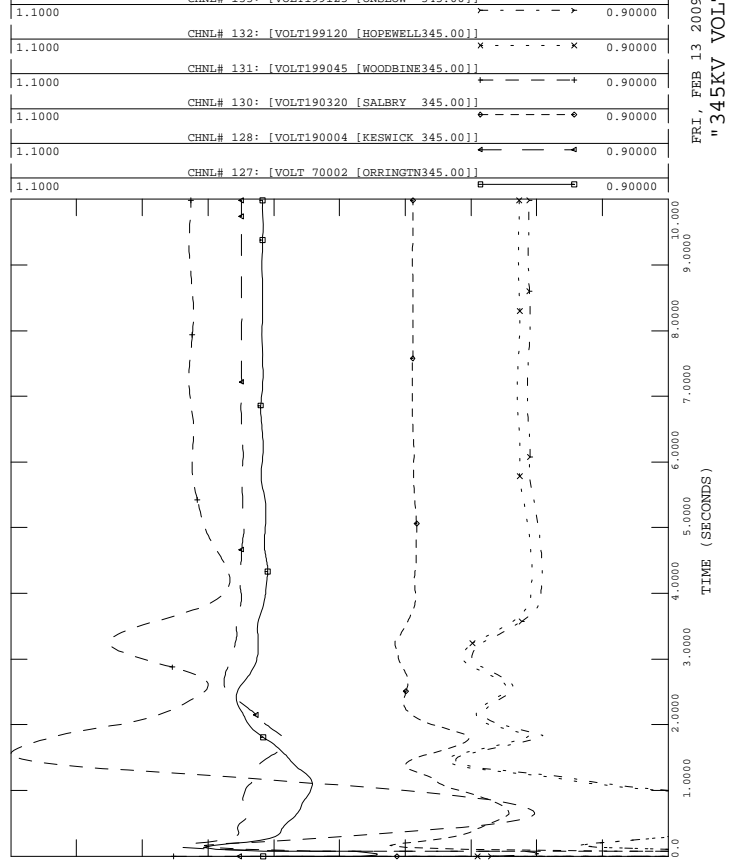

FRI, FEB 13 2009 22:13
345KV VOLTAGE"



2013 WINTER PEAKL8004 OUT N-1
 NS-NB=0; NB-NE=500; CBX=660 ONI=819 ONS=709
 3 PHASE FAULT ON WEST END OF L7004
 OPENS IN 5.5 CYCLES

FILE: b99-7004w_3ph_67N-2013WP-N-1-8004.out
 CHNL# 79: [POWER IR141-DIGBY]

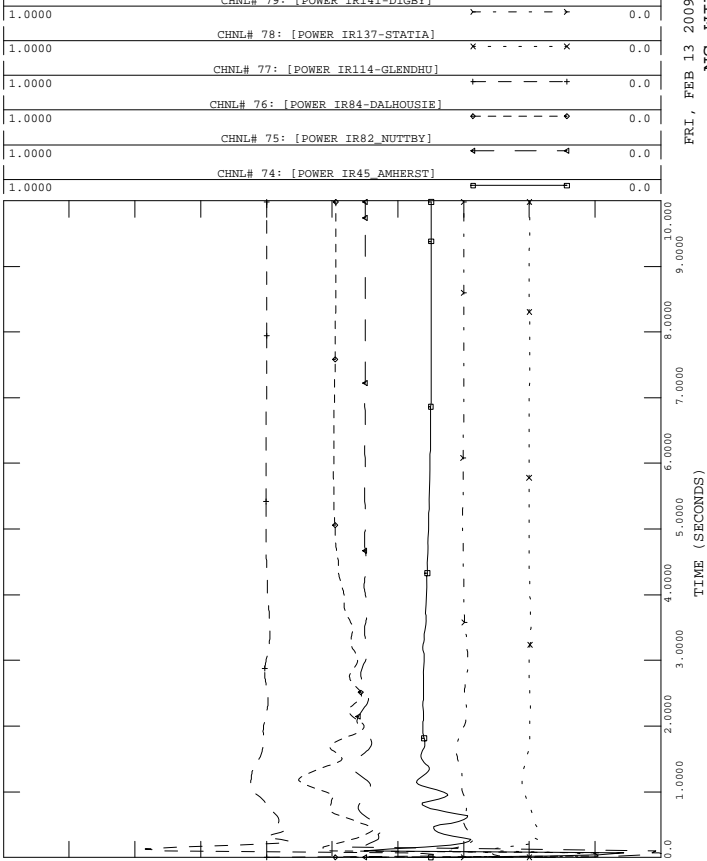

FRI, FEB 13 2009 22:13
NS WIND MW



2013 WINTER PEAKL8004 OUT N-1
 NS-NB=0; NB-NE=500; CBX=660 ONI=819 ONS=709
 3 PHASE FAULT ON WEST END OF L7004
 OPENS IN 5.5 CYCLES

FILE: b99-7004w_3ph_67N-2013WP-N-1-8004.out
 CHNL# 125: 60*(1+[FREQ199125 [ONSLow 345.00]])

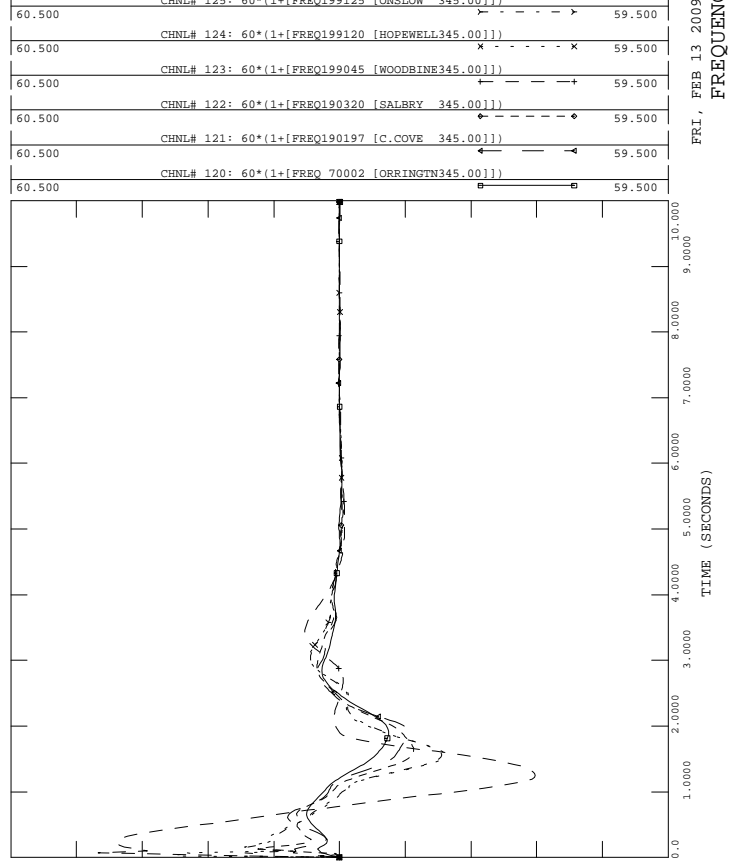

FRI, FEB 13 2009 22:13
FREQUENCY HZ



2013 WINTER PEAKL8004 OUT N-1
NS-NB=0; NB-NE=500; CBX=660 ONI=819 ONS=709
3 PHASE FAULT ON WEST END OF L7004
OPENS IN 5.5 CYCLES

FILE: b99-7004w_3ph_67N-2013WP-N-1-8004.out
CHNL# 146: [VOLT199280 [TUSKET_A138.00]]

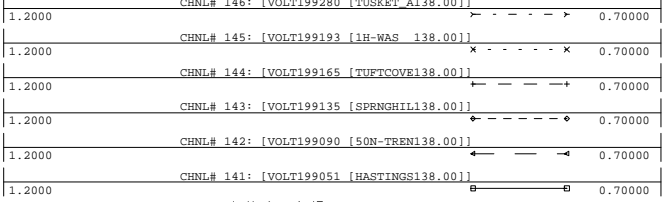

FRI, FEB 13 2009 22:13
138KV BUS VOLTS

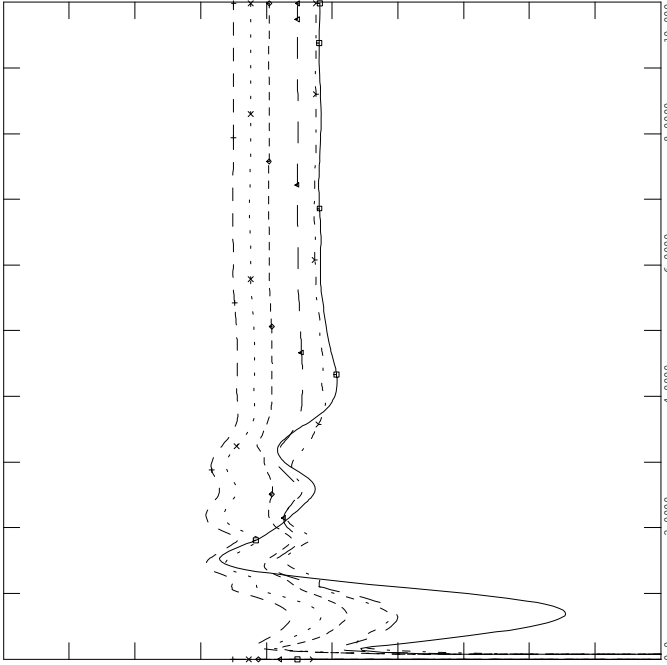

2013 WINTER PEAKL8004 OUT N-1
NS-NB=0; NB-NE=500; CBX=660 ONI=819 ONS=709
3 PHASE FAULT ON WEST END OF L7004
OPENS IN 5.5 CYCLES

FILE: b99-7004w_3ph_67N-2013WP-N-1-8004.out
CHNL# 217: [L6513NMW]

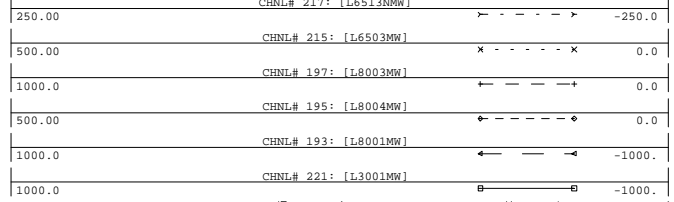

FRI, FEB 13 2009 22:13
LINE FLOW MW

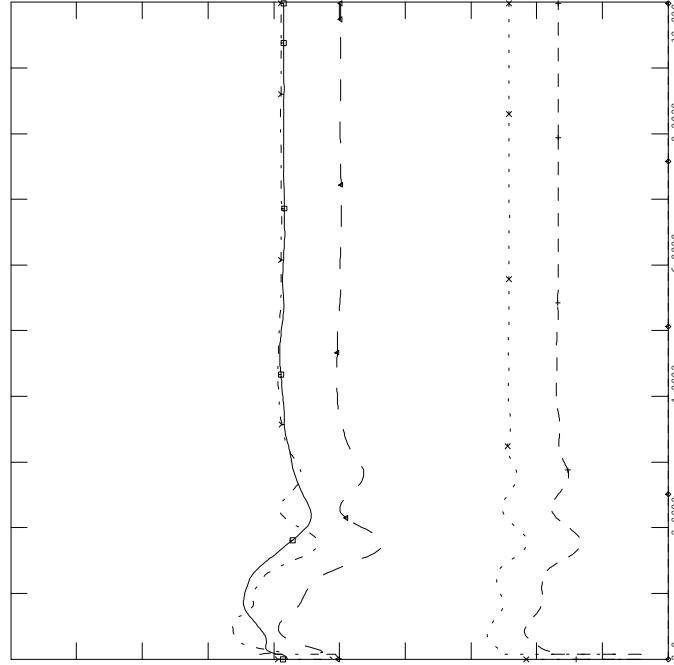

2013 WINTER PEAKL8004 OUT N-1
NS-NB=0; NB-NE=500; CBX=660 ONI=819 ONS=709
3 PHASE FAULT ON WEST END OF L7004
OPENS IN 5.5 CYCLES

FILE: b99-7004w_3ph_67N-2013WP-N-1-8004.out
CHNL# 140: [VOLT199240 [BWATER_A230.00]]

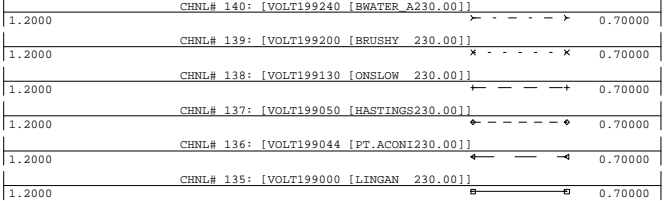

FRI, FEB 13 2009 22:13
230KV BUS VOLTS

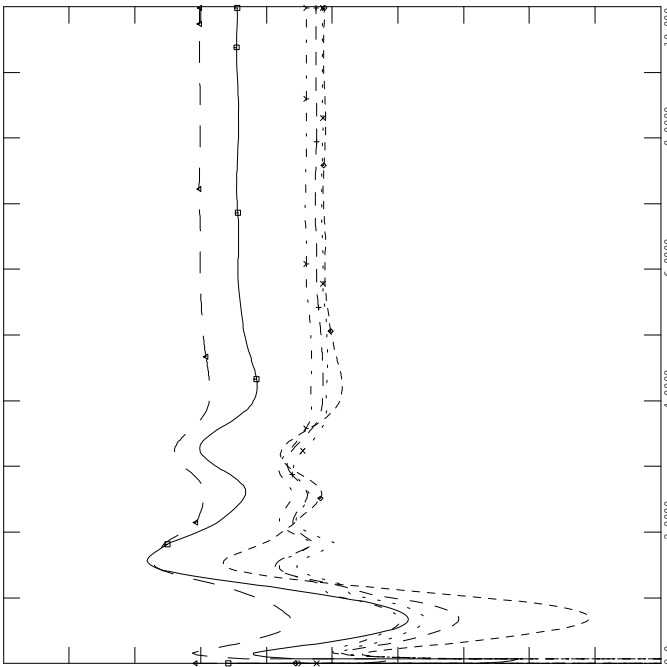

2013 WINTER PEAKL8004 OUT N-1
NS-NB=0; NB-NE=500; CBX=660 ONI=819 ONS=709
3 PHASE FAULT ON WEST END OF L7004
OPENS IN 5.5 CYCLES

FILE: b99-7004w_3ph_67N-2013WP-N-1-8004.out
CHNL# 154: [IR141-DIGBYH69.0 VOLTS]

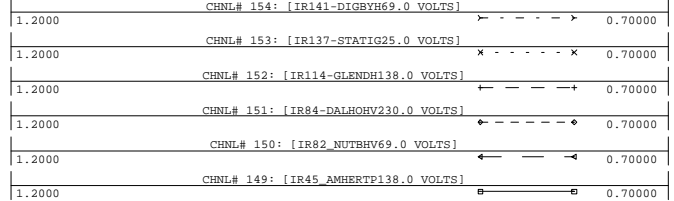

FRI, FEB 13 2009 22:13
WIND BUS VOLTS

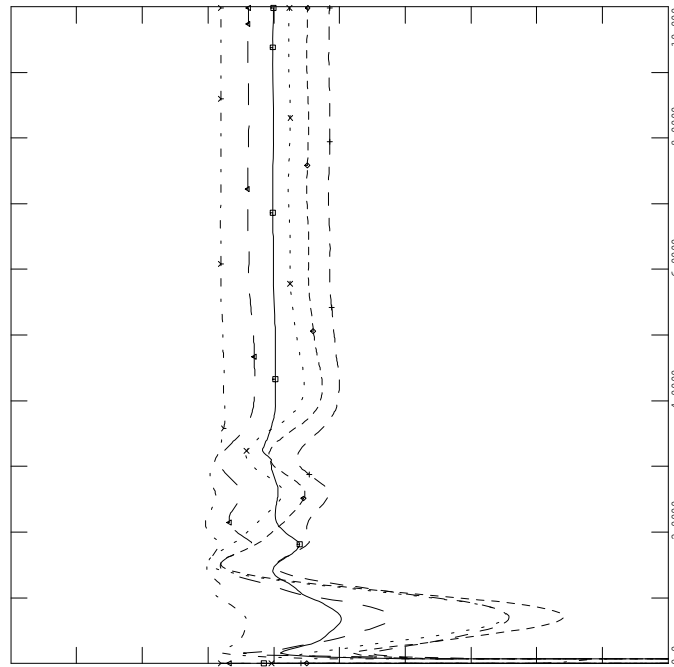

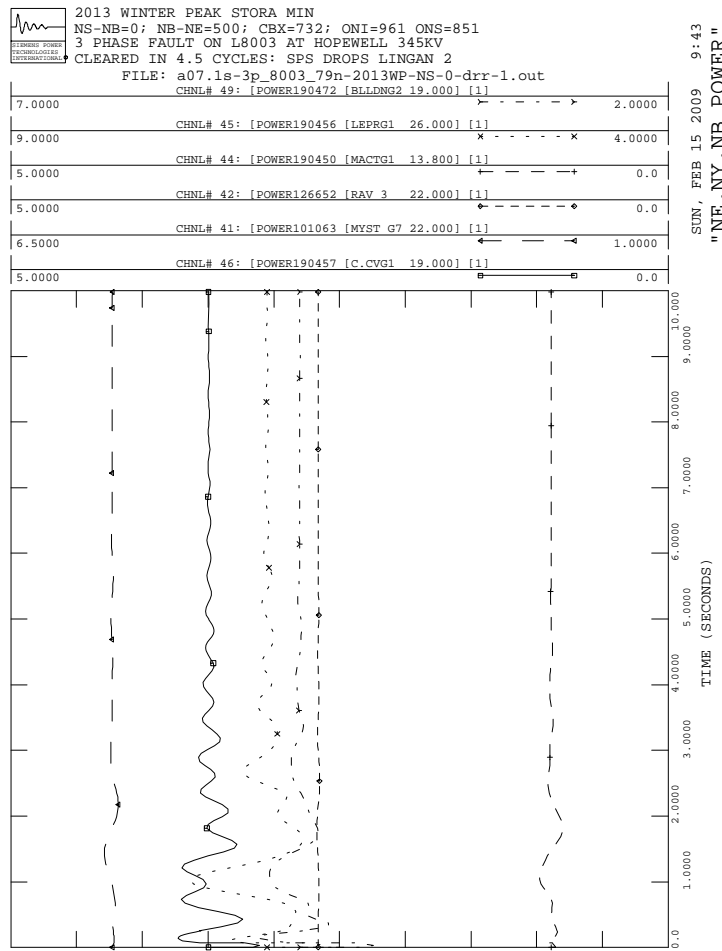
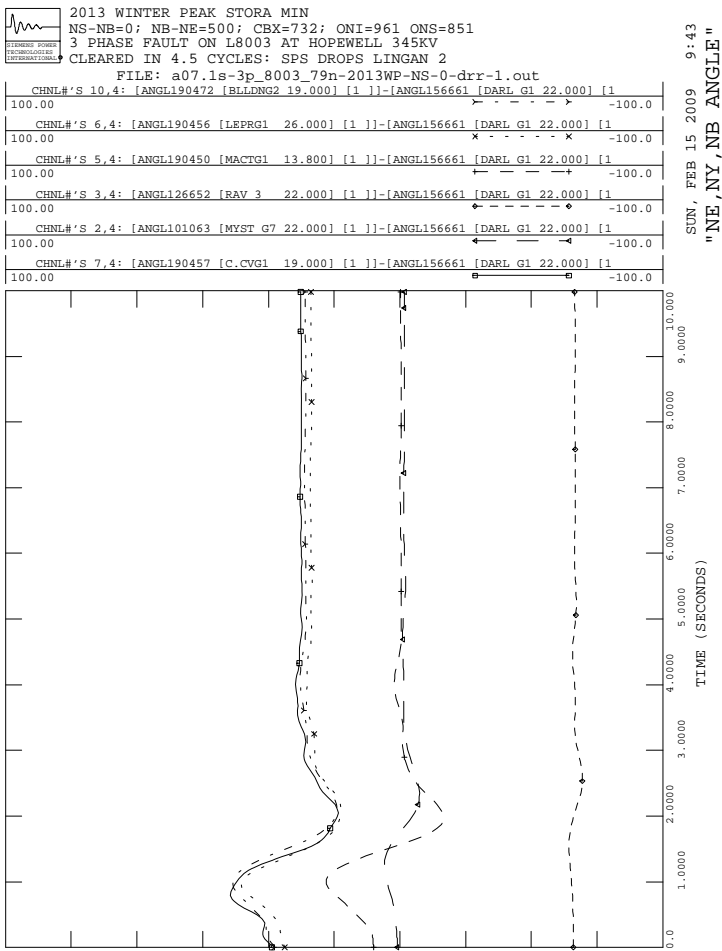
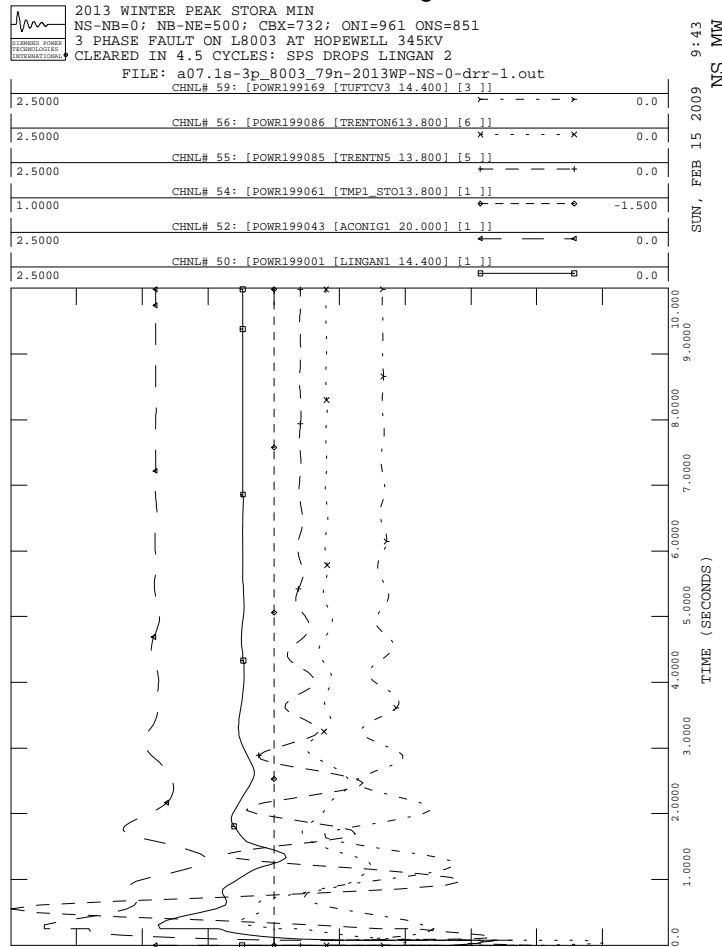
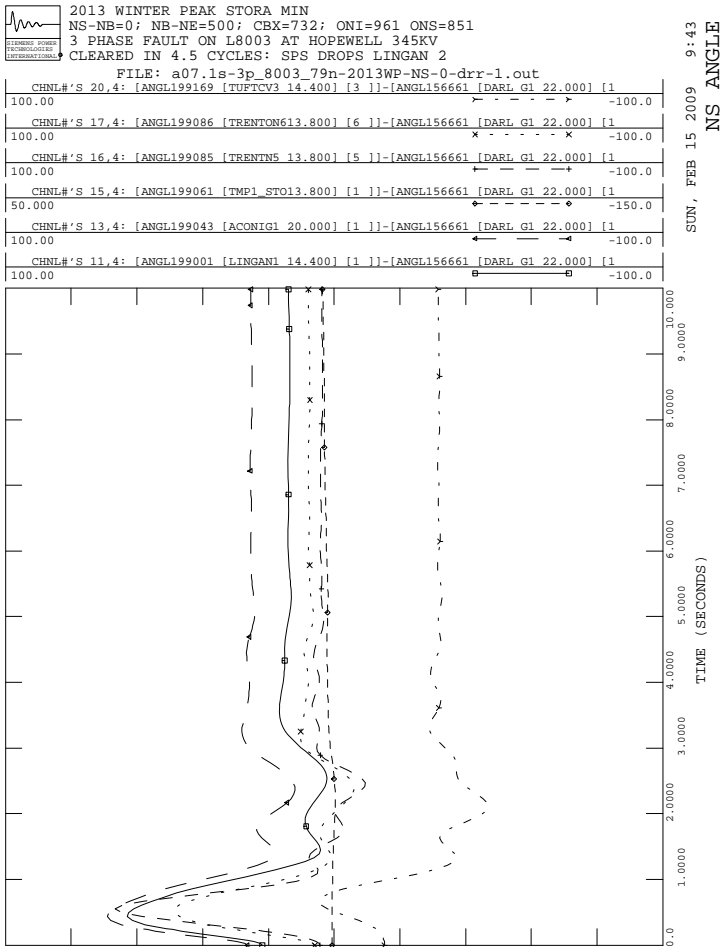



2013 WINTER PEAK STORA MIN
 NS-NB=0; NB-NE=500; CBX=732; ONI=961 ONS=851
 3 PHASE FAULT ON L8003 AT HOPEWELL 345KV
 CLEARED IN 4.5 CYCLES: SPS DROPS LINGAN 2
 FILE: a07.1s-3p_8003_79n-2013WP-NS-0-drr-1.out
 CHNL# 119: [VARS IR141-DIGBY]

SUN, FEB 15 2009 9:43
 NS WIND MV

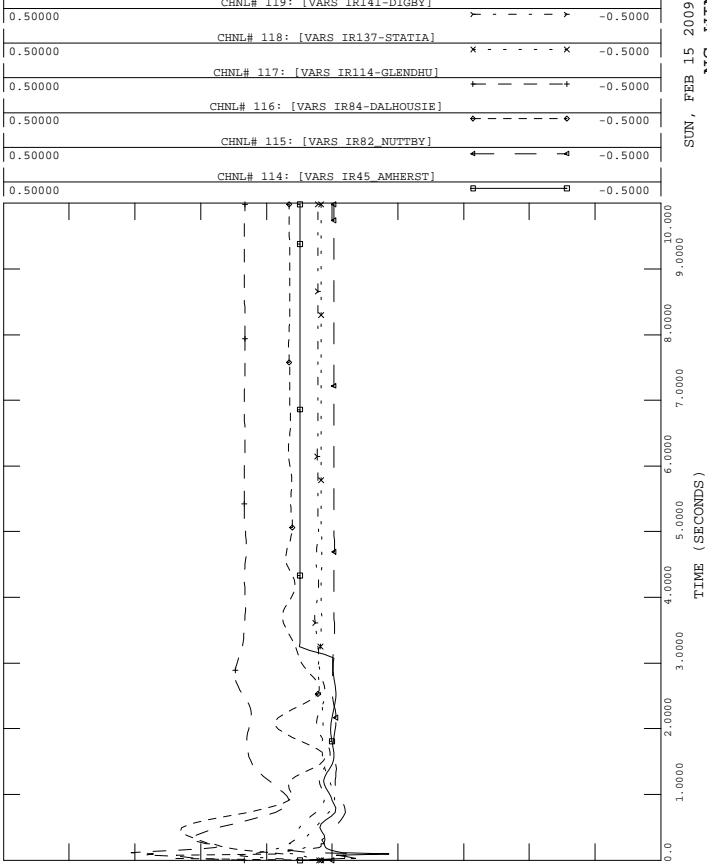

2013 WINTER PEAK STORA MIN
 NS-NB=0; NB-NE=500; CBX=732; ONI=961 ONS=851
 3 PHASE FAULT ON L8003 AT HOPEWELL 345KV
 CLEARED IN 4.5 CYCLES: SPS DROPS LINGAN 2
 FILE: a07.1s-3p_8003_79n-2013WP-NS-0-drr-1.out
 CHNL# 133: [VOLT199125 [ONSLow 345.00]]

SUN, FEB 15 2009 9:43
 "345KV VOLTAGE"

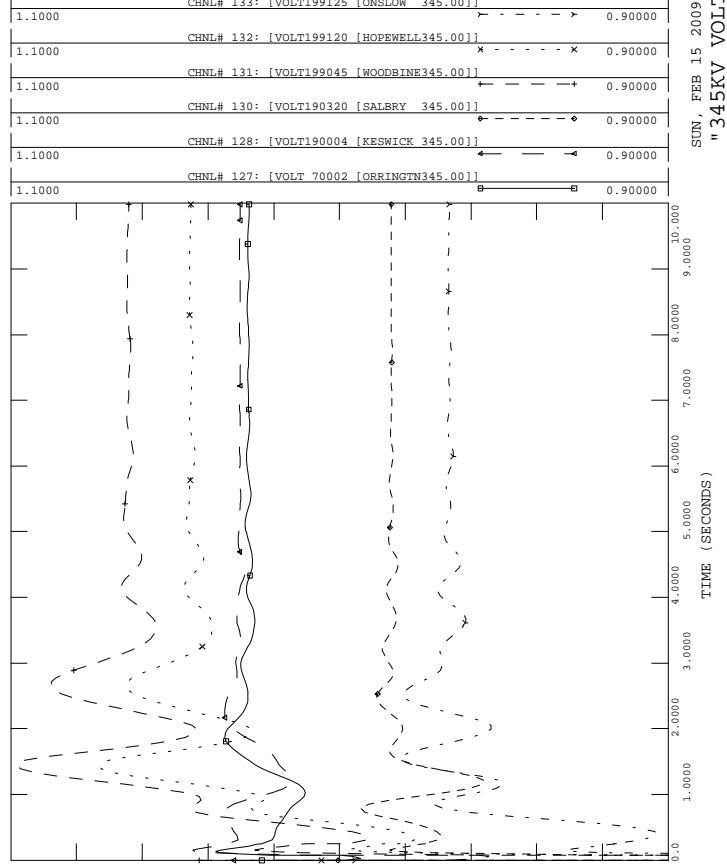

2013 WINTER PEAK STORA MIN
 NS-NB=0; NB-NE=500; CBX=732; ONI=961 ONS=851
 3 PHASE FAULT ON L8003 AT HOPEWELL 345KV
 CLEARED IN 4.5 CYCLES: SPS DROPS LINGAN 2
 FILE: a07.1s-3p_8003_79n-2013WP-NS-0-drr-1.out
 CHNL# 79: [POWER IR141-DIGBY]

SUN, FEB 15 2009 9:43
 NS WIND MW

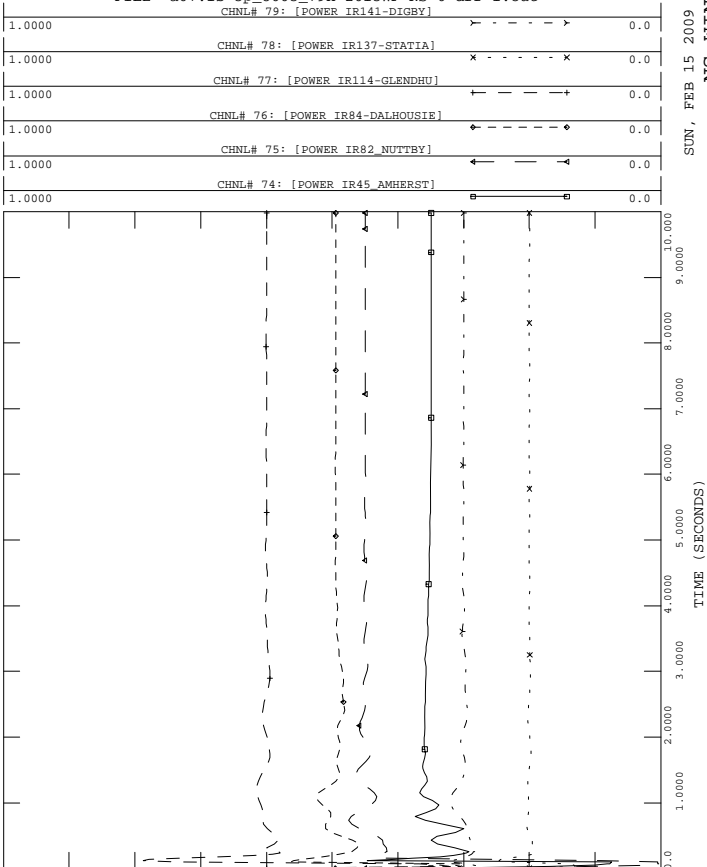

2013 WINTER PEAK STORA MIN
 NS-NB=0; NB-NE=500; CBX=732; ONI=961 ONS=851
 3 PHASE FAULT ON L8003 AT HOPEWELL 345KV
 CLEARED IN 4.5 CYCLES: SPS DROPS LINGAN 2
 FILE: a07.1s-3p_8003_79n-2013WP-NS-0-drr-1.out
 CHNL# 125: 60*(1+[FREQ199125 [ONSLow 345.00]])

SUN, FEB 15 2009 9:43
 FREQUENCY HZ

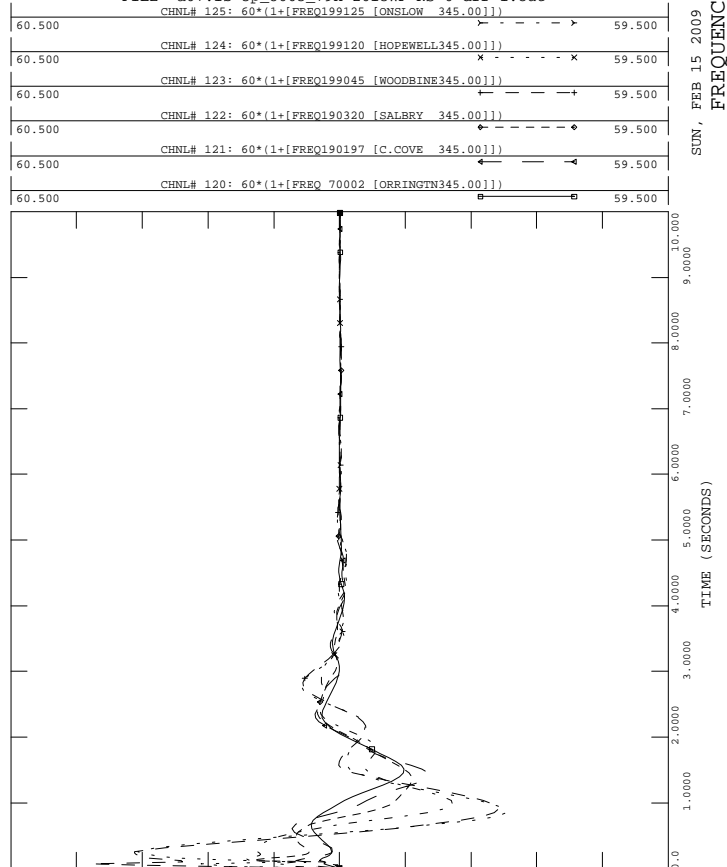



2013 WINTER PEAK STORA MIN
 NS-NB=0; NB-NE=500; CBX=732; ONI=961 ONS=851
 3 PHASE FAULT ON L8003 AT HOPEWELL 345KV
 CLEARED IN 4.5 CYCLES: SPS DROPS LINGAN 2
 FILE: a07.1s-3p_8003_79n-2013WP-NS-0-drr-1.out
 CHNL# 146: [VOLT199280 [TUSKET_A138.00]]

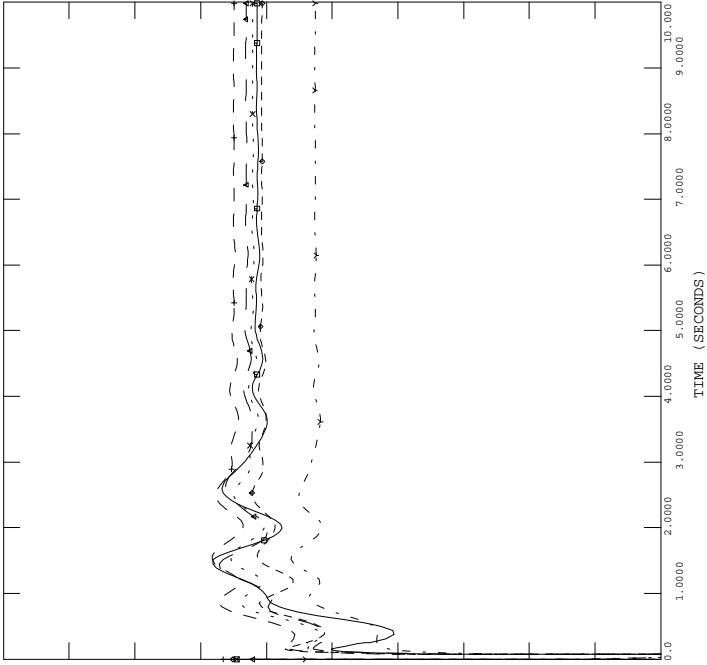
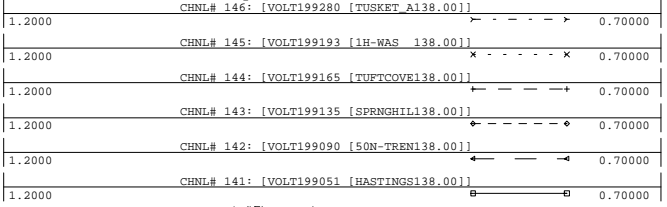

SUN, FEB 15 2009 9:43
 138KV BUS VOLTS



2013 WINTER PEAK STORA MIN
 NS-NB=0; NB-NE=500; CBX=732; ONI=961 ONS=851
 3 PHASE FAULT ON L8003 AT HOPEWELL 345KV
 CLEARED IN 4.5 CYCLES: SPS DROPS LINGAN 2
 FILE: a07.1s-3p_8003_79n-2013WP-NS-0-drr-1.out
 CHNL# 217: [L6513MM]

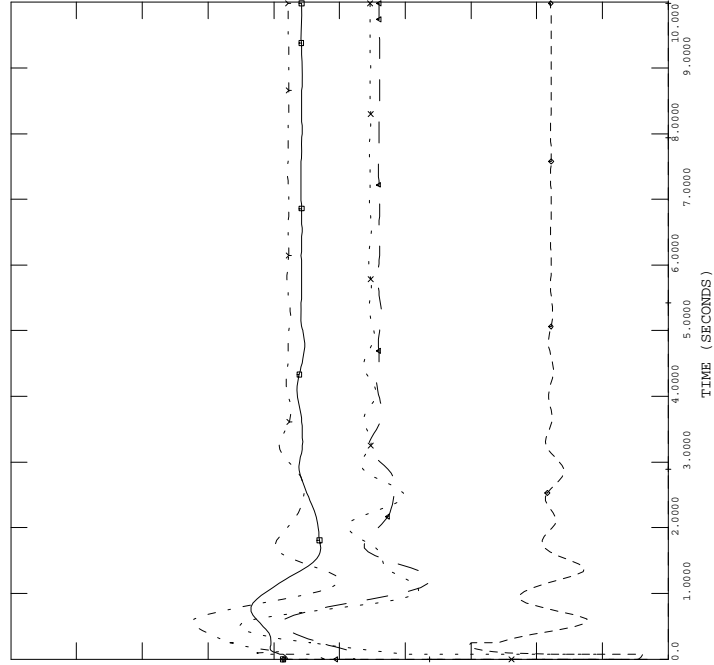
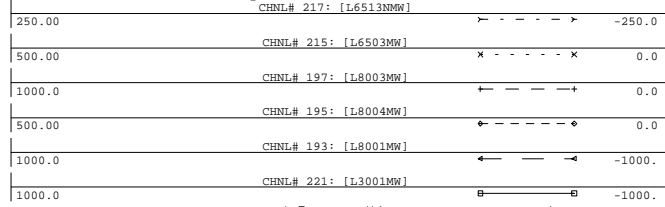

SUN, FEB 15 2009 9:43
 LINE FLOW MW



2013 WINTER PEAK STORA MIN
 NS-NB=0; NB-NE=500; CBX=732; ONI=961 ONS=851
 3 PHASE FAULT ON L8003 AT HOPEWELL 345KV
 CLEARED IN 4.5 CYCLES: SPS DROPS LINGAN 2
 FILE: a07.1s-3p_8003_79n-2013WP-NS-0-drr-1.out
 CHNL# 140: [VOLT199240 [BWATER_A230.00]]

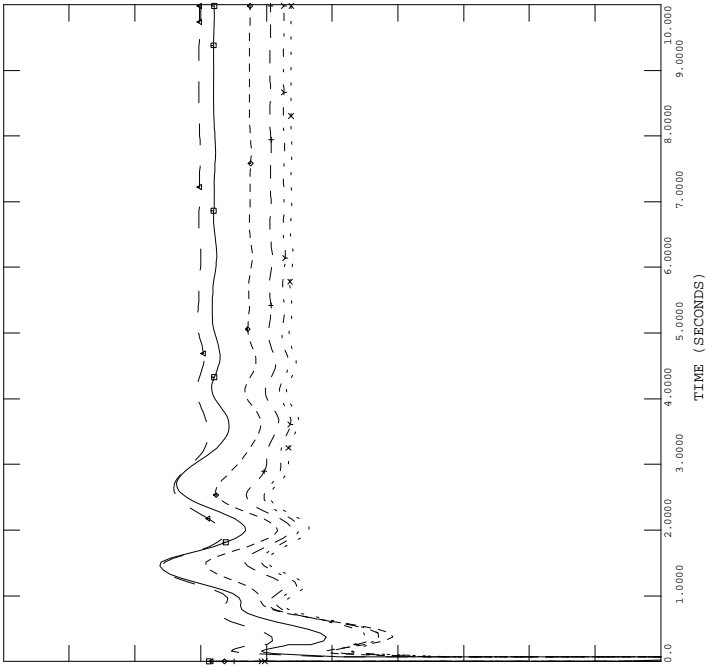
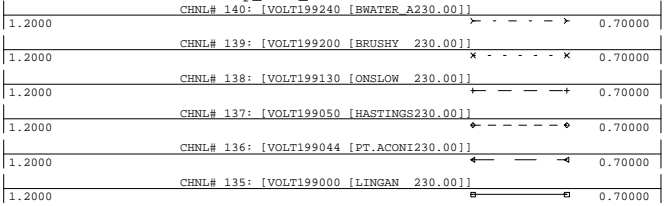

SUN, FEB 15 2009 9:43
 230KV BUS VOLTS



2013 WINTER PEAK STORA MIN
 NS-NB=0; NB-NE=500; CBX=732; ONI=961 ONS=851
 3 PHASE FAULT ON L8003 AT HOPEWELL 345KV
 CLEARED IN 4.5 CYCLES: SPS DROPS LINGAN 2
 FILE: a07.1s-3p_8003_79n-2013WP-NS-0-drr-1.out
 CHNL# 154: [IR141-DIGBYH69.0 VOLTS]

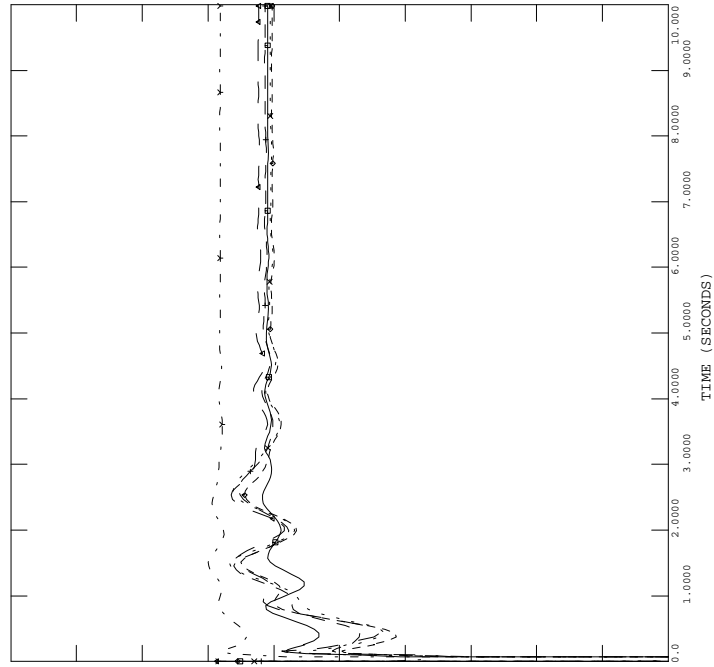
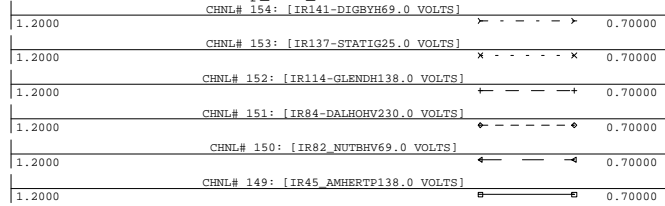

SUN, FEB 15 2009 9:43
 WIND BUS VOLTS



2013 WINTER PEAK STORA MIN
NS-NB=0; NB-NE=500; CBX=732; ONI=961 ONS=851
3 PHASE FAULT LAKESIDE B62, CLEARED IN
4 CYCLES, CLEARING L6008 AND L6016

FILE: a14-3ph_103h_b62-2013WP-NS-0-drr-1.out

CHNL#*S 20,4:	[ANGL199169 [TUFTCV3 14.400] [3]]-[ANGL156661 [DARL G1 22.000] [1]]	-100.0
CHNL#*S 17,4:	[ANGL199086 [TRENTON613.800] [6]]-[ANGL156661 [DARL G1 22.000] [1]]	-100.0
CHNL#*S 16,4:	[ANGL199085 [TRENTN5 13.800] [5]]-[ANGL156661 [DARL G1 22.000] [1]]	-100.0
CHNL#*S 15,4:	[ANGL199061 [TMP1 ST013.800] [1]]-[ANGL156661 [DARL G1 22.000] [1]]	-150.0
CHNL#*S 13,4:	[ANGL199043 [ACONIG1 20.000] [1]]-[ANGL156661 [DARL G1 22.000] [1]]	-100.0
CHNL#*S 11,4:	[ANGL199001 [LINGANI 14.400] [1]]-[ANGL156661 [DARL G1 22.000] [1]]	-100.0

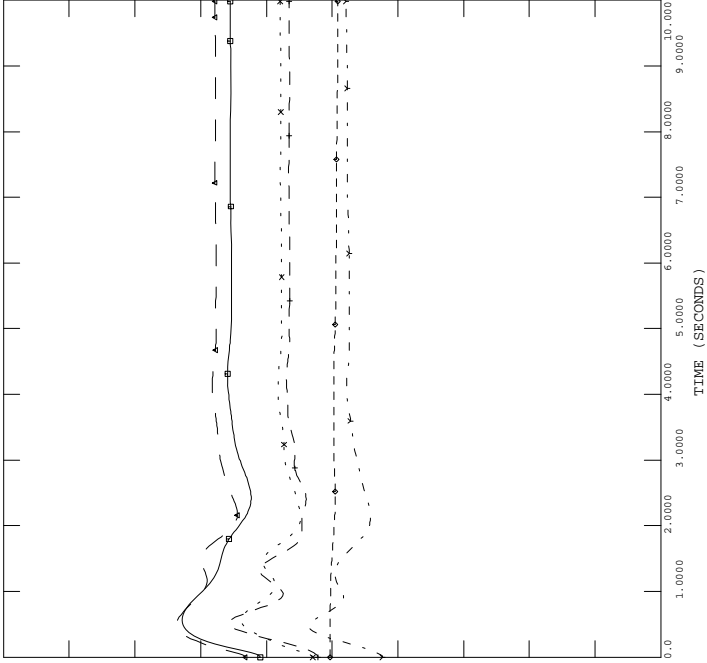

NS ANGLE
SUN, FEB 15 2009 9:43



2013 WINTER PEAK STORA MIN
NS-NB=0; NB-NE=500; CBX=732; ONI=961 ONS=851
3 PHASE FAULT LAKESIDE B62, CLEARED IN
4 CYCLES, CLEARING L6008 AND L6016

FILE: a14-3ph_103h_b62-2013WP-NS-0-drr-1.out

CHNL# 56:	[POWR199086 [TRENTON613.800] [6]]	0.0
CHNL# 55:	[POWR199085 [TRENTN5 13.800] [5]]	0.0
CHNL# 54:	[POWR199061 [TMP1 ST013.800] [1]]	0.0
CHNL# 52:	[POWR199043 [ACONIG1 20.000] [1]]	-1.500
CHNL# 50:	[POWR199001 [LINGANI 14.400] [1]]	0.0

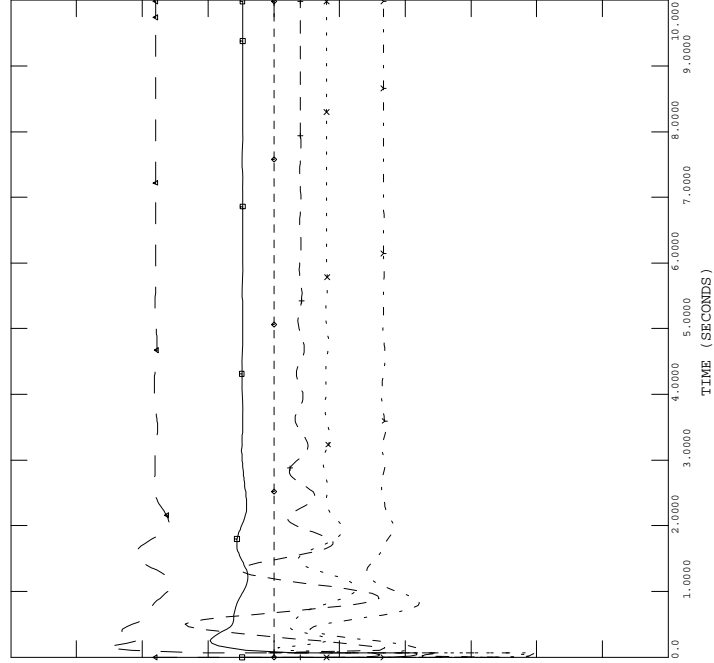

NS MW
SUN, FEB 15 2009 9:43



2013 WINTER PEAK STORA MIN
NS-NB=0; NB-NE=500; CBX=732; ONI=961 ONS=851
3 PHASE FAULT LAKESIDE B62, CLEARED IN
4 CYCLES, CLEARING L6008 AND L6016

FILE: a14-3ph_103h_b62-2013WP-NS-0-drr-1.out

CHNL#*S 10,4:	[ANGL190472 [BLDNG2 19.000] [1]]-[ANGL156661 [DARL G1 22.000] [1]]	-100.0
CHNL#*S 6,4:	[ANGL190456 [LEPRG1 26.000] [1]]-[ANGL156661 [DARL G1 22.000] [1]]	-100.0
CHNL#*S 5,4:	[ANGL190450 [MACTG1 13.800] [1]]-[ANGL156661 [DARL G1 22.000] [1]]	-100.0
CHNL#*S 3,4:	[ANGL126652 [RAV 3 22.000] [1]]-[ANGL156661 [DARL G1 22.000] [1]]	-100.0
CHNL#*S 2,4:	[ANGL101063 [MYST G7 22.000] [1]]-[ANGL156661 [DARL G1 22.000] [1]]	-100.0
CHNL#*S 7,4:	[ANGL190457 [C.CVG1 19.000] [1]]-[ANGL156661 [DARL G1 22.000] [1]]	-100.0

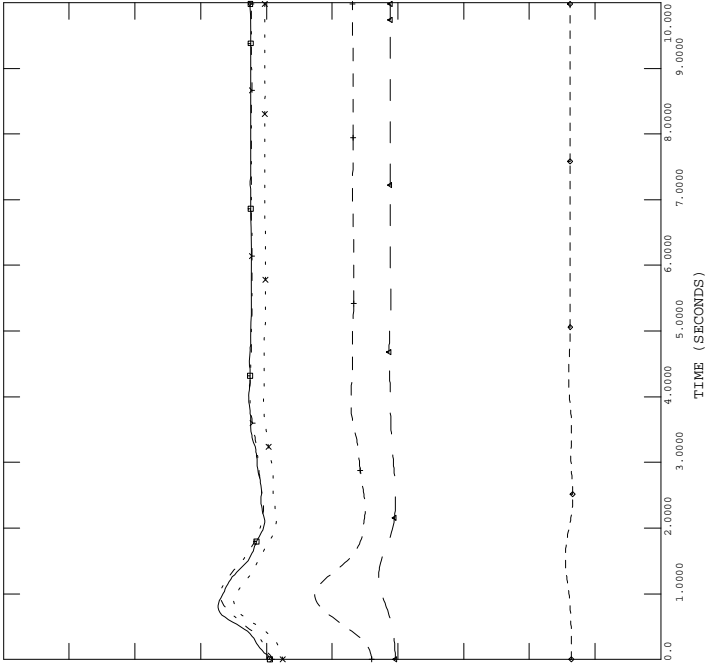

"NE, NY, NB ANGLE"
SUN, FEB 15 2009 9:43



2013 WINTER PEAK STORA MIN
NS-NB=0; NB-NE=500; CBX=732; ONI=961 ONS=851
3 PHASE FAULT LAKESIDE B62, CLEARED IN
4 CYCLES, CLEARING L6008 AND L6016

FILE: a14-3ph_103h_b62-2013WP-NS-0-drr-1.out

CHNL# 49:	[POWER190472 [BLDNG2 19.000] [1]]	2.0000
CHNL# 45:	[POWER190456 [LEPRG1 26.000] [1]]	4.0000
CHNL# 44:	[POWER190450 [MACTG1 13.800] [1]]	0.0
CHNL# 42:	[POWER126652 [RAV 3 22.000] [1]]	0.0
CHNL# 41:	[POWER101063 [MYST G7 22.000] [1]]	1.0000
CHNL# 46:	[POWER190457 [C.CVG1 19.000] [1]]	0.0

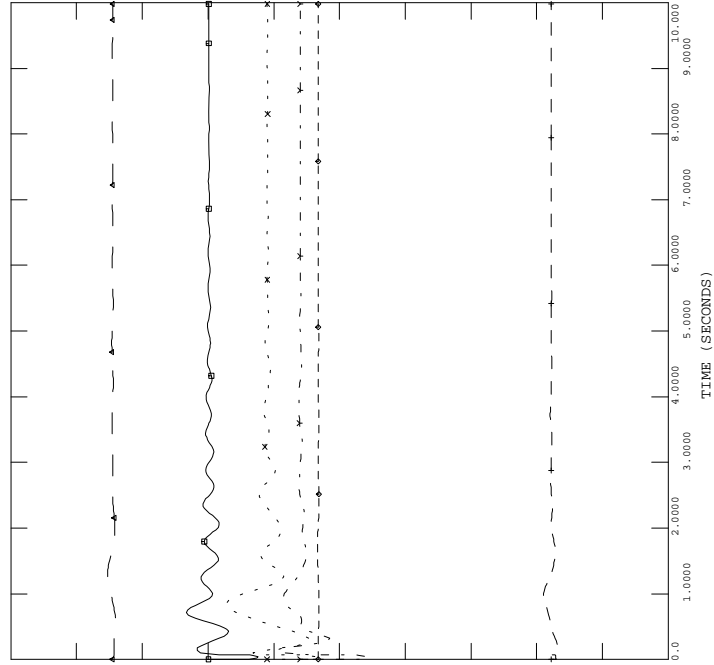

"NE, NY, NB POWER"
SUN, FEB 15 2009 9:43



2013 WINTER PEAK STORA MIN
 NS-NB=0; NB-NE=500; CBX=732; ONI=961 ONS=851
 3 PHASE FAULT LAKESIDE B62, CLEARED IN
 4 CYCLES, CLEARING L6008 AND L6016

FILE: a14-3ph_103h_b62-2013WP-NS-0-drr-1.out
 CHNL# 119: [VARS IR141-DIGBY]

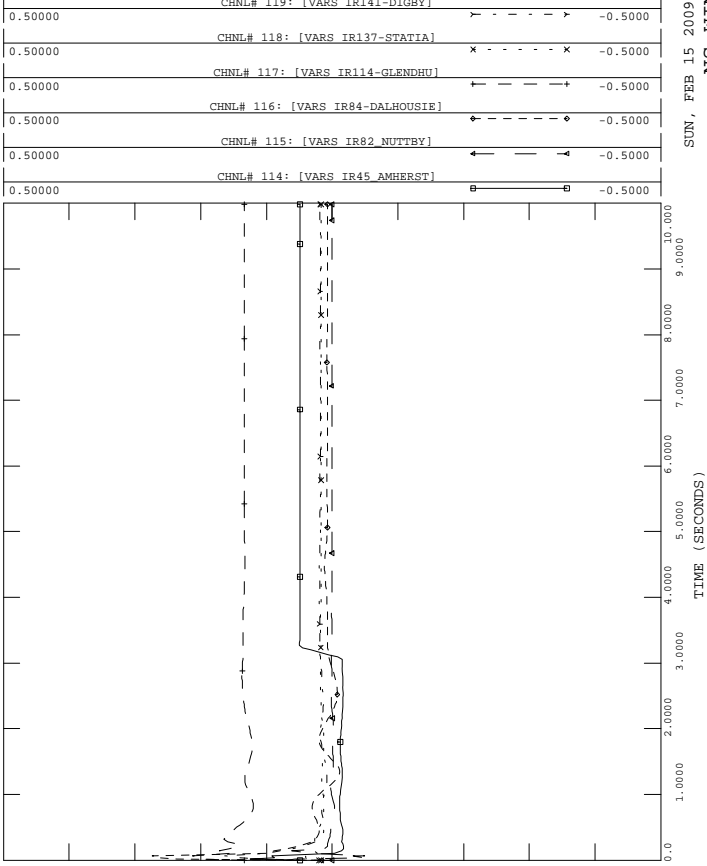

SUN, FEB 15 2009 9:43
 NS WIND MV



2013 WINTER PEAK STORA MIN
 NS-NB=0; NB-NE=500; CBX=732; ONI=961 ONS=851
 3 PHASE FAULT LAKESIDE B62, CLEARED IN
 4 CYCLES, CLEARING L6008 AND L6016

FILE: a14-3ph_103h_b62-2013WP-NS-0-drr-1.out
 CHNL# 133: [VOLT199125 [ONSLow 345.00]]

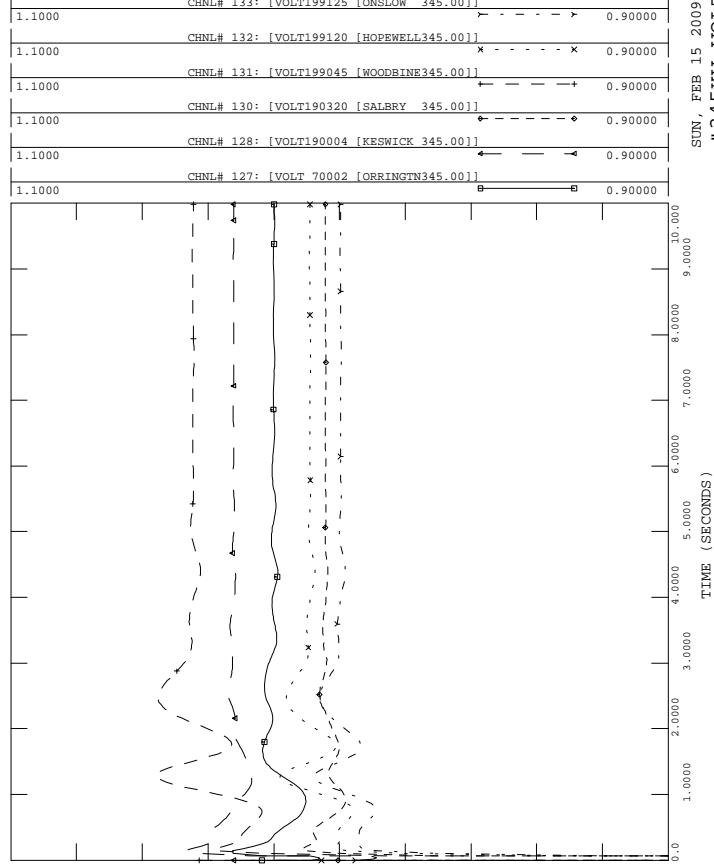

SUN, FEB 15 2009 9:43
 "345KV VOLTAGE"



2013 WINTER PEAK STORA MIN
 NS-NB=0; NB-NE=500; CBX=732; ONI=961 ONS=851
 3 PHASE FAULT LAKESIDE B62, CLEARED IN
 4 CYCLES, CLEARING L6008 AND L6016

FILE: a14-3ph_103h_b62-2013WP-NS-0-drr-1.out
 CHNL# 79: [POWER IR141-DIGBY]

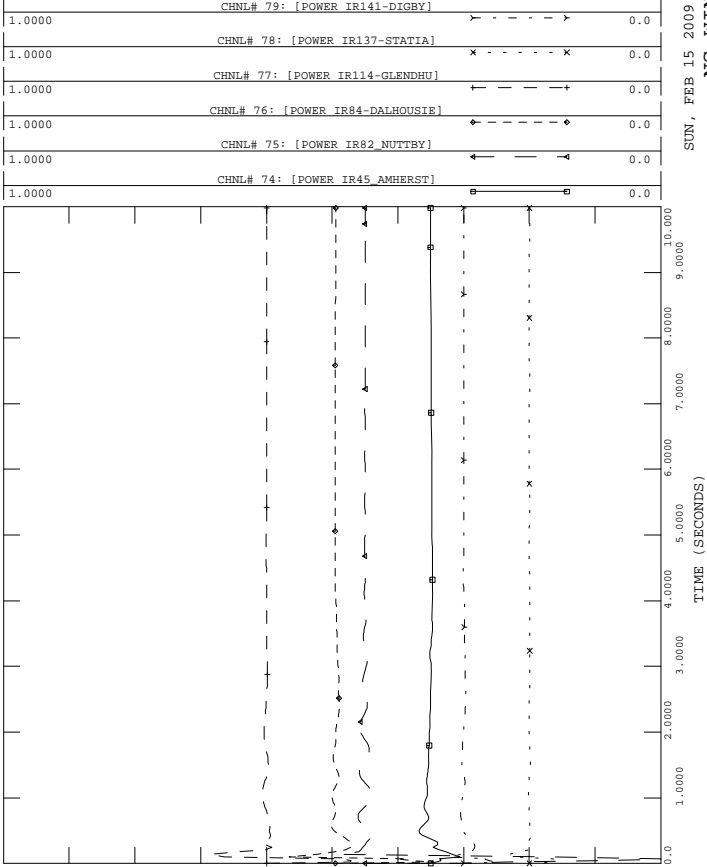

SUN, FEB 15 2009 9:43
 NS WIND MW



2013 WINTER PEAK STORA MIN
 NS-NB=0; NB-NE=500; CBX=732; ONI=961 ONS=851
 3 PHASE FAULT LAKESIDE B62, CLEARED IN
 4 CYCLES, CLEARING L6008 AND L6016

FILE: a14-3ph_103h_b62-2013WP-NS-0-drr-1.out
 CHNL# 125: 60*(1+[FREQ199125 [ONSLow 345.00]])

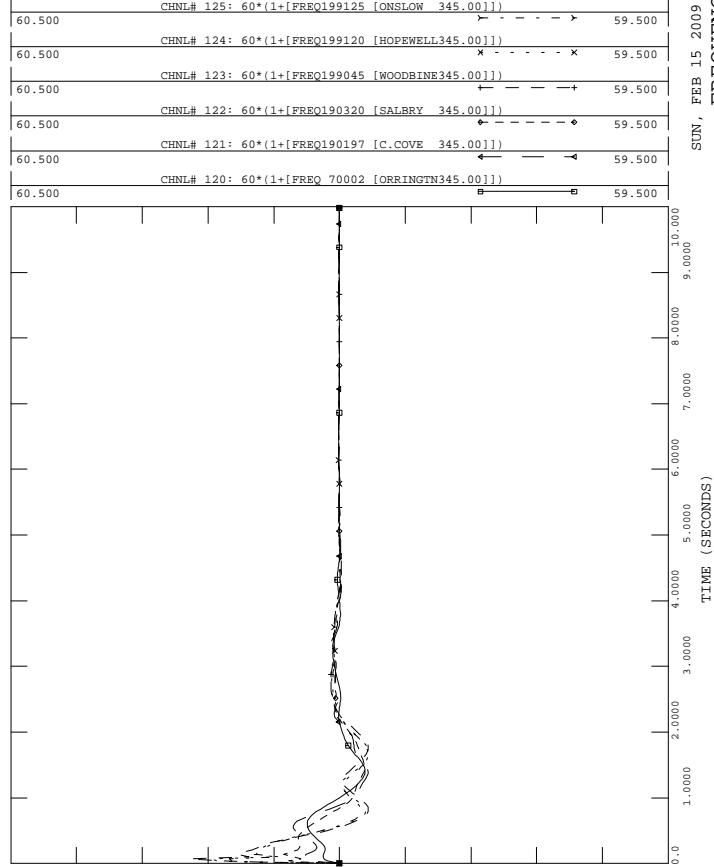

SUN, FEB 15 2009 9:43
 FREQUENCY HZ



2013 WINTER PEAK STORA MIN
 NS-NB=0; NB-NE=500; CBX=732; ONI=961 ONS=851
 3 PHASE FAULT LAKESIDE B62, CLEARED IN
 4 CYCLES, CLEARING L6008 AND L6016

FILE: a14-3ph_103h_b62-2013WP-NS-0-drr-1.out
 CHNL# 146: [VOLT199280 [TUSKET_A138.00]]

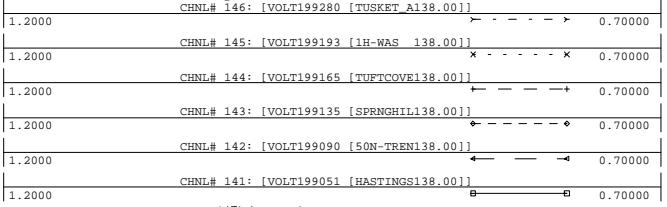

SUN, FEB 15 2009 9:43
 138KV BUS VOLTS



2013 WINTER PEAK STORA MIN
 NS-NB=0; NB-NE=500; CBX=732; ONI=961 ONS=851
 3 PHASE FAULT LAKESIDE B62, CLEARED IN
 4 CYCLES, CLEARING L6008 AND L6016

FILE: a14-3ph_103h_b62-2013WP-NS-0-drr-1.out
 CHNL# 217: [L6513NMW]

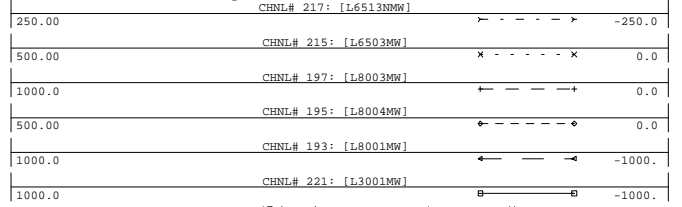

SUN, FEB 15 2009 9:43
 LINE FLOW MW



2013 WINTER PEAK STORA MIN
 NS-NB=0; NB-NE=500; CBX=732; ONI=961 ONS=851
 3 PHASE FAULT LAKESIDE B62, CLEARED IN
 4 CYCLES, CLEARING L6008 AND L6016

FILE: a14-3ph_103h_b62-2013WP-NS-0-drr-1.out
 CHNL# 140: [VOLT199240 [BWATER_A230.00]]

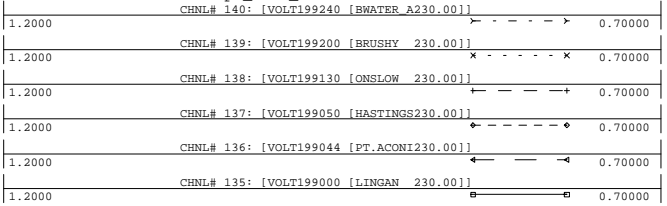

SUN, FEB 15 2009 9:43
 230KV BUS VOLTS



2013 WINTER PEAK STORA MIN
 NS-NB=0; NB-NE=500; CBX=732; ONI=961 ONS=851
 3 PHASE FAULT LAKESIDE B62, CLEARED IN
 4 CYCLES, CLEARING L6008 AND L6016

FILE: a14-3ph_103h_b62-2013WP-NS-0-drr-1.out
 CHNL# 154: [IR141-DIGBYH69.0 VOLTS]

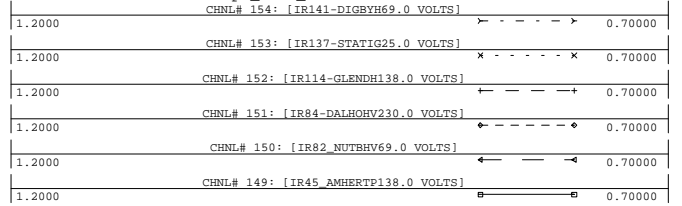

SUN, FEB 15 2009 9:43
 WIND BUS VOLTS

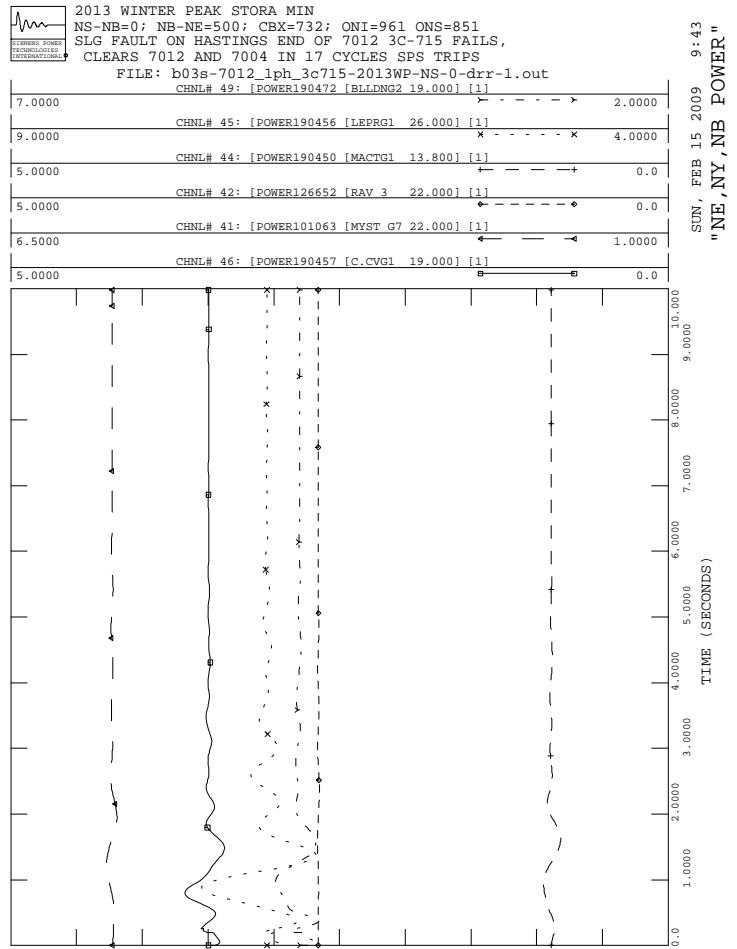
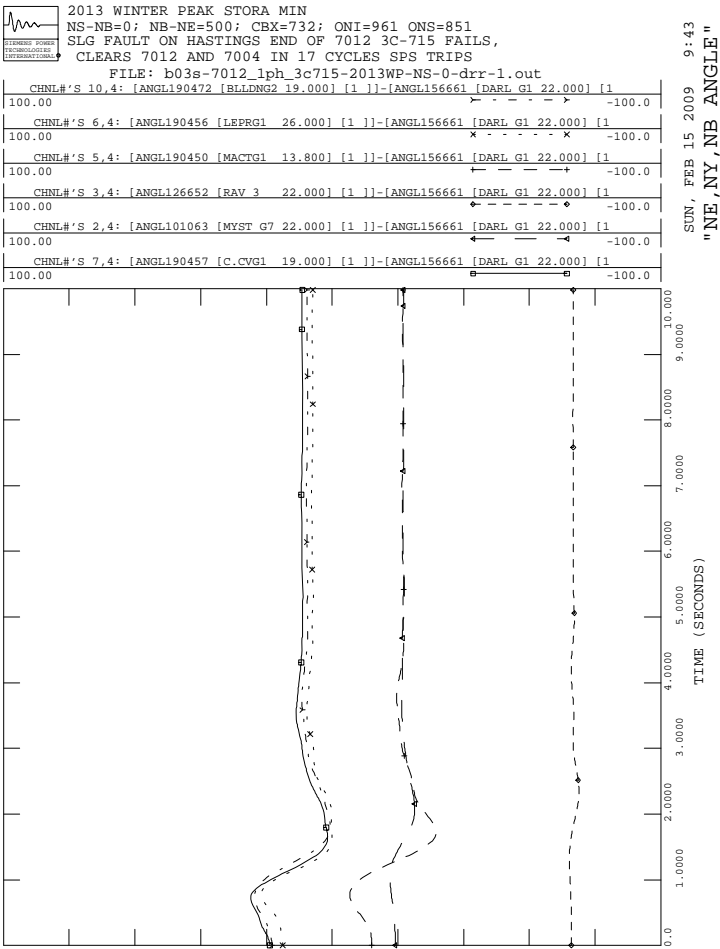
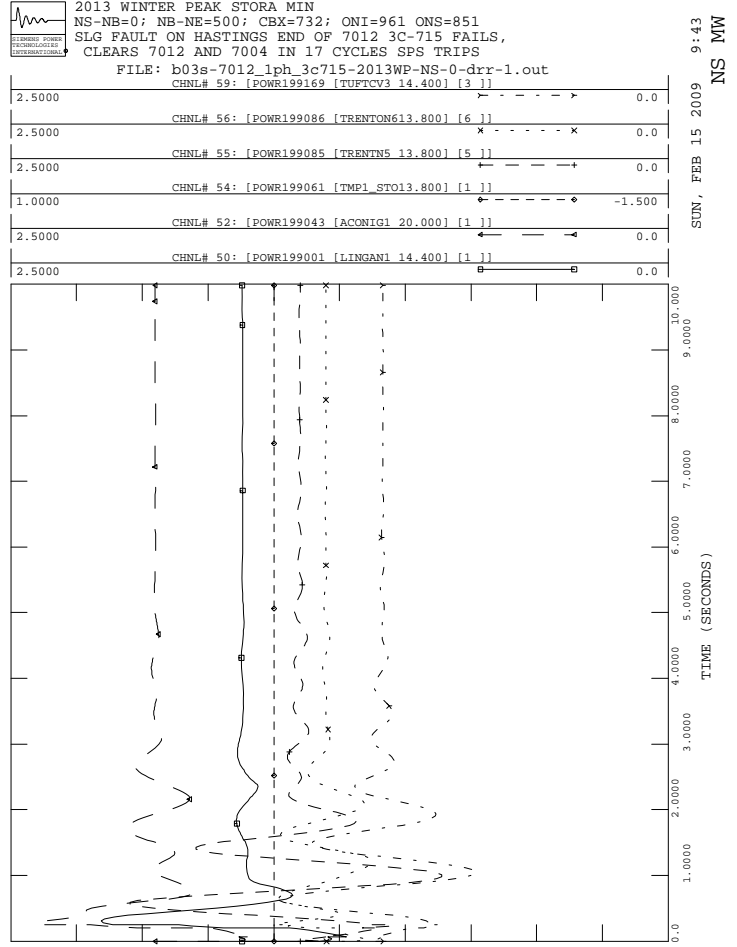
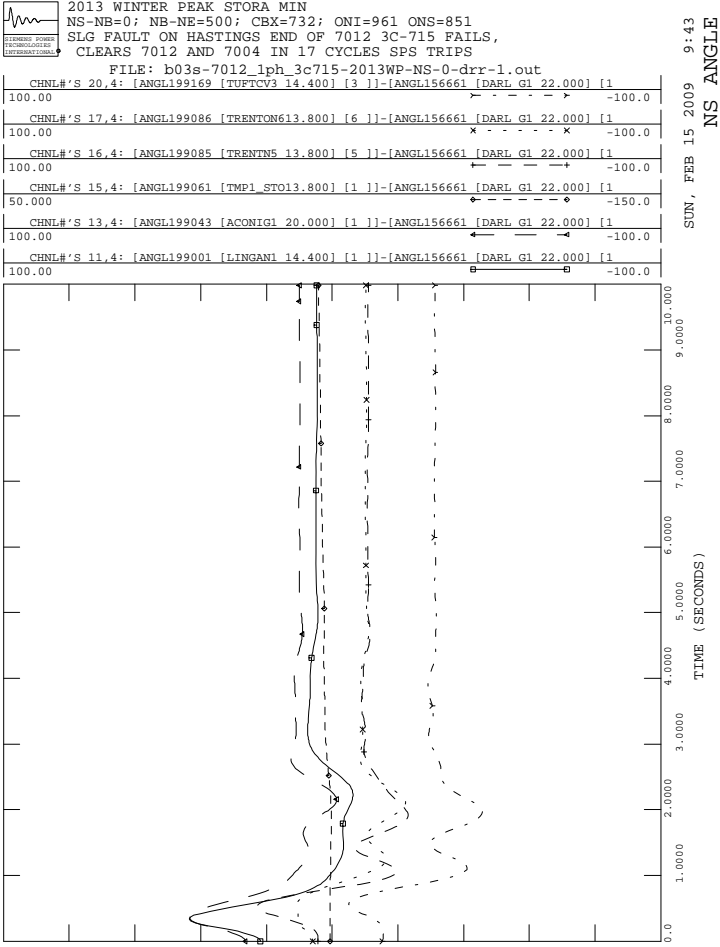



2013 WINTER PEAK STORA MIN
 NS-NB=0; NB-NE=500; CBX=732; ONI=961 ONS=851
 SLG FAULT ON HASTINGS END OF 7012 3C-715 FAILS,
 CLEARS 7012 AND 7004 IN 17 CYCLES SPS TRIPS
 FILE: b03s-7012_lph_3c715-2013WP-NS-0-drr-1.out
 CHNL# 119: [VARS IR141-DIGBY]

SUN, FEB 15 2009 9:43
 NS WIND MV

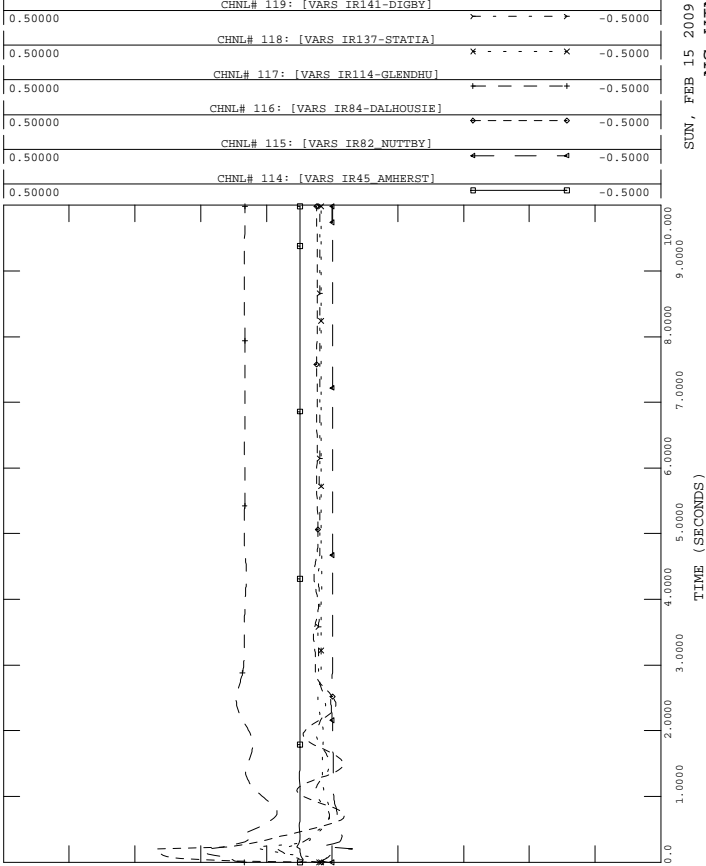

2013 WINTER PEAK STORA MIN
 NS-NB=0; NB-NE=500; CBX=732; ONI=961 ONS=851
 SLG FAULT ON HASTINGS END OF 7012 3C-715 FAILS,
 CLEARS 7012 AND 7004 IN 17 CYCLES SPS TRIPS
 FILE: b03s-7012_lph_3c715-2013WP-NS-0-drr-1.out
 CHNL# 133: [VOLT199125 [ONSLow 345.00]]

SUN, FEB 15 2009 9:43
 "345KV VOLTAGE"

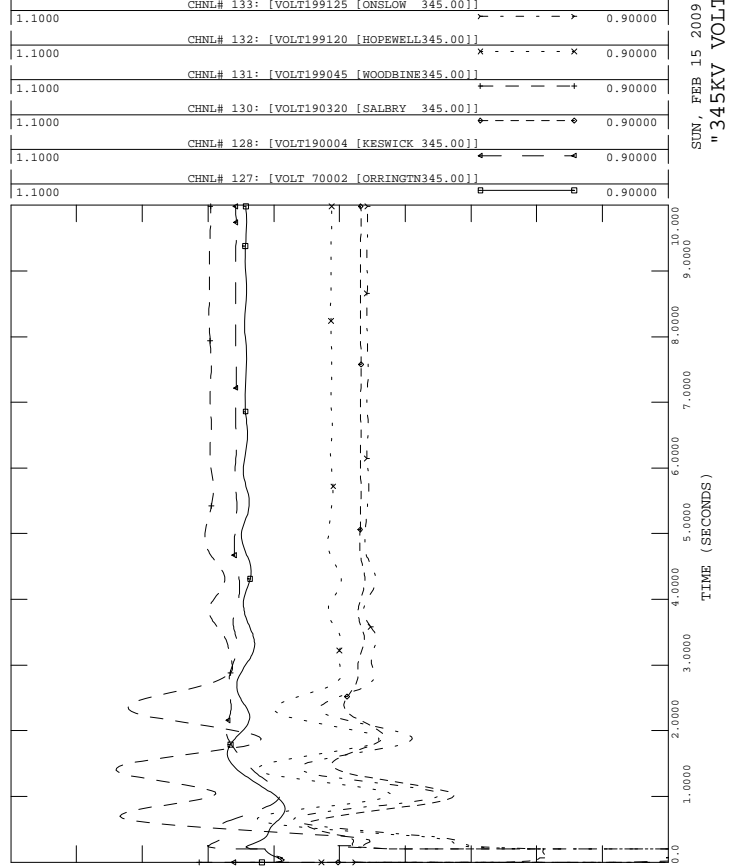

2013 WINTER PEAK STORA MIN
 NS-NB=0; NB-NE=500; CBX=732; ONI=961 ONS=851
 SLG FAULT ON HASTINGS END OF 7012 3C-715 FAILS,
 CLEARS 7012 AND 7004 IN 17 CYCLES SPS TRIPS
 FILE: b03s-7012_lph_3c715-2013WP-NS-0-drr-1.out
 CHNL# 79: [POWER IR141-DIGBY]

SUN, FEB 15 2009 9:43
 NS WIND MW

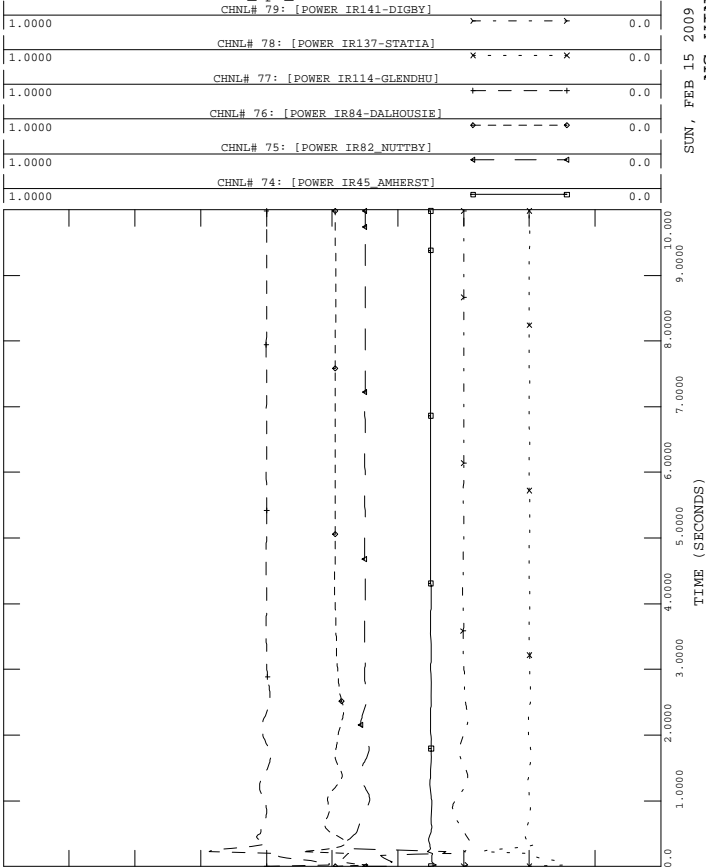

2013 WINTER PEAK STORA MIN
 NS-NB=0; NB-NE=500; CBX=732; ONI=961 ONS=851
 SLG FAULT ON HASTINGS END OF 7012 3C-715 FAILS,
 CLEARS 7012 AND 7004 IN 17 CYCLES SPS TRIPS
 FILE: b03s-7012_lph_3c715-2013WP-NS-0-drr-1.out
 CHNL# 125: 60*(1+[FREQ199125 [ONSLow 345.00]])

SUN, FEB 15 2009 9:43
 FREQUENCY HZ

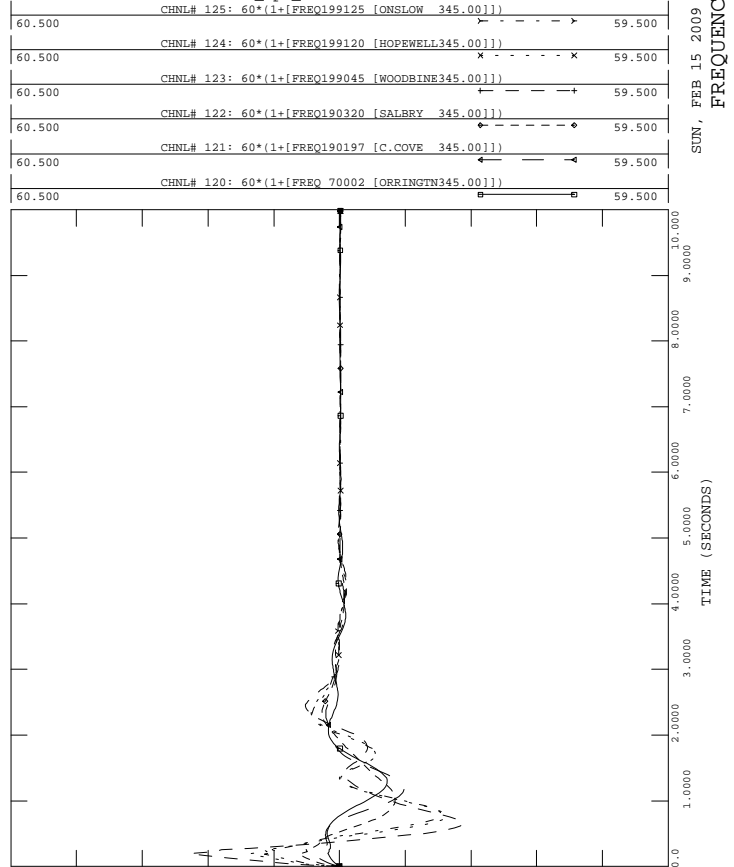



2013 WINTER PEAK STORA MIN
 NS-NB=0; NB-NE=500; CBX=732; ONI=961 ONS=851
 SLG FAULT ON HASTINGS END OF 7012 3C-715 FAILS,
 CLEARS 7012 AND 7004 IN 17 CYCLES SPS TRIPS
 FILE: b03s-7012_lph_3c715-2013WP-NS-0-drr-1.out
 CHNL# 146: [VOLT199280 [TUSKET_A138.00]]

1.2000	CHNL# 145: [VOLT199193 [1H-WAS 138.00]]	0.70000
1.2000	CHNL# 144: [VOLT199165 [TUFTCOVER138.00]]	0.70000
1.2000	CHNL# 143: [VOLT199135 [SPRNGHIL138.00]]	0.70000
1.2000	CHNL# 142: [VOLT199090 [50N-TREN138.00]]	0.70000
1.2000	CHNL# 141: [VOLT199051 [HASTINGS138.00]]	0.70000

SUN, FEB 15 2009 9:43
 138KV BUS VOLTS

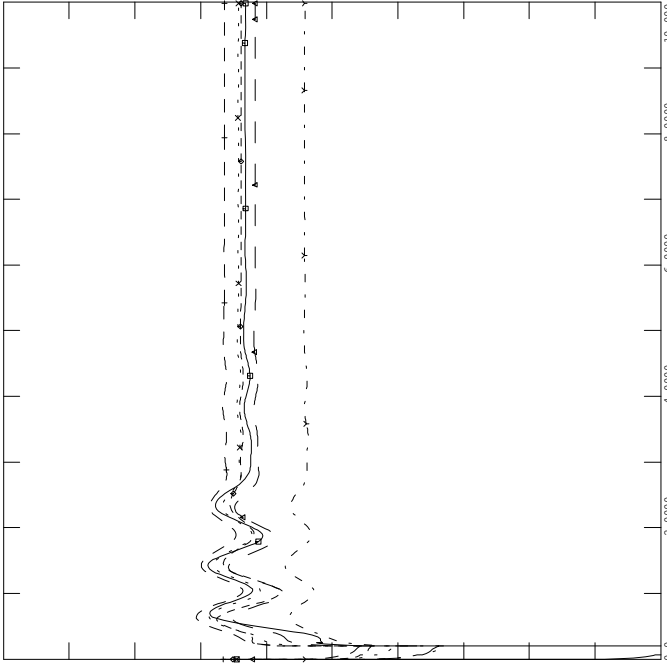

2013 WINTER PEAK STORA MIN
 NS-NB=0; NB-NE=500; CBX=732; ONI=961 ONS=851
 SLG FAULT ON HASTINGS END OF 7012 3C-715 FAILS,
 CLEARS 7012 AND 7004 IN 17 CYCLES SPS TRIPS
 FILE: b03s-7012_lph_3c715-2013WP-NS-0-drr-1.out
 CHNL# 217: [L6513MMW]

250.00	CHNL# 215: [L6503MMW]	-250.0
500.00	CHNL# 197: [L8003MMW]	0.0
1000.0	CHNL# 195: [L8004MMW]	0.0
500.00	CHNL# 193: [L8001MMW]	0.0
1000.0	CHNL# 221: [L3001MMW]	-1000.0
1000.0		-1000.0

SUN, FEB 15 2009 9:43
 LINE FLOW MW

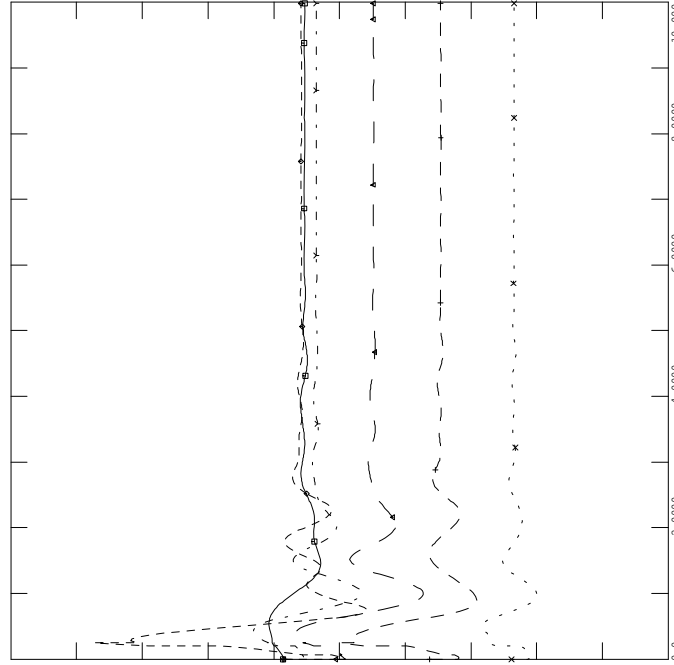

2013 WINTER PEAK STORA MIN
 NS-NB=0; NB-NE=500; CBX=732; ONI=961 ONS=851
 SLG FAULT ON HASTINGS END OF 7012 3C-715 FAILS,
 CLEARS 7012 AND 7004 IN 17 CYCLES SPS TRIPS
 FILE: b03s-7012_lph_3c715-2013WP-NS-0-drr-1.out
 CHNL# 140: [VOLT199240 [BRATER_A230.00]]

1.2000	CHNL# 139: [VOLT199200 [BRUSHY 230.00]]	0.70000
1.2000	CHNL# 138: [VOLT199130 [ONSLow 230.00]]	0.70000
1.2000	CHNL# 137: [VOLT199050 [HASTINGS230.00]]	0.70000
1.2000	CHNL# 136: [VOLT199044 [PT.ACONI230.00]]	0.70000
1.2000	CHNL# 135: [VOLT199000 [LINGAN 230.00]]	0.70000

SUN, FEB 15 2009 9:43
 230KV BUS VOLTS

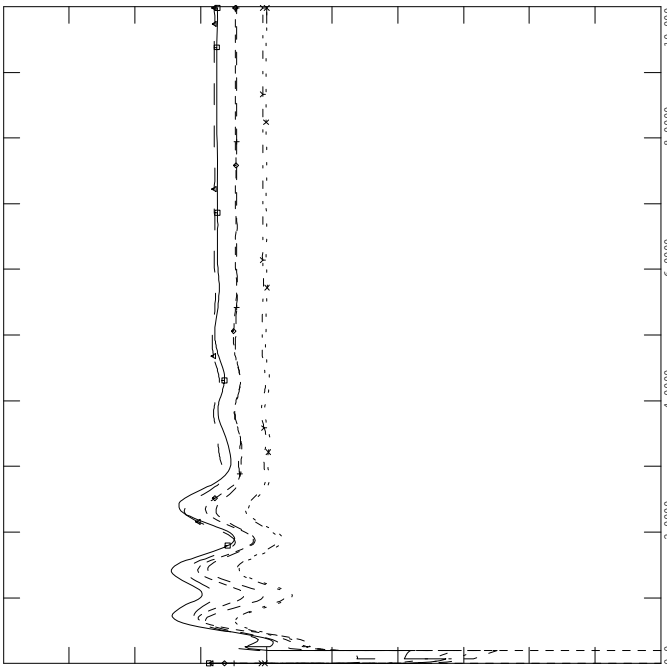

2013 WINTER PEAK STORA MIN
 NS-NB=0; NB-NE=500; CBX=732; ONI=961 ONS=851
 SLG FAULT ON HASTINGS END OF 7012 3C-715 FAILS,
 CLEARS 7012 AND 7004 IN 17 CYCLES SPS TRIPS
 FILE: b03s-7012_lph_3c715-2013WP-NS-0-drr-1.out
 CHNL# 154: [IR141-DIGBYH69.0 VOLTS]

1.2000	CHNL# 153: [IR137-STATIG25.0 VOLTS]	0.70000
1.2000	CHNL# 152: [IR114-GLENDH138.0 VOLTS]	0.70000
1.2000	CHNL# 151: [IR84-DALHOHV230.0 VOLTS]	0.70000
1.2000	CHNL# 150: [IR82-NUTBHV69.0 VOLTS]	0.70000
1.2000	CHNL# 149: [IR45-AMHERTP138.0 VOLTS]	0.70000

SUN, FEB 15 2009 9:43
 WIND BUS VOLTS

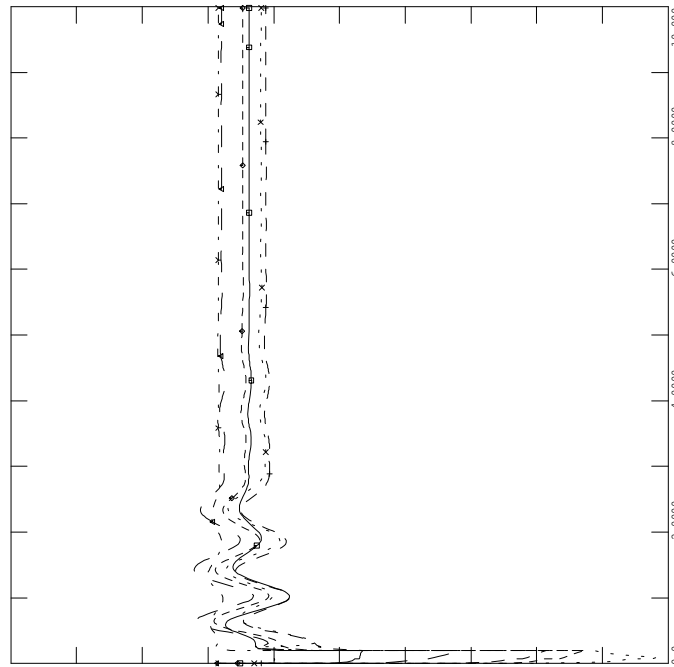

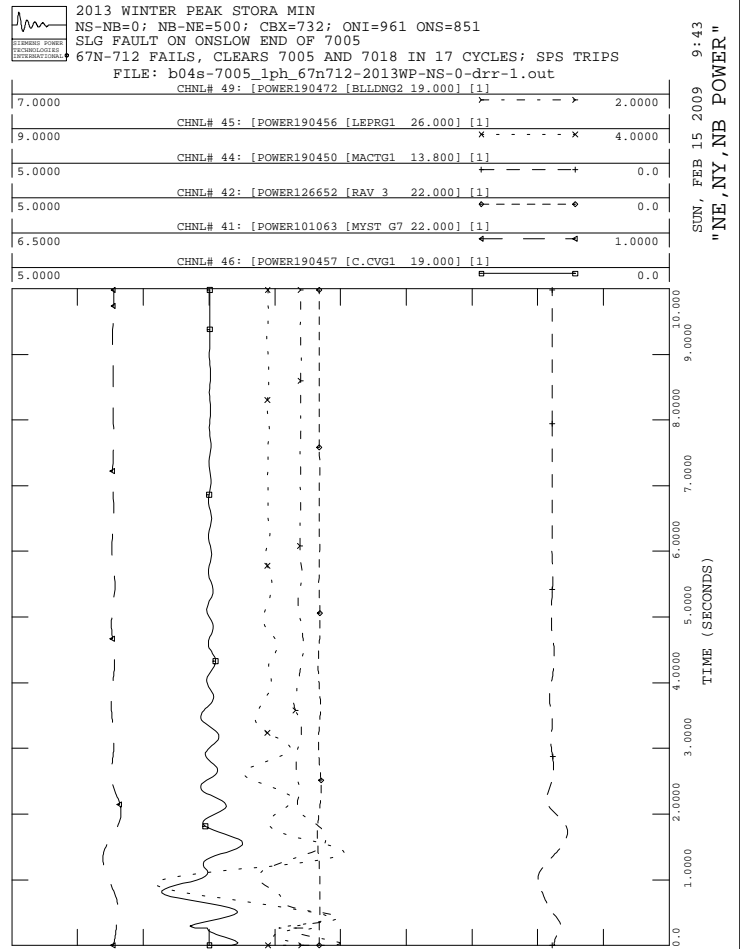
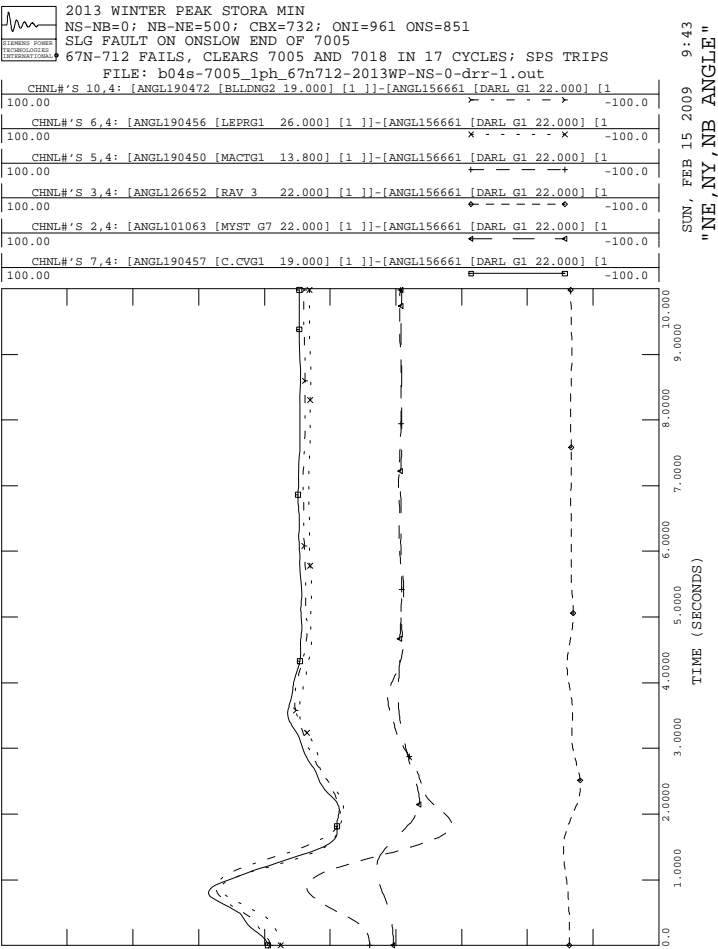
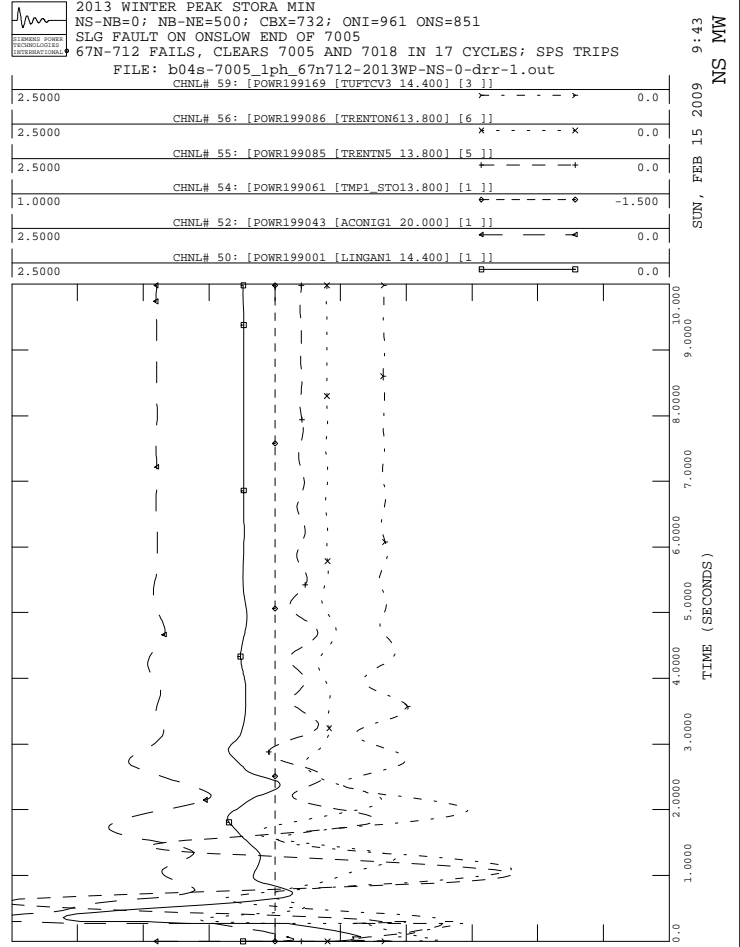
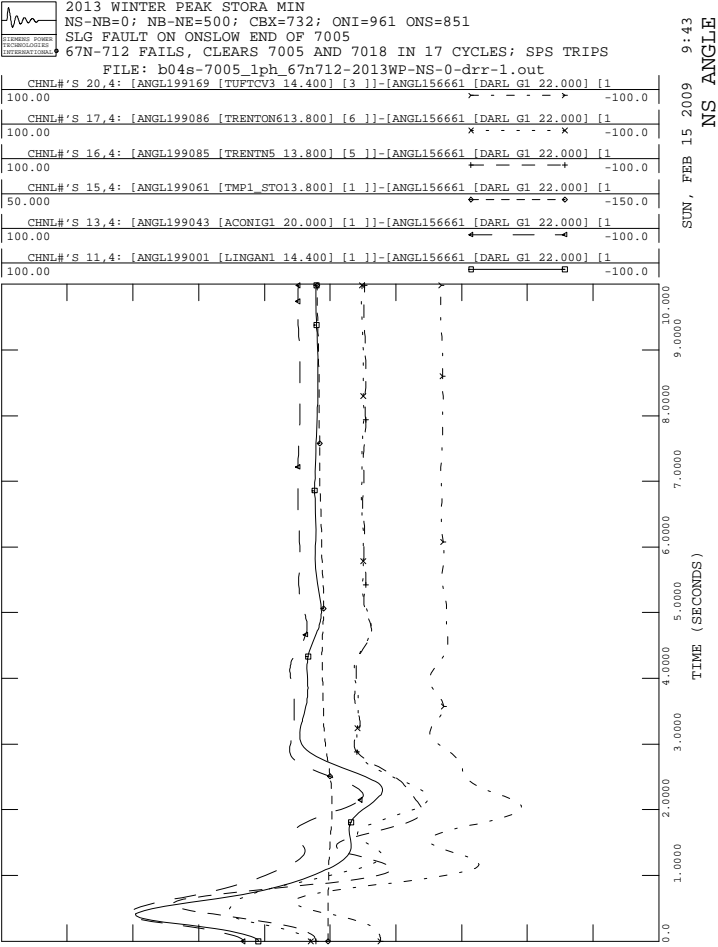



2013 WINTER PEAK STORA MIN
NS-NB=0; NB-NE=500; CBX=732; ONI=961 ONS=851
SLG FAULT ON ONSLOW END OF 7005
67N-712 FAILS, CLEARS 7005 AND 7018 IN 17 CYCLES; SPS TRIPS
FILE: b04s-7005_lph_67n712-2013WP-NS-0-drr-1.out
CHNL# 119: [VARS IR141-DIGBY]

SUN, FEB 15 2009 9:43
NS WIND MV

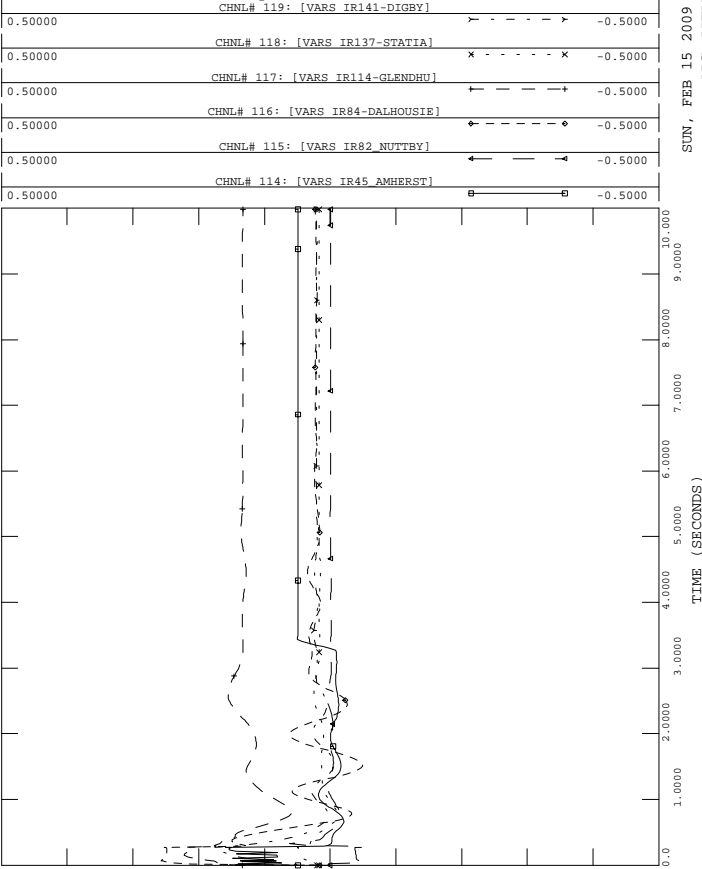

2013 WINTER PEAK STORA MIN
NS-NB=0; NB-NE=500; CBX=732; ONI=961 ONS=851
SLG FAULT ON ONSLOW END OF 7005
67N-712 FAILS, CLEARS 7005 AND 7018 IN 17 CYCLES; SPS TRIPS
FILE: b04s-7005_lph_67n712-2013WP-NS-0-drr-1.out
CHNL# 133: [VOLT199125 [ONSLow 345.00]]

SUN, FEB 15 2009 9:43
" 345KV VOLTAGE "

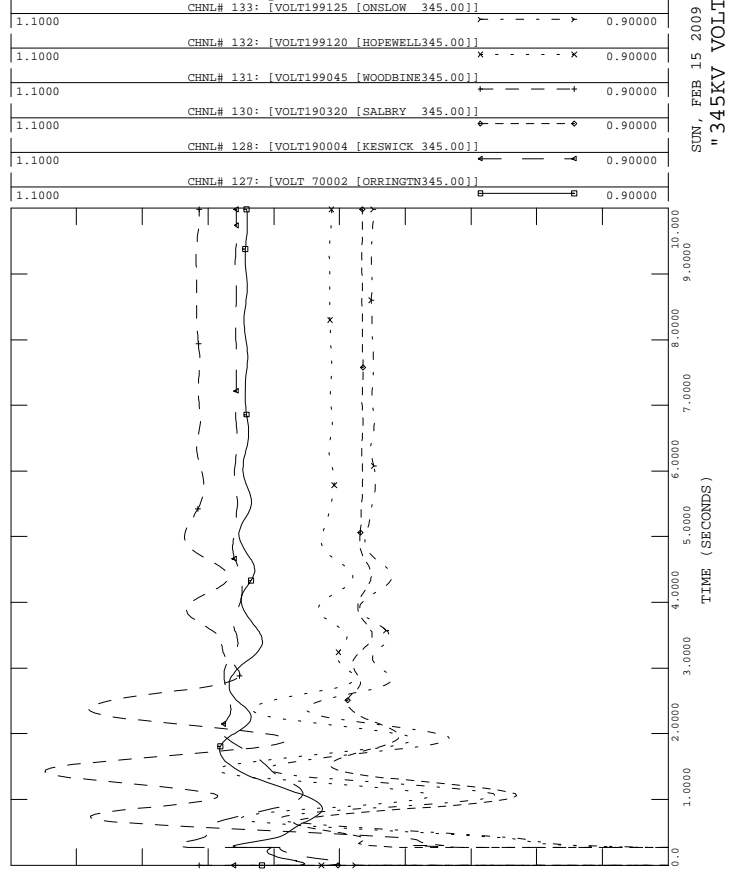

2013 WINTER PEAK STORA MIN
NS-NB=0; NB-NE=500; CBX=732; ONI=961 ONS=851
SLG FAULT ON ONSLOW END OF 7005
67N-712 FAILS, CLEARS 7005 AND 7018 IN 17 CYCLES; SPS TRIPS
FILE: b04s-7005_lph_67n712-2013WP-NS-0-drr-1.out
CHNL# 79: [POWER IR141-DIGBY]

SUN, FEB 15 2009 9:43
NS WIND MW

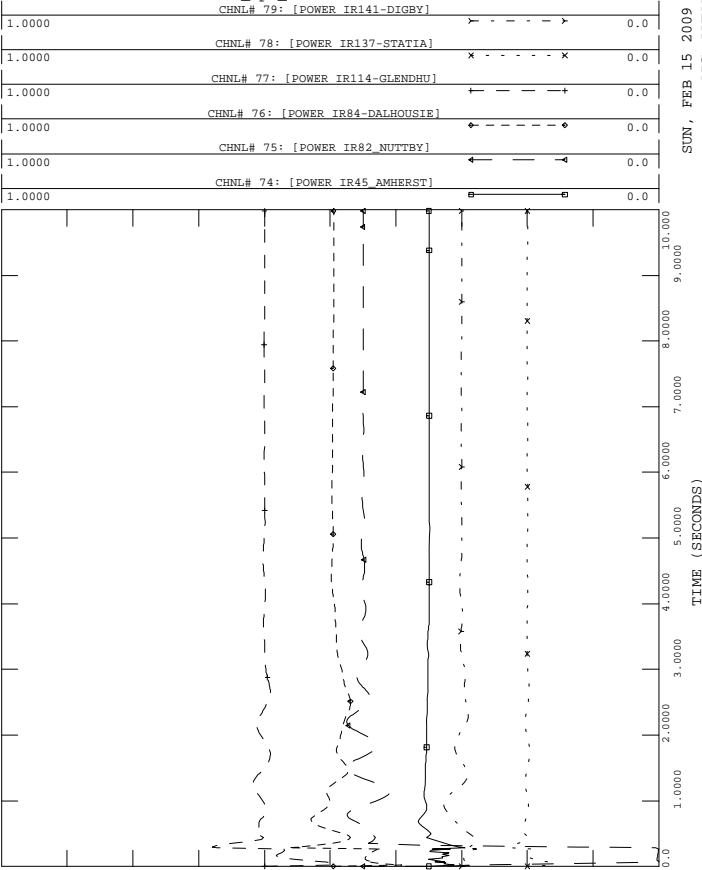

2013 WINTER PEAK STORA MIN
NS-NB=0; NB-NE=500; CBX=732; ONI=961 ONS=851
SLG FAULT ON ONSLOW END OF 7005
67N-712 FAILS, CLEARS 7005 AND 7018 IN 17 CYCLES; SPS TRIPS
FILE: b04s-7005_lph_67n712-2013WP-NS-0-drr-1.out
CHNL# 125: 60*(1+[FREQ199125 [ONSLow 345.00]])

SUN, FEB 15 2009 9:43
FREQUENCY HZ

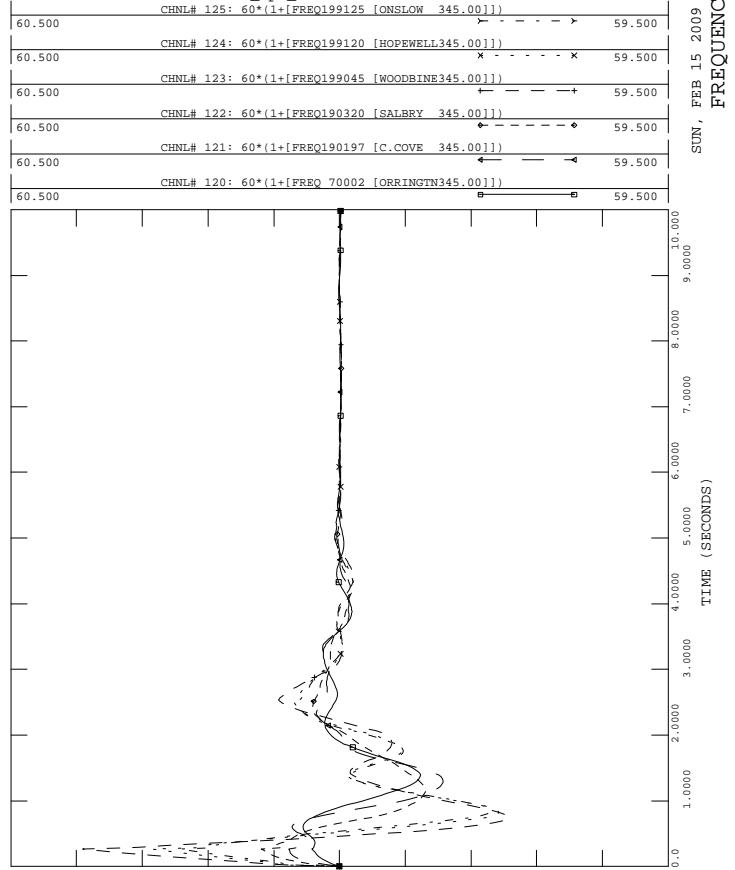



2013 WINTER PEAK STORA MIN
 NS-NB=0; NB-NE=500; CBX=732; ONI=961 ONS=851
 SLG FAULT ON ONSLOW END OF 7005
 67N-712 FAILS, CLEARS 7005 AND 7018 IN 17 CYCLES; SPS TRIPS
 FILE: b04s-7005_lph_67n712-2013WP-NS-0-drr-1.out
 CHNL# 146: [VOLT199280 [TUSKET_A138.00]]

SUN, FEB 15 2009 9:43
 138KV BUS VOLTS

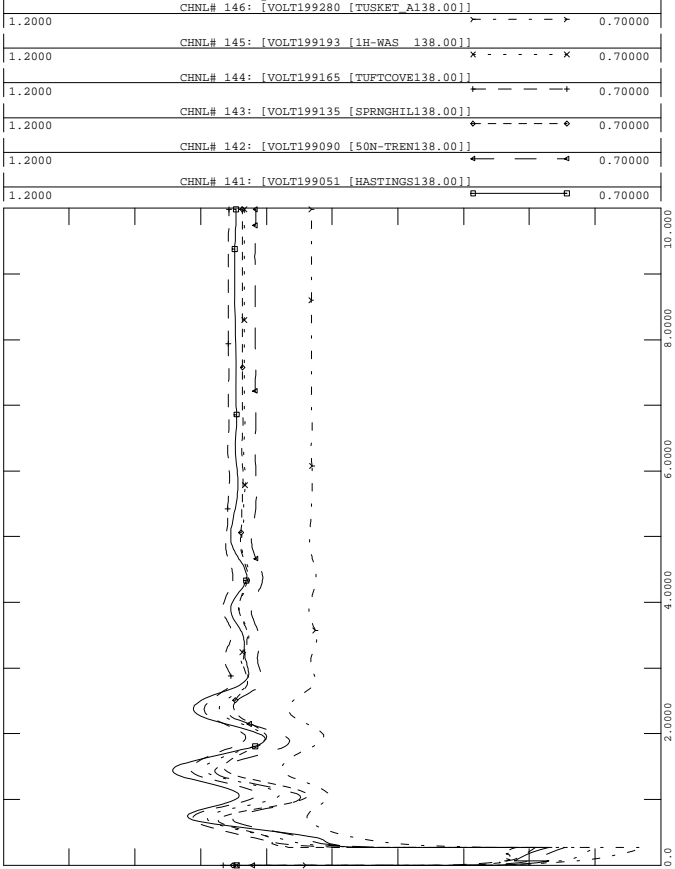

2013 WINTER PEAK STORA MIN
 NS-NB=0; NB-NE=500; CBX=732; ONI=961 ONS=851
 SLG FAULT ON ONSLOW END OF 7005
 67N-712 FAILS, CLEARS 7005 AND 7018 IN 17 CYCLES; SPS TRIPS
 FILE: b04s-7005_lph_67n712-2013WP-NS-0-drr-1.out
 CHNL# 217: [L6513MMW]

SUN, FEB 15 2009 9:43
 LINE FLOW MW

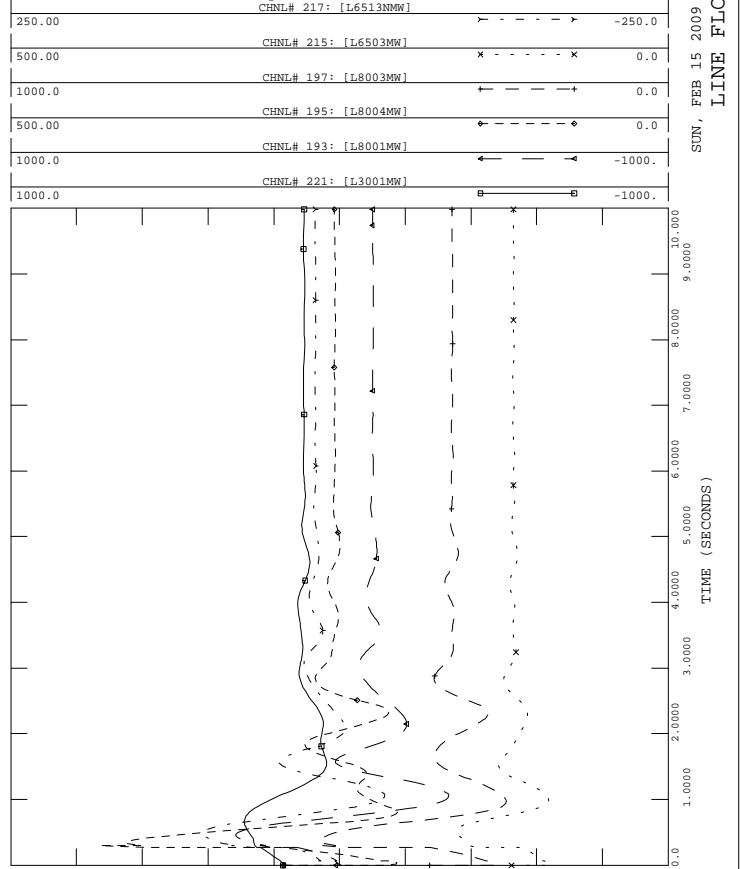

2013 WINTER PEAK STORA MIN
 NS-NB=0; NB-NE=500; CBX=732; ONI=961 ONS=851
 SLG FAULT ON ONSLOW END OF 7005
 67N-712 FAILS, CLEARS 7005 AND 7018 IN 17 CYCLES; SPS TRIPS
 FILE: b04s-7005_lph_67n712-2013WP-NS-0-drr-1.out
 CHNL# 140: [VOLT199240 [BRATER_A230.00]]

SUN, FEB 15 2009 9:43
 230KV BUS VOLTS

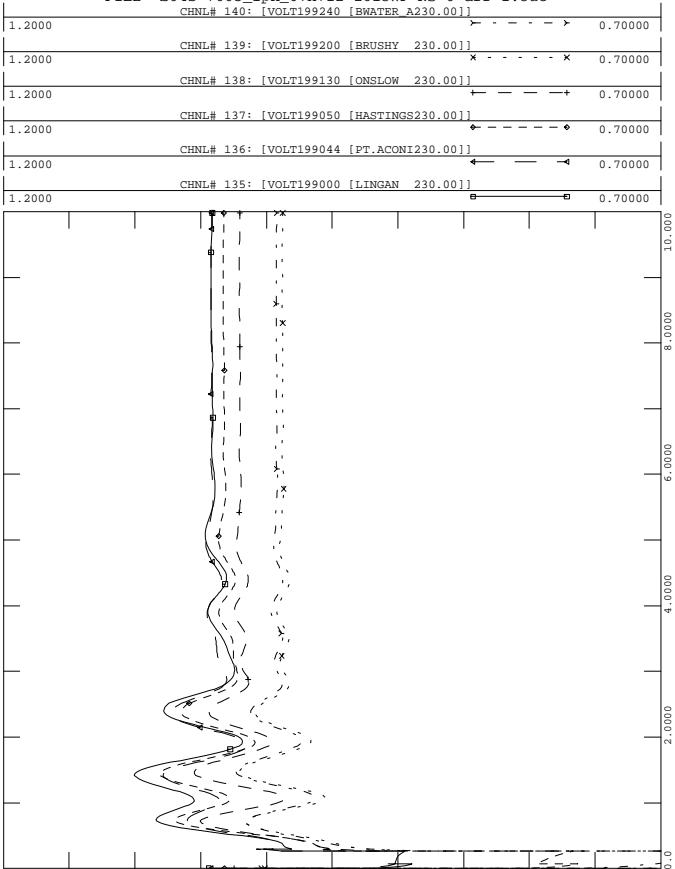

2013 WINTER PEAK STORA MIN
 NS-NB=0; NB-NE=500; CBX=732; ONI=961 ONS=851
 SLG FAULT ON ONSLOW END OF 7005
 67N-712 FAILS, CLEARS 7005 AND 7018 IN 17 CYCLES; SPS TRIPS
 FILE: b04s-7005_lph_67n712-2013WP-NS-0-drr-1.out
 CHNL# 154: [IR141-DIGBYH69.0 VOLTS]

SUN, FEB 15 2009 9:43
 WIND BUS VOLTS

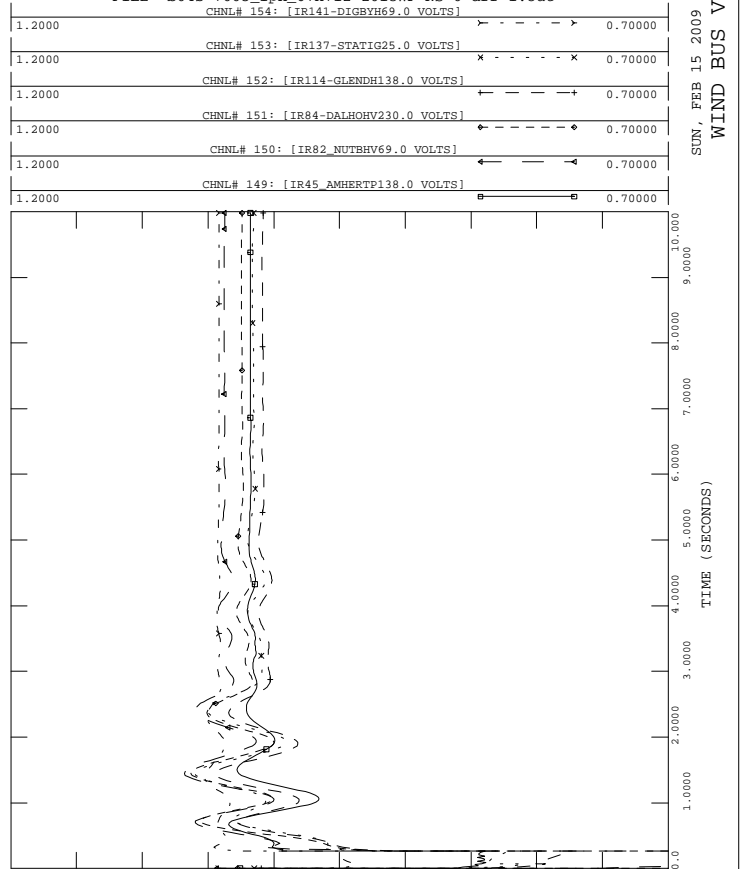

2013 WINTER PEAK STORA MIN
NS-NB=0; NB-NE=500; CBX=732; ONI=961 ONS=851
SLG FAULT ON ONSLOW END OF 8003
67N-812 FAILS, CLEARS 8003 AND 8002; SPS TRIPS 1 LINGAN UNIT
FILE: b06s-8003_lph_67n812-2013WP-NS-0-drr-1.out

Table with 2 columns: CHNL# and S values. Rows include channel identifiers like CHNL#S 17,4 and CHNL#S 16,4, along with their respective parameters and values.

NS ANGLE
SUN, FEB 15 2009 9:43

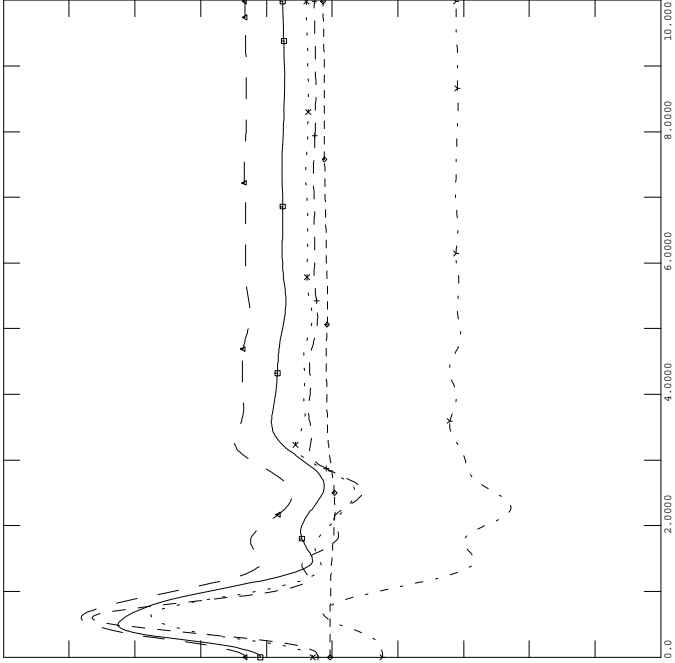

2013 WINTER PEAK STORA MIN
NS-NB=0; NB-NE=500; CBX=732; ONI=961 ONS=851
SLG FAULT ON ONSLOW END OF 8003
67N-812 FAILS, CLEARS 8003 AND 8002; SPS TRIPS 1 LINGAN UNIT
FILE: b06s-8003_lph_67n812-2013WP-NS-0-drr-1.out

Table with 2 columns: CHNL# and S values. Rows include channel identifiers like CHNL# 56 and CHNL# 55, along with their respective parameters and values.

NS MW
SUN, FEB 15 2009 9:43

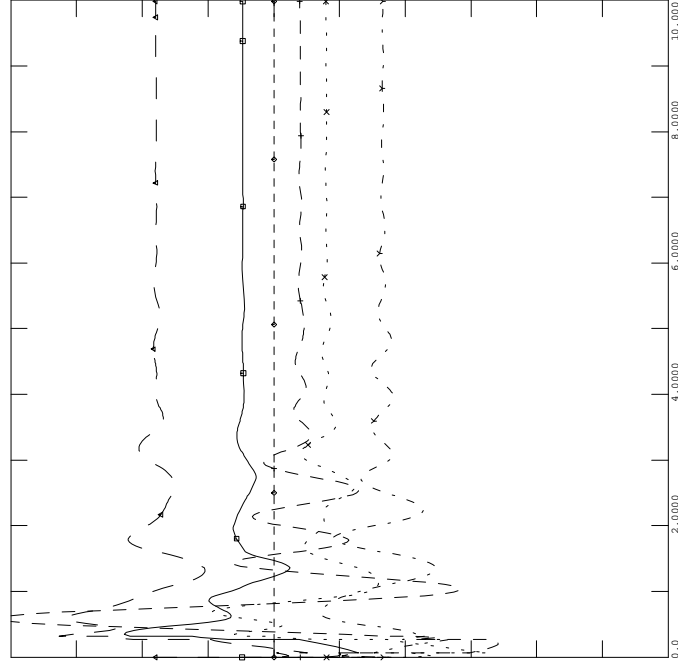

2013 WINTER PEAK STORA MIN
NS-NB=0; NB-NE=500; CBX=732; ONI=961 ONS=851
SLG FAULT ON ONSLOW END OF 8003
67N-812 FAILS, CLEARS 8003 AND 8002; SPS TRIPS 1 LINGAN UNIT
FILE: b06s-8003_lph_67n812-2013WP-NS-0-drr-1.out

Table with 2 columns: CHNL# and S values. Rows include channel identifiers like CHNL#S 10,4 and CHNL#S 6,4, along with their respective parameters and values.

"NE, NY, NB ANGLE"
SUN, FEB 15 2009 9:43

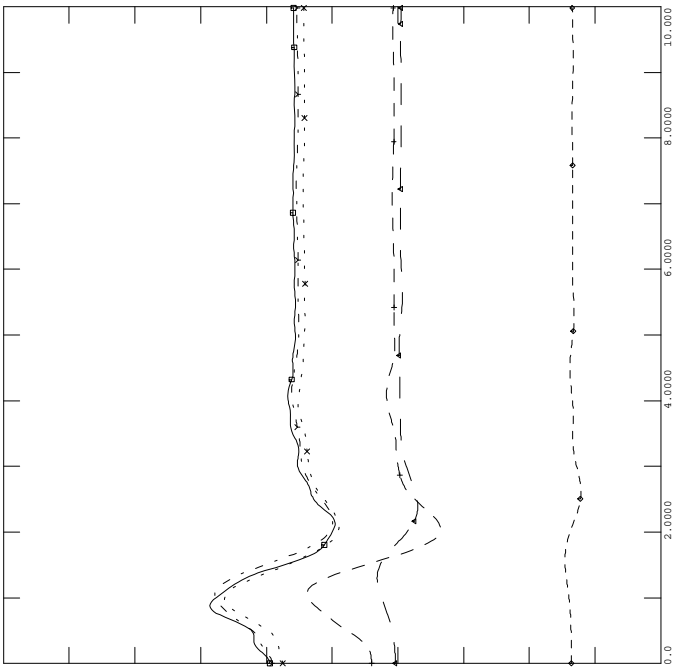

2013 WINTER PEAK STORA MIN
NS-NB=0; NB-NE=500; CBX=732; ONI=961 ONS=851
SLG FAULT ON ONSLOW END OF 8003
67N-812 FAILS, CLEARS 8003 AND 8002; SPS TRIPS 1 LINGAN UNIT
FILE: b06s-8003_lph_67n812-2013WP-NS-0-drr-1.out

Table with 2 columns: CHNL# and S values. Rows include channel identifiers like CHNL# 49 and CHNL# 45, along with their respective parameters and values.

"NE, NY, NB POWER"
SUN, FEB 15 2009 9:43

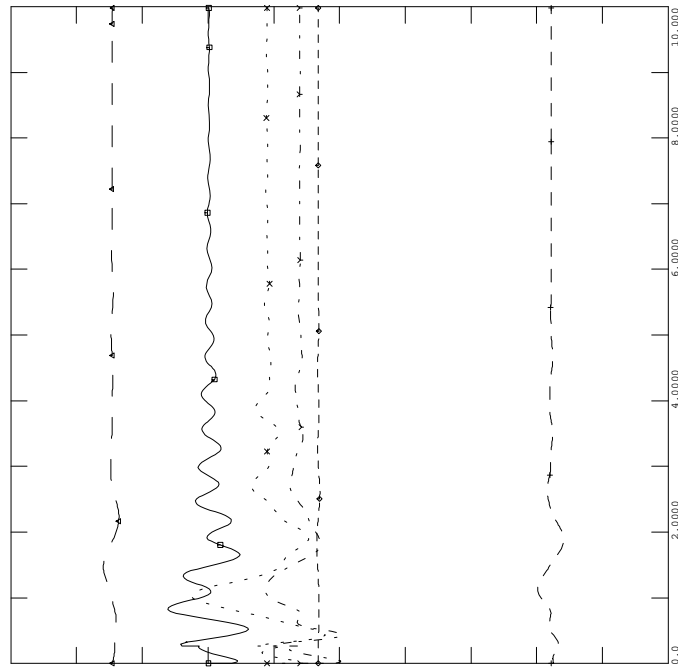



2013 WINTER PEAK STORA MIN
 NS-NB=0; NB-NE=500; CBX=732; ONI=961 ONS=851
 SLG FAULT ON ONSLOW END OF 8003
 67N-812 FAILS, CLEARS 8003 AND 8002; SPS TRIPS 1 LINGAN UNIT
 FILE: b06s-8003_lph_67n812-2013WP-NS-0-drr-1.out
 CHNL# 119: [VARS IR141-DIGBY]

SUN, FEB 15 2009 9:43
 NS WIND MV

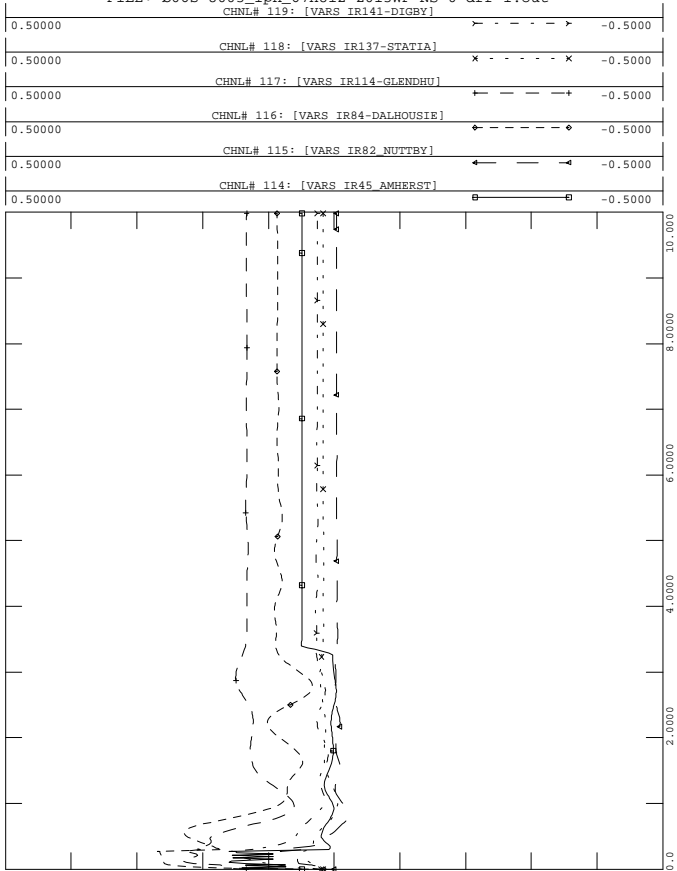

2013 WINTER PEAK STORA MIN
 NS-NB=0; NB-NE=500; CBX=732; ONI=961 ONS=851
 SLG FAULT ON ONSLOW END OF 8003
 67N-812 FAILS, CLEARS 8003 AND 8002; SPS TRIPS 1 LINGAN UNIT
 FILE: b06s-8003_lph_67n812-2013WP-NS-0-drr-1.out
 CHNL# 133: [VOLT199125 [ONSLow 345.00]]

SUN, FEB 15 2009 9:43
 "345KV VOLTAGE"

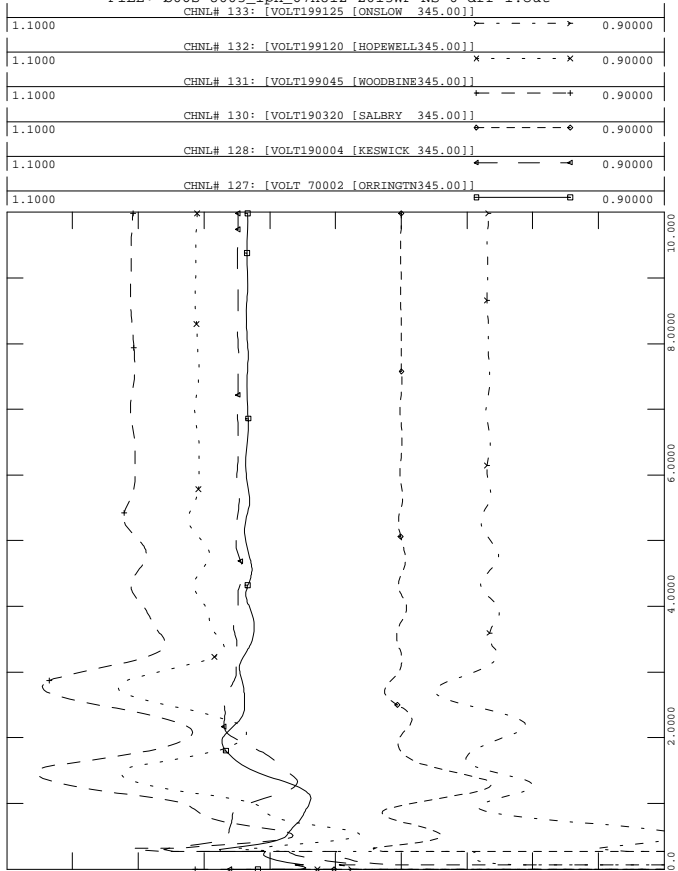

2013 WINTER PEAK STORA MIN
 NS-NB=0; NB-NE=500; CBX=732; ONI=961 ONS=851
 SLG FAULT ON ONSLOW END OF 8003
 67N-812 FAILS, CLEARS 8003 AND 8002; SPS TRIPS 1 LINGAN UNIT
 FILE: b06s-8003_lph_67n812-2013WP-NS-0-drr-1.out
 CHNL# 79: [POWER IR141-DIGBY]

SUN, FEB 15 2009 9:43
 NS WIND MW

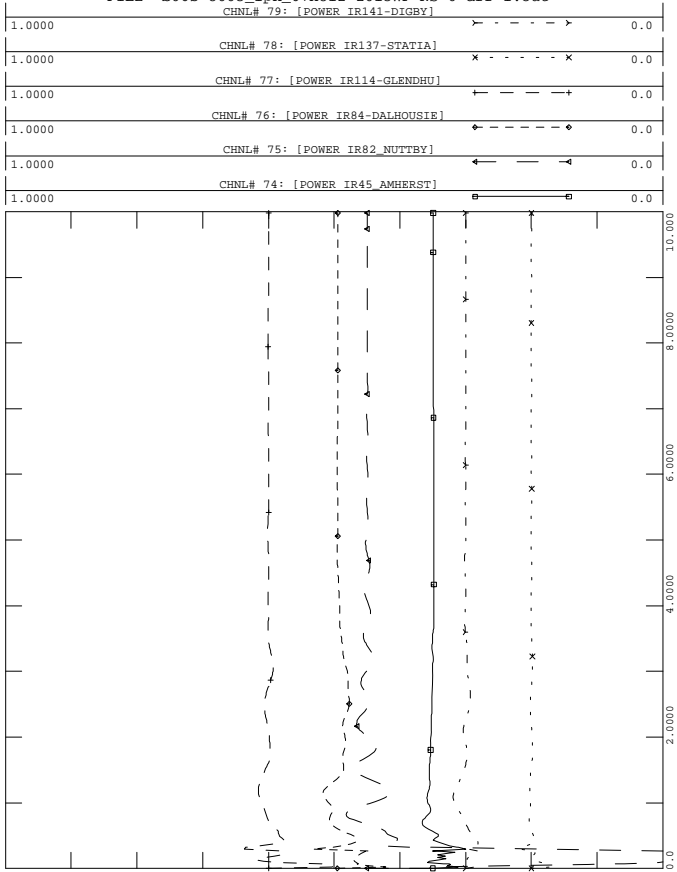

2013 WINTER PEAK STORA MIN
 NS-NB=0; NB-NE=500; CBX=732; ONI=961 ONS=851
 SLG FAULT ON ONSLOW END OF 8003
 67N-812 FAILS, CLEARS 8003 AND 8002; SPS TRIPS 1 LINGAN UNIT
 FILE: b06s-8003_lph_67n812-2013WP-NS-0-drr-1.out
 CHNL# 125: 60*(1+[FREQ199125 [ONSLow 345.00]])

SUN, FEB 15 2009 9:43
 FREQUENCY HZ

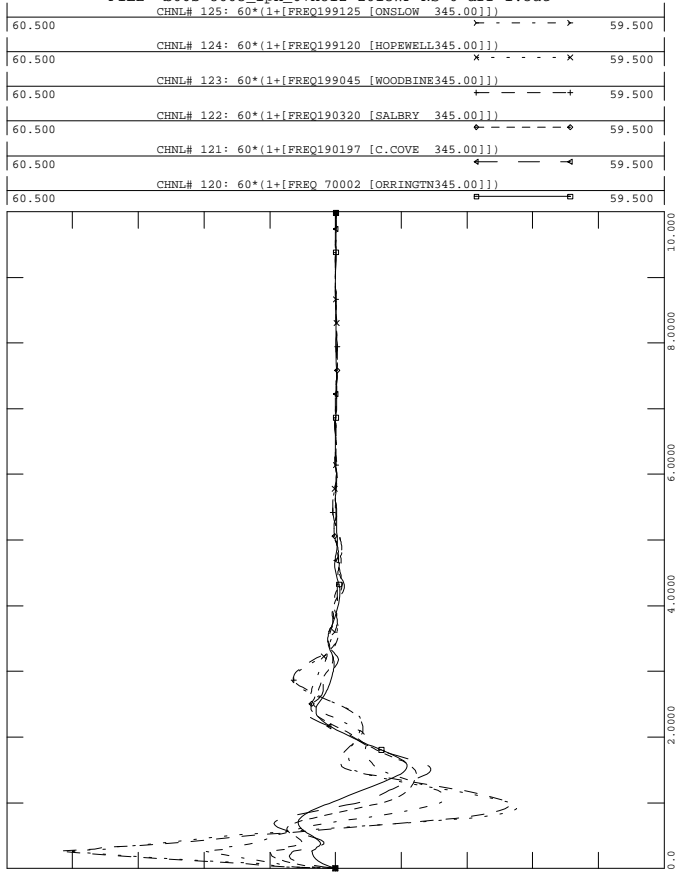

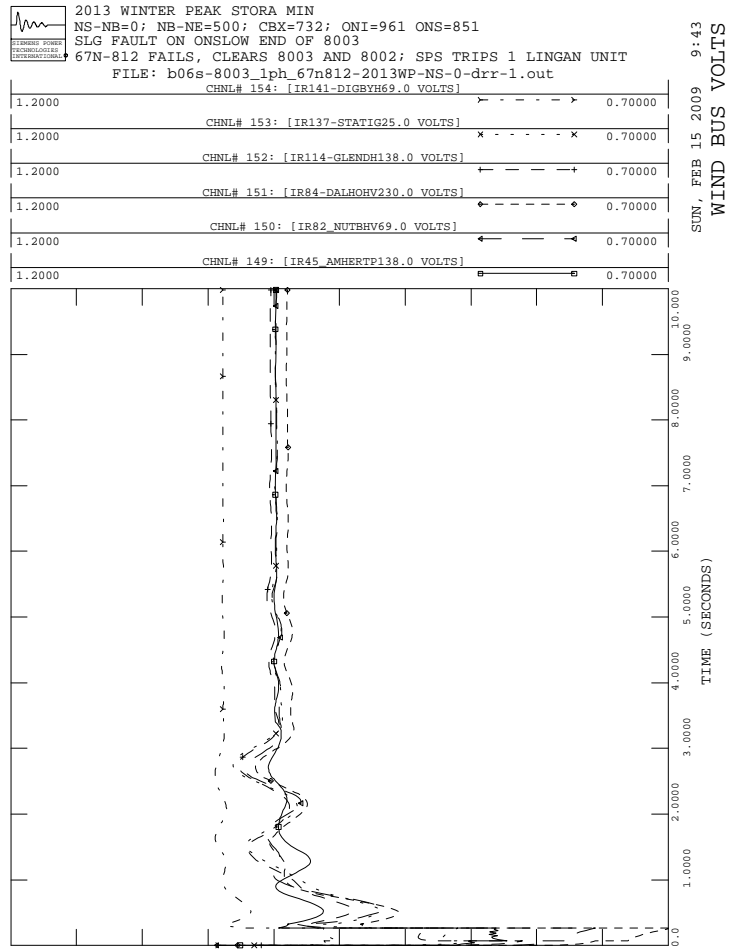
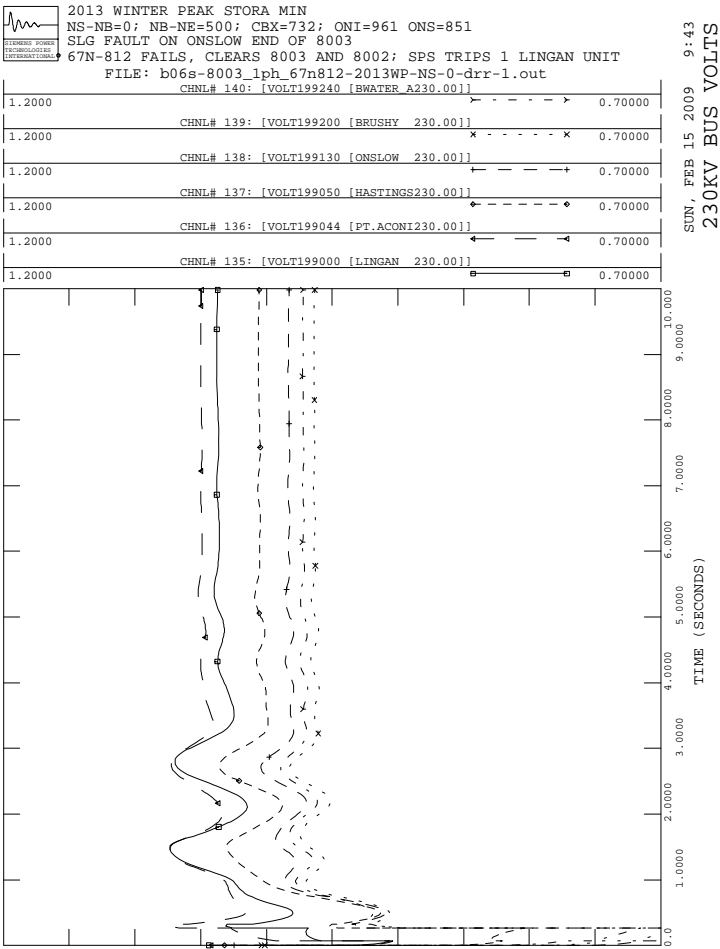
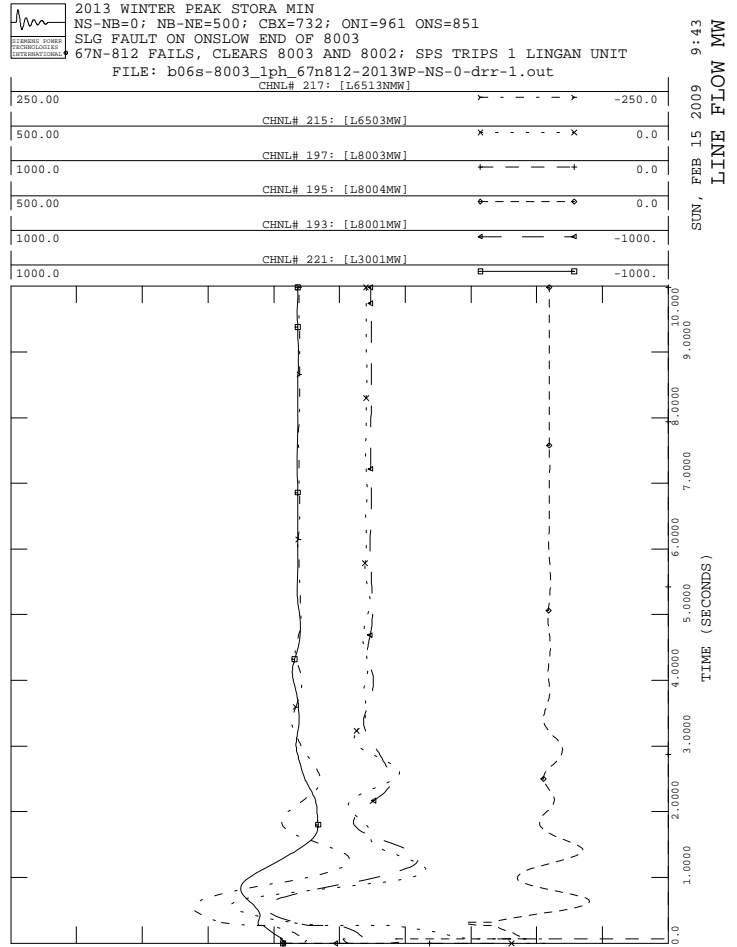
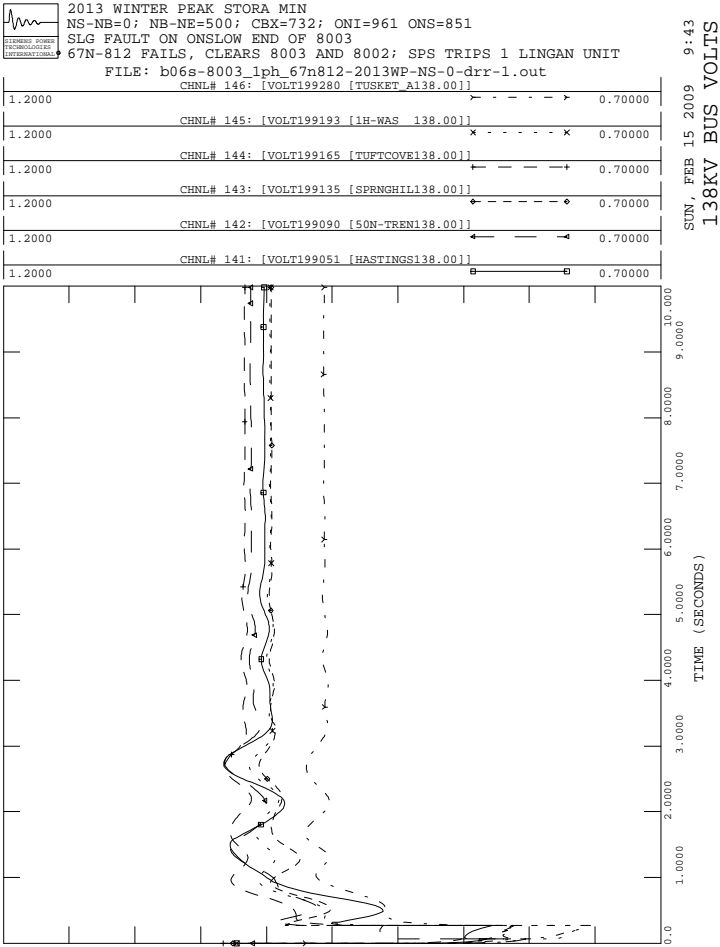



2013 WINTER PEAK STORA MIN
NS-NB=0; NB-NE=500; CBX=732; ONI=961 ONS=851
SLG FLT ON SEPARATE PHASES OF DOUBLE CKT TOWER
7003 AND 7004 NEAR TRENTON CLEARED IN 5 CYCLES

FILE: c01s-pg_7003_7004_50n-2013WP-NS-0-drr-1.out

CHNL#*S 20,4:	[ANGL199169 [TUFTCV3 14.400] [3]]-[ANGL156661 [DARL G1 22.000] [1]]	-100.0
100.00		
CHNL#*S 17,4:	[ANGL199086 [TRENTON613.800] [6]]-[ANGL156661 [DARL G1 22.000] [1]]	-100.0
100.00		
CHNL#*S 16,4:	[ANGL199085 [TRENTN5 13.800] [5]]-[ANGL156661 [DARL G1 22.000] [1]]	-100.0
100.00		
CHNL#*S 15,4:	[ANGL199061 [TMP1_STO13.800] [1]]-[ANGL156661 [DARL G1 22.000] [1]]	-150.0
50.0000		
CHNL#*S 13,4:	[ANGL199043 [ACONIG1 20.000] [1]]-[ANGL156661 [DARL G1 22.000] [1]]	-100.0
100.00		
CHNL#*S 11,4:	[ANGL199001 [LINGANI 14.400] [1]]-[ANGL156661 [DARL G1 22.000] [1]]	-100.0
100.00		

SUN, FEB 15 2009 9:43
NS ANGLE

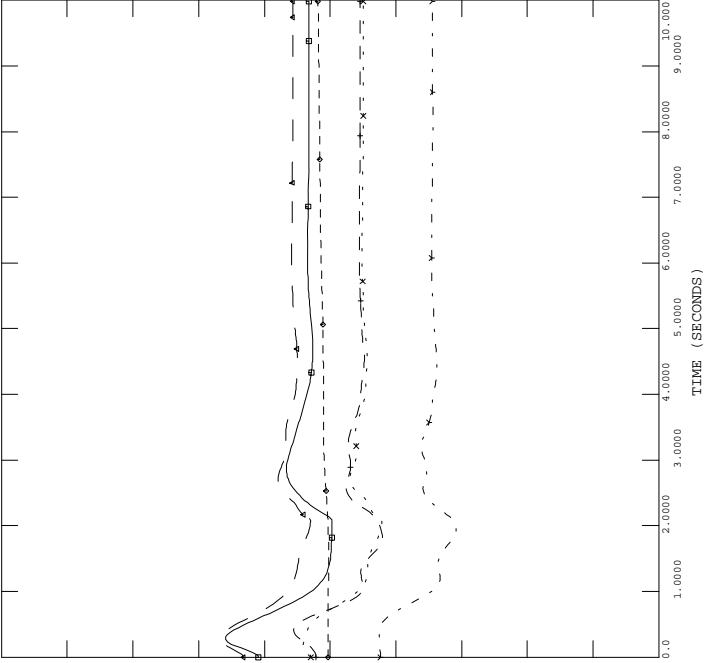

2013 WINTER PEAK STORA MIN
NS-NB=0; NB-NE=500; CBX=732; ONI=961 ONS=851
SLG FLT ON SEPARATE PHASES OF DOUBLE CKT TOWER
7003 AND 7004 NEAR TRENTON CLEARED IN 5 CYCLES

FILE: c01s-pg_7003_7004_50n-2013WP-NS-0-drr-1.out

CHNL# 56:	[POWR199086 [TRENTON613.800] [6]]	0.0
2.5000		
CHNL# 55:	[POWR199085 [TRENTN5 13.800] [5]]	0.0
2.5000		
CHNL# 54:	[POWR199061 [TMP1_STO13.800] [1]]	0.0
1.0000		
CHNL# 52:	[POWR199043 [ACONIG1 20.000] [1]]	-1.500
2.5000		
CHNL# 50:	[POWR199001 [LINGANI 14.400] [1]]	0.0
2.5000		

SUN, FEB 15 2009 9:43
NS MW

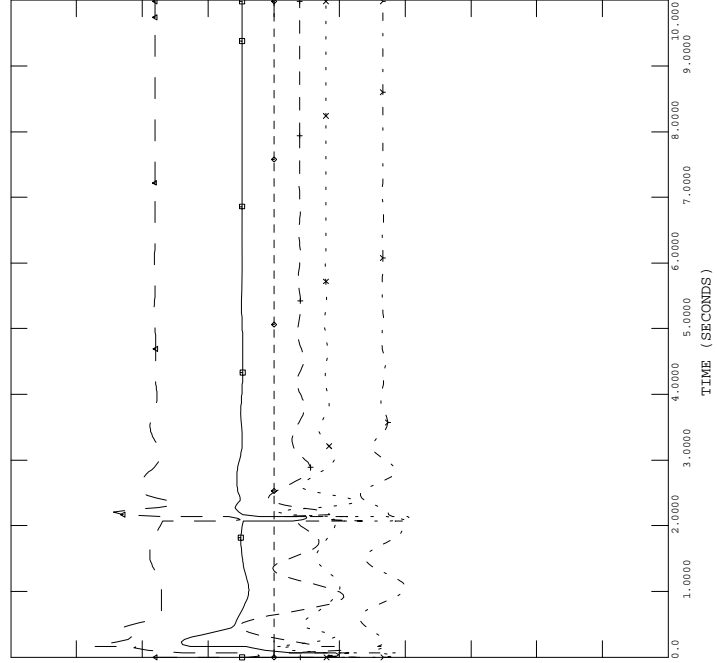

2013 WINTER PEAK STORA MIN
NS-NB=0; NB-NE=500; CBX=732; ONI=961 ONS=851
SLG FLT ON SEPARATE PHASES OF DOUBLE CKT TOWER
7003 AND 7004 NEAR TRENTON CLEARED IN 5 CYCLES

FILE: c01s-pg_7003_7004_50n-2013WP-NS-0-drr-1.out

CHNL#*S 10,4:	[ANGL190472 [BLDNG2 19.000] [1]]-[ANGL156661 [DARL G1 22.000] [1]]	-100.0
100.00		
CHNL#*S 6,4:	[ANGL190456 [LEPRG1 26.000] [1]]-[ANGL156661 [DARL G1 22.000] [1]]	-100.0
100.00		
CHNL#*S 5,4:	[ANGL190450 [MACTG1 13.800] [1]]-[ANGL156661 [DARL G1 22.000] [1]]	-100.0
100.00		
CHNL#*S 3,4:	[ANGL126652 [RAV 3 22.000] [1]]-[ANGL156661 [DARL G1 22.000] [1]]	-100.0
100.00		
CHNL#*S 2,4:	[ANGL101063 [MYST G7 22.000] [1]]-[ANGL156661 [DARL G1 22.000] [1]]	-100.0
100.00		
CHNL#*S 7,4:	[ANGL190457 [C.CVG1 19.000] [1]]-[ANGL156661 [DARL G1 22.000] [1]]	-100.0
100.00		

SUN, FEB 15 2009 9:43
"NE, NY, NB ANGLE"

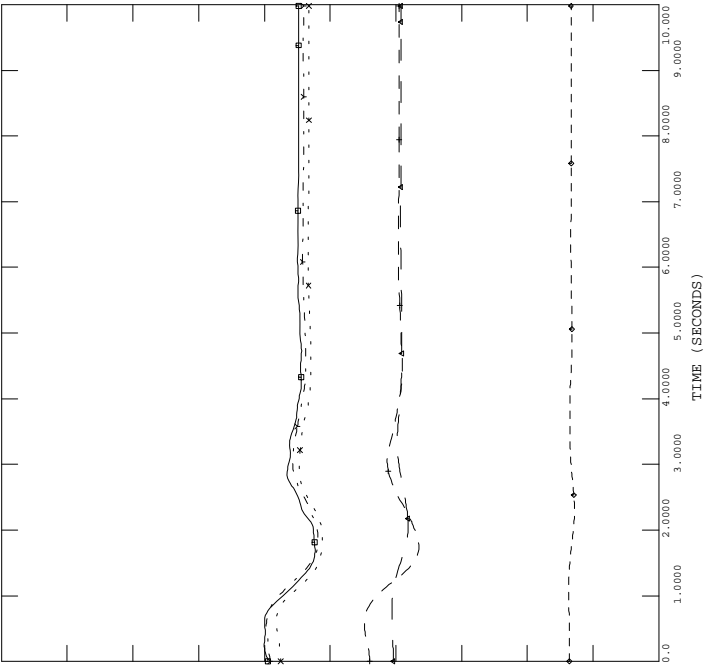

2013 WINTER PEAK STORA MIN
NS-NB=0; NB-NE=500; CBX=732; ONI=961 ONS=851
SLG FLT ON SEPARATE PHASES OF DOUBLE CKT TOWER
7003 AND 7004 NEAR TRENTON CLEARED IN 5 CYCLES

FILE: c01s-pg_7003_7004_50n-2013WP-NS-0-drr-1.out

CHNL# 49:	[POWER190472 [BLDNG2 19.000] [1]]	2.0000
7.0000		
CHNL# 45:	[POWER190456 [LEPRG1 26.000] [1]]	4.0000
9.0000		
CHNL# 44:	[POWER190450 [MACTG1 13.800] [1]]	0.0
5.0000		
CHNL# 42:	[POWER126652 [RAV 3 22.000] [1]]	0.0
5.0000		
CHNL# 41:	[POWER101063 [MYST G7 22.000] [1]]	1.0000
6.5000		
CHNL# 46:	[POWER190457 [C.CVG1 19.000] [1]]	0.0
5.0000		

SUN, FEB 15 2009 9:43
"NE, NY, NB POWER"

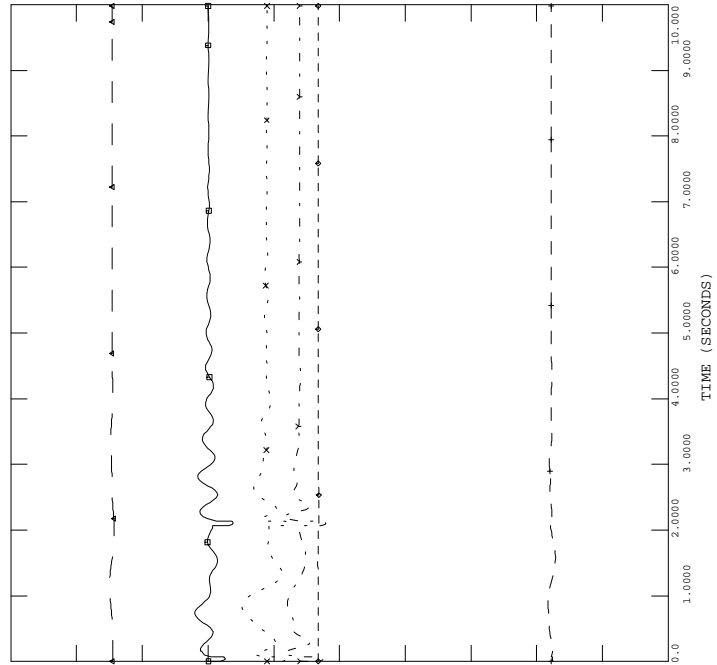



2013 WINTER PEAK STORA MIN
 NS-NB=0; NB-NE=500; CBX=732; ONI=961 ONS=851
 SLG FLT ON SEPARATE PHASES OF DOUBLE CKT TOWER
 7003 AND 7004 NEAR TRENTON CLEARED IN 5 CYCLES
 FILE: c01s-pg_7003_7004_50n-2013WP-NS-0-drr-1.out
 CHNL# 119: [VARS IR141-DIGBY]

SUN, FEB 15 2009 9:43
 NS WIND MV

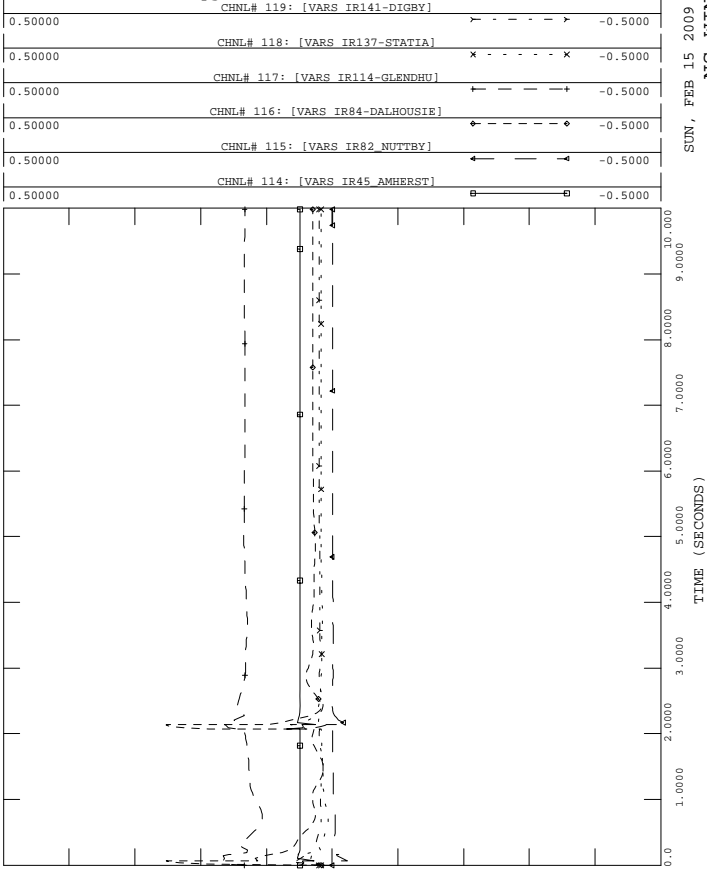

2013 WINTER PEAK STORA MIN
 NS-NB=0; NB-NE=500; CBX=732; ONI=961 ONS=851
 SLG FLT ON SEPARATE PHASES OF DOUBLE CKT TOWER
 7003 AND 7004 NEAR TRENTON CLEARED IN 5 CYCLES
 FILE: c01s-pg_7003_7004_50n-2013WP-NS-0-drr-1.out
 CHNL# 133: [VOLT199125 [ONSLOW 345.00]]

SUN, FEB 15 2009 9:43
 "345KV VOLTAGE"

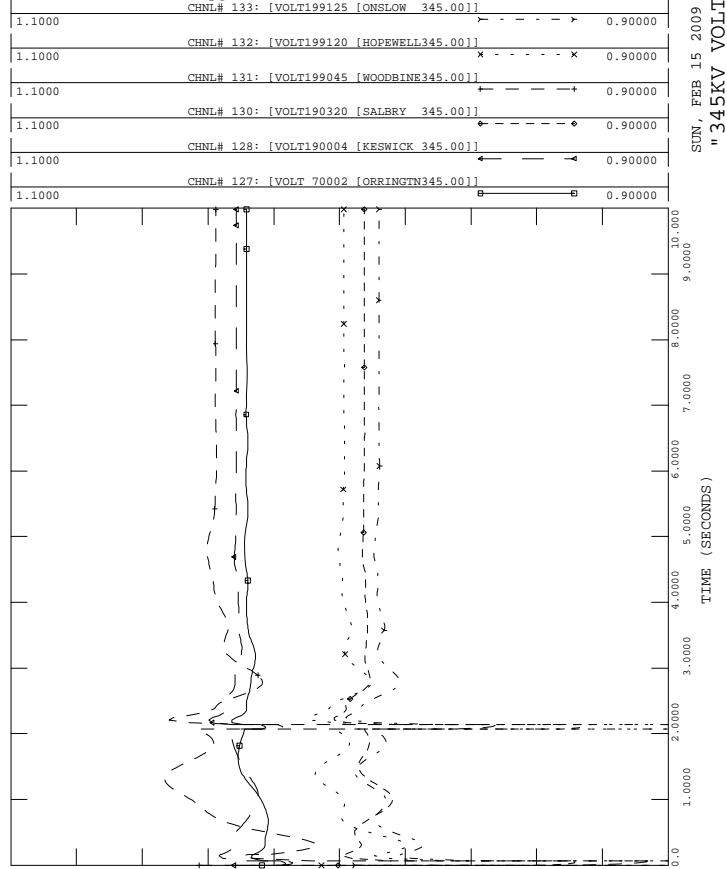

2013 WINTER PEAK STORA MIN
 NS-NB=0; NB-NE=500; CBX=732; ONI=961 ONS=851
 SLG FLT ON SEPARATE PHASES OF DOUBLE CKT TOWER
 7003 AND 7004 NEAR TRENTON CLEARED IN 5 CYCLES
 FILE: c01s-pg_7003_7004_50n-2013WP-NS-0-drr-1.out
 CHNL# 79: [POWER IR141-DIGBY]

SUN, FEB 15 2009 9:43
 NS WIND MW

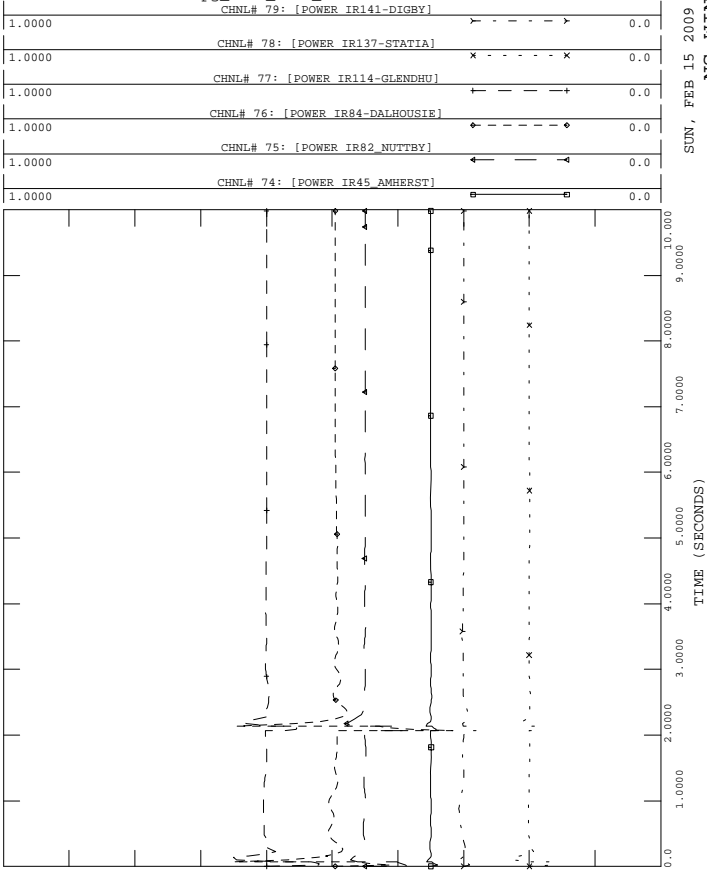

2013 WINTER PEAK STORA MIN
 NS-NB=0; NB-NE=500; CBX=732; ONI=961 ONS=851
 SLG FLT ON SEPARATE PHASES OF DOUBLE CKT TOWER
 7003 AND 7004 NEAR TRENTON CLEARED IN 5 CYCLES
 FILE: c01s-pg_7003_7004_50n-2013WP-NS-0-drr-1.out
 CHNL# 125: 60*(1+[FREQ199125 [ONSLOW 345.00]])

SUN, FEB 15 2009 9:43
 FREQUENCY HZ

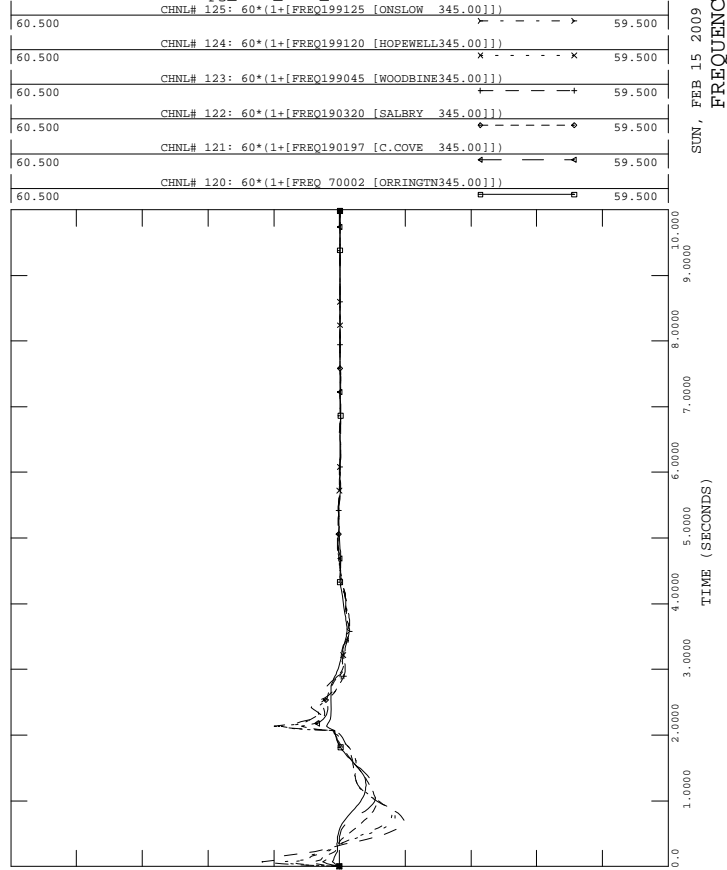



2013 WINTER PEAK STORA MIN
NS-NB=0; NB-NE=500; CBX=732; ONI=961 ONS=851
SLG FLT ON SEPARATE PHASES OF DOUBLE CKT TOWER
7003 AND 7004 NEAR TRENTON CLEARED IN 5 CYCLES
FILE: c01s-pg_7003_7004_50n-2013WP-NS-0-drr-1.out
CHNL# 146: [VOLT199280 [TUSKET_A138.00]]

1.2000	CHNL# 145: [VOLT199193 [1H-WAS 138.00]]	0.70000
1.2000	CHNL# 144: [VOLT199165 [TUFTCOVER138.00]]	0.70000
1.2000	CHNL# 143: [VOLT199135 [SPRNGHIL138.00]]	0.70000
1.2000	CHNL# 142: [VOLT199090 [50N-TREN138.00]]	0.70000
1.2000	CHNL# 141: [VOLT199051 [HASTINGS138.00]]	0.70000

SUN, FEB 15 2009 9:43
138KV BUS VOLTS

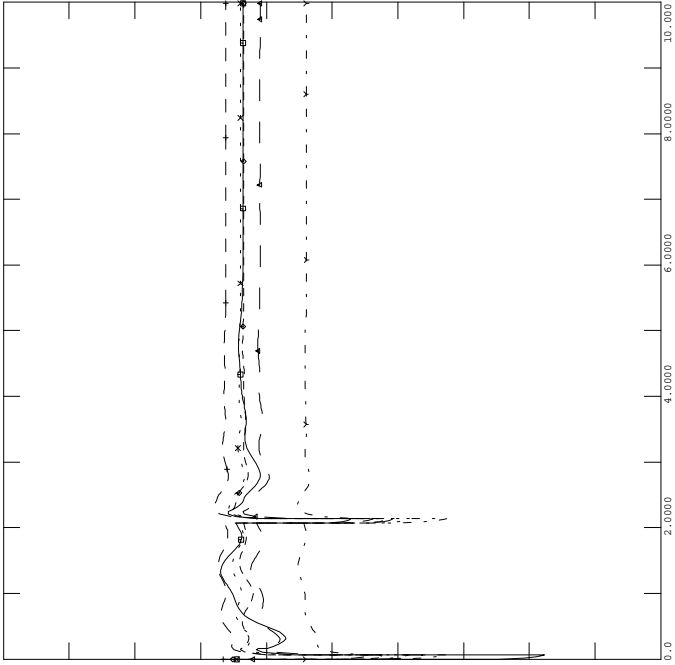

2013 WINTER PEAK STORA MIN
NS-NB=0; NB-NE=500; CBX=732; ONI=961 ONS=851
SLG FLT ON SEPARATE PHASES OF DOUBLE CKT TOWER
7003 AND 7004 NEAR TRENTON CLEARED IN 5 CYCLES
FILE: c01s-pg_7003_7004_50n-2013WP-NS-0-drr-1.out
CHNL# 217: [L6513NMW]

250.00	CHNL# 215: [L6503MMW]	-250.0
500.00	CHNL# 197: [L8003MMW]	0.0
1000.00	CHNL# 195: [L8004MMW]	0.0
500.00	CHNL# 193: [L8001MMW]	0.0
1000.00	CHNL# 221: [L3001MMW]	-1000.0

SUN, FEB 15 2009 9:43
LINE FLOW MW

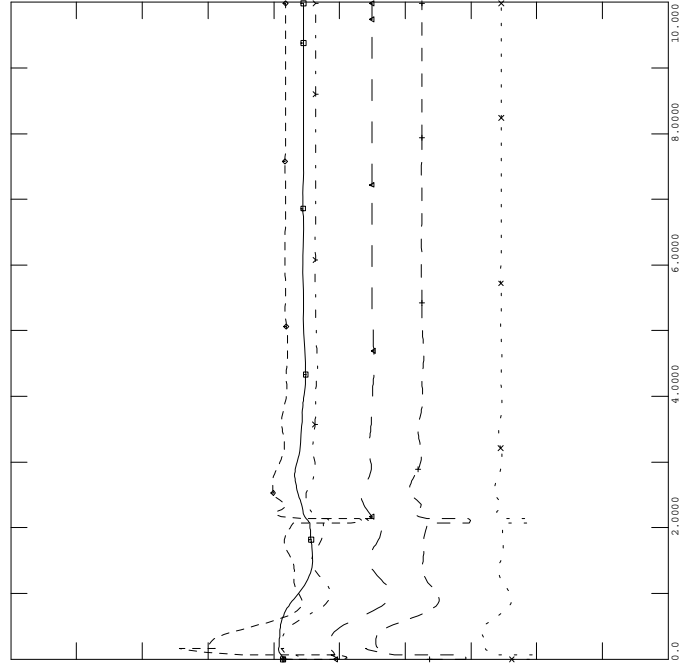

2013 WINTER PEAK STORA MIN
NS-NB=0; NB-NE=500; CBX=732; ONI=961 ONS=851
SLG FLT ON SEPARATE PHASES OF DOUBLE CKT TOWER
7003 AND 7004 NEAR TRENTON CLEARED IN 5 CYCLES
FILE: c01s-pg_7003_7004_50n-2013WP-NS-0-drr-1.out
CHNL# 140: [VOLT199240 [BRATER_A230.00]]

1.2000	CHNL# 139: [VOLT199200 [BRUSHY 230.00]]	0.70000
1.2000	CHNL# 138: [VOLT199130 [ONSLow 230.00]]	0.70000
1.2000	CHNL# 137: [VOLT199050 [HASTINGS230.00]]	0.70000
1.2000	CHNL# 136: [VOLT199044 [PT.ACON1230.00]]	0.70000
1.2000	CHNL# 135: [VOLT199000 [LINGAN 230.00]]	0.70000

SUN, FEB 15 2009 9:43
230KV BUS VOLTS

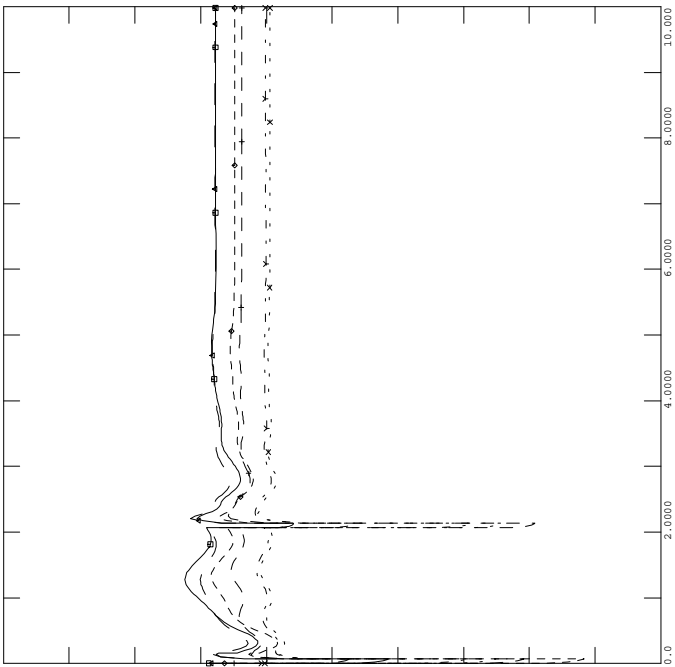

2013 WINTER PEAK STORA MIN
NS-NB=0; NB-NE=500; CBX=732; ONI=961 ONS=851
SLG FLT ON SEPARATE PHASES OF DOUBLE CKT TOWER
7003 AND 7004 NEAR TRENTON CLEARED IN 5 CYCLES
FILE: c01s-pg_7003_7004_50n-2013WP-NS-0-drr-1.out
CHNL# 154: [IR141-DIGBYH69.0 VOLTS]

1.2000	CHNL# 153: [IR137-STATIG25.0 VOLTS]	0.70000
1.2000	CHNL# 152: [IR114-GLENDH138.0 VOLTS]	0.70000
1.2000	CHNL# 151: [IR84-DALHOHV230.0 VOLTS]	0.70000
1.2000	CHNL# 150: [IR82-NUTBHV69.0 VOLTS]	0.70000
1.2000	CHNL# 149: [IR45-AMHERTP138.0 VOLTS]	0.70000

SUN, FEB 15 2009 9:43
WIND BUS VOLTS

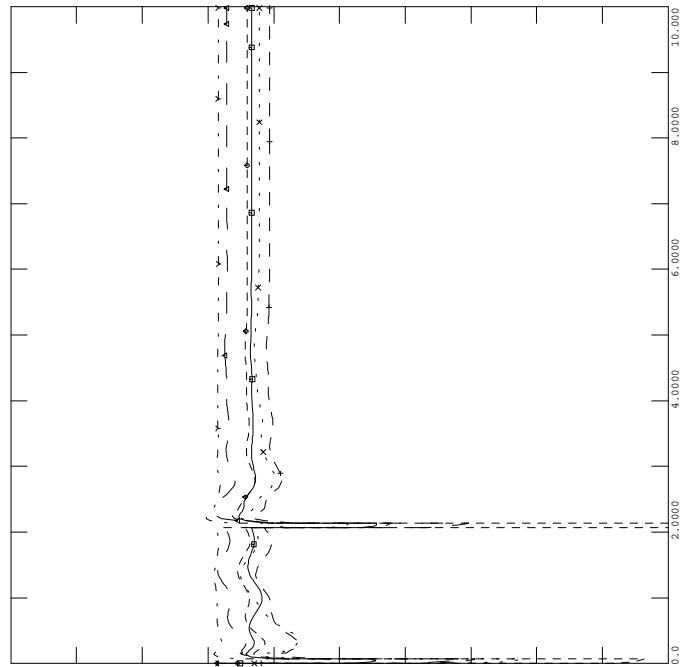

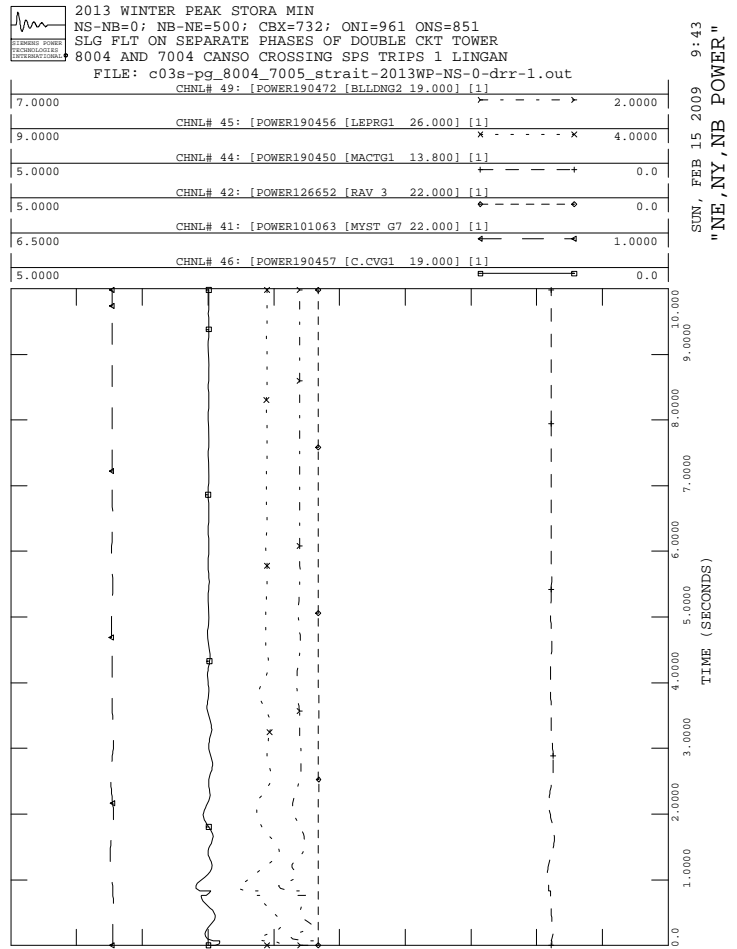
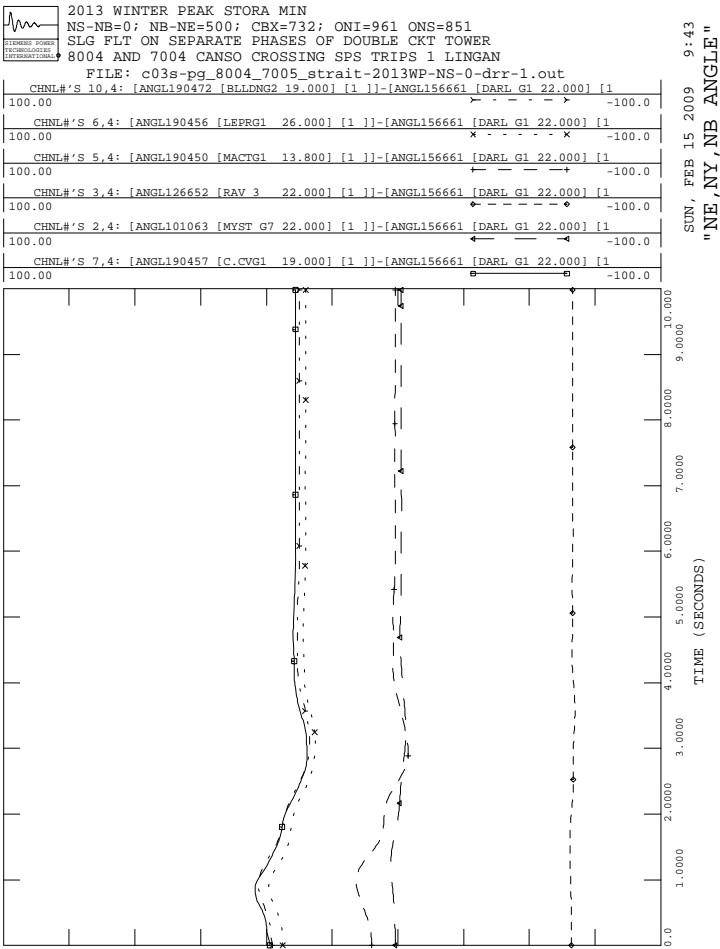
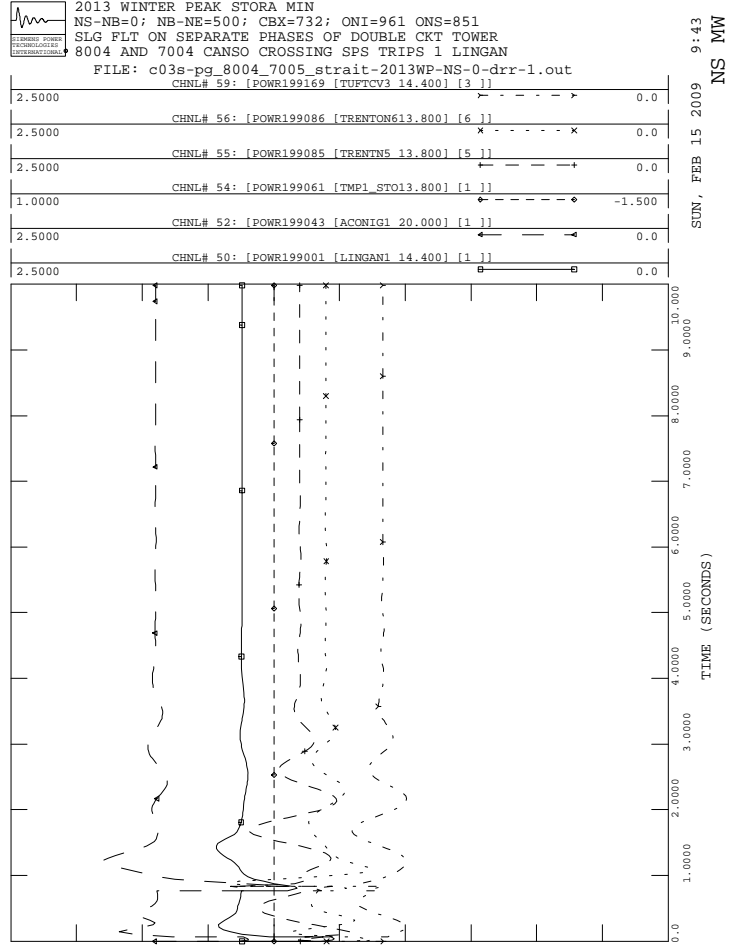
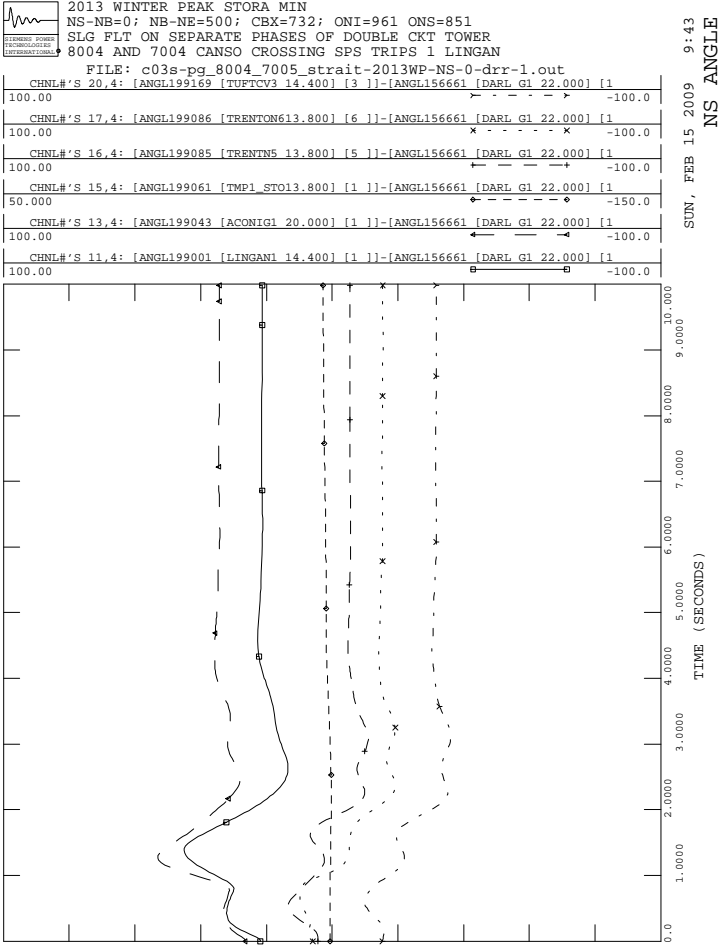



2013 WINTER PEAK STORA MIN
 NS-NB=0; NB-NE=500; CBX=732; ONI=961 ONS=851
 SLG FLT ON SEPARATE PHASES OF DOUBLE CKT TOWER
 8004 AND 7004 CANSO CROSSING SPS TRIPS 1 LINGAN
 FILE: c03s-pg_8004_7005_strait-2013WP-NS-0-drr-1.out
 CHNL# 119: [VARS IR141-DIGBY]

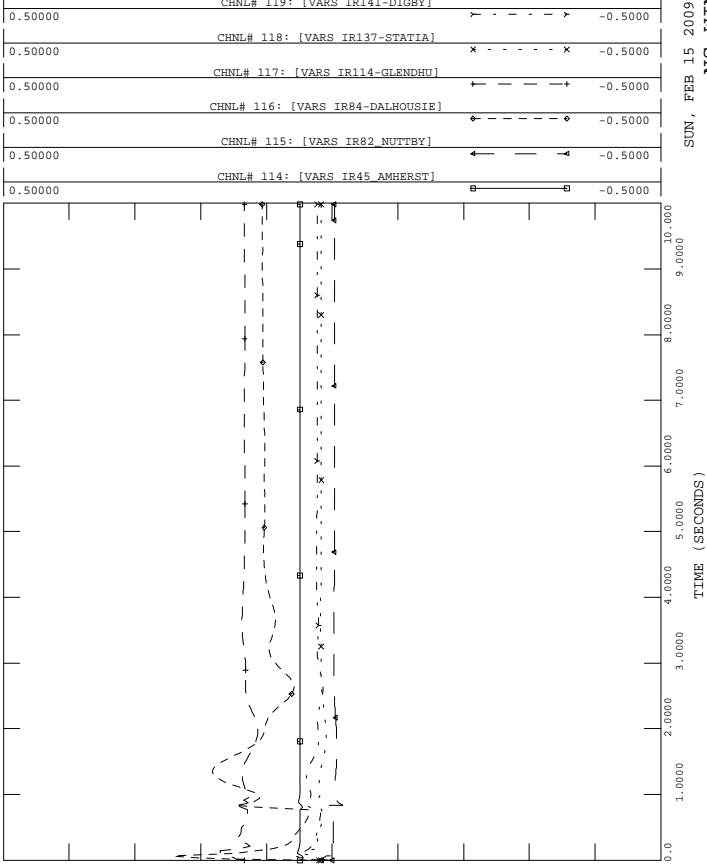

SUN, FEB 15 2009 9:43
 NS WIND MV



2013 WINTER PEAK STORA MIN
 NS-NB=0; NB-NE=500; CBX=732; ONI=961 ONS=851
 SLG FLT ON SEPARATE PHASES OF DOUBLE CKT TOWER
 8004 AND 7004 CANSO CROSSING SPS TRIPS 1 LINGAN
 FILE: c03s-pg_8004_7005_strait-2013WP-NS-0-drr-1.out
 CHNL# 133: [VOLT199125 [ONSLow 345.00]]

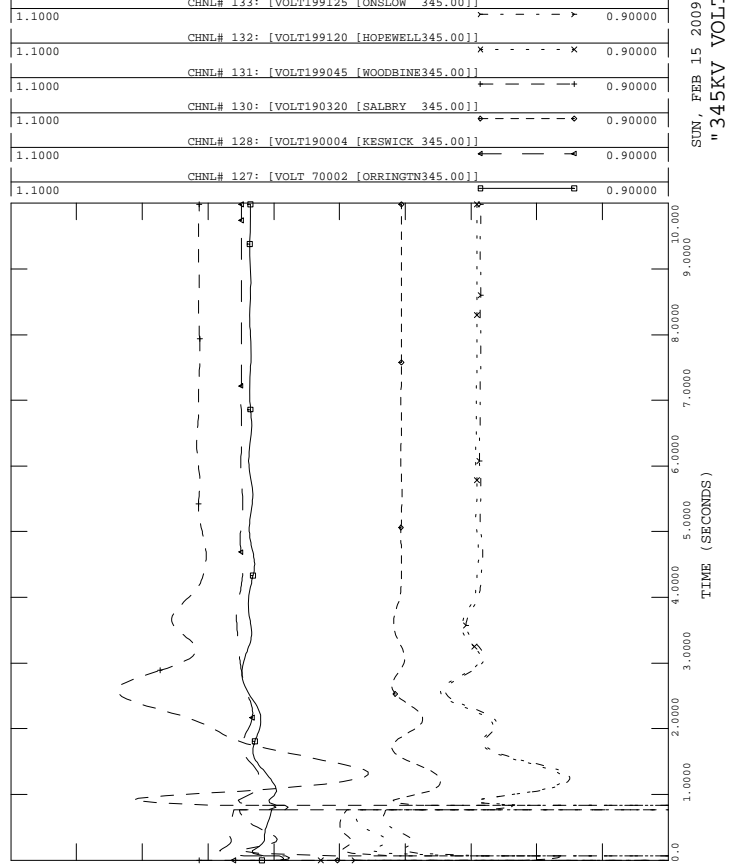

SUN, FEB 15 2009 9:43
 "# 345KV VOLTAGE"



2013 WINTER PEAK STORA MIN
 NS-NB=0; NB-NE=500; CBX=732; ONI=961 ONS=851
 SLG FLT ON SEPARATE PHASES OF DOUBLE CKT TOWER
 8004 AND 7004 CANSO CROSSING SPS TRIPS 1 LINGAN
 FILE: c03s-pg_8004_7005_strait-2013WP-NS-0-drr-1.out
 CHNL# 79: [POWER IR141-DIGBY]

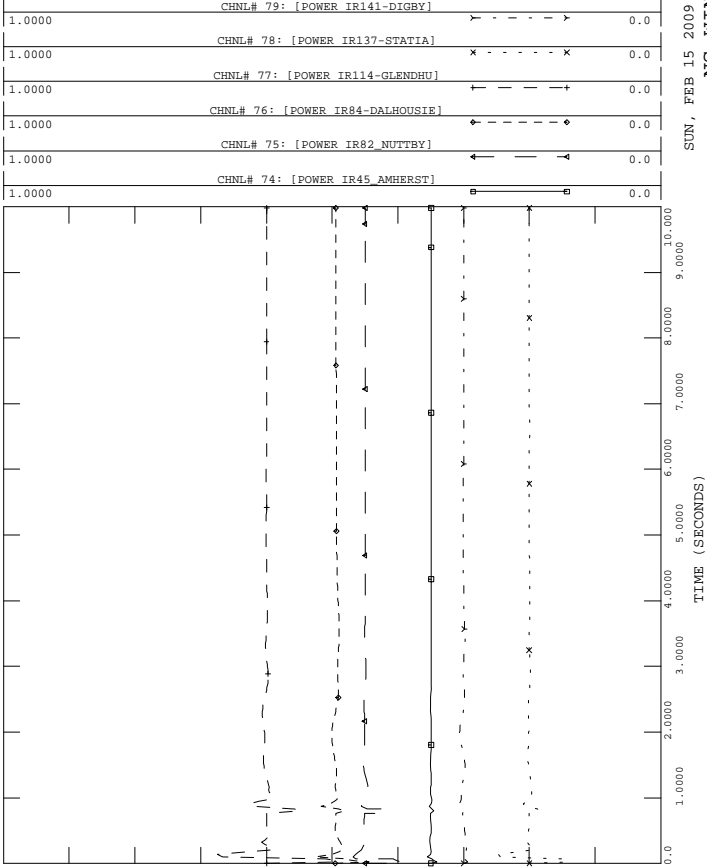

SUN, FEB 15 2009 9:43
 NS WIND MW



2013 WINTER PEAK STORA MIN
 NS-NB=0; NB-NE=500; CBX=732; ONI=961 ONS=851
 SLG FLT ON SEPARATE PHASES OF DOUBLE CKT TOWER
 8004 AND 7004 CANSO CROSSING SPS TRIPS 1 LINGAN
 FILE: c03s-pg_8004_7005_strait-2013WP-NS-0-drr-1.out
 CHNL# 125: 60*(1+[FREQ199125 [ONSLow 345.00]])

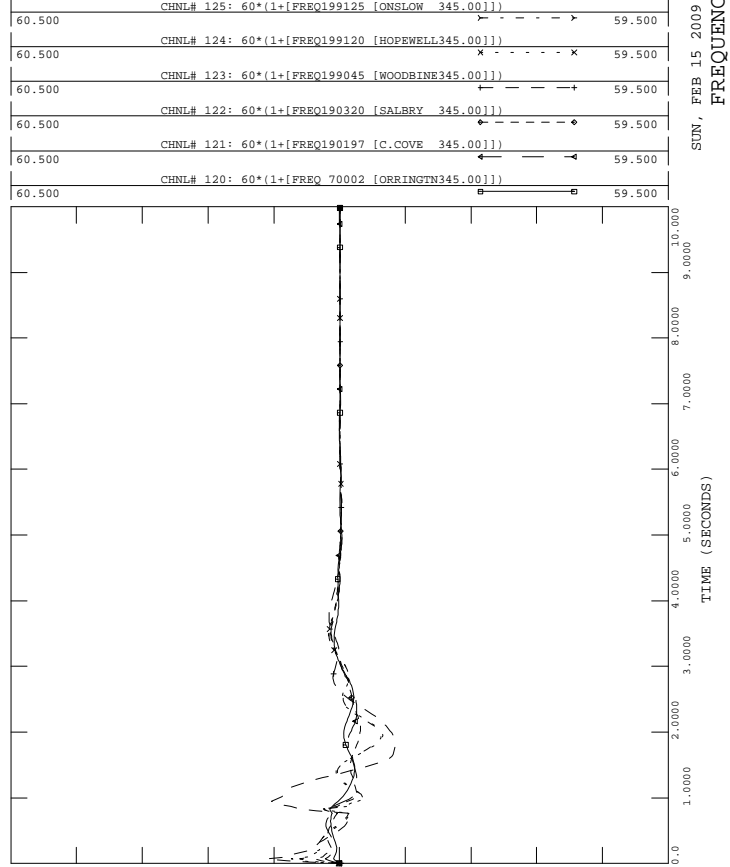

SUN, FEB 15 2009 9:43
 FREQUENCY HZ

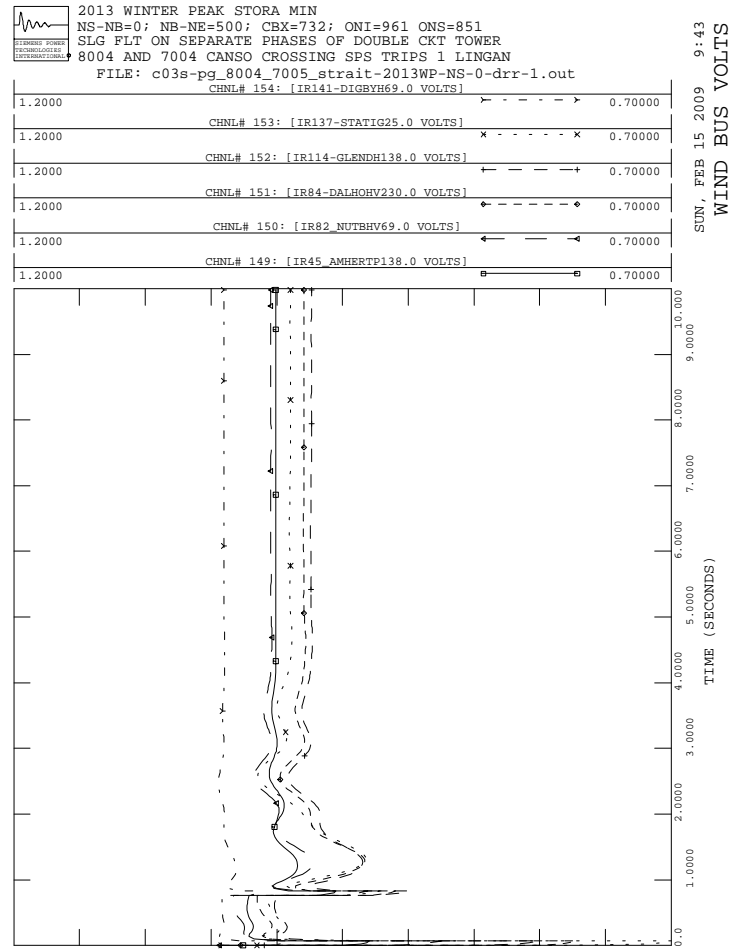
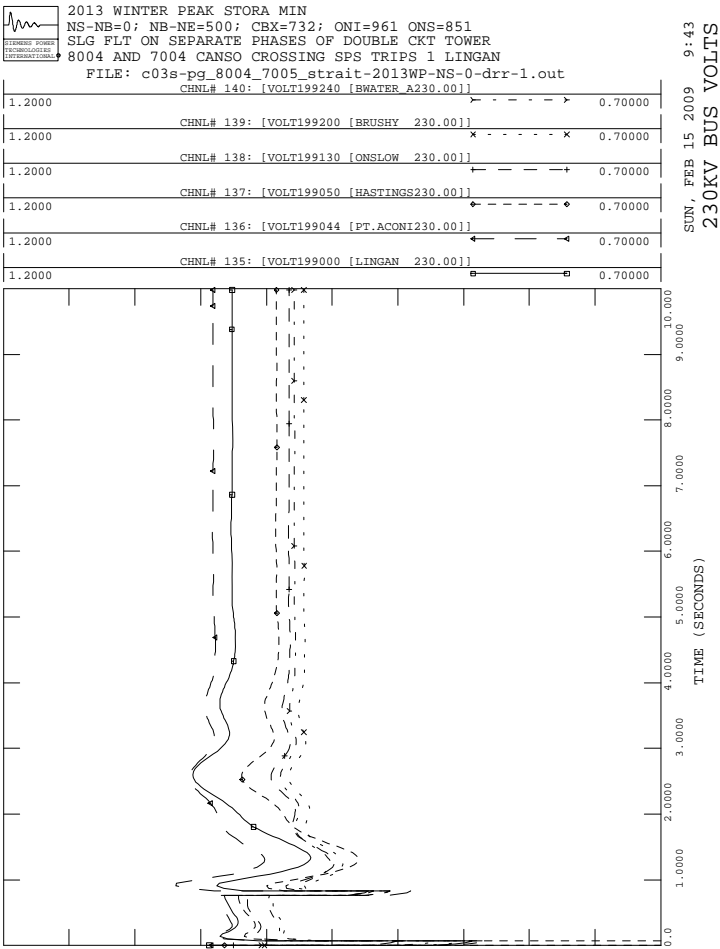
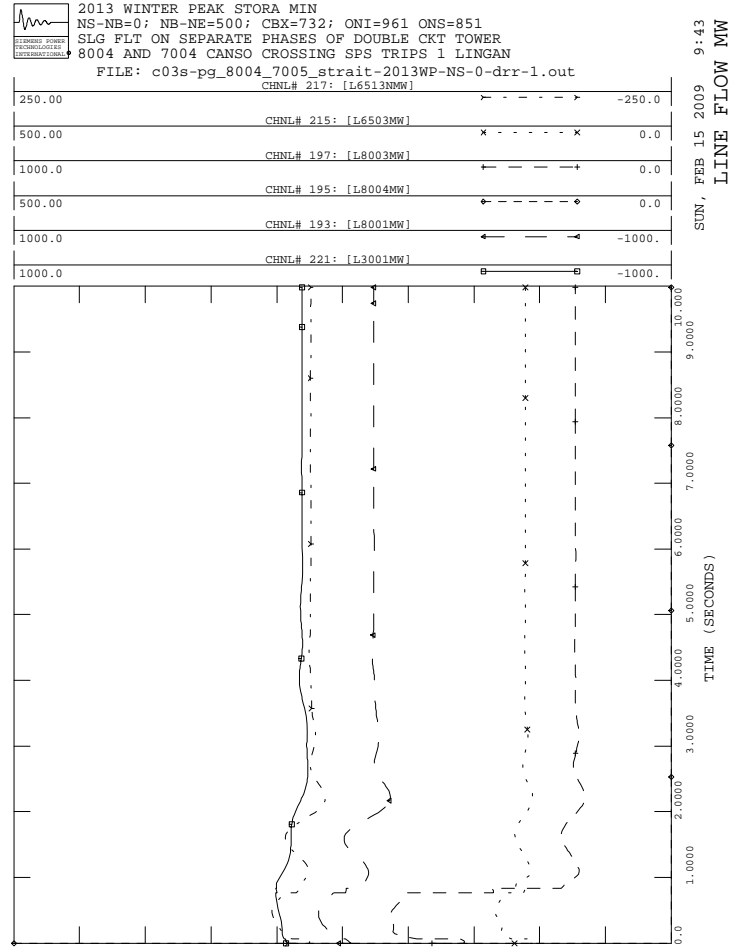
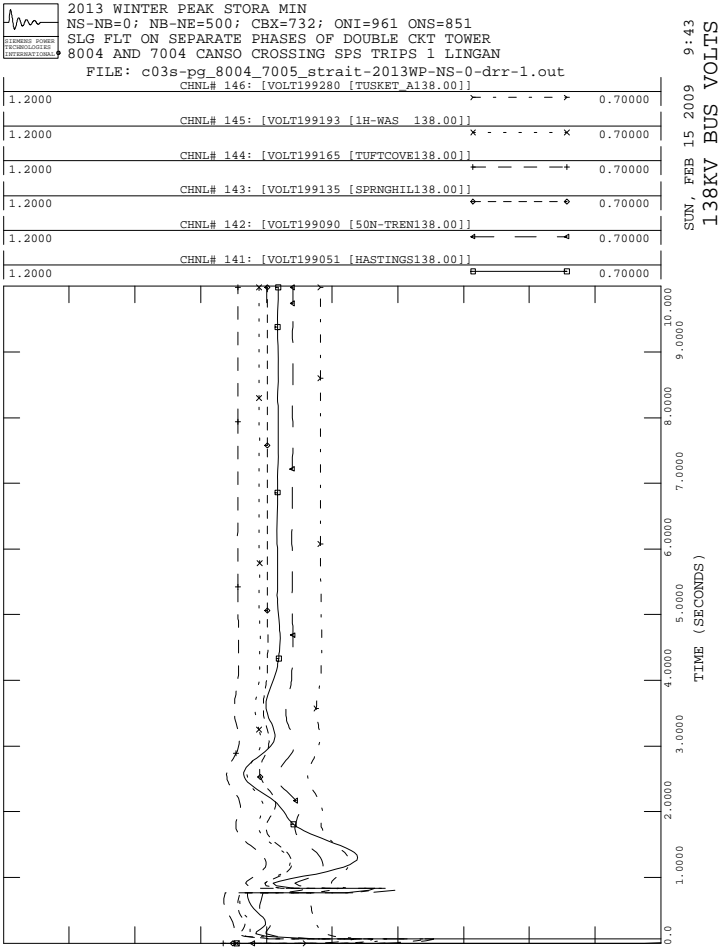

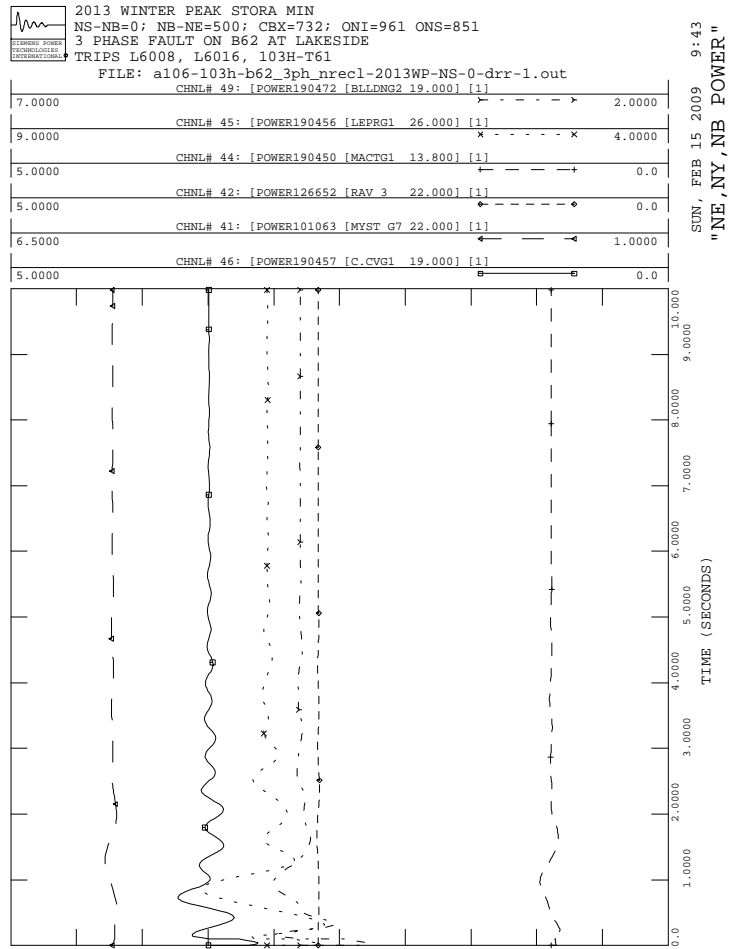
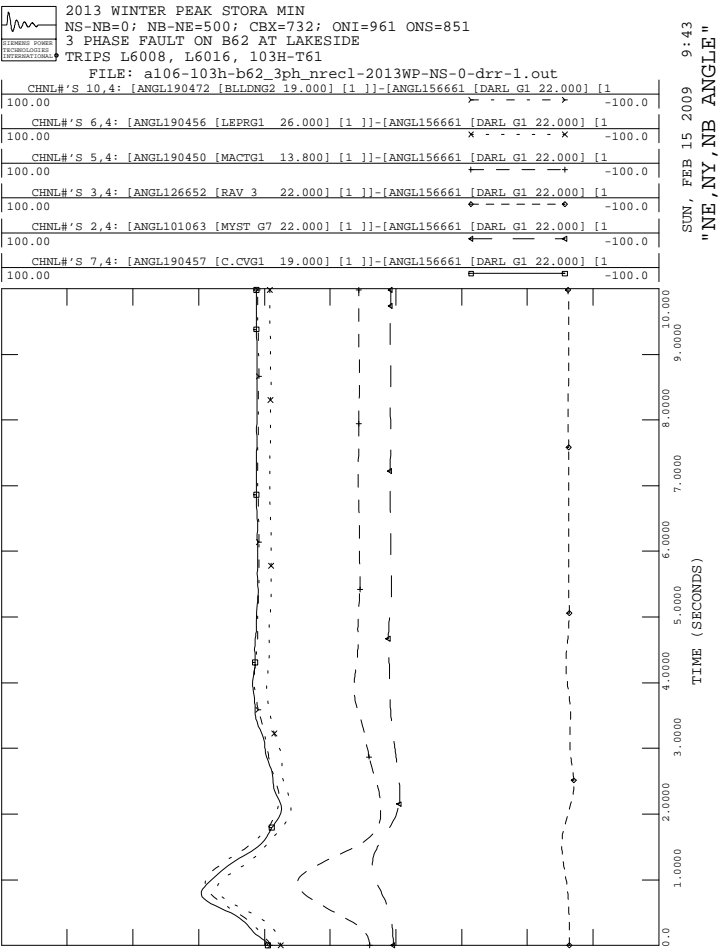
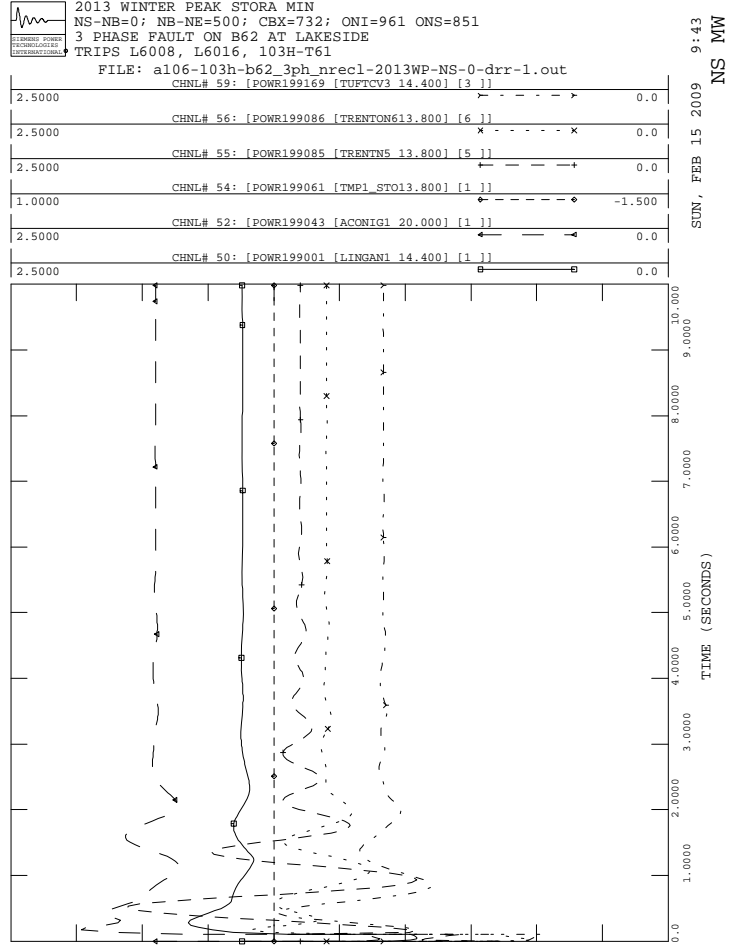
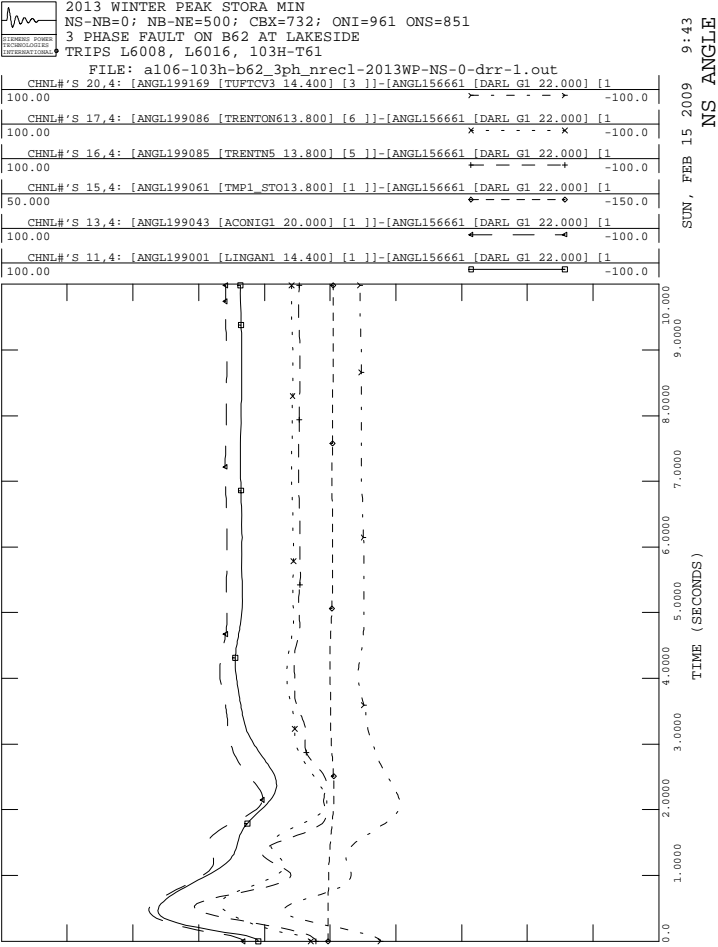



2013 WINTER PEAK STORA MIN
 NS-NB=0; NB-NE=500; CBX=732; ONI=961 ONS=851
 3 PHASE FAULT ON B62 AT LAKESIDE
 TRIPS L6008, L6016, 103H-T61

FILE: a106-103h-b62_3ph_nrecl-2013WP-NS-0-drr-1.out
 CHNL# 119: [VARS IR141-DIGBY]

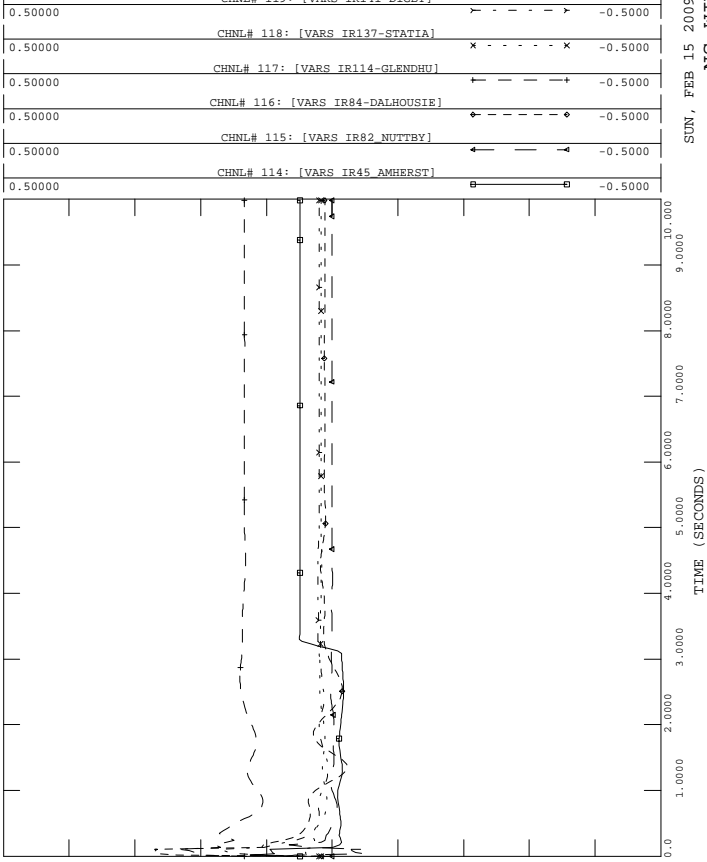

SUN, FEB 15 2009 9:43
 NS WIND MV



2013 WINTER PEAK STORA MIN
 NS-NB=0; NB-NE=500; CBX=732; ONI=961 ONS=851
 3 PHASE FAULT ON B62 AT LAKESIDE
 TRIPS L6008, L6016, 103H-T61

FILE: a106-103h-b62_3ph_nrecl-2013WP-NS-0-drr-1.out
 CHNL# 133: [VOLT199125 [ONSLOW 345.00]]

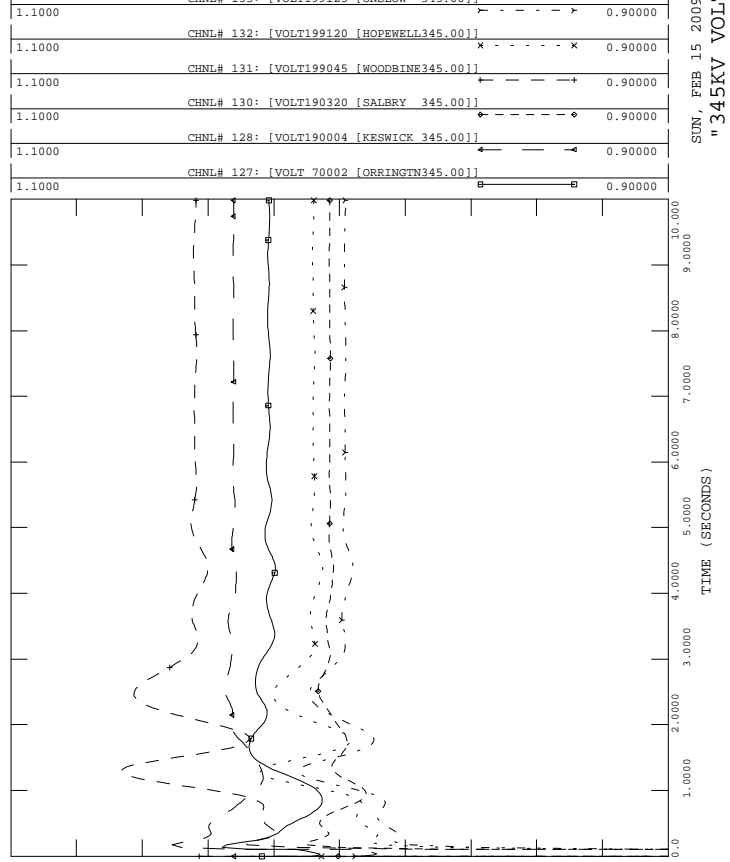

SUN, FEB 15 2009 9:43
 "# 345KV VOLTAGE"



2013 WINTER PEAK STORA MIN
 NS-NB=0; NB-NE=500; CBX=732; ONI=961 ONS=851
 3 PHASE FAULT ON B62 AT LAKESIDE
 TRIPS L6008, L6016, 103H-T61

FILE: a106-103h-b62_3ph_nrecl-2013WP-NS-0-drr-1.out
 CHNL# 79: [POWER IR141-DIGBY]

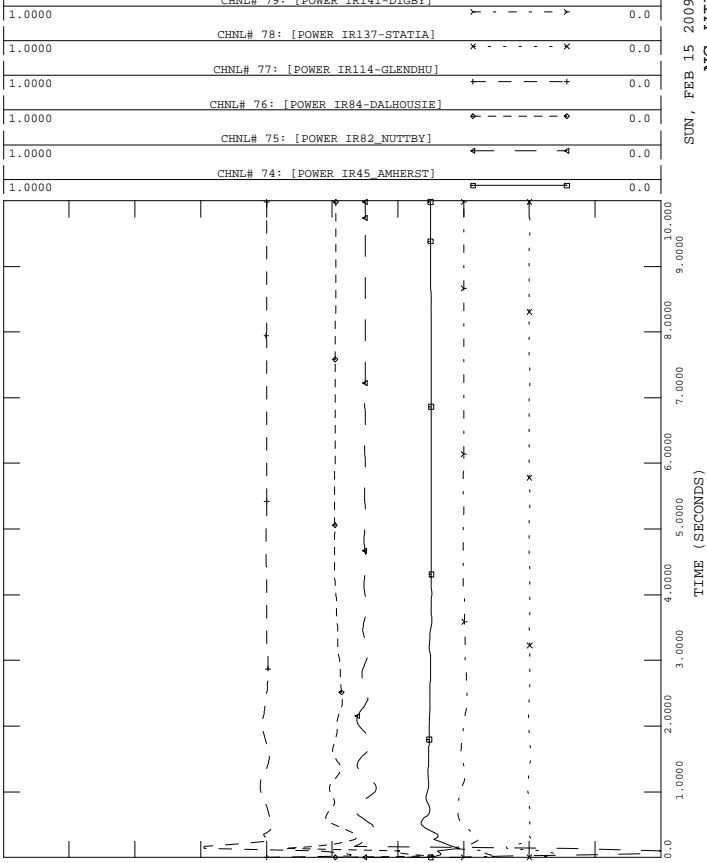

SUN, FEB 15 2009 9:43
 NS WIND MW



2013 WINTER PEAK STORA MIN
 NS-NB=0; NB-NE=500; CBX=732; ONI=961 ONS=851
 3 PHASE FAULT ON B62 AT LAKESIDE
 TRIPS L6008, L6016, 103H-T61

FILE: a106-103h-b62_3ph_nrecl-2013WP-NS-0-drr-1.out
 CHNL# 125: 60*(1+[FREQ199125 [ONSLOW 345.00]])

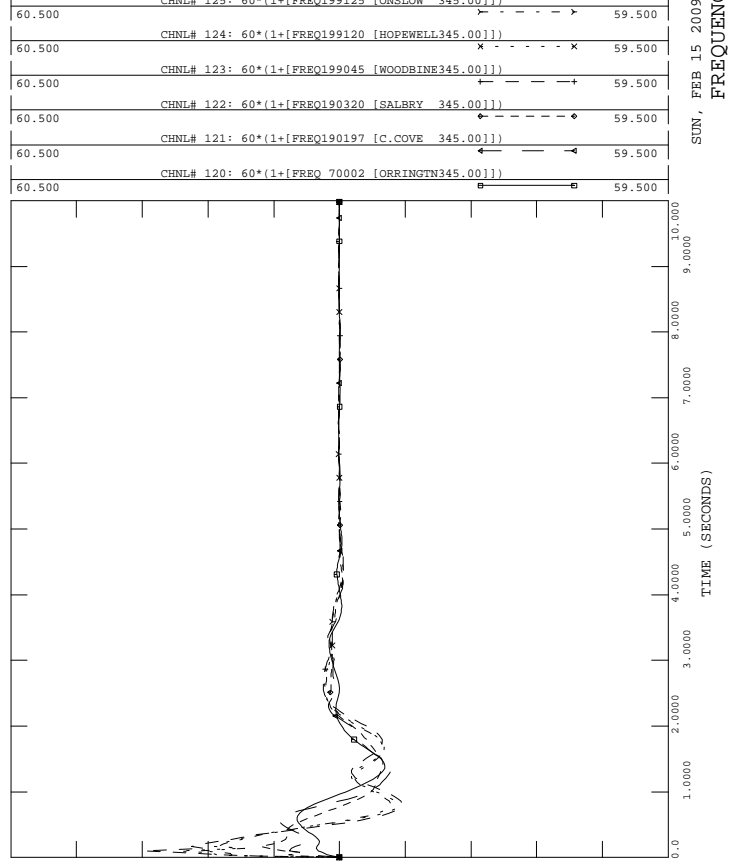

SUN, FEB 15 2009 9:43
 FREQUENCY HZ



2013 WINTER PEAK STORA MIN
NS-NB=0; NB-NE=500; CBX=732; ONI=961 ONS=851
3 PHASE FAULT ON B62 AT LAKESIDE
TRIPS L6008, L6016, 103H-T61

FILE: a106-103h-b62_3ph_nrecl-2013WP-NS-0-drr-1.out
CHNL# 146: [VOLT199280 [TUSKET A138.00]]

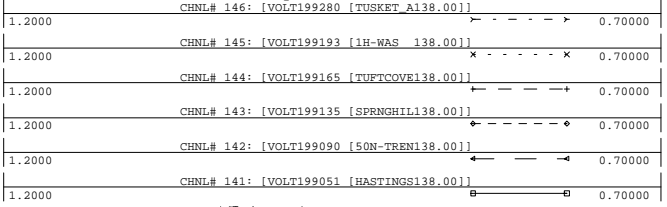

SUN, FEB 15 2009 9:43
138KV BUS VOLTS



2013 WINTER PEAK STORA MIN
NS-NB=0; NB-NE=500; CBX=732; ONI=961 ONS=851
3 PHASE FAULT ON B62 AT LAKESIDE
TRIPS L6008, L6016, 103H-T61

FILE: a106-103h-b62_3ph_nrecl-2013WP-NS-0-drr-1.out
CHNL# 217: [L6513NMW]

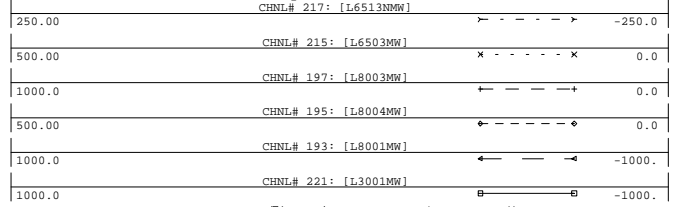

SUN, FEB 15 2009 9:43
LINE FLOW MW



2013 WINTER PEAK STORA MIN
NS-NB=0; NB-NE=500; CBX=732; ONI=961 ONS=851
3 PHASE FAULT ON B62 AT LAKESIDE
TRIPS L6008, L6016, 103H-T61

FILE: a106-103h-b62_3ph_nrecl-2013WP-NS-0-drr-1.out
CHNL# 140: [VOLT199240 [BWATER A230.00]]

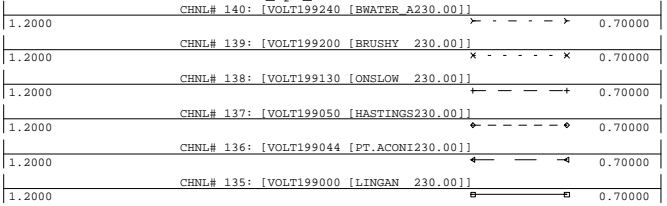

SUN, FEB 15 2009 9:43
230KV BUS VOLTS



2013 WINTER PEAK STORA MIN
NS-NB=0; NB-NE=500; CBX=732; ONI=961 ONS=851
3 PHASE FAULT ON B62 AT LAKESIDE
TRIPS L6008, L6016, 103H-T61

FILE: a106-103h-b62_3ph_nrecl-2013WP-NS-0-drr-1.out
CHNL# 154: [IR141-DIGBYH69.0 VOLTS]

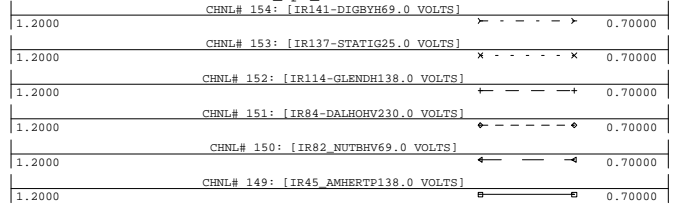

SUN, FEB 15 2009 9:43
WIND BUS VOLTS

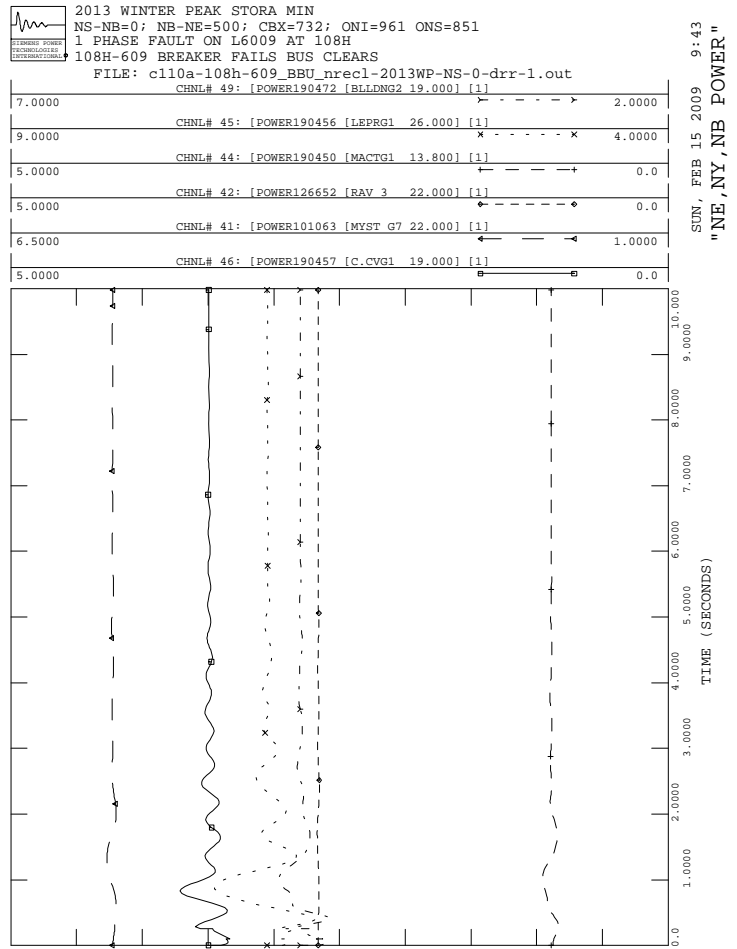
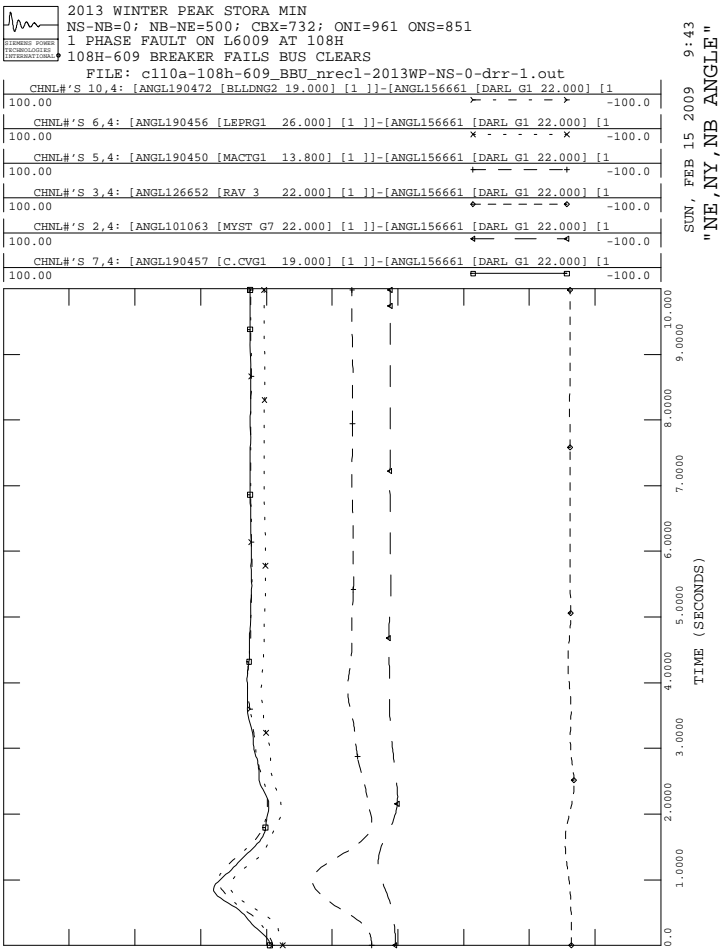
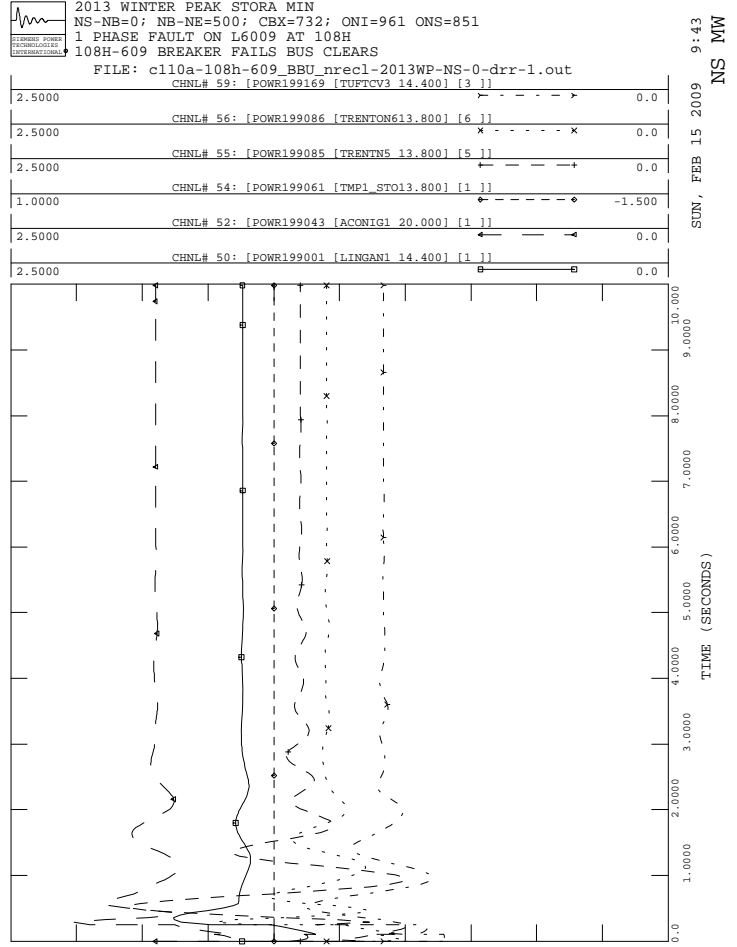
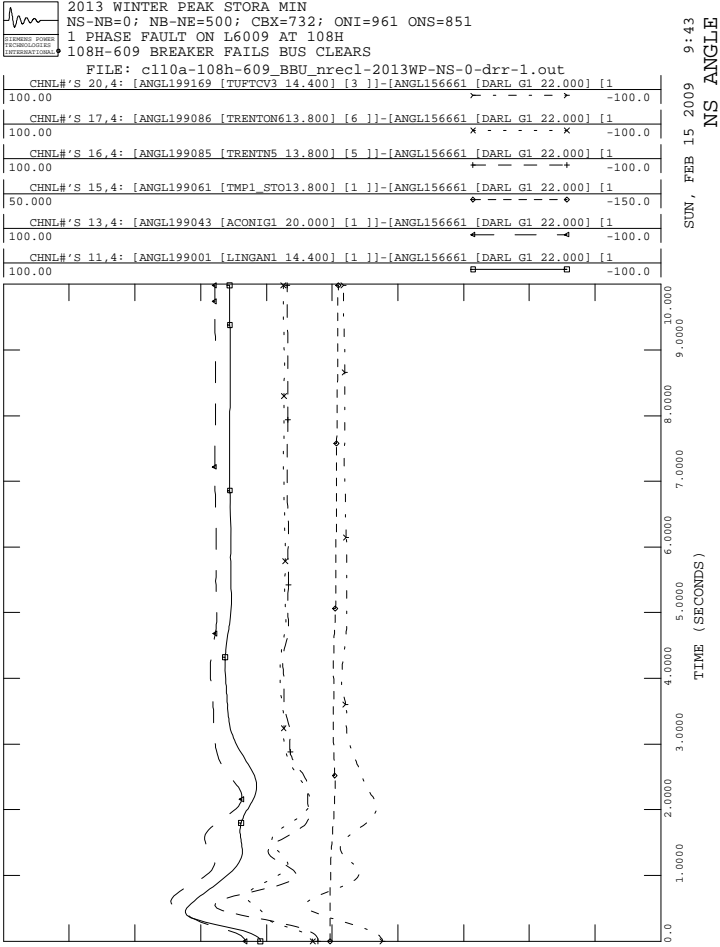



2013 WINTER PEAK STORA MIN
NS-NB=0; NB-NE=500; CBX=732; ONI=961 ONS=851
1 PHASE FAULT ON L6009 AT 108H
108H-609 BREAKER FAILS BUS CLEARS

FILE: c110a-108h-609_BBU_nrecl-2013WP-NS-0-drr-1.out
CHNL# 119: [VARS IR141-DIGBY]

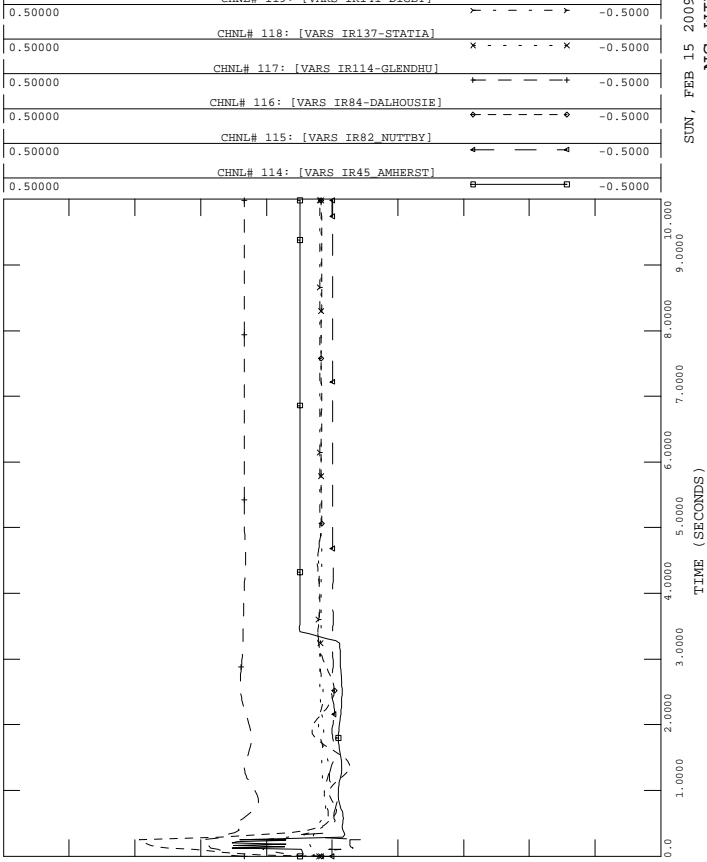

SUN, FEB 15 2009 9:43
NS WIND MV



2013 WINTER PEAK STORA MIN
NS-NB=0; NB-NE=500; CBX=732; ONI=961 ONS=851
1 PHASE FAULT ON L6009 AT 108H
108H-609 BREAKER FAILS BUS CLEARS

FILE: c110a-108h-609_BBU_nrecl-2013WP-NS-0-drr-1.out
CHNL# 133: [VOLT199125 [ONSLow 345.00]]

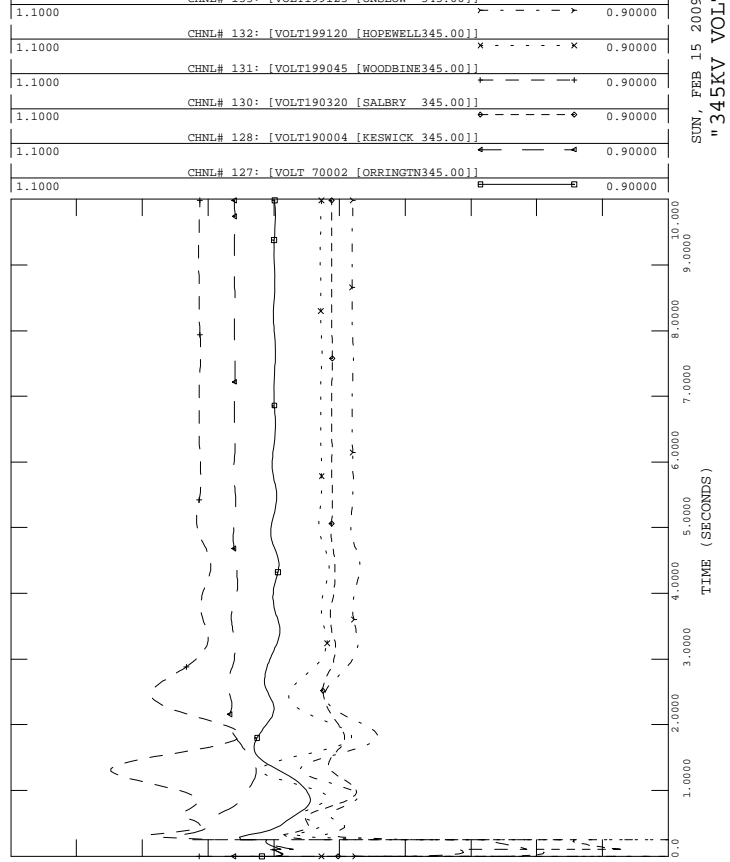

SUN, FEB 15 2009 9:43
" 345KV VOLTAGE "



2013 WINTER PEAK STORA MIN
NS-NB=0; NB-NE=500; CBX=732; ONI=961 ONS=851
1 PHASE FAULT ON L6009 AT 108H
108H-609 BREAKER FAILS BUS CLEARS

FILE: c110a-108h-609_BBU_nrecl-2013WP-NS-0-drr-1.out
CHNL# 79: [POWER IR141-DIGBY]

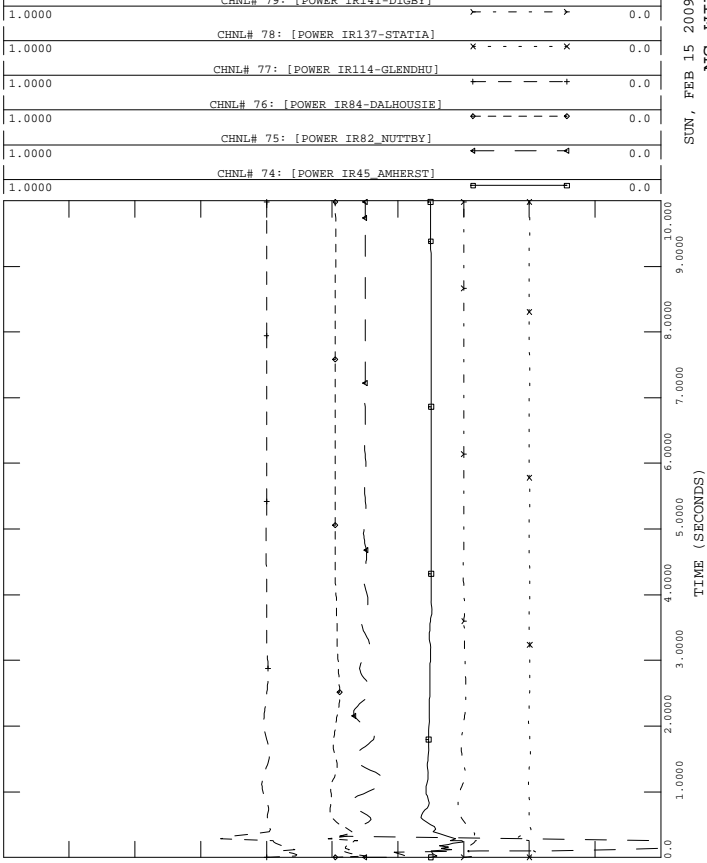

SUN, FEB 15 2009 9:43
NS WIND MW



2013 WINTER PEAK STORA MIN
NS-NB=0; NB-NE=500; CBX=732; ONI=961 ONS=851
1 PHASE FAULT ON L6009 AT 108H
108H-609 BREAKER FAILS BUS CLEARS

FILE: c110a-108h-609_BBU_nrecl-2013WP-NS-0-drr-1.out
CHNL# 125: 60*(1+[FREQ199125 [ONSLow 345.00]])

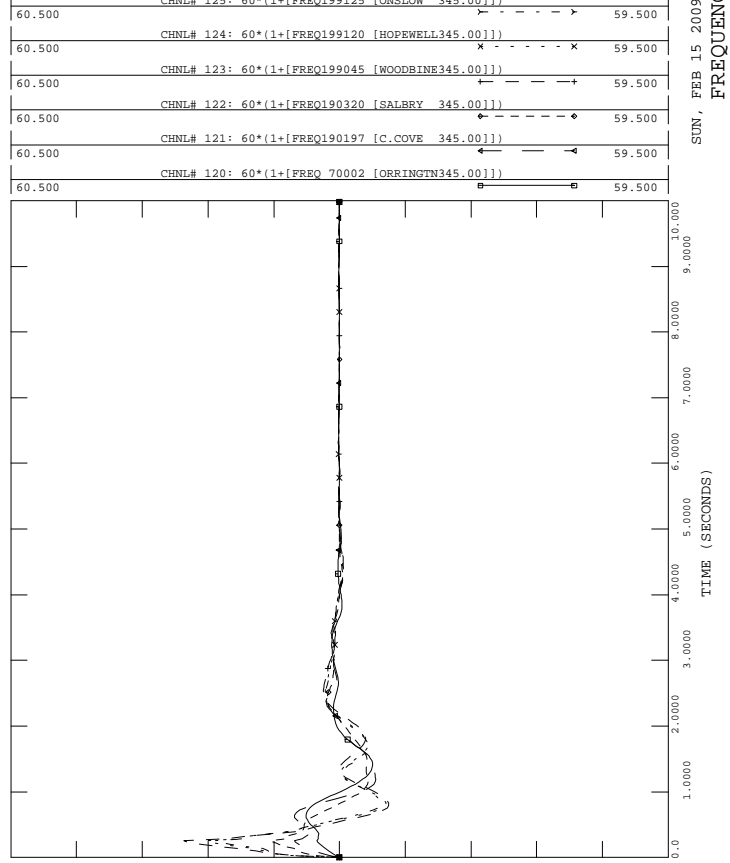

SUN, FEB 15 2009 9:43
FREQUENCY HZ



2013 WINTER PEAK STORA MIN
NS-NB=0; NB-NE=500; CBX=732; ONI=961 ONS=851
1 PHASE FAULT ON L6009 AT 108H
108H-609 BREAKER FAILS BUS CLEARS

FILE: c110a-108h-609_BBU_nrecl-2013WP-NS-0-drr-1.out
CHNL# 146: [VOLT199280 [TUSKET_A138.00]]

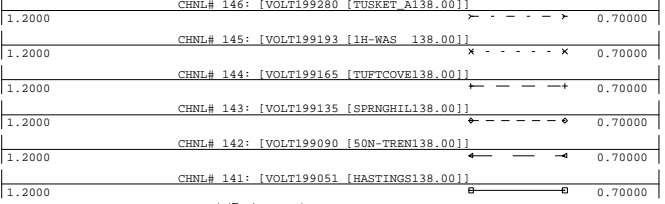

SUN, FEB 15 2009 9:43
138KV BUS VOLTS



2013 WINTER PEAK STORA MIN
NS-NB=0; NB-NE=500; CBX=732; ONI=961 ONS=851
1 PHASE FAULT ON L6009 AT 108H
108H-609 BREAKER FAILS BUS CLEARS

FILE: c110a-108h-609_BBU_nrecl-2013WP-NS-0-drr-1.out
CHNL# 217: [L6513NMW]

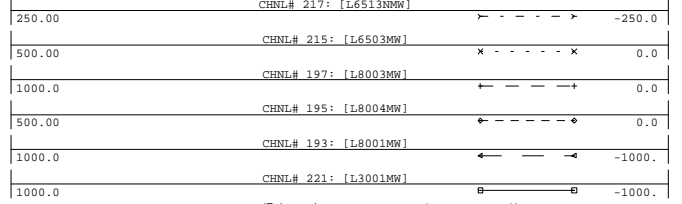

SUN, FEB 15 2009 9:43
LINE FLOW MW



2013 WINTER PEAK STORA MIN
NS-NB=0; NB-NE=500; CBX=732; ONI=961 ONS=851
1 PHASE FAULT ON L6009 AT 108H
108H-609 BREAKER FAILS BUS CLEARS

FILE: c110a-108h-609_BBU_nrecl-2013WP-NS-0-drr-1.out
CHNL# 140: [VOLT199240 [BWATER_A230.00]]

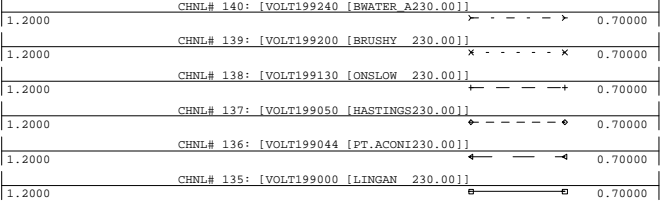

SUN, FEB 15 2009 9:43
230KV BUS VOLTS



2013 WINTER PEAK STORA MIN
NS-NB=0; NB-NE=500; CBX=732; ONI=961 ONS=851
1 PHASE FAULT ON L6009 AT 108H
108H-609 BREAKER FAILS BUS CLEARS

FILE: c110a-108h-609_BBU_nrecl-2013WP-NS-0-drr-1.out
CHNL# 154: [IR141-DIGBYH69.0 VOLTS]

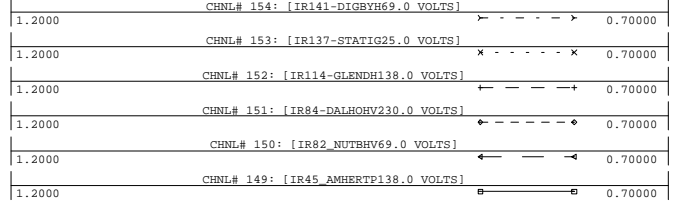

SUN, FEB 15 2009 9:43
WIND BUS VOLTS



2013 WINTER PEAK STORA MIN
NS-NB=0; NB-NE=500; CBX=732; ONI=961 ONS=851
3 PHASE FAULT ON WEST END OF L7004 AT 67N
OPENS IN 5.5 CYCLES

FILE: a99.1-7004w_3ph_67N-2013WP-NS-0-drr-1.out

CHNL# 'S 20,4:	[ANGL199169 [TUFTCV3 14.400] [3]]-[ANGL156661 [DARL G1 22.000] [1]]	-100.0
CHNL# 'S 17,4:	[ANGL199086 [TRENTON613.800] [6]]-[ANGL156661 [DARL G1 22.000] [1]]	-100.0
CHNL# 'S 16,4:	[ANGL199085 [TRENTN5 13.800] [5]]-[ANGL156661 [DARL G1 22.000] [1]]	-100.0
CHNL# 'S 15,4:	[ANGL199061 [TMP1_STO13.800] [1]]-[ANGL156661 [DARL G1 22.000] [1]]	-150.0
CHNL# 'S 13,4:	[ANGL199043 [ACONIG1 20.000] [1]]-[ANGL156661 [DARL G1 22.000] [1]]	-100.0
CHNL# 'S 11,4:	[ANGL199001 [LINGANI 14.400] [1]]-[ANGL156661 [DARL G1 22.000] [1]]	-100.0

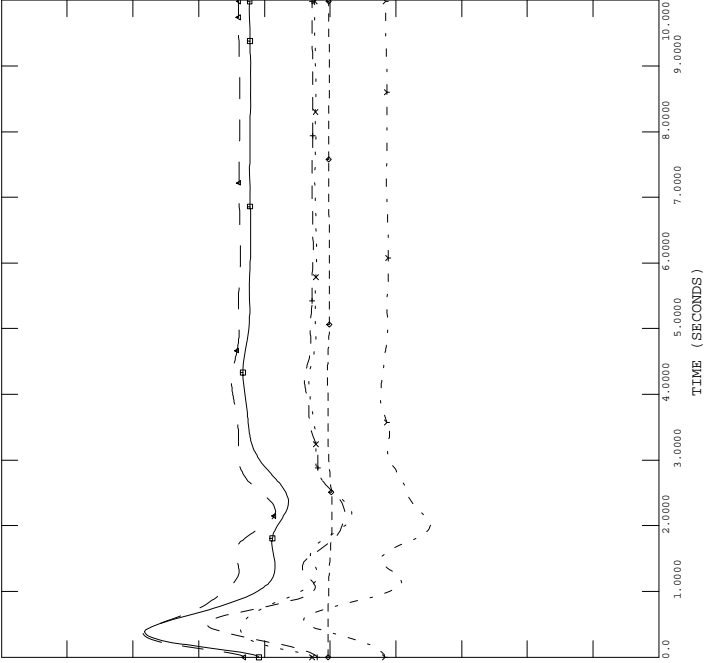

NS ANGLE
SUN, FEB 15 2009 9:43



2013 WINTER PEAK STORA MIN
NS-NB=0; NB-NE=500; CBX=732; ONI=961 ONS=851
3 PHASE FAULT ON WEST END OF L7004 AT 67N
OPENS IN 5.5 CYCLES

FILE: a99.1-7004w_3ph_67N-2013WP-NS-0-drr-1.out

CHNL# 56:	[POWR199086 [TRENTON613.800] [6]]	0.0
CHNL# 55:	[POWR199085 [TRENTN5 13.800] [5]]	0.0
CHNL# 54:	[POWR199061 [TMP1_STO13.800] [1]]	0.0
CHNL# 52:	[POWR199043 [ACONIG1 20.000] [1]]	-1.500
CHNL# 50:	[POWR199001 [LINGANI 14.400] [1]]	0.0

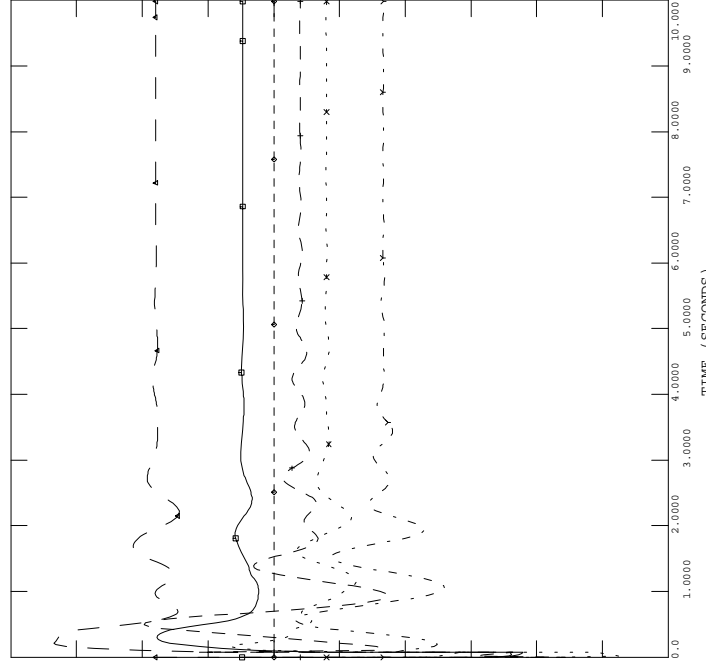

NS MW
SUN, FEB 15 2009 9:43



2013 WINTER PEAK STORA MIN
NS-NB=0; NB-NE=500; CBX=732; ONI=961 ONS=851
3 PHASE FAULT ON WEST END OF L7004 AT 67N
OPENS IN 5.5 CYCLES

FILE: a99.1-7004w_3ph_67N-2013WP-NS-0-drr-1.out

CHNL# 'S 10,4:	[ANGL190472 [BLDNG2 19.000] [1]]-[ANGL156661 [DARL G1 22.000] [1]]	-100.0
CHNL# 'S 6,4:	[ANGL190456 [LEPRG1 26.000] [1]]-[ANGL156661 [DARL G1 22.000] [1]]	-100.0
CHNL# 'S 5,4:	[ANGL190450 [MACTG1 13.800] [1]]-[ANGL156661 [DARL G1 22.000] [1]]	-100.0
CHNL# 'S 3,4:	[ANGL126652 [RAV 3 22.000] [1]]-[ANGL156661 [DARL G1 22.000] [1]]	-100.0
CHNL# 'S 2,4:	[ANGL101063 [MYST G7 22.000] [1]]-[ANGL156661 [DARL G1 22.000] [1]]	-100.0
CHNL# 'S 7,4:	[ANGL190457 [C.CVG1 19.000] [1]]-[ANGL156661 [DARL G1 22.000] [1]]	-100.0

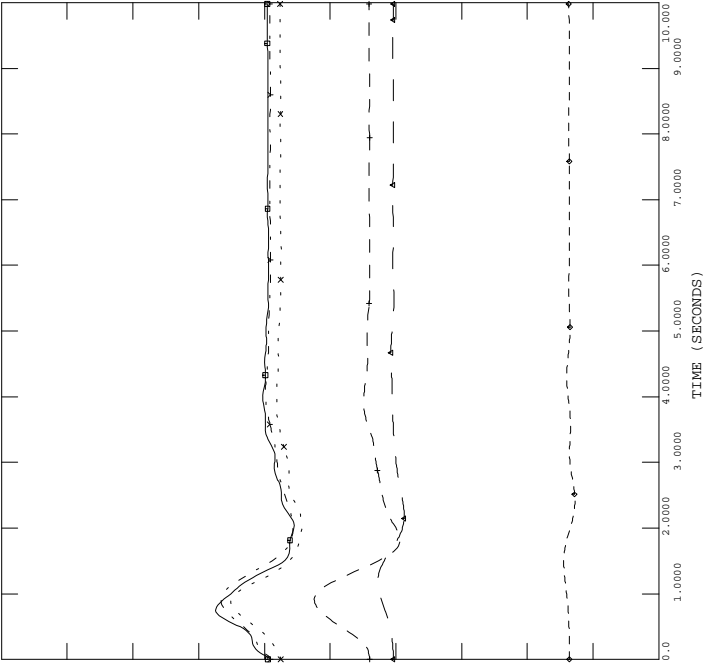

"NE, NY, NB ANGLE"
SUN, FEB 15 2009 9:43



2013 WINTER PEAK STORA MIN
NS-NB=0; NB-NE=500; CBX=732; ONI=961 ONS=851
3 PHASE FAULT ON WEST END OF L7004 AT 67N
OPENS IN 5.5 CYCLES

FILE: a99.1-7004w_3ph_67N-2013WP-NS-0-drr-1.out

CHNL# 49:	[POWER190472 [BLDNG2 19.000] [1]]	2.0000
CHNL# 45:	[POWER190456 [LEPRG1 26.000] [1]]	4.0000
CHNL# 44:	[POWER190450 [MACTG1 13.800] [1]]	0.0
CHNL# 42:	[POWER126652 [RAV 3 22.000] [1]]	0.0
CHNL# 41:	[POWER101063 [MYST G7 22.000] [1]]	0.0
CHNL# 46:	[POWER190457 [C.CVG1 19.000] [1]]	1.0000

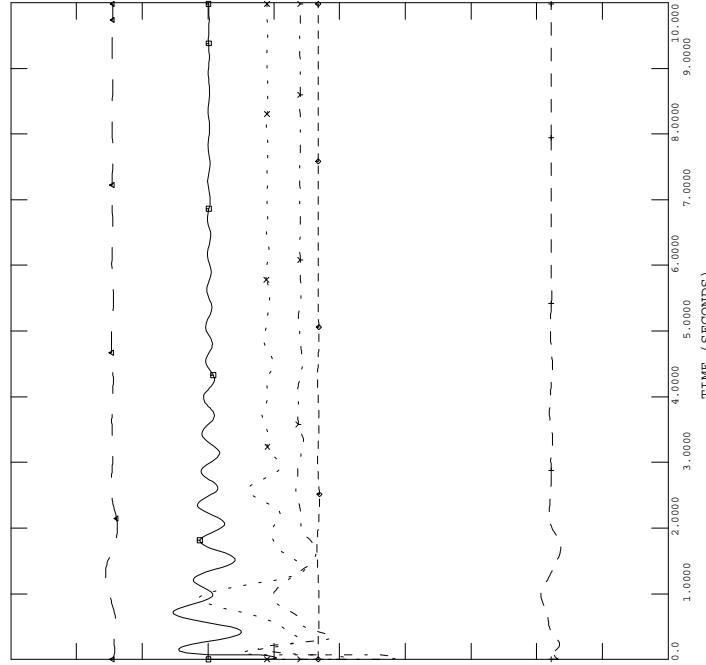

"NE, NY, NB POWER"
SUN, FEB 15 2009 9:43



2013 WINTER PEAK STORA MIN
 NS-NB=0; NB-NE=500; CBX=732; ONI=961 ONS=851
 3 PHASE FAULT ON WEST END OF L7004 AT 67N
 OPENS IN 5.5 CYCLES

FILE: a99.1-7004w_3ph_67N-2013WP-NS-0-drr-1.out
 CHNL# 119: [VARS IR141-DIGBY]

SUN, FEB 15 2009 9:43
 NS WIND MV

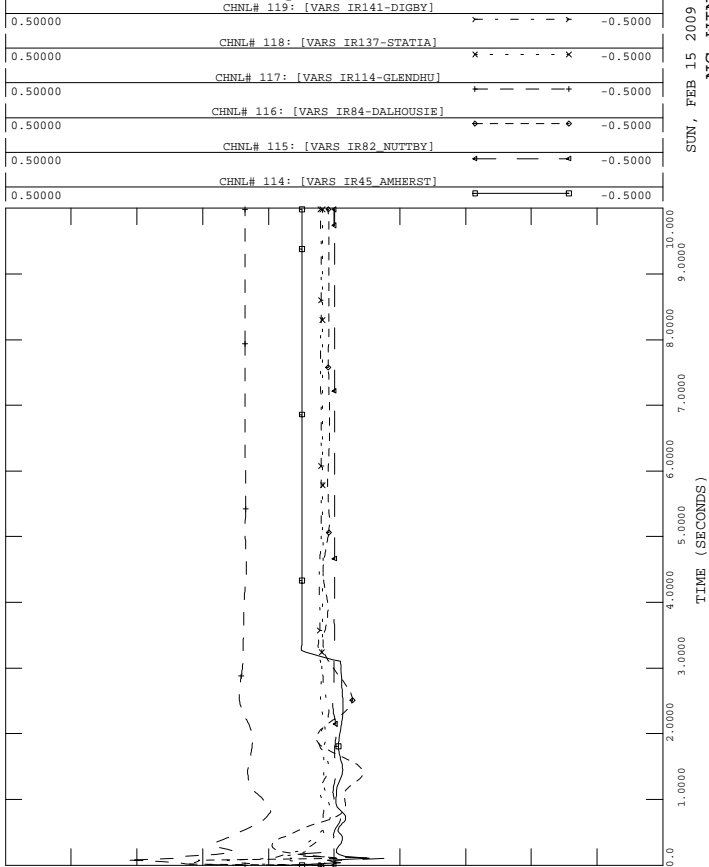

2013 WINTER PEAK STORA MIN
 NS-NB=0; NB-NE=500; CBX=732; ONI=961 ONS=851
 3 PHASE FAULT ON WEST END OF L7004 AT 67N
 OPENS IN 5.5 CYCLES

FILE: a99.1-7004w_3ph_67N-2013WP-NS-0-drr-1.out
 CHNL# 133: [VOLT199125 [ONSLow 345.00]]

SUN, FEB 15 2009 9:43
 "345KV VOLTAGE"

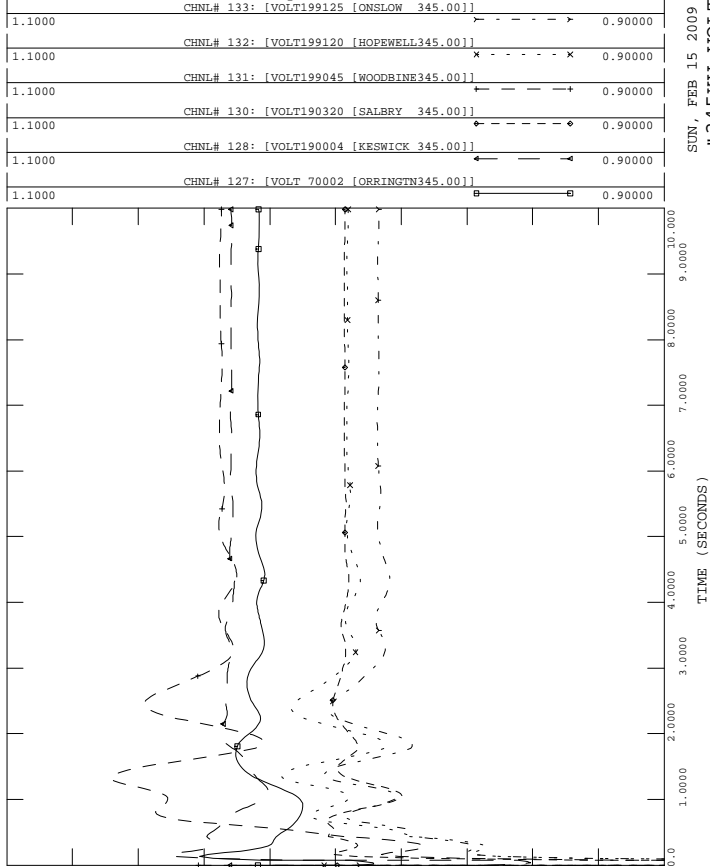

2013 WINTER PEAK STORA MIN
 NS-NB=0; NB-NE=500; CBX=732; ONI=961 ONS=851
 3 PHASE FAULT ON WEST END OF L7004 AT 67N
 OPENS IN 5.5 CYCLES

FILE: a99.1-7004w_3ph_67N-2013WP-NS-0-drr-1.out
 CHNL# 79: [POWER IR141-DIGBY]

SUN, FEB 15 2009 9:43
 NS WIND MW

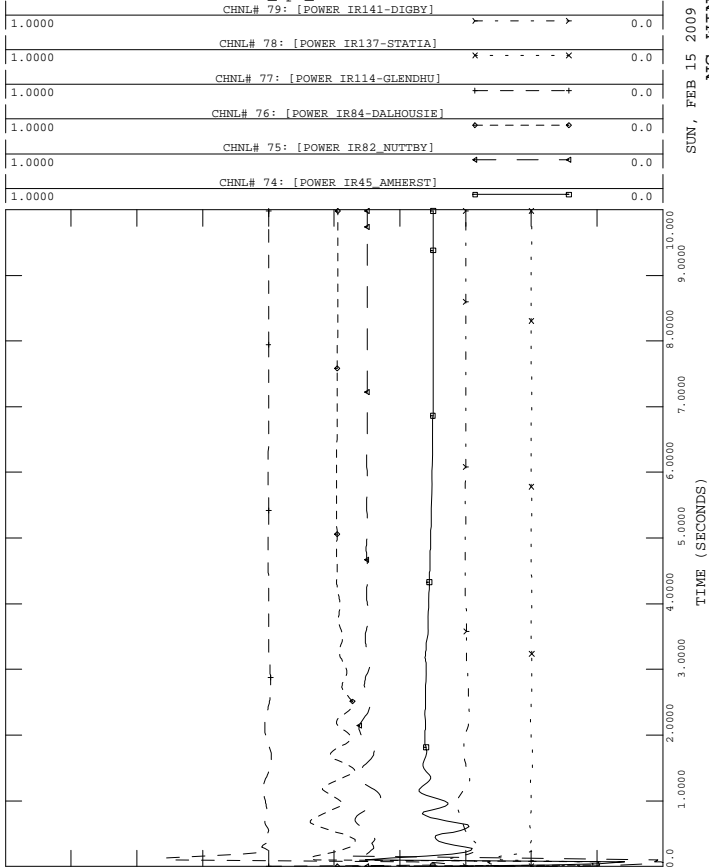

2013 WINTER PEAK STORA MIN
 NS-NB=0; NB-NE=500; CBX=732; ONI=961 ONS=851
 3 PHASE FAULT ON WEST END OF L7004 AT 67N
 OPENS IN 5.5 CYCLES

FILE: a99.1-7004w_3ph_67N-2013WP-NS-0-drr-1.out
 CHNL# 125: 60*(1+[FREQ199125 [ONSLow 345.00]])

SUN, FEB 15 2009 9:43
 FREQUENCY HZ

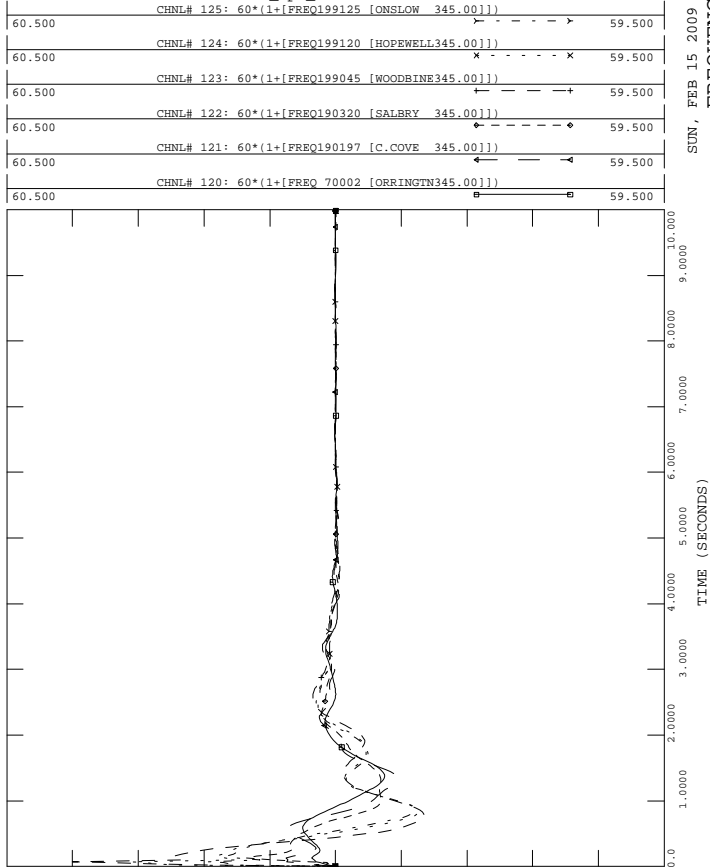



2013 WINTER PEAK STORA MIN
 NS-NB=0; NB-NE=500; CBX=732; ONI=961 ONS=851
 3 PHASE FAULT ON WEST END OF L7004 AT 67N
 OPENS IN 5.5 CYCLES

FILE: a99.1-7004w_3ph_67N-2013WP-NS-0-drr-1.out

1.2000	CHNL# 145: [VOLT199193 [1H-WAS 138.00]]	0.70000
1.2000	CHNL# 144: [VOLT199165 [TUFTCOVER138.00]]	0.70000
1.2000	CHNL# 143: [VOLT199135 [SPRNGHIL138.00]]	0.70000
1.2000	CHNL# 142: [VOLT199090 [50N-TREN138.00]]	0.70000
1.2000	CHNL# 141: [VOLT199051 [HASTINGS138.00]]	0.70000
1.2000	CHNL# 146: [VOLT199280 [TUSKET_A138.00]]	0.70000

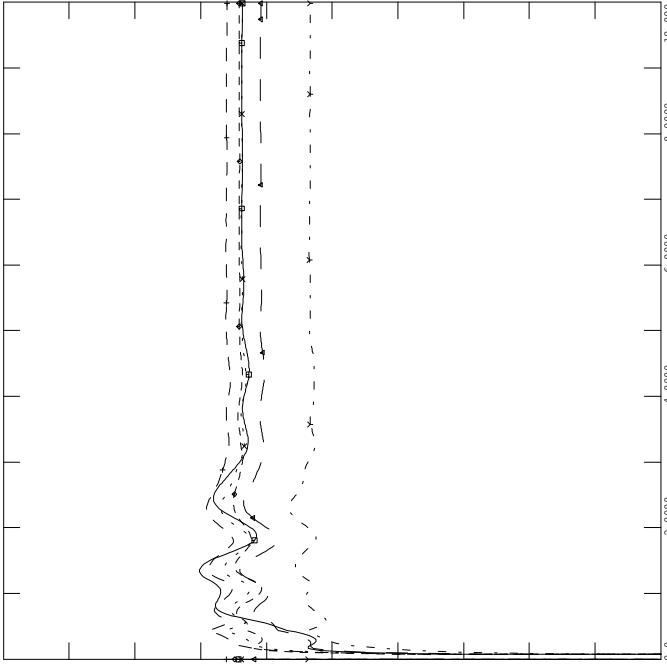

SUN, FEB 15 2009 9:43
 138KV BUS VOLTS



2013 WINTER PEAK STORA MIN
 NS-NB=0; NB-NE=500; CBX=732; ONI=961 ONS=851
 3 PHASE FAULT ON WEST END OF L7004 AT 67N
 OPENS IN 5.5 CYCLES

FILE: a99.1-7004w_3ph_67N-2013WP-NS-0-drr-1.out

250.00	CHNL# 215: [L6503MM]	-250.0
500.00	CHNL# 197: [L8003MM]	0.0
1000.00	CHNL# 195: [L8004MM]	0.0
500.00	CHNL# 193: [L8001MM]	0.0
1000.00	CHNL# 221: [L3001MM]	-1000.0
1000.00	CHNL# 217: [L6513MM]	-1000.0

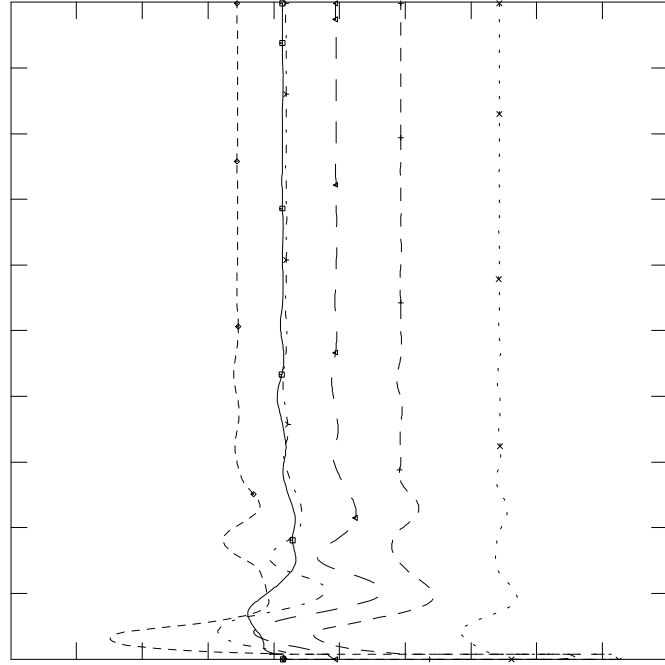

SUN, FEB 15 2009 9:43
 LINE FLOW MW



2013 WINTER PEAK STORA MIN
 NS-NB=0; NB-NE=500; CBX=732; ONI=961 ONS=851
 3 PHASE FAULT ON WEST END OF L7004 AT 67N
 OPENS IN 5.5 CYCLES

FILE: a99.1-7004w_3ph_67N-2013WP-NS-0-drr-1.out

1.2000	CHNL# 140: [VOLT199240 [BWATER A230.00]]	0.70000
1.2000	CHNL# 139: [VOLT199200 [BRUSHY 230.00]]	0.70000
1.2000	CHNL# 138: [VOLT199130 [ONSLow 230.00]]	0.70000
1.2000	CHNL# 137: [VOLT199050 [HASTINGS230.00]]	0.70000
1.2000	CHNL# 136: [VOLT199044 [PT.ACON1230.00]]	0.70000
1.2000	CHNL# 135: [VOLT199000 [LINGAN 230.00]]	0.70000

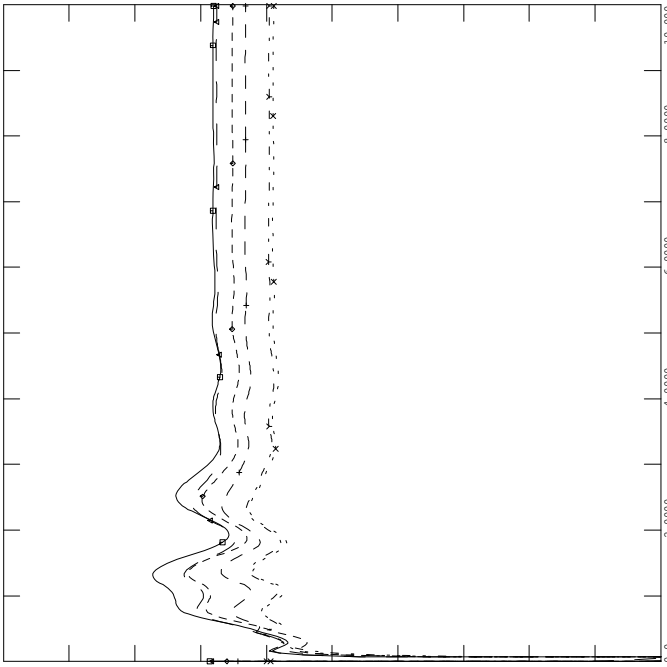

SUN, FEB 15 2009 9:43
 230KV BUS VOLTS



2013 WINTER PEAK STORA MIN
 NS-NB=0; NB-NE=500; CBX=732; ONI=961 ONS=851
 3 PHASE FAULT ON WEST END OF L7004 AT 67N
 OPENS IN 5.5 CYCLES

FILE: a99.1-7004w_3ph_67N-2013WP-NS-0-drr-1.out

1.2000	CHNL# 154: [IR141-DIGBYH69.0 VOLTS]	0.70000
1.2000	CHNL# 153: [IR137-STATIG25.0 VOLTS]	0.70000
1.2000	CHNL# 152: [IR114-GLENDH138.0 VOLTS]	0.70000
1.2000	CHNL# 151: [IR84-DALHOHV230.0 VOLTS]	0.70000
1.2000	CHNL# 150: [IR82-NUTBHV69.0 VOLTS]	0.70000
1.2000	CHNL# 149: [IR45-AMHERTP138.0 VOLTS]	0.70000

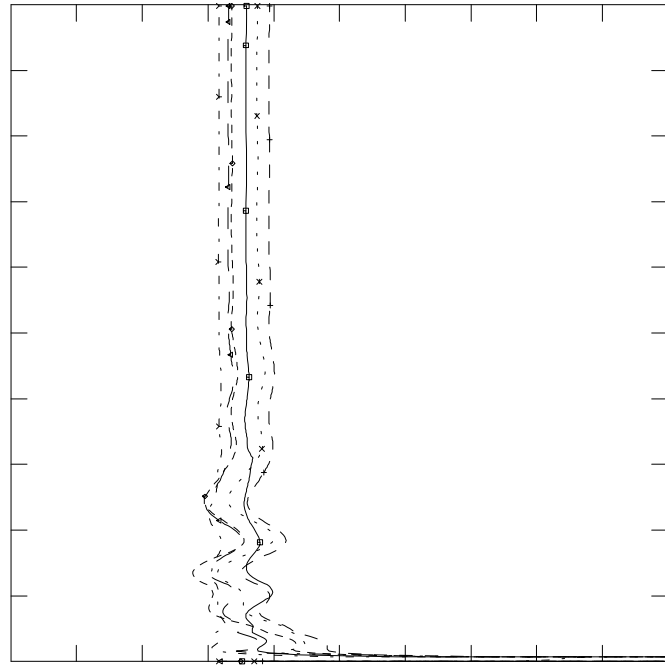

SUN, FEB 15 2009 9:43
 WIND BUS VOLTS



2013 WINTER PEAK STORA MIN
NS-NB=0; NB-NE=500; CBX=732; ONI=961 ONS=851
3 PHASE FAULT ON WEST END OF L7004 AT IR084
OPENS IN 5.5 CYCLES

FILE: a99.2-7004w_3ph_ir84-2013WP-NS-0-drr-1.out

CHNL#S 20,4:	[ANGL199169 [TUFTCV3 14.400] [3]]-[ANGL156661 [DARL G1 22.000] [1]]	-100.0
CHNL#S 17,4:	[ANGL199086 [TRENTON613.800] [6]]-[ANGL156661 [DARL G1 22.000] [1]]	-100.0
CHNL#S 16,4:	[ANGL199085 [TRENTN5 13.800] [5]]-[ANGL156661 [DARL G1 22.000] [1]]	-100.0
CHNL#S 15,4:	[ANGL199061 [TMP1 ST013.800] [1]]-[ANGL156661 [DARL G1 22.000] [1]]	-150.0
CHNL#S 13,4:	[ANGL199043 [ACONIG1 20.000] [1]]-[ANGL156661 [DARL G1 22.000] [1]]	-100.0
CHNL#S 11,4:	[ANGL199001 [LINGANI 14.400] [1]]-[ANGL156661 [DARL G1 22.000] [1]]	-100.0

NS ANGLE
SUN, FEB 15 2009 9:43

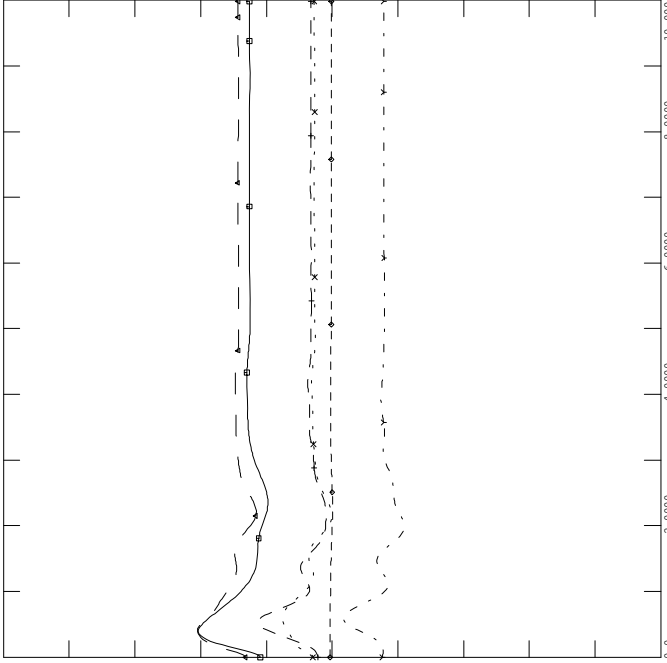

2013 WINTER PEAK STORA MIN
NS-NB=0; NB-NE=500; CBX=732; ONI=961 ONS=851
3 PHASE FAULT ON WEST END OF L7004 AT IR084
OPENS IN 5.5 CYCLES

FILE: a99.2-7004w_3ph_ir84-2013WP-NS-0-drr-1.out

CHNL# 56:	[POWR199086 [TRENTON613.800] [6]]	0.0
CHNL# 55:	[POWR199085 [TRENTN5 13.800] [5]]	0.0
CHNL# 54:	[POWR199061 [TMP1 ST013.800] [1]]	0.0
CHNL# 52:	[POWR199043 [ACONIG1 20.000] [1]]	-1.500
CHNL# 50:	[POWR199001 [LINGANI 14.400] [1]]	0.0

NS MW
SUN, FEB 15 2009 9:43

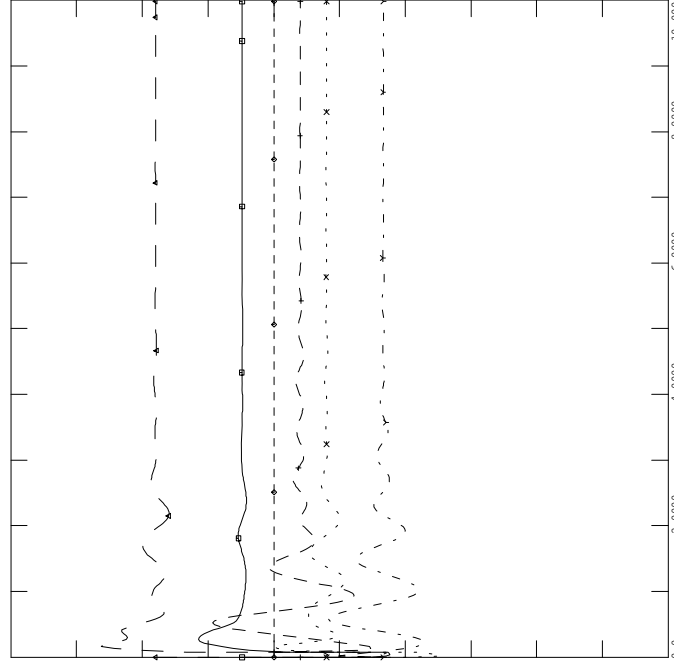

2013 WINTER PEAK STORA MIN
NS-NB=0; NB-NE=500; CBX=732; ONI=961 ONS=851
3 PHASE FAULT ON WEST END OF L7004 AT IR084
OPENS IN 5.5 CYCLES

FILE: a99.2-7004w_3ph_ir84-2013WP-NS-0-drr-1.out

CHNL#S 10,4:	[ANGL190472 [BILLDNG2 19.000] [1]]-[ANGL156661 [DARL G1 22.000] [1]]	-100.0
CHNL#S 6,4:	[ANGL190456 [LEPRG1 26.000] [1]]-[ANGL156661 [DARL G1 22.000] [1]]	-100.0
CHNL#S 5,4:	[ANGL190450 [MACTG1 13.800] [1]]-[ANGL156661 [DARL G1 22.000] [1]]	-100.0
CHNL#S 3,4:	[ANGL126652 [RAV 3 22.000] [1]]-[ANGL156661 [DARL G1 22.000] [1]]	-100.0
CHNL#S 2,4:	[ANGL101063 [MYST G7 22.000] [1]]-[ANGL156661 [DARL G1 22.000] [1]]	-100.0
CHNL#S 7,4:	[ANGL190457 [C.CVG1 19.000] [1]]-[ANGL156661 [DARL G1 22.000] [1]]	-100.0

"NE, NY, NB ANGLE"
SUN, FEB 15 2009 9:43

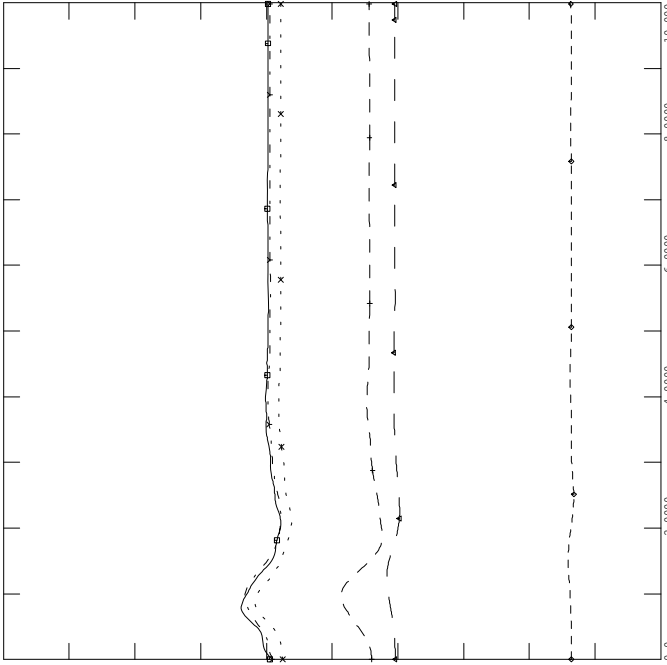

2013 WINTER PEAK STORA MIN
NS-NB=0; NB-NE=500; CBX=732; ONI=961 ONS=851
3 PHASE FAULT ON WEST END OF L7004 AT IR084
OPENS IN 5.5 CYCLES

FILE: a99.2-7004w_3ph_ir84-2013WP-NS-0-drr-1.out

CHNL# 49:	[POWER190472 [BILLDNG2 19.000] [1]]	2.0000
CHNL# 45:	[POWER190456 [LEPRG1 26.000] [1]]	4.0000
CHNL# 44:	[POWER190450 [MACTG1 13.800] [1]]	0.0
CHNL# 42:	[POWER126652 [RAV 3 22.000] [1]]	0.0
CHNL# 41:	[POWER101063 [MYST G7 22.000] [1]]	0.0
CHNL# 46:	[POWER190457 [C.CVG1 19.000] [1]]	1.0000

"NE, NY, NB POWER"
SUN, FEB 15 2009 9:43

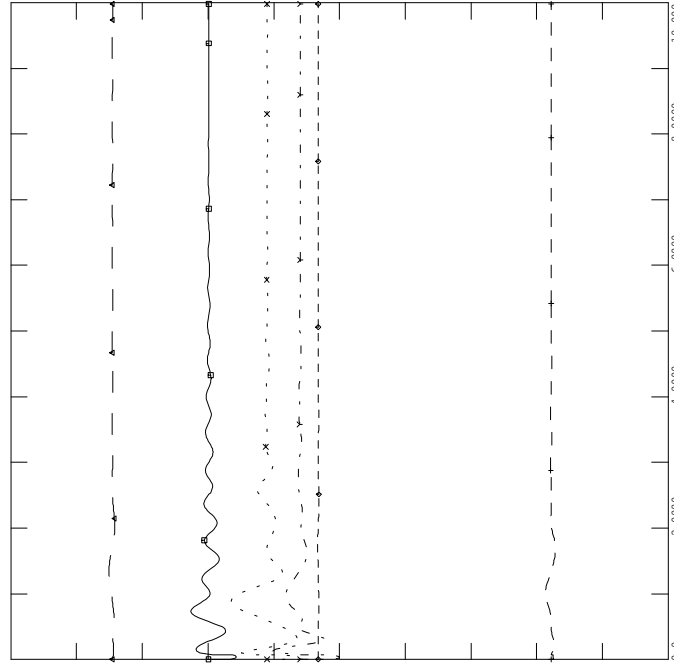



2013 WINTER PEAK STORA MIN
 NS-NB=0; NB-NE=500; CBX=732; ONI=961 ONS=851
 3 PHASE FAULT ON WEST END OF L7004 AT IR084
 OPENS IN 5.5 CYCLES

FILE: a99.2-7004w_3ph_ir84-2013WP-NS-0-drr-1.out

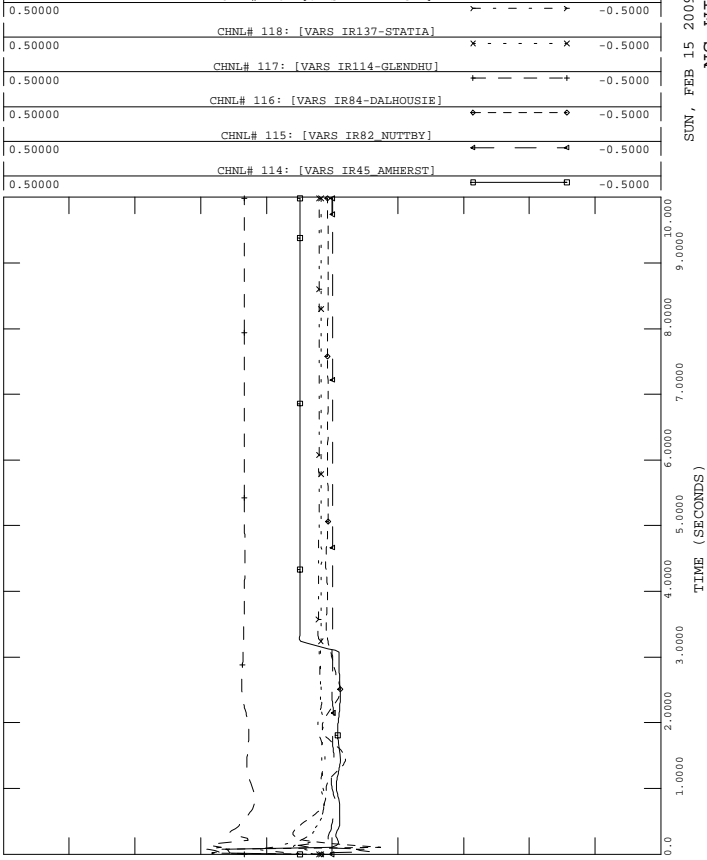

2013 WINTER PEAK STORA MIN
 NS-NB=0; NB-NE=500; CBX=732; ONI=961 ONS=851
 3 PHASE FAULT ON WEST END OF L7004 AT IR084
 OPENS IN 5.5 CYCLES

FILE: a99.2-7004w_3ph_ir84-2013WP-NS-0-drr-1.out

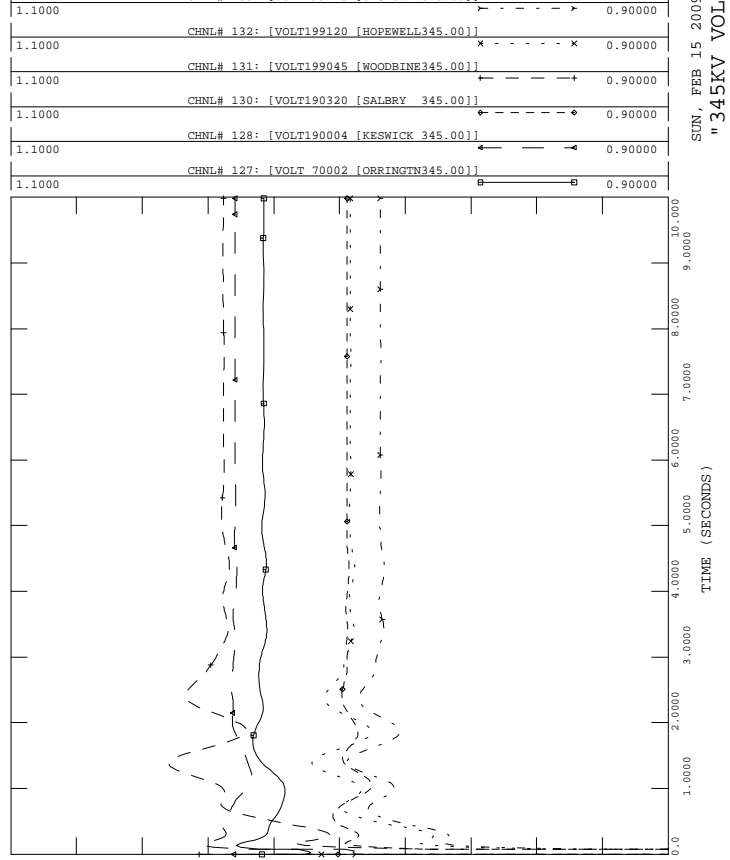

2013 WINTER PEAK STORA MIN
 NS-NB=0; NB-NE=500; CBX=732; ONI=961 ONS=851
 3 PHASE FAULT ON WEST END OF L7004 AT IR084
 OPENS IN 5.5 CYCLES

FILE: a99.2-7004w_3ph_ir84-2013WP-NS-0-drr-1.out

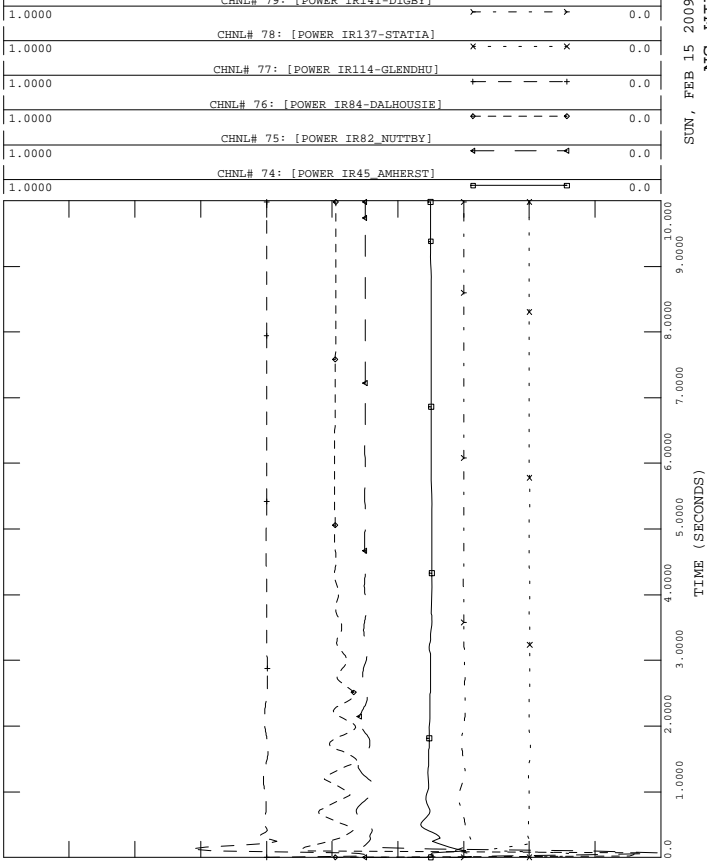

2013 WINTER PEAK STORA MIN
 NS-NB=0; NB-NE=500; CBX=732; ONI=961 ONS=851
 3 PHASE FAULT ON WEST END OF L7004 AT IR084
 OPENS IN 5.5 CYCLES

FILE: a99.2-7004w_3ph_ir84-2013WP-NS-0-drr-1.out

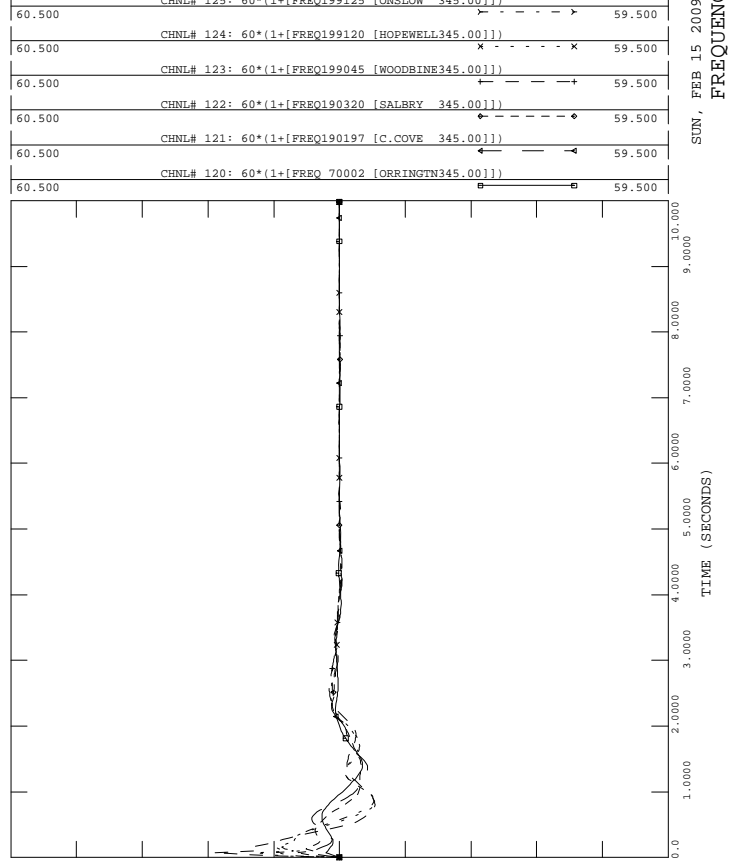



2013 WINTER PEAK STORA MIN
 NS-NB=0; NB-NE=500; CBX=732; ONI=961 ONS=851
 3 PHASE FAULT ON WEST END OF L7004 AT IR084
 OPENS IN 5.5 CYCLES

FILE: a99.2-7004w_3ph_ir84-2013WP-NS-0-drr-1.out
 CHNL# 146: [VOLT199280 [TUSKET_A138.00]]

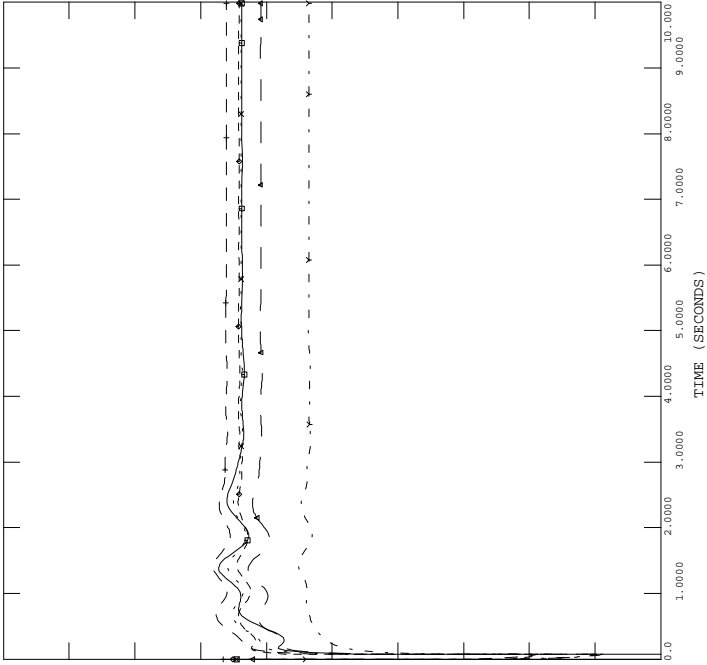
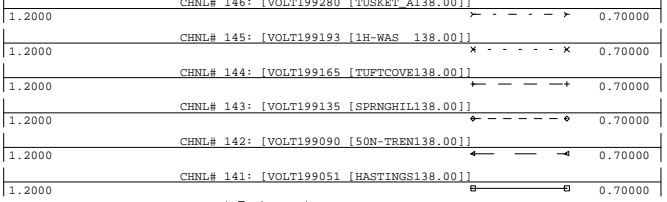

SUN, FEB 15 2009 9:43
 138KV BUS VOLTS



2013 WINTER PEAK STORA MIN
 NS-NB=0; NB-NE=500; CBX=732; ONI=961 ONS=851
 3 PHASE FAULT ON WEST END OF L7004 AT IR084
 OPENS IN 5.5 CYCLES

FILE: a99.2-7004w_3ph_ir84-2013WP-NS-0-drr-1.out
 CHNL# 217: [L6513NMW]

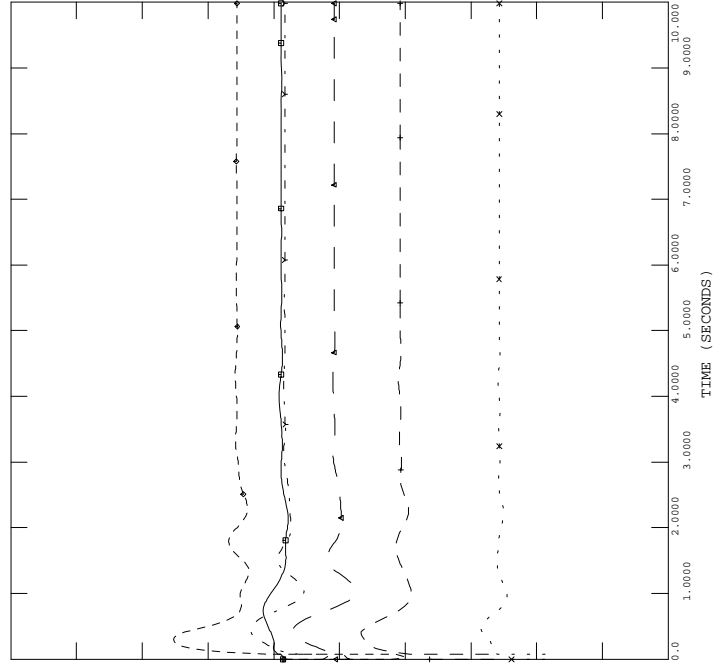
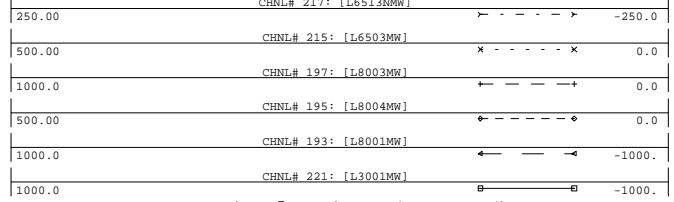

SUN, FEB 15 2009 9:43
 LINE FLOW MW



2013 WINTER PEAK STORA MIN
 NS-NB=0; NB-NE=500; CBX=732; ONI=961 ONS=851
 3 PHASE FAULT ON WEST END OF L7004 AT IR084
 OPENS IN 5.5 CYCLES

FILE: a99.2-7004w_3ph_ir84-2013WP-NS-0-drr-1.out
 CHNL# 140: [VOLT199240 [BRATER_A230.00]]

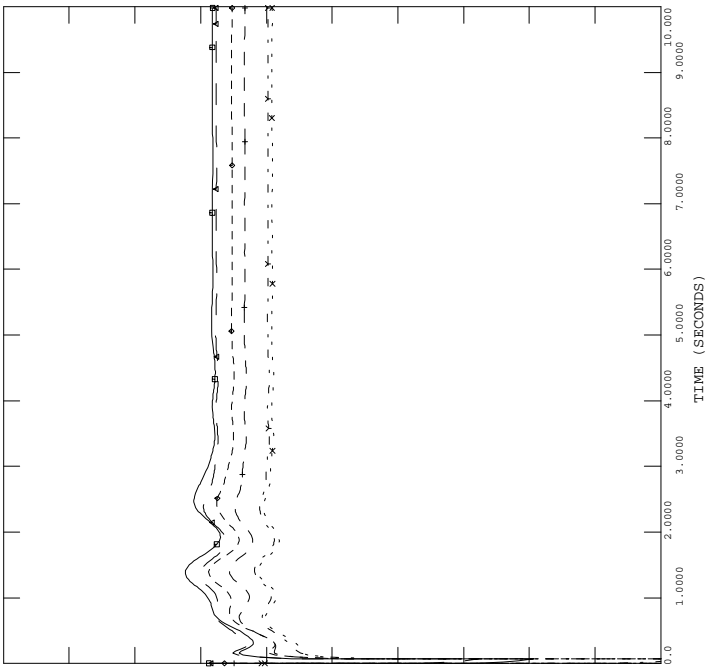
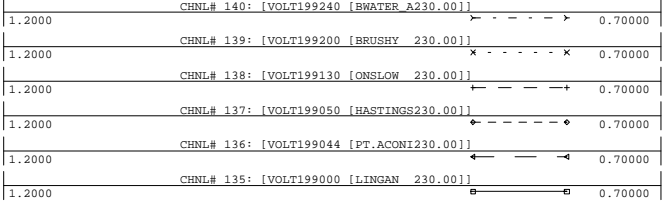

SUN, FEB 15 2009 9:43
 230KV BUS VOLTS



2013 WINTER PEAK STORA MIN
 NS-NB=0; NB-NE=500; CBX=732; ONI=961 ONS=851
 3 PHASE FAULT ON WEST END OF L7004 AT IR084
 OPENS IN 5.5 CYCLES

FILE: a99.2-7004w_3ph_ir84-2013WP-NS-0-drr-1.out
 CHNL# 154: [IR141-DIGBYH69.0 VOLTS]

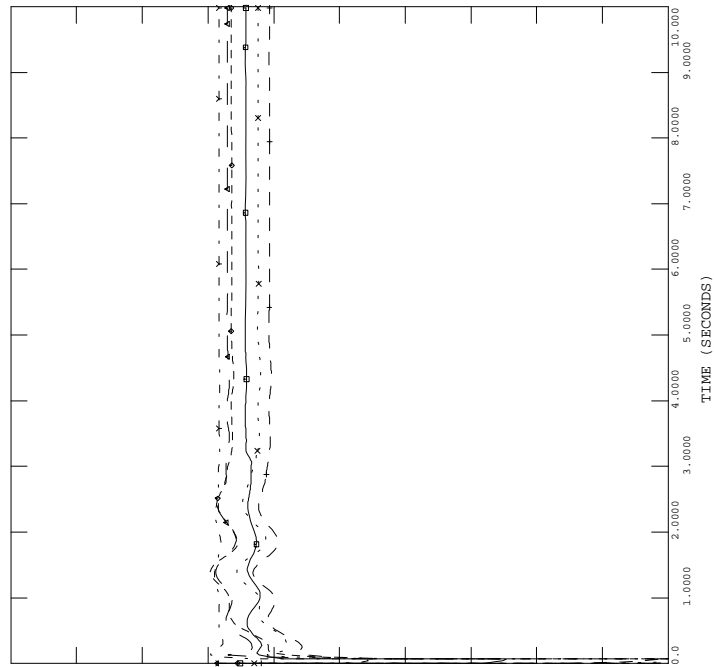
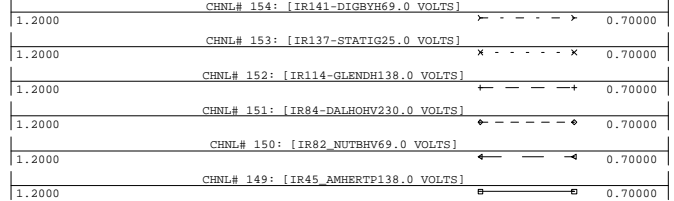

SUN, FEB 15 2009 9:43
 WIND BUS VOLTS

